

**THE BOOK WAS  
DRENCHED**

UNIVERSAL  
LIBRARY

**OU** **166576**

UNIVERSAL  
LIBRARY



**OSMANIA UNIVERSITY LIBRARY**

Call No. *581.13342/S0 67C* Accession No. *3432*

Author *Society . . . . . biology*

Title *Carbon dioxide . . . . . photosynthesis*

This book should be returned on or before the date last marked below.



SYMPOSIA OF THE  
SOCIETY FOR EXPERIMENTAL BIOLOGY

NUMBER V

*Other Publications of the Company of Biologists*

THE JOURNAL OF EXPERIMENTAL BIOLOGY  
THE QUARTERLY JOURNAL OF MICROSCOPICAL SCIENCE

---

*The Oxford University Press on behalf of  
the Society for Experimental Biology publishes*

THE JOURNAL OF EXPERIMENTAL BOTANY

---

*Previous volumes in this series:*

VOL. I (1947): NUCLEIC ACID

VOL. II (1948): GROWTH IN RELATION TO DIFFER-  
ENTIATION AND MORPHOGENESIS

VOL. III (1949): SELECTIVE TOXICITY AND ANTI-  
BIOTICS

VOL. IV (1950): PHYSIOLOGICAL MECHANISMS IN  
ANIMAL BEHAVIOUR

SYMPOSIA OF THE  
SOCIETY FOR EXPERIMENTAL BIOLOGY

---

NUMBER V

CARBON DIOXIDE FIXATION  
AND  
PHOTOSYNTHESIS

*Published for the Company of Biologists  
on behalf of the Society for Experimental Biology*

CAMBRIDGE: AT THE UNIVERSITY PRESS  
1951

PUBLISHED BY  
THE SYNDICS OF THE CAMBRIDGE UNIVERSITY PRESS

London Office: Bentley House, N.W. 1

Agents for U.S.A., Academic Press Inc.,  
125 East 23rd Street, New York, 10

Agents for Canada, India, and Pakistan: Macmillan

*Printed in Great Britain at the University Press, Cambridge  
(Brooke Crutchley, University Printer)*

## CONTENTS

	PAGE
<i>Preface</i>	vii
Carbon Dioxide Fixation in Animal Tissues <i>by</i> H. A. KREBS	1
A Consideration of some Reactions Involving Carbon Dioxide Fixation <i>by</i> H. G. WOOD	9
Biosynthesis of Dicarboxylic and Tricarboxylic Acids by Carbon Dioxide Fixation <i>by</i> S. OCHOA	29
Oxalacetic Decarboxylase and Carbon Dioxide Assimilation in Bacteria <i>by</i> D. HERBERT	52
Carbon Dioxide Fixation and Acid Synthesis in Crassulacean Acid Metabolism <i>by</i> M. THOMAS	72
Assimilation by Green Leaves with Stomatal Control Eliminated <i>by</i> O. V. S. HEATH	94
Some Physical Aspects of Assimilation and Transpiration <i>by</i> H. L. PENMAN <i>and</i> R. K. SCHOFIELD	115
The Photochemical Formation and Reactions of Atoms and Radicals in Aqueous Systems <i>by</i> M. G. EVANS <i>and</i> N. URI	130
Photochemical Oxidation-Reduction Processes in Aqueous Systems <i>by</i> J. WEISS	141
Resonance Transfer of Energy between Molecules <i>by</i> E. J. BOWEN	152
The Physical Background of Photosynthesis <i>by</i> J. FRANCK	160
The Maximum Efficiency of Photosynthesis <i>by</i> M. S. NISHIMURA, C. P. WHITTINGHAM <i>and</i> R. EMERSON	176
Photo-Induced Interactions in Metabolism of Green Plant Cells <i>by</i> B. KOK	211

	PAGE
Reduction by Chloroplasts <i>by</i> R. HILL	222
The Photochemical Reduction Process in Photosynthesis <i>by</i> C. S. FRENCH <i>and</i> H. W. MILNER	232
The Reducing Action of Light in Photosynthesis <i>by</i> E. C. WASSINK	251
Intermediates in Photosynthesis: Formation and Transformation of Phosphoglyceric Acid <i>by</i> H. GAFFRON, E. W. FAGER <i>and</i> J. L. ROSENBERG	262
Carbon Dioxide Assimilation in Plants <i>by</i> M. CALVIN, J. A. BASSHAM, A. A. BENSON, V. H. LYNCH, C. OUELLET, L. SCHOU, W. STEPKA <i>and</i> N. E. TOLBERT	284
Extensions of Photosynthetic Experimentation <i>by</i> O. WARBURG, D. BURK <i>and</i> A. L. SCHADE	306
Three-Vessel and One-Vessel Manometric Techniques for Measuring CO <sub>2</sub> and O <sub>2</sub> Gas Exchanges in Respiration and Photo- synthesis <i>by</i> D. BURK, A. L. SCHADE, J. HUNTER <i>and</i> O. WARBURG	312
The Use of 'CO <sub>2</sub> -Buffers' in Manometric Measurements of Cell Metabolism <i>by</i> H. A. KREBS	336

## PREFACE

The papers presented in this volume were originally read at a Symposium meeting of the Society for Experimental Biology held at Sheffield in July 1950. The meeting was held in the Biochemistry Department of the University of Sheffield, and we have to thank the Council of the University for extending an invitation to the Society for this occasion.

The expenses involved in holding the meeting and in preparing this volume have been met partly by generous contributions from various bodies. In this connexion we wish to thank particularly the Rockefeller Foundation, the British Council, and Imperial Chemical Industries Ltd. We also wish to thank the Cambridge University Press for the kindness and courtesy with which they have assisted us in producing this report.

J. F. DANIELLI

R. BROWN

*Honorary Symposium Secretaries  
Society for Experimental Biology*



# CARBON DIOXIDE FIXATION IN ANIMAL TISSUES

By H. A. KREBS

Medical Research Council Unit for Research in Cell Metabolism,  
Department of Biochemistry, The University of Sheffield

## I. INTRODUCTION

In this introductory paper I propose to consider four aspects of CO<sub>2</sub> fixation in animal tissues. They are, first, the historical development of present knowledge; secondly, the number of primary fixation reactions; thirdly, the question of the quantities of CO<sub>2</sub> that can be fixed; fourthly, the problem of the physiological significance of CO<sub>2</sub> fixation in animal tissues. I omit the discussion of the enzymic mechanisms, as these will be dealt with by subsequent writers.

## II. HISTORICAL DEVELOPMENT

Knowledge of CO<sub>2</sub> fixation in animal tissues may be regarded as having started in 1940 (Evans & Slotin, 1940, 1941; Wood, Werkman, Hemingway & Nier, 1941, 1942; Krebs & Eggleston, 1940*b*). It is true that it had already been clear before 1940 that CO<sub>2</sub> is not an entirely inert end-product of metabolism. It was known to combine with haemoglobin and amino-acids to form carbamino compounds (Roughton, 1935), and it was generally accepted that it serves as the source of carbon in the synthesis of urea (Krebs & Herseleit, 1932). However, these reactions were not looked upon as 'fixation' of CO<sub>2</sub> because they do not lead to the incorporation of CO<sub>2</sub> into the cell structure. The formation of carbamino compounds is a non-enzymic process which is independent of cell metabolism—though not necessarily without physiological significance. As for urea, it was thought (until 1948, when the tracer experiments of Leifer, Roth & Hempelmann (1948) cast doubt on this concept) that it was merely an end-product which was lost by excretion, so that any carbon it contained could not be regarded as 'fixed' by the organism.

The discovery of CO<sub>2</sub> fixation in animal tissues arose from studies of the fate of pyruvic acid in pigeon liver carried out almost simultaneously at Sheffield (Krebs & Eggleston, 1940*b*), Chicago (Evans & Slotin, 1940) and Ames (Wood *et al.* 1941, 1942). This tissue was known to be capable of synthesizing a five-carbon chain from added pyruvic acid. It forms

glutamine from ammonium pyruvate (Örström, Örström, Krebs & Eggleston, 1939) and  $\alpha$ -ketoglutarate from sodium pyruvate (Evans 1940). It was already postulated in 1937 (Krebs & Johnson, 1937; Krebs & Eggleston, 1940*a*) that ketoglutarate can be synthesized in animal tissues when pyruvic acid and oxaloacetic acid are present, the intermediary reactions being stages of the 'citric acid cycle':

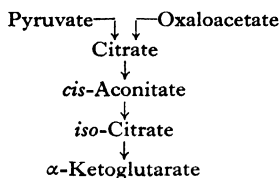

The special feature of pigeon liver was the ability to form ketoglutarate from added pyruvate without addition of a dicarboxylic acid, and the idea suggested itself (Krebs & Eggleston, 1940*b*) that this tissue is capable of synthesizing oxaloacetic from pyruvic acid and  $\text{CO}_2$  and can therefore dispense with an external supply of oxaloacetic. This idea was experimentally supported by the observation that the rate of synthesis of  $\alpha$ -ketoglutaric acid in pigeon liver depended on the concentration of  $\text{CO}_2$ , and that the synthesis is always accompanied by a synthesis of malic acid and of smaller quantities of succinic and citric acid (Krebs & Eggleston, 1940*b*). Thus the metabolic products accumulating in the presence of pyruvate and  $\text{CO}_2$  are identical with those appearing on addition of oxaloacetate (Krebs, Eggleston, Kleinzeller & Smyth, 1940).

Decisive support for this hypothesis came from experiments with isotopic carbons carried out by Evans & Slotin (1940) and Wood *et al.* (1941, 1942). These experiments demonstrated directly the participation of  $\text{CO}_2$  in the synthesis of  $\alpha$ -ketoglutaric acid and of malic acid. In accordance with the theory the fixed carbon was found in the carboxyl groups of the dicarboxylic acids.

Shortly after the discovery of  $\text{CO}_2$  fixation in pigeon-liver preparations, Hastings and his team at Harvard (Wood, Vennesland & Evans, 1945), who had been applying the isotope technique to a study of the conversion of lactate into glycogen, reported that the liver glycogen of fasting rats contained isotopic carbon when the animals had received, together with lactic acid, radioactive carbon in the form of bicarbonate injections (Wood *et al.* 1942). This was confirmed by experiments on liver slices *in vitro* (Buchanan, Hastings & Nesbitt, 1942). The carbon was later located in the carbon atoms 3 and 4 of the glucose molecules (Utter & Wood, 1945, 1946; Vennesland, Evans & Altman, 1947). Calculations

showed that about one in eight carbon atoms of glycogen was derived from bicarbonate (Wood *et al.* 1942).

Tables 1 and 2 list the compounds which, in the investigations already quoted and the subsequent work, have either been directly shown to contain fixed CO<sub>2</sub> or which may, on the grounds of indirect evidence, be assumed to contain fixed CO<sub>2</sub>.

Table 2. *Substances which may be inferred to contain carbon atoms derived from CO<sub>2</sub>*

Substance	Location of fixed carbon	Evidence	Reference
Citrulline	Carbamyl group	Intermediate in the synthesis of arginine	Krebs & Henseleit, 1932; Cohen & Hayano, 1946; Ratner & Pappas, 1949
Guanidino acetic acid	Amidine group	Amidine C is derived from amidine C of arginine	Borsook & Dubnoff, 1940, 1941; Bloch & Schoenheimer, 1940, 1941; du Vigneaud, Chandler, Cohn & Brown, 1940
Creatine	Amidine group	Amidine C is derived from amidine C of arginine	Borsook & Dubnoff, 1940, 1941; Bloch & Schoenheimer, 1940, 1941; du Vigneaud, Chandler, Cohn & Brown, 1940
Hypoxanthine, xanthine, adenine, guanine	Carbon no. 6	Purine bases are immediate precursor in synthesis of uric acid in the pigeon	Edson, Krebs & Model, 1936
Intermediates in the anaerobic reactions leading from glycogen to lactic acid, viz. phosphorylated hexoses and trioses and related compounds	Carbon no. 1 of the phosphates of pyruvate, glycerate, trioses and carbons 3 and 4 of hexose phosphates	Applies if the assumption, that the synthesis of glycogen from lactate is brought about by a reversal of glycolysis, proves correct	
Intermediates in the tricarboxylic acid cycle	Carboxyl groups except that attached to the tertiary carbon of citric acid and those derived from this carboxyl	Applies if the assumption, that oxaloacetate reacts according to the tricarboxylic acid cycle, is correct	

### III. NUMBER OF PRIMARY FIXATION REACTIONS

The results given in Tables 1 and 2 can all be accounted for on the assumption that there are four primary fixation reactions in animal tissues. These may be formulated thus:

- (a) CO<sub>2</sub> + pyruvic acid → oxaloacetic acid.
- (b) CO<sub>2</sub> + α-ketoglutaric acid → oxalosuccinic acid.
- (c) Ornithine + CO<sub>2</sub> + NH<sub>3</sub> → citrulline (primary step probably glutamic acid + CO<sub>2</sub> + NH<sub>3</sub> → carbamyl glutamic acid, Cohen & Grisolia, 1950).
- (d) CO<sub>2</sub> + glycine + formic acid + NH<sub>3</sub> → hypoxanthine (the reaction in pigeon liver leading to the incorporation of CO<sub>2</sub> in position 6 of the purine ring; it cannot be formulated in detail; see Buchanan, Sonne & Delluva, 1947).

Substances which may contain fixed carbon as a result of secondary reactions of the primary fixation product are shown in Table 3. It will be seen that the number of substances which can be formed from the primary reactions (b), (c) and (d) is relatively small. It should be especially emphasized with reference to reaction (b) that no metabolic reactions of the tricarboxylic acids are known which would lead to the incorporation of fixed carbon into other cell constituents (Grisolia & Vennesland, 1947).

Table 3. *Secondary reactions following primary fixation of CO<sub>2</sub>*

Primary product	Oxaloacetic acid	Oxalosuccinic acid	Citrulline	Hypoxanthine
Products of secondary reactions	Pyruvic acid Lactic acid Malic acid Fumaric acid Succinic acid $\alpha$ -Ketoglutaric acid Citric acid <i>cis</i> -Aconitic acid <i>iso</i> -Citric acid Glutamic acid Aspartic acid Alanine Glucose, glycogen Intermediates between lactic acid and glucose	Citric acid <i>iso</i> -Citric acid <i>cis</i> -Aconitic acid	Arginine Guanidino acetic acid Creatine	Xanthine Amino purines Uric acid

On the other hand, the variety of substances that may contain fixed carbon as the result of secondary reactions of oxaloacetate is considerable. The secondary reactions postulated are:

- (i) The reactions of the tricarboxylic acid cycle, including a reversal of this cycle causing a conversion of oxaloacetate into fumarate.
- (ii) The amination of  $\alpha$ -ketoglutarate, oxaloacetate and pyruvate.
- (iii) A synthesis of carbohydrate by the reversal of the reactions of glycolysis.

All the reactions here postulated have been shown to occur either in the intact body or in enzyme preparations. The formation of glutamic acid is brought about by reductive aminations from ammonia and  $\alpha$ -keto-glutarate, that of aspartic acid and alanine by transamination.

## IV. QUANTITATIVE ASPECTS

The results so far discussed are all of a qualitative nature. Relatively little precise information is available on the quantities of  $\text{CO}_2$  that are fixed in the animal body.

Stern (1948), using non-isotopic procedures, tried to measure the rates of the carboxylation of pyruvate and of ketoglutarate in various isolated tissues. The rate of formation of oxaloacetate was investigated by incubating tissues with pyruvate and  $\text{CO}_2$  and determining the accumulation of succinate and  $\alpha$ -ketoglutarate either anaerobically or aerobically in the presence of malonate. Results obtained by this procedure are, at best, as pointed out by Stern, minimum values.

The highest rate of carboxylation of pyruvate was found in pigeon liver,  $Q_{\text{oxaloacetate}}$  ( $\mu\text{l. oxaloacetate}$  formed per mg. dry tissue per hr.) being 19. Sheep-kidney cortex gave a value of 1.7, and in all the other tissues tested (pigeon brain, rat liver, kidney cortex and muscle, guinea-pig liver and brain, and sheep liver, heart, brain, spleen, pancreas and lung) no  $\text{CO}_2$  fixation by pyruvate could be detected with the technique employed, which meant that  $Q_{\text{oxaloacetate}}$  must have been less than one in these tissues. It is thus no accident that pigeon liver was the first animal tissue in which  $\text{CO}_2$  fixation was discovered.

The rate of  $\text{CO}_2$  fixation by carboxylation of  $\alpha$ -ketoglutarate was studied by measuring the formation of citrate under anaerobic conditions. Again pigeon liver showed the highest activity. The rate was very fast within the first few minutes after the addition of  $\alpha$ -ketoglutarate to the tissue suspension, but it fell very rapidly to zero within a few minutes. During the first minute  $Q_{\text{citrate}}$  was 30. Measurable quantities of citrate were formed in pigeon-breast muscle, livers of various mammalian species, and heart muscle and kidney cortex of sheep.

Other quantitative data have been supplied by Hastings and his collaborators. Figures given by Buchanan *et al.* (1942) on the rate of glycogen synthesis in rabbit-liver slices and on the amount of  $\text{CO}_2$  incorporated into the glycogen, form the basis for calculations which show that  $Q_{\text{CO}_2}$  was between  $-0.14$  and  $-0.48$  in four experiments (average  $-0.26$ ). As aspartic and glutamic acids containing  $\text{CO}_2$  were synthesized at the same time (Anfinsen, Beloff, Hastings & Solomon, 1947), these figures are minimum rates. They point to the same order of magnitude as the experiments of Stern, suggesting that the rate of carboxylation of pyruvate is below one in mammalian liver. As the rate of  $\text{CO}_2$  production from respiration, in terms of  $Q_{\text{CO}_2}$ , is about 8-10 in this tissue, the amount of  $\text{CO}_2$  which re-enters metabolism by fixation is less than 10% of that formed.

Quantitative data on the living mouse have been supplied by Skipper, White & Bryan (1949), who injected  $\text{NaHC}^{14}\text{O}_3$  intraperitoneally and examined the  $\text{C}^{14}$  content of the tissues, urine and expired air. More than 90% of the injected carbon appeared in the respiratory  $\text{CO}_2$  within 1 hr., indicating that less than 10% of the injected  $\text{CO}_2$  was fixed. After 25 hr. 1.37% of the injected dose was recovered from the various tissues; most of this was present in the form of organic compounds and not as bicarbonate. Neglecting any  $\text{C}^{14}$  in the bicarbonate of the tissues, this figure could be regarded as giving the minimum for the proportion of  $\text{CO}_2$  fixed, and it would follow that more than 1.37% of the  $\text{CO}_2$  arising in the body was fixed in the experiment. This suggests the same order of magnitude as the data previously quoted. Thus the information so far available indicates that a small percentage of the  $\text{CO}_2$  formed is fixed in the animal body.

With reference to the contribution made to fixation by the various organs, Table 4 (quoted from Skipper *et al.*) is of interest. The highest specific activity was found in the jejunum, liver and blood. The authors suggest that the rapid uptake of carbon by the jejunum may be connected with its high mitotic activity. Of course the recovery of fixed carbon from a tissue does not mean that the primary fixation reaction has occurred in that tissue.

Table 4. *Specific activity (microcuries per mole of carbon) of mouse tissues 24 hr. after injection of  $\text{NaHC}^{14}\text{O}_3$  (18  $\mu\text{c}$ .)*

(According to Skipper *et al.* 1949)

Tissue	Specific activity
Blood	1.09
Spleen	0.73
Liver	1.11
Kidney	0.78
Lungs	0.57
Brain	0.26
Jejunum	2.16
Muscle	0.75
Skin and hair	0.21
Long bones	1.01

## V. PHYSIOLOGICAL SIGNIFICANCE OF $\text{CO}_2$ FIXATION

A reason for the occurrence of  $\text{CO}_2$  fixation suggests itself in a number of cases where  $\text{CO}_2$  is used in the synthesis of substances required by the organism. This may be said in particular of the reactions leading to the formation of oxaloacetate and of the purine derivatives. On the other hand, it cannot be claimed that the significance of the carboxylation of  $\alpha$ -ketoglutarate or of the incorporation of  $\text{CO}_2$  into glucose is understood.

The Harvard group (Solomon, Vennessland, Klemperer, Buchanan & Hastings, 1941) had originally suggested that oxaloacetate may be an obligatory intermediate in the formation of phosphopyruvate from pyruvate, but this hypothesis lost its appeal when it became known (Lardy & Ziegler, 1945) that pyruvate can be phosphorylated directly. The assumption is made by Topper & Hastings (1949) that a 'shuttle' mechanism is continuously proceeding at a relatively rapid rate, whereby lactic acid, via pyruvic and oxaloacetic acids, is reversibly converted into fumaric acid, according to the following scheme:

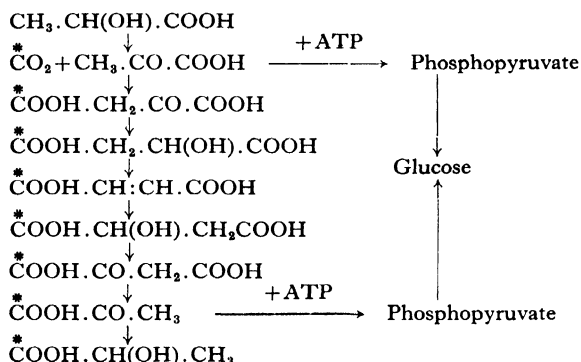

The 'shuttle' results in the incorporation of fixed  $\text{CO}_2$  into the carboxyl group of pyruvic acid. If this mechanism is to account for the incorporation of  $\text{CO}_2$  into glycogen, the rate of incorporation of fixed  $\text{CO}_2$  into pyruvic acid through the 'shuttle' must be about four times as fast as the direct phosphorylation of pyruvic acid (Topper & Hastings, 1949). All the component reactions of the 'shuttle' have been shown to take place, but its significance is still a matter for conjecture. Perhaps this 'shuttle' is part of that 'dynamic state' which causes most constituents of living matter to undergo continuous breakdown and rebuilding. This 'dynamic state' is known to apply to tissue proteins, phospholipids, nucleic acids and other substances. Even inorganic cell constituents are continuously exchanged with the environment (Krebs, Eggleston & Turner, 1950). It appears that the dynamic state is an attribute of living matter generally and the possibility cannot be dismissed that some of the fixation reactions in animal tissues (excepting, e.g. purine synthesis) are part of this dynamic behaviour. Before we can hope to understand their full significance we may therefore have to wait until the meaning of the dynamic state of cell constituents in general has been elucidated.

## REFERENCES

- ANFENSEN, C. B., BELOFF, A., HASTINGS, A. B. & SOLOMON, A. K. (1947). *J. Biol. Chem.* **168**, 771.
- ANFENSEN, C. B., BELOFF, A. & SOLOMON, A. K. (1949). *J. Biol. Chem.* **179**, 1001.
- BLOCH, K. & SCHOENHEIMER, R. (1940). *J. Biol. Chem.* **133**, 633.
- BLOCH, K. & SCHOENHEIMER, R. (1941). *J. Biol. Chem.* **138**, 167.
- BORSOOK, H. & DUBNOFF, J. W. (1940). *J. Biol. Chem.* **132**, 559.
- BORSOOK, H. & DUBNOFF, J. W. (1941). *J. Biol. Chem.* **138**, 389.
- BUCHANAN, J. M., HASTINGS, A. B. & NESBETT, F. B. (1942). *J. Biol. Chem.* **145**, 715.
- BUCHANAN, J. M., SONNE, J. C. & DELLUVA, A. M. (1947). *J. Biol. Chem.* **173**, 81.
- COHEN, P. P. & GRISOLIA, S. (1950). *J. Biol. Chem.* **182**, 747.
- COHEN, P. P. & HAYANO, M. (1946). *J. Biol. Chem.* **166**, 239 and 251.
- DELLUVA, A. M. & WILSON, D. W. (1946). *J. Biol. Chem.* **166**, 739.
- EDSON, N. L., KREBS, H. A. & MODEL, A. (1936). *Biochem. J.* **30**, 1380.
- EVANS, E. A. Jr. (1940). *Biochem. J.* **34**, 829.
- EVANS, E. A. Jr. & SLOTIN, L. (1940). *J. Biol. Chem.* **136**, 301.
- EVANS, E. A. Jr. & SLOTIN, L. (1941). *J. Biol. Chem.* **141**, 439.
- GRISOLIA, S. & VENNESLAND, B. (1947). *J. Biol. Chem.* **170**, 461.
- KREBS, H. A. & EGGLESTON, L. V. (1940a). *Biochem. J.* **34**, 442.
- KREBS, H. A. & EGGLESTON, L. V. (1940b). *Biochem. J.* **34**, 1383.
- KREBS, H. A., EGGLESTON, L. V., KLEINZELLER, A. & SMYTH, D. H. (1940). *Biochem. J.* **34**, 1234.
- KREBS, H. A., EGGLESTON, L. V. & TERNER, C. (1950). *Biochem. J.* **47** (in the Press).
- KREBS, H. A. & HENSELEIT, K. (1932). *Hoppe-Seyl. Z.* **210**, 33.
- KREBS, H. A. & JOHNSON, W. A. (1937). *Enzymologia*, **4**, 148.
- LARDY, H. A. & ZIEGLER, J. A. (1945). *J. Biol. Chem.* **159**, 343.
- LEIFER, E., ROTH, L. J. & HEMPELMANN, L. H. (1948). *Science*, **108**, 748.
- LORBER, V., HEMINGWAY, A. & NIER, A. O. (1943). *J. Biol. Chem.* **151**, 647.
- MEHLER, A. H., KORNBERG, A., GRISOLIA, S. & OCHOA, S. (1948). *J. Biol. Chem.* **174**, 961.
- OCHOA, S. (1948). *J. Biol. Chem.* **174**, 133.
- OCHOA, S., MEHLER, A. H. & KORNBERG, A. (1948). *J. Biol. Chem.* **174**, 979.
- ÖRSTRÖM, A., ÖRSTRÖM, M., KREBS, H. A. & EGGLESTON, L. V. (1939). *Biochem. J.* **33**, 995.
- RATNER, S. & PAPPAS, A. (1949). *J. Biol. Chem.* **179**, 1183 and 1199.
- ROUGHTON, F. J. W. (1935). *Physiol. Rev.* **15**, 241.
- SKIPPER, H. E., WHITE, L. Jr. & BRYAN, C. E. (1949). *J. Biol. Chem.* **180**, 1187.
- SOLOMON, A. K., VENNESLAND, B., KLEMPERER, F. W., BUCHANAN, J. M. & HASTINGS, A. B. (1941). *J. Biol. Chem.* **140**, 171.
- STERN, J. R. (1948). *Biochem. J.* **43**, 616.
- TOPPER, Y. J. & HASTINGS, A. B. (1949). *J. Biol. Chem.* **179**, 1255.
- UTTER, M. F. & WOOD, H. G. (1945). *J. Biol. Chem.* **160**, 375.
- UTTER, M. F. & WOOD, H. G. (1946). *J. Biol. Chem.* **164**, 455.
- VENNESLAND, B., EVANS, E. A. Jr. & ALTMAN, K. I. (1947). *J. Biol. Chem.* **171**, 675.
- DU VIGNEAUD, V., CHANDLER, J. P., COHN, M. & BROWN, G. B. (1940). *J. Biol. Chem.* **134**, 787.
- WOOD, H. G., LIFSON, N. & LORBER, V. (1945). *J. Biol. Chem.* **159**, 475.
- WOOD, H. G., VENNESLAND, B. & EVANS, E. A. Jr. (1945). *J. Biol. Chem.* **159**, 153.
- WOOD, H. G., WERKMAN, C. H., HEMINGWAY, A. & NIER, A. O. (1941). *J. Biol. Chem.* **139**, 483.
- WOOD, H. G., WERKMAN, C. H., HEMINGWAY, A. & NIER, A. O. (1942). *J. Biol. Chem.* **142**, 31.

# A CONSIDERATION OF SOME REACTIONS INVOLVING CARBON DIOXIDE FIXATION

By HARLAND G. WOOD

Department of Biochemistry, Western Reserve University,  
Cleveland 6, Ohio

## I. INTRODUCTION

During the fifteen years that have elapsed since the discovery of CO<sub>2</sub> fixation by heterotrophic bacteria (Wood & Werkman, 1935, 1936), it has been shown that utilization of CO<sub>2</sub> occurs in most forms of life (cf. Werkman & Wood, 1942; Krebs, 1943; Evans, 1944; Ochoa, 1946; Buchanan & Hastings, 1946; Wood, 1946). The number of compounds in which CO<sub>2</sub> has been found to be incorporated by animals, bacteria, yeast and molds is quite extensive, and will undoubtedly grow from year to year. It includes the members of the oxidative citric acid cycle as well as the amino-acids which are derived from these compounds, and, in addition, many other compounds. The list was summarized in 1946 (Wood, 1946), and since then the most notable additions have been the purines (Sonne, Buchanan & Delluva, 1948) and pyrimidines (Heinrich, Wilson & Gurin, 1949).

## II. ESSENTIAL FUNCTION OF CO<sub>2</sub>

Much remains to be done before the full significance of CO<sub>2</sub> fixation can be assessed in metabolism. One of the questions that remain unanswered is whether or not CO<sub>2</sub> fixation is an essential step in normal heterotrophic metabolism or whether the occurrence of fixed CO<sub>2</sub> is due largely to side reactions which are not required for metabolism. For example, the route of CO<sub>2</sub> into many compounds probably stems from the initial fixation of CO<sub>2</sub> in the C<sub>4</sub>-dicarboxylic acid, oxalacetate or malate. The problem presented is whether or not this fixation reaction is the main source of the C<sub>4</sub>-dicarboxylic acids or whether the source is another reaction and the CO<sub>2</sub> fixation is a side path. By way of illustration the formulae on p. 10 may serve as examples of two different possible mechanisms.

In (I), CO<sub>2</sub> fixation is essential since the fixation reaction is considered the only mechanism of making C<sub>4</sub>-dicarboxylic acids. In (II), the CO<sub>2</sub> fixation is an alternative way of making C<sub>4</sub>-dicarboxylic acids, but is not essential. Its role would depend upon the relative rates of the condensation of CH<sub>3</sub>COX to give a C<sub>4</sub>-dicarboxylic acid and the fixation reaction. The

condensation of  $2\text{CH}_3\text{COX}$  to a  $\text{C}_4$ -dicarboxylic acid has long been speculated upon, and the evidence for such a reaction is accumulating; for example, see Foster, Carson, Anthony, Davis, Jefferson & Long (1949) for the most recent evidence of such a reaction.

I.  $\text{CO}_2$  fixation essential:

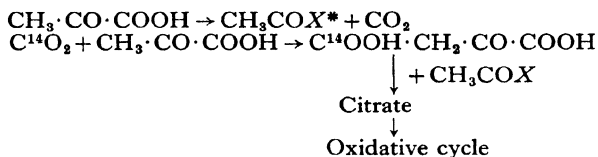

II.  $\text{CO}_2$  fixation non-essential:

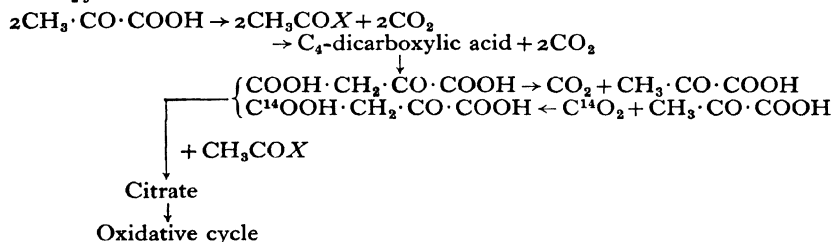

Even though  $\text{C}_4$ -dicarboxylic acids may be formed in some instances by mechanisms other than  $\text{CO}_2$  fixation, there is reason to believe that the  $\text{CO}_2$  fixation reaction is an essential part of oxidation at least in certain systems. For example, Krebs & Eggleston (1940) with pigeon liver and Green, Loomis & Auerbach (1948) with a rabbit-kidney preparation, showed that the presence of  $\text{CO}_2$  stimulates oxidation and with Green's system  $\text{CO}_2$  was necessary for oxidation of pyruvate. Furthermore, if  $\text{CO}_2$  is carefully excluded from the medium, bacteria, yeast and fungi fail to grow or grow slowly (Rockwell & Highberger, 1927; Winslow, Walker & Stutermeister, 1932; Gladstone, Fildes & Richardson, 1935), but in this case it is by no means clear what the function of  $\text{CO}_2$  is; possibly it is necessary for nucleic acid synthesis.

This discussion emphasizes a fairly obvious point which none the less often is omitted from consideration, i.e. when an isotope is found to enter a compound it does not necessarily follow that it is an essential part of the synthesis. The isotope may enter by side reactions, a possibility which was recognized early in  $\text{CO}_2$  fixation studies (Werkman & Wood, 1942, p. 176).

\*  $\text{CH}_3\text{COX}$  is used to indicate that a  $\text{C}_2$  compound is formed which is probably a derivative of acetate.

## III. PRIMARY FIXATION REACTIONS

Another problem of importance is the determination of the number of primary fixation reactions and what is the detailed mechanism of these primary reactions. A primary fixation is defined as a reaction by which an organic carbon-to-carbon linkage is initially formed between  $\text{CO}_2$  and some compound, and it is contrasted with the secondary reactions, whereby a great many compounds are derived from the primary fixation product. Recognition and elucidation of the primary fixation reactions is at the present time probably the most important problem which confronts investigators of  $\text{CO}_2$  fixation. Once the primary products of  $\text{CO}_2$  fixation are known it will be possible to elucidate the pathways whereby  $\text{CO}_2$  carbon finds its way into other compounds. Furthermore, the information gained about the kinetics and intimate chemistry of these primary reactions will be important not only for the fundamental information it will give relative to general biochemistry, but also for the insight it may give into the problem of photosynthesis. While there may be arguments pro and con as to whether or not photosynthesis can occur by reactions similar to those studied in heterotrophs, it is nevertheless apparent that information on the mechanism of a primary reaction would be welcome knowledge to have as a basis for designing studies of photosynthesis.

The task of elucidating the details of the primary reaction may be more difficult than was that of the demonstration of the universality of  $\text{CO}_2$  fixation. It is quite easy with isotopes to learn that a compound is formed from  $\text{CO}_2$ , but this finding by no means establishes the mechanism by which  $\text{CO}_2$  enters the compound. For an understanding of the mechanism it is necessary to know the intermediate products, the properties of the enzyme, the prosthetic groups involved, etc. The studies on the mechanism and details of the primary reaction will undoubtedly require enzyme purification in order to limit the reaction to a few controlled steps that may be analysed in detail.

These few introductory remarks will serve to point out that the studies in this field have passed through the exploratory stage in which  $\text{CO}_2$  fixation has been found to be a universal process and to note that we now are at the stage of investigating the details of the mechanism of the primary reactions and of assessing the essential functions of  $\text{CO}_2$  fixation. The remainder of the discussion will be devoted to a consideration of primary fixation reactions and will be limited to fixation of  $\text{CO}_2$  in oxalacetate and malate.

## IV. EARLY STUDIES ON OXALACETATE CARBOXYLASE\*

From the earliest investigations to the present time oxalacetate has been considered to be linked with a primary fixation reaction. At first the proposal was based on the purely arbitrary grounds that  $\text{CO}_2$  fixation appeared involved stoichiometrically in succinate formation from glycerol by propionic acid bacteria. Pyruvate seemed to be the most likely  $\text{C}_3$  compound to serve as an intermediate to combine with  $\text{CO}_2$ , and largely on this basis the reaction was suggested (Wood & Werkman, 1938). Support was given to this idea when it was found with  $\text{C}^{13}\text{O}_2$  in the propionic acid fermentation that the isotope appeared exclusively in the carboxyl groups of the succinate (Wood, Werkman, Hemingway & Nier, 1941*a*). This was in agreement with the following proposed reactions:

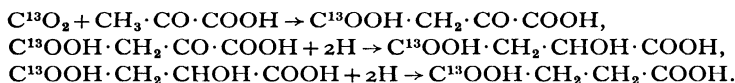

The next important step was the finding that  $\text{CO}_2$  is fixed by pigeon liver in  $\alpha$ -ketoglutarate (Evans & Slotin, 1940), and that the  $\text{CO}_2$  carbon was in the  $\alpha$ -carboxyl only (Wood *et al.* 1941*b*, 1942; Evans & Slotin, 1941). This was interpreted as having occurred by fixation in oxalacetate with the  $\alpha$ -carboxyl labelled  $\alpha$ -ketoglutarate being formed by subsequent transformations through the citric acid cycle.† Furthermore, the distribution of isotope in the other compounds of the cycle such as malate, fumarate and succinate was consistent with these ideas of fixation since  $\text{CO}_2$  carbon was in all cases in the carboxyl groups (Wood *et al.* 1942).

Up to this point, however, there had been no direct studies of the reaction with oxalacetate. Therefore when Krampitz & Werkman (1941) found an enzyme in *Micrococcus lysodeikticus* which catalysed the decarboxylation of oxalacetate it was the first direct indication of the reaction. A short time later Evans, Vennesland & Slotin (1943) and Evans (1944)

\* A more complete review is given in Werkman & Wood (1942) and Wood (1946); only a brief mention of some of the major developments can be given here.

† It is amazing that it required seven years, 1941–8, for biochemists to realize that the fact that  $\text{CO}_2$  was fixed only in the  $\alpha$ -carboxyl of  $\alpha$ -ketoglutarate, was *not* conclusive proof that citrate was not an intermediate in the Krebs cycle. The suggestion (Wood *et al.* 1941*b*, 1942; Evans & Slotin, 1941; Krebs, 1941) that the symmetrical molecule citrate could not give rise to a labelled  $\alpha$ -ketoglutarate with isotope in one carboxyl was accepted by a host of biochemists as proof that citrate did not occur in the cycle. It remained for Ogston (1948) to announce that the isotopic data might be explained on the basis of a 'three-point landing' of citrate on the enzyme surface. Subsequent experiments, first by Heidelberger & Potter (1949) and later by Rudney, Lorber, Utter & Cook (1950), have shown that citrate is indeed a possible intermediate. In retrospect it is clear that enzymes frequently do not treat molecules in a random fashion; as is witnessed by the fact that optically active isomers are produced from symmetrical molecules. This fact indicates that in certain cases symmetrical compounds are activated or accepted by enzymes only when their groups are oriented in a given way.

found a similar enzyme in extracts from acetone-dried pigeon liver. Since that time the bacterial enzyme and the pigeon-liver enzyme and more recently the plant enzymes (Vennesland, Gollub & Speck, 1948) have been the major sources of material for studies of fixation of  $\text{CO}_2$  in oxalacetate and malate.

Although it was not possible with the *M. lysodeikticus* enzyme to show a net conversion of  $\text{CO}_2$  and pyruvate to oxalacetate,\* since no oxalacetate accumulated, it was possible with labelled  $\text{CO}_2$  to present evidence that the reaction probably was reversible since  $\text{CO}_2$  entered the  $\beta$ -carboxyl of the oxalacetate (Krampitz, Wood & Werkman, 1943).

#### V. CONDITIONS OF THE OXALACETATE $\beta$ -CARBOXYLASE TEST

It is important at this point to note the conditions under which this experiment is conducted, because it is largely on the basis of this test that the evidence for primary fixation in oxalacetate has been obtained. Oxalacetate, labelled bicarbonate and the enzyme preparations are the beginning components of the mixture and the reaction is conducted under anaerobic conditions. The reaction is allowed to proceed until about 50% of the oxalacetate is broken down, and then the residual oxalacetate is degraded to determine the location of the isotope in the molecule. The test is based on the following reasoning. Even though the equilibrium is far toward pyruvate and  $\text{CO}_2$ , so that a net synthesis of oxalacetate cannot be obtained, if the reaction is reversible, there should be synthesis as well as breakdown at all times. In this way isotopic  $\text{CO}_2$  would enter the oxalacetate. By stopping the reaction before it reaches equilibrium (at which time little oxalacetate would remain) there is sufficient oxalacetate left for a degradation of the oxalacetate and the location of the isotope can then be accomplished quite readily.

The enzyme preparations used in these tests usually were not purified, but under the conditions of the experiment appear to give a quantitative conversion of oxalacetate to pyruvate and  $\text{CO}_2$  (Krampitz & Werkman, 1941; Utter & Wood, 1945, 1946):

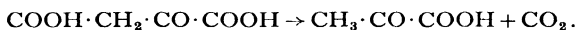

Although the conversion appears to be a simple decarboxylation reaction it is to be noted that it is not certain that there may not be intermediate products in the reaction. Pyruvate and  $\text{CO}_2$  as such may not be the direct

\* Kalnitsky & Werkman (1944) have observed the formation of oxalacetate or a chemically similar compound from pyruvate and bicarbonate under anaerobic conditions with an extract of *E. coli*. There were other reactions occurring in the mixture, so it is not certain that the 'oxalacetate' was formed by a direct reaction.

reactants in the reversal of the reaction, i.e. in the synthesis of 'oxalacetate', in fact we shall see that there is some evidence that neither  $\text{CO}_2$  nor pyruvate is the direct reactant in the fixation.

It is to be noted that oxalacetate is written above in quotes. This is done because it remains possible that the compound that is analysed as oxalacetate may be a derivative of oxalacetate which has properties similar to oxalacetate or under conditions of the test is converted to oxalacetate. For purposes of illustration, the following reaction is written in which  $(C_4)$ ,  $(C_3)$  and  $(C_1)$  represent derivatives of oxalacetate, pyruvate, and  $\text{CO}_2$  respectively:

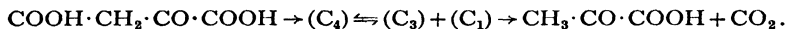

In most of the tests for fixed  $\text{CO}_2$  in 'oxalacetate' the oxalacetate has not been isolated but rather the carboxyl of the 'oxalacetate' has been obtained by treatment of the deproteinized reaction mixture with either aniline citrate,  $\text{Al}^{+++}$ , or acid and heat. These treatments are believed to be fairly specific for decarboxylation of the  $\beta$ -carboxyl of  $\beta$ -keto acids,  $\text{Al}^{+++}$  probably being the most specific. The  $\text{CO}_2$  resulting from the decarboxylation has been analysed for isotope, and the fact that this  $\text{CO}_2$  contains isotope has been taken as an indication that  $\text{CO}_2$  is fixed in the  $\beta$ -carbon of oxalacetate. Thus the  $\text{CO}_2$  obtained by aniline-citrate,  $\text{Al}^{+++}$ , or acid-heat reactions is used as an indicator of the reversal of the oxalacetate  $\beta$ -carboxylase reaction. It is of course evident that a derivative of oxalacetate, the  $(C_4)$  in the equation, might be decarboxylated as well as the oxalacetate and yield the isotopic  $\text{CO}_2$ . We shall see in discussing the work of Utter (1950) that he has attempted to test this point by subjecting the reaction mixture to partition chromatography on silica gel. The acid containing fixed  $\text{CO}_2$  behaves exactly as oxalacetate; thus if  $(C_4)$  is not oxalacetate, it probably is very labile and yields oxalacetate under the conditions of the separation.

Typical results from an early experiment (Krampitz *et al.* 1943, Table I) with *M. lysodeikticus* were as follows:

<i>Oxalacetate</i>	
Excess $\text{C}^{13}$ (%)	
0.14	0.02
$\text{COOH}\cdot\text{CH}_2\cdot\text{CO}\cdot\text{COOH}$	
$\beta$	$\alpha$

The original bicarbonate of the reaction contained 7.1% excess  $\text{C}^{13}$ . The isotope in the  $\alpha$ -carboxyl was obtained by ceric sulphate oxidation, after the  $\beta$ -carboxyl was removed by treatment with acid heat, and was considered of questionable significance.

VI. PIGEON LIVER OXALACETATE  $\beta$ -CARBOXYLASE

Although it was possible with *M. lysodeikticus* to obtain what appeared to be a direct fixation of  $\text{CO}_2$  in 'oxalacetate' with oxalacetate and  $\text{CO}_2$  as the only substrates, it was not at first possible to obtain the same results with the pigeon-liver extract. Although the pigeon-liver extract decarboxylated oxalacetate to pyruvate rapidly (Evans *et al.* 1943), it did not fix  $\text{CO}_2$  in 'oxalacetate' under conditions of the oxalacetate  $\beta$ -carboxylase test (Wood, Vennesland & Evans, 1945). On the other hand, on a mixed substrate of fumarate and pyruvate a very rapid fixation of  $\text{CO}_2$  occurred (Evans *et al.* 1943) and the fixed  $\text{CO}_2$  was exclusively in the carboxyl groups of the resulting fumarate, malate, pyruvate and lactate (Wood *et al.* 1945). The reaction was believed to involve conversion of the fumarate to malate and then oxidation of the malate to oxalacetate with pyruvate acting as the hydrogen acceptor. The oxalacetate was believed to pick up  $\text{CO}_2$  by reversibility of the oxalacetate  $\beta$ -carboxylase reaction and by dynamic equilibrium between the different compounds, the isotope was dispersed into all carboxyl groups. This system gave a remarkably high fixation and was obviously very suitable for studies of  $\text{CO}_2$  assimilation. It remained a puzzle why the direct test for reversibility of the oxalacetate  $\beta$ -carboxylase should be negative. A partial answer was obtained by Utter & Wood (1945, 1946) who found, when ATP was added, that there was a rapid fixation of  $\text{CO}_2$  in 'oxalacetate'.

Whether or not ATP was generated in the reaction studied by Evans *et al.* (1943) and Wood *et al.* (1945), and this permitted the fixation to occur with the mixed substrate is not entirely certain. We shall see in considering  $\text{CO}_2$  fixation by the malate enzyme that it is possible that the  $\text{CO}_2$  was fixed with the mixed substrates by the malate enzyme of Ochoa.

VII.  $\text{CO}_2$  FIXATION WITH THE MALATE ENZYME

We shall now consider another method of investigating  $\text{CO}_2$  fixation which seems to be very closely linked with oxalacetate  $\beta$ -carboxylase fixation of  $\text{CO}_2$  but nevertheless presents differences which cannot be adequately explained at the time of this writing.

Ochoa and co-workers (Ochoa, Mehler & Kornberg, 1947; Mehler, Kornberg, Grisolia & Ochoa, 1948; Ochoa, Mehler & Kornberg, 1948) took up the study of  $\text{CO}_2$  fixation in  $\text{C}_4$ -dicarboxylic acid using spectrophotometric methods such as were employed in their discovery of fixation of  $\text{CO}_2$  in tricarboxylic acids (Ochoa, 1948). From the extract of acetone-dried pigeon liver they obtained a partially purified and new enzyme which catalysed reversibly the following TPN-specific reaction

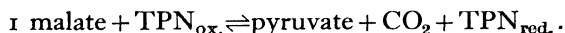

The reaction may be followed spectrophotometrically by measurement of light absorption by the TPN at  $340\text{ m}\mu$ . For example, starting with malate and oxidized TPN, as the reaction proceeds the TPN is reduced and the absorption at  $340\text{ m}\mu$  increases so that the rate and extent of the reaction can be measured by the light taken up by the reduced TPN. On the other hand, with the enzyme, reduced TPN, and pyruvate the reaction is very slow (light absorption does not decrease) unless  $\text{CO}_2$  as  $\text{NaHCO}_3$  is added. This shows the requirement of  $\text{CO}_2$  for the reaction.

The equilibrium point is far toward pyruvate and  $\text{CO}_2$ , so that it is necessary to couple the reaction with another reaction which will remove the oxidized TPN if it is desired to drive the reaction toward malate. This has been accomplished by adding glucose-6- $\text{PO}_4$  and glucose-6- $\text{PO}_4$ -dehydrogenase to the reaction. In this way  $\text{TPN}_{\text{ox}}$  is reduced by the glucose-6- $\text{PO}_4$  which in turn is converted to 6-phosphogluconate:

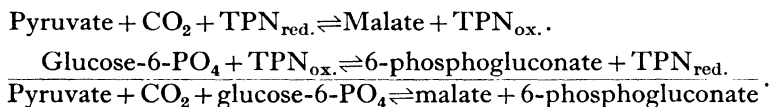

The equilibria of this coupled reaction are such that malate will accumulate. Using this method, the synthesis of malate from pyruvate and  $\text{CO}_2$  has been accomplished. The malate was identified by enzymatic methods (Ochoa *et al.* 1948).

During purification of the enzyme the activity for decarboxylation of oxalacetate is retained, and in fact the ratio of the anaerobic decarboxylation of oxalacetate and the dehydrogenation of malate is practically constant throughout the purification (Ochoa *et al.* 1948). This fact seems to indicate that a single enzyme or functional enzyme unit may be involved in the two reactions.

#### VIII. COMPARISON OF MALATE ENZYME AND OXALACETATE $\beta$ -CARBOXYLASE

**OXALACETATE.** The malate enzyme decarboxylates oxalacetate as does the oxalacetate  $\beta$ -carboxylase, but there has been no evidence that the malate enzyme utilizes oxalacetate as an intermediate in the fixation of  $\text{CO}_2$ . Attempts to obtain reduction of oxalacetate with  $\text{TPN}_{\text{red.}}$  and the malate enzyme have in fact been unsuccessful (Ochoa *et al.* 1948, p. 996), such a reaction would probably occur if oxalacetate was an intermediate.

**TPN.** The malate enzyme requires TPN for the fixation of  $\text{CO}_2$  whereas the oxalacetate  $\beta$ -carboxylase fixation is not greatly influenced by TPN (Vennesland, Evans & Altman, 1947; Utter, 1948).

*ATP.* The fixation of  $\text{CO}_2$  by the malate enzyme is not increased by ATP and is fully active in the absence of inorganic phosphate. Ochoa *et al.* (1948, p. 996) indicate that this may exclude phosphorylated intermediates as components of the reaction, although they note that it remains possible that the third phosphate of TPN might be involved in phosphorylation. The function of ATP in the oxalacetate  $\beta$ -carboxylase test cannot be to phosphorylate DPN to give TPN, since TPN has little effect on the fixation.

Since the studies with ATP and oxalacetate have been done with relatively crude enzyme preparations, Ochoa (1950) has suggested that the ATP effect may be indirect and that malate may be the initial fixation product in all cases. He has suggested that the crude dialysed enzyme preparation may not be free of DPN or TPN, and he has proposed that the ATP might act by inducing malate formation from oxalacetate. The  $\text{CO}_2$  would first be fixed in malate, and it in turn would be transformed to oxalacetate. The action of ATP would be as follows: the glycogen present in the extracted crude-liver enzyme would be acted on by ATP, phosphorylase, phosphohexokinase, and aldolase to yield triose phosphate. Triose phosphate thus formed would, through a coupled action of triose- $\text{PO}_4$ -dehydrogenase and malate dehydrogenase, yield malate and phosphoglycerate:

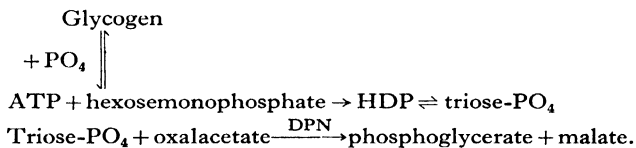

The malate would then react through the malate enzyme and exchange  $\text{CO}_2$  in the  $\beta$ -carboxyl; it would then be converted to oxalacetate by malic dehydrogenase. Accordingly, ATP and oxalacetate would have no direct action in the  $\text{CO}_2$  fixation.

The problem posed was whether malate was the first compound in which isotope appeared in the oxalacetate  $\beta$ -carboxylase system. This question has been investigated by Dr M. F. Utter as part of an extensive study which he has been conducting on  $\text{CO}_2$  fixation at Western Reserve University. These experiments are the subject of the following discussion.

#### IX. FIXATION IN OXALACETATE IN THE $\beta$ -CARBOXYLASE REACTION

If ATP has an indirect effect on  $\text{CO}_2$  fixation in oxalacetate by causing a production of malate, then malate should replace the ATP in the oxalacetate  $\beta$ -carboxylase reaction. Utter (1950) therefore studied the

effect of replacement of ATP by malate and found that addition of malate in the absence of ATP caused only a slight fixation in the oxalacetate. It remained possible, however, that the ATP served to aid both in the synthesis of malate and TPN, and that addition of ATP was equivalent to addition of both TPN and malate.

In order to obtain more conclusive evidence that malate was not a precursor in the oxalacetate  $\beta$ -carboxylase reaction it was desirable to determine the specific activity of the  $\beta$ -carboxyl of both oxalacetate and malate in a reaction mixture to which ATP was added. If malate as such is a precursor of oxalacetate, its activity should be at least as high as the oxalacetate at all times. The reaction, therefore, was set up with the dialysed extract, ATP ( $6.25 \times 10^{-4}M$ ) and equal amounts of oxalacetate and malate ( $0.037M$ ). The bicarbonate contained 20,000 counts/min./mg. C and was  $0.05M$ . The reaction was allowed to proceed for varying lengths of time, and then the activity of the malate and oxalacetate was measured. This was accomplished by decarboxylating one-half of the reaction mixture with  $Al^{+++}$  to obtain the  $\beta$ -carboxyl of the oxalacetate. The other half was used to obtain the malate. The oxalacetate was first removed through decarboxylation by heating in acid solution, then the mixture was placed on a celite column and the fumaric and pyruvic acids were removed by elution with 5% butyl alcohol in chloroform. Subsequently the malic acid was eluted with ether and was then decarboxylated with *Lactobacillus arabinosus* (Korkes & Ochoa, 1948). This separation was necessary because *L. arabinosus* decarboxylates fumarate and oxalacetate. Also with a mixture of malate and pyruvate more than 1 mM. of  $CO_2$  per mM. of malate was obtained, although pyruvate alone was not decarboxylated, and with malate alone the ratio of  $CO_2$  to malate decomposed by the bacteria was 1 to 1.

The results of an experiment on fixation of  $CO_2$  in malate and oxalacetate in the presence of ATP were as follows:

Time in min.	Counts/min./mg. C in $\beta$ -carboxyl		Ratio of activities
	Oxalacetate	Malate	
4	649	207	3.13
8	810	400	2.04
16	947	781	1.21

It is seen from these results that the fixation during the first 4 min. is more than three times as rapid in the oxalacetate as in the malate. As the time is increased the malate reaches almost the same activity as the oxalacetate. This equality may have been accomplished either by intercon-

version of the oxalacetate to malate through the DPN malate dehydrogenase enzyme or through fixation of  $\text{CO}_2$  in malate by the TPN malate enzyme. It is probable that a combination of both reactions occurs. At any rate when the enzyme extract of the acetone-dried pigeon liver was given a preliminary treatment with washed and centrifuged rat-brain particles which contained DPNase and perhaps TPNase and the test was done as above, at 4 min. a ratio of 9 to 1 was obtained for the  $\beta$ -carboxyl of oxalacetate to that of malate. Even at 16 min. the ratio was 5 to 1. Thus under these conditions, where DPN was removed from the enzyme, the fixation in oxalacetate was far faster than it was in malate. From these results it is rather clear that malate is not an obligatory precursor of oxalacetate. Some of the assumptions made in reaching this and subsequent conclusions are discussed later in the paper.

#### X. FIXATION IN MALATE BY THE MALATE ENZYME

It was of interest to conduct the same type of experiment under conditions in which the malate enzyme would be favoured, to determine if under these conditions malate acquired isotope more rapidly than did oxalacetate. To test this point the experiment was set up as in the previous case except that the ATP was omitted and was replaced with  $2.5 \times 10^{-4}\text{M}$  TPN. The results were as follows:

Time in min.	Counts/min./mg. C in $\beta$ -carboxyl		Ratio of activities
	Oxalacetate	Malate	
4	86	361	0.24
8	250	436	0.57
16	597	799	0.75

These results show that in this case fixation of  $\text{CO}_2$  in oxalacetate was only one-fourth as fast as it was in malate. It may be concluded, therefore, that in the presence of TPN there is fixation in malate without oxalacetate occurring as a precursor. This then confirms Ochoa's (1950) idea that oxalacetate is not directly involved in the reaction of the malate enzyme. On the basis of these results it might be concluded that the reactions of the malate enzyme and oxalacetate  $\beta$ -carboxylase are completely independent, although this may not necessarily be the case as will be seen from later discussion.

#### XI. PURITY OF THE OXALACETATE AND MALATE

The question of whether or not the reactions used to obtain the  $\beta$ -carboxyl of malate and oxalacetate are specific is of considerable importance as noted previously, since it is possible that there may be intermediate compounds

formed in which the isotopic  $\text{CO}_2$  is fixed. This is especially true in the case of the 'oxalacetate' as determined by the  $\text{Al}^{+++}$  reaction, since the test was done on the unfractionated mixture. To obtain information on this problem Utter (1950) separated the acids from a reaction mixture using partition chromatography with butanol-chloroform on a silica gel column. For this purpose the reaction was set up to secure the largest fixation in oxalacetate, i.e. 4 min. with ATP and no added TPN, and with enzyme treated with washed centrifuged rat-brain particles to destroy the DPN. An aliquot of the reaction was treated with  $\text{Al}^{+++}$  in the usual way to obtain the  $\beta$ -carboxyl value. The remainder of the mixture was chromatographed, and the fraction of eluate containing oxalacetate was split into three approximately equal sections. These parts were then degraded with  $\text{Al}^{+++}$ . If the material were homogeneous, all portions should contain equal specific activity. The results were as follows:

Direct determination	Fractions from silica gel column		
	First	Middle	Last
369	416	429	440
396	432	444	445

The values are from duplicate  $\text{BaCO}_3$  plates in counts/min./mg. C on the  $\beta$ -carboxyl of the oxalacetate. The results indicate that the carbon obtained by the direct determination may have been slightly contaminated by a small amount of normal carbon. The three fractions obtained from the silica gel column were homogeneous in so far as activity of the  $\beta$ -carboxyl was concerned, and thus there was no evidence by this method that the fixation was in any compound other than oxalacetate. If there was such fixation, the compound must have been converted to oxalacetate by the mild chemical treatment.

Malate from a similar experiment was separated from the silica column, and the diphenylacetyl ester prepared and purified by recrystallization. The malate was recovered from the ester by saponification and degraded with *L. arabinosus*. The results were as follows:

Direct determination	Phenylacetyl ester
58.3	60.2
58.8	57.6

The figures are counts/min./mg. C of the  $\beta$ -carboxyl. The data show that the fraction analysed as malate, using the bacterial degradation, had the same activity as the purified diphenylacetyl ester. On this basis, therefore,

there was no evidence that the fixed  $\text{CO}_2$  was in a derivative of malate. If such were present, either the derivative was acted on by the bacteria or the derivative was broken down to malate during the fractionation.

## XII. PRECURSORS OF PYRUVATE AND $\text{CO}_2$ IN $\beta$ -CARBOXYLATION

It is seen from the above discussion that 'oxalacetate' is the product of the oxalacetate  $\beta$ -carboxylase enzyme and 'malate' of the malate enzyme. Before discussing these results further I would like to present another portion of the investigation which Dr Utter (Utter & Chenoweth, 1949) has undertaken.

It was indicated previously in discussing the oxalacetate  $\beta$ -carboxylase test that there was a possibility that pyruvate was not the direct reactant in the test. By way of illustration the reaction was written as follows:

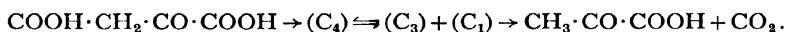

The above equation indicates that  $\text{CO}_2$  or a derivative ( $\text{C}_1$ ) may react with an intermediate  $\text{C}_3$ -compound rather than with pyruvate. In this case the transformation of pyruvate to 'oxalacetate' would depend on its prior conversion to the  $\text{C}_3$ -compound.

If  $\text{CO}_2$  is converted to oxalacetate by combining directly with pyruvate, the uptake of labelled  $\text{CO}_2$  and labelled pyruvate in oxalacetate would be expected to be the same in the  $\beta$ -carboxylase test when the concentration and the specific activity of the pyruvate and  $\text{CO}_2$  were the same. Furthermore, with carboxyl-labelled pyruvate, the isotope from pyruvate would be in the  $\alpha$ -carboxyl and that from the  $\text{CO}_2$  in the  $\beta$ -carboxyl, therefore the ratio of the activities of  $\beta$ -carboxyl to  $\alpha$ -carboxyl would be 1. It thus seemed possible to obtain some information about this hypothesis by conducting the oxalacetate  $\beta$ -carboxylase test in the presence of labelled pyruvate and labelled  $\text{CO}_2$ . Therefore pyruvate labelled in the carboxyl group was synthesized from  $\text{C}^{14}$ -NaCN and normal acetyl bromide by way of pyruvonitrile and pyruvamide (Anker, 1948). In testing the reaction the procedure was more complicated than the usual  $\text{CO}_2$  fixation experiment because it was necessary to obtain the oxalacetate free of the added  $\text{C}^{14}$ -pyruvate. This was accomplished by precipitation of the mercurous salt of oxalacetate and by silica gel chromatography. The isolated oxalacetate was degraded as follows:

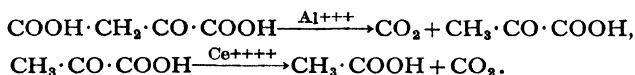

The activity of the  $\text{CO}_2$  from these two reactions was considered representative of the  $\beta$ -carboxyl and  $\alpha$ -carboxyl respectively of the oxalacetate.

Some typical results of experiments are shown in the following table. The reaction mixture contained the pigeon-liver enzyme, normal oxalacetate,  $\text{NaHC}^{14}\text{O}_3$ ,  $\text{CH}_3 \cdot \text{CO} \cdot \text{C}^{14}\text{OOH}$ , ATP and  $\text{Mn}^{++}$ , and the incubation time was 30 min. These preparations were different in age and treatment and have been selected to show wide variation in the ratio.

Preparation	Counts/min./mg. C		$\frac{\beta\text{-COOH}}{\alpha\text{-COOH}}$
	$\beta\text{-COOH}$	$\alpha\text{-COOH}$	
A	103	173	0.6
B	308	289	1.06
C	935	161	5.8
D	282	15	18.8

All counts are based on addition of 10,000 counts each of  $\text{NaHC}^{14}\text{O}_3$  and  $\text{CH}_3 \cdot \text{CO} \cdot \text{C}^{14}\text{OOH}$ . Values for  $\alpha\text{-COOH}$ 's have been corrected by subtraction of controls.

As noted above, if the pyruvate and  $\text{CO}_2$  were the actual reactants and the added isotopic  $\text{CO}_2$  and pyruvate were in complete equilibrium on the enzyme surface with the enzymatically formed substances, then the ratio of the  $\beta$  to  $\alpha$  carboxyls should be 1. Actually with the four different preparations there was a wide variation in the ratios. There were instances where only 0.6 molecule of the added radioactive  $\text{CO}_2$  was fixed for every molecule of added pyruvate, and others where the situation was just reversed and as many as 19 molecules of  $\text{CO}_2$  were fixed for each molecule of pyruvate. It is apparent from experiments such as these that there was no correlation between  $\text{CO}_2$  fixation and pyruvate incorporation. These observations indicate that  $\text{CO}_2$  may be fixed in oxalacetate by combination with a molecule other than pyruvate, and therefore that pyruvate may not be the immediate 3-carbon fragment that combines with  $\text{CO}_2$ . There is also evidence of the reverse situation. These conclusions are based on the assumption, which will be discussed in further detail later, of complete equilibration of the reactants and added pyruvate and  $\text{CO}_2$ . It is to be noted that these experiments were done prior to the experiments discussed above in which it was shown that there is fixation in both malate and oxalacetate, especially during the relatively long 30 min. incubation period. It therefore is possible that both the malate enzyme and the oxalacetate  $\beta$ -carboxylase enzyme may be concerned in these results.

As far as is known at present the different ratios were a consequence of the use of different enzyme preparations. Preparations which had been held for some period of time or which had been prepared by acetone treatment at higher temperatures seemed to have lost all or part of the ability to incorporate pyruvate, while retaining some of the ability to fix  $\text{CO}_2$ .

XIII. EFFECT OF ATP ON PYRUVATE  
 AND CO<sub>2</sub> INCORPORATION

It had been shown previously that ATP greatly stimulates CO<sub>2</sub> fixation (Utter & Wood, 1945, 1946), and it therefore was of interest to determine what the effect of ATP would be on the incorporation of pyruvate in oxalacetate. The results were as follows:

Exp. no.	Additions			Counts/min./mg. C	
	ATP	NaHC*O <sub>3</sub>	CH <sub>3</sub> ·CO·C*OOH	β-COOH	α-COOH
A	+	—	+	0	321
A	—	—	+	0	246
B	+	+	—	342	0
B	—	+	—	21	0
B	+	+	+	323	303
B	—	+	+	43	171

C<sup>14</sup> added: approximately 11,000 counts each as NaHC<sup>14</sup>O<sub>3</sub> and CH<sub>3</sub>·CO·C<sup>14</sup>OOH.

In the experiments where labelled bicarbonate or pyruvate was not added it was replaced with an equivalent amount of the non-labelled compound.

It is seen that omission of ATP has far less effect on incorporation of pyruvate than it does on CO<sub>2</sub> fixation, and that the pyruvate carboxyl goes only to the α-carboxyl of oxalacetate and CO<sub>2</sub> only to the β-carboxyl. The experiment of the last line of the table is of special interest. Here, where both the NaHCO<sub>3</sub> and pyruvate were equally labelled and in the same concentration and no ATP was added, the pyruvate went into the oxalacetate four times as fast as did the CO<sub>2</sub>. This shows that not only can CO<sub>2</sub> be fixed without simultaneous pyruvate incorporation but the reverse is true, that pyruvate can be incorporated in oxalacetate without equivalent CO<sub>2</sub> fixation. In some experiments the ratio of activities of the α-carboxyl to β-carboxyl in the oxalacetate were as high as 10 to 1. These results are obtained by simply omitting ATP which is necessary for CO<sub>2</sub> fixation. It is possible that the pyruvate is entering the oxalacetate through action of the malate enzyme and that CO<sub>2</sub> is not a direct reactant with this enzyme. It is just as likely, however, that the incorporation of pyruvate is by the oxalacetate β-carboxylase reaction and that pyruvate can be converted to the C<sub>3</sub> precursor in the absence of ATP, but CO<sub>2</sub> cannot be converted to the C<sub>1</sub> precursor as illustrated below:

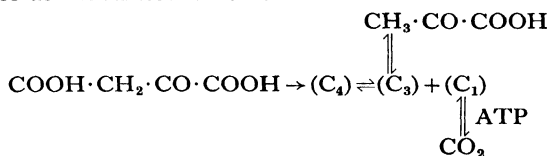

There is, of course, the possibility that the precursors are not simple derivatives of  $\text{CO}_2$  and pyruvate; the process might be a cyclic process where a larger molecule is formed by combination of pyruvate or  $\text{CO}_2$  with a carrier.

The results of Utter's investigations on this phase of the problem can be summarized as follows:

Type of enzymatic preparation	ATP	Type of oxalacetate formed in presence of $\text{NaHC}^*\text{O}_3$ and $\text{CH}_3\cdot\text{CO}\cdot\text{C}^*\text{OOH}$
Aged (?)	—	$\text{COOH}\cdot\text{CH}_2\cdot\text{CO}\cdot\text{COOH}$
	+	$\text{C}^*\text{OOH}\cdot\text{CH}_2\cdot\text{CO}\cdot\text{COOH}$
Fresh	—	$\text{COOH}\cdot\text{CH}_2\cdot\text{CO}\cdot\text{C}^*\text{OOH}$
	+	$\text{C}^*\text{OOH}\cdot\text{CH}_2\cdot\text{CO}\cdot\text{C}^*\text{OOH}$

Thus, in the absence of ATP, certain preparations incorporate neither  $\text{CO}_2$  nor pyruvate in significant amounts, but with addition of ATP there is fixation of  $\text{CO}_2$  in 'oxalacetate'. In other preparations in the absence of ATP there is substantial incorporation of pyruvate but very little  $\text{CO}_2$  is fixed; when ATP is added both  $\text{CO}_2$  and pyruvate are incorporated.

In considering the significance of these results it is to be noted that it is assumed that the added  $\text{C}^{14}$  compounds are equilibrated with the corresponding compounds formed on the enzyme. It therefore remains possible that the difference in rate of incorporation of  $\text{CO}_2$  and pyruvate may not be due to a difference in rate of conversion to  $\text{C}_3$ - and  $\text{C}_1$ -precursors but may be the result of differences in rate of exchange on the enzyme surface by the  $\text{C}^{14}$ -pyruvate and  $\text{C}^{14}\text{O}_2$  as illustrated below:

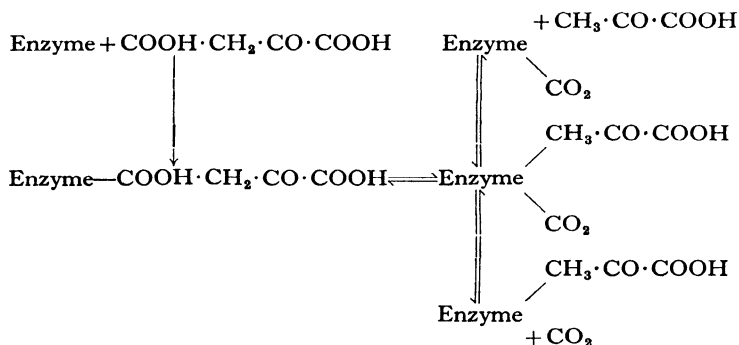

Accordingly the differences might be due to differences in the rate of exchange of the enzyme-pyruvate complex and as compared to this enzyme- $\text{CO}_2$  complex, and these rates might be influenced by ATP as well as by other circumstances. It is to be noted that the enzyme-pyruvate

complex and enzyme-CO<sub>2</sub> complex may be considered precursors in themselves. The complex may involve a rather stable linkage between pyruvate or CO<sub>2</sub> with the protein or a prosthetic group and formation of this linkage may be dependent on ATP or a TPN-linked oxidation.

In these experiments, as in the previous experiments in which activities of oxalacetate and malate are compared, it is necessary to assume that all forms of a given compound are in equilibrium. For example, in the case of CO<sub>2</sub>, there would be gaseous CO<sub>2</sub>, H<sub>2</sub>CO<sub>3</sub>, HCO<sub>3</sub><sup>-</sup>, CO<sub>3</sub><sup>=</sup> or for oxalacetate the *cis* enol, *trans* enol and *keto* forms, etc. Thus if the *cis* enol form was the type added and the type formed in the enzyme reaction was the *trans* enol form, it would be necessary to assume that equilibration of the *cis* and *trans* forms were not the rate-limiting reactions. Stated briefly, in a test such as this, the added radioactive compound must undergo conversion to the form that is involved in the enzyme reaction, it must combine with the enzyme and undergo reaction to yield the oxalacetate and the oxalacetate must split off from the enzyme. It is obvious that in comparing incorporation of two compounds all these factors must be taken into consideration. The assumptions made in this study are the same as those made in many isotope experiments and, in fact, fewer assumptions are made than often is the case, since the enzyme system is cell-free and the reaction under study is relatively simple. Although it is clear that no final conclusion can be reached, from the results it nevertheless appears probable to the author that the large differences observed would not be obtained unless both CO<sub>2</sub> and pyruvate involved precursors of some type in the fixation reaction.

#### XIV. FIXATION OF CO<sub>2</sub> IN OXALACETATE BY *MICROCOCCUS LYSODEIKTICUS*

Another part of the investigation of CO<sub>2</sub> fixation at Western Reserve University is being conducted by Miss McManus (1950), with *M. lysodeikticus*. It will be recalled that Krampitz *et al.* (1943) did not add ATP in their tests of fixation of CO<sub>2</sub> in oxalacetate. They were using an acetone-washed bacterial suspension, so it remained possible that ATP was present in the cells. Miss McManus has now studied the fixation, using cell-free, thoroughly dialysed extracts which were obtained from centrifuged lysed cell suspensions. ATP has been found to have little effect on the rate of this fixation. This finding is in marked contrast to the results with the pigeon-liver enzyme (Utter & Wood, 1945, 1946; Vennessland *et al.* 1947), but is similar to the results found with the plant enzymes by Vennessland *et al.* (1948).

McManus's results are of further interest because she has shown that the enzyme preparation is apparently free of the malate enzyme. When the bacterial extract obtained from lysed cells was incubated with  $\text{NaHC}^{14}\text{O}_3$ , oxalacetate and malate, and the relative specific activities of the  $\beta$ -carboxyls of the two acids were compared, it was found that even after 25 min. there was no fixation in the malate, whereas there was substantial fixation in the oxalacetate. Furthermore, the addition of TPN had little effect on the fixation in either compound. When the  $\text{CO}_2$  fixation experiments were done with lysed suspensions a small amount of  $\text{CO}_2$  entered the malate, but the fixation was small compared to the oxalacetate.

Time (min.)	TPN	Extract		Lysed suspension	
		Oxalacetate*	Malate*	Oxalacetate*	Malate*
5	+	237	0	245	5
25	-	362	0	350	38
	+	401	3	339	38

\* All values are counts/min./mg. C of the  $\beta$ -COOH of the compound.

It appears from these results that malate is not an intermediate in the fixation of  $\text{CO}_2$  in oxalacetate in this system, and that  $\text{CO}_2$  enters malate very slowly as compared with the pigeon-liver enzymes. The lack of effect of TPN gives an indication that Ochoa's 'malate' enzyme may be absent or inactive in this preparation.

It is interesting to record that in the experiments performed thus far DPN also has no stimulatory effect on the fixation of  $\text{CO}_2$  in oxalacetate or malate. Since the preparation used contains malate dehydrogenase, it would be expected that the 'oxalacetate' would come to equilibrium with the malate as it does with the pigeon-liver extracts. Apparently the 'oxalacetate' formed by the fixation reaction is not reduced by the malate dehydrogenase, which suggests that it is a different form of oxalacetate and recalls the results of Krampitz, Wood and Werkman (1943) who found a so-called physiological form of oxalacetate to be formed from fumarate by *M. lysodeikticus*.

#### XV. SUMMARY OF FIXATION OF $\text{CO}_2$ IN $\text{C}_4$ -DICARBOXYLIC ACIDS

The above-described investigations show that the oxalacetate  $\beta$ -carboxylase fixation occurs without malate as a direct participant. With the pigeon-liver enzyme, ATP is directly concerned in the reaction in some manner and seems to be coupled with the activation of  $\text{CO}_2$  in an unknown fashion. On the other hand, Utter has confirmed and extended the idea expressed by

Ochoa that the malate enzyme does not involve oxalacetate as a direct intermediate in the fixation of  $\text{CO}_2$  in malate. The results further seem to indicate that neither pyruvate nor  $\text{CO}_2$  are direct reactants in the oxalacetate  $\beta$ -carboxylase reaction, although it remains possible that the direct precursor is an enzyme complex or isomeric form of the added compounds. The interrelation of the malate enzyme and the oxalacetate  $\beta$ -carboxylase remains obscure. It seems unlikely that they are not linked in some way, and it remains possible that there is a labile  $\text{C}_4$ -dicarboxylic acid intermediate which is common to both reactions.\* Possibly in the presence of ATP this intermediate accumulates and is analysed by procedures so far used for oxalacetate. In the presence of TPN this intermediate would presumably be reduced to malate. The conversion of the  $\text{C}_4$  intermediate to oxalacetate might be non-enzymatic but more likely enzymatic. It seems reasonable, in view of the number of steps which appear to occur, that the conversion may involve more than one enzyme. There is no indication that the function of ATP is to stimulate synthesis of one of the known coenzymes. Utter has attempted to replace ATP by numerous known coenzymes and in no case has there been an indication of activity by known cofactors. Further speculation is not justified at the present moment on the mechanism of the reaction, and more work with purified enzymes will probably be required before a final solution of the problem is available. It is truly surprising that this seemingly straightforward reaction between oxalacetate,  $\text{CO}_2$  and pyruvate should be so involved and the solution of the mechanism of this, the earliest recognized primary fixation, will be awaited with great interest.

The author wishes to thank Dr M. F. Utter for permission to use his unpublished data and for his contribution through extensive discussions of the interpretation of the significance of the data.

#### REFERENCES

- ANKER, H. S. (1948). *J. Biol. Chem.* **176**, 1333.  
BUCHANAN, J. M. & HASTINGS, A. B. (1946). *Physiol. Rev.* **26**, 120.  
EVANS, E. A., Jr. (1944). *Harvey Lectures*, **39**, 273.

\* Utter has obtained evidence for such a compound.  $\text{C}^{14}$ -oxalacetate was prepared in the oxalacetate  $\beta$ -carboxylase test system and then the reaction mixture was adjusted to pH 5 and the  $\text{C}^{14}\text{O}_2$  was removed. The residual oxalacetate was then allowed to decarboxylate under  $\text{N}_2$  and the activity of the  $\beta$  carboxyl was determined at 15 minute intervals with  $\text{Al}^{+++}$ . It was found that its activity increased with time. It thus seems apparent that the residual oxalacetate was not homogeneous but contained at least two fractions both of which are decarboxylated by  $\text{Al}^{+++}$ , the fraction with the higher specific activity being the least susceptible to the enzymatic decarboxylation. Both fractions apparently are converted to a single homogeneous fraction during the chromatographic separation. It seems probable that the compound with the high specific activity may be the postulated common precursor.

- EVANS, E. A. Jr. & SLOTIN, L. (1940). *J. Biol. Chem.* **136**, 301.
- EVANS, E. A. Jr. & SLOTIN, L. (1941). *J. Biol. Chem.* **141**, 439.
- EVANS, E. A. Jr., VENNESLAND, B. & SLOTIN, L. (1943). *J. Biol. Chem.* **147**, 771.
- FOSTER, J. W., CARSON, S. F., ANTHONY, D. S., DAVIS, J. B., JEFFERSON, W. E. & LONG, M. V. (1949). *Proc. Nat. Acad. Sci., Wash.*, **35**, 663.
- GLADSTONE, G. P., FILDES, P. & RICHARDSON, G. M. (1935). *Brit. J. Exp. Path.* **16**, 335.
- GREEN, D. E., LOOMIS, W. F. & AUERBACH, V. H. (1948). *J. Biol. Chem.* **172**, 389.
- HEIDELBERGER, C. & POTTER, V. R. (1949). *Nature, Lond.*, **164**, 180.
- HEINRICH, M. R., WILSON, D. W. & GURIN, S. (1949). *Fed. Proc.* **8**, 205.
- KALNITSKY, G. & WERKMAN, C. H. (1944). *Arch. Biochem.* **4**, 25.
- KORKES, S. & OCHOA, S. (1948). *J. Biol. Chem.* **176**, 463.
- KRAMPITZ, L. O. & WERKMAN, C. H. (1941). *Biochem. J.* **35**, 595.
- KRAMPITZ, L. O., WOOD, H. G. & WERKMAN, C. H. (1943). *J. Biol. Chem.* **147**, 243.
- KREBS, H. A. (1941). *Nature, Lond.*, **147**, 560.
- KREBS, H. A. (1943). *Advances in Enzymology*, **3**, 191.
- KREBS, H. A. & EGGLESTON, L. V. (1940). *Biochem. J.* **34**, 1383.
- McMANUS, R. (1950). *Fed. Proc.* **9**, 203.
- MEHLER, A. H., KORNBERG, A., GRISOLIA, S. & OCHOA, S. (1948). *J. Biol. Chem.* **174**, 961.
- OCHOA, S. (1946). *Currents in Biochemical Research*. New York: Interscience.
- OCHOA, S. (1948). *J. Biol. Chem.* **174**, 133.
- OCHOA, S., MEHLER, A. & KORNBERG, A. (1947). *J. Biol. Chem.* **167**, 871.
- OCHOA, S., MEHLER, A. H. & KORNBERG, A. (1948). *J. Biol. Chem.* **174**, 979.
- OGSTON, A. G. (1948). *Nature, Lond.*, **162**, 963.
- ROCKWELL, G. E. & HIGHBERGER, J. H. (1927). *J. Infect. Dis.* **40**, 438.
- RUDNEY, H., LORBER, V., UTTER, M. F. & COOK, M. H. (1950). *Fed. Proc.* **9**, 221.
- SALLES, J. B. V., HARARY, I., BANFI, R. & OCHOA, S. (1950). *Nature, Lond.*, **165**, 675.
- SONNE, J. C., BUCHANAN, J. M. & DELLUVA, A. M. (1948). *J. Biol. Chem.* **173**, 69.
- UTTER, M. F. (1948). Cf. Wood, H. G., *Isotopes in Biology and Medicine*, p. 239. Madison: Wisconsin University Press.
- UTTER, M. F. (1950). *Fed. Proc.* **9**, 240.
- UTTER, M. F. & CHENOWETH, M. T. (1949). *Fed. Proc.* **8**, 261.
- UTTER, M. F. & WOOD, H. G. (1945). *J. Biol. Chem.* **160**, 375.
- UTTER, M. F. & WOOD, H. G. (1946). *J. Biol. Chem.* **164**, 455.
- VENNESLAND, B., EVANS, E. A. Jr. & ALTMAN, K. I. (1947). *J. Biol. Chem.* **171**, 675.
- VENNESLAND, B., GOLLUB, M. C. & SPECK, J. F. (1948). *J. Biol. Chem.* **178**, 301.
- WERKMAN, C. H. & WOOD, H. G. (1942). *Advances in Enzymology*, **2**, 135.
- WINSLOW, C. E. A., WALKER, H. H. & STUTERMEISTER, M. (1932). *J. Bact.* **24**, 185.
- WOOD, H. G. (1946). *Physiol. Rev.* **26**, 198.
- WOOD, H. G. & WERKMAN, C. H. (1935). *J. Bact.* **30**, 332.
- WOOD, H. G. & WERKMAN, C. H. (1936). *Biochem. J.* **30**, 48.
- WOOD, H. G. & WERKMAN, C. H. (1938). *Biochem. J.* **32**, 1262.
- WOOD, H. G., WERKMAN, C. H., HEMINGWAY, A. & NIER, A. O. (1941 a). *J. Biol. Chem.* **139**, 365.
- WOOD, H. G., WERKMAN, C. H., HEMINGWAY, A. & NIER, A. O. (1941 b). *J. Biol. Chem.* **139**, 483.
- WOOD, H. G., WERKMAN, C. H., HEMINGWAY, A. & NIER, A. O. (1942). *J. Biol. Chem.* **142**, 31.
- WOOD, H. G., VENNESLAND, B. & EVANS, E. A. Jr. (1945). *J. Biol. Chem.* **159**, 153.

# BIOSYNTHESIS OF DICARBOXYLIC AND TRICARBOXYLIC ACIDS BY CARBON DIOXIDE FIXATION\*

By SEVERO OCHOA

New York University College of Medicine, New York, N.Y.

## I. INTRODUCTION

The biosynthesis of tricarboxylic acids by CO<sub>2</sub> fixation was discovered in 1945. The occurrence of this reaction is due to the reversibility of the oxidative decarboxylation of isocitric acid (Ochoa, 1945) catalysed by an enzyme which is widely distributed in animal and plant cells.

The biosynthesis of dicarboxylic acids by CO<sub>2</sub> fixation was discovered in 1938. Wood & Werkman (1938, 1940) found that CO<sub>2</sub> is utilized for the synthesis of succinic acid during the fermentation of glycerol by propionic acid bacteria and suggested the occurrence of the following reactions:

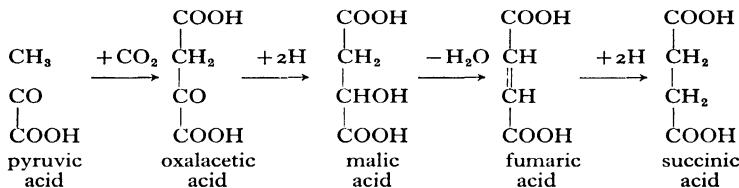

Under these conditions C<sup>13</sup>O<sub>2</sub> is incorporated in the carboxyl groups of succinic acid (Wood *et al.* 1941). These findings explained the observation (Elsden, 1938) that the rate of succinic acid formation in *Escherichia coli* depends on the CO<sub>2</sub> pressure.

CO<sub>2</sub> fixation was also found to be involved in the synthesis of dicarboxylic acids in animal tissues. In the presence of malate, pyruvate, manganous ions, and pyridine nucleotides, cell-free pigeon liver extracts incorporate CO<sub>2</sub> in the carboxyl groups of malate (Evans *et al.* 1943; Wood *et al.* 1945; Moulder *et al.* 1945).

The finding of an enzyme which catalyses the decarboxylation of oxalacetic acid to pyruvic acid and CO<sub>2</sub> (Krampitz & Werkman, 1941; Evans *et al.* 1943; Kalnitsky & Werkman, 1944), suggested that this enzyme might be involved in the synthesis of dicarboxylic acids by CO<sub>2</sub> fixation. Although incorporation of isotopic CO<sub>2</sub> in oxalacetate was obtained with crude

\* This work was aided by grants from the United States Public Health Service, The American Cancer Society (upon recommendation by the Committee on Growth, National Research Council), The Office of Naval Research, and the Rockefeller Foundation.

preparations of this enzyme (Krampitz *et al.* 1943), there is now evidence that this incorporation is not due to straight reversal of oxalacetate decarboxylation.

Light has been shed on the mechanism of synthesis of dicarboxylic acids by CO<sub>2</sub> fixation by the isolation from pigeon liver of an enzyme catalysing the reversible oxidative decarboxylation of malic acid to pyruvic acid and CO<sub>2</sub> (Ochoa *et al.* 1947). This enzyme has subsequently been found to be present in other animal tissues as well as in bacteria and in the tissues of higher plants.

The purpose of the present paper is to review the studies on the enzymic mechanisms of synthesis of dicarboxylic and tricarboxylic acids by CO<sub>2</sub> fixation carried out in our laboratory during the last few years.

## II. BIOSYNTHESIS OF TRICARBOXYLIC ACIDS

Dialysed extracts of washed, acetone-dried, pig heart and partially purified enzyme solutions, obtained from the extracts by fractionation with ammonium sulphate and ethanol (Ochoa, 1948; Graffin & Ochoa, 1950), catalyse the following reactions:

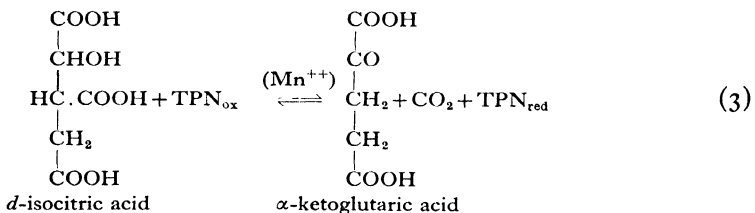
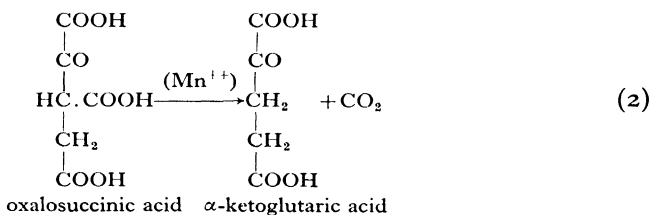
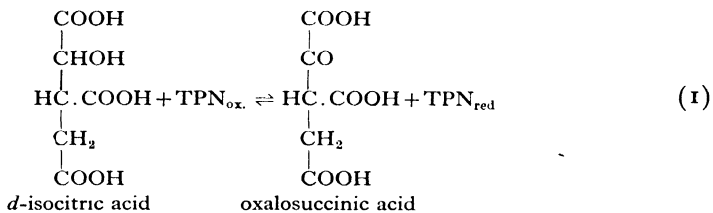

Reaction (1) occurs in the absence of Mn<sup>++</sup>. Its progress in either direction can be followed spectrophotometrically at 340 mμ owing to the

absorption of light of this wavelength by the reduced triphosphopyridine nucleotide.\* There is no evidence that oxalosuccinic acid accumulates when the reaction proceeds to the right, but addition of synthetic oxalosuccinic acid when the reaction to the right comes to a standstill results in a decrease of optical density indicating oxidation of  $\text{TPN}_{\text{red}}$  and progress of the reaction to the left (Ochoa, 1948). Evidence for the occurrence of reaction (2), i.e., the enzyme-catalysed decarboxylation of oxalosuccinic acid, has been independently obtained in two laboratories (Ochoa & Weisz-Tabori,

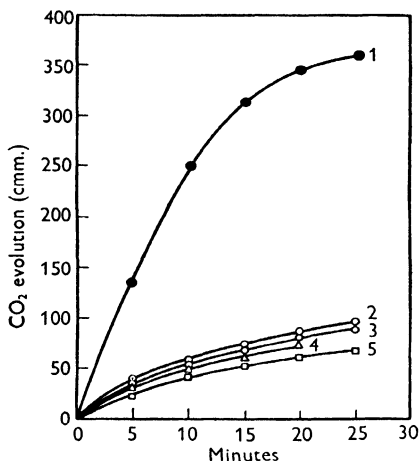

Fig. 1.

Fig. 1. Enzymic decarboxylation of oxalosuccinic acid. 1, complete system (pig-heart enzyme +  $\text{Mn}^{++}$  + oxalosuccinate); 2, no enzyme; 3, no  $\text{Mn}^{++}$ ; 4, boiled enzyme; 5, no enzyme, no  $\text{Mn}^{++}$ . Temperature,  $14^\circ$ .

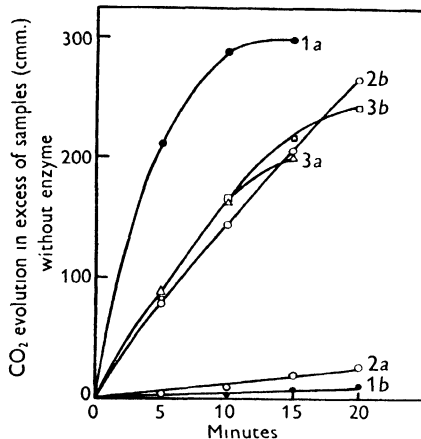

Fig. 2.

Fig. 2. Specificity of oxalosuccinic and oxalacetic carboxylase. a, oxalosuccinate (temperature,  $16^\circ$ ); b, oxalacetate (temperature,  $25^\circ$ ). 1, pig-heart enzyme; 2, *Micrococcus lysodeikticus* enzyme; 3, pigeon-liver extract.

1948; Lynen & Scherer, 1948). Oxalosuccinic acid is very unstable in aqueous solution and rapidly undergoes decarboxylation. Nevertheless, a thermolabile enzyme, present together with isocitric dehydrogenase in enzyme solutions from a variety of sources, catalyses the decarboxylation of the  $\beta$ -keto acid in the presence of  $\text{Mn}^{++}$ . This is illustrated in Fig. 1. The enzyme which catalyses the decarboxylation of oxalosuccinic acid is not identical with the one which catalyses the decarboxylation of oxalacetic acid as is evidenced by the curves in Fig. 2.

\* The following abbreviations are used: DPN, diphosphopyridine nucleotide (coenzyme I); TPN, triphosphopyridine nucleotide (coenzyme II).  $\text{DPN}_{\text{ox}}$  and  $\text{TPN}_{\text{ox}}$ , oxidized form of coenzyme;  $\text{DPN}_{\text{red}}$  and  $\text{TPN}_{\text{red}}$ , reduced form of coenzyme. ATP, adenosine triphosphate (adenyl pyrophosphate).

Progress of reaction (3) in either direction can be readily shown to occur by the spectrophotometric method at 340 m $\mu$ . In the experiment illustrated in Fig. 3, TPN<sub>ox.</sub> was first reduced by glucose-6-phosphate in the presence of glucose-6-phosphate dehydrogenase (Zwischenferment). At arrow 1, a solution of  $\alpha$ -keto-glutaric acid was added along with Mn<sup>++</sup> and a small amount of a solution of bicarbonate saturated with CO<sub>2</sub>; this resulted in some decrease of the optical density of the mixture due to dilution, but

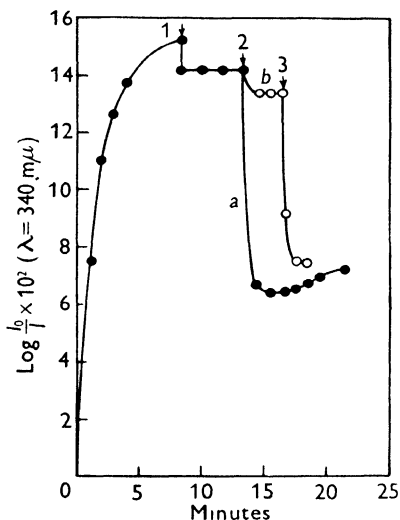

Fig. 3. Optical demonstration of reversibility of reaction 3. Details in text.

after this initial drop it remained stationary until, at arrow 2, a small amount of enzyme solution from pig heart was added. The rapid drop of the optical density (curve *a*) indicates oxidation of TPN<sub>red.</sub> by  $\alpha$ -keto-glutarate and CO<sub>2</sub> in the presence of the heart enzyme and Mn<sup>++</sup>. Curve *b* shows the result of the addition of heart enzyme prior to  $\alpha$ -ketoglutarate. There was no reaction until the keto acid was added (at arrow 3), thus making the enzyme system complete.

By means of the spectrophotometric method it has been possible to determine the equilibrium constant of reaction (3) (Ochoa, 1948). The equilibrium constant of the reaction



was found to have an average value of 1.3 (litres  $\times$  mole<sup>-1</sup>) at 22° and pH 7.0.

$$K = \frac{(d\text{-isocitrate}^{\equiv})(\text{TPN}^+)}{(\alpha\text{-ketoglutarate}^{\equiv})(\text{CO}_2)(\text{TPNH})} = 1.3 \text{ (litres } \times \text{ mole}^{-1}\text{)}.$$

The  $\text{CO}_2$  concentration was calculated from the Bunsen absorption coefficient of  $\text{CO}_2$  by water, at the experimental temperature and  $\text{CO}_2$  partial pressure corrected for the water-vapour pressure. This value gives the total concentration in solution of free  $\text{CO}_2$  as well as of undissociated  $\text{H}_2\text{CO}_3$ . Since the equilibrium of the reaction is probably dependent on the concentration of free  $\text{CO}_2$  in solution, the value for the constant obtained in this way must be considered to contain the hydration equilibrium constant of  $\text{CO}_2$ . The possibility that  $\text{CO}_2$  rather than the bicarbonate ion is involved in biological carboxylations and decarboxylations is strengthened by the results of Krebs and Roughton (1948) who studied the kinetics of urease and carboxylase, in the absence or presence of carbonic anhydrase, and reached the conclusion that  $\text{CO}_2$  is produced directly by the action of the above enzymes on their substrates.

From the experimentally determined value of the equilibrium constant of reaction (3), it can be calculated that for  $(\text{TPN}^+) = (\text{TPNH})$ , in an atmosphere containing 5%  $\text{CO}_2$  ( $(\text{CO}_2) = 1.86 \times 10^{-3}$  moles per litre), the concentration of *d*-isocitrate in equilibrium with 1 mole of  $\alpha$ -ketoglutarate per litre would be 0.0024 mole per litre at pH 7.0 and 22°, or about 0.25% of the ketoglutarate concentration. Thus, although the reaction is readily reversible, its equilibrium position is very far in the direction of decarboxylation. As is evident from a consideration of reaction (3), the reaction can be shifted to the left, i.e. towards  $\text{CO}_2$  fixation, by coupling with a dehydrogenase system of low oxidation-reduction potential, capable of reducing  $\text{TPN}_{\text{ox}}$ . This has been accomplished by means of the glucose-6-phosphate dehydrogenase system of Warburg & Christian.

The following reactions then occur:

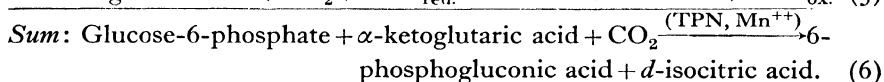
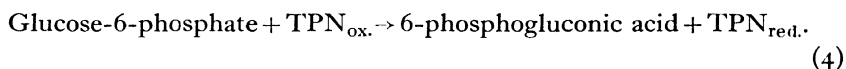

The net result of reactions (4) and (5) is reaction (6). The latter reaction is a TPN-linked dismutation whereby one molecule each of  $\alpha$ -ketoglutaric acid and  $\text{CO}_2$  combine with simultaneous reduction to form *d*-isocitric acid at the expense of the oxidation of one molecule of glucose-6-phosphate to phosphogluconic acid. Glucose-6-phosphate thus furnishes hydrogens and energy for the reductive carboxylation of  $\alpha$ -ketoglutarate. Further shifting of equilibrium in the direction of  $\text{CO}_2$  fixation occurs in the presence of the enzyme aconitase, since over 90% of the isocitric acid is then removed to

form *cis*-aconitic and citric acids. Aconitase catalyses the following reaction (Martius & Leonhardt, 1943; Krebs & Eggleston, 1943):

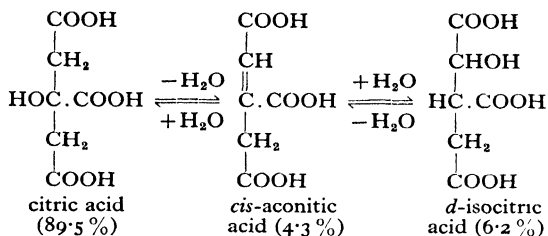

The figures in brackets give the percentage of the three reactants at equilibrium. Because the aconitase equilibrium is so far in favour of citric acid, the overall reaction thus obtained can be written

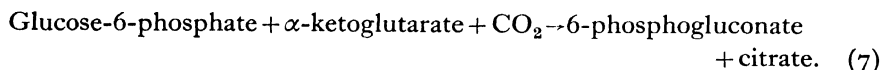

Evidence for the production of *d*-isocitric acid via reaction (6) is presented in Table 1.  $\alpha$ -Ketoglutarate and glucose-6-phosphate were incubated for 1 hr. at 20° in the presence of pig-heart enzyme, glucose-6-phosphate dehydrogenase, bicarbonate, CO<sub>2</sub>, and catalytic amounts of TPN and Mn<sup>++</sup>; pH 7.2. The isocitrate was isolated as a crude barium

Table 1. *Enzymatic identification of d-isocitric acid formed by reaction 6*

Details in text. Values expressed in  $\mu\text{g}$ .

	Time of incubation with aconitase at 25° (min.)	<i>d</i> -Isocitric acid found	Citric acid found
1 c.c. aliquot + aconitase	0	182.0	—
1 c.c. aliquot + aconitase	5	12.6	—
3 c.c. aliquot + aconitase	0	546.0	45°
3 c.c. aliquot + aconitase	10	—	45°

salt. The barium salt was converted to the sodium salt and aliquots of the latter solution were incubated with a crude aconitase preparation from pig heart (Ochoa, 1948). The disappearance of *d*-isocitric acid on incubation with aconitase was followed by enzymic determination (Ochoa, 1948) and the results given in column 3 of Table 1. Column 4 gives the formation of citric acid, determined by a chemical method, on incubation of another aliquot with aconitase. Both the disappearance of *d*-isocitric acid and the formation of citric acid are close to the change expected for establishment of the aconitase equilibrium.

The course of the dismutation between glucose-6-phosphate and

$\alpha$ -ketoglutarate +  $\text{CO}_2$  can be readily followed manometrically at pH 7.0 in a bicarbonate-containing medium. While the absorption of one  $\text{CO}_2$  equivalent is compensated by the liberation from the bicarbonate of another  $\text{CO}_2$  equivalent by the third carboxyl group of the tricarboxylic acid formed ( $\text{pK}_3$  of citric acid at  $25^\circ$ , 5.4), the oxidation of glucose-6-phosphate to phosphogluconic acid creates an extra carboxyl group which displaces a  $\text{CO}_2$  equivalent. Fig. 4 illustrates the course of such a reaction and demonstrates the accelerating effect of aconitase on the reaction rate.

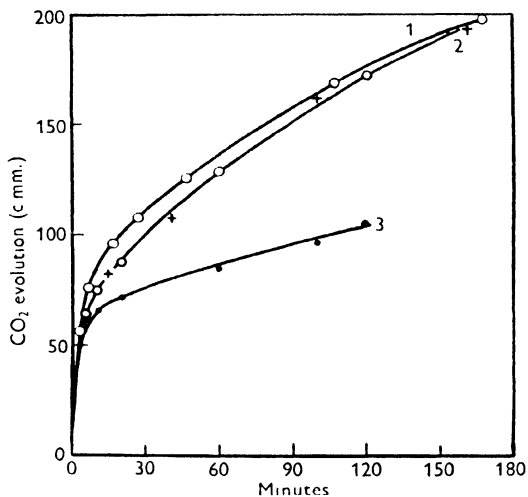

Fig. 4. Time course of dismutation between glucose-6-phosphate and  $\alpha$ -ketoglutarate +  $\text{CO}_2$ . Reaction followed manometrically as explained in text. Initial amount of reactants, 30–70  $\mu\text{mol}$ . of  $\alpha$ -ketoglutarate, 25–65  $\mu\text{mol}$ . of glucose-6-phosphate, 80  $\mu\text{mol}$ . of  $\text{NaHCO}_3$ . Volume, 2 c.c.; gas, 20%  $\text{CO}_2$  and 80%  $\text{N}_2$ ; pH 7; temperature,  $25^\circ$ . 1 and 2, in the presence of aconitase; 3, in the absence of aconitase.

Table 2 shows the results of experiments in which the course of the dismutation, in the absence or presence of aconitase, was followed by separate enzymic determination, at various time intervals, of both *d*-isocitric acid and total tricarboxylic acids (Ochoa, 1948). The heart enzyme used for these experiments contained some aconitase, hence the amount of total tricarboxylic acids in experiment 1 was somewhat higher than that of isocitric acid. Table 3 shows one experiment in which the course of the dismutation in the presence of aconitase (reaction (7)) was followed for 6 hours; both the disappearance of  $\alpha$ -ketoglutarate and glucose-6-phosphate and the production of citrate and phosphogluconate were determined. As explained above, the  $\text{CO}_2$  evolution, which was followed on an aliquot of the reaction mixture, is a measure of the formation of phosphogluconate

from glucose phosphate. Glucose phosphate,  $\alpha$ -ketoglutarate, and citrate were determined by chemical methods on aliquots withdrawn from the main reaction mixture at various time intervals. The reaction mixture was equilibrated with a gas mixture of 80% N and 20% CO<sub>2</sub> throughout the incubation period. While there was a fairly good agreement between the CO<sub>2</sub> evolution (formation of phosphogluconic acid) on the one hand, and

Table 2. *Enzymatic synthesis of tricarboxylic acids by dismutation between glucose-6-phosphate and  $\alpha$ -ketoglutarate + CO<sub>2</sub>*

34  $\mu$ mol. of  $\alpha$ -ketoglutarate, 25  $\mu$ mol. of glucose-6-phosphate, 80  $\mu$ mol. of NaHCO<sub>3</sub>, 2  $\mu$ mol. of MnCl<sub>2</sub>, 0.15  $\mu$ mol. of TPN, pig-heart enzyme, and glucose-6-phosphate dehydrogenase. Volume, 2 c.c.; gas, 20% CO<sub>2</sub> and 80% N<sub>2</sub>; pH 7; temperature, 25°. Values expressed in micrograms.

Exp.	Further additions	Tricarboxylic acid determined	Tricarboxylic acid found			
			10 min.	20 min.	60 min.	120 min.
1	None	<i>d</i> -isocitric	151	202	270	325
1	None	Total	164	225	320	404
2	Aconitase	<i>d</i> -isocitric	18	12	30	32
2	Aconitase	Total	102	180	408	588

Table 3. *Chemical balance of dismutation between glucose-6-phosphate and  $\alpha$ -ketoglutarate + CO<sub>2</sub> in the presence of aconitase*

275  $\mu$ mol. of  $\alpha$ -ketoglutarate, 250  $\mu$ mol. of glucose-6-phosphate, 800  $\mu$ mol. of NaHCO<sub>3</sub>, 20  $\mu$ mol. of MnCl<sub>2</sub>, 1.3  $\mu$ mol. of TPN, pig-heart enzyme, glucose-6-phosphate dehydrogenase, and aconitase. Volume, 20 c.c.; gas, 20% CO<sub>2</sub> and 80% N<sub>2</sub>; pH 7; temperature, 25°. Values expressed in  $\mu$ mol.

Incubation time (hr.)	$\Delta$ Glucose phosphate	$\Delta$ Acid (phosphogluconic)	$\Delta\alpha$ -Ketoglutarate	$\Delta$ Citrate
0.5	—	+27.2	—	+11.2
1	-39	+36.5	—	+20.8
2	—	+46.0	-46.7	+30.5
3	—	+59.0	-57.0	+38.2
6	-102	—	-106.0	+44.0

the removal of  $\alpha$ -ketoglutarate and glucose-6-phosphate on the other, the amounts of citric acid found fell short of the expected values even if increased by 10 or 11% to obtain the value for total tricarboxylic acid. The discrepancy is due to the occurrence of some reductive amination of  $\alpha$ -ketoglutarate to glutamate at the expense of the oxidation of an equivalent amount of glucose-6-phosphate to phosphogluconate.\* The reductive amination of  $\alpha$ -ketoglutarate is catalysed by glutamic dehydrogenase, which was present in small amounts in the heart extracts; NH<sub>4</sub><sup>+</sup> was supplied by

\* J. R. Stern, unpublished experiments.

the aconitase preparation used which was an ammonium sulphate fraction from heart muscle dialysed only for a short time to avoid inactivation.

The ready reversibility of reaction (3) has also been established by experiments with isotopic  $\text{CO}_2$ . Grisolia & Vennesland (1947) reported rapid incorporation of  $\text{C}^{14}\text{O}_2$  in the tertiary carboxyl group of isocitric acid on incubation of this compound with  $\alpha$ -ketoglutaric acid and  $\text{NaHC}^{14}\text{O}_3$  in the presence of dialysed pigeon-liver extracts and of small amounts of  $\text{Mn}^{++}$  and TPN. Interesting in these experiments is the fact that, owing to the lack of hydrogen acceptors or donors, there was no net chemical change, and the concentrations of tricarboxylic acid and  $\alpha$ -ketoglutaric acid remained constant. Further evidence for the reversibility of the reaction has been presented by Floyd *et al.* (1947) and by Stern (1948).

It was earlier thought (Ochoa, 1948) that the reversible oxidative decarboxylation of isocitric acid (reaction (3)) was catalysed by the combined action of two enzymes, isocitric dehydrogenase and oxalosuccinic carboxylase, each catalysing reactions (1) and (2) respectively. However, partial purification has failed to separate two distinct enzymic activities (Grafflin & Ochoa, 1950) and it seems possible that reaction (3) may be catalysed by a single enzyme. This possibility is strengthened by the results obtained with a similar system, catalysing the reversible oxidative decarboxylation of malic acid, to be discussed below.

### III. BIOSYNTHESIS OF DICARBOXYLIC ACIDS

#### (1) 'Malic' enzyme of pigeon liver

Liver and other tissues, such as brain and the tissues of higher plants, contain an enzyme which in the presence of manganous ions catalyses the following reactions:

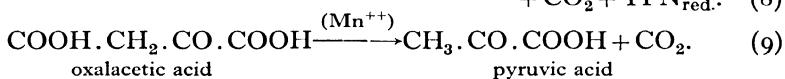
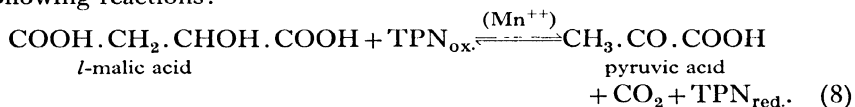

The enzyme is probably present in kidney, but appears to be absent from muscle. It is also present in some bacteria. Avian liver, and especially pigeon liver, are very good sources of the enzyme. Owing to interference by other enzymes present in liver extracts, an unequivocal demonstration of the reversibility of reaction (8) only became possible after extensive purification of the enzyme (Ochoa *et al.* 1948). The purification from acetone powder of pigeon liver is outlined in Table 4. The rate of reduction of  $\text{TPN}_{\text{ox}}$  followed spectrophotometrically at wavelength  $340 \text{ m}\mu$ , in the

presence of the enzyme, *l*-malate, and  $Mn^{++}$ , was used as the measure of enzyme activity which was expressed in arbitrary units. In the course of purification some enzymes present in large amounts in the original extract, such as fumarase, glutamic dehydrogenase, and the isocitric enzyme (catalysing reaction (3)) were completely removed. Malic dehydrogenase was removed to a large extent, but removal of lactic dehydrogenase was less complete. The reactions catalysed by fumarase, malic dehydrogenase, and lactic dehydrogenase are shown below; the equilibrium position of the latter two reactions is very far in the direction indicated by the solid arrow.

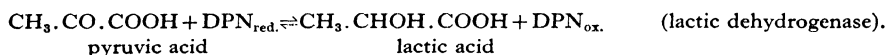
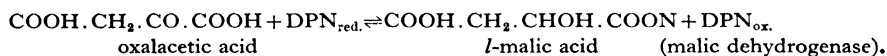
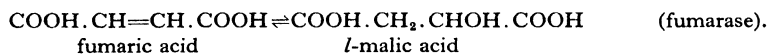

Malic and lactic dehydrogenases are not strictly specific for DPN, they can also react with TPN although at a much smaller rate (Mehler *et al.* 1948). For this reason lactic dehydrogenase interferes with the spectrophotometric demonstration of the reversibility of reaction (8), because if it is present in relatively large amounts  $\text{TPN}_{\text{red.}}$  will be oxidized in the presence of pyruvic acid.

Table 4. Purification of 'malic' enzyme from pigeon liver

Step	Units	Specific activity (units/mg. protein)	Yield
Aqueous extract of 100 g. of acetone powder	148,000	5-6	100
First ethanol fractionation (30% ethanol; fraction between -5 and -15°)	177,000*	20	—
Refractionation with ethanol	150,000	60	—
Fractional adsorption on alumina gel and elution with 0.1 M phosphate buffer pH 7.4	39,000	660	25

\* Partial removal of enzymes interfering with the activity test is responsible for the apparently higher amount of enzyme recovered.

The purified pigeon-liver enzyme is strictly specific for *l*-malic acid and pyruvic acid. It does not react with either fumaric or *d*-malic acid; it is also inactive toward phospho(enol)pyruvic acid. Orthophosphate or adenosine triphosphate are not required and do not influence the reaction. In analogy with the isocitric enzyme, discussed in the previous section, the malic enzyme of pigeon liver is strictly specific for TPN and it is inactive with DPN.

Reaction (8) is readily reversible. Its progress in either direction can easily be followed spectrophotometrically as illustrated in Fig. 5. Curve 1 shows the course of the forward reaction with 14.5 micrograms of enzyme protein. Curves 2 and 3 show the course of the back reaction with 29 micrograms of protein. The first portion of curve 2 illustrates the interference by the small amount of lactic dehydrogenase which contaminates the enzyme preparation, since mixing at zero time of enzyme,  $\text{TPN}_{\text{red.}}$ ,  $\text{Mn}^{++}$ , and pyruvate, results in slow oxidation of  $\text{TPN}_{\text{red.}}$ .

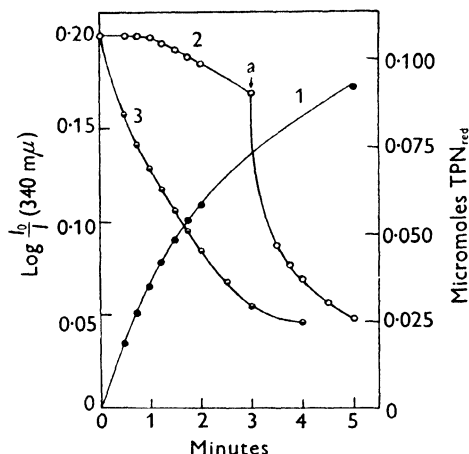

Fig. 5. Optical demonstration of reversibility of reaction (8). Details in text.

However, addition of a small amount of bicarbonate solution saturated with  $\text{CO}_2$ , at the time indicated by arrow *a*, results in very rapid oxidation of  $\text{TPN}_{\text{red.}}$  indicating progress of reaction (8) to the left. In curve 3, enzyme was added at zero time to an otherwise complete reaction mixture, i.e., one that contained pyruvate, bicarbonate- $\text{CO}_2$ ,  $\text{Mn}^{++}$ , and  $\text{TPN}_{\text{red.}}$ .

The purified pigeon-liver enzyme also catalyses reaction (9), i.e. the decarboxylation of oxalacetic acid. This action of the enzyme is specifically and markedly activated by TPN (Vennesland *et al.* 1947) whether oxidized or reduced. The mechanism of this activation is not understood. Both reactions (8) and (9) are probably catalysed by one and the same protein, for over a 100-fold purification the ratio of one activity to the other remained constant. Each of the activities, however, has a distinct sharp pH optimum. The optimum for oxidative decarboxylation of *l*-malic acid, i.e. for reaction (8), is at pH 7.5, whereas the optimum for decarboxylation of oxalacetic acid, i.e. for reaction (9), is at pH 4.5 (Salles & Ochoa, 1950). At pH 7.5 the enzyme does not catalyse the decarboxylation of the

oxalacetate while at pH 4.5 it does not catalyse the oxidative decarboxylation of malate. The enzyme exhibits no malic dehydrogenase activity within the pH range, 4.5 to 7.5, i.e. it does not catalyse the reduction of oxalacetate by either reduced DPN or TPN. The enzyme, therefore, is not a malic dehydrogenase; in fact, at pH 7.5 the enzyme is neither a malic dehydrogenase nor an oxalacetic carboxylase (or decarboxylase). To avoid confusion with malic dehydrogenase the enzyme is referred to as 'malic' enzyme.

There is strong evidence that free oxalacetate is not an intermediate in the reversible oxidative decarboxylation of malate catalysed by the 'malic' enzyme. First, the enzyme, as already pointed out, does not decarboxylate oxalacetate at pH 7.5. Secondly, when highly purified 'malic' enzyme is allowed to act on *l*-malate, in the presence of TPN,  $Mn^{++}$ ,  $C^{14}O_2$ , and oxalacetate,  $C^{14}$  is incorporated in the  $\beta$ -carboxyl group of malate but not in that of oxalacetate (Salles *et al.* 1950). The latter results\* are illustrated in Table 5. The Table also shows that incorporation of  $C^{14}O_2$  in the  $\beta$ -carboxyl of oxalacetate does occur if purified malic dehydrogenase is added to the above reaction mixture. In the latter case, isotopic malate, formed by the action of the 'malic' enzyme, is oxidized to isotopic oxalacetate by malic dehydrogenase. Thus, under these conditions, the incorporation of isotopic  $CO_2$  in oxalacetate is indirect.

Table 5. *Incorporation of  $C^{14}O_2$  in the  $\beta$ -carboxyl groups of *l*-malic and oxalacetic acid*

Highly purified pigeon-liver 'malic' enzyme incubated for 1 hr. in the absence or presence of highly purified malic dehydrogenase, with 10  $\mu$ mol. of *l*-malate, 170  $\mu$ mol. of oxalacetate, 20  $\mu$ mol. of  $MnCl_2$ , 2  $\mu$ mol. of TPN, 220  $\mu$ mol. of orthophosphate pH 7.4, and 50  $\mu$ mol. of  $NaHC^{14}O_3$ . Volume, 9 c.c.  $\beta$ -carboxyl of oxalacetic acid obtained by heat decarboxylation;  $\beta$ -carboxyl of *l*-malic acid obtained by specific decarboxylation with *L. arabinosus* enzyme. Specific radioactivity expressed as counts per minute per micromole.

Temperature	Malic dehydrogenase	Specific radioactivity at end of incubation		
		Bicarbonate	<i>l</i> -Malate	Oxalacetate
25°	—	3740	1070	14
25°	+	2400	680	94
15°	—	—	1340	5
15°	+	—	670	38

It might be expected that reaction (8) could be brought about by a combination of reactions (10) and (11) below.

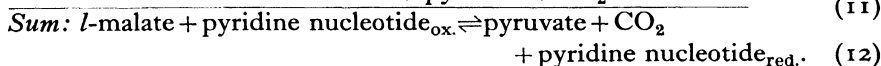
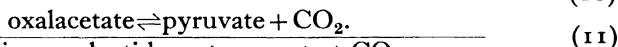
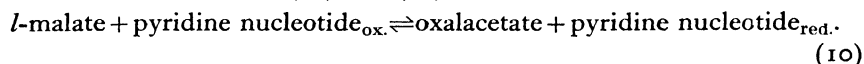

\* I. Harary, J. B. Veiga Salles and S. Ochoa, unpublished experiments.

Reaction (10) is catalysed by malic dehydrogenase, and reaction (11) (in the direction to the right) by oxalacetic carboxylase. Each of these enzymes can be obtained free from 'malic' enzyme; the former from pig heart (Straub, 1942), the latter from *Micrococcus lysodeikticus* (Mehler *et al.* 1948) or *Azotobacter vinelandii* (Plaut & Lardy, 1949). However, attempts to couple reactions (10) and (11) to give reaction (12), with a combination of purified malic dehydrogenase and oxalacetic carboxylase,  $Mn^{++}$ , and TPN or DPN, gave negative results (Mehler *et al.* 1948; Ochoa *et al.* 1948).<sup>\*</sup> Reaction (10) is readily reversible, but its equilibrium position is far to the left. There is no evidence for reversibility of reaction (11) (Plaut & Lardy, 1949; Salles *et al.* 1950); if at all reversible, its equilibrium position must be very far to the right. Thus, the 'malic' enzyme does not have the properties of either malic dehydrogenase or oxalacetic carboxylase, and the combination of malic dehydrogenase and oxalacetic carboxylase does not reproduce the action of the 'malic' enzyme.

It would appear that the 'malic' enzyme possesses two active centres concerned with oxidation-reduction and decarboxylation-carboxylation respectively. The reaction might be assumed to occur in two steps with enzyme-bound oxalacetate as an intermediate. Alternately, the reaction might occur by a mechanism similar to that proposed by Weil-Malherbe (1936) for the oxidative decarboxylation of  $\alpha$ -ketoglutaric acid. This reaction would result in the formation of enol-pyruvate and  $CO_2$  from malate (reaction (13)); a hypothetical oxalacetic hydrate lactone, rather than oxalacetic acid, is assumed to be the intermediate.

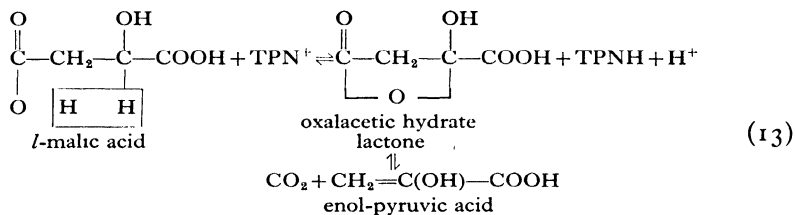

The equilibrium position of the reversible oxidative decarboxylation of malic acid is far in the direction of decarboxylation. However, as in the case of the reversible oxidative decarboxylation of isocitric acid, the reaction

<sup>\*</sup> Note added at proof correction. Herbert (*Biochem. J.* 47, 1, 1950) has recently succeeded in purifying the *M. lysodeikticus* oxalacetic carboxylase (which catalyses reaction (11) from left to right) to a very high degree. With a combination of this highly active enzyme, malic dehydrogenase, and DPN he was able to obtain oxidative decarboxylation of malate. This positive result was undoubtedly made possible by the use of large amounts of carboxylase. Nevertheless, under similar conditions he failed to obtain the reverse reaction, i.e. reductive carboxylation of pyruvate, as indicated by the failure of  $DPN_{red}$  to be oxidized in the presence of high concentrations of pyruvate and  $CO_2$  (D. Herbert, this Symposium).

can be shifted in the direction of  $\text{CO}_2$  fixation by coupling with the glucose-6-phosphate dehydrogenase system. The following reactions then occur:

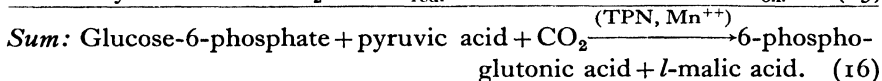
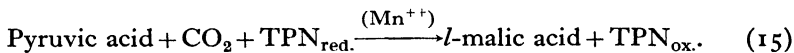
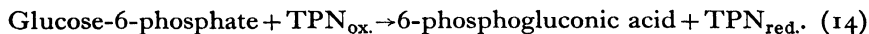

The net result of reactions (14) and (15) is reaction (16). The latter reaction is a TPN-linked dismutation whereby one molecule each of pyruvic acid and  $\text{CO}_2$  combine with simultaneous reduction to form *l*-malic acid at the expense of the oxidation of one molecule of glucose-6-phosphate to phosphogluconic acid. Glucose phosphate furnishes hydrogens and energy for the reductive carboxylation of pyruvate. Some further shifting of equilibrium in the direction of  $\text{CO}_2$  fixation occurs in the presence of the enzyme fumarase, since about 25% of the *l*-malate formed is then dehydrated to fumarate.

The dismutation between glucose-6-phosphate and pyruvate +  $\text{CO}_2$  can be followed manometrically when occurring at pH 7.0 in a bicarbonate-containing medium. Under these conditions the absorption of one  $\text{CO}_2$  equivalent is compensated by liberation from the bicarbonate of another  $\text{CO}_2$  equivalent by the second carboxyl group of the newly formed dicarboxylic acid ( $\text{pK}_2$  at 25°; *l*-malic acid, 5.08; fumaric acid, 4.54), while the oxidation of glucose-6-phosphate to phosphogluconate creates an extra carboxyl group which displaces a  $\text{CO}_2$  equivalent. A chemical balance of the dismutation is illustrated in Table 6 (Ochoa *et al.* 1950). The experiment was carried out with a highly purified preparation of pigeon-liver 'malic' enzyme and a preparation of glucose-6-phosphate dehydrogenase from yeast. The latter enzyme was rather crude and was contaminated with fumarase; hence, the dicarboxylic acid formed by reductive carboxylation of pyruvic acid was a mixture of fumaric and *l*-malic acids. This was determined enzymically, using the enzyme from *Lactobacillus arabinosus*, described below, together with purified fumarase. The formation of phosphogluconic acid was determined manometrically as outlined above. The disappearance of glucose-6-phosphate and pyruvic acid was measured by enzymic methods. The reaction mixture (final volume, 2.0 c.c.) contained 300 micromoles of  $\text{NaHCO}_3$ , 0.54 micromole of TPN, and 4 micromoles of  $\text{MnCl}_2$  in addition to the substrates and enzymes. It was equilibrated with 75%  $\text{CO}_2$  and 25% N, resulting in a pH of about 7.0, and incubated for 4 hr. at 25°. The amount of fumarate + malate formed was only about 74% of the amount of phosphogluconic acid produced. The

latter agreed satisfactorily with the amounts of glucose-6-phosphate and pyruvate disappearing. The discrepancy is explained by the slight contamination of the 'malic' enzyme with lactic dehydrogenase. Some of the pyruvate is reduced to lactate, under these conditions, by an equivalent amount of glucose phosphate which undergoes oxidation to phosphogluconate.

Table 6. *Chemical balance of dismutation between glucose-6-phosphate and pyruvate + CO<sub>2</sub>*

Details in text. Values expressed in  $\mu\text{mol}$ .

	Initial	Final	Change
Acid production (phosphogluconic)	—	64	+64
<i>l</i> -malate + fumarate	0	48	+48
Glucose-6-phosphate	188	127	-61
Pyruvate	192	122	-70

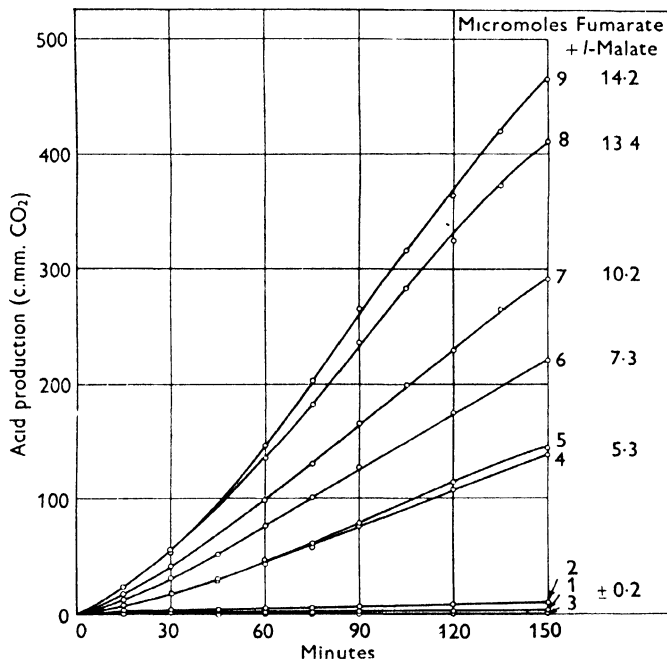

Fig. 6. Rate of dismutation between glucose-6-phosphate and pyruvate + CO<sub>2</sub> as a function of the concentration of 'malic' enzyme. Reaction followed manometrically as explained in text. Initial amount of reactants, 100  $\mu\text{mol}$ . of each pyruvate, glucose-6-phosphate, and NaHCO<sub>3</sub>, MnCl<sub>2</sub>, 2  $\mu\text{mol}$ .; TPN, 0.27  $\mu\text{mol}$ . (curve 4, 0.14  $\mu\text{mol}$ .). Volume, 1 c.c.; gas, 50% CO<sub>2</sub> and 50% N<sub>2</sub>; pH 7; temperature, 25°. (1) No Zwischenferment; 48 units 'malic' enzyme. (2) No 'malic' enzyme. (3) No TPN; 48 units 'malic' enzyme. (4) and (5) Complete; 48 units 'malic' enzyme. (6) Complete; 96 units 'malic' enzyme. (7) Complete; 108 units 'malic' enzyme. (8) Complete; 218 units 'malic' enzyme. (9) Complete; 324 units 'malic' enzyme.

Fig. 6 illustrates the effect of increasing concentrations of 'malic' enzyme on the rate of dismutation, as well as the absence of reaction when either glucose-6-phosphate dehydrogenase, 'malic' enzyme, or TPN, is omitted. The reaction was followed manometrically and at the end of the incubation period the amount of *l*-malate + fumarate formed was determined enzymically. These values are shown at the right of the figure facing the corresponding curves. The effect of increasing the concentration of CO<sub>2</sub> at constant pH on the rate of dismutation is illustrated in Fig. 7. The reaction

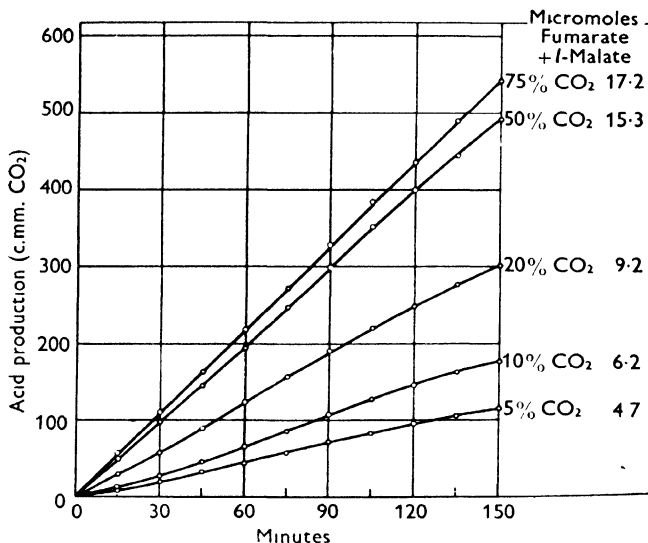

Fig. 7. Rate of dismutation between glucose-6-phosphate and pyruvate + CO<sub>2</sub> as a function of the tension of CO<sub>2</sub>. 150 units of 'malic' enzyme. Details as in Fig. 6. NaHCO<sub>3</sub> used in concentrations sufficient to result in pH 7 for each of indicated CO<sub>2</sub> concentrations.

proceeds at an appreciable rate even when the concentration of CO<sub>2</sub> in the gas phase is as low as 5%. This indicates that the system is remarkably effective in bringing about fixation of CO<sub>2</sub>.

Experiments of Utter & Wood (1946) suggest that there may exist a mechanism of incorporation of CO<sub>2</sub> in dicarboxylic acids other than via reductive carboxylation of pyruvate. Thus, crude pigeon-liver preparations incorporate isotopic CO<sub>2</sub> in the  $\beta$ -carboxyl group of oxalacetate when incubated with this keto acid, Mn<sup>++</sup>, and ATP. No such incorporation occurs with highly purified preparations of 'malic' enzyme from pigeon liver whether in the presence or absence of purified malic dehydrogenase,\* or with purified preparations of bacterial oxalacetic carboxylase (Plaut &

\* I. Harary, J. B. Veiga Salles, and S. Ochoa, unpublished experiments.

Lardy, 1949; Salles *et al.* 1950). Utter & Wood have recently found that addition of ATP to dialysed pigeon-liver extracts, in the presence of isotopic  $\text{CO}_2$ ,  $\text{Mn}^{++}$ , malate, and oxalacetate, results in incorporation of the isotope in oxalacetate in preference to malate, while addition of TPN instead of ATP results in preferential incorporation of the isotope in malate.\* The latter result is in agreement with our own observations on mixtures of highly purified 'malic' enzyme and malic dehydrogenase (cf. Table 5). The former result, however, suggests that incorporation of  $\text{CO}_2$  in oxalacetate may occur by a pathway not involving malate as an intermediate. Nothing is as yet known regarding the nature or significance of this reaction.

(2) '*Malic*' enzyme of *Lactobacillus arabinosus*

When *L. arabinosus* (strain 17-5) is grown on the usual media, with glucose as the energy source, the cells exhibit but negligible metabolic activity towards malic acid. However, when malic acid is present in the growth medium, the metabolic activity of the cells towards malate is enormously increased. *l*-Malic acid is quantitatively converted to lactic acid and  $\text{CO}_2$ ; *d*-malic acid is not metabolized. On subculture of these cells on a malate-free medium their activity toward malate disappears almost completely. This observation, together with the fact that an enzyme system active on malic acid can be extracted from cells grown on malate-containing media but not from cells grown on malate-free media, indicates that an adaptive enzyme is formed in the presence of malate (Korkes & Ochoa, 1948). This conclusion appears justified since the above facts eliminate the selection of a malate-active mutant or an increase in the permeability of the cells to malate as the cause of the increased activity towards malic acid.

The enzyme system has been isolated and extensively purified from acetone-dried cells of malate-adapted *L. arabinosus* (Korkes *et al.* 1950). It catalyses the following reactions:

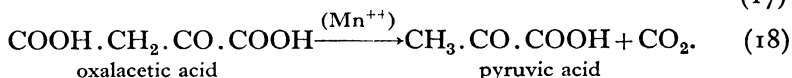
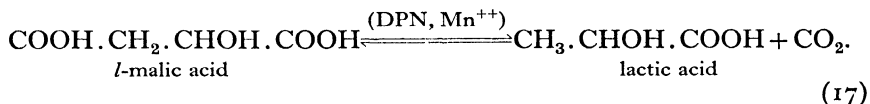

Neither reaction (17) nor (18) is catalysed to a significant extent by extracts of unadapted cells but *both* reactions appear as a result of adaptation to malate. Reaction (17) has a sharp optimum at pH 6.0; reaction 18 at

\* H. G. Wood, personal communication. These results have been confirmed in our laboratory.

pH 4.5. The extent of purification so far achieved (about 40-fold from the initial extract) has completely failed to separate one activity from the other. Reversibility of reaction (17) has been demonstrated with isotopic  $\text{CO}_2$  which becomes incorporated in the  $\beta$ -carboxyl group of *l*-malic acid (Korkes *et al.* 1950), but its equilibrium position is so far to the right that the conversion of *l*-malate to lactate and  $\text{CO}_2$  is practically quantitative. For this reason the enzyme preparation from malate-adapted *L. arabinosus* is an excellent tool for the specific and rapid manometric determination of *l*-malic acid. On addition of fumarase to this preparation, fumaric acid can also be determined.

Reaction (17) requires the presence of  $\text{Mn}^{++}$  and DPN. TPN cannot replace DPN. The presence of orthophosphate is essential for optimum

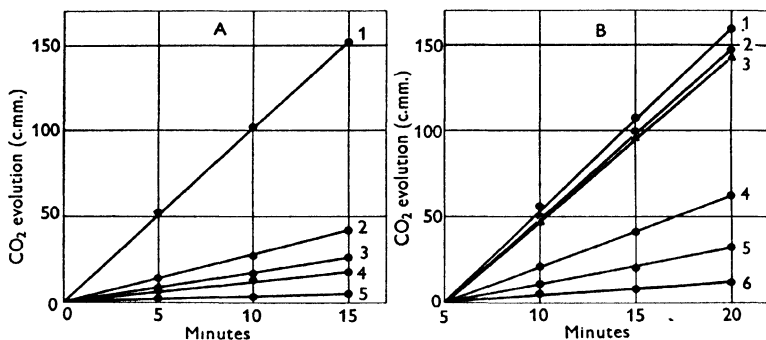

Fig. 8. Components of reactions catalysed by *L. arabinosus* enzyme. A. Reaction (17). 1, complete system (enzyme + malate + orthophosphate +  $\text{Mn}^{++}$  + DPN; pH 6); 2, no orthophosphate; 3, no  $\text{Mn}^{++}$ ; 4, either no DPN, or TPN in place of DPN; 5, no malate. B. Reaction (18). 1, complete system (enzyme + oxalacetate + orthophosphate +  $\text{Mn}^{++}$ ; pH 4.5); 2, no orthophosphate; 3, complete plus DPN; 4, complete plus 0.05 M *l*-malate; 5, complete plus 0.05 M malonate; 6, no  $\text{Mn}^{++}$ . Temperature, 25°.

activity of reaction (17) but its mode of action is not understood.\* Reaction (18) requires only the presence of  $\text{Mn}^{++}$ . Fig. 8 illustrates these facts. The figure also shows that the decarboxylation of oxalacetate is inhibited by malate and malonate; this is also true of the decarboxylation catalysed by the pigeon-liver 'malic' enzyme.

It is evident that reaction (17) cannot be a direct decarboxylation of

\* Note added at proof correction. The activation appears to be due to the cation potassium and not to the phosphate ion (potassium phosphate was the buffer used). When potassium succinate is substituted for the sodium succinate, formerly used as buffer in the absence of phosphate, the system was found to be quite active. The effect of  $\text{K}^+$  on malate dissimilation by cell suspensions of adapted *L. arabinosus* was recently discovered by P. M. Nossal in the laboratory of H. A. Krebs (*Biochem. J.* **48**, xvii, 1951). An activating effect of  $\text{K}^+$  on a similar system in cell suspensions of *Moraxella lwoffii* had been described earlier by A. Lwoff & H. Ionesco (*C.R. Acad. Sci., Paris*, **224**, 1664, 1947).

malate; the requirement for DPN suggests that an oxidation-reduction is involved. Reaction (17) is probably the result of the reactions below:

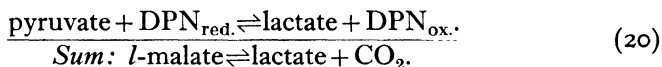
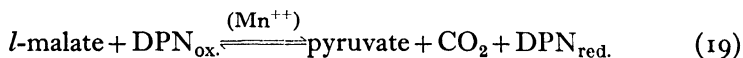

Reaction (19) would be catalysed by a 'malic' enzyme identical to the one from pigeon liver except for its specificity for DPN instead of TPN. Reaction (20) is catalysed by lactic dehydrogenase. The latter enzyme is constitutive in *L. arabinosus* and is present in large amounts in extracts from acetone-dried cells irrespective of whether they are adapted or not to malate. Since lactic dehydrogenase still contaminates the purest preparations so far obtained of the *L. arabinosus* enzyme, it appears very likely that reaction (17) is the result of an interaction between a DPN-specific 'malic' enzyme and lactic dehydrogenase as formulated above.

#### IV. INTERACTION BETWEEN DICARBOXYLIC AND TRICARBOXYLIC SYSTEMS

A consideration of the reactions catalysed by the isocitric enzyme (reaction (3)) and by the 'malic' enzyme of pigeon liver (reaction (8)), both TPN-specific, suggests that interaction between the two systems will occur to give the reversible reaction below:

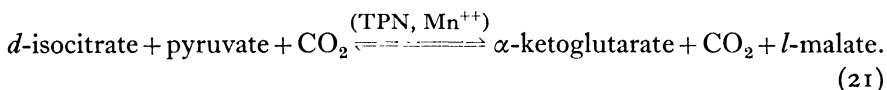

This reaction is a TPN-linked dismutation resulting in the reductive carboxylation of pyruvate, at the expense of the oxidative decarboxylation of isocitrate, or in the reverse reaction. Typical experiments demonstrating the occurrence of reaction (21) in either direction are illustrated in Table 7 (Ochoa *et al.* 1950). Experiments 1 and 2 show the formation of malate when the reaction proceeds from left to right. The small production of acid is probably due to the fact that the third carboxyl of isocitrate is replaced by the stronger second carboxyl of malate. Experiments 3 and 4 show the formation of *d*-isocitrate and pyruvate when the reaction proceeds from right to left. No attempts were made to determine the equilibrium constant of reaction (21), but it is apparent that this reaction markedly favours the reductive carboxylation of pyruvate.

Table 7. *Dismutation between isocitrate and pyruvate + CO<sub>2</sub> or between malate and  $\alpha$ -ketoglutarate + CO<sub>2</sub>*

150  $\mu$ mol. of NaHCO<sub>3</sub>, 0.27  $\mu$ mol. of TPN, 2  $\mu$ mol. of MnCl<sub>2</sub>, 'malic' enzyme, isocitric enzyme (partially purified from pig heart), and other additions as indicated. Volume, 1 c.c.; gas, 75% CO<sub>2</sub> and 25% N<sub>2</sub>; pH 7; temperature, 25°. Values expressed in  $\mu$ mol.

Exp. no.	Incubation time (min.)	Additions			
		<i>d</i> -Isocitrate	Pyruvate	<i>l</i> -Malate	$\alpha$ -Ketoglutarate
1	210	100	100	—	—
2	210	100	100	—	—
3	210	—	—	100	100
4	240	—	—	100	100
Change					
		<i>d</i> -Isocitrate	Pyruvate	Fumarate + <i>l</i> -malate	Acid (manometric)
1	210	—	—	+32.3	+5.9
2	210	—	—	+26.0	+5.4
3	210	+2.6	+3.8	—	—
4	240	+2.3	+2.6	—	—

#### V. DISTRIBUTION AND BIOLOGICAL FUNCTION OF ISOCITRIC AND MALIC ENZYMES

Enzymes catalysing the oxidative decarboxylation of isocitric acid are widely distributed in the animal and plant kingdom (Martius, 1937, 1938; Adler *et al.* 1939). Using the spectrophotometric method, Ceithalm & Vennessland (1949) have recently demonstrated the reversibility of the reaction with an enzyme preparation from parsley root. The distribution of enzymes catalysing the reversible oxidative decarboxylation of malic acid is somewhat more restricted. Of special interest, because of the possible function of these enzymes in photosynthesis, are the studies of Vennessland and her collaborators (Vennessland *et al.* 1949; Conn *et al.* 1949) demonstrating the widespread occurrence of a TPN-specific 'malic' enzyme in the tissues of higher plants.

In animal tissues and heterotrophic bacteria, the reversibility of the oxidative decarboxylation of dicarboxylic and tricarboxylic hydroxy acids is probably important for the maintenance and regulation of the level of these important metabolites in the cell, thus controlling respiration and metabolism. It also appears possible that the enzymes catalysing the above reactions may perform an essential function in cells where CO<sub>2</sub> fixation is vital, namely in autotrophic cells, and may be involved in photosynthesis and chemosynthesis. The view is gradually gaining ground that the basic mechanisms of CO<sub>2</sub> fixation may be essentially the same in both autotrophic

and heterotrophic cells, differing only in the way in which energy is supplied and in the source of hydrogens for reduction. It is conceivable that the photolytic cleavage of water by illuminated chloroplast preparations might under appropriate conditions substitute for the dehydrogenase systems which, as described in the foregoing pages, can be used to supply hydrogens and energy for the reductive carboxylation of pyruvate and  $\alpha$ -ketoglutarate. Such a result would be expected if photolysis could bring about directly or indirectly a reduction of pyridine nucleotides.

We have recently succeeded in demonstrating the photochemical reduction of pyridine nucleotides by chloroplast preparations (W. Vishniac & S. Ochoa, *Fed. Proc.* 1951, in the Press). Both DPN and TPN are reduced in the light by green grana of spinach leaves prepared essentially as described by Warburg (*Schwermetalle als Wirkungsgruppen von Fermenten*, Saenger, Berlin, 1948). The reduction of DPN was detected by the formation of lactate when pyruvate, DPN and rabbit muscle lactic dehydrogenase were incubated with green grana in the light. Negligible amounts of lactate were found in the dark or in the absence of DPN or lactic dehydrogenase. The reduction of TPN was detected by the formation of *l*-malate from pyruvate and CO<sub>2</sub> in the presence of pigeon-liver 'malic' enzyme. No malate was found in the dark or in the absence of TPN or 'malic' enzyme. Complete anaerobiosis and a pH of 7.0 were required for these reductions. The reduction produced the stoichiometric equivalent of O<sub>2</sub>. The liberated O<sub>2</sub> was absorbed in acid CrCl<sub>2</sub> and determined by electrometric titration with I<sub>2</sub>. These results show that the chloroplast preparations can catalyse the overall reaction

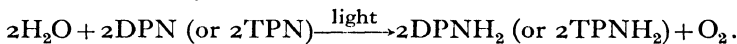

This reaction can then couple either with the reaction

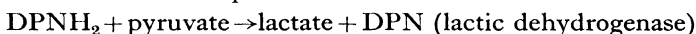

or with

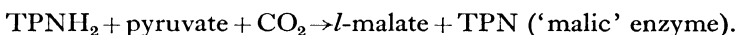

The possibility that such a reaction mechanism might occur in photosynthesis has been previously suggested (S. Ochoa, *Fed. Proc.* 9, 551, 1950, and Ochoa *et al.* (1950)).

A typical experiment illustrating the photochemical synthesis of *l*-malic acid from pyruvic acid and CO<sub>2</sub> is given in Table 8. *l*-Malic acid was determined enzymatically with pigeon-liver 'malic' enzyme (Ochoa *et al.* 1948). In experiments of somewhat larger scale the synthesis of *l*-malate has been measured manometrically with the *L. arabinosus* enzyme. The synthesis of malate by the above system, occurring exclusively in the light, has also been demonstrated with C<sup>14</sup>O<sub>2</sub>.

Table 8. *Photochemical synthesis of malate from pyruvate and CO<sub>2</sub>*

The complete system (20 c.c.) contained 15 c.c. green grana suspension (15 mg. of chlorophyll), 200  $\mu$ mol. KHCO<sub>3</sub>, 150  $\mu$ mol. pyruvate, 12.5  $\mu$ mol. MnCl<sub>2</sub>, 0.45  $\mu$ mol. TPN, 7.5  $\mu$ mol. ATP (to protect TPN from enzymatic destruction), and 40 units of pigeon-liver 'malic' enzyme. Gas, 5% CO<sub>2</sub> and 95% N<sub>2</sub> (pH of mixture about 7); temperature, 15°.

Incubation time (min.)	Total <i>l</i> -malic acid found ( $\mu$ mol.)			
	Complete system	No 'malic' enzyme	No TPN	No light
0	0.02	0.06	0	0.12
40	0.20	0.09	0.02	0.09
80	0.53	0.09	0.05	0.06
120	0.69	0.11	0.06	0.06

## REFERENCES

- ADLER, E., VON EULER, H., GUNTHER, G. & PLASS, M. (1939). *Biochem. J.* **33**, 1028.  
 CEITHALM, J. & VENNESLAND, B. (1949). *J. Biol. Chem.* **178**, 133.  
 CONN, E., VENNESLAND, B. & KRAEMER, L. M. (1949). *Arch. Biochem.* **23**, 179.  
 ELSDEN, S. R. (1938). *Biochem. J.* **32**, 187.  
 EVANS, E. A., JR., VENNESLAND, B. & SLOTIN, L. (1943). *J. Biol. Chem.* **147**, 771.  
 FLOYD, N. F., MEDES, G. & WEINHOUSE, S. (1947). *J. Biol. Chem.* **171**, 663.  
 GRAFFLIN, A. L. & OCHOA, S. (1950). *Biochim. Biophys. Acta*, **4**, 205.  
 GRISOLIA, S. & VENNESLAND, B. (1947). *J. Biol. Chem.* **170**, 461.  
 KALNITSKY, G. & WERKMAN, C. H. (1944). *Arch. Biochem.* **4**, 25.  
 KORRES, S. & OCHOA, S. (1948). *J. Biol. Chem.* **176**, 463.  
 KORRES, S., DEL CAMPILLO, A. & OCHOA, S. (1950). *J. Biol. Chem.* **187**, 891.  
 KRAMPITZ, L. O. & WERKMAN, C. H. (1941). *Biochem. J.* **35**, 595.  
 KRAMPITZ, L. O., WOOD, H. G. & WERKMAN, C. H. (1943). *J. Biol. Chem.* **147**, 243.  
 KREBS, H. A. & EGGLESTON, L. V. (1943). *Biochem. J.* **37**, 334.  
 KREBS, H. A. & ROUGHTON, F. J. W. (1948). *Biochem. J.* **43**, 550.  
 LYNEN, F. & SCHERER, H. (1948). *Ann. Chem.* **560**, 163.  
 MARTIUS, C. (1937). *Hoppe-Seyl. Z.* **247**, 104.  
 MARTIUS, C. (1938). *Hoppe-Seyl. Z.* **257**, 29.  
 MARTIUS, C. & LEONHARDT, H. (1943). *Hoppe-Seyl. Z.* **278**, 208.  
 MEHLER, A. H., KORNBERG, A., GRISOLIA, S. & OCHOA, S. (1948). *J. Biol. Chem.* **174**, 961.  
 MOULDER, J. M., VENNESLAND, B. & EVANS, E. A. JR. (1945). *J. Biol. Chem.* **160**, 305.  
 OCHOA, S. (1945). *J. Biol. Chem.* **159**, 243.  
 OCHOA, S. (1948). *J. Biol. Chem.* **174**, 133.  
 OCHOA, S., MEHLER, A. H. & KORNBERG, A. (1947). *J. Biol. Chem.* **167**, 871.  
 OCHOA, S., MEHLER, A. H. & KORNBERG, A. (1948). *J. Biol. Chem.* **174**, 979.  
 OCHOA, S., SALLES, J. B. V. & ORTIZ, P. J. (1950). *J. Biol. Chem.* **187**, 863.  
 OCHOA, S. & WEISZ-TABORI, E. (1948). *J. Biol. Chem.* **174**, 123.  
 PLAUT, G. W. E. & LARDY, H. A. (1949). *J. Biol. Chem.* **180**, 13.  
 SALLES, J. B. V., HARARY, I., BANFI, R. F. & OCHOA, S. (1950). *Nature, Lond.*, **165**, 675.  
 SALLES, J. B. V. & OCHOA, S. (1950). *J. Biol. Chem.* **187**, 849.  
 STERN, J. R. (1948). *Biochem. J.* **43**, 616.  
 STRAUB, F. B. (1942). *Hoppe-Seyl. Z.* **275**, 63.

- UTTER, M. F. & WOOD, H. G. (1946). *J. Biol. Chem.* **164**, 455.
- VENNESLAND, B., EVANS, E. A. Jr. & ALTMAN, K. I. (1947). *J. Biol. Chem.* **171**, 675.
- VENNESLAND, B., GOLLUB, M. & SPECK, J. F. (1949). *J. Biol. Chem.* **178**, 301.
- WEIL-MALHERBE, H. (1936). *Nature, Lond.*, **138**, 551.
- WOOD, H. G., VENNESLAND, B. & EVANS, E. A. Jr. (1945). *J. Biol. Chem.* **159**, 153.
- WOOD, H. G. & WERKMAN, C. H. (1938). *Biochem. J.* **32**, 1262.
- WOOD, H. G. & WERKMAN, C. H. (1940). *Biochem. J.* **34**, 129.
- WOOD, H. G., WERKMAN, C. H., HEMINGWAY, A. & NIER, A. O. (1941). *J. Biol. Chem.* **139**, 365, 377.

# OXALACETIC DECARBOXYLASE AND CARBON DIOXIDE ASSIMILATION IN BACTERIA

By DENIS HERBERT

National Institute for Medical Research, Mill Hill, London, N.W. 7

## I. INTRODUCTION

The synthesis of carbohydrate, fat or other organic material from  $\text{CO}_2$  and  $\text{H}_2\text{O}$  results in an increase in the free-energy content of the system, and thus requires energy in order to proceed. This is another way of saying that  $\text{CO}_2$  assimilation is an endergonic reaction, which can only be brought about by coupling with some exergonic reaction involving a decrease in free energy.

In bacteria the energy for carbon dioxide assimilation can be obtained in three different ways. The photosynthetic autotrophs utilize radiant energy for  $\text{CO}_2$  fixation, while the chemosynthetic autotrophs utilize energy derived from the oxidation of inorganic substances. In heterotrophic bacteria, on the other hand, the required energy must be obtained from the oxidation or fermentation of organic foodstuffs.

In all three types of bacteria there are therefore these two aspects of the carbon assimilation process to be considered: the actual chemical reactions by which  $\text{CO}_2$  is built up into carbon-to-carbon linkages, and also the energy-coupling mechanisms which drive these reactions forward. The *primary reactions* of  $\text{CO}_2$  fixation may possibly be the same in all living organisms; at least it seems probable that in heterotrophic bacteria they are very similar to the primary reactions of  $\text{CO}_2$  fixation in higher animals.

However, there is one fundamental difference between autotrophic and heterotrophic  $\text{CO}_2$  assimilation when the overall process is considered. Autotrophs, like plants, can grow with  $\text{CO}_2$  as sole carbon source, synthesizing all their organic cell constituents by  $\text{CO}_2$  assimilation. Heterotrophs, on the other hand, can only assimilate carbon dioxide by simultaneously breaking down organic foodstuffs. In heterotrophic  $\text{CO}_2$  fixation, therefore, *there can be no net gain of organic cell-constituents*. This prompts the question: what is the point of heterotrophic carbon assimilation? Is it a process of any real importance to the organism, or is it, perhaps, an evolutionary relic of no more use than the human appendix?

For the higher animals these questions are difficult to answer, but there is little doubt where bacteria are concerned that  $\text{CO}_2$  fixation is a process

of major importance. In the terminology of Fildes (1940),  $\text{CO}_2$  is an 'essential metabolite' for most, if not all, bacterial species, and might indeed be termed a growth factor since growth does not occur in its absence.

This fact was first clearly demonstrated by Gladstone, Fildes & Richardson (1935), who showed that bacteria would not grow in otherwise adequate synthetic media when continually bubbled with  $\text{CO}_2$ -free air (or nitrogen in the case of anaerobes), while they grew normally if small amounts of  $\text{CO}_2$  were added to the gas stream. There is a reciprocal relation between rate of aeration with  $\text{CO}_2$ -free air and inoculum size, large inocula needing higher rates of aeration to suppress growth. It appears that bacterial growth requires a certain minimum concentration of  $\text{CO}_2$  in the external environment, which will not be attained if that produced by metabolism is swept away as fast as it is formed.

The reason for this, according to present views, is that carbon dioxide is required for the synthesis of certain dicarboxylic acids which function as respiratory catalysts. The evidence for this has been thoroughly reviewed in the earlier papers in this Symposium, and will not be repeated here. It is strongly supported by the discovery that bacterial growth in the absence of any external source of  $\text{CO}_2$  is stimulated if these dicarboxylic acids (e.g. succinic, malic, aspartic,  $\alpha$ -ketoglutaric) are supplied in the growth medium (Lwoff & Monod, 1947; Ajl & Werkman, 1948).

Such experiments emphasize the importance of the dicarboxylic acids in bacterial metabolism, and the importance of  $\text{CO}_2$  fixation as a mechanism for synthesizing these compounds. Recent work on  $\text{CO}_2$  fixation has largely been devoted to investigating the precise details of this process.

## II. PRIMARY REACTIONS OF CARBON DIOXIDE FIXATION

One could write down on paper several different chemical mechanisms by which a molecule of  $\text{CO}_2$  might add on to some other molecule to form a carbon-to-carbon linkage. In biological  $\text{CO}_2$  fixation, however, evidence has only been found for one type of mechanism, in which the fixed  $\text{CO}_2$  molecule appears as a new carboxyl group as symbolized by the equation:

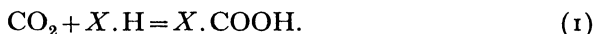

This type of reaction is the reverse of a decarboxylation and is therefore sometimes referred to as a 'carboxylation' of  $X.H$ .

The product  $X.COOH$  is usually called the 'primary product' of  $\text{CO}_2$  fixation, and it will be convenient to refer to  $X.H$  as the 'primary reactant'.

A variety of primary fixation mechanisms has been postulated, including the following:

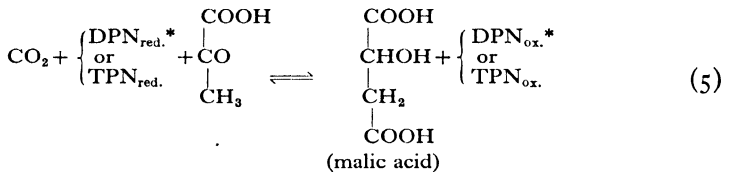
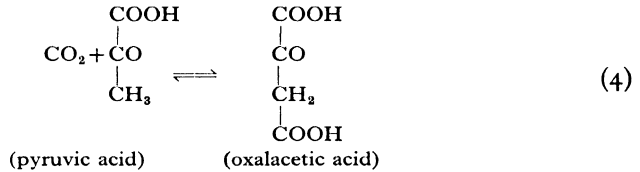
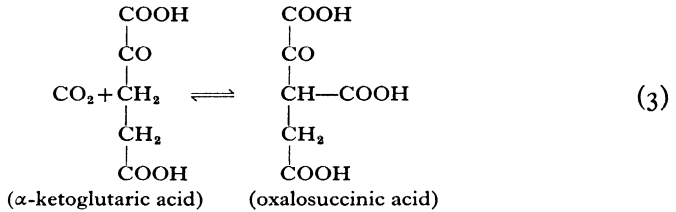
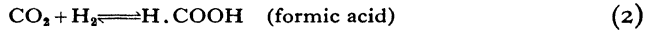

Reaction (2), due to the enzyme system formic hydrogenlyase, is known to occur in many bacteria and is suspected, with little direct evidence as yet, of occurring in higher plants; there is so far no evidence for its occurrence in higher animals. Reaction (3) has been demonstrated in isolated enzyme preparations from pig heart (Ochoa & Weisz-Tabori, 1948) and from higher plants (Vennesland *et al.* 1947).

The quantitative importance of reactions (2) and (3) is at present problematical, and reactions (4) and (5) are usually regarded as representing the major pathways of CO<sub>2</sub> fixation. In both these reactions the primary reactant is pyruvic acid. In reaction (4) this combines with CO<sub>2</sub> by simple addition to form oxaloacetic acid, a reaction usually known as the 'Wood-Werkman reaction'. In reaction (5), which might very well be named the 'Ochoa reaction', this addition is combined with a simultaneous reduction, giving malic acid as the (apparently) primary product.

The remainder of this paper will be devoted to a discussion of the enzymes which catalyse (or are believed to catalyse) reactions (4) and (5).

\* DPN=diphosphopyridine nucleotide (coenzyme 1). TPN=triphosphopyridine nucleotide (coenzyme 2). Subscripts 'ox.' and 'red.' denote oxidized and reduced forms of the coenzymes.

### III. ENZYMIC MECHANISMS OF CARBON DIOXIDE FIXATION

#### *Oxalacetic decarboxylase*

It has already been mentioned that the primary reaction of  $\text{CO}_2$  fixation can be regarded as the reverse of a decarboxylation, and it is a fairly plausible hypothesis that such a reaction might be catalysed by an enzyme of the decarboxylase type acting 'in reverse'. This suggestion was first put forward by Krampitz & Werkman (1941), who discovered in *Micrococcus lysodeikticus* an enzyme, 'oxalacetic decarboxylase', which catalyses the decarboxylation of oxalacetate to pyruvate and  $\text{CO}_2$ ; i.e. the reverse of the 'Wood-Werkman reaction' shown in equation (4). Similar enzymes have been found in *Escherichia coli* (Kalnitsky & Werkman, 1944) and in *Azotobacter vinelandii* (Plaut & Lardy, 1949).

Under normal circumstances the decarboxylation of oxalacetate by this enzyme goes virtually to completion. Nevertheless, Krampitz & Werkman suggested that oxalacetic decarboxylase might bring about fixation of  $\text{CO}_2$  by catalysing the reverse reaction (equation (4)). This suggestion has played a prominent role in all subsequent discussions of the subject, and will be considered in some detail.

#### *Malic dehydrogenase and the 'malic enzyme'*

At first sight the suggestion of Krampitz & Werkman seems unlikely on thermodynamic grounds, since the reported free energy change of reaction (4) is 5250 cal., corresponding to an equilibrium very much in favour of decarboxylation (Table 1).

Table 1. *Decarboxylation of oxalacetate*

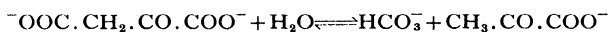

$$\Delta F = -RT \ln K = -5250 \text{ cal. (Evans et al. 1943)}$$

$$K = \frac{[\text{OAA}^{-}]}{[\text{PA}^{-}][\text{HCO}_3^{-}]} = 0.2 \times 10^{-3} M^{-1}$$

Concentrations at equilibrium (M)

$\text{PA}^{-}$	$\text{HCO}_3^{-}$	$\text{OAA}^{-}$
1.0	1.0	$0.2 \times 10^{-3}$
0.1	0.1	$0.2 \times 10^{-5}$
0.01	0.01	$0.2 \times 10^{-7}$
0.001	0.001	$0.2 \times 10^{-9}$

$\text{PA}^{-}$  = pyruvate;  $\text{OAA}^{-}$  = oxalacetate.

However, if this reaction were coupled with another highly exergonic reaction, converting the oxalacetate to some other product, then, in theory at least, a reversal of the decarboxylation (i.e. a fixation of  $\text{CO}_2$ ) should be thermodynamically possible.

Ochoa (1946) suggested that this could be brought about by the reduction of oxalacetate to malate by malic dehydrogenase and  $\text{DPN}_{\text{red}}$ . This reaction involves a large negative free-energy change, which can be calculated from the oxidation-reduction potentials of the systems:

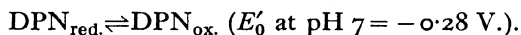
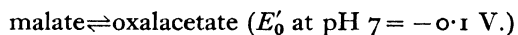

For the potential difference  $\Delta E = 0.18 \text{ V.}$ ,  $\Delta F = nF\Delta E = -8300 \text{ cal.}$  This scheme is shown in Table 2.

Table 2. *Combined action of oxalacetic decarboxylase and malic dehydrogenase*

Reaction	Enzyme	$\Delta F$ (cal.)
(i) Pyruvate + $\text{HCO}_3^- \rightleftharpoons$ oxalacetate	Oxalacetic decarboxylase	+ 5250
(ii) Oxalacetate + $\text{DPN}_{\text{red.}} \rightleftharpoons$ malate + $\text{DPN}_{\text{ox.}}$	Malic dehydrogenase	- 8300
(iii) Pyruvate + $\text{HCO}_3^- + \text{DPN}_{\text{red.}} \rightleftharpoons$ malate + $\text{DPN}_{\text{ox.}}$	Both enzymes	- 3050

$$K = \frac{[PA^-][\text{HCO}_3^-][\text{DPN}_{\text{red}}]}{[MA^-][\text{DPN}_{\text{ox}}]} = 1.7 \times 10^2.$$

In the *overall* reaction (which, it will be noticed, is identical with equation (5) above), there is a calculated decrease of free energy of 3050 cal. per molecule of  $\text{CO}_2$  fixed as malate. *The overall reaction should therefore favour  $\text{CO}_2$  fixation*, as shown by the calculated equilibrium constant in Table 2. However, the overall  $\Delta F$  and equilibrium constant are not too large, so that it should also be possible to reverse the overall reaction, resulting in a *decarboxylation of malate*.

If these free-energy data are correct, therefore, it would seem that  $\text{CO}_2$  fixation by this mechanism must be possible. Surprisingly, however, Ochoa *et al.* (1948) found that a mixture of oxalacetic decarboxylase, malic dehydrogenase and DPN did not catalyse either the carboxylation of pyruvate or the decarboxylation of malate. They found, however, that pigeon liver contains an enzyme that in the presence of  $\text{Mn}^{++}$  ions catalyses the reversible reaction:

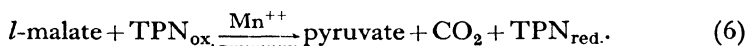

Korkes & Ochoa (1948) found a similar, but DPN-specific, enzyme in *Lactobacillus arabinosus*; apart from their coenzyme specificities the two enzymes appear identical, and are usually referred to as the 'malic enzyme'.

The 'malic enzyme' has the following properties: (i) it acts as a 'malic decarboxylase', i.e. it catalyses reaction (6) in the direction from left to right. This can be shown spectrophotometrically by following the produc-

tion of  $\text{TPN}_{\text{red}}$ . (measured by its absorption band at  $340 \text{ m}\mu$ ) when malate is added to  $\text{TPN}_{\text{ox}}$ . Alternatively, the production of carbon dioxide from malate can be shown manometrically; in this case, when catalytic amounts of TPN are used, some system must be added to reoxidize the  $\text{TPN}_{\text{red}}$ . This can be done by adding lactic dehydrogenase\* and pyruvate, when we have the so-called 'malate-pyruvate dismutation':

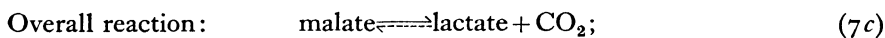
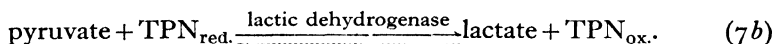
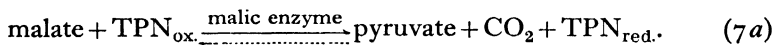

(ii) Secondly, the malic enzyme also acts as an oxalacetic decarboxylase, catalysing the reaction:

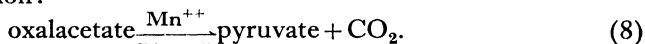

From this it might be thought that the malic enzyme is not a single enzyme but a mixture of a TPN-specific malic dehydrogenase and an oxalacetic decarboxylase, and that reaction (6) occurs in the two stages:

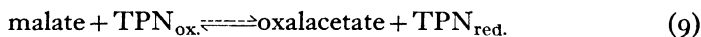

followed by reaction (8). The sum of these two reactions would be reaction (6), and the whole scheme would be similar, except for the coenzyme involved, to that shown in Table 2.

This, however, does not appear to be the case, for the malic enzyme, when partially purified, does not contain such a TPN-specific malic dehydrogenase; in particular there is no reaction when oxalacetate and  $\text{TPN}_{\text{red}}$  are added. Ochoa therefore believes that the malic enzyme is a single enzyme with a double function, catalysing both reactions (6) and (8), but not (9).

As indicated by the dotted arrows in equation (6), the equilibrium of the reaction catalysed by the malic enzyme is markedly in favour of decarboxylation. However, it can be shifted in the opposite direction through a TPN-linked dismutation with the glucose-6-phosphate dehydrogenase system, since this reaction has a large negative  $\Delta F$  ( $-6890 \text{ cal.}$ ). This leads to a synthesis of malic acid from pyruvic acid and  $\text{CO}_2$ :

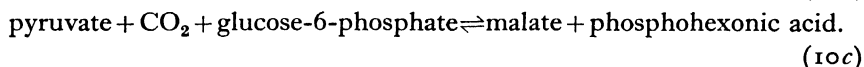
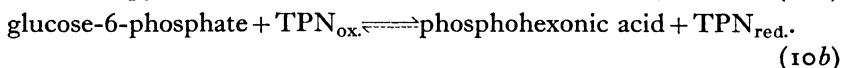
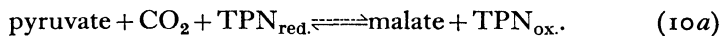

\* Lactic dehydrogenase was formerly thought to be DPN-specific, but it can also act, though more slowly, with TPN (Mehler *et al.* 1948).

This is the only reaction by which a *net fixation* of  $\text{CO}_2$  (as opposed to isotopic exchange reactions) has so far been demonstrated with pyruvate as primary reactant.

*Isotopic experiments and 'exchange reactions'*

Krampitz, Wood & Werkman (1943) found that when crude preparations of *Micrococcus lysodeikticus* decarboxylase are allowed to act on oxalacetate in the presence of  $\text{NaHC}^{13}\text{O}_3$  until about half the added oxalacetate has been decarboxylated, the remaining oxalacetate contains excess  $\text{C}^{13}$  in the  $\beta$ -carboxyl group. This certainly suggests that the decarboxylation of oxalacetate must be reversible to some extent.

If, however, the main path of  $\text{CO}_2$  fixation is not through this reaction (equation (4)) but through the malic enzyme (equation (5)), then we would expect malate to be the main primary product.

In the extensive isotopic experiments with dialysed pigeon-liver extracts reported by Dr H. G. Wood in a previous paper in this Symposium, he found that fixation of  $\text{C}^{14}\text{O}_2$  in oxalacetate is promoted by adenosine triphosphate, while fixation in malate is promoted by adding TPN. Wood suggests an 'active' or isomeric form of oxalacetate as the primary product, which may then be converted either to oxalacetate or malate.

Ochoa, on the other hand, suggests that malate is the primary product, and may subsequently be converted to oxalacetate by malic dehydrogenase; he has shown that this happens in systems consisting of purified malic enzyme and malic dehydrogenase. With oxalacetic decarboxylase from *Micrococcus lysodeikticus* (crude preparations), the reverse seems to be the case;  $\text{C}^{14}\text{O}_2$  exchanges with the  $\beta$ -carboxyl of oxalacetate but not of malate, unless malic dehydrogenase and DPN are added.

Anyone who has read thus far will probably agree that the overall picture is somewhat confusing. One reason for this is that much of the work done up to now has inevitably had to be carried out with tissue extracts or only slightly purified enzyme preparations, and it is difficult to be certain which of the many enzymes such preparations may contain is responsible for the observed isotope exchanges. For instance, a crude *M. lysodeikticus* preparation will (a) decarboxylate oxalacetate, and (b) incorporate labelled  $\text{CO}_2$  into the  $\beta$ -COOH of oxalacetate, but for all we know these effects may be entirely unrelated. The remedy for this situation is to isolate the enzymes responsible for each observed effect. The writer has attempted this in the case of oxalacetic decarboxylase, and has obtained this enzyme in highly purified form; in the remainder of this paper the properties of this purified enzyme will be described.

IV. ISOLATION AND PROPERTIES OF  
OXALACETIC DECARBOXYLASE*Method of isolation*

The enzyme was isolated from *Micrococcus lysodeikticus*. This organism is a convenient starting material, since it is readily lysed by quite small amounts of crystalline lysozyme; the initial step of extracting the enzyme from the cells, often a difficulty when purifying bacterial endoenzymes, is thereby greatly simplified. (This technique had been used previously (Herbert & Pinsent, 1948) in the isolation of crystalline catalase from the same organism.)

*M. lysodeikticus* is grown on agar for 24 hours at 35°, and thick (5%) suspensions are lysed by adding crystalline lysozyme (1 mg./g. bacteria). Viscous impurities are precipitated with acetone (33% v/v) at pH 5.9 and -5° C.; the enzyme is then precipitated by raising the acetone concentration to 80%, and obtained as a stable dry powder. On adjusting solutions of the acetone powder in 10% (NH<sub>4</sub>)<sub>2</sub>SO<sub>4</sub> to pH 3.8, the enzyme is quantitatively precipitated, along with much denatured protein; on extraction of this precipitate with water and adjusting to pH 5.6, most of the denatured protein remains undissolved while the enzyme is extracted. Two repetitions of this process give a *c.* 70-fold purification with almost quantitative yields. Fractionation with acetone at -5° raises the purity level to *c.* 400 times that of the starting material, and two careful fractionations with ammonium sulphate raise the degree of purification to almost 4000-fold.

At this stage the enzyme crystallizes from ammonium sulphate in fine needles, whose activity can be raised a further 20-50% by recrystallization. The purest preparations had a  $Q_{CO_2}$  of 1,200,000, compared with 200 for the starting material, representing a purification of 6000-fold. The overall yield was 20-30%. (The activity of the enzyme was determined manometrically, by measuring the CO<sub>2</sub> evolved from oxalacetate (M/100) in the presence of enzyme and MnSO<sub>4</sub> (M/1000), at pH 5.4 and 30° C.)

Although the purest preparations obtained were crystalline, and more active than the majority of pure enzymes, they are not homogeneous in the ultracentrifuge, which reveals three components. This is one more example of the danger of accepting crystalline form alone as an index of purity of proteins.

It is estimated that these preparations are only 30-50% pure, so that the activity of the pure enzyme would be  $Q_{CO_2} = 2-3,000,000$ . Probably it would not be too difficult to obtain the enzyme completely pure if sufficient starting material were available, since it is quite a stable enzyme and the

yields throughout are good. The practical obstacle is the large quantity of bacteria required, since the amount of enzyme they contain is exceedingly small.

Table 3. *Purification of oxalacetic decarboxylase*

Stage	Vol. (ml.)	Total protein (g.)	Total enzyme (g.)	$Q_{CO_2}$
Lysed bacteria	11,800	600	0.098	200
Acetone powder	—	203	0.090	510
pH 3.8 pptn.	234	7.6	0.086	14,200
Two acetone fractionations	23	0.92	0.068	89,000
Two $(NH_4)_2SO_4$ fractionations	11	0.068	0.042	760,000
Crystalline preparation	—	0.030	0.030	1,200,000

As shown in Table 3, 100 g. (dry weight) of bacteria contain only 0.016 g. of enzyme of  $Q_{CO_2}$  1,200,000, and their content of pure enzyme is probably only about 0.005%. This is in striking contrast to the catalase content of this organism, which may be as high as 1.5% of the dry weight.

While for academic purposes further purification of the enzyme might be desirable, there is little doubt that the purification already achieved has removed other enzymes likely to interfere with a study of its essential properties, and it may perhaps be termed 'functionally pure'.

#### *Prosthetic group*

The purified enzyme is a colourless protein, and in the ultraviolet shows only the usual absorption peak at  $275 m\mu$  due to tyrosine and tryptophane. There have been various suggestions that biotin is concerned in the decarboxylation of oxalacetate and in  $CO_2$  fixation; however, it was not possible to detect the presence of biotin or any other prosthetic group in the purified enzyme.

#### *Catalytic effect of metallic cations*

Krampitz & Werkman (1941) had found that even crude preparations of oxalacetic decarboxylase are greatly activated by  $Mn^{++}$  ions, and to a less extent by  $Mg^{++}$  ions; the purified enzyme is completely inactive in their absence. Since fixation of  $CO_2$  by pigeon liver or bacterial extracts also requires  $Mn^{++}$  ions, the activation of the decarboxylase by metallic cations was studied in more detail.

It was found that activation of the enzyme was not confined to  $Mg^{++}$  and  $Mn^{++}$ , but that a variety of divalent cations would activate to a greater or less extent. It was already known that oxalacetic acid, like other  $\beta$ -keto acids, undergoes spontaneous decarboxylation at a slow but measurable

rate, which is accelerated by various heavy metals. A comparison of various metallic cations, alone and with the enzyme, is shown in Table 4.

Table 4. *Effect of cations*

Additions	$\mu\text{l. CO}_2$ in 3 min.		
	Cation	Cation + enzyme	Difference
None	4	4	0
Ca <sup>++</sup>	15	35	20
Ba <sup>++</sup>	5	5	0
Mg <sup>++</sup>	5	83	78
Mn <sup>++</sup>	11	297	286
Cd <sup>++</sup>	18	289	271
Co <sup>++</sup>	48	254	206
Zn <sup>++</sup>	59	101	42
Ni <sup>++</sup>	72	134	62
Fe <sup>++</sup>	14	37	23
Fe <sup>+++</sup>	23	22	- 1
Al <sup>+++</sup>	85	44	-41
Cr <sup>+++</sup>	46	48	2
La <sup>+++</sup>	36	38	2

CaCl<sub>2</sub> and BaCl<sub>2</sub> 0.01 M. Other cations 0.001 M.

It will be seen that the enzyme is activated by divalent cations only; for example, it is activated by Fe<sup>++</sup> but not by Fe<sup>+++</sup>.

These results are similar to those obtained with the pyruvic decarboxylase of yeast (Green, Herbert & Subrahmanyam, 1941). There is no obvious relationship between the catalytic activities of the metals by themselves, and their ability to activate the decarboxylase; for instance, trivalent cations are active catalysts, but do not activate the enzyme. However, it seemed likely that a study of the divalent metals as 'decarboxylase models' might throw some light on the mode of action of the enzyme, and this has been carried out in some detail.

The kinetics of the process are fairly simple. The spontaneous decarboxylation of oxalacetate is a first-order reaction (equation (11)). The metal-catalysed decarboxylation is also first order, but the value of the observed velocity constant is a linear function of the concentration of metallic cation. Writing  $A$  for the concentration of oxalacetate and  $M$  for the concentration of metal cation, the rate equations are:

$$-\frac{dA}{dt} = k_s A \quad (\text{spontaneous decarboxylation}). \quad (11)$$

$$-\frac{dA}{dt} = k_m AM \quad (\text{metal-catalysed decarboxylation}). \quad (12)$$

These are assumed to proceed independently, giving the overall rate equation:

$$-\frac{dA}{dt} = (k_s + k_m M)A, \quad (13)$$

where the term  $(k_s + k_m M)$ , which is constant for constant  $M$ , is the observed first-order rate constant,  $k$ .

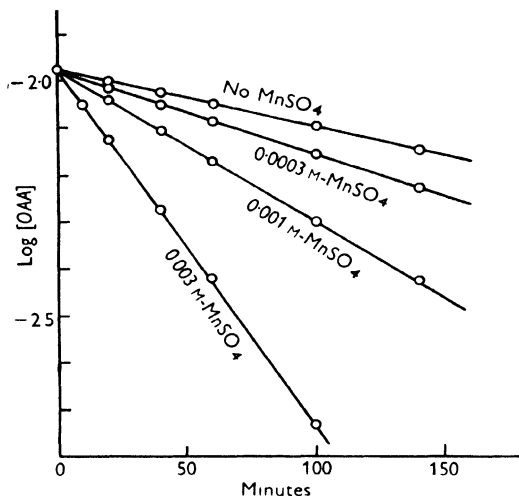

Fig. 1. Decarboxylation of oxalacetate by  $Mn^{++}$ .

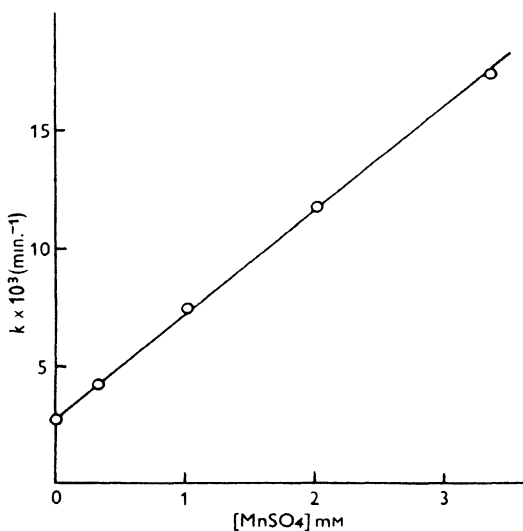
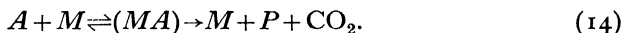

Fig. 2. Decarboxylation of oxalacetate by  $Mn^{++}$ ; relation between  $k$  and  $Mn^{++}$  concentration.

These equations are simply a statement of the facts, as is illustrated by Figs. 1 and 2.

These kinetics can be explained by assuming that the metallic cation forms a coordination complex with oxalacetate which decarboxylates faster than the free acid:



The dissociation constant of the complex is assumed high so that only a small fraction of the metal is bound, and decarboxylation of the complex is assumed slow compared with its rate of formation; from these assumptions equations (11)–(13) follow. Other assumptions do not fit the facts, e.g. if formation of the complex were the rate-limiting step, the reaction would be second order. Similarly, the composition of the complex is presumably  $(MA)$  and not  $(MA_2)$ , for the latter would also imply second-order kinetics. The complex might be formulated as either  $A$  or  $B$ , but the enol form ( $A$ ) seems more likely.

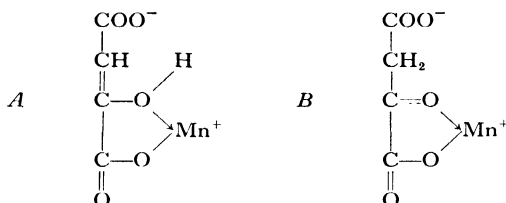

A high dissociation-constant of the metal-oxalacetate complex is confirmed by the results of Fig. 3 and the lower curve of Fig. 5, where the oxalacetate concentration  $[OAA]$ , is varied with constant  $[\text{Mn}^{++}]$ . The initial velocity is very nearly proportional to  $[OAA]$ , while the velocity constant  $k$  hardly alters; hence the fraction of metal bound as complex is directly proportional to  $[OAA]$ , at least up to a concentration of  $M/50$ . Obviously very high concentrations of oxalacetate would be needed to 'saturate' the metal.

Figs. 4 and 5 illustrate the kinetics of the enzyme, giving the initial velocity as a function of  $[\text{Mn}^{++}]$  and  $[OAA]$ . In each case a typical hyperbolic dissociation curve is observed, indicating that both substrate and metal combine reversibly with the enzyme ( $E$ ) to form a ternary enzyme-metal-substrate complex ( $E-M-A$ ). This leads to the rate equation:

$$-\frac{dA}{dt} = k_e E \left( \frac{A}{K_a + A} \right) \left( \frac{M}{K_m + M} \right),$$

where  $K_a$  and  $K_m$  are the dissociation constants ('Michaelis constants') for substrate and metal respectively. The values of these constants are approx.  $2 \times 10^{-3}M$  for  $OAA$ , and  $2 \times 10^{-4}M$  for  $\text{Mn}^{++}$ .

It can immediately be seen from these constants that the affinity of the enzyme for both substrate and metal is very much higher than their affinity

for each other in the absence of enzyme (the dissociation of the metal-*OAA* complex is too high for convenient measurement, but in the case of  $Mn^{++}$  is at least  $0.2 M$  and probably higher). The addition of enzyme to a solution containing substrate and metal therefore increases the amount of complex by bringing the reactants together on the surface of the enzyme. This

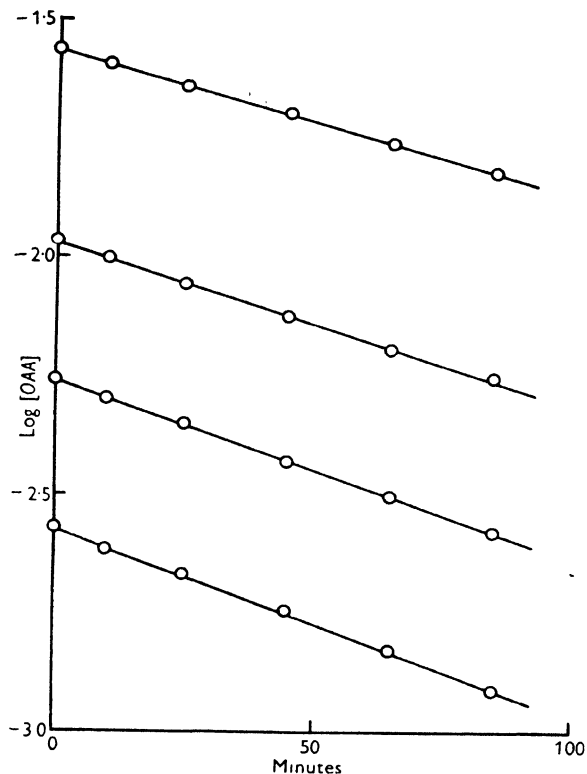
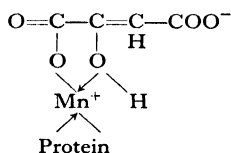

Fig. 3. Decarboxylation of oxalacetate by  $Mn^{++}$ ; variation of oxalacetate concentration with constant  $MnSO_4$  concentration ( $10^{-3}M$ ).

fact alone would go far towards explaining the catalytic effect of the enzyme, and is in accord with the spectrophotometric observations of Kornberg *et al.* (1948).

It is suggested that the ternary enzyme-substrate-metal complex has the following structure



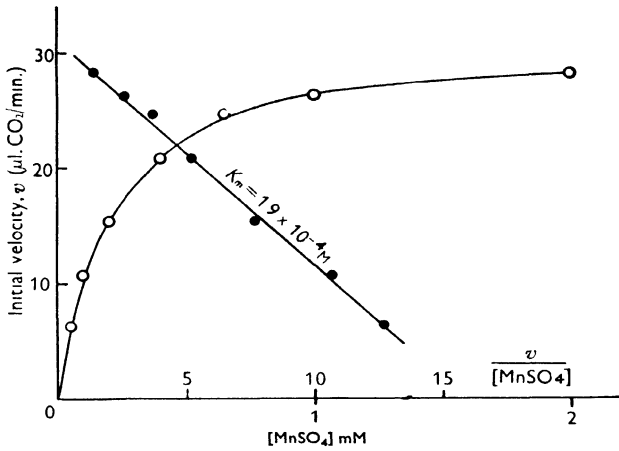

Fig. 4. Oxalacetic decarboxylase; velocity as a function of  $\text{Mn}^{++}$  concentration. (Circles, plot of  $v$  against  $[\text{MnSO}_4]$ ; points, plot of  $v$  against  $\frac{v}{[\text{MnSO}_4]}$ ).

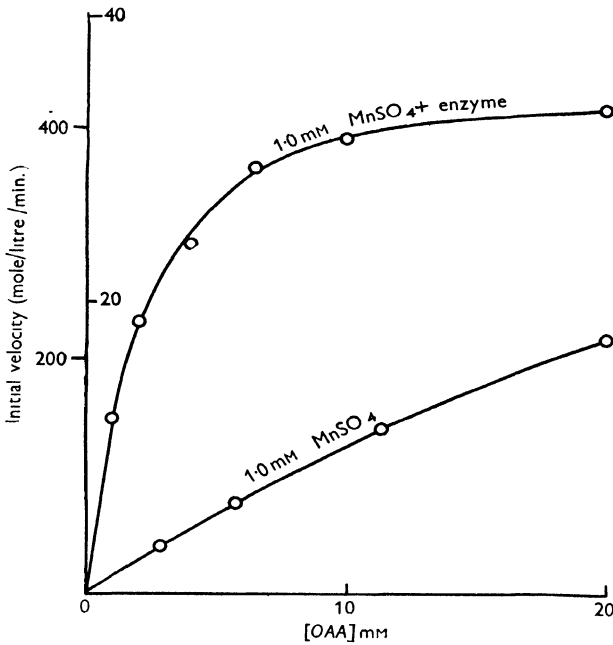

Fig. 5. Effect of oxalacetate concentration. (Left-hand ordinates refer to the upper curve, right-hand ordinates to the lower curve.)

in which the metal is coordinated with both substrate and protein. The kinetic data are entirely consistent with this view, though they do not actually prove it.

#### V. COMBINED ACTION OF OXALACETIC DECARBOXYLASE AND MALIC DEHYDROGENASE

Experiments were carried out with the purified enzyme and pure malic dehydrogenase to test the possibility of obtaining fixation of carbon dioxide through the sequence of reactions given in Table 2.

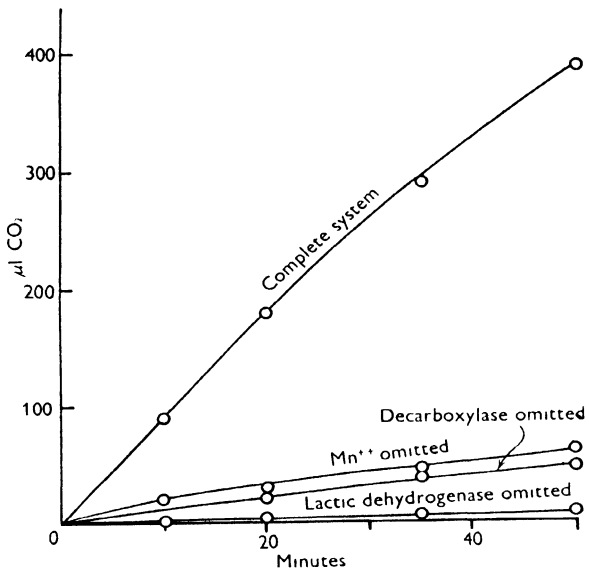

Fig. 6. Malate-pyruvate dismutation with purified oxalacetic decarboxylase. Complete system contained: lactic and malic dehydrogenases, 25 units each; oxalacetic decarboxylase, 90 units; malate and pyruvate,  $10^{-2}M$ ;  $MnSO_4$ ,  $10^{-3}M$ ; DPN, 1 mg.; glycerophosphate buffer pH 6.8,  $0.1M$ ; total vol. 3 ml.; temp.  $30^\circ C$ . (One 'unit' is the quantity of enzyme decomposing one micromole of substrate in 1 min.)

As a preliminary, the reverse reaction, i.e. the oxidative decarboxylation of malate, was tested manometrically. It was found that on the addition of purified lactic dehydrogenase and pyruvate to the system at pH 6.8, the 'malate-pyruvate dismutation' readily occurred (equations 7a-c); the results are shown in Fig. 6.

Mehler *et al.* (1948) had previously tried this experiment at pH 5 with negative results, probably due to the lack of a sufficiently active decarboxylase and the low activity of malic dehydrogenase at this pH.

Instead of using lactic dehydrogenase and pyruvate, the oxidative

decarboxylation of malate may be brought about with ferricyanide as *H*-acceptor, as shown in Fig. 7. Alternatively, the reduction of DPN by the malate-malic dehydrogenase-oxalacetic decarboxylase system may be demonstrated directly, by spectrophotometric determination of the  $\text{DPN}_{\text{red}}$  formed (Fig. 8).

It will be seen that as far as the oxidative decarboxylation of malate is concerned, a mixture of oxalacetic decarboxylase and malic dehydrogenase behaves exactly like the 'malic enzyme'. This suggested that the reverse reaction, i.e. the reductive carboxylation of pyruvate to malate, could also

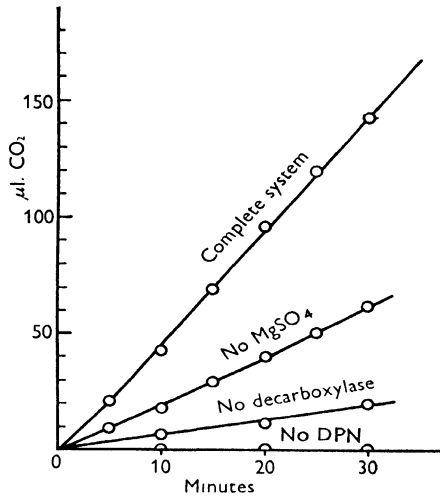

Fig. 7. Decarboxylation of malate with ferricyanide as *H*-acceptor. Complete system contained: malic dehydrogenase, 25 units; oxalacetic decarboxylase, 90 units; malate,  $10^{-2}$ M; ferricyanide,  $10^{-2}$ M;  $\text{MgSO}_4$ ,  $3 \times 10^{-3}$ M; DPN, 1 mg.; glycerophosphate buffer pH 6.8, 0.1M; total vol. 3 ml.; temp.  $30^\circ\text{C}$ .

be brought about by the same system. So far, however, all attempts to demonstrate the reverse reaction experimentally have failed.

In such experiments, large amounts of purified decarboxylase and malic dehydrogenase were used, and high concentrations of substrates (e.g. 0.1M-pyruvate, 0.1M- $\text{NaHCO}_3$  saturated with 50%  $\text{CO}_2$ , pH 6.9) to drive the reaction in the direction of  $\text{CO}_2$  fixation; however, on incubating with  $10^{-3}$ M- $\text{MgSO}_4$  or  $\text{MnSO}_4$  and  $10^{-4}$ M- $\text{DPN}_{\text{red}}$ , there was no measurable formation of  $\text{DPN}_{\text{ox}}$ , which would have indicated synthesis of oxalacetate.

Such results are not easy to understand if the thermodynamic data of Tables 1 and 2 are correct. According to the presumed equilibrium constant of the oxalacetate decarboxylation, the quantities of pyruvate and  $\text{CO}_2$  used in these experiments should have been sufficient to form, at equi-

brium, a concentration of  $0.2 \times 10^{-3} M$ -oxalacetate. The actual formation of even one-fifth of this amount would have caused 40% oxidation of the  $DPN_{red.}$  present in a few seconds, as could be demonstrated by actually adding this amount of oxalacetate to the test system; yet no detectable formation of  $DPN_{ox.}$  occurred.

The conclusion is that the equilibrium constant given in Table 1, calculated from the free-energy data given in the literature, is at least 10 times too high, i.e. that the decarboxylation of oxalacetate is even more difficultly reversible than has hitherto been supposed.

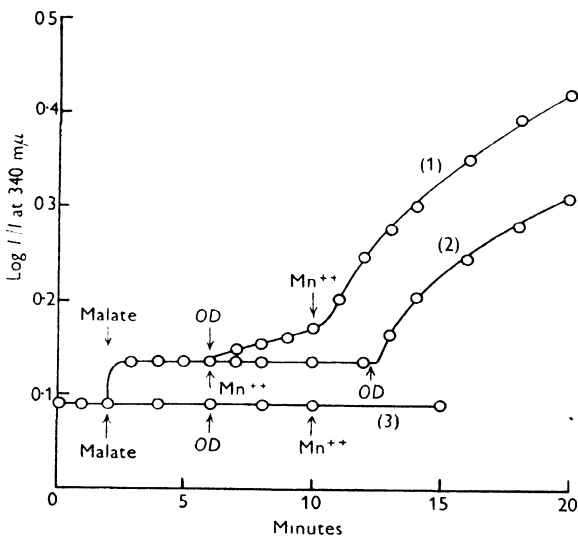

Fig. 8. Oxidative decarboxylation of malate-spectrophotometric. Curves 1 and 2: malic dehydrogenase, 20 units;  $DPN$ ,  $10^{-4} M$ ; glycerophosphate buffer pH 6.8,  $0.05 M$ ; total vol. 3 ml.; temp.  $25^{\circ} C$ . Added at points indicated by arrows: malate,  $0.05 M$ ; oxalacetic decarboxylase ( $OD$ ), 20 units;  $MnSO_4$ ,  $0.003 M$ . Curve 3: as above, but malic dehydrogenase omitted.

This, in fact, agrees with Ochoa's experience with the 'malic enzyme'. The reaction catalysed by the 'malic enzyme' (eqn. (6)) is identical with the overall reaction catalysed by a mixture of oxalacetic decarboxylase and malic dehydrogenase (Table 2), and on thermodynamic grounds the free-energy and equilibrium constant of the reaction must be the same whatever the catalytic mechanism. However, the calculations from accepted thermodynamic data given in Table 2 indicate that the equilibrium point of this reaction should favour fixation of  $CO_2$ , while Ochoa's experimental findings with the malic enzyme show exactly the reverse, the equilibrium in fact favouring decarboxylation of malate. It seems most likely that the thermo-

dynamic data are incorrect, and that the free energy of decarboxylation of oxalacetate is considerably larger than the accepted figure of  $-5250$  cal.

The fact has still to be explained, however, that the 'malic enzyme' will catalyse the fixation of  $\text{CO}_2$  to pyruvic acid, while a mixture of malic dehydrogenase and oxalacetic decarboxylase does not. The explanation probably lies in the fact that thermodynamics gives information on ultimate equilibrium states, but is vague on the time required for equilibrium to be reached. The experimenter, however, requires velocities to be not merely finite, but also to be measurable.

Now the concentration of oxalacetate formed from pyruvate and  $\text{CO}_2$  by the action of oxalacetic decarboxylase can never be higher than the thermodynamic equilibrium concentration, and as we have seen, this may be even smaller than had been supposed. If it is small compared with the Michaelis constant of malic dehydrogenase, the reduction of the oxalacetate to malate by this enzyme may be too slow for convenient measurement. With the 'malic enzyme', on the other hand, if its two active groups are in sufficiently close proximity, oxalacetate formed as an intermediate might be reduced to malate without ever leaving the enzyme surface.

## VI. SUMMARY AND DISCUSSION

The preceding sections should have made it clear that our knowledge of the detailed mechanisms of  $\text{CO}_2$  fixation is still far from complete. We may summarize them by saying that at the moment two competing theories hold the field—the Wood-Werkman mechanism, with oxalacetate as the primary product of fixation, and the Ochoa mechanism in which the primary product is malate. These two mechanisms, however, are not necessarily mutually exclusive.

What part, if any, oxalacetate decarboxylase plays in either of these mechanisms is still not clear; the evidence is still insufficient either to confirm or deny its importance. We may note, however, that *all biological preparations that will fix  $\text{CO}_2$  will also decarboxylate oxalacetic acid*. This applies equally to crude plant, bacterial and pigeon-liver extracts, and to the highly purified 'malic enzyme' prepared by Ochoa, and in the writer's view it is too striking a fact to be regarded as a mere coincidence.

This is not meant to suggest that the 'malic enzyme' is a simple mixture of an oxalacetic decarboxylase and a malic dehydrogenase; indeed, all the evidence suggests that it is either some kind of enzyme complex, or a single enzyme with two active centres. It is suggested, however, that the ability of the enzyme to decarboxylate oxalacetic acid is closely related to its ability to fix  $\text{CO}_2$  to pyruvic acid. It seems possible that oxalacetate may

be the actual intermediate in this process, although the oxalacetate molecule may never leave the surface of the enzyme.

Following on this suggestion, we may speculate whether, in some cells, malic dehydrogenase and oxalacetic decarboxylase may together be enabled to catalyse the same reactions as the 'malic enzyme', by being bound in juxtaposition on insoluble cell structures such as mitochondria. In this connexion, we may recall such complex insoluble enzyme systems as succinoxidase and 'cyclophorase', whose functioning seems to depend on such 'structural' factors. Green and co-workers have shown that the functioning of some of the cyclophorase enzymes is altered when they are removed from the complex and brought into solution, and the same may be the case for the enzymes of CO<sub>2</sub> fixation.

This should not discourage workers on CO<sub>2</sub> fixation from attempting to isolate in a pure state the enzymes concerned. The best way to understand a complex mechanism is usually to take it to pieces, though one should bear in mind that some of the parts may become altered in the process. In particular, it would seem highly desirable that further attempts should be made to isolate the 'malic enzyme', in spite of the technical difficulties.

Another approach which might give useful results would be a study of the role of metallic cations in CO<sub>2</sub> fixation, both with the purified 'malic enzyme', and with crude bacterial, plant and pigeon-liver preparations. These are all known to require Mn<sup>++</sup> or Mg<sup>++</sup>, but other metals do not seem to have been tested. A comparison of the cation specificities of these systems with those of oxalacetic decarboxylase should throw light on the possible role of the latter in CO<sub>2</sub> fixation.

On reviewing our present knowledge of the mechanisms of CO<sub>2</sub> fixation, the picture may appear somewhat confused, and every fresh fact discovered as often as not appears to complicate rather than simplify the situation. This, however, is usually the case when knowledge is advancing rapidly. We may take comfort from the fact that such a state of affairs often indicates that a problem is approaching solution.

#### REFERENCES

- AJL, S. J. & WERKMAN, C. H. (1948). *Arch. Biochem.* **19**, 483.  
EVANS, E. A., VENNESLAND, B. & SLOTIN, L. (1943). *J. Biol. Chem.* **147**, 771.  
FILDES, P. (1940). *Lancet*, **i**, 955.  
GLADSTONE, G. P., FILDES, P. & RICHARDSON, G. M. (1935). *Brit. J. Exp. Path.* **16**, 335.  
HERBERT, D. & PINSENT, J. (1948). *Biochem. J.* **43**, 193.  
KALNITSKY, G. & WERKMAN, C. H. (1944). *Arch. Biochem.* **4**, 25.  
KORKES, S. & OCHOA, S. (1948). *J. Biol. Chem.* **176**, 463.

- KORNBERG, A., OCHOA, S. & MEHLER, A. L. (1948). *J. Biol. Chem.* **174**, 961.
- KRAMPITZ, L. O. & WERKMAN, C. H. (1941). *Biochem. J.* **35**, 595.
- KRAMPITZ, L. O., WOOD, H. G. & WERKMAN, C. H. (1943). *J. Biol. Chem.* **147**, 243.
- LWOFF, A. & MONOD, J. (1947). *Ann. Inst. Pasteur*, **73**, 323.
- MEHLER, A., KORNBERG, A., GRISOLIA, S. & OCHOA, S. (1948). *J. Biol. Chem.* **174**, 961.
- OCHOA, S. (1946). *Currents in Biochemical Research*, p. 165. New York: Interscience Publishers.
- OCHOA, S., MEHLER, A. H. & KORNBERG, A. (1948). *J. Biol. Chem.* **174**, 979.
- OCHOA, S. & WEISZ-TABORI, E. (1948). *J. Biol. Chem.* **174**, 123.

# CARBON DIOXIDE FIXATION AND ACID SYNTHESIS IN CRASSULACEAN ACID METABOLISM

By M. THOMAS

Department of Botany, King's College, Newcastle-upon-Tyne

## I. INTRODUCTION

In the green parts of plants belonging to the Crassulaceae, Cactaceae and certain other families (see Bennet-Clark, 1933), under natural conditions from the late spring to early autumn, vegetable acids may accumulate during the night and show a tendency to disappear on the following day. This diurnal rhythm of dark acidification and light deacidification is described as Crassulacean acid metabolism. Clearly, plants showing it are well suited for the study of the factors which affect the production and consumption of di- and tricarboxylic acids.

In this paper there will be presented and discussed a selection of such experimental results obtained at Newcastle (by Dr H. Beevers in 1946 and by Dr S. L. Ranson subsequently), as bear upon the hypothesis (see Thomas, 1947, 1949) that  $\text{CO}_2$  is a metabolite in acid synthesis and a product of acid breakdown.

The idea that the Wood and Werkman reaction (see, for example, Werkman & Wood, 1942; Krebs, 1943*a*) might occur in plants showing Crassulacean acid metabolism came from a reconsideration of the significance of (*a*) the low values of respiratory quotients, which sometimes fall to zero, found for organs during dark acidification and (*b*) the troughs in very accurate charts for the  $\text{CO}_2$  output (not  $\text{CO}_2$  production) of darkened green organs of *Sedum* (Bennet-Clark, 1933) and *Kleinia* (Thoday & Richards, 1944). In *Sedum* Bennet-Clark found these troughs to be deepest when acidification was at its maximum value. It appeared possible to the present writer that both (*a*) and (*b*) might be explained if a fraction of the  $\text{CO}_2$  produced in normal aerobic respiration, instead of being liberated to give a measurable  $\text{CO}_2$  output, were metabolically consumed in acid synthesis. Later it became clear that many other experimental results obtained in the last century as well as in this could be similarly explained (Thomas, 1949), and new experimental evidence, summarized in §II of the present paper, was obtained in support of this explanation (Thomas & Beevers, 1949). Additional experimental work done by Ranson on dark acidification is described in §§I, II and III.

The present writer's conclusion was that the main factors favouring acid production in a given organ having the power of Crassulacean acid metabolism were a high carbohydrate content, such as may be found at the end of a fine day in summer, and a continuous supply of  $\text{CO}_2$ . These conditions are satisfied immediately on darkening green organs that have been previously illuminated. Accordingly, acid synthesis proceeds so rapidly as to exceed acid consumption, and therefore results in dark acidification. In organs illuminated in air, however, the  $\text{CO}_2$  produced in respiration and absorbed from the atmosphere is consumed in photosynthesis. Little or none is available for acid synthesis, which therefore, in spite of a high carbohydrate content, occurs at a very slow rate or stops altogether. Acid consumption continues; accordingly light deacidification sets in. If this explanation is correct, it clearly follows that light deacidification should be retarded by enriching the atmosphere with  $\text{CO}_2$ , and so ensuring a supply of this gas to centres of acid synthesis as well as to chloroplasts. With a sufficient  $\text{CO}_2$  supply light acidification should be induced. By treating *Bryophyllum* leaves in this way, Thomas & Beevers (1949) obtained evidence of the occurrence of  $\text{CO}_2$  fixation in acid synthesis by illuminated leaves, and, subsequently, Ranson has performed extensive experiments on retarded light deacidification and on light acidification. The results of these Newcastle experiments will be summarized in §§IV and V.

Bonner & Bonner (1948), in Pasadena, have come to conclusions similar to the present writer's about the controlling influence of  $\text{CO}_2$  on acid metabolism. They were led to work in this field by the contemplation of certain unexplained experimental results obtained at Leipzig by Wolf (1939), especially his discovery (*a*) that the normally slow liberation of  $\text{CO}_2$  by leaves synthesizing acids in the dark is still further retarded by the addition of pyruvic acid, and (*b*) that this effect of pyruvate is inhibited by malonate. Bonner & Bonner suggested that 'the formation of acids by succulents results from carbon dioxide fixation, perhaps by pyruvate, with the formation of four-carbon dicarboxylic acids'. Some of the evidence which they obtained in support of their suggestion that acidification depends upon  $\text{CO}_2$  fixation will be mentioned on p. 82.

It may be noted here that, using  $\text{C}^{14}\text{O}_2$ , Thurlow & Bonner (1948) obtained convincing evidence of the dark fixation of  $\text{CO}_2$  by *Bryophyllum* leaves. They found that after 60 hr. at  $2-3^\circ\text{C}$ . a considerable fraction of the labelled carbon was incorporated in the organic acids which had accumulated. Some of the labelled carbon was, however, present in amino-acids, proteins, carbohydrates and other cell constituents. They laid emphasis on the final wide distribution of the carbon contained in the  $\text{CO}_2$

fixed in the dark, and called attention to the work of Benson & Calvin (1948; see below) as supplying further evidence of this distribution. If this conclusion is generally valid, it would explain why, in our Newcastle experiments (see p. 91), the amount of titratable acid accumulating in the dark has often been less than the calculated acid equivalent of the  $\text{CO}_2$  fixed in the dark.

The part played by acid metabolism in aerobic respiration (see Krebs, 1943*b*) and in normal photosynthesis in green cells has been much discussed. It is recalled that Ruben, Hassid and Kamen were the first workers not only to use tracer methods in the study of photosynthesis but also to obtain evidence that the dark fixation of  $\text{CO}_2$  by green cells results in the synthesis of carboxylic groups (for bibliography, see Kamen, 1949). The results of more recent and extensive experiments with  $\text{C}^{14}\text{O}_2$  in Calvin's laboratory (see e.g. Benson & Calvin, 1948) have provided much additional evidence of the power possessed by photosynthesizing cells in general to fix  $\text{CO}_2$  in the synthesis of acids in the dark.

There is no reason to suppose that photosynthesis and aerobic respiration in such green cells as can show Crassulacean acid metabolism proceed along lines different from those followed by these processes in other green cells. Nevertheless, in the present paper it is still convenient to assume provisionally that, in those specialized plants showing Crassulacean acid metabolism, diurnal variations in titratable acidity are governed at enzymic centres which are distinct from those concerned with such acid metabolism as may occur in aerobic respiration and normal photosynthesis.

Some elucidation of the possible connexion between the events of Crassulacean acid metabolism and the processes occurring in aerobic respiration and photosynthesis may come from the development of certain preliminary Newcastle experiments. Ranson has obtained evidence (*a*) that when  $\text{CO}_2$  fixation in the dark is inhibited in concentrations greater than 50%, aerobic respiration may become disordered (p. 82), and (*b*) that in  $\text{CO}_2$  concentrations greater than 15% in the light, oxygen is no longer liberated, but a certain measure of  $\text{CO}_2$  fixation in acid synthesis may continue. It would be premature to attempt an interpretation of these findings.

They are recorded here to emphasize the possibility that a more intricate form of analysis than that so far adopted may be required, when we possess more detailed knowledge of the biochemistry of acid production and consumption, and of the influence of environmental conditions on these processes.

## II. EVIDENCE OF CO<sub>2</sub> ABSORPTION IN THE DARK FROM GAS MIXTURES DURING ACIDIFICATION IN LEAVES OF *BRYOPHYLLUM* AND OTHER GREEN ORGANS SHOWING CRASSULACEAN ACID METABOLISM

The results of experiments performed in the dark on *Bryophyllum* leaves in 1946 have already been reported (Thomas & Beevers, 1949). Leaves were enclosed in a gas mixture containing CO<sub>2</sub> and, at intervals, changes in gas composition and in titratable acid were measured. During the opening phase of dark metabolism acid accumulated at a relatively fast rate, and CO<sub>2</sub> and oxygen were simultaneously absorbed from the surrounding gas mixture. Accordingly the measured R.Q. had a negative value during this phase. During the next phase the rate of acidification gradually declined, and simultaneously the R.Q.'s rose to positive values and eventually approached, reached or became greater than unity.

The following conclusions were drawn:

(i) The oxygen uptake was attributable to the normal aerobic respiration of carbohydrate, with an R.Q. of unity. In the opening phase, however, the respiratory CO<sub>2</sub> produced was not evolved but was consumed in the synthesis of vegetable acids by the Wood & Werkman reaction and, possibly, in other CO<sub>2</sub> fixations. In the later phase, as the rate of acid synthesis declined, an increasing amount of the respiratory CO<sub>2</sub> was evolved. When the acid accumulation had reached its maximum value, all the respiratory CO<sub>2</sub> was evolved and the measured R.Q. was unity, characterizing the oxidation of carbohydrate when not masked by some other process. When dark deacidification set in, the R.Q. rose above unity.

(ii) In the opening phase CO<sub>2</sub> supply was the factor which limited the rate of acid synthesis. Accordingly, in addition to the complete consumption of respiratory CO<sub>2</sub>, there occurred an absorption and metabolic fixation of CO<sub>2</sub> from the gas mixture around the leaves. It is because CO<sub>2</sub> is the limiting factor in experiments such as these on plant organs showing Crassulacean acid metabolism, that it is possible with such plants to get convincing evidence of the metabolic fixation of CO<sub>2</sub> fed to these organs, without having recourse to gas with labelled carbon atoms.

(iii) Since it has been shown (see Thomas & Beevers, 1949, and the evidence given on p. 84 below) that, except for the construction of exact balance sheets, we may ignore such solution of CO<sub>2</sub> in cell sap as has occurred in our experiments, it is maintained that a negative R.Q. symbolizes the undoubted occurrence of the fixation of environmental CO<sub>2</sub>. If this conclusion is accepted, it follows that a zero R.Q. in air means that respiratory CO<sub>2</sub> is completely fixed in acid synthesis, and R.Q. values less

than unity mean that a fraction of the respiratory  $\text{CO}_2$  is consumed in this process. Thomas (1949) has already given detailed consideration to the interpretation of values of the R.Q. obtained since de Saussure (1804) opened this field of study by his experiments, remarkable for the time, on *Opuntia* in the dark. He virtually detected negative R.Q.'s in this genus, and may therefore possibly be regarded as the first investigator to have obtained evidence of  $\text{CO}_2$  fixation by living organisms in the absence of light. That is why the present writer has described the absorption of  $\text{CO}_2$  in the dark during acidification as the *de Saussure effect*\*. It should be noted, however, that de Saussure makes no mention of the occurrence of acids in *Opuntia*. The phenomenon of Crassulacean acid metabolism was not discovered until many years after de Saussure's time. The few later investigators (e.g. Warburg, 1886; Aubert, 1892) who mentioned de Saussure's finding attributed the absorption of  $\text{CO}_2$  to solution in the sap of the succulent organs of *Opuntia*.

In 1947 and subsequently Ranson has confirmed all the experimental results which had been obtained by Beevers during the summer of 1946 with the limited amount of plant material then available at Newcastle. Ranson worked with larger samples of *Bryophyllum* leaves, at several temperatures and with  $\text{CO}_2$  concentrations ranging from zero to 90%. The effects of temperature and  $\text{CO}_2$  concentration on acid synthesis and  $\text{CO}_2$  fixation will be briefly discussed in the next two sections. Here the general statement may be made that in all of Ranson's numerous experiments, whenever dark acidification has occurred vigorously in *Bryophyllum* leaves placed in a gas mixture containing  $\text{CO}_2$ , negative R.Q.'s have been obtained during the opening phase, and later, as in Beevers's experiments of 1946, the R.Q. has gradually risen to unity. In general, R.Q.'s have been greater than unity, sometimes much greater, when acid consumption has been faster than acid production in the dark.

Values of R.Q.'s, changing from negative to positive and rising beyond unity, are noted below the graphical record of one of Ranson's experiments which is displayed in Fig. 1. This record will serve as a summary of the main facts discovered at Newcastle about  $\text{CO}_2$  fixation by *Bryophyllum* leaves in the dark. Attention is called to the following points:

- (i) Aerobic respiration proceeded throughout the experiment at the

\* In his important article, 'Neuere Vorstellungen vom Chemismus des Säurestoffwechsels', which appeared in the 1949 number of *Planta*, Dr J. Wolf reconsiders the results of older work, his own and those of others, in the light of the knowledge of the dark fixation of  $\text{CO}_2$ . Quite independently of the present writer he has recognized the significance of de Saussure's observations, and has suggested that the uptake of  $\text{CO}_2$  in the dark by living tissue should be described as the *De Saussure Effekt*. One if not the only cause of the de Saussure effect is the occurrence of the Wood and Werkman reaction.

steady rate of about 5 mg. oxygen uptake per 100 g. fresh weight per hour. If the R.Q. is taken as unity, CO<sub>2</sub> would have been continuously *produced* by aerobic respiration at the steady rate of 7 mg. (approximately) per hour.

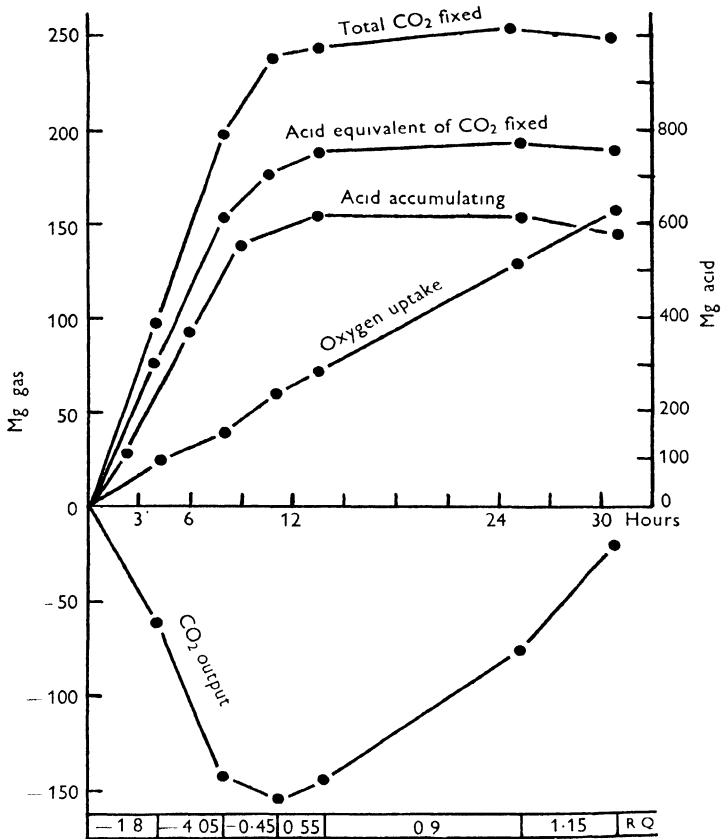

Fig. 1. Records of measurements, given in mg./100 g. fresh weight, of gaseous exchange and increases or decreases in titratable acid for *Bryophyllum* leaves kept in the dark at 12° C. in a gas mixture containing initially 5% CO<sub>2</sub>. (Experiment performed by Ranson, 1 September 1947, confirming experimental results obtained by Beevers in 1946 (see Thomas & Beevers, 1949).)

Actually during the last 15 hr. of the experiment CO<sub>2</sub> was *liberated* from the leaves at about this rate.

(ii) During the opening 11 hr. of the experiment, however, CO<sub>2</sub> was *absorbed* by the leaves (i.e. the CO<sub>2</sub> output, and the R.Q.'s were negative). For about 8 hr. this absorption was at the fast rate of about 18 mg./hr., and the R.Q.'s had high negative values. During the next 3 hr. the rate of CO<sub>2</sub>

absorption declined and the negative value of the R.Q. was lower. Between the eleventh and fourteenth hours  $\text{CO}_2$  liberation set in and the R.Q.'s became positive, but were much less than unity.

(iii) Conclusive evidence has been obtained (see p. 84) that, in the main at least,  $\text{CO}_2$  absorption must be attributed to metabolic consumption and not to solution in the cell sap of the *Bryophyllum* leaves.

(iv) Titratable acid accumulated in the leaves, immediately after they were placed in the dark, at the fast average rate of about  $15 \frac{5}{100} \text{ mg./hr.}$ , which was maintained for about 9 hr., whilst  $\text{CO}_2$  absorption was at its fastest and R.Q.'s had their highest negative values. Between the ninth and the fourteenth hour acid continued to accumulate, but at a slower rate. During this phase  $\text{CO}_2$  was liberated, but the R.Q. was much less than unity. Subsequently, until the twenty-fifth hour, the rates of production and consumption of acid were the same, i.e. acid accumulation was maintained at its maximum value. The R.Q. had approached unity.

(v) Clear evidence was thus obtained of a connexion between the absorption of  $\text{CO}_2$  and acid synthesis during the opening 11 hr. in the dark. In the light of knowledge of the Wood & Werkman reaction the conclusion was drawn that the absorbed  $\text{CO}_2$  was metabolically consumed in this synthesis. In addition, respiratory  $\text{CO}_2$  would be consumed, and the average rate of  $\text{CO}_2$  fixation at centres of acid synthesis during this 11 hr. period works out approximately at 25 mg./hr. After the eleventh hour the  $\text{CO}_2$  fixed in such acid synthesis as occurred was not absorbed from the environment but virtually came from the respiratory centres in the cells. The R.Q.'s were positive, but less than unity, showing that some of the  $\text{CO}_2$  produced by respiration was metabolically fixed, and only a fraction was liberated from the leaves to give a measurable  $\text{CO}_2$  output.

(vi) There was a clear tendency for dark deacidification to set in after 25 hr., and the rise in the R.Q. above unity may be significant (see p. 80).

(vii) Reference will be made on p. 91 to the graph for the acid equivalent of the total  $\text{CO}_2$  fixation.

By relating rises in the R.Q. from negative values up to positive values of unity, or greater than unity, to the progress of acidification, the attainment of acid maxima and the phenomenon of dark deacidification, Ranson was able to get evidence that what had been discovered for *Bryophyllum* occurred also in the following genera which are known to possess the power of Crassulacean acid metabolism: *Opuntia*, *Sedum*, *Crassula* and *Kleinia*. The evidence obtained from some of his experiments (for example, those on *Kleinia*) was not so convincing as that given by experiments on *Bryophyllum*, but pieces of *Opuntia* absorbed  $\text{CO}_2$  so strongly in the dark, that even in air the first measured value of the R.Q. was negative.

A record is given in Table 1 of one of Ranson's experiments on pieces of *Opuntia*. It will be seen that up to 24 hr. the trend of the results was such as might have been predicted from the conclusions drawn from earlier experiments on *Bryophyllum*. In 0.05% CO<sub>2</sub> initially (i.e. laboratory air) acid accumulated gradually; and, in the opening phase, since the R.Q. was zero, we may conclude that respiratory CO<sub>2</sub> was completely consumed in acid synthesis. Later, as the process of acidification became weaker, respiratory CO<sub>2</sub> escaped to an increasing extent and the R.Q. rose in the direction of unity. In the gas mixtures containing 5 and 9.5% CO<sub>2</sub> negative R.Q.'s were found during the opening phase of acidification, and the results suggest that even with an external value of 5%, CO<sub>2</sub> concentration was the factor which limited the rate of acid synthesis. The average R.Q.'s were low but positive during the period 9–24 hr. when, clearly, further accumulation of acid took place in these gas mixtures.

Table 1. *The relation of changes in R.Q.'s to acid metabolism in Opuntia placed in the dark in gas mixtures containing initially the concentration of CO<sub>2</sub> stated at the head of each pair of columns.*

(Late August 1948 at 22° C.)

Hours	0.05% CO <sub>2</sub>		5% CO <sub>2</sub>		9.5% CO <sub>2</sub>	
	R.Q.	T.A.N.	R.Q.	T.A.N.	R.Q.	T.A.N.
0	0.00	(22, 8)	—	(22, 8)	—	(22, 8)
3	0.01	—	-2.41	—	-7.92	—
6	0.75	—	-2.53	—	-3.17	—
9	0.56	(31, 26)	-0.75	(42, 59)	-2.87	(54, 57)
24	0.87	(58, 33)	0.20	(100, 68)	0.20	(110, 57)
33	0.78	—	0.86	—	1.97	—
48	0.81	(59, 30)	0.79	(82, 82)	—	(90, 102)
72	—	(35)	0.96	(73)	2.57	(55)

N.B. The T.A.N.'s placed in brackets with a comma separating them were titratable acid numbers obtained in separate samples. Differences are mainly attributable to the smallness of the samples and to the differences in the age of the parts sampled. The symbol T.A.N. denotes the number of c.c. of decinormal sodium hydroxide required to neutralize the acid contained in the boiled residue and liquid originating from 100 g.\* of leaf tissue.

\* In the paper by Thomas & Beevers (1949, p. 423) this weight is incorrectly given as mg.

The results obtained after 24 hr. are difficult to interpret, because of the large sampling error in determining the titratable acid numbers (T.A.N.). These results probably have little bearing on the subject-matter of the present section, but are included to make it clear that quantitative experiments in this field present many difficulties. To obtain results of statistical significance a large amount of plant material would be required, and a team of research workers to deal with it in a simultaneous effort. The present writer's inclination is to attach more significance to fluctuations in R.Q.'s than in those of T.A.N.'s because the R.Q.'s were determined on a single sample. The results recorded in Table 1 for times after 24 hr. suggest to him that in the initial concentrations of 0.05 and 5% CO<sub>2</sub> acidification had not reached its maximum value by 72 hr., but in the initial gas mixture of 9.5% CO<sub>2</sub> not only had this maximum been reached, but dark deacidification was occurring in the samples of *Opuntia* used for the experiments on gas analysis. Much evidence has been obtained at Newcastle to confirm the results of earlier work (see Bennet-Clark, 1933; Thomas, 1949) that it is a characteristic of dark deacidification that the R.Q. should rise above unity and reach the high values of 2 or more.

### III. THE INFLUENCE OF TEMPERATURE ON DARK ACIDIFICATION AND CO<sub>2</sub> FIXATION

It has long been known (see Bennet-Clark, 1933) that the value of the acid maximum reached by dark acidification may be higher at moderate temperatures (e.g. 20° C. or lower) than at higher temperatures (e.g. 30° C. or higher). In 1947 Ranson carried out a number of experiments, some in air and some in gas mixtures containing 5% CO<sub>2</sub>, at different temperatures within the range 12–38° C. In every set of parallel experiments it was found that both the total amount of CO<sub>2</sub> consumed and the value of the acid maximum were inversely related to the temperature. This finding is illustrated by the graphical record of one experiment given in Fig. 2, in which acid accumulation and the calculated malic acid equivalent of the metabolically consumed CO<sub>2</sub> (see p. 91) are plotted against time.

In every set of experiments negative R.Q.'s were obtained longest at the lowest temperature used. Indeed, at temperatures greater than 30° C. during such acidification as occurred, the R.Q.'s were positive, but less than unity. Since the temperature coefficient for oxygen uptake was positive, and had values ranging from 1.5 to 2 over the temperature range used, the metabolic consumption of respiratory CO<sub>2</sub> in acid synthesis was not inconsiderable even when the R.Q.'s were 0.5 or higher.

Emphasis is laid on the contrast between the positive temperature

coefficient for oxygen uptake, i.e. for the aerobic oxidation of carbohydrate, and the negative temperature coefficients for both acid synthesis and CO<sub>2</sub> fixation. This conjunction of an unusual type of temperature coefficient for these two last processes provides additional evidence that they are causally related.

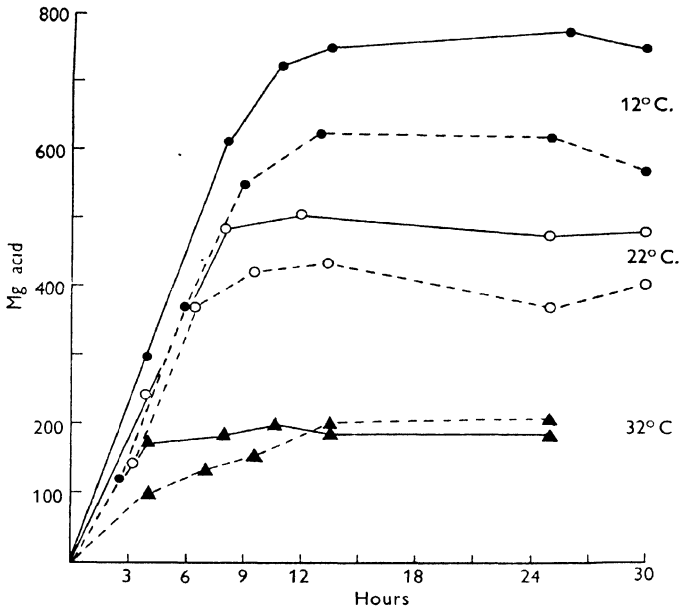

Fig. 2. Measured increases at 12, 22 and 32° C. of titratable acid (interrupted lines), and of the calculated acid equivalent of total CO<sub>2</sub> fixed (continuous lines) as mg. malic acid per 100 g. fresh weight *Bryophyllum* leaves kept in the dark in a gas mixture containing initially 5% CO<sub>2</sub>. The recorded values for the acid equivalent of total CO<sub>2</sub> fixed have been obtained by multiplying the measured values of CO<sub>2</sub> fixation by 3.05 (see p. 91).

#### IV. THE INFLUENCE OF CO<sub>2</sub> CONCENTRATION ON THE RATE OF DARK ACIDIFICATION AND CO<sub>2</sub> FIXATION

Ranson has carried out a number of experiments in which he measured the accumulation of acid in *Bryophyllum* leaves exposed to continuous currents of gas of known composition. In parallel experiments, but with leaves kept in closed vessels, he measured the gaseous exchange between the leaves and gas of initially the same composition as that of each mixture used in the continuous-current experiments. At a constant temperature in the dark the effect of increasing the external CO<sub>2</sub> concentration from zero to some value lying between 1 and 10% was to increase both the rate of

dark acidification and that of  $\text{CO}_2$  fixation. In most of the experiments the maximum rates were obtained in gas mixtures containing about 5%  $\text{CO}_2$ . Acid accumulation and  $\text{CO}_2$  fixation were both strongly retarded in 50%  $\text{CO}_2$ , and may have been completely inhibited in some of the higher concentrations.

Some evidence has been obtained that, in these higher concentrations, ethyl alcohol accumulates in the leaves. Thomas (1925) has described the process that leads to such an accumulation as  $\text{CO}_2$  zymasis, and regards it as a respiratory disorder. In Ranson's finding there is a faint suggestion that there may be a connexion between  $\text{CO}_2$  fixation and normal aerobic respiration (see p. 81). It remains to be established, however, that zymasis is occasioned by the inhibition of  $\text{CO}_2$  fixation.

In the summary of Ranson's experimental results given below, the approximate average hourly rates of malic acid accumulation and, when determined, of  $\text{CO}_2$  fixation, are expressed as mg./100 g. fresh weight of leaves. Respiratory quotients are recorded in brackets. It is recalled that, in gas mixtures containing  $\text{CO}_2$ , the higher the negative value of the R.Q. the faster is the rate of  $\text{CO}_2$  fixation. In air the nearer the R.Q. is to zero the more rapid is the rate of consumption of respiratory  $\text{CO}_2$ .

(i) *The average hourly rates of dark acidification over 10 hr. at 20° C. (20 April 1949)*

$\text{CO}_2$ -free air	Lab. air	2% $\text{CO}_2$	5% $\text{CO}_2$	50% $\text{CO}_2$	70% $\text{CO}_2$	90% $\text{CO}_2$
19	35	62	58	4	0	0

Acidification was promoted by increasing the external  $\text{CO}_2$  concentration from zero to some value not greater than 2%. Within this range the concentration of  $\text{CO}_2$  was the factor which limited the rate of acid synthesis in this experiment. Acidification continued in 50%  $\text{CO}_2$  during the second phase of this experiment. Clearly, at this concentration, there is very quickly seen a strong retardation of acid synthesis, but not a complete inhibition. Concentrations greater than 70% completely inhibited acidification.

Prior to the performance of this experiment at Newcastle, Bonner & Bonner (1948) had demonstrated that there was a tenfold greater accumulation of acid in certain *Bryophyllum* leaves kept in the dark for 2 days at 11° C. in ordinary air than in those kept under parallel conditions in  $\text{CO}_2$ -free air. In another experiment, performed in the dark at 3° C. for 2 days with continuous currents of gas, they found that acid accumulation was approximately a linear function of  $\text{CO}_2$  pressure in the surrounding atmos-

phere between the levels of 0.00 and 0.1% of CO<sub>2</sub>, and that between 0.1 and 10% CO<sub>2</sub> acidification continued to increase, but at a slower rate. The results of these experiments led them to suggest 'that the CO<sub>2</sub> pressure prevailing within the leaf (in such succulent plants as exhibit typical succulent metabolism) may control the diurnal fluctuation of acid content through the direct fixation of CO<sub>2</sub> as organic acid'. There may be a shade of difference between this conclusion and the present writer's. Bonner & Bonner stress the importance of the partial pressure of CO<sub>2</sub> within the leaf. They noted with some surprise that acidification proceeds at a not inconsiderable rate in a CO<sub>2</sub>-free atmosphere. By evacuation experiments they satisfied themselves that leaves contain CO<sub>2</sub> or some substance that readily yields this gas, and came to the conclusion that 'the small amount of organic acid formation in leaves in carbon-dioxide-free air is compatible with the amount of residual carbon dioxide present'. The present writer does not deny that such residual CO<sub>2</sub> as may be present in a leaf may be used in acid synthesis, but maintains that the process of aerobic respiration in ordinary or CO<sub>2</sub>-free air is sufficiently active, as judged by the oxygen uptakes we have observed in our Newcastle experiments, to provide enough CO<sub>2</sub> for fairly rapid acid synthesis. The fact that the R.Q. in the early stages in the dark may be zero in CO<sub>2</sub>-free air and negative in ordinary air shows that this respiratory CO<sub>2</sub> is efficiently fixed.

(ii) *Average hourly rates of dark acidification, and average R.Q.'s over 6 hr. at 20° C. (22 September 1947)*

Lab. air	5% CO <sub>2</sub>	10% CO <sub>2</sub>	15% CO <sub>2</sub>
22 (0.15)	33.5 (-0.3)	26.8 (-0.2)	20.1 (0.0)

CO<sub>2</sub> concentration was again the factor limiting the rate of acid synthesis in laboratory air. Increase in the CO<sub>2</sub> concentration above 5% led to a decreased rate of synthesis and of CO<sub>2</sub> fixation.

(iii) *Average hourly rates of dark acidification and average R.Q.'s over 8½ hr. at 22° C. (13 July 1948)*

Lab. air	1% CO <sub>2</sub>	3% CO <sub>2</sub>	5% CO <sub>2</sub>
20 (0.06)	60 (-0.6)	67 (-1.1)	74 (-1.25)

CO<sub>2</sub> concentration was the factor limiting the rate of acid synthesis and CO<sub>2</sub> fixation not only in laboratory air, but also in 3% CO<sub>2</sub>.

(iv) *Average hourly rates of dark acidification and average R.Q.'s over 9 hr. at 22° C. (27 July 1948)*

Lab. air	30% CO <sub>2</sub>	90% CO <sub>2</sub>
44 (0.01)	37 (0.65)	4 (1.7)

It is noteworthy that the values for malic acid accumulation and of the R.Q.'s show that 30% CO<sub>2</sub> retarded CO<sub>2</sub> fixation sufficiently to cause acid synthesis to be slower than it is in air. This effect on dark acidification of concentrations of CO<sub>2</sub> of this order was observed in the last century. It led to the erroneous conclusion that CO<sub>2</sub> has a retarding influence on acidification at all concentrations. It is doubtful whether the positive value for acidification in 90% CO<sub>2</sub> is significant. However, an unmistakable increase in the alcohol content of the leaves occurred in this high concentration in spite of the fact that the gas mixture contained 10% oxygen. The high value of the R.Q. may have been mainly owing to the onset of zymasis, but the possibility cannot be excluded that some dark deacidification took place in the experiments in closed vessels.

The high positive value of the R.Q. in the experiment with 30% CO<sub>2</sub> coupled with the evidence given in (ii) above that the negative values of R.Q.'s are lower in 10 and 15% than in 5% CO<sub>2</sub>, provides conclusive proof that negative R.Q.'s found during acid synthesis in gas mixtures containing CO<sub>2</sub> cannot be attributed to solution of this gas in cell-sap (see p. 75).

(v) *Average hourly rates of dark acidification and of CO<sub>2</sub> fixation and average R.Q.'s over 7½ hr. at 22° C. (1 October 1947)*

	Lab. air	5% CO <sub>2</sub>	10% CO <sub>2</sub>	15% CO <sub>2</sub>
Malic acid accumulation	20	25	21.5	11.5
CO <sub>2</sub> fixation	6.6	9.5	8.5	3.9
$\frac{\text{Acid accumulation}}{\text{CO}_2 \text{ fixation}}$	3.0	2.6	2.4	3.0
R.Q.	(0.20)	(-0.34)	(-0.26)	(0.48)

The maximum values of acid accumulation and of CO<sub>2</sub> fixation (here recorded as an absolute value) had been reached in 5% CO<sub>2</sub>. The values of the R.Q.'s point to the same conclusion. It is noteworthy that both acidification and CO<sub>2</sub> fixation were less in 15% CO<sub>2</sub> than in air. Clearly the rates

of acid accumulation and CO<sub>2</sub> fixation were directly related. As there still remain many difficulties in measuring exactly gaseous exchanges simultaneously with increases in acid, it is not surprising that the values for the quotient (acid accumulation)/(CO<sub>2</sub> fixation) are not more closely alike. The values obtained for this quotient may possibly provide some little evidence in support of the view (see Thomas, 1947, 1949) that acid synthesis may be summarized by the following overall equation:



On the basis of this equation the value of the quotient (acid accumulation)/(CO<sub>2</sub> fixation) should be 3.05. It will be reported on p. 91, however, that in some experiments the value of this quotient has been less than 2.

(vi) *Average hourly rates of dark acidification and average R.Q.'s over 12 hr. at 12° C. (24 September 1947)*

Lab. air	5% CO <sub>2</sub>	10% CO <sub>2</sub>	15% CO <sub>2</sub>
17 (0.02)	31 (-2.5)	26 (-1.3)	18 (-0.4)

At the lower temperature used in this experiment the quantitative effects of CO<sub>2</sub> fixation were in the same order as at higher temperatures (cf. (v) above). We have already seen that the maximum amounts of CO<sub>2</sub> fixed and acid synthesized may be greater at 12 than at 20° C. It has been concluded from the results of the experiments recorded in this present section that the optimum CO<sub>2</sub> concentration under the condition of these experiments was about 5%. Accordingly, it is not surprising that the accumulation of malic acid in *Bryophyllum* leaves exposed to 5% CO<sub>2</sub> at 12° C. reached in 30 hr. the high value of 490 mg./100 g. fresh weight of leaves. This corresponds to a metabolic consumption of 163 mg. of respiratory and absorbed CO<sub>2</sub>. Moreover, the form of the progress curve suggested that still more acid would have accumulated had the experiment lasted longer.

As far as our present experience at Newcastle goes, the best conditions for getting a maximum amount of dark acidification, and therefore of dark CO<sub>2</sub> fixation, by *Bryophyllum* leaves of a given age, is to pick the leaves at the end of a sunny day, when their malic acid content will be low and their carbohydrate content high, and feed them in the dark with CO<sub>2</sub> at a concentration of from 2% to 5% at a temperature of 12° C. or lower.

V. EVIDENCE OF CO<sub>2</sub> FIXATION IN ACID PRODUCTION  
FROM EXPERIMENTS WITH ILLUMINATED  
*BRYOPHYLLUM* LEAVES

By experiments designed to test the hypothesis that light deacidification is the inevitable result of the shortage of the essential metabolite, CO<sub>2</sub>, at centres of acid synthesis in illuminated *Bryophyllum* leaves, Beevers (see Thomas & Beevers, 1949) succeeded in obtaining convincing evidence that the rate of light deacidification may be retarded by augmenting the CO<sub>2</sub> concentration around the leaves, and some evidence that, under certain conditions in these CO<sub>2</sub>-enriched atmospheres, acid accumulation may be induced. Both of these effects had been observed by earlier workers (see Thomas, 1949), but the retarded light deacidification was attributed to the narcotic influence of CO<sub>2</sub> on acid consumption. The phenomenon of light acidification received no explanation. Thomas (1947) concluded that light acidification and retarded light deacidification result from the promotion of CO<sub>2</sub> fixation and, therefore, of acid synthesis by feeding leaves with carbon dioxide. Bonner & Bonner (1948) arrived at a similar conclusion, after considering the retardations reported by Wolf.

The unpublished results of Ranson's researches at Newcastle have confirmed and substantially extended those obtained by Beevers. All of these results can be interpreted on the assumption that the enzyme mechanism that governs acid synthesis remains potentially active in the light, but requires a supply of CO<sub>2</sub> as one of its substrates, the other substrate coming from carbohydrate which is already present in the leaf or is produced by photosynthesis. Two main groups of experiments may be distinguished.

(i) *Experiments with leaves which had initially high acid values and, presumably, a low carbohydrate content.* *Bryophyllum* leaves were kept in the dark until acid accumulation neared its maximum value and were then illuminated in air. Light deacidification proceeded at a high rate. This rate, however, was markedly retarded by increasing up to 5% the CO<sub>2</sub> concentration around the leaves. Indeed, in two experiments, acid accumulation remained unchanged over a period of 24 hr. in 5% CO<sub>2</sub>; i.e. acid synthesis in the CO<sub>2</sub>-fed leaves kept pace with acid consumption. The results obtained with 5 and 10% CO<sub>2</sub> were similar. At some value, as yet undetermined, between 10 and 50% CO<sub>2</sub>, the inhibitory effect of CO<sub>2</sub> on the cell system which governs acid synthesis may be relatively more powerful than the acceleration brought about by the increase of its concentration as a substrate. Additional difficulty is added to the interpretation of results because acid consumption is probably retarded by high

concentrations of  $\text{CO}_2$ . Accordingly the maintenance of a high initial acid value in leaves illuminated in 70%  $\text{CO}_2$  may not have been a result of a high rate of acid synthesis (indeed, this may have been zero) but of a complete inhibition of the process of acid consumption. In the light deacidification of leaves with an initially high acid value, retardations brought about by  $\text{CO}_2$  feeding at the lower levels of concentration may, however, with confidence be attributed to supplying centres of acid synthesis with an essential substrate, which is in deficient supply in experiments in air, owing to its rapid consumption in photosynthesis.

(ii) *Experiments with leaves which had initially low acid values, and, presumably, a high carbohydrate content.* *Bryophyllum* leaves were strongly illuminated until their acidity fell to a low value. Presumably as a result of photosynthesis, their starch content would have been high (see Pucher, Leavenworth, Ginter & Vickery, 1947; and Pucher, Vickery, Abrahams & Leavenworth, 1949). Experiments were performed on the leaves during further periods of from 24 to 30 hr. of illumination. In all the experiments the acid values of the leaves that were still kept in air remained unchanged. Feeding with  $\text{CO}_2$  up to some concentration between 15 and 50% led to acid accumulation. Beevers (see Thomas & Beevers, 1949) had earlier obtained fairly good evidence of light acidification. Ranson's experiments leave no doubt that this phenomenon can be demonstrated at will. It provides better support than does retarded light deacidification for the view that the cell system controlling acid synthesis is potentially active in the light as well as in the dark.

In one experiment the rate of light acidification was nearly twice as fast in 5%  $\text{CO}_2$  as in 3%. In another, the initial rate in 5% was at least as fast as in 10% (cf. the effects of  $\text{CO}_2$  feeding on dark acidification (p. 81)). Light acidification occurred very slowly in 50%  $\text{CO}_2$  and not at all in 70%. This finding provided further evidence that light acidification and dark acidification, being similarly retarded or inhibited by high concentrations of  $\text{CO}_2$ , are governed by the same cell mechanism. If this is the case, since we have proved the occurrence of  $\text{CO}_2$  fixation in acid synthesis in the dark, it follows that  $\text{CO}_2$  fixation occurs during acid synthesis in the light. The results of Ranson's measurements of assimilatory quotients have provided confirmation of this conclusion.

VI. APPARENT ASSIMILATORY QUOTIENTS DURING LIGHT DEACIDIFICATION AND LIGHT ACIDIFICATION, A FURTHER CONSIDERATION OF RESPIRATORY QUOTIENTS, AND POSSIBLE REACTIONS IN ACID PRODUCTION AND CONSUMPTION

When the only processes involving gaseous exchange are normal photosynthesis and the aerobic respiration of carbohydrate, the value of the assimilatory quotient (vol. of oxygen liberated)/(vol. of CO<sub>2</sub> absorbed) is unity. In his experiments on *Bryophyllum* leaves in air and in gas mixtures containing CO<sub>2</sub>, Ranson has found that during light deacidification the A.Q. is greater than unity and during light acidification it is less than unity. Values of about unity were obtained when the acid content of the leaves remained approximately constant. These findings and the fluctuations in R.Q.'s reported earlier in this paper can be explained by supposing that in the light and in the dark aerobic respiration proceeds according to the equation

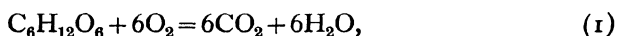

and acid production and consumption according to the equation



and that in the light, in addition, photosynthesis occurs according to the equation

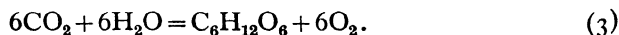

There are, of course, newer forms of equations (1) and (3), but the argument is not affected by using the older forms.

It should be noted that the reversibility of equation (2) has not yet been proved. Some evidence has, however, been obtained that malic acid may be converted into carbohydrate. The suggestion in its modern form that this conversion may take place was first made by Bennet-Clark (1933), and he has developed the idea and obtained some experimental support for it (1949). Furthermore, Pucher *et al.* (1947) and Pucher *et al.* (1949) found 'that the diurnal variation of the organic acid content of excised leaves of *Bryophyllum calycinum* cultured in water under normal light conditions in the greenhouse is accompanied by a diurnal variation of the starch content in the opposite sense'. These observations suggested a close relationship between the metabolism of acid and starch, and they cited them in support of Bennet-Clark's hypothesis. The carbohydrate was transformed into malic and citric acids (with the former as the main component of this fluctuating fraction of titratable acidity) during the night, and the reverse change is believed to have taken place during the day. Isocitric acid was present in relatively high but unchanging amounts.

The possibility remains that some acid may be lost by oxidative catabolism



but in the present writer's view no evidence of the occurrence of this type of oxidation has come as yet from the results of Newcastle experiments. It can be confidently stated that if reaction (4) occurs it is not reversible, since there is not a shred of evidence that  $\text{CO}_2$  fixation in the dark is accompanied by the liberation of oxygen.

On the basis of equations (1), (2) and (3) it is clear that during light deacidification the A.Q. would rise above unity because atmospheric  $\text{CO}_2$  would be spared by the  $\text{CO}_2$  coming from the decarboxylation of vegetable acids. During light acidification in  $\text{CO}_2$ -enriched atmospheres,  $\text{CO}_2$  would be absorbed in acid synthesis as well as in photosynthesis; consequently, the A.Q. would fall below unity. If it is conclusively established that the A.Q. remains at unity when the rates of acid production and consumption are equal, it follows that if acid production is summarized by equation (2), consumption cannot be attributed to reaction (4).

Evidence supporting the view that acid consumption is summarized by equation (2) comes from the results of Ranson's measurements of the R.Q. of *Bryophyllum* leaves in the dark and of organs of other plants which show Crassulacean acid metabolism. It has long been known (see Bennet-Clark, 1933) that when these organs are kept continuously in the dark, the amount of acid in them, after accumulating to a maximum value, gradually declines, and that whereas during the phase of dark acidification the R.Q. is less than unity, during that of dark deacidification it rises above unity, sometimes reaching values of 2 or more. Ranson's results confirm these earlier findings. Bennet-Clark (1933) pointed out that if the only form of gaseous exchange occurring during dark deacidification was that expressed by equation (4), the maximum R.Q. would be 1.33. Since higher values of the R.Q. had been found, he argued that malic acid consumption does not occur exclusively by oxidative catabolism, and made the important suggestion that deacidification should in part at least be attributed to the reconversion of acid into carbohydrate. Whether or not the reconversion is accurately described as oxidative anabolism remains to be determined. The summary of reconversion given in the overall equation (2) does not necessarily imply that acid will be continuously converted into carbohydrate anaerobically (see Thomas, 1949, p. 395). Partial reactions comprised in the two overall equations (1) and (2) may well be linked through coenzymes. In some preliminary experiments Ranson has found that both acidification and deacidification may begin in a gas mixture containing 0.5% oxygen at a rate not much less than that occurring in air. In the

complete absence of oxygen, however, if acid synthesis occurred at all, it did so only to a slight extent. At 20° C. the leaves were quickly injured.

The simultaneous occurrence of reactions (1) and (2) will obviously account not only for R.Q.'s less than unity while acid is accumulating, but for R.Q.'s much greater than unity when dark deacidification accompanies feeble aerobic respiration. Further, Thomas (1949) has already argued that values of unity found for the R.Q. at maximum acid accumulation, i.e. when the rates of production and consumption are the same, rule out the possibility of acid consumption by reaction (4) if production occurs by reaction (2), and are explicable if consumption is summarized by equation (2).

The results of Newcastle experiments do not prove that acid production and consumption are governed by the same enzyme mechanism, i.e. are strictly reversible; but there is sufficient evidence of the reversibility of carboxylase action (e.g. for bacteria see Krampitz & Werkman (1941), for animal tissue see Ochoa (1945), for parsley root see Gollub & Vennesland (1947)) to regard reversibility of the production and consumption of acids *in vivo* as a reasonable hypothesis. In a much simplified scheme in which we leave out phosphorylated compounds and oxaloacetic acid as possible intermediates, Crassulacean acid metabolism may be outlined thus:

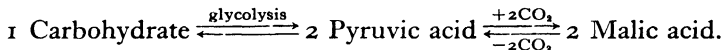

In this statement no mention is made of citric acid, isocitric acid, and an undetermined acid fraction (including oxalic acid) which Pucher *et al.* (1949), by their highly skilful work, have found to accompany malic acid in the leaves of *Bryophyllum*. It is recalled that the arguments in the present paper attach to the conclusion of these U.S.A. workers that diurnal fluctuations of acidity in *Bryophyllum* are mainly attributable to the appearance and disappearance of malic acid and to a much lesser extent of citric acid; but the presence of acids that are supposed to take part in the Krebs cycle suggests that this cycle may be operative in Crassulacean acid metabolism. No details have, however, been established as yet. Indeed, Pucher *et al.* (1949) have written: 'It is possible that the enzymatic mechanisms involved are analogous to those described by the Krebs tricarboxylic acid cycle, but the direct part taken by citric acid and the failure of isocitric acid to share at all cannot easily be accounted for by the hypothesis that the Krebs cycle, in the form widely accepted as the explanation of carbohydrate oxidation in animal tissues, exactly defines the mechanism of diurnal variation of acidity in *Bryophyllum calycinum* leaves.' Bennet-Clark (1949) has given some consideration to this problem of interconversion of acids in plants.

Attempts have been made to test the validity of equation (2) by making certain calculations from the experimental results obtained at Newcastle. On the basis of certain assumptions (see Thomas & Beevers, 1949), the net  $\text{CO}_2$  consumption attributable to acid synthesis can be calculated from the primary experimental data. Similar calculations can be made to determine the net  $\text{CO}_2$  consumption during such light acidification as may be induced by  $\text{CO}_2$  feeding, and also to determine the weight of that fraction of  $\text{CO}_2$  set free during dark or light deacidification which cannot be attributed to normal aerobic respiration. The results so far obtained are summarized below.

If acidification proceeds according to equation (2), the value of the quotient (acid accumulation)/(net  $\text{CO}_2$  consumption) should be 3.05. The three values obtained for dark acidification by Beevers in 1946 were 1.8, 2.7 and 2.0. Since that date Ranson has performed about a hundred experiments from the results of which this quotient may be calculated. In a number of these experiments the experimental error may have been high. The values obtained range from 1.4 to 3.8, with a mean of about 2.6. About forty of them are within the range 2.7–3.3. For light acidification the values obtained by Ranson are 2.4, 3.1, 2.6, 2.3, 2.1, 1.4, 2.8. The proximity to the theoretical value of 3.0 in a certain number of instances suggests that, under certain conditions, equation (2) may not be far from the truth as an overall summary of acid synthesis. The reasons for the departure from the theoretical value in other instances are not yet known. As will be seen by an inspection of the graphs on Figs. 1 and 2 the acid equivalent (calculated on the basis of equation (2)) of the  $\text{CO}_2$  fixed is often somewhat greater than the acid accumulation which is actually measured. This finding is in accord with the results obtained by Thurlow and Bonner (see p. 73).

For light deacidification the value of the quotient (acid lost)/( $\text{CO}_2$  liberation not attributable to aerobic respiration) should be 3.05 if acid consumption occurs exclusively according to equation (2). Most of the values so far obtained by Ranson, viz. 2.8, 1.7, 1.6, 1.3, 1.5, 1.4, 1.5, departed somewhat widely from the theoretical value.

Evidently before reliable balance sheets can be constructed, further and more accurate experimental work is required in which measurements are made not only of gaseous exchanges and changes in acid concentration, but also of carbohydrate. From the results of their superior analytical experiments on *Bryophyllum* leaves Pucher *et al.* (1949) have calculated the value of the quotient (moles change of acid concentration)/(moles change of glucose concentration) during dark acidification and light deacidification. They cautiously state that: 'The figures are offered for consideration with some reserve and should be regarded as merely preliminary in nature, for

only analytical determinations of unusual accuracy made upon samples that duplicate each other in initial composition even more closely than the present ones could be expected to yield reliable results.' The reported values of the quotient are 1.16, 1.07, 0.64, 0.92, 1.25, 1.51, giving a mean of  $1.09 \pm 0.29$ . Tentatively they suggest that approximately one molar proportion of glucose (mostly derived from starch) is transformed to one molar proportion of malic and citric acids during the night and that the reverse action occurs during the day. Clearly this conclusion is different from that which has been summarized in equation (2). According to this equation one molar proportion of glucose should be equivalent to two molar proportions of acid. It is possible, however, that in the experiments made at Connecticut by Pucher *et al.* glucose was (a) consumed in aerobic respiration as well as in producing acid in the dark, and (b) produced by normal photosynthesis as well as by the anabolism of acid in the light. If the arguments put forward in the present paper are sound, it is the quotient (moles change of acid concentration)/(moles change of glucose concentration not attributable to normal photosynthesis or respiration) which should have the value of 2. The calculation of this quotient requires the results of measurements of gaseous exchange as well as of change in acid and carbohydrate concentration. Records of measurements of gaseous exchanges have not yet come from Connecticut, and so far at Newcastle only gaseous exchanges and changes in titratable acidity have been measured. Moreover, since in our experiments in Newcastle sampling errors were probably even greater than they were in the Connecticut experiments, the present writer endorses the view of Pucher *et al.* that all conclusions drawn about the quantitative relations between carbohydrate and acid should be regarded as tentative. Possibly, however, it will be allowed that it is still permissible to retain equation (2) as a working hypothesis, since from it and equations (1) and (3) all the results of our experiments on gaseous exchanges could have been deduced.

## REFERENCES

- AUBERT, M. E. (1892). *Rev. gén. Bot.* **4**, 203.  
BENSON, A. A. & CALVIN, M. (1948). *Cold Spr. Harb. Symp. Quant. Biol.* **13**, 6.  
BENNET-CLARK, T. A. (1933). *New. Phytol.* **32**, 37, 128, 197.  
BENNET-CLARK, T. A. (1949). *Ann. Rev. Biochem.* **18**, 639.  
BONNER, W. & BONNER, J. (1948). *Amer. J. Bot.* **35**, 113.  
DE SAUSSURE, T. (1804). *Recherches chimiques sur la végétation*. Paris.  
GOLLUB, M. & VENNESLAND, B. (1947). *J. Biol. Chem.*, **169**, 233.  
KAMEN, M. D. (1949). *Photosynthesis in Plants*, pp. 365-80. The Iowa State College Press.  
KRAMPITZ, L. O. & WERKMAN, C. H. (1941). *Biochem. J.* **35**, 595.  
KREBS, H. A. (1943a). *Ann. Rev. Biochem.* **12**, 529.

- KREBS, H. A. (1943*b*). *Advances in Enzymology*, **3**, 191.
- OCHOA, S. (1945). *J. Biol. Chem.* **159**, 243.
- PUCHER, G. W., LEAVENWORTH, C. S., GINTER, W. D. & VICKERY, H. B. (1947).  
*Plant Physiol.* **22**, 360.
- PUCHER, G. W., VICKERY, H. B., ABRAHAMMS, M. D. & LEAVENWORTH, C. S. (1949).  
*Plant Physiol.* **24**, 610.
- THODAY, D. & RICHARDS, K. M. (1944). *Ann. Bot., Lond., N.S.*, **8**, 189.
- THOMAS, M. (1925). *Biochem. J.* **19**, 927.
- THOMAS, M. (1947). *Plant Physiology*, chapter xv. London.
- THOMAS, M. (1949). *New Phytol.* **48**, 390.
- THOMAS, M. & BEEVERS, H. (1949). *New Phytol.* **48**, 421.
- THURLOW, J. & BONNER, J. (1948). *Arch. Biochem.* **19**, 509.
- WARBURG, O. (1886). *Unters. bot. Inst. Tübingen*, **2**, 53.
- WERKMAN, C. H. & WOOD, H. G. (1942). *Advances in Enzymology*, **2**, 135.
- WOLF, J. (1939). *Planta*, **29**, 450.

# ASSIMILATION BY GREEN LEAVES WITH STOMATAL CONTROL ELIMINATED

By O. V. S. HEATH

Research Institute of Plant Physiology, Imperial College  
of Science and Technology, London, S.W. 7

## I. INTRODUCTION

The intrinsic technical difficulties in the experimental investigation of the relation between carbon assimilation and stomatal movement are well indicated by the fact that, as far as the author is aware, no detailed experimental results for changes of stomatal opening and assimilation simultaneously followed in the same leaf have been published since the pioneer work of Maskell (1928). In the critical analysis of his results Maskell devised his important 'resistance formula', which he applied in the first instance to the interaction of factors in photosynthesis. This resolved the apparent contradiction between data which approximated to Blackman's (1905) 'law of limiting factors' (Blackman & Smith, 1911) and those found by some other workers which gave much less sharply inflected curves (Warburg, 1919; Harder, 1921). Maskell shows theoretically that the so-called 'law' of limiting factors, even as an approximation, only applies at certain extreme levels of the various internal and external factors interacting with the factor experimentally varied; by changing the levels of these other factors all gradations can be obtained between a curve with a relatively sharp 'corner' approximating to the 'limiting factor' type and a smooth curve which 'passes *gradually* from a region of rapid increase with increase in the variable factor to a region in which increase with increase in the variable is zero'. Nevertheless, Maskell's paper has been consistently overlooked by most workers on the continent, who continue to accept it as axiomatic that all data for the effects of interacting factors *should* conform to the limiting factor 'law'.

Work in this Institute on problems of stomatal control of assimilation was begun by Newton (1936). Whereas Maskell had taken advantage of the diurnal periodicity in the apertures of the stomata of cherry laurel under constant illumination and used air enriched with CO<sub>2</sub>, Newton measured assimilation from ordinary air over 5 min. periods while the stomata were opening in the light after a period of darkness. He obtained, for *Pelargonium*, curves relating apparent assimilation to 'stomatal aperture' much resembling those found by Maskell using cherry laurel. It was very

desirable, however, also to measure assimilation rates with stomatal control eliminated. For this purpose, at the suggestion of Prof. F. G. Gregory, Newton used the method of drawing an air stream *through* the inter-cellular space system into a chamber attached to the leaf and thence through the conductivity cell (Newton, 1935) used in the determination of CO<sub>2</sub> content, the initial concentration of CO<sub>2</sub> in the laboratory air used being determined on parallel samples which had not passed through the leaf. Stomatal movement was followed by means of the resistance porometer (Gregory & Pearse, 1934) with the assimilation chamber serving also as the porometer cup. The latter method, also due to Prof. Gregory, had the advantage that the same stomata were concerned in both assimilation and porometer determinations, now known to be a matter of great importance (Heath, 1950).

Newton's results suggested that assimilation rose and fell as the stomata opened and closed, even when their diffusive resistance had been eliminated by the method of drawing a mass flow of air through them so that it came into direct contact with the assimilating cells. This seemed to show simultaneous control of both stomata and assimilation by some internal factor. It should be noted that Newton, except in one experiment, was unable to maintain a constant rate of flow of air through the leaf. In his later experiments, in order to define the leaf area concerned, the leaf was trimmed to the periphery of the chamber and the cut edge vaselined. Air was drawn into the leaf through the upper stomata and out through the lower stomata into the assimilation chamber, where a constant reduced pressure was maintained by the aspirator which drew the air stream through the conductivity cell. The rate of flow thus varied with and was controlled by stomatal aperture. Newton assumed that this variation in rate of CO<sub>2</sub> supply could be allowed for by correcting all observed assimilation rates to a constant mean CO<sub>2</sub> content of 0.03%, and for this purpose estimated the mean CO<sub>2</sub> content to which the assimilating cells were exposed as

$$\frac{C_1 - C_2}{\log_e (C_1/C_2)},$$

where  $C_1$  and  $C_2$  are the initial and residual concentrations observed. When this correction had been applied, assimilation showed an approximately linear relation to 'stomatal area' as estimated with the resistance porometer.

In the single experiment mentioned above, Newton maintained an approximately constant flow of about 1.2 l./hr. through 5.4 sq.cm. of the leaf by the difficult method of varying the head in the aspirator. During this experiment the stomata closed steadily; the calculated assimilation rates were at first low and fell later to negative values after he had detached

the leaf in order to cause further stomatal closure by wilting. It should be noted that owing to the limitations of his technique Newton had to draw *dry* laboratory air through the leaf.

The finding that assimilation continued to vary with aperture of the stomata when their diffusive resistance was eliminated clearly demanded the fullest possible confirmation and further investigation. In 1936 the writer began work with this end in view, and also to obtain further evidence as to the relation between stomatal diffusive resistance and assimilation of CO<sub>2</sub> from air passing *over* the leaf surface. The interpretation of the results bearing on the latter problem awaits the calibration of the resistance porometer in terms of stomatal diffusive resistance. The considerable body of data already collected by the writer for this calibration may prove worthless in view of the recently discovered effect upon the apertures of the stomata of enclosure in a permanently attached porometer cup (Heath & Williams, 1948; Williams, 1949; Heath, 1950), and much further experimental work is needed. The detailed consideration of the 'over' experiments must therefore be postponed yet further. No such difficulty applies to the results of the 'through' experiments, in the interpretation of which it seems sufficient to follow from porometer readings the opening and closure of the stomata without evaluating their diffusive resistances. Work on this subject was, however, interrupted by the war, and it is only recently that an opportunity for detailed analysis of the results has occurred. Such analysis is not yet complete and the conclusions reached in a preliminary communication (Heath, 1949) and further elaborated here may require some modification when all the data have been examined.

## II. EXPERIMENTAL METHOD

Leaves of *Pelargonium zonale* var. Paul Crampel 'Clone 5' (Heath, 1941) were used; experiments were also carried out on leaves of *Begonia sanguineum*.

The technique has already been described in detail (Heath, 1939) and a brief résumé must suffice here.

As in Newton's work the method of F. F. Blackman (1895) of attaching assimilation chambers to the leaf, instead of enclosing the whole leaf in a chamber, was used. Two pairs of shallow transparent leaf chambers were attached to the upper and lower leaf surface respectively, exactly one above the other. Each pair consisted of an inner chamber of 9 sq.cm. area completely surrounded by an outer chamber of equal area (Pl. 1, figs. 1, 2).

In 'over' experiments, air of the same known carbon dioxide content was passed over the leaf surface in each chamber, the rates of flow being

approximately proportional to the numbers of stomata enclosed, i.e. for *Pelargonium*, equal rates of flow through each of the lower chambers and one-tenth the rate through each of the upper chambers. For *Begonia*, which is hypostomatous, no flow was passed through the upper chambers. In these 'over' experiments, pressure in the chambers was maintained atmospheric by balanced push and pull, so that there should be no tendency for mass flow through the stomata. The two outer chambers served as 'guard rings' to minimize errors due to lateral diffusion of CO<sub>2</sub> through the leaf to or from the inner chambers, and the air streams from these outer chambers were therefore discarded. The air streams leaving the two inner chambers were mixed and passed through a conductivity cell for estimation of the CO<sub>2</sub> content.

In 'through' experiments the air was forced into the leaf from the outer chambers with a certain increased pressure and withdrawn into the inner chambers with an equally reduced pressure. It thus travelled laterally through the leaf in the intercellular spaces, and the mean pressure in the leaf should have been approximately atmospheric. Mass flow to the exterior should thus have been largely avoided, but unfortunately, when CO<sub>2</sub>-enriched air was used, lateral diffusion of CO<sub>2</sub> caused large errors, there being no guard rings when the chambers were used in this way. It was therefore found necessary, after a few preliminary experiments, to trim the leaf to the periphery of the chamber and grease the cut edges; a detached portion of lamina without water supply was thus used. It was found necessary to humidify the air before passage through the leaf, even in experiments with an entire leaf attached to the plant or provided with a water supply. Flow through the leaf was kept constant for considerable periods, by altering the pressures as the stomata opened or closed, and when varied was changed by predetermined amounts. Thus all stomatal control of the CO<sub>2</sub> supply to the intercellular space system was eliminated. As in the 'over' experiments the air from the inner chambers, or the lower inner chamber only in the case of *Begonia*, was passed through the conductivity cell. The general procedure was to carry out a 'through' experiment on a leaf that had already been used for an 'over' experiment so that a direct comparison could be made.

In both 'over' and 'through' experiments assimilation was estimated over 5 min. periods, air flow being interrupted for (generally) 20 sec. in each period while a reading of the resistance porometer (Gregory & Pearse, 1934; Heath, 1941) was taken. For this purpose the lower inner chamber served as porometer cup, so that, as in Newton's experiments, the same stomata were concerned as in the assimilation measurements. In order to change from assimilation to porometer and vice versa two

'composite' taps, each operating on five flow lines, were turned simultaneously through  $90^\circ$ . After some preliminary experiments it was found desirable to take bridge readings for conductivity determination before and after the porometer reading as well as at the beginning and end of each 5 min. period. Ultimately, the procedure was adopted of estimating assimilation over two 100 sec. periods at the beginning and end respectively of the 5 min. with an interruption of flow for the porometer reading between the 105th and 125th seconds. This allowed 75 sec. for the time lag in passage of air from leaf chambers to conductivity cell, and for re-establishment of gradients after the disturbance due to the porometer.

The source of light was a 1000 W. lamp with reflector and water screen, giving about 2450 f.c. at the leaf surface, and the temperature in the chambers was  $25-30^\circ$  C.

The conductivity method was made sensitive to 0.0011 mg. of  $\text{CO}_2$  (or less), the quantity in 1.8 c.c. of ordinary air, and although this represented an eight-fold improvement over Newton's apparatus for the same size of cell it seriously limited the accuracy of the determinations over such short periods as 100 sec. Thus at 2 l./hr., 55 c.c. pass through the cell in 100 sec., and if the true residual  $\text{CO}_2$  content were 0.01% this would represent 0.011 mg. Since the apparatus was, at the beginning of a run, only sensitive to 0.0011 mg., errors of 20% of the true value for *single* periods might easily arise from this cause alone. With 0.7 l./hr. flow the corresponding error would be 57%; individual periods might then show as little as 0.0043% or as much as 0.0157%  $\text{CO}_2$  (cf. Text-fig. 3). The sensitivity improved somewhat as  $\text{CO}_2$  was absorbed in the cell.

### III. RESULTS

The first two 'over' experiments ('Over' Exps. 1 and 1a) carried out on successive days with the same large attached leaf of *Pelargonium*, and using a constant flow of 1.9 l./hr.\* of low  $\text{CO}_2$  air (0.03%), gave curves for 'corrected' assimilation *v.* 'porometer rate' much resembling those of Maskell and of Newton (Text-fig. 1). The maximum rate attained (15 mg./dm.<sup>2</sup>/hr.) was also similar to that obtained by Newton. It will be seen, however, that after the first six 5 min. periods during which assimilation rose as the stomata opened, the constant assimilation rate associated with further opening represented the removal of all but 0.01% of  $\text{CO}_2$  in the air supply. Later 'over' experiments with low  $\text{CO}_2$  air gave similar results, and the constant  $\text{CO}_2$  content of about 0.01% in the air after passage across the leaf when the stomata had opened considerably was apparently little if

\* All flow rates are calculated at N.T.P. The actual rates were therefore about 8% higher.

at all affected by the rate of flow over the range investigated, viz. 1.0–1.9 l./hr. (Table 2, Exp. 23).

Two 'through' experiments were next carried out with the same leaf and on the same day as 'Over' Exp. 1*a*. In the first of these ('Through' Exp. 1*a*) a flow of 1.0 l./hr. of the low CO<sub>2</sub> air was maintained for 65 min. In this experiment the air leaving the leaf had a somewhat *higher* CO<sub>2</sub> content (a mean over seven 4½ min. periods of 0.016%), although the rate

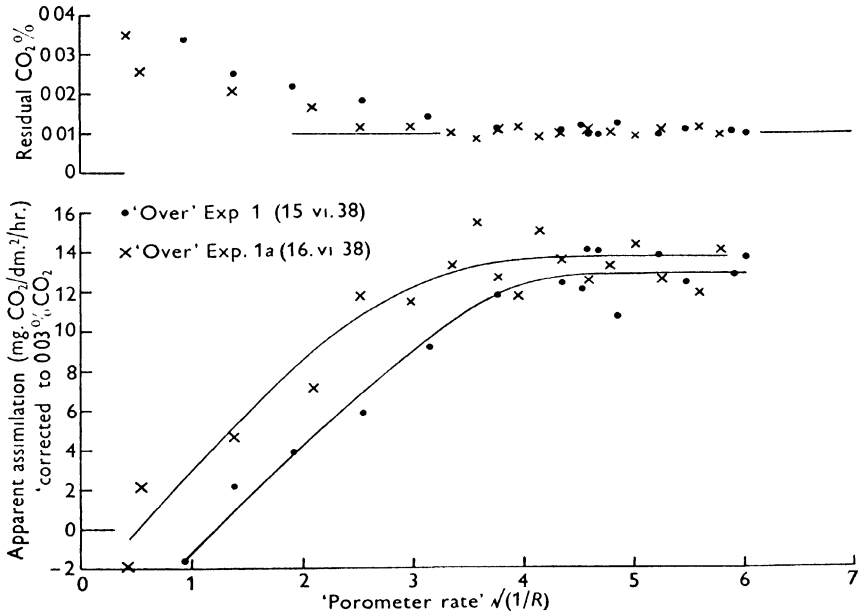

Text-fig. 1. 'Over' Exps. 1 and 1*a*. Below: apparent assimilation. Above: residua CO<sub>2</sub> %. Both plotted against 'porometer rate'.

of flow was half that in the 'over' experiments, the leaf area concerned was doubled, and stomatal diffusive resistance had been eliminated. In the second 'through' experiment (1*b*) a flow of 1.9 l./hr. was passed through the leaf for 75 min. Carbon dioxide was *emitted* into the air stream throughout the experiment, even in the light, and the dark respiration measured at the beginning (10.57 mg./dm.<sup>2</sup>/hr.) was much higher than in the three preceding experiments (3.07, 2.62 and 3.13 respectively). Much condensed moisture was seen in the tubes leaving the inner leaf chambers, and it was thought that the low apparent assimilation might have been due to desiccation, which had been put forward by Maskell (1928, p. 481) as an

explanation of the decline in photosynthesis with time shown by leaves 'slashed' between the veins to admit  $\text{CO}_2$  without stomatal control. However, his suggestion of this effect being due to reduced diffusion of  $\text{CO}_2$  through the partially dried cell walls could not apply here as  $\text{CO}_2$  was actually diffusing out of the cells. The low or negative assimilation rates found in these two 'through' experiments resembled those found by Newton in his constant-flow experiment (p. 95).

In subsequent experiments the air entering the leaf chambers was humidified by blowing against water contained in small bulbs; these were adjacent to the chambers and thus at a similar temperature. The next 'through' experiment (2*a*), also with *Pelargonium*, lasted for 170 min., and the following rates of flow of low  $\text{CO}_2$  air through the leaf were investigated: 0.94, 1.76, 2.04 and 1.21 l./hr. Assimilation increased during the first three 5 min. periods following illumination of the leaf; thereafter it was entirely controlled by rate of flow, for the  $\text{CO}_2$  content in the air emerging from the leaf was approximately constant at the low level of about 0.005%. The mean residual  $\text{CO}_2$  contents with the above rates of flow were 0.0048, 0.0046, 0.0044 and 0.0050% respectively. The mean dark respiration rate found was also low, being 1.70 mg./dm.<sup>2</sup>/hr. The stomata opened steadily throughout the 2 hr. 10 min. period of illumination. Clearly, if rate of flow of air had been controlled by the stomata, results much like Newton's would have been obtained, with assimilation rising throughout as the stomata opened. The constant  $\text{CO}_2$  content of the air after passing through the leaf suggested that this had reached equilibrium with a minimum concentration at the surfaces of the assimilating cells, and the much lower values than in 'Through' Exps. 1*a* and 1*b* suggested that the dry air in the latter had been responsible for the low or negative assimilation observed.

Two further preliminary 'through' experiments (3 and 3*a*) were carried out with *Pelargonium* but using air with a high  $\text{CO}_2$  content, viz. 0.83%, and it is of interest to note that the stomata opened much less than in the previous experiments using low  $\text{CO}_2$ . In these experiments considerable losses of  $\text{CO}_2$  were recorded with the leaf in darkness, and there seemed little doubt that this was due to lateral diffusion from the outer chambers through the leaf to the exterior. In all subsequent 'through' experiments, therefore, the leaf was trimmed to the periphery of the outer chambers and the cut edge greased. For this purpose a knife made of razor-blade strip was mounted outside the lower outer chamber (see Pl. 1, fig. 2). This drastic procedure resulted in the portion of leaf under investigation being without water supply, and several 'over' experiments were carried out before and after such trimming. The results so far calculated show little

effect of the operation, either on assimilation or respiration. Thus 'Over' Exps. 8 and 8a (*Pelargonium*) were carried out with low CO<sub>2</sub> air before and after 'Through' Exp. 8a in which such air was passed through the leaf at 2 l./hr. for 90 min. and at other rates of flow for a further 45 min. Here assimilation in the second 'over' experiment (8a) was relatively low, air emerging from the chambers with a residual CO<sub>2</sub> content of 0.02%, but this was associated with little stomatal opening and was similar to the result obtained while stomatal resistance was still high in the early part of 'Over' Exp. 8 (before trimming). Moreover, the respiration rates showed no significant differences between the three experiments, giving mean values of 2.93 and 3.29 mg./dm.<sup>2</sup>/hr. for the two 'over' experiments and 2.71 mg./dm.<sup>2</sup>/hr. for the 'through' experiment. 'Over' Exps. 17 and 17a (*Pelargonium*) carried out before and 1 hr. after trimming the leaf, with air containing 0.184% CO<sub>2</sub>, also gave similar results in each experiment: for similar stomatal resistances, all but about 0.03% CO<sub>2</sub> was removed from the air, and the mean dark respiration rates found were 2.44 mg./dm.<sup>2</sup>/hr. for Exp. 17 and 2.88 for Exp. 17a.

In view of the approximately constant CO<sub>2</sub> content of the air which had passed through the leaf in 'Through' Exp. 2a, the assimilation rates calculated per unit leaf area seemed without meaning; apparently the leaf area used (23 cm.<sup>2</sup>) was large enough to remove all but a constant residual concentration of CO<sub>2</sub> at all rates of flow tried, and the CO<sub>2</sub> supply was completely 'limiting' assimilation rate, at least for that light intensity. Further 'through' experiments were carried out both with low (0.03%) and medium (0.148 or 0.184%) CO<sub>2</sub> for *Pelargonium*, and with medium (0.148%) CO<sub>2</sub> for *Begonia*; these gave essentially similar results. (The conductivity cell in use was found unsuitable for 'high' CO<sub>2</sub> such as had been used in 'Through' Exps. 3 and 3a, and no further such experiments were performed.)

In the lower part of Text-fig. 2, the CO<sub>2</sub> content of air after passage through the leaf is plotted against CO<sub>2</sub> supply expressed as mg./dm.<sup>2</sup>/hr. for all 'through' experiments with either species, excepting those with dry air or 'high CO<sub>2</sub>' air. The corresponding flow rates in l./hr. at N.T.P. are also shown for the different initial CO<sub>2</sub> concentrations used. The points plotted are means of varying numbers (1-14) of successive short-period determinations at single rates of flow. In calculating the regression lines shown all the *Begonia* data were used, but for *Pelargonium* the points shown in solid black were omitted: the two highest levels of CO<sub>2</sub> supply in Exp. 19 because it appeared that here CO<sub>2</sub> was no longer so severely 'limiting', and the data from the preliminary Exp. 2a because it was thought that the very low apparent level of residual CO<sub>2</sub> might have been

an artefact due to loss of some of the air supply laterally through the untrimmed leaf. The difference in level of the two lines is less than its standard error; the slopes are almost identical and do not differ significantly from zero ( $P > 0.1$ ). Over the range of  $\text{CO}_2$  supply from 0 to 13 or 16 mg./dm.<sup>2</sup>/hr., therefore, there is little evidence of a trend in residual  $\text{CO}_2$ , and the mean values for the two species are 0.009 and 0.010%.

In the upper part of Text-fig. 2 the same data are presented in a different way, apparent assimilation (not 'corrected') being plotted against  $\text{CO}_2$  supply. The straight lines drawn are not here regressions calculated from the data but represent the theoretical relations for the 'low' (0.0298%) and 'medium' (mean 0.166%) initial  $\text{CO}_2$  contents if all but 0.009%  $\text{CO}_2$  is assimilated. Except for the two highest rates of supply in Exp. 19 and two points from Exps. 7a and 8a respectively (both with 0.0298%  $\text{CO}_2$ ), the agreement with expectation appears excellent. Clearly, however, the test is not a sensitive one in view of the high proportion of  $\text{CO}_2$  assimilated—60% with the 'low  $\text{CO}_2$ ' air and 94 or 95% with the 'medium  $\text{CO}_2$ ' air. It serves to illustrate the relation that would have been obtained between apparent assimilation and porometer readings (in terms of leaf conductance) if the air had been drawn through the leaf with a constant pressure and thus at a rate controlled by the stomata.

That assimilation was in fact independent of stomatal movement in such 'through' experiments is indicated in Text-fig. 3, where residual  $\text{CO}_2$  and 'porometer rate' (i.e. square root of leaf conductance) are plotted against time for 'Through' Exps. 23 and 19 respectively—the former with 0.0298% initial  $\text{CO}_2$  content and the latter with 0.184%. With the low  $\text{CO}_2$  air entering the leaf, in Exp. 23, the residual  $\text{CO}_2$  content dropped to the minimum of about 0.01% in the first 5 min. after illumination; with medium  $\text{CO}_2$  (Exp. 19) about 20 min. were required. It seems reasonable to suppose that with six times the initial  $\text{CO}_2$  concentration, much longer might be required for the establishment of a new steady state. In Text-fig. 3a and b it appears that the stomata first opened and then closed, residual  $\text{CO}_2$  content showing little relation to the 'porometer rate'. Such closure might reasonably be attributed to water loss by the guard cells and epidermis of the detached piece of lamina, even with humidified air. There is some evidence, however, that it was in part an artefact and due to shrinkage of the intercellular spaces, for as the experiments proceeded increasing pressures were needed to maintain the air flow rates through the leaf for assimilation measurement, even in some cases while porometer readings indicated slightly *opening* stomata. (This last was doubtless because much of the air for the porometer passed straight through the leaf from upper to lower stomata, especially at

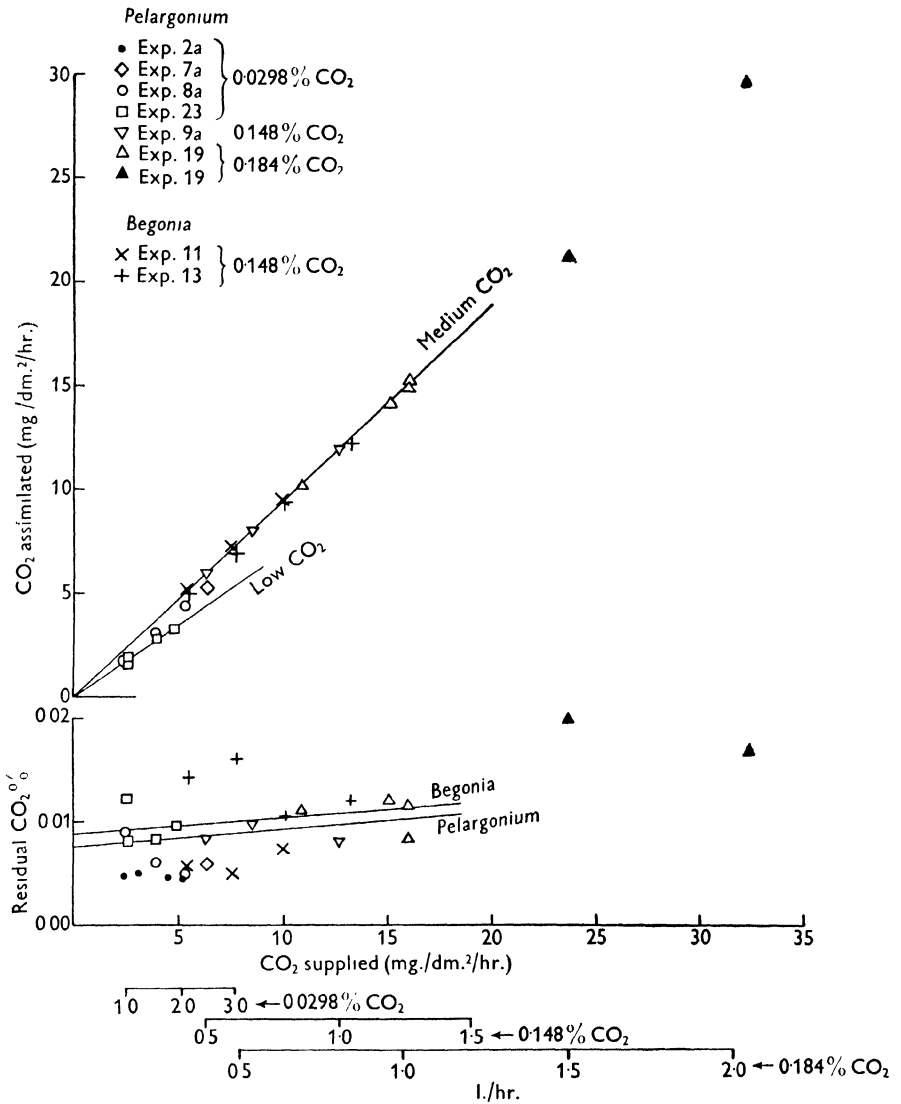

Text-fig. 2. 'Through' experiments. Mean data at different rates of flow. Below: residual CO<sub>2</sub> % plotted against CO<sub>2</sub> supply; also calculated regressions (solid black points omitted). Above: CO<sub>2</sub> assimilated plotted against CO<sub>2</sub> supply; also lines showing theoretical relation. For further explanation see text.

wide stomatal apertures (Heath, 1941). In the assimilation periods, on the other hand, *all* the air passed laterally through the mesophyll for at least the width of the washer separating the outer and inner chambers and was thus affected much more by any shrinkage than was the air flow for the porometer.)

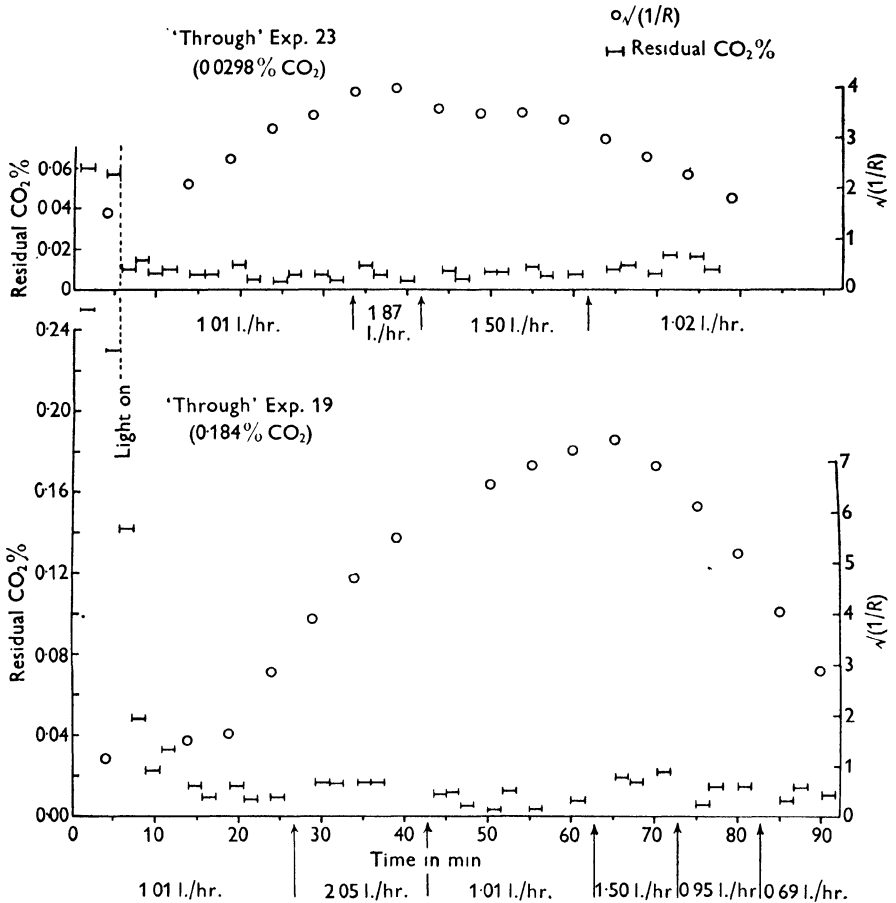

Text-fig. 3. 'Through' Exps. 23 and 19. Residual CO<sub>2</sub>% and porometer rate [ $\sqrt{(1/R)}$ ] plotted against time. Changes in rate of flow indicated by arrows.

In Text-fig. 3 changes in rate of air flow are indicated by arrows, and in Exp. 23 there is little evidence of corresponding changes in residual CO<sub>2</sub>; in Exp. 19 at the two highest rates of flow the residual CO<sub>2</sub> is appreciably higher. These facts account for the relations seen in the upper part of Text-fig. 2.

Respiration rates were determined in darkness at the beginning and when possible at the end of each 'through' experiment, but some experiments were terminated prematurely by breakdown of the gelatine washers forming the side walls of the chambers. Such respiration rates served to indicate whether the metabolism of the leaf had been markedly affected by the treatments, as did also those in 'over' experiments carried out before

Table 1. *Carbon dioxide output in darkness*

Exp.	Date	Experimental details	Mean CO <sub>2</sub> output mg./dm. <sup>2</sup> /hr.	
			Initial	Final
(a) <i>Pelargonium zonale</i>				
Over 1	15. vi. 38	Untrimmed 1.9 l./hr. dry low CO <sub>2</sub> air	—	+3.07
Over 1a	16. vi. 38	Untrimmed 1.9 l./hr. dry low CO <sub>2</sub> air	+2.32	+3.03
Through 1a	16. vi. 38	Untrimmed 1.0 l./hr. dry low CO <sub>2</sub> air	+3.91	+3.13
Through 1b	16. vi. 38	Untrimmed 1.9 l./hr. dry low CO <sub>2</sub> air	+10.57	—
Through 2a	28. vi. 38	Untrimmed 0.7-2.0 l./hr. moist low CO <sub>2</sub> air	+1.93	+1.23
Through 7a	27. ix. 38	Trimmed 2.5 l./hr. moist low CO <sub>2</sub> air	+2.23	—
Over 8	4. x. 38	Untrimmed 1.9 l./hr. moist low CO <sub>2</sub> air	+3.32	+2.55
Through 8a	5. x. 38	Trimmed 1.0-2.1 l./hr. moist low CO <sub>2</sub> air	+2.03	+4.07
Over 8a	5. x. 38	Trimmed 1.9 l./hr. moist low CO <sub>2</sub> air	+2.82	+4.01
Through 9a	11. x. 38	Trimmed 0.5-1.0 l./hr. moist medium CO <sub>2</sub> air	+2.49	—
Over 17	17. vii. 39	Untrimmed 1.0 l./hr. moist medium CO <sub>2</sub> air	+2.86	+2.16
Over 17a	18. vii. 39	Trimmed 1.0 l./hr. moist medium CO <sub>2</sub> air	+2.53	+3.00
Through 19	24. vii. 39	Trimmed 0.7-2.0 l./hr. moist medium CO <sub>2</sub> air	+4.91	—
Over 23	25. viii. 39	Untrimmed 1.0-1.9 l./hr. moist low CO <sub>2</sub> air	+1.99	+2.11
Through 23	25. viii. 39	Trimmed 0.7-1.9 l./hr. moist low CO <sub>2</sub> air	+2.46	—
(b) <i>Begonia sanguineum</i>				
Over 11	10. xi. 38	Untrimmed 1.0 l./hr. moist medium CO <sub>2</sub> air	-3.71	-3.09
Through 11	10. xi. 38	Trimmed 0.4-0.8 l./hr. moist medium CO <sub>2</sub> air	-5.42	-5.00
Over 12	15. xi. 38	Untrimmed 1.0 l./hr. moist medium CO <sub>2</sub> air	-1.31	—
Through 13	17. xi. 38	Trimmed 0.4-1.0 l./hr. moist medium CO <sub>2</sub> air	-0.99	—
Over 14	18. xi. 38	Untrimmed 1.9 l./hr. moist low CO <sub>2</sub> air	+0.15	+0.58
Over 14a	18. xi. 38	Trimmed 1.9 l./hr. moist low CO <sub>2</sub> air	+1.75	+1.16
Over 15	22. xi. 38	Untrimmed 1.9 l./hr. moist low CO <sub>2</sub> air	-0.03	+0.53
Over 15a	22. xi. 38	Trimmed 1.9 l./hr. moist low CO <sub>2</sub> air	+0.38	+0.85

and after trimming as mentioned earlier. The data so far calculated are presented in Table 1. The random variation is large owing to the shortness of the periods and lack of temperature control, but there is little consistent evidence of any harmful effect. A particularly interesting situation is revealed by the data for *Begonia*, for here with low CO<sub>2</sub> air passing across the leaf, the mean output of CO<sub>2</sub> in the dark was very low, while with medium CO<sub>2</sub> air passing over or through the leaf appreciable uptake was recorded consistently. Unfortunately no 'through' experiments with low CO<sub>2</sub> were carried out with *Begonia*. It seems likely, however, that with stomatal diffusive resistance eliminated and the CO<sub>2</sub> supply brought into contact with the chlorenchyma instead of being separated from it by a considerable thickness of presumably respiring hypodermis (cf. Heath,

1941, fig. 2), consistent dark uptake might have been found here also. It would be most interesting to know how far the *Begonia* leaf could deplete the CO<sub>2</sub> content of a slow stream of low CO<sub>2</sub> air in darkness and whether a minimum residual CO<sub>2</sub> content again holds. The relatively low apparent dark uptake of CO<sub>2</sub> in 'Through' Exp. 13, as compared with 'Through' Exp. 11, may perhaps have been due to a higher respiration rate of the hypodermis affecting the residual CO<sub>2</sub> in the emerging air. This might also account for the especially high values of residual CO<sub>2</sub>% found at the *lower* rates of flow in the light in the former experiment (cf. Text-fig. 2).

The 'through' experiments thus provide a technique for the investigation of the uptake of CO<sub>2</sub> in darkness by plants with the 'Crassulacean type' of acid metabolism.

Another interesting aspect of the *Begonia* data is that whereas the assimilation rate in 'through' experiments was virtually the same as that of *Pelargonium*, in 'over' experiments *Begonia* proved approximately half as efficient in depleting the air of CO<sub>2</sub>. Some data for 'over' experiments, showing the mean residual CO<sub>2</sub>% for periods with wide open stomata, are presented in Table 2. It seems reasonable to attribute this relative inefficiency of the *Begonia* leaf to the distribution of the stomata in small localized areas and to the long diffusion paths through the hypodermis. The respiration of the hypodermis itself would also, as already implied, reduce the steepness of the gradient across the stomata and thus tend to diminish assimilation from the air stream in light as well as in darkness. It must be remembered also that in the *Pelargonium* leaf both surfaces were assimilating since one-tenth of the air stream passed over the upper surface.

Table 2. *Residual CO<sub>2</sub> percentage in 'over' experiments with wide open stomata in the light*

Exp. no.	Date	Flow l./hr. at N.T.P.	Initial CO <sub>2</sub> content %	Mean residual CO <sub>2</sub> %
(a) <i>Pelargonium zonale</i>				
23	25. viii. 39	1·89	0·0298	0·0091
		1·01		0·0054
		1·89		0·0074
17	17. vii. 39	1·00	0·184	0·0229
20	26. vii. 39	1·02	0·184	0·0223
(b) <i>Begonia sanguineum</i>				
14	18. xi. 38	1·92	0·0298	0·0132
15	22. xi. 38	1·88	0·0298	0·0163
11	10. xi. 38	1·02	0·148	0·0578
12	15. xi. 38	1·03	0·148	0·0422

The data in Table 2a show that even when the CO<sub>2</sub> had to diffuse into the *Pelargonium* leaf through the stomata, when these were wide open the

uptake was remarkably efficient. Low  $\text{CO}_2$  air was reduced to the same residual  $\text{CO}_2$  content as in 'through' experiments, more or less independent of rate of flow, although the leaf area concerned was now only 9 sq.cm. instead of about 23 sq.cm. This result may be largely attributed to the leaf-chamber design, which reduced the diffusion path to the leaf surface to 2 mm. at most; it suggests that in similar 'over' experiments, with a non-turbulent flow of low  $\text{CO}_2$  air but in the more usual and deeper type of leaf chamber, the  $\text{CO}_2$  content close to part of the leaf surface *may* be reduced to the minimum of about 0.01%, although the mean content found for the air emerging from the chamber may be much higher. The effective area of leaf would thus be reduced, as in the 'over' experiments here described, by an unknown amount, and any calculation of assimilation rate per unit area invalidated. Further, the calculation from the initial and final concentrations measured of the mean content to which the leaf was exposed and the use of this estimate to 'correct' assimilation to a constant  $\text{CO}_2$  content would be quite unjustified in these circumstances. With relatively closed stomata, or with 'medium'  $\text{CO}_2$  air as in 'Over' Exps. 17 and 20 (Table 2a), the *Pelargonium* leaves failed to reduce the  $\text{CO}_2$  content to the minimum, although even here 88% of the  $\text{CO}_2$  supplied was assimilated in some cases. It seems likely, however, that the above criticisms would not apply to experiments with medium and high  $\text{CO}_2$  contents in the air used.

#### IV. THE MEANING OF THE MINIMUM RESIDUAL $\text{CO}_2$ CONTENT

The data from the 'through' experiments strongly suggest that for the light intensity and temperature conditions prevailing the assimilating cells of either species could reduce the  $\text{CO}_2$  content of the air in the intercellular spaces to about 0.01% but no further. This suggestion is in no way invalidated by the higher residual  $\text{CO}_2$  content found with the two highest rates of  $\text{CO}_2$  supply in 'through' Exp. 19 (Text-fig. 2), for it clearly must be possible to increase the supply until light or some other factor appreciably limits the increase in uptake. The picture presented by the results with lower rates of supply is, in fact, not so much one of mere ' $\text{CO}_2$  limitation' as of a large excess of assimilating surface such that virtually *all the available*  $\text{CO}_2$  is taken up before the air emerges. That this can occur with a supply of as much as 16 mg. of  $\text{CO}_2/\text{dm}^2/\text{hr}$ . implies remarkable efficiency of uptake once the  $\text{CO}_2$  has entered the leaf. A similar picture, of an excess of leaf area, is presented by the results with wide open stomata in 'over' experiments where low  $\text{CO}_2$  air was used. Extrapolation from the

results of the 'through' experiments implies that a similar residual  $\text{CO}_2$  content would be found with zero  $\text{CO}_2$  supply, i.e. with a very slow stream of  $\text{CO}_2$ -free air drawn through the leaf, and if the entirely non-significant regression coefficients (Text-fig. 2) are taken at their face value the residual  $\text{CO}_2$  estimated for these conditions is 0.009% for *Begonia* and 0.008% for *Pelargonium*. If the regression coefficients were in fact zero, the corresponding values would be 0.010 and 0.009%. Unfortunately 'through' experiments with  $\text{CO}_2$ -free air were not carried out owing to the outbreak of war, and in the absence of direct experimental investigation one might hesitate to make such an extrapolation. Recently, however, Gabrielsen (1948) carried out closed system experiments with leaves of *Sambucus nigra* enclosed in still air containing either about 0.03%  $\text{CO}_2$  or 0.0024%  $\text{CO}_2$  and illuminated at 1100 f.c. light intensity. In either case the leaves brought the  $\text{CO}_2$  content to an equilibrium value of 0.009% in about 3 hr., which is in striking agreement with the results here presented. In experiments with *moving*  $\text{CO}_2$ -free air Gabrielsen (1949) has also found  $\text{CO}_2$  given out by illuminated leaves of the same species. Furthermore, Audus (1947) found that even at high light intensities leafy shoots of cherry laurel gave out  $\text{CO}_2$  into a slow stream of  $\text{CO}_2$ -free air, although F. F. Blackman (1895) and Maskell (1928) had failed to detect  $\text{CO}_2$  emission by illuminated leaves under these conditions.

Some further confirmation of the minimum residual  $\text{CO}_2$  content of about 0.01% is provided by Newton's data for his 'through' experiments with *Pelargonium*. In these, the lowest value of residual  $\text{CO}_2$  content found was 0.0081%, two others were below 0.009% and a considerable number between 0.0108 and 0.0150%.\* Another, but teleological, indication of a minimum content of 0.01% in the intercellular spaces under natural conditions is provided for the wheat leaf by some data for the effect of external  $\text{CO}_2$  concentration on stomatal opening (Heath & Milthorpe, 1950). Here reduction of external  $\text{CO}_2$  content from 0.03 to 0.01% caused considerable stomatal opening, but from 0.01% to zero no further opening was found. *If* it can be assumed that the stomata respond *only* over the range of  $\text{CO}_2$  content which occurs in nature, a minimum internal content of about 0.01% is implied.

There appear to be two possible explanations of this relatively constant minimum  $\text{CO}_2$  content which has been found for such diverse genera as *Pelargonium*, *Begonia*, *Sambucus* and perhaps *Triticum*. Gabrielsen (1948, 1949) concludes that it represents a threshold value which must be reached 'in the surroundings of the assimilation centres before they start working'.

\* The author wishes to thank Dr R. G. Newton for freely placing these and other unpublished data at his disposal.

'Below this threshold no carbon dioxide assimilation takes place.' A simpler suggestion seems to be that some photosynthesis takes place at all  $\text{CO}_2$  levels and that the 0.01%  $\text{CO}_2$  represents the concentration which must be maintained in the intercellular spaces to give a rate of assimilation high enough to balance the respiration rate; in fact that it is the 'compensation point' for  $\text{CO}_2$  concentration. In this case, however, one would expect a higher value in those leaves having much cytoplasm relatively remote from the chloroplasts, although if assimilation and respiration go on independently *some*  $\text{CO}_2$  would tend to escape owing to respiration even at or within the chloroplasts themselves. It seems remarkable, therefore, that such a nearly constant value is found for such very different species and also at the various light intensities used, viz. 2450 f.c. (Heath), 1300 f.c. (Newton), 1100 f.c. (Gabrielsen) and 275-925 f.c. (Heath & Milthorpe). Audus also found no obvious relation between  $\text{CO}_2$  output and light intensity over an eight-fold range.

It therefore seems necessary to postulate a constant tension of free  $\text{CO}_2$  maintained in the cytoplasm at the cell surface in light above a certain intensity. Under conditions of  $\text{CO}_2$ -free air,  $\text{CO}_2$  of respiration produced at or very close to the chloroplasts would then be mainly assimilated, but especially that produced near the cell surface would tend to escape until the external concentration had been raised to 0.01% but no further. The possible mechanisms of such a 'buffered' tension, or of Gabrielsen's suggested threshold concentration, are obscure in the extreme. A true threshold value seems somewhat improbable, and Gabrielsen's experimental evidence may be examined from the points of view implied by the above two hypotheses.

In his closed-system experiments (1948) the rate of output of  $\text{CO}_2$  into the low  $\text{CO}_2$  air, as estimated from the slope of the time curve for  $\text{CO}_2$  content, was the same as the respiration rate found in darkness; in moving  $\text{CO}_2$ -free air experiments (1949) also, the output of  $\text{CO}_2$  by *shade* leaves was the same in the light as in the dark. Gabrielsen interprets these data as showing that respiration rate is unaffected by light and postulates that no re-assimilation of respiratory  $\text{CO}_2$  was then occurring. On the hypothesis of a 'buffered' tension at the cell surface such agreement of the light and dark output would be fortuitous, and since some re-assimilation would be occurring an increase in respiration due to light would be implied. For the purposes of this discussion 'respiration' will be defined as  $\text{CO}_2$  production. Audus's (1947) results suggest that light does in fact increase respiration rate as just defined. (On the other hand, Warburg, Burk, Schocken, Korzenovsky & Hendricks (1949), and Burk, Hendricks, Korzenovsky, Schocken & Warburg (1949), have found that in *Chlorella* the  $\text{O}_2$  consumption can be practically the same in light and darkness, while

Kok (1948) concludes that light suppresses respiration of *Chlorella* altogether—see below, pp. 111–112.) In his moving-air experiments Gabrielsen found that when dark respiration was low (shade leaves at 20° C., or sun leaves at 5° C.), output was the same in light and darkness implying no re-assimilation ( $Q_r = 0^*$ ). With high dark respiration (sun leaves at 20° C. or shade leaves at 30° C.) output in the light was much lower than in the dark ( $Q_r > 0$ ). Conditions favouring escape of CO<sub>2</sub> from the leaf tended to reduce  $Q_r$ , and increasing the flow rate from 15.0 to 32.9 ml./cm.<sup>2</sup>/min. had no effect on the dark CO<sub>2</sub> output of sun leaves but reduced  $Q_r$  from 0.50 to 0.

Such experiments with varying rate of flow would seem to supply a test between the two hypotheses. If a 'buffered' tension of CO<sub>2</sub> is maintained at the cell surface and some photosynthesis occurs at all CO<sub>2</sub> levels, with the corollary arising out of Gabrielsen's 'closed system' data of an increased respiration rate in light, it should be possible by increasing the rate of flow sufficiently to find a greater CO<sub>2</sub> output in light than darkness, i.e. a negative  $Q_r$ . If, in Gabrielsen's experiments,  $Q_r$  was reduced to zero at a rate of flow considerably less than the highest rate used, a steady value of zero and the absence of negative values over a considerable range of increasing flow rates would be strong evidence against the 'buffered' tension hypothesis; that is *unless* there were an effect of light on respiration depending on some product of photosynthesis, e.g. sugar. In the latter case, by increasing the rate of flow until virtually no assimilation was occurring the effect of light on respiration would be removed and hence no increase over the dark rate would be obtained.  $Q_r$  would thus remain zero. If, on the other hand, increasing the rate of flow sufficiently gave a negative  $Q_r$ , then a light effect on respiration would be shown and Gabrielsen's closed system experiments would no longer support a threshold value hypothesis. The detailed publication of his results will throw light upon this question.

It is clear that direct experimentation on the effect of light intensity upon the minimum residual CO<sub>2</sub> concentration, and also investigation of the interaction of light and temperature, are urgently needed for an elucidation of the problem and such experiments are about to be attempted.

## V. EFFECT OF LIGHT ON RESPIRATION

That this is still a subject for controversy is indicated by the recent papers of Audus (1947), Gabrielsen (1948, 1949), Kok (1948, 1949), van der Veen (1949), Burk *et al.* (1949), Warburg *et al.* (1949) and Warburg, Burk,

\* Where  $Q_r = (\text{dark output} - \text{light output}) \div \text{dark output}$ .  $Q_r$  is thus the proportion of respiratory CO<sub>2</sub> re-assimilated, on the assumption that respiration is unaffected by light.

Schocken & Hendricks (1950). In view of its importance for the elucidation of the results presented here, a little space may be devoted to discussing the findings of these investigators. As already mentioned, 'respiration' will be defined as  $\text{CO}_2$  production for the purposes of the present discussion.

Audus (1947) found that leafy shoots of cherry laurel, starved in the dark and then illuminated, either in  $\text{CO}_2$ -free air or air containing about 5%  $\text{CO}_2$ , showed on being darkened once again a marked stimulation of respiration above the normal drift for starving leaves. He used white (tungsten-filament) light of various intensities up to some 4000 f.c. He concluded: 'Results indicate that in the light respiration builds up to an asymptotic value determined by the light intensity.' He also found that during illumination in  $\text{CO}_2$ -free air, the shoots gave out  $\text{CO}_2$  at a rate which was on the average 0.089 of the dark rate and which appeared to be independent of light intensity over an eight-fold range. Clearly, therefore, respiration was not *suppressed* in the light and as mentioned he interpreted his other results as indicating an actual stimulation.

Gabrielsen's results and his conclusion that respiration is unaffected by light have already been discussed in detail. These data, and also the present findings, show at least that light did not suppress respiration completely.

Warburg *et al.* (1949, 1950), Burk *et al.* (1949), using thick suspensions of *Chlorella* and completely absorbed red light, obtained evidence that with  $\text{CO}_2$  pressure maintained low by NaOH the  $\text{O}_2$  consumption was practically identical in light and in darkness, and the quantum yield in photosynthesis was found to be the same both above and below the compensation point. These investigators therefore conclude that (red) light does not inhibit respiration *per se*.

Kok (1948), who worked with thin suspensions of *Chlorella* illuminated by sodium light, states: 'Upon illumination, dark respiration is completely suppressed and substituted by a mechanism providing the cell with a form of energy, obtained with a high yield from absorbed light quanta.' This arises from his conclusion that above the compensation point the quantum yield is half that at extremely low light intensities. The quantum yield at relatively high light is estimated from the slope of the line relating oxygen evolution to light absorbed, and the change in quantum yield is inferred entirely from the very considerable extrapolation of this line to zero light intensity, it being assumed that a rigid 'limiting factor law' applies. Such extrapolation is said to cut the axis, *on the average*, half-way between the oxygen uptake in dark respiration and zero. However, Kok states that the point of intersection of the axis in all cases lay *between* the value for dark respiration and zero, and the really important question is whether the experimental points obtained in fact represented a rectilinear or a curvi-

linear relation. In the latter case the magnitude of the intercepts obtained would be without meaning. In this paper it is not possible to judge of the goodness of fit of the straight lines extrapolated as no actual data are presented for the relation between light intensity and oxygen evolution but only idealized diagrams. In the absence of any experimental points, a more reasonable assumption might seem to be that the relation did not in fact consist of two discontinuous straight lines, as in Kok's diagrams, but that the apparent fall in quantum efficiency was due to increasing importance of other interacting internal or external factors, with the rise of light intensity, giving smooth curves of the 'resistance formula' type. In a later paper Kok (1949) presents actual experimental points, both below and above the compensation point, relating  $O_2$  evolution to light absorbed (green and yellow mercury lines). These data leave little doubt that in his *algal* experiments (*Chlorella* and *Haematococcus*) two discontinuous straight lines were concerned. However, he finds not only that the point of intersection of the two straight lines comes at various levels above or below the compensation point with different cultural methods, but also that with algae grown in the absence of glucose the ratio of the slopes was less than  $1:\frac{1}{2}$  and approximated to  $1:\frac{2}{3}$ . He interprets these results as showing that in some cases a part of the dark respiration is not suppressed by light. His data for the leaves of *Cabomba*, even after 'correction' for a falling assimilation rate, would be well fitted by a smooth curve.

Van der Veen (1949) presents graphically the actual data in an experiment to investigate the relation between light intensity (from 1 to 3200 lux—quality not mentioned) and assimilation by a tobacco leaf-fragment. In his fig. 13, three of the six experimental points lie close to each of two straight lines which intersect near the compensation point. A smooth curve would, however, fit these points reasonably well and in the case of a leaf of a land plant 'resistances' other than the photo-chemical 'resistance' are especially likely to be of importance, thus leading to a curvilinear relation.

It is not the intention here to enter deeply into the theoretical aspects of this controversy. As Warburg *et al.* point out, light might inhibit respiration *per se* 'either anti-catalytically (as by inactivating respiratory enzymes), or by reducing intermediates of respiration'. If the former process occurs, it would be expected that evidence from non-chlorophyllous tissues or organisms would confirm its existence, and the author is unaware of any conclusive evidence of this kind; if the latter process alone holds, it would seem that all the respiring protoplasm must be very much nearer to the assimilatory centres than to the exterior of the cell or an appreciable

quantity of  $\text{CO}_2$  would be expected to be formed and escape. Perhaps in this connexion 'nearer' should be interpreted in terms of the relative resistances to movement of  $\text{CO}_2$  and the intermediates concerned, and though on grounds of molecular size one would expect the  $\text{CO}_2$  to move more rapidly this may be an unjustified assumption. However, in the case of a land leaf, much of the cytoplasm, which presumably respire, is so relatively remote from the chloroplasts that the second method of inhibition would seem *a priori* unlikely to have more than a very partial effect. That anti-catalytic inhibition does not occur and that inhibition by reduction of intermediates is very far from complete, if it occurs at all, is shown for land leaves by the experiments of Gabrielsen (1948, 1949) with still or moving  $\text{CO}_2$ -free air, and by the experiments with moving  $\text{CO}_2$ -free air of Audus (1947). The practically constant  $\text{CO}_2$  content of 0.01% in air which has passed through the leaf, as found in the experiments described in the present paper, suggests, as already mentioned, that a similar value would be obtained with very slowly moving  $\text{CO}_2$ -free air passing into the leaf; this therefore provides additional evidence against the hypothesis that light inhibits respiration.

The discrepancies discussed above may perhaps be due not only to fundamental differences of interpretation but also to differences in technique; as, for instance, in the quality or the intensity levels of illumination, the use of dark-starved shoots (Audus) or detached leaves (Gabrielsen) or portions of leaf (Heath)—though here it is noteworthy that van der Veen used leaf fragments—or to the use of thick suspensions of *Chlorella* with intermittent light (Warburg *et al.*) as against thin suspensions and continuous light (Kok). In his 1949 paper Kok appears to have withdrawn from the conclusion that light necessarily inhibits all respiration; whether light partially suppresses or stimulates respiration or is without effect seems at present somewhat doubtful and is clearly a matter of great importance in the interpretation of the present results and those of Gabrielsen.

#### REFERENCES

- AUDUS, L. J. (1947). The effects of illumination on the respiration of shoots of the cherry laurel. *Ann. Bot., Lond.*, N.S., **11**, 165.
- BLACKMAN, F. F. (1895). Experimental researches on vegetable assimilation and respiration. II. On the paths of gaseous exchange between aerial leaves and the atmosphere. *Philos. Trans. B*, **186**, 503.
- BLACKMAN, F. F. (1905). Optima and limiting factors. *Ann. Bot., Lond.*, **19**, 281.
- BLACKMAN, F. F. & SMITH, A. M. (1911). Experimental researches on vegetable assimilation and respiration. IX. On assimilation in submerged water-plants and its relation to the concentration of carbon dioxide and other factors. *Proc. Roy. Soc. B*, **83**, 389.

- BURK, D., HENDRICKS, S., KORZENOVSKY, M., SCHOCKEN, V. & WARBURG, O. (1949). The maximum efficiency of photosynthesis: a rediscovery. *Science*, **110**, 225.
- GABRIELSEN, E. K. (1948). Threshold value of carbon dioxide concentration in photosynthesis of foliage leaves. *Nature, Lond.*, **161**, 138.
- GABRIELSEN, E. K. (1949). Photosynthesis in leaves at very low carbon dioxide concentrations. *Nature, Lond.*, **163**, 359.
- GREGORY, F. G. & PEARSE, H. L. (1934). The resistance porometer and its application to the study of stomatal movement. *Proc. Roy. Soc. B*, **114**, 477.
- HARDER, R. (1921). Kritische Versuche zu Blackmans Theorie der 'begrenzenden Faktoren' bei der Kohlensäureassimilation. *Jb. wiss. Bot.* **60**, 531.
- HEATH, O. V. S. (1939). Experimental studies of the relation between carbon assimilation and stomatal movement. I. Apparatus and technique. *Ann. Bot., Lond., N.S.*, **3**, 469.
- HEATH, O. V. S. (1941). Experimental studies of the relation between carbon assimilation and stomatal movement. II. The use of the resistance porometer in estimating stomatal aperture and diffusive resistance. Part 1. A critical study of the resistance porometer. *Ann. Bot., Lond., N.S.*, **5**, 455.
- HEATH, O. V. S. (1949). Carbon dioxide in the intercellular spaces of leaves during photosynthesis. *Nature, Lond.*, **164**, 822.
- HEATH, O. V. S. (1950). Studies in stomatal behaviour. V. The role of carbon dioxide in the light response of stomata. Part 1. Investigation of the cause of abnormally wide stomatal opening within porometer cups. *J. Exp. Bot.* **1**, 29.
- HEATH, O. V. S. & MILTHORPE, F. L. (1950). Studies in stomatal behaviour. V. The role of carbon dioxide in the light response of stomata. Part 2. Preliminary experiments on the interrelations of light intensity, carbon dioxide concentration and rate of air flow in controlling the movement of wheat stomata. *J. Exp. Bot.*, **1**, 227.
- HEATH, O. V. S. & WILLIAMS, W. T. (1948). Studies in stomatal action. Adequacy of the porometer in the investigation of stomatal aperture. *Nature, Lond.*, **161**, 178.
- KOK, B. (1948). A critical consideration of the quantum yield of chlorella-photosynthesis. *Enzymologia*, **13**, 1.
- KOK, B. (1949). On the interrelation of respiration and photosynthesis in green plants. *Biochim. Biophys. Acta*, **3**, 625.
- MASKELL, E. J. (1928). Experimental studies on vegetable assimilation and respiration. XVIII. The relation between stomatal opening and assimilation—A critical study of assimilation rates and porometer rates in leaves of cherry laurel. *Proc. Roy. Soc. B*, **102**, 488.
- NEWTON, R. G. (1935). An improved electrical conductivity method for the estimation of carbon dioxide and other reactive gases. *Ann. Bot., Lond.*, **49**, 381.
- NEWTON, R. G. (1936). The investigation of the relation between rates of assimilation and stomatal aperture in leaves. Ph.D. Thesis, University of London.
- VAN DER VEEN, R. (1949). Induction phenomena in photosynthesis. I. *Physiol. Plantarum*, **2**, 217.
- WARBURG, O. (1919). Über die Geschwindigkeit der photochemischen Kohlensäurezersetzung in lebenden Zellen. I. *Biochem. Z.* **100**, 230.
- WARBURG, O., BURK, D., SCHOCKEN, V., KORZENOVSKY, M. & HENDRICKS, S. B. (1949). Does light inhibit the respiration of green cells? *Arch. Biochem.* **23**, 330.
- WARBURG, O., BURK, D., SCHOCKEN, V. & HENDRICKS, S. B. (1950). The quantum efficiency of photosynthesis. *Biochim. Biophys. Acta*, **4**, 335.
- WILLIAMS, W. T. (1949). Studies in stomatal behaviour. III. The sensitivity of stomata to mechanical shock. *Ann. Bot., Lond., N.S.*, **13**, 309.

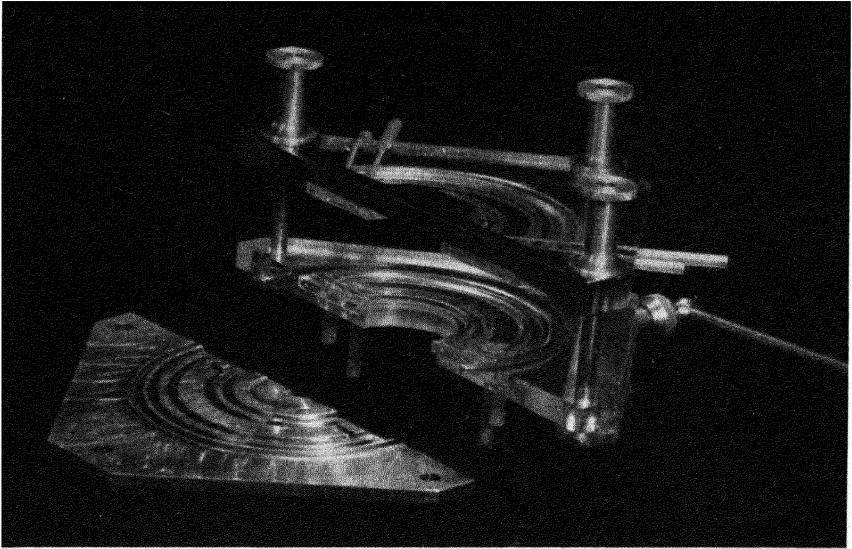

Fig. 1. General view of upper and lower leaf chambers; also brass mould used for casting the gelatine walls of the chambers.

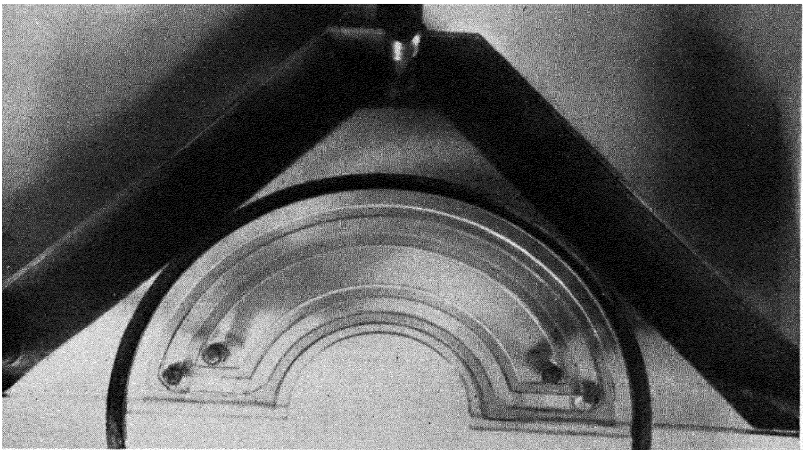

Fig. 2. Lower leaf chambers seen from above. Note the inner and outer chambers and the knife surrounding the latter for trimming the leaf.

From *Ann. Bot., Lond.*, N.S. 3, 1939 (Pl. XIV, Figs. 2 and 5).



# SOME PHYSICAL ASPECTS OF ASSIMILATION AND TRANSPIRATION

BY H. L. PENMAN AND R. K. SCHOFIELD

Rothamsted Experimental Station

## I. INTRODUCTION

Assimilation and transpiration are diffusive processes in which a difference of partial pressure of gas or vapour causes a flow from the region of higher pressure to that of lower pressure, the rate of flow being governed by the nature of the diffusing molecules (coefficient of diffusion  $D$  cm.<sup>2</sup>/sec.), the magnitude of the concentration difference causing flow ( $\rho$ , expressed in cubic centimetres of gas or vapour measured at normal pressure per unit volume of air), the area of cross-section across which flow takes place ( $a$ , cm.<sup>2</sup>) and the distance between the two regions ( $l$ , cm.). When conditions are steady the diffusion current is given by  $D\rho a/l$  c.c./sec., measured at normal pressure.\* By analogy with the flow of electric current, we might regard  $D\rho$  as corresponding to a potential difference,  $l/a$  as corresponding to a resistance, and its reciprocal,  $a/l$ , as corresponding to a 'conductance'. When the flow takes place through stomata a precise specification of  $a$  and  $l$  is not easy, but considerable progress in the study of stomatal movements can be made by using porometers to determine values of stomatal conductance for diffusive flow (Heath, 1941; Penman, 1942). It would be very useful to be able to express the stomatal conductance in terms of stomatal dimensions, and in a classic of biophysics, Brown & Escombe (1900) attempted to do this. Unfortunately, a misplacement of emphasis in their paper has led to distortions in many of the standard text-books, most of which appear to suggest that evaporation from an open-water surface, for example, will be increased by placing a multi-perforated barrier over the surface; which is absurd. Experimenting on diffusion through circular apertures in thin membranes, Brown & Escombe found that reduction of the area to one-quarter did not reduce the flow rate to one-quarter; the reduction was to about one-half, but neither their experimental

\* Use of this equation, symbolizing Fick's law, and use of the term 'flow', are convenient ways of expressing empirically what is in fact a rather more complicated process. For example, in the inward diffusion of carbon dioxide, which is an essential phase in assimilation, what is here described as the 'flow' across area  $a$  is actually the net molecular movement across the area arising from the random thermal movement of the molecules; the unequal and opposite movements across the area can be estimated from the work of Einstein, and thence the balance can be expressed in terms of the concentration gradient as in Fick's law.

technique nor the consistency of their results was adequate to justify the statement that the smaller rate was exactly one-half the greater, i.e. in general, that the diffusion rate was proportional to the diameter of the orifice and not to the area. Even if only approximately true, however, it is obvious that if no other factor intervenes it will be possible to choose an array of a large number of small apertures through which the total diffusion rate would be bigger than if the whole area containing the array were available for unhindered gas movement. As a consequence, Brown & Escombe made absurdly large estimates of assimilation rates on this basis. Maskell (1928) was able to state the nature of the neglected factor, which, taken into account, removes the absurdity. In terms of transpiration, all the separate diffusion streams passing out through the stomata merge at a short distance from the leaf surface, and thereafter this bulk flow encounters resistance as it moves away from the leaf. It was neglect of this external resistance to flow that led to the earlier absurd estimates of flow rates. As there is still considerable confusion of thought on this topic it may be worth while setting out the Brown & Escombe estimates of assimilation, and then incorporating, quantitatively, the suggestion of Maskell.

## II. STOMATAL AND EXTERNAL RESISTANCE TO DIFFUSION

Any attempt to give a physical interpretation of diffusive flow through the surface of a leaf must involve some idealization of the shape of a stoma. Brown & Escombe regarded the stoma as a cylindrical tube through the epidermis. Three estimates of the diffusion rate can then be made.

(i) The first could have been made by Brown & Escombe without doing any experiments other than to measure stomatal dimensions and population, and a value of  $D$  for carbon dioxide. (Their value for the latter,  $0.145 \text{ cm.}^2/\text{sec.}$ , was a little greater than the present-day estimate of  $0.139$ , but it will be retained, as the error is small compared with other sources of uncertainty.) If  $a$  and  $l$  are the area of cross-section (fully open) and length of a stoma, and there are  $n$  stomata per  $\text{cm.}^2$ , the flow rate is  $nDpa/l$  c.c.  $\text{CO}_2/\text{cm.}^2/\text{sec.}$  For a leaf of *Helianthus annuus* ( $a=9.1 \times 10^{-7} \text{ cm.}^2$ ;  $l=1.07 \times 10^{-3} \text{ cm.}$ ;  $n=33,000$  per  $\text{cm.}^2$ ), assuming  $\rho=3 \times 10^{-4}$  c.c./c.c., the flow rate is  $3.35$  c.c.  $\text{CO}_2/\text{cm.}^2$  leaf/hr.

This assumes that the concentration difference is maintained between the ends of a stoma. Actually the regions of higher and lower partial pressure are away at some distance from the ends of the cylinder, and passage of the molecules from one to the other is not quite so easy, for the

gas has to flow up to one circular aperture and away from the other, encountering extra resistance on both parts of the journey.

(ii) A second estimate can be made when the magnitude of these extra resistances is known, and the diffusion experiments of Brown & Escombe gave them a way of making such an estimate. The gas has to diffuse up to a circular aperture, through a cylinder, and then away from a second circular aperture, and the flow rate will correspond to that through a cylinder of the same cross-section but having a length greater than its measured length, the 'effective length' exceeding the other by an amount depending on the size of the aperture. (In the analogous problem in acoustics this extra amount is known as the 'end-correction' and must be allowed for to calculate the true pitch of an organ pipe.) Retaining the Brown & Escombe symbol,  $x$ , for the 'end-correction', the effective length is  $l + 2x$ , and their experiments satisfied them that  $x$  depends on the radius in the way predicted by Stefan (1881) and by Larmor in 1900 (see Larmor, 1918 and also Jeffreys, 1918), i.e. that  $x = \frac{1}{4}\pi r$ , where  $r$  is the radius of the cylinder. The second estimate of flow is, therefore,  $nD\rho a/(l + 2x)$ , and the calculated rate of assimilation for the leaf is now 2.09 c.c. CO<sub>2</sub>/cm.<sup>2</sup>/hr. Note that this value, calculated by Brown & Escombe, makes use of their many diffusion experiments only to determine an end-correction leading to a *slower* assimilation rate than could have been deduced from the assumptions of (i) above. Brown & Escombe set out to explain why the assimilation rate for a leaf with only about 1% of its surface permeable to gases was so great; the problem they left, unstated, is why are the estimates so absurdly great, for both the above estimates are about thirty times too big.

(iii) Taking in of the contribution of Maskell will lead to an acceptable order of magnitude. The carbon dioxide has to diffuse up to the leaf as a whole in exactly the same way as it would diffuse up to the absorbent surface of a dish of caustic soda of the same size, and in approaching both leaf and dish it encounters the same resistance, a resistance that can be estimated from the work of Brown & Escombe, for it is the resistance encountered in moving up to an aperture of the size of the leaf or the dish. Assuming for simplicity that the leaf is circular, of radius  $R$ , then the 'effective length' of the aperture will be given by the same expression as before; if we symbolize it by  $L$ , then  $L = \frac{1}{4}\pi R$ . Alternatively, the resistance to flow up to the leaf (or dish) will be given by  $L/A$ , where  $A$  is the area of the leaf. As  $A = \pi R^2$  and  $L = \frac{1}{4}\pi R$ , the external resistance of the leaf as a whole is  $\frac{1}{4}R$ . This is the only resistance encountered in diffusing up to the dish, but in assimilation there are added the resistances of the individual stomata. These are in parallel, so the total transmission

resistance of the leaf is  $(l+2x)/naA$ , since the total number of stomata is  $na$ ; the combined resistance, internal plus external, is  $L/A + (l+2x)/naA$ , and the assimilation rate, for the whole leaf, is  $D\rho/[L/A + (l+2x)/naA]$ , or  $DA\rho/[L + (l+2x)/na]$ . The rate per unit area, an average rate not necessarily the same at all points on the leaf, is  $D\rho/[L + (l+2x)/na]$ . For a dish of caustic soda, the corresponding average rate is  $D\rho/L$  per  $\text{cm.}^2$ . Putting  $R=5$  cm. to get an order of magnitude,  $L=\frac{1}{4}\pi R=3.93$  cm.; for the *Helianthus* leaf  $(l+2x)/na=0.075$  cm.; the assimilation rates are then:

For the leaf:  $3.91 \times 10^{-2}$  c.c.  $\text{CO}_2/\text{cm.}^2/\text{hr.}$ ;

For the caustic soda:  $3.98 \times 10^{-2}$  c.c.  $\text{CO}_2/\text{cm.}^2/\text{hr.}$

Brown & Escombe do not give any observed values for this leaf, but do give values for another species exposed alongside a dish of caustic soda in a moderately still atmosphere. They are  $7 \times 10^{-2}$  c.c./ $\text{cm.}^2/\text{hr.}$  for the leaf and  $12 \times 10^{-2}$  c.c./ $\text{cm.}^2/\text{hr.}$  for the caustic soda. The order of magnitude is correct, and the discrepancy is to be attributed to the impossibility of controlling experimental conditions so that the air is absolutely still. Anticipating a later result, the best conditions obtainable indoors involve sufficient air movement to decrease the resistance to flow up to the leaf, and an effective value of  $L$  for such conditions is about 1.57 cm. rather than 3.93 cm. (Maskell suggests  $L \doteq 1.0$  cm.). For the leaf and caustic soda, the values of assimilation and absorption rates are then 9.5 and  $10.0 \times 10^{-2}$  c.c./ $\text{cm.}^2/\text{hr.}$ , surprisingly close to the values observed by Brown & Escombe. The overwhelming importance of the external resistance, here revealed, has two noteworthy consequences: (a) under still, or nearly still conditions, stomatal control of assimilation and transpiration is very slight, and the stomata must be nearly closed before they cut down the rate appreciably—in much the same way as the closing of the last small gap in a doorway cuts down the audibility of noise from a neighbouring room. Flow rates are, however, fairly small. As the degree of ventilation increases the external resistance decreases (see below) and stomatal movement becomes a more significant controlling factor. (b) To interpret experimental data, either from laboratory or field sources, it is more important to obtain exact estimates of the external resistance than to obtain exact specification of the stomatal structure and population.

### III. ESTIMATION OF STOMATAL RESISTANCE

Before dismissing the stomatal factor it is worth while considering how it is to be estimated. For most purposes it will be sufficient to regard a stoma as being circular in plan, the equivalent diameter to be taken as the geometric mean of the lengths of the long and short axes of the ellipse to

which the plan approximates. (If  $a$  and  $b$  are the semi-axes, take  $r^2 = ab$ .) Probably the best generalization about the shape of a stomatal section is that it is hyperbolic, rather than rectangular, and in a problem of fluid flow this is an attractive shape to study, for if the stoma were merely an aperture in an infinitesimally thin sheet, then the flow lines from one side to the other through the aperture would be hyperbolae. It is a straightforward, though lengthy, calculation to estimate what the resistance to flow of a stomatal tube would be if its walls were regarded as coinciding with the flow surfaces for an aperture in a thin lamina. We have made such a calculation, but the estimate of resistance of a single stoma differs so little from that obtained by the treatment already outlined that it is not worth while setting out the analysis. As a working rule, to be used until experience indicates the need for improvement, we recommend that the quantities  $l$ ,  $r$  and  $a$  needed to estimate stomatal resistance be obtained as follows:

$l$  is to be the thickness of cuticle and epidermis;

$r_t$  is to be the radius of the throat, i.e. the smallest part of the stoma;

$r_m$  is to be the radius of the mouth, i.e. the value at the leaf surface;

$a$ , the area of cross-section, is to be taken as  $\pi r_t \sqrt{(r_t r_m)}$ . (Some kind of average must be taken, and it must satisfy the condition that it is zero when the throat diameter is zero. The simplest possible average would be  $\pi r_t r_m$ , but this gives too much weight to the aperture at the mouth.)

$x$ , the end correction, is to be taken as  $\frac{1}{4}\pi r$ , where  $r^2 = r_t \sqrt{(r_t r_m)}$ .

The resistance of a single stoma will then be given by  $(l + 2x)/a = (l + \frac{1}{2}\pi r)/\pi r^2$ . For  $l = 10 \mu$  (i.e.  $10^{-3}$  cm.),  $r_m = 10 \mu$ ,  $r_t = 5 \mu$ , this expression gives a value of  $1.72 \times 10^3$  cm. $^{-1}$ ; the more complex analysis gives  $1.73 \times 10^3$  cm. $^{-1}$ . For  $l = 7.5 \mu$ ,  $r_m = 7.5 \mu$ ,  $r_t = 5 \mu$ , the values are 1.73 and  $1.85 \times 10^3$  cm. $^{-1}$  respectively.

#### IV. EXTERNAL RESISTANCE IN STILL AIR

The residual discrepancy between observed and calculated assimilation rates noted in §II was attributed to the impossibility of obtaining still conditions. The possibility of an error in the equation  $L = \frac{1}{4}\pi R$  must also be considered. As already noted, this is also the end-correction for an acoustical pipe, for which the basic theory is the same when the pipe has an infinite flange, and experience confirms its accuracy. For an ordinary pipe, without a flange, the end-correction is about  $0.61R$  (cf.  $0.785R$  above), and we should expect a corresponding decrease in diffusive resistance when flow round the edges into or from the space below the surface is possible.

When water evaporates from a circular surface the rate of evaporation is not the same at all distances from the centre; it is greater at the edges, and the surface there is cooled more than at the centre, and the saturation vapour pressure falls with the temperature. Although conduction and convection in the water will go far toward equalizing the surface temperature the action is slow, and there remain temperature and vapour-pressure differences between the centre and perimeter. The first may cause slight mass movement of air; the second may cause slight diffusive movement of vapour. To these two disturbing actions is added a more important third. The air at the water surface is saturated with water vapour and is generally cooler than the unsaturated air away from the surface; consequently the density of the surface air may—and usually will—differ from that of the remainder, and convection currents will be set up to disturb the imposed still conditions. Sharpley & Boelter (1938) and Powell (1942) found the effect to be very marked, the latter measuring air currents of 10 cm./sec. over water in 'still' air. From his experiments Powell found that  $L$  was proportional to  $R^{0.6}$ , and, combining this result with a few other single recorded results, including some by Brown & Escombe, and adding some unpublished data of our own, we find that under the most quiet conditions obtainable indoors the 'effective length' of a circular surface of up to 10 cm. diameter is given by  $L = 0.6R^{0.6}$ . (For  $R = 5$  cm.,  $L = 1.57$ ; cf.  $L = 3.93$  above.) Very slight casual draughts would decrease  $L$  still further, and as similar disturbances will arise in the assimilation of carbon dioxide by a dish of caustic soda we must conclude that without extraordinary complications in experimental design no confirmation of the equation  $L = \frac{1}{4}\pi R$  is likely to be obtained in diffusion experiments. We believe it to be true, and that it can safely be employed to determine the end-correction for a stomatal tube. For large surfaces, some centimetres or more in diameter, the problem of its accuracy is academic, and for all practical purposes is unimportant. For our present purpose it will be more profitable to proceed to consider the effect of ventilation on  $L$  assuming that the basic theory is valid for the stomata.

## V. THE EFFECT OF VENTILATION

It is easy to show that for normal spacings of stomata the merging or parting of the individual diffusion currents outside the stomatal openings takes place within a few stomatal diameters of the leaf surface, and that except under violently turbulent conditions the first sheet of equal concentration characteristic of the leaf as a whole will lie well within the layer of air close to the leaf in which air movement is non-turbulent. In

effect, the stomatal component of total resistance to diffusion is independent of wind speed. For a single stoma with the fixed high gas concentration at an infinite distance on one side and the fixed low concentration at an infinite distance on the other, the stomatal resistance will be as estimated at the end of §III. In fact, one of these regions of fixed concentration is quite close to the inside of the 'stomatal opening', and the first 'leaf layer' of equal concentration is closer still to the outside opening, so the resistance between these layers is less than it would be in a doubly infinite space. The reduction is small, because nearly all the resistance arises in the stoma itself, and the more complex analysis shows it to be about 10% of the total, i.e. the effective resistances for the two examples given will be  $1.56 \times 10^3 \text{ cm.}^{-1}$

The external component does vary with wind speed, but as aerodynamical evaluation of it is not yet completely possible for all types of experimental arrangement from small surfaces in a wind tunnel or a porometer to extended areas in the field, an empirical treatment must suffice, and in any case will be adequate for the two examples to be considered. For the wind tunnel or porometer, experiments on evaporation from an open-water surface (or saturated fabric) will lead to a result of the form  $E_o = (e_s - e_a) f_1(u) \phi(R)$ , where  $E_o$  is the rate of evaporation from the whole area of radius  $R$ ,  $e_s - e_a$  is the difference between the partial pressure of water vapour at the surface and in the moving air, and  $f_1(u)$  is a function of the velocity of the air. In the open, where observations are made on a sample area in the middle of an extended area of the same kind, the rate *per unit area* is given by a simpler expression of the type  $(e_s - e_a) f_2(u)$ .

(a) *Wind-tunnel conditions.* Powell has given detailed results for evaporation from many shapes of saturated surface, including circular disks. From his fig. 9 it appears that the results for small circular areas are not very different according to whether the disk is facing, tangential or has its back to the air stream. From the middle curve (tangential) of his figure we estimate that  $L = 1.19R^{0.44}u^{-0.56}$ , where  $L$  and  $R$  are in cm. and  $u$  is in cm./sec. (For a porometer in which a leaf of 5 cm. radius has air drawn over it at 100 cm./sec., the value of  $L$  will be 0.184 cm. Using the value of  $1.56 \times 10^3 \text{ cm.}^{-1}$  for the resistance of a single stoma, and assuming a population ( $n$ ) of 20,000 per  $\text{cm.}^2$ , the internal resistance per unit area is  $1.56 \times 10^3/20,000$ , i.e. 0.078  $\text{cm.}^{-1}$ , so that for 1  $\text{cm.}^2$  the contribution of the stomata to the total effective length is 0.078 cm. The total is, therefore, 0.184 + 0.078, i.e. it is 0.262 cm., and the assimilation rate per  $\text{cm.}^2$  is then  $D\rho/0.262 \text{ c.c./sec.}$ , which for  $D=0.139$ ,  $\rho=3 \times 10^{-4}$  reduces to  $1.59 \times 10^{-4} \text{ c.c./cm.}^2/\text{sec.}$  As the rate is fairly high it might be necessary to measure  $\rho$  after passage over the leaf and to correct for the decrease in concentration owing to assimilation.)

In passing, it might be noted that Powell's results indicate that the diffusive processes in and out of a leaf will not be greatly affected by the orientation of the leaf with respect to the wind. In the open, leaf flutter would probably speed up the processes and reduce the differences to still smaller amounts.

(b) *Evaporation from extended areas of vegetation.* During recent years comparisons of evaporation from equal areas of open water and of turf with non-limiting water supply have been made at Rothamsted (Penman, 1948). Wind velocity, sunshine, humidity and surface temperatures were measured, and on a semi-empirical basis a relation has been obtained between the open-water evaporation rate and the prevailing weather. It is:  $E_o = 0.35(e_s - e_a)(1 + u_2 \times 10^{-2})$  mm./day, where  $e_s$  and  $e_a$  are in mm. of mercury, and  $u_2$ , the wind velocity at 2 m. above the surface, is in miles/day. Transformation of this expression gives for the effective length over each cm.<sup>2</sup> the value  $L = 0.65/f(u)$ , where  $f(u) = (1 + u_2 \times 10^{-2})$  (e.g. for  $u_2 = 0$ ,  $L = 0.65$  cm.; for  $u_2 = 120$ , i.e. 5 miles/hr.,  $L \doteq 0.30$  cm.; for  $u_2 = 240$ ,  $L = 0.206$  cm.). It is assumed that this value of  $L$  will be the same for both open water and a continuous crop cover, in spite of the difference in the nature of the surfaces, and will be the same for assimilation as well as transpiration.

To obtain an estimate of the ratio of evaporation from a plant cover to that from open water, it is necessary to know the internal resistance of the plant leaves, and a number of assumptions are necessary: (i) the experimental area will be regarded as a small part of an extremely large flat leaf. This is physically reasonable, for as transpiration rates are mainly determined by incoming energy supply, the important quantity is the projected surface on a horizontal plane; the evaporation from a piece of wet blotting paper is not increased by putting another wet piece underneath it. (ii) The stomata are fully open during daylight and fully closed during darkness. (iii) In the absence of knowledge of the stomatal geometry of the plants, the dimensions when fully open are as given in §III, i.e. the resistance per stoma is  $1.56 \times 10^3$  cm.<sup>-1</sup>, and the population is 20,000 per cm.<sup>2</sup>, giving for the daylight contribution of the stomata to the total effective length 0.078 cm. The night value is infinite.

If we represent the effective length in the air as  $L_a$  and of the stomatal array as  $L_s$ , then  $L_a = 0.65/f(u)$ , and  $L_s = 0.078$  while the stomata are open and  $L_s = \infty$  while the stomata are closed. Note that these are geometrical factors independent of the type of gas flow and will apply to both transpiration and assimilation. Adding self-explanatory suffixes to the diffusion constants and density differences, for the former we can state that the instantaneous rate of evaporation from an open-water surface will be

$D_{\text{H}_2\text{O}} \rho_{\text{H}_2\text{O}}/L_a$ , and from a crop it will be  $D_{\text{H}_2\text{O}} \rho_{\text{H}_2\text{O}}/(L_a + L_s)$ ; for the latter, the assimilation rate of a crop will be  $D_{\text{CO}_2} \rho_{\text{CO}_2}/(L_a + L_s)$ . Obviously a short cut can now be taken to give a ratio of assimilation to transpiration, but this will not give any information about either process separately. The calculation is made later (§VIII), but for the present it will be more helpful to examine the relationship between transpiration from a crop and evaporation from an open-water surface. As  $\rho_{\text{H}_2\text{O}}$  goes through a cyclic change in the course of 24 hr., during part of which  $L_s$  is infinite, it is necessary to determine how the length of daylight affects the total transpiration from a crop.

## VI. THE EFFECT OF DAY LENGTH ON TRANSPIRATION

The following assumptions are made: (i) The stomata are fully open from half an hour before sunrise to half an hour after sunset, so that if the maximum possible duration of bright sunshine is  $N$  hr., then the 'day-length' is  $N + 1$  hr. (ii) The saturation vapour pressure,  $e_s$ , of the water inside the leaf varies sinusoidally during the day with a midday maximum and midnight minimum. (iii) The vapour pressure of the air at a standard height,  $e_a$ , remains constant during the day. (iv) The wind speed remains constant during the day.

Then it can be shown that the ratio of the daily transpiration from a cropped surface to the evaporation from an open-water surface is given by

$$\frac{E_T}{E_O} = \frac{\bar{e}_{ST} - e_a}{\bar{e}_{SO} - e_a} \frac{L_a}{L_a + L_s} \left[ \frac{N + 1}{24} + \frac{b_T}{a_T \pi} \sin \pi \left( 1 - \frac{N + 1}{24} \right) \right],$$

where  $\bar{e}_{ST}$  is the mean saturation vapour pressure of water in the leaves,  $\bar{e}_{SO}$  is the corresponding value for the surface of the open water,  $b_T$  is the amplitude of the variation in  $e_{ST}$ , and  $a_T = (\bar{e}_{ST} - e_a)$ .

The ratio contains three factors. The first is a vapour-pressure factor which will normally differ from unity because the diurnal temperature cycle of a crop cover is different from that of an open-water surface. The second is the geometrical factor already discussed. The third is a day-length factor in which an adequate estimate of  $b/a$  can be obtained from temperature records by putting  $b/a = \frac{1}{2}(T_s \text{ max.} - T_s \text{ min.})/(\bar{T}_s - \bar{T}_d)$ , where  $\bar{T}_d$  is the mean dew-point temperature.

For assimilation the corresponding ratio is much simpler. Comparing assimilation by a crop ( $A_T$ ) with that by a hypothetical extended sheet of caustic soda ( $A_O$ ), and assuming that assimilation (and absorption) is complete and that the carbon dioxide concentration ( $\rho$ ) in the air is

constant throughout the day, then the equivalents of  $\bar{e}_{ST}$  and  $\bar{e}_{SO}$  are equal, and that of  $b_T$  is zero; hence

$$\frac{A_T}{A_O} = \frac{L_a}{L_a + L_s} \frac{N + 1}{24}.$$

Although more complex, the evaporation ratio is more amenable to experimental test, particularly as the assumption about complete assimilation inside the epidermis may be greatly in error.

#### VII. COMPARISON OF OBSERVED AND ESTIMATED RELATIVE EVAPORATION RATES

The theoretical ratio of  $E_T/E_O$  contains three factors. The first is usually slightly greater than unity; as the next two are always less than unity, the product is less than unity, i.e.  $E_O > E_T$ . The amount of energy received from the sun and sky is the same for both, and as less is used up in evaporation from turf than from open water, in spite of differences in reflexion there is normally a little more energy available for warming the turf than the water, that is, the mean surface temperature of the turf will normally be a little greater than that of the open water; hence the mean surface vapour pressure will normally be greater, or  $\bar{e}_{ST} > \bar{e}_{SO}$ .

The second factor gives expression to the extra diffusion path encountered in passing from inside the leaf to the outside. The value of  $L_a$  is to be taken as  $0.65/(1 + u_2 \times 10^{-2})$  cm., where  $u_2$  is in miles/day. There is no knowledge of the stomatal geometry and population of the herbage on the experimental plot, and these almost certainly changed as an initially high fraction of clover was reduced to a negligible quantity in the course of the cuttings between May 1944 and October 1945. As a guess, to give an order of magnitude, we shall retain the values already used for illustration (§ V(a) above), i.e. assume that the value of the effective length of the stomatal array is 0.078 cm. during the hours of daylight.

During the night we assume  $L_s = \infty$ , i.e. that the stomata are completely closed at night and that there is no other way for water to pass through the epidermis. We have found it more convenient to take account of this effect in the third factor, the daylight factor, which is a method of weighting  $L_a/(L_a + L_s)$  to take account of the fact that  $L_s = \infty$  for part of the period. The values of  $b/a$  have not been worked out for the whole of the periods; instead, mean values for 1944 and 1945 have been determined from the temperature records for about 70 days in each year, and as these have been reasonably constant the time-saving procedure is justified, particularly as  $b/a$  occurs in the smaller part of the daylight factor.

Excepting the last, all the columns in Table 1 are self-explanatory. The estimates based on an energy balance have been included for interest as an alternative approach to field transpiration problems. Details have been published elsewhere (Penman, 1948), but, briefly, the estimates are made by measuring or calculating all the sources of radiant energy received by the surface and then allocating the total to its various sinks such as transpiration (the largest) and warming of the air. The main difference between turf and open water lies in the amounts of short-wave radiation reflected (roughly 20 and 5% respectively), so that less energy is available for producing evaporation from vegetation than from open water.

Table 1. *Relative evaporation rates*

Month	Factors			Product	Observed $E_T/E_0$	Energy balance estimate
	Vapour pressure	Stomatal	Daylight			
1944 May	1.11	0.79	0.80	0.70	0.83	0.73
June	1.12	0.79	0.83	0.73	0.88	0.75
July	1.10	0.81	0.82	0.73	0.89	0.79
Aug.	1.03	0.81	0.77	0.64	0.78	0.76
Sept.	0.86	0.81	0.70	0.49	0.79	0.77
Oct.	0.91	0.79	0.60	0.43	0.48	0.56
1945 May	1.12	0.81	0.83	0.75	0.69	0.75
June	1.04	0.80	0.85	0.76	0.72	0.78
July	1.29	0.80	0.85	0.88	0.71	0.75
Aug.	1.14	0.82	0.80	0.75	0.96	0.73
Sept.	1.13	0.80	0.74	0.67	0.61	0.67

The estimates are of the right order of magnitude, i.e. in spite of possible errors in the estimates of stomatal spacing and geometry, and in spite of crude physical measurements that were never intended to be subject to such a stress, the diffusion of water vapour through the epidermis and away from the leaf does appear to be accounted for quantitatively by the factors of stomatal resistance, resistance to bulk flow, and by the length of day. It seems reasonable, therefore, to assume that given the corresponding differences of partial pressure of carbon dioxide then assimilation rates could be similarly calculated.

#### VIII. TRANSPIRATION RATIO

(a) *Theoretical value.* The ratio is usually defined as the weight of water transpired per unit weight of dry matter produced. In practice, it is so variable that it is a useless concept, chiefly because transpiration and growth are dependent upon different factors which may change, or be changed independently, but the preceding analysis offers a way of making a theoretical estimate at least in a limiting case.

The transpiration rate, reduced to fundamental units, is

$$E_T = D_{H_2O} \frac{\bar{e}_{ST} - e_d}{p} \frac{1}{L_a + L_s} \left[ \frac{N+1}{24} + \frac{b}{a} \frac{1}{\pi} \sin \pi \left( 1 - \frac{N+1}{24} \right) \right] \times 24 \times 3600$$

c.c./cm.<sup>2</sup>/day (at N.T.P.), where  $D_{H_2O}$  is the coefficient of diffusion of water vapour into air (to be taken as 0.24 cm.<sup>2</sup>/sec.), and  $p$  is the atmospheric pressure (to be taken as 760 mm.).

The corresponding assimilation rate is

$$A_T = D_{CO_2} (\rho_2 - \rho_1) \frac{1}{L_a + L_s} \left[ \frac{N+1}{24} \right] \times 24 \times 3600$$

c.c./cm.<sup>2</sup>/day (at N.T.P.), where  $D_{CO_2}$  will be taken as 0.14 cm.<sup>2</sup>/sec.,  $\rho_2$  is the concentration of carbon dioxide in the atmosphere (to be taken as constant at  $3 \times 10^{-4}$  c.c./c.c.), and  $\rho_1$  is the concentration inside the epidermis (to be taken as constant).

It is not possible to generalize about the second term in brackets in  $E_T$ , but as it is a small fraction of the first in summer, it will be sufficient to use a particular value (from Table 1), knowing that it is of the right order of magnitude. For the four months May to August the bracketed term in  $E_T$  is 0.8; similarly, the bracketed term in  $A_T$  is 0.7. Putting  $\bar{e}_{ST} - e_d = \Delta e$ , then

$$\frac{E_T}{A_T} = \frac{D_{H_2O}}{D_{CO_2}} \frac{\Delta e}{(\rho_2 - \rho_1)p} \frac{0.80}{0.70}$$

The density ratio of water vapour: carbon dioxide is 18:44, and, assuming that 44 g. of carbon dioxide produce 30 g. of carbohydrate, the ratio becomes

$$\begin{aligned} \frac{E}{A} &= \frac{0.24}{0.14} \frac{\Delta e}{(\rho_2 - \rho_1) 760} \frac{0.80}{0.70} \frac{18}{30} \text{ g. water/g. carbohydrate} \\ &= 5.2 \times \frac{\Delta e}{1 - \rho_1/\rho_2} \text{ g./g.} \end{aligned}$$

A typical value of  $\Delta e$  for summer in south-east England is  $\Delta e \doteq 5$  mm., i.e. the transpiration ratio can be expected to be

$$E/A \doteq 25/(1 - \rho_1/\rho_2),$$

and if assimilation is complete, i.e. if  $\rho_1 = 0$ , then

$$E/A \doteq 25.$$

(b) *Observed values.* Published values of the 'transpiration ratio' range from 200 to 1500, but there is plenty of evidence available to show that parallel plots of the same crop, exposed to the same weather, will transpire the same amount of water, although the crop yields may differ widely because of different management. As an illustration, during the

Rothamsted experiments already referred to, two turfed plots were kept short of nutrients, while a third was plentifully fertilized. The transpirations from all three were equal within a few per cent.; the crop yield from the fertilized plot was almost three times that of the others. Recently (Penman, 1949), we have obtained yield and transpiration data from an irrigation experiment on sugar beet grown on soil in a high state of fertility. The experiment was designed so that water supply was never a limiting factor, meteorological observations of temperature and humidity on the site gave a reliable value of  $\Delta e$ , and both roots and tops were weighed when the crop was harvested.

In round figures, the summer transpiration was 11 in., i.e. 1100 tons/acre. The crop yield was 23 tons of roots and 32 tons of tops/acre, containing 67 cwt. of sugar, and (say) 63 cwt. of dry matter in the tops; in all 130 cwt. of dry matter/acre. The transpiration ratio is 170.

This crop yield is exceptionally high; the transpiration ratio is exceptionally low but is still some seven times as big as the value worked out earlier (where  $\Delta e = 5$  mm. was taken from the records obtained during this particular experiment).

(c) *Discussion.* It is improbable that the discrepancy arises in the numerator of the ratio. The transpiration estimates were checked by measurement of rainfall and of changes in soil-moisture content, and are not more than a few per cent in error. Some of the water regarded as 'transpired' was, of course, evaporated directly from wet leaves, and so never passed through the plant, but the amount thus denied an opportunity of contributing to metabolic processes cannot exceed 20% and was probably much less than this.

The discrepancy is almost certainly in the denominator. A small part of it can be attributed to neglect of respiration, but as this process can account for only about one-fifth of the carbon dioxide uptake it cannot be responsible for six-sevenths of the uptake in this particular experiment, nor for fractions nearer unity in more general cases, particularly as this would imply that those plants making the poorest growth are respiring most rapidly. The remaining and most important part of the discrepancy arises from the assumption of instantaneous absorption of carbon dioxide on the surface of the mesophyll tissue, and the maintenance of zero concentration there. Normally the absorption will cease when the concentration of carbon dioxide in the cell (or that of some complex containing carbon dioxide) reaches a value at which it is in equilibrium with the concentration of carbon dioxide in the air over the surface. For pure water this equilibrium concentration is very low so that only a very slight uptake of the gas is possible. To increase the uptake one or both of two conditions must be

satisfied. If the chemical content of the cells or cell water encourages absorption, then it may be possible to build up a high concentration of the carbon dioxide complex which can persist in contact with, and grow at the expense of, a very small gas concentration in the neighbouring air. It is known that cells and cell water do carry such materials (carbonates, phosphates etc.) in small quantities that vary with plant type and that can be altered for a given type by suitable crop management. But even with this chemical aid to absorption a state will be reached in which the carbon dioxide in the gaseous phase is in equilibrium with the concentration of the complex in the liquid phase, and no more absorption will take place. For maintained absorption it is necessary to remove the complex from the place where it is formed; in the plant this must be a diffusive process, a slow process that will depend upon a concentration difference and a resistance to movement in a way similar to the gaseous diffusion from the outside to the inside of the leaf. The greater the concentration gradient, the greater will be the diffusion rate, so that the presence of absorbing or buffering material in the cell water will assist in translocation too.

Under field conditions it appears that the combined effect of the two factors is very small even when most efficient, and that a luxuriant crop grows with a concentration of gaseous carbon dioxide inside the leaf which is only 10–20% less than that in the outside air. For normal crops the concentration difference between outside and inside can only be a few per cent. An alternative way of expressing this can be found by regarding the assimilation process as a whole, in which carbon dioxide moves from outside the leaf to some region inside. There are two stages of gaseous diffusion, first up to the leaf and then into the leaf, and then there is diffusion in a liquid medium (perhaps in more than one stage). The relative resistances for a favourable case are 4:1:30, but for normal outdoor conditions (transpiration ratio of about 500) may be 4:1:100. The stomatal component (the second) is the least important, and it is obvious that in many assimilation problems all that need be known about the stomata is whether they are open or not. Assimilation is limited by translocation in the liquid phase; normal leaf structure and external weather conditions could maintain a rate several times greater than any found out-of-doors.

#### IX. SUMMARY

Assimilation and transpiration can be treated as formally identical apart from a change in sign of the concentration gradient. The diffusive flow of carbon dioxide and water vapour is hindered by resistance arising partly outside the leaves and partly in the epidermis. Combination of the results

of recent Rothamsted work on the physics of evaporation with a suggestion of Maskell's and some of the results of Brown and Escombe leads to a quantitative estimate of assimilation rates for indoor conditions which is of the right order. For outdoor conditions the length of daylight must be taken into account, and it is shown that the theoretical ratio of transpiration from turf to evaporation from open water agrees quite well with the value found experimentally. Extension to assimilation is attempted through evaluation of a 'transpiration ratio'—normally a useless concept—for the limiting case when absorption is complete at the surface of the mesophyll tissue. It is shown that the very variable observed values of this ratio are many times the limiting theoretical ratio, i.e. that assimilation rates are never more than a very small fraction of what they could be. The discrepancy is attributed to the building up of relatively high carbon dioxide gas concentrations inside the leaf—almost reaching the normal atmospheric value—because the transfer of material in solution is much too slow to remove the absorbed carbon dioxide as fast as gaseous diffusion could supply it.

## REFERENCES

- BROWN, H. T. & ESCOMBE, F. (1900). Static diffusion of gases and liquids in relation to the assimilation of carbon and translocation in plants. *Philos. Trans. B*, **193**, 223.
- HEATH, O. V. S. (1941). The use of the resistance porometer in estimating stomatal aperture and diffusive resistance. *Ann. Bot., Lond.*, N.S., **5**, 455.
- JEFFREYS, H. (1918). Some problems of evaporation. *Phil. Mag.* **35-36**, 270.
- LARMOR, J. (1918). On transpiration through leaf stomata. *Phil. Mag.* **35-36**, 350.
- MASKELL, E. J. (1928). The relation between stomatal opening and assimilation. *Proc. Roy. Soc. B*, **102**, 488.
- PENMAN, H. L. (1942). Theory of porometers used in the study of stomatal movements in leaves. *Proc. Roy. Soc. B*, **130**, 416.
- PENMAN, H. L. (1948). Natural evaporation from open water, bare soil and grass. *Proc. Roy. Soc. A*, **193**, 120.
- PENMAN, H. L. (1949). An account of the physics of irrigation control. *Quart. J. R. Met. Soc.*, **75**, 293.
- POWELL, R. W. (1942). Further experiments on the evaporation of water from saturated surfaces. *Trans. Inst. Chem. Engng*, **18**, 136.
- SHARPLEY, B. F. & BOELTER, L. M. K. (1938). Evaporation of water into quiet air. *Industr. Engng Chem.* **30**, 1125.
- STEFAN, J. (1881). *S.B. Akad. Wiss. Wien*, **83**, 943.

# THE PHOTOCHEMICAL FORMATION AND REACTIONS OF ATOMS AND RADICALS IN AQUEOUS SYSTEMS

BY M. G. EVANS AND N. URI

Department of Chemistry, University of Manchester, Manchester 13

## INTRODUCTION

Rabinowitch has pointed out that one part of the problem of photosynthesis may be concerned with the problem of the photo-oxidation of water by substances incapable of achieving this oxidation in the dark, and it is the purpose of this communication to discuss the mechanism of oxidation-reduction reactions involving hydroxyl ions or water molecules and in particular to refer to the photochemical aspects of this problem. In this discussion we shall be mainly concerned with the individual reaction steps which occur in these reactions and the characterization of the entities formed in the primary reaction processes.

The thermal and photochemical formation of free radicals in the gas phase is well established. The formation of atoms and free radicals by irradiation of aqueous solutions is a comparatively new subject. It has been shown that  $\text{H}_2\text{O}_2$  in aqueous solution can be split into OH radicals (Kornfeld, 1935; Lea, 1949):

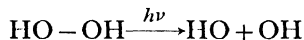

which subsequently lead to the decomposition of hydrogen peroxide in accordance with the Haber-Weiss (1934) mechanism

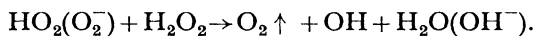
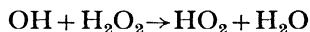

Weiss & Porret (1937) interpreted the photo-oxidation of water by ceric ions as a process involving the intermediate formation of OH radicals, i.e.

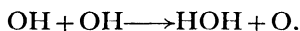
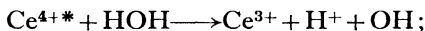
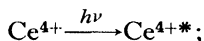

The quenching of fluorescence of certain dyes has been interpreted as an electron transfer leading to the formation of free radicals (Weiss, 1938); this subject ought to be further clarified, before definite conclusions can be drawn.

Franck & Scheibe (1928) have initiated, and in particular Farkas & Farkas have developed, the investigation of the ultraviolet spectra of anions in aqueous solutions, and have interpreted them as electron transfer spectra (Farkas & Farkas, 1938), involving the anion and water molecules, i.e.  $X^-(H_2O) \xrightarrow{h\nu} X(H_2O^-)$ .  $X$  atoms (e.g. halogens) are thus produced. Rabinowitch (1942) has postulated that the absorption spectra of ion pair complexes be interpreted as electron transfer spectra, i.e.

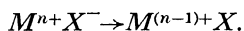

Rabinowitch (1942), in this connexion, remarked that 'if the interpretation of the absorption bands of anion-cation complexes as electron transfer bands is correct, . . . the primary process must be the reduction of the cation and the oxidation of the anion . . . no photochemical changes (in these systems) have been reported but perhaps nobody has looked for them closely enough'. Arising out of the work of Evans & Baxendale (1946*a, b*) on the primary reaction between ferrous ion and hydrogen peroxide

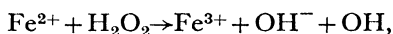

it was shown conclusively that this primary reaction involved the formation of a hydroxyl radical, and these radicals initiated polymerization by attacking the double bond of an unsaturated compound:

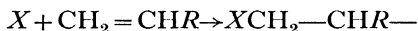

This has afforded a sensitive method of detecting the presence of hydroxyl radicals in aqueous solution, and indeed this method has recently been extended to other atoms and free radicals. Evans & Uri (1949*a, b*) have shown that in the presence of a polymerizable substrate the free  $X$  atoms or radicals formed from ion pair complexes as a result of a photo-excited electron transfer process lead to the polymerization of vinyl compounds. This means that strong experimental evidence has been put forward that atoms or free radicals are formed in this system; this evidence also indicates that it is the ion pair complex which is the photochemically active species.

In this paper we shall be mainly concerned with the reactions of radicals produced by irradiation of ion pair complexes in aqueous solution.

*Ion pair complex formation and the formation of atoms and free radicals by photo-excitation*

The data available in literature are mainly based on spectrophotometric data. Fromherz & Lih (1931) postulated the formation of lead halide ion pair complexes. Rabinowitch & Stockmayer (1942) have established valuable data on ferric ion pair complexes. We have partly repeated their work and

132 THE PHOTOCHEMICAL FORMATION AND REACTIONS OF partly enlarged upon it (1950). The following table shows a summary of our data.

Table 1. *Ion pair complexes with ferric ion*

Reaction	$K$	$\Delta G^\circ$ (kcal.)	$\Delta H^\circ$ (kcal.)	$\Delta S$ (cal./degree)
$\text{Fe}^{3+} + \text{OH}^- \rightleftharpoons \text{Fe}^{3+}\text{OH}^-$	$5 \times 10^{11}$	-16.0	-1.2	50 (a)
$\text{Fe}^{3+} + \text{O}_2\text{H}^- \rightleftharpoons \text{Fe}^{3+}\text{O}_2\text{H}^-$	$2 \times 10^9$	-12.5	1.8	49 (b)
$\text{Fe}^{3+} + \text{F}^- \rightleftharpoons \text{Fe}^{3+}\text{F}^-$	$0.8 \times 10^6$	-6.9	7.5	49 (b)
$\text{Fe}^{3+} + \text{Cl}^- \rightleftharpoons \text{Fe}^{3+}\text{Cl}^-$	30	-2.0	8.5	35 (c)
$\text{Fe}^{3+} + \text{Br}^- \rightleftharpoons \text{Fe}^{3+}\text{Br}^-$	4	-0.8	6.1	23 (c)
$\text{Fe}^{3+} + \text{N}_3^- \rightleftharpoons \text{Fe}^{3+}\text{N}_3^-$	$1.3 \times 10^4$	-5.7	-4.3	5 (b)
$\text{Fe}^{3+} + \text{C}_2\text{O}_4^- \rightleftharpoons \text{Fe}^{3+}\text{C}_2\text{O}_4^-$	$3.0 \times 10^9$	-13.2	-0.3	43 (b)

(a) Own data and Rabinowitch & Stockmayer (*loc. cit.*)

(b) Own data.

(c) Rabinowitch & Stockmayer (*loc. cit.*)

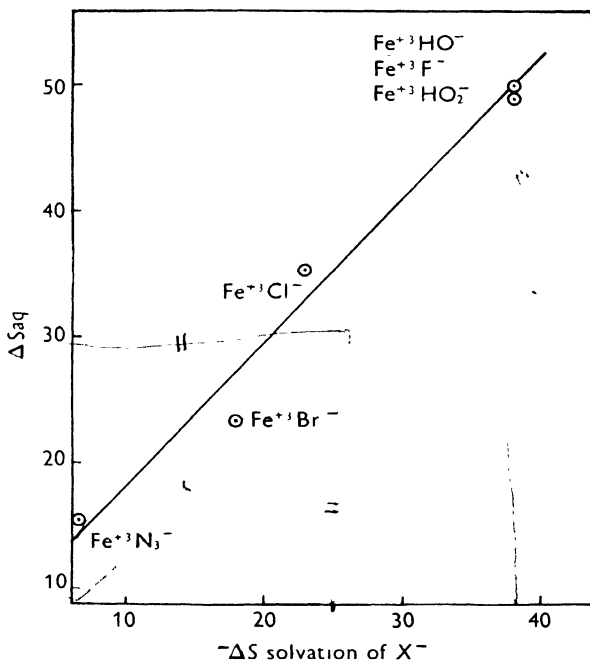

Fig. 1.

These data show the free energy changes, the heat and entropy changes accompanying the formation of the ion pair complexes, and it is important to note the large entropy changes associated with these equilibrium constants. These entropy changes are positives and, as shown in Fig. 1, are closely connected with the entropy of solvation of the negative ion.

In Table 2 we compare the energy change corresponding to the absorption with the energy change involved in the overall reaction  $\text{Fe}^{3+} + \text{X}^- \rightarrow \text{Fe}^{2+} + \text{X}$ , and we note that the energy of absorption is much higher than that corresponding to the overall change. This difference in energy is to be understood in terms of the Franck-Condon principle; the positions of the nuclei in the excited state will be the same as those in the ground state, and therefore will be occupying non-equilibrium positions which will involve repulsion energies of compression. Another interesting point is that the sequence of absorption maxima for a constant positive ion follows the sequence of electron affinities plus solvation energies of the negative ion. If the negative ion is maintained constant in the ion pair the energy of the absorption follows the sequence of ionization potentials in solution of the reduced metal ion.

Table 2

	Absorption maximum (kcal.)	Heat of reaction in the fully dissociated and solvated state (kcal.)
$\text{Fe}^{3+}\text{OH}^- \xrightarrow{h\nu} \text{Fe}^{2+}\text{OH}$	90	44
$\text{Fe}^{3+}\text{Cl}^- \xrightarrow{h\nu} \text{Fe}^{2+}\text{Cl}$	91.5	48
$\text{Fe}^{3+}\text{Br}^- \xrightarrow{h\nu} \text{Fe}^{2+}\text{Br}$	76	34
$\text{Fe}^{3+}\text{F}^- \xrightarrow{h\nu} \text{Fe}^{2+}\text{F}$	120	74
$\text{Fe}^{3+}\text{O}_2\text{H}^- \xrightarrow{h\nu} \text{Fe}^{2+}\text{O}_2\text{H}$	80	31

### Subsequent reactions

The radicals so formed can lead to polymerization, oxidation or possibly even reduction reactions.

(a) *Polymerization of vinyl compounds.* Baxendale, Evans & Park (1946a) have shown that OH radicals produced in the Haber-Weiss reaction

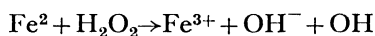

can be detected by their ability to initiate the polymerization of vinyl compounds in accordance with

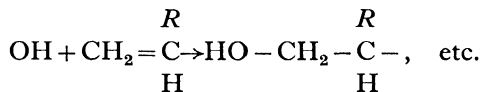

Similarly polymerization occurs when  $\text{Fe}^{3+}\text{OH}^-$  solutions are irradiated in the presence of a vinyl monomer with light of wavelength in the range 300–380 m $\mu$ , where no direct photopolymerization of the monomer would occur. The experimental results obtained by Mr Santappa may be summarized as follows.

(1) *Active photosensitizers.* The following ion pair complexes have been shown to be active photosensitizers for the initiation of polymerization,  $\text{Fe}^{3+}\text{OH}^-$ ,  $\text{Fe}^{3+}\text{Cl}^-$ ,  $\text{Fe}^{3+}\text{F}^-$ ,  $\text{Fe}^{3+}\text{N}_3^-$ ,  $\text{Fe}^{3+}\text{C}_2\text{O}_4^{2-}$ ,  $\text{Fe}^{3+}\text{C}_2\text{O}_4^-$ ,  $\text{Fe}^{3+}\text{HCitr.}^-$ ,  $\text{Pb}^{2+}\text{Cl}^-$ . In the case of  $\text{Fe}^{3+}\text{Cl}^-$  and  $\text{Fe}^{3+}\text{F}^-$  it has been shown by comparison of a micro-analytical end group determination with a viscometric molecular weight estimation that the polymers contain two Cl and F atoms respectively.

(2) *Kinetic results.* The reaction has been studied by measuring the rate of ferrous ion formation (colorimetrically with *O*-phenanthroline), the rate of monomer disappearance (by bromine addition to the excess of unsaturated monomer and by the weight of the dried polymer) and the chain length of the polymer (viscometrically). As to the influence of various factors the following data were established:

(i)  $k_c$  = light absorption fraction due to the ion pair complex. The rate of ferrous ion formation is proportional to  $k_c$ . The rate of monomer disappearance is proportional to the square root of  $\sqrt{k_c}$ . The chain length is inversely proportional to the latter. Since in the case of  $\text{Fe}^{3+}\text{OH}^-$  the change of the concentration of the ion pair complex has been effected by a change in pH only, it is obvious that it is  $\text{Fe}^{3+}\text{OH}^-$  and not the hydrated  $\text{Fe}^{3+}$  ion which is the active species.

(ii)  $I$  = light intensity. The initial rate of ferrous ion formation is proportional to the light intensity. After prolonged periods of irradiation the rate of ferrous ion formation decreases owing to accumulation of ferrous ion. The rate of monomer disappearance is proportional to the square root of the light intensity and the chain length is inversely proportional to the latter.

(iii) Effect of monomer concentration ( $= [M]$ ). The rate of ferrous ion formation is independent of the monomer concentration. The rate of monomer disappearance and the chain length of the resulting polymer are proportional to  $M$ . In the absence of monomer the free radicals formed would be consumed by impurities in the distilled water.

(iv) The maximum quantum yield ( $\gamma$ ).  $\gamma$  depends on the nature of the ion pair complex used as sensitizer. With  $\text{Fe}^{3+}\text{OH}^-$  the maximum value is  $\sim 5 \times 10^{-2}$ , with  $\text{Fe}^{3+}\text{Cl}^- \sim 0.13$ , and with  $\text{Fe}^{3+}\text{N} \sim 0.5$ .

(v) Effect of initially added ferrous ion. A straight line was obtained when  $1/d\text{Fe}^{2+}/dt$  is plotted against  $\text{Fe}^{2+}$ . Owing to experimental difficulties the range in which this relationship could be verified was limited between  $5 \times 10^{-5} \text{M-Fe}^{2+}$  and  $10^{-4} \text{M-Fe}^{2+}$ .

(3) *The mechanism.* The experimental results can be explained on the basis of the following scheme.



(ii) Primary dark back reaction

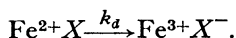

(iii) Dissociation of excited complex

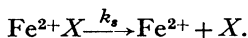

(iv) Secondary dark back reaction

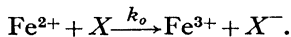

(v) Initiation of polymerization by free radicals

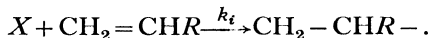

(vi) Propagation of polymerization



(vii) Termination



Assuming stationary state conditions for  $\text{Fe}^{2+}X$ ,  $X$  and  $X(\text{CH}_2\text{CHR})_n^-$ , the following equations can be derived, which are in close agreement with the experimental results.

$$[\text{Fe}^{2+}X] = \frac{k_e I}{k_d + k_s},$$

$$[X] = \frac{k_s k_e I}{(k_d + k_s)(k_o[\text{Fe}^{2+}] + k_i[M])},$$

$$\frac{d\text{Fe}^{2+}}{dt} = \frac{k_s k_e I}{k_d + k_s} \frac{k_i[M]}{k_o[\text{Fe}^{2+}] + k_i[M]}.$$

It may be pointed out that on the assumption of the initiation of polymerization by the primary product  $\text{Fe}^{2+}X$  it would have been impossible to derive quantum yields for  $d\text{Fe}^{2+}/dt$  smaller than unity and yet practically independent of monomer concentration.

Furthermore, 
$$\frac{-d[M]}{dt} = \frac{k_p}{\sqrt{(k_t)}} \sqrt{\left(\frac{k_s k_e I}{k_d + k_s}\right)} [M],$$

and the chain length of the polymer:

$$N = \frac{2k_p}{\sqrt{(k_t)}} \frac{[M]}{\sqrt{\left(\frac{k_s k_e I}{k_d + k_s}\right)}}.$$

It is seen that this mechanism is supported by the experimental results. A detailed account of this work is in the course of publication (Evans, Santappa & Uri).

(b) *Subsequent oxidation reactions.* In the presence of an organic substrate free radicals produced by photochemical electron transfer excitation may be consumed for its oxidation. Stein & Weiss (1948) have shown that OH radicals may attack the benzene nucleus. Using  $\text{Fe}^{3+}\text{OH}^-$  as photo-initiator Mr Bates proved benzoic acid to be a very suitable substrate, as the reaction

could be followed by both the formation of ferrous ion and salycilic acid, as the latter forms an intensely coloured complex with ferric ion. The mechanism has been found similar to the one described in the previous section.

The reaction scheme is:

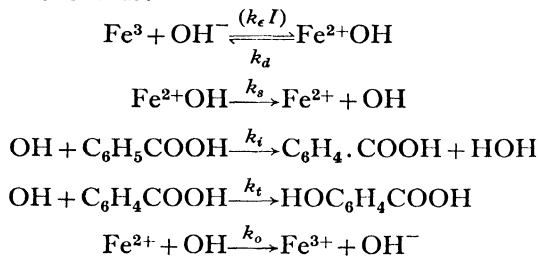

Stationary state kinetics lead to the equation

$$-\frac{d[S]}{dt} = \frac{1}{2} \frac{d[\text{Fe}^{2+}]}{dt} = \frac{1}{2} \frac{k_s k I}{k_d + k_s} \times \frac{2k_i [S]}{k_o [\text{Fe}^{2+}] + 2k_i [S]},$$

where  $[S]$  = substrate concentration.

The equation has been verified experimentally by Bates, Evans & Uri (1950). The value obtained for  $k_i/k_o$  is approximately unity. It can be easily demonstrated by this method that  $\text{Fe}^{3+}\text{OH}^-$  is the active species. In the presence of  $\text{Fe}^{3+}(\text{H}_2\text{O})_6$  as in  $\text{N-HClO}_4$  practically no salycilic is formed under similar conditions.

(c) *The photo-oxidation of water.* We have shown that  $\text{Ce}^{4+}\text{OH}^-$  also is an active species in the photo-initiation of vinyl-polymerization. Weiss & Porret (1937) were the first to report the photo-oxidation of water by ceric ions. Heidt & Smith (1948) have made a more detailed study, but their interpretation assuming an active ceric dimer (which may be deactivated by cerous ions) cannot hold ground. Our spectrophotometric measurements show conclusively that there is no dimerization. All their kinetic results and those obtained by Mr Simon can be accounted for on the basis of the following scheme:

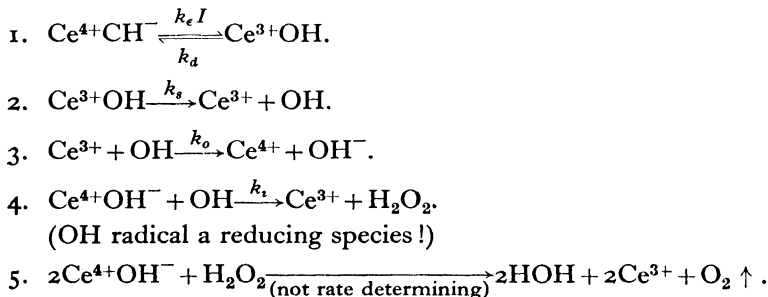

From stationary state kinetics we obtain:

$$[\text{Ce}^{3+}\text{OH}] = \frac{k_e I}{k_d + k_s}$$

$$\text{OH} = \frac{k_s k_e I}{(k_d + k_s)(k_o[\text{Ce}^{3+}] + k_l[\text{Ce}^{4+}\text{OH}^-])}$$

The net quantum yield with regard to  $\text{Ce}^{3+}$  ion formation is:

$$\gamma_{\text{net}} = \frac{d\text{Ce}^{3+}}{dt} \bigg/ k_e I = \frac{4k_s}{k_d + k_s} \times \frac{k_l[\text{Ce}^{4+}\text{OH}^-]}{k_o[\text{Ce}^{3+}] + k_l[\text{Ce}^{4+}\text{OH}^-]}$$

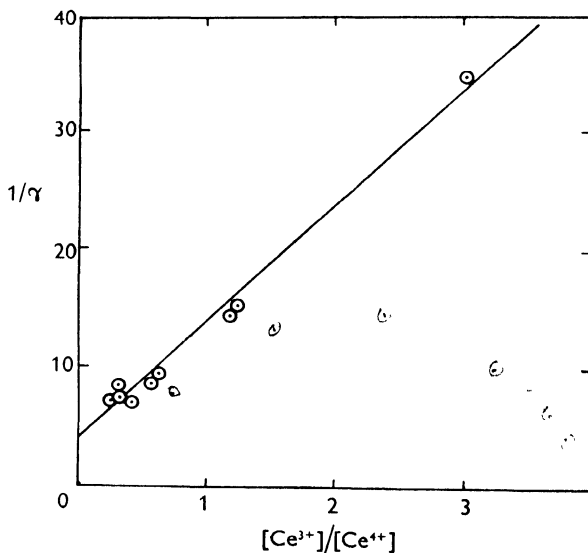

Fig. 2.

The maximum quantum yield is  $\frac{4k_s}{k_d + k_s}$ . The experimental observations would lead to a value of  $\sim 5 \times 10^{-2}$  for  $\frac{k_s}{k_d + k_s}$ , i.e. of a similar order to that observed for  $\text{Fe}^{3+}\text{OH}^-$ . It is obvious that

$$\frac{d\text{O}_2}{dt} = \frac{1}{4} \frac{d\text{Ce}^{3+}}{dt}$$

When the results obtained by Heidt & Smith are utilized for a plot of  $1/\gamma$  against the ratio  $[\text{Ce}^{3+}]/[\text{Ce}^{4+}]$  a straight line is obtained leading to values of  $\sim 5 \times 10^{-2}$  for  $\frac{k_s}{k_d + k_s}$  and 10 for  $k_o/k_l$ .

(d) *Influence of the oxidation reduction potential,  $M^{n+}/M^{(n-1)+}$ .* When we compare the ion pair complexes  $\text{Co}^{3+}\text{OH}^-$ ,  $\text{Ce}^{4+}\text{OH}^-$ ,  $\text{Fe}^{3+}\text{OH}^-$ , the oxidation reduction potential will have a profound influence on the reaction mechanism. First it will be noted that the light absorption is shifted towards higher wavelengths. While  $\text{Fe}^{3+}\text{OH}^-$  is sensitive to ultra-violet light only,  $\text{Ce}^{4+}\text{OH}^-$  shows activity (though reduced) when exposed to the visible. The photochemistry of  $\text{Co}^{3+}\text{OH}^-$  has not yet been investigated. It is known, however, that the cobaltic oxalate complex is photolysed by irradiation with blue light ( $\sim 480\text{ m}\mu$ ), while the ferric oxalate complex requires light of wavelength  $< 380\text{ m}\mu$ . In agreement with our view on the absorption process, the shift in the absorption maximum follows almost quantitatively the shift in the ionization potential of  $M^{(n-1)+}$  in aqueous solution. The oxidation-reduction potential  $M^{n+}/M^{(n-1)+}$  will also affect the rate of secondary reactions.

Evans (1950) has pointed out that the rate of reactions involving free radicals and ions will be governed by the overall free energy change. Considering the reaction leading to the photo-oxidation of water by ferric ion

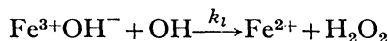

and the reaction

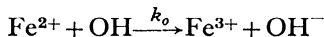

one would expect the ratio  $k_0/k_1$  to be much larger than in the case with ceric ion. Indeed, very high light intensities are required to observe a measurable oxygen evolution from irradiated  $\text{Fe}^{3+}\text{OH}^-$  solutions. The problem of the photo-oxidation of water is now being investigated in our laboratories (with Mr Simons).

*Dye-stuff sensitized oxidations. The system, ferrous ion plus thionine, in water and alcohol*

The importance of a shift in the oxidation-reduction potential is illustrated in this chapter. The reversible photo-bleaching of aqueous solutions of thionine in the presence of ferrous ion has been investigated by Weiss (1935), Rabinowitch (1940) and others. It is assumed that the reactions proceed in accordance with the scheme:

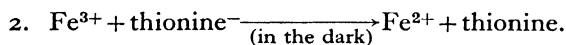
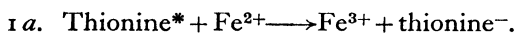
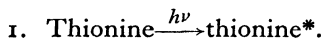

Mr Brealey has recently observed that in the presence of excess lithium chloride in alcoholic solution the oxidation-reduction potential  $\text{Fe}^{3+}/\text{Fe}^{2+}$  (presumably  $\text{FeCl}_4^-/\text{FeCl}_4^{2-}$ ) is shifted to such an extent that thionine would

oxidize ferrous ion *in the dark*. As a result thionine would be bleached when irradiated in oxygen-free alcoholic solutions in the presence of  $\text{FeCl}_4^-$  (with  $365\text{ m}\mu$ ), the scheme being: (1) photo-reduction of ferric ion by electron-transfer excitation and subsequent oxidation of alcohol; (2) instantaneous oxidation of ferrous ion thus formed by thionine. The leucothionine would be slowly reoxidized when the bleached solution in the reaction cell is opened to the air and instantaneously reoxidized by ferric ion present when diluted with water effecting a shift in the oxidation-reduction potential of at least 500 mV. This example well indicates the possibilities that might lie in complex formation, and the subsequent shift in the oxidation-reduction potential.

### SUMMARY

It has been demonstrated that the correct interpretation of the photochemistry of ferric ion (and metal ion in a wider sense) solutions involves the formation of an ion pair complex as active species. By irradiation of the ion pair an electron transfer is effected with the result that the metal ion is reduced to a lower valency stage and the anion is oxidized to an atom or free radical ( $M^{n+}X^- \xrightarrow{h\nu} M^{(n-1)+}X$ ). The latter would lead to the polymerization of vinyl compounds (e.g. methyl methacrylate, acrylonitrile, methacrylic acid), to the oxidation of organic substrates (e.g. benzoic acid) and to the photo-oxidation of water. In the latter case the formation of  $\text{H}_2\text{O}_2$  as intermediate product is postulated to occur (at least in the case of ceric ion) through the reduction of the  $M^{n+}\text{OH}^-$  ion pair by an OH radical. Reaction mechanisms are put forward and substantiated by experimental evidence. The importance of a shift in the oxidation-reduction potential  $M^{n+}/M^{(n-1)+}$  on the photo-oxidation of water is discussed and the practical occurrence of such a shift ( $> 0.5\text{ V.}$ ) is illustrated in the case  $\text{FeCl}_4^-/\text{FeCl}_3$  in water and ethyl alcohol.

### REFERENCES

- BATES, EVANS & URI (1950). *Nature, Lond.* (in the Press).  
BAXENDALE, EVANS & PARK (1946*a*). *Trans. Faraday Soc.* **42**, 155.  
BAXENDALE, EVANS & KILHAM (1946*b*). *Trans. Faraday Soc.* **42**, 668.  
EVANS (1950). Tilden Lecture (in the Press).  
EVANS, SANTAPPA & URI (1950). In course of publication.  
EVANS & URI (1949*a*). *Nature, Lond.*, **164**, 404.  
EVANS & URI (1949*b*). *J. Soc. Dy. Col., Bradford*, **65**, 709.  
EVANS & URI (1950). In course of publication.  
FARKAS & FARKAS (1938). *Trans. Faraday Soc.* **34**, 1113.  
FRANCK & SCHEIBE (1928). *Z. phys. Chem. A*, **139**, 22.  
FROMHERZ & LIH (1931). *Z. phys. Chem. A*, **153**, 321.  
HABER & WEISS (1934). *Proc. Roy. Soc. A*, **147**, 332.  
HEIDT & SMITH (1948). *J. Amer. Chem. Soc.* **70**, 2476.

- KORNFELD (1935). *Z. phys. Chem. B*, **29**, 205.  
LEA (1949). *Trans. Faraday Soc.* **45**, 81.  
RABINOWITCH (1940). *J. Chem. Phys.* **8**, 551.  
RABINOWITCH (1942). *Rev. Mod. Phys.* **14**, 112.  
RABINOWITCH & STOCKMAYER (1942). *J. Amer. Chem. Soc.* **64**, 335.  
STEIN & WEISS (1948). *Nature, Lond.*, **161**, 650.  
WEISS (1935). *Nature, Lond.*, **136**, 784.  
WEISS (1938). *Trans. Faraday Soc.* **34**, 451.  
WEISS & PORRET (1937). *Nature, Lond.*, **139**, 1019.

# PHOTOCHEMICAL OXIDATION-REDUCTION PROCESSES IN AQUEOUS SYSTEMS

By JOSEPH WEISS

University of Durham, King's College, Newcastle-on-Tyne 1

Photochemical oxidations and reductions correspond closely to hydrogenation and dehydrogenation reactions which play such an important role in metabolic processes and particularly also in photosynthesis where one deals, in a sense, with the photo-reduction of carbon dioxide.

The simplest type of photochemical oxidation can be represented by the equation:



These types of processes which have been studied by G. N. Lewis and his school (Lewis & Lipkin, 1942; Lewis & Bigeleisen, 1943) are the nearest analogue to the physical picture of a simple photoelectric process. When this experiment is carried out with a leuco-dye ( $\text{DH}_2$ ), one has the reactions:

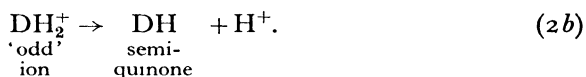
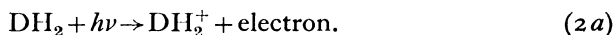

The above equations show that (via the 'odd' ion) a semiquinone is formed which has been shown to be identical with the one produced by ordinary chemical means.

These experiments make it again quite clear that *single* electron transfer processes lead inevitably to the intermediate formation of 'odd' ions and free radicals or atoms. However, the representation by equation (1) is actually an over-simplification, since this process can only take place if a suitable acceptor molecule is present for the electron which is ejected from the molecule  $A$ , acting as electron donor.

In general, photochemical reductions or hydrogenations require suitable donor molecules. In many biological processes and particularly in photosynthesis the most important source of the hydrogen is *water*. Therefore, a considerable interest attaches to the photolysis of water under different conditions. In order to decompose water directly a considerable amount of energy is required. Pure water does not appreciably absorb light of a wavelength above 1900 Å., which corresponds to an energy of about 150 kcal.

The photochemical primary process in this region is probably represented by:



which can lead eventually to the formation of molecular hydrogen and oxygen according to:

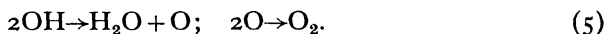

The quantum yield of the overall decomposition is low, which is due probably to the efficiency of the back reactions particularly:



However, photolysis of water can be accomplished with much less energy if the process is suitably 'photosensitized', for instance, if water is irradiated in the presence of suitable ions.

The case of iodide ions has been studied in the classical researches of Franck & Scheibe (1928) and Franck & Haber (1931). The photochemical primary process following on the irradiation of iodide ions in aqueous medium in the near ultra-violet ( $\lambda \sim 2500 \text{ \AA}$ . corresponding to  $\sim 110 \text{ kcal.}$ ) is represented by:

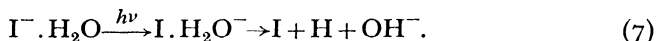

As shown by equation (7) light absorption leads to an electron transfer to the water *molecules* in the hydration shell which, as has been suggested by Farkas & Farkas (1938), may lead to the intermediate formation of something resembling ( $\text{H}_2\text{O}^-$ ). This can break up as indicated above, eventually leading to the formation of molecular hydrogen according to equation (4) and to iodine ( $2\text{I} \rightarrow \text{I}_2$ ). It has been known for some time that the quantum yield of this process increases with increasing concentration of HI. In non-aqueous solvents this is presumably due to the reaction:



as has been proposed already by Warburg & Rump (1928). In aqueous solution, the quantum yield increases generally with increasing hydrogen ion concentration and it has been suggested that this may be due to the intervention of the hydrogen molecule ion in solution according to Weiss (1950):



However, photosensitized decomposition of water is not confined to negative ions. Weiss (1936, 1941) and Potterill, *et al.* (1936) found that, if solutions of ferrous salts (e.g. the sulphate) are irradiated in the near ultra-

violet ( $\lambda \sim 2700 \text{ \AA}$ .), molecular hydrogen and an equivalent amount of ferric salt are formed. The primary process can be represented by:

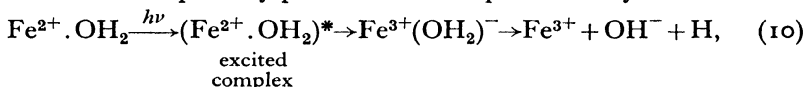

molecular hydrogen being formed again according to equation (4).

While in the case of negative ions the formation of excited complexes is very improbable, this is different with positive ions although the significance of these excited complexes is not fully clarified.

In all the reactions discussed above, the water molecule ( $\text{H}_2\text{O}$ ) suffers a net decomposition into  $\frac{1}{2}\text{H}_2$  and  $\text{OH}^-$ . The energy is clearly less than that required for the photolysis of pure water because energy is gained here from the accompanying processes such as the formation of  $\text{OH}^-$  and, e.g., the ferrous-ferric oxidation.

Similar processes are also known where water is photolysed into molecular oxygen and the hydrogen appears in the form of hydrogen ions, with the simultaneous reduction of a suitable ion or of some other substance.

Porret & Weiss (1937) found that if ceric salts (e.g. ceric perchlorate) are irradiated, molecular oxygen and an equivalent amount of cerous salt are formed with a quantum yield of the order of about 0.1. The photochemical primary process can be represented by:

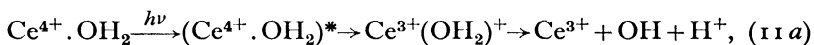

or in the case of the ion pair (Sherill *et al.* 1943):

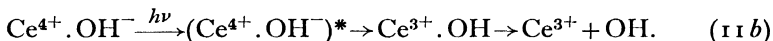

Originally (Porret & Weiss, 1937) it was suggested that molecular oxygen is produced according to the reactions (5) with



as a back reaction. However, recent work of Heidt & Smith (1948) on the kinetics of the reaction have shown that the process is not quite as simple. Evans & Uri (1950) have suggested that oxygen formation goes via the intermediate formation of hydrogen peroxide.

However, it cannot be ruled out that ceric ions (and other ions of a sufficiently high oxidation potential) could react directly with OH radicals according to:

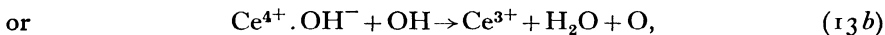
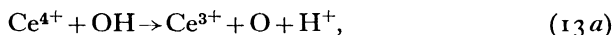

and then molecular oxygen is formed according to ( $2\text{O} \rightarrow \text{O}_2$ ).

The corresponding reaction with ferric ions is of considerable interest in view of the importance of iron systems in biological processes. Dr G. Stein,

in my laboratory, has carried out some experiments with ferric perchlorate. We were only able to conclude that in this case the quantum yield was certainly less than 0.01 as our apparatus was not sensitive enough to measure smaller yields. Dain & Kachan (1948) have recently reported on the photolysis of aqueous solutions of ferric perchlorate in the ultra-violet and they have found quantum yields of the order of  $10^{-3}$ . Some of their results are given in Table 1.

Table 1. *Photochemical formation of oxygen by irradiation of solutions of ferric perchlorate (according to Dain & Kachan, 1948)*

No.	Composition of the illuminated solution in mols./l.		Average velocity of gas evolution, mm. <sup>3</sup> /min. $\times 10^2$ (N.T.P.)
	Fe(ClO <sub>4</sub> ) <sub>3</sub>	HClO <sub>4</sub>	
17	0.33	5.06	5.0
14	0.32	3.08	5.2
15	0.32	1.06	5.3
16	0.33	0.10	2.5

With regard to these reactions in general it is of considerable interest that Evans & Uri (1949) have demonstrated the presence of OH radicals by their polymerization technique when ferric salts are irradiated in the region of 3000 Å.

The photolysis of water leading to the production of molecular oxygen bears a certain resemblance to the *Hill reaction* (Hill, 1939; Hill & Scarisbrick, 1940), in which oxygen is evolved when isolated chloroplasts are irradiated by visible light in aqueous suspension in the presence of suitable oxidizing agents (ferricyanide, quinone, indophenol, etc.). The Hill reaction may be considered to be, in a sense, a photosensitized version of the photolysis of water discussed above. Thus one may attempt to discuss the Hill reaction in terms of simple photochemical processes although in reality we are still very far from an understanding of this important process.

Evidently the light-absorbing species is a chlorophyll complex, most likely a chlorophyll-metal complex which we shall denote by (Me<sup>2+</sup>.C). Its reduced form is then represented by (Me<sup>+</sup>.C). The general idea is outlined in the following equations, (I, 1) to (I, 6):

(Me<sup>2+</sup>.C) light-absorbing chlorophyll-metal complex

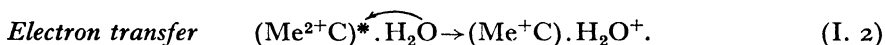
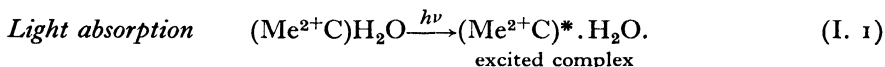

*Formation of molecular oxygen*



*Action of added oxidizing agent*

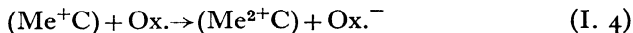

$\text{Ox}^- = \text{FeCy}_6^{3-}$ ;  $\text{C}_6\text{H}_4\text{O}_2$ ; indophenol, etc.

$\text{Ox}^- = \text{FeCy}_6^{4-}$ ;  $\text{C}_6\text{H}_4\text{O}_2^- \xrightarrow{\text{H}^+} \text{C}_6\text{H}_4\text{O}_2\text{H}$  (semiquinone)  $\rightarrow$  hydroquinone.

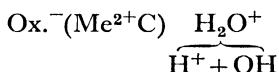
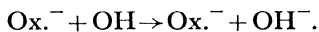
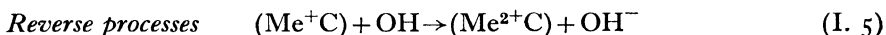

After light absorption (equation (I. 1)) the electron transfer process (equation (I. 2)) leads to the formation of OH radicals which can be the source of molecular oxygen, which is formed either directly according to equation (5) or by the mechanism proposed by Uri & Evans (1950) or by processes of the type of equations (13a), (13b). The reverse processes (equations (I. 5)), to which OH should be subject, would then lead to a suppression of the oxygen formation. However, these reverse processes can be inhibited if the reduced complex (Me.<sup>+</sup>C) is reoxidized by the added oxidizing agent (equation (I. 4)), the function of which is thus to suppress the reverse reactions (equations (I. 5)).

It is not obvious what prevents the reaction between the reduced form (Ox.<sup>-</sup>) and the OH radicals. Possibly there is too little of the reduced form present to take up the OH radicals or else there may be structural (geometric) reasons which prevent the OH radicals from coming into contact with the Ox.<sup>-</sup> This appears to be a reasonable assumption, as it is known that at least the partly intact structure of the chloroplasts are necessary for the Hill reaction to proceed. In such a structural unit one could have a sort of electron migration (oxidation-reduction chain along a certain path (equation (I. 6)), OH being released at one end and the reduced form at the other end. There are various possibilities for the formation of molecular oxygen as indicated above. In view of the fact that O<sub>2</sub> production is not affected by catalase poisons as found by French & Holt (1949), it is not very likely that hydrogen peroxide acts here as an intermediate.

The mechanism of the Hill reaction as outlined above is certainly a gross over-simplification, as in nearly all biological oxidation processes one would

expect to have a sequence of steps between the initial and the final products. It is therefore most likely that a number of oxidation-reduction systems are interposed between the light-absorbing and the oxygen-producing system ( $I.P. \rightleftharpoons A \rightleftharpoons C \dots \rightleftharpoons E.P.$ ). Clearly a system with a number of *small* energy steps is also much more efficient from a thermodynamic point of view and in the case of electron transfer processes, in general, small energy steps would favour the rate of the reactions between adjacent carriers.

The Hill reaction is an example of a photosensitized reaction, the detailed mechanism of which is not known at present. There are, however, other photosensitized reactions which are fairly well understood and where some of the individual steps can be studied separately. In these simple systems one has generally the following components:

- (1) the light-absorbing molecules ('dye'), e.g. eosine, methylene blue etc. which in many cases show fluorescence under suitable conditions;
- (2) the substance which is oxidized;
- (3) the oxidizing agent (e.g. molecular oxygen).

When the 'dye' absorbs a light quantum it goes over into an excited state (this can be pictured in the way that an electron is promoted to a higher level), on returning to the ground state (i.e. when the electron 'falls back') a light quantum is emitted and fluorescence is observed. However, as is well known, fluorescence is the exception rather than the rule and the light energy absorbed primarily can be used up by (i) 'internal conversion' within the molecule itself (this process has been discussed by Professor Franck in his contribution to this Symposium); or else it can be used by (ii) a chemical reaction between the excited molecule and another substance present in the solution, which brings about the quenching of the fluorescence (Weiss, 1939, 1943, 1946; Carter & Weiss, 1940; Franck & Livingston, 1941).

A simple example is represented by the system, methylene blue or thionine, and ferrous ions which exert a quenching action on the (red) fluorescence of these dyes (Weiss, 1939, 1943, 1946; Carter & Weiss, 1940; Franck & Livingston, 1941). The quenching process is represented by reaction (II. 3). It is a light-induced electron transfer process (in this case followed by a proton transfer) leading to the formation of the reduced dye (leuco-dye) and the oxidized acceptor (i.e. ferrous  $\rightarrow$  ferric). In a sense, it corresponds to a photolysis of the water in the hydration shell of the ferrous ions by the electron transfer. The photolysis is brought about here with light of a wavelength of  $\lambda \sim 6500 \text{ \AA}$ . ( $\sim 46 \text{ kcal.}$ ). However, it must be borne in mind that no gaseous hydrogen or oxygen is formed in these reactions: the hydrogen appears in the leuco-dye ( $DH_2$ ), the oxygen as  $OH^-$

and the formation of these is accompanied by the ferrous → ferric oxidation. In general the dye-reduction process is reversible in the dark as the ferric ions formed can reoxidize the leuco-dye (equation (II. 4)).

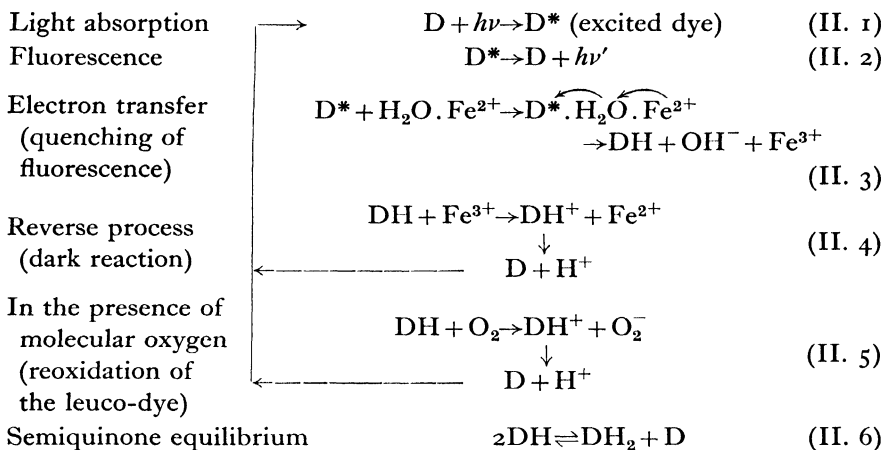

The leuco-dye generally absorbs light at shorter wavelengths and is often colourless. Thus, if one irradiates a 'dye' and an acceptor (in the absence of oxygen), reversible 'bleaching' can occur as discussed above. This can be very easily demonstrated by the system represented summarily by Weiss (1939):

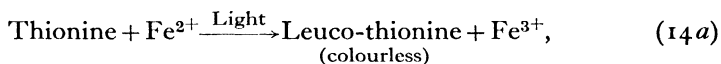

and when the light is turned off:

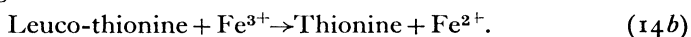

The reversible bleaching effect has been observed and studied also in a number of other cases. However, in certain cases extremely sensitive optical arrangements have to be employed to detect and to measure it (Weiss, 1939).

In the presence of oxygen this represents the simplest type of a photo-sensitized aerobic oxidation. The leuco-dye is then more or less rapidly oxidized by the molecular oxygen, according to equation (II. 5). This also is a free radical reaction and passes through the stages



the oxygen being reduced simultaneously in single steps, involving the free radicals  $HO_2$  and  $OH$  (Weiss, 1935; LuValle & Weissberger, 1947):

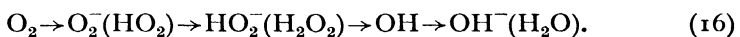

Thus the net process is the oxidation of the acceptor and, in the cases discussed above, the primary process (reaction (II. 3)) in the photosensitized

reaction is clearly identical with the elementary process of quenching of fluorescence.

These are, however, not the only types of processes by which quenching and photosensitized oxidations can occur. The excited state of the light-absorbing molecule which has a relatively loosely bound electron can give off the latter to a suitable acceptor molecule. It will thus prevent the return of the 'excited electron' to the ground state and lead to the quenching of fluorescence. This happens in many of those cases where molecular oxygen acts as quenching agent (Bowen & Williams, 1939; Weil-Malherbe & Weiss, 1942, 1943; Weiss, 1939, 1943, 1946; Carter & Weiss, 1940) of the fluorescence, viz. according to the electron transfer process:



The electron transfer process according to equation (17) is generally favoured, since it proceeds without change in multiplicity. However, Terenin (1943), while not denying processes of the type discussed above, has suggested that in many instances—where strong quenching of the fluorescence by oxygen has been observed—this is due to the paramagnetism of the oxygen molecule. The quenching of the fluorescence of iodine vapour in a magnetic field has been known for some time and has been studied by Turner (1930). However, this is a rather special case where quenching is due to 'magnetic predissociation'. In order to investigate the effect of paramagnetic substances on the fluorescence we have studied the action of a number of paramagnetic ions on the fluorescence of several substances in solution, the fluorescence of which is known to be strongly quenched by molecular oxygen. The results of our experiments are given in Table 2. It is obvious that whereas oxygen shows a very strong quenching effect in all these cases the paramagnetic ions, some of which possess a high number of Bohr magnetons, show practically no quenching at all. In the case of the action of paramagnetic substances the theoretical treatments suggest that the effect should be roughly parallel to the square of the number of magnetons (van Vleck, 1932). In view of the negative results obtained throughout, one must conclude that paramagnetic quenching is absent in all these cases.

Equation (17) represents the simplest type of photochemical oxidation, and is due to the fact that the ionization potential of the excited dye is lowered by an amount of the order of its excitation energy. Reaction (17) can lead first to an unstable peroxide of the form  $(A \cdot O_2)$  which has been observed in many cases. This primary product is often unstable, and reaction (17) is then reversible; e.g. if the oxygen is pumped off, the original state is more or less restored:

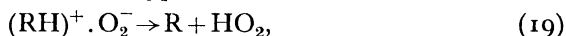

Table 2. *Action of oxygen and of paramagnetic ions on the fluorescence of various substances\**

Fluorescent compound (in abs. alcohol 0.01 mg./ml.)	Quenching substance	Quenching (%)
Oxygen (1 atm.), O <sub>2</sub> (2.83 B.m.)		
Anthracene	conc. = 6.5 10 <sup>-3</sup> mols./l.	+60
3:4 Benzpyrene		+86
20-Methylcholanthrene		+92
Cerous nitrate, Ce <sup>3+</sup> (2.5 B.m.)		
Anthracene	conc. = { 4.5 10 <sup>-3</sup> mols./l. 20.7 10 <sup>-3</sup> mols./l.	{ -4 -2
3:4 Benzpyrene		{ -3 -3
20-Methylcholanthrene		{ 0 +3.5
Manganous nitrate, Mn <sup>2+</sup> (5.88 B.m.)		
Anthracene	conc. = { 5.1 10 <sup>-3</sup> mols./l. 19.2 10 <sup>-3</sup> mols./l.	{ 0 0
3:4-Benzpyrene		{ -4 -6.5
20-Methylcholanthrene		{ 0 -2
Erbium nitrate, Er <sup>3+</sup> (9.5 B.m.)		
Anthracene	conc. = { 5.0 10 <sup>-3</sup> mols./l. 18.5 10 <sup>-3</sup> mols./l.	{ 0 -9
3:4 Benzpyrene		{ +2 +7
20-Methylcholanthrene		{ +7 +12

\* These experiments were carried out in collaboration with Dr H. Weil-Malherbe.

There is, however, also the possibility of a proton transfer if a labile proton is present, e.g. in a compound of the type RH:



in which free radicals are formed which can initiate an oxidation process, or else this can lead to the formation of a hydroperoxide:



The latter can also be formed intramolecularly by the shift of a proton:

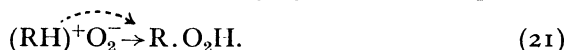

Finally, the primary peroxide can be stabilized as a transannular peroxide, as is presumably the case with anthracene and possibly with some of the other polycyclic hydrocarbons.

Photosensitizing action is shown also by certain coloured substances, which are normally only weakly fluorescent or practically non-fluorescent, and furthermore where the acceptor molecules do not show any very marked quenching effect on the fluorescence.

In this connexion it is of great importance that G. N. Lewis and his collaborators (1944) have shown that many dyes after absorption of light and transformation into an excited state can pass into an active long-lived state. These authors have also demonstrated in a number of cases that this long-lived state is a triplet state (which chemically corresponds to a diradical state).

This is presumably true, for instance, in the cases where chlorophyll acts as a photosensitizer.

It is well known that chlorophyll solutions show a red fluorescence of low quantum yield, and this fluorescence is not appreciably influenced by molecules which can act as acceptors (e.g. iodide ions, thiosinamine, etc.) and is relatively only slightly affected by molecular oxygen.

On the basis of the experiments of Gaffron (1927, 1933) the following mechanism (Weiss, 1949) can be put forward for this type of photosensitized process:

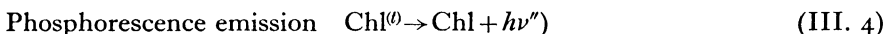
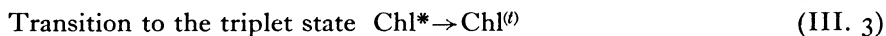
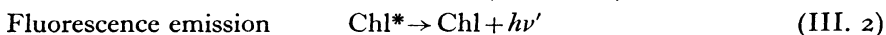
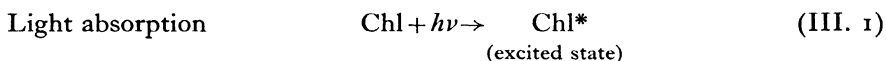

Self-quenching of the triplet state



Interaction with the acceptor (which initiates the photosensitized process)

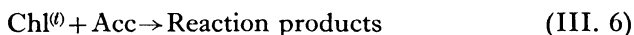

Chl = chlorophyll.

The ordinary fluorescence emission (reaction (III. 2)) has a low quantum yield because in this case the transition to the triplet state (reaction (III. 3)) is a favoured process. The long-lived triplet state ( $\text{Chl}^{(l)}$ ) can give emission of phosphorescence (i.e. fluorescence of longer duration), yet it must be concluded that self-quenching by the unexcited dye-molecules present (reaction (III. 5)) reduces the yield of this process to such an extent that, even in the absence of an acceptor, the total light emission is relatively low and not strongly affected by reaction (III. 6) with the acceptor.

Taking into account reactions (III. (1), (2), (3), (5), (6)), one obtains an expression for the quantum yield  $\gamma$  of the photosensitized reaction:

$$\text{Quantum yield: } \gamma = \frac{k_3 k_6}{k_5(k_2 + k_3)} \frac{[\text{Acc}]}{k_5[\text{Chl}] + k_6[\text{Acc}]} = \frac{k_3 k_6}{k_5(k_2 + k_3)} \frac{[\text{Acc}]}{1 + \frac{k_6}{k_5} \frac{[\text{Acc}]}{[\text{Chl}]}}$$

which is identical with Gaffron's (1927, 1933) empirical equation.

## SUMMARY

The photolysis of water and of some corresponding photosensitized reactions has been discussed in detail in relation to some processes which are of importance in photosynthesis. The mechanism of photosensitized oxidation and reduction processes has been reviewed in the light of recent experimental results.

## REFERENCES

- BOWEN & WILLIAMS (1939). *Trans. Faraday Soc.* **35**, 765.  
CARTER & WEISS (1940). *Proc. Roy. Soc. A*, **174**, 351.  
DAIN & KACHAN (1948). *C.R. Acad. Sci. U.R.S.S.* **61**, 471.  
EVANS & URI (1950). *This Symposium*. 130.  
FARKAS & FARKAS (1938). *Trans. Faraday Soc.* **34**, 1113.  
FRANCK & SCHEIBE (1928). *Z. phys. Chem. A*, **139**, 22.  
FRANCK & HABER (1931). *S.B. preuss. Akad. Wiss.* 250.  
FRANCK & LIVINGSTON (1941). *J. Chem. Phys.* **9**, 184.  
FRENCH & HOLT (1949). *Photosynthesis*, ed. Franck & Loomis, p. 271. Iowa.  
GAFFRON (1927). *Ber. dtsh. chem. Ges.* **60B**, 755.  
GAFFRON (1933). *Biochem. Z.* **269**, 251.  
HEIDT & SMITH (1948). *J. Amer. Chem. Soc.* **70**, 2476.  
HILL (1939). *Proc. Roy. Soc. B*, **127**, 192.  
HILL & SCARISBRICK (1940). *Proc. Roy. Soc. B*, **129**, 238.  
LEWIS & LIPKIN (1942). *J. Amer. Chem. Soc.* **64**, 2801.  
LEWIS & BIGELEISEN (1943). *J. Amer. Chem. Soc.* **65**, 2419, 2424.  
LEWIS & KASHA (1944). *J. Amer. Chem. Soc.* **66**, 1579, 2100.  
LUVALLE & WEISSBERGER (1947). *J. Amer. Chem. Soc.* **69**, 1567.  
PORRET & WEISS (1937). *Nature, Lond.*, **139**, 1019.  
POTTERILL, WALKER & WEISS (1936). *Proc. Roy. Soc. A*, **156**, 561.  
SHERILL, KING & SPOONER (1943). *J. Amer. Chem. Soc.* **65**, 170.  
TERENIN (1943). *Acta Physicochem. U.R.S.S.* **18**, 211.  
TURNER (1930). *Z. Phys.* **65**, 464, 480.  
URI & EVANS (1949). *Sympos. Photochem., J. Soc. Dy. Col., Bradford*, **65**, 709.  
VAN VLECK (1932). *Phys. Rev.* **40**, 544.  
WARBURG & RUMP (1928). *Z. Phys.* **47**, 305.  
WEIL-MALHERBE & WEISS (1942). *Nature, Lond.*, **149**, 471.  
WEIL-MALHERBE & WEISS (1943). *Nature, Lond.*, **151**, 449.  
WEISS (1935). *Naturwissenschaften*, **23**, 64.  
WEISS (1936). *Nature, Lond.*, **137**, 71.  
WEISS (1939). *Trans. Faraday Soc.* **35**, 48.  
WEISS (1941). *Trans. Faraday Soc.* **37**, 463.  
WEISS (1943). *Nature, Lond.*, **152**, 176.  
WEISS (1946). *Trans. Faraday Soc.* **42**, 133.  
WEISS (1949). *Sympos. Photochem, J. Soc. Dy. Col., Bradford*, **65**, 135.  
WEISS (1950). *Nature, Lond.*, **165**, 728.

# RESONANCE TRANSFER OF ENERGY BETWEEN MOLECULES

By E. J. BOWEN, M.A., D.Sc., F.R.S.

Physical Chemistry Laboratory, Oxford

## I. INTRODUCTION

Molecules possess energy in a variety of forms, translational, rotational, vibrational, electronic, and chemical. In a closed system these forms come into an equilibrium with each other, as described by the laws of statistical mechanics. The fundamental law of such equilibrium is that the probability of any molecule having energy  $\epsilon$  in any specified form is proportional to  $e^{-\epsilon/RT}$  where  $T$  is the absolute temperature. The *rate* at which equilibrium is attained in a set of molecules in disequilibrium involves considerations of energy transfer and redistribution which are theoretically very complex. Experimental methods of determining such rates are limited in nature, and on the theoretical side we have usually to be content with simplified models. Redistributions of chemical energy depend on activation energies; interconversions of translational and vibrational energy can be followed by work with supersonic waves. Reactions occurring in flames often produce molecules with momentarily abnormally high rotational energies, but their rate of equilibration cannot yet be determined. The general nature of several kinds of interconversion can be visualized by means of potential energy curves, whose exact shapes for real molecules, however, are only known in simple cases. In Fig. 1  $AB$  represents a diatomic molecule. The  $x$ -axis measures interatomic distance  $A-B$ , and the  $y$ -axis energy, the atom  $A$  being kept fixed along the latter. The curve  $GNBEH$  represents the vibration amplitudes of  $B$  relative to  $A$  for all vibrational energies of the normal molecule. An upper curve  $\check{y}CMDFK$  similarly represents the vibrations of an electronically excited molecule of  $AB$  in which the bond length has increased through weakening of the link ( $D$  to right of  $B$ ). Another curve  $LPH$  represents a second excited state in which the attraction between  $A$  and  $B$  is changed to repulsion, and which therefore has no minimum or possibilities of vibration. A molecule may be raised from the bottom curve to either of the upper ones by the absorption of light, and the transition occurs chiefly up a vertical line because the electronic change is swifter than atomic movements. Starting with a normal molecule at  $B$ , then, we have as one possibility (e.g. with the molecule HI) a passage to point  $P$ , followed by dissociation of the molecule into atoms,

as represented by passage along the curve  $LPH$  to infinity. Electronic energy equivalent to the length  $BP$  is thus converted into chemical energy equivalent to the height of  $H$  above the  $x$ -axis and the remainder into translational energy. Another possibility (e.g. with the halogens) is a passage to point  $C$  on curve  $JDK$ . If  $C$  is higher than the limit  $K$ , the molecule again dissociates; if below, a vibrating excited molecule is formed. This may lose its excess vibrational energy by collisions, reaching point  $D$ ,

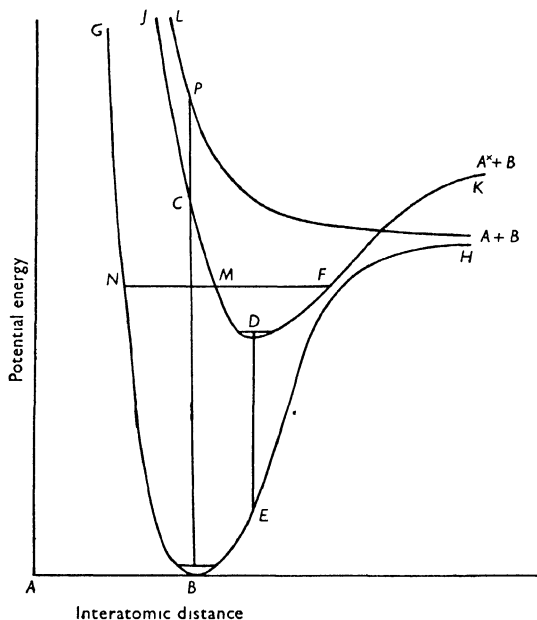

Fig. 1.

and if sufficiently stable may drop back to the lower curve at  $E$  with emission of *fluorescence*. This process usually has a 'mean life' of  $10^{-8}$  sec., and is therefore only observed in examples where the electronic energy is not dissipated in other ways. In many molecules the lower curve  $GBH$  may approach the upper curve  $JDK$  closely at some point  $F$ . An electronically excited molecule vibrating along  $MF$  may then switch over without radiating into a lower state molecule with the high vibrational energy of  $NF$ , which will be quickly lost by thermal redistribution. The fluorescent power of molecules is reduced by rise of temperature or by molecular interactions and collisions. The first allows more molecules to rise from  $D$  to the  $NMF$  level before radiation has occurred and the second, by 'detuning' the molecules, destroys the sharpness of the curves of Fig. 1

and enhances their 'merging' at point  $F$ . In this qualitative way we can understand the conditions for fluorescence and for fluorescence 'quenching'; for fluorescence, the potential energy curves should be well separated, no dissociation or chemical interactions should occur on light absorption, and there should be no way for the molecule to leave point  $D$  except by  $D$  to  $E$ ; 'quenching' is favoured by possibilities of chemical reaction or by effects increasing radiationless transitions through point  $F$  to heat energy (Bowen, 1947).

## II. PHOTOLENSITIZED FLUORESCENCE

The remainder of this paper deals with the transfer of electronic energy virtually intact from one molecule to another. This effect was first investigated for monatomic gases at low pressures, and called *photosensitized fluorescence* (Cario & Franck, 1923; Franck, 1924). Two facts emerged, that for efficient transfer there must be good *resonance* between energy levels, i.e., the second molecule must be capable of taking up practically the whole energy of the first in a single step, and further that in favourable cases the electronic energy is transferred over very long distances. If mercury vapour is excited by one component of the fine structure of the 2537 Å. line, re-emission of the neighbouring isotope lines is observed, and if the energy difference, already small, is further reduced by the action of a magnetic field the apparent 'collisional cross-section' for transfer is over 1000 times the ordinary 'kinetic' section (Mrozowski, 1932, Buhl, 1938). Similar effects are obtained when sodium vapour is excited by one  $D$ -line only; energy is transferred to other atoms which emit the other  $D$ -line with a large characteristic cross-section (Wood *et al.*, 1914, 1918; Lochte-Holtgreven, 1928). In a mixture of mercury and sodium vapours, if the mercury atoms are excited by light at 2537 Å. to the  $6^3P_1$  level, of electronic energy 112 Kcal./atom, sodium atoms by collision (+ a little heat energy) obtain from them 112.5 Kcal./atom of energy, and pass from the  $3S$  to the  $9S$  level, as shown by the emission of the sodium line  $9S \rightarrow 3P$ . Under similar conditions, but in presence of added nitrogen, the mercury atoms take up a lower metastable level  $6P_0$  of 107.8 Kcal./atom; the sodium atoms are now observed to rise preferentially to the  $7S$  level of 108.5 Kcal./atom (Beutler *et al.*, 1928, 1929). The above effects are experimentally well definable because of the sharp energy levels of atoms and their associated fine-line spectra, so that no confusion can exist over the interpretation of the facts.

In liquid solutions the diffuse nature of absorption and fluorescence spectra requires that experimental observations be carefully examined for

spurious effects. A clear example of electronic energy transfer is found in benzene solutions of europium benzoyl acetate (Weismann, 1942). Ultra-violet light undoubtedly absorbed by the organic part of the molecule causes a red-orange emission of europium fluorescence. An inverse transfer of energy rare-earth to organic part has also been observed (Tomaschek, 1944). 'Resonance' between the frequencies involved is here non-existent, but the effect is found only in compounds with covalent, not with ionic, bonds. The second feature of abnormal cross-section for transfer is therefore also absent, and this system is not comparable to the gaseous ones quoted. In certain mixed dye solutions, however, true photosensitized fluorescence has been observed. For example, acriflavine in solution has an absorption band at 4600 Å. (max.) and emits a blue-green fluorescence at about 5200 Å. Rhodamine B absorbs at 5550 Å. (max.) and fluoresces orange at about 5800 Å. When rhodamine B is progressively added to a solution of acriflavine excited by light at 4600 Å. the fluorescence emission changes over from blue-green to orange (Förster, 1949). In order to show that this effect is a true resonance energy transfer, it must be proved (a) that the exciting light is not primarily absorbed by the rhodamine, and (b) that acridine fluorescence is not absorbed by the rhodamine and re-emitted as its fluorescence. The second presents the greatest difficulty, since the absorption band of the rhodamine overlaps the fluorescence band of the acriflavine, but by working at very low total concentrations re-absorption can be eliminated. Calculations then show that electronic energy passes from acriflavine to rhodamine molecules over distances of 60 Å. or more (Förster, 1948). Here again we have an association of good energy resonance with long distances of transfer. We evidently have to picture the electronic clouds of the  $\pi$ -orbitals in the molecules as stretching out in a way able to interact with other molecules much further than ordinary molecular radii would lead us to expect.

Additional information on these processes is found in the phenomenon of concentration depolarization (Franck & Livingston, 1949). When dilute solutions of dyes in water are excited by plane-polarized light, the fluorescence is almost unpolarized. This is because the molecules rotate to other orientations in the period of about  $10^{-8}$  sec. between absorption and emission. In highly viscous solvents the rotation is rendered negligible, and those molecules whose axes are appropriately oriented to the electric vector of the exciting light absorb it, re-emitting polarized fluorescent light similarly oriented in vector direction to a molecular axis. If now the concentration is increased, the fluorescence is found to become increasingly depolarized. This can only be due to the electronic energy passing from one molecule to another of different orientation, so that when emission occurs

the original electric vector direction has been lost. Further increase of concentration leads to 'concentration quenching' of the fluorescence. This occurs at concentrations about 1 gm./l., but depolarization is observed at concentrations less than 0.01 gm./l., where the molecules are separated by 100 Å. or more, and long distance resonance effects must again be postulated.

Resonance transfer of electronic energy is shown in a very unambiguous form by solid solutions of certain aromatic hydrocarbons (Bowen *et al.*

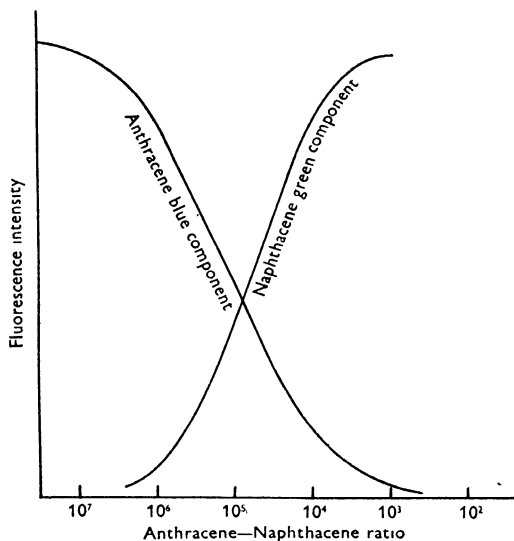

Fig. 2.

1949). When traces of naphthalene c1ccc2ccccc2c1 are added to anthracene c1ccc2cc3ccccc3cc2c1 and the crystals illuminated with long-wave ultraviolet light the blue fluorescence of the latter is suppressed and replaced by the green fluorescence of the former. The flat molecules of anthracene lie roughly parallel in the crystal, and the naphthalene molecules present are similarly oriented. Fig. 2 shows how the blue and green fluorescence intensities vary with naphthalene concentration. They become equal when the naphthalene-anthracene ratio by weight is about  $10^{-5}$ . The magnitudes of the extinction coefficients of these substances in long-wave ultraviolet light show that the exciting light must be overwhelmingly absorbed by anthracene molecules. The proof that the green emission from naphthalene molecules is not excited by reabsorption of blue fluorescence can be given

in four ways: (a) the light absorption by anthracene may be calculated to be more intense than the reabsorption of blue fluorescence by the naphthalene at low concentrations, (b) the fluorescence returns to blue if green fluorescent crystals are dissolved in benzene, (c) homogeneous mixed crystals of the two substances show relatively more green-to-blue fluorescence than heterogeneous mixtures of equal overall composition, and (d) in crystals which are largely green-fluorescent the residual blue fluorescence still preserves its normal spectral distribution, instead of having one side of the band preferentially reduced by re-absorption (Bowen & Lawley, 1949). Similar effects are shown by dilute solid solutions of anthracene in naphthalene, fluorene or phenanthrene illuminated by ultra-violet light about 3000 Å.; the ultra-violet fluorescence bands of these hydrocarbons are suppressed and replaced by the blue fluorescence of anthracene. The literature is full of false statements about the colour of the fluorescence of such substances, in the crystalline state, due to the effects of traces of anthracene or other impurities.

The handing on of energy from molecule to molecule may be formally treated in a manner similar to the kinetics of polymerization reactions, i.e., in terms of initiation, chain propagation and chain transfer, and chain ending processes, as shown in the scheme below ( $A$ =anthracene,  $N$ =naphthalene):

- (1)  $A + h\nu \rightarrow A^x$  Initiation (excitation),
- (2)  $A^x + A \rightarrow A + A^x$  Propagation (resonance transfer),
- (3)  $A^x + N \rightarrow A + N^x$  Chain transfer (resonance transfer),
- (4)  $A^x \rightarrow A + h\nu'$  } Chain ending (fluorescence).
- (5)  $N^x \rightarrow N + h\nu''$  }

A back transfer from  $N^x$  to  $A$  is excluded since the level of  $N^x$  is lower than  $A^x$ , and in process (3) excess energy is dissipated as heat and is not recoverable at ordinary temperatures. Simple treatment then shows that the fluorescence intensity of  $A = 1/(1 + \tau k[N])$  and of  $N = \tau k[N]/(1 + \tau k[N])$ , where  $\tau$  = mean life of the fluorescence of  $A$  in process (4) and  $k[N]$  represents the dependence of process (3) on the naphthalene concentration. From the data of Fig. 2,  $k$  has the value of about  $10^5$  when  $[N]$  is expressed as concentration by weight.

It will be seen that the measurements give no information about the length of the transfer process (2) between anthracene molecules. In Fig. 1, light absorption is represented as a passage from the lower curve to the higher, and the wavelength most strongly absorbed by  $BC$ , where the interatomic distance does not change during the rapid electronic transition ( $10^{-15}$  sec.) (Frank-Condon principle). Since the equilibrium distance from  $D$  to the vertical axis for the excited molecule is longer than  $BA$  for

the normal molecule, the former finds itself in a compressed state. It therefore vibrates from *C* to the other limb of the curve with a period of about  $10^{-12}$  sec., but after an unknown but probably small number of oscillations the excess vibrational energy is redistributed and brought into temperature equilibrium. The excited molecule thus reaches *D*, and then falls back to the lower level at *E* and emits fluorescence with a mean life of about  $10^{-8}$  sec. If it is to hand on excitation energy to another molecule of the same kind, it must do so before the excess vibrational energy is dissipated; for if it has reached point *D* it cannot pass on its energy to a normal molecule. The Franck-Condon principle requires that interatomic distances remain unchanged during electronic transitions, and a molecule dropping from *D* to *E* has insufficient energy to raise another from *B* to *C*. Resonance transfer corresponding to process (2) above will therefore only be fully efficient for molecules in which, for Fig. 1, point *D* lies nearly vertically over point *B*, i.e., where interatomic distances are little changed by excitation. The more highly conjugated a molecular system is, the more will it approximate to this condition owing to the spread of excitation over many linkages.

Conditions may be more favourable for processes of type (3) where the energy is to be transferred to a *different* molecule. If the absorption band of the latter overlies the fluorescence band of the primarily excited molecule, the ideal conditions for resonance are realized and transfer can occur during the relatively long period a molecule spends on the average at point *D*. This is very clearly brought out in certain anthracene solid solutions. The 'constant'  $\tau k$ , described above for traces of naphthacene in

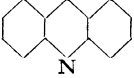
anthracene, is  $10^5$ . The substances acridine  and phenazine

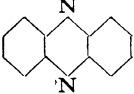
 are themselves negligibly fluorescent in the solid state, and

in dilute solid solution they can receive excitation energy from anthracene, but 'quench' the energy without reradiating. They thus show curves corresponding to the left-hand one of Fig. 2 only. Their 'constants' are respectively  $10^3$  and  $10^5$ . Phenazine absorbs in the blue-like naphthacene, in the same region as the fluorescence emission of anthracene. Acridine has a much smaller constant, and its absorption band is very nearly coincident with that of anthracene itself. These differences may be ascribed as much to effective changes of  $\tau$  as to changes of  $k$ .

The optimum conditions for electronic energy transfer thus seem to be (a) ability of the primarily excited molecules to resist other deactivating processes, and (b) close energy resonance between these excited molecules

after becoming thermally stabilized for vibrational energy and the excitation requirements of the receptor molecules according to the Franck-Condon principle: i.e., in Fig. 1, length  $DE$  for first molecule =  $BC$  for second molecule. If in one molecule  $DE$  practically equals  $BC$ , as shown by close coincidence of the absorption and fluorescence band, transfers of the type  $A^x + A \rightarrow A + A^x$  become likely. Chlorophyll is a molecule whose absorption and fluorescence bands in the red are almost identical in position. Energy transfer between chlorophyll molecules, even when separated by distances of 100 Å. or more is therefore to be expected. How far this possibility is of importance in the actual photosynthetic behaviour of chlorophyll, as has been suggested (Franck & Herzfeld, 1941) is a matter for further biological study. Photosynthesis involves a large number of intermediate step-reactions, many of which are reversible if the illumination ceases. Free electronic energy transfer between chlorophyll molecules would certainly facilitate the attainment of high photochemical efficiencies at low light intensities and under conditions where a few only of the molecules are in a position to utilize a light quantum on their own account.

## REFERENCES

- BOWEN, E. J. (1947). *Quart. Rev. Chem. Soc.*, **1**, 1.  
 BOWEN, E. J. & LAWLEY, P. D. (1949). *Nature, Lond.*, **164**, 572.  
 BOWEN, E. J., MIKIEWICZ, E. & SMITH, F. W. (1949). *Proc. Phys. Soc. A*, **62**, 26.  
 BEUTLER, H. (1928). *Phys. Z.* **29**, 893.  
 BEUTLER, H. & JOSEPHI, B. (1929). *Z. Phys.* **53**, 747.  
 BUHL, O. (1938). *Z. Phys.* **109**, 180; **110**, 395.  
 CARIO, G. & FRANCK, J. (1923). *Z. Phys.* **17**, 202.  
 FÖRSTER, J. (1948). *Ann. Phys.* **2**, 55.  
 FÖRSTER, T. (1949). *Z. Naturforsch.* **4**, 321.  
 FÖRSTER, T. (1949). *Z. Elektrochem.* **53**, 93.  
 FRANCK, J. (1924). *Z. Phys.* **25**, 312.  
 FRANCK, J. & HERZFELD, K. F. (1941). *J. Phys. Chem.* **45**, 978.  
 FRANCK, J. & LIVINGSTON, R. (1949). *Rev. Mod. Phys.* **21**, 505.  
 LOCHTE-HOLTEGREVEN, W. (1928). *Z. Phys.* **47**, 362.  
 MROZOWSKI, S. (1932). *Z. Phys.* **78**, 826.  
 TOMASCHEK, R. (1944). *Reichber. Phys.*, **1**, 139.  
 WEISSMANN, S. I. (1942). *J. Chem. Phys.* **10**, 214.  
 WOOD, R. W. & DUNOYER, L. (1914). *Phil. Mag.* **27**, 1018.  
 WOOD, R. W. & MOHLER, F. L. (1918). *Phys. Rev.* **11**, 70.

# THE PHYSICAL BACKGROUND OF PHOTOSYNTHESIS

By JAMES FRANCK

Institute of Biophysics and Radiobiology; Fels Fund,  
University of Chicago

## INTRODUCTION

Much valuable information in the field of photosynthesis has been gathered by the use of the methods of physics and physical chemistry. However, in many cases general agreement has not been reached about the interpretation of the results. This is not astonishing since all of the problems of photosynthesis are complicated. The time available for the discussion of the physical background of photosynthesis is too short to cover the whole field; thus only a few chapters have been singled out in this report in the hope that they might be of interest to the present audience.\*

## DISCUSSION ON CHEMICAL KINETICS

It has been known for many years that light saturation of photosynthesis is reached when the rate of one or another of the enzymic reactions of photosynthesis cannot keep up with the rate of the photochemical reactions. Thus the saturation rate becomes dependent upon all the external factors which influence the rate of enzymic reactions, such as changing temperature, presence of specific enzyme poisons, etc. Since Blackman was the first to introduce the concept of limiting factors, Warburg used the term 'Blackman reaction' for these dark reactions and 'Blackman period' for the time they need to go to completion. Extending Warburg's pioneer work with light flashes, Emerson & Arnold (1932, 1933) succeeded in measuring the half-time of the Blackman period and found that with algae at room temperature in the presence of sufficient carbon dioxide it is approximately  $1/100$  sec. With light flashes of high intensity, the yield per flash becomes constant if the flashes are separated by dark periods longer than  $1/100$  sec. Lowering of the temperature or addition of cyanide apparently prolongs the Blackman period without changing the maximum yield per flash. They

\* In the meantime the present author has written a more comprehensive survey about the same subject matter for the 1951 edition of *Ann. Rev. Plant Physiol.* The reader will be referred, by means of footnotes, to this critical survey where supplementary information on problems treated in this report may be particularly useful.

interpreted the maximum yield per flash as a measure of the number of carbon dioxide molecules connected with the photosynthetic apparatus at the moment of each flash. This number was believed to be several thousand times smaller than the number of chlorophyll molecules present. Gaffron & Wohl (1936), who had calculated from the shape of a saturation curve what the duration of a Blackman period should be if all the chlorophyll molecules absorb and make use of their excitation energy independently, found that a Blackman period responsible for saturation should be several thousand times longer than the observed  $1/100$  sec. This factor is, of course, the same as the one calculated by Emerson & Arnold for the ratio between the numbers of chlorophyll molecules and carbon dioxide molecules. Both groups concluded that a 'photosynthetic unit' must exist in which the energy absorbed by different individuals of the several thousand chlorophyll molecules in the unit is directed to one carbon dioxide molecule. Originally they explained the unit by 'exciton migration'; i.e., an exceedingly quick migration of excitation energy through thousands of chlorophyll molecules. This idea had to be abandoned because it was realized that such a migration would cause great changes in the absorption spectrum of the chlorophyll in the chloroplasts as compared with that in dilute solutions of chlorophyll Franck & Teller (1938). Such changes are not observed. However, the migration theory was recently revived by Förster (1948) who found that a much slower passage of energy through chlorophyll molecules must occur in the chloroplasts. The time for migration through approximately 1000 molecules at this slower rate would be nearly equal to the lifetime of the excited state of chlorophyll so that a large percentage of the absorbed light should be re-emitted as fluorescence. Since the actual fluorescence yield is only about one per thousand, the energy can only have passed through a few molecules during the actual lifetime of the excited state.\* Wohl (1940, 1941) has introduced another modification of the unit theory which is free of these difficulties. He assumes that energy-carrying molecules transport the energy from the excited chlorophyll molecules to reaction centres which contain the carbon dioxide to be reduced. The number of these centres is several thousand times smaller than the number of chlorophyll molecules. This theory still has many adherents in spite of the principal objections raised against all unit theories. The main objection is the following: If a unit exists, it must be possible to calculate from the saturation rate the duration of the particular dark reaction which is

\* The conclusion that, in the process of photosynthesis, excitation energy of the chlorophyll molecules can migrate only through a few of them before the energy is used for photochemical processes remains valid for a possible migration of excitation energy in the lowest metastable triplet state of chlorophyll, formed indirectly by a radiationless, internal, singlet-triplet transition (compare *Ann. Rev. Plant Physiol.* 1951).

responsible for saturation under the prevailing external conditions. For instance, if the saturation rate is reduced by a factor 3 by the addition of cyanide, the slowest dark reaction can only be three times slower than the one without the poison if the photosynthetic unit is the correct picture. However, this consequence of the unit theory is not in accordance with observations. Only the Blackman period responsible for saturation at relatively high temperatures, in the presence of excess carbon dioxide and in the absence of poison, is abnormally short ( $1/100$  sec.). If, by lowering the temperature or by addition of cyanide, the saturation rate is decreased by a small factor, the limiting Blackman period has a duration of a higher order of magnitude. That can, for instance, be deduced from Weller & Franck's (1941) observation that illumination with strong light flashes separated by dark pauses of  $\sim 1/100$  sec. give in presence of cyanide a rate of gas exchange identical to the saturation rate of continuous irradiation. Rieke & Gaffron's (1943) observations with a more direct method for separating long and short Blackman periods gave the same results. It is furthermore significant that under carbon dioxide limitation due to the presence of cyanide McAlister (1940) and Aufdemgarten (1939) found that the rate of carbon dioxide consumption does not drop sharply to zero when the light is turned off but decreases gradually for a time which may be a minute or more. Thus the period of  $1/100$  sec. is an exception and needs a special explanation. The theory of Franck & Herzfeld (1941) assumes that it is the working period of an enzyme which reacts with unstable photo products of a lifetime at least ten times smaller than  $1/100$  sec. If the number of these unstable molecules made by a very short, strong light flash is greater than the number of enzyme molecules present, only those photo-products which make contact with the enzyme during their short lifetime will be stabilized and the surplus will be removed by back reactions which occur long before the stabilization enzyme becomes available for a second round of reactions. The enzymic reaction, according to the hypothesis made, consists in the transfer of a hydrogen atom from an unstable to a stable position. The maximum yield per flash is then equal to the number of molecules of this stabilization enzyme. However, the saturation yield per flash may become smaller if the time needed for the diffusion of the enzyme molecules to the unstable photoproducts (or vice versa) becomes longer than the lifetime of the unstable molecules. This seems to be the explanation of Tamiya's (1949) new results in which he finds that at low temperature the saturation yield per flash becomes smaller. He is probably right in his suggestion (previously made by Weller & Franck) that in the low-temperature experiments of Emerson & Arnold, flash saturation was not reached, but this criticism cannot be applied to Weller & Franck's results

which seem to be unknown to Tamiya. However, Weller & Franck used strong light flashes of longer duration than those used by Emerson, Arnold & Tamiya. Thus the prolongation of the diffusion time by low temperature did not have the effect that a part of the available enzyme molecules arrived too late to catch the unstable photoproducts before back reaction occurred. The saturation yield per flash, therefore, was not lower, or only very little lower, than at higher temperatures. Accordingly Tamiya's results are not, as he supposes, in contradiction with our kinetic theory. In the next section it will be mentioned that our explanation is also in good agreement with observations on the fluorescence of chlorophyll. Of special interest are new results obtained by Clendenning (1950). He has given convincing evidence that the Blackman period of  $1/100$  sec. occurs in the photochemical reduction of the so-called Hill reagents by illuminated chloroplasts just as it does in normal photosynthesis. This is in accord with our assumption that this particular Blackman period corresponds to a stabilization reaction directly concerned with the photolysis of water and does not represent a reaction involved in the specific reduction of carbon dioxide.

In conclusion to the remarks on the photosynthetic unit it may be pointed out that the experiments with carbon 14 are in agreement with the consequence of Franck & Herzfeld's theory that the concentration of intermediate products during photosynthesis below saturation must be comparable to chlorophyll concentration. The concentration of two-carbon compound, Calvin and co-workers (1949), which adds the carbon dioxide, can be calculated from the rate of appearance of tracer ( $C^{14}$ ) in the various positions in phosphoglyceric acid and the estimated overall photosynthetic rate. Such a calculation indicates that the two-carbon compound was present at the moment of addition of tracer in a concentration comparable to that of chlorophyll.

Finally we have to discuss the influence of oxygen on the saturation rate of photosynthesis. A recent paper of Tamiya & Huzisige (1949) presents new observations and comes to conclusions which are different from ours. The observations of these authors show, first, that the percentage reduction of the saturation rate by oxygen is much higher if carbon dioxide concentration is the limiting factor responsible for saturation than if this gas is present in abundance; secondly, that the inhibitory effect of oxygen in the presence of cyanide is smaller than in its absence; and, thirdly, that the inhibitory influence of cyanide is less pronounced if the oxygen pressure is high. They conclude that the cause of the oxygen inhibition is a reversible combination of oxygen with an enzyme engaged in the dark fixation of carbon dioxide (as observed by Ruben & Kamen, 1940), the process being similar to the oxygen and carbon dioxide combination with

haemoglobin, and that the cyanide inhibition cannot be acting on the first step of the carbon dioxide dark uptake, an idea ascribed to Franck & Herzfeld, but involves a later enzymic step in that process.

In so far as the present author understands Tamiya & Huzisige correctly, there is no difference of opinion concerning the influence of cyanide, but rather a misunderstanding of our statement. However, it is not worth while to argue that point since the work with carbon 14 done recently by the Chicago group leaves little doubt that cyanide does poison an enzyme involved in the primary carboxylation reaction of photosynthesis (1950).

We cannot accept the interpretation of oxygen inhibition given by Tamiya. For a long time we have applied the idea (compare Weiss (1938) or Franck & Livingston (1941)) that photo-oxidation sensitized by chlorophyll *in vitro* is a reaction in which hydrogen is transferred to molecular oxygen resulting in hydrogen peroxide radicals or hydrogen peroxide itself. The peroxide then oxidizes the substrate. The cause of oxygen inhibition of photosynthesis in plants, is quite similar to that of photo-oxidation *in vitro*. Molecular oxygen competes with carbon dioxide complexes (molecules into which carbon dioxide has been incorporated as a prelude to reduction) for the hydrogen atoms made available by the light-excited chlorophyll, in other words, oxygen is a 'Hill reagent'. The smaller the concentration of carbon dioxide complexes, the more effective is this competition by oxygen. Thus it has been known for many years (Noack (1926) was probably the first observer) that, when carbon dioxide is rate-limiting, photo-oxidation occurs in plants. The real problem in this situation, to which we have given much thought, is the explanation of the mechanism whereby leaves exposed to sunlight in normal air prevent destructive photo-oxidation. Under these conditions the carbon dioxide limitation is very strong but destructive photo-oxidation occurs only when other factors such as light, temperature, etc. are extreme. We may introduce the improbable hypothesis that oxygen is a very inefficient Hill reagent. While this would be in accord with the observation of Franck & French (1941) that oxygen consumption by photo-oxidation in leaves exposed to strong light in carbon dioxide-free air has a rate comparable to respiration, it fails entirely to explain the much greater inhibition of photosynthesis in normal air and even in air enriched several times as to carbon dioxide concentration. This inhibition is one of the reasons why we introduced the assumption that photo-oxidation in normal plants forms a narcotizing substance (or substances) which covers a part of the chlorophyll and inactivates it, both for photosynthesis and for photo-oxidation. Only enough of the chlorophyll remains active to enable the photosynthetic activity to balance the formation and photochemical consumption of the carbon dioxide

complexes. In other words, the photosynthetic apparatus adjusts itself to the limited supply of carbon dioxide complexes by inactivating so much of the chlorophyll that, for the part which remains active, the so-called carbon dioxide limitation is avoided. Thus the layer made by oxidation lowers the rate of photosynthesis and checks photo-oxidation very efficiently. The rate of the latter process would go to zero if the narcotic-acting substance were stable. Since it is unstable (compare Franck, French & Puck, 1941), sufficient photo-oxidation remains to replenish its loss.

Tamiya's explanation of his observations that the presence of oxygen inhibition makes the rate less sensitive against cyanide is a quite general one and fits his particular assumption as well as ours. The non-additivity of the two inhibitions indicates only that oxygen and cyanide do not attack the same enzyme. If, by addition of oxygen, the photosynthetic rate is lowered, less of the cyanide-sensitive enzyme is needed to keep up with the lower rate. Thus a part of these enzyme molecules can be inactivated without influencing the rate.

More about the self-adjusting device for protection against photo-oxidation will be said in the next section. A discovery which fits in very well with these ideas was made during the last few months by Dr Mehler in our laboratory (his paper will appear soon). Mehler showed that in the absence of carbon dioxide the rate of oxygen uptake by irradiated chloroplasts can be brought to the same height as the rate of oxygen evolution accompanying photochemical reduction of quinone by the same chloroplasts if ethyl alcohol, as a substrate to be oxidized, and catalase, to function as a peroxidase, are added. The alcohol is oxidized to acetaldehyde and, as the high rate of oxygen uptake indicates, this substance does not have the quality of a narcotizing inhibitor of the photochemical activity of the chlorophyll.

#### DISCUSSION ON FLUORESCENCE ANOMALIES OF CHLOROPHYLL

Since Kautsky\* first observed that changes in the intensity of the fluorescence of chlorophyll are connected with changes in the rate of photosynthesis, a great many observations have been published and there is no disagreement between different groups of observers in regard to the experimental facts. However, two schools of thought interpret these results in entirely different ways. Two years ago the present author wrote

\* For references to the extensive literature on fluorescence of chlorophyll, cp. E. J. Rabinowitch, *Photosynthesis*, Interscience Publishers Co., New York.

As regards the differences of theoretical interpretations, compare for instance the papers of Wassink and co-workers, published in *Enzymologia*, 1938-41, and J. Franck, chap. 19 of *Photosynthesis in Plants*, Iowa State College Press, 1949.

an extensive survey on this subject and it is not his intention, nor is there the time, to discuss all that material again. However, he wants to give a very brief résumé of the two opposing points of view. The chief reason is that one of the main contributors to this field and the principal proponent of the interpretation which differs from that favoured by the present author is here to-day, Dr Wassink, whom hitherto I had not had the opportunity to meet personally. The second reason is that I would like to draw the attention of biochemists and plant physiologists to some parts of the literature not usually seen by them, namely, to papers concerning the physical background of the photochemistry of complex molecules.

Light absorbed by molecules can certainly not be used to promote endothermic chemical reactions if it is re-emitted as fluorescence. Therefore, fluorescence is quenched if the excited molecules have occasion to undergo reactions or to promote reactions in other molecules with which they collide during the lifetime of the excited states.

In monatomic and diatomic molecules there is indeed usually perfect antagonism between fluorescence and photochemistry because in most cases there is only the choice between re-emission of the light or transformation of it into chemical energy. Wassink and co-workers, as well as others, applied this property of simple molecules to the fluorescence of chlorophyll, a complex molecule, and came therefore to the conclusion that a rise in the fluorescence yield of chlorophyll in plants must be an indication that molecules which make use of the excitation energy of the chlorophyll are either absent or present in lower concentrations than usual. We, on the other hand, maintain that it cannot be concluded that complex molecules such as chlorophyll show the same antagonism between light emission and photochemistry. The main reason is that complex molecules have the ability, not present in simpler molecules, to perform internal radiationless transformations from higher to lower electronic states whereby the energy difference between the electronic states is converted into interatomic oscillation energy of the molecule. If a metastable electronic state exists which does not lie too deep below the original excited state, a great part of the energy absorbed may be temporarily stored in this metastable state, On account of small transition probability, the chlorophyll molecules excited in the metastable state have, in living cells, no occasion to dispose of their excitation energy by radiation; the energy is rather utilized *in toto* for one or another photochemical reaction. Unwanted reactions—such as oxidation reactions which occur with high efficiency if molecular oxygen is given an opportunity to interact with metastable excited molecules—can only be avoided if the photosynthetic reduction reactions utilize the excitation energy so quickly that oxygen molecules have no chance to

meet the chlorophyll molecules in the metastable state.\* Observations, of which one example is discussed below, have shown that the fluorescence yield in green plants is not influenced by contact with substances to be photosynthesized. Thus, we conclude that an intramolecular factor is responsible for the limitation of the fluorescence of the chlorophyll molecules; i.e. the internal conversion. Theoretically it cannot be predicted whether the time lapse between the moment of excitation and the radiationless conversion of the excitation energy is influenced by the presence or absence of photosensitive substances and if so, whether the time lapse is enlarged or diminished. Very small changes (for instance in the strength of adsorption) may cause quantitative differences and may even change the sign of the effect. The experimental fact that, in green plants, the interaction with photosynthesates does not change the fluorescence yield is then an indication that in these cells the time lapse of internal conversion is not altered.† However, if a light-induced oxidation of some easily oxidized material in the plant occurs, there is a rise of the fluorescence by a factor 2 to 3. Our interpretation is that by this oxidation a substance of narcotic action is formed as was mentioned earlier. It is known that narcotics are able to enhance the chlorophyll fluorescence yield. It does not play a role whether that oxidation is a normal photo-oxidation via hydrogen peroxide, made by the reaction between hydrogen atoms and molecular oxygen, or whether an oxidation occurs because the oxygen-liberating enzyme is inactivated thus permitting the photosynthetic peroxides to react with the particular oxidizable substance. The latter happens, according to our interpretation, during normal induction periods, as well when higher plants are overloaded with food, or when a green plant is subjected to long periods of anaerobicity, and also at normal light saturation in purple bacteria.

To-day we want to give only one example of changes in the fluorescence of chlorophyll *in vivo* (others can be found in the survey noted above).

Fig. 1 taken from McAlister's (1940) observations shows two light saturation curves; the one is measured in a nitrogen atmosphere containing only enough oxygen to permit tissue respiration; the other is measured in air. In both cases the carbon dioxide concentration is so small that at saturation it is strongly rate-limiting. The influence of the higher oxygen concentration is quite marked in the curve measured in air. The two other

\* An estimate shows (compare *Ann. Rev. Plant Physiol.* 1951) that the actual lifetime of the metastable state must be reduced to  $10^{-7}$  seconds to avoid observable photoxidation at low light intensity.

† Wassink's observations on the fluorescence of diatoms are seen as an indication (compare *Ann. Rev. Plant Physiol.* 1951) that in these cells conditions are such that contact with a photosynthetically reducible substance prolongs the time lapse and thus raises the fluorescence yield.

curves—fluorescence versus light intensity—are measured under the same conditions as the corresponding rate curves. As the straight line measured in nitrogen indicates, the fluorescence yield remains constant far into the region of saturation intensities while in the air curve the first indications of a rise in the fluorescence yield are visible at the same light intensities which caused the first deviations of the saturation curve from linearity. If we want to explain this difference using Wassink and co-workers' hypothesis, we would have to conclude that in the nitrogen atmosphere containing little oxygen the photosynthetic apparatus would not begin to

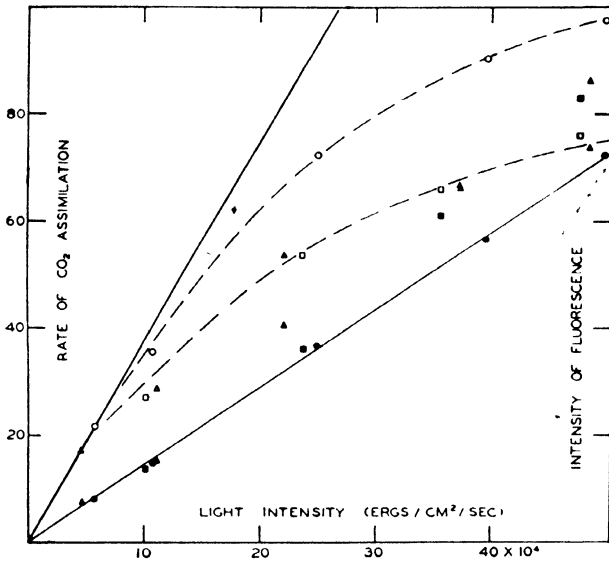

Fig. 1. CO<sub>2</sub> assimilation and intensity of fluorescence versus incident light intensity. A comparison of low and normal oxygen pressures for wheat at 0.03% CO<sub>2</sub>.

become empty at the transition to saturation in spite of the strong carbon dioxide limitation, while in the presence of air (20% oxygen) the denudation would start as soon as the rate curve began to bend over. Since Wassink and co-workers are in favour of the hypothesis that a reducing agent which reduces carbon dioxide in a dark reaction is made photochemically during photosynthesis, they would argue, as they did to explain another type of experiment, 'The fluorescence yield will not be changed so long as the mother substance from which the reducing agent is made photochemically is present in surplus. Saturation caused by lack of carbon dioxide depends upon the usage of the reducing agent which, in turn, may depend upon the carbon dioxide concentration while the production rate of

the reducing agent depends only upon the supply of its mother substance'. Even in the one particular case which I have chosen for our discussion out of many, this hypothesis does not suffice to explain the curve. If, in the atmosphere poor in oxygen, at light intensities higher than saturation, more reducing agents are made than the limited supply of carbon dioxide consumes, then, according to my understanding, reduced substances must accumulate until the supply of the mother substance becomes so small that the production rate of the reducing agent equals its consumption by carbon dioxide reduction. Thus, even if in the beginning a surplus of mother substance were present, it would soon be used up and the chlorophyll surface would again have a deficit of material to be reduced. This should result in an increase in the fluorescence yield of chlorophyll. The surplus of mother substance originally present would, as a consequence of Wassink's hypothesis, appear as 'stored reducing power' at the end of the irradiation period. Since the idea of a surplus of mother substance does not seem to be sufficient to explain the observations, one may add other hypotheses. For instance, the proposal has been advanced that the reducing agent has a limited lifetime because it may be used up for other reduction processes, but the 'stored reducing power' claimed by Calvin has, according to him, a lifetime of minutes. Gaffron, Fager & Rosenberg offer an explanation for Calvin's and their own observations which does not contain the idea of 'stored reducing power'. More about that will be found in Gaffron's contribution to this Symposium. In any case it is difficult to see how no rise whatever of the fluorescence can occur at saturation in nitrogen while in air the rise occurs exactly where the rate curve starts to bend over. I will not pursue this matter further and will only say that Wassink's theory needs a considerable number of extra hypotheses to explain these and other observations of the fluorescence behaviour under various conditions. Our own explanation is that the fluorescence yield remains constant in nitrogen because no narcotic-acting substance is made (no photo-oxidation occurs), while it will be made if sufficient oxygen is present. Our hypothesis permits a rough calculation of the concentration of carbon dioxide complexes present and the estimate gives values of the same order of magnitude as the chlorophyll concentration. We make use of the fact, discussed in the previous section, that oxygen *in vitro* as well as in plants (in the absence of carbon dioxide) is a good hydrogen acceptor, apparently as efficient, as far as experiment shows, as are the carbon dioxide complexes and intermediates of photosynthesis. We accept further the hypothesis that a narcotic-acting substance is formed by photo-oxidation and that thereby each act of oxidation influences the saturation rate. If the oxygen consumes about 1% of the

photochemically available hydrogen while the rest goes to the carbon dioxide complexes, the difference between the fluorescence curves measured in nitrogen and in air may just become observable due to the formation of the narcotic. We know that the concentration of oxygen in the chloroplasts in equilibrium with air, plus a small additional amount from photosynthetic oxygen evolution, is between  $10^{-3}$  and  $10^{-4}$  molar, i.e., about  $1/400$  of the chlorophyll concentration. To win in the competition for the photochemically produced hydrogen by a factor 100, the concentration of carbon dioxide complexes must be about 100 times greater than that of oxygen which makes it about  $1/4$  of the chlorophyll concentration. Other estimates, for instance, the one mentioned in the previous section, are a few times greater than this, but such agreement is all that we may expect from our crude estimate. I emphasize that all estimates—another will be mentioned in connexion with remarks on induction periods—indicate that the substance to be reduced photochemically must be present in a high concentration. Biochemists who are inclined to assume that one or another of the enzymes acting as hydrogen carriers in respiration will be the *primary* acceptors of the photochemically produced hydrogen are forced to the assumption that the enzyme is present in an exceedingly high concentration in the chloroplasts. Enzymes involved at a later stage in the process of photosynthesis may of course be present in much smaller concentration and still not impose limitations on the photosynthetic rate.

#### DISCUSSION ON INDUCTION PHENOMENA

During the induction period of photosynthesis, irregularities of the rates occur as well as of the fluorescence intensities. Fig. 2 shows the irregularities and their relations as they usually appear in leaves in air. Whenever the photosynthetic rate goes down the fluorescence rises and when the rate rises the fluorescence yield goes down. There are, however, more complicated cases where neither the systematic anti-parallelism between fluorescence and rate nor the simple shape of the curves is preserved.

Fig. 3 shows a case in which two maxima of the fluorescence-time curve and two minima of the rate curve can be seen. However, as McAlister (1940) has found, the second maximum of the fluorescence does not coincide with the second minimum of the rate curve. According to the hypothesis we have proposed in earlier publications, the induction phenomena are caused by a metabolic inactivation of the oxygen-liberating enzyme and its recovery in the light. While it was possible to explain even the more complicated curves on this basis there are indications that another effect has a considerable influence on the induction phenomena after

longer dark periods. McAlister found, and so did we, that during one minute of darkness the induction phenomenon develops quickly, then a break occurs in the tempo of further changes; i.e., the growth of the induction phenomena becomes quite slow. Aufdemgarten (1939) studied induction phenomena with an apparatus in which the heat conductivity

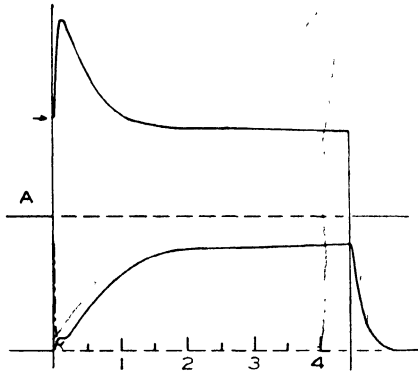

Fig. 2.

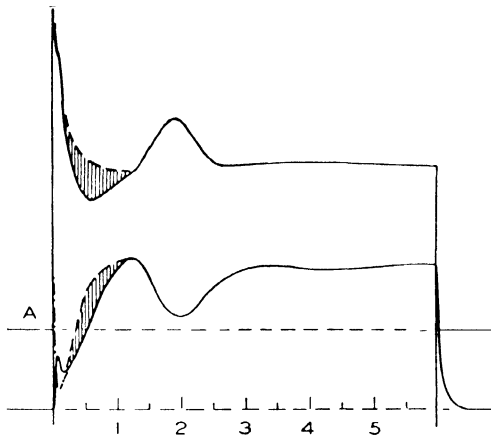

Fig. 3.

of the gas atmosphere was used to follow reasonably quickly the changes in rate of photosynthetic carbon-dioxide uptake. We, on the other hand, developed an apparatus to measure the time course of photosynthetic oxygen production in plants under anaerobic conditions (Franck *et al.* 1947). Recently van der Veen (1949), using an apparatus like Aufdemgarten's, repeated and extended the measurements of the time course of carbon-dioxide uptake and obtained interesting results.

Figs. 4 and 5 show how similar the rate curves can be for carbon-dioxide uptake and for oxygen production.\* Fig. 4 is taken from van der Veen's recent publication and Fig. 5 is an example of our oxygen curves. Van der Veen found that after a certain treatment of the plants (for instance, subjection to very low temperature), the small maximum of carbon-dioxide uptake right after the start of irradiation is all that remains of the carbon dioxide uptake, the usual rise to a higher constant rate (van der Veen's adaptation period) being suppressed. Thereby he has

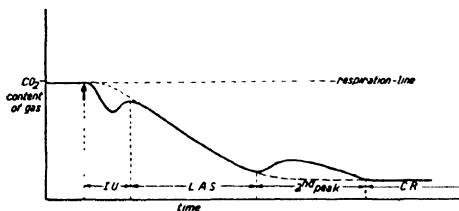

Fig. 4.

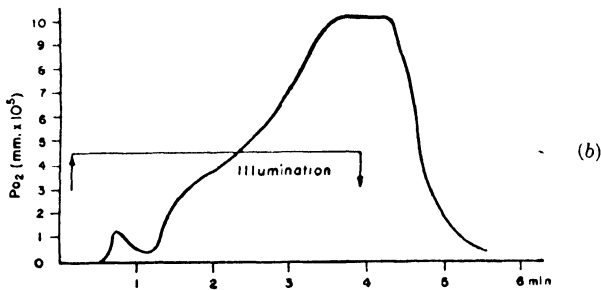

Fig. 5.

shown that the initial uptake has a different origin and behaves differently than the adaptation period. Without going into details, I may be permitted to state briefly on which points we agree with van der Veen's interpretations and where we differ. It is our opinion that the induction phenomenon which develops in one minute of darkness finds its satisfactory explanation in our hypothesis mentioned above. However, the phenomena which develop only during prolonged dark periods and in the presence of a high concentration of carbon dioxide must be regarded as an indication that, in addition to inactivation of the oxygen-liberating enzyme, another factor is

\* The similarity exists, however, only if the plants are badly aerated (compare *Ann. Rev. Plant Physiol.* 1951).

responsible for these more complicated phenomena. Van der Veen came to the conclusion that the adaptation period is an indication that something has to be made photochemically to reach the normal rate of photosynthesis and he said that a connexion must exist between this phenomenon and the new result of Calvin and co-workers. We agree entirely with this point of view and believe that it is justifiable to state specifically that the adaptation period is the time necessary to build up a concentration of Calvin's 'two-carbon compound' high enough to permit photosynthesis to proceed with its final rate. It, therefore, does not play a role, whether one prefers

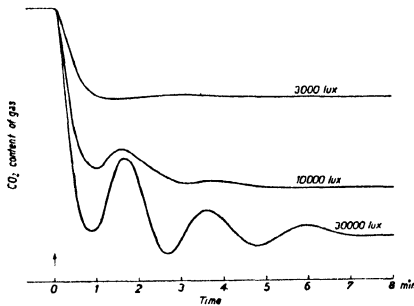

Fig. 6.

Calvin's production cycle of the carbon compound or, as I do, the one discussed by Gaffron, Fager and Rosenberg. I do not, however, agree with van der Veen's explanation of the initial uptake of carbon dioxide. The fact that the response of the initial uptake to external conditions is different from that of the adaptation period does not necessarily indicate that different photochemical steps are responsible for the carbon dioxide uptake in the two different parts of the induction period. According to our interpretation, it rather indicates that the concentration of the substances to be photosynthetically reduced varies in a complicated way with the duration of irradiation. We assume that after a long dark period the precursor of the unknown two-carbon compound will be present in a certain concentration. By illumination this substance is transferred into the two-carbon carbon dioxide acceptor which by carboxylation becomes phosphoglyceric acid which, in turn, is reduced to triose. Since the new formation of the precursor is a complicated process consisting in, or at least including, temperature-sensitive dark reactions of freshly formed photosynthetic products, its consumption at the beginning of the irradiation may be quicker than its replacement because of the lack of freshly formed photosynthetic products. Thus the precursor concentration and thereby the carbon dioxide uptake may sink temporarily below the starting value,

by accumulation of photosynthetic products, before the rise of the adaptation period sets in. The very low final rate at 0° C. is explained by the slowness of new formation of the two-carbon compound. Thus, practically only the initial uptake of carbon dioxide, which is independent of the new formation, is visible at low temperatures.\*

We may further mention that the duration of the adaptation time permits an estimate of the concentration of photosynthetic intermediates needed to satisfy the rate and to avoid denudation of the photosynthetic apparatus which would cause a rise in fluorescence. The result is, as our estimate described before, that the concentration must be comparable to that of chlorophyll.

In his last publication, van der Veen describes experiments that show that at very high light intensities a sequence of several maxima and minima may occur in the carbon dioxide uptake during and at the end of the adaptation period. McAlister found earlier, although not so clearly, that under similar conditions corresponding maxima and minima of the fluorescence occur. During strong irradiation such phenomena are quite possible before the final balance between formation and consumption of the carbon dioxide acceptor is reached. If, for instance, at a certain moment more carbon compound is consumed for the formation of phosphoglyceric acid than is produced, the rate must fall and the photosynthetic apparatus will become somewhat denuded. Thereby the narcotic inhibitor is made and, consequently, the rate is reduced further. In the meantime carbon formation may rise because of the increase in freshly formed precursor; thus the rate rises again and a similar cycle of events may be repeated with declining amplitude.

Of importance for the whole interpretation of the induction period is a new observation of Clendenning (1950) that no induction phenomena occur in the time course of photoreduction of Hill reagents by algae or chloroplasts. This agrees with the observation of Shiao & Franck (1947) who found that no anomalies of the fluorescence occur with quinone as the substance to be reduced. This absence of an induction period is understandable because neither is there a reason to expect in presence of Hill reagents an inactivation of the oxygen-liberating enzyme by the dark metabolic products, nor is the formation of an acceptor molecule necessary.

\* An explanation of van der Veen's other interesting observations of the initial uptake can be found in *Ann. Rev. Plant Physiol.* (1951).

## REFERENCES

- AUFDEMGARTEN, N. (1939). *Planta*, **29**, 643.  
AUFDEMGARTEN, N. (1939). *Planta*, **31**, 643.  
BENSON, A. A., CALVIN, M. *et al.* (1949). Chap. 19 of *Photosynthesis in Plants*.  
Ames, Iowa: Iowa State College Press.  
BENSON, A. A., CALVIN, M., BANHAM, J. A. *et al.* (1950). *J. Amer. Chem. Soc.* **72**,  
1710.  
CLENENNING, K. A. (1950) (in the Press).  
EMERSON, R. & ARNOLD, W. (1932). *J. Gen. Physiol.* **15**, 391.  
EMERSON, R. & ARNOLD, W. (1933). *J. Gen. Physiol.* **16**, 19.  
FAGER, E. W., ROSENBERG, J. L. & GAFFRON, H. (1950) (in the Press).  
FÖRSTER, T. (1948). *Ann. Phys.* **2**, 1948.  
FRANCK, J. & HERZFELD, K. F. (1941). *J. Phys. Chem.* **45**, 978.  
FRANCK, J. & FRENCH, C. S. (1941). *J. Gen. Physiol.* **25**, 309.  
FRANCK, J. & LIVINGSTON, R. (1941). *J. Chem. Phys.* **9**, 184.  
FRANCK, J. & TELLER, E. J. (1938). *J. Chem. Phys.* **6**, 861.  
FRANCK, J., PRINGSHEIM, P. & TERWOOD, L. (1945). *Arch. Biochem.* **7**, 103  
GAFFRON, H. & WOHL, K. (1936). *Naturwissenschaften*, **24**, 81, 103.  
LIVINGSTON, R. *et al.* (1947). *J. Phys. Chem.* **51**, 777.  
LIVINGSTON, R. *et al.* (1948). *J. Phys. Chem.* **52**, 662.  
LIVINGSTON, R. *et al.* (1948). *J. Amer. Chem. Soc.* **70**, 1510.  
LIVINGSTON, R. *et al.* (1949). *J. Amer. Chem. Soc.* **71**, 1542.  
LIVINGSTON, R. *et al.* (1950). *J. Amer. Chem. Soc.* **72**, 909.  
MCALISTER, E. D. & MYERS, J. (1940). *Smithsonian Misc. Coll.* **99**, no. 6.  
NOACK, K. (1926). *Naturwissenschaften*, **14**, 385.  
RIEKE, F. & GAFFRON, H. (1943). *J. Phys. Chem.* **47**, 299.  
RUBEN, S., KAMEN, M. O. & PERRY, L. (1940). *J. Amer. Chem. Soc.* **62**, 3450.  
TAMIYA, H. (1949). *Tokugawa Institute for Biological Research*, **6**, no. 2.  
TAMIYA, H. & HUZISIGE, H. (1949). *Acta Physicochimica*, **15**, no. 1.  
VAN DER VEEN, R. (1949). *Physiologia Plantarum*, **2**, 217.  
VAN DER VEEN, R. (1949). *Physiologia Plantarum*, **2**, 287.  
WEISS, J. (1938). *Nature, Lond.*, **141**, 248  
WELLER, J. & FRANCK, J. (1941). *J. Phys. Chem.* **45**, 978.  
WOHL, K. (1940). *New Phytol.* **39**, 33.  
WOHL, K. (1941). *New Phytol.* **40**, 34.

# THE MAXIMUM EFFICIENCY OF PHOTOSYNTHESIS

## A CRITIQUE OF CERTAIN MANOMETRIC METHODS USED FOR MEASURING RATES OF PHOTOSYNTHESIS

BY M. S. NISHIMURA, C. P. WHITTINGHAM  
AND ROBERT EMERSON

Department of Botany, University of Illinois, Urbana, Illinois

### CONTENTS

	PAGE
I. Origin of controversy as to maximum attainable efficiency . . . . .	176
(a) Significance of efficiency . . . . .	176
(b) Reasons for emphasis upon manometric techniques . . . . .	178
(c) Principles of manometric techniques used . . . . .	179
(d) Comparison of application of techniques by Warburg and co-workers, and by Emerson and Lewis . . . . .	179
II. Potential sources of error in two-vessel technique, as applied by Warburg and Burk . . . . .	183
(a) Principles and equations of the two-vessel technique . . . . .	183
(b) Choice of vessel shapes . . . . .	187
(c) Light source . . . . .	189
(d) Time intervals, and physical lag . . . . .	193
III. Experimental tests of Warburg and Burk's application of the two-vessel method . . . . .	198
(a) Two-vessel experiment, acid culture medium . . . . .	198
(b) Carbonate buffer experiment . . . . .	199
(c) Longer period measurements by two-vessel technique . . . . .	204
IV. Discussion . . . . .	206
V. Summary and Conclusions . . . . .	209

### I. ORIGIN OF CONTROVERSY AS TO MAXIMUM ATTAINABLE EFFICIENCY

(a) *Significance of efficiency.* The efficiency of photosynthesis may be expressed as the number of light quanta absorbed by the plant (green leaf, algal cell, etc.) per molecule of oxygen produced in the synthesis of carbohydrate from carbon dioxide and water. The symbol for the efficiency in these terms is  $\phi^{-1}$ , the reciprocal of the symbol used in photochemistry to designate the number of molecules undergoing photochemical change per quantum of radiation absorbed.

The efficiency of photosynthesis is of special interest because the energy of a single quantum of red light (*c.* 40 kcal./einstein) is far smaller than the increase in free energy involved in this endergonic reaction (*c.* 120 kcal./mol. of carbon dioxide). The mechanism by which the green plant accumulates the necessary energy from photons supplying much smaller units is still a matter of speculation. The minimum number of quanta,

with which the plant can bring about this change, may be regarded as setting a limit on the number of primary photo-processes involved in the reaction chain.

It is conceivable that under some circumstances, the cell may evolve oxygen which does not represent the complete synthesis of carbohydrate from carbon dioxide and water. Such oxygen evolution would not represent as great an increase in free energy as the complete process. Under these circumstances there may be no need for the accumulation of energy from more than a single photon per molecule of oxygen evolved, and the observed quantum requirement for oxygen production becomes irrelevant to the problem of energy accumulation. Therefore measurements of oxygen production, which represent something less than the synthesis of carbohydrate from carbon dioxide and water, have no direct bearing on the problem discussed here.

Values of  $\phi^{-1}$  for photosynthesis have been determined by many investigators. Diverse techniques have been applied to a wide variety of plant material, so it is hardly surprising that the reported values cover a considerable range. It is therefore noteworthy that in nearly all cases the minimum value of  $\phi^{-1}$  (indicating maximum efficiency in utilization of light) is not smaller than about 8 or 10. This suggests that 8 or 10 may be close to the minimum number of quanta with which the green plant is capable of converting one molecule of carbon dioxide to carbohydrate, with the evolution of oxygen.

On the other hand, a few sets of measurements have led to much smaller values for  $\phi^{-1}$ , in the neighbourhood of 3 or 4 instead of 8 or 10. Even if these high efficiencies are obtainable only under restricted conditions, they may nevertheless be of great theoretical significance, provided the measured oxygen production really represents the quantum requirement for carbohydrate synthesis from carbon dioxide and water. Correct formulation of the mechanism of the photochemical primary process need provide only for the maximum possible efficiency. There are many conceivable reasons why, with certain organisms, or under certain experimental conditions, it might be impossible to attain or demonstrate the maximum efficiency of photosynthesis. The reliability of unusually low values for  $\phi^{-1}$  should therefore not be doubted simply because the great majority of measurements lead to higher values.

Apart from experimental evidence, it seems theoretically improbable that three or four quanta of red light could provide sufficient energy for the conversion of carbon dioxide and water to carbohydrate with the evolution of free oxygen. A discussion of the theoretical difficulties will be found in Gaffron & Wohl (1936) and Wohl (1937). Franck (1949) has therefore

suggested that when very low values for  $\phi^{-1}$  are observed, partially oxidized intermediates of respiration may be reduced, leading to oxygen evolution with smaller theoretical energy requirement than when carbon dioxide and water are the starting materials. There is some evidence in favour of this suggestion, but in our opinion a different question requires prior answer. One should ask first whether the observations, upon which the very high efficiencies are based, really represent the rates of photosynthesis claimed.

This statement of the problem implies that we are not raising the question of whether the measurements of absorbed light energy are correct. The quantum efficiencies to be especially scrutinized in this communication are based upon measurements of light energy made with the ethyl chlorophyllide actinometer (Warburg & Schocken, 1948). We are not in agreement with Warburg & Burk as to the energy values indicated by measurements made according to their specifications, but the errors involved are small compared with the discrepancies in photosynthetic efficiency reported by Warburg and co-workers, and by Emerson and co-workers. We have therefore followed their specifications for the actinometric measurement of light energy, in order to avoid confusion, and to enable us to focus attention on the principal source of the discrepancy, the measurement of oxygen liberation and carbon dioxide consumption. If the absorbed energy is established, the value of  $\phi^{-1}$  will depend only on the rate of photosynthesis.

(b) *Reasons for emphasis on manometric techniques.* It is inevitable that some readers will be struck by the narrow limitation of our discussion to the results obtained by certain specialized manometric techniques for measuring photosynthesis, more especially because we shall show that small deviations from correct application of these techniques can lead to large errors. Many other methods are available for measuring photosynthesis, some of which have been applied to the study of photosynthetic efficiency. Pressure measurements are ambiguous because they do not tell us unequivocally what part of a given pressure change is due to oxygen, and what part to carbon dioxide. If the manometric measurements of photosynthesis have led to controversy regarding maximum efficiency, why should we concern ourselves with these techniques, to the exclusion of more direct methods? The reason is that all other techniques thus far applied to the problem have failed to show efficiencies comparable with the highest values claimed on the basis of manometric photosynthesis measurements. If the highest efficiencies have only been obtained by manometric measurements of photosynthesis, it is possible that manometry affords some special advantages, which enable the plant to demonstrate higher photosynthetic efficiency than can be found by other methods. The advantages

of manometry are well known and need not be discussed here. One must either demonstrate the presence of some error in the manometric measurements, sufficient to account for the difference between the results obtained by manometry and by other methods, or else recognize the manometric determinations as significant.

(c) *Principles of manometric techniques used.* If a single gas is exchanged in a system connected to a manometer, the volume of the exchanged gas can be calculated from the known constants of the system and the pressure change  $H$  observed on the manometer. Warburg (1919) has described a manometric technique in which two gases, oxygen and carbon dioxide, are freely exchanged in cell metabolism, but pressure changes are due to oxygen exchange alone, because the carbon dioxide pressure is buffered by a mixture of carbonate and bicarbonate. Oxygen exchange can be calculated directly from observed pressure change, just as if only a single gas were being exchanged. The buffer most commonly used is a mixture of 85 parts M/10-bicarbonate and 15 parts M/10-carbonate. The term 'carbonate buffer' is used in this paper to designate this particular mixture. Its pH is about 9.

If both oxygen and carbon dioxide are exchanged without buffering of either gas, the observed pressure change for a single system will not permit the calculation of gas exchange, unless the ratio of exchange of the two gases is known. The ratio,  $\text{CO}_2/\text{O}_2$ , is designated by  $\gamma$ . If  $\gamma$  is not known, the gas exchange may be calculated from two pressure measurements,  $H$  and  $h$ , both representing the same gas exchange, but taking place in systems in which the ratios of gas volume to fluid volume are different. The principles of both the single-system and the two-system technique have been fully explained by Warburg (1926, pp. 102-7), who has also derived the proper equations for calculating gas exchange from pressure changes. We shall use the term 'two-vessel method' in referring to the technique in which two pressures,  $H$  and  $h$ , are obtained for the same gas exchange taking place in different systems.

For the two-vessel method, an acid medium (pH 5) is ordinarily used, to avoid special corrections for retention of part of the exchanged carbon dioxide in the form of carbonates and bicarbonates. For the same reason, single-vessel experiments in which the exchange of two gases is to be calculated from known or assumed values of  $\gamma$  are also usually made at about pH 5.

All three of these techniques, the single-vessel and two-vessel methods with acid medium, and the single-vessel method with carbonate buffer, have been applied to measurements of photosynthetic efficiency, and the results will be discussed below.

(d) *Comparison of techniques used by Warburg and co-workers, and by Emerson and Lewis.* Exceptionally low values for  $\phi^{-1}$  have been published

by Warburg & Negelein (1922, 1923), by Warburg (1947), by Burk, Hendricks, Korzenovsky, Schocken & Warburg (1949) and by Warburg, Burk, Schocken & Hendricks (1950). To avoid the problems of integrating scattered light transmitted by leaves or thin suspensions of algal cells, Warburg has used dense (totally absorbing) suspensions. The cells (*Chlorella pyrenoidosa*) have been suspended in their culture medium, the pH of which was about 5. Rates of photosynthesis have been measured manometrically. Warburg's measurements of  $\phi^{-1}$ , up to and including his work published in 1947, were based on single-vessel measurements in acid culture medium, which reflect the exchange of both oxygen and carbon dioxide. As explained in § (c) above, the rate of photosynthesis can be calculated from single-vessel manometer readings only if  $\gamma$ , the ratio of exchange of carbon dioxide and oxygen, is known or assumed. Warburg assumed a value of approximately  $-1$ , on the basis of other measurements made under conditions very different from those prevailing during the efficiency measurements.

Emerson & Lewis (1939, 1941) questioned the reliability of photosynthesis measurements in acid medium based on single-vessel experiments, because they observed that under the conditions of Warburg & Negelein's experiments, *C. pyrenoidosa* showed large deviations of  $\gamma$  from the assumed value of  $-1$ . Emerson & Lewis used the two-vessel method to investigate changes in  $\gamma$  during short periods of light and darkness. Their measurements showed that when previously darkened *Chlorella* cells were illuminated (or when the light intensity was increased), there was a brief burst of carbon dioxide production, in addition to the change in gas exchange due to photosynthesis. When the cells were again darkened (or when the intensity was decreased), there was a temporary deficit in carbon dioxide production, as compared to the oxygen consumed. By the time the normal  $\gamma$  value of approximately  $-1$  was restored, the total deficit in carbon dioxide production was about equal to the amount of carbon dioxide produced in response to change in illumination. It was as if the cells contained a reservoir for carbon dioxide, which filled slowly in the dark, and emptied suddenly in the light.

Extra carbon dioxide exchange, distributed in this way during light and dark periods, introduces two sources of error in the calculation of photosynthesis from single-vessel pressure measurements in acid culture medium. It alters the value of  $\gamma$ , and changes the pressure differences from which photosynthesis is calculated. The effect on  $\gamma$  is to make it less negative. The value of  $\gamma$  enters into the calculation of the single-vessel constant as follows:

$$K_{O_2} = \frac{k_{O_2} k_{CO_2}}{k_{CO_2} + \gamma k_{O_2}}.$$

Less negative values of  $\gamma$  decrease the value of the constant  $K_{O_2}$ , so that if the true value of  $\gamma$  is less negative than the value actually used, the value of  $K_{O_2}$  will be too large. The rate of oxygen production from photosynthesis is obtained by multiplying  $K_{O_2}$  by the pressure change due to *light action*. The *light action* pressure change is the difference between the observed *light* and *dark* pressure changes. The effect of the extra carbon dioxide exchange is to make the *dark* pressure change more negative, and the *light* pressure change more positive, so that the *light action* pressure change is increased. The influence of the extra carbon dioxide exchange on both  $\gamma$  and the pressure changes is to make the calculated oxygen production appear larger than the correct value.

Emerson & Lewis therefore rejected the single-vessel method with acid culture medium as a technique of measuring photosynthesis for the purpose of establishing the quantum requirement. They might have substituted the two-vessel technique, which they had used for demonstrating the presence and nature of the extra carbon dioxide exchange. Their fig. 3 (1941) includes data from which the quantum requirement can be calculated. But they saw in their application of the two-vessel technique certain disadvantages for the purposes of precise determination of the quantum requirement, and to them there seemed to be no reason why the single-vessel carbonate buffer technique could not be satisfactorily applied.

Their reservations about the two-vessel method were connected with their desire to establish the quantum requirement on the basis of photosynthesis rates determined over short periods of light and darkness. The use of longer periods involves greater risk that the observed rate of pressure change in darkness may represent a rate of respiration appreciably different from the rate prevailing during the light exposure. This would make the difference between light and dark pressure changes a less precise measure of the pressure change due to light action. They therefore wished to use light and dark periods of the order of 10 min. Although in principle the two-vessel method should eliminate the errors which are inherent in the single-vessel method when there is extra carbon dioxide exchange, Emerson & Lewis emphasized that the two-vessel technique had previously been applied only to the measurement of steady rates of gas exchange. Its application to the rapidly changing rates of pressure change brought about by extra carbon dioxide exchange during the first few minutes of light and dark periods seemed to them fraught with risk of error. Their equipment did not permit them to make the pressure measurements simultaneously. The measurements had to be made first in one vessel, and later in the other member of the pair. This was satisfactory for qualitative demonstration of the gross phenomenon of the carbon dioxide burst, but it appeared unsuitable for the quantitative determination of photosynthetic efficiency,

because one could not be sure that the sequence of pressure changes in the two vessels followed the sequence of changes in gas exchange exactly alike. As we shall show below, small differences in the response of the two vessels to changing rates lead to large errors in calculated results.

On the other hand, Emerson & Lewis regarded their two-vessel measurements during steady-rate pressure change, after the extra carbon dioxide exchange had run its course in light or dark, as quantitatively reliable. They noted that rates of photosynthesis calculated from the final 10 min. of 40 min. periods of light and dark (cf. their fig. 3) were nearly the same, whether based on two-vessel measurements in acid culture medium, or on single-vessel measurements in alkaline carbonate buffer. It is interesting to note that single-vessel measurements in acid culture medium, calculated on assumed  $\gamma$  values, also gave the same results, as was to be expected, because the value of  $\gamma$  for light action had become approximately  $-1$ .

Since the measurements of oxygen exchange for long periods of light and darkness showed essential agreement between acid culture medium and alkaline carbonate buffer, it seemed not unreasonable to assume that for short light and dark periods as well, the efficiency of photosynthesis would not be adversely affected by the high pH of the carbonate buffer. The near-equality of oxygen exchange in the initial and later portions of the light and dark periods shown in Emerson & Lewis's fig. 3 (1941) was regarded by them as evidence in support of their opinion that even for short periods of light and dark, the efficiency in acid culture medium was not appreciably better than in carbonate buffer, and that the carbonate buffer could therefore be used for measuring minimum values of  $\phi^{-1}$  in experiments with short light and dark periods, in order to avoid the uncertainties inherent in the two-vessel method during periods of changing rates of gas exchange.

Warburg (1947), on the other hand, attributed the low efficiencies reported by Emerson & Lewis to the 'unphysiological' alkalinity of the carbonate buffer. He made two-vessel measurements of  $\gamma$  which were considerably less elaborate than those described by Emerson & Lewis, and found no evidence of extra carbon dioxide exchange. He then repeated his earlier single-vessel experiments (with slight modifications), again calculated the results on the assumption that  $\gamma$  was equal to about  $-1$ , and again found values of about 4 for  $\phi^{-1}$ .

Nishimura & Emerson (1948) objected that Warburg's (1947)  $\gamma$  measurements were inconclusive at best, and that the  $\phi^{-1}$  measurements were made under quite different conditions. This is important, because the amount of extra carbon dioxide exchange may be negligible under some conditions and large under others.

Warburg (1947) proposed the application of his two-vessel technique to the simultaneous measurement of both  $\gamma$  and  $\phi^{-1}$ , but his first experiments of this kind (referred to by Warburg & Burk, 1950) were made later, in our laboratory. There was disagreement as to the interpretation of these results, for reasons discussed below, under II (b), 'Choice of vessel shapes'. The papers of Warburg *et al.* (1950) and of Burk *et al.* (1949) constitute an extension of the preliminary trials of the technique, made in our laboratory. These communications show measurements of photosynthetic efficiency, based almost entirely upon short periods of light and darkness. Efficiencies even higher than those reported by Warburg & Negelein were found. Values for  $\phi^{-1}$  range from about 4 down to 3 or less. A few experiments in carbonate mixture indicate  $\phi^{-1}$  of about 10, in agreement with Emerson & Lewis.

Warburg & Burk again conclude that the lower efficiencies reported by Emerson & Lewis were due to the 'unphysiological' carbonate buffer. Emerson & Lewis found no better yields in their two-vessel experiments in acid culture medium, but this is not conclusive evidence that better yields could not have been obtained in acid culture medium with shorter time intervals. Emerson & Lewis published only longer-period experiments by two-vessel method (40 min. light, 40 min. dark). It could also be argued that Emerson & Lewis failed to grow their cultures in such a way that the cells were capable of maximum photosynthetic efficiency. Warburg & Burk (1950) say they obtained maximum efficiencies in experiments with illumination up to 60 min., but as we shall explain in part IV their evidence for the longer periods is not convincing, although these should be free from the errors inherent in the experiments with short light and dark periods to be discussed below.

Emerson & Lewis's objections to the single-vessel experiments of Warburg & Negelein, and Nishimura & Emerson's objections to Warburg's (1947) experiments, do not apply to the two-vessel experiments of Warburg *et al.* and Burk *et al.* It is therefore necessary to inquire into the significance of these experiments, upon which Warburg & Burk base their very high efficiencies.

## II. POTENTIAL SOURCES OF ERROR IN THE TWO-VESSEL TECHNIQUE AS APPLIED BY WARBURG & BURK

(a) *Principles and equations of the two-vessel technique.* A fundamental requirement of the two-vessel technique is that corresponding pressure changes,  $H$  and  $h$  (in Warburg & Burk's notation  $H^1$  and  $H$ ), always represent exactly the same gas exchange. Throughout the period of an experiment, each change in gas exchange brought about by a change from

light to dark or dark to light in one vessel must be equal to the gas exchange for the corresponding period in the other vessel. As explained above, Emerson & Lewis doubted that with their experimental arrangement (which

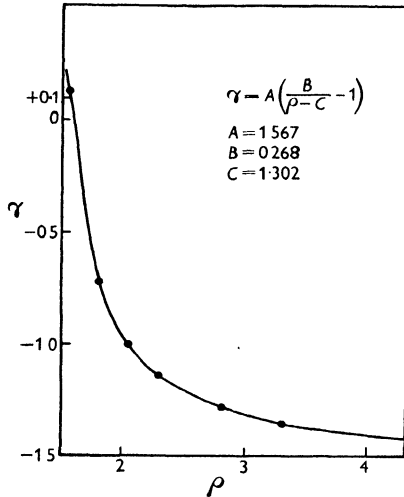

Fig. 1.  $\gamma$  as a function of  $\rho$ , for the vessel pair used by Warburg & Burk. The volumes of their vessels were, for determination of  $H$ , 13.913 ml.; for determination of  $h$ , 17.993 ml.

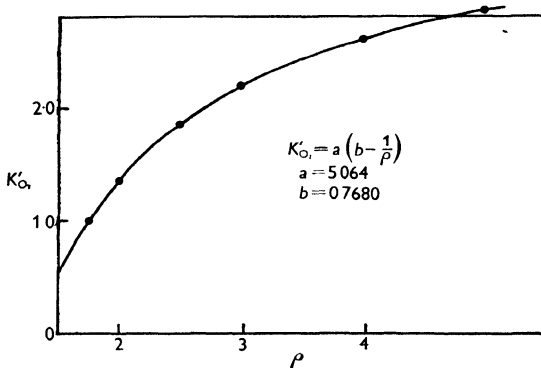

Fig. 2.  $K'_{O_2}$  as a function of  $\rho$ , for the vessel pair used by Warburg & Burk. The oxygen exchange represented by a pair of pressure readings  $H$  and  $h$ , is obtained by multiplying  $H$  by  $K'_{O_2}$ .

required first a series of readings covering a succession of light and dark periods with one vessel, followed by a corresponding series covering a subsequent but equal succession of light and dark periods), they could approach this ideal sufficiently closely in practice. This reservation applied

only to the short periods of light and darkness, when rates of gas exchange were changing rapidly, and not to the long-period steady-rate measurements. The primary question, with regard to Warburg & Burke's experiments, is the extent to which they were able to approach the ideal of equality of gas exchange in the two vessels. As we shall explain in II (d), the inequalities arising from physical lag in response of the manometers were of special importance. It will be helpful to consider first the sensitivity of the two-vessel technique to errors in the pressure readings  $H$  and  $h$ .

To anyone who has not had experience with the two-vessel method, it may be a surprise to find how sensitive is this technique to small errors. Equations (1) and (2), and Figs. 1 and 2, show the reasons for this sensitivity. The equations apply in general to the two-vessel method, and the figures are for the particular pair of vessel volumes used by Warburg & Burk.

If we designate the pressure changes and vessel constants for the larger vessel by small letters, and the corresponding values for the small vessel by capital letters, the solution for  $\gamma$  in terms of  $H$  and  $h$  may be obtained as follows:

$$H \frac{K_{O_2} K_{CO_2}}{K_{CO_2} + \gamma K_{O_2}} = h \frac{k_{O_2} k_{CO_2}}{k_{CO_2} + \gamma k_{O_2}},$$

(cf. Warburg, 1926, p. 104). Let  $H/h = \rho$  and solve for  $\gamma$ :

$$\gamma = \frac{k_{CO_2}}{k_{O_2}} \left[ \frac{\frac{k_{O_2}}{K_{O_2}} - \frac{k_{CO_2}}{K_{CO_2}} - 1}{\rho - k_{CO_2}} \right] = A \left( \frac{B}{\rho - C} - 1 \right). \tag{1}$$

For the vessel pair used in most of Warburg & Burk's experiments,  $A = 1.567$ ,  $B = 0.2689$ , and  $C = 1.302$ . We can now plot  $\gamma$  as a function of  $\rho$ , the ratio of corresponding pressure changes in the small and large vessels. Fig. 3 shows that when  $\rho$  becomes more than 2, the value of  $\gamma$  becomes extremely insensitive to changes in  $\rho$ . On the other hand, as  $\rho$  becomes less than 2,  $\gamma$  goes from  $-1$  to zero, and rises steeply to  $+\infty$ .

The corresponding curve showing the sensitivity of calculated oxygen exchange to  $\rho$  may be obtained as follows:

$$\chi_{O_2} = H \frac{K_{CO_2} K_{O_2} k_{O_2}}{K_{CO_2} k_{O_2} - K_{O_2} k_{CO_2}} - h \frac{K_{O_2} k_{O_2} k_{CO_2}}{K_{CO_2} k_{O_2} - K_{O_2} k_{CO_2}}.$$

Let  $H/h = \rho$ ,

$$\chi_{O_2} = H \left[ \frac{K_{O_2} k_{O_2} k_{CO_2}}{K_{CO_2} k_{O_2} - K_{O_2} k_{CO_2}} \left( \frac{k_{CO_2}}{K_{CO_2}} - \frac{1}{\rho} \right) \right].$$

Let the value in square brackets =  $K'_{O_2}$ ,

$$K'_{O_2} = a \left( b - \frac{1}{\rho} \right). \tag{2}$$

Equation (2) shows the dependence of  $K'_{O_2}$ , the constant by which  $H$  is to be multiplied to calculate oxygen exchange from pressure change, upon  $\rho$ . Fig. 4 shows  $K'_{O_2}$  plotted as a function of  $\rho$ , for the vessel pair used by Warburg & Burk. This curve shows that as  $\rho$  becomes greater than 2,  $K'_{O_2}$  remains very sensitive to changes in  $\rho$ . A change from 2 to 3 more than doubles  $K'_{O_2}$ , although the same change represents a change in  $\gamma$  only from about  $-1.0$  to  $-1.3$ .

The gas exchange may also be calculated from  $h$ , according to equation (3):

$$x_{O_2} = h \left[ \frac{K_{CO_2} K_{CO_2} k_{CO_2}}{K_{CO_2} k_{O_2} - K_{O_2} k_{CO_2}} \left( \rho - \frac{k_{CO_2}}{K_{CO_2}} \right) \right]. \quad (3)$$

If we designate the expression in square brackets as  $k'_{O_2}$ , then we may write

$$k'_{O_2} = e(\rho - f).$$

$k'_{O_2}$  is a linear function of  $\rho$ . For the vessel pair used by Warburg & Burk,  $e = 3.889$  and  $f = 1.302$ .

For small values of  $\rho$ , the hyperbolas shown in Figs. 1 and 2 each have another branch, not continuous with the curves shown in these figures. Values of  $\rho$  ordinarily encountered in *light action* measurements do not require the use of these branches.

We may now use the curves in Figs. 1 and 2 to test the sensitivity of Warburg & Burk's photosynthesis measurements to small systematic errors. Table 1 shows the data from their Example 1 (*Science*, 2 September 1949, p. 228). From these data they calculate  $\gamma = -1.04$ , and  $\phi^{-1} = 4.2$ . The data show that the values of  $H$  and  $h$  from which these results were calculated were obtained from four 10 min. dark periods and four 10 min. light periods. Systematic errors might arise in the measurement of either  $H$  or  $h$ , or of both. The calculated oxygen exchange is more sensitive to  $h$  than to  $H$ , so we will suppose there was no systematic error in the pressure changes from which  $H$  was calculated, but that there was systematic error in the pressure measurements from which  $h$  was calculated. By systematic errors we mean errors due either to consistent inequalities in the gas exchange taking place in the two vessels, or to consistent failure of one or both manometers to register the full gas exchange brought about by the cells during the time intervals between readings. Since Warburg & Burk's data for this experiment show no readings of fractions of a millimetre, we may assume that they read their manometers to the nearest millimetre. Let us see what would be the effect of changing the individual readings upon which  $h$  is based, by increments of 0.3 mm., an amount smaller than the uncertainty of their readings. Table 1 shows that the value of  $h$  is derived from  $-44$  for four 10 min. dark periods, an average of  $-11$  per period; and  $-28$  for four 10 min. light periods, an average of  $-7$  per period. The lower part of Table 1 shows how  $\gamma$  and  $\phi^{-1}$  would be affected

if these average values had been different, by increments of 0.3. The figures show that a systematic error, smaller than the uncertainty of each individual reading, can change the value of  $h$  enough to alter the calculated quantum requirement by more than a factor of 2. The tabulated pairs of light and dark pressure changes by increments of 0.3 lead to increasing values for  $h$  light action, and these in turn lead to decreasing values of  $K'_{O_2}$ . Underestimation of  $h$  leads to overestimation of photosynthesis. Evidence to be presented in part III (b) shows that Warburg & Burk's application of the two-vessel technique involved systematic errors which would lead to underestimation of  $h$ .

Table 1. Sensitivity of Warburg-Burk vessel pair to systematic errors. Data taken from example 1, Science, 2 September, 1949, p. 228

	Pressure changes in mm.	
	Small vessel	Large vessel
4 × 10 min. dark	-95	-44
4 × 10 min. light	-61	-28
40 min. light action	$H = +34$	$h = +16$

Let  $H$  remain unchanged, but let the changes from which  $h$  is calculated vary by increments of 0.3 mm. per 10 min. period. The second row of the table below (10 min. dark = -11, 10 min. light = -7) represents the original data of Warburg & Burk, reduced to single 10 min. periods.

Assumed pressure changes, in mm.						
10 min. dark	10 min. light	$h$ , 10 min. light action	$\rho$	$\gamma$	$K'_{O_2}$	$\phi^{-1}$
-10.7	-7.3	+3.4	2.50	-1.21	1.85	3.3
11.0	7.0	4.0	2.12	1.05	1.48	4.4
11.3	6.7	4.6	1.85	0.82	1.13	5.6
11.6	6.4	5.2	1.63	0.20	0.76	8.4

Now that we have seen the sensitivity of the two-vessel method to what would ordinarily be considered minor errors in the determination of  $H$  and  $h$ , we may attempt to assess the relative importance of the potential sources of error in Warburg & Burk's application of this technique.

(b) *Choice of vessel shapes.* Vessel shapes influence both light absorption and the mixing of liquid content. The choice of certain vessel shapes to obtain the necessary differences in constants for the two-vessel calculations will lead to inequality in the gas exchange represented by the two pressure measurements. Warburg's original two-vessel arrangement (vessels  $A$  and  $B$  in Fig. 3) is particularly open to this criticism if it is applied to photochemical experiments, because different liquid volumes are used in vessels of approximately equal size. Because of the difference in suspension depth,

this arrangement leads to inequality of light absorption when the vessels are shaken, and also inequality in rate of gas equilibration between liquid and gas phases. Emerson & Lewis (1941) recognized that vessel pairs of this type would be unsuitable for photochemical work, especially if quick response to changes in rate were important. They used instead a pair of vessels (see their fig. 1, 1941, p. 790) in which equal volumes of suspension were shaken in two identically shaped spaces with different adjoining gas volumes. The circulation of the suspension was as similar as possible in the two members of the pair, and equality of light absorption was maintained. Warburg & Burk at first thought this improvement was not important. Their first experiments were made in our laboratory with a vessel pair like *A* and *B* in Fig. 3.

At that time it was agreed that there was unequal absorption of light in the two vessels, and that there might be other inequalities associated with the different fluid volumes and cell concentrations, which could result in failure to maintain both equality of gas exchange and correct manometric registration of the exchanged gas. Warburg & Burk later modified the technique by substituting a vessel of shape *C*, instead of *B*, for the determination of *h*. Vessel *C* is like vessel *A* in all dimensions except depth. Its depth is greater, so that when equal volumes of suspension are put into vessels *A* and *C*, the remaining gas volume is larger in *C*. This might be an improvement over the *A-B* combination, but the circulation of the liquid brought about by shaking will still be unequal in the two vessels because the greater depth of the *C* vessel permits the cell suspension to rise higher as it is thrown from end to end. When the two vessels *A* and *C* are shaken over a light source, it can be clearly seen that the *C* vessel transmits more light than the *A* vessel. Quantitatively, this difference may be unimportant, but it is convincing evidence of difference in liquid circulation. The unusually dense cell suspensions recommended by Warburg & Burk (300 cmm. cells in 7 ml.) are probably intended to give total, and therefore equal, absorption of light in the two vessels during shaking. However, even these very dense suspensions do not obscure the difference in liquid circulation. The greater light transmission of the *C* vessel is still clearly distinguishable. The *A* and *C* vessel combination used by Warburg & Burk may therefore fail to meet the requirement of the two-vessel technique, that the gas exchanged by the cell samples in the two vessels be distributed with equal speed between the gas and liquid phases. Inequality in light absorption could cause errors in both long- and short-term experiments, while the effect of differences in liquid circulation might be limited to periods of changing rates of exchange. Warburg & Burk's choice of vessels was therefore unfavourable for main-

tenance of equality of gas exchange represented by the two pressure measurements, especially for short alternating periods of light and darkness, which require the manometers to register equally the repeated changes in rate of exchange.

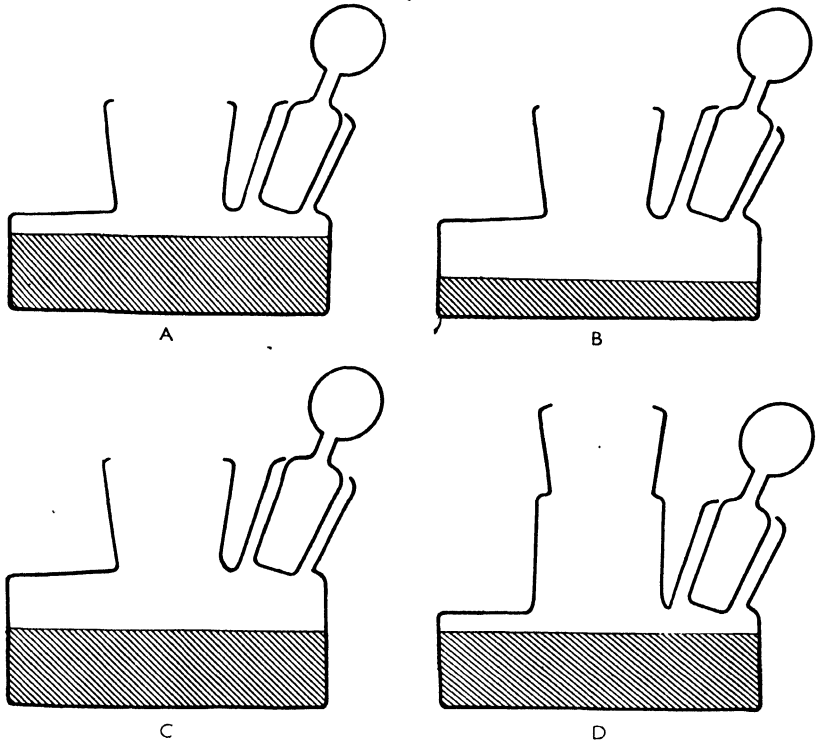

Fig. 3. Comparison of vessel shapes used for determining pairs of pressure changes,  $H$  and  $h$ , for calculation of oxygen and carbon dioxide exchange by the 'two-vessel method'. The method as originally described by Warburg (1926) called for two vessels of equal size (like A and B above), containing unequal volumes of fluid. Vessel A was used for determining  $H$ , vessel B for  $h$ . Warburg & Burk modified the method by using a deeper vessel (C) for the determination of  $h$ , in order to permit the use of equal volumes of fluid for determination of  $H$  and  $h$ . We have used vessels of shape D for determination of  $h$ . This permits the use of equal volumes of fluid for both  $H$  and  $h$  determination, and also maintains equality of mixing and light absorption, conditions which are not fulfilled with the A-C vessel combination.

(c) *Light source, and the problem of equal illumination of two vessels during corresponding periods.* The light source and arrangement for illuminating the two vessels in Warburg & Burk's experiments also appear to involve risk of inequality of gas exchange in the two vessels. Only a single light beam was used. Alternate illumination of the two vessels was provided by movement of a  $45^\circ$  mirror. The beam passed under one vessel on its

way to the other, so that one vessel was exposed to scattered light during its dark period, while the other was not. They explained that this procedure was not always followed, particularly when auxiliary light was used. For those experiments, the  $45^\circ$  mirror was left in one position. First one vessel was shaken over the mirror for a series of light and dark periods, and then it was replaced by the other for a similar series. These details introduce the possibility of error due to small changes in the metabolic activity of the cells with time. Indeed, Warburg & Burk recognize the possibility of such error, for they have objected that in Emerson & Lewis's two-vessel experiments (also done with a single beam) there was a lapse of time between the measurements with the two vessels, in some cases as long as 24 hr. The question, however, is not how long a time elapses between the two sets of determinations, but whether the two cell suspensions are in exactly like condition at the start of each series of measurements. We have found that this is not the case when, as in Warburg & Burk's experiments, the vessels are both prepared at the same time, and one is kept waiting while the other is put through its cycle of readings. Emerson & Lewis made control experiments and found that a satisfactory method was to prepare duplicate cultures for each two-vessel experiment, and to grow each culture for the same number of hours before harvesting the cells for preparation and filling of the two manometer vessels. The culture destined to be used for the first vessel filling would be placed in the culture bath earlier than the second culture, by a length of time equal to the number of hours required for the preparation of cell suspension, filling of one manometer vessel, and carrying out the predetermined sequence of light and dark readings. The same time schedule was followed for both sequences, from the growing of the cultures to the completion of the readings. Thus although the readings for the two vessels were taken in succession instead of simultaneously, there was no opportunity for differences to arise through keeping one batch of cells longer in any part of the processing than the other. By close attention to detail it was possible to produce closely comparable series of measurements of  $H$  and  $h$ .

There may be difference of opinion as to whether Emerson & Lewis's provisions for minimizing errors arising from two-vessel measurements with one light beam were superior to Warburg & Burk's. But it is significant that Emerson & Lewis, in spite of their more elaborate precautions to maintain comparability between  $H$  and  $h$ , nevertheless hesitated to rely on the two-vessel technique for the measurement of quantum requirements, while Warburg & Burk apparently proceeded to do so without first investigating the errors which might be involved.

There are advantages in illuminating the two vessels simultaneously

instead of alternately, especially for the purpose of demonstrating the errors which can arise from alternate exposure. This can be accomplished either by placing the two vessels over a uniform field of diffuse light, fitting them with diaphragms of equal area, and excluding all light not entering through the diaphragms, or by using two equal beams of limited area. We have had experience with both methods. The diffuse light was

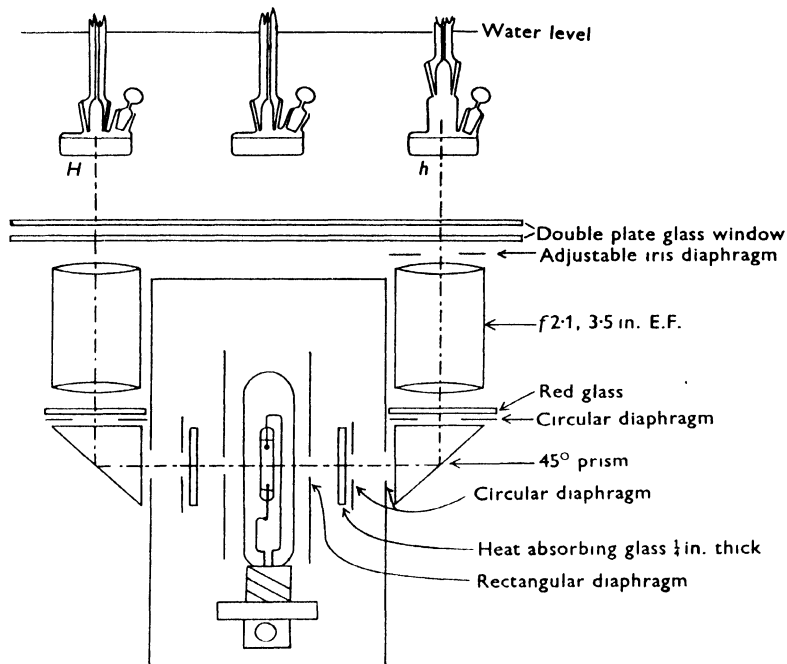

Fig. 4. Diagram of lighting system used for simultaneous illumination of the two vessels used for determining  $H$  and  $h$ , with beams of red light of equal intensity. The middle vessel (unilluminated) is the barometer control. The red glasses and heat-absorbing glasses indicated on the diagram served to isolate the red cadmium line ( $644 m\mu$ ). The two beams were brought to equality by means of the adjustable diaphragm.

obtained from a grid of 30 in. fluorescent tubes, with heat filter and red glass. The twin beams were from a cadmium lamp, as shown in Fig. 4. The  $644 m\mu$  line was isolated with filters. An advantage of the diffuse light source is that a given amount of energy can be absorbed in the cell suspension without exposing any of the cells to such high intensity as is necessary with a concentrated beam. It is also possible to approach total absorption with thinner cell suspensions over the diffuse source than over concentrated beams. However, in spite of the use of diaphragms of equal area, small inequalities in the dimensions of the manometers and vessels

make it difficult to maintain exact equality of illumination, and only selected vessel pairs can be used. The potential advantage of illuminating and darkening the two vessels simultaneously instead of alternately is illustrated in Table 2. It shows the results of a set of measurements made

Table 2. Comparison of values of  $\phi^{-1}$  calculated from different combinations of  $H$  and  $h$ .

Each pair of values for  $H$  and  $h$  shown in the table represents light-action pressure changes from observations covering simultaneous exposure of the two vessels to alternating periods of light and darkness. The first column of values for  $\phi^{-1}$  shows the results obtained from corresponding values of  $H$  and  $h$ , just as the pairs are tabulated. The second column for  $\phi^{-1}$  shows the results obtained by pairing the first  $h$  with the second  $H$ , the second  $h$  with the third  $H$ , etc. The third column for  $\phi^{-1}$  shows the results from pairing the first  $H$  with the second  $h$ , the second  $H$  with the third  $h$ , etc. The last two columns show the effect of combining the first four values of  $H$  with the last four of  $h$ , and vice versa.

*Experimental details:* Values of  $H$  and  $h$  for 10 min. light action were based on the sequence of readings indicated by line C in Fig. 5. The light and dark periods were respectively 10 and 20 min. The vessel for determination of  $h$  was of the shape D in Fig. 1. Its volume was 21.88 ml. The vessel for determination of  $H$  had a volume of 14.06 ml. In each vessel, 8 ml. of cell suspension, in acid culture medium, 165 mm.<sup>3</sup> cells in each vessel. Temperature, 10° C. Light energy equivalent to 4.5 mm.<sup>3</sup> O<sub>2</sub>/min. (actinometer).

Millimetres pressure change for 10 min. light action		Calculated values for $\phi^{-1}$				
$H$	$h$	From simultaneous values of $H$ and $h$	From alternate values, $h$ first	From alternate values, $H$ first	From first 4 $H$ , last 4 $h$	From first 4 $h$ , last 4 $H$
11.7	6.1	9.2	23.8	5.9	—	—
10.1	5.1	9.7	14.2	7.8	—	—
9.3	4.7	10.5	12.8	8.8	—	—
8.9	4.4	10.3	11.3	9.7	6.16	32.9
8.7	4.3	10.5	11.1	9.3	—	—
8.6	4.1	9.7	10.1	9.2	—	—
8.5	4.0	9.5	9.9	9.0	—	—
8.4	3.9	9.3	—	—	—	—
Average:		9.86	13.3	8.54	—	—

with a vessel pair fitted with equal diaphragms, and shaken over diffuse light from fluorescent tubes. The corresponding values of  $H$  and  $h$  lead to a consistent series of results, while alternated values of  $H$  and  $h$  lead to a variety of yields depending on whether the smaller or larger vessel is illuminated first, or a series of light and dark periods is given to first one vessel and then the other. The values of  $H$  and  $h$  change considerably in the course of time, but the calculated value of  $\phi^{-1}$  remains reasonably constant as long as corresponding values of  $H$  and  $h$  are used, as shown in the column headed 'Simultaneous values of  $H$  and  $h$ '. The next two columns show how the results would have been modified in this experiment if the vessels had been alternately instead of simultaneously illu-



line *B*. This makes it impossible to include in the measurement the photosynthesis which takes place immediately after turning on the light. Warburg & Negelein used the system shown on line *C*, and made the readings cover the entire light period, by starting the light reading at the moment of the start of illumination, and terminating it some minutes after the light was turned off. Warburg & Burk, on the other hand, made no allowance whatever for physical lag. They began and ended each light and dark reading at the beginning and end of each light and dark period, as shown on line *A*. They state that in their experiments mixing was so efficient that there was no physical lag in the response of the manometer to the successive light and dark periods. They publish no data in support of this statement, but adduce two pieces of evidence. They say that with 10 min. periods of light and darkness, the first and second 5 min. intervals of each period gave (within the limit of error) the same pressure change, and also that they obtained the same yield regardless of the length of the light and dark periods used.

If readings were taken, as appears from their data, only to the nearest half millimetre, approximate equality between the first and second 5 or 10 min. periods would still leave room for a significant error, since, as we have shown in Table 1, only about a half millimetre error per 10 min. may suffice to alter the yield by a factor of 2. But even if the first and second 5 min. were precisely equal, this would not exclude the existence of physical lag. Emerson & Nishimura (1949) have shown how a combination of carbon dioxide burst and physical lag can result in linear increase in pressure from the start of a period of illumination, in spite of physical lag.

Concerning the question of extra carbon dioxide exchange, Warburg & Burk state that in their experiments they always found  $\gamma$  *light action* to be about  $-1$ . Figs. 1 and 2 show that the two-vessel method is subject to the same sort of limitations as a tool for measuring  $\gamma$ , as for measuring oxygen exchange. Whatever reservations we may have regarding the adequacy of Warburg & Burk's application of the technique to photosynthesis measurements, apply also to  $\gamma$ , because  $\gamma$  and  $\phi^{-1}$  were calculated from the same measurements. Our confidence in their  $\gamma$  measurements is not increased when we find that the  $\gamma$  *light action* values near  $-1$  are derived from pressure changes which lead to quite different values of  $\gamma$  for the light and dark periods taken separately. They publish no separate values for  $\gamma$  *light* and  $\gamma$  *dark*. Separate calculation of  $\gamma$  with and without measured light would of course be meaningless in the majority of their experiments, which were made with continuous unmeasured auxiliary light, because there is no assurance that the action of the auxiliary light

was the same in both vessels. But Exps. 1 and 3 (Warburg & Burk, 1950, pp. 432, 434) were done without auxiliary light, and provide data from which we can calculate values of  $\gamma$  *light* and  $\gamma$  *dark*. In each case we have done this from the sum of the light pressure changes, and from the sum of the dark pressure changes. We have also calculated  $\gamma$  for the total net pressure change of each experiment. The resulting values are shown in Table 3.

Table 3. Calculation of  $\gamma$  values, and oxygen and carbon dioxide exchange, from Warburg & Burk's Exps. 1 and 3 (1950)

Tabulated values for  $H$  and  $h$ , the pressure changes in millimetres, are taken directly from their data. Their calculations were made from the *light action* pressure changes only. We show in addition the results calculated separately, for gas exchange in the dark, in the light, and for the total net pressure changes of the entire experiments.

	Pressure change in mm.		$\rho$	$\gamma$	$K'_{O_2}$	Gas exchange in mm. <sup>3</sup>		Excess of CO <sub>2</sub> over O <sub>2</sub> exchange (%)
	$H$	$h$				$\chi_{O_2}$	$\chi_{CO_2}$	
Exp. 1:								
60 min. dark	- 55.0	- 11.5	4.78	- 1.45	+ 2.83	- 156	+ 225	45
60 min. light	+ 4.0	+ 20.0	0.20	- 1.95	- 21.43	- 86	+ 167	95
Total net pressure change for 120 min.	- 51.0	+ 8.5	- 6.00	- 1.63	+ 4.73	- 241	+ 392	63
60 min. light action	+ 59.0	+ 31.5	1.87	- 0.83	+ 1.19	+ 70	- 58	- 17
Exp. 3:								
30 min. dark	- 68.5	- 28.0	2.45	- 1.20	+ 1.82	- 125	+ 149	20
30 min. light	- 38.5	- 13.5	2.85	- 1.30	+ 2.11	- 81.4	+ 105	30
Total net pressure change for 60 min.	- 107.0	- 41.5	2.58	- 1.24	+ 1.93	- 206	+ 255	24
30 min. light action	+ 30.0	+ 14.5	2.07	- 1.02	+ 1.44	+ 43.2	- 44.0	2

One might think there is no reason for special interest in the values of  $\gamma$  for the light and dark periods taken separately, or for the total net pressure change, since, for calculation of photosynthesis,  $\gamma$  *light action* is the only significant value. On the other hand, there is a considerable body of evidence, from several different investigators, that under ordinary conditions both the respiration and photosynthesis of *Chlorella* involve nearly equal exchange of oxygen and carbon dioxide. Therefore, if there is no extra carbon dioxide exchange, respiration alone, or any combination of respiration and photosynthesis, might reasonably be expected to lead to  $\gamma$  values not far from  $-1$ . In our experience, if  $\gamma$  is determined by correct methods over a long succession of light and dark periods, this is generally true. Table 3 shows that in these experiments of Warburg & Burk it

was not the case. For both the light and the dark periods, and for the total net pressure change, there is a large excess of carbon dioxide production over oxygen consumption. Closest approach to equality of exchange is from the *light action* pressure changes. The values of  $H$  and  $h$  for the light periods are such as would be associated with carbon dioxide 'burst'. This is most striking in Exp. 1, where  $H$  and  $h$  are +4 and +20, respectively. One might think that these positive pressures would indicate photosynthesis above compensation, but because  $h$  is larger than  $H$ , the oxygen exchange is negative, and the carbon dioxide positive, and twice as large as the oxygen exchange. This might be interpreted as evidence of extra carbon dioxide exchange like that described by Emerson & Lewis, were it not for the fact that in the dark, also, carbon dioxide exchange exceeded oxygen consumption, instead of being less than the oxygen respired, as reported by Emerson & Lewis. Therefore a carbon dioxide burst in the light, compensated by pick-up of a corresponding amount of carbon dioxide in the dark, would not account for these results calculated from Warburg & Burk's data.

Any experimental procedure which led to the pairing of pressure changes in the large and small vessels that represented different stages in the gradually changing metabolic rates of the two cell samples could be expected to lead to incorrect  $\gamma$  values. We have explained how various features of Warburg & Burk's two-vessel technique were particularly likely to involve this kind of error, so perhaps the most probable explanation for the results shown in Table 3 is that they are simply the result of calculation from values of  $H$  and  $h$  which represent different gas exchanges. It is therefore doubtful whether their values for  $\gamma$  and  $\phi^{-1}$  are of any particular significance.

In support of Warburg & Burk's statement that the yield is independent of the time interval chosen, we find a single experiment in their data (1950, exp. 4). This experiment is discussed in part IV, where we explain why it does not convince us that there was no lag in the response of their manometers to changes in rate of gas exchange.

Unpublished experiments performed in their laboratory for the purpose of demonstrating their technique to Mr A. Stanley Holt, afford strong evidence of lag in response. Mr Holt has very kindly made these data available to us. Among them we find two sets of manometer readings at 5 min. intervals for 30 min. periods of light and darkness, one set in alkaline carbonate mixture, the other in acid culture medium. Fig. 6 is a diagram showing the progress of pressure change in the carbonate experiment. There is clear evidence of physical lag. After each change, the first 5 min. interval shows less response than the subsequent intervals.

Fig. 7 is a similar diagram for the culture medium experiment at about pH 5 (one vessel only). The first two 5 min. readings after the light-dark and dark-light changes do indeed appear to be roughly equal, but when

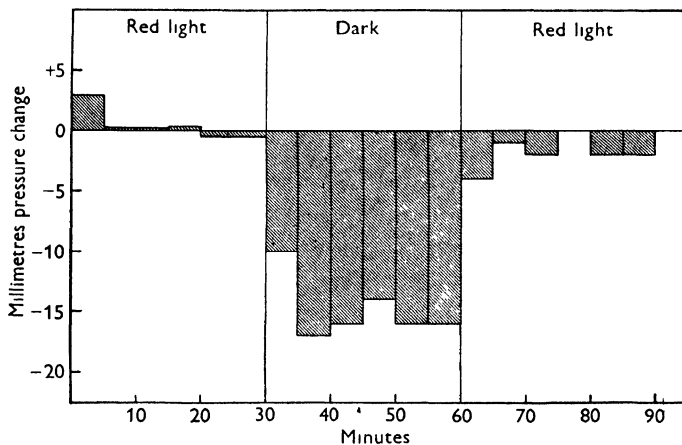

Fig. 6. Plot of unpublished data from an experiment done in Warburg & Burk's laboratory, with cells suspended in carbonate buffer. Shaking and light intensity were the same as used in their measurements of photosynthetic efficiency. Pressure changes are in millimetres per 5 min. Note that the readings show a definite lag in response to the changes from light to dark and from dark to light.

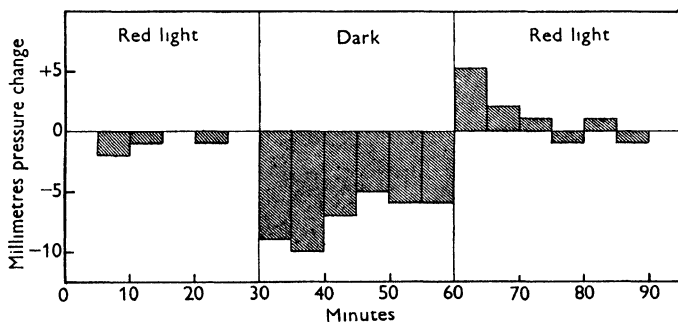

Fig. 7. Plot of unpublished data from an experiment done in Warburg & Burk's laboratory, with cells suspended in acid culture medium. Shaking and light intensity were the same as used in their measurements of photosynthetic efficiency. Pressure changes are in millimetres per 5 min. Note that after the light-dark and dark-light transitions, the readings show the opposite of physical lag, and the course of pressure change is similar to that shown by Emerson & Lewis (1941, Fig. 2 (upper part)).

compared with the subsequent readings they show the opposite of a physical lag. They represent the same sort of pressure changes which Emerson & Lewis found to be associated with extra carbon dioxide exchange.

These experiments were done with the same speed and amplitude of

shaking as specified by Warburg & Burk for the two-vessel quantum requirement measurements. They indicate both lag in response of the manometers, and extra carbon dioxide exchange. For more decisive information, we turn now to our own experimental tests of Warburg & Burk's two-vessel technique, and to our experiments in carbonate buffer, to look for evidence of lag.

### III. EXPERIMENTAL TESTS OF WARBURG & BURK'S APPLICATION OF THE TWO-VESSEL METHOD

(a) *Two-vessel experiment in acid culture medium, to test duplicability of Warburg & Burk's results.* The tests which we describe would be of little significance unless we could show that our technique was capable of producing results similar to those reported by Warburg & Burk. Table 4 indicates that we have been successful in fulfilling this requirement. We followed their specifications not only in regard to the manometer measurements, but also in regard to the technique of growing the cells.

The vessels were like shapes *A* and *C* in Fig. 3. Their volumes were as close as we could get to the volumes specified by Warburg & Burk for the vessel pair they used. The experiment was done with continuous incandescent light, the intensity of which was adjusted to give apparent compensation (approximately) in the two vessels. Readings were taken at 5 min. intervals without interrupting the shaking of the manometers, and periods of 10 min. exposure to the measured beam of red light were alternated with 10 min. periods without the red light. Our only departure from their specifications was in our use of the twin light beams, for simultaneous instead of alternate illumination of the two vessels.

The observed pressure changes are shown in the upper portion of the table. In agreement with Warburg & Burk (though their statement was not supported by detailed readings), we find the first and second 5 min. readings are the same, within the limit of reading error.

From these observed pressure changes, the pressure changes due to *light action* have been calculated on the different bases shown in the lower part of the table: from the entire 10 min. periods, from the first 5 min. of each period, and from the second 5 min. In each case the figures listed under *H* and *h* represent the difference between the sum of the appropriate 'white light' readings and the sum of the corresponding 'white light plus red light' readings. Following the *light action* pressure changes are the corresponding values of  $\rho$  (from  $H/h$ ),  $\gamma$ ,  $K'_{O_2}$  and  $\phi^{-1}$ . The values of  $\gamma$  and  $K'_{O_2}$  are taken from curves similar to Figs. 1 and 2, but plotted with the slightly different constants for this vessel pair, as indicated in the heading of Table 4.

The values for  $\phi^{-1}$  are in satisfactory agreement with those of Warburg & Burk. As we should expect from the approximate equality of the first and second 5 min. readings of the 10 min. periods, it makes no important difference whether we calculate  $\phi^{-1}$  from the entire 10 min. periods, or from the first or second halves of the periods.

Table 4. *Two-vessel measurement of quantum requirement, with cells suspended in acid culture medium*

The purpose of this experiment is to show that if we follow the specifications of Warburg & Burk, both for culturing the cells and for making the photosynthesis measurements, we obtain results in close agreement with theirs. The vessels used were the same pair that was used for the carbonate buffer experiment shown in Table 3, a close match for Warburg & Burk's vessels.

*Experimental details.* Large vessel, vol. 17.60 ml.; small vessel, vol. 14.10 ml. In each vessel, 7 ml. of culture medium, containing 300 mm.<sup>3</sup> cells. Gas space 5% carbon dioxide in air. Vessels were continuously illuminated with white light of unmeasured intensity. At 10 min. intervals, they were given 10 min. exposures to red light (cadmium line) of measured intensity. Energy of red light was equivalent to 50.1 mm.<sup>3</sup> O<sub>2</sub>/10 min. Temperature, 20° C.

$$K_{O_2} = 5.720 \left( 0.7964 - \frac{1}{\rho} \right), \quad \gamma = 1.587 \left( \frac{0.2216}{\rho - 1.256} - 1 \right).$$

Four cycles of auxiliary white light-red light plus auxiliary white light. First cycle omitted from calculations.

Observed pressure changes in mm.:

	Small vessel (for <i>H</i> )				Large vessel (for <i>h</i> )			
	White light		White light plus red light		White light		White light plus red light	
	5 min.	5 min.	5 min.	5 min.	5 min.	5 min.	5 min.	5 min.
First cycle	—	-2.6	+3.5	+4.0	—	0.0	+4.0	+3.5
Second cycle	-1.5	-1.5	4.0	3.5	+0.5	0.0	3.0	2.5
Third cycle	-1.0	-1.5	3.5	2.0	0.0	0.0	2.5	2.0
Fourth cycle	-1.0	-0.5	3.0	2.0	0.0	+1.0	3.0	1.0

Calculated quantum requirements:

Basis of calculation	mm. light action per 10 min.		$\rho$	$\gamma$	$K'_{O_2}$	$\phi^{-1}$
	<i>H</i>	<i>h</i>				
Entire 10 min. periods	+8.34	+4.16	2.03	-1.13	1.74	3.45
First 5 min. of each period	9.34	5.32	1.75	-0.87	1.28	4.70
Second 5 min. of each period	7.34	3.00	2.44	-1.29	2.21	3.08

(b) *Carbonate buffer experiment.* The significance of the results in Table 4 depends upon whether the corresponding values of *H* and *h* represent the same gas exchange, and whether the gas exchange represented includes all that was actually exchanged by the cells in response to the measured light. In our discussion we have indicated several reasons for suspecting that these requirements may not have been fulfilled. Our first concern is whether the two manometers are capable of representing

the same gas exchange during the intervals upon which the measurements are based. We cannot tell from the two sets of manometer readings in Table 4 whether they represent the same gas exchange, because the exchanges have to be assumed equal in order to make any calculation whatever. We need an experiment from which we can calculate the gas exchange independently for each vessel. This can be done, if carbonate buffer instead of acid culture medium is used as suspending fluid. We shall be limited to oxygen exchange, and can learn nothing about carbon dioxide exchange or  $\gamma$ . But comparison of oxygen exchange separately for the two vessels will help us to evaluate their usefulness for the two-vessel technique.

Table 5. *Comparison of gas exchange in members of vessel pair used for two-vessel experiments.*

Cells were suspended in carbonate buffer, so pressure changes represent oxygen exchange alone, and single-vessel pressure measurements suffice for calculation of gas exchange. The vessels were the same pair used in Exps. 4 and 6.

Data are presented for 5, 15, and 30 min. periods of light and darkness. For the 5 min. series, there is no alternative but to include the transitions in calculation of quantum requirements. For the 15 min. series, yields are shown for the first, second, and third 5 min. intervals. For the 30 min. series, yields are shown only for the final 25 min. of the periods, the first 5 min. of each period being omitted.

Note that for the 5 min. cycles, and for the first 5 min. of the 15 min. cycles, the yields for the large and small vessels are unequal. They become nearly equal, both for the 15 min. and the 30 min. cycles, when the first 5 min. of each period are omitted.

*Experimental details.* Large vessel volume 17.60 ml.,  $k_{O_2} = 1.009$ . Small vessel volume 14.10 ml.,  $k_{O_2} = 0.683$ . 315 mm.<sup>3</sup> cells in 7 ml. carbonate buffer in each vessel. Temperature, 20° C. Light energy equivalent to 50.2 mm.<sup>3</sup> O<sub>2</sub> in 10 min. Accessory white light.

Basis of calculation	mm. <sup>3</sup> oxygen production/10 min.		$\phi^{-1}$		
	Small vessel	Large vessel	Small vessel	Large vessel	
7 cycles, 5 min. light-5 min. dark	3.02	2.29	16.5	22.0	
5 cycles, 15 min. light- 15 min. dark	1st 5 min.	3.14	2.22	16.0	23.0
	2nd 5 min.	5.46	5.25	9.2	9.5
	3rd 5 min.	5.19	5.05	9.6	9.9
One cycle, 30 min. dark-30 min. light-30 min. dark, omitting 1st 5 min. of each period	5.46	5.56	9.2	9.0	

Table 5 shows the results of three series of readings, taken with cells suspended in carbonate buffer. The cells were like those used for the measurements shown in Table 4. In all these experiments, we have used essentially the same shaking as Warburg & Burk, 146 complete strokes (back and forth) per minute, with 2 cm. amplitude, and readings were taken without interrupting the shaking. As we should expect from Fig. 6, 5 min. periods of light and darkness lead to lower rates of photosynthesis

than longer periods. This difference, manifest in both the large and the small vessel, is the result of lag in response to turning the measured red light on and off. The first 5 min. periods of the 15 min. cycles show good agreement with the 5 min. cycles. Not only is there evidence of lag, there is also evidence of *differential lag*. The value for  $h$  for the first 5 min. is smaller than the corresponding value for  $H$ . The second and third 5 min. portions of the 15 min. cycles also show smaller values for oxygen exchange calculated from  $h$  than from  $H$ , but the differences are too small to be conclusive. One can say that practically all of the lag is over after the first 5 min. However, if we recall from Table 1 the sensitivity of the two-vessel calculations to small changes in  $h$ , we must recognize that differences as small as those shown for the second and third 5 min. periods in Table 5, if they were consistent, would lead to significant errors in the results calculated from two-vessel experiments.

The results in Table 5 for the 30 min. periods show the only clear evidence that the manometers for the large and small vessels can register equal rates of photosynthesis. It is true that the differences shown for the second and third 5 min. portions of the 15 min. cycles are no greater than for the experiment with 30 min. periods, but these small differences for the 15 min. cycles are still in the same direction as the much larger differences for the first 5 min. of the 15 min. cycles or for the 5 min. cycles. Therefore this experiment does not exclude the possibility that a consistent difference in response may persist for longer than 5 min.

Greater lag in the vessel used for determining  $h$  will lead, in experiments with 5 or 10 min. periods, to under-estimation of negative pressure changes due to respiration, and under-estimation of the extent to which these negative pressures are reversed by the tendency of photosynthesis to produce positive pressures. The effect upon calculated light action pressure changes will be the same, whether measured light is alternated with darkness, or with unmeasured auxiliary light. In both cases, the greater lag shown in Table 5 for  $h$  will lead to under-estimation of  $h$  compared to  $H$  in the two-vessel experiments.

The direction of the effect of differential lag upon  $h$  explains why, in the testing for sensitivity to error shown in Table 1, we used increments in light and dark pressure readings in opposite directions. Had we used increments in the same direction, increasing or decreasing both light and dark readings by the same amount, the value of  $h$  *light action* would have remained unchanged. But since the effect of lag is to make the light readings less positive, and the dark readings less negative, than they would be otherwise, the effect upon *light action* will be as indicated in Table 1.

We note that Warburg & Burk's published data show not a single

measurement of quantum requirement in carbonate mixture in the vessel used for  $h$  in the two-vessel experiments. Apparently all carbonate mixture experiments were made in the vessel used for  $H$ , in which, as we have seen, the lag is less. Also, all their carbonate buffer experiments were done with cycles longer than 5 min. The lag could hardly have escaped notice if carbonate mixture experiments had also been done in the  $h$  vessel, or with 5 min. cycles.

Table 5 shows that there is also lag in the response of the  $H$  vessel, and although it is smaller than in the  $h$  vessel, the effect again is to make the *light action* pressure changes smaller than they should be. In the two-vessel calculations, values of  $H$  which are too small have the opposite effect from too small values of  $h$ , but the errors cannot be expected to balance, because the two-vessel constant is made more sensitive to  $h$  than to  $H$ , and because the lag in  $H$  is smaller.

We should also bear in mind that in the two-vessel experiments there may be effects from extra carbon dioxide exchange. We explained in part I (*d*) that in single-vessel measurements, the effect of extra carbon dioxide exchange is to make the calculated rates of photosynthesis too large. If in two-vessel measurements we have to contend with both differential lag effects and extra carbon dioxide exchange, it is not possible to predict what will be the direction of the resultant error in calculated rates of photosynthesis.

Our decision to look for evidence of physical lag in the carbonate buffer experiment by calculating *light action* pressure changes from corresponding intervals of the periods with and without red light, implies the assumption that the gas exchange taking place in the metabolizing cells responded immediately to changes in illumination, and was maintained at essentially constant rate for the duration of each period with or without red light. The differential manometer experiments of Emerson & Lewis (1941) support this assumption. In their measurements, physical lag in response of the manometer was minimized by high-speed shaking (*c.* 500 r.p.m.), and by a glass paddle fused into the side of the manometer vessel, to increase turbulence of the cell suspension. Their fig. 5 shows that with carbonate buffer, steady rates of pressure change were attained almost immediately after changes in illumination.

There might be some question as to whether the *Chlorella* cells grown according to Warburg & Burk's specifications are also capable of immediate response to changes in illumination. This must be answered before we can be sure that the lag shown in Table 5 is not characteristic of the high pH of the carbonate buffer, and is therefore to be anticipated in the two-vessel measurements with acid culture medium as well.

The conventional manometer vessels are not suitable for this purpose. Rates of shaking much higher than the speed of 146/min. used in the above experiments are not practical for several reasons, and cannot be counted upon to improve mixing because there is a tendency to set up 'standing waves' in the cell suspensions. Also, readings at intervals shorter than 5 min. are hardly significant because of the impossibility of estimating pressure changes to less than 0.5 mm. without stopping the manometer. Therefore to test the speed of response of cell suspensions in carbonate

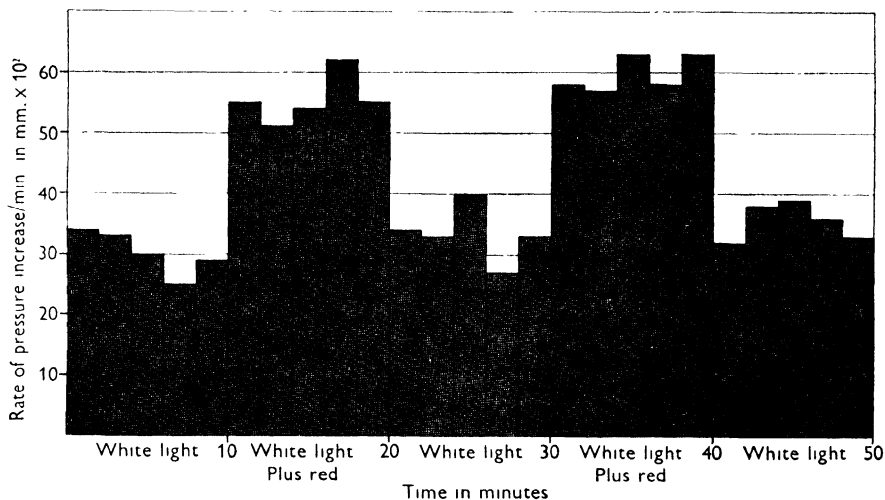

Fig. 8.

buffer under improved conditions of mixing, we have used a differential manometer set-up, like that described by Emerson & Lewis (1941). The experiment described below was done with a shaking speed of 530 r.p.m., and an eccentricity of about 3 mm. Readings were made to the nearest 0.01 mm., without interrupting the shaking. From the standpoint of speed of response and precision of pressure measurement, this arrangement is superior to the simple manometer technique used by Warburg & Burk.

Fig. 8 shows a plot of rate of pressure change per minute in hundredths of a millimetre, for a suspension of 265 mm.<sup>3</sup> *Chlorella* cells in 25 ml. carbonate buffer. Readings were made at 1 min. intervals, and plotted by 2 min. intervals. All pressure changes are positive because respiration was over-compensated with auxiliary white light of unmeasured intensity. The energy of the beam of red light (monochromator,  $\lambda = 635-650 \text{ m}\mu$ ) was measured bolometrically, and was adjusted to be approximately equal to the energy of the red beam in the Warburg-Burk experiments (approx.

$2.4 \mu\text{einsteins}/10 \text{ min.}$ ). The figure shows that each time the red light was turned on or off, the rate came to its steady-state value within the first 2 min. From this we conclude that the lag shown in Fig. 6 and in Table 5 cannot have been associated with the high pH of the carbonate buffer, because it became insignificant with the faster shaking of the differential manometer.

If differential lag is the principal source of error in the two-vessel experiment shown in Table 4, one might ask why the calculated yield is essentially the same for the first and second halves of the 10 min. periods, as for the whole periods. This may be connected with the presence of extra carbon dioxide exchange. It must also be remembered that although Table 5 shows no clear evidence that the lag in response to oxygen exchange lasts longer than 5 min., the carbonate buffer experiment tells us nothing about carbon dioxide exchange. In the two-vessel measurements there may be lag effects connected with carbon dioxide which last longer than 5 min., so it should not be surprising if periods longer than this are required to eliminate errors due to lag.

(c) *Longer period measurements by two-vessel technique.* Table 6 shows two sets of data, representing 15 min. periods with and without red light, and 30 min. periods. This experiment also was done with cells grown according to Warburg & Burk's specifications. Auxiliary incandescent light was used, and in general their procedure was followed, just as for the experiments represented by Tables 4 and 5. The two upper portions of the table show the manometer readings, which were taken at 5 min. intervals without interruption of shaking. For the three 15 min. cycles, the readings are tabulated just as they were taken, reading the rows of figures from left to right. For the 30 min. cycles, this would have required too wide a table, so the *white light plus red* readings are shown below, instead of to the right of the *white light* readings.

The lower portion of the table shows the values for  $H$  and  $h$  light action per 10 min. red light, calculated from the pressure readings shown in the upper two sections of the table. The values of  $\rho$ ,  $\gamma$ ,  $K_{O_2}$ ,  $x_{O_2}$  and  $\phi^{-1}$  are calculated from the pairs of  $H$  and  $h$ . The figures for  $H$  and  $h$  derived from the entire 15 min. periods lead to a value for  $\phi^{-1}$  essentially the same (4.8) as if the first 5 min. of each period are omitted (4.5). But if the first 10 min. of each period are omitted,  $\phi^{-1}$  becomes 6.1, and if 30 min. periods are used, it becomes 9.5. As indicated in the table, the initial 5 min. of each 30 min. period were omitted from calculation of  $H$  and  $h$ , but in this case it makes little difference whether or not anything is omitted. The omission of some initial minutes is done, of course, to allow for physical lag.

Table 6. *Effect of inclusion and exclusion of transition periods on quantum requirement calculated from observations by two-vessel method, with cells suspended in acid culture medium*

Auxiliary white light was used, as in Table 5. Two sets of data are shown, one for 15 min. periods of white light and red light plus white light; and one for 30 min. periods. Experimental details same as in Table 4.

Observed pressure changes (mm.). For 15 min. cycles:

	White light			White light plus red		
	5 min.	5 min.	5 min.	5 min.	5 min.	5 min.
Small vessel (for $H$ )	+2.5	+3.0	+2.0	+7.5	+5.0	+5.5
	3.0	3.0	3.5	6.0	5.5	5.0
	3.5	3.5	4.0	5.5	5.5	5.5
Large vessel (for $h$ )	+2.0	+4.0	+3.0	+5.0	+4.0	+4.0
	3.5	2.5	3.5	4.5	4.0	4.5
	3.0	4.0	3.0	4.0	4.0	4.0

For 30 min. cycles:

	White light					
	5 min.	5 min.	5 min.	5 min.	5 min.	5 min.
Small vessel (for $H$ )	—	—	—	+2.0	+2.0	+2.0
	+1.5	+2.0	+2.5	2.5	3.0	3.0
	2.5	2.5	2.0	3.5	3.0	3.0
Large vessel (for $h$ )	—	—	—	+2.5	+2.5	+2.0
	+1.5	+2.0	+3.0	2.0	2.0	3.0
	1.5	2.5	2.0	3.5	2.5	2.5
White light plus red						
	5 min.	5 min.	5 min.	5 min.	5 min.	5 min.
Small vessel (for $H$ )	+5.0	+4.5	+3.5	+3.5	+4.5	+4.5
	4.5	4.5	4.5	4.5	4.5	5.0
Large vessel (for $h$ )	+4.0	+3.5	+3.5	+2.5	+3.0	+3.5
	3.0	3.5	3.0	3.0	3.5	4.0

Calculated quantum requirements:

Basis of calculation	mm. light action per 10 min.		$\rho$	$\gamma$	$K'_{O_2}$	$x_{O_2}$	$\phi^{-1}$
	$H$	$h$					
Entire 15 min. periods	+5.12	+2.22	2.30	-1.25	2.06	10.5	4.8
Omitting 1st 5 min. of each period	4.33	1.50	2.88	1.30	2.50	10.9	4.5
Omitting 1st 10 min. of each period	4.33	2.00	2.16	1.20	1.90	8.2	6.1
30 min. periods, 2nd cycle only, 5 min. of each period omitted	3.67	2.00	1.84	0.99	1.44	5.3	9.5

## IV. DISCUSSION

The change in quantum requirement with time interval, shown in Table 6, should not be interpreted as proving that the value of 9.5 for the 30 min. cycles is necessarily correct. We have not proved that the values of  $H$  and  $h$  from which this figure was derived represent the same gas exchange. By taking longer cycles we have diminished the error, which we can see from Table 5 is large if we attempt to base calculations upon cycles of 15 min. or less, and include the first 5 min. But one might still ask what is the quantum requirement for the first 5 or 10 min., measured by some technique which would avoid the errors discussed above.

We had hoped that this question could be settled by the use of a vessel of shape  $D$  (Fig. 3) instead of  $C$ , for the determination of  $h$ . Shape  $D$  fulfils the same need as the vessel designed by Emerson & Lewis for measuring  $h$  in their differential manometer experiments. It provides for the same sort of liquid circulation in the vessels for both  $H$  and  $h$ , and the same liquid volume, although the total volume is different. If the density of cell suspension is adjusted to give total absorption of the red light beam in vessel  $A$  during shaking, it also gives total absorption in vessel  $D$ . We explained earlier that when vessel  $C$  is shaken, it always transmits more light than  $A$ , showing that circulation is different in  $A$  and  $C$ , and it is to this difference that we attribute the difference in physical lag shown in Table 5.

We have done a number of experiments with various pairs of vessels of shapes  $A$  and  $D$ , and in general we have found quantum requirements of about 10 instead of 3-4. This has been done with cells grown in such a way as to give values of  $\phi^{-1}$  of 3 or 4 when the measurements are made in vessels  $A$  and  $C$ , by the Warburg-Burk method. But due to the sensitivity of the two-vessel technique to small errors in  $h$ , and the uncertainty of reading the simple manometers to fractions of a millimetre without interruption of shaking, it is extremely difficult to demonstrate beyond doubt that these measurements lead to correct rates of photosynthesis. The measurements with the  $A$ - $D$  pair are open to some of the same criticisms we have levelled against Warburg & Burk's measurements with the  $A$ - $C$  pair. By substituting the  $D$  for the  $C$  shape, we may have eliminated the *differential lag*, but there may still be some error from lag, even if equal in the two vessels. Most of the lag is over in the first 5 min. after each change in lighting, so by excluding the first 5 min. from calculation of light action we probably obtain approximately correct values of  $H$ . The values of  $\rho$  are nearly correct if we have eliminated *differential lag*, so the values of  $K_{O_2}$  could be expected to be nearly correct.

We do not consider the results of these experiments sufficiently decisive to justify publication of details for sample experiments. Rather, we believe it will be preferable to develop the technique of making two-vessel measurements with the differential manometer, with simultaneous illumination of both vessels. The more rapid circulation of liquid will bring the duration of lag down to 1 or 2 min., and the double cathetometer will permit reading manometers to the nearest 0.01 mm.

Up to this point, our discussion of Warburg & Burk's results has been based upon the assumption that no errors were introduced through limitation of choice of experimental values from which  $H$  and  $h$  *light action* were calculated. There has been no need to question this assumption because, without resorting to any special selection of data, we obtained results in close agreement with Warburg & Burk's (cf. our Table 4). Our rejection of these results is based upon our demonstration that the application of the technique specified by Warburg & Burk leads to systematic errors because of differential lag in response of the two vessels (cf. Table 5). We find, however, that there are reasons for questioning Warburg & Burk's calculation of results. We mentioned earlier that there are several instances in which they have calculated *light action* for  $H$  and  $h$  from different time intervals. For example, in the second part of their Exp. 1 (1950, lower part of p. 431),  $H$  was calculated from five cycles with and five cycles without measured red light, while  $h$  was calculated from only three cycles. This deviation from correct application of the technique might have led to no serious error if the successive cycles had been in reasonably good agreement. Our Table 2, which we introduced to illustrate the sort of errors that can be anticipated if non-corresponding values of  $H$  and  $h$  are used for calculating gas exchange, shows that successive cycles tend to give declining values for  $H$  and  $h$ . No great error would result from the inclusion or exclusion of one or two of the values for either  $H$  or  $h$  in Table 2. But the data in Warburg & Burk's experiment referred to above show large random variations. The five successive cycles for  $H$  lead to *light actions* of 6.5, 3.0, 3.0, 7.5 and 8.0 mm. With such a small number of values, of such large variability, one can hardly say that the inclusion of one or two extra cycles will diminish the error of the mean. If  $H$  is calculated from the first three instead of from all five of the cycles shown, and if the value of  $h$  is taken from the apparently corresponding three cycles for the other vessel,  $\gamma$  is changed from  $-1.03$  (Warburg & Burk's value) to  $-0.43$ , and  $\phi^{-1}$  is changed from 2.9 (Warburg & Burk's value) to 7.6.

The fitness of these five cycles for the calculation of  $H$  may also be tested by calculating the oxygen production for each cycle individually.

For this purpose we may use the average value for *h light action*, because the three cycles shown for *h* lead to values (2.5, 3.5 and 1.5) which are in agreement within reasonable limits of error. The individual values for *H light action*, paired with 2.5, the average value for *h*, lead to values of 12.65, -0.975, -0.975, 16.52, and 18.47 for the cubic millimetres oxygen production due to 5 min. photosynthesis in the measured light. The average of these leads to a value of 2.83 for  $\phi^{-1}$ , but we wonder who would trust an average based upon five individual values which range from -0.9 to +18. We leave to the reader the responsibility of deciding whether it was justifiable to include in the calculation of *H light action* two extra cycles which lead to values in such extreme disagreement with the average of the first three cycles.

The data for about half of Warburg & Burk's experiments show instances of the calculation of *light action* from different time intervals for *H* and *h*. Among these experiments, and also among others in which there is no direct evidence that *light actions* were calculated from different time intervals, there are cases where the value obtained for  $\phi^{-1}$  depends upon a single reading which is particularly out of line with the others. In these cases the omission of the aberrant reading leads to much larger values for  $\phi^{-1}$  than any of those shown in Warburg & Burk's tables for measurements in acid culture medium. However, we do not wish to criticize their conclusion that two-vessel measurements with successive short periods with and without measured light can lead to calculated values of about 4 for  $\phi^{-1}$  and about -1 for  $\gamma$ . Our own measurements, without inclusion of any aberrant readings, confirm this conclusion, and in regard to the short-period experiments we disagree with Warburg & Burk only on the significance of the calculated results, which we think are incorrect for the reasons set forth in the discussion of Table 5.

As to measurements with longer periods of time, we disagree with Warburg & Burk's opinion that these also lead to quantum requirements of about 4. They say (p. 427) that periods from 5 to 60 min. give the same efficiencies. Among their published experiments we find none with 60 min. periods. Their Exp. 4 (p. 435) shows one 10, one 20 and one 30 min. cycle, with and without measured light. The three light actions have been added together, and calculated for 60 min. *light action*, because, they say, each cycle gave, within the limits of error, the same light action per unit time. We have calculated  $\gamma$  and  $\phi^{-1}$  for these three cycles separately, and find the  $\gamma$  values are -1.1, -1.3 and -1.3, and  $\phi^{-1}$  values are 4, 2.6 and 2.9. Certainly these values are within the limits of error, but they hardly constitute convincing evidence that efficiency is independent of time interval. We have shown how greatly the inclusion of one or two extra

readings may alter the calculated yield of photosynthesis, even when the readings cover several cycles. A yield calculated from only one cycle is practically without significance. Our own measurements with repeated cycles always show higher values for  $\phi^{-1}$  when the periods are 15 min. or longer (cf. Table 6).

We find in Warburg & Burk's data no evidence to persuade us that their specifications for obtaining highest efficiencies of photosynthesis are significant, regardless of what future experiments may prove. We note that some of their specifications are directly contradictory to the requirements emphasized by Warburg up to 1947. They mention the use of chloride in the culture solution, the importance of growing the cells in unsterilized medium prepared with well water, the avoidance of sedimentation, the temperature of 20° being favourable for highest efficiency, etc. We find in the papers of Warburg & Negelein (1922, 1923) and of Warburg (1947) quite other specifications for obtaining highest efficiency. No chloride was added to the culture medium, and it was categorically stated that sedimentation during culture growth did not affect photosynthetic efficiency adversely. A temperature of 10° was specified as essential for obtaining maximum efficiency. Up to 1947 it was stated that shaking the cells in a manometer vessel results in progressive damage, and ultimately in zero photosynthesis. In 1950 it is stated that cells are only damaged by shaking in darkness, and that they may be shaken indefinitely in the light without suffering injury. In no case are these specifications supported by experimental evidence. Possibly they represent only *ad hoc* assumptions.

## V. SUMMARY AND CONCLUSIONS

The need for assessing the dependability of the two-vessel manometric method for measuring photosynthetic efficiency is explained. The application of this method by Warburg and co-workers is compared with the application made by Emerson & Lewis, and the modifications introduced by the authors of the present paper. The equations for calculation of gas exchange from two-vessel measurements show that the method is sensitive to errors which in single-vessel experiments would be trifling. Examination of Warburg & Burk's results, and comparison with our own experiments, show that among the several possible sources of error, differential lag in response of the two manometers is the most important. In Warburg & Burk's application of the technique, no allowance was made for lag in response of the manometers, nor for differential lag. There is clear evidence of both lag and differential lag. The effect of differential lag would be to make the calculated rate of photosynthesis, and therefore the apparent

efficiency, higher than it should be. In our opinion the measurements of Warburg & Burk therefore fail to demonstrate the efficiencies which they report. Whether green plants are capable of such high efficiencies, is a question which requires the application of better techniques than those used by Warburg & Burk.

## REFERENCES

- BURK, D., HENDRICKS, S., KORZENOVSKY, M., SCHOCKEN, V. & WARBURG, O. (1949). The maximum efficiency of photosynthesis: a rediscovery. *Science*, **110**, 225-9.
- EMERSON, ROBERT & LEWIS, CHARLTON M. (1939). Factors influencing the efficiency of photosynthesis. *Amer. J. Bot.* **26**, 808-22.
- EMERSON, ROBERT & LEWIS, CHARLTON M. (1941). Carbon dioxide exchange and the measurement of the quantum yield of photosynthesis. *Amer. J. Bot.* **28**, 789-804.
- FRANCK, JAMES (1949). An interpretation of the contradictory results in measurements of the photosynthetic quantum yields and related phenomena. *Arch. Biochem.* **23**, 293-314.
- GAFFRON, H. & WOHL, K. (1936). Zur Theorie der Assimilation. *Naturwissenschaften*, **24**, 81-90.
- NISHIMURA, M. S. & EMERSON, ROBERT (1949). The quantum requirement of photosynthesis. Chapter 10, pp. 219-38, in *Photosynthesis in Plants*, edited by James Franck & W. E. Loomis. Ames, Iowa: Iowa State College Press.
- WARBURG, O. (1919). Ueber die Geschwindigkeit der photochemischen Kohlen-säurezersetzung in lebenden Zellen. *Biochem. Z.* **100**, 230-70.
- WARBURG, O. (1926). *Ueber den Stoffwechsel der Tumoren*. Berlin: Julius Springer.
- WARBURG, O. (1947). Assimilatory quotient and photochemical yield. *Amer. J. Bot.* **35**, 194-204.
- WARBURG, O. & BURK, D. (1950). The maximum efficiency of photosynthesis. *Arch. Biochem.* **25**, 410-43.
- WARBURG, O. & NEGELEIN, E. (1922). Ueber den Energieumsatz bei der Kohlen-säure-assimilation. *Z. phys. Chem.* **102**, 235-66.
- WARBURG, O. & NEGELEIN, E. (1923). Ueber den Einfluss der Wellenlänge auf den Energieumsatz bei der Kohlensäure-assimilation. *Z. phys. Chem.* **106**, 191-218.
- WARBURG, O. & SCHOCKEN, V. (1949). A manometric actinometer for the visible spectrum. *Arch. Biochem.* **21**, 363-9.
- WARBURG, O., BURK, D., SCHOCKEN, V. & HENDRICKS, S. (1950). The quantum efficiency of photosynthesis. *Biochemica et Biophysica Acta*, **4**, 335-46.
- WOHL, K. (1937). Zur Theorie der Assimilation. II. Die Assimilationstheorie von Franck und Herzfeld. *Z. phys. Chem. (B)*, **37**, 122-47.

# PHOTO-INDUCED INTERACTIONS IN METABOLISM OF GREEN PLANT CELLS

By B. KOK

T.N.O. Solar Energy Research Project  
Laboratory for Plant Physiological Research, Agricultural  
University, Wageningen, Netherlands

The conversion of light energy into chemical bonds is a fascinating process occurring on a large scale exclusively in photosynthesis. Moreover, since Warburg & Negelein (1923) estimated that the yield was 70% for this conversion, it is quite understandable that many investigators gave photosynthesis a unique place in cellular activities. It was considered to be a straightforward process, using exclusive pathways which were coupled with other processes only by way of the final products.

For many years only very few indications, derived chiefly from comparative biochemistry, pointed against such isolation. In recent years, however, the picture has changed rather fundamentally; it was shown that CO<sub>2</sub> reduction was not the monopoly of green cells, that the quantum yield was only about half the value originally accepted, that the action of light was ultimately independent of CO<sub>2</sub> reduction, and that the function of light could be restricted to supplying reducing cellular metabolites.

CO<sub>2</sub> reduction having lost its unique position, a further difficulty disappeared; earlier theories always had to deal with the problem of how several units of light energy (quanta) could act together in synthesizing one much larger unit of cellular energy (for the reducing of one CO<sub>2</sub> molecule to the carbohydrate level). A study of dissimilatory processes revealed that in living systems units of reducing power smaller in energy content than 1 quantum of red light are common. Next, pathways were discovered along which a number of such units combine to reduce CO<sub>2</sub>. This smoothed the way for conceptions which wove photosynthesis into the pattern of cell metabolism.

Ruben (1943) and others (Ochoa, 1946; Lipmann, 1946) suggested a pathway for CO<sub>2</sub> reduction, having in general a similarity to that occurring in respiration but in reverse direction. More recent work with tracers confirmed these hypotheses, and more insight into the character of intermediates and their kinetic behaviour was gained. An interaction between

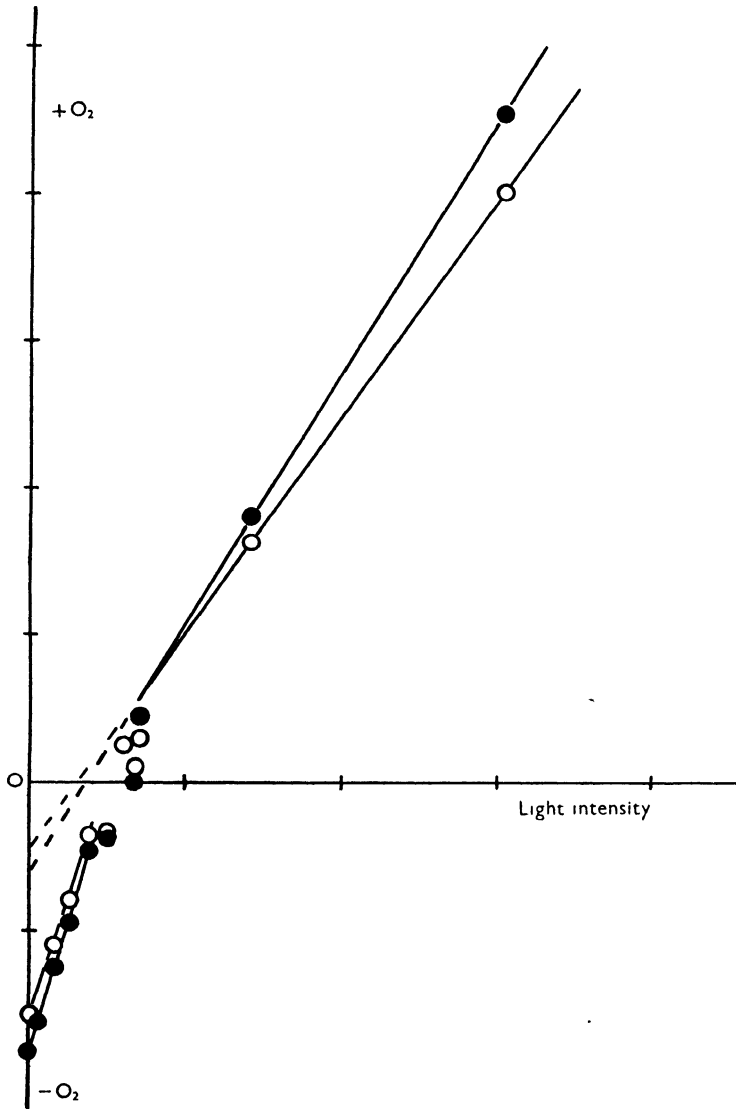

Fig. 1. Light intensity-assimilation curve.  $3 \mu\text{l. Chlorella}/\text{cm.}^2$  irradiated surface (Hg light) in carbonate mixture pH 9.2 with Knop salts.  $t = 28^\circ \text{C}$ . Two series of measurements (first: closed circles; second: open circles). In both the dark value was measured first, after which light intensity was increased stepwise. Duration of experiment 4 hr.

the two closely related processes of dissimilation and assimilation can hardly be called unexpected.

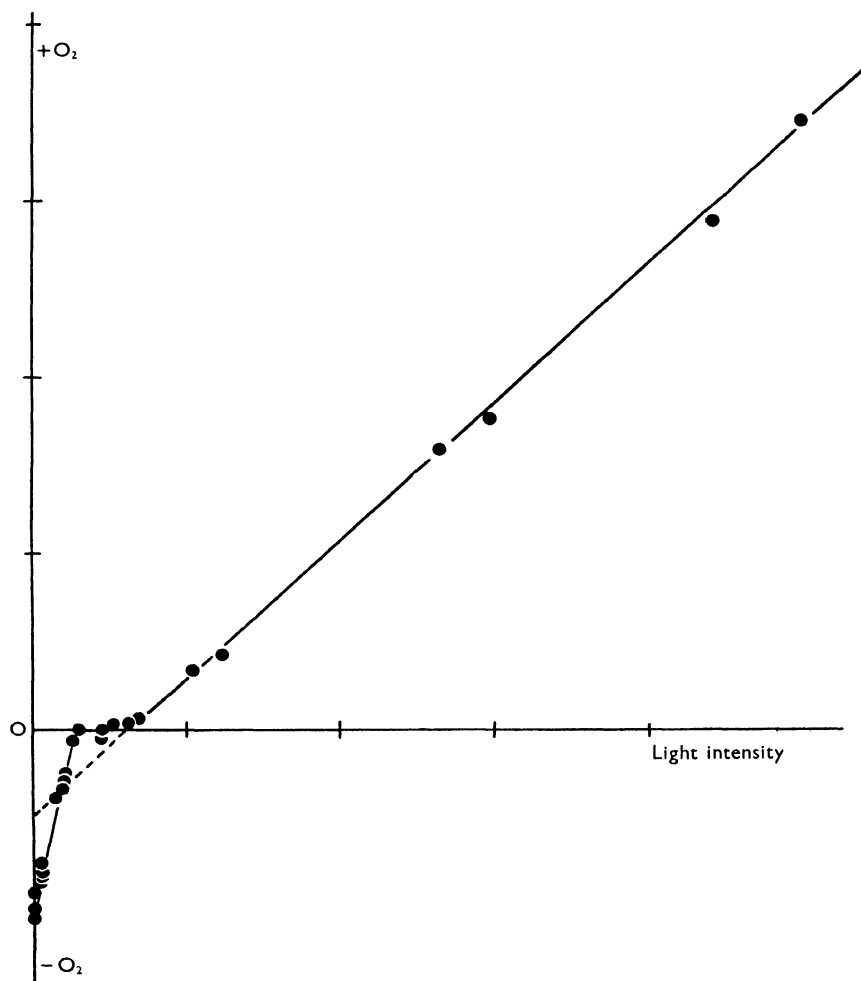

Fig. 2.  $2 \mu\text{l. Chlorella/cm.}^2$  Carbonate mixture pH 10.5 with Knop salts.  $t=28^\circ \text{C.}$  Two series of measurements in which light intensity was stepwise increased, respectively decreased. Duration of experiment 5 hr.

The character of light intensity-assimilation curves, which I obtained with several types of green cells (Kok, 1948, 1949), indeed, indicates such an interaction. At low-light intensities a high quantum yield—up to twice that at medium ones—is found, and a correlation with the rate of dark respiration is evident. A reverse relation (lower yield at low intensities)

was first found by French (1937) in purple bacteria. From fluorescence measurements, Wassink, Katz & Dorrestein (1942) concluded that transfer of light energy occurred in a normal way in this region, and these S-shaped curves too were explained by interference with cellular metabolism.

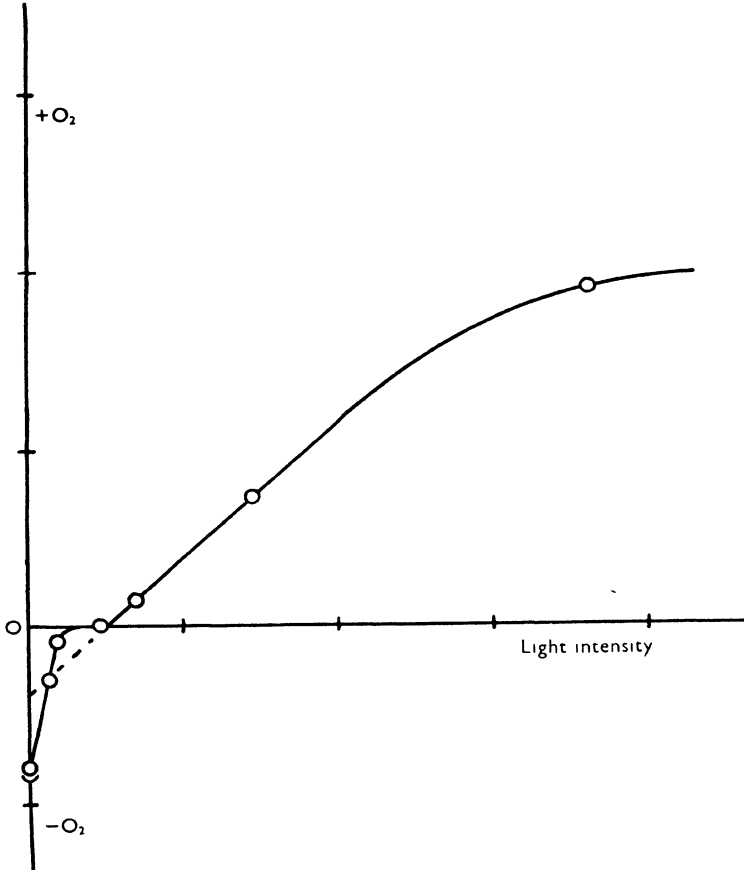

Fig. 3.  $1.5 \mu\text{l. Chlorella}/\text{cm.}^2$  Carbonate mixture pH 11.2 with Knop salts.  $t = 28^\circ \text{C}$ . Dark value measured before and after other points. Duration of experiment 3 hr.

We measured the enhanced yield in low light intensities with *Chlorella*, suspended in Warburg's carbonate buffer mixture no. 9. Generally, however, in these alkaline media, lower rates are found than in more neutral ones, and their use may lead to unreliable results. Figs. 1-3 show measurements with algae suspended in manometric different carbonate-bicarbonate mixtures in which Knop nutrient salts were dissolved. At pH 9.2 a transition occurs just in the compensation range (in buffer without

nutrient salts a 'mixed' curve is found), and the lower slope is exactly twice the upper one. At pH 10.5 the respiration rate is lower, but the first slope is not materially influenced; the second slope, however, is decreased (to  $\frac{1}{4}$  of the first slope). At pH 11.2, next to this, saturation is obtained at lower light intensities.

It is remarkable that the prolongation of the upper curve (photosynthesis) cuts the ordinate invariably at half the dark respiration value.

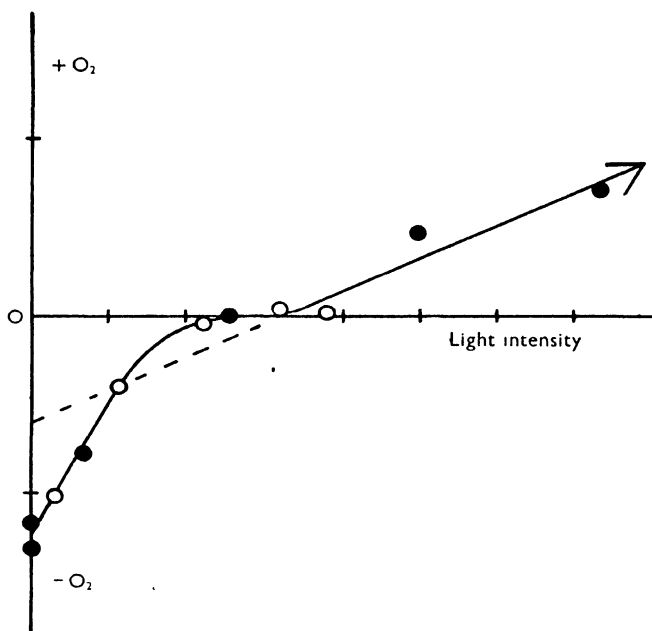

Fig. 4.  $1.5 \mu\text{l. Chlorella}/\text{cm.}^2$  Carbonate mixture pH 10.5 with Knop salts.  $t = 28^\circ \text{C}$ . Photosynthesis curve was perfectly straight until  $20\times$  compensation intensity (cf. Fig. 2). Open circles: intermittent light caused by rotating disk  $\frac{1}{10}$  light, 300 rev./min.

Secondly, the horizontal part between both lines, yielding a typical 'saturation' curve for the first process, is of interest (e.g. at pH 10.5). In this case no oxygen exchange at all is observed until doubling the quantity of light required to compensate respiration. Only at still higher intensities does photosynthesis set in, characterized by positive oxygen-pressure changes.

Fig. 4 presents the first part of a curve measured at pH 10.5 on an enlarged scale, showing the same character. Points given as open circles have been measured with intermittent light. This was made in order to check in thin suspensions a claim of Burk, *et al.* (1949) that short flashes of strong light (such as occur in shaken, thick suspensions) may give

higher yields than constant light. At low mean intensities not the slightest difference could be detected in this and other experiments.

It is obvious that alkaline buffers may influence the results, and so it was attempted to perform measurements in more natural media. In a medium containing ammonium (after Spoehr & Milner, 1949), in which we obtained abundant growth of *Chlorella*, we may expect  $\gamma$  not to differ materially from 1.0 (Cramer & Myers, 1948). Fig. 5 shows one of the established curves. Thus, the phenomena discussed are found at lower pH as well; moreover, any relation to  $\text{NO}_3^-$  reduction (theoretically possible with half as much light as  $\text{CO}_2$  reduction) becomes improbable.

Van der Veen (1949), using a heat conductivity method, estimated  $\text{CO}_2$  exchanges as a function of light intensity with intact tobacco leaves, and obtained similar results. Thus the occurrence of two different light-induced processes with a quantum number differing by a factor two seems to be rather well established.

Contrary to the study of intermediates (Calvin, 1949; Kamen, 1949), kinetic studies of photosynthesis so far revealed practically no further indications of an interaction with respiration, and in various cases seem to negative such an interaction. Wassink & Kersten (1945) found that in diatoms different temperatures caused markedly different respiration rates. Consequently even the sign of the measured gas exchange might be reversed for identical incident light intensities at very different temperatures. However, after correction for dark respiration, the action of light appeared independent of temperature. A close examination of the data shows that they do not necessarily disprove a 50% diminished  $\text{O}_2$  uptake in light, provided the claim of a constant overall yield of the 'photochemical process' is dropped.

Generally, when the 7 and 8-quanta processes occur mixed over a long range of intensities, a minor difference between the two slopes results and the bend may be shifted to a region where confusion with light saturation easily occurs.

If the primary photochemical products are not distributed over both processes in a constant ratio—independent of light intensity—the whole curve may become slightly bent, instead of consisting of two rectilinear parts.

In recent work (Burk *et al.* 1949; Warburg *et al.* 1950), the quantum yield for *Chlorella* was again estimated. Some experiments were performed below the compensation point and high yields (4 quanta/mol.  $\text{O}_2$ ) were found; these yields did not materially differ from earlier measurements and those made by us in weak light. In other experiments respiration was compensated or over-compensated, and again a yield of 4  $h\nu$ /mol.  $\text{O}_2$  was

found. However, no precautions were taken to observe really steady-state photosynthesis in these experiments and systematic errors may have influenced the results.

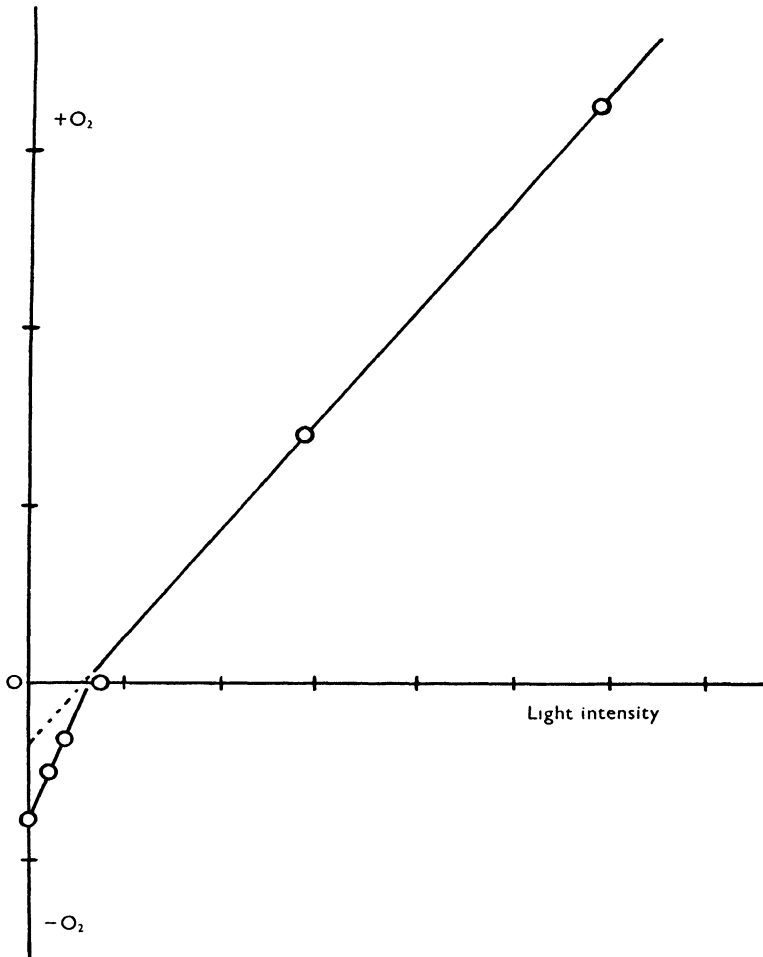

Fig. 5.  $2 \mu\text{l. Chlorella/cm.}^2$  grown in Knop solution, after washing resuspended in a medium pH = 7.0 containing  $\text{NH}_4^+$ . Gas phase: air + 5%  $\text{CO}_2$ .  $\gamma$  assumed to be = 1.0 (sodium light).

At the same time these authors published an experiment which, they claimed, went to prove the lack of any interaction of photosynthesis and respiration. After careful removal of  $\text{CO}_2$  from a manometer vessel, no action of weak light on  $\text{O}_2$  uptake was found. This would mean that light

could only act by reducing  $\text{CO}_2$ . We tried in vain to corroborate this experiment. A special vessel was used (Fig. 6). Much weaker intensities than those used by Warburg gave clear effects, and smooth curves in relation to light intensity were obtained differing below the compensation point not materially from curves measured with the same algal suspension in carbonate buffer. In some experiments induction effects occurred—increasing light intensity giving enhanced  $\text{O}_2$  uptake for about 5 min. In the same experiments, above the compensation point initially enhanced evolutions of  $\text{O}_2$ , as compared to more steady rates, were observed.

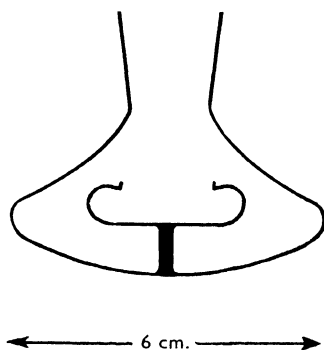

Fig. 6. Vessel adapted to removal of  $\text{CO}_2$ . Inner vessel supplied with disk of filter-paper, diameter 25 mm. and 1 ml. KOH 30%. Main compartment contained 4–8 ml. algal suspension (40–200  $\mu\text{l}$ . *Chlorella*) forming in several expts. a layer of only about 1 mm. thickness. Shaking: circular movement, diameter 8 mm., 300 rev./min.

It appeared that in Knop solution containing  $\text{NO}_3^-$  in the absence of  $\text{CO}_2$ ,  $\text{O}_2$  evolution occurred, which could not be suppressed by addition of ammonia. When  $\text{NO}_3^-$  was replaced by  $\text{NH}_4^+$ , respiration could not be over-compensated. Figs. 7 and 8 show some curves as computed from 'steady' states ( $\text{O}_2$  uptake slows down after some time, ca. 30–60 min.).

These experiments point to direct  $\text{NO}_3^-$  reduction by light and support again the idea of interchangeability of reducing power generated by light and by dark respiration.

Thus, we found strong evidence in favour of a light-induced process having precedence over photosynthesis with a high quantum yield at low light intensities, and more attention should be paid to its possible character.

Dark respiration of the cell proceeds to fulfil the demand of energy-consuming processes at the cost of cellular reserves.

When respiration is exactly compensated by light, the cell takes up from the light the amount of energy it requires to keep living. There are good reasons to assume that in the light this amount of energy is just as great as in the dark, in any case not lower. If respiration be compensated because

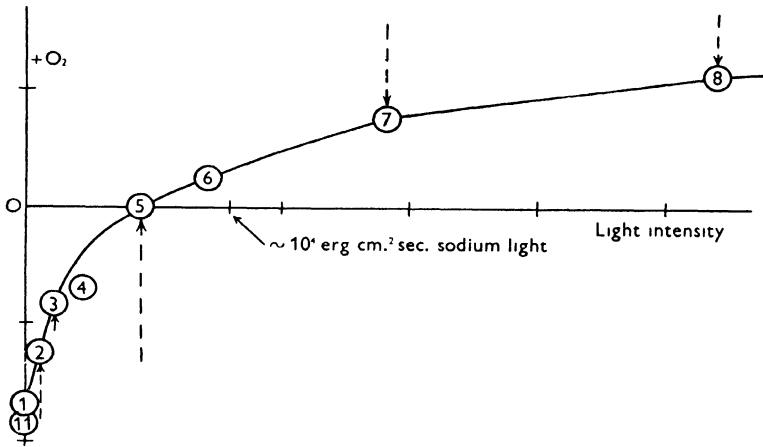

Fig. 7.  $4 \mu\text{l. Chlorella}/\text{cm.}^2$  in Knop solution, pH 5. Sequence of measurements indicated in circles. Readings taken every minute. Arrows indicate change of rate with time (induction effects). Steady states computed by omission first 5-10 min. No. 4 was observed only 6 min.

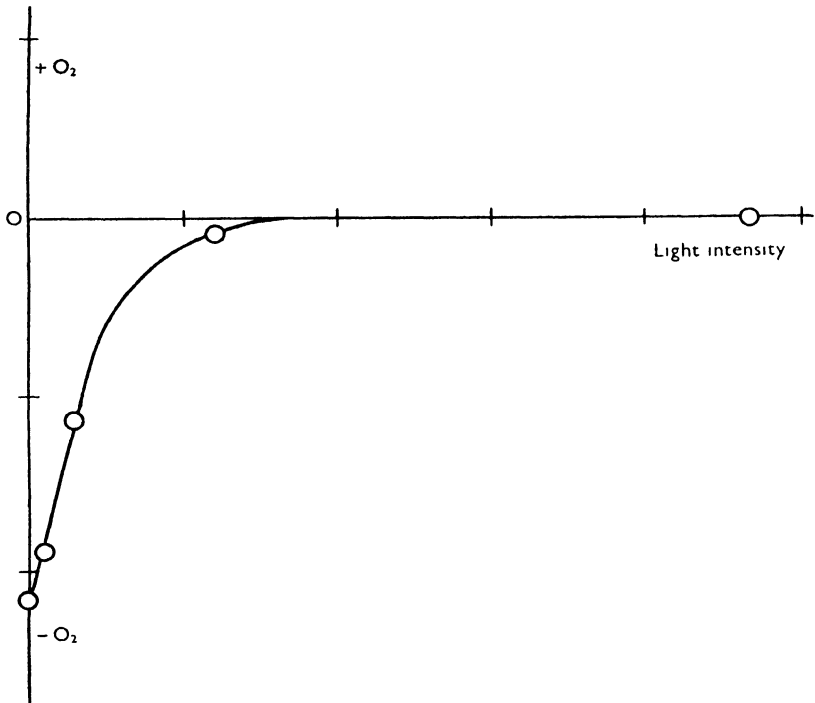
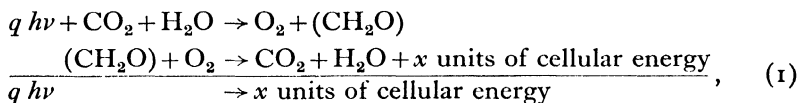

Fig. 8.  $6 \mu\text{l. Chlorella}/\text{cm.}^2$  after washing resuspended in  $\text{NH}_4^+$  containing nutrient medium. No oxygen evolution is found.

photosynthesis independently carried out the reverse overall reaction, then under *all* circumstances cell metabolism obtains its energy according to the reaction sequence:



$q$  standing for the quantum number of complete photosynthesis. But the finding that in weak light the conversion from light into cellular energy runs twice as efficiently, indicates that (1) is not valid in these conditions.

We shall now consider more evidence for the hypothesis of a constant energy demand by cell metabolism which is the basis of our whole reasoning. Arguments arise from the inability of various authors to record any signs of enhanced respiration after a period of intense photosynthesis.  $\text{C}^{14}$  labelled intermediates of photosynthesis are not respired in the light (Calvin, 1949) and according to Brown, Fager & Gaffron (1949) not even in subsequent dark periods. On the other hand, light can act directly on cell metabolism, e.g. Audus (1947) found that starved leaves, in which respiration was decreased to a fraction of normal rate, showed in light an instantaneous restoration of cell metabolism to the original rate under non-starved conditions, falling slowly down again in a following dark period.

A strong argument can be taken from comparative biochemistry: the interaction of fermentation and respiration. Anaerobically a yeast cell ferments sugar molecules to  $\text{CO}_2$  and alcohol, this process liberating 1 mol. of A.T.P. per  $\text{CO}_2$  evolved. Oxygen causes switching over to respiration, in which process according to Ochoa's (1943) estimations about six  $\sim P$  bonds are generated per  $\text{CO}_2$  evolved. Now, aerobically much less substrate is used, as would be expected if glycolysis went on as fast as during anaerobiosis (Pasteur effect). The finding of Meyerhof quotients of about 2 instead of  $\frac{1}{3}$  means that only one-sixth of the expected amount of  $\text{CO}_2$  is evolved; and this in turn means that the total supply of A.T.P. to the cell per unit of time remains constant with or without  $\text{O}_2$ . It is proposed from several sides to see in  $\text{PO}_4^=$  or A.T.P. content of uncoloured cells a mean regulating factor, adapting the rate of energy-liberating processes to the demand of energy-consuming ones. For green cells analogy with the Pasteur effect is obtained by assuming a more efficient conversion of substrate (light quanta) into cellular energy below than above the compensation point.

From this point of view it appears irrelevant to discuss merely whether photosynthesis acts on intermediates of respiration or vice versa (Franck, 1949). We have to look for steps in both processes normally

accompanied with heat losses and then look for possible ways nature has found to avoid these in weak light. Pathways, mainly consisting of reversible steps, are known, leading from CO<sub>2</sub> and cellular energy to carbohydrate. On first sight it looks improbable that overall efficiency could be doubled by a mere change or short-circuiting of this carbon cycle in weak light. However, photosynthesis is shown not to be the reversal of respiration, and we have to wait until a definite insight is obtained.

Liberation of oxygen by light (splitting of water) together with terminal respiration (reformation of water) represents the cycle of hydrogen, mainly driving the metabolic wheel of the green cell.

These processes are known to be accompanied by heat losses, and earlier (Kok, 1948) we tried to explain the increased efficiency in weak light by assuming a change in this cycle.

A direct supply of cellular energy by light was supposed, substituting the supply by the respiratory process, which would mean a suppression of respiration.

Definite solution of this problem can only be expected from tracer work. Some preliminary observations are made by both the California and the Chicago groups (pers. comm.). Up to now, the results do not seem to be fully conclusive.

#### REFERENCES

- AUDUS, L. J. (1947). *Ann. Bot., Lond., N.S.*, **11**, 42.  
BROWN, A. H., FAGER, E. W. & GAFFRON, H. (1949). *Photosynthesis in Plants*. New York.  
BURK, D., HENDRICKS, S., KORZENOVSKY, M., SCHOCKEN, V. & WARBURG, O. (1949). *Science*, **110**, 225.  
CALVIN, M. (1949). *J. Chem. Ed.* **26**, 639.  
CRAMER, M. & MYERS, J. (1948). *J. Gen. Physiol.* **32**, 93.  
FRANCK, J. (1949). *Arch. Biochem.* **23**, 297.  
FRENCH, C. S. (1937). *J. Gen. Physiol.* **20**, 711.  
KAMEN, M. D. (1949). *Photosynthesis in Plants*. New York.  
KOK, B. (1948). *Enzymologia*, **13**, 1.  
KOK, B. (1949). *Biochim. et biophys. acta*, **3**, 625.  
LIPMANN, F. (1946). *Adv. Enzymol.* **6**, 231.  
OCHOA, S. (1943). *J. Biol. Chem.* **155**, 55.  
OCHOA, S. (1946). *Currents in Biochemical Research*. New York.  
RUBEN, S. (1943). *J. Amer. Chem. Soc.* **65**, 279.  
SPOEHR, H. A. & MILNER, H. W. (1949). *Plant Physiol.* **24**, 120.  
VAN DER VEEN, R. (1949). *Physiol. Plant.* **2**, 217.  
WARBURG, O., BURK, D., SCHOCKEN, V., KORZENOVSKY, M. & HENDRICKS, S. B. (1949). *Arch. Biochem.* **23**, 330.  
WARBURG, O. & BURK, D. (1950). *Arch. Biochem.* **25**, 410.  
WARBURG, C., BURK, D., SCHOCKEN, V. & HENDRICKS, S. B. (1950). *Biochim. et biophys. acta*, **4**, 335.  
WARBURG, O., & NEGELEIN, E. (1923). *Z. phys. Chem.* **106**, 191.  
WASSINK, E. C., KATZ, E. & DORRESTEIN, R. (1942). *Enzymologia*, **10**, 269.  
WASSINK, E. C. & KERSTEN, J. A. H. (1945). *Enzymologia*, **11**, 282.

# REDUCTION BY CHLOROPLASTS

By R. HILL

Agricultural Research Council, Unit of Plant Biochemistry,  
University of Cambridge

We shall be concerned in what follows with the *in vitro* properties of chloroplasts obtained from the higher plants. If we break the green cell, it is possible to separate a fluid containing the chloroplasts and chloroplast fragments from the tissue residue. This green juice can no longer assimilate carbon dioxide, but, in the case of many plants, the insoluble green material for a time at least is still capable of giving oxygen in light (Inman, 1935; Molisch, 1925). This evolution of oxygen takes place in the presence of soluble substances contained in the plant juice, or better by the addition of reagents which can act as hydrogen acceptors (Hill, 1939). These substances are of a type with oxidation-reduction potentials well below the oxygen electrode and could not possibly yield molecular oxygen unless energy in some form is supplied. The cell-free preparations then, though not showing photosynthesis, can still convert light into a form of chemical energy. The production of molecular oxygen in this way, by a system less organized than the whole cell, is unique among biological systems and previously unknown in chemistry itself. We may very well call this the *chloroplast reaction*. The effect of several inhibitors is very nearly the same as their effect on photosynthesis (Hill & Scarisbrick, 1940; Holt & French, 1948). Many of us, therefore, have considered that the study of this reaction of the chloroplast *in vitro* will help towards elucidating the mechanism of photosynthesis in the living plant.

It has been concluded from experiments with chloroplasts *in vitro* that when oxygen is evolved in light a corresponding amount of hydrogen is added to another substance. This conclusion can be expressed in terms of the important generalization made by van Niel (van Niel, 1931; Rabinowitch, 1945), by saying that the chlorophyll containing part of the plastids in light shows a tendency to split water. Let us say for the moment that the system shows a tendency towards splitting into hydrogen and free oxygen. This water-splitting tendency, under given experimental conditions, could in theory be measured if we knew at a given oxygen pressure both the characteristic oxidation-reduction potential of the substance being reduced and its percentage reduction. Let us first postulate an imaginary model system working under ideal conditions where the light intensity affects the

speed of reaction and not the equilibrium position. If, for example, water was to be split completely by this imaginary system, there would have to be a difference of potential between two catalytic parts of 1.2 V.—the difference between the hydrogen and oxygen electrodes. In this case, given a suitable reagent having an oxidation-reduction potential (referred to the normal hydrogen electrode) of  $-400$  mV. at pH 7, we should find that it became half reduced, when illuminated in presence of this imaginary system. If this particular system is granted, I think the arguments which have followed are valid if the conditions are ideal. Ideal conditions necessitate the complete specificity of the two catalytic parts as regards oxygen and the reagent used and the complete absence of any direct reoxidation of the reagent used. This implies also that the two catalytic parts must be separated in space and connected in a chemical sense only at the instant of effective light absorption.

Now molecular oxygen is the characteristic product of the chloroplast system, and has been shown to originate from the water by Holt & French (1949). It is therefore convenient to define a water-splitting tendency as the energy fraction:

*Oxygen electrode minus reagent potential/oxy-hydrogen potential.*

A splitting of water into  $2\text{H}_2$  and  $\text{O}_2$  would thus be a tendency of unity.

We know from experiments described by Warburg & Luttgens (1946) that quinone is almost completely reduced to hydroquinone and can yield almost exactly the equivalent of molecular oxygen in presence of the chloroplast substance and light. From this it is sure that the water-splitting tendency exceeds one-half (see Fig. 1). It is, however, not possible yet to define the conditions of equilibrium with light, so that we cannot say by how much this tendency exceeds one-half. It was also found (Hill, 1939) that, at a pressure of about 4 mm. of oxygen, ferric oxalate is almost completely reduced; in this case the energy fraction must exceed two-thirds. Again, it cannot be stated by how much because we have not determined the ideal equilibrium. Theoretically this difficulty could be resolved by taking a series of oxidation-reduction indicators of increasing reduction potential and finding where reduction by the illuminated chloroplast ceases. Practically, as was shown by the work of Aronoff (1946), it is found that there is so far no smooth relationship between potential and capacity for being reduced. This is apparently due to there being so few substances known at present which are capable of being reduced by the chloroplast and not reoxidized by oxygen.

So far then, experiment has only given us a fractional estimate for the water-splitting capacity of the chloroplast. Following this conception we

are led to realize that for the direct reduction of carbon dioxide to give carbohydrate and oxygen (Rabinowitch, 1945), this energy fraction would be improper—more than unity. However this may be, the maximum reducing power of the chloroplast *in vitro* has not (so far as I know) been satisfactorily determined.

In the conception of the oxygen-producing reaction of the chloroplast substance as mentioned previously, it seems necessary to postulate at least two catalysts or enzymic activities, one specific towards oxygen and one

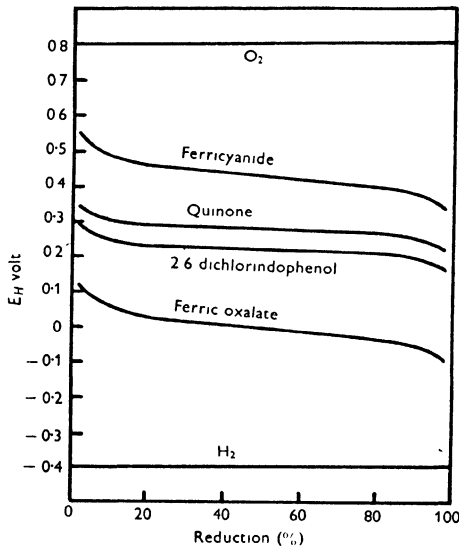
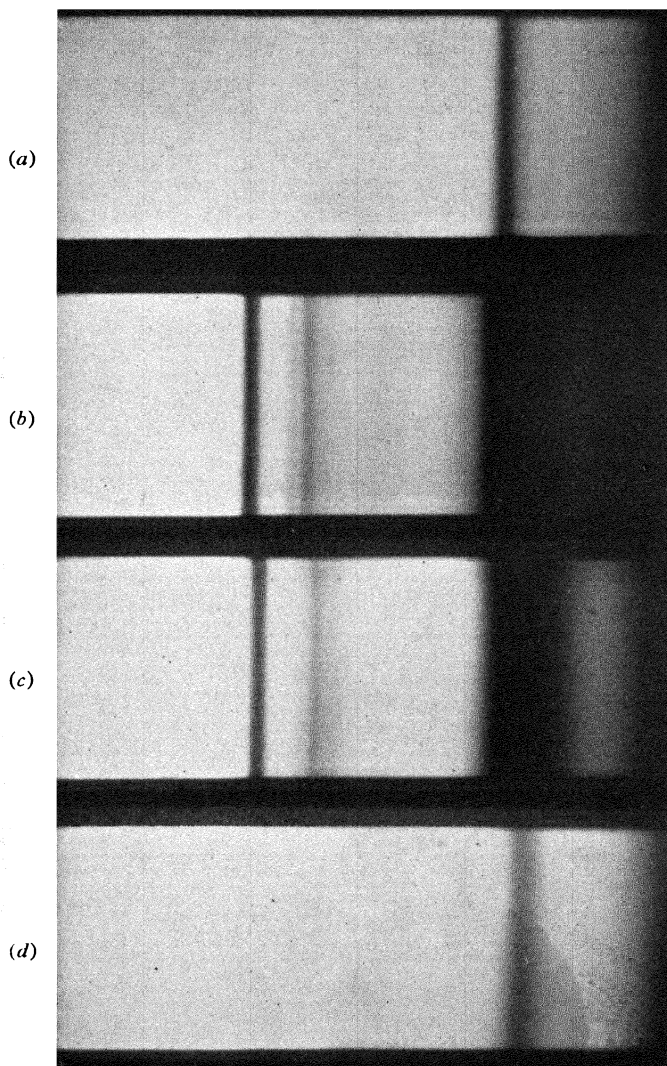

Fig. 1. Potentials and percentage reduction of reagents relative to the oxygen electrode and hydrogen electrodes at pH 7.

specific towards the added reagent which accepts hydrogen. It has also been found that the spectrum of the chlorophylls in the chloroplast is different from any artificial preparation that we can make from the purified pigments themselves. Yet no changes in the spectrum can be observed, either in presence of active reagents and inhibitors of chloroplast activity or when the activity is lost by storage under mild conditions. Let us assume, then, that the chlorophyll itself, perhaps also in combination with a protein (Smith, 1940), is additional to these two enzymic activities, though the evidence rests on negative facts. Possibly there will be general agreement of the supposition—at any rate as a working hypothesis—that the chloroplast reaction is brought about by a complex of at least three entities, a large amount of chlorophyll and a much smaller amount of two



PLATE 1



*For explanation see p. 231*

*To face p. 225*

specific catalysts. If this view is accepted, we become forced to see a certain analogy between the chloroplast substance and the insoluble group, or complex, of enzymes connected with aerobic cellular respiration, in which haematin compounds play so important a part (Keilin & Hartree, 1939). Hill & Scarisbrick (1951) attempted to find out the nature of haematin compounds in leaves. While we could only account for a fraction of about a third of the total haematin present, this search certainly established that in the higher plants there is a characteristic cytochrome component associated with the chloroplasts. We proposed to call this cytochrome *f* (Scarisbrick, 1948). This haematin compound can be most easily separated by grinding fresh leaves with one part v.v. of alcohol containing ammonia. The first purification consists in cold acetone precipitation, the second is by ammonium sulphate fractionation and the third stage (Davenport & Hill, 1951) is by adsorption on tricalcium phosphate. We have recently found that this preparation of purified cytochrome *f* contains but one-tenth of the haem in relation to protein as cytochrome *c*. A low concentration of ammonium sulphate (one-third saturated) will precipitate cytochrome *f* and it can be precipitated by dialysis. It is very stable on drying and the preparations always remain completely in the reduced form. In solution it is non-oxidizable and does not combine with carbon monoxide. The absorption spectrum is similar to that of cytochrome *c*, but the bands are very distinctly sharper and occur 50 m $\mu$  to the red end, as can be seen in Plate 1 and Fig. 2. Keilin & Hartree (1949) have examined the effect of low temperatures on the absorption spectra of haemoproteins; if cytochrome *c* is gradually cooled in liquid air, the bands become sharper and show more fine structure. The spectrum of *c* at one stage during the cooling resembles cytochrome *f* at room temperature. At liquid air temperature cytochrome *f* shows further sharpening and now the two haem pigments show a similar degree of sharpening. It could easily be imagined that the sharp spectrum shown by cytochrome *f* at ordinary temperature indicates a shielding of the haem group from thermal effects of neighbouring molecules, and that this is a property allowing a more perfect transfer of energy, in some form, by this haem compound in the chloroplasts.

The pigment may be extracted from a variety of leaves, but we still have technical difficulties in the purification except in the two plants we have used so far, elder and parsley, the latter being the better. We obtained good evidence that cytochrome *f* or a similar pigment occurs in the three algae *Vaucheria* sp., *Euglena gracilis* (given to us by Professor E. G. Pringsheim and grown for us by the kindness of Dr E. F. Gale) and *Fucus serratus*. These belong to three different groups; which suggests that this finding in the higher plants may be relevant to other green cells.

Cytochrome *f*, while resembling component *c* in several ways, is far more difficult to detach from the cellular contents. We think our experiments indicate that cytochrome *f* is actually part of the structure of the chloroplast substance because it has not been possible to obtain any separation without drastic treatment. Our estimates of the amount present in relation to the chlorophyll could support the view that it bears a function in photosynthesis analogous to the function of a cytochrome component in

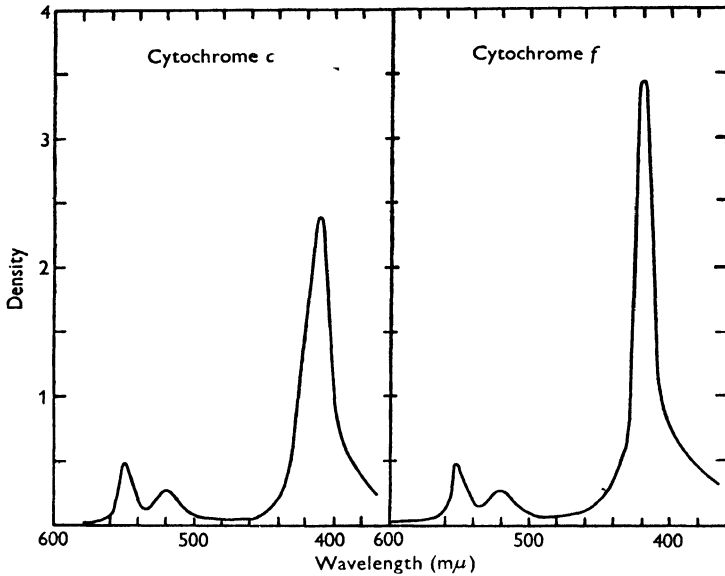

Fig. 2. Absorption spectrum curves of cytochromes *f* and *c*.

aerobic respiration (Table 1). The potential of cytochrome *f* is more oxidizing than cytochrome *c* and is very near to catechol-orthoquinone. It happens that this potential is midway between the oxygen electrode and the maximum estimate for the water-splitting tendency of the chloroplast.

Table 1. Comparison of yeast and leaves relating activity to content of cytochrome components *c* and *f*. Concentrations expressed as mg. atoms haematin iron per ml. of living cells. In leaves the molecular ratio *f*/chlorophyll lies between 1/1800 and 1/200

Leaves (Data from Hill & Scarisbrick, in the Press, and from Davenport, unpublished)	Baker's yeast (Data from Keilin & Hartree, 1940)
$Q_{O_2}$ 40-100 (Photosynthesis) Extractable <i>f</i> $0.16 \times 10^{-5}$ M <i>f</i> visible in acetone residue $2.0 \times 10^{-6}$ M	$Q_{O_2}$ 200 (Respiration) Extractable <i>c</i> $0.4 \times 10^{-5}$ M <i>c</i> visible in living suspension $3.6 \times 10^{-5}$ M

With these observations before us it is almost inevitable that we should suppose that cytochrome *f* is a part of the oxidation-reduction chain which somehow has to connect the two postulated enzymic activities inside the active bits of chlorophyll-containing substance. These active bits are now shown by recent work in the laboratory of C. S. French to be quite small, when compared with the whole chloroplast.

We have thus tried to show briefly how the reducing properties of the chloroplast is related to its composition and to added reagents. The next stage would be to see what evidence there is for hydrogen acceptors within the plant.

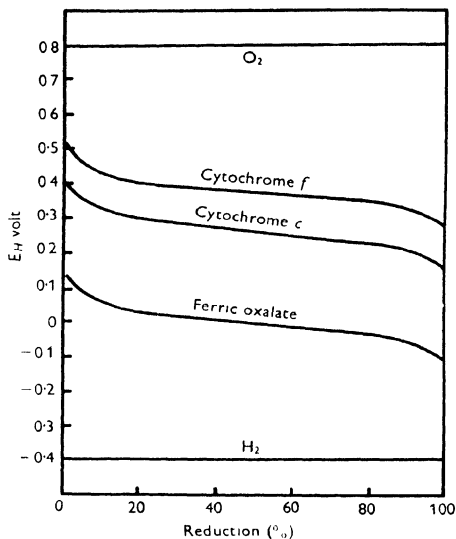

Fig. 3. Potentials and percentage reduction of cytochromes *c* and *f* compared with ferric oxalate at pH 7.

Preparations from whole leaves have long been known to evolve small quantities of oxygen in the light. It is found that the oxygen is only produced when the water-soluble fraction is present; washing removes the activity (Molisch, 1925; Inman, 1935). When an acetone powder is made from leaves it is found that the aqueous extract from it will apparently act as a hydrogen acceptor with the chloroplasts (Hill, 1939). Using muscle haemoglobin in this case we can measure the oxygen produced and its pressure. It was found that the haemoglobin never became more than half saturated with oxygen, indicating that a pressure of less than 1 mm. Hg. could be attained in light. Using blood haemoglobin with less affinity for oxygen and having the S-shaped dissociation curve, no oxygen could be

detected. Davenport (1949) found that the haemoglobins of *Ascaris* have a very high affinity for oxygen. He found that with chloroplasts in the extract of an acetone powder of leaves the haemoglobin became fully saturated (Fig. 4). This allows us to conclude that we have an active system giving a very low pressure of oxygen.

Hill & Scarisbrick (1940) showed that muscle methaemoglobin in presence of air could be used as an indirect hydrogen acceptor for illuminated chloroplasts. It had the advantage of not being reduced directly by our preparation of chickweed chloroplasts, so that by means of it we were

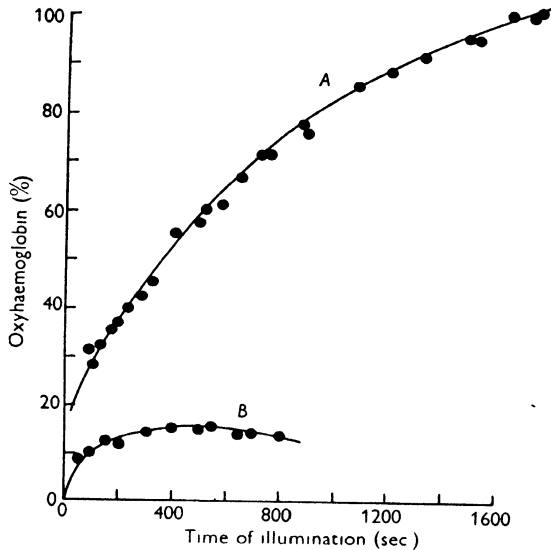

Fig. 4. Comparison of the oxygenation of *Ascaris* haemoglobin and ox-muscle haemoglobin by oxygen produced in the chloroplast reaction under the same conditions. Haemoglobin,  $0.7 \times 10^{-4}$  M haematin;  $23^{\circ}$  C.; pH 7.4; 0.4 ml. chloroplast suspension; 7300 lux. Curve A, *Ascaris* haemoglobin. Curve B, ox-muscle haemoglobin. (From Davenport, 1949.)

able to study the reduction of an added reagent such as ferric oxalate. The ferrous oxalate thus produced reduces the methaemoglobin to haemoglobin which thereupon combines with oxygen and this can then easily be estimated. We found that the aqueous extract from the acetone leaf could replace ferric oxalate and allow a reduction of methaemoglobin by chloroplasts to take place in light. More recently (Hill, Davenport & Whatley, 1951), have found that untreated chloroplast suspensions from many other plants show an active capacity for reducing muscle methaemoglobin in light. When the chloroplast suspension is diluted, the activity (in terms of chlorophyll

present) falls off in a way showing the presence of a soluble factor. The washed chloroplasts were incapable of reducing methaemoglobin in light, but addition of the soluble fraction of the leaf juice restored the activity. The soluble 'methaemoglobin reduction factor' is thermolabile. In the case of one plant it can be concentrated by salt precipitation in a small albumin fraction. All the activity is lost at 75° as the protein becomes coagulated. In this one plant, it has been shown that the factor is absent from the roots and the underground shoots, but always present in the leaves, until they become yellow with age. We think that a study of this factor will help in the analysis of how oxygen is produced when chloroplasts are suspended in the extract of acetone leaves. This work is in progress and the results have not been published. I take the liberty of mentioning it now because it suggests that the chloroplast can react with a soluble substance of high molecular weight actually derived from the plant as well as with the smaller molecules that we add as reagents such as chloroindophenol (Holt & French, 1948), quinones and ferric oxalate. So far we have never observed any effect of presence or absence of carbon dioxide with the chloroplasts *in vitro*. With the natural hydrogen acceptors the reducing potential is definitely higher than the iron oxalate system, but at the same time the pressure of oxygen is much lower; hence even from experiments with the plant extracts we cannot find a water-splitting tendency of more than about two-thirds for the isolated chloroplasts in light.

From an examination of the data on the oxygen production and simultaneous reduction of added reagents shown by chloroplasts *in vitro* it is quite clear that there is no measurable latent period. The reaction begins with maximum rate at the instant of illumination. I add again that no easily measurable effect due to (reduction of) carbon dioxide has yet been observed under the conditions relevant to these data. This means, I think, that the *in vitro* chloroplast reaction is similar to an initial small oxygen production (Rabinowitch, 1945) which, at the instant of illumination, has been shown to occur in a plant, previously kept in the dark, before the steady state of assimilation is approached. Shall we say, then, that our experiments *in vitro* have not yet even begun to surmount a latent period, after which the possibility of a measurable carbon dioxide reduction would only gradually be built up. This, indeed, may well be the most hopeful way of relating the chloroplast reaction *in vitro* to photosynthesis in the living plant. As, however, the treatment of the cells seems to produce damage to the mechanism (which can be shown by experiments with living cells), this may be considered by some of us to be altogether too hopeful. Table 2 shows a comparison of the activity of oxygen production in the living cell and in preparations of chloroplasts as light saturation is approached. The

$Q_{O_2}$  is based on the chlorophyll content, not on total dry weight. It is seen that *in vitro* we have not yet reached the high activities shown in the plant.

Table 2. Comparison of  $Q_{O_2}^{chl}$ , maximum values with chloroplast preparations and with living leaves

Chloroplasts		Photosynthesis of leaves (Willstatter & Stoll, 1918)	
Arnon & Whatley (1949), Beet	1,600	Normal green	8,000
Hill & Scarisbrick (1940), Chickweed	1,400	Golden elder	66,000
Warburg & Luttgens (1946), Spinach (well below light saturation)	550		

The tentative hypothesis that I originally put forward (Hill, 1939) was that the reduction of carbon dioxide in higher plants was in essence chemosynthetic rather than directly photochemical. It simply stated in present terminology that the *initial* reduction by the chloroplasts does not split water to the extent necessary to reduce carbon dioxide to the level of carbohydrate. It postulated that oxygen must be consumed again in order to give the necessary additional energy for the process. This means first a reduction of a substance by chloroplasts giving oxygen and then a reoxidation of the reduced substances by part of the oxygen together with a simultaneous reduction of the necessary equivalent of carbon dioxide. The important discovery of Gaffron (Rabinowitch, 1945) in *Scenedesmus* of the coupled reduction of carbon dioxide with the reaction in the dark of free hydrogen with free oxygen would at first seem to support a chemosynthetic view of photosynthesis. That is, of course, only if we consider *Scenedesmus* to have a normal system with simply the addition of a hydrogenase which is inactivated by more than traces of oxygen. How far the chemosynthetic view is useful in an interpretation of normal photosynthesis from the study of chloroplasts *in vitro* is really a matter for discussion.

In this present discussion of the measurement of reducing power of chloroplasts we took the oxygen electrode as the reference point. This we did because molecular oxygen is the product of the action of light on our system. This can be justified again because in experiments with chloroplasts we cannot find direct evidence of anything produced with a higher oxidizing potential than oxygen itself—for instance, a peroxide. But we have to admit that our experiments only give evidence for a fraction of the light energy being transformed into chemical energy.

On the other hand, for those of us who are more concerned with the photochemical end of the process it may be useful to disregard our present treatment for a moment. Shall we assume a tendency to split water into H and OH? If this is happening, the OH's will tend to unite with them-

selves, giving hydrogen peroxide, or with other substances, giving peroxides. Taking, for reference, the peroxyhydrogen reaction we see that light of 700 m $\mu$  is just too low a frequency to give enough energy to split water in this way. So we say, let an organic peroxide be formed. Return now to our chemosynthetic scheme; replace part of the molecular oxygen by this peroxide in the reoxidation of the hydrogen acceptor, and in theory the efficiency for the reduction of carbon dioxide would be greatly increased.

To sum up, then, a water-splitting tendency in relation to molecular oxygen (as we first defined it) of more than unity would be required for the direct reduction of carbon dioxide. Experiment *in vitro* shows a direct reducing capacity of not more than two-thirds. One type of theory demands that we should look for the extra chemical energy at the oxygen end of the water-splitting rather than at the reducing end. So far there is no clear evidence *in vitro* that any substance can be produced *directly* by light having an oxidation potential greater than molecular oxygen.

## REFERENCES

- ARNON, D. I. & WHATLEY, F. R. (1949). *Arch. Biochem.* **23**, 141.  
 ARONOFF, S. (1946). *Plant Physiol.* **21**, 393.  
 DAVENPORT, H. E. (1949). *Proc. Roy. Soc. B*, **136**, 281.  
 DAVENPORT, H. E. & HILL, R. (1951). *Proc. Roy. Soc. B* (in the Press).  
 HILL, R. (1939). *Proc. Roy. Soc. B*, **127**, 192.  
 HILL, R. (1943). *Biochem. Soc. Proc.* **37**, xxiii.  
 HILL, R., DAVENPORT, H. E. & WHATLEY, F. R. (1951). *Proc. Roy. Soc. B* (in the Press).  
 HILL, R. & SCARISBRICK, R. (1940). *Proc. Roy. Soc. B*, **129**, 238.  
 HILL, R. & SCARISBRICK, R. (1951). *New Phytol.* (in the Press).  
 HOLT, A. S. & FRENCH, C. S. (1948). *Arch. Biochem.* **19**, 368.  
 HOLT, A. S. & FRENCH, C. S. (1949). *Photosynthesis in Plants*, p. 277. Iowa.  
 INMAN, O. L. (1935). *Cold Spr. Harb. Symp. Quant. Biol.* **3**, 184.  
 KEILIN, D. & HARTREE, E. F. (1939). *Proc. Roy. Soc. B*, **127**, 167.  
 KEILIN, D. & HARTREE, E. F. (1940). *Proc. Roy. Soc. B*, **129**, 277.  
 KEILIN, D. & HARTREE, E. F. (1949). *Nature, Lond.*, **164**, 254.  
 MOLISCH, H. (1925). *Z. Bot.* **17**, 577.  
 VAN NIEL, C. B. (1931). *Arch. Microbiol.* **3**, 1.  
 RABINOWITCH, E. I. (1945). *Photosynthesis*, vol. I. New York.  
 SCARISBRICK, R. (1948). *Ann. Rep. Chem. Soc. for 1947*, **44**, 236.  
 SMITH, E. L. (1940). *Science*, **91**, 199.  
 WARBURG, O. & LUTTGENS, W. (1946). *Biochemiya*, **11**, 303.  
 WILLSTÄTTER, R. & STOLL, A. (1918). *Untersuchungen über die Assimilation der Kohlensäure*. Berlin.

## EXPLANATION OF PLATE I

Visible absorption spectrum  $\times 3$ , diffraction grating 14941 lines to inch, camera lens e.f.l. 5.75 in., slit width 5 A. *a*, cytochrome *f* (from parsley leaves) showing  $\gamma$  band; *b*, the same, conc.  $\times 6.7$ , showing  $\alpha$  and  $\beta$  bands; *c* and *d*, cytochrome *c* (from horse heart) at the same two concentrations. (Red end of spectrum on left; violet end on right.)

# THE PHOTOCHEMICAL REDUCTION PROCESS IN PHOTOSYNTHESIS

BY C. S. FRENCH AND H. W. MILNER

Carnegie Institution of Washington, Division of Plant  
Biology, Stanford, California

## I. INTRODUCTION

On an occasion such as this, all of us who are working towards a common goal by using very different experimental techniques and theoretical concepts may well take time from the detailed presentation of the latest results to ask ourselves and our colleagues just what it is that we want to know about photosynthesis. Having asked this question, one may follow it by inquiring into the value of finding the answers to the specific questions we are planning to ask of nature when we return to our separate laboratories. In order to ask these questions clearly and precisely, in a way which may be applied by each of us to our own particular problems, we must first attempt an evaluation of the present state of affairs. By comparing our present knowledge with those aspects of photochemical  $\text{CO}_2$  assimilation which are not yet understood, but which nevertheless are not too far removed from the known facts of to-day, we may gain some perspective useful in the detailed planning of experimental work. Since we are forced to limit our immediate aspirations to attainable objectives, the continual reconsideration of the developments in related sciences may bear very directly on our research planning and may appreciably broaden the scope of our undertakings. In order that these objectives may have significance, they must fit in with the overall state of knowledge as it applies to the correlation of our findings with the wider theoretical understanding of chemical biology.

To visualize the problems involved in the investigation of photosynthesis it is convenient to use an analogy. Imagine a box which has an opening into which water and carbon dioxide may be poured and a spout from which oxygen and carbohydrates emerge when the box is illuminated. Our problem is to find out what is in the box. If we take the cover off the box to look inside, then carbohydrates stop coming out. The process is interfered with when the cell is destroyed. About ten years ago Hill discovered that it is possible to saw the box in half and to investigate separately one step of photosynthesis, namely, the splitting of water. We may now represent photosynthesis by two separate boxes, the first one of which is

amenable to study in extracts. This first box represents the reducing activity of illuminated chloroplasts, now known as the Hill reaction, and it can be opened for inspection without stopping its action. The second box represents the reduction of carbon dioxide by a reducing substance which

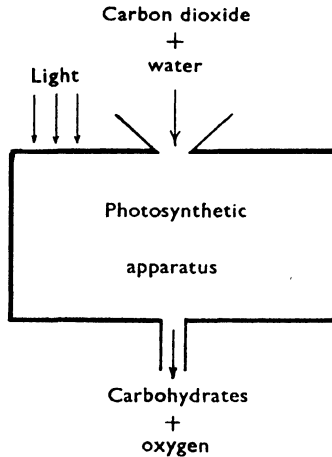

Fig. 1. An analogy. The photosynthesis problem is to find out the nature of the mechanism inside the box.

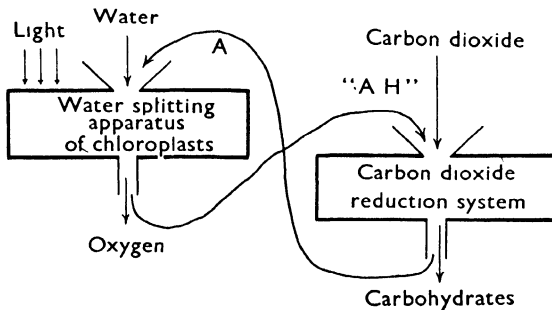

Fig. 2. A further analogy. Two parts of the photosynthesis problem can be separately investigated by different means. The process represented in the box on the left can be carried out by plant extracts while intact cells are required for the overall process or to make the reduction product from the light reaction act on the  $\text{CO}_2$  fixation mechanism.

is formed by the first box. This substance 'A' is still chemically unknown and represents a hypothetical link between the known step carried out in box 1 and the unknown steps in box 2. We do not know what this link between the boxes actually is in nature, but we do know of common reducible substances that can be used in its place for the investigation of

the action of box 1 in water splitting and hydrogen transfer. We do not yet have an extract which could be represented by box 2.

At present, a striking thing about the field of photosynthesis is that the investigators are mainly divided into two armies, one of which is attacking the photochemical part of the cycle. Those of us who belong to this camp are speaking of the first step of photosynthesis as the splitting of water molecules. The other army, busy laying siege to the mechanism of  $\text{CO}_2$  reduction, refer to the first step of photosynthesis as the reaction between carbon dioxide and some carbon dioxide acceptor molecule to form the first product of photosynthesis. It is obvious that these two armies are allies approaching a common objective—that is, the detailed understanding of the mechanism of photochemical  $\text{CO}_2$  reduction. It is indeed fortunate that representatives of these two different lines of approach can meet together here for the discussion of current experimentation and the clarification of the next immediate objectives in our individual research programmes.

The mechanism of photosynthesis appears to function in a cyclical manner. At whatever point one chooses to attack this cycle, that part of the process appears to be the first step of the reaction. Many steps in the cycle cannot be approached directly by the experimental procedures which are now available.

As the result of experiments by many different workers, particularly during the last quarter of a century, it is becoming obvious that the first step in the cycle which takes place after the absorption of light is a reaction involving the splitting of water molecules. The oxygen which is evolved by photosynthesis comes from the water and not from the carbon dioxide molecule, according to the opinions of the majority of workers in this field (reviewed by Johnston and Myers, 1943; French, 1946; Holt & French, 1948*a*; contrary evidence discussed by Yosida, Morita, Tamiya *et al.* 1942). The driving power for  $\text{CO}_2$  fixation is provided by this first photochemical reaction, and is made available in the form of a reduction product. The nature of this product itself is not yet known, but we have some information on the process by which it comes into being. We speak of the first step as being the splitting of water, yet we must continue to realize that this first detectable change may itself be brought about by the consecutive action of several distinct mediators. We know roughly what the overall result of this part of the process is. The question now becomes: How is the reaction carried out and by means of what specific catalysts? We may also ask whether or not there is a single reduction product which serves as a reservoir for the storage of chemical energy immediately after its conversion from light energy. The uniqueness in nature of green plants is their

ability to use light as power for the formation of a host of specific compounds.

The knowledge of the various parts of the process of photosynthesis appears to be in direct proportion to the availability of techniques for studying the individual parts of the mechanism. Isotopic tracers have given the means for investigating the part of the cycle in which carbon dioxide enters our second box and also the source of oxygen from the first box. Photochemical techniques have indicated the nature of the participation by pigments. Studies of the function of pigmented and non-pigmented components of chloroplasts have been carried nearly to the limits of the available methods. Progress leading to a real break-through into a realm of understanding at a deeper level appears clearly dependent upon finding suitable techniques for the separation and identification of the components of chloroplasts which catalyse the oxygen evolution step in photosynthesis.

## II. EXPERIMENTAL TECHNIQUES FOR THE INVESTIGATION OF WATER-SPLITTING BY CHLOROPLASTS

*Isolation of chloroplasts.* Chloroplast suspensions containing fragments of cells and cell sap may easily be prepared by grinding leaves in a mortar with or without sand followed by mere straining through cloth. This simple procedure was used by Hill in his pioneering work. It is still generally true that the introduction of refinements designed to obtain more nearly pure chloroplast suspensions results in preparations which have a lower specific activity. Disintegration of leaves in the Waring Blendor for short periods of approximately a minute, either in water or in 0.5M sucrose has been used by many investigators. Such suspensions, after straining, may be treated by differential centrifugation to give as pure preparations as may be necessary for the particular purposes for which they are to be used. By the microscopic observation of sediments and supernatants, suitable conditions may be worked out for the isolation of chloroplasts from practically any plant material. On centrifuging, starch and cell nuclei separate out at the bottom of the tube with a layer of chloroplasts above this. With low-speed centrifugation the broken chloroplasts and finer particles may be made to remain in suspension and thus may be discarded.

The procedure which we regularly use represents a compromise between procedures which give a high purity and those which yield material of a high specific activity. In brief, the procedure (Milner *et al.* 1950) now consists of disintegrating 100 g. of leaves in 150 c.c. of water in the Waring Blendor for one-half to one minute. This mixture is then filtered through

cloth on a Buchner funnel and centrifuged for 15 min. at 12,000 g at 0° C. This procedure leaves a heavy layer of starch and cell nuclei on the bottom of the tube with a layer of chloroplast material above. The supernatant liquid, after this high-speed centrifugation, is brown and contains very little of the chloroplast material. This liquid is discarded. The green layer of chloroplast material is removed from the starch with a spatula. The whole and broken chloroplasts are then resuspended in water or other medium. This suspension is then used directly or is subjected to a fine disintegration procedure.

*Methods of measuring the activity of chloroplast suspensions.* Probably the safest and most straightforward method of measuring activity is to determine the oxygen evolution manometrically. This has been done by workers with various substrates, such as the ferric oxalate-ferricyanide mixture of Hill, ferricyanide alone, quinone, indophenol dyes, or dichromate. The substances which chloroplast suspensions have been found to reduce are relatively limited in number. The direct measurement of oxygen eliminates any complication introduced by side reactions which may remove substrate by some mechanism which does not produce oxygen. Since the methods based on oxygen determinations, either by haemoglobin (Hill, 1937) or by manometric procedures (Hill & Scarisbrick, 1940; Aronoff, 1946; Arnon & Whatley, 1949; Warburg, 1946), are so well known and have been so widely used, we will discuss here only the two procedures which we have found to be particularly convenient for rapid measurements of a large number of samples.

One simple procedure used with ferricyanide as a substrate, either with or without the presence of ferric oxalate, which has proved to be quite satisfactory as a routine activity measurement is based on the titration of the acid produced by the reduction of ferricyanide. This procedure has been described by Holt & French (1946). It has the advantage of requiring only simple equipment, and measurements may be made rapidly without waiting for temperature equilibrium to be obtained as precisely as is necessary for manometric determinations. The equipment consists simply of a beaker surrounded by water at a constant temperature of about 10° C. This beaker is illuminated through the bottom by a beam of light filtered through red glass. This filtering is necessary to prevent the decomposition of the reagents by light. Above the beaker is mounted a fine-bore burette with a water jacket; a glass electrode connected to a pH meter dips into the beaker. One adjusts the initial pH to a definite value, such as 6.5 or 7, by the addition of drops of dilute acid or alkali. After the light is turned on, dilute sodium hydroxide solution is allowed to flow into the stirred mixture from the burette. The flow rate is controlled to keep the pH constant.

A plot of the burette readings against time gives a straight line for 5 or 10 min. The slope of this line is in direct proportion to the activity of the chloroplast preparation. This procedure has been used extensively by Clendenning & Gorham (1950*a, b*) of the Canadian Research Council. These workers found that chloroplasts from many species have the ability to catalyse dark reactions which cause some interference. However, the species related to spinach were remarkably free from these interfering complications. With spinach chloroplasts the stoichiometry of the reaction has been checked by Holt and by the Canadian group.

Another procedure dependent upon the photometric measurement of dye concentration has been developed by Holt & R. F. Smith and described in an improved form by Milner, French, Koenig, & Lawrence (1950). The advantages of this method lie in its extreme ease of operation and in the small quantities of chloroplast material which are required for a single determination. Holt & French (1948) found that the quantities of oxygen determined manometrically for the complete reduction of the dye indophenol, agree quantitatively with the amount of indophenol added to the reaction mixture. By using a substituted dye, 2, 6-dichlorophenol indophenol, which is blue at pH 6.5, we were able to work with much smaller amounts of material than with the red indophenol. Since this dye is so highly coloured, it is not possible to make manometric determinations in its presence, because the amount of dye required to give a measurable pressure change absorbs so much light that the chloroplasts do not receive enough for their photochemical action. It is probably justifiable to assume that its stoichiometry is as reliable as that of the unsubstituted indophenol.

We have an arrangement whereby the intensity of light transmitted by a mixture of dye and chloroplast suspension in a square cell of 1 cm. thickness actuates a photocell, which, by means of an amplifier and a Brown recorder, plots the light transmission of the mixture as a function of time. Using suitable calibration data, all that is necessary to make a measurement is to insert a cell containing the chloroplast suspension but not the dye, adjust the recorder deflexion to full scale, then replace the cell with a similar mixture containing the dye and allow the machine to run for two minutes. At the end of two minutes the abscissa of the recorded curve is compared with a previously prepared table which gives the first-order velocity constant for the reaction. This constant is proportional, over a wide range, to the amount of chloroplasts added, the light intensity being high enough so that the mixture is completely saturated with light. With this procedure the time required for pipetting samples is just about equal to the time used in allowing the reaction to proceed. This method has been used as a routine for several years and seems to be well adapted to the

measurement of activities of different fractions obtained from intact or disintegrated chloroplast preparations. The composition of the reaction mixture is given in Table 1.

Table 1. *Reaction mixture*

Dye, 2, 6-dichlorophenol indophenol	$3.3 \times 10^{-5}$ M
K phosphate, pH 6.5	0.0133 M
KCl	0.0033 M
Chloroplast material	0.02-1.0 mg./ml.
Chlorophyll in chloroplast material	0.001-0.06 mg./ml.
Volume	3.0 ml.
Temperature	15° C.

By measuring the electrical potential of a platinum electrode immersed in the mixture of chloroplast material, buffer, and a suitable oxidant, it is possible to determine the changes in the ratio of the oxidized and reduced form of the oxidant. By this means Macdowall (unpublished work in this laboratory) and Spikes, Lumry, Eyring & Wayrynen (1950) have made determinations of the photochemical activity of chloroplasts. The sensitivity and speed of this procedure are greatly in its favour and it will presumably be used in many future studies.

*The disintegration of chloroplasts.* Our ultimate objective in this whole undertaking has been to separate from each other the various components of chloroplasts which are required for the photochemical catalysis of the water-splitting reaction. We have, therefore, paid particular attention to means of disintegrating chloroplasts into extremely small particles. It has been the hope that it might be possible to break chloroplasts apart to such small dimensions that the individual particles might differ from each other in chemical composition and might contain different components of the active system. With sufficient reduction in size, it may be that the methods of protein separation could be applied, thus yielding preparations of the various components. The great difficulty in such work is to find means of very thorough disintegration which are not so drastic as to cause great loss of activity. Problems of this type are continually being faced by those who wish to investigate an enzyme which is not easily water-soluble.

Prolonged grinding in sand in a mortar does give some small active particles which will remain in solution after high-speed centrifugation. The yield is, however, extremely small. Another method of obtaining a low concentration of disintegrated chloroplasts is by treating the chloroplast suspension in a Waring Blendor for 10 min. or more. Neither of these methods has proved to be very satisfactory. A much better means has been the use of supersonic vibrations applied to the water suspension of chloroplasts (French, Holt, Powell & Anson, 1946). By the use of this procedure we have obtained many moderately concentrated preparations of

finely homogenized chloroplast preparations. In our hands, however, this procedure has not proved to be reliable, since the yield and activity of the material obtained vary greatly from one preparation to another and the dispersions obtained are only about one-half the concentration of those prepared by the valve method to be described below. Strangely enough, fairly active preparations are obtained by grinding in sand the sediment obtained by high-speed centrifugation of a supersonically treated chloroplast suspension. This, however, requires half-an-hour of grinding after the supersonic treatment and yields very small amounts of material at low

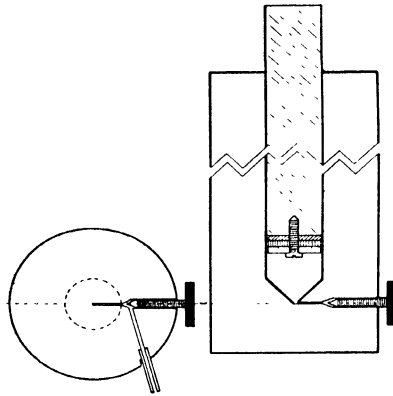

Fig. 3. Apparatus for the very fine disintegration of biological material suspended in water. The suspension is forced through the needle valve by the piston which is pushed down by a large hydraulic press. Leakage is prevented by a rubber washer. Between the rubber and the steel piston is a leather washer which keeps the rubber from creeping between the cylinder wall and the piston. Both washers are held in place by a screw and a loose steel disk. Owing to the high pressure the steel cylinder should have the bottom of the bore rounded off as it starts to taper.

concentration. While the use of supersonic irradiation does not prove satisfactory as a routine procedure for obtaining quantities of disintegrated material, it did, however, demonstrate the feasibility of fine homogenization of chloroplast material with the retention of appreciable activity. A number of experiments with detergents which can be made to give finely dispersed solutions of chloroplast material have, in general, been unsatisfactory, due to the loss of activity. With a very few detergents narrow ranges of concentration have been found which decrease the particle size of chloroplast homogenates without causing complete loss of activity. The use of detergents has not, however, proved to be useful for preparative purposes.

The best method that we have yet found for breaking chloroplasts into extremely small fragments is simple in operation (Milner *et al.* 1950*b*). By forcing the chloroplast suspension at very high pressure through a

needle valve to atmospheric pressure, very extensive and fine disintegration takes place. This procedure is carried out in a thick-walled steel cylinder with a needle valve at one end and a plunger at the other end as in Fig. 3. The plunger is forced into the cylinder by means of a hydraulic press. The chloroplast suspension, as it emerges from the needle valve, is caught in a refrigerated container. The whole assembly is packed in ice before use. By this means the material is not appreciably inactivated by the rise in temperature during passage through the valve, which takes place at the rate of about 5 c.c./min. from a pressure of 20,000 lb./sq.in. With this equipment we find that a large fraction of the chloroplast material may be finely dispersed with a resulting loss of about two-thirds of the activity or, by using lower pressures, we may obtain less complete dispersion with greater retention of activity. Within the limits of 2-16 ml./min. the results are unaffected by the rate of flow. At slower rates inactivation of the material takes place due to prolonged exposure to this pressure. At much faster rates, the valve is so wide open that disintegration is not achieved. If the rate is held within the above limits, the extent of dispersion and loss of activity are both dependent on the pressure used. Throughout these experiments we used the criterion of withstanding centrifugation for 30 min. at 12,000 g as a definition of dispersion.

The superiority of the valved material to that dispersed by supersonic vibration is shown in Fig. 4. The particle size of the valved material appears much smaller since it separates out slower when centrifuged at high speed.

*Stabilization of chloroplast activity.* Of all the modifications in the procedure for working with isolated chloroplasts none has proved to be more important than the finding that such preparations may be partially stabilized. The number of experiments done by many different investigators in the attempts to find a satisfactory method of stabilizing chloroplast suspensions has indeed been large, and the problem has by no means been completely and satisfactorily solved at the present time.

Drying from the frozen state which is so widely satisfactory with various enzyme preparations has proved to be somewhat disappointing when applied to chloroplast preparations. Some years ago it was found possible to lyophilize chloroplast preparations without too great loss in activity (French *et al.* 1946). However, the material never resuspends to give small particle size after this treatment. It appears as though the lipid content caused considerable trouble. It may be that when the water is removed the lipid spreads over the little particles and acts as a sort of cement which prevents their redispersion. Removal of only a small part of the total lipid content of the material completely inactivates it. Lyophilization of intact

chloroplast preparations has been extensively investigated by Clendenning & Gorham (1950c) and it is evident from their experiments that nearly complete activity may be retained by lyophilized chloroplast preparations provided sucrose is added to the medium before freezing. However, it is necessary to store the material at extremely low temperatures to avoid inactivation even from a lyophilized state. Until some satisfactory means can be found for redispersing lyophilized preparations of disintegrated chloroplasts it will probably be necessary to continue to rely on the use of wet preparations.

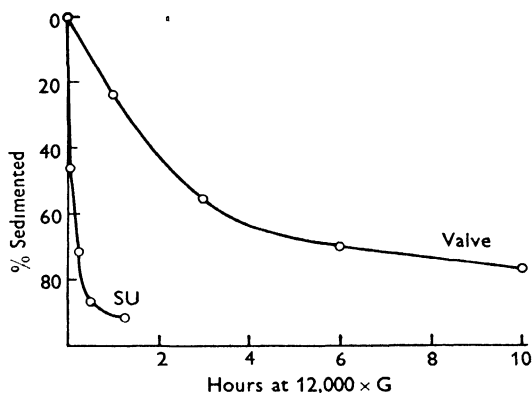

Fig. 4. Comparative sedimentation rate of chloroplast dispersion prepared by supersonic vibration (*SU*) and by pressing through the needle valve at 20,000 lb./sq.in.

Warburg has reported that the use of phosphate buffer with a low concentration of KCl improves the stability of disintegrated chloroplasts. This method, unfortunately, does not stabilize the material which we use. Holt & French (1949) used 15% propylene glycol to increase the stability, but this stabilization is far from adequate for most purposes and the incorporation of the propylene glycol greatly complicates micro determinations of protein nitrogen.

In the course of experiments designed to fractionate the dispersed chloroplast material it was unexpectedly found that 15% methanol in water is the best stabilizer yet tried. In Fig. 5 we have the activity of dispersed chloroplast material in water and in aqueous methanol plotted against time of storage. By the use of 15% methanol it is possible to store these preparations at  $-5^{\circ}\text{C}$ . Under these conditions the half-life of a preparation has been prolonged from about a day without stabilizer to a week or 10 days in the presence of 15% methanol. It is thus possible to use a batch of dispersed chloroplast material for a week instead of for a day

only. Since the preparation takes some hours, this has indeed proved to be a great technical improvement.

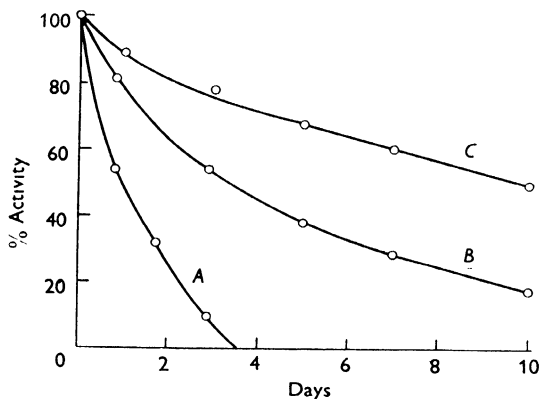

Fig. 5. The stabilization of chloroplast dispersion with methanol. A, a dispersion stored in water at  $0^{\circ}\text{C}$ . B, the same dispersion in 15% aqueous methanol at  $0^{\circ}\text{C}$ . C, the same dispersion in 15% aqueous methanol at  $-5^{\circ}\text{C}$ .

### III. CHARACTERISTICS OF DISPERSED CHLOROPLAST MATERIAL

*Particle size.* Some properties of dispersed and stabilized chloroplast material will now be discussed. Microscopic observation of chloroplasts either in the intact cell or after isolation shows that they are obviously not homogeneous in structure. They are commonly considered to be composed of so-called grana, round or perhaps disk-like bodies containing the chlorophyll imbedded in colourless material called stroma. The electron-microscope pictures of Granick (1947) clearly illustrate such a structure. They show, furthermore, that mere disruption of the chloroplasts does not by any means separate the grana from the stroma. It appears as though the two are tightly stuck together and that the fragments contain bits of both grana and stroma. A number of authors speak lightly of using suspensions of grana for experimental purposes. We know of no evidence which would support the contention that suspensions of grana free of stroma have ever been prepared. In fact, the disruption of chloroplasts, to an extent which would produce in large amounts particles the size of grana, would appear to be very difficult indeed and would require extended differential centrifugation to get a preparation which even roughly approximated to a suspension of grana in particle size. Even so, the stroma would undoubtedly be present in about equal amounts. We therefore prefer to speak of dispersed chloroplast material, the particles of which are smaller than grana

and consist of material from both grana and stroma. However valuable it would be to make preparations of grana only, much work still remains to be done before this objective can be accomplished.

The material obtained by forcing chloroplasts through the valve homogenizer followed by centrifugation for 30 min. at 12,000 g has been used in all the following experiments. An investigation of this material, in a quantitative analytical ultracentrifuge using green light which is moderately well transmitted by a thin layer of this material, showed no evidence for the existence of discrete groups of particle size that would be indicated by the formation of sediment boundaries. At the very beginning of the sedimentation a slight boundary appeared, but after the first few minutes became invisible. Thereafter the material came down as though it were completely heterogeneous. It appeared to contain a random distribution of particles about one-quarter of which separated out in 15 min. at 20,000 g and the rest after 10 min. at 60,000 g. These experiments were kindly performed for us by Drs Clark Griffin and Lafayette Noda. Another experiment carried out in a high-speed angle centrifuge by Dr Robert Lashbrook showed that 90% of the material in our preparations had a molecular weight of 6-7 millions; 10% of the material appeared to have a molecular weight smaller than this. Again, no evidence was found for any appreciable amount of material of any particular particle size.

Electron-microscope pictures of preparations of this type were kindly made by Mr Ernest Fullam of the General Electric Company. From this one batch of pictures with a single preparation it appeared that most of the material was smaller than about 20 A. in size; a number of particles of about 80 A. appeared to be present; and conglomerate particles of about 250 A. were seen containing the 80-A. particles. Groups of this particle size did not, however, appear in the sedimentation experiments. Since the centrifugation and the electron microscope experiments were performed with different batches of material at different times of the year, they are not in direct contradiction to each other; they present conflicting evidence which is as yet unresolved. Further centrifugal and electron-microscope investigations would appear to have great value in elucidating the nature of this material.

#### IV. FRACTIONATION EXPERIMENTS

By the methods which have been described it is possible to obtain clear green dispersions of chloroplast material which retain the activity for photochemical reduction and yet the chloroplast material in these preparations has been reduced to colloidal size. Whether these preparations should

be considered as solutions of protein molecules with various attached lipids or whether they are more accurately described as colloidal suspensions of very fine bits of organized material is difficult to answer. In any case the material seems to be as well dispersed as are a good many proteins and enzymes. It therefore appears as though a straightforward approach by the usual means of enzyme chemistry might result in the isolation of the active components of this solution.

By adding 0.25 saturated ammonium sulphate to a dispersion of chloroplast material in water all or nearly all of the green material is removed. Remaining in the solution there is a still measurable amount of colourless protein. Perhaps one-third of the original protein concentration would be a maximum value for the colourless protein. These green precipitates, when stirred up in water, resuspend very poorly, but have some activity. Their activity is, however, far lower than that of the starting material, either on a nitrogen or a chlorophyll basis. There seems to be no hope of concentrating active material by salt precipitation. By lowering the pH, even at very low buffer concentrations, a green precipitate may also be obtained. Numerous fractional precipitation experiments by pH lowering have given results slightly better than those obtained by salting out. The activity is, however, never as great as that of the original dispersion.

Precipitates obtained by treatment with dilute salt of dispersions in 15% methanol have a higher activity than the starting material. This, however, is an activation phenomenon and not an effect due to a concentration of active components. It will be discussed in detail below.

A peculiar property of the dispersed chloroplast material is its solubility in salt-free ethanol. The addition of alcohol even up to 95% does not form a precipitate of protein unless allowed to stand for some hours while protein denaturation takes place. This denaturation and formation of a white protein precipitate takes place slowly and only above 50% alcohol concentration.

The failure of all fractionation experiments immediately suggests that the activity may be due to the concerted action of several different components. Thus the purification of any one of these components would automatically result in a diminished activity due to the loss of other factors needed for the reaction. Numerous experiments have been performed to test this possibility. The readdition of fractions previously separated from each other has never as yet resulted in activities greater than the sum of the individual activities. The effects of reactivation by aggregation do, however, indicate that several components might be involved which by precipitation are brought closer together. If various components exist, there is at present no direct means of preparing solutions containing varying proportions of these different factors.

Separations have been carried out by long-continued differential centrifugation at high speed. These experiments also do not show any fractions which contain more activity on a chlorophyll or protein basis than does the starting material. All supernatant fractions obtained by centrifugal fractionation have lower activity than the starting material. The differences indicate that the larger particles have greater activity than the smaller ones.

One great technical difficulty in these fractionation experiments is the trouble caused by the practical impossibility of suitably redispersing precipitated chloroplast material. It can be stirred up in water as a turbid suspension and tests for activity can be made. It is not possible, however, to compare such measurements with the activity of other fractions in a different state of dispersion. This difficulty in redispersion caused by precipitation may be due to the lipid content of the material. Most of the results of fractionation experiments have therefore been obtained by testing the activity of supernatant fractions.

Fractional adsorption of dispersed chloroplast material by fuller's earth or by charcoal, if carried out far enough so that all but a small percentage of the material is removed by adsorption, gives a high activity of the unadsorbed material. The activity of the supernatants obtained by this procedure may be two or three times that of the starting material.

#### V. THE INCREASE IN ACTIVITY OF DISPERSIONS BY REAGGREGATION

The addition of salts to the colloiddally dispersed chloroplast preparations in the presence of 10–30% methanol gives precipitates at much lower salt concentrations than in the absence of methanol.

The addition of salts to colloiddally dispersed chloroplast material in water has no significant effect upon the activity until the salt concentration becomes high enough to cause precipitation of the chloroplast material. Such precipitation is accompanied by loss of activity, until at complete precipitation the material is almost wholly inactivated.

When salts are added to chloroplast material dispersed in dilute methanol, the effects are quite different. Precipitation occurs at much lower salt concentrations, and the precipitates show an *increase* in activity (Milner *et al.* 1950a). No significant increase in activity is found unless there is also precipitation, while, as has been pointed out, precipitation under other conditions is accompanied by a loss of activity. In order to obtain an increase in activity, the precipitation must occur under special conditions.

A number of experiments were made at methanol concentrations from 10 to 30% and salt concentrations from zero to 0.2M. Using KCl as the

precipitating salt, a strong activation effect was observed at 0.1 M-KCl with the dispersion in 20% MeOH. Under these conditions precipitation of the chloroplast material was complete, and the activity of the precipitate was occasionally almost equal to, but never above, the activity of the chloroplast suspension before dispersion of the material. Ordinarily the 'salt reactivation' gave a 100–200% increase in the activity of the dispersion.

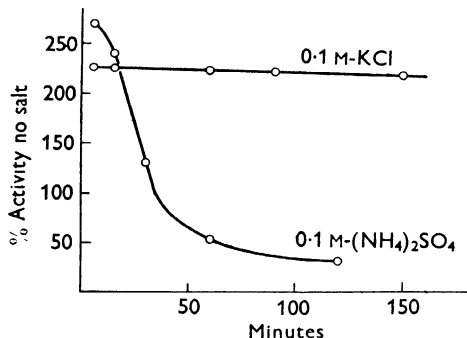

Fig. 6. The salt activation effect measured at various times after adding either KCl or  $(\text{NH}_4)_2\text{SO}_4$  to a chloroplast dispersion in 15% methanol whose initial activity without salt was taken as 100%.

The activation effect reaches a maximum a few minutes after addition of salt to dispersed chloroplast material in dilute methanol. This activation slowly disappears, until after some hours the material treated with salt has the same activity as an untreated control stored under the same conditions. One exception to this slow loss of activation was noted in dispersions treated with  $(\text{NH}_4)_2\text{SO}_4$ . Not only was the loss of activation rapid, but it was followed by an inactivation of the chloroplast material. Fig. 6 illustrates the difference in the effect of KCl and  $(\text{NH}_4)_2\text{SO}_4$ , both in 20% methanol. Because of this effect the activity of all such mixtures is ordinarily measured within a few minutes after their preparation.

In addition to the influence of the salt and the methanol concentration on the activation, the concentration of the dispersed material itself plays a part. More concentrated preparations give a greater rise in activity for the same treatment as shown in Fig. 7.

This reactivation effect is not specific for K-ion or Cl-ion, nor for KCl. It was obtained by addition of a number of other salts to dispersions of chloroplast material in aqueous methanol. It seems likely that it is a cation effect, because larger activations were obtained by addition of  $\text{Na}_2\text{SO}_4$  and  $\text{K}_2\text{SO}_4$  than by equimolar additions of the corresponding chlorides. Also, some divalent cations gave good activation effects at concentrations much lower than those found for monovalent cations.

Fig. 8 shows the effect of treating dispersed chloroplast material in 20% methanol with 0.01M phosphate buffer at various pH values. The 0.01M phosphate in slightly acid solution produced the same type of activation

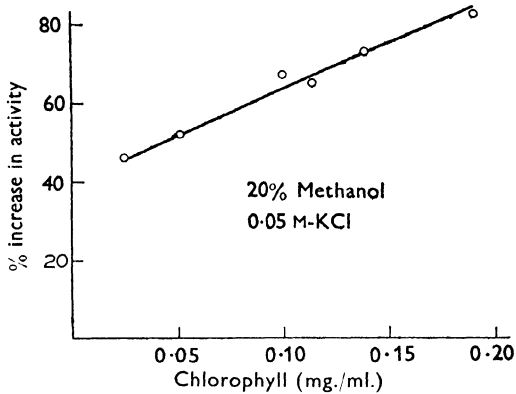

Fig. 7. The activation produced by the addition of a salt to a chloroplast dispersion in aqueous methanol is greater the higher the concentration of the chloroplast material.

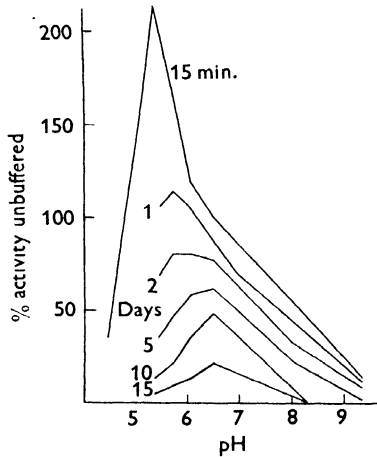

Fig. 8. Lowering the pH of a preparation of dispersed chloroplast material in 20% methanol gives an activation effect correlated with the formation of a precipitate as seen in the top curve measured 15 min. after the addition of buffer. The other curves show the gradual loss of activity at different pH values of these same preparations.

with precipitation as found with 0.1M neutral salts, both in 20% methanol. After the disappearance of the activation effect during the first two days, the maximum stability appears to be at about pH 6.5. All samples were stored at 0° C. for the duration of the experiment.

This reactivation of dispersed chloroplast material by its precipitation under controlled conditions suggests that the activity which we measure is a surface phenomenon. In the colloidal dispersions the lowered activity may be due to spatial separation of component parts of the reactive system. In the salt precipitation, these reactive centres are again brought close together and the reaction rate is increased.

#### VI. STUDIES OF THE PHOTOCHEMICAL STEP IN INTACT ORGANISMS IN RELATION TO CHLOROPLAST ACTIVITY

There are a number of different types of experiment with living cells which lead to the conclusion that for the first step, the splitting of water, other factors than chlorophyll are concerned. Recent experiments by Smith (1950) have shown that the other factors necessary for the evolution of oxygen by leaves which have recently formed chlorophyll take a longer time to develop than does chlorophyll itself. It may thus be possible to investigate the rate of formation of the accessory factors, as well as chlorophyll, in etiolated leaves when they are exposed to light.

The Hill reaction is observable in intact *Chlorella* cells and recently Davis (1948, 1950) has found mutants of *Chlorella* which contain chlorophyll but are not capable of doing photosynthesis. One strain of these *Chlorella* mutants is capable of giving the Hill reaction, whereas in two other strains some factor which is required for this reaction is missing. It may be that these partially greened leaves of Smith or the *Chlorella* mutants of Davis may yield biochemical preparations which can be combined with extracts of normal leaves to give an assay method for the separate components responsible for the activity of chloroplasts.

#### VII. SOME UNSOLVED PROBLEMS OF THE PHOTO- CHEMICAL REDUCTION PROCESS

In conclusion, it may be well to emphasize some of the more important questions which have been raised by the experiments that have already been made. It seems as though some of the fundamental questions may profitably be investigated in the near future.

One of the major gaps in our knowledge of photosynthesis, if not in all biology and chemistry, is the chemical nature of chloroplastin. To the naked eye this is the most obvious organic substance on the face of the earth. Yet its exact chemical nature is far from being clear. The absorption spectrum, stability and photochemical behaviour of chlorophyll extracted by organic solvents has been studied in detail, but it is well known that such extracted chlorophyll differs greatly in all these properties from

chlorophyll in its natural state. A beginning has indeed been made in the clarification of the nature of this natural complex as it occurs in leaves by the investigations of Lubimenko (1927), Stoll & Wiederman (1938), Emil Smith (1938), and many other workers. There is, however, no definite evidence that the substance has ever been or can be prepared in a pure state, free of other proteins, various extraneous lipids, and the other plant pigments. While the analogy of chloroplastin to haemoglobin has been valuable and has stimulated interest in attempts to define its nature more clearly, this analogy is decidedly limited in its application. Since chloroplastin contains far more chlorophyll molecules than it does protein molecules, it may well be that, if this substance can be prepared and studied by adequate chemical and physical methods, it will prove to be a somewhat different type of complex than has yet been recognized by biochemists. The fact that it does not seem to fit the usual categories of well-understood substances has prevented the use of the ordinary techniques in elucidating its structure. Presumably the attempted preparations of this substance have yielded chloroplast particles containing other chloroplast constituents in addition to chloroplastin itself. The first need is a means of disintegrating chloroplasts to even smaller particles than has yet been accomplished, and then the application of adequate separation methods to obtain something containing the chlorophyll which could be called a chemical compound. Whether or not this substance will turn out to be a protein with chlorophyll as a prosthetic group or whether it is a complex of variable composition including various lipids and other pigments and perhaps even various proteins cannot yet be predicted. The composition of chloroplastin preparations from various species and from leaves treated in various ways and also the fractions obtained by different methods of preparation are greatly in need of careful investigation, both by ordinary analytical chemical methods and also by the physical apparatus of protein chemists.

One of our most pressing problems is to obtain definite evidence for or against the hypothesis that other factors than chloroplastin are really participating in the first photochemical step carried out by chloroplast material. If these other factors do exist, some means of testing for their activity and preparing them in a relatively pure state must be devised. Presumably, the method of testing the activity of these hypothetical components would be to use a preparation of pure but undenatured chloroplastin which when added to the extracts containing the hypothetical extra factors would cause the photochemical process to take place.

The participation of phycoerythrin and phycocyanin in photosynthesis raises the question whether or not other natural pigments may carry out

photochemical reduction or whether this is a peculiarity of chlorophyll. The work of Haxo & Blinks (1950), showing that these other pigments are even more effective in photosynthesis than is chlorophyll itself, has brought this problem into the foreground. There is, however, no evidence so far that these pigments can act as photosensitizers for the Hill reaction.

The nature of the natural hydrogen acceptor which in the experiments described here has been replaced by a reducible dye needs much investigation. Is this natural hydrogen acceptor always the same substance or may various metabolic products be produced directly by the photochemical system? The nature of linkage between the photochemical reduction process and the reduction of carbon dioxide remains one of the more intriguing problems in the whole field of photosynthesis.

## REFERENCES

- ARNON, D. I. & WHATLEY, F. R. (1949). *Arch. Biochem.* **23**, 141.  
 ARONOFF, S. (1946). *Plant Physiol.* **21**, 393.  
 CLENDENNING, K. A. & GORHAM, P. R. (1950a). *Can. J. Res. C*, **28**, 78.  
 CLENDENNING, K. A. & GORHAM, P. R. (1950b). *Can. J. Res. C*, **28**, 102.  
 CLENDENNING, K. A. & GORHAM, P. R. (1950c). *Can. J. Res. C*, **28**, 114.  
 DAVIS, E. A. (1948). *Science*, **108**, 110.  
 DAVIS, E. A. (1950). *Science*, **112**, 113.  
 FRENCH, C. S. (1946). *Ann. Rev. Biochem.* **15**, 397.  
 FRENCH, C. S., HOLT, A. S., POWELL, R. D. & ANSON, M. L. (1946). *Science*, **103**, 505.  
 GRANICK, S. & PORTER, K. R. (1947). *Amer. J. Bot.* **34**, 545.  
 HAXO, F. & BLINKS, L. R. (1950). *J. Gen. Physiol.* **33**, 389.  
 HILL, R. (1937). *Nature, Lond.*, **139**, 881.  
 HILL, R. & SCARISBRICK, R. (1940). *Nature, Lond.*, **146**, 61.  
 HOLT, A. S. (Manuscript in preparation.)  
 HOLT, A. S. & FRENCH, C. S. (1946). *Arch. Biochem.* **9**, 25.  
 HOLT, A. S. & FRENCH, C. S. (1948). *Arch. Biochem.* **19**, 368.  
 HOLT, A. S. & FRENCH, C. S. (1948a). *Arch. Biochem.* **19**, 429.  
 HOLT, A. S. & FRENCH, C. S. (1949). Chap. 14 in J. Franck and W. E. Loomis, *Photosynthesis in Plants*. Ames, Iowa, U.S.A.: The Iowa State College Press.  
 HOLT, A. S., SMITH, R. F. & FRENCH, C. S. (Unpublished experiments.)  
 JOHNSTON, E. S. & MYERS, J. E. (1943). *Ann. Rev. Biochem.* **12**, 473.  
 LUBIMENKO, V. N. (1927). *Rev. gen. Bot.* **39**, 619.  
 MILNER, H. W., FRENCH, C. S., KOENIG, M. L. G. & LAWRENCE, N. S. (1950). *Arch. Biochem.* **28**, 193.  
 MILNER, H. W., KOENIG, M. L. G. & LAWRENCE, N. S. (1950a). *Arch. Biochem.* **28**, 185.  
 MILNER, H. W., LAWRENCE, N. S. & FRENCH, C. S. (1950b). *Science* **111**, 633.  
 SMITH, E. (1938). *Science*, **88**, 170.  
 SMITH, J. H. C. (1950). *Carnegie Institution of Washington Year Book*, no. 49, p. 89.  
 SPIKES, J. D., LUMRY, R., EYRING, H. & WAYRYNEN, R. (1950) *Arch. Biochem.* **28**, 78.  
 STOLL, A. & WIEDERMAN, E. (1938). *Fortschr. Chemie Org. Naturstoffe*, **1**, 159.  
 WARBURG, O. (1946). Chap. 20 of *Schwermetalle als Wirkungsgruppen von Fermenten*, Berlin, Germany.  
 YOSIDA, T., MORITA, N., TAMIYA, H. *et al.* (1942). *Acta Phytochimica*, **13**, 1.

# THE REDUCING ACTION OF LIGHT IN PHOTOSYNTHESIS

By E. C. WASSINK

Laboratory of Plant Physiological Research, Agricultural  
University, Wageningen, Netherlands

The oxygen production of illuminated green parts of plants was discovered between 1770 and 1780. Founded upon the preliminary work of Priestley, Jan Ingen-Housz (1779, 1789) presented the first detailed account of the conditions under which  $O_2$  production takes place, recognizing the green colour and the presence of light as essential. There are good indications that the importance of the light factor in this respect was observed a year earlier by W. van Barneveld (van Barneveld, 1781; Rauwenhoff, 1853; Wassink, 1948). Robert Mayer (1845) recognized the role of light as the source of energy in photosynthesis. The meaning of the gas exchange, the connexion of  $CO_2$  uptake with  $O_2$  production, and the relation between light and dark metabolism, still remained obscure in many respects. Sachs (1865, p. 18) may be deemed to be the first who strictly formulated the hypothesis that the evolution of  $O_2$  in photosynthesis is a sign that a process of reduction is going on: 'Demnach ist die Sauerstoffabscheidung das äusserlich wahrnehmbare Zeichen, dass im Innern der Zellen verbrennliche Substanz erzeugt wird auf Kosten von Kohlensäure, Wasser und anderer hochoxydierter Verbindungen.'

A second phase was initiated when F. F. Blackman and his collaborators clearly established that a process like photosynthesis is constituted of various successive links, each of which, according to the external conditions, may act as a 'limiting factor' (Blackman, 1905). Further application of this extremely important principle to the analysis of photosynthesis came from various investigators; O. Warburg (1928) and T. H. van den Honert (1930) may be mentioned. The results of these studies opened the way for a more detailed analysis of the meaning of the various steps. The relevant work was chiefly carried out during the last 10–12 years. In the following pages a number of observations will be mentioned which, in a rather conclusive way, indicate that light is more or less directly operative in the generation of a 'reducing power' which then is available for dark reactions with  $CO_2$  or its preliminary combinations. It thus seems that the function of light energy in photosynthesis is its power to build up a reducing agent, strong enough to reduce  $CO_2$  or its immediate derivatives, which can only

be achieved in the dark with great difficulty, if at all. The lines of research that contributed to this result were, in chronological order: combined studies of photosynthesis and chlorophyll fluorescence; biochemical studies; studies of the redox potential in relation to photosynthesis; studies with tracer carbon, especially  $C^{14}$ ; studies of phosphate exchange in relation to photosynthesis. Several of these studies were carried out with green plant material, others with purple sulphur bacteria. Some results will now be examined in more detail.

Simultaneous measurements of the rate of photosynthesis and the intensity of chlorophyll fluorescence in dilute suspensions of the unicellular green alga *Chlorella* had suggested that the light, absorbed by chlorophyll, leads to an excited state of this pigment; this excited state transfers the excitation energy to an 'energy acceptor', called  $A_0$ , which in the case of *Chlorella* is present in abundance (Ornstein, Wassink, Reman & Vermeulen, 1938). In the discussion of the developed path of photosynthesis, it was stated: 'Experiments, which will be published soon, favour strongly the conception that this compound, accepting the energy from the chlorophyll, is changed into a reducing substance of the type RH, which will be called *A*. This reducing substance acts chemically with  $CO_2$  and its primary reduced stages' (Ornstein *et al.* 1938, p. 112). These experiments were chiefly concerned with the observation of fluorescence-time curves under various external conditions (Wassink & Katz, 1939). Fig. 1 (see Wassink & Katz, 1939, fig. 3) shows some fundamental observations, in which fluorescence-time relations are compared in air and in  $N_2$ , with and without complete poisoning of photosynthesis by cyanide. The important facts are: (1) fluorescence in  $N_2$  starts at a level higher than in air; (2) in both gas phases the initial part of the fluorescence-time curve is not sensitive to cyanide; (3) the final decrease of fluorescence is obvious in both gas phases in non-poisoned suspensions, fluorescence tending to virtually the same level (see Wassink & Katz, 1939, fig. 5); (4) in the presence of cyanide, this decline is suppressed, and, instead, a secondary rise, only indicated in unpoisoned suspensions, becomes very obvious. It quickly brings fluorescence (within about 20 sec.) above its initial value.

The following conclusions were drawn: With reference to observations by Kautsky & Hirsch (1935), the decline may be considered to be due to the  $O_2$  produced in photosynthesis. Thus it is not remarkable that it is suppressed in the presence of cyanide, but the rise above the starting point in the presence of cyanide calls for special attention. Remembering the quenching influence of  $O_2$  upon fluorescence, and with reference to point (2) mentioned above, we may consider the rise of the cyanide-air curve above its starting point 'as a proof for the reducing action of the light in

the immediate neighbourhood of the chlorophyll' (Wassink & Katz, 1939, p. 152).

Additional, still more direct evidence for this conclusion was obtained from the fact that the steepness of the slope of this fluorescence rise in the presence of cyanide depends upon the  $O_2$  tension present in the gas phase with which the suspension is in equilibrium (shaken Warburg vessels being used) in a way antagonistic to that of light intensity (cf. Figs. 2 and 3, being figs. 6 and 8 of Wassink & Katz, 1939). The slope becomes steeper with decreasing  $O_2$  tension and increasing light intensity (up to a certain value; at higher intensities, irregularities arise).

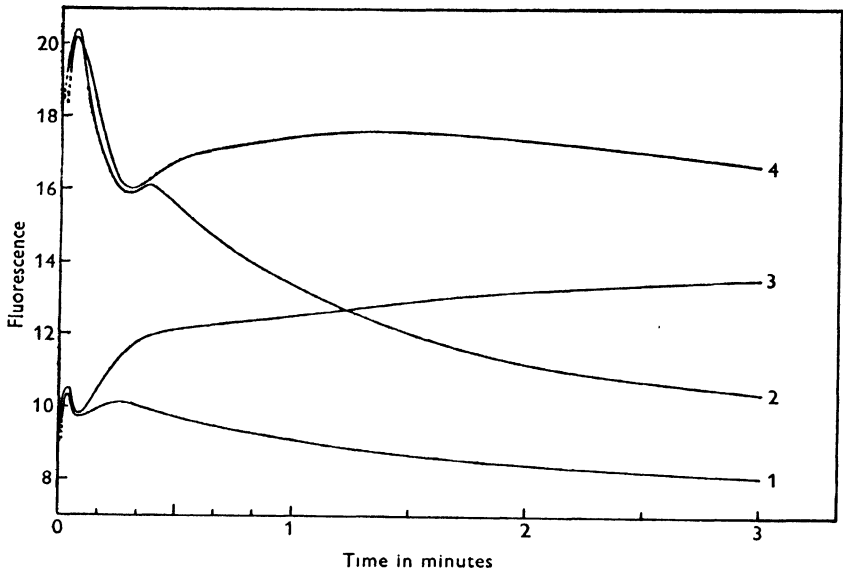

Fig. 1. Fluorescence-time relations in suspensions of *Chlorella*. In air (curves 1, 3) and in nitrogen (2, 4), with poisoning by cyanide (3, 4) and without (1, 2). (Light intensity, Na-light,  $1.38 \times 10^4$  ergs/cm.<sup>2</sup> sec., temp. 29° C.) High fluorescence associated with low  $O_2$  content. The reducing effect of light is especially manifest in curve 3 from about 10 sec. onward. (From Wassink & Katz, 1939, fig. 3.)

It may be remarked here that Gaffron (1937) had suggested that at the beginning of a light period, a catalyst of the 'Blackman system' is brought into a reduced state by light, which reduced state was assumed to be the active one. Some observations with *Scenedesmus*, yielding higher initial photosynthesis in  $N_2$  than in air, were reported as support for the above suggestion. Without attempting a detailed interpretation of these results, it may be remarked that, in general, the overall effect of light in photosynthesis does not result in establishing a more reduced state. This is shown (1) by the downward trend of fluorescence of green cells while illumination lasts as indicated above, yielding the same

ultimate value when starting in N<sub>2</sub> or in air; (2) by direct measurements of redox potentials which indicate that, under normal conditions for photosynthesis, a potential shift towards the oxidized side occurs (Tang & Lin, 1937); (3) by

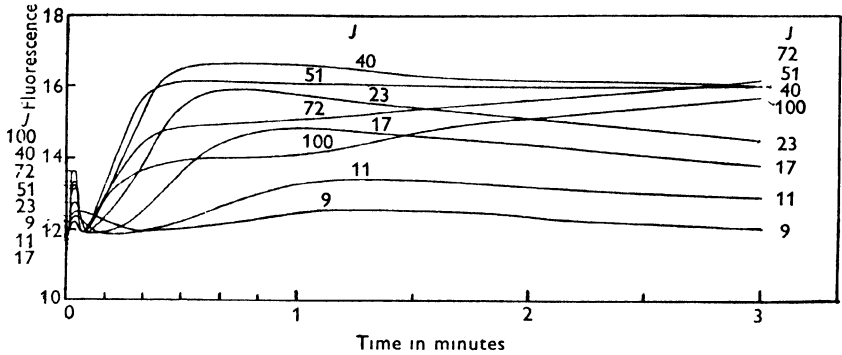

Fig. 2. Fluorescence-time relations in suspensions of *Chlorella* as a function of Na-light intensity ( $100 = 1.90 \times 10^4$  ergs/cm.<sup>2</sup> sec., gas phase air, temp. 29° C., total inhibition of photosynthesis by cyanide). Steepness of ascending slope, beginning at about 6 sec. illumination, increasing with light intensity (irregularities at the highest values). (From Wassink & Katz, 1939, fig. 6.)

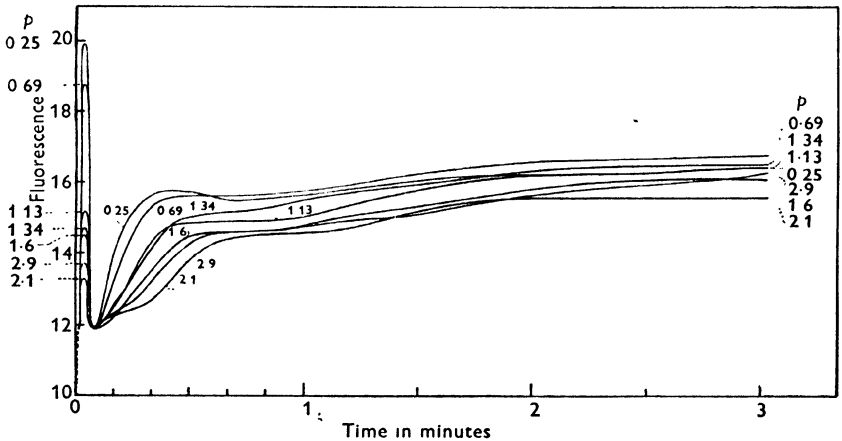

Fig. 3. Fluorescence-time relations in suspensions of *Chlorella* as a function of O<sub>2</sub> tension ( $p =$  percentage O<sub>2</sub> in gas phase, Na-light intensity  $1.38 \times 10^4$  ergs/cm.<sup>2</sup> sec., temp. 29° C., total inhibition of photosynthesis by cyanide). Steepness of ascending slope, beginning at about 6 sec. illumination, increasing as oxygen tension decreases. (From Wassink & Katz, 1939, fig. 8.)

observations on brief illuminations which show an increased reactivation of Gaffron's dark system the longer illumination and O<sub>2</sub> production last. This was observed in *Chlorella* (Wassink & Kersten, unpubl.) and in diatoms (Wassink & Kersten, 1944).

It thus would appear that in general the evidence is in favour of the view that a dark system connected with photosynthesis is, at least in green plant cells, reactivated by a shift towards the oxidized, rather than the reduced side. However, this is very likely not a *direct* effect of the light and thus does not belong to the strict subject of the present discussion.

Later on, however, Gaffron presented more conclusive evidence for a reducing effect of light in the photosynthetic apparatus. I mean the photo-activation of a hydrogenase, reflected in the evolution of  $H_2$  from irradiated suspensions of 'adapted cells' of *Scenedesmus* in  $N_2$ . According to Gaffron this photochemical evolution of  $H_2$  depends upon the presence of suitable hydrogen donors in the cell. These cells also produce  $H_2$  in a  $N_2$  atmosphere in the dark, but the reaction is accelerated at least ten times in the light (Gaffron & Rubin, 1942; Gaffron, 1944). This photo-acceleration of a hydrogenase activity may well be considered as evidence for a direct reducing effect of light.

A probably related phenomenon was observed by Wassink and Kuiper in experiments on redox potential and gas exchange in suspensions of *Chromatium* (Wassink, 1947*a, b*, 1949; Wassink & Kuiper, in prep.). The redox potential in suspensions of *Chromatium* depends, for example, on the following factors: light, composition of gas phase, pH of suspension medium. Temperature and many other factors have not yet been studied. At pH 6.6 (phosphate buffer), in a gas phase containing no  $H_2$  (used as H-donor) but containing  $CO_2$ , a conspicuous rise of the redox potential is observed upon illumination. A much lower rise occurs in the presence of  $H_2$  and  $CO_2$ , and a still lower one in the presence of  $H_2$  alone. (For additional observations and discussion of these phenomena, see Wassink, 1947*a*.) At increased pH, e.g. 8.0, the behaviour in the presence of  $CO_2$ , and  $H_2 + CO_2$ , in principle is the same as above, but in the absence of  $CO_2$ , with  $H_2$  alone, a *decrease* of potential is observed upon illumination (Fig. 4). In these cases, rather appreciable uptakes of gas, probably  $H_2$  alone, were noticed. It is not known, so far, to which acceptor this  $H_2$  is transferred with the aid of light energy. But—keeping in mind that these experiments are still of a somewhat preliminary nature, and apart from further detailed interpretations—the behaviour of the potential indicates that, under these conditions, illumination creates an increasingly reduced state. These observations thus constitute another example of a direct reducing effect of the light upon a part of the photosynthetic system. The potential shift is ascribed to the activation of a special hydrogenase by light. Under the conditions of the experiments it is unlikely that  $CO_2$  is the ultimate acceptor for the hydrogen activated by this hydrogenase, but it may play a role in the normal photosynthetic chain as well. The hydrogenase mentioned is very

sensitive to cyanide; slight doses bring the potential curve under  $H_2$  at pH 8.0 into the position it shows at pH 6.6, the specific hydrogenase activation by light no longer shows up. For a complete discussion of redox observations with *Chromatium* the reader is referred to Wassink (1947*a, b*, 1949) and to the forthcoming more extensive paper (Wassink & Kuiper, in prep.). One additional remark perhaps should not be omitted, that there is no

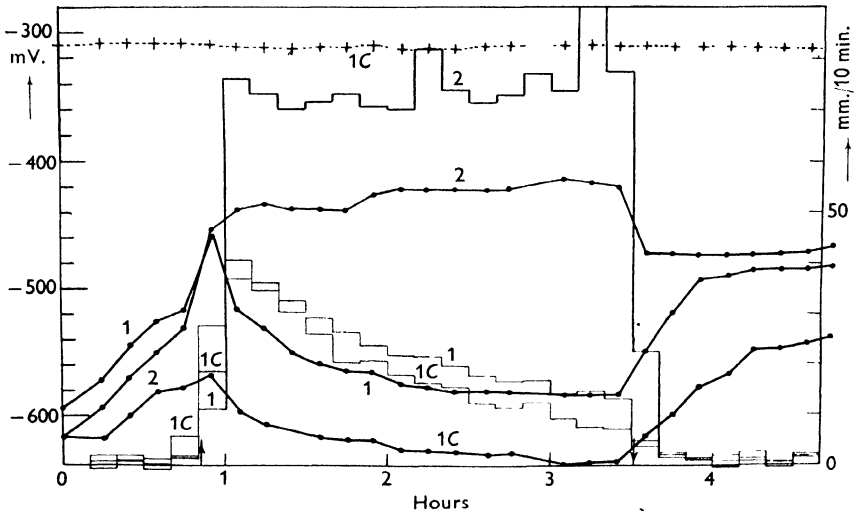

Fig. 4. Photosynthesis and redox potentials in suspensions of *Chromatium*, strain D. Phosphate buffer, pH 8.0, temp. 29° C. Heavy lines: potential differences of platinum electrodes in suspension against saturated KCl-calomel electrode (left scale). Dotted line with +: glass electrode (pH shifts). Thin lines: uptake of gas (right scale).  
 ↑ Light on (0 hr. 50 min.).  
 ↓ Light off (3 hr. 30 min.).  
 Curve 1:  $N_2 + 30\% H_2$ .  
 Curve 1C:  $N_2 + 30\% H_2$ , KOH in touch with gas phase.  
 Curve 2:  $N_2 + 30\% H_2 + 5\% CO_2$ .  
 Shift of potential to the reduced side upon illumination in the absence of  $CO_2$ .  
 (From Wassink & Kuiper, in preparation.)

direct correlation of the potential shifts with the overall gas exchange, but rather with the state of oxido-reduction of important catalysts or carrier systems. Not the amount of substance transferred but the position of the equilibrium of the catalysts appears significant.

Passing on to a further, more or less direct, manifestation of the reducing action of the light in the photosynthetic chain, we may consider the reactions developed by cell-free chlorophyllous systems as studied by Hill, Scaresbrick, French, Warburg and others (cf. Holt & French, 1949). These systems develop  $O_2$  at the expense of water in the light. The hydrogen of the

water is capable of acceptor reduction. In these systems,  $\text{CO}_2$  is so far not a suitable acceptor. We may thus say that part of the 'path of hydrogen' has been isolated in these preparations. Various acceptors have been tried. Among the most suitable ones are quinones, suggested by Warburg & Lüttgens (1944). In the presence of chloroplast preparations and water these compounds are reduced in the light to hydroquinones, with evolution of  $\text{O}_2$ . This reaction, essentially, may be interpreted as an activation of hydrogen by light. Aronoff once suggested that various quinones act at a rate dependent on their own redox potential (Aronoff, 1946*a*). Later experiments appeared somewhat less conclusive in this respect (Aronoff, 1946*b*). This was due chiefly to the fact that a dark reaction appeared to be involved, which was not taken into consideration in the earlier experiments. The relation of the rates for various quinones was different at low and at high light intensities. The involvement of at least one dark reaction was confirmed by other investigators (Holt & French, 1949). Holt & French's finding that the evolution of  $\text{O}_2$  is not inhibited by catalase inhibitors seems important.

The first who, after the work of Wassink *et al.* discussed above, explicitly accept the generation of a reducing power by light, are Calvin & Benson (1948). Their study was made with *Scenedesmus*, observing the dark uptake of  $\text{C}^{14}\text{O}_2$ . After an illumination of 10 min. in a  $\text{CO}_2$ -free atmosphere (helium), preceded by 1 hr. in 4%  $\text{CO}_2$ - $\text{N}_2$  and 20 min. in helium in darkness, the fixation of  $\text{C}^{14}\text{O}_2$  in the first minutes after the light period was many times higher than if the light period was omitted (Fig. 5). The authors state: '... the initial extremely rapid fixation observed... after pre-illumination is quite obviously closely connected with the effect of the light, and its initial slope is approaching that of steady-state photosynthesis. In our view, the initial rapid rise corresponds to the storage by the plant of reducing power generated during the pre-illumination period.' Already 30 sec. pre-illumination brings the reducing power near to its maximum value. It seems to me that this suggests that only a small capacity for this power is available, which seems intelligible since in photosynthesis quantitatively appreciable separations between uptake of hydrogen donor and conversion of  $\text{CO}_2$  as a rule do not occur.

The authors interpret it as a steady-state condition between the rate of its photochemical production and its natural decay. In a cited experiment this decay—in the absence of added  $\text{CO}_2$ —showed a half lifetime of some 5 min. The further extensive exploration by Calvin and his co-workers (Calvin, 1949; Benson & Calvin, 1949) of the first carbon compounds occurring in photosynthesis revealed that the very first products are very likely phosphate esters (chiefly 2- and 3-phosphoglyceric acid).

Experiments of Wassink, Tjia & Wintermans (1949) with *Chromatium* showed that illumination of suspensions under an  $N_2$ - $H_2$  atmosphere results in a marked phosphate uptake from the medium, which is much less when  $CO_2$  is also available. The phosphate uptake mentioned lasts as

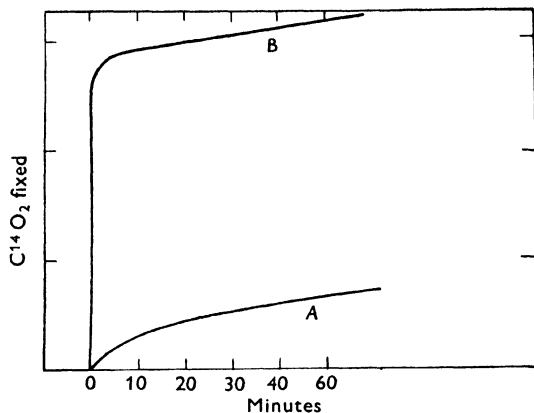

Fig. 5. Dark fixation rate of  $C^{14}O_2$  by 2-day-old *Scenedesmus*. A, without pre-illumination; B, with pre-illumination for 10 min. in  $2 \times 17,000$  lux, in  $CO_2$ -free gas phase. Increase of binding capacity for  $CO_2$  after pre-illumination in the absence of  $CO_2$ . (From Calvin & Benson, 1948, fig. 1.)

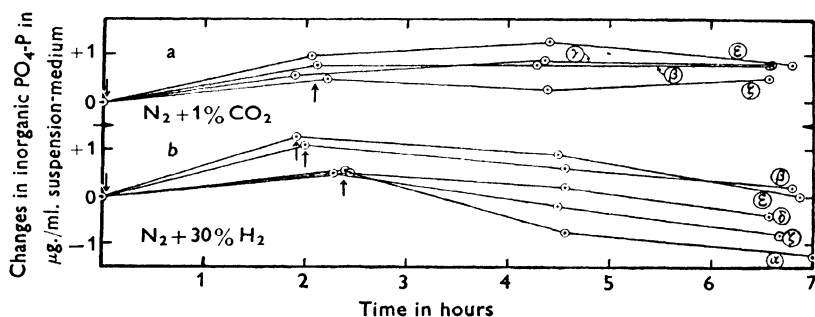

Fig. 6. Phosphate uptake in suspensions of *Chromatium*, strain D, in light, in the presence of hydrogen, without  $CO_2$  (curves b).  $\uparrow$  Light begins.  $\downarrow$  Darkness begins. Presence of light and hydrogen is essential (cf. also curves a). (From Wassink *et al.* 1949, fig. 8.)

a rule a long time, but is strongest in the first hour. Recent experiments have shown that a phosphate starvation procedure results in much increased phosphate uptake under  $N_2$ - $H_2$  in light. It has already been mentioned that under  $N_2$ - $H_2$  in the light a significant prolonged uptake of  $H_2$  occurs. It may be suggested tentatively that the two phenomena are correlated and that, with the aid of light energy, hydrogen is active in building up a reduced

phosphate compound which may, eventually, serve as acceptor for  $\text{CO}_2$ . This would thus represent the step preceding Calvin's fixation of  $\text{CO}_2$  in phosphate compounds and be identical with his 'generation of reducing power'. The nature of the compounds arising remains to be established.

A very interesting manifestation of hydrogenase activity in a photosynthetic organism in light is contained in the recent observations of Gest & Kamen on  $\text{H}_2$  evolution in light in a strain of *Rhodospirillum rubrum* (Gest & Kamen, 1949*a, b*; Kamen & Gest, 1949) and its obvious connexion with  $\text{N}_2$  metabolism. It is remarkable that one of the conditions to be fulfilled for photochemical  $\text{H}_2$  production seems to be the availability of a relatively oxidized 'substrate', e.g. fumarate and malate. This phenomenon may be related in some respects to Gaffron's  $\text{H}_2$  production in *Scenedesmus*. Since it does not occur in the dark, it may be taken as a sign for the generation of reducing power in the light. It is an interesting question, why the  $\text{H}_2$  is not coupled photochemically to  $\text{CO}_2$  as in *Chromatium*. This reaction also seems to be possible in *Rhodospirillum* (Gest & Kamen, 1949*a*). The only possible answer, I think, must be that in *Rhodospirillum* substrate hydrogen is very much more active than molecular  $\text{H}_2$  in reducing  $\text{CO}_2$ . From the fact that  $\text{NH}_4$ -ions and molecular  $\text{N}_2$  inhibit the  $\text{H}_2$  evolution, Kamen & Gest (1949) conclude that there is 'a specific effect of molecular nitrogen on hydrogenase activity and a stimulating effect of light on turnover of molecular nitrogen'. From the viewpoint of the present paper it is tempting to summarize these conclusions as demonstrating the generation by the light energy of a reducing power to which  $\text{N}_2$  (and, eventually,  $\text{NH}_4$ -compounds) is susceptible.

#### SUMMARY

Various kinds of evidence for the generation of a reducing power by light in the process of photosynthesis have been collected. This reducing power may now well be considered as definitely established, notwithstanding the fact that none of the demonstrations so far available is a direct one, that is to say, that the substance(s) undergoing a direct reduction by the acceptance of light energy is still unknown. The 'more or less direct' demonstrations collected above comprise observations on green cells and purple bacteria, from various aspects of photosynthesis, by various authors. They may be briefly put together as follows:

- (1) Rising chlorophyll fluorescence *Chlorella* (1938-9) (Ornstein *et al.* 1938; Wassink & Katz, 1939).
- (2) Photochemically induced hydrogenase activity, *Scenedesmus*, 1942 (Gaffron & Ruben, 1942, 1944); *Rhodospirillum*, 1949 (Gest & Kamen, 1949*a, b*; Kamen & Gest, 1949).

- (3) Reduction of H-acceptors in chloroplast preparations, green cells (1939-49) (Warburg & Lüttgens, 1944; Aronoff, 1946*a, b*; Holt & French, 1949).
- (4) Fixation of tracer CO<sub>2</sub> after CO<sub>2</sub>-free illumination, *Chlorella*, *Scenedesmus* (1948-9) (Calvin & Benson, 1948; Calvin, 1949; Benson & Calvin, 1949).
- (5) Shift of redox potential to the reduced side upon illumination in the presence of H<sub>2</sub>, *Chromatium* (1946-9) (Wassink, 1947*a, b* and in prep.).
- (6) Phosphate uptake coupled with H<sub>2</sub> uptake, *Chromatium* (1949) (Wassink *et al.* 1949).

## REFERENCES

- ARONOFF, S. (1946*a*). *Science*, **104**, 503-5.
- ARONOFF, S. (1946*b*). *Plant Physiol.* **21**, 393-409.
- BENSON, A. A. & CALVIN, M. (1949). The path of carbon in photosynthesis. VII (for publication in 'Nature', seen in manuscript).
- BLACKMAN, F. F. (1905). *Ann. Bot., Lond.*, **19**, 281-95.
- CALVIN, M. & BENSON, A. A. (1948). *Science*, **107**, 476-80.
- CALVIN, M. (1949). The path of carbon in photosynthesis. VI. Peter Reilly Lectures, Univ. of Notre Dame, April (seen in manuscript).
- GAFFRON, H. (1937). *Naturwissenschaften*, **25**, 460-1, 715-16.
- GAFFRON, H. & RUBIN, J. (1942). *J. Gen. Physiol.* **26**, 219-40.
- GAFFRON, H. (1944). *Biol. Rev.* **19**, 1-20.
- GEST, H. & KAMEN, M. D. (1949*a*). *Science*, **109**, 558-9.
- GEST, H. & KAMEN, M. D. (1949*b*). *J. Bacteriol.* **58**, 239-45.
- HOLT, A. S. & FRENCH, C. S. (1949). In Franck, J. & Loomis, W. E. *Photosynthesis in Plants*, pp. 277-85. Ames, Iowa: Iowa State College Press.
- INGEN-HOUSZ, J. (1779). *Experiments upon Vegetables, Discovering their Great Power of Purifying the Common Air in the Sunshine, and of Injuring it in the Shade and at Night*. London: Elmsly and Payne.
- INGEN-HOUSZ, J. (1789). *Expériences sur les Végétaux*, **2**. Paris: Barrois.
- KAMEN, M. D. & GEST, H. (1949). *Science* **109**, 560.
- KAUTSKY, H. & HIRSCH, A. (1935). *Biochem. Z.* **278**, 373-85.
- MAYER, J. R. (1845). *Die organische Bewegung in ihrem Zusammenhang mit dem Stoffwechsel*. (Cf. E. I. Rabinowitch, *Photosynthesis*. 1945. New York: Interscience.)
- ORNSTEIN, L. S., WASSINK, E. C., REMAN, G. H. & VERMEULEN, D. (1938). *Enzymologia*, **5**, 110-18.
- RAUWENHOFF, N. W. P. (1853). Onderzoek naar de betrekking der groene plantendelen tot de zuurstof en het koolzuur des dampkrings, onder den invloed van het zonnelicht. Thesis, Utrecht.
- SACHS, J. (1865). *Handbuch der Experimental-Physiologie der Pflanzen*. (Vol. 4 of Hofmeister's *Handbuch der physiologischen Botanik*.) Leipzig: Engelmann.
- TANG, P. S. & LIN, C. Y. (1937). *J. Cell. Comp. Physiol.* **9**, 149-63.
- VAN BARNEVELD, W. (1781). *Verh. Prov. Utrechts Genootschap*, **1**, 408-72. (Manuscript submitted, for the greater part, in 1778.)
- VAN DEN HONERT, T. H. (1930). *Rec. trav. Bot. néerl.* **27**, 149-286. (Published as thesis, Utrecht, in Dutch language, 1928.)
- WARBURG, O. (1928). *Ueber die katalytischen Wirkungen der lebendigen Substanz*. Berlin: Springer (papers of 1919-25).

- WARBURG, O. & LÜTTGENS, W. (1944). *Naturwissenschaften*, **32**, 161, 301.
- WASSINK, E. C. (1947*a*). *Antonie v. Leeuwenhoek, J. Microbiol. Serol.* **12**, 281-93.
- WASSINK, E. C. (1947*b*). *Abstr. Comm. 4th Int. Congr. Microbiol.* pp. 173-4.  
Copenhagen.
- WASSINK, E. C. (1948). Licht als factor in plantenphysiologisch Onderzoek.  
Publ. lecture, Agricultural University, Wageningen.
- WASSINK, E. C. (1949). *Rep. Proc. 4th Int. Congr. Microbiol.* pp. 455-6.  
Copenhagen.
- WASSINK, E. C. & KATZ, E. (1939). *Enzymologia*, **6**, 145-72.
- WASSINK, E. C. & KERSTEN, J. A. H. (1944). *Enzymologia*, **11**, 282-312.
- WASSINK, E. C., TJIA, J. E. & WINTERMANS, J. F. G. M. (1949). *Proc. K. Akad. Wet. Amst.* **52**, 412-22.

# INTERMEDIATES IN PHOTOSYNTHESIS: FORMATION AND TRANSFORMATION OF PHOSPHOGLYCERIC ACID

By H. GAFFRON, E. W. FAGER, AND J. L. ROSENBERG

Institute of Radiobiology and Biophysics, and Department of  
Biochemistry, University of Chicago (Fels Fund) Chicago, Illinois

Those among you who were there will remember that last year at Cambridge I disagreed with Professor Calvin concerning the role of phosphoglyceric acid in photosynthesis.

Benson & Calvin (1948) exposed assimilating plants to labelled carbon dioxide for a few seconds and found over 50% of the fixed tracer carbon in the carboxyl group of phosphoglyceric acid. They stated that this compound must therefore be a direct product of or intermediate in photosynthesis. I objected on the grounds that in our apparently similar experiments the amount of label in phosphoglyceric acid hardly surpassed that in half a dozen other compounds which appeared labelled simultaneously, and very likely were the products of secondary dark transformations. Furthermore, in the absence of proof of a photochemical transformation of phosphoglyceric acid it was possible that it was not an intermediate but rather a side-product of photosynthesis. Since that time—mainly by using larger concentrations of bicarbonate—my colleagues, Drs Fager and Rosenberg, have confirmed the observations made at Berkeley. We have furthermore shown for the first time that labelled phosphoglyceric acid is itself transformed much faster in the light than in the dark (Fager, Rosenberg & Gaffron, 1950). Thus this compound fulfils the requirements of an intermediate in photosynthesis, and the conflict of last year no longer exists.

However, in discussing the formation and transformation of phosphoglyceric acid in illuminated algae, I shall have to point out that we are still—or again, as the case may be—in disagreement with some of the interpretations which the group at California have suggested for their data. This disagreement involves such fundamental questions as the photochemical formation of a long-lived general reductant acting in photosynthesis and the possibility of a second carboxylation reaction in addition to the one leading to phosphoglyceric acid.

*Isolation and identification of phosphoglyceric acid*

Table 1 shows the results of some analyses of derivatives of glyceric acid. The latter compound contained the major portion of labelled carbon assimilated during 30 seconds of normal photosynthesis.

Table 1. *Analyses\* of glyceric acid derivatives**Barium glycerate*

Calculated: Ba, 39.5; C, 20.7; H, 2.9 %

Found (after vacuum drying at 110°): Ba, 40.0; C, 20.6; H, 3.1 %

*p-Phenylphenacyl glycerate*

Calculated: C, 68.0; H, 5.3 %

Found: C, 67.6, 68.0; H, 5.2, 5.3 %

*p-Bromphenacyl glycerate*

Calculated: C, 43.5; H, 3.6; Br, 26.4 %

Found: C, 43.5; H, 3.5; Br, 26.4 %

\* Analyses by Mr Wm. Saschek, Department of Chemistry, University of Chicago.

I shall not take time in describing methods of isolation and purification. They have been published elsewhere (Fager & Rosenberg, 1950). I may mention in passing that hydrolysing phosphoglyceric acid into glyceric and phosphoric acids by means of a phosphatase is, as expected, far better than the purely chemical hydrolysis. Oxidation of the glyceric acid with periodic acid enables one to isolate the carboxyl and alpha carbons as the hydrazone of glyoxylic acid, the beta carbon as the hydrazone of formaldehyde.

*Time course of tracer fixation in phosphoglyceric and pyruvic acids*

For many years it has been postulated that any compound, *RH*, serving as an acceptor for the continuous fixation of  $\text{CO}_2$  during photosynthesis must itself be formed by a photochemically driven reaction. In the specific case where *RCOOH* is phosphoglyceric acid this particular cycle in the mechanism of photosynthesis must continuously produce a 2-carbon fragment which can serve as the alpha and beta carbons of the 3-carbon acids.

Calvin, Bassham & Benson (1950) observed that a few minutes of photosynthesis were sufficient not only to introduce the labelled carbon into the alpha and beta positions but to make all three carbons of phosphoglyceric acid equally radioactive. Our results concerning the time course of fixation of tracer in phosphoglyceric and pyruvic acids during normal photosynthesis are shown in Fig. 1. The top line shows the percentage of water-extractable tracer fixed in the alpha carbon plus carboxyl of phosphoglyceric acid. The curve for the activity in the beta carbon begins to rise after 10 sec. and reaches about half the counts present in the other two carbons after about 2 min. This means that the phosphoglyceric acid becomes

saturated with tracer during this period under the conditions of our experiments; that is, at 25° C. and about two-thirds light saturation.

The ratio of total activity in phosphoglyceric acid to that in pyruvic acid remains at about 6 to 1 for the entire range of times. This is of considerable significance considering the value 3 to 1 which has been found for the equilibrium established between these two substances (via phosphopyruvate) by the enzyme enolase at 25° C. (Meyerhof & Oesper, 1949). If the algae are allowed to metabolize in the dark for 20 sec. before being killed, the ratio found decreases to less than 4 to 1, indicating the presence of an enolase which, however, does not seem to work rapidly enough to

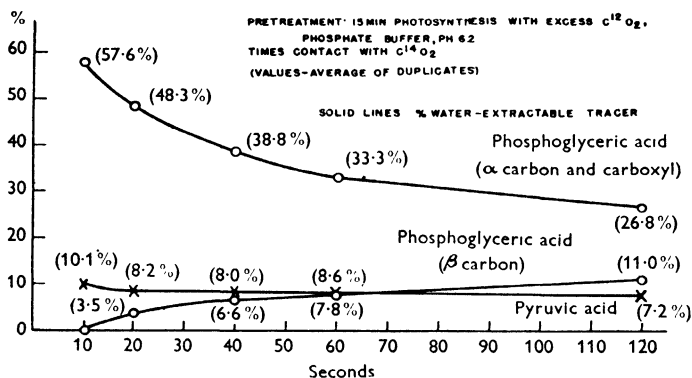

Fig. 1. Time course of fixation of tracer carbon in phosphoglyceric and pyruvic acids. Algae, *Scenedesmus obliquus*, strain D 3.

keep up with the photosynthetic production of phosphoglyceric acid. If phosphopyruvate preceded phosphoglycerate during photosynthesis and the transformation were the normal enzymic one, the ratio could not exceed 3 to 1.

These experiments, confirming and extending those reported from the Berkeley laboratory, leave no doubt that phosphoglyceric acid is not only the first stable compound into which free  $CO_2$  is incorporated in the form of a carboxyl group, but that it is also involved in the formation of the acceptor *RH*.

The following rather obvious questions have now to be answered:

Do precursors to phosphoglyceric acid exist which already contain the labelled carboxyl group?

Is the 2-carbon acceptor a substance of the reduction level of acetic acid and glycolaldehyde, or is it photochemically reduced to the level of acetaldehyde before it reacts with carbon dioxide?

What is the source of such a carbon acceptor?

Is this carboxylation—the formation of phosphoglyceric acid—the only one connected with the photochemical mechanism, or must we look for a second or even a third fixation reaction?

What about the six or ten substances which appear or, equally important, fail to appear on the radio-chromatograms obtained at Berkeley?

You all know, of course, the development in recent years: no sooner was a decarboxylation reaction discovered to be reversible than it was offered as a possible mechanism of carbon fixation in photosynthesis. Imagine the situation if all of these fixation reactions were found to proceed simultaneously and at an accelerated rate when the plants are illuminated. Every one of the authors of the different schemes would think himself happily right. This is, unfortunately, not just an amusing hypothesis but a disconcerting possibility. Most of the known dark fixations do occur here and there in plant tissues, and if not described to-day for green leaves they may be so to-morrow. Let us assume that the photochemical part of photosynthesis consisted invariably in the production of the same general reductant from water, a hydrogen carrier  $XH_2$  having the nature of a stable reduced coenzyme. With such a device, the fixation of carbon dioxide—or even its complete reduction—could hypothetically start at several points and produce not one but a few new compounds at once. In addition, therefore, to the questions raised above, we must ask: Is there such a thing as a stable, general photochemical reductant capable of serving as a hydrogen carrier for more than just one specific carboxylation reaction?

*Time course of tracer distribution of carbon fixed during  
photosynthesis and photoreduction*

Three years ago on the occasion of the first conference on the use of carbon isotopes in photosynthesis at Madison, Wisconsin, we showed this graph (Fig. 2) representing the time course of tracer distribution among three fractions obtained from photosynthesizing algae by extraction with boiling alcohol. *A* is the benzene-soluble, *B* is the water-soluble, and *C* is the insoluble fraction. *B* has less than 1% of the total weight of the algae, but at zero time contains all the fixed carbon. I am showing the slide again to-day to point out how fast under the conditions of normal photosynthesis the labelled carbon is shifted into the high molecular substances and into the lipids. Forty seconds of photosynthesis are quite sufficient, according to Dr Clendenning who investigated the benzene-soluble fraction in our laboratory, to introduce as much labelled carbon into the higher fatty acids as goes, for instance, during comparable experiments of Calvin & Benson, into sucrose (Clendenning, 1950).

The rapid transformation within the water-soluble fraction of the

primary fixation products into all kinds of cell constituents has been proven by chromatography (Benson & Calvin, 1950).

Among these compounds must be also the precursors for the fats and the other water-insoluble substances; that is, compounds not directly connected with  $\text{CO}_2$  reduction. Studies on the pure dark fixation of  $\text{CO}_2$  in algae had told us before that the non-photochemical fixation proceeds even under anaerobic conditions. The products, however, remain in the

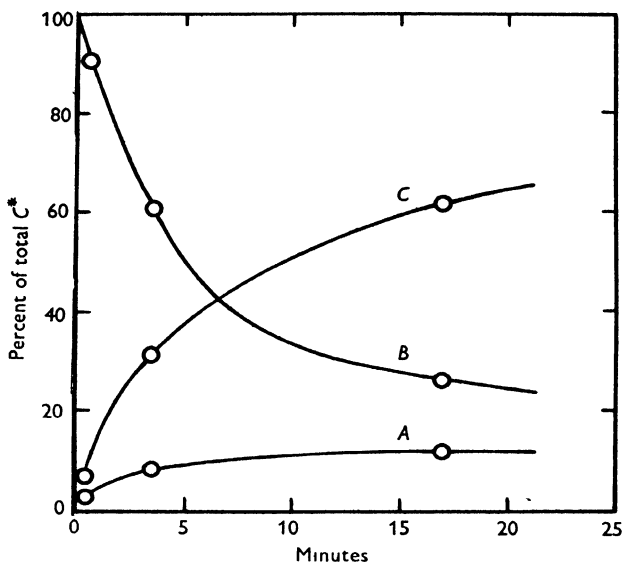

Fig. 2. Time course of tracer distribution during photosynthesis (after Brown, Fager & Gaffron, 1948). A, lipid and pigment fraction. B, water-soluble fraction. C, residue, water-insoluble fraction. Algae, *Scenedesmus obliquus*.

water-soluble fraction until oxygen is admitted. Only respiration transfers the labelled carbon into the fats and into the larger molecules; i.e. starch, proteins, etc. (Brown *et al.* 1948).

For this reason we studied the formation of phosphoglyceric acid under anaerobic conditions hoping to isolate the reaction by suppressing respiration. The time-course experiments were repeated under conditions where respiratory reactions and the evolution of oxygen were eliminated by letting the algae reduce  $\text{CO}_2$  with molecular hydrogen.

This type of reaction, photoreduction, is normal for photosynthetic purple bacteria, but can be induced in several species of blue-green, green and red algae by anaerobic incubation (Frenkel, Gaffron & Battley, 1950). High light intensities as well as free oxygen, however, make such 'adapted' algae revert to normal photosynthesis with the evolution of oxygen. Even

if only a few algal cells among many thousands revert in this manner, the experiment is eventually spoiled. To prevent this, certain poisons which block the mechanism of oxygen evolution can be used (Gaffron, 1945). Orthophenanthroline, oxy-methyl naphthoquinone and similar inhibitors given in the adapted state insure proper behaviour of the algae. In addition, and this is an important point, under the poisoned conditions photoreduction can be studied at high light intensities. The rates are then

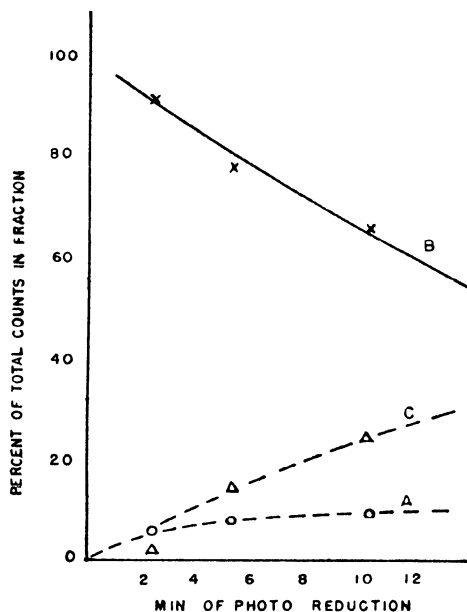

Fig. 3. Time course of tracer distribution during photoreduction with hydrogen. Reaction stabilized by addition of inhibitor. Fractions as in Fig. 2. Algae, *Scenedesmus obliquus*, strain D 3. Phosphate buffer pH 6.2.

comparable to normal photosynthesis, and secondary dark transformations could be expected to be slow in comparison with the reactions we wanted to measure. Fig. 3 is the result of measurements of the distribution of assimilated tracer in different fractions in the course of time under conditions of stabilized photoreduction.

To our disappointment the overall picture turned out to be practically the same as under aerobic conditions. The transfer of labelled carbon into the insoluble and into the lipid fraction is definitely slower than normal, but nevertheless it is there. We learn, on the other hand, from this experiment how closely linked even in green plants is the photosynthetic

mechanism to other synthetic reactions which, in the respiring plant, take place in the dark and presumably have nothing to do with the photochemical process. Had we been willing to assume that adapted algae behave in this respect like purple bacteria, which grow anaerobically, this outcome would have been the expected one.

*Dark fixation after normal photosynthesis; 'pick-up'*

Ever since photosynthesis was first systematically investigated, students have wondered whether the reduction of  $\text{CO}_2$  stops abruptly when the light is turned off or whether it continues for a little while at least in the form of a partial reaction; for instance, the simple fixation or 'pick-up' of  $\text{CO}_2$ . Such after-effects have indeed been reported by McAlister (1939) and by McAlister & Myers (1940). In the latter series of experiments the effect was visible only when the carbon dioxide concentration was low. Aufdemgarten reported a 'pick-up' which was strongly influenced by cyanide (Aufdemgarten, 1939). The newest observations are by Van der Veen (1949) who repeated the experiments of Aufdemgarten. Using radioactive carbon dioxide we have found that there is an enhanced dark fixation immediately following normal aerobic photosynthesis in the presence of ample  $\text{CO}_2$ .

The after-effects or 'pick-ups' which occur after normal photosynthesis are shown in Fig. 4. The shaded parts of the columns represent either pure dark fixation or 'pick-up' of  $\text{CO}_2$  in the dark, the non-shaded parts straightforward photosynthesis; that is, the columns having no shaded part mean that the algae have been killed immediately after exposure without an interposed dark period. Column *a* refers to a control; that is, pure dark fixation when tracer was added 2 min. after the light was turned off. At this time all special effects of previous illumination have faded. Column *b* represents the definitely larger amount of labelled carbon that becomes fixed in the cells if the radioactive  $\text{CO}_2$  is added immediately after the light has been turned off. Column *c* shows the result of 10 sec. of photosynthesis with labelled carbon; that is, the labelled carbon was added during normal photosynthesis with  $\text{C}^{12}\text{O}_2$  and 10 sec. later the algae were dropped into boiling water. Thus they had no opportunity to continue with dark reactions. The next column, *d*, shows again the effect of 10 sec. photosynthesis, followed this time by a dark period of 20 sec. before the algae were killed. After this dark period the amount of tracer carbon fixed in the cell is more than doubled. This represents either a net uptake of carbon dioxide or the stabilization of a thermolabile compound. Such a compound might be an addition complex of  $\text{CO}_2$  and the 2-carbon

acceptor. The next column, *e*, shows that waiting longer than 20 sec. (in this case, 30 sec.) does not increase the after-effects. Whatever happens is over within 20 sec. The next two columns, *f* and *g*, show that an extension of the photosynthesis period with labelled carbon preceding the dark pick-up also does not influence the size of the pick-up. This shows that it cannot be due to an exchange between the tracer CO<sub>2</sub> and unlabelled carboxyl groups in the cell for after 20 sec. of photosynthesis complete equilibration has been effected as is shown by the constant rate of

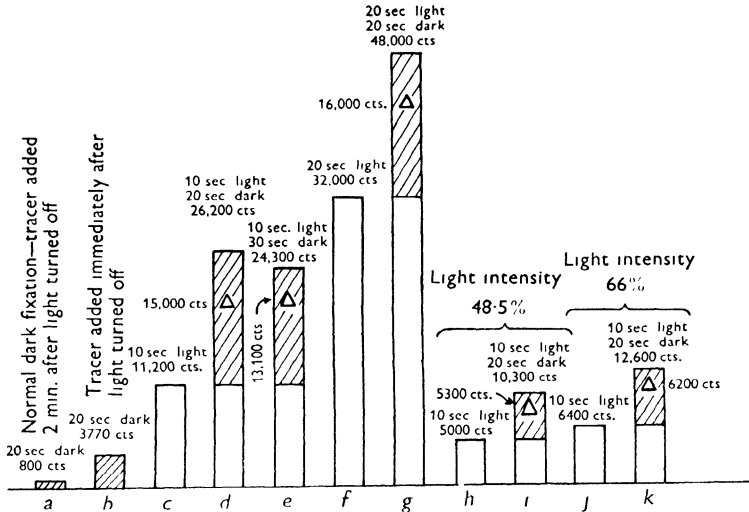

Fig. 4. CO<sub>2</sub> 'pick-up'. Tracer fixed in the dark after normal photosynthesis. Influence of light intensity. See text.

tracer uptake. Thus we learn from this series of experiments that 10 sec. photosynthesis are sufficient to produce an after-effect of about the same magnitude and that this after-effect does not last longer than 20 sec. Some of you may have wondered, after comparing columns *c* and *f*, why 20 sec. photosynthesis with labelled carbon gives three times as much fixation as 10 sec. We have no ready explanation for this except that there must be some delay in the mixing of the newly added CO<sub>2</sub> with that already present in the cell or in the chloroplasts.\* Yet such a delay does not quite account for the great difference between the amount of radio-carbon fixed in the dark when tracer is added immediately after the light period, column *b*, and the much greater amount fixed during a comparable dark period if the

\* Our experience here, I would like to point out, is in disagreement with the observation shown in Fig. 2 of the paper by Calvin *et al.* (1950) in which the rate of uptake during the first moments of photosynthesis with tracer is much greater than it is after 30 sec.

labelled carbon has been already present, at least for a few seconds, during the preceding light period, columns *d* and *g*.

The rule that the after-effect, dark 'pick-up', is equivalent to about 10 sec. of photosynthesis holds for different light intensities. This can be learned by comparing the three pairs of columns: *h* and *i*, *j* and *k*, *c* and *d*. This result is of some theoretical importance, for it shows that the magnitude of the dark fixation is directly dependent upon the photosynthetic rate (light intensity) and that, therefore, the 'pick-up' is intimately associated with the process of photosynthesis.

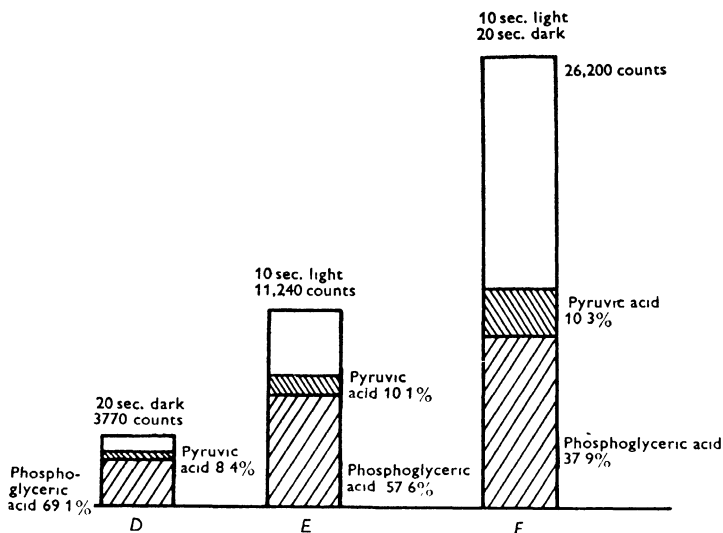

Fig. 5.  $\text{CO}_2$  'pick-up' after normal photosynthesis. Percentage of total tracer found in 3-carbon acids. *D*, tracer present during 20 sec. dark 'pick-up'. *E*, tracer present during 10 sec. photosynthesis. *F*, tracer present during 10 sec. photosynthesis followed by 20 sec. dark 'pick-up'.

If we turn now to the distribution of phosphoglyceric and pyruvic acids in these same experiments, we find the following: column *D* in Fig. 5, corresponds to column *b* in Fig. 4. The algae were photosynthesizing normally with sufficient  $\text{C}^{12}\text{O}_2$ .  $\text{C}^{14}\text{O}_2$  was added immediately after the light was turned off, and after 20 sec. the algae were killed. Of the tracer fixed, 69% is in phosphoglyceric acid and 8% in pyruvic acid, while the rest, about 20%, is distributed among other compounds. Photosynthetic fixation of tracer for 10 sec. followed immediately by killing, column *E*, gives a higher percentage of unknowns; that is, only 68% of the tracer is in phosphoglyceric and pyruvic acids. If we follow the 10 sec. of photosynthetic fixation by 20 sec. in the dark before killing, the algae double the

amount of  $\text{CO}_2$  fixed, the number of counts increasing in all fractions. Phosphoglyceric and pyruvic acids, however, now account for only 50% of the total, column *F*. Much more phosphoglyceric acid must have been formed, but a great part of it was transformed, reduced or oxidized, into other compounds.\*

*Dark fixation after illumination in the absence of carbon dioxide and oxygen; 'pre-illumination'*

We compare now the pick-up after running photosynthesis, which you have just seen, with an effect already described by Benson, Calvin, Haas, Aronoff, Hall, Bassham & Weigl (1949). They found a considerable uptake of  $\text{CO}_2$  in the dark after the plants had been illuminated for several minutes under anaerobic conditions while  $\text{CO}_2$  was absent. Chromatograms analysing this type of experiment were shown last year by Dr Calvin to demonstrate the great similarity between the pattern given by normal photosynthesis of short duration and the one produced by this type of pure dark fixation. Calvin and co-workers (Benson & Calvin, 1950) state that their experiments on 'pre-illumination dark fixation', which resulted in the fixation of 39% of the tracer in alanine, 37% in several other substances, among them sucrose, and only 24% in phosphoglyceric acid, support the view of a complete reduction of  $\text{CO}_2$  in the dark by means of a 'reducing power supplied by the photochemical reaction involving the photolysis of water. Furthermore, the reducing power so provided is in the form of a definite chemical species...'. In other words, the example of a reduced co-enzyme mentioned a moment ago would serve such a description quite well. We have duplicated their experiments as described, using *Scenedesmus* instead of *Chlorella* which they used. Our results are not in agreement with their findings. The purpose of a pre-illumination experiment is obviously to deplete the cell of  $\text{CO}_2$ . To do this thoroughly, respiration should also be suppressed by providing anaerobic conditions. Benson *et al.* used helium. We have used helium, nitrogen, or hydrogen; all with the same results. We have found that it takes at least 15 min. of illumination in an atmosphere free from carbon dioxide and oxygen to bring the oxygen evolution of the algae, suspended in a medium of pH 6.8, to a very low and more or less constant rate. For clear-cut results it is certainly better to pre-illuminate for a longer than for a

\* *Note added in proof:* Increasing the  $\text{CO}_2$  concentration from about 0.1 to 4% for the preceding photosynthetic period did not change the amounts of phosphoglyceric acid and pyruvic acid obtained by the treatment shown in column *E* of Fig. 5 but did alter the amounts for columns *D* and *F*. Under these conditions the carboxyl groups of phosphoglyceric and pyruvic acids account for all of the tracer fixed in the dark, after subtraction of estimated normal dark fixation (Fig. 4, *a*). These results approach those obtained following pre-illumination (Fig. 6, *A* and *C*).

shorter period. You see in Fig. 6 data on the analysis of algae tagged with labelled carbon in the same manner as I described for Fig. 5, the only difference being that here the illumination before tagging was done in the absence of both  $\text{CO}_2$  and oxygen. The middle column, *B*, represents 10 sec. photosynthetic fixation of tracer  $\text{CO}_2$  followed immediately by killing. Although, in contrast to the preceding series of experiments, the algae had no other  $\text{CO}_2$  to work upon than that which was given

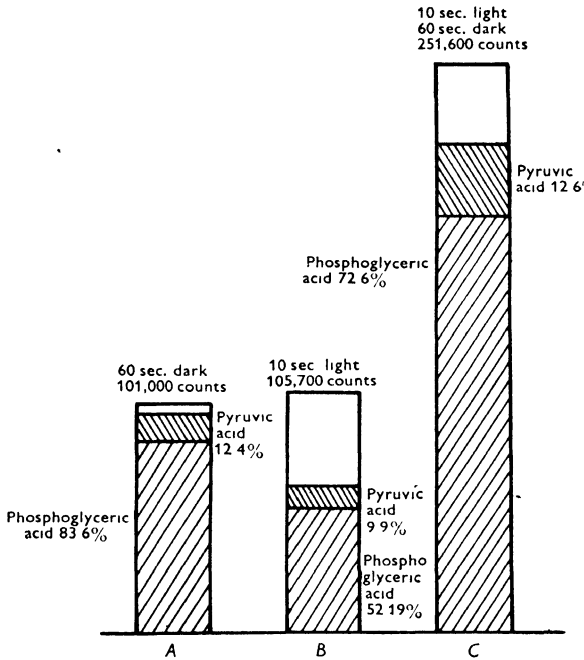

Fig. 6. Dark fixation of  $\text{CO}_2$  after pre-illumination. Percentage of total tracer found in 3-carbon acids. Times: *A*, *B*, *C*, like *D*, *E*, *F* in Fig. 5.

during this period of 10 sec., the result is identical with the corresponding experiment, Fig. 5, column *E*, shown before, in that 62% (compared to 68%) of the fixed tracer was found in phosphoglyceric plus pyruvic acids. Thus pre-illumination does not change in any remarkable way the distribution of the products made photosynthetically during 10 sec. of illumination. When the light period is followed by 20 sec. dark, column *C*, we obtain not only the same remarkable increase of over 100% for the amount of tracer carbon fixed (see Fig. 5, column *F*) but this time the increase is entirely due to the formation of phosphoglyceric and pyruvic acids. They now make up 85% of the total tracer fixed. Thus it

seems a reduction beyond the stage of phosphoglyceric occurs in the light only and does not continue in the dark. The proof of this can be seen in the first column, *A*, which was intended to be a repetition of the experiments reported by the Berkeley group. In this type of experiment, the labelled  $\text{CO}_2$  is not added until the moment the light is turned off. We have here, therefore, the result of pure dark reactions occurring after pre-illumination in absence of oxygen and carbon dioxide. As you see, 96% of the fixed activity is in phosphoglyceric and pyruvic acids and only 4% in unknowns.

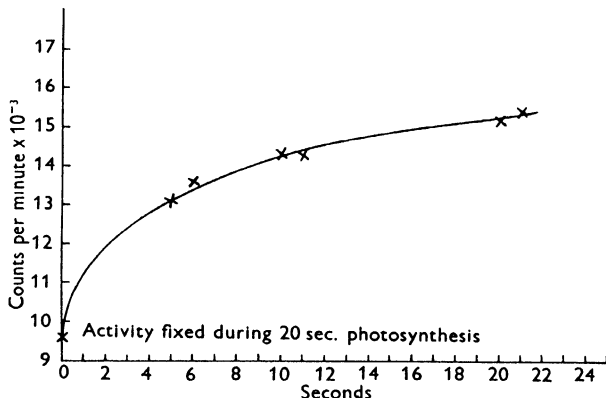

Fig. 7. Time course of tracer fixation in the dark after 15 min. photosynthesis with excess  $\text{C}^{14}\text{O}_2$ . Tracer added as  $\text{Na}_2\text{C}^{14}\text{O}_3$  20 sec. before light turned off. Algae, *Scenedesmus obliquus*, suspended in pH 6.2 phosphate buffer; concentration, 0.0064 c.c. algae per 1 c.c. solution.

This 4% can easily be accounted for by other dark fixations which must occur because the algae had been totally depleted of  $\text{CO}_2$ . Our results, therefore, differ quite surprisingly from those reported by Benson & Calvin, and appear much simpler and more straightforward. In order to make some points clearer, I should like you to compare again Fig. 5 with Fig. 6. In Fig. 6 you have pre-illumination in the absence of both  $\text{CO}_2$  and oxygen; in Fig. 5, normal photosynthesis in the presence of air and excess  $\text{CO}_2$ . A pure dark fixation is small in the latter case, but it amounts to about 15 sec. worth of photosynthesis in the case of pre-illumination. The gain in fixed carbon due to a dark period following 10 sec. of photosynthesis with tracer is the same in both cases; somewhat over 100%. After pre-illumination, the dark reaction proceeds only one step, namely, to the fixation of the added  $\text{CO}_2$  in the carboxyl groups of phosphoglyceric and pyruvic acids. There the reaction stops.

There is an important difference in the velocities of the two dark-fixation reactions. That following photosynthesis is definitely faster than

that following pre-illumination. A time-course experiment, Fig. 7, shows that the half-life of the dark fixation following running photosynthesis is 3-4 sec., and that the fixation is complete in 20 sec. On the other hand, to fix the maximum amount of  $\text{CO}_2$  in the dark after pre-illumination, the algae need to be left for at least 1 min. in the presence of the labelled carbon. In this case the half-life is around 15 sec. (Fig. 8). The time course for the formation of phosphoglyceric and pyruvic acids in the dark after pre-illumination is shown in Fig. 8. The reaction consists from beginning to

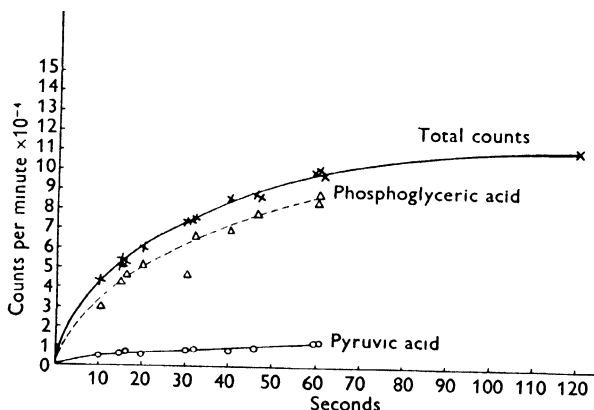

Fig. 8. Time course of tracer fixation in the dark after 15 min. illumination in the absence of  $\text{CO}_2$ , under  $\text{N}_2$  or He. Tracer added as  $\text{Na}_2\text{C}^{14}\text{O}_3$  in the dark. Algae, *Scenedesmus obliquus*, suspended in pH 6.2 phosphate buffer; concentration, 0.0064 c.c. algae per 1 c.c. solution.

end (60 sec.) in the formation of phosphoglyceric and pyruvic acids. The ratio 8 to 1 has been found in all such experiments and certainly indicates that phosphopyruvate is not a precursor to phosphoglyceric acid.

#### *Long-lived reducing power or carbon dioxide acceptor?*

The chromatography used in California showed that even sucrose was formed in the dark after pre-illumination. Thus it is understandable that Professor Calvin interpreted his results as a survival of a general reducing agent capable of doing a complete job of  $\text{CO}_2$  reduction in the absence of light. In our experiments, as I said before, the process does not continue beyond the appearance of a new carboxyl group. One may, of course, blame the discrepancy on a difference in the photosynthetic process in *Chlorella* as compared with *Scenedesmus* but this seems unlikely. We prefer to assume different rates of secondary dark transformations in the two organisms if a metabolic difference exists at all, and to attribute the pick-up not so much to the survival of a reducing agent but to that of an

acceptor for carbon dioxide which continues to be carboxylated in the dark as rapidly or as slowly as the circumstances allow. In the case of running photosynthesis, where there is an excess of carbon dioxide present all the time, it is probably not the acceptor but, rather, a labile complex with  $\text{CO}_2$  which survives—a 3-carbon precursor to phosphoglyceric acid. This can explain why the addition of labelled  $\text{CO}_2$  immediately after the light has been turned off results in a much smaller fixation than occurs in the dark when tracer has been added in the light shortly before. Such a precursor becomes labelled only by exchange.

We can summarize what I have just said in this way:

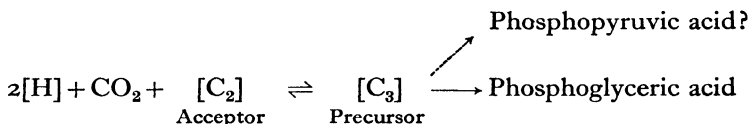

The reductive carboxylation of the acceptor leads to a labile precursor, possibly on the surface of an enzyme, where  $\text{CO}_2$  can still be exchanged. The work of Wood, reported at the beginning of this symposium, may serve as an example of the existence and reaction of such labile intermediates. The 3-carbon precursor becomes stabilized preferentially in the form of phosphoglyceric acid and to a lesser extent in the form of phosphopyruvate. The distinction we make between acceptor and precursor agrees very well with the different reaction half-times which I have mentioned above, Figs. 7 and 8. Furthermore, the assumption of a surviving 2-carbon acceptor in the case of pre-illumination fits better the rather long lifetime observed for the surviving agent as long as no external carbon dioxide is given to the plant. Fig. 9 shows in curve *B* the decline of the 'reducing power' with time. It has fallen to 50% in about 2 min.; and traces of the reaction can still be observed after 6 min. This agrees qualitatively with the observations of Benson *et al.* (1949).

In the so-called 'Hill reaction' quite a number of compounds are reduced photochemically by illuminated chloroplasts. If the photochemical reduction were to function exclusively via a long-lived reducing agent, an after-effect should be detectable also for the 'Hill reaction'.

Dr Franck mentioned yesterday an experiment with chloroplasts by Dr A. H. Mehler in which pre-illumination had no effect at all. I should like to show you the data, Table 2. The chloroplast suspensions are either mixed directly in the dark with the dyestuff, or mixed in the dark immediately after they have been pre-illuminated in an atmosphere of nitrogen. The pre-illumination has neither diminished the absorption of the dye nor has it destroyed the capacity of the chloroplasts to reduce the dyestuff when

illuminated a second time. Inasmuch as the chloroplasts are supposed to contain the complete photochemical mechanism, they should work via the same general reducing agent that normally leads to the reduction of  $\text{CO}_2$ . If a special hydrogen transferring agent were present in the intact cells, which the chloroplasts have lost, the pre-illumination of the intact cells should indeed produce the effect shown in the chromatograms of Calvin & Benson, namely, a subsequent reduction of  $\text{CO}_2$  to the level of carbohydrate. Under the conditions of our experiments this is evidently not so.

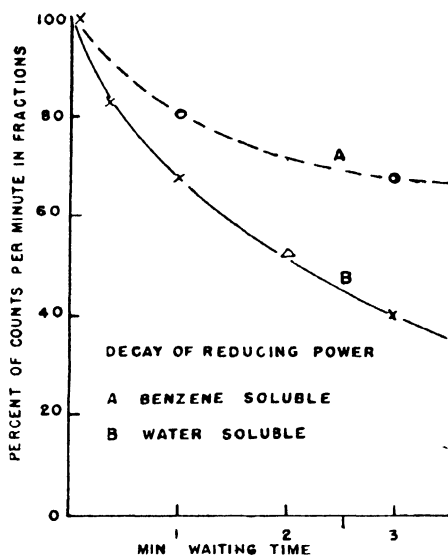

Fig. 9. Dark fixation of tracer  $\text{CO}_2$  after anaerobic pre-illumination. Decline of effect with time after illumination.

Table 2. *Absence of an after-effect with pre-illuminated chloroplasts*

Material: Separated spinach chloroplasts with 2, 6-dichlorophenol-indophenol added immediately following pre-illumination. Light absorption measured at 610  $\text{m}\mu$ .

Minutes of pre-illumination	0	$\frac{1}{2}$	0	1	0	2
Initial $\log I_0/I$	0.440	0.440	0.445	0.440	0.440	0.442
$\log I_0/I$ after 15 sec. illumination	0.360	0.361	0.360	0.563	0.360	0.359

#### *Cyanide sensitivity of the carboxylation reaction*

The pre-illumination reaction, as we have it now, appears simple enough to make an attempt to elucidate its mechanism. As a result of kinetic studies various inhibitors of photosynthesis have in the past been found to act upon different parts of the process. Hydroxylamine and ortho-

phenanthroline are supposed to inhibit the reactions associated with the evolution of oxygen. Cyanide inhibits mainly the fixation of  $\text{CO}_2$ . Iodoacetic acid and dinitrophenol inhibit both partial reactions, although in different proportions, and so forth. It seems natural, therefore, to look for possible similarities in their sensitivity towards poisons between normal photosynthesis and the fixation of  $\text{CO}_2$  after pre-illumination. We did such experiments and found, for instance, that dinitrophenol is a stronger inhibitor when given in the light during pre-illumination than if added in the dark together with the  $\text{CO}_2$ . At the moment, however, this did not appear to be sufficiently significant to follow up. Experiments with hydroxylamine confirm the expectation that a high concentration of this poison given in the dark has no effect whatsoever upon the uptake of  $\text{CO}_2$ , while a smaller amount given 2 min. before in the light inhibits very strongly (Table 3). Working with hydroxylamine presents some difficulties because of the slow penetration of this substance into the cell. Therefore, an amount more than ten times greater than that necessary for complete inhibition of normal photosynthesis was added in the dark simultaneously with the radioactive carbon dioxide. The distribution of tracer into various fractions, as shown in Table 3, appears to indicate that hydroxylamine has no other effect than would be found if, instead of poisoning the algae, the light intensity were lowered.

Table 3. *Effect of hydroxylamine on dark fixation of  $\text{CO}_2$  after pre-illumination*

Treatment: 40 min. light in stream of  $\text{H}_2$ . Tracer added in dark, 1 min. Numbers are corrected counts/min.

	Lipids	Water-soluble	Residue	Total
Control	46	2740	147	2933
M/1500 $\text{NH}_2\text{OH}$ added in the light 2 min. before tagging	75	1460	188	1723
M/300 $\text{NH}_2\text{OH}$ added together with tracer in the dark	49	2840	41	2930

By contrast cyanide inhibits very strongly whether it is added before or after the light has been turned off. The total uptake of  $\text{CO}_2$  is drastically diminished and its distribution changed in such a way that the water-soluble substances are particularly affected (Table 4). In other words, the carboxylation of the 2-carbon acceptor is a reaction quite specifically sensitive to cyanide, and I would like to point out that among the metabolic reactions dealing with the fixation of  $\text{CO}_2$  which have been discussed during the previous days there is only one—the reaction between hydrogen and  $\text{CO}_2$  giving formic acid—which is similarly inhibited.

I must also mention a reaction involving pyruvate which is sensitive to cyanide and carbon monoxide and which has been observed in certain butyric acid bacteria (Kempner, 1933). Here the presence of cyanide directs the fermentation towards the formation of lactic acid, presumably because the decarboxylation of pyruvic acid becomes inhibited. Normally the decarboxylation to a 2-carbon compound is followed by a reductive condensation of two of these molecules to butyric acid. It may be useful to keep both these reactions in mind when we have to consider the possible mechanism of the formation of phosphoglyceric acid.

Table 4. *Effect of cyanide on dark fixation following pre-illumination*

Total fixation			
Time of cyanide addition	Cyanide concentration	Total tracer fixed	
Control	0	7440	
In light, 1 min. before C <sup>14</sup>	0.002 M	1230	
In light, 2 min. before C <sup>14</sup>	0.002 M	260	
With C <sup>14</sup> in dark	0.001 M	2360	
With C <sup>14</sup> in dark	0.002 M	1070	
Tracer distribution			
	Lipids (%)	Water-soluble (%)	Residue (%)
Control	3	95	2
0.002 M cyanide added in light, 1 min. before C <sup>14</sup>	10	34	56

The question now arises whether the cyanide sensitivity is peculiar to the reductive carboxylation leading to the 3-carbon acids or whether it affects every one of the reduction steps involved in photosynthesis.

#### *Photochemical transformation of phosphoglyceric acid*

This question leads us directly to another one which so far we have not discussed, but which is, of course, fundamental; namely, that of the further photochemical reduction of phosphoglyceric acid. If it is truly an intermediate in photosynthesis, or not farther removed from the photosynthetic process than a simple equilibrium with another 'active' 3-carbon compound, phosphoglyceric acid should be metabolized faster—if not differently—in the light than in the dark. And this light reaction, if it could be observed, should be tested as to its cyanide sensitivity. A few experiments in this direction have been made. Tagged phosphoglyceric acid was produced in the algae by pre-illumination and dark fixation

(as Fig. 6, column *A*). The cells were then washed in dilute bicarbonate several times on the centrifuge, the resulting suspension now free of labelled  $\text{CO}_2$  divided into two parts, and both batches killed after one of them was exposed to light for 1 min. The analysis showed that after about 7 min. required by the procedure the dark control still contained 50–55% of the phosphoglyceric acid initially present, while the 1 min. exposure brought this figure down to about 15–25% (Table 5). There was no marked influence of cyanide on this reaction.

Table 5. *Photochemical transformation of phosphoglyceric acid*

Treatment: 15 min. illumination in absence of both  $\text{CO}_2$  and  $\text{O}_2$ ; 1 min. tracer fixation in dark; washed to remove unfixated tracer; part illuminated, part kept in dark. Total time from fixation to killing, 6–7 min.

	Total counts	% Total counts in pyruvic acid	% Total counts in phosphoglyceric acid	% Removal of tagged phosphoglyceric acid by light
Exp. 1				
Dark	84,100	14	47	—
Light (40 sec.)	81,500	10	16	65
Exp. 2				
Dark	69,300	13	42	—
Light (60 sec.)	73,600	9	11	73
Exp. 3				
Dark	46,000	—	45	—
Light (60 sec.)	51,500	—	20	56
Light + $\text{CN}^-$ (60 sec.)	40,000	—	19	58

#### *Acceptor cycle with one or with two carboxylations*

To illustrate the probable paths of carbon in photosynthesis more and more complicated schemes (Calvin, 1949) have been put forward by the Berkeley investigators showing how a 2-carbon acceptor may be produced via a second carboxylation leading from the 3-carbon acids to the 4-carbon dicarboxylic acids (see also Scheme III). The substances concerned are those with which we are familiar as intermediates in fermentation and respiration, but only one of the compounds, phosphoglyceric acid, has been definitely proved to belong to the photosynthetic as well as to the respiratory mechanism. For all of the others more direct proof is still needed. The incorporation of labelled carbon into their molecules during short exposure to illumination does not exclude that they are products of secondary reactions. By secondary I mean reactions not forming a part of the mechanism indispensable for the continuous production of carbohydrates from carbon dioxide. This applies particularly to the 4-carbon dicarboxylic acids. Perhaps it is not unreasonable under these circum-

stances to approach the problem of the cycle in another way and to ask: What are the minimum requirements for an acceptor cycle which is consistent with the known chemical and kinetic facts of photosynthesis? As can be seen from Scheme I, it is quite feasible to construct a cycle containing only one photochemical reduction step and one carboxylation reaction. The photochemical step must be the reduction of phosphoglyceric acid to triose. Of six triose molecules so made, one can be stored away as a permanent gain for the plant. Three others are needed as hydrogen donors for the reductive carboxylation of three acceptor molecules. This is a pure dark reaction leading to six molecules of phosphoglyceric acid. The remaining two triose molecules must serve to reproduce the three acceptor molecules. This very simple scheme implies a strict specificity of the photochemical part which is coupled only with one reduction step. The hydrogen transfer agent for the dark reduction by triose could, on the other hand, well be a coenzyme of the pyridine nucleotide type with a lesser specificity. The scheme explains why, after the light has been turned off, a fixation of  $\text{CO}_2$  continues at a high rate for only a few seconds; i.e. for as long as freshly made triose or  $\text{C}_2$  compound remains available, the amount available being proportional to the light intensity. It also explains why the fixation does not go beyond the level of phosphoglyceric acid to any measurable extent. This would require additional energy.

A variation of this, Scheme II, couples both reduction steps, the reductive carboxylation as well as the reduction of phosphoglyceric acid, with the photochemical mechanism. For every three triose molecules formed, one is stored and the two others are transformed again into three acceptor molecules. In order to explain the dark fixations following illumination, Scheme II requires that either a fully reduced 2-carbon acceptor for  $\text{CO}_2$  survives or that what survives is a 3-carbon precursor of phosphoglyceric acid with a carboxyl group capable of rapid exchange as long as it is not yet stabilized in the form of phosphoglyceric acid. There is still a third possibility. An enzymic dark reduction may substitute for the action of light during the dark pick-up. The drawback to these schemes is that we must invent a new reaction to produce the acceptor; namely, an enzymic de-condensation of a hexose into three 2-carbon acceptor molecules.

Examining Scheme III, where the acceptor is formed via the continued reduction of, say, oxalacetic acid, we find the following advantages: first, biochemists are familiar with most of its many steps; secondly, it can explain the unequal activity sometimes found in the positions 2, 5 and 1, 6 respectively within sugar molecules synthesized during short periods of photosynthesis with labelled carbon dioxide. On the other hand, there



products of the second carboxylation should either be unstable against extraction with hot alcohol, or be promoted at very high speed into acceptor molecules. This latter feat would be out of the question if the successive reductions were directly coupled with a photochemical mechanism. Thus, comparing the 'one carboxylation' with the 'two carboxylation' type of cycle, we find that the latter does not explain more than the former, has no more direct support in fact, and requires, contrary to expectations, a greater number of *ad hoc* assumptions. The elusive nature of the acceptor is, of course, a problem which is common to both schemes.

*Note added in proof.* Badin & Calvin (1950) have shown that as the light intensity is decreased to quite low values, the proportion of fixed tracer found in malic acid increases until it ultimately becomes the most important site of tracer fixation. This does not invalidate the arguments speaking against the participation of 4-carbon compounds in the specific photosynthetic cycle. At low light intensities the photochemical reactions will proceed at about the same rate as general metabolism. Malic acid will be tagged by the latter process. In addition, the photochemically produced 3-carbon acids could easily be utilized in secondary reactions at rates comparable to the diminished photosynthetic rate. A likely secondary reaction would be the transformation of phosphoglyceric acid to pyruvic acid followed by reductive carboxylation to malic acid.

In connexion with this a very important observation has been made on the possibility of linking  $\text{CO}_2$  fixation with the photochemical activity of chloroplasts by means of a typical coenzyme, triphosphopyridine nucleotide. Ochoa and Vishniac (personal communication) have shown that the synthesis of malate in a system containing chloroplasts, pyruvate,  $\text{CO}_2$  and their malic enzyme is markedly increased by illumination. Simultaneously L. J. Tolmarch in our laboratory has found that the small evolution of oxygen which can be observed in green plant juices upon illumination becomes very pronounced upon the addition of 3-carbon acids or TPN. He and Dr A. H. Mehler therefore investigated the fixation of labelled  $\text{CO}_2$  by plant juices to which had been added TPN, pyruvate and malic enzyme. They observed some increase in  $\text{CO}_2$  fixation upon illumination. The endogenous fixation could be greatly reduced by using washed chloroplasts in place of the whole plant juice. Under these conditions the fixation was increased about ten-fold by illumination.

As I said at the beginning of this report, plants contain many of the enzymes known to catalyse various reversible decarboxylations. It is therefore possible that several different  $\text{CO}_2$  fixation reactions proceed simultaneously during photosynthesis. However, the experimental results

we have described show that in intact photosynthesizing cells the carboxylation leading to phosphoglyceric acid certainly predominates at moderate to high light intensities. In view of the above-mentioned CO<sub>2</sub> fixation by chloroplast preparations, it follows that the next task is to establish whether malic and other dicarboxylic acids are formed in the cell in competition with, or even in place of, carbohydrates under certain conditions (low light intensity, etc.), or whether this or an analogous reaction constitutes an integral part of the photochemical mechanism for the synthesis of sugars.

## REFERENCES

- AUFDEMGAERTEN, H. (1939). *Planta*, **29**, 643.  
 BADIN, E. J. & CALVIN, M. (1950). *J. Amer. Chem. Soc.* **72**, 5266.  
 BASSHAM, G. A., BENSON, A. A. & CALVIN, M. (1950). *J. Biol. Chem.* **185**, 781.  
 BENSON, A. A. & CALVIN, M. (1950). *J. Exp. Bot.* **1**, 63.  
 BENSON, A. A., CALVIN, M., HAAS, V. A., ARONOFF, S., HALL, A. G., BASSHAM, J. A. & WEIGL, J. W. (1949). *Photosynthesis in Plants*, p. 381. Ames, Iowa: Iowa State Coll. Press.  
 BROWN, A. H., FAGER, E. W. & GAFFRON, H. (1948). *Arch. Biochem.* **19**, 407.  
 CALVIN, M. (1949). *J. Chem. Educ.* **26**, 639.  
 CALVIN, M. & BENSON, A. A. (1948). *Science*, **107**, 476.  
 CALVIN, M., BASSHAM, G. A. & BENSON, A. A. (1950). *Fed. Proc.* **9**, 524.  
 CLENDENNING, K. A. (1950). *Arch. Biochem.* **27**, 75.  
 FAGER, E. W. & ROSENBERG, J. L. (1950). *Science*, **112**, 617.  
 FAGER, E. W., ROSENBERG, J. L. & GAFFRON, H. (1950). *Fed. Proc.* **9**, 535.  
 FRENKEL, A. W., GAFFRON, H. & BATTLE, H. (1950). *Biol. Bull. Woods Hole*, **99**, 157.  
 GAFFRON, H. (1945). *J. Gen. Physiol.* **28**, 259.  
 KEMPNER, W. (1933). *Biochem. Z.* **257**, 41.  
 MCALISTER, E. D. (1939). *J. Gen. Physiol.* **22**, 613.  
 MCALISTER, E. D. & MYERS, J. (1940). *Smithson. Misc. Coll.* **99**, no. 6.  
 MEYERHOF, O. & OESPER, P. (1949). *J. Biol. Chem.* **179**, 1371.  
 VAN DER VEEN, R. (1949). *Physiol. Plantarum*, **2**, 287.

# CARBON DIOXIDE ASSIMILATION IN PLANTS\*

BY M. CALVIN, J. A. BASSHAM, A. A. BENSON,  
V. H. LYNCH, C. OUELLET, L. SCHOU,  
W. STEPKA AND N. E. TOLBERT

Radiation Laboratory, Department of Chemistry and Division of  
Plant Nutrition, University of California, Berkeley

If someone tells me that in making these conclusions I have gone beyond the facts I reply: 'This is true, that I have freely put myself among ideas which cannot be rigorously proved. That is my way of looking at things. Every time a chemist concerns himself with these mysterious phenomena and every time he has the luck to make an important step forward he will be led instinctively to attribute their prime cause to a class of reactions in harmony with the general results of his own researches. That is the logical course of the human mind, in all controversial matters.'

LOUIS PASTEUR, 1857

## I. INTRODUCTION

The reactions which comprise the process of photosynthesis appear to be at least as numerous and complex as those of any other biological process. The classification of these reactions has evolved from the experiments of many workers within the past three decades. For example, the work of Warburg and Christian with intermittent light and that of Hill on the photolysis of water by isolated chloroplasts in the absence of carbon dioxide gave strong support to the theory of separation of water photolysis from carbon reduction. By employing the results of studies not only of photosynthesis in green plants but also of photosynthetic bacteria and other biological systems, van Niel had presented a strong argument for the division of these reactions into two major classes. The first group of reactions involves the primary absorption of light energy and its conversion to chemical energy and the employment of this energy to decompose water, forming oxygen and reducing power. The other group of reactions is comprised of those processes by which this reducing power converts carbon dioxide to the various organic compounds formed in photosynthesis.

Further confirmation of the proposal that CO<sub>2</sub> reduction is accomplished entirely by dark reactions was obtained through pre-illumination studies conducted in this laboratory (Calvin & Benson, 1948; Benson & Calvin, 1948, 1950; Benson, Calvin, Haas, Aronoff, Hall, Bassham & Weigl, 1949).

\* The work described in this paper was sponsored by the Atomic Energy Commission. [The Path of Carbon in Photosynthesis. X.]

In these experiments green algae, *Chlorella* and *Scenedesmus*, were first illuminated in the absence of carbon dioxide and then allowed to fix  $C^{14}O_2$  in the dark. When the cells were killed and analysed, the  $C^{14}$ -labelled products were found to be the same as those formed when the algae were allowed to fix  $C^{14}O_2$  in the light for short periods and then killed immediately. Moreover, these experiments indicated that the reducing power had a half-life of several minutes in the dark. With the point of view engendered by these results, the efforts in this laboratory have been directed toward the revelation of the mechanism of the utilization of this energy in carbon dioxide reduction.

Normal photosynthesis is a steady-state process. The rates of the individual reactions involved are highly dependent upon external factors

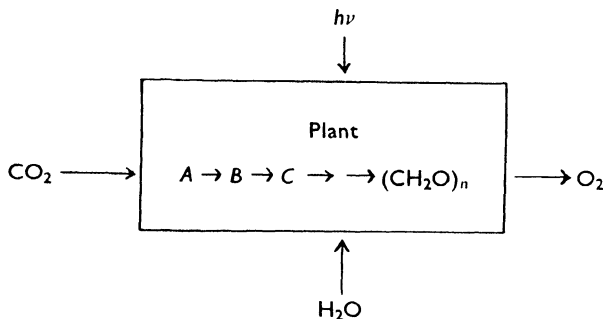

Text-fig. 1.

such as light intensity, carbon dioxide pressure, temperature and nutrient conditions. An intermediate between carbon dioxide and protein, fat and carbohydrate will exist in amounts dependent upon the relative rates of its formation and conversion. It is seen, then, that the amounts of isolable intermediates may vary considerably, and that one might expect rather low concentrations of many important metabolites.

Experiments with high specific activity  $C^{14}O_2$  have allowed a great number of observations on this hitherto almost impenetrable system of reactions. The advantages of such a method lie first in its sensitivity; intermediates of concentrations of less than  $10^{-6}$  M may be readily determined in a few milligrams of plant material. Secondly, addition of labelled carbon to a plant in steady-state photosynthesis with  $C^{12}O_2$  allows one to follow the path of carbon in the normal reduction of carbon dioxide. When labelled carbon dioxide ( $C^{14}O_2$ ) is added to that being absorbed by the plant (Text-fig. 1), the reservoirs of the intermediate products are consecutively labelled with  $C^{14}$ . The specific radioactivity of each reservoir

increases to a maximum (equal to that of the initial carbon dioxide) prior to that of any subsequent intermediate. Analysis of the products of photosynthesis in  $C^{14}O_2$  by two-dimensional paper chromatography has allowed separation of most of the low molecular weight products. When the plant is exposed to radiocarbon for shorter periods it is found that fewer polymeric products are formed. As the time is decreased, the amount of radioactivity incorporated into the fats, protein and carbohydrate approaches zero, and only the intermediates of hexose and amino-acid synthesis are detectable. Text-fig. 2 shows the relative rate of appearance of radioactivity in intermediates soluble in aqueous alcohol.

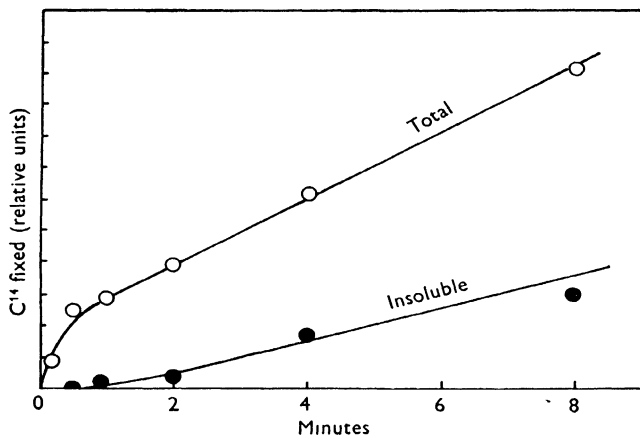

Text-fig. 2.  $C^{14}O_2$  fixation by *Scenedesmus*. Total radioactivity fixed, O. Radioactivity fixed in 80% ethanol-insoluble products, ●. Light intensity, 500 f.c. 4% carbon dioxide in air. Temperature 20° C.

Exposure of various plants to  $C^{14}$ -labelled carbon dioxide under a variety of conditions, both in the light and in the dark, followed by killing the plants, and analysis of the labelled compounds formed has led to the following experimental results and conclusions.

## II. PRODUCTS OF SHORT PHOTOSYNTHESIS

The length of exposure of an actively photosynthesizing plant to labelled carbon dioxide in the light was shortened until all the labelled carbon fixed by the plant was found in a few compounds (Benson & Calvin, 1950; Calvin & Benson, 1949; Benson, Basham, Calvin, Goodale, Haas & Stepka, 1950). These compounds were found to be phosphoglyceric acid, phosphopyruvic acid, malic acid and sometimes glyceric acid. For example, when the green alga *Scenedesmus* was allowed to photosynthesize at 10,000 f.c.

for 5 sec., analysis showed that 87% of the activity was incorporated in phosphoglyceric acids, 10% in phosphopyruvic acid and 3% in malic acid. Radioactive products of 1 and 60 sec. photosynthesis by barley leaves in  $C^{14}O_2$  are shown in the radiograms of Pl. 1, fig. 1. These are radioautographs of paper chromatograms of the products extracted from 50 mg. of leaf tissue.

*Identification of phosphoglyceric acid.* Acid hydrolysis of phosphoglyceric acid which was isolated chromatographically produced glyceric acid. The glyceric acid was identified by subjection to periodate oxidation. All of the radioactivity initially present in the glyceric acid could be accounted for in the expected products of periodate oxidation, carbon dioxide, formic acid and formaldehyde. Phosphoglyceric acid was identified independently by its isolation from *Scenedesmus* which had photosynthesized for 5 sec. in  $C^{14}O_2$ . Over 65% of the fixed activity was so isolated, and the product characterized as the barium salt by its solubility, specific rotation, phosphorus analysis and ion-exchange resin adsorption properties (Benson *et al.* 1950). Phosphoglyceric acid had previously been identified as a major constituent of the products of 30 sec. photosynthesis by *Scenedesmus* by its adsorption properties on anion exchange resins (Calvin & Benson, 1948). The phosphoglycerate so isolated was hydrolysed to glyceric acid which was identified by physical properties, distribution coefficient, acid strength, by ion resin adsorption properties, and by conversion to the *p*-bromphenacyl ester (Calvin & Benson, 1948; Benson *et al.* 1949).

*Sequence of the intermediates in photosynthesis.* As longer exposures to  $C^{14}O_2$  in the light are permitted (15–60 sec.), radioactivity is found not only in the above compounds but also in aspartic acid, alanine, serine, glycine, glycolic acid and triose phosphates, hexose phosphates, hexose diphosphate, sucrose and several other as yet unidentified phosphorus-containing compounds (Text-fig. 3). Radioactivity accumulated more slowly in succinic, fumaric, citric and glutamic acids, glucose, fructose and a number of amino-acids (threonine, phenylalanine, glutamine, asparagine, tyrosine). It should be noted that appearance of a labelled compound in the light and not in the dark indicates that that compound is a product but not necessarily an intermediate of photosynthesis.

The identity of a number of these phosphate esters with those involved in glycolysis suggested that the synthesis of sucrose is accomplished through a reversal of glycolysis. When sucrose isolated from *Chlorella* which had photosynthesized for 30 sec. in  $C^{14}O_2$  was hydrolysed, the specific activity of the fructose was twice that of the glucose moiety. This result is that expected from a reversal of the glycolytic sequence. Further support for this suggested mechanism of sucrose synthesis is found in the

identity of the distribution of  $C^{14}$  in the 3, 4, the 2, 5 and the 1, 6 carbons of hexose with that in the carboxyl, alpha and beta carbons, respectively, of glyceric acid (Table 1).

The protein of the insoluble products formed during 60 sec. photosynthesis by *Scenedesmus* contains radioactive amino-acids in approximately the same proportion as those found in the soluble products. The proteins synthesized in longer times show that the proportion of amino-acid constituents differs greatly from that of the free amino-acids. The insoluble

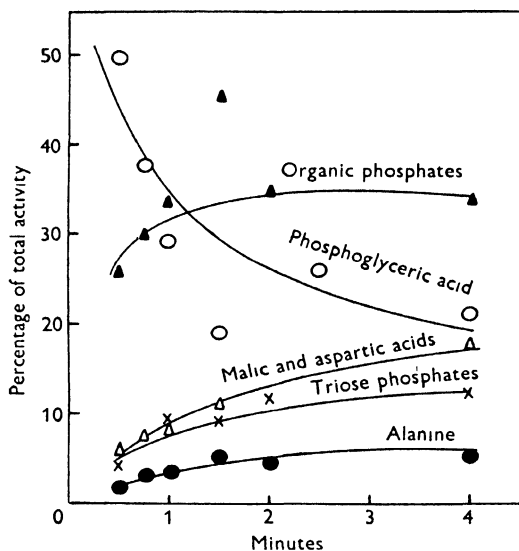

Text-fig. 3. Incorporation of  $C^{14}$  in products of short photosynthesis by *Scenedesmus*. Light intensity, 500 f.c. Temperature  $20^{\circ}C$ . The radioactivity as defined by the radio-autograph was determined directly on the series of paper chromatograms. Large thin-window Geiger-Müller tubes (K. G. Scott type) were used for radioactivity determination. The products chromatographed include only those soluble in 80% ethanol.

products synthesized by barley in 5 min. consist largely (> 95%) of polyglucose compounds; those of *Scenedesmus* are about half polysaccharide and half protein, of which alanine and aspartic acid are the major constituents.

### III. EFFECT OF LIGHT INTENSITY ON EARLY PRODUCTS

As the light intensity is decreased the number of products formed in 30 sec. decreases until at 400 f.c. the principal products are the three carbon compounds as is seen in the radiograms (Pl. 1, fig. 2). These are phosphoglyceric



acid and phosphopyruvic acid. It has not yet been possible to differentiate 2- and 3-phosphoglycerate with certainty on paper chromatograms. The collection of information available is consistent with the possibility that the major compound in the 400 f.c. radiogram is 3-phosphoglycerate, while that below and to the right of it is 2-phosphoglycerate. Separate experiments performed at high light intensity (4000 f.c.) and low temperature (2° C.) showed reversal of radioactivity accumulation in this pair of compounds. At low temperature one might expect the equilibrium between 2- and 3-phosphoglycerate to be slowly attained, hence the prior labelling in the 2-isomer. At higher temperature and low light intensity the greater amount of radioactivity in the 3-isomer is attributed to its rapid formation from the less stable 2-isomer.

The radioactivities determined by counting of radioactive areas of the chromatograms defined by the radiograms in Pl. 1, fig. 2, are given in Table 2.

Table 2. *Effect of light intensity on early products*

Fraction of radioactive carbon fixed, expressed in per cent, in products of steady-state photosynthesis in 4% CO<sub>2</sub> in air by *Scenedesmus-D<sub>3</sub>* in 30 sec.

Light intensity (a) (f.c.)	400	800	4000	8000
Total C <sup>14</sup> fixed (b) c.p.m. × 10 <sup>-6</sup>	0.36	0.65	3.6	3.7
3-Phosphoglyceric acid	55	33	10	12
2-Phosphoglyceric acid (c)	3	17	~ 5	~ 5
Phosphopyruvic acid (d)	12	10	5	5
Triose phosphates	1	1.3	1.6	1.5
Hexose phosphates	15	17	69	62
Malic acid	3.0	4.1	4	6.1
Aspartic acid	1.8	2.5	1.5	2.0
Alanine	1.7	1.2	1.5	1.6
Serine	—	0.3	0.3	0.5
Glycine	—	0.2	0.2	0.4
Glycolic acid	—	0.3	0.2	0.8
Sucrose	—	0.3	0.5	1.0
Fats	—	—	0.6	2.4
Succinic acid	0.5	—	0.2	0.1
Fumaric acid	—	—	0.2	0.15
Citric acid	2	1.2	0.5	0.6

(a) One c.c. of packed cells in 70 ml. of suspension in a 1.5 cm. thick vessel between two light beams of the given intensity. After 30 min. photosynthesis of adaptation in the light, 100 μc. NaHC<sup>14</sup>O<sub>3</sub> was added. The algae were killed 30 sec. later.

(b) Eight disintegrations per count.

(c) This compound has not been definitely identified as the 2-isomer.

(d) Due to instability of this compound, the counting data are approximate.

*Dark-fixation products.* Two types of dark fixation of labelled carbon were observed. The first type was obtained when plants were exposed to C<sup>14</sup>O<sub>2</sub> immediately following a period of illumination in the absence of carbon dioxide (Pl. 2, fig. 1 a), in which case the labelled products as well as their rates of formation were found to be nearly the same as in short

exposures (15–60 sec.) in the light (Pl. 2, fig. 1*b*). The proportion of radiocarbon found in malic acid, aspartic acid and alanine to the total radiocarbon fixed was appreciably greater (Benson & Calvin, 1950). Depletion of the malic acid ( $C_4$ ) and alanine ( $C_3$ ) reservoirs by pre-illumination (reduction to hexose) resulted in their restoration with labelled compounds as soon as a source of carbon dioxide became available.

The second type of fixation was obtained when the exposure to radioactive carbon dioxide in the dark did not follow soon after a period of illumination (Pl. 2, fig. 1*c*). A much slower rate of fixation of radiocarbon (one-tenth to one-hundredth the rate) was observed, and the labelled products (95% of the total) were malic, succinic, fumaric, citric, glutamic and aspartic acids, and alanine (Benson & Calvin, 1950). These compounds are believed to be labelled by fixation of carbon dioxide through reversibility of the common carboxylation reactions. The effect of light on the labelling of some of these compounds will be discussed later.

Those compounds labelled in the light and in pre-illumination experiments only are considered products of photosynthesis, while alanine, malic acid and aspartic acid, labelled slowly in non-pre-illuminated dark experiments and much more rapidly in light and pre-illuminated dark experiments, are considered to be products of both photosynthesis and reversible respiration reactions.

#### IV. DEGRADATION STUDIES

Degradation of hexose formed during short periods of photosynthesis with labelled carbon dioxide revealed that the highest percentages of labelled carbon were in the 3 and 4 positions, the next highest in the 2 and 5 positions and the least in the 1 and 6 positions. In some cases, labelling of the 1, 6 positions was found equal to that in the 2, 5 positions (Benson *et al.* 1949; Bassham, Benson & Calvin, 1950). Degradation of phosphoglyceric acid and of alanine demonstrated that the greatest labelling was in the carboxyl groups. Exceptions to this distribution (Benson *et al.* 1949; Gibbs, 1949) have been considered caused by brief photosynthesis or exchange with  $C^{12}O_2$  immediately before killing the plant. This resulted in decreased carboxyl labelling and 3, 4 labelling in hexoses. The results of a number of degradations are given in Table 1. It is seen that as the length of exposure of the plant to  $C^{14}O_2$  is shortened, the proportion of radiocarbon in the carboxyl group of glyceric acid to the total radiocarbon in the molecule becomes large and is large in the case of the pre-illumination experiment. This result suggests that phosphoglyceric acid which is the first isolable product of photosynthesis is formed by a carboxylation of some  $C_2$  compound.

Malic and aspartic acids from short-term photosynthesis with  $C^{14}O_2$  have been degraded, and again most of the labelling has been found in the carboxyl groups. This distribution of activity, together with the early appearance of labelled malic acid and phosphopyruvic acid, suggests that phosphoglyceric acid is converted to phosphopyruvic acid which then is carboxylated as in the Wood-Werkman reaction (Wood, Werkman, Hemingway & Nier, 1941) to give oxaloacetic acid from which, in turn, malic and aspartic acids would arise. The enzyme system for such a carboxylation has been found in higher plants by Vennesland, Gollub & Speck (1949). Thus, there would be two carboxylations involved in carbon dioxide reduction in the light, one a  $C_1$  to  $C_2$  addition, and the other a  $C_1$  to  $C_3$  addition.

Additional evidence for these two fixation mechanisms was obtained from comparison of tracer studies at high and low light intensities. While the predominant labelled product of short exposures to  $C^{14}O_2$  at high light intensity (400–10,000 f.c.) is phosphoglyceric acid, the principal labelled product at low light intensities (50 f.c. and lower) is malic acid (Badin & Calvin, 1950). This variation in products is thought to be the result of variation with light intensity in the concentrations of the respective carbon dioxide acceptors.

The  $C_2$  carbon dioxide acceptor must be a highly reduced compound. It would be formed readily in the presence of photochemically produced reducing power, but in the dark it would probably be formed only by reversal of the  $C_2$  to  $C_1$  carboxylation, and in the latter case subsequent rapid oxidative reactions might keep its concentration at a very low level.

The concentration of  $C_3$  carbon dioxide acceptor, probably phosphopyruvic acid, would depend on the rate of glycolysis and on the forward and reverse rates of the two carboxylations. In the dark, the concentration of  $C_3$  carbon dioxide acceptor is maintained by glycolysis, while concentration of  $C_2$  carbon dioxide acceptor will be very small, as discussed in the preceding paragraph. Consequently, in the dark and at low light intensities, the predominant product will be malic acid in short-term exposures. As the light intensity is increased, the concentration of  $C_2$  carbon dioxide acceptor tends to increase, causing an increase in the rate of  $C_2$  to  $C_1$  carboxylation.

Ultimately, the  $C_2$ - $C_1$  reaction becomes the faster of the two carboxylations, with the result that at high light intensities phosphoglyceric acid is the predominant product formed in short times.

*Generation of  $C_2$  compound.* There remains the necessity for continuously generating the two-carbon compound which, according to the above proposals, is carboxylated to give phosphoglyceric acid. One possible

mechanism for forming a  $C_2$  compound would be a  $C_1$ - $C_1$  condensation. This possibility is being investigated, but is considered unlikely for several reasons. The direct coupling of two carbon dioxide molecules with simultaneous reduction seems an improbable mechanism. Moreover, the expected product of such a reaction, oxalic acid, has not been found labelled, even with the very sensitive methods of detection employed.

If carbon dioxide is first reduced to some other  $C_1$  compound, then labelled formaldehyde or formic acid should be found. However, the most labelling we have found in these compounds, after 2 min. exposure of the *Scenedesmus* to radioactive carbon dioxide during which a total of  $1.7 \times 10^6$  dis./sec. was fixed, was as follows: The formaldehyde, isolated by adsorption chromatography as the 2,4-dinitrophenylhydrazone, contained about 33 dis./sec., while the total volatile acids not reacting with 2,4-dinitrophenylhydrazine contained about 200 dis./sec. There is good reason to believe the latter is mostly acetic acid, but in the following calculations it is assumed to be all formic acid. The specific activity of labelled carbon dioxide used was  $1.7 \times 10^{11}$  dis./mole. sec. Consequently, if the molar specific activity of the formic acid and formaldehyde were that of the  $C^{14}O_2$  used, as it would have to be if these compounds were actual intermediates in photosynthesis yet present in such small concentrations, the actual quantities of these compounds would be  $2 \times 10^{-10}$  moles of formaldehyde and  $12 \times 10^{-10}$  moles of formic acid in 1 g. of wet packed cells. There is evidence that even these small quantities of formic acid and formaldehyde may be artifacts. Labelled triose phosphate is known to be present in these experiments, and from triose phosphate one obtains some pyruvaldehyde under the conditions of analysis of the plant extract. Commercial pyruvaldehyde contains appreciable amounts of acetaldehyde and formaldehyde which probably are decomposition products. Labelled pyruvic acid might give some formic and acetic acids.

Another argument against  $C_1$ - $C_1$  condensation can be based on the absence of appreciable radioactivity in two-carbon compounds in short-term experiments. Glycine and glycolic acid are not found to be significantly labelled in short experiments (1 sec. barley photosynthesis showed no detectable glycolate or glycine), and this evidence is in agreement with the fact that the alpha and beta carbon atoms of glyceric acid possess only 5% of the total label of the glyceric acid molecule in these experiments. If the  $C_2$  compound were formed by condensation of  $C_1$  compounds, present in very small concentrations, then the  $C_2$  compounds should become labelled very rapidly.

Finally, there is good evidence that the labelled carbon which is eventually incorporated in the  $C_2$  compound must first be incorporated in a  $C_3$  or  $C_4$

compound. If plants are illuminated in  $C^{14}O_2$  for short periods under conditions where the  $C_3$  and  $C_4$  compounds are normally found to be labelled and then are illuminated for an additional period in the absence of carbon dioxide, there is found to be a disappearance of  $C_3$  and  $C_4$  compounds and an accumulation of labelled glycolic acid and glycine. This suggests the close relationship between the latter two compounds and the  $C_2$  carbon dioxide acceptor. This carbon dioxide acceptor must be formed as a direct result of the photochemically produced reducing power and must itself accumulate in the absence of carbon dioxide. This explains why the formation of phosphoglyceric acid is the light-sensitive carboxylation.

If glycolic acid and glycine, accumulated by illumination in the absence of carbon dioxide, are assumed to be derived from or are precursors of the  $C_2$  acceptor molecule, one must conclude that the  $C_2$  acceptor is not the product of  $C_1$  reduction and  $C_1$ - $C_1$  condensation. The formation of such a  $C_2$  compound by direct reduction of carbon dioxide and  $C_1$ - $C_1$  addition would be highly dependent upon the amount of carbon dioxide available, and conditions of low carbon dioxide pressure would not lead to the observed great increase in two-carbon compounds.

If the  $C_1$ - $C_1$  condensation is dismissed as the mechanism of  $C_2$  formation, there is left the alternative of splitting the  $C_2$  compound from a larger molecule. The only larger molecules found to be labelled in the very short-term photosynthesis experiments were the three- and four-carbon acids, phosphoglyceric acid, phosphopyruvic acid and malic acid, while, at the same time, a small but significant labelling of the alpha and beta carbons of phosphoglyceric acid was found. Since the sum of the radioactivity found in the three- and four-carbon compounds in such short-term experiments was equal, within experimental error, to the total activity fixed during the experiment, it appears that all appreciably labelled compounds were detected by the methods of analysis employed. The splitting of a three-carbon compound would result in either a profitless decarboxylation or in the formation of formaldehyde or formic acid, neither of which has been found to be labelled significantly even in longer experiments. Consequently, the most likely regenerative mechanism would appear to be the cleavage of a four-carbon dicarboxylic acid to give two two-carbon molecules which would be converted to the two-carbon carbon dioxide acceptor. Thus, there would be a regenerative cycle consisting of  $C_1$  to  $C_2$  addition,  $C_1$  to  $C_3$  addition, and splitting of a  $C_4$  compound to two  $C_2$  compounds. This proposed cycle will be designated as cycle A in this paper. Thus far no experimental evidence has been found which would contradict the existence of the proposed cycle.

Varner & Burrell (1950) report experiments in which *Bryophyllum* leaves

were exposed to  $C^{14}O_2$  in the dark and then exposed to light in an atmosphere free of  $C^{14}O_2$ . Degradation of malic acid formed in one of these experiments gave 21% of the total labelling of the molecule in carbon atoms 2 and 3, 34% in carbon 1 (alpha carboxyl), and 45% in carbon 4 (beta carboxyl). Degradation of glucose from starch in the same experiments gave for the 3,4 carbon atoms 52% and for the 2,5 and 1,6 positions (total for four atoms) 48%. Varner & Burrell concluded that the conversion of malic acid to carbohydrate does not take place via the cycle A mechanism described above, since this mechanism should produce hexose predominantly labelled in the 2,5 positions rather than the 3,4 positions. They further concluded that the labelling found could be accounted for by a reversal of the Wood-Werkman reaction. Unfortunately, although it is stated that the plants are exposed to light in an atmosphere free of  $C^{14}O_2$ , no mention was made as to whether or not unlabelled carbon dioxide was excluded at the same time. If carbon dioxide was excluded, then cycle A by itself, of course, could not operate since it involves a carboxylation. Even if carbon dioxide were not excluded during illumination it would not be surprising if *Bryophyllum*, which stores carbon in a large reservoir of malic acid in the dark, should, upon illumination, convert this carbon to phosphoglyceric acid via the reversible Wood-Werkman reaction. It is unlikely that this plant could depend upon its internal environment, notably deficient in carbon dioxide, to supply sufficient carbon dioxide for conversion of malic to carbohydrate entirely through cycle A. It seems likely that the carbon dioxide, temporarily 'freed' by the Wood-Werkman decarboxylation, never actually escapes the cell, but rather is used immediately in the carboxylation of  $C_2$  compound and possibly in other carboxylation reactions not related to photosynthesis. If only  $C_2$  to  $C_1$  carboxylation is involved, then for each two malic acid molecules decomposed via the Wood-Werkman reaction, one is cleaved via cycle A. If, in Varner & Burrell's experiments, the combination cycle A and Wood-Werkman reaction mechanism described above were operating, the resulting distribution of labelling in hexoses would be 53% in the 3,4 position and 47% in the 2,5 plus 1,6 positions. If only the Wood-Werkman transformation were involved, these figures would be 62 and 38%, respectively. Consequently, the *Bryophyllum* experiments are by no means in contradiction to the proposed cycle.

In attempting to elucidate details of cycle A, several dicarboxylic acids have been considered as possible intermediates. Succinic and fumaric acids, tentatively suggested in earlier papers, appear more likely to be respiration intermediates than photosynthetic intermediates, since their specific activities increase only slowly during photosynthesis. In fact, in

some cases, alpha, beta labelled glyceric acid and 2,5 plus 1,6 labelled hexose have been found in the complete absence of any labelled succinic acid. However, malic acid, because of its more rapid labelling in the light, seemed a possible intermediate in the proposed cycle.

In order to ascertain whether malic acid might be such an intermediate, an attempt was made to inhibit its formation during short periods of photosynthesis (Bassham *et al.* 1950). *Scenedesmus* was pretreated with sodium malonate buffer in the dark, and resuspended in malonate-free buffer in the light. Finally, after a suitable adaptation period in the light the actively photosynthesizing cells were exposed to  $C^{14}O_2$  for short periods. It was found on analysis of the cell constituents that although total fixation of labelled carbon was decreased only slightly (12–35%) over that fixed under similar conditions by non-malonate pretreated cells, the radiocarbon incorporated as malic acid was strongly decreased (60–97%). The other products of this short-term exposure were relatively unchanged. Moreover, degradation of glyceric acid from the malonate-treated cells and untreated cells showed a labelling of the alpha and beta carbon atoms which was not decreased by malonate pretreatment. This result is interpreted as indicating that malic acid is not itself an intermediate between carbon dioxide and the alpha and beta carbon atoms of glyceric acid in photosynthesis. Consequently, if the conclusion, that phosphoglyceric acid is an intermediate in carbohydrate photosynthesis, is correct and if carbohydrate is formed from phosphoglyceric acid by a reversal of glycolysis reactions, then malic acid is not an intermediate in photosynthesis. The role of malic acid appears, therefore, to be that of a carbon reservoir, readily derived from an intermediate in photosynthesis.

Since neither malic acid, fumaric acid nor succinic acid appears to be an intermediate in cycle A, the four-carbon compound which is split to two  $C_2$  fragments must be either a four-carbon dicarboxylic acid or some other four-carbon compound that can be derived from oxaloacetic acid without first being converted to malic acid. There are four such dicarboxylic acids with the terminal carboxyl groups as would be expected from the proposed carboxylation mechanism. Oxaloacetic acid itself might cleave hydrolytically to give one molecule of glycolic acid and one molecule of glyoxylic acid. Tartaric acid, the hydration product of oxaloacetic acid, would give the same products. Dihydroxymaleic acid, which might be formed by oxidation of oxaloacetic acid (or tartaric acid), could give two molecules of glyoxylic acid. Diketosuccinic acid could cleave hydrolytically to one molecule of oxalic acid and one molecule of glyoxylic acid.

Of these various possibilities the two most plausible seem to be the cleavage of tartaric acid, analogous to glycolytic splitting of hexose, and

the cleavage of dihydroxymaleic acid by a reversal of the benzoin condensation. The benzoin type reaction is known to occur in certain organisms which form acetoin from acetaldehyde. Thus far, we have been unable to demonstrate the presence of labelled tartaric acid in short term experiments with labelled  $C^{14}O_2$ .

An alternative mechanism for the cleavage of a four-carbon molecule involves the preliminary reduction of one or both of the carboxyl groups of the four-carbon acid followed by subsequent cleavage of the product. An analogy for such a reduction is found in the reduction of 1,3-diphosphoglyceric acid to 1,3-diphosphoglyceraldehyde. A very similar mechanism could be postulated for the reduction of 1,3-diphosphotartaric acid to 1,3-diphosphotartaric acid aldehyde.

This product could either be split to phosphoglycolic acid and phosphoglyoxal or further reduced to diphosphotartaric dialdehyde which could then be cleaved to phosphoglycolaldehyde and phosphoglyoxal. This mechanism, although as yet unsubstantiated by any experimental evidence, is made attractive by the close analogies for all the reactions involved that can be found in the reactions of glycolysis. Thus, the cleavage of diphosphotartaric dialdehyde bears a close resemblance to the splitting of 1,6-fructose diphosphate by aldolase.

The various paths from  $C_4$  to  $C_2$  fragments described above are shown in Text-fig. 4. For the sake of simplicity, only the non-phosphorylated forms are shown. Whatever the mechanism of the cleavage, the products presumably would be reduced to the  $C_2$  carbon dioxide acceptor, either vinyl phosphate or glycol phosphate.

If the cleavage is at the dicarboxylic acid level, then glyoxylic acid and glycolic acid might be intermediates in this reduction, but if the splitting is at the dialdehyde level these two-carbon acids are formed by side reactions. The latter mechanism gains support from the degradation studies of glycolic acid and glyceric acid obtained from 15 sec. exposure of barley leaves to  $C^{14}O_2$  in the light (Table 1). Since more than one-half the label of the glyceric acid was in the carboxyl group, it is to be expected that after another carboxylation with  $C^{14}O_2$  at least two-thirds of the label of the four-carbon intermediates was in the two carboxyl groups. If the  $C_4$  acid were split directly to two  $C_2$  acids, the carboxyl group of the  $C_2$  acid would arise from the carboxyl groups of the  $C_4$  acid and should carry two-thirds of the label of the  $C_2$  molecule. If the cleavage took place at the dialdehyde level, there is the possibility of obtaining symmetrically labelled products which could then be oxidized to symmetrically labelled glycolic acid. The distribution of radiocarbon found in the glycolic acid is in accord with the latter mechanism.

However, it should be noted that a number of experiments have been reported both from this laboratory and from others (Benson *et al.* 1949; Gibbs, 1949; Varner & Burrell, 1950) in which the 2,5 carbon atoms of a hexose do not have the same specific activity as the 1,6 carbon atoms. This implies that there exist routes in which the  $C_2$  fragment maintains its unsymmetrical labelling throughout the cycle.

The formation of labelled glycolic acid during short periods of photosynthesis with  $C^{14}O_2$  was found to be dependent on the partial pressure of

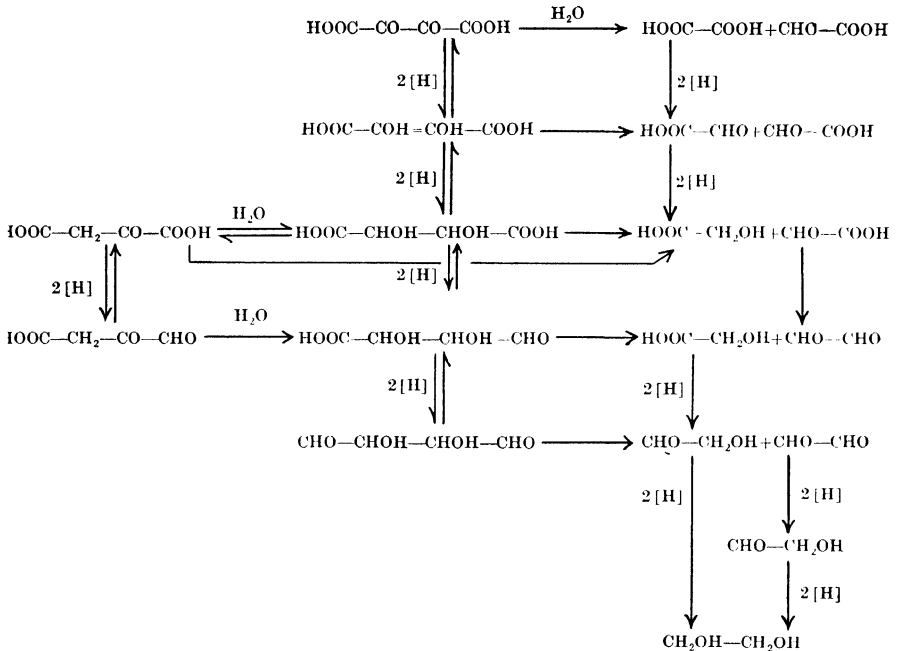

Text-fig. 4. Possible routes between the four-carbon and the two-carbon carbon dioxide acceptor molecules. Reduction steps are written downward while cleavage and other reactions are written to the right.

oxygen. Thus, in corresponding lengths of exposure to  $C^{14}O_2$ , the percentage of total fixed activity found in glycolic acid was about ten times greater when the atmosphere surrounding the plant contained 20% oxygen than when the plant was exposed in an atmosphere containing 1% oxygen. This effect might be explained in two ways, depending on which of the above cleavage mechanisms is correct. The oxygen might be used in the oxidation of oxaloacetic acid to dihydroxymaleic acid if the latter is an intermediate in cycle A. In this case the operation of cycle A would be accelerated by the increase in oxygen pressure described above.

If the cleavage of  $C_4$  compound occurs at the lower reduction levels, then the initial  $C_2$  cleavage products would be more reduced than glycolic acid and the oxidation of these reduced compounds would be favoured at increased oxygen concentrations. In this case, the formation of  $C_2$  carbon dioxide acceptor would be decreased by increased oxygen. It may be possible in future experiments to measure the rate of formation of  $C_2$  carbon dioxide acceptor in the presence of high and low oxygen pressures by degrading the labelled phosphoglyceric acid and thus to discover which of the above explanations of oxygen-enhanced glycolic acid formation is the more probable.

#### V. RELATION OF RESPIRATION TO PHOTOSYNTHESIS

The processes involved in respiration in animal tissues and in yeasts have been shown to be operative in plant tissue (Goddard & Meeuse, 1950). Evidence that the major oxidative and decarboxylation reactions are in accord with the existence of a tricarboxylic acid cycle is rapidly accumulating.

The rate of respiration is approximately one-twentieth that of photosynthesis at saturating light intensities, but a vast number of experiments have been reported at intensities near the compensation point. In an attempt to understand the relationships between the chemical reactions of photosynthesis and respiration we have performed a number of experiments (Benson & Calvin, 1950).

*Dark respiration.* As described earlier, the series of reversible reactions ending in decarboxylations has been shown to involve the intermediates of the Krebs tricarboxylic acid cycle, aspartate (oxaloacetate), citrate, isocitrate, glutamate ( $\alpha$ -ketoglutarate), succinate, fumarate and malate. Aspartic acid, malic acid and alanine become labelled with  $C^{14}$ , both in photosynthesis and in dark  $C^{14}O_2$  fixation experiments. It is possible that the reservoirs of these compounds are common to both photosynthesis and respiration.

A series of experiments was performed with *Scenedesmus* and barley leaves in which the products of short (30 sec.) photosynthesis were partially respired in the dark immediately afterwards. Algae rapidly converted the phosphate esters involved in sucrose synthesis to glutamate, succinate, fumarate and citrate. The steady decrease in radioactivity in the cells showed that  $C^{14}O_2$  was being lost by decarboxylations. The compounds observed to be most susceptible to respiration in these experiments were glycolic acid and the phosphate esters. One hour of dark respiration in air diminished the amount of labelled phosphate esters to about 10% of its value immediately following 30 sec. photosynthesis. After 18 hr. dark

respiration the products closely resembled those found by dark exchange of  $C^{14}O_2$  in the respiratory intermediates. Barley leaves have not produced observable amounts of labelled succinate and fumarate, except in extended periods of dark respiration. Labelled glutamic acid appears, but only after 1 hr. of respiration by barley compared to its appearance in copious amounts in algae after 2 min. Radioactivity in glutamine invariably parallels that of glutamate, although equilibrium between the two is not rapidly attained. If the gradual disappearance of radioactive hexose, triose and glyceric acid phosphates in barley leaves involves succinate and fumarate as intermediates, the concentration of these acids must be very low.

In 5 min. of photosynthesis barley leaves synthesize sucrose as the major product. Sucrose synthesized by 30 sec. of steady-state photosynthesis in  $C^{14}O_2$  is not appreciably respired in the dark after an hour. During this dark time the amounts of radioactivity in phosphorylated intermediates of sucrose synthesis is rapidly and greatly diminished without notable decrease in sucrose radioactivity. When intact barley seedlings are allowed to photosynthesize for 30 sec. followed by 18 hr. dark respiration in air, the amount of radioactive sucrose remaining in the leaves is almost negligible. The roots, on the other hand, were found to contain the active citrate, malate, alanine, phosphoglycerate and some sucrose. In these experiments, the carbon of sucrose was transferred to the roots where it appeared in respiratory products.

*Light respiration.* When algae or barley leaves photosynthesize (approximately 8000 f.c.) in  $C^{14}O_2$  for 30 sec. and then, in one case, are illuminated in carbon-dioxide-free air for a short time and, in another case, allowed to respire in the dark for the same length of time, the amounts of labelled tricarboxylic acid cycle intermediates formed in the light-respiration experiment are much smaller than those found in the dark-respiration experiment. Anaerobically in the light the absence of respiration intermediates is even more striking. Such experiments must be done in the absence of  $C^{12}O_2$ , since the latter rapidly displaces the  $C^{14}$ -labelled products of the preceding photosynthesis which are converted to polymeric products.

The major effect of aerobic illumination in the absence of carbon dioxide is the formation of glycolic acid and glycine. Up to 30% of the fixed radioactivity may be converted to glycolic acid in this way (Pl. 2, fig. 2). Thus, glycolic acid rapidly accumulates in the light and very rapidly disappears in the dark (Benson & Calvin, 1950). The possibility remaining to be investigated is that glycolic acid oxidation, catalysed by an enzyme system widely distributed in green plants (Clagett, Tolbert & Burris, 1949) and demonstrated in colourless algae (Anderson, 1945) represents an alternate oxidative mechanism in the higher plants.

The inhibition of respiration by light was demonstrated by van Niel (1941) in acetate metabolism in *Rhodospirillum rubrum*. The stability of photosynthetic intermediates towards oxidation in the light is also in accord with the kinetic results of Weigl (1949) who worked with barley leaves. Weigl observed a ten-fold increase in specific radioactivity of respiratory carbon dioxide produced by previously photosynthesized intermediates immediately upon cessation of illumination. The carbon dioxide respired during photosynthesis then came from relatively non-radioactive sources. It is possible that the physical site of light respiration may be quite different from that of photosynthesis.

These results mean that light does at least affect respirability of intermediates of sucrose synthesis (Benson & Calvin, 1950). The fact that some compounds are found to be intermediates in both respiration and photosynthesis suggests that the same molecules of the compounds may be involved in both processes. This is not necessarily the case, since the processes may be physically separated. The inhibition of the respiration of newly photosynthesized materials by light would seem to indicate a close interaction between the two processes. This interaction is at present best interpreted in terms of a reduction of the steady-state concentrations of respiratory intermediates which are used as photosynthetic intermediates in the light. This leads to a lower rate of appearance of newly incorporated carbon in the tricarboxylic acid cycle in the light.

Inhibition of respiration by illumination is dependent upon the light intensity. The experiments referred to above involved intensities of 10,000 f.c. As the light intensity is decreased, the rates of appearance of radiocarbon in respiratory intermediates and in photosynthetic intermediates approach each other. Text-fig. 5 shows the relationship of the rate of formation of radioactive respiratory intermediates (succinate, fumarate, glutamate, citrate) to that for the intermediates and related reservoirs of sucrose synthesis (including alanine, aspartate and malate).

*Feeding experiments.* A number of feeding experiments with both algae and barley have been performed. The interpretation of such experiments is complicated by such questions as the penetration of the substance into the cell and the fact of complex internal organization within the cell entailing the possibility of different sites of metabolism for the same substance. However, the feeding of labelled acetate to *Scenedesmus* had led to a definite result. In the dark (Pl. 3 *a*) acetate is respired through the expected tricarboxylic acid cycle intermediates. In the light (Pl. 3 *b*), whether carbon dioxide is present or not, acetate is converted to fats in addition to the tricarboxylic acid cycle intermediates. Only a small fraction of the acetate consumed is converted to sucrose or its precursors. It is thus apparent

that reducing power resulting from the photochemical reactions may be used to convert acetate directly into fats.

*Poisoning experiments.* A number of poisoning experiments have been performed, using those poisons previously employed in the study of photosynthesis. In addition to the difficulties encountered in the interpretation of the feeding experiments there is the question of the number of sites and the relative degree to which they are affected by a given poison.

When photosynthesis in *Chlorella* suspended in  $1.5 \times 10^{-4}$  M-iodoacetamide is inhibited as much as 90%, as measured by  $C^{14}O_2$  fixation, the absolute rate of sucrose synthesis (as measured by the amount of  $C^{14}$  in sucrose) is not decreased but is increased at lower degrees of inhibition. No abnormal phosphoglyceric acid accumulation occurs in the presence of iodoacetamide.

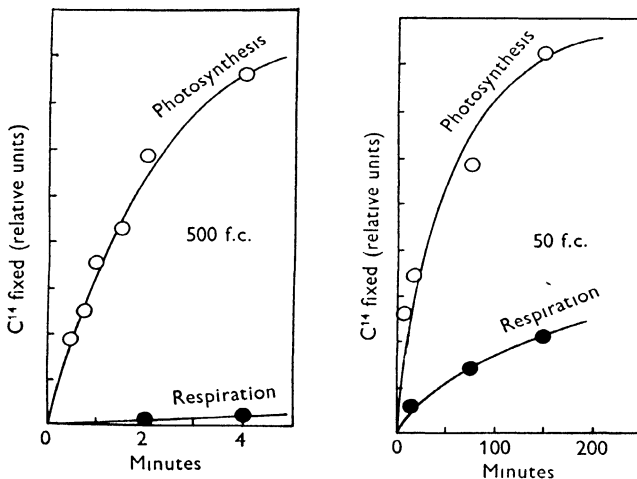

Text-fig. 5. Effect of light intensity on incorporation of  $C^{14}O_2$  into photosynthesis products and some respiration products. The lower curves include radioactivity in succinic, fumaric, citric and glutamic acids only. The curves for photosynthesis include the remainder of the 80% ethanol-soluble products. It should be noted that the time as well as the radioactivity scales are different in the two plots. The relative slopes, however, are quite different.

In view of the known action of iodoacetamide on other enzyme systems beside triose phosphate dehydrogenase it is possible that these other systems are more sensitive to this poison. Such selective action might possibly result in the blocking of other paths of carbon utilization and lead to a more rapid sucrose synthesis at certain iodoacetamide concentrations. Alternatively, sucrose may be synthesized by a path not involving triose phos-

phate although this is in contradiction to the present accumulated information.

Cyanide and hydroxylamine are strong inhibitors of photosynthesis. We have shown that these poisons do not prevent the initial carboxylation step with the formation of phosphoglyceric acid. *Scenedesmus* (Gaffron D-3 strain) was placed aerobically in the light without carbon dioxide for 30 min. in order to increase the concentration of the C<sub>2</sub> acceptor. The poison was then given to the algae 1 min. before adding C<sup>14</sup>O<sub>2</sub>. In this length of time the poison becomes effective, but the light-generated C<sub>2</sub> acceptor will not have completely decomposed. Phosphoglyceric acid and malic acid are formed in large amounts, and little of the C<sup>14</sup> appears in the other compounds normally formed during photosynthesis, such as the phosphate esters and sugars (Table 3).

Table 3. *Effect of cyanide and hydroxylamine on C<sup>14</sup>O<sub>2</sub> fixation by Scenedesmus during photosynthesis*

Compound	No inhibition	Percentage of total soluble C <sup>14</sup> fixed	
		5 × 10 <sup>-3</sup> M-hydroxylamine (75 % inhibition)	3 × 10 <sup>-4</sup> M-cyanide (95 % inhibition)
Phosphoglyceric	16.1	7.7	23.4
Glyceric	4.0	2.9	0.0
Triose and hexose PO <sub>4</sub>	36.0	1.0	7.3
Malic	24.0	62.1	26.3
Glutamic	0.5	2.2	0.0
Aspartic	9.0	0.0	5.6
Alanine	3.6	0.0	16.1
Succinic	0.8	5.3	1.2
Fumaric	0.8	1.9	0.8
Citric ( <i>iso</i> )	0.8	6.3	2.3
Sucrose	0.1	0.0	0.0

It has been suggested that hydroxylamine inhibits the oxygen-liberating state of photosynthesis. This oxygen-liberation step need not occur simultaneously with the first carboxylation, and the formation of phosphoglyceric acid in the presence of hydroxylamine verifies this suggestion. The formation of glutamic acid and also of succinic, fumaric and citric acid during 1 min. photosynthesis in the presence of hydroxylamine is much greater than in an equivalent period of either dark fixation or carbon dioxide or of uninhibited photosynthesis. This indicates that hydroxylamine may reverse the light inhibition of respiration and therefore the rate of appearance of newly assimilated carbon in the respiratory intermediates.

*Effect of pH on carbon dioxide fixation.* In an attempt to influence the rates of the enzymatic processes and consequently the proportions of the

products, a number of 1 min. photosynthesis experiments were carried out on suspensions of *Scenedesmus* which had been photosynthesizing for 10 min. at 3000 f.c. in M/300-phosphate solutions of various pH values ranging between 1.6 and 11.4. The rate of fixation of  $C^{14}O_2$  remained approximately normal between pH 4 and 9; it was still 50% or more at pH 2 and 10, but it fell abruptly above pH 10.5. The depressed rates observed were not further affected by letting the cells stand for 30 min.; moreover, the normal rate could be restored by bringing the pH back to 7.

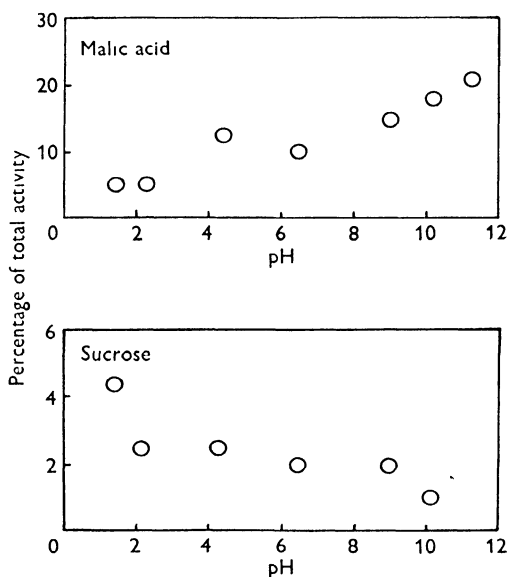

Text-fig. 6. Effect of pH on fraction of sucrose and malic acid in products of 60 sec. photosynthesis by *Scenedesmus*. These figures were obtained by direct counting on paper chromatograms of several series of experiments.

Radiochromatography of the samples revealed no striking differences between the nature and relative amounts of the radioactive products formed at those different pH values, except for malic acid and sucrose. As shown in Text-fig. 6, on passing from pH 1.6 to 11.4 the percentage of malic acid increases from 5 to 25%, while that of sucrose decreases from about 7 to 0%. Phosphopyruvic acid seems to follow malic acid in that the absolute amounts of both these compounds show a sharp maximum at pH 9. On the whole, the general pattern does not break down, even at extreme pH values. On the other hand, there are some compensation effects, such as a larger production of acidic material (malic) to counteract the alkalinity.

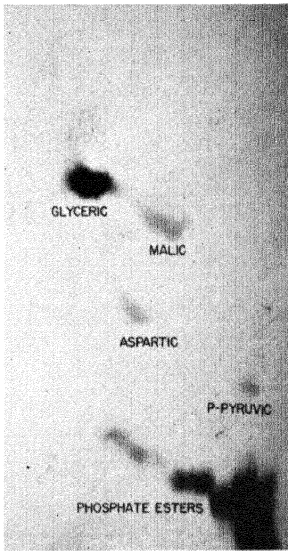

Fig. 1 a

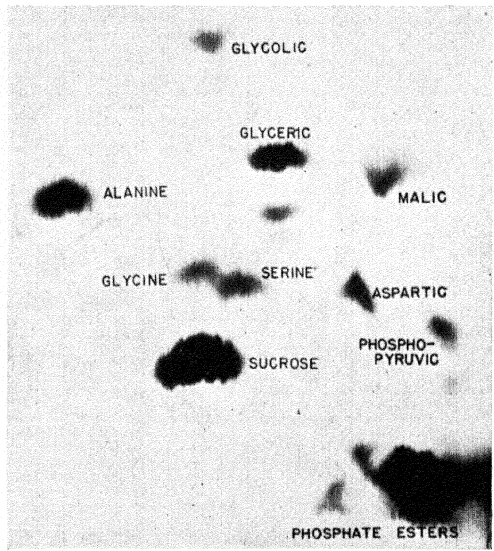

Fig. 1 b

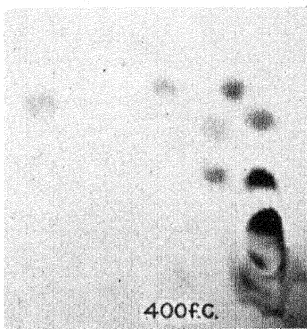

Fig. 2 a



Fig. 2 b

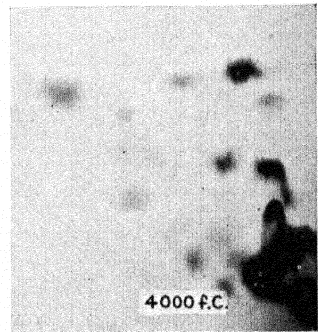

Fig. 2 c

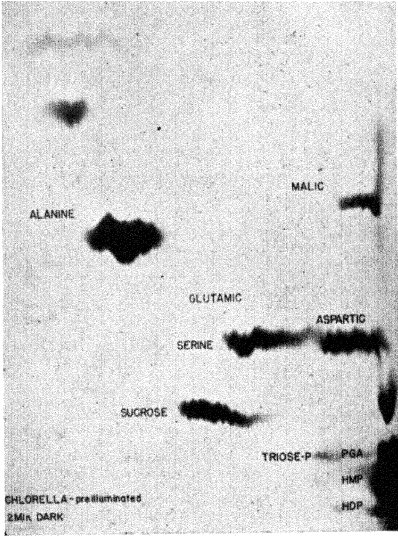

Fig. 1 a

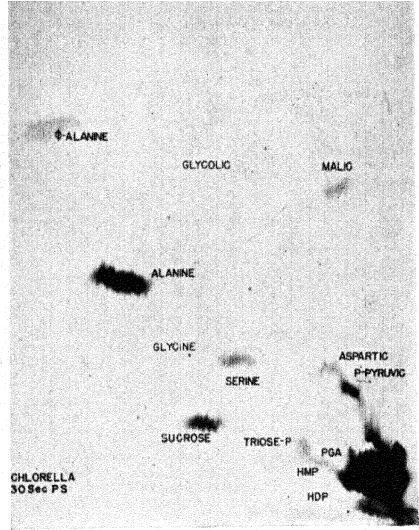

Fig. 1 b

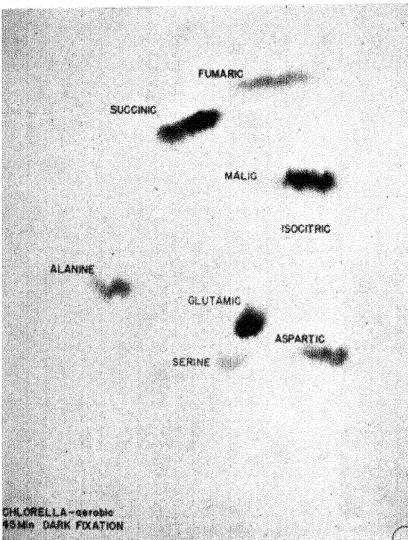

Fig. 1 c

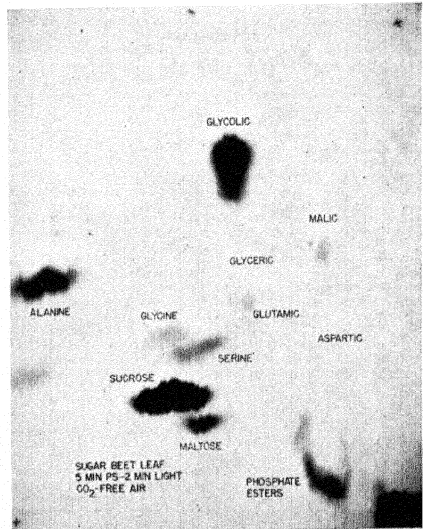

Fig. 2

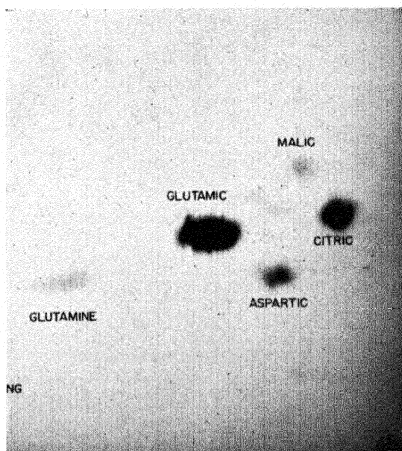

Fig. a

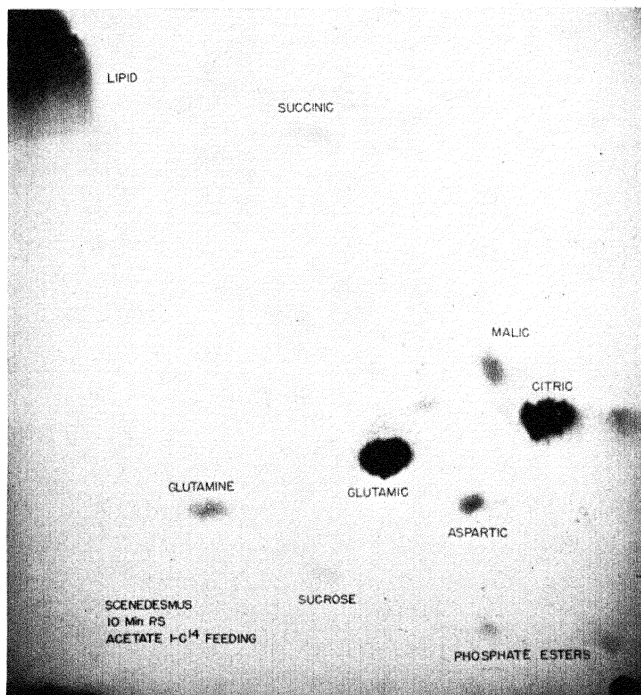

Fig. b



## REFERENCES

- ANDERSON, E. H. (1945). *J. Gen. Physiol.* **28**, 297.
- BADIN, E. & CALVIN, M. (1950). The Path of Carbon in Photosynthesis. IX. *J. Amer. Chem. Soc.* (in the Press).
- BASSHAM, J. A., BENSON, A. A. & CALVIN, M. (1950). *J. Biol. Chem.* (in the Press).
- BENSON, A. A., BASHAM, J. A., CALVIN, M., GOODALE, T. C., HAAS, V. A. & STEPKA, W. (1950). *J. Amer. Chem. Soc.* **72**, 1710.
- BENSON, A. A. & CALVIN, M. (1948). *Cold Spr. Harb. Symp. Quant. Biol.* **13**, 6.
- BENSON, A. A. & CALVIN, M. (1950). *J. Exp. Bot.*, **1**, 63.
- BENSON, A. A., CALVIN, M., HAAS, V. A., ARONOFF, S., HALL, A. G., BASSHAM, J. A. & WEIGL, J. W. (1949). *Photosynthesis in Plants*, ch. 19, p. 381. Iowa: The Iowa State College Press.
- CALVIN, M. & BENSON, A. A. (1948). *Science*, **107**, 476.
- CALVIN, M. & BENSON, A. A. (1949). *Science*, **109**, 140.
- CLAGETT, C. O., TOLBERT, N. E. & BURRIS, R. H. (1949). *J. Biol. Chem.* **178**, 977.
- GIBBS, M. (1949). *J. Biol. Chem.* **179**, 499.
- GODDARD, M. R. & MEEUSE, B. J. C. (1950). *Ann. Rev. Pl. Physiol.*, **1**, 207.
- VAN NIEL, C. B. (1941). *Adv. Enzymol.* **1**, 263.
- PETERS, R. A. (1941). *Toxicity and Antibiotics*, p. 51. Cambridge University Press.
- VARNER, J. E. & BURRELL, R. C. (1950). *Arch. Biochem.* **25**, 280.
- VENNESLAND, B., GOLLUB, M. & SPECK, J. F. (1949). *J. Biol. Chem.* **178**, 301.
- WEIGL, J. W. (1949). The Relation of Photosynthesis to Respiration. *Thesis, University of California*.
- WOOD, H. G., WERKMAN, C. H., HEMINGWAY, A. & NIER, A. O. (1941). *J. Biol. Chem.* **139**, 365.

## EXPLANATION OF PLATES

## PLATE 1

- Fig. 1. Radiograms of 1 and 60 sec. steady-state photosynthesis by barley leaves. The paper chromatograms from which these radio-autographs were prepared were developed horizontally in phenol and vertically in butanol-propionic acid-water solvent (Benson *et al.* 1950). Free glyceric and phosphoglyceric acids are the major products.
- Fig. 2. Effect of light intensity upon products of 30 sec. photosynthesis by *Scenedesmus*. Aqueous ethanol extracts of approximately equal amounts of cells were used in these radiograms. The two major compounds in the 400 f.c. radiogram were identified as phosphoglyceric acid and phosphopyruvic acid. The spot with increased radioactivity in the 800 f.c. radiogram was also identified as phosphoglyceric acid.

## PLATE 2

- Fig. 1. Dark and photosynthetic C<sup>14</sup>O<sub>2</sub> fixation by *Chlorella*. *a*, 2 min. dark fixation by *Chlorella* which had been pre-illuminated in nitrogen 5 min. at 5000 f.c. *b*, 30 sec. steady-state photosynthesis, 8000 f.c. *c*, 45 min. dark C<sup>14</sup>O<sub>2</sub> fixation by non-pre-illuminated cells.
- Fig. 2. Products synthesized by sugar-beet leaf during 5 min. photosynthesis followed by 2 min. aerobic illumination. Glycolic acid represents almost 30 % of the 50 % ethanol-soluble radioactive products.

## PLATE 3

- Assimilation of acetate 1-C<sup>14</sup> by *Scenedesmus*. Algae were given labelled acetate for 30 min. ( $8.5 \times 10^{-4}$  M., pH 4) immediately after steady-state photosynthesis (8000 f.c.). Half of the cells were killed in 80 % ethanol in the dark (*a*). The remainder was illuminated 10 min., 8000 f.c., and killed (*b*). Considerable unused labelled acetate remained after the 30 min. dark period. During the whole experiment, 4 % carbon dioxide in nitrogen was passed through the cell suspension.

# EXTENSIONS OF PHOTOSYNTHETIC EXPERIMENTATION

BY OTTO WARBURG, DEAN BURK\*  
AND ARTHUR L. SCHADE†

Kaiser Wilhelm Institut für Zellphysiologie, Berlin-Dahlem

*Chlorella pyrenoidosa* was cultivated as previously described (Warburg & Burk, 1950) in acid culture medium prepared with water taken from a deep well. The culture bottles filled with 200 c.c. medium were inoculated with 100 cm. cells and placed at a distance of 25 cm. from a 200 watt incandescent lamp in a water bath at 25° C. and aerated with 5% carbon dioxide in air. After 24 hr., when the cells had multiplied 4-fold, they were used for the experiments. No settling of cells occurred during the culturing.

## I. CENTRIFUGING

The cells were centrifuged in thin layers in broad cups for so short a time that by gentle shaking they could be resuspended in a few seconds. The use of strong, angle centrifuging, such as we had at our disposal at Urbana two years ago, is to be avoided. Heavily centrifuged cells are damaged, and partly destroyed by the process of resuspending, especially when mechanical agents are employed. Such cell suspensions contain white *Chlorella* 'shadows' and must be discarded.

## II. USE OF AMMONIA

The photosynthetic efficiency of the cells after harvest was determined in culture medium, the nitrate of which was replaced by ammonia at 1/10 the concentration of the nitrate (0.15 g.  $\text{NH}_4\text{Cl/l.}$ ). In such solutions the assimilatory quotient of the young cultures employed was always near 1 (cf. Myers, 1949). In experiments of long duration the pH was not shifted to the alkaline side as could happen with nitrate as a source of nitrogen, so that there was no danger of carbon dioxide retention being developed. When the pH at the beginning of the experiment was 4.8, it was about 3.5 after 7 hr. of illumination. No influence of this acidification on the efficiency was observed. It was a further advantage of using ammonia that

\* Public Health Service Special Research Fellow of the National Cancer Institute, and Guest Research Worker of the Kaiser Wilhelm Institut für Zellphysiologie.

† Chief Biochemist, Overly Biochemical Research Foundation, and Guest Research Worker, Kaiser Wilhelm Institut für Zellphysiologie.

possible discussions as to whether the oxygen of the nitrate might have to be considered in the computation of the energy transformation were eliminated.

### III. OPTICAL ARRANGEMENT

The light source was a 200 watt high-pressure mercury lamp (Osram). A condenser of the aperture 1:1 provided a parallel light beam from which the green line  $546\text{ m}\mu$  was isolated by the following filters; 5 cm. water, 2 cm. 5%  $\text{CuSO}_4 \cdot 10\text{H}_2\text{O}$ , 1 cm. tartrazin (20 mg./100 c.c.  $\text{H}_2\text{O}$ ), and 1 cm. Didym-plate (Schott-Jena).

The intensity of this green light beam was about  $15\ \mu\text{mol. quanta}$  ( $330\text{ mm.}^3$ ) per min., or one hundred times that first employed by us at Urbana and twenty-five to fifty times that used in Bethesda. The green light beam was split by four totally reflecting prisms into two beams of equal intensities. These were measured by a bolometer (Lummer-Kurlbaum) of 9 cm. area, standardized against an American National Bureau of Standards lamp obtained through the courtesy of Dr Curtis J. Humphreys, Chief of the Radiometry Section. The manometric actinometer was standardized against the bolometer.

### IV. THE TWO-VESSEL METHOD

The divided light beam effected an improvement in the employment of the two-vessel method since the two vessels could be illuminated and darkened simultaneously. The two vessels, each with its equal-sized thermobarometer, were fastened on two opposite sides of the thermostat. The two branches of the divided light beam entered the thermostat in horizontal directions and were reflected by two  $45^\circ$  mirrors into the two vessels.

A second improvement that made efficiency determinations possible at high light intensities was the employment of increased motion of the cell suspension in vessels of increased volume. In our very earliest experiments it was sometimes observed that in the smaller of the two vessels then employed ( $v = 13\text{ c.c.}$ ,  $v_F = 7$ ) the motion of the liquid was inhibited by striking the upper wall, whereas in the larger vessel ( $v = 20\text{ c.c.}$ ,  $v_F = 7$ ) the liquid could swing freely, the consequence being that the motion of the cell suspensions in the two vessels was clearly different, and stronger in the greater vessel. We have now used as the smaller vessel the volumes  $v = 20\text{ c.c.}$  and  $v_F = 7$ , and as the larger vessel the volumes  $v_F = 30\text{ c.c.}$  and  $v_F = 7$ . The bottom area of both these vessels was again about  $7.5\text{ cm.}^2$ . The vessels were shaken by horizontal motion at the increased rate of 220 per min., and when the helmets (male parts) of the attaching manometers were hollow, no splashing in the manometer capillaries occurred no matter how

rapid the shaking. No foaming occurred even in experiments of 7 hr, duration.

In these two vessels of 20 and 30 c.c. volume, the 7 c.c. of cell suspension could swing freely and showed during the motion of the vessels the same geometrical outline, that is, a downwardly concave surface with a height lowest in the middle that was not less than one-half the height at the ends of the vessels.

These remarks will emphasize that the two-vessel method applied to bio-photochemistry needs special considerations not demanded by routine manometry, especially when high light intensities and light actions are involved. Not only is equal physical equilibration in the two vessels demanded, but also equal intermittency of illumination. The unusual  $\gamma$  ( $\text{CO}_2/\text{O}_2$ ) values of photosynthesis reported in the literature are in our opinion caused in part by inadequate motion of the smaller vessel. In fact, such  $\gamma$  values can often be normalized by increasing the shaking rate.

#### V. ADJUSTMENT OF THE COMPENSATING LIGHT

By the principle of the light increment (Warburg & Burk, 1950) the technical and theoretical difficulties caused by respiration may be overcome. Respiration is overcompensated by unmeasured white light and photosynthetic yield measured only for an *increment of measured light*. When this increment is small in comparison with the compensating light, the general conditions of the cells are virtually not altered by the addition of the increment, as is required when photosynthesis is computed by our equations.

Since it was found in our earlier experiments (Warburg & Burk, 1950) that a given light increment, added to dark or compensated or considerably overcompensated cells, proved to be equally efficient, it is unnecessary to adjust the compensating light in such a way that in both vessels exactly the same amount of compensating light is absorbed. But if such an exact adjustment is desired, the following method has been found to be useful. Cells are suspended in carbonate mixture and equal volumes placed into the two vessels used for the two-vessel method. A 100-watt incandescent lamp is placed above the thermostat and shifted until photosynthesis is found to be equal in the two vessels. Because of the scattering of the light by the cells, this method is to be preferred to an adjustment by means of two corresponding chemical actinometers.

#### VI. LONG EXPERIMENTS

It has been confirmed that the efficiency of photosynthesis remains constant for longer periods of time when respiration is overcompensated by

diffuse white light in such a manner that all cells are constantly illuminated. Such a result may be expected, since the conditions are then those of the culturing; a chemical or physical explanation is lacking.

## VII. USE OF CARBONATE MEDIA

Although it is now widely considered that maximum efficiencies cannot be obtained in carbonate solutions, such solutions may be useful in many respects as an experimental tool. Equal parts of  $M/10$   $K_2CO_3$  and  $M/10$   $NaHCO_3$  may be mixed to yield a pH of about 10. The quantum requirement of our cells suspended in such a mixture was about 10.

A first application of carbonate solution has already been mentioned in Section IV. A second application may be made to check that the motion of both vessels in the two-vessel method is adequate. Equal amounts of cells, suspended in 7 c.c. carbonate mixture, are placed in each of the two vessels that are then shaken and illuminated as in the efficiency experiments in acid medium. When equal photosynthesis is obtained in both vessels then one has an indication that not only physical equilibration but also light intermittency are equal in the two vessels for the special conditions of vessels, amounts of liquid and cells, and light intensity, etc., employed.

A third application may be made to transmission experiments. Increasing amounts of cells, say from 25 to 300 mm.<sup>3</sup>, are suspended in 7 c.c. carbonate mixture, and placed in turn into the same vessel and photosynthesis effected by a given beam of light determined. One thereby obtains a curve showing for each amount of cells the relative photosynthesis obtained up to the maximum that may be reached with  $\gamma = 546 m\mu$  at 300 c.m. cells where light absorption is virtually complete. Then photosynthesis at any given cell concentration, divided by the maximum photosynthesis, represents the fraction  $\alpha$  of the absorbed light, or  $(1 - \alpha)$  is the transmission. It is necessary in applying this method that the light intensity be so low at all cell concentrations that photosynthesis is proportional to light intensity.

*Note.* When cells suspended in carbonate mixtures are used as described for comparative actinometric purposes, it is important to know that in carbonate there is an induction period of minutes until the light action is fully developed manometrically. The cause of this induction is chemical; it cannot be merely physical equilibration, because for the same shaking rates and same conditions there is no corresponding induction if the cells are suspended in acid culture medium. With cells in carbonate, therefore, transition periods of at least 5 min. have to be considered, whereas with cells in acid culture medium this is not ordinarily necessary if the light intensity is not extreme.

## VIII. ACTINOMETRIC DETERMINATION OF TRANSMISSION

Another method of determining light transmission through cell suspensions may be based on the chemical actinometer. A small vessel, such as used for the two-vessel method, contains the cell suspension. It is surrounded by a larger vessel that contains the actinometric liquid and is connected

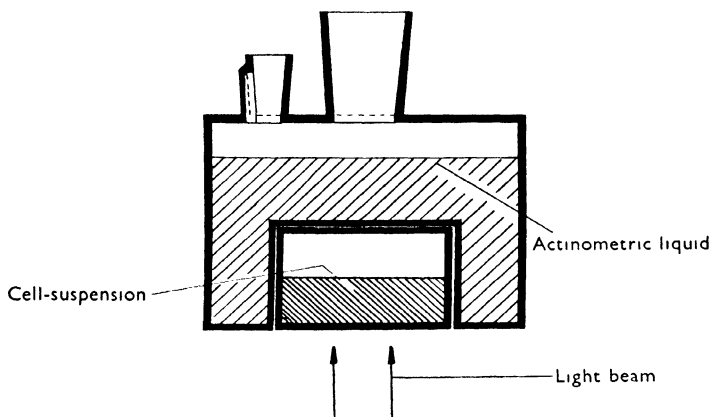

Fig. 1. Actinometric vessel for measuring light transmission of *Chlorella* cell suspension, contained in inner separable compartment, under conditions of manometric shaking.

with a manometer for measuring oxygen consumption. Both vessels are quartz vessels, blown by Lempert, Berlin-Reinickendorf (Fig. 1). The volume of the small vessel is about 20 c.c., that of the large vessel 120 c.c. 7 c.c. of cell suspension are inserted into the small vessel through a small stopperable aperture (not illustrated), and 80 c.c. of actinometric liquid are put into the big vessel. The small vessel is not connected to the large vessel but is held in place by rubber bands.

The combined two vessels are shaken at a rate of 200 turns per min. A collimated light beam enters through the bottom of the small vessel. The fraction of the light not absorbed leaves the vessel only negligibly (less than 1%) in the back direction, but goes mainly through the upper wall and secondarily the side walls into the actinometric chamber, where it is completely absorbed, producing oxygen consumption.

Two measurements have to be made, first while the small vessel contains water, and second when it contains the cell suspension. Let the first pressure change be  $(\Delta p)_{\text{water}}$  and the second  $(\Delta p)_{\text{cells}}$ , then if

$$\phi = O_2/h\nu = 1,$$

then the light transmission through the cell suspension is

$$\frac{(\Delta p)_{\text{cells}}}{(\Delta p)_{\text{water}}}$$

There is the difficulty that  $\phi = 1$  only at low light intensities. At higher light intensities  $\phi$  declines, very possibly owing to a back reaction on the part of the primary photochemical products. In consequence, the transmission has to be determined at light intensities of  $1/15 \mu\text{mol. quanta per min.}$ , as used in earlier calibration experiments (Warburg & Schocken, 1949). Experiments at higher light intensities, corrected by an intensity response curve, are not generally advisable, because of the difficulty of estimating the intensities at which the scattered light enters the actinometric vessel.

### IX. RESULTS

With the various extensions of technique described here we have continued to confirm our previously reported results (Warburg & Burk, 1950). With  $300 \text{ mm.}^3$  of cells per vessel where absorption of the green mercury line is essentially complete, a quantum requirement of 4, with fluctuations between 3 and 5, per molecule of carbon dioxide consumed or oxygen produced, has been observed. Again, *with low light intensities*, no influence of timing on yield was noted. The yield remained the same whether the light increment was added and removed every 5 (or 10 or 15) min., or if the sequence was 1 hr. with increment and 5 (or 10 or 15) min. without increment, and so forth. Again, the assimilatory quotient and the respiratory quotient were either equal or different. Equality of these two quotients is immaterial, and to ask that they should be equal is to misunderstand the equations of the two-vessel method.

With  $50 \text{ mm.}^3$  cells per vessel, that is, about  $6.5 \text{ mm.}^3$  cells per sq.cm. of bottom area, about 50% of the wavelength  $546 \text{ m}\mu$  was transmitted by the cell suspension in motion. To obtain the same or greater light action pressure changes, as obtained with  $300 \text{ mm.}^3$  of cells, higher light intensities were applied, so high that photosynthesis often amounted to 30% of the value at light saturation. Under such conditions the observed quantum yields were consistent with the minimum requirement of 3 to 5 quanta at lower light intensities, and were a function of light increment intermittency\* and intensity.

### REFERENCES

- MYERS, J. (1949). Chap. 17 of *Photosynthesis in Plants*, by J. Franck and W. F. Loomis. Iowa: The Iowa State College Press.  
 WARBURG, O. & BURK, D. (1950). *Arch. Biochem.* **25**, 410.  
 WARBURG, O. & SCHOCKEN, V. (1949). *Arch. Biochem.* **21**, 363.

\* See Burk, D. & Warburk, O., *Naturwissenschaften*, **37**, 560 (1950), and *Z. Naturforsch.* (in the Press, 1951).

# THREE-VESSEL AND ONE-VESSEL MANOMETRIC TECHNIQUES FOR MEASURING CO<sub>2</sub> AND O<sub>2</sub> GAS EXCHANGES IN RESPIRATION AND PHOTOSYNTHESIS

BY DEAN BURK,\* ARTHUR L. SCHADE,†  
JEHU HUNTER AND OTTO WARBURG

Kaiser Wilhelm-Institut für Zellphysiologie, Berlin-Dahlem

This paper will present experimental protocols illustrating new procedures for measuring CO<sub>2</sub> or O<sub>2</sub> gas exchanges by a 'three-vessel' method and by three different 'one-vessel' methods. The techniques to be briefly outlined here may be employed in a great variety of manometric problems and processes, biochemical, biophysical, or analytical. Since this Symposium is concerned primarily with CO<sub>2</sub> fixation and photochemical processes, the illustrative protocols will be drawn mainly from experiments on photochemical CO<sub>2</sub> fixation and oxygen production, and the related converse process of respiration. Equally useful applications of the new methodology to tumor and tissue metabolism will be presented elsewhere.

## I. THE THREE-VESSEL METHOD

In this method three vessels are employed, A, B, and C, in each of which, as in the well-known two-vessel method (Warburg & Burk, 1950), the ratio of the volume of fluid phase to that of gas phase,  $v_F/v_G$ , is varied. Then, with equal amounts of cells or tissue in each vessel, the same CO<sub>2</sub>/O<sub>2</sub> gas exchange produces different pressures in each of the three vessels, owing to the widely different solubilities of CO<sub>2</sub> and O<sub>2</sub>. For each of the three possible combinations of paired vessels, A-B, A-C, and B-C, one has, as in the two-vessel method, two different pressure changes and hence two simultaneous equations from which may be calculated single solutions for each of the unknowns,  $x_{CO_2}$  and  $x_{O_2}$ , the mm.<sup>3</sup> of CO<sub>2</sub> and O<sub>2</sub> exchanged, and from this further the important quotient  $x_{CO_2}/x_{O_2} = \gamma$ .

By the addition of a third vessel to the ordinary two-vessel method, one thus obtains not one but three pairs of simultaneous equations, from which may be calculated not one but three solutions for  $x_{CO_2}$ , and likewise three solutions for  $x_{O_2}$  (or, similarly, more if a fourth or more vessels were added).

\* Public Health Service Special Research Fellow of the National Cancer Institute, and Guest Research Worker of the Kaiser Wilhelm-Institut für Zellphysiologie.

† Chief Biochemist, Overly Biochemical Research Foundation, and Guest Research Worker, Kaiser Wilhelm-Institut für Zellphysiologie.

The third vessel does more than provide additional information of a replicatory nature such as might be obtained by mere replication of either of the two vessels in the two-vessel method. By greatly extending the range of  $v_F/v_G$ , and yielding not one but three pairs of simultaneous equations that must concur in any numerical result, the third vessel provides a stringent test and internal confirmation of the adequacy of the two-vessel method as applied under any given set of conditions, viz., frequency, amplitude, and smoothness (or otherwise) of the shaking motion; values of  $v_F$  and  $v_G$  and their ratios; vessel geometry; quantities of cells or tissue; rate of metabolism; type of illumination if employed; dark-light timing sequences; temperature; partial gas pressures; assumed gas solubilities; possible involvement of a third gas, etc. All of these conditions must, as in manometry generally, be integrated into an effective working arrangement whose overall adequacy must be continually checked in various ways, including ordinary replication, variation of the experimental conditions over somewhat wider limits than customarily employed, and, in the proposed three-vessel method, by the measure of agreement obtained among the three solutions for  $x_{\text{CO}_2}$  (likewise three solutions for  $x_{\text{O}_2}$ ). It is important to bear in mind that the checking of adequacy must, in part, be empirical. For, whereas many of the foregoing conditions listed can be known accurately, the influence of some of them, such as conditions of shaking and vessel geometry, on satisfactory fluid-gas equilibration in the two-vessel method,\* can never be the subject of exact precalculation, but must be tested operationally.

As an illustrative protocol of the three-vessel method, let us now consider an experiment with two rectangular vessels, A and B, similar to those already reported upon extensively (Warburg & Burk, 1950; Burk, Hendricks, Korzenovsky, Schocken & Warburg, 1949; Warburg, Burk, Schocken, Korzenovsky & Hendricks, 1949; Warburg, Burk, Schocken & Hendricks, 1950), and a third vessel, C, with a considerably different set of  $v_F$ - $v_G$  values, and each with characteristics as indicated in Table 1. All three vessels had the same bottom surface area of about 8 cm.<sup>2</sup> (3.2 cm. × 3.8 cm. inside dimensions). Vessels A and C were of the same height, but B was  $\frac{1}{2}$  cm. less in height.

Although in our previous work the variation in  $v_F/v_G$  of only 0.64 to 1.01 (vessels A and B) was found quite satisfactory, the third vessel C provides a great extension to  $v_F/v_G = 2$ ; and the ratio  $k_{\text{CO}_2}/k_{\text{O}_2}$  is similarly extended from 1.562 and 1.885 to 2.696, which will greatly broaden the range of magnitude of the two-vessel constants  $R_{\text{CO}_2}$ ,  $R'_{\text{CO}_2}$ ,  $R_{\text{O}_2}$ , and  $R'_{\text{O}_2}$ , defined

\* The two-vessel method, elegant in experienced hands, is especially adapted to discovery by virtue of the fact that two gases may be measured simultaneously as a continuous function of time, with customary even if not extreme manometric accuracy. The three-vessel method not only tests but also enhances this accuracy.

below, in the paired vessel combinations A-C and B-C as compared with the combination A-B previously reported upon (Warburg & Burk, 1950; Burk *et al.* 1949; Warburg *et al.* 1950). It will further be noted that the combination A-B yields the arrangement in which  $v_F$ , the volume of fluid, is the same in both vessels, which is the procedure generally preferred as providing the best chance for equal light absorption in the two vessels. In the A-C and B-C combinations, however,  $v_F$  is considerably different in the two vessels of each pair, but, as will become evident from the data, the possible factor of unequal light absorption is negligible providing the quantity of light-absorbing cells and the shaking are adequate, as in the following experiment.

Table 1. *Characteristics and single-vessel constants of vessels A, B, and C*

	Vessel		
	A	B	C
Vessel volumes (c.c.): Total ( $v_T$ )	18.00	13.90	18.00
Fluid ( $v_F$ )	7.00	7.00	12.00
Gas ( $v_G$ )	11.00	6.90	6.00
$v_F/v_G$	0.64	1.01	2.00
Single-vessel constants (cm. <sup>2</sup> )			
$= \left( \frac{273.1 v_G / 293.1 + v_F \alpha_G}{10} \right) : k_{CO_2}$	1.634	1.252	1.603
$k_{O_2}$	1.046	0.664	0.595
$k_{CO_2}/k_{O_2}$	1.562	1.885	2.696

$$\alpha_{CO_2} = 0.87 \text{ and } \alpha_{O_2} = 0.03 \text{ at } 20^\circ \text{ C.}$$

*Experiment.* Technical conditions as in Warburg & Burk (1950), Burk *et al.* (1949) and Warburg *et al.* (1949, 1950). 20° C. pH 5.0 ± 0.1 throughout duration of experiment (7 hr.). *Chlorella pyrenoidosa* cells from 7-day culture (total growth 2800 mm.<sup>3</sup> from inoculum of 160 mm.<sup>3</sup> in 400 c.c. medium) washed once in 400 c.c. fresh nitrate medium, and 300 mm.<sup>3</sup> cells employed in each vessel (A, B, C). Vessels gassed on thermostat with 5% CO<sub>2</sub> in air for 20 min. with overhead white light illumination from a 40 watt fluorescent tube placed parallel to and just above the thermostat (and extending 1 ft. beyond each end thereof). Shaking 144 cycles per min. at 20 mm. amplitude. Vessels equilibrated 25 min. more in white light after gassing stopped and closure of vents, then 30 min. in darkness, then pressure changes measured for 3 hr. at 15 min. intervals. A single beam of actinometrically measured red light (= 340 mm.<sup>3</sup>/60 min., wavelength 630–660 mμ) was shifted in rotation from one vessel to another every 15 min. Pressure changes in red light (total of 60 min. per vessel) and in dark (total of 120 min. per vessel) in each of the three vessels were summed

separately (Table 2) and converted by calculation (Table 3) to mm.<sup>3</sup> gas exchange/60 min./300 mm.<sup>3</sup> cells. Finally, fluorescent *white* light illumination of all vessels was restored simultaneously, and pressure changes 20 min. with, and 10 min. before and 10 min. after without, added *red* light beam measured with each vessel consecutively placed over reflecting mirror kept in fixed position, and mm. pressure changes calculated per 60 min. for consistency with red-dark data. The mirror was not shifted in the white-red series of experiments in order to avoid (Warburg & Burk, 1950, p. 427) possible alteration of the white light distribution during a white-white plus red-white light sequence applied to a given vessel.

Table 2. *Pressure change data of three-vessel experiment*

$h = \text{mm. pressure change/60 min.}$

	Vessel		
	A	B	C
Illumination conditions:			
(a) Dark	-30.7	-89.7	-155.7
(b) Dark + red light	-4.5	-34.5	-74.0
(c) White light	42.0	63.0	60.0
(d) White light + red light	69.0	117.0	144.0
Calculated light actions:			
I. Red light (added in dark) ( $b-a$ )	26.2	55.2	81.7
II. Red light (added in white) ( $d-c$ )	27.0	54.0	84.0
III. White light (minus dark) ( $c-a$ )	72.7	152.7	215.7
IV. White + red lights (minus dark) ( $d-a$ )	99.7	206.7	299.7

The  $h$  mm. pressure changes per 60 min. given in Table 2 were converted into  $x$  mm.<sup>3</sup> volume changes per 60 min. (per 300 mm.<sup>3</sup> cells) by the following two-vessel constant formula, and the calculated results are given in Table 2. For any given pair of vessels (prime marks for second vessel):

$$\begin{aligned}
 x_{\text{CO}_2} &= h \frac{k_{\text{O}_2}}{k_{\text{O}_2}/k_{\text{CO}_2} - k'_{\text{O}_2}/k'_{\text{CO}_2}} - h' \frac{k'_{\text{O}_2}}{k_{\text{O}_2}/k_{\text{CO}_2} - k'_{\text{O}_2}/k'_{\text{CO}_2}} & (I) \\
 &= hR_{\text{CO}_2} & - h'R'_{\text{CO}_2} & (Ia) \\
 \text{mm.}^3 &= \text{mm.} \times \text{mm.}^2 & - \text{mm.} \times \text{mm.}^2 &
 \end{aligned}$$

$x_{\text{O}_2}$ ,  $R_{\text{O}_2}$ , and  $R'_{\text{O}_2}$  are obtained similarly by reversing the O<sub>2</sub>-CO<sub>2</sub> subscripts in equations (I) and (Ia).

It will be noted that the experimental data obtained above will permit the calculation of three  $x_{\text{CO}_2}$ , three  $x_{\text{O}_2}$ , and three  $\gamma$  values for not merely one illustrative process, such as dark respiration,  $a$ , but in fact for a number of illustrative processes,  $b$ ,  $c$ , and  $d$ , from which four further light action processes (photosyntheses), I, II, III, and IV, may also be calculated by simple algebraic subtractions as indicated in Table 2. However, only in

Table 3. mm.<sup>3</sup> CO<sub>2</sub> and O<sub>2</sub> exchanged,  $\gamma (= x_{\text{CO}_2}/x_{\text{O}_2})$ , and quantum requirements of various processes measured by the three-vessel method

	Vessel pair			
	A-B	A-C	B-C	Average
Two-vessel constants (mm. <sup>2</sup> ): $R_{\text{CO}_2}$	9.53	3.89	4.17	—
$R_{\text{CO}_2}$	6.05	2.21	3.74	—
$R_{\text{O}_2}$	-5.05	-1.44	-1.55	—
$R'_{\text{O}_2}$	-3.87	-1.42	-1.98	—
$x_{\text{CO}_2}$ (mm. <sup>3</sup> CO <sub>2</sub> /hr./300 mm. <sup>3</sup> cells):				
Dark action:				
(a) Respiration	247	225	208	227
Light actions:				
I. Red (added in dark)	-84	-79	-77	-80
II. Red (added in white)	-70	-81	-89	-80
III. White	-231	-194	-170	-198
IV. White + red	-300	-275	-260	-278
Approximate compensation (mixed action):				
(c) Respiration + white light	16	31	38	29
$x_{\text{O}_2}$ (mm. <sup>3</sup> O <sub>2</sub> /hr./300 mm. <sup>3</sup> cells):				
Dark action:				
(a) Respiration	-192	-177	-169	-179
Light actions:				
I. Red (added in dark)	82	78	77	79
II. Red (added in white)	73	80	82	79
III. White	224	201	190	205
IV. White + red	296	281	273	283
Approximate compensation (mixed action):				
(c) Respiration + white light	32	24	21	26
$\gamma (= x_{\text{CO}_2}/x_{\text{O}_2})$ :				
Dark action:				
(a) Respiration	-1.28	-1.27	-1.23	-1.26
Light actions:				
I. Red (added in dark)	-1.02	-1.01	-1.00	-1.01
II. Red (added in white)	-0.96	-1.01	-1.08	-1.01
III. White	-1.03	-0.97	-0.89	-0.96
IV. White + red	-0.99	-0.98	-0.95	-0.97
Approximate compensation (mixed action):				
(c) Respiration + white light	(+0.50)	(+1.29)	(+1.81)	(+1.11)
$1/\phi = \text{quanta per CO}_2 \text{ or O}_2 \text{ molecule}^*$ (red light = 340 mm. <sup>3</sup> /60 min.):				
Quanta per CO <sub>2</sub> molecule:				
I. Red (added in dark)	4.05	4.3	4.4	4.25
II. Red (added in white)	4.85	4.2	3.8	4.25
Quanta per O <sub>2</sub> molecule:				
I. Red (added in dark)	4.15	4.35	4.15	4.3
II. Red (added in white)	4.65	4.25	4.15	4.3

\*  $\frac{\text{mm.}^3 \text{ red light/60 min.}}{\text{mm.}^3 \text{ CO}_2 \text{ (or O}_2\text{)/60 min.}}$

I, II, *a*, and *b* of this experiment can the triplicate determinations of  $x_{\text{CO}_2}$ ,  $x_{\text{O}_2}$ , and  $\gamma$  necessarily be anticipated to yield good agreements, for only in these are the light quantities *absorbed* (340 mm.<sup>3</sup> red light/60 min., or zero) definitely known to be equal in the three vessels. In the other processes, III, IV, *c*, and *d*, the unmeasured white light absorbed by each of the three vessels may or may not have been sufficiently equal, in spite of the virtually equalized incident light intensity effected by the uniform fluorescent tube and the highly reflective inside surfaces of the thermostat bath. However, since the final calculations of these secondary data do indicate virtual equality, they have been included in Table 3 because of certain features of incidental interest with respect to extent of compensation, over-compensation, and respiratory quotient, and because of new confirmatory information regarding the absence of effect of light upon respiration *per se*. The mm.<sup>3</sup> calculations are not given in Table 3 for the processes *b* and *d*, since these represent merely the sums of two ostensibly unrelated processes, but they may be obtained readily by appropriate algebraic mm.<sup>3</sup> subtractions of data in Table 3.

Before discussing the results of Table 3, let us take from it the experimentally determined  $\gamma$  values for photosynthesis and respiration and recalculate, as in Table 4, the pressure change data of Table 2 by the well-known one-vessel method for two gases (Warburg & Burk, 1950) wherein

$$x_{\text{CO}_2} = h \frac{k_{\text{CO}_2} k_{\text{O}_2}}{k_{\text{CO}_2} / \gamma + k_{\text{O}_2}} \quad (2)$$

$$= h K_{\text{CO}_2} \quad (2a)$$

and

$$x_{\text{O}_2} = h \frac{k_{\text{CO}_2} k_{\text{O}_2}}{k_{\text{CO}_2} + \gamma k_{\text{O}_2}} \quad (3)$$

$$= h K_{\text{O}_2}. \quad (3a)$$

Table 4 will not only provide numerical confirmation of Table 3, but will also give a better idea of the comparability of light and dark actions in each one of the vessels A, B, and C considered independently rather than in pairs.

*Comments.* The triplicate determinations of  $x_{\text{CO}_2}$ ,  $x_{\text{O}_2}$ ,  $\gamma$ , and  $1/\phi$  provided by the three pairs A-B, A-C, and B-C show a very satisfactory measure of agreement in spite of the stringent conditions set by the wide range of  $v_F/v_G$  values (0.64-2.00) and of  $R_{\text{CO}_2}$  values (2.21-9.53) and  $R_{\text{O}_2}$  values (1.42-5.05). This is true for not only the processes of respiration and photosynthesis in measured red light but also photosynthesis in the unmeasured but evidently equalized white (fluorescent) light. The variations from the mean were, as in most such manometry, usually of the order of  $\pm 5\%$ , with some cases in the extreme of the order of  $\pm 10\%$ , matched in instances by exceptionally

good agreement. The variation was greater by the two-vessel method of calculation (Table 3) than by the one-vessel method (Table 4) since the propagated error is necessarily greater in two-vessel calculations.

Table 4. *Recalculation of data of Table 2 by the one-vessel (two-gas) method employing  $\gamma$  values for photosynthesis and respiration from Table 3*

	Vessel			Average	(Average from Table 3)
	A	B	C		
$-K_{CO_2} = K_{O_2}$ , for $\gamma = -1.00$ (photosynthesis) (mm. <sup>2</sup> )	2.90	1.48	0.95	—	—
$-K_{CO_2}$ for $\gamma = -1.26$ (respiration) (mm. <sup>2</sup> )	6.74	2.62	1.40	—	—
$+K_{O_2}$ for $\gamma = -1.26$ (respiration) (mm. <sup>2</sup> )	5.44	2.08	1.12	—	—
$+x_{CO_2} = -x_{O_2}$ for $\gamma = -1.00$ (photosynthesis) (mm. <sup>3</sup> ):					
I. Red light (added in dark)	-76.0	-81.5	-77.5	-78.5	(-79)
II. Red light (added in white)	-78.5	-80.0	-80.0	-79.5	(-79)
III. White light	-211	-225	-206	-214	(-202)
IV. White light + red light	-290	-305	-284	-293	(-280)
$x_{CO_2}$ for $\gamma = -1.26$ (respiration) (mm. <sup>3</sup> )	+207	+235	+218	+220	(+227)
$x_{O_2}$ for $\gamma = -1.26$ (respiration) (mm. <sup>3</sup> )	-167	-186	-174	-176	(-179)

It is clear that in this comprehensive experiment of long duration and large pressure readings no notable or decisive role has been played by numerous factors alleged (cf. Emerson & Nishimura, 1949) to interfere with the essential effectiveness of the two-vessel method as applied to measurements of respiration and quantum yield, viz., inadequate gas-liquid equilibration; unequal light absorption by pairs of vessels (whether or not they are of the same size and geometry, and do or do not contain equal amounts of liquid phase); the possible effect of light upon respiration *per se*; marked fluctuations in  $\gamma$ ; differences in  $\gamma$  for respiration and photosynthesis (here quite different,  $-1.26$  compared to  $-1.00$ ); employment of too few or too many cells per vessel; possible involvement of a third gas; inadequate duration of experiment, etc.

The data show excellent confirmation of our previously reported (Warburg & Burk, 1950; Burk *et al.* 1949; Warburg *et al.* 1949, 1950) high quantum yields obtained with measured red light added either in the dark or with diffuse white light above the compensation point, and also confirmation of  $\gamma$  values of the order of minus one. The action of the unmeasured white light was essentially identical with that of the measured red light with respect to  $\gamma$ , and was virtually of the same magnitude in all three vessels with respect to mm.<sup>3</sup> gas exchange.

*Bearing of  $\gamma$  data on non-action of light on respiration.* The data of Table 3 also provide a new, third demonstration of the absence of notable effect of light upon respiration *per se* at low (if not high) light intensities where high photosynthetic yields may be obtained. This was earlier shown (Warburg & Burk, 1950; Burk *et al.* 1949; Warburg *et al.* 1949) by two quite different types of experiments. In the present experiment, advantage may be taken of the fact that  $\gamma$  for respiration was different from, and much greater than, that for photosynthesis (as frequently found by Myers, 1949). If up to compensation light merely inhibited respiration catalytically, then at compensation with respect to oxygen one would also obtain compensation with respect to CO<sub>2</sub>, regardless of the  $\gamma$  value of the respiration. This is not the case at all in the present experiment. In the absence of light, 48 mm.<sup>3</sup> more CO<sub>2</sub> were produced than O<sub>2</sub> consumed in the dark respiration (Table 3, average column,  $x_{\text{CO}_2} = 227$  compared to  $x_{\text{O}_2} = -179$ ). In the presence of white light, the observed  $x_{\text{O}_2}$  was +26, just above compensation. If the white light merely inhibited all the respiration and produced 26 mm.<sup>3</sup> O<sub>2</sub> in photosynthesis, then, with its demonstrated  $\gamma$  of photosynthesis of -0.96,  $x_{\text{CO}_2}$  of photosynthesis due to white light should have been -25. Actually, however, the observed value of  $x_{\text{CO}_2}$  was +29, or an algebraic difference of +54 (29 - (-25)), which is in excellent agreement with the aforementioned value of +48, within the experimental error. Clearly, the production of CO<sub>2</sub> has continued, quantitatively, the same in white light as it did in the dark, yielding a positive  $\gamma$  value of the order of (+1.11) for the combined processes of respiration and photosynthesis taking place near the compensation point, even with respective individual  $\gamma$  values of -1.26 and -0.96. The positive overall  $\gamma$  value obtained here, for the sum of two processes each with a negative  $\gamma$  value, obviously comes about from the facts that the  $\gamma$  of respiration is greater than that of photosynthesis and the signs of the numerators and denominators are reversed,  $x_{\text{CO}_2}$  being positive in respiration and negative in photosynthesis, and conversely with respect to  $x_{\text{O}_2}$ . This instance of a positive  $\gamma$  value obtained in the neighbourhood of the compensation point is in no wise to be confused with alleged, short-duration positive  $\gamma$  values obtained from CO<sub>2</sub> bursts supposed to occur immediately following illumination (Emerson & Nishimura, 1949). The positive  $\gamma$  values reported in Table 3 are a necessary, predictable consequence of a combination of unrelated circumstances conveniently occurring in the present experiment.\*

\* The  $\gamma$  values for process *c* in Table 3 are placed in parentheses because obviously no good degree of replication can necessarily be expected at a light intensity where the sign of  $\gamma$  for a 'mixed action' process is in the critical range for undergoing change. Likewise, the absolute error in the individual  $x_{\text{CO}_2}$  and  $x_{\text{O}_2}$  values for process *c* in Table 3 must obviously be greater than for the other 'unmixed' processes where the  $x_{\text{CO}_2}$  and  $x_{\text{O}_2}$  values are farther from zero and do not represent 'algebraic compensation'.

*Determination of three gases.* Finally, it may be remarked that the three-vessel method might also be employed in quite another manner than hereinbefore indicated, namely, in the determination of gas exchanges wherein three gases instead of two are involved, for the three vessels would provide three simultaneous equations for solving for three unknowns.

*Note on approximate one-vessel determination of  $x_{O_2}$ .* Although the well-known one-vessel method for two gases (cf. Warburg & Burk (1950), and equations (2) and (3)) requires an independent knowledge of  $\gamma$  for exact calculation of  $x_{O_2}$ , obviously this requirement becomes less and less exacting as the fraction of  $CO_2$  exchange takes place increasingly in the fluid phase and decreasingly in the gas phase. This will be the case as  $v_F/v_G$  is increased, as in the series of vessels, A, B, C ( $v_F/v_G = 0.64, 1.01, \text{ and } 2.00$ , respectively).

A numerical instance of the trend described may be seen from the values of  $K_{O_2}$  reported in Table 4, where for  $\gamma = -1.00$ , one has  $K_{O_2} = 2.90, 1.48, \text{ and } 0.95$ , and for  $\gamma = -1.26$  one has  $K_{O_2} = 5.44, 2.08, \text{ and } 1.12$ , or differences of 88, 41, and 18%, respectively, for vessels A, B, and C. With certain problems, such as the determination of whether the maximum quantum requirement in photosynthesis is 4 or 10, an uncertainty of 18% might well be neglected, though scarcely 41 or 88%. If, in vessel C,  $v_F/v_G$  were increased from 2 to 15 c.c./3 c.c. = 5 (as experience shows is feasible if suitable manometer helmets (male parts) are employed),  $K_{O_2}$  at  $\gamma = -1.00$  and  $-1.26$  would be 0.41 and 0.44, respectively, or a difference of only 7%.

Since in our experience the variation from unity of  $\gamma$  in photosynthesis can be made far less than 26% (especially by the use of ammonia-nitrogen in the medium (Myers, 1949; Warburg, Burk & Schade, 1951)), it is evident that with proper arrangements useful one-vessel experiments can be carried out in acid medium at high  $v_F/v_G$  values with virtual neglect of  $CO_2$  exchange and  $\gamma$ , just as in the well-known carbonate medium method under alkaline conditions, or even at neutral pH values where the ratio of bicarbonate  $CO_2$  is likewise sufficiently high to permit the same neglect.

## II. A ONE-VESSEL METHOD FOR DETERMINING $CO_2$ EXCHANGES AT CONSTANT $O_2$ PRESSURE OBTAINED WITH OXY-BIS (COBALTODIHISTIDINE-LIKE) REAGENTS

It was suggested earlier that practical use might be made in manometry of  $O_2$  buffering provided by the readily reversible reaction between oxygen gas, cobaltous ion, and histidine (or histidine-like amino acid derivatives) (Burk, Hearon, Caroline & Schade, 1946; Hearon, Burk & Schade, 1949, p. 352). An actual illustrative experiment is given in Table 5, but for the many variations in temperature, pressures of  $O_2$  and  $CO_2$ , and histidine-like reagents, etc., that it might be desirable to employ, a study of the original

papers just referred to is necessary. An exhaustive methodology remains to be worked out. Thus, histamine has the advantage over histidine in that at any given temperature the histamine complex is more stable with respect to further irreversible oxidation, whereas at low pH values histidine yields the more effective reagent. In the following experiment the reagent was placed in the two side-arms of an ordinary rectangular vessel, but the type of vessel

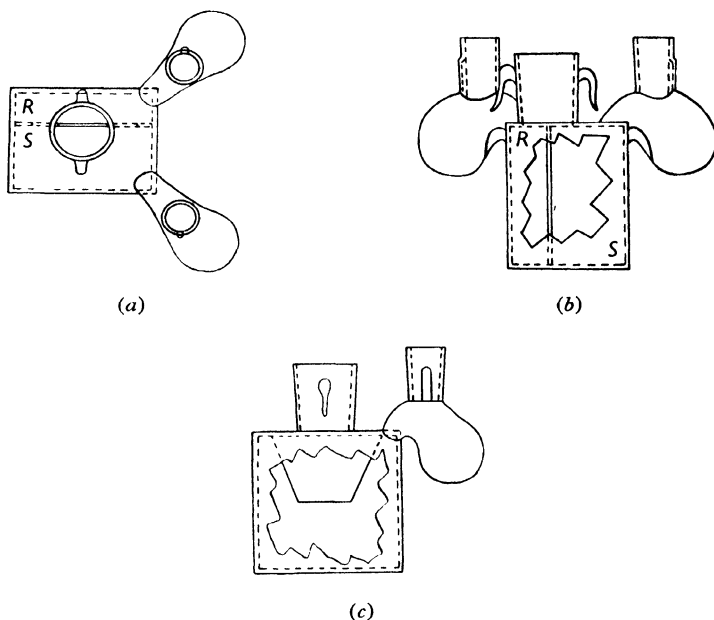

Fig. 1. Two-compartment vessel for measuring with rapid equilibration the pressure changes of one gas (e.g. CO<sub>2</sub> or O<sub>2</sub>) while the pressure of another is kept constant (e.g. O<sub>2</sub> or CO<sub>2</sub>, resp.), by oxy-bis(cobaltdiamines) or by diethanolamines, or alkalis placed in the reagent compartment R, with tissue in compartment S. (a) top view; (b) end view; (c) side view. Length (internal dimensions), 35 mm.; width, 28 mm.; height, 38 mm. (or, in another model, 20 mm., with top 18 mm. part eliminated).

indicated in Fig. 1 is in general preferable in view of the larger surface of exposed reagent presented and the better type of shaking feasible. The reagent components may be pre-mixed and equilibrated before placing in the smaller of the two floor compartments of the vessel. On the other hand, under some conditions it may be desirable not to form the absorbing reagent until after the experiment has started, in which case one of the reagent components (Co<sup>++</sup> or histidine) may be kept in the side-arm until ready for tipping into the other reagent component in the smaller of the main compartments. Convenient gas mixtures are 1-5% CO<sub>2</sub> in unpurified

nitrogen either containing some  $O_2$  or to which up to several per cent  $O_2$  may have been added. The  $x_{CO_2}$  values may be calculated from the observed pressure changes multiplied by a single vessel constant that will include a small or negligible factor taking care of the retention of the  $CO_2$  in the absorbing reagent, the retention being calculated from the measured pH of the latter, and the relationship,  $(HCO_3^-) = (CO_2) \times \text{antilog}(pH - pK)$ , as illustrated in the following experiment and equation for  $k_{CO_2}$ .

Table 5. *Quantum requirement of  $CO_2$  assimilation at constant  $O_2$  pressure maintained by oxy-bis(cobaltdihistamine)*

Pre-illumination (fluorescent white light) ... Red light intensity (mm. <sup>3</sup> /min.) ...	0-1st hr. 9·2		3rd-5th hr. 4·7	
	Time (min.)	<i>h</i> (mm.)	Time (min.)	<i>h</i> (mm.)
A. Fluorescent white light	15	— 2	10	— 6
B. Fluorescent white light + red light	30	— 34	20	— 23·5
C. Fluorescent white light	15	— 1	10	— 6
mm. red light action (B - A - C)	30	— 31	20	— 11·5
mm. <sup>3</sup> red light action ( <i>h</i> × $k_{CO_2}$ )	30	— 71·5	20	— 26·5
Quanta of red light per $CO_2$ assimilated	$\frac{30 \times 9\cdot2}{71\cdot5} = 3\cdot9$		$\frac{20 \times 4\cdot7}{26\cdot5} = 3\cdot6$	

*Experiment.* Technical conditions as in Warburg & Burk (1950), Burk *et al.* (1949), Warburg *et al.* (1949, 1950).  $10^\circ C$ . 300 mm.<sup>3</sup> *Chlorella pyrenoidosa* cells from 7-day culture were centrifuged, washed, and placed in 7 c.c. nitrate-medium (pH 5·2) in main compartment of a two side-arm rectangular vessel of 19·05 c.c. volume. Each side-arm contained 0·40 c.c. 0·43 M- $CoCl_2$ -0·57 M-histamine (pH 7·0). After gassing on bath with 5%  $CO_2$  in tank  $N_2$  (c. 0·2%  $O_2$ ), the vessels were pre-illuminated with overhead fluorescent lighting, as in the previous experiment, for one hour, then pressure readings were measured for 15 min. without added red light, 30 min. with added red light (9·2 mm.<sup>3</sup> 630-660  $m\mu$ /min.), and again 15 min. without red light. After two further hours of continued white light illumination a similar experiment was performed with red light of intensity 4·7 mm.<sup>3</sup> per minute. Pressure readings in mm. were converted to mm.<sup>3</sup> by multiplying by  $k_{CO_2}$  obtained as follows ( $v_G = 11\cdot25$  c.c.;  $v_F = (7 + 0\cdot8)$  c.c.):

$$k_{CO_2} = ((11\cdot25 \times \frac{27\frac{2}{3}}{28\frac{2}{3}}) + (7\cdot8 \times 1\cdot19) + (0\cdot8 \times 1\cdot19) \times \text{antilog}(7\cdot0 - 6\cdot5)) / 10 \\ = (10\cdot8 + 9\cdot3 + 2\cdot9) / 10 = 2\cdot30 \text{ mm.}^2$$

In this experiment the white fluorescent light brought the cells to virtual compensation, so that the large pressure changes induced by red light represented largely photosynthetic  $CO_2$  assimilation, with an unambiguous quantum requirement of 4 within the experimental error. In other similar

experiments carried out in darkness, the CO<sub>2</sub> produced in respiration as positive pressure agreed with  $x_{\text{CO}_2}$  determinations made simultaneously by other manometric methods.

### III. A ONE-VESSEL METHOD FOR DETERMINING $x_{\text{O}_2}$ AT CONSTANT CO<sub>2</sub> PRESSURE MAINTAINED BY MEANS OF DIETHANOLAMINE REAGENT

We have made a large number of experiments to measure respiration and photosynthesis of *Chlorella* cells by means of the diethanolamine reagent proposed by Pardee (1949) whereby  $x_{\text{O}_2}$  can be determined at physiological and constant CO<sub>2</sub> pressures in acid media. This type of reagent has a special advantage in photosynthetic studies in that it provides a virtually inexhaustible supply of carbon dioxide, so that experiments at high light intensities may be performed for days in a given manometer vessel without danger of CO<sub>2</sub> depletion, and so necessitating regassing. Our first experiments were carried out with the reagent supplied in side-arms or wells of vessels, but we later developed the vessels shown in Fig. 1 (and still later, Fig. 2) that would permit the much better shaking and equilibration especially needed at high rates of gas exchange. In these vessels the O<sub>2</sub>-CO<sub>2</sub> equilibration is as rapid as that obtained with ordinary conical vessels containing KOH or NaOH in the well or side-arms, as in the following experiment. (Fig. 1 vessels with KOH in compartment R may be used to great advantage in studying the effect of very low CO<sub>2</sub> pressures on tissue respiration or other metabolism.)

*Experiment.* Technical conditions as in Warburg *et al.* (1951). 20° C. Gas phase, air. pH, 4.5 ± 0.3 throughout duration of experiment, which ran for 18 hr. 66 hr. culture of *Chlorella pyrenoidosa* cells (inoculated with 100 mm.<sup>3</sup> cells per 200 c.c. medium to yield 1400 mm.<sup>3</sup> cells total) centrifuged, washed once in, and finally taken up in, 'ammonia-medium' (0.15 g. NH<sub>4</sub>Cl, 5 g. MgSO<sub>4</sub>·7H<sub>2</sub>O, 2.5 g. KH<sub>2</sub>PO<sub>4</sub>, 2 g. NaCl, 1.8 c.c. N-H<sub>2</sub>SO<sub>4</sub>, and 6 c.c. FeSO<sub>4</sub>·7H<sub>2</sub>O (1 mg./c.c. in N-H<sub>2</sub>SO<sub>4</sub>) per litre) at 40 mm.<sup>3</sup> cells per c.c. medium. 7 c.c. were placed in the large compartment (S) of the quartz vessel shown in Fig. 1 (total of 280 mm.<sup>3</sup> cells), and 3 c.c. diethanolamine solution (36 c.c. diethanolamine (union carbide and carbon), 42 c.c. H<sub>2</sub>O, 30 c.c. 35.5 N-HCl, and 18 g. KHCO<sub>3</sub>) were placed in the smaller, adjacent reagent compartment (R). 3 c.c. of cell suspension were also placed in an ordinary conical vessel containing 0.3 c.c. N-NaOH in the well. Both vessels were shaken on the thermostat at 150 cycles per minute, with amplitude 18 mm., and readings commenced after 35 min., with identical respiratory results, as reported in Table 6. The exact agreement of  $x_{\text{O}_2}$  = -80 is happenstance.

Table 6. Comparison of  $x_{O_2}$  respiration of *Chlorella* as measured with diethanolamine and with NaOH as regulators of  $CO_2$  pressure

	Vessel A	Vessel B
Vessel type	Diethanolamine	NaOH
Vessel volume (c.c.)	51.0	21.92
$k_{O_2}$	3.85	1.74
$mm.^3$ cells/c.c. medium	280 $mm.^3/7$ c.c.	120 $mm.^3/3$ c.c.
Pressure change in dark, 30 min. (mm.)	- 29	- 28
(fluorescent lighting, 30 min. + 5 min. dark re-equilibration, then):		
Pressure change in dark, 30 min.	- 29	- 27
Total pressure change, 60 min. (mm.)	- 58	- 55
$mm.^3 O_2/60$ min.	- 224	- 96
$mm.^3 O_2/60$ min./100 $mm.^3$ cells (respiration, % of cell volume per hr.)	- 80	- 80

After further illumination with diffuse light, vessel A was subjected to exposure to a beam of 8.0  $mm.^3$  of light per minute (green Hg line, obtained by Schott-Jena BG23 and GG11 and 546  $m\mu$  interference filters, from a high pressure Hg lamp). The beam was of about 2  $cm.^2$  area and was essentially completely absorbed by the cells in the main compartment (S) whose shaking bottom area always covered the beam. The bottom area of the compartment was about 2  $cm. \times 4$   $cm. = 8$   $cm.^2$ . The beam was added both in the absence of any other light, and in the presence of diffuse incandescent lamp lighting (200 watt) that brought the cell suspension approximately to compensation, with results as indicated in Table 7.

The experiment was continued at higher intensities of both diffuse and measured light and combinations thereof for many hours, and finally

Table 7. Quantum requirement of  $O_2$  production at constant  $CO_2$  pressure maintained by diethanolamine reagent

	Pressure change (mm.)	Light action		Quanta absorbed/ $O_2$ produced
		(mm.)	( $mm.^3$ )	
10 min. dark	- 12			
20 min. 160 $mm.^3$ measured green light	- 14	10/20 min.	38.5/20 min.	4.2
10 min. dark	- 12			
60 min. 480 $mm.^3$ measured green light	- 42.5	28/60 min.	108/60 min.	4.4
10 min. dark	- 11.5			
200 watt lamp illumination at 12 in.				
30 min. adaptation				
10 min. white light	+ 0.5			
10 min. white light + 80 $mm.^3$ measured green light	+ 5.0	5/10 min.	19.2/10 min.	4.2
10 min. white light	- 0.5			
(Rate of respiration, % of cell volume per hr.)	(-97)			

concluded by following the respiration for a further 10 hr. Similar experiments have likewise been continued in one and the same vessel for as long as a week, as a result of the various advantages offered by the diethanolamine reagent, which has proved eminently satisfactory. At higher temperatures the auto-oxidation of the reagent becomes very appreciable, both in the experimental vessel and in the control diethanolamine thermobarometer, but this auto-oxidation may be largely eliminated, according to a communication from Dr H. Krebs, by the addition of 0.02 % dithiozone or thiourea.

In Tables 5 and 7 we have illustrated one-vessel methods for obtaining quantum requirements of assimilation of CO<sub>2</sub> and of production of O<sub>2</sub> at constantly maintained pressures of O<sub>2</sub> and of CO<sub>2</sub> respectively. These methods are not subject to various of the difficulties, real or otherwise, often ascribed to the two-vessel method (Emerson & Nishimura, 1949), and they provide new evidence of the high quantum efficiency attainable in photosynthesis, independent of the evidence already obtained by the two-vessel method. The illustrations provided have all involved (1) cells maintained in acid medium (to insure maximum yields), and (2) heavy cell suspensions to attain complete light absorption of measured light beams employed. In order to measure quantum requirements with thin cell suspensions that transmit a considerable fraction of the incident light, the following compound, two-manometer, metabolism-actinometer vessel was devised.

#### IV. COMPOUND TWO-MANOMETER VESSEL FOR MEASURING QUANTUM EFFICIENCIES OF LIGHT-TRANSMITTING CELL SUSPENSIONS

The compound vessel illustrated in Fig. 2 contains an inner vessel of proportions similar to those shown for the two-compartment vessel of Fig. 1, with the modification that the compartment containing the reagent material (R) is not so deep as the main compartment (S) containing the cell suspension. An outer, actinometric vessel (A) completely surrounds the inner vessel to a depth of at least one centimetre, except for the bottom of the inner vessel compartment (S) through which the incident light beam enters into the cell suspension. The distance from the top of the inner vessel to the top of the outer is approximately 2 cm. In the outer vessel (A) is put any actinometric fluid suitable for absorption and measurement of the incident light beam, or of that light transmitted when a thin cell suspension is contained in the cell compartment (S). Enough actinometric fluid is used to cover the top of the inner vessel to a depth of 15 mm. A removable, two-sectioned, dark metal box (not illustrated), with its bottom so cut out as to allow the incident light to fall only on the bottom of the cell compartment (S), covers the entire flat surface of the outside of the compound vessel. Each

vessel (A, and R-S) is attached to its own manometer, and both manometers are mounted on a single supporting stick.

With this compound vessel it is possible to determine with one and the same apparatus the value of the incident light with which one wishes to illuminate the cell suspension, and the amount of this incident light that is absorbed by the cell suspension, throughout the course of an experiment. One can use not only as heretofore, a collimated light beam focused upon a given area of the bottom of compartment (S), which upon shaking of the

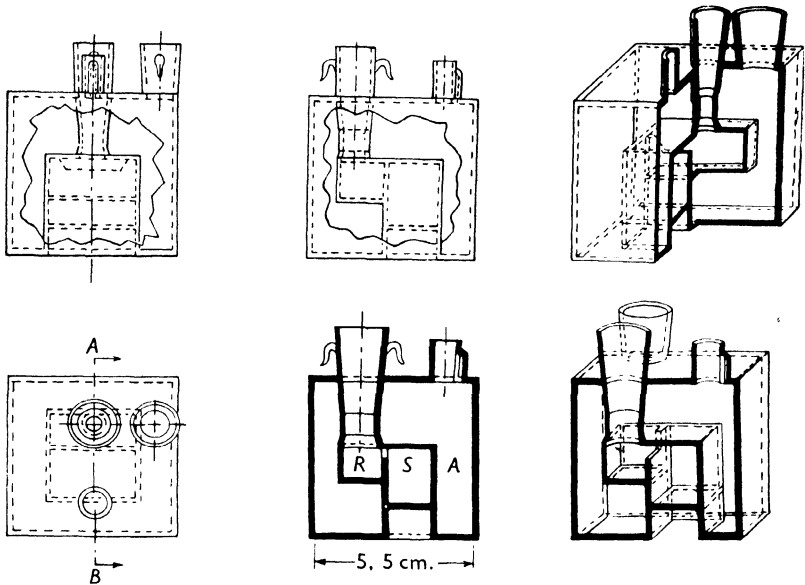

Fig. 2. Compound two-manometer vessel for measuring actinometrically in A the light transmitted from S, containing cells whose metabolism is measured by manometer above the reagent compartment R. Similarly useful for measuring fluorescence transmitted into A by a substance in S. Incident light enters S from bottom.

vessel is alternately illuminated and darkened, but one can also use an uncollimated beam of such diameter that, regardless of the excursion of the vessel during shaking, the entire bottom surface of the cell compartment (S) (c. 2 cm.  $\times$  4 cm.) is never in the dark. When the latter arrangement is employed, it is necessary that the manometers be fixed rigidly to their supporting stick, and the stick clamped securely to the shaking apparatus, in order that exactly the same area of the beam be employed throughout the experiment. This requirement was not found difficult to meet, and could continually be checked actinometrically during the course of an experiment by the manometric readings of compartment A.

In a more recently constructed vessel of the type shown in Fig. 2, the reagent compartment (R) has been deepened by 5 mm., and the distance from the top of the inner compartment to the outer has been increased by 10 mm. in order to have a longer 'chimney' arising from the reagent compartment. The new chimney is now placed at the end, not in the middle, of the compartment, and is of staircase construction (two zigs and one zag), in order to eliminate any small loss of light that might otherwise pass directly up and out without entering the actinometric fluid.

Experience has shown that the manometric responses of both the actinometric and metabolic compartments are remarkably rapid and reproducible in this compound vessel, and an illustrative experiment will now be presented.

*Experiment.* Technical conditions as in Warburg *et al.* (1951). 20° C. Shaking 180 cycles/min. at 18 mm. amplitude. pH of cell medium,  $4.5 \pm 0.3$  throughout duration of experiment, which extended over 8 hr. 24 hr. culture of *Chlorella pyrenoidosa* cells (inoculated with 200 mm.<sup>3</sup> cells per 400 c.c. medium to yield 800 mm.<sup>3</sup> cells total), centrifuged, washed once in, and finally taken up in, 'ammonia-medium' as in previous experiment. 25 mm.<sup>3</sup> cells in 3 c.c. ammonia-medium (*thin* cell suspension) placed (after conclusion of control actinometric run described below) in main compartment of inner vessel (S) of compound vessel and 300 mm.<sup>3</sup> cells in 6 c.c. ammonia-medium (*dense* cell suspension) placed in main compartment of vessel of type shown in Fig. 1 (vessel number 3). In the reagent compartments, R, of each vessel (S and 3) were placed four glass beads (0.25 c.c.) and 0.75 c.c. diethanolamine reagent (consisting of 18 c.c. diethanolamine, 12 c.c. 35.5 N-HCl, 15 c.c. H<sub>2</sub>O, and 9 g. KHCO<sub>3</sub>, and yielding at equilibrium in a closed volume 6% CO<sub>2</sub> in the gas phase, as determined by direct gas analysis of the latter). Vessels S and 3, and their respective thermobarometers, were then placed on opposite sides of the thermostat, as in the arrangement shown in Fig. 3, and subjected to simultaneous (though in this instance not closely equalized) illumination by divided beams of light from a high pressure Hg lamp filtered first through Schott-Jena BG23 and GG11 1 mm. glass plates to yield approximately 400–650 m $\mu$  and then finally an interference filter that gave the yellow 589 m $\mu$  line. The beam of this light directed upwards into vessel 3 was focused, as usual, to about 2 cm.<sup>2</sup> area at the point of entry, but the beam directed into the bottom of vessel S covered the entire exposed surface area (*c.* 8 cm.<sup>2</sup>) at all times during the shaking. The total intensity of light entering vessel S, per unit of time, was of the order of one-third that entering vessel 3, and the intensity per unit surface per unit time was therefore correspondingly about one-twelfth as great (one-third  $\times$  2 cm.<sup>2</sup>/8 cm.<sup>2</sup>).

Variations in the total beam intensity were obtained with Schott-Jena neutral glass filters calibrated, for a given wavelength, with a Lummer-Kurlbaum bolometer.

The data for the intensity values just mentioned were obtained in actinometric experiments carried out immediately prior to the experiments with cells, and may be detailed first. The actinometry of the beam eventually supplied to vessel 3 when containing cells was performed with vessel 10, with characteristics indicated in Table 8, and the beam to vessel S containing cells was first run in the absence of the cells, but with the same volume of medium (3 c.c.). Such measurements were often carried out after, as well

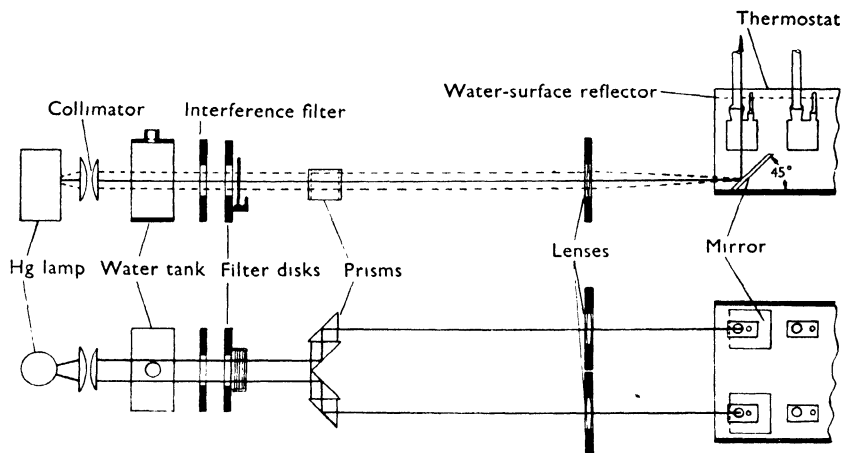

Fig. 3. Arrangement (top and side view) for split-beam illumination of two vessels simultaneously by means of totally reflecting prisms.

as before, the cell experiments, in order to obtain control or added information whose need became evident during the course of the cell experiment. The actinometric solution employed was composed of 6 g. thiourea, 125 mg. phaeophytin, and 125 c.c. pyridine, and has been much studied and calibrated actinometrically against light intensity in this institute with the aid of a Lummer-Kurlbaum bolometer calibrated against a National Bureau of Standards standard energy lamp. Although in certain types of vessels and filling, difficulties with bubble formation may be encountered with phaeophytin containing actinometric solution, this was not the case with vessels 10 and the actinometric compartment (A) of the compound vessel. Vessel 10 was filled with 14 c.c. of the actinometric solution, and vessel A with 105 c.c. Table 8 gives the results of the measurements, wherein a neutral Schott-Jena filter NG3 (transmission 0.086) was used to obtain low intensities.

Table 8. *Actinometric measurement of incident intensities applied to cell suspensions*

Beam for eventual use on vessel ...	3 (cells)	A (cells)
Vessel used for intensity measurement ...	10 (no cells)	A (no cells)
Total volume (c.c.)	30.61	125.6
Volume of actinometric solution ( $v_F$ ) (c.c.)	14.00	105.0
Gas volume (c.c.)	16.61	20.6
$v_F/v_G$	0.88	5.1
$k_{O_2}$ ( $\alpha_{O_2}$ in actinometric solution, 0.092) (mm. <sup>2</sup> )	1.67	2.89
Pressure change, 90 min. (neutral filter, 0.086 trans.) (mm.)	-157	-31
$x_{O_2}$ (mm. <sup>3</sup> )	-262	-89.5
mm. <sup>3</sup> light per min. per vessel	2.91	1.00
(mm. <sup>3</sup> light per min. per vessel per cm. <sup>2</sup> (c.))	1.5	0.12
Calculated intensity of beam without 0.086 neutral filter (mm. <sup>3</sup> /min.)	33.4	11.4

The 3 c.c. medium in vessel S was now replaced with 3 c.c. medium containing 25 mm.<sup>3</sup> cells, and actinometric measurements were repeated with vessel A, with results as given in Table 9 (vessel S:  $v_T$ , 24.59 cm.<sup>3</sup>;  $k_{O_2}$ , 1.93).

 Table 9. *Determination of light absorption and transmission by 25 mm.<sup>3</sup> Cells in vessel S*

Pressure change, 60 min. (neut. filter, trans. 0.086) (mm.)...	15.5 (in vessel A)
$x_{O_2}$ (mm. <sup>3</sup> ) ...	44.8 (in vessel A)
mm. <sup>3</sup> light per min. transmitted by vessel S	0.75 (into vessel A)
mm. <sup>3</sup> light per min. absorbed by vessel S	0.25 (= 25% absorption)

The 25 mm.<sup>3</sup> *Chlorella* cells in vessel S thus absorbed 25% of the incident yellow light under the conditions employed. In Table 10 are reported the yields of photosynthesis obtained at different incident light intensities that yielded approximately equal absorption in the thin and dense cell suspensions employed in vessels S and 3.

This experiment, like all others reported in this paper except the first, was carried out far more extensively than space permits elaboration here. Several light intensities and types of light were employed in the course of this particular experiment, and all concurred in giving high photosynthetic yields in the thin cell suspension, and also in the dense suspension except at the highest total intensities, where, as described earlier (Warburg & Burk, 1950, p. 416), the shaking may become limiting for the light intensity per unit surface area of the focused beam employed. It has seemed of greatest interest here to present comparable data for the thin and dense suspensions at a point where the absorbed light was virtually equal (2.85 and 2.89 mm.<sup>3</sup>/min.) although the cell quantity varied greatly (12-fold), as

did the respiration also ( $-180$  and  $-87\%$ ). The same high yields (within the experimental error of about  $\pm 0.5$  quanta) obtained in both suspensions show that the former high yields reported by us for thick suspensions (Warburg & Burk, 1950; Burk *et al.* 1949; Warburg *et al.* 1949, 1950) may also be obtained with quite thin suspensions in which the light intensity is essentially the same for each cell.

Table 10. *Quantum efficiencies in thin and dense cell suspensions providing incomplete and complete absorption of yellow light*

Suspension ...	Thin	Dense
Cell quantity ...	25 mm. <sup>3</sup> cells/3 c.c.	300 mm. <sup>3</sup> cells/6 c.c.
Light absorption (589 m $\mu$ ) ...	Incomplete	Complete
% Light absorption (Table 9) ...	25	c. 100
Vessel ...	S.	3
<hr/>		
Vessel volumes (c.c.): $v_T$	24.34	51.75
$v_F$	3.75*	6.75*
$v_A$	20.59	45.0
Vessel constant (mm. <sup>2</sup> ), $k_{O_2}$	1.93	4.20
Light intensity (mm. <sup>3</sup> /min.):		
Incident	11.4 (no neutral filter)	2.89 (0.086 neutral filter employed)
Absorbed	2.85	2.89
(Absorbed/min./cm. <sup>2</sup> ) ( $c$ )	0.35	1.4
Pressure changes (mm.):		
Dark, 15 min.	-5.5	15 min. - 16
Light, 15 min.	-0.5	60 min. - 50
Dark, 15 min.	-5.5	15 min. - 15
Light, 45 min.	-1.5	
Dark, 15 min.	-5.5	
Light action: mm./60 min.	+20	+12
mm. <sup>3</sup> /60 min.	+38.6	+50.4
mm. <sup>3</sup> /min.	+0.64	+0.84
$i/\phi$ , quanta per O <sub>2</sub> produced		
(light absorbed/light action)	4.4	3.5
Rate of respiration, as % of cell volume per hr.	-170	-87

\* = c.c. of medium plus 0.75 c.c. diethanolamine reagent.

*Experiment with Green Light.* In an experiment similar to that reported in Tables 8-10, but with a green 546 m $\mu$ , instead of yellow 589 m $\mu$ , interference filter, and with 180 (not 300) mm.<sup>3</sup> *Chlorella* cells in vessel 3, and 60 (not 25) mm.<sup>3</sup> *Chlorella* cells in vessel S that were found by vessel A to absorb 58 (not 25) % of the incident light, equivalent results were obtained, as reported in Table 11.

Table 11 illustrates the use of the actinometric compartment A during the course of an experiment, which, in this instance, had already been proceeding for many hours previously, during which time efficiency measurements at other light intensities had been carried out. With the *two* divided light beams, one is here simultaneously illuminating the *three* vessels 3, S, and A, whereas in Table 10 the measurements on vessels 3 and S, each with

Table 11. *Quantum efficiencies with partial and nearly complete absorption of green light*

Cell suspension density ...	—	Medium	Thick
Cell quantity per vessel ...	—	60 mm. <sup>3</sup> /3 c.c.	180 mm. <sup>3</sup> /6 c.c.
Light absorption (546 m $\mu$ ) ...	Complete	Partial	Nearly complete
% Light absorption ...	100	58	90-100
Incident light area exposed (cm. <sup>2</sup> ) ...	> 8	(c.) 8	(c.) 2
Vessel type ...	Fig. 2	Fig. 2	Fig. 1
Vessel ...	A	S	3
Vessel volume (c.c.): $v_T$ ...	125.6	24.34	51.75
$v_F$ ...	105.0	3.75	6.75
$v_G$ ...	20.6	20.59	45.00
Vessel constant (mm. <sup>2</sup> ): $k_{O_2}$ ...	2.89	1.93	4.20
Pressure changes (mm.):			
Dark, 60 min.	0	-24	-24
Light, 90 min.	-22	-24	-22
Dark, 30 min.	0	-12	-12
Light action:			
mm./90 min.	-22	+12	+14
mm. <sup>3</sup> /90 min.	-63.7	+23.2	+58.8
mm. <sup>3</sup> /1 min.	-0.708	+0.258	+0.653
Light intensity (mm. <sup>3</sup> /1 min., with 0.086 neutral filter):			
Incident	0.708	1.69 (0.708/0.42)	3.04 (vessel 10)
Absorbed	0.708	0.98 (1.69 $\times$ 0.58)	2.74-3.04
Absorbed/1 min./cm. <sup>2</sup> (c.)	<0.09	0.11	1.4-1.5
1/ $\phi$ , quanta per O <sub>2</sub> produced (absorption per 1 min./light action per 1 min.)		3.8 (0.98/0.258)	4.2-4.7
Rate of respiration, as % of cell volume per hr.		-78	-56
7 hr. later:			
Pressure changes (mm.):			
Dark, 30 min.	0	-10	-9
Light, 150 min.	-30	-34.5	-25
Dark, 30 min.	-0.5	-9.5	-8
Light action:			
mm./150 min.	-30.5	+14.3	+17.5
mm. <sup>3</sup> /150 min.	-88.5	+27.6	+73.5
mm. <sup>3</sup> /1 min.	-0.59	+0.184	+0.49
Light intensity (mm. <sup>3</sup> /1 min., with 0.070 filter and sector)*:			
Incident	0.59	1.40 (0.59/0.42)	2.48
Absorbed	0.59	0.81 (1.40 $\times$ 0.58)	2.23-2.48
Absorbed/1 min./cm. <sup>2</sup> (c.)	<0.07	0.1	1.1-1.25
1/ $\phi$ , quanta per O <sub>2</sub> produced (absorption per 1 min./light action per 1 min.)		4.4 (0.81/0.184)	4.5-5.0
Rate of respiration, as % of cell volume per hr.		-62	-40

\* Schott-Jena glass neutral filters with transmission 0.14 (calibrated with bolometer) plus rotating sector of 0.02 sec. dark -0.02 sec. light = 0.070 total transmission.

different divided light beam intensities, happened by chance to have been run consecutively rather than simultaneously. In one-vessel experiments such as illustrated in Tables 10 and 11, which may run indefinitely for hours or days as a result of advantages provided by the diethanolamine reagent,

simultaneous comparison of two vessels, as in the two-vessel method, is no longer necessary.

As noted in Tables 10 and 11, and throughout this paper, a high photosynthetic yield may be obtained regardless of wide variations in the rate of respiration (here 40 to 170% of the cell volume per hr.; also in other undetailed experiments lasting days, during which time the respiration fell from over 200 to 20% of the cell volume per hr.). A possible proviso to this conclusion is that it may be desirable or necessary that the cells be illuminated at intervals with measured or unmeasured white light, or a component thereof, at an intensity up to the order of, or even greater than that of, compensating intensity. In any event, the observed wide independence of maximum photosynthetic yield upon rate of respiration adds a fourth line of evidence, in addition to a third given in this paper and two earlier (Warburg & Burk, 1950; Burk *et al.* 1949; Warburg *et al.* 1949), in favour of the conclusion that light has no notable effect on respiration as a quantitative factor during measurements of maximum yield at *low* light intensities. In the experiments of both Tables 10 and 11, the cells in vessel 3 and S had had somewhat different previous light histories in terms of total light exposures received since placing the vessels on the thermostat, with resultant variation in the levels to which the rates of respiration had fallen by any given time.

*Experiment with thin suspension at light intensity several  
times compensation*

The following experiment reported in Table 12 was similar to the experiment reported in Tables 8–10, except that the thin cell suspension was illuminated at an intensity that gave a steady state rate of photosynthesis that was five times the steady state rate of respiration in the dark; and the light was of variable wavelength (400–650 m $\mu$ , obtained from a high-pressure Hg lamp with Schott-Jena filters BG23 and GG11, but consisting mainly of the blue 436, green 546 and yellow 589 lines).

In this experiment the light intensity employed was so high as to show light–dark transition effects under the conditions involved, and hence calculation of the quantum requirement from the light and dark steady states is to be preferred. However, if the calculation is carried out to include the transition periods (35 min. light, 10 min. dark transition), then the calculated light action is 2.76 mm.<sup>3</sup>/min. instead of 2.9, and the corresponding quantum requirement 5.8 instead of 5.5, a virtually negligible difference, but one in any event favouring a lower requirement in the steady rather than transition state. On the other hand, if the calculation is carried out to exclude the light transition phase (where incidental loss due to

induction may be involved), but to include the dark transition (where the result of previous light action is clearly involved), the calculated light action is 3.25 mm.<sup>3</sup>/min. and the quantum requirement only 4.9. However, the calculations involving transition states are only of passing interest here, since by lengthening the steady-state light period the various effects of the transition periods could be essentially eliminated.

Table 12. *Steady state quantum efficiency in a thin cell suspension at light intensity five times compensation (one-third saturation)*

(Experimental material and arrangements as in Tables 8-10, but without neutral or interference filters)

Vessel ...	S (surrounded by actinometric vessel A of compound vessel)
Suspension density ...	25 mm. <sup>3</sup> <i>Chlorella</i> cells/3 c.c. (bottom area 8 cm. <sup>2</sup> )
Illumination, wave length ...	400-650 mμ (Schott-Jena filters BG23, GG11)
Vessel constant (mm. <sup>2</sup> ): k <sub>O<sub>2</sub></sub> ...	1.93
Light intensity (mm. <sup>3</sup> /min.):	
Incident	80 (from vessel A data, no cells in vessel S)
Absorbed	16 (64 in vessel A, when cells in vessel S)
Absorbed/min./cm. <sup>2</sup>	2 (16 mm. <sup>3</sup> /8 cm. <sup>2</sup> area)
Pressure changes (mm.):	
Dark, 15 min.	-4.5 steady state
Dark, 15 min.	-4.5 steady state
Light: 10 min.	(+7.0) transition, including induction phase
5 min.	(+5.5) transition
5 min.	+6.0 steady state
5 min.	+6.0 steady state
5 min.	+6.0 steady state
5 min.	+6.0 steady state
Dark, 10 min.	(+0.5) transition
Dark, 20 min.	-6.0 steady state
Light action, steady state:	
mm./20 min.	+30 (+24 mm. to -6 mm.)
mm. <sup>3</sup> /20 min.	+58 (30 mm. × 1.93 mm. <sup>3</sup> )
mm. <sup>3</sup> /min.	+2.9 (58 mm. <sup>3</sup> /20 min.)
Quanta per O <sub>2</sub> in steady state (Absorption per min./light action per min.)	5.5 (16 mm. <sup>3</sup> /min./2.9 mm. <sup>3</sup> /min.)
Light action as % of photosynthesis at light saturation (where rate of O <sub>2</sub> produced is approximately 20 times the cell volume per hr.)	35 ((2.9 mm. <sup>3</sup> /1 × 60 min./20 × 25 mm. <sup>3</sup> cells) × 100)
Photosynthesis/respiration	5 (30 mm./20 min./6 mm./20 min.)
Rate of respiration, as % of cell volume per hr.	-140 (1.93 × 3 × 6 mm./min./25 mm. <sup>3</sup> cells) 100

The quantum requirement of 5.5 per molecule of O<sub>2</sub> obtained at 35% of light saturation (35% of maximum photosynthesis) is in harmony with the lower requirement of 4 obtained at lower light intensities (Warburg & Burk, 1950; Burk *et al.* 1949; Warburg *et al.* 1949, 1950; Warburg *et al.* 1951, and elsewhere in this report). As indicated earlier (Warburg & Burk, 1950, p. 416) *Chlorella* and most plants may commonly show a relative rate of photosynthesis that deviates from linearity with respect to light intensity

only when the light intensity begins to surpass 20–30% of light saturation (maximum photosynthesis) values. Furthermore, in this experiment a certain fraction of the light consisted of the blue region, which might have been absorbed in part by the carotinoid pigments with unascertained effect, favourable or unfavourable, on photosynthetic yield. •

The vessel in Fig. 2 provides an excellent method for determining fluorescence efficiency, notably in cases where an actinometric solution may be employed in compartment A that absorbs all the fluorescent light derived from the fluorescing solution in compartment S, but none of the incident light directed into S. In our experience this situation is easy to arrange.

#### SUMMARY

New manometric procedures and vessels are illustrated for measuring exchanges of one, two, or three gases in biochemical, photochemical, or analytical processes. A three-vessel method is demonstrated to provide confirmation and extension of the well-known two-vessel method. Several one-vessel methods are outlined whereby the exchange of a single gas may be measured in the presence of another gas maintained at constant, physiological pressure. In particular, aqueous oxy-bis(cobaltodiamine) compounds have been employed as an O<sub>2</sub> buffer, and diethanolamine as a CO<sub>2</sub> buffer in vessels specially designed to establish rapid physiochemical gas-liquid equilibration in studies of cellular respiration and photochemical yield.

The techniques proposed are well adapted to illustration and test in measurements of the process of photosynthesis, which involves a two-gas exchange in the light, the converse exchange in the dark, and the possibility of instant imposition of the one condition or the other. It is shown that the high photosynthetic efficiency of no more than ~4 quanta of red, yellow, or green light per molecule of CO<sub>2</sub> consumed or O<sub>2</sub> produced may be obtained whether the *Chlorella* cell suspension absorbs all or only a small part of the incident light; whether the measured light is supplied at an intensity above or below the respiration compensating intensity; and whether the measured light is only a part or the whole of the illumination.

The high quantum efficiency of ~4 was obtained not only by the well-known two-vessel method, but also by three-vessel and one-vessel methods that were employed, with adequate physical gas-liquid equilibration, over very wide variations of duration of the experiments; timing sequence of light-dark periods; uniformity or otherwise of light absorption throughout the cell suspension; incident light intensity per unit surface area or unit volume; geometry of the vessels; ratio of liquid/gas volumes; concentration

of cells per unit volume of medium; rate of respiration (tenfold); and numerous other factors that must necessarily be studied and controlled.

Two new lines of evidence, confirming two provided earlier (Warburg & Burk, 1950; Burk *et al.* 1949; Warburg *et al.* 1949, 1950), have been obtained further in favour of the view that light has no notable quantitative effect on *Chlorella* respiration at limiting low light intensities that give high photosynthetic yields.\*

## REFERENCES

- BURK, D., HEARON, J., CAROLINE, L. & SCHADE, A. L. (1946). Reversible complexes of cobalt, histidine, and oxygen gas. *J. Biol. Chem.* **165**, 723-4.
- BURK, D., HENDRICKS, S., KORZENOVSKY, M., SCHOCKEN, V. & WARBURG, O. (1949). *Science*, **110**, 225-9.
- EMERSON, R. & NISHIMURA, M. S. (1949). The quantum requirement of photosynthesis, Chap. 10 of *Photosynthesis in Plants* by J. Franck and W. E. Loomis. Iowa: The Iowa State College Press.
- HEARON, J., BURK, D. & SCHADE, A. L. (1949). Physicochemical studies of reversible and irreversible complexes of cobalt, histidine, and molecular oxygen. *J. Nat. Cancer Inst.* **9**, 337-77.
- MYERS, J. (1949). The pattern of photosynthesis in *Chlorella*, Chap. 17 of *Photosynthesis in Plants*, by J. Franck and W. E. Loomis. Iowa: The Iowa State College Press.
- PARDEE, A. B. (1949). Measurement of oxygen uptake under controlled pressures of carbon dioxide. *J. Biol. Chem.* **179**, 1085-91.
- WARBURG, O. & BURK, D. (1950). The maximum efficiency of photosynthesis. *Arch. Biochem.* **25**, 410-43.
- WARBURG, O., BURK, D., SCHOCKEN, V. & HENDRICKS, S. B. (1950). *Biochimica et Biophysica Acta*, **4**, 335-46.
- WARBURG, O., BURK, D., SCHOCKEN, V., KORZENOVSKY, M. & HENDRICKS, S. B. (1949). *Arch. Biochem.* **23**, 330-33.
- WARBURG, O., BURK, D. & SCHADE, A. L. (1951). Extensions of photosynthetic experimentation. This volume, p. 306.

\* (Note added in proof: At high light intensities, and intermittent illumination with light-dark periods of the order of 1 min. each, it is possible to observe in the dark periods a combustion process ( $x_{\text{CO}_2}/-x_{\text{O}_2} = -1$  to  $-1.2$ ) that may attain at least ten times the rate of the ordinary respiration rate. In the light periods, one may observe a quantum yield of 1 for the light action ( $\phi = \text{CO}_2/h\nu = 1$ ;  $-x_{\text{CO}_2}/x_{\text{O}_2} = -1$  to  $-1.2$ ); that is, 1 mole of absorbed light-quanta causes the absorption of 1 mole of CO<sub>2</sub> and the development of 0.8-1 mole of O<sub>2</sub>. These rapid dark and light reactions, which may be experimentally separated and observed by using high light intensities and intermittent illumination, are bound together in a cyclic process, and are mutually dependent quantitatively. In the combustion phase, which also proceeds in the light periods, some two-thirds or more of the organic product formed in the photochemical phase is immediately burned to yield the chemical energy necessary to form a photosynthetic substrate wherewith one quantum only is needed to effect consumption of one molecule of CO<sub>2</sub> and production of one molecule of O<sub>2</sub>. This two-phase energy cycle is the solution of the long-standing quantum problem in photosynthesis, namely, of how an overall chemical reaction that thermodynamically requires the energy equivalent of several light quanta is accomplished by several such low energy quanta acting together. Three to four revolutions of this photosynthetic energy cycle have been found sufficient to provide a permanent gain of 1 mole of CO<sub>2</sub> fixed and 1 mole of O<sub>2</sub> produced, in harmony with observations reported earlier in this and preceding papers. (See Burk, D. & Warburg, O., *Naturwissenschaften*, **37**, 560, 1950, and *Z. Naturforsch.* (in the Press), 1951.))

# THE USE OF 'CO<sub>2</sub>-BUFFERS' IN MANOMETRIC MEASUREMENTS OF CELL METABOLISM

BY H. A. KREBS

Medical Research Council Unit for Research in Cell Metabolism,  
Department of Biochemistry, University of Sheffield

## I. INTRODUCTION

A valuable addition to manometric technique has recently been made by A. B. Pardee (1949), who introduced the use of what may be called 'CO<sub>2</sub>-buffers'. These buffers are solutions of a base which react with CO<sub>2</sub> according to the equation

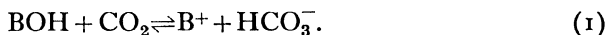

Within certain limits they can maintain a practically constant CO<sub>2</sub> pressure in the gaseous atmosphere. Any CO<sub>2</sub> formed by metabolic processes is removed by the above reaction proceeding from left to right and any CO<sub>2</sub> used is replaced by the reverse process. The method is generally useful in the study of systems where CO<sub>2</sub> and a second gas are formed or used, and where changes in the pressure of the second gas are to be measured. Examples are the measurements of the respiratory oxygen uptake in the presence of CO<sub>2</sub>, the evolution of oxygen in photosynthesis, or changes in hydrogen pressure in bacterial fermentations. There are reasons for believing that CO<sub>2</sub> plays a greater role in cell metabolism than is as yet realized and the method is therefore likely to be of great value in studying physiological effects of CO<sub>2</sub>. Warburg (1919) was the first to use this principle in the form of solutions containing carbonate and bicarbonate, but only very low CO<sub>2</sub> pressures of the order of a few mm. Hg can be maintained by this system. Pardee's CO<sub>2</sub> buffers, employing diethanolamine as the base, can maintain CO<sub>2</sub> pressures of 25 or more mm. Hg.

The method has recently been studied in some detail in the Sheffield laboratory as the result of the observation that the procedure, as suggested by Pardee, is liable to give rise to errors owing to the autoxidation of the buffer solution. Another point which has been investigated in more detail, from the theoretical as well as the practical standpoint, is the efficiency of the buffers. It is thought that a brief discussion of the theory and scope of the method will be of interest.

II. REMARKS ABOUT THE THEORY OF CO<sub>2</sub> BUFFERS\*

In simple systems where buffering is solely due to reaction (1) the approximate buffering capacity can be calculated if the dissociation constant of the base ( $K_B$ ), the apparent first electrolytic dissociation constant of carbonic acid ( $K_{H_2CO_3}$ ), the dissociation constant of water ( $K_W$ ), the total concentration of the base ( $c$ ) and the Bunsen absorption coefficient of CO<sub>2</sub> for the buffering solution ( $\alpha_{CO_2}$ ) are known. It is further necessary for the calculation to make some simplifying assumption, namely that no other reactions between the base and CO<sub>2</sub> (especially no formation of carbamate) occur and that the second stage of dissociation of carbonic acid is negligible.

In practice it is necessary to measure the buffering capacity directly (which is easy) as the theory only holds for dilute solutions. But the calculation of the buffering capacity is nevertheless a matter of interest because it reveals the manner in which the variables of the system are expected to affect the buffering capacity. The basis of the calculation is the quantitative relationship between CO<sub>2</sub> pressure and the concentration of bound CO<sub>2</sub> in the solution. It follows from the equation defining the electrolytic dissociation constants of the reactants that:

$$[HCO_3^-] = \sqrt{\left\{ \frac{cK_B K_{H_2CO_3} [CO_2]}{K_W} + \left( \frac{K_B K_{H_2CO_3} [CO_2]}{2K_W} \right)^2 \right\}} - \frac{K_B K_{H_2CO_3} [CO_2]}{2K_W} \quad (2)$$

where the square brackets refer to concentrations in the solution. Using this formula, bicarbonate concentration of a base solution can be calculated for any CO<sub>2</sub> pressure.

Differentiating (2) with respect to CO<sub>2</sub> one obtains the following equation which allows the calculation of the retention at varying CO<sub>2</sub> concentrations for the conditions to which the simplifying premises used in the derivation of the equation apply:

$$\frac{d[HCO_3^-]}{d[CO_2]} = \frac{\frac{cK_B K_{H_2CO_3}}{K_W} + \left( \frac{K_B K_{H_2CO_3}}{K_W} \right)^2 \frac{CO_2}{2}}{2 \sqrt{\left\{ \frac{cK_B K_{H_2CO_3} [CO_2]}{K_W} + \left( \frac{K_B K_{H_2CO_3} [CO_2]}{2K_W} \right)^2 \right\}}} - \frac{K_B K_{H_2CO_3}}{2K_W} \quad (3)$$

One of the conclusions which can be drawn from this formula is that  $\frac{d[HCO_3^-]}{d[CO_2]}$ , i.e. the buffering capacity or 'retention', is always the greater the lower the concentration of CO<sub>2</sub> in the absorbing solution. As this concentration depends on the CO<sub>2</sub> pressure in the gas phase and the

\* For a fuller treatment see Krebs, H. A. (1951), *Biochem. J.* **48**, 349.

absorption coefficient, it is to be expected that retention for a given CO<sub>2</sub> pressure is increased by reducing the absorption coefficient of the solution, e.g. by addition of neutral salts. It is further obvious that the retention increases with the concentration  $c$  of the base and that it is governed by the dissociation constant of the base  $K_B$ . Little retention will occur when  $K_B$  is above  $10^{-3}$  or below  $10^{-6}$ . The  $K_B$  value giving maximum retention at a given CO<sub>2</sub> pressure can be calculated by differentiating (2) with respect to  $K_B$  and equating to zero, which leads to the following equation:

$$K_B^{\max.} = \frac{2K_W c(\sqrt{2} - 1)}{[\text{CO}_2] K_{\text{H}_2\text{CO}_3}},$$

where  $K_B^{\max.}$  is the dissociation constant giving maximum retention at the CO<sub>2</sub> concentration  $[\text{CO}_2]$ .  $K_B^{\max.}$  is directly proportional to the concentration of the base and inversely proportional to the concentration of CO<sub>2</sub>. In other words, the base giving optimal retention varies with the CO<sub>2</sub> pressure, but only at higher concentrations of CO<sub>2</sub>, say above 3%, is it important to use a base with an optimal  $K_B$  value.

### III. MEASUREMENT OF RETENTION

The retention of any solution, as Warburg (1925) has shown, can be directly measured by liberating a known amount of CO<sub>2</sub> in a manometric flask containing the retaining fluid and determining the amount of CO<sub>2</sub> absorbed. Flasks after Dickens & Simer (1931) are especially suitable for the present case; they are fitted with a large centre compartment of 4-5 ml. capacity and with valve stoppers which make it possible to pass a gas mixture through the vessels whilst they are shaken in the water bath. Over 200 measurements were made in order to find CO<sub>2</sub> buffers giving the highest retention at 25° and 40°. The number of bases that are expected to be suitable is limited by the following three requirements: the solubility must be high enough to allow high concentrations; the substance must not be volatile so that it cannot distil into other compartments of the manometric vessel (which excludes ammonia and many alkyl amines);  $K_B$  must be of the order of  $10^{-5}$ . Among many substances tested, diethanolamine, in 4 molar solution, was, in agreement with Pardee's findings, found to be the most effective CO<sub>2</sub> buffer. A few representative data are given in Table 1. According to expectation the retention falls as the CO<sub>2</sub> pressure rises, but contrary to expectation addition of inorganic salts was not found to have a major effect on the retention. No solutions appreciably more effective than those recommended by Pardee have so far been found.

The data shown in Table 1 may be used for calculating the degree of retention for varying experimental conditions, the percentage retention

Table 1. *Retention of CO<sub>2</sub> by diethanolamine solutions*('Retention' =  $\mu$ l. CO<sub>2</sub> bound per ml. amine solution per mm. (manometric fluid) rise in CO<sub>2</sub>-pressure)

Temp. (° C.)	Initial CO <sub>2</sub> content of gas mixture (% v/v)	Solution tested	Retention
40	0.94	4 M-Diethanolamine	50
		Pardee's solution	51
40	1.98	4 M-Diethanolamine	28
		Pardee's solution	41
40	3.09	4 M-Diethanolamine	16.7
		Pardee's solution	22.0
40	3.93	4 M-Diethanolamine	12.3
40	5.74	3.75 M-Diethanolamine	10.2
25	0.94	4 M-Diethanolamine	29
		Pardee's solution	140
25	1.98	4 M-Diethanolamine	25.6
		Pardee's solution	25.3
25	3.09	4 M-Diethanolamine	16.6
		Pardee's solution	17.3
25	3.93	4 M-Diethanolamine	10.3
		Pardee's solution	6.6
25	5.74	4 M-Diethanolamine	9.5

being  $\frac{V_F R}{V_F R + K_{CO_2}} \times 100$ , where  $V_F$  is the volume of the retaining fluid,  $K_{CO_2}$  the vessel constant for CO<sub>2</sub> and  $R$  the retention, as given in the last column of Table 1. To increase retention, given a fixed value for the retaining capacity of the solution, it is necessary to reduce  $K_{CO_2}$  or to increase  $V_F$ . The effects of variation in  $K_{CO_2}$  and  $V_F$  may be seen from Table 2.

Table 2. *Volume of retaining fluid (4 M-diethanolamine) required for 90% and 95% absorption of CO<sub>2</sub> (40° C.)*

CO <sub>2</sub> concentration (%)	Retention	Volume required (ml.)			
		$K_{CO_2} = 1.5$		$K_{CO_2} = 2.5$	
		90% absorption	95% absorption	90% absorption	95% absorption
1	50	0.27	0.57	0.45	0.95
2	28	0.48	1.02	0.50	1.79
3	17	0.80	1.68	1.32	2.80
4	12	1.10	2.33	1.88	3.95

Except in the case of 1% CO<sub>2</sub> the volumes of retaining fluid required for effective (e.g. 95%) absorption are larger than those which can be used in the centre well of the conventional conical manometer flask. On the other

hand, the cups designed by Dickens & Šimer (1931), already recommended by Pardee, or those described by Warburg, Kubowitz & Christian (1931), are suitable; either the centre compartment or the outer ring can be filled with several ml. of fluid. In these cups sufficiently large volumes of retaining fluid can be used to make even 98% retention practicable at 1% and 2% CO<sub>2</sub>, but not at higher CO<sub>2</sub> pressures. It is clear that 'complete' absorption of CO<sub>2</sub> is not always obtainable, but in many types of experiment 90% or 95% retention may be satisfactory.

#### IV. CONTROL OF AUTOXIDATION

At 40° 1 ml. 4 M-diethanolamine solution in equilibrium with 3 or 5% CO<sub>2</sub> in O<sub>2</sub> was found to absorb between 15 and 100 μl. O<sub>2</sub> per hour. The rate increased usually with the time of incubation. Solutions made from freshly recrystallized diethanolamine showed a very low uptake during the first 30 min. but the rate gradually rose to the same values as those of the commercial material. Addition of sec. octanol increased the rate of oxidation. Among the many substances tested for inhibitory activity, thiourea (0.1%) was found to be the most effective. The autoxidation, however, is not completely abolished and a control manometer, registering the residual autoxidation, is still required. Three ml. 4 M-diethanolamine solution containing 0.1% thiourea and equilibrated with 3% CO<sub>2</sub> in O<sub>2</sub> absorbed about 20 μl. CO<sub>2</sub> per hr. at 40°.

#### V. PREPARATION OF CO<sub>2</sub>-BUFFERS

It is essential to equilibrate the buffer solution, before it is pipetted into the vessel, with the same CO<sub>2</sub> mixture as is used in the experiment. The equilibration has to be carried out at the temperature at which the solution is finally used, but a stock of equilibrated buffer may be kept for several weeks at room temperature if stored in a stoppered cylinder.

Stock solutions of 4 M-diethanolamine buffer are prepared by passing first a rapid stream of 100% CO<sub>2</sub> through one-third of the desired quantity of solution until saturation is obtained. This is tested with phenolphthalein (pH ~ 8) and can be achieved in 30 min. if a sintered glass distributor of the type used for aerating aquaria is used. The remaining two-thirds of the untreated solution are then added and the gas mixture to be used in the manometer is passed through the solution at the appropriate temperature for 1 or 2 hours, again through a sintered glass distributor. Whether equilibrium has been reached may be tested as follows: the solution (3 or 4 ml.), together with a few glass beads of 4-5 mm. diameter, is placed

in a manometer provided with a valve stopper (Warburg & Kubowitz, 1929) and the gas mixture is passed through the vessel whilst it is being shaken in the bath.

## VI. TEST OF EFFICIENCY

To test the efficiency of the CO<sub>2</sub>-buffers yeast suspensions were placed in manometer vessels with and without a CO<sub>2</sub>-buffer. The gas phase of the vessels contained 4% CO<sub>2</sub> and 96% N<sub>2</sub>. If the CO<sub>2</sub>-buffer operates according to expectations, only a small percentage of the CO<sub>2</sub> produced on addition of glucose should appear in the gas phase if the buffer is present. In fact in the first two 10 min. periods the absorption of CO<sub>2</sub> was less complete than expected, being about 20–40% in the first 10 min. period and 70–80% in the second. Afterwards it was as expected, namely 95%. In other words, after about 20 min. a steady state developed where the CO<sub>2</sub> pressure was somewhat (15–30 mm.) above the equilibrium pressure. Once the steady state was attained the rate of absorption was of the expected order. The excess CO<sub>2</sub> pressure in the steady state varied with the rate of CO<sub>2</sub> production, the rate of shaking and the shape and size of the manometer vessels, but irrespective of these variations the steady state was generally established within 20 or 30 min. of the start of the reaction. If a continuous reaction is being studied, most of this time will fall within the usual period of gas equilibration.

In further tests the rate of oxygen uptake of washed suspensions of *E. coli* (40°) and of baker's yeast (25°) was measured in the presence of 3% CO<sub>2</sub> in O<sub>2</sub>, with the CO<sub>2</sub>-buffer in the centre compartment of the manometer vessels, and compared with the rate in the presence of O<sub>2</sub> with NaOH in the centre compartment. The measurements began 20 min. after addition of the substrates. The  $Q_{O_2}$  values obtained by the two methods agreed within the limits of accuracy.

The tests show that under suitable conditions Pardee's carbon dioxide buffers satisfactorily maintain a 'constant' CO<sub>2</sub> pressure. It may not be unnecessary to point out that attention to the design of the manometer vessel, rate of shaking and rate of the metabolic processes is here even more critical than in the usual manometric measurements.

Limitations of the method arise from lack of buffers which control CO<sub>2</sub> pressure above, say, 5%. The type of buffer proposed by Pardee, as the theory shows, is unlikely to lend itself for use at higher CO<sub>2</sub> pressures. But it is feasible that other types of buffer systems, e.g. binary systems, containing an insoluble carbonate or bicarbonate, might fill the gap.

## REFERENCES

- DICKENS, F. & ŠIMER, F. (1931). *Biochem. J.* **25**, 973.  
KREBS, H. A. (1951). *Biochem. J.* **48**, 349.  
PARDEE, A. B. (1949). *J. Biol. Chem.* **179**, 1085.  
WARBURG, O. (1919). *Biochem. Z.* **100**, 230.  
WARBURG, O. (1925). *Biochem. Z.* **160**, 307.  
WARBURG, O. & KUBOWITZ, F. (1929). *Biochem. Z.* **214**, 5.  
WARBURG, O., KUBOWITZ, F. & CHRISTIAN, W. (1931). *Biochem. Z.* **242**, 170  
(especially p. 178, Fig. 2).











