

UNIVERSAL  
LIBRARY

**OU\_166934**

UNIVERSAL  
LIBRARY



OUP—881—5-8-7 415.000

**OSMANIA UNIVERSITY LIBRARY**

Call No. **671-521** Accession No. **G17922**

Author **TSE**  
**Tregelsky, V.**

Title **Electric welder (a manual)**

This book should be returned ~~on or~~ before the date last marked below.



V. T S E G E L S K Y

**THE ELECTRIC  
WELDER**

(A MANUAL)

FOREIGN LANGUAGES PUBLISHING HOUSE

M o s c o w

TRANSLATED FROM THE RUSSIAN BY B. KUZNETSOV

DESIGNED BY V. DOBER

# CONTENTS

	<i>Page</i>
Introduction . . . . .	7
<b>Chapter I. FUNDAMENTALS OF METALS</b>	
1. General . . . . .	9
2. Properties of Metals . . . . .	9
3. The Crystalline Structure of Metals . . . . .	15
4. Ferrous Alloys . . . . .	16
5. Heat Treatment of Steel . . . . .	20
6. Surface Impregnation . . . . .	22
7. Nonferrous Metals and Alloys . . . . .	23
<b>Chapter II. POWER SOURCES FOR ARC WELDING: THEIR DESIGN AND OPERATION</b>	
<b>FUNDAMENTALS OF ELECTRICAL ENGINEERING</b>	
8. Basic Electrical Units and Laws . . . . .	26
9. Thermal and Chemical Effects of Electric Current . . . . .	28
10. Electromagnetism . . . . .	30
11. Electromagnetic Induction . . . . .	31
12. General Principles of D.C. Generators . . . . .	32
13. Operating Principle of D.C. Motors . . . . .	36
14. Alternating Current and Its Generation . . . . .	37
15. Resistance of an A.C. Circuit, Ohm's Law for A.C. Circuits . . . . .	39
16. A.C. Circuits Containing Resistance, Inductance and Capacitance, Volt-amperes and Power Factor . . . . .	40
17. Three-phase Current . . . . .	42
18. The Revolving Magnetic Field . . . . .	43
19. A.C. Three-phase Motors . . . . .	45
20. Transformers . . . . .	46
21. Electrical Instruments . . . . .	48
<b>THE ELECTRIC ARC</b>	
22. Electric Properties of the Arc . . . . .	49
23. Welding Properties of the Arc . . . . .	51

## SOURCES OF CURRENT SUPPLY FOR ARC WELDING

24. Arc Welding Equipment . . . . .	53
25. Requirements for Sources of Current Supply for Arc Welding . . . . .	56
26. Single-operator Direct-current Welding Sets . . . . .	58
27. Multi-operator D.C. Welding Sets . . . . .	67
28. Single-operator Welding Transformers . . . . .	68
29. Multi-operator Welding Transformers . . . . .	77
30. Rectifier-type Welding Sources . . . . .	78
31. Welding Frequency Converters . . . . .	79
32. Care of Welding Sources . . . . .	80
33. Arc Welding Equipment Failures . . . . .	81
34. Parallel Operation of Welding Sources . . . . .	82

### Chapter III. *METALLURGICAL ASPECTS OF WELDING*

35. Specific Features . . . . .	84
36. Refinement of the Weld Metal . . . . .	85
37. The Structure of the Weld Metal and Near-weld Area . . . . .	87

### Chapter IV. *WELDING ELECTRODES*

38. General . . . . .	91
39. Core Wire Materials . . . . .	92
40. Electrode Coatings . . . . .	92
41. Electrode Manufacture . . . . .	95

### Chapter V. *MANUAL ARC WELDING OF LOW-CARBON STEELS*

42. Welded Joints . . . . .	98
43. Weld Types . . . . .	100
44. Technique of Manual Arc Welding . ✓ . . . .	102
45. Positions of Welds . . . . .	107
✓46. Arc Welding with D.C. and A.C. . . . .	115
47. Advanced Arc Welding Techniques . . . . .	116
48. Welding at a Low Temperature . . . . .	118

### Chapter VI. *EXPANSION, CONTRACTION, DISTORTION AND RESIDUAL STRESSES IN WELDING*

49. Causes of Thermal Strains and Stresses . . . . .	120
50. Methods of Controlling Distortion and Stresses in Welding . . . . .	122

### Chapter VII. *MANUAL ARC WELDING OF SPECIAL STEELS*

51. General . . . . .	127
52. General Technique for Welding Alloy Steels . . . . .	128
53. Welding of Various Special Steels . . . . .	130

### Chapter VIII. *REPAIR WELDING*

54. Building Up . . . . .	134
55. Repair Welding Applications . . . . .	138

**Chapter IX. *HARD FACING***

56. Hard Facing with Diamond Substitutes . . . . .	142
57. Hard Facing with Powdered Alloys . . . . .	142
58. Hard Facing with Ferrous Alloy Rods . . . . .	144

**Chapter X. *PRODUCTION WELDING OF STEEL STRUCTURES***

59. Types of Weldments . . . . .	145
60. Stages of Fabrication by Welding . . . . .	145
61. Welding Applications . . . . .	146
62. Pipe Welding . . . . .	154
63. Arc Welding of Reinforcement Bars for Ferro-concrete Structures . . . . .	156

**Chapter XI. *CAST IRON WELDING***

64. General . . . . .	163
65. Welding of Cast Iron Without Preheating . . . . .	163
66. Welding of Cast Iron with Preheating . . . . .	167

**Chapter XII. *WELDING OF NONFERROUS METALS***

67. Welding of Copper and Its Alloys . . . . .	169
68. Welding of Aluminium and Aluminium Alloys . . . . .	172

**Chapter XIII. *ARC CUTTING***

69. Cutting with a Carbon Electrode . . . . .	174
70. Cutting with a Metal Electrode . . . . .	175
71. Air-arc Cutting . . . . .	176

**Chapter XIV. *MACHINE WELDING***

72. General Principles of Machine Arc Welding . . . . .	177
73. Basic Design of Automatic Welding Heads . . . . .	178
74. Fluxes . . . . .	187
75. Electrode Wire . . . . .	189
76. Techniques and Procedures of Automatic Welding . . . . .	190
77. Automatic Welding Units . . . . .	197
78. Electroslag Welding . . . . .	199
79. Semi-automatic Submerged-arc Welding . . . . .	203
80. Machine Gas-shielded Arc Welding . . . . .	206
81. Machine Welding with Powder-cored Electrodes . . . . .	209

**Chapter XV. *RESISTANCE WELDING***

82. Basic Principles . . . . .	211
83. Upset and Flash Butt Welding Equipment and Techniques . . . . .	213
84. Spot and Seam Welding Equipment and Techniques . . . . .	217

**Chapter XVI. *WELDING PROCEDURES***

85. Welding Procedure Defined . . . . .	225
86. Welding Specifications and Instructions . . . . .	228

## Chapter XVII. *WELD INSPECTION*

87. Scope of Inspection or Quality Control . . . . .	230
88. Welding Defects . . . . .	231
89. Visual Inspection . . . . .	233
90. Tightness Tests . . . . .	234
91. Mechanical Tests . . . . .	235
92. Internal Flaw Detection . . . . .	235

## Chapter XVIII. *SAFETY RULES*

93. General . . . . .	238
94. Protection from Arc Rays . . . . .	238
95. Precautions Against an Electric Shock . . . . .	239
96. Precautions Against Burns . . . . .	240
97. General Safety Measures . . . . .	240

## Chapter XIX. *FOR BETTER WELDING*

98. Welding Tools and Accessories . . . . .	242
99. Upkeep of a Welding Station. Reduction of Welding Cost	245

## INTRODUCTION

All existing welding processes may be classed into two broad systems: pressure welding and fusion welding.

Pressure welding encompasses welding processes in which two pieces of metal are united by heating and by applying pressure to bring about a marked plastic deformation at the joint. Some metals do not require heating.

In fusion welding metals are welded together by bringing them to the molten state at the surfaces to be joined and allowing the metals to flow together without the application of mechanical pressure.

Pressure welding processes are:

*Resistance welding*—in which the fusion temperature is generated at the joint by the resistance to the flow of an electric current passed directly through the workpiece. The heat generated at the point of contact reduces the metal to a plastic state; the pieces are then pressed together to complete the weld.

Resistance welding covers many processes of which the basic are butt welding, spot welding, and seam welding.

*Gas-pressure welding*—in which the pieces of metal to be joined are heated by a gas torch to a plastic state and then pressed together to obtain the weld.

*Friction welding*—in which coalescence is produced by the heat obtained from the friction between the ends of the pieces and by the application of pressure.

*Cold pressure welding* (or bonding)—in which the molecular continuity of the workpieces is obtained by deep plastic deformation at the joint. This process is applicable to highly ductile metals, such as copper and aluminium.

The field of fusion welding is broken into several processes, the most important of which are arc welding, inert gas shielded arc welding, electroslag welding, and gas welding.

*Arc welding*, the most commonly used welding process, is based on the heat of the arc. Metallic arc welding (the Slavianoff process), both its manual and automatic submerged-arc variety, is extremely versatile as it can be applied to a wide range of work sizes—from very small to large and heavy.

Wide use has recently been made of shielded arc welding in which the arc and metal are protected from the air by argon, carbon dioxide, etc.

*Electroslag welding* is a new welding process designed specifically for heavy gauges. In this process the welding heat is generated by the passage of an electric current from the welding rod to the workpiece through a blanket of molten flux (slag).

This process compares favourably both economically and technically with arc welding as far as heavy-gauge metal is concerned.

*Gas welding* is a method in which the pieces to be joined are heated to a molten state by burning a mixture of oxygen and a suitable fuel gas (acetylene, hydrogen, etc.) at the joint. This process is applicable to sheet metal, nonferrous metals, and in repair jobs involving cast iron or aluminium.

Standing apart from the other welding processes is *ultrasonic welding*. In this process, a weld is formed by the energy given out by ultrasonic oscillations applied to the point of contact between the pieces to be joined. Ultrasonic oscillations (with a frequency of 20,000 c.p.s. and higher) are generated by magnetostrictive transducers<sup>1</sup> or suitable r-f oscillators with an output of 3 to 10 kW.

---

<sup>1</sup> "Magnetostriction" literally implies contraction under magnetic influence.

# *Chapter 1*

## **FUNDAMENTALS OF METALS**

---

### *1. General*

Metals and their alloys are the basic materials of the engineering and allied industries. They are also indispensable in building, transport, agriculture, and other fields.

Metals are chemical elements possessing a number of distinctive features—lustre, opacity, good heat and electrical conductivity, malleability, fusibility, and weldability.

The metals most widely occurring in nature are iron, aluminium, copper, tin, lead, zinc, nickel, magnesium, chromium, tungsten, cobalt, vanadium, and molybdenum. In engineering practice, however, they are employed in alloy form rather than in a pure state. An alloy is a mixture of two or more metals melted together. For example, steel and cast iron are alloys of iron, carbon, silicon, manganese, and some other elements. Brass is an alloy composed mainly of copper and zinc and sometimes containing small percentages of lead and iron. Duralumin is an alloy of aluminium, copper, manganese, magnesium, and some other elements.

Metals are divided into ferrous and nonferrous groups. The ferrous group embraces iron and its alloys (various steels and cast irons) and the metals chromium and manganese. The nonferrous group includes copper, aluminium, nickel, lead, tin and some other metals and their alloys, such as bronze, brass, and duralumin.

### *2. Properties of Metals*

The utility of any metal depends upon its mechanical and physical properties. The *mechanical properties* of importance in metals for engineering purposes are strength, hardness, ductility, and impact resistance.

The *strength* of a metal is its ability to stand up to the action of external forces without breaking. To determine the strength of a metal accurately, a specimen is clamped in the jaws of a tensile testing machine and pulled, i.e., a load is applied until the specimen breaks.

The load is increased gradually. Before rupture occurs the specimen will at first stretch (elongate) in proportion to the pulling (tensile) load  $P$ , i.e., the elongation of the specimen will increase exactly as many times as the tensile load. This will go on until a certain point is reached where

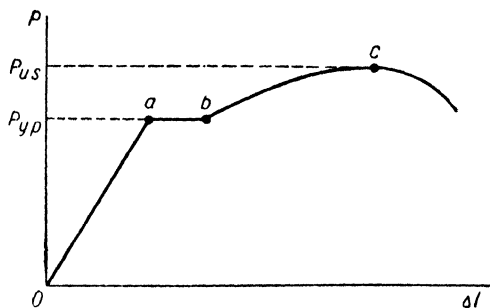

Fig. 1. Steel in tension

the load has the value  $P_{vp}$  and the specimen will continue to elongate without any increase in the load (point  $a$  in Fig. 1). At point  $b$  the load will have to be increased again to stretch the specimen further. The load will increase until the specimen breaks at point  $c$  where the load will be  $P_{vs}$ .

Denoting the original cross-sectional area of the specimen (measured in square millimetres) by  $A_0$ , and the load (in kilograms) under which the specimen elongates without any increase in it by  $P_{vp}$ , we shall obtain what is known as *the yield point*

$$YP = \frac{P_{vp}}{A_0} \text{ kg/sq mm.}$$

For a specimen with an original cross-sectional area of  $5 \times 20 = 100$  sq mm and  $P_{vp} = 3,500$  kg, the yield point will be

$$YP = \frac{3,500}{100} = 35 \text{ kg/sq mm.}$$

Denoting the load which occurs at rupture by  $P_{us}$ , the *ultimate tensile strength* of a given material will be obtained by the equation

$$UTS = \frac{P_{us}}{A_0} = \text{kg/sq mm.}$$

If  $P_{us} = 4,200$  kg, the ultimate tensile strength of the same specimen will be

$$UTS = \frac{4,200}{100} = 42 \text{ kg/sq mm.}$$

The ultimate tensile strength is a measure of the durability of a material.

*Hardness* may be defined as the resistance of a metal to local penetration by a harder body. In most cases, the hardness of metals is measured by forcing a hard steel ball (2.5 to 10 mm in diameter) into the surface of a specimen under a definite weight in a hardness testing machine.

The hardness may be found by the equation

$$H_B = \frac{P}{A},$$

where  $H_B$  is the Brinell hardness number in kg/sq mm,  $P$  is the load applied to the ball (in kg), and  $A$  is the area of the impression left by the ball (in sq mm).

These calculations need not be made each time as there are tables in which the area of the spherical impression is related directly to hardness numbers.

*Ductility* is the property possessed by metals that allows them to be drawn, stretched or otherwise changed in shape without breaking and to retain the changed shape after the load has been removed.

A measure of the ductility of a material may be obtained by pulling a specimen in a tensile machine and by finding what is known as the *per cent* (or *percentage*) *elongation*. This is found by dividing the increase in the gauge length measured across the fracture by the original gauge length, the ratio multiplied by 100 per cent, or:

$$PE = \frac{l_1 - l}{l} \times 100 \text{ per cent,}$$

where  $l$  is the original gauge length of the specimen (in mm) and  $l_1$  is the gauge length at fracture (also in mm).

For a specimen with an original gauge length of 50 mm and with a gauge length at fracture of 55 mm, the per cent elongation will be

$$\frac{55-50}{50} \times 100 = 10 \text{ per cent.}$$

The ductility of a metal can also be measured by the bend test (Fig. 2). This test is often employed in testing welded joints for strength.

*Impact resistance.* Per cent elongation is a measure of the ductility of metals subjected to static loads. A metal of satisfactory ductility under static loads may fail, however, under dynamic loads or impacts.

The resistance of a metal to impacts is evaluated in terms of impact strength.

Impact strength is usually determined by the Charpy or the Izod test, both using the same type of machine known as the pendulum machine (Fig. 3a).

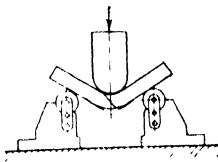

Fig. 2. Bend test

A Charpy test specimen is a beam supported at both ends and containing a 45

degree notch in the centre. The specimen is placed on the supports (Fig. 3b) and struck with the pendulum on the side opposite the notch so that it ruptures.

The impact strength of a metal is determined by measuring the energy absorbed in the fracture  $E$  by the equation

$$E = P(H-h) \text{ kg-m,}$$

where  $P$  is the weight of the pendulum (in kg),  $H$  is the height (in m) at which the pendulum is released to strike the specimen, and  $h$  is the height (also in m) to which the pendulum swings after it has struck the specimen.

The impact strength is found by the equation

$$IS = \frac{E}{A},$$

where  $IS$  is the impact strength (in kg-m/sq cm) and  $A$  is the cross-sectional area of the specimen (in sq cm).

The basic *physical properties of metals* are density, fusibility, electrical conductivity, and thermal expansion.

*Density and specific gravity.* The density of a metal is its mass per unit volume. If the gram is used as the unit of mass and the centimetre as the unit of volume, the density may be found by dividing the weight of a specimen in grams by its volume in cubic centimetres, or

$$d = \frac{P}{V},$$

where  $d$  is the density (in g/cu cm),  $P$  is the weight of the specimen (in grams) and  $V$  is the volume of the specimen

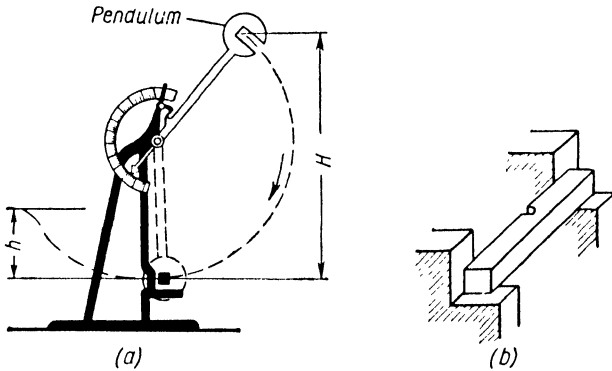

Fig. 3. Impact test:

a—a pendulum impact testing machine; b—an impact test specimen

(in cubic centimetres). When so expressed, the density of a material will, for all practical purposes, be equal to its specific gravity.

Metals differ widely in specific gravity. For example, the specific gravity of steel (iron) is 7.8, of lead 11.4, and of aluminium 2.6.

The *fusibility* of a metal is assessed on the basis of its melting point—the point at which a metal changes from a solid into a molten state. The melting point of iron is

+1,528°C, of copper +1,083°C, of tin +232°C, and that of mercury 39°C below zero.

*Electrical conductivity* may be defined as the capacity of a metal to conduct an electric current. A measure of electrical conductivity is provided by the conductance of a given material, which is equal to the reciprocal of the resistance (see Chapter II).

*Expansion* is the increase in the dimensions of metals due to heat. The expansion of metals in a longitudinal direction is known as the linear expansion. The expansion in volume is called the volumetric expansion. Linear expansion per unit length for one degree of temperature increase is called the *coefficient of linear expansion*, while volumetric expansion per unit volume for one-degree rise in temperature is called the *coefficient of volumetric expansion*; this latter is three times the former.

The coefficient of linear expansion varies from metal to metal. For steel it is 0.000012. In other words, a steel rod 1 m long will expand 0.012 mm when its temperature is increased one degree Centigrade, and 1.2 mm, when it is raised 100°C in temperature.

If the length of a part and the rise in its temperature are known, the magnitude of the linear expansion can be found. For example, a rail 12 m long, when heated to 40°C, will expand  $0.012 \times 12 \times 40 = 5.76$  mm.

The coefficient of linear expansion of copper is 0.000017, and of aluminium, 0.000023. Thus, nonferrous metals expand more when heated. This should be borne in mind when welding them.

Also important in metals for engineering purposes are their workability properties, namely machinability, weldability, malleability, and fluidity in a molten state.

The degree of machinability of a metal can be determined by means of a file or a chisel and hammer. Weldability is usually assessed by what is known as the Tee bend test in which two pieces of metal are welded into a Tee joint which is then broken by a sledge hammer—the appearance of the fracture will show how sound the weld was. The degree of malleability can be evaluated by bending a specimen of the metal being tested.

### 3. The Crystalline Structure of Metals

It has been shown by means of X-ray analysis that the atoms in metals are arranged so as to form minute crystals of regular geometrical outline. These atomic arrangements are known as space or cubic lattices (Fig. 4).

It is these lattices—their shape and aggregation, number, arrangement and distance of the atoms in a lattice—that govern the mechanical and other properties of metals. The atomic arrangements are in turn affected by the conditions under which a given metal was produced and worked.

The crystalline structure of iron and, in fact, of any metal, changes with heating and cooling. At room temperature iron exhibits a body-centred cubic lattice as shown in Fig. 4a and is then called *alpha iron*, or *ferrite*.

Alpha iron, when heated to 906°C, changes its body-centred cubic arrangement to a face-centred cubic structure as shown in Fig. 4b, which is called *gamma iron*. The transition from alpha to gamma iron is of special importance in heat treatment, as it is accompanied by a change in the crystallographic form of the iron (secondary crystallisation).

This transformation affects the solubility relations of the iron and carbon. Alpha iron may contain up to 0.04 per cent carbon, while gamma iron will hold up to 1.7 per cent carbon in solid solution. The gamma iron containing carbon in solid solution is called *austenite*.

Ferrite is very soft and weak; it has high plasticity and magnetic properties, but loses them when heated to 768°C. Austenite is only present at high temperatures, or above what is known as the critical point of steel. When the steel is cooled to below its critical point, the austenite will undergo a transformation. Addition of sufficient amounts of some alloying elements, however, either lowers the critical temperature or slows down the rate of transformation, thus

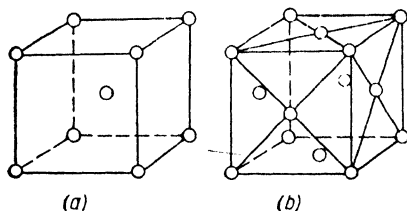

Fig. 4. Space lattices of iron

allowing retention of the austenite. Steels remaining in the austenitic form when cold are called austenitic steels. They are tough and highly resistant to abrasion and corrosion.

The structure of metals is studied with the aid of a metallographic microscope. In preparing a microsection, i.e., the specimen to be examined, a flat surface is first formed by filing or grinding, and this surface is then given a high polish to obtain a mirror finish.

The structure and internal condition of metals as revealed on a ground and polished sample either by the naked eye or under low magnifications is called *macrostructure*. The structure visible through a microscope at high magnifications is called *microstructure*. Macroscopic studies reveal inclusions, impurities, gas pockets, and cracks, while microscopic studies make it possible to identify the nature, type and amount of microconstituents.

The microstructure of steel containing 0.83 per cent carbon is called pearlite, which is a mechanical mixture of pure ferrite and cementite.

The microstructure of steel containing less than 0.83 per cent carbon is a mixture of ferrite and pearlite. If the carbon content is over 0.83 per cent, the microconstituents of steel will be cementite and pearlite. Cementite is a chemical compound of iron and carbon,  $\text{Fe}_3\text{C}$  (iron carbide), and is extremely hard and brittle.

#### 4. Ferrous Alloys

The known examples of ferrous or iron-carbon alloys are steel and cast iron. They differ in the content of carbon and other elements such as silicon, manganese, sulphur, phosphorus, etc.

*Steels* are iron-carbon alloys containing up to 1.7 per cent carbon, while *cast irons* are alloys of iron with more than 1.7 per cent carbon.

The carbon content of steel or cast iron has a direct bearing on its melting point—the higher the carbon content, the lower the melting point.

Carbon content also influences the weldability of a metal. Steels grow increasingly more difficult to weld as their carbon content increases.

**Steels** may be classified in a variety of ways.

(1) By the manufacturing process—open-hearth, Bessemer, electric, etc., steels.

(2) By carbon content—low-carbon (less than 0.25 per cent carbon), medium-carbon (0.30-0.55 per cent carbon) and high-carbon (more than 0.6 per cent carbon) steels.

(3) By application—structural and tool steels.

(4) By fabrication technique—cast and rolled steels.

Engineering structures are fabricated from carbon steels which may be in sheet or plate form and in structural shapes, such as angles, I- and H-beams, channels, etc. In the Soviet Union steels are manufactured to State Standards. There are several State Standards covering steels for different uses.

Structural steel is designated with the Russian letters "Ст" (short for "Steel") followed by a numerical index which gives the approximate carbon content of a given steel grade in "points", or hundredths of one per cent. Thus Ст.1 contains up to 0.12 per cent carbon; Ст.2, up to 0.15 per cent; Ст.3, up to 0.22 per cent; Ст.4, up to 0.27 per cent, etc.

Table 1 presents some data on the composition and properties of general-purpose carbon steel.

Carbon has a marked effect on the mechanical properties of steel and cast iron. The higher the carbon content of steel or cast iron, the harder and stronger they are.

Apart from carbon, steels and cast irons contain impurities, such as sulphur, phosphorus, manganese, and silicon.

Sulphur and phosphorus are harmful impurities.

*Sulphur* makes steels red-short, i.e., brittle at high temperatures.

*Phosphorus* is responsible for cold-shortness, or brittleness at low temperatures.

Sulphur and phosphorus find their way into steel from pig iron when manufactured in open-hearth furnaces, Bessemer converters, etc.

The relevant State Standards limit the content of sulphur and phosphorus to 0.04 to 0.08 per cent, depending on the grade of steel.

*Manganese* is a useful impurity, as through its strong affinity for oxygen and sulphur, it readily combines with

Table 1

## Chemical Analyses (per cent) and Properties of Plain Carbon Steels

Steel	C	Mn	Si	S	P	Ultimate strength, kg/sq mm	Percentage elongation	Weldability
Cr. 0	Up to .23	—	—	max. .06	max. .07	32-47	18-22	Good
Cr. 1	.07-.12	.35-.50	—	.055	.05	32-40	28-33	Good
Cr. 2	.09-.15	.35-.50	—	.055	.05	34-42	26-31	Good
Cr. 3	.14-.22	.35-.65	.12-.30	.055	.05	38-47	23-27	Good
Cr. 4	.18-.27	.40-.70	.12-.30	.055	.05	42-52	21-25	Satisfactory
Cr. 5	.28-.37	.50-.80	.17-.35	.055	.05	50-62	17-21	Satisfactory
Cr. 6	.38-.50	.50-.80	.17-.35	.055	.05	60-72	13-15	Limited
Cr. 7	.50-.63	.55-.85	.17-.35	.055	.05	70-80	9-11	Poor

oxygen, reduces the iron, and withdraws much of the sulphur into the slag.

In order to increase the strength, resistance to heat and other special properties of steels (corrosion resistance and the like), certain amounts of other elements may be added to them. These additions, called alloying elements, are chromium, nickel, molybdenum, silicon, vanadium, copper, tungsten, titanium, and some other elements. Steels containing one or more alloying elements are called *alloy steels*. They are more difficult to weld, as a rule, than low-carbon steels.

In the Soviet Union alloy steels bear numerical and letter designations. Numerals on the left of the letter index indicate the carbon content of a given alloy steel in tenths of one per cent, if the carbon content is less than unity. The letters (Russian alphabet) stand as follows: "Г" for manganese, "С" for silicon, "Х" for chromium, "В" for tungsten, "Ф" for vanadium, "Н" for nickel, "М" for molybdenum, and "Е" for niobium. Numerals on the right of the letter index give the average content of the respective alloying element in per cent. Thus the designation 20XHM indicates a chromium-nickel steel containing 0.15 to 0.25 per cent carbon and less than one per cent of chromium, nickel and molybdenum.

Steel 15XФ contains up to 0.15 per cent carbon and less than one per cent of chromium and vanadium.

Steel 12X2H4 contains up to 0.12 per cent carbon, about 2 per cent chromium, and about 4 per cent nickel.

High-speed steels are obtainable in two grades, P18 and P9, the numerals showing the tungsten content in per cent.

**Cast Iron.** Besides steel, engineering construction widely uses cast iron. The general term "cast iron" includes grey, white and malleable cast iron, to name only a few cast irons.

*Grey cast iron* is obtained by allowing the molten metal to cool and solidify slowly. It presents dull-grey fracture and has most of its carbon in the form of graphite flakes. The increased silicon content is responsible for the formation of free carbon, as it prevents solution of carbon in iron. Grey cast iron is soft and is easily worked by cutting tools. It is the most widely used cast metal.

Grey cast iron is fairly easy to arc-weld provided a suitable welding procedure is followed.

*White cast iron* contains carbon in the combined form. The presence of cementite, or iron carbide ( $\text{Fe}_3\text{C}$ ), makes the metal hard and brittle, and the absence of graphite gives the fracture a white colour. White cast iron is hard to work or machine.

*Malleable cast iron* is produced by subjecting white cast iron to heat treatment in soaking pits at 800 to 950°C in which substantially all the combined carbon is converted to free or temper carbon. As a result, the metal becomes tougher. The term "malleable" is in fact inaccurate, as malleable cast iron cannot be readily hammered.

Malleable cast iron is difficult to weld due to the chilling effect in the heat-affected zone.

Engineering construction also uses special grades of cast iron, known as high-strength or inoculated cast irons. In casting them, some agents are added to the molten metal to bring about the rejection of carbon in the form of globules. While the chemical analysis of inoculated cast irons remains unchanged, their mechanical properties are appreciably improved by this treatment.

Cast irons in the Soviet Union are designated as follows: the letters (Russian alphabet) stand for the type of cast iron, such as "СЧ" for grey cast iron, "КЧ" for malleable cast iron; while the numerals indicate their mechanical properties. Thus the designation СЧ 12-28 indicates a grey cast iron with an average ultimate tensile strength of 12 kg/sq mm and an ultimate bend strength of 28 kg/sq mm. The designation КЧ 37-12 denotes a malleable cast iron with an ultimate strength of 37 kg/sq mm and an elongation of 12 per cent. МСЧ 38-60 is an inoculated cast iron with an ultimate tensile strength of 38 kg/sq mm and an ultimate bend strength of 60 kg/sq mm.

### 5. Heat Treatment of Steel

Heat treatment is an operation involving the heating and cooling of steel in the solid state, for the purpose of obtaining certain desirable conditions or properties. The temperature of heating and the rate of cooling vary accord-

ing to the metal and the purpose of heat treatment. Heat treatment changes the properties of steel as it brings about crystallographic transformations in the metal.

Some of the principal purposes of heat treatment are: (a) to increase strength, ductility, hardness and toughness; (b) to relieve internal strains and stresses; (c) to refine the grain; (d) to remove gases; (e) to normalise steel after mechanical or heat treatment.

The principal heat-treating operations are full and process annealing, normalising, hardening, and tempering.

*Annealing* is a comprehensive term which may involve the refining of the grain (as this improves the mechanical properties of steel, i.e., reduces its hardness, improves ductility and machinability), and the removal of the stresses set up by forging, casting, or welding.

The temperature of the operation depends on the carbon content of the material.

In full annealing, steel containing over 0.8 per cent carbon should be heated to 750-760°C, and steel with less than 0.8 per cent carbon to 930-950°C. This temperature should be maintained just long enough to heat the entire piece evenly throughout. The piece should then be allowed to cool slowly to room temperature (20°C). The cooling rate for carbon steels is anywhere from 100 to 200 degrees Centigrade per hour; for low-alloy steels, 50 to 60 degrees Centigrade per hour; and for high-alloy steels, even slower.

In process annealing, used mainly to relieve internal stresses and strains, the material is heated to 750-760°C, irrespective of the carbon content.

*Normalising* creates a uniform, unstressed condition of proper grain size and refinement so that the steel will properly respond to further heat treatment. It may be defined as heating the steel above the critical temperature and cooling it freely in air.

*Hardening* is employed to produce a superior hardness in the steel. The operation consists in heating the steel above the upper critical temperature and in quenching it rapidly at the rate of 150 to 200°C per second. To this end, the piece is immersed in a suitable quenching medium which may be brine, water, oil, or molten lead, depending on the steel grade and the cooling rate desired.

When the steel is quenched rapidly, a martensitic structure is obtained before the austenite is transformed into ferrite and cementite. Martensite is extremely hard, strong and brittle.

*Tempering* of fully hardened steel is carried out to relieve quenching stresses and to recover a limited degree of toughness and ductility. In tempering, the piece is heated to at least 720°C, held at this temperature for some time, and then allowed to cool. The cooling rate is of minor importance.

## 6. Surface Impregnation

Surface impregnation brings about changes in both the structure and composition of the steel. The composition of steel changes due to the impregnation of the surface layer of the heated steel by carbon, nitrogen, chromium, or aluminium. As a result, articles are produced, having a soft ductile interior and a very hard surface.

The surface-impregnation processes of importance for engineering purposes are carburising, nitriding, cyaniding, and calorising.

*Carburising* involves heating the steel to 890-930°C in contact with materials high in carbon, known as carburisers. The usual carburising compound is a mixture of birch-tree charcoal and barium carbonate. Carburisers may also be gaseous (a mixture of producer gas and benzene or natural gas) and liquid.

Carburising is followed by normalising, quenching and tempering.

*Nitriding* is carried out by heating steel to a temperature of 500 to 600°C inside a chamber through which a controlled stream of ammonia gas (consisting of nitrogen and hydrogen) is passed. The nitrogen combines with the iron to form nitrides in the surface layer, thus making it very hard.

In *cyaniding*, surface hardening of steel is produced by heating an article in a bath of molten cyanide, or by dipping it into a container of powdered cyanide, or by holding it in a cyaniding atmosphere. The surface layer is formed by the absorption of carbon and nitrogen.

*Calorising* is a process by which a coating of aluminium is produced on iron and steel. The operation is carried out at 900 to 1,050°C.

The parts to be calorised are placed in a tight box filled with a mixture of 49 per cent finely divided metallic aluminium, 49 per cent aluminium oxide, and 2 per cent sal ammoniac.

The treatment usually lasts 5 to 15 hours. Calorised steels are very heat-resistant and are very useful where direct contact with flame is unavoidable.

## 7. Nonferrous Metals and Alloys

The most commonly used nonferrous metals are copper and its alloys (brass and bronze), aluminium and its alloys, magnesium, zinc, lead, and tin.

*Copper* has a melting point of 1,083°C, is ductile, and is a good conductor of electricity and heat. Commercial copper contains up to 1 per cent impurities (bismuth, arsenic, iron, nickel, etc.). It is of reddish colour and oxidises readily (combining with oxygen when heated).

Because of its high heat conductivity and affinity for oxygen, copper is difficult to arc-weld. Copper has many uses in electrical engineering and some other industries.

Table 2 presents data on the composition of various grades of copper.

*Brass* is a copper alloy containing zinc and some other elements, such as lead, tin, aluminium, etc. Zinc percentage varies from grade to grade and may be as high as 50 per cent. The melting point of brass is anywhere from 800 to 900°C, depending on its composition. The higher the percentage of zinc, the lower the melting point of brass.

For industrial applications brass is obtainable in the form of castings, sheets, rods, tubes, etc. It is difficult to arc-weld due to the evaporation of zinc.

*Bronze* is an alloy composed mainly of copper and tin, and sometimes containing small percentages of other elements. Apart from tin bronzes, there are aluminium bronzes, manganese bronzes, etc. The melting point of bronzes is anywhere between 720 and 1,000°C. The more tin there is in a bronze, the lower its melting point. Bronzes cast

Table 2

## Composition of Different Types of Copper

Copper	Min. cop- per content	Max. content of impurities										Max. total content of impurities	Suggested use	
		Bi	Sb	As	Fe	Ni	Pb	Sn	S	O	Zn			
M0	99.95	.002	.002	.002	.005	.002	.005	.002	.005	.02	.005	.05	.05	Current con- ductors, high- purity alloys
M1	99.90	.002	.002	.002	.005	.002	.005	.002	.005	.008	.005	.1	.1	Current con- ductors, rolled shapes, non-tin bronzes
M2	99.70	.002	.005	.01	.05	.2	.01	.05	.01	.1	—	.3	.3	High-quality semi-products (except current conductors) copper-base al- loys for shaping
M3	99.5	.003	.05	.05	.05	.2	.05	.05	.01	.1	—	.5	.5	Rolled shapes of ordinary copper-base al- loys, and other cast alloys
M4	99.0	.005	.2	.2	.1	—	.3	—	.02	.15	—	1.0	1.0	Cast bronzes and non-essential alloys

well into bearings, rubbing parts, and fittings for boilers and similar equipment (cocks, valves, water gauges, etc.).

Bronzes are satisfactorily welded by the arc process.

*Aluminium* is a metal remarkable for its light weight (specific gravity 2.6) and good electrical conductivity. Its melting point is  $658^{\circ}\text{C}$ .

When molten, aluminium readily combines with oxygen to form an oxide with a high melting point (about  $2,050^{\circ}\text{C}$ ). Solid aluminium also combines with atmospheric oxygen to produce a fine oxide film on its surface.

While aluminium is valuable for many light-weight machine parts, for many other purposes it is soft and lacking in tensile strength and rigidity. In order to increase the strength, and at the same time retain the valuable property of lightness, aluminium may be alloyed with manganese, silicon, copper, magnesium, and other elements in various proportions. Strong and light in weight, these alloys are widely used in the aircraft, automotive and other industries. A more recent trend favours the use of aluminium alloys in building construction.

## Chapter II

# POWER SOURCES FOR ARC WELDING: THEIR DESIGN AND OPERATION

### FUNDAMENTALS OF ELECTRICAL ENGINEERING

#### 8. Basic Electrical Units and Laws

The basic practical units for the measurement of electrical quantities are the ampere, the volt, the ohm, and the watt.

The ampere is the practical unit of electric current or the flow of electricity around a circuit.

The volt is the practical unit of potential difference and electromotive force (e.m.f.).

The ohm is the practical unit of resistance offered to a current by conductors.

The watt is the practical unit of power.

Table 3

Symbols for Electrical Units

Quantity	Symbol	Units	
		Name	Abbreviation
Current . . . . .	$I, i$	ampere	A, amp.
Potential difference and electromotive force . . . . .	$E, e$ or $V, v$	volt	V
Resistance . . . . .	$R, r$	ohm	ohm
Power . . . . .	$P$	watt, kilowatt	W, kW

The resistance of a conductor in ohms can be found by the equation:

$$R = \frac{\rho \cdot l}{A},$$

where  $\rho$  (the Greek letter "rho") is the resistivity of the conductor;  $l$  is the length of the conductor in metres; and  $A$  is the cross-sectional area of the conductor in square mm.

Electric resistivity ( $\rho$ ) is the resistance, in ohms, of a conductor of a given material (copper, aluminium, steel, etc.) 1 metre long and 1 square mm in cross-section at 0°.

Electric power is the product of a current and a voltage ( $P=VI$ ). One watt is the amount of energy expended per second by an unvarying current of one ampere under a voltage of one volt. In engineering, it is customary to measure power in kilowatts (1 kW=1,000 watts).

The expenditure of electric energy is expressed as the product of power and time and is measured in kilowatt-hours (kWh for short).

The basic law of an electric circuit is Ohm's law which may be expressed as follows:

$$I = \frac{V}{R},$$

where  $I$  is the current in amperes,  $V$  is the potential difference in volts, and  $R$  is the resistance in ohms.

Circuits may have conductors connected in series, in parallel, and in series-parallel.

When the conductors in a circuit are connected in series, the equivalent resistance of the circuit is equal to the sum of the resistances of the individual conductors.

If the resistances of conductors connected in parallel are equal, the total resistance of the circuit will be equal to the resistance of one conductor divided by the number of conductors in the combination.

In a series-parallel circuit some of the conductors are in series and some in parallel.

Sources of electric energy (generators, dry-cell batteries and storage batteries) can also be connected in series or in parallel.

When electric energy sources are arranged in series, the

positive side of one source must be taken to the negative side of another. The voltage around the circuit will then be equal to the sum of the voltages of the sources connected in series.

In a parallel arrangement of electric energy sources the voltage around the circuit will not increase but remain equal to the voltage of a single source. The current in the circuit will be the sum of the currents of the sources connected in parallel.

Electric energy sources are connected in series when the desired voltage exceeds that of a single source.

Parallel arrangement of energy sources is resorted to when the circuit must deliver a larger current than one source can supply.

In welding, power sources are often connected in parallel for operation with heavy currents.

### 9. *Thermal and Chemical Effects of Electric Current*

When a current is passed through a solution of salt, acid or alkali, or through molten salt, the solution decomposes into its constituents. This is known as *electrolysis*.

If water is poured into a jar, to which is added a certain amount of acid, alkali, or salt, and an electric current is passed through, bubbles will soon appear at the electrodes. At the cathode (the “—” electrode) the gassing will be more violent than at the anode (the “+” electrode). As a result, the passage of current through the water will decompose it into hydrogen and oxygen—its components. Hydrogen is evolved at the cathode. As there is more hydrogen in water than oxygen, more bubbles appear in the solution at the cathode.

This property is used by welders in determining the polarity of d.c. welding generators.

The electrochemical effect is the basis of electroplating, i.e., the deposition of a layer of metal on metal objects and of galvanoplasty, i.e., producing precise replicas of objects.

Primary cells and storage batteries also depend for their action on the chemical effect of electric current.

Metals and other solid conductors have free or roaming electrons in addition to those of the molecules of a conduc-

tor. The molecules are always in motion. The higher the temperature of a body, the quicker the motion of the molecules. When an e.m.f. is applied to a conductor, the free electrons collide with the molecules and lose part of their momentum. This loss accounts for the Joulean heat set free in all conductors.

This property is utilised in incandescent lamps. The amount of heat thus dissipated depends on the electrical resistance of a conductor and the current passing through it.

The law governing the thermal effect of electric current was first formulated by E.H. Lenz of Russia.

The quantity of heat developed in a conductor is:

$$H=0.24I^2Rt \text{ calories,}$$

where  $t$  is time in seconds.

The equation can be rewritten as:

$$H=0.24IIRt.$$

From Ohm's law,  $IR=V$ , hence:

$$H=0.24IVt \text{ calories.}$$

**Example:** An electric arc maintained for 1 hour at  $I=200$  A and  $V=20$  V will produce the following amount of heat:

$$H=0.24 \times 200 \times 20 \times 3,600 = 3,456,000 \text{ cal} = 3,456 \text{ kcal.}$$

The thermal effect of electric current is utilised in fuses. The greater the cross-sectional area of a conductor, the greater the load current it can carry without overheating.

Each type and size of conductor has a definite current-carrying capacity. If this is exceeded, the conductor will become dangerously hot if not insulated, or, if insulated, the insulation may deteriorate due to heat. An excessive current may appear in a circuit when it is overloaded, i.e., too many electrical machines are connected to it, or the circuit is shorted somewhere.

A *short circuit* is an accidental fault in electric wiring when the current is allowed to flow without going through high resistances.

To protect electric circuits from overloads and short circuits, fuses are used; these are fine wires of suitable alloys, worked into a porcelain plug or clamped between

two screws on a porcelain tube. An overload or a short circuit will cause the wire, or fuse link, to blow, and the circuit will open.

## 10. Electromagnetism

Some grades of iron ore can attract iron and steel objects. Such ore is called magnetite, or magnetic iron ore. Once acted upon by magnetic forces, iron and steel also become magnetic, i.e., can attract other pieces of iron or steel. They become artificial magnets, as distinct from natural magnets—magnetites.

The pull of a magnet is strongest at its ends—the *poles of a magnet*. The imaginary line connecting the centres of the two poles is called the *axis of a magnet* (Fig. 5).

If a magnet in the form of a small needle is suspended by a thread, the needle will always take up a definite position relative to the earth's poles, so that its axis coincides with the magnetic axis of the globe. This property of a magnetic needle is used in the magnetic compass—a device which indicates direction to the earth's poles.

By tradition, the north-seeking end of a magnet is called the North pole (designated by the letter N), and the south-seeking end, the South pole (designated by the letter S). The space around a magnet where magnetic forces are at work is called the *magnetic field*.

A magnetic field may be represented by lines, called magnetic lines of force, which emerge from the North pole and enter the South pole. These lines are continuous, i.e., have neither beginning nor end (Fig. 5).

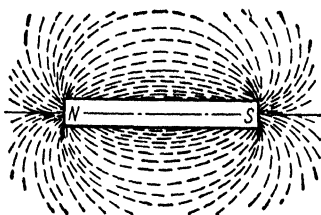

Fig. 5. A magnet

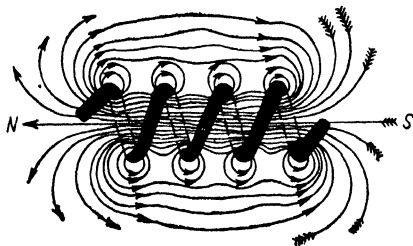

Fig. 6. A solenoid

When an electric current is passed through a conductor, a magnetic field is set up around it. Its presence can be detected by means of a magnetic needle suspended by a thread. When brought close to a current-carrying conductor, the needle will tend to set itself at right angles to the conductor.

If a conductor is wound into a helix, its magnetic field becomes many times stronger than that of a straight conductor. This is because the magnetic fields of all turns are added together to produce a total field. Such conductors are called *solenoids* (Fig. 6).

When a soft iron core is placed inside a solenoid, the latter becomes an *electromagnet* (Fig. 7).

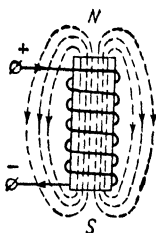

Fig. 7. An electromagnet

## 11. Electromagnetic Induction

Just as an electric current gives rise to a magnetic field, a magnetic field, under certain conditions, can induce an electric current.

If a conductor is moved in a magnetic field so that it cuts across the magnetic lines of force, an e.m.f. will be induced in the conductor. If the conductor is a completed circuit, an electric current will flow in it. This phenomenon is called *electromagnetic induction*.

This will also take place if a conductor is stationary and the magnetic field around it is made to vary. In this case, too, an e.m.f. will be generated in the conductor.

If two coils of wire, 1 and 2, are placed side by side (Fig. 8) and an electric current is passed through one of them (2) and then the other coil (1) is moved towards or away from the coil 2 an e.m.f. will be induced in the coil 1. An e.m.f. will also be generated in the coil 1 if the two coils are left stationary, while the cur-

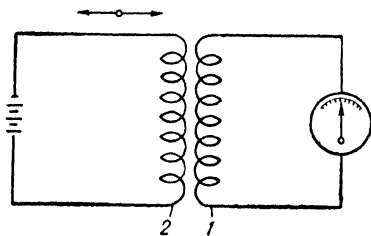

Fig. 8. Mutual induction

rent in the coil 2 is varied or the coil itself is alternately opened or closed. This is called *mutual induction*.

If the current in a conductor is varied, or the supply circuit is alternately opened and closed, the magnetic field around the conductor will also change. With the change, the magnetic field will cut across the conductor to induce an e.m.f. in it. This is called *self-induction*, and the e.m.f. thus generated is known as the *e.m.f. of self-induction*. This e.m.f. is proportional to the time rate of change of the magnetic flux.

## 12. General Principles of D. C. Generators

Electromagnetic induction is the basis of the operation of electric generators. This is shown in Fig. 9. On a cylinder, called the *armature*, is wound a conductor the ends of which are connected to a lamp. The armature is rotated between two magnets which set up a magnetic field. The wire wound on the armature cuts across the magnetic field, and an e.m.f. is induced in the wire. Fig. 9 shows a generator diagrammatically.

The e.m.f. induced in the winding of the rotating armature is transmitted into an external circuit by means of a commutator (Fig. 10). The commutator 2 consists of copper segments or bars insulated from each other by mica. The segments make up a cylinder of a smaller diameter than the armature 3. The commutator is seated on the armature

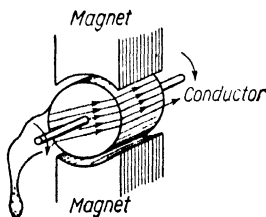

Fig. 9. Diagram of a generator

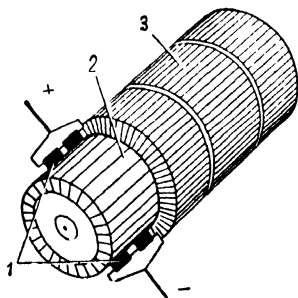

Fig. 10. Armature and commutator

shaft or hub, and the leads of the armature winding are soldered to the commutator segments. Riding on the commutator are two carbon brush assemblies *1*, placed stationary and opposite each other. Wires connect the brushes to the external circuit.

Apart from transmitting the e.m.f. induced in the armature into an external circuit, the commutator also rectifies the alternating current induced in the armature winding into a direct current fed into an external circuit. This operation of a commutator merits a more detailed discussion.

Fig. 11 shows a diagram of an electrical machine whose armature only carries two conductors (*1-1* and *2-2*). For simplicity, the armature core is omitted. The front end of each conductor is connected to a separate ring. The conductor *1-1* is soldered to one ring *3*, and the conductor *2-2*, to the other ring *4*. The rear ends of the two conductors are connected by a conductor *1-2* to form a turn, *1-1-2-2*. The turn and rings rotate together about axis *AB* between the poles *N* and *S*. The brushes *a* and *b*, connected to the lamp *L*, are stationary and ride the rings.

The relative direction of flux, e.m.f. and conductor motion in a magnetic field may be determined by Fleming's right-hand rule. The thumb, index and middle fingers must be placed so as to form the three axes of a co-ordinate system; the index finger must then be pointed in the direction of the flux (North to South) and the thumb in the direction of conductor motion; the middle finger will give the direction of the induced e.m.f.

With the turn *1-1-2-2* rotating in the direction indicated by the arrow, the e.m.f. generated in the conductor *1-1* placed under the North pole (Fig. 11*a*) will be directed from left to right, while the e.m.f.s in the conductor *2-2* under the South pole will be directed from right to left. As the end of the conductor *1-1* is connected to the beginning of the conductor *2-2* (series connection), the e.m.f.s of the two conductors will coincide, and the aggregate e.m.f. of the turn will be twice that of each conductor.

With the e.m.f. directed as above, the current in the circuit will flow as indicated by the arrows, i.e., the brush at *a* will be positive (the current leaves the machine), and

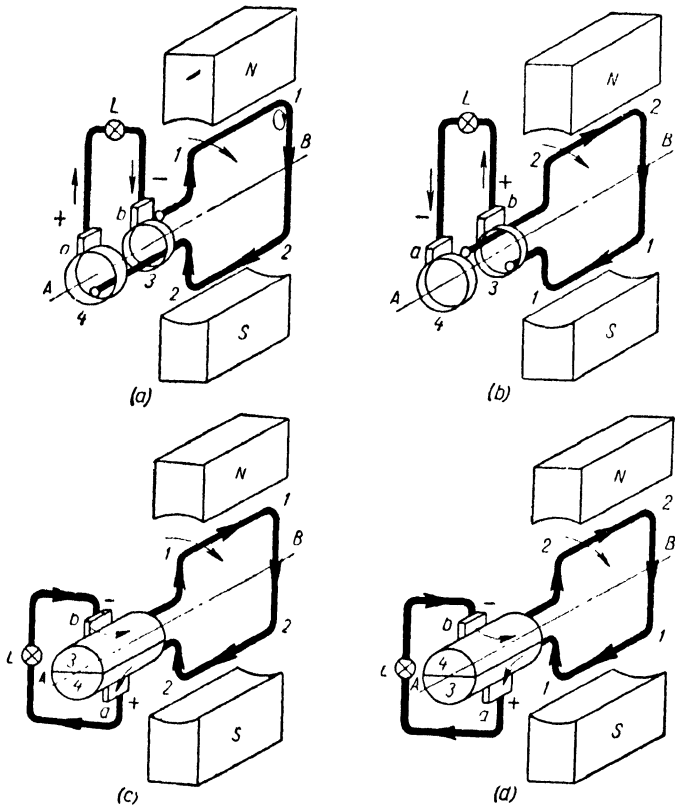

Fig. 11. Operating principle of a commutator.

the brush at  $b$  will be negative (the current enters the machine).

When the turn rotates through  $180^\circ$ , i.e., when the conductor  $1-1$  is under the South pole, i.e., and the conductor  $2-2$  is under the North pole (Fig. 11*b*), the e.m.f. reverses from a given value in one direction to the same value in the opposite direction. In the conductor  $1-1$  it will now be directed from right to left, and in the conductor  $2-2$ , from left to right. The direction of the load current will

also change, and the brush at  $a$  will be negative, while the brush at  $b$  will be positive.

The polarity of the brushes will change again when the turn has rotated through another  $180^\circ$ , and so on every  $180^\circ$ .

The current which reverses cyclically is termed an *alternating current*, as distinct from a *direct current* whose direction remains constant.

To obtain a direct current the slip rings of a generator are replaced by a commutator.

The leads of the turn  $1-1-2-2$  are now connected to the commutator bars. In our example there will only be two bars in the commutator insulated from each other by a layer of mica.

Fig. 11c is similar to Fig. 11a, except that the two slip rings are replaced by a commutator of two bars, 3 and 4, soldered to the conductors  $1-1$  and  $2-2$ , respectively. Each commutator bar is in contact with a brush ( $a$  or  $b$ ), which is connected to a circuit containing a lamp. As is shown in Fig. 11c, the current in the conductor  $1-1$  flows from left to right, and in the conductor  $2-2$ , from right to left. With this distribution of current in the armature conductors, the commutator bar 4 is positive, as is the brush  $a$  which collects current from the bar 4. The brush  $b$  rides the commutator bar 3 receiving the current from the external circuit; the brush  $b$  therefore is negative. In Fig. 11d the coil has rotated through  $180^\circ$  and the conductors  $1-1$  and  $2-2$  have changed places. The commutator bars 3 and 4 have changed their polarity and brushes, as the latter have remained stationary. When negative, the bar 3 is in contact with the brush  $b$ , and when positive, with the brush  $a$ . When positive, the commutator bar 4 touches the brush  $a$ , and when negative, it comes in contact with the brush  $b$ . Thus, with a commutator, the polarity of the brushes remains unchanged and a direct current circulates in the external circuit.

Fig. 12 shows a d.c. generator. In order to obtain strong magnetic fields, the pole cores carry coils wound with an insulated wire and connected to a source of current, thus making up magnets. These coils are called *field coils*, as they provide the magnetic field to excite the generator, without which no e.m.f. can be induced and no current

can be obtained. The current for the field coils is supplied by the generator itself, and the generator is said to be *self-excited*. The dotted lines in Fig. 12 show the distribution of magnetic fluxes.

Two circuits branch off from the brushes: an external circuit, and the field circuit. When the armature is sta-

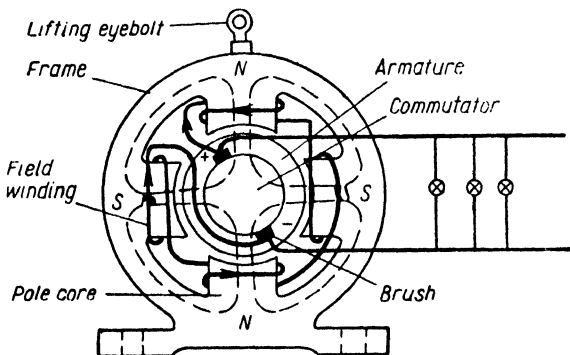

Fig. 12. D.c. shunt-wound generator (as viewed from the commutator end)

tionary, no current flows in the field windings, but the cores retain a weak magnetic flux (residual magnetism) which induces an e.m.f. when the generator starts up. As soon as an e.m.f. is induced, however small it may be, a current begins to flow in the field winding to restore the magnetic flux in the poles.

For a generator to produce a current, the armature must be actuated by a prime mover. The prime mover can operate on steam, oil, water (hydraulic turbines), wind, electric power, etc. Thus an *electric generator converts mechanical energy into electric energy*.

### 13. Operating Principle of D. C. Motors

When placed in a magnetic field, a current-carrying conductor tends to move at right angles to that field. This is because the magnetic field set up around the conductor interacts with the main field.

This principle is the basis of the operation of d.c. motors. As far as construction is concerned they are identical with d.c. generators. An ordinary d.c. generator will operate satisfactorily as a motor if, instead of rotating its armature, a current is passed through the armature. In other words, an *electric motor converts electric into mechanical power.*

#### 14. Alternating Current and Its Generation

An *alternating current* is a current that alternates cyclically in direction and magnitude.

The alternating current employed in industry and in the home reverses cyclically according to a sine function.

A sine function may be presented graphically in the following manner (Fig. 13). Let the vector  $OA$  represent, to scale, an e.m.f. or a current, and rotate counter-clockwise round the point  $O$ . The end of the vector will

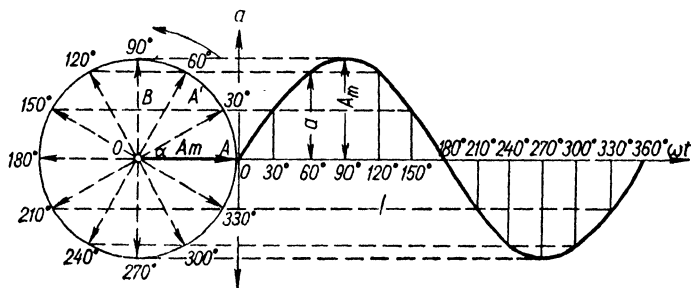

Fig. 13. Sinusoidal current

describe a circle. Depending on the angle of rotation  $\alpha$  the projection of the vector  $OA$  on the  $Y$ -axis will be

$$OB = OA' \cdot \sin \alpha = OA \cdot \sin \alpha.$$

When  $\alpha = 90^\circ$ ,  $\sin \alpha = 1$ . Therefore, the projection of the vector  $OB = OA$ . When  $\alpha = 180^\circ$ ,  $\sin \alpha = 0$ , and  $OB = 0$ . When  $\alpha = 270^\circ$ ,  $\sin \alpha = -1$ , and  $OB = -OA$ .

The angle through which the vector moves per unit time is the angular velocity of the vector; its symbol is  $\omega$  (the Greek letter omega).

The time required for a variable (e.m.f., voltage, or current) to build up from zero to its maximum, then drop gradually back to zero, and pass through the same increase and decrease in the opposite direction is called a period and is denoted by the letter  $T$ . A period is measured in seconds. The complete set of these events during a period is called a cycle.

The number of cycles per second is called the frequency of an alternating current and is denoted by the letter  $f$ .

The period and the frequency are reciprocals, i.e.,

$$T = \frac{1}{f} \quad \text{and} \quad f = \frac{1}{T}.$$

During one cycle the vector  $OA$  moves through an angle  $\alpha = 2\pi$ , or a complete circle. Therefore, its angular frequency will be

$$\omega = \frac{2\pi}{T} \left[ \frac{1}{\text{sec}} \right].$$

As  $\frac{1}{T} = f$ , then

$$\omega = 2\pi f \left[ \frac{1}{\text{sec}} \right].$$

During the time  $t$  the vector will move through an angle

$$\alpha = \omega t = 2\pi f t.$$

The angle  $\alpha$  is called the *phase angle* or simply the *phase*.

Just as in Fig. 13 the vector  $OA$  expresses, to scale, a quantity  $A_m$  (e.m.f. or current); the instantaneous value of the quantity as a function of the angle of rotation will thus be

$$a = A_m \cdot \sin \alpha = A_m \cdot \sin \omega t.$$

In order to find the sine curve it is necessary first to determine the instantaneous values of the quantity as the projections of its vector  $A_m$  on the vertical axis (Fig. 13); then to lay off the angle of rotation of the vector  $A_m$

---

<sup>1</sup> In engineering it is customary to measure angles in radians. A radian is the angle at the centre of a circle which embraces an arc equal in length to the radius of the circle. The length of a circle is  $C = 2\pi R$ . Therefore a circle contains  $\frac{2\pi R}{R} = 2\pi$  radians.

away from the horizontal axis counterclockwise (on the right in Fig. 13) on the horizontal axis. Now the projections of the vector  $A_m$  on the vertical axis, i.e., the instantaneous values of a given quantity (e.m.f. or current) must be laid off on the Y-axis. The curve drawn through the ends of the lines representing the instantaneous values of the quantity will be a *sine curve*.

Standard frequency in the Soviet Union is 50 cycles.

Alternating current is produced by generators which, as distinct from d.c. generators, have no commutators and use a rotating field, i.e., rotating poles, and stationary armature winding, i.e., the winding in which an e.m.f. is induced.

### 15. Resistance of an A.C. Circuit.

#### *Ohm's Law for A.C. Circuits*

In an alternating-current circuit, apart from the resistance of the conductor, the current has to overcome the effects of inductance and capacitance.

When an alternating current is passed through a conductor, an alternating magnetic field is set up around it, inducing an e.m.f. of self-induction in the conductor (see Sec. 11). This e.m.f. of self-induction acts against the e.m.f. of the circuit. That part of the circuit voltage which goes to overcome (balance) the e.m.f. of self-induction is called the inductive voltage drop.

The e.m.f. of self-induction is

$$E_L = \omega LI = 2\pi f LI,$$

where  $L$  is the inductance of the circuit, in henries, and may be expressed as  $L = \frac{\Phi}{I}$  ( $\Phi$  is the magnetic flux).

Assuming that  $2\pi f L = X_L$  gives

$$E_L = X_L I.$$

High values of inductance are usual in coils, generator windings and other conductors setting up heavy magnetic fluxes when traversed by an alternating current.

Ohm's law for alternating-current circuits possessing an inductance can thus be expressed as follows:\_\_\_\_\_

$$I = \frac{E_L}{X_L} = \frac{V_L}{X_L},$$

where  $V_L$  is the voltage across the circuit possessing an inductance; and  $X_L$  is the inductive reactance.

For an alternating-current circuit possessing a capacitance<sup>1</sup> Ohm's law will be

$$I = \frac{V_C}{X_C},$$

where  $V_C$  is the voltage across the circuit possessing a capacitance ( $V_C$  is also termed the capacitive voltage drop), and  $X_C$  is the capacitive reactance of the circuit.

Inductive reactance ( $X_L$ ) varies directly with the frequency of an alternating current, and capacitive reactance varies inversely with the frequency.

#### *16. A. C. Circuits Containing Resistance, Inductance and Capacitance. Volt-amperes and Power Factor*

When an alternating-current circuit contains only resistances (incandescent or arc lamps, short straight conductors), the voltage and current are in phase.

Should an alternating-current circuit contain both resistance and inductance in series, the current will lag behind the voltage by an angle varying with the ratio of the inductance to the resistance.

If an alternating-current circuit incorporates resistance and capacitance in series, the current will lead the voltage.

In an alternating-current circuit containing resistances, inductances and capacitances in series, the phase angle between the current and voltage will depend on the ratio of the three parameters.

In alternating-current circuits, both the current and the voltage vary rapidly and may not pass through their maximum and minimum values simultaneously. Therefore, the power may have both positive and negative values in

---

<sup>1</sup> Capacitance is the property of conductors to store and retain an electric charge. It is denoted by the letter  $C$ . The unit is the farad ( $F$  or  $f$ );  $\mu F$  is one-millionth of a farad.

each cycle. For this reason the average power for a sinusoidal alternating current will be given by the expression

$$P=VI \cos \varphi,$$

where  $\varphi$  is the phase angle or time displacement between current and voltage expressed in electrical degrees.

With resistance only in a circuit, the current and the voltage, as has been noted, are in phase with each other. Therefore the phase angle  $\varphi$  is zero, and  $\cos \varphi=1$ . Then the true power will be:

$$P=VI,$$

i.e., the true power of an a.c. circuit containing resistance only is equal to the power of a d.c. circuit.

$\cos \varphi$  is termed the power factor (P.F. or p.f. for short).

$$\text{The power factor} = \frac{\text{true power } P \text{ (watts)}}{\text{apparent power } VI \text{ (volt-amp.)}}$$

The true power is always less than the apparent power. The apparent power is the vector sum of the true power and the reactive power.

With a resistive load only in an a.c. circuit, the apparent power is the true power, and the power factor is unity.

The greater the true component in the apparent power, the less the difference between the numerator and the denominator, and the closer the power factor is to unity.

Reactive power in power systems should ordinarily be made as low as possible. The lower the power factor in a line, the greater the power that must be provided at the supplying power station, as the efficiency of generators and transformers drops with decreasing  $\cos \varphi$ .

A decrease in the power factor results in heavier power losses in line wires; to reduce them the cross-sectional area of wires has to be increased. For this reason every effort must be made so as to make the power factor as high as possible.

It should be noted that welding transformers have a rather low power factor due to the fact that they incorporate coils having high inductive reactances ( $X_L$ ). Welding

transformers, therefore, must not have power ratings higher than is necessary for the performance of the assigned job. Nor should they be run at no-load for a long time.

### 17. Three-phase Current

If the coils on the armature of an a.c. generator are spaced  $120^\circ$  apart, the generator will produce a three-phase current (Fig. 14). As each coil has two leads, a three-phase system will have six wires (1, 1', 2, 2', 3, 3'). Such a system is obviously too cumbersome. To simplify it, the coils of a three-phase generator are connected as shown in Figs. 15 and 16. The arrangement in Fig. 15 is termed the *star* connection. In the star connection the ends of the three coils spaced  $120^\circ$  apart meet at a common point, *O*, whence one wire, instead of three, is taken to the system. The beginnings of the same coils (1, 2, 3) are left as the terminals of a 3-phase star system. Thus, instead of six, the system has four wires. The wire running from the common point *O* is called the *neutral*, as in the case of a balanced load on the three phases (1, 2, 3) no current will flow in it.

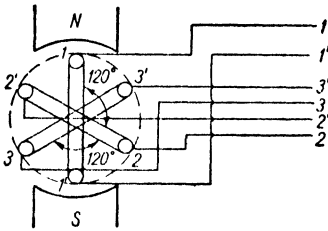

Fig. 14. Generator with three armature windings spaced  $120^\circ$  apart

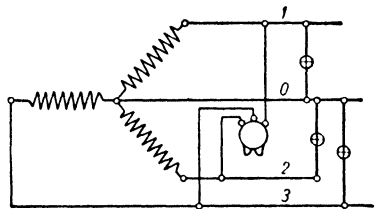

Fig. 15. Windings connected in a star

In the *mesh* or *delta* connection (Fig. 16) the end of a coil is connected to the beginning of another coil, and the common points form the terminals of a 3-phase delta system. This system has only three wires.

In the star connection, the wires running from the beginnings of the coils are called the *phase* wires. The voltage

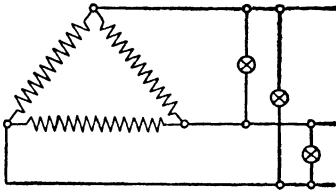

Fig. 16. Windings connected in a delta

between any two phase wires, or line voltage, is 1.73 times phase voltage, i.e., the voltage between any phase wire and the neutral. This system is convenient in that a power load can be connected for a higher voltage, i.e., between the phase wires, while lighting and other household loads can be connected for a lower voltage,

i.e., between a phase wire and the neutral (see Fig. 15). This reduces the danger of accidents due to a current shock.

In practice currents of 127/220 V and 220/380 V are mainly used.

In the delta connection, the line voltage is equal to the phase voltage.

In a three-phase system the power is:

$$P = 1.73 VI \cos \varphi \text{ (watts),}$$

where  $I$  and  $V$  are the line current and the line voltage, respectively.

### 13. The Revolving Magnetic Field

When three coils ( $I$ ,  $II$ ,  $III$  in Fig. 17) spaced  $120^\circ$  apart are energised by a three-phase current, they set up a revolving magnetic field—a phenomenon underlying the operation of three-phase motors.

The current traversing each coil sets up a magnetic flux which varies precisely as the current does, i.e., to a sine function, and the changes in the magnetic fluxes are displaced by  $120^\circ$  in time. The three magnetic fluxes com-

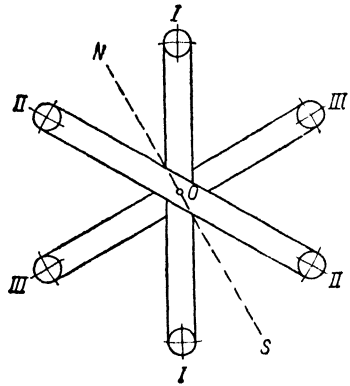

Fig. 17. Diagram of a three-phase winding

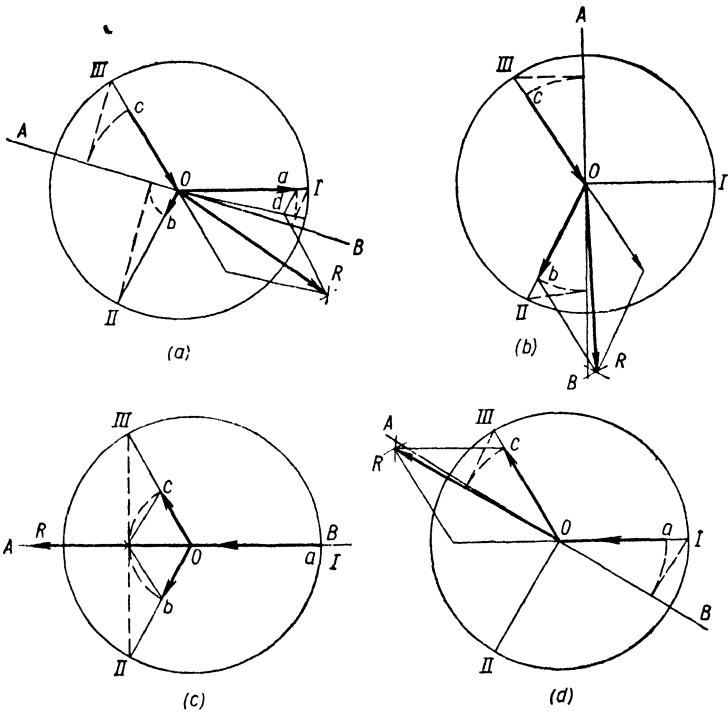

Fig. 18. Vector diagrams of a three-phase revolving magnetic field

bine together to produce a magnetic flux, constant in magnitude but revolving in space, as if a two-pole magnet were rotated around the centre of the winding.

This is better demonstrated by Fig. 18 which shows four consecutive diagrams of a three-phase revolving field. The vectors marked *I*, *II* and *III* show the direction of the magnetic fields in the three coils spaced  $120^\circ$  apart.

The line *AB* marks an instance, and the magnitudes of the magnetic fluxes are determined at this instance. This is done by projecting on *AB* vectors *I*, *II* and *III*, representing the directions and maximum magnitudes of the magnetic fluxes in each phase. The values obtained are then laid off on vectors *I*, *II* and *III* and added together as forces are

combined in mechanics, taking into account the directions of the fluxes.

The instantaneous values of fluxes  $I$  and  $II$ , represented by the vectors  $oa$  and  $ob$ , are added (Fig. 18a). The resultant vector  $od$  is then added to the vector  $oc$  representing the instantaneous value of magnetic flux  $III$ . The resultant vector  $OR$  represents the resultant magnetic flux of the three-phase coils displaced by  $120^\circ$  both in magnitude and in direction.

The same procedure is followed for other instances (Fig. 18b, c and d). Then the three vectors of instantaneous values are added to give the resultant vector  $OR$ , constant in magnitude but revolving around the point  $O$ . Thus, three coils displaced by  $120^\circ$  and energised by a three-phase current set up a *revolving magnetic field*.

### 19. A.C. Three-phase Motors

An a.c. motor (Fig. 19) has two windings, one being carried by the stator (the stationary part, or yoke, of the motor) and the other carried by the rotor (the moving part of the motor).

The stator carries a three-phase winding connected to a three-phase mains. The winding produces, therefore, a

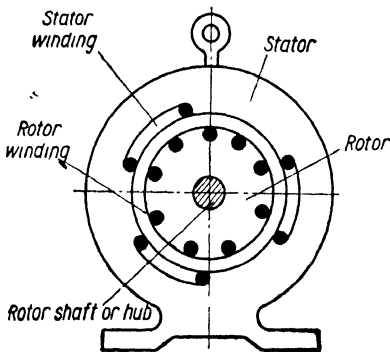

Fig. 19. Construction of a three-phase electric motor

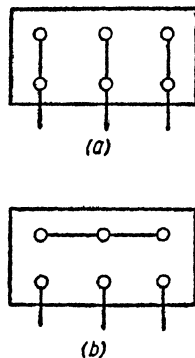

Fig. 20. Motor terminals connected in a delta (a) and in a star (b)

revolving magnetic field, moving through the stator and inside the space bounded by the stator. The shaft within the stator carries the rotor whose slots receive conductors. The revolving magnetic field of the stator cuts across the rotor conductors and induces an e.m.f. in them. The resultant current sets up a magnetic flux around the rotor winding, which interacts with the magnetic flux of the stator, thus setting the rotor in motion.

The stator winding may be either star- or delta-connected, and one and the same motor can be run at two voltages. If the stator winding is designed for 127 V when delta-connected, it may run from 220 V mains when connected in star.

A three-phase motor has a terminal panel where the leads of the three coils are brought out. The panel carries six terminals in all, three of which receive connections from a three-phase power mains, while the remaining three are connected either in a star or in a delta, depending on the duty to be performed by the motor. To obtain the delta connection, each upper terminal is linked with each lower terminal (Fig. 20*a*). For the star connection, the three upper terminals are made common (Fig. 20*b*).

The rotor winding may be either short-circuited (as in squirrel-cage motors), or connected across a resistance by means of rotating rings and brushes to reduce the current in the rotor at starting (as in slip-ring motors). As the rotor is brought up to speed, the rate at which its conductors cut across the magnetic flux of the stator is reduced and the current induced in the rotor winding drops.

Squirrel-cage rotors are usually employed in small motors. Both types may be encountered in welding equipment.

Motors are coupled to the driven machines by means of either V-belts or couplings provided at the ends of the motor and machine shafts. In some welding machines the motor and the generator have a common shaft.

## 20. Transformers

Electromagnetic induction, i.e., the generation of an e.m.f. in a conductor, takes place both when the conductor cuts across magnetic lines of force and when a stationary

conductor is placed in an alternating magnetic field, i.e., a field which changes cyclically in direction and magnitude.

Such an alternating magnetic field is set up around a conductor carrying an alternating current.

This property is utilised in *transformers*—devices transforming energy at low voltage to energy at high voltage, or vice versa; in like manner, a current of a given value in one circuit may be transformed into a current of another value in a different circuit.

A transformer (Fig. 21) consists essentially of an iron core and two windings wound upon the core with insulated wire. One of the windings is connected to the supply line and is called the *primary* ( $I$  in Fig. 21). The other winding delivers the desired voltage (or current) and is referred to as the *secondary* ( $II$  in Fig. 21).

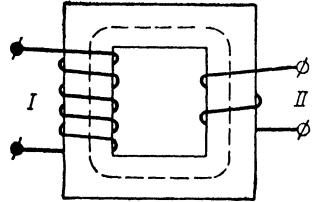

Fig. 21. Diagram of a transformer

When an alternating current is passed through the primary, an alternating magnetic flux is produced in the iron core. This flux links both the primary and the secondary (as shown by dotted lines in Fig. 21) and induces an e.m.f. in the secondary by its rate of change, i.e., by virtue of electromagnetic induction. The e.m.f. thus induced is directly proportional to the number of turns in the winding.

In a step-up transformer, the primary has fewer turns than the secondary, while in a step-down transformer the opposite is the case.

Welding transformers are of the step-down type. Fig. 21 shows a transformer diagrammatically. In practice, the primary and the secondary are each wound on both limbs of the core.

A transformer connected into a d.c. circuit will not operate because the non-alternating magnetic flux set up in the core will not induce any e.m.f. in the secondary.

## 21. Electrical Instruments

Voltage and current are measured by voltmeters and ammeters respectively. They are identical in the principle of operation, but differ in the calibration of scales, size of coils, and connection into the circuit.

All electrical instruments can be classed by design and the electrical principle employed. They can be moving-coil,

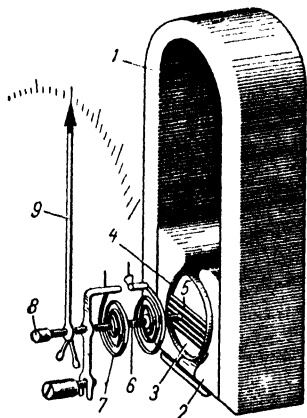

Fig. 22. Sketch of a moving-coil instrument

two small, flat, coiled springs 7 which also serve to conduct the current to the coil.

When the unknown current (or voltage) is fed into the coil 5, the interaction of the magnetic field around the coil and the fixed magnetic field of the permanent magnet causes the coil to deflect in proportion to the current in the coil.

In current measurements ammeters are connected in series with the circuit, as the total current must pass through the instrument to give the correct reading.

moving-iron, electrodynamic, hot-wire, thermocouple, induction and other types.

Fig. 22 shows a sketch of a moving-coil instrument.

A horseshoe-shaped magnet 1, produces a magnetic field. The ends of the magnet have pole pieces 2. The steel core 3, placed between the pole pieces, reduces the reluctance of the air gap. The core carries a light aluminium frame 4 wound with a coil 5. The shaft 6 of the frame is carried by bearings 8. The pointer 9 attached to the shaft 6, travels over a graduated scale.

The motion is restrained by

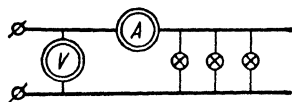

Fig. 23. Connection of an ammeter and a voltmeter into a circuit

In voltage measurements voltmeters are connected across the circuit, i.e., to the two wires of a system (Fig. 23).

## THE ELECTRIC ARC

### 22. Electric Properties of the Arc

An electric arc is an electric discharge in gases, accompanied by high heat and a bright glow.

An electric arc is formed when two conductors of an electric current (i.e., electrodes) are brought together to make electrical contact, and then separated. This introduces a considerable resistance to the flow of the current and the tips of the electrodes are raised to a high temperature, as is the air gap between them.

The electrons emerging from the negative electrode collide with the molecules and atoms of air, breaking them up into ions and free electrons and causing the air gap to become a conductor of electricity due to ionisation. This maintains the current through the air gap and sustains the arc. |

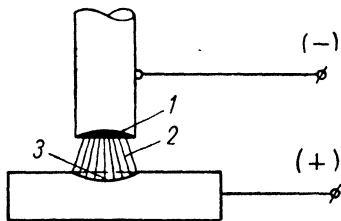

Fig. 24. Diagram of an electric arc

For an arc to strike, a higher voltage is necessary than to maintain it because some of the voltage goes to ionise the air gap.

An electric arc is made up of the following regions (Fig. 24): the cathode space 1 where electrons break away from the cathode towards the anode (the surface of the cathode space is called the cathode spot); the arc stream 2 which is nearly as long as the arc and where the atoms and molecules of air are ionised; and the anode space 3 where positive ions concentrate themselves.

To maintain an arc, the electrodes must be at a potential which depends on the material of the electrodes, the length of the arc, the gas in the gap, and the current of the arc.

The voltage across an arc can be graphically related to the current of the arc. The arc current must be plotted on the X-axis, and the respective arc voltage on the Y-axis, while a smooth line should be drawn through the points of intersection, as shown in Fig. 25. This line is called the *static characteristic* or *volt-ampere curve* of an arc. Referring to the chart, it will be seen that the voltage across

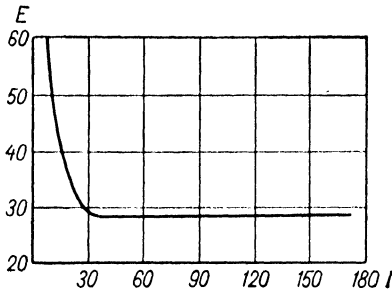

Fig. 25. Static (or volt-ampere) characteristic of an electric arc

the arc drops at first to about 30 V as the current rises. The further increase in the current does not appreciably affect the voltage across the arc.

Fig. 25 shows a drooping characteristic typical of arcs with low current densities in the electrode (of the order of 50 to 60 A/sq mm). At high current densities (upwards of 100 A/sq mm)

the volt-ampere characteristic may be flat (the voltage remains constant as the current increases) or rising (the voltage increases with the current). This is typical of shielded arc welding with small-size electrodes and of automatic submerged-arc welding with large currents.

The electric arc is an extremely flexible conductor which may be deflected by a variety of factors. Normally, the arc stream is oriented along the axis of the electrode, rather than along the shortest distance between the electrode and the work.

The space around the arc and in the adjacent metal is always threaded by magnetic fields which tend to deflect the arc. This is known as *arc blow*.

Arc blow may considerably hamper welding, especially when large currents are used, as the magnetic field intensity is directly proportional to the square of the current: doubling the current will increase the associated magnetic field four times.

A magnetic field tends to deflect an arc when it is not

uniformly distributed relative to the arc. The distribution of a magnetic field in the welding circuit depends on where the ground is positioned on the workpiece, the shape of the workpiece, presence of a gap at the joint, and certain other factors.

In Fig. 26 the arc is deflected to the right because the magnetic field is stronger at *A*.

Arc blow is less pronounced with heavily coated electrodes and in submerged-arc welding than with bare or washed electrodes. This is also true of welding with alternating current.

The action of this magnetic phenomenon can be corrected by using a short arc, as a longer arc is more likely to waver from its intended path; by placing the ground as close as possible to the weld; by pointing the electrode tip in the direction of arc blow; and by varying the angle between the electrode and the work, depending on the intensity and direction of arc magnetism.

The arc will also tend to waver from the intended path under the action of appreciable ferromagnetic mass, should any be placed near the arc. The force of electromagnetic attraction between the arc and the iron will tend to bring them together. As a result the arc will waver towards the iron.

The arc stream may also be deflected by hot gases produced in welding. This is particularly pronounced in welding vertical walls, through holes, and the first bead of a butt weld.

### 23. *Welding Properties of the Arc*

In metal-arc welding (the Slavianoff process), the arc is maintained in a gas gap filled with vapours of electrode metal, electrode coating, or flux. The parent metal in the path of the arc is melted forming a pool of molten metal. The electrode metal is also melted and is transferred into the metal pool in the form of globules of molten metal.

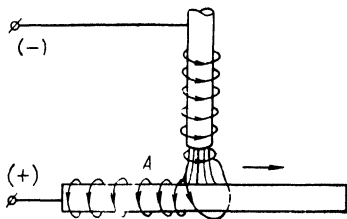

Fig. 26. Arc blow by a magnetic field

The molten globules are formed every 0.001 to 0.01 sec and are heated to a high temperature. The heated molten metal readily combines with oxygen of the air to form oxides which in turn are dissolved in a globule while it is still at the tip of the electrode. The carbon monoxide forming inside it expands and breaks the globule away from the electrode to throw it into the metal pool. Apart from the expanding gas, droplet transfer is assisted by electric and other forces.

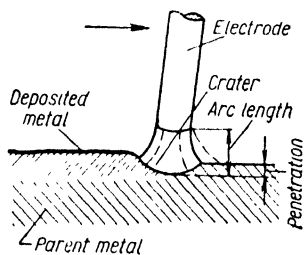

Fig. 27. Diagram of a welding arc

The blast of the arc forces the molten metal out of the pool, thus forming a small depression in the parent metal, around which molten metal is piled up. This is known as the arc crater. The distance through the centre of the arc from the tip of the electrode to the bottom of the arc crater is termed *arc length* (Fig. 27).

Arc length is a vital variable in a welding process and should be 3 to 4 mm. An important reason for this is that the globules of molten electrode metal in the process of deposition should have the smallest possible chance of coming in contact with the ambient air and should absorb as little oxygen from it as possible, because oxygen has an adverse effect on the mechanical properties of the weld metal. It is obvious that with a shorter arc the time of contact will be shorter than with a longer arc. Manual welding with a long arc produces a rough surface. A long arc will be wild and make a wide, shallow bead while much heat will be wastefully radiated into the air; this will result in poor penetration. The globules of molten electrode metal will be deposited on a poorly heated surface, spatter and produce poor fusion. In addition to this, a long arc reduces weld production and efficiency.

The *arc column* extends between the bottom of the arc crater and the molten globule at the tip of the electrode. According to some investigators, the temperature of the gas in the arc core along its axis is as high as 6,000°C. The

core is surrounded by a stream of bluish light (the arc stream) which is irregular in shape due to the fact that it is affected by gas currents and magnetic fields. The temperature of the gas drops sharply as we move away from the centre towards the periphery of the stream.

As experiments have shown, an open metal arc imparts some 50 to 60 per cent of its watts to the weld metal in the form of thermal energy. In the case of submerged arc, the proportion of heat imparted to the metal being welded is greater. The balance of the arc watts is dissipated into the ambient atmosphere through radiation, convection and vapours.

In the case of a carbon arc, the positive electrode (the anode) gives up some 42 per cent of the total heat, and the negative electrode (the cathode) generates about 38 per cent, while the arc core accounts for the remaining 20 per cent. The temperature in the cathode or negative glow reaches 3,200°C, and in the positive column it is about 3,400°C.

Metal-arc welding still suffers from a lack of reliable data on the distribution of temperature and heat generation in the various regions of the arc.

The heat given up by the metal arc is mainly concentrated within a very limited area immediately under the arc. Observation through a dark glass shows a white-hot spot in and around the crater. The temperature of the metal, however, quickly drops, as we move away from the crater, to the temperature of the parent metal within a certain distance depending on the size of the electrode and the welding current.

The metal arc, therefore, only heats the parent metal locally, in the area surrounding the crater.

## **SOURCES OF CURRENT SUPPLY FOR ARC WELDING**

### **24. Arc Welding Equipment**

A station for manual arc welding (Fig. 28) has a source of current supply *1*, flexible welding cables *2*, an electrode holder *3*, and a clamp *4* to attach the ground, or return cable, to the workpiece, bench or welding jig.

The equipment of an arc welding station varies with the nature of the job in hand, size of the workpiece, the adopted welding process or procedure, the layout of other welding stations, and certain other factors.

Mention may be made of two possible layouts: (1) a welding station set up inside a welding booth; and (2) a welding station set up in the open (in the shop) for welding bulky jobs.

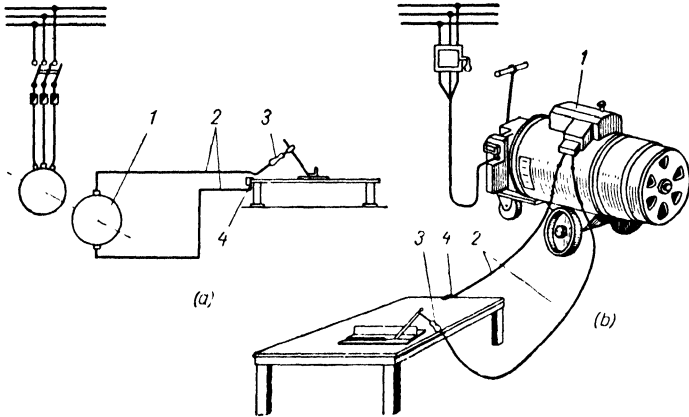

Fig. 28. A welding station: (a—plan of layout; b—general view)

- 1—welding source; 2—welding cables; 3—electrode holder;  
4—clamp connecting a return cable to the welding table

Welding booths are convenient when welding relatively small jobs which need no jigs or fixtures for fit-up and welding.

The equipment of a welding station may also include (Fig. 29) a welding table or bench 3, a welder's stool 4, an exhaust hood 2, a lighting fixture 1, and a tarpaulin curtain 5 over the entrance to the welding booth. The working area inside a booth must be 3 to 4 sq m. For a free flow of air, the walls of the booth should be 200 to 250 mm short of the floor. The booth walls should be painted dead gray, blue or yellow on the inside to prevent reflection of the arc rays.

The welding table or bench may be stationary (Fig. 30a),

or rotating and adjustable for height (Fig. 30b). For work in a sitting position, the height of the table must be 0.5 to 0.6 m, and in a standing position, about 0.9 m. The top of the table 2 (Fig. 30a) is a steel plate 10 to 15 mm thick or a cast-iron plate some 25 mm thick, the latter being less susceptible to warpage due to welding heat. The table top should be about 1 sq m in area. The terminal 3 for the ground (or the return cable) is welded to one of the legs of the table, while the box 1 for electrodes is welded to another leg, closer to the operator. Two more boxes 4 hold tools and drawings.

Every operator may, of course, have his own idea of the proper type of welding table.

The source of current supply for arc welding (a welding transformer or a d.c. welding set) may be located inside the booth, or outside the booth when it simultaneously powers a group of stations. In the latter case, the welding current is far more difficult to control, but it facilitates care of the welding equipment.

Where the welding head must be taken out of the booth to the work (which is the case with bulky jobs), it is advisable to surround the scene of welding operation with portable screens (Fig. 31) 1.2 to 1.5 m high, so as to protect other workers from the arc rays.

If the operator works some distance above the floor, portable screens on high supports should be used.

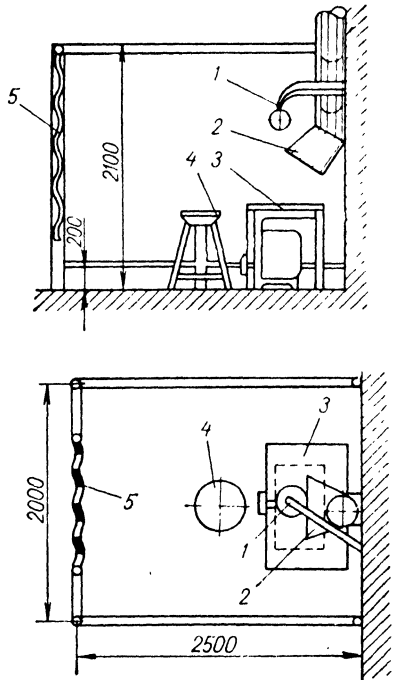

Fig. 29. Plan and elevation of a welding booth

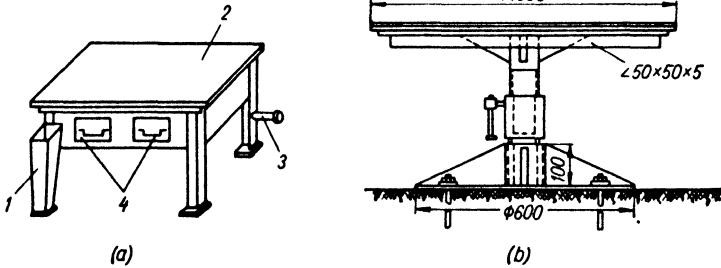

Fig. 30. Welding tables

In work outside welding booths, the source of current supply should be placed near the scene of welding operation. When one source of power is used to supply several operators, stationary switchboards must be provided in the shop,

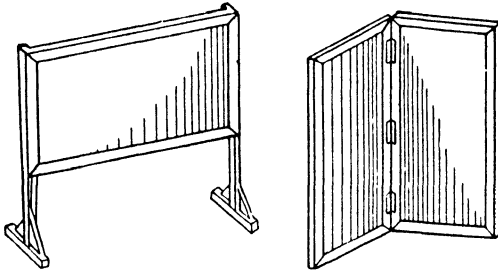

Fig. 31. Portable welding screens

spaced at regular intervals, and connected to the power source by permanent wiring.

### 25. Requirements for Sources of Current Supply for Arc Welding

Either alternating or direct current may be used for arc welding.

The electric properties of the arc determine the requirements that should be met by a source of current supply for

arc welding. To initiate an arc, a higher voltage is required than to maintain it under normal conditions. For this reason the open-circuit voltage of a power source (when there is no arc drawn between the electrode and the work) must be higher than the arc, or closed-circuit, voltage (when there is an arc drawn between the electrode and the work).

With direct current, the open-circuit voltage must be at least 30 or 35 V, while with alternating current it should be not lower than 50 or 55 V. An open arc will be sustained at 18 to 25 V.

To initiate an arc, the electrode is touched to the work and is then withdrawn a short distance, usually 2 to 4 mm. On contact, the electrode shorts the welding circuit, as the resistance of the welding cables is negligible compared with the arc resistance. It should be remembered that an inadvertent short circuit may give rise to an excessive current in the circuit, which may dangerously heat and even burn the insulation. A power source for welding should therefore be able to limit the surge of current, when the arc is started, to a small percentage above the desired value.

In metal-arc welding the globules of molten electrode metal are carried across the arc, thus changing the resistance of the arc and consequently the arc voltage and current. In fact, the arc resistance is continually varying within broad limits in very short periods of time. The point is that the molten globules of metal pass from the electrode to the plate at the rate of 30 or more per second, continually causing approximate short circuits from the electrode to the work. If the arc is not to go out, the power source must be able to quickly vary its voltage with the resistance of the arc.

Of special importance is the ability of a power source to restore the voltage quickly after a globule of molten metal has broken away from the electrode. The arc will only re-strike at not less than 25 V. The voltage should therefore recover to 25 V within 0.05 sec.

The curve relating the voltage of a source and the welding current is known as the *static* (or volt-ampere) *characteristic* of that source, which may be a welding transformer or a welding generator.

For manual welding with coated electrodes the static characteristic must be the shape shown in Fig. 32. This is a drooping characteristic. The line  $Oa$  is a scale representation of the open-circuit voltage of a power source. The point  $b$  on the curve  $ae$  shows the instant when the arc strikes. The line  $Ob$  represents, also to scale, the arc or

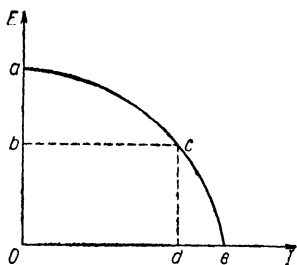

Fig. 32. Static (volt-ampere) characteristic of a welding source

closed-circuit voltage (with the voltage drop across the welding cables neglected). The line  $Od$  is a scale representation of the arc current, and the line  $Oe$  of the short-circuit current. At this point the voltage of the source drops to zero. With this type of volt-ampere characteristic the short-circuit current in the welding circuit is reduced to a safe enough limit for the windings of the welding generator or transformer.

In the case of an arc having a flat or a rising volt-ampere characteristic (such as in shielded-arc welding, automatic welding with large currents), the power source should also have a flat or a rising characteristic, respectively.

To sum up, welding generators and transformers for manual arc welding should meet the following requirements:

- the open-circuit voltage must be sufficient for an arc to strike without difficulty, but safe to the operator (under 80 V);
- the short-circuit current must be within limits of safety for generator or transformer windings;
- the voltage of the power source must vary rapidly with changes in arc length;
- the watts of the power source should be sufficient to give the desired arc current.

## 26. Single-operator Direct-current Welding Sets

As the name implies, this type of source can only supply welding current to one arc.

A mains-operated set of this type consists of an electric

motor arranged for the current available in the shop, and a welding generator producing direct current for the arc. As a rule the rotor of the motor and the armature of the generator are mounted on a common shaft. Sometimes they are seated on separate shafts, and the shafts are connected together by couplings.

A more recent trend has been towards welding sets with the motor and generator built into a common frame.

To obtain the desired drooping volt-ampere characteristic and to limit the short-circuit current, appropriate refinements are introduced into the circuitry of generators.

One such arrangement is a *third-brush generator with a demagnetising series winding* (Fig. 33) which has two field windings. An e.m.f. in the generator is induced by the magnetic flux of the winding connected to the generator brushes *a* and *c*. The voltage between the main brush *a* and the additional brush *c* remains almost unchanged and independent of the generator load. The magnetic flux  $\Phi_b$  of this winding therefore also remains constant. The winding is called the *independent excitation winding*.

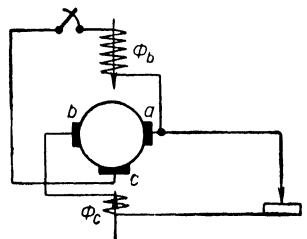

Fig. 33. Diagram of a third-brush welding generator (with a demagnetising series winding)

The voltage between the main brush *a* and the additional brush *c* remains almost unchanged and independent of the generator load. The magnetic flux  $\Phi_b$  of this winding therefore also remains constant. The winding is called the *independent excitation winding*.

When the arc is started, the welding current flows in the series field winding connected so that its magnetic flux opposes the magnetic field  $\Phi_b$  of the independent excitation winding. The larger the current in the welding circuit, the stronger the demagnetising action of the series winding, and the lower the generator voltage, as the e.m.f. induced in the armature winding of the generator depends on the resultant magnetic field.

At a short circuit the magnetic flux of the series winding is almost equal to the magnetic flux of the main field winding, the resultant magnetic flux of the generator becomes negligible in magnitude, and the terminal voltage of the generator drops to zero. In other words, the demagnetising

series field winding produces the desired drooping characteristic of the welding generator.

The *bipolar welding generator* has a different operating principle. This generator has four main poles and three sets of brushes riding the commutator (Fig. 34). As distinct from the conventional d.c. generator in which North and South poles alternate, in a bipolar generator the like poles are placed side by side ( $S_1S_2$  and  $N_1N_2$ ). Two adjacent like poles may be regarded, magnetically, as a single pole split into two parts.

The magnetic flux linking the poles may be divided into two fluxes. One flux moves from  $N_1$  to  $S_2$ , and the other

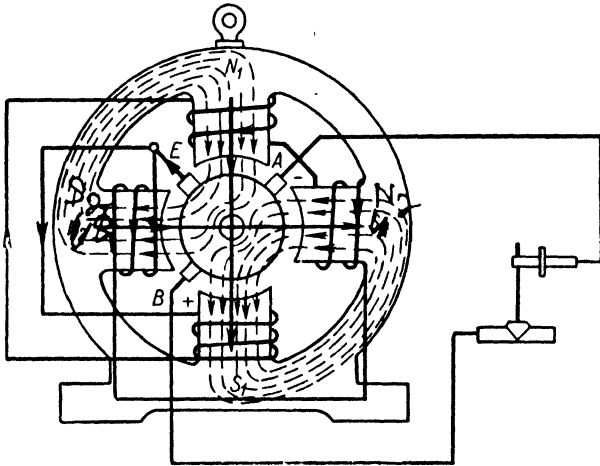

Fig. 34. Diagram of a bipolar generator

from  $N_2$  to  $S_1$ . The magnitude of the e.m.f. in the armature depends on the density of these two fluxes: the denser the flux cut across by the armature conductors, the greater the e.m.f. of the armature. The welding circuit is connected to the brushes A and B, and the field coils wound upon the magnetic poles are connected to the brushes A and E.

When the arc is started, the current flowing through the armature winding sets up a magnetic field around it.

The magnetic flux emerges from the armature core and spans the air space between the armature and the poles. Part of the flux enters  $S_1$ , threads through the frame,  $S_2$ , and links through the air gap in the armature core. The other part of the flux threads through  $N_2$ , the frame,  $N_1$ , and crosses the air space to enter the armature core. In Fig. 34 the path of the magnetic flux in the armature is shown by dotted lines.

The larger the current in the armature [winding, the stronger the magnetic flux.

Referring to the diagram, it will be seen that the magnetic flux in the armature winding moves with the magnetic flux in the poles  $N_1$  and  $S_1$  (shown by solid lines in Fig. 34) and against the magnetic flux in the poles  $N_2$  and  $S_2$ . In other words, the armature magnetic flux tends to build up the magnetic flux in the poles on the one side, and to kill it on the other.

The magnetic poles  $N_1$  and  $S_1$  are so constructed that they operate in conditions of magnetic saturation, and the addition of the armature magnetic flux cannot increase it any more, much as a saturated solution cannot dissolve any more salt.

The magnetic flux of the armature, which opposes the magnetic flux in the poles  $N_2$  and  $S_2$ , reduces this flux and, in fact, almost kills it, when there is a short circuit in the arc. The attenuating action of the main magnetic flux increases as the current in the welding circuit increases. A weaker magnetic flux in the poles produces a lower generator voltage.

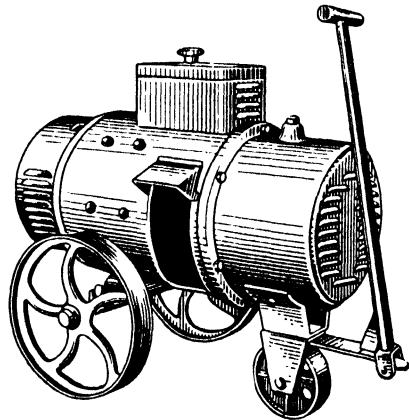

Fig. 35. General view of IICO-500 welding set

Thus in this case the drooping characteristic is obtained by the demagnetising action of the magnetic flux of the armature winding (armature reaction).

*Type IIC0-500 welding motor generator set* consists of a Type A-72/4 three-phase induction motor and a Type ICO-500 generator built into a common frame. The frame is mounted on wheels for portability (Fig. 35).

The set supplies direct current for manual arc welding, automatic submerged-arc welding, and semi-automatic gun welding.

The Type ICO-500 generator is of the third-brush type. The welding current is set by a rheostat incorporated in the series field winding circuit. The rheostat has a hand-wheel located on top of the machine. Rotation of the hand-wheel clockwise will increase the current setting.

The terminal panel of the generator has two positive terminals. One of them is used in welding with 125 to 300 A, and the other, with 300 to 600 amperes.

*Type IIC-300M welding motor generator set*, like the previous type, consists of a three-phase squirrel-cage motor and a Type CI-300M generator. Both the motor and the generator are built into a common frame mounted on wheels for portability.

The Type CI-300M generator is of the bipolar type. The welding current is set by means of a rheostat incorporated in the cross-field circuit. Rotation of the handwheel clockwise will increase the current setting. The ampere dial is mounted on the rheostat enclosure.

*Type IIC1-350 welding set* is designed for automatic and semi-automatic shielded-arc welding with a consumable electrode. With the series field brought fully in, the generator has a rising volt-ampere characteristic. With some of its turns brought out, its static characteristic becomes flat.

*Type CAM-400 welding set* comprises a Type MAΦ-82-73/4 three-phase induction motor and a Type CΠI-3-Y welding generator. The motor and the generator are mounted on a common base plate and connected by a coupling (Fig. 36).

The CΠI-3-Y generator is of the third-brush type. The current is set by a rheostat in the cross-field circuit. The terminal panel carries two positive terminals, one for welding with 120 to 300 A, and the other, with 300 to 600 A.

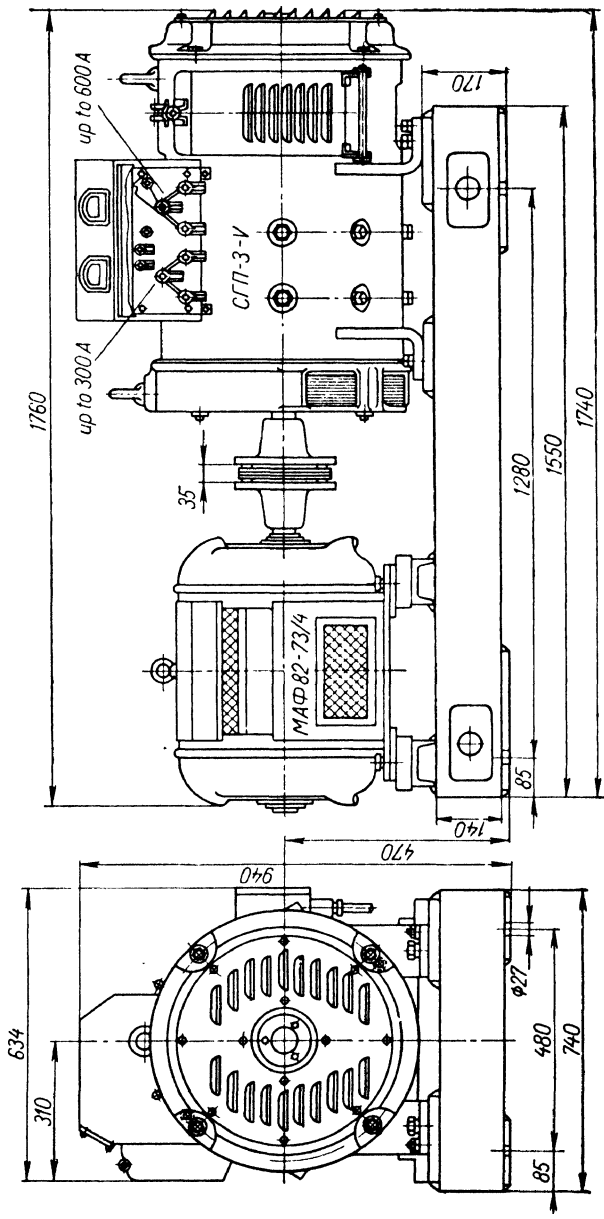

Fig. 36. CAM-400 welding set

Technical Data on Single-operator Motor-generator Sets

Set designation	Welding generator						Electric	
	Type	No-load voltage, V	Rated voltage, V	Rated duty cycle, per cent	Rated current, A	Current range, A	Type	Power rating, kW
ICO-120	ICO-120	48-65	25	65	120	30-60 60-120	AB-42/2 induction, squirrel-cage	4
ICO-500	ICO-500	58-86	40	65	500	125-300 250-600	A-72/4 induction, squirrel-cage	28
CAM-400	СГП-3-У	60-90	40	65	500	120-600	MAΦ-82-73/4 induction, squirrel-cage	32
IC-300M	CI-300M	50-76	30-35	65	340	80-380	A-62/2 induction, squirrel-cage	14
CVF-2P	CMF-2r-II	50-68	30	65	300	45-100 75-175 130-320	A-62/4 induction, squirrel-cage	14
ICI-350	ICI-350	—	30	65	350	50-350	AB-61/2 induction, squirrel-cage	14

The ratings of the most commonly used welding motor generator sets are tabulated in Table 4.

The rated voltage, current and duty cycle are as quoted by the manufacturers. A duty cycle of 65 per cent means that a generator (or a set) operates at load 65 per cent of a 5 minute cycle, and runs at no-load for the remaining 35 per cent. With 100 per cent duty cycle, a welding generator should be rated down.

**Engine-driven welding sets.** An engine-driven welding set consists of internal-combustion engine driving a d.c. welding generator through a flexible coupling. Several types of engine-driven welding sets are commercially available.

The engine may be either a petrol or a diesel type, fitted with an efficient and sensitive governor capable of main-

motor			Welding set					
Voltage, V	RPM	PF	Construction	Efficiency	Weight, kg	Overall dimensions, mm		
						length	width	height
220/380	2,900	.88	Common frame, wheeled for portability	.47	155	1,055	550	730
220/380	1,450	.86	Ditto	.54	780	1,275	770	1,080
220/380	1,460	.86	Separate frames, stationary, on bed-frame	.50	1,450	1,760	740	940
220/380	1,450	.87	Common frame, wheeled for portability	.57	600	1,200	755	1,180
220/380	1,450	.87	Separate frames, truck-mounted for portability	.50	550	1,620	626	1,080
220/380	2,900	.87	Common frame, wheeled for portability	.63	400	1,085	555	980

taining constant engine speed, and regulators providing for quick voltage recovery in a change-over from a short circuit to open circuit.

The generator may be either the Type СГП-3 third-brush generator (such as in the Type ИАС-400 welding set), the Type CMF-2r bipolar generator (such as in the Type САК-2r welding set), or the Type IC-300 third-brush generator in the Type АСБ-300 welding set.

The ratings of single-operator, engine-driven welding sets are given in Table 5.

Engine-driven sets are mainly used for site welding where no electric power supply is available, such as in laying trunk pipelines, erecting metal supports for high-voltage transmission lines, and so on.

Technical Data on Engine-driven Single-operator Welding Sets

Set designation	Welding generator						Engine				Welding set			
	Type	No-load voltage, V	Rated voltage, V	Rated duty cycle, per cent	Rated welding current, A	Current range, A	Type	Power, h.p.	RPM	Construction	Weight, kg	Overall dimensions, mm		
												length	width	height
ПАС-1000	СГ-1000-1	68-92	45	65	1,000	300-1,200	Diesel, ДВ-150-150	1,500	1,500	Portable, frame-mounted, with canopy and screens	4,000	3,920	1,500	2,100
ПАС-400-VI	СГП-3-VI	60-90	40	65	500	120-400 350-600	Petrol, ЗИС-120 truck	90	1,600	Ditto	1,900	2,870	880	1,920
АСБ-300-2	ГО-300	47-73	30	65	300	75-180 175-320	Petrol, ГАЗ-МФ truck	30	1,450	Ditto	850	2,080	810	1,730
САР-2-IV	СМГ-2-IV	50-68	30	65	300	45-100 75-175 130-320	Petrol, ГАЗ-МФ truck	30	1,430	Ditto	900	2,120	806	1,730

## 27. Multi-operator D. C. Welding Sets

As the name implies, these sets supply current to several arcs.

A multi-operator generator has two field windings, one shunt and the other series, accordant connected. The magnetic flux of the series winding coincides in sense with that of the shunt winding. Because of this the generator has a flat rather than a drooping volt-ampere characteristic.

From a multi-operator generator the current is taken to busbars, and from there to a group of welders (Fig. 37). As the generator has a flat volt-ampere characteristic, the voltage across the busbars remains constant and independent of the load. To obtain a drooping characteristic, ballast rheostats are connected in series with the arcs at the scene of the welding operation. The rheostats also serve to control the welding current.

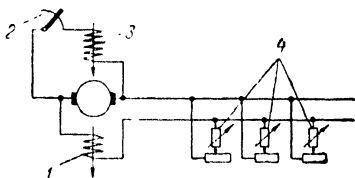

Fig. 37. Layout of a multi-operator set:

1 — accordant-connected series field winding; 2 — voltage regulator; 3 — shunt field winding; 4 — ballast rheostats at welding stations

One such multi-operator welding set is the Type ПСМ-1000 which consists of a Type СГ-1000 d.c. welding generator and a three-phase induction motor. Both the generator and the motor have a common shaft carried by bearings and a common frame. The generator produces a constant voltage of 60 V.

Every Type ПСМ-1000 set is furnished with nine Type РБ-200 ballast rheostats controlling the welding current from 10 to 200 A. The desired current is set by means of five knife switches on the rheostat. If more than 200 A is required, two rheostats are connected in parallel.

The motor in the Type ПСМ-1000 set is rated at 75 kW at 220/380 V. The set weighs 1,700 kg and is mounted on a foundation.

Multi-operator sets take up less space than single-operator units serving the same number of operators. Therefore, this type of plant is economical for installations where

work is concentrated in one shop. They are also cheaper than the equivalent number of single-operator sets, and are more economical to service and maintain.

### 28. Single-operator Welding Transformers

Alternating current for arc welding can be supplied by transformers. A welding transformer steps down the mains voltage to the value necessary for striking an a.c. arc, i.e., to 55 or 65 V.

Welding transformers should satisfy the following requirements:

(a) they should have a drooping characteristic;

(b) the surge of current during a short circuit should be limited to the least possible percentage above the arc current;

(c) the open-circuit voltage should not exceed 80 V;

(d) the current should be controllable continuously over a wide range.

Fig. 38. Diagram of a welding transformer with an external reactor

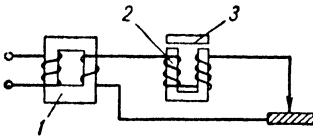

Single-operator transformer sets used in the welding industry can be classed into those having an external reactor, and those having a reactor wound on the transformer core.

The former type is a regular step-down single-phase transformer (1 in Fig. 38) with a secondary (the welding circuit) to which a moving-core reactor 2 is connected.

The purpose of the reactor is to reduce the transformer voltage to the value required to maintain the arc, and to absorb the secondary voltage when there is a short circuit in the arc, i. e., to provide the desired drooping characteristic in the supply system of each arc. The reactor also serves to control the current.

The core of the reactor consists of a fixed portion carrying the winding, and a moving limb 3 which can be shifted away from and towards the fixed core by a suitable arrangement, thus varying the air gap between them. An increased air gap adds to the reluctance of the magnetic circuit of

the reactor, while its self-induction and inductive reactance drop, so that the welding current increases.

When the air gap is reduced, the reluctance of the magnetic circuit is also reduced, the magnetic flux increases, as does the inductive reactance of the coil, and the welding current drops. In this manner the welding current can be adjusted very accurately and continuously.

A transformer with a reactor wound on a common core (Fig. 39) has a primary *I*, a secondary *II*, and a reactor winding *III*. This arrangement has been devised by V.P. Nikitin, Member of the Soviet Academy of Sciences. Apart from the main limbs, the core has additional limbs carrying the reactor winding. The current is adjusted by means of the moving core *C* placed between the additional limbs.

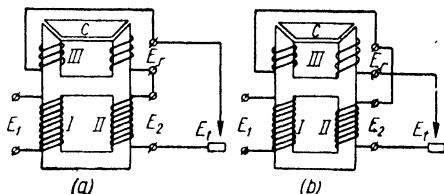

Fig. 39. Diagram of a welding transformer with a reactor wound on a common core

The part which carries windings *I* and *II* is in fact the transformer proper, and the part carrying winding *III* is the regulator.

The reactor can be connected with the secondary either in opposition or in accordance.

When the reactor is accordant connected (Fig. 39a) the open-circuit voltage of the transformer will be

$$E_1 = E_2 + E_r,$$

where  $E_2$  is the secondary voltage of the transformer and  $E_r$  is the reactor voltage.

Accordant connection produces a stable arc at low currents and is employed for welding on small plate thicknesses.

When the reactor is connected in opposition (Fig. 39b), its voltage is subtracted from the open-circuit voltage of the transformer:

$$E_1 = E_2 - E_r.$$

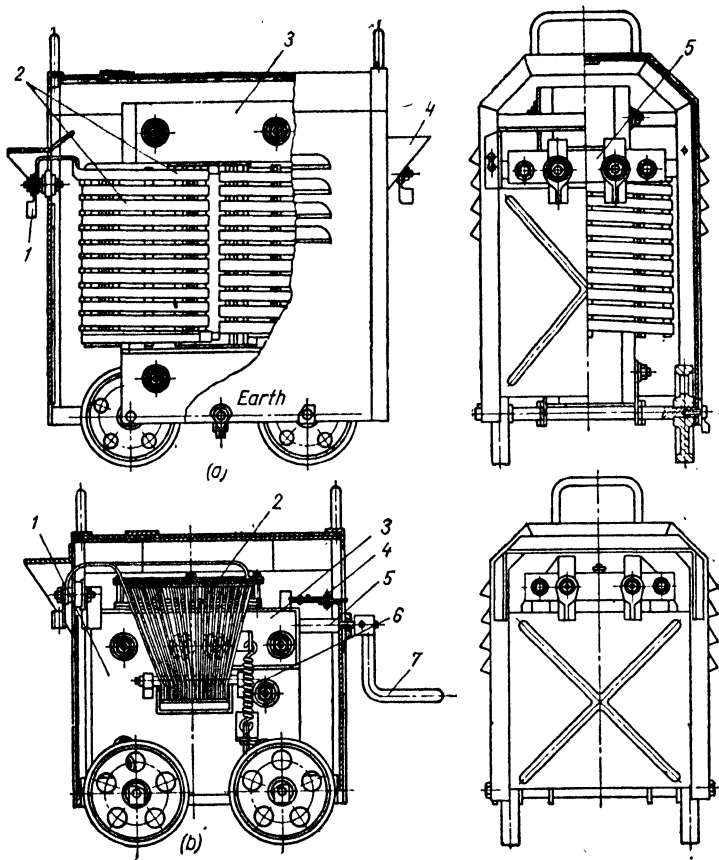

Fig. 40. CTЭ welding transformer:  
 a — transformer proper; b — reactor

Opposition connection is used for welding with heavy currents.

*Type CTЭ welding transformer.* This is a transformer with an external reactor. It consists of a single-phase transformer proper (Fig. 40a) and a reactor (Fig. 40b).

The primary is arranged for connection into the supply line at the terminals marked A and X (Fig. 41), and the sec-

ondary is connected in series with the regulator at the terminals marked *a* and *x*, and into the welding circuit. The primary side is wound for a normal low-tension mains voltage of 220, 380 or 500 V, whichever is indicated on the transformer's nameplate. The secondary voltage of the transformer at no-load is 65 V.

Both the transformer and the regulator are naturally air-cooled. They are built into enclosures of sheet steel and mounted on wheels for portability.

The transformer core (3 in Fig. 40a) is built up of transformer steel punchings 0.5 mm thick. The transformer windings consist each of two cross-over coils wound with two layers of insulated copper wire (in the primary) and one outer layer 2 of bare copper strip (in the secondary).

For a supply voltage of 380 V the primary coils are connected in series, and for 220 V, in parallel. In both cases the secondary coils are connected in series.

The primary terminal panel 4 is mounted on an end wall of the transformer enclosure, while the secondary terminal panel 5 is situated on the opposite end wall. Each terminal has a lug 1 for soldering a wire of the appropriate cross-section.

The reactor core (Fig. 40b) is also stacked of transformer steel laminations 0.5 mm thick. The reactor winding 2 is wound with bare copper strip in layers interleaved with asbestos impregnated with a heat-resistant varnish.

The air gap in the reactor is adjusted by means of a moving strap 3 above the stationary limbs of the reactor. Air gap adjustment is effected by a handwheel 7 mounted

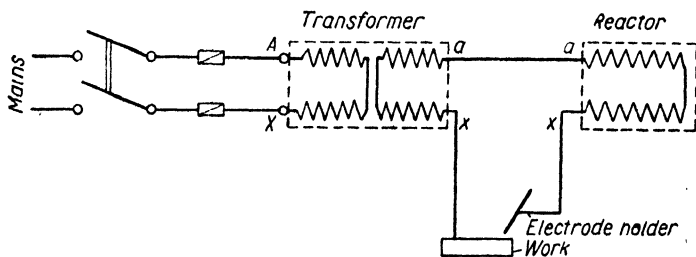

Fig. 41. Connection of the transformer and reactor in a CTθ set

Table 6

Technical Data on Single-operator Welding Transformers

Type designation	kVA rating	Primary voltage, V	No-load secondary voltage, V	Rated welding current, A	Current range, A	Efficiency	P.F.	Weight, kg	Overall dimensions, mm		
									length	width	height
CTЭ-24	24	220 or 380	65	350	70-500	.83	.52	140*	646	314	660
								90	594	320	545
CTЭ-34	34	220 or 380	60	500	150-700	.85	.52	200	690	370	660
								120	669	320	545
CTH-350	24.5	220	70	350	80-450	.85	.5	220	—	—	—
CTH-500	32	220 or 380	60	500	150-700	.85	.54	270	796	410	840
CTH-700	43.5	220 or 380	60	700	200-900	.85	.66	380	796	429	840
TCД-500	42	220 or 380	80	500	200-600	.87	.55	450	950	818	1,215
								534	950	818	1,215
TCД-1000	76	220 or 380	69 and 78	1,000	400-1,200	.9	.62	950	1,050	900	1,300
								950	1,050	900	1,300
TCД-2000	180	220 or 380	72 and 84	2,000	800-2,200	.9	.60	950	1,050	900	1,300
								950	1,050	900	1,300
TC-120	9	220 or 380	60	120	50-160	.80	.46	85	505	420	790
TC-300	20	220 or 380	60	300	110-385	.84	.50	185	760	520	970
TC-500	32	220 or 380	60	500	170-650	.86	.54	250	840	575	1,060
TCK-300	20	380	60	300	110-385	.84	.64	215	760	520	970
TCK-500	32	380	60	500	170-650	.86	.68	280	840	575	1,060

\* The numerator stands for the transformer and the denominator for the reactor.

on a screw 5 which fits into a nut embedded into the moving strap.

Clockwise rotation of the handwheel increases the air gap, reduces the inductive reactance and, consequently, raises the welding current. Counterclockwise rotation reduces the welding current.

The moving strap is held down by two spiral springs 6 to prevent heavy vibration. In some types of reactor a suitable hold-down screw serves this purpose.

The current setting can be read from the current indicator 4 arranged above the moving strap screw on the end wall and fitted with a dial graduated in amperes. The indicator reads accurate to within 10 per cent at the rated mains voltage and a secondary voltage of 30 V.

For the ratings of Type CTЭ transformers see Table 6.

Type CTH welding transformer has a reactor wound on a common core, with the secondary and reactor windings connected in opposition. The transformer core (6 in Fig. 42) is built up of transformer steel laminations 0.5 mm thick and is common to the primary, secondary and reactor windings.

The transformer windings consist of two coils each wound with two layers of insulated copper wire (the primary winding) and one layer of bare copper strip 8 (the secondary winding).

The reactor coil 2 is wound with bare copper strip interleaved with asbestos impregnated with a heat-resistant varnish.

The top portion of the core carrying the reactor is a moving strap 3 for adjustment of the air gap.

The moving strap is actuated in a way similar to that used in the regulator of the CTЭ transformer. Rotation of the handwheel 5 clockwise widens the air gap; the inductive reactance is reduced, and the welding current rises. Rotation of the handwheel counterclockwise reduces the welding current. As before, the current setting is read from an indicator.

The moving strap is held down by suitable springs 4 to prevent vibration under load.

The end walls of the transformer enclosure carry terminal panels, panel 1 receiving the primary leads, and panel 7,

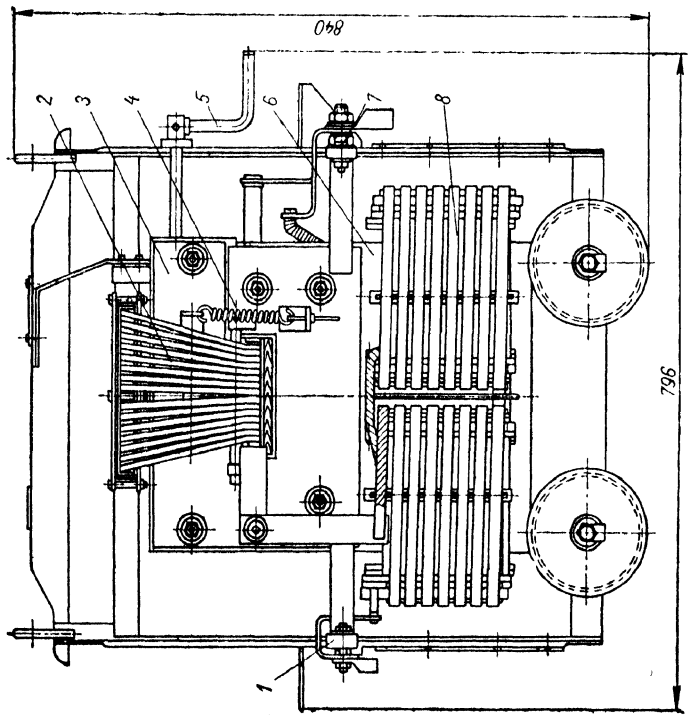
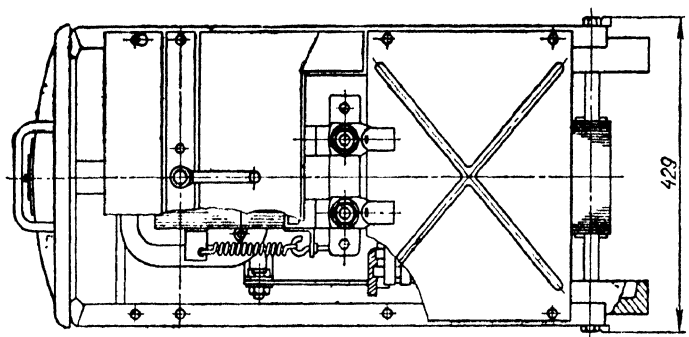

Fig 42. CTH welding transformer

one secondary lead and one reactor lead. The other leads of the secondary and the reactor are connected to each other (Fig. 43).

The transformer is wheel-mounted for portability. Its technical data are tabulated in Table 6.

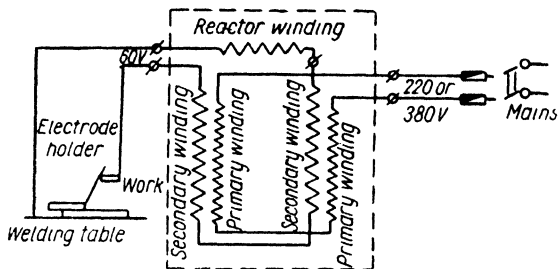

Fig. 43. Connection of CTH transformer

Type TCД welding transformers also carry a reactor on their core. They mainly serve to supply current for automatic arc welding.

As distinct from transformers for manual welding, the current in Type TCД transformers is adjusted by means of an electric motor which actuates the moving core strap through a worm transmission, thus varying the air gap.

The motor is started by means of two magnetic starters, one of which serves to reduce the welding current, and the other to raise it.

The push-button of the magnetic starters may be set on the control panel of the automatic welding set for remote current regulation, which is more convenient for work with automatic welding equipment.

The windings of Type TCД transformers are cooled through ventilating ducts.

Approximate indication of the welding current is given by a dial mounted on the transformer.

The technical data on Type TCД welding transformers are summarised in Table 6.

Type TC and TCK welding transformers are transformers with an increased magnetic leakage. The welding current is regulated by varying the relative position of the

primary and the secondary, which is accomplished by moving the coils of the secondary winding. Type TCK transformers differ from Type TC transformers in that they have capacitors for power factor correction. The technical data on both types are also presented in Table 6.

*Three-phase welding transformers*, as their name implies, supply current for a three-phase arc. The advantages of this technique are (a) increased production rates; (b) saving in power consumption; (c) improved power factor; and (d) balanced load on the lines.

In welding with a three-phase arc, use is made of twin electrodes insulated from each other and clamped in a specially designed electrode holder which establishes current connection to each electrode. Two phases are connected to the electrodes (Fig. 44), and the third phase to the work. Three arcs are maintained at a time, two of which, *a* and *c*, are drawn between each electrode and the work, while the third, *b*, is drawn between the electrodes.

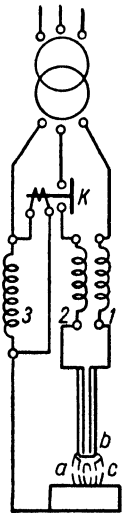

Fig. 44.  
Welding  
with a three-  
phase arc

A three-phase welding set consists of a three-phase transformer, a welding current regulator, and a magnetic contactor.

The three-phase primary winding is either star- or delta-connected (for 380 V or 220 V, respectively).

The secondary consists of two coils, each wound with bare copper strips on one of the core limbs. The open-circuit secondary voltage is 68 V. In addition, the secondary is tapped at 34 V and 110 V for electrically heating concrete and certain other applications.

The current regulator has two independent single-phase magnetic circuits with a variable air gap. The magnetic circuits are built into a common iron casing mounted on wheels.

The regulator incorporates three coils, two of which are carried by one magnetic circuit, and the third is wound upon the other magnetic circuit. Coils 1 and 2 on the first core are series-connected to the electrodes, while coil 3 on the other core is connected to the work.

The welding current is set by means of two controls which vary the air gaps in the regulator cores, one control setting the current in the two electrodes simultaneously, while the other sets it in the line connected to the work.

To prevent vibration in operation, the cores are held fast by two screws on top of the regulator cover. These screws should be loosened before the air gap in the cores can be changed. With this type of regulator the current can be continuously adjusted in the three phases simultaneously.

When the operator stops welding, he withdraws the electrodes from the work. The arcs between the electrodes and the work go out, but the arc between the electrodes remains. To quench the arc, the three-phase welding set incorporates a magnetic contactor *K*. The electromagnet of the contactor is connected across the terminals of the regulator coil 3.

When just switched on, the transformer operates single-phase. There is a voltage only between one of the electrodes and the work. On contact with the work, the electrodes short the welding circuit, a current traverses the coil 3, and a voltage appears across the terminals of this coil. The contactor *K* switches in the coil 2 of the regulator and, consequently, the other electrode.

When the operator separates the electrodes from the work the flow of current in the coil 3 ceases, the voltage across the coil disappears, and the contactor *K* interrupts the circuit of the coil 2, thus extinguishing the arc between the electrodes.

The three-phase welding transformer just described is rated at 45 kVA, with a welding current of up to 450 A.

The Type TTC-400 transformer is intended for manual three-phase arc welding with 400 A, and the Type TTCД-1000 transformer for automatic welding with 1,000 A.

### *29. Multi-operator Welding Transformers*

A multi-operator welding transformer may be either of the single-phase or three-phase variety, and, like a multi-operator d.c. generator, has a flat volt-ampere characteristic curve (see Sec. 27).

A disadvantage of single-phase multi-operator transformers is that they put an unbalanced load on the three-phase supply mains. If a multi-operator transformer is to have a voltage which will not vary with the load (the maximum variation should not exceed 5 per cent), it should have a low magnetic leakage, i.e., a low inductive reactance.

Soviet manufacturers do not make special multi-operator welding transformers. Instead, use may be made of Type CTЭ single-operator transformers, suitably connected to supply two or more arcs, if low currents are used.

The number of arcs (or welders) which may be connected to a welding transformer may be found by the equation

$$n = \frac{I_t}{I_a k},$$

where  $n$  = number of arcs (or welders);

$I_t$  = rated current of the welding transformer;

$I_a$  = arc current;

$k$  = diversity factor.

The diversity factor  $k$  takes into account the fact that the welders operating from one and the same source do not work simultaneously;  $k$  is reduced as the number of welders operating from the transformer increases. Usually,  $k$  is assumed to be anywhere between 0.6 and 0.8.

Each arc is connected through a separate variable choke (current regulator), which provides a steeply drooping static characteristic curve for each welding circuit. The welding circuits are connected in parallel, as with this arrangement the source is better utilised when welding with low currents (of the order of 70 to 100 A).

### 30. Rectifier-type Welding Sources

This type of welding source makes use of rectifiers, usually made of semiconductors for converting alternating current into direct current, which is then supplied to one or more arcs.

A semiconductor and, in fact, any rectifier, conducts current in one direction only—a property which is the basis of current rectification.

The most commonly used rectifiers are made of selenium. More recently good progress has been made with germanium and silicon rectifiers which are superior to selenium rectifiers in performance.

A rectifier-type welding source incorporates a transformer and a semiconductor rectifier. In comparison with a motor-generator set, it has the following advantages:

- (a) no rotating parts;
- (b) smaller weight, size, and cost;
- (c) higher efficiency.

Among the rectifier-type welding sources developed in the Soviet Union and available commercially are the Type ЦИГ-100 incorporating a germanium rectifier and rated at 100 A, and the Types ЦПС-300 and ВСС-300-2 both for 300 A.

The Type ВСС-300-2 set consists of a step-down three-phase transformer with a moving coil, and a welding current rectifier unit. The set has two adjustment ranges, one for low currents (with the primary and the secondary star-connected), and the other for heavier currents (with the windings connected in a delta).

### *31. Welding Frequency Converters*

Welding frequency converters are devices which receive a.c. energy at low voltage and commercial frequency and deliver it at high voltage and high frequency.

Converters are connected in parallel with conventional welding transformers when the stability of the arc has to be improved. As a converter supplies a voltage of 2,000 to 3,000 V at 150,000 c/s or higher, the arc is started easily without touching the work with the electrode. The arc remains stable even with bare and washed electrodes.

Converters come in particularly useful when welding on small thicknesses as they make it possible to use an alternating current of 20 to 25 A.

A converter consists of a step-up transformer and an oscillatory circuit which generates a high-frequency current.

The power consumption of a converter does not exceed 80 watts.

Connection from a converter to a mains supply is by rubber-covered wires 1.5 sq mm in cross-section, and to a welding circuit by a single-conductor high-voltage wire 1.5 sq mm in cross-section, encased in a metal braiding to reduce radio interference. The converter frame should be earthed.

Converters should be handled with care, avoiding shocks and jarring. In operation, the converter should be switched on before the welding circuit, and on finishing the welding it is essential to switch off the converter.

### *32. Care of Welding Sources*

If welding sources are to operate reliably and for a long time, proper care is necessary.

Although the maintenance of electric welding equipment is the duty of electricians, welding operators should be acquainted with the basic rules of care.

The welding generator must be kept clean and tidy; dust should be removed by a jet of compressed air; the generator frame should be wiped with dry wastes daily.

Special care must be taken of the commutator and brush gear, as good contact between the commutator and brushes is an important component of efficient welding.

The brushes should be well bedded to the commutator bars, otherwise they will overheat and crumble. Defective brushes should be replaced immediately.

When installed outdoors, welding generators should be protected from rain and snow. This is of particular importance when the welding equipment is not regularly in use, as moisture entering the machine may find its way through the cracks in the coat of varnish and into the winding insulation. The resistance of damp insulation drops sharply, and the winding insulation may be ruptured when the generator starts up.

Welding transformers are simpler to service and maintain as they have no rotating parts. For good service the following must be borne in mind: the welding current should not exceed the value indicated on the nameplate; all terminal nuts must be tightened snugly; a welding transformer or current regulator should never be pulled by

the welding cables connected to them; if a transformer or a regulator has to be moved to another place, it should be carried by the handles on the side walls of the enclosure; when using a crane, it is essential that the rope makes an angle of not more than  $30^{\circ}$  with the vertical.

Welding sources should be given regular inspection and preventive maintenance. Welding sets may be connected to a mains supply only by electricians. Welding cables may be connected by the operator.

The enclosures of welding machines and transformers should be reliably earthed by electricians.

### *33. Arc Welding Equipment Failures*

In the course of its service life welding equipment may develop various troubles. A few important cases which the operator must know are as follows.

(1) The rotor of the motor fails to rotate, but is humming heavily. The probable cause is a broken lead or a broken turn in the stator winding.

(2) The stator of the motor becomes overheated. The trouble may lie in overload. If, with the load reduced, the stator remains hot, the cause may be a short circuit in the stator winding.

(3) The welding generator supplies no voltage. The trouble may be a break in the field circuit. If a check fails to detect a break, the generator should be magnetised from an external source, say, from another welding generator after the correct direction of the magnetising current has been determined.

(4) Severe sparking at the generator brushes. The cause may lie in a dirty commutator, poor contact between the brushes and commutator, a misaligned brush yoke or rocker arm, protruding mica insulation between the commutator bars, or crumbled brushes.

(5) Sparking at the brushes. Local carbon deposit on the commutator. The cause may be a broken turn or turns in the armature or a broken soldered joint between an armature lead and a commutator bar.

(6) Sparking at the brushes accompanied by an appreciable carbon deposit at some place on the commutator and exces-

sive heating of the armature winding. The cause may be shorted turns in the armature winding.

(7) Excessive heating of the transformer winding. The trouble may be a short between winding turns (interturn short).

(8) The transformer core and studs are overheated. The cause may lie in damaged insulation between the core punchings and studs.

(9) Loud humming in the core of the transformer and reactor. The trouble may be due to loosened mechanical

fastenings. Humming in the movable strap is due to weak springs and the slackened drive screw.

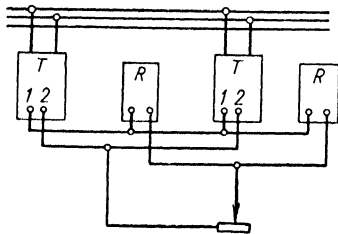

Fig. 45. Connection of welding transformers for parallel operation

Damaged insulation between the winding and frame or between the windings is the most dangerous trouble in welding transformers, as it may lead to a current shock. It is essential, therefore, to test the insulation in welding transformers at regular intervals by means of a megger or a lamp-type tester.

Should the operator detect a trouble in the welding equipment, he must immediately report it to the foreman or electrician in charge.

### 34. Parallel Operation of Welding Sources

Should a single welding source prove inadequate to supply the desired welding current, two or more single-operator welding sources may be connected in parallel.

The welding generators to be paralleled should be similar in type and in static characteristics.

To connect generators for parallel operation, the like terminals of the generators are connected together, and the welding cables are run from the common points thus obtained to the electrode holder and the work.

To balance the voltage of the paralleled generators the

shunt winding of the first generator is arranged to be powered from the other generator, and vice versa.

When paralleling two welding transformers, their primary sides should be connected to one and the same mains supply (Fig. 45).

The like terminals on the secondary (the welding circuit) side are also connected together. Before connecting them, it is a good plan to see whether they are at an equal potential. To do so, any two terminals should be connected by a link so that they are common, and a voltmeter or a lamp should be connected to the other pair. If the voltmeter reads zero or the lamp does not go on, the terminals are paired correctly. If this is not so the connection should be changed.

Only identical or similar transformers may be connected for parallel operation.

# *Chapter III*

## **METALLURGICAL ASPECTS OF WELDING**

---

### *35. Specific Features*

The metallurgical phenomena which take place when the arc melts the metal differ somewhat from those observed in open-hearth furnaces, Bessemer converters, or electric furnaces.

In arc welding, the molten metal solidifies in a matter of a few seconds. The amount of molten metal in manual arc welding rarely exceeds 8 cubic centimetres. The source of heat and the metal pool have a temperature which is appreciably higher than in steel-making furnaces.

Due to the fact that the weld pool cools off quickly, the chemical reactions initiated in the molten metal and slag have no time to be completed. The high temperature of the arc breaks up some of the oxygen and nitrogen in the arc zone into atoms. Atomic gases are more aggressive than in the molecular state. The oxygen combines with the iron to form FeO (ferrous oxide) and some other oxides. For this reason, the weld metal in open-arc welding may have as much as 0.2 to 0.3 per cent oxygen, while in open-hearth steel the figure is 0.01 to 0.02 per cent. Excess oxygen has an adverse effect on the mechanical properties of the weld metal, especially on its impact strength.

The oxygen content of the weld metal varies with arc length, welding current, and the type of shielding employed (electrode covering, fluxes, gas shielding).

With a long arc, the molten metal, as it passes from the electrode to the work, will be exposed to the atmosphere and may absorb much oxygen.

With a larger welding current more globules are carried from the electrode into the weld pool, thus increasing the

surface area of molten electrode metal exposed to the air.

When the electrode is coated, a shield of slag and gas is formed around the molten metal, thus protecting it from the air and reducing the oxygen content in the weld metal. In automatic welding this purpose is served by fluxes (submerged-arc welding), while in mechanical welding this is performed by gas shields (shielded-arc welding).

In open-arc welding the weld metal may contain as much as 0.12 to 0.18 per cent nitrogen, while this figure for the parent metal (open-hearth steel) may be within 0.001-0.008 per cent.

An increase in nitrogen content improves the strength and hardness of the weld metal but adversely affects its impact strength.

### *36. Refinement of the Weld Metal*

Apart from protecting the weld pool from the ambient atmosphere, electrode coatings, similar to fluxes in automatic arc welding, partly remove oxygen from the molten metal due to the deoxidisers included in their composition.

Deoxidation is the reduction of ferrous oxide and other iron compounds into iron by some other element which has a greater affinity for oxygen than iron and forms oxides which dissolve in iron in negligible amounts.

The deoxidising agents employed in electrode coatings include various ferroalloys, such as ferromanganese, ferrosilicon, ferrotitanium, etc., as well as aluminium, carbon, hydrogen, and carbon dioxide.

The oxides formed by the deoxidation of the weld pool should float up and mix with the molten slag, which means that the specific gravity of the oxides should be lower than that of the molten metal in the weld pool.

Manganese is the most commonly used deoxidiser. Reduction by manganese can be written as follows:

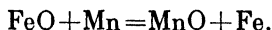

The resultant MnO mainly goes into the slag. Manganese serves another purpose in that it removes sulphur from the weld metal by the following reaction:

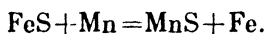

The manganese sulphide ( $\text{MnS}$ ), which is insoluble in iron, floats up to be absorbed by the slag.

Iron sulphide ( $\text{FeS}$ ), incidentally, is a factor responsible for the formation of hot (crystallisation) cracks in welded joints and in the near-weld area. The melting point of iron sulphide is below the solidifying point of steel. As the steel solidifies, the iron sulphide remains in the molten state between the grains, preventing their intergrowth and leading to discontinuities, or cracks.

In welding, the electrode coating or flux melts to form liquid slag which, by virtue of its lower specific weight, floats up to form a protective blanket on the surface of the metal pool. The chemical composition of slag has a decisive effect on the quality of the welded joint.

Reacting with the molten metal at the interface, slag acts as a deoxidiser, protects the metal from the ambient temperature, and reduces the rate of cooling of the weld pool.

In addition to certain chemical properties, slag should have some definite physical properties. When the parent and electrode metal melts and the weld metal solidifies, gases are evolved, and the slag should not hamper their escape, or the gases will form gas pockets in the weld metal. For molten slag to cover the surface of the molten weld metal uniformly, it should have a low surface tension which depends on the chemical composition of slag.

Among other things, titanium dioxide and fluorspar ( $\text{CaF}_2$ ) reduce the surface tension of slag. Upon cooling, the slag should easily come off the surface of the weld. This property depends on the difference between the temperature coefficients of expansion of the metal and slag.

Slag may have either an acid or a basic reaction depending on the oxides it contains. The acidity of slags is determined by the ratio (by weight) of acid to basic oxides:

$$k = \frac{\text{SiO}_2 + \text{TiO}_2}{\text{CaO} + \text{FeO} + \text{MnO} + \text{Na}_2\text{O}}.$$

If  $k > 1$ , slag is termed as having an acid reaction, and if  $k < 1$ , as having a basic reaction.

The melting point of slag should be below that of the parent metal, otherwise the slag will not be able to float up to the surface of the molten metal and will hamper the escape of the gases given up by the metal into the atmosphere.

The ingredients of electrode coatings may be classed into several groups according to their purpose:

(1) Gas-forming ingredients which produce gases protecting the molten metal from the harmful effects of the ambient temperature. These are starch, wood flour, cellulose, and some other organic substances.

(2) Slag-forming ingredients such as feldspar, manganese ore (pyralusite), titanium concentrate (ilmenite), chalk, marble, kaolin, granite, etc.

(3) Reducing ingredients, such as ferroalloys, aluminum, graphite, etc.

(4) Alloying agents, incorporated in some coatings and fluxes so as to control the physical and mechanical properties of the weld metal, to increase its resistance to corrosion, abrasion, etc. These are mainly ferroalloys, such as ferromanganese, ferrosilicon, ferromolybdenum, ferrotitanium, ferrochromium, etc.

### *37. The Structure of the Weld Metal and Near-weld Area*

A weld is obtained by melting the parent metal and an electrode so that the metals are completely fused, forming a single solid mass after solidification.

The solidification of the molten metal in the weld pool is diagrammatically shown in Fig. 46. As the arc progresses, the temperature of the weld pool drops (due to the heat abstraction into the parent metal and radiation into the ambient atmosphere) and the molten metal solidifies.

Grains first appear at the line of fusion where the temperature is relatively low. Grains grow at different rates because the conditions of their growth differ. The growing grains may push nonmetallic inclusions out to the surface of the weld. This is the reason why, in overhead welding, slag appears on the weld surface rather than floats up to the weld root.

The steady solidification of the metal pool is upset by remelting when subsequent passes are applied. This may result in pockets of molten metal where the grain growth is retarded. These spots are likely to have slag inclusions (Fig. 47). The structure of the weld metal and the proper solidification of the metal pool to some extent depend on

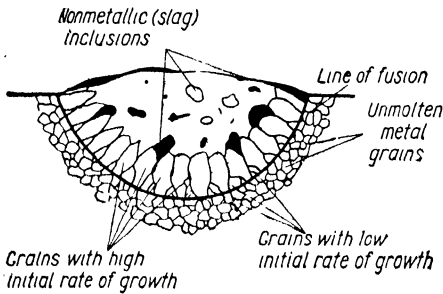

Fig. 46. Crystallisation of the weld pool

the aspect ratio of the weld (which is the ratio of the weld width to the depth of penetration). If the aspect ratio is less than unity, the pockets of molten metal last to form will be found in the centre of the cross-section of the weld (Fig. 48b), and accumulations of slag, gas and the like are possible there.

With normal aspect ratios (greater than unity), the molten metal pockets last to form (Fig. 48a) will be in the middle of the weld surface, and all impurities will be removed from the weld metal.

That portion of the parent metal which is immediately

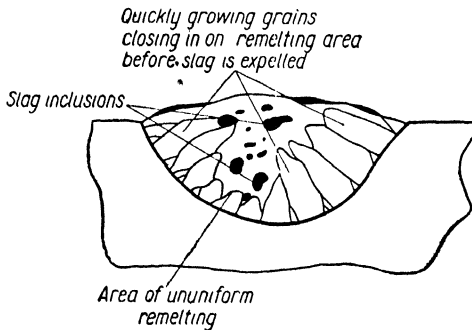

Fig. 47. Slag entrapment in a solidifying weld pool

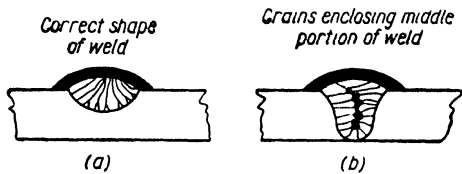

Fig. 48. Effect of weld pool shape on solidification

adjacent to the weld is called the *near-weld zone*. As the structure of this zone is altered by the heat of welding, this zone is also termed the *heat-affected area*.

Fig. 49 shows alterations in the structure of the heat-affected area in a low-carbon steel.

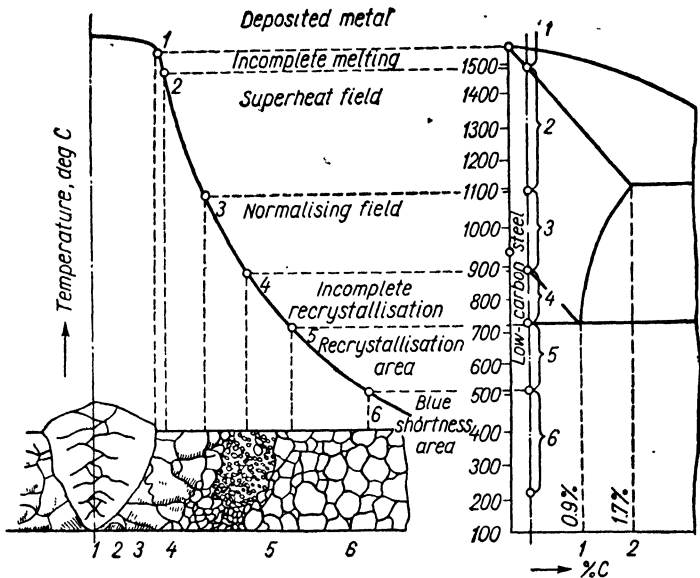

Fig. 49. Structure of the near-weld zone

Adjacent to the weld is an area of incomplete melting (1) where the metal is heated to a high temperature and coarse grains form. As we move away from the weld (2), the temperature and amount of overheating decrease, and so

does the grain size. In the normalising field (3) the grain is fine, as the time of heating is not long enough for austenitic grains to intergrow, and the subsequent cooling rejects fine grains of pearlite and ferrite. The normalising field is followed by an area of incomplete recrystallisation (4) where grains of pearlite break up into still finer grains. The recrystallisation area (5) is characterised by the recovery of grains deformed by rolling.

Structural alterations in the heat-affected area usually vary with the content of carbon and alloying elements in a steel.

As the temperature of the near-weld zone varies from place to place, the metal of the heat-affected area also varies in structure as do the mechanical properties of that area. In the normalising area the weld metal may be superior to the parent metal. In the overheated area where the grain is coarse, the metal loses some of its ductility, especially impact strength. The heat-affected area also shows changes in hardness, especially in the case of steels sensitive to heat treatment. An increase in hardness is usually accompanied by increased brittleness and reduced ductility. The hardness of the weld metal should be not less than 300 to 350 Brinell.

It should be noted that in welding plain low-carbon steels structural changes in the near-weld zone do not appreciably affect the strength of weldments. Indeed, the adequate welding technique may reduce to a minimum the effect of welding heat on the properties of the metal being welded.

# *Chapter IV*

## **WELDING ELECTRODES**

---

### *38. General*

Either metal or carbon electrodes may be used in arc welding. In both cases they serve to conduct current between the electrode and the arc. In metal arc welding the electrode is also a source of filler metal.

Electrodes may be further classed into bare and coated. Coated electrodes may have either a dip coating or an extruded coating.

Manual welding uses electrodes cut into rods of definite length, while semi-automatic and automatic welding use electrode wire in coils.

The Slavianoff process (metal arc welding) uses steel, cast-iron and other metal electrodes.

Steel electrodes for arc welding are manufactured to relevant U.S.S.R. State Standards covering coated steel electrodes. These standards provide electrode classifications, mechanical properties of the deposited metal and welded joint, electrode sizes, specifications for their manufacture, acceptance, testing, marking and certification, but leave out the chemical composition of coating compounds.

By usability electrodes may be classed into those for welding structural steels, alloy steels, heat-resistant steels, surfacing, etc.

Structural steels may be welded with fifteen classifications of electrodes: Э34, Э42, Э42А, Э46, Э46А, Э50, Э50А, Э55, Э60, Э60А, Э70, Э85, Э100, Э125 and Э145. The digits in the classification number indicate the guaranteed tensile strength, and the letter А stands for increased ductility of both the weld metal and the welded joint. Electrodes of classifications Э34, Э42, Э42А, Э46 and Э46А go to weld low-carbon and low-alloy steels; the next three classifica-

tions are for medium-carbon and low-alloy steels, while the remaining seven classifications are for structural steels of increased strength.

Heat-resistant steels may be welded with seven classifications of electrodes, namely,  $\Theta$ -M,  $\Theta$ -MX,  $\Theta$ -XM,  $\Theta$ -XM $\Phi$ , and  $\Theta$ -XM $\Phi$ B.

Separate U.S.S.R. Standards provide electrode classifications for ferritic, austenitic and other steels.

### *39. Core Wire Materials*

Core wire materials are made to a corresponding U.S.S.R. Standard which specifies the wire gauges, technical conditions, acceptance rules, test methods, packing and marking.

The Standard provides 56 types of welding wire. Electrodes for the manual and automatic arc welding of low- and medium-carbon and low-alloy steels are mostly made from CB-08, CB-08A, CB-08 $\Gamma$ A, CB-10 $\Gamma$ A, CB-10 $\Gamma$ 2, CB-08 $\Gamma$ C, and CB-08 $\Gamma$ 2C wire.

CB-08 and CB-08A wire contains not more than 0.1 per cent carbon and 0.35 to 0.6 per cent manganese. CB-08 $\Gamma$ A, CB-10 $\Gamma$ A and CB-10 $\Gamma$ 2 have an increased manganese content. CB-08 $\Gamma$ C and CB-08 $\Gamma$ 2C run an increased amount of both manganese and silicon.

Excess silicon in welding wire results in heavy sputtering, gassing in the weld pool, and nonmetallic inclusions in the weld metal. Silicon content therefore is kept down to 0.95 per cent.

Carbon welding wire also contains chromium (up to 0.2 per cent) and nickel (not more than 0.3 per cent).

The content of sulphur and phosphorus, both harmful impurities, should not exceed 0.04 per cent each. In CB-08A and CB-08 $\Gamma$ A wire as well as in alloy wire the maximum should be 0.03 per cent.

### *40. Electrode Coatings*

The coatings of welding electrodes serve several purposes: (1) to facilitate the establishment and maintenance of the arc; (2) to protect the molten metal from the oxygen and

nitrogen of the air by producing a shield of gas around the arc and weld pool; (3) to provide a slag blanket on the weld so as to reduce the rate of cooling; and (4) to provide a means of introducing alloying elements not contained in the core wire.

A large number of electrode coatings have been developed to date, more or less meeting the above requirements.

Coatings applied in a thin layer to a metal rod only serve the first purpose, i.e., they stabilise the arc, whence they are called *stabilising coatings*. No attempt is made to prevent oxidation and no slag is formed on the weld, nor are the mechanical properties of the weld metal improved. For this reason *lightly coated (or washed) electrodes may only be used for welding nonessential jobs*.

Of all stabilising coatings widest use is made of chalk which is made by solving 80 to 85 parts (by weight) of ground and screened chalk in 15 to 20 parts (by weight) of water glass. Other light coatings (A-1, R-3, OMA-2, etc.) have more complicated chemical compositions.

*Heavy coated electrodes*, sometimes referred to as *shielded-arc electrodes*, are used to obtain a weld metal of high quality, comparable with, and even superior to, the parent metal in terms of mechanical properties.

Soviet manufacturers produce a large variety of heavy coated electrodes developed by various research establishments and industrial laboratories. The compositions of some of them are presented in Table 7.

The welding characteristics of some coated electrodes are described below.

The most commonly used electrodes are OMM-2 electrodes which are of classification Э42 and are suitable for all-position welding with both a.c. and d.c. Their melting rate is 7.25 g/A-hr.

ЦМ-7 electrodes are also of classification Э42 and are widely employed for shop welding. They have a higher melting rate of 11 g/A-hr. ЦМ-7c electrodes have a heavier coating than ЦМ-7 electrodes and may only be used for welding in the downhand position with deep penetration (see Sec. 47).

ЦМ-7 electrodes are superior to the OMM-5 in that the welding speed is 30 to 40 per cent greater; the slag easily

Table 7

## Chemical Composition of Electrode Coatings

Classification	Coating ingredients	Proportion, per cent (by weight)
OMM-5 (developed by Orgametal)	Manganese ore (pyrolusite)	21
	Ferromanganese	20
	Starch or wood flour	9
	Titanium concentrate	37
	Feldspar	13
		<i>Total</i> 100
	Water glass mixed with water (2 parts in 1 part)	30 to 35 per cent (by weight) of dry ingredients
ИМ-7 (developed by the Central Heavy Engineering Research Institute)	Hematite (iron ore containing 95 per cent iron oxide [ $Fe_2O_3$ ])	33
	Granite	32
	Ferromanganese	30
	Starch	5
		<i>Total</i> 100
	Water glass	25 to 30 per cent (by weight) of dry ingredients
УОНН-13/45	Marble	53
	Fluorspar	18
	Quartz	9
	Ferromanganese	2
	Ferrosilicon	3
	Ferrotitanium	15
	<i>Total</i> 100	
	Water glass	25 to 30 per cent (by weight) of dry ingredients

comes off the weld and the coating does not contain any scarce ingredients.

VOHH-13/45 electrodes are of classification Э42А. They produce a weld metal of high quality and are well suited for essential applications. They operate on direct current, reversed polarity, i.e., with the electrode connected to the positive side and the work to the negative side of the welding generator.

Medium-carbon and alloy steels not heat treated upon welding are best welded with VOHH-13/55 electrodes producing a weld-metal tensile strength of at least 55 kg/sq mm and an impact resistance of 13 kg-m/sq cm.

#### 41. *Electrode Manufacture*

Electrode manufacture comprises the following operations:

- (1) Preparation of core wire.
- (2) Preparation of coating ingredients (drying, grinding and screening).
- (3) Proportioning.
- (4) Application of the coating.
- (5) Drying of coated electrodes.
- (6) Quality inspection of coated electrodes.
- (7) Grading and packing.

*Preparation of core wire* consists in cleaning, cutting and straightening the wire. The wire is cleaned of dirt and grease by washing it in hot water containing 5 per cent soda ash. It is then cut and straightened in machines at the rate of up to 200 electrodes per minute. Degreased and dried by heating to 80 or 90°C, the bare rods are sorted and stored in a dry room before they are given a coating.

*Preparation of coating ingredients* consists in roasting them to 2 or 3 per cent moisture content at 100 or 120°C in braziers or in rotary drum ovens. If the ingredients (ferroalloys, feldspar and quartz) are supplied in large lumps, they are reduced after roasting to smaller pieces (5 to 10 mm across) in jaw crushers or rolls. Both the crushed components and the components coming in already crushed (such as pyrolusite, ilmenite and scale) are ground in ball mills, screened and stored in separate closed bins or hoppers.

*Proportioning* consists in weighing the screened ingredients as prescribed by a given formula and mixing them intimately first in dry pans and then in mixers or manually, with water and soluble glass. The mixing lasts from half an hour to several hours, depending on the type of the coating produced. After mixing, the paste is passed through a sieve with 1,200 meshes per square centimetre to remove blobs or foreign matter.

*The core wire coating* can be applied either by dipping or by extrusion.

In the case of dip coatings some 25 to 30 rods are clamped vertically in a frame and immersed in a bath holding the coating compound. The dwell of the core wire material in the bath should be sufficient for the coating to spread over the core in a uniform layer of the desired thickness. This also depends on the consistency of the coating compound. If a single dipping does not result in the coating of the desired thickness, the electrodes should be allowed to dry in air for 30 or 40 minutes and dipped again as before.

The dipping technique suffers from low production rates, low quality, and is therefore not employed in large electrode-making shops.

In the case of extruded coatings, the core wire material passes through an extrusion press in which the coating compound is held in a cylinder under a pressure of 400 to 900 atmospheres. The actual application of the coating takes place in a die which has two accurately sized openings, an inlet (the diameter of the bare rod) and an outlet (the diameter of the coated electrode). By changing the die, it is possible to apply coatings to different rod sizes and to obtain various coating thicknesses.

The extrusion technique is preferable as it produces a uniform coating which melts steadily and makes welds of constant quality; the coating is stronger and is cheaper to apply.

*Electrodes with a dip coating are dried* either in the air or in well ventilated rooms at room temperature for 12 to 20 hours until the coating finally solidifies.

After drying, both dipped and extruded electrodes are roasted for 1 to 2 hours at up to 350°C, depending on the type of coating, to remove excess moisture, as this may im-

pair the stability of the arc. The moisture ~~content~~<sup>content</sup> should not exceed 4 per cent.

Coated electrodes are roasted in <sup>crs + gl</sup> pot furnaces, ventilated drying ovens, or electric-heated cabinets.

In modern electrode-making shops coated electrodes emerging from extrusion presses are fed into zone furnaces which both dry and roast the electrodes.

Quality control in electrode-making shops calls for constant check on the fineness of the ground ingredients, their proportioning and mixing, application procedures, moisture content, and drying conditions. In addition, the chemical analysis of the core wire is determined, the coating thickness is measured, and the electrodes are tested on trial plates.

Finished coated electrodes are sorted, wrapped in waxed paper, and bulk packed in wooden boxes. Each box weighs 25 to 40 kg. Before packing, the bare ends of electrodes are painted for identification. Electrodes are issued with certificates stating the name of the manufacturer, electrode classification, type and size, number of the batch, core wire grade, number of the Standard or chemical analysis of the core wire, date of manufacture, and test results.

# *Chapter V*

## **MANUAL ARC WELDING OF LOW-CARBON STEELS**

---

### *42. Welded Joints*

A weldment usually consists of several parts united by welded joints. There are several types of welded joints.

*The butt joint.* In a butt joint the two ends of the plates are abutted squarely against each other without overlapping.

The edges are prepared for welding, the type of edge preparation being determined by the thickness of the parts to be joined. The object of the edge preparation is to ensure the degree of penetration and ease of welding necessary to obtain a sound weld. Fig. 50 shows the basic types of edge preparations. The types of butt joints, edge preparations and welds are specified by an appropriate U.S.S.R. Standard.

When the parts to be welded are of light section, full penetration can be obtained if the edges of the parts to be welded are squared (*I* in Fig. 50). This is termed the square butt preparation. On a plate more than 5 to 8 mm thick the single-vee (or V) preparation is employed (*II* in Fig. 50).

The edges are bevelled so as to leave a root face at the bottom of the groove. This is done in order to prevent a burn-through when the first bead is run. The gap between the edges is left for better penetration. Its width should allow for some contraction when tack-welds are applied in a fit-up.

For a plate thickness of more than 12 mm, the double-V or X preparation is preferable. In this type of preparation (*III* in Fig. 50) the edges of both components are double-bevelled so that the groove profile forms two opposite V's or an X.

Joints welded from both sides offer the following advantages: for a given plate thickness the amount of filler metal per unit length of weld is almost halved; electrode and power consumption is lowered; and so is the welding time.



Type of joint preparation	Plate thickness, mm	Electrode size	Joint preparation
I	up to 5-8	3-4	
II	4-26	4-5	
III	12-60	4-6	

Fig. 50. Joint preparation for butt welding

Butt joints are best suited for plate weldments, such as vessels, pipes, boilers, etc. With butt welds, there are no steps on the surface of cylindrical weldments, and a uniform diameter is obtained along the whole length of the work. As full penetration is ensured through the entire thickness of the plate, the resultant joints have no cracks or irregularities where corrosion may start.

Butt joints are free from sharp changes in section or shape and other defects where stresses usually concentrate—a feature entirely undesirable in essential products, as they may develop cracks and fail in service.

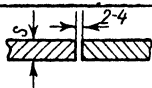
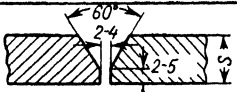
*The lap joint.* A lap joint is one in which the edges of two plates are set one above the other so that they overlap. The overlapping portion is called the lap (Fig. 51).

The width of the lap may be 3 to 5 times the thickness,  $s$ , of the plates to be welded. Welds are usually run on either side of the lap.

No edge preparation is required for a lap joint, and the joint is easy to line up. But the lap joint has its drawbacks in comparison with the butt joint: (1) some metal is wasted on the lap; (2) courses or tiers of cylindrical products to be lap-welded have to be of different diameters.

In essential weldments lap joints must be welded from both sides. The lap joint should not be used on plate thickness above 10 mm.

*The tee joint.* A tee joint is obtained by placing an edge of one part on a surface of another part at right angles to each other (Fig. 52). This type of joint is common in engineering structures.

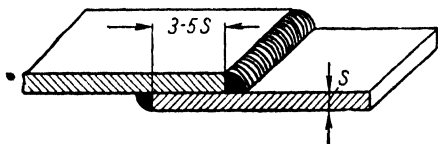

Fig. 51. Lap joint

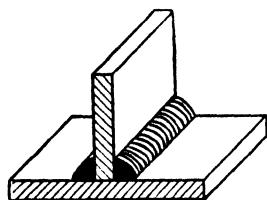

Fig. 52. Tee joint

Each of the listed joints has a number of variations, and their selection is governed by the shape of the weldment, and the purpose and service conditions of the resultant joints. In each particular case the designer should choose the best welded joint from the view-point of both welding and service.

### 43. Weld Types

A weld is a localised consolidation of metal by a welding process. Welds may be classed into butt (or groove) welds and fillet welds. Butt welds apply to butt joints, and fillet welds to lap and tee joints.

In outline, welds may be convex, flush and concave (Fig. 53). Convex welds are of heavier cross-section. Another name for them is reinforced welds. The excess metal shown at *a* is called reinforcement and is usually 0.2 of the thickness of the butt-welded plates.

Welds may be continuous or intermittent. A continuous weld runs the entire length of a joint, while an intermittent weld is a weld whose continuity is broken by unwelded spaces. In a tee or lap joint an intermittent weld may be

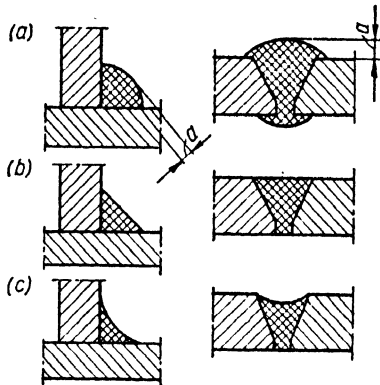

Fig. 53. Welds:  
*a*—convex or reinforced welds; *b*—flat welds; *c*—concave welds

straight, as in Fig. 54*b*, called the chain intermittent fillet weld, or staggered, as in Fig. 54*a*, called the staggered intermittent fillet weld. Each increment of welding *l* is 50 to 150 mm long. The unwelded space *m* is usually of the same length. Intermittent welds are employed when a tight

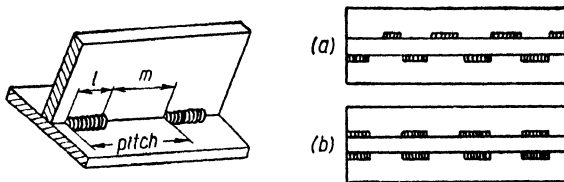

Fig. 54. Intermittent fillet welds:  
*a*—staggered intermittent fillet weld; *b*—chain intermittent fillet weld

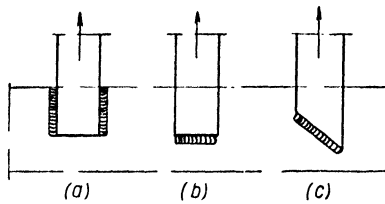

Fig. 55. Weld position relative to load:  
 a—longitudinally loaded; b—transversely  
 loaded; c—obliquely loaded

joint is not essential and when it is found that a minimum amount of welding will suffice to sustain a given load.

According to the direction of the load applied to welds they may be classed into longitudinal (or side), transverse (or end), and oblique welds (Fig. 55).

#### 44. *Technique of Manual Arc Welding*

To strike an arc, the operator marks the spot where it will be drawn, and brings an electrode, clamped in the electrode holder, close to the work. When the tip of the electrode is within 10 mm of the work, he raises his hand shield or brings forward his helmet (whichever may be used) to protect his face and eyes from harmful light and heat rays, quickly touches the work with the electrode tip and then immediately withdraws it a short distance (3 to 4 mm).

The arc should be held at exactly the right length throughout the welding operation by feeding the electrode into the welding zone as it melts.

In starting an arc, the operator may either jab at the work with the electrode tip (Fig. 56a), or strike at it as with a match (Fig. 56b). In both cases the electrode should be separated from the work, otherwise it may freeze to the metal.

Under normal conditions the operator has to restrike the arc only when changing electrodes. But it often happens that the arc has to be re-ignited when it goes out inadvertently. This seldom happens with an experienced operator and a stable arc. Apart from the skill of the operator, the stability of the arc depends on the welding source em-

ployed, the quality of the electrodes, and the welding procedure (welding amperage) adopted.

To pick up the weld when the arc has been broken, the arc should be struck just ahead of the crater, then quickly moved back along the completed weld, then the welding should proceed forward after the crater is completely remelted (Fig. 57). Where the arc was broken the weld metal

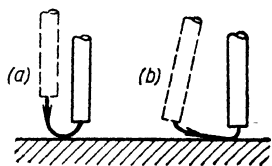

Fig. 56. Starting an arc:  
a—jabbing; b—match striking

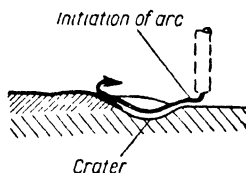

Fig. 57. Restarting a broken arc

may be of inferior quality; therefore, the operator should maintain the arc without interruption until the electrode is consumed. In starting a new electrode it is essential to thoroughly remelt the spot where the arc was interrupted. A crack may appear in the crater at the end of the weld, and so it should be filled up completely.

*Penetration.* For a weld to be sound, it is essential that absolute fusion be obtained between the parent metal and electrode metal. Therefore, the surface of the parent metal should be thoroughly melted so as to form a crater of sufficient depth; otherwise, a shallow crater, if any, will result. In such a case the globules of molten electrode metal will not be able to fuse with the parent metal, and some of them will be deposited on an unmelted surface. The resultant weld will be poor. To obtain a good weld, the depth of penetration must be not less than 1.5 to 2 mm. In manual arc welding it may vary between 1.5 and 5 mm, depending on the welding current. A measure of penetration can be provided by the appearance of the crater. When the arc is broken and the crater solidifies, its size remains the same as in the presence of the arc. Penetration usually extends 1 to 2 mm beneath the bottom of the crater.

The depth of penetration depends on the amount of heat given up by the arc, which in turn depends on the arc current. A section through several beads deposited on a plate of steel with various welding currents may give an idea of how the welding current affects the depth of fusion.

Bead *I* (Fig. 58) was deposited with an appropriate welding current, bead *II*, with too low a current, and bead *III*,



Fig. 58. Section through beads deposited with different currents

with excess current. The toes of bead *I* smoothly change into the parent metal. The parent metal beneath the bead was penetrated thoroughly, and the bead has fused with the parent metal to give a sound joint.

Due to insufficient current in depositing bead *II* there was lack of penetration. Therefore, the electrode metal has only fused with the parent metal at the middle of the bead to a shallow depth. The toes of the bead are rounded, sharply changing into the parent metal. This weld lacks strength.

Due to excess current in depositing bead *III*, the crater has not been filled with electrode metal, and undercuts have formed at the toes of the bead, reducing the thickness of the parent metal and, consequently, the strength of the weldment. Undercuts are places where stresses concentrate, and are especially dangerous in the case of fatigue and impact loads, as they may give rise to cracks.

The following equation may serve as a rough guide in selecting the welding current:

$$I = (40 \text{ to } 60) d,$$

where  $I$  is the welding current in amperes, and  $d$  is the core wire diameter in millimetres.

Thinly coated electrodes require lower currents, while heavily coated electrodes should be used with large currents.

The optimum welding current for a given electrode type and size and for a given section and nature of the parent metal may be found by trial and error, depositing beads on trial plates with different welding currents (as found from the above equation) and watching the crater and the

appearance of the weld. Larger currents should be chosen for heavier sections and electrode sizes, as more heat is required to obtain good penetration in a heavy section which acts as an efficient heat sink. First, an electrode size for a given plate thickness (see Fig. 50) should be chosen, and then the welding current matched with it.

*Motions of the electrode.* In manual operation of the metal electrode process there are three essential motions of the electrode.

One motion is the continuous downward feeding of the electrode (1 in Fig. 59) to compensate for the metal melted off its end. The operator should learn how to determine the feed rate: if the electrode is fed slower than it melts the length of the arc will increase and the arc may possibly break. When the electrode is fed faster than it melts, it may touch and freeze to the work. The arc length, therefore, should be as short as possible without sticking.

The second is the advancing motion of the arc along the joint (2 in Fig. 59). The rate of arc advance has a marked effect on the weld quality and depends on the welding current, electrode size, weld type, etc. When the arc is moved too fast along the joint, there is not sufficient time for the parent metal to melt, and there will be lack of penetration. In addition, the bead will be low and of small cross-section. When the arc is advanced too slowly, a broad bead with excessive reinforcement will result, which involves waste of metal and power, reduces welding speed and overheats the metal.

If the rate of arc advance is chosen correctly, the bead should be of regular cross-section, as shown at 1 in Fig. 58. When the arc is advanced without any criss-cross movement, the width of the bead is usually 1 or 2 mm greater than the electrode diameter. This is called a string bead.

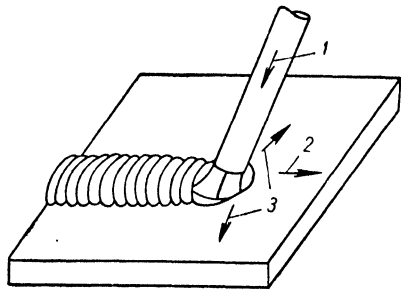

Fig. 59. Motion of a welding electrode

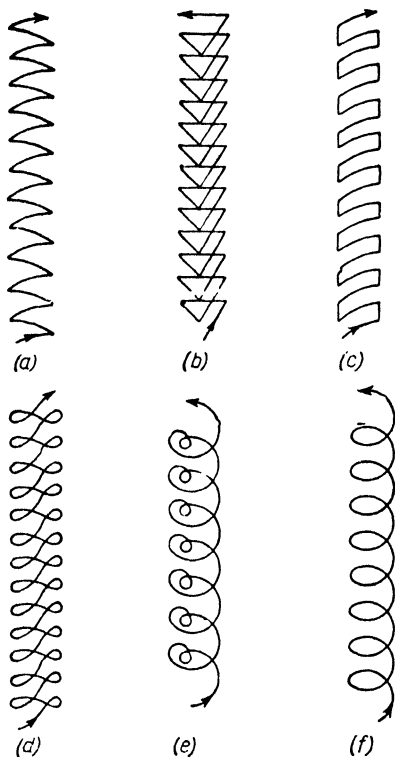

Fig. 60. Diagram of weaving motion of electrodes

The third is the sidewise or lateral motion ( $\mathcal{B}$  in Fig. 59). This motion, or weaving, is used when a spread (or weave) bead is required. Weave beads are common in butt and fillet welds.

Weaving may be accomplished in a variety of patterns, depending on the type of weld and joint preparation. Fig. 60 shows various weaving patterns. Those shown at *a* and *b* are most common in butt welds. To obtain adequate penetration there should be a hesitation in the weaving motion for a short interval at the sides of the groove. For fillet welds weaving patterns *b* and *c* are appropriate. The pattern *d* is employed where more heat has to be applied to the middle of the weld. The pattern *e* is used for the heavier plates.

The width of a bead does not usually exceed 2.5 diameters of the electrode.

If the width of a bead is to be the same over the entire length of a joint, the swing of the weaving motion should be constant. It requires some practice to get the knack of weaving the electrode in equal swings.

A correct, well penetrated and sound weld of high quality can only be obtained if the operator's movements are precise in all three directions—which is also acquired by practice.

To sum up the conditions necessary for high-quality welding, the operator must:

—properly adjust the welding current to suit the type and size of electrode, welding position (downhand, vertical, or overhead) and plate thickness;

—hold the arc at exactly the right length;

—not break the arc before the electrode is fully melted;

—thoroughly remelt and fill in any craters occurring when the arc is broken;

—maintain a correct and constant rate of electrode motion in the three directions;

—deposit a weld only on a well prepared and thoroughly cleaned surface.

#### 45. Positions of Welds

By their position all welds may be classed into four basic groups, namely, downhand (or flat), horizontal, vertical, and overhead. There may also be intermediate welds.

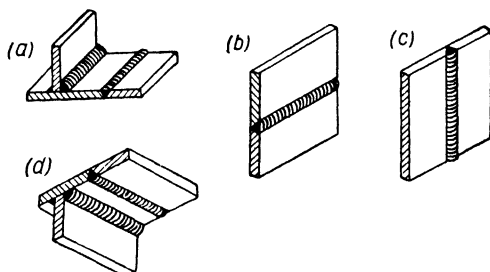

Fig. 61. Positions of welds:

a—downhand welds; b—horizontal weld;  
c—vertical weld; d—overhead weld

Under Soviet nomenclature,<sup>1</sup> a *downhand* (or *flat*) weld is a weld running in any direction on a horizontal surface (Fig. 61a); a *horizontal* weld is one which runs horizontally

<sup>1</sup> The classification of welds and positions of welding adopted in the Soviet Union places under the heading of "downhand welding" fillet welds made in both the downhand position proper and in what is termed the horizontal position in American usage (see "AWS Definitions. Welding and Cutting", 1961, p. 36) or the inclined position in British usage (see "British Standard 499:1952")—*T\**.

on a vertical surface (Fig. 61b); a *vertical* weld is one which runs vertically on a vertical surface (Fig. 61c); and an *overhead* weld is one which has to be deposited above the operator's head (Fig. 61d).

**Downhand welds** are the easiest to make as the molten metal will not run out of the crater. The globules of molten electrode metal fall into the weld pool. Downhand welds are also convenient to watch in progress. Therefore, in welding various jobs, they should be positioned to allow welding in the downhand position.



Fig. 62. Section through deposited beads

Downhand welding applies to padding welds, butt welds, and fillet welds.

A *padding* weld is a succession of overlapping weld beads merging so as to produce an even surface. It is used in building up broken or worn parts, in repairing machining defects, for obtaining local bosses on a part, and for filling in large cavities when heavy sections are being welded.

A padding weld may be of either the single-layer or the multilayer type. Before depositing a padding weld, the surface should be thoroughly cleaned with a steel wire brush, and the first run using a narrow or a slightly spreading bead deposited at the edge of the surface. Then the next run is deposited, watching that it unites thoroughly with both the parent metal and the first bead, as shown in Fig. 62a. Should the two adjacent padding beads be separated by a depression, the padding will not be continuous (see Fig. 62b). Before adding the next bead, the beads already deposited should be thoroughly deslagged with a pointed chisel or hammer and a steel wire brush.

In multilayer padding, each layer should be thoroughly cleaned of slag, sputter, etc. Cleaning should be particularly thorough when using heavy coated electrodes, as they produce more slag than thinly coated ones. Every next layer of padding beads should be deposited across the one lying beneath.

**Downhand welding of butt welds.** In the case of the square butt preparation, which is usual on plate up to 5 or 8 mm thick, the gap is 2 to 4 mm wide.

A slightly spreading bead is deposited along the joint. The operator should take care that the fusion faces are well melted and that the reinforcement does not exceed 2 mm. After the joint has been welded from one side, the job is turned over and welded from the other side. Before welding from the reverse side, excess metal should be chipped back and the joint should be thoroughly cleaned with a steel wire brush.

In the case of the single-V preparation in plate 6 to 8 mm thick, a single-layer weld is deposited. Special emphasis

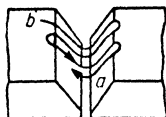

Fig. 63. Electrode motion in a single-V groove weld



Fig. 64. Build-up sequence

should be placed on the proper penetration of the fusion faces *a* (Fig. 63). The arc should be started at *b* near the edge of the bevel and then shifted into the groove so as to obtain good penetration at the root of the weld. The arrows in Fig. 63 show the progress of the arc.

When traversing the fusion faces, the advance of the arc should be slowed down so as to obtain better penetration. When going over from one fusion face to the other, the electrode should be moved quickly, otherwise the weld root may be burned through.

In plate more than 8 mm thick, the weld is deposited in two or more layers. The first layer is built up to a height of 4 or 5 mm with an electrode 3 or 4 mm in diameter. After the first layer has been cleaned, the next layer is deposited with an electrode 4 to 5 mm in diameter. In multilayer welding it is essential that every preceding layer be cleaned of slag and spatter. The fusion faces should be well penetrated (Fig. 64). After the groove is filled, the work is turned over, the joint is chipped back on the reverse side either manually or with an air hammer and a sealing bead is deposited. When there is no access to the weld root from

the reverse side, it should be sealed thoroughly by the first layer.

The procedure for joints with the double-V preparation is the same as for the single-V preparation.

The double-V preparation is applicable to plate over 12 to 20 mm thick. The groove is filled with multilayer beads from either side. The number of layers depends on the plate thickness.

A disadvantage of the double-V preparation is that the job has to be turned over if the reverse side is to be welded in the downhand position.

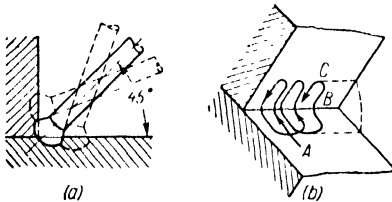

Fig. 65. Electrode motion in welding a fillet weld

**Welding of fillet welds.** Fillet welds are usually welded in the downhand position<sup>1</sup>, one surface being placed horizontally and the other vertically. The weld is

deposited in the angle formed at the intersection of the two surfaces. Fillet welds often suffer from poor fusion at one surface and poor penetration at the root of the weld. In welding fillet welds the electrode should make an angle of 45° with both surfaces (Fig. 65). This angle, however, may vary when more heat is required on any of the surfaces (Fig. 65a).

As is the case with butt welds, fillet welds can be deposited either in a single pass or in many passes. Fillet welds up to 10 mm in size are usually made in a single pass. In welding a fillet weld, the arc is struck on the horizontal surface, at a distance equal to the fillet leg plus 3 or 4 mm (at point A in Fig. 65b). Then the electrode is moved as shown in Fig. 65b.

The weld should not be started at B or C (Fig. 65b), as molten metal will run over the unmelted parent metal, and there will be lack of penetration and incomplete fusion at the root.

<sup>1</sup>Classed as the horizontal position in the U.S. and the inclined position in the U.K.—Tr.

When making a fillet weld in two passes, the first layer is deposited with an electrode 3 or 4 mm in diameter without weaving, ensuring good penetration at the root of the weld. The other layer is deposited with the electrode moved as shown in Fig. 65*b* or Fig. 66.

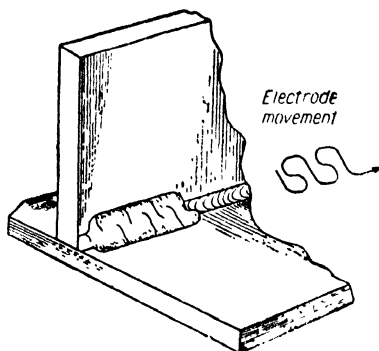

Fig. 66. Electrode motion in welding a fillet weld in two passes

The following are the most common defects in butt welds:

(1) Lack of root penetration, Fig. 67*a*. This reduces the strength of the weld and may give rise to cracks. In most cases it occurs when no scaling run is applied to the reverse side of the joint.

(2) Lack of fusion at the fusion faces, Fig. 67*b* and incomplete penetration, Fig. 67*d*. The causes may be too low a welding current, too long an arc, and improper weaving procedure.

(3) Misalignment of the edges in assembly. This may result in poor penetration at the root, Fig. 67*c*.

(4) Excessive or insufficient reinforcement. Reinforcement should usually be 0.2 of the plate thickness. Excessive reinforcement, Fig. 67*f*, does not improve the strength of the weld, but increases electrode consumption. Due to sharp changes in plate thickness, stresses may concentrate at this point, leading to the failure of the welded joint. On the other hand, a weld with the top layer finished below the plane of the parent metal reduces the strength of the welded joint.

(5) Undercuts at the toes of a weld, Fig. 67*e*. They reduce the cross-section of the plate and may lead to failure of the welded joint. Undercuts result from incorrect welding procedure with too heavy a current.

The most common defects in fillet welds are:

(1) Lack of root penetration, Fig. 68*a*, which appreciably reduces the strength of the weld.

- (2) Undercuts at the toes of the weld, Fig. 68b and c.  
 (3) Overlaps, Fig. 68b or protrusion of weld metal at the toe of a weld beyond the limits of fusion.

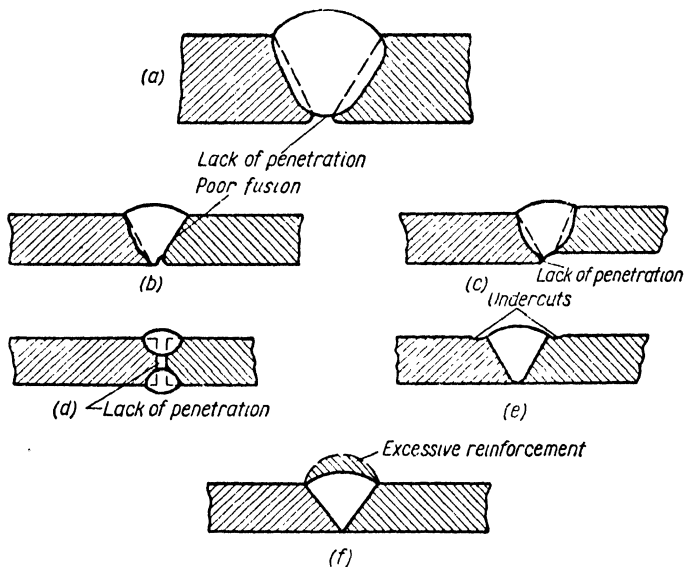

Fig. 67. Most common defects of butt welds

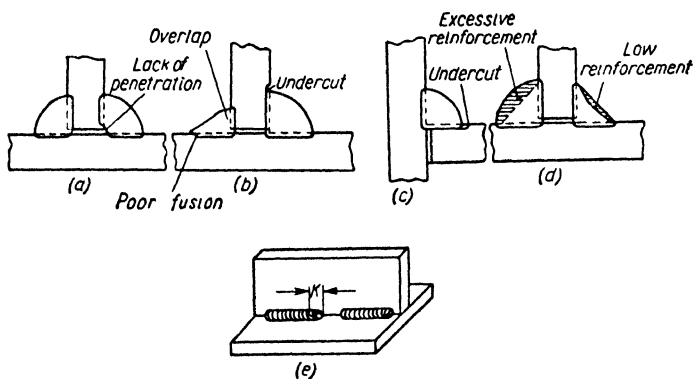

Fig. 68. Most common defects of fillet welds

In addition to these defects, fillet welds may suffer from the same defects as butt welds, such as excessive or low reinforcement as in Fig. 68*d*.

Unfilled craters (at *K* in Fig. 68*e*) are also welding defects.

**Welding in the vertical position.** In vertical welding, globules of molten electrode metal and molten metal in the crater tend to flow downwards, Fig. 69*a*. Therefore, a short arc is essential, so as to reduce the distance between the molten electrode tip and the weld pool to a point where mutual attraction comes into play. The globule at the electrode tip merges with the molten metal in the crater, Fig. 69*b*. When the globule goes across into the weld pool, the crater becomes overfilled, and excess metal may spill off by gravity. To avoid this, the electrode should be rapidly run up or aside without breaking the arc. Then the weld pool will solidify without spilling any molten metal. Vertical welding may be recommended both in the upward and downward direction.

In welding *upward*, the arc is struck at the bottom of the joint and is gradually moved up. The rate of arc advance should correspond to the rate of metal deposition. If the arc is allowed to dwell too long at one point, the deposited metal will flow down. As soon as the arc is moved farther up, the deposited metal solidifies, forming a shelf on which the subsequent globules of molten filler metal are deposited. This facilitates vertical welding in the upward direction. The electrode should be slightly tilted in the direction of welding, Fig. 69*c*. This gives good penetration of both the parent and deposited metal.

In welding *downward*, the arc is struck at the top and the electrode is held at right angles to the surface, as at *1* in

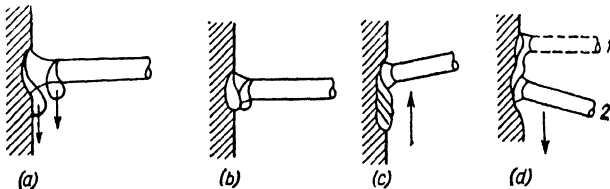

Fig. 69. Electrode position in vertical welding

Fig. 69d. As soon as a globule of molten metal forms at the tip of the electrode, the latter should be tilted downwards, as shown at 2 in Fig. 69d, in order that the arc may be played on both the parent metal and the deposited metal. The arc should be short enough for the electrode tip to be able to uphold the molten metal, and for the globules at the electrode tip to be transferred into the weld pool by attraction.

In both cases the electrode should be moved from side to side in advancing the arc so as to obtain proper fusion and size of bead.

It should be noted that in welding downwards, fusion is not so good as in welding upwards, as the molten metal does flow over the unmelted parent metal. Besides, the welding speed is higher, and this also influences the amount of penetration.

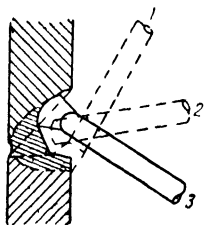

Fig. 70. Electrode position in horizontal welding of a butt weld

Vertical butt welds with a single-V and double-V preparation, as well as vertical fillet welds, are made by much the same technique as their downhand counterparts. In vertical welding it is good practice to use electrodes not more than 4 mm in diameter, as with larger electrodes it is more difficult to prevent the molten metal from spilling downwards.

In some cases the first bead in multilayer vertical welds is deposited downwards, and the subsequent beads from the bottom up.

**Horizontal welding** bears a very close resemblance to vertical welding. Most common are horizontal butt welds in vessels and reservoirs. The joint preparation is usually limited to a single bevel on the upper member (Fig. 70). The arc is started somewhere on the lower horizontal edge and is then moved onto the bevelled fusion face, while tilting the electrode backwards, as shown at 1, 2 and 3 in Fig. 70. At c welding resembles overhead welding, and the appropriate procedure must be followed. In plate more than 8 or 10 mm thick, horizontal welds are made in several subsequent passes.

**Overhead welding.** Overhead welds are far more difficult

to make than others. The puddle here is upside down, and the molten metal tends to run down.

The most important point in overhead welding is that the arc should be held as short as possible in order to facilitate the transfer of the electrode metal into the puddle. When the molten electrode end touches the overhead pool, forces of surface tension and adhesion lift the globule off the electrode and cause it to spread over the pool surface.

Fig. 71 illustrates metal transfer in overhead welding. Overhead welding requires much practice to learn how to deposit good welds.

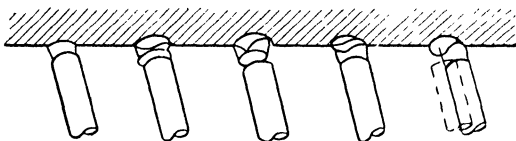

Fig. 71. Droplet transfer in overhead position of welding

In overhead welding the current and electrode size must be smaller than in downhand welding, as the pool is not so large and the amount of molten metal is reduced.

#### 46. Arc Welding with D. C. and A. C.

Arc welding is possible with both d.c. and a.c.

When welding with d.c., it is customary to connect the work to the positive side of the generator, and the electrode to the negative side. This is known as welding on *straight polarity*. When the electrode is connected positive and the work negative, the arrangement is termed *reversed polarity*.

Low-carbon steels are almost always welded on straight polarity, as more heat is liberated at the positive connection which, in this case, is the work itself. This assists the heating of the work.

Reversed polarity is used in welding with some electrode types and in welding light gauges and some special steels.

When alternating current is used, the polarity is reversed 100 times per second (if a current of 50 c/s is used),

and there is no difference in the heat developed at either side (work and electrode). Polarity therefore ceases to be important.

Both d.c. and a.c. can inherently produce equally good welds provided suitable electrode types and welding procedures are employed. From an economical point of view, a.c. welding is preferable as less electric power is consumed, a.c. equipment is less expensive and simpler to service, compared with d.c. equipment.

#### *47. Advanced Arc Welding Techniques*

The **touch** (deep penetration) **technique** is an advanced welding method improving both production rate and weld quality.

With the touch technique the arc is struck as usual. The electrode is then slightly pushed on so that the lip of the coating bears upon the parent metal. The electrode is advanced straight along the seam, with slight pressure applied along the axis of the electrode. The electrode should be tilted 10 to 15 degrees from the vertical in the direction of welding. The rate of electrode advance should be such that the molten metal and slag are left behind and the electrode cannot be short-circuited to the parent metal through the weld pool. When narrow welds are desired, the pressure on the electrode in the direction of welding is increased. A decrease in pressure will produce a broader weld. Electrodes should be of a heavy coated variety. Good results have been obtained with IJM-7c electrodes. The heavy coating is necessary in order to have a durable lip with which to bear upon the parent metal in welding.

This technique gives a deeper penetration than any conventional method, as the heat of the arc is concentrated within the small area bounded by the lip of the coating. For the same reason the production rate is some 50 per cent higher. The touch technique is mainly applicable to downhand single-layer welds in tee (Fig. 72), lap and corner joints, and to single-layer butt welds. It is less efficient, though feasible, on multilayer welds.

**The bunched-electrode technique.** Two or more electrodes are bunched by means of a fine wire at two or three places

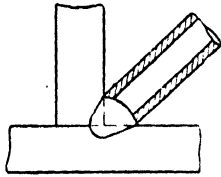

Fig. 72. Touch technique of welding

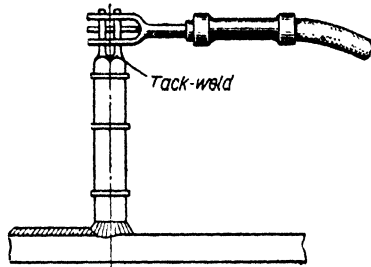

Fig. 73. Welding with bunched electrodes

along their lengths and tack-welded where they are clamped in an electrode holder (Fig. 73). Current is conducted simultaneously to all the electrodes in the bunch.

The arc is maintained between the work and the nearest electrode. As soon as one electrode melts the arc is initiated at the next electrode closest to the work. Thus the arc travels from one electrode to another as each one melts. This technique increases the production rate by about 30 per cent compared with single-electrode techniques using the same size of electrode. This is because it is possible to raise the welding current without running the risk of overheating the electrodes; the time for electrode replacement is reduced and the heat of the arc can be better utilised.

Unfortunately, it is impossible, with this technique, to maintain the weld size constant along the entire length of lap welds. For this reason it cannot be recommended for use where lap joints are employed in essential structures

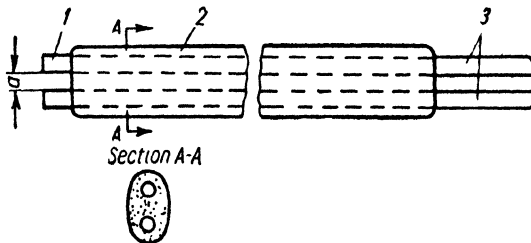

Fig. 74. Electrodes for three-phase arc welding

(such as bridges). Another drawback is that electrodes have to be specially bunched.

**The three-phase arc.** The equipment for three-phase arc welding is described in Chapter II. This technique also calls for a specially designed twin electrode (Fig. 74), consisting of two rods 1, covered with a suitable coating 2. At one end 3 the rods are stripped of their coating for connection to a special electrode holder which conducts current to each of the rods separately.

In welding, two phases of a welding source are connected to the electrode holder, and the third phase is connected to the work. The rod spacing  $a$  is 5 to 6 mm.

The metal is melted simultaneously by the three arcs which produce a large amount of heat. As a result, the melting rate of the electrodes and the production rate are almost doubled in comparison with a single-phase arc. As the heat of the arc is better utilised, energy consumption per kilogram of deposit averages 2.75 kWh instead of the 3.5 or 4 kWh with a single-phase current. The welding technique with a three-phase arc is somewhat hampered by the increased weight of the electrode holder which has to take two twin electrodes.

**Welding with large-size electrodes.** Another way to raise production rates in welding is to use electrodes 6.5, 8 and 10 mm in diameter.

It should be noted that the usability of electrodes 8 and 10 mm in diameter is limited, as they require an oversized electrode holder. The total weight of 8 and 10 mm electrodes and an electrode holder is rather large and quickly tires the operator.

#### *48. Welding at a Low Temperature*

At a low ambient temperature the molten metal of the weld pool is cooled faster than under normal conditions. This results in a higher content of gas and nonmetallic inclusions in the weld metal and impairs the mechanical properties of welded joints. To avoid this, measures should be taken to retard the cooling of the molten metal. One way is to increase the welding current 10 to 20 per cent above that for normal ambient temperature.

Heavy gauges should be welded by a technique resembling padding (see Sec. 50). In some cases preheating and concurrent heating should be used, as in putting a patch in a plate.

When working outdoors in winter it is a good plan to put up screens around the scene of welding operations and especially around the seam being welded.

The work should never be struck with a sledge in assembly or welding at low temperatures.

The metal should be free to contract after welding.

Preference should be given to electrodes which produce a deposit of maximum toughness and ductility such as E42A and E50A electrodes.

The adverse effect of low temperature on the mechanical properties of welded joints limits the usability of welding in some of the cases mentioned in the relevant specifications and standards for weldments.

# Chapter VI

## EXPANSION, CONTRACTION, DISTORTION AND RESIDUAL STRESSES IN WELDING

### 49. Causes of Thermal Strains and Stresses

In arc welding the work is raised to the melting point within a very limited area, but the temperature drops sharply as we move away from the heated spot. This is due to the high thermal conductivity of the workpiece, the subsequent rapid runaway of the heat, and the insignificant volume of the heated metal. This condition prevents the uniform expansion of the metal and may produce serious internal strains, distortion, and warping.

To illustrate the internal stresses set up in the plate during arc welding, we will assume a plate of steel divided into

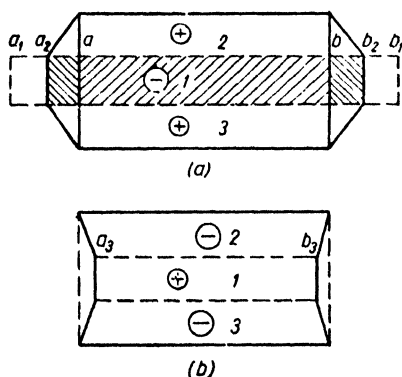

Fig. 75. Stresses set up in steel plate by welding:  
a—in heating; b—in cooling

three zones of equal width (1, 2, and 3 in Fig. 75a).

As zone 1 is raised in temperature, it will tend to expand. If it were free to expand longitudinally, its length would soon be  $a_1b_1$ . However, zones 2 and 3 restrain its longitudinal expansion, as they are not so hot as zone 1. This will result in compression stresses (marked with the minus sign) in zone 1, and in tension stresses in zones 2 and 3 (marked

with the plus sign). Zone 1 is now free to expand to  $a_2b_2$  only, and it may be considered compressed by the amount  $a_1a_2 + b_2b_1$ , or subjected to plastic flow.

In cooling, zone 1 will tend to contract longitudinally by the amount  $aa_1 + bb_1$ . But it will be restrained from contracting by zones 2 and 3. As a result, zone 1 will be under residual tension stresses, and zones 2 and 3 under compression stresses.

When fully cooled, zone 1 will have the length  $a_3b_3$  (Fig. 75b), which is shorter than the original length  $ab$ , resulting in a plastic flow or permanent deformation of metal.

The halves of a butt-welded plate cut along its axis, Fig. 76a, will warp as shown in Fig. 76b. The butt weld restrains warping. The resultant transverse stresses in the weld will be distributed as follows (Fig. 76c): tension stresses will be set up in the middle of the weld, and the ends of the weld will be under compression stresses.

The *structural changes* brought about in the metal by the welding heat are accompanied by volumetric changes and, therefore, give rise to locked-up stresses. This happens in the following way. When reaching a definite point in heating or cooling, the structure of steel undergoes a transformation, the different structures having different densities. For example, when low-carbon steel is raised to the point at which its ferritic structure transforms into austenite, its volume is somewhat reduced, as austenite has a higher density than ferrite. When steels high in carbon are cooled rapidly, the austenite changes into martensite at 200 to 350°C. The martensite is of lower density and has a greater volume than the austenite. This change brings about internal stresses.

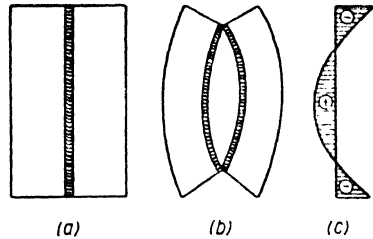

Fig. 76. Transverse strains and stresses

## 50. *Methods of Controlling Distortion and Stresses in Welding*

The operator should have a working knowledge of the causes of stresses in metal during arc welding and of the ways and means of controlling them.

Molten metal expands in volume; when it cools, it contracts. In welding, both the heated and cold metal are parts of a whole. Therefore, when contracting in cooling, the heated metal will cause the adjacent cold metal also to contract. If this contraction is not restrained, no stresses will be set up in the weld, but the work may warp. Conversely, if the cold parent metal restrains the contraction of the weld, no warping will take place, but contraction stresses will be set up in the weld.

Internal stresses remain locked up in welded joints, as contraction in them is usually restrained. But these stresses vary widely in magnitude from negligible to very large. They may sometimes exceed the strength of the metal and will then give rise to cracks in the weld or in the parent metal. Locked-up stresses are harmful, as they may impair the strength of the weldment; it sometimes happens that the internal stresses only require a slight addition from external loads to exceed the strength of the structure and thus produce failure.

The best method to relieve stresses is to anneal weldments. Unfortunately, this can only be accomplished in furnaces which cannot accommodate any weldment. Stress-relieving heat treatment therefore is obligatory only for essential articles, such as boiler drums and high-pressure vessels. In some cases this heat treatment may result in warping.

Apart from corrective heat treatment in the form of annealing, distortion and stresses may be controlled by suitable welding sequences, welding of unclamped parts, etc.

In welding heavy gauges, use is sometimes made of preheating and the cascade sequence, a variety of multipass welding (Fig. 77).

In welding by the cascade sequence, the first to be deposited is a short increment *1* about 200 to 300 mm long. It is then overlapped by another layer *2*, which is twice as long. The third layer *3* is 200 to 300 mm longer than the

second layer, and so on. The layers are deposited until the groove is filled for a small length of the joint. Short beads are then deposited on either side of the metal already deposited. With this sequence the welding zone is kept hot



Fig. 77. Cascade sequence of welding

until the weld is completed. This amounts to concurrent heating which reduces locked-up stresses and prevents cracking.

It should also be borne in mind that the amount of contraction increases with the amount of metal deposited, while internal stresses grow in magnitude if the contraction is restrained. Therefore,

no excess metal should be deposited. All welds should be made to drawings, without increasing their cross-section "just in case".

The gap between the plates to be weld-

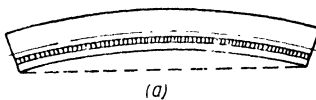

(a)

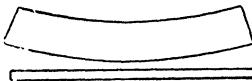

(b)

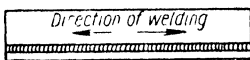

(c)

Fig. 78. Welding a Tee-beam from two strips:

a—warpage in a Tee-beam welded from two strips; b—counter-camber prior to welding; c—Tee-beam after welding (arrows show welding sequence)

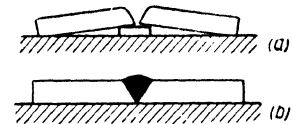

Fig. 79. Control of warpage in butt welding of two plates

ed should be as small as possible but sufficient for good penetration. Excessive gaps should be avoided. The included angle should not exceed  $60^\circ$ . For heavy sections the double-V preparation should be preferred.

The warpage caused by internal stresses may be effectively controlled by a counter or opposing effect or distortion. In a tee joint, for example, warpage usually occurs due to the contraction of the weld, Fig. 78a. By giving the vertical member a slight reverse bend, or counter-camber, prior to welding, Fig. 78b, the weldment will straighten itself after welding, Fig. 78c.

In welding two plates with a single-V preparation, it is a good plan to place a backing strip under the joint so that an increased opening is formed, as shown in Fig. 79a. After welding the plates will align themselves.

Where the counter-distortion is not possible, study of the job may be recommended so as to arrange the welds in a sequence that will keep distortion to a minimum. The

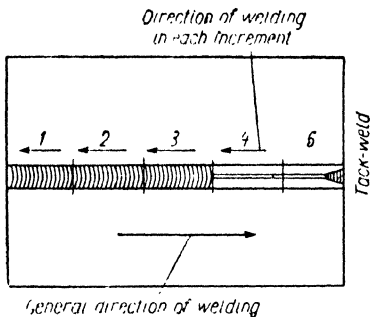

Fig. 80. Back-step sequence of welding

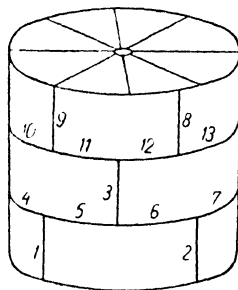

Fig. 81. Welding sequence for a reservoir

direction of welding should be away from the point of restraint and towards the point of maximum freedom.

For butt welds an efficient sequence is the back-step method of welding (Fig. 80). The weld is broken up into short increments 150 to 200 mm long, and each increment is welded separately, working in the sequence shown in Fig. 80.

This technique eliminates almost all warpage, due to the fact that the increments are short, and so the longitu-

dinal stresses, which grow with the length of a continuous weld, never reach any appreciable magnitude.

The back-step method is effective against longitudinal warpage and should be applied to long seams, while taking care to remelt and fill up the craters where the increments meet.

When welding a cylindrical vessel consisting of several courses or tiers, the longitudinal seams should be welded first, followed by the circumferential seams (Fig. 81). If welded in reverse order, the longitudinal welds would be restrained.

In welding jobs of a large surface area consisting of several plates (such as vessel bottoms, platforms, decks, etc.), the transverse seams should be welded first, followed by the longitudinal seams (Fig. 82).

In welding an I- or H-beam, the first to be welded are the joints within each web plate and flange, and then the butt joints between the web plates and flanges of a beam. If an I- or H-beam has stiffeners, they should be welded in place before the webs and flanges are assembled (Fig. 83).

It is impossible to give exact sequences for all possible cases. In each particular case the welder should learn the instructions for a given weldment, including the sequence of welds. In many cases he may follow a sequence of his own, provided he knows the way residual stresses work in his job.

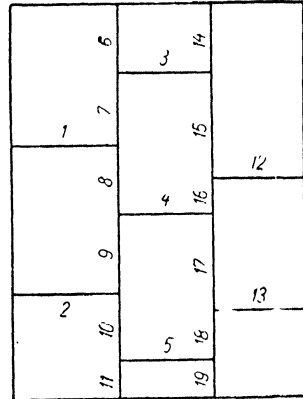

Fig. 82. Welding sequence for a plate decking

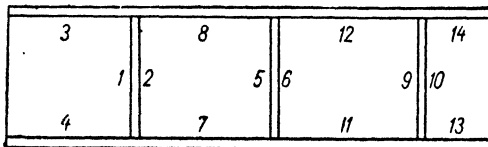

Fig. 83. Welding sequence for an H-beam with stiffeners

When light gauges are welded, it is advisable to place copper chill blocks under the joints. As copper has a high thermal conductivity, it will abstract much heat from the weld, thus reducing the heating and warpage of the plates.

If a weldment warps despite the precautions taken, there are ways and means of correcting the defect, using either mechanical or thermal methods.

Mechanical methods involve presses, jack-screws, straightening rolls, sledges, and special fixtures.

Thermal methods involve the local heating of a warped spot. Any source of heat may be employed—an oxyacetylene torch, a carbon arc, powerful oil or gas burners, etc. This technique is based on the fact that metal distorts when heated nonuniformly and contracts in cooling.

Thermal methods apply to metals which do not change their properties when heated to the corrective temperature.

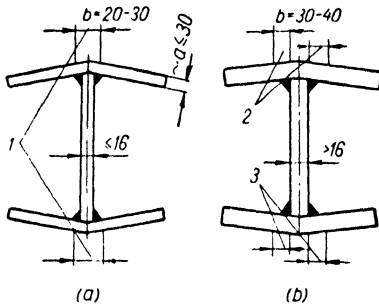

Fig. 84. Correction of mushroomed flanges of welded H-beams; 1, 2, 3—areas of heating

Heat should always be applied on the convex side of the warped work. Repeated applications may be required if the plate is badly distorted, working gradually from the middle outwards. The heating zone in a single pass may be one or two plate thicknesses. Fig. 84 shows distortion correction on the mushroomed flanges of H-beams. With a web thickness of not more than 16 mm and a flange thickness of not more than 30 mm as in Fig. 84a, heat is applied to a single area 20 to 30 mm wide along the axis of the beam, raising the temperature to 700 or 800°C.

When the web thickness is greater than 16 mm, heat is applied to two areas each 30 to 40 mm wide, running over the web seams. Sometimes repeated applications may be required for this.

## *Chapter VII*

# **MANUAL ARC WELDING OF SPECIAL STEELS**

---

### *51. General*

In welding high-carbon and alloy steels, difficulties may be encountered which do not arise with low-carbon steels.

These difficulties are increased hardness and reduced ductility (due to welding heat) which lead to cracking, changes in analysis and structure and, as a corollary, changes in the physical properties of the metal in the heat-affected zone.

Welding procedures have a direct bearing on these changes.

Higher welding speeds promote hardening in the near-weld area, as the rate of cooling is then also increased. A similar effect is produced by reduced welding currents, especially when welding substantial jobs. The wind, draughts and frost also work in the same direction. On the other hand, preheating to 80 or 100°C will reduce the rate of cooling from the quenching temperature and will reduce the hardness of the quenched layer in the heat-affected zone.

Cracks are mainly caused by appreciable stresses set up by changes in the volume of the metal due to heating and cooling.

The difficulties that may be encountered in welding an alloy steel, may be gauged by an approximate assessment of its weldability. By this method, the aggregate content of alloying elements (manganese, silicon, chromium and nickel) in a steel is related to its carbon content. The ratio gives a measure of steel weldability (Table 8).

## Weldability of Steels

Aggregate content of manganese, silicon, chromium, and nickel, per cent	Weldability			
	good	satisfactory	limited	poor
	Carbon content, per cent			
Max. 1 . . . . .	max. .25	.25-.35	.35-.45	min. .45
From 1 to 3 . . . . .	max. .20	.20-.30	.30-.40	min. .40
Min. 3 . . . . .	max. .18	.18-.28	.28-.38	min. .38

Phosphorus and sulphur have an adverse effect on the weldability of steels. In alloy steels the phosphorus content should not exceed 0.02-0.025 per cent.

### 52. General Technique for Welding Alloy Steels

Alloy steels should be welded with as few interruptions as practical. The welding current should be somewhat lower than for low-carbon steels.

In setting the welding current the following considerations should be taken into account. On light and medium plate thicknesses, an increase in the welding current will add more heat to the weld zone, thus reducing the rate of cooling. As a result, the steel will not harden so much, and the danger of cracking due to an increase in the annealed zone will be reduced.

Increased welding currents and speeds may only be used by skilful operators experienced in welding alloy steels.

The considerations governing the selection of electrodes are as follows. On heavy gauges, small electrodes will not be able to give full penetration, while the metal will be unduly hardened. Conversely, large electrodes are not acceptable for light gauges, as alloy steel is sensitive to overheating.

The number of passes in making a weld depends on the plate thickness and the welding properties of a given metal. It is advisable to deposit multiple beads, as this reduces the hardening of the parent metal.

In multipass welding, the individual beads should be

of approximately the same cross-section. This is essential in order that the hardening of the metal in the heat-affected area may be reduced. If this is done the annealing effect produced by the subsequent beads will cover the hardening zone left by the previously deposited bead, and the entire heat-affected zone will be uniformly annealed. When the individual beads differ in cross-section, the annealing effect will be distributed unevenly, and streaks of hardened steel may be left near the weld, causing quench cracks.

The beads deposited last produce a hardening zone extending to the surface of the work near the weld. To avoid this, use is usually made of what is known as the *annealing bead* (Fig. 85) which anneals the hardened zone of the last-deposited beads. An annealing bead should be so run that it does not reach the parent metal, otherwise its hardening effect may affect the parent metal.

Too short a distance between the annealing bead and the parent metal will produce a hardening effect on the parent metal, while too great a distance will minimise the annealing effect. This distance depends on the welding current, electrode size, bead size, and certain other factors.

For small welds an annealing bead may be deposited with a small-size electrode. On very narrow welds, an annealing bead should be applied from the side where cracking is less critical.

An annealing bead is deposited with the weld raised to about 300°C. If the weld is hotter no annealing effect will be produced, while if it is below that point, the hardening may be completed and cracks appear in the hardened zone before the annealing bead is applied.

Proper electrode manipulation is essential for a high quality weld to be obtained in alloy steels. It differs from that

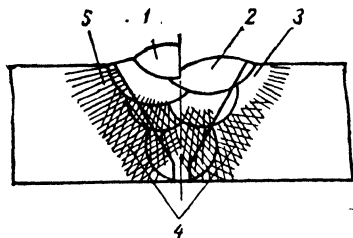

Fig. 85. Depositing an annealing bead:

1—annealing bead; 2—bead last deposited; 3—hardening due to bead last deposited; 4—annealing due to first beads; 5—annealing zone of annealing bead

used in welding low-carbon steels. In depositing narrow beads the electrode should be moved forward and then back a little, rather than straight forward. In this way the previously deposited layer will be remelted. In depositing broad beads it is not recommended to move the electrode simply from side to side, as pores may form at the bead toes. The electrode should instead make a loop at the bead edges. Another factor to be considered is that the hardening effect is most pronounced at the start and finish of an individual bead. Therefore, instead of moving the arc on as soon as it is struck, it should be played on the crater at the start of the weld until it is fully filled. The same applies to the crater at the end of a weld. This reduces the hardening.

The proper shape of a weld is of particular importance in welding hardening alloy steels. Undercuts must be avoided as they run across the most dangerous hardened area of the weld metal. Surface irregularities, sharp changes in section, a sharp upper edge in lap welds, etc., may all lead to cracking.

Weldments of alloy steels may be given post-weld heat treatment before they cool down. This will relieve locked-up stresses, prevent cracking, improve mechanical properties, anneal the hardened area, and enhance the machinability of the weld metal.

The simplest form of heat treatment is tempering. Depending on the temperature (which may be anywhere between 200 and 600°C), tempering prevents cracking, reduces hardness, improves machinability and raises impact resistance.

### *53. Welding of Various Special Steels*

*Low-alloy steels.* The alloying elements in low-alloy steels are manganese, silicon, nickel, chromium, copper and some others, running a total of not more than 2.5 or 3 per cent.

The relevant U.S.S.R. Standard provides 24 grades of low-alloy steels. They have increased mechanical properties as compared with plain low-carbon steels, and their use therefore effects an economy of metal in structures.

Welding of low-alloy steels may be accomplished with electrodes of classifications Э50А and Э55А (Types УОИИ-13/55, ДС-50, etc.). No preheating is required as a rule.

Craters should never be left unfilled, nor should they be brought out for filling on the parent metal. In multipass welding, each bead should be cleaned thoroughly and any defects chipped out before succeeding beads are deposited. Before a sealing run is applied, the weld root should be grooved.

The most commonly used low-alloy steels, such as steel 15XCHД, will have 0.12-0.22 per cent carbon, 0.5-0.8 per cent manganese, 0.3-0.5 per cent silicon, 0.3-0.5 per cent copper, 0.4-0.8 per cent chromium, and 0.3-0.7 per cent nickel.

*Chromium steels.* These steels containing up to 12 or 14 per cent chromium are of the hard-to-weld type. The trouble lies in the fact that they are self-hardening steels, and the weld and the near-weld area, cooling in the air, become hardened and embrittled. These steels should be preheated to 280-320°C and annealed after welding to restore normal hardness. The annealing procedure includes heating to 700 or 750°C, holding at that temperature for at least 10 minutes per millimetre of plate thickness, and slow cooling.

The hardness brought about by the welding heat sets up internal stresses which may lead to cracking.

The electrodes recommended for welding chromium steels are classifications ЭФК-06X17 and ЭФК-10X25.

Chromium easily combines with oxygen to form oxides; the electrode coating should therefore produce fluid slag easily dissolving the chromium oxides. The ingredients recommended for electrode coatings are fluorspar, iron oxide, and manganese oxide.

*Chrome-nickel steels.* These are austenitic chrome-nickel alloys. The most commonly and most widely used is the so-called 18/8 group of stainless steels, having approximately 18 per cent chromium and 8 per cent nickel. Another variety is the 25/12 group (25 per cent chromium and 12 per cent nickel) of heat-resistant steels. The carbon content should be limited to 0.1-0.15 per cent, as with more carbon present the chromium carbides are precipitated, and the valuable properties of austenitic steel are impaired.

The difficulty in welding these steels is that at 600 to 800°C (which is below the austenitising temperature) the austenite in the heat-affected area decomposes to form carbides. This upsets the homogeneity of the structure and

results in intergranular corrosion. In welding chrome-nickel steels, therefore, the holding time at high temperature and the heat input should be reduced to a minimum. The run-away of heat should be assisted by copper back-up strips and water cooling. Quenching from 1,050 or 1,100°C is also necessary.

The precipitation of chromium carbides can be prevented by introducing more efficient carbide-forming agents than chromium, such as titanium or niobium. The titanium readily combines with the free carbon, thus preventing the formation of chromium carbide and the decomposition of the austenite. Chrome-nickel steels should be welded with electrodes of classifications ЭАК-04Х18Н9, ЭАК-10Х18Н9, ЭАК-10Х18Н9Б, etc., which may be Types ЦЛ-2, ЦЛ-3, ЦЛ-4, ЦЛ-8, ЦЛ-11 as well as УОНИ-13/НЖ.

*Chrome-molybdenum steels.* These steels are made into steam pipes and boilers operating at high pressures and temperatures.

Chrome-molybdenum steels contain 0.12-0.35 per cent carbon, 0.8-1.1 per cent chromium, and 0.15-0.65 per cent molybdenum.

These steels should be welded with electrodes having a УОНИ-13/55 coating to which are added 5 per cent ferrochromium and 3.5 per cent ferromolybdenum, or ЦЛ-6 electrodes with a coating containing 3 per cent each of ferromolybdenum and ferrotitanium.

The work should be preheated to 200-300°C and the weld should be deposited in multiple passes. Interruptions should be avoided. If an interruption is unavoidable, the work should be reheated before the weld is resumed. Welding should not be performed in a strong wind, draughts, or at an ambient temperature below zero. After welding the weld should be heat-treated as prescribed for a given grade of steel.

In welding boiler drums of heavy-gauge molybdenum plate, joints should be given the single-V preparation, and the weld should be deposited in multiple passes, with 4 to 5 mm of metal being laid in each pass. The electrodes used are of classification Э50, such as Type ЦЛ-7 with ferromolybdenum and ferrotitanium added to the coating in the amounts advised above. In production welding, boiler drums of mo-

lybdenum steel are usually fabricated by the automatic arc process or by the electroslag process.

*High manganese steels.* These steels are remarkable for high resistance to abrasion and hardness. They go to make railroad frogs and crossings, power shovel buckets, parts of rock and ore crushing machinery, etc., where resistance to wear or abrasion is highly essential. Manganese steels have low thermal conductivity (one-quarter to one-fifth of that of low-carbon steels), marked contraction and a high coefficient of linear expansion.

The welder usually has to deal with manganese steels in building up worn parts. The electrode should be of a manganese steel containing 1.1-1.35 per cent carbon, 11-14 per cent manganese, 0.1-0.2 per cent silicon, 0.017-0.04 per cent phosphorus, and 0.02-0.04 per cent sulphur. As an alternative the electrode may be of nickel-manganese steel containing 4-4.5 per cent nickel, 11-13 per cent manganese, and 0.6-1 per cent carbon.

A low-carbon welding rod may also be used, such as C<sub>8</sub>-08 or C<sub>8</sub>-08A coated with 22 per cent chalk, 16 per cent fluor spar, 60 per cent ferrochromium, 2 per cent graphite, and 30 per cent water glass.

When using low-carbon steel electrodes with the above coating the metal should be deposited in a single layer, as some manganese from the parent metal goes over into the weld metal. In building up a worn part, the latter should be heated as little as possible.

The basic rules for building up parts of manganese steel may be summed up as follows:

(1) Use d.c., reversed polarity, and weave beads for the easier escape of gas.

(2) Deposit every bead in short pads and peen each pad as soon as it is deposited. This will eliminate pipes and porosity.

(3) After an electrode is consumed, cool the bead by water or a strong jet of air. This is essential in order to obtain a hard and tough structure, as slow cooling leads to embrittlement and crumbling out.

## *Chapter VIII*

# *REPAIR WELDING*

---

### *54. Building Up*

Building up is an efficient way of reclaiming worn parts. The use of hard alloys for this purpose (or hard facing) is discussed in Chapter IX. Here attention is devoted to the reconditioning of worn parts of plain carbon steels which do not need very hard or abrasion-resisting surfaces to be deposited.

After building up, the part is usually machined to obtain a smooth surface. Should the deposited metal be of

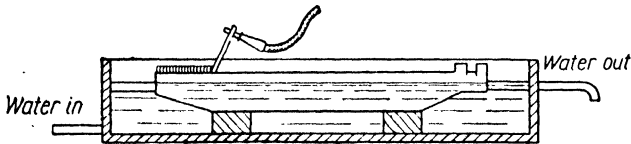

Fig. 86. Building up a worn part with water cooling

inferior quality, the machined surface will reveal holes and slag inclusions. The basic rules of welding are therefore equally binding upon building-up operations.

Building up is applicable to any shape and surface, including holes.

As is the case with welding, the built-up plate tends to warp. To counteract this, the work to be built up should be heated as little as possible. Beads should be laid parallel to the longest dimension of the work rather than cross-wise; this will cause the heat of the arc to spread over a larger area and not to concentrate in the weld metal.

Sometimes, when the warpage must be reduced to a minimum, the work may be cooled by running water (Fig. 86).

In building up, allowance should be made for the subsequent machining, as the top layer of the deposited metal contains oxides, is porous, and should therefore be removed.

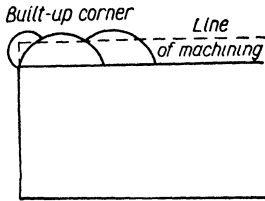

Fig. 87. Building up a corner of a part

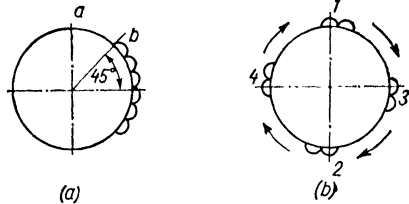

Fig. 88. Manual building up of round parts

The allowance may be anywhere from 1 to 3 mm, depending on the skill of the operator.

To obtain the desired angle at the edge by subsequent machining, a shelf should be laid as shown in Fig. 87.

In building up cylindrical parts, the first bead is laid at *a* (see Fig. 88*a*). Then the work is turned through an angle, and the next bead is applied at *b*, so that the central angle between *a* and *b* is 45°. The subsequent beads are all laid in this welding position, as it is convenient for the operator and produces a dense weld metal.

For better heat dissipation and uniform heating, it is recommended to build up cylindrical parts in a definite sequence (points 1, 2, 3 and 4 in Fig. 88*b*), where the second bead is laid 180° from the first, the third bead 90° from the second, the fourth 180° from the third, after which the operator skips back to the initial point and repeats the sequence. Each consecutive bead should, as has already been noted, be laid at point *b*, Fig. 88*a*.

An example of building up may be provided by the reclamation of worn locomotive and railway carriage wheels.

The building up of worn wheel flanges effects an appreciable economy of metal and labour. The point is that the relevant codes allow but a very limited wear on wheel flanges,

after which a worn rim should either be replaced or turned on a lathe to the normal profile by removing a large amount of stock.

Fig. 89a shows the original contour of a wheel flange at *A*, the contour of the same flange after a period of service at *B*, and the contour of the flange after reconditioning on a lathe at *C*. The cross-hatched area gives an idea

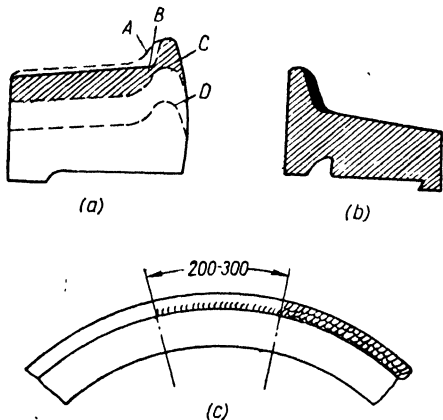

Fig. 89. Building up the flange of a carriage wheel

of how much metal has been removed in turning. *D* shows the contour of a flange for the least permissible thickness of the rim.

Fig. 89b shows a built-up flange, the blackened portion being the deposited metal after machining. In building up a wheel, beads are laid all the way round the rim in short increments, usually 200 to 300 mm long, as shown in Fig 89c. The best results are obtained

in an inclined position, with the beads laid upwards. Each time an increment 200 to 300 mm long is deposited, the wheel is turned in the direction of welding, and the next increment is laid.

At the present time cylindrical surfaces are mostly built up by the automatic submerged-arc process. The typical equipment for this purpose incorporates a stationary suspended welding head, with the work rotated at the speed of welding. The head may be of the single-arc or the multiple-arc type (two or three arcs), or two or more heads working simultaneously may be used.

Another variety of building up is the reduction of the diameter of bushings, holes, etc.

An example of this application may be provided by a locomotive crosshead. At the piston rod end the crosshead

has a bushing which receives the piston rod cone. Due to friction, the bushing grows in diameter, and the crosshead may be knocked out of service. A worn bushing is reclaimed by building it up on the inside and then boring it on a lathe.

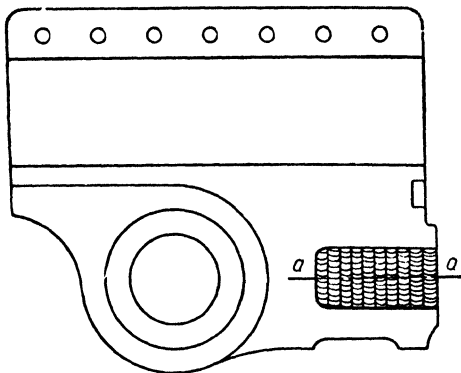

Fig. 90. Building up the bushing of a crosshead

Fig. 90 shows a crosshead cut along the bushing. The bushing is built up by laying beads all the way round the inside diameter, holding the crosshead so that the axis *aa* of the bushing runs vertically. Circular beads are deposited one after another from the bottom up. Sometimes vertical beads may be deposited parallel to the axis of the bushing.

Another use of padding is for filling in large holes. Despite its apparent simplicity, this technique calls for special attention and proper procedure. Each bead deposited in a hole must be considered as a part of the parent metal, and the next bead must unite with it thoroughly as though it were being laid on the

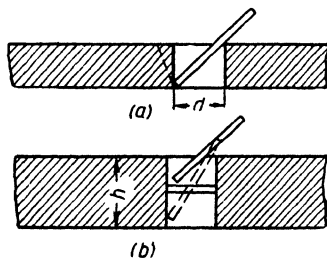

Fig. 91. Filling in a hole

parent metal. If this is not done correctly the weld metal will be only a plug which is easy to knock out by the blow of a hammer. For good fusion, the electrode should be held at an angle to the inside surface of the hole being filled (Fig. 91). When the diameter  $d$  of the hole is smaller than its depth  $h$ , the hole should be reamed as in Fig. 91a, or a washer should be inserted as in Fig. 91b, and the hole should be filled from both sides. If this precaution is not taken, the electrode, when inclined at the desired angle, will bear upon the top edge of the hole, as in Fig. 91a.

### 55. Repair Welding Applications

The following shows several applications of arc welding to repair.

Fig. 92 illustrates the repair of an engine crankshaft, which has a crack in one of its crankpins, Fig. 92a. As the

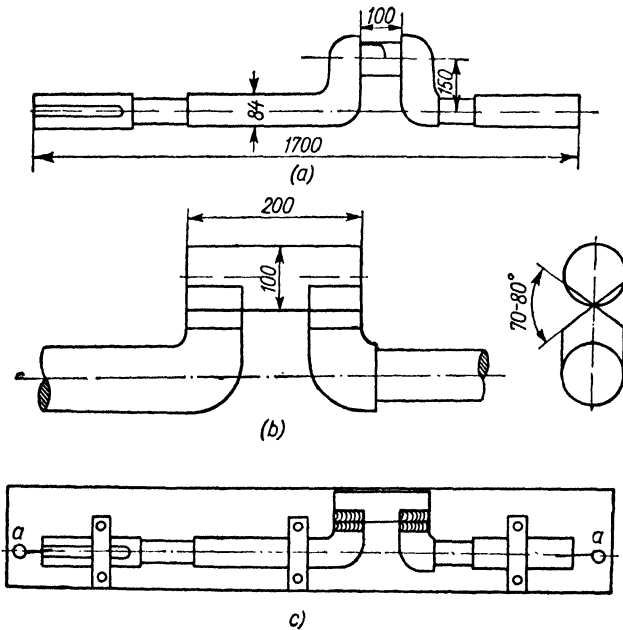

Fig. 92. Repair welding of a crankshaft

building up of the crankpin at the weld for strength is out of the question, the procedure is as follows.

The cracked crankpin is entirely cut away together with parts of the webs, and a round bar 100 mm in diameter and 200 mm long is inserted as shown in Fig. 92*b*. The remaining parts of the webs and the ends of the round bar are bevelled to an included angle of 70 or 80° on two sides, i.e., in a double-V pattern. After welding, the bar is turned on a lathe to the diameter of the crankpin.

The grooves are gradually filled with narrow straight beads using electrodes 4 mm in diameter. During welding the shaft should be checked at short intervals for possible deformation; this should be done by means of a reference line scribed along the shaft and two shifting gauges (*a*) at the ends of the shaft, with their points put on the scribe line as in Fig. 92*c*. Warping, if any, can be controlled by changing the direction in which beads are laid or by turning over the shaft and depositing beads from the other side. When the grooves are filled, a reinforcement is deposited.

A very important point in the repair of a crankshaft is to keep it in proper alignment. Even the slightest misalignment will spoil the work, as the shaft will "beat", i.e., rotate eccentrically. As a precaution against misalignment, crankshafts are sometimes repaired while carried by the

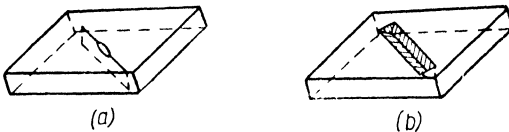

Fig. 93. Preparation of a crack for welding up;  
a—original crack; b—vee'd-out crack

engine bearings and rotated as the weld progresses. Any warping will immediately prevent the shaft from rotating in the bearings. One method for correcting the warpage is to deposit beads on the opposite side.

Operators often have to weld up cracks. Before welding up a crack, it should be vee'd to obtain full penetration (Fig. 93).

The crack should be drilled at the ends to prevent its propagation during bevelling and welding. Wherever it is possible, it is recommended to apply a sealing bead from the other side of the crack. Before doing so, overflows and slag should be removed from the root of the weld.

When a plate work (a boiler, vessel, etc.) develops a cluster of cracks, the faulty area is cut out and a patch is welded in. Fig. 94 suggests a technique for patching. The corners of the patch are rounded, for sharp angles are places where stresses usually concentrate, thus giving rise to cracks. The patch should be slightly dished, the idea being that

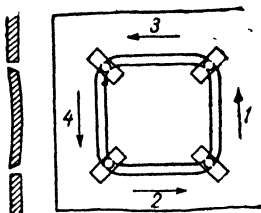

Fig. 94. Welding-in a patch (welding sequence is indicated by numerals 1, 2, 3 and 4)

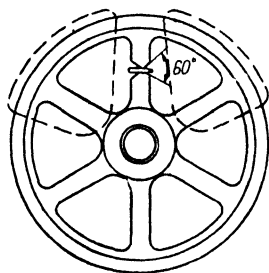

Fig. 95. Welding up a crack in a spoke of a pulley

the contraction during welding will just about take up the dishing and straighten out the plate, thus relieving all strains. Fig. 94 shows a welding sequence. The four clamps show an easy method of holding the patch in place, simply putting a bolt through from the inside and clamping down with a strip and nut on the outside (for heavy gauges). Alternatively, the patch may be held in place by tack welds.

In some crack welding operations, precautions must be taken to prevent cracks due to contraction of the deposited metal. These measures mainly aim at providing conditions under which the contraction is facilitated.

This, incidentally, applies to cracked spokes in steel pulleys (Fig. 95). The cracked portion is cut away, and the edges are bevelled to an included angle of  $60^\circ$  on both sides.

A wedge is then driven into the groove so as to make a gap of 2 to 3 mm. In welding, care must be taken to melt the wedge completely. The length of the wedge jutting outside the spoke must be cut away. After the weld metal contracts, the spoke which has been set apart pulls together without leaving any residual stresses. Welding without a wedge may result in a new crack either in the spoke or in the rim, as the metal of the spoke will restrain the contraction of the weld metal. Instead of a wedge the ends of a cracked spoke can be set some distance apart by heating the adjacent spokes and part of the rim as shown by dotted lines in Fig. 95. The usual source of heat is charcoal in a box of perforated iron suspended from the rim of the pulley.

## *Chapter IX*

### *HARD FACING*

---

#### *56. Hard Facing with Diamond Substitutes*

Hard facing may be defined as a process of welding a face, edge or point of hard abrasion-resisting metal to parts subject to excessive wear (such as dies, worms, gears, drills, coal cutters, etc.).

Diamond substitute alloys are mainly represented by tungsten carbides, such as the B-K3. It consists primarily of tungsten and chromium carbides bonded by cobalt and iron. Cheaper grades, such as Sormite, contain neither tungsten nor cobalt.

These alloys have a melting point of about 1,300-1,350°C. The best results are obtained by the oxy-acetylene process, although the arc process may also yield good results. In the latter case the electrode may be a cast rod 5 to 8 mm in diameter, 300-400 mm long, with YOHI-13 coating.

Diamond substitutes are usually supplied in the form of small castings, known as inserts, but are also available as hard-facing rods, in which the hard particles and the ingredients improving the arc stability and producing a shield are packed in steel tubes or casings.

#### *57. Hard Facing with Powdered Alloys*

A powdered alloy is a black coloured mixture consisting of grains 1 to 3 mm in size.

The most commonly used powdered alloys are wocar and stalinite.

Wocar is a mixture of powdered commercial tungsten and carburising agents, such as carbon black, ground coke, etc.

The ingredients are mixed in a thick paste, using molasses or resin. The paste is then briquetted, baked, ground and sieved. Wocar has a high bulk weight.

Stalinite is a cheaper grade as it does not contain expensive tungsten and consists of a mixture of cheap ferro-alloys, such as ferrochromium and ferromanganese.

It has a lower melting point (1,300-1,350°) than wocar (approx. 2,700°C).

Powdered alloys should be stored so as to protect them from moisture. They are best applied by the carbon arc process.

The surface to be hard-faced must be thoroughly cleaned (by a grinding stone or metal wire brushes, etc.) to remove rust, grease and dirt.

Prior to hard facing, the part is heated until it becomes red hot, at which point a very thin layer of roasted borax (0.2-0.3 mm) is sprinkled over the base metal, and then a powdered alloy is applied in a layer 2 to 3 mm thick over the borax. To obtain the desired shape of hard face, moulds or retainers of copper, graphite or carbon may be used. The layer of powdered alloy is evenly spread and rammed down by a tamper. The carbon arc is started on the layer of powder, using d.c. and straight polarity. Alternating current and a frequency convertor may also be used to improve arc stability.

In hard facing, a carbon electrode should be manipulated in a weaving pattern, keeping the current at 150 to 200 A.

The resultant hard face is usually 60 to 65 per cent lower than the original layer of powder in the case of stalinite and 35 to 50 per cent lower in the case of wocar.

Stalinite should be applied in two or three passes, as the first pass will not produce the desired properties, because the carbon arc melts much of the deposited metal. There should be no interruptions until the end of the hard-facing operation. The subsequent layers should be applied while the previous layer is still hot.

After hard facing the work should be allowed to cool slowly so as to avoid cracking.

It is good practice to anneal a hard-faced part at 900°C for 1 to 2 hours so as to improve the hardness of the hard face and to relieve internal stresses.

## 58. Hard Facing with Ferrous Alloy Rods

The desired hardness and abrasion resistance of the hard face may be attained by means of suitable rods. The core wire usually contains only a small proportion of the alloying elements, the bulk being contained in the coating. The basic ingredients of the coating are ferromanganese, ferrochromium, ferrotungsten, marble, fluorspar, etc.

The most commonly used types of hard-facing electrodes are tabulated in Table 9.

Table 9

Hard-facing Electrodes

U.S.S.R. Standard classification	Electrode type	Hardness of deposit, Rockwell C	Purpose
ЭHX-30	ЦН-350 ОЗН-350	30	Building up of worn parts of carbon steel where high hardness is essential. Preheat to 300-400°C
	ЦН-5	40	Cutting lips of knives, shears and similar metal-cutting equipment
ЭНГ-50	ЦШ-3	50	Forging, pressing and cutting-off equipment operating at elevated temperatures
	ЦН-4	50	
ЭНЭ-45	НЖ-2	50	Preheat to 250-500°C
	ЦН-2	40-50	Fittings of high-pressure, high-temperature boilers of any size. Preheat to 600-700°C
	ЦН-3	40-50	

Both a.c. and d.c. can be used for hard facing with ferrous alloy rods.

To reduce the dilution of the deposit by the parent metal it is recommended to apply it in two or three passes, while keeping the welding current at a minimum.

# *Chapter X*

## **PRODUCTION WELDING OF STEEL STRUCTURES**

---

### *59. Types of Weldments*

In most cases welded structures are fabricated from rolled steel. According to the type of rolled stock they may be principally classed into the following:

*Lattice structures*, welded from standard rolled shapes (angles, channels, I- and H-beams, etc.), such as trusses, columns, building frameworks, reinforcement frames for ferro-concrete structures, frames of railway carriages, etc.

*Plate structures*, such as various vessels, solid-web girders, equipment for hydropower and irrigation projects, and all other weldments where the basic material is steel plate.

*Combination structures*, such as bedframes of various machine tools and presses; frames of electrical generators and motors; pulleys, etc. Both structural shapes and plate go to make engineering structures.

### *60. Stages of Fabrication by Welding*

Fabrication by welding includes preparation of the work for welding, fit-up and assembly, and welding proper.

In the preparatory stage the metal is straightened, cut to size and given joint preparation.

The metal is straightened in straightening rolls or presses in the cold state. Cutting may be performed either by shears or by automatic-, semi-automatic or manual oxy-acetylene cutters.

Joint preparation involves planing or milling by machines, or mechanised flame gouging.

The components thus prepared are fitted up and assembled for welding in jigs or fixtures. For proper alignment in welding they may be tack-welded, or clamped in place by wedges, screw clamps, toggle clamps or any other fit-up tools.

The following is a description of some basic fabrication processes employed in welding practice.

### 61. Welding Applications

*Lattice structures* may be of the plane and the space type. The former is exemplified by a roof truss, and the latter by the bedframe of a press or machine-tool, or a gas pipeline support.

A frame structure consists of component parts which are usually made from structural shapes (angles, channels, etc.).

Two bars in a lattice structure meet at what is known as the *joint*. Fig. 96 shows the joint of a welded truss in which each element is made up of two angles welded by fillet welds to a gusset.

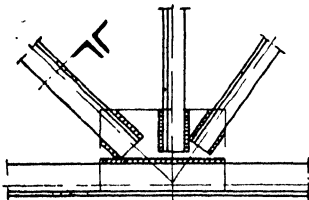

Fig. 96. Joint of a welded truss

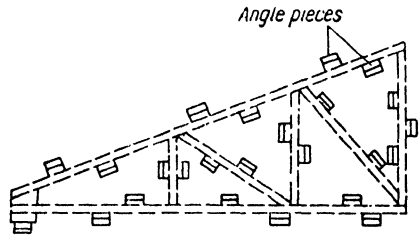

Fig. 97. A truss assembled for welding by means of limit stops

Plane lattice structures are assembled for welding on racks. For proper alignment the component parts are held in place by angle pieces which are laid out on a rack according to the relevant drawing (Fig. 97). The component parts are then tack-welded at the joints and welded. Welding may be carried out on the same rack, or the assembled frame may be removed from the rack to make room for another frame to be assembled. In such a case, the frame is welded on a welding rack.

A space lattice is designed in separate plane elements which are assembled and welded as described above. The welded elements are then erected vertically and braced together. The space structure thus assembled has to be turned over by a crane so that the joints and splices can be welded from all sides.

Examples of *plate structures* are plate girders and I-beam columns with a continuous web, made from steel plate.

A built-up I-beam has a vertical member, the web, and two horizontal members, the top and the bottom flanges (Fig. 98). Sometimes the webs of deep beams are reinforced by stiffeners welded to the web and flanges.

I-beams are assembled for welding in jigs which keep the beam members in precise alignment.

Currently, I-beams are fabricated by the automatic submerged-arc process. In the case of fabrication by manual arc welding, it is a good plan for two operators to weld flanges to a web simultaneously from two sides so as to control warpage. Welds should be deposited from the middle outwards, using the back-step sequence.

Vessels may also be classed as plate structures. Some vessels may be transported intact by rail, while others must be transported unassembled and put together at the site. Transportable vessels are usually horizontal in shape and have a cylindrical shell and two heads which may be flat, cone-shaped, or spherical. The plates of the shell are either butt- or lap-welded.

The plates are formed in bending rolls, are assembled, and the longitudinal seams between them are welded, making shell courses or tiers. In mass production, longitudinal seams are welded by a tractor-type welding machine (see Chapter XIV). Then the circumferential seams between the tiers are welded to make a shell.

Circumferential seams are welded with a vessel placed on a roller bed. The shell is then rotated with a circumferential speed equal to the welding speed so that the seam is always being welded at the top of the circumference.

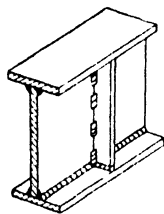

Fig. 98. Built-up beam

Either automatic or manual welding may be used, depending on the number of vessels to be made. The heads are also welded to the shell on a roller bed.

At the present time transportable horizontal vessels are fabricated by what may be termed the furl method described below.

The shell plates are laid out on a plating block, fitted up and welded together by a welding tractor, thus making

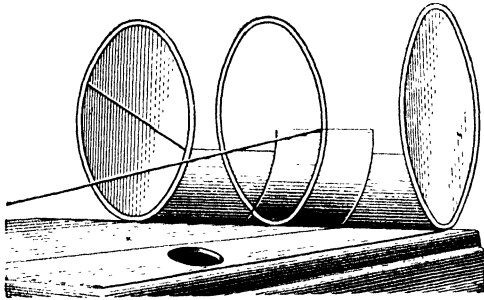

Fig. 99. Furling a shell round heads and a stiffener in reservoir fabrication

an unfurled shell. When the seams have been welded from one side, a suitable lifting device turns the shell over, and the seams are welded from the other side. By that time the heads have already been assembled and welded, and now they are tack-welded to the ends of the shell, together with the end angles, while a stiffening ring is tack-welded in the middle of the unfurled shell. Then the shell is furled on the heads and stiffener by a winch, with its rope made fast to the shell (Fig. 99).

After the longitudinal seam is welded, the vessel is placed on a roller stand where the heads are welded to the end angles from the outside.

The furl method makes it possible to employ the automatic process in the most convenient downhand position. Welding inside the vessel is reduced to a minimum. Shell plates no longer have to be roll-formed, nor is there any difficulty in joining the individual shell tiers. This method is applicable to plate up to 5 mm thick.

Very large or nontransportable vessels are fabricated in two stages—the component parts are manufactured at a factory for assembly and welding into a vessel at the site.

In making these vessels the roll method is used, by which the factory does the main bulk of the welding involved in the fabrication of the shell and bottom of a vessel. The shell and bottom are lap- or butt-welded from plates on a suitable stand into continuous strips. As more plates are welded together, the shell and bottom strips are wrapped around a centre shaft to make rolls about 3 m in diameter and as long as the vessel (in the case of a shell) or as the diameter or radius of the vessel (in the case of a bottom).

At the site, the bottom roll is placed on a bed of sand, unfolded, and the bottom is welded from two halves. The shell roll is placed vertically at the edge of the bottom, and a tractor unfolds it. As it is unfolded, the shell is welded to the bottom, while rafters are mounted at its top by a truck crane. When the shell is unfolded, the only longitudinal seam is welded, and roofing material is placed on the rafters.

*Combination structures* differ widely both in size and shape. They are made from steel plate of various thickness, standard rolled shapes (channels, beams, angles, etc.), square, and round bars and strips, forgings, pressings, and steel castings.

Tee-joints and fillet welds are most common in combination engineering structures. They are usually short and rather complex in contour.

As a rule, combination structures are machined both prior to and after welding, in part or as a whole.

In the fabrication of combination engineering structures a very essential role is played by jigs, fixtures, positioners, rotators and other welding aids. These welding aids reduce labour and time requirements and increase production rates. Besides, they make welding a precise operation and, by rigid clamping, are instrumental in obtaining weldments of the desired shape.

Fig. 100 shows a mobile assembly gantry. It is employed in the assembly by tack-welds of box girders for cranes (Fig 101). The gantry is a U-shaped metal structure riding a rail track laid along an assembly rack. It has two side air cylinders 3 and one top cylinder 8 with hold-down blocks

attached to their spindles. The side blocks hold up the vertical walls of a box girder against the transverse stiffeners. The top block holds the top horizontal plate down to the vertical walls of the girder, though it can also serve to press

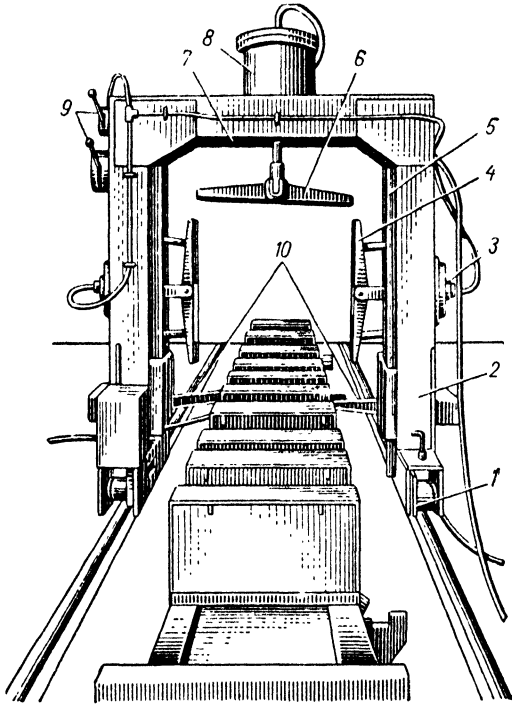

Fig. 100. Mobile assembly gantry:

1—wheels; 2—gantry; 3—side air cylinder; 4—side hold-down blocks; 5—rod; 6—top hold-down block; 7—top cylinder base; 8—top cylinder; 9—air valve; 10—lugs

the lower horizontal plate to the vertical walls. The top cylinder is mounted on a base 7 to which are attached four rods 5 terminating in lugs 10. When air is admitted to the top cylinder 8 the block 6 descends until it comes in contact with the edges of the vertical plates of the girder. With air still being admitted to the top cylinder, the base, cylinder,

rods and lugs move upwards. The lugs grasp the lower horizontal plate of the girder and press it against the webs of the girder.

Box girders are assembled in the following way. The horizontal plate (which is the chord of a girder) is placed by a crane on the rack so that the accuracy of its position relative to the long axis of the gantry is ensured by limit stops. Transverse stiffeners are then mounted, tack-welded, and welded to the chord.

Next the two vertical walls are set up by a crane and held in a vertical position by suitable clamps (Fig. 102) attached to the transverse stiffeners. The gantry is brought to the first stiffener, and while the side blocks hold up the webs to the stiffener and chord, the members are tack-welded by an electric welding process. The gantry is then moved to the next stiffener, and the cycle is repeated. After the stiffeners have been

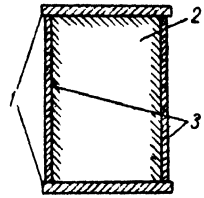

Fig. 101. Section through a box girder:

1—chords; 2—stiffener; 3—webs

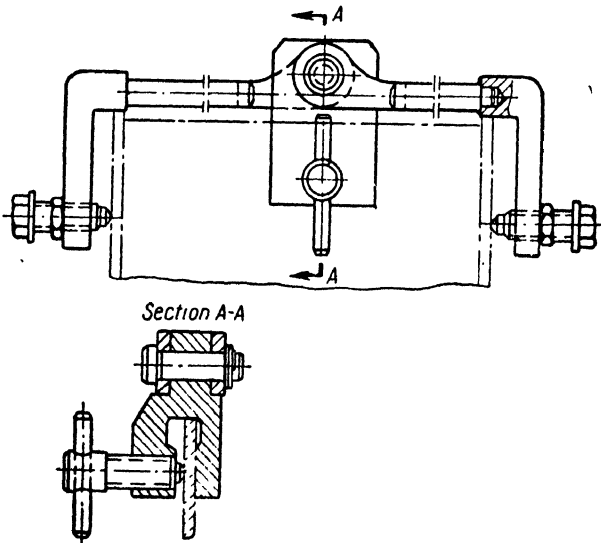

Fig. 102. Clamps for holding side vertical walls in place

welded to the webs by vertical fillet welds, the other chord is set in place and pressed down to the vertical walls by the top cylinder, and then tack-welded. A crane transfers the tack-welded girder onto another rack for final welding.

In order to facilitate the placing of a bulky weldment in a convenient position for welding, a variety of mechanical devices, called positioners,

have been designed. One road-plant factory uses a positioner to facilitate the fabrication of plough bottoms. The plough bottom shown in Fig. 103 consists of mouldboards 1 and cheeks 4. For the cheeks to be conveniently welded to the mouldboards, the bottom has to be positioned in the plane of the cheeks and then turned through a half-circle. For the struts 2 to be welded to the mouldboards the bottom has also to be positioned conveniently for welding. The gusset 3 is welded in the downhand

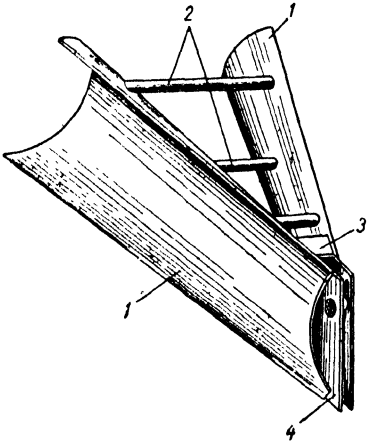

Fig. 103. Plough bottom

position. The positioner handling these plough bottoms is constructed as follows (Fig. 104). A channel 3 with a turning mechanism 2 is mounted on two supports 1. The channel carries a vertical shaft 5 on which is seated a cross-

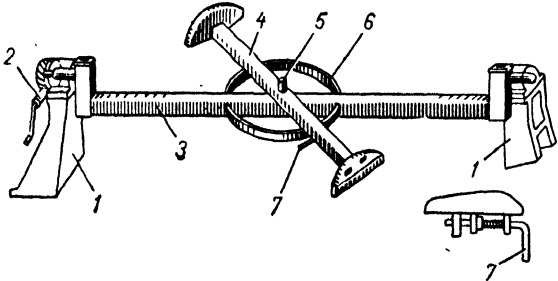

Fig. 104. Hand-operated positioner

piece 4 with clamps for holding the work in place, and a lock 7 for locking the crosspiece relative to the channel. To steady the crosspiece a ring 6 is welded to the channel. The operator can easily rotate the channel by means of the turning mechanism 2. The crosspiece carrying the work is rotated manually. With this positioner, the work can be quickly mounted and set in a convenient position for welding.

Fig. 105 shows a universal power-operated positioner.

The parts to be welded are secured to the plane table of the positioner, and the entire assembly may be tipped through any angle, or rotated to any position, convenient for welding.

The positioner consists essentially of a square cast-iron plane table 1 with radial slots to receive the bolts which secure the work; a pedestal 2 which houses the tilting and lifting drives of the plane table;

and a bedframe 4. The pedestal rotates on a shaft 3 thus lifting or lowering the plane table. The two drives are remote-controlled from two portable push-button stations and in addition the controls are duplicated at the main control panel.

The positioner can handle jobs up to 5,000 kg in weight. Fig. 105 shows the positioner with the plane table in the upper position. The work secured to the plane table is shown by dots and dashes.

Power-operated positioners reduce the auxiliary time by a factor of 1.5 to 2 and the welding time, by 10 to 15 per cent.

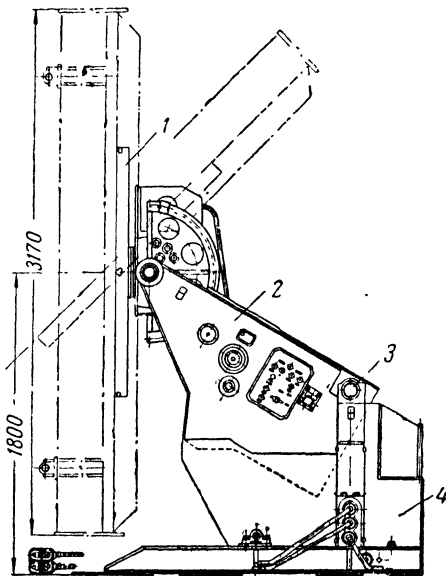

Fig. 105. Power-operated positioner

## 62. Pipe Welding

Pipes are usually joined by butt welds with the single-V joint preparation. Where it is impossible to deposit a sealing bead at the weld root from the inside, back-up rings or liners are used (Fig. 106). Prior to welding, the pipes to be welded are lined up so that their ends are abutting. The pipes come with their ends mill-bevelled.

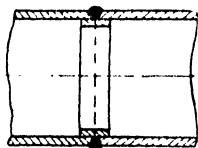

Fig. 106. A back-up ring or liner used in pipe welding

In lining up pipes, care must be taken to have a uniform gap all the way round the circumference and to see that the edges properly meet each other at a joint. After fit-up, the joints are tack-welded by short tacks. There may be 3 to 8 tack-welds 40 to 60 mm long, depending on the pipe diameter. Tack-welds are deposited with the same electrodes as will be used for welding.

Pipes may be joined by either position welding or roll welding.

In *roll* (or rotation) *welding* the pipes are rotated as the weld progresses, so that the weld is deposited either in the downhand or in the semivertical position of welding.

In *position welding* the pipes remain stationary, but the operator makes the weld all the way round the pipe in consecutively the overhead, vertical and downhand position of welding.

In manual arc welding pipe lengths are first welded into long strings of several pipes, each on suitable supports which allow the pipes to be rotated for convenient welding.

In this case two or three beads are required. The first layer, or the stringer bead, is laid so as to completely melt the root faces on both sides of a joint. There must be no flash on the inside, as this reduces the clear cross-section of a pipe and increases the resistance to the flow of viscous liquids (oil, etc.).

The use of back-up rings or liners eliminates the danger of burn-throughs when depositing the first bead.

When no back-up rings or liners are used, roll welding is performed in the following way. The circumference of

the joint is divided into four equal parts (Fig. 107). The first bead is laid from *A* to *B* in the vertical position, as this reduces to a minimum the possibility of molten metal finding its way inside the pipe, and very little flash metal will be left in it. Then the seam is welded on the opposite side of the pipe, from *D* to *C*. This sequence is followed on all other joints of a given section of pipes. After that

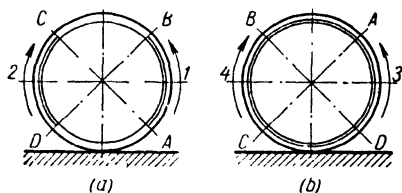

Fig. 107. Roll welding of pipes

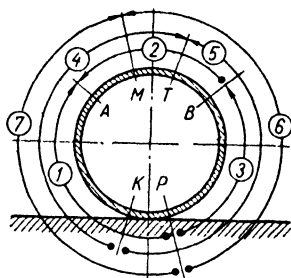

Fig. 108. Position welding of pipes

the section is rotated through 90 degrees (Fig. 107b) so that the top of the pipe and the unwelded bottom portions are placed sideways, and the joint is welded from *D* to *A* and from *C* to *B*.

The first bead is laid with electrodes 4 mm in diameter in the upward direction, with a current of 130 to 150 A, so as not to burn through and not to allow molten metal to flow inside the pipe. The second and third beads are laid in one direction with electrodes 5 or 6 mm in diameter and with a higher current, while the pipes are gradually rotated so that the welding is carried on between partial turns from a point one-quarter of the distance down the side to the top of the pipe.

Successive beads should be laid in opposite directions as this to some extent reduces contraction stresses in the weld.

Position welding is utilised when long welded sections are tied in to make a single or a multiple pipeline, or when it is impossible for one reason or another to roll the pipes (as in site welding).

Manual position welds are carried out in two or three layers. The following technique may be used for position welds on pipes 250 to 500 mm in diameter (Fig. 108). The first bead is laid in three increments, starting at *P* and proceeding upwards as far as *A*. Then the bead is laid from *B* to *A*, followed by an increment from *P* to *B* in the upward direction. This welding sequence minimises contraction stresses and is convenient for welding. The second layer is welded in two increments, each as long as half the circle from *K* to *T* on one side of the joint and from *K* to *T* on the other side in the upward direction.

When three layers are deposited, the third one should also be laid as the second one, i.e., in two increments, starting at *P* and finishing at *M*.

In the position welding of large-diameter pipes it is a good plan to divide the joint into six or eight parts. The stringer bead is first laid in the upward direction on the side portions on each side of the pipe; then the bottom of the pipe is welded in the overhead position, and the seam is closed by welding the top of the pipe, running the beads towards each other.

The whole of the first layer and the overhead portion of the other layers should be welded with electrodes 4 mm in diameter, while the remaining layers and sections of the seam should be deposited with electrodes 5 to 6 mm in diameter.

It requires some practice for the operator to be able to make overhead welds on pipes.

At present cross-country pipelines (both for oil and gas) are welded primarily by the automatic submerged-arc process.

### ***63. Arc Welding of Reinforcement Bars for Ferro-concrete Structures***

Round and regular-shaped reinforcement bars for ferro-concrete structures are arc-welded both in field and in shop where there is no resistance-welding equipment available.

A variety of joints can be welded by the arc process. Fig. 109 shows diagrammatically a welded joint between

round bars, using a fluted backing-up strip, with the weld completed in the downhand position (the bars are placed horizontally).

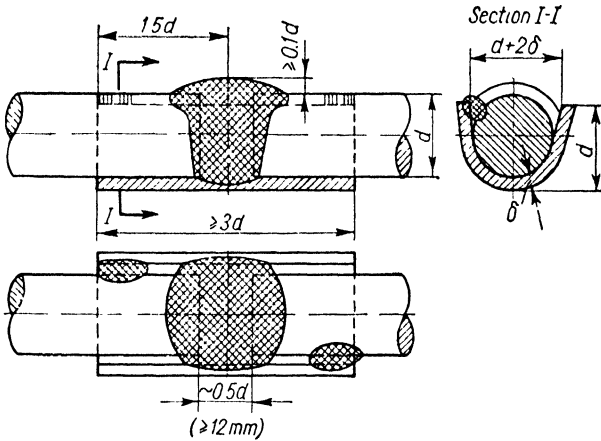

Fig. 109. Butt-welding of round bars with a fluted back-up strip

A *backing-up plate* is an auxiliary member of a joint, mainly serving as a mould for the weld and only bearing a negligible share of the load.

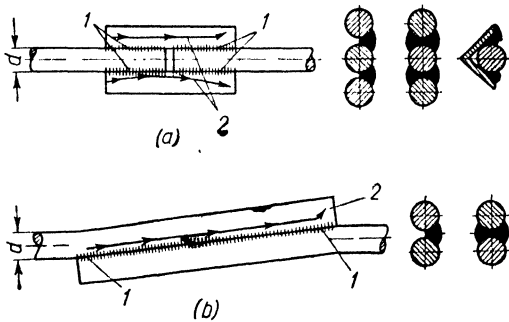

Fig. 110. Welding sequence for round bars: a—welding with the bars or angles; b—lap welding longitudinally loaded welds on one and two sides; 1—tack-welds; 2—bringing out a crater

A *tie plate* is another auxiliary member of a joint, designed to bear the whole or a larger part of the load.

When bars are welded with backing-up and tie plates in the vertical position, the upper bar should be chamfered to an angle of 35 to 45° and have a root face 3 to 4 mm in diameter. The abutting ends of the bars to be welded should be spaced 5 to 6 mm apart.

Longitudinally loaded welds in butt-strap or lap joints are made in the sequence shown in Fig. 110a and b.

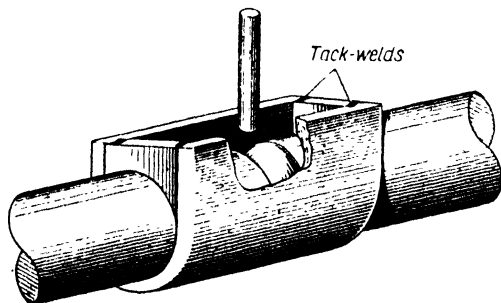

Fig. 111. Welding horizontal bars by the mould method

The height of the weld should be  $0.25 d$ , but not less than 4 mm, and the width should be  $0.7 d$ , but not less than 10 mm.

In the case of joints with four longitudinally loaded welds, downhand welding is carried out by rotating the joint. Welding on an incline or in the vertical position is performed in the upward direction. Buttons, or the finishing craters of the welds, should be brought out onto the tie plates.

The procedure for *backed-up butt welds on reinforcement bars* is described below. The weld is started at the bottom of the Vee, formed by the ends of the bars being welded. The corners where the bars and the back-up strip meet are welded and then the groove is filled. Should too much slag form in the process, it should be removed at regular intervals so as to facilitate welding. After the groove has been

filled, the reinforcement is deposited 1.2 to 1.5 d in length and 0.1 to 0.2 d in height.

The electrode size depends on the diameter of the bars to be welded, and the welding current is chosen to suit the electrode size and type, and the welding position.

Suggestions of welding currents for various electrode sizes in the downhand position are given in Table 10.

Table 10

Limits of Welding Currents for Various Electrode Sizes

Variables	Bar diameter, mm		
	5-10	10-20	20-32
Electrode size, mm . . . . .	3	4	5
Welding current, A . . . . .	100-150	150-200	200-250

Large bars are welded by the so-called *mould method*.

The mould method is shown in Fig. 111. The ends of the bars to be welded are first cleaned of rust, scale and dirt and then lined up so that their centre lines coincide (the gap between the ends should not exceed 1.5 times the electrode size).

The joint is enclosed by a mould (back-up) of sheet metal to prevent the molten metal from running off. Side retainers are also provided to prevent the slag and molten metal from spreading over the bars. This precaution is especially important in welding with a three-phase arc, when a lot of slag is formed.

The electrodes usually used are 5 to 8 mm in diameter, with YOHH-13/50 or YOHH-13/55 coatings.

The welding is carried on with d.c., reversed polarity (the electrode positive).

Table 11 suggests welding currents for horizontal welding by the mould method with a single-phase arc.

The weld is carried out as follows. It is started at the bottom of the mould in the gap between the bar ends. The electrode is moved along the gap. In welding care must be taken not to let the deposited metal solidify. Electrodes should be changed as quickly as possible. When the level

Table 11

**Welding Current for Horizontal Welding by the Mould Method  
with a Single-phase Arc**

Variables	Bar diameter, mm						
	20	30	40	50	60	80	100
Electrode size, mm	5	5	5	6	6	6	8
Welding current, A	240	275	275	300	300	400	450

of the puddle rises above the middle of the cross-section of the bars, the heat input should be reduced. The arc should be pointed at the middle of the puddle. The weld metal should be deposited on the surface of the bars so as to obtain the desired reinforcement. To speed up the solidification of the puddle at the end of the welding operation, the arc is made to short-circuit at a high rate.

When welding reinforcing bars by the mould method in the vertical position, the upper bar is double-veed to a solid angle of  $70^\circ$ , leaving a root face 4 to 6 mm. The ends are spaced 2 to 3 mm apart, and a cone-shaped mould is welded to the lower bar as shown in Fig. 112. The lower bar should fit 10 to 15 mm into the mould.

The welding conditions for vertical welds by the mould method are indicated in Table 12.

Table 12

**Welding Conditions for Vertical Moulded Welds**

Variables	Bar diameter, mm			
	20	30	40	60
Electrode size, mm . . . . .	4	5	6	6
Welding current, A . . . . .	180	280	320	340

The first to be deposited is a circular bead joining the lower bar and the inside surface of the mould. The arc is then played on the fusion faces of the upper bar in a semicircu-

lar motion. The weld is completed by making alternate movements from one side to the other, without letting the molten surface solidify. If too much slag accumulates on the pool it should be run off by burning a hole in the mould.

Alternatively, reinforcing bars may be butt-welded with a three-phase arc. This, however, calls for a gap of 10 to 15 mm. The electrodes recommended for this application are K-5 and K-5A, 6+6 mm and 8+8 mm in diameter, suitable for welding with a.c. For better utilisation of the arc heat, filler rods 4 to 5 mm in diameter are tied to the electrodes by a length of fine wire. This raises the deposition rate to 20 g/A-hr. The weld is started at the bottom of the metal mould, and the gap between the bars is filled by manipulating the electrode in a weaving pattern along the gap. The blanket of slag over the molten pool of metal should be 5 to 8 mm deep. If, during solidification, blisters appear on the surface of the slag blanket, the arc should be restarted, and at these spots the upper layer of the solidified metal should be remelted.

If, during solidification after welding, the slag cools to a dull cherry-red, this is an indication that the weld metal is dense and has solidified the entire depth of the mould.

Table 13 suggests welding conditions for horizontal mould-type welds with a three-phase arc.

Bars in steels Cr. 0 through Cr. 3 are welded with  $\text{E}42$  electrodes, and in steels Cr. 5 and 25FC, with  $\text{E}42\text{A}$  and  $\text{E}50\text{A}$  electrodes.

Horizontal bars can be butt-welded by the electroslag process, using a temporary copper chill put around the joint to be welded, and a flux-retaining box. The electrode

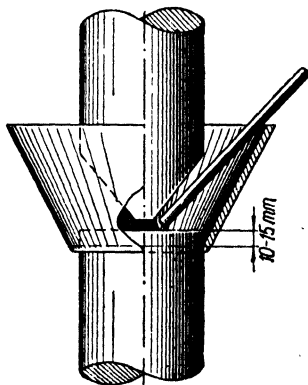

Fig. 112. Welding vertical bars by the mould method

Table 13

**Welding Conditions for Horizontal Mould-type Welding  
with a Three-phase Arc**

Bar diameter, mm	Electrode size, mm	Welding current per phase, A	Arc voltage, V	Filler metal, in per cent of electrode metal	Welding time per butt weld, min
50	6+6	280-400	30-35	90	2.5-3.2
100	8+8	450-600	40-55	90	6.25-7.0

is a steel strip clamped in an electrode holder. The strip is introduced into the gap between the bars and sprinkled with flux, after which the welding current is switched on. As soon as a pool of molten slag and metal is formed the arc changes into a steady flow of current through the slag (see Sec. 78). The prescribed length of electrode is melted, the weld is allowed to cool, and the flux-retaining box and the copper chill are removed. The power source may be CTH-700, ТСД-1000 or equivalent types of welding transformers.

# Chapter XI

## CAST IRON WELDING

---

### 64. General

Cast iron differs from steel in many respects, one of which is greater brittleness.

If a cast-iron article is exposed to a high temperature, steam, water, or to solutions of acids and salts for a long time, some oxygen gradually finds its way inside the cast iron, and its metallographic structure is changed; when heated, it will not melt. Instead, coating of oxides will form on its surface, and the metal will be destroyed. This is what is called *burnt* iron, which does not lend itself to welding.

Cast iron is usually welded for repair purposes. The welding of cast iron is a complicated and critical job calling for a high degree of skill on the part of the operator.

The welding of cast iron may be performed with or without preheating.

### 65. Welding of Cast Iron Without Preheating

In welding cast iron without preheating, the electrode to use is CB-08 low-carbon steel wire covered by a regular chalk coating or OMM-5 compound applied in a layer up to 0.3 mm thick.

Steel makes a poor bond or union with cast iron. Therefore, resort is made to what is known as studding.

The cast iron is veed, drilled and tapped along the vee so that studs may be screwed into the bevelled fusion faces in a staggered pattern (Fig. 113). The diameter and number of studs depends on the thickness of the cast-iron piece to be welded. As a rule, they are from 5 to 13 mm in diameter. The studs should be long enough to be screwed into the

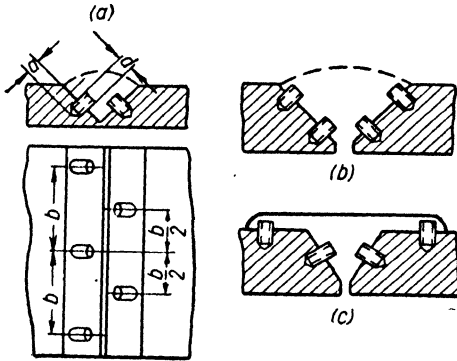

Fig. 113. Studding in welding cast iron without preheat

casting to a depth,  $a$ , of at least the diameter of the studs (Fig. 113a), and to project above the cast iron surface not more than their diameter. This adds up to a length which is twice the diameter of the studs. The studs should be placed apart 4 to 8 times their diameter.

On heavy sections, two or more rows of studs may be required (Fig. 113b and c). The welding procedure is as follows. To begin with, beads are welded around the projecting ends of the studs as shown in Fig. 114. Next the fusion faces are built up between the beads so that the cast iron surface is covered by a steel deposit. Then the groove is filled as in welding steel.

The first layer absorbs some of the carbon from the cast iron, and so, if allowed to cool quickly, the weld will be chilled and become hard and brittle.

Subsequent layers, however, somewhat anneal the first layer, and also pick up less carbon, becoming tough enough not to crack in contracting. With this in mind, the gap between the edges of the work is left wide enough to require several beads to fill it. Otherwise, the carburised layer, being especially brittle, will crack and separate from the cast iron due to contraction. The weld metal should be deposited in thin layers, and the piece near the

weld should be just hot enough for the operator's hand to stand the heat. Excess heating in welding cast iron without preheating is dangerous, as localised heat sets up stresses. These stresses, together with those left after casting, give rise to cracks.

The first layers deposited directly on the cast iron should be laid with small-size electrodes (2 to 3 mm) with 70 to 120 amperes. It is not advisable to deposit the first layers with larger-size electrodes, as the heat input will be increased, more carbon will be absorbed by the weld metal, and the latter will be chilled and brittle.

Before welding up cracks in cast iron parts, it is important to drill small holes at the ends of each crack so as to prevent them from extending further. The cracks are then veed out, drilled and tapped for studs. Cast-iron welding without preheating is convenient in that the faulty part may be repaired in place without dismantling.

Good results are obtained in welding cast iron with non-ferrous electrodes. With these electrodes a firmer bond of weld metal with the cast iron can be made and a fairly machinable weld is produced.

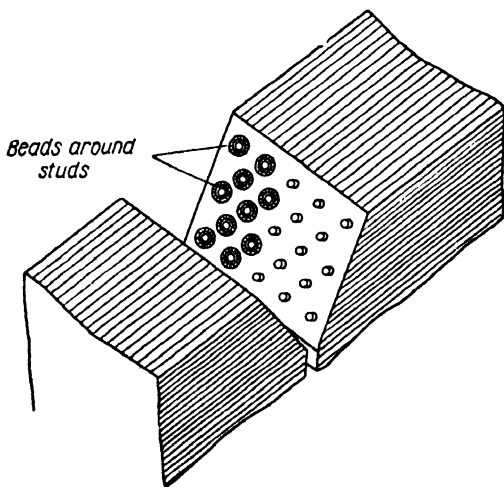

Fig. 114. Depositing beads around studs in welding cast iron without preheat

One of the nonferrous electrodes widely used in the arc welding of cast iron is the *Monel metal* type. Monel is an alloy of 30 per cent copper, 65 per cent nickel, 1.5 per cent manganese, 3 per cent iron, and 0.22 per cent silicon. A typical coating for Monel electrodes runs 45 per cent graphite, 15 per cent silica, 20 per cent fire-clay, 10 per cent wood ash, and 10 per cent soda.

Monel electrodes produce weak welded joints. Therefore they should only be used where weld metal machinability is important and its strength is not critical.

Monel electrodes have a lower melting point than the cast-iron parent metal. For this reason the work is only slightly heated during the process of welding, and there is less danger of cracking than when welding with steel electrodes.

Another electrode used in the welding of cast iron without preheating is a combination of copper and steel. Initially this method was used for filling up defects in large castings. A composite copper-steel electrode consists of a copper core 2 to 5 mm in diameter and 400 to 450 mm long served with a spiral of tinfoil or roofing iron 0.3 to 0.8 mm thick and 5 to 8 mm wide. The ends of the serving are anchored on the core by a fine wire. The served electrode is then dipped to apply a coating of chalk, which should be not less than 0.3 to 0.4 mm thick on each side. This should be allowed to dry in the air at room temperature, followed by drying at 70° to 100°C for 1 or 2 hours.

Nazarov, a Soviet operator, has suggested the use of a cluster of copper and steel rods. The cluster consists of two copper rods 3 mm in diameter and a steel rod of the same diameter.

The procedure for welding cast iron with composite electrodes, including preparation, welding conditions and electrode manipulation, remains unchanged.

A variety of electrode types have been developed for the welding of cast iron without preheating, having a steel or cast-iron core and a suitable coating. These electrodes produce strong welds without the use of studs. Among them are ЭМЧС, ЭМЧ, АМЧ and ИЧ-4 electrodes. The welding is done with d.c., reversed polarity, depositing beads of a small thickness.

## 66. Welding of Cast Iron with Preheating

When welding cast iron by the metallic arc process with cast-iron electrodes, it is usually necessary to preheat the casting. The welding procedure may be divided into five stages: mechanical preparation of the piece for welding; moulding; heating; welding up the break or crack; and cooling.

*Mechanical preparation* in most cases consists of veeing out the crack to an included angle of  $90^\circ$ . Before veeing out, it is advisable to drill holes at the ends of the crack. The double-vee preparation is less desirable, as welding has then to be done from both sides.

A *mould* is provided in order to retain the molten cast iron and to shape it during solidification. The mould varies with the nature of the crack or break and ranges from a coating of moulding paste applied to the bottom and sides of the crack to odd-shaped boxes.

Materials for the mould may be graphite blocks, screened sand mixed with water glass, and sometimes clay.

Fig. 115 shows an iron mould box used in the repair of broken teeth on a cast-iron gear. The area to be repaired is fenced off by graphite blocks. The space between the mould box and the graphite blocks is filled with sand. After welding the teeth are milled.

After the mould is filled and rammed, it is dried at not more than  $50^\circ\text{C}$  until the sand-and-water glass mixture solidifies. After that the work may be heated over a fire.

Cast-iron parts are heated in charcoal hearths or furnaces. Large jobs (such as locomotive cylinders) can conveniently be heated in temporary furnaces built with fire-brick without cement. The parts should be heated at a steady rate to  $500$  or  $600^\circ\text{C}$ . When the part to be repaired is of simple design, without sharp changes in section, bosses, or stiffeners, heating may be localised around the spot to be repaired.

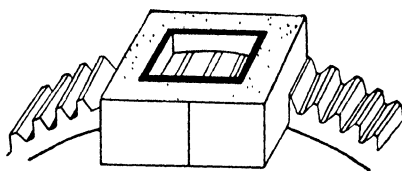

Fig. 115. A mould box for welding cast iron with preheat

In heating care must be taken not to melt thin sections. Before heating, the work should be placed so that the spot to be repaired lies in a horizontal plane. It is important to avoid turning over the part when it is heated.

After preheating and before welding, the part should be covered with sheets of asbestos, leaving open the spot to be welded, which should be cleaned by a jet of air to remove ash, dirt and dust.

The cast-iron electrodes to use should be 6 to 20 mm in diameter. The welding current is suggested in Table 14.

*Table 14*

**Current for Cast-iron Welding**

Cast-iron electrode size, mm	Current, A
6-12	300-400
12-15	400-500
15-20	500-1,000

In preheating welding, the weld metal remains molten until the required amount of deposit has been laid, after which it is allowed to solidify. The welding should be carried on without any interruptions. To speed up the welding operation, it is good practice to add pieces of broken cast-iron electrodes to the molten pool at intervals long enough for the previous piece to melt before the next one is added. Oxidation of the weld metal can be prevented by adding borax to the weld pool, as it forms slags which dissolve the oxides. To make up for the burnt silicon, small pieces of ferrosilicon may be added to the molten pool of metal.

The repaired part should be allowed to cool slowly, or else the weld metal will be chilled (the carbon will not have enough time to form graphite) and become very hard. Quick cooling may result in cracks. A good way of cooling a welded cast-iron part is to leave it in the hearth or furnace, cover it with ashes and embers or asbestos sheets, and allow it to cool with the furnace.

Preheating welding produces very tight and strong welds.

## *Chapter XII*

# **WELDING OF NONFERROUS METALS**

---

### *67. Welding of Copper and Its Alloys*

Copper and its alloys are far more difficult to weld than steel. The reason for this lies in the properties of copper. Among other things, it has six times the thermal conductivity of low-carbon steel; it loses much of its ductility at high temperatures and becomes very brittle and weak.

Molten copper readily absorbs gases but they are released when the metal starts to solidify. Heated copper eagerly picks up hydrogen—the cause of what is known as the hydrogen disease of copper.

This results from the fact that hydrogen penetrating the copper reacts with the cuprous oxide:

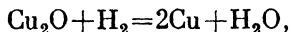

producing water vapour. The water vapour, remaining in the copper and concentrating where there are oxides, appreciably raises the pressure, breaking up the metal and giving rise to hair-line cracks. As a consequence, the copper grows brittle and loses much of its strength.

Copper combines with oxygen to form cuprous oxide ( $\text{Cu}_2\text{O}$ ) and cupric oxide ( $\text{CuO}$ ). The eutectic<sup>1</sup> of copper and cuprous oxide melts at 1,064°C, or at a point below that of copper. This eutectic is the last to crystallise and, in doing so, it envelopes the grains, thus impairing adhesion between them, which reduces the strength and toughness of the metal.

This is the reason why copper for welded structures should have the least possible oxygen content; this is called de-

---

<sup>1</sup> An eutectic is a mixture in which the different substances crystallise out at the same time, and the melting point is the lowest possible for any other mixture of those substances.

oxidised copper, usually made by adding deoxidisers, such as phosphorus or silicon.

The best method for welding copper is by the oxy-acetylene process, though arc welding is also possible, using carbon or graphite electrodes, direct current, and straight polarity. The arc should be at least 10 to 15 mm long. The filler metal may be copper containing 4 to 10 per cent phosphorus, or phosphor bronze containing about as much tin. The surface of the work should be sprinkled with flux consisting of 70 per cent dehydrated borax, 10 per cent boric acid, and 20 per cent potable salt (by weight).

Carbon arc welding is only possible in the downhand position. The filler rod should be held ahead of the carbon electrode so that the rod tip is within 5 or 6 mm of the surface of the parent metal. Table 15 indicates the appropriate welding conditions.

Table 15

Copper Welding with Graphite Electrodes

Copper thickness, mm	Graphite electrode size, mm	Arc voltage, V	Welding current, A
0.9	4.0	40-45	130-180
2.0	6.0	40-45	190-260
4.0	6.0	40-50	250-330
6.0	8.0	40-50	320-430
12.0	9.0	40-50	420-550

It is good practice to peen the weld after welding.

An alternative is a copper electrode with a coating of the same composition as the flux.

Some manufacturers weld copper with electrodes consisting of a copper core coated with 10 per cent fluorspar, 12 per cent feldspar, 50 per cent ferromanganese, 8 per cent ferrosilicon, and 20 per cent water glass. The coating is 0.4 mm thick on each side. Before use, electrodes are maintained at 300°C for two hours. The welding is done with direct current, reversed polarity.

Brass is very difficult to weld because some of the zinc of the parent metal vapourises when the work is heated. Zinc melts at about 420°C and boils at 907°, or very near to the melting point of brass. The fumes evolved during

brass welding carry particles of zinc oxide and are very harmful. As a precaution a respirator should be worn when welding brass, and ample ventilation should be provided.

Brass can be welded with graphite and consumable electrodes. In the case of a graphite electrode, direct current is used, with the electrode worked on the positive side of the circuit. The arc should be 5 or 6 mm long. The end of the graphite electrode should be tapered. The welding current should be maintained somewhere between 300 and 450 A. The flux used should contain 12.5 per cent sodium chloride, 50 per cent potassium chloride, 35 per cent cryolite, and 2.5 per cent charcoal.

The filler metal is brass of the same analysis as the parent metal, or tin-phosphor bronze having 8-11 per cent tin, 0.2-0.4 per cent phosphorus, with copper in the balance.

The Urals Heavy Engineering Works uses ОВ-5 electrodes to fill up defects in castings of JIMnC-58-2-2 alloy (58 per cent copper, 2 per cent manganese, 2 per cent lead, with zinc making up the rest). These electrodes are cast from an alloy of 7-9 per cent tin, 1-1.6 per cent nickel, 0.25-0.4 per cent phosphorus, the remainder being copper. The coating is made up of fluorspar, sodium fluoride, graphite, ferromanganese, and powdered aluminium.

For an electrode diameter of 6 mm the welding current is 225, A d.c., reversed polarity.

*Bronze* (an alloy of copper, tin, zinc, aluminium and some other elements) is welded mainly with the same electrode types and fluxes as brass and copper.

At the Urals Heavy Engineering Works aluminium bronzes containing 9-10 per cent aluminium, 3-4 per cent iron and up to 1.5 per cent manganese are welded with АБ-2 electrodes.

The cores of these electrodes are cast from aluminium bronze of the same analysis as the parent metal. The coating is made up of 33 per cent potassium chloride, 9 per cent sodium chloride, 28 per cent sodium fluoride, 5 per cent graphite, 14 per cent fluorspar, and 11 per cent bentonite.

The dry ingredients are added to water glass (1 kg of dry mass to 150 grams of water glass). After drying, the electrodes are held at 200°C for 1½ hours.

The welding is done with direct current, reversed polarity. Heavy sections require preheating to 200 or 250°C.

### *68. Welding of Aluminium and Aluminium Alloys*

Aluminium may be welded by the carbon or metallic arc process and the argon-arc process, using both nonconsumable and consumable electrodes.

On melting, aluminium forms a film of oxide which has a much higher melting point than pure aluminium (2,050°C and 658°, respectively). The aluminium oxide, formed during the welding process, envelopes the grains of the metal and hampers its coalescence. The oxide film may be removed by mechanical means, but it is more convenient to do this with fluxes. The fluxes consist of fluorides and chlorides, although cryolite may also be used.

In storage the fluxes should be protected from moisture, preferably in air- and moisture-tight containers. After welding the weld should be rinsed with hot water to remove excess flux, otherwise it may attack the aluminium.

In the manual arc welding of aluminium with consumable electrodes various coatings are used instead of fluxes.

One such coating contains 50 per cent potassium chloride, 30 per cent sodium chloride, and 20 per cent cryolite.

The ingredients are mixed in water in the proportion of 100 grams of dry mixture to about 25 grams of water, and one or two layers of coating are applied by dipping. For a core wire of 4 to 5 mm in diameter the coating thickness is 0.8 to 0.9 mm on each side. Dipped electrodes are dried and held at 150°C for 2 or 3 hours.

Direct current is used with these electrodes, which are worked on the positive side of the circuit.

Electrodes should be handled with care, as their coatings are mechanically very weak. Neither water glass nor organic cements may be used as the binding agent because they contain oxides likely to attack the aluminium.

Electrodes are also made from A-0 or A-1 aluminium wire. The core rods are pickled with 10 per cent solution of caustic soda, washed and dried. The coating contains 18 per cent sodium chloride, 33 per cent potassium chloride, 9 per cent

lithium chloride, 5 per cent sodium fluoride, and 35 per cent cryolite.

The ingredients are made to pass through a sieve with 1,600 meshes per square centimetre. The dry mixture is mixed with water to a paste which is passed through a paint grinder. The coating is applied in one layer by dipping. It should be 1 to 1.2 mm thick for a core rod diameter of 4 mm.

Dipped electrodes are held at 20 to 25°C for 24 to 48 hours and then the temperature is gradually raised to 180°C, at which they are held for up to 2 hours, and then allowed to cool with the oven.

The welding is done with direct current, reversed polarity. Welding conditions are indicated in Table 16.

Table 16

Welding Conditions for Manual Aluminium Welding

Aluminium electrode size, mm	Electrode length, mm	Welding current, A	Metal thickness, mm	Preheat, deg. C
4	350	150-200	4	—
5	400	220-280	5	100
6	400	300-400	6-8	150
8	450	400-500	up to 20	up to 400

Aluminium can be successfully welded by the argon-arc process using tungsten electrodes. The shield is provided by argon and helium (free from nitrogen, water vapour and oxygen). Prior to welding the surface of the work is pickled. No fluxes need be used.

The manual argon-arc welding of aluminium is done with alternating current supplied by a converter.

Automatic machines have been developed for the argon-arc process in which filler rod is fed mechanically.

*Aluminium alloys*, such as silumin (an alloy of aluminium and silicon), AM $\Pi$ , AMr and AMr-5 (alloys of aluminium, manganese and magnesium) are welded by approximately the same processes.

## *Chapter XIII*

### *ARC CUTTING*

---

#### *69. Cutting with a Carbon Electrode*

Arc cutting is based on the melting of the metal at the cut by the heat of an electric arc. The resultant kerf is rough, with fused edges.

Arc cutting is inferior to flame cutting both in quality and rate of cutting and is only resorted to when the appearance of the kerf is not critical, or when for some reason flame cutting cannot be used.

Applications for arc cutting include production cutting of cast iron, alloy steels, and nonferrous metals, as well as demolition and scrap cutting.

Either carbon, graphite or metallic electrodes may be used. Graphite electrodes permit higher current densities, remain sharp for a long time, and produce a neater kerf than carbon electrodes. Cutting is carried on with direct current, with the electrode on the negative side of the circuit.

Arc cutting is better achieved with either the plate placed horizontally, or in the vertical position in an upward direction to permit the metal to flow readily out of the cut.

Table 17 gives rough estimates of the rate of steel plate cutting with graphite electrodes.

The drawbacks of carbone arc cutting include: a rough kerf due to the arc jumping from one side to the other, a broad cut up to 25 mm wide, a low rate of cutting on heavy sections, appreciable carbon pick-up by the kerf handicapping subsequent machining (this is of no consequence in scrap cutting), and high current requirements which can only be met by powerful welding equipment.

Rate of Steel Plate Cutting with Graphite Electrodes

Plate thickness, mm	Graphite electrode diameter, mm	Current, A	Rate of cutting, m/hr
6	10	400	21.00
10	10	400	18.00
16	10	400	10.50
25	15	600	4.80
50	15	600	2.70
75	15	600	1.80
100	15	600	1.00
200	20	800	0.45
300	20	800	0.24

### 70. Cutting with a Metal Electrode

Metal arc cutting is superior to carbon because the cut is narrower (approximately the diameter of a coated electrode), a smoother surface of the kerf is obtained, and alternating current may be used.

In metal arc cutting preference should be given to coated electrodes. The core material may be any low-carbon steel, even that unsuitable for welding, as impurities in the core metal are of minor consequence.

The coating slows down the melting of the electrode, stabilises the arc, and isolates the core from the work as the electrode is being fed into the cut.

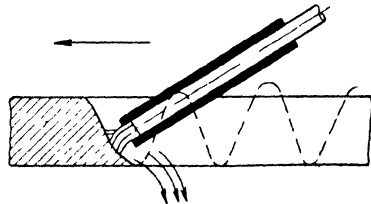

Fig. 116. Metal-arc cutting

Arc cutting may be performed with metal electrodes and with sources of current supply (welding transformers or d.c. motor-generator sets) used for arc welding. Fig. 116 shows diagrammatically a piece of metal being cut with a coated metal electrode, dotted lines show the travel of the electrode, and the arrows indicate the flow of the molten metal out of the cut.

## 71. Air-arc Cutting

In air-arc cutting, the metal melted by the arc along the cut is blown out by a jet of air. The air is continually supplied from the shop line under a pressure of at least 4 atmospheres into the torch (electrode holder), along the electrode and into the cut. The amount of metal melted from the cut is proportional to the arc current.

Fig. 117 shows a torch for air-arc cutting, in which air is

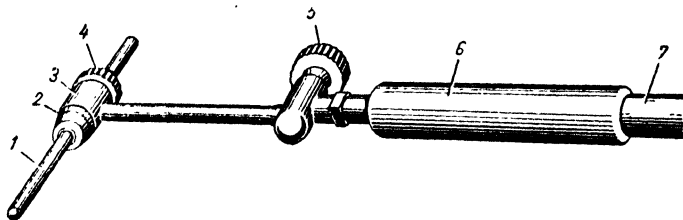

Fig. 117. Torch for air-arc cutting:

1—carbon or graphite electrode; 2—nozzle; 3—chuck; 4—chuck clamping knob; 5—air supply control; 6—grip; 7—air hose and cable

supplied through an annular orifice around the carbon electrode. In some torches air is supplied from the side. The rate of air-arc cutting is higher than that of metal-arc cutting.

A more recent addition is the oxy-arc cutting process using carbon electrodes. By this method, a jet of oxygen is played on the molten metal some distance from the arc; the oxygen readily oxidises the metal and removes both the oxidised and molten metal from the cut. The current is supplied by a d.c. welding generator.

Air-arc and oxy-arc cutting is successfully employed to remove surface defects from welded joints, to vee a joint prior to welding, to melt out cracks, etc.

Air-arc cutting can also be performed with a metal electrode. In this case an annular nozzle is fitted onto the torch, through which air is supplied under pressure. This process comes in especially handy in field welding when the operator has to trim a poorly fitted-up joint or to remove defects from a weld.

## *Chapter XIV*

# *MACHINE WELDING*

---

### *72. General Principles of Machine Arc Welding*

The basic stages of an arc welding operation are those of striking the arc, feeding the electrode, holding the arc at just the right length, and manipulating the arc along the seam.

In automatic welding the entire welding operation is controlled by machinery, while in semi-automatic welding the control is shared by machinery and the operator.

A modern automatic welding machine incorporates:

(1) a welding head which strikes the arc, feeds welding wire, and maintains the arc at the desired length;

(2) a truck to carry the welding head along the seam or a roller stand to move the work relative to the welding head;

(3) jigs and fixtures to hold the work in alignment and to turn it over when necessary;

(4) a track for the truck;

(5) a push-button station;

(6) a switchgear box housing the electrical equipment of the automatic welding machine;

(7) a source of current supply (a welding generator or a transformer);

(8) supply and auxiliary cables and wires.

In some cases the components of an automatic machine may be combined into composite units. By way of illustration, a welding head and a truck may be united into a tractor. Welding tractors do not usually require any tracks as they move directly on the work.

Automatic machines for vertical seams have running gear for travel on vertical surfaces.

The first automatic and semi-automatic arc welding machines were developed by the Russian inventors of arc welding N. N. Bernardos and N. G. Slavianoff, while the first automatic welding head capable of performing all the functions of modern automatic machines was built by D. A. Dulchevsky, a Soviet engineer, in 1924.

Nowadays wide use in the Soviet Union is made of the automatic submerged metal-arc process developed in 1940 by the Paton Electric Welding Institute (the Ukrainian Academy of Sciences). A more recent trend is towards wider use of automatic and semi-automatic argon and CO<sub>2</sub> shielded-arc welding.

The principal advantages offered by machine welding, in comparison with manual processes, are easier work for the operator, a higher production rate, and better welded joints.

### 73. Basic Design of Automatic Welding Heads

An automatic welding head is basically a welding wire feed mechanism. It consists essentially (Fig. 118) of a wire drive motor 5, a reduction gear 4 to transmit rotation of the motor, and feed rollers 2. One of the rollers is a drive roller and the other is a driven roller. The wire is passed between the rollers and emerges from the director nozzle 1, which guides the wire along the seam and conducts current to it. The wire is supplied by a coil loaded on a reel 3 in the welding head.

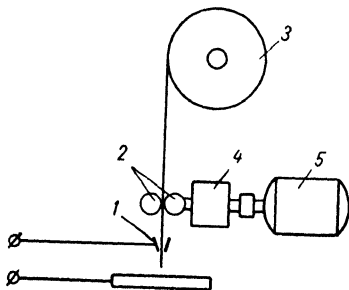

Fig. 118. Diagram of an automatic welding head

Depending on the design and purpose, a given welding head may have some additional features. In the case of submerged-arc welding the head has a device to supply flux to the weld and to retrieve surplus flux for further use; there may be an additional device to straighten welding wire from the coil; tracer

rollers may be provided to guide the head accurately along the seam, etc.

An automatic welding head should feed welding wire to the arc so that its length and, consequently, its voltage are maintained constant, as the voltage across an arc depends on its length. The arc length will be constant if the rate of wire feed,  $r_{wf}$ , is equal to the melting rate,  $r_m$ .

The equality  $r_{wf} = r_m$  is continually upset during the welding process by a variety of factors, such as variations in the mains voltage, surface irregularities of the edges being welded, a slip of the wire between the feed rollers, etc. It is essential, therefore, that an automatic welding head be capable of restoring the equality as soon as it is upset.

By the method of wire feed, welding heads can be classed into those with variable and those with constant wire feed rates.

*In variable feed rate welding heads* the feed rate varies with the voltage across the arc. This is accomplished by connecting the wire drive motor to carry the arc voltage (Fig. 119). As the length of the arc increases, the arc voltage rises, and the motor armature gains speed. The feed rolls are driven quicker, and more wire is fed to the arc, thus restoring the normal arc length. Should the arc length be shortened inadvertently, the voltage across it drops, the motor armature slows down, less wire is fed to the arc, and the arc length is again brought back to normal.

Variable feed rate welding heads are intricate in electric circuitry, which is a definite inconvenience.

*Constant feed rate welding heads* came into being with the advent of the submerged-arc process. The submerged arc is more stable than the open arc, as it is capable of self-regulation. This property has been embodied in a new simplified type of automatic welding head in which the wire feed rate is maintained constant and independent.

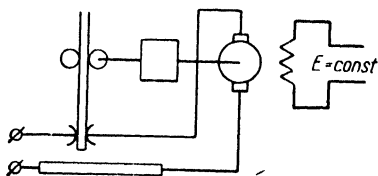

Fig. 119. Diagram of an automatic welding head with variable wire feed rate

This welding head incorporates a three-phase induction motor connected across a mains supply (Fig. 120). The speed of the motor is independent of the arc length, as is the rate of feed which remains constant.

In this type of automatic head the arc length is self-regulated by variations in the melting rate of wire which

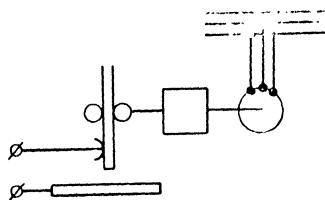

Fig. 120. Diagram of an automatic welding head with fixed wire feed rate

increases with a shorter arc and decreases with a longer arc. The melting rate of wire is almost proportional to the welding current. In turn, the arc current varies with the arc length, i.e., with the arc voltage.

When the arc grows longer, the welding current is decreased; when the arc becomes shorter, the welding current is increased. The melting rate varies accordingly. With the wire fed at a constant rate, variations in the melting rate will restore the equality  $r_{wf} = r_m$ .

*Constant feed rate welding heads* use simpler electric circuits, which fact has promoted their wider application in industry.

Automatic welding heads are available in a variety of types and makes. The most widely used are those developed by the Paton Electric Welding Institute.

The ABC welding head (Fig. 121) consists of three sets.

Set A is a wire feed mechanism incorporating a three-phase 1,450 rpm, 36 V, 0.1 kW induction motor 5 coupled to a reduction gear and actuating a drive roll 6.

The welding wire is clamped between the drive roll 6 and an idler which is held up to the wire by a spring. The coiled wire is straightened by a device 9 consisting of four staggered rolls. The director nozzle has two contact rolls 7 between which the wire picks up the welding current. An index 8 mounted on the director nozzle makes it possible to guide the arc precisely along the seam.

The control box 4 has push-buttons to control the ABC head. The push-buttons marked "Up-Stop 2", "Down-Stop 1"

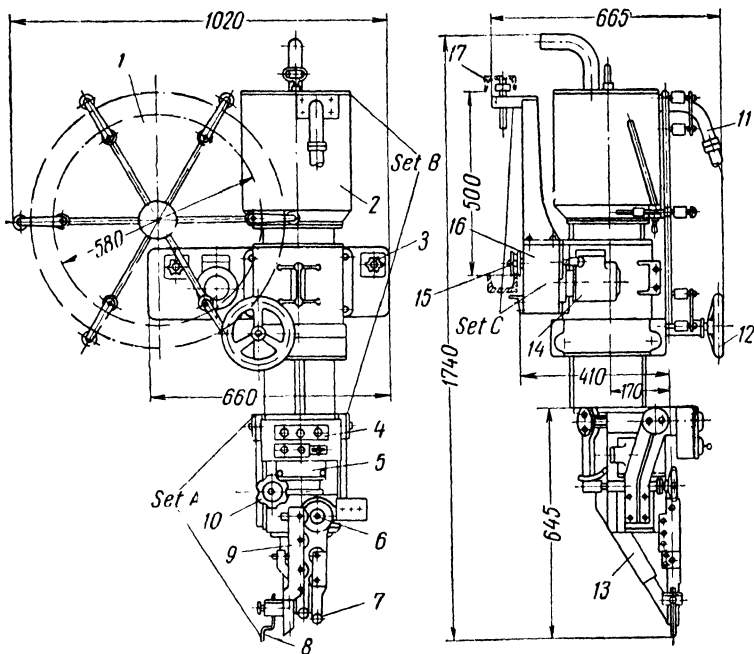

Fig. 121. ABC welding head

and "Start" serve to control the welding operation. Two push-buttons marked "Forward" and "Backward" enable the ABC head to be moved to and fro when no welding is in progress. The control box also has a switch to set the direction of travel of the ABC head in welding.

The straightener and the director nozzle together can rotate about the axis of the drive roll 6 through an angle of  $45^\circ$  from the vertical.

There is also a transverse adjustment mechanism which makes it possible to move the electrode tip across the seam 75 mm each way by means of a handwheel 10.

Set B consists of a hoist, a flux supply and retrieval device, and a wire reel 1.

Actuated by a handwheel 12 the hoist can move set A 100 mm up and down.

The top of the head carries a hopper 2 from which flux is supplied to the weld by a tube 13. Surplus flux from the weld is retrieved by suction set up in another tube 11 which terminates in a bell. The necessary suction of 4 to 5 atmospheres is set up by air forced through by an injector. The mixture of surplus flux and air is returned to the hopper where the flux settles on the bottom, and the air, with its velocity reduced, escapes into the atmosphere by a filter in the cyclone separator.

Set *C* is a self-propelled carriage incorporating a traction motor 14 which actuates the drive roll of the carriage through a friction clutch 16. On an idle run, the friction clutch is disengaged by a handwheel 3. The carriage has two vertical rolls 15 and one horizontal roll 17 to hold the carriage in a vertical plane.

The component sets may be combined in a variety of ways. A stationary suspended welding head may be obtained by using set *A* singly or in conjunction with set *B*. The three sets make up a portable self-propelled welding head.

This head is capable of welding butt, corner and lap joints. The maximum current of the head is 2,000 A. Welding wire is fed at a constant rate.

When necessary, the rate of wire feed may be varied by changing a pair of spur gears in the reduction train; this can conveniently be done by removing the cover from the rear of the head housing.

The head is furnished with assorted change gears so that the rate of wire feed can be set at anywhere from 28.5 to 225 m/hr.

Similarly the speed of head travel and, consequently, the welding speed can be set at will. This is effected by changing a pair of spur gears in the carriage reduction train. The assorted change gears supplied with the head make it possible to adjust the speed of head travel from 13.5 to 112 m/hr.

*ABC* welding heads may also feature the automatically controlled rate of wire feed. In such a case the motor shaft is coupled to the reduction gear by an electromagnetic clutch which is automatically energised or de-energised, depending on variations in the arc voltage. When the arc voltage drops below the set value, the clutch is automatical-

ly disengaged, and the wire feed comes to a halt. The arc gap increases, and the arc voltage rises. When the arc voltage is restored to normal, the clutch is automatically engaged, and the wire is again fed to the arc at the normal rate.

To strike the arc, the electrode must be brought in contact with the work. To effect this the "Down-Stop 1" push-button is pressed. When the electrode comes in contact with the work, the joint is sprinkled with flux, and the "Start" button is pressed. The motor begins to rotate and the feed rolls lift the electrode, thus withdrawing it from the work. As soon as the arc is struck, the "Start" button is released (it should be held down for not more than half a second), and the motor is reversed, as the contacts of the "Start" button in the released position reconnect two of its phases. Now the feed rolls feed the wire down to the arc. When the seam is completed, the "Down-Stop 1" button is again pressed to de-energise the circuits of the motor and the carriage. This stops the wire feed to the arc and, consequently, the advance of the arc. The arc fills up the crater, grows longer (as no wire is fed) and goes out. Following this, with the "Down-Stop 1" still held down, the "Up-Stop 2" push-button is pressed to disconnect the welding circuit. Holding the "Up-Stop 2" button down will start the motor of the head, and the wire will be withdrawn from the slag and flux.

*The TC-17M tractor-type welding machine* is a self-propelled welding head travelling directly on the work.

The TC-17M is a universal welding machine with a constant wire feed rate. It is designed to operate with a welding current of up to 1,000 A and welding wire 1.6 to 5 mm in diameter. The weight of the welder, without wire and flux, is 42 kg.

It is capable of welding any butt joints in the down-hand position, fillet welds with a vertical and an inclined electrode (see p. 193), as well as inside and outside circumferential seams on cylindrical vessels not less than 1,200 mm in diameter. ❧ ❧

The TC-17M is the simplest in design and circuitry, more compact and lighter in weight than any other tractor-type welders (such as the Soviet-made YT-2000, YT-1200 and the АДС-1000).

A diagram of the TC-17M is shown in Fig. 122. The electric motor 14 is coupled to the wire feed mechanism 6 and to the traction mechanism.

The wire feed mechanism consists of a reduction gear and two rollers, one of which is a driven roller and the other an idler, held up to the driven roller by a spring. The tension of the spring can be adjusted by means of a screw.

The traction mechanism consists of a reduction gear and a pair of rubber-tired wheels 16. The reduction gear is coupled to the wheel shaft by a friction clutch which can be disengaged by means of a handwheel 15. This is necessary when the tractor has to be manually set up at the beginning of a welding operation.

The rate of wire feed and the speed of the tractor can be adjusted by means of change gears in the reducers, the necessary gears being selected by reference to the appropriate rate and speed tables. The assorted change gears supplied with the tractor make it possible to select the rate of wire feed in the range 52-403 m/hr and a welding speed of 16-126 m/hr.

The tractor is furnished complete with two director nozzles to accommodate welding wire differing in diameter size. One of them 7 is used for welding wire 3 to 5 mm in diameter. This nozzle has two bronze contact jaws 11 at the bottom. Passing between the jaws, the wire picks up the welding current. A spring 8 holds the jaws tight on the wire. Flux is charged into a stub 10 mounted on the director nozzle which also carries a needle-type index 23 to guide the arc accurately along the seam.

When welding wire is 1.6 to 2 mm in diameter, a director nozzle is used consisting of a tube and a bronze sleeve. The axis of the bronze sleeve is offset in relation to the axis of the tube by about 5 mm. Passing through the nozzle the wire is bent, thus building up the necessary pressure for good electric contact.

The wire fed from the reel is straightened by three rollers arranged directly above the wire feed mechanism. The pressure of the rollers can be adjusted by a screw 22.

To thread welding wire into the wire feed mechanism, the top straightening roller and the hold-down feed roller

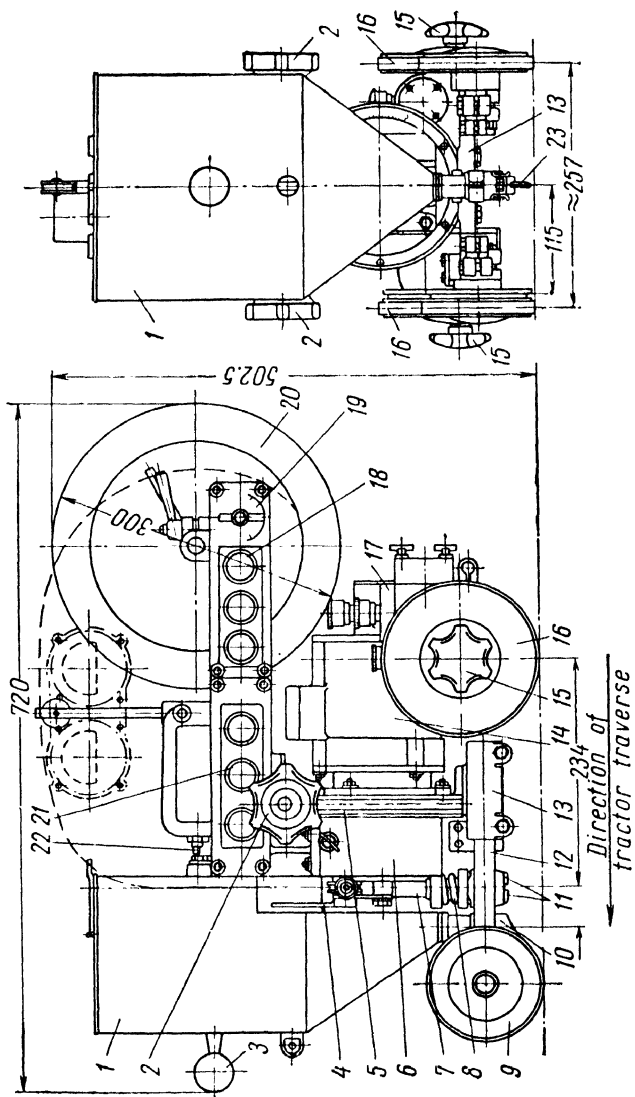

Fig. 122. TC-17M tractor-type welding machine

are brought apart by means of the lever 4, and the wire is threaded between them.

The tractor has a device for tilting the electrode transversely so that it may be accurately aligned with the seam; in welding fillet welds with an inclined electrode this device enables the director nozzle and the head to be properly tilted together.

This device consists of a bracket 19 carrying a worm and worm quadrant 5 mounted on the reduction gear box. Seated on both ends of the worm are handwheels 2 with which it is possible to rotate the worm which meshes with the teeth of the stationary quadrant. Rotation of any of the two handwheels will turn the bracket 19 in the necessary direction. The bracket also carries the wire straightening mechanism, the control boxes 18 and 21 and the wire reel 20.

The flux hopper 1 communicates with the stub 10 through which the flux is supplied to the joint. The thickness of the flux blanket can be varied by adjusting the stub for height.

There are, in fact, two interchangeable flux hoppers, one used in welding with a vertical electrode, and the other with an inclined electrode (see p. 193).

The front free wheels of the tractor are mounted on a cast-aluminium crosspiece 13 in which two telescopic rods 12 are secured.

The free wheels can be changed to suit the welding process chosen and the joint type to be welded.

In welding lap and square butt joints two identical rubber-tired wheels 9 are used, and the tractor is moved by hand along the seam by means of the lever 3 on the hopper 1.

In the case of bevelled butt welds, the rubber-tired wheels on one of the rods 12 are replaced by a tracer consisting of two tandem rollers clamped by a common bracket. As the weld progresses, the rollers move on inside the groove, thus guiding the tractor.

When fillet welds are welded in the downhand position the two front wheels are replaced by a single tracer roller mounted on a special rod. This roller rides the root of the seam ahead of the director nozzle thus guiding the arc along the seam. In this case the tractor traverses one

of the two inclined surfaces (say, of an H-beam), and gravity tends to pull the tractor down. To prevent this, a supporting roller is fastened at the rear of the housing, bearing upon the other surface, which is normal to the one traversed by the tractor, and thus prevents it from skidding down.

The welding machine is also capable of welding with an electrode inclined across the joint, such as lap joints, for example (see pp. 107 and 193).

Each of the two push-button boxes on the welder has three buttons. One box serves to control the tractor proper. The other comes in useful when welding circumferential seams on tanks, drum shells, and other cylindrical pieces, and for controlling the roller bed which rotates the work.

For higher production rates in automatic welding double- and triple-arc heads are employed. These heads have two or three director nozzles and as many wire feed drives.

#### 74. Fluxes

In submerged-arc welding the seam is shielded by a blanket of granular fusible material called a flux, and the arc therefore is "submerged", or maintained within a flux blister (Fig. 123), formed in the welding zone. Some of the flux blanket (which may be up to 40 mm thick) melts forming molten slag which, when it solidifies, lodges as a crust on the weld.

This granular material, flux, serves several purposes. In the first place, it acts as a good insulator and concentrates heat in a relatively small welding zone, thus improving the fusion of the welding rod and the melted parent metal. Secondly, the molten portion of the flux floats as a liquid blanket over the molten pool of the electrode and parent metal, protecting it from the atmosphere and reducing to a minimum the pick-up of oxygen and nitrogen. A third function of the flux is its action as a cleanser for the weld metal, absorbing impurities and adding alloying elements, such as manganese and silicon. Consequently, the weld metal is clean and dense, and has excellent physical properties.

Last but not least, the blanket of flux reduces sputter and burning losses, which are unavoidable with the open arc.

According to their method of fabrication fluxes may be classed into fused and nonfused.

*Fused fluxes* are obtained by fusing the ingredients in electric or fuel-fired furnaces. The molten flux is tapped from the furnaces and allowed to flow in a thin jet into cold running water where it solidifies in the form of small grains. The grains are dried and screened to obtain the desired grain sizes.

Grains of fused fluxes are chemically uniform, possess sufficient mechanical strength, and can be re-used many times, as part of the flux applied to a seam remains unused and can be retrieved.

*Nonfused fluxes* are mechanical mixtures of various naturally occurring minerals and ferroalloys.

To obtain a nonfused flux of uniform composition, the ingredients are powdered, thoroughly mixed, and added to water glass. The paste thus made is granulated into grains 1.5 to 2 mm in diameter by extruding the mixture through a sieve or by other suitable techniques; the grains are then dried.

Of the fused fluxes most commonly used at the present time, mention should be made of classifications OCI-45,

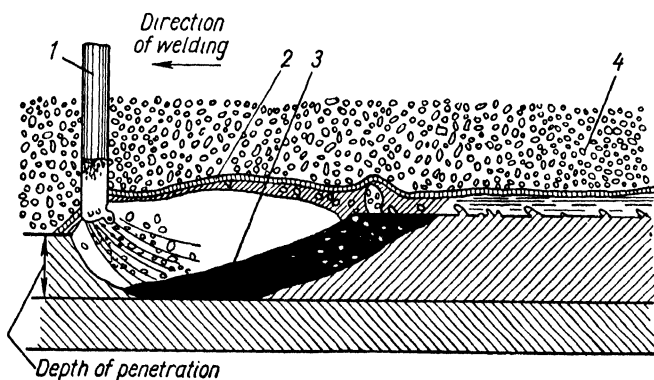

Fig. 123. Diagram of submerged-arc welding:

1—electrode; 2—envelope of flux; 3—molten metal; 4—flux

and AH-348A. These fluxes have been successfully employed for the automatic welding of low-carbon and low-alloy steels.

Among nonfused fluxes wide use has been made to date of the so-called *ceramic fluxes* developed by K. K. Khrenov, Member of the Academy of Sciences of the U.S.S.R. One such flux, designated K-2, is intended for the single-layer automatic and semi-automatic welding of low-carbon and low-alloy steels. It contains 55-58 per cent tungsten concentrate (ilmenite), 13 per cent feldspar, 10 per cent fluorspar, 8-10 per cent ferrosilicon, and 14 per cent ferromanganese.

The principal drawback of ceramic fluxes is that they readily absorb moisture and their grains are of inferior mechanical strength. A damp flux may result in porosity in the weld. Therefore a flux should be stored in dry locations in metal or wooden containers with snugly fitting lids, at a temperature of not lower than 15°C. Fluxes should never be stored or shipped in bags.

### 75. *Electrode Wire*

The compatibility of a given flux and a welding wire in terms of composition and physical properties has a direct bearing on the quality of the submerged-arc weld.

In welding with fluxes high in manganese the welding wire should be CB-08 or CB-08A, low in carbon. The CB-08A wire contains less sulphur and phosphorus (0.03 per cent of each) than the CB-08 wire (not more than 0.04 per cent of each).

For particularly important structures CB-08ΓA is used containing 0.8-1.1 per cent manganese, and not more than 0.03 per cent each of sulphur and phosphorus.

In special cases, such as high-speed welding (upwards 100 m/hr) and the welding of certain low-alloy steels of increased strength, CB-10ΓC should be employed for best results. This is a silicon-manganese wire containing 0.8 to 1.1 manganese and 0.6 to 0.9 per cent silicon. The sulphur content is limited to 0.03 per cent.

CB-10ΓC should also be used when welding with a flux low in manganese, as the wire supplies the necessary manganese to the weld metal.

Wire for automatic welding should be accurately sized by cold drawing and should have a clean surface.

The most commonly used wire sizes are 1.6, 2, 3, 4, 5, and 6 mm.

### *76. Techniques and Procedures of Automatic Welding*

Submerged-arc welding calls for a more thorough joint preparation and better fit-up than manual welding. The reason is as follows. In submerged-arc welding a large molten pool of metal is formed, and so, if fit-up is poor, the molten metal and slag may run off through gaps, thus spoiling the weld.

In the case of hand welding, if the joint preparation is not uniform, and if the material does not fit together uniformly, the operator will make up for those deviations by changing the rate of advance or manipulation of the electrode. An automatic welding machine, however, is adjusted to make a satisfactory weld under a given set of conditions, and the machine will feed welding wire at the predetermined speed and rate of travel between the electrode and the joint. Therefore, when the prepared joint or the space between the members is not uniform, the metal deposited by the automatic machine may be satisfactory at some points and unsatisfactory at others.

The techniques of edge preparation for automatic arc welding are the same as for hand welding. As free-hand flame cutting cannot ensure the desired accuracy of beveling, a mechanically guided torch should be employed.

The importance of cleaning the fusion faces cannot be emphasised too strongly. Poorly cleaned fusion faces will result in porosity in the weld. Both the fusion faces and the adjacent metal for a width of up to 50 mm should be thoroughly cleaned. It is good practice to clean and align the parts to be welded just before welding, as rust will cover them again in no time.

Cleaning the fusion faces after assembly does not produce the required result because specks of rust will lodge in the gaps between the abutting and overlapping edges, leading to pores in the weld.

Modern welding shops working on a flow-line basis use pickling and passivating<sup>1</sup> instead of the inefficient methods of edge cleaning, so that the fusion faces need not be cleaned immediately before welding.

Special emphasis should be placed on the spacing of the parts to be welded. The spacing should be uniform and remain within the prescribed limits. When back-up strips, a flux bed and such are provided as a precaution against the

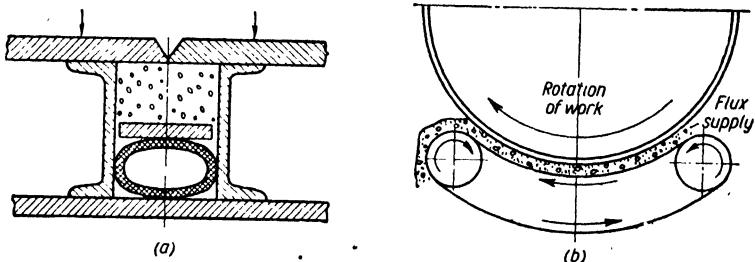

Fig. 124. Bed of flux

molten slag running off, the gap in a butt joint should not exceed 2 mm for a metal thickness of up to 16 mm, and not over 3 mm for a plate thickness of over 16 mm.

If prior to final welding the parts have been assembled by means of manual tacks, heavily covered electrodes should be used, as bare or washed electrodes will produce pores and voids at the tack-welds.

*Butt joints*, depending on plate thickness and work design, may be welded from one or both sides, in one or several passes, and with or without bevelling or chamfering.

When welding from one side, it is difficult to make a full penetration weld, while avoiding the run-off of molten metal and a burn-through at the edges. Therefore, welding from one side is assisted by the following device.

*Welding on a flux bed* (Fig. 124). A flux bed prevents molten metal from running off and helps mould the root

---

<sup>1</sup> Passivating is a process by which a thin film of oxides is formed on the surface of a metal in order to make it rust-proof and to improve its appearance.

bead. For the flux bed to be able to serve this purpose, it should be uniformly held up to the edges of the joint.

Fig. 124a shows a flux bed for the butt welding of plates. The flux bed is held up to the parts by a durite hose into which compressed air is admitted from the shop line under a pressure of up to 4 atmospheres. The compressed air inflates the hose and makes it bear upon the flux through a spacer.

If the flux bed is not held up tightly to the edges, molten metal will sink through the flux, forming flash and streaks of metal on the underside. When held up too tightly, an insufficient throat at the root will result.

Fig. 124b shows a flux bed suitable for welding inside seams in cylindrical pieces. In this case the flux bed is carried by an endless belt.

There are other types of flux bed, including those in which flux is carried by grooved copper bars or plates.

*Welding with copper back-up bars or plates.* The high heat conductivity of such a back-up bar or plate prevents it sticking to the weld metal.

A copper back-up bar or plate should fit closely to the plates being welded. It may be smooth or have a groove to receive flux. With the latter, a well-shaped bead is obtained on the underside.

When using a copper back-up plate, the watts of the arc should be increased by 10 to 15 per cent to make up for the runaway of heat through the back-up plate.

As a rule, copper back-up bars or plates are 40 to 60 mm wide and 4 to 6 mm thick. For sections upwards of 20 mm, copper back-up plates should be not less than half the thickness of the metal.

Where the back-up plate may be left in the weld, consumable *steel inserts* (located in the gap at the root of the weld) may be used. If the root is accessible, the root run may be deposited manually, and the remainder of the joint may be filled by the automatic process.

For better quality, root runs should be deposited with heavily covered (shielded-arc type) electrodes. The root run should be not less than one-third of the plate thickness, but not more than 6 to 8 mm.

For important structures preference should be given to

*double-vee butt welds* welded from both sides by the automatic process.

In this case a butt joint is first welded by an automatic machine from one side so as to obtain approximately 50 per cent penetration. The piece is then turned over and the joint is welded from the other side so as to penetrate the root of the first bead (Fig. 125). This technique needs no back-up strips, flux beds, or manual root runs, but it requires careful fit-up and a spacing of not more than 1 mm between the edges.

If the weld gap is more than 1 mm, the same precautions must be taken against molten metal running out as in the case of welding from only one side.

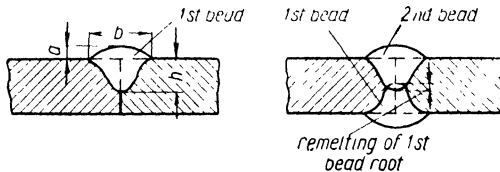

Fig. 125. Welding from both sides

When butt welds, single- or double-veed, are welded in one run, no edge preparation is usually necessary. Edge preparation is essential on plate thicker than 16 mm so as to avoid excessive weld height (with a reinforcement as great as one-fifth of the plate thickness). The vee is made to an included angle of 50 or 60 degrees, and the groove is not more than one-third to one-half of the plate thickness.

*Multiple-pass* welding is used when heavy sections have to be welded and only low-power sources are available, which are not capable of completing the joint in a single pass. With multiple-pass welding it is essential to vee the edges.

**Fillet welds** may be welded either as shown in Fig. 126*a*, when the electrode is held upright<sup>1</sup>, or as shown in Fig. 126*b*, when the electrode is held at an angle to the horizontal member<sup>2</sup>. In the former case the work has to be tilted for

<sup>1</sup> The downhand position in U.K. usage (flat in the U.S.).—*Tr.*

<sup>2</sup> The horizontal position for fillet welds in U.S. usage (the inclined position in the U.K.).—*Tr.*

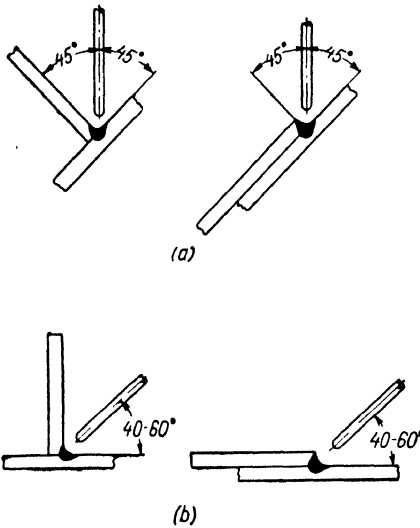

Fig. 126. Electrode and welding position in welding fillet welds

welding and the gap between the members must be kept to a minimum. This technique is applicable to heavy sections, as it enables them to be welded in a single pass. In the latter case, the molten metal tends to run down onto the horizontal surface, and a leg greater than 8 or 9 mm is hard to obtain; for this reason large-size fillet welds have to be made in many passes. The electrode should make an angle (the work angle) of 40 to 60° with the horizontal. To avoid undercuts on the vertical member and overlaps

on the horizontal member, the electrode should be advanced accurately along the seam. The deviation from the centre line of the seam should not exceed 1 mm.

Lap joints may also be welded with an upright electrode by the so-called *melt-off edge method* (Fig. 127). The upright electrode is moved along the upper edge of the lap joint (Fig. 127a). If the electrode is shifted to the right, as in Fig. 127b, the lower plate will be penetrated

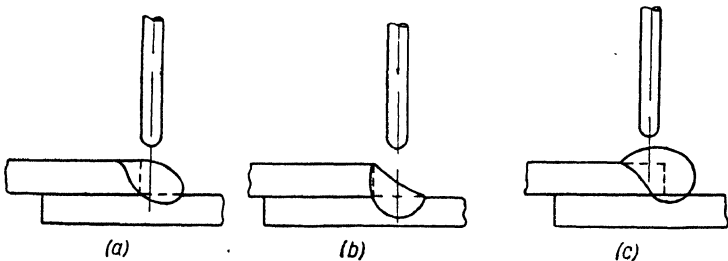

Fig. 127. Melt-off technique of welding

too much. When the electrode is shifted to the left, as in Fig. 127c, penetration is reduced, and overlaps result on the weld.

The melt-off edge technique is applicable to lap joints in which the upper plate is not more than 9 to 10 mm thick.

**Welding procedure.** The key factors in an automatic welding procedure are welding current, arc voltage, and welding speed. They determine the depth of fusion, the shape and size of the weld, and should be chosen to obtain the highest possible production rate with the least possible expenditure of electrodes and power. This is called the *optimal* welding procedure.

Table 18 illustrates the effect of welding conditions on the shape and size of welds.

Table 18

Effect of Welding Conditions on Shape and Size of Welds

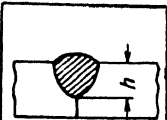
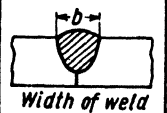
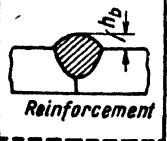
Weld characteristics (dimensions of cross-section)	Effect of increase in:				
	welding current	electrode size	arc voltage	welding speed	flux grain size
 <p>Depth of fusion (penetration)</p>	increases	decreases	decreases slightly	decreases at over 40 m/hr	decreases slightly
 <p>Width of weld</p>	increases slightly	increases	increases	decreases	increases slightly
 <p>Reinforcement</p>	increases	decreases	decreases	increases slightly	decreases slightly

In choosing the welding procedure reference is usually made to tables compiled on the basis of actual experience.

The welding procedure thus chosen is tested on a trial plate, adjusted, and is then applied to the work in hand.

Table 19 indicates welding conditions for the automatic welding of double-vee butt joints without back-up plates, a bed of flux, or manual sealing runs. Table 20 suggests them for the automatic welding of fillet welds in the down-hand position.

Table 19

**Welding Conditions for Automatic Welding  
of Double-vee Butt Joints Without Backing**

Plate thickness, mm	Included angle on each side, deg.	Depth of veeing on each side, mm	Root face, mm	No. of weld	Amperes	Volts	Welding speed, m/hr	Electrode size, mm
20	60	6	8	1	800	37-38	32	6
				2	1,000	38-40	30	6
22	60	6	6	1	800	37-38	32	6
				2	1,000	38-40	28	6
24	60	7	10	1	900	37-38	32	6
				2	1,100	38-40	26	6
26	60	8	10	1	900-1,000	38-39	30-32	6
				2	1,100	39-41	20-22	6
28	60	9	10	1	900-1,000	38-39	30-32	6
				2	1,100	39-41	20-22	6
30	60	9	12	1	1,000	38-39	30-32	6
				2	1,100	39-41	18-20	6

Note: The weld gap should not exceed 1 mm.

Table 20

**Welding Conditions for Automatic Welding of Fillet Welds  
in Downhand Position**

Leg, mm	Amperes	Volts	Welding speed, m/hr	Electrode size, mm
6	650-700	} 34-36	40	5
8	700-750		25	5
10	750-800		18	5
12	850-900		15	5
14	850-900		10	5
16	900-950		8	5

### 77. Automatic Welding Units

An automatic welding unit incorporates all the mechanisms and facilities necessary for automatic welding. The key components of an automatic welding unit are listed in Sec. 72.

There exist automatic welding units for straight, circular, curvilinear and vertical seams. There may also be special-purpose welders designed for particular welding operations.

Each welding shop or factory may set up units to handle the repetitive jobs in their manufacture. These units differ in the jigs and fixtures employed to keep the parts in alignment and to rotate them for convenient welding.

The limited space available in this book does not permit an exhaustive coverage of all makes and types of automatic welding units employed commercially.

Fig. 128 shows an automatic unit for welding long beams up to 1.5 m deep.

This unit incorporates a self-propelled truck 1 and an electric motor 2. The truck can travel at different speeds, depending on the gear ratio of the reductor. The gear-box enables the welding speed to be selected within the desired limits. The truck carries an upright 11 and a cross piece 10 which can move up and down the upright. The crosspiece has an extensible boom 9 from which are suspended the welding head 4, flux hopper, and wire reel. The head can be adjust-

ed for height by a motor drive 6 installed on top of the upright 11. The boom 9 can be slewed manually by means of a chain sprocket 5. The H-beams to be welded with a vertical electrode (see p. 193) are placed on supports 3. The current is conducted to the electrode through a flexible wire held by travelling suspensions 7 which move along the guide rail 8. The rail is made fast either to columns or to brackets built into the wall.

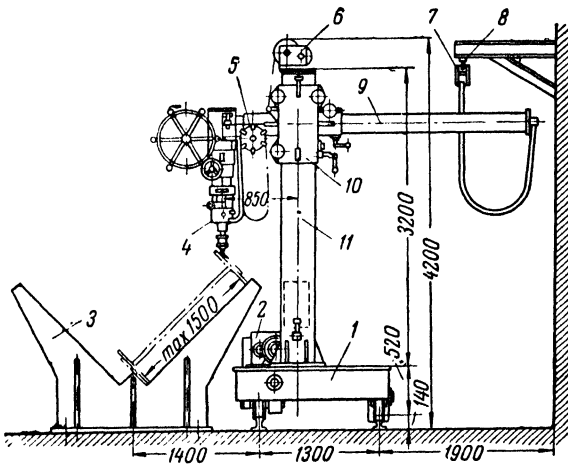

Fig. 128. Automatic welding outfit for beams

Wide use is currently made of tractor-type machines (described earlier in the book) which do not require any intricate running gear. When welding beams, a tractor-type machine rides directly on the plate of a beam. Fig. 129 shows an example of a tractor-type machine employed in an automatic welding unit for circumferential seams in cylindrical pieces.

Both the inside and outside circumferential seams of a cylinder are welded by a tractor-type machine which rides directly on the shell of the cylinder being welded. The shell is supported by a roller bed with motor-driven rolls. The shell is rotated with the welding speed. The machine moves with the same speed but in the opposite direction so

that it always remains at the top of the shell when welding the outside seam or at the bottom of the shell when welding the inside seam. The electrode should be somewhat set off from the vertical diameter, in the opposite direction to the rotation of the shell. The offset depends on the speed of rotation and the diameter of the shell.

For some jobs in heavy-gauge plate two automatic welding heads may be placed in tandem so that two layers can be deposited in a seam during a single run.

In flow-type production, automatic welding heads are part of automatic lines. At the Chelyabinsk Pipe Mill, for example, submerged-arc welding is a key operation in the automatic line welding large-diameter pipes. Skelps are formed from plate in powerful presses and the longitudinal seams are welded by automatic arc welders.

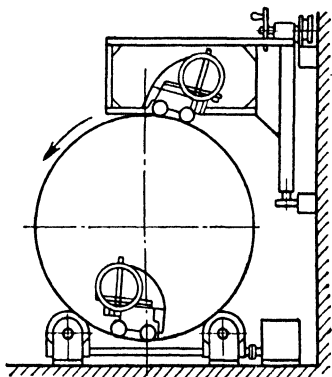

Fig. 129. Outfit for welding circumferential seams on vessel shells

### 78. Electroslag Welding

The Paton Electric Welding Institute has developed a welding process, called electroslag welding, especially adapted to welding vertical seams with the weld moulded by a suitable device. This process boils down to the following. The plates to be welded are placed vertically without any edge preparation, leaving a gap of 10 mm or more. Placed on the far side of the joint is a copper back-up plate (1 in Fig. 130) water-cooled on the inside. In some cases the stationary back-up plate may be replaced by a travelling copper block. On the near side of the joint moves a welding head which incorporates a travelling shoe of copper 2, also water-cooled. Welding wire 4 is positioned an equal distance from the edges by a suitable carrier or a current-conducting guide. The weld metal is deposited within a

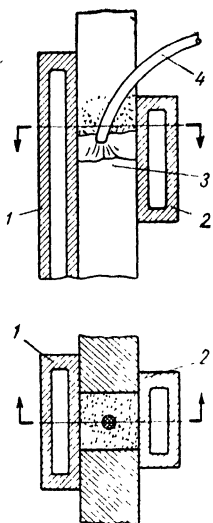

Fig. 130. Electroslag welding as applied to vertical seams

closed space in the upward direction. The already deposited metal 3 is the bottom of the space, while the edges and copper blocks are the walls, and the blanket of flux, its cover.

The weld pool is contained within this space and, due to contact with the copper blocks, it cools, solidifies, and is shaped.

When heavy sections (upwards of 25 or 30 mm) are welded by this process, a large volume of molten slag is formed, and the welding current passes through the molten slag owing to its high electrical conductivity. The density of the arc current decreases to a point where the arc becomes unstable and goes out. The heat is now generated by the passage of the current through the molten slag.

This arcless process has been termed *electroslag welding* by its inventor G. Z. Voloshkevich. Electroslag welding is shown diagrammatically in Fig. 131. The space bounded by the edges 1, the copper shoes 4, and the deposited metal, holds the pool 5 of molten electrode metal 2 and parent metal. The weld pool is covered by a blanket of molten flux (or slag) 3. The depth of molten slag depends on the level of the metal pool with respect to the top of the copper shoes. The heat given up by the passage of the welding current through the slag melts the electrode and edges and keeps the molten flux in the molten state.

Flux consumption in electroslag welding is only a fraction of what it is in arc welding, because just as much flux is fed into the welding zone at one time as is needed to form a crust of slag 1 to 1.5 mm thick on the surface of the weld. This amounts to 2 or 3 per cent of the deposited metal (by

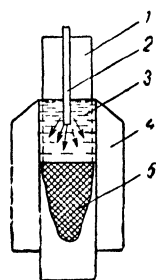

Fig. 131. Diagram of electroslag welding

weight). As there is no arc, a negligible amount of gases is evolved and spatter is reduced to a minimum.

Using electroslag welding, vertical seams can be welded in a single pass in plate of practically any thickness without edge preparation.

As commercial experience has proved, the electroslag process is economical not only when downhand welding

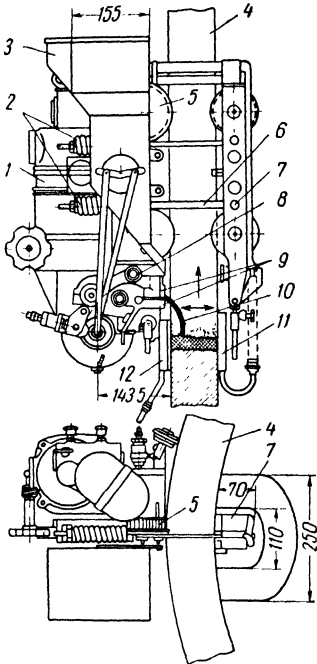

Fig. 132. Automatic machine for vertical seams

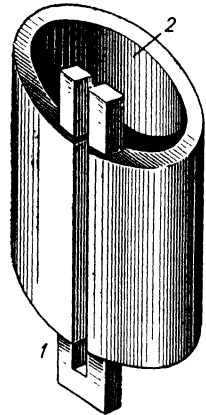

Fig. 133. Use of run-on and run-off plates in electroslag welding

cannot be utilised, but also on plate thicknesses upwards of 30 mm.

Sections heavier than 60 mm can be welded to advantage by automatic machines which

impart the welding wire a transverse motion, backwards and forwards.

The speed of welding can be stepped up by feeding two or three wires into the same weld pool simultaneously.

One such electroslag welding machine for vertical seams is shown in Fig. 132.

The automatic head 1 rides up directly on the plates

to be welded 4 on wheels 5 whose flanges fit into the groove and are held tight to one of the edges by springs 2 and bolts 6 passed through the gap at the joint and attached to the truck 7 on the other side of the plates.

The weld is moulded by copper shoes 11 and 12. One of them 11 is carried by the truck 7 and the other by the automatic welding head 1. Wire 10 is supplied by reels 8 through a guide 9 into the weld pool. Flux is supplied from a hopper 3. For uniform heating of heavy sections the end of the wire is made to oscillate along the edges. In Fig. 132 this motion is shown by a double-headed arrow.

The fluxes used in electroslag welding are AH-8, AH-22 and  $\Phi\Pi-7$ .

Electroslag welds are started on run-on plates 1 and finished on run-off plates 2 (also known as starting and finishing tabs); this improves the quality of the weld metal (see Fig. 133).

The Paton Institute has also developed automatic electroslag welding machines using electromagnets to climb up

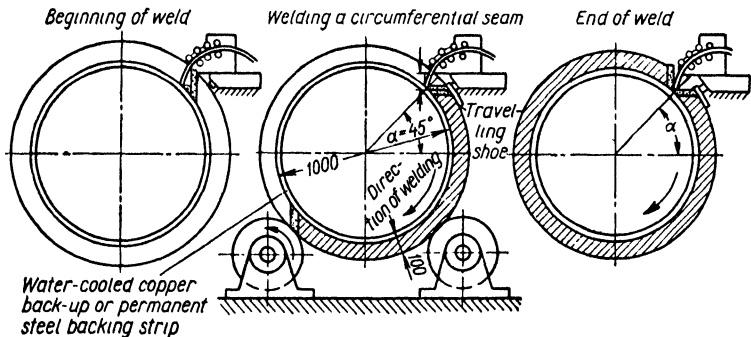

Fig. 134. Electroslag welding of circumferential seams

the work. As the movement of the electromagnets resembles walking, the machines are termed walking-magnet welding machines.

Circumferential seams can also be welded by the electroslag process, using special devices to overcome the difficulty of joining the start and finish of a weld.

The electroslag welding of a circumferential seam is shown diagrammatically in Fig. 134.

The bead on the reverse side can be moulded by a water-cooled copper chill ring, a permanent steel ring, or a travelling shoe.

Pieces of variable cross-section can be electroslag welded using consumable electrode guides. The technique of welding guide-vanes for a hydraulic turbine is shown diagrammatically in Fig. 135.

Referring to Fig. 135, a steel insert 5, which is the shape of a turbine vane, is placed between the vane parts to be welded. Welding wire 4 is fed through a steel tube or electrode guide 3 by a suitable wire feed mechanism. As the groove is filled by molten metal and the slag blanket 1 rises, the insert and guide are melted together with the electrode wire. The pool is retained by copper blocks 2 fitting closely to the surface of the plates at the joint.

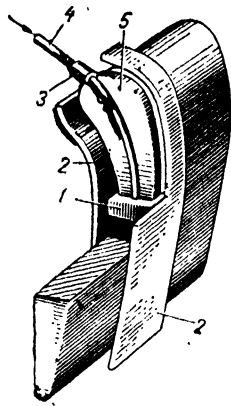

Fig. 135. Electroslagwelding with a consumable electrode guide

Electroslag welding has brought about sweeping changes in the fabrication of heavy presses, rolling plant, etc., from sections up to 1,000 mm or more thick. Replacement of cast-welded, forged-welded and rolled-welded structures for straight castings and forgings saves much metal and labour and increases production without any expansion in facilities or floor space.

### 79. Semi-automatic Submerged-arc Welding

In semi-automatic welding wire is fed to the arc mechanically, while the arc is advanced along the seam by hand.

To reduce the weight and size of the welding head moved along the seam, the wire feed mechanism is made external to the head. In fact, the head is a combination of an electrode holder and a flux-supply device. Welding wire 1 to 2 mm in diameter is fed mechanically to the head inside a flexible metal contact tube up to 3.5 m long.

A diagram of a semi-automatic welding unit is shown in Fig. 136.

Bare wire 1 to 2 mm in diameter is fed from a reel 7 into a flexible metal tube 8 by a wire feed mechanism 5, driven by a three-phase induction motor.

Current to the arc is conducted by a wire, also placed inside the flexible metal tube.

The head 9 is advanced along the seam by hand. The head carries a flux hopper and a start push-button.

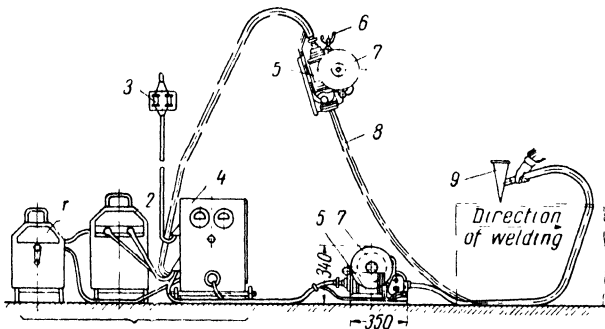

Fig. 136. Semi-automatic welding unit

Current for the semi-automatic unit is supplied by a conventional welding transformer or a d.c. motor-generator set. The transformer 2 and reactor 1 are connected to the head through a switchboard 4 which is in turn connected to the mains supply panel 3.

This welding equipment is easily portable, and a single welding head can cover a considerable area in a welding shop. In some cases it has been found convenient to suspend the wire feed mechanism above the operator's station by a hook 6.

Welding heads are available in a variety of types and makes. The most commonly used are the IIII-54 welding head (a successor to the IIII-5) developed by the Paton Institute, and the ПДIII-500 manufactured by the Elektrik Factory.

The two heads are similar in their principle of operation but differ in circuitry and the manner in which flux is supplied to the arc.

In ПIII-5 and ПIII-54 heads welding wire is fed at a constant and independent rate, while in the ПДIII-500 head the rate of wire feed varies with the voltage across the arc.

Flux in the ПДIII-500 is supplied to the arc through a flexible metal tube by compressed air.

The ПДIII-500M, which is a later modification of the ПДIII-500, features a simpler circuitry and a constant rate of wire feed. Flux is supplied from a hopper by a rubber tube instead of through a flexible metal tube.

The same fluxes may be used for semi-automatic welding as for automatic welding. Preference should be given to fine-grained fluxes as they provide a more efficient shielding. In addition to this, a fine-grained flux stabilises the arc—a factor of special importance when the arc is advanced by hand and its length varies.

Semi-automatic heads are mainly used to make fillet welds. The most satisfactory method of striking the arc is to brush the end of the electrode across the work in a manner similar to lighting a match.

When using a ПIII-5, ПДIII-500 or ПДIII-500M units, the start button on the head should be pressed simultaneously with striking the arc so as to switch on the wire feed mechanism. The ПIII-54 head has no start button, but provision is made in its circuitry for automatically starting the wire feed mechanism as soon as the electrode touches the work. The feed of wire is stopped automatically the moment the arc is broken.

When welding a fillet weld so that one member is horizontal and the other vertical<sup>1</sup>, the end of the wire should be moved along the seam so that it is shifted 1 mm away from the corner towards the horizontal member.

Electrode stick-out, i.e., the distance from the end of the arc to the holder, should be 15 to 25 mm, and the electrode should make an angle of 30 to 40 deg. with the vertical member.

---

<sup>1</sup> See the footnotes on page 193.—*Tr.*

Electrode stick-out and position in the seam are maintained constant by placing the holder tip on the work serving as a guide for the welding head. The head should be advanced at a uniform rate in accordance with the adopted procedure.

The backhand welding techniques should be used with the handle of the head placed at a right angle to the direction of welding.

A leg of not more than 8 mm can be deposited in a single pass. With a larger leg, the deposited metal will spread over the horizontal member. Therefore, where legs of more than 8 or 10 mm are required, fillet welds should be made in two or more passes.

In welding intermittent fillet welds, the arc should be played on the end of the increment until the crater is filled up, and then moved on to the start of the next increment in a quick and snappy movement.

The main considerations governing the choice of a welding procedure are the highest production rate and high quality welds.

The aspect ratio (or the ratio of weld width to depth of fusion) should be 2 to 1. To maintain the desired aspect ratio, the arc voltage should be raised with the welding current.

The rate of wire feed depends on the welding current and voltage chosen. In ПИИ-5 welding units the desired rate of wire feed is set by changing a pair of gears in the reduction box of the feed mechanism. In ПИИ-54 units this is accomplished by means of a gearbox, and in ПДШ-500 units, by means of the rheostat of the wire drive motor.

Table 21 shows welding current and arc voltage related to wire feed rate.

Semi-automatic heads can operate on both a.c. and d.c. In the case of light gauges the best results are obtained with low values of current and welding, using d.c. and reversed polarity.

### *80. Machine Gas-shielded Arc Welding*

Welding in an envelope of an inert gas to protect the molten pool from the air was suggested by N. N. Bernardos of Russia as far back as 1883. His idea, however, has only been put to practical use in recent years.

Table 21

## Welding Current and Arc Voltage vs. Wire Feed Rate

Wire size, mm	Amperes	Arc volts	Feed rate, m/hr
1.6	140-150	24-26	79
1.6	170-180	24-26	101
1.6	200-210	24-26	126
1.6	220-230	24-26	156
1.6	280-290	26-28	191
2.0	180-200	32-34	79
2.0	220-250	32-34	101
2.0	240-275	32-34	126
2.0	275-320	32-34	156
2.0	340-380	32-34	191
2.0	380-420	34-38	260
2.0	450-480	34-38	306
2.0	500-540	38-40	378
2.0	550-600	38-40	472
2.0	630-670	40-44	600

Shielding gases may be classed into two broad groups: gases soluble in, or reacting with, metals (such as hydrogen, carbon dioxide, and nitrogen); and inert gases (helium and argon).

Argon and carbon dioxide are the most widely used.

Argon is obtained as a by-product in the separation of air to produce oxygen. Purified argon contains 97 to 98 per cent argon, while commercial argon contains 13 to 14 per cent nitrogen. It is cheaper and is therefore used for commercial purposes. Argon is supplied in cylinders under a pressure of 150 atmospheres.

Before use argon should be dried by passing it through caustic or silicagel, and then purified of oxygen.

Automatic argon-arc welding has been successfully employed for welding thin stainless steel (0.8 to 3 mm), aluminium and aluminium alloys.

The argon-arc process may use either nonconsumable or consumable electrodes.

With a nonconsumable electrode, the arc is maintained between a tungsten electrode and the work. A shield of argon is projected around the electrode. When filler metal is used, it is introduced separately into the arc.

With a consumable electrode, the arc is maintained between a metal electrode and the work.

Steel is widely welded by the semi-automatic  $\text{CO}_2$  shielded-arc process. As compared with submerged-arc welding this process offers the following advantages: the arc can be easily watched; no devices are required to retain flux or recover surplus flux; and there is almost no deslagging in multiple-pass welding.

$\text{CO}_2$  shielded-arc welding equipment is diagrammatically shown in Fig. 137.

The equipment incorporates a torch 1, a wire feed mechanism 2, a gas-flow rate meter 3, a gas pressure regulator 4, a  $\text{CO}_2$  desiccator 5, a  $\text{CO}_2$  cylinder 6, and a welding generator 7.

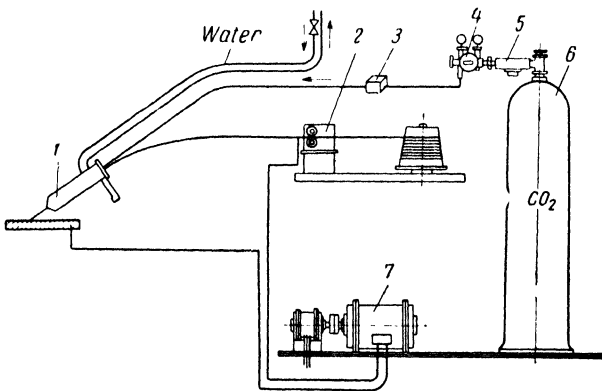

Fig. 137.  $\text{CO}_2$  shielded-arc welding equipment

4, a  $\text{CO}_2$  desiccator 5, a  $\text{CO}_2$  cylinder 6, and a welding generator 7.

The torch is water-cooled as far as the nozzle. The water and gas hoses are held in place by coupling nuts. The parts close to the arc are chrome-plated for ease of cleaning from spatter.

To get the equipment ready for operation, the generator and wire feed mechanism are started, the water-cooling tap and the valve on the  $\text{CO}_2$  cylinder are opened, the desired gas pressure is set on the regulator, and the arc is struck as in semi-automatic submerged-arc welding.

A stable arc is obtained with a current density of over 100 A/sq mm (with 2 mm electrode size). At lower densities the arc becomes unstable, and the melting of the wire is accompanied by a continuous popping sound.

Low-carbon and low-alloy steels are best welded with wire high in silicon (0.8 to 1.1 per cent) and in manganese (1.0 to 1.3 per cent), such as CB-08ΓC and CB-08Γ2C.

CO<sub>2</sub> shielded-arc welding has a higher melting rate, which is a measure of arc efficiency, than submerged-arc welding. With straight polarity it is 1.5 to 1.8 times higher than with reversed polarity.

A disadvantage of CO<sub>2</sub> shielded-arc welding is that it is sensitive to weld contamination. Rust on the surface of the work or atmospheric nitrogen finding its way into the arc zone usually lead to porosity in the weld metal. Air may be sucked in either through leaks in the torch, or when the nozzle is too distant from the work, or when too little gas is supplied, or when the torch is advanced along the seam too fast.

For currents of the order of 200 to 300 amperes, torches for CO<sub>2</sub> shielded-arc welding may have no water cooling.

The sources of current supply for the arc maintained in the shield of carbon dioxide should have a rising or a flat volt-ampere characteristic (see Sec. 25).

Welding guns or torches are being continually improved. Main emphasis is placed on reduction in the weight of the component parts so as to construct a compact and highly portable torch capable of using currents up to 500 or 600 amperes without water cooling.

### *81. Machine Welding with Powder-cored Electrodes*

In 1959 the Paton Electric Welding Institute developed a new semi-automatic welding process which dispenses with both flux and gas shielding and uses tubular powder-cored electrodes.

This process has a decisive advantage over semi-automatic submerged and gas-shielded arc welding, as no devices to contain flux are required and welding is possible in any position. It holds out special promise for site welding

in the wind or draughts, when a gas shield fails to protect the arc and molten metal.

As the name implies, a tubular powder-cored electrode is a length of tubular casing filled with a powdered mixture which supplies a blanket of slag and a gas envelope around the arc in welding.

Tubular casings for powder-cored electrodes are made from cold-drawn low-carbon steel strip 15 mm wide and 0.3 to 0.5 mm thick. A suitable machine feeds a length of strip through a die to form it into tubing. Before the strip is fed into the machine, a charge of core powder is placed on it. Emerging from the forming die, the canned powder is made to pass through a succession of sizing dies until it is reduced to the desired diameter (anywhere from 1.2 to 3 mm).

For carbon steels the Paton Institute recommends IIII-AH2 powder-cored electrodes, using d.c., reversed polarity.

Electrode size may be 1.2, 1.4, 1.6, 1.8, 2.0 and 3 mm, depending on the welding position. For all-position welding, electrode sizes up to 2 mm may be employed, and sizes upwards of 2 mm preferably for downhand and horizontal welding (see p. 193).

With IIII-AH2 powder-cored electrodes, well-shaped butt and fillet welds are obtained in all positions of welding; slag easily comes off the weld metal; spatter loss is negligible, and the arc is steady. The deposition rate with 3 mm electrodes is 16.5 g/A-hr with a current of 320 A. As the current is increased, the deposition rate is raised. At 490 A, it is 22.3 g/A-hr.

## *Chapter XV*

# **RESISTANCE WELDING**

---

### *82. Basic Principles*

In resistance welding, coalescence is produced by the heat obtained from the resistance offered by the work to the flow of electric current in a circuit, of which the work is a part. The quantity of heat thus generated is determined by Joule's law as follows

$$H=KI^2Rt,$$

where  $K$  is the constant (0.24 calories),  $R$  is the total resistance of the welding circuit (including contact resistance and that of the work) in ohms,  $I$  is the current in amperes, and  $t$  is the current flow time in seconds.

The basic resistance welding processes are butt (or upset) welding, flash butt (or simply flash) welding, spot welding, and seam welding (Fig. 138).

In butt or upset welding (Fig. 138*a*) the parts to be welded are secured in the current-conducting copper clamps (by a force  $Q$ ) of a butt welding machine, are then mechanically brought together, and the welding current is switched on. Maximum heat is generated at the point of contact. The ends are heated to a plastic state, are upset (by a force  $P$ ) to complete the weld, and at that moment the current is switched off.

In flash butt welding, the parts are brought together lightly, with current flowing, and then separated slightly to create a "flashing" action at the joint. As flashing continues the metal at the joint reaches a very high temperature until it is at a fusion condition and the adjoining metal is at the appropriate plastic temperature. At that moment the pressure on the moving clamps is quickly and greatly increased, and the current is switched off. This upset ac-

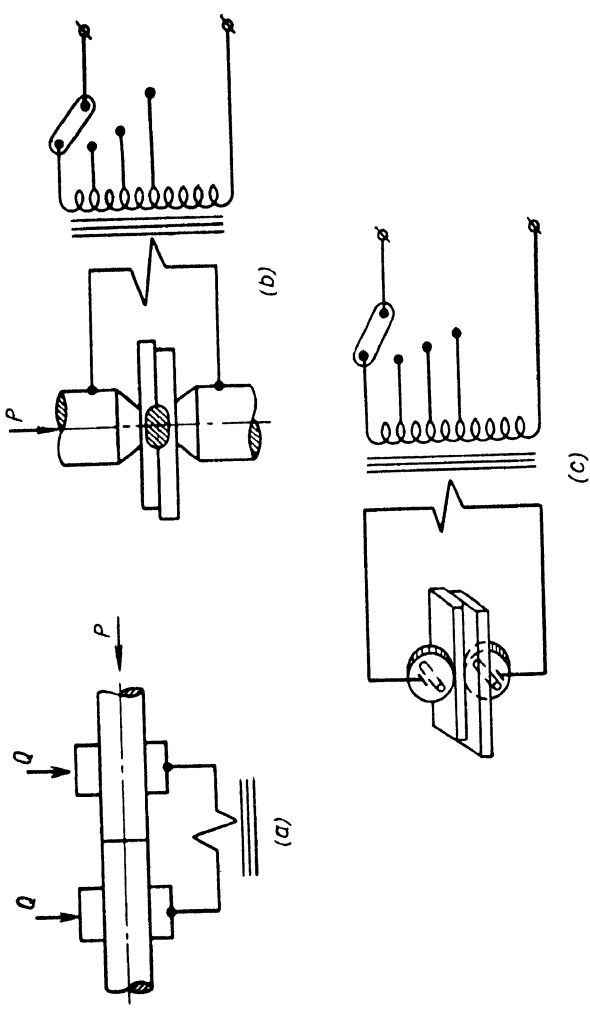

Fig. 138. Resistance welding processes:  
 a—butt or upset welding; b—spot welding; c—seam welding

tion causes the slag, excess molten metal and oxides to be expelled out of the joint.

The spot weld is made by overlapping the parts and gripping the overlapping section between two electrode points, through which the current is passed for localised heating (Fig. 138*b*). After the current is switched off, the molten metal solidifies, leaving a welded spot.

In seam welding the parts to be joined are clamped between two copper roller electrodes (Fig. 138*c*). With the rollers rotating at the requisite speed and the current switched on and off at appropriate intervals, a weld is produced either in the form of a series of closely spaced individual spot welds, or overlapping spot welds, or a continuous weld nugget.

### *83. Upset and Flash Butt Welding Equipment and Techniques*

A resistance butt welding machine consists essentially of a bedframe, table-top and guides; a moving and a stationary platen; a clamp or clamps; a feeding and upset mechanism; a transformer; a tap-change switch; and switches.

Fig. 139 is a diagram of a Type АСИФ-75 butt welding machine featuring a hand lever to feed the moving platen. The stationary platen *1* carries a clamp *2*. The moving platen *4* slides in cylindrical guides *5* and carries another clamp *3*. The moving platen *4* is fed by means of a hand lever *9* through an adjusting nut *6*. Pressure on the handle *10* brings the roller *7* down onto the segment *8* which acts through a system of linkages to actuate the contact *11*, and the latter completes the primary circuit of the transformer. When the parts are being upset, the roller *7* comes off the segment at a predetermined instant, the contact *11* breaks, thus interrupting the transformer primary and de-energising the transformer secondary. The welding current can be adjusted in eight steps. The welding transformer is rated at 75 kVA and supplies a secondary (welding) voltage of 3.5 to 7 V. The maximum rod size weldable by this machine is 45 mm. More powerful machines incorporate a motor or a hydraulic drive to feed the moving platen and

air-hydraulic clamps. Table 22 summarises the performance of some of these machines.

In *resistance butt welding* it is necessary to prepare the opposing faces so that they are reasonably flat and parallel when clamped. This process is applicable, therefore, to rods and bars up to 20 mm in diameter.

Designing for butt welding involves four elements: pro-

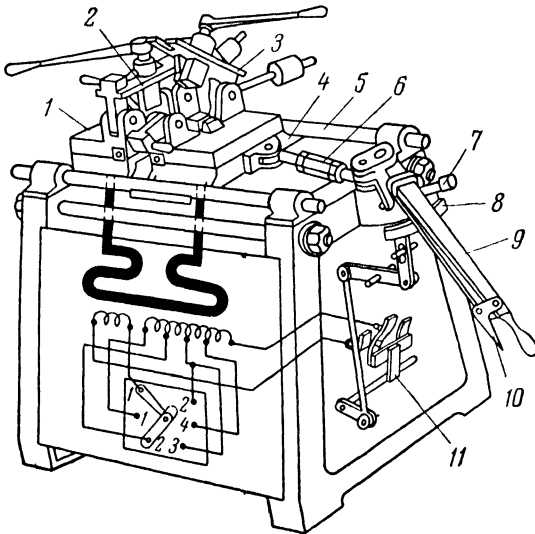

Fig. 139. Diagram of АСНФ-75 resistance butt welding machine

jecting length, upset force, heating time, and welding current.

The projecting length, or the distance from the end to be welded to the clamping jaws of the machine, for the butt welding of round bars, is  $0.75 d$  where  $d$  is the diameter of the bar in millimetres.

The projecting length varies with the resistivity of the metal being welded: it is longer for metals with a lower resistivity, and shorter for metals with a higher resistivity.

Performance Data on Resistance Butt Welding Machines

Characteristics	АЧИФ-5	АСП-10	АЧИФ-75	МСП-100	МСМ-150	МСГ-200	МСГ-500	АСМК-600
Rating, kVA . . .	5	10	75	100	150	200	500	600
Secondary voltage, V	1.16-1.74	1.2-3.2	3.5-7	4.5-7.6	4.53-7.75	4.75-8.49	7.6-15.1	—
Welding current adjustment steps . . .	4	7	8	8	8	8	8	6
Welding cross-section in low-carbon steel, sq mm: nom./max., intermittent operation . . . . .	60/100	60/100	500/1,600	1,000/2,500	2,400	3,600	3,000/8,000	9,000
Welds per hour . . .	100	30-50	75	30	120	50	20	300
Max. upset force, kg . . . . .	400	400	3,000	4,000	6,500	12,000	20,000	6,500
Drive and clamps . . .	hand-operated	hand-operated	screw-type	air-operated	air-operated	hydraulic	air-hydraulic	air-operated
Feed and upset mechanism . . .	ditto	ditto	hand-operated	hand-operated	motor-driven	ditto	hydraulic	motor-driven

The upsetting force has a direct bearing on the quality of the weld metal. For a temperature of 1,200 to 1,350°C the specific upset pressure for low-carbon steel should be up to 3 kg/sq mm. The upset action builds up the weld and thus shortens the piece. The contraction of bars in low-carbon steel due to the upset action may be roughly estimated as follows:

Bar diameter, mm . . . . .	10-15	20-25	30-35	40-44
Contraction, mm . . . . .	2.0	3.5	4.5	6.0

The current density for steel depends on the current flow time and ranges from 20 to 60 A/sq mm. The density should be increased for a shorter weld time and decreased for a longer weld time.

*Flash butt welding* may be either continuous or intermittent.

To establish intermittent flashing, the ends to be fused are briefly brought together and then separated again a short distance.

When the ends are separated, the welding circuit is interrupted, thus causing intensive flashing and sputtering. By repeatedly bringing the ends together and apart at a high rate the entire cross-section of the ends is flashed. This makes the contact surface smooth. When the ends have been thus flashed, the upset pressure is applied at the same time as the welding current is switched off. The upset pressure squeezes almost all molten metal out of the joint, leaving a burr of flash at the top and bottom of the weld.

When continuous flashing is employed, the parts to be welded are slowly brought together. At first they touch only at a few projections of the ends, where the current density rapidly rises. While the metal at the projections is being expelled by flashing (referred to as "burn-off"), the ends come in contact over a wider area, and gradually the entire cross-section is burned off. As the work reaches the molten state, the pressure on the moving clamps is quickly and greatly increased, as if in a kick, and the weld is upset.

Table 23 indicates the procedures for intermittent and continuous flash butt welding.

Table 23

## Procedures for Continuous and Intermittent Flash Butt Welding

Welding variables	Units	Continuous flashing	Intermittent flashing
Specific rating . . . . .	kVA/sq mm	0.2-0.8	0.1-0.5
Weld time . . . . .	sec	(0.4-0.6) <i>d</i>	(0.7-1) <i>d</i>
Flashing rate . . . . .	mm/sec	1-7	—
Upset time . . . . .	sec	10-25	5-10
Specific pressure . . . . .	kg/sq mm	5-8	3-4
Allowance for flashing and upset . . . . .	mm	(0.5-0.75) <i>d</i>	(0.3-0.5) <i>d</i>
Projecting length (for each part):			
low-carbon steel . . . . .	mm	0.75 <i>d</i> +0.75 <i>d</i>	—
Steel Cr. 5 . . . . .	mm	0.5 <i>d</i> +0.5 <i>d</i>	—
Steel Cr. 3 to steel Cr. 5 . . . . .	mm	1 <i>d</i> +0.5 <i>d</i>	—

Note: "d" stands for the diameter of the bars to be welded, in mm.

#### 84. Spot and Seam Welding Equipment and Techniques

Both spot and seam welding machines consist of a bed-frame housing a transformer and a pressure mechanism with an interlocked switch. In addition to this, a seam welding machine incorporates a roller electrode drive system.

The cycle of operation involved in the making of a spot or a seam weld is as follows:

(1) Pressure is applied to the parts to be welded by the electrodes.

(2) The current is switched on (and in the seam welding machine, the roller electrode drive is also started). This begins the welding operation.

(3) The current is switched off (and in the seam welding machine, the roller electrode drive is stopped). This ends the seam welding operation.

(4) In spot welding the pressure between the electrodes is still maintained or increased for a short while and then the electrodes automatically come apart. This ends the spot welding operation.

Spot and seam welding machines are available in a variety of designs, capacities and pressures.

In small machines the electrode pressure is provided by a foot-pedal mechanical leverage system. The current is switched on and off by mechanical switches.

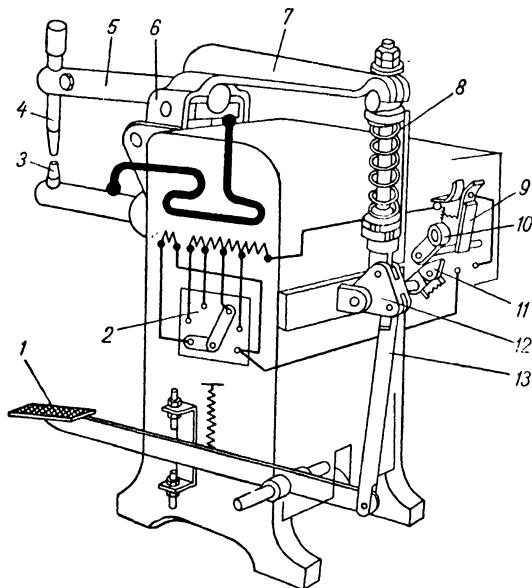

Fig. 140. Diagram of ATII-25 spot welding machine

Fig. 140 shows a diagram of a Type ATII-25 spot welding machine in which the pressure is obtained by a foot-pedal leverage system and the current is mechanically interrupted.

Pressure on the treadle 1 pushes up the vertical movable member 13 thereby turning the bell crank 12. Rotation of the bell crank overcomes a spring 8, making the rocker arm 7 tilt about the shaft 6. This causes the copper electrode 4 held in the horn 5 to approach the lower copper electrode 3, thereby clamping the work (omitted in the picture). Further movement of the treadle compresses the spring 8 and builds up pressure between the electrodes 4 and 3.

As the pressure continues, the cam *11*, rigidly coupled to the bell crank, bears upon a roller *10* to close the contact *9* in the transformer primary circuit, and a current starts flowing in the secondary, through the electrodes and the work. Further movement of the treadle makes the cam slip over the roller, thereby breaking the contact and interrupting the welding circuit. Holding the treadle fully down provides the necessary upset pressure with the current off.

When the treadle is released, the top electrode goes up, and the machine is ready to make another spot weld.

The weld time can be adjusted by means of another cam *11*, while the electrode pressure is set by varying the tension of the spring *8*. The welding current is selected by the tap-change switch *2* in the transformer primary circuit.

Table 24 summarises the performance data of some spot welding machines.

Prior to welding, steel plate should be thoroughly cleaned where spot welds are to be made. This can be done by an emery wheel, a power-driven steel wire brush, and pickling with warm 10 per cent sulphuric acid followed by neutralisation in a solution of sodium hydrate and flushing with water (in the case of large-scale production welding).

The strength of a spot weld depends on its size (cross-section or diameter), which in turn is governed by the tip diameter (contact face), work thickness, electrode pressure, welding current, and current flow time.

When welding current is low and the weld time is short, the resultant spot weld is too weak.

The following considerations should be taken into account when selecting spot welding procedure.

Low-carbon steel up to 5 mm thick may be spot-welded with both a short and a long weld time.

In the first case the weld time will range from 0.25 to 1.5 sec, depending on the thickness of the work.

Sections upwards of 5 mm in thickness should preferably be joined with a long weld time.

Table 25 indicates procedures for the spot welding of steel.

A generally accepted formula for obtaining tip size (contact face) is:

$$d_t = 1.5\delta + 5 \text{ mm,}$$

Performance Data on Spot Welding Machines

Characteristics	AT-10	АТП-25	АТП-75	МТМ-50	МТП-100	МТП-200	МТП-400
Rating, kVA . . . . .	10	25	75	50	100	200	400
Adjustment range of secondary voltage, V . . . . .	1.6-2.75	2.0-3.5	3.5-7.5	2.9-5	3.4-6.8	4.6-9.3	5.1-10.3
Throat depth*, mm . . . . .	250	250	350	300	500	550	550
Max. metal thickness, mm:							
(a) nonautomatic operation . . . . .	1.5+1.5	2+2	5+5	—	8+8	12+12	16+16
(b) automatic operation . . . . .	—	—	—	2+2	4+4	6+6	8+8
Spots per hour:							
(a) nonautomatic operation . . . . .	1,000	800	300	450	—	—	—
(b) automatic operation . . . . .	—	—	—	3,000	3,000	3,900	2,400
Pressure mechanism . . . . .	foot-pedal	foot-pedal	foot-pedal	motor-driven	air-operated	air-operated	air-operated

\* The distance from the centre line of the electrode to the first obstruction limiting the insertion of work in a spot welding machine. Throat depth is usually measured in a horizontal plane, as distinct from throat opening, which is measured at right angles to throat depth.

## Procedures for Spot Welding of Steel

Weld time	Average am- peres per sq mm of spot-weld cross-section	Specific pressure, kg/sq mm	
		for thickness less than 1.5 mm	for thickness over 1.5 mm
Short . . . . .	120-220	1.5-5	5-9
Long . . . . .	70-120	—	1.5-4

where  $d_t$  is the tip diameter (contact face) in mm, and  $\delta$  is the single thickness of metal in mm.

The spacing of spot welds in the direction of effective stress should be not less than  $2.5 d_{sw}$ , and the edge distance must be at least  $1.5 d_{sw}$  (where  $d_{sw}$  is the diameter or size of the spot), if not otherwise specified in the drawing or sketch of the weldment.

Where large-quantity production is involved, a great advantage is obtained in using what is known as multipoint or multi-spot welding. Most modern multi-welding machines incorporate a built-in oil-draulic pump which

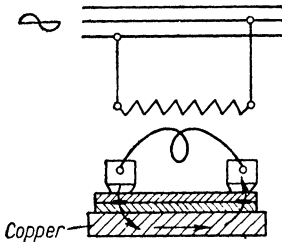

Fig. 141. Diagram of twin-spot welding

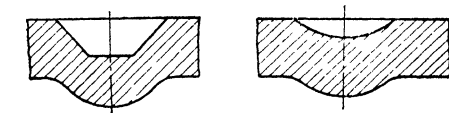

Fig. 142. Preparation of work for projection welding

actuates the pressure mechanism, and operates on the principle of twin-spot welding (see Fig. 141).

In twin-spot welding, both electrodes are on one side of the material. The current is taken through a copper backing bar or plate below the bottom sheet, and the welding current flows through the first electrode to the material, on to the copper back-up bar or plate, back to the material, and fi-

nally to the other electrode. Two spots are welded at a time.

A number of spot welds can also be made simultaneously by projection welding. In this process projections or embossments are raised on the work pieces to form the welded zone (Fig. 142).

The workpieces are loaded into a projection welding press in which the electrode is a substantial slab. When

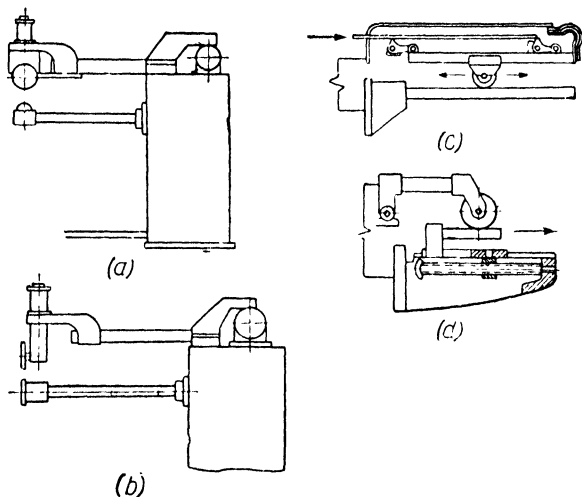

Fig. 143. Seam welding:

*a*—longitudinal joint; *b*—transverse joint; *c*—by single roller or wheel electrode; *d*—by roller or wheel electrode and moving mandrel

the current is switched on, a highly localised heat is created at each projection, and the metal at the projections rises quickly to a plastic temperature. Under the action of the electrode force the component parts collapse at the projections so that both sheets come into intimate contact, as many spot welds are made during a single stroke of the machine as there are projections.

Where the work to be welded is of a bulky nature, such as railway cars, aircraft, motor vehicles, etc., and where

it would not be feasible to carry out the necessary welding on fixed or pedestal-type machines, portable gun welders are extensively used, in which the electrode pressure is provided pneumatically. To reduce the weight of a portable spot welder, the transformer is mounted externally to it and is connected by flexible leads.

Another technique, called stitch welding, is a variety of spot welding, as it produces a series of overlapped spot welds which, however, appear similar to the line of welds obtained in resistance seam welding.

The main difference between stitch welding and seam welding is that in the latter case the current is conducted through the workpieces by means of electrode wheels or rolls with the pressure applied continuously and the current switched on and off at predetermined intervals. In the case of stitch welding, the electrodes reciprocate automatically, so that spot welds are made consecutively and overlapping, and the current is switched on just as the electrodes stop.

Several schemes of electrode shape and arrangement are employed in seam and stitch welding (see Fig. 143). Either both electrodes or one of them (top or bottom) can be driven, depending on the design of a given welding machine. The performance data on some of them are summarised in Table 26.

Table 26

Characteristic	Welder type designation			
	АИИП-25	АИИ-50	МИИП-100	МИИП-150
kVA rating . . . . .	25	50	100	150
Max. material thickness (low-carbon steel), mm . . .	1.5+1.5	2+2	1.5+1.5	2+2
Welding speed, m/min . . .	.86-3.4	.8-4.7	.8-3.5	.8-3.5
Steps of current adjustment	8	8	8	8
Secondary voltage, V . . .	2.2-4.5	2.0-4.5	3.3-6.7	3.9-7.8
Throat depth, mm . . . .	400	400	800	800
Pressure mechanism . . . .	pedal-operated	motor-driven	air-operated	air-operated
Max. electrode force, kg . .	250	400	800	800
Max. welding current, A . .	10,000	18,000	17,000	21,000

Current to the electrodes can be conveyed either continuously or intermittently (the latter being called multi-impulse or pulsation welding). The results are better with

multi-impulse or pulsation welding. AИИИ-25 and АИИ-50 welding machines operate on a continuously flowing current and can successfully weld low-carbon steels. In-МИИИ-100 and МИИИ-150 welding machines the current is applied in a series of impulses, which makes it possible to weld not only low-carbon steel, but also nonferrous metals, tinned galvanized and nickel-plated steels.

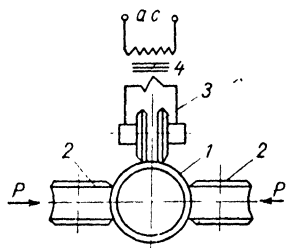

Fig. 144. Diagram of butt-seam welding of pipes

A further technique of seam welding, used principally in the fabrication of steel tubes and pipes up to 600 mm in diameter and a wall thickness of 0.5 to 12 mm is butt-seam welding. Fig. 144 shows diagrammatic outlines of this technique. A steel skelp is fed into a machine forming it into a circular shape as it passes through several rolls. After the circular shape *I* is secured, two electrode rollers *3* connected to a welding transformer *4* apply the welding current, one on each side of the joint, while steel side rollers *2* apply pressure effecting the longitudinal weld.

## *Chapter XVI*

# **WELDING PROCEDURES**

---

### *85. Welding Procedure Defined*

A well thought out welding procedure goes a long way towards efficient fabrication and high-quality weldments.

To meet this requirement suitable codes, rules, and regulations have been established for the welding of boilers and pressure vessels, piping, railway rolling stock, ships, structures, etc.

In drawing up a welding procedure account must be taken of the relevant standards and rules of welding practice.

A welding procedure must ensure the necessary strength of the resultant welds, the lowest possible stresses and strains and the lowest cost of manufacture.

Welding procedures are mapped out on the basis of the shop drawing of a given work. A shop drawing, compiled in accordance with the appropriate standards for mechanical drawings, should give the necessary data, including the type of parent and electrode metal, number and weight of component members and finished weldments, the places to be machined and welded joints to be made.



The means of placing complete information about welds on drawings is provided by symbols. In the Soviet Union they are specified for machine drawings by a relevant State Standard covering welded joints made by manual arc welding, automatic and semi-automatic submerged-arc welding, gas welding, resistance welding, and gas shielded-arc welding.







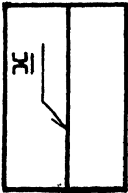

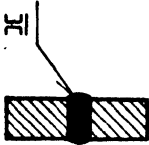
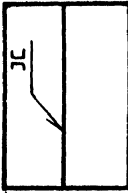
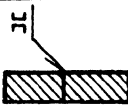
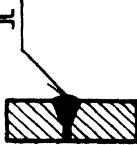
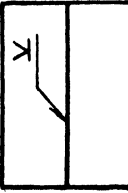
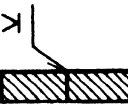
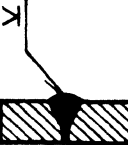

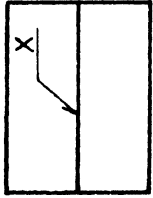
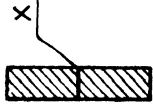
Examples of standard welding symbols used in the U.S.S.R. are presented in Table 27.

A welding symbol is located on a broken reference line which consists of a horizontal and an inclined leg, the latter terminating in an arrow indicating the place where a given weld is to be made. For visible members the symbol and

Table 27

Some Welding Symbols

Type of weld	Plan and elevation of welds when work measures less than 5 mm in thickness on drawing		Elevation of welds when work measures more than 5 mm thick on drawing
	visible welds	hidden welds	
Square butt weld, welded from both sides			
Ditto, welded from one side			
Single-vee butt weld, welded from both sides (with sealing run)			

Type of weld	Plan and elevation of welds when work measures less than 5 mm in thickness on drawing		Elevation of welds when work measures more than 5 mm thick on drawing
	visible welds	hidden welds	
Double-vee butt weld (equal preparation)	 		
Double fillet weld, square	 		
Double lap weld, square	 		

dimensions are located above the horizontal leg, and for hidden members beneath the horizontal leg.

Welding procedures should cover:

(1) preparation, listing all operations involved in the preparation of the component members;

(2) assembly, indicating the sequence of operations for the constituent members and the work as a whole, and the necessary jigs and fixtures;

(3) welding, indicating the method and sequence of welding, welding variables, electrode type and other data conducive to high-quality welds;

(4) weld inspection and testing, giving the requisite methods and procedures.

### *86. Welding Specifications and Instructions*

The description of a welding procedure is presented as a welding specification and/or instructions. A welding specification may be filled out on a ruled form, giving the necessary information for the work to be done. Each stage in a welding operation may be described in separate specifications, the general rule being to cover preparation and welding by a common specification. Welding specifications, therefore, may of necessity differ from one another, as they may convey different information.

Welding specifications should include:

(1) a sketch of the work or reference to an accompanying drawing, giving all the joints to be welded and their dimensions;

(2) the welding process to be employed (manual, semi-automatic or automatic arc welding, etc.);

(3) number of layers per weld;

(4) electrode size and type for each layer;

(5) current for each electrode size;

(6) welding position and sequence (downhand, vertical, etc.);

(7) source of welding current (a d.c. motor-generator set, a transformer, etc.);

(8) electrode consumption per weldment;

(9) whether or not peening, preheating, etc., is required;

(10) time allocation and payment rates.

As far as possible all welded structures should be covered by welding specifications, especially articles produced in quantity or on a mass scale. On the other hand, when only a single weldment of a given type is fabricated, welding specifications may be dispensed with, in which case the necessary information may be conveyed to the workmen by a shop foreman or a gang leader by word of mouth.

Instructions are drawn up when the information contained in a welding specification is inadequate for the scope of work in hand. Instructions may be warranted when welding a new grade or type of steel or a new type of work.

Welding instructions include a short description of the welding sequence; characteristics of the parent and electrode metal; requirements for welding equipment and aids; requirements for joint preparation and fit-up; and other information which cannot be included in a welding specification.

## *Chapter XVII*

### **WELD INSPECTION**

---

#### *87. Scope of Inspection or Quality Control*

The principal objective of inspection or quality control is to ensure the high quality of products through the careful examination of the component parts at each stage of manufacture.

Systems of inspection or quality control vary from factory to factory and from industry to industry, depending on the type and scope of production, managerial structure, and technical standards.

When properly organised, inspection should be able to cover each link of the production chain so as to prevent spoilage, to trace out its causes when it occurs, to suggest ways and means of eliminating it, and to certify the quality of the finished product.

To perform their duty intelligently, inspectors should have a working knowledge of the relevant drawings, procedures and specifications.

In a welding shop proper organisation of weld inspection is essential as it reduces rework costs and ensures high-quality weldments.

Apart from welded joints, the quality of a weldment depends on certain other factors:

(a) whether or not a given design is convenient for welding; the magnitude of residual strains and stresses set up by welding heat; and the layout of welded joints from the viewpoint of load distribution;

(b) the quality of the parent metal, electrodes, welding wire, flux, and shielding gases;

(c) the quality of work preparation and fit-up.

The quality of welded joints depends on the performance of welding equipment, on whether or not the proper welding

procedure has been chosen; and on the skill of the operator.

The inspection (quality control) department must therefore see that:

(1) The parent metal, electrodes, welding wire and flux comply with the appropriate specifications. In the absence of certificates covering these materials, they should be tested for quality by suitable procedures.

(2) The joint is prepared and the work is fitted up properly; more specifically, whether (a) the components are formed and dimensioned within the tolerance limits in accordance with the blueprint specifications; (b) the parts to be welded are spaced properly at the joint; (c) fit up produces no initial stresses; and (d) the fusion faces are free from dirt, rust, grease, etc.

(3) The operator uses the correct welding procedure, including welding current, electrode size, welding sequence and number of layers, arc length, rate of arc advance, bead cleaning in multipass welding, chipping back when a sealing run is applied, etc.

The inspection department takes part in the testing of weldments in accordance with the rules and procedures established for a given class of work. After the tests and flaw elimination, the inspection department draws up a final report on the acceptance of the finished product and supplements it with the pertinent information as to its quality (certificates covering the parent metal, electrodes and other materials, specimen test results, evaluation of the welded joints on the basis of physical tests, etc.).

### *88. Welding Defects*

Welding defects may be classed into external and internal.

*External defects* include irregular width and height of beads, deviation of the weld from the prescribed dimensions, unfilled craters on the surface of welds, undercuts, slag on the surface of welds, porosity in the outer layer of a weld, visible cracks in and around the weld.

*Internal defects* include poor fusion, hidden porosity in the deposited metal, hidden cracks in the weld and parent

metal, poor fusion between layers in multiple-layer welding, and entrapment of slag and oxides.

External defects can be detected by careful visual examination. Internal defects, which are very detrimental to the strength of a weld, can be detected in a variety of ways.

*Poor fusion*, which is among the most dangerous defects, is lack of thorough and complete union between the deposited and parent metal, or between individual layers in multiple-layer welding. Lack of fusion impairs the strength of welds and makes welded structures unreliable.

Causes of poor fusion may be:

- (a) low welding current for a given electrode size;
- (b) improper weaving procedure or too rapid arc advance, so that the edges are not melted thoroughly;
- (c) improper joint preparation and fit-up (inadequate bevelling and narrow spacing);
- (d) improper edge cleaning from slag (after flame cutting), dirt, rust, scale, etc.

*Porosity of the deposited metal*. Porosity is entirely ruled out in weldments where tight seams are critical (pressure vessels, storage tanks, pipelines, etc.).

Porosity may be brought about by insufficient puddling, as this does not give time for the trapped gas to escape from the molten metal before it solidifies. The gas remaining in the molten metal forms gas pockets. They may be scattered about or link up into strings of pores, giving the weld metal a spongy appearance. Porosity makes welds leaky, pervious to liquids and gases, and weak.

*Cracks* in welds may arise from locked-up stresses set up by nonuniform heating and cooling, excess sulphur or phosphorus in the weld metal, and some other causes.

Cracks most often occur in butt welds and may be either longitudinal or transverse. Apart from visible cracks, there may be hair cracks, usually appearing at the line of fusion between the parent and deposited metal. They may be brought about by lack of fusion, large gas pockets or slag inclusions where thermal stresses concentrate, giving rise to hair cracks which may develop into large cracks. For this reason hair cracks are intolerable.

Welds may be inspected and tested in a variety of ways,

depending on the nature and type of a given welded structure, its application, and the test equipment available.

In most cases weldments are (a) inspected visually for defects which can be detected by examination and measurement; (b) tested for tightness; (c) tested for mechanical strength; and (d) examined for hidden flaws by physical methods.

### *89. Visual Inspection*

Prior to visual inspection the surface of the weld should be thoroughly cleaned with a steel wire brush and chisel to remove sputtered metal, scale and slag.

The items to consider in visual inspection are the appearance of ripples on the weld, undercuts and overlaps in fillet welds, hair cracks, location of craters, size and shape of beads.

The appearance of a weld is considered to be good if ripples are spaced regularly. Irregular ripples as well as the varying width and height of the weld are an indication that the arc was broken many times during the welding process and that its watts varied within broad limits, which fact may result in lack of fusion and holes. Irregular welds should be tested for internal defects by one method or another.

Hair cracks may be detected with a magnifying glass.

Craters on the surface of the weld should be thoroughly melted and filled. Examination of unfilled craters may give an idea of the welding procedure used by the operator. A very deep and spongy crater results from an excessive welding current and overheating. A shallow crater points to a low current and the likelihood of poor fusion.

Welds are inspected for size and shape by means of welding gauges. These are metal plates with cuts corresponding to the cross-section of a given size and type of weld (Fig. 145a).

On each gauge numerals are punched indicating the thickness of the work in millimetres for butt welds, and the leg in millimetres for fillet welds. As it is difficult to keep the size of a weld within accurate limits, each gauge has cuts for the maximum and minimum size of a

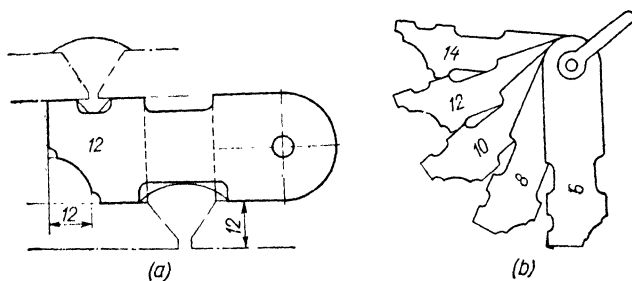

Fig. 145. Welding gauges

given weld. A set of gauges for the most commonly used weld sizes (say, from 6 to 14 mm) is clamped by a ring or a bolt (Fig. 145*b*).

### 90. Tightness Tests

The welded seams of vessels intended to hold liquids or gases are tested for tightness by either kerosene, hydrostatically, or pneumatically.

Kerosene is usually used for testing open vessels. The seam under test is painted with kerosene from one side. Should the seam have open pores or gas pockets, it will pass through them to show up as a dark spot on the other side of the seam. For better observation of the test it is a good plan to paint the opposite side of the seam with white-wash.

Boilers, pressure vessels and pipelines are given a hydrostatic test. This test in fact checks not only seams for tightness but also vessels or pipelines for strength. In a hydrostatic test the vessel to be tested is filled completely with water and all air bubbles are allowed to escape to eliminate air pockets. After all outlets have been closed with lids, gaskets and bolts, a pump is operated until the desired pressure is obtained inside the vessel. This pressure is held for some time, while the vessel is carefully examined for possible leaks along the seams. Any defective spots detected are marked with chalk, chipped out after the test, and rewelded.

## 91. Mechanical Tests

The mechanical strength of welded joints is determined on specimens cut from the welds, or on test plates welded by the same operator, using the same welding procedure and under the same conditions as the work itself.

A specimen should be taken so that the welded joint is in the middle. The reinforcement is removed flush with the parent metal. Specimens are prepared for tensile tests, free-bend tests and, sometimes, impact tests.

A typical tensile test specimen is shown in Fig. 146. The specimen is loaded in a tensile testing machine, the load at rupture being a measure of the strength of the weld. The load in kilograms is divided by the cross-sectional area of the specimen in square millimetres, and the result is the ultimate tensile strength of the specimen.

The free-bend test is conducted to determine the ductility of the weld metal. The test is performed by bending a specimen in a vice or press until the first crack appears.

The angle of bending also gives a measure of the quality of the weld. When the weld metal is ductile, the specimen can be doubled without cracking. Similar specimens are welded by operators in qualification tests.

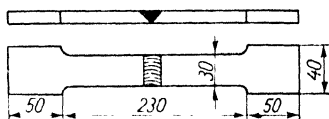

Fig. 146. Tensile specimen for weld testing

## 92. Internal Flaw Detection

The inspection methods described above all suffer from the common drawback in that they do not permit the inside condition of a weld to be adequately assessed. Welds may suffer from lack of fusion, slag inclusions, cracks, blow-holes and other defects—all hidden inside the weld metal and not detectable by any of the methods described in the previous section. At the same time, they may result in the failure of a welded structure in service.

Nowadays internal defects in welded joints can be detected by X-ray or gamma-ray inspection, ultrasonic and magnetic flaw detection.

X-rays give a clear and instructive picture of any hidden flaws in welded joints.

X-rays are electromagnetic rays, similar to light rays but possessing some special properties. They are produced by the passage of a high-voltage current across an X-ray tube, which is an evacuated glass envelope holding three metal electrodes suitably arranged. X-rays are invisible to the eye. They are capable of penetrating many materials impervious to light (cardboard, wood, human tissues and bones, metals, etc.), much as light can pass through glass, mica, or ice.

If an X-ray tube is placed on one side of an object and a photographic film or plate on the other, the object is made clearly visible on the film, denser materials like metals showing as spots of comparative whiteness. Similarly, weld metals can be X-rayed and their internal defects made visible on an exograph (an X-ray picture). If, within a weld, there are holes, lack of fusion, internal cracks, etc., they will show up as dark areas on the film, as the less dense regions of the weld offer least resistance to the passage of X-rays. In this way an accurate indication of internal defects is obtained.

Newer than, but similar in method to, X-ray inspection is inspection by gamma-rays. Gamma-rays are emitted by various radioactive elements, such as radium, mesothorium, radium emanation or radon, and man-made isotopes<sup>1</sup> of cobalt, cesium, iridium, europium, etc.

A radioactive source is placed in a capsule enclosed in a lead container. Nuclear radiations are very harmful to man, and lead is a very effective shield against them. Fig. 147 shows a diagram of an equipment for gamma-ray inspection of welded seams.

Under the relevant U.S.S.R. Standard covering X-ray and gamma-ray inspection, defects are classed according to their distribution into Group A (scattered defects),

---

<sup>1</sup> Isotopes are atoms of different atomic weights, but chemically the same substance.

Group B (strings of defects), and Group C (clustered defects). Welded seams may or may not be allowed to have any of these defects, depending on the application of a given weldment.

*Ultrasonic inspection* involves the use of ultrasonic waves (with a frequency of over 50 kc/s) which are made to pass through the weld metal to be tested. When the metal is uniform, the ultrasonic pulses meet no obstruction to their passage, but they will be reflected from discontinuities, such as non-metallic inclusions, blow-holes, and cracks in the weld metal. The reflected pulses are picked up by a probe to be converted into electrical pulses and displayed on a suitable instrument.

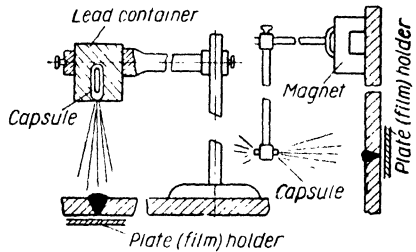

Fig. 147. Weld inspection by gamma-rays

*Magnetic flaw detection* is based on the fact

that the magnetic reluctance of a ferromagnetic material is increased by any flaw in it. Hence, when the weld being tested is magnetised, there will be more leakage flux directly over the faults than at the good portions of the weld.

This property has been utilised in the magnetographic method of weld inspection developed by the Pipeline Research Institute in the U.S.S.R.

As distinct from other methods of magnetic flaw detection, the magnetographic method records flux-leakage fields on a ferromagnetic tape.

After testing, the tape will have spots of higher magnetisation where it was placed over defective spots of the weld under test. When "played back" on a tape recorder, the tape will produce electromagnetic pulses which can be displayed on a cathode-ray oscillograph. The waveforms observed on the screen of the oscillograph will give a measure of the defect detected in the weld.

## *Chapter XVIII*

### *SAFETY RULES*

---

#### *93. General*

Every welding operator should have a good knowledge of the rules in force at the shop, proper operation of his equipment, measures for fire prevention, and also have a good command of safe welding techniques. Negligence on his part may do much harm to himself, those working around him, and set fire to combustible materials in the shop or on the site.

#### *94. Protection from Arc Rays*

An electric arc is a source of visible light and invisible infra-red and ultra-violet rays. Its intensity is 10,000 times that of light safe to man's eyes. For this reason the arc should not be looked at with the unprotected eye. Failure to observe this rule may result in various degrees of eye-burn or flashed eyes. The symptoms of this malady are a pronounced irritation under the eyelids, a feeling as if there were "sand in the eye", fear of light, and an overflow of tears.

Arc rays may cause affliction not only to the eyes but also to the skin of the operator. The naked eye and the skin, therefore, must not be exposed to the rays within at least 15 to 20 metres of the arc where the effect of the arc rays is substantially reduced, and grows practically imperceptible at a greater distance.

The skin of the operator's body is sufficiently protected by his work clothing. To protect his face and eyes, it is essential that a face shield or a head shield be used, with a welding lens in the window to protect his eyes. A gauntlet

type of glove should be used by the operator for protecting his hands from the arc, spatter of molten metal, sparks, etc.

The operator also runs the risk of receiving severe burns on the back of his neck or on the back of his ears or of experiencing eye-burn by reflections from a bright surface. Therefore the helmets, face shields, portable screens, booth and shop walls should be painted dull with zinc white, yellow paint or titanium white, as they absorb ultra-violet rays and reduce reflection.

Other workmen around an arc or persons visiting the welding shop can be readily protected as follows.

The scene of welding operations should be enclosed by portable plywood panels or screens; when welding outside the shop, tarpaulin tents or other enclosures should be set up.

No person without goggles or face shield must be admitted to the welding shop.

Caution signs in large letters should be provided at the scene of each welding operation, warning those around the arc of the dangers of arc rays.

### *95. Precautions Against an Electric Shock*

An electric welding operator has to deal with electric current. In touching the welding circuit, the work, the welding workbench, the electrode holder or electrode, the operator allows a current to pass through his body.

Currents up to 0.01 A are not dangerous to human life, although they may cause painful sensations. Currents upwards of 0.1 A are lethal. The current passing through a human body depends on the voltage difference between the points of contact and the total resistance of the circuit, including the body.

The resistance of the body is not constant and depends on a variety of factors. The highest resistance to the passage of a current is offered by the skin. When wet, the skin conducts current better than when it is dry. Under normal conditions, the voltages a welding operator has to deal with are not dangerous to his life. He must bear in mind, however, that his welding machine is connected to a mains supply

which carries a lethal voltage. Should a fault develop in the welding equipment, this voltage may be set up across the electrode holder, the frame of the welding machine, or the work. This may be due to faulty insulation in the motor winding or the transformer primary. In such cases contact with the metal parts of the machine will produce an electric shock. To avoid dangerous consequences, the frames and enclosures of electric welding machines should be earthed.

Special care must be exercised when welding inside boilers, tanks or pipes which have ample contact with the ground as, due to the low contact resistance, even the open-circuit voltage of the welding equipment may become dangerous to the operator.

For this reason the operator, when welding steel structures close to the ground or set up on foundations, should avoid touching simultaneously the structure and the noninsulated parts of the welding circuit.

For dry locations, a safe voltage is less than 36 V, and for damp locations, less than 12 V.

### *96. Precautions Against Burns*

In welding operations it is highly advisable that the operator should wear a tarpaulin jacket and tarpaulin trousers as protection against sparks, globules of molten or hot metal. The pockets of his jacket should be covered by flaps, and the jacket itself should be worn over the trousers. The trousers should be long and worn over the shoes, which should be tightly laced. The cap should have no peak, or it will obstruct a face or head shield. Leather aprons of a full type should be worn for protection against the intense heat emitted in welding with heavy currents.

### *97. General Safety Measures*

General measures which improve working conditions in the welding shop are:

- (1) effective ventilation to remove welding fumes;
- (2) convenient posture for the operator during a welding operation;

- (3) safety belts for welding high above the ground;
- (4) comfortable temperature.

It should be borne in mind that sparks and globules of molten metal, unavoidable in welding, may set fire to combustible materials. Adequate measures should therefore be taken to prevent a fire when working on a field site where there may be dry boards, shavings, tow, and so on.

Special precautions must be taken when tanks and vessels which have contained petrol, kerosene or other inflammable liquids or gases have to be repaired by welding. Before welding, it is essential to clean them out thoroughly and remove the possibility of any inflammable liquid or vapours remaining in them. In a cleaned tank there must be no smell of the fuel. The most efficient way to wash out a tank is with a steam jet. Barrels which have been in use with petrol can be safely repaired by welding when filled with water.

When welding inside boilers, vessels, etc., effective ventilation should be provided, and an assistant should stand outside to keep an eye on the operator and help him when necessary.

# Chapter XIX

## FOR BETTER WELDING

---

### 98. Welding Tools and Accessories

**Electrode holders.** An electrode holder is a device for clamping an electrode and conducting an electric current to it.

An electrode holder should meet the following requirements:

(1) To hold the electrode in a position convenient for welding.

(2) To establish a reliable current connection to the electrode.

(3) To allow an easy and quick change of electrodes without the operator having to touch any current-conducting or hot parts.

(4) To have a handle which will not grow hot during the welding operation.

(5) To weigh not more than 600 grams for a maximum current of 300 A.

A broad variety of designs of holders exists, some of them very simple, which can be made by small shops, and others more sophisticated manufactured by factories.

Fig. 148 shows some electrode holder designs.

The operator should handle his electrode holder with care and keep watch on its condition, for efficiency and weld quality depend on whether his electrode

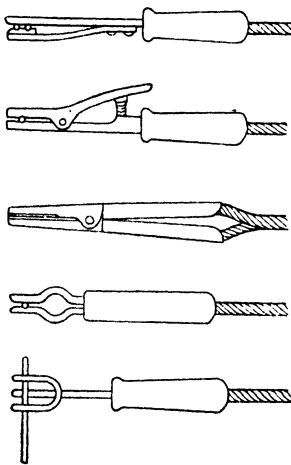

Fig. 148. Various types of electrode holders

holder is convenient to handle and is in working order.

**Welding cables.** The welding current is conducted from a generator or transformer to the work by welding cables.

A welding cable should not be longer than 20 to 30 metres, as a longer cable may appreciably reduce the welding voltage.

For flexibility, which is especially important where a cable is attached to an electrode holder, welding cables are made of a large number of annealed and tinned copper wires (0.18 to 0.20 mm in diameter) enclosed in a cotton braid and covered by a layer of vulcanised rubber. For good wear resistance welding cables are slipped inside a very tough rubber sheath. It is essential that all contacts between welding cables are clean and tight.

The size of welding cables varies, being dependent on the welding current employed, but it should be sufficient for a temperature rise of 80°C (Table 28).

*Table 28*

**Cable Size and Welding Current**

Max. amperes	Cable size, mm
200	25
300	50
450	70
600	95

**Hand screens and helmets.** Hand screens and helmets (Fig. 149) serve to protect the operator's face and eyes from the arc rays.

They are made of light-weight materials (vulcanised fibre or plywood). A hand screen (Fig. 149a) or a helmet (Fig. 149b) should weigh not more than 600 grams. They should be large enough to protect the whole of the face and have peaks to protect the face and eyes from reflected rays.

Both types of protective shields have a window fitted with a suitable filter or welding lens, which gives the necessary means of watching the progress of a welded seam and also protects the operator's eyes, as it absorbs a larger

proportion of visible light and injurious infra-red and ultra-violet rays. Welding lenses differ in their transparency. For welding work using currents up to 100 amperes an  $\text{AC-100}$

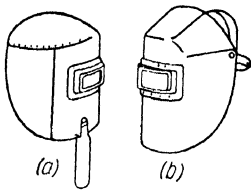

Fig. 149. Hand screen (a), helmet (b)

lens should be used, while an  $\text{AC-300}$  is suitable for welding with 100 to 350 amperes, and for currents 350 to 500 amperes an  $\text{AC-500}$  may be employed. The welding lens in a helmet or face shield is protected from molten metal sputter by a common glass, covering the exposed side of the lens. The covering glass may be replaced when it begins to lose some of its transparency.

A face shield should be held by the operator by the handle at the bottom. A helmet has a headband of two fibre strips hinged to the helmet, a chin-strap, and two fibre strips to hold the helmet down to the head. When not in use, the helmet can be thrown back on the head and brought forward to welding position at will. A helmet is more convenient than a face shield as this leaves both hands free.

**Miscellaneous accessories.** Every operator should have the following accessories.

A chipping hammer (Fig. 150a) for removing slag from finished welds.

A broad brush on a wooden block (Fig. 150b) for cleaning the work and welds, and a narrow round brush for cleaning the edges prior to welding in tight places (Fig. 150c).

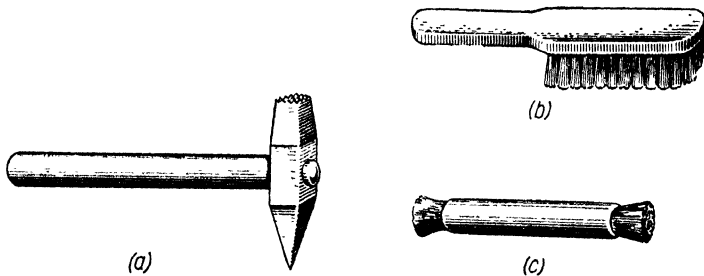

Fig. 150. Welder's accessories:  
a—pointed hammer; b—broad wire brush; c—round brush

A chisel and hammer for removing sputtered metal and chipping back defects in welds.

Assorted welding micrometers and gauges.

The operator's stamp for marking the welded joints.

### *99. Upkeep of a Welding Station. Reduction of Welding Cost*

A well-kept welding station goes a long way towards high production rates and high-quality welds. This applies above all to the care of welding equipment and tools.

Welding cables should have reliable insulation; if the insulation is worn, suitable rubber sheaths should be slipped on the cables.

If the welding cables have no armouring, it is good policy to slip rubber sheaths on them or wrap them with tarpaulin before their insulation wears out.

The cable should be reliably connected to the electrode holder both electrically and mechanically, or the electrode holder will grow hot and uncomfortable for the operator.

The face shield or helmet should be kept in good condition and its lens free from sputtered metal. The operator should also have with him a wire brush, chisel, and hammer.

Electrodes should be kept in a special container with compartments for tools and electrode stubs.

When making erection welds, the operator should stand on good scaffoldings with railings. If, for one reason or another, scaffoldings cannot be used, the operator should wear a safety belt chained to an anchored structure.

When welding some distance above the ground, the welder should be assisted by a helper to control the current at the source by command from the operator and to carry electrodes. When the welding current is supplied by an engine-generator set, these functions are performed by the motor mechanic. In shop welding, the work should be fitted up for welding and tacked by a line-up and tacking crew who may not be so skilled as the firing line welders.

In multipass welding the welding operation should be so arranged that after the first pass has been completed the welder can weld another work or length of the seam while the helper is cleaning the bead already deposited. After

the first pass has been deposited on the other work or length of the seam, the welder lays another pass on the first work or length of the seam, while the helper is cleaning the weld on the second work.

The operator should always seek to reduce welding costs by the use of better techniques. By raising his production rate, the welder will thus earn more and cut down the fabrication costs.

One way of achieving this is to reduce electrode consumption. This may be accomplished by leaving as short electrode stubs as possible, i.e., by melting an electrode until a stub of 10 to 15 mm is left, long enough for the holder to grasp the electrode and for the arc not to be shorted through the holder jaws. Sometimes welders leave long stubs accounting for as much as 30 to 40 per cent of the entire electrode length. Thus, using electrodes 350 mm long, a welder leaves a stub 100 mm long, the waste being about 30 per cent. With stubs 50 mm long, the wastes can be reduced to 15 per cent. Electrodes should be cut in standard lengths. A stub 50 mm long accounts for 15 per cent waste with an electrode length of 350 mm, and only 11 per cent with a length of 450 mm.

Many operators employ what they call a "stubless" technique. With this technique, the electrode holder has a steel rod instead of clamps. The lower end of an electrode is pushed onto the work, and the upper end is made to touch the flat face of the holder rod. At the point of contact the electrode freezes to the holder. In welding, the whole of the electrode is melted, leaving no stub. A new electrode is changed in the same way, and the welding operation is continued. It takes the operator less time to freeze a new electrode to the holder than to unclamp the stub and to insert a new electrode in the usual way. An electrode should be welded to the holder with the face turned aside to protect the eyes from the arc rays.

Appreciable economies may be achieved by welding seams precisely to the blueprint dimensions. When welding variables are chosen incorrectly, much metal is sputtered and more electrode metal is wasted.

Savings in electrode metal may substantially reduce the fabrication costs of a welded structure, as the deposit-

ed metal usually accounts for 1 to 2 per cent of the weight of the entire weldment. For an output of 100 tons of welded products the share of electrode metal will be 2 tons. With wastes averaging 25 per cent, a total of 2.66 tons of electrode metal will be used up. In other words, about 600 kg of electrode metal will be wasted.

Another important item in welding costs is power. The operator should always bear in mind that when no arc is maintained the welding machine is still consuming no-load power (or petrol in the case of an engine-generator set). For this reason the welding machine should be switched off when any idle period occurs in the course of a welding operation.

Proper care of welding equipment and timely elimination of all troubles and faults are also conducive to lower welding costs, as maintenance and repair costs are included in the welding costs.

It is essential to give welding equipment a check and to carry out preventive maintenance at regular intervals so as to reduce the necessity of major repairs.

**В. Цегельский**  
**ЭЛЕКТРОСВАРЩИК**

*На английском языке*

**36**

**Printed in the Union of Soviet Socialist Republics**







