

UNIVERSAL
LIBRARY

OU_164986

UNIVERSAL
LIBRARY

OSMANIA UNIVERSITY LIBRARY

Call No. 510.4/H38P ^{No 17} Accession No. 909

Author Havelock, T. H.

Title Propagation of disturbances

This book should be returned on or before the date last marked below.

Cambridge Tracts in Mathematics
and Mathematical Physics

GENERAL EDITORS

G. H. HARDY, M.A., F.R.S.

J. G. LEATHAM, M.A.

No. 17

The Propagation of Disturbances in
Dispersive Media

CAMBRIDGE UNIVERSITY PRESS

C. F. CLAY, MANAGER

London: FETTER LANE, E.C.

Edinburgh: 100 PRINCES STREET



Berlin: A. ASHER AND CO.

Leipzig: F. A. BROCKHAUS

New York: G. P. PUTNAM'S SONS

Bombay and Calcutta: MACMILLAN AND CO., LTD.

Toronto: J. M. DENT AND SONS, LTD.

Tokyo: THE MARUZEN-KABUSHIKI-KAISHA

All rights reserved

THE PROPAGATION OF DISTURBANCES
IN DISPERSIVE MEDIA

BY

T. H. HAVELOCK, M.A., F.R.S.,

D.Sc. Armstrong College, Newcastle-on-Tyne.

Cambridge :
at the University Press

1914

Cambridge:

PRINTED BY JOHN CLAY, M.A.

AT THE UNIVERSITY PRESS

The thanks of the author are due to Mr J. G. Leatham, to whom he is indebted for advice and for criticism of the manuscript.

CONTENTS

	PAGE
CHAPTER I. SIMPLE GROUPS AND GROUP VELOCITY.	
1. Introduction	1
2. Definitions of simple group	2
3. Simple group as an integral	5
4. Hamilton's theory of a finite train of waves	6
CHAPTER II. THE VELOCITY OF LIGHT.	
5. Fizeau's method	10
6. Aberration	12
7. Foucault's revolving mirror	15
8. Gutton's experiments	16
CHAPTER III. THE KELVIN METHOD FOR WAVE GROUPS.	
9. The Fourier integral for a concentrated initial disturbance	19
10. Evaluation of a predominant group	21
11. Some geometrical constructions. Earthquake waves	23
12. Group method for any limited initial disturbance	26
CHAPTER IV. ILLUSTRATIONS OF GROUP ANALYSIS.	
13. Medium with constant group velocity	28
14. Flexural waves on a rod	30
15. Water waves due to concentrated line displacement	32
16. Water waves from initial displacement of finite breadth	34
17. Finite train of simple water waves	37
18. Concentrated initial displacement on water of finite depth	40
19. Travelling point impulse on the surface of water	42
20. Wave patterns from a travelling point source	45

	PAGE
CHAPTER V. ACTION OF A PRISM UPON WHITE LIGHT.	
21. White light as an aggregate of pulses	47
22. Prism with constant group velocity	49
23. Separation of pulse into groups	50
24. Analogy with wave pattern of moving source	51
CHAPTER VI. THE FLOW OF ENERGY.	
25. Energy and group velocity	55
26. Infinite regular wave-train	56
27. Equation of continuity for energy	57
28. Vibrations of string with dispersion	58
29. Sellmeier's model of dispersion	59
30. Medium with general form of potential energy function	61
31. Electromagnetic waves	62
32. Electron theory and energy flow	64
33. Natural radiation	66
CHAPTER VII. PROPAGATION OF WAVE-FRONTS WITH DISCONTINUITIES.	
34. Non-uniform convergence and discontinuity	67
35. Characteristics and wave-fronts	71
36. Riemann's method applied to string with dispersion	72
37. Fourier integral with complex variable : localised impulse on string with dispersion	74
38. Medium with group velocity greater than velocity of wave- front	79
39. Light signal : interrupted source of light waves	82
BIBLIOGRAPHY	85

CHAPTER I

SIMPLE GROUPS AND GROUP VELOCITY

1. Introduction. In the theoretical analysis of wave motion the simplest form is that of an infinite train of regular waves represented by $\cos \kappa(x - Vt)$, where Ox is in the direction of propagation and V is the velocity of transmission of phase. If the medium in which the motion occurs is such that V is the same for infinite trains of all wave-lengths, the velocity V has additional physical significance; it is for instance the rate of advance of a finite train of waves, or of any arbitrary disturbance, into a region previously undisturbed, or again it is the rate of transmission of energy. But if the phase velocity V is a function of the wave-length, a fact which we may express by describing the medium as dispersive, we have no longer this ideal simplicity; in general the various velocities we have mentioned are all different, and depend upon the circumstances of each case. The present Tract deals with the manner in which a limited initial disturbance spreads out into a dispersive medium, and with allied problems. A considerable amount of research has been carried out in this direction in various fields; it is hoped that gain may result from the act of collecting the main results and setting them in relation to each other. It is unnecessary to state in detail the method of treatment, as that may be inferred from the list of contents and from the bibliography. The leading general ideas are those of a group of waves and group velocity, and the work is largely a series of illustrations and applications of these in various regions. It is hardly necessary to explain that there is no attempt to give here a complete study of any subject from which illustrations are drawn; for example, the list of references to work on water waves includes only those which deal especially with the present point of view and others to which reference is made for comparison of results, and a similar remark applies to the chapter on optical problems. The first

analytical expression of group velocity is usually ascribed to Stokes (1876) with subsequent development by Lord Rayleigh. It appears however that as early as 1839 Hamilton had made investigations into the rate of advance of a finite train of waves in a dispersive medium ; unfortunately his researches were only published in short abstracts and have been entirely overlooked until recently. Later extensions have originated in the group method of approximation due to Lord Kelvin. These methods, and their applications, occupy the first five chapters of this Tract, including a short discussion of the action of a prism. The sixth chapter is devoted to the important dynamical significance of group velocity in connection with the rate of transmission of energy. In the last chapter we deal with more general methods of treating the Fourier integral which represents the disturbance, more especially in cases where it represents a discontinuous function, that is where the medium is such that there may be a definite wave-front travelling with finite velocity.

2. Definitions of Simple Group. If one observes a finite train of waves advancing over the surface of still water, it will be seen that the individual waves move more quickly than the group as a whole ; as the group advances new waves arise at the rear, move through the group, and disappear at the front. For an explanation of this phenomenon, which seems to have been recorded first by Scott Russell⁽²⁾, we must analyse the group into component simple harmonic waves of various wave-lengths, each component moving with the phase-velocity appropriate to its wave-length. Leaving the particular problem for more detailed study later, we begin with an ideally simple case. Consider the superposition of two infinite simple wave-trains in a dispersive medium ; the combined effect is given by

$$y = A \cos \frac{2\pi}{\lambda} (x - Vt) + A \cos \frac{2\pi}{\lambda'} (x - V't) \dots\dots\dots(1).$$

We suppose the waves to be of equal amplitude, and the wave-lengths λ and λ' to differ by a small amount $d\lambda$; the phase-velocities V and V' differ by a corresponding small amount. With these conditions, we have approximately

$$y = 2A \cos \left\{ \frac{\pi \cdot d\lambda}{\lambda^2} (x - Ut) \right\} \cos \frac{2\pi}{\lambda} (x - Vt) \dots\dots\dots(2),$$

where
$$U = V - \lambda \frac{dV}{d\lambda} \dots \dots\dots(3).$$

The expression (2) may be regarded as representing at any instant a train of wave-length λ whose amplitude varies slowly with x in a long period of distance $2\lambda^2/d\lambda$. The point at which any given amplitude, say the maximum, is to be found moves forward with a velocity U , called the group velocity. We may express this also by noticing that in the vicinity of an observer travelling with velocity U , the disturbance continues to be an approximately simple harmonic train of assigned amplitude and of wave-length λ . The formula (2) does not represent a form which moves forward unchanged; but it has a certain periodic quality, for the form at any given instant is repeated after equal intervals of time $\lambda/(V - U)$ displaced forward through equal distances $\lambda U/(V - U)$.

This form of group may be generalised to include any finite number of component wave-trains, if we write

$$y = \sum C \cos \kappa (Vt - x - a),$$

where the summation covers a series of terms in which κ and V vary only slightly. Defining the phase of any term as the whole argument of the trigonometrical function, its value at time $t + dt$ at a place $x + dx$ differs from its value at time t at the position x by an amount $\kappa V dt - \kappa dx$. Hence the change of phase will be approximately the same for all the terms of the series if

$$d(\kappa V) \cdot dt - d\kappa \cdot dx = 0 \dots\dots\dots(4).$$

From this point of view the velocity of the group is given by

$$U = \frac{dx}{dt} = \frac{d(\kappa V)}{d\kappa} \dots\dots\dots(i),$$

an expression which agrees with the form (3).

Another equivalent form for U may be noted; if we write n for frequency (n equal to κV) we obtain the relation

$$\frac{1}{U} = \frac{1}{V} - \frac{n}{V^2} \frac{dV}{dn} \dots\dots\dots(6).$$

So far we have considered a group as built up from infinite trains of simple harmonic waves. To look at the matter from another point of view let us begin by defining a group as a long train of waves in which the distance between successive crests, and the amplitude, vary only slightly. We shall see later, in various examples, that this state of affairs may arise from the effects of a limited initial disturbance in a medium in which the wave velocity varies with the frequency; after a certain time the disturbance is a wave system in which the different

wave-lengths, travelling with different velocities, become gradually separated out. Thus in the vicinity of any point at any instant the waves are approximately simple harmonic and of wave-length λ , but the value of λ will vary with the position and with the time; λ may then be regarded as a function of x and t . Further, we may imagine the observer to move so as always to remain in touch with any assigned value of λ ; let us then define the group velocity U as the velocity of a point moving so that the disturbance in its neighbourhood appears as an approximately simple train of assigned wave-length λ . We can find an expression for U which results from these definitions.

The rate of change of wave-length is zero for an observer travelling with velocity U , hence

$$\frac{\partial \lambda}{\partial t} + U \frac{\partial \lambda}{\partial x} = 0 \dots\dots\dots(7).$$

Further, if we imagine a point travelling with the waves, the rate of change of wave-length is

$$\frac{\partial \lambda}{\partial t} + V \frac{\partial \lambda}{\partial x};$$

but this rate, which is also the rate of separation of two consecutive wave crests, is also equal to $\lambda dV/dx$, or to $\lambda dV/d\lambda \cdot d\lambda/dx$. Hence we have

$$\frac{\partial \lambda}{\partial t} + V \frac{\partial \lambda}{\partial x} = \lambda \frac{\partial V}{\partial \lambda} \frac{\partial \lambda}{\partial x} \dots\dots\dots(8).$$

The equations (7) and (8) give for U precisely the same expression as in (3); accordingly the various points of view give consistent results.

The formula is capable of a geometrical interpretation. If a curve is drawn to represent the relation between V and λ , as in Fig. 1, the group velocity corresponding to a point P is given by OQ , the intercept made by the tangent at P on the axis of V .

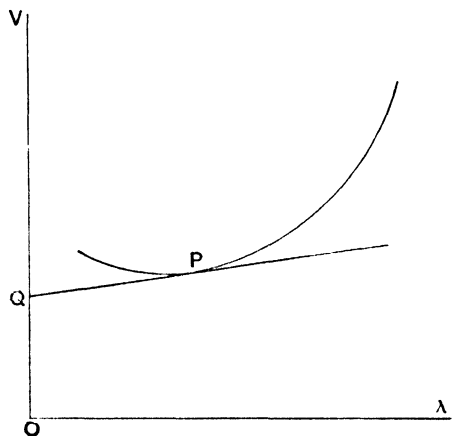

Fig. 1.

3. Simple Group as an integral. We may generalise further the expression for a simple group by considering an infinite series of terms clustered round a central term of given wave-length ; replacing summation by an integration we have now

$$y = \int_{\kappa_0 - \epsilon}^{\kappa_0 + \epsilon} C_{\kappa} e^{i\{\kappa(x - Vt) - \alpha\}} d\kappa \dots\dots\dots(9).$$

We use the exponential form for simplicity, taking real parts of the expressions ultimately. The range of integration is supposed to be small and the amplitude, phase and velocity of the members of the group are assumed to be continuous, slowly varying, functions of κ . Granting that κV can be expanded in a Taylor's series we have

$$\kappa V = \kappa_0 V_0 + \frac{\partial(\kappa V)_0}{\partial \kappa_0} (\kappa - \kappa_0) + \frac{1}{2!} \frac{\partial^2(\kappa V)_0}{\partial^2 \kappa_0} (\kappa - \kappa_0)^2 + \dots \dots(10).$$

Neglecting second and higher powers of $\kappa - \kappa_0$, and substituting in (9) we obtain

$$y = e^{i\kappa_0^2 t \frac{\partial V}{\partial \kappa}} \int_{\kappa_0 - \epsilon}^{\kappa_0 + \epsilon} C_{\kappa} e^{i\{\kappa(x - U_0 t) - \alpha\}} d\kappa,$$

where $U = d(\kappa V)/d\kappa$.

Hence we obtain, in real quantities,

$$y = \cos \left(\kappa_0^2 t \frac{\partial V}{\partial \kappa_0} \right) \int_{\kappa_0 - \epsilon}^{\kappa_0 + \epsilon} C_{\kappa} \cos \{ \kappa (x - U_0 t) - \alpha \} d\kappa \\ - \sin \left(\kappa_0^2 t \frac{\partial V}{\partial \kappa_0} \right) \int_{\kappa_0 - \epsilon}^{\kappa_0 + \epsilon} C_{\kappa} \sin \{ \kappa (x - U_0 t) - \alpha \} d\kappa \dots\dots(11).$$

Each integral by itself represents a form which is propagated with velocity U_0 without change of type, and we can express the whole disturbance in the form

$$y = f(x - U_0 t) \cos \left(\kappa_0^2 t \frac{\partial V}{\partial \kappa_0} \right) + F(x - U_0 t) \sin \left(\kappa_0^2 t \frac{\partial V}{\partial \kappa_0} \right) \\ = f(x - U_0 t) \cos \{ \kappa_0 (U_0 - V_0) t \} \\ + F(x - U_0 t) \sin \{ \kappa_0 (U_0 - V_0) t \} \dots(12).$$

We have the same interpretation as in the previous simpler cases. For the neighbourhood of a point travelling with velocity U_0 the wave form is approximately simple harmonic of wave-length $2\pi/\kappa_0$. Also the actual form at any instant is repeated after a time $2\pi/\kappa_0(U_0 - V_0)$ moved forward through a distance $2\pi U_0/\kappa_0(U_0 - V_0)$.

It should be noticed that the above expression is only strictly correct for a medium in which U is independent of κ , that is when $V = a + b\lambda$; we shall examine this case in more detail later. In general the approximation implies that

$$t \left[\frac{1}{2} \epsilon^2 \frac{\partial U}{\partial \kappa} + \frac{1}{6} \epsilon^3 \frac{\partial^2 U}{\partial \kappa^2} + \dots \right]$$

is small. The larger the value of t the smaller must be the range 2ϵ of integration. In other words, as time goes on the group represented by (9) becomes itself separated appreciably into constituent simpler groups to each of which the previous analysis may be applied. We shall return to this point of view when considering the Fourier integral representing an arbitrary limited initial disturbance.

4. Hamilton's theory of a finite train of waves. The problem which presents itself most frequently is the manner and rate of advance of a finite train of simple waves into regions previously undisturbed, assuming that its identity persists appreciably. We shall see later that such a train may be regarded in the main as a collection of simple groups; if the train contains initially a large number of waves of wave-length λ , it approximates the more closely to a single group associated with the wave-length λ . In 1839 Hamilton had studied certain problems of this nature and communicated short abstracts of his results to the Royal Irish Academy; for details reference was made to the memoir itself, "which will be published in the Transactions of the Academy, and will be found to contain many other investigations respecting vibrating systems, with application to the theory of light." Unfortunately this intention does not appear to have been carried out; the memoir has not been traced in any publication. It may be of interest to reproduce the main results which were obtained by Hamilton.

"An indefinite series of equal and equally distant particles, m_{-1}, m_0, m_1, \dots , situated in the axis of x , at the points $\dots -1, 0, +1, \dots$, being supposed to receive, at the time 0, any very small transversal displacements $\dots y_{-1,0}, y_{0,0}, y_{1,0}, \dots$, and any very small transversal velocities $\dots \dot{y}_{-1,0}, \dot{y}_{0,0}, \dot{y}_{1,0}, \dots$, it is required to determine their displacements $\dots y_{-1,t}, y_{0,t}, y_{1,t}, \dots$ for any other time t ; each particle being supposed to attract the one which immediately precedes or follows it in the series, with an energy equal to a^2 , and to have no sensible influence on any of the more distant particles." The problem is considered as

equivalent to that of integrating generally the equation in mixed differences

$$\ddot{y}_{x,t} = a^2 (y_{x+1,t} - 2y_{x,t} + y_{x-1,t}).$$

The solution is given in the form

$$\begin{aligned} \ddot{y}_{x,t} = & \frac{2}{\pi} \sum_{l=-\infty}^{\infty} y_{x+l,0} \int_0^{\frac{\pi}{2}} \cos 2l\theta \cos (2at \sin \theta) d\theta \\ & + \frac{1}{a\pi} \sum_{l=-\infty}^{\infty} \dot{y}_{x+l,0} \int_0^{\frac{\pi}{2}} \operatorname{cosec} \theta \cos 2l\theta \sin (2at \sin \theta) d\theta, \end{aligned}$$

the first line expressing the effect of the initial displacements, the second that of the initial velocities. [These integrals could of course be written and evaluated as Bessel functions.]

Suppose now that the initial conditions are such that

$$y_{x,0} = \eta \operatorname{vers} 2x \frac{\pi}{n}; \quad \dot{y}_{x,0} = -2a\eta \sin \frac{\pi}{n} \sin 2x \frac{\pi}{n}$$

for all values of the integer x between the limits 0 and $-rn$, r and n being positive and large, but finite integers, and that for all other values of x the functions $y_{x,0}$ and $\dot{y}_{x,0}$ vanish : which is equivalent to supposing that at the origin of t , and for a large number r of wave-lengths n behind the origin of x , the displacements and velocities of the particles are such as to agree with the undulation

$$y_{x,t} = \eta \operatorname{vers} \left(2x \frac{\pi}{n} - 2at \sin \frac{\pi}{n} \right) \dots\dots\dots(13),$$

but that all the other particles are, at that moment, at rest : it is required to determine the subsequent motion. The solution in this case is given by

$$y_{x,t} = \frac{\eta}{\pi} \left(\sin \frac{\pi}{n} \right)^2 \int_0^{\pi} \frac{\sin rn\theta}{\sin \theta} \frac{\cos (2x\theta + rn\theta - 2at \sin \theta)}{\cos \theta - \cos (\pi/n)} d\theta,$$

an expression which tends indefinitely to become

$$\begin{aligned} y_{x,t} = & \frac{1}{2} \eta \operatorname{vers} \left(2x \frac{\pi}{n} - 2at \sin \frac{\pi}{n} \right) \\ & - \frac{\eta}{2\pi} \left(\sin \frac{\pi}{n} \right)^2 \int_0^{\pi} \frac{\sin (2x\theta - 2at \sin \theta)}{\sin \theta \{ \cos \theta - \cos (\pi/n) \}} d\theta \end{aligned}$$

as the number r increases without limit. The approximate values which these rigorous integrals acquire, when the value of t is large, are discussed. It is found that a vibration, of which the phase

and the amplitude agree with the law (13), is propagated forward, but not backward, so as to agitate successively new and more distant particles (and to leave successively others at rest, if r be finite), with a velocity of progress which is expressed by $a \cos \frac{\pi}{n}$, and which is therefore less, by a finite though small amount, than the velocity of passage $a \frac{n}{\pi} \sin \frac{\pi}{n}$ of any given phase, from one vibrating particle to another within that extent of the series which is already fully agitated. In other words, the communicated vibration does not attain a sensible amplitude until a finite interval of time has elapsed from the moment when one would expect it to begin, judging only by the law of the propagation of phase through an indefinite series of particles which are all in vibration already. A small disturbance, distinct from the vibration (13), is also propagated, backward as well as forward, with a velocity a , independent of the length of the wave. [The latter would be expressed now in terms of the Kelvin group method as a predominant group associated with $n = \infty$, forming what might be called a solitary wave propagated with velocity a , the limiting value of the phase velocity for infinitely long waves.]

Hamilton then proceeds to more general equations which are said to be analogous to, and to include, those which Cauchy has considered in his memoir on the dispersion of light. The solutions are discussed and lead to the following conclusions among others. If initially there is a finite train of undulations

$$y = \cos (\epsilon + st - \kappa x),$$

valid for a large range of negative values of x limited by the origin ; then we have the approximate expressions for subsequent times

$$y = 0 ; \text{ if } x > t \frac{ds}{d\kappa},$$

$$y = A \cos (\epsilon' + st - \kappa x) ; \text{ if } x < t \frac{ds}{d\kappa},$$

and the latter becomes more nearly true as the values of x and t become larger.

“The formulæ lead to this remarkable result, that the velocity with which such vibration spreads into those portions of the vibratory medium which were previously undisturbed, is in general different from the velocity of a passage of a given phase from one particle to

another within that portion of the medium which is already fully agitated ; since we have

$$\text{velocity of transmission of phase} = \frac{s}{\kappa},$$

but

$$\text{velocity of propagation of vibrating motion} = \frac{ds}{d\kappa}.$$

Applied to the theory of light, it appears to show that if the phase of vibration in an ordinary dispersive medium be represented for some one colour by

$$\epsilon + \frac{2\pi}{\lambda} \left(\frac{t}{\mu} - x \right),$$

so that λ is the length of an undulation for that colour and for that medium, and if it be permitted to represent dispersion by developing the velocity $1/\mu$ of the transmission of phase in a series of the form

$$\frac{1}{\mu} = M_0 - M_1 \left(\frac{2\pi}{\lambda} \right)^2 + M_2 \left(\frac{2\pi}{\lambda} \right)^4 - \dots,$$

then the *velocity wherewith light of this colour conquers darkness*, in this dispersive medium, by the *spreading of vibration into parts which were not vibrating before*, is *somewhat less than* $1/\mu$, being represented by this other series

$$M_0 - 3M_1 \left(\frac{2\pi}{\lambda} \right)^2 + 5M_2 \left(\frac{2\pi}{\lambda} \right)^4 - \dots."$$

We may notice that Hamilton operates with a long train of waves which is effectively equivalent to a simple group ; we shall see later that there is an actual wave-front which moves with a velocity equal to that of light in free space, but the magnitude of the disturbance so propagated is negligible compared with that of the main group.

CHAPTER II

VELOCITY OF LIGHT

5. Fizeau's method. We consider now some early applications of group velocity in connection with various methods of determining the velocity of light.

In Fizeau's method a parallel beam of light passes through the gaps in a rotating toothed wheel, is reflected back along its path and passes again through the wheel and so to the eye of the observer ; it is found that the observed intensity of light varies periodically with increasing speed of rotation of the toothed wheel. One can see in a general manner that one has to deal with the forward motion of finite lengths of a beam of light. Since the wave-length is very short, the finite wave-train will be to a large extent like the simple groups already analysed ; thus the velocity which enters into the calculations will be the group velocity U and not the phase velocity V . In other words, we are dealing with the propagation of a variation in amplitude impressed upon a wave-train, and this involves the group velocity U .

It can be shown with more detail how the light consists of a group of simple waves of different frequencies⁽¹⁵⁾. Let the axis Ox be in the direction of the beam of light, the toothed wheel being at $x=0$; consider the vibration in the region of x positive, assuming that the medium is non-dispersive. Then if u represents the light-vector, the differential equation to be satisfied is

$$\frac{\partial^2 u}{\partial x^2} - \frac{1}{c^2} \frac{\partial^2 u}{\partial t^2} = 0 \dots\dots\dots(14).$$

Idealise the action of the toothed wheel and suppose its effect is to produce a continuous variation of period $2\pi/\nu$ in the intensity of light at the origin ; then if the period of the light vibration is $2\pi/n$, we have the condition

$$u = A \cos^2 \frac{1}{2}\nu t \sin nt, \text{ for } x = 0 \dots\dots\dots(15).$$

Further suppose that at the initial instant the light was passing through undisturbed, like a simple wave

$$u = A \sin n \left(t - \frac{x}{c} \right).$$

Then we have the conditions

$$u = -A \sin \frac{nx}{c}; \quad \frac{\partial u}{\partial t} = nA \cos \frac{nx}{c}; \quad \text{for } t = 0 \dots\dots(16).$$

The solution of (14) under the conditions (15) and (16) can be obtained by Riemann's method. Write y for ct ; then the data of the problem are the values of $\partial u/\partial x$ and $\partial u/\partial y$ along the axes of x and y . We have in fact

$$\frac{\partial u}{\partial x} = -\frac{n}{c} A \cos \frac{nx}{c}; \quad \frac{\partial u}{\partial y} = \frac{n}{c} A \cos \frac{nx}{c}; \quad \text{for } y = 0,$$

$$\frac{\partial u}{\partial x} = \frac{1}{2} \frac{\nu}{c} A \sin \frac{\nu y}{c} \sin \frac{ny}{c} - \frac{n}{c} A \cos^2 \frac{\nu y}{2c} \cos \frac{ny}{c}; \quad \frac{\partial u}{\partial y} = -\frac{\partial u}{\partial x}; \quad \text{for } x = 0.$$

If $P(x, y)$ is the point at which we require the value of u , we draw the characteristics through P to cut the axes in α and β . Then the general solution is

$$2u_P = u_\alpha + u_\beta + \int_\alpha^\beta \left(\frac{\partial u}{\partial x} dy + \frac{\partial u}{\partial y} dx \right),$$

where the integration follows the path $\alpha O \beta$.

Noticing that dx is zero along αO , and dy zero along $O \beta$, and that α is the point $(0, y-x)$ and β the point $(y+x, 0)$ we obtain

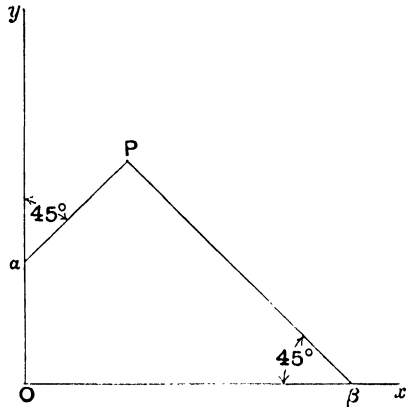

Fig. 2.

$$2u = A \cos^2 \frac{1}{2} \frac{\nu}{c} (y-x) \sin \frac{n}{c} (y-x) - A \sin \frac{n}{c} (x+y) + \frac{1}{2} \frac{\nu}{c} A \int_{y-x}^0 \sin \frac{\nu y}{c} \sin \frac{ny}{c} dy - \frac{n}{c} A \int_{y-x}^0 \cos^2 \frac{\nu y}{2c} \cos \frac{ny}{c} dy + \frac{n}{c} A \int_0^{y+x} \cos \frac{nx}{c} dx.$$

On evaluation and putting ct for y we obtain finally

$$u = \frac{1}{2} A \sin n \left(t - \frac{x}{c} \right) + \frac{1}{4} A \sin (n + \nu) \left(t - \frac{x}{c} \right) + \frac{1}{4} A \sin (n - \nu) \left(t - \frac{x}{c} \right) \dots (17).$$

The result is that after the light has passed through the rotating screen it can be analysed into components of three different frequencies, one of the original value n and the other two $n + \nu$ and $n - \nu$. The number ν in the actual problem depends on the number of teeth in the wheel and its angular speed; in any case it is small compared with n . Consequently the light is in fact substantially a simple group of waves. If the medium is dispersive the solution (17) does not hold exactly, since the differential equation (14) is no longer true; we may however assume it to hold approximately with the various terms having wave velocities corresponding to their frequencies. Hence the velocity determined by Fizeau's method is the group velocity U , a result which may be confirmed by a more detailed study of the intensity of the light after passing through a second toothed wheel rotating in synchronism with the first.

6. Aberration. It is generally stated, after Lord Rayleigh⁽⁶⁾, that the velocity deduced from measurements of aberration must give the phase velocity V and not the group velocity U , since it does not depend upon observing the propagation of a peculiarity impressed upon a train of waves and therefore has no relation to U . This statement has been criticised recently by Ehrenfest⁽¹⁶⁾, who compares the circumstances in aberration with the following scheme. Two parallel infinite

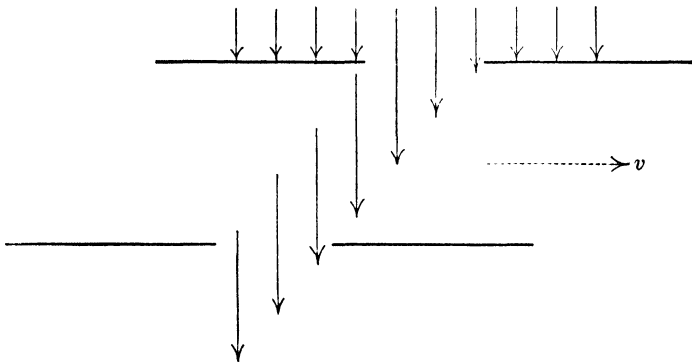

Fig. 3.

plates, each with an opening, move with common uniform velocity v from left to right. Monochromatic light falls normally upon the upper plate. It is required to determine the angle through which the lower opening must be displaced relatively to the upper one so that an observer placed there would receive maximum intensity of

light. It appears that this angle depends on the velocity with which finite trains of light waves move forward, that is upon the group velocity. Lord Rayleigh⁽⁷⁾ admits that Ehrenfest has shown that the circumstances in aberration do not differ materially from those of the toothed wheel in Fizeau's method, although the peculiarity imposed upon the regular wave motion seems to be artificial rather than inherent in the nature of the case; he also supplies an alternative analysis.

Homogeneous plane waves moving parallel to Oz with velocity V are incident normally upon an ideal screen occupying the xy plane. The effect of the screen is to make the amplitude have a factor $\cos m(vt - x)$, where m and v/V are small, so that the amplitude has a variation of long period which travels slowly along Ox . In the absence of the screen we should have

$$u = \cos(nt - \kappa z),$$

giving

$$u = \cos nt \text{ for } z = 0.$$

With the screen in operation we have

$$\begin{aligned} u &= \cos m(vt - x) \cos nt, \text{ for } z = 0 \\ &= \frac{1}{2} \cos \{(n + mv)t - mx\} + \frac{1}{2} \cos \{(n - mv)t + mx\}. \end{aligned}$$

Hence at positions beyond the screen we have

$$u = \frac{1}{2} \cos \{(n + mv)t - mx - \mu_1 z\} + \frac{1}{2} \cos \{(n - mv)t + mx - \mu_2 z\},$$

where μ_1 and μ_2 are determined so that u satisfies

$$\frac{\partial^2 u}{\partial x^2} + \frac{\partial^2 u}{\partial z^2} = \frac{1}{V^2} \frac{\partial^2 u}{\partial t^2},$$

for each wave separately with the requisite value of V , the medium being dispersive. We have therefore

$$\begin{aligned} (n + mv)^2 &= V_1^2 (m^2 + \mu_1^2) \\ (n - mv)^2 &= V_2^2 (m^2 + \mu_2^2) \end{aligned} \dots\dots\dots(18).$$

Further, the expression for u can be put in the form

$$u = \cos \{mvt - mx - \frac{1}{2}(\mu_1 - \mu_2)z\} \cos \{nt - \frac{1}{2}(\mu_1 + \mu_2)z\},$$

where the first factor may be regarded as an amplitude slowly varying with t . Thus the lines of constant amplitude at a given time are

$$mx + \frac{1}{2}(\mu_1 - \mu_2)z = \text{constant}.$$

The amplitude which occurs at $x = 0$ also occurs along the line

$$-\frac{x}{z} = \frac{1}{2} \frac{\mu_1 - \mu_2}{m}.$$

We may regard the aberration angle as given by $(\mu_1 - \mu_2)/2m$.

From (18), since m and v/V are small we have

$$\mu_1^2 + m^2 = \frac{n^2}{V^2} \left(1 + \frac{2mv}{n} - \frac{2mv}{V} \frac{dV}{dn} \right),$$

with a similar expression for μ_2 . Hence we obtain for the aberration angle, using also (6),

$$\frac{\mu_1 - \mu_2}{2m} = \frac{nv}{V} \left(\frac{1}{n} - \frac{1}{V} \frac{dV}{dn} \right) = \frac{v}{U}.$$

In this illustration the group velocity occurs in the result because the expression of the variation involves the introduction of more than one frequency.

A method which seems less artificial in its application to aberration may be obtained by using the Doppler principle which allows a variation in the effective frequency or wave-length of the light emitted by a moving source. Let S be a source of light giving out vibrations of frequency n and moving with uniform velocity v along a line OS . At the instant when the source is at S the light received by an observer

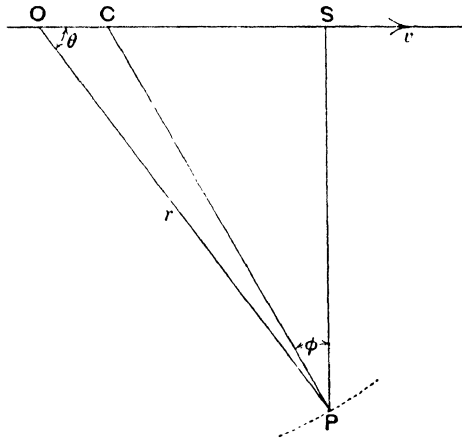

Fig. 4.

at P was emitted by the source at some time t previously, the source being then at O , where $OS = vt$. The vibrations emitted at O in the direction OP have a wave-length which is shortened owing to the velocity of O along OP relative to P . If V is the velocity of waves of frequency n and if v/V is small we may say that the effective frequency of the vibrations along OP is

$$n \left(1 + \frac{v \cos \theta}{V} \right),$$

and consequently the velocity of the waves along OP is

$$V + \frac{nv \cos \theta}{V} \frac{dV}{dn}.$$

With OP equal to r we have

$$r = \left(V + \frac{nv \cos \theta}{V} \frac{dV}{dn} \right) t \dots\dots\dots(19).$$

This equation defines the wave surface near P at the instant in question, namely when the source is actually at S . But to first powers of v/V the equation represents a sphere of radius Vt with its centre at C such that

$$CP = Vt; \quad OC = \frac{nvt}{V} \frac{dV}{dn}.$$

Thus to an observer at P the source appears to be at C ; and the aberration angle ϕ is given by

$$\sin \phi = \frac{CS}{CP} = \frac{1}{V} \left(v - \frac{nv}{V} \frac{dV}{dn} \right) = \frac{v}{U}.$$

7. Foucault's revolving mirror. In this method one measures the rotation of a beam of light which is reflected from a rotating mirror to a fixed mirror and back to the rotating one for another reflection. The velocity which is measured in this way has given rise to some discussion; Lord Rayleigh obtained V^2/U in a calculation which was withdrawn later, Schuster⁽¹⁰⁾ gave $V^2/(2V - U)$, and Willard Gibbs⁽¹¹⁾ simply the group velocity U . Some experiments by Michelson appeared to favour the latter result. He caused the beam of light to pass through carbon disulphide in its path between the two mirrors, so as to have an appreciable difference between U and V ; assuming a mean frequency for the light, which was only approximately monochromatic, the velocity V' computed from observations was given by $c/V' = 1.76 \pm 0.02$, c being velocity of light in free space. The corresponding numbers obtained by calculation were

$$\frac{c}{U} = 1.745; \quad c \frac{(2V - U)}{V^2} = 1.737.$$

We may apply Doppler's principle to this problem in a manner suggested by Gouy⁽⁸⁾.

If a source of light is in front of a plane mirror moving towards it with velocity v , the velocity of the image is $2v$. Thus in the reflection of a beam of plane waves by a mirror rotating with angular velocity ω we may regard an element of the mirror at distance r from the axis of

rotation as a source of light moving with velocity $2r\omega$. As in the previous section, it follows that the velocity of waves of frequency p for normal reflection is altered to

$$V + \frac{2r\omega n}{V} \frac{dV}{dn}$$

at each point. In any case, whether the reflection be normal or not, after reflection the planes of equal phase have an angular velocity of rotation in space equal to

$$\frac{2\omega n}{V} \frac{dV}{dn}, \text{ or } 2\omega(U - V)/U.$$

Let l be the distance between the rotating and fixed mirrors. The total rotation of the beam is made up of two parts, one due directly to the rotation of the moving mirror and the other to the rotation of the planes of equal phase; taking account of the directions of these, we have

$$\text{total rotation} = \left\{ 2\omega - \frac{2(U - V)\omega}{U} \right\} \cdot \frac{2l}{V} = \frac{4l\omega}{U}.$$

By this method it appears that it is the group velocity U that is measured.

8. Gutton's experiments. Some interesting experiments have been made recently by Gutton⁽¹⁷⁾ on the velocity of light in dispersive media. The method makes use of two facts: under certain conditions the velocity of high frequency electric waves along wires is practically equal to the velocity of light in free space; also when carbon disulphide is submitted to the action of an electric field it becomes doubly refracting. Fig. 5 shows a diagrammatic plan of the apparatus. Electric oscillations are generated at E and separate at O along the wires OA , OF . The length of wire in one arm is capable of accurate adjustment at H . C_1 and C_2 are condensers containing carbon disulphide; in C_1 the plates are vertical, in C_2 they are horizontal. S is the source of light, P the observing telescope; M and N are two crossed Nicol prisms with their principal sections at 45° ; L is a tube containing the dispersive medium through which the light passes. An experiment is made by first setting the analysing prism for extinction, when there are no electric waves. Then electric waves are sent from O along the two branches to the condensers C_1 and C_2 . When the waves reach C_1 they charge the condenser and make the carbon disulphide doubly refracting; thus the light is depolarised at C_1 .

If when the light reaches C_2 it finds this condenser in the same state as that in which it left C_1 , then the polarisation is re-established, for the plates of the condensers are crossed. In this case the light will be rejected by the analysing prism. It follows that the time taken by the electric waves for the path $OABC_1$ together with the time for the light to traverse the path C_1C_2 must equal the time for the electric waves for the path $OFHC_2$. By making experiments with and without the tube L , one can deduce the time for the light and hence the velocity of the light in the liquid contained in the tube.

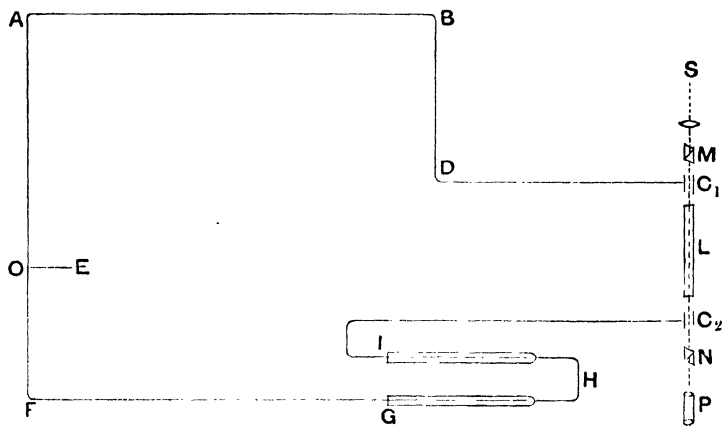

Fig. 5.

The peculiarity impressed on the train of light-waves in this case is a periodic variation in the state of polarisation. The analytical expression of such a beam of light necessarily involves more than one frequency; consequently we should expect that in this case also the velocity deduced from the experiments would be the group velocity U . The results confirm this interpretation. If V' is the observed velocity, C the velocity of light in air, Gutton obtained the following measurements.

For water, C/V' equals 1.32 for yellow light, 1.36 for blue. These values are practically those of the ordinary index of refraction, 1.33 and 1.34. However, for water the values of U and V are practically the same in this region.

The results for more highly dispersive liquids like carbon disulphide and naphthalene monobromide are shown in Fig. 6.

The crosses show the experimental values of C/V' ; the lower curve

in each case is drawn from the ordinary index of refraction C/V , while the upper curve represents C/U . One sees that V' is practically the same as the group velocity U , allowing for experimental errors.

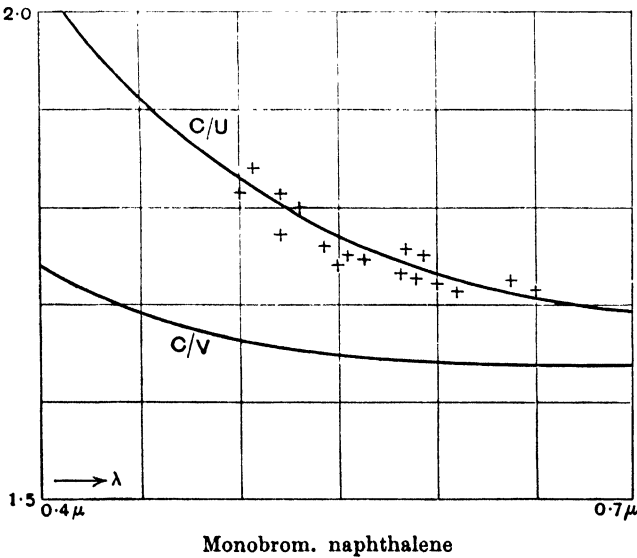
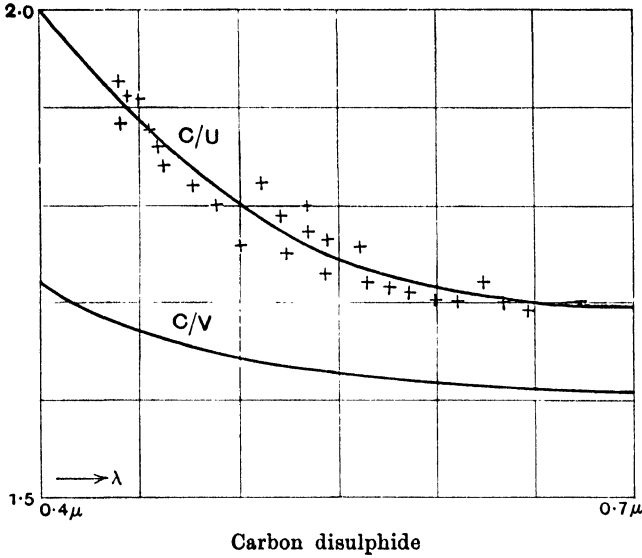

Fig. 6.

CHAPTER III

THE KELVIN METHOD FOR A LIMITED INITIAL DISTURBANCE

9. The Fourier integral for a concentrated initial disturbance. Let y , the vector whose variation we are considering, be a displacement and suppose it a function of position x and time t . Let the initial conditions be

$$y = f(x); \quad \frac{\partial y}{\partial t} = 0; \quad \text{for } t = 0.$$

We assume that the function $f(x)$ which we use in physical problems can be in general expressed as a Fourier integral in the form

$$f(x) = \frac{1}{\pi} \int_0^{\infty} d\kappa \int_{-\infty}^{\infty} f(\omega) \cos \kappa(x - \omega) d\omega.$$

If in addition $f(x)$ is an even function of x , the initial displacement being symmetrical with respect to the origin, then

$$f(x) = \frac{1}{\pi} \int_0^{\infty} \phi(\kappa) \cos \kappa x d\kappa, \quad \text{where } \phi(\kappa) = \int_{-\infty}^{\infty} f(\omega) \cos \kappa \omega d\omega \dots (20).$$

If V is the velocity of waves of length $2\pi/\kappa$, the solution for y at any subsequent position and time with the given initial conditions is

$$y = \frac{1}{2\pi} \int_0^{\infty} \phi(\kappa) \cos \kappa(x - Vt) d\kappa + \frac{1}{2\pi} \int_0^{\infty} \phi(\kappa) \cos \kappa(x + Vt) d\kappa.$$

Let $f(x)$ be zero everywhere except in the range $-\epsilon < x < \epsilon$ and let it have a constant value $1/2\epsilon$ in that range. Then we have

$$\phi(\kappa) = \int_{-\epsilon}^{\epsilon} \frac{1}{2\epsilon} \cos \kappa \omega d\omega = \frac{\sin \kappa \epsilon}{\kappa \epsilon}.$$

In the limit when $\epsilon = 0$ we have $\phi(\kappa) = 1$. The initial disturbance is then an infinitely intense displacement concentrated at the origin; at any subsequent time

$$y = \frac{1}{2\pi} \int_0^{\infty} \cos \kappa(x - Vt) d\kappa + \frac{1}{2\pi} \int_0^{\infty} \cos \kappa(x + Vt) d\kappa \dots (21).$$

A method of evaluating integrals of this type by approximate group methods has been given by Lord Kelvin⁽¹⁸⁾. We confine our attention to one of the integrals in (21), namely

$$y = \frac{1}{2\pi} \int_0^{\infty} \cos \kappa (x - Vt) d\kappa \dots\dots\dots(22).$$

We shall assume for the present that V has one value, real and positive, for all positive real values of κ , and we also ignore meantime any difficulties which may arise from non-convergence of the integral. The integral represents the disturbance as the superposition of the effects of an infinite number of trains of simple waves of all possible wave-lengths and of equal amplitude. Initially all the wave-trains have the same phase at the origin and their effects reinforce each other there; at other places there are differences of phase resulting in mutual interference and zero displacement. At any subsequent time the effect can be obtained by summing the contributions of all the regular wave-trains when each has been moved forward a distance corresponding to its wave-velocity. Now it is clear that at no subsequent time will all the wave-trains in (22) agree in phase at any position (except in certain particular cases of V as a function of κ). But we may be able to find positions and times at which an exceptionally large number of elements have the same phase; if this were the case, these elements would reinforce each other and would produce the predominant part of the total effect, all the other elements mutually interfering owing to differences of phase. Thus we may be able to select for proper values of x and t a predominant group from the integral, consisting of an infinite number of terms clustering round a certain central value κ_0 , and represented by an integral such as we considered in § 3. The state of affairs we have described will occur when the phase is stationary with respect to κ ; hence the condition is

$$\frac{d}{d\kappa} \{\kappa (x - Vt)\} = 0$$

or $x - Ut = 0$; where $U = \frac{d}{d\kappa} (\kappa V) \dots\dots\dots(23).$

U is the group velocity for waves of length κ , and the equation we have obtained gives the time for a given position, or the position for a given time, at which any assigned wave-length is the predominant wave-length. In other words, if a point start from the origin and move with any assigned velocity U , the predominant wave-length in the neighbourhood of the point will be that for which the group velocity has the value U .

It appears then that we may speak of points of predominance of wave-trains of nearly equal wave-length and velocity. In the particular problem under discussion these points of predominance are initially concentrated at the origin. At any subsequent time each has travelled out at its corresponding group velocity. As time goes on the separation of these points becomes more and more complete, the wave form in the neighbourhood of each becoming continually more nearly homogeneous. It follows from the relation (23) that the points of predominance of waves κ and $\kappa + \delta\kappa$ are continually separating from each other at the rate

$$\frac{dU}{d\kappa} \cdot \delta\kappa.$$

Thus the points of predominance for lengths between κ and $\kappa + \delta\kappa$ occupy at time t a length of the medium given by

$$t \frac{dU}{d\kappa} \cdot \delta\kappa.$$

In course of time this becomes appreciable no matter how small $\delta\kappa$ may be, provided $dU/d\kappa$ is not zero. We have noticed a similar result already in §3 when dealing with a group defined by

$$\int_{\kappa_0 - \epsilon}^{\kappa_0 + \epsilon} C_{\kappa} \cos \{ \kappa(x - Vt) - a \} d\kappa.$$

10. Evaluation of a predominant group. Assuming now that sufficient time has elapsed for the predominant group at any time and place to give the main part of the disturbance, we have to evaluate it. Let κ_0 be the predominant value at position x at time t and suppose that the phases of the members of the group are given with sufficient accuracy by three terms of a Taylor series, namely

$$\begin{aligned} \kappa(x - Vt) &= \kappa_0(x - V_0t) + (\kappa - \kappa_0) \frac{d}{d\kappa_0} \{ \kappa_0(x - V_0t) \} \\ &\quad + \frac{(\kappa - \kappa_0)^2}{2} \frac{d^2}{d\kappa_0^2} \{ \kappa_0(x - V_0t) \} \\ &= \kappa_0(x - V_0t) - \frac{1}{2} t \left(\frac{dU}{d\kappa} \right)_0 (\kappa - \kappa_0)^2 \dots\dots\dots(24), \end{aligned}$$

since $\frac{d}{d\kappa_0} \{ \kappa_0(x - V_0t) \} = x - U_0t = 0.$

We have then to evaluate a group of the form

$$\frac{1}{2\pi} \int_{\kappa_0 - \epsilon}^{\kappa_0 + \epsilon} \cos \left\{ \kappa_0(x - V_0t) - \frac{1}{2} t \left(\frac{dU}{d\kappa} \right)_0 (\kappa - \kappa_0)^2 \right\} d\kappa.$$

Suppose that t is of sufficient value so that $\frac{1}{2}t \left(\frac{dU}{d\kappa}\right)_0 (\kappa - \kappa_0)^2$ is very large at the limits of this integral; then if we change the variable by putting

$$\sigma^2 = \frac{1}{2}t \left| \left(\frac{dU}{d\kappa}\right)_0 \right| (\kappa - \kappa_0)^2$$

we may take the limits for σ to be $\pm \infty$. We obtain for the value of the predominant group

$$y = \frac{1}{2\pi} \sqrt{\frac{2}{t \left| \left(\frac{dU}{d\kappa}\right)_0 \right|}} \int_{-\infty}^{\infty} \cos \{ \kappa_0 (x - V_0 t) \mp \sigma^2 \} d\sigma \dots \dots (25),$$

where the upper or lower sign is taken according as $\left(\frac{dU}{d\kappa}\right)_0$ is positive or negative.

Since
$$\int_{-\infty}^{\infty} \cos \sigma^2 d\sigma = \int_{-\infty}^{\infty} \sin \sigma^2 d\sigma = \sqrt{\frac{\pi}{2}},$$

we have

$$y = \frac{1}{2\pi} \left\{ \frac{2\pi}{t \left| \left(\frac{dU}{d\kappa}\right)_0 \right|} \right\}^{\frac{1}{2}} \cos \left\{ \kappa_0 (x - V_0 t) \mp \frac{\pi}{4} \right\} \dots \dots \dots (26),$$

in which κ_0 can be replaced in terms of x and t from $x - U_0 t = 0$.

Returning to the complete solution in (21) with two integrals, we have found an approximate value (26) for the first when x and t satisfy $x - Ut = 0$; we obtain a similar result for the second under the condition $x + Ut = 0$. Hence when U is positive, as is usually the case, and when t is positive, the main part of the disturbance in the region of x positive is supplied by the first integral only, and for x negative by the second integral.

We may notice that for a certain type of medium the group solution may hold for all values of t ; this occurs if the equation (24) is exact, that is if $d^2U/d\kappa^2$ and higher derivatives are zero. We also leave for further consideration, as they occur, cases when $dU/d\kappa$ is zero or when the predominant value of κ coincides with one of the limits 0 and ∞ .

It may be that $x - Ut = 0$ as an equation for κ has more than one real positive root. In this case there is a predominant group for each value of κ and the total effect is given by a sum of terms like (26).

11. Some geometrical constructions. The process we have described may be illustrated by various graphical methods due to Professor Lamb^{(12), (22)}.

Construct a curve showing the relation between Vt and λ , the wave-length, as in Fig. 7. Along the axis of Vt set off OQ equal to any assigned value of x . Let ON be any assigned wave-length, NP the corresponding ordinate. Then we have

$$\frac{PR}{RQ} = \frac{PN - OQ}{ON} = \frac{Vt - x}{\lambda} = \frac{\kappa(Vt - x)}{2\pi}.$$

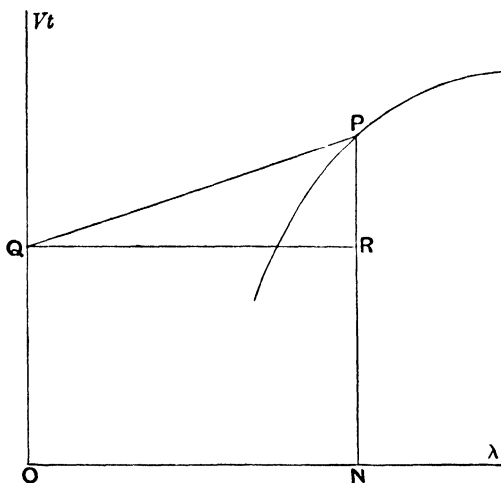

Fig. 7.

Hence the phase at position x at time t of an elementary wave-train κ is proportional to the gradient of the line QP . The phase will be stationary in value if QP is a tangent to the curve, and the predominant wave-lengths will then be given by the abscissae of the points of contact of tangents from Q . For all such values the group velocity U has the assigned value x/t .

As an example consider deep-water waves for which

$$V = \sqrt{g/\kappa}; \quad V^2 t^2 = g t^2 \lambda / 2\pi.$$

The Vt, λ curve is a parabola, to which only one tangent can be drawn (apart from QO). We see from Fig. 8 that for a given instant, increasing values of x give continually larger values for the predominant wave-length.

Another example is for waves on water when both gravity and capillarity are taken into account; then

$$\kappa^2 V^2 = g\kappa + T\kappa^3,$$

$$V^2 t^2 = \frac{g\lambda t^2}{2\pi} + \frac{2\pi T t^2}{\lambda}.$$

The form of the curve is shown in Fig. 9. In this case U has a minimum value, say U_0 . It follows that if $OQ < U_0 t$ no tangent, apart from the axis OQ , can be drawn to the curve and for such values of x there is no predominant group. If

$$OQ > U_0 t,$$

there are two possible tangents to the curve; consequently for any position in advance of the point $U_0 t$ there are two predominant groups superposed.

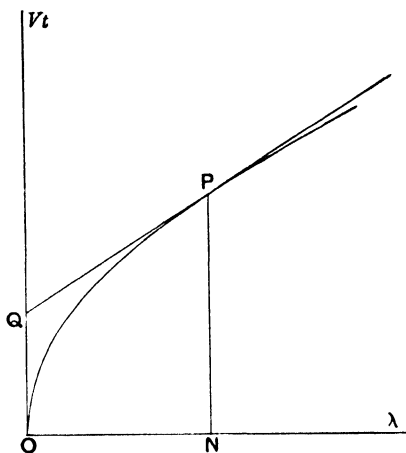

Fig. 8.

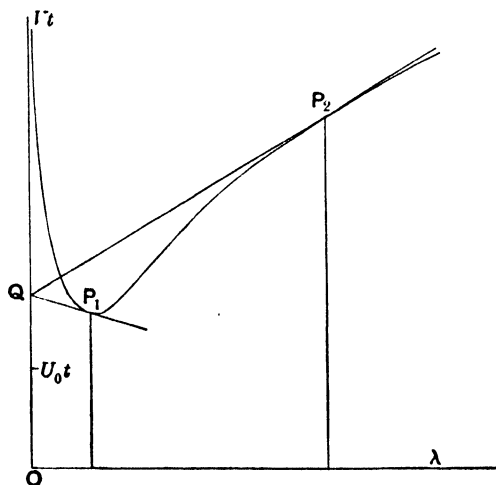

Fig. 9.

A graph can be drawn which gives some idea of the relative importance of the predominant wave-length at any position x at time t . Draw the curve corresponding to the relation between κVt and κ , as in Fig. 10. Draw a line OA whose gradient in these coordinates is the assigned value of x .

For any particular wave-train, for instance with a value of κ given by ON , the phase $\kappa Vt - \kappa x$ is equal to PQ , the difference of the ordinates of the corresponding points on the curve and on the line OA . The phase is stationary when the tangent to the curve is parallel to the line OA , that is when

$$\frac{d(\kappa Vt)}{d\kappa} = x.$$

Further the amplitude of the predominant group depends upon the effective range of values of κ for which the phase is sensibly constant. Thus the disturbance will be the more intense, the greater the vertical

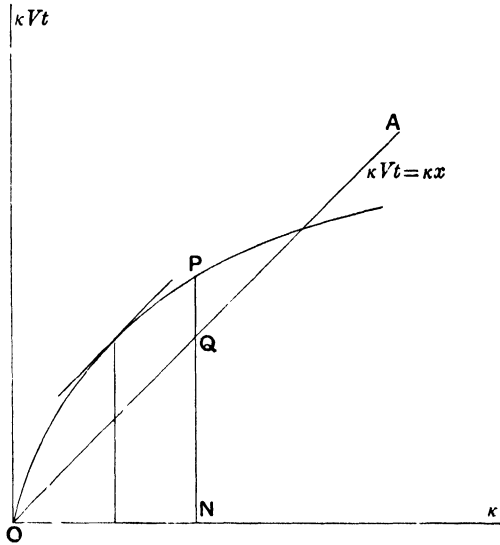

Fig. 10.

chord of curvature of the curve, a statement which is consistent with the occurrence of the factor $tdU/d\kappa$, or $d^2(\kappa Vt)/d\kappa^2$, in the denominator of the group formula (26).

In connection with these graphical methods it has been suggested by Professor Lamb⁽²²⁾ that group methods may be applicable to the theory of earthquake waves and in interpreting seismometric records. A theoretical study of the effects due to a limited initial disturbance near the surface of an elastic body such as the Earth, shows that there are three main stages in the disturbance as it reaches a distant point on the Earth's surface. The disturbance begins after an interval corresponding to the propagation of a wave of irrotational dilatation ;

a second stage begins later with the arrival of a wave of equi-luminous distortion; and finally the disturbance takes the form of surface waves which have slower velocities than the other two types.

It is in the third stage where certain observed effects might be attributed to dispersion, that is to a variation of the velocity of the surface waves with their periods; such theories might be tested by group methods.

For instance, the period of the waves which pass any particular point will become longer or shorter as time goes on, according as the graph of the relation between V and λ is concave or convex upwards: a result which can be inferred from the graphs or can be proved analytically.

12. The Group method for any limited initial disturbance. We have so far assumed a very special kind of limited initial condition, an intense displacement concentrated at the origin or similarly an intense distribution of velocity. It is necessary to see how far the same methods can be extended to less artificial conditions. We should have, more generally, to consider the integral

$$y = \frac{1}{2\pi} \int_0^{\infty} \phi(\kappa) \cos \kappa(x - Vt) d\kappa \dots\dots\dots(27),$$

where

$$\phi(\kappa) = \int_{-\infty}^{\infty} f(\omega) \cos \kappa\omega d\omega,$$

assuming for simplicity an initial distribution symmetrical with respect to the origin. We can also take advantage of the introduction of the amplitude factor $\phi(\kappa)$ by supposing it to be such that the integral (27) is convergent.

The general argument of the Kelvin method, stated in §10, has considerable affinity with the theoretical explanation of diffraction and other optical phenomena in terms of the mutual interference of large numbers of elementary wave-trains; in fact a predominant point is a sort of travelling focus, the introduction of a phase difference $\pi/4$ in the expression (26) being analogous to the abrupt change of phase along an optical ray in passing through a focus.

In applying the same method to the more general form (27) we should expect the group evaluation to be valid only in regions in which we can suppose the amplitude factor $\phi(\kappa)$ to be sensibly constant, the cosine factor on the other hand varying rapidly. On this hypothesis the prominent part of the integral (27) for given x and t would, as

before, be contained within a small range of values of κ for which the phase is stationary and the effects of the elements cumulative; thus the amplitude of the component trains of the predominant group would occur simply as a factor and we should have

$$y = \frac{1}{2\pi} \left\{ \frac{2\pi}{t \left| \frac{dU}{d\kappa} \right|_0} \right\}^{\frac{1}{2}} \phi(\kappa_0) \cos \left\{ \kappa_0 (x - V_0 t) \mp \frac{\pi}{4} \right\} \dots (28).$$

In this way the trains for which $\phi(\kappa)$ is a maximum show prominently in the formula; in fact its validity is limited to the neighbourhood of the maxima. In the cases we shall examine, the effect is due to a limited initial disturbance and the salient features are due to the circumstance that $\phi(\kappa)$ has well-defined maxima; thus the prominent part of the disturbance can be expressed in the form of simple groups associated with the neighbourhood of each maximum.

The limitations of this approximation can only be studied with advantage when dealing with some definite case in an assigned medium; in some of the examples given in the next Chapter we have the advantage of being able to compare the results with those that have been obtained previously by other methods.

As an example of a class of problem which awaits further detailed study, we may notice a difficulty which arises when dealing with surface waves on water. A first approximation to the value of (27) for points at a sufficient distance from a limited initial disturbance would be to make $\phi(\kappa)$ a constant factor, equal to the total integral displacement, involving in this case t being not too large; the integral (27) would then equal (22) multiplied by a constant factor and it could be given the corresponding asymptotic group value from (26), implying t being not too small. There would thus be doubt as to the existence of a range of values of t satisfying both conditions to a reasonable degree. It may be noted that the group value given above, as in (28), corresponds to a second approximation; in the present case of water waves comparison may be made with the well-known approximations of Cauchy and Poisson⁽²⁴⁾. We proceed to illustrate the group method by examining certain definite cases.

CHAPTER IV

ILLUSTRATIONS OF GROUP ANALYSIS

13. Medium with constant group velocity. Particular cases may be devised in which the group analysis takes a special form. If $dU/d\kappa$ is zero for all values of κ , there is no separation of predominant groups as time goes on ; for all the groups move forward with the same group velocity. Suppose in the first place that V is constant ; then U has also the same constant value, say c . The equation $x - ct = 0$ indicates "predominance" for every value of κ . We might illustrate this graphically by the construction we have had

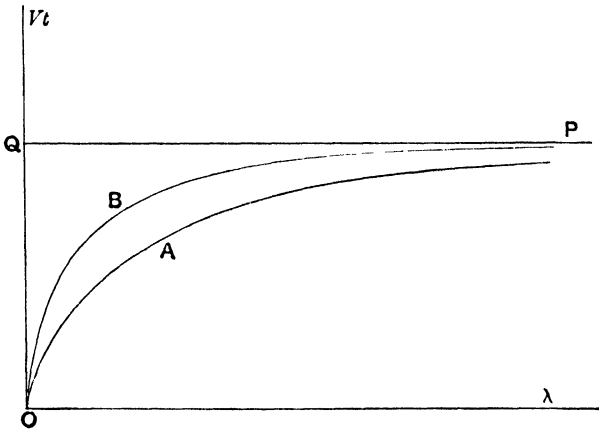

Fig. 11.

previously. The curve OAP represents the Vt, λ curve for waves on water of depth h , in which case

$$\kappa^2 V^2 = c^2 \kappa h \tanh(\kappa h).$$

When $OQ = c$, the tangent QP is horizontal and shows predominance of large wave-lengths. As h is made larger, the curve takes forms like OBP in which more of the curve is in practical contact with QP .

Finally in the limit when V is constant, we should have QP itself as the curve. Of course in this case there are direct methods of evaluating the integrals; one knows that any disturbance is propagated with constant velocity without change of form.

The most general case for which $dU/d\kappa$ is zero is given by

$$V = a + \frac{b}{\kappa}; \quad U = a \dots\dots\dots (29),$$

where a, b are constants.

Here again we have predominance of every value of κ , and the group method fails to evaluate the integral as is obvious from the method used to obtain (26) when we remember that $dU/d\kappa$ and all higher derivatives are zero. In this case the Vt, λ curve would be a straight line inclined to the axis of λ . To follow the propagation of a disturbance we have to fall back upon the original integrals. For an initial distribution

$$y = f(x); \quad \frac{\partial y}{\partial t} = 0; \quad t = 0$$

we have

$$f(x) = \frac{1}{\pi} \int_0^\infty d\kappa \int_{-\infty}^\infty f(\omega) \cos \kappa(x - \omega) d\omega.$$

Write also

$$\phi(x) = \frac{1}{\pi} \int_0^\infty d\kappa \int_{-\infty}^\infty f(\omega) \sin \kappa(x - \omega) d\omega.$$

Then for the disturbance at any subsequent time we have

$$y = \frac{1}{2\pi} \int_0^\infty d\kappa \int_{-\infty}^\infty f(\omega) \cos \{\kappa(x - at - \omega) - bt\} d\omega \\ + \frac{1}{2\pi} \int_0^\infty d\kappa \int_{-\infty}^\infty f(\omega) \cos \{\kappa(x + at - \omega) + bt\} d\omega.$$

Consider the first integral, representing a disturbance travelling in the positive direction of Ox ; we have

$$y = \frac{1}{2} f(x - at) \cos bt + \frac{1}{2} \phi(x - at) \sin bt.$$

After equal intervals of time $2\pi/b$, the initial form $\frac{1}{2}f(x)$ is exactly repeated and is displaced forward a distance $2\pi a/b$. But at intermediate times there is no simple displacement, and the form may be quite different. At a time π/b we have $y = -\frac{1}{2}f(x)$, indicating a complete reversal.

An example which admits of complete solution has been given by Professor Schuster⁽²⁵⁾, who graphed the form at various instants. If

$$f(x) = \frac{a^2}{x^2 + a^2},$$

it can be shown that

$$\phi(x) = \frac{ax}{x^2 + a^2}.$$

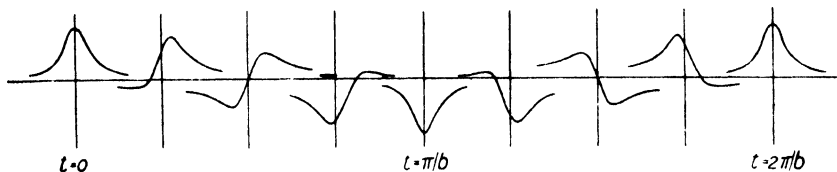

Fig. 12.

If a disturbance travelling in the positive direction is given by $y = f(x)$ initially, we have at subsequent times

$$y = \frac{a^2 \cos bt}{(x - at)^2 + a^2} + \frac{a(x - at) \sin bt}{(x - at)^2 + a^2} \dots\dots\dots(30).$$

The graphs in Fig. 12 illustrate the change in shape of the wave as it goes through a complete cycle.

14. Flexural waves on a rod. When developing the phase of an elementary train in three terms of a Taylor series in (24), we remarked that the expression would be exact if the remaining terms were zero ; in this case by putting $d^2 U/d\kappa^2$ zero we obtain

$$V = \frac{a}{\kappa} + b + c\kappa,$$

where a, b, c are constants.

It follows that the group evaluation holds without being limited to large values of t .

An example is supplied by the ordinary theory of transverse vibrations of an elastic rod ; with suitable units the equation of motion is

$$\frac{\partial^2 y}{\partial t^2} + \frac{\partial^4 y}{\partial x^4} = 0.$$

Assuming as a solution an infinite regular train $\cos \kappa(x - Vt)$ this gives

$$V = \kappa ; \quad U = d(\kappa V)/d\kappa = 2\kappa = 2V.$$

The group velocity for any wave-length is twice the phase velocity. Consider the case of an infinite intense displacement concentrated at the origin initially ; for subsequent times

$$y = \frac{1}{\pi} \int_0^\infty \cos \kappa x \cos \kappa Vt \, d\kappa \dots\dots\dots(31).$$

From (26) the group evaluation in this case is

$$y = \frac{1}{2\pi} \left\{ \frac{2\pi}{t \frac{dU}{d\kappa}} \right\}^{\frac{1}{2}} \cos \left\{ \kappa (x - Vt) - \frac{\pi}{4} \right\},$$

with $\kappa = x/2t$.

Thus we obtain

$$y = \frac{1}{2} (\pi t)^{-\frac{1}{2}} \sin \left(\frac{\pi}{4} + \frac{x^2}{4t} \right) \dots\dots\dots(32).$$

But the integral (31) has a known exact solution ; we have in fact

$$y = \frac{1}{\pi} \int_0^\infty \cos \kappa x \cos \kappa^2 t \, d\kappa = \frac{1}{2} (\pi t)^{-\frac{1}{2}} \sin \left(\frac{\pi}{4} + \frac{x^2}{4t} \right) \dots(33).$$

We have accordingly in this illustration a case in which the group method gives a result which is exact for all times. It is of interest to see how the more general case works out. Suppose the conditions are

$$y = f(x) ; \quad \frac{\partial y}{\partial t} = 0 ; \quad \text{for } t = 0.$$

The solution is given by

$$y = \frac{1}{\pi} \int_0^\infty d\kappa \int_{-\infty}^\infty f(\omega) \cos \kappa (x - \omega) \cos \kappa Vt \, d\omega \dots\dots(34).$$

Remembering that κV is equal to κ^2 , and changing the order of integration, an exact solution can be obtained by known methods in the form

$$y = \frac{1}{2\sqrt{\pi t}} \int_{-\infty}^\infty f(\omega) \sin \left\{ \frac{\pi}{4} + \frac{(x - \omega)^2}{4t} \right\} d\omega \dots\dots\dots(35).$$

For comparison apply the group method of (28) to this case.

We should express (34) in a form representing positive and negative waves. For x and t positive, predominant groups will arise only from the former, so that we are only concerned with

$$y = \frac{1}{2\pi} \int_0^\infty \phi(\kappa) \cos \kappa (x - Vt) \, d\kappa + \frac{1}{2\pi} \int_0^\infty \psi(\kappa) \sin \kappa (x - Vt) \, d\kappa,$$

where $\phi(\kappa) = \int_{-\infty}^\infty f(\omega) \cos \kappa \omega \, d\omega ; \quad \psi(\kappa) = \int_{-\infty}^\infty f(\omega) \sin \kappa \omega \, d\omega.$

Hence in the manner of (28) we obtain

$$y = \frac{1}{2\pi} \left(\frac{\pi}{t}\right)^{\frac{1}{2}} \phi\left(\frac{x}{2t}\right) \cos\left(\frac{x^2}{4t} - \frac{\pi}{4}\right) + \frac{1}{2\pi} \left(\frac{\pi}{t}\right)^{\frac{1}{2}} \psi\left(\frac{x}{2t}\right) \sin\left(\frac{x^2}{4t} - \frac{\pi}{4}\right) \\ = \frac{1}{2\sqrt{\pi t}} \int_{-\infty}^{\infty} f(\omega) \sin\left(\frac{\pi}{4} + \frac{x^2}{4t} - \frac{x\omega}{2t}\right) d\omega \dots\dots\dots(36).$$

This differs from the exact form by omitting a term $\omega^2/4t$ in the argument of the sine. Any detailed study of the approximation would need a specification of the function $f(\omega)$, but we see how the result is of use when the initial disturbance is limited in extent, that is when $f(\omega)$ is zero everywhere except within a limited range of the variable. The condition involved is that x should be large compared with any effective value of ω in the integration; thus the group method must only be applied for positions at some considerable distance from the confines of the initial disturbance, and after the lapse of a sufficient interval of time.

15. Water waves due to concentrated line displacement. In taking illustrations from the motion of water waves we are dealing with problems of more practical interest than those we have examined hitherto; we have moreover the advantage of being able to compare results obtained by various methods in the numerous researches in this region.

We begin with the somewhat artificial conception of an intense initial displacement concentrated at the origin. This was the case given originally by Lord Kelvin to show the agreement of his group method with earlier results of Cauchy, and we may set aside meantime the question of convergence of the integral.

We have as before

$$y = \frac{1}{2\pi} \int_0^{\infty} \cos \kappa(x - Vt) d\kappa + \frac{1}{2\pi} \int_0^{\infty} \cos \kappa(x + Vt) d\kappa \dots(37),$$

with $V = \sqrt{g/\kappa}$; $U = \frac{1}{2} \sqrt{g/\kappa} = \frac{1}{2} V$.

There are symmetrical groups of waves proceeding in the two directions from the origin. For x and t positive the chief group comes from the first integral, and the predominant wave-length is given by

$$\kappa = \frac{gt^2}{4x^2}.$$

Applying the formula (26) we obtain

$$y = \frac{g^{\frac{1}{2}} t}{2\pi^{\frac{1}{2}} x^{\frac{3}{2}}} \cos\left(\frac{gt^2}{4x} - \frac{\pi}{4}\right) \dots\dots\dots(38).$$

At any considerable distance from the origin this indicates oscillations succeeding each other with continually increasing amplitude and frequency ; also if we follow a group of waves with a given wavelength the amplitude varies inversely as $t^{\frac{1}{2}}$, or inversely as $x^{\frac{1}{2}}$.

The degree of approximation of (38) can be estimated by comparison with Poisson's result for $gt^2/2x$ large, involving a semi-convergent expansion

$$y = \frac{g^{\frac{1}{2}}t}{2\pi x^{\frac{3}{2}}} \cos\left(\frac{gt^2}{4x} - \pi\right) - \frac{1}{\pi x} \left\{ \frac{1}{\omega} - \frac{1 \cdot 3 \cdot 5}{\omega^3} + \frac{1 \cdot 3 \cdot 5 \cdot 7 \cdot 9}{\omega^5} - \dots \right\},$$

where

$$\omega = gt^2/2x.$$

Another comparison is of interest in connecting the group method with Fresnel's treatment of diffraction. It can be shown that the solution (37) is equivalent to an exact expression

$$\begin{aligned} y &= \frac{\omega^{\frac{1}{2}}}{2\pi x} \left\{ \cos \frac{1}{2}\omega \int_0^\omega \cos \frac{1}{2}u \frac{du}{\sqrt{u}} + \sin \frac{1}{2}\omega \int_0^\omega \sin \frac{1}{2}u \frac{du}{\sqrt{u}} \right\} \\ &= \frac{g^{\frac{1}{2}}t}{\pi x^{\frac{3}{2}}} \left\{ \cos \frac{gt^2}{4x} \int_0^{\left(\frac{gt^2}{4x}\right)^{\frac{1}{2}}} \cos v^2 dv + \sin \frac{gt^2}{4x} \int_0^{\left(\frac{gt^2}{4x}\right)^{\frac{1}{2}}} \sin v^2 dv \right\}. \end{aligned}$$

Hence y is given by the real part of

$$y = \frac{g^{\frac{1}{2}}t}{\pi x^{\frac{3}{2}}} e^{i \frac{gt^2}{4x}} \int_0^s e^{-iv^2} dv \dots\dots\dots(39),$$

where

$$s = (gt^2/4x)^{\frac{1}{2}}.$$

If we draw Cornu's spiral, as in Fig. 13, with $OA = \frac{1}{2} \sqrt{\pi}$ and $AOX = 45^\circ$ and if s is the arc from the origin up to a point (r, θ) on the curve, we have

$$re^{-i\theta} = \int_0^s e^{-iv^2} dv.$$

The exact value of y at any time and position is accordingly given by

$$y = \frac{g^{\frac{1}{2}}t}{\pi x^{\frac{3}{2}}} r \cos\left(\frac{gt^2}{4x} - \theta\right) \dots\dots\dots(40),$$

where r and θ are obtained for an assigned value of s equal to $gt^2/4x$. When s is large, r and θ oscillate more and more closely about their

final limiting values of $\frac{1}{2}\sqrt{\pi}$ and $\frac{\pi}{4}$ respectively. It should be noticed that the above results have been obtained for a very special type of initial disturbance and there are certain limitations in their direct application to cases of an initial displacement of breadth which is finite though small. If $y = f(x)$ gives the initial form we should have in place of (37) similar integrals each containing a factor $\phi(\kappa)$ where

$$\phi(\kappa) = \int_{-\infty}^{\infty} f(\omega) \cos \kappa \omega d\omega.$$

In putting $\phi(\kappa)$ equal to a constant, one introduces, as Cauchy showed, the limitation that $gt^2/4x^2$ should be very small, l being the effective breadth of the initial disturbance. Thus if one attempts to apply (38) directly in cases where l has a small finite value, this question has been left unresolved: whether for a given position there is an appreciable range of time for which $gt^2/4x^2$ is very small and $gt^2/4x$ is very large. It is more satisfactory to consider directly some cases.

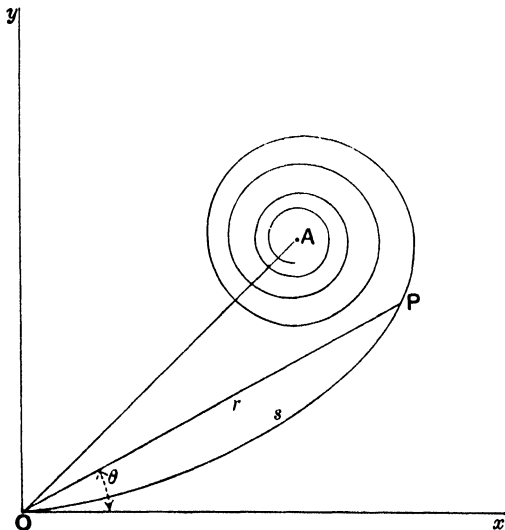

Fig. 13.

16. Water waves from initial displacement of finite breadth. Let the initial conditions be

$$y = \frac{ca^2}{a^2 + x^2}; \quad \frac{\partial y}{\partial t} = 0, \quad \text{for } t = 0 \dots\dots\dots(41),$$

where α is supposed small, so that 2α is the effective breadth of the initial displacement. Then we have

$$y = \frac{1}{\pi} \int_0^\infty d\kappa \int_{-\infty}^\infty \frac{c\alpha^2}{\alpha^2 + x^2} \cos \kappa x \cos \kappa Vt \cos \kappa \omega d\omega \dots \dots (42).$$

Before applying the group method we recall some results obtained by Professor Burnside⁽²³⁾, who investigated the solution in detail under the condition α/x a small quantity. Retaining all terms of equal order it was found that

$$y = \frac{c\alpha}{x} \left(\frac{gt^2}{4x}\right)^{\frac{1}{2}} e^{-gt^2\alpha/4x^2} \left[\pi^{\frac{1}{2}} \sin\left(p + \frac{\pi}{4}\right) - \frac{1}{2} \left(\frac{gt^2}{4x}\right)^{-\frac{3}{2}} + \frac{1 \cdot 3 \cdot 5}{2^3} \left(\frac{gt^2}{4x}\right)^{-\frac{5}{2}} - \dots \right],$$

where $p = gt^2x/4(x^2 + \alpha^2) \dots \dots \dots (43).$

From this it follows that when $gt^2/4x$ is a moderately large quantity, y is of the order α/x ; but when $gt^2/4x$ is very large and of the order of α/α , then y is of the order $\sqrt{\alpha/x}$. For such values of t all the terms of the semi-convergent series included in (43) can be omitted. Further when $gt^2/4x$ is of the order x^2/α^2 , we may substitute $gt^2/4x$ for p . Hence we obtain for the displacement at a given place, valid for the range of time during which its magnitude is comparable with its maximum value,

$$y = \frac{c\alpha\pi^{\frac{1}{2}}}{x} \left(\frac{gt^2}{4x}\right)^{\frac{1}{2}} e^{-\frac{gt^2\alpha}{4x}} \sin\left(\frac{gt^2}{4x} + \frac{\pi}{4}\right) \dots \dots \dots (44).$$

To apply the group method to (42) we consider the part involving positive waves, as we are concerned with positive values of x , and we have

$$y = \frac{1}{2\pi} \int_0^\infty \phi(\kappa) \cos \kappa(x - Vt) d\kappa,$$

where $\phi(\kappa) = \int_0^\infty \frac{c\alpha^2}{\alpha^2 + \omega^2} \cos \kappa \omega d\omega = \pi c\alpha e^{-\alpha\kappa} \dots \dots \dots (45).$

The group formula is

$$y = \frac{1}{2\pi} \left\{ \frac{2\pi}{\frac{du}{d\kappa_0}} \right\}^{\frac{1}{2}} \phi(\kappa_0) \cos \left\{ \kappa_0(x - V_0t) - \frac{\pi}{4} \right\} \dots \dots \dots (46),$$

and was obtained with the assumption that $\phi(\kappa_0)$ was a slowly varying quantity compared with the cosine factor; in other words, the result

is to be interpreted in terms of simple groups associated with the maxima of the amplitude factor. Using the relations

$$V = \sqrt{g/\kappa}; \quad U = \frac{1}{2}\sqrt{g/\kappa}; \quad \kappa_0 = gt^2/4x^2;$$

and evaluating (46) we obtain precisely the expression (44). We can also verify that the sine term varies rapidly compared with the other factors in (44), so that the maximum value of the latter gives the position of maximum displacement; one obtains for the maximum

$$\frac{x}{t} = \sqrt{\frac{1}{2}ga}.$$

This must be the group velocity for the predominant wave-length near the maximum; hence the value of this wave-length is $4\pi a$. Another case in which we recover simply results obtained by other methods by Burnside is when the initial displacement has a constant value A for a range c on either side of the origin and is zero elsewhere. Then

$$\phi(\kappa) = 2A \frac{\sin \kappa c}{\kappa} \dots\dots\dots(47).$$

With the same argument as before we consider the value of y at a point as due to the most important of a succession of simple groups; and we can obtain from the previous results an expression for the group which is valid at least in the vicinity of the travelling maxima of the disturbance. We have

$$y = \frac{4A}{\pi^{\frac{1}{2}}} \left(\frac{x}{gt^2}\right)^{\frac{1}{2}} \sin \frac{gt^2 c}{4x^2} \cos \left(\frac{gt^2}{4x} - \frac{\pi}{4}\right) \dots\dots\dots(48).$$

Here we have a succession of maxima given by those of

$$\left(x/gt^2\right)^{\frac{1}{2}} \sin(gt^2 c/4x^2),$$

that is at times given by $\tan \theta = 2\theta$, where $\theta = gt^2 c/4x^2$. The maxima as they pass any point diminish continually in magnitude with the time, and each is propagated with uniform velocity equal to the group velocity of the predominant wave-length in its vicinity.

An interesting graphical illustration can be obtained from curves given by Lord Kelvin⁽¹⁹⁾ representing his solution for a particular form of limited disturbance; the numerical study from the point of view of group velocity is due to Green⁽²⁰⁾. The diagrams of Fig. 14 show the actual calculated form of the water surface initially and at the times indicated; the units are such that $2/\sqrt{\pi}$ is the phase velocity of an infinite train of simple harmonic waves of wave-length 2. The zero-points are numbered in the order in which they occur in time.

Assume that we may take twice the distance between any two consecutive zeros as an estimate of the predominant wave-length in the neighbourhood of the maximum between them. Then we can calculate the corresponding group velocity, and multiplying it by the time we find where the maximum ought to be according to group theory.

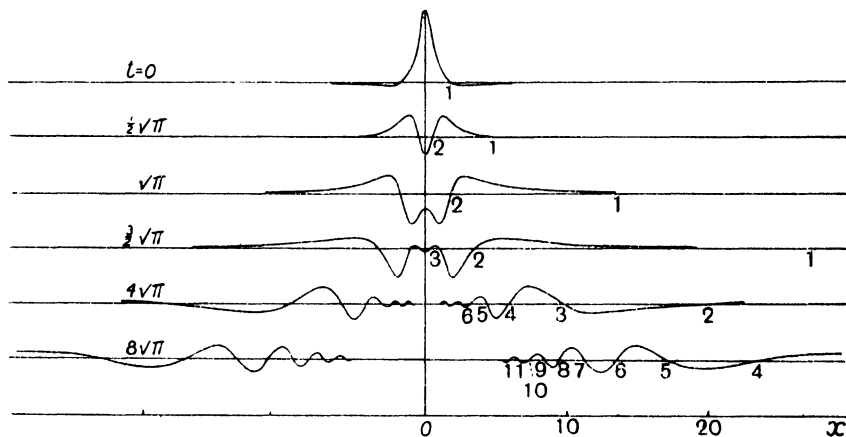

Fig. 14.

Time	Position of Maximum	
	On Diagram	By group velocity
$\frac{1}{2}\sqrt{\pi}$	1.3	1
$\sqrt{\pi}$	3	3.4
$\frac{3}{2}\sqrt{\pi}$	5	7.3
"	2	2.3
$8\sqrt{\pi}$	19.8	19.9
"	15.1	15.2
"	12.2	12.2
"	10.3	10.3
"	8.8	8.8
"	8.0	8.0

The table shows the result of such a comparison. One sees that the agreement becomes very good as time goes on and as the change of wave-length between zeros is small.

17. Finite train of simple water waves. Another interesting example is the case of an initial displacement consisting of a limited train of harmonic waves. If $f(x)$ is symmetrical with respect

to the origin and is zero except for a range of $(2n + \frac{1}{2})$ wave-lengths within which it is $\cos \kappa'x$, we have

$$\phi(\kappa) = 2 \int_0^{(2n + \frac{1}{2})\pi/\kappa'} \cos \kappa' \omega \cos \kappa \omega d\omega = 2\kappa' \frac{\cos \{(2n + \frac{1}{2})\pi\kappa/\kappa'\}}{\kappa'^2 - \kappa^2} \dots(49).$$

Hence we have the surface elevation y , of which we write down only the part necessary for x positive,

$$y = \frac{\kappa'}{\pi} \int_0^\infty \frac{\cos(2n + \frac{1}{2})\pi\kappa/\kappa'}{\kappa'^2 - \kappa^2} \cos \kappa(x - Vt) d\kappa \dots\dots(50).$$

If n is very large the main feature consists of the component waves round the value κ' ; but in general a series of subsidiary components appears, whose effects may be appreciable. The component waves are cumulative for values of x and t such that $\kappa = gt^2/4x^2$; and the prominent effect at time t , of any group of parameter κ , will be at localities where κ has the value κ' or else a value belonging to one of the subsidiary maxima. Evaluating in the usual way we find

$$y = \frac{16g^{\frac{1}{2}}\pi^{-\frac{1}{2}}\kappa'x^{\frac{3}{2}}t}{16\kappa'^2x^4 - g^2t^4} \cos \left\{ (2n + \frac{1}{2}) \frac{\pi gt^2}{4\kappa'x^2} \right\} \cos \left(\frac{gt^2}{4x} - \frac{\pi}{4} \right) \dots(51).$$

We can obtain the prominent travelling groups above referred to by calculating the maxima of the amplitude factor

$$\frac{t}{16\kappa'^2x^4 - g^2t^4} \cos(2n + \frac{1}{2}) \frac{\pi gt^2}{4\kappa'x^2}.$$

The form of this function is shown in Fig. 15, which was obtained by plotting the curve

$$\eta = \frac{\tau}{1 - \tau^2} \cos \frac{9}{2} \pi \tau^2,$$

where τ is proportional to t , and further, $\tau = 1$ corresponds to $\kappa = \kappa'$. The curve represents the variation of the displacement at a given point with the time, neglecting the rapid local variations due to the last cosine factor in (51); it shows the grouped propagation of an initial displacement consisting of $4\frac{1}{2}$ complete wave-lengths of a cosine wave of wave-length $2\pi/\kappa'$ or λ' .

The main undulatory disturbance appears as a simple group around the predominant wave-length λ' moving forward with the corresponding group velocity $\frac{1}{2}V'$. But in advance of this main group of undulations there are two or three subsidiary groups of sensible magnitude with wave-lengths in the neighbourhood of $\frac{9}{2}\lambda'$, $\frac{3}{2}\lambda'$, $\frac{3}{8}\lambda'$ and with corresponding group velocities. Thus in advance of the main group we have

slighter groups of larger wave-lengths moving with group velocities which may be larger than V' . In the rear of the main group we have also a series of alternating groups, following each other much more quickly and with their wave-lengths and velocities less separated out than in the front of the main group. Hence the disturbance in the rear, especially at not very great distances from the origin, may be expected

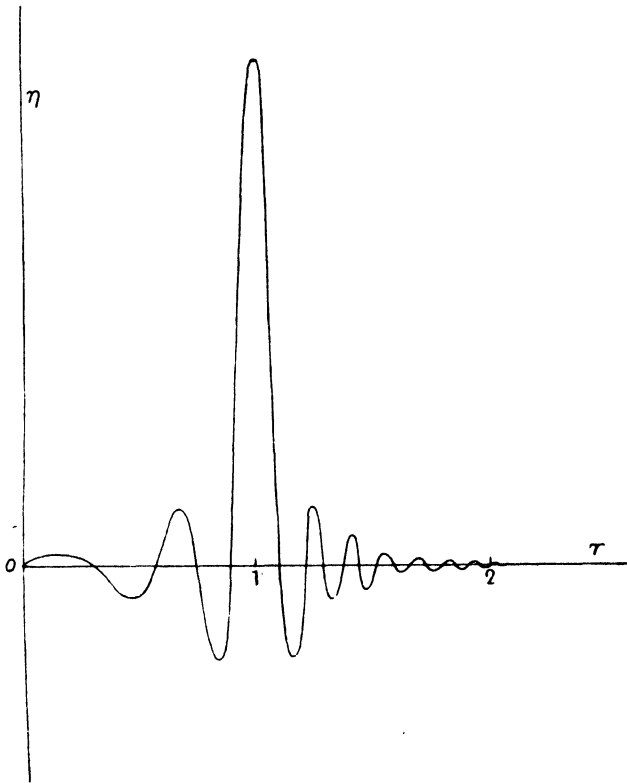

Fig. 15.

to consist of small, more irregular, motion resulting from the superposition of this latter system of groups; thus there should be a more distinctive rear of disturbance moving with velocity $\frac{1}{2}V'$. These inferences may be compared with some results given by Lord Kelvin⁽²⁰⁾. Starting from a solution of the equations for an initial elevation in the form of a single crest, the results were combined graphically so as to show in a series of curves the propagation of an initial disturbance consisting of five crests and four hollows of approximately sinusoidal

shape; it is of interest to notice his remarks on the diagrams. "Immediately after the water is left free, the disturbance begins analysing itself into two groups of waves, seen travelling in contrary directions from the middle line of the diagram. The perceptible fronts of these two groups extend rightwards and leftwards from the end of the initial static group far beyond the hypothetical fronts, supposed to travel at half the wave-velocity, which (according to the dynamics of Osborne Reynolds and Rayleigh, in their important and interesting consideration of the work required to feed a uniform procession of water-waves) would be the actual fronts *if* the free groups remained uniform. How far this *if* is from being realised is illustrated by the diagrams, which show a great extension outwards in each direction far beyond distances travelled at half the wave-velocity. While there is this great extension of the fronts outward from the middle, we see that the two groups, after emergence from coexistence in the middle, travel with their rears leaving a widening space between them of water not perceptibly disturbed, but with very minute wavelets in ever augmenting number following slower and slower in the rear of each group. The extreme perceptible rear travels at a speed closely corresponding to the half wave-velocity.... Thus the perceptible front travels at a speed actually higher than the wave-velocity, and this perceptible front becomes more and more important relatively to the whole group with the advance of time."

This extract will serve to emphasise the importance of strict definition and use of the word 'group.' A simple group, of whatever structure, has associated with it one definite velocity depending only on the wave-length and the type of medium; but this is not the case for an arbitrary limited disturbance, even if composed of harmonic undulations. In certain cases, as in the present, we have found it convenient to analyse such into its important elementary groups, each with its definite group velocity; only in special cases may the disturbance be considered practically equivalent to one simple group.

18. Concentrated initial displacement on water of finite depth. We choose the next example because it includes the possibility of $dU/d\kappa$ being zero for a particular value of κ .

For waves on water of depth h , arising from a concentrated line displacement at the origin, we have as before

$$y = \frac{1}{2\pi} \int_0^{\infty} \cos \kappa (x - Vt) d\kappa + \frac{1}{2\pi} \int_0^{\infty} \cos (\kappa + Vt) d\kappa,$$

with
$$V = \left(\frac{g}{\kappa} \tanh \kappa h\right)^{\frac{1}{2}} ;$$

$$U = \frac{1}{2} \left(\frac{g}{\kappa} \tanh \kappa h\right)^{\frac{1}{2}} \left(1 + \frac{2\kappa h}{\sinh 2\kappa h}\right) \dots\dots\dots (52).$$

The relation $x/t = U$ gives one real positive value of κ and we can obtain the corresponding group value in general from the formula (26). But that expression, having $dU/d\kappa$ in the denominator of the amplitude factor, fails if this quantity is zero. In the present case, we have

$$\frac{dU}{d\kappa} = 0; \quad V = \sqrt{2gh}; \quad \text{for } \kappa = 0.$$

We must then modify the group formula for times and places at which $x/t = \sqrt{2gh}$, the predominant wave-length at such being infinitely long. We return to the expansion of the phase in a Taylor series and add another term so that

$$\kappa(x - Vt) = \kappa_0(x - V_0t) + (x - U_0t)(\kappa - \kappa_0) + \frac{1}{2}t \frac{dU}{d\kappa_0} (\kappa - \kappa_0)^2 + \frac{1}{6}t \frac{d^2U}{d\kappa_0^2} (\kappa - \kappa_0)^3.$$

Accordingly for the predominant group in this case we have

$$\kappa(x - Vt) = \kappa_0(\kappa - V_0t) + \frac{1}{6}t \left(\frac{d^2U}{d\kappa^2}\right) (\kappa - \kappa_0)^3.$$

The group value then becomes, under similar conditions as before,

$$y = \frac{1}{2\pi} \left\{ \frac{6}{t \left| \frac{d^2U}{d\kappa_0^2} \right|} \right\}^{\frac{1}{3}} \int_{-\infty}^{\infty} \cos \{ \kappa_0(x - V_0t) + \sigma^3 \} d\sigma$$

$$= \frac{1}{2\pi} \left\{ \frac{6}{t \left| \frac{d^2U}{d\kappa_0^2} \right|} \right\}^{\frac{1}{3}} \cdot \frac{2}{3} \sin \frac{\pi}{3} \Gamma\left(\frac{1}{3}\right) \cdot \cos \{ \kappa_0(x - V_0t) \} \dots\dots\dots (53),$$

provided the particular value κ_0 does not coincide with one of the limits 0 or ∞ , of the original integral; in that case we should take one-half of the above result.

In the present case

$$\kappa_0 = 0; \quad d^2U/d\kappa_0^2 = -g^{\frac{1}{2}} h^{\frac{5}{2}};$$

and the above formula gives for $x = t\sqrt{2gh}$,

$$y = \frac{1}{6\pi} \Gamma\left(\frac{1}{3}\right) \sin \frac{\pi}{3} \cdot \left(\frac{xh^2}{6}\right)^{-\frac{1}{3}} \dots\dots\dots (54).$$

Lord Rayleigh has obtained the same result from a somewhat different point of view ; he considers it as representing a sort of solitary wave in advance of the Kelvin groups, its occurrence being due to specially enhanced values of the original integral when x and t are so related that the phase is approximately zero for small values of κ . It is in fact only a particular case of the group scheme, whose form is rather unusual on account of special circumstances in the velocity function.

19. Travelling point impulse on the surface of water.

The formation of wave-patterns is a subject in which we can use with advantage the interference methods with which we are concerned. To make the problem definite we shall consider a point source of impulse acting down upon the surface of deep water. Let the axes of x and y be in the undisturbed surface of the water, the axis of z vertically upwards ; write ϖ for $\sqrt{x^2 + y^2}$, and let ρ be the density of the water. Let the initial data be symmetrical round the origin and consist of an initial distribution of impulse given by $f(\varpi)$, without initial displacement. The consequent surface elevation ζ is given by

$$\zeta = -\frac{1}{g\rho} \int_0^\infty \phi(\kappa) \kappa V J_0(\kappa\varpi) \sin(\kappa Vt) \kappa d\kappa,$$

where
$$\phi(\kappa) = \int_0^\infty f(a) J_0(\kappa a) a da \dots\dots\dots(55).$$

In general we may suppose the factor $\phi(\kappa)$ to be such that the above integral is convergent ; for illustrative purposes it is sufficient to consider an initial concentrated point impulse for which we may take $\phi(\kappa)$ equal to $1/2\pi$; then

$$\begin{aligned} \zeta &= -\frac{1}{2\pi g\rho} \int_0^\infty J_0(\kappa\varpi) \kappa V \sin(\kappa Vt) \kappa d\kappa \\ &= -\frac{1}{\pi^2 g\rho} \int_0^\pi d\beta \int_0^\infty \kappa V \cos(\kappa\varpi \cos \beta) \sin(\kappa Vt) \kappa d\kappa \\ &= \frac{1}{2\pi^2 g\rho} \int_0^\pi d\beta \int_0^\infty \kappa V \{ \sin \kappa(\varpi \cos \beta - Vt) \\ &\quad - \sin \kappa(\varpi \cos \beta + Vt) \} \kappa d\kappa \dots\dots\dots(56). \end{aligned}$$

Using the same group methods as before, we separate a real principal group from the integral with respect to κ representing diverging waves ; it occurs round the value of κ given by

$$\frac{\varpi \cos \beta}{t} = U = \frac{1}{2} \sqrt{\frac{g}{\kappa}}.$$

We then evaluate this group by the usual formula (26) and substitute its value instead of the integral with respect to κ ; thus we are left with

$$\zeta = - \frac{g^{\frac{3}{2}} t^4}{16\pi^{\frac{3}{2}} \rho \omega^{\frac{3}{2}}} \int_0^{\frac{\pi}{2}} \frac{d\beta}{\cos^{\frac{3}{2}} \beta} \sin \left(\frac{gt^2}{4\omega \cos \beta} - \frac{\pi}{4} \right) \dots\dots(57).$$

To find the principal value of this integral we use the same method. The important group of terms occurs when the phase of the sine factor is stationary, that is for β zero; since this is one of the limits of the integral we take one-half of the result given by the group formula, and obtain finally by this means the known approximate result

$$\zeta = - \frac{gt^3}{2^{\frac{7}{2}} \pi \rho \omega^4} \sin \frac{gt^2}{4\omega} \dots\dots\dots(58).$$

Now let us suppose this impulse system to be moving along Ox with uniform velocity c ; let B be the position at time t , A at any previous time t_0 , and suppose the system to have been moving for an infinitely long time.

We have

$$\begin{aligned} OA &= ct_0; & OB &= ct; \\ PB &= \omega \{(ct-x)^2 + y^2\}^{\frac{1}{2}} \\ \cos \alpha &= (ct-x)/\omega. \end{aligned}$$

Then in (56) we have to substitute

$\{\omega^2 - 2c(t-t_0)\cos\alpha + c^2(t-t_0)^2\}^{\frac{1}{2}}$
 for ω , $t-t_0$ for t , and integrate with respect to t_0 from $-\infty$ to t ; writing u for $t-t_0$ we have

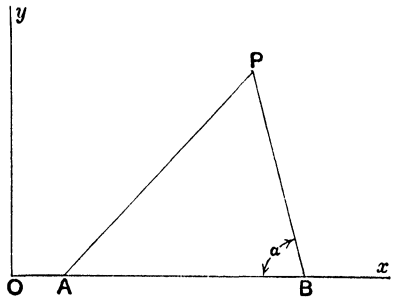

Fig. 16.

$$\begin{aligned} \zeta &= \frac{1}{2g\rho\pi^2} \int_0^{\frac{\pi}{2}} d\beta \int_0^{\infty} du \int_0^{\infty} \kappa V [\sin \kappa \{\cos \beta (\omega^2 - 2\omega cu \cos \alpha + c^2 u^2)\}^{\frac{1}{2}} - Vu] \\ &\quad - \sin \kappa \{\cos \beta (\omega^2 - 2\omega cu \cos \alpha + c^2 u^2)\}^{\frac{1}{2}} + Vu] \kappa d\kappa \dots\dots(59). \end{aligned}$$

We select the group round the value of κ given by

$$\kappa^{-1} = 4 \cos^2 \beta (\omega^2 - 2cu\omega \cos \alpha + c^2 u^2)/gu^2,$$

the chief group in respect to β occurs at $\beta = 0$, and we obtain as before

$$\begin{aligned} \zeta &= - \frac{g}{2^{\frac{7}{2}} \pi \rho} \int_0^{\infty} \frac{u^3 du}{(\omega^2 - 2cu\omega \cos \alpha + c^2 u^2)^2} \\ &\quad \sin \left\{ \frac{gu^2}{4(\omega^2 - 2cu\omega \cos \alpha + c^2 u^2)} \right\} \dots\dots(60). \end{aligned}$$

Finally we choose the chief group or groups of terms in u from the condition

$$\frac{d}{du} \left\{ \frac{1}{4} g u^2 (\varpi^2 - cu\varpi \cos \alpha + c^2 u^2)^{\frac{1}{2}} \right\} = 0 \dots\dots\dots(61).$$

Having found the values of u we could use the group formula again and could investigate the amplitude of the resulting disturbance ; but for that purpose it would be more satisfactory to revert to the integral in (55) with $\phi(\kappa)$ corresponding to a less artificial type of initial impulse, for which the validity of the approximations could be examined more closely. We shall not pursue this further but shall confine our attention to the condition for the chief groups in u . It leads to

$$c^2 u^2 - 3cu\varpi \cos \alpha + 2\varpi^2 = 0$$

or $cu = \frac{1}{2} \varpi \{ 3 \cos \alpha \pm (9 \cos^2 \alpha - 8) \} \dots\dots\dots(62).$

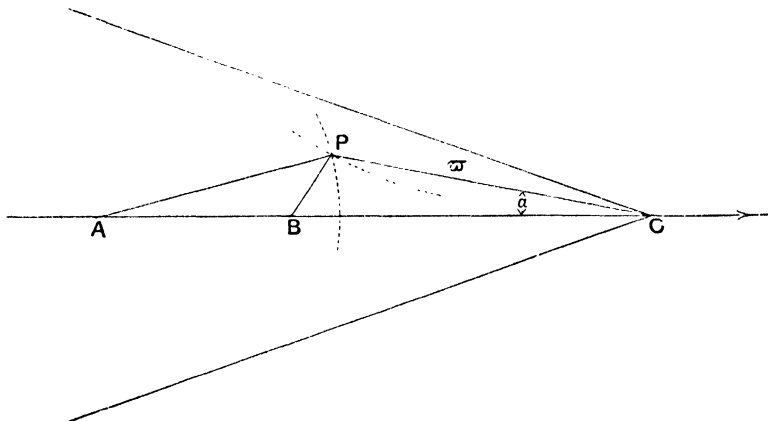

Fig. 17.

It is clear that each value of cu gives a position of the moving impulse, at time u previously, for which the waves sent out reinforce each other at the point (ϖ, α) at the time t .

In the region where $9 \cos^2 \alpha < 8$, both roots are imaginary ; thus the previous position is non-existent and there is no principal group for the integral in u . Hence all the regular wave-pattern is contained within two straight lines radiating from the point-impulse, each making with the line of motion an angle $\cos^{-1} 2\sqrt{2}/3$, or approximately $19^\circ 28'$.

When $9 \cos^2 \alpha > 8$, there are two different real roots for cu . Thus there are two chief groups in the integral, corresponding to two regular wave systems superposed on each other.

If u_1 and u_2 are the two roots in u , then for any point P within the

two bounding radii the main disturbance consists of two parts: one group sent out from A at time u_1 previously, where $OA = cu_1$, and another group sent out from B at time u_2 previously, with $OB = cu_2$. Hence arise the two wave-systems, the transverse and diverging waves, forming the well-known wave-pattern which accompanies a moving pressure point.

20. Wave-patterns from a travelling point source. If

we wish to study the form of the wave-pattern only without estimating the amplitude, the matter may be stated much more briefly. Consider a point impulse moving with uniform velocity c over the surface of a dispersive medium for which U and V are respectively the group velocity and the wave velocity for a wave-length $2\pi/\kappa$.

Let the disturbance from the impulse when in the neighbourhood of a point A combine so as to produce waves κ at P at the present moment when the source is at O . Then the problem of finding the possible persistent wave-systems which accompany the moving source is contained simply in the conditions

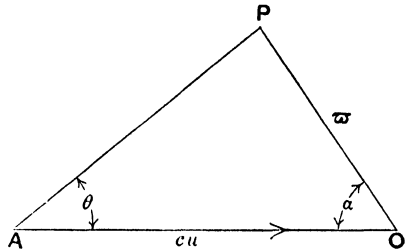

Fig. 18.

$$\frac{AP}{AO} = \frac{U}{c}; \quad c \cos \theta = V \dots\dots\dots(63),$$

that is, in

$$\left. \begin{aligned} (\omega^2 - 2cu\omega \cos \alpha + c^2u^2)^{\frac{1}{2}}/u &= U \\ c(cu - \omega \cos \alpha)/(\omega^2 - 2cu\omega \cos \alpha + c^2u^2)^{\frac{1}{2}} &= V \end{aligned} \right\} \dots\dots(64).$$

The wave-pattern depends upon the character of the positive roots of these equations for cu and κ ; each such value of cu defines a wave-system with wave front through P at right-angles to AP , and each system can be expressed in the form

$$\zeta = F(\omega, \alpha) \cos \{ \kappa (\omega^2 - 2cu\omega \cos \alpha + c^2u^2)^{\frac{1}{2}} + \epsilon \} \dots\dots(65),$$

with cu and κ as functions of ω and α .

Some simple examples occur when the medium is such that the group velocity bears a constant ratio to the wave velocity, that is when

$$U = \frac{1}{2} (n + 1) V$$

with n independent of κ .

Then the equations (64) lead to a quadratic for cu

$$(1 - n)c^2u^2 + (n - 3)cu\varpi \cos \alpha + 2\varpi^2 = 0 \dots\dots\dots(66).$$

When $n = 0$ we have the previous case of water-waves, with a double pattern contained within two definite lines.

For capillary surface-waves n is 2. Then there is only one positive root of the quadratic and it is real for all values of α ; there is only one wave system but it extends over the whole surface.

For flexural waves on a plate, $n = 3$. There is one system, extending over the whole surface, corresponding to the root $cu = \varpi$.

In general, when u/V is not constant, the equations (64) lead to complicated wave-patterns. For example, for surface-waves under gravity and capillarity combined, it may be shown that in certain positions there are four wave-branches through each point.

CHAPTER V

ACTION OF A PRISM UPON WHITE LIGHT

21. White Light as an aggregate of pulses. It is generally admitted that white light, from an incandescent solid, is not composed of regular trains of waves of given periodicities, but is an aggregate of a vast number of irregular disturbances or pulses. We have to reconcile this view with the fact that a prism of dispersive material analyses white light into a sequence of periodic waves more or less homogeneous according to the resolving power of the prism. We should require accordingly in the first place a theory of the action of a prism upon a single concentrated pulse. Further, in white light we have an immense number of such pulses and we should have to consider whether there is any degree of coordination between them: to what extent the Fourier element from an aggregate of pulses is affected by the random distribution of phase of the components from separate pulses. It appears that the regular wave represented by a Fourier element from a random aggregate of similar pulses does not differ appreciably from that due to a single pulse.

Our present aim is not so much to show the analytical equivalence of an aggregate of pulses with trains of regular waves of all possible frequencies, as to obtain an adequate picture of the mode of action of a prism in effecting this resolution. If the former were the main object there would possibly be no reason to go beyond the traditional method, as Lord Rayleigh has remarked⁽³⁴⁾; by Fourier analysis a pulse is equivalent to a series of regular infinite waves, and problems can be solved on this basis so long as we take for granted the dispersive character of the medium which is specified by the relation of velocity to wave-length.

On the other hand, if we press for an ultimate physical explanation we must take into account the constitution of the medium. In that case a large class of examples of dispersive action has no direct bearing

on the present problem ; we refer to the propagation of waves in bodies of limited form, as in all such cases we are practically concerned with surface effects : for example, surface-waves on water or elastic bodies, or flexural waves on rods. In dealing with dispersive effects in the body of a medium we appear to be forced ultimately to assume periodicities of time or place inherent in the constitution of the medium.

However, without pursuing the physical analysis so far, we may obtain valuable analogies from the method of groups and wave-patterns developed in the previous chapters. Before doing so we may recall the action of a grating upon a single pulse. It is easy to see in a general manner how a grating produces periodicities in reflecting a pulse.

Let a thin plane impulse fall normally upon an ideal grating consisting of narrow parallel strips, equally spaced and alternately reflecting and non-reflecting. A lens S brings to a focus at F the light reflected in any given direction θ .

It is clear that the pulses reflected from the strips at A_1, A_2, A_3, \dots , reach F successively, separated by equal intervals of time

$$A_1 A_2 \sin \theta / V,$$

where V is the velocity of the pulses. Thus the grating transforms the single incident pulse into a periodic disturbance which more closely resembles a homogeneous simple wave of wave-length

$$A_1 A_2 \sin \theta,$$

the greater the number of reflecting strips in the grating.

Compare this with the action of the grating upon a simple homogeneous wave incident upon it from the same direction as the pulse. The reflected light is not altered in periodicity but its amplitude depends upon the direction in which it is observed ; according to the theory of a simple grating the first principal maximum of amplitude will be in the direction $A_2 B_2 F$ of Fig. 19, provided the wave-length of the incident train is equal to $A_1 A_2 \sin \theta$, that is, provided it is equal to the wave-length of the periodic disturbance into which the single pulse is transformed by the grating.

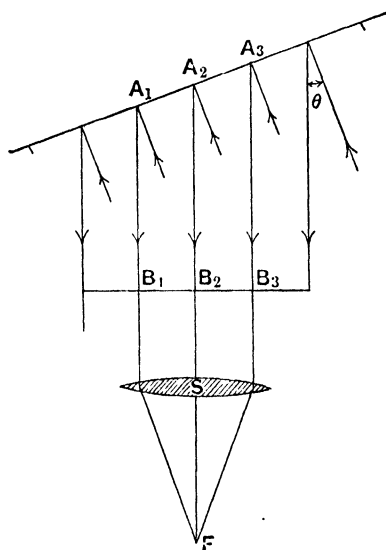

Fig. 19.

22. Prism with constant group velocity. Turn now to the action of a prism on a thin plane pulse incident normally upon the first face. To make the theory satisfactory we must choose a special ideal substance for the prism such that the phase-velocity V for wave-length λ is

$$V = a + b\lambda \dots\dots\dots(67).$$

We discussed this medium in § 13 ; it has special properties because the group velocity U is constant. A pulse is not propagated unchanged in form in general, but the original form is repeated after equal intervals of time $1/b$ moved forward through equal distances a/b ; at intermediate positions it is reversed. There is accordingly a special kind of periodicity about the motion.

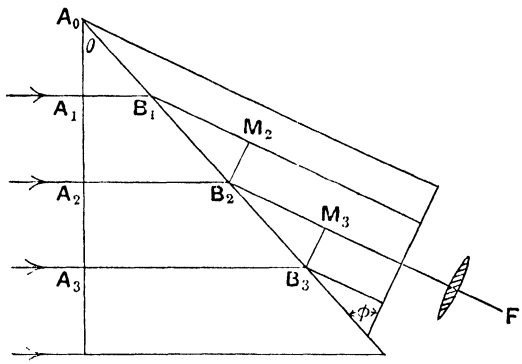

Fig. 20.

The pulse is incident normally on the face $A_0 A_1 A_2$. Draw lines $A_1 B_1, A_2 B_2, \dots$ parallel to the base of the prism and such that

$$A_1 B_1 = a/b ; \quad A_2 B_2 = 2a/b ; \text{ etc.}$$

Regarding the points of the second face as new centres of disturbance, we see that the pulse in its original form (as a crest) is emitted at the points B_1, B_2, \dots . Consider the emergent pulses for any assigned direction indicated by the angle ϕ ; the disturbance brought to a focus F will have a certain periodicity and a certain equivalent wave-length λ which we have to determine. From the figure we obtain

$$B_1 M_2 = B_2 M_3 = \dots = \frac{a \sin \phi}{b \sin \theta} \dots\dots\dots(68).$$

Further there is a time-difference of $1/b$ for emergence of the pulse at B_1, B_2, \dots ; hence the wave-length λ is given by

$$\lambda = \frac{c}{b} - \frac{a \sin \phi}{b \sin \theta} \dots\dots\dots(69),$$

where c is the velocity of disturbances in free space outside the prism. Now apply the ordinary laws of refraction for regular waves of wave-length λ incident normally on the prism; if λ' is the wave-length inside the prism we have

$$\frac{V}{\lambda'} = \frac{c}{\lambda}; \quad V = a + b\lambda' \dots\dots\dots(70).$$

Further, θ being the angle of incidence, if ϕ is the angle of refraction,

$$\sin \theta = \frac{V}{c} \sin \phi \dots\dots\dots(71).$$

From the equations (70) and (71) we obtain for λ the same value as in (69). We have then verified that for this medium if a telescope be pointed towards the prism in any direction, the disturbance at the focus has a periodicity depending upon the direction; and further, the corresponding wave-length is exactly that of the train of regular waves which would be brought to a focus there if incident on the prism instead of the pulse.

This method is devised to show the analogy with the action of a grating and is satisfactory in so far as the special medium is concerned. It may be supposed to apply to any dispersive medium by considering the group velocity, though variable with the wave-length, to be practically constant within any assigned small range of wave-length. But in that case we should be operating with a simple group and not with a narrow pulse, and we have seen that in general the latter is equivalent to a collection of simple groups.

23. Separation of pulse into groups. Consider a single pulse incident normally on the face of a prism of any dispersive substance. We may conceive the effective action in the medium as a drawing out of the pulse into sequences of approximately homogeneous wave-trains, the place where any predominant wave-length occurs travelling out with corresponding group velocity U . When the various wave-lengths have been sorted out appreciably, the amplitude changes slowly in the time required for many simple oscillations. Consequently as these wave-trains arrive at the second face of the prism, they may be supposed to be in the main refracted according to the ordinary law for regular waves.

An objection that may be urged is that a single unsupported pulse is so enfeebled in the process of being spread over a finite range in the dispersive medium that the emergent trains of waves would be of inappreciable amplitude. That would depend largely upon the

intensity and character of the original pulse, and upon the consequent distribution of energy among its Fourier elements. A question which arises in this connection is the different manner in which a prism treats white light and Röntgen rays, assuming both to be composed of aggregates of abrupt pulses; in the latter case there is no appreciable refraction. The propagation of a discontinuous wave-front will be treated more fully later. For light waves, it may be stated generally that such an abrupt front in a dispersive medium is possible and travels with the same velocity whatever the medium; the analytical reason is that the wave-velocity function has a finite limiting value for zero wave-length, thus the abrupt front is associated with extremely short waves and moves always with the velocity of light in free space. It appears then that in every case of pulses incident upon a prism there is a certain amount of radiation which is not refracted. The relative amount of energy associated with the non-refracted front compared with that in the subsequent trains of waves doubtless depends upon the character of the pulse, its intensity and its effective breadth and degree of abruptness. Generally, and in white light in particular, the non-refracted part is presumably very minute, whereas one supposes the converse to be the case in Röntgen rays.

We have assumed that the dispersive character of the medium is specified completely by an assigned functional relation between velocity and wave-length; but in practice, for instance in dispersion formulae for light, the conditions under which the relation is obtained may not hold for very small wave-lengths, so that our conclusions about short waves may be subject to limitations on this account. Further, the question whether the front of a pulse can be treated adequately as abrupt or discontinuous depends ultimately upon the physical constitution of the medium and is no doubt to be determined by its time of duration compared with what Sir Joseph Larmor⁽³⁵⁾ has called the time of optical relaxation of the dispersing medium.

24. Analogy with wave-pattern of moving source. If we consider oblique incidence of a pulse upon a prism we can work out a satisfactory analogy with the wave-pattern produced by a moving source, following the method of Green⁽³⁶⁾.

Let a thin plane pulse moving with velocity c meet the face of a prism at an angle θ . The point of contact P may be regarded as a constant impressed source moving along the face of the prism with

velocity v equal to $c/\sin \theta$, considering a plane section as in the diagram. In working out the wave-pattern in the dispersive medium, as for example in § 19, we suppose the source to have been moving for a considerable time so that regular effects may be fully established. In the present case if OA is the length of the face of the prism we

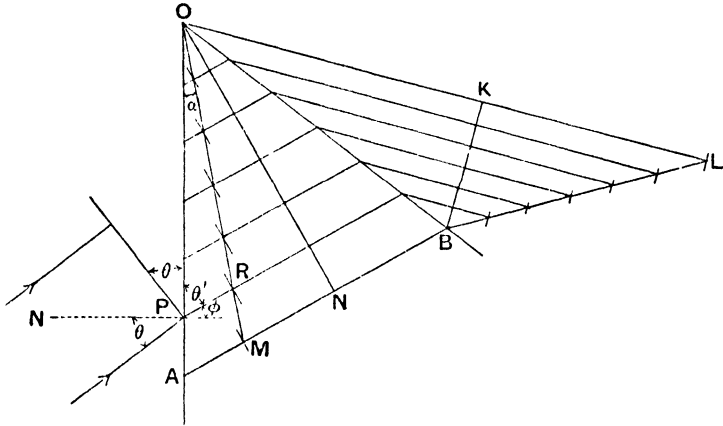

Fig. 21.

shall have minor irregularities at the beginning and end of the process, but we may ignore these in comparison with the main regular features. If, as in § 20, the disturbances from the impulse when in the neighbourhood of a point P combine to produce waves of wave-length $2\pi/\kappa'$ at a point R at the present moment when the impulse is at O , then to determine the persistent wave systems which accompany the source we have

$$\frac{PR}{PO} = \frac{U}{v} ; v \cos \theta' = V \dots\dots\dots(72),$$

where V is the phase velocity and U the group velocity of waves κ' in the prism.

If t is the time the source takes in moving from P to O these may be written

$$\left. \begin{aligned} (r^2 - 2vtr \cos \alpha + v^2t^2)^{\frac{1}{2}} &= Ut \\ v(vt - r \cos \alpha)(r^2 - 2vtr \cos \alpha + v^2t^2)^{-\frac{1}{2}} &= V \end{aligned} \right\} \dots\dots\dots(73),$$

where

$$OR = r ; ROP = \alpha.$$

The wave-pattern depends upon the positive roots for vt and κ' given by these equations ; each root of vt defines a wave system with wave-

front through R at right angles to PR and each system can be expressed in the form

$$y = F(r, \alpha) \cos \{ \kappa' (r^2 - 2vtr \cos \alpha + v^2t^2)^{\frac{1}{2}} + \epsilon \} \dots\dots\dots(74),$$

where vt and κ' are functions of r and α given by the equations (73). The lines of crests are given in polar coordinates (r, α) by

$$\kappa' (r^2 - 2vtr \cos \alpha + v^2t^2)^{\frac{1}{2}} + \epsilon = (2n + 1) \pi \dots\dots\dots(75).$$

Further, the equations (73) are homogeneous in r and t ; thus the line OR cuts successive lines of crests at the same angle, at places where κ' has the same value, that is OR is the locus of points at which a given wave-length is to be found. A different value of α would give the locus of some other corresponding wave-length. Also the direction of motion of these crests, placed in echelon along OR , is in a direction parallel to PR .

When the trace of the pulse has passed from A to O we have in the prism sets of wave-crests, the diagram indicating those associated with an assigned wave-length.

The line PN being normal to AO , the angles θ and ϕ correspond to the angles of incidence and refraction, respectively, for the front face; we have from (72)

$$v \cos \theta' = v \sin \phi = V.$$

Hence
$$\sin \phi = \frac{V}{v} = \frac{V}{c} \sin \theta \dots\dots\dots(76).$$

Since V is the wave velocity of waves of length $2\pi/\kappa$ in the prism, the ordinary law of refraction holds for these crests in echelon, just as if they were regular homogeneous waves.

Now follow this train of crests in its motion, till it is clear of the prism. Let AB be the greatest length traversed in the prism, then we write

$$AB = \text{thickness of base of prism} = T.$$

Draw ON perpendicular to AB , and let t be the time for the trace of the pulse to move from A to O . The length of the train in the direction of its motion

$$= MN = AN - AM = vt \sin \phi - Ut = (V - U) t \dots\dots\dots(77).$$

The rear M of the group advances through the prism with the group velocity U and takes a further time t' to reach B , where

$$t' = \frac{BM}{U} = \frac{T - AM}{U} = \frac{T - Ut}{U} \dots\dots\dots(78).$$

In the same time the front of the group of waves advances from O in free space in a direction OL which is given by the ordinary law of refraction, just as on entering the prism ; for we are dealing with the emergence of regular trains of waves although arranged in echelon. Further, the point L reached by the front of the train is given by

$$OL = ct' = \frac{c(T - Ut)}{U} \dots\dots\dots(79).$$

It follows that after the rear of the group has emerged at B , the crests are all arranged in echelon along BL and are all parallel to a line BK which is drawn perpendicular to OL . Further the wave-length λ along BL corresponds in the ordinary way with the value $2\pi/\kappa'$ inside the prism. Thus BL is the locus of points where a wave-length λ is to be observed, just as if the crests were ordinary regular waves proceeding in the direction OL except that their formation and their finite number limits their approach to homogeneity.

From the law of refraction we have

$$OK = \frac{c}{V}BN = \frac{c}{V}(T - Vt).$$

Therefore the length of the train on emergence

$$= KL = OL - OK = c \left\{ \frac{T - Ut}{U} - \frac{T - Vt}{V} \right\} = cT \left(\frac{1}{U} - \frac{1}{V} \right).$$

But μ being the refractive index and λ the wave-length outside the prism we have

$$\frac{c}{V} = \mu; \quad \frac{c}{U} = \mu - \lambda \frac{d\mu}{d\lambda},$$

$$\therefore \text{Length of train on emergence} = -T\lambda \frac{d\mu}{d\lambda} \dots\dots(80).$$

Consequently the number of wave-lengths after emergence is

$$-T d\mu/d\lambda,$$

agreeing with the ordinary result for the resolving power of a prism.

We conclude that the analogy of a travelling source gives a working idea of the action of a prism. A reservation might be made for regions of selective or anomalous dispersion ; on certain theories such regions might correspond to gaps in the wave system, the velocity V having imaginary or complex values as a function of κ .

CHAPTER VI

THE FLOW OF ENERGY

25. Energy and group velocity. We have hitherto ignored entirely one important aspect of group velocity, its connection with the rate of flow of energy. It is impossible to treat such questions adequately without specifying the dynamical or physical properties of the medium, but we may obtain a broad idea of the matter with the help of one or two assumptions; then we can proceed to greater detail later. In dealing with the fluctuations of a vector y , a function of x and t , assume that the density of energy at any position and time is proportional to y^2 . If the disturbance forms a simple group of advancing waves we have

$$y = \int_{\kappa_0 - \epsilon}^{\kappa_0 + \epsilon} C_{\kappa} \cos \{ \kappa (x - Vt) - a \} d\kappa,$$

with ϵ small.

Further we have seen how, under certain conditions, this is approximately equivalent to

$$y = f(x - U_0 t) \cos \{ \kappa_0 (U_0 - V_0) t \} + F(x - U_0 t) \sin \{ \kappa_0 (U_0 - V_0) t \}.$$

where we may regard the functions f and F as slowly varying amplitude factors compared with the cosine- and sine-factors. We square y and take the mean value over a time which includes many oscillations of the latter quantities without f and F altering appreciably; so we obtain

$$\text{Mean energy density} \propto \frac{1}{2} [\{f(x - U_0 t)\}^2 + \{F(x - U_0 t)\}^2] \dots (81).$$

Hence the mean energy density is a function of $x - U_0 t$, and suggests the possibility of regarding energy as being transmitted on the average with the group velocity U_0 .

Or again if we consider the initial concentrated displacement of which we have had various examples, the energy associated with each small range of wave-length is initially concentrated at the origin; at later times the same total amount appears in the neighbourhood of a point which has moved out with the corresponding group velocity and is spread out over an increasing range of the medium as time goes on.

26. Infinite regular wave-train. If we apply a similar argument to the ideal case of an absolutely regular, and therefore infinite, train of simple waves, the mean energy density is constant. On the other hand, consider the work done at any point, say the origin; for waves advancing in the positive direction, without dissipation, there must necessarily be an increase by an equal amount in the total energy on the positive side of the origin.

Hence we in fact imagine some appreciable front of the waves, though at an immense distance, advancing with some corresponding group velocity; or what is equivalent, we imagine a sink at infinity which absorbs energy at the required rate. In other words, in dealing with the infinite regular train in this matter, as in others, we think of it as a limiting case of a simple group. The connection between rate of work done at any point and the group velocity may easily be obtained by direct calculation in any specified medium with an infinite train, but in order to resolve the mental difficulty suggested we remind ourselves that we are dealing with a limiting case of a group. The same kind of difficulty is referred to by Lord Rayleigh⁽⁶⁾ in his study of energy and group velocity; he asks why the comparison of energies should introduce the consideration of variation of wave-length, and gives a proof in which the increment of wave-length is imaginary. The theorem is well-known but it illustrates this point of view so clearly that we repeat it here briefly.

Consider a dynamical medium, composed of small particles of mass m . Introduce a small frictional force hmv such that the motion which in the absence of friction would be given by $\cos(nt - \kappa x)$ is now $e^{-\mu x} \cos(nt - \kappa x)$, to first order in h . Assume that energy is proportional to square of amplitude; then the ratio of the total energy for x positive to the energy density at the origin = ratio of $\int_0^\infty e^{-2\mu x} dx$ to $1 = 1/2\mu$. Also the energy transmitted through the origin in unit time must equal the energy dissipated in unit time in the range of x positive; and the latter is equal to h times the total energy in the same range. Hence

$$\frac{\text{Energy transmitted through origin in unit time}}{\text{Energy density at origin}} = \frac{h}{2\mu}.$$

The argument is completed by noticing that the effect of introducing friction is to replace $\partial^2/\partial t^2$ in the differential equation by $\partial^2/\partial t^2 + h\partial/\partial t$; hence it is shown that, to first powers of h , μ is equal to $\frac{1}{2}hdk/dn$. Thus $h/2\mu = dn/dk = U$, the group velocity. Accordingly, in time

averages, the energy transmitted per unit time through the origin is equal to the energy in a length U of the medium. The method adopted would lose its meaning if applied directly to an infinite regular train; in fact the theorem is derived by considering what is equivalent to a simple group, a wave form with slowly varying amplitude. The infinite, regular train of waves is deduced as a limiting case.

The first direct calculation for infinite simple waves was made by Osborne Reynolds⁽⁴⁾ for waves on deep water, and a similar calculation was made for water of constant finite depth by Lord Rayleigh. The same method can be followed in any case in which the dynamical properties of the medium are known. One can calculate the average rate at which work is being done by the forces acting across any imagined plane at right angles to the direction of propagation of the waves; in every case it is found that the average work in unit time is equal to the average energy in a length U of the medium, provided there are no impressed external forces which supply or abstract energy.

27. Equation of continuity for energy. Let E be the total energy of a dynamical system. We say that the energy can be localised if we can express E in the form

$$E = \int e dV,$$

where dV is an element of volume, and e depends upon the condition of each element and may be called the density of energy at each point.

Further, consider the rate of change of energy contained within a closed surface S ; if we are able to express this in the form of a surface integral over S , that is if

$$\frac{\partial E}{\partial t} = \frac{\partial}{\partial t} \int e dV = - \int f_n dS \dots\dots\dots(82),$$

where f_n is the normal component of a vector f , then we say there is a current of energy at each point given in magnitude and direction by the vector f . The differential form of this equation is

$$\frac{\partial e}{\partial t} = - \operatorname{div} f \dots\dots\dots(83),$$

or in fact we have the ordinary equation of continuity

$$\frac{\partial e}{\partial t} + \frac{\partial f_x}{\partial x} + \frac{\partial f_y}{\partial y} + \frac{\partial f_z}{\partial z} = 0 \dots\dots\dots(84),$$

applied to energy and its flow.

Of course in both these definitions, of e and of f , there is room for ambiguity; for example we could add to any solution for f a vector

whose divergence is zero without affecting the system as a whole. However there are generally other considerations in any given case which decide the particular solutions we adopt as the real distribution of energy or the real current. In physical dimensions f/e is a velocity; hence the components of the rate of flow of energy at any point are $f_x/e, f_y/e, f_z/e$. In this manner⁽³⁸⁾ we may study generally the flow of energy in the motion of fluids or elastic solids in ordinary non-dispersive cases.

We shall consider here some simple illustrations in one-dimensional problems involving dispersion.

28. Vibrations of string with dispersion. In the first instance consider the simple elastic medium specified by a stretched string; for transverse vibrations we have

$$e = \frac{1}{2}\rho \left(\frac{\partial y}{\partial t}\right)^2 + \frac{1}{2}P \left(\frac{\partial y}{\partial x}\right)^2; \quad \rho \frac{\partial^2 y}{\partial t^2} = P \frac{\partial^2 y}{\partial x^2} \dots\dots\dots(85).$$

Hence if we consider a length of the string from x_1 to x_2 we have, omitting a step in the reduction,

$$\frac{\partial}{\partial t} \int_{x_1}^{x_2} e dx = - \int_{x_1}^{x_2} \frac{\partial}{\partial x} \left(-P \frac{\partial y}{\partial x} \frac{\partial y}{\partial t} \right) dx.$$

The rate of flow of energy along the string is given by

$$U = -P \frac{\partial y}{\partial x} \frac{\partial y}{\partial t} / e \dots\dots\dots(86).$$

The numerator, of course, expresses simply the rate of work of the tension of the string at any point. For simple harmonic waves and for mean time values we have $U = \sqrt{(P/\rho)}$.

We may obtain a dispersive medium by supposing that each element of the string is attracted to its equilibrium position by a force proportional to the displacement. Then

$$e = \frac{1}{2}\rho \left(\frac{\partial y}{\partial t}\right)^2 + \frac{1}{2}P \left(\frac{\partial y}{\partial x}\right)^2 + \frac{1}{2}hy^2 \dots\dots\dots(87),$$

and the differential equation of motion is

$$\rho \frac{\partial^2 y}{\partial t^2} = P \frac{\partial^2 y}{\partial x^2} - hy.$$

Making the same reduction we obtain

$$\frac{\partial e}{\partial t} - \frac{\partial}{\partial x} \left(P \frac{\partial y}{\partial x} \frac{\partial y}{\partial t} \right) = 0.$$

Therefore the rate of flow of energy is

$$U = -P \frac{\partial y}{\partial x} \frac{\partial y}{\partial t} / e \dots\dots\dots(88).$$

Assuming a solution $y = \cos(nt - \kappa x)$ and using the relation

$$\rho n^2 = P \kappa^2 - h,$$

we find for mean values

$$U = \kappa P / n \rho = dn / d\kappa = \text{group velocity} \dots\dots\dots(89).$$

The difference between equations (86) and (88) for the two cases is interesting. The introduction of a natural period for each particle of the string affects the density of energy but does not alter the rate at which work is done across any section. In the limit in the second case with P zero we should have no transfer of energy, each particle oscillating independently; other examples of this nature have been specified by Lord Rayleigh⁽³⁷⁾, but, as he remarks, they can hardly be regarded as examples of continuous media.

29. Sellmeier's model of dispersion. It is possibly open to question whether the previous case should not be considered as the limit of two interacting media, vibrating particles with their natural period connected by stretches of uniform string. This idea appears to be suggested in a remark by Prof. Poynting⁽⁴⁰⁾ on Sellmeier's model of dispersion, that possibly the connection between energy flow and group velocity would not hold in this case as we might regard the vibrating particles as outside the medium and so supplying energy to, or abstracting it from, the wave in its progress. However this may be in an ultimate analysis, we can work out Sellmeier's model by the present method, treating it as a single medium whose state is specified by two coordinates at each point. The Maxwell-Sellmeier model is a dynamical illustration of the interaction between matter and aether. Each atom of matter is represented by a single massive particle supported symmetrically by springs from the inner surface of a massless spherical shell. If the shell were fixed, the particle would execute simple harmonic vibrations about the centre with some natural frequency n_0 . The outer surface of the shell is in contact with, and attached to, the aether at all points. Further, an immense number of such atoms is supposed to be embedded in unit volume of the composite medium made up of atoms and aether in this manner.

Let η be the displacement of the aether at each point. Suppose that the potential energy of strain is $\frac{1}{2} E' (\partial \eta / \partial x)^2$, where E' is an elastic

constant; and further, that the kinetic energy is $\frac{1}{2}\rho(\partial\eta/\partial t)^2$, where ρ is the density of the aether. Let σ be the mass of the atomic particles in unit volume, and let $\eta + \zeta$ be the total displacement of an atomic particle at any position x at time t . From the above specification it follows that the potential energy of the atomic particles per unit volume is $\frac{1}{2}\sigma n_0^2 \zeta^2$, and their kinetic energy

$$\frac{1}{2}\sigma \left(\frac{\partial\eta}{\partial t} + \frac{\partial\zeta}{\partial t} \right)^2.$$

Thus we can write down the density e of total energy of the compound medium, and can derive therefrom the differential equations of motion; we have

$$\begin{aligned}
 e &= \frac{1}{2}\rho \left(\frac{\partial\eta}{\partial t} \right)^2 + \frac{1}{2}\sigma \left(\frac{\partial\eta}{\partial t} + \frac{\partial\zeta}{\partial t} \right)^2 + \frac{1}{2}E \left(\frac{\partial\eta}{\partial x} \right)^2 + \frac{1}{2}\sigma n_0^2 \zeta^2, \\
 \left. \begin{aligned}
 \rho \frac{\partial^2\eta}{\partial t^2} + \sigma \left(\frac{\partial^2\eta}{\partial t^2} + \frac{\partial^2\zeta}{\partial t^2} \right) &= E \frac{\partial^2\eta}{\partial x^2} \\
 \sigma \left(\frac{\partial^2\eta}{\partial t^2} + \frac{\partial^2\zeta}{\partial t^2} \right) + \sigma\rho_0^2\zeta &= 0
 \end{aligned} \right\} \dots\dots\dots(90).
 \end{aligned}$$

We obtain in this case as before

$$\frac{\partial\rho}{\partial t} - \frac{\partial}{\partial x} \left(E \frac{\partial\eta}{\partial x} \frac{\partial\eta}{\partial t} \right) = 0,$$

$$U = \text{Rate of flow of energy} = - E \frac{\partial\eta}{\partial x} \frac{\partial\eta}{\partial t} / e \dots\dots\dots(91).$$

Assuming simple harmonic solutions

$$\eta = A \cos (nt - \kappa x); \quad \zeta = B \cos (nt - \kappa x);$$

we have from the differential equations

$$n^2 A = (n_0^2 - n^2) B; \quad n^2 \rho + \frac{n^2 n_0^2 \sigma}{n_0^2 - n^2} = E \kappa^2 \dots\dots\dots(92).$$

Also the mean value of U

$$= \frac{E \kappa n A^2}{\frac{1}{2}\rho n^2 A^2 + \frac{1}{2}\sigma (A + B)^2 n^2 + \frac{1}{2}E \kappa^2 A^2 + \frac{1}{2}\sigma n_0^2 B^2}.$$

It can easily be verified that

$$\begin{aligned}
 \text{Mean velocity of energy flow} &= \frac{E \kappa}{n \left\{ \rho + \frac{\sigma n_0^4}{(n_0^2 - n^2)^2} \right\}} \\
 &= \frac{dn}{d\kappa} = \text{group velocity} \dots(93).
 \end{aligned}$$

30. Medium with general potential energy function.

Some of the cases we have examined and others may be put under a rather more general form. We divide the energy function e into two parts: a kinetic energy T of the form $\frac{1}{2}\rho (\frac{\partial y}{\partial t})^2$ and a potential energy W . In general W might be a function of y and its derivatives with respect to x and t , limited by the condition that a simple harmonic wave may be a possible state of motion. We shall simplify the statement by assuming

$$T = \frac{1}{2}\rho \left(\frac{\partial y}{\partial t}\right)^2; \quad W = \frac{1}{2}a_0 y^2 + \frac{1}{2}a_1 \left(\frac{\partial y}{\partial x}\right)^2 + \frac{1}{2}a_2 \left(\frac{\partial^2 y}{\partial x^2}\right)^2 + \dots \dots (94).$$

For a solution $y = \cos (nt - \kappa x)$, the mean values of the kinetic and potential energies are equal; hence

$$\frac{1}{2}\rho n^2 = \frac{1}{2} (a_0 + a_1 \kappa^2 + a_2 \kappa^4 + \dots) \dots \dots (95),$$

$$\frac{dn}{d\kappa} = \frac{\kappa}{\rho n} (a_1 + 2a_2 \kappa^2 + 3a_3 \kappa^3 + \dots) \dots \dots (96).$$

The differential equation of motion may be obtained from the variational equation

$$\delta \int_{t_1}^{t_2} dt \int_{x_1}^{x_2} (T - W) dx = 0 \dots \dots (97).$$

We write y' for $\frac{\partial y}{\partial x}$; carrying out the variation in the usual manner we obtain

$$\rho \frac{\partial^2 y}{\partial t^2} = - \frac{\partial W}{\partial y} + \frac{\partial}{\partial x} \frac{\partial W}{\partial y'} - \frac{\partial^2}{\partial x^2} \frac{\partial W}{\partial y''} + \dots \dots (98).$$

We have now to obtain the equation of continuity for the total energy: we have

$$\begin{aligned} \frac{\partial e}{\partial t} &= \rho \frac{\partial y}{\partial t} \frac{\partial^2 y}{\partial t^2} + \frac{\partial W}{\partial t} \\ &= \frac{\partial y}{\partial t} \left(- \frac{\partial W}{\partial y} + \frac{\partial}{\partial x} \frac{\partial W}{\partial y'} - \frac{\partial^2}{\partial x^2} \frac{\partial W}{\partial y''} + \dots \right) \\ &\quad + \frac{\partial W}{\partial y} \frac{\partial y}{\partial t} + \frac{\partial W}{\partial y'} \frac{\partial y'}{\partial t} + \frac{\partial W}{\partial y''} \frac{\partial y''}{\partial t} + \dots \\ &= \frac{\partial}{\partial x} \left(\frac{\partial W}{\partial y'} \frac{\partial y}{\partial t} \right) + \frac{\partial}{\partial x} \left(\frac{\partial W}{\partial y''} \frac{\partial y'}{\partial t} - \frac{\partial^2 W}{\partial x \partial y''} \frac{\partial y}{\partial t} \right) + \dots \dots (99). \end{aligned}$$

Hence the mean rate of flow of energy

$$\begin{aligned}
 &= \text{Mean } \frac{-\frac{\partial W}{\partial y'} \frac{\partial y}{\partial t} - \frac{\partial W}{\partial y''} \frac{\partial y'}{\partial t} + \frac{\partial^2 W}{\partial x \partial y'} \frac{\partial y}{\partial t} - \dots}{2T} \\
 &= \frac{a_1 \kappa n + a_2 \kappa^3 n + a_2 \kappa^3 n + \dots}{\rho n^2} = \frac{\kappa}{\rho n} (a_1 + 2a_2 \kappa^2 + \dots) = \frac{dn}{d\kappa} \\
 &= \text{group velocity} \dots\dots\dots(100).
 \end{aligned}$$

This example includes the first two cases and also flexural waves on a rod; the method could no doubt be extended by assuming more general forms for the energy functions T and W .

31. Electromagnetic waves. The modern idea of a current of energy received its main impetus from Poynting's theorem for electromagnetic waves. We shall state it for plane waves in free space and then consider its extension to dispersive media.

Consider plane polarised waves advancing along Ox with the electric force E along Oy and the magnetic force H along Oz , all the quantities being proportional to $\cos(pt - \kappa x)$; with the ordinary notation and rational units, the equations are

$$\frac{1}{c} \frac{\partial D}{\partial t} = - \frac{\partial H}{\partial x}, \quad \frac{1}{c} \frac{\partial B}{\partial t} = - \frac{\partial E}{\partial x} \dots\dots\dots(101);$$

together with, for free space,

$$D = E \text{ and } B = H \dots\dots\dots(102),$$

leading in this case to

$$\frac{p}{c} D = \kappa H; \quad \frac{p}{c} B = \kappa E \dots\dots\dots(103).$$

Further, the total energy ϕ is localised under the form

$$\phi = \frac{1}{2} ED + \frac{1}{2} HB \dots\dots\dots(104).$$

From the above relations the equation of continuity becomes

$$\frac{\partial e}{\partial t} = E \frac{\partial D}{\partial t} + H \frac{\partial B}{\partial t} = - \frac{\partial}{\partial x} (cEH).$$

Hence there is a flow of energy cEH in the direction of propagation of the waves, and the mean rate of flow

$$= \text{Mean } \frac{cEH}{\frac{1}{2} E^2 + \frac{1}{2} H^2} = \frac{p}{\kappa} = c.$$

Following the method of Abraham⁽⁴¹⁾, we may extend this to a more general type of medium which has dispersive properties.

The equations (101) give in general

$$E \frac{\partial D}{\partial t} + H \frac{\partial B}{\partial t} = - \frac{\partial}{\partial x} (cEH) \dots\dots\dots(105).$$

We take this to be the energy equation; so that the density of energy ϕ must be determined from

$$\frac{\partial \phi}{\partial t} = E \frac{\partial D}{\partial t} + H \frac{\partial B}{\partial t} \dots\dots\dots(106).$$

The character of the medium depends upon the relation between D and E and between B and H . Suppose that D does not depend only upon the instantaneous value of E , as in (102), but upon its derivatives with respect to the time, and similarly for B and H . Assume in fact that for a non-absorbing medium the relations can be expressed in the series

$$D = a_0 E + a_2 \frac{\partial^2 E}{\partial t^2} + \dots = \sum_0^{\infty} a_{2s} \frac{\partial^{2s} E}{\partial t^{2s}},$$

$$B = \sum_1^{\infty} b_{2s} \frac{\partial^{2s} H}{\partial t^{2s}} \dots\dots\dots(107).$$

For vibrations of frequency p we have, assuming convergency of the series,

$$D = \epsilon E = \sum_0^{\infty} (-1)^s a_{2s} p^{2s} \cdot E; \quad B = \mu H = \sum_0^{\infty} (-1)^s b_{2s} p^{2s} \cdot H.$$

Separate the energy density ϕ into two parts, and write

$$\frac{\partial \phi_1}{\partial t} = E \frac{\partial D}{\partial t} = \frac{\partial}{\partial t} \left(\frac{1}{2} ED \right) + \frac{1}{2} \left(E \frac{\partial D}{\partial t} - D \frac{\partial E}{\partial t} \right);$$

$$E \frac{\partial D}{\partial t} - D \frac{\partial E}{\partial t} = \frac{1}{2} \sum_1^{\infty} a_{2s} \left(E \frac{\partial^{2s+1} E}{\partial t^{2s+1}} - \frac{\partial E}{\partial t} \frac{\partial^{2s} E}{\partial t^{2s}} \right)$$

$$= \frac{\partial}{\partial t} \sum_1^{\infty} a_{2s} \left[\frac{1}{2} E \frac{\partial^{2s} E}{\partial t^{2s}} + \frac{1}{2} (-1)^s \left(\frac{\partial^s E}{\partial t^s} \right)^2 \right.$$

$$\left. + \sum_{r=1}^{s-1} (-1)^r \frac{\partial^r E}{\partial t^r} \frac{\partial^{2s-r} E}{\partial t^{2s-r}} \right].$$

Hence ϕ_1 is obtained in the form

$$\phi_1 = \frac{1}{2} ED + \sum_1^{\infty} a_{2s} \left[\frac{1}{2} E \frac{\partial^{2s} E}{\partial t^{2s}} + \frac{1}{2} (-1)^s \left(\frac{\partial^s E}{\partial t^s} \right)^2 \right.$$

$$\left. + \sum_{r=1}^{s-1} (-1)^r \frac{\partial^r E}{\partial t^r} \frac{\partial^{2s-r} E}{\partial t^{2s-r}} \right].$$

Taking mean values with respect to the time

$$\bar{\phi}_1 = L^2 \left[\frac{1}{4} \epsilon + \frac{1}{2} \sum_1^{\infty} (-1)^s s a_{2s} p^{2s} \right] \dots\dots\dots(108),$$

and similarly for the other part of the energy

$$\bar{\phi}_2 = M^2 \left[\frac{1}{4} \mu + \frac{1}{2} \sum_1^{\infty} (-1)^s s b_{2s} p^{2s} \right] \dots\dots\dots(109),$$

where $(E, H) = (L, M) \cos(pt - \kappa x)$.

Also the general differential equations give

$$\frac{M}{L} = \frac{p\epsilon}{\kappa c} = \frac{\kappa c}{p\mu}; \quad \kappa^2 c^2 = p^2 \epsilon \mu.$$

Therefore

$$2\kappa c^2 = \left(2p\epsilon\mu + p^2\mu \frac{d\epsilon}{dp} + p^2\epsilon \frac{d\mu}{dp} \right) \frac{dp}{d\kappa}.$$

From the definition of ϵ it can be verified that

$$\frac{d\epsilon}{dp} = 2 \sum_1^{\infty} (-1)^s s a_{2s} p^{2s-1},$$

with a similar expression for $d\mu/dp$. We substitute these in the expressions for $\bar{\phi}_1$ and $\bar{\phi}_2$. Then we obtain finally

$$\begin{aligned} \text{Mean rate of flow of energy} &= \frac{c\bar{E}\bar{H}}{\bar{\phi}_1 + \bar{\phi}_2} \\ &= \frac{\frac{1}{2} c LM}{\frac{1}{4} L^2 \left(\epsilon + p \frac{d\epsilon}{dp} \right) + \frac{1}{4} M^2 \left(\mu + p \frac{d\mu}{dp} \right)} \\ &= \frac{2\kappa c^2}{2p\epsilon\mu + p^2\mu \frac{d\epsilon}{dp} + p^2\epsilon \frac{d\mu}{dp}} = \frac{dp}{d\kappa} \\ &= \text{group velocity} \dots\dots\dots(110). \end{aligned}$$

We have accordingly the connection between energy flow and group velocity for electromagnetic waves in a medium whose dispersion formula is of the type

$$n^2 = \frac{\kappa^2 c^2}{p^2} = \text{power series in } p^2.$$

32. Electron theory and energy flow. Although, from the calculation for Sellmeier's model and the previous case, the same result may be inferred for a dispersion formula based on electronic vibrations, it is of interest to work out the relation independently.

The medium is now a compound structure made up of free aether together with N simple vibrators per unit volume; each vibrator is of mass m , carries a charge e , and can oscillate about a

position of equilibrium with a natural frequency. The equation of motion of one vibrator is

$$m\ddot{\xi} + f\xi = e(E + \frac{1}{3}Ne\xi) \dots\dots\dots(111),$$

where E is the electric force in the train of light waves, and the right-hand side of the equation gives the effective force on a vibrator. Also the electromagnetic equations are now

$$\frac{1}{c} \frac{\partial}{\partial t} (E + Ne\xi) = -\frac{\partial H}{\partial x} \dots\dots\dots(112),$$

$$\frac{1}{c} \frac{\partial H}{\partial t} = -\frac{\partial E}{\partial x} \dots\dots\dots(113).$$

Multiplying (112) by E , (113) by H , adding and then substituting for E from (111) we get the energy equation in the form

$$\frac{\partial}{\partial t} \left\{ \frac{1}{2} E^2 + \frac{1}{2} H^2 + \frac{1}{2} Nm\xi^2 + \frac{1}{2} N(f - \frac{1}{3}Ne^2)\xi^2 \right\} + \frac{\partial}{\partial x} (cEH) = 0 \dots\dots(114).$$

The density of energy is given, as we should expect, as the sum of the energy of the aethereal electromagnetic field together with the kinetic and potential energy of the vibrators; the Poynting vector retains its usual form cEH .

For plane waves we have

$$E = \sin(pt - \kappa x); \quad H = \frac{\kappa c}{p} \sin(pt - \kappa x);$$

$$\xi = \frac{e}{f - \frac{1}{3}Ne^2 - mp^2} \sin(pt - \kappa x) \dots\dots\dots(115).$$

Hence we have the dispersion formula

$$\frac{\kappa^2 c^2}{p^2} = 1 + \frac{Ne^2}{f - \frac{1}{3}Ne^2 - mp^2}.$$

Consequently

$$\frac{dp}{d\kappa} = \kappa c^2 / \left\{ p + \frac{Ne^2 p (f - \frac{1}{3}Ne^2)}{(f - \frac{1}{3}Ne^2 - mp^2)^2} \right\} \dots\dots\dots(116).$$

Finally, from the energy equation we have

$$\begin{aligned} \text{Mean rate of energy flow} &= \text{Mean} \frac{cEH}{\frac{1}{2} E^2 + \frac{1}{2} H^2 + \frac{1}{2} Nm\xi^2 + \frac{1}{2} N(f - \frac{1}{3}Ne^2)\xi^2} \\ &= \kappa c^2 / \left\{ p + \frac{Ne^2 p (f - \frac{1}{3}Ne^2)}{(f - \frac{1}{3}Ne^2 - mp^2)^2} \right\} \\ &= \frac{dp}{d\kappa} = \text{group velocity} \dots\dots\dots(117). \end{aligned}$$

33. Natural radiation. Planck's theory of natural radiation involves the effect of radiation upon a vibrator whose equation necessarily includes a term to represent damping due to the emission of energy by the vibrator; dispersion is accompanied by some degree of absorption. On this theory, Laue⁽²⁶⁾ has investigated the connection between mean intensity of natural radiation and group velocity and has shown that in general the energy is propagated with the group velocity.

Exception must be made for regions of selective absorption; but when the coefficient of absorption is large, simple group ideas are no longer applicable nor in fact are the usual statistical conventions for the mean intensity of natural radiation. Assuming that we could still operate with a simple group in such a region, we should have the possibility of negative group velocity.

Dynamical media have been devised with negative group velocity⁽¹³⁾, the variations of phase moving in the opposite direction from the flow of energy; but it is improbable that the idea has much physical bearing in the present connection.

Similar remarks apply to another suggestion regarding the spreading of a pulse in a dispersive medium. The different wave-lengths become sorted out, and when the process is fully developed we might imagine the possibility of treating them as independent wave-trains; consequently we should come into conflict with the second law of thermodynamics in its application to radiation. Even if we admit these assumptions, the difficulty is not of practical consequence, as before any such stage was reached the intensity of the wave-trains would be infinitesimal.

CHAPTER VII

PROPAGATION OF WAVE-FRONTS WITH DISCONTINUITIES

34. Non-uniform convergence and discontinuity. In interpreting the propagation of limited initial disturbances in terms of regular waves or of simple groups, there arise certain paradoxes to which attention has been called by various writers. For example, for waves on water of constant finite depth h both the wave velocity and the group velocity extend only over the finite range from zero to $\sqrt{2gh}$; yet with a limited initial disturbance the motion begins instantaneously at every point of the surface—there is no definite wave-front travelling out with finite velocity, as one might expect at first sight.

Again, to take the opposite case, a medium can be specified for which one can prove by exact methods that a discontinuity moves forward with a definite finite velocity c , while the group velocity is greater than c for all wave-lengths for which regular waves are possible.

A similar difficulty has been raised for light waves. On ordinary theories of dispersion, one has the possibility that for certain frequencies the wave velocity and group velocity may be greater than the velocity of light in free space; but on various grounds, for example from electron theory or from the theory of relativity, one cannot admit that this could be the case for an abrupt light signal, whatever the medium. Such questions can only be resolved ultimately by a fuller specification of the physical constitution of the medium; but we may remove analytical difficulties by attention to certain matters which have been tacitly ignored in the previous chapters, seeing that they did not arise in the particular examples. Such matters include the nature of the convergence of the Fourier integrals which have been used, also the character of the velocity V as a function of the wave-length.

We shall examine in some detail later two definite examples of wave-fronts in dispersive media, using the method of the Fourier

integral with a complex variable. Before doing so we may obtain suggestions in other ways as to the possibility of a travelling discontinuous wave-front.

We may draw some inferences from the connection between non-uniform convergence and discontinuity. In the first place we assume convergence for the integrals with which we deal. Of course in some of the examples in the previous chapters that is not the case, for example when the initial disturbance is infinitely intense and concentrated near the origin ; but there is not much harm done in a particular case when one is aware of the fact and can allow for it in any deductions. We assume convergence in general, and we wish to find under what conditions the function represented by the integral is discontinuous.

Consider first a continuous function $f(\kappa, x)$ of two variables x and κ , and the function $F(x)$ defined by

$$F(x) = \int_a^\infty f(\kappa, x) d\kappa \dots\dots\dots(118).$$

This integral converges uniformly in a certain range of x , say the interval (x_0, x_1) , if to every positive number ϵ however small there corresponds a number X , independent of x , in the interval considered

such that
$$\left| \int_{X'}^\infty f(\kappa, x) d\kappa \right| < \epsilon ; X' > X \dots\dots\dots(119).$$

Further, it follows that the function $F(x)$ is continuous in the same range. Conversely, if $F(x)$ is discontinuous at any value of x , the fact is expressed in the non-uniform convergence of the integral for that value.

In the Fourier integrals with which we are concerned $f(\kappa, x)$ is of the form $\phi(\kappa) \cos \kappa(x - Vt)$, where V is a function of κ . We may begin with some simple forms.

Consider
$$F(x) = \int_0^\infty \phi(\kappa) e^{i\kappa x} d\kappa \dots\dots\dots(120),$$

where $\phi(\kappa)$ is such that for large values of κ it can be expanded in a series

$$\phi(\kappa) = \frac{A_1}{\kappa} + \frac{A_2}{\kappa^2} + \dots \dots\dots(121).$$

In this case the integral is uniformly convergent everywhere except at the point $x = 0$; accordingly the function $F(x)$ is discontinuous at $x = 0$. Or to take a rather more general form

$$F(x) = \int_0^\infty \phi(\kappa) e^{i\kappa(x-a)} d\kappa \dots\dots\dots(122),$$

with the same conditions for $\phi(\kappa)$, the function $F(x)$ has a single discontinuity at the point $x = a$.

We notice also that the test of uniformity of convergence given in (119) shows that in the present example the matter depends on the behaviour of the group of terms near infinitely large values of κ , that is upon the group of terms of infinitesimal wave-lengths. Suppose that our initial disturbance is given by $F(x)$ as in (122) and that subsequently we have, considering positive waves only,

$$F(x, t) = \int_0^\infty \phi(\kappa) e^{i\kappa(x - Vt - a)} d\kappa \dots\dots\dots(123);$$

the question arises under what conditions for V would this mean a definite wave-front of discontinuity travelling forward with finite velocity. We have accordingly to examine the uniformity of convergence of the new integral.

Let the function V be such that for large values of κ we have the expansion

$$\kappa V = \kappa c + \frac{A_1}{\kappa} + \frac{A_2}{\kappa^2} + \dots\dots\dots(124),$$

where c is a finite constant; in fact the limiting value of V for κ infinite. Then we can write

$$F(x, t) = \int_0^\infty \psi(\kappa) e^{i\kappa(x - ct - a)} d\kappa \dots\dots\dots(125),$$

where
$$\psi(\kappa) = \phi(\kappa) e^{-it\left(\frac{A_1}{\kappa} + \frac{A_2}{\kappa^2} + \dots\right)} \dots\dots\dots(126).$$

The integral is now in the same form as the simpler one in (122) and $\psi(\kappa)$ satisfies the same conditions as $\phi(\kappa)$ in regard to large values of κ . Consequently we infer that the integral is non-uniformly convergent for $x - ct - a = 0$. Thus the disturbance $F(x, t)$ has a travelling discontinuity which moves out with uniform velocity c . Under the conditions we specified for V , the group velocity U has the same limiting value c for κ infinite. We conclude, from the test for non-uniform convergence and as we should expect from physical considerations, that a travelling discontinuity is associated with waves of infinitely small wave-length; such a definite wave-front moves with the group velocity for infinitely small waves and is only in evidence when that is a finite quantity.

These considerations, which are only the outlines of a theoretical discussion, may be illustrated by a few examples in which we can confirm the deduction by other methods.

For the dispersive medium of §28, a stretched string of which the particles have an independent natural period, we have

$$V = \sqrt{(c^2 + n_0^2/\kappa^2)}; \quad U = \kappa c^2 / \sqrt{(\kappa^2 c^2 + n_0^2)} \dots \dots \dots (127).$$

For κ infinite both V and U have the limiting value c ; hence a discontinuous wave-front moves with this velocity.

Similarly in the case mentioned above, with

$$V = \sqrt{(c^2 - n_0^2/\kappa^2)}; \quad U = \kappa c^2 / \sqrt{(\kappa^2 c^2 - n_0^2)} \dots \dots \dots (128);$$

the same conclusion holds good, in spite of the fact that $U > c$ for all wave-lengths for which regular waves are possible.

For flexural waves on a rod, $V = a\kappa$, $U = 2a\kappa$; both U and V become infinite with κ . No travelling wave-front is possible.

A similar inference follows in the case of water waves, where $V = \sqrt{(g/\kappa)}$ and $U = \frac{1}{2} \sqrt{(g/\kappa)}$. Here U and V are zero for κ infinite; hence if a discontinuity is possible at any point, it exists permanently at that point.

In the case of light waves we may have a dispersion formula of the type

$$\frac{\mu^2 - 1}{\mu^2 + 2} = \sum_s \frac{a_s}{p_s^2 - p^2},$$

giving an equation between V and κ ,

$$\frac{c^2 - V^2}{c^2 + 2V^2} = \sum_s \frac{a_s}{p_s^2 - \kappa^2 V^2} \dots \dots \dots (129).$$

Here again both V and U have the limiting value c for infinitely short waves. Consequently the front of an abrupt light signal is propagated in any such medium with the same velocity as in free space.

It should be noticed that we assume the relation between V and κ to hold for all values. Whether that is justifiable in any case depends upon the physical assumptions made in obtaining it; for example, the dispersion formula for light waves assumes that the wave-length is large compared with molecular distances. In fact in dealing with any medium which we regard as ultimately molecular in constitution we must examine each case on physical grounds before we can decide how far it is legitimate to treat an abrupt variation as a mathematical discontinuity. All that is suggested by the above argument is that if a discontinuity in a quantity y is allowable and if regular waves in y have a phase velocity V given as a function of wave-length, then the discontinuity travels with a velocity equal to the limiting value which V approaches for infinitely small wave-lengths, provided the latter is finite.

35. Characteristics and wave-fronts. Another analytical method of treating wave-fronts with discontinuities is connected with the theory of the characteristics of the partial differential equation of motion. An attempt to present an adequate account of this method would take us too far from our main object of study, the Fourier integral; but it may be as well to state the leading idea briefly for one or two simple cases with which we are concerned. For further information reference may be made to memoirs or treatises dealing specially with discontinuous wave-fronts and characteristics^{(60) (51)}.

Consider the differential equation which we had in § 28 for the stretched string with a dispersive property; it can be written as

$$\frac{\partial^2 y}{\partial t^2} - c^2 \frac{\partial^2 y}{\partial x^2} + n_0^2 y = 0 \dots\dots\dots(130).$$

Let there be at any instant a definite wave-front separating two possible states of motion of the string, such that y , $\partial y/\partial x$ and $\partial y/\partial t$ are continuous at the wave-front: the discontinuity being in derivatives of a higher order. Now regard for a moment y , x and t as space coordinates, and any solution of (130) as an integral surface in this space; then the statement is equivalent to postulating two integral surfaces touching along a certain curve which projects into the wave-front on the x, t plane. But from the theory of the characteristics of an equation like (130), such a curve of contact of two integral surfaces is a characteristic curve of which the projection on the x, t plane satisfies

$$dx^2 - c^2 dt^2 = 0.$$

Consequently the wave-front moves with uniform velocity c in either the positive or negative direction of Ox , and we notice that this holds independently of the dispersive property which is specified by the term $n_0^2 y$ in the equation (130).

The argument can be extended in certain cases to include wave-fronts in which the discontinuity is of the first order. In the case of (130) it is unnecessary that y , $\partial y/\partial x$, and $\partial y/\partial t$ should be each continuous at the wave-front, corresponding to Cauchy's condition in the theory of the partial differential equation; it is sufficient that two quantities, y and one of the quantities $\partial y/\partial x \pm \partial y/c\partial t$, should be continuous and the correspondence of wave-front and characteristic follows.

We cannot in general identify characteristics with wave-fronts in which the discontinuity is of the first order without falling back upon physical principles. Naturally the differential equation of the second

order may have been obtained under assumptions which are not valid when the differential coefficients of the first order are not continuous ; accordingly an independent study of such a discontinuity may be equivalent to discarding the differential equation and might lead to a different velocity of propagation, a case in point being explosion-waves in a gas.

Contrast equation (130) with one like

$$\frac{\partial^2 y}{\partial t^2} + c^2 \frac{\partial^2 y}{\partial x^2} + n_0^2 y = 0.$$

In this case the characteristic curves are imaginary, and there is no propagation of wave-fronts with definite finite velocity. A similar conclusion holds for an equation such as that for the flow of heat, in which the families of characteristics are real but coincident.

If the medium is specified by a single partial differential equation of the second order which is of hyperbolic type, having two real and different families of characteristics, we may conclude that there may be definite wave-fronts moving with finite velocity. A similar inference can be drawn in certain cases for equations of higher order and for systems of equations.

36. Riemann's method applied to dispersive string.

Before leaving the theory of characteristics, we may apply Riemann's method to obtain an exact solution of the differential equation (130) under given initial conditions. In the equation, y represents the transverse displacement of a string stretched along Ox at constant tension and such that every point is attracted to its position of equilibrium by a force proportional to its displacement.

Simplify the equation by writing x for cx/n_0 and t for t/n_0 ; then we have

$$\frac{\partial^2 y}{\partial x^2} - \frac{\partial^2 y}{\partial t^2} - y = 0 \dots\dots\dots(131).$$

With $x - t = \xi$; $x + t = \eta$

the equation reduces to the standard form

$$\frac{\partial^2 y}{\partial \xi \partial \eta} - y = 0 \dots\dots\dots(132),$$

in which the characteristics are lines parallel to the axes of ξ and η .

To apply Riemann's method we suppose the values of $y, \partial y/\partial \xi, \partial y/\partial \eta$ to be given at points of a curve G in the plane of $\xi\eta$. If P is the point, in the same plane, at which we require the value of z , we draw through P two characteristics, parallel in this case to the axes of ξ and η ;

then the value of z at P is expressed in terms of the initial data upon the part of the curve G cut off between the two characteristics. In the particular problem for the original equation in x and t we should assume initial data of the form

$$z = f(x); \quad \frac{\partial z}{\partial t} = F(x); \quad \text{for } t = 0 \dots \dots \dots (133).$$

In the new coordinates, this would be equivalent to data along the line

$$\xi - \eta = 0.$$

In particular, suppose we have an initial disturbance which is limited in range, so that $f(x)$ and $F(x)$ are zero outside this range; then the data in ξ, η would be given along a finite range $\alpha\beta$ of the bisector of the angle between $O\xi$ and $O\eta$.

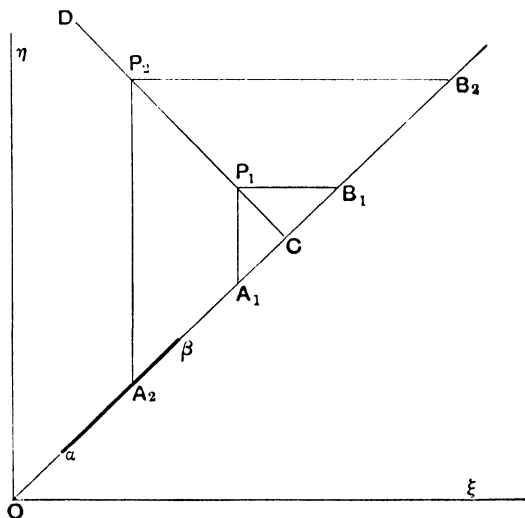

Fig. 22.

Consider the sequence of events at an assigned position x , outside the original disturbance; as time goes on, t ranging from 0 to ∞ , the corresponding point P moves along a line such as CD at right angles to OC . At a time when P is at a position like P_1 , the range A_1B_1 cut out by the characteristics through P_1 includes nothing from $\alpha\beta$; accordingly the value of z is zero at such a time. It is easy to see that z remains zero until a certain instant at which the disturbance begins definitely; the instant is determined by the time taken for a discontinuous wave-front to travel from the nearest point of the

original limited disturbance. We may note incidentally that there is no definite rear to the disturbance.

It is unnecessary to work through the details of the exact solution of (130) under the initial conditions given in (133); the equation is similar to one which has been studied in connection with damped electric vibrations, known as the telegraphists' equation, and in fact only differs from it by the coefficient of z in the last term being positive instead of negative.

An exact solution can be obtained in the form

$$z = \frac{1}{2}f(x-t) + \frac{1}{2}f(x+t) + \frac{1}{2}t \int_{x-t}^{x+t} \frac{1}{p} J_0'(p) f(q) dq + \frac{1}{2} \int_{x-t}^{x+t} J_0(p) F(q) dq,$$

where $p = \sqrt{t^2 - (x-q)^2}$ (134).

In particular, put $f(x) = 0$, and $F(x) = \pi/\epsilon$ in the range $-\epsilon < x < \epsilon$ and zero outside it; then proceed to the limit with ϵ small. We obtain an intense distribution of initial velocity concentrated at the origin, and the motion at any subsequent time, for x and t positive, is given by

$$z = 0; \text{ for } t < x, \\ z = \pi J_0(\sqrt{t^2 - x^2}); \text{ for } t > x \text{(135).}$$

We can compare this solution with the approximate evaluation by group methods applied to a Fourier integral. Before doing so, it is of interest to obtain it in any other way by using a Fourier integral with complex variable.

37. Localised impulse on dispersive string. We begin by stating the problem in real variables. The differential equation for transverse vibrations of the string is

$$\frac{\partial^2 z}{\partial x^2} - \frac{\partial^2 z}{\partial t^2} - z = 0 \text{(136).}$$

If initially we have a simple harmonic distribution of velocity, so that

$$z = 0; \quad \frac{\partial z}{\partial t} = \cos \kappa x; \quad t = 0 \text{(137),}$$

the subsequent motion is given by

$$z = \frac{\sin(t\sqrt{\kappa^2 + 1}) \cos \kappa x}{\sqrt{\kappa^2 + 1}} \text{(138).}$$

For an initial distribution of velocity $F'(x)$ we can generalise by Fourier's theorem; finally if the distribution is intense and concentrated at the origin we have as before

$$z = 2 \int_0^\infty \sin(t \sqrt{\kappa^2 + 1}) \cos \kappa x \frac{d\kappa}{\sqrt{\kappa^2 + 1}}$$

$$= \int_0^\infty e^{i(\kappa x + t \sqrt{\kappa^2 + 1})} \frac{d\kappa}{i \sqrt{\kappa^2 + 1}} - \int_0^\infty e^{i(\kappa x - t \sqrt{\kappa^2 + 1})} \frac{d\kappa}{i \sqrt{\kappa^2 + 1}} \dots (139).$$

Each of these integrals comes under the class discussed in § 34.

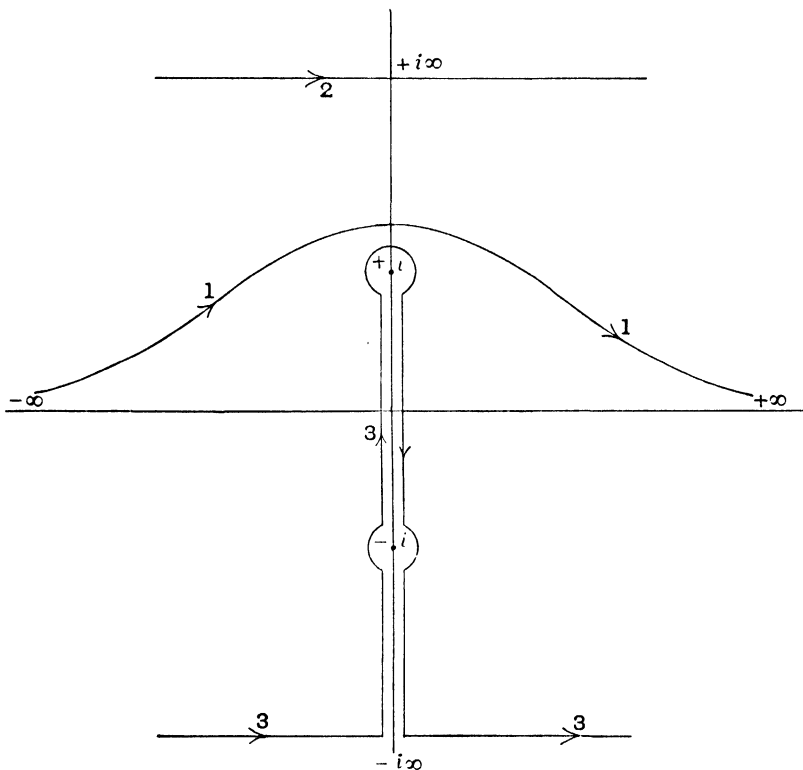

Fig. 23.

For κ large we can write

$$e^{i(\kappa x + t \sqrt{\kappa^2 + 1})} = e^{i\kappa(x+t)} \phi(\kappa),$$

where $\phi(\kappa)$ is a power series in $1/\kappa$. It follows that discontinuities occur at the places given by

$$x + t = 0 \text{ and } x - t = 0.$$

These places travel out from the origin with unit velocity, which in this case is the limiting value of the group velocity for infinitely short waves.

We may evaluate the above integrals by taking them along suitable paths in the plane of κ considered as a complex variable. Take the second integral, in the form

$$I_2 = \int_{-\infty}^{+\infty} e^{i(\kappa x - t\sqrt{\kappa^2+1})} \frac{d\kappa}{2i\sqrt{\kappa^2+1}} \dots\dots\dots(140).$$

The integrand has singularities at the points $\pm i$. Consider the integral along a path such as (1) in Fig. 23, and confine our attention to positive values of x . When $t = 0$, I_2 is zero; for we can transform the path (1) into a path (2) at $+\infty$, in which case the exponential in I_2 has a real negative exponent.

When t is positive and such that $x - t > 0$, the same conclusion follows; the integral along the path (2) is zero as long as $t < x$.

But when $x - t < 0$, the exponential has a real positive exponent along the path (2), so deformation of the path in that way is of no assistance in evaluating the integral. In this case we deform the

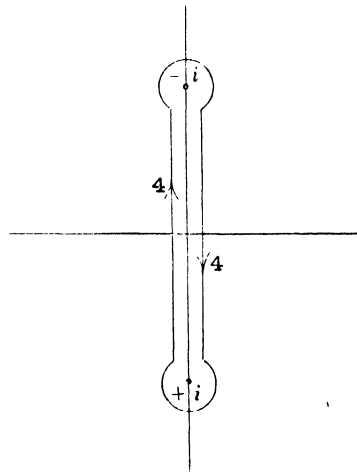

Fig. 24.

path into the form (3), where we can say that the integral along the part of the path at $-\infty$ is zero. We are in fact left with the integral I_2 taken round the path (4) or any equivalent path enclosing the two points $\pm i$.

If we write $\xi = ix$; $\tau = it$; $q = i\kappa$;

we have
$$I_2 = \int e^{i(qt - \tau\sqrt{q^2 - 1})} \frac{dq}{2i\sqrt{q^2 - 1}} \dots\dots\dots(141),$$

where the integral is taken round a contour enclosing the singular points, which are now at ± 1 . This integral can be evaluated in terms of Bessel functions and is in fact equal to $-\pi K_0(\sqrt{t^2 - x^2})$; accordingly we have

$$I_2 = \int_{-\infty}^{\infty} e^{i(\kappa x - t\sqrt{\kappa^2 + 1})} \frac{d\kappa}{2i\sqrt{\kappa^2 + 1}} = -\pi J_0(\sqrt{t^2 - x^2}), \text{ for } t - x > 0$$

$$= 0, \text{ for } t - x < 0 \dots\dots(142).$$

Similar conclusions hold in regard to the first integral in (139); in particular, for x and t positive the first integral is zero. The final result is given for x and t positive by

$$z = 0, \text{ for } t < x$$

$$= \pi J_0(\sqrt{t^2 - x^2}), \text{ for } t > x \dots\dots\dots(143).$$

This indicates a disturbance moving out from the origin, having a definite front moving with unit velocity.

The diagram in Fig. 25 shows the disturbance at a particular instant, namely $t = 50$, graphed from the above formula. It is interesting to notice how the form bears out the general ideas of group propagation. As t is increased, the number of zeros in a small range of x behind the wave-front rapidly increases, indicating a greater predominance of smaller wave-lengths at the front as time goes on. To make a numerical comparison, we apply the Kelvin group method to this example.

From (139) we have

$$z = \int_0^{\infty} \sin(\kappa x + t\sqrt{\kappa^2 + 1}) \frac{d\kappa}{\sqrt{\kappa^2 + 1}}$$

$$- \int_0^{\infty} \sin(\kappa x - t\sqrt{\kappa^2 + 1}) \frac{d\kappa}{\sqrt{\kappa^2 + 1}} \dots\dots(144).$$

For x and t positive a predominant group occurs in the second integral for κ given by

$$\frac{x}{t} = U = \frac{\kappa}{\sqrt{\kappa^2 + 1}}.$$

In this case the result is consistent with the exact solution, for $\kappa/\sqrt{\kappa^2 + 1}$ is less than 1 for all positive values of κ ; hence the predominant group occurs at places and times for which $x < t$, that is, it

occurs behind the wave-front. The value of the group is given by

$$z = - \left\{ \frac{2\pi}{t dU/dk} \right\}^{\frac{1}{2}} \phi(\kappa) \sin \left\{ \kappa(x - Vt) - \frac{\pi}{4} \right\} \dots\dots\dots(145).$$

Using the value of κ given above, this reduces to

$$z = \frac{(2\pi)^{\frac{1}{2}}}{(t^2 - x^2)^{\frac{1}{4}}} \cos \left(\frac{\pi}{4} - \sqrt{t^2 - x^2} \right) \dots\dots\dots(146).$$

This agrees precisely with the asymptotic value of $\pi J_0(\sqrt{t^2 - x^2})$, being the first term in the semi-convergent expansion of the Bessel function for large arguments. The comparison between the group value (146) and the exact result (143) can easily be made in this case. For any considerable value of t the agreement is in fact very close up to fairly small distances from the wave-front, the differences becoming less further behind the front. For example, the first two zeros behind the wave-front occur at x equal to 49.942 and 49.694, while the group formula gives the values 49.945 and 49.697 respectively; later zeros agree more closely. Similar results hold if we calculate any actual value of z from the two formulæ. In fact in the graph for t equal to 50 which is shown in Fig. 25 there would be no appreciable difference until practically at the wave-front. Of course for the state of affairs actually at the wave-front we should have to retrace our steps and reconsider the assumptions made in regard to the initial distribution of velocity. It was supposed to be concentrated practically at the origin. In order to study more carefully the disturbance at $x = t$ it would be advisable to start from some continuous initial disturbance of finite though small range, and then if necessary consider the limiting value of the exact solutions.

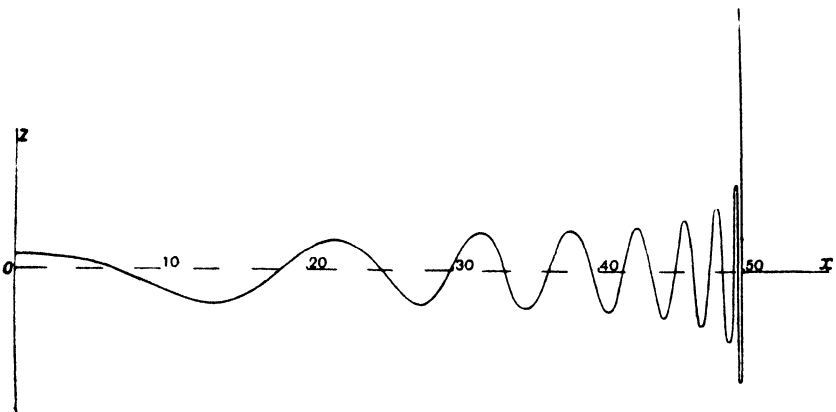

Fig. 25.

In the case of pulses of light, even using the simplest type of dispersion formulæ, mathematical solutions become extremely complicated. One might investigate various problems for the dynamical medium of the previous section with more chance of success; exact solutions can be written down in the form (134) as integrals involving Bessel functions, though they would probably have to be evaluated by approximate methods. By considering an infinite string of which one-half is dispersive and the other a simple non-dispersive string, one might illustrate the reflection and transmission of pulses of varying types or of a finite train of regular waves; or one might examine the proportion of energy which persists near the front of the pulse in various cases.

38. Medium with group velocity greater than velocity of wave-front. Returning to the concentrated initial distribution of velocity at the origin we consider a medium suggested by Ehrenfest as a case in which the group method fails. The medium may be specified as a string under constant tension and with each element repelled transversely by a force proportional to the transverse displacement; accordingly the differential equation is of the form

$$\frac{\partial^2 z}{\partial x^2} - \frac{\partial^2 z}{\partial t^2} + z = 0 \dots\dots\dots(147).$$

It must be noticed in the first place that the string is in unstable equilibrium in its position of rest. However if we assume an infinite regular wave $\cos \kappa(x - Vt)$ as a possible solution, V is real if $\kappa > 1$; for we have

$$V = \frac{\sqrt{\kappa^2 - 1}}{\kappa}; \quad U = \frac{\kappa}{\sqrt{\kappa^2 - 1}} \dots\dots\dots(148).$$

As we have seen previously in § 34 or by the method of § 35, a definite wave-front moves in this medium with unit velocity; while the group velocity is greater than unity for all values of κ for which regular waves are possible.

If $\kappa < 1$, the corresponding form of solution is

$$e^{\pm t\sqrt{1-\kappa^2}} \cos \kappa x \dots\dots\dots(149),$$

which does not represent a wave propagation in the ordinary use of the term.

If we attempt to build up in the Fourier method a solution corresponding to an arbitrary initial form, the Fourier integral breaks up into two parts, one representing regular waves and the other part

non-waves. To revert to the original example of the Kelvin method, consider the integral

$$z = \frac{1}{2\pi} \int_0^\infty \cos \kappa (x - Vt) d\kappa \dots\dots\dots(150).$$

In the group evaluation of this integral it was assumed that V was a function of κ having a real value for all values of κ ; consequently the terms oscillate and cancel each other out on the average except for certain predominant groups for which the phase is stationary. But clearly this method fails to take account of any range of κ for which V is imaginary; in cases where this occurs the group method only gives an approximation for the parts of the integral which represent ordinary wave propagation, and the other parts must be evaluated separately.

For the present case we may illustrate by the same problem as in the previous section. Let the displacement be zero initially, and let there be an intense concentrated distribution of velocity. Then we obtain the solution z as a Fourier integral in a complex variable κ in the form

$$z = \int_{-\infty}^\infty e^{i(\kappa x + t\sqrt{\kappa^2 - 1})} \frac{d\kappa}{2i\sqrt{\kappa^2 - 1}} - \int_{-\infty}^\infty e^{i(\kappa x - t\sqrt{\kappa^2 - 1})} \frac{d\kappa}{2i\sqrt{\kappa^2 - 1}} \dots(151).$$

These integrals are of the same form as those of the previous section; they can be evaluated by contour integration in a similar manner, and the final result is

$$z = 0, \quad \text{for } t < x \\ = \pi K_0(\sqrt{t^2 - x^2}) = \pi J_0(i\sqrt{t^2 - x^2}), \quad \text{for } t > x \dots\dots(152).$$

If we graph this solution we have an abrupt front to the wave followed by a steadily and rapidly increasing displacement, without any oscillation; the result is in direct contrast with that of the previous example, and it agrees with the fact that the medium is not stable.

Compare this with the group method. As we have seen, this method gives an approximate value of the part of the integral which represents regular waves, in this case, for positive x ,

$$- \int_1^\infty \sin(\kappa x - t\sqrt{\kappa^2 - 1}) \frac{d\kappa}{\sqrt{\kappa^2 - 1}} \dots\dots\dots(153).$$

The predominant group is given by

$$\frac{x}{t} = U = \frac{\kappa}{\sqrt{\kappa^2 - 1}}.$$

But since $U > 1$, the predominant group occurs at places and times for which $x > t$, that is, in advance of the definite travelling front of the disturbance. Further if we apply the group formula in the usual manner, we have as the contribution of the regular waves in the region $x > t$,

$$\frac{(2\pi)^{\frac{1}{2}}}{(x^2 - t^2)^{\frac{1}{4}}} \cos\left(\frac{\pi}{4} - \sqrt{x^2 - t^2}\right) \dots\dots\dots(154),$$

which is the asymptotic value of $\pi J_0 \sqrt{x^2 - t^2}$, or of $\pi K_0 \sqrt{t^2 - x^2}$, for $x > t$ and $x - t$ large.

If we attempt to separate the complex integrals in (151) into two parts representing waves and non-waves, as in the diagram, we have difficulty in the region of the points ± 1 ; or in other words we cannot

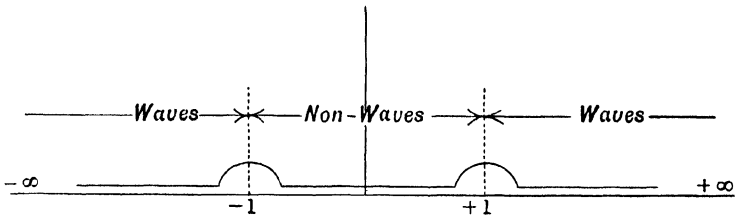

Fig. 26.

distinguish between the two cases : a regular wave in which the phase is transmitted with infinitely large velocity, and a non-wave in which the phase appears established everywhere at once. In any case, since the total integral is zero in advance of the wave-front, the part due to the regular waves must exactly equal, and be of opposite sign from, that due to the non-waves. One could then retain the idea of groups of waves in this case by such considerations : the non-waves represent a disturbance with phase established instantaneously, while the regular waves form groups in advance of the position $x = t$ of such a value as to cancel exactly the part due at such places to the non-waves, the result being a definite wave-front leaving the disturbance behind as it advances. Such would be a possible statement for the present problem ; whether it would apply for similar cases in other media is unresolved. The question arises how far such considerations affect the utility of the group method, for example in light waves. In this respect it should be noticed that the medium studied above is very exceptional in that $U > c$ for all wave-lengths possible, while on usual theories of dispersion this would be the case only for narrow regions of selective absorption ; it would be a matter for investigation whether these regions were of importance in the Fourier integral for any given case.

39. Light signal: interrupted source of light waves.

In the simple dynamical media which we have considered above, the vibrations being in a coordinate y , the problem is determinate if we are given the values of y and $\partial y/\partial t$ initially for all values of x . The matter is more complex for electromagnetic waves in a dispersive medium; for example, for the simplest type of dispersion formula with one natural frequency, there may be two values of V for any assigned wave-length; the two values correspond to different frequencies. As we saw when dealing with the flow of energy, the state at any point, say the electrical displacement, does not depend only on the actual electric force at that point but also on its time derivatives. However there is a single value of V for any assigned frequency; accordingly one can deal with problems which involve a Fourier analysis into frequencies. Such problems occur when the disturbance is given as a definite function of the time at some assigned position; in other words we deal with the effects of a localised source whose magnitude varies with the time in an assigned manner.

Sommerfeld⁽⁶⁴⁾ has discussed recently the propagation of a light signal in a dispersive medium from this point of view, and we give a short account of his method.

Suppose the disturbance to be given at the origin $x=0$ by a function $f(t)$ defined by

$$f(t) = 0, \text{ for } t < 0 \text{ and for } t > T$$

$$= \sin \frac{2\pi t}{\tau}, \text{ for } 0 < t < T \dots\dots\dots(155);$$

where the time T includes a complete number of periods τ .

We could represent $f(t)$ by a Fourier integral ranging over all possible frequencies. We can also think of the disturbance as a semi-infinite regular vibration beginning at $t=0$ on which is superposed another semi-infinite vibration of opposite phase beginning at $t=T$ so as to cancel out the effect for $t > T$. Using the complex form of the Fourier integral we can then represent one such semi-infinite vibration at the origin by

$$z = f(t) = \frac{1}{\tau} \int e^{-i p t} \frac{d p}{p^2 - (2\pi/\tau)^2} \dots\dots\dots(156).$$

At any position x in the dispersive medium we shall have

$$z = f(t, x) = \frac{1}{\tau} \int e^{-i(p t - \kappa x)} \frac{d p}{p^2 - (2\pi/\tau)^2} \dots\dots\dots(157),$$

where the medium is supposed to have a dispersion formula

$$\kappa^2 = \frac{p^2}{c^2} \left(1 + \frac{a^2}{p_0^2 - 2ip\rho - p^2} \right) \dots\dots\dots(158).$$

The integral is to be taken along any path such as *u* in Fig. 27. This path can be deformed in the manner of the simpler examples in the previous sections.

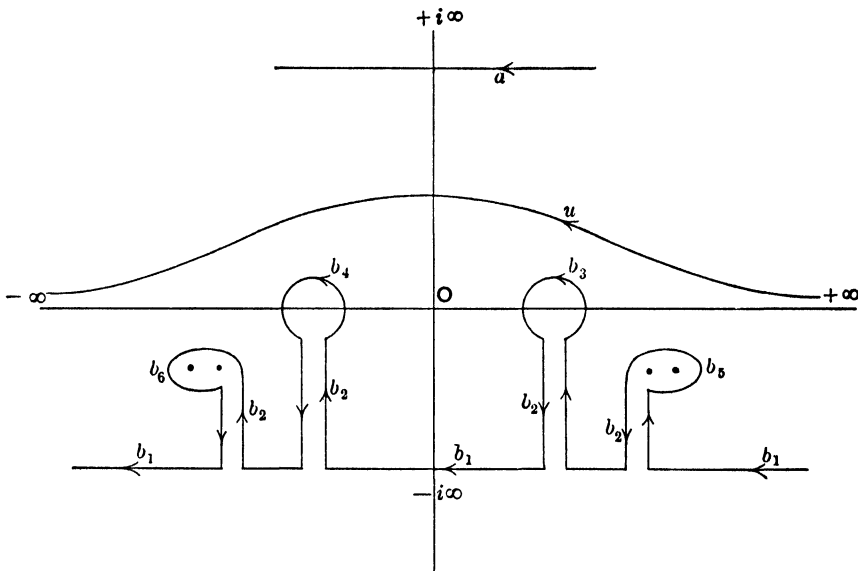

Fig. 27.

When $ct < x$, the path *u* can be deformed into the path *a* entirely at $+i\infty$, for which the integral is zero.

When $ct > x$, the path is deformed into the path *b*. Of this path, b_1 is at $-i\infty$ and contributes zero, and the parts b_2 also have zero value on the whole. The circuits b_3 and b_4 are round the singular points $p = \pm 2\pi/\tau$; while b_5 and b_6 enclose the branch points

$$-i\rho \pm \sqrt{p_0^2 - \rho^2} \text{ and } -i\rho \pm \sqrt{p_0^2 + a^2 - \rho^2}.$$

The integrals round b_3 and b_4 are calculated in the form

$$e^{-2n\kappa x/\lambda} \sin 2\pi \left(\frac{t}{\tau} - \frac{x}{\lambda} \right) \dots\dots\dots(159),$$

representing a forced wave of the frequency of the source and with suitable wave-length and extinction-coefficient.

The integrals b_0 and b_1 are not evaluated. They represent the free natural vibrations of the vibrating particles in the medium. Their value at $x = ct$ is such that the total disturbance is zero there. In advance of the position ct at any time there is no disturbance, so we have a definite wave-front.

Sommerfeld discusses also the uniqueness of the solution, the spectrum of the disturbance and its connection with group methods, and also obtains an approximate expression for the immediate rear of the wave-front when the coefficient of absorption is negligible. Even when the simplest type of dispersion formula is assumed, it appears that the integrals involved are too complicated for exact evaluation; as was suggested in a previous section one might obtain analogous results of interest by applying similar methods to a dynamical medium of simpler specification*.

* Mention may be made here of work which has been published while this Tract has been in the Press. A very interesting extension of Sommerfeld's analysis has been made by Brillouin⁽⁵⁵⁾, who uses contour integrations and a method of approximation which forms a generalisation of the group method. Some further references for this method have been added to the Bibliography⁽⁵⁶⁾, ⁽⁵⁷⁾. Energy distribution and the action of a prism on white light have been discussed by Green⁽⁵⁸⁾ and by Houston⁽⁵⁹⁾, ⁽⁶⁰⁾.

BIBLIOGRAPHY

1. Sir W. R. HAMILTON. Researches respecting vibration, connected with the theory of light. *Proc. Roy. Irish Acad.*, Vol. I. p. 267 and p. 341. 1839.
2. J. SCOTT RUSSELL. Report on Waves. *Brit. Association Reports*, p. 369. 1844.
3. Sir G. G. STOKES. Smith's Prize Examination, Cambridge. 1876.
4. O. REYNOLDS. On the rate of progression of groups of waves, etc. *Nature*, xvi. p. 343. 1877.
5. Lord RAYLEIGH. On progressive Waves. *Proc. Lond. Math. Soc.* ix. p. 21. 1877.
6. — On the velocity of light. *Nature*, xxiv. p. 382; xxv. p. 52. 1881.
7. — Aberration in a dispersive medium. *Phil. Mag.* xxi. p. 130. 1911.
8. M. GOUY. Sur la théorie des miroirs tournants. *Comptes Rendus*, ci. p. 502. 1885.
9. — Sur la vitesse de la lumière. *Ann. de Chim. et de Phys.*, xvi. p. 262. 1889.
10. A. SCHUSTER. On the velocity of light as determined by Foucault's revolving mirror. *Nature*, xxxiii. p. 439. 1886.
11. J. WILLARD GIBBS. On the velocity of light, etc. *Nature*, xxxiii. p. 582. 1886.
12. H. LAMB. Geometrical representation of the relation between Wave-velocity and Group-velocity. *Manchester Memoirs*, xliv. 1900.
13. — On group velocity. *Proc. Lond. Math. Soc.*, I. p. 473. 1904.
14. Sir J. LARMOR. On the dynamical significance of Kundt's law of selective dispersion, in connection with the transmission of the energy of trains of dispersive waves. *Proc. Camb. Phil. Soc.*, xiii. p. 21. 1904.
15. M. CANTOR. Zur Bestimmung der Lichtgeschwindigkeit nach Fizeau. *Ann. der Phys.*, xxiv. p. 439. 1907.
16. P. EHRENFEST. Misst der Aberrationswinkel im Fall einer Dispersion des Aethers die Wellengeschwindigkeit? *Ann. der Phys.*, xxxiii. p. 571. 1910.
17. C. GUTTON. Expériences sur la vitesse de la lumière dans les milieux réfringents. *Journ. de Phys.*, II. p. 196. 1912.

18. Lord KELVIN. On the waves produced by a single impulse in water of any depth, or in a dispersive medium. *Proc. Roy. Soc.*, XLII. p. 80. 1887.
19. ——— Deep sea Ship-Waves. *Phil. Mag.*, XI. p. 1. 1906.
20. ——— Initiation of deep sea waves. *Phil. Mag.*, XIII. p. 1. 1907.
21. H. LAMB. On deep-water waves. *Proc. Lond. Math. Soc.*, II. p. 371. 1904.
22. ——— On Wave-trains due to a single impulse. *Proc. Inter. Congress of Math.*, II. p. 279. 1912.
23. W. BURNSIDE. On deep-water waves resulting from a limited original disturbance. *Proc. Lond. Math. Soc.*, XX. p. 22. 1888.
24. H. BURKHARDT. Die Untersuchungen von Cauchy und Poisson über Wasserwellen. *Sitzungsber. Akad. Wiss. München*, p. 97. 1912.
25. A. SCHUSTER. On group velocity. *Boltzmann Festschrift*, p. 569. 1904.
26. A. LAUE. Die Fortpflanzung der Strahlung in dispergierenden und absorbierenden Medien. *Ann. der Phys.*, XVIII. p. 523. 1905.
27. T. H. HAVELOCK. The propagation of groups of waves in dispersive media. *Proc. Roy. Soc.*, A, LXXXI. p. 398. 1908.
28. G. GREEN. On group velocity and the propagation of waves in a dispersive medium. *Proc. Roy. Soc. Edin.*, XXIX. p. 445. 1909.
29. ——— Waves in a dispersive medium, resulting from a limited initial disturbance. *Proc. Roy. Soc. Edin.*, XXX. p. 242. 1909.
30. A. SCHUSTER. Interference Phenomena. *Phil. Mag.*, XXXVII. p. 509. 1894.
31. ——— On Talbot's Bands. *Phil. Mag.*, VII. p. 1. 1904.
32. J. S. AMES. Analysis of white light by a prism. *Astrophys. Journ.*, XXII. p. 67. 1905.
33. Sir J. LARMOR. On the constitution of natural radiation. *Phil. Mag.*, X. p. 574. 1905.
34. Lord RAYLEIGH. The origin of the prismatic colours. *Phil. Mag.*, X. p. 401. 1905.
35. ——— On the constitution of natural radiation. *Phil. Mag.*, XI. p. 123. 1906.
36. G. GREEN. Illustration of the Modus Operandi of the Prism. *Proc. Roy. Soc. Edin.*, XXXI. p. 290. 1911.
37. Lord RAYLEIGH. On iso-periodic systems. *Phil. Mag.*, XLVI. p. 567. 1898.
38. W. WIEN. Ueber den Begriff der Localisirung der Energie. *Ann. der Phys.*, XLV. p. 685. 1892.
39. G. MIE. Entwurf einer allgemeiner Theorie der Energieübertragung. *Sitzungsber. K. Akad. Wien*, CVII. II A, p. 1113. 1898.
40. J. H. POYNTING. The wave-motion of a revolving shaft. *Proc. Roy. Soc.*, A, LXXXII. p. 560. 1909.
41. M. ABRAHAM. Sulla velocità di gruppo in un mezzo dispersivo. *Nuovo Cimento*, I. p. 443. 1911.

42. O. FERRARI. Flusso di energia e velocità di gruppo. *Rendiconti R. Accad. Lincei*, xxii. p. 761. 1913.
43. Lord RAYLEIGH. On the instantaneous propagation of disturbance in a dispersive medium, etc. *Phil. Mag.*, xviii. p. 1. 1909.
44. T. H. HAVELOCK. On the instantaneous propagation of disturbance in a dispersive medium. *Phil. Mag.*, xix. p. 160. 1910.
45. F. B. PIDDUCK. On the propagation of a disturbance in a fluid under gravity. *Proc. Roy. Soc., A*, lxxxiii. p. 347. 1910.
46. — The wave-problem of Cauchy and Poisson for finite depth and slightly compressible fluid. *Proc. Roy. Soc., A*, lxxxvi. p. 396. 1912.
47. W. VOIGT. Ueber die Aenderung der Schwingungsform des Lichtes. *Ann. der Phys.*, lxviii. p. 598. 1899.
48. — Weiteres zur Aenderung der Schwingungsform. *Ann. der Phys.*, iv. p. 209. 1901.
49. H. POINCARÉ. Sur la propagation de l'électricité. *Comptes Rendus*, cxvii. p. 1027. 1893.
50. J. HADAMARD. Leçons sur la propagation des Ondes. Paris. 1903.
51. R. D'ADHÉMAR. Les équations aux dérivées partielles à caractéristiques réelles. *Scientia*. 1907.
52. E. PICARD. Sur l'équation aux dérivées partielles qui se rencontre dans la théorie de la propagation de l'électricité. *Comptes Rendus*, cxviii. p. 16. 1894.
53. J. BOUSSINESQ. Intégration de l'équation du son, etc. *Comptes Rendus*, cxviii. p. 162. 1894.
54. A. SOMMERFELD. Über die Fortpflanzung des Lichtes in dispergierenden Medien. *Weber Festschrift*, p. 338. 1912. Also *Ann. der Phys.* xliv. p. 177. 1914.
55. L. BRILLOUIN. Über die Fortpflanzung des Lichtes in dispergierenden Medien. *Ann. der Phys.*, xliv. p. 203. 1914.
56. B. RIEMANN. Sullo svolgimento del quoziente di due serie ipergeometriche in frazione continua infinita. *Math. Werke*, p. 400. 1863.
57. P. DEBYE. Näherungsformeln für die Zylinderfunktionen. *Math. Ann.*, lxvii. p. 535. 1908.
58. G. GREEN. Some views on Lord Kelvin's work. *Science Progress*, viii. p. 419. 1913.
59. R. A. HOUSTON. The mathematical representation of a light pulse. *Proc. Roy. Soc., A*, lxxxix. p. 399. 1913.
60. — The dispersion of a light pulse by a prism. *Proc. Roy. Soc., A*, xc. p. 298. 1914.

Cambridge:

PRINTED BY JOHN CLAY, M.A.

AT THE UNIVERSITY PRESS.

