

**TEXT FLY WITHIN  
THE BOOK ONLY**

UNIVERSAL  
LIBRARY

**OU\_160055**

UNIVERSAL  
LIBRARY



**OSMANIA UNIVERSITY LIBRARY**

Call No. *537.52 // 836* Accession No. *9187*

Author *Franklin, W.*

Title *Electric Wave*

This book should be returned on or before the date last marked below.

---



# ELECTRIC WAVES



# ELECTRIC WAVES

AN ADVANCED TREATISE ON  
ALTERNATING-CURRENT THEORY

BY

WILLIAM SUDDARDS FRANKLIN

PROFESSOR OF PHYSICS IN LEHIGH UNIVERSITY

COPYRIGHT 1909

By THE MACMILLAN COMPANY

---

Set up and electrotyped. Published October, 1909

PRESS OF  
THE NEW ERA PRINTING COMPANY  
LANCASTER, PA

## PREFACE.

In a recent treatise on Optics is the statement that "any effect which is periodic and which is propagated at a finite velocity is wave motion." One can understand how entirely meaningless this statement is if one considers the Gatling gun, the effects of which are periodic and propagated at a finite velocity. In fact, periodicity is a thing which exists only in bounded systems (oscillating systems) and which sometimes escapes into space; periodicity is by no means an essential feature of wave motion. Indeed, in many cases, it is impossible to assign a definite velocity to wave motion, as every one knows who is familiar with the distinction between what is called group velocity and wave velocity, and as any one can understand from the discussion of wave distortion in Art. 9. In the mathematical formulation of wave motion, however, periodic functions must be employed if one is to make use of Fourier's series or of Fourier's integral *for the calculation of actual numerical results in any given case*,\* and it is on account of this mathematical necessity that the idea of periodicity has come to dominate all modern theories of wave motion.

\* Chapter V includes a discussion of wave motion on a transmission line when the applied electromotive force is harmonic, wire resistance and line leakage being not ignored. *When the applied electromotive force is periodic but not harmonic, Fourier's series must be used for actual numerical calculations.*

Chapter IV includes a discussion of a simple form of wave pulse on a transmission line, wire resistance and line leakage being ignored. A wave pulse may be defined in general as the wave motion produced by a non-periodic applied electromotive force, and *when the applied electromotive force is not periodic, Fourier's integral must be used for actual numerical calculations*, wire resistance and line leakage being not ignored.

It is perhaps needless to say that no existing engineering problem (considering the available data) warrants the complete development in an applied-science text of Fourier's methods for the calculation of numerical results. These methods are, however, at the present time fully developed and available for the engineer who wishes to use them. The best treatise on Fourier's methods and on the closely related methods of calculation in three dimensions by means of spherical and cylindrical harmonics, is Byerly's *Fourier's Series and Spherical Harmonics*, Ginn & Co., 1893.

The object of this treatise is to develop the physical or conceptual aspects of wave motion, and it has seemed advisable to refer the student to other treatises for the more elaborate mathematical developments. This treatise is, however, complete as far as it goes, both mathematically and physically, although it has been put together rapidly and pushed through the press with all possible speed for the sake of a small group of students in the 1909 Summer School at Columbia University.

This treatise is intended as an advanced course in alternating-current theory. Chapters I to VI treat of electric waves with special reference to the phenomena of transmission lines and telephone lines, and Chapters VIII and IX treat of non-harmonic electromotive forces and currents with respect to the behavior of commercial types of alternating-current machinery. Chapter VII is a very brief discussion of electric-wave telegraphy.

Existing courses of instruction in our technical schools place an excess of emphasis upon designing engineering and neglect operating engineering; and the most important thing for the operating engineer is to know his physics — not the physics of stuff which is so important to the researching physicist in his study of the properties of rarified gases and radioactive substances, but the physics of machines; of telescopes and stills, and tackle blocks and dynamos. Such being the author's point of view, this treatise is frankly devoted to the thesis "How Electric Waves Wave" and, with the exception of the theory of coupled circuits and resonance (the author has deliberately avoided the elaborate discussion of the oscillations of systems of the first class, concentrated inductance and concentrated capacity, as being quite adequately treated elsewhere, in Fleming's *Principles of Electric Wave Telegraphy*, for example), the author believes that the "How much" aspect of the subject is developed to an extent that is fully commensurate with obtainable data and the results that it is worth while to derive from them.

The instructor who uses this text should impress on his class the fact that some of the most important ideas in Chapters I, II

and IV are not fully established until the mathematical theory of wave motion is taken up in Chapter VI. Thus, the idea of a pure wave as a wave which travels without change of shape and in which the potential energy and kinetic energy are everywhere and at all times equal to each other is established in Art. 40 for the simple kind of water waves which are described in Chapter I and in Art. 57 for plane electromagnetic waves.

The author wishes particularly to emphasize the importance of Chapter VI; especially the part which treats of scalar and vector fields. This chapter is a slight modification of a treatment of this subject which was inserted as Chapter I in the first edition of Nichols & Franklin's *Elements of Physics*, Vol. II, under the mistaken idea than even an undergraduate could be expected to master this branch of geometry. Experience shows that this was a mistake, but it is certain, nevertheless, that it is precisely this branch of geometry which stands between most physicists and a clear understanding of electromagnetic theory.

W. S. FRANKLIN.

July 22, 1909.



## TABLE OF CONTENTS.

	PAGES.
INTRODUCTION . . . . .	1-6
PART I. ELECTRIC WAVES.	
CHAPTER I. Water Waves . . . . .	9-35
CHAPTER II. Wave Trains and Modes of Oscillation . . . . .	36-56
CHAPTER III. Electromagnetic Action . . . . .	57-74
CHAPTER IV. Electromagnetic Waves . . . . .	75-115
CHAPTER V. Transmission Line Oscillation . . . . .	116-153
CHAPTER VI. General Electromagnetic Equations . . . . .	154-204
CHAPTER VII. Electric Wave Telegraphy . . . . .	205-214
PART II. NON-HARMONIC ELECTROMOTIVE FORCES AND CURRENTS.	
CHAPTER VIII. Harmonic Analysis . . . . .	217-247
CHAPTER IX. Non-harmonic Electromotive Forces and Cur- rents . . . . .	248-268
APPENDIX A.	
INDUCTANCE AND CAPACITY OF TRANSMISSION LINES . . . . .	269-278
APPENDIX B.	
ELECTROMAGNETIC AND ELECTROSTATIC SYSTEMS, OF UNITS. . . . .	279-283
APPENDIX C.	
PROBLEMS . . . . .	284-311



# ELECTRIC WAVES.

## INTRODUCTION.

In the discussion of oscillatory motion and of wave motion, it is necessary to distinguish two very different cases, namely, (*a*) the case in which the elasticity of a system is wholly confined in one part of the system and the mass in another part of the system as in the case of a heavy weight hung upon a helical spring of which the mass is negligible, and (*b*) the case in which the elasticity and mass are both distributed throughout the moving system as in the case of a vibrating string. In the first case the system is capable of but one particular mode of simple harmonic oscillation of a certain definite frequency, and in the second case the system is capable of a whole series of modes of oscillation as explained in Art. 17. In the case of an oscillating string the vibrations are always periodic, that is to say, no matter how complicated the motion of the string may be, the string returns repeatedly to its initial configuration after equal intervals of time. In the case of an oscillating steel rod or plate, however, the system does not return repeatedly to its initial configuration, or in other words, the motion is not periodic.

An important phenomenon in an elastic system like a stretched string or an air column is the phenomenon of wave motion. A given part of the system is disturbed and the disturbance travels out from this part, usually at a definite velocity, and eventually reaches every part of the system.

*Concentrated capacity and distributed capacity.*—Figure I represents a valveless pump *P* which causes an alternating current of water to surge back and forth through a circuit of pipe and through a chamber *CC* across which an elastic diaphragm

## ELECTRIC WAVES.

*DD* is stretched; and Fig. II represents an alternator which causes an alternating current of electricity to surge back and forth through a circuit of wire which includes a condenser. The alternating pressure generated by the pump in Fig. I must not only

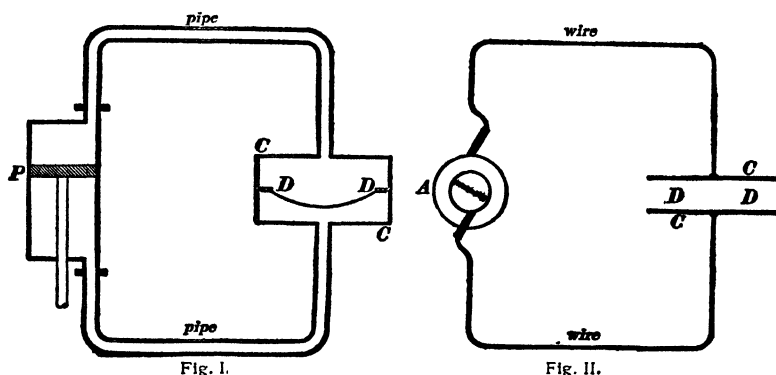

overcome the resistance of the pipe and the inertia of the water in the pipe, but a portion of the pressure developed by the pump must be used to distort the elastic diaphragm *DD*. Similarly, the alternating electromotive force generated by the alternator in Fig. II must not only overcome the electrical resistance of the wire, and the electrical inertia or inductance of the circuit, but a portion of the electromotive force developed by the alternator must be used to produce the electrical stress which is created in the insulating material *DD* between the condenser plates *CC* as these plates are electrically charged first in one direction (upper plate positive and lower plate negative) and then in the reverse direction (upper plate negative and lower plate positive), repeatedly.

Figure III represents a valveless pump which causes an alternating current of water to surge back and forth through a circuit of distensible rubber tube. When the piston starts upwards, the rapidly increasing pressure in the portion *a* of the rubber tube causes this portion of the tube to swell, and the rapidly decreasing pressure in the portion *b* of the rubber tube causes this por-

tion of the tube to shrink. The swelling and shrinking of the rubber tube extends with diminishing intensity to the middle point *c*, as shown by the tapering of the tube and as indicated by the positive and negative signs of decreasing size. One result of the elasticity of the tube is that the whole of the water current which enters the tube at *a* does not flow around to *b*, and the whole of the water current that leaves the tube at *b* does not flow around from *a*, but the value of the current (volume of water passing a point of the tube per second) decreases from *a* to *c* and from *b* to *c*, or, in other words, the current of water does not have the same value all along the circuit of pipe. Similarly,

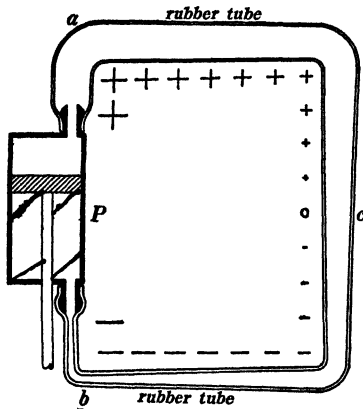

Fig. III.

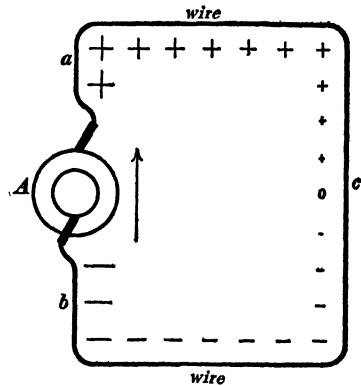

Fig. IV.

when the alternator in Fig. IV starts a pulse of electric current in the direction of the arrow, a large electric current enters the wire at *a*, part of this current goes to charge the wire positively and therefore the current decreases in value towards the point *c*; and the current which enters the alternator at *b* does not flow all the way around from *a* but part of it comes from the wire and leaves the wire negatively charged. The action is analogous in every detail to the action which takes place in Fig. III.

In Fig. I the only appreciably elastic element is the diaphragm *DD* whereas in Fig. III the entire circuit of pipe is elastic. In

Fig. II the only place where an appreciable amount of electric charge accumulates is on the two metal plates  $CC$ , the amount of charge that accumulates on the wire being negligible in comparison. In Fig. IV the charge that accumulates on the wire is supposed to be appreciable. This is true only when the circuit of wire is very long like a long transmission line. The metal plates in Fig. II constitute what is called a *concentrated capacity*, and the wire in Fig. IV constitutes what is called a *distributed capacity*. It is important to understand that a portion of the wire near  $a$  in Fig. IV is to be *paired off*, as it were, with a corresponding portion of the wire at  $b$ , Fig. IV, these two portions constituting two plates or elements of a condenser. In the case of a long transmission line, *short portions of the two line wires* constitute the elements of the distributed capacity.

The phenomena which occur in an electric circuit which contains an appreciable amount of distributed capacity differ greatly from the phenomena which occur in an electric circuit which contains only concentrated capacity; *electric wave motion exists in the former case but does not exist in the latter case*. In order to understand more clearly the distinction between concentrated and distributed capacity, let us consider a simple mechanical analogue. Figure V represents a large mass suspended at the end of a helical spring, the mass of the spring itself being negligible. If the weight is drawn down below its position of equilibrium and released, it will oscillate up and down, performing simple harmonic motion. Figure VI, on the other hand, represents a massive helical spring which has been stretched and released. In this case the extreme lower end  $A$  of the spring is relieved of stretch and set in motion at the instant of release, a *wave of starting*  $WW$  travels up the spring, the portion of the spring below  $WW$  is in uniform motion and entirely relieved from stretch, and each point of the spring above  $WW$  remains in its initial stationary stretched condition until the wave  $WW$  reaches that point. The system represented in Fig. V is capable of but one simple type of oscillatory motion, whereas the system repre-

sented in Fig. VI is capable of an infinite variety of complicated types of oscillatory motion. In Fig. V, all of the elasticity is in one part of the system and all of the mass is in another part of the system, whereas in Fig. VI, the elasticity and the mass are

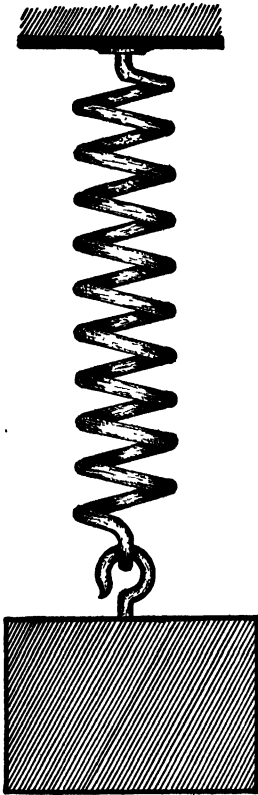

Fig. V.

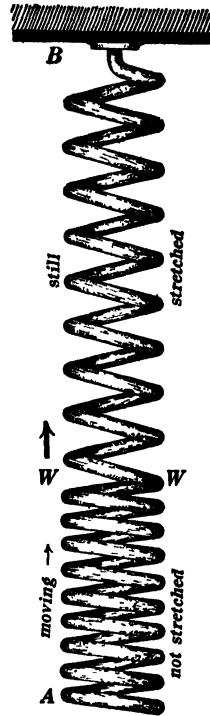

Fig. VI.

both distributed throughout the system. In Fig. V, the elasticity and the mass are both concentrated, and in Fig. VI the elasticity and the mass are both distributed.

In the elementary working theory of alternating currents, the effects of distributed capacity are always ignored because they are usually small in magnitude, and because the mathematical theory of alternating currents becomes so complicated as to be of little

or no practical value when the effects of distributed capacity are taken into account. The practical problems of long-distance power transmission and of telephone transmission, however, require for their adequate treatment that the effects of distributed capacity be taken into account.

*Harmonic and non-harmonic electromotive forces and currents.*—The purely electrical problems in engineering are in most cases the finding of one or two of the quantities: voltage, current and power when the other or others are given and when the circuit conditions are specified; and the relations between voltage, current and power in an alternating-current circuit can be simply formulated only for the ideal case in which the voltage and current are of the type which is represented by a curve of sines, and when the capacity is concentrated. Therefore, in most alternating-current problems, voltage and current are assumed to be of this type which is called harmonic, and the effects of distributed capacity are ignored as pointed out above.

*Object of this treatise.*—The object of this treatise is to develop the essential features of the methods for handling alternating-current problems when the electromotive forces and currents are not harmonic or when the capacity is not concentrated, or both. The first part of the treatise containing Chapters I to VII is devoted to the phenomena of electric waves, and the second part of the treatise is devoted to the discussion of non-harmonic electromotive forces and currents in circuits having concentrated capacity.

PART I  
ELECTRIC WAVES



## CHAPTER I.

### WATER WAVES.

**1. Wave motion.**—The group of ideas relating to that kind of mechanical action which is called wave motion is perhaps more generally useful in physics than any other group of mechanical ideas. Nearly every phenomenon of Sound and Light, a large group of phenomena in Electricity and Magnetism, and nearly all of the phenomena of oscillatory motion become easily intelligible in terms of the ideas of wave motion. In undertaking to establish the more important ideas of wave motion, however, we are confronted with a serious difficulty, namely, that ordinary water waves, the only kind of waves with which every one is familiar, are excessively complicated; invisible sound waves in the air and the even more intangible electromagnetic waves in the ether, in their more important aspects at least, are very simple in comparison. The wave theory, however, originated in the applications to sound and light of the ideas which grow out of a familiarity with the behavior of water waves, and in attempting to establish the wave theory one is obliged to base it upon the familiar phenomena of wave motion as exemplified by water waves.

**2. Wave media.**—The material or substance through which a wave passes is called a *wave transmitting medium*. Thus, the air is the medium which transmits sound waves, and the ether is the medium which transmits electromagnetic waves (including light waves). During the passage of a wave through a material medium, such as water or air, the medium always moves to some extent, but the velocity with which the medium actually moves is generally very much less than the velocity of progression of the wave,\* and indeed, in many cases, the medium does not move

\* The mathematical theory of wave motion in material media is developed on the assumption that the actual velocity  $v$  of the medium is very small in comparison with the velocity of wave progression  $V$ .

in the direction of wave progression. Thus, when the end of a long rope is moved rapidly to and fro sidewise, waves travel along the rope, and each point of the rope moves to and fro sidewise as the waves pass by. In some cases, the medium is left permanently displaced after the passage of a wave, and in other cases the medium returns to its initial position after the passage of a wave.

**3. Wave pulses and wave trains.**—When a stone is pitched into a pond, a wave emanates from the place where the stone strikes. When a long stretched wire is struck sharply with a hammer, a single wave (a bend in the wire) travels along the wire in both directions from the point where the wire is struck. When a long steel rod is struck on the end with a hammer, a single wave (an endwise compression of the rod) travels along the rod. When an explosion takes place in the air, the firing of a gun, for example, a single wave (a compression of the air) travels outwards from the explosion. Such isolated waves are called *wave pulses*. When a disturbance at a point in a medium is repeated in equal intervals of time, the disturbance is said to be periodic. Such a disturbance sends out a succession of similar waves constituting what is called a *wave train*.

The wave pulse involves all of the important physical actions of wave motion except that action which serves as a basis for the theory of the dispersion of light,\* and the physics of wave motion can be developed in the simplest possible manner by considering the behavior of wave pulses.

**4. Wave shape.**—A term which is frequently used in the discussion of wave motion is the term wave shape, and the meaning of this term may be best explained by considering wave motion along a stretched wire or string.† Let us first consider an entirely

\* The theory of the dispersion of light is outlined in Drude's *Theory of Optics* (translated by Mann & Millikan), pages 382–399. The subject of dispersion is not touched upon in this text.

† The theory of wave motion along a wire or string as here developed assumes that the wire or string is perfectly flexible, or in other words, that no elastic forces are produced by the bending of the wire or string.

general case as follows: Let  $AB$ , Fig. 1, be a wire under a tension of  $T$  dynes, and suppose that each centimeter of the wire weighs  $m$  grams. Imagine the wire to be drawn at velocity  $V$  centimeters per second through a bent tube  $WW'$ , and let it be

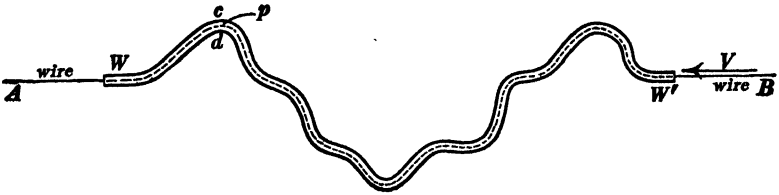

Fig. 1

assumed that the wire slides through the tube without friction. Then the wire will not exert any force against the sides of the tube if the velocity  $V$  satisfies the equation

$$V = \sqrt{\frac{T}{m}} \tag{1}$$

At this velocity, therefore, the moving wire would retain its bent (stationary) shape if the tube could be removed, that is to say, each portion of the rapidly moving wire would travel along the irregularly curved path in Fig. 1 even if the tube were non-existent. This tendency of a bend once established in a rapidly moving flexible wire or chain to persist is strikingly illustrated by the behavior of the loose chain of a differential pulley when the pulley is being rapidly lowered, and a series of stationary bends is often seen on a rapidly moving belt.

Absence of force action between tube and wire in Fig. 1 may be shown as follows: Consider any point  $p$  of the tube. A portion of the tube in the immediate neighborhood of this point is a portion of a circle of a certain radius  $r$ . Therefore, the tension of the wire tends to pull it against the side  $d$  of the tube, and if the wire were stationary this side force against the tube would be equal to  $T/r$  dynes per centimeter of length of wire; \* but to

\* See Franklin and MacNutt's *Elements of Mechanics*, pages 85 and 86.

constrain the particles of the moving wire to the circular path at  $\rho$ , an unbalanced force equal to  $mV^2/r$  dynes per centimeter of length of wire must act upon the wire pulling it towards the side  $d$  of the tube.\* Therefore when  $T/r = mV^2/r$ , or when  $V = \sqrt{T/\overline{m}}$ , the side force due to the tension of the wire is just sufficient to constrain the particles of the moving wire to the curved path at  $\rho$ , whatever the curvature at that point may be, and no force need act upon or be exerted by either side of the guiding tube. An example of this condition is furnished by a high speed belt as it circles round a pulley. When the velocity of the belt satisfies equation (1) then the belt circles round the pulley without exerting any force upon it except in so far as bending forces are necessitated by the stiffness of the belt. A perfectly flexible belt driven at the proper speed would continue to follow its path (round a pulley) if the pulley were removed.

Figure 1 represents a fixed or immovable wave on a rapidly moving wire. The action between the wire and tube, however, depends only upon their motion relative to each other. Therefore the action would remain unchanged if the wire were stationary and the tube moving to the right in Fig. 1 at velocity  $V$ ; the wire would slide through the moving tube without exerting any forces upon the sides of the tube, so that the bend  $WW'$  would continue to move along the stationary wire without changing its shape even if the tube were non-existent. Such a moving bend constitutes a wave, and the only motion of a given point of the wire during the passage of the wave is its sidewise motion.† The term wave shape refers to the distribution of the velocity of the medium (sidewise velocity of the wire in Fig. 1) in a wave. This matter may be made clear by the following example. Imagine a straight guiding tube  $WW'$ , Fig. 2, to slide along the wire  $AB$  at velocity  $V$  thus producing a wave. Throughout the tube the wire is moving sidewise at a constant velocity

\* See Franklin and MacNutt's *Elements of Mechanics*, pages 79-85.

† Longitudinal motion as well as sidewise motion is possible in a wave like that shown in Fig. 1, but it is convenient here to consider only the sidewise motion.

$v$  as indicated by the small arrows, and the portion of the wire in the tube is uniformly stretched. The uniform stretch of the wire in the tube in Fig. 2 is evident when we consider (a) that

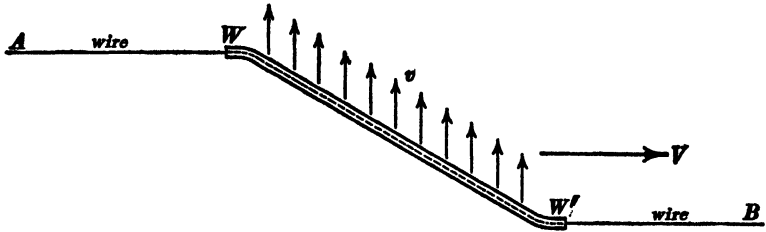

Fig. 2.

the horizontal component of the tension of the wire in the tube must be equal to the tension  $T$  of the portions of the wire beyond the tube, so that the total tension of the wire in the tube is greater than  $T$ , and therefore the wire in the tube is somewhat stretched; and (b) that the tube is straight so that the tension of the wire in the tube must be uniform.

In discussing waves, it is convenient to draw an axis  $OO$ , Fig. 3, in the direction of progression of the wave, and to repre-

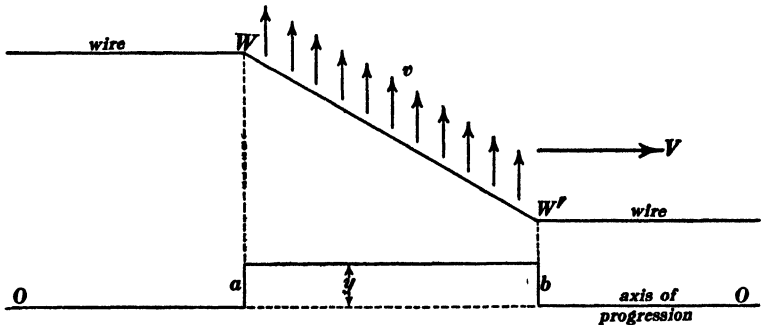

Fig. 3.

sent the *actual velocity of the medium at each point in the wave* by an ordinate  $y$  as shown; or to represent the *actual stretch*† of

† That is, stretch in *addition* to whatever degree of stretch may exist in the undisturbed portion of the wire beyond the boundaries of the wave.

the medium at each point by the ordinate  $y$ . Thus the wave shown in Fig. 2 would be represented by the rectangle  $ab$  in Fig. 3, inasmuch as the sidewise velocity of the wire and the stretch of the wire in Fig. 2 are everywhere constant in value between  $W$  and  $W'$ . The wave which is represented in Fig. 2 is therefore called a *rectangular wave* or a *rectangular wave pulse*. Nearly the whole of the following discussion of wave pulses refers to rectangular wave pulses because rectangular wave pulses are the simplest to describe.

**5. Wave pulses in a canal.** \*—A consideration of the simplest kind of wave motion in a canal, namely, *the kind in which the only perceptible motion of the water in the wave is a uniform horizontal flow*, will serve better than anything else as an introduction to the discussion of electric waves. Consider a canal of rectangular section filled to a depth of  $D$  centimeters with water. Imagine the water to be flowing at uniform velocity (small) of  $v$  centimeters per second, and imagine the flow to be suddenly stopped by a gate as shown in Fig. 4. The water, in being brought to rest against the gate, heaps up to a definite depth  $D + h$ , and a *wave of arrest* †  $W$  moves along the canal at a definite velocity  $V$ . The water at a given point in the canal continues to move with unchanged velocity until the wave of arrest reaches that point, when the water suddenly comes to rest and heaps up to

\* A good discussion of ordinary water waves is to be found in *Encyclopedia Britannica*, Ninth Edition, Article "Wave," Sections 5-8. A fascinating discussion of waves produced by ships may be found in the third volume of Sir William Thomson's (Lord Kelvin's) *Popular Lectures and Addresses*.

† The idea of the *wave of arrest* (and of the *wave of starting*) is so important in the discussion of wave pulses that it is worth while to illustrate it as follows: Imagine a troop of soldiers to be marching along in single file at a distance of three feet apart, and imagine every soldier to continue to march as long as there is room in front of him. If the front man in the troop is suddenly stopped, the other men are stopped in succession as they come against each other, and the stopping occurs at a point which travels uniformly from the front to the rear of the column, a *wave of arrest*, as it were. If the front man starts, the other men in the column start in succession, and the starting occurs at a point which travels uniformly from the front to the rear of the column, a *wave of starting*, as it were.

the depth  $D + h$ . The velocity of progression of the wave of arrest  $W$  is

$$V = \sqrt{gD} \quad (2)$$

in which  $V$  is expressed in centimeters per second,  $g$  is the acceleration of gravity in centimeters per second per second, and  $D$  is the depth of the water in the canal in centimeters. It is interesting to note that the velocity  $V$  is the velocity that would be gained by a body falling freely through distance  $D/2$ .

Precisely the same action that has been described as taking place in Fig. 4 may be produced in a still water canal by moving a gate along the canal like a piston at a low velocity  $v$  as indicated in Fig. 5. The water, in being set in motion by the mov-

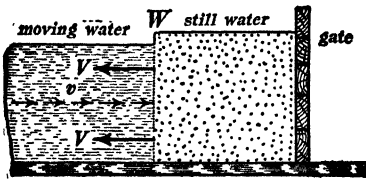

Fig. 4.

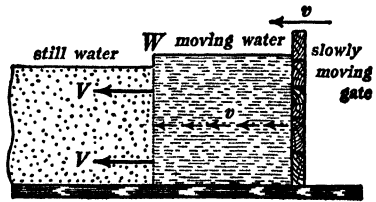

Fig. 5.

ing gate, heaps up to a definite depth  $D + h$ , and a wave of starting  $W$  moves along the canal at a definite velocity  $V$ . If the moving gate is suddenly stopped, the wave of starting  $W$  continues to move along as before, the water next to the gate in being stopped drops to its normal depth  $D$ , and a wave of arrest  $W'$  moves along the canal as indicated in Fig. 6.

The uniformly moving and uniformly elevated body of water  $A$ , Fig. 6, constitutes what is called a *complete wave*, or simply a *wave*. The water in front of the wave is continually set in motion at velocity  $v$ , and raised to the depth  $D + h$ ; the water in the back of the wave is continually brought to rest and lowered to the normal depth  $D$ , and the state of motion which constitutes the wave  $A$  travels along the canal without changing its character, friction being neglected.

The physical action which takes place in the wave of starting

$W$ , Fig. 5, or in the wave of arrest  $W'$ , Fig. 6, may be understood by considering the case in which the waves of starting and arrest are spread out as shown by  $WW$  and  $W'W'$  in Fig. 7, which represents a wave moving in the direction of the arrow  $V$ .

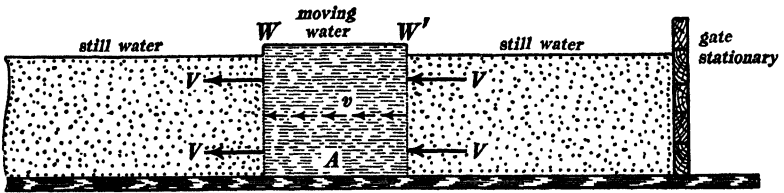

Fig. 6.

The velocity of the water in the wave is represented by the arrows at the bottom of the figure, and the elevation of the water at each point of the wave is represented by the broken line  $WW'W'$ . Consider a thin slice of water  $ab$ ; the pressure on the side  $b$  is greater than the pressure on the side  $a$  because of the greater depth of water along the side  $b$ , and because of this unbalanced force the slice  $ab$  must be gaining velocity; the

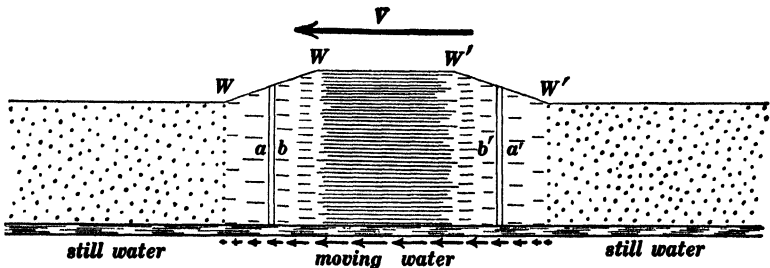

Fig. 7.

velocity of the water along the side  $b$  is greater than the velocity along the side  $a$  as indicated by the arrows at the bottom of the figure, so that more water is flowing into the slice across side  $b$  than is flowing out of it across side  $a$  and therefore the slice must be increasing in height. Exactly the reverse of these actions takes place in the slice  $a'b'$ , that is to say, the pressure

on the side  $b'$  is greater than pressure on the side  $a'$ , and therefore the velocity of the water in the slice is decreasing, and more water is flowing out of the slice through side  $b$  than is flowing into it through side  $a$ , so that the height of the slice is decreasing.\*

*Proof of equation (2).*—Let  $b$  be the breadth of the canal. Consider a transverse slice of water one centimeter thick. The volume of this slice is  $bD$  cubic centimeters, and its mass is  $\delta bD$  grams, where  $\delta$  is the density of the water in grams per cubic centimeter. Therefore the kinetic energy of this slice of water when it is moving at a velocity  $v$  centimeters per second is  $\frac{1}{2}\delta bDv^2$  (one half mass times velocity squared). When the wave of arrest  $W$ , Fig. 4, reaches the slice of water under consideration, the slice, as it comes to rest, is squeezed together and increased in depth to  $D + h$ . The slice is decreased in thickness in proportion to its increase in depth, so that its thickness is reduced to  $D/(D + h)$ , or to  $(1 - h/D)$  of a centimeter, since  $h$  is very small. Therefore the decrease of thickness is  $h/D$  of a centimeter. The force acting to reduce the thickness of the slice is to be considered as the force which is due to the *increase* of pressure in the water produced by the *increase* of depth  $h$ . This increase of pressure is equal to  $h\delta g$  dynes per square centimeter when the slice has reached its greatest height, so that the average increase of pressure due to increasing depth is  $\frac{1}{2}h\delta g$ , and it produces over the face of the slice a force equal to  $\frac{1}{2}h\delta g \times bD$  dynes. Multiplying this force by the decrease of thickness of the slice, we have the work done in decreasing the thickness, and this work is equal to the original kinetic energy of the slice.† Therefore

\*The physical action which takes place in wave motion is best expressed by a differential equation. See Chapter VI.

† This is true because the work required to increase the height of the slice comes from the kinetic energy of the slice. In a complete wave like  $A$ , Fig. 6, the kinetic energy of the moving water (at velocity  $v$ ) is at each part of the canal equal to the potential energy due to the elevation of the water surface in the wave; and in a complete wave like  $A$ , Fig. 8, the kinetic energy of the moving water (at velocity  $v$ ) is at each point of the canal equal to the potential energy due to the depression of the water surface in the wave. See Art. 6, section (c).

$$\frac{1}{2}\delta b D v^2 = \frac{1}{2}\delta b h^2 g$$

or

$$v^2 = \frac{g h^2}{D} \quad (i)$$

Consider the instant  $t$  seconds after the closing of the gate in Fig. 4. The wave of arrest has then reached a distance  $Vt$  from the gate, and the excess of water that is represented by the raising of the water level ( $= Vt \times h \times b$  cubic centimeters) is the amount of water supplied by the flow of the canal in  $t$  seconds ( $= bDvt$  cubic centimeters). Therefore

$$Vihb = bDvt$$

or

$$V = \frac{Dv}{h} \quad (ii)$$

whence, substituting the value of  $v$  from equation (i) in equation (ii) we have equation (2).

### 6. Additional details concerning wave pulses in a canal. (a)

*Waves of elevation and waves of depression.* — The wave shown in Fig. 6 may be called a wave of elevation, inasmuch as the water in the wave is elevated above the normal level of the water in the canal. In this case the velocity of flow  $v$  is in the *same direction* as the velocity of progression  $V$  of the wave. If the gate in Fig. 5 be moved slowly to the right, the water next to

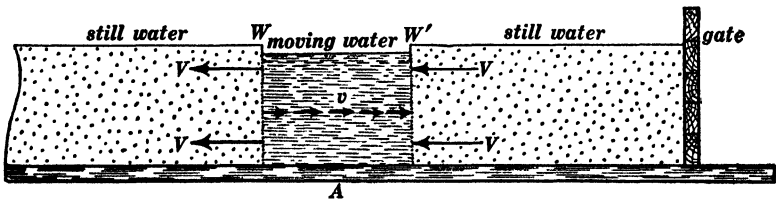

Fig. 8.

the gate in being set in motion, is lowered below the level of the still water in the canal, and a wave of depression is formed as shown in Fig. 8. In this case the velocity of flow of the water in the wave is *opposite* to the velocity of progression of the wave.

After the passage of the wave of elevation which is shown in Fig. 6, the water in the canal is left permanently displaced by an

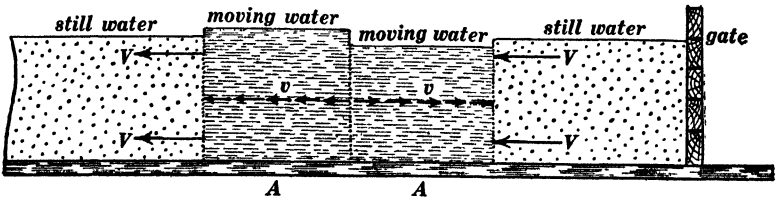

Fig. 9.

amount which is equal to the original movement of the gate, and the same is true of the wave of depression which is shown in Fig. 8. Figure 9 shows a wave which is produced by a to-and-fro

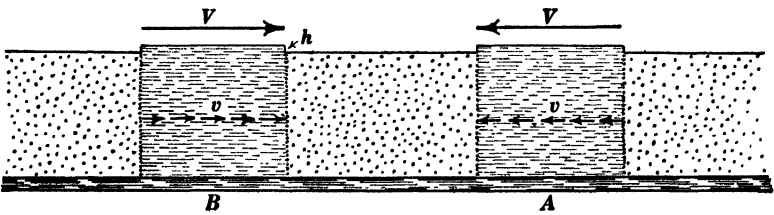

Fig. 10.

movement of the gate, a wave of elevation followed by a wave of depression. In this case, the water at any point in the canal is left in its initial position after the passage of the wave.

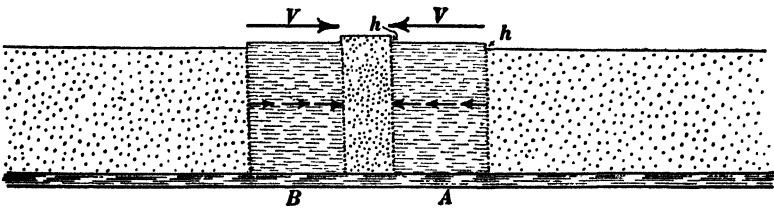

Fig. 11.

(b) *Superposition of oppositely moving waves.* — Figure 10 shows two waves of elevation traveling in opposite directions. When these waves begin to overlap, as shown in Fig. 11, the velocity of the water in the overlapping portions of the waves is the algebraic

sum of the velocities in the individual waves, and the elevation of the water in the overlapping portions is the algebraic sum of the elevations in the individual waves. Therefore, since the velocities

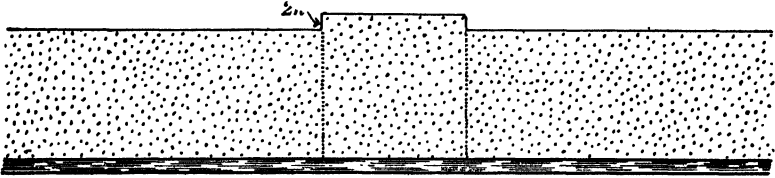

Fig. 12.

of flow are in opposite directions in the two waves, the overlapping portion of the waves *A* and *B* in Fig. 11 is a stationary body of water elevated to the height  $2h$  above the normal

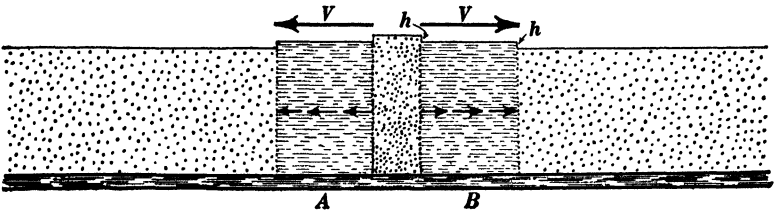

Fig. 13.

level of the water in the canal. At a later instant, when the two waves *A* and *B* overlap completely, the two waves form a uniformly elevated stationary body of water as shown in Fig. 12.

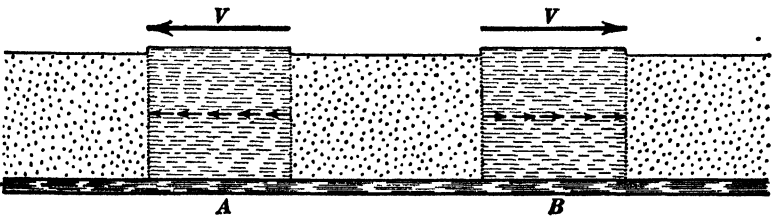

Fig. 14.

Figure 13 represents the state of affairs after the waves have begun to separate, and Fig. 14 represents the state of affairs after the two waves are entirely separated. Figures 15, 16, 17, 18 and 19

show the successive aspects of two oppositely moving waves  $A$  and  $B$ , a wave of elevation and a wave of depression, as they pass through each other. In this case, the velocity of flow is in the same direction in both waves, and the overlapping portion of the waves in Figs. 16, 17 and 18 is a uniformly flowing body

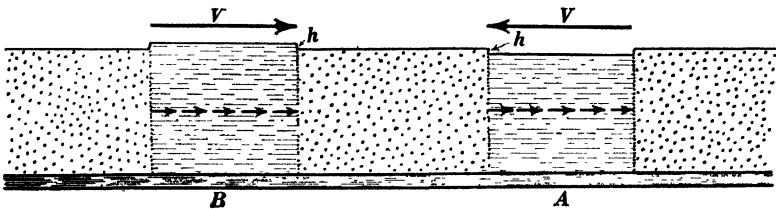

Fig. 15

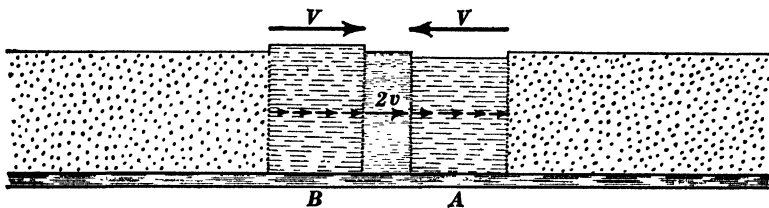

Fig. 16.

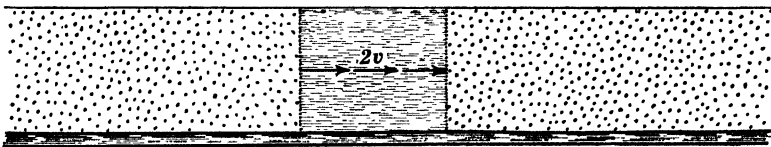

Fig. 17.

of water which is at the normal level of the still water in the canal.

It is especially interesting to note that the uniformly elevated and stationary body of water in Fig. 12, and that the uniformly moving body of water in Fig. 17 which is neither elevated nor depressed, both break up into two oppositely moving waves as shown in Figs. 13 and 14 on the one hand, and in Figs. 18 and 19 on the other hand.

(c) *Pure and impure waves.*—The waves which are shown in Figs. 6, 7, 8, 9, 10, 14, 15 and 19 all have this common prop-

erty, namely, that the kinetic energy which is associated with the motion of the water in the wave is equal at each point to the potential energy which is associated with the elevation or depression. Such a wave, which is called a *pure wave*, progresses without change of shape.\* When, however, the potential energy of elevation or depression is not equal to the kinetic energy of flow, we have what is called an *impure wave*. Thus, the uniformly elevated body of water in Fig. 12 and the uniformly flowing body of water in Fig. 17 are extreme cases of impure

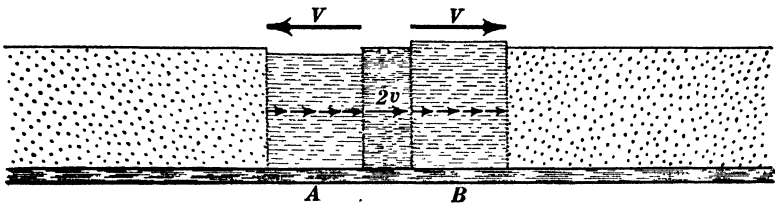

Fig. 18.

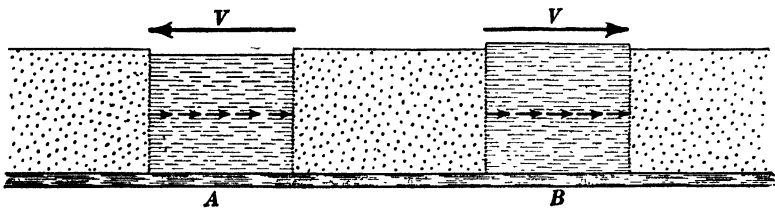

Fig. 19.

waves. An impure wave always breaks up into two oppositely moving pure waves. Thus, the uniformly elevated body of water in Fig. 12 breaks up as indicated in Figs. 13 and 14, and the uniformly flowing body of water in Fig. 17 breaks up as indicated in Figs. 18 and 19.

(d) *Reflection of waves.*—Imagine a wave like that which is shown in Fig. 6 to approach a rigid dam. When the wave reaches the dam, the moving water in the wave, in being brought to rest at the face of the dam, is heaped up to a double elevation as shown in Fig. 20; the wave of arrest  $W'$  in Fig. 20 travels

\* This matter is fully discussed in Chapter VI.

to the right, and at a certain instant the state of affairs is as represented in Fig. 21, the entire energy of the wave being represented at this instant by the double elevation of the water in a portion of the canal one half as long as the original wave. The body of stationary water in Fig. 21 begins to flow at the point  $P$ , and the potential energy of elevation is partly transformed into kinetic energy of flow as shown in Fig. 22 (compare Figs. 21 and 22 with the right-hand halves of Figs. 12 and 13); and when the wave of starting  $W''$  in Fig. 22 reaches the dam, the water

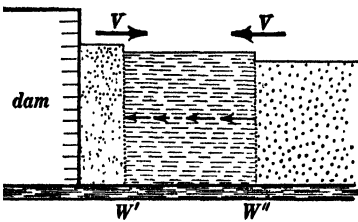

Fig. 20.

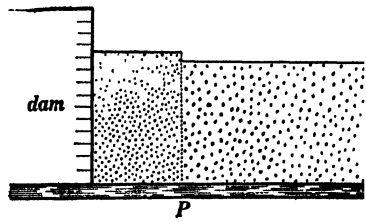

Fig. 21.

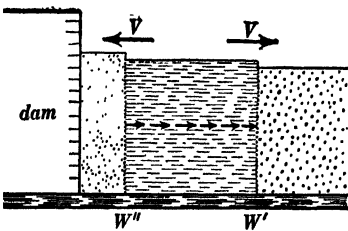

Fig. 22.

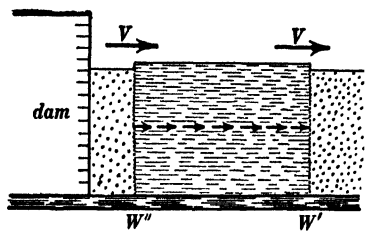

Fig. 23.

next to the dam is brought to rest and lowered to the normal level of the water in the canal as shown in Fig. 23. Figure 23 represents the complete reflected wave which is exactly like the original wave, except that its velocity of flow has been reversed.

Imagine a gate  $G$  in Fig. 24 which is free to move along the canal like a piston and upon which acts a force  $F$  barely sufficient to balance the normal push of the still water in the canal. Imagine the gate, furthermore, to be without inertia, so that the least increase of push of the water would cause the gate to move promptly to the left, or the least decrease of push of the water would cause the gate to move promptly to the right. When the

advancing wave which is shown in Fig. 24 reaches the gate, the gate begins at once to move at velocity  $2v$ , and the water next to the gate drops to the normal level of the water in the canal as shown in Fig. 25. This is evident when we consider that the

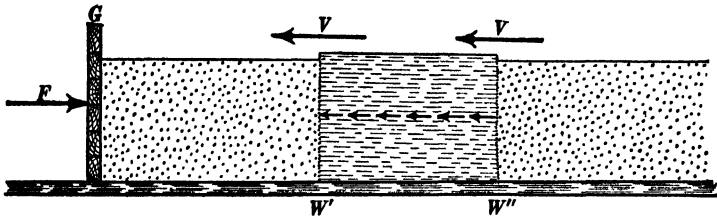

Fig. 24.

gate (which is assumed to be without inertia) would have velocity  $v$  imparted to it by the *motion* of the water in the wave, and when we consider that the gate is assumed to yield immediately to the slightest additional pressure due to the elevation of the water in the wave so that the energy of elevation is at once converted into additional energy of flow. A moment later the entire energy of

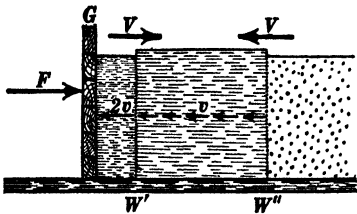

Fig. 25.

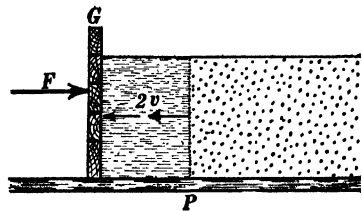

Fig. 26.

the original wave is represented by the energy of flow (at doubled velocity) of the water in a portion of the canal one half as long as the original wave, as shown in Fig. 26; then the water level at the point  $P$  is suddenly lowered (compare Figs. 26 and 27 with the left-hand halves of Figs. 17 and 18), and the velocity of flow is reduced to the value  $v$  in a region which widens out in both directions from  $P$  by a wave of starting  $W'$  and a wave of semi-arrest  $W''$ , as shown in Fig. 27. Figure 28 shows the complete reflected wave which is exactly like the

original wave, except that the original wave is a wave of elevation, whereas the reflected wave is a wave of depression.

(e) *Reflection with and without phase reversal.*—A wave always consists of two elements, namely, motion and distortion traveling along together and mutually sustaining each other, and it is convenient to speak of the motion of the medium in the wave as the *velocity phase* of the wave and to speak of the distortion (eleva-

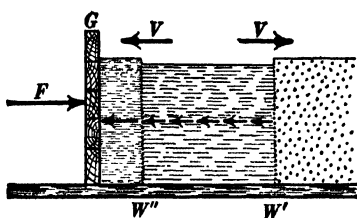

Fig. 27.

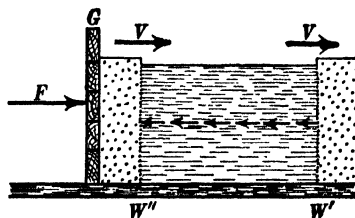

Fig. 28.

tion or depression in the case of water waves) as the *distortional phase* of the wave. When a wave is reflected from a rigid boundary, as shown in Figs. 20 to 23, the velocity phase of the wave is reversed by reflection but the distortional phase is not reversed. When a wave is reflected from a free boundary, as shown in Figs. 24 to 28, the distortional phase of the wave is reversed but the velocity phase is not reversed.

**7. Oscillation of the water in a short canal.**—If a wave is started along a portion of a canal the ends of which are terminated by rigid dams, as shown in Figs. 20 to 23, or by freely moving gates as shown in Figs. 24 to 28, then the wave will be repeatedly reflected from the ends of the canal, and the to-and-fro motion of the wave along the canal will constitute a clearly defined type of oscillation of the water in the canal. The time required for one complete cycle of movements of the water in the canal is related to the velocity of the wave and to the length of the canal as follows: (a) If both ends of the canal are rigid dams, then the wave, starting from end *A*, is reflected with reversal of velocity phase at end *B* and again reflected with reversal of velocity phase at end *A*, so that, after two reflec-

tions, the wave is in exactly its initial condition, and, therefore, one complete cycle of movements of the water in the canal takes place during the time required for the wave to travel from one end of the canal to the other and back again. This is also true if both ends of the canal are formed by freely moving gates as shown in Figs. 24 to 28.

(*b*) If one end of the canal is formed by a rigid dam and the other by a freely moving gate, then a complete cycle of movements of the water in the canal takes place in the time required for the wave to travel over four times the length of the canal. Starting from the dam-end of the canal, the distortional phase of the wave is reversed by reflection at the gate-end, then the velocity phase is reversed by reflection at the dam-end, then the distortional phase is again reversed by reflection at the gate-end, and finally the velocity phase is again reversed by reflection at the dam-end, thus bringing the wave into its initial condition after two reflections from each end.

Figure 29 shows a string  $AB$  which is pulled to one side at the point  $P$ ; a canal  $CD$  in which the water in one end is elevated and the water in the other end is depressed; and a transmission line  $EF$  which is broken at the center and connected to a battery which produces a uniform electric field between the two wires of the line, the field being directed upwards in one half of the line and downwards in the other half of the line. When the stretched string  $AB$  is released it oscillates, and  $A'B'$  shows the state of affairs at a later instant. When the gate is lifted from the canal  $CD$ , the water in the canal oscillates, and  $C'D'$  shows the state of affairs at a later instant. When the switch in  $EF$  is closed, the transmission line oscillates electrically, and  $E'F'$  shows the state of affairs at a later instant.\*

\*The student should make a series of drawings showing, say, eight successive stages of one complete oscillation of the string  $AB$ , and a series of drawings showing eight successive stages of one complete oscillation of the water in the canal  $CD$ . The details of oscillation of a transmission line are discussed later. The student should also plot a curve like that which would be traced upon a uniformly moving strip of paper by a pencil point attached to any given point on the string  $AB$ , Fig.

*Relationship between kinetic energy and potential energy in an oscillating system.* — In a pure wave which is travelling in a given direction as shown in Figs. 6, 7, 8, 9, 10, 14, 15 and 19, the

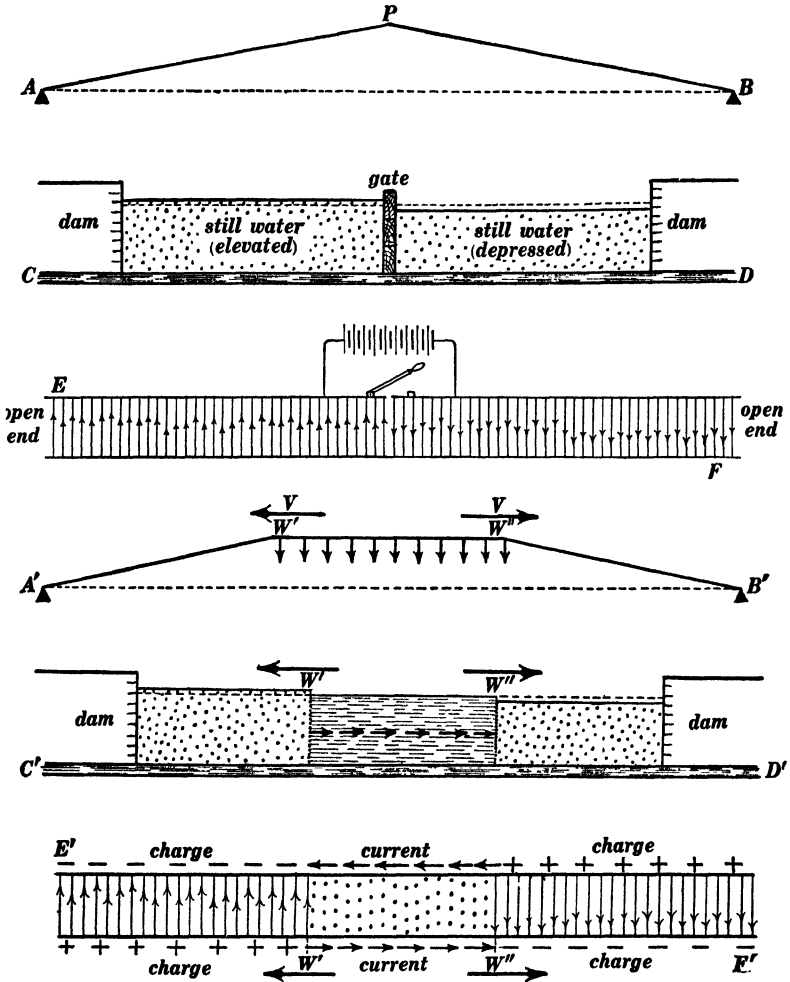

Fig. 29.

29, or by a pencil point carried by a float at any given point in the canal *CD*, Fig. 29; the direction of motion of the strip of paper being at right angles to the direction of motion of the pencil point in each case.

kinetic energy of the medium is at each point equal to the potential energy of the medium. When, however, two oppositely moving waves partly overlap each other as shown in Figs. 11, 12, 13, 16, 17 and 18, and as shown for the case of an advancing and a reflected wave in Figs. 20, 21, 22, 25, 26 and 27, the potential energy is not equal to the kinetic energy at each point. In an oscillating system the energy is transformed wholly into kinetic energy, then wholly into potential energy, back again into kinetic energy, and so on repeatedly.\* Thus, the energy of an oscillating pendulum is wholly kinetic when the pendulum is at the middle point of its swing, and the energy is wholly potential when the pendulum is at its maximum distance from the middle point. The energy of the vibrating string in Fig. 29 is wholly potential at the instant of release, and it is wholly kinetic when the line  $W'W''$  (see sketch  $A'B'$ ) becomes coincident with the line  $A'B'$ . The energy of the water in the oscillating canal in Fig. 29 is wholly potential when the gate at the middle of the canal is in place, and it is wholly kinetic when the waves of starting  $W'$  and  $W''$  reach the ends of the canal in the sketch  $C'D'$ . In many cases the energy of an oscillating system is not only transformed back and forth from kinetic to potential energy, but the energy may also shift back and forth in space, being at one instant largely concentrated in one region as potential energy and at another instant largely concentrated in another region as kinetic energy. Thus, if a weight suspended from a helical spring is set oscillating up and down, the energy is all stored in the weight as kinetic energy when the weight is at the middle point of its up-and-down movement, and the energy is wholly stored in the spring as potential energy when the weight is at the highest or lowest point of its swing.

**8. Transverse waves and longitudinal waves.** — In the waves which are shown in Figs. 1 and 2 the motion of the medium (the wire or string) is at right angles to the direction of progression

\* Except in certain rather complicated types of oscillation.

of the wave. Such waves are called *transverse waves*. In the waves which are shown in Figs. 6, 7, 8, and so on, the motion of the medium (the water in the canal) is parallel to the direction of progression of the wave. Such waves are called *longitudinal waves*.

**9. Wave distortion.\*** — A wave like *A*, Fig. 6, would travel along a canal without changing its shape if the water in the canal were frictionless. As a matter of fact, however, the velocity of flow of the water in the wave is continually reduced by the friction of the water against the sides and bottom of the canal, whereas there is no action tending to reduce the elevation of the water in the wave. The result is that the wave becomes impure (kinetic energy of flow not equal to potential energy of elevation), and *that portion of the elevation which is in excess of what is required to constitute a pure wave with what remains of the velocity of flow*

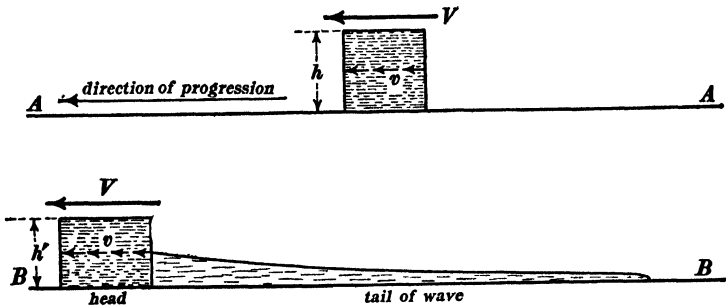

Fig. 30.

behaves exactly like the elevated body of still water in Fig. 12, that is, this excess of elevation breaks up into two pure waves *A* and *B* as shown in Fig. 13, one of these, *A* or *B*, merges with the original wave and the other shoots backwards. The upper part of Fig. 30 represents on an exaggerated scale the elevated portion of water of a rectangular wave pulse in a canal. The velocity of flow  $v$  in this wave is continually reduced by friction as the wave travels along, and the excess of elevation

\* Wave distortion is sometimes called wave diffusion.

which is being thus continually left in the wave causes a long-drawn-out wave to shoot backwards; after a time the wave takes on the form shown in the lower part of the figure. The energy in the head of the wave is greatly reduced, partly because of the direct losses due to friction and partly because of the shooting of a portion of the energy backwards into the tail of the wave.

If the canal is brimful of water so that the elevation of the water in the wave causes an overflow or spill, the tendency is for a wave to remain pure and therefore to be propagated without change of shape (without the development of a tail), because the elevation is reduced by spill, and the velocity of flow  $v$  is reduced by friction. This is analogous to the action which takes place on a poorly insulated telephone line and which sometimes causes such a line to transmit speech more distinctly than the same line would if it were thoroughly insulated.

**10. Longitudinal wave pulses along a steel rod.**— Before proceeding to discuss the production of a complete wave (of compression or stretch) along a steel rod, it is of interest to consider the behavior of a steel rod when it is moving endwise at a small velocity  $v$  and strikes a rigid wall as shown in Fig. 31. The

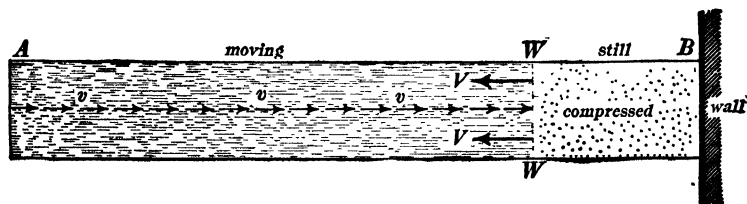

Fig. 31.

action which takes place in this case is exactly similar to the action which is represented in Fig. 4. The portion of the rod next to the wall is suddenly brought to rest and compressed, and a wave of arrest  $W$  moves along the rod as indicated by the arrows  $VV$ . At the instant when the wave of arrest reaches the free end  $A$  of the rod in Fig. 31, the entire rod is stationary and uniformly compressed. Therefore, balanced forces act on every

portion of the rod except the layer of material at the extreme end  $A$ , so that this layer is relieved from compression as it starts to move at reversed velocity  $v$  (away from the wall), and a wave of starting  $WW$  travels back along the rod as indicated in Fig. 32. When this wave of starting reaches the end  $B$  of the

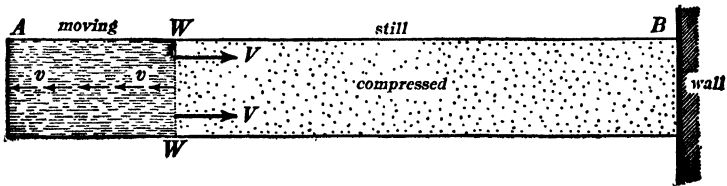

Fig. 32.

rod, the entire rod is free from compression and is moving away from the wall at the same velocity  $v$  at which it was originally moving towards the wall.

If the rod be glued fast, as it were, to the wall, then the end  $B$  of the rod is immediately brought to rest and stretched, and a wave of arrest travels along the rod as shown in Fig. 33. When this wave of arrest reaches the free end  $A$  of the rod, the entire rod is stationary and uniformly stretched, so that the end layer at  $A$  is relieved of stretch and begins to move towards the wall,

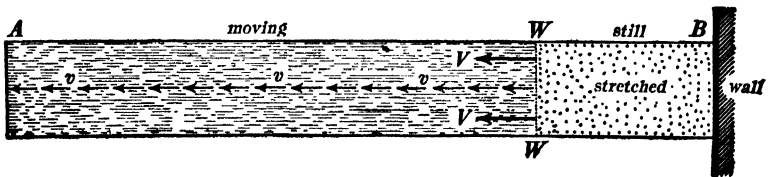

Fig. 33.

and a wave of starting travels back towards the wall as indicated in Fig. 34. When this wave of starting reaches  $B$ , the entire rod is in precisely its initial condition, namely, moving towards the wall at uniform velocity  $v$ .

The action here described takes place so rapidly that it cannot be followed with the eye. In fact, the waves of arrest and starting in Figs. 31 to 34 travel at a velocity of about 17,000 feet per

second in a steel rod, so that the entire cycle of movements above described would take place 425 times per second in a steel rod 10 feet long.

A helical spring may be made to perform the same series of movements as a steel rod as above described, and at a much

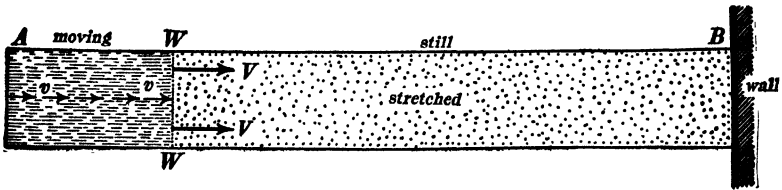

Fig. 34.

slower rate. Thus, if one end of a helical spring be attached to a wall as shown in Fig. 35, the spring may be uniformly stretched by pulling on the end  $A$ . If the spring is then released, the free end is suddenly relieved of stretch and begins to move towards the wall, and a wave of starting travels towards the wall exactly as described in connection with Fig. 34. Then a wave of arrest travels back from  $B$  to  $A$ , exactly as described in connection with Fig. 31; a wave of starting (velocity  $v$  away from the wall) then travels from  $A$  to  $B$ ; and then a wave of arrest travels

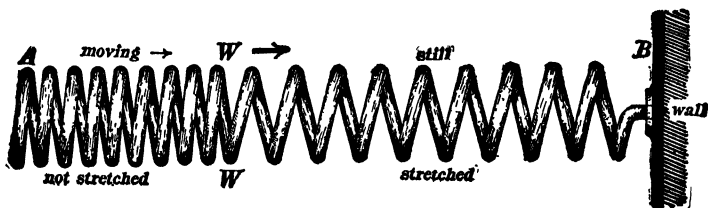

Fig. 35.

from  $B$  to  $A$ , bringing the spring into its initial uniformly stretched condition.

A complete wave of compression may be produced in a steel rod in a manner analogous to the production of a complete water wave in a canal by a moving gate as indicated in Fig. 5. Thus, one end of a long steel rod  $AB$ , Fig. 36, is struck with a hammer, and let us assume, for the sake of simplicity, that the ham-

mer continues to move at a constant velocity  $v$  while it pushes on the end of the rod and then rebounds. The result of such a hammer blow would be to set up a wave of starting  $W$ , and the

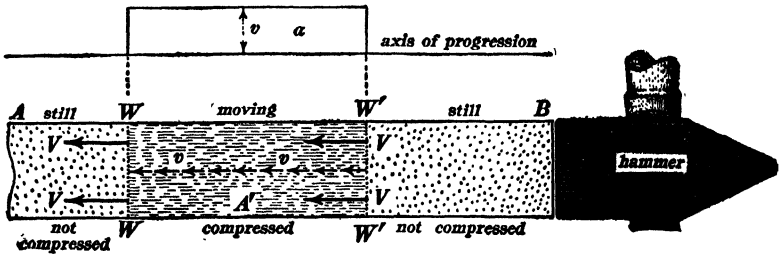

Fig. 36.

portion of the rod behind  $W$  would be moving at uniform velocity  $v$  and would be uniformly compressed. At the instant of rebounding of the hammer, however, the compression in the moving portion of the rod would cause the end layer  $B$  of the rod to stop, this action would relieve the end layer of compression, and a wave of arrest  $W'$  would follow the wave of starting  $W$  as indicated in the figure.

The above description applies to the production of a wave of compression in a steel rod. A sudden pull on the end  $B$  of the steel rod in Fig. 36 would produce a complete wave of expansion or stretch. Such a wave is shown in Fig. 37.\*

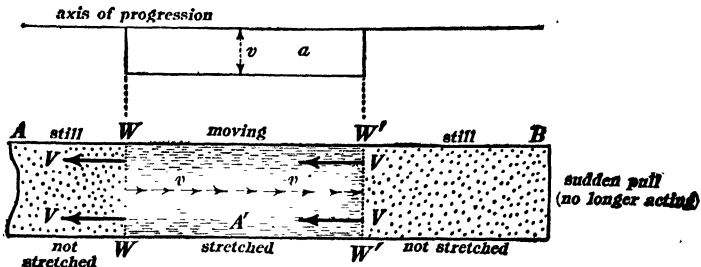

Fig. 37.

\* The student should make sketches similar to Figs. 20 to 23 showing the reflection of a wave of compression from the rigid end (resting against a wall) of a steel rod. In this case the reflected wave is still a wave of compression, but the velocity  $v$

11. **Wave pulses in air and water pipes.** — Figure 38 represents a long pipe containing air, one end of the pipe being provided with a piston. If the piston is moved at a small velocity  $v$  for a short time and then brought to rest, a complete wave of com-

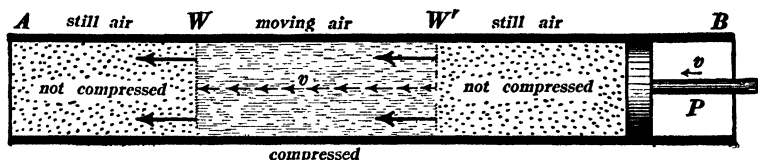

Fig. 38.

pression is produced which travels along the tube as shown in the figure. This wave of compression is similar in every detail to the complete wave of compression which is produced by striking the end of a steel rod with a hammer. If the piston  $P$  in Fig. 38 is moved at a small velocity  $v$  in an outward direction (to the right in the figure) and then stopped, a complete wave of rarefaction is produced.

An interesting and important phenomenon of wave motion occurs when a wide open hydrant is suddenly closed. The moving water is suddenly brought to rest against the valve and compressed to a very high pressure, and a wave of arrest  $WW$ , Fig. 39, travels backwards along the supply pipe as indicated. At

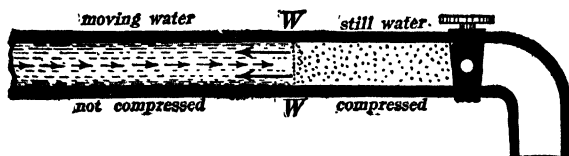

Fig. 39.

the place where the small supply pipe widens out into a large street main, the action is very similar to the action which takes place at the free end of a steel rod as described in Art. 10. In the wave is reversed. The student should also make sketches similar to Figs. 25 to 28 showing the reflection of a wave of compression from the free end of the steel rod. In this case, the velocity in the reflected wave is unchanged in direction, but the reflected wave is a wave of stretch instead of a wave of compression.

Therefore, when the wave of arrest *WW* in Fig. 39 reaches the street main, the uniformly compressed water in the supply pipe starts the water moving backwards into the street main, and this motion is established by a wave of starting which travels from the street main to the hydrant. When this wave of starting reaches the hydrant, the water in the supply pipe is at normal pressure and moving towards the street main at uniform velocity.\* This backward movement of the water is immediately stopped † in the neighborhood of the valve or hydrant, producing a great decrease of pressure there, and a wave of arrest again travels from the hydrant to the street main. When this second wave of arrest reaches the street main, the stationary water in the supply pipe is uniformly expanded (at a low pressure), and the water starts flowing towards the hydrant again, this motion being established by a second wave of starting which travels from the street main to the hydrant. When this second wave of starting reaches the hydrant, the water is at normal pressure and in motion towards the hydrant as at the start (when the hydrant was suddenly closed), and the above-described action is then repeated. This cycle of movements is often repeated five or six times when a hydrant is suddenly closed, producing five or six sharp clicks in succession as the water is repeatedly brought to rest against the closed valve of the hydrant.

\* In this discussion the complicating influences of friction and leakage are ignored for the sake of simplicity of statement.

† Generally a vacuum is produced in the neighborhood of the valve by this backward movement of the water. This produces complications in the character of the wave-reflection which takes place at the hydrant.

## CHAPTER II.

### WAVE TRAINS AND MODES OF OSCILLATION.

**12. Simple and compound vibrations of a particle.** — When a particle moves to and fro along a straight line performing simple harmonic motion,\* its vibrations are called *simple vibrations*. When the to-and-fro motion of a particle is periodic but not simply harmonic, its vibrations are called *compound vibrations*.†

*Graphical representation of simple and compound vibrations.* — Consider a point  $p$ , Fig. 40, vibrating up and down along the

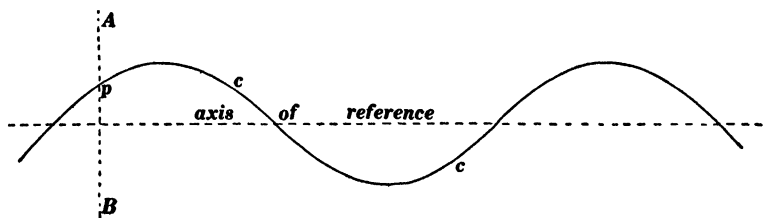

Fig. 40.

line  $AB$ , and imagine the paper to move with uniform velocity to the right; then the point  $p$  will trace a curved line  $cc$ . If the vibrations of  $p$  are simple, the curve  $cc$  will be a curve of sines. If the vibrations of  $p$  are compound, the curve  $cc$  will

\* Simple harmonic motion is the projection on a fixed straight line of uniform motion in a circle.

† The importance of simple harmonic motion as a fundamental type of vibratory motion is due to the fact that any mechanical system, such as a heavy weight on the end of a spring, in which the entire mass is concentrated in one part of the system and the elasticity in another part of the system, performs simple harmonic motion. Such a system is sometimes described by saying that it has but one degree of freedom. In a mechanical system like a stretched string or air column, every part of the system has an appreciable mass and every particle in a system is capable of independent motion subject to elastic reactions between itself and the contiguous parts of the system. A given particle in such a system may perform any type of oscillatory motion whatever, and in some cases the oscillatory motion is not even periodic.

be a periodic curve, that is, each section of it will be exactly similar to every other section, but it will not be a curve of sines.

The curve shown in Fig. 40 is a curve of sines, and it represents a simple vibration of the point  $p$ . The curve shown in Fig. 41 is a periodic curve but it is not a curve of sines, and it represents a compound vibration of the point  $p$ .

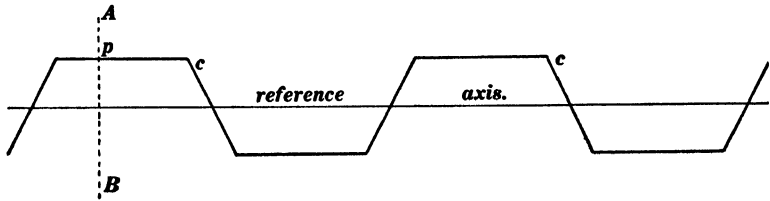

Fig. 41.

*Definitions.* — The number of complete vibrations per second of a vibrating particle is called the *frequency* of the vibrations. The duration of one complete vibration is called the *period* of the vibrations, and one half the distance through which the particle moves to and fro is called the *amplitude* of the vibrations.

**13. Wave trains.** — A periodic disturbance is one which is repeated in every detail in equal intervals of time. The time interval  $\tau$  during which one repetition of the disturbance takes place is called the period of the disturbance, and the number of repetitions per second is called the frequency. A periodic disturbance sends out a succession of similar waves constituting what is called a wave train, as stated in Art. 3. The distance  $\lambda$  between similar parts of two adjacent waves of a train is called the *wave length* of the train; it is the distance traveled by the waves during the period  $\tau$ . Let  $V$  be the velocity of progression of the waves, then we have

$$\lambda = V\tau \quad (3)$$

*Example.* — One end of a long rubber tube is fixed to a wall, the other end is held in the hand, and the hand is moved up and

down periodically, one movement being of any character whatever, simple or complicated. Under these conditions, a wave train is transmitted along the rubber tube from the hand. The motion of the rubber tube in this case is complicated by the fact that the waves which go out from the hand are reflected from the fixed end of the tube. Immediately after beginning to move the hand, however, and before the waves have reached the distant end of the tube, the wave train may be seen very distinctly, and

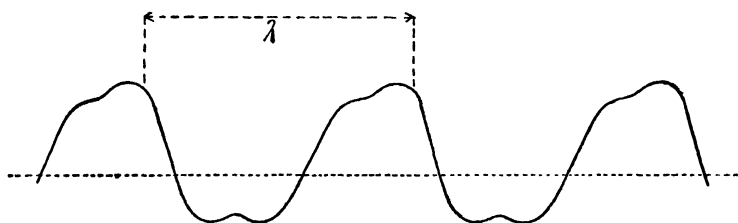

Fig. 42.

an instantaneous photograph of the rubber tube would show a series of similar bends like Fig. 42, for example. The dotted line in Fig. 42 represents the undisturbed position of the rubber tube.

*Graphical representation of a wave train.*—For many purposes, it is best to think of the shape of a wave as having reference to the velocity of the medium at each point of the wave, as explained in Art. 4. For present purposes, however, it is more convenient to represent the shape of a wave at a given instant by a curve like Fig. 42 in which the ordinate of the curve at each point represents the distance of the medium at that point from its equilibrium position, the displacement of the medium, as it is called.

*Simple wave trains and compound wave trains.*—When a wave train passes through a medium, each particle of the medium oscillates. When each particle of the medium performs simple harmonic motion during the passage of a wave train, the wave train is called a simple wave train. A simple wave train is represented

graphically by a curve of sines,\* as shown in Fig. 43. When, during the passage of a wave train, the particles of the medium perform periodic movements which are not simply harmonic, the wave train is called a compound wave train. A compound wave

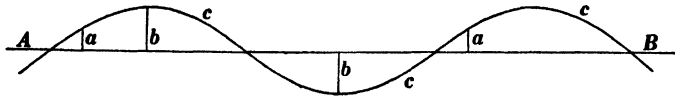

Fig. 43.

train is represented graphically by a periodic curve (a curve of which the successive portions are exactly alike), which is not a curve of sines.

The character of the motion of a medium during the passage of a simple train of longitudinal waves may be understood from Fig. 44, which represents a simple wave train traveling along a canal. Where the velocity of flow is greatest to the right, there the elevation of water surface is greatest, and where the velocity of flow is greatest to the left, there the depression of the water surface is greatest. The velocity of flow is represented by the

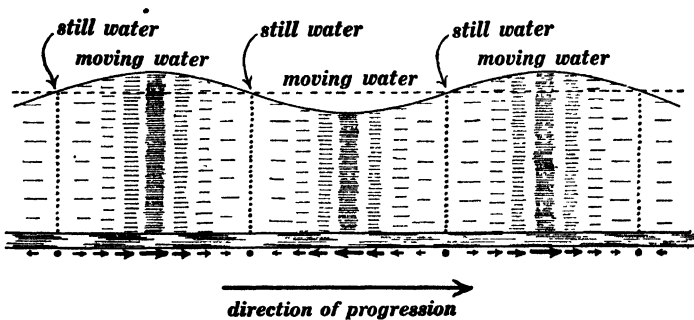

Fig. 44

shading and also by the horizontal arrows at the bottom of the figure. At certain points the water is at its normal level and immediately beneath these points the water is stationary. The

\* This is true whether the ordinates of the curve represent the velocity of the medium at each point or the displacement of the medium at each point.

entire state of motion as represented in Fig. 44 travels along at a definite velocity  $V$  which is usually many times as great as the actual velocity of flow of the water at any point in the wave train.

When a simple wave train (of longitudinal waves) travels along the air in a pipe or through the open air, the motion of the air is exactly like the motion of the water as represented in Fig. 44, but in this case compression of the air corresponds to elevation of the water surface, and rarefaction of the air corresponds to depression of the water surface.

**14. The wave front.** — Every one is familiar with the fact that waves on the surface of a pond always resolve themselves into *clearly defined ridges* at a distance from the disturbance, however complicated the disturbance may be. Thus, when a handful of pebbles is thrown into a pond, the wave motion in the immediate neighborhood of the disturbance is excessively complicated, but the waves become a clearly defined series of ridges at a considerable distance from the disturbance.

Consider a region  $AB$ , Fig. 45, on the surface of a pond,  $C$  being a distant center of disturbance. The above-mentioned fact

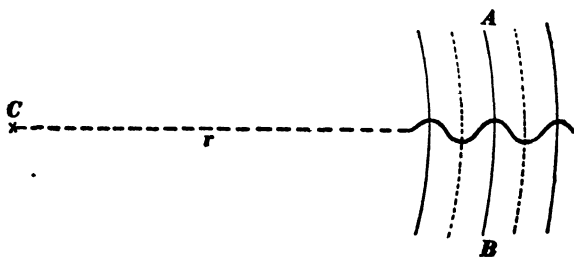

Fig. 45.

that the waves from  $C$  resolve themselves into clearly defined ridges at a distance from  $C$  means that all points on the water surface which lie in a certain line  $AB$  rise and fall together, or, in other words, the line  $AB$  on the water surface moves up and down as a whole as the waves pass by. Such a line is called a *wave front*.

Sound waves in the air and electromagnetic waves (or light waves) in the ether always resolve themselves at a great distance from the disturbance into a *clearly defined layer* or *series of layers* (if they could but be seen), and an indefinitely thin portion of such a layer moves up and down or to and fro \* as a whole and is called a *wave front*.

The direction of progression of a water wave is at right angles to its front. The direction of progression of a sound wave or light wave is at right angles to its front. †

A wave which has a plane front is called a *plane wave*; a wave which has a spherical front is called a *spherical wave*.

In extending the ideas of Art. 13 to waves in space, such as sound waves and electromagnetic waves, the idea of the wave front is of fundamental importance. Thus, the curve in Fig. 43 represents the displacements of the particles which normally lie along the straight line  $AB$ , and exactly similar curves represent the displacements of particles which normally lie on straight lines alongside of  $AB$  and parallel to  $AB$ ; that is, a given ordinate  $a$  of the curve in Fig. 43 represents the displacement of the medium at all points in a plane perpendicular to the line  $AB$ .

**15. Superposition of simple vibrations and superposition of simple wave trains. Fourier's theorem.** ‡—A particle may perform simultaneously two or more distinct vibratory movements; in such a case the vibrations are said to be superposed. Thus, if the hand be moved slowly up and down, and if at the same time

\* In the case of electromagnetic waves, it is not permissible to speak of the motion of the medium in the ordinary meaning of that term. This matter is discussed later.

† When the medium through which the wave passes has different properties in different directions, the direction of progression may not be at right angles to the front. Thus, in a substance like wood, which has a grained structure, a sound wave does not in general progress in a direction at right angles to its front, and in a crystal like Iceland spar, a light wave does not in general progress in a direction at right angles to its front.

‡ A simple treatise on Fourier's theorem in its application to problems in alternating currents is given in Part II. A very full mathematical discussion of Fourier's theorem is Byerly's *Fourier's Series and Spherical Harmonics*; Ginn & Co., 1893.

one finger be moved quickly up and down, the moving finger would trace a curve somewhat similar to the curve in Fig. 46.



Fig. 46.

In this example, one vibration is assumed to be of low frequency and the other of high frequency in order that the movements may not be too greatly confused; as a matter of fact, however, any number of vibratory movements, whatever their amplitudes and frequencies, may be performed by a particle simultaneously.

*Fourier's theorem.*—Any periodic vibration of frequency  $n$ , however complicated, may be matched by superposing simple vibrations of which the frequencies are  $n$ ,  $2n$ ,  $3n$ ,  $4n$ , and so on, provided that the respective amplitudes are properly chosen. That is to say, any given compound vibration of frequency  $n$  may be thought of as composed of a series of superposed simple vibrations of which the frequencies are  $n$ ,  $2n$ ,  $3n$ ,  $4n$ , and so on. Fourier's theorem may be stated geometrically as follows: Any periodic curve, the curve shown in Fig. 41, for example, may be matched by superposing a series of sine curves of which the wave lengths are  $\lambda$ ,  $\lambda/2$ ,  $\lambda/3$ ,  $\lambda/4$ , etc., where  $\lambda$  is the wave length of the given periodic curve. Therefore a compound wave train may be thought of as made up of a series of simple wave trains of which the wave lengths are as above specified. It is for this reason that a wave train which is not represented by a curve of sines is called a compound wave train.

**16. The physical and mathematical significance of Fourier's theorem in its application to oscillations and wave motion.**—The significance of Fourier's theorem may be best explained by referring to the familiar phenomena of sound. The fibers of the basilar membrane in the inner ear are the elements which respond to musical sounds. These fibers are more or less like pendulums and they perform approximately simple harmonic motion when

they are disturbed in any way. A compound wave train striking the ear affects those particular fibers of the basilar membrane which vibrate in unison with the respective simple wave trains which enter into the composition of the compound wave train. It is for this reason that the simple components of the compound wave train are important and significant; and the simple components of a compound vibration are significant because they produce simple wave trains or are produced by simple wave trains.

The simple-vibration components of a compound vibration and the simple-wave-train components of a compound wave train are important from the mathematical point of view because of the comparative ease with which a compound vibration or a compound wave train can be formulated mathematically in terms of these components.

It must be remembered that the terms *simple vibration* and *simple wave train* do not refer to simplicity in the ordinary sense; thus the extremely simple mode of oscillation of a stretched string which is described in connection with Fig. 29, is certainly much simpler than what is hereafter called a "simple mode of oscillation of a string," but the sound waves which are produced by the oscillating string in Fig. 29 have a complex action on the ear whereas the sound waves which are produced by a "simple mode of oscillation" in the special sense in which this term is used in the theory of sound, produce a simple effect on the ear.

A simple vibration and a simple wave train in the special sense in which these terms are used in this text are easily formulated mathematically and it is therefore convenient to resolve any given vibration or any given wave train into such components in the development of the mathematical theory of oscillations and of waves.

**17. Simple modes of oscillation of stretched strings and air columns.** — When a stretched string is pulled to one side and released, the string vibrates in a manner which is partially represented in Fig. 29, and more completely represented in Fig. 47. In Fig. 47,  $A_1B_1$  represents the configuration of the string at

the instant of release, and  $A_2B_2$ ,  $A_3B_3$ , etc., represent successive instantaneous configurations at intervals separated by eighths of

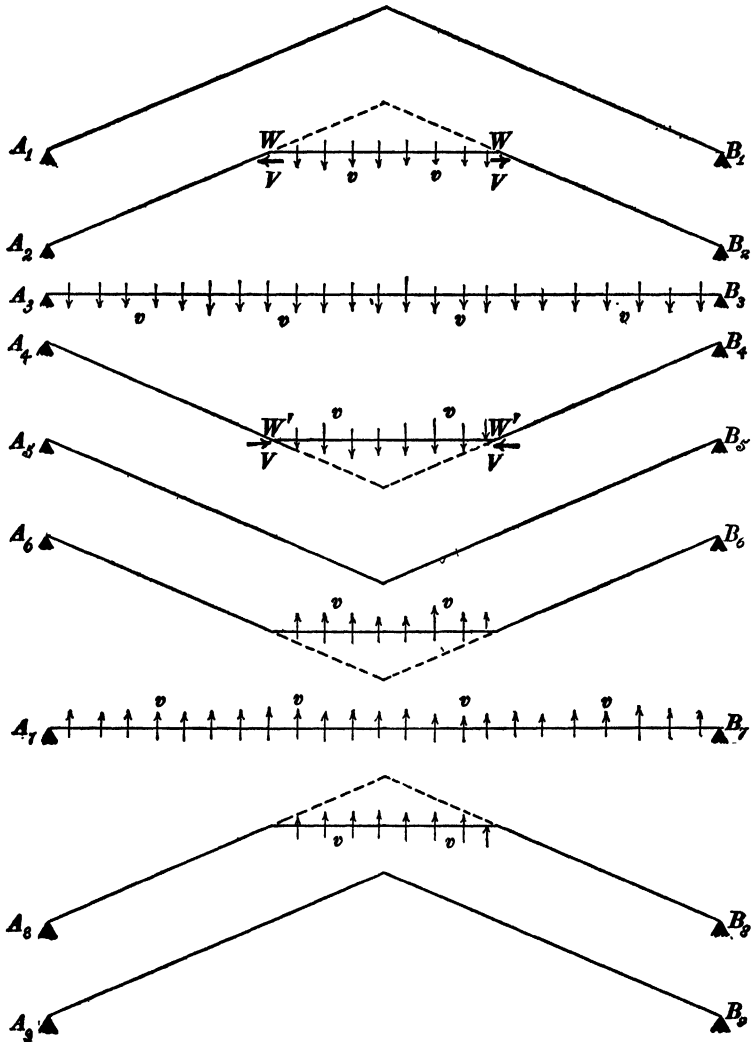

Fig. 47.

a period (time of one complete oscillation). The points  $WW$  (waves of starting) travel towards the ends of the string in the

sketch  $A_2B_2$ . The portion of the string between  $W$  and  $W'$  is straight and it moves sidewise at uniform velocity  $v$  as indicated by the small vertical arrows. When the waves of starting  $WW'$  reach the ends of the string, they are reflected, and they travel back towards the middle of the string as shown in  $A_4B_4$ , and so on.

Any given point of the string in Fig. 47 remains stationary until the wave of starting  $W$  in  $A_2B_2$  reaches it, the given point then moves at uniform velocity  $v$  until the reflected wave of arrest  $W'W'$  in  $A_4B_4$  reaches it, after which the point remains stationary for a time, and then it moves at constant velocity  $v$  in the reverse direction, and so on repeatedly.

Consider a long tube closed at both ends, and imagine the air in the tube to be slightly compressed in one end, and slightly rarefied in the other end by a gate valve  $G$  as shown in the upper part of Fig. 48. If the gate valve is suddenly opened, the

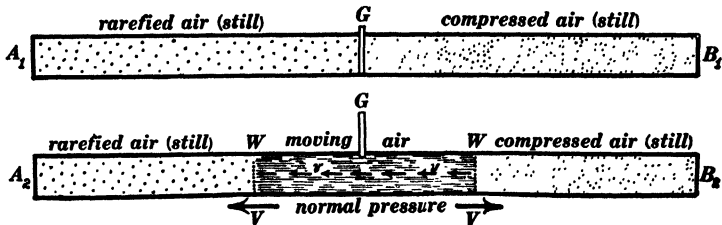

Fig. 48.

air at the middle of the tube suddenly falls to normal pressure, and is set in uniform motion as shown in the lower part of Fig. 48. This condition of uniform motion and normal pressure is established by two waves of starting  $WW'$  which travel towards the ends of the tube at the velocity of sound in air, and the air in the tube performs one complete oscillation during the time required for a sound wave to travel over twice the length of the tube. The oscillation of the air in the tube shown in Fig. 48 is exactly similar to the oscillation of the water in a short canal, as described in Art. 7, and it is precisely analogous to the oscillation of a string which is plucked at its center as shown in Figs. 29 and 47.

After the gate valve  $G$  in Fig. 48 is opened, the air at the middle of the tube remains always at normal atmospheric pressure, and the air in each half of the tube would oscillate in the

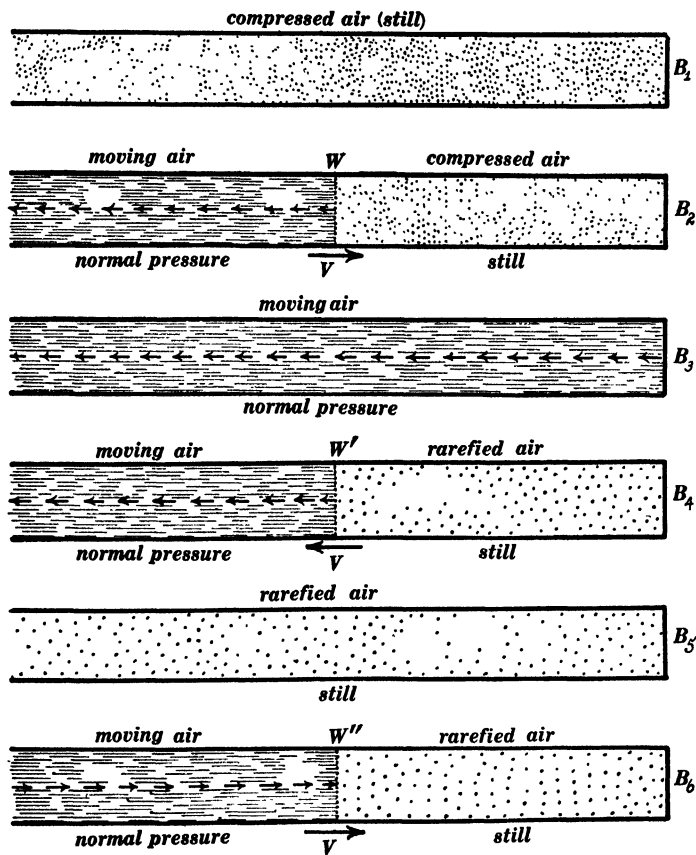

Fig. 49.

same way if the tube were cut in two at the middle and left open to the air. Thus, Fig. 49 represents six successive stages of the oscillation of the air in a tube (open at one end and closed at the other) in which at the start air is uniformly compressed. One complete oscillation takes place in the time required for a sound wave to travel over four times the length of the tube, as may be

seen by following the details of Fig. 49 carefully (Fig. 49 shows only five eighths of a complete oscillation).

*Simple modes of oscillation.* — In the above-described oscillations of strings and air columns each particle of the string or air column performs periodic motion which is very far from being simple harmonic motion. It is desirable, however, to consider those modes of oscillation of a string or air column in which each particle of the string or each particle of air *does* perform simple harmonic motion, because such a type of oscillation is easily formulated mathematically and because any other type of oscillation of a string or air column can be thought of as built up of a series of these simple modes in accordance with Fourier's theorem. *When every particle of an oscillating string or air column performs simple harmonic motion of a given frequency, the string or air column is said to oscillate in a simple mode.* Figure 50, for

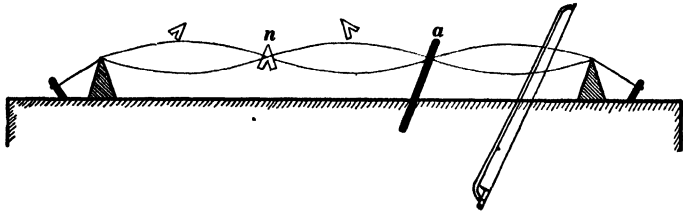

Fig. 50.

example, shows a string vibrating in a simple mode. Every particle of the string performs simple harmonic motion of the same frequency. A simple mode of oscillation of a string is frequently called a stationary or standing wave train, as explained in the following discussion.

It is evident from the discussion in Arts. 7, 10 and 11 that the oscillation of a string or air column involves wave motion along the string or air column, and a discussion of what are called simple modes of oscillation may be carried out with the greatest ease by considering the passage of a simple wave train (outgoing wave train) along a string or air column, and its reflection (returning wave train) from the end of the string or air column.

The superposition of the outgoing and returning wave trains gives what is called a standing wave train, and such a standing wave train constitutes a simple mode of oscillation of the string or air column.

*Standing wave trains.*—When one end of a stretched rubber tube is moved rapidly up and down, the tube quickly settles to a steady state of oscillation in which a series of points *nnnn* along the tube remain stationary, while the intervening portions of the tube surge up and down as indicated in Fig. 51. The

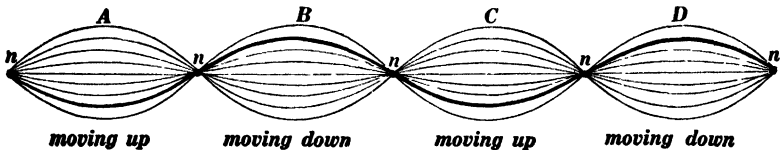

Fig. 51.

heavy line in Fig. 51 shows the position of the tube at a given instant, a snap-shot of the tube as it were. This oscillatory motion of the rubber tube, which is entirely devoid of progressive character is called a *standing wave train*. The stationary points *nnnn* are called *nodes*, the intervening portions of the vibrating tube or string are called *vibrating segments*, and the middle point of a vibrating segment is called an *antinode*. It is important to keep in mind the distinction between an advancing wave train (which is usually called simply a wave train) and a standing wave train. In an advancing wave train, no portion of the medium remains stationary; in fact, every particle of the medium moves in precisely the same way and to exactly the same extent, but not simultaneously, each succeeding particle being a little later in its movements. Thus, every particle of water in Fig. 44 oscillates to and fro, and the particles of water which at a given instant are stationary are merely at the extreme points of their oscillations. In a standing wave train, on the other hand, the medium does not move at all at the nodes, the amplitude of motion increases from node to antinode, and all the particles

move simultaneously; that is to say, all the particles in a vibrating segment move to and fro or up and down together. Furthermore, in an advancing wave train, the kinetic energy is at each point and at all times equal to the potential energy, whereas in a standing wave train the energy is at one instant wholly kinetic (at the instant when the rubber tube in Fig. 51 is straight), and one quarter of a period later the energy is wholly potential.

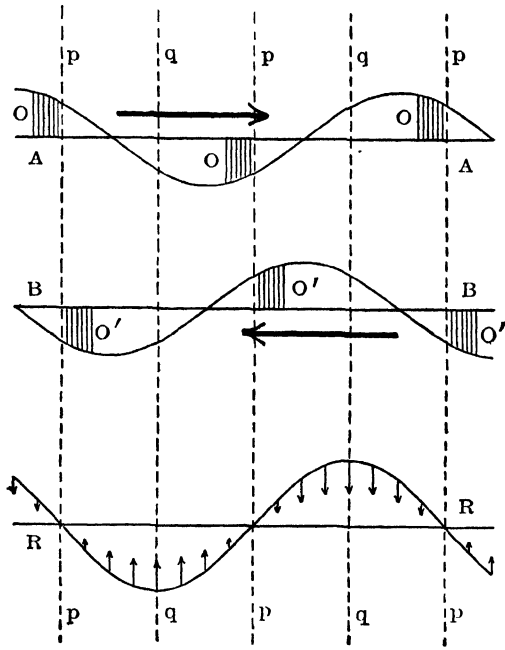

Fig. 52.

The discussion of the oscillatory motion of the water in a short canal, as carried out in Art. 7, involves the use of the idea of progressive wave motion, although the oscillation itself has no progressive character, and the most satisfactory method of studying the vibratory motion which is represented in Fig. 51 is to resolve the standing wave train into two oppositely moving (progressing) wave trains. Consider two similar progressing wave trains *AA*

and  $BB$ , Figs. 52, 53 and 54, moving in opposite directions as indicated by the heavy arrows. These wave trains are supposed to be traversing the same region at the same time, and  $AA$  is drawn above  $BB$  merely to avoid confusion. According to the principle of superposition, the actual displacement of each particle of the medium is equal at each instant to the sum of the displacements of that particle due to each wave train, and the actual

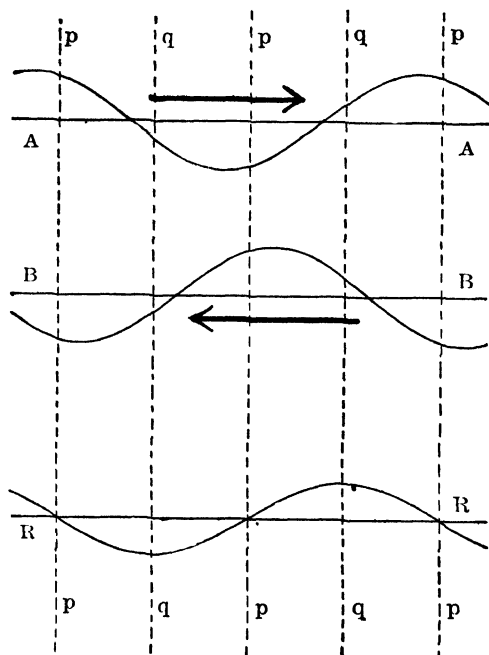

Fig. 53.

velocity of each particle at each instant is equal to the sum of the velocities of that particle due to each wave train. The ordinates  $O$  of the wave train  $AA$ , Fig. 52, which reach the points  $pppp$  as the wave train  $AA$  moves to the right are at each instant equal and opposite to the ordinates  $O'$  of the wave train  $BB$  which reach the points  $pppp$  as the wave train  $BB$  moves to the left. Therefore the points  $pppp$  of the medium remain

stationary. The regions between the points  $pp$ , on the other hand, move up and down (to right and left in the case of a longitudinal wave) as the two wave trains  $AA$  and  $BB$  travel through or over each other. The resultant of the two wave

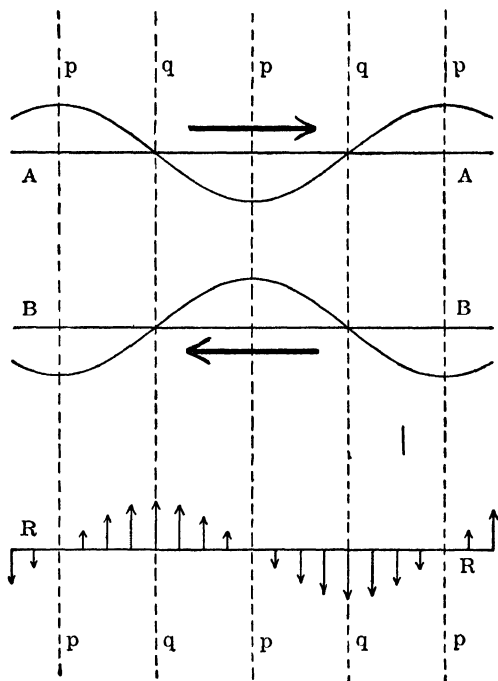

Fig. 54.

trains  $AA$  and  $BB$  is therefore a stationary wave train with nodal points at  $pppp$ .

Figure 52 shows the positions of the two wave trains  $AA$  and  $BB$  and their resultant  $RR$  at a given instant. The small vertical arrows in the sketch  $RR$  show the velocities of the various parts of the medium at the given instant. Figure 53 shows the positions of the two oppositely moving wave trains  $AA$  and  $BB$  and their resultant  $RR$  at a later instant when  $AA$  has moved  $\frac{1}{16}$  of a wave length to the right and  $BB$  has moved  $\frac{1}{16}$  of a wave length to the left. Figure 54 shows the positions of  $AA$

and  $BB$  and their resultant  $RR$  (a straight line) at a still later instant when  $AA$  has moved  $\frac{1}{8}$  of a wave length to the right and  $BB$  has moved  $\frac{1}{8}$  of a wave length to the left. The small vertical arrows in the sketch  $RR$  show the velocities of the various parts of the medium as before.

*Simple modes of vibration of strings.*—Consider an indefinitely long stretched string  $AB$ , Fig. 55, fixed to a rigid support at

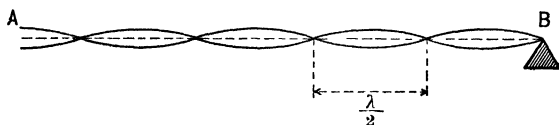

Fig. 55.

one end  $B$ . Imagine a simple wave train of transverse waves of wave length  $\lambda$  to approach the end  $B$ . This wave train will be reflected at  $B$ , the reflected train and advancing train will together form a standing wave train, and the nodes of this stationary wave train will be at a distance  $\lambda/2$  from each other, as shown in Fig. 55, the fixed end  $B$  of the string being also a node.

This standing wave train being once established, a rigid support might be placed under the string at any one of the nodes, and the string between this new support and  $B$  would continue its vibratory motion unchanged, except, of course, that its motion would be slowly stopped by friction. Therefore the length  $l$  of a vibrating string may be any multiple of  $\lambda/2$  or, rather,  $\lambda/2$  may be any aliquot part of  $l$ , where  $\lambda$  is the wave length of the two oppositely moving wave trains whose superposition constitutes the actual oscillatory motion of the string, that is,

$$l = \frac{n\lambda}{2} \quad (i)$$

where  $n$  is any whole number. Let  $V$  be the velocity with which a wave train travels along the stretched string, let  $\tau$  be the period of one oscillation of the string, and let  $f$  be the number of oscillations per second (the frequency). Then, we have

$$\lambda = V\tau \tag{ii}$$

as explained in Art. 13. Substituting this value of  $\lambda$  in equation (i) and solving for  $\tau$ , we have

$$\tau = \frac{2l}{nV} \tag{iii}$$

or since  $f = 1/\tau$ ,

$$f = \frac{nV}{2l} \tag{iv}$$

This equation expresses the frequency of oscillation of a string (vibrating in a simple mode) in terms of the velocity of progression  $V^*$  of waves along the string, and the length  $l$  of the string,  $n$  being any whole number.

When  $n$  is unity, the whole string is one vibrating segment, the string vibrates in what is called a *fundamental mode*, and gives what is called its *fundamental tone*. When  $n = 2$ , the string vibrates in two segments, when  $n = 3$ , the string vibrates in three segments, and so on.

*Simple modes of vibration of air columns.*—Consider an indefinitely long tube  $AB$ , Fig. 56, closed at one end  $B$ . Imagine

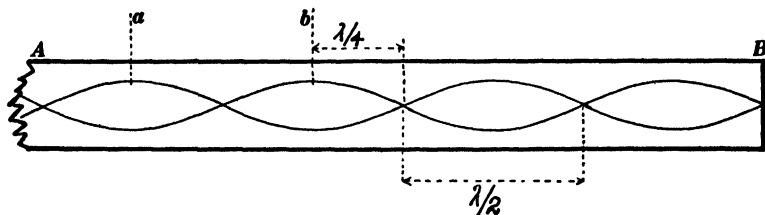

Fig. 56.

a simple wave train of longitudinal waves, of wave length  $\lambda$ , to approach the closed end  $B$ , in the tube. This wave train will be reflected at  $B$ , the reflected train and advancing train will together form a standing wave train, and the nodes of the standing wave train will be at a distance  $\lambda/2$  from each other, as shown in Fig. 56, the closed end  $B$  of the tube being also a

\* See equation (1), Art. 4.

node. Once this standing wave train is established, an air-tight gate-valve might be placed in the tube at any one of the nodes, and the air between this gate and the closed end  $B$  would continue its vibratory motion unchanged, except of course that its motion would be slowly stopped by friction. Therefore, the length  $l$  of a vibrating column (closed at both ends) may be any multiple of  $\lambda/2$ , or rather,  $\lambda/2$  may be any aliquot part of  $l$ , where  $\lambda$  is the wave length of the two oppositely moving wave trains whose superposition constitutes the actual vibratory motion of the air. Therefore

$$l = \frac{n\lambda}{2} \left( \text{tube} \begin{cases} \text{closed} \\ \text{open} \end{cases} \text{ at both ends} \right) \quad (\text{v})$$

in which  $n$  is any whole number. Substituting for  $\lambda$  the value  $V\tau$ , where  $V$  is the velocity of sound and  $\tau$  is the period of one oscillation of the air column, and solving for  $\lambda$  we have

$$\tau = \frac{2l}{nV} \left( \text{tube} \begin{cases} \text{closed} \\ \text{open} \end{cases} \text{ at both ends} \right) \quad (\text{vi})$$

or, since  $f = 1/\tau$ , we have

$$f = \frac{nV}{2l} \left( \text{tube} \begin{cases} \text{closed} \\ \text{open} \end{cases} \text{ at both ends} \right) \quad (\text{vii})$$

This equation expresses the frequency of oscillation of an air column (closed at both ends or open at both ends) in terms of the velocity of sound  $V$  and the length  $l$  of the column,  $n$  being any whole number.

The air pressure at any antinode of a standing wave train in Fig. 56 is invariable and equal to atmospheric pressure, although the air at an antinode surges back and forth (parallel to the axis of the tube). Therefore the tube may be cut off and left open at any antinode or at any two antinodes, such as  $a$  and  $b$ , Fig. 56, and the vibratory motion of the air in the detached portion  $ab$  (open at both ends), or in the detached portion  $bB$  (closed at one end) would continue unchanged, except that the motion would die away because of friction and because of the emission

of sound waves from the open end or ends. Therefore the length  $l$  of a vibrating air column which is open at both ends may be any multiple of  $\lambda/2$ , or, in other words,  $\lambda/2$  may be any aliquot part of  $l$ , so that equations (v), (vi) and (vii) apply to a tube open at both ends as well as to a tube closed at both ends.

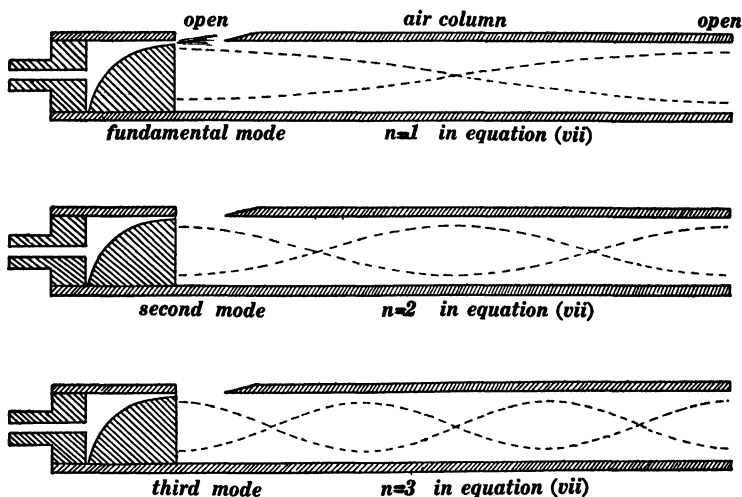

Fig. 57.

It follows also from the above statement, that the length  $l$  of a vibrating air column which is closed at one end may be any odd multiple of  $\lambda/4$ , where  $\lambda$  is the wave length of the two oppositely moving wave trains whose superposition constitutes the actual oscillatory motion of the air; that is,

$$l = \frac{n'\lambda}{4} \text{ (tube closed at one end)} \quad \text{(viii)}$$

in which  $n'$  is any odd number. Substituting for  $\lambda$  the value  $V\tau$ , where  $V$  is the velocity of sound and  $\tau$  is the period of one oscillation of the air column, and solving for  $\tau$ , we have

$$\tau = \frac{4l}{n'V} \text{ (tube closed at one end)} \quad \text{(ix)}$$

or, since  $f = 1/\tau$ , we have

$$f = \frac{n' V}{4l} \quad (\text{tube closed at one end}) \quad (x)$$

This equation expresses the frequency of oscillation of an air column (closed at one end) in terms of the velocity of sound  $V$  and the length  $l$  of the column,  $n'$  being any odd number.

The organ pipe is a device in which a column of air is set into vibration so as to produce a musical tone. Sectional views of

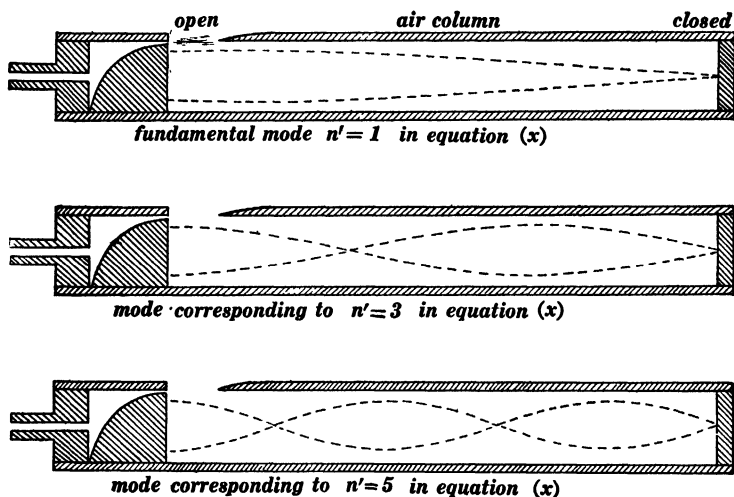

Fig. 58.

organ pipes are shown in Figs. 57 and 58. The dotted curves in Fig. 57 are intended to show the character of the oscillations of the air column in an organ pipe which is open at both ends, and the dotted curves in Fig. 58 are intended to show the character of the oscillations of the air in an organ pipe which is closed at one end. The oscillatory motion of the air in Figs. 57 and 58 is to and fro along the tube.

## CHAPTER III.

### ELECTROMAGNETIC ACTION.

#### 18. Mechanical conceptions of magnetic and electric fields.\*—

Before proceeding to the discussion of electromagnetic waves, it is helpful to establish clear ideas of electromagnetic action on the basis of which electromagnetic wave motion may be understood. In no other way is it possible to gain a simple physical insight into this subject. Maxwell was the first to work out clear conceptions of magnetic and electric fields, and Maxwell's conceptions are used in the present chapter. Everything in the present chapter refers strictly to two dimensions; certain inconsistencies arise in the attempt to extend Maxwell's conceptions to three dimensions.

*Maxwell's mechanical model of the ether.*—The ether is to be considered as built up of very small cells of two kinds, positive cells and negative cells, in such a way that only unlike cells are in contact. These cells are imagined to be gear wheels provided with rubber-like teeth so that if a cell be turned while the adjacent cells are kept stationary then a torque due to the elastic distortion of the gear teeth is brought to bear upon the turned cell. Figure 59 shows five positive cells and four negative cells geared together

\* Sir Oliver Lodge's *Modern Views of Electricity* is perhaps the best elementary treatise on this subject.

The most complete mechanical conception of the electromagnetic field is that which is based upon Lord Kelvin's gyrostatic model of the ether. This gyrostatic model of the ether is a mechanical structure which is capable of reproducing most of the known phenomena of electricity and magnetism and of light. See *Aether and Matter*, by Joseph Larmor, Appendix E, Cambridge, 1900. Lord Kelvin's gyrostatic model of the ether has led to a hydrodynamic conception of the ether, due chiefly to Larmor, in which the ether is assumed to be a perfect fluid which is endowed with the necessary elastic properties by an indefinitely fine-grained whirling motion. On the basis of Lord Kelvin's gyrostatic conception of the ether and also on the basis of Larmor's turbulent ether, the magnetic field is thought to consist of a simple flow of the ether along the lines of force of the magnetic field. This conception of the magnetic field is very different from the conception (Maxwell's) which is outlined in this text.

in the manner specified. In subsequent figures, these cells or cog-wheels are represented by plain circles for the sake of simplicity.

*Conception of the magnetic field.*—The ether cells at a point in a magnetic field are thought of as rotating about axes which are parallel to the direction of the magnetic field at the point, the angular velocity of the cells being proportional to the intensity of the field. The positive cells rotate in the direction in which a right-handed screw would be turned that it might move in the direction of the field, and the negative cells rotate in the opposite direction. This opposite rotation of positive and negative cells is mechanically possible because unlike cells only are geared

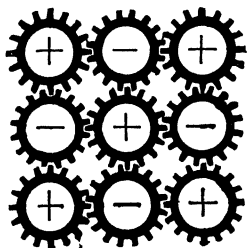

Fig. 59.

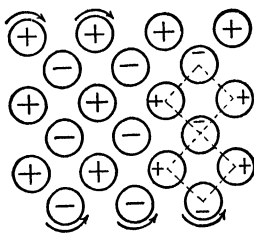

Fig. 60.

together. Thus, in Fig. 60, the positive cells are represented as rotating in a clockwise direction, and the negative cells as rotating in a counter-clockwise direction; this is a state of motion which represents a magnetic field perpendicular to the plane of the paper and directed away from the reader. The energy of the magnetic field is represented by the kinetic energy of rotation of the ether cells.

*Conception of the electric field.*—The positive ether cells at a point in an electric field are thought of as being displaced in the direction of the field while the negative cells are displaced in the opposite direction, and this displacement is assumed to be proportional to the electric field intensity. Thus, Fig. 61 represents the positive cells as being displaced towards the bottom page relatively to the negative cells, as shown by the arrows, that is to say, the distortion of the ether structure which is shown in Fig.

61 represents an electric field directed towards the bottom of the page. Figure 62 shows two meshes of the cellular structure of the distorted ether of Fig. 61. These two meshes are square in the undistorted ether as shown in Fig. 60, whereas the downward displacement of the positive cells in Fig. 61 has distorted these meshes as shown in Figs. 61 and 62. Inasmuch as the cell structure of the ether is assumed to be elastic (the gear teeth in Fig. 59 being made of substance like rubber), the distortion of the ether structure which is shown in Fig. 61 represents potential energy, and this energy is the energy of the electric field.

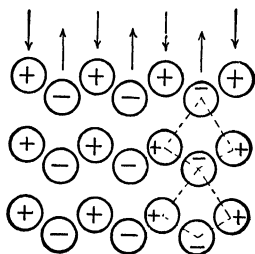

Fig. 61.

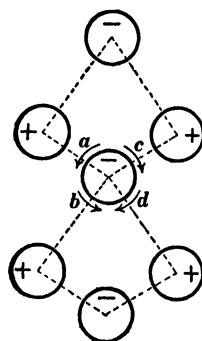

Fig. 62.

An understanding of the magnetic action of what may be called a tapering electric field may be arrived at by considering the torque action which is exerted upon a given cell by the elastic distortion which is represented in Figs. 61 and 62. Consider the two positive cells to the left of the middle cell in Fig. 62; these two positive cells have been displaced downwards with respect to the middle cell, and they exert torques upon the middle cell which are represented by the small curved arrows *a* and *b*. Consider the two positive cells to the right of the middle cell in Fig. 62; these two positive cells have been displaced downwards with respect to the middle cell, and they exert torques upon the middle cell which are represented by the small curved arrows *c* and *d*. If the electric field is uniform (same value on both sides

of the middle cell in Fig. 62), then the torques  $a$  and  $b$  balance the torques  $c$  and  $d$ , and the distortion which is represented in Fig. 61 has no influence upon the rotatory motion of the cells.

*Magnetic action of a tapering electric field.* — Imagine an electric field of which the lines of force are straight, as shown in Fig. 63, but of which the intensity falls off as shown in Fig. 63,

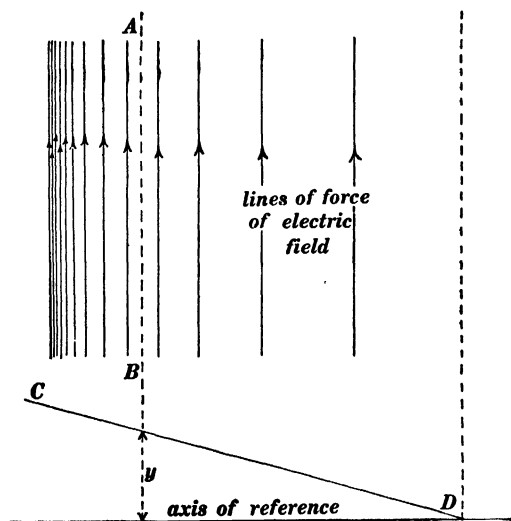

Fig. 63.

that is to say, the intensity of the electric field along any line  $AB$  in Fig. 63 is represented by the ordinate  $y$  of an inclined straight line  $CD$ . Such an electric field is called a *tapering field* for the sake of brevity. Imagine the ether cells in Fig. 61 to be displaced in a manner to represent the tapering electric field of Fig. 63. Then the two positive cells to the left of the middle cell in Fig. 62 are displaced downwards more than the two positive cells to the right of the middle cell in Fig. 62, so that the two torques  $a$  and  $b$  exceed the two torques  $c$  and  $d$ , that is, the middle cell is acted upon by an unbalanced torque, and, therefore, the middle cell must be gaining angular velocity about an axis perpendicular to the plane of the paper. What is here

said of this particular cell is true of all the ether cells in Fig. 61 in the case of a tapering electric field; therefore, *a tapering electric field produces a continuously increasing magnetic field at right angles to itself.\**

This magnetic action of a tapering electric field is exactly analogous to the dynamic action of an inclined water surface, as explained in connection with Fig. 7.

*Electric action of a tapering magnetic field.* — Hereafter a chain of geared cells which is free from distortion will be thought of as standing in a straight

row as shown in Fig. 64a, and the opposite displacements of positive and negative cells which

constitute an electric field will be thought of as changing such a straight

row to a zigzag row, as shown in Fig. 64b. Con-

sider a number of geared cells which tend by an elastic action of any kind to stand in a straight row like Fig. 64a. Such a row is converted into a zigzag row as shown in Fig. 64b if the cell *a* is turned while the cell *b* is kept stationary.

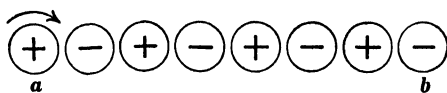

Fig. 64a.

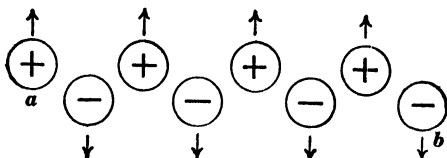

Fig. 64b.

Figure 65 represents a tapering magnetic field the intensity of which at any place *AB* is represented by the ordinate *y* of the inclined straight line *CD*. Looking endwise at the lines of force of the magnetic field one may, as it were, see the ether cells rotating as shown by the curved arrows in the end view, Fig. 65, cell

\* This is a modified form of statement of the law of induced electromotive force. It is a verbal statement of the differential equation

$$\frac{dM}{dt} = A \frac{dZ}{dx}$$

in which *M* is the *y* component of magnetic field, and *Z* is the *z*-component of electric field. This differential equation is derived and discussed in Chapter VI.

*a* rotating at high speed and cell *b* being stationary. The result of this difference of speed is to cause an increasing zigzag distortion of the chain of ether cells *ab*, and this zigzag distortion constitutes an electric field at right angles to the magnetic

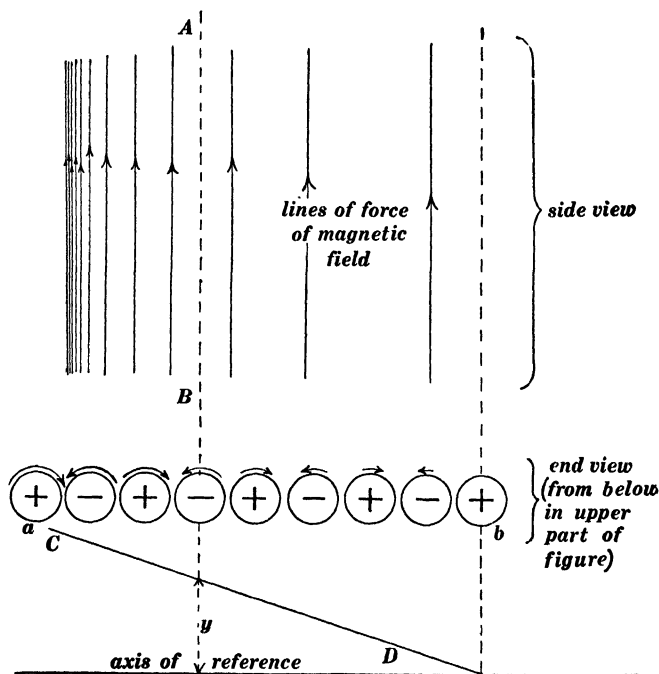

Fig. 65.

field in Fig. 65, that is to say, *a tapering magnetic field produces a continuously increasing electric field at right angles to itself.\**

This electric action of a tapering magnetic field is exactly analogous to the action of a "tapering" velocity of flow of the water in a canal, as explained in connection with Fig. 7.

\* This is a modified form of statement of the law of induced magnetomotive force. It is a verbal statement of the differential equation

$$\frac{dY}{dt} = A \frac{dN}{dx}$$

in which *Y* is the *y*-component of electric field and *N* is the *x*-component of magnetic field. This differential equation is derived and discussed in Chapter VI.

*The electric current.* — Consider a wire\*  $AB$ , Fig. 66, along which an electric current is flowing steadily from  $B$  towards  $A$ . The magnetic field on opposite sides of  $AB$  is in opposite directions, so that the positive ether cells at  $p$  and  $p'$  are rotating in opposite directions as indicated. A steady electric current may be maintained for an indefinite length of time, but the opposite rotations of positive ether cells on the two sides of  $AB$ , Fig. 66, cannot be accom-

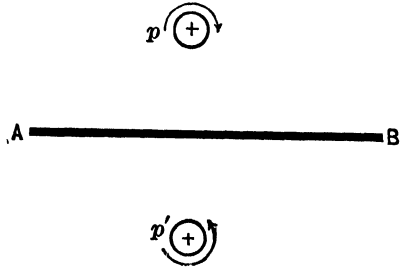

Fig. 66.

modated by an ever-increasing ether distortion (distortion of the rubber-like teeth of the ether cells as shown in Fig. 59), there must be a slip between adjacent cells somewhere between  $p$  and  $p'$ . This slip between adjacent ether cells takes place in the material of the wire and constitutes the electric current.

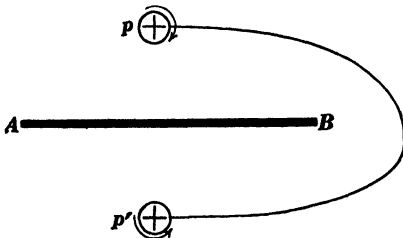

Fig. 67.

Steady electric currents flow in closed circuits. Maxwell's conception of the ether shows that this must be true as follows: Consider the opposite rotations of like ether cells at  $p$  and  $p'$ , Fig. 66, and consider a chain of geared cells passing from  $p$

to  $p'$  around the end of  $AB$  as shown by the curved line in Fig. 67. The current in  $AB$  is assumed to be maintained indefinitely and therefore the opposite rotation of  $p$  and  $p'$  is assumed to continue indefinitely, but this continued opposite rotations of  $p$  and  $p'$  cannot be accommodated by ever-increasing distortion of the elastic gear teeth of the ether cells along the chain which

\* Strictly, a broad metal sheet. Maxwell's conceptions apply to two dimensions only.

passes around the end of  $AB$ , a slip must take place between adjacent cells at some point along this chain. Therefore the line of flow of the current  $AB$  (line of slip of geared cells) must form a closed circuit which cuts across every possible chain of geared cells extending from  $p$  to  $p'$ .

When a current flows along a path which does not form a closed circuit, then an increasing ether distortion (electric field) is produced around the end portions of the path as explained in Art. 21.

**19. The flow of energy in the electromagnetic field. Poynting's theorem.** — It has been shown by J. H. Poynting\* from theoretical considerations that energy streams through an electromagnetic field in a direction at right angles both to the electric field and to the magnetic field at each point, and that the amount of energy per second which streams across one square centimeter of area is proportional to the product of the electric and magnetic field intensities. If the electric and magnetic fields are not at right angles to each other, the energy stream is proportional to the product of the intensities of the two fields and the sine of the included angle.

*Conception of the energy stream.* — Consider a row of gear wheels, as shown in Fig. 68. Imagine the wheel  $W$  to be

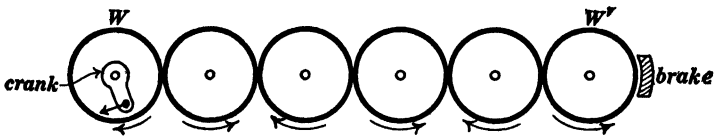

Fig. 68.

turned steadily by a crank, and the wheel  $W'$  to be hindered by a brake. Under these conditions, energy would be continuously transmitted along the chain of gear wheels from  $W$  to  $W'$ . Each wheel of the chain would be acted upon by equal and opposite torques by the wheels on either side of it, the trans-

\* See *Philosophical Transactions*, Vol. 175, Part II, page 343, 1884. This original paper by Poynting is well worth reading.

mission of energy along the chain would depend upon this torque action combined with the rotatory motion of the wheels, and the rate at which energy would be transmitted along the chain would be proportional to the product of the speed of the wheels and the torque action between adjacent wheels.

Imagine the ether cells in Fig. 61 to be rotating, positive cells in one direction and negative cells in the other direction, about axes perpendicular to the plane of the paper. This rotatory motion constitutes a magnetic field perpendicular to the plane of the paper and perpendicular to the electric field which is towards the bottom of the page in Fig. 61. On account of the torque action between the cells (as explained in connection with Fig. 62) combined with the rotation of the cells, energy is transferred to the right (or left) by each horizontal chain of geared cells in Fig. 61 at a rate which is proportional to the product of the intensity of the magnetic field and the intensity of the electric field; and the energy per second flowing across an area (at right angles to both electric and magnetic fields) is proportional to the product of the respective field intensities and proportional to the area, inasmuch as the area determines the number of rows of cells which participate in the transfer of the energy.

**20. Examples of Poynting's theorem.** (a) *The flow of energy in the neighborhood of a wire carrying an electric current when no electric charge resides on the surface of the wire.*—In general, the surface of a wire which carries an electric current is charged,\*

\*The component of the electric field which is parallel to the surface of a wire is always equal to  $RI$ , where  $R$  is the resistance of the wire per centimeter of length, and  $I$  is the current flowing in the wire; but the component of the electric field at right angles to the surface of the wire may have any value whatever. The electric lines of force which terminate on the surface of the wire on account of the existence of this normal component of the electric field involve a stationary electric charge on the surface of the wire. The electric current may be considered to be a transfer of electric charge along a wire, but the stationary charge here referred to has nothing directly to do with the current. When a voltaic cell is on open circuit, the electric field in the surrounding region may be such that the volts per centimeter along a given *path* may vary in the most irregular way; but when this path is occupied by a wire through which the voltaic cell produces current, then the electric field in the whole

and this charge is associated with the lines of force of electric field which is perpendicular to the surface of the wire. There is always a point on any wire circuit, however, where the wire is not charged or, in other words, where the electric field is parallel to the surface of the wire. In any case, it is permissible to consider that *part* of the energy flow which depends upon the component of the electric field parallel to the wire. Figure 69 shows

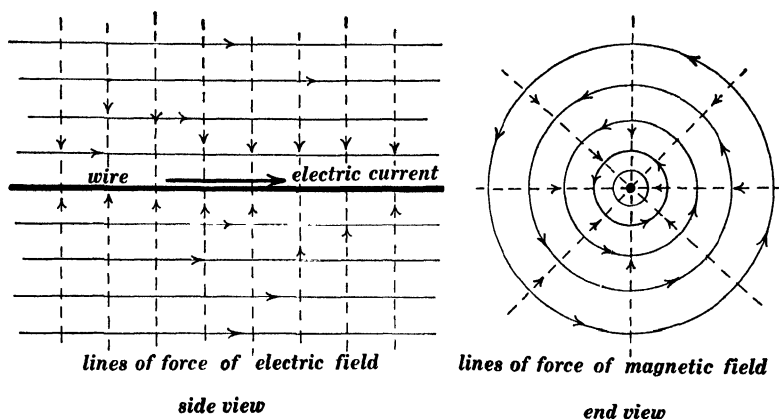

Fig. 69.

a straight wire carrying electric current. The lines of force of the electric field are parallel to the wire as shown in the side view, and the lines of force of the magnetic field encircle the wire as shown in the end view. The dotted lines represent the energy stream which flows in towards the wire from all sides.

The equation for the energy stream in an electromagnetic field surrounding region is modified by the stationary charge on the surface of the wire so as to make the component of the electric field parallel to the wire everywhere equal to  $RI$ , as above specified. Energy appears in each unit length of the wire at the rate of  $RI^2$  ergs per second. This amount of energy must flow into every unit length of the wire, and the electric field in the neighborhood of the wire must be so distributed as to give this necessary distribution of the energy stream. It is to be remembered that the trend of the magnetic field in the neighborhood of an electric circuit depends only on the shape of the circuit but not at all on the relative resistances of the various parts of the circuit, and, therefore, the proper distribution of the energy stream to supply the  $RI^2$  losses at each part of a circuit depends, one might say, chiefly upon the modification of the electric field due to surface charges on the wire.

may be established by considering the inward flow of energy in the neighborhood of a wire carrying an electric current as follows: Let  $R$  be the resistance of the wire in abohms per centimeter of length, and let  $I$  be the current in the wire in abamperes, then  $RI$  is the intensity of the surrounding electric field in abvolts per centimeter. The intensity of the magnetic field at a distance of  $r$  centimeters from the axis of the wire is  $2I/r$  gaussses.\* The intensity of the energy stream (ergs of energy per second per square centimeter) at points distant  $r$  centimeters from the axis of the wire is proportional to the product of the electric field and the magnetic field intensities, and it may therefore be written  $k \times RI \times 2I/r$ , where  $k$  is an unknown proportionality factor. Multiplying this expression for the intensity of the energy stream by the area of a cylindrical surface  $l$  centimeters in length and  $r$  centimeters in radius (cylindrical surface coaxial with wire), we have the total ergs per second streaming into  $l$  centimeters of the wire, and this must be equal to  $l \times RI^2$ . Therefore we have

$$2\pi r l \times k \times RI \times \frac{2I}{r} = l \times RI^2$$

whence

$$k = \frac{1}{4\pi}$$

Therefore, we have in general

$$S = \frac{1}{4\pi} H e \quad (4)$$

in which  $S$  is the energy in ergs per second which streams across one square centimeter of area at right angles to a magnetic field of which the intensity is  $H$  gaussses and at right angles to an electric field of which the intensity is  $e$  abvolts per centimeter,  $H$  and  $e$  being at right angles to each other.

(b) *The flow of energy in the neighborhood of wires assumed to be of zero resistance.*—In this case the component of the electric field parallel to the surface of the wires is equal to zero, and the

\* See Franklin and MacNutt's *Elements of Electricity and Magnetism*, page 101.

only electric field which exists, if any, is that which is associated with charges on the surfaces of the wires or ribbons. An ideally simple case is shown in Fig. 70, in which *AA* and *BB* are straight wires (ribbons), assumed to be of zero resistance, which deliver current from a voltaic cell to a fine resistance wire (ribbon) *w*. The electric field between the ribbons *AA* and *BB* is uniform, and the lines of force of the electric field are represented by the fine horizontal lines in the figure; the intensity of the electric field is equal to the electromotive force of the voltaic cell divided by the distance between the ribbons. The magnetic field between the ribbons is uniform, and the lines of force of the magnetic field are perpendicular to the plane of the paper in Fig. 70 as indicated by the dots between *AA* and *BB*. The energy stream, being everywhere at right angles to the electric and magnetic fields, is straight upwards as indicated by the dotted arrows. If the wires (ribbons) in Fig. 70 have resistance, then the lines of force of the electric field turn slightly downwards (in the figure) near each ribbon on account of the  $RI$  drop along the ribbons, and the energy stream, instead of flowing straight upwards, turns to some extent into the ribbons where

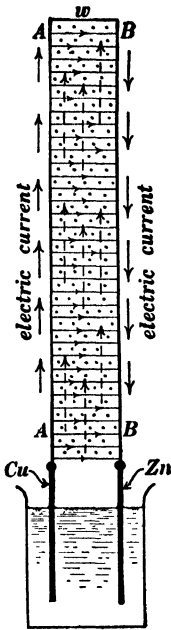

Fig. 70.

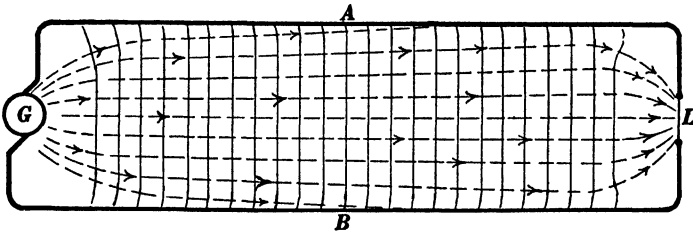

Fig. 71.

it appears as the  $RI^2$  loss. This is shown roughly in Fig. 71 which represents the flow of energy from a generator along a

transmission line  $AB$  to a distant lamp  $L$ . It is impracticable in this case to represent the exact trend of the lines of force of the electric and magnetic fields in the neighborhood of the generator and in the neighborhood of the lamp.\*

(c) *The flow of energy in an electromagnetic wave.*—The energy in an electromagnetic wave flows continuously from the back part of the wave to the forward part of the wave, as explained in Art. 23, and this energy flow is due to the coexistence of electric and magnetic fields at right angles to each other in the wave.

**21. The Hertz oscillator.**—A clear understanding of the details of action of the Hertz oscillator depends upon an insight into what

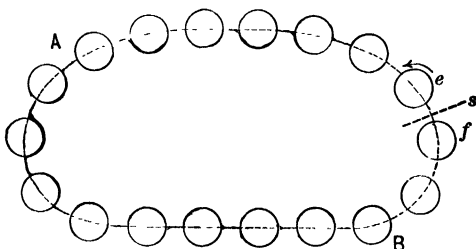

Fig. 72.

takes place when a condenser is charged and discharged. Before discussing the Hertz oscillator, therefore, it is necessary to consider the charge on a condenser and its mode of disappearance when the condenser plates are connected by a wire. Consider a closed (endless) chain of gear wheels  $AB$ , Fig. 72, which tend to stand in a smooth row. If the gears are allowed to slip at any point  $s$ , the gear  $f$  being held stationary and the gear  $e$  being turned in the direction of the arrow, then the chain of gears will be distorted into a zigzag row, as shown in Fig. 73. Conversely,

\* Some examples of the theorem of energy flow are given in Poynting's original paper in the *Philosophical Transactions* for 1884. Some interesting examples of Poynting's theorem are given by W. S. Franklin, in the *Physical Review*, Vol. XIII, pages 165-181, 1901. The details of field distribution and energy flow in the neighborhood of two long parallel cylindrical conductors (line wires) are given by G. Mie, *Zeitschrift für Physikalische Chemie*, Vol. XXXIV, page 522.

a chain of geared cells which by elastic action tend to stand in a smooth row, will be relieved from such a zigzag distortion as shown in Fig. 73 by permitting the gears to slip at any point  $s$ ,

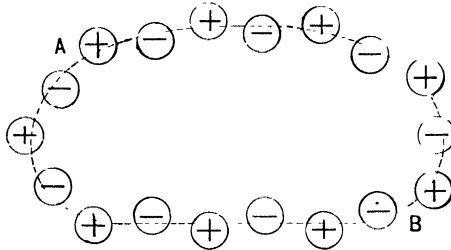

Fig. 73.

and the potential energy stored in the distorted chain will be geared towards  $s$  from both sides.

Let  $A$  and  $B$ , Fig. 74, be two metal plates, and let the dotted lines represent closed chains of geared ether cells, each

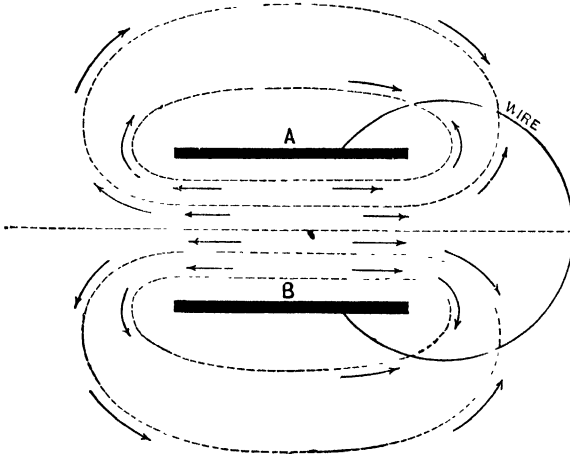

Fig. 74.

chain being like Fig. 72. Imagine the two plates  $A$  and  $B$  to be connected by a wire,\* and an electric current to be forced

\* Strictly the wire in Fig 74 must be thought of as a broad ribbon. All figures in this discussion represent two dimensional distributions of electric and magnetic fields.

through this wire by means of a voltaic cell, thus causing the plates  $A$  and  $B$  to become charged. The forcing of electric current through the wire means a forced slipping of ether cells at every point of the wire, and each chain of geared cells, initially like Fig. 72 becomes distorted like Fig. 73. Throughout the region between  $A$  and  $B$ , the positive ether cells are displaced downwards and the negative ether cells are displaced upwards, that is, the region between  $A$  and  $B$  becomes an electric field, the direction of which is downwards from the positively charged plate  $A$  to the negatively charged plate  $B$ .

Given two charged metal plates  $A$  and  $B$  as above explained, each dotted curve in Fig. 74 being supposed to represent an endless *zigzag* chain of ether cells like Fig. 73. Then a wire (ribbon) connected from  $A$  to  $B$  will cut across every one of the *zigzag* chains of geared ether cells, slipping will begin at every point on the wire, each *zigzag* chain of cells will begin to be relieved from its *zigzag* distortion, the energy of each distorted chain will be transmitted along the chain to the wire where it will appear as heat, and the entire region between and surrounding the plates  $A$  and  $B$  will be relieved from electrical stress. The explanation here given of the entire relief of the electrical stress between two plates by the establishment of a conducting line (line of slip) between them applies to two adjacent oppositely charged bodies of any shape. An electric spark is a line of slip (a conducting line), and the energy of the electric field flows in upon the spark as it does upon a wire. The slipping of ether cells in a conductor is imagined to be opposed by a frictional drag.

*The Hertz oscillator.* — Let  $A$  and  $B$ , Fig. 75, be two metal balls connected to two short rods between which is an air gap (spark gap). Imagine charge to have been collecting on  $A$  and  $B$ , positive charge on  $A$ , negative charge on  $B$ , until a spark jumps across the air gap, thus establishing a conducting path from  $A$  to  $B$ , and causing  $A$  and  $B$  to be discharged. This discharge is usually oscillatory like the movement of a string which is pulled to one side and suddenly released, as follows: Consider

a chain of geared ether cells which when undistorted lies smoothly along the dotted line in Fig. 75, this dotted line being everywhere perpendicular to the lines of force of the electric field. When  $A$  is positively charged this chain is distorted as shown (in part), but, inasmuch as it is a closed chain, its distortion is fixed as explained in connection with Fig. 73. When a spark is formed across the gap, however, a line of slip is established which cuts across the distorted chain, and the distortion disappears as explained in con-

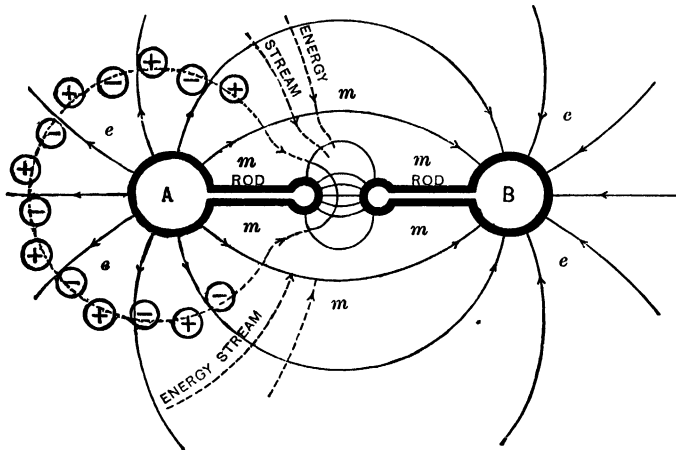

Fig. 75.

nection with Figs. 72, 73 and 74. What is said of the single chain of ether cells is true of every chain which surrounds  $A$  or  $B$  in Fig. 75.

If the slip which relieves the distortion of the chain of ether cells takes place with great friction (great electrical resistance of the conducting path formed by the spark), the cells near the spark begin turning slowly and the entire energy of the distorted chain is geared into the spark and converted at once into heat. If the slip which relieves the distortion of the chain of ether cells is almost frictionless (low electrical resistance of the conducting path formed by the spark), then the energy of the distorted chain is used mainly in overcoming the inertia of the cells in the neighborhood of the spark as they are set rotating, and after a very short

interval of time the whole of the electrical energy will have been converted into kinetic energy of the rotating cells (magnetic energy). During this conversion the energy, streaming along the dotted lines in Fig. 75, largely disappears from the regions *ee* and *ee* and is distributed mainly in the region *mmm*. When the chains of ether cells have been relieved from distortion, the rotatory motion of the ether cells in the region *mmm* will have reached a maximum, and the cells will continue to rotate because of their momenta, thus producing reversed distortion of each chain of ether cells. During the time that this reversed distortion is being produced the energy streams back from the region *mmm* to the regions *ee* and *ee*, being converted again into potential energy of ether distortion, and the balls *A* and *B* become charged in a reversed sense. This reversed distortion of the chains of ether cells is then relieved by a reversed slip (a reversed current in the rods and along the spark), and the above-described action is repeated over and over again until the original energy of the electric field has been dissipated.

When one end of a stretched rubber tube is held in the hand and moved up and down slowly, the tube has time to accommodate itself to the changing position of the hand. If, however, the hand is moved up and down rapidly, the portions of the tube remote from the hand do not follow the changing position of the hand promptly, and the result is that waves are produced which pass out from the moving hand. The oscillatory changes above described in connection with Fig. 75 take place so rapidly that the portions of the distorted ether which are remote from the oscillator do not follow the changes promptly. This gives rise to electrical waves which pass out from the oscillator. In the immediate neighborhood of the oscillator the action is rather complicated, but at a distance from the oscillator the wave motion becomes very simple.\* The following chapter is devoted to the discussion of electric waves.

\*Hertz's researches on electric waves, experimental and theoretical, have been published in book form (see *Electric Waves* by Heinrich Hertz, translated by D. E. Jones, Macmillan and Company, 1893).

A very good discussion of Hertz's experimental researches is given by J. A. Fleming on pages 306-326 of his *Principles of Electric Wave Telegraphy*, Longmans, Green and Company, 1908.

A good discussion of the mathematical theory of the Hertz oscillator is given by Fleming on pages 326-352 of his *Principles of Electric Wave Telegraphy*. This theoretical discussion of Fleming's follows the original paper by Hertz which was published in 1889 (see pages 137-159 of Hertz's *Electric Waves*).

## CHAPTER IV.

### ELECTROMAGNETIC WAVES.

**22. An electromagnetic wave** is a state of ether distortion and a state of ether motion traveling along together and mutually sustaining each other. The ether distortion is *electric field* and the ether motion is *magnetic field*. An electromagnetic wave may be either *bounded*, or *free* in the same way that a sound wave may be bounded or free. Thus, a sound wave which travels along a speaking tube is bounded, and a sound wave which travels through the open air is free; an electric wave which travels along a transmission line is bounded, and an electric wave which travels through open space is free. In the following discussion of electromagnetic waves, bounded waves will be treated first because of their greater simplicity, and free waves will be treated afterwards.

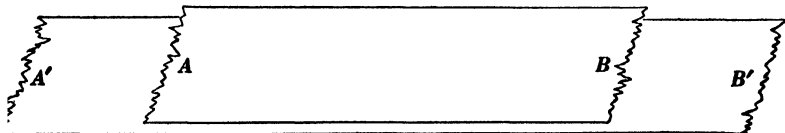

Fig. 76.

*Electromagnetic wave pulse bounded by two metal ribbons.*— Figure 76 is a perspective view of two broad parallel metal ribbons  $AB$  and  $A'B'$ , and Fig. 77 is an edgewise view of the two metal ribbons of Fig. 76 with a rectangular\* electromagnetic wave pulse represented as traveling along between them at velocity  $V$ . The fine vertical lines represent the electric field which is directed towards the top of the page, and the dots repre-

\* The ordinate  $y$  of the rectangle in the lower part of Fig. 77 represents the value of electric field or the value of the magnetic field throughout the wave. Compare Fig. 77 with Fig. 6.

sent the lines of force of the magnetic field which is perpendicular to the plane of the paper and directed towards the reader. *An electromagnetic wave pulse consists of a layer of electric field and magnetic field, the lines of force of the electric field and the lines of*

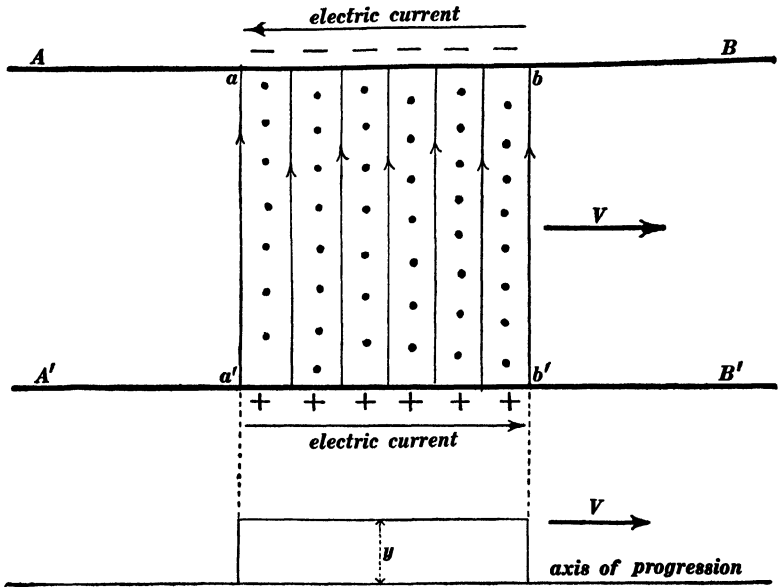

Fig. 77.

*force of the magnetic field lie in the plane of the layer and at right angles to each other, and the entire layer moves sidewise at a definite velocity  $V$  (the velocity of light).*

Where the lines of force of the electric field emanate from the lower ribbon  $A'B'$  in Fig. 77, the ribbon has a positive electric charge, and where the lines of force of the electric field terminate on the upper ribbon  $AB$  in Fig. 77, the ribbon has a negative electric charge. Furthermore, the portion  $a'b'$  of the lower ribbon in Fig. 77 which bounds the magnetic field of the wave has an electric current flowing in it in the direction of progression of the wave as indicated by the arrow, and the portion  $ab$  of the upper ribbon in Fig. 77 which bounds the magnetic field of the wave has an electric current flowing in it in the direction opposite

to the direction of progression of the wave. The existence of these electric currents is in accordance with the conception of electric current as explained in Art. 18 because the uniformly rotating ether cells in the region  $aba'b'$ , Fig. 77, may be thought of as slipping where they come in contact with the wires (ribbons)  $AB$  and  $A'B'$ .

It is important to note that the electric charges represented in Fig. 77 are surface charges on the inner faces of the ribbons. These charges are stationary, the electric current *in* the lower ribbon continually transfers positive charge from  $a'$  to  $b'$ , and the electric current *in* the upper ribbon continually transfers negative charge from  $a$  to  $b$ .

*Electromagnetic wave pulse bounded by two parallel wires.*—Figure 77 represents a rectangular electromagnetic wave pulse traveling along between two very broad metal ribbons. An electromagnetic wave pulse can also be completely bounded by two parallel cylindrical wires like the two wires of a transmission line. In this case, however, the lines of force are not straight lines. Thus, Fig. 78 represents a rectangular electromagnetic wave pulse traveling along two parallel wires  $AB$  and  $A'B'$ . In this case the lines of force of the electric field and the lines of force of the magnetic field lie in planes perpendicular to the transmission wires (when the resistance of the transmission wires is negligibly small), as shown in the side view in Fig. 78. The dots in this side view represent the lines of force of the magnetic field, and the fine lines in the side view represent the lines of force of the electric field. The end view in Fig. 78 shows the trend of the magnetic lines of force *mmmm* and the trend of the electric lines of force *eeee* in a plane at right angles to the transmission lines  $AB$  and  $A'B'$ . In Fig. 78 the portions  $ab$  and  $a'b'$  of the transmission wires have stationary electric charges on their surfaces, and electric current flows *in* these portions of the wires very much as in the ribbons in Fig. 77. The end view in Fig. 78 shows the wave traveling towards the reader.

The effect of line resistance is to cause the lines of force of

electric field to bend slightly backwards (towards  $A$  and  $A'$  in Fig. 78) in the immediate neighborhood of the two wires. It is desirable, however, to ignore the effects of line resistance in our preliminary discussion of electromagnetic waves on transmission

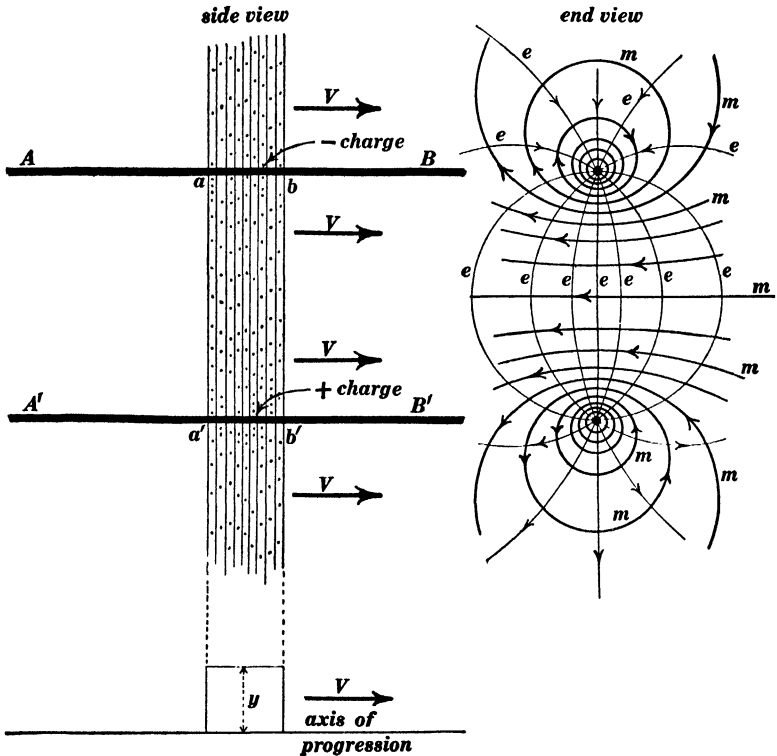

Fig. 78.

lines. By doing so the fundamental ideas of electromagnetic wave motion are greatly simplified, and it is possible to take approximate account of the effects of line resistance after the fundamental ideas have been established. Therefore in all the following discussion, the line resistance is supposed to be zero unless it is specifically stated to the contrary.

**23. Conceptions of electromagnetic wave motion.**—Figure 79 is intended to show the details of the physical action which takes

place in a rectangular electromagnetic wave pulse. A single horizontal chain of geared cells is shown in the figure, although a complete representation of what takes place in the wave would necessitate the showing of a number of horizontal chains of geared cells, every one of which would be parallel to and exactly similar to the chain which is shown in Fig. 79. Within the region of

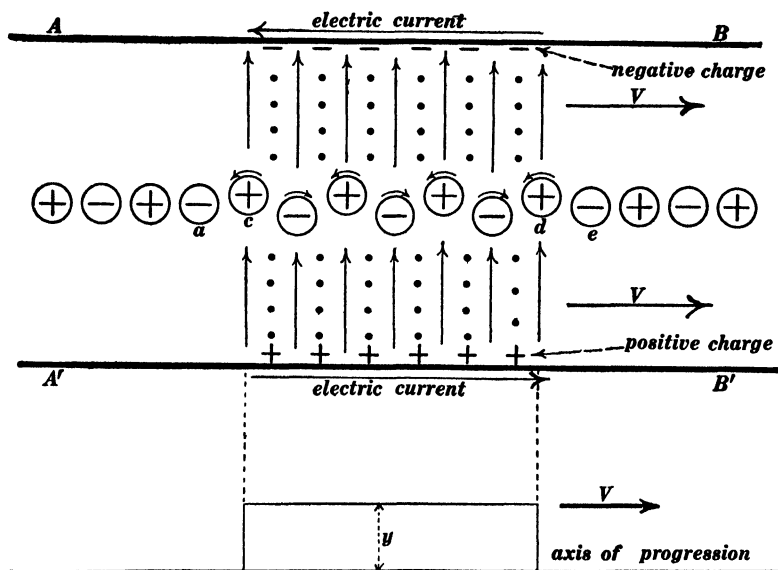

Fig. 79.

the wave, the ether cells are all in uniform rotation as indicated by the small curved arrows; and within the region of the wave the cell structure is uniformly distorted, positive cells being displaced upwards with respect to the negative cells, as shown in the figure. Throughout the middle portion of the wave, each rotating cell is acted upon by equal and opposite torques by the adjacent cells ahead of it and behind it (because of equality of electric field intensity ahead of it and behind it), and therefore all of the cells in the middle portion of the wave continue to rotate at unchanging speed; also the zigzag distortion of the chain of ether cells remains unchanged throughout the middle portion of the

wave because of the equal speeds of rotation of all the ether cells. The middle portion of this rectangular wave pulse is in fact an ordinary stationary magnetic field and an ordinary stationary electric field, and there is no progressive motion of any kind in the middle portion of such a wave pulse, except the progressive motion of energy, as explained later. The peculiar action which leads to a progressive motion of a wave pulse is the action which takes place at the front boundary  $d$  and causes the building up of electric and magnetic fields in the region immediately ahead of the wave pulse, and the action which takes place at the back boundary  $c$  and causes the electric and magnetic fields to die away in this part of the wave pulse. This action can be best understood by considering a wave pulse in which the electric and magnetic fields taper gradually to zero in the front region and also in the back region of the wave as shown in Fig. 80. The tapering electric field in the region  $cd$ , Fig. 80, causes a con-

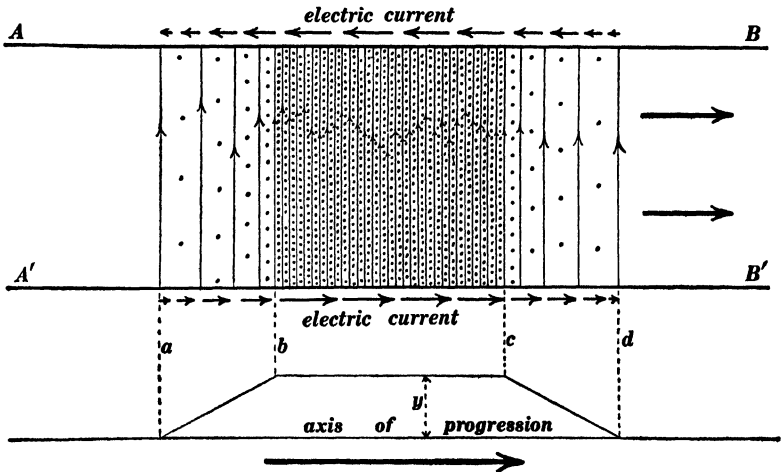

Fig. 80.

tinual growth of magnetic field throughout this region, and the tapering magnetic field in the region  $cd$  causes a continual growth of electric field throughout this region; whereas the tapering magnetic field throughout the region  $ab$  causes a

continual dying away of the electric field throughout this region, and the tapering electric field in the region *ab* causes a continual dying away of the magnetic field in this region as explained in Art. 18. The action here described is analogous to that which is described in connection with Fig. 7, which represents a water wave in a canal.

*Energy stream in an electromagnetic wave.*—The coexistence of the electric and magnetic fields throughout the waves in Figs. 79 and 80 causes a streaming of energy from the back part of the waves, where the fields are dying away, to the front part of the waves, where the fields are being built up, as explained in Art. 19.

*Electromagnetic wave train.*—Figures 77 to 79 represent what is called a rectangular electromagnetic wave pulse, and Fig. 80

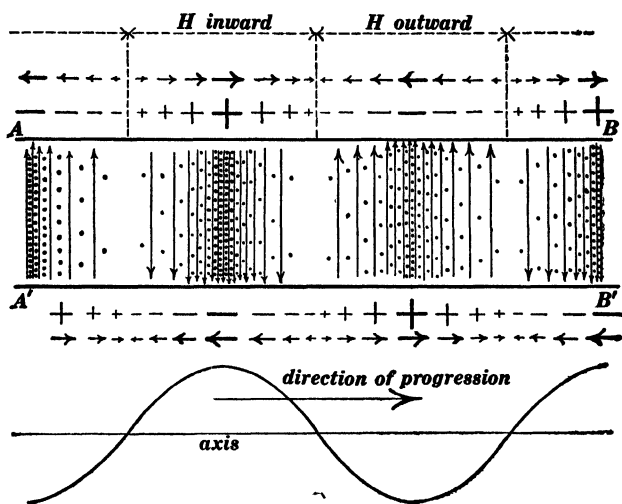

Fig. 81.

represents such a wave pulse which tapers at front and back. When a simple train of electromagnetic waves travels along between two metal ribbons, the distribution of electric and magnetic fields, the distribution of electric charges on the ribbons, and the distribution of electric current in the ribbons, are as shown

in Fig. 81. The fine vertical lines in this figure represent the lines of force of the electric field, and the dots represent the lines of force of the magnetic field  $H$  which is perpendicular to the plane of the paper and directed inwards or outwards as indicated. The distribution of electric charges on the ribbons is indicated by the positive and negative signs, and the distribution of electric current in the ribbons is represented by the short horizontal arrows. Large positive and negative signs represent large amounts of charge per unit area, and small positive and negative signs represent small amounts of charge per unit area; heavy horizontal arrows represent strong current, and small arrows represent weak current. The ordinates of the curve of sines in the lower part of the figure represent either the magnetic field intensity, or the electric field intensity, or the amount of electric charge per unit area of ribbons, or the current strength at different points along the ribbons.

**24. Calculation of velocity of progression of an electromagnetic wave.\*** — It was pointed out in Art. 23 that the middle portions of a rectangular electromagnetic wave pulse are stationary, and that the only thing which moves forwards is the energy as it streams from the back part of the wave pulse where the electric and magnetic fields are dying away to the front part of the wave pulse where the fields are being built up. It is convenient, however, to think of the electric and magnetic fields as moving along sidewise at the velocity of progression of the wave. On the basis of this idea, the moving magnetic field may be thought of as in-

\* The straightforward development of the mathematical theory of electromagnetic wave motion is based upon the differential equations which express the magnetic action of a tapering electric field and the electric action of a tapering magnetic field (see Art. 18). This method of development is outlined in Chapter VI. The method of the present chapter, however, is to develop conceptions of electromagnetic wave motion which enable one to understand what takes place without recourse to differential equations; and, in keeping with this method, it is desirable to show how the velocity of progression of a free electromagnetic wave depends upon the inductivity and permeability of the transmitting medium, and how the velocity of progression of an electromagnetic wave which is bounded by the wires of a transmission line depends upon the capacity and inductance of the line per unit of length.

ducing and thereby sustaining the electric field, according to the well-known law of induced electromotive force; and the moving electric field may be thought of as inducing and thereby sustaining the magnetic field, according to a law of induced magnetomotive force which is not so well known.

Let  $H$  be the intensity in gausses of the magnetic field in the region of the wave in Fig. 77, let  $e$  be the intensity of the electric field in abvolts per centimeter, let  $l$  be the distance across from wire to wire (ribbon to ribbon), and let  $V$  be the velocity of progression of the wave. The sidewise motion of the magnetic field at velocity  $V$  induces an electromotive force between the wires (ribbons) in the region of the wave, and this electromotive force is given by the well-known equation

$$E = lHV$$

Therefore the electric field intensity  $E/l$  in the wave is given by the equation

$$e = HV \tag{5}$$

in which  $e$  is expressed in abvolts per centimeter,  $H$  is expressed in gausses and  $V$  is expressed in centimeters per second

The simplest procedure in the discussion of the velocity of progression of an electromagnetic wave is to use, in conjunction with equation (5), another equation which expresses the intensity of magnetic field induced by the moving electric field, namely,

$$H' = ae'V \tag{6}$$

in which  $H'$  is the magnetic field induced by the sidewise motion at velocity  $V$  of an electric field  $e'$ . This is a simplified form of the law of induced magnetomotive force. It is not, however, familiar to the student of elementary electricity and magnetism,\* and therefore it is better to discuss the velocity of

\* An electromagnetic wave consists of a magnetic field and an electric field moving along together and mutually sustaining each other. The electric field is at right angles to the magnetic field and the direction of motion is at right angles to both. *The action involved in the sustaining of an electric field by a moving magnetic field is familiar to everyone as the law of induced electromotive force; that is to say, a moving mag-*

progression of an electromagnetic wave on the basis of equation (5) together with the condition that the magnetic energy per cubic centimeter in a wave is equal to the electric energy per cubic centimeter. The magnetic energy in ergs per cubic centimeter in a magnetic field is equal to  $H^2/8\pi$  where  $H$  is expressed in gauss, and the electric energy in ergs per cubic centimeter in an electric field is equal to  $e^2/(2.262 \times 10^{22})$ ,\* where  $e$  is expressed in abvolts per centimeter. Therefore on the basis of equality of electric and magnetic energy, we have

$$\frac{H^2}{8\pi} = \frac{e^2}{2.262 \times 10^{22}} \quad (7)$$

Solving equations (5) and (7) for  $V$ , we have

$$V = 2.996 \times 10^{10} \frac{\text{cm.}}{\text{sec.}}$$

**25. Transformation of equations (5), (6) and (7).**—Equations (5), (6) and (7) apply in their simple form to free electromagnetic waves in air, or to electromagnetic waves on a plain transmission

netic field induces an electric field at right angles to itself. *The sustaining of a magnetic field by a moving electric field is an action which is not familiarly known.* As a matter of fact, however, a moving electric field induces a magnetic field at right angles to itself such that

$$H' = ae'V \quad (6)$$

in which  $e'$  is the intensity of the moving electric field in abvolts per centimeter,  $V$  is the velocity at which the electric field is moving (sidewise),  $H'$  is the intensity in gauss of the magnetic field which is induced by the moving electric field, and  $a$  is a constant. In an electromagnetic wave the magnetic field  $H$  which sustains the electric field  $e$  by its inducing action in accordance with equation (5) is itself sustained by the inducing action of the electric field according to equation (6). That is to say, equations (5) and (6) may be considered to be simultaneous equations in their application to a pure electromagnetic wave, or, in other words,  $e$  and  $e'$  refer to identically the same electric field in both equations, and  $H$  and  $H'$  refer to identically the same magnetic field in both equations. Therefore, eliminating the ratio  $H/e$  from these two equations, we find

$$a = \frac{1}{V^2} \quad (8)$$

\* See Franklin and MacNutt's *Elements of Electricity and Magnetism*, pages 76 to 81, for a discussion of the energy of a magnetic field, and pages 185 and 186 for a discussion of the energy of an electric field.

line with air insulation. It is desirable, however, to transform these equations so that they may apply not only to air but to any medium, and so that they may apply to a transmission line which has any sort of insulation, to a transmission line which has small inductance coils inserted in it at intervals as shown in Fig. 82, to a transmission line which has condensers connected

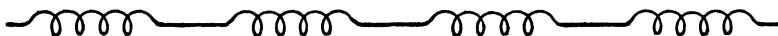

Fig. 82.

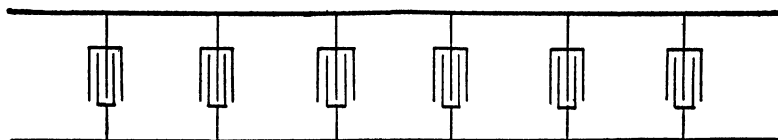

Fig. 83.

across it as shown in Fig. 83, or to a transmission line which combines the features of Figs. 82 and 83. Equations (5), (6) and (7) may be applied to any medium by introducing the permeability  $\mu$  and the inductivity  $\kappa$  as follows:

$$e = \mu HV \quad (5a)$$

$$H' = a\kappa e' V \quad (6a)$$

$$\frac{\mu H^2}{8\pi} = \frac{\kappa e^2}{2.262 \times 10^{22}} \quad (7a)$$

The following transformations are intended to bring equations (5), (6) and (7) into the form in which they are most conveniently applied to a transmission line.

*Transformation of equation (5).*\* Equation (5) was derived by looking upon the electromotive force between the transmission

\* See Appendix A for a discussion of inductance and capacity of a transmission line.

wires as due to the inducing action of the traveling magnetic field in the wave. Let  $L$  be the inductance of the transmission line per unit of length,\* and let  $I$  be the current (outward in one wire, backward in the other wire) in the line. Then  $LI$  is the amount of flux which passes between or links with the transmission wires in unit length of the line, and, if  $V$  is the velocity of progression of the electromagnetic wave, then  $1/V$  of a second is the time required for all of the flux between the wires of unit length of the line to travel forwards unit distance and sweep across an imaginary line drawn from wire to wire. Therefore,  $LI$  divided by  $1/V$ , or  $LIV$ , is the electromotive force induced between the wires; therefore equation (5) becomes

$$E = LIV \quad (5b)$$

In this equation everything may be expressed in c.g.s. units, † or  $E$  may be expressed in volts,  $L$  in henrys per mile,  $I$  in amperes, and  $V$  in miles per second. This equation (5b) applies to two flat ribbons or to an ordinary transmission line with cylindrical wires.

*Transformation of equation (6).*—Let  $C$  be the capacity of the two wires of a transmission line per unit length of the line, the two wires being looked upon as the plates of a condenser. Then  $CE$  is the charge on each wire per unit length of the line, positive charge on one wire and negative charge on the other. The current  $I$  in the transmission line transfers this charge from the back part of the wave to the front part of the wave, as explained in Art. 22, the amount of charge thus transferred in  $t$  seconds is the charge on length  $Vt$  of the wires, and this amount of charge is  $CEVt$ . Therefore,  $It = CEVt$ , or

$$I = CEV \quad (6b)$$

This equation (6b) applies to two flat ribbons or to an ordinary transmission line with cylindrical wires.

\* In this text one mile of transmission line means one mile of pole line. The two wires together constitute a transmission line.

† The units of the electromagnetic system, only, are used in this text.

*Transformation of equation (7).*—Equation (7) expresses the equality of magnetic energy and electric energy in a pure electromagnetic wave. The magnetic energy of unit length of transmission line is  $\frac{1}{2}LI^2$ , and the electric energy of unit length of transmission line is  $\frac{1}{2}CE^2$ . Therefore, equation (7) becomes

$$\frac{1}{2}LI^2 = \frac{1}{2}CE^2 \quad (7b)$$

in which  $L$  is the inductance of unit length of the transmission line,  $C$  is the capacity of unit length of the transmission line,  $I$  is the current in the line which is associated with the wave, and  $E$  is the voltage across the line due to the electric field in the wave. In this equation everything may be expressed in c.g.s. units\* or  $L$  may be expressed in henrys per mile,  $C$  may be expressed in farads per mile,  $I$  may be expressed in amperes, and  $E$  may be expressed in volts.

*Wave velocity on a transmission line.*—Solving equations (5b) and (6b) for  $V$ , or solving equations (5b) and (7b) for  $V$ , we have

$$V = \sqrt{\frac{1}{LC}} \quad (9)$$

The velocity of progression of an electromagnetic wave along a transmission line is thus given in terms of the inductance and capacity of the line per unit length. If  $L$  is expressed in henrys per mile and  $C$  in farads per mile, then  $V$  is expressed in miles per second. In a plain transmission line,  $V$  is the same as the velocity of light in the dielectric which separates the wires. Equations (5b), (6b), (7b) and (9) apply also to a cable with a metal core and sheath separated by a dielectric. When a transmission line is "loaded" with inductances as shown in Fig. 82, or when it is provided with condensers as shown in Fig. 83, the velocity of progression of an electromagnetic wave along the line is greatly reduced in accordance with equation (9).

\* The units of the electromagnetic system, only, are used in this text.

26. Additional details concerning electromagnetic wave pulses on a transmission line. (a) *Superposition of oppositely moving waves.* — Figure 84 shows two rectangular electromagnetic wave

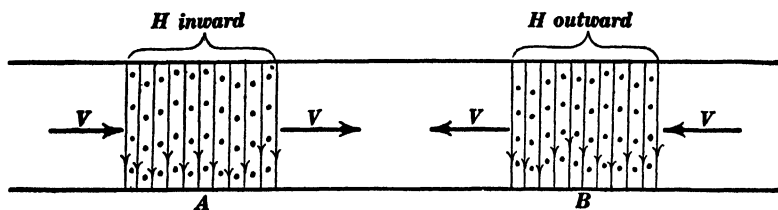

Fig. 84.

pulses traveling in opposite directions along a transmission line. When these waves begin to overlap, the magnetic field in the overlapping portions of the waves is the algebraic sum of the magnetic fields in the individual waves, and the electric field in the overlapping portions is equal to the algebraic sum of the electric fields in the individual waves. Figure 85 shows the state of

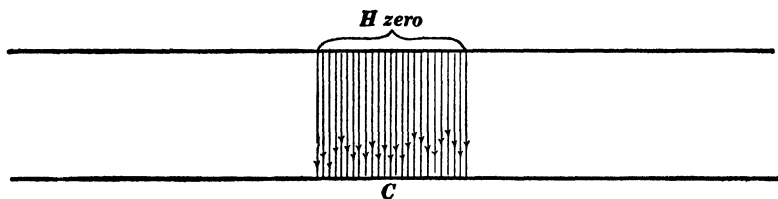

Fig. 85.

affairs when the two waves *A* and *B* in Fig. 84 come into complete superposition; the magnetic field is then everywhere zero and the electric field is of doubled intensity.

Figure 86 also shows two rectangular electromagnetic wave pulses traveling along a transmission line, and Fig. 87 shows the state of affairs at the instant when these two waves come into complete superposition, giving a region in which the electric field is zero and the magnetic field is of doubled intensity.\*

\* The student should make sketches showing the partial superposition of the waves in Figs. 84 and 85 and the partial superposition of the waves in Figs. 86 and 87, and these sketches should be compared with Figs. 10 to 14 and with Figs. 15 to 19.

(b) *Pure waves and impure waves.* — The waves which are shown in Figs. 77, 78, 79, 80 and 81, and in Figs. 84 and 86 all have this common property, namely, that the kinetic energy which is associated with the magnetic field in the wave is at each point equal to the potential energy which is associated with the electric field. Such a wave, which is called a *pure electromagnetic wave*, progresses without change of shape. When, however, the potential energy of the electric field is not equal to the kinetic energy of the magnetic field, we have what is called an *impure wave*.

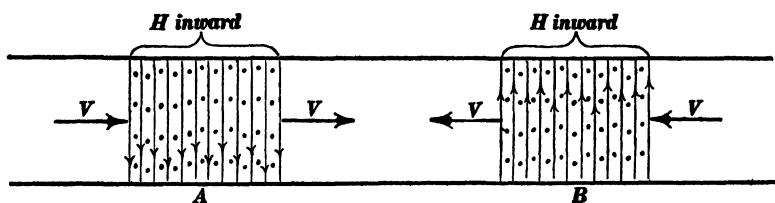

Fig. 86.

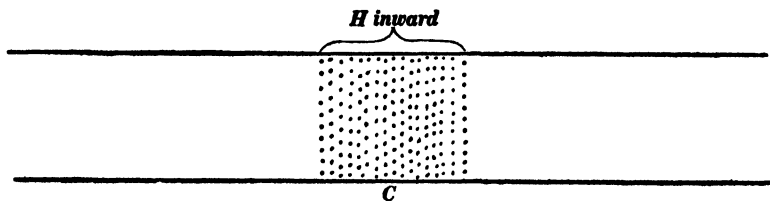

Fig. 87.

*wave.* Thus, the region of uniform electric field in Fig. 85 and the region of uniform magnetic field in Fig. 87 constitute extreme cases of impure waves. An impure wave always breaks up into two oppositely moving pure waves as may be understood by comparing Figs. 85 and 87 with Figs. 10 to 14 and Figs. 15 to 19, respectively.

(c) *Reflection of an electromagnetic wave pulse at the end of a transmission line.* — The open end of a transmission line is analogous to a rigid dam at the end of a canal, and the details of the reflection of a rectangular electromagnetic wave pulse from the open end of a transmission line can be understood from Figs. 20

to 23 which are exactly analogous to Figs. 91 to 94. The short-circuited end of a transmission line is analogous to a freely moving gate at the end of a canal, as shown in Fig. 24, and the details of the reflection of an electromagnetic wave pulse from the short-circuited end of a transmission line can be understood from Figs. 25 to 28 which are exactly analogous to Figs. 96 to 99.

The action which takes place at the open end of a transmission line is represented in Fig. 88. A uniform current flows out-

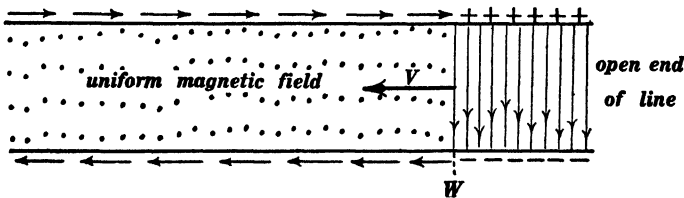

Fig. 88.

ward in one line, through a short-circuit at the end of the line and backward in the other line, producing a uniform magnetic field between the lines, and the end of the line is suddenly opened (resistance of line wires assumed to be negligible). The current at the extreme end of the line suddenly drops to zero value, and the energy of the magnetic field is transformed into

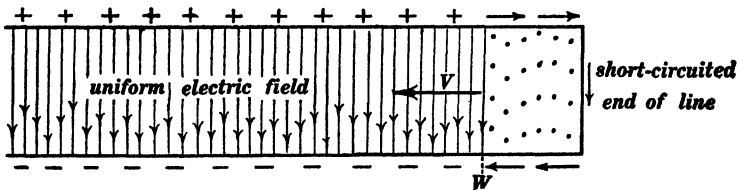

Fig. 89.

energy of electric field. This transformation of magnetic into electric energy extends rapidly over the line as a wave of arrest  $W$  which travels away from the end of the line as indicated by the arrow  $V$  in Fig. 88.

The action which takes place at the short-circuited end of a transmission line is shown in Fig. 89. Both ends of the line are

open and the two transmission wires are charged, by a battery, for example, like the two plates of a condenser, so that a uniform electric field exists between the wires from end to end of the line; then one end of the line is suddenly short-circuited. The charge immediately disappears from the extreme end of the line producing electric current as indicated by the small horizontal arrows, and the electric energy is transformed into magnetic energy. This transformation of electric into magnetic energy extends rapidly over the line in the form of a wave of starting  $W$  which travels away from the short-circuited end of the line, as indicated by the arrow  $V$  in Fig. 89.

Imagine a wave pulse like that shown in Fig. 90 to approach the open end of a transmission line. When the wave reaches the

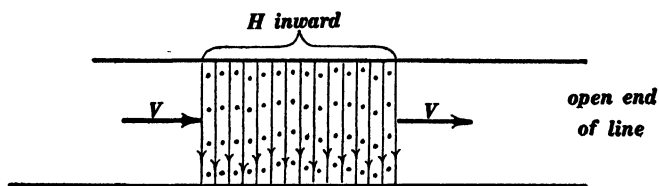

Fig. 90.

open end of the line, the current in the wave is reduced to zero at the extreme end of the line, and, in being reduced to zero, it builds up a region of doubled electric field as shown in Fig. 91.

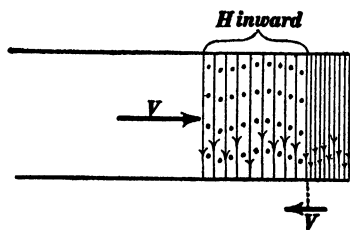

Fig. 91.

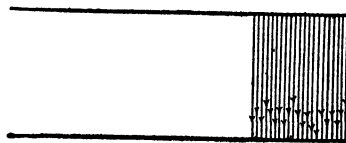

Fig. 92.

A moment later the state of affairs is as shown in Fig. 92; a region of doubled electric field (magnetic field equal to zero) half as long as the original wave exists at this instant. A little later,

the state of affairs is as shown in Fig. 93, and Fig. 94 shows the complete reflected wave.

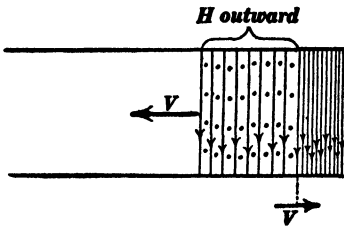

Fig. 93.

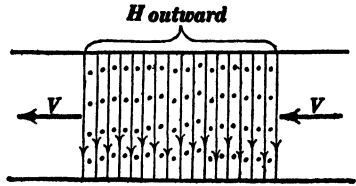

Fig. 94.

Figure 95 shows an electromagnetic wave pulse approaching the short-circuited end of a transmission line. When this wave

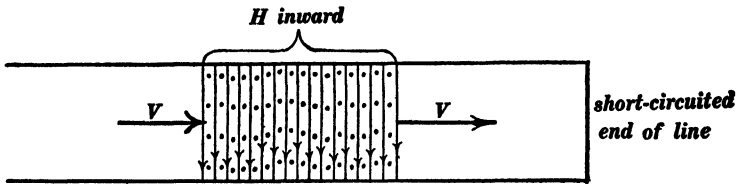

Fig. 95.

reaches the short-circuited end of the line, the electric field is reduced to zero at the extreme end of the line, and, in being reduced to zero, it establishes a doubled current at the extreme end of the line and builds up a magnetic field of doubled intensity

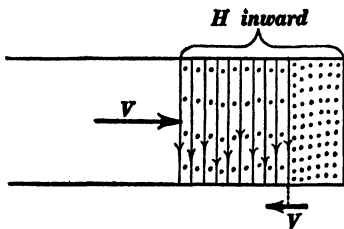

Fig. 96.

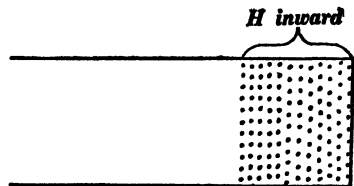

Fig. 97.

as shown in Fig. 96. A little later, the state of affairs is as shown in Fig. 97; a region of doubled magnetic field (electric field equal to zero) half as long as the original wave exists at this

instant. Figure 98 shows the state of affairs a moment later, and Fig. 99 shows the complete reflected wave.

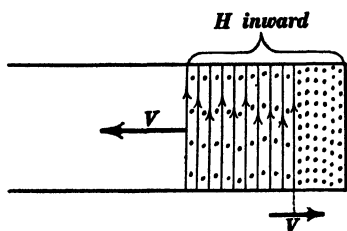

Fig. 98.

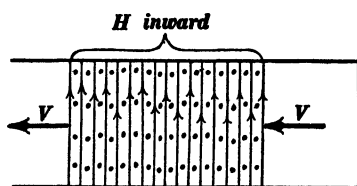

Fig. 99.

(d) *Reflection with and without phase reversal.* — An electromagnetic wave always consists of two elements, namely, magnetic field and electric field, traveling along together, and it is convenient to speak of the magnetic field in the wave as the *magnetic phase* of the wave and to speak of the electric field in the wave as the *electric phase* of the wave. When an electromagnetic wave is reflected from the open end of a transmission line as represented in Figs. 90 to 94 the magnetic phase of the wave is reversed but the electric phase is not reversed. When an electromagnetic wave is reflected from the short-circuited end of a transmission line as represented in Figs. 95 to 99, the electric phase of the wave is reversed but the magnetic phase is not reversed. The student should compare Figs. 90 to 99 with Figs. 20 to 28.

**27. Electric oscillation of a transmission line.** — If an electromagnetic wave is started along a transmission line, the wave will be repeatedly reflected from the ends of the line, and the to-and-fro motion of the wave will constitute a clearly defined type of electric oscillation of the line. The time required for one complete oscillation of the line is related to the velocity of the wave and to the length of the line as follows: (a) If both ends of the line are open, then the wave, starting from end *A* is reflected with reversal of magnetic phase at end *B* and again reflected with reversal of magnetic phase at end *A*, so that, after two re-

flections, the wave is exactly in its initial condition. Therefore one complete cycle of electric "movement" takes place during the time required for the wave to travel from one end of the line to the other and back again. This is also the case when both ends of the line are short-circuited. (b) If one end of the line is open and the other end short-circuited, then a complete cycle of electric "movement" takes place in the time required for the wave to travel over four times the length of the line. Starting from the open end of the line, the electric phase of the wave is reversed by reflection at the short-circuited end, then the magnetic phase is reversed by reflection at the open end, then the electric phase is again reversed by reflection at the short-circuited end, and then the magnetic phase is again reversed at the open end, thus bringing the wave into its initial condition.

A particular case of oscillation of a transmission line is represented in Fig. 29 in which  $EF$  represents the initial condition of the line, and  $E'I'$  represents the state of affairs at a given instant after the switch has been closed.\*

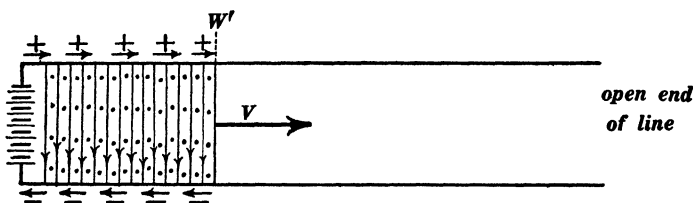

Fig. 100.

The electric oscillation of a transmission line which is produced when a generator is suddenly connected to one end of the line is partly shown in Figs. 100 and 101. When the generator (a battery is shown in Figs. 100 and 101) is suddenly connected

\*The student should make a series of drawings showing, say, eight successive stages of one complete oscillation of the transmission line  $EF$  in Fig. 29, and a curve should be plotted of which the ordinates represent successive values of the current at any given point on the transmission line and of which the abscissas represent elapsed times. The student should also plot a curve of which the ordinates represent the successive values of the voltage across the transmission line at a given point and of which the abscissas represent elapsed times.

to the line, a pure electromagnetic wave shoots out along the line, full generator voltage and the corresponding current [see equation (7*b*)] are established by a wave of starting  $W'$ , Fig. 100; when this wave of starting reaches the open end of the line, the current in the line and the magnetic field between the line wires are both reduced to zero at the extreme end of the line, a doubled electric field is built up, and a wave of arrest  $W''$ , Fig.

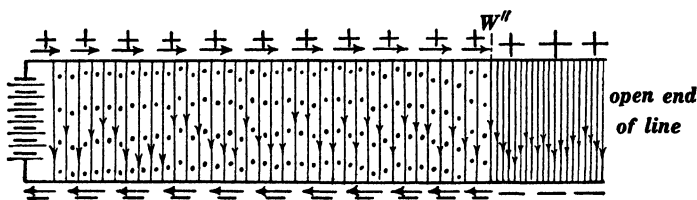

Fig. 101.

101, travels back towards the generator. When this wave of arrest reaches the generator, the electric field at the generator end of the line suddenly drops from the doubled value to the value which corresponds to generator voltage, and a reversed current is established through the generator.\* This reversed current together with normal generator voltage across the line are then established over the whole line by a wave of starting very much like  $W'$  in Fig. 100; when this second wave of starting reaches the open end of the line the reversed current and normal voltage across the line are both reduced to zero at the extreme end of the line, and this neutral condition of the line is established by a second wave of arrest very much like  $W''$ , Fig. 101, which travels back towards the generator. When this second wave of arrest reaches the generator, the entire line is in its initial condition, and therefore one complete oscillation has taken place.

Figure 102 represents a direct-current generator delivering a steady current over a transmission line of negligible resistance to a receiver of negligible resistance (zero voltage across line everywhere). When the receiver is suddenly opened, the current is

\* The generator is here assumed to have zero resistance.

reduced to zero at the opened end of the line, and, in being reduced to zero, it builds up a voltage between the lines of which the value is  $IV\sqrt{L}/C$ , according to equation (7*b*). This condi-

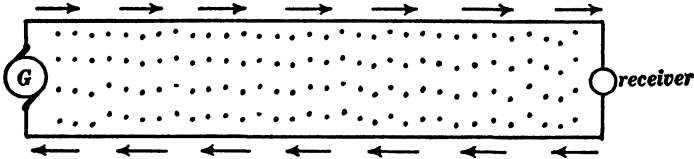

Fig. 102.

tion is established by a wave of arrest  $W''$ , Fig. 103, which travels towards the generator, and when this wave of arrest reaches the generator, one quarter of a complete oscillation of the transmission line has taken place.\* In case the receiver in Fig.

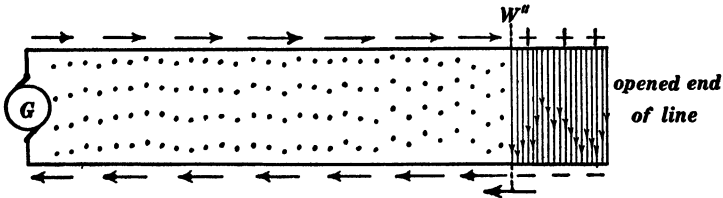

Fig. 103.

102 has resistance  $R$ , the line oscillates in precisely the manner here described, when the receiver is opened, except that the initial voltage  $RI$  between the line wires is added algebraically to the voltage which is associated with the electric oscillations of the line.

**28. Reflection from a non-inductive receiving circuit.**—Consider a pure electromagnetic wave shooting out from a generator along a transmission line as shown in Fig. 104. When the wave reaches the end of the line, it is partly reflected. Let  $E_1$  be the voltage across the transmission line and  $I_1$  the current in the line (outgoing current in one wire and returning current in the

\* The student should trace the details of the remainder of an oscillation by making a series of sketches. The generator has zero voltage if receiver resistance  $R$  is zero, line resistance being negligible: that is, the generator is, in effect, a dead short-circuit. The details of the oscillations may be easily followed by considering the canal analog of Fig. 103.

other wire) which are associated with the outgoing wave, and let  $E_{11}$  and  $I_{11}$  be voltage and current which are associated with the reflected wave. Then, from equation (7*b*) we have

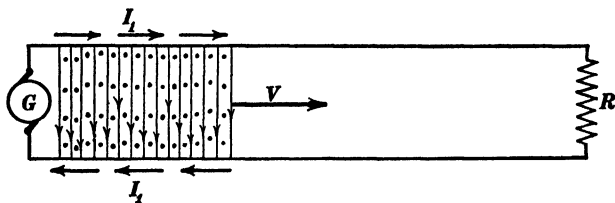

Fig. 104.

and 
$$\frac{1}{2}LI_1^2 = \frac{1}{2}CE_1^2 \quad (i)$$

whence 
$$\frac{1}{2}LI_{11}^2 = \frac{1}{2}CE_{11}^2 \quad (ii)$$

and 
$$E_1 = \pm I_1 \sqrt{\frac{L}{C}} \quad (iii)$$

and 
$$E_{11} = \pm I_{11} \sqrt{\frac{L}{C}} \quad (iv)$$

Let  $E_1$  and  $I_1$  be taken as positive, then equation (iii) becomes

$$E_1 = + I_1 \sqrt{\frac{L}{C}} \quad (v)$$

and, since reflection must be accompanied by reversal of  $E$  or  $I$  to give a wave traveling backwards, equation (iv) becomes

$$E_{11} = - I_{11} \sqrt{\frac{L}{C}} \quad (vi)$$

and the expression  $\sqrt{L/C}$  is to be hereafter considered as positive.

The total current at the end of the line (the current which enters the receiving circuit) is  $I_1 + I_{11}$ , and the total voltage across the end of the line is  $E_1 + E_{11}$ , and therefore, since the total current at the end of the line must enter the receiving circuit  $R$  in Fig. 104, we have

$$I_1 + I_{11} = \frac{E_1 + E_{11}}{R} \quad (vii)$$

Three special cases of reflection may be understood at once from equation (vii) if one keeps in mind the fact that the ratio  $E_{11}/I_{11}$  is a constant according to equation (7b) so that  $E_{11}$  is zero when  $I_{11}$  is zero, and if one remembers that either  $E_{11}$  or  $I_{11}$  must be negative.

(a) When  $R$  is zero, then  $E_1 + E_{11}'$  must be zero according to equation (vii), since the current cannot be infinite. Therefore  $E_1 = -E_{11}$ . That is, reflection takes place from a short-circuited end ( $R = 0$ ) with reversal of voltage phase, and the reflection is complete (all of the energy is turned back into the line).

(b) When  $R$  is infinity (open-ended line), then  $I_1 + I_{11}$  is zero, or  $I_1 = -I_{11}$ . That is, reflection takes place with reversal of current phase and the reflection is complete.

(c) When  $I_1 = E_1/R$ , that is, when  $R = E_1/I_1$  [ $= \sqrt{L}/C$ , see equation (iii)], then  $E_{11} = I_{11} = 0$ , or, in other words, there is no reflection, and all of the energy of the advancing wave is swallowed up by the non-inductive receiving circuit.

In order to determine the values of  $E_{11}$  and  $I_{11}$  in the reflected wave for any given value of  $R$ , substitute the values of  $E_1$  and  $E_{11}$  from equations (v) and (vi) in equation (vii), and we have

$$I_1 + I_{11} = \frac{(I_1 - I_{11}) \sqrt{\frac{L}{C}}}{R} \quad \text{(viii)}$$

from which we find

$$I_{11} = -I_1 \left( \frac{1 - \frac{1}{R} \sqrt{\frac{L}{C}}}{1 + \frac{1}{R} \sqrt{\frac{L}{C}}} \right) \quad \text{(ix)}$$

and using equations (v) and (vi) we find

$$E_{11} = E_1 \left( \frac{1 - \frac{1}{R} \sqrt{\frac{L}{C}}}{1 + \frac{1}{R} \sqrt{\frac{L}{C}}} \right) \quad \text{(x)}$$

Equations (ix) and (x) give the values of  $E_{11}$  and  $I_{11}$  for any given value of  $R$ . It is instructive to substitute the values  $R=0$ ,  $R=\infty$ , and  $R=\sqrt{L/C}$  in equations (ix) and (x), and to compare the results with the statements given above under (a), (b) and (c).

When the receiving circuit has resistance and inductance, a rectangular wave like that shown in Fig. 104 is reflected in a manner which, in the early stages, depends upon the inductance but eventually upon the resistance alone as above explained.

When the receiving circuit contains a condenser, a rectangular wave like that shown in Fig. 104 is reflected in a manner which, in the early stages, depends upon the capacity of the condenser but eventually the reflection settles to the kind which corresponds to a simple open-ended line.

The reflection of a rectangular wave like Fig. 104 from a receiving circuit which contains inductance is completely described in the next article.

**29. Reflection from an inductive receiving circuit.** — Let  $E_1$  and  $I_1$  be the voltage and current which are associated with the advancing rectangular wave (very long) which is shown in Fig. 104, let  $e$  and  $i$  be the voltage and current (at the extreme end of the line) which are associated with the reflected wave at an instant  $t$  seconds after the front of the advancing wave reaches the end of the line, and let  $R$  and  $L_0$  be the resistance and inductance of the receiving circuit. It is desired to determine  $e$  and  $i$  as functions of  $t$ .

At the instant of arrival of the front of the wave at the end of the line there can be no current in the receiving circuit, and, consequently, at this instant, the receiving circuit reflects like a simple open-ended line. Therefore when  $t=0$  we have

$$\left. \begin{aligned} e_0 &= E_1 \\ i_0 &= -I_1 \end{aligned} \right\} \quad (i)$$

The total voltage across the end of the line at any time  $t$  is

$E_1 + e$  (algebraic sum). The total current at the end of the line at any time  $t$  is  $I_1 + i$  (algebraic sum). Therefore we have

$$E_1 + e = R(I_1 + i) + L_0 \frac{di}{dt} \quad (\text{ii})$$

This equation is evident when we consider that  $E_1 + e$  is the voltage acting on the receiving circuit, that  $I_1 + i$  is the current in the receiving circuit, and that  $di/dt$  is the rate of increase of current in the receiving circuit.

According to equation (7*b*) we have

$$\frac{1}{2} Li^2 = \frac{1}{2} Ce^2 \quad (\text{iii})$$

whence

$$e = -i \sqrt{\frac{L}{C}} \quad (\text{iv})$$

the negative sign being chosen for reasons explained in the previous article. Substituting the value of  $e$  from equation (iv) in equation (ii) we have

$$E_1 - i \sqrt{\frac{L}{C}} = RI_1 + Ri + L_0 \frac{di}{dt}$$

or

$$E_1 - RI_1 = \left( R + \sqrt{\frac{L}{C}} \right) i + L_0 \frac{di}{dt} \quad (\text{v})$$

In order to integrate this differential equation let

$$y = \frac{E_1 - RI_1}{R + \sqrt{\frac{L}{C}}} - i \quad (\text{vi})$$

whence

$$\frac{dy}{dt} = -\frac{di}{dt}$$

so that equation (v) becomes

$$y = -\frac{L_0}{R + \sqrt{\frac{L}{C}}} \cdot \frac{dy}{dt} \quad (\text{vii})$$

which, by integration, gives

$$y = A e^{-\frac{L_0}{R + \sqrt{L/C}} \cdot t} \quad (\text{viii})$$

in which  $A$  is a constant of integration which may be determined by substituting in (viii) the value of  $y$  when  $t = 0$ . Now  $i = -I_1$  when  $t = 0$  so that (vi) gives

$$y = \frac{E_1 - RI_1}{R + \sqrt{\frac{L}{C}}} + I_1$$

when  $t = 0$ , whence, from equation (viii), we find

$$A = \frac{E_1 - RI_1}{R + \sqrt{\frac{L}{C}}} + I_1 \quad (\text{ix})$$

Substituting this value of  $A$  and the value of  $y$  from equation (vi) in equation (viii) and solving for  $i$ , we have

$$i = \frac{E_1 - RI_1}{R + \sqrt{\frac{L}{C}}} - \left( \frac{E_1 - RI_1}{R + \sqrt{\frac{L}{C}}} + I_1 \right) e^{-\frac{R + \sqrt{L/C}}{L_0} \cdot t} \quad (\text{x})$$

This equation expresses the changing value of the current (and voltage  $e = -i\sqrt{L/C}$ ) in the reflected wave on the assumption that the transmission line is very long so that the second reflection of the reflected wave from the generator end of the line need not be considered; it also shows that  $i = -I_1$  when  $t = 0$ , and that  $i$  approaches the value

$$\frac{E_1 - RI_1}{R + \sqrt{\frac{L}{C}}}$$

as time elapses as shown in Fig. 105. This ultimate value of  $i$  (and of  $e$ ) in the reflected wave is the value which would exist from the beginning if the receiving circuit were non-inductive.

30. The transfer of energy back and forth from one part to another of a complex oscillating system. — When a transmission line is made up of several sections differing from each other in inductance and capacity, or when a transmission line is connected to a generator at one end and to a receiver at the other end, the oscillation of the line is usually accompanied by a back-and-forth

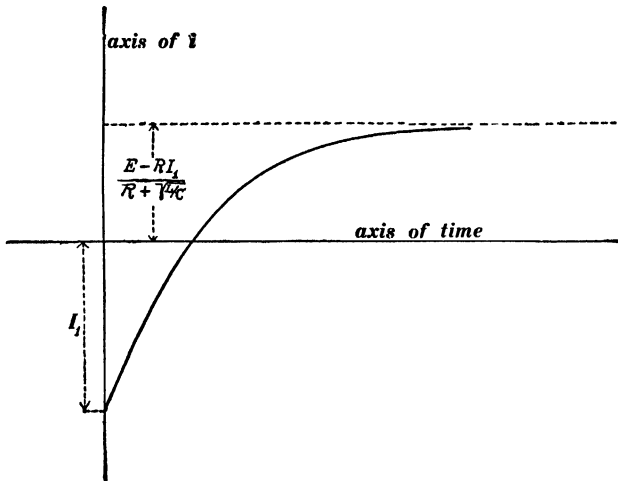

Fig. 105

transfer of energy from one section of the line to another section, or by a back-and-forth transfer of energy from the line to the generator or receiver. A great variety of particular cases might be considered but the following extremely simple case must suf-

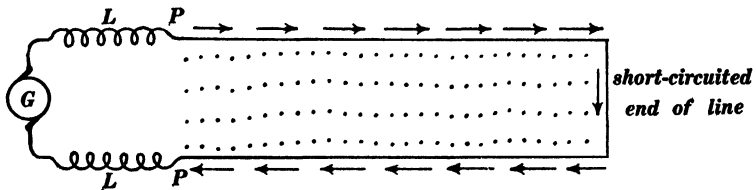

Fig. 106a.

fice. A generator  $G$  delivers direct current through two large inductances  $LL$  to a transmission line as shown in Fig. 106a.

The end of the line is short-circuited, a heavy short-circuit current is established (with negligible voltage across the lines), the short-circuited end of the line is then suddenly opened, and the whole system is thus set into oscillation. Let us assume for the sake of simplicity that the inductance  $LL$  is very great so that a sensibly constant current continues to flow into the line for a considerable time after the end of the line is opened, and let us consider the oscillations of the line on the assumption that the line resistance is negligible. At the instant of opening of the end of the line, the current at the end of the line drops to zero, the end of the line becomes charged, and a wave of arrest  $W''$  travels towards the generator as described in connection with Figs. 102 and 103. When this wave of arrest reaches the point  $PP$  in Fig. 106*a*, the current is zero over the whole line, and the voltage across the line has everywhere the value of  $E = I\sqrt{L/C}$  according to equation (7*b*), where  $I$  is the initial value of the current in the line. The current entering the line at the point  $PP$  under the assumed conditions maintains a constant value, and this current and doubled voltage  $2E (= 2 \times I\sqrt{L/C})$  are established in the line by a wave of starting. When this wave of starting reaches the opened end of the line, the current is again reduced to zero and the voltage increased to  $3E$  by a wave of arrest which travels back towards the generator. The current  $I$  and quadrupled voltage  $4E$  are then established by a wave of starting, and when this wave of starting reaches the opened end of the line, the current is again reduced to zero and the voltage increased to  $5E$  by a wave of arrest which travels back towards the generator, and so on. In this case the kinetic energy of the portion  $LL$  of the system is transferred into the line as the line oscillates and this energy is converted step-wise into the electrical energy which is associated with the increasing voltage across the line wires.

A better understanding of the above-described slow transfer of energy from the large inductances  $LL$  into the oscillating line may be obtained as follows: The system shown in Fig. 106*a* has

two \* simple modes of oscillation, namely, (a) the inductance  $LL$  and the line (considered as a large condenser) constitute a slowly oscillating system, and (b) the line itself, as the electric waves are reflected back and forth between its ends is a rapidly oscillating system. The above-mentioned transfer of energy from  $LL$  into the oscillating line is merely the first part of a long-drawn-out oscillation of the type (a). It is evident from this statement of the case, that energy would be slowly given back to  $LL$  by the oscillating line at a later stage. In fact this later stage is realized at the start if the initial condition is *high charges on the line wires* instead of *heavy currents in the line wires*, that is to say, if the line wires are charged one wire positively and the other wire negatively, and if oscillations are started by suddenly connecting the lines to  $LL$ , then, as the line oscillates, its energy is slowly transferred to  $LL$ .†

The canal analogue of the oscillating system above described (Fig. 106a) would be a tremendously massive piston moving along the canal and causing the water to move with it, the moving water coming against a rigid dam at the end of the canal. A more intelligible analogue, however, is shown in Figs. 106b and 106c. A heavy weight  $W$  and a helical spring  $SS$ , which

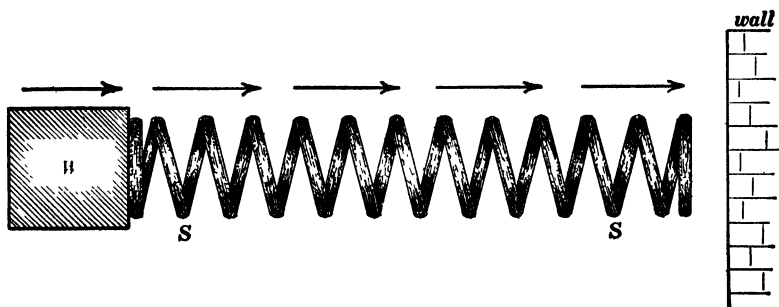
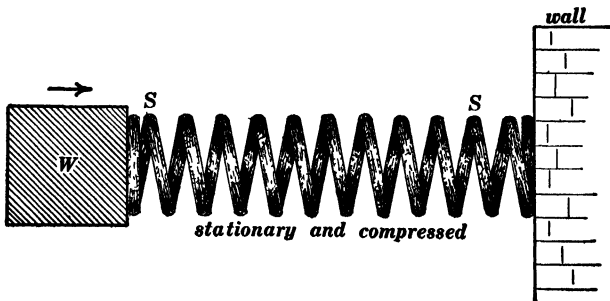

Fig. 106b.

\* The system has an infinite series of simple modes of oscillation but it is sufficient for present purposes to consider only two.

† The student should be able to describe the details of this action on the assumption that the inductances  $LL$  are very large, resistances being negligible.

is in its normal condition as regards stretch, move along together as indicated by the horizontal arrows, and the end of the spring comes against a rigid wall. At the instant when the end of the spring in Fig. 106*b* comes against the wall, a *wave of arrest* travels along the spring from the wall towards the weight, behind this wave of arrest the spring is at rest and uniformly compressed and ahead of this wave of arrest the spring is in its initial condition of uniform motion and free from compression. Figure 106*c* represents the instant when the wave of arrest has reached the moving weight, at this instant the spring is everywhere at rest and uniformly compressed, the continued motion of the heavy weight sets the end of the spring into motion and doubles its compression; this condition of the spring is established by a *wave*

Fig. 106*c*.

*of starting* which travels toward the wall, and when this wave of starting reaches the wall the spring is in uniform motion and uniformly compressed. Thus, the compression of the spring is increased stepwise, and of course after a time the increasing compression of the spring brings the weight to rest and then sets it in motion in a reversed direction. The system represented in Figs. 106*b* and 106*c* has two types\* of oscillation, namely, (a) the oscillation of the weight and spring forming a system of the first class (concentrated elasticity and concentrated mass),

\* The system has an infinite series of simple modes of oscillation, but it is sufficient for present purposes to consider only two.

and the spring alone oscillates as a system of the second class (distributed mass and distributed elasticity).

**31. The lightning arrester.**—When a short-circuit current flows over a transmission line as described in connection with Figs. 102 and 103, or as described in connection with Fig. 106a, a sudden opening of the circuit is followed by electrical oscillations of the line (or surges of current, as such oscillations are sometimes called). *The magnetic energy of a short-circuit current is dissipated with a minimum of surging by inserting a **low resistance** across the end of the line instead of opening the line completely.*

When the two wires of a transmission line are highly charged, as represented in Fig. 89, the short-circuiting of the end of the line causes the line to oscillate electrically as described in connection with Fig. 89. *The electrical energy of a highly charged line such as is shown in Fig. 89, is dissipated with a minimum of current surging by inserting a **high resistance** across the end of the line instead of short-circuiting it.*

When a pure electric wave containing equal amounts of electric and magnetic energy is created on a transmission line, by a lightning discharge for example, *the energy of the wave is dissipated with a minimum of surging of current if the two wires at the ends of the line are connected by non-inductive resistances of which the value is  $\sqrt{L/C}$ .* This is evident when we consider that a resistance of this value does not reflect any portion of a wave but swallows up its energy completely, as explained in Art. 28.

Some idea of the mode of generation of an electric wave by a lightning discharge may be obtained by considering a simple case as follows: Lines of force of electric field are gradually established between a line wire and a cloud, the cloud is suddenly discharged by a lightning stroke and the electric lines of force which emanate from the wire turn at once into the ground giving an electric field between line wire and ground, very much like the electric field between two line wires as shown in Fig. 85. This electric field

immediately breaks up into two oppositely moving electric waves as explained in connection with Figs. 84 and 85. (See Figs. 12 and 13.)

Figure 107 shows the connections of a so-called multi-gap lightning arrester from a line wire to earth. Two such lightning arresters connected from two line wires to earth are equivalent to

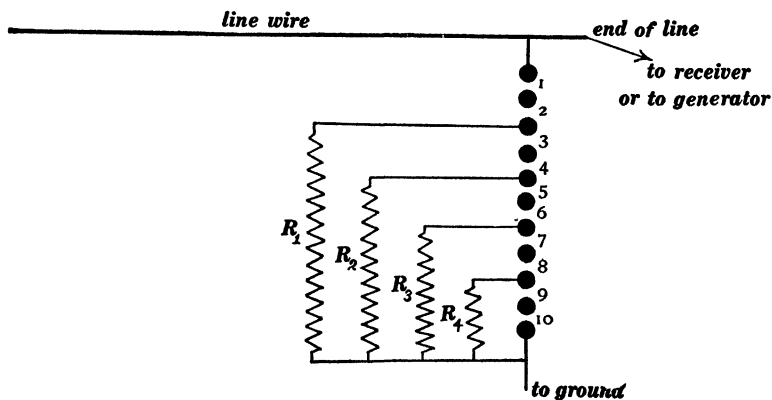

Fig. 107.

a single multi-gap arrester connected between the lines. Such a lightning arrester automatically inserts a low resistance, or a high resistance between the line wires, or between each line wire and the earth, according as the energy to be dissipated is large or small.\* The action of the multi-gap arrester may be understood from the following considerations. Consider a heavy short-circuit current due, for example, to the momentary arcing from line to line near the receiving station. When this arc is blown out by the upward current of air which is formed by the heat of the arc, the receiving end of the line is suddenly opened, and the

\* It is usually claimed for the multi-gap arrester that it automatically inserts a low resistance or a high resistance between the line wires according as the energy to be dissipated is magnetic energy (due to short-circuit current), or electric energy (due to static charge on the wires). This, however, is not exactly true. It is solely a matter of the amount of energy per unit length of the line to be dissipated, although as a matter of fact the energy due to static charge of a transmission line can never reach anything near the value of the energy due to a heavy short-circuit current. See problems in Appendix C.

tendency is for the voltage to rise to an excessive value as described in connection with Figs. 102 and 103. The moment the voltage rises slightly above normal line voltage, however, the air gaps 1 and 2, Fig. 107, on each arrester break down, and the line current tends to flow through the resistances  $R_1$  of the two arresters. This resistance  $R_1$  is, however, fairly large, and the heavy line current in flowing through it leaves the voltage across the end of the line sufficiently large to break across the gaps 3 and 4 of both arresters. The line current then flows through resistances  $R_1$  and  $R_2$  in parallel (on both arresters). If the short-circuit current in the line is excessive, the voltage may still remain sufficiently high in value to break across the air gaps 5 and 6, thus bring the resistance  $R_3$  (on both arresters) into parallel with  $R_1$  and  $R_2$ , and so on, until the resistance through which the short-circuit current flows is reduced to a value sufficiently small to prevent the break-down of any more of the spark gaps.

**32. Wave distortion and line losses.**—The distortion of a water wave in a canal, as described in Art. 9, is due to the loss of energy by the friction of the moving water against the sides and bottom of the canal. Imagine, on the other hand, a canal brimful of water and imagine the water to be frictionless; then there would be wave distortion due to the loss of energy by leakage or spill; but if the loss of energy by friction were equal to the loss of energy by leakage then there would be no wave distortion. The phenomenon of wave distortion on a transmission line is analogous in every detail to wave distortion in a canal; so close, indeed, is the analogy, that wave distortion on a transmission line can be clearly understood from the discussion given in Art. 9 if one understands: (*a*) that a pure electromagnetic wave on a transmission line consists of electric and magnetic fields traveling along together and mutually sustaining each other, (*b*) that the immediate effect of wire resistance is to cause a continual decay of the magnetic field in the wave, and (*c*) that the immediate effect of imperfect insulation between the transmission wires is to

cause a continual decay of the electric field in the wave. For the sake of brevity the energy loss in the transmission wires due to their resistance is called the *wire loss*, and the energy loss due to the imperfect insulation between the transmission wires is called the *leakage loss*.

When an electric current is left to itself in a circuit of wire, the resistance of the wire causes the current to decay, and of course the magnetic field in the surrounding region dies away with the current. Consider the rotating ether cells in the region of the wave in Fig. 79; the slipping of the ether cells on each other within the material of the wires constitutes the electric current in the wires according to the conceptions developed in Art. 18, the resistance of the wires is a frictional opposition to this slipping and this friction causes the rotatory motion of the cells to die away.

When a charged condenser is left to itself with the charging battery disconnected, the slight electrical conductivity of the dielectric between the condenser plates causes the condenser to discharge slowly. This discharge consists of the slow decay of the electric stress (electric field) in the dielectric. The slow decay of electric field in an imperfectly insulating dielectric may be understood with the help of the discussion of Figs. 72, 73 and 74; the distortion of the chain of cells in Fig. 73 is relieved by slipping of adjacent cells on each other anywhere, and in a slightly conducting dielectric the cells slip on each other everywhere.

The effect of wire resistance in causing a continual decay of magnetic field in an electromagnetic wave on a transmission line is analogous to the effect of friction in causing the decay of velocity of flow of the water in a water wave as it travels along a canal. The effect of line leakage in causing a continual decay of the electric field in an electromagnetic wave on a transmission line is analogous to the effect of overflow or spill in causing the reduction of elevation of a water wave as it travels along a canal.

One effect of wire resistance and of line leakage is loss of energy, so that a given wave delivers less energy to the distant

end of a transmission line than it would if the wires were of zero resistance and perfectly insulated from each other. Another effect of wire resistance alone or of line leakage alone is to cause wave distortion in a manner exactly analogous to the distortion of water waves in a canal as fully explained in Art. 9.

Wire-resistance and leakage-from-wire-to-wire of a transmission line are important to the telephone engineer for two reasons. In the first place both cause loss of energy and thus tend to reduce the loudness of the reproduced speech at the distant end of the line, and in the second place either alone tends to produce wave distortion and thus lessen the distinctness of the reproduced speech at the distant end of the line.

*Ratio of line losses to total energy of a pure wave is independent of voltage and current.* — From equation (7*b*) it is evident that an increase of voltage in a pure electromagnetic wave involves a corresponding increase of current in the wave,\* and it is not possible to reduce the line losses relative to the amount of energy delivered by the wave to the distant end of the line by increasing the voltage of the alternator or other device which produces the waves. In this respect transmission by pure waves is very different from ordinary power transmission, where there is no fixed relation between voltage and current.

Consider a long wave like that shown in Fig. 77. The rate at which energy is lost in unit length of the line on account of line resistance is  $2R_w I^2$  where  $R_w$  is the resistance of unit length of one of the wires and  $I$  is the current in the wires where they bound the wave. The rate at which energy is lost in unit length of the line by leakage from wire to wire is equal to  $E^2/R_l$  where  $R_l$  is the insulation resistance between the wires of unit length of the transmission line. To double the voltage in a pure wave involves the doubling of the current also, according to equation (7*b*), and therefore the quadrupling of the total energy in the wave according to the same equation; but the doubling of the voltage

\* That is to say, in the wires where they bound the wave. The expressions *current in a wave* and *voltage in a wave* are used for the sake of brevity.

quadruples the rate at which energy is lost by leakage ( $E^2/R_l$ ), and the doubling of the current quadruples the rate at which energy is lost because of wire resistance ( $2R_w I^2$ ). Therefore, if the voltage in a pure wave is doubled the current is also doubled, the total energy in the wave is quadrupled and the losses are quadrupled. The ratio of losses to the total energy depends only upon the capacity  $C$  and inductance  $L$  per unit length of the line as explained below.

*Reduction of wire loss by loading.\** — A transmission line of which the inductance is increased by the insertion of coils as indicated in Fig. 82 is called a loaded line. The effect of the loading of a transmission line (increase of  $L$ ) is to decrease the value of the current for a given value of voltage according to equation (7b). Suppose, for example, that the inductance of a line per unit length is quadrupled by loading. The value of the current  $I$  for a given value of voltage is halved according to equation (7b), and the rate of loss of energy due to wire resistance ( $2R_w I^2$ ) is quartered. The quadrupling of the inductance, however, halves the velocity of progression according to equation (9), so that the time required for the wave to traverse a given length of line is doubled; and therefore the loss of energy in the wires (the rate of which has been quartered) continues for twice as long a time. Consequently the actual loss of energy due to wire resistance during the passage over a line of a wave of given total energy is reduced to one half by the quadrupling of the inductance.

The quadrupling of line inductance leaves the rate of loss of energy due to line leakage unchanged in value for a given value of voltage, but the loss continues for double the time on account of the reduced velocity of transmission. Therefore the total loss of energy by line leakage during the passage over a line of a wave of given total energy is doubled by quadrupling the line inductance.

\* To arrange a transmission line like Fig. 83 causes a decrease of leakage loss and an increase of wire loss relative to the total energy of a wave. A *very very poorly insulated telephone line* would be improved by the arrangement shown in Fig. 83.

In a well-constructed telephone line the wire loss ( $2R_w I^2$ ) is very much greater than the leakage loss ( $E^2/R_l$ ), and therefore the total loss of energy during the transmission of a wave may be reduced by loading the line. One advantage of the loading of a telephone line is this reduction of line loss and the consequent increase of energy efficiency of transmission. Another advantage is that the loading of a line in which the wire loss is greater than the leakage loss reduces the wave distortion as explained in the following paragraphs.

*The distortionless line.* — When the resistance per unit length of a transmission line (counting both wires) is related to the leakage resistance between unit length of the wires in such a way as to cause an equal decay of the magnetic and electric fields in a wave [so that  $\frac{1}{2}LI^2 = \frac{1}{2}CE^2$  at all times, see equation (7*b*)], then the wave travels along without distortion. Such a line is called a distortionless line.

The rate at which energy is lost in unit length of the line by wire resistance is  $2R_w I^2$  and the rate at which energy is lost in unit length of the line by leakage is  $E^2/R_l$ , as explained above. In order that the line may not distort an electromagnetic wave these two rates of loss must be equal to each other, that is, we must have

$$2R_w I^2 = \frac{E^2}{R_l} \quad (i)$$

but the ratio  $E^2/I^2$  is equal to  $L/C$  according to equation (7*b*) so that equation (i) gives

$$R_w = \frac{L}{2C} \cdot \frac{1}{R_l} \quad (10)$$

This equation expresses the relation between the resistance  $R_w$  of unit length of one of the line wires, and the resistance  $R_l$  between unit lengths of the line wires, in order that the line may not distort an electric wave.

In a well-constructed telephone line the wire resistance  $R_w$  is too large, relatively, to give distortionless transmission. Under

these conditions to increase  $L$  by loading the line is advantageous, because, in the first place, it reduces the wire loss more than it increases the leakage loss as explained in the previous paragraph, and in the second place it makes the wire loss more nearly equal to the leakage loss so that the condition of distortionless transmission is approximately satisfied.

When the wire resistance of a telephone line is very great, an increase of leakage loss may improve the transmission because the wire loss of energy is already very great and a considerable increase of leakage loss of energy may be negligible in comparison, whereas the increase of leakage loss greatly lessens the wave distortion. Thus when iron wires were used in the early days of moderately long-distance telephone work it was frequently noticed that the transmitted speech was much more distinct during wet weather when the line insulation was poor than during dry weather when the line insulation was good. It is not desirable, however, to improve the distinctness of telephone transmission by increasing the leakage of the line because of the great decrease of loudness due to increased energy loss in the line, it is much better to increase the distinctness by lowering the line resistance (by using copper wires) and by loading the line, or by both. In this way the line losses are decreased and the distinctness is increased.\*

\* A very interesting account of the influence of leakage on the attainable speed in submarine telegraphy is given by Heaviside on pages 417-428 of *Electromagnetic Theory*, Vol. 1, London, 1893. To understand this discussion of Heaviside's the student should read pages 328-331 of Franklin and MacNutt's *Elements of Electricity and Magnetism*.

Heaviside mentions a case in which a leak on a submarine cable impaired the action, and another case in which a leak improved the action. In fact the action was impaired where a type of receiver was used which required for its operation a considerable amount of energy, and the action was improved where an extremely sensitive syphon recorder was used. In the former case the increased loss due to a leak was a serious matter, and in the latter case the increased loss was not a serious matter whereas the increased distinctness of the current pulses at the receiving end of the cable was a great help.

One case in particular is mentioned by Heaviside which is especially interesting. A submarine cable had an old style receiver (presumably an ordinary relay and

*The canal analogue of the loaded telephone line.*— Imagine a large number of very heavy and very thin boards placed like gates across a canal, as shown in Fig. 108, and imagine the boards

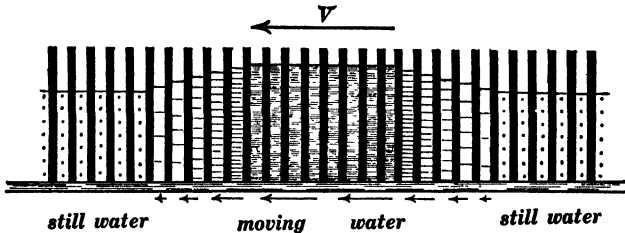

Fig. 108.

to be movable like pistons along the canal but without friction. Those boards would add greatly to the inertia of the water so that a greatly reduced velocity of flow would represent a given amount of kinetic energy, but a given elevation of water between the boards (which are supposed to be very thin) would represent the same amount of potential energy as in the "unloaded" canal. Therefore, in a pure wave containing a given total amount of energy, the velocity of the water would be greatly reduced and the energy losses due to the friction of the water against the sides and bottom of the canal would be greatly lessened by "loading."

The water wave shown in Fig. 108 is like that shown in Fig. 7, and the water level is represented as rising step-wise in the successive compartments in the front and back parts of the wave. An abrupt wave like that shown in Fig. 6 would be greatly modified in traveling along a "loaded" canal like Fig. 108 because of the repeated partial reflection of the wave from the successive boards.

The effect of the separation of the boards in Fig. 108 can be best stated by considering the transmission of a simple train of

Morse recorder) at one end, and one of Lord Kelvin's newly invented syphon recorders at the other end, and a very bad leak developed in the cable. The result was that signals could not be transmitted at all to the relay and Morse recorder, whereas the syphon recorder received better than ever before, a slight increase of battery, only, being required.

waves as follows: If the wave length of the train is long compared with the distance between boards, the effect is sensibly the same as if the inertia of the boards were uniformly distributed throughout the water, whereas, if the wave length of the train is of the same order of magnitude as the distance between boards, local oscillations take place, and the energy of the wave train is rapidly dissipated. In fact, the arrangement shown in Fig. 108 cannot transmit to any distance a wave train of which the half wave length (in the unloaded canal) is approximately equal to or less than the distance between the boards.

The highest pitch tones that need be considered in the transmission of speech by the telephone are in the neighborhood of about 10,000 vibrations per second which corresponds to a wave length (on an unloaded line) of about 18 miles, and the distance between the inductance coils which are used for loading a telephone line must be small as compared with 18 miles.\*

\* The mathematical theory of the loaded telephone line has been worked out in great detail by Professor M. I. Pupin. See *Transactions American Institute of Electrical Engineers*, Vol. XVII, pages 445-506, May 19, 1900.

The theory of wave distortion in transmission lines and cables was first developed by Heaviside. The second half, pages 306-454, of Heaviside's *Electromagnetic Theory*, Vol. I (London, 1893), is an extremely simple and interesting discussion of this subject.

## CHAPTER V.

### TRANSMISSION LINE OSCILLATION.

**33. Simple modes of oscillation of a transmission line** (*wire resistance and line leakage being neglected*).—The type of oscillation of a transmission line which is represented in Fig. 29 is perhaps the simplest kind of oscillation of which a transmission line is capable. In this type of transmission-line oscillation, however, the voltage between the wires at any given point is not a harmonically varying voltage, and the current in the wires at any given point is not a harmonically varying current; in fact, the voltage and current curves in this case are rectangular or block-like curves. Notwithstanding the physical simplicity of the type of oscillation which is represented in Fig. 29 the most important mode of oscillation of a transmission line is that in which the current in the wires at each point and the voltage between the wires at each point are both simply harmonic, because such a type of oscillation is easily formulated mathematically and because any other type of oscillation of a transmission line can be thought of as built up of a series of these harmonic modes of oscillation in accordance with Fourier's theorem. *When the current at every point in the wires and the voltage between the wires at every point of an oscillating transmission line are harmonic, the transmission line is said to oscillate in a simple mode.*

It is evident from the discussion of Fig. 29 that the oscillation of a transmission line involves wave motion back and forth along the line, and the discussion of simple modes of oscillation of a transmission line may be carried out with the greatest ease by considering the passage of a simple wave train (outgoing wave train) along the transmission line and its reflection (returning wave train) from the end of the transmission line. The super-

position of the outgoing and returning wave trains gives what is called a stationary or standing wave train, and such a stationary or standing wave train constitutes a simple mode of oscillation of the transmission line. The discussion of the simple modes of oscillation of stretched strings and air columns which is given in Art. 17 can be applied with a very slight modification in terminology to the simple modes of oscillation of a transmission line. Thus the period of the fundamental mode of oscillation of a transmission line is equal to the time required for an electromagnetic wave to travel from one end of the line to the other and back again, if the line is open at both ends or closed at both ends; or it is equal to the time required for an electromagnetic wave to travel from one end of the line to the other and back again *twice* if the line is open at one end and closed at the other. Taking the frequency of the fundamental mode as unity, the frequencies of the successive higher modes are 2, 3, 4, 5, 6, etc., for a transmission line which is open or closed at both ends, and 3, 5, 7, 9, etc., for a transmission line which is open at one end and closed at the other, as explained in Art. 17.

The above statement as to the frequency of oscillation of the fundamental and higher modes of oscillation of a transmission line is based upon the assumption that the reflection takes place exactly at the end of the line. This is sensibly true when the wires of the transmission line are close together, but when the distance between the wires is large, the reflection\* takes place, as it were, at a point beyond the actual end of the line. The result is that the distance from the open end of a transmission line to the first voltage node is slightly less than a quarter of a wave length, and the distance from the short-circuited end of a transmission line to the first current node is slightly less than a quarter of a wave length.

A clear understanding of the simple oscillation of a transmis-

\* Indeed some of the wave energy is not reflected at all at the end of a transmission line; the end of the line gives out electromagnetic waves into the surrounding region in a manner analogous to the giving out of sound waves from the open end of an organ pipe.

sion line may be obtained by a careful study of Art. 17, it being kept in mind that an electromagnetic wave train is reflected from an open end of a transmission line with reversal of current phase but without reversal of voltage phase, and that such a wave train is reflected from the short-circuited end of a transmission line with reversal of voltage phase but without reversal of current phase.

The actual distribution of current and the actual distribution of voltage in a standing wave train on a transmission line is shown in Fig. 109. This figure represents several vibrating segments in the middle portion of a long line. The upper part of the figure  $ABA'B'$  represents the current distribution in the wires at the instant when the voltage between the wires is everywhere equal to zero, the value of the current at each point being represented by the ordinate of sine curve  $i_1$ . This current rapidly charges the wires (one wire positively and the other wire negatively) in the regions  $N$ , and as the charges increase the current values decrease. The ordinate of the successive curves  $i_1, i_2, i_3, i_4$  and  $i_5$  represent the successive values of the current at each point in the line, and the ordinates of the successive curves  $e_1, e_2, e_3, e_4$  and  $e_5$  represent successive values of voltage across the line. The lower part of the figure  $CDC'D'$  represents the distribution of electric field (voltage between the wires) at the instant when the current is everywhere equal to zero. The sine curves  $i_1, i_2, i_3$ , etc., and  $e_1, e_2, e_3$ , etc., in Fig. 109, represent the successive current and voltage distributions during one quarter of a cycle, that is, from the instant when voltage is everywhere zero to the instant when current is everywhere zero. At the instant which is represented by curve  $e_5$  (when electric field is distributed as shown in diagram  $CDC'D'$ ), current starts to flow at each point in the transmission line in the opposite direction to the currents shown in the diagram  $ABA'B'$ , and these currents grow until they reach values represented by the ordinates of the curve  $i_9$  at which instant the voltage is again everywhere zero. This reversed current then begins to produce

reversed charges in the regions  $N_v$ , and after another quarter of a cycle these currents are reduced to zero, and the voltage dis-

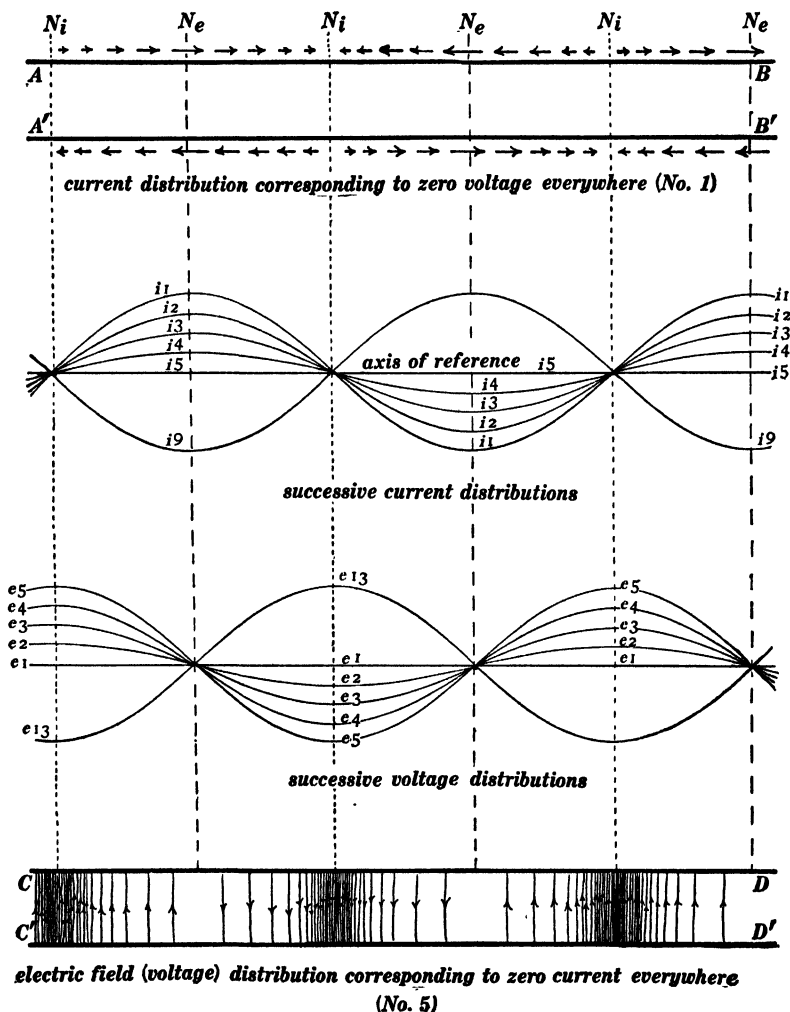

Fig. 109.

tribution over the line is represented by ordinates of the curve  $e_{13}$ . The electric field distribution corresponding to the curve  $e_{13}$  then establishes currents in the line which grow to maximum

values, bringing the line back to its initial condition  $ABA'B'$  after one complete oscillation.

The actual distribution of electric current and magnetic field at the instants represented by curves  $i1$  and  $i9$  are shown in

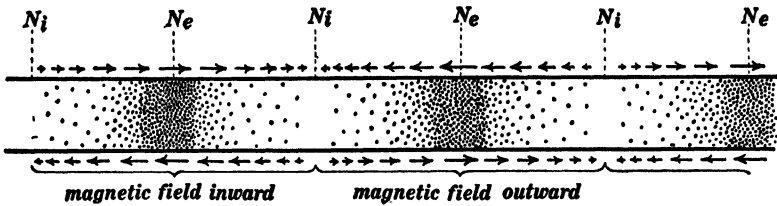

Fig. 110.

Figs. 110 and 112; and the actual distributions of electric charge and electric field at the instants represented by curves  $e5$  and  $e13$  are shown in Figs. 111 and 113.

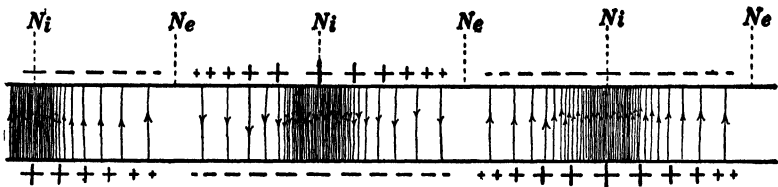

Fig. 111.

The portions of dotted sine curves in Fig. 114 show the current and voltage distributions over a transmission line, open at the distant end, when the line is vibrating in its fundamental mode, the

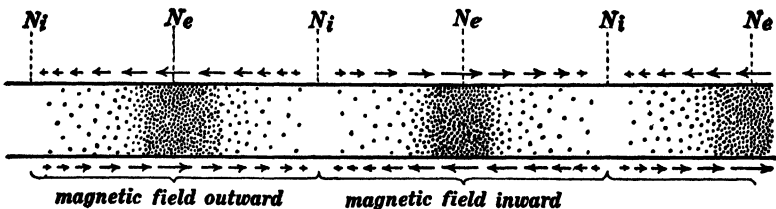

Fig. 112.

vibrations being produced by the alternator  $A$  of proper frequency. When the current is everywhere zero, the voltages across the line are represented by the ordinates of one of the

dotted curves in the upper half of the figure ; and a quarter of a cycle later, when the voltage is everywhere zero, the currents in the wires are represented by the ordinates of one of the dotted curves in the lower half of the figure.

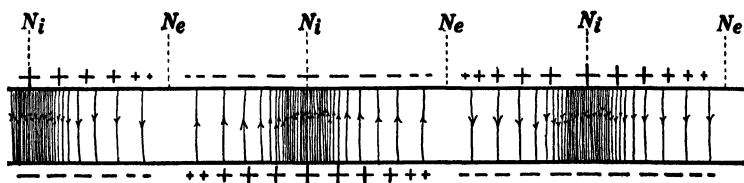

Fig. 113.

The dotted sine curves in Fig. 115 represent voltage and current distributions over a transmission line when it is oscillating in its second mode, the oscillations being produced by the alternator *A* of proper frequency.\*

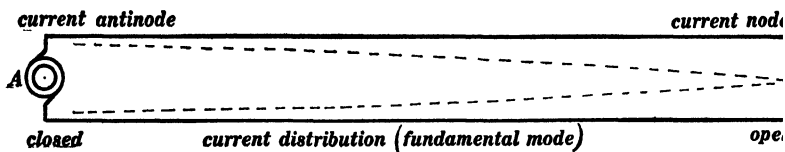
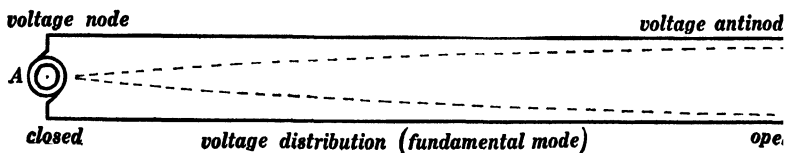

Fig. 114.

An important problem in connection with transmission-line oscillation is to consider the character and violence of the oscillations of a transmission line produced by an applied electromotive

\* The student should make diagrams similar to Figs. 110 and 111 showing voltage and current distributions for the first and second modes of oscillation of a transmission line closed at the distant end.

force of any specified frequency. If this frequency coincides with the frequency of one of the simple modes of oscillation of the transmission line, the violence of the oscillations will be very

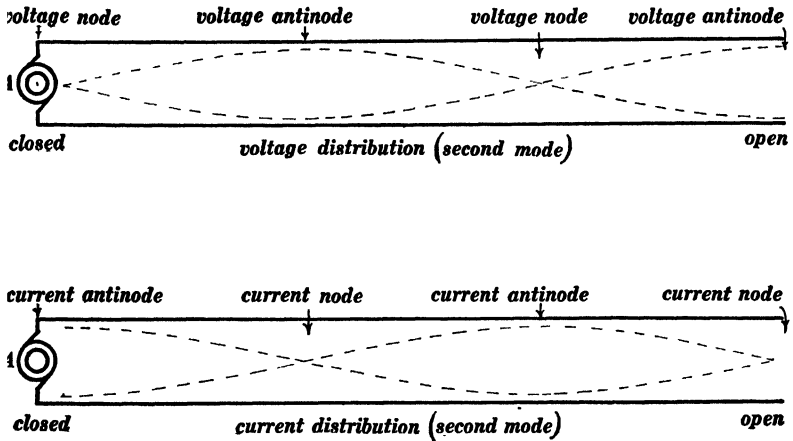

Fig. 115.

great if the line losses are small. In this case, indeed, the violence of the ultimate oscillations which are built up is limited only by the line losses.

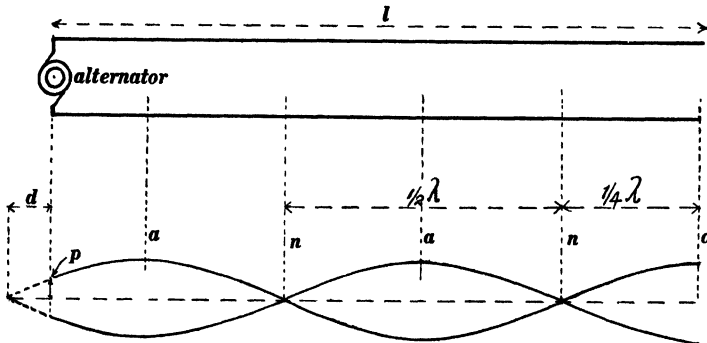

Fig. 116.

When the frequency of the impressed electromotive force does not coincide with the frequency of one of the simple modes of oscillation of the line, the ultimate steady state of oscillation of

the line is determined as follows (line losses being ignored). Figures 116 and 117 represent the voltage distributions over a transmission line which is connected to an alternator, the distant end of the line being open; and Figs. 118 and 119 represent the

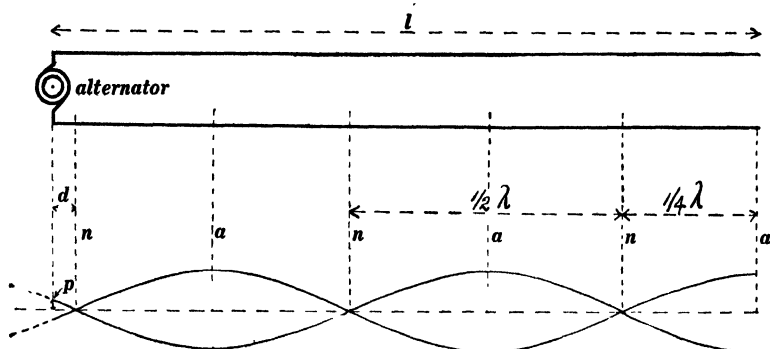

Fig. 117.

voltage distributions over a transmission line which is connected to an alternator, the distant end of the line being closed. The action which takes place during the time that the steady state of oscillation of the transmission line is being built up is

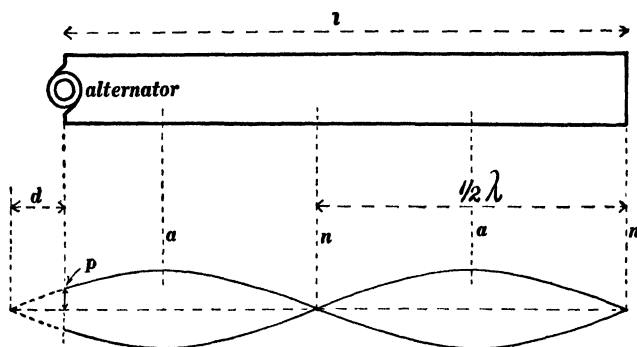

Fig. 118.

rather complicated and will not be considered. The ultimate state of oscillation of the line is a standing wave train of which the wave length  $\lambda$  is equal to the distance traveled by an electromagnetic wave during one complete cycle of the electromotive

force of the alternator; for example, if the alternator has a frequency of 10,000 cycles per second,  $\lambda$  will be 186 miles. The voltage nodes (antinodes of current) of this stationary wave train are at  $n, n, n$ , etc., and the voltage antinodes (current nodes) are at the points  $a, a, a$ , etc. The voltage across the line at any point is an alternating voltage at the frequency of the alternator, and the effective value of the voltage across the line at any point is represented by the ordinate at that point of one of the sine

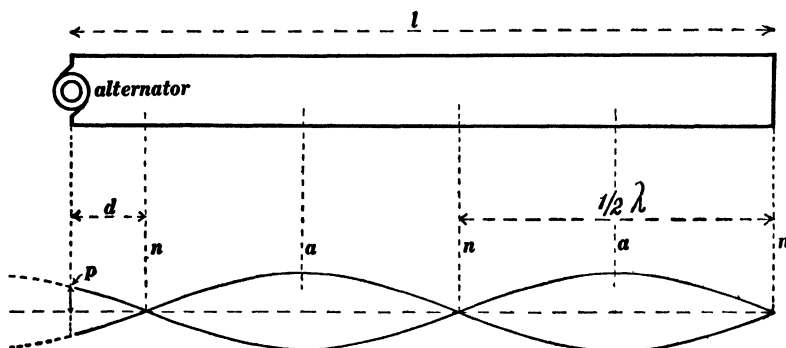

Fig. 119.

curves in Figs. 116 to 119. Let  $E$  be the effective (or maximum) value of the voltage between wires at any voltage antinode  $a$ . Then the effective (or maximum) voltage between wires at a point distant  $x$  from any voltage node  $n$  is  $E \sin x/\lambda$ . The condition which must be satisfied when the ultimate steady state of line oscillation is reached is that the distribution of voltage over the line (which is represented by the sine curves in Figs. 116 to 119) should conform to or fit the alternator voltage at the generator end. Therefore the ultimate state of line oscillation in Figs. 116 to 119 is determined as follows: Beginning at the distant end of the line draw a series of sine curves (beginning at a maximum point in Figs. 116 and 117, and beginning on the axis in Figs. 118 and 119) and determine the distance  $d$  which is left over at the generator end. Then the effective voltage  $E$  at one of the voltage antinodes when the line has reached its steady state of oscillation is determined by the equation

$$E \sin \frac{d}{\lambda} = G$$

where  $G$  is the effective (or maximum) value of the generator voltage.

This analysis of the ultimate steady state of oscillation of a transmission line (on which the losses are assumed to be zero) produced by an impressed electromotive force of any specified frequency and value may be more clearly understood by outlining the corresponding problem in the vibration of a string. This corresponding problem will not be given, however, in the exact analogous form which would be the finding of the ultimate steady state of oscillation of a string when the end is acted upon by a periodic *force* of specified frequency and value; a much simpler and equally suggestive problem will be given, namely: The end of a stretched string is moved to and fro sidewise at a specified frequency and through a specified amplitude, the motion being harmonic. Required the ultimate steady state of oscillation of the string, ignoring friction. The ultimate steady state of oscillation of the string is a standing wave train of wave length  $\lambda$ , where  $\lambda$  is the distance traveled by a wave on the string during one complete cycle of the impressed motion of the end. Let  $D$  be the amplitude of motion of the string at an antinode. Then  $D \sin x/\lambda$  is the amplitude of motion at any point, where  $x$  is the distance of that point from a node. Lay off a series of half wave lengths from the fixed end of the string and determine the length  $d$  which is left over as in Figs. 116-119. The amplitude of oscillation of the string at an antinode when the string reaches its ultimate steady state of oscillation is then determined by the equation

$$D \sin \frac{d}{\lambda} = G$$

where  $G$  is the given amplitude of oscillation of the end of the string.

**34. Experimental demonstration of stationary electric waves on a pair of straight wires.** — The velocity of electromagnetic waves

on a plain transmission line is the same as the velocity of light, namely, 186,000 miles per second, and therefore it is necessary to use an alternating electromotive force of extremely high frequency if one is to produce a stationary wave train upon a plain transmission line of moderate length. The arrangement used by Lecher is shown in Fig. 120. Two flat plates of metal  $C$  and

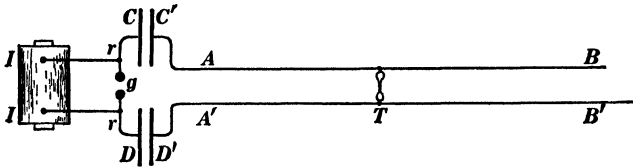

Fig. 120.

$D$ , together with the rods  $r$  and the air gap  $g$ , constitute a Hertz oscillator which is excited from the induction coil  $II$ ; and  $C'D'$  are two auxiliary metal plates which are connected to the long pair of wires  $AB$  and  $A'B'$ . The repeated reversals of electric charge on the plates  $C$  and  $D$  (produced by the electric oscillations of the system  $CrgrD$ ) induce reversals of charge upon the plates  $C'$  and  $D'$  and set the pair of wires  $AB$  and  $A'B'$  into oscillation. The voltage distribution over the "transmission line"  $ABA'B'$  may be investigated by bridging a small vacuum tube across the line as shown at  $T$  in Fig. 120. When this vacuum tube is slid along the wires it shows no luminosity at or near the voltage nodes and it shows a maximum of lumi-

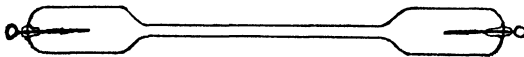
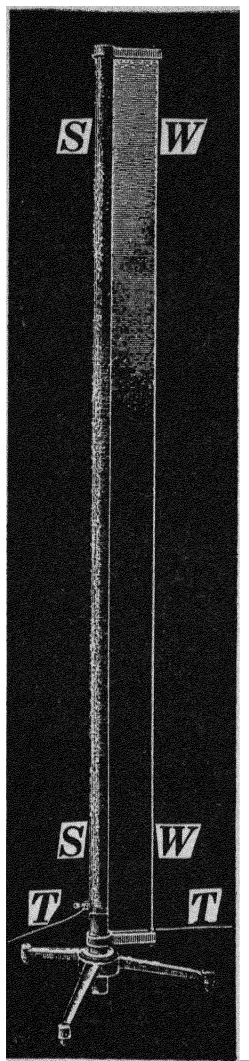

Fig. 121.

nosity at or near the voltage antinodes. The best form of vacuum tube for this purpose is shown in Fig. 121. The narrow portion of the tube should have a bore of about one millimeter and it should preferably be filled with the rare gas neon at a pressure of 2 or 3 millimeters of mercury. Such a vacuum tube glows with a bright orange-red light which is visible in broad daylight. If neon is not available the tube should be filled with



(a)

Fig. 122.

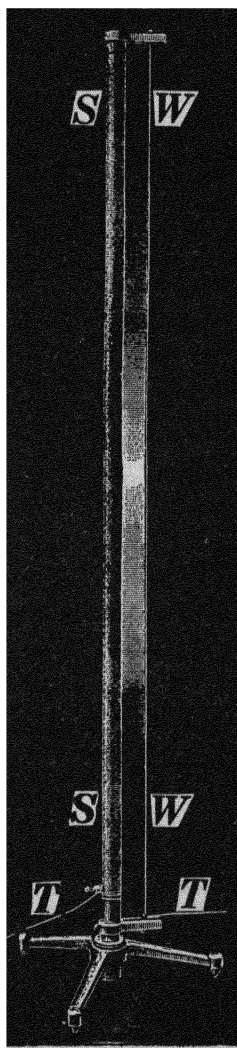

(c)

Fig. 123.

rarefied carbon dioxide gas and the walls of the tube should be made of uranium glass which by its fluorescence intensifies the luminosity of the tube during discharge.

The open end  $BB'$  of the "transmission line" in Fig. 120 is a voltage antinode, and usually a number of voltage nodes are found upon moving the vacuum tube  $T$  towards the end  $AA'$  of the line. It is interesting to note in this connection that the frequency of the oscillations of the system  $CrgD$  may be found by measuring the distance between adjacent voltage nodes on the "transmission line"  $ABA'B'$ , and considering that this is the distance traveled by an electromagnetic wave during one half of a complete oscillation. Thus, if the distance between adjacent voltage nodes is 3 feet, the total wave length is 6 feet, and one oscillation is the time required for an electromagnetic wave to travel over this distance, namely,  $3.05 \times 10^{-9}$  of a second, which corresponds to a frequency of 327,000,000 oscillations per second.

Figures 122 and 123 show Seibt's arrangement for demonstrating stationary wave trains on a pair of parallel wires. One of the "wires"  $SS$  consists of a single layer of fine wire wound on a long wooden rod, and the other  $WW$  is a very fine bare wire stretched alongside of and parallel to  $SS$ . In Fig. 122 the upper end of the "transmission line" is open, that is, the long coil  $SS$  and the fine wire  $WW$  are insulated from each other at the upper end; and in Fig. 123 the upper end of the "transmission line" is short-circuited, that is, the long coil  $SS$  and the fine wire  $WW$  are connected at the upper end by a metal bar in Fig. 123. In order to produce a stationary wave train, the arrangement shown in Figs. 122 and 123 is connected as shown in Fig. 124. An induction coil  $II$  charges a condenser  $C$

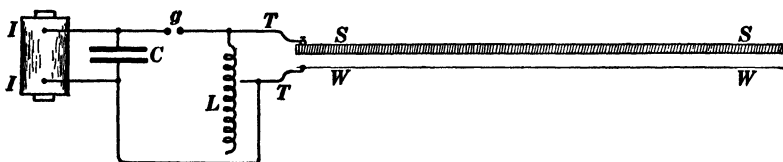

Fig. 124.

which discharges repeatedly across the air gap  $g$  and through the adjustable inductance  $L$ . Each discharge is oscillatory (fre-

quency equal to  $1/2\pi\sqrt{LC}$ ) and the terminals  $TT$  are connected across the inductance as shown.

Figure 122 shows the "transmission line," open at the upper end, oscillating in its fundamental mode, the voltage at and near the voltage antinode being sufficient to cause a brush discharge between the fine wire and the long coil  $SS$ , as shown by the white shading in the upper part of the figure. Figure 123 shows the "transmission line," short-circuited at the upper end, oscillating in its fundamental mode, the voltage at and near the voltage antinode being sufficient to produce a brush discharge between the fine wire and the coil  $SS$  as shown by the white shading in the middle part of the figure. The object of using the fine bare wire as one wire of the "transmission line" is to facilitate the formation of a brush discharge. The inductance and capacity of the "transmission line" in Figs. 122 and 123 is discussed in Appendix A.

**35. Clock-diagram models of moving and of standing wave trains.** — Let  $I$  be the maximum value of the harmonic alternating

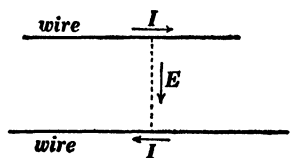

Fig. 125.

current at a point on a transmission line and let  $E$  be the maximum value of the harmonic voltage across the line at the point, positive directions being indicated by the arrows in Fig. 125. Let the instantaneous values of current and voltage at the

point on the line be represented by  $i$  and  $e$ . Then we may write:

$$i = I \sin \omega t \quad (11)$$

$$e = E \sin (\omega t + \theta) \quad (12)$$

in which  $\omega = 2\pi f$ , where  $f$  is the frequency in cycles per second, and  $\theta$  is the angular phase difference between  $e$  and  $i$ . When  $e$  is ahead of  $i$  in phase the angle  $\theta$  is to be considered as positive, and when  $e$  is behind  $i$  in phase the angle  $\theta$  is to be considered as negative.

Consider the two lines  $OI$  and  $OE$  in Fig. 126 whose lengths represent the maximum values  $I$  and  $E$  to scale, and imagine these lines to rotate uniformly about the point  $O$  at a speed of  $f$  revolutions per second or  $\omega (= 2\pi f)$  radians per second. Then the projections of  $OI$  and  $OE$  on the fixed line  $AB$  represent at each instant the values of  $i$  and  $e$  respectively. The diagram, Fig. 126 (which is imagined to be rotating), is called a *clock diagram*.\*

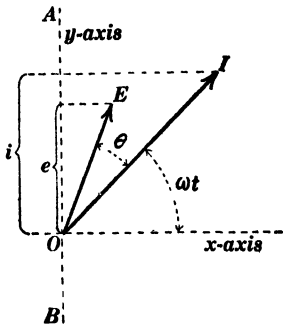

Fig. 126.

The clock diagram is the simplest scheme for showing the essential details of any problem in alternating currents when voltage and current are harmonic, and one reason why the clock

diagram method is so simple is that *time* does not enter explicitly into it but is taken care of by the assumed rotation of the clock diagram. It is therefore to be expected that the simplest algebraic formulation of any alternating-current problem, when voltage and current are harmonic, is that which formulates the geometrical relationships of the clock diagram and which does not involve explicitly any consideration of elapsed time. Thus let  $i_1$  be the  $x$ -component and  $i_{11}$  the  $y$ -component of the vector  $OI$  in Fig. 126, and let  $e_1$  and  $e_{11}$  be the  $x$  and  $y$ -components respectively of the vector  $OE$ . Then we may write

$$I = i_1 + j i_{11} \quad (13)$$

$$E = e_1 + j e_{11} \quad (14)$$

in which  $j = \sqrt{-1}$ . These expressions for the clock-diagram vectors  $I$  and  $E$  constitute the basis of the use of complex

\* The student is supposed to be familiar with the methods of representing sums and differences of harmonic currents (or voltages) by vector sums and vector differences of current (or voltage) lines in the clock-diagram. See pages 53-57 of Franklin and Esty's *Elements of Electrical Engineering*, Vol. II, The Macmillan Co., 1908.

quantity in alternating-current theory.\* A clock-diagram vector must represent the *maximum value* of current or voltage if its projection is to represent the actual instantaneous value  $i$  or  $e$ . It is usual, however, to represent *effective values* of current and voltage by clock-diagram vectors.† *In all the following discussion effective values  $I$  and  $E$  are understood to be represented by clock-diagram vectors.*

*Clock-diagram model of moving wave train.*—The parallel lines in the upper part of Fig. 127 represent a portion of a transmission

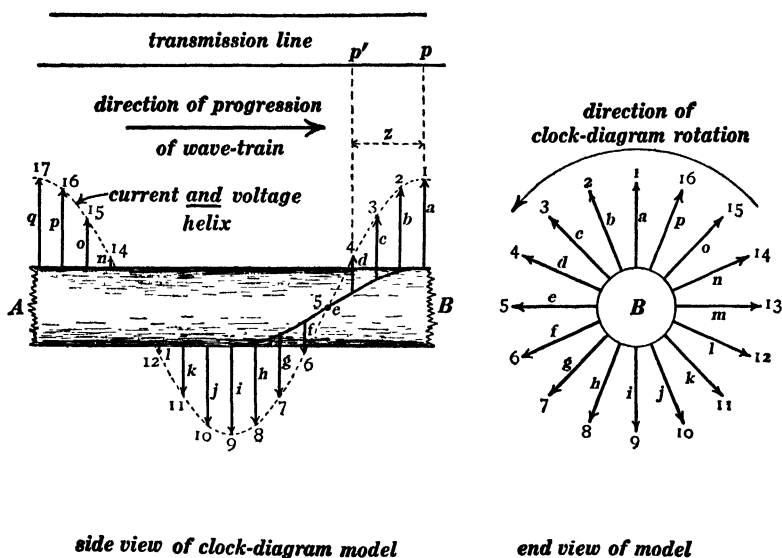

Fig. 127.

line;  $AB$  represents a long cylinder of wood with equidistant radial rods (arrows) set into it in a helical row; the cylinder with its attached arrows is supposed to be rotating at a speed of  $f$  revolutions ( $= 2\pi f$  radians) per second in a counter-clock-wise direction as seen from the end  $B$ ; and the projections on the plane of the paper of the attached arrows represent the values at

\* See pages 88-97, Franklin and Esty's *Elements of Electrical Engineering*, Vol. II.

† See page 62, Franklin and Esty's *Elements of Electrical Engineering*, Vol. II.

the various points of the transmission line of the alternating current  $i$  which is associated with a simple wave train of electromagnetic waves moving along the transmission line from left to right. In a moving wave train  $i$  and  $e$  are in phase with each other everywhere so that the projections of the radial arrows in Fig. 127 represent the values of  $e$  as well as the values of  $i$ .

We have chosen to consider both  $i$  and  $e$  positive (or both negative) in an electromagnetic wave moving to the right along the transmission line in Fig. 127. Therefore, in an electromagnetic wave moving to the left, the current and voltage must everywhere be opposite in sign, that is, wherever the one is positive the other must be negative. Thus the projections upon the plane of the paper of the numbered arrows in Fig. 128 represent the

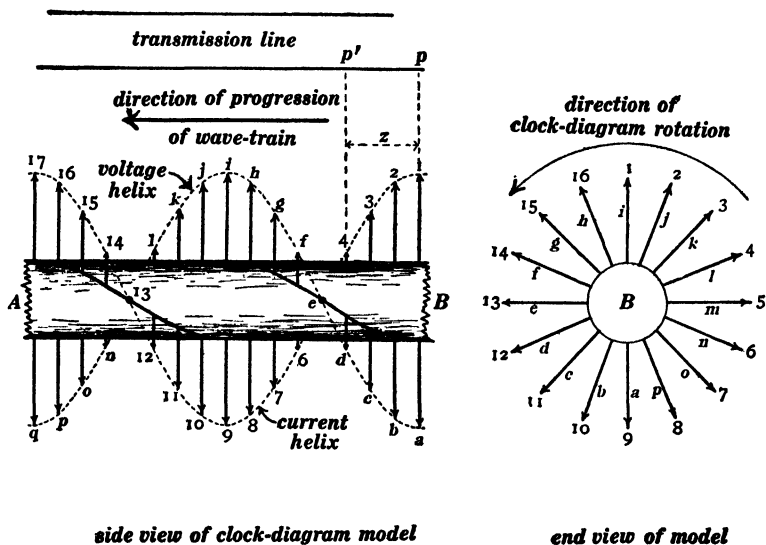

Fig. 128.

instantaneous values at the various points of a transmission line of the alternating currents  $i$  which are associated with a simple wave train moving from right to left, and the projections of the lettered arrows represent the instantaneous values of the alternating voltage  $e$ .

*Clock-diagram model of standing wave train.*—Figure 130 shows two sine curves in planes at right angles to each other, and the ordinates  $i_1, i_2, i_3 \dots e_1, e_2, e_3, \dots$  etc., of these sine curves are clock-diagram vectors which represent\* the values at

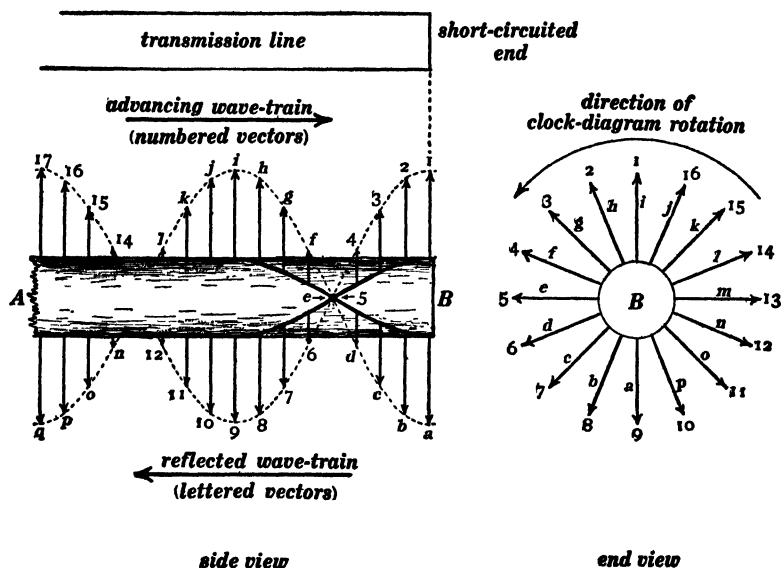

Fig. 129.

the various points along a transmission line of the alternating current  $i$  and of the alternating voltage  $e$  which are associated with a standing wave train. The clock-diagram model Fig. 130 may be derived from Figs. 127 and 128 by considering that a standing wave train is the superposition of two oppositely moving wave trains of equal amplitudes. Let us first consider the voltage distribution in a standing wave train with the help of Fig. 129, in which the numbered arrows constitute the voltage helix from Fig. 127 (that is, the numbered arrows in Fig. 129 represent the voltages in a wave train moving to the right), and the lettered

\*It is convenient to speak of the vectors in a clock diagram,  $OI$  and  $OE$  in Fig. 126 for example, as *representing* an alternating current and an alternating voltage respectively, although of course it is the *projections*  $i$  and  $e$  of the vectors  $OI$  and  $OE$  which represent the current and voltage.

arrows constitute the voltage helix from Fig. 128 (that is, the lettered arrows in Fig. 129 represent the voltages in a wave train moving to the left). The voltage at each point in a standing wave is the sum of the voltages at that point in the two oppositely moving wave trains, and it is represented therefore by a clock-diagram line which is the vector sum of the clock-diagram lines which represent the voltages in the respective moving trains. Now the vector sum of arrows 1 and  $a$  in Fig. 129 is evidently

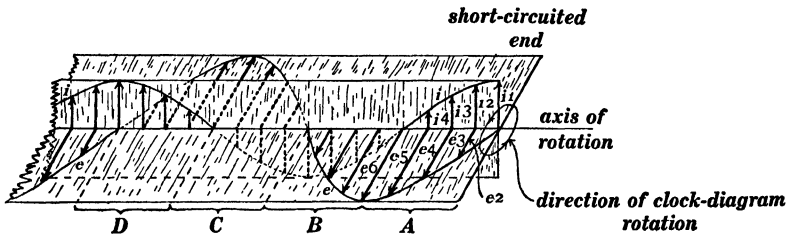

Fig. 130.

zero, the vector sum of arrows 2 and  $b$  in Fig. 129 is the arrow  $e2$  in Fig. 130, the vector sum of arrows 3 and  $c$  in Fig. 129 is the arrow  $e3$  in Fig. 130, and so on.

Let us now consider the current distribution in a standing wave train with the help of the current helices in Figs. 127 and 128. The vector sum of arrows No. 1 in Figs. 127 and 128 is the arrow  $i1$  in Fig. 130, the vector sum of arrows No. 2 in Figs. 127 and 128 is the arrow  $i2$  in Fig. 130, the vector sum of arrows No. 3 in Figs. 127 and 128 is the arrow  $i3$  in Fig. 130, and so on.

**36. Reflection of simple wave trains.** — Before proceeding to the discussion of the influence of line resistance and line leakage upon electromagnetic wave motion on a transmission line, it is desirable to consider more in detail the reflection of simple wave trains from the end of the line. The reflection of a simple wave train from the short-circuited end of a line gives a standing wave train with a voltage node and a current antinode at the end of the line. Figure 130 is the clock-diagram model referring to this case. The reflection of a simple wave train from the open end of a

line gives a standing wave train with a voltage antinode and a current node at the end of the line. If one quarter of a wave length ( $\lambda/4$ ) of the end of the model in Fig. 130 were cut off, what remained would be a clock-diagram model representing the stationary wave train which is produced by the reflection of a simple wave train from the open end of a transmission line.

*Reflection of a simple wave train from an inductive receiving circuit of negligible resistance.* — In this case no energy is absorbed by the receiving circuit after the steady state is reached, and therefore the reflected wave train is of the same intensity as the original advancing wave train. The result is the production of a standing wave train. The clock-diagram model of Fig. 130 represents the state of affairs on the line, the only thing to be determined being *how much of the end of the model must be cut off*. Let  $I$  be the current and  $E$  the voltage in the original advancing wave train. Then

$$\frac{1}{2}LI^2 = \frac{1}{2}CE^2 \quad (i)$$

according to equation (7*b*), where  $L$  is the inductance of the line per unit length and  $C$  is the capacity of the line per unit length. The length of the current vector  $iI$  in Fig. 130 is  $2I$ , and the length of the voltage vector  $eE$  in Fig. 130 is  $2E$ , as is evident from the mode of derivation of Fig. 130 from Figs. 127 and 128. Consider a point at a distance  $z$  from the end of the clock-diagram model of Fig. 130. The length of the current vector (in the vertical plane) at the point  $z$  is  $2I \cos 2\pi z/\lambda^*$  and the length of the voltage vector (in the horizontal plane) at the point  $z$  is  $2E \sin 2\pi z/\lambda$ . Therefore the ratio of the voltage vector to the current vector at the point  $z$  is

$$\frac{2E \sin \frac{2\pi z}{\lambda}}{2I \cos \frac{2\pi z}{\lambda}} = \frac{E}{I} \tan \frac{2\pi z}{\lambda} \quad (ii)$$

\* The sine curves of Fig. 130 pass through a complete cycle from  $z=0$  to  $z=\lambda$ ; therefore the distance  $\lambda$  corresponds to a whole circumference or  $2\pi$  radians, and the distance  $z$  corresponds to  $z/\lambda \times 2\pi$  radians.

and throughout the region  $z = 0$  to  $z = \lambda/4$  in Fig. 130 the voltage is  $90^\circ$  ahead of the current in phase.

Let  $X$  be the reactance of the receiving circuit, then effective voltage divided by effective current at the end of the line must be equal to  $X$ , and the voltage must be  $90^\circ$  ahead of the current in phase\* because the voltage at the end of the line is the voltage which acts on the receiving circuit and the current at the end of the line is the current which enters the receiving circuit. Therefore, from equation (i) we have

$$\frac{E}{I} \tan \frac{2\pi z}{\lambda} = X \quad (\text{iii})$$

and solving this equation for  $z$  we have

$$z = \frac{\lambda}{2\pi} \times \text{angle whose tangent is } \frac{XI}{E} \quad (\text{iv})$$

but the ratio  $I/E$  is equal to  $\sqrt{C/L}$  according to equation (i) whence equation (iv) becomes

$$z = \frac{\lambda}{2\pi} \times \text{angle whose tangent is } X\sqrt{C/L} \quad (\text{v})$$

which is the length is to be cut off the end of the clock-diagram model of Fig. 130 in order that the model may correctly represent the standing wave train which is produced by the reflection of a simple train of electromagnetic waves from the given receiving circuit. Thus, if  $X$  is zero we have a short-circuited end and  $z = 0$ ; if  $X$  is indefinitely large,  $z = \lambda/4$ , and the reflection is of the same character as that which takes place at the open end of a line.

When  $X\sqrt{C/L}$  is equal to unity, that is, when the reactance of the receiving circuit is equal to  $\sqrt{L/C}$ , then  $z = \lambda/8$ . The clock-diagram lines at the end of the transmission line in this case (at a point distant  $\lambda/8$  from the end of the model in Fig. 130)

\* See pages 68-71 of Franklin and Esty's *Elements of Electrical Engineering*, Vol. II.

are shown in Fig. 131. The two vectors  $A$  represent current and voltage at end of line due to the original advancing wave train, the two vectors  $R$  and  $R'$  represent current and voltage at end of line due to the reflected wave train, and the two vectors  $S$  and  $S'$  represent the actual resultant current and voltage of the standing wave train at the end of the line. It is interesting

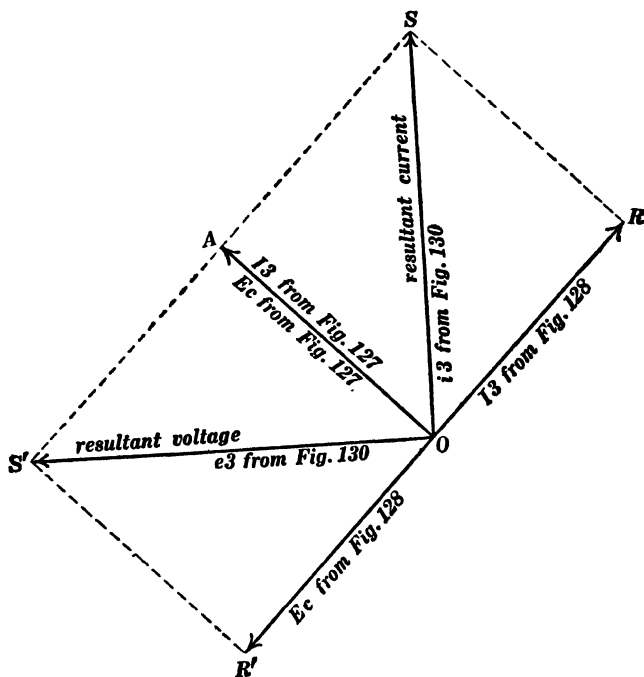

Fig. 131.

to note that the reflection which is represented in Fig. 131 (when  $X = \sqrt{L/C}$ ) retards the current phase by  $90^\circ$  ( $OA$  to  $OR$ ) and advances the voltage phase by  $90^\circ$  ( $OA$  to  $OR'$ ).

When the receiver at the end of a line is a condenser, the reflection is such as to be represented by the clock-diagram model of Fig. 130 with a length of more than  $\lambda/4$  and less than  $\lambda/2$  cut off the end, according to the capacity of the condenser.

*Reflection of a simple wave train from a non-inductive receiver of given resistance.* — If the resistance of the receiver is equal to

$\sqrt{L/C}$  no reflection takes place as explained in Art. 28. If the resistance of the receiver is greater than  $\sqrt{L/C}$ , a portion ( $a$ ) of the advancing wave train is absorbed, and the remainder ( $r$ ) is reflected with reversal of current phase; and the current and voltage distribution over the transmission line is the sum of two distributions, namely, (1) the distribution corresponding to the absorbed part ( $a$ ) of the original advancing wave train and (2) the distribution corresponding to a standing wave train made up of the reflected wave train and the portion ( $r$ ) of the original advancing wave train. If the resistance of the receiver is less than  $\sqrt{L/C}$ , a portion ( $a$ ) of the advancing wave train is absorbed, and the remainder ( $r$ ) is reflected with reversal of voltage phase; and the current and voltage distribution over the line is the sum of two distributions as before.\*

*Reflection of a simple wave train from a receiving circuit of given resistance  $R$  and given reactance  $X$ .*—From equation (7*b*) we have

$$\frac{I}{\sqrt{C}} = \frac{E}{\sqrt{L}} \quad (\text{vi})$$

where  $I$  is the current and  $E$  the voltage in any traveling wave,  $L$  is the inductance of the line per unit length, and  $C$  is the capacity of the line per unit length. Therefore  $I$  and  $E$  in any traveling wave may be represented by clock-diagram vectors of the same length if current be represented to the scale  $k\sqrt{C}$  amperes per inch and voltage to the scale  $k\sqrt{L}$  volts per inch,  $k$  being any constant. Let  $I_0$  and  $E_0$  be the current in and the voltage across the given receiving circuit. Then

$$\frac{E_0}{I_0} = \sqrt{R^2 + X^2}$$

is known and

$$\tan \theta = \frac{X}{R}$$

\* This matter is illustrated by problems in Appendix C.

is known,\* where  $\theta$  is the angular lag of  $I_0$  behind  $E_0$  in phase. Draw the line  $OE_0$ , Fig. 132, of any arbitrary length, and draw the line  $OI_0$  making it  $\sqrt{L/C}/\sqrt{R^2 + X^2}$  times as long as  $OE_0$ . Draw the line  $E_0I_0$  and bisect it at  $p$ . Then the line  $Op$  represents the current (scale  $k\sqrt{C}$  amperes per inch) and it also represents the voltage (scale  $k\sqrt{L}$  volts per inch) in the original advancing wave train; and, inasmuch as the original advancing wave train must be given, it is evident that  $k$  may be found. Then the line  $pE_0$  represents the voltage in the reflected wave train (scale  $k\sqrt{L}$  volts per inch) and the line  $pI_0$  represents the current in the reflected wave train (scale  $k\sqrt{C}$  amperes per inch).† Having given the resistance and reactance of the receiving circuit, the line constants  $L$  and  $C$ , the wave length  $\lambda$  of the original advancing wave train, and the current and voltage values in the original advancing wave train, the resultant current and voltage vectors

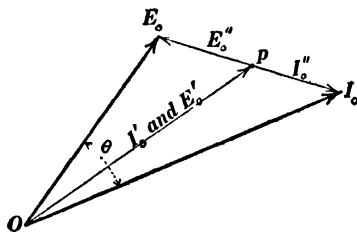

Fig. 132.

at a point on the transmission line at a given distance  $z$  from the end of the line may be found as follows: Having constructed the diagram, Fig. 132, turn the vectors  $I'$  and  $E'$  in a counter-clockwise direction through the angle  $2\pi z/\lambda$ , turn the vectors  $I''$  and  $E''$  in a clockwise direction through the angle  $2\pi z/\lambda$ , and take the resultant of the two current vectors and the resultant of the two voltage vectors so found. To understand why one should turn  $I'$  and  $E'$  in a counter-clockwise direction, look at end  $B$  of the clock-diagram model, Fig. 127, and consider the angle between arrow  $1a$  and the arrow distant  $z$  from

\* See pages 66-71 of Franklin and Esty's *Elements of Electrical Engineering*, Vol. II.

† It needs no argument to make the truth of Fig. 132 evident.  $I'$  and  $E'$  must be equal (in length) and in the same direction,  $I''$  and  $E''$  must be equal (in length) and opposite in direction,  $I_0$  must be the vector sum of  $I'$  and  $I''$ , and  $E_0$  must be the vector sum of  $E'$  and  $E''$ .

the end of the model. To understand the turning of  $I''$  and  $E''$ , look at end  $B$  of the clock-diagram model, Fig. 128.

**37. Algebraic formulas for simple wave trains.** — Before taking up the discussion of wave motion on a transmission line where wire resistance and line leakage are not negligible, it is desirable to establish the algebraic formulas for simple wave trains\* on a transmission line of negligible resistance and leakage. The most useful † algebraic formulation is that which expresses by the use of complex quantity the geometrical relations in the clock-diagram models of Figs. 127 and 128, lapse of time being omitted from the equations and left to the imagination as the assumed rotation of the clock-diagram model.

Consider a vector  $I$  in the clock diagram. The *product*,  $Ie^{j\theta} = I(\cos \theta + j \sin \theta)$ , is a vector of the same length as  $I$  but

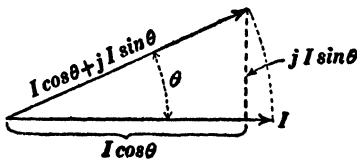

Fig. 133.

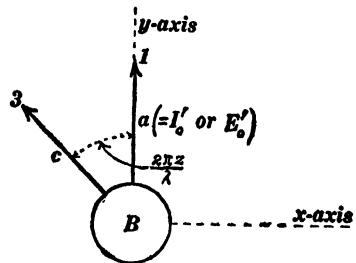

Fig. 134.

turned through the angle  $\theta$  in a counter-clockwise direction, where  $e$  is the Napierian base and  $j = \sqrt{-1}$ . This is evident from Fig. 133. ‡ Let Fig. 134 represent the clock-diagram model

\* A simple wave train cannot exist on a line having appreciable wire resistance or leakage.

† The formulation which corresponds to equations (11) and (12) where the time enters explicitly is as follows :

$$i = I \sin 2\pi \left( \frac{z}{\lambda} - \frac{t}{T} \right) \quad e = E \sin 2\pi \left( \frac{z}{\lambda} - \frac{t}{T} \right)$$

where  $\lambda$  is the wave length of the wave train,  $T$  is the periodic time of the wave train,  $z$  is the distance measured along the axis of progression from a chosen origin to any given point of the wave train, and  $t$  is elapsed time.

‡ See pages 88-97, Franklin and Esty's *Elements of Electrical Engineering*, Vol. II.

of Fig. 127 as seen from the end  $B$ ; the vertical arrow is the same as the vertical arrow in Fig. 127 and it is the clock-diagram vector which represents the current (or voltage) at the point  $p$  of the transmission line. At a point  $p'$  distant  $z$  from  $p$  the clock-diagram vector is the arrow  $Bc$  in Fig. 134, and, representing the vector  $B1$  (or  $Ba$ ) by  $I_0'$  (or by  $E_0'$ ), we have

$$I' = I_0' \epsilon^{j \cdot \frac{2\pi z}{\lambda}} \quad (15)$$

and

$$E' = E_0' \epsilon^{j \cdot \frac{2\pi z}{\lambda}} \quad (16)$$

where  $I'$  is the current vector and  $E'$  is the voltage vector at the point  $p'$  on the transmission line as shown in Fig. 127. Figure 127 represents a simple wave train traveling to the right (in the direction of decreasing  $z$ ), and equations (15) and (16) represent a simple wave train traveling in the negative direction along the  $z$ -axis (direction of decreasing  $z$ ). A simple wave train traveling in the positive direction along the  $z$ -axis (as represented by the clock-diagram model of Fig. 128) is given by

$$I'' = I_0'' \epsilon^{-j \cdot \frac{2\pi z}{\lambda}} \quad (15a)$$

$$E'' = E_0'' \epsilon^{-j \cdot \frac{2\pi z}{\lambda}} \quad (16a)$$

**38. Harmonic decaying waves on a transmission line having appreciable resistance and leakage.** — Consider a point on a trans-

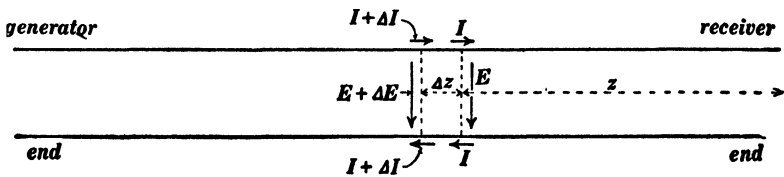

Fig. 135.

mission line at a distance  $z$  from the receiver end, as indicated in Fig. 135. Let  $I$  (a clock-diagram vector) be the current in the line at the point, and let  $E$  (a clock-diagram vector) be the

voltage across the line at the point. The arrows in Fig. 135 represent *positive directions* of current and voltage.

Consider an element of the transmission line of length  $\Delta z$ , and let  $I + \Delta I$  and  $E + \Delta E$  be the current and voltage at the end of the element, as shown in Fig. 135. Let  $R$  be the resistance, counting both wires,\* of unit length of the line; then  $R \cdot \Delta z$  is the resistance of the element  $\Delta z$ . Let  $X$  be the reactance of unit length of the line (equals  $2\pi fL$  where  $f$  is the wave frequency and  $L$  is the inductance of the line per unit length). Then  $RI \cdot \Delta z$  is the loss of voltage in the element due

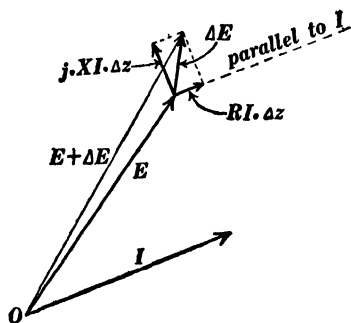

Fig. 136.

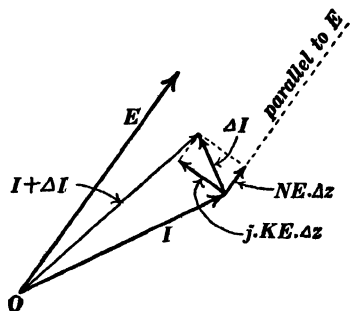

Fig. 137.

to resistance, and this loss is in phase with (parallel to)  $I$  as shown in Fig. 136; and  $XI \cdot \Delta z$  is the loss of voltage in the element due to reactance, and this loss, being  $90^\circ$  ahead of  $I$  in phase as shown in Fig. 136, is properly expressed algebraically as  $j \cdot XI \Delta z$ . Therefore the total voltage loss in the element  $\Delta z$  is  $\Delta E = (RI + jXI)\Delta z$  whence

$$\frac{dE}{dz} = (R + jX)I \quad (17)$$

Let  $C$  be the capacity of unit length of line, then  $E/(1/2\pi fC)$  is the current which charges unit length of line, and it is  $90^\circ$  ahead of  $E$  in phase.† Therefore, writing  $K$  for  $2\pi fC$ , and

\* In equation (10)  $2R$  is the resistance of both wires of unit length of the transmission line.

† See pages 66-68, Franklin and Esty's *Elements of Electrical Engineering*, Vol. II.

multiplying by  $\Delta z$ , we have an expression for the charging current of the element, namely,  $KE \Delta z$ ; and inasmuch as this charging current is  $90^\circ$  ahead of  $E$  in phase it is properly written  $j \cdot KE \cdot \Delta z$ . Let  $1/N$  be the insulation resistance of unit length of the line, then the resistance between the wires of the element  $\Delta z$  is  $1/N \times 1/\Delta z$ ; dividing  $E$  by this resistance we have the leakage current  $NE \cdot \Delta z$  across the line element  $\Delta z$ , and this leakage current is in phase with (parallel to)  $E$ . The total difference between the current which enters the element  $\Delta z$  from the left, namely,  $I + \Delta I$ , and the current which flows out of the element  $\Delta z$  to the right is

$$NE \cdot \Delta z + jKE \cdot \Delta z$$

and this is equal to  $\Delta I$ . Therefore

$$\frac{dI}{dz} = (N + jK)E \quad (18)$$

Differentiating equations (17) and (18) with respect to  $z$  we have

$$\frac{d^2 E}{dz^2} = (R + jX) \frac{dI}{dz}$$

and

$$\frac{d^2 I}{dz^2} = (N + jK) \frac{dE}{dz}$$

whence, using the values of  $dI/dz$  and  $dE/dz$  from equations (17) and (18) we have

$$\frac{d^2 E}{dz^2} = (R + jX)(N + jK)E \quad (19)$$

and

$$\frac{d^2 I}{dz^2} = (R + jX)(N + jK)I \quad (20)$$

Let us consider equation (20) which determines the distribution of current over a line having resistance and leakage, and for the sake of brevity let us write :

$$(\alpha + j\beta)^2 = (R + jX)(N + jK) \quad (21)$$

from which by separating real and imaginary parts we have

$$\alpha = + \sqrt{\frac{1}{2}[(R^2 + X^2)(N^2 + K^2)]^{\frac{1}{2}} + \frac{1}{2}(RN - XK)} \quad (22)$$

and

$$\beta = + \sqrt{\frac{1}{2}[(R^2 + X^2)(N^2 + K^2)]^{\frac{1}{2}} - \frac{1}{2}(RN - XK)} \quad (23)$$

in which  $R$  is the resistance of both wires in unit length of line,  $X$  is equal to  $2\pi \times$  frequency  $\times$  inductance of unit length of line,  $1/N$  is the insulation resistance between the wires of unit length of line, and  $K$  is equal to  $2\pi \times$  frequency  $\times$  capacity of unit length of line.

Two particular solutions of equation (20) are

$$I' = I'_0 \epsilon^{(\alpha + j\beta)z} \quad \text{and} \quad I'' = I''_0 \epsilon^{-(\alpha + j\beta)z}$$

in which  $\epsilon$  is the Naperian base; or, separating the exponentials into two factors, we have

$$I' = I'_0 \epsilon^{\alpha z} \epsilon^{j\beta z} \quad (24)$$

and

$$I'' = I''_0 \epsilon^{-\alpha z} \cdot \epsilon^{-j\beta z} \quad (25)$$

in which  $I'_0$  and  $I''_0$  are undetermined constants of integration. The complete significance of equation (24) is shown by the clock-diagram model, Fig. 138, and the complete significance of equation (25) is shown by the clock-diagram model, Fig. 139. When  $z = 0$  we have  $I = I_0$  in both equations (24) and (25); that is to say, the constant of integration is in each case the current vector at the origin of coördinates (the point on the line from which  $z$  is measured). At the point  $p$  on the line at a distance  $z$  from the origin, as shown in Fig. 138, the *length* of the current vector is  $I'_0 \epsilon^{\alpha z}$  and the factor  $\epsilon^{j\beta z}$  [see equation (24)] signifies the turning of the current vector through the angle  $\beta z$  in the counter-clockwise direction (see end view in Fig. 138) starting from the direction of the current vector  $I'_0$  at the origin. The clock-diagram model, Fig. 138, is a left-handed helix of which the *length* of the radius is  $I'_0 \epsilon^{\alpha z}$  as indicated by the ordinates of the curve  $CC$ , and, as this helix rotates  $f$  revolutions per sec-

ond, it represents the current values in a decaying wave train traveling from left to right in the figure. The clock-diagram

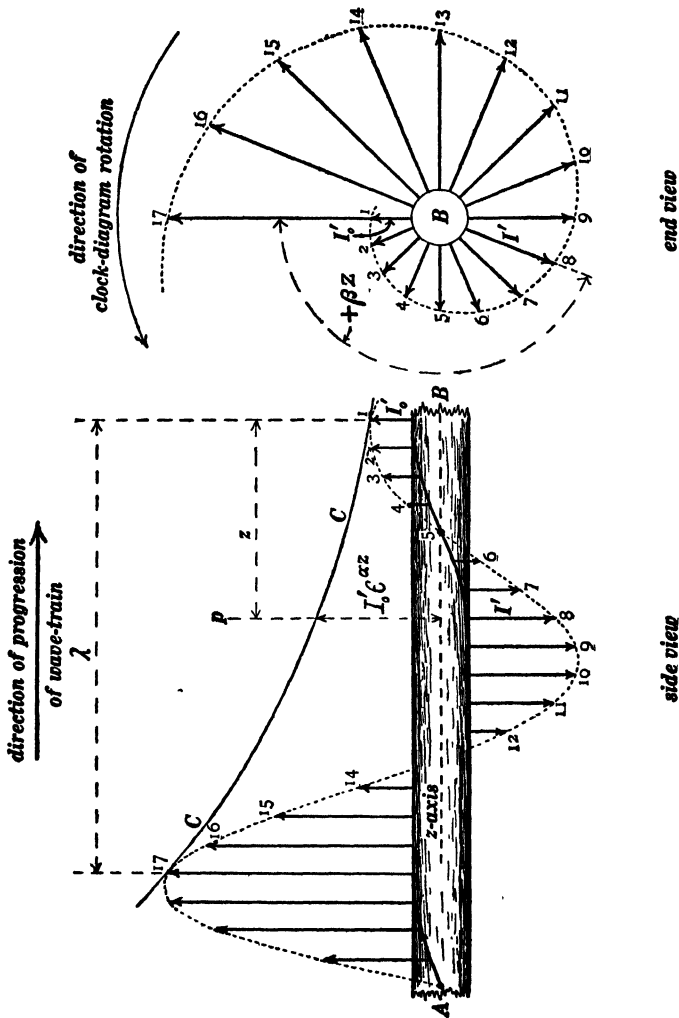

Fig. 138.

model, Fig. 139, is a right-handed logarithmic helix, and, as it rotates  $f$  revolutions per second, it represents the current values in a decaying wave train traveling from right to left in the figure.

In Fig. 127, which represents a simple wave train traveling from left to right, current and voltage vectors are at each point coincident in direction; and in Fig. 128 current and voltage vec-

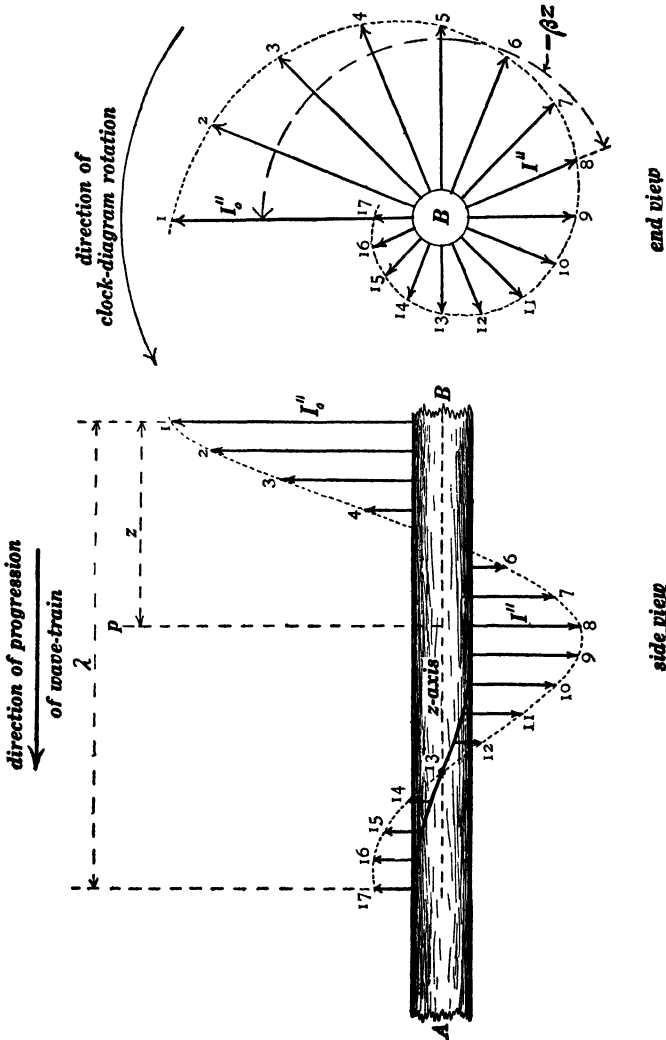

Fig. 139.

tors are at each point opposite in direction. *This is not the case in Figs. 138 and 139.* To find expressions for voltage, differen-

tiate equations (24) and (25) with respect to  $z$  and make use of equation (18). We thus find:

$$E' = \frac{\alpha + j\beta}{N + jK} \cdot I' \quad (26)$$

and

$$E'' = -\frac{\alpha + j\beta}{N + jK} \cdot I'' \quad (27)$$

Therefore the voltage vectors  $E'$  in the clock diagram, Fig. 138, are all ahead of the current vectors  $I'$  by the phase angle  $\phi$ , where

$$\tan \phi = \frac{N\beta - K\alpha}{N\alpha + K\beta} \quad (28)$$

and the voltage vectors  $E''$  in Fig. 139 are ahead of the current vectors  $I''$  by the phase angle  $180^\circ + \phi$ . The expression for  $\tan \phi$  is zero when the line losses are zero and also when the condition of distortionless wave transmission is satisfied (see Art. 32).

Furthermore, from equations (26) and (27) we have:

$$\frac{E'}{\alpha + j\beta} = \frac{I'}{N + jK}$$

and

$$\frac{E''}{\alpha + j\beta} = -\frac{I''}{N + jK}$$

whence

$$\frac{\text{numerical value of } E'}{(\alpha^2 + \beta^2)^{\frac{1}{2}}} = \frac{\text{numerical value of } I'}{(N^2 + K^2)^{\frac{1}{2}}} \quad (29)$$

and

$$\frac{\text{numerical value of } E''}{(\alpha^2 + \beta^2)^{\frac{1}{2}}} = \frac{\text{numerical value of } I''}{(N^2 + K^2)^{\frac{1}{2}}} \quad (30)$$

Therefore, if currents be represented in the clock diagram to the scale  $k\sqrt{N^2 + K^2}$  amperes per inch, and if voltages be represented to the scale  $k\sqrt{\alpha^2 + \beta^2}$  volts per inch, then the lengths of  $E'$  and  $E''$  are at each point (each value of  $z$  in Figs. 138 and 139) equal to the lengths of  $I'$  and  $I''$  respectively,  $k$  being any constant.

*Wave length and velocity of a decaying wave train.*—The wave length  $\lambda$  in Fig. 138 is the distance between any two current vectors for which the angle  $\beta z$  is equal to  $2\pi$ . Therefore placing  $\beta\lambda = 2\pi$  we have

$$\lambda = \frac{2\pi}{\beta} \quad (31)$$

The question as to the velocity of a decaying wave train is rather complicated unless we define the velocity as the wave length  $\lambda$  divided by the period ( $1/f$ ) of the wave train giving

$$V = \frac{2\pi f}{\beta} \quad (32)$$

As a matter of fact it is not possible to assign a definite physical velocity to waves on a transmission line having resistance and leakage, except when the condition of distortionless transmission is satisfied.

*Logarithmic decrement of a decaying wave train.*—The lengths of the successive arrows in Fig. 138 constitute a geometric series, and the ratio of lengths of two arrows one wave length apart is found by substituting  $z = 2\pi/\beta$  in the expression  $e^{\alpha z}$  giving  $e^{2\pi\alpha/\beta}$ , and the natural logarithm of this ratio is  $2\pi\alpha/\beta$ .

**39. Voltage drop on a long transmission line.**—The current and voltage on any alternating-current transmission line (generator and receiver voltages and currents assumed to be harmonic) consists of the superposition of a decaying wave train of current and voltage [ $I'$  and  $E'$  of equations (24) and (26)] traveling out from the generator, and a decaying wave train of current and voltage [ $I''$  and  $E''$  of equations (25) and (27)] reflected by the receiver and traveling back towards the generator end of the line. Following is an outline of the application of equations (22) to (30) to the exact calculation of voltage drop and power loss on a transmission line.\* This outline refers to the graphical solution of the problem; the analytical solution using complex quantities follows exactly the same steps as the graphical solution.

\* Engineers always use approximate methods for these calculations.

A receiver circuit of known power factor ( $\cos \theta$ ) takes a specified amount of current  $I_0$  at a specified terminal voltage  $E_0$  and at a given frequency from a transmission line of which the constants  $R$ ,  $X$ ,  $N$  and  $K$  are known. It is required to find the voltage and current at the generator terminals of the line and the power losses in the line.

Represent voltages in the clock diagram to the scale  $k\sqrt{\alpha^2 + \beta^2}$  volts per inch, and represent currents to the scale  $k\sqrt{N^2 + K^2}$  amperes per inch, where  $k$  is any arbitrary constant, as explained in connection with equations (29) and (30). Represent the given values of  $E_0$  and  $I_0$  at receiver to the chosen scales, making the angle between  $E_0$  and  $I_0$  equal to  $(\theta - \phi)^*$  as shown in Fig. 140

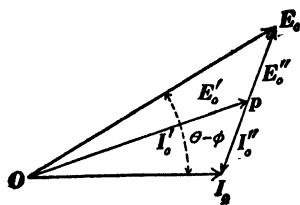

Fig. 140.

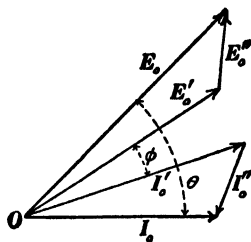

Fig. 141.

(or in Figs. 142, 144 or 146). Bisect the line  $E_0 I_0$  at the point  $p$ , draw the arrows  $Op$ ,  $pE_0$  and  $pI_0$  and then rotate the triangle  $OpE_0$  through the angle  $\phi$  as shown in Fig. 141 (or in Figs. 143, 145 or 147) thus giving the correct clock diagram Fig. 141 (or Figs. 143, 145 or 147). In this clock diagram the vectors  $E_0'$  and  $I_0'$  represent at the receiver end of the line the voltage and current which are associated with the decaying wave train coming from the generator, and the vectors  $E_0''$  and  $I_0''$  represent at the receiver end of the line the voltage and current which are associated with the decaying wave train which is re-

\* Figures 140 and 141 are constructed on the assumption that  $\theta$  and  $\phi$  are both positive; that is, on the assumption that  $E_0$  is ahead of  $I_0$  in phase and that the expression equation (28) is positive; Figs. 142 and 143 are constructed on the assumption that  $\theta$  is negative and  $\phi$  positive; that is, on the assumption that  $I_0$  is ahead of  $E_0$  in phase and that the expression equation (28) is positive; and so on.

flected by the receiver. To find the vectors which represent voltage and current at the generator, turn  $E_0'$  and  $I_0'$  in a counter-clockwise direction through the angle  $\beta l$  radians, and multiply the length of each by  $\epsilon^{\alpha l}$ , where  $l$  is the length of the transmission line; and turn  $E_0''$  and  $I_0''$  in a clockwise direction through the angle  $\beta l$  radians and multiply the length of each by  $\epsilon^{-\alpha l}$ . We thus find the vectors  $E_g'$ ,  $I_g'$ ,  $E_g''$  and  $I_g''$  which represent at the generator end of the line the currents and voltages which are associated with the respective decaying wave trains.

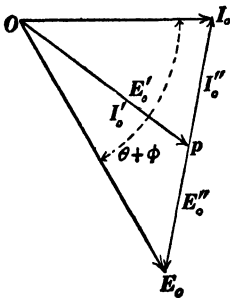

Fig. 142.

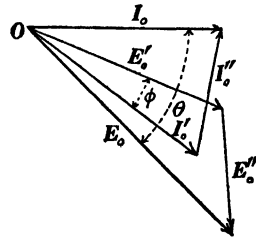

Fig. 143.

Then the resultant of  $E_g'$  and  $E_g''$  is the clock-diagram vector  $E_g$  which represents the total actual voltage across the generator terminals, and the resultant of  $I_g'$  and  $I_g''$  is the vector  $I_g$  which represents the current delivered by the generator. The difference between the numerical values of  $E_g$  and  $E_0$  is the required voltage drop in the line, and the difference between the generator output of power ( $E_g I_g \times \cos$ ine of phase difference between  $E_g$  and  $I_g$ ) and the power delivered to the receiver ( $E_0 I_0 \times \cos$ ine of phase difference between  $E_0$  and  $I_0$ ) is the power lost in the line.

This graphical solution is not capable of the precision that is necessary to justify the use of this rigorous method of line calculation, and the outline of the graphical method is given in order that the successive steps of the following analytical solution may be understood. In this analytical solution the current vector  $I_0$

at the receiver end is chosen as the reference axis of phases so that  $I_0$  is its own  $x$ -component, or, in other words,  $I_0$  is wholly real. The arbitrary factor  $k$  in the above discussion permits of a convenient sized drawing to be made; this factor may be taken equal to unity in the following discussion.

The length of the line  $OI_0$  in Fig. 140 is  $I_0/(N^2 + K^2)^{\frac{1}{2}}$ , and the complex expression for the line  $OE_0$  is  $E_0/(\alpha^2 + \beta^2)^{\frac{1}{2}} \times e^{j(\theta - \phi)}$ .

The lines  $E'_0$  and  $I'_0$  in Fig. 140 are both equal to half the vector sum of the lines  $OI_0$  and  $OE_0$ ; in order to turn the line  $E'_0$  into its proper position as shown in Fig. 141 it must be multiplied by  $e^{j\phi}$ ; and the lines  $E'_0$  and  $I'_0$  so found must be multiplied by  $\sqrt{\alpha^2 + \beta^2}$  and  $\sqrt{N^2 + K^2}$  respectively to give the correct expressions for  $E'_0$  and  $I'_0$  in volts and amperes. Therefore

$$E'_0 = \frac{1}{2}E_0 e^{j\theta} + \frac{1}{2}I_0 \cdot \frac{(\alpha^2 + \beta^2)^{\frac{1}{2}}}{(N^2 + K^2)^{\frac{1}{2}}} \cdot e^{j\phi} \tag{33}$$

and

$$I'_0 = \frac{1}{2}I_0 + \frac{1}{2}E_0 \cdot \frac{(N^2 + K^2)^{\frac{1}{2}}}{(\alpha^2 + \beta^2)^{\frac{1}{2}}} \cdot e^{j(\theta - \phi)} \tag{34}$$

The line  $E''_0$  in Fig. 140 is equal to half the vector difference

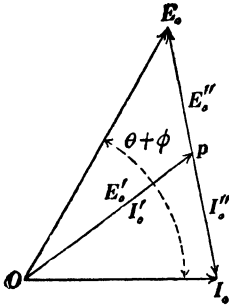

Fig. 144.

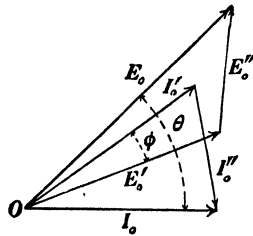

Fig. 145.

$OE_0 - OI_0$ , and the line  $I''_0$  is equal to half the vector difference  $OI_0 - OE_0$ ; in order to turn the line  $E''_0$  into its proper position as shown in Fig. 141 it must be multiplied by  $e^{j\phi}$ ; and the lines  $E''_0$  and  $I''_0$  so found must be multiplied by  $\sqrt{\alpha^2 + \beta^2}$

and  $\sqrt{N^2 + K^2}$  respectively to give the correct expressions for  $E_0''$  and  $I_0''$  in volts and amperes. Therefore

$$E_0'' = \frac{1}{2}E_0\epsilon^{j\theta} - \frac{1}{2}I_0 \cdot \frac{(\alpha^2 + \beta^2)^{\frac{1}{2}}}{(N^2 + K^2)^{\frac{1}{2}}} \cdot \epsilon^{j\phi} \quad (35)$$

and

$$I_0'' = \frac{1}{2}I_0 - \frac{1}{2}E_0 \cdot \frac{(N^2 + K^2)^{\frac{1}{2}}}{(\alpha^2 + \beta^2)^{\frac{1}{2}}} \cdot \epsilon^{j(\theta-\phi)} \quad (36)$$

To turn  $E_0'$  and  $I_0'$  in a counter-clockwise direction through the angle  $\beta l$  we must multiply both by  $\epsilon^{j\beta l}$ , and when so

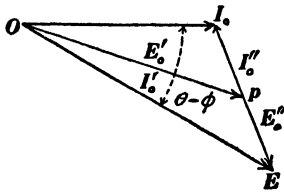

Fig. 146.

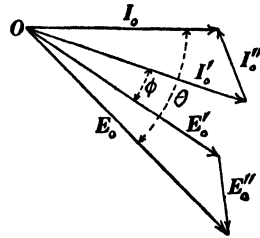

Fig. 147.

turned they must both be multiplied by  $\epsilon^{al}$  to give  $E_g'$  and  $I_g'$ . Therefore

$$E_g' = \frac{1}{2}E_0\epsilon^{(a+j\beta)l+j\theta} + \frac{1}{2}I_0 \cdot \frac{(\alpha^2 + \beta^2)^{\frac{1}{2}}}{(N^2 + K^2)^{\frac{1}{2}}} \cdot \epsilon^{(a+j\beta)l+j\phi} \quad (37)$$

and

$$I_g' = \frac{1}{2}I_0\epsilon^{(a+j\beta)l} + \frac{1}{2}E_0 \cdot \frac{(N^2 + K^2)^{\frac{1}{2}}}{(\alpha^2 + \beta^2)^{\frac{1}{2}}} \cdot \epsilon^{(a+j\beta)l+j(\theta-\phi)} \quad (38)$$

To turn  $E_0''$  and  $I_0''$  in a clockwise direction through the angle  $\beta l$  we must multiply both by  $\epsilon^{-j\beta l}$ , and when so turned they must be multiplied by  $\epsilon^{-al}$  to give  $E_g''$  and  $I_g''$ . Therefore

$$E_g'' = \frac{1}{2}E_0\epsilon^{-(a+j\beta)l+j\theta} - \frac{1}{2}I_0 \cdot \frac{(\alpha^2 + \beta^2)^{\frac{1}{2}}}{(N^2 + K^2)^{\frac{1}{2}}} \cdot \epsilon^{-(a+j\beta)l+j\phi} \quad (39)$$

and

$$I_g'' = \frac{1}{2}I_0\epsilon^{-(a+j\beta)l} - \frac{1}{2}E_0 \cdot \frac{(N^2 + K^2)^{\frac{1}{2}}}{(\alpha^2 + \beta^2)^{\frac{1}{2}}} \cdot \epsilon^{-(a+j\beta)l+j(\theta-\phi)} \quad (40)$$

Whence, adding  $E_g'$  and  $E_g''$  to get  $E_g$ , and adding  $I_g'$  and  $I_g''$  to get  $I_g$  we find:

$$E_g = \frac{1}{2}E_0\epsilon^{j\theta}(\epsilon^{(\alpha+j\beta)l} + \epsilon^{-(\alpha+j\beta)l}) \\ + \frac{1}{2}I_0 \cdot \frac{(\alpha^2 + \beta^2)^{\frac{1}{2}}}{(N^2 + K^2)^{\frac{1}{2}}} \cdot \epsilon^{j\phi}(\epsilon^{(\alpha+j\beta)l} - \epsilon^{-(\alpha+j\beta)l}) \quad (41)$$

and

$$I_g = \frac{1}{2}I_0(\epsilon^{(\alpha+j\beta)l} + \epsilon^{-(\alpha+j\beta)l}) \\ + \frac{1}{2}E_0 \cdot \frac{(N^2 + K^2)^{\frac{1}{2}}}{(\alpha^2 + \beta^2)^{\frac{1}{2}}} \cdot \epsilon^{j(\theta-\phi)}(\epsilon^{(\alpha+j\beta)l} - \epsilon^{-(\alpha+j\beta)l}) \quad (42)$$

To find the numerical values of  $E_g$  and  $I_g$  separate the expressions of equations (41) and (42) each into real and imaginary components and take the square root of the sum of the squares of the components;\* and to find the power delivered by the generator multiply  $x$ -component of  $E_g$  by  $x$ -component of  $I_g$ , and multiply  $y$ -component of  $E_g$  by  $y$ -component of  $I_g$ ; and take the sum of the two products with due regard to algebraic signs.†

\* Thus the square root of the sum of the squares of the components which are given in equation (13) is  $\sqrt{i_1^2 + i_{11}^2}$ , that is to say, the factor  $j$  which marks the  $y$ -component is not a part thereof, the  $y$ -component is  $i_{11}$  not  $ji_{11}$ .

† See page 95, Franklin and Esty's *Elements of Electrical Engineering*, Vol. II.

## CHAPTER VI.

### GENERAL EQUATIONS OF THE ELECTROMAGNETIC FIELD. FREE ELECTROMAGNETIC WAVES.

**40. Need of more elaborate mathematical theory.** — The discussion of electromagnetic waves as given in Chapters IV and V is based almost solely upon the physical ideas of Art. 18, and in working out the details in Chapter IV, extensive use has been made of the analogies between electric waves and waves in material media. This is perhaps the best possible method as far as it goes, but an analytical theory of electromagnetic action is necessary for the treatment of the more complicated phenomena of electric waves.

The analytical theory of electromagnetic action involves an important branch of pure geometry which is not generally understood, the geometry of scalar and vector fields, and the greater part of this chapter is of necessity devoted to this subject. Before proceeding to the discussion of scalar and vector fields, however, it is desirable to establish the differential equations of the simple kind of canal waves which are discussed in Chapter I, and, by finding the general solution of these equations, to verify some of the important ideas which have been introduced without preliminary proof into Chapters I and II.

*Differential equations of water waves in a canal.* — The physical actions in the tapering parts of the water wave which is shown in Fig. 7 may be easily formulated as follows, the elevation of the water level in the wave being very small as compared with the depth  $D$  of the still water in the canal. Let  $h = f(x)$  be the equation to the curve  $WWW'W'$ , Fig. 7, formed by the surface of the water in the wave,  $h$  being an ordinate measured from the normal water level, and  $x$  being an abscissa measured to the right from a chosen origin as shown in

Fig. 148. Let  $\Delta x$  be the thickness of the slice  $AB$ ; then the excess of hydrostatic pressure over every part of face  $B$  of the slice is  $dh/dx \Delta x \times \delta \times g$ , where  $dh/dx \cdot \Delta x$  is the difference of level of the water on the two sides of the slice,  $\delta$  is the density of the water, and  $g$  is the acceleration of gravity. Therefore

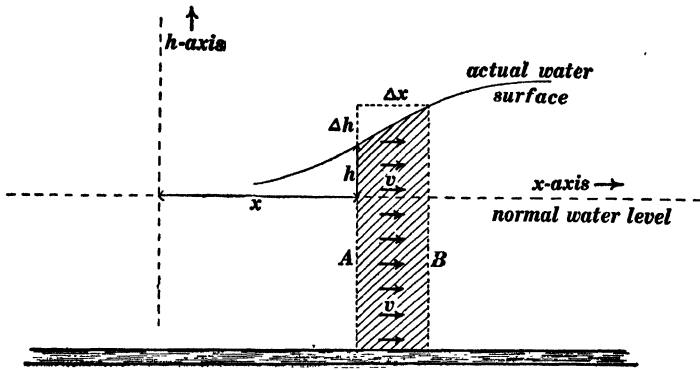

Fig. 148.

the unbalanced force which is pushing the slice to the left in Fig. 148 is  $dh/dx \cdot \Delta x \times \delta \times g \times Db$ , where  $b$  is the breadth of the canal.

The volume of the slice is  $Db \cdot \Delta x$ , its mass is  $Db \cdot \Delta x \times \delta$ , and its acceleration is  $dv/dt$ . Therefore placing unbalanced force equal to mass times acceleration we have

$$\frac{dv}{dt} = -g \frac{dh}{dx} \tag{i}$$

The negative sign is chosen for the reason that the acceleration is negative (to the left in Fig. 148) when  $dh/dx$  is positive (as it is in Fig. 148).

Let  $dh/dt$  be the rate at which the water level of the slice is rising;\* then  $dh/dt \cdot \Delta t$  is the actual rise during the interval  $\Delta t$ , and  $dh/dt \cdot \Delta t \times b \times \Delta x$  is the volume of water which accumulates in the slice during the interval  $\Delta t$ . The volume of water per

\* As a matter of fact the water level of the slice  $AB$  in Fig. 148 is falling, that is,  $dh/dt$  is negative in Fig. 148.

second which flows into the slice across face  $A$  is  $vDb$  where  $v$  is the velocity of flow of the water at face  $A$ ; and the volume of water per second which flows out of the slice across face  $B$  is  $(v + dv/dx \cdot \Delta x)Db$ . Therefore the volume of water which accumulates in the slice during the interval  $\Delta t$  is  $[vDb - (v + dv/dx \cdot \Delta x)Db] \cdot \Delta t$  or  $-Db \cdot dv/dx \cdot \Delta x \cdot \Delta t$ . Hence, placing these two expressions for the accumulated volume of water equal to each other, we have

$$\frac{dh}{dt} = -D \frac{dv}{dx} \quad (\text{ii})$$

Differentiating equation (i) with respect to  $t$  and equation (ii) with respect to  $x$ , we have

$$\frac{d^2v}{dt^2} = -g \frac{d^2h}{dxdt}$$

and

$$\frac{d^2h}{dxdt} = -D \frac{d^2v}{dx^2}$$

from which we have

$$\frac{d^2v}{dt^2} = gD \frac{d^2v}{dx^2} \quad (\text{iii})$$

Similarly, by differentiating equation (i) with respect to  $x$  and equation (ii) with respect to  $t$  we find

$$\frac{d^2h}{dt^2} = gD \frac{d^2h}{dx^2} \quad (\text{iv})$$

Two particular solutions of equation (iv) are

$$h = f(x - Vt) \quad (\text{v})$$

and

$$h = F(x + Vt) \quad (\text{vi})$$

in which  $F$  and  $f$  represent any functions whatever, and in which

$$V = \sqrt{gD} \quad (\text{vii})$$

It is evident that equations (v) and (vi) satisfy equation (iv), because by differentiating equation (v) or equation (vi) we have

$$\frac{d^2h}{dt^2} = V^2 \frac{d^2h}{dx^2}$$

Equation (v) represents a wave, of any wave shape whatever as represented by the undetermined function  $f$ , traveling at velocity  $V$  in the direction of increasing  $x$  without any change of shape; and equation (vi) represents a wave, of any wave shape whatever, traveling at velocity  $V$  in the direction of decreasing  $x$  without any change of shape. To show this, consider a curve of which the equation is

$$h = f(x') \tag{viii}$$

and imagine this curve to travel at velocity  $V$  in the direction of increasing  $x$ . After  $t$  seconds the curve will have traveled a distance  $Vt$ , the equation of the curve referred to a *moving origin* will be equation (viii) as before, but the equation to the moving curve referred to a fixed origin may be found by substituting  $(x - Vt)$  for  $x'$  in equation (viii).

Knowing the value of  $h$  which is associated with a pure wave traveling in the direction of increasing  $x$  [see equation (v)], the correct expression for  $v$  in the same wave may be found with the help of equation (ii) as follows: Differentiate equation (v) with respect to  $t$ , place the value of  $dh/dt$  so found equal to  $-D \cdot dv/dx$  according to equation (ii), and solve for  $dv/dx$ ; and we have

$$\frac{dv}{dx} = \frac{V}{D} \cdot f'(x - Vt)$$

or, substituting the value of  $V$  from equation (vii), we have

$$\frac{dv}{dx} = \sqrt{\frac{g}{D}} \cdot f'(x - Vt),$$

whence by integration we find

$$v = \sqrt{\frac{g}{D}} \cdot f(x - Vt) + \text{a constant}$$

or, using equation (v), we have :

$$v = \sqrt{\frac{g}{D}} \cdot h + \text{a constant} \quad (\text{ix})$$

The constant of integration is a velocity of the medium which has nothing to do with wave motion and it may, therefore, be taken equal to zero.

Equations (v) and (vi) represent pure waves (waves which travel without change of shape); and the equality of potential and kinetic energy at each point in such a wave may be shown from equation (ix) as follows: The kinetic energy of the moving water in a canal wave per unit length of the canal is  $\frac{1}{2} \delta v^2 \times D b$ , the potential energy of the water per unit length of the canal is  $\frac{1}{2} \delta g h^2 \times b$ ,\* and these two expressions are equal to each other according to equation (ix). Equations (iii) and (iv) are identical to the differential equations of plane electromagnetic waves as derived in Art. 57 at the end of this chapter.

**41. Scalar and vector fields.** — In certain physical investigations, it is necessary to consider the temperature at the various points in a body, the pressure at the various points in a fluid, the density at the various points of a substance, or the electric charge per unit volume at each point in a region. Such a distribution of temperature, hydrostatic pressure, or density is called a *scalar field* because the quantity under consideration is itself a scalar and it has a definite value at each point in a region or field of space. The distribution is said to be *homogeneous* or *uniform* when the scalar quantity has the same value throughout the field; otherwise the distribution is said to be *non-homogeneous*. An example of a non-homogeneous scalar field is the pressure in the atmosphere which decreases with increasing altitude. The density of the atmosphere is also an example of a non-homogeneously distributed scalar.

In certain physical investigations it is necessary to consider the velocity at different points of a fluid, the direction and magnitude

\* See discussion on page 17.

of the flow of heat at different points in a substance, or the direction and intensity of an electric or magnetic field at different points in space. Such a distribution of fluid velocity or other vector is called a *vector field* because the quantity under consideration is a vector, and it has a definite value and direction at each point in a region or field of space. The distribution is said to be *homogeneous* or *uniform* when the vector has the same value and is in the same direction throughout the field; otherwise the distribution is said to be non-homogeneous.

Examples of non-homogeneous vector fields are: the water in a rotating bowl, the magnetic field surrounding an electric wire, and the electric field surrounding a charged body.

**42. Volume integral of a distributed scalar.**—Let  $\psi$  be the value of a distributed scalar at a given point, the density of a substance at the given point, for example, then  $\psi\Delta\tau$  is the mass of material in the volume element  $\Delta\tau$  at the point, and the total mass  $M$  of the body is

$$M = \Sigma\psi \cdot \Delta\tau$$

or

$$M = \int\psi \cdot d\tau \quad (43)$$

This summation or integral is called the volume integral of the distributed scalar  $\psi$ . The physical significance of volume integral is not in every case so simple as in the case of density. If  $\psi$  is the volume density of electric charge, then equation (43) gives the total electric charge in the region throughout which the summation or integration is extended. If  $\psi$  is the energy per unit volume in an electric field, in a magnetic field, in a strained solid, or in a moving fluid, then equation (43) gives the total energy in the region throughout which the summation or integration is extended.

**43. Gradient of a distributed scalar.**—Let  $\psi$  be the value of a distributed scalar at a point  $p$  and let  $\psi + \Delta\psi$  be its value at an adjacent point distant  $\Delta x$  from  $p$ ; then  $\Delta\psi/\Delta x$  is called

the *gradient* of  $\psi$  in the direction of  $x$ , or in the direction of the  $x$ -axis of reference. We may, therefore, write

$$X = \frac{d\psi}{dx}, \quad Y = \frac{d\psi}{dy}, \quad Z = \frac{d\psi}{dz} \quad (44)$$

where  $X$ ,  $Y$  and  $Z$  are the components of a definite vector which is called the *resultant gradient* or simply the *gradient* of  $\psi$  at the point  $p$ . The gradient of a distributed scalar is therefore a distributed vector.\*

\* To show that the gradient of a distributed scalar is a vector, it is only necessary to show that its gradient in any arbitrary direction  $s$  is equal to  $d\psi/dx \cdot \alpha + d\psi/dy \cdot \beta + d\psi/dz \cdot \gamma$ , where  $\alpha$ ,  $\beta$  and  $\gamma$  are the direction cosines of  $s$ . To understand the significance of this condition, consider a simple case in two dimensions where  $R$  is a vector,  $X$  and  $Y$  are its  $x$ - and  $y$ -components, and  $S$  is its component in any arbitrary direction, as shown in the adjoining sketch.

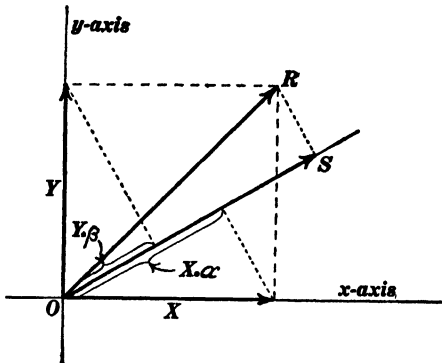

The above condition as applied to two dimensions means that the length of  $OS$  is equal to the component of  $X$  parallel to  $OS$  ( $= X \cdot \alpha$ , where  $\alpha$  is the cosine of the angle between  $OS$  and the  $x$ -axis) plus the component of  $Y$  parallel to  $OS$  ( $= Y \cdot \beta$ ,

where  $\beta$  is the cosine of the angle between  $OS$  and the  $y$ -axis). In order to apply this condition, let us consider the value of the distributed scalar  $\psi$  in the immediate neighborhood of a point, and let us choose this point as the origin of coördinates. Now  $\psi$  has a definite value at every point  $[x, y, z]$  in space, that is,  $\psi$  is a function of the coördinates  $x$ ,  $y$  and  $z$ , and it is a continuous function; therefore it may be expanded by MacLaurin's theorem, and the higher terms of the series so obtained may be ignored in the small region under consideration. We thus obtain

$$\psi = \psi_0 + \frac{d\psi}{dx} \cdot x + \frac{d\psi}{dy} \cdot y + \frac{d\psi}{dz} \cdot z$$

for the value of  $\psi$  at any point  $x, y, z$ , the coefficients  $d\psi/dx$ ,  $d\psi/dy$ , and  $d\psi/dz$  being constants. Differentiating this expression with respect to a variable  $s$ , we have, by the ordinary rules of differentiation,

$$\frac{d\psi}{ds} = \frac{d\psi}{dx} \cdot \frac{dx}{ds} + \frac{d\psi}{dy} \cdot \frac{dy}{ds} + \frac{d\psi}{dz} \cdot \frac{dz}{ds}$$

but

A scalar quantity may be represented at each point of a plane by a height measured up from the plane. The complete distribution of the scalar quantity will then be represented by a raised surface or hill and the gradient of the scalar will be represented by the steepness or grade of the hill at each point.

The most familiar case in which it is necessary to consider the gradient of a distributed scalar in space is in the study of heat flow in an extended solid in which the temperature varies from point to point. The heat flow at each point is in the direction of the resultant temperature gradient and is proportional thereto. Thus, if the temperature at a given point is  $50^{\circ}$  C. and at a point distant 0.1 of a centimeter in a given direction it is  $51^{\circ}$  C. then the component of the temperature gradient in the given direction is  $10^{\circ}$  per centimeter, and the resultant temperature gradient at the point is the vector sum of the temperature gradients in three chosen directions. One example of the gradient of a distributed scalar which is very familiar is the varying hydrostatic pressure in liquid under the influence of gravity. Thus, the buoyant force of a liquid upon a submerged body is equal to the volume of the body multiplied by the gradient of the pressure in the liquid.

**44. Permanent and varying states of scalar distribution.** — When the value of a distributed scalar at each point in space remains unchanged, the distribution is said to be permanent. When the value at each point is changing, we have what is called a varying state of distribution. Thus, the density in a gas which is being compressed, the temperatures throughout a body which is being heated or cooled, and the energy density at various points in a region into which energy is flowing or out of which energy is

$$\frac{dx}{ds} = \alpha, \quad \frac{dy}{ds} = \beta \quad \text{and} \quad \frac{dz}{ds} = \gamma$$

as may be easily seen by considering  $dx$ ,  $dy$  and  $dz$  as the components of  $ds$ . Therefore the gradient of  $\psi$  in the direction  $s$  may be found from the gradients in the directions of the axes of reference exactly as if these gradients in the directions of the reference axes were the components of a vector. Indeed the gradients in the directions of the reference axes are the components of a vector and this vector is the resultant gradient or simply the gradient of the given distributed scalar.

flowing are examples of varying scalar distributions. When the density of a substance at a point is decreasing, there is a flow of material away from the point ; when the energy density at a point is decreasing, there is a flow of energy away from the point. Thus, the time rate of change of a distributed scalar at a point is sometimes associated with a peculiar vector distribution in the neighborhood of that point. Thus the time-rate-of-change-of-density of a fluid at a point (which is a scalar) is the essential feature of the peculiar diverging distribution of the fluid velocity near the point. This scalar aspect of the divergence of a vector in the neighborhood of a point is called the *divergence* of the vector at the point. See Art. 50.

**45. Stream lines of a distributed vector.**—A line drawn through a field so as to be at each point in the direction at that point of a distributed vector is called a *stream line* of the distributed vector. The manner of distribution of a vector is clearly represented by the use in imagination of such lines. In electric and magnetic fields, these lines are called lines of force but the term stream line will be used in general statements.

**46. Permanent and varying states of vector distribution.**—When the magnitude and direction of a distributed vector at each point in a vector field are constant, the vector is said to have a permanent state of distribution ; otherwise the vector is said to be in a varying state of distribution. Thus, when an orifice in a large tank of water is suddenly opened a perceptible time elapses before the jet of water becomes established. During this interval the velocity of the water is changing rapidly at each point. After the jet becomes steady, however, the velocity of the water at each point remains constant in magnitude and in direction. The magnetic field in the neighborhood of a moving magnet or in the neighborhood of a moving or changing electric current is in a varying state. The electric field in the neighborhood of a moving charged body is in a varying state.

*Rate of change of a distributed vector at a point.*— Let the line

$\alpha$ , Fig. 149, represent the value at a given instant of the velocity of a fluid at the point  $p$ , and let the line  $\alpha + \Delta\alpha$  represent the velocity of the fluid at the point after an interval  $\Delta t$  has elapsed. Then  $\Delta\alpha/\Delta t$  is the rate of change of  $\alpha$  or the acceleration of the fluid velocity at the point  $p$ .\* This acceleration is also a distributed vector and it has a definite value and direction at every point in space.

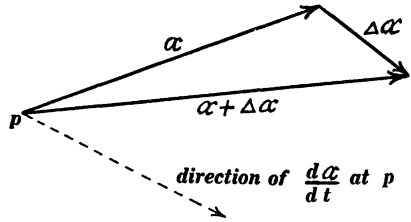

Fig. 149.

The rate of change of an electric field at each point and the rate of change of a magnetic field at each point are very important matters for consideration in Maxwell's theory of the electromagnetic field.

There is a particular type of vector distribution in the neighborhood of a point, namely, a divergence of the vector from the point, which has a scalar property, as explained in Art. 44. There is also a particular type of vector distribution in the neighborhood of a point which has a vector property. Consider, for example, the water in a uniformly rotating bowl. Every small portion of water in the bowl is rotating at the same angular velocity as the bowl itself, and therefore the velocity of a small part of the water at any point is a motion of translation combined with a motion of rotation about an axis parallel to the axis of the bowl. Ignoring the motion of translation, what remains is a simple motion of rotation. Therefore, ignoring the motion of translation the remainder of the fluid velocity near a point in the bowl curls round the point. This curling of the fluid velocity round each point in a rotating bowl is the angular velocity of the fluid at each point, this angular velocity is itself a vector, and it is called

\* In this illustration the velocity under consideration is the changing velocity of the successive particles of the fluid as they pass the point  $p$ , not the changing velocity of a given particle while it is traveling along near  $p$ . The latter velocity may be changing from instant to instant even though the former is invariable.

the *curl* of the fluid velocity at the point. In fact, the angular velocity is equal to one half the curl, according to the definition of curl given in Art. 53.

The time rate of change of a distributed scalar, itself a scalar, is frequently associated with or identified as the divergence of a related distributed vector, as explained in Arts. 44 and 50; and it is interesting to note that the time rate of change of a distributed vector, itself a vector, is frequently associated with or identified as the curl of a related distributed vector; see Art. 53. Thus the time rate of change of electric field is proportional to the curl of magnetic field and the time rate of change of magnetic field is proportional to the curl of electric field. See Art. 57.

**47. The line integral of a distributed vector.** — Consider a line or path  $pp'$ , Fig. 150, in a vector field. Let  $\Delta s$  be an element of this line or path, let  $R$  be the value of the distributed vector at the element  $\Delta s$ , and let  $\epsilon$  be the angle between  $R$  and  $\Delta s$ . Then  $R \cos \epsilon$  is the resolved part of  $R$  parallel to  $\Delta s$ ,  $R \cos \epsilon \Delta s$  is the scalar part of the product of  $R$  and  $\Delta s$ ,\* and the summation

$$E = \Sigma R \cos \epsilon \cdot \Delta s$$

or

$$E = \int R \cos \epsilon \cdot ds \quad (45a)$$

is called the line integral of the distributed vector  $R$  along the line or path over which this summation is extended. The angle  $\epsilon$  is reckoned between  $R$  and the positive direction of  $\Delta s$ , the positive direction of  $\Delta s$  being the direction in which  $\Delta s$  would be passed over in traveling along the line  $pp'$  in a chosen direction. If the chosen direction be changed,  $\cos \epsilon$  will change sign at each element. Therefore the line integral from  $p$  to  $p'$  is equal but opposite in sign to the line integral from  $p'$  to  $p$  in Fig. 150.

\*The product  $R \cdot \Delta s$  is part vector and part scalar, so also is the sum  $\Sigma R \cdot \Delta s$  or  $\int R \cdot ds$ ; but the scalar part only is of great importance in the theory of electricity and magnetism.

*Examples.* — The line integral of electric field along a path is called the electromotive force along the path. The line integral of a magnetic field along a path is called the magnetomotive force along the path. The line integral of fluid velocity along a path is called the circulation of the fluid along the path.

*Cartesian expression for line integral.* — The most intelligible basis for the derivation of the Cartesian expression for the line integral of a distributed vector is as follows: Let

$X$ ,  $Y$  and  $Z$  be the components of the vector  $R$  and let  $dx$ ,  $dy$  and  $dz$  be the components of the line element  $ds$ ; then we have

$$R = X + Y + Z \quad (\text{vector equation}) \quad (i)$$

and

$$ds = dx + dy + dz \quad (\text{vector equation}) \quad (ii)$$

The product of the two vectors  $R$  and  $ds$  is part scalar and part vector; \* and the product of  $X + Y + Z$  and  $dx + dy + dz$  gives a number of scalar terms, namely,  $X \cdot dx$ ,  $Y \cdot dy$  and  $Z \cdot dz$ , and a number of vector terms such as  $X \cdot dy$ ,  $Y \cdot dx$ , etc. Therefore, multiplying equations (i) and (ii) member by member, and discarding the vector terms we have

$$\text{Scalar part of } R \cdot ds = R \cdot \cos \epsilon \cdot ds = X \cdot dx + Y \cdot dy + Z \cdot dz \quad (iii)$$

so that the Cartesian expression for line integral is

$$E = \int (X \cdot dx + Y \cdot dy + Z \cdot dz) \quad (45b)$$

*Line integral of the gradient of a distributed scalar.* — The line integral of the gradient of a distributed scalar  $\psi$  along a path from  $p$  to  $p'$  is the difference in the values of  $\psi$  at  $p$  and

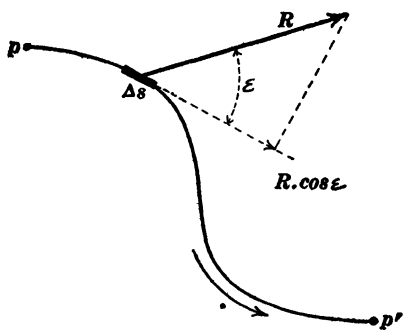

Fig. 150.

\* See Franklin and MacNutt's *Elements of Mechanics*, pages 40 and 41.

$p'$ , respectively. This is evident from the following considerations. Let  $R$ , Fig. 150, be the gradient of  $\psi$  at the element  $\Delta s$ . Then the resolved part  $R \cos \epsilon$  of  $R$  in the direction of  $\Delta s$  is, according to Art. 43, the gradient  $d\psi/ds$  in the direction of  $\Delta s$ . Therefore, we have

$$R \cos \epsilon \cdot \Delta s = \frac{d\psi}{ds} \cdot \Delta s = \Delta\psi$$

so that

$$E = \sum R \cos \epsilon \cdot \Delta s = \sum \Delta\psi = \psi' - \psi \quad (46)$$

where  $\psi$  is the value of the given distributed scalar at  $p$ , and  $\psi'$  is its value at  $p'$ .

*Corollary (a).* — The line integral of the gradient of a distributed scalar is the same for all paths from  $p$  to  $p'$ ; that is, the line integral of the gradient of the distributed scalar is independent of the path over which the integration is performed provided the ends of the path are fixed. An exception in the case of a multi-valued scalar is discussed in Art. 48.

(*b*). — The line integral of the gradient of a distributed scalar around a closed loop is zero. An exception in the case of a multi-valued scalar is discussed in Art. 48.

*Note.* — When  $X$ ,  $Y$  and  $Z$ , equation (45*b*), are the component gradients of a distributed scalar  $\psi$ , then as pointed out above

$$X \cdot dx + Y \cdot dy + Z \cdot dz = d\psi$$

that is,  $X \cdot dx + Y \cdot dy + Z \cdot dz$  is the complete differential of a definite function, that is, of a quantity  $\psi$  which has a definite value at each point in space. Therefore by differentiating the two expressions  $d\psi/dx = X$  and  $d\psi/dy = Y$  with respect to  $y$  and  $x$ , respectively, we have

$$\frac{d^2\psi}{dx dy} = \frac{dX}{dy}$$

$$\frac{d^2\psi}{dy dx} = \frac{dY}{dx}$$

but the two differentials  $d^2\psi/dxdy$  and  $d^2\psi/dydx$  are equal to each other, so that we have

$$\frac{dY}{dx} - \frac{dX}{dy} = 0 \quad (47a)$$

and by similar argument it may be shown that

$$\frac{dZ}{dy} - \frac{dY}{dz} = 0 \quad (47b)$$

and that

$$\frac{dX}{dz} - \frac{dZ}{dx} = 0 \quad (47c)$$

These are the conditions which the components of a distributed vector must satisfy at each point in a field or region in order that the distributed vector may be looked upon as a gradient of a distributed scalar in that region.

**48. Irrotational vector distribution. Potential.** — When a distributed vector satisfies equations (47), it may be looked upon as the gradient of a distributed scalar, and this distributed scalar is called its *scalar potential*. In case of fluid velocity, the potential, if it exists, is called *velocity potential*; in the case of electric field, the potential, if it exists, is called *electric potential*; and in case of magnetic field, the potential, if it exists, is called *magnetic potential*. When a distributed vector has a potential, the distribution of the vector is said to be irrotational for reasons which are explained later.

*Examples.* — The two heavy black circles in Fig. 151 represent in section two long parallel metal cylinders one of which is positively charged and the other of which is negatively charged, and the fine curved lines (with arrow-heads) represent the lines of force of the electric field between the charged cylinders. The intensity of the electric field at a given point is so many volts per centimeter parallel to the lines of force at that point. Let the plane of the paper in Fig. 151 be a horizontal plane, and imagine a hill built upon this plane in such a way that its slope lines as

seen projected upon the base plane coincide with the lines of force in Fig. 151. If the height of this hill is measured in volts, then its slope or grade will be expressed in volts per centimeter at each point, in fact its gradient is a complete representation of the electric field in the plane of Fig. 151. *The height at a point of*

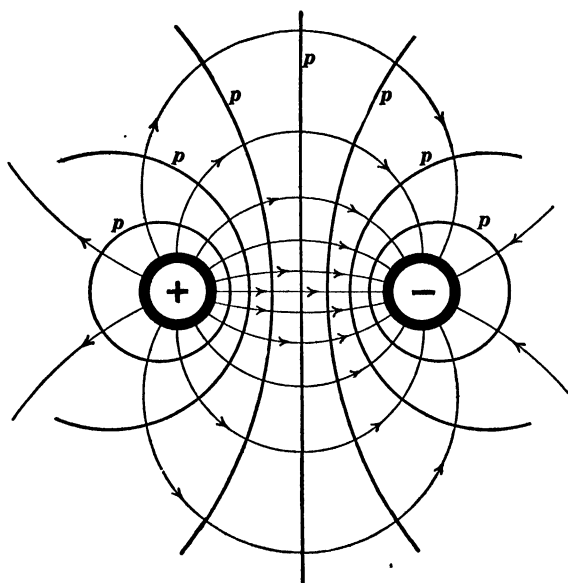

Fig. 151.

*an imagined hill whose slope is everywhere equal to a given electric field is called the electric potential of the field at that point.* The heavy curved lines *ppp* in Fig. 151 are the contour lines or lines of equal level on the potential hill which is imagined to be built as described above. The potential is the same at every point along each of the heavy curved lines, and these lines are therefore called lines of equi-potential.

The above example refers to the distribution of electric field in two dimensions, and in this case the potential hill may be actually constructed as a geometrical hill. In general, however, this is not possible, that is to say, it is not possible to construct a geometri-

cal representation of the potential hill. A clear idea of potential in this general case may be obtained as follows: Imagine any given distribution of electric field, the electric field surrounding a charged sphere for example, and imagine the region surrounding the sphere to vary in temperature from point to point in such a way that the temperature gradient (degrees per centimeter) at each point may be equal to the electric field (volts per centimeter) at that point. Then the temperature at each point represents the electrical potential at that point. Any surface drawn so as to be at each point at right angles to the lines of force at that point is a surface of equi-potential. In the above example, of the field surrounding a charged sphere, the lines of force are radial straight lines and the surfaces of equi-potential are spheres concentric with the charged sphere.

In order to completely establish the value of the electric potential at different points in space (that is to say, the heights at the different points of the potential hill), a region of zero potential must be arbitrarily chosen. That is to say, an arbitrarily chosen region must be taken as the zero of potential. Then the potential at any other point is equal to the electromotive force  $E$  between the arbitrarily chosen region of zero potential and the given point.

*Multivalued potential.* — The magnetic potential in the region near an electric wire is multivalued. Imagine a plane perpendicular to the wire, and consider the distribution of magnetic field in this plane. The lines of force of this field are concentric circles with their centers at the wire. If this field is to be looked upon as a gradient, or in geometrical terms as the slope of a raised surface or hill, it is evident that the hill must be similar to a winding stair or screw surface surrounding the electric wire, and having an infinite series of heights above any given point in the plane. These heights correspond to the possible values of the magnetic potential at the given point in the plane.

The line integral of the magnetic field in the neighborhood of an electric wire around a closed curve or loop is zero if the loop

does not enclose the wire and therefore the line integral of the magnetic field along any two paths between two points is the same if the paths do not together constitute a closed loop which encircles the wire.

**49. The surface integral of a distributed vector. Flux.** — Let  $A$  and  $B$ , Fig. 152, be the points of intersection of a closed

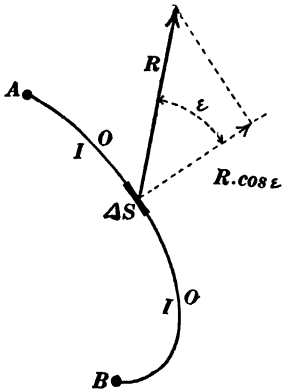

Fig. 152.

curve or loop with the plane of the paper, and let the curved line  $AB$  represent a diaphragm stretched across this loop. Let  $\Delta S$  be the area of an element of the diaphragm, let  $R$  represent the value at  $\Delta S$  of a distributed vector, and let  $\epsilon$  be the angle between  $R$  and the normal to  $\Delta S$ , this normal being always drawn from the same side  $OO$  of the diaphragm. Then  $R \cos \epsilon$  is the resolved part of  $R$  normal to  $\Delta S$ ,  $R \cos \epsilon \cdot \Delta S$  is the scalar part of the product of  $R$  and  $\Delta S$ ,

and the summation

$$\Phi = \Sigma R \cos \epsilon \cdot \Delta S$$

or

$$\Phi = \int R \cos \epsilon \cdot dS \quad (48a)$$

is called the surface integral of the distributed vector  $R$  over that portion of the diaphragm over which the summation is extended. If the normal to  $\Delta S$  in Fig. 152 is drawn in the reverse direction, that is, from the side  $II$  of the diaphragm, then  $\cos \epsilon$  will be everywhere reversed in sign, and the surface integral, retaining its numerical value unchanged, will be reversed in sign. In the integration over a closed surface like a box or sphere, the normal is understood to be drawn outwards always.

\* The product  $R \cdot \Delta S$  is part scalar and part vector; so also is the sum  $\Sigma R \cdot \Delta S$  or  $\int R \cdot dS$ ; but the scalar part only is of great importance in the theory of electricity and magnetism. See Franklin and MacNutt's *Elements of Mechanics*, pages 40 and 41.

*Examples.*—The surface integral of fluid velocity over a surface is the flux of fluid through the surface in cubic centimeters per second. The surface integral of any distributed vector is called the *flux* of the vector. Thus we speak of the flux of magnetic field, the flux of electric field, etc. In case of a closed surface we speak of the flux into or out of the region bounded by the surface.

*Cartesian expression for surface integral.*—Let  $X$ ,  $Y$  and  $Z$  be the components of the vector  $R$ , and let the *areas*\* of the projections of the surface element  $dS$  on the coordinate reference planes be  $dy \cdot dz$ ,  $dz \cdot dx$  and  $dx \cdot dy$  respectively. Then  $dy \cdot dz$ ,  $dz \cdot dx$  and  $dx \cdot dy$  are the components of  $dS$  considered as a vector. Therefore we have

$$R = X + Y + Z \quad (\text{vector equation}) \quad (i)$$

and

$$dS = dy \cdot dz + dz \cdot dx + dx \cdot dy \quad (\text{vector equation}) \quad (ii)$$

Multiplying equations (i) and (ii) member by member, and discarding the vector terms, we have

$$\begin{aligned} \text{Scalar part of } R \cdot dS &= R \cos \epsilon \cdot dS \\ &= X \cdot dydz + Y \cdot dzdx + Z \cdot dxdy \end{aligned} \quad (iii)$$

so that the Cartesian expression for surface integral is

$$\Phi = \iint (X \cdot dydz + Y \cdot dzdx + Z \cdot dxdy) \quad (48b)$$

**50. Divergence of a distributed vector.** — Consider a small region of volume  $\Delta\tau$  in the neighborhood of a point  $p$ . Let  $\Delta\Phi$  be the flux of a distributed vector  $R$  out of this region. It can be shown, when  $R$  is physically continuous, that the ratio  $\Delta\Phi/\Delta\tau$  approaches a definite limiting value as the volume element  $\Delta\tau$  grows small.† This limiting value of  $\Delta\Phi/\Delta\tau$  is called the *diver-*

\* We are not concerned with the fact that  $dy \cdot dz$ , etc., are square, whereas the projections of  $dS$  may be any shape.

† To prove this statement rigorously one would have to consider the expansion of the components of the distributed vector by MacLaurin's theorem as in Art. 56. See in particular the discussion of velocity  $v'$  in Art. 56.

gence of the vector  $R$  at the point  $p$ . From this definition we have

$$\Delta\Phi = \rho \cdot \Delta\tau \quad (49)$$

in which  $\Delta\Phi$  is the flux of a distributed vector  $R$  out of a small region  $\Delta\tau$  in the neighborhood of a point, and  $\rho$  is the divergence of  $R$  at the point. The divergence of a distributed vector is a distributed scalar. A negative divergence is sometimes called a *convergence*.

*Cartesian expression for divergence.\** — Consider at a given point  $p$  a small cubical region of which the edges are  $\Delta x$ ,  $\Delta y$  and  $\Delta z$ . Let  $X$ ,  $Y$  and  $Z$  be the components of  $R$  at  $p$ . The flux of  $R$  across one of the  $\Delta y \cdot \Delta z$  faces of the cube is  $X \cdot \Delta y \cdot \Delta z$  into the region, and the flux of  $R$  across the other  $\Delta y \cdot \Delta z$  face is  $(X + dX/dx \cdot \Delta x) \cdot \Delta y \Delta z$  out of the region. Therefore the total flux out of the region across these two faces is

$$\frac{dX}{dx} \cdot \Delta x \cdot \Delta y \cdot \Delta z$$

Similar expressions hold for the other two pairs of faces, so that the total flux out of the region is

$$\left( \frac{dX}{dx} + \frac{dY}{dy} + \frac{dZ}{dz} \right) \Delta x \cdot \Delta y \cdot \Delta z$$

and this quantity divided by the volume of the region  $\Delta x \cdot \Delta y \cdot \Delta z$  gives the divergence  $\rho$  so that

$$\rho = \frac{dX}{dx} + \frac{dY}{dy} + \frac{dZ}{dz} \quad (50)$$

Several problems illustrating the meaning of this equation are given in Appendix C.

**51. Breaking up of a surface integral over a closed surface into volume elements.** — Consider the surface integral of a distributed vector  $R$  over a closed surface, normal directed outwards as stated

\*A rigorous derivation of equation (50) would have to be based upon the expansion of  $X$ ,  $Y$  and  $Z$  by MacLaurin's theorem as exemplified in equations (56).

in Art. 49. Imagine the enclosed region to be broken up into a number of small cells. *The surface integral of  $R$  over the given closed surface is equal to the sum of the surface integrals of  $R$  over the enclosing surfaces of the various cells, normal directed outwards in each case ; this is evident when we consider that every wall which separates two contiguous cells is integrated over twice with direction of normal reversed (see Art 49), so that the only surface integrals which are not canceled in this way are the integrals over the various parts of the given closed surface.*

Let  $\Delta\Phi$  be the surface integral of  $R$  over one of the cells, and let  $\Sigma R \cos \epsilon \Delta S$  be the surface integral of  $R$  over the given closed surface. Then, from the above statement, we have

$$\Sigma R \cos \epsilon \cdot \Delta S = \Sigma \Delta\Phi$$

or, using equation (49), we have

$$\int R \cos \epsilon \cdot dS = \int \rho \cdot d\tau \quad (51)$$

where the first term is the surface integral of a distributed vector  $R$  over a closed surface, and the second term is the volume integral of  $\rho$  (the divergence of  $R$ ) throughout the enclosed region.

*Example.* — According to Gauss's theorem, the total electric flux out of a region is equal to  $4\pi$  times the total amount of electric charge in the region ; \* but the electric flux out of a region is equal to the surface integral of electric field over the boundary of the region, and the total charge in the region is equal to the volume integral of the density of electric charge in the region ; therefore Gauss's theorem involves an equation like equation (51) between a surface integral of electric field  $R$  and a volume integral, and it follows from Gauss's theorem that the divergence of electric field is at each point equal to  $4\pi$  times the volume density of electric charge at the point.

**52. Solenoidal vector distribution.** — A distributed vector is said to have solenoidal distribution in a region throughout which

\* When units of the electrostatic system are employed.

its divergence is zero. The surface integral of such a distributed vector is zero over any closed surface. This is evident when we consider that the volume integral of the divergence of the vector is zero throughout any region because the divergence itself is everywhere zero, so that the surface integral of the vector over the boundary of any closed region must be equal to zero by equation (51).

*Tube of flow.* — Imagine stream lines to be drawn in a vector field from each point of the periphery of a closed curve or loop. These stream lines form a tubular surface which is called a tube of flow of the given distributed vector.

Consider a number of diaphragms across a tube of flow; the flux is the same across them all. This is evident when we consider that any two diaphragms together with the walls of the tube constitute a closed surface out of which the total flux is zero; but the flux across the walls of the tube is zero, so that the flux into the enclosed space across the one diaphragm must be equal to the flux out of the enclosed space across the other diaphragm.

*Unit tube.* — A tube of flow is called a unit tube when the flux through the tube is unity. For example, a unit tube has a sectional area of 0.1 square centimeter in a magnetic field of which the intensity is 10 gauss.

Imagine the entire solenoidal region of a distributed vector to be divided up into unit tubes. Then the flux across any surface anywhere in the region is equal to the number of these unit tubes which pass through the surface. Each unit tube may be conveniently represented in imagination by the single stream line along the axis of the tube. Then the flux across any surface in the region is equal to the number of these lines passing through the surface. In the case of electric and magnetic fields the lines of force are always thought of as representing each a unit tube, and the quantity of magnetic flux or electric flux through a surface is expressed by the number of lines of force which pass through the surface.

**53. Curl of a distributed vector.** — Consider a small plane area  $\Delta S$  at a point  $p$  in a vector field. Let  $\Delta L$  be the line integral of the distributed vector  $R$  around the boundary of this surface element. It can be shown, when  $R$  is physically continuous, that the ratio  $\Delta L/\Delta S$  approaches a definite limiting value as the surface element  $\Delta S$  grows small and remains fixed in direction.\* This limiting value of  $\Delta L/\Delta S$  is the component of a new vector in the direction of the normal to the surface element  $\Delta S$ , and this new vector is called the *curl* of  $R$ . From this definition we have

$$\Delta L = C \cos \epsilon \cdot \Delta S \tag{52}$$

in which  $\Delta L$  is the line integral of a given distributed vector  $R$  around the boundary of a small plane element of area  $\Delta S$ ,  $C$  is the curl of  $R$ , and  $\epsilon$  is the angle between  $C$  and the normal to  $\Delta S$ .

To understand what is meant by the curl of a distributed vector, let us consider a simple case of fluid motion, namely, the uniform rotation of a bowl of water about a vertical axis at angular velocity  $\omega$ . Consider the fluid motion in the neighborhood of the point  $p$ , Fig. 153, distant  $d$  from the axis of rotation of the bowl. The motion of this small portion of the fluid may be thought of as made up of a uniform motion of translation and a motion of rotation at angular velocity  $\omega$  about a vertical

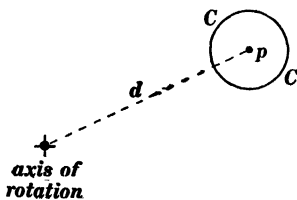

FIG. 153.

axis through  $p$ . In considering the line integral of the fluid velocity around a circle  $CC$  in Fig. 153, the uniform motion of translation of the fluid in the neighborhood of  $p$  need not be considered, the line integral depends only upon the rotary motion. Therefore let us ignore the translatory motion of the fluid near  $p$  and consider only its rotary motion about  $p$ . Let  $r$  be the

\* To prove this statement rigorously one would have to consider the expansion of the components of the distributed vector by MacLaurin's theorem as in Art. 56. See in particular the discussion of velocity  $v''$  in Art. 56.

radius of the circle  $CC$ . The velocity of the fluid at every point along the circle is equal to  $\omega r$  and it is tangential to the circle at each point. Therefore the line integral of the fluid velocity around the circle is equal to the product of this fluid velocity by the circumference of the circle which gives  $2\pi r^2\omega$ . It is therefore evident that the line integral is proportional to the area of the circle so that the line integral divided by the area of the circle gives a constant. The proportionality constant in this case is the curl of the fluid velocity in the rotating bowl, that is to say, it is not necessary in this case to consider the limiting value of  $\Delta L/\Delta S$ . Therefore dividing the line integral  $2\pi r^2\omega$  by the area of the circle  $\pi r^2$  we find that the curl of the fluid velocity in a rotary bowl is equal to  $2\omega$  at every point in the bowl, where  $\omega$  is the angular velocity of the bowl.

This example in which the curl of fluid velocity is shown to be equal to two times the angular velocity of the particles of the fluid at each point is of course a very special case, but it can be shown (see Art. 56) that the motion of a fluid in a small region in the neighborhood of a point can always be resolved into three parts, namely, (*a*) a uniform motion of translation of the whole element of fluid, (*b*) a uniform rotation of the entire element of fluid at a definite angular velocity about a definite axis, and (*c*) a uniform dilatation of the fluid in three mutually perpendicular directions. The uniform translatory motion of the fluid does not contribute to a line integral around any closed curve nor does that part of the fluid motion which is associated with the three dilatations, so that a uniform rotation of a small body of fluid covers the case completely. If the plane of the paper in Fig. 153 is not at right angles to the axis of rotation of the bowl, then we need consider only that component of the angular velocity which is at right angles to the plane, the resultant value of  $\Delta L/\Delta S$  will be the component of the curl perpendicular to the plane of the paper, and it will be equal to two times the component perpendicular to the plane of the paper of the angular velocity of the bowl.

*Cartesian expression for curl.\** — Consider the value of a distributed vector  $R$  in the neighborhood of a point. Let  $X$ ,  $Y$  and  $Z$  be the components of  $R$  at the point. Consider the line integral of  $R$  around a small rectangle whose sides are  $\Delta y$  and  $\Delta z$ , the shaded rectangle in Fig. 154, the curved arrow show-

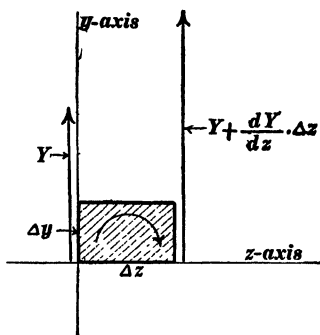

Fig. 154.

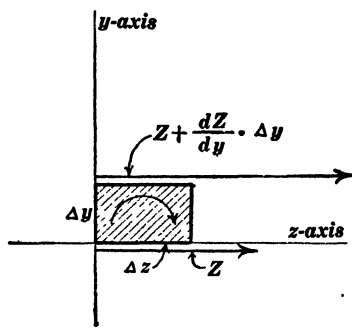

Fig. 155.

ing the direction in which the line integral is to be taken. The line integral of  $R$  along the side  $\Delta y$  is  $Y \cdot \Delta y$ ; along the opposite side the line integral is

$$-\left(Y + \frac{dY}{dz} \cdot \Delta z\right) \Delta y$$

and therefore the total line integral along these two sides is

$$-\frac{dY}{dz} \cdot \Delta y \cdot \Delta z$$

Similarly, the total line integral along the two sides  $\Delta z$  is

$$+\frac{dZ}{dy} \cdot \Delta y \cdot \Delta z$$

as may be understood from Fig. 155, and therefore the total line integral around the rectangle is

$$\left(\frac{dZ}{dy} - \frac{dY}{dz}\right) \Delta y \cdot \Delta z$$

\* A rigorous derivation of equations (53) depends upon the use of MacLaurin's theorem. See Art. 56.

which, divided by the area  $\Delta y \cdot \Delta z$  of the rectangle gives the  $x$ -component of the curl of  $R$  at the given point. In a similar manner the expressions for  $y$  and  $z$  components of the curl may be found, giving

$$C_x = \frac{dZ}{dy} - \frac{dY}{dz}, \quad C_y = \frac{dX}{dz} - \frac{dZ}{dx}, \quad C_z = \frac{dY}{dx} - \frac{dX}{dy} \quad (53)$$

where  $C_x$ ,  $C_y$  and  $C_z$  are the components of the curl of a distributed vector  $R$  at a point, and  $X$ ,  $Y$  and  $Z$  are the components of the vector.

*Examples of curl.*—The angular velocity of a particle of a moving fluid is equal to one half the curl of the fluid velocity at each point. Electric current density, that is, the electric current per unit of sectional area of a wire is equal to  $1/4\pi$  times the curl of the magnetic field when proper units are employed.

**54. Breaking up of a line integral around a closed curve into surface elements.**—The region surrounding the heavy line  $AB$  in Fig. 156 is a vector field and let it be assumed that the line

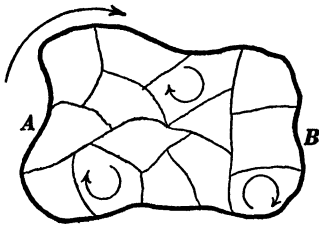

Fig. 156.

integral of the distributed vector around the closed loop  $AB$  is not equal to zero. The arrow represents the direction in which this line integral is taken (a reversal of this direction reverses the algebraic sign of the line integral as explained in Art. 47).

*The line integral around  $AB$  is equal to the sum of the line integrals around the various meshes of any net-work, plane or otherwise, constructed in  $AB$ , the line integrals around the various meshes being taken in the same direction as the line integral around  $AB$ , as shown by the two or three small curled arrows. This proposition is evident if we consider (1) that in integrating around the various meshes each portion of the closed loop  $AB$  is integrated over but once and in the direction of the large arrow in Fig. 156, and (2) that in integrating around the*

various meshes each dividing line is integrated over twice and in opposite directions.

Let  $\Delta L$  be the line integral around one of the meshes in Fig. 156, then from the above proposition, we have

$$\int R \cdot \cos \epsilon \cdot ds = \Sigma \Delta L$$

where  $\int R \cos \epsilon \cdot ds$  is the line integral of  $R$  around  $AB$  in Fig. 156

Substituting the value of  $\Delta L$  from equation (52), we have

$$\int R \cos \epsilon \cdot \Delta s = \int C \cos \epsilon \cdot \Delta S \quad (54)$$

in which the first member is the line integral of a distributed vector  $R$  around a closed curve or loop and the second member is the surface integral of the curl of  $R$  over any diaphragm to the loop.

*Solenoidal character of curl.* — The curl of a distributed vector is itself a distributed vector and its distribution is always solenoidal, that is to say, the divergence of a curl is always and everywhere equal to zero. This may be made evident as follows: Consider two diaphragms to a given closed curve or loop. The integral of  $C$  must be the same over both diaphragms because each surface integral is equal to the line integral of  $R$  around the closed curve or loop (normal to surface of integration being drawn toward the same side of the diaphragm in each case). If the direction of the normal be reversed over one of the diaphragms then the surface integral of  $C$  over that diaphragm will be reversed in sign, or, in other words, the surface integral of  $C$  over one diaphragm is equal and opposite to the surface of integral of  $C$  over the other diaphragm, so that the surface integral of  $C$  over both diaphragms is zero. But the two diaphragms form a closed surface and therefore  $C$  is a distributed vector whose flux out of or into a closed surface is always equal to zero, so that its divergence must be equal to zero as explained in Art. 50.

**55. Rotational and irrotational vector distribution. Vector potential and scalar potential.** When a distributed vector has curl

the vector is said to be *rotationally distributed*. When the curl of a distributed vector is equal to zero, however, the vector is said to be *irrotationally distributed*. By comparing equations (47) and (53) and considering the statement in Art. 48, it is evident that a distributed vector can have a scalar potential only when its curl is everywhere equal to zero, that is to say, scalar potential exists only for irrotationally distributed vectors. A rotationally distributed vector cannot be looked upon as the gradient of a distributed scalar or potential. See problem 66.

If a given distributed vector has no divergence, that is to say, if its distribution is solenoidal, it may be looked upon as the curl of another distributed vector. The new distributed vector of which the given distributed vector is the curl is called the *vector potential* of the given distributed vector.

The above statements may be made more easily intelligible by rearranging them as follows :

(a) We have rotationally or irrotationally distributed vectors according as curl does or does not exist ; a distributed vector which has curl can have no scalar potential ; and a distributed vector which has no curl can have a scalar potential.

(b) We have vector distributions which have divergence and vector distributions which do not have divergence. This latter kind of vector distribution is called solenoidal ; a distributed vector which has divergence cannot have a vector potential ; and a distributed vector which has no divergence can have a vector potential.

It is possible to separate any distributed vector into two parts, one of which has curl but does not have divergence and therefore has vector potential, and the other of which has divergence but does not have curl and therefore has scalar potential.

The simplest example of that relationship between two distributed vectors which is referred to in speaking of one of the vectors as the vector potential of the other, is found in fluid motion as follows : The rotatory motion of the various small portions of a moving fluid is a distributed vector ordinarily called

the vortex vector, and lines may be drawn through a moving fluid so as to be at each point parallel to the axis about which the small parts of the fluid are rotating. These lines are called vortex lines. The vortex motion of a fluid is a distributed vector which is equal to the curl of the fluid velocity and therefore the fluid velocity is the vector potential of the vortex motion.

**56. The linear vector function.**—The simplest mode of distribution of a vector throughout a vector field is that in which the components of the vector are linear functions of the coördinates of the various points. In this case we have

$$\begin{aligned} X &= X_0 + a_{11}x + a_{12}y + a_{13}z \\ Y &= Y_0 + a_{21}x + a_{22}y + a_{23}z \\ Z &= Z_0 + a_{31}x + a_{32}y + a_{33}z \end{aligned} \quad (55)$$

where  $X$ ,  $Y$  and  $Z$  are the components of the vector at the point  $x, y, z$ ;  $X_0$ ,  $Y_0$  and  $Z_0$  are the components at the origin of coördinates; and the various coefficients  $a$  are constants.

It is important to understand that the distribution of a vector throughout a very small portion of any vector field is of the character represented by equations (55). This is evident when we consider first that each of the three components  $X$ ,  $Y$  and  $Z$  is a continuous function of the coördinates  $x, y$  and  $z$ , so that each may be expanded in a series of ascending powers of the coördinates  $x, y$ , and  $z$  by MacLaurin's theorem, and second that all terms of higher orders are negligible within a small region near the origin of coördinates. That is, we may write

$$\begin{aligned} X &= X_0 + \frac{dX}{dx} \cdot x + \frac{dX}{dy} \cdot y + \frac{dX}{dz} \cdot z \\ Y &= Y_0 + \frac{dY}{dx} \cdot x + \frac{dY}{dy} \cdot y + \frac{dY}{dz} \cdot z \\ Z &= Z_0 + \frac{dZ}{dx} \cdot x + \frac{dZ}{dy} \cdot y + \frac{dZ}{dz} \cdot z \end{aligned} \quad (56)$$

in which  $X_0$ ,  $Y_0$  and  $Z_0$  are the components of the distributed vector at the origin of the coördinates, and the coefficients of  $x$ ,  $y$  and  $z$  are the values of the differential coefficients  $dX/dx$ ,  $dX/dy$ ,  $dX/dz$ , etc. at the origin.

Throughout the following discussion the letters  $a_{11}$ ,  $a_{12}$ ,  $a_{13}$ , etc. are understood to represent the values at the origin of the corresponding differential coefficients in equations (56). In order to make the further discussion of equations (55) and (56) as simple as possible, let us think of  $X$ ,  $Y$  and  $Z$  as the components of the velocity of a fluid, and let us consider the actual velocity of the various parts of the fluid in the neighborhood of the origin as consisting of three parts, namely, (1) a uniform velocity  $v_0$  of which the components are  $X_0$ ,  $Y_0$  and  $Z_0$ , (2) a velocity  $v'$  whose components  $X'$ ,  $Y'$  and  $Z'$  are given by the equations

$$\begin{aligned} X' &= \frac{1}{2}(a_{12} - a_{21})y + \frac{1}{2}(a_{13} - a_{31})z \\ Y' &= \frac{1}{2}(a_{23} - a_{32})z + \frac{1}{2}(a_{21} - a_{12})x \\ Z' &= \frac{1}{2}(a_{31} - a_{13})x + \frac{1}{2}(a_{32} - a_{23})y \end{aligned} \quad (57)$$

and (3) a velocity  $v''$  of which the components  $X''$ ,  $Y''$  and  $Z''$  are given by the equations

$$\begin{aligned} X'' &= a_{11}x + \frac{1}{2}(a_{12} + a_{21})y + \frac{1}{2}(a_{13} + a_{31})z \\ Y'' &= \frac{1}{2}(a_{12} + a_{21})x + a_{22}y + \frac{1}{2}(a_{23} + a_{32})z \\ Z'' &= \frac{1}{2}(a_{13} + a_{31})x + \frac{1}{2}(a_{23} + a_{32})y + a_{33}z \end{aligned} \quad (58)$$

The vector sum  $v_0 + v' + v''$  is seen to be equal to the total velocity of the fluid at each point because  $X$  as given by equation (55) is equal to  $X_0 + X' + X''$  and the same is true of the other components.

The velocity  $v_0$  represents a translatory motion of the entire body of fluid in the neighborhood of the origin, the velocity  $v'$  represents a simple motion of rotation about a definite axis of the entire body of fluid in the neighborhood of the origin, and the velocity  $v''$  represents a steady increase of dimensions of the

portion of fluid near the origin in three mutually perpendicular directions, three dilatations as they are called.

*Discussion of velocity  $v'$ .* — Consider a rotating rigid body, of which the axis of rotation passes through the origin of coordinates, and let  $\omega_x$ ,  $\omega_y$ , and  $\omega_z$ , be the components of the angular velocity of the body around the  $x$ ,  $y$ , and  $z$  axes of reference, respectively. Consider a point  $p$  of the body of which the coordinates are  $x$ ,  $y$ , and  $z$  as indicated in Figs. 157, 158 and 159. Consider, for example, Fig. 157. The velocity of the

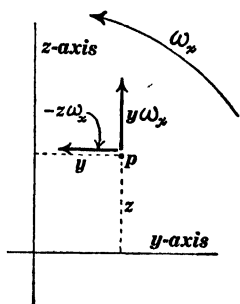

Fig. 157.

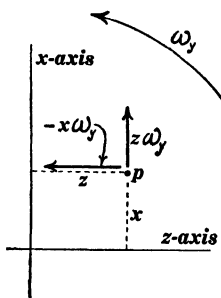

Fig. 158.

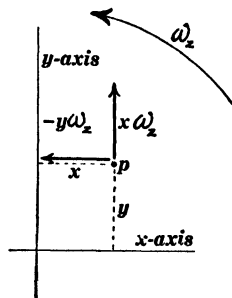

Fig. 159.

particle  $p$  due to the  $x$ -component of the angular velocity of the body  $\omega_x$  consists of two parts,  $+y\omega_x$  and  $-z\omega_x$  as indicated, and the same considerations apply to Figs. 158 and 159. Therefore, picking out the  $x$ -components of velocity in Figs. 158 and 159, we have

$$X' = z\omega_y - y\omega_z$$

and in a similar manner we find

$$\begin{aligned} Y' &= x\omega_z - z\omega_x \\ Z' &= y\omega_x - x\omega_y \end{aligned} \tag{59}$$

By comparing these equations with equations (57) we find that

$$\omega_x = \frac{1}{2}(a_{32} - a_{23}) = \frac{1}{2}\left(\frac{dZ}{dy} - \frac{dY}{dz}\right) \tag{60}$$

$$\omega_y = \frac{1}{2}(a_{13} - a_{31}) = \frac{1}{2} \left( \frac{dX}{dz} - \frac{dZ}{dx} \right)$$

$$\omega_z = \frac{1}{2}(a_{21} - a_{12}) = \frac{1}{2} \left( \frac{dY}{dx} - \frac{dX}{dy} \right)$$

*Discussion of velocity  $v''$ .* — As pointed out above, the velocity  $v''$  represents a steady increase of dimensions of a portion of fluid near the origin in three mutually perpendicular directions. This part of the motion of a fluid near a point or this part of any vector field near a point is the part upon which the divergence of the distributed vector depends, and it is this part which must be considered if one wishes to establish rigorously the proposition in Art. 50, namely, that the ratio  $\Delta\Phi/\Delta\tau$  approaches a finite limiting value as  $\Delta\tau$  approaches zero.

To show that  $v''$  represents three mutually perpendicular dilatations, let us assume three dilatations parallel to three rectangular axes of reference  $x_1, y_1,$  and  $z_1$ . The three component velocities being

$$\text{and } \left. \begin{aligned} X_1 &= b_1 x_1 \\ Y_1 &= b_2 y_1 \\ Z_1 &= b_3 z_1 \end{aligned} \right\} \quad (\text{i})$$

In order to transform these equations to new rectangular axes of reference  $x, y,$  and  $z,$  it is very helpful to make use of the velocity potential  $P$  which, from equations (i) is

$$P = \frac{1}{2}(b_1 x_1^2 + b_2 y_1^2 + b_3 z_1^2) \quad (\text{ii})$$

Let  $\alpha_1, \beta_1, \gamma_1; \alpha_2, \beta_2, \gamma_2; \alpha_3, \beta_3, \gamma_3$  be the direction cosines of the new axes of reference  $x, y, z$  referred to the old axes  $x_1, y_1, z_1$ . Then

$$\left. \begin{aligned} x_1 &= \alpha_1 x + \beta_1 y + \gamma_1 z \\ y_1 &= \alpha_2 x + \beta_2 y + \gamma_2 z \\ z_1 &= \alpha_3 x + \beta_3 y + \gamma_3 z \end{aligned} \right\} \quad (\text{iii})$$

Substituting these values of  $x_1, y_1, z_1$  in equation (ii), we have the expression for the velocity potential referred to the new axes,

and differentiating this expression for velocity potential with respect to  $x$ , with respect to  $y$  and with respect to  $z$ , in succession, we find the expressions for the three components of the fluid velocity referred to the new axes, namely

$$\left. \begin{aligned} X'' &= (b_1\alpha_1^2 + b_2\alpha_2^2 + b_3\alpha_3^2)x + (b_1\alpha_1\beta_1 + b_2\alpha_2\beta_2 + b_3\alpha_3\beta_3)y \\ &\quad + (b_1\gamma_1\alpha_1 + b_2\gamma_2\alpha_2 + b_3\gamma_3\alpha_3)z \\ Y'' &= (b_1\alpha_1\beta_1 + b_2\alpha_2\beta_2 + b_3\alpha_3\beta_3)x + (b_1\beta_1^2 + b_2\beta_2^2 + b_3\beta_3^2)y \\ &\quad + (b_1\beta_1\gamma_1 + b_2\beta_2\gamma_2 + b_3\beta_3\gamma_3)z \\ Z'' &= (b_1\gamma_1\alpha_1 + b_2\gamma_2\alpha_2 + b_3\gamma_3\alpha_3)x + (b_1\beta_1\gamma_1 + b_2\beta_2\gamma_2 + b_3\beta_3\gamma_3)y \\ &\quad + (b_1\gamma_1^2 + b_2\gamma_2^2 + b_3\gamma_3^2)z \end{aligned} \right\} \text{(iv)}$$

These equations exhibit the same kind of symmetry as equations (58), that is the coefficient of  $y$  in the expression for  $X''$  is equal to the coefficient of  $x$  in the expression for  $Y''$ , and so on, and each set of equations (58), and (iv), contains six distinct coefficients. Therefore these two sets of equations are identical; equations (iv) express exactly the same type of motion as is expressed by equations (58). Therefore equations (58) express uniform dilatations of a portion of the fluid in three mutually perpendicular directions.

It is interesting to note that  $dX'/dx + dY'/dy + dZ'/dz = 0$ , according to equations (57), so that the divergence of the total fluid velocity  $v_0 + v' + v''$  is equal to the divergence of  $v''$ . From equations (iv) we have

$$\frac{dX''}{dx} + \frac{dY''}{dy} + \frac{dZ''}{dz} = b_1 + b_2 + b_3$$

inasmuch as

$$\alpha_1^2 + \beta_1^2 + \gamma_1^2 = 1, \quad \alpha_2^2 + \beta_2^2 + \gamma_2^2 = 1, \quad \alpha_3^2 + \beta_3^2 + \gamma_3^2 = 1$$

Therefore the divergence of a fluid velocity at a point is equal to the sum of the three mutually perpendicular dilatations  $b_1 + b_2 + b_3$  of a small portion of the fluid near the point.

**57. General equations of the electromagnetic field.** A complete theory of electromagnetic waves involves a consideration of the general equations of the electromagnetic field in moving media as well as in stationary media. It is sufficient for the purposes of this text, however, to discuss the general equations of the electromagnetic field for a stationary medium in which the inductivity is  $\kappa$  and the permeability is  $\mu$ .\*

*Conduction current and displacement current. First group of general equations.* — An ordinary electric current flowing through

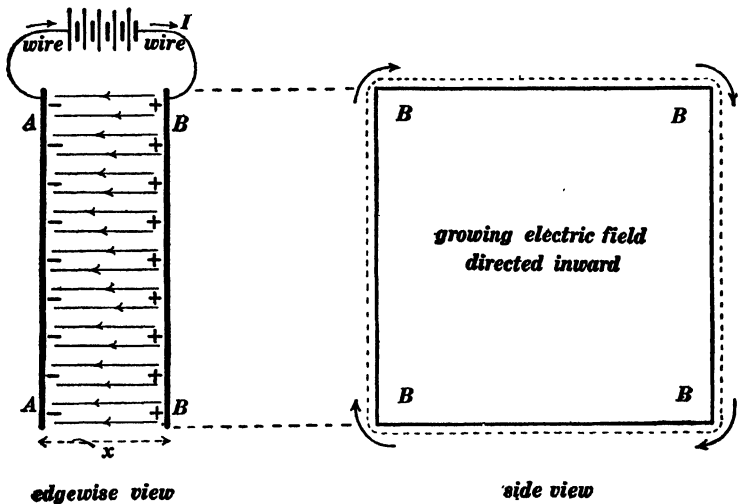

Fig. 160.

a wire is called a conduction current, and the magnetic action of such a current is discussed in every elementary treatise on elec-

\* The discussion here given follows somewhat closely that of Hertz. See Jones's translation of Hertz's *Electric Waves*, pages 195-240. A discussion of the electromagnetic equations in moving media is given on pages 241-268.

A good discussion of electromagnetic waves (which follows mainly the development given by Hertz) is to be found in *The Principles of Electric Wave Telegraphy*, by J. A. Fleming, Longmans, Green & Co., 1908, pages 282-352.

One of the simplest and best of the recent treatises on Electromagnetic Theory is that of Föppl and Abraham, the first volume of which is devoted to the theory of electromagnetic action and the second volume of which is devoted to the modern electron theory.

tricity and magnetism. The formulation of the equations of the electromagnetic field depend, however, upon a clear understanding of the magnetic action of an increasing electric field. In order to bring this matter into relation with things which are familiar to a beginner, let us consider a condenser  $AABB$ , Fig. 160, which is being charged by a current  $I$  as indicated, the insulating material between the plates  $AA$   $BB$  having an inductivity  $\kappa$ . The capacity of the condenser  $AABB$  is given by the equation

$$C = \frac{I}{4\pi V^2} \cdot \frac{\kappa A}{x} \quad (i)^*$$

in which  $C$  is expressed in abfarads.  $A$  is the sectional area of the dielectric and  $x$  is its thickness.

The amount of charge which flows into the condenser during a small interval of time  $\Delta t$  is

$$\Delta Q = I \cdot \Delta t \quad (ii)$$

and the increment of electromotive force across the plates of the condenser is given by the equation

$$\Delta E = \frac{\Delta Q}{C} \quad (iii)$$

Substituting the value of  $C$  from equation (i) and the value of  $\Delta Q$  from equation (ii) in equation (iii) and solving for  $I$  we have :

$$I = \frac{I}{4\pi V^2} \cdot \frac{\kappa A}{x} \cdot \frac{\Delta E}{\Delta t} \quad (iv)$$

The intensity of the electric field between the plates  $AA$  and  $BB$ , Fig. 160, is  $e = E/x$  so that  $\Delta e = \Delta E/x$ . Therefore equation (iv) becomes

$$I = \frac{I}{4\pi V^2} \cdot \kappa A \cdot \frac{de}{dt} \quad (v)$$

\* The factor  $1/4\pi V^2$  is a single constant, and it is written in this form so as to involve explicitly the velocity of light  $V$ . See Franklin and MacNutt's *Elements of Electricity and Magnetism*, pages 178-180.

In so far as the magnetic action of the electric current in Fig. 160 is concerned, the circuit is complete, a *conduction current*  $I$  flows through the metallic part of the circuit (the wire), what is called a *displacement current* exists in the dielectric, and the displacement current

$$\frac{1}{4\pi V^2} \cdot \kappa A \cdot \frac{de}{dt} \text{ is equal to } I$$

The line integral of the magnetic field (magnetomotive force) around any closed curve or loop which encircles the path of the current in Fig. 160 is equal to  $4\pi I$ .\* Consider the closed curve or loop which encircles the region where the displacement current exists, the dotted line in the side view Fig. 160, and let us think of the magnetomotive force around this dotted line as dependent upon the displacement current, then

$$\left. \begin{array}{l} \text{line integral of magnetic field around} \\ \text{the dielectric of the condenser} \end{array} \right\} = 4\pi I = \frac{1}{V^2} \cdot \kappa A \cdot \frac{de}{dt} \quad (\text{vi})$$

This equation applies to any small portion of dielectric in which a changing electric field exists, and it leads at once to one set of general equations of the electromagnetic field as follows: Let  $X$ ,  $Y$ , and  $Z$  be the components of an electric field at a point in abvolts per centimeter, let  $L$ ,  $M$  and  $N$  be the components of the magnetic field, and let  $\kappa$  be the inductivity of the dielectric. Suppose that the component  $X$  of the electric field is changing, then  $1/4\pi V^2 \cdot \kappa(\Delta y \cdot \Delta z) \cdot dX/dt$  is the displacement current in abamperes across the area  $\Delta y \cdot \Delta z$ . Now the line integral of the magnetic field around the element  $\Delta y \cdot \Delta z$  is equal to the product of the area of the element and the  $x$ -component of the curl of the magnetic field at the point. But the  $x$ -component of the curl of the magnetic field at the point is  $dN/dy - dM/dz$  according to equation (53). Therefore, when applied to the elementary area  $\Delta y \cdot \Delta z$ , equation (vi) becomes

\* See pages 121 Nichols and Franklin's *Elements of Physics*, Vol. II.

$$\left(\frac{dN}{dy} - \frac{dM}{dz}\right)\Delta y \cdot \Delta z = \frac{1}{V^2} \cdot \kappa(\Delta y \cdot \Delta z) \cdot \frac{dX}{dt} \quad (\text{vi})$$

or

$$\frac{dX}{dt} = \frac{V^2}{\kappa} \left(\frac{dN}{dy} - \frac{dM}{dz}\right)$$

and similarly we may obtain

$$\frac{dY}{dt} = \frac{V^2}{\kappa} \left(\frac{dL}{dz} - \frac{dN}{dx}\right) \quad (\text{6I})$$

and

$$\frac{dZ}{dt} = \frac{V^2}{\kappa} \left(\frac{dM}{dx} - \frac{dL}{dy}\right)$$

These equations constitute the first group of general equations of the electromagnetic field in a stationary isotropic medium.

*Induced electromotive force. Second group of general equations.* Consider a small element of area  $\Delta y \cdot \Delta z$  at a point in an electromagnetic field. The magnetic flux through the area is equal to  $\mu L \cdot \Delta y \cdot \Delta z$ , the rate of change of this flux is equal to  $\mu \cdot dL/dt \cdot \Delta y \cdot \Delta z$ , and this rate of change of flux is equal to the electromotive force around the boundary of the surface element. The electromotive force around the surface element (line integral of electric field around the element), however, is equal to the product of the area of the element and the  $x$ -component of the curl of electric field. Therefore, we have

$$\mu \cdot \frac{dL}{dt} \cdot \Delta y \cdot \Delta z = - \left(\frac{dZ}{dy} - \frac{dY}{dz}\right) \Delta y \cdot \Delta z \quad (\text{vii})$$

The negative sign is chosen for the reason that an increasing magnetic field through a closed curve or loop produces an electromotive force around the loop in the direction in which a *left-handed* screw would have to be turned in order that it might travel in the direction of the increasing magnetic field, whereas in Fig. 160 a growing electric field as shown in the side view produces a magnetomotive force around the dotted line in the direction in which a *right-handed* screw would have to be turned

in order that it might travel in the direction of the increasing electric field.

Equation (vii) reduces at once to

$$\frac{dL}{dt} = -\frac{1}{\mu} \left( \frac{dZ}{dy} - \frac{dY}{dz} \right)$$

and similarly we may obtain

$$\frac{dM}{dt} = -\frac{1}{\mu} \left( \frac{dX}{dz} - \frac{dZ}{dx} \right) \quad (62)$$

and

$$\frac{dN}{dt} = -\frac{1}{\mu} \left( \frac{dY}{dx} - \frac{dX}{dy} \right)$$

These equations constitute the second group of general equations of the electromagnetic field in a stationary isotropic medium.

*Equations of continuity.*—It is the object of this treatise to discuss electromagnetic waves in regions where there is no free electric charge and no free magnet poles, indeed such a thing as a free magnet pole does not exist. Therefore the divergence of the electric field is zero and the divergence of the magnetic field is zero. That is

$$\frac{dX}{dx} + \frac{dY}{dy} + \frac{dZ}{dz} = 0 \quad (63)$$

and

$$\frac{dL}{dx} + \frac{dM}{dy} + \frac{dN}{dz} = 0 \quad (64)$$

*Electromagnetic equations containing but one dependent variable.*—No one of the differential equations (61), (62), (63) or (64) can be solved because each of these equations contains more than one dependent undetermined variable. A set of equations each containing but one dependent variable may be derived as follows:

Differentiate the first of equations (61) with respect to  $t$  and we have

$$\frac{d^2X}{dt^2} = \frac{V^2}{\kappa} \left( \frac{d^2N}{dydt} - \frac{d^2M}{dsdt} \right) \quad (i)$$

Differentiate the third of equations (62) with respect to  $y$  and the second with respect to  $z$  and we have

$$\frac{d^2N}{dydt} = -\frac{1}{\mu} \left( \frac{d^2Y}{dxdy} - \frac{d^2X}{dy^2} \right) \quad (\text{ii})$$

and

$$\frac{d^2M}{dzdt} = -\frac{1}{\mu} \left( \frac{d^2X}{dz^2} - \frac{d^2Z}{dxdz} \right) \quad (\text{iii})$$

Substituting these values of  $d^2M/dzdt$  and  $d^2N/dydt$  in equation (i) we have

$$\frac{d^2X}{dt^2} = \frac{V^2}{\mu\kappa} \left( -\frac{d^2Y}{dxdy} - \frac{d^2Z}{dxdz} + \frac{d^2X}{dy^2} + \frac{d^2X}{dz^2} \right) \quad (\text{iv})$$

Differentiating equation (63) with respect to  $x$  we find

$$\frac{d^2X}{dx^2} = -\frac{d^2Y}{dxdy} - \frac{d^2Z}{dxdz} \quad (\text{v})$$

Whence, equation (iv) becomes

$$\frac{d^2X}{dt^2} = \frac{V^2}{\mu\kappa} \left( \frac{d^2X}{dx^2} + \frac{d^2X}{dy^2} + \frac{d^2X}{dz^2} \right) \quad (\text{65})$$

Similarly, we may derive:

$$\frac{d^2Y}{dt^2} = \frac{V^2}{\mu\kappa} \left( \frac{d^2Y}{dx^2} + \frac{d^2Y}{dy^2} + \frac{d^2Y}{dz^2} \right) \quad (\text{66})$$

and exactly similar equations for  $Z$ ,  $L$ ,  $M$  and  $N$ .

*Plane wave.* — Consider a layer of electromagnetic field perpendicular to the  $x$ -axis of reference, and suppose the state of the field to be exactly the same over the whole of such a layer. Such a layer constitutes a plane wave according to the definitions given in Art. 14. Inasmuch as the electromagnetic field is assumed to be the same over any plane layer perpendicular to the  $x$ -axis it is evident that all derivatives with respect to  $y$  and  $z$  are equal to zero. Therefore equations (65) and (66) become

$$\frac{d^2 X}{dt^2} = \frac{V^2}{\mu\kappa} \cdot \frac{d^2 X}{dx^2} \quad (\text{vi})$$

and

$$\frac{d^2 Y}{dt^2} = \frac{V^2}{\mu\kappa} \cdot \frac{d^2 Y}{dx^2} \quad (\text{vii})$$

But from equation (63) we have

$$\frac{dX}{dx} = -\frac{dX}{dy} - \frac{dX}{dz}$$

which is equal to zero because there is no variation with respect to  $y$  and  $z$ . Therefore  $d^2 X/dx^2$  is also equal to zero and equation (vi) vanishes. *There can be no  $x$ -component of electric field (nor an  $x$ -component of magnetic field) in a plane wave perpendicular to the  $x$ -axis.\** That is to say, the electric field (and also the magnetic field) in a plane electromagnetic wave lies in the plane of the wave. Electromagnetic waves are therefore transverse waves.

The equations like (vi) and (vii) which do not vanish in a plane wave perpendicular to the  $x$ -axis are the ones containing  $Y$ ,  $Z$ ,  $M$  and  $N$ . Suppose, however, that we wish to consider the values of  $Y$  alone, assuming that  $Z = 0$ ; then it is evident from the second of equations (62) that  $dM/dt = 0$ , so that  $M$  is invariable and if it is other than zero its value depends upon an outside action which has nothing to do with the wave motion. Therefore if we wish to consider a plane electromagnetic wave perpendicular to the  $x$ -axis and if we are concerned only with the  $y$ -component of the electric field we need only use the following equations

$$\frac{d^2 Y}{dt^2} = \frac{V^2}{\mu\kappa} \cdot \frac{d^2 Y}{dx^2} \quad (\text{67})$$

and

$$\frac{d^2 N}{dt^2} = \frac{V^2}{\mu\kappa} \cdot \frac{d^2 N}{dx^2} \quad (\text{68})$$

\* Unless indeed the electric or magnetic field is associated with some outside action having nothing to do with the wave motion.

These equations are identical in form to equations (iii) and (iv) of Art. 40, and their solution is similar. The velocity of an electromagnetic wave is therefore equal to  $V/\sqrt{\mu\kappa}$ , and in air ( $\mu = 1$  and  $\kappa = 1$ ) the velocity is  $V$ , where  $V$  is equal to  $2.99 \times 10^{10}$ . The equality of magnetic and electric energy at each point in a pure wave (wave which travels without change of shape) may be shown by an argument similar to that which is used in Art. 40 to show the equality of potential and kinetic energy at each point in a pure wave in a canal.

### 58. Energy of the electromagnetic field. Poynting's Theorem.

The magnetic energy per unit volume near a point in an electromagnetic field is  $\mu/8\pi \cdot (L^2 + M^2 + N^2)$ ,\* and the electric energy per unit volume near the point is  $\kappa/8\pi V^2 \cdot (X^2 + Y^2 + Z^2)$ .† Therefore the total energy in a volume element  $\Delta\tau$  is  $1/8\pi \cdot [\mu(L^2 + M^2 + N^2) + \kappa/V^2 \cdot (X^2 + Y^2 + Z^2)] \cdot \Delta\tau$  and the total energy in a given region is expressed by the volume integral:

$$W = \frac{1}{8\pi} \int \left[ \mu(L^2 + M^2 + N^2) + \frac{\kappa}{V^2}(X^2 + Y^2 + Z^2) \right] d\tau \quad (69)$$

the integral being extended throughout the given region.

*Poynting's theorem.* If the quantity of energy  $W$  in a given portion of an electromagnetic field is changing it is evident that energy must be flowing into or out of the region across its bounding surface. But the rate at which energy flows across a bounding surface is a surface integral, and the rate at which the total energy in the region is changing is a volume integral, being the summation of the rates of change of energy in all the small portions of the region. Therefore to establish an expression for the energy stream it is necessary to find a distributed vector whose surface integral taken over the bounding surface of a region is equal to the following volume integral extended over the whole of the enclosed region.

\* See Franklin and McNutt, *Electricity and Magnetism*, page 185.

† See Franklin and McNutt, *Electricity and Magnetism*, pages 76–81.

$$\frac{dW}{dt} = \frac{1}{4\pi} \int \left[ \mu \left( L \frac{dL}{dt} + M \frac{dM}{dt} + N \frac{dN}{dt} \right) + \frac{\kappa}{V^2} \left( X \frac{dX}{dt} + Y \frac{dY}{dt} + Z \frac{dZ}{dt} \right) \right] d\tau \quad (70)$$

The desired formulation can be made without much difficulty by substituting the values of the time derivatives from equations (61) and (62) in equation (70), and making use of the ideas developed in Art. 51. It is in this way that Poynting's theorem was originally established.\* It is desirable, however, to assume Poynting's theorem as stated on page 64, establish an expression for the surface integral of energy flow out of a given region, and show that this surface integral is equal to the expression given in equation (70).

Let  $A$ ,  $B$  and  $C$  be the components of the energy stream at a point so that  $A \cdot dydz$  is the energy per second which flows across the element of area  $dy \cdot dz$ ,  $B \cdot dzdx$  is the energy per second which flows across the the element of area  $dz \cdot dx$ , and  $C \cdot dx dy$  is the energy per second which flows across the element of area  $dx dy$ . Then the divergence of the energy stream is  $dA/dx + dB/dy + dC/dz$  (see Art. 50), and according to Art. 51 we have

$$\left. \begin{array}{l} \text{Surface integral of energy} \\ \text{stream over the boundary} \\ \text{of a region} \end{array} \right\} = \left\{ \begin{array}{l} \text{volume integral of divergence} \\ \text{of energy stream throughout} \\ \text{the region} \end{array} \right.$$

or, according to equations (48*b*) (50) and (51)

$$\begin{aligned} & \int \int (A dydz + B dx dz + C dx dy) \\ & = \int \int \int \left( \frac{dA}{dx} + \frac{dB}{dy} + \frac{dC}{dz} \right) dx dy dz \quad (71) \end{aligned}$$

in which  $dx dy dz$  is written for  $d\tau$ . It remains to show that the

\* *Philosophical Transactions*, Vol. 175, Part II, page 343, 1884. A very good discussion of Poynting's theorem is given on pages 337-340 of *Principles of Electric Wave Telegraphy*, by J. A. Fleming.

second member of equation (71) is equal to the second member of equation (70).

The general expression for the energy stream at a point, according to equation (4) on page 67, is  $\frac{1}{4\pi} H e \sin \epsilon$ , where  $H$  is the intensity of the magnetic field at the point,  $e$  is the intensity of the electric field at the point, and  $\epsilon$  is the angle between  $H$  and  $e$ . Therefore the components of the energy stream are \*

$$\left. \begin{aligned} A &= \frac{1}{4\pi} (MZ - YN) \\ B &= \frac{1}{4\pi} (NX - ZL) \\ C &= \frac{1}{4\pi} (LY - XM) \end{aligned} \right\} \quad (72)$$

and

Substituting the values of  $A$ ,  $B$  and  $C$  from equations (72) in the right hand member of equation (71), and collecting terms in the proper order, we have :

$$\begin{aligned} \iint A dy dz + B dz dx + C dx dy &= \frac{1}{4\pi} \int \left[ X \left( \frac{dN}{dy} - \frac{dM}{dz} \right) \right. \\ &+ Y \left( \frac{dL}{dz} - \frac{dN}{dx} \right) + Z \left( \frac{dM}{dx} - \frac{dL}{dy} \right) - L \left( \frac{dZ}{dy} - \frac{dY}{dz} \right) \\ &\left. - M \left( \frac{dX}{dz} - \frac{dZ}{dx} \right) - N \left( \frac{dY}{dx} - \frac{dX}{dy} \right) \right] d\tau \end{aligned} \quad (73)$$

in which  $d\tau$  has been written instead of  $dx dy dz$ . But, by referring to equations (61) and (62), it is clear that the second member of (73) is identical to the right hand member of (70). Therefore :

$$\frac{dW}{dt} = \iint (A dy dz + B dz dx + C dx dy) \quad (74)$$

\* The simplest view to take of equations (72) is to look upon them as the vector parts of the product of the vector  $(X + Y + Z)$  by the vector  $(L + M + N)$ , remembering that the vector product  $MZ$  is in the + direction of the  $x$ -axis, and that the vector product  $NY$  is in the - direction of the  $x$ -axis, so that the total  $x$ -component of the product of  $(X + Y + Z)$  by  $(L + M + N)$  is  $MZ - YN$ .

This result, namely, that the rate of change of the total electromagnetic energy in a region is the surface integral of the vector  $A + B + C$  over the boundary of the region, establishes the correctness of equations (72) as expressions for the components of the energy stream in the electromagnetic field.\*

**59. Wave motion generated by moving charges †.**—Imagine a charged sphere to be set in motion carrying its electric field along with it. Those points on the sphere at the ends of a diameter parallel to the motion may be called the poles of the sphere, and

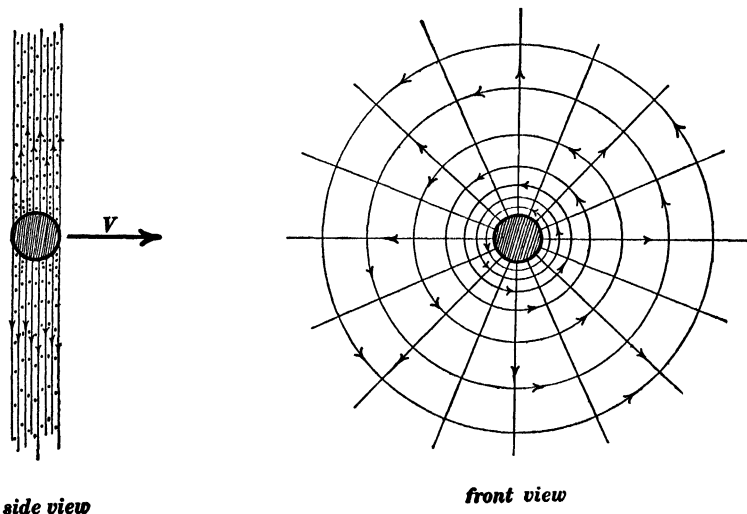

Fig. 161.

the region on the sphere midway between its poles may be called its equatorial region. The electric field which emanates from the equatorial region of the sphere moves sidewise and creates a magnetic field which circles around the sphere in planes at right

\* This proof is much simpler than the original proof given by Poynting because it avoids all consideration of the limits of a partial integration; but of course the proof here given would hardly be considered satisfactory if we had not previously and independently derived an expression for the energy stream.

† This entire article could be made to refer to wave motion produced by moving magnet poles by substituting the words *magnetic field* for *electric field*, and *electric field* for *magnetic field* throughout.

angles to the direction of the motion. Consider the electric field which emanates from the sphere at any point distant  $\phi^\circ$  from the equator. The component, parallel to the equatorial plane, of this field moves sidewise and produces magnetic field which circles around the sphere in planes parallel to the equatorial plane. The magnetic field which is thus produced in the neighborhood of a moving charged sphere intensifies by its inducing action the component of the electric field which is parallel to the equatorial plane at each point, and the result is that the electric lines of force which emanate from the charged sphere turn more and more into directions parallel to the equatorial plane as the speed of the sphere increases. At low speeds this concentration of the electric field into the equatorial plane is entirely negligible, but at speeds approaching the velocity of light the effect is very marked. The general equations of the electromagnetic field lead one to infer that the electric lines of force would emanate from a charged sphere as shown by the fine lines in the side view of Fig. 161 if the sphere were moving at the velocity of light in the direction of the heavy arrow  $V$ . The dots in the side view in Fig. 161 represent the magnetic lines of force which circle around the charge as shown in the front view. The radial lines in the front view are the lines of force of the electric field.\* A detailed discussion of the theory of moving charges is beyond the scope of this text but the state of affairs represented in Fig. 161 is extremely useful in giving a simple insight into some of the most important phenomena of electromagnetic waves.

*Wave sheets in space.* — The mathematical investigation of the electromagnetic effects due to charges moving at moderate velocities is quite complicated. This is exemplified by the theory of the Hertz oscillator as originally developed by Hertz.† When

\*The solution of the general equations of the electromagnetic field in the region surrounding a moving charged sphere was first developed by J. J. Thomson. See *Recent Researches*, pages 16–23, Oxford, 1893.

† This theoretical discussion may be found in Jones's translation of Hertz's *Electric Waves* on pages 137–155.

A good discussion of this matter is given on pages 330–352 of Fleming's *Principles of Electric Wave Telegraphy*.

the velocity of a moving charge is equal to the velocity of light, however, the wave motion, as inferred from the general equations of the electromagnetic field, becomes very simple, and some of the most important facts concerning the establishment of electric and magnetic fields can be clearly understood by considering the wave sheets which would be produced by charges moving at the velocity of light.\* Consider a positive charge at  $p$ , Fig. 162,

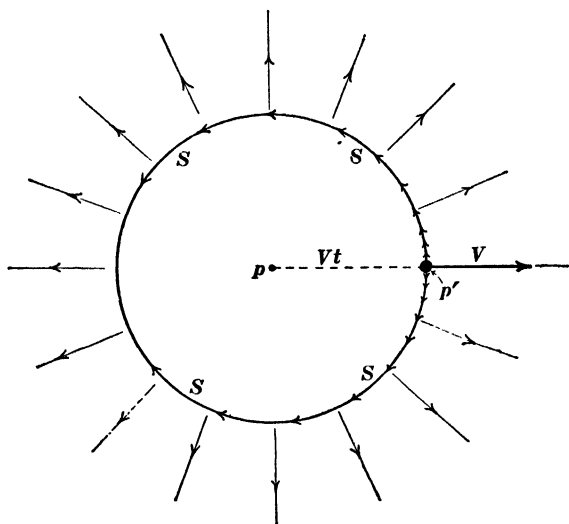

Fig. 162.

with electric field emanating from it in all directions, and imagine this charge to be suddenly jerked into motion at the velocity of light as indicated by the heavy arrow  $V$  in Fig. 162. After  $t$  seconds the charge would be at  $p'$ , having moved through the distance  $Vt$ ; this sudden motion of the charge generates a spherical wave sheet  $SSSS$  with its center at  $p$ ; this spherical wave sheet as it moves outwards at velocity  $V$  in all directions from  $p$  wipes out the electric field, as it were; and when the distance  $Vt$  becomes very great, the spherical sheet  $SSSS$  becomes

\* This method is due to Heaviside. See *Electromagnetic Theory*, Vol. I, pages 57-65, and Vol. II, pages 367-372.

sensibly a plane sheet with the charge at its center, as represented in Fig. 161. The electric lines of force in the wave sheet  $SSSS$ , Fig. 162, emanate from the positive charge at  $p'$  and trend along the "meridian lines" of the spherical sheet as indicated by the arrow-heads. The magnetic lines of force in the wave sheet  $SSSS$  circle around the point  $p'$  along "parallels of latitude."

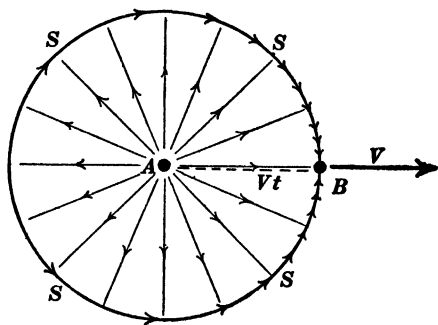

Fig. 163.

Consider two equal and opposite charges  $A$  and  $B$  lying close together and producing no electric field. If one of these charges  $B$  were suddenly jerked into motion at the velocity of light as indicated by the heavy arrow  $V$  in Fig 163, a spherical wave sheet

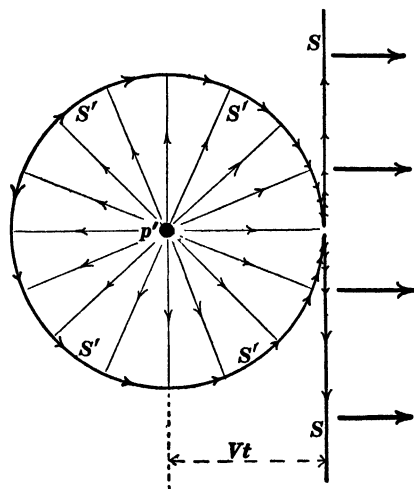

Fig. 164.

$SSSS$  would travel outwards from  $A$ ; and this wave sheet would establish the radial electric field which is represented by the fine radial lines of force in Fig. 163. According to the modern electron theory a free charge (positive or negative) is always produced by the separation of positively and negatively charged particles, and, if one of these charges remains stationary, the electric field is built up around it by wave motion

some what as represented in Fig. 163. The heavy arrow-heads in Fig. 163 show the trend of the electric lines of force in the

wave sheet, and the magnetic lines of force in the wave sheet circle around  $B$  as in Fig. 162.

Imagine the moving charge at  $p'$  in Fig. 162 to have traveled to a great distance from the point  $p$ . Then the spherical wave sheet in the neighborhood of  $p'$  would be a plane wave sheet like that represented in Fig. 161. Fig. 164 represents what would take place if the moving charge were to be suddenly brought to rest. The wave sheet  $SS$ , Fig. 164, would continue to travel at the velocity of light, and a spherical wave sheet  $S'S'S'S'$  would travel outwards from  $p'$ , laying down the electric field around the stationary charge at  $p'$  as represented by the radial arrows.

Imagine two equal and opposite charges moving towards each other with the velocity of light, each charge being accompanied by a plane wave sheet as represented in Fig. 161, and imagine the two charges to be brought to rest at the instant they come together. Figure 165 represents the state of affairs  $t$  seconds after

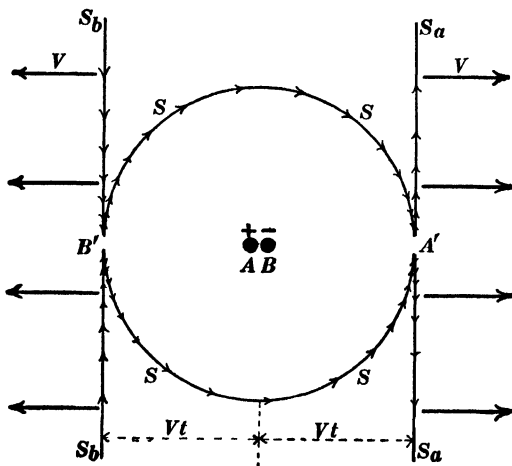

Fig. 165.

the collision, if collision it may be called. The plane wave sheets  $S_a S_a$  and  $S_b S_b$  which were moving with the charges, continue to travel onwards, and the spherical sheet  $SSSS$  emanates from the

point where the collision took place. In this case, however, no electric field is laid down by the spherical wave sheet as it spreads out from its center  $AB$ .

Figure 166 shows what takes place when two equal and opposite charges  $A$  and  $B$  are jerked apart each at the velocity of light. A spherical wave sheet  $SSSS$  emanates from the point  $p$  where the two charges  $A$  and  $B$  were initially located.

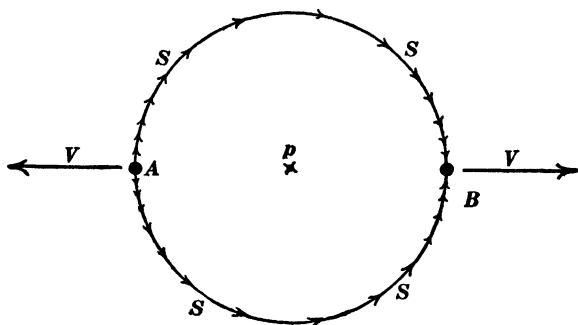

Fig. 166.

**60. Theory of the Hertz oscillator.** The solution of the general equations of the electromagnetic field, namely, equations (61), (62), (63) and (64) in the region surrounding a very small Hertz oscillator was first established by Hertz.\* Some idea of the action of the Hertz oscillator may be obtained by imagining the oscillating charges to be jerked backwards and forwards at the velocity of light. In this case the waves which emanate from the oscillator would be very simple, as shown in Figs. 167 and 168.

Two equal and opposite charges  $A$  and  $B$  are located initially at the point  $O$  in Figs. 167 and 168, and suddenly jerked apart at the velocity of light and brought to rest in the positions  $A$

\* See Jones's translation of Hertz's *Electric Waves*, pages 137-155. A good treatment of this subject is to be found in Fleming's *Principles of Electric Wave Telegraphy*, pages 329-342. This discussion in Fleming's book includes also a derivation of the equation expressing the rate at which energy is radiated by an oscillator.

The theory of the damped oscillator has been developed by Karl Pierson and Alice Lee. See *Principles of Electric Wave Telegraphy*, pages 343-352.

and  $B$  as shown in Fig. 167. A spherical wave sheet  $ssss$ , emanates from the point  $O$  at the instant of separation of the two charges; when the two charges have reached the points  $A$  and  $B$ , this wave sheet is a sphere of which  $AB$  is a diameter; at the instant of stopping of the charges  $A$  and  $B$  two spherical wave sheets  $S_a S_a$  and  $S_b S_b$  emanate from the points  $A$  and  $B$ ; and Fig. 167 shows the position of the three wave

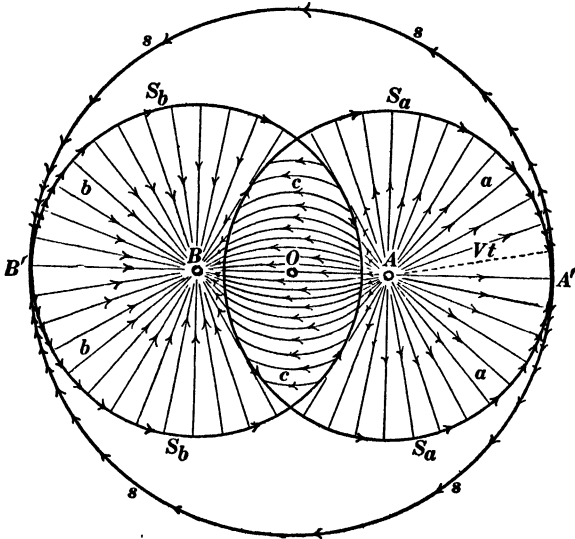

Fig. 167.

sheets at a given instant. The wave sheet  $S_a S_a$  establishes the radial field due to the positive charge  $A$  alone, the wave sheet  $S_b S_b$  establishes the radial field due to the negative charge  $B$  alone, and the region which is enclosed by both  $S_a$  and  $S_b$  is the region in which the total electric field due to both charges is fully established.

Imagine the wave sheets in Fig. 167 to have traveled outwards to a great distance, thus establishing the field due to the two stationary charges  $A$  and  $B$ ; the fine curved lines  $ccc$  in Fig. 168 represent this field. After this field has been established, imagine the two charges  $A$  and  $B$  to be jerked into motion at

the velocity of light towards each other, and brought to rest when they reach the point  $O$  in Fig. 168. At the instant of starting a spherical wave sheet  $S_a S_a$  would emanate from  $A$ ,

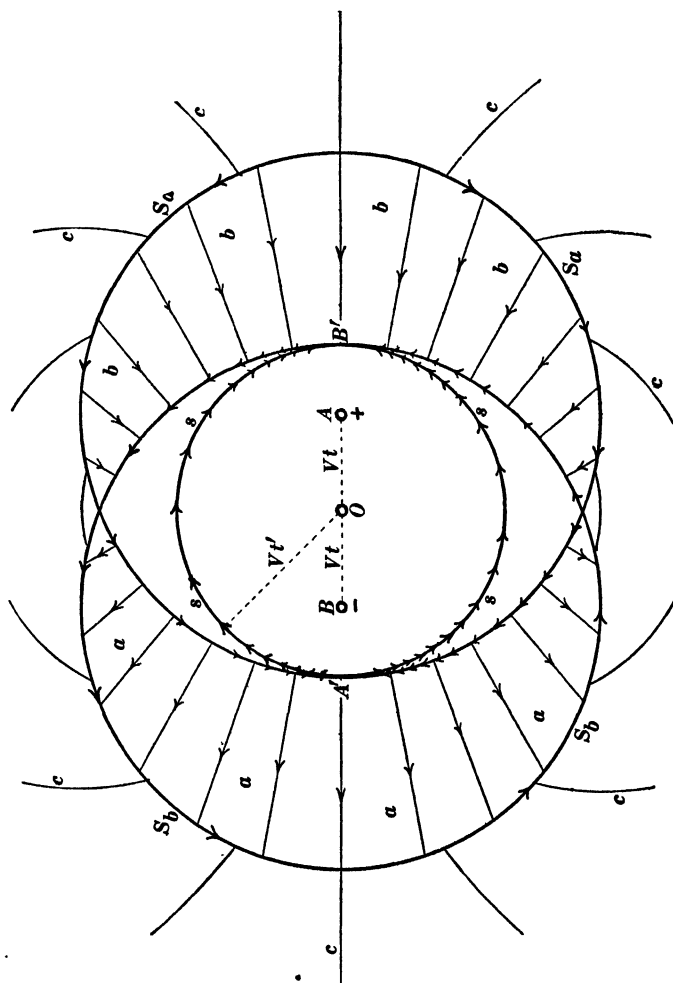

Fig. 168.

and a spherical wave sheet  $S_b S_b$  would emanate from  $B$ , as explained in connection with Fig. 162; the wave sheet  $S_a S_a$  wipes out that part of the field which is due to the charge  $A$ , leaving in the region  $bbb$  the field which is due to charge  $B$ , alone;

and the wave sheet  $S_b S_b$  wipes out the field which is due to charge  $B$ , leaving in the region  $aaa$  the field which is due to charge  $A$  alone. In the region which is enclosed by both  $S_a$  and  $S_b$  the electric field is entirely obliterated, except in the wave sheet  $ssss$  which emanates from the point  $O$  at the instant when the charges  $A$  and  $B$  come together, as explained in connection with Fig. 165.

## CHAPTER VII.

### ELECTRIC WAVE TELEGRAPHY.\*

**61. Marconi's work.** † — A complete installation of apparatus for electric wave telegraphy consists of a Hertz oscillator at the sending station with arrangements for setting it into oscillation, and a similar oscillator (resonator) at the receiving station with a detector device which is actuated by the electric oscillations of the receiving resonator. The oscillator at the sending station and the resonator at the receiving station were at first made in the form of long vertical wires suspended by kites or held in position by insulating supports, and they are usually called *antennæ*. Figure 169 shows Marconi's apparatus for electric wave telegraphy as used in 1896;  $A_1A_2$  are strips of wire netting supported by insulators  $NV$  from cross-arms at the top of two tall masts  $MM$ . These strips of wire netting together with their connections to earth constitute the sending antenna and the receiving antenna respectively. The transmitting antenna is connected to earth through a series of short spark gaps  $S$ , and its electric oscillations are excited by the induction coil  $I$  by closing the key  $K$ . The electric waves emitted by the sending antenna produce electrical oscillations in the receiving antenna, and the slight amount of electric current which surges to and fro through the coherer  $C$  causes the coherer to become conducting, so that the battery  $B$  produces current

\* For a full discussion of this subject see J. A. Fleming's splendid work, *The Principles of Electric Wave Telegraphy*, Longmans, Green & Co., 1908. This work contains a very complete discussion of the following subjects, (a) electric oscillations, (b) high frequency electric measurements (measurement of high frequency current and of inductance and capacity), (c) damping and resonance, and (d) electromagnetic waves on pages 1-418, and a very complete survey of the methods and appliances in electric wave telegraphy is given on pages 419-653.

† A full account of the work of Marconi is given on pages 419-463, and an account of the contributions to the development of electric wave telegraphy by others is given on pages 465-544 of Fleming's *Principles of Electric Wave Telegraphy*.

through the coherer and actuates a relay  $R$ , which in turn actuates a telegraph sounder or recorder  $T$ . Two coils of wire (inductances)  $LL$  prevent the high frequency current in  $C$  from flowing through the relay  $R$  to earth while they permit the current from the battery  $B$  to flow through the coherer.

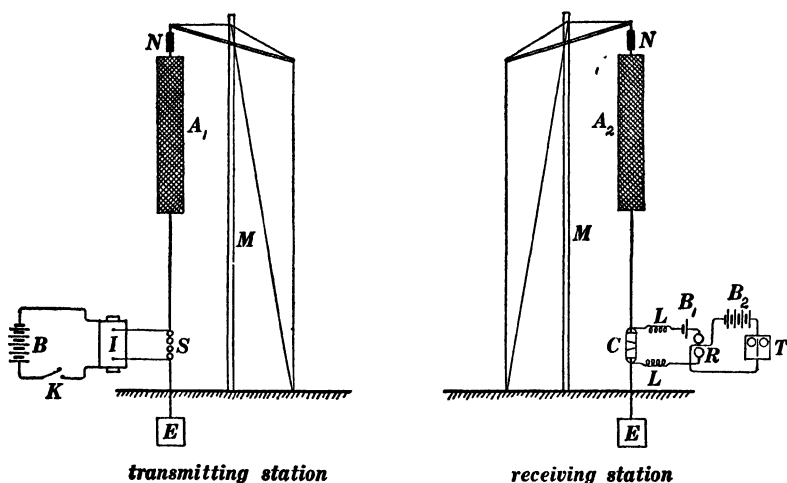

Fig. 169.

Figure 169 shows the essential features of the present-day apparatus for electric wave telegraphy, and the improvements which have been made since 1896 may be described under three headings: (1) The methods of exciting the electrical oscillations of the sending antenna, (2) the details of construction of the sending and receiving antennæ; and (3) the design of the detector  $C$ .

**62. Simple modes of oscillation of a Hertz oscillator.** — The electrical oscillation of a straight rod, as described in detail in Art. 21, is very different from the electrical oscillation of the two wires of a transmission line. An element of a transmission line includes a portion of each of the wires, and every such element of a transmission line has the same inductance  $L$  and the same capacity  $C$ ; the velocity of progression of an electric wave is therefore the same at all points along a transmission line; con-

sequently a transmission line which is vibrating in a higher mode breaks up into a number of vibrating segments of equal length, except the segments which are at the ends of the lines, exactly as in the vibration of an air column with open ends; and therefore the frequencies of the successive simple modes of oscillation of a transmission line are approximately proportional to the successive whole numbers. The vibrating segments of a straight rod, however, are not of equal length, and the frequencies of the successive simple modes of oscillation of a straight rod are not even approximately proportional to the successive whole numbers 1, 2, 3, 4, 5, etc.

Consider those successive simple modes of oscillation of a straight rod for which there is a voltage node at the center

of the rod. For every such mode of oscillation the middle of the rod might be connected to an infinite conducting plane at right angles to the rod without altering the character of the oscillations. The presence of the conducting plane makes the two ends of the rod electrically independent of each other, and therefore a rod which stands upon an infinite conducting plane (like the sending or receiving antenna in Fig. 169, for example) vibrates exactly as one half of a rod of doubled length. Figure 170 represents the voltage and current distributions along an antenna which is oscillating in its fundamental mode. The horizontal distance from the vertical line to the dotted curve in the left-hand part of the figure represents the effective value of the alternating voltage between that point on the rod and the ground, and the distance

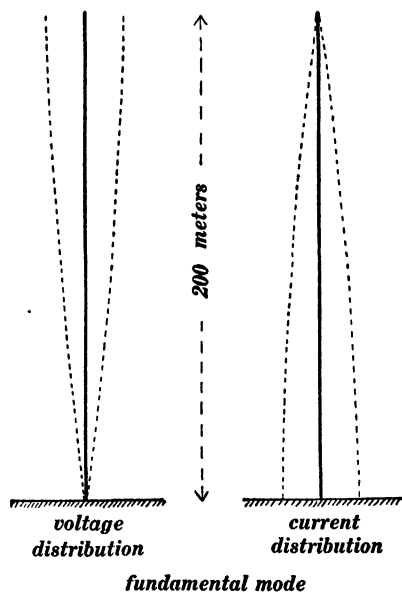

Fig. 170.

from the vertical rod to the dotted curve in the right-hand part of the figure represents the effective value of the alternating current at the given point in the rod. Figure 171 represents the current and voltage distributions along an antenna which is oscillating in its second mode, and Fig. 172 represents the current and voltage distributions along an antenna which is oscillating in its third mode.\*

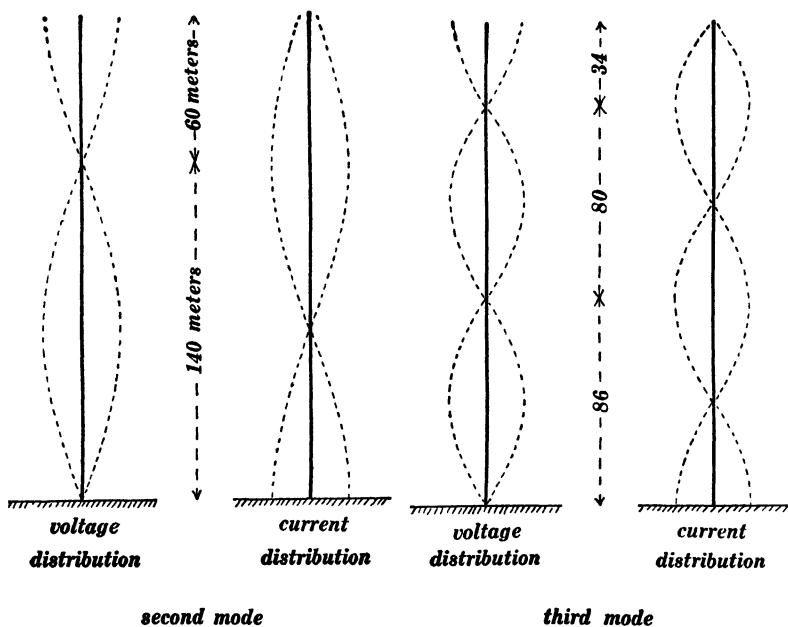

Fig. 171.

Fig. 172.

oscillating in its second mode, and Fig. 172 represents the voltage and current distributions along an antenna which is oscillating in its third mode.\* The oscillation of the antenna  $A_1$  in Fig. 169 which is produced by the formation of a spark across gaps  $S$  consists principally of the fundamental mode, although higher modes of oscillation are present to some extent. The length of

\* The numerical values in Figs. 171 and 172 are taken from the observed positions of the nodes on a long coil like  $SS$  in Fig. 123 with the small fine wire  $WV$  removed. See Fleming's *Principles of Electric Wave Telegraphy*, page 256. The positions of the nodes on a straight rod or long coil depend upon the shape of the conducting surface upon which the rod or coil stands, and this is not specified in the experiments of Fleming.

the antenna in Fig. 170 is approximately equal to one quarter \* of the wave-length of the electromagnetic waves which are emitted, and the length of one of the vibrating segments in Figs. 171 and 172 is approximately equal to one half of the wave-length of the electromagnetic waves which are emitted by the antenna.

**63. System of waves emitted by a Hertz oscillator.** — Figure 173 shows a snap-shot, as it were, of the electric lines of force in the waves which are emitted by an oscillating antenna *A*. The dots represent the lines of force of the magnetic field. †

**64. Recent forms of sending antennæ.** — In order to produce electric waves of great energy intensity, it is necessary to store as much electric energy as possible in the antenna before the breaking down of the spark gap *S* in Fig. 169. This initial store of energy is wholly electric energy, and its amount is proportional to the capacity of the upper part of the antenna with respect to earth, and proportional to the square of the voltage which is required to break across the spark gap. Therefore it is desirable to give the antenna a very large capacity with respect to the earth. ‡ Figure 174 shows the sending antenna at the Marconi station at Cape Breton, Nova Scotia. The supporting towers are 210 feet high, and they support (by means of insulating links) the large funnel-shaped net-work of wires which constitutes the antenna proper.

\* Exactly equal to  $1/5.06$  of the wave-length if the antenna is very slender. See Adams' Prize Essay on "Electric Waves" by H. M. Macdonald, Cambridge University Press, 1902, page 111.

† This sketch is based upon Hertz's solution of the general equations of the electromagnetic field in the neighborhood of a small oscillator. See Hertz's *Electric Waves* (Jones's translation), pages 137–150. See also Fleming's *Principles of Electric Wave Telegraphy*, pages 328–352.

‡ A very large capacity with respect to the earth might be obtained by using a large horizontal wire net forming a large-capacity condenser with respect to the surface of the ground. When such a net is discharged, however, it does not emit its energy rapidly in the form of electromagnetic waves, because such a system is to some extent a closed oscillating system. Thus, an oscillating transmission line radiates energy only at its ends and such a transmission line is to a great extent a closed oscillating system.

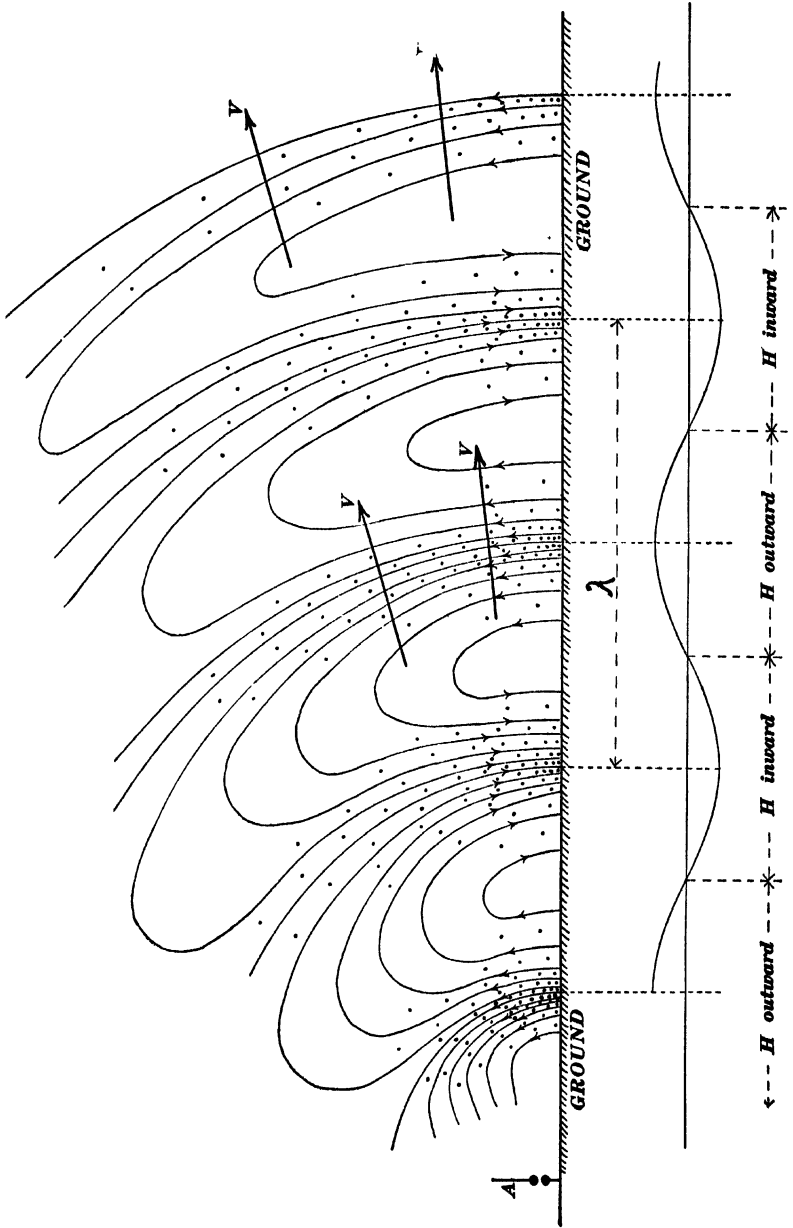

Fig. 173.

Marconi showed in 1906\* that the radiations of an inclined antenna are much more intense in the direction opposite to that in which the inclined antenna points than in any other direction ; such an inclined antenna is most strongly affected by waves com-

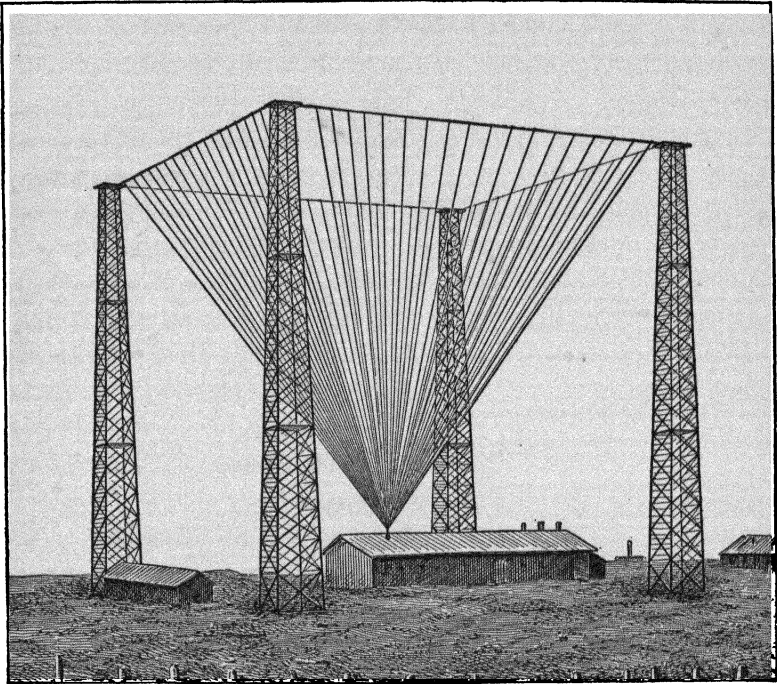

Fig. 174.

ing from the direction in which its radiation would be most intense. When it is desired to send signals from a wireless telegraph station in a certain direction, this property of an inclined antenna is made use of, the practical form of the inclined antenna being a long band of horizontal wires supported at a considerable

\*See paper "On Methods Whereby the Radiation of Electric Waves May be Mainly Confined to Certain Directions, and Whereby the Receptivity of a Receiver May be Restricted to Electric Waves Coming from Certain Directions," *Proceedings of the Royal Society of London*, Series A, vol. 77, page 413, 1906. See *Principles of Electric Wave Telegraphy*, J. A. Fleming, pages 624-644.

height by insulating supports and brought down at one end to the spark gap in the sending station.

The above described property of the inclined antenna is sometimes made use of to locate the direction of an invisible ship from which electric wave signals are being received. An inclined receiving antenna is turned around until the signals are at a maximum intensity. The inclined antenna then points directly away from the ship.

**65. Methods of exciting electric oscillations.**—The method usually employed to excite the oscillations of a sending antenna is by charging the antenna and allowing it to discharge across a spark gap to earth as above described. In some cases the oscillations are produced by charging an auxiliary condenser and allowing it to discharge through an inductance coil, the oscillations of this circuit being delivered to the sending antenna by some mode of coupling. Thus Fig. 175 shows what is called

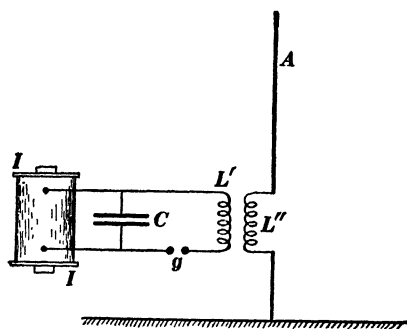

Fig. 175.

inductive coupling. The induction coil  $I$  charges the condenser  $C$ , and the condenser discharges across the spark gap  $g$  through the inductance  $L'$ . The inductance  $L'$  constitutes the primary coil of a transformer of which the secondary coil  $L''$  is in the antenna circuit.

When the mutual inductance of the two coils  $L' L''$  is very large, we have what is called *rigid coupling* and when the mutual inductance is small, we have what is called *loose coupling*.\*

Figure 124 shows a slight modification of inductive coupling. The terminals  $TT$  may be connected across a portion only of

\*The theory of loosely coupled circuits is given in some detail in Fleming's *Principles of Electric Wave Telegraphy*, pages 217-230. This theory has been developed in the most complete manner by Louis Cohen of the United States Bureau of Standards. See *Bulletin of Bureau of Standards*, for 1909.

the inductance  $L^*$  thus giving what is equivalent to the arrangement known among electrical engineers as the autotransformer. Figure 120 shows what is called electrostatic coupling, a modification of which is sometimes used in electric wave telegraphy.

*The singing arc.*† — It was shown by Poulsen in 1903 that electric oscillations of very considerable intensity are steadily maintained through an inductance and condenser which are connected in series with each other across the terminals of an electric arc, as shown in Fig. 176, in which  $B$  is a ballast consisting of resistance and inductance, and  $L$  and  $C$  constitute the oscillating circuit. This mode of exciting electric oscillations has been applied to electrical wave telegraphy and more recently to electric wave telephony.

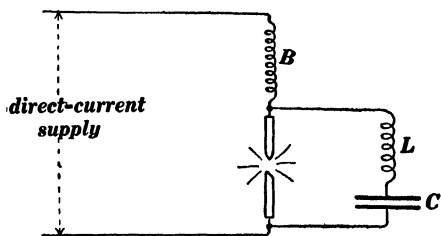

Fig. 176.

**66. Electric wave detectors.** ‡ — The type of detector which was used in the early experiments of Marconi was Branly's coherer which consists of a small quantity of metal filings lying loosely between the ends of two metal rods. Figure 177 shows the

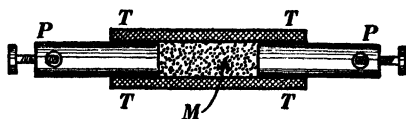

Fig. 177.

essential features of the coherer;  $TT$  is a containing tube of glass or porcelain, and  $M$  represents the metal filings between

\* Fig. 124 shows only a portion of  $L$  in the condenser circuit, the statement here refers to the connection of the terminals  $TT$  across a portion of this portion.

† The Poulsen arc is quite fully discussed in Fleming's *Principles of Electric Wave Telegraphy*, pages 644-653.

‡ A very complete discussion of electric wave detectors is given in Fleming's *Principles of Electric Wave Telegraphy*, pages 353-404.

the two metal plugs  $PP$ . The coherer is inserted in the circuit of the receiving antenna as shown at  $C$  in Fig. 169. The containing tube is kept in constant mechanical vibration so as to continually separate the metal filings, and under these conditions the battery current from  $B_1$  in Fig. 169 can flow through the coherer only while the receiving antenna is oscillating electrically under the influence of waves from the sending antenna.

Another form of detector due to Klemencic is shown in Fig. 178 as arranged for observations in the laboratory. A Hertz

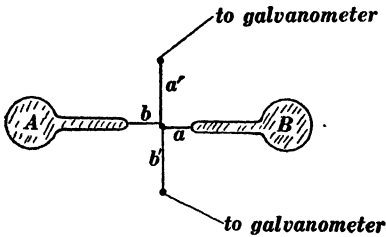

Fig. 178a.

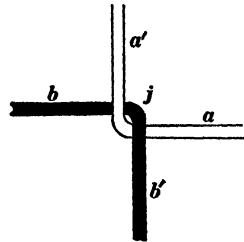

Fig. 178b.

oscillator (resonator)  $AB$  is set into oscillation by waves from a similar Hertz oscillator. The surges of current flow through the extremely fine wires  $ab$  of iron and constantin and heat the junction  $j$ . The wires  $a'$  and  $b'$  thus constitute a thermoelement, and connections are made to a very sensitive galvanometer as indicated in Fig. 178a.

PART II.

HARMONIC ANALYSIS AND NON-HARMONIC  
ELECTROMOTIVE FORCES AND  
CURRENTS.



## CHAPTER VIII.

### HARMONIC ANALYSIS.

**67. Harmonic analysis. Fourier's theorem.** — Before undertaking to discuss the causes of non-harmonic electromotive forces and currents, and before undertaking to describe the phenomena which are associated with non-harmonic electromotive forces and currents in the principal types of alternating-current machines, it is necessary to discuss a theorem concerning the resolution of any given non-harmonic electromotive force or current into harmonic parts. A general statement of this theorem is as follows: Consider any periodic electromotive force or current of which the period is  $T$  seconds. This electromotive force or current may

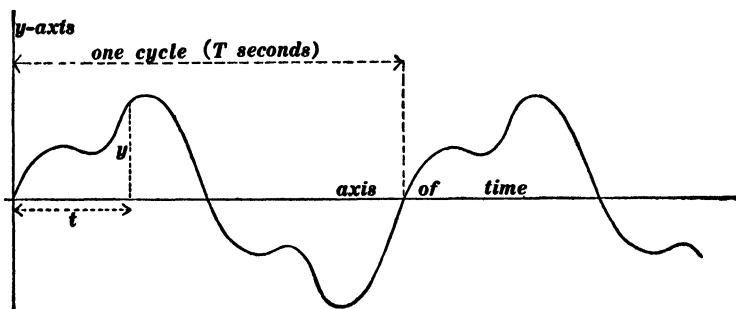

Fig. 179.

be resolved into a series of harmonic parts of which the periods are,  $T$ ,  $T/2$ ,  $T/3$ ,  $T/4$ ,  $T/5$ , etc., the effective value of each of these parts being determinate, as explained later. Stated in another way, this theorem is as follows: A periodic curve of any shape whatever, for example, the periodic curve shown in Fig. 179, may be exactly matched by piling, one upon another, a series of sine and cosine curves of which the *wave-lengths* are  $T$ ,  $T/2$ ,  $T/3$ ,  $T/4$ ,  $T/5$ , etc., where  $T$  is the wave-length of the given

periodic curve, the amplitudes of the various sine and cosine curves being determinate as explained later.\*

The harmonic parts into which any given alternating electromotive force or current may be resolved are called the *harmonic components* or simply the *harmonics* of the given electromotive force or current. That harmonic which is of the same frequency as the given alternating electromotive force or current is called the *fundamental harmonic*, and the others are called the *double harmonic*, the *triple harmonic*, the *quadruple harmonic*, etc., in order. It is shown later that only odd harmonics occur in the electromotive force and current curves which are ordinarily met with in practice.

**68. Mathematical formulation of Fourier's theorem.**— Before attempting to formulate Fourier's theorem it is necessary to consider the algebraic equations for sine or cosine curves of which the wave-lengths are  $T, \dagger T/2, T/3$ , etc. Thus the equation to a sine curve of which the period is  $T/n$  is

$$y = A_n \sin \frac{2\pi nt}{T}$$

where  $A_n$  is a constant and  $t$  is elapsed time reckoned from any chosen instant. The angle  $2\pi nt/T$  changes from zero to  $2\pi n$  (that is, from zero to  $n \times 360^\circ$ ) while  $t$  changes from zero to  $T$ , that is during one period of the given non-harmonic electromotive force or current. Therefore  $A_n \sin 2\pi nt/T$  is a harmonic electromotive force or current which passes through  $n$  complete cycles during one period of the given electromotive force or current, and the coefficient  $A_n$  is its maximum value, or  $A_n/\sqrt{2}$  is its effective value.

\* One of the best mathematical discussions of Fourier's theorem is to be found in Byerly's *Fourier's Theory and Spherical Harmonics*, Ginn & Co., 1893, pages 4-8 and 30-68.

† The words *period* and *wave-length* are used synonymously in this discussion of Fourier's theorem. The period is the time of a complete cycle of electromotive force or current, and the wave-length is the length of one complete wave of the electromotive force or current curve.

Other matters which must be clearly understood before entering into a discussion of Fourier's theorem are the following :

(1) The average value, during a complete cycle, of the sine square (or the average value of the cosine square) of a uniformly variable angle \* is equal to one-half.

(2) The average value, during a complete cycle, of the product

$$\sin \frac{2\pi nt}{T} \times \sin \frac{2\pi mt}{T}$$

is equal to zero when  $n$  and  $m$  are different integers.

(3) The average value, during a complete cycle, of the product

$$\cos \frac{2\pi nt}{T} \times \cos \frac{2\pi mt}{T}$$

is equal to zero when  $n$  and  $m$  are different integers.

(4) The average value, during a complete cycle, of the product

$$\sin \frac{2\pi nt}{T} \times \cos \frac{2\pi mt}{T}$$

is equal to zero when  $n$  and  $m$  are integers, equal or unequal.

A clear understanding of these four propositions is absolutely essential, and the discussion of a few particular cases is more to the purpose than an elaborate algebraic proof. It is important to note that the only difference between a sine curve and a cosine curve is that the ordinate of the sine curve is zero where the ordinate of a cosine curve is a maximum. Thus both curves in Fig. 180 are sine curves if the abscissas (angles) are measured from the point  $O$ ; both curves in Fig. 181 are cosine curves if the abscissas (angles) are measured from the point  $O$ ; one of the curves in Fig. 182*a* is a sine curve and the other is a cosine curve if abscissas are measured from the point  $O$ ; and curve 1 is a sine curve and curve 2 is a cosine curve in Fig. 182*b*, if abscissas are measured from the point  $O$ .

\* Thus  $2\pi nt/T$  is a uniformly variable angle because it is proportional to the elapsed time  $t$ ,  $2\pi n/T$  being a constant.

Figure 180 represents a special case of proposition (2) above, namely, the case in which  $n = 1$ , and  $m = 2$ . Figure 181

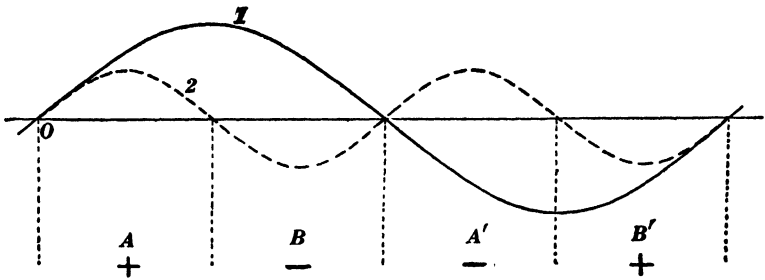

Fig. 180.

represents a special case of proposition (3) above, namely, when  $n = 1$  and  $m = 2$ . Figure 182a represents a special case of proposition (4), namely, when  $n = 1$  and  $m = 1$ , and Fig. 182b

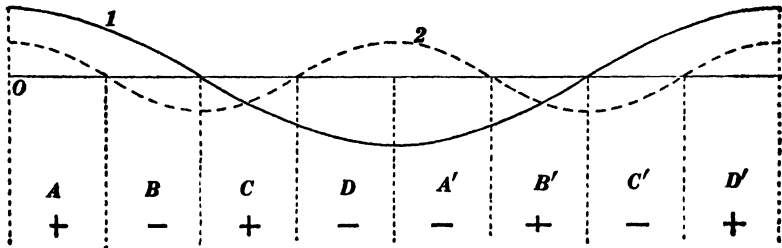

Fig. 181.

represents a special case of proposition (4), namely when  $n = 1$  and  $m = 2$ . The product of the ordinates of the two curves in each of these figures passes through exactly similar sets of values

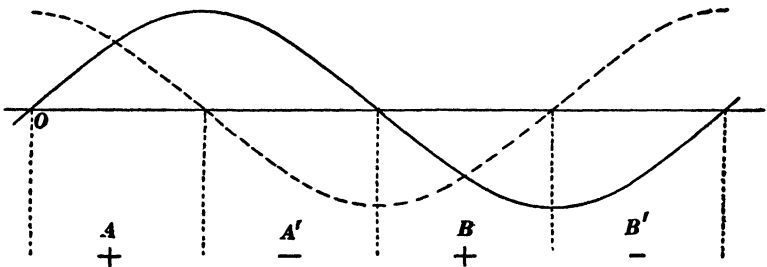

Fig. 182a.

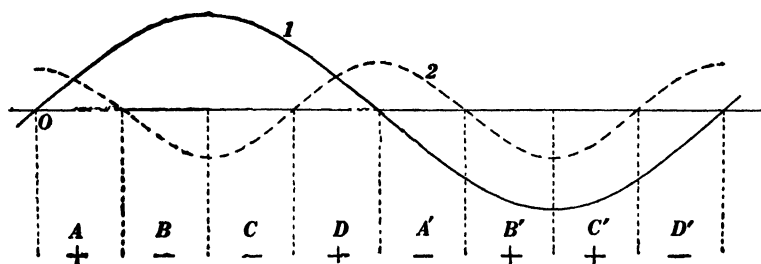

Fig. 182b.

in the regions  $A$  and  $A'$ , in the regions  $B$  and  $B'$ , etc., but the values are opposite in sign, so that the average value of the product is in each case equal to zero.

A curve which is to be resolved into harmonic components may be either an *arbitrary* curve, of which a complete wave is made up of simple algebraic curves such as portions of straight lines,

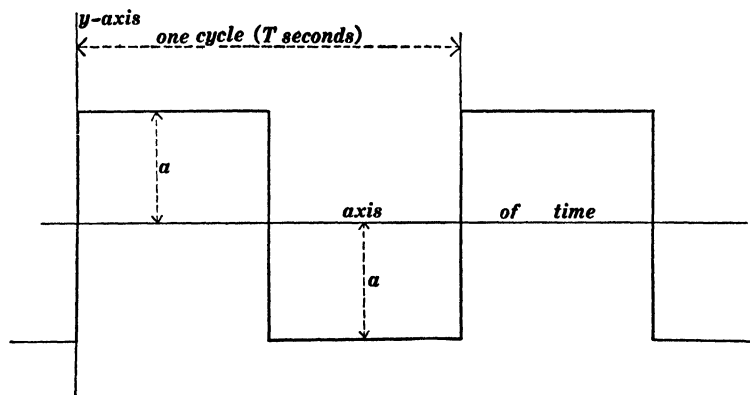

Fig. 183.

arcs of circles, and so on; or a curve to be resolved into harmonic components may be an *actual* electromotive force or current curve as determined by an oscillograph, or an actual tide curve as determined by a tide recorder. Thus, Figs. 183, 184,

\* The student should plot the curves of which the ordinates represent the products of the ordinates of the sine and cosine curves in Figs. 180, 181 and 182; and drawings should be made somewhat similar to Figs. 180, 181 and 182, but for other values of  $n$  and  $m$ .

185 and 186 are arbitrary periodic curves of which one complete wave (one complete cycle) is made up of portions of straight lines, and Fig. 214 is one half of a complete alternating electromotive force wave as determined by actual observation.

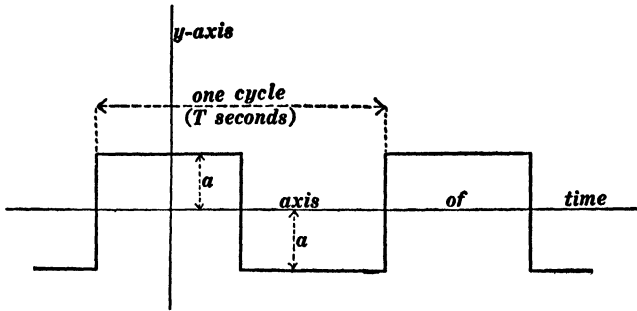

Fig. 184.

Let  $y$  be the ordinate of a given periodic curve at time  $t$ , as indicated in Fig. 179. Then Fourier's theorem may be written in the form

$$y = A_0 + A_1 \sin \frac{2\pi t}{T} + A_2 \sin \frac{4\pi t}{T} + \dots + A_n \sin \frac{2\pi n t}{T} + \dots \quad (75)$$

$$+ B_1 \cos \frac{2\pi t}{T} + B_2 \cos \frac{4\pi t}{T} + \dots + B_n \cos \frac{2\pi n t}{T} \dots$$

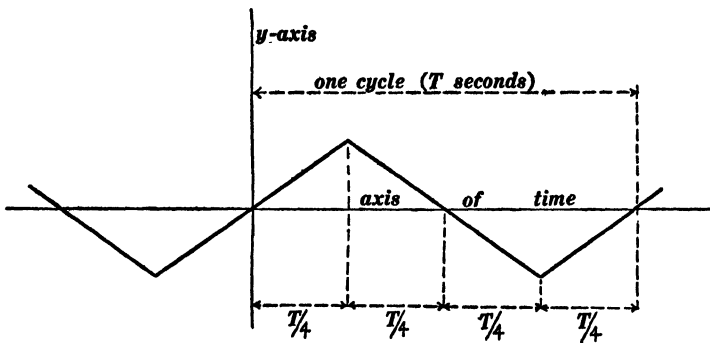

Fig. 185.

To understand the significance of the terms in equation (75), let us consider the general term  $A_n \sin \frac{2\pi n t}{T}$ , and the general

term  $B_n \cos 2\pi nt/T$ . Now the angle  $2\pi nt/T$  is equal to zero when  $t = 0$ , and it is equal to  $2\pi$  or  $360^\circ$ , when  $t = T/n$ , so that the angle  $2\pi nt/T$  increases from zero to  $2\pi$  (that is from

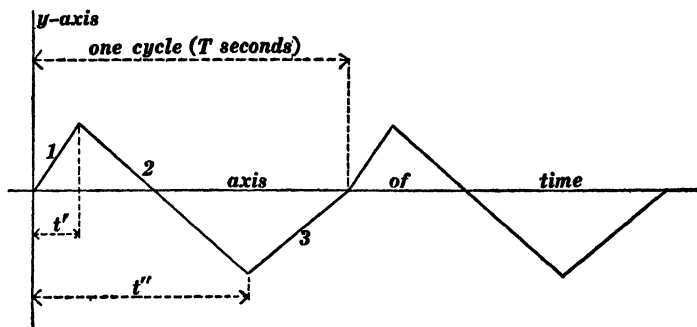

Fig. 186.

zero to  $360^\circ$ ) while  $t$  changes from zero to  $T/n$ , that is, during  $1/n$ th of a cycle. That is to say,  $A_n \sin 2\pi nt/T$  is the ordinate of a sine curve which has  $n$  complete cycles during one cycle of the original given curve. Similarly, the expression  $B_n \cos 2\pi nt/T$

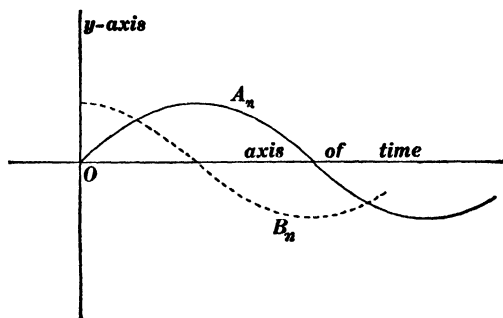

Fig. 187.

Positive values of  $A_n$  and  $B_n$ .

is the ordinate to a cosine curve which has  $n$  complete cycles during one cycle of the original given curve. Equation (75) therefore expresses the ordinate of the given periodic curve as the sum of the ordinates of a series of sine and cosine curves of which the periods are  $T$ ,  $T/2$ ,  $T/3$ ,  $T/4$ , etc.

The trend of the sine and cosine curves which correspond to positive and negative values of the coefficients  $A_n$  and  $B_n$  is shown in Figs. 187 and 188.

*Concerning coefficient  $A_0$ .*—Consider the average value of each member of equation (75) during a complete cycle. The average

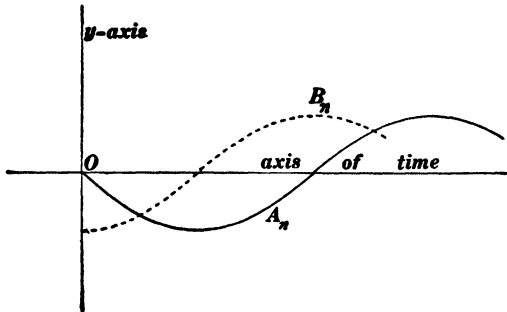

Fig. 188.  
Negative values of  $A_n$  and  $B_n$ .

value of the left-hand member is the average value of  $y$  during the cycle, and the average of every term in the right-hand

member is zero except the constant term  $A_0$ . Therefore  $A_0$  is equal to the average value of  $y$  during one cycle, that is,

$$A_0 = \frac{1}{T} \int_0^T y \cdot dt \quad (76)$$

The coefficient  $A_0$  is therefore equal to zero when the average value of the ordinate of the periodic curve during

one complete cycle is equal to zero. This is always the case in alternating electromotive force and current curves.

*Conditions under which the  $A$  coefficients or the  $B$  coefficients are equal to zero.*—Figure 189 shows the portion of a sine curve

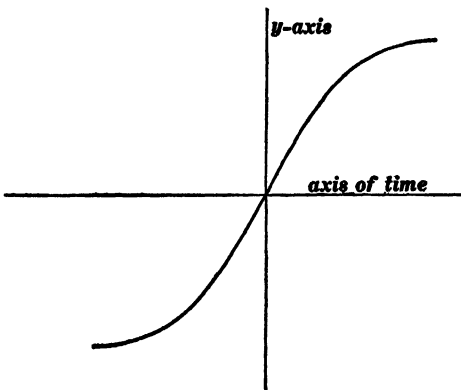

Fig. 189.

near the origin of coördinates, and Fig. 190 shows a portion of a cosine curve near the origin of coördinates. In Fig. 189 (sine curve) the ordinates corresponding to the abscissas  $+t$  and  $-t$  are equal to each other in value but opposite in sign. In Fig. 190 (cosine curve) the ordinates corresponding to abscissas  $+t$  and  $-t$  are equal to each other in value and of the same sign. Whenever the given periodic curve has the kind of symmetry with respect to the  $y$ -axis, that is possessed by a sine curve (Fig. 189), then the  $B$  coefficients in equation (75) are equal to zero; that is, the given periodic curve is resolvable into a series of sine curves. Thus, the curves shown in Figs. 183 and 185 are resolvable into series of sine curves.

Whenever the given periodic curve has the kind of symmetry with respect to the  $y$ -axis, that is possessed by a cosine curve (Fig. 190), then the  $A$  coefficients are equal to zero; that is, the given periodic curve is resolvable into a series of cosine curves. Thus, the periodic curve shown in Fig. 184 is resolvable into a series of cosine curves.

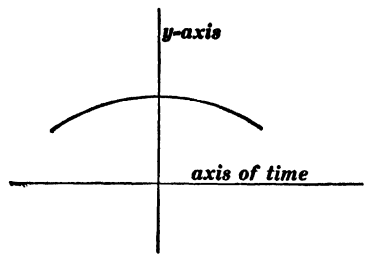

Fig. 190.

It often happens that a given periodic curve may be resolved into a series of sine curves or into a series of cosine curves according to the choice of the origin of coördinates. Thus, the curve shown in Fig. 183 is resolvable into a series of sine curves and the same curve in Fig. 184 is resolvable into a series of cosine curves.

Whenever a given periodic curve possesses neither kind of symmetry (Figs. 189 and 190), then the curve is resolvable into a series of sine curves and a series of cosine curves. Thus, the curves in Figs. 179 and 186 are each resolvable into a series of sine curves and a series of cosine curves.

*Resultant harmonic of the  $n$ th order.* — The two terms of the  $n$ th order in equation (75), namely,  $A_n \sin 2\pi nt/T$  and  $B_n \cos 2\pi nt/T$ ,

are together equivalent to a single harmonic curve because we may write

$$A_n \sin \frac{2\pi nt}{T} + B_n \cos \frac{2\pi nt}{T} = C_n \sin \left( \frac{2\pi nt}{T} + \theta_n \right) \quad (77)$$

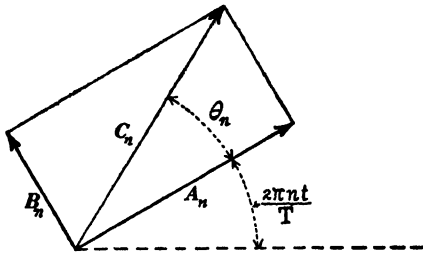

Fig. 191.

in which  $C_n$  and  $\theta_n$  are constants which depend upon  $A_n$  and  $B_n$ . In fact

$$C_n = \sqrt{A_n^2 + B_n^2} \quad (78)$$

$$\tan \theta_n = \frac{B_n}{A_n} \quad (79)$$

This is evident when we consider that  $A_n \sin 2\pi nt/T$  and  $B_n \cos 2\pi nt/T$  are two harmonic electromotive forces (or currents) in quadrature with each other as shown in the clock-diagram,

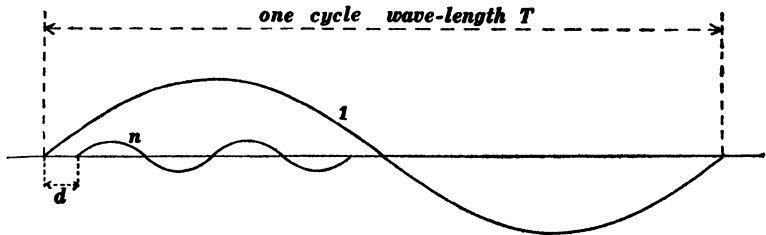

Fig. 192.

Fig. 191. In determining the value of  $\theta_n$  the algebraic signs of  $A_n$  and  $B_n$  must be duly considered. If it is desired to plot the resultant  $n$ th harmonic as shown in Fig. 192, the distance  $d$  must be made equal to  $\theta_n T / (360n)$ , the value of  $\theta_n$  being expressed in degrees.

**69. Even and odd harmonics.** — Under certain conditions, a periodic curve has odd harmonics only (no harmonic of an order divisible by two), under certain conditions a periodic curve has no harmonic of an order divisible by 3, under certain conditions a periodic curve has no harmonic of an order divisible by 4, and so

on. The most important case for present purposes is the case in which only odd harmonics occur. Thus, *the alternating electromotive force and current curves which occur in practice have only odd harmonics.* This is evident from the following considerations :

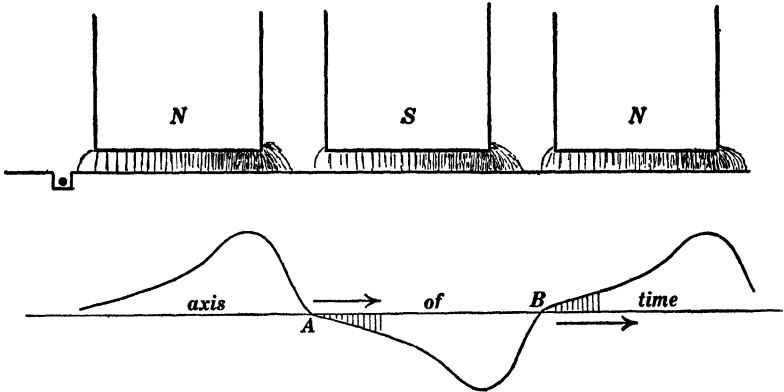

Fig. 193.

The north and south poles of an alternator are always alike as shown in Fig. 193. Therefore an alternating electromotive force curve always has the kind of symmetry which is shown by the

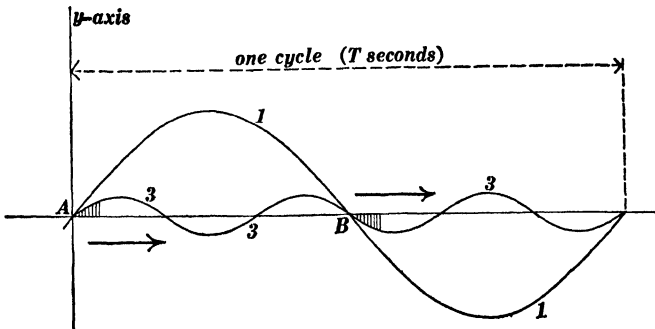

Fig. 194.

curve in Fig. 193 ; *starting from A or B (half a period apart), equal and opposite values of y occur in order, as shown by the fine vertical lines in the lower part of Fig. 193.* This kind of symmetry is possessed by all odd harmonics but not possessed by any

even harmonic, so that a curve like that shown in Fig. 193 cannot have an even harmonic.

Figures 194 and 195 show that the triple harmonic curve No. 3 has the kind of symmetry above specified, and the same is easily

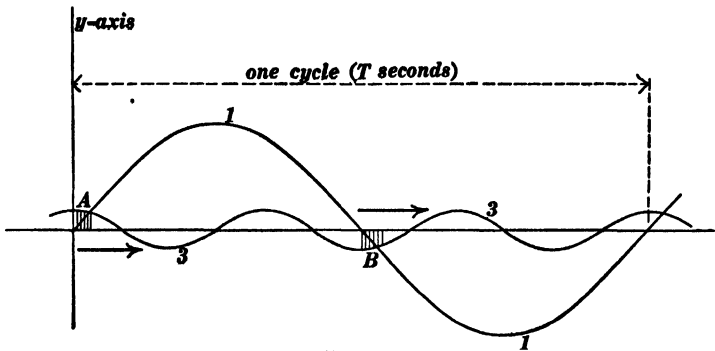

Fig. 195.

shown for any odd harmonic (sine or cosine). Every even harmonic (sine or cosine), on the other hand, passes through *like values of like sign* when one starts from two points *A* and *B*

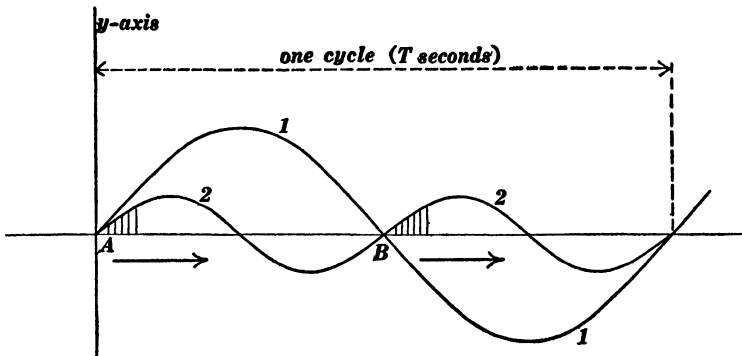

Fig. 196.

(half a period apart), as shown for the double harmonic sine curve in Fig. 196.

**70 Evaluation of coefficients in equation (75).**— The general method of evaluating the coefficients  $A_n$  and  $B_n$  in equation (75) is as follows :

The value of  $A_0$  is given by equation (76), which is derived in Art. 68.

Multiply both members of equation (75) by  $\sin 2\pi nt/T$ , and consider the average value of each member of the resulting equation during a whole cycle  $T$ . The average value of the left-hand member ( $y \sin 2\pi nt/T$ ) will be

$$\frac{1}{T} \int_0^T y \cdot \sin \frac{2\pi nt}{T} \cdot dt$$

and the average value of every term in the right-hand member will be zero except the term  $A_n \sin^2 2\pi nt/T$ ; and the average value of this term is  $A_n/2$ .\* Therefore,

$$\frac{1}{2} A_n = \frac{1}{T} \int_0^T y \sin \frac{2\pi nt}{T} \cdot dt$$

or

$$A_n = \frac{2}{T} \int_0^T y \sin \frac{2\pi nt}{T} \cdot dt \quad (80)$$

Multiply both members of equation (75) by  $\cos 2\pi nt/T$ , consider the average value of each member of the resulting equation as above, and we find:

$$B_n = \frac{2}{T} \int_0^T y \cos \frac{2\pi nt}{T} \cdot dt \quad (81)$$

*Example.* — Consider the periodic curve which is shown in Fig. 197. The first wave of this curve consists of the straight line of which the equation is  $y = t$ . Therefore, substituting  $t$  for  $y$  in equations (76), (80) and (81), we find the values of the coefficients in equation (75), giving:

$$y(=t) = \frac{T}{2} - \frac{T}{\pi} \left( \sin \frac{2\pi t}{T} + \frac{1}{2} \sin \frac{4\pi t}{T} + \dots + \frac{1}{n} \sin \frac{2\pi nt}{T} + \dots \right) \quad (82)$$

This series gives the value  $t$  between the limits  $t = 0$  to  $t = T$ .

\* See propositions (1)† (2), (3) and (4) in Art. 68.

Beyond these limits it gives the ordinate of the given periodic curve which is shown in Fig. 197 because each term in equation (82) remains unchanged in value when  $t$  is increased by any multiple of  $T$ , inasmuch as this is equivalent to increasing the angle  $2\pi nt/T$  by a multiple of  $360^\circ$ .

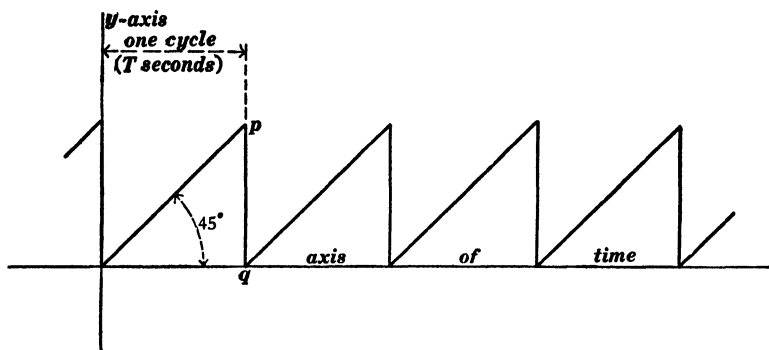

Fig. 197.

**71. Fischer-Hinnen's method for evaluating the coefficients in equation (75).\*** — The integrations involved in equations (76), (80) and (81) cannot be performed algebraically unless  $y$  is a known algebraic function of  $t$ . Therefore the coefficients in equation (75) cannot be determined algebraically from an experimentally determined electromotive force or current curve. To determine the  $A$  and  $B$  coefficients for a given experimentally determined curve, actual step-by-step integration or mechanical integration may be resorted to. Thus a large number of equidistant ordinates (included in one cycle) may be measured, these ordinates may be multiplied by the corresponding values of  $\sin 2\pi nt/T$ , and the sum of these products may be multiplied by 2 and divided by  $T$  [according to equation (80)] to give the value of  $A_n$ ; or the equidistant ordinates of the given experimentally determined curve may be multiplied by the corresponding values of  $\cos 2\pi nt/T$ , and the sum of these products may be multiplied by 2 and divided

\* This method is described by J. Fischer-Hinnen in the *Electrotechnische Zeitschrift* for May 19, 1901. A very good discussion of the method is given by P. M. Lincoln in the *Electric Journal* for July, 1908.

by  $T$  [according to equation (81)] to give the value of  $B_n$ . This method for evaluating the coefficients in equation (75) is very tedious except when the integrations are performed by the harmonic analyzer as explained in the following article. Fischer-Hinnen's method for determining the harmonic components of a given periodic curve is very easy to apply when the higher harmonics are negligible; the method depends upon two propositions as follows:

(1) Consider  $n$  equidistant ordinates of a sine or cosine curve (wave-length  $T$ ), the distance between adjacent ordinates being  $T/n$ . *The algebraic sum of these ordinates is zero.* Thus the algebraic sum of the equidistant ordinates in Figs. 198 to 201 is in each case equal to zero. In Fig. 198 the first ordinate  $a$  is

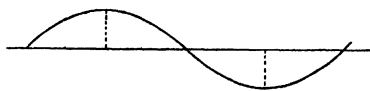

Fig. 198.

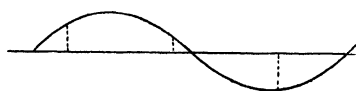

Fig. 199.

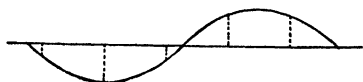

Fig. 200.

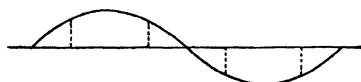

Fig. 201.

at the middle point of a half-wave, but the algebraic sum of the two ordinates is equal to zero wherever the first ordinate may be. Similarly, the algebraic sum of the sets of ordinates in Figs. 199, 200 and 201, respectively, is equal to zero no matter where the first ordinate of a set may be placed.

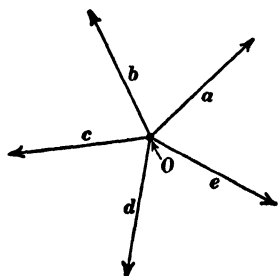

Fig. 202.

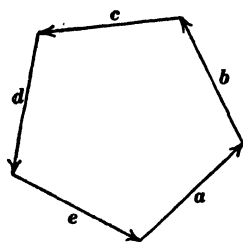
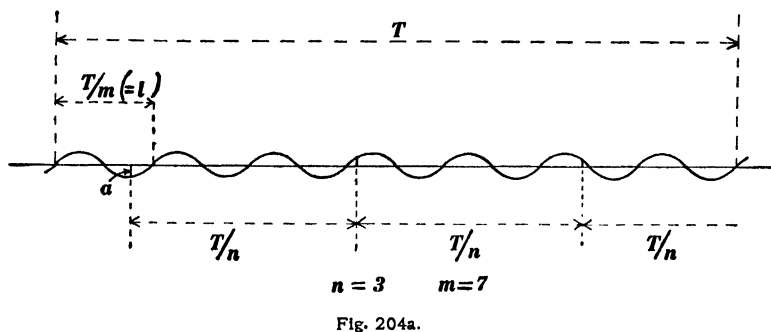
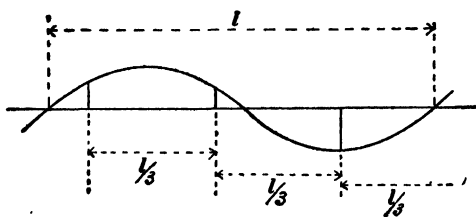

Fig. 203.

The above proposition may be easily established in its general form by means of the clock-diagram which is so much used in the elementary theory of alternating currents. Equidistant ordinates of a sine or cosine curve are equal to the respective projections on any fixed line of equidistant vectors  $a, b, c, d,$  etc.,



as shown in Fig. 202; and these equidistant vectors may be arranged as the sides of a regular polygon as shown in Fig. 203. Therefore, the vector sum of  $a, b, c, d,$  etc., is zero, and consequently the algebraic sum of their projections on any fixed line is zero. Figures 202 and 203 are constructed for  $n = 5$ .



(2) Consider  $n$  equidistant ordinates of the  $m$ th harmonic curve (wave-length,  $T/m$ ), the distance between adjacent ordinates being  $T/n$ . The algebraic sum of these ordinates is zero if  $m$  is not multiple  $n$ . The truth of this proposition may be made evident by a detailed consideration of Figs. 204, 205 and 206, as follows: The first ordinate  $a$  in Fig. 204a being located

arbitrarily, the distances to the other ordinates of the set are  $\frac{1}{3}l$  and  $\frac{1}{3}4l$ , or  $2\frac{1}{3}l$  and  $4\frac{2}{3}l$ , respectively, where  $l(= T/m)$  is the wave-length of the given harmonic. These ordinates are evidently the same exactly as ordinates at distances of  $\frac{1}{3}l$  and  $\frac{2}{3}l$

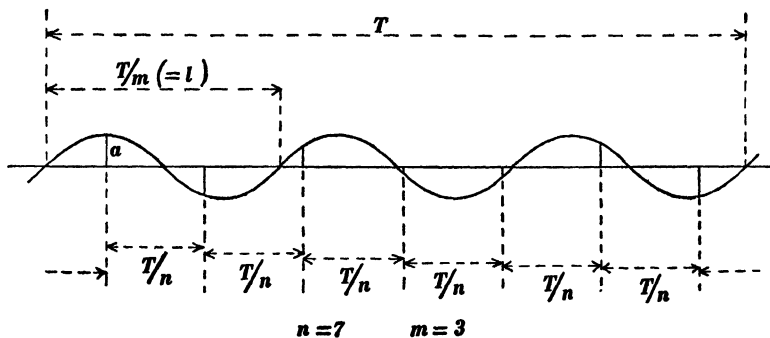

Fig. 205a.

from  $a$ , as shown in Fig. 204*b*. Therefore the algebraic sum of the set of three ordinates is zero according to proposition (I).

The first ordinate  $a$  being located arbitrarily in Fig. 205*a* the distances to the other ordinates of the set are  $\frac{3}{7}l$ ,  $\frac{6}{7}l$ ,  $1\frac{2}{7}l$ ,  $1\frac{6}{7}l$ ,  $2\frac{1}{7}l$  and  $2\frac{4}{7}l$ , respectively, where  $l$  is the wave-length of the given harmonic. These ordinates are evidently the same exactly

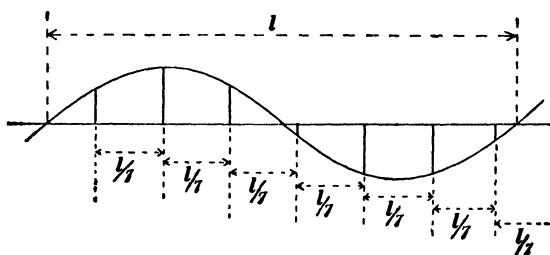

Fig. 205b.

as ordinates at distances of  $\frac{1}{7}l$ ,  $\frac{2}{7}l$ ,  $\frac{3}{7}l$ ,  $\frac{4}{7}l$ ,  $\frac{5}{7}l$  and  $\frac{6}{7}l$  from  $a$ , as shown in Fig. 205*b*. Therefore, the algebraic sum of the set of seven ordinates is zero, according to proposition (I).

An example where  $m$  is a multiple of  $n$  is shown in Fig. 206. In this case the ordinates lie in identically similar positions

in the different waves of the given harmonic, so that the ordinates are all of the same value and of the same sign. Therefore their sum is not equal to zero.

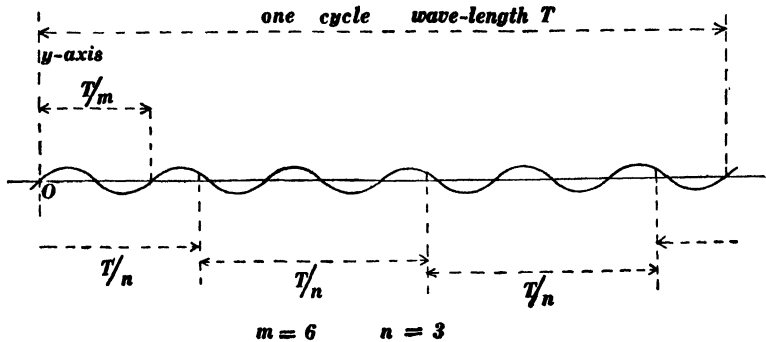

Fig. 206.

When  $n$  is a multiple of  $m$  there are  $n/m$  equidistant ordinates in each complete wave of the given harmonic, and their sum is equal to zero according to proposition (1).

When  $n$  and  $m$  have a common divisor  $d^*$ , then we have  $n/d$  equidistant ordinates in  $m/d$  wave-lengths of the given harmonic, and  $m/d$  is not a multiple of  $n/d$ . This case, therefore, falls under one of the cases discussed in connection with Figs. 204 and 205, and therefore the algebraic sum of the ordinates is zero.

*Determination of the highest appreciable harmonic by Fischer-Hinnen's method.* — Fischer-Hinnen's method is practicable only when all harmonics higher than a certain order are negligible. Thus, in the alternating electromotive force and current curves which occur in practice, harmonics above the 13th or 15th are usually negligible. Figures 207 and 208 show a given periodic curve, the origin  $O$  being arbitrarily chosen. Consider one complete cycle of the given curve, measured from  $O$  as indicated in both figures. The  $n$ th harmonic of the given curve is equivalent to the two curves  $A$  and  $B$  added together (ordinates added).

\* Greatest common divisor.

Curve  $A$  is a sine curve of which the maximum ordinate is the value of coefficient  $A_n$  in equation (75), and  $B$  is a cosine curve of which the maximum ordinate is the value of the coefficient  $B_n$  in equation (75). Figures 207 and 208 are constructed for  $n = 3$  for the sake of clearness, but in the discussion of

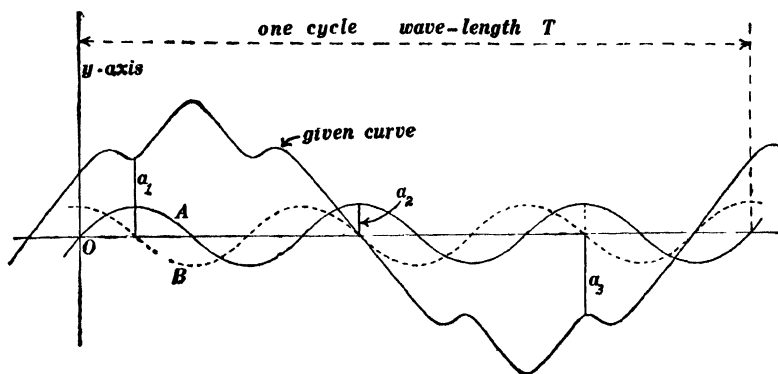

Fig. 207.

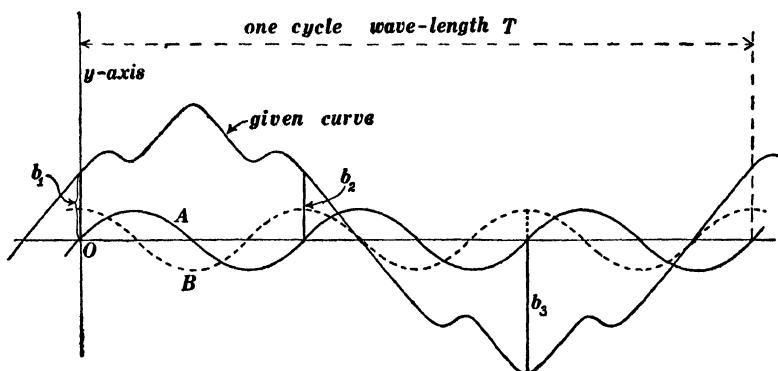

Fig. 208.

Figs. 207 and 208,  $n$  is understood to refer to the highest order harmonic that is appreciable in value.

Consider the  $n$  equidistant ordinates  $a_1, a_2, a_3$ , etc., of the given curve in Fig. 207; the first of the set  $a_1$  being at middle point of the first half-wave of the curve  $A$  (distance of  $a_1$  from  $y$ -axis equal to  $T/4n$ ). The algebraic sum of  $a_1, a_2, a_3$ , etc., is equal to  $nA_n$ . This is evident when we consider that the ordi-

nate of the given curve at any point is equal to the sum of the ordinates of all its harmonics at that point, when we consider that the ordinates of the  $B$  curve in Fig. 207 are zero at the points  $a_1, a_2, a_3$ , etc., and when we remember that the algebraic sum of all other harmonics (not including the  $n$ th) of the given curve at the points  $a_1, a_2, a_3$ , etc., is equal to zero according to propositions (1) and (2) above, the multiple harmonics,  $2n, 3n, 4n$ , etc., being negligible. Therefore, we have **for the highest appreciable harmonic**

$$A_n = \frac{1}{n}(a_1 + a_2 + a_3 + \dots) \quad (83)$$

in which  $a_1$  is distant  $T/4n$  from the origin, and the distances  $a_1$  to  $a_2$ ,  $a_2$  to  $a_3$ ,  $a_3$  to  $a_4$  and so on are equal to  $T/n$ .

Consider the  $n$  equidistant ordinates  $b_1, b_2, b_3$ , etc., of the given curve in Fig. 208, the first of the set  $b_1$  being coincident with the  $y$ -axis. The algebraic sum of  $b_1, b_2, b_3$ , etc., is equal to  $nB_n$ , so that **for the highest appreciable harmonic**, we have

$$B_n = \frac{1}{n}(b_1 + b_2 + b_3 + \dots) \quad (84)$$

in which  $b_1$  is at the origin and the distances  $b_1$  to  $b_2$ ,  $b_2$  to  $b_3$ ,  $b_3$  to  $b_4$  and so on are equal to  $T/n$ .

*Determination of the lower harmonics by Fischer-Hinnen's method.* — If the highest appreciable harmonic is, say, the 15th, then the 13th, the 11th, the 9th and the 7th can be determined by the above method, using equations (83) and (84); but the 5th harmonic cannot be so determined because the algebraic sum of five equidistant ordinates of the given curve depends upon the 15th harmonic as well as upon the 5th harmonic; 15 being a multiple of 5 [see proposition (2) above].

The true value of the coefficient  $A_5$  is given by the equation

$$A_5 = A_5' + A_{15} \quad (85)$$

in which  $A_5'$  is the *incorrect* value of  $A_5$  as calculated by equa-

tion (83). The truth of this formula may be shown by considering Fig. 209 which shows the harmonic curves  $A_5 \sin 2\pi 5t/T$  and  $A_{15} \sin 2\pi 15t/T$ . The positions of the two curves in Fig. 209 correspond to positive values of the coefficients  $A_5$  and  $A_{15}$ .

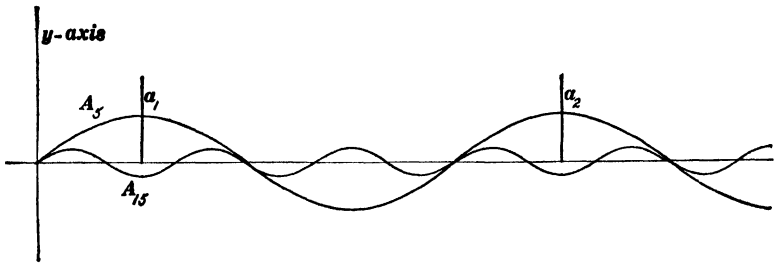

Fig. 209.

The sum of the five equidistant ordinates of the given curve  $a_1, a_2, a_3,$  etc., depends only upon the curves  $A_5$  and  $A_{15}$  according to propositions (1) and (2) above, and it is evident from Fig. 209 that one fifth of the sum of the five equidistant ordinates (which is equal to  $A_5'$ ) is equal to  $A_5 - A_{15}$ , so that equation (85) follows at once.

The true value of  $B_5$  is given by the equation

$$B_5 = B_5' - B_{15} \tag{86}$$

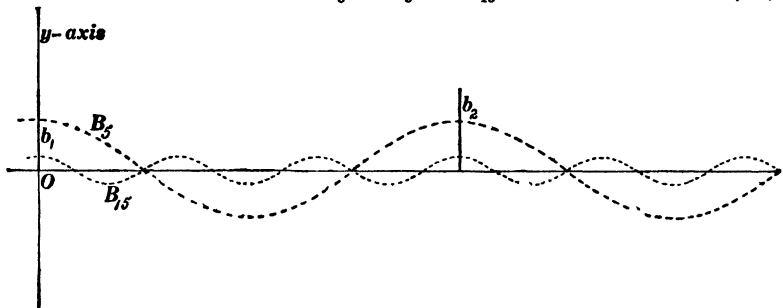

Fig. 210.

in which  $B_5'$  is the *incorrect* value of  $B_5$  as calculated by equation (84). The truth of this equation is evident from Fig. 210 which shows the harmonic curves corresponding to positive values of the two coefficients  $B_5$  and  $B_{15}$ , and which shows

two of the five equidistant ordinates of the given curve, namely,  $b_1, b_2, b_3, b_4$  and  $b_5$ .

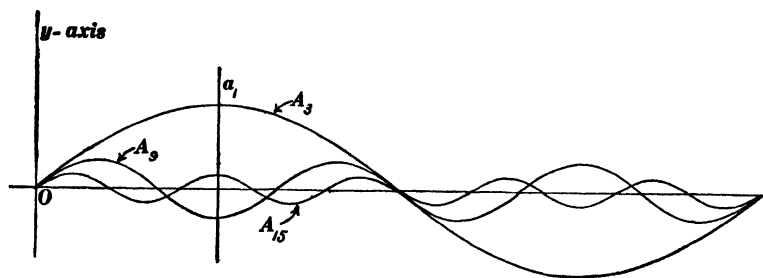

Fig. 211.

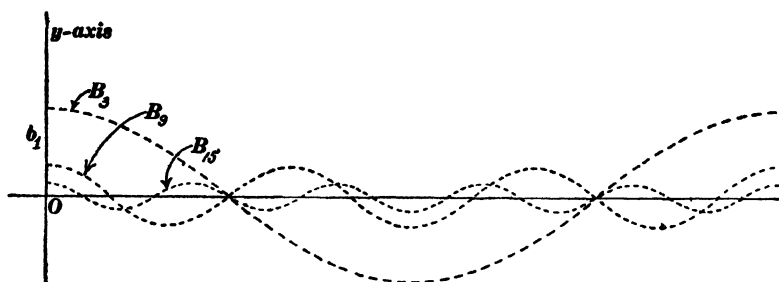

Fig. 212.

An argument similar to the above based on propositions (1) and (2) and upon Figs. 211 and 212 leads to the following equations for the true values of  $A_3$  and  $B_3$ ; namely

$$A_3 = A_3' + A_9 - A_{15} \quad (87)$$

$$B_3 = B_3' - B_9 - B_{15} \quad (88)$$

in which  $A_3'$  and  $B_3'$  are the *incorrect* values of  $A_3$  and  $B_3$  as calculated by equations (83) and (84).

*Determination of the fundamental harmonic.*—Figure 213 shows (for positive values of the coefficients) the trend of the harmonic curves corresponding to  $A_1, A_3, A_5$ , etc., and the ordinate  $a$  of the given curve is evidently equal to  $A_1 - A_3 + A_5 - A_7 + A_9 -$  etc., so that

$$A_1 = a + A_3 - A_5 + A_7 - A_9 + A_{11} - A_{13} + A_{15} \quad (89)$$

Similarly, that ordinate of the given curve which is coincident with the  $y$ -axis is equal to  $B_1 + B_3 + B_5 + B_7$ , etc., so that we have

$$B_1 = b - B_3 - B_5 - B_7 - B_9 - B_{11} - B_{13} - B_{15} \quad (90)$$

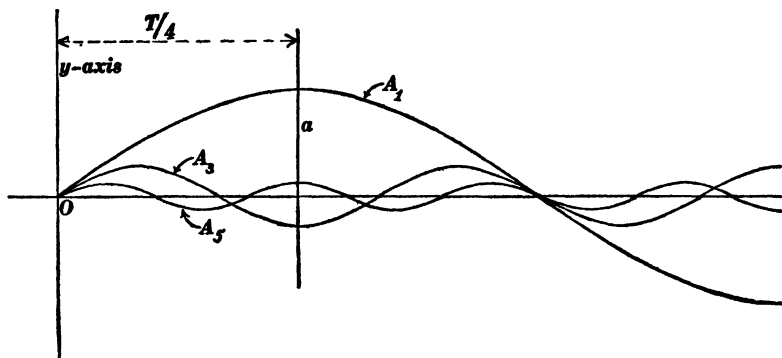

Fig. 213.

*Note.* Equations (85) to (90) refer to the case in which the 21st and higher harmonics are negligible. It is of course necessary to attend carefully to algebraic signs in the use of equations (83) to (90).

*Example.*—The full line curve  $A$  in Fig. 214\* is the experimentally determined electromotive force curve of a certain unitooth alternator (armature winding placed in  $p$  slots, where  $p$  is the number of field magnet poles). The curve  $CC$  is the remainder beyond the 13th harmonic, and the dotted curve  $B$  is the sum of the odd harmonics from 1 to 13. Choosing the origin of coordinates at the point where the fundamental harmonic cuts the axis of abscissas and taking the maximum value of the fundamental harmonic as 1.000, the maximum values of the various harmonics and their phases are as given in the following table. The maximum values given in this table are the values of the expression  $\sqrt{A_n^2 + B_n^2}$ , and the phases are the values of the angles whose tangents are equal to  $B_n/A_n$ . In case one would wish to plot these various harmonics, the phase angle for each

\* Taken from *Alternating Current Phenomena* by C. P. Steinmetz. Figures 218, 219, and 220 are also taken from Steinmetz.

harmonic would have to be laid off using the wave-length of that harmonic as  $360^\circ$ .

Fundamental Harmonic,	Max. Value.	Phases.
Fundamental Harmonic,	1.000	$0^\circ$
3d "	0.12	$177^\circ.7$
5th "	0.23	$178^\circ.5$
7th "	0.134	$-6^\circ.2$
9th "	0.002	$-152^\circ.3$
11th "	0.046	$174^\circ.5$
13th "	0.031	$-61^\circ.5$

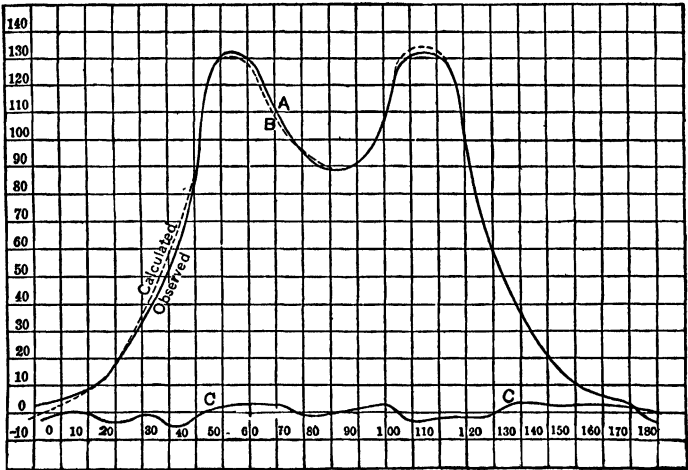

Fig. 214.

**72. The harmonic analyzer.** — The method outlined in Art. 71 for the determination of the various harmonics of an experimentally determined curve is tedious, and several machines have been devised for carrying out mechanically the integrations which are described in Art. 70. [See equations (76), (80) and (81).] The best known and perhaps the simplest of these machines is the one which was suggested by Professor James Thomson and perfected by Sir William Thomson (Lord Kelvin).\* The inte-

\* See Section 37 of the article on *Tides* in the *Encyclopædia Britannica*, ninth edition. See also articles by James Thomson and by Sir William Thomson in *Proceedings of the Royal Society*, Vol. XXIV, 1876, page 262 and pages 269 and 271. See also a paper by Sir William Thomson in the *Proceedings of the Institute of Civil Engineers (British)*, Vol. LXV.

grating part of the machine consists of a circular disk of steel  $DD$ , Fig. 215, which is mounted upon an inclined spindle as

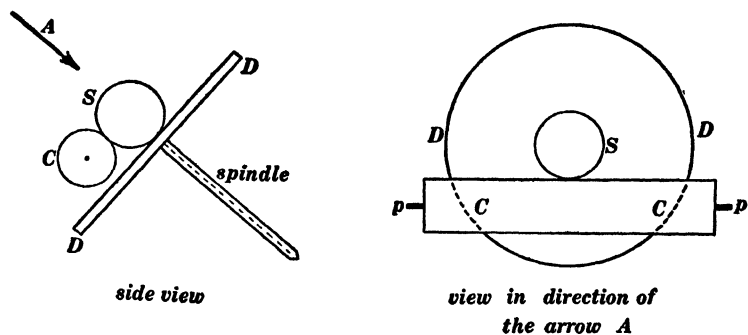

Fig. 215.

shown, a steel sphere  $S$  and a steel cylinder  $CC$  which is carried upon two pivots  $pp$ . This integrating mechanism is also shown in Fig. 216. The periodic curve which is to be analyzed is traced upon paper and wrapped around a cylinder  $EE$ , Fig. 216, the circumference of the cylinder being equal to one complete wavelength of the periodic curve. As the cylinder  $EE$  is slowly turned, the tracing point  $P$  is made to follow one complete cycle of the curve, and the steel fork  $F$  pushes the sphere back and forth along the diameter  $DD$  of the circular disk so that the distance of the center of the sphere from the axis of the disk is at each instant equal to the ordinate  $y$  of the given curve as shown in Figs. 216 and 217.

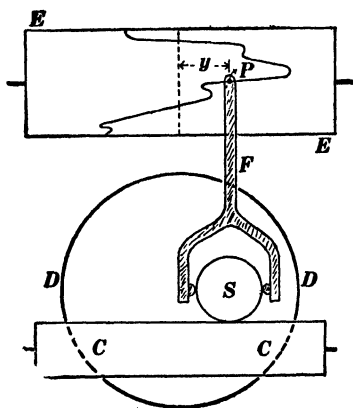

Fig. 216.

This cylinder  $EE$  is geared to a series of cranks any one of which may be so connected to the disk  $DD$  as to cause it to oscillate back and forth about the supporting spindle as an axis as

the cylinder  $EE$  is turned. One of the cranks would cause the disk  $DD$  to make one complete oscillation while the cylinder  $EE$  makes one revolution, the next crank would cause the disk

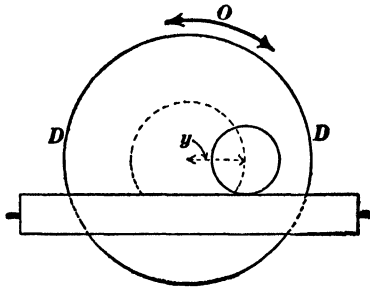

Fig. 217.

$DD$  to make two oscillations while the cylinder  $EE$  makes one revolution, the next crank would cause the disk  $DD$  to make three oscillations during one revolution of the cylinder  $EE$ , and so on. Thus, the  $n$ th crank would cause the disk  $DD$  to make  $n$  complete oscillations during one revolution of

the cylinder  $EE$ . Let  $T$  be the time of one revolution of the cylinder  $EE$ , then the angular velocity of the oscillating disk at any given instant is equal to  $\sin 2\pi nt/T$ .\* The sphere  $S$  rolls on the oscillating disk and against the cylinder  $CC$  causing the cylinder to turn at an angular velocity which is at each instant equal to  $y/c \times \sin 2\pi nt/T$ , where  $c$  is the radius of the cylinder  $CC$ . Therefore the total angle turned by  $CC$  during one complete revolution of the cylinder  $EE$ , that is, in  $T$  seconds, is

$$\frac{1}{c} \int_0^T y \sin \frac{2\pi nt}{T} \cdot dt$$

Therefore, according to equation (80), the coefficient  $A_n$  is equal to  $2c/T$  times the angle in radians turned by the cylinder  $CC$  during one revolution of the cylinder  $EE$ , and this angle may be determined by attaching a pointer to the cylinder  $CC$  and reading the position of the pointer on a divided circle.

**73. Examples of the distortion of electromotive force curves by triple and quintuple harmonics.**—The upper curve in Fig. 218 shows a simple sine curve, and the curves  $a, b, c, d$  and  $e$

\* This means that the disk makes  $n$  complete oscillations in  $T$  seconds, and it means that the maximum angular distance of the oscillating disk from its mean or middle position is  $T/2\pi n$  of a radian.

show resultant curves obtained when a triple harmonic is added to the given curve. The curve *a* is obtained when the triple harmonic passes through zero at the same instant that the funda-

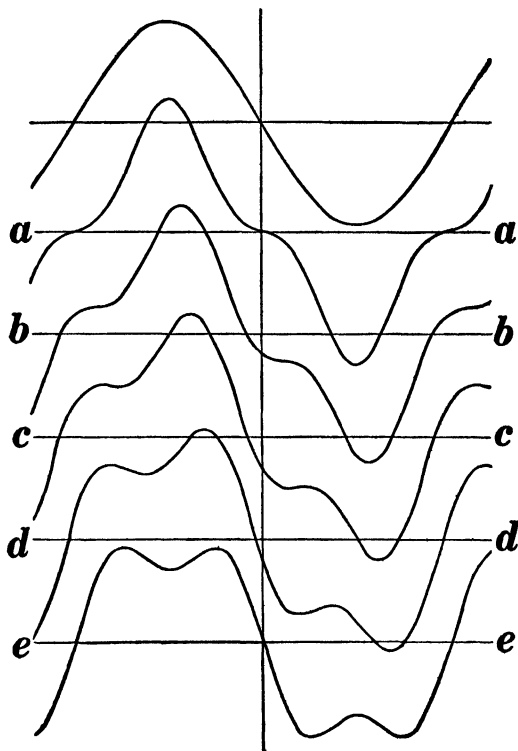

Fig. 218.

mental harmonic passes through zero, but in a reverse direction, that is, the triple harmonic is changing from positive to negative at the instant that the fundamental is changing from negative to positive; and the successive curves *b*, *c*, *d* and *e* are obtained by shifting the triple harmonic to the right, step by step,  $\frac{1}{2}$  of  $T$  at each step, where  $T$  is the wave-length of the fundamental wave. \*

\* The student should plot the fundamental harmonic and the triple harmonic in the various positions to give the resultant curves *a*, *b*, *c*, *d* and *e*.

The upper curve in Fig. 219 shows a simple sine curve, and the curves *a*, *b*, *c*, *d* and *e* show resultant curves obtained when a quintuple harmonic is added to the given curve. The curve *a* is obtained when the quintuple harmonic passes through zero at the same instant that the fundamental harmonic passes

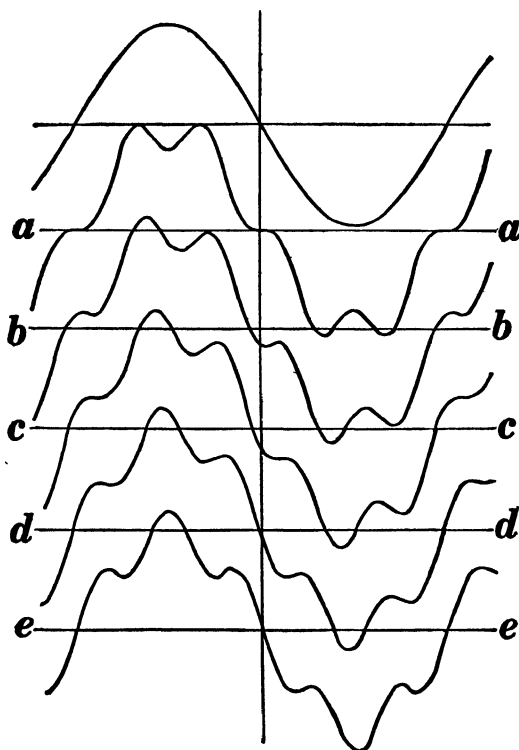

Fig. 219.

through zero, but in a reverse direction, that is, the fundamental changes from negative to positive at the instant that the quintuple harmonic changes from positive to negative; and the successive curves, *b*, *c*, *d* and *e*, are obtained by shifting the quintuple harmonic step by step,  $\frac{1}{5}$  of  $T$  at each step, where  $T$  is the wave-length of the fundamental curve.\*

\* The student should plot the fundamental harmonic and the quintuple harmonic in the various positions corresponding to curves *a*, *b*, *c*, *d* and *e*.

Figure 220 shows some characteristic wave shapes which contain fundamental, triple, and quintuple harmonics. Taking the maximum value of the fundamental harmonic as unity, the equations to these curves are as follows :

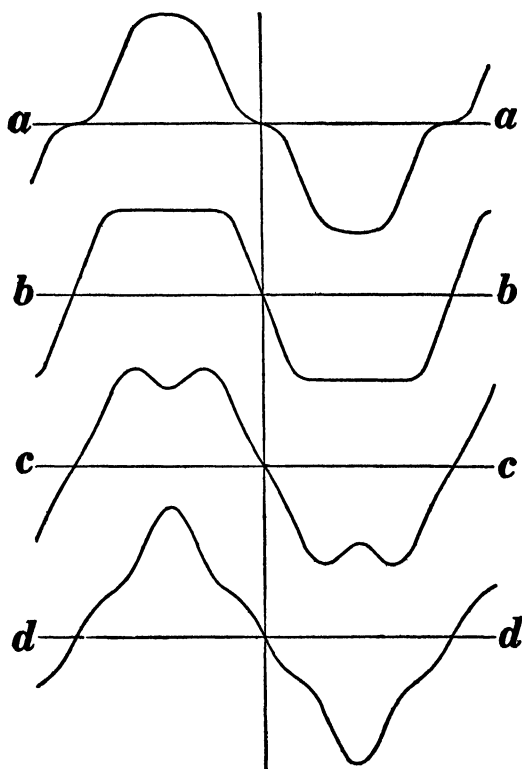

Fig. 220.

Curve *aa* :

$$y = 1.0 \sin \beta + 0.15 \sin (3\beta + 180^\circ) + 0.10 \sin (5\beta + 180^\circ)$$

Curve *bb* :

$$y = 1.0 \sin \beta + 0.225 \sin 3\beta + 0.05 \sin 5\beta$$

Curve *cc* :

$$y = 1.0 \sin \beta + 0.15 \sin 3\beta + 0.10 \sin (5\beta + 180^\circ)$$

Curve *dd* :

$$y = 1.0 \sin \beta + 0.15 \sin (3\beta + 180^\circ) + 0.10 \sin 5\beta *$$

**74. Effective value of a non-harmonic electromotive force (or current) expressed in terms of its harmonic components.** — Consider the electromotive force

$$e = A_1 \sin \frac{2\pi t}{T} + A_3 \sin \frac{6\pi t}{T} + \dots \quad (i)$$

Squaring both members of this equation and we have

$$\left. \begin{aligned} e^2 = A_1^2 \sin^2 \frac{2\pi t}{T} + A_3^2 \sin^2 \frac{6\pi t}{T} + \dots \\ + 2A_1A_3 \sin \frac{2\pi t}{T} \sin \frac{6\pi t}{T} + \dots \end{aligned} \right\} \quad (ii)$$

Now the average value of  $\sin^2 2\pi nt/T$  is one half, and the average value of any cross-product like  $\sin 2\pi nt/T \times \sin 2\pi mt/T$  is zero, so that

$$\text{average } e^2 = \frac{A_1^2}{2} + \frac{A_3^2}{2} + \frac{A_5^2}{2} + \dots \quad (iv)$$

But  $A_1^2/2$ ,  $A_3^2/2$ , etc., are the squares of the effective values of the respective harmonics and therefore we have the proposition: *The square of the effective value of an alternating electromotive force or current is equal to the sum of the squares of the effective values of its harmonics.* This proposition is here derived for the special case in which the harmonics are expressible by a series of sines, but the derivation may be easily generalized so as to include both the sine series and the cosine series in equation (75).

**75. Power relations of the various harmonics of an alternating electromotive force and of an alternating current.** — Consider the electromotive force

$$e = E_1 \sin \frac{2\pi t}{T} + E_3 \sin \frac{6\pi t}{T} + E_5 \sin \frac{10\pi t}{T} + \dots \quad (i)$$

\* The student should plot the fundamental, and the triple and quintuple harmonics in the positions corresponding to these equations.

and the current

$$i = I_1 \sin \frac{2\pi t}{T} + I_3 \sin \frac{6\pi t}{T} + I_5 \sin \frac{10\pi t}{T} + \dots \quad (\text{ii})$$

The instantaneous power is

$$ei = E_1 I_1 \sin^2 \frac{2\pi t}{T} + E_3 I_3 \sin^2 \frac{6\pi t}{T} + \dots \left. \begin{array}{l} \\ \\ \\ \end{array} \right\} (\text{iii})$$

$$+ (E_1 I_3 + E_3 I_1) \sin \frac{2\pi t}{T} \sin \frac{6\pi t}{T} + \dots$$

and the average power,  $P$ , is

$$P = \frac{E_1 I_1}{2} + \frac{E_3 I_3}{2} + \frac{E_5 I_5}{2} + \dots \quad (\text{iv})$$

inasmuch as the average value of every cross-product of the form  $\sin 2\pi nt/T \times \sin 2\pi mt/T$  is zero, or in other words, *every harmonic of the current is "wattless" with respect to every harmonic of the electromotive force except the harmonic of the same order, and every harmonic of the electromotive force is "wattless" with respect to every harmonic of the current except the harmonic of the same order.*

The above discussion is limited to the sine series in equation (75) for the sake of simplicity; but it may be easily extended to include both the sine series and the cosine series in equation (75).

## CHAPTER IX.

### NON-HARMONIC ELECTROMOTIVE FORCES AND CURRENTS IN PRACTICE.

**76. Causes of non-harmonic electromotive forces of alternating-current generators.** (*a*) *Distribution of a field flux and distribution of armature windings.*—Figure 221 shows a two-pole alter-

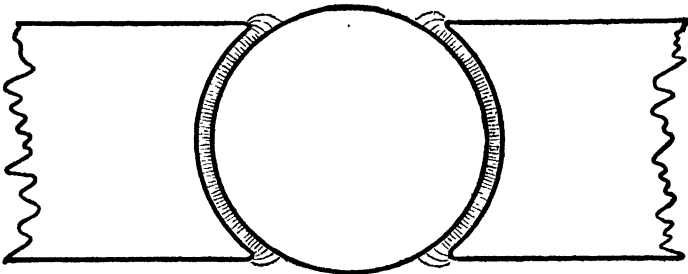

Fig. 221.

nator with a uniformly distributed flux under the pole-faces and with a fringe of flux beyond the pole tips, and Fig. 222 shows an

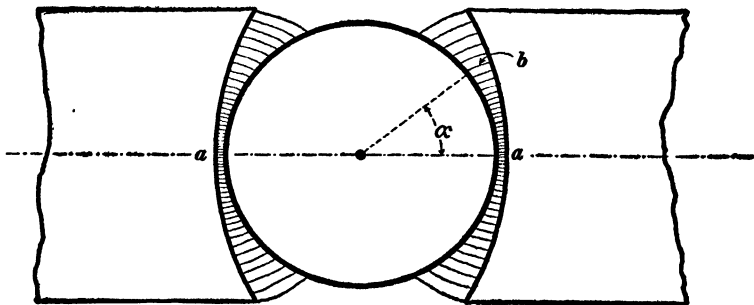

Fig. 222.

armature between two nearly flat pole-faces. If the flux density at the point *b* in Fig. 222 is proportional to the cosine of  $\alpha$  the flux is said to be harmonically distributed.

When the armature winding is concentrated (one slot per pole) the electromotive force curve is similar to the curve of distribution

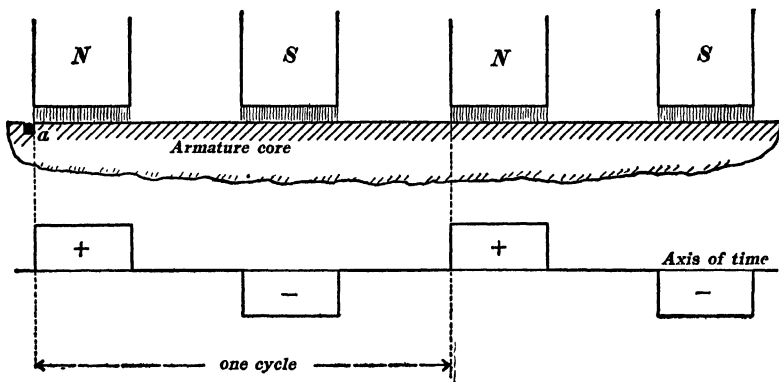

Fig. 223.

of flux if the slots are small. When, however, the winding is distributed, the electromotive force curve is different from the curve

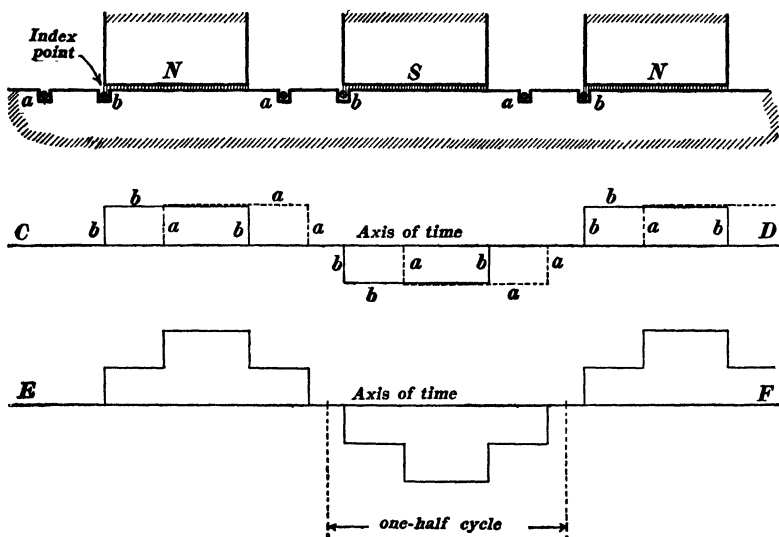

Fig. 224.

of flux distribution. Thus, Fig. 223 shows the electromotive force curve produced in a concentrated winding by a flux which

is uniformly distributed under the pole faces (fringe of flux beyond the pole tips is ignored so that the drawings may be simple), Fig. 224 shows the two electromotive force curves *aaa aaa*

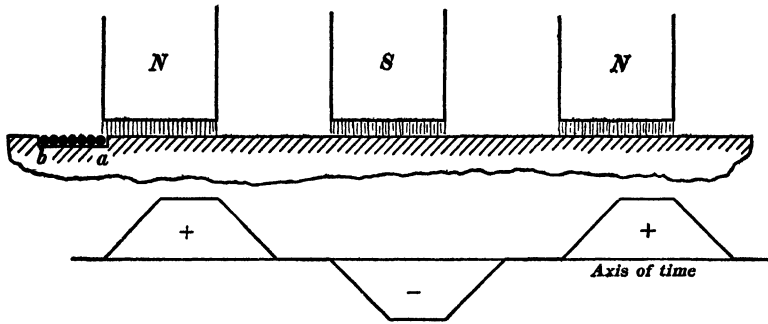

Fig. 225a.

*aaa* and *bbb bbb bbb* due to two separate concentrated windings, *a* and *b*, and the curve *EF* in the lower part of Fig. 224 is the electromotive force curve produced by the two windings *a* and *b* connected in series, thus giving a winding which is distributed

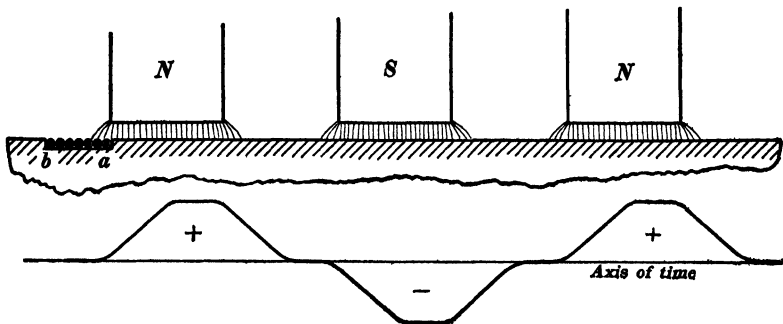

Fig. 225b.

in two slots per pole. In this case, also, the fringe of flux beyond the pole tips is ignored. Figures 225a and 225b show the electromotive force curve which is produced by a band of conductors *ab*.

When the field flux of an alternator is harmonically distributed,

then the electromotive force of the alternator is harmonic whether the winding is distributed or concentrated.

(b) *Armature reaction.* — When an alternator is loaded, the armature current tends to crowd the field flux under the trailing pole tips, as shown in Fig. 193, and the electromotive force curve is distorted in a manner which is at once evident from Fig. 193.

The armature reaction of an alternator affects the electromotive force curve of the machine not only by distorting the field as shown in Fig. 193, but also by alternately strengthening and weakening the field, as the armature rotates. As a given armature coil comes into the position in which it surrounds a field pole, the magnetizing action of the current in the coil either helps or opposes the field flux according as the alternator delivers *leading* current or *lagging* current to its receiving circuit. This magnetizing or demagnetizing action of the armature current is pulsating and it causes the electromotive force of the alternator to become non-harmonic to some extent.

(c) *Pulsation of inductance.* — The inductance of an alternator armature (the inductance of one of its windings if it is a polyphase armature) varies with the position of the armature. As the armature is turned slowly the inductance reaches a maximum value when the pole pieces bridge over the slots in which the armature winding is placed, and it reaches a minimum value when the slots in which the winding is placed lie between the pole tips. Therefore the inductance of an alternator armature pulsates when the armature rotates. The effect of this pulsating inductance is to cause the electromotive force of the alternator to become to some extent non-harmonic.\*

**77. Causes of non-harmonic currents.** — The causes of non-harmonic electromotive forces of alternating-current generators are discussed in Art. 76. The production of a non-harmonic current may depend upon the use of an alternator having a non-

\* Any attempt to formulate the actions described in this article would lead to equations of extreme complexity and the results would not warrant the labor involved.

harmonic electromotive force, or the reactions of a receiving circuit may cause an alternator having a harmonic electromotive force to deliver a non-harmonic current; and the reaction of a receiving circuit may in turn result in the production of non-harmonic electromotive forces across *a certain portion* of the receiving circuit even though the electromotive force of the generator be harmonic. Therefore, in discussing the production of non-harmonic current, we shall consider first the production of non-harmonic current by a generator of which the electromotive force is non-harmonic, we shall then consider the production of non-harmonic current by a generator having a harmonic electromotive force, and we shall finally consider the production of non-harmonic electromotive forces by the reactions of a receiving system. Before entering upon this discussion, however, it is important to consider constant versus pulsating resistances and inductances.

The current produced in any ordinary non-inductive circuit is proportional to the electromotive force. That is to say, the ratio  $E/I (= R)$  is a constant for such a circuit. In an electric arc, however, the current is not proportional to the voltage across the terminals and therefore the ratio  $E/I (= R)$  is *not* constant in an arc. An electric arc is said to have a *pulsating resistance*.

The inductance,  $L$  of a coil may be defined as the quotient  $\Phi/I$  where  $\Phi$  is the flux-turns corresponding to a given value of the current  $I$ . When the coil does not contain an iron core,  $\Phi$  is proportional to  $I$ , so that the ratio  $\Phi/I (= L)$  is constant. When, however, the coil contains an iron core,  $\Phi$  is not proportional to  $I$  and the ratio  $\Phi/I (= L)$  is *not* constant. In fact, this ratio falls off in value with increasing value of  $I$  on account of the magnetic saturation of the iron. Therefore when an alternating current flows through a coil of wire wound on an iron core the value of  $\Phi/I (= L)$  varies as the current rises and falls. A coil with an iron core is therefore said to have a *pulsating inductance*.

**Non-harmonic currents in circuits of constant resistance and constant inductance.** — Consider a non-harmonic electromotive

force of which the values of the fundamental and successive harmonics are  $A_1, A_2, A_3, A_4$ , etc. The values of the fundamental and successive harmonics of the current which is produced by this electromotive force through a non-inductive circuit are proportional to  $A_1, A_2, A_3, A_4$ , etc., and the *current curve is of exactly the same shape as the electromotive force curve*. The values of the fundamental and successive harmonics of the current which is produced by this electromotive force through a highly inductive circuit (without iron) are proportional to  $A_1, A_2/2, A_3/3, A_4/4$ , etc. The values of the fundamental and successive harmonics of the current which is produced by this electromotive force through a condenser (resistance of circuit negligible) are proportional to  $A_1, 2A_2, 3A_3, 4A_4$ , etc.\* The effect of inductance is, therefore, to tend to eliminate the higher harmonics of current whereas the effect of a condenser is to exaggerate the higher harmonics of current. This is shown very strikingly in Fig. 226, in which  $A$

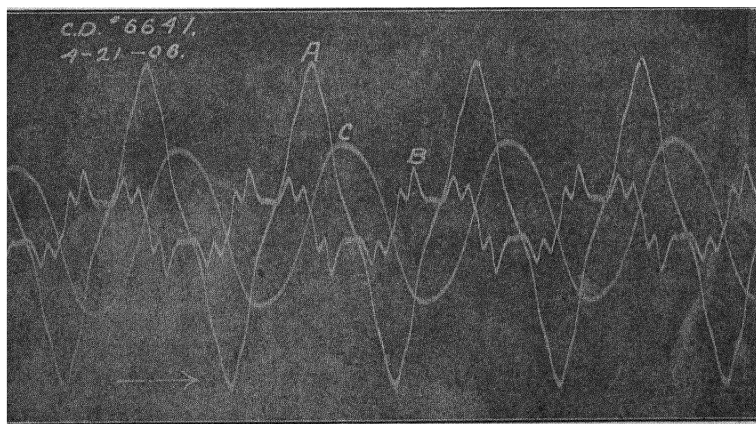

Fig. 226.

is a non-harmonic electromotive force curve,  $C$  is the curve of the current produced by  $A$  in a highly inductive circuit (with-

\* These relations are evident from the discussion of the fundamental problem of alternating currents on pages 66-70, Franklin and Esty's *Elements of Electrical Engineering*, Vol. II.

out iron), and  $B$  is the curve of current produced by  $A$  through a condenser (resistance of the circuit very small).

**Production of higher harmonics by reaction of a receiving circuit having pulsating resistance or pulsating inductance.** — Figure 227 shows the magnetizing-current curve  $m$  of a transformer which is supplied from an alternator which gives a harmonic electro-

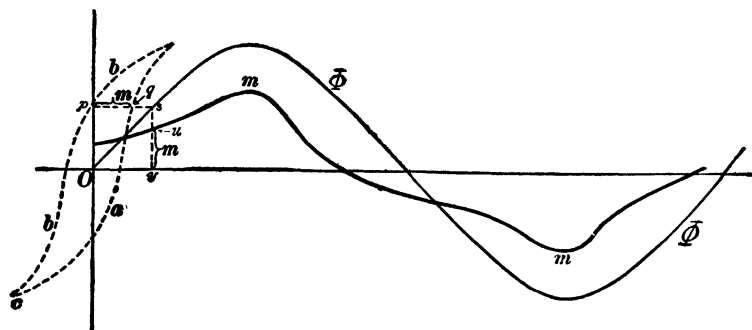

Fig. 227.

motive force. The electromotive force being harmonic, the curve of core flux of the transformer  $\Phi$ , Fig. 227, must be harmonic if the resistance of the primary coil is small, and the current corresponding to each value of  $\Phi$  may be determined from the hysteresis curve of the transformer core (the dotted curve in Fig. 227).

If a harmonic current be caused to flow through a winding of wire on an iron core, the electromotive force across the terminals of the winding is *non-harmonic*. In order to produce a harmonic current through a winding of wire on an iron core (or through an electric arc) it is necessary to use a high-voltage alternator giving a harmonic electromotive force and to include a very large non-inductive resistance in series with the coil (or arc) so that the electromotive force across the coil (or arc) may be negligible in comparison with the total electromotive force of the alternator. Figure 228 shows the electromotive force curve  $ee$  across a winding of wire on an iron core when a harmonic current flows through the coil. This electromotive force curve may be plotted as follows

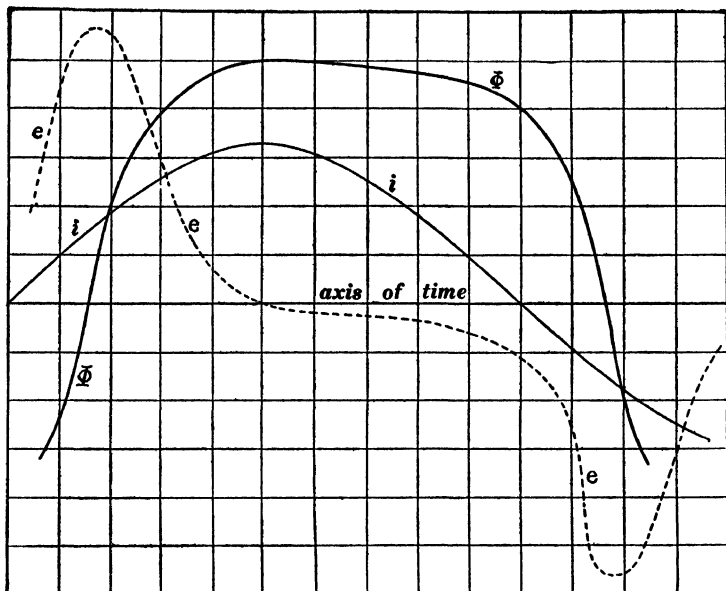

Fig. 228.

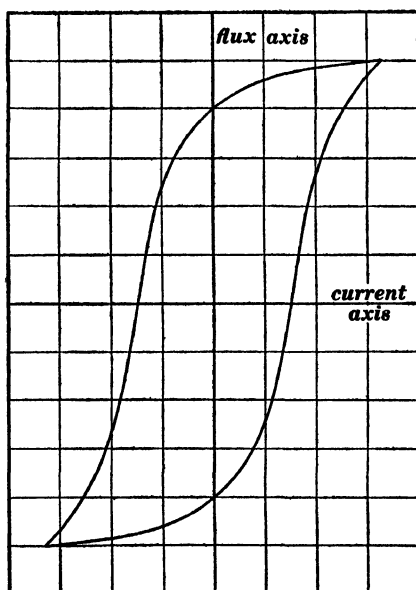

Fig. 229.

on the assumption that the resistance of the winding is zero. Having given the hysteresis loop for the given range of current, as shown in Fig. 229, the flux corresponding to each value of the current is known, and the flux curve  $\Phi$ , Fig. 228, may be plotted. The ordinate of the electromotive force curve is then proportional to the *steepness* of the flux curve at each point of time.

Figure 230 shows the curve of current  $i$  through an arc lamp, and the curve of electromotive force  $e$  across the terminals of the arc. If the arc lamp were to be connected in series with a very large non-inductive resistance to an alternator giving a harmonic electromotive force, then the current curve would be har-

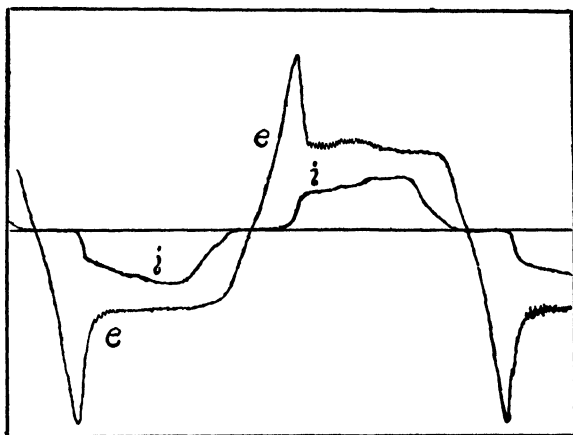

Fig. 230.

monic as above explained. The curves in Fig. 230 were obtained with a moderate amount of resistance and some inductance in series with the arc, and neither the electromotive force curve nor the current curve are harmonic, although the electromotive force of the generator was approximately harmonic.

**78. Effects of higher harmonics.** — Nearly the whole of alternating-current engineering is based upon a simple working theory in which the alternating electromotive forces and currents are assumed to be harmonic; as a matter of fact, however, the elec-

tromotive forces and currents are never exactly harmonic, and therefore the behavior of the various alternating-current machines departs to some extent from the simple working theory. This departure or difference in behavior due to the non-harmonic character of electromotive forces and currents may be spoken of as the effect of higher harmonics. It is not usually considered in practical work except in a few instances.

*In general, the details of behavior of an alternating-current machine of any kind when electromotive forces and currents are non-harmonic may be thought of as the combination or summation of the different effects which would be produced by the several harmonics taken singly.* This is exactly true in those cases in which an exact proportional relationship exists between electromotive force and current (when resistances and inductances do not pulsate). When, however, the system contains arc lamps or inductances with iron cores, then the effects of the various harmonics taken singly cannot be added together to give the effects of all together. For practical purposes, however, the effects of non-harmonic electromotive forces and currents may usually be thought of as the summation of the effects which would be produced by the various harmonic components taken singly.

*The synchronous motor.* — Consider an alternator delivering current to a synchronous motor, and suppose the electromotive force curve of one machine to differ from the electromotive force curve of the other machine because of the presence, say, of a quintuple harmonic. The action of the two machines due to the fundamental harmonics of their electromotive forces is that which is described in any ordinary discussion of the synchronous motor, and the effect of the quintuple harmonic in the electromotive force of one machine is as follows: This quintuple harmonic is an electromotive force which is not opposed by any corresponding electromotive force in the other machine, that is to say, the circuit of the two machines is a short-circuit in so far as this quintuple harmonic of electromotive force is concerned. This quintuple harmonic of electromotive force produces, therefore, a short-circuit quintuple-

harmonic current. It must be remembered, however, that when an alternator is short-circuited, the short-circuit current is limited mainly by the very large inductance of the alternator armature, and the power which is represented by the short-circuit current is not excessively large. In the case of the quintuple harmonic the short-circuit current is even more effectively limited by the inductance of the two alternator armatures because of the higher frequency, so that the short-circuit quintuple-harmonic current is not very large, and it represents but a very small additional power output of the alternator because it is nearly  $90^\circ$  behind the quintuple harmonic of electromotive force in phase.

Another way of looking at the effect of a non-harmonic electromotive force of an alternating-current generator which drives a synchronous motor is as follows: Suppose that an ordinary alternator is short-circuited through a zero resistance. The short-circuit current in the alternator armature may be thought of as modifying the field flux in such a way as to reduce the actual induced electromotive force in the alternator armature to that value which is capable of producing the actual short-circuit current through the armature resistance. In the same way, the short-circuit quintuple harmonic current which is described in the foregoing paragraph may be thought of as modifying the flux distribution of the generator so as to cause a great reduction in the value of the quintuple harmonic in the generator electromotive force curve, and as modifying the flux distribution of the synchronous motor so as to introduce an opposing quintuple harmonic in its electromotive force curve. If the resistance of the circuit were zero, then the quintuple harmonic electromotive force which is introduced into the electromotive force curve of the motor would exactly balance the reduced quintuple harmonic in the electromotive force curve of the generator, and the short-circuit quintuple-harmonic current would be the amount of quintuple-harmonic current required to so modify the field fluxes of the two machines as to bring about this result.

*The induction motor.*— The behavior of the induction motor

due to the fundamental harmonic of the electromotive forces of supply is that which is discussed in any elementary treatise on the induction motor. The effect of the presence of, say, a triple harmonic in the supply electromotive forces may be described as follows: This triple harmonic produces its own rotating stator magnetism which, of course, rotates at a speed three times as great as the stator magnetism due to the fundamental harmonic of the supply voltages. With respect to this high-speed stator magnetism the rotor runs at a very great slip with large  $RI^2$  losses in the rotor. That is to say, the motor behaves with reference to the triple harmonic of the supply voltages in a manner similar to what its behavior would be with reference to the fundamental harmonic of the supply voltages at very low speed.

*Influence of higher harmonics upon core losses in transformers.*—The maximum flux density reached in the core of a transformer is proportional to the area under the half-wave of the electromotive force curve,\* the smaller this area the lower the value of the maximum flux density and consequently the lower the hysteresis loss in the iron core for a given frequency. Consider two kinds of electromotive force curve, a flat-topped curve and a peaked curve, the effective values being the same, say, 1,000 volts. The flat-topped electromotive force curve will have a greater area under its half-wave than the peaked electromotive force curve. Therefore, the hysteresis loss in a transformer core is less when the alternating electromotive force curve is peaked than it is when the alternating electromotive force curve is flat, both electromotive forces having the same effective value and the same frequency. The eddy current loss, on the other hand, depends only upon the effective value of the electromotive force.

*Effects of higher harmonics in long-distance transmission.*—The frequency of the fundamental mode of oscillation of a transmission line is in every practical case much higher than the frequency of the alternating current used in power transmission.

\* See Franklin & Esty's *Elements of Electrical Engineering*, Vol. II, pages 208-210.

Thus a transmission line 200 miles long, open at the distant end, would have a fundamental frequency of 232 cycles per second, and the frequency of the second mode of oscillation would be 696 cycles per second, as explained in Chapter V, whereas, the frequency usually employed in alternating-current power transmission is 25 cycles per second. Therefore, transmission lines are not usually set into very violent electrical oscillation. If, however, higher harmonics exist in the electromotive force of the generator, or if higher harmonics are introduced into the system by the reactions of the receiving circuit, and if the frequency of one of these higher harmonics happens to coincide\* with the frequency of one of the simple modes of oscillation of the transmission line, then very violent transmission line oscillations may be produced, and the insulation of the line may be endangered.

**79. The elimination of triple harmonics in a three-wire three-phase system.** — Some very interesting and important effects are produced in three-wire three-phase systems because the three-wire scheme of connections makes it impossible for the triple harmonics of the electromotive forces of a Y-connected three-phase generator to contribute to the voltages between mains, and because the armature windings of a  $\Delta$ -connected three-phase generator afford a short-circuit for the triple harmonics of the electromotive forces. Also some interesting effects are produced when the receiving circuits of a three-wire three-phase system produce triple harmonics of electromotive force or current by their reaction, as explained in Art. 77.

(a) *Y-connected generator.* — Figure 231 represents a Y-connected generator, and the arrows indicate the chosen positive directions in the armature windings *A*, *B* and *C*. On the basis of these chosen positive directions, the three electromotive

\* Coincidence of frequency of an alternator, and frequency of one of the simple modes of a transmission line means that the generator end of the line is very near to a voltage node. If this distance is *d*, as shown in Figs. 116, 117, 118 or 119, then the value of the voltage across the line at a voltage antinode is equal to  $1/(\sin d/\lambda)$  times the generator voltage as explained on page 125, on the assumption that the receiver end of the line reflects completely, and on the assumption that line losses are zero.

forces  $A$ ,  $B$  and  $C$  may be considered to be  $120^\circ$  apart in phase so that they may be represented by three vectors  $120^\circ$  apart in a clock diagram or by the three sine curves  $A$ ,  $B$  and

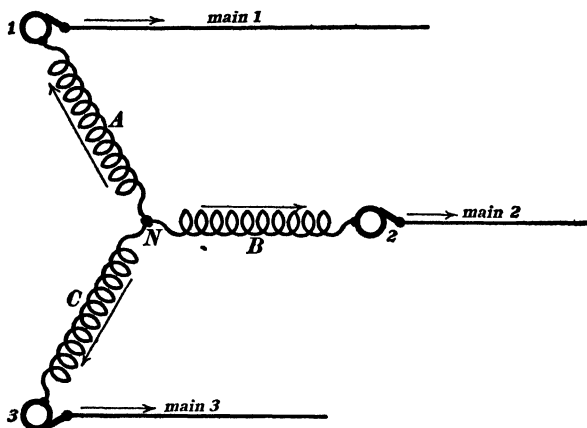

Fig. 231.

$C$  in Fig. 232. A small portion only of each of the sine curves  $A$ ,  $B$  and  $C$  is shown in Fig. 232 in order to avoid confusion. The three armature windings of a three-phase generator may be assumed to be exactly alike, so that if the electromotive forces  $A$ ,  $B$  and  $C$  are non-harmonic, the triple harmonic of each must be related to the fundamental in precisely the same way. Sup-

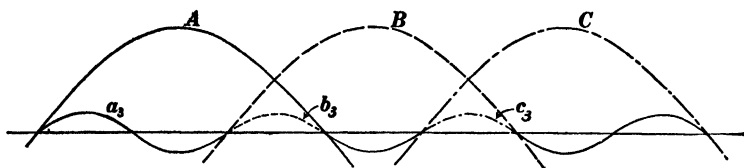

Fig. 232.

pose, for example, that the triple harmonic of  $A$  is represented by the curve  $a_3$  in Fig. 232, then the triple harmonic of  $B$  will be represented by the curve  $b_3$ , and the triple harmonic of  $C$  will be represented by the curve  $c_3$ . But the curves  $a_3$ ,  $b_3$  and  $c_3$  are portions of the same triple-frequency curve, as shown in Fig. 232. Therefore, on the basis of the choice of signs which is

represented by the arrows in Fig. 231, the triple harmonics of the three electromotive forces are in phase with each other, that is to say, the triple harmonics of  $A$ ,  $B$  and  $C$  are all in the directions of the arrows in Fig. 231, or all in the reverse direction, simultaneously, and *these triple harmonics do not contribute to the electromotive forces between the mains*. This is evident when we consider that an electromotive force in the winding  $A$ , Fig. 231, in the direction of the arrow and an equal electromotive force in the winding  $B$  in the direction of the arrow raise both of the collector rings 1 and 2 to a certain potential higher than the potential of the neutral junction  $N$  without producing a difference of potential between the rings. That is to say, even if the electromotive forces of a Y-connected three-phase alternator contain triple harmonics, these triple harmonics are absent from the electromotive forces between the mains.\*

(b) *Delta-connected generator*.—Figure 233 represents a delta-connected three-phase generator, and the arrows indicate the

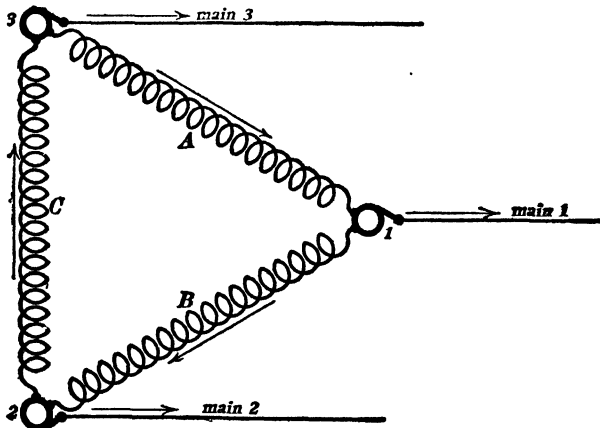

Fig. 233.

\* The absence of the third harmonic from the electromotive force between the terminals of a Y-connected three-phase generator is a particular case of the following general fact: Consider  $n$  separate armature windings displaced  $360/n$  electrical degrees from each other and properly connected to give a \*-connected  $n$ -phase generator. Then the  $n$ th harmonic is absent from the electromotive forces across the terminals of the machine.

chosen positive directions. The triple harmonics of the three electromotive forces,  $A$ ,  $B$  and  $C$  are in phase with each other, as explained in connection with Fig. 232, that is to say, these triple harmonics of electromotive force are all in the direction of the arrows in Fig. 233, or all in the opposite direction simultaneously, or, in other words, they all work together around the short-circuit formed by the delta-connected windings. The delta-connected three-phase alternator is, therefore, short-circuited with respect to the triple harmonics of its electromotive forces. The effect of this short-circuited condition may be described as follows, if the armature resistance be neglected (it usually is negligible as a matter of fact). The triple harmonic of current which is produced reacts upon the field of the alternator and alters the distribution of the field flux so that the triple harmonics of the electromotive forces are reduced to imperceptible values.

(c) *The three-wire line provides no return circuit for triple harmonics of current*, and therefore, even if triple harmonics of electromotive force were not annulled as above explained, no triple harmonic of current could be delivered to a balanced three-phase receiving system by a three-wire line. This is evident from what was stated under ( $\alpha$ ), above, as to the fact that all three triple harmonics of three-phase voltages or currents are positive simultaneously and negative simultaneously so that all three triple harmonics of current would have to flow outwards (in the directions of the arrows in Fig. 231) in all three line wires simultaneously, which is obviously impossible inasmuch as no return circuit is provided for currents which flow outwards in all three mains simultaneously.

**80. The influence of triple harmonics on the current and voltage relations in three-wire three-phase systems.** — On the assumption that voltages and currents are all simply harmonic, that is consisting of the fundamental sine waves alone without higher harmonics, it can be shown\* that the voltage across the terminals

\* See Franklin and Esty's *Elements of Electrical Engineering*, Vol. II, pages 108 and 109.

of a Y-connected three-phase generator is equal to  $\sqrt{3}$  times the voltage of one armature winding, and that the current in one line is  $\sqrt{3}$  times the current in one armature winding of a  $\Delta$ -connected three-phase generator.

In the Y-scheme of connections the triple harmonics tend to make the line voltage less than  $\sqrt{3}$  times the voltage of one winding because the triple harmonics are present in the windings but balanced out across the lines.

In the  $\Delta$ -scheme of connections the triple harmonics tend to make the current in each winding very much more than  $1/\sqrt{3}$  of the line current because of the short-circuited triple harmonic of current in the three windings and the entire absence of the triple harmonic current in the line wires.

**81. Appearance of triple harmonics in balanced three-phase receiving systems.** — It is pointed out in Art. 80 that triple harmonics in a three-phase generator are balanced out and not trans-

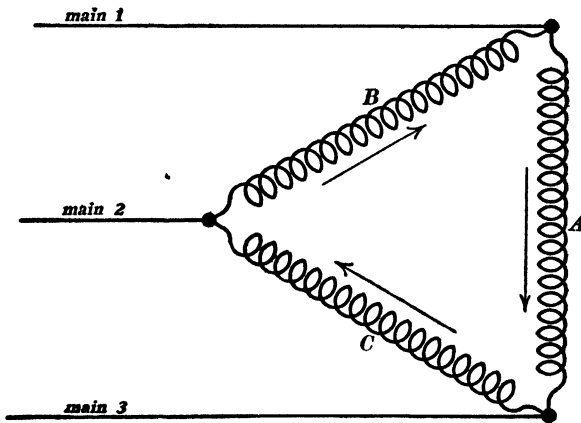

Fig. 234.

mitted by a three-wire line. Such triple harmonics cannot therefore influence the receiving circuits. When the receiving circuits contain pulsating reactances or pulsating resistances (see Art. 77) triple harmonics of electromotive force or current appear in the receiving system without showing themselves on the line and of

course without influencing the generator. In the following discussion the line voltages and line currents are assumed to be simply harmonic, that is to consist of fundamental sine waves of electromotive force and current without any higher harmonics, and the discussion is limited to the effects of pulsating reactances (primary coils of transformers). A very slight modification would adapt the discussion to the effects of pulsating resistances.

(a) *Delta-connected receivers.*—Let  $A$ ,  $B$  and  $C$ , Fig. 234, be three primary coils of three transformers which are supplied over a three-wire three-phase line, and let us consider the magnetizing currents of the three transformers. The voltage across each transformer being harmonic the magnetizing current must

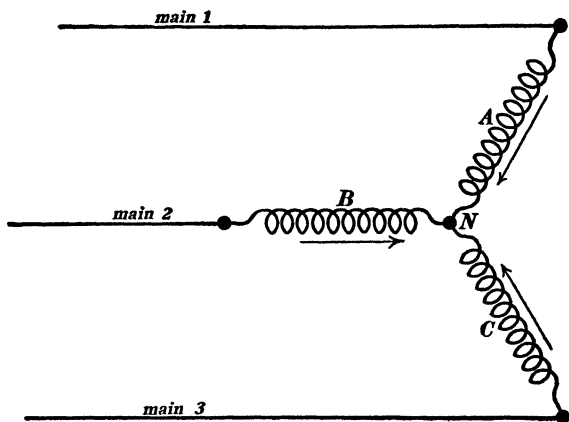

Fig. 235.

be non-harmonic as explained in Art. 77. Consider the triple harmonics of the three magnetizing currents. These triple harmonics are all in the directions of the arrows in Fig. 234 or all in the opposite directions simultaneously. Therefore the triple harmonics of the magnetizing currents of three  $\Delta$ -connected transformers circulate back and forth around the short-circuit formed by the  $\Delta$ -connections.

(b) *Y-connected receivers.*—Let  $A$ ,  $B$  and  $C$ , Fig. 235, be the three primary coils of three transformers supplied over a three-

wire three-phase line. The magnetizing currents of the three transformers must be simply harmonic \* because triple harmonics of current would have to flow all in the directions of the arrows or all in the reverse direction simultaneously which is obviously impossible. Therefore the electromotive forces across the transformer primaries must be non-harmonic as explained in Art. 77. This non-harmonic character of the electromotive forces across the primaries of Y-connected transformers consists chiefly of the presence of triple harmonics which of course balance out between the line wires so that no effect of these harmonics is transmitted back to the generator.

(c) *Influence of a 4th wire on triple harmonics in three-phase transmission.* — Consider a Y-connected three-phase generator delivering current over a three-wire line to Y-connected receiving circuits as shown in Fig. 236. The generator voltages may

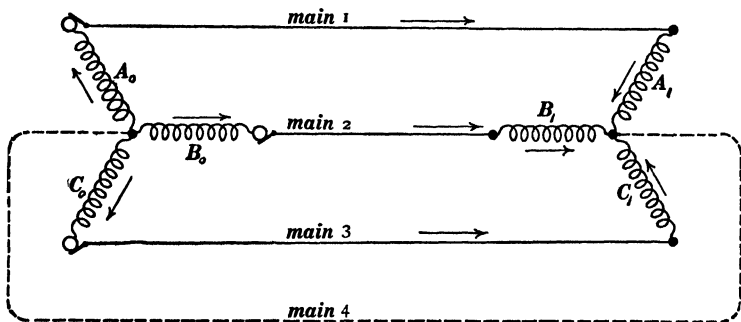

Fig. 236.

contain triple harmonics without influencing the line voltages or the line currents, and triple harmonics may be created by pulsating reactance in the receiving circuits without affecting the line voltages or the line currents, as already explained.

If a 4th main is connected as shown in Fig. 236 then complete circuits are established from generator to receiver for triple harmonics of current and the three phases become independent of each other as in an ordinary single-phase system. Suppose, for

\* Harmonics of 5th and higher orders not here considered.

example, that the generator voltages  $A_0$ ,  $B_0$  and  $C_0$  contain no triple harmonics, whereas triple harmonics of electromotive force are introduced into the voltages  $A_1$ ,  $B_1$  and  $C_1$  as explained under (b) above. Then the unbalanced triple harmonics of  $A_1$ ,  $B_1$  and  $C_1$  will produce triple frequency currents over the three mains 1, 2 and 3 and over main 4; or, if both neutral junctions (of generator and of receiver) are grounded, the triple frequency currents over 1, 2 and 3 will have a ground return.

If one neutral junction only is grounded, say the neutral junction of the generator, then a voltmeter connected from the other neutral junction to ground will show the value of the triple harmonic of  $A_0 + A_1$  (which is of course the same as the triple harmonic of  $B_0 + B_1$  or of  $C_0 + C_1$ ); this voltage between a "neutral" junction and ground may amount to several thousands of volts in the case of a high voltage transmission system. According to the simple working theory of alternating currents (electromotive forces and currents assumed to be harmonic, or, in other words, effects of higher harmonics ignored) there would be no electromotive force between the neutral junction of Y-connected receiving transformers and ground when the neutral junction of the step-up transformers at the generating station is grounded, and an inexperienced operating engineer who is guided wholly by the simple working theory is likely to be ignorant of the danger which is involved in the existence of this voltage between a neutral junction and ground.

**82. Influence of triple harmonics upon the power factor of a three-phase generator which supplies currents over a three-wire line.** — A three-wire distributing system constitutes an open circuit with reference to the triple harmonics of electromotive force of a Y-connected three-phase generator; and therefore the power delivered by each winding of such a generator to a non-inductive receiving system is not equal to  $EI$  where  $E$  is the electromotive force across the winding, as measured by a voltmeter, and  $I$  is the current in the winding as measured by an ammeter. The actual power delivered by the winding is less than  $EI$ . That

is to say, the power factor of the generator is less than unity.\* That is, the output capacity of a Y-connected three-phase generator may be slightly increased by providing a fourth line wire as shown in Fig. 236, if triple harmonics exist.

When a three-phase generator having triple harmonics of electromotive force is  $\Delta$ -connected to a three-wire line its output capacity is less than it would be if four line wires were used as in Fig. 236 for two reasons, namely, first the short-circuit triple harmonic of current reduces the available voltage of each winding by annulling the triple harmonic of electromotive force by armature reaction, and second the short-circuit triple harmonic of current adds to the heat generated in the armature windings, and the capacity rating of the machine is thereby reduced.

\* The student should be able to derive an expression for the power factor in terms of the effective values of the fundamental and triple harmonics of the generator electromotive forces, higher harmonics being ignored. See Art. 75.

## APPENDIX A.

### INDUCTANCE AND CAPACITY OF TRANSMISSION LINES.

**83. Inductance of transmission line.** — The inductance of a transmission line is given by the formula

$$L = 0.001483 \times \log_{10} \left( \frac{D - R}{R} \right) \quad (91)$$

in which  $L$  is the inductance of the line in henrys per mile (actual mile of pole line),  $D$  is the distance apart of the two wires center to center, and  $R$  is the radius of each wire,  $D$  and  $R$  being both expressed in terms of the same unit. This equation is only approximately true as will appear in the following derivation, and indeed for most practical purposes we may use the equation

$$L = 0.001483 \log_{10} \left( \frac{D}{R} \right) \quad (92)$$

because the radius of transmission wires is usually quite small as compared with their distance apart.

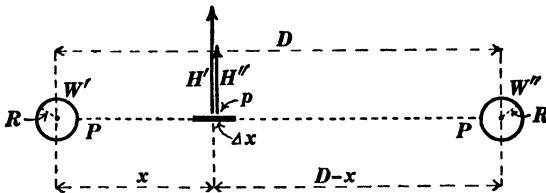

Fig. 237.

*Derivation of equation (91).* — Figure 237 is a sectional view of the two wires  $W'W''$  of a transmission line with outflowing current  $I$  abamperes in one wire and returning current  $I$  in the other wire. In order to determine the inductance of one mile

of the line (161,000 centimeters of line) it is necessary to find the magnetic flux which passes between \* the wires of one mile of the line, that is to say, it is necessary to find the magnetic flux which crosses the plane  $PP$ , Fig. 237. Consider an element of this plane of which the width is  $\Delta x$  and the length is 161,000 centimeters, and of which the distance from the center of the wire  $W'$  is  $x$ . The magnetic field intensity at this element due to the current in wire  $W'$  is

$$H' = \frac{2I}{x} \quad (\text{i})$$

and the magnetic field intensity at this element due to the current in wire  $W''$  is

$$H'' = \frac{2I}{D-x} \quad (\text{ii})$$

Multiplying the total magnetic field intensity  $H' + H''$  at the element by the area of the element ( $161,000 \cdot \Delta x$ ) we have the flux across the element, whence, using the values of  $H'$  and  $H''$  from equations (ii) and (iii), we find

$$\Delta\Phi = 322,000 \left( \frac{dx}{x} + \frac{dx}{D-x} \right) \quad (\text{iii})$$

Integrating this equation between the limits  $x = R$  and  $x = D - R$ , we have

$$\Phi = 644,000 \log_e \left( \frac{D-R}{R} \right) \quad (\text{iv})$$

but the magnetic flux which passes between the wires is equal to the inductance of the wires multiplied by the current, that is  $\Phi = LI$ . Therefore, from equation (iv) we have

$$L = 644,000 \log_e \left( \frac{D-R}{R} \right) \quad (\text{v})$$

This gives the inductance of one mile of the line in abhenrys. To find the inductance in henrys divide by  $10^9$ , whence, using ordi-

\* The flux which crosses through the material of the wires is neglected in this discussion, and therefore equation (91) is only approximately true.

nary logarithms instead of natural logarithms, we get equation (91).

**84. Capacity of transmission line.** — The capacity of a transmission line is given by the formula

$$C = \frac{1.943}{10^8 \times \log_{10} \left( \frac{D-R}{R} \right)} \quad (93)$$

in which  $C$  is the capacity of the line in farads per mile (actual mile of pole line),  $D$  is the distance apart of the two wires center to center, and  $R$  is the radius of each wire,  $D$  and  $R$  being both expressed in terms of the same unit. This equation is only approximately true as will appear in the following discussion, and indeed for most practical purposes we may use the formula

$$C = \frac{1.943}{10^8 \times \log_{10} \left( \frac{D}{R} \right)} \quad (94)$$

Equation (93) for the capacity of a transmission line may be derived from equation (91) by using equation (9) on page 87. It is instructive, however, to derive equation (93) directly as

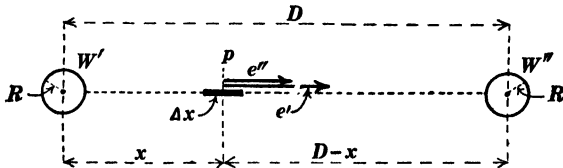

Fig. 238.

follows : Figure 238 is a sectional view of the two wires  $W' W''$  of a transmission line, and to find the capacity it is necessary to determine the voltage between the wires with an assumed amount of charge per unit length on each, positive on one wire and negative on the other. The wires are small in diameter as compared with their distance apart, and therefore the charge is uniformly distributed around each wire,\* and the electric field due to either

\* This assumption of uniform distribution of charge around each wire is not of course exactly true, and therefore equation (93) is only approximate.

of the wires alone is symmetrical with respect to the wire. Let  $e'$  be the intensity of the electric field due to charge on  $W'$  at all points distant  $x$  centimeters from the center of  $W'$ . Then  $2\pi x l e'$  is the electric flux outwards from  $l$  centimeters of the positively charged wire, and this flux is, according to Gauss's theorem, proportional to the charge  $lQ$  on the wire. In fact the flux when expressed in volts per centimeter  $\times$  square centimeters is equal to  $1.131 \times 10^{13} \times$  the charge in coulombs. Therefore

$$2\pi x l e' = 1.131 \times 10^{13} \times Q \times l$$

whence

$$e' = \frac{1.131 \times 10^{13} \cdot Q}{2\pi \cdot x} \quad (i)$$

in which  $e'$  is expressed in volts per centimeter and  $Q$  is expressed in coulombs. The electric field intensity  $e''$  at the point  $p$ , Fig. 238, due to the negative charge on wire  $W''$  is given by the equation

$$e'' = \frac{1.131 \times 10^{13} \cdot Q}{2\pi \cdot (D - x)} \quad (ii)$$

The total field intensity at the point  $p$  in Fig. 238 is  $e' + e''$  volts per centimeter, which, multiplied by the small element  $\Delta x$  of the dotted line gives the voltage along this element, namely,

$$\Delta E = (e' + e'') \Delta x \quad (iii)$$

Substituting the values of  $e'$  and  $e''$  from equations (i) and (ii) in equation (iii) and integrating the resulting expression from  $x = R$  to  $x = D - R$ , we have

$$E = \frac{1.131 \times 10^{13}}{\pi} \cdot Q \log_e \left( \frac{D - R}{R} \right) \quad (iv)$$

in which  $E$  is the electromotive force in volts between the wires and  $Q$  is the charge in coulombs on each centimeter of each wire, positive charge on one and negative charge on the other. The charge on one mile (161,000 centimeters) of one wire is 161,000  $Q$ , whence, from equation (iv) we have

$$\left. \begin{array}{l} \text{Charge on one mile} \\ \text{of either wire} \end{array} \right\} = E \left[ \frac{161,000\pi}{1.131 \times 10^{13} \times \log_e \left( \frac{D-R}{R} \right)} \right] (v)$$

so that the quantity in the square brackets is the capacity of one mile of the transmission line in farads, and we get equation (93) by changing to the common logarithm in the denominator.

*Rigorous formula for the capacity of parallel cylinders.*— A point charge is an electric charge concentrated at a point, and a line charge is an electric charge distributed uniformly along a straight line. Point charges and line charges are of course mathematical ideals. Let  $A$  and  $B$ , Fig. 239, represent two

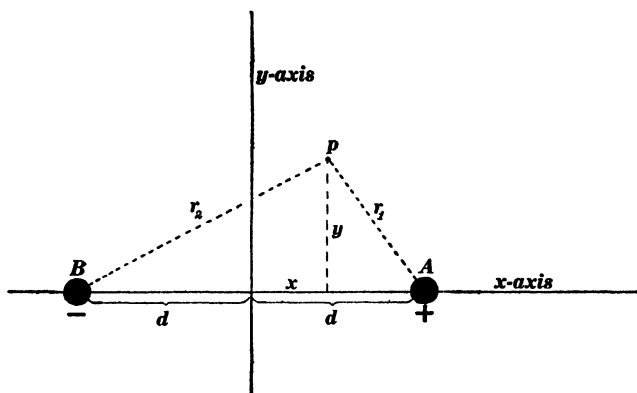

Fig. 239.

line charges, positive and negative, perpendicular to the plane of the paper, there being  $Q$  coulombs of positive charge per centimeter of length of  $A$  and  $Q$  coulombs of negative charge per centimeter length of  $B$ . Consider the electric field due to  $A$  alone. This electric field is given by the equation

$$e = \frac{1.131 \times 10^{13} \cdot Q}{2\pi r} \quad (vi)$$

By integrating this expression between the limits  $r = r_1$  to  $r = d$  we have

$$\frac{1.131 \times 10^{13}}{2\pi} \cdot Q(\log_e d - \log_e r_1)$$

as the potential difference between the origin and the point  $p$  in so far as this potential difference depends upon the charge  $A$ . Similarly we find

$$\frac{1.131 \times 10^{13}}{2\pi} \cdot Q(\log_e r_2 - \log_e d)$$

as the potential difference between the origin and the point  $p$  in so far as this potential difference depends upon the charge  $B$ . Therefore the total potential difference between the origin and the point  $p$  due to both charges is

$$\psi = \frac{1.131 \times 10^{13}}{2\pi} \cdot Q(\log_e r_2 - \log_e r_1)$$

which may be written in the form

$$\psi = KQ \log_e \left( \frac{r_2}{r_1} \right) \quad (\text{vii})$$

in which  $K$  is written for the constant  $1.131 \times 10^{13}/2\pi$ .

The equipotential surfaces may be found by placing  $\psi = a$  constant, which gives

$$\frac{r_2}{r_1} = \text{a constant} \quad (\text{viii})$$

which is the equation to a system of circles, as shown in Fig. 240, that is to say, the equipotential surfaces are a system of circular cylinders with their axes parallel to the linear charges  $A$  and  $B$ , and the circles in Fig. 240 are the intersections of these cylinders with the plane of the paper.

An equipotential surface in an electric field may be replaced by a thin metal shell without altering the distribution of the field in any way.\* Thus, the plane equipotential surface  $CD$  in Fig.

\* The line of argument in this paragraph gives rise to the theory of electric images. See *Elements of Electricity and Magnetism*, by J. J. Thomson, pages 140-185, Cambridge, 1904.

240 may be replaced by a plane sheet of metal, and any one of the cylindrical surfaces, for example the surface  $EF$ , may be replaced by a cylindrical shell of metal. Under these conditions, the total charge on  $CD$  is negative, and on each unit length of  $CD$  perpendicular to the plane of the figure the amount of charge is the same as on the line  $B$ ; also the amount of charge per unit length of the cylinder  $EF$  is the same as the charge per

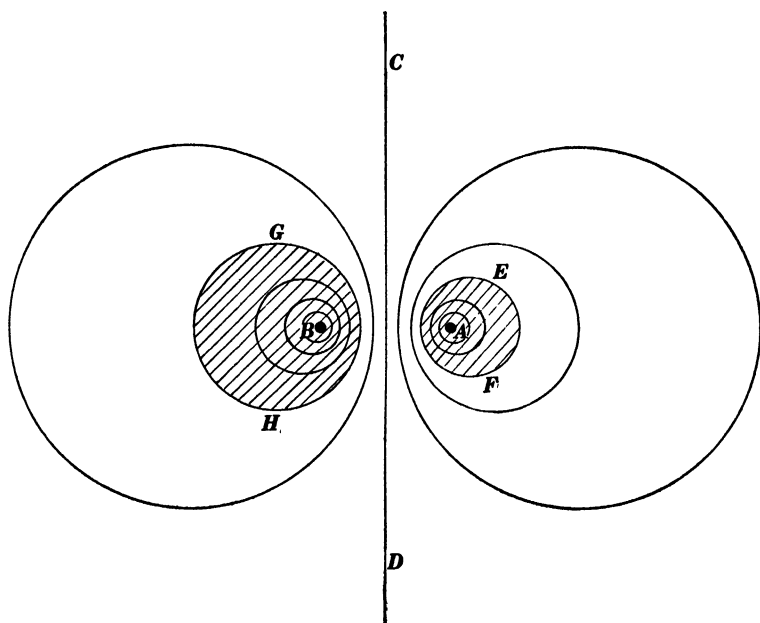

Fig. 240.

unit length of the line  $A$ ; and equation (vii) is an expression for the potential difference between the plane  $CD$  and that particular cylinder  $EF$  which corresponds to the chosen value of the ratio  $r_2/r_1$  in Fig. 239. Therefore the factor by which  $Q$  is multiplied in equation (vii) is the reciprocal of the capacity per unit length of the cylinder  $EF$  and the plane  $CD$  taken together to form a condenser.

To derive an expression for the capacity of two parallel cylinders  $GH$  and  $EF$ , Fig. 240, consider that equation (vii) ex-

presses the potential difference between  $CD$  and  $EF$ , and that the potential difference between  $GH$  and  $CD$  may be expressed by an equation similar to (vii), namely

$$\psi' = KQ \log_e \left( \frac{r_1'}{r_2'} \right) \quad (\text{ix})$$

Therefore the total potential difference between  $GH$  and  $EF$  is

$$\psi + \psi' = KQ \log_e \left( \frac{r_2' r_1'}{r_1 r_2'} \right) \quad (\text{x})$$

The coefficient of  $Q$  in this equation is the reciprocal of the capacity per length of the cylinders  $GH$  and  $EF$ . This expression for capacity may be transformed so as to contain the radius  $R_1$  of  $EF$ , the radius  $R_2$  of  $GH$  and the distance  $D = (D_1 + D_2)$  between centers of  $EF$  and  $GH$ , giving for the value of  $C$  in "electrostatic" units per centimeter length of pair of cylinders:—

$$\frac{1}{2 \log_e \left\{ \frac{D^2 - (R_1^2 + R_2^2) + \sqrt{[D^2 - (R_1 + R_2)^2][D^2 + (R_1 - R_2)^2]}}{2R_1 R_2} \right\}} \quad (95)^*$$

To derive this equation from equation (x) consider Fig. 241 in which the fine-line circle of which the diameter  $2d$  is equal to the distance between the line charges  $A$  and  $B$ . This circle cuts both  $EF$  and  $GH$  orthogonally; therefore  $cOp$  and  $c'Op'$  are right triangles and we have:

$$d^2 = D_1^2 - R_1^2 \dots \quad (\text{xi})$$

and

$$d^2 = D_2^2 - R_2^2 \dots \quad (\text{xii})$$

The ratio of two lines drawn from  $A$  and  $B$  to any point on  $EF$  is equal to  $r_2/r_1$  according to equation (viii). Consider the point  $q$ . The distance  $Aq$  is equal to  $d - (D_1 - R_1)$  and the distance  $Bq$  is equal to  $d + (D_1 - R_1)$ . Therefore

$$\frac{r_2}{r_1} = \frac{d + (D_1 - R_1)}{d - (D_1 - R_1)} \quad (\text{xiii})$$

\* See *The Theory of Electricity and Magnetism*, by A. G. Webster, Macmillan and Company, 1897, pages 311-315.

and similarly, by considering the point  $q'$  on this circle  $GH$  we have

$$\frac{r_1'}{r_2'} = \frac{d + (D_2 - R_2)}{d - (D_2 - R_2)} \tag{xiv}$$

Also we have

$$D = D_1 + D_2 \tag{xv}$$

Using equations (xiii) and (xiv), we have at once an expression for  $r_2 r_1' / r_1 r_2'$  which can be reduced to a form containing  $D$ ,  $R_1$  and  $R_2$  by using equations (xi), (xii) and (xv).

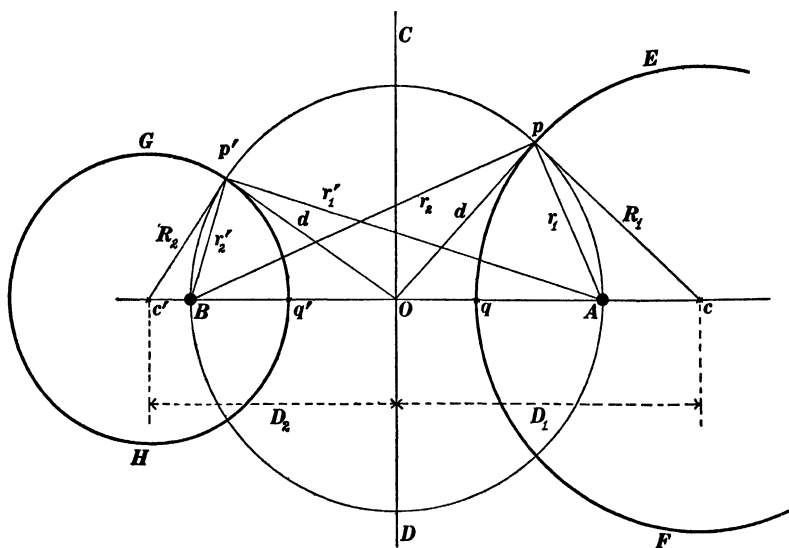

Fig. 241.

**85. Inductance and capacity of Seibt's artificial transmission line as shown in Figs. 122 and 123.** — The inductance per unit length of this arrangement of Seibt's is mainly dependent upon the inductance of the long solenoid or coil, which is equal to  $4\pi^2 z^2 r^2 / 10^9$  henrys per centimeter of length, where  $z$  is the number of turns of wire per centimeter length of the solenoid and  $r$  is the radius of the solenoid in centimeters.\*

The capacity of Seibt's arrangement per unit length is sensibly

\* See Franklin & MacNutt's *Elements of Electricity and Magnetism*, page 154.

the same as the capacity of two metal cylinders one of which has the same radius as the long solenoid and the other of which is the fine wire  $WW$  in Fig. 122. Therefore the capacity per unit length is given by equation (95).

## APPENDIX B.

### ELECTROMAGNETIC AND ELECTROSTATIC SYSTEMS OF UNITS.

One of the greatest annoyances in the study of any branch of physical science is the entirely unnecessary multiplicity of units in common use. Thus, we have in the theory of electricity and magnetism the *electromagnetic c.g.s. system* of units, the *electromagnetic practical system* of units, and the *electrostatic system* of units where a single system of units would suffice. Certain electric and magnetic units are defined in the same way in all of these systems. Thus a wire has one unit of resistance when one unit of current generates one energy-unit of heat in the wire per second, a condenser has unit capacity when one unit of charge is forced into it by one unit of electromotive force, an electric circuit has one unit of inductance when one unit current in the circuit has one half a unit of kinetic energy.\* On the other hand, certain electric and magnetic units are defined differently in the electromagnetic and electrostatic systems and a clear insight into the electrostatic and electromagnetic systems of units may be obtained by considering only those units which are differently defined in the two systems as follows :

*The electromagnetic c.g.s. system of units* is based upon the following five equations :

$$(i) \quad F = \frac{1}{\mu} \frac{m_1 m_2}{d^2}$$

in which  $F$  is the force in dynes with which two magnet poles  $m_1$  and  $m_2$  repel each other,  $d$  is the distance between the poles in centimeters, and  $\mu$  is the magnetic permeability of the inter-

\* It does not follow that the units of resistance, capacity, inductance, etc., are same in the different systems. Thus the unit of resistance is defined in terms of the unit of current and the unit of current is different in the different systems.

vening medium. Taking the value of  $\mu$  arbitrarily equal to unity for air, this equation defines the "electromagnetic" unit of magnet pole, that is to say, the unit pole in the electromagnetic system is a pole of such strength that it will exert a force of one dyne upon an equal pole at a distance of one centimeter in air.

$$(ii) \quad F = mH$$

in which  $F$  is the force in dynes with which a magnet pole of strength  $m$  is acted upon when it is placed at a point in a magnetic field of which the intensity is  $H$ . This equation defines the "electromagnetic" unit of magnetic field intensity, the gauss. A magnetic field has an intensity of one gauss when it exerts a force of one dyne upon an "electromagnetic" unit pole.

$$(iii) \quad S = \frac{1}{4\pi} \cdot He$$

in which  $S$  is the intensity of the energy stream in an electromagnetic field in ergs per square centimeter per second,  $H$  is the intensity of the magnetic field in gausses, and  $e$  is the intensity of the electric field in "electromagnetic c.g.s." units (abvolts per centimeter);  $S$ ,  $H$  and  $e$  being mutually perpendicular. This equation defines the abvolt per centimeter.

$$(iv) \quad F = qe$$

in which  $F$  is the force in dynes exerted upon a charge  $q$  by an electric field of which the intensity is  $e$  abvolts per centimeter. This equation defines the "electromagnetic c.g.s." unit of charge (the abcoulomb) as that charge which is acted upon by a force of one dyne when it is placed in an electric field of which the intensity is one abvolt per centimeter.

$$(v) \quad F = \frac{1}{\kappa} \cdot \frac{q_1 q_2}{d^2}$$

in which  $F$  is the force in dynes with which two concentrated charges  $q_1$  and  $q_2$  (both expressed in abcoulombs) attract each other. This equation defines the inductivity  $\kappa$  of the medium.

A medium would have an inductivity of one "electromagnetic c.g.s." unit if an abcoulomb of concentrated charge exerted a force of one dyne upon another abcoulomb of concentrated charge at a distance of one centimeter in that medium. The inductivity of air in "electromagnetic c.g.s." units is  $1.11 \times 10^{-21}$  units.

The *electrostatic system of units* is based upon the same equations as above, but with the inductivity of the air taken arbitrarily equal to unity; and the equations are used in the reverse order in defining the various units:

$$(v) \quad F = \frac{1}{\kappa} \cdot \frac{q_1 q_2}{d^2}$$

in which  $\kappa$  is arbitrarily taken equal to unity for air, and the "electrostatic" unit of charge is defined as that charge which will exert a force of one dyne upon an equal charge at a distance of one centimeter in air.

$$(iv) \quad F = qe$$

On the basis of this equation the "electrostatic" unit of electric field intensity is defined as a field which will exert one dyne upon an "electrostatic" unit of charge.

$$(iii) \quad S = \frac{1}{4\pi} \cdot Hc$$

On the basis of this equation the "electrostatic" unit of magnetic field is defined as a field of such intensity as to give an energy stream of  $1/4\pi$  ergs per square centimeter per second in conjunction with an "electrostatic" unit of electric field;  $H$ ,  $e$  and  $S$  being at right angles to each other.

$$(ii) \quad F = mH$$

On the basis of this equation the "electrostatic" unit of magnet pole is defined as a pole which will be acted upon by a force of one dyne by a magnetic field of one "electrostatic" unit intensity.

$$(i) \quad F = \frac{1}{\mu} \cdot \frac{m_1 m_2}{d^2}$$

On the basis of this equation the "electrostatic" unit of permeability is a permeability such that an "electrostatic" unit pole would exert a force of one dyne upon an equal pole at a distance of one centimeter in a medium of which the permeability is one "electrostatic" unit.

TABLE.

## RELATIVE VALUES OF UNITS.

$$v = 3 \times 10^{10} \text{ centimeters per second.}$$

The units of the practical system are the ampere, the volt, the ohm, the coulomb, the farad and the henry. It is convenient to use the prefix *ab* to designate the "electromagnetic c.g.s." units, namely, the abampere, the abvolt, the abohm, the abcoulomb, the abfarad and the abhenry.

One "electrostatic" unit of charge  $= 1/v$  abcoulombs  $= 10/v$  coulombs.

One "electrostatic" unit current  $= 1/v$  abamperes  $= 10/v$  amperes.

One "electrostatic" unit magnetic field  $= 1/v$  gausses. The unit of magnetic field intensity in the "electromagnetic" system is called the gauss.

One "electrostatic" unit of electromotive force  $= v$  abvolts  $= v/10^8$  volts.

One "electrostatic" unit of electric field  $= v$  abvolts per centimeter  $= v/10^8$  volts per centimeter.

One "electrostatic" unit magnet pole  $= v$  "electromagnetic" units of magnet pole.

One "electrostatic" unit of capacity  $= 1/v^2$  abfarads  $= 10^9/v^2$  farads.

One "electrostatic" unit of inductance  $= v^2$  abhenrys  $= v^2/10^9$  henrys.

One "electrostatic" unit of resistance  $= v^2$  abohms  $= v^2/10^9$  ohms.

The reason for the appearance of the velocity of light  $v$  in this table of ratios of electric and magnetic units may be seen from equations (5*a*) and (6*a*) on page 85 as follows. Consider equation (6) on page 84. The factor  $\alpha$  in this equation is the inductivity of the air in "electrostatic" units and it is equal to  $1/v^2$  according to the footnote on pages 83 and 84; and the factor  $\alpha\kappa$  in equation (6*a*) on page 85, which should be represented by the single letter  $\kappa$ , is the inductivity of any given medium. Consider what the velocity  $V$  in equations (5*a*) and (6*a*), page 85 would have to be in order that  $e$  which is induced by the motion of  $H$  may be the same thing as  $e'$  which by its motion induces  $H'$ , and in order that  $H'$  may be the same thing as  $H$ . Under these conditions  $V$  is the velocity of light, the same thing as  $v$  in the above table. Therefore, writing  $v$

for  $V$  in equations (5a) and (6a) on page 85, and solving, we find

$$v = \frac{1}{\sqrt{\mu\kappa}} \quad (\text{vi})$$

that is, the velocity of an electromagnetic wave in any medium is equal to the square root of the product of the permeability of the medium and the inductivity of the medium. Therefore, whatever units are employed, we have

$$\mu\kappa = \frac{1}{v^2} \quad (\text{vii})$$

In the "electrostatic" system  $\kappa$  for air is taken arbitrarily equal to unity so that equation (v) for air becomes

$$F = \frac{q_1 q_2}{d^2} \quad (\text{viii})$$

when "electrostatic" units are employed. On the other hand, in the "electromagnetic" system  $\mu$  for air is taken arbitrarily equal to unity so that the inductivity of air in this system is equal to  $1/v^2$  according to equation (vii). Therefore in the "electromagnetic" system equation (v) becomes

$$F = v^2 \cdot \frac{Q_1 Q_2}{d^2} \quad (\text{ix})$$

Given two charges which exert a force of one dyne on each other at a distance of one centimeter ("electrostatic" unit charges). The force exerted by these two charges is of course unchanged if we assume both charges to be expressed in "electromagnetic" units according to equation (ix), that is,  $F$  in equation (ix) is one dyne if  $Q$  and  $Q'$  are each one "electrostatic" unit, but when expressed in "electromagnetic" units, the numerical values of  $Q$  and  $Q'$  must each be equal to  $1/v$  to give  $F$  equal to one dyne. That is to say, to express a given charge in "electromagnetic" units requires a number  $v$  times as small as to express the same charge in "electrostatic" units. Therefore the "electromagnetic" unit of charge is  $v$  times as large as the "electrostatic" unit of charge.

## APPENDIX C.

### PROBLEMS.

#### CHAPTER I. WATER WAVES.

1. The sidewise velocity of the wire in the tube  $WW'$ , Fig. 2, page 13, is the same at every part of the tube, that is to say, the velocity is represented by the ordinate  $y$  of the rectangle in Fig. 3. Suppose the tube  $WW'$  to be parabolic in shape with the vertex of the parabola at  $W$  and the axis of the parabola in the direction  $Wa$ . Under these conditions determine the shape of the curve  $ab$ , the ordinates of which represent the sidewise velocity at each point of the wire in the tube.

2. What is the most suitable velocity of propulsion of a canal boat in a canal 7 feet deep? Ans. 15 feet per second.

*Note.* — When a canal boat is propelled at the velocity of wave progression in the canal, it rides on the wave which it produces, and less force is required to propel it than would be required to propel it at a considerably less velocity; also the agitation of the water is less pronounced than it would be if the boat were traveling at considerably less velocity, and the washing of the canal banks is correspondingly less. This fact was discovered by John Scott Russell about 1830. See Section 6 of Article "Wave" in *Encyclopædia Britannica*, Ninth Edition.

3. An earthquake in Japan usually produces a wave in the adjoining ocean. The motion of the water in such a wave is approximately a uniform horizontal flow from top to bottom of the ocean at a given point, and therefore the velocity of progression of such a wave is determined by equation (2) on page 15. If the average depth of the ocean between Japan and San Francisco is 18,000 feet, how long a time will be required for an earthquake wave in the ocean to travel from Japan to San Francisco, a distance of approximately 5,000 miles? Ans. 9.64 hours.

4. In a tidal wave which travels up a river from the ocean the motion of the water is approximately a uniform horizontal flow

from top to bottom of the river at a given point and therefore the velocity of progression of such a wave is determined by equation (2) on page 15. How much later does high tide occur at a point 100 miles up a river than at the mouth of the river, the depth of the river being, say, 20 feet? Ans. 5.77 hours.

5. Find the period of oscillation of the water in a rectangular trough 10 feet long and 2 feet deep.

6. The duration of a lunar day (interval between two successive passages of the moon over a given meridian) is about 24.8 hours. Find the depth of a canal in which a wave would travel once around the earth's equator in one lunar day. Ans. 13 miles deep.

*Note.* — The passage of a wave round and round a reëntrant canal constitutes a state of oscillation of the water in such a canal, and one period of oscillation is the time required for a wave to travel once around. If the tropical ocean were a belt of water of uniform width and uniform depth around the earth, and if its depth were such as to cause its period of oscillation as here defined to be equal to one lunar day then the tendency would be for the tide-producing action of the moon to build up excessive tides because of resonance.

7. Make a series of drawings and plot a series of curves as suggested in the footnote on page 26.

8. Two steel rails each 30 feet long, moving at velocity of 4 feet per second, strike together endwise as shown in Fig. 8*p*. For

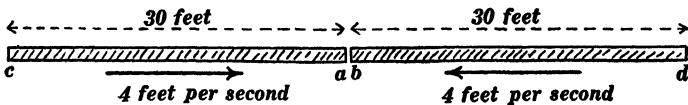

Fig. 8*p*.

how long a time do the ends *ab* of the rails remain in contact? What is the minimum distance between the ends *cd*? The velocity of longitudinal waves along a steel rail is 17,000 feet per second. Ans. 0.00353 second; 59.97176 feet.

9. A steel rail 30 feet long strikes against a rigid wall as explained on page 30, and the rail is assumed to stick fast to the wall so that it may continue to oscillate as described in Art. 10. Plot a curve of which the ordinates represent the varying distance of the free end of the rail from the wall and of which the abscissas

represent elapsed times. Plot a curve of which the ordinates represent the varying distance of the middle point of the rail from the wall and of which the abscissas represent elapsed times. Plot a curve of which the ordinates represent the varying velocity of a point 7.5 feet from the free end of the rail and of which the abscissas represent elapsed times.

10. Plot a curve of which the ordinates represent the varying distance of the middle point of the helical spring of Fig. 35 from the fixed end of the spring and of which the abscissas represent elapsed time, the initial stretch of the spring being 2 inches.

11. Assuming the face of the hammer to come squarely against the end of the steel rod in Fig. 36, calculate the greatest velocity of the hammer which will not batter the end of the rod (1) on the assumption that the material of the hammer is absolutely rigid, and (2) on the assumption that the hammer is made of the same kind of steel as the rod and that the hammer is in the form of a short cylinder of the same diameter as the rod. Ans. (1) 30.7 feet per second; (2) 61.4 feet per second.

*Note.* — The resilience of a material is the amount of potential energy per unit volume in the substance when it is strained to its elastic limit. The density of steel is 584 pounds per cubic foot and its resilience is 8640 foot-pounds per cubic foot. If the hammer in Fig. 36 is assumed to be perfectly rigid, the velocity  $v$  of the steel in the wave is equal to the velocity of the hammer before it strikes the end of the rod. If the hammer is of the same material as the rod and if it is cylindrical and of the same diameter as the rod, then the velocity  $v$  of the steel in the wave is equal to half the velocity of the hammer before it strikes the end of the rod.

12. Many substances, for example cast iron and glass, sustain a much greater stress under compression than under tension. Imagine a rectangular wave of compression, 2 inches long, to travel along a glass tube and be reflected from the free end of the tube, and suppose the compression in this wave to be approximately at the limit of strength of the material. Plot a sketch showing the region where the compression first changes to tension at the time of reflection. How long a portion of the end of the tube will be broken off? Ans. 1 inch.

## CHAPTER II. WAVE-TRAINS AND MODES OF OSCILLATION.

13. Plot two sine curves along the same axis of abscissas, one of the sine curves to represent a snap-shot of a simple wave-train traveling along a rubber tube, and the ordinates of the other sine curve to represent the sidewise velocity of the rubber tube or the degree of stretch of the tube at each point.

14. Given two oppositely moving similar trains of waves  $A$  and  $B$ , Fig. 14*p*;  $a = 1.5$  inches,  $b = 2.5$  inches, and  $c = 5.5$

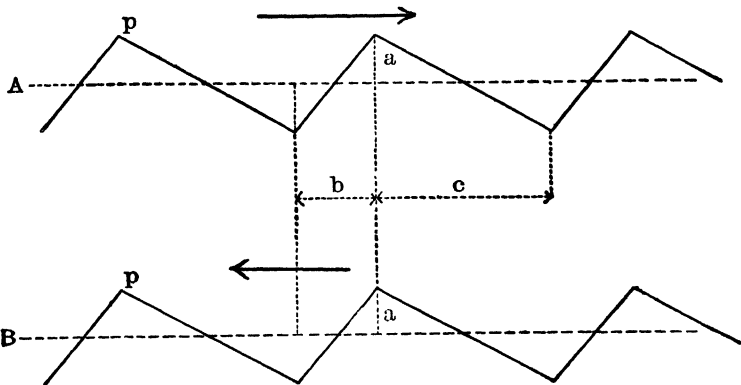

inches. Draw these two wave-trains with point  $p$  of the upper train directly over the point  $p$  of the lower train, as shown in the figure, and draw the resultant of the two trains for this position. Make five additional drawings showing  $A$  and  $B$  and their resultant  $\frac{1}{8}$  of a period later,  $\frac{3}{8}$  of a period later,  $\frac{4}{8}$  of a period later, and  $\frac{5}{8}$  of a period later, a period being the time required for the waves to travel over the distance  $b + c$ .

15. A simple train of sound waves coming from a distant body vibrating 256 times per second, strikes a wall perpendicularly and is reflected. A standing wave-train results. At certain distances from the wall, or at certain points  $A$ , the air is subjected alternately to compression and rarefaction but does not move; and at certain distances from the wall, or at certain points  $B$ , the air moves to and fro but is not condensed or rarefied. What are

the points  $A$  called, and what are the distances of this series of points from the wall? What are the points  $B$  called, and what are the distances of this series of points from the wall? To which series of points does the surface of the wall belong? Ans. Distances to points  $A$  64.5, 129, 193.5 centimeters, etc.; distances to points  $B$  32.25, 96.75, 161.25 centimeters, etc.

16. The ear is affected only by variations of pressure, not by air movements. At what distance, or distances, from a reflecting wall will the sound of a distant body become inaudible when the body makes 125 vibrations per second and the sound strikes the wall perpendicularly? Ans. 66, 198, 330 centimeters, etc.

### CHAPTER III. ELECTROMAGNETIC ACTION.

17. An electric field like that which is represented in Fig. 63 decreases in intensity at the space-rate of 100 volts-per-centimeter per centimeter of distance along the axis of reference. (a) Find the electromotive force around a rectangle in the plane of the paper in Fig. 63, the rectangle being 30 centimeters long (parallel to  $AB$  Fig. 63) and 20 centimeters wide. (b) Find the rate at which the magnetic flux through this rectangle must be changing in order to produce this electromotive force around it. (c) Find the rate at which the magnetic field in Fig. 63 perpendicular to the paper is changing because of the tapering of the electric field. Ans. (a) 60,000 volts; (b)  $6 \times 10^{12}$  maxwells per second; (c)  $1 \times 10^{10}$  gaussses per second.

18. Consider two line wires (ribbons)  $AA' BB'$  Fig. 18*p*, and imagine the current in these wires (ribbons) to be distributed so that the current at any point  $p$  is represented by the ordinate  $y$  of a straight line  $CC$ . The magnetic field between the ribbons is a tapering field as described in connection with Fig. 65 on page 62, the lines of force of the field being perpendicular to the paper in Fig. 18*p* and directed away from the reader. The intensity of the magnetic field in gaussses at any point  $p$  is equal to  $4\pi$  times the ampères of current per centimeter of width of ribbons. The

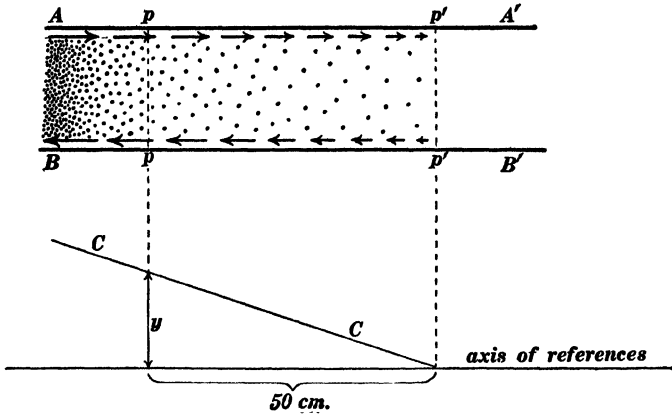

Fig. 18p.

current at the point  $pp$  is 50 amperes, and the current at point  $p'p'$  is zero. Find the rate at which the electric field from ribbon  $AA'$  across to ribbon  $BB'$  is increasing in volts per centimeter per second.

*Note.* — The simplest method of handling this problem is to calculate the rate at which charge is accumulating on each square centimeter of the inner faces of the ribbons due to the tapering current, positive charge on ribbon  $AA'$  and negative charge on ribbon  $BB'$ , and to consider, with the help of Gauss's theorem, the intensity of the electric field which is associated with these charges as follows. Consider one square centimeter of the inner face of the upper ribbon. The current which flows into this area across one side is one ampere greater than the current which flows out of it on the other side according to the data of the problem, and therefore one coulomb of charge is collecting per second upon each square centimeter of the inner faces of the ribbons. The total electric flux which emanates from one coulomb of charge is  $1.131 \times 10^{18}$  lines, where one line is the amount of flux crossing one square centimeter in an electric field of which the intensity is one volt per centimeter. Therefore, since one coulomb of charge is collecting per second on each square centimeter of the ribbon  $AA'$ , it follows that the electric field between the ribbons is increasing at the rate of  $1.131 \times 10^{18}$  volts per centimeter per second. See Franklin and MacNutt's *Elements of Electricity and Magnetism*, Arts. 91 and 98.

19. A long wire of which the resistance per centimeter of length is 0.02 ohm carries a current of 30 amperes. (a) Find the rate at which energy flows in upon each centimeter of length of the wire in ergs per second. (b) Find the intensity of the energy stream in ergs per second per square centimeter at a point dis-

tant 15 centimeters from the axis of the wire. (c) Find the intensity of the electric field parallel to the wire in abvolts per centimeter. (d) Find the intensity of the magnetic field in gaussess at a point distant 15 centimeters from the axis of the wire. Ans. (a)  $18 \times 10^7$  ergs per second; (b)  $1.91 \times 10^6$  ergs per square centimeter per second; (c)  $6 \times 10^7$  abvolts per centimeter; (d) 0.4 gauss.

20. Consider two line wires in the form of two flat metal ribbons 50 centimeters wide and 3 centimeters apart. At a given point  $p$  the electromotive force between the ribbons is 100 volts and the current in each ribbon is 10 amperes. (a) Find the rate in ergs per second at which energy flows past the point  $p$  from the generator towards the receiver in ergs per second using the ordinary formula,  $P = EI$ . (b) The electric field intensity be-

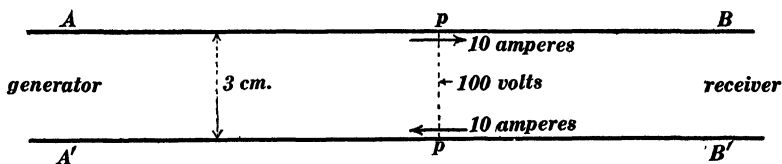

Fig. 20p.

tween the ribbons at the point  $p$  is 33.3 volts per centimeter and the magnetic field between the ribbons is uniform and perpendicular to the plane of the paper in Fig. 20p. Find the intensity of the magnetic field in gaussess. Ans. (a)  $10^{10}$  ergs per second; (b) 0.251 gauss.

*Note.* — The energy which is transmitted past the point  $p$  streams through the region between the ribbons and therefore the sectional area of the energy stream is 150 square centimeters. See Arts. 19 and 20. It is intended that the magnetic field intensity be calculated with the help of equation (4) on page 67.

#### CHAPTER IV. ELECTROMAGNETIC WAVES.

21. The capacity of one mile of a transmission line is 0.1 microfarad, and the voltage between the wires is 1,000 volts. Find the amount of charge on one mile of each of the wires, and calculate the current required to transfer this charge forwards into

the next mile of the line during the time required for an electromagnetic wave to travel one mile ( $1/186,000$  of a second). Ans. 18.6 amperes.

*Note.*— This problem illustrates the meaning of equation (6*b*) on page 86.

**22.** Make a series of sketches as suggested in the footnote on page 88.

**23.** Make a series of sketches as suggested in the footnote on page 94.

*Note.*— The successive configurations of the oscillating line in Fig. 100 may be thought out in the simplest possible manner by imagining a long-drawn-out wave *W**W**W**W*, Fig. 23*p*, to shoot out from the battery *B* very much like a ribbon

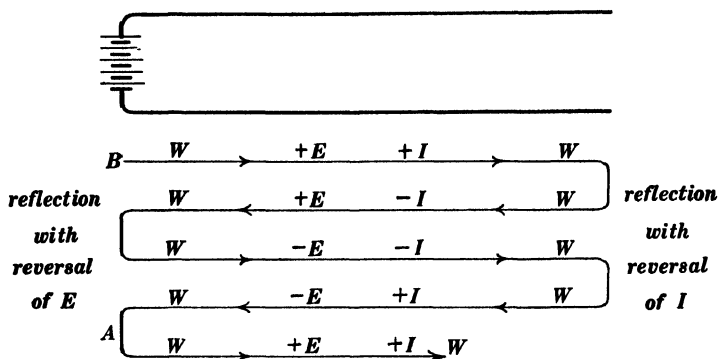

Fig. 23*p*.

coming continuously out of the mouth of a prestidigitateur. The total current in the line and the total voltage across the line at any given point and at any given instant is found by adding up the voltages and currents associated with the successive laps of the long-drawn-out wave. From *B* to *A* is one complete oscillation of the line.

**24.** Make a series of sketches as suggested in the footnote on page 96.

**25.** A transmission line consists of two copper wires each 0.5 inch in diameter at a distance of 36 inches apart center to center and has a current of 100 amperes in it due to short-circuit at the end of the line. The end of the line is suddenly opened. Calculate the value to which the voltage between the wires would rise if it were not for the breaking down of the insulation. Ans. 59,620 volts.

*Note.* — See Appendix A for formulas for calculating inductance and capacity of transmission lines. The answers to this and the following problems are calculated from capacity and inductance as determined by equations (92) and (94).'

**26.** The transmission line specified in problem 25 is open at the distant end and it has an electromotive force of 100,000 volts connected between the wires so as to charge them as the two plates of a condenser. The distant end of the line is then suddenly short-circuited. Find the value of the current which is established in the line wires immediately after the short-circuit. Ans. 167.7 amperes.

**27.** A 100-volt battery of negligible resistance is connected to a transmission line the distant end of which is short-circuited. The diameter of the wires of the transmission line is  $\frac{1}{2}$  inch, their distance apart center to center is 36 inches, their resistance is assumed to be negligible and they are assumed to be perfectly insulated from each other. Plot a curve of which the ordinates represent the successive instantaneous values of the current at the battery end of the line and of which the abscissas represent elapsed times, the length of the line being 5 miles.

*Note.* — At first a wave shoots out from the battery as indicated in Fig. 100, the voltage in this wave being equal to the battery voltage, and the current being related to the voltage according to equation (7b). When this wave reaches the short-circuited end of the line, the voltage at the extreme end of the line drops to zero and the current is doubled. This condition of zero voltage and doubled current is established over the whole line by a wave of arrest which travels back towards the battery end of the line; and when this wave reaches the battery end, battery voltage and trebled current are established over the whole line by a wave of starting. When this wave of starting reaches the short-circuited end of the line the voltage drops to zero again and the current rises to a quadrupled value, and this quadrupled current and zero voltage are established over the whole line by a wave of arrest which travels back towards the battery end of the line, and so on. See Note to problem 23.

**28.** Describe the precise manner in which a train gains velocity under the constant pull of a locomotive suddenly applied, ignoring friction.

*Note.* — The manner of starting the train is precisely analogous to the manner of setting up current in the transmission line in problem 27.

**29.** The transmission line specified in problem 27 has its distant end open. Plot a curve showing the successive instantaneous

values of current at the middle of the line when a 100-volt battery of negligible resistance is suddenly connected to one end of the line.

*Note.*—See Note to problem 23.

**30.** The rear end of a train is tied to a post. Describe the behavior of the train under the constant pull of a locomotive suddenly applied, ignoring friction.

*Note.*—The behavior of the train in this case is precisely analogous to the oscillations of the open-ended transmission line under the conditions specified in problem 29.

**31a.** Calculate the resistance of a non-inductive receiving circuit which will completely absorb an electromagnetic wave on the transmission line specified in problem 27. Ans. 596.2 ohms.

**31b.** A transmission line has such inductance and capacity per unit length that a pure wave with 10,000 volts across the line has 10 amperes in each wire. A long-drawn-out rectangular electromagnetic wave comes up to the end of this transmission line where a non-inductive receiving circuit is connected across the line. The voltage in the wave is 7,000 volts and the resistance of the receiving circuit is 500 ohms. Find the current and voltage in the reflected wave and specify which is reversed at reflection. Ans. Current equals 2.333 amperes, voltage equals 2333 volts. Voltage is reversed.

**31c.** A battery of which the resistance is 500 ohms and of which the electromotive force is 8,000 volts is at a given instant connected to the end of the line which is specified in problem 31*b*. Find the value of current and voltage in the pure wave which starts out from the battery. Ans.  $I = 5.333$  amperes,  $E = 5333$  volts.

*Note.*—Let  $I$  be the current in the wave (and of course in the battery). Then  $8000 - R_b I$  is the voltage across the terminals of the battery or the voltage in the wave, and we have

$$\frac{1}{2}C(8000 - R_b I)^2 = \frac{1}{2}L I^2$$

which determines  $I$ .

**32.** A 10,000-volt battery of negligible resistance is connected to the end of a five-mile transmission line like that specified in

problem 27, and the distant end of the transmission line is connected to a non-inductive receiving circuit of which the resistance is 1,192.4 ohms. Plot a curve of which the ordinates represent the values of the current at the battery end of the line and of which the abscissas represent times reckoned from the instant of connecting of the battery. Resistance of line wires assumed to be negligible.

*Note.* — Under the conditions specified in this problem, a first wave, of battery voltage and corresponding current, shoots out from the battery end of the line and is partially reflected from the receiver end of the line, as explained in Art. 28. This reflected wave is then completely reflected from the battery end of the line with reversal of voltage phase, and this completely reflected wave is again partially reflected from the receiver end, and so on. The successive instantaneous values of current at the generator end of the line are represented by the ordinates of the broken curve in Fig. 32*p*. The ordinate *a* of the dotted line is equal to the ultimate steady value of

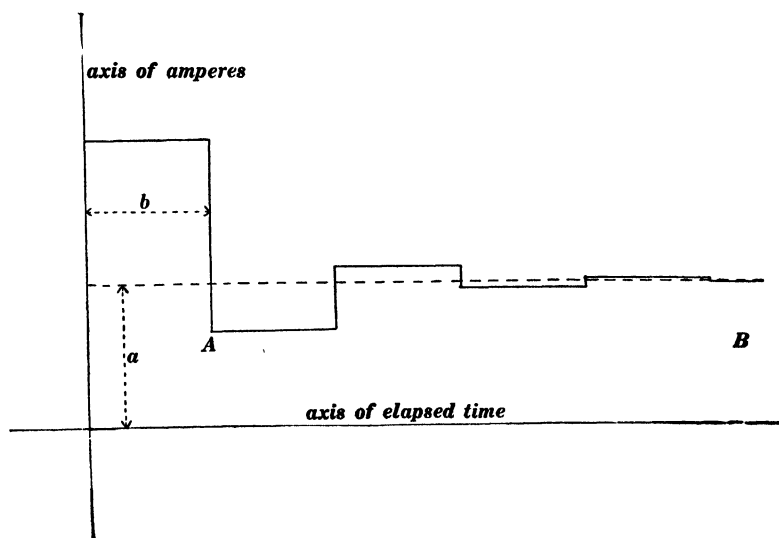

Fig. 32*p*.

the current (10,000 volts divided by 1,192.4 ohms) and the distance *b* is equal to the time required for an electromagnetic wave to travel over twice the length of the line.

In this problem the initial value of the battery current is greater than the ultimate current because the receiving circuit has a resistance greater than  $\sqrt{L/C}$ . It is interesting to consider the case in which the resistance of the receiving circuit is less than  $\sqrt{L/C}$ . Then the initial value of the battery current is less than the ultimate steady value and it approaches the ultimate value in a curve exactly similar to the portion *AB* of the curve in Fig. 32*p*.

**33.** A battery of which the resistance is equal to  $\sqrt{L/C}$  is suddenly connected to a transmission line, the distant end of which is short-circuited. Describe what takes place.

*Note.* — In this case the system settles to a steady unchanging state after the time required for a wave to travel over twice the length of the line.

**34.** The distant end of the transmission line in problem 33 is open. Describe what takes place.

*Note.* — In this case the system settles to a steady unchanging state after the time required for a wave to travel over twice the length of the line

**35.** Calculate the leakage resistance between the wires on one mile of the transmission specified in problem 27 in order that the line may transmit electric waves without distortion. Resistance of line wires not assumed to be negligible. Ans. 809,000 ohms.

*Note.* — In calculating the answer to this problem, the resistance of the wires is calculated on the assumption that the resistance of one "mil-foot" of copper is 10.4 ohms. In all of the following problems where it is required to calculate the resistance of copper wires the same value, 10.4 ohms per mil-foot, is used for the specific resistance of copper.

**36.** A 200-mile line with sufficient leakage to make it distortionless, as specified in problem 35, has a 10,000-volt battery of negligible resistance connected to one end. Find the value of voltage and current in the front part of the wave at the instant it reaches the distant end of the line. Ans. 8,240 volts; 13.82 amperes.

*Note.* — The condition of distortionless transmission being satisfied, each small part of the long-drawn-out wave which shoots out from the battery end of the line may be considered independently of the adjoining parts of the wave. Consider such a short portion of the wave which has reached a point distant  $x$  from the battery  $t$  seconds after the battery is connected. During the succeeding time interval  $\Delta t$  this portion of the wave will travel the additional distance  $\Delta x$ , and the decrement of voltage in the portion of the wave during the interval  $\Delta t$  will be given by the equation

$$\Delta E = - \frac{I}{C} \cdot \frac{E}{R_l} \Delta t \quad (i)$$

inasmuch as  $C \cdot \Delta E$ , the decrease of charge per unit length of the line, is equal to the product of the leakage current  $E/R_l$  per unit length of line times the time interval  $\Delta t$ . The decrement of current in the portion of the wave under consideration during the interval  $\Delta t$  is given by the equation

$$\Delta I = -\frac{R_w}{L} \cdot I \cdot \Delta t \quad (\text{ii})$$

inasmuch as the self-induced electromotive force  $L \cdot \Delta I / \Delta t$  due to the decaying current in unit length of the line is wholly used to overcome the wire resistance and is therefore equal to  $R_w I$ , where  $R_w$  is the resistance of both wires in unit length of the line.

From equations (i) and (ii) we have

$$\frac{dE}{dt} = -\frac{1}{CR_l} \cdot E \quad (\text{iii})$$

and from equation (ii) we have

$$\frac{dI}{dt} = -\frac{R_w}{L} \cdot I \quad (\text{iv})$$

Therefore, by integration, we have

$$E = E_0 e^{-\frac{1}{CR_l} \cdot t} \quad (\text{v})$$

and

$$I = I_0 e^{-\frac{R_w}{L} \cdot t} \quad (\text{vi})$$

These equations are true only when the line is distortionless, and when the line is distortionless the coefficients of  $t$  in the exponents in equation (v) and (vi) are equal to each other.

The value  $x/V$  may be substituted for  $t$  in equations (v) and (vi) giving the equation to the curves which represent the voltage and current distribution throughout the long-drawn-out wave which shoots out from the battery, namely

$$E = E_0 e^{-\frac{1}{CR_l V} \cdot x} \quad (\text{vii})$$

and

$$I = I_0 e^{-\frac{R_w}{L V} \cdot x} \quad (\text{viii})$$

**37.** The distant end of the line in problem 36 is short-circuited so that the wave when it reaches the end of the line is reflected with reversal of voltage phase. Find the value of voltage and current at the middle point of the line when the front of the reflected wave reaches that point. Ans. 275 volts; 29.01 amperes.

*Note.*—The voltage and current in the reflected wave may be treated independently of the voltage and current in the original advancing wave when the condition of distortionless transmission is satisfied, and both voltage and current continue to decay according to the exponential law, as explained in the note to problem 36.

**38.** A 200-mile metallic-circuit telephone line has two No. 14 B. & S. steel wires (91 ohms per "mil-foot"). Find its resistance. The distance between wires is 18 inches; find the leakage

resistance between wires of one mile of line for which the leakage loss is one tenth of one per cent. of the wire loss in a pure electromagnetic wave. Ans. Wire resistance of whole line 46,880 ohms ; leakage resistance of one mile of line 1,952,000 ohms.

39. In what ratio would the total loss of energy on the line specified in problem 38 be increased by reducing the leakage resistance of the line in the ratio of 400 : 1 ? Ans. 1 to 1.4.

40. Calculate the inductance per mile required to give distortionless transmission on the telephone line specified in problem 38, and find how much (*for given amount of energy transmitted*) the total loss of energy on the line is reduced by increasing the inductance to this value. Ans. 3.632 henrys per mile ; total energy lost is reduced in the ratio of 1.001 to 0.06324.

41. The leakage resistance between wires of one mile of a line consisting of two No. 8 B. & S. bare copper wires laid 12 inches apart in pure distilled water would be about 25 ohms. (*a*) Find the capacity per unit length of line to give distortionless transmission, and (*b*) find the capacity which would have to be added as indicated in Fig. 83, page 85 to produce this result, the inductivity of pure water being equal to 90. Ans. (*a*) 5.03 microfarads per mile ; (*b*) 4.26 microfarads per mile.

42. What part of the initial energy of a wave would be delivered to the end of a 10-mile line like that specified in problem 41, with sufficient capacity to give distortionless transmission ? Ans.  $1/2.784$  of the energy would be delivered.

*Note.* — Calculate the time of transit of the wave. Then the fraction of the energy lost during transit is equal to the fraction of the electrical energy which would be lost during the time of transit if the whole line were charged at any assigned initial voltage and allowed to stand.

43. An inductance  $L_0$  of 0.016 henry (of negligible resistance) is connected across one end of a 2.5-mile transmission line, of which the other end is open as shown in Fig. 43*p*. The line consists of two wires, each 0.064 inch in diameter, 18 inches apart. Find the approximate frequencies of the first, second and third simple modes of oscillation of the system, ignoring resist-

ance of line-wires. Ans.  $f_1 = 9,470$  cycles per second,  $f_2 = 39,540$  cycles per second, and  $f_3 = 75,550$  cycles per second.

*Note.* — A fairly accurate estimate of the frequency  $f_1$  of the fundamental mode may be obtained by ignoring the inductance of the line. The system then becomes a system of the first class, with concentrated capacity, and its frequency is given by the well-known formula

$$f_1 = \frac{1}{2\pi} \sqrt{\frac{1}{L_0 C_0}} \quad (\text{i})$$

in which  $C_0$  is the capacity of the 2.5-mile line.

The frequency  $f_n$  of the  $n$ th mode may be estimated very closely by considering: (a) that a voltage antinode exists at a short distance  $x$  from  $L_0$ ; (b) that the remainder of the line is equal to  $(n - 1)$  half-wave-lengths, where a half-wave-length is equal to  $V/(2f_n)$ , so that

$$2.5 - x = (n - 1) \frac{V}{2f_n} \quad (\text{ii})$$

in which  $V [= \sqrt{1/(\overline{LC})}]$  is the wave velocity on the transmission line; and (c) that the short portion  $x$  of the line together with the inductance  $L_0$  may be looked upon as a system of the first class whose frequency of oscillation is

$$f_n = \frac{1}{2\pi} \sqrt{\frac{1}{L_0 C_x}} \quad (\text{iii})$$

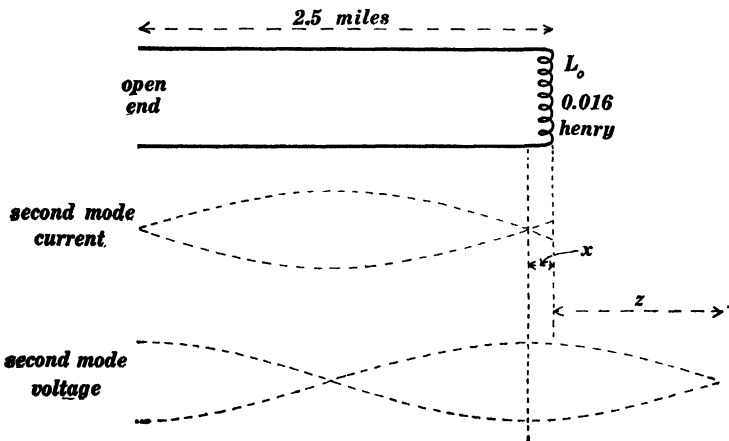

Fig. 43*f*.

where  $C_x$  is the capacity of the portion  $x$  of the line. Therefore, substituting the value of  $f_n$  from equation (iii) in equation (ii) and using  $\sqrt{1/(\overline{LC})}$  for  $V$  we have

$$2.5 - x = (n - 1) \pi \sqrt{\frac{L_0 x}{L}} \quad (\text{iv})$$

from which the approximate value  $x$  may be calculated, whence the approximate value of  $f_n$  may be found from equation (iii).

To determine the frequency of oscillation of the system represented in Fig. 43*p* with precision, consider that the line oscillation which accompanies any given mode of oscillation of the system is part of a standing wave-train of wave-length equal to  $V/f_n$ . This standing wave-train is represented by a portion of the clock-diagram model of Fig. 130, and the distance  $z$  in Fig. 43*p* is given by equation (v) on page 136, in which  $X$  is the reactance value ( $= 2\pi f_n L_0$ ) of the inductance  $L_0$ . Consider for example the second mode which is shown in Fig. 43*p*. Its frequency is  $f_2$  and its wave-length is  $V/f_2$ . Using the approximate value of  $f_2$  as above determined, calculate the approximate value of  $X$  and  $V/f_2$ , and then calculate the value of  $z$  from equation (v) on page 136. Then, for the second mode,  $2.5 + z$  is  $\frac{3}{4}$  of a wave-length so that  $V$  divided by  $\frac{4}{3}(2.5 + z)$  gives a second approximation to the value of  $f_2$ . A third approximation may be made in the same way, and so on. Thus, the successive approximations to the value of  $f_1$  for the system shown in Fig. 43*p* are, 1st, 9,470 cycles per second; 2d, 8,770 cycles per second; 3d, 8,614 cycles per second; 4th, 8,579 cycles per second; and 5th, 8,572 cycles per second. The correct value is about 8,570 cycles per second. The successive approximations converge more rapidly to the correct value in the higher modes.

**44.** A mass of 160 grams ( $= L_0$ ) hangs from a helical spring as shown in Fig. 44*p*. Under these conditions the spring is 150 centimeters long; each centimeter of the spring has a mass of 0.5 gram ( $= L$ ), and a stretching force (additional to the weight of the 160-gram load) of 100,000 dynes produces a two per cent. elongation of the spring so that the ratio : per cent. elongation divided by stretching force is  $2 \times 10^{-7}$  ( $= C$ ). Find three successive approximations to the frequency of oscillation (through a small amplitude) of the fundamental mode of the system. Ans. First approximation 7.27 vibrations per second; second approx. 6.85 vibrations per second; third approx. 6.67.

*Note.* — The answers to this problem were worked out by means of a four place table of logarithms. To carry the approximation further a more complete logarithmic table would have to be used.

## CHAPTER V. TRANSMISSION-LINE OSCILLATION.

**45a.** A 20-mile transmission line consisting of two No. 8 B. & S. wires 18 inches apart center to center and short-circuited at the distant end is connected to a 10,000-cycle alternator of which the electromotive force is 500 volts effective. Find positions of voltage antinodes, and find maximum voltage between the line

wires at the voltage antinodes when the ultimate steady state of oscillation of the line is established, line resistance being neglected. Also find positions of current antinodes and find maximum value of current in the line at the current antinodes. Ans. Voltage

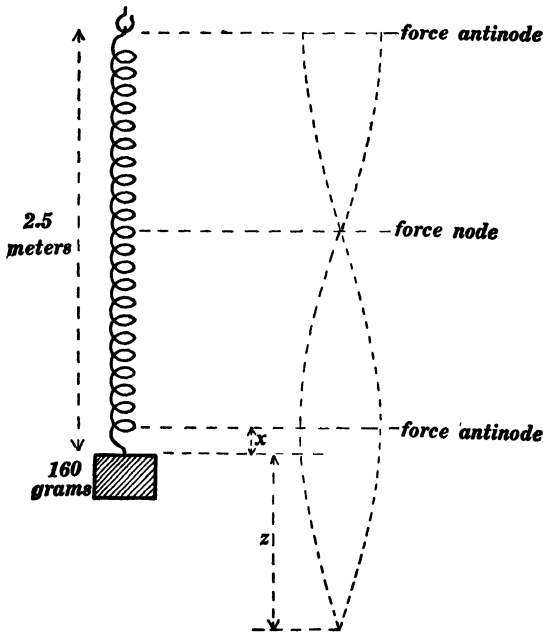

Fig. 44*b*.

nodes at distances of 0, 9.3 and 18.6 miles from short-circuited end of line ; maximum voltage at voltage antinodes 1,552 volts. Current nodes at distances of 4.65 and 13.95 miles from short-circuited end of line ; maximum current at current antinodes 2.293 amperes.

**45*b*.** A coil of which the inductance is ten millihenrys and of which the resistance is negligible is connected to one end of a 26-mile transmission line consisting of two No. 8 B. & S. wires 18 inches apart center to center, and a 500-volt (effective) 10,000-cycle alternator is connected to the other end of the line. Find positions of voltage and current antinodes and find maximum

values of voltage and current at voltage and current antinodes respectively. Ans. Voltage antinodes at distances of 2.434, 11.734, and 21.034 miles from the end of line where inductance is connected; maximum voltage at voltage antinodes 6,631 volts. Current antinodes are at distances of 7.084, 16.384 and 25.684 miles from the end of the line where the inductance is connected; maximum current at current antinodes is 9.8 amperes.

**46.** The inductance at the end of the transmission line in problem 45*b* is replaced by a condenser of which the capacity is 0.02653 microfarad and of which the resistance is negligible. Find positions of voltage and current antinodes and effective values of voltage and current at the respective antinodes. Ans. Voltage antinodes are at distances of 7.17, 16.47, and 25.77 miles from the end of the line where the condenser is connected; effective voltage at voltage antinodes is 501.6 volts. Current antinodes are at distances of 2.52, 11.82 and 21.12 miles from the end of the line where the condenser is connected; effective current at current antinodes is 0.7481 amperes.

**47.** A receiving circuit of which the resistance is 571.7 ohms and the inductance is ten millihenrys is connected to the end of a transmission line consisting of two No. 8 B. & S. wires 18 inches apart center to center, and a simple train of electromagnetic waves in which the wave-length is 20 miles and in which maximum voltage is 2,000 volts is reflected from the receiving circuit. Find the current maximum in the original advancing wave-train, find the voltage and current maxima in the reflected wave-train, and specify the phase displacements produced in voltage and current at reflection. Resistance of line wires negligible.

*Note.* — The resistance and inductance of the receiving circuit have been chosen in this problem to give a  $45^\circ$  phase difference between resultant voltage and current at the end of the transmission lines so as to facilitate the solution of the problem. See pages 138 and 139

**48.** The transmission line specified in problem 47 is indefinitely long. Find the effective values of voltage and current at a point 22.5 miles from the end of the line due to the superposition of

the original advancing wave-train and the reflected wave-train, and specify the phase angles between each and the current which is associated with the original advancing wave-train at the point.

*Note.*—The distance 22.5 miles is chosen so that the vectors  $E'$ ,  $I'$ ,  $E''$ , and  $I''$  in Fig. 132 on page 139 will have to be turned through angles which can be easily laid off by a draughtsman's triangle. This problem is to be solved graphically.

49. A 200-mile transmission line consisting of two copper wires 0.5 inch in diameter and 36 inches apart center to center delivers 35 amperes (effective) of current at 60,000 volts (effective) and 25 cycles per second to a receiving circuit of which the power factor is 0.8. Find the effective value of the generator voltage and find the resistance losses in the line wires, assuming line leakage to be negligible. Solve this problem by the approximate method as outlined in Franklin & Esty's *Elements of Electrical Engineering*, Vol. II, pages 346–353, and also by the rigorous method outlined on pages 149–153, and compare the results.

#### CHAPTER VI. ELECTROMAGNETIC THEORY.

50. A vessel one meter wide, one meter long and one meter deep contains a fluid of which the density is one gram per cubic centimeter at the top, increasing steadily to 2 grams per cubic centimeter at the bottom. Find the volume integral of the density of the fluid. Ans. 1,500,000 grams.

51. The gradient of the density in problem 50 is uniform throughout the vessel and equal to one gram per cubic centimeter per meter and it is directed vertically downwards. Suppose the downward gradient of the density to be a linear function of the distance from the top of the vessel, changing from zero at the top to 2 grams per cubic centimeter per meter at the bottom. Find the volume integral of the density of the liquid throughout the vessel, the density being one gram per cubic centimeter at the top. Ans. 1,333,333 grams.

52. The value at all points in space of a distributed scalar is given by the equation  $\psi = Q/r$  in which  $r$  is distance meas-

ured from the origin of co-ordinates. Find the  $x$ ,  $y$  and  $z$  components of the gradient of  $\psi$ . Ans. The  $x$ -component is  $-Qx/(x^2 + y^2 + z^2)^{3/2}$ .

53. Any one of the components of the gradient of a distributed scalar may be considered itself a distributed scalar. Find the  $x$ ,  $y$  and  $z$  components of the gradient of  $d\psi/dx$ , where  $\psi = Q/r$ , as in problem 52.

Ans. The  $x$ -component is

$$\left[ -\frac{1}{(x^2 + y^2 + z^2)^{3/2}} + \frac{3x}{(x^2 + y^2 + z^2)^{5/2}} \right] Q$$

*Note.*—The gradient  $d/dx(Q/r)$  considered as a distributed scalar (indeed the  $x$ -component at all points of space of any distributed vector is a distributed scalar) is the electric potential due to an electrical doublet placed at the origin, the *moment* of the doublet being  $Q$ . Successive derivatives of  $Q/r$  are possible electric potential distributions, they are called spherical harmonics, and by superposing spherical harmonics (of potential) in a proper way any potential distribution whatever may be built up. The most instructive discussion of spherical harmonics is that which is given in Maxwell's treatise on Electricity and Magnetism. Byerly's *Fourier's Series and Harmonic Analysis* (see preface) is the best mathematical treatise on Spherical Harmonics for the student of physics.

54. The intensity of the magnetic field at the point  $p$  in Fig. 54p is  $H = 1,000$  gausscs. The magnet  $NS$  is rotated about

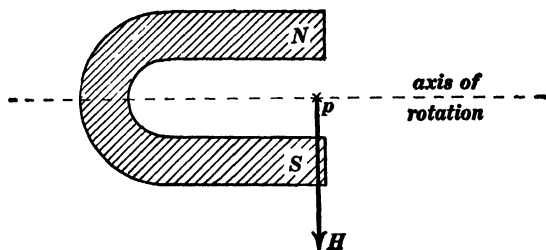

Fig. 54p.

the dotted line as an axis at a speed of 20 revolutions per second. Find an expression for the rate of change of  $H$  at the point  $p$ . Ans. The  $x$ -component of  $dH/dt$  is  $-125,664 \sin(40\pi t)$  and the  $y$ -component is  $125,664 \cos(40\pi t)$ .

*Note.*—The rotating magnetic field  $H$  may be expressed thus:

$$H = 1000 \epsilon^{40\pi j t}$$

in which  $j$  is equal to  $\sqrt{-1}$  and  $t$  is equal to elapsed time. See Art. 37.

**55.** Find the differential equations of the lines of force in the neighborhood of an isolated magnet pole of strength  $m$  and integrate the differential equations so as to find the integral equations of the lines of force.

*Note.* — Let  $dx$  and  $dy$  be the components of a small element  $ds$  of a line of force. The ratio  $dy/dx$  is equal to the ratio of the components of the field, at the point, that is to say the general differential equations of a line of force is

$$\frac{dy}{dx} = \frac{Y}{X}$$

and

$$\frac{dz}{dx} = \frac{Z}{X}$$

**56.** Find the differential equations of the lines of force in the neighborhood of a slim magnet 10 centimeters long, its poles being assumed to be concentrated at its ends; strength of poles being  $+m$  and  $-m$ .

**57.** A strip of steel 10 centimeters wide and 0.1 centimeter thick is magnetized in the direction of its breadth to an intensity of 1,000 units pole per square centimeter sectional area. (a) Find the direction and intensity of the magnetic field at a point 6 centimeters from one edge and 8 centimeters from the other edge of the strip. (b) Derive the differential equation of the lines of force of the magnetic field. (c) Integrate this differential equation and show that the lines of force are a system of circles.

**58.** Consider a uniform electric field of which the intensity is 1,000 volts per centimeter. A circle 100 centimeters in radius is drawn in this field with a diameter in the direction of the field. Consider one half of this circle. (a) Find the line integral of the electric field along this half circle. (b) Find the line integral of the electric field around the entire circle.

**59.** A large vessel of water is rotated at a uniform angular velocity of 2 revolutions per second about a vertical axis. Choose this axis as the  $x$ -axis of reference, and choose the  $y$ - and  $z$ -axes in a horizontal plane. (a) Derive expressions for the three components of the velocity of the fluid at the point whose coördinates are  $x$ ,  $y$  and  $z$ . (b) Find the line integral of this fluid

velocity about a small circle of which the plane is horizontal, of which the center is 10 centimeters to one side of the axis of rotation of the vessel, and of which the radius is 15 centimeters.  
 Ans. (a)  $Y = -4\pi z$ ,  $Z = +4\pi y$ ; (b) 17,760 cm.<sup>2</sup> per second.

60. Show that the velocity of the fluid in problem 59 cannot have a potential.

61. All space is filled with a liquid moving parallel to the  $x$ -axis of reference at a velocity of 10 centimeters per second. Find an analytical expression for the velocity potential of the liquid. Ans.  $\psi = 10 \text{ cm. per sec.} \times x + \text{any constant}$ .

62. Given a uniformly moving fluid of which the velocity components are everywhere the same and equal to  $a$ ,  $b$  and  $c$  respectively. Find the velocity potential of the fluid. Ans.  $ax + by + cz + \text{any constant}$ .

63. Given a fluid of which the velocity is everywhere parallel to the  $x$ -axis of reference and equal at each point to  $ax$ . Find the velocity potential of the fluid. Ans.  $\psi = \frac{1}{2}ax^2 + \text{a constant}$ .

64. Given a fluid of which the velocity components are  $ax$ ,  $by$  and  $cz$ , respectively. Find its velocity potential. Ans.  $\psi = \frac{1}{2}ax^2 + \frac{1}{2}by^2 + \frac{1}{2}cz^2 + \text{a constant}$ .

65. A viscous fluid flowing over a plane has a velocity which is expressed by the equation  $X = ay$  as indicated in Fig. 65*p*. Show that no velocity potential exists in this case.

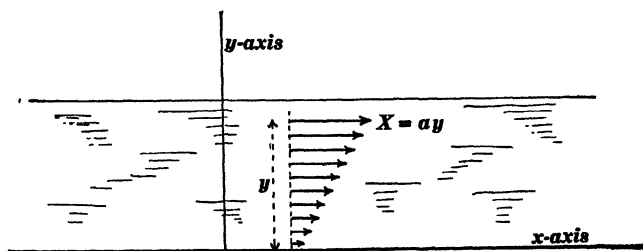

Fig. 65*p*.

66. The lines of force of a tapering electric field are shown in Fig. 66*p*, and the intensity of this field at each point is expressed

by the equation  $Y = ax$ . Show that this electric field has no potential.

*Note.* — Consider that the potential at a point in an electric field is the height at that point of an imagined hill whose slope is everywhere equal to the electric field. It is impossible to construct a hill whose slope lines are as shown in Fig. 66p, the degree of slope increasing from a certain value at one side  $AA'$  of the figure to a greater value at the other side  $BB'$  of the figure. Thus if the lines of forces in Fig. 66p be thought of as lines of slope of a hill it would have to be a hill on which one would not go down hill at all in traveling from  $A'$  to  $A$  and thence to  $B$  whereas one would go down hill a great deal in traveling from  $A'$  to  $B'$  and thence to  $B$ . The slope (in the direction of the lines of force) would increase from the side  $AA'$

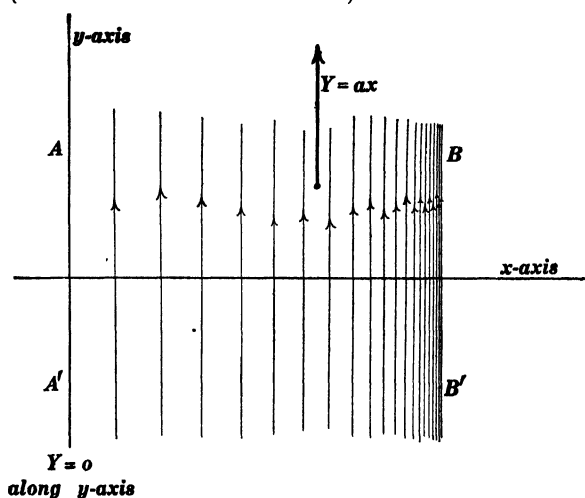

Fig. 66p.

to the side  $BB'$  but there would be no slope at right angles to the lines of force. Such a hill is impossible. If however an additional slope in the direction of the  $x$ -axis be added such that  $X = ay$ , then  $dY/dx - dX/dy$  would be equal to  $a - a = 0$ ; the electric field of which the components are  $Y = ax$  and  $X = ay$  has a potential.

**67.** Liquid flows over an infinite plane towards a circular spot 20 centimeters in radius where the liquid leaks through the plane at the rate of 2 cubic centimeters per second for each square centimeter of area of the leaky portion. The liquid has a uniform depth of 10 centimeters over the entire plane. Find: (a) Formulas expressing the components of the horizontal velocity of the liquid in the region over the leaky part of the plane, (b) formulas expressing the components of the velocity of the liquid

in the region outside of the leaky portion of the plane. (c) Show that velocity potential exists in both regions, (d) choosing the edge of the leaky portion as the region of zero potential, derive a formula for the velocity potential outside of the leaky spot and another formula for the velocity potential inside the leaky spot, using distance from center of leaky spot as a variable in each case. (e) Draw a sketch of the plane as seen from above, showing the contour lines of the potential hill, the contour lines being drawn for equal potential differences.

*Note.* -- In this problem it is understood that only the horizontal part of the velocity of the fluid over the leaky spot is to be considered.

Ans. (a)  $x$ -component of velocity in region of leaky spot =  $x/10$ ; (b)  $x$ -component of velocity in region beyond leaky spot =  $40x/(x^2 + y^2)$ ; (c) —; (d) potential in leaky spot =  $(x^2 + y^2)/20 - 20$ , potential beyond leaky spot =  $20 \log_e(x^2 + y^2) - 20 \log_e 400$ .

68. A long cylinder of insulating material 20 centimeters in radius is uniformly charged with  $\frac{1}{2}\pi$  electrostatic units of charge per cubic centimeter. Find: (a) Formulas expressing the components of the electric field in the material of the rod, inductivity of the rod being equal to 2, (b) formulas expressing the electric field intensity at points outside of the rod, (c) show that the electric field has a potential inside of the rod and outside of the rod. (d) Choosing the surface of the rod as the region of zero electric potential, derive a formula for the potential outside of the rod and another formula for the potential inside of the rod.

Ans. (a)  $x$ -component of field in rod =  $x/10$ ; (b)  $x$ -component of field outside of rod =  $40x/(x^2 + y^2)$ ; (c) —; (d) potential in rod =  $\frac{x^2 + y^2}{20} - 20$ , potential outside of rod

$$= 20 \log_e(x^2 + y^2) - 20 \log_e 400.$$

*Note.* — When electric charge and electric flux are both expressed in units of the electrostatic system Gauss's theorem becomes: Total electric flux out of a region equals  $4\pi$  times the total charge in the region.

69. A wire 20 centimeters in radius carries one abampere of current per square centimeter of section. Find: (a) Formulas ex-

pressing the components of the magnetic field intensity at a point outside of the wire, and (b) formulas expressing the components of the magnetic field intensity at a point inside of the wire.

Ans. (a)  $x$ -component =  $2\pi y$ ,  $y$ -component =  $-2\pi x$ ; (b)  $x$ -component =  $800\pi y/(x^2+y^2)$ ,  $y$ -component =  $-800\pi x/(x^2+y^2)$ .

70. Show that the magnetic field inside of the wire in problem 69 does not have a potential.

71. Show that the magnetic field outside of the wire in problem 69 does have a potential, and derive a formula expressing the value of this potential at each point (a) in terms of rectangular coördinates and (b) in terms of polar coördinates. Ans. Potential =  $2I\theta$  or  $2I \tan^{-1}y/x$ .

72. Find the surface integral of fluid velocity over a plane area 20 centimeters long and 10 centimeters high placed in a fluid moving as specified in problem 67; find the surface integral (a) for the case in which the center of the plane area is 5 centimeters from the center of the leaky spot and (b) for the case in which the center of the plane area is 30 centimeters from the center of the leaky spot. Ans. (a) 100 cubic centimeters per second; (b)  $800 \tan^{-1}0.333$  cubic centimeters per second.

73. Find the divergence of the fluid velocity in problem 67 (a) in the region over the leaky spot and (b) in the region surrounding the leaky spot. In this problem ignore the vertical velocity of the fluid over the leaky spot. Ans. (a)  $\frac{1}{8}$  cubic centimeter per second per cubic centimeter; (b) zero.

74. Find the divergence of the electric field which is specified in problem 68, (a) for points inside of the insulating rod and (b) for points outside of the rod. Ans. (a)  $\frac{1}{6}$  electrostatic unit of electric flux per cubic centimeter; (b) zero.

75. Find the curl of the fluid velocity which is specified in problem 59. Ans.  $-8\pi$  per second.

76. Find the curl of the fluid velocity which is specified in problem 65. Ans.  $-a$ .

77. Find the curl of the electric field which is specified in problem 66. Ans.  $+a$ .

**78.** Find the curl of the magnetic field which is specified in problem 69. Ans. —  $4\pi$  units of magnetomotive force per square centimeter inside of wire; zero outside of wire.

## CHAPTER VIII. HARMONIC ANALYSIS.

**79.** Find the harmonic components of the periodic curve shown in Fig. 197. The answer is given by equation (82) in Art. 70.

**80.** Find the harmonic components of the curve shown in Fig. 183. Ans.

$$y = \frac{4a}{\pi} \left[ \sin \frac{2\pi t}{T} + \frac{1}{3} \sin \frac{6\pi t}{T} + \frac{1}{5} \sin \frac{10\pi t}{T} + \frac{1}{7} \sin \frac{14\pi t}{T} + \dots \right]$$

*Note.* — In this case the given function  $y$  is equal to  $+a$  from  $t=0$  to  $t=T/2$ , and it is equal to  $-a$  from  $t=T/2$  to  $t=T$ . Therefore equation (80) becomes

$$A_n = \frac{2a}{T} \int_0^{T/2} \sin \frac{2\pi nt}{T} \cdot dt - \frac{2a}{T} \int_{T/2}^T \sin \frac{2\pi nt}{T} \cdot dt$$

**81.** Find the harmonic components of the curve shown in Fig. 184. Ans.

$$y = \frac{4a}{\pi} \left[ \cos \frac{2\pi t}{T} - \frac{1}{3} \cos \frac{6\pi t}{T} + \frac{1}{5} \cos \frac{10\pi t}{T} - \frac{1}{7} \cos \frac{14\pi t}{T} + \dots \right]$$

*Note.* — Solve this problem directly by means of equations (76), (80) and (81), and also derive the result from the answer to problem 80 by shifting the origin or coordinates from the position shown in Fig. 183 to the position shown in Fig. 184.

In applying equation (81) in this case we have:

$$B_n = \frac{2a}{T} \int_{-T/4}^{T/4} \cos \frac{2\pi nt}{T} \cdot dt - \frac{2a}{T} \int_{3T/4}^{5T/4} \cos \frac{2\pi nt}{T} \cdot dt$$

**82.** Find the harmonic components of the curve shown in Fig. 185, the maximum ordinate of the curve being equal to  $kT/4$ . Ans.

$$y = \frac{2Tk}{\pi^2} \left[ \sin \frac{2\pi t}{T} - \frac{1}{9} \sin \frac{6\pi t}{T} + \frac{1}{25} \sin \frac{10\pi t}{T} - \frac{1}{49} \sin \frac{14\pi t}{T} + \dots \right]$$

*Note.* — The given function  $y$  is in this case as follows :

$$y = kt \text{ from } t = 0 \text{ to } t = T/4$$

and

$$y = kT/2 - kt \text{ from } t = T/4 \text{ to } t = 3T/4$$

$$y = kt - kT \text{ from } t = 3T/4 \text{ to } t = T.$$

Therefore equation (80) becomes

$$A_n = \frac{2k}{T} \int_0^{T/4} \sin \frac{2\pi nt}{T} \cdot dt + \frac{2k}{T} \int_{T/4}^{3T/4} \left( \frac{T}{2} - t \right) \sin \frac{2\pi nt}{T} \cdot dt \\ + \frac{2k}{T} \int_{3T/4}^T (t - T) \sin \frac{2\pi nt}{T} \cdot dt$$

83. Find the harmonic components of the curve shown in Fig. 83*p*, the maximum ordinate being equal to  $kT/4$ . Ans.

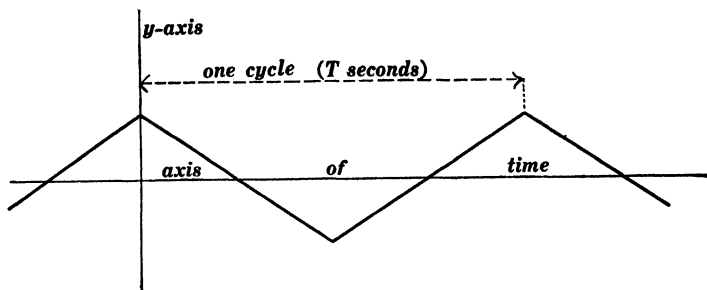

Fig. 83*p*.

$$y = \frac{2Tk}{\pi^2} \left[ \cos \frac{2\pi t}{T} + \frac{1}{9} \cos \frac{6\pi t}{T} + \frac{1}{25} \cos \frac{10\pi t}{T} + \frac{1}{49} \cos \frac{14\pi t}{T} + \dots \right]$$

*Note.* — Solve this problem directly by the use of equations (76), (80) and (81), and also derive the result from the answer to problem 82 by shifting the origin of co-ordinates from the position shown in Fig. 185 to the position shown in Fig. 83*p*.

The given function  $y$  is in this case as follows :

and

$$y = kt \text{ from } t = 0 \text{ to } t = T/2$$

$$y = kt - kT/2 \text{ from } t = T/2 \text{ to } t = T$$

Therefore equation (81) becomes

$$B_n = \frac{2k}{T} \int_0^{T/2} \left( \frac{T}{2} - t \right) \cos \frac{2\pi nt}{T} \cdot dt + \frac{2k}{T} \int_{T/2}^T \left( t - \frac{T}{2} \right) \cos \frac{2\pi nt}{T} \cdot dt$$

84. Derive the answer to problem 82 by integrating the answer to problem 81.

*Note.* — It is evident that the constant  $A_0$  is equal to zero in the series which expresses the periodic curve shown in Fig. 185. Therefore the constant which is introduced by the integration of the answer to problem 81 is equal to zero.

A Fourier's series always remains convergent after the various terms of the series have been integrated, but in many cases a Fourier's series becomes divergent after differentiation. Thus, the series which expresses the periodic curves in Figs. 183 and 184 become divergent when differentiated.

**85.** Ignoring all harmonics above the 9th, that is, ignoring the 11th and higher harmonics, determine by Fischer-Hinnen's method the coefficients  $A_1, A_3, A_5, A_7,$  and  $A_9$  for the curve shown in Fig. 185, and compare the approximate values of the coefficients so obtained with the correct values in the answer to problem 82. Ans

<i>By F-H method.</i>	<i>Correct values.</i>
$A_9 = + 0.00309kT$ .....	$+ 0.00250kT$
$A_7 = - 0.00510$ " .....	$- 0.00413$ "
$A_5 = + 0.01000$ " .....	$+ 0.00810$ "
$A_3 = - 0.02470$ " .....	$- 0.0225$ "
$A_1 = + 0.20710$ " .....	$+ 0.2026$ "

**86.** Measure off 36 equidistant ordinates throughout one cycle of the curve shown in Fig. 185, multiply these measured ordinates by the corresponding values of  $\sin 2\pi nt/T$ , where  $n = 5$ , add these products together, and determine the value of  $A_5$  as explained in the first part of Art. 71. Compare the approximate value of  $A_5$  so obtained with the correct value found in the answer to problem 82. Ans.  $A_5 = 0.008644 kT$ ; correct value  $= 0.00810 kT$ .

### CHAPTER IX. NON-HARMONIC ELECTROMOTIVE FORCES AND CURRENTS.

**87.** Each winding of a three-phase alternator develops 1,000 volts effective. The windings are Y-connected to a three-wire transmission line, and the electromotive force between any two wires of the line is observed to be 1,640 volts. Assuming that the voltage of each armature winding contains only a triple harmonic in addition to the fundamental, and assuming that the three voltages are equal and exactly  $120^\circ$  apart in phase, calcu-

late the effective value of the triple harmonic in the voltage of each armature winding. Ans. 53.2 volts.

**88.** The alternator which is described in problem 87 delivers current over a three-wire line to three similar non-inductive receiving circuits. Find the power factor of the system due to the elimination of triple harmonic currents by the three-wire line. Ans. 94.68.

*Note.* — Find the product of generator voltage times any assumed current  $I$  in each generator winding. The current in each receiving circuit is the same as  $I$  but the voltage across each receiving circuit is less than the generator voltage according to problem 87. The desired value of the power factor is equal to receiver voltage times receiver current divided by generator voltage times generator current.

# INDEX.

- Air and water pipes, wave pulses in, 34  
 columns, simple modes of oscillation  
 of, 43
- Antennæ for wave telegraphy, 206  
 recent forms of, 209
- Antinode, definition of, 48
- Branly's coherer, 213
- Canal, oscillation of water in, 25  
 wave pulses in, 14  
 waves, 14  
   differential equations of, 154  
   reflection of, 22  
   superposition of, 19  
   velocity of, 15
- Capacity and inductance of transmission  
 lines, 269  
 concentrated and distributed, 1
- Clock-diagram models of wave trains, 129
- Coherer, the, 213
- Compound vibrations of a particle, 36  
 wave trains, 38
- Concentrated capacity and distributed  
 capacity, 1
- Conduction current and displacement cur-  
 rent, 186
- Curl of a distributed vector, 175
- Current, displacement, 186
- Currents, harmonic and non-harmonic, 6
- Decaying wave trains on a transmission  
 line, 141
- Diffusion of waves, 29
- Displacement current and conduction cur-  
 rent, 186
- Distortion of waves, 29
- Distortionless line, the, 112
- Distributed capacity and concentrated  
 capacity, 1
- Divergence of a distributed vector, 171
- Drude's *Theory of Optics*, translated by  
 Mann & Millikan, 10
- Electric action of a tapering magnetic  
 field, 61  
 current, conception of, 63  
 field, mechanical conceptions of, 57  
   tapering, magnetic action of, 60  
 oscillation of a transmission line, 93  
 oscillator, the, 69  
 wave detectors, 213  
 wave telegraphy, 205
- Electromagnetic action, 57  
 and electrostatic systems of units,  
 279  
 field, general equations of, 186  
 wave, energy stream in, 81  
   distortion, 108  
   motion, conceptions of, 78  
   train, 81  
   velocity of, 82  
 waves, 75  
   pure and impure, 89
- Electromotive force, induced, general  
 equations of, 189  
 forces, harmonic and non-harmonic, 6
- Electrostatic and electromagnetic systems  
 of units, 279
- Energy, flow of, in electromagnetic field,  
 64  
 stream in an electromagnetic wave,  
 81  
   in an electromagnetic field, con-  
   ception of, 64  
   equation of, 67
- Ether, Kelvin's gyrostatic model of, 57  
 Maxwell's mechanical model of, 57
- Fields, scalar and vector, 158

- Fischer-Hinnen's method of harmonic analysis, 230
- Fleming's *Principles of Electric Wave Telegraphy*, 74
- Fourier's theorem, 41, 217
- Franklin & Esty's *Elements of Electrical Engineering*, 130  
& MacNutt, *Elements of Electricity and Magnetism*, 84  
*Elements of Mechanics*, 11
- General equations of the electromagnetic field, 154
- Gradient of a distributed scalar, 159
- Harmonic analysis, 217  
Fischer-Hinnen's method, 230  
analyzer, the, 240  
and non-harmonic electromotive forces and currents, 6
- Harmonics, effects of, in alternating-current machinery, 256
- Heaviside's *Electromagnetic Theory*, 113
- Hertz oscillator, methods of exciting, 212  
simple modes of oscillation of, 206  
the, 69  
waves emitted by, 210
- Hertz's *Electric Waves*, translated by D. E. Jones, 73
- Impure waves and pure waves, 21
- Induced electromotive force, general equations of, 189
- Inductance and capacity of transmission lines, 269
- Irrotational vector fields, 167, 180
- Kelvin's *Popular Lectures and Addresses*, 14
- Klemencic detector, the, 214
- Larmor's *Aether and Matter*, 57
- Lecher's arrangement for demonstrating line oscillation, 126
- Lightning arrester, the, 106
- Line integral in a vector field, 164
- Linear vector function, the, 181
- Loaded telephone lines, 111
- Lodge's *Modern Views of Electricity*, 57
- Longitudinal waves and transverse waves, 28
- Magnetic action of a tapering electric field, 60  
field, mechanical conceptions of, 57  
tapering, electric action of, 61
- Marconi's work, 205
- Mechanical conceptions of magnetic and electric fields, 57
- Moving charges, wave motion associated with, 196
- Node, definition of, 48
- Non-harmonic currents, causes of, 251  
electromotive forces, causes of, 248
- Oscillation, electric, of a transmission line, 93  
modes of, and wave trains, 36  
of transmission line, 116  
of water in a short canal, 25  
simple modes of, of stretched strings and air columns, 43
- Oscillator, the electric, 69
- Pipes, air and water, wave pulses in, 34
- Potential, multivalued, 169  
of a distributed scalar, 167  
scalar and vector, 179
- Poulsen's singing arc, 213
- Poynting's theorem, 64, 193  
examples of, 65
- Pure and impure waves, 21  
electromagnetic, 89
- Rectangular wave pulse, the, 13
- Reflection at end of transmission line, 89  
from receiving circuit at end of transmission line, 96  
of simple wave trains on transmission lines, 134  
of waves on a canal, 22
- Rotational vector fields, 180
- Scalar and vector fields, 158  
field, gradient of, 159  
volume integral of, 159

- Seibt's arrangement for demonstrating line oscillation, 128
- Simple vibration of a particle, 36  
 modes of oscillation of stretched strings and air columns, 43  
 wave trains, 38
- Solenoidal character of curl, 179  
 vector fields, 173
- Standing wave train, 48
- Stationary wave trains, see standing wave trains
- Steel rod, wave pulses on, 30
- Stream lines in a vector field, 162
- Strings, simple modes of oscillation of, 43
- Surface integral of a distributed vector, 170
- Tapering electric field, magnetic action of, 60  
 magnetic field, electric action of, 61
- Telegraphy, electric-wave, 205
- Transmission line, decaying wave trains on, 141  
 electric oscillation of, 93  
 voltage drop on, 148  
 wave pulses on, 88  
 oscillation, 116  
 lines, inductance and capacity of, 269
- Transverse waves and longitudinal waves, 28
- Tube of flow, 174
- Unit tube, 174
- Units, electromagnetic and electrostatic systems of, 279
- Vector and scalar fields, 158  
 fields, rotational and irrotational, 180  
 potential, 179
- Vibrations, simple and compound, of a particle, 36
- Voltage drop on transmission line, 148
- Volume integral of a distributed scalar, 159
- Water and air pipes, wave pulses in, 34  
 waves, 9  
 in a canal, differential equations of, 154
- Wave distortion and line losses, electromagnetic, 108  
 or diffusion, 29  
 electromagnetic, velocity of, 82  
 front, the, 40  
 length, 37  
 media, 9  
 motion associated with moving charges, 196  
 electromagnetic, conceptions of, 78  
 pulse, electromagnetic, 77  
 the rectangular, 13  
 pulses and wave trains, 10  
 in a canal, 14  
 in air and water pipes, 34  
 on a steel rod, 30  
 on transmission lines, 88  
 shape, 10  
 telegraphy antennæ, 206  
 train, electromagnetic, 81  
 trains, 37  
 and modes of oscillation, 36  
 simple and compound, 38  
 standing, 48  
 velocity, electromagnetic, on a transmission line, 87
- Waves, electromagnetic, 75  
 bounded and free, 75  
 pure and impure, 89  
 on stretched wires, 11  
 pure and impure, 21  
 transverse and longitudinal, 28
- Wires, waves on, 11



**By Edward L. Nichols and W. S. Franklin**

## **The Elements of Physics**

A College Text-Book in three 8vo volumes with numerous illustrations.

Volume I. Mechanics and Heat. *x+290 pp., \$1.90 net.*

Volume II. Electricity and Magnetism.

*vii+303 pp., \$1.90 net.*

Volume III. Light and Sound. *viii+262 pp., \$1.50 net.*

**By W. S. Franklin and R. B. Williamson**

## **The Elements of Alternating Currents**

Second Edition. Rewritten and enlarged.

*Cloth, 8vo, xi+349 pp., \$2.50 net.*

**By W. S. Franklin and Wm. Esty**

## **The Elements of Electrical Engineering**

**A Text-Book for Technical Schools and Colleges**

Volume I. Direct Current Machines, Electric Distribution, and Lighting. *Cloth, 8vo, xiii+517 pp., \$4.50 net.*

Volume II. Alternating Currents.

*Cloth, viii+328 pp., \$3.50.*

## **Dynamos and Motors**

This book is a re-arrangement of those parts of the *Elements of Electrical Engineering* which relate to Dynamo Electric Machines, including Direct-Current Machines and Alternating-Current Machines, and the Elementary Theory of Alternating Currents. *Cloth, viii+490 pp., \$4.00 net.*

## **Dynamo Laboratory Manual**

Part I. Direct-Current Studies and Tests. *\$1.75 net.*

Part II. Alternating-Current Studies and Tests.

*Cloth, viii+152 pp., \$1.75 net.*

---

**THE MACMILLAN COMPANY, Publishers**

**By W. S. Franklin and Barry MacNutt**

## **The Elements of Mechanics**

**A Text-Book for Colleges and Technical Schools**

*Cloth, 8vo, xi+283 pp. ; \$1.50 net.*

Its special aim is to relate the teaching of mechanics to the immediately practical things of life, to cultivate suggestiveness without loss of exactitude.

## **Elements of Electricity and Magnetism**

*Cloth, 351 pp., \$1.60 net.*

## **Light and Sound**

*Cloth, 344 pp., \$1.60 net.*

## **Elementary Theory of Heat**

*Will be ready June, 1910.*

**By W. S. Franklin, C. M. Crawford and Barry MacNutt**

## **Practical Theory**

A Laboratory Manual for Colleges and Technical Schools.

Volume I. Precise Measurements. Measurements in Mechanics and Heat. *\$1.25 net.*

Volume II. Elementary and Advanced Measurements in Electricity and Magnetism. *\$1.25 net.*

Volume III. Photometry. Experiments in Light and Sound. *\$.90 net.*

---

# **THE MACMILLAN COMPANY**

**64-66 Fifth Ave., New York**

**BOSTON CHICAGO ATLANTA SAN FRANCISCO**



















