

TIGHT BINDING BOOK

UNIVERSAL
LIBRARY

OU_154139

UNIVERSAL
LIBRARY

OSMANIA UNIVERSITY LIBRARY

Call No. *640/1968* Accession No. *1527*

Author *Lynde C.T.*

Title *Physics of the Home* 415

This book should be returned on or before the date
last marked below.

PHYSICS
OF THE
HOUSEHOLD

BY

CARLETON JOHN LYNDE, Ph.D.

PROFESSOR OF PHYSICS IN MACDONALD
COLLEGE, CANADA

New York

THE MACMILLAN COMPANY

1919

All rights reserved

COPYRIGHT, 1914,

By THE MACMILLAN COMPANY.

— — —
Set up and electrotyped. Published May, 1914.

Norwood Press

**J. S. Cushing Co. — Berwick & Smith Co.
Norwood, Mass., U.S.A.**

PREFACE

THIS is an elementary textbook of physics, written for students of household science. It covers the ground usually covered by elementary textbooks, but differs from many of them in two ways: first, the illustrative examples and applications are taken largely from the home; second, the common system of weights and measures is used, in addition to the metric system.

The writer believes that we teach physics to young students for these reasons: first, that they may obtain knowledge of the physical world about them; and second, that they may gain, through this knowledge, the power to control the forces of nature for their own benefit, and for the benefit of others. In other words, we wish them to acquire knowledge which they will use in everyday life.

The reason for using illustrations taken from household appliances known to the student is obvious. It is good pedagogy to lead from the known to the unknown, and to illustrate the unknown by means of the known. This is the method followed in this book.

The use of the common system of weights and measures is, in the writer's opinion, justified by the desirability of having the students acquire their knowledge in terms of the weights and measures which they *must* use should they ever apply the knowledge in everyday life. Furthermore, the writer, although a strong advocate of the metric system, believes that it is pedagogically unsound to try to teach elementary physics by means of the metric system exclusively. It is an attempt to teach an unknown subject by means of an unknown system of weights and measures and leads to confusion and lack of power on the

part of the student. Long experience leads the writer to believe that the correct method is to introduce the subject by means of the common system, later to teach the metric system and point out its advantages, and then to use the two systems side by side. This is the method followed in this book.

The writer wishes to thank the Macmillan Company for permission to use illustrations from other textbooks published by them. He has used illustrations from: "An Elementary Course of Physics" by Aldous; "A Classbook of Physics" by Gregory and Hadley; "Elementary General Science" by Simmons and Jones; "Elements of Physics" by Andrews and Howland; "Lessons in Elementary Physics" by Balfour Stewart; "Science of Common Life" by Simmons and Stenhouse; "College Physics" by Reed and Guthe; "A Textbook of Physics" by Spinney; "Elementary Lessons in Electricity and Magnetism" by Sylvanus P. Thompson; "Heat, Light, and Sound" by D. E. Jones; "Elements of Physics" by Crew and Jones. In addition, the writer wishes to thank the Stover Mfg. Co., of Freeport, Ill., for figure 13, the Andrews Heating Co., of Minneapolis, Minn., for figure 45, Messrs. Fay and Bowen of Geneva, N.Y., for figure 158, and Messrs. Sturgis & Walton, of New York, for permission to use illustrations from the writer's book, "Home Waterworks."

In conclusion the writer wishes to thank Dr. H. C. Sherman, of Columbia University, for many valuable suggestions, and Mr. A. Norman Shaw, of Macdonald College, for assistance with the proofreading and for excellent suggestions.

C. J. L.

CONTENTS

	PAGE
CHAPTER I	
MECHANICS — SOLIDS	1
Mechanical appliances in the home. Lever appliances. Mastery. Wheel and axle appliances.	
CHAPTER II	
MECHANICAL APPLIANCES (<i>continued</i>)	13
Pulley appliances. Screw appliances.	
CHAPTER III	
WORK	20
Units of work. The law of work.	
CHAPTER IV	
MEASUREMENT	24
The common system. The metric system. Advantages of the metric system.	
CHAPTER V	
MECHANICS — LIQUIDS	30
Water supply. Laws relating to pressure in liquids. Pascal's law. The law of Archimedes. Density.	
CHAPTER VI	
MECHANICS — GASES	49
Air has weight. Atmospheric pressure. The barometer. Laws which apply to gases. Boyle's law. Henry's law.	
CHAPTER VII	
AIR APPLIANCES	61
Pumps. Pneumatic tank water supply system. The hydraulic ram. Vacuum cleaners. The fire extinguisher. Traps. The gas meter. Appliances which use compressed air.	

CHAPTER VIII		PAGE
HEAT IN THE HOME		79
The fire the center of the home. Expansion. Thermometers. Expansion of gases in cooking. Why a stove draws. Draft in a kitchen range. Hot-air heating system. Hot-water heating system. The hot-water tank. Nature of heat.		
CHAPTER IX		
MOVEMENT OF HEAT. HEAT APPLIANCES		102
Conduction, convection, and radiation. Cooking utensils. Fireless cooker. Thermos bottle. Walls of houses. Clothes. Ventilation.		
CHAPTER X		
MEASUREMENT OF HEAT		116
The British Thermal Unit and calorie. Comparing fires, cooking utensils, fireless cookers, and foot warmers. Cooling effect of ice. Heating effect of steam.		
CHAPTER XI		
HEAT CAPACITY, SPECIFIC HEAT, LATENT HEAT		126
Applications of latent heat. Refrigerator. Freezing mixtures. Artificial ice machine. Steam heating. Steam cookers. Distillation.		
CHAPTER XII		
EVAPORATION, DEW POINT, BOILING POINT		144
Why clothes dry. Causes of cloud, rain, hail, snow, and dew. Change in boiling point. Applications of boiling.		
CHAPTER XIII		
SOURCES OF HEAT. HEAT AND WORK		152
Cost of fuels. Steam engine. Gasoline engine. Horse power.		
CHAPTER XIV		
ELECTRICITY IN THE HOME		161
Household electrical appliances. Electric cells.		

	PAGE
CHAPTER XV	
MAGNETISM AND THE ELECTROMAGNET	169
Magnetic induction. Magnetic field. How magnets are made. The electromagnet. The electric bell. The electric telegraph.	
CHAPTER XVI	
THE ELECTRIC MOTOR IN THE HOME	182
How the electric current runs the motor. The motor in the kitchen.	
CHAPTER XVII	
ELECTRIC HEATING, COOKING, AND LIGHTING APPLIANCES IN THE HOME	187
Electric iron, stove, coffee percolator, oven, etc. The incandescent lamp. The arc lamp.	
CHAPTER XVIII	
ELECTROPLATING	195
Electrolysis. Electroplating. Laws of electrolysis. The storage cell.	
CHAPTER XIX	
ELECTRICAL TERMS AND MEASURES	202
The ampere, ohm, volt, and watt. Ohm's law. Joule's law. Electrical terms applied to common appliances. Electrical calculations.	
CHAPTER XX	
MEASURING INSTRUMENTS, SERIES AND PARALLEL CONNECTIONS .	212
Galvanometer. Voltmeter. Ammeter. Resistance.	
CHAPTER XXI	
INDUCED CURRENTS. THE DYNAMO	219
How induced currents are produced. The direction of induced currents. Alternating-current dynamo. Direct-current dynamo. Sources of electrical energy.	

	PAGE
CHAPTER XXII	
INDUCED CURRENTS (<i>continued</i>)	230
Transformer. Induction coil. Telephone.	
CHAPTER XXIII	
WIRELESS TELEGRAPH. CATHODE RAYS. X RAYS. RADIUM	237
Wireless sending and receiving stations. Properties of cathode rays. Nature of X rays. Radium.	
CHAPTER XXIV	
LIGHT IN THE HOME.	246
Arrangement of lighting fixtures in the home. Intensity of illumination. Nature of light.	
CHAPTER XXV	
REFLECTION AND REFRACTION OF LIGHT	253
Law of reflection. Laws of refraction.	
CHAPTER XXVI	
LENSES AND OPTICAL INSTRUMENTS.	259
Real and virtual images. Camera. Projecting lantern. Eye. Spectacles. Magnifying glass. Telescope. Compound microscope. Opera glass. Stereoscope.	
CHAPTER XXVII	
COLOR	269
Composite nature of white light. Why objects are colored. The Young-Helmholtz theory of color vision.	
CHAPTER XXVIII	
SOUND.	274
How sound is produced. Nature of sound waves. Noises and musical sounds. Pitch.	

CHAPTER XXIX

	PAGE
MUSIC AND MUSICAL INSTRUMENTS	279
Musical scale. Stringed instruments. Fundamental, octaves, and overtones. Quality. Wind instruments. Resonance. Harmony and discord. The phonograph.	

CHAPTER XXX

A FURTHER STUDY OF MECHANICS	289
Gravitation. Composition of forces. Falling bodies. New- ton's laws of motion. Units of force. Units of work. Potent- tial and kinetic energy.	

APPENDIX

WEIGHTS AND MEASURES	303
THE METRIC SYSTEM	305
EQUIVALENTS	307

PHYSICS OF THE HOUSEHOLD

CHAPTER I

MECHANICS. SOLIDS

MECHANICAL APPLIANCES IN THE HOME

IN the first two chapters we shall study some of the household mechanical appliances which are related to the lever, wheel and axle, screw, and pulley.

LEVERS

A simple lever is represented in Fig. 1. A yardstick is suspended from a string and balanced, then a weight of 2 lb., 8 in. from the turning point, is balanced by a weight of 1 lb., 16 in. from the turning point on the other side.

It will be noticed that when this lever is balanced, the weight on one side, multiplied by its distance from the turning point, is equal to the weight on the other side, multiplied by its distance from the turning point; that is, $2 \times 8 = 1 \times 16$. This is the law of the

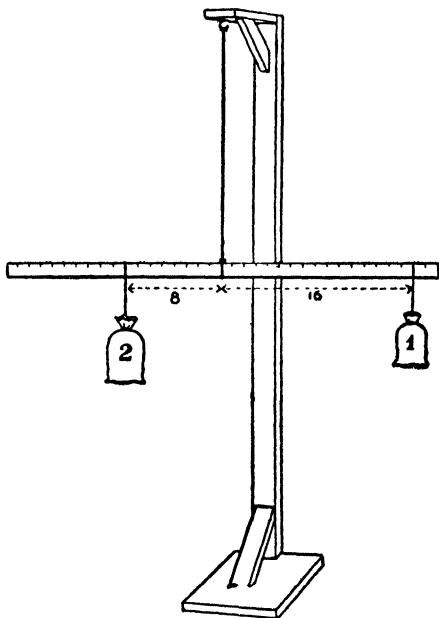

FIG. 1. — A simple lever.

lever and is true in all cases; for example, 2 lb., 5 in. from the turning point, is balanced by 1 lb., 10 in. from the turning point, and $2 \times 5 = 1 \times 10$; also 3 lb., at 4 in., is balanced by 1 lb., at 12 in., and $3 \times 4 = 1 \times 12$; etc.

Definitions. — The turning point of any lever is called the *fulcrum* (see Fig. 2). The product obtained by multiplying a

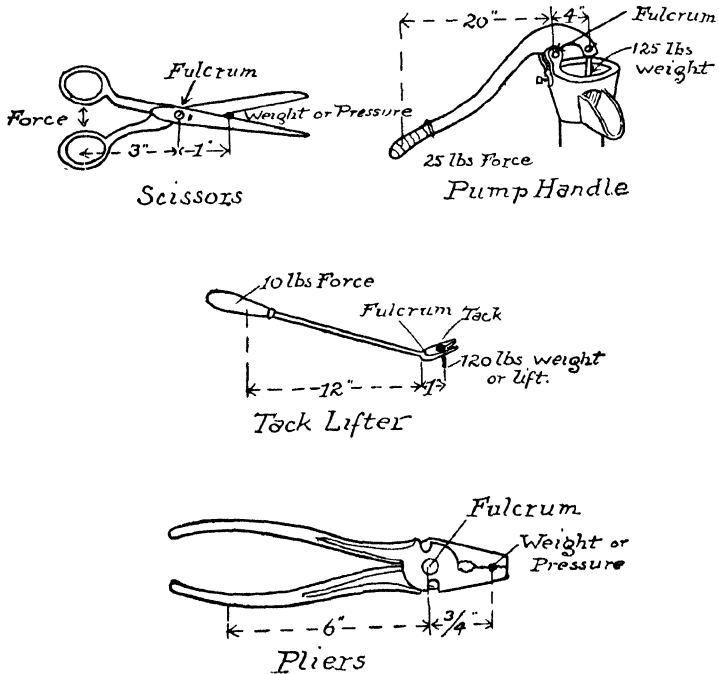

FIG.2. — Household lever appliances showing position of fulcrum, force, and weight.

weight by its distance from the fulcrum is called the *moment* of the weight. The weight or force applied to any lever, by the hand or otherwise, is called simply the *force*. The distance from the force to the fulcrum is called the *force arm*. The weight, pressure, or lift exerted by a lever is called simply the *weight*.

The distance from the weight to the fulcrum is called the *weight arm*.

The lever law. — *Any lever is balanced when the moment on one side of the fulcrum is equal to the moment on the other.* This is the lever law. It can be stated also as follows: A lever is balanced when, weight \times weight arm = force \times force arm.

If there are a number of weights on each side of the fulcrum, the lever is balanced when the sum of the moments on one side is equal to the sum of the moments on the other.

Lever appliances. — A number of lever appliances are shown in Fig. 2, namely, the scissors, pump handle, tack lifter, and pliers. Since these appliances are levers, the lever law holds for them. The lever law is, when a lever is balanced, weight \times weight arm = force \times force arm. There are four quantities in this equation, and if we know any three of them, we can calculate the fourth.

In the case of the tack lifter shown above, it has been found by measurement that the weight arm is 1 in. long and the force arm 12 in. long. Let us calculate the weight or lift produced when we exert 10 lb. of force on the handle. We do this as follows:

$$\begin{aligned}\text{Weight} \times \text{weight arm} &= \text{force} \times \text{force arm} \\ \text{Weight} \times 1 &= 10 \times 12 \\ \text{Weight} &= 120 \text{ lb.}\end{aligned}$$

That is, if we apply 10 lb. of force on the handle, the lift given to the tack is 120 lb.

In the case of the pump handle it has been found by measurement that the weight arm is 4 in., and the force arm 20 in. long. Let us calculate the weight or lift produced when we apply 25 lb. of force to the handle. As before:

$$\begin{aligned}\text{Weight} \times \text{weight arm} &= \text{force} \times \text{force arm} \\ \text{Weight} \times 4 &= 25 \times 20 \\ \text{Weight} &= 125 \text{ lb.}\end{aligned}$$

That is, if we apply 25 lb. force to the handle, we produce a lift of 125 lb. on the pump rod.

In the case of the pliers it has been found by measurement that the weight arm is $\frac{3}{4}$ in. long and the force arm 6 in. long. Let us calculate the force necessary to produce 40 lb. weight or pressure.

$$\text{Weight} \times \text{weight arm} = \text{force} \times \text{force arm}$$

$$40 \times \frac{3}{4} = \text{force} \times 6$$

$$30 = \text{force} \times 6$$

$$5 = \text{force}$$

That is, an object in the jaws of the pliers is subjected to 40 lb. pressure when we exert 5 lb. force in drawing the handles together.

By a similar calculation we find that in the case of the scissors shown above each pound of force used to pull the handles together produces 3 lb. pressure on the object between the blades.

Mastery. — These examples show how the lever law gives us greater mastery over lever appliances. We have greater mastery because we know *why* and *how much* the appliance helps us, also we know how the appliance can be altered to help us still more.

Let us consider these points for the case of the tack lifter. The reason *why* the tack lifter helps us is that it acts as a lever and changes the small force applied by the hand to a large lift exerted on the tack.

We find out *how much* it helps us by *dividing the force arm by the weight arm*. This gives us the *advantage* of the lever or how much it helps us. In this case it is $\frac{12}{1} = 12$. That is, each pound of force exerted by the hand is multiplied by 12, and produces 12 lb. lift on the tack.

We can see that there are two ways in which the tack lifter could be altered to help us still more; namely, by lengthening the force arm or by shortening the weight arm. For example, if the force arm were made twice as long, or 24 in., the ad-

vantage of the lever would be $\frac{24}{1} = 24$, or twice as great; that is, each pound of force would be turned into a lift of 24 lb. instead of 12 lb. Similarly, if the weight arm were made one half as long, or $\frac{1}{2}$ in., the force arm being the same, 12 in., the advantage would be twice as great, $\frac{12}{\frac{1}{2}} = 24$. That is, each pound of force would produce a lift of 24 lb. instead of 12 lb.

Three classes of levers.

— Levers are divided into three classes according to the relative positions of the weight, fulcrum, and force.

Lever in which the fulcrum is between the weight and the force are known as levers of the *first class*. See (1), Fig. 3. The appliances which we studied above are levers of this class.

Lever in which the weight is between the fulcrum and the force are levers of the *second class*, and those in which the force is applied at some point between the fulcrum and the weight are levers of the *third class*.

Lever of the second class. — The appliances shown in Fig. 4 are levers of the second class, because the weight is between the fulcrum and the force.

The lever law applies to these levers, and if we find the weight arm and force arm of each by measurement, we can calculate the relation between the force and weight in each case.

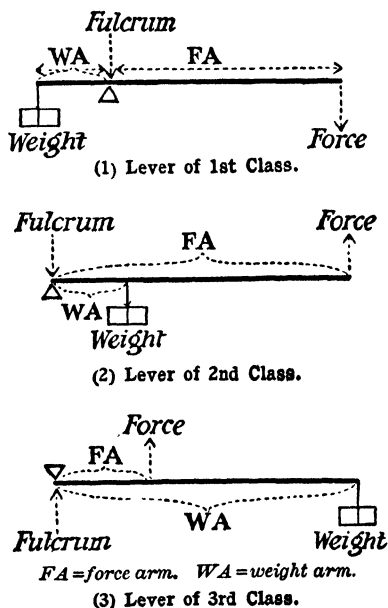

FIG. 3. — The three classes of levers.

In the case of the can opener, the weight arm is 1 in. long, and the force arm 6 in. long; therefore, 1 lb. of force produces a cutting pressure of 6 lb., 5 lb. of force a cutting pressure of 30 lb., etc. Similarly, 1 lb. of force exerted in drawing together the handles of the nut cracker, lemon squeezer, or fruit

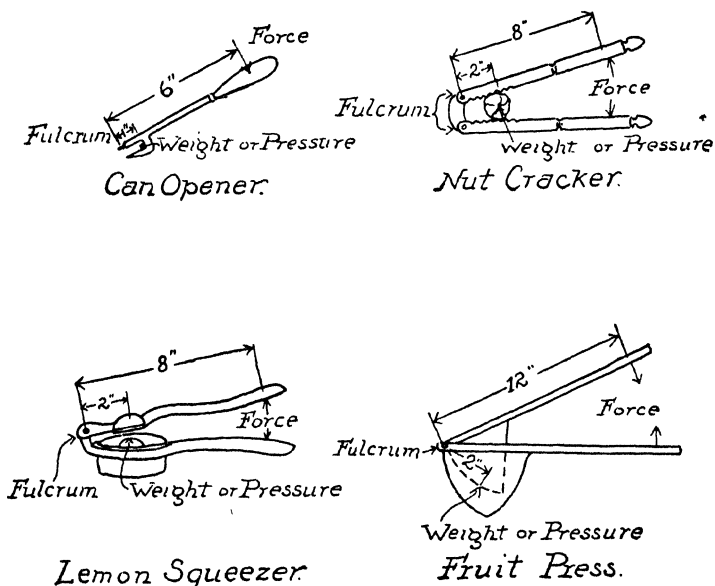

FIG. 4.—Levers of the second class.

press produces a weight or pressure of 4 lb., 4 lb., or 6 lb., respectively.

Levers of the third class.—The appliances shown in Fig. 5 are levers of the third class, because in each case the force is applied at a point between the fulcrum and the weight.

The lever law applies to these levers, and by measuring the force arm and weight arm of each we can calculate the relation between the weight and force as above.

It will be noticed that in levers of the third class the force arm is shorter than the weight arm; therefore, the weight or pressure produced is always less than the force exerted.

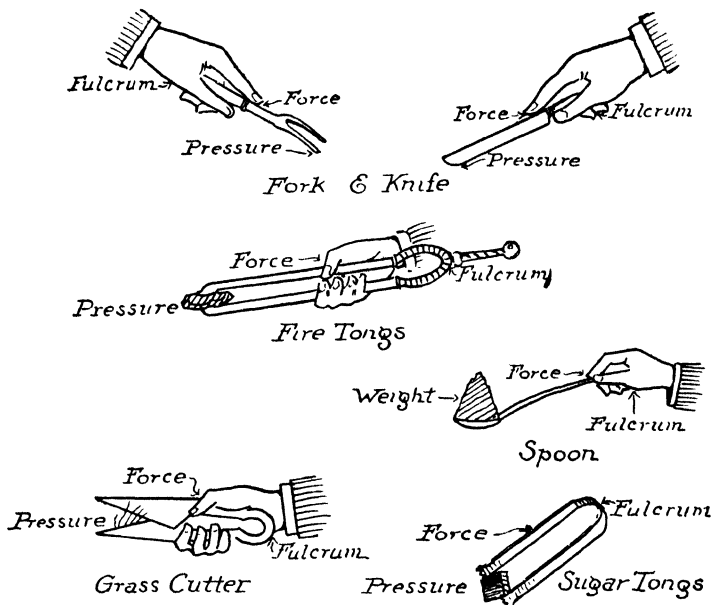

FIG. 5. — Levers of the third class.

WHEEL AND AXLE

The wheel and axle, Fig. 6, consists of a large and small wheel fastened together or fastened to the same axle. *It is in reality a lever*; for example, in Fig. 6, C is the fulcrum, P is the force, AC , the radius of the large wheel, is the force arm, Q is the weight, and CB , the radius of the small wheel, is the weight arm. If we find the force arm and weight arm by measurement, we can use the

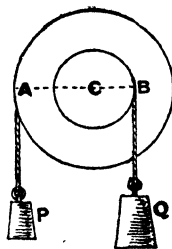

FIG. 6. — Wheel and axle.

lever law to find the relation between the force and weight as we did in the case of the levers.

Example. — If AC is 12 in. and CB is 6 in., a force P of 10 lb. will support a weight Q of 20 lb., because according to the lever law the wheel and axle balances when

$$\text{Weight} \times \text{weight arm} = \text{force} \times \text{force arm}$$

$$\text{Weight} \times 6 = 10 \times 12$$

$$\text{Weight} = \frac{10 \times 12}{6} = 20 \text{ lb.}$$

The windlass, Fig. 7, is one form of wheel and axle. It consists of a drum turned by a crank. The weight is attached to a rope wound on the drum and the force is applied to the crank handle. The radius of the drum is the weight arm, and the crank arm is the force arm.

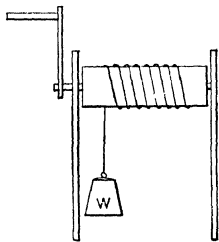

FIG. 7. — The windlass.

Wheel and axle appliances. — The appliances shown in Fig. 8 are wheel and axle appliances of the windlass type. The force arm of each is the length of the crank arm. The weight arm in the grate shaker, wringer, and ice-cream freezer is

the radius of the grate, of the roll, and of the can, respectively. In the ice-cream freezer there are cogwheel gears at the top, but they are of the same size, and thus do not affect the relation between the force and the weight. In the case of the coffee mill, the weight arm is approximately the distance from the axle to the middle of the grinding surface. In the case of the bread mixer, the weight arm is approximately half the radius of the mixer.

If we measure the force arm and weight arm of any of these appliances, we can calculate the relation between the force and weight by means of the lever law.

Example 1. — The crank arm of a wringer is 9 in. long, the radius of the roll is 1 in. If 10 lb. force is applied to the

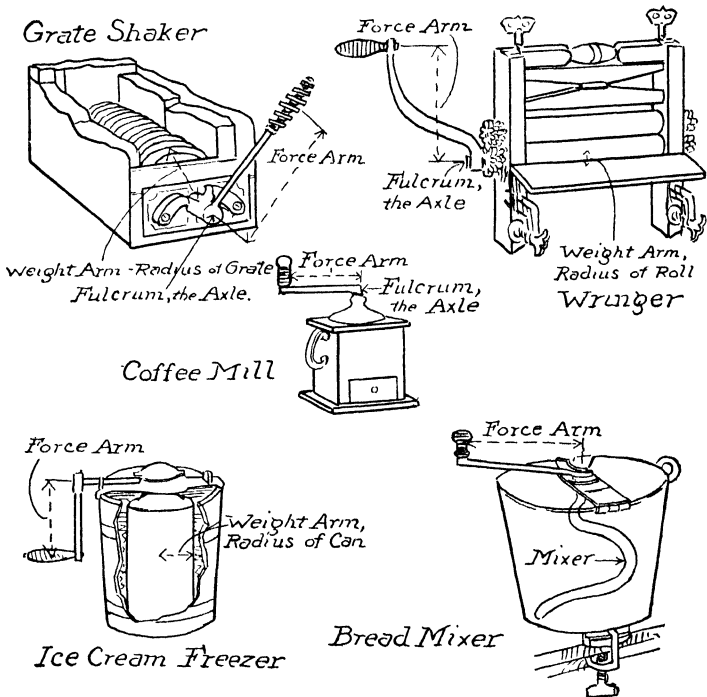

FIG. 8. — Household appliances of the windlass type.

handle, what is the pressure forcing the clothes between the rolls?

$$\text{Weight} \times \text{weight arm} = \text{force} \times \text{force arm}$$

$$\text{Weight} \times 1 = 10 \times 9$$

$$\text{Weight or pressure} = 90 \text{ lb.}$$

That is, if 10 lb. force is used on the handle, the pressure forcing the clothes between the rolls is 90 lb.

Example 2. — The handle of a grate shaker is 15 in. long. The radius of the grate is 3 in. The force is 10 lb. With what pressure is the grate moved under the ashes?

$$\text{Weight} \times \text{weight arm} = \text{force} \times \text{force arm}$$

$$\text{Weight} \times 3 = 10 \times 15$$

$$\text{Weight or pressure} = 50 \text{ lb.}$$

That is, 10 lb. of force applied to the handle produces a pressure of 50 lb. moving the grate under the ashes.

It will be noticed that we can increase the advantage of these machines, as in the case of the levers, either by increasing the length of the force arm or by decreasing the length of the weight arm.

EXERCISES

1. State the law of the lever.
2. Define fulcrum, moment, force arm, weight arm.
3. A yardstick is balanced at the middle. If 1 lb. is attached 10 in. from the fulcrum, where must 2 lb. be placed to balance it? Where 5 lb.? Make a sketch of each.
4. If on the yardstick of (3) 2 lb. is placed 15 in. from the fulcrum, where will 3 lb. balance it? Where 5 lb.? Make a sketch of each.
5. If 2 lb. is placed 10 in. from the fulcrum and 1 lb. 5 in. from the fulcrum on the same side, where will 5 lb. balance them? Make a sketch.
6. Describe how the advantage of a lever is found.
7. The force arm of a pump handle is $2\frac{1}{2}$ ft. long and the weight arm is $\frac{1}{2}$ ft. long. What is the advantage? What lift would be given to the piston by 12 lb. of force? Make a sketch.
8. In a tack lifter the force arm is 8 in. long and the weight arm is $\frac{1}{2}$ in. long. What is the advantage? What lift is given to the tack by 20 lb. of force? Make a sketch.
9. In using large shears, the hand applies the force 10 in. from the rivet, and the cloth is $1\frac{1}{4}$ in. from the rivet. What is the advantage? What force will exert 60 lb. of pressure on the cloth at that point? When the cloth is 2 in. from the rivet, what is the advantage? What force will exert 60 lb. of pressure? When the cloth is 3 in. from the rivet, what force will be needed to exert the same pressure?
10. The handles of the pliers are 6 in. long, and the object in the jaws is $\frac{3}{4}$ in. from the rivet. What is the advantage? What pressure will be exerted by 10 lb. of force? Make a sketch. If the object is $1\frac{1}{2}$ in. from the rivet, what is the advantage? What is the pressure with 10 lb. of force?

11. When is a lever said to be of the first class? of the second class? of the third class? Make a diagram of each.

12. Name three appliances, other than those given above, which are levers of the second class.

13. Name three lever appliances of the third class other than those given above.

14. A lemon squeezer has force arm 9 in. and weight arm 3 in. What is the advantage? What pressure is exerted by 6 lb. of force? Neglect the weight of upper half of squeezer. Make a sketch.

15. A nut cracker has a force arm of 6 in. and the center of the nut is 2 in. from the fulcrum. What is the advantage? What force will be required to exert 12 lb. pressure on the nut? Neglect the weight of the upper half of nut cracker. Make a sketch.

16. On a fruit press the distance from the fulcrum to the center of the hand is $12\frac{1}{2}$ in., and the pressure is exerted $2\frac{1}{2}$ in. from the fulcrum. What is the advantage? What pressure will be exerted by 10 lb. of force? Neglect the weight of the upper half of the fruit press. Make a sketch.

17. In using a can opener, if we place the center of the hand 5 in. from the fulcrum and the knife cuts at a distance of $\frac{1}{2}$ in. from the end, what is the advantage? What is the cutting pressure with 10 lb. of force? Neglect the weight of the can opener. Make a sketch.

18. On a carving knife the distance from the little finger (fulcrum) to the thumb and forefinger is 4 in., and from the little finger to the part of the blade at which the cutting is done is 12 in. What cutting pressure will be exerted by 15 lb. of force? Neglect the weight of the knife. Make a sketch.

19. If the distance from the center of the bowl of a tablespoon to the end of the handle is 6 in., and the distance from the thumb and forefinger to the end of the handle is 3 in., what force will the thumb and forefinger exert to lift 2 oz. of salt in the bowl? Neglect weight of spoon. Make a sketch.

20. Why is the force always greater than the weight in levers of the third class?

21. How could the advantage of a lever of the third class be increased?

22. The radius of the drum of a windlass is 4 in. and the crank arm is 16 in. long. What force will just balance 100 lb. of weight? Make a sketch.

23. The radius of the roll in a wringer is $1\frac{1}{4}$ in., and the handle is 10 in. The hand exerts 5 lb. of force. What is the force driving the clothes between the rolls? Neglect friction. Make a sketch.

24. The handle of a bread mixer is 9 in. long; the radius of the blades is 3 in. What is the pressure on the blade, if the hand exerts a force of 12 lb.? Neglect friction. Make a sketch.

25. The crank arm of an ice-cream freezer is 6 in. long; the radius of the can is 3 in. What is the moving force on the edge of the can when the hand exerts a force of 15 lb.? Neglect the friction. Make a sketch.

26. The radius of a grate is 3 in.; the hand applies the force to the handle 12 in. from the center of the axle. What force will give a moving force of 60 lb. to the top of the grate? Neglect friction. Make a sketch.

27. In your own home measure the force arm and weight arm and calculate the advantage of a pair of scissors, a wringer, and at least two other appliances.

CHAPTER II

MECHANICAL APPLIANCES (continued)

PULLEYS

FOUR systems of pulleys are shown in Fig. 9. We will use these to illustrate the law of the pulley. This law is: *If*

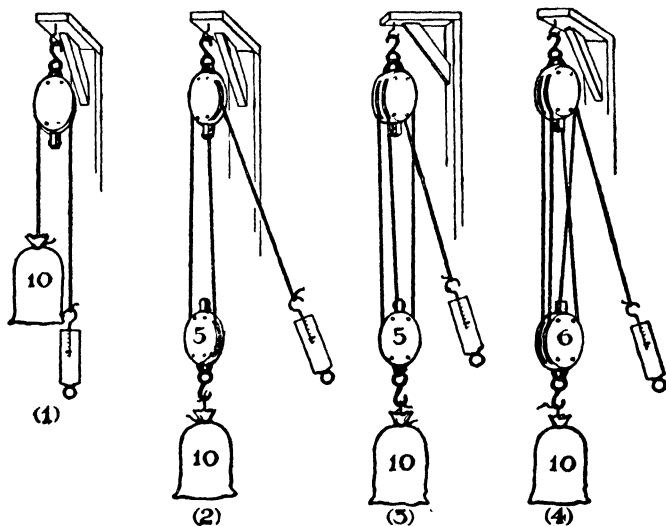

FIG. 9.— Four pulley systems.

there is no friction, the force is equal to the weight divided by the number of ropes supporting the weight.

In (1) the weight is 10 lb. and there is one rope supporting it. The force which must be applied to the spring balance to support the weight is 10 lb.

In (2) there are two ropes supporting a total weight (pulley + weight) of 15 lb.; each rope supports only half this weight and the force necessary is half the weight, or $7\frac{1}{2}$ lb.

In (3) three ropes support a total weight of 15 lb. The force needed is one third of this, or 5 lb.

In (4) four ropes support a total weight of 16 lb. The force needed is one fourth of this, or 4 lb.

These illustrate the law of the pulley stated above.

Window pulleys and hanging lamp pulleys are familiar applications of the pulley in the home.

The law of machines. — The law of machines is: *If there is no friction, the weight times the distance the weight moves, is equal to the force times the distance the force moves.* We can illustrate this law by means of the pulleys above. In (2), Fig. 9, the weight is 15 lb., and the force supporting it is $7\frac{1}{2}$ lb. If we move the force down 4 ft., the weight is raised only 2 ft., because each rope supporting the weight is shortened only 2 ft. Thus

Weight \times distance weight moves = force \times distance force moves

$$\begin{aligned} 15 \times 2 &= 7\frac{1}{2} \times 4 \\ 30 &= 30 \end{aligned}$$

Similarly, in (3) if the 5 lb. of force is moved 3 ft., the 15 lb. of weight is raised only 1 ft., and

Weight \times distance weight moves = force \times distance force moves

$$\begin{aligned} 15 \times 1 &= 5 \times 3 \\ 15 &= 15 \end{aligned}$$

Machines. — *Any contrivance by means of which a force applied at one point exerts a force or pressure at another point is called a machine.* Each of the appliances we have studied so far is a machine, and the law of machines applies to them, as indeed it does to all machines.

Show by experiment or by simple examples that this law applies to the levers and the wheel and axle.

THE SCREW

We may now study household appliances which have a screw motion. A number of these are shown in Fig. 10; namely,

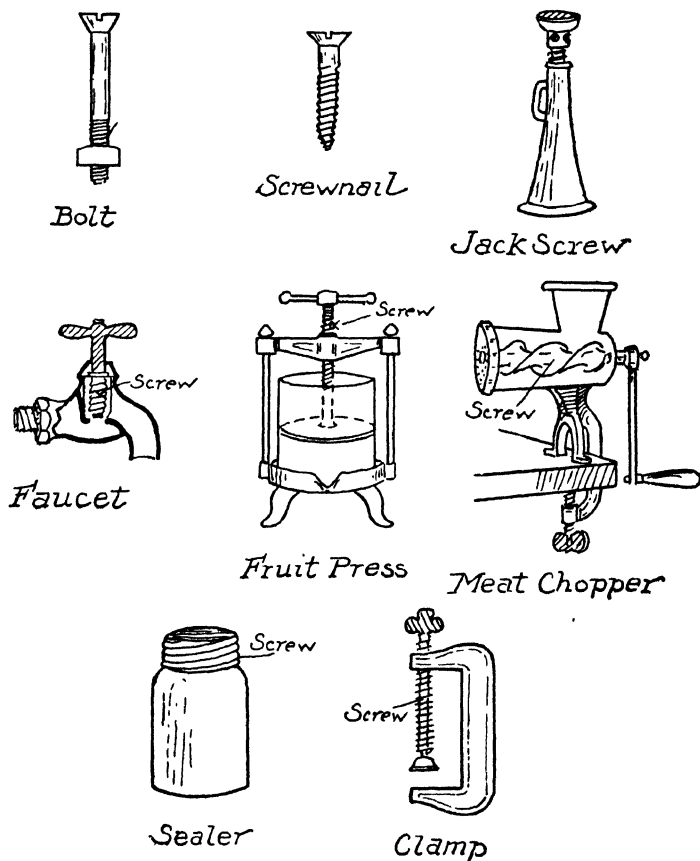

FIG. 10. — Household screw appliances.

the bolt, screw nail, and jackscrew, faucet, fruit press, meat chopper, sealer, and clamp.

An appliance with a screw motion is used when it is necessary to exert a great pressure, or to lift a great weight for a short distance. For example, the clamp, bolt, and screw nail are used to hold things together firmly. Also, the screw motion in the meat chopper gives the great pressure needed to force the meat through the holes at the end. Similarly, the screw in the fruit press gives the heavy pressure needed to force the juice out of the fruit. The screw top of the sealer exerts great pressure on the glass cover, etc. Again, when it is necessary to lift a great weight, such as a house, the jackscrew is used.

We see, then, that we use the screw motion when we desire to exert a great pressure or lift a great weight. Let us now get a deeper insight into this screw motion.

The law of machines applies to the screw. — The jackscrew is one of the simplest of the screw appliances, and for this

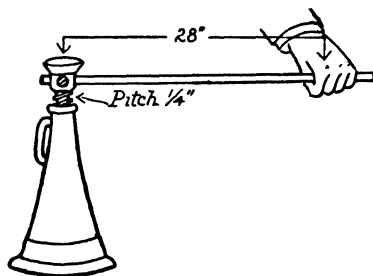

FIG. 11. — The jackscrew.

reason we will use it to illustrate the principle of the screw.

We can understand the screw most readily by means of the "law of machines." We learned in the last section that the "law of machines" is, — if there is no friction in a machine :

Weight \times distance weight

moves = force \times distance force moves.

This law applies to all screw appliances.

A jackscrew is shown in Fig. 11. The weight to be raised is placed on the head of the screw, and the force is applied at the end of the handle. When the force moves the handle through one complete turn, the weight is raised a distance equal to the distance from one thread on the screw to the next. The distance from one thread to the next is called the *pitch* of the screw.

The jackscrew in Fig. 11 has a handle 28 in. long and the

pitch is $\frac{1}{4}$ in., let us calculate the weight that can be raised by 10 lb. of force.

In one complete turn, the force at the end of the handle moves a distance equal to the circumference of a circle of 28 in. radius.

The circumference of a circle is calculated as follows:

$$\begin{aligned}\text{Circumference} &= 2 \times \pi \times \text{radius} \\ \pi &\text{ is } 3.1416 \text{ or } \frac{22}{7} \text{ (nearly)}\end{aligned}$$

The force then moves $2 \times \frac{22}{7} \times 28 = 176$ in.

When the screw makes one complete turn, the weight is raised a distance equal to the pitch of the screw, in this case $\frac{1}{4}$ in.

The force is 10 lb.

The law of machines is, if there is no friction :

Weight \times distance weight moves = force \times distance force moves

$$\text{Weight} \times \frac{1}{4} = 10 \times 176$$

$$\text{Weight} = 10 \times 176 \times 4 = 7040 \text{ lb.}$$

We see, then, that with this jackscrew a force of 10 lb. raises the enormous weight of 7040 lb., or over $3\frac{1}{2}$ tons. This result is obtained on the assumption that there is no friction. There is friction, however, in every machine, and in the jackscrew it is over 50 per cent. For this reason the weight raised by 10 lb. of force would actually be somewhat less than half of 7040 lb., or about 3000 lb. But making all allowances for friction, we see that the screw enables us to lift a very large weight with a small force.

Advantage. — The advantage of a screw is found by dividing the “distance the force moves” by the “distance the weight moves,” and when found it tells how many times greater the weight is than the force used. For example, the advantage of the jackscrew above is,

$$\frac{\text{Distance force moves}}{\text{Distance weight moves}} = \frac{176}{\frac{1}{4}} = 704, \text{ and}$$

$$\frac{\text{Weight}}{\text{Force}} = \frac{7040}{10} = 704.$$

That is, the advantage is 704, and the weight raised is 704 times as great as the force used.

Screw appliances. — The clamp, faucet, meat chopper, and fruit press are similar to the jackscrew, and the advantage is found as stated above.

We can increase the advantage in each case by lengthening the handle. For example, if a water faucet in the kitchen turns with difficulty, it can be made to turn with less force by making the handle longer. If the handle is made twice as long, the force required is $\frac{1}{2}$; if it is made three times as long, the force is $\frac{1}{3}$; if 10 times as long, the force is $\frac{1}{10}$; etc. Similarly, if we double the length of the handle on the meat chopper, the force necessary is one half as great, etc. We see from these examples and those given above that there are many appliances used about the home which would require less force if their handles were lengthened.

The sealer, screw, and bolt have no handles. On the sealer the force is applied directly to the edge of the screw top; on the screw the force is applied by means of a screw driver. In the case of the bolt, the wrench used is the handle.

EXERCISES

1. Make diagrams of systems of pulleys in which (a) one, (b) two, (c) three, (d) four, ropes support the weight.
2. State the law of the pulley.
3. Name two household pulley appliances.
4. A window weighs 30 lb.; it is supported by two counterpoise weights, one on each side, working over pulleys. What must each counterpoise weigh to balance the window?
5. State the law of machines.
6. In the case of the jackscrew what are the following: the weight; the distance the weight moves; the force; the distance the force moves.
7. The handle of a jackscrew is 14 in.; the pitch of the screw is $\frac{1}{4}$ in. What weight may be lifted by 10 lb. of force? Neglect friction.
8. A clamp handle is 1 in. long; the pitch of the screw is $\frac{1}{4}$ in. What pressure is exerted by 7 lb. of force? Neglect friction. Make a sketch.
9. A fruit press handle is 7 in. long; the pitch is $\frac{1}{4}$ in. What is the pressure on fruit from 10 lb. of force? Neglect friction. Make a sketch.

10. On a sealer the radius of the screw cap is $1\frac{1}{2}$ in., and the pitch of the screw is $\frac{1}{4}$ in. What pressure will be exerted on the glass top by 14 lb. of force? Neglect friction.

11. The handle of a wrench is 7 in. long from the center of the jaws to the center of the hand; the pitch of the thread of a bolt is $\frac{1}{24}$ in. What is the pressure exerted by the nut when the hand is exerting 14 lb. of force? Neglect friction.

CHAPTER III

WORK

IN the preceding chapters we have studied various mechanical appliances, and we have found that, with the exception of levers of the third class, the appliances enable us to exert greater pressure than the force we use. It might appear from this that the appliances enable us to obtain something for nothing. We shall see, in our study of work, however, that this is not the case.

Work. — Work is done when a force is exerted through any distance. For example, when a window is raised, work is done because a force is exerted through the distance the window is raised; when a scuttle of coal is carried upstairs, work is done because a force is exerted through a distance equal to the vertical height of the stairway.

Before we go further we should distinguish carefully between the terms *force* and *work*.

Force is that which tends to change a body's state of rest, or of motion in a straight line. That is, if a body is standing still, anything which tends to set it in motion is a force; also, if a body is moving, anything which tends to stop it or change the direction in which it is moving is a force.

Work is done when a force produces or destroys motion, and the amount of work done is equal to the force multiplied by the distance the force moves in the direction in which it is acting.

Units of work. — The common units of work are the *foot pound* and the *gram centimeter*.

A foot pound of work is the amount of work done when a pound of force is exerted through a distance of one foot. If

a 1 lb. weight is raised one foot against the force of gravity, one foot pound of work is done. If 10 lb. of force is required to raise a window, and the window is raised 2 ft., 20 foot pounds of work are done. If a scuttle of coal weighing 25 lb. is carried up a stairway 8 ft. high, $25 \times 8 = 200$ foot pounds of work are done. In this case, if the man carrying the coal weighs 150 lb., he does, in addition, $150 \times 8 = 1200$ foot pounds of work in lifting his own body up the stairs. If a force does not produce motion, there is no work done in the scientific sense. For instance, a man supporting a pound weight is exerting a force of 1 lb. against gravity, but he is not doing work, because there is no motion. Also, if a man is supporting a weight and moves it horizontally, there is no work done because the motion is not in the direction of the force; the man is exerting 1 lb. of force upward, and to do work he must move the weight in the direction the force is acting; that is, upward.

A gram centimeter of work is done when a force of 1 gram is exerted through a distance of 1 cm. If a gram weight is raised 1 cm. against the force of gravity, 1 gram centimeter of work is done, etc.

The law of work. — Now that we understand the meaning of the term *work*, we are in a position to show that we do not obtain “something for nothing” when we use any appliance. We shall see that in any appliance “*if there is no friction, the work we obtain from an appliance is just equal to the work we put into it.*” This is the *law of work*.

We will illustrate the meaning of this law, by showing how it applies to levers and pulleys.

The lever, Fig. 1, has a force arm 16 in. long and a weight arm 8 in. long. The force is 1 lb. and the weight 2 lb. If we move the force down 1 ft., the weight is raised only $\frac{1}{2}$ ft. because the weight arm is only one half as long as the force arm.

The work we obtain is $2 \times \frac{1}{2} = 1$ foot pound, and this is equal to the work we do; namely, $1 \times 1 = 1$ foot pound. That is, the law of work applies to the lever.

The pulley (4), Fig. 9, has four ropes supporting a weight of 16 lb. The force required is 4 lb. If the force moves down 8 ft., the weight is raised only 2 ft. The work obtained is $16 \times 2 = 32$ foot pounds, and this is equal to the work we do; namely, $4 \times 8 = 32$ foot pounds. That is, the law of work applies to the pulley.

Law of work holds for all appliances. — We have considered only two appliances, but the law of work holds for all appliances: “If there is no friction, the work obtained from an appliance is equal to the work put into it.”

This is in reality the “law of machines,” stated in terms of work. The law of machines states that “if there is no friction, the force times the distance the force moves equals the weight times the distance the weight moves.” The “force times the distance the force moves” is the work put into a machine, and “the weight times the distance the weight moves” is the work obtained from a machine. We see then that the law of machines and the law of work are simply different ways of stating the same law.

Friction. — In every appliance there is a certain amount of friction or resistance to motion, and therefore part of the work we put into the appliance is used up in moving against this friction. As a result, the work we obtain from any appliance in actual use is never quite equal to that which we put into it.

The advantage of the appliances we have studied is, that in general they enable us to lift a large weight or exert a great pressure by the exertion of a small amount of *force*. In every case, however, the *work* we actually do is greater than the work we obtain by means of the appliance.

EXERCISES

1. Define work, foot pound, and gram centimeter.
2. A girl weighing 100 lb. walks up a stairway 20 ft. high. How much work does she do?
3. A boy pulls a sled with a force of 5 lb. through a distance of 100 yd. How much work does he do?

4. A man carries a scuttle of coal weighing 20 lb. up a stairway 15 ft. high. How much work does he do?

5. A man carries a 20-lb. scuttle of coal horizontally from the cellar door to the stove. How much work does he do?

6. A boy weighing 120 lb. jumps over a fence 4 ft. high. How much work does he do in going up? How much work does the attraction of the earth do in pulling him down?

7. A horse pulls on a load with a force of 100 lb. and moves it 1 mile. How much work does the horse do?

8. The force arm of a pump handle is 3 ft. long, the weight arm $\frac{1}{2}$ ft. long; 10 lb. of force moves the handle 1 ft. If there is no friction, what is the weight? How far is it moved? How much work is put into the appliance, and how much is obtained from it?

9. The handle of a wringer is 8 in. long, the radius of the roll is 1 in. In wringing out a garment the hand exerts 10 lb. of force and moves 16 ft. If there is no friction, how much work is put into the wringer and how much is obtained from it?

CHAPTER IV

MEASUREMENT

SCIENTIFIC knowledge is our ordinary knowledge made exact and extended. In order to make knowledge exact, we must measure everything involved. You will notice that in the sections above we made our knowledge of household appliances more exact by measurement. We measured force arm, weight arm, force, weight, etc. We will now make experiments in order to gain some experience in measurement, particularly in the measurements required about the home.

Experiment 1. Weights and measures.¹

Teaspoon, tablespoon, and cup. Use sugar, salt, or flour, to find,

- (1) the number of level teaspoons in 1 level tablespoon =
- (2) the number of level tablespoons in 1 level cup =

Cup, pint, quart, gallon. Use water to find,

- (3) the number of cups in 1 pt. =
- (4) the number of pints in 1 qt. =
- (5) the number of quarts in 1 gal. =

Cubic inches in quart or gallon. Measure the inside depth and diameter of the quart or gallon measure and calculate,

- (6) the number of cubic inches in 1 qt. =
- (7) the number of cubic inches in 1 gal. =

[*Note.*—The volume of cylinder = $\pi \times (\text{radius})^2 \times \text{depth}$, where $\pi = 3.1416$ or $2\frac{2}{7}$ (nearly).]

Weight of 1 qt. and of 1 gal. of water. Weigh the quart and gallon measures when empty and then when filled with water, to determine,

- (8) the weight of 1 qt. of water = lb.
- (9) the weight of 1 gal. of water = lb.

Dry Measure. Use oats or wheat to find,

- (10) the number of quarts in 1 pk. =
- (11) the number of pecks in 1 bu. =

¹ See tables of weights and measures, page 303 *et seq.*

Experiment 2. Metric weights and measures.

Centimeter, inch, and foot. Draw on paper a line 10 in. long, measure it in centimeters and calculate,

$$(1) \ 1 \text{ in.} = \quad \text{cm.}$$

Draw a line 1 ft. long and measure it in centimeters.

$$(2) \ 1 \text{ ft.} = \quad \text{cm.}$$

Cubic centimeters in 1 l. Measure in centimeters the inside depth and diameter of a cylindrical liter measure and calculate,

$$(3) \ 1 \text{ l.} = \quad \text{c.c.}$$

Weight of 1 l. of water in grams. Weigh in grams the liter measure when empty and when full of water, to determine

$$(4) \ 1 \text{ l. of water} = \quad \text{grams.}$$

Liter and quart. Fill a liter measure with water and pour the water into a quart measure to determine roughly

$$(5) \ 1 \text{ qt.} = \quad \text{liters.}$$

Kilogram and pound. Weigh a kilogram weight in pounds to determine

$$(6) \ 1 \text{ kg.} = \quad \text{lb.}$$

WEIGHTS AND MEASURES

In English-speaking countries there are two systems of weights and measures, the common system and the metric system. In the common system, which is used in commerce, the units are the yard, the gallon, and the pound. In the metric system, which is used in all scientific work, the units are the meter, the liter, and the kilogram. We shall now devote a little time to the study of these two systems.

Advantages and disadvantages of the common system.—The common system has one great advantage; namely, we are all acquainted with it. It has, however, many disadvantages. These may be summarized as follows:

1. The multiples are irregular. For example, 12 in. = 1 ft.; 3 ft. = 1 yd.; $5\frac{1}{2}$ yd. = 1 rd.

2. There are no simple relations between the units of length, volume, and weight. For example, in the United States 1 qt. = 57.75 cu. in., and 1 qt. of water weighs 2.082 lb. In Great Britain and Canada 1 qt. = 69.318 cu. in., and 1 qt. of water weighs 2.5 lb.

3. Some units have the same name, but different values. For example, the ounce and pound Troy are different from the ounce and pound avoirdupois.

4. The units are not the same as those used in other countries.

The common system is the result of centuries of usage, and, like the English system of coinage, is very awkward. In the United States and Canada a decimal system of coinage has been adopted, but the old system of weights and measures is still used.

History of the metric system. — At the time of the French Revolution the weights and measures used in France were in a worse condition than ours are at the present time, because the units had different values in different parts of the country. To remedy this condition of affairs, the French government appointed a commission to devise a new system of weights and measures. It was the aim of the commission to obtain a system in which all measures should be based upon one invariable unit and in which the simplest possible relations should exist between the different units of the system.

The unit of length adopted was the meter, and all other units were based upon this unit of length. The commission attempted to make the meter equal in length to the ten-millionth part of the quadrant of the earth's meridian. This was to be the invariable unit. The earth's quadrant was measured and the meter was made equal to the one ten-millionth part of this length. The meter measure was made of platinum, and the distance between two transverse scratches on this bar was made equal to one meter. It was found later that an error had been made in the measurement of the quadrant of the earth's meridian. It was decided, however, not to change the length of the meter, and the meter is now defined, not as the ten-millionth part of the earth's quadrant, but as the distance between the two scratches on the bar mentioned above.

The commission made simple relations between the units of

length, volume, and mass as follows. The unit of length is the *meter*. The unit of volume is one tenth meter cubed; it is called a *liter*. The unit of mass is a piece of platinum which has the same weight as a liter of water at 4° C. This is called a *kilogram*.

Advantages of the metric system. — The metric system has the following advantages:

1. The multiples are simple; namely, ten, one hundred, and one thousand.
2. There are simple relations between the units of length, area, volume, and mass.
3. The system is used in scientific work in all civilized countries. It is used also in trade in many European countries, and is being so used more and more in English-speaking countries.

The common system of weights and measures is expensive because an unnecessary amount of time is needed to make calculations with it. The difference between the two systems in this respect can be illustrated by two simple problems as follows:

1. If a pound of meat costs 20 cents, what is the cost of 6 oz. of meat?

$$\text{Ans. } \frac{6}{16} \times 20 = 7\frac{1}{2} \text{ cents.}$$

2. If a kilogram of meat costs 50 cents, what is the cost of $\frac{6}{10}$ of a kilogram?

$$\text{Ans. } \frac{6}{10} \times 50 = 30 \text{ cents.}$$

To solve the first problem we need a pencil and paper, while the last can be solved mentally. This illustrates the difference between the two systems. To make calculations in the common system requires more time, and since time is worth money, the cost each year to the country using it is very great. The metric system is being used more and more in trade, and it is hoped that those who read this book will aid its introduction by advocating it and using it where possible.

UNITS

Standard units. — When a unit becomes legalized by statute or custom it is called a standard unit. For example in English-speaking countries the standard units of length and mass are the yard and the pound.

The standard yard is defined as the distance at 62° F. between the lines on two gold plugs inserted in a bronze bar deposited in the office of the Exchequer in London. The standard foot is one third the standard yard.

The standard pound of mass is a cylinder of platinum deposited in the office of the Exchequer in London.

In the metric system the standard units of length and mass are the meter and the kilogram. These have been defined above.

The standard unit of time in both systems is the second. There are 24 hr. in one day, 60 min. in one hour, and 60 sec. in one minute, therefore there are $24 \times 60 \times 60 = 86,400$ sec. in one day. The standard second is the $\frac{1}{86400}$ th part of a mean solar day.

Fundamental and derived units. — All physical measurements may be reduced to measurements of length, mass, and time. For example, the measurement of an area consists of measurements of length; the measurement of a volume consists of measurements of length; the measurement of velocity consists of a measurement of length and a measurement of time.

The units of length, mass, and time are called *fundamental units*. The units of area, volume, velocity, etc., are called *derived units*, because they are derived from measurements with the fundamental units.

Mass and weight. — In the sections above we have used the two terms *mass* and *weight*. It is necessary to distinguish between these. The *mass* of a body is defined as the quantity of matter the body contains. The *weight* of a body is the measure of the earth's attraction for the body.

The difference between mass and weight may be readily understood from the following example: Let us suppose that a body could be raised one million miles above the earth. Would there be any change in its mass or weight? There would be no change in its mass, because the quantity of matter in the body would remain the same. There would, however, be a change in weight. The earth would attract the body with less force, and therefore the weight of the body would be less.

Household measurements. — The measurements most often made in the home are those of volume, weight, time, and temperature. For example, a good cook in making a cake measures the *volume* or *weight* of the ingredients. She mixes these ingredients and places them in an oven at a certain *temperature* and leaves them there for a certain *time*.

As was stated above, the chief difference between ordinary knowledge and scientific knowledge is that the latter is more exact. Knowledge is made exact by measurement. A cook, to do exact or scientific work, must have in the kitchen: a cup of known volume to measure volume, a balance to measure weight, a clock to measure time, and an oven thermometer to measure temperature.

EXERCISES

1. How many teaspoonfuls make one tablespoonful, and how many tablespoonfuls make one cup?
2. How many cups in 1 pt.; pints in 1 qt.; quarts in 1 gal.?
3. How many cubic inches are there in 1 qt.? in 1 gal.?
4. What is the weight of 1 qt of water? of 1 gal. of water?
5. How many quarts are there in 1 pk.? pecks in 1 bu.?
6. How many centimeters are there in 1 in.? in 1 ft.?
7. How many cubic centimeters are there in 1 l.?
8. What is the weight in grams of 1 l. of water; of 1 c.c. of water?
9. How many liters are there in 1 qt. (about)?
10. How many pounds are there in 1 kg.?
11. State the advantages and disadvantages of the common system of weights and measures.
12. State the advantages of the metric system.

CHAPTER V

MECHANICS. LIQUIDS

WATER SUPPLY

City water supply. — One of the most important problems which a city government has to meet is that of providing an ample supply of water for all parts of the city. There are a

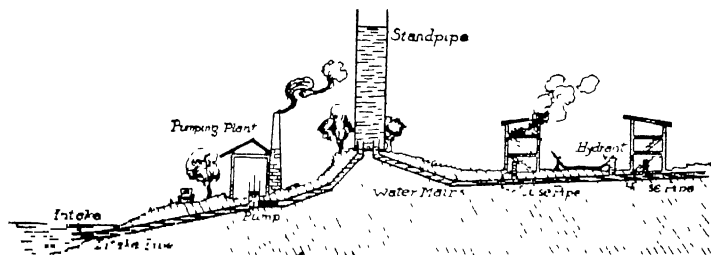

FIG. 12 — Water supply system for towns and cities

number of ways in which this is done. One of these is illustrated in Fig. 12. A large pump in the municipal pumping station draws water from a river or lake, and forces it into a large standpipe. From the standpipe the water runs by gravity through the mains and submains to the houses, hydrants, etc.

If the city is situated near a hill, the usual practice is to build a large reservoir on the hill and pump the water into this, instead of into a standpipe. The water then runs by gravity from the reservoir through the mains and submains.

In many cities neither standpipe nor reservoir is used; the water is pumped directly into the mains. In this case the engine which drives the pump is equipped with an automatic regu-

lator which is operated by the water pressure in the mains. This regulator is so arranged that the water pressure in the mains is kept within a few pounds of a certain amount.

If the city is situated near a hill on which there is a lake of sufficient size, above the level of the highest buildings, a pipe line is laid from the lake to the city mains. This is the most satisfactory system because the water runs by gravity and there is no outlay for pumping.

Water supply for country homes. — There are a number of methods of supplying country homes with running water. One of these is illustrated in Fig. 13. The water from a well, cistern, river, or lake is pumped in to an elevated tank from which it runs by gravity to the various fixtures. The elevated tank

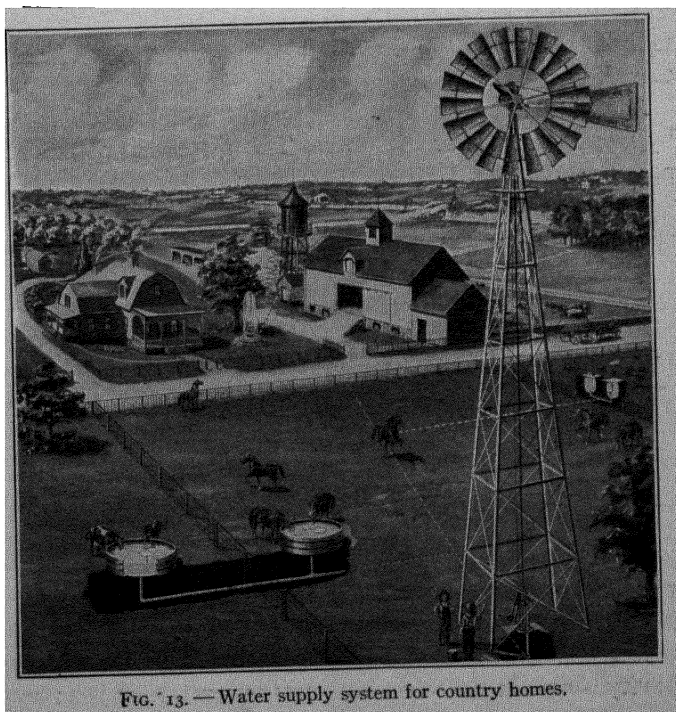

FIG. 13. — Water supply system for country homes.

is placed in the attic of the house, in the hayloft of the barn, on a near-by hill, or on a tower. The pumping is done by hand or by some form of power appliance, such as a windmill or gasoline engine. In Fig. 13 the windmill operates a pump and forces water from the well to an elevated tank on a tower. The water from the tank runs by gravity to the house, fountain, stable, and to the troughs in the fields.

If the house is near a stream which has a fall of at least $1\frac{1}{2}$ ft., the water can be pumped into the elevated tank by means of a hydraulic ram. The hydraulic ram is described on page 64.

If the house is near a spring which has an elevation greater than that of the highest house tap, the water can be piped directly from the spring to the house supply pipes. In this case a tank in the house is unnecessary; but if the spring is small, a storage tank just below the spring may be advisable.

Another method of supplying water to country homes is by means of a pneumatic tank. This method is described on page 62.

Wells. — The source of all water supply is the water which falls upon the earth as rain or snow. Part of this rain or snow

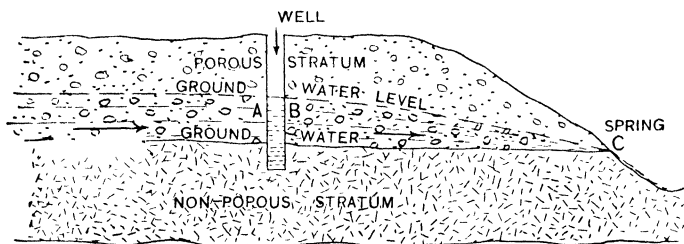

FIG. 14 — Source of water in wells and springs.

water sinks into the ground and finds its way underground to the neighboring streams. When water enters the ground it sinks until it comes to a nonporous stratum, and then flows by gravity along the surface of this stratum until it finds an outlet

in a stream, lake, or spring. This moving water is called *ground water*, and its surface is called the *ground water level*. The surface well shown in Fig. 14 is filled with ground water. The water is flowing towards the spring *C* through the porous stratum and above the nonporous stratum. The well is filled as high as the ground water level. The ground water level rises in wet weather and falls in dry weather; and the water level in the well rises and falls with it. Since the ground water is moving, the water in the well is constantly changing. Water flows in on the side *A* and out on the side *B*. This illustrates how surface wells and springs are supplied with water.

Artesian wells.—The conditions producing an artesian or flowing well are illustrated in Fig. 15. The earth's surface in

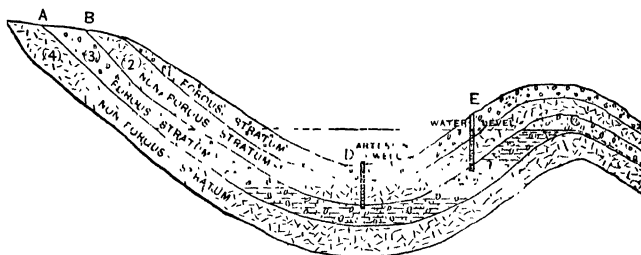

FIG. 15.—Conditions which produce artesian or flowing wells.

many parts is made up of distinct strata; some of these are porous to water, and others are nonporous. Four strata are represented in Fig. 15. Two are porous and two nonporous. These strata may be hundreds of miles in extent. Rain which falls on the hills, between the points *A* and *B*, sinks by gravity into the second porous stratum. This stratum has an impervious stratum above it and another beneath it. If the hollow is bowl-shaped, the water fills the second porous stratum until it finds an outlet at some point *C*. The water in the second porous stratum is then at the level of the dotted line. If a well is sunk at *E* into the second porous stratum, the water rises in the well to the level of the dotted line. If a well is sunk at *D*,

the water rises above the surface and the well is a flowing well. If there were no friction in the soil and in the casing of the well, the water would shoot up as high as the dotted line. Since there is a great deal of friction, however, particularly in the soil, the water does not rise to this height.

Well on a hillside. — Water which falls upon the hills and sinks into the earth flows underground by gravity down the hillsides to the valleys and down the valleys to the streams. In some parts of the country a supply of running water is secured by sinking a well on a hillside (see Fig. 16). The ground water fills this well to the ground water level at that point. If this

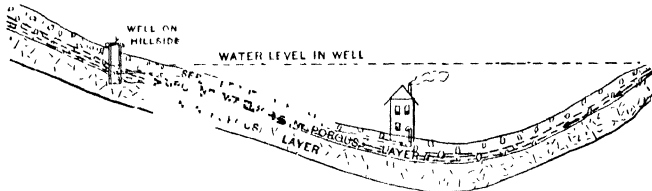

FIG. 16 — Water supply from a hillside well.

level is above the highest house tap and a pipe is laid from the well to the house, the water runs from the well to the highest house tap by gravity.

LAWS RELATING TO PRESSURE IN LIQUIDS

Pressure in liquids. — When a tap is opened in a house supplied with running water, the water comes out with more or less force, according to the pressure upon it. The pressure may be due to the force exerted on the water by the piston of the pump at the city pumping station, or it may be due to the force of gravity on the water in a standpipe, reservoir, or elevated tank. In order to get a deeper insight into this and into other properties of liquids, we will now study the laws relating to pressure in liquids.

One cubic foot of water weighs approximately 62.5 lb. If then a tank is filled with water to a depth of 1 ft., the pres-

sure on each square foot of the bottom is 62.5 lb. If the tank is filled to a depth of 4 ft., the pressure on each square foot is $4 \times 62.5 = 250$ lb. That is, the pressure on a given surface is proportioned to the depth.

If a tank has a bottom 6 sq. ft. in area and it is filled to a depth of 4 ft., the total pressure on the bottom is $6 \times 4 \times 62.5 = 1500$ lb. That is,

$$P = a \times h \times d$$

$$P = 6 \times 4 \times 62.5 = 1500 \text{ lb.}$$

where P = total pressure, a = area of surface, h = height of water, d = density of water.

That is, *the total pressure of a liquid on a surface is equal to the area of the surface times the depth of the liquid times the density of the liquid.*

Example. — The area of the base of a tank is 200 sq. cm.; the depth of the water is 60 cm.; what is the pressure on the base? Note, 1 c.c. of water weighs 1 g.

$$P = a \times h \times d$$

$$P = 200 \times 60 \times 1 = 12,000 \text{ g.}$$

The pressure upward at any point in a liquid is equal to the pressure downward at this point. If a glass lamp chimney *A*, Fig. 17, is fitted with a thin ground glass bottom *O* which is held over one end with a thread *C*, while this end is placed in water, it is found that the bottom remains on when the thread is released. This shows that water exerts pressure *upward*.

If now water is poured into the chimney, the bottom remains on until the level of the water inside the chimney is the same as the level outside. This shows that the pressure upward in the water is equal to the pressure downward of the column of liquid inside the chimney. In other

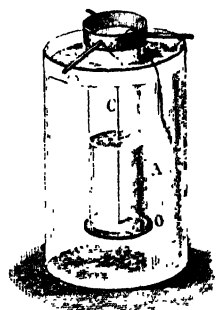

FIG. 17. — Liquids exert pressure upwards.

words, *in liquids the pressure upward is equal to the pressure downward at any depth.*

Pressure at any point in a liquid is the same in all directions.

— The bent tubes, Fig. 18, are filled with mercury to the same

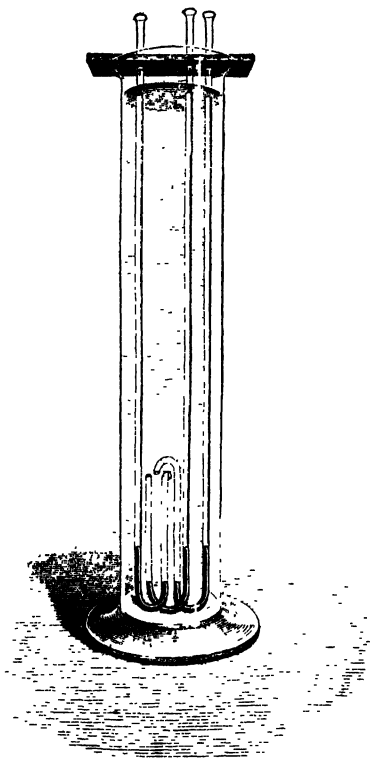

FIG. 18. — The pressure at any point in a liquid is the same in all directions.

depth. The short arm of each tube is open. The short ends point upward, sidewise, and downward, respectively. When these tubes are lowered to the same depth in a liquid the mercury shows the same pressure in each tube. This experiment shows that *at any depth in a liquid the pressure of the liquid is the same in all directions, downward, sidewise, and upward.*

This explains, for example, why the pressure at a tap is the same, no matter whether it is attached to the top, bottom, or side of a pipe, provided that in each position it is the same distance below the water surface.

The hydrostatic paradox. Pressure independent of volume. — A

striking fact regarding liquid pressure is shown by the following experiment:

A cone-shaped vessel, 1, Fig. 19, is arranged with a loose bottom *AB*, held up by weights on the pan of the balance (not shown);

the weights are so adjusted that the pressure of the water forces the base off when it reaches a certain height.

If then the cone-shaped vessel is replaced by the top shown in 2, which has a much smaller volume, it is found again that the base is forced off when the water reaches the same height.

Also, when 2 is replaced by the top 3 with a still smaller volume, it is found again that the base is forced off when the level of the water reaches the same height. This is called the hydrostatic paradox, because, although the weight of water is very

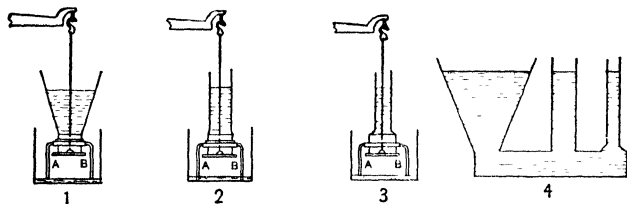

FIG. 19.—The hydrostatic paradox.

different in each case, the pressure on a given base is the same for equal depths of water.

We conclude, then, that *the pressure exerted by a liquid on any surface depends only upon the area of the surface, the depth and density of the liquid, and not at all upon the volume of the liquid.*

This is shown also in 4. The water is at the same level in each top, although the volume of liquid in each is different.

We learn from this, for example, that the pressure per square inch at any faucet is independent of the size or shape of the storage tank in the attic or elsewhere. It depends only upon the distance the tap is below the surface of the water, and upon the density of the water.

Pascal's law. — The apparatus shown in Fig. 20 is a syringe with a number of nozzles. If it is filled with water and the piston is pushed in, pressure is exerted upon the liquid, and some of the water flows out at each nozzle.

Since the pressure is exerted in the direction of the end nozzle,

we should naturally expect that the stream from this would be the longest. If, however, we place the nozzles in the same horizontal plane and make the experiment, we find that the streams from the nozzles are all of the same length. From

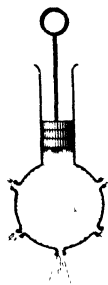

FIG. 20 -- The streams are of the same length

this we see that when pressure is exerted on a confined liquid, it is transmitted equally in all directions.

If each nozzle is fitted with a pressure gauge and a pressure of 10 lb. per square inch is exerted on the piston, we find that *each* nozzle registers a pressure of 10 lb. per square inch. This shows that the pressure exerted on a confined liquid is transmitted *equally* and *undiminished* in all directions.

From experiments such as these the French physicist Pascal (1623-1662) was led to the discovery of a law of nature applying to liquids, named after the discoverer, *Pascal's law*; namely, "*Pressure exerted on a confined liquid is transmitted equally and undiminished in all directions.*"

Applications of Pascal's law. — In Fig. 21, two cylinders are connected and filled with water; each cylinder is fitted with a piston; the area of cross section of the small piston is 1 sq. in., and of the large piston is 25 sq. in. If the pistons are frictionless, and a 10-lb. weight is placed on the small piston *A*, the pressure on the water in the small cylinder is 10 lb. per square inch. According to Pascal's law this pressure is transmitted equally and undiminished by the water; therefore the pressure upward on the large piston *B* is 10 lb. per square inch, or a total pressure of $10 \times 25 = 250$ lb. This is the principle of the hydrostatic bellows and the hydraulic press.

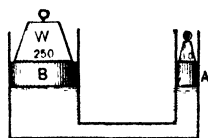

FIG. 21 -- A weight of 10 lb. balances a weight of 250 lb.

The hydrostatic bellows. — Pascal's law can be illustrated in a striking manner by means of the hydrostatic bellows shown in Fig. 22. The bellows consists of two disks of wood connected by a waterproof canvas cylinder, thus making a collapsible drum. A small pipe passes through the lower disk and opens into the drum.

If now the drum is filled with water and a man stands on the upper disk, a small amount of water is forced into the small tube. The striking thing is that a very small weight of water will balance the man's weight. In fact, a mere thread of water *AB* in the small tube will support any weight, provided the disks are made large enough.

Pascal's law gives us the explanation of this. If, for example, the small tube is 1 sq. in. in area and the upper disk is 500 sq. in. in area, 1 lb. of water in the small tube above the level of the upper disk exerts 1 lb. pressure on each square inch of the disk, or a total of 500 lb. That is, 1 lb.

of water in the small tube supports 500 lb. on the bellows.

The hydraulic press. The hydraulic press is a device used when great pressure is required; it is based on Pascal's law. For example, if the pump piston in *A*, Fig. 23, has an area of 1 sq. in., and the large piston in *B* an area of 1000 sq. in., and if we neglect friction, each pound of pressure on the



FIG. 22 - The hydrostatic bellows.

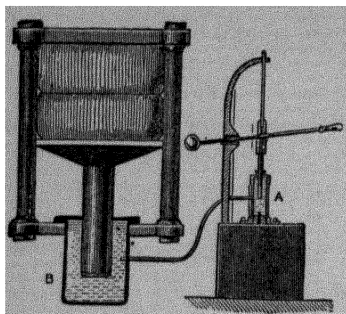

FIG. 23. — The hydraulic press.

pump piston exerts a total force of 1000 lb. on the large piston.

Hydraulic elevators, hydraulic lift locks, hydraulic gun testers, etc., are based on this principle.

Pressure in water pipes. —

Another illustration of Pascal's law is as follows. In cities which have neither standpipe nor reservoir, the water is pumped directly into the mains and is kept at a certain pressure. When a fire occurs the pressure is increased. If the pressure is increased 20 lb. per square inch at the pump, the pressure at each hydrant and faucet in the city is increased by 20 lb per square inch. That is, the pressure exerted on the confined liquid is transmitted equally and undiminished in all directions.

THE LAW OF ARCHIMEDES

A body when placed in a liquid loses weight equal to the weight of the liquid displaced. This is the law of Archimedes.

This law holds for bodies which sink in water and for bodies which float. We can illustrate it by means of the apparatus shown in Fig. 24, as follows:

Bodies which sink in water. — Fill the large vessel with water until water runs out at the spout. Weigh the small vessel empty. Weigh the heavy body in air and then when immersed in the water in the large vessel. Catch the water displaced by the body, in the small vessel, and weigh it.

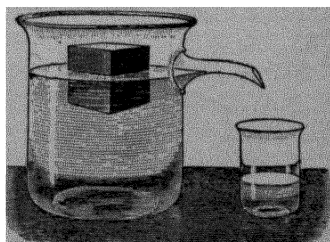

FIG. 24. — The body loses weight equal to the weight of the liquid displaced.

We find that the body loses weight equal to the weight of the water displaced

Bodies which float on water. — If we make the same experiment with a floating body, we find that the floating body loses all of its weight when placed on the water in the large vessel. We find, however, that its loss in weight is just equal to the weight of the water it displaces

Cup and cylinder — The law of Archimedes can be illustrated also by means of the experiment shown in Fig 25.

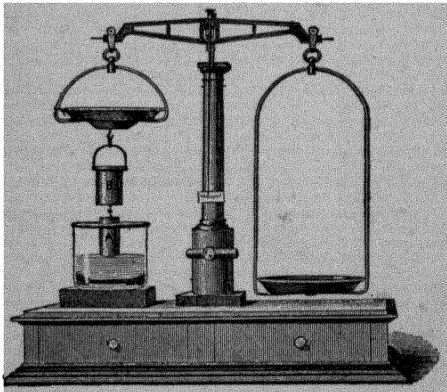

FIG. 25 Cup and cylinder experiment

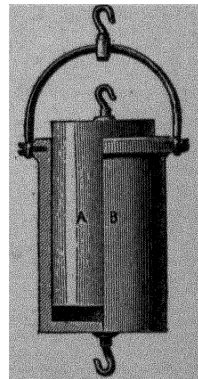

FIG. 26 — The volume of the cylinder is equal to that of the cup

The solid cylinder *A* is so made that it just fills the cup *B*. That is, the cylinder has the same volume as the cup (Fig. 26).

The experiment is as follows: *A* is attached to the bottom of *B*, and both are suspended from one pan of a balance. Weights are added to the other pan until the cup and cylinder are just balanced. If then a vessel of water is raised up under the cylinder until it is completely submerged, the cup and cylinder lose weight, because the water buoys up the cylinder. If now the cup *B* is filled with water, the balance is restored. This shows that the weight of water which just fills *B* is equal to the weight lost by *A*.

Since *A* and *B* have the same volume, we see from this experiment that when a body is placed in a liquid it is buoyed up by a force equal to the weight of the liquid it displaces. This is the law of Archimedes.

Explanation of the law of Archimedes. — In the experiment with the lamp chimney described on page 35 we learned that water exerts pressure upward, and that this upward pressure is equal to the pressure downward at the same depth.

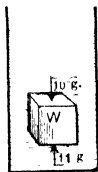

FIG. 27 — The buoyant force is one gram.

In Fig. 27 a cube 1 cm. on each edge is represented as placed with the lower surface 11 cm. beneath the surface of the water.

Since the area of each surface is 1 sq. cm. and the lower surface is 11 cm. beneath the surface, the pressure upward on it is :

$$\text{total pressure} = a \times h \times d = 1 \times 11 \times 1 = 11 \text{ g.}$$

The pressure downward on the top is :

$$\text{total pressure} = a \times h \times d = 1 \times 10 \times 1 = 10 \text{ g.}$$

The body then is buoyed up with a force of $11 - 10 = 1$ g. Therefore, it weighs 1 g. less in water than it does in air.

Since its volume is $1 \times 1 \times 1 = 1$ c.c., it displaces 1 c.c. of water, or 1 g. of water. Therefore, the loss in weight equals the weight of the liquid displaced.

We see then that the reason a body loses weight in a liquid is that the upward pressure on the bottom is greater than the downward pressure on the top, by an amount equal to the weight of liquid displaced by the body.

APPLICATIONS OF THE LAW OF ARCHIMEDES

Volume of irregular solids. — One application which can be made of the law of Archimedes is in determining the volume of irregular solids. For example, if a body weighs 200 g. less in water than in air, we know at once from this law that it displaces 200 g. of water. Since 1 g. of water occupies 1 c.c.,

the body displaces 200 c.c. of water; therefore, its volume must be 200 c.c.

Similarly, if we find that a body when weighed in water loses a certain weight in pounds, we can find its volume in cubic feet by dividing the loss by 62.5, the weight in pounds of 1 cu. ft. of water. For example, if the body loses 125 lb. weight, its volume is $\frac{125}{62.5} = 2$ cu. ft.

Density of a substance. — *The density of any substance is the weight of a unit volume of that substance.* Since in scientific work the cubic centimeter is usually taken as the unit volume, the density of a substance, unless otherwise stated, is understood to be the weight (in grams) of 1 c.c. of the substance.

Density of solids heavier than water. — The law of Archimedes is an aid to us in finding the density of solids, because it gives us an easy method of finding the volume of an irregular solid, as explained above. The loss of weight in grams is numerically equal to the volume in cubic centimeters.

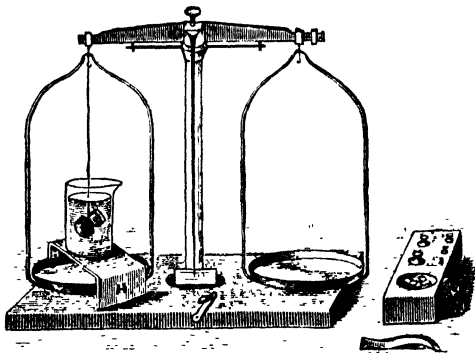

FIG. 28. — Finding the density of a body heavier than water.

To find the density of a substance heavier than water we proceed as follows: Find the weight in grams of the substance in air and then in water. Find the loss of weight in grams; this is numerically equal to the volume in cubic centimeters.

Divide the weight in air by the volume in cubic centimeters.

This gives the weight of 1 c.c. of the substance; that is, its density.

For example: If the glass stopper shown in Fig. 28 weighs 20 g. in air, and 12 g. in water, the loss in weight is 8 g.; therefore, its volume is 8 c.c. We can say then

8 c.c. of the glass weighs 20 g.

\therefore 1 c.c. of the glass weighs 2.5 g.

\therefore the density of the glass is 2.5 g. per cubic centimeter.

A short statement of the work above is:

$$\text{Density} = \frac{\text{weight in air}}{\text{loss in water}} = \frac{20}{8} = 2.5 \text{ g. per cubic centimeter.}$$

Density of solids lighter than water. — Solids lighter than water float, and in order to find their volume we must make

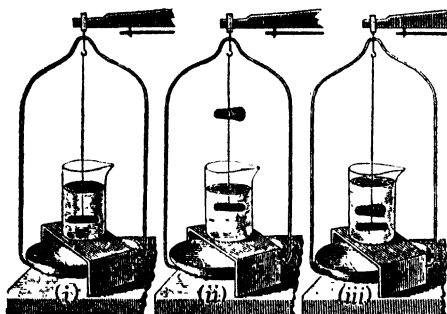

FIG. 20 — Finding the density of a body lighter than water.

them sink. To do this we find the weight of a sinker *in water* (see (i), Fig. 29) and then attach it to the body.

We will illustrate the method of finding the density of a floating body by means of an example. Let us suppose that we wish to find the density of a piece of cork.

We weigh the cork in air, the sinker in water, then attach the sinker to the cork and weigh them together in water. Let us suppose that the cork weighs 10 g. in air, the sinker 15 g. in water, and that together they weigh 5 g. in water.

If the cork and sinker were weighed as shown in (ii), Fig. 29, they would weigh 25 g., because the cork in air weighs 10 g. and the sinker in water weighs 15 g.

When the cork is placed with the sinker in water as shown in

(iii), Fig. 29, they weigh only 5 g. That is, the loss in weight is 20 g. Since this loss is due to the buoyant force of the water on the cork, the cork must displace 20 c.c. of water. Therefore the volume of the cork is 20 c.c.

We can say, then :

20 c.c. of cork weighs 10 g.

∴ 1 c.c. of cork weighs $\frac{10}{20} = .5$ g.

The density of cork is .5 g. per cubic centimeter.

If we find it by the short method given above,

$$\text{Density} = \frac{\text{weight in air}}{\text{loss in water}} = \frac{10}{20} = .5 \text{ g. per cubic centimeter}$$

Density of liquids. — Three methods of finding the density of liquids are described here; namely, by means of the density bottle, the density bulb, and the hydrometer.

The density bottle. — The density bottle (Fig. 30) is a bottle with its volume marked on the side, usually 50 c.c. or 100 c.c. The stopper of the bottle has a small hole bored through it to allow the surplus liquid to escape.

In finding the density of a liquid we first weigh the bottle when empty and then again when filled with the liquid. The difference in weight is the weight of 50 or 100 c.c. of the liquid. The density of the liquid is then found by dividing the weight of the liquid by its volume. For example, if the bottle has a volume of 100 c.c. and the oil it holds weighs 70 g.,

$$\text{Density of oil} = \frac{70}{100} = .7 \text{ g. per cubic centimeter}$$

Density bulb. — The density bulb is a bulb made of metal or glass; the method of using it is as follows: weigh the bulb in air and then in water; the difference gives the volume of the bulb in cubic centimeters (law of Archimedes).

Then weigh it in the liquid to be tested. The difference be-



FIG. 30. — The density bottle.

tween the weight in air and in the liquid is the weight of a volume of liquid equal to the volume of the bulb.

The density of the liquid is then found by dividing the weight of the liquid by its volume.

Example. The bulb weighs 100 g. in air, 60 g. in water, and 72 g. in oil. The loss in water is 40 g., \therefore the volume of the bulb is 40 c.c. The loss in oil is 28 g., \therefore 40 c.c. of the oil weighs 28 g., \therefore 1 c.c. of oil weighs $\frac{28}{40} = .7$ g.

Density = .7 g. per cubic centimeter

Hydrometer. — The hydrometer, Fig. 31, is made of glass and weighted at the bottom with shot or mercury; the stem is graduated to give the density directly. The principle upon which it works is as follows: A floating body sinks in a liquid until it displaces its own weight of the liquid (law of Archimedes). The hydrometer sinks to a certain mark in water. In a liquid lighter than water, it sinks deeper before it displaces its own weight of the lighter liquid. In liquids heavier than water it does not sink so far as it does in water, because it does not need to sink so far to displace its own weight. The stem is so graduated that to find the density of a liquid it is necessary only to place the hydrometer in the liquid and read the figure on the stem opposite the liquid level. This is the density of the liquid. The thermometer, sealed in the bulb, gives the temperature at which the density of the liquid is taken.

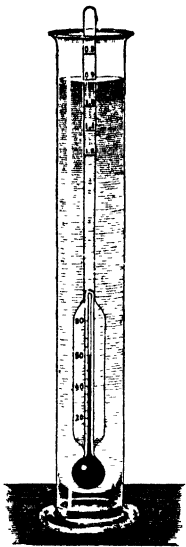

FIG. 31 — The hydrometer.

Summary. — In this chapter we have studied a number of water supply systems for cities and for country homes. We have also learned the following laws relating to liquids:

(1) The law of liquid pressure :

$$\text{Pressure} = \text{area} \times \text{height} \times \text{density}$$

(2) Pascal's law. Pressure exerted on a confined liquid is transmitted equally and undiminished in all directions.

(3) The law of Archimedes. A body placed in a liquid is buoyed up by a force equal to the weight of the liquid displaced.

EXERCISES

1. State the different methods of supplying water to cities.
2. State the different methods of supplying running water to country homes.
3. Upon what does the pressure of a liquid depend?
4. What is the hydrostatic paradox?
5. State Pascal's law.
6. State the law of Archimedes.
7. The level of the water in an attic tank is 30 ft. above the level of the kitchen faucet. What is the pressure per square inch at the faucet?
8. The level of the water in a city standpipe is 80 ft. above the level of a faucet in a kitchen. What is the pressure per square inch at the faucet?
9. In (8) a bathroom faucet is 15 ft. above the level of the kitchen faucet. What is the pressure per square inch at this faucet?
10. The level of the water in a city reservoir is 100 ft. above the city mains, a kitchen faucet is 10 ft. above the mains, and a bathroom faucet is 20 ft. above the mains. What is the pressure per square inch at each faucet?
11. What height must the water in a city reservoir be above the kitchen faucet to give a pressure of 40 lb. per square inch at the faucet? Make a sketch.
12. In a hydraulic press, the area of the small piston is 2 sq. in., and of the large piston is 400 sq. in. If 100 lb. force is applied to the small piston, what is the upward lift on the large piston? Neglect friction. Make a sketch.
13. If in (12) a handle is put on the small piston, the force arm being 35 in. and the weight arm $3\frac{1}{2}$ in., what is the upward lift on the large piston if the 100-lb. force is applied to the handle? Neglect friction. Make a sketch.
14. A boy weighs 126 lb. When he is entirely immersed in water he weighs only 1 lb., *i.e.* 1 lb. of force keeps him from sinking deeper. What is his volume in cubic feet?

15. A piece of rock loses 24 g. in weight when placed in water. What is the volume in cubic centimeters?

16. A tank will hold 1250 lb. of water. What is its volume in cubic feet?

17. A bottle holds just 100 g. of water at 4° C. What is its volume in cubic centimeters?

18. A piece of rock weighs 250 g. in air, but only 150 g. in water. What is its volume? What is the density of this rock in grams per cubic centimeter?

19. A piece of wood weighs 180 g., a sinker weighs 200 g. in water. When they are weighed together in water they weigh only 20 gr. What is the density of the wood in grams per cubic centimeter? Make a sketch.

20. A bottle holds 100 g. of water at 4° C. It holds 103 g. of milk, 80 g. of alcohol, 180 g. of sulphuric acid. What is the density in grams per cubic centimeter of milk, alcohol, and sulphuric acid?

21. A glass ball weighs 250 g. in air, 150 g. in water, 170 g. in alcohol. What is the density of the alcohol in grams per cubic centimeter?

22. A ship's displacement is 12,500 tons. What is its weight? What is the volume of the hull below the water line?

23. If your home is supplied with running water, trace the water pipes, starting at the point where the water enters the house and following each pipe to the tap at which it empties. Make a diagram showing the pipes from the point at which the water enters to the principal fixtures (sink, laundry tub, bath tub, etc.). At what point could you shut off the water in case of accident?

CHAPTER VI

MECHANICS. GASES

THERE are many household appliances the working of which depends upon one or more of the physical properties of gases, particularly of the gas, air. In this section we shall study some of these appliances, namely, different kinds of pumps, the pneumatic tank system of water supply, the hydraulic ram, the vacuum cleaner, the fire extinguisher, and others.

In order to understand these and similar appliances, we shall first study the physical properties of gases and the laws of nature which apply to gases, particularly to the gas, air.

Air has weight. — If we were asked the question, “How much does air weigh?” we should probably answer, “Air has no weight at all.” A very simple experiment, however, will show us that air *has* weight, and that it would take three or four strong men to lift a weight equal to the weight of air in a moderately large classroom.

The experiment is as follows: A glass flask (Fig. 32), fitted with a stopper and tap is attached to an air pump, and as much as possible of the air is pumped out. The tap is then closed and the flask is attached to one pan of a scale and balanced by weights on the other pan. If now the tap is opened, air enters the flask, and when weighed

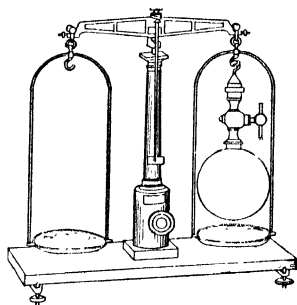

FIG. 32. — Showing that air has weight

the flask plus the air in it weighs more than the flask alone. This shows that air has weight.

At atmospheric pressure and the ordinary temperature, 1 cu. ft. of air weighs about $1\frac{1}{4}$ oz., and 1 l. of air about $1\frac{1}{3}$ g.

Weight of air in a classroom. — Since we know that 1 cu. ft. of air weighs $1\frac{1}{4}$ oz. we can calculate the weight of the air in a classroom of any size. For example, let us calculate the weight of the air in a classroom 40 ft. long by 24 ft. wide by 12 ft. high. The volume of the room in cubic feet is $40 \times 24 \times 12 = 11,520$ cu. ft. Since each cubic foot of air weighs $\frac{5}{4}$ oz., the air in the room weighs $11,520 \times \frac{5}{4} = 14,400$ oz., and since there are 16 oz. in 1 lb., the air weighs $\frac{14,400}{16} = 900$ lb.

We see then that it would take a number of strong men to carry a weight equal to the weight of the air in this classroom.

ATMOSPHERIC PRESSURE

We have found that air has weight and we know that we all live at the bottom of an ocean of air (the atmosphere) which is some miles deep. It is easy for us to understand then that this ocean of air exerts pressure on everything at the earth's surface.

Demonstrations of atmospheric pressure. — In Fig. 33 some of the methods of demonstrating atmospheric pressure are shown. In I a rubber sheet is fastened air-tight over one end of a hollow cylinder, and the other end is connected with an air pump. When the air is pumped out, it is found that the rubber sheet is forced in by the pressure of the air above, see II.

In III is represented a pair of Magdeburg hemispheres, which were invented and experimented with by Otto von Guericke, burgomaster of Magdeburg, Germany, in 1654. These hemispheres are made of iron, and the edges are ground smooth, so that when the two halves are placed together the joint is air-tight. When there is air inside, the hemispheres can be pulled apart with ease; but when the air is pumped out, a large force is required to separate them. When the hemispheres are filled

with air, the air on the outside is pressing them together, but the air on the inside is pressing them apart and the one pressure balances the other. When the air inside is removed, however,

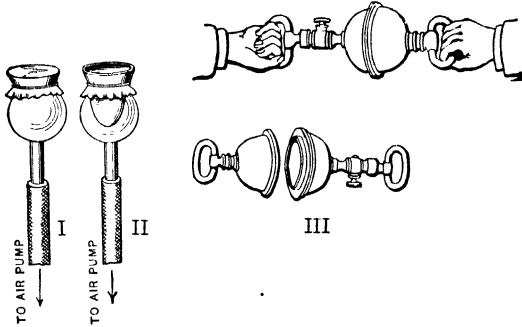

FIG. 33. — Illustrating atmospheric pressure.

there is left only the air outside which is pressing the hemispheres together. In order to separate them then a force must be exerted equal to the pressure of the atmosphere on the outside.

If a tumbler is filled with water, then covered with a piece of paper and the paper is held on with the hand while the glass is inverted, it is found that the paper remains on when the hand is removed, Fig. 34.

The reason is that the pressure of the atmosphere upward on the paper is greater than the weight of the water in the glass.

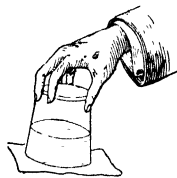

FIG. 34 — The paper is supported by atmospheric pressure.

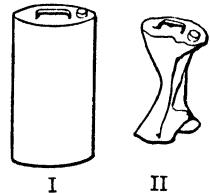

FIG. 35. — The can is crushed by atmospheric pressure.

If a sirup can (Fig. 35) with a little water in it is placed on the fire and the water is allowed to boil for a time, the steam gradually drives out the air. If now the can is removed from the fire and at the same time closed air-tight with a rubber stopper, it is found that in a short time the can collapses.

The reason for this is as follows: When the water has boiled for some time, the steam has driven out the greater part of the air, and there is practically nothing in the can then but water and steam. When the can is closed air-tight and allowed to cool, the steam condenses. There is then nothing in the can but a little water, the space above the water being nearly a vacuum. Since there is practically nothing inside pressing outward, the can must stand the whole pressure of the atmosphere on the outside. If it is not strong enough to do this, it collapses.

These four experiments demonstrate that the atmosphere exerts pressure.

Torricelli. — An Italian named Torricelli (1608–1647) was the first to prove that the atmosphere exerts pressure and to measure this pressure. He was led to the discovery as follows: It had been known from ancient times that if one end of a pipe is placed in water and the air is pumped out at the top, the water rises in the pipe. The ancients explained this by the saying, “Nature abhors a vacuum,” which, of course, was no explanation at all. About 1640 a deep well was dug near Florence, and it was found that, no matter how perfect the pump, water could be raised only 33 ft. It seemed then that nature’s horror of a vacuum stopped at 33 ft. The true explanation was supplied by Torricelli. He came to the conclusion that it is the pressure of the atmosphere which forces the water up the pipe, and that the pressure of the atmosphere is great enough to support a column of water 33 ft. high. He reasoned that, if this be true, a column of any liquid heavier than water would be raised to a height less than 33 feet. He decided to make a test with mercury, which is 13.6 times as heavy as water, and therefore would be lifted only $1/13.6$ times as high as water.

Torricelli’s experiment, 1643. — Torricelli’s experiment is as follows (Fig. 36): A glass tube 4 ft. long, closed at one end, is entirely filled with mercury. The finger is then placed over the open end and the tube is inverted over an open dish of mercury. When the finger is removed from the open end under

mercury, the mercury in the tube sinks until the level inside is about 30 in. above that outside.

Torricelli concluded from this experiment that it is the pressure of the atmosphere which supports the column of mercury 30 in. high, and since mercury is 13.6 times as heavy as water, the atmosphere should support a column of water $13.6 \times 30 = 408$ in. high = 34 ft. high. It is found by experiment that the atmosphere supports a column of water a little over 33 ft. high. The height is slightly less than 34 ft., because the water evaporates into the vacuum at the top of the tube, and the water vapor thus formed exerts a slight pressure downward on the column of water.

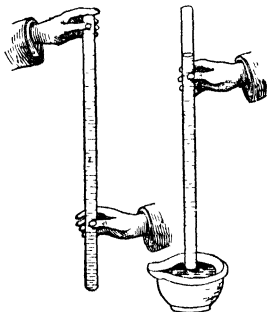

FIG. 36 — Torricelli's experiment.

Pascal's proof, 1648. — Pascal devised an experiment which added further proof that it is the pressure of the atmosphere which supports the mercury in the tube. He reasoned that, if it is the atmosphere which supports the mercury, then, since as we go up a mountain there is less air above us, the pressure should be less on a mountain. Torricelli's experiment was repeated at the base and at the top of a mountain, and it was found that the level was lower by 3 in. on the top of a mountain two thirds of a mile high.

The barometer. — The barometer is an instrument used to foretell the weather. As is seen in Fig. 37, it is similar to the apparatus used by Torricelli in his experiment. The pressure of the atmosphere on the mercury in the short tube holds up the mercury in the long tube, and since this pressure varies from hour to hour the height of the mercury varies also. Weather predictions are based on this variation. The height at sea level is about 30 in. or 76 cm. It has been found that if the mercury falls much below this height, stormy weather is to be

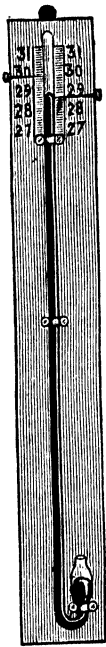

FIG. 37. -- The barometer.

expected; and if the mercury rises much above it, we may look for fine and dry weather.

Height of mercury independent of the size and shape of tube and dish. — If we repeat Torricelli's experiment, using a number of tubes of different sizes and shapes, standing in vessels of different sizes and shapes, we find, in every case, that if the tubes are filled with mercury and then inverted in a dish of mercury, as in Torricelli's experiment, the level is the same in each case. That is, the height of the mercury in the tube is independent of the size and shape of the tube and dish, provided the tube is over 30 in. long and the mercury in the dish is open to the air.

Pressure of the atmosphere per square inch. —

Since the height of the mercury is the same, no matter what the size of the tube, we may consider the inside cross section to be just 1 sq. in. Then it is evident that the atmospheric pressure on 1 sq. in. at *A*, Fig. 38, is holding up a column of mercury *BC* containing just 30 cu. in. of mercury. One cubic inch of mercury weighs .49 lb. Therefore the pressure of the atmosphere on 1 sq. in.

is $.49 \times 30 = 14.7$ lb. That is, the atmosphere exerts a pressure of 14.7 lb. (nearly 15 lb.) per square inch, on everything on the earth's surface.

Pressure of the atmosphere per square centimeter. — To calculate the pressure of the atmosphere on each square centimeter, we consider the tube to have an inside cross section of just 1 sq. cm.; then the atmospheric pressure on 1 sq. cm. at *A* holds up a column of mercury *BC* containing just 76 cu. cm. Now

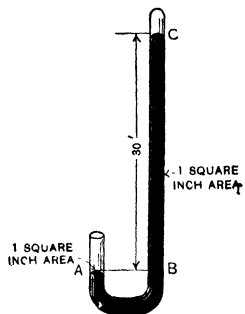

FIG. 38 — Measuring atmospheric pressure.

1 cu. cm. of mercury weighs 13.6 g. Therefore the pressure of the atmosphere on 1 sq. cm. is $13.6 \times 76 = 1033.6$ g.

LAWS OF NATURE WHICH APPLY TO GASES

Gases have weight and exert pressure. — We have found that air has weight; that, like liquids, it exerts pressure on anything immersed in it; and that this pressure increases with the depth of air.

In liquids the pressure is proportional to the depth of liquid above an object. This is not true, however, in gases, because, while all liquids are nearly incompressible, all gases, as we shall learn later, are very compressible, and therefore the gas near the bottom of a column is denser than gas near the top. For example, a cubic foot of air at the base of a mountain has a greater weight than a cubic foot near the top.

Gases, then, have weight, and exert pressure on objects immersed in them. The other laws of nature which we have found to apply to liquids also apply to gases, namely, Pascal's law and the law of Archimedes.

Pascal's law applied to gases. — Pascal's law as applied to gases is: *pressure on a confined gas is exerted equally and undiminished in all directions.* This is shown in a number of ways.

If in a steam boiler the pressure is 100 lb. per square inch on one square inch of the inside surface of the boiler, it is found to be 100 lb. on every other square inch of the inside of the boiler at the same level. That is, the pressure is transmitted equally and undiminished in all directions.

If a piece of rubber is stretched over one end of a lamp chimney, and if some of the air is pumped out through the other end, the rubber is driven in by the pressure of the air on the outside. If now we move the lamp chimney around so that the rubber surface points upward, sidewise, or downward, the rubber remains in the same position. This shows that the pressure of the air is equal in all directions at the same level.

Also, when air is pumped out of the Magdeburg hemispheres,

they are forced together with the same force, no matter how we turn them, showing again that the pressure of the air is equal in all directions at the same level.

These experiments show that Pascal's law applies to gases.

The law of Archimedes applies to gases. — The law of Archimedes as applied to gases is, — *All bodies immersed in a gas are buoyed up by a force equal to the weight of the gas displaced.* This is shown by the experiment illustrated in

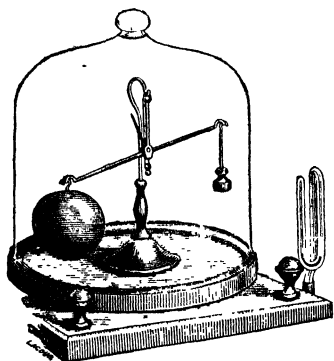

FIG. 39 — Illustrating the buoyant force of air

Fig. 39. A sealed glass globe is balanced in air by a small brass or iron weight. Now since the globe is larger than the weight, it displaces more air, and therefore is buoyed up by a greater force than is the weight. When the air is pumped out of the receiver, this buoyant force is removed and the balance is destroyed.

The buoyant force on a balloon is another illustration of this law. The buoyant force exerted by the air upon a balloon is equal to the weight of air displaced by the balloon. For example, if the balloon displaces 12,800 cu. ft. of air, the total buoyant force on it is equal to the weight of 12,800 cu. ft. of air. This is $12,800 \times \frac{5}{4} = 16,000$ oz. = $\frac{16,000}{16} = 1000$ lb. The balloon, then, could lift a total weight of 1000 lb.

Laws. We have now studied three different laws of nature applying to gases, namely: —

1. Gases have weight and exert pressure.
2. Pascal's law.
3. The law of Archimedes.

We may now take up two other laws, the last which we shall consider in this chapter, namely, Boyle's law and Henry's law.

Boyle's law. — *The volume of a gas varies inversely as the pressure on it.* This is an important law which applies to all gases. It is called Boyle's law after Robert Boyle, an Englishman, who discovered it in 1666.

This law means that if a gas is confined under a certain pressure and we double the pressure, the gas is compressed to one half its first volume; if we treble the pressure, the gas is compressed to one third its first volume; and so on. Also it means that if we halve the pressure, the gas expands to twice its first volume, and so on.

Boyle's law can be illustrated by means of the apparatus shown in Figs. 40 and 41.

The apparatus in Fig. 40 is a U-shaped tube with mercury in the bend. The short closed tube holds a certain volume of gas, confined by the mercury. The pressure on this gas is one atmosphere because the mercury is at the same level in both tubes. If now we pour mercury in the large open tube, until it stands 30 in. above the level in the small tube, the pressure on the gas is two atmospheres (one the air and one the mercury). We find then

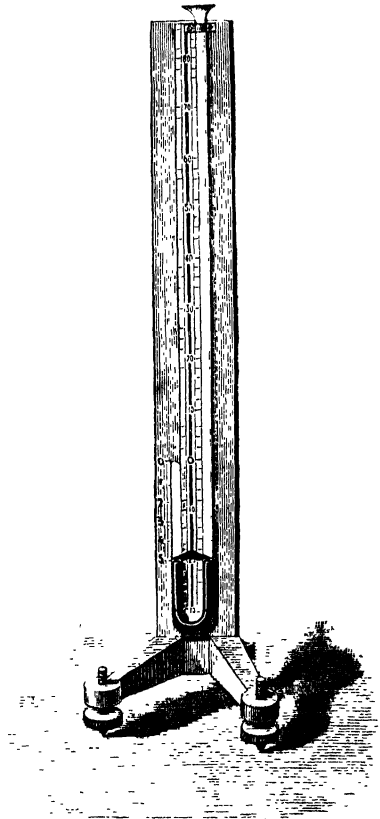

FIG. 40 — Illustrating Boyle's law for pressure greater than one atmosphere.

that the gas has been compressed in the small tube to one half its first volume. If we make the pressure three atmospheres, the gas is compressed to one third its first volume, and so on. This illustrates Boyle's law for increasing pressures.

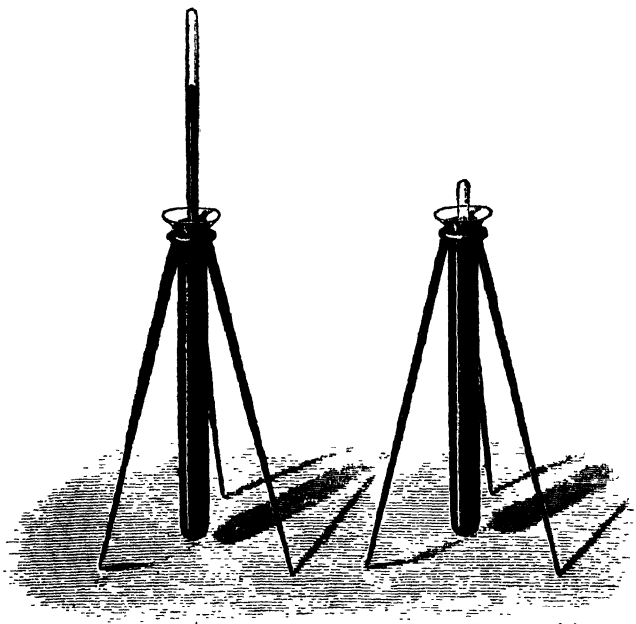

FIG. 41. — Illustrating Boyle's law for pressures less than one atmosphere.

We can illustrate the law for decreasing pressures by means of the apparatus shown in Fig. 41. The large tube filled with mercury holds a smaller tube which is open at the lower end, and contains a small volume of gas.

When the apparatus is in the position shown on the right of the figure, the level of the mercury in the tubes is the same; therefore, the gas is under a pressure of one atmosphere. If now we raise the small tube until the mercury in it is 15 in. ($\frac{1}{2}$ atmosphere) above that in the large tube, the pressure on

the gas is only $\frac{1}{2}$ atmosphere. We find then that the volume of the gas is twice what it was at first. If we raise the inner tube until the mercury is 20 in. ($\frac{2}{3}$ atmosphere) above that in the large tube, the pressure on the gas is $\frac{1}{3}$ atmosphere. We find that the volume of the gas is three times what it was at first. This illustrates Boyle's law for decreasing pressures.

Henry's law. — If a gas stands in contact with a liquid, part of the gas dissolves in the liquid. This is a general property of gases. The American scientist, Henry, investigated this property of gases, and in 1803 announced the law which states the relation between the amount of gas dissolved and the pressure. This is known as Henry's law. It is, *If a gas does not combine chemically with a liquid, the amount of gas dissolved is directly proportional to the pressure.* That is, if, for example, we double the pressure, we double the amount dissolved.

We have now studied five laws of nature which apply to gases :

1. Gases have weight and exert pressure.
2. Pascal's law.
3. Law of Archimedes.
4. Boyle's law.
5. Henry's law.

A knowledge of these laws will enable us to understand the working of many appliances used about the home and elsewhere.

EXERCISES

1. How can we show that air has weight?
2. Describe four experiments, each of which shows that the atmosphere exerts pressure.
3. Describe Torricelli's.
4. How is the pressure of the atmosphere, per square inch, found?
5. State Pascal's law as applied to gases.
6. State the law of Archimedes as applied to gases.
7. State Boyle's law.
8. Could you carry the air contained in a room 40 ft. long, 20 ft. wide,

and 10 ft. high (1 cu. ft. of air weighs $1\frac{1}{4}$ oz.)? What is the weight of the air in the room?

9. How many kilograms of air are there in a room 10 m. long, 5 m. wide, and 3 m. high? (Take the weight of 1 l. of air as $1\frac{1}{2}$ g.)

10. A cubic inch of mercury weighs .49 lb. What is the pressure of the atmosphere on each square inch, on days when the barometer stands 29, 30, and 31 in. high?

11. A cubic centimeter of mercury weighs 13.6 g. What is the pressure of the atmosphere on each square centimeter, on days when the barometer stands 75, 76, and 77 cm. high?

12. If the pressure of the atmosphere is 14.7 lb. per square inch, what force is necessary to pull apart Magdeburg hemispheres having an inside diameter of 4 in., when the air is all removed from the inside?

13. A rectangular sirup can is $12'' \times 6'' \times 4''$. What is the total pressure of the atmosphere on the outside?

14. Mercury is 13.6 times as heavy as water; on a day when the mercury is 30'' high in a mercury barometer, how high will the water be in a water barometer?

CHAPTER VII

AIR APPLIANCES

The lift pump. — The working of the lift pump is illustrated in Fig. 42. There are two valves in the pump, each of which opens upward. One valve *A* is located in the plunger and the other *C* at the bottom of the barrel. When we move the plunger up and down we remove air from the barrel and

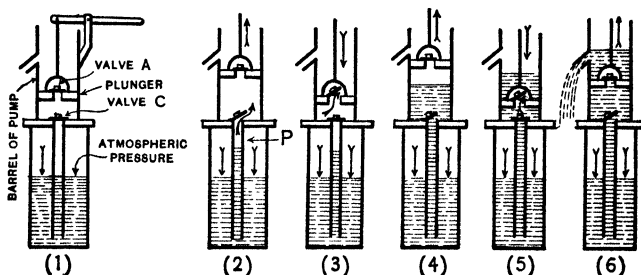

FIG. 42. — Showing how the lift pump works.

suction pipe *P*. This decreases the air pressure in the barrel and suction pipe and the pressure of the atmosphere, on the water in the well, forces water up into the pump.

Since the pressure of the atmosphere is sufficient to lift water only 33 ft., the plunger is placed within this distance of the water. In actual practice it is usually placed not more than 20 or 25 ft. above the water. In deep wells the plunger is placed in a cylinder, and the cylinder is placed on the end of a pipe long enough to bring it within 20 ft. of the water.

The force pump. — When we desire to force water above the level of the pump spout we use a force pump, one form of

which is shown in Fig. 43. It is the same as the lift pump shown above except that the top of the barrel is closed. The pump rod passes through a stuffing box which is water-tight.

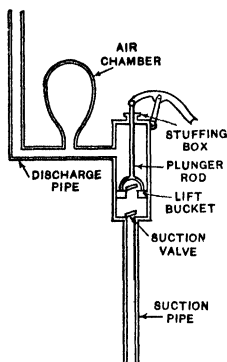

FIG. 43. — The force pump.

The air chamber on the discharge pipe serves to prevent strains on the pump, and also to keep up a steady stream in the pipe. While the plunger or lift bucket is moving up, part of the water is forced into the discharge pipe and part into the air chamber. The water which enters the air chamber compresses the air and increases its pressure. While the plunger is moving down, the air in the chamber expands and forces the water out of the chamber and into the discharge pipe. Thus a steady stream is maintained in the discharge pipe.

The pneumatic tank system of water supply. — The arrangement of a pneumatic tank system of water supply for a private home is shown in Fig. 45. A sectional view of the tank is shown in Fig. 44. The system consists of an air-tight steel tank, a force pump, and the necessary pipes. It works as follows: Water is forced into the tank at the bottom. This compresses the air in the tank to a smaller volume and increases its pressure. The pressure of this air forces water up the discharge pipe to the fixtures in the rooms above.

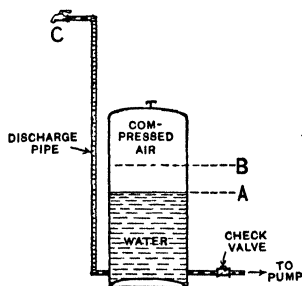

FIG. 44. — Sectional view of the pneumatic tank.

Boyle's law, which we studied on page 57, enables us to understand a number of things about this system. For example, if at the beginning the tank is full of air at a pressure of 1 atmosphere, we know that when the tank

is half full (A), Fig. 44, the air is compressed to half its volume and the pressure is 2 atmospheres, when the tank is two thirds full of water (B), Fig. 44, the air is compressed to one third its volume, and the pressure is 3 atmospheres; when

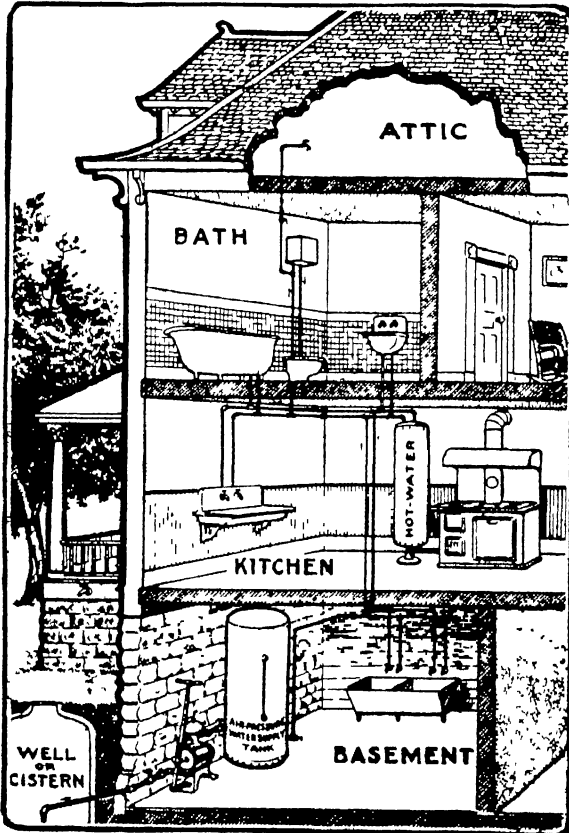

FIG. 45 — The pneumatic tank system of water supply for country homes.

the tank is three fourths full, the air is compressed to one fourth its volume, and the pressure is 4 atmospheres, and so on.

Lifting pressure. — Since the pressure of the atmosphere is exerted upon everything, the water flows from a tap against the pressure of 1 atmosphere. For this reason, when the actual pressure in the tank is 2 atmospheres, the pressure which lifts the water, or the lifting pressure, is only 1 atmosphere; when the actual pressure is 3 atmospheres, the lifting pressure is 2 atmospheres; and so on. A pressure of 1 atmosphere lifts water 34 ft., a pressure of 2 atmospheres lifts water 68 ft., and so on.

The hydraulic ram. — The hydraulic ram, Fig 46, is an automatic pumping appliance. It can be used where there is a brook or spring with a fall of at least $1\frac{1}{2}$ feet. The operation of the ram is as follows. The water from the brook or spring flows

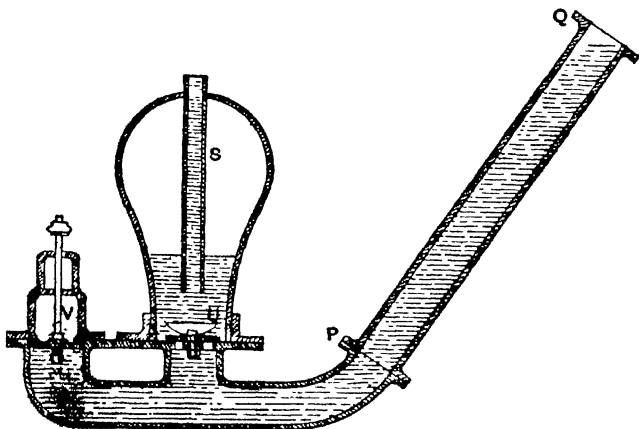

FIG 46 — The hydraulic ram.

down the drive pipe QP , and out at the working valve OV . The velocity of the water rapidly increases, and at a certain velocity the working valve V is suddenly closed by the force of the water. The momentum of the water in the drive pipe forces the valve U open and drives part of the water into

the air chamber. The air in the chamber is thereby compressed, and its pressure is increased. The air pressure stops the water, and for an instant starts it back up the drive pipe. This reaction closes the valve *U*, and allows the valve *V* to open. The water then starts flowing down the drive pipe again and out at *OV*, this valve again closes and more water is forced into the air chamber, and so on. This operation is repeated from 20 to 200 times a minute, according to the conditions. The compressed air in the air chamber forces the water out of the air chamber up through the discharge pipe *S*, and into an elevated tank. From here the water runs to the house fixtures by gravity.

The air pump. — A sectional view of an air pump is shown in Fig. 47. The construction of the pump is the same in principle

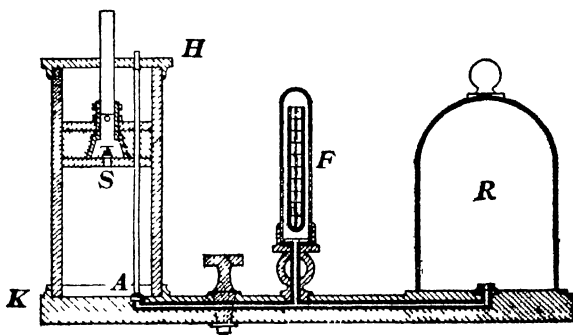

FIG. 47. — The air pump

as the ordinary lift pump. One valve *S* is in the plunger, and the other valve *A* is in the base of the pump. The rod attached to *A* passes through the plunger. There is a slight amount of friction between the plunger and the rod, and this helps raise *A* on the up stroke of the plunger.

Air is pumped from the receiver *R* as follows: When the plunger moves up, the air in the pump barrel *KS* is given more room. It expands and its pressure is decreased. The air in

R is then at a greater pressure than that in the barrel. It therefore expands and part of it passes through A and into the barrel. When the plunger moves down, this air passes out of the pump through the valve S . On the next upstroke of the plunger, part of the air left in R expands into KH , and on the down stroke it is forced out. This is repeated at each stroke.

It will be seen that we pump air out of anything by making use of one property of gases, namely, a gas will expand indefinitely if we give it room to expand (Boyle's law).

If, for example, when the plunger moves up, it increases the volume which the air in the receiver and cylinder can occupy, from say 3 volumes to 4 volumes, then one fourth of the air is taken out in the first stroke. On the second stroke, one fourth of what is left is taken out, on the next stroke, one fourth of what is left, and so on. If the pump were perfect we could continue this indefinitely, but we could never get quite all of the air out of the receiver.

Vacuum cleaners. — The vacuum cleaner shown in Fig. 48 is a hand power machine. Those shown in Figs. 50 and 51 are driven by means of electric motors.

In all vacuum cleaners there are three operations performed. These operations are:

1. A partial vacuum is produced in the machine by some means.

2. The pressure of the atmosphere forces air into this partial vacuum, and as the air enters through the nozzle or otherwise it carries the dust and dirt in with it.

3. The air is strained through one or more layers of cloth and thereby freed from dirt.

A sectional view of a vacuum cleaner is given in Fig. 49. Let us see how the three operations mentioned above are performed.

At the beginning all the air in the machine is at the same pressure as the atmosphere outside. When the handle of the air pump is moved back and forth, air is pumped out of the

cleaning chamber. This decreases the pressure of the air, or, in other words, produces a partial vacuum in the chamber. This is operation number one.

As soon as the pressure of the air in the cleaning chamber is less than that of the atmosphere, the pressure of the atmosphere outside forces air into the chamber through the nozzle,

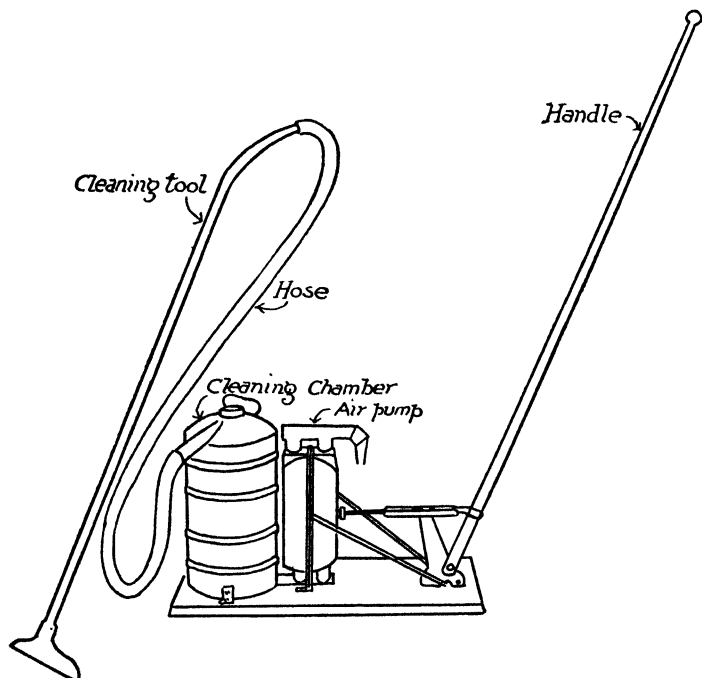

FIG. 48. — A hand power vacuum cleaner.

cleaning tool, and hose, and the dust and dirt are carried in with the air. This is operation number two.

As the air passes through the cleaning chamber on its way to the pump, it is strained through the cloth bag. It is thereby freed from the dirt, which is retained in the bag. This is operation number three.

The air pump. — The air pump shown in Fig. 49 is what is known as a double-acting diaphragm pump. It is in reality two pumps in one. The diaphragm piston consists of a solid disk in the center of a large disk of rubber or leather. This piston is air tight. It divides the pump into two chambers.

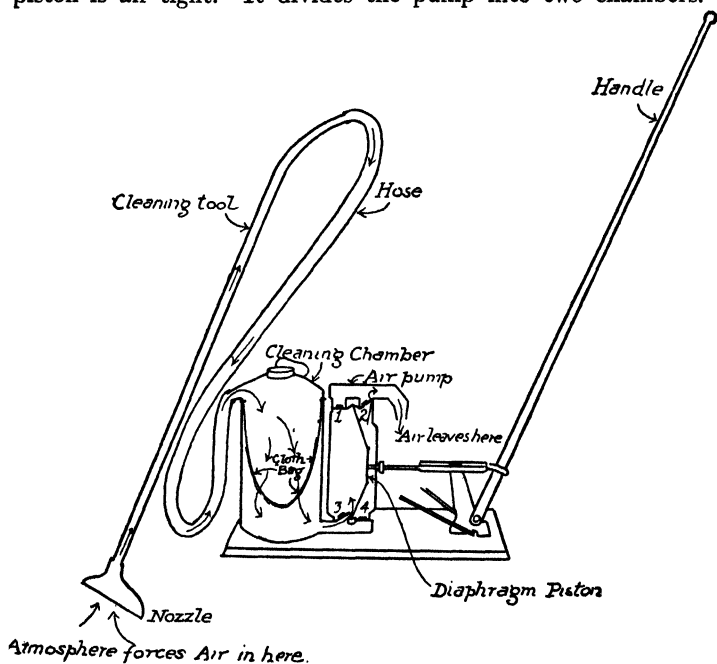

FIG. 49. — Showing how the vacuum cleaner works.

There are two valves in each chamber, 1 and 3 in one, 2 and 4 in the other. All of these valves open upward.

When the piston is moved to the right, as in the figure, the size of the left-hand chamber is increased and that of the right-hand chamber decreased. Air then enters the left-hand chamber through the valve 3, and the air in the right-hand chamber is forced out through the valve 2. When the piston is moved to the left, the air in the left-hand chamber is forced out through

the valve 1 and air enters the right-hand chamber through the valve 4. We see, then, that on each half stroke of the piston air enters the pump from the cleaning chamber. This shows how the partial vacuum is produced in the cleaning chamber by this type of air pump.

The cleaner shown in Fig. 50 has a diaphragm pump driven by an electric motor.

Other methods of producing the partial vacuum. — Vacuum cleaners may be divided into three main classes, according to the way in which the partial vacuum is produced. It is produced either by an air pump, by a fan, or by a centrifugal fan.

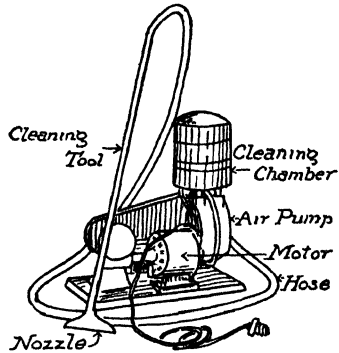

FIG. 50. — Vacuum cleaner with motor-driven air pump.

The air pump has been described above. The fan is similar to the ordinary electric fan used for stirring the air in a room. The air is driven in a direction at right angles to the plane in which the fan blades are moving. The partial vacuum

is produced behind the fan. In the centrifugal fan the air is driven towards the outer end of the fan blades, and the partial vacuum is produced at the center of the fan.

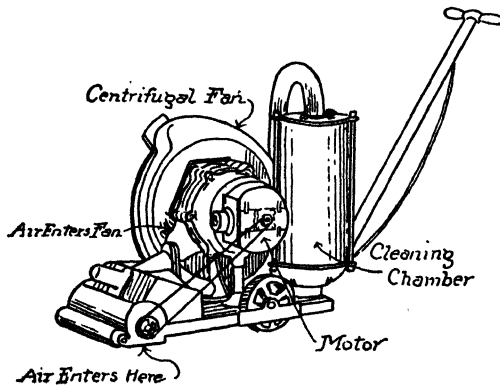

FIG. 51. — Vacuum cleaner with motor-driven centrifugal fan.

The cleaner shown in Fig. 51 has a centrifugal fan driven by an electric motor. The air enters just behind the revolving brush. It passes into the fan at the center and is forced to the outer edge of the fan and casing. It then passes through the cleaning chamber and out into the open air.

We see, then, that in all vacuum cleaners we make use of one of the forces of nature, namely, the force of gravitation. It is the attraction of the earth, or the force of gravitation, which gives air its weight, and which thus produces the pressure of the atmosphere. All vacuum cleaners are so arranged that the pressure of the atmosphere forces the air and dirt into the chamber.

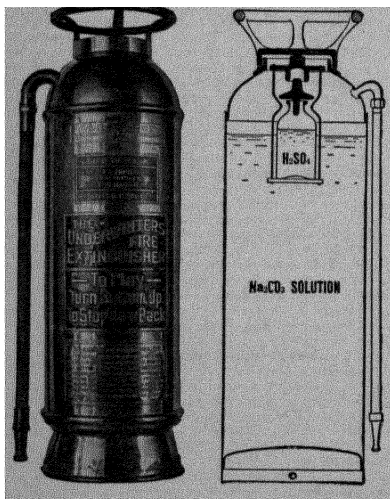

FIG. 52 — The fire extinguisher

The fire extinguisher. — The working of the ordinary household fire extinguisher is based upon the physical and chemical properties of the gas, carbon dioxide.

The extinguisher (Fig 52) is a strong brass cylinder with a short piece of stout hose attached at the top. The extinguisher is charged as follows. In the bottom is poured a solution of $1\frac{1}{2}$ lb. of sodium bicarbonate in $2\frac{1}{2}$ gal. of water. Above this is supported an 8-oz. bottle containing 4 oz. of strong sulphuric acid. This bottle is fitted with a loose lead stopper which falls out when the extinguisher is turned upside down.

To use the extinguisher, it is carried *right side up* to the fire. It is then turned *upside down*, and the stream of water and gas is directed upon the fire by means of the short hose.

The action which takes place in the extinguisher is as follows: When it is turned upside down, the sulphuric acid and sodium bicarbonate react chemically and produce a large quantity of carbon dioxide gas. The volume of gas produced is many times the volume of the extinguisher above the solution. The gas being confined in a small volume has a great pressure (Boyle's law) and therefore drives the liquid out through the hose with great force.¹

The fire is extinguished, partly by the water, and partly by the carbon dioxide gas. The gas acts by smothering the fire. Let us look into this further.

Carbon dioxide has three properties which make it valuable in a fire extinguisher: first, it dissolves readily in water, and the greater the pressure, the greater the amount of gas dissolved (Henry's law); second, it does not support combustion; third, it is heavier than air.

When the gas is produced in the extinguisher a large part of it is dissolved in the water under the great pressure in the extinguisher. It comes out of the extinguisher in the water. Since the pressure of the atmosphere is less than the pressure in the extinguisher, the greater part of the dissolved carbon dioxide escapes from the water when it leaves the extinguisher. The water moves from the nozzle to the fire very rapidly, therefore the greater part of the gas is released from the water after the water is in the fire. The released carbon dioxide surrounds the fire and displaces the air. It does this the more readily because it is heavier than air. The carbon dioxide gas smothers the fire because it does not support combustion and because it displaces the air, which does.

The siphon. — If we fill a curved tube, *AEDB*, Fig. 53, with water, close the ends, invert the tube, place the ends in water and open them, we find that the water runs uphill from *A* to *E*, then downhill from *D* to *B*. Let us see why the water runs uphill.

¹ For this reason the hose should be grasped firmly *before* turning the cylinder upside down.

The atmosphere presses upon the surface of the water in both vessels, *A* and *B*. The pressures are practically equal, but if anything a little greater at *B* than at *A*. In the short tube the atmosphere holds up a column of water 10 ft. long; in the long tube a column of water 15 ft. long. Let us consider the pressure to the right and to the left at the highest point *C*.

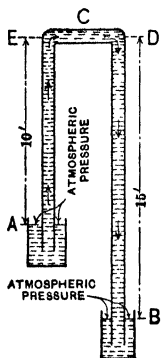

FIG. 53. — The siphon.

The pressure to the right is the atmosphere minus the weight of 10 ft. of water. The pressure to the left is the atmosphere minus the weight of 15 ft. of water. Since 15 is greater than 10, the pressure to the right is the greater. Therefore the water at *C* moves to the right, the atmosphere forces more water up to *C* from *A*, it moves to the right, and so on. The water thus moves from vessel *A* up to *C* and down into the vessel *B*.

The trap. — The traps shown in Fig. 54 are used on the waste pipes from wash bowls, sinks, bathtubs, etc., to prevent sewer gas from passing up into the house. This is accomplished by the water which remains in the U-shaped part of the trap after each discharge of waste water. This is called a water seal.

It will be noticed that the part of the trap to the right of *S* in (1) Fig. 54 is a siphon, and therefore, as the water discharges, the atmospheric pressure forces the level in tube *T* down to *A*. In the next instant air is forced around the bend; atmospheric pressure is restored in *B* and the water falls back to the position shown in (2) and (3). The middle pipe *M* in modern traps is made larger than the other part of the pipe, as shown in (3). With this form of trap the proportion of the water carried over by the siphonage is less; therefore, when the water falls back it has a greater depth, that is, it makes a better seal. The screw caps *S* are placed at the bottom of the traps in order that they may be cleaned out from time to time.

In (4) are shown the air chambers used to prevent hammering in the pipes. The hammering is the noise heard when water is shut off. It is caused by the moving water banging against the end of the pipe when it is suddenly brought to rest. The air chamber is air tight and full of air. When the running water is shut off, it moves up into the air chamber, and is brought to rest *gradually* in compressing the air. There is no noise because there is no sudden jar given to the pipes.

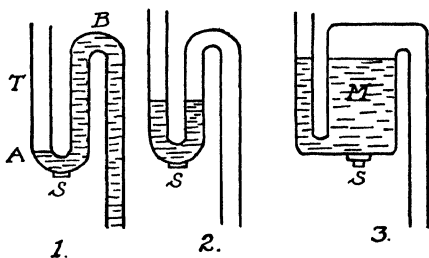

The gas meter. —

The gas meter is used to measure illuminating gas as it comes into the house from the street mains. In Fig. 55, *A* is a fixed partition. *B* and *C* are two movable partitions, each connected to *A* by four plaited leathersides,

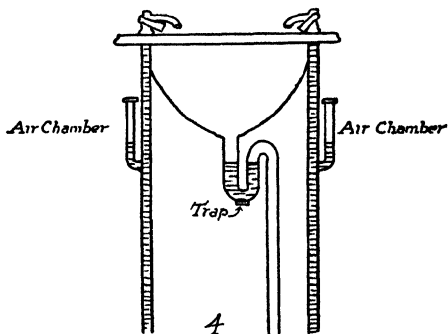

FIG. 54. — Traps and air chambers.

making the two chambers marked (2) and (3) which open and close like the sides of an accordion. The zigzag lines represent the leather sides. The long arrows represent gas entering the meter; the short arrows, gas going to the burners and lights. The gas entering, opens one leather chamber and closes the other. In (a), (2) is being closed and (3) is being opened. Gas is being forced out of (2) and (4) and into (1) and (3). When

the partitions *B* and *C* reach the end of their motion in one direction, they force the valve *V* in the opposite direction (by a mechanism not shown in the figure) and the gas enters through the other opening, as shown in (*b*). The partitions are then forced back by the entering gas and (2) and (4) are filled and (1) and (3) emptied into the burners and lights. This

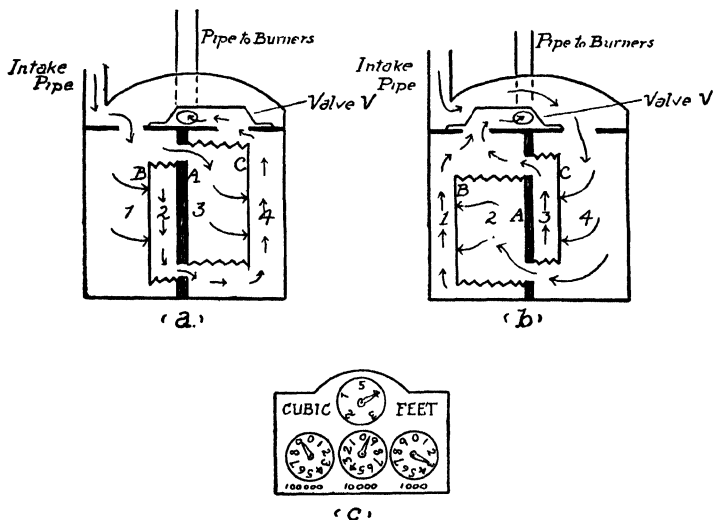

FIG. 55. — The gas meter.

operation is repeated over and over again. The moving partitions move the valve *V* and also, by clockwork, the hands on the meter dial shown in (*c*). This dial registers the number of cubic feet of gas which pass through the meter.

Other uses. — The properties of air and gases are turned to man's use in many other ways. We have not sufficient space to describe them in detail, but those who are interested may find descriptions of them in other publications. A few of these uses are as follows:

The balloon. — The property of air made use of in the balloon is "All bodies immersed in air are buoyed up by a force

equal to the weight of air displaced" (the law of Archimedes). The balloon bag is filled with gas lighter than air, usually hydrogen, which weighs about one fourteenth as much as air. The load which can be carried is equal to the weight of air displaced, minus the weight of the bag, car, machinery, and the gas in the bag.

Aëroplanes. — When we move rapidly through the air, as on a bicycle, automobile, or train, we feel the air pressing us back, even though it be a perfectly calm day. This is because air has a certain mass (proportional to its weight) and offers resistance to anything which shoves it aside. This is the property made use of in aëroplanes. The planes slant slightly downwards from front to back, and as they are moved rapidly through the air, by the motors and propellers, part of the force of resistance exerted by the air acts in a perpendicular direction and keeps the aëroplane in the air.

Compressed air. — Compressed air is put to many uses, for example, in hammers, drills, etc. In the pneumatic hammer, a piston is driven back and forth by compressed air, very much as the piston of a steam engine is driven by steam. This piston strikes the blow. The advantage of the pneumatic hammer is that it strikes many blows in the time in which a man could strike one; thus one man can do the work of many.

Submarine divers are supplied with a tank of compressed air on their backs. This tank is connected with the helmet and suit, and the air is used as needed. The air that has been used is allowed to escape through a small valve at the base of the helmet; when the diver wishes to go to the surface, he allows his suit to fill up with air; thus he displaces more water and increases the buoyant force until it is sufficient to float him to the surface.

In many cases firemen use a similar tank and helmet to enable them to enter buildings filled with smoke.

Diving bell. — If a tumbler is turned upside down and forced under water, it is noticed that the water enters only slightly.

The action of the diving bell (Fig. 56) is similar to this. It is an iron bell large enough to hold one or more men, heavy enough to sink in water, and strong enough to stand the pressure of the water. It is used to enable men to work under water. The atmospheric pressure is equal to the weight of a column of water 33 ft. high, and therefore when the bell is 33 ft. under water the air in it is under a pressure of two atmospheres (one atmosphere at the surface and one more when under 33 ft. of water). The air then is compressed to half its volume. At a depth of 66 ft. the air is compressed to one third its volume,

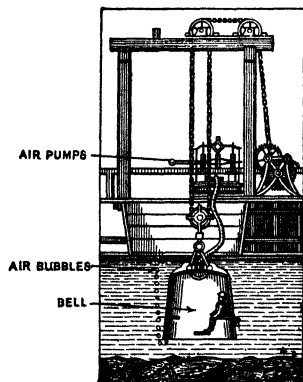

FIG. 56. — The diving bell.

because the pressure is 3 atmospheres. At a depth of 66 ft. the water enters the bell to two thirds its height. Men cannot work conveniently in this water, and to get rid of it compressed air is pumped in through a pipe until the water is forced out to the bottom of the bell. Then they work on land.

Air brakes. — Every railroad engine is supplied with an air compressor from which compressed air is led through pipes to the air brakes under each car.

The air brakes are operated by compressed air, and since the engineer controls the compressed air, he controls all the brakes on the train.

Pneumatic tubes. — In many cities the mail is distributed to the sub-postoffices through pneumatic tubes. These are smooth tubes placed underground. The mail is placed in cylinders which just fit these tubes, and which are driven through the tubes by compressed air. In many large stores money is carried from the counters to the central office and the change is returned through pneumatic tubes.

Pintsch gas system.—The gaslight on trains is an application of the fact that gases are very compressible. Ordinary illuminating gas is compressed under high pressure in tanks under the cars. It escapes through an automatic valve which regulates the flow, and is carried in pipes to the lights in the cars.

Summary.—In this chapter we have studied the following appliances: lift pump, force pump, pneumatic tank system of water supply, hydraulic ram, air pump, vacuum cleaner, fire extinguisher, siphon, trap, air chamber, gas meter, balloon, aëroplane, pneumatic hammer, diving suit, diving bell, air brake, pneumatic tube, and Pintsch gas system.

EXERCISES

1. Describe what happens in the first few strokes of a lift pump. Make a drawing.
2. Make a drawing of a force pump, and describe how it pumps water.
3. Make a drawing of a pneumatic tank system of water supply, and describe how it works.
4. Make a drawing of a hydraulic ram and describe how it works.
5. Make a drawing of an air pump and describe how it pumps air out of a flask.
6. Make a drawing of a vacuum cleaner, and describe how it works.
7. What three operations occur in all vacuum cleaners?
8. Describe how the fire extinguisher puts out a fire.
9. Make a drawing of a siphon and explain how and why it works.
10. Make a drawing of a trap; explain why it is used and how it works.
11. Make a drawing of a gas meter, and explain how it works.
12. The air in an air chamber is at atmospheric pressure (15 lb. per square inch) when the pumping is started. What pressure does it exert on the water when it has been compressed to one third its first volume?
13. The air in the air chamber of a hydraulic ram is at atmospheric pressure when the ram is started. What pressure does the air exert on the water when it has been compressed to one fourth its first volume?
14. If the air in an air chamber is at a pressure of 30 lb. per square inch above atmospheric pressure, how high will it lift water?

15. The pressure of the air in a pneumatic tank is 4 atmospheres. How high will it lift water?

16. Unscrew the top of a fire extinguisher and examine the interior. Replace the top. Take the extinguisher outside. Make a bonfire. When the fire is burning vigorously, grasp the hose firmly, invert the extinguisher, and extinguish the fire. Rinse the extinguisher and recharge it according to the directions on the case.

17. In your home trace the gas pipes from the point at which they enter the house to each fixture (if possible). Make a diagram showing the path of the gas from the point it enters the house to at least two fixtures. Read the gas meter on the same day of the month for a period of six months and compare your readings with those of the gas company.

CHAPTER VIII

HEAT IN THE HOME

IN this chapter we take up the study of *heat in its relation to the home*. This is probably the most important part of our course in "Physics of the Household."

The common household heat appliances are the grate, stove, hot-air furnace, hot-water heating system, steam heating system, double boiler, steam cooker, fireless cooker, thermos bottle, refrigerator, and ice-cream freezer.

There are many interesting questions which we should like to answer about these and other heat appliances. In order to do so, however, it will be necessary first to learn something of heat and of the laws of nature which apply to heat.

The fire in the home. — Next to the members of the family, the fire is the most important thing in the home. For, besides being the source of heat and the means of cooking food, it is the center of the family life. It has been so since the beginning. One of the first steps which distinguished man from the lower animals was taken when man learned to use fire, and civilization has advanced with the use of fire in the home and in industrial pursuits.

At first the fire was made in the open, as our camp fires are. Then it was placed under shelter, and the smoke found its way out as it could. Later a chimney was added, and it became a grate fire. In 1742 Franklin invented the first stove, and our modern stoves and furnaces are later developments of this.

For thousands of years the social life of our ancestors centered round the fire, and the social influence of the fire is still very

strong in us. We all like an open fire. It seems to be an inherited instinct; we want to see the fire. A group of people may be finding it very hard to be sociable, but the instant an open fire is started, every one is at home and happy. A social instinct is satisfied.

The systems of hot-air heating, hot-water heating, and steam heating, invented in the last fifty years, are great improvements over the old method of heating houses. They have, however, destroyed to some extent the social influence of the fire. They have a scattering influence on the family, because each member of the family can be warmed by the radiator in his or her room, and there is no one spot in the home about which the family naturally gathers. A home which has a modern heating system, and which also has a family room in which there is an open fire, retains the best of both the old and new methods of heating. The home is equably heated, and at the same time there is one spot around which the family life centers. A grate fire is an attractive open fire, but is very inefficient, the greater part of the heat being wasted up the chimney. An open grate stove is an improvement, because it is a much more efficient heater.

Let us now take up the study of heat, and learn something of the ways in which man has turned it to use in the home.

EXPANSION

Solids, liquids, and gases expand when heated, and contract when cooled. — We may begin our study of heat by finding its effect on solids, liquids, and gases. This effect can be illustrated by means of the apparatus shown in Figs. 57, 58, and 59.

Solids. — The brass ball, Fig. 57, is so made that when it is cold it just passes through the ring. When it is heated, however, we find that it does not pass through the ring. This shows that the metal expands when heated.

If the ball is cooled, by placing it in water or otherwise, we find

that it again passes through the ring. This shows that when metal is cooled it contracts.

Liquids. — The effect of heat on a liquid can be illustrated as follows: Fill a flask with cold water and insert a rubber stopper and glass tube, see Fig. 58. Mark the level of the water in the tube. If now the water is heated, the level rises in the tube, and if it is cooled, the level falls.

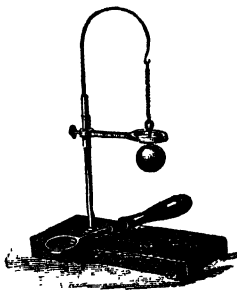

FIG. 57 — The brass ball expands when heated and contracts when cooled.

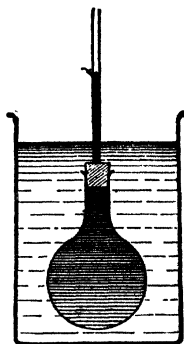

FIG. 58. — Liquids expand when heated and contract when cooled.

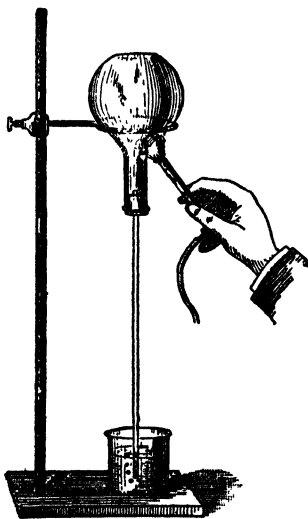

FIG. 59. — Gases expand when heated and contract when cooled.

These experiments show that the water expands when heated, and contracts when cooled.

Gases. — If a flask filled with air is arranged as shown in Fig. 59, and heated, the air expands, and bubbles of air issue from the lower end of the tube. This shows that when air is heated it expands. If now the air is allowed to cool, it decreases in volume, and water is forced up the tube by atmospheric pressure. This shows that air contracts when cooled.

These experiments illustrate the effect of heat on only one solid, one liquid, and one gas. It is found, however, that it has a similar effect on nearly all solids, liquids, and gases.

With a few exceptions, *solids, liquids, and gases expand when heated and contract when cooled.* This is the *law of expansion and contraction.*

Rates of expansion. — It has been found by careful experiment that all solids and all liquids have different rates of expansion, but that all gases have the same rate of expansion. These properties can be illustrated by means of the apparatus shown in Fig. 60.

Solids. — The compound bar, 1, Fig. 60, is made of a bar of brass riveted to a similar bar of steel. When this compound bar is heated it bends into the form of a curve, with the brass

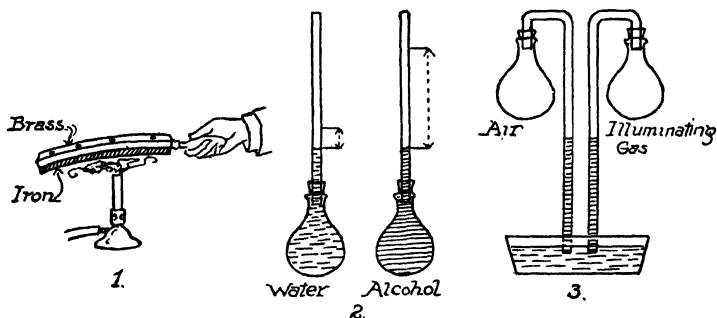

FIG. 60. — Solids and liquids expand at different rates, all gases at the same rate.

on the outside of the curve. This shows that brass has a greater rate of expansion than steel. It is found by experiments of a different kind that brass expands about $\frac{2}{3}$ as much as steel for an equal change in temperature.

Liquids. — One method of comparing the rates of expansion of liquids is illustrated in 2, Fig. 60. In this case the liquids compared are water and alcohol. The flasks are of equal volume and are fitted with long tubes of equal size. One flask is filled with cold water, and the other with alcohol at the same temperature. The level of each liquid is marked on the tube, and the flasks are placed side by side in a vessel of warm water. When the liquids have been warmed to the temperature of the

warm water, it is found that the alcohol has expanded much more than the water. This method can be used to compare the rates of expansion of any two liquids.

Gases. — It is a remarkable fact that all gases have the same rate of expansion. This can be illustrated for any two gases by means of the apparatus shown in 3, Fig. 60. The flasks are of equal volume, and are fitted with tubes of equal size. The lower ends of the tubes are submerged in water to the same depth, about $\frac{1}{2}$ in. In the case illustrated above, one flask is filled with air, and the other with illuminating gas. The flasks are firmly attached to a support (not shown). To warm the gases to the same temperature, the flasks are placed side by side, and a vessel containing warm water is raised under them until both flasks are submerged in the warm water. When the gases have ceased to bubble out of the lower end of the tubes, the vessel of warm water is removed and the gases are allowed to cool to the temperature of the room. As the gases cool they contract, and the pressure of the atmosphere forces water up the tubes. The heights of these columns of water serve as a measure of the amount of gas forced out of each flask by the expansion. It is found that the water rises to the same height in each tube. This shows that the gases, air and illuminating gas, have the same rate of expansion.

Coefficient of expansion. — *The coefficient of expansion of any substance is the increase in unit length or unit volume of the substance when warmed 1° C.* For example, the coefficient of expansion of iron is .000012. This means that a bar of iron one foot long expands twelve millionths of a foot when warmed 1° C., or a bar of iron 1 centimeter long expands twelve millionths of a centimeter when warmed 1° C., etc.

Coefficients of expansion for 1° C.

SOLIDS	LIQUIDS
Marble000004	Mercury00018
Pine000006	Water00043
Glass000009	Petroleum . . .00090
Platinum000009	Turpentine . . .00094
Sandstone000011	Alcohol00120
Iron000012	Benzine00125
Copper000017	
Brass000018	GASES
Aluminium000026	All gases . . .00366
Lead000028	= $\frac{1}{273}$ of volume at 0°C.

In the table above, some solids and some liquids appear to have equal coefficients. If, however, we give the coefficients in greater detail, we find they differ slightly.

The laws of expansion and contraction. — We have now illustrated three laws of nature which relate to heat. They are:

- (1) Nearly all substances, whether solids, liquids, or gases, expand when heated and contract when cooled.
- (2) All solids and liquids have different coefficients of expansion.
- (3) All gases have the same coefficient of expansion.

APPLICATIONS OF EXPANSION AND CONTRACTION

Before taking up the other laws of nature which relate to heat, let us stop to see how man has made use of his knowledge of the laws of expansion and contraction in some of the ordinary heat appliances.

Thermometers. — Thermometers are used to find out how hot or how cold a body is. In some cases the expansion and contraction of solids is used to indicate the temperature. In others, this property of liquids or gases is used.

Solid Thermometers. — A solid thermometer is illustrated in Fig. 61. The spiral *AB* is made of two metals, a strip of brass on the outside and a strip of steel on the inside. When the temperature rises, the spiral becomes more curved; and when the temperature falls, it becomes less curved. The thermometer

shown here is a recording thermometer. A strip of paper is fastened to the drum *D*, which is revolved by clockwork. The point *C* of the lever *BC* rests on the paper. As the temperature rises, the increased curvature of the spiral forces *C* up, and as

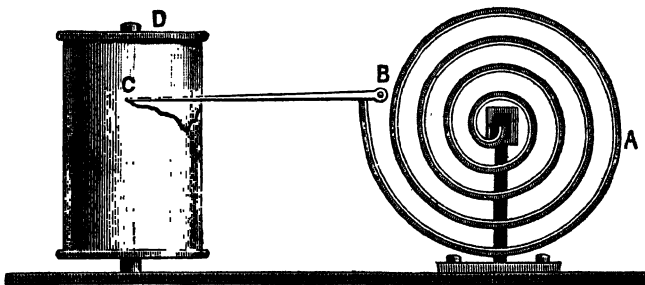

FIG. 61. — A solid recording thermometer.

the temperature falls the decreased curvature lowers the point *C*. A pen attached to the point *C* makes a trace on the paper and thus records the temperature.

The ordinary oven thermometers are solid thermometers. In some cases they are made with a spiral of two metals, as above. In other cases, the expansion of a metal bar is multiplied by levers, the last lever being a pointer which moves across a temperature scale.

Liquid thermometers. — In ordinary thermometers the expansion and contraction of some liquid, usually mercury, is used to indicate the change in temperature. Household thermometers consist of a glass tube with a bulb at one end. The bulb and part of the tube contain mercury. The bore of the tube is small compared to the volume of the bulb, and as a result, a small expansion of the liquid in the bulb produces a large increase in the length of the liquid column in the tube. The thermometer scale is marked on the tube or on the thermometer back beside the tube.



FIG. 62. — An oven thermometer.

Gas thermometers.—The most accurate of all expansion thermometers¹ are those which use the expansion of a gas to measure temperature. They are the most accurate because the rate of expansion of gases is very regular. The hydrogen thermometer is the standard thermometer for scientific purposes, but as it is not a thermometer in common use we need not study it here.

Fixed points of the thermometer.—In order to mark the scale of degrees on a thermometer, it is necessary to have two fixed points, between which the divisions may be made.

It has been found that pure ice melts at a constant temperature, and that pure water boils at a constant temperature, when the pressure is one atmosphere. These two temperatures are used as the fixed points of all thermometers.

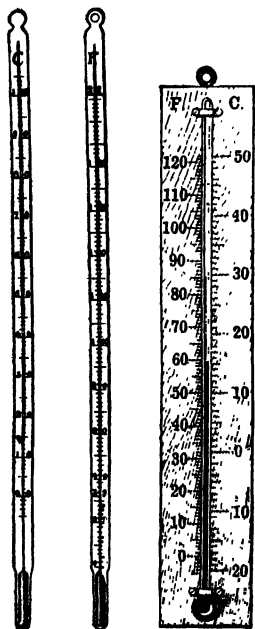

FIG. 63.—Household mercury thermometers.

The two thermometers in common use are the centigrade and Fahrenheit thermometers. The centigrade thermometer is used in all scientific work, and the Fahrenheit is the thermometer in common use in Great Britain and North America.

These thermometers differ only in the manner in which the scale is marked; see Fig. 64. On the centigrade thermometer the melting point of ice is called 0° C.,

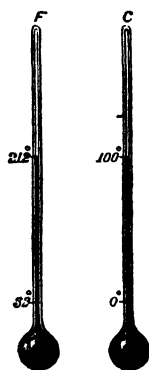

FIG. 64.—Showing the fixed points of the Fahrenheit and centigrade thermometers.

¹ Electrical thermometers are more accurate than expansion thermometers.

and the boiling point of water 100° C., and the space between these two is divided into 100 degrees. On the Fahrenheit thermometer the melting point of ice is called 32° F., and the boiling point of water 212° F., and the space between is divided into 180 degrees.

The melting point of ice is found by placing the bulb of the thermometer in melting ice. The boiling point of water is found by placing the bulb and stem of the thermometer in the steam of boiling water.

Comparison of thermometers. — From the diagrams of the centigrade and Fahrenheit thermometers, Fig. 64, we see that the temperature 0° C. corresponds to 32° F., and 100° C. to 212° F. Between 0° C. and 100° C. there are 100 centigrade degrees, and between 32° F. and 212° F. there are 180 Fahrenheit degrees. We see then that 100 centigrade degrees equal 180 Fahrenheit degrees, or 1 centigrade degree = $\frac{9}{5}$ Fahrenheit degrees. If we have the temperature of a body in centigrade degrees, and wish to express it in Fahrenheit degrees or *vice versa*, we must remember that 0° C. corresponds to 32° F.

Example. (1) A temperature of 20° C. is 20 centigrade degrees above the melting point of ice; this equals $20 \times \frac{9}{5} = 36$ Fahrenheit degrees above the melting point of ice, or a temperature of $32 + 36 = 68^{\circ}$ F. That is, 20° C. = 68° F.

(2) A temperature of 50° F. equals $50 - 32 = 18$ Fahrenheit degrees above the melting point of ice; this equals $18 \times \frac{5}{9} = 10$ centigrade degrees above the melting point of ice. That is, 50° F. = 10° C.

The method of transfer from degrees of one thermometer to those of the other, as illustrated in the examples above, can be expressed as follows:

$$F = \frac{9}{5} C + 32, \text{ or}$$

$$C = \frac{5}{9} (F - 32)$$

where F and C stand for temperature Fahrenheit and temperature centigrade, respectively.

Applications of the expansion of gases and liquids. — We may now study some other ways in which man makes use of the expansion of gases and liquids. In doing so we shall learn something of the way in which the expansion of gases is used in cooking. Also we shall answer such questions as

1. Why does a stove draw?
2. How does a stove heat a room?
3. How does a hot-air furnace heat a house?
4. How does a hot-water furnace heat a house?
5. How is the hot-water system in a house arranged?

Expansion of gases in cooking. — *Bread.* — In making homemade bread, certain quantities of flour, water, salt, and yeast are mixed to form a dough. The dough is then set in a warm place to rise. The process of rising is as follows: In the presence of moderate heat the yeast plant grows rapidly, and in the process of growth gives off carbon dioxide gas. This gas is liberated all through the dough, and forms thousands of small closed pockets filled with the gas. As more gas is liberated these pockets increase in size and others are formed. This expands the dough and it rises. The dough is then molded into loaves and placed in the oven. The heat of the oven gradually kills the yeast plant, and the production of carbon dioxide gas ceases. The dough, however, continues to rise for three reasons: first, the carbon dioxide gas expands as it is heated, and swells the dough; second, the carbon dioxide gas, absorbed by the water at low temperatures, leaves the water at high temperatures and swells the dough; third, the water in the dough turns to steam when heated, and swells the dough.

In many large modern bakeries yeast is not used in making bread. The flour, water, and salt are mixed with compressed carbon dioxide gas in an air-tight mixer; here the compressed carbon dioxide gas is intimately mixed with the dough. When the mixer is opened, the pressure on the dough is decreased, the gas in the dough expands, and the dough rises at once. It

is then molded into loaves and placed in the oven. The further rising takes place as described above. We see, then, that the expansion of gas, when heated, plays an important part in the making of bread.

Baking powder. — The baking powder used in making cake, biscuit, etc., is composed of substances which, in the presence of moisture and heat, produce carbon dioxide gas. This carbon dioxide gas swells the cake dough and makes it light. In this case the rising takes place in the oven; the heat of the oven liberates and expands the gas, also it turns the water into steam. These together cause the dough to rise.

Eggs and pie crust. — When an egg is beaten, air is inclosed; similarly, when the dough for a pie crust is rolled and folded, air is inclosed in the dough. When the egg and dough are heated, the air in them expands and they are made lighter. It is recommended that eggs and dough, etc., be mixed with air in a cool place. There are two reasons for this: first, the egg and dough are stronger and therefore hold more air; second, the cooler the air the greater the change of temperature when it is heated to the temperature of the oven, and therefore the greater the expansion.

Expansion of gases in cooking. — From the table on page 84, we see that the coefficient of expansion of all gases is .00366 of their volume at 0° C. for each 1° C. The Fahrenheit degrees are only $\frac{5}{9}$ the length of a centigrade degree, therefore the coefficient of expansion of gases is $.00366 \times \frac{5}{9} = .002$ of their volume at 32° F. for each 1° F. This means that if a gas is inclosed in any material at 32° F. it will increase in volume .002 or $\frac{1}{500}$ for each degree Fahrenheit that it is warmed. For example, if air is beaten into an egg at 32° F. and then warmed to 532° F. in the oven, the change in temperature is $532 - 32 = 500^{\circ}$ F. The air then expands $\frac{500}{500}$, or it just doubles in volume. If it is heated to 432° F. it expands $\frac{400}{500}$ or $\frac{4}{5}$, and its volume is $\frac{3}{5}$ its volume at 32° F.; if heated to 332° F., it expands $\frac{300}{500}$ or $\frac{3}{5}$, and its volume is $\frac{2}{5}$ its volume at 32° F.

Water and air weigh less per cubic foot when hot than when cold. — Before trying to answer the questions, "Why does a stove draw?" etc., it will be well to show that hot water weighs less than the same volume of cold water, and that hot air weighs less than the same volume of cold air. This can be shown by experiment, as follows:

To show that hot water weighs less than the same volume of cold water. Weigh a flask filled to overflowing with cold water. Place the flask in a vessel filled with boiling water. When the water in the flask has ceased to expand, remove it from the hot water, and allow the outside to dry. Then weigh the flask again. It will be found that the flask filled with hot water weighs less than when filled with cold water.

To show that a flask filled with hot air weighs less than when filled with cold air. Fit a flask with a rubber stopper, and weigh it, when filled with cold air, on a delicate balance. Remove

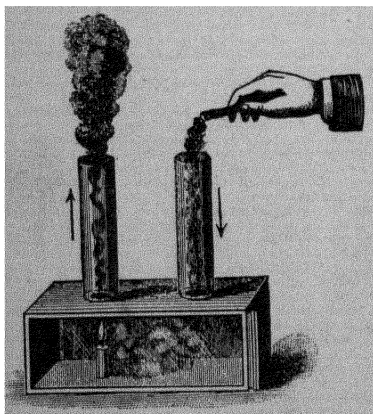

FIG 65 — A convection current in air

the stopper and heat the flask, then replace the stopper and weigh the flask again. It will be found that the flask when filled with hot air weighs less than when filled with cold air.

Why does a stove draw?

— To understand why a stove draws we will first make the experiment illustrated in Fig. 65. The apparatus consists of a rectangular wooden box with a glass front and with two holes in the top, each fitted with a lamp chimney. A candle is placed beneath one chimney and when it is lighted a draft of air passes down the cold chimney and up the warm chimney. This draft can be made visible by holding lighted

smoke paper or a lighted Chinese joss stick over the cold chimney.

We learned above that cold air is heavier, volume for volume, than hot air. The weight of any body is due to the attraction of the earth for it. The cold air, then, is pulled down by the attraction of the earth with a greater force than the hot air. The cold air is therefore pulled to the bottom of the box, and forces up the hot air. This cold air is in turn warmed by the candle, and is forced up by more cold air. This circulation of air continues as long as the candle burns. This is the explanation of the draft produced by the candle, and is also the explanation of the draft produced by any fire. This movement of air due to difference in temperature is called a *convection current* in air.

Draft in grate and stove. — When a fire is lighted in a grate, the air in the chimney is heated. It expands and becomes lighter per cubic foot than the air in the room and the air outside of the house. The cooler, heavier air then sinks down on account of the greater attraction of the earth, and forces the warm air up the chimney. The cool air is in turn warmed and is forced up by more cold air, see 1, Fig. 66. This process continues as long as the air in the chimney is warmer than the air in the room. Similarly, when a fire is lighted in a stove, 2, Fig. 66, the air in the stove, stovepipe, and chimney is warmed, and is forced up by the cooler air from the room and from outside the house. This, then, answers our first question, — “Why does a stove draw?”

We have all observed that when a fire is started in a cold stove the stove smokes for a short time. The reason is as follows: Before the fire is lighted, the air in the stove, stovepipe, and chimney is at the same temperature as the air in the room and therefore there is no draft. As soon as the air in the stove, stovepipe, and chimney is heated, however, the cooler,

When we understand the cause of the draft in a stove we are in a position to understand the use of the opening in the stovepipe just above the stove, 3, Fig. 66. This is opened to check

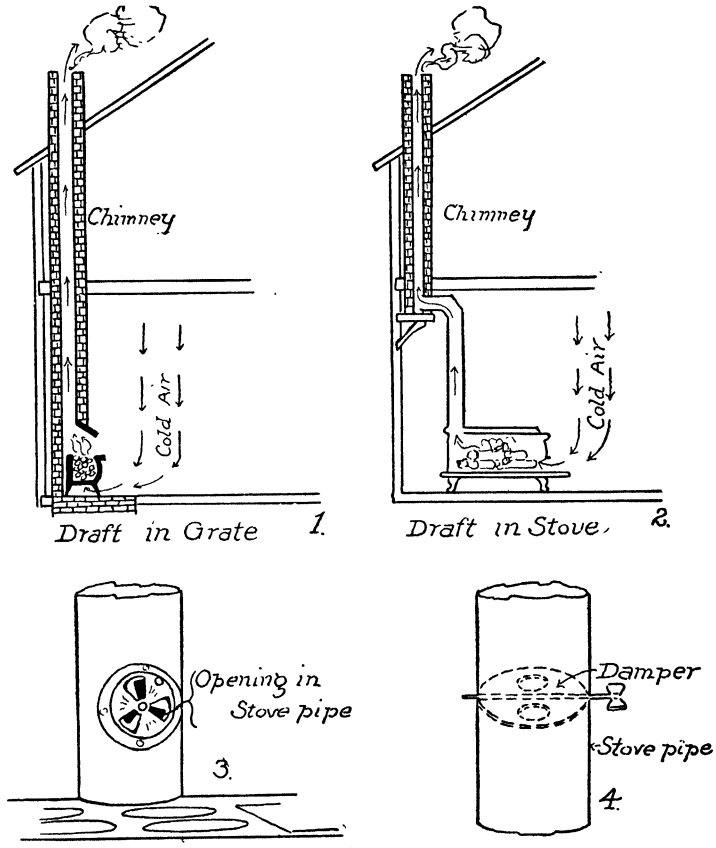

FIG. 66. — Illustrating the draft in grates and stoves and the use of dampers.

the draft in the stove. It does this as follows: first, air passes directly into the stovepipe, therefore less air passes through the stove; that is, there is less draft through the stove: second,

the cold air cools the air in the stovepipe to some extent, there is thus less difference in the weight per cubic foot between the air in the stovepipe and that in the room, therefore there is less draft.

The stovepipe damper, 4, Fig. 66, checks the draft by making the passage in the pipe smaller.

Since the draft in a chimney is due to the difference in temperature between the air in the chimney and that outside, it can be seen that a good chimney is one that is easily kept warm. For this reason a chimney should be made of non-conducting material, and should be built inside the house rather than outside. A chimney built outside of the house is cooled on all sides, and therefore gives a poorer draft than if it were in the house.

Draft in a kitchen range. — The arrows in Fig. 67 show the path of the draft in a kitchen range when the oven is “turned on.” The air enters below the grate, and above the ash pan. It passes up through the fire in the fire box and supplies oxygen

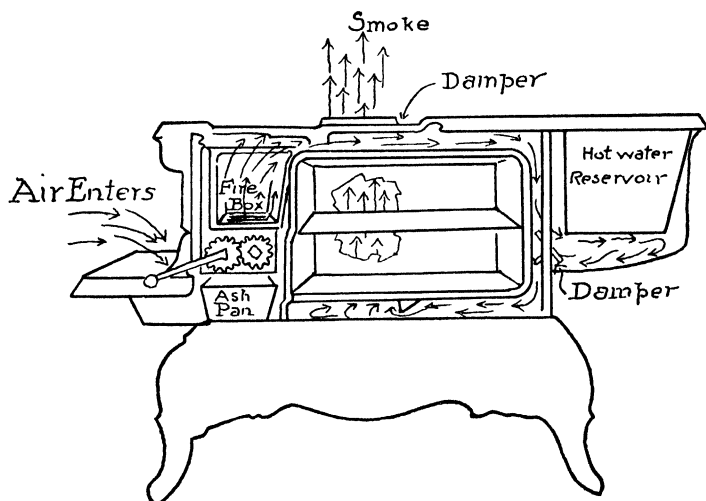

FIG. 67. — The draft in a kitchen range.

to the burning fuel. After leaving the fire box it is hot smoke; it passes over the oven, under the hot-water reservoir, and under the oven. Beneath the oven there is a partition which extends about halfway from the back to the front. The hot smoke passes in front of this, and then up behind the oven and into the stovepipe. We see, then, that the hot smoke heats the oven on all sides except the front, where the door is placed.

If the damper beneath the hot-water reservoir is closed, the hot smoke does not pass under the hot-water reservoir. In this case the water is not heated, but the oven receives more heat, because the smoke is hotter when it passes under the oven.

If the oven is not needed, a damper leading into the stovepipe is opened and the hot smoke passes directly from the fire box into the stovepipe.

How does a stove heat a room? — When a fire is burning in a stove, the air near the stove is warmed. It therefore expands

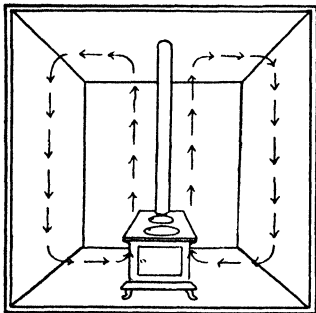

FIG. 68. — How a stove heats a room.

and becomes lighter per cubic foot than the air near the sides of the room. The cooler, heavier air then sinks down along the sides of the room, and forces the warmer air up to the top of the room, see Fig. 68. This cool air is in turn warmed, and is forced up by more cool air; that is, the air is heated by convection. This convection current continues as long as

the stove is warmer than the air in the room. This explains how a stove heats a room.

How does a hot-air furnace heat a house? — The diagram, Fig. 69, illustrates the hot-air furnace. Examine this diagram, and using your knowledge that warm air is lighter than cold air, explain how the hot-air furnace heats a house.

Circulation of water. — Before we study the hot-water heating system and the hot-water tank, we may illustrate the circulation of water, due to difference in temperature, by means of the apparatus shown in Fig. 70. It is a rectangular glass tube filled with water. When the water in one side is heated, the water in the tube circulates in the direction shown by the arrows.

The reason for this is as follows. Cold water is heavier than the same volume of hot water. This was shown on page 90.

The cold water, then, is pulled down by the attraction of the earth with greater force than the warm water. It is therefore pulled down to the bottom of the tube, and forces up the warm water. This cold water is in turn heated, and is forced up by more cold water. This circulation continues as long as the water on one side of the tube is warmer than that on the other. This is the explanation of the circulation of water in the hot-water heating system and the hot-water tank. This movement of water due to difference in temperature is called a *convection current* in water.

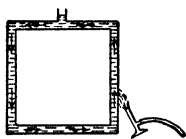

FIG. 70. — A convection current in water.

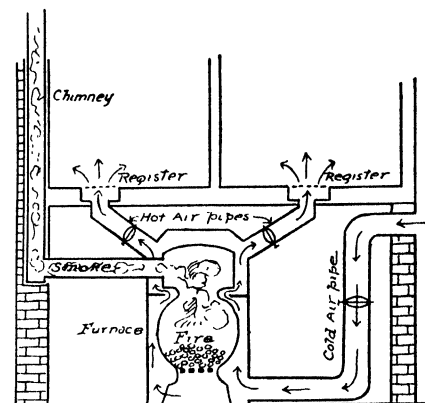

FIG. 69. — The hot-air heating system.

The hot-water heating system. — In Fig. 71 is shown a hot-water heating system. The furnace contains a fire box and a hot-water boiler. The boiler is connected with each hot-water

radiator by two pipes. The system works as follows: When a fire is lighted in the fire box, the water in the boiler is heated. It therefore expands and becomes lighter, per cubic foot, than cold water. The cooler water in the radiator, being heavier, sinks from the radiator into the furnace boiler and forces the

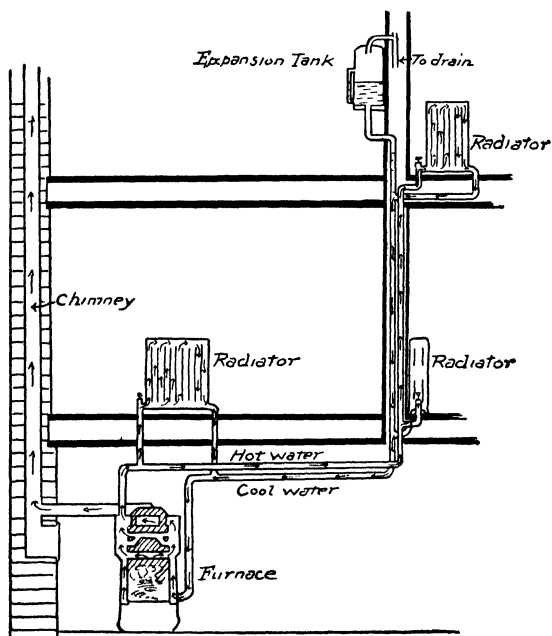

FIG. 71. — A hot-water heating system.

hot water up from the boiler into the radiator. This hot water gives up its heat to the air in the room, and thus cools, contracts, and becomes heavier. It then sinks back into the boiler, and forces more hot water into the radiator. This convection current continues as long as there is a fire in the furnace.

The expansion tank. — The expansion tank, Fig. 71, is placed above the highest radiator. It provides space for the expansion and contraction of the water in the system. The house-

holder should see that the water level in the tank is at all times above the bottom of the water glass on the tank.

The hot-water tank.—The water in a hot-water tank is heated by convection. The manner in which the tank is connected with the water front of a kitchen range is illustrated in Fig. 72. The water in the tank is heated as follows: When a

fire is lighted in the range, the water in the water front is heated. It expands and thus becomes lighter volume for volume than the cooler water in the tank. The cool water then sinks from the tank into the water front and forces the hot water to the top of the tank. This cool water is in turn heated and is forced up by cooler water from the tank. By this convection current the water is kept circulating, from the bottom of the

tank to the bottom of the water front, through the water front to the top of the tank, from the top of the tank to the bottom, etc. This explains how the water in the tank is heated.

It will be noticed in Fig. 72, that the end of the cold water pipe is above the level of the water front. It is arranged in this way to prevent the water from being siphoned out of the water front. If the end of the pipe were lower than the water front, the water might be siphoned out when the water supply was stopped, as follows. If a cold water tap in the basement

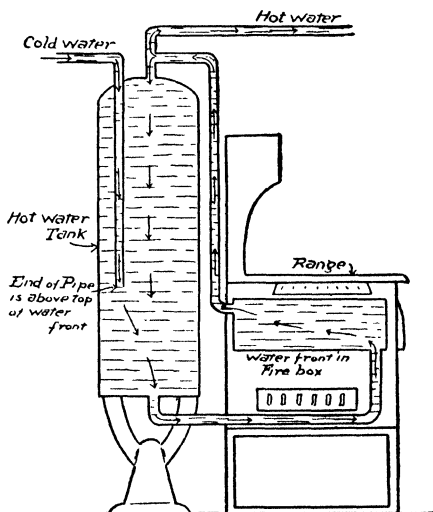

FIG. 72. — The hot-water tank and the water front.

should be open and also a hot water tap at any point above the basement, the cold water pipe would act as a siphon and lower the water in the tank and water front to the level of the end of the cold water pipe in the tank. If the water front should be empty and there should be a hot fire in the range, the water front might be ruined.

A peculiarity in the expansion of water. — When water at 0°C . or 32°F . is slowly warmed, careful measurement of the change in volume discloses the remarkable fact that from 0°C . to 4°C . the volume of the water *decreases*. From 4°C . upwards the volume increases. If the measurements are made with a Fahrenheit thermometer, the volume decreases from 32°F . to 39.2°F ., and increases above 39.2°F .; that is, water is heaviest at 4°C . or 39.2°F .

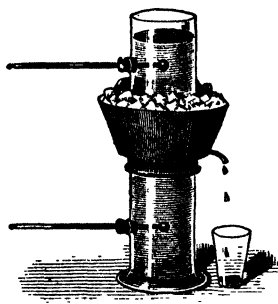

FIG. 73. — Water has its greatest density at 4°C .

The apparatus shown in Fig. 73 can be used to show that water has its greatest density at 4°C . The apparatus consists of a tall cylinder surrounded at the middle by a circular trough. A thermometer is inserted into the cylinder near the top, and another near the bottom. The experiment is as follows: Fill the cylinder with water and fill the trough with ice and salt. Observe the change in temperature of the water at the top and at the bottom of the cylinder. It will be observed, after a little time, that the water at the bottom is at 4°C ., while the water at the top is above 4°C . This shows that water at 4°C . is *heavier* than water which is *warmer*. A little later it will be observed that the water at the bottom is still at 4°C ., while the water at the top is below 4°C . This shows that water at 4°C . is *heavier* than water which is *colder*. This experiment shows that water at 4°C . is heavier than water above 4°C ., and is also heavier than water below 4°C . In other words, it shows that

water has its greatest density at 4°C . or 39.2°F . This property of water has important consequences in nature.

How a lake cools. — A lake cools in winter as follows: The surface layer cools, contracts, and sinks; the new surface layer then cools, contracts, and sinks. This continues until all the water in the lake is cooled to 4°C . After this the surface layer cools below 4°C ., *expands*, and remains at the surface. After cooling to 0°C . the surface layer turns to ice, and in doing so expands still further.

Since all the water in the lake cools to 4°C . before any freezing takes place, a deep lake freezes more slowly than a shallow lake of the same size. Since water at 4°C . is heavier than water below this temperature, the water at the bottom of a lake is at 4°C . in the coldest weather; thus aquatic plants and animals are not destroyed.

NATURE OF HEAT

Heat a form of energy. — Until about a hundred years ago heat was believed to be a weightless fluid. This supposed fluid was called *caloric*. It was believed that when a substance was warmed by a fire, caloric flowed from the fire into the substance; and when the substance cooled, caloric flowed out of the substance into the air. This theory accounted for many of the observed effects produced by heat, but it failed to account for the heat produced by friction, and for this reason it was discarded.

It is now known that heat is a form of energy. This needs further explanation.

The molecular constitution of matter. — For very many reasons, some of which will be given later, scientists believe that all substances are composed of very minute particles which are called molecules. The molecule of any substance is defined as the smallest particle of that substance which can exist, and still retain the properties of the substance. For example, a molecule of salt (sodium chloride) is the smallest particle of salt that can exist and still retain the properties of salt. It is be-

lieved that the molecules exert an attractive force upon one another, and that it is this force which holds the molecules together. This force is called *cohesion*.

Heat is the energy of molecular motion. — It is known from experiment that heat is a form of energy because it can be produced from and converted into other forms of energy, such as mechanical energy, chemical energy, electrical energy, etc. Heat is believed to be the *energy of motion of the molecules*. According to this theory, when a body is absolutely cold, that is, when it is at a temperature of -273° C., the molecules are still and are held in contact with one another by the force of cohesion. When a body is warmed, however, the molecules are set in motion; they move about and strike against each other; and the force of these collisions separates them slightly against the force of cohesion. The higher the temperature, the greater the velocity of the molecules, and therefore the farther they are separated against the force of cohesion.

Why do substances expand when heated and contract when cooled? The theory that heat is "the energy of molecular motion" accounts for the expansion of a body when heated. When the body is warmed the molecules move more rapidly and strike each other with greater force; therefore, they separate farther against the force of cohesion. If each molecule is a little farther from its neighbors, the body as a whole occupies more space, that is, it expands.

This theory also explains why a body contracts when cooled. When the body cools, its molecules move with less velocity and strike each other with less force; therefore, the force of cohesion draws each molecule closer to its neighbors. The body as a whole then occupies less space, that is, it contracts.

Summary. — In this chapter we have studied: expansion and contraction, thermometers, the expansion of gases in cooking, the draft of a stove, how a stove heats a room, the hot-air heating system, the hot-water heating system, the hot water tank, how a lake cools, and the nature of heat.

EXERCISES

1. How can we show that solids, liquids, and gases expand? Make drawings.
2. How can we show that solids and liquids have different rates of expansion, and that gases have the same rate? Make drawings.
3. Describe a solid thermometer.
4. Draw a Fahrenheit and a centigrade thermometer, and mark the freezing and boiling point of water on each.
5. How many Fahrenheit degrees are there between the freezing and boiling points of water? How many centigrade degrees?
6. Show that 1 Fahrenheit degree is equal to $\frac{5}{9}$ centigrade degrees, and that 1 centigrade degree is equal to $\frac{9}{5}$ Fahrenheit degrees.
7. Show that 0°C ., 20°C ., and 50°C . are the same as 32°F ., 68°F ., and 122°F .
8. What centigrade temperatures correspond to 40°F ., 86°F ., 158°F .?
9. Explain how homemade bread dough is made lighter.
10. Explain how baker's bread is made lighter.
11. Explain how cake and biscuit dough are made lighter.
12. Why is it advisable to beat eggs in a cool place?
13. Air is folded into the dough of pie crust at 32°F . The pie is baked in an oven at 332°F . How much does the air expand?
14. Why does a stove draw? Make a drawing.
15. Make a drawing showing the path of the draft through a kitchen range. Describe it.
16. How does a stove heat a room? Make a drawing.
17. How does a hot-air furnace heat a house? Make a drawing.
18. How does a hot-water furnace heat a house? Make a drawing.
19. How is the water in a hot-water tank kept hot? Make a drawing.
20. Describe three or more other ways in which man has made use of the laws of expansion.
21. What is heat?
22. State the molecular theory of matter.
23. What is cohesion?
24. Why do substances expand when heated and contract when cooled?
25. In your home examine the appliance by which water is heated for the sink and bath. Trace the path of the water from the cold water pipe through the hot water tank, the water front, and to the taps at the sink. Make a diagram showing the path of the water.

CHAPTER IX

MOVEMENT OF HEAT. HEAT APPLIANCES.

WE all know of many cases in which heat moves from one place to another; for example, from a fire to the food being cooked, from a furnace to the rooms heated, and from the sun to the earth. We also know of cases in which the movement of heat is prevented or decreased; for example, by the clothes we wear, by the walls of houses, by the sawdust in ice houses, and by double windows. In this section we will study first the different ways in which heat moves from one place to another, and then we will study a number of household appliances which man has devised to control the movement of heat.

There are three ways in which heat moves from one place to another, namely, by conduction, by convection, and by radiation.

Conduction. — If a rod of metal is held with one end in a flame, it is found that the heat moves along the metal readily and that in time the metal becomes too hot to hold. If a rod of glass is held in the flame in a similar manner, however, it is found that the heat moves along the glass very slowly. These experiments show that the metal is a good conductor of heat and that glass is a poor conductor of heat. *When heat moves from one part of a substance to another without visible motion of the parts of the substance, the method of heat movement is known as conduction.* The process of conduction is as follows: The molecules of that part of the body which is heated vibrate very rapidly. These molecules strike the molecules near them, and set them in more rapid vibration. These molecules strike others farther

away, and so on. Thus the energy of motion of the molecules, or heat, moves from the hot part of the body to the cooler part.

We can make a rough comparison of the conducting power of solids by the experiment illustrated in Fig. 74. Rods of the solids are coated with paraffin and placed on a non-conducting block, with one end of each rod in a flame. The paraffin is melted most rapidly on the solid which has the greatest conductivity.

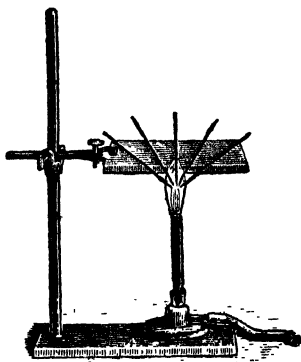

FIG. 74. — Conduction in solids.

Conduction in liquids and gases.

— All liquids, except liquid metals, are very poor conductors of heat. This can be shown by the experiments illustrated in Fig. 75. If a test tube filled with water is held

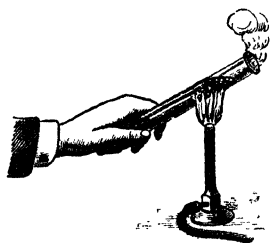

FIG. 75. — Liquids are poor conductors of heat.

in the hand, and the water at the top of the test tube is heated, the water can be made to boil at the top while the water at the bottom remains cold. The molecules of water at the top are in very rapid vibration, but the energy of vibration does not move readily from one part of the liquid to the other. That is, water is a poor conductor of heat.

It is very difficult to illustrate the conducting power of gases, on account of the disturbing effects of convection and radiation. The results of the experiments which have been made, however, show that *gases are very poor conductors of heat*. This is shown in many familiar ways; double doors

and double windows are effective in retarding the escape of heat, because the air between the doors and between the windows is a poor conductor of heat. Also, fur, feathers, straw,

etc., are poor conductors of heat, chiefly because they contain a great deal of air.

Convection. — Liquids and gases are poor *conductors* of heat, but they transfer heat readily from one place to another by the process known as convection. *The movement of heat from one place to another by the movement of the heated matter is known as convection.* We have already illustrated convection in gases and liquids by means of the apparatus shown in Fig. 65 and Fig. 70. When a gas or liquid is heated, it expands and therefore becomes lighter, volume for volume, than the cold gas or liquid. The cool gas or liquid then sinks down and forces the warm gas or liquid to a higher level. This is the cause of convection. The currents of air or liquid thus set up are called *convection currents*.

In the last chapter we studied a number of ways in which man makes use of convection in air: in the draft of a stove; in the hot-air furnace; etc.; also ways in which he makes use of convection in liquids; in the hot-water heating system, in the hot-water tank, etc.

Radiation. — A person sitting in front of a grate fire receives heat from the fire by radiation. A person standing in sunlight receives heat from the sun by radiation. A body held near an incandescent electric light receives heat from the filament by radiation. These are examples of the movement of heat by radiation. The process of heat movement by radiation is as follows: The molecules of the hot body are in very rapid vibration; each to and fro vibration of a molecule sets up a wave in the ether; when these waves fall upon a body, they set the molecules of the body in more rapid vibration, that is, they heat the body. *The movement of heat from one place to another by means of ether waves is known as radiation.*

The ether is believed to be a medium which fills all space, the space between the planets, and the space between the molecules and atoms of bodies. It has been necessary to assume the ex-

istence of such a medium in order to account for many heat, light, and electrical phenomena.

The waves set up in the ether by the molecules of a hot body constitute a form of energy called radiant energy. These waves are similar to light waves and will be discussed further in the chapters on Light. It may be said here, however, that the waves of radiant energy travel in straight lines, with a velocity of 186,000 miles a second, and may pass through a medium without heating it. Radiant energy is not heat, but it is converted into heat when it falls upon a substance which absorbs it, and for this reason these waves are commonly called heat waves.

We can obtain a clearer idea of radiation and of the distinction between radiation, conduction, and convection by considering further a number of familiar examples of radiation.

Radiation from a grate fire. A person sitting in front of a grate fire does not receive heat by conduction because air is a very poor conductor of heat. He does not receive heat by convection, because the convection currents move towards the fire and up the chimney. He receives heat only by radiation. The molecules of the burning fuel are in rapid vibration, and set up waves in the ether. When these waves fall upon any body, they set the molecules of the body in more rapid vibration, that is, they heat the body.

Radiation from the sun. — Heat passes from the sun to the earth by radiation. The molecules of the substances in the sun are in very rapid vibration and set up waves in the ether. These waves travel in all directions from the sun, and a small part of them fall upon the earth. When they fall upon any body on the earth, they set the molecules of the body in more rapid vibration, that is, they heat the body.

Radiation from an incandescent electric light. — When the hand is held near a lighted incandescent electric light, it receives heat from the hot filament by radiation. It does not receive heat by conduction because the interior of the bulb is a vacuum and the glass is a very poor conductor of heat. It does not

receive heat by convection, because there is no gas in the bulb to carry the heat by convection. The movement of heat by radiation is specially interesting in this case because it shows that the waves of radiant energy pass through a vacuum as readily as they do through air, glass, etc. As a matter of fact it can be shown by experiment that radiant energy passes through a vacuum more readily than it does through any substance.

APPLIANCES WHICH CONTROL THE MOVEMENT OF HEAT

We have learned above the three ways in which heat moves from one place to another, namely, by conduction, by convection, and by radiation. We will now study a number of appliances which man has devised to control the movement of heat.

Specific thermal conductivity. — *The specific thermal conductivity of any material is the number of calories of heat which pass per second across each square centimeter of a layer of the material 1 cm. thick, when the difference in temperature between the surfaces of the layer is 1° C.*

Specific Thermal Conductivity of Materials

Silver 1.0	Glass002	Silk00022
Copper9	Water0014	Mineral wool . .00019
Gold7	Cement0007	Cork00013
Aluminium . . .5	Asbestos paper . .0006	Sawdust00012
Brass26	Cotton cloth . .00055	Felt00009
Tin16	Wood0005	Horn000085
Iron12	Paper0003	Cotton wool . .00005
Porcelain0025	Flannel00023	Air00004

From the table above we see that metals are good conductors of heat, and that nonmetals are poor conductors of heat. We see also that water is a poor conductor and that air is a very poor conductor of heat.

If three cooking utensils, made of copper, aluminium, and iron respectively, are of the same size and of the same thickness,

we can see from the table that the copper utensil will conduct over seven times as much heat, and the aluminium utensil over four times as much heat as the iron utensil, in the same time, and from the same fire. Tinware is sheet iron covered with a thin coating of tin; tinware utensils, therefore, may be considered as iron utensils.

Cooking utensils. — Cooking utensils are made of metal for a number of reasons: first, the metals do not burn readily: second,

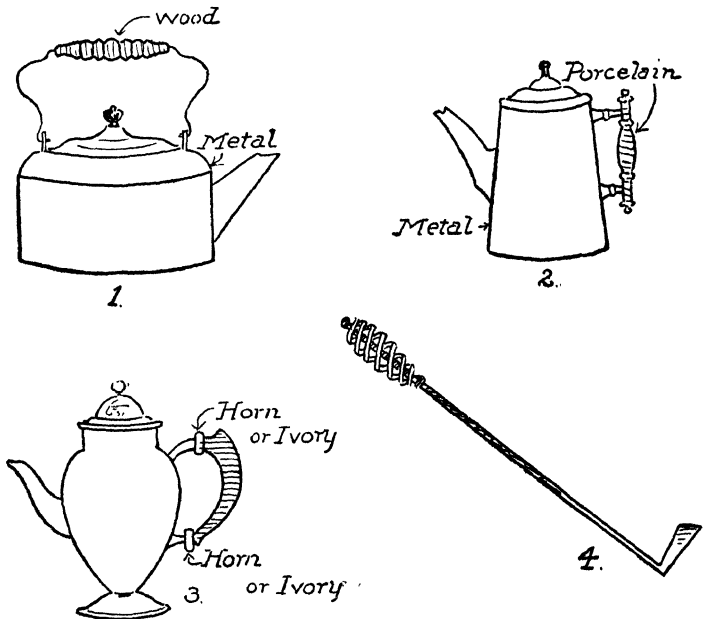

FIG. 76. — Illustrating the use of conductors and nonconductors in cooking utensils.

they do not melt readily; third, they do not break when struck; fourth, they do not crack when subjected to sudden changes of temperature; fifth, they conduct heat readily. Of the common metals it will be noticed in the table above that copper is the best conductor, and that aluminium comes next. Alu-

minium has an advantage in its lightness. The density of copper is 8.9 and of aluminium is 2.58, therefore copper is about $3\frac{1}{2}$ times as heavy as aluminium.

Handles. — Wood and porcelain are used for the handles of cooking utensils (see 1 and 2, Fig. 76), because they are poor conductors of heat. A glance at the table above shows us that wood makes a much better handle than porcelain, because it is a much poorer conductor of heat.

A felt or cotton wool pad is frequently used to cover the handle of a flatiron, and to handle other hot bodies. Felt and cotton wool are excellent for this purpose because they have low specific conductivities.

The pieces of horn inserted in the handles of a coffeepot (see 3, Fig. 76), check the movement of heat towards the handle. It is the best hard solid for this purpose because it has the smallest conducting power.

The wire handle on pokers and other appliances used about the stove makes a fairly cool handle, because the wire makes a long path for the heat to travel, and also it has a large surface from which the heat radiates.

The fireless cooker. — The fireless cooker, Fig. 77, is a box in which one or more pails are surrounded by a thick layer of non-conducting material.

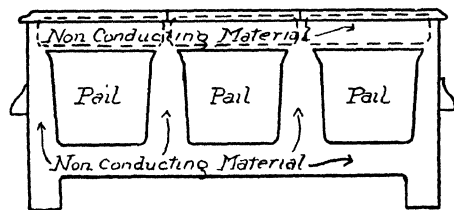

FIG. 77. — The fireless cooker.

The substance to be cooked is placed in a pail and heated thoroughly. The pail is then placed in the box, and the heat contained in the substance slowly

completes the operation of cooking. The nonconducting material may be felt, feathers, mineral wool, cotton, straw, shavings, etc. The nonconducting property of these substances is due largely to the air they contain. Each material

gives the best results with a certain closeness of packing. It should be loose enough to contain air, and still close enough to prevent convection currents in the air.

The refrigerator. — The fireless cooker is designed to keep heat in and the refrigerator is designed to keep heat out. They are, however, similar in principle and somewhat similar in construction. The refrigerator is a box with double walls, the space between the walls being filled with a nonconducting material such as is used in the fireless cooker. We shall study the refrigerator further in a later section.

The thermos bottle. — The thermos bottle is designed to keep heat in or out, as desired. It is different in principle

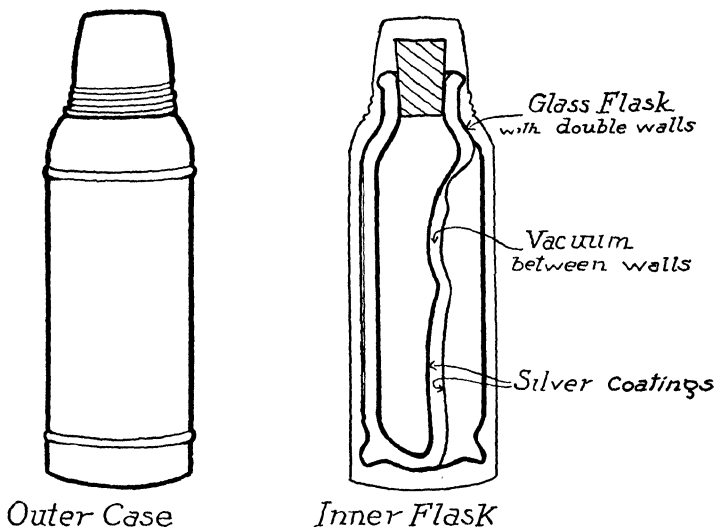

FIG. 78. — The thermos bottle.

from the fireless cooker and the refrigerator. It consists of two bottles blown one inside the other and sealed together at the neck, Fig. 78. The outside of the inner bottle, and the inside of the outer bottle are silvered, then the air is pumped out of

the space between the bottles, and this space is sealed airtight.

It will be remembered that there are three ways in which heat moves from one place to another, namely, by conduction, by convection, and by radiation. It is difficult for heat to enter or leave the thermos bottle in any of these ways.

Let us first consider that the bottle contains a cold substance, and determine how heat is kept out of the bottle. Heat does not pass through the sides of the bottle by radiation because, when the heat waves reach the bottle, they are reflected by the bright silvered surfaces in the same way that light is reflected by the silvered surface of a mirror. A small amount of heat, however, can pass into the bottle by radiation down the neck.

Heat does not enter the bottle by convection because there is no gas or liquid in the space between the bottles in which convection currents can form. It does not enter the neck of the bottle by convection because the substance is cold and the air in contact with it is colder and heavier than the warmer outer air, therefore no convection currents can occur.

Heat does not pass through the sides of the bottle by conduction, because there is a vacuum between the bottles, and a vacuum does not carry heat by conduction. Heat does, however, enter the bottle by conduction down the glass neck of the bottle. This is a slow process, because glass is a poor conductor of heat.

The neck of the bottle then is the door by which heat enters the bottle. It enters here slowly, partly by conduction and partly by radiation. It is probable also that a little heat is absorbed by the silver surface of the outer bottle and is conducted by the silver to the coating of the inner bottle and thus through the glass to the substance.

If we consider the bottle to be filled with a hot substance, and think of the ways in which heat is retained, we find that it is retained in each of the ways that it is kept out when the substance is cold. Heat escapes, however, in one more way than it enters the bottle. It escapes by convection in the air in the neck

of the bottle. It is a matter of observation that the thermos bottle keeps a substance cool longer than it keeps a substance hot, and the reason is that given above. Heat can escape from the bottle in one more way than it can enter.

Walls of houses. — The walls of houses serve to keep heat in, in winter, and out, in summer. They are made of layers of nonconducting material with a layer of air between them. When the air in a room is heated, part of the heat is transferred to the walls and furniture. Any one in the room is warmed partly by heat from the air, and partly by heat radiated from the walls and furniture. The walls help to keep heat in as follows. The inside surface of the inner layer absorbs heat from the air, and radiates part of it back into the room. Part, however, is conducted through the layer and transferred to the second layer by radiation and convection. The inside surface of the outer layer absorbs this heat and radiates part of it back to the inner layer. Part of it is, however, conducted through the layer and escapes by radiation and convection into the outer air.

Heat is kept out in summer by the reverse operation.

Clothes. — Clothes are made of nonconducting material with layers of air between them. They help to keep us warm in winter and cool in summer. Our bodies are warmed from within by the heat produced by the oxidation of the food we eat. Every one radiates heat at all times. If heat waves produced the sensation of sight as light waves do, every person would be luminous. The heat radiated by the body is partly absorbed by the clothing nearest the body. Some of this is radiated back to the body, and some passes on to the next garment. This process is repeated at each garment.

Ventilation. — The ventilation of dwellings is brought about by convection currents in air. These convection currents can be detected by means of experiments similar to that illustrated in Fig. 79. If a door leading from a warm to a cold room is opened, cold air enters the warm room at

the bottom and forces the warm air out at the top. A lighted candle held in different positions indicates the direction of these currents. The flame of the candle *a* is blown towards the warm room, the direction in which the cold air moves. The candle *c* is blown towards the cold room, the direction in which the warm air moves. The flame of the candle *b* is stationary, or moves first in one direction then in the other, because the air at this point is between the warm and cold currents.

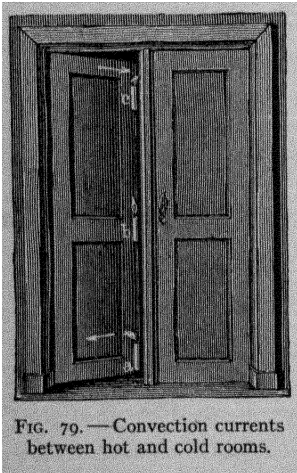

FIG. 79. — Convection currents between hot and cold rooms.

Similarly, if the window of a warm room is opened at the top and bottom on a still, cold day, a lighted candle shows that air enters at the bottom and leaves at the top. Cold air enters at the bottom, and forces warm air out at the top.

A strong wind, blowing against one side of the house, forces fresh air into the house through the crevices about the windows and doors on this side of the house. The foul air is then forced out

through the crevices about the doors and windows on the other sides. Thus the house is ventilated.

Other means of ventilation. — A lighted stove provides a certain amount of ventilation, because air from the room enters the stove to make the draft. This decreases the pressure of the air in the room slightly. Fresh air from outside is then forced into the room through the crevices about the doors and windows by atmospheric pressure. Thus a continuous supply of fresh air is forced into the room, and the room is ventilated.

A lighted grate or grate stove is a still better means of ventilation. A certain amount of the air of the room enters the grate below the fire to make the draft, but a still larger amount

enters above the fire and passes up the chimney Fresh air is then forced in from outside to take the place of this air,

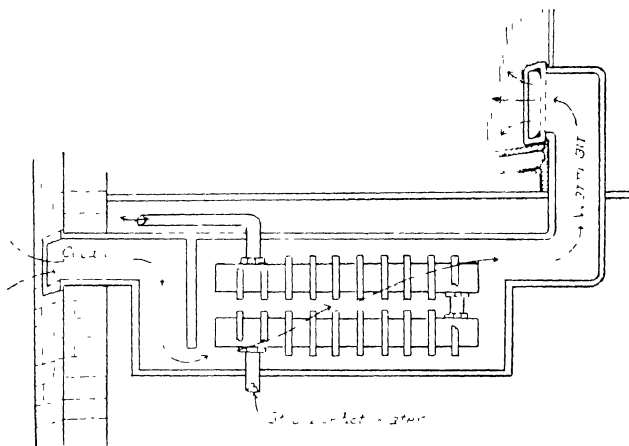

FIG. 80 — One method of ventilating a house

and thus the room is ventilated. The grate and grate stove provide excellent ventilation.

One method of bringing fresh air into the house is illustrated in Fig 80 Cold air from outside is heated by steam or hot-water pipes and is forced up into the rooms above by more cold air from outside.

Another method is illustrated in Fig 81; cold air from outside is admitted beneath a radiator which is inclosed except at the top. The air enters as described above.

Ventilating a soil pipe. — The ordinary soil pipe is a 4-in. cast-iron pipe. It carries the wastes from the sink, bath, water closet, etc., to the cess-pool, septic tank, or sewer. It is the usual practice to have an opening at

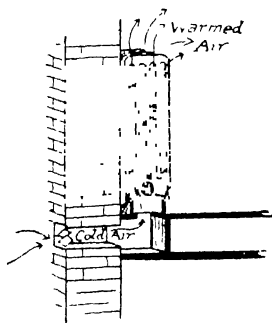

FIG. 81 — Ventilating by means of a radiator.

the bottom and top of this pipe to provide ventilation. The arrangement of the soil pipe is shown in Fig. 82. It will be noticed that there is a fresh-air inlet near the bottom, and that the pipe extends through the roof and is open at the top. The ventilation is produced by convection as follows: The air in the pipe is warmer than the air outside the house, therefore the air in the pipe is lighter, volume for volume, than the air outside. Thus the cold air sinks down into the fresh-air inlet, and forces the warmer air out at the roof vent. The cold air is warmed and is forced out by more cold air, and so on.

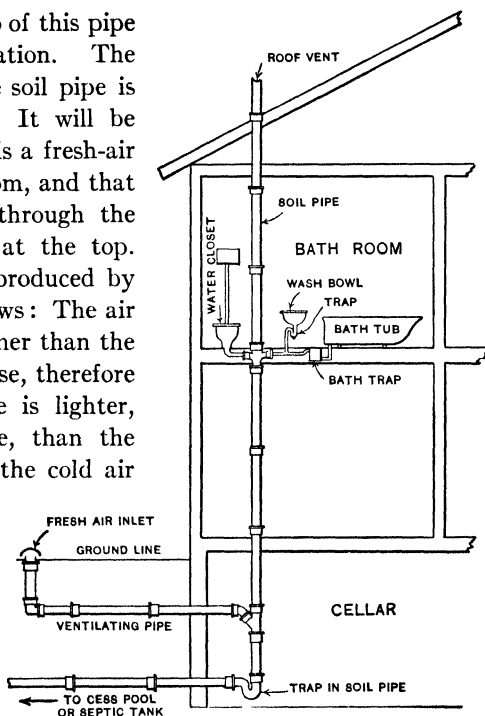

FIG. 82. — The soil pipe and its ventilation.

EXERCISES

1. Describe how heat moves by conduction.
2. Describe an experiment to show that liquids are poor conductors of heat.
3. Describe how heat moves by convection.
4. Name some household appliances in which heat moves by convection.
5. Describe how heat moves from one place to another by radiation.
6. Name three examples of the transfer of heat by radiation.
7. Define specific conductivity.
8. Why are cooking utensils made of metal?
9. Describe the fireless cooker.

10. Describe how the thermos bottle is made.
11. Describe how the thermos bottle keeps heat away from a cold substance.
12. Describe how the thermos bottle retains the heat of a hot substance.
13. Describe how the walls of a house help to keep the heat in.
14. Describe how clothes help to retain the heat of the body.
15. Describe three ways in which a room can be ventilated.
16. Draw a soil pipe and describe how it is ventilated.
17. Test a fireless cooker by measuring the amount of heat which passes out through the walls in a given time, as follows: Weigh the largest pail. Pour into it 10 pounds of water, put on the cover unclamped, and heat until the water boils. Place the pail in the fireless cooker, clamp the cover, close the cooker, and allow it to stand for one half hour. This allows the cooker to warm up. Open the cooker and take the temperature of the water. Close the cooker and allow it to stand for 5, 10, or 20 hours. Find the temperature of the water. Calculate the number of B. T. U. lost in the time chosen.

CHAPTER X

MEASUREMENT OF HEAT

Heat units and how to use them. — We find the temperature of a body by means of a thermometer, but the temperature alone does not indicate the quantity of heat in a body. Two bodies may be at the same temperature and still contain very different quantities of heat. We all know, for example, that a much smaller quantity of heat is required to warm a cup of water to the boiling point than to warm a teakettle of water to the same temperature.

If you were asked to measure out a pound of heat or a quart of heat, you would find it impossible to do so. You could, however, measure out a pound or quart of some hot substance. This is the method we use to measure *quantity* of heat; we measure the weight and temperature of some hot substance. Liquids are convenient for this purpose, and water, being the most common liquid, is the one generally used.

In engineering work in Great Britain and North America, *the unit quantity of heat is the amount of heat required to raise the temperature of 1 lb. of water 1° F.* It is called the *British Thermal Unit (B. T. U.)*.

In scientific work in all countries, *the unit quantity of heat is the amount of heat required to raise the temperature of 1 g. of water 1° C.* It is called the *calorie*.

Also, if 1 lb. of water cools 1° F., it gives up 1 B. T. U. of heat, and if 1 g. of water cools 1° C. it gives up 1 calorie of heat, etc.

Experiment 3. Heat units.

Object. To illustrate the meaning of the terms "British Thermal Unit" and "calorie."

Method. The British Thermal Unit. In a vessel such as a saucepan or 3-qt. pail, weigh out 2 lb. of cold water. Take the temperature of the water in degrees Fahrenheit.

Place the vessel on the fire for a certain time, say 3 min., remove it from the fire and find the temperature of the water in degrees Fahrenheit.

Calculate the number of B. T. U. which the 2 lb. of water received in 3 min.

Example. If the 2 lb. of water is warmed 25° F. the water receives $2 \times 25 = 50$ B. T. U. of heat.

Place the hot water in a cool place for a certain time, say 3 min. Find its temperature.

Calculate the number of B. T. U. the water lost in 3 min.

The Calorie. Weigh out 500 g. of cold water. Find its temperature in degrees centigrade.

Place it on the fire for a certain time and again find its temperature.

Calculate the number of calories the water received.

Example. If the 500 g. of water is warmed 30° C., it receives $500 \times 30 = 1500$ calories of heat.

Place the water in a cool place for a certain time. Find its temperature.

Calculate the number of calories the water lost.

Record. In ... minutes the water gained B.T.U.

In ... minutes the water lost. B.T.U.

In ... minutes the water gained calories.

In ... minutes the water lost. calories.

The B. T. U. and calorie. — In the experiment above we have gained some experience in measuring heat by means of the heat units, British Thermal Unit (B. T. U.) and calorie.

Examples. — If 4 lb. of water is warmed from 55° F. to 85° F. the water receives $4 \times 30 = 120$ B. T. U. of heat.

If 4 lb. of water cools from 85° F. to 70° F. it loses $4 \times 15 = 60$ B. T. U. of heat.

If 300 g. of water is warmed from 25° C. to 45° C., it receives $300 \times 20 = 6000$ calories of heat.

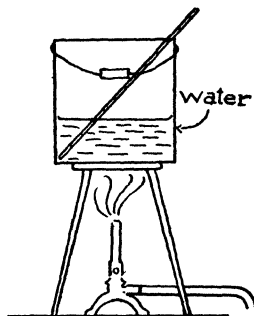

FIG. 83. — Measuring heat.

If 300 g. of water cools from $45^{\circ}\text{C}.$ to $30^{\circ}\text{C}.$, it loses $300 \times 15 = 4500$ calories of heat.

We shall gain further experience in using heat units in later experiments.

It may be noted that another heat unit, the greater calorie or kilogram calorie, the amount of heat required to raise the temperature of one kilogram of water one degree centigrade, is also in common use. Often the greater or kilogram calories are spoken of simply as calories. Students of household science are apt to meet this use of the term in books on food and nutrition. Since the greater calorie is a thousand times the lesser calorie, there will usually be no difficulty in judging from the context which is intended.

Experiment 4. Comparing fires and cooking utensils.

Part I

Object. To compare the heating effect of one gas burner with that of another.

Method. In a vessel, such as a saucepan, weigh out 2 or 3 lb. of cold water. Find the temperature of the water in degrees Fahrenheit.

Place the vessel over one gas burner for a certain time, say 5 min.

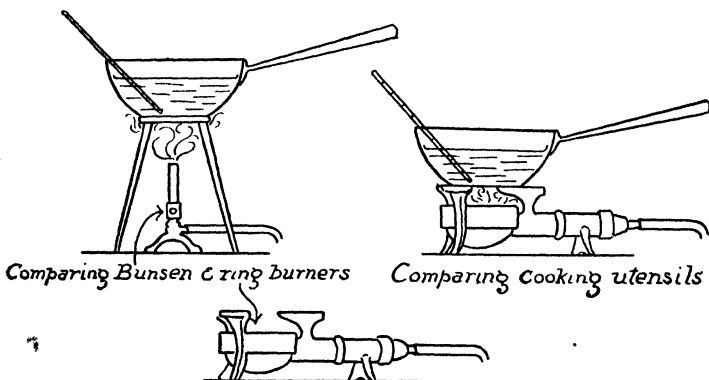

FIG. 84. — Comparing the amounts of heat given by two fires, and the amounts conducted by two cooking utensils.

Find the temperature of the water, and calculate the number of B. T. U. of heat which the fire gave to the water.

Repeat the experiment, using the same vessel on the second burner. Which burner gave the greater amount of heat to the water?

Part II

Object. To compare the conductivity of one vessel with that of another.

Method. Let us suppose we wish to compare the conductivity of a copper saucepan with that of a granite ware saucepan of the same shape and size.

Weigh out a certain weight of cold water in the copper vessel, say 2 lb. Find the temperature of the cold water in Fahrenheit degrees. Place it on the fire for a certain time, say 4 min. Find the temperature of the water again and calculate the number of B. T. U. which passed through the bottom of the copper vessel into the water.

Repeat the experiment, using the granite ware vessel. Which vessel is the better conductor of heat?

Record. Part I.

Burner (1) gave B. T. U. in minutes.

Burner (2) gave . . . B. T. U. in minutes.

Burner . . . gave the greater amount of heat.

Part II.

Vessel (1) absorbed . . . B. T. U. in . . . minutes.

Vessel (2) absorbed . . . B. T. U. in . . . minutes.

Vessel is the better conductor of heat.

Comparing fires. — In the experiment above we used the heat units to compare the heating effect of one fire with that of another.

If one fire warms 5 lb. of water from 60° F. to 95° F. in a certain time, and the other fire warms 5 lb. of water from 60° F. to 90° F. in the same length of time, we know that the first fire gives more heat than the second. The first fire gives the water $5 \times 35 = 175$ B. T. U. of heat, and the second $5 \times 30 = 150$ B. T. U. of heat in the same length of time.

In the experiment we compared the heating effect of one gas burner with that of another. If, however, we wish to determine which burner is the more economical, we must measure the quan-

tity of gas used by each burner in a certain time, as well as the amount of heat produced in this time.

Comparing cooking utensils. — In the experiment above we learned also how to use the heat units to compare the conductivity of one utensil with that of another.

If in one utensil 5 lb. of water is warmed from 60° F. to 100° F. in a certain time, and in the other 5 lb. of water is warmed from 60° F. to 80° F., on the same fire and in the same length of time, we know that the first utensil has the greater conductivity. The first utensil conducts $5 \times 40 = 200$ B. T. U. of heat, and the second $5 \times 20 = 100$ B. T. U. of heat, from the same fire in an equal time.

This method can be used to measure the conductivity of cooking utensils in general.

Comparing fireless cookers. — We can also use the heat units in comparing the heat-holding power of one fireless cooker with that of another, as follows: Place equal weights of boiling water (212° F.) in each fireless cooker. Find the temperature of the water in each after a certain time, say 1 hr. Calculate the quantity of heat lost through the sides of each fireless cooker in the given time. The one which loses the smaller quantity of heat has the greater heat-holding power, and, other things being equal, is the better fireless cooker.

Experiment 5. Foot warmers.

Object. To compare the amount of heat given up by two different foot warmers which have the same weight and are at the same temperature.

Let us suppose that we wish to find out which makes the better foot-warmer, a flatiron or the water in a hot-water bag, the iron and water to have the same weight and to be at the same temperature.

Method. Balance a pail on one pan of the scales. Then place the flatiron on the other pan and pour enough water into the pail to balance the iron.

We now have equal weights of iron and water.

Place the iron in the water, cover the pail, and heat the iron and water to the boiling point of water.

We now have equal weights of iron and water both at 212°F .

In each of two other pails weigh out a certain weight of cold water, say 3 lb. Find the temperature Fahrenheit of the water in each pail. Place the hot iron in one pail, and the hot water in the other.

Find the temperature of the water in each pail after 1 or 2 min.

Calculate the number of B. T. U. the hot iron gave to the cold water, and the number of B. T. U. the hot water gave to the cold water.

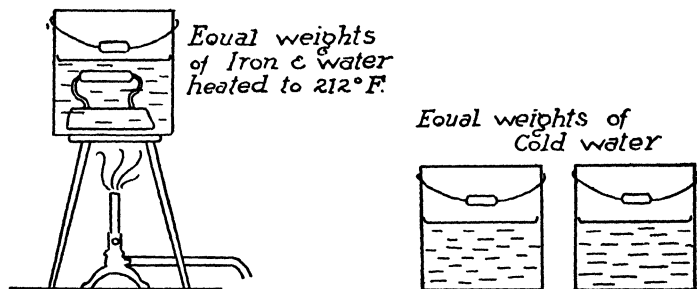

FIG. 85 — Comparing iron and water as foot warmers

Example. If the hot iron warmed the 3 lb. of cold water 15°F ., the iron gave up $3 \times 15 = 45^{\circ}$ B. T. U., etc.

Which foot warmer gave up the greater amount of heat, that is, which is the better foot warmer?

You will find that one substance gives up much more heat than the other. This substance is said to have the greater *heat capacity*.

Record. The hot iron warmed the . . . lb. of cold water $^{\circ}\text{F}$., therefore the *hot iron* gave the cold water B. T. U.

The hot water warmed the . . lb. of cold water $^{\circ}\text{F}$., therefore the *hot water* gave the cold water . . . B. T. U.

The is the better foot warmer.

Comparing foot warmers. — In the experiment above we used the heat units in comparing foot warmers. A good foot warmer is one that stores up a large quantity of heat which it gives up gradually. We compared two foot warmers, namely: a flat-iron and the water in a hot-water bag. We found that the hot water gave up much more heat than the hot iron. We concluded then that the water in a hot-water bag is a better foot warmer than a flatiron of equal weight heated to the same tem-

perature. Water is a better material for a foot warmer than iron, because water has a greater capacity for heat than iron. This will be taken up further in a later section.

Experiment 6. Cooling effect of ice and ice water.

Object. To compare the cooling effect of 1 lb. of ice at 32° F., with that of 1 lb. of ice water at 32° F.

Method. Ice water. Weigh out 2 lb. of water, cover the pail, and heat the water to the boiling point, 212° F. Pour into this 1 lb. of ice water and find the temperature after stirring for one minute.

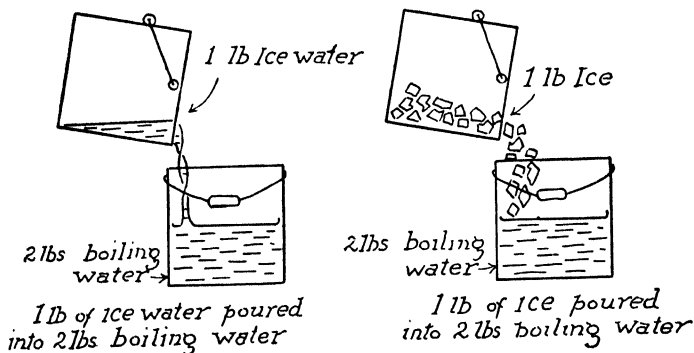

FIG. 86. — Comparing the cooling effect of a pound of ice with that of a pound of ice water.

Calculate the number of B. T. U. which the ice water took from the 2 lb. of hot water.

Example. If the 2 lb. of hot water at 212° was cooled to 152° , the ice water took $2 \times 60 = 120$ B. T. U. of heat from the hot water.

This represents the cooling effect of 1 lb. of ice water.

Ice. Weigh out 2 lb. of water and heat it to the boiling point, 212° F. Put into this 1 lb. of ice or snow. Take the temperature after all the ice is melted.

Calculate the number of B. T. U. which the ice took from the 2 lb. of hot water.

This represents the cooling effect of 1 lb. of ice.

Which has the greater cooling effect, 1 lb. of ice water or 1 lb. of ice?

Note. To make ice water, put enough snow or ice in water to reduce its temperature to 32° F. Then strain the water through a cloth to remove the ice which is not melted.

Record.

1 lb. of *ice water* cooled 2 lb. of water from 212° F. to $^{\circ}$ F. Therefore the 1 lb. of ice water absorbed . . . B. T. U.

1 lb. of *ice* cooled 2 lb. of water from 212° F. to $^{\circ}$ F. Therefore the 1 lb. of ice absorbed . . . B. T. U.

Therefore 1 lb. of has a greater cooling effect than 1 lb. of

Ice and ice water. — We can use the heat units in measuring the cooling effect of different materials. In the experiment above we compared the cooling effect of 1 lb. of ice water at 32° F., with that of 1 lb. of ice at 32° F. We found that ice has a much greater cooling effect than an equal weight of ice water at the same temperature. Ice has a greater cooling effect than ice water because a large quantity of heat is required to change the ice to ice water. To change 1 lb. of ice at 32° F. to 1 lb. of water at 32° F. requires 144 B. T. U. of heat. This is known as the latent heat of ice. We shall study it further in a later section.

Experiment 7. The heating effect of steam and of boiling water.

Object. To compare the heating effect of 1 lb. of steam at 212° F. with that of an equal weight of water at 212° F.

Method. Boiling water. Weigh out 4 lb. of cold water and find its temperature. Leave the vessel and water on the scales and pour into it $\frac{1}{4}$ lb. of water at 212° F. and find the temperature again.

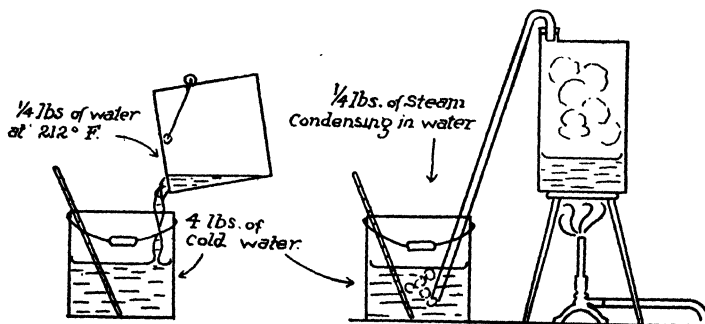

FIG. 87. — Comparing the heating effects of steam and boiling water.

Calculate the number of B. T. U. received by the 4 lb. of cold water. This is the heating effect of the $\frac{1}{4}$ lb. of water at 212° F.

Steam. Weigh out 4 lb. of cold water and take its temperature.

Place the vessel and water on a balance and note its weight. Leave it on the balance and pass live steam into the water until $\frac{1}{4}$ lb. of steam has condensed in the cold water. Find the temperature again.

Calculate the number of B. T. U. received by the 4 lb. of cold water.

This is the heating effect of the $\frac{1}{4}$ lb. of steam.

Which has the greater heating effect, water at 212° F. or the same weight of steam at 212° F.?

Record. The $\frac{1}{4}$ lb. of *boiling water* warmed 4 lb. of cold water from $^{\circ}$ F. to $^{\circ}$ F. Therefore the $\frac{1}{4}$ lb. of boiling water gave up . . . B. T. U.

The $\frac{1}{4}$ lb. of *steam* warmed 4 lb. of cold water from $^{\circ}$ F. to $^{\circ}$ F. Therefore the $\frac{1}{4}$ lb. of steam gave up B. T. U.

A certain weight of has a greater heating effect than the same weight of

Steam and boiling water.—We can use the heat units in measuring the heating effect of any material. In the experiment above we compared the heating effect of 1 lb. of boiling water with that of 1 lb. of steam at the same temperature. We found that steam has a much greater heating effect than an equal weight of water at the same temperature. Steam has a greater heating effect than water at the same temperature because steam gives up a large quantity of heat when it changes from steam at 212° F. to water at 212° F. When 1 lb. of steam at 212° F. changes to 1 lb. of water at 212° F. it gives up 966 B. T. U. of heat. This is known as the latent heat of steam. We shall study it further in the next section.

EXERCISES

1. Define British Thermal Unit and calorie.
2. What quantity of heat is required to warm 12 lb. of water from 55° F. to 205° F.?
3. What quantity of heat is required to warm 600 g. of water from 20° C. to 100° C.?
4. On one fire, 4 lb. of water is warmed from 55° F. to 85° F. in 5 min. On another 4 lb. of water is warmed from 55° F. to 80° F. in the same

vessel and in an equal time. How much heat does each fire give to the water?

5. In one saucepan 5 lb. of water is warmed from 60° F. to 110° F. in a certain time. In another 4 lb. of water is warmed from 60° F. to 120° F. on the same fire in an equal time. What quantity of heat passes through the bottom of each vessel in the given time? Which vessel is the better conductor of heat?

6. In one fireless cooker 8 lb. of water at 212° F. cools to 180° F. in a certain time. In another 8 lb. of water at 212° F. cools to 175° F. in an equal time. What quantity of heat is lost through the sides of each fireless cooker in the given time? Which is the better heat retainer?

7. Why is water a better material for a foot warmer than iron?

8. Why has ice a greater cooling effect than an equal weight of ice water?

9. Why has steam a greater heating effect than an equal weight of water at the same temperature?

CHAPTER XI

HEAT CAPACITY, SPECIFIC HEAT, LATENT HEAT

Heat capacity. — *The heat capacity of any substance is the amount of heat required to warm unit weight of the substance 1° , or the heat given up when unit weight of the substance cools 1° .*

If we use British Thermal Units to measure heat, the heat capacity of any substance is the number of B. T. U. required to heat 1 lb. of the substance 1° F., or what is the same thing, the number of B. T. U. given up when 1 lb. of the substance cools 1° F.

If we use calories to measure the heat, the heat capacity of any substance is the number of calories required to warm 1 g. of the substance 1° C., or the number of calories given up when 1 g. of the substance cools 1° C.

The number expressing the heat capacity is the same, no matter which heat unit we use.

Specific heat. — *The specific heat of a substance is the ratio between its heat capacity and that of water.* Since, however, the heat capacity of water is 1, the numbers expressing the specific heat are the same as those expressing heat capacity.

Experiment 8. Heat capacity.

Object. To find the heat capacity of iron.

Method. Weigh a piece of iron in pounds, say a flatiron. Place it in boiling water for about five minutes, until its temperature becomes that of boiling water, 212° F.

In a separate vessel weigh out a certain quantity of cold water, say 5 lb. Take its temperature in degrees Fahrenheit.

Place the hot iron in the cold water and find the temperature after stirring for 1 or 2 min.

Calculate the number of B. T. U. given up by 1 lb. of iron in cooling 1° F., that is, calculate its *heat capacity*.

Example. 4 lb. of iron at 212° F. placed in 5 lb. of water at 55° F. warms the water to 67° F. What is the heat capacity of iron?

The water absorbed the number of B. T. U. of heat which the iron gave up. The 5 lb. of water was warmed from 55° to 67° or through

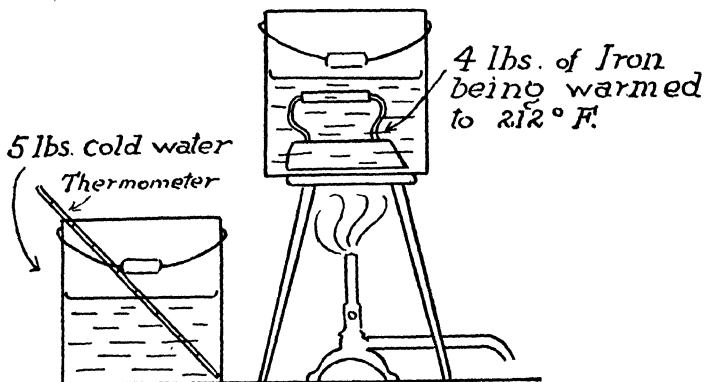

FIG. 88. — Measuring the heat capacity of iron.

12° , therefore the water received $5 \times 12 = 60$ B. T. U. This heat came from the iron.

The 4 lb. of iron cooled from 212° F. to 67° F., or through 145° F., therefore we can say:

4 lb. of iron in cooling 145° gave up 60 B. T. U.

1 lb. of iron in cooling 145° gave up $\frac{60}{4} = 15$ B. T. U.

1 lb. of iron in cooling 1° gave up $\frac{15}{145} = \frac{1}{10}$ B. T. U.

The 1 lb. of iron in cooling 1° gave up $\frac{1}{10}$ B. T. U., therefore the heat capacity of the iron is .1 B. T. U.

Heat capacity of a substance. — The method of finding the heat capacity of a substance is illustrated in the experiment above. We found the heat capacity of iron to be $\frac{1}{10}$ B. T. U. per pound. If we make the same experiment but measure the weight of the iron in grams and the quantity of heat in calories, we find the heat capacity of iron to be $\frac{1}{10}$ calorie per gram. That is, the number expressing the heat capacity is the same in each system of measurement.

In this experiment we found the heat capacity of iron. The heat capacity of other substances can be found in the same way.

Table of Heat Capacities

Air25	Iron11
Alcohol6	Lead031
Brass09	Mercury033
Brick2	Silver057
Copper09	Soapstone2
Earth2	Tin056
Glass2	Water	1.
Ice5	Zinc095

Use of heat capacity. — When we know the heat capacity and weight of a body, we can calculate the quantity of heat it will take up or lose for a given change of temperature.

Example. A 5-lb. brick used as a foot warmer cools from 200° F. to 60° F. What quantity of heat does it give up?

Ans. $5 \times 140 \times .2 = 140$ B. T. U.

LATENT HEAT

Experiment 9. Latent heat of ice.

Object. To find the number of B. T. U. required to change 1 lb. of ice at 32° F. to 1 lb. of water at 32° F., that is, to find the latent heat of ice.

Method. Weigh out 5 lb. of water in a pail and warm it to about 80° F. Take its temperature.

Pour into it 1 lb. of dry powdered ice or snow.

Stir and take the resulting temperature when all the ice is melted.

Calculate the number of B. T. U. required to melt the pound of ice. This is the latent heat of ice.

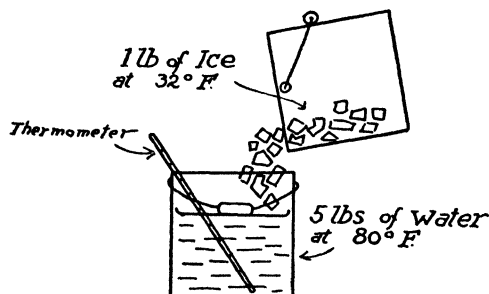

FIG. 89. — Measuring the latent heat of ice.

Example. 1 lb. of ice at 32° F. is mixed with 5 lb. of water at 80° F., and the resulting temperature is 48° F. What is the latent heat of ice?

The 5 lb. of water is cooled from 80° F. to 48° F., that is, through 32° . Therefore it gave up $5 \times 32 = 160$ B. T. U. of heat.

This heat was absorbed by the ice.

It will be noticed that two things happened: the ice melted and the resulting water was warmed to 48° F.; that is, first, the 1 lb. of ice at 32° F. was changed to 1 lb. of water at 32° F., and second, the 1 lb. of water was warmed from 32° F. to 48° F.

To warm 1 lb. of water from 32° F. to 48° F., or through 16° F., requires 16 B. T. U.

The total heat used was 160 B. T. U. Of this, 16 B. T. U. were used in warming the ice water. The remainder was used to melt the 1 lb. of ice.

That is, $160 - 16$ or 144 B. T. U. were used to change 1 lb. of ice at 32° F. to 1 lb. of water at 32° F.

Therefore, the latent heat of ice is 144 B. T. U. per pound.

Latent heat of ice. — *The quantity of heat required to change unit weight of ice to water without changing its temperature is called the latent heat of ice.*

If we are using British Thermal Units to measure the quantity of heat, the latent heat of ice is the number of B. T. U. of heat required to change 1 lb. of ice at 32° F. to 1 lb. of water at 32° F. We found in the experiment above that to change 1 lb. of ice at 32° F. to 1 lb. of water at 32° F. requires 144 B. T. U. of heat. This is the *latent heat of ice* when expressed in B. T. U.

If we are using calories to measure quantity of heat, the latent heat of ice is the number of calories required to change 1 g. of ice at 0° C. to 1 g. of water at 0° C. To change 1 g. of ice at 0° C. to 1 g. of water at 0° C. requires 80 calories of heat. This is the latent heat of ice when expressed in calories.

When water turns to ice each pound or gram *gives up* its latent heat. When 1 lb. of water at 32° F. turns to ice at 32° F., it gives up 144 B. T. U. of heat, and when 1 g. of water at 0° C. turns to ice at 0° C. it gives up 80 calories of heat.

It will be noticed that the latent heat of ice expressed in

calories is $\frac{5}{9}$ of the latent heat expressed in B. T. U., that is, $144 \times \frac{5}{9} = 80$. The reason is, the degree C. is $\frac{5}{9}$ as large as the degree F., therefore in measuring equal changes in temperature there are $\frac{5}{9}$ as many degrees C. as degrees F.

When any solid is turned to a liquid, a certain amount of heat is required to produce the change. The amount required for 1 lb. or 1 g. is the *latent heat of fusion* of the substance. When the liquid changes back to a solid, this heat is given up again.

Latent Heats of Fusion

Ice	144	B. T. U. per pound
Aluminium	140	“ “ “
Copper	77	“ “ “
Zinc	50	“ “ “
Silver	39	“ “ “

Experiment 10. Latent heat of steam.

Object. To find the number of B. T. U. of heat given up when 1 lb. of steam at 212° F. changes to 1 lb. of water at 212° F., that is, to find the latent heat of steam.

$\frac{1}{4}$ lbs of Steam at
 212° F. passing into
water

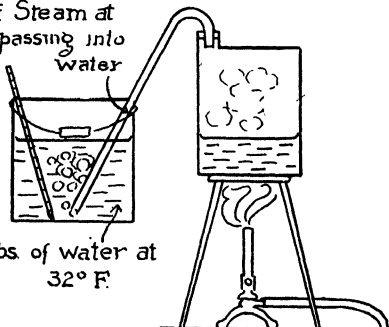

5 lbs. of water at
 32° F.

Method. Weigh an empty pail and pour into it 5 lb. of ice water (32° F.).

Place pail and water on a balance and pass live steam (212° F.) into it until $\frac{1}{4}$ lb. of steam has condensed in the water.

Calculate the latent heat of steam.

FIG. 90. — Measuring the latent heat of steam.

Example. 1 lb. of steam at 212° F. is

passed into 20 lb. of water at 32° F. The resulting temperature is 86.5° F. What is the latent heat of steam?

The 20 lb. of water is warmed from 32° F. to 86.5° F. or through 54.5° F., therefore the water received $20 \times 54.5 = 1090$ B. T. U.

This heat came from the steam.

The steam gave up heat in two ways. First, when 1 lb. of steam at 212° F. changed to water at 212° F., second, when this water cooled from 212° F. to 86.5° F.

When 1 lb. of water at 212° F. cools to 86.5° F. it gives up $212 - 86.5 = 125.5$ B. T. U.

The total heat given up by the steam was 1090 B. T. U.; of this 125.5 B. T. U. came from the water formed by the steam.

The remainder, $1090 - 125.5 = 964.5$ B. T. U. was given up by 1 lb. of steam in changing from steam at 212° F. to water at 212° F. This is the latent heat of steam per pound.

Note. The correct value of the latent heat of steam is 966 B. T. U. per pound.

Latent heat of steam. — *The quantity of heat required to change unit weight of water into steam without changing its temperature* is called the *latent heat of steam*. In the experiment above we learned that to change 1 lb. of water at 212° F. to 1 lb. of steam at 212° F. requires 966 B. T. U. of heat. This is the *latent heat of steam* when we measure heat in B. T. U.

If 1 lb. of steam at 212° F. condenses to 1 lb. of water at 212° F., it *gives up* its latent heat, namely, 966 B. T. U. of heat.

To change 1 g. of water at 100° C. to 1 g. of steam at 100° C. requires 537 calories of heat. This is the *latent heat of steam* when we measure heat in calories.

If 1 g. of steam at 100° C. condenses to 1 g. of water at 100° C., it gives up 537 calories of heat.

It will be noticed again that the latent heat expressed in calories is $\frac{5}{9}$ of the latent heat expressed in B. T. U., that is, $966 \times \frac{5}{9} = 536.6$, approximately 537. We shall use the whole number 537.

When any substance is changed from a liquid to a vapor, a certain quantity of heat is required to produce the change. The amount required for 1 lb. or 1 g. is the *latent heat of vaporization* of the substance. When the vapor changes to a liquid again, this heat is given up.

Latent Heats of Vaporization

Water	966	B. T. U.	per pound
Alcohol	370	"	" "
Benzine	180	"	" "
Turpentine	120	"	" "

Latent heat is work. — The heat which disappears when a solid is turned to a liquid or a liquid to a gas does not affect the thermometer. Formerly it was thought that this heat was hidden in some way, and for this reason it was called "latent" heat. We now know that when the *heat disappears*, it has been turned into *work*; and when it *reappears*, the *work* has been changed back into *heat*. In other words, *latent heat is not heat at all. It is work.* This needs some explanation.

Work is done when anything is moved in opposition to a force. Now the molecules of a solid are closer together than the molecules of a liquid. When a solid is turned to a liquid, the molecules are moved apart in opposition to their mutual attraction (cohesion). This requires work, and the latent heat of fusion is turned into this work.

Similarly, the molecules of a vapor are much farther apart than the molecules of a liquid. The latent heat of vaporization is turned into the work necessary to force these molecules apart.

When the vapor turns back to a liquid, and the liquid to a solid, this work is turned back again into heat.

Ice lighter than water. — In the paragraph above we stated that the molecules of a solid are closer together than the molecules of a liquid. This seems to be contradicted by the fact that ice is lighter than water. We all know this to be true, since ice floats on water, and water expands when it freezes. In fact 1 cu. ft. of water becomes 1.09 cu. ft. of ice. How are these statements reconciled? We have all noticed ice forming in a pool or on a window pane. How does it form? In crystals, does it not? Now a block of ice is a mass of these crystals. A pound of iron in the shape of nails takes up more space than

a pound of iron in one piece, because there are spaces between the nails; so it is with the crystals in a block of ice. The molecules of ice are closer together in the crystals than the molecules are in water. But a pound of ice takes up more space than a pound of water, because there are open spaces between the crystals.

APPLICATIONS OF LATENT HEAT

Now that we know the meaning of the terms *latent heat of ice* and *latent heat of steam*, we are in a position to understand the ways in which man has turned this knowledge to his own use. For example, in the refrigerator, artificial refrigeration, steam heater, steam cookers, distillation, etc.

The refrigerator. — We learned on page 109 that the refrigerator is a box with double walls between which there is a layer of insulating material.

The food placed in a refrigerator is cooled as follows: The ice is placed in the upper part of the refrigerator. The air in contact with it is cooled, and therefore contracts and becomes heavier, volume for volume, than the remainder of the air in the refrigerator. This cold, heavy air sinks down through an opening in the bottom of the ice chamber, and forces the warmer, lighter air up along the sides of the refrigerator, see arrows, Fig. 91. The warm air comes into contact with the ice, is cooled, contracts, becomes heavier, and sinks. The cold air in its downward passage comes into contact with the food and absorbs heat from it. This explains how the food is cooled.

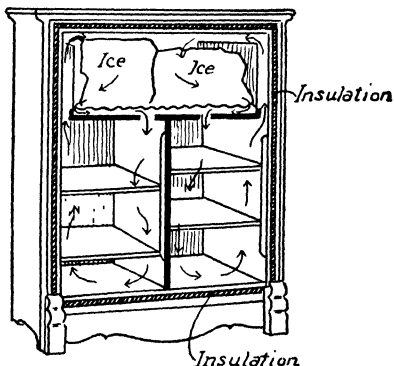

FIG. 91. — The refrigerator.

The cold air is warmed by contact with the food, and also by contact with the bottom and sides of the refrigerator. It thus becomes lighter than the air in contact with the ice, and is in turn forced up by this cooler, heavier air. This circulation of air is a convection current. The convection current continues as long as the bottom and sides of the refrigerator are at a higher temperature than the ice.

The motion of the cold downward current of air can be illustrated by means of a paper spiral supported on a pin point below the ice. The spiral is made to revolve by the cold downward current.

Temperature of the air in a refrigerator. — The temperature to which the air and food in a refrigerator are cooled by the ice depends upon the non-conducting or insulating power of the walls and upon the temperature of the outside air. The temperature of melting ice is 32° F. If the walls of the refrigerator were perfect insulators, the ice would absorb heat and melt until the temperature of the air in the refrigerator was reduced to 32° F. Then the ice would stop melting and the air would remain at 32° F. That is, if the walls were perfect insulators, the ice would last forever, and the air would remain forever at 32° F. There is, however, no such thing as a perfect insulator, therefore when the outside air is above 32° F., heat passes into the refrigerator through the walls. The amount of heat which passes through the walls in a given time increases as the temperature of the outside air rises, and decreases as it falls. If the walls are good insulators, the amount of heat which enters is small; if they are poor insulators, it is large. Also each time the door of the refrigerator is opened the cold air falls out at the bottom and is replaced by warm air; this admits heat to the refrigerator.

If the doors are kept closed the ice gradually cools the food, the air, and the inside walls. As the inside temperature is lowered, heat flows in more rapidly from the outside. The temperature finally reached inside is the temperature at which

the heat which enters through the walls each second is just equal to that which the ice can absorb each second.

Comparing refrigerators. — We can measure the quantity of heat which passes through the walls of a refrigerator in a day by finding the weight of ice melted per day. We learned on page 129 that 144 B.T.U. of heat are required to melt 1 lb. of ice. Therefore, if 20 lbs. of ice melt in the refrigerator per day, we know that $20 \times 144 = 2880$ B.T.U. of heat have passed through the walls of the refrigerator in one day. If the water formed by the melting ice leaves the refrigerator at a temperature of, say, 40° F., we know that the 20 lb. of water have been warmed from 32° F. to 40° F., or through 8° F. This requires $20 \times 8 = 160$ B.T.U. of heat. The total amount of heat which passed through the walls in one day is then $2880 + 160 = 3040$ B.T.U.

We can compare two refrigerators as follows. Place in each blocks of ice of the same shape and of the same weight. Allow the refrigerators to stand closed for the same length of time, say 24 hr. Find the temperature of the water in each at the point it leaves the refrigerator. At the end of the given time find the weight of ice remaining in each, and from this the amount of ice melted in each. Calculate the amount of heat which passed through the walls of each in 24 hr. as above. Other things being equal, the better refrigerator is the one through the walls of which the lesser amount of heat passes.

Freezing mixtures. — We all know that ice and salt when mixed produce a low temperature. We have probably all used this mixture to freeze ice cream.

There are many substances which may be mixed with snow or ice to produce a low temperature. For example, 1 lb. of potassium chloride with 3 lb. of snow produces a temperature of 12° F.; 1 lb. of ammonium chloride with 4 lb. of snow, 5° F.; 1 lb. of ammonium nitrate with 2 lb. of snow, 2° F.; 1 lb. of sodium nitrate with 2 lb. of snow, 0° F.; 1 lb. of sodium chloride

(common salt) with 3 lb. of snow, -6° F.; $1\frac{1}{2}$ lb. of calcium chloride crystals with 1 lb. of snow, -58° F.

The lowest temperature produced by any mixture is the freezing point of the saturated solution of that mixture. If an excess of the salt is added to the snow or ice, the low temperature is produced more quickly, but it does not go below the freezing point of the saturated solution. If an excess of snow or ice is added, the temperature decreases more slowly and does not reach the freezing point of a saturated solution.

Ice cream can be frozen by any of the mixtures given above. A mixture of salt and ice is generally used, because salt is cheap and also because the mixture produces a lower temperature than many of the others. The usual proportion of salt to ice is 1 of salt to 3 of ice or snow. If, however, we wish to freeze the ice cream quickly, we add an excess of salt. If we wish to freeze it more slowly, we add an excess of ice.

Why do ice and salt produce a low temperature? When a block of ice is in a room which is at any temperature above 32° F., it melts, because heat passes from the room into the ice. The rate at which the ice melts depends upon the rate at which the heat moves from the room into the ice. The heat increases the velocity of the ice molecules until they are able to overcome the attraction of their fellows. Separated ice molecules are water molecules.

When we place salt on ice, the ice melts more rapidly, because the salt molecules attract the ice molecules. This attraction enables more of the ice molecules to separate from their fellows in a given time, and therefore the melting takes place more quickly. The room can supply heat to the ice at a certain rate. If the salt makes the ice melt at a more rapid rate, the latent heat necessary to do the melting comes from the mixture of salt and ice, also part of the salt dissolves in the water formed by the melting ice, and the heat needed to change the solid salt to a liquid comes from the mixture of salt and ice. Both of these causes lower the temperature of the mixture of salt and ice.

We see then that the reason salt and ice produce a low temperature is that the salt makes the ice melt more rapidly than it would melt by the heat of the room alone. The heat which is not supplied by the room comes from the mixture of salt and ice itself, and therefore the temperature of the mixture is lowered. The lowest temperature produced is the freezing point of a concentrated solution of salt and water, -6° F.

When the mixture of salt and ice is used to freeze ice cream, part of the latent heat necessary to change the ice and salt to the liquid condition is taken from the ice cream and the ice cream is frozen.

Artificial ice and artificial cooling. — We know that when steam is condensed to water it gives up its latent heat, and when it is again changed from water to steam it takes up this latent heat.

This is true of all gases, and is the principle upon which the successful artificial ice machines are built. The gas in most common use is ammonia. It is used because it is easily condensed to liquid ammonia, and liquid ammonia boils at a very low temperature, -29° F., when the pressure is 1 atmosphere.

The artificial ice machine, Fig. 92, is designed to cool cold storage rooms, or to make artificial ice, as desired. It consists of a compressor (*A*), two sets of coils (*B*) and (*C*), a valve for expanding the gas to lower pressure, and the ice tank (*D*) containing brine, usually calcium chloride dissolved in water. The coils of pipe are charged with liquid ammonia free from water.

The operation of the machine is as follows: The compressor is driven by some form of power appliance, such as a steam engine, gas engine, etc. It pumps ammonia gas from the coils (*C*) and forces it into the coils (*B*) at a pressure of about 135 lb. per square inch above atmospheric pressure. Under this pressure the ammonia gas is turned to a liquid, and in turning to a liquid gives up its latent heat. This heat is absorbed by a stream of cold water which is kept flowing through the condenser (*B*). The expansion valve is simply a valve with a very small opening, through which the liquid ammonia passes in a small stream and enters the coils in (*C*). In (*C*) the pressure is kept at about 16 lb. per square inch above atmospheric pressure. Here the liquid ammonia turns to a gas, and in doing so absorbs its latent heat again. It takes this heat from the brine which is kept flowing through the evaporator. It thus lowers the tem-

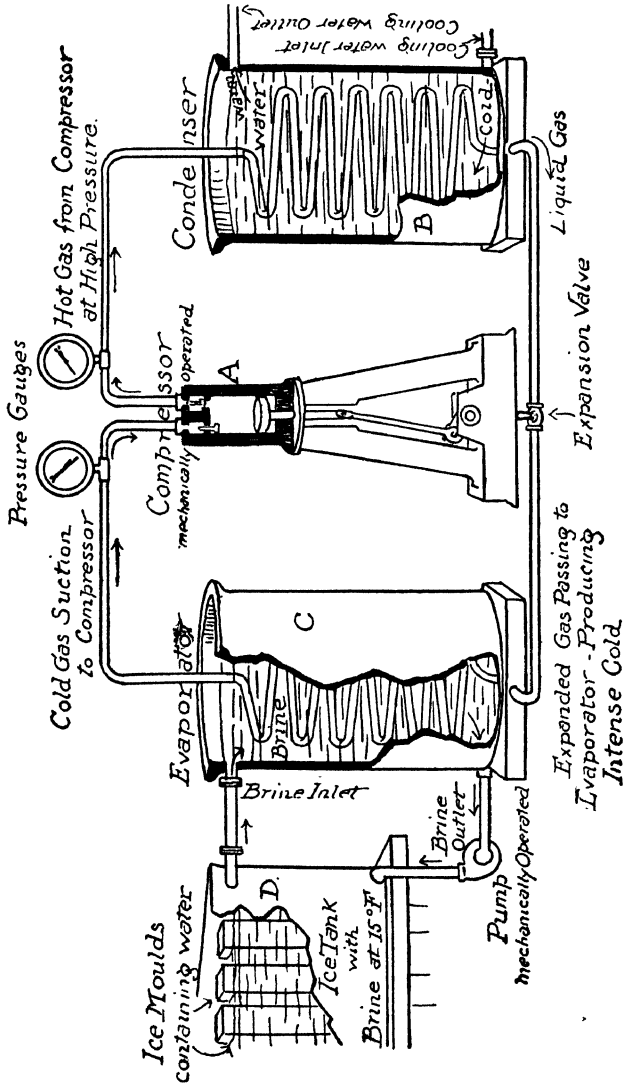

FIG. 92. — Artificial ice machine.

perature of the brine. At a gauge pressure of 16 lb. ammonia liquid boils, that is, turns to a gas, at a temperature of 0° F. The brine is cooled to about 20° F.

The ammonia gas is then pumped again into (B) and the whole operation is repeated continuously.

When it is desired to cool a cold storage room in a house, hotel, steamship, or cold storage warehouse, the brine is pumped from the ice tank to coils of pipe placed near the ceiling of the room. The brine is kept circulating between the tank and the coils, and cools the cold storage room precisely as a block of ice cools a refrigerator.

When it is desired to make artificial ice, long narrow cans filled with pure water are placed in the ice tank, as shown in the figure. The cold brine freezes the water to a solid block in from 40 to 48 hr.

Steam heating system.—

The steam heating system of a house is arranged as shown in Fig. 93. The fire under the boiler boils the water and generates steam. This steam passes up the steam pipe and into the radiator; here it condenses to water and gives up its latent

heat to the air in the room. The water flows back through the steam pipe to the boiler, is again turned to steam, and so on. The operation is repeated as long as there is sufficient fire under the boiler. Each pound of steam that condenses in the radiator gives up its latent heat, 966 B. T. U. of heat. In

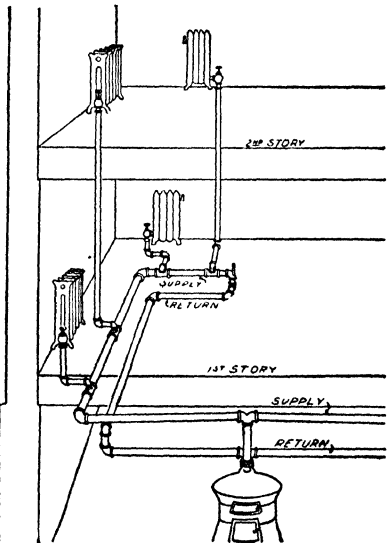

FIG. 93. — A steam heating system.

addition, if the water leaves the radiator at a temperature of, say, 100°F , each pound of steam water cools from 212° to 100° , or 22°F , and in doing so gives up 22 B. T. U. of heat. Under these circumstances the total amount of heat given up by each pound of steam is $966 + 22 = 988$ B. T. U.

Steam cookers — Food is cooked in a steam cooker as follows. Water is boiled in the bottom of the cooker and the steam formed passes up into the divisions above. Here the steam heats the food, partly by convection and radiation, and partly by condensation. A pound of steam in condensing gives 966 B. T. U. of heat to the food. The food is cooked at a temperature never above 212°F .

Distillation. — Pure water can be obtained from impure water by distillation. The impure water is boiled and the

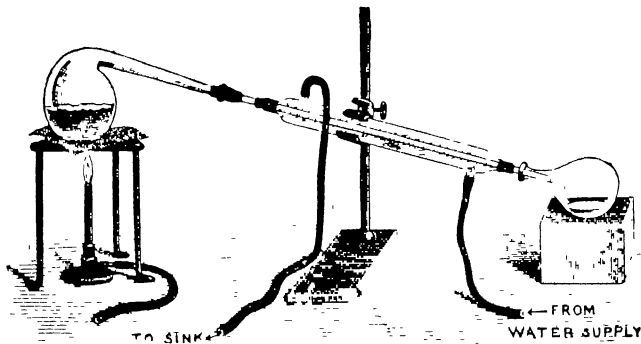

FIG. 94. Distilling apparatus.

steam formed is condensed to water again. The condensed steam is pure water. One form of distilling apparatus is shown in Fig. 94. The impure water is boiled in a flask, and the resulting steam is condensed in the condenser. The pure water is caught in a flask at the lower end of the condenser. The condenser consists of a tube with a water jacket; cold water is made to enter the water jacket at the bottom and leave it

at the top. This cold water condenses the steam. When the impure water is boiled, the nonvolatile impurities are left in the flask and the steam is pure water. If the impurities are volatile, they cannot be separated from the water by this process, because they vaporize and pass over with the steam.

Domestic distilling apparatus — A common form of domestic still is shown in Fig. 95. It consists of three sections which fit one into the other. The water is boiled in the bottom section, the distilled water is caught in the middle section, and a reserve supply of cold water to be distilled is kept in the upper section. A pipe passes up through the bottom of the middle section. The water is distilled as follows. The steam formed by the boiling water in the lower section passes through the pipe of the middle section and strikes against the cold bottom of the upper section. It is here condensed to water and falls into the middle section. This is the distilled water which accumulates in the middle section.



FIG. 95 — A domestic still

EXERCISES

- 1 Which would make the better foot warmer, 5 lb of water at 212° F or 5 lb of iron at 350° F? Assume that they both cool to 80° F. How much heat does each give up?
- 2 How many B. T. U. are given up when 5 lb of each of the following cool 10° F, — air, alcohol, glass, iron, silver?
- 3 How many B. T. U. are required to heat 10 lb of each of the following 20° F — water, brass, glass, ice, mercury?
- 4 If a room is $24 \times 12 \times 10$ ft, how many pounds of air are there in it? (1 cu ft of air weighs $1\frac{1}{2}$ oz.) How many B. T. U. will this air give up if it cools from 70° F to 40° F?
- 5 In a hot-water heating system the water enters the radiator at 180° F, and leaves it at 110° F. How many B. T. U. does each pound of water give to the room?

6. In a hot-air furnace the air enters the furnace at 20° F., and leaves it at 180° F. How many B. T. U. does each pound of air receive in the furnace?

7. A hot-water bottle has 5 lb. of water in it at 180° F. at night. In the morning the temperature is 70° F. How many heat units have escaped?

8. A carriage foot warmer made of brick weighs 6 lb., its temperature is 400° F. How much heat does it give up in cooling to 60° F.?

9. Define latent heat of fusion, latent heat of vaporization.

10. How many heat units are required to melt 10 lb. of ice and warm it up to 82° F.?

11. Four lb. of ice at 32° F. when placed in 5 lb. of water at 150° F. melts and lowers the temperature to 62° F. Calculate the latent heat of ice from this experiment.

12. How many heat units are given up when 10 lb. of steam condenses in a radiator?

13. When potatoes are being boiled in water, what is the temperature of the water? Can this temperature be increased by turning on more gas? What is the extra heat doing? Is it a waste of gas to boil things vigorously?

14. When vegetables are kept in a cellar, sometimes a tub of water is placed in the cellar to prevent them from freezing. If the tub holds 200 lb. of water, how many B. T. U. will it give out in changing from water at 32° F. to ice at 32° F.?

(Note. The juices in vegetables are solutions, and solutions freeze at temperatures below 32° F.)

15. There is 50 lb. of ice in a refrigerator. If 400 B. T. U. leak through the sides of the refrigerator per hour, how long will the ice last?

16. If 50 lb. of ice lasts in a refrigerator 20 hr., how many B. T. U. leak through the sides in one hour?

17. A room is warmed by a steam radiator. If 5 lb. of steam condenses in the radiator every hour, how much heat does the room receive each hour?

18. A pound of coal gives up 15,000 B. T. U. when burned. How many pounds of boiling water could be turned to steam by the heat from 1 lb. of coal?

19. Explain the statement, "Latent Heat is Work."

20. If 30 lb. of ice melts in one day in a refrigerator, how many heat units pass through the walls of the refrigerator per hour?

21. Make a drawing showing how the ice cools the air in a refrigerator.

22. Explain the operation of an artificial ice machine. Make a drawing.

23. Make a drawing illustrating the steam heating system. Explain the operation of the system.

24. If 4 lb. of steam at 212° F. enters a radiator and leaves as water at 180° F., how many heat units has it given up?

25. If 4 lb. of steam condenses in a radiator, how many heat units does it give up?

26. Explain how the food is cooked in a steam cooker.

27. Make a drawing of the distillation apparatus, and explain how the water is purified.

28. Describe a domestic still.

29. State some other ways in which man makes use of latent heat.

CHAPTER XII

EVAPORATION, DEW POINT, BOILING POINT

Evaporation. — We are all familiar with many examples of evaporation. For instance, when a floor dries after being scrubbed, the water leaves by evaporation; when dishes are washed and dried, the thin film of water remaining on each dish leaves by evaporation; when clothes are hung on a line to dry, the water leaves by evaporation; etc. Let us now learn why liquids evaporate.

Our theory regarding the constitution of matter and our theory regarding the nature of heat give us an explanation of evaporation. These theories assume that all liquids are composed of molecules which are held together by their mutual attraction. When the liquid is warmed above -273° C., the molecules are in constant and rapid motion, and as a result there are spaces between them. If a liquid could be very much enlarged, it would look something like a swarm of gnats, the molecules (the gnats) being in very rapid motion. The average velocity of the molecules is constant at any given temperature, but the individual velocities of the molecules vary greatly and change from instant to instant. This variation is due to the frequent impact between molecules.

The explanation of evaporation is as follows: Molecules which are near the surface of the liquid and which have a high velocity escape from it. Some are drawn back into the liquid by the attraction of the surface molecules, but some escape into the air above, and gradually all escape in this way.

The explanation of evaporation, then, is that *molecules*

which are near the surface and which have a great velocity escape from the liquid into the space above.

Cooling by evaporation. — We are all familiar with the cooling effect produced by evaporation. For example: the evaporation of water sprinkled on the floor cools the air in the room; the evaporation of water from the ground after a rain cools the air outdoors; the evaporation of perspiration cools our bodies.

The explanation of this cooling effect is as follows: When a liquid turns to a vapor in any way, it absorbs its latent heat from objects near it and cools them. This heat passes into the water and turns into work; it turns into the work necessary to separate the molecules against the force of cohesion.

Air saturated with water vapor. — If a jar filled half full of water is left open, all the water evaporates in time. If, however, the jar is closed, the water does not evaporate. In the open jar, water molecules escape from the surface of the liquid and pass into the air above. When in the air they move about freely, just as air molecules do; they collide with each other, and with air molecules. In this irregular motion some of the water molecules strike back into the liquid again, but some pass out of the jar and are lost. Gradually all of the water molecules pass out of the jar in this way, that is, the liquid evaporates.

In the closed jar, water molecules leave the liquid and pass into the air, but none escape from the jar. The water molecules in the air move about as above, and some strike back into the liquid. In time the air is so filled with vibrating water molecules that *the number that go back into the liquid in one second is just equal to the number which leave the liquid in one second.* When the air is in this condition it is said to be *saturated* with water vapor.

The number of water molecules required to saturate a given volume of air increases with the temperature, or, in other words, a given volume of warm saturated air contains more water vapor than the same volume of cold saturated air. If warm

saturated air is cooled, a certain amount of the water vapor condenses to liquid water, and the air remains saturated at the lower temperature.

Clothes drying on a line. — Let us now examine carefully one instance of evaporation. When we understand this, we shall have a deeper insight into all cases of evaporation. Let us consider the case of clothes drying on a line.

Let us answer the question, “Why do clothes dry more rapidly on a windy day than on a day when the air is still?” When the wet clothes are hung out on a line on a still day the water molecules pass *from the clothes to the air* near the clothes. This air soon becomes nearly saturated, and many of the water molecules *pass back from the air to the clothes again*. Some, of course, penetrate into the outer air, and are lost, and gradually all do so. In this way the clothes dry *slowly*. When the wet clothes are hung out to dry on a windy day, however, the water molecules escape into the air, as above, but since the air is in motion the water molecules are carried away with the air, and few of them strike back into the clothes. In this way the clothes are dried *rapidly*. This explains why clothes dry more rapidly on a windy day than on a still day.

Let us now answer the question, “Why do clothes dry more rapidly when the air is dry than when it is moist?” When the air is dry, water molecules pass *from the clothes to the dry air*, and a few pass back *from the air to the clothes*. When the air is moist, however, just as many water molecules pass *from the clothes to the air*, but a greater number pass *from the air to the clothes*, and therefore the clothes dry more slowly. If the air is saturated with water vapor, as it is when there is a heavy fog, or at times just before a rain, the clothes do not dry at all. In this case, at a given temperature, just as many water molecules leave the clothes per second as when the air is dry, but the number of molecules which pass from the air to the clothes is equal to the number passing from the clothes to the air. The result is the clothes do not dry.

What has been said of evaporation in connection with the drying of clothes is true of evaporation in general.

Evaporation in nature. — The process of evaporation is of great importance in nature. All the moisture which falls upon the earth in the form of rain, snow, hail, or dew is water which passed into the air by evaporation. The heat of the sun causes water to evaporate from the surface of the ground and from the surface of oceans, lakes, and rivers. This water vapor enters the air and moves with it over the earth. When the air is cooled it becomes saturated, and on further cooling the moisture separates in the form of liquid drops in cloud, fog, rain, hail, snow, or dew.

Cloud, rain, hail, and snow. — If the air at some distance above the earth's surface is cooled somewhat below the temperature of saturation, the water forms minute drops about dust particles in the air. These minute drops constitute clouds. If the air is cooled somewhat more, the drops increase in size and fall as *rain*. If the rain in falling to the earth passes through a layer of air at a temperature below freezing, the rain freezes and becomes *hail*. If the water vapor condenses from the air at a temperature below freezing, it forms snow crystals and falls as *snow*.

Dew and fog. — When the sun goes down at night, the earth cools by radiation. Heat radiates more rapidly from earth, grass, leaves, etc., than it does from air, and as a result these may be quite cool while the air is still warm. When warm, moist air comes in contact with the cold grass, leaves, etc., it is cooled, and if the temperature to which it is cooled is below the temperature at which the air is saturated, moisture is deposited on the grass, leaves, etc. This moisture is *dew*. If the air itself cools below the temperature of saturation, the water condenses as minute drops on dust particles in the air. These minute drops constitute *fog*. A fog is simply a cloud formed at the surface of the earth, instead of above it. Fogs at sea are formed when a warm moisture-laden current of air

is cooled, either by meeting a cold current of air, or by radiation.

Dew point and relative humidity. — The *dew point* of air is the temperature at which the air is saturated and dew deposits. The dew point varies of course with the amount of moisture in the air. If the air is nearly saturated, the dew point is near the temperature of the air. If the air is very dry, the dew point is a temperature much below that of the air. The *relative humidity* of the air at any time is the ratio of the quantity of moisture it contains per unit volume, to the quantity it could contain per unit volume at that temperature. For example, air at any temperature has a relative humidity of 50 per cent when it contains one half as much moisture as it could contain at this temperature.

Boiling point. — If we place a thermometer in a liquid and then heat the liquid, we find that the liquid boils at a certain temperature. If we place two burners under the liquid to increase the amount of heat supplied, we find that the liquid still boils at the same temperature. This temperature is the boiling point of the liquid. The normal boiling point of any liquid is the highest temperature to which it can be heated when under a pressure of one atmosphere.

This is one definition of the boiling point of a liquid. It can be defined in other ways. If we watch a liquid boiling in a glass vessel, we notice that bubbles form at the bottom and rise to the top, increasing in size as they rise. Since the bubbles rise to the top, it is evident that the pressure of the vapor passing from the liquid into the bubble is equal to the pressure above the liquid. The normal boiling point of a liquid then may be defined as the temperature at which the pressure of the vapor passing from the liquid is equal to one atmosphere.

Boiling point varies with the pressure. — It can be shown that a liquid boils at a higher temperature when the pressure upon it is increased, as follows: Arrange a flask as shown in Fig. 96. The flask contains water and is fitted with a rubber

stopper with two holes. In one is placed a thermometer, and in the other a bent tube C which is tapered slightly at the lower end and cut off in a slanting direction. By pouring successive quantities of mercury into the cylinder D the pressure is increased. It will be found that the water boils at higher temperatures as the pressure upon it is increased.

It can be shown that a liquid boils at a lower temperature when the pressure on it is decreased, as follows: Arrange a flask as shown in Fig 97. Boil water in the flask, then remove it from the fire and attach the bent tube to an air pump. Start pumping the air and steam out of the flask and observe the thermometer. It will be found that the water boils at a low temperature when the pressure on it is decreased.

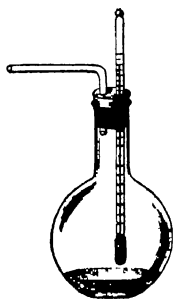

FIG. 97 - To boil water under decreased pressure

This can be shown also by means of the apparatus illustrated in Fig 98. Proceed as follows. Boil water in a round-bottomed flask, then remove it from the fire, and close it air-tight. The water will cease to boil when removed from the fire. If now the flask is inverted and cold water is poured on the bottom, the water will begin to boil vigorously, although it is being cooled. The cold water condenses the water vapor in the flask, and thereby decreases the pressure on the water. The water is at a temperature below its normal boiling point, but it boils because its boiling point under reduced pressure is lower than the normal boiling point.

Why change of pressure affects the boiling point of a liquid. — When a liquid boils, the molecules which escape from it are those which have sufficient velocity to overcome the attrac-

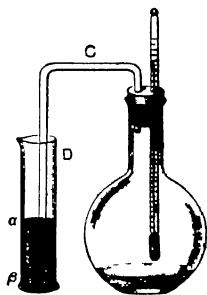

FIG. 96 - To find the boiling point of water under increased pressure. The mercury column α, β gives the increased pressure

a temperature never above the boiling point, namely, 212° F. Also, when food is cooked in a double boiler, Fig. 99, the temperature at which it is cooked is never above the boiling point of the water in the outer vessel, 212° F. Pure water boils at 212° F., no matter how fiercely the fire is burning; therefore in boiling food it is economy to use a fire which keeps the water just boiling. Any greater amount of fire is wasted in boiling away the water.

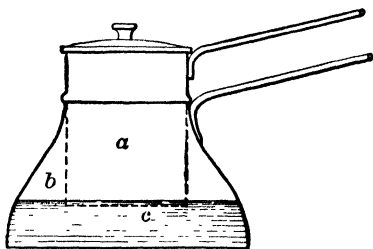

FIG. 99 — The double boiler. The food in *a* is cooked by heat received from the water *c* and the steam *b*.

When water has any substance dissolved in it, it boils at a temperature somewhat above 212° F. When vegetables, fruits, meats, etc., are boiled in water, some of their constituents dissolve in the water, and therefore the boiling point is slightly above 212° F.

EXERCISES

1. Explain why liquids evaporate.
2. Explain why evaporating water cools surrounding objects.
3. When is air said to be saturated with water vapor?
4. Explain why clothes dry more rapidly on a windy day than on a still day.
5. Explain why clothes dry more rapidly on a dry day than on a moist day.
6. Explain how clouds, rain, hail, and snow are formed.
7. Define dew point and relative humidity.
8. What is the boiling point of a liquid?
9. Explain why a change in the pressure upon water changes its boiling point.
10. What are the differences between evaporation and boiling?
11. What is the advantage of a double boiler?

CHAPTER XIII

SOURCES OF HEAT. HEAT AND WORK

Fuels. — The common sources of artificial heat are wood, coal, oil, gas, alcohol, coke, charcoal, and the electric current. The amount of heat obtained from some of these sources is approximately¹ as follows :

<i>Heat per Pound of Fuel</i>	B. T. U.
Anthracite coal (high grade)	14,500
Bituminous coal (high grade)	15,000
Wood (air dried)	7,500
Petroleum	20,000
Gasoline	21,000
Alcohol	12,000

Heat from Gas per Cubic Foot and per Pound

GAS	B. T. U. PER CUBIC FOOT	B. T. U. PER POUND
Natural gas	1,000	22,000
Coal gas	600	18,000
Water gas	320	7,000
Producer gas	140	2,100

Heat from electricity. — One kilowatt hour = 3412 B. T. U. This is about equal to the heat produced when $\frac{1}{4}$ lb. of coal is burned.

¹ The figures given in these tables are necessarily approximations because fuels vary in composition.

Weights of fuels. —

Coal	2000 lb. per ton
Hardwood	4000 lb. per cord
Pine	2000 lb. per cord
Petroleum	{ 6.5 lb. per U. S. gallon 8 lb. per Imperial gallon
Gasoline	{ 5.5 lb. per U. S. gallon 6.5 lb. per Imperial gallon
Alcohol 90 per cent	{ 6.8 lb. per U. S. gallon 8.3 lb. per Imperial gallon
Natural gas	45.5 lb. per 1000 cu. ft.
Coal gas	32 lb. per 1000 cu. ft.
Water gas	45.5 lb. per 1000 cu. ft.
Producer gas	65.5 lb. per 1000 cu. ft.

Comparison of fuels. — When we know the prices of the different fuels, we can use the tables above to compare the amounts of heat purchased for \$1. For example:

Bituminous coal at \$4 per ton gives $500 \times 15,000 = 7,500,000$ B. T. U. for \$1.

Hard wood at \$8 per cord gives $500 \times 7500 = 3,750,000$ B. T. U. for \$1.

Petroleum at 20 ct. per U. S. gallon gives $6\frac{1}{2} \times 5 \times 20,000 = 650,000$ B. T. U. for \$1.

Gasoline at 20 ct. per U. S. gallon gives $5\frac{1}{2} \times 5 \times 21,000 = 577,500$ B. T. U. for \$1.

Natural gas at \$1 per 1000 cu. ft. gives 1,000,000 B. T. U. for \$1.

Electricity at 5 ct. per kilowatt hour gives $3412 \times 20 = 68,240$ B. T. U. for \$1.

At the prices quoted above it will be noticed that for \$1 coal gives $7\frac{1}{2}$ times as much heat as natural gas, and about 110 times as much heat as electricity.

Gas and electricity have certain advantages, such as convenience, cleanliness, etc., which offset to some extent the

greater cost of the heat supplied by them, but coal is much the cheapest source of heat.

HEAT AND WORK

Heat engines. — The human race has made great progress in the last hundred years, and this progress has been made possible largely by the steam engine. In steam engines, part of the heat produced by burning fuel is turned into work. These engines do work which was formerly done by human beings or by animals, or not done at all. In this way the human race has been freed from heavy drudgery, and the energy thus saved is devoted to higher forms of work.

Steam engines are called heat engines because in them heat is turned into work. Another form of heat engine is the gas or gasoline engine. Let us now study these two types of heat engine, and learn how they turn heat into work.

The steam engine. — Steam is generated in the boiler *B*, Fig. 100, by the heat of the fire under the boiler. It passes

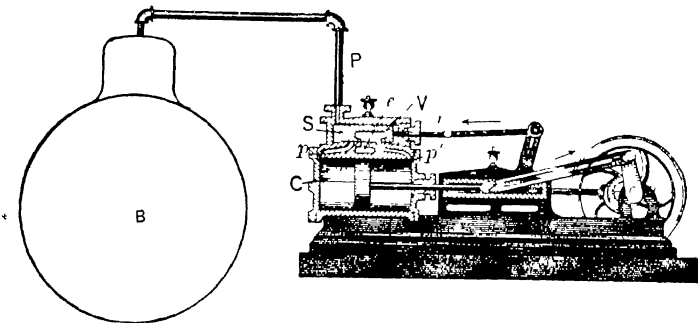

FIG. 100 — The boiler and steam engine

from the boiler through the steam pipe *P*, and into the steam chest *S*, of the engine. From here it passes first into one end of the cylinder and then into the other. It is in the cylinder *C* that heat is turned into work. The live steam from the boiler

forces the piston first in one direction and then in the other, and in doing so forces the shaft, pulley, and flywheel to revolve. The machinery to be operated is driven by a belt on the pulley or flywheel. Thus the steam does work in turning machinery.

When live steam from the boiler forces the piston in one direction or the other, it does work, and part of its heat is turned into this work. This explains how the steam engine turns heat into work.

Let us now study the steam chest more closely and learn how steam is admitted to the cylinder, first at one end and then at the other, and how the exhaust steam is allowed to escape. This is controlled by a slide valve *V*. This valve moves in the steam chest and is so connected to the shaft that it is always be-

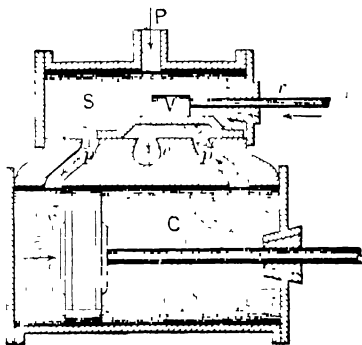

FIG. 101. — The cylinder and steam chest of a steam engine

tween one fourth and one half stroke ahead of the piston. When the slide valve *V* is in the position shown in Fig. 101, live steam enters the cylinder by the port *p* on the left. The exhaust steam escapes by the port *p'* on the right and leaves the engine through the exhaust pipe *e*. When the piston moves to the right, the slide valve moves to the left, the live steam is then admitted to the cylinder by the right port and the exhaust steam escapes by the left port. The exhaust steam is cooler than the live steam because part of the heat of the live steam has been turned into the work done in driving the machinery.

The gas engine and gasoline engine. — Gas engines and gasoline engines are the same in principle. In each, energy is derived from the explosion of a mixture of gas and air. We shall

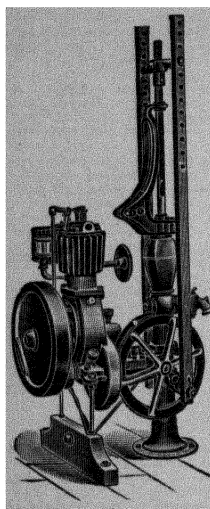

FIG. 102 — Gasoline engine at work

study the gasoline engines because they are the more common. They are used to drive motor cars, motor boats, aeroplanes, small pumping plants, etc. A vertical air-cooled gasoline engine is shown in Fig. 102. It is connected with a pump jack and pump.

The common type of a gasoline engine is the four-cycle engine. It is called this because it makes four strokes (two revolutions) for each power stroke. These four strokes are represented in Fig. 103. They are called the charging stroke, the compression stroke, the power stroke, and the exhaust stroke. Since there is only one power stroke in four strokes, a gasoline engine must be equipped with one or two heavy flywheels. It is the momentum of

these wheels which drives the engine between power strokes.

The charging stroke is represented in (1). The flywheel is pulling the piston down. This leaves a vacuum in the cylinder, and the pressure of the atmosphere forces open the intake valve *I* and forces air and gasoline vapor into the cylinder from the carburetor (not shown). This stroke charges the cylinder with a mixture of gasoline vapor and air.

On the next stroke (2) the flywheel forces the piston up again. The intake valve closes, and the mix-

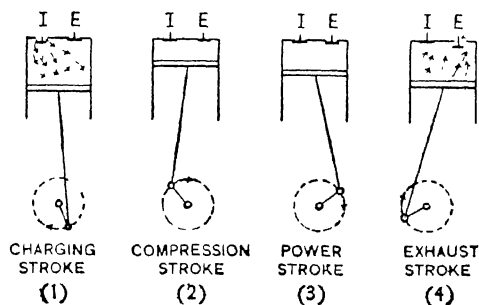

FIG. 103 — The four strokes of a four-cycle gasoline engine.

ture is compressed to about one fifth of its volume. This is the compression stroke.

When the piston on the compression stroke is at or near its highest point, an electric spark is produced in the compressed mixture (by a device not shown). This ignites the mixture, and the force of the explosion drives the piston down. This is the power stroke (3).

On the next stroke the flywheel forces the piston up and the burned gases are forced out through the exhaust valve *E*, which is opened automatically during the stroke. This is the exhaust stroke (4).

On the next stroke the cylinder is charged again, and these operations are repeated as long as the engine runs.

Heat turned to work. — When the mixture of gasoline vapor and air is burned in the cylinder, a large amount of heat is produced, and the mixture is raised to a very high temperature. As the mixture drives the piston down, it does work and part of its heat is turned into this work. The mixture is cooler at the end of the power stroke than at the beginning because part of its heat has been turned into work.

Horse power. — The power of an engine is the amount of work it can do in a given time. The common unit of power is the *horse power*. An engine is working at the rate of 1 h. p. when it does 33,000 foot pounds of work per minute.

The horse power of an engine is calculated by means of the formula :

$$\text{Horse power} = \frac{P \times L \times A \times N}{33000}$$

where *P* is the mean effective pressure in pounds per square inch in the cylinder, *L* is the length of the stroke in feet, *A* is the area of the piston in square inches, and *N* is the number of power strokes per minute.

Example. A steam engine has a mean effective pressure of 30 lb. per square inch. The length of stroke is 1 ft. The area of the piston is 55 sq. in. and the engine makes 240

power strokes per minute. What is the horse power of the engine?

$$\frac{30 \times 1 \times 55 \times 240}{33000} = 12 \text{ h. p.}$$

Heat and work. — By the work of Dr. Joule of Manchester, between 1843 and 1849, and of Professor Rowland of Baltimore in 1879 it has been learned that the relationship between heat and work is as follows: When 1 B. T. U. of heat is turned into work, it produces 778 foot pounds of work. That is, the small amount of heat required to warm 1 lb. of water 1° F. produces 778 foot pounds of work. When 1 calorie of heat is turned into work, it produces 42,700 gram centimeters of work. The work done when one heat unit is turned into work is known as the *Mechanical Equivalent of Heat*.

Cost of work. — The best steam engines use about 1 lb. of coal per horse power per hour. With coal at \$4 a ton, the cost of 1 h. p. hour of work is .2 ct. The ordinary steam engine uses about 5 lb. of coal per horse power per hour. The cost of 1 h. p. hour of work then is about 1 ct.

A gasoline engine uses about $\frac{1}{10}$ gal. of gasoline per horse power per hour. With gasoline at 20 ct. a gallon, 1 h. p. hour of work costs 2 ct.

A team of horses with driver costs \$4 per day. If each horse is working at the rate of 1 h. p., the team in 10 hr. does 20 h. p. hours of work, and the cost of 1 h. p. hour is 20 ct.

A man, working hard, works at the rate of about $\frac{1}{10}$ h. p. and in a day of 10 hr. he does $\frac{1}{10} \times 10 = 1$ h. p. hour of work. If his wage is \$1.50 per day, the cost of 1 h. p. hour of work done by a man is \$1.50.

Cost of 1 h. p. Hour of Work

By best steam engine2 ct.
By ordinary steam engine	1 ct.
By gasoline engine	2 ct.
By horse	20 ct.
By man	150 ct.

Heat engines are of great service to the human race, not only because they free the race from heavy drudgery, but also because, as we see from the above table, they do work at a much smaller cost than it can be done by human beings.

EXERCISES

1. If 2 scuttles of coal per day are used in the kitchen range, and the coal in each scuttle weighs $12\frac{1}{2}$ lb., how long will a ton of coal (2000 lb.) last?

2. If the coal (1) costs \$6 a ton, what is the cost of fuel per day?

3. If hard wood costs \$6 a cord, how much more expensive is it as a source of heat than bituminous coal at \$6 a ton?

4. If anthracite coal costs \$5 a ton, how many B. T. U. of heat are purchased for \$1?

5. If natural gas costs 80 ct. per 1000 cu. ft., how many B. T. U. of heat are purchased for \$1?

6. If electricity costs 10 ct. per kilowatt hour, how many B. T. U. of heat are purchased for \$1?

7. If coal gas costs \$1 per 1000 cu. ft., how many B. T. U. of heat are purchased for \$1?

8. If gasoline costs 20 ct. a gallon, how many B. T. U. of heat are purchased for \$1?

9. If the boiler of a hot-water heating system absorbs only 60 per cent of the heat produced by the coal burned under it, how much money is wasted if 20 T. of coal at \$5 a ton are burned during the winter?

10. If bituminous coal costs \$5 a ton and electricity 5 ct. per kilowatt hour, calculate the number of B. T. U. of heat purchased for \$1 in each case.

11. Make a diagram of a boiler and engine.

12. Describe the path of the steam in the boiler and steam engine. Use the diagram made in (11).

13. Explain the part played by the slide valve.

14. Make a diagram illustrating the four strokes of a four-cycle gasoline engine. Describe each stroke.

15. Where is heat turned into work in the steam engine?

16. Where is heat turned into work in the gasoline engine?

17. A steam engine is working at a mean effective pressure of 36 lb. per square inch; the length of stroke is 1 ft.; the area of the piston is 44 sq. in. and the engine makes 250 strokes per minute. At what horse power is the engine working?

18. The water for a country house is pumped by a 1 h. p. gasoline engine working 1 hr. per day. What is the cost of the pumping per day if gasoline costs 25 ct. a gallon?

19. How long would it take a man to do the same amount of work as in (18) if he works at the rate of .1 h. p.? What would be the cost of the pumping per day if his wages are \$1.50 per day?

CHAPTER XIV

ELECTRICITY IN THE HOME

Household electrical appliances. — In this section we shall study household electrical appliances. There are many such appliances; for example, the electric bell, electric iron, electric oven, electric stove, electric light, electric motor, motor-driven sewing machine, motor-driven vacuum cleaner, motor-driven washing machine, and the telephone.

In the case of each appliance we shall try to learn “how the current works,” that is, how it rings the bell; how it heats the iron, oven, and stove; how it turns the motor and how it operates the telephone. In other words, we shall try to learn what is going on inside of each device. In order to do this we shall take up the study of electricity in a systematic manner, and when we come to those portions of the subject which have a bearing on one or more of the electrical appliances used in the home, we shall make a study of these appliances.

What is electricity?—A natural question to ask at the beginning of the study of electricity is “What is electricity?” and the very simple answer is “We do not know.” There have been many theories advanced regarding the nature of electricity, but the fact remains that up to the present time we do not know what electricity is. We do know, however, a great many facts about electricity; how it can be produced; how it acts under different circumstances; and the laws which describe its action. It is by means of this knowledge that electricity has been made a servant of mankind.

How electricity is produced. — The three most important methods of producing electricity are (1) by friction, (2) by chemical action in an electric cell, (3) by means of a dynamo.

Electricity produced by friction. — Electricity may be produced by rubbing together any two different substances. Probably you have all produced electricity in this way at one time or another. For example, when the air is very dry, as it often is in winter, you have noticed your hair trying to follow your comb, also you have noticed the crackling sound produced when you stroked a cat's fur, when you separated a blanket from a sheet, or when you touched anything after having scraped your shoes on the carpet. All of these effects are produced by electricity. When any two different substances are rubbed together, one becomes charged with what is known as *positive* electricity, and the other with *negative* electricity. These two kinds of electricity attract each other. If the objects charged with them are brought near together, the electricities unite across the intervening air space, and give rise to small electric sparks which cause the crackling sound.

The quantity of electricity produced by friction at any one time is very small. It is not large enough to be of any practical use in the home, and for this reason we shall not study frictional electricity further.

The electric current used in the home or elsewhere is produced either in an electric cell, or by means of a dynamo. We shall first study the electric cell and later on the dynamo.

ELECTRIC CELLS

It is found by experiment that an electric current is produced whenever two different metals are placed in water or in a solution of an acid, a base, or a salt, and then joined by a wire.

Such an arrangement is known as a simple electric cell. The electric cells in actual use are modifications of this simple cell. You have probably heard electric cells called electric batteries.

The name "battery" properly belongs to a combination of two or more cells, but it is now very commonly applied to a single cell.

Electric cells are used in a number of ways about the home; for example, to ring electric bells and to operate the telephone. The electric cell is then the first household electrical appliance for us to study. Let us see what takes place inside an electric cell.

The simple cell. — If a plate of copper and a plate of zinc are placed in a dilute solution of sulphuric acid, it is found that the copper plate becomes charged with positive electricity, and the zinc plate with negative electricity, as illustrated in Fig. 104. When the two plates are joined by a wire, the two kinds of electricity flow along the wire and unite. As soon as the electricities begin to leave the plates, more is formed by the chemical action in the cell, and thus there is a continuous flow of electricity through the wire. It is assumed that the current is flowing in the direction the positive electricity moves, that is, from the copper to the zinc through the wire and from the zinc to the copper through the liquid.

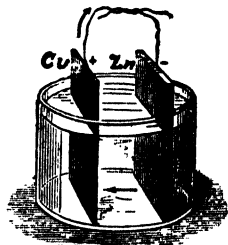
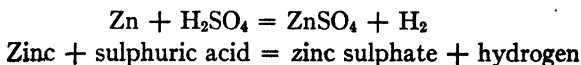

FIG. 104. — A simple cell.

There have been many experiments made on electric cells, and as a result the following facts about them have been learned.

In every electric cell, (1) there must be two different metals; (2) the liquid must dissolve one more readily than the other; (3) the more soluble metal is always charged with negative electricity and the other with positive electricity.

Chemical action in a simple cell. — The chemical action in the simple cell is as follows. The zinc dissolves in the sulphuric acid and forms zinc sulphate and hydrogen. The chemical equation is



The current given by the cell stops when all the zinc is dissolved, or when all the sulphuric acid is turned to zinc sulphate.

We should naturally expect that the hydrogen gas formed by the action of the sulphuric acid on the zinc plate would appear at the zinc plate, but this is not the case. When the current is running, the hydrogen travels with (or carries) the current through the liquid and is deposited on the copper plate. The copper plate is not dissolved by the liquid.

Polarization. — If the current is allowed to run for some time in a simple cell, it is found that the current gradually decreases in strength, and at the same time it is noticed that a great deal of hydrogen gas collects on the copper plate. A gas is a very poor conductor of electricity, and, therefore, the layer of hydrogen on the copper plate gradually stops the current. When the current in a cell stops from this cause, the cell is said to be *polarized*.

Polarization is a serious defect in an electric cell, and many methods of overcoming it have been invented. We may now study a few of the more important cells, and learn how polarization has been prevented or decreased in each.

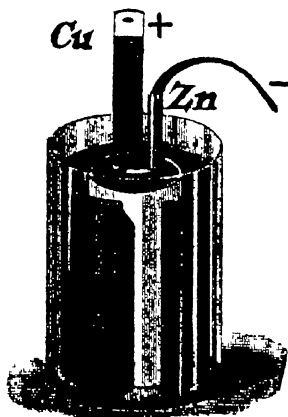
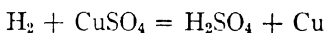

FIG. 105. — The Daniell cell.

The Daniell cell — In the Daniell cell (Fig. 105) polarization is prevented almost entirely. The metals are zinc and copper. There are two liquids, a dilute solution of sulphuric acid or of zinc sulphate, and a strong solution of copper sulphate (blue vitriol). The zinc plate is placed in a porous earthenware cup which holds the dilute solution of sulphuric acid or of zinc sulphate. The copper plate surrounds the porous cup and is immersed in the strong solution of copper sulphate.

The chemical action occurs in two

parts, as follows. The zinc dissolves in the sulphuric acid, and forms zinc sulphate and hydrogen, as in the simple cell. The hydrogen moves towards the copper plate and when it passes through the porous cup, comes in contact with the copper sulphate. It acts on the copper sulphate and forms sulphuric acid and copper.



Hydrogen + copper sulphate = sulphuric acid + copper

Thus copper is deposited on the copper plate instead of hydrogen, and since copper is an excellent conductor of electricity, there is practically no polarization

The gravity cell — The gravity cell (Fig. 106) is a modification of the Daniell cell. The copper plate is placed on the bottom of the cell and is covered with crystals of copper sulphate and with a strong solution of copper sulphate. This solution fills the lower half of the cell

The zinc plate is suspended from the side of the cell near the top and is shaped like a crow's foot, hence the cell is sometimes called a "crowfoot" cell. The zinc is immersed in a dilute solution of sulphuric acid or of zinc sulphate. The chemical action is the same as that in the Daniell cell.

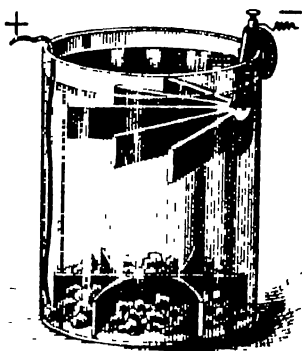

FIG. 106 — The gravity cell

The copper sulphate solution is heavier than the other solution and thus the liquids are kept apart by the force of gravity — hence the name "gravity cell."

The Daniell cell and the gravity cell are important cells because they can be used on "closed circuits," that is, on circuits which use a steady current for a long time.

The Leclanché cell. — The Leclanché cell (Fig. 107), is in very common use in houses, especially for operating doorbells, etc.

The "metals" are zinc and carbon and the liquid a strong solution of ammonium chloride ("sal ammoniac"). Polarization

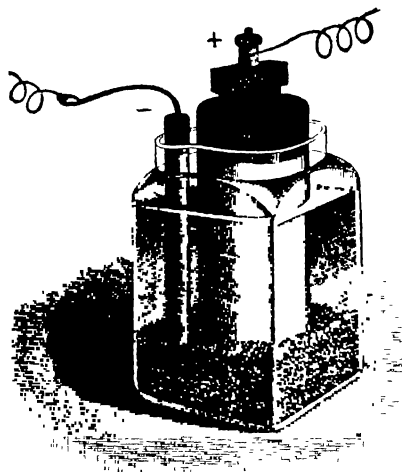

FIG. 107 — The Leclanché cell

is decreased as follows. The carbon plate is placed in a porous cup and is surrounded by manganese dioxide and particles of carbon. The manganese dioxide decreases polarization by oxidizing the hydrogen to form water. The particles of carbon are distributed through the manganese dioxide and may be considered as part of the carbon plate.

The Leclanché cell gives a strong current for a short time, but since the manganese dioxide is not rapid in its action, the hydrogen accumulates and decreases the current. If the cell is left on open circuit for a short time, the manganese dioxide oxidizes the hydrogen and the cell is again ready for use.

The cell is used only on open-circuit work, that is, on work where the current is needed only for a short time and the cell has time to recover before it is needed again, for example, on electric bells and the telephone.

The dry cell — The most convenient cell for use in the home is the dry cell (Fig. 108). It is portable; the liquids cannot spill or evaporate; it gives a large current and has a useful life of one or two years.

There are many forms of the dry cell on the market, but they are all modifications of

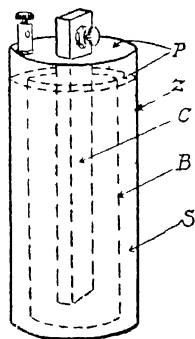

FIG. 108 — The dry cell.

the Leclanché cell. The metals are zinc and carbon and the chief constituent of the liquid is ammonium chloride. The arrangement is as follows. The zinc plate is the whole outer cylinder *Z* which holds the cell; next to this is a strong solution of "sal ammoniac" *S* mixed with plaster of Paris to make a stiff paste. Inside of this is a cylinder of blotting paper *B* which takes the place of the porous cup used in the Leclanché cell. The blotting paper cylinder holds the carbon plate *C* and the manganese dioxide and carbon particles which surround the carbon. The whole cell is moistened and the top is sealed with pitch *P*. The cell is a moist cell rather than a dry cell.

Electromotive force, resistance, and current. — The force which moves electricity through a cell and the outer circuit is known as electromotive force. It is measured in *volts*. The electromotive force of a cell depends on the nature of the metals and on the nature of the liquid.

When electricity passes through any substance, solid or liquid, it encounters a certain amount of resistance, which is measured in *ohms*. The resistance of a cell depends on the nature of the plates and of the liquid, also on the size of the plates and the distance between them.

The current produced by a cell is measured in *amperes*. It is found by dividing the electromotive force in volts by the total resistance in ohms.

The terms volt, ohm, and ampere are explained further in the chapter on electrical terms (Chapter XIX).

We give below the approximate volts, ohms, and amperes of the cells mentioned above.

ELECTRIC CELLS	DANIELL	GRAVITY	LECLANCHÉ	DRY
Electromotive force in volts . .	1	1	1.5	1.5
Approximate resistance in ohms	1	$\frac{1}{2}$	$\frac{1}{2}$	$\frac{1}{10}$
Current in amperes on short circuit	1	2	3	15

Conductors and insulators.—Substances through which electricity passes readily are called *conductors* of electricity. Substances through which electricity does not pass readily are called *nonconductors* or *insulators*.

Metals, carbon, and solutions of acids, bases, and salts are conductors. The nonmetals are insulators. There is no hard and fast line between conductors and insulators. All conductors offer some resistance to the electric current, and all insulators conduct electricity to some extent. The metals are the best conductors, and of the common metals silver is the best. They stand in the following order: silver, copper, gold, aluminium, zinc, iron, platinum, nickel, tin, lead, mercury. The common insulators are sulphur, glass, porcelain, hard rubber, mica, shellac, wood, silk, oils, cotton, and air.

All electrical appliances make use of both conductors and insulators. For example, in the electric cells which we have been studying, the metal plates and solutions are conductors. The glass jars holding the solutions are insulators. The wire with which we joined the plates of the cells is made of the conductor, copper; the covering of the wire is the insulator, cotton or silk. Telephone wires are made of the conductor, copper; telegraph wires of the conductor, iron. They are attached to the poles by means of insulators made of glass or porcelain.

As we proceed with the study of electricity we shall find that in every case both conductors and insulators are used in the construction of electrical appliances.

EXERCISES

1. Describe the simple electric cell.
2. Describe the Daniell cell. Make a drawing.
3. Describe the gravity cell. Make a drawing.
4. Describe the Leclanché cell. Make a drawing.
5. Describe the dry cell. Make a drawing.
6. Name four conductors and four insulators.

CHAPTER XV

MAGNETISM AND THE ELECTROMAGNET

BEFORE we proceed with our study of electrical appliances, it will be necessary to learn something about magnets, because magnets are used in many of these appliances.

Natural and artificial magnets — In many parts of the earth an iron ore is found which has the property of attracting particles of iron or steel. A piece of this ore is known as a *natural magnet* or lodestone. If a piece of steel is stroked with a natural magnet, it acquires the property of attracting iron or steel, and is known as an *artificial magnet*. Other ways of making artificial magnets are described below.

Magnetic substances — Iron and steel are the only substances which have strong magnetic properties. Cobalt, nickel, and certain alloys are slightly magnetic, other substances are practically nonmagnetic.

Magnet poles — If we dip a magnet into iron filings, we find that the filings cling to the ends, but scarcely at all to the middle of the magnet (Fig. 109). The places near the end where the magnetic effect is strong are called the *poles* of the magnet.

If a magnet is suspended in a stirrup as in Fig. 110, it comes to rest in a north and

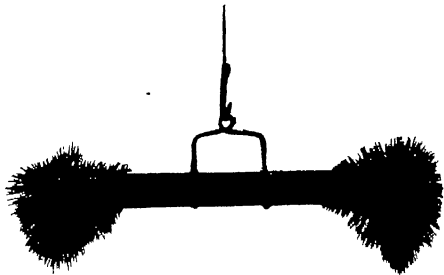

FIG. 109 — The magnetic effect of a magnet is stronger at the ends than at the middle.

south position. The end which points to the north is called the north-seeking pole or simply the *north pole* of the magnet. The other end is called the *south pole*.

If we suspend a magnet in a stirrup and then bring the north pole of another magnet near the north pole of the suspended magnet, we find that they repel each other.

If, however, we bring a south pole to the north pole of the suspended magnet, we find that they attract each other. Similarly it is found that two south poles repel each other. From experiments of this kind we have the rule. *Like magnet poles repel each other and unlike magnet poles attract each other.*

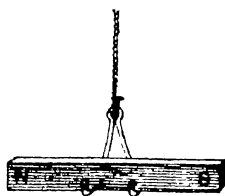

FIG. 110 — A suspended magnet points north and south

Magnetic induction. — *If an iron object is brought near or into contact with a magnet, it becomes a magnet (Fig. 111).* This action of a magnet on iron or steel is known as *magnetic induction*.

If the object is made of soft iron,¹ it is readily magnetized, but loses all of its magnetism as soon as the magnet is removed. If it is made of steel, it is not readily magnetized, but retains some of its magnetism when the magnet is removed. A substance which becomes strongly magnetic when near a magnet is said to possess *permeability*, a substance which resists magnetization or demagnetization is said to possess *retentivity*. Soft iron is more permeable than steel, but has less retentivity.

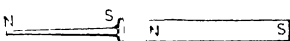

FIG. 111 — The nail is magnetized by induction

Magnetic lines of force — It is important that we learn the meaning of the term *magnetic line of force* because we use it to explain the working of many electrical appliances.

A magnetic line of force is defined as the line along which a free north pole would move in going from the north pole to the

¹ Soft iron is iron practically free from carbon

south pole of a magnet. We cannot obtain a free north pole, that is, a north pole separate from a south pole, but we can use a small magnetic needle to mark out the magnetic lines of force of a magnet.

If a small compass is placed near the north pole of a magnet and then moved a short distance at a time in the direction its north pole points, it travels from the north to the south pole along a magnetic line of force, Fig 112

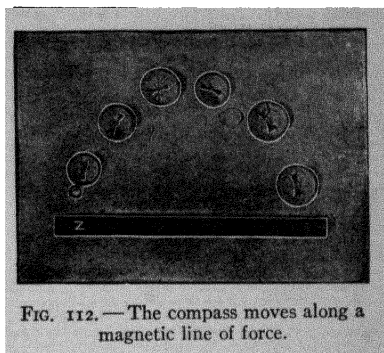

FIG. 112.—The compass moves along a magnetic line of force.

Magnetic field of a magnet. — *The region about a magnet in which its effect can be detected* is called the *magnetic field* of the magnet. The magnetic field is filled with lines of force. The arrangement of these lines can be determined as follows: Place a magnet under a pane of glass and sift iron filings over the glass. Tap the glass gently and the filings arrange themselves along the lines of force.

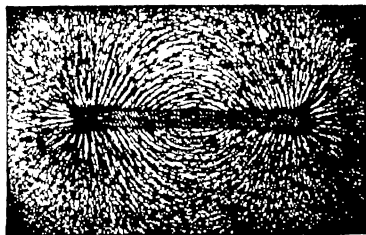

FIG. 113.—The magnetic field about a bar magnet

The lines of force about a bar magnet are shown in Fig 113 and about a horseshoe magnet in Fig. 114

Each iron filing becomes a magnet by induction when it enters the field of the magnet. It is in reality a small compass; and when

the glass is tapped, the filing is turned by the magnet until it is in the direction of the magnetic line of force at the point it occupies. It will be noticed that the direction of a magnetic line of force at any point is the direction of the force

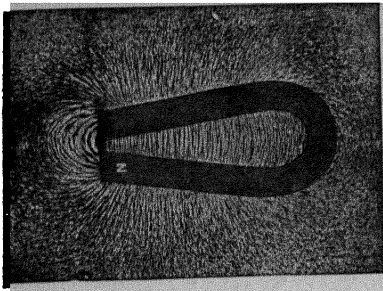

FIG. 114 — The magnetic field about a horseshoe magnet

of the magnet at this point. A magnetic line is considered to move from north to south outside of the magnet and from south to north in the magnet.

Strength of a magnet pole — A magnet pole is of unit strength when it repels an exactly similar pole at a distance of 1 cm.

with a force of 1 dyne (See Chapter XXX for definition of dyne.)

The magnetic lines of force are used to represent the strength of a magnet. If the magnet has unit strength, it is represented as sending one magnetic line of force through each square centimeter at a distance of one centimeter. If it has a strength of 100, it is represented as sending 100 lines of force through each square centimeter at a distance of 1 cm, etc.



FIG. 115 — Making a magnet

We see, then, that the magnetic lines of force are used to represent the direction and strength of the magnetic field about a magnet.

How artificial magnets are made. — A piece of steel can be made a magnet by stroking it in one direction with one pole of a strong magnet, Fig. 115. If *AB* is stroked, in the

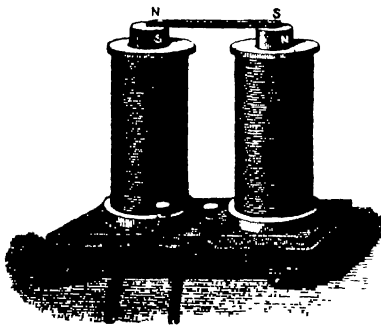

FIG. 116 — Making a magnet by means of an electromagnet

direction AB only, with a north pole, the end B becomes a south pole and A a north pole.

If a piece of steel is laid on the poles of a strong electromagnet, Fig 116, and hammered, it becomes a strong magnet. The end in contact with the north pole becomes a south pole and *vice versa*.



FIG. 117 — Making a magnet by means of an electric current

If a piece of steel is wound with insulated wire (Fig 117), and a strong electric current is passed through the wire, the steel becomes a strong magnet.

These are three ways of making a magnet

Theory of molecular magnets. — To account for certain facts about magnets it is assumed that *each molecule of iron or steel is a magnet*. This is the *theory of molecular magnets*. When the iron or steel is a magnet, the small molecular magnets are supposed to point all in the same direction Fig 120. When the iron or steel is not a magnet, the small molecular magnets are supposed to point in different directions. In the latter case, there would be an equal number of molecular north and south poles pointing in any direction, and the one would neutralize the other.

We can represent one pole neutralizing the effect of an opposite pole by the experiment shown in Fig 118. A nail is attracted by a north pole of one magnet, but if we slide a south pole of another magnet up to the north pole, the nail falls.

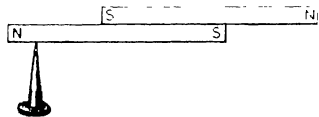

FIG. 118 — Opposite poles neutralize one another

This shows that the south pole neutralizes the effect of the north pole.

The theory of molecular magnets explains the following:

When a piece of steel is stroked with the north pole of a magnet, the end last touched is a south pole because the south poles of the molecular magnets are left pointing in this direction.

When a piece of steel is magnetized by an electromagnet,

the poles of the steel are opposite to those of the electromagnet because the north pole of the electromagnet attracts the south poles of the molecular magnets and the south pole of the electromagnet attracts the north poles of the molecular magnets

A magnet shows no magnetic effect at the middle, but if it is broken at this point, each piece is a magnet and two strong poles

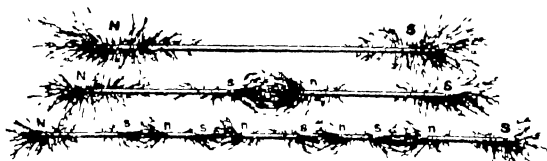

FIG. 119 — Breaking a magnet produces new magnetic poles

appear at the point which formerly had no magnetic effect (Fig. 119). When the magnet is broken, the ends of the molecular magnets exposed on one piece are all north poles and on the other all south poles, Fig. 120. Thus two new poles are formed.

A magnet can be demagnetized by heating it red hot, because the molecular magnets are set in rapid vibration and assume a heterogeneous arrangement. Thus at any point an equal

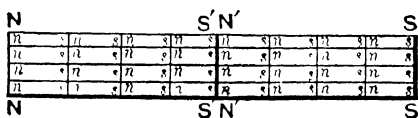

FIG. 120 — The molecular poles exposed on one side of the break are all south poles, on the other side all north poles

number of molecular north and south poles point in a given direction and they neutralize one another.

The mariner's compass. — The simplest form of mariner's compass (Fig. 121), is a magnetized needle fastened under a circular card. The upper surface of the card is divided by radii into thirty-two divisions. These are called the points of the compass.

In order that the compass may remain horizontal in spite of the rolling and pitching of the ship, it is supported on gimbals. That is, the compass turns on pivots fastened to a ring, and the ring turns on pivots at right angles to those of the compass.

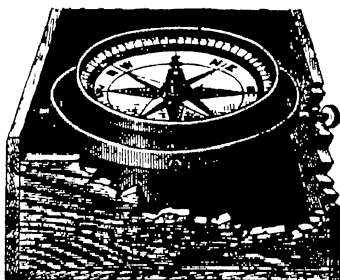

FIG. 121 — The mariner's compass

Permanent magnets and electromagnets. — The steel magnets we have been studying are called permanent magnets. An electromagnet consists of a core of soft iron magnetized by an electric current. It is a magnet only when the current is flowing. Of the two, the electromagnet is the more important.

THE ELECTROMAGNET

Oersted's discovery. — In 1819 a Dane named Oersted discovered that if an electric current is passed over or under a magnetic needle, the needle tends to set itself at right angles to the current (Fig. 122). This was an important discovery

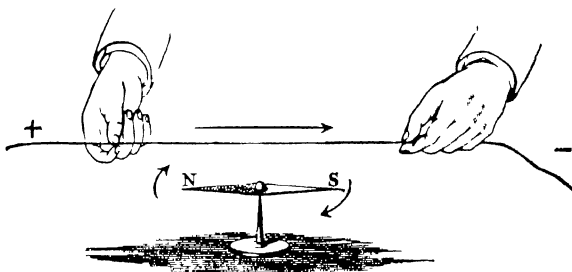

FIG. 122 — Oersted's experiment.

because it showed for the first time that there is a relation between electricity and magnetism.

If the needle is under the wire, the north pole turns in one

direction; if it is above the wire, it turns in the opposite direction. If the needle is kept in one position and the direction of the current is reversed, the direction in which the north pole turns is reversed.

Magnetic field about a current. — It is now known that a wire carrying a current is surrounded by a magnetic field, and that the needle turns because it tends to set itself parallel to this field.

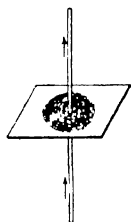

FIG. 123 — The magnetic field about a wire carrying a current

The magnetic field about a wire carrying a current can be shown by means of the experiment illustrated in Fig. 123. A wire carrying a strong current passes through a piece of cardboard, and iron filings are sprinkled on the cardboard. If the cardboard is tapped gently, the filings arrange themselves in concentric circles about the wire. These circles show the paths of the magnetic lines of force about the wire.

Direction of the lines of force. — A magnetic needle turns until its north pole points in the direction of the magnetic lines of force. A small compass can be used to find the direction of the magnetic lines of force about a wire carrying a current. It is found that the direction of the lines is reversed when the current is reversed.

The following rule will be found a convenient aid in remembering the direction of the magnetic lines of force about a wire: "Grasp the wire in the *right* hand with the extended thumb pointing in the direction of the current; the fingers then point in the direction of the magnetic lines of force."

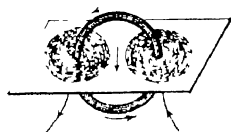

FIG. 124 — The magnetic field about a coil carrying a current

In Fig. 124 the current passes through a coil of wire in the direction shown by the arrows. By means of the rule given above we find that the magnetic field about one side of the coil is in the opposite direction of that about the other. It will be

noticed, however, that at the middle of the coil both fields move in the same direction. A magnetic needle placed at the middle is turned in the same direction by the magnetic field of both sides of the coil. In fact, the magnetic field about every part of the coil turns the needle in the same direction when it is at the middle of the coil.

The electromagnet. — If we wind a coil of insulated wire around a *soft iron* bar and pass a current through the wire,

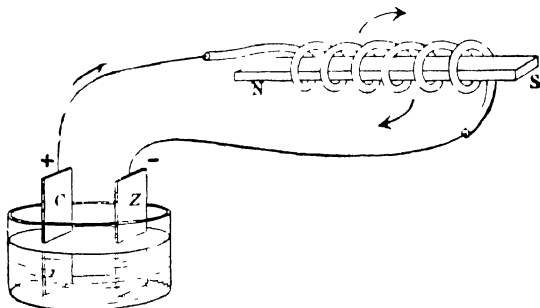

FIG. 125 — A straight electromagnet

the iron becomes a strong magnet. If we stop the current, the iron ceases to be a magnet. A soft iron bar wound with insulated wire is an *electromagnet*.

The electromagnet is the most useful form of magnet because it is under our control. It becomes a magnet when we turn on the current, and ceases to be a magnet when we stop the current. We shall find that the electromagnet is an important part of all electrical appliances which are used to produce motion.

If we pass the current through the coil in one direction, the north pole is at one end of the soft iron bar, if we reverse the current, it is at the other end. The position of the north pole depends on the direction of the current and on the way the wire is wound on the soft iron.



FIG. 126 — A horseshoe electromagnet.

We shall find the following rule an aid in determining the position of the north pole when we know the direction of the current : " Grasp the coil in the *right* hand with the fingers in the direction the current is flowing, the extended thumb then points to the north pole of the electromagnet "

A straight electromagnet is shown in Fig. 125. If we apply the above rule, we find that the north pole is as shown. A horse-shoe electromagnet is shown in Fig. 126.

APPLICATIONS OF THE ELECTROMAGNET

The electric bell — The electric bell is the most common of household electrical appliances. The diagram, Fig. 127, shows an electric bell connected with a push button and battery.

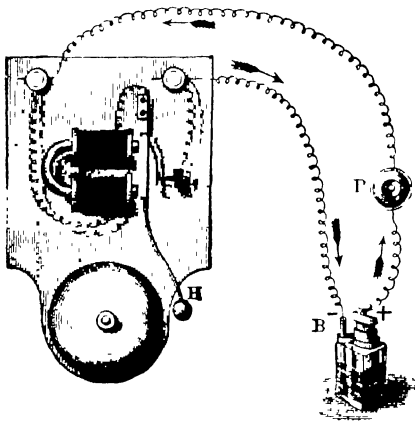

FIG. 127 — Electric bell, push button, and battery

Let us see how the electric current rings the bell. We shall find that it does so by means of an electromagnet.

In the diagram, *B* is an electric battery, *P* a push button, *E* an electromagnet, *H* the bell hammer, and *C* the point of contact between a set screw and one end of a steel spring. The upper end of this spring holds a

soft iron bar a short distance from the poles of the electromagnet.

The current rings the bell as follows: When the button *P* is pressed, the current flows from the battery through the electromagnet, along the steel spring and set screw, and back to the battery. When the current starts, *E* becomes a magnet and

draws over the soft iron bar. This movement of the bar does two things: it makes H strike the bell and it "breaks" the current at C . When the current ceases, E is no longer a magnet and the spring draws the soft iron bar back. This backward movement of the bar "makes" the current again at C , and the whole operation is repeated, that is, the current starts, E becomes a magnet and draws over the bar, thus makes H strike the bell again and also "breaks" the current at C again. This operation is repeated in rapid succession as long as the push button is pressed.

The push button — A diagram of the push button is shown in Fig. 128. The wires are attached to metal strips, one of which is a spring, when the button P is pushed, the spring is brought into contact with the lower metal strip and the current starts.

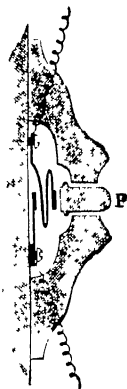

FIG. 128 — The push button

Bell circuits — The diagram (Fig. 129) shows the manner in which three bells and their push buttons are joined to one battery. The battery is made up of three cells joined in series.

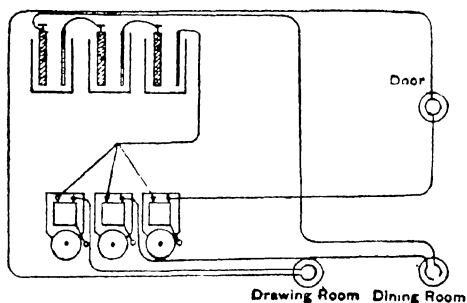

FIG. 129 — Bell circuits

It is usually placed in the basement, and the bells in the kitchen. The buttons, as shown, are placed at the front door, in the dining room, and in the drawing room. If we start at the left side of the battery, the current in each

case runs as follows: from the battery through the button and the bell, and back to the battery.

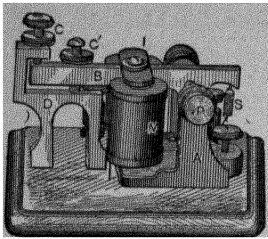

FIG. 130 — The telegraph sounder

The electric telegraph. — The telegraph is one of the most important electrical servants of mankind. It is another application of the electromagnet. The equipment of a telegraph station usually consists of a sounder, key, relay, and batteries.

The sounder (Fig. 130) gives the message. The important part of it is an electromagnet. When the current enters the electromagnet *M*, the iron armature *I* is drawn down. This draws down the bar *B*, and the screw *C*' strikes the brass piece *D*. This makes a click. When the current stops, *M* ceases to be a magnet, and the spring *S* raises the armature *I* and the bar *B*. *B* then strikes the screw *C* and makes another click.

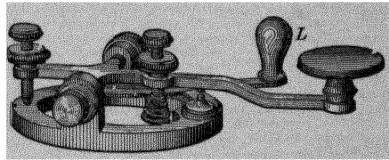

FIG. 131 — The telegraph key

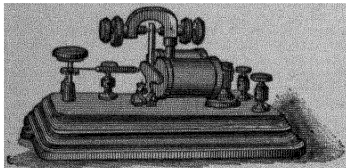

FIG. 132 — The telegraph relay

The message is sent by dots and dashes. A dot is a short time between clicks. A dash is double the time of a dot and a double dash, treble the time.

The key (Fig. 131) is used to send the message, by starting and stopping the current. The lever *L* is used to close the key except when a message is being sent. The relay, Fig. 132, is used at each station on long lines. It introduces a local battery to operate the sounder. It is another application of the electromagnet.

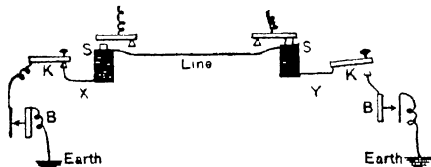

FIG. 133. — Diagram of simple telegraph line.

A diagram of a simple telegraph is shown in Fig. 133. It shows two stations *X* and *Y*, each equipped with a battery *B*, key *K*, and sounder *S*. The wire at each station is grounded and the earth serves as the return wire. When no message is being sent, both keys are closed and the current flows continuously. When one operator wishes to telegraph, he does so by opening and closing his key at the right intervals.

EXERCISES

1. What is a magnet pole?
2. How would you find the north pole of a magnet?
3. What is magnetic induction?
4. What is a magnetic line of force?
5. How can you show the lines of force in the magnetic field of a magnet?
6. State the theory of molecular magnets.
7. State three facts about magnets which this theory explains.
8. Describe Oersted's discovery.
9. State the rule by which we remember how the north pole of a magnetic needle turns when brought near a wire carrying an electric current.
10. Define electromagnet. Why is the electromagnet the most important form of magnet?
11. State the rule for finding the north pole of an electromagnet.
12. Make a diagram of an electric bell showing the path of the current through the bell.
13. Describe how the current rings the bell.
14. Make a drawing showing a battery connected with three bells and three push buttons. In your home trace the wires from the battery to each push button and bell.
15. Describe the telegraph sounder.
16. Make a diagram of two telegraph stations connected, each station having battery, key, and sounder.

CHAPTER XVI

THE ELECTRIC MOTOR IN THE HOME

AN electric motor is one of the most useful of household electrical appliances. Some of the ways in which it is used are

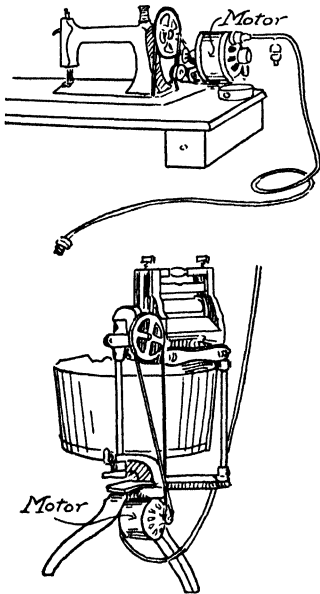

FIG. 134. — Motor-driven sewing machine and washing machine and wringer.

shown in Fig. 134; namely, to run the sewing machine, washing machine, and wringer. It is also used to run the vacuum cleaner, knife sharpener, silver polisher, meat chopper, potato peeler, coffee grinder, cake mixer, egg-beater, ice-cream freezer, etc.

The kitchen is the workshop of the home, and as in other workshops, a certain amount of power is required to do the work. The electrical motor supplies this power. Let us now learn how the electric current runs the motor.

How does the electric current run a motor? — In Fig. 135 we have two straight magnets pivoted between the poles of a horseshoe magnet. We know that in this case the straight

magnets will turn in the direction indicated by the arrows, because each pole of the horseshoe magnet attracts the opposite

poles of the straight magnets. The straight magnets stop, however, when their north poles are opposite the south pole of the horseshoe magnet, and their south poles opposite the north pole. If we had some means of reversing the poles of the straight magnets when they reach this position, they would move through another half turn. If this process of reversing the poles could be repeated at the proper intervals, the straight magnets would revolve continuously. This is precisely what takes place in the motor.

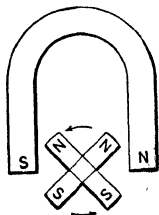

FIG. 135. — Illustrating the principle of the electric motor.

The part of a motor which revolves is called the *armature*; it is represented above by the straight magnets. The armature revolves in the magnetic field of a large magnet called the *field magnet*. The field magnet is represented above by the horseshoe magnet.

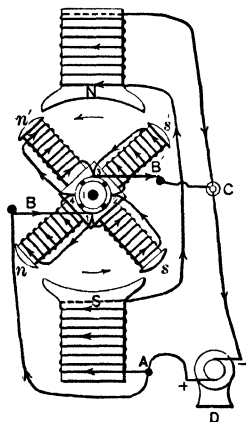

FIG. 136. — Diagram of an electric motor.

The diagram, Fig. 136, represents an electric motor driven by a dynamo. *D* is the dynamo, very much reduced in size. *N* and *S* are the north and south poles of the field magnet. The parts *n*, *n'*, *s*, *s'* are the poles of the magnets on the armature. All the magnets in a motor are electromagnets.

The parts marked 1, 2, 3, and 4 are segments of the commutator. *B* and *B'* are the brushes. The commutator and brushes serve to change the direction of the current in the electromagnets of the armature. The direction of the current is changed twice in each revolution.

Let us now see how the electric current makes the armature of the motor revolve. To do this we must review the rule for finding the poles of an electromagnet. This has already been stated. It is: "Grasp the electromagnet in the right hand,

with the fingers pointing in the direction in which the current passes around the magnet; the extended thumb then points to the north pole of the magnet."

The current from the dynamo D enters the motor at A , where it divides. Part flows around the poles of the field magnet. If we use the rule above, we find that S is a south pole and N a north pole. Part of the current goes to the brush B , then to the segment of the commutator marked 1. Here it divides again; part of it flows around the electromagnets n and n' in such a way as to make the ends marked n and n' north poles; part of it flows around the electromagnets s and s' in such a way as to make the ends marked s and s' south poles. These two parts of the current unite on the segment 3, and leave the armature by the brush B' . The current then flows back to the dynamo.

Since n and n' are north poles, they are attracted by S and repelled by N ; also, since s and s' are south poles, they are attracted by N and repelled by S . These attractions and repulsions cause the armature to revolve in the direction indicated by the arrows.

When the armature has made one quarter turn, the current enters on segment 4 of the commutator and leaves on segment 2. At each quarter turn, the segments on which the current enters and leaves the armature are changed. The result is that the ends n and n' of the electromagnets on the left of the armature are always north poles, and the ends s and s' of the electromagnets on the right of the armature are always south poles. The armature thus revolves continuously, as long as the current passes through the motor.

Commercial motors. — Commercial motors are similar in principle to that shown in Fig. 136, but differ in design. The motors used with household appliances are almost always inclosed in an iron casing to protect the operator and also the motor. The armature is usually of the type known as the drum armature, Fig. 137. The wire is wound lengthwise on a soft iron drum.

The motor described above uses a direct current. A direct current is one which flows in the same direction all the time. An alternating current is one which changes its direction many times a second. Alternating current motors are in very common use in the home and elsewhere. They are simpler in construction than direct current motors, but the theory of their construction is more difficult and the study of it would lead us beyond the scope of this book.



FIG. 137 — The drum armature

The motor in the kitchen. — A convenient power table for the kitchen is shown in Fig. 138. It is equipped with a $\frac{1}{4}$ h. p. electric motor which is connected with the power head

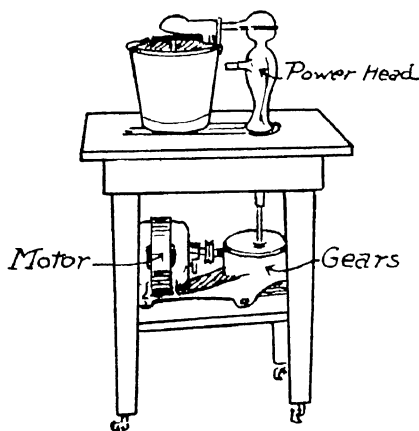
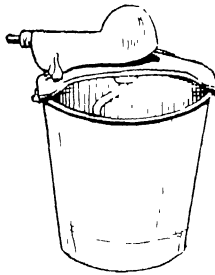

FIG. 138 — A kitchen power table

may be connected with the pulley on the axle of the motor, or with one of the two horizontal shafts which project from the power head. There is a slot in the top of the table by means of which various appliances can be fastened securely to the table. In Fig. 138 the power table is shown operating a bread mixer.

A number of attachments for the power table are shown in Fig. 139; namely, the bread mixer, cake mixer, egg beater, and meat grinder. In addition the power table can be used to operate the washing machine, wringer, mangle, knife sharpener, silver polisher, coffee grinder, food chopper, ice cream freezer, vegetable slicer, etc.

We have now learned some of the ways in which the motor aids in the work of the home. New uses are constantly being



Bread Mixer

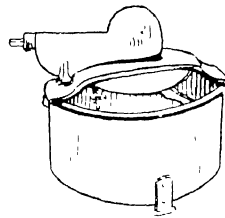

Cake Mixer

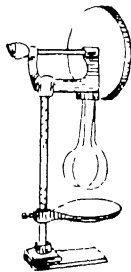

Egg Beater

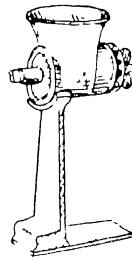

Meat Grinder

FIG. 139 — Attachments for kitchen power table

found, and it is probable that the readers of this book will be able to devise new ways of making it of service in the home.

EXERCISES

1. Make a diagram of an electric motor, showing how the current flows in each part
2. Explain why the armature of a motor revolves
3. Describe a kitchen power table. Name some of the appliances it will operate

CHAPTER XVII

ELECTRIC HEATING, COOKING, AND LIGHTING APPLIANCES

IN recent years there have been many electrical heating and cooking appliances placed on the market. Some of these are illustrated in Fig. 141, namely, the electric iron, the disk heater or stove, the chafing dish, coffee percolator, electric oven, luminous radiator, and warming pad, also the current regulator or rheostat. Other common appliances are the air heater, broiler, and toaster.

The heating of these appliances depends on the heating effect of an electric current. When an electric current is sent through any substance which offers resistance to the current, heat is produced. The rate at which the heat is produced increases with the current and with the resistance. In most of these appliances the heat is produced by sending an electric current through a long thin wire. This wire is known as the *heating element*.

The electric iron — One method of heating an electric iron is illustrated in Fig. 140. The heating element (1) consists of two coils of thin wire wound upon heavy brass cores. The current enters and leaves by the contact tongues (2) and (3). The current heats the thin wire and this heat is transferred by radiation and conduction to the heavy bottom plate of the iron.

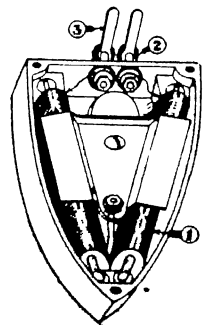

FIG. 140 — Showing the heating element of an electric iron.

*Sød Iron**Disk Heater**Chafing Dish**Coffee Percolator**Electric
Oven**Luminous Radiator**Rheostat**Warming Pad*

FIG. 141. — Household electric heating and cooking appliances.

In another type of iron the heating element is a long thin wire baked in enamel to the bottom plate of the iron. The current heats the wire and the enamel conducts the heat to the bottom of the iron.

The disk stove. — The heating element of the disk stove is made as follows. A long coil of thin wire is wound in the form of a spiral. This is embedded in enamel, and the enamel is baked to the under side of the top plate of the stove. The current heats the wire and the heat is conducted by the enamel to the top of the stove.

The chafing dish and coffee percolator. — The heating element of these appliances is similar to that of the disk stove described above. The lower part of each appliance is a disk stove over which the upper part fits closely. They are made close fitting in order to use the greatest possible amount of the heat from the stove.

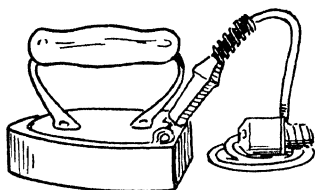
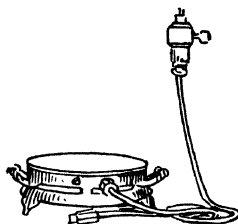
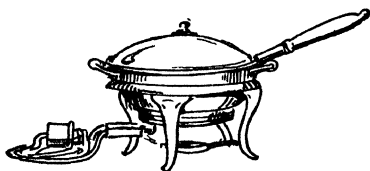
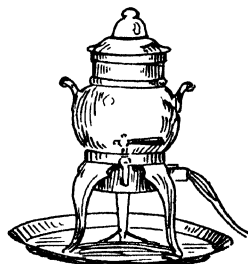
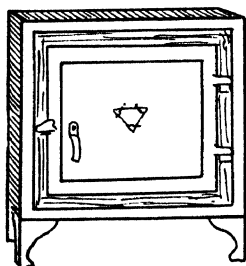
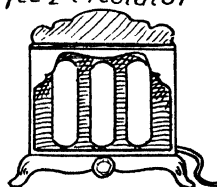
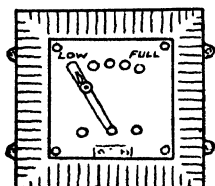
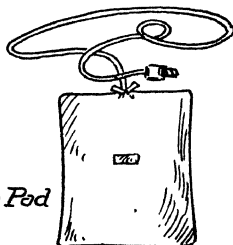
The oven and luminous radiator. — In the oven there is an iron grid at the top and another at the bottom. The enamel with the wire embedded in it is baked to the top of the upper grid, and to the bottom of the lower grid. The current heats the wire and the heat is conducted by the enamel to the grid and then to the air in the oven. The sides of the oven are double, and the space between is filled with asbestos to retain as much heat as possible.

The luminous radiator consists of a number of large incandescent lamps placed in front of a reflector. When the current is turned on, the lamps give out heat and light.

The warming pad. — The warming pad is heated by passing the current through fine wire. The wire is made long and thin, so that it has a high resistance, and therefore the current which passes through it is small and the heat developed is moderate. The wire is inclosed in asbestos cloth to avoid any danger from fire, and the whole pad is covered with flannel.

The current is brought to the pad by means of a cord and plug, which may be attached to any electric light socket.

The rheostat — The rheostat is an adjustable resistance. It controls the temperature of any appliance by controlling the amount of current which reaches it. It is made of a series of coils of wire through which the current passes.

When a rheostat is used with any appliance it is so arranged in the circuit that the current passes through the rheostat as well as through the appliance. When the sliding contact arm is in the position marked "low," Fig. 141, the current passes through all the coils of the rheostat. The resistance in the circuit is then greatest and the current least. The appliance then has its lowest temperature. When the sliding contact arm is moved to the right, some of the coils of the rheostat are cut out, and when it reaches the position marked "full," all the coils are cut out. The resistance in the circuit is then least and the current greatest. The appliance then has its highest temperature.

The air heater, broiler, and toaster. — The heating element of the air heater is a series of bare coils of rather large iron wire. The heater case is open at the bottom and at the top. When the current is turned on, the wires are heated and an air convection current is started. Cold air enters at the bottom of the case, is heated, and leaves as warm air at the top.

The heating element of the electric broiler is similar to that of the air heater, except that the coils are made of finer wire and are therefore heated to a higher temperature by the same amount of current. The meat to be broiled is fastened in a holder and placed in the broiler close to the hot coils.

The heating element of the toaster is a series of bare coils of thin wire. These coils are placed in a horizontal position beneath a wire screen. The bread to be toasted is placed on this screen. The current heats the wire coils and the heat passes up to the bread by convection and radiation.

We have now examined a number of electrical heating and cooking appliances, and we find in each case that the heating element is a wire which is heated by an electric current. In a

later chapter we shall take up the question of just how the quantity of heat produced per second varies with the quantity of current, amount of resistance, etc.

ELECTRIC LIGHTS IN THE HOME

The incandescent light. — We are all familiar with the incandescent light. We know that when we turn on the electric current, by means of a button or switch, the fine wire in the bulb is heated to the temperature at which it gives white light. The explanation of the light from the incandescent lamp is the same as that which we found to apply to the heating and cooking appliances studied in the preceding section, namely, when an electric current is passed through a wire of high resistance, the wire is heated.

If we examine an incandescent light bulb, Fig. 142, we find that the part which screws into the socket consists of a metallic button *B* in the center, insulated from an outer metallic screw cylinder *S*. These two metallic parts make electrical contact with the corresponding parts in the socket.

If we break up an old lamp, we find that each of these metallic pieces is joined to one of the copper wires in the sealed glass tube *G* which projects into the bulb. The fine filament *F* in the bulb of the common incandescent lamp is made of carbon and its ends are joined to the copper wires in the tube by means of short platinum wires sealed into the glass. Platinum is used for the wires through the glass because it expands and contracts at the same rate as the glass, and therefore does not crack it when the temperature changes. The filament is made of carbon, because carbon does not melt easily. The temperature at which it melts is greater than that at which it gives white light. Carbon, however, burns readily when heated in air, and to avoid this, the air is pumped from the bulb and the bulb is sealed air-tight.

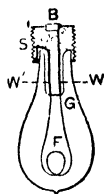

FIG. 142. — An incandescent lamp.

The path of the current through the lamp is as follows. If it enters at the bottom *B*, it moves through a copper wire to *W*, then through platinum to *G*, then through the filament *F* and out through the other platinum and copper wires to the screw cylinder *S*. The lamp is lighted equally well if the current enters at *S* and leaves at *B*. In fact, incandescent lamps are usually lighted by means of an alternating current which changes its direction many times a minute.

Metal filament lamps. — Recently the incandescent lamp has been improved by replacing the carbon filament by one made of the metal tantalum or the metal tungsten.

The advantage possessed by these metals is that they will stand a much higher temperature than carbon without disintegration, and the higher the temperature of the filament the greater is the amount of light produced from the same current. For example, with 50 watts of electrical energy the carbon filament lamp produces a 16 candle-power light, the tantalum filament a 25 candle-power light and the tungsten filament lamp a 40 candle-power light.

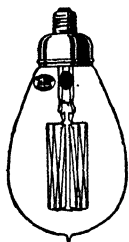

FIG. 143. — The tungsten lamp.

Since electric current is paid for at a certain price per watt hour or kilowatt hour, it will be seen that for the same money $2\frac{1}{2}$ times as much light is secured from the tungsten filament lamp as from the carbon filament lamp. It is evident then that in a few years all incandescent lamps will be of the tungsten filament type, unless a lamp of higher light-giving power is produced in the meantime.

The metals tantalum and tungsten offer less resistance than carbon to the electric current, and for this reason the filaments made of these metals must be of greater length to give the required amount of resistance. From the illustration (Fig. 143) it will be noticed that the tungsten lamps have a long filament supported on a frame.

The arc light. — The arc light is used to illuminate streets and large buildings. It is different in principle from the incandescent light. We may show how the light is produced as follows:

Pass the current from a power circuit through a rheostat (to limit the amount used) and then through two carbon rods. If the ends of the rods are placed together at first and then pulled apart about three-eighths of an inch, a brilliant light is produced. The ends of the carbon become white hot, and the space between is filled with small particles of carbon. The space between the carbons is called the arc (Fig. 144). The positive carbon is the brighter and is cupped out. It is made the upper carbon of the arc light in order to throw the greatest amount of light downward.

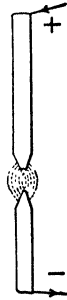

FIG. 144.—
The arc.

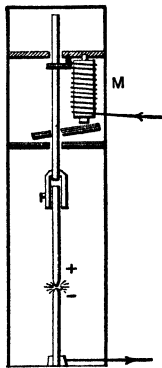

FIG. 145.— The
arc lamp.

In arc lamps the carbons are controlled by an electromagnet. This magnet does two things: first, when the current is started, it separates the carbons about three eighths of an inch, and forms the arc; second, it keeps the carbons apart this distance.

The diagram (Fig. 145) illustrates roughly the working of the electromagnet. The current enters the electromagnet and then passes down through the positive and negative carbons and out.

Before the current is started the carbons are together. When the current starts, however, *M* becomes a magnet and lifts one end of the iron bar shown below. The bar grips the rod and lifts the rod and the positive carbon. This forms the arc.

As the current continues to flow, it gradually wears away the carbons and lengthens the arc. The longer the arc the greater its resistance and therefore the less the

current. As the current decreases, M decreases in strength and the iron bar drops down. This allows the carbons to come closer together. The instant the carbons come closer together the arc is shortened, its resistance is decreased, and therefore the current increases. The magnet then becomes stronger and the bar is drawn up again, etc. The magnet is so adjusted that the carbons are kept about three eighths of an inch apart.

EXERCISES

1. Name five electric cooking appliances and five electric heating appliances.
2. Describe the heating element of the electric iron, stove, oven, and chafing dish.
3. Describe the air heater, luminous radiator, warming pad, and rheostat. Make a diagram of each.
4. Make a diagram of the carbon filament incandescent lamp. Describe it.
5. Make a diagram of the tungsten filament incandescent lamp. Describe it.
6. Describe an experiment to show that an arc is formed when a strong current is passed through two pieces of metal and they are separated a short distance.
7. Make a diagram of the regulating mechanism of the arc lamp. Describe it.
8. In your home, trace the electric light wires from the point they enter the house to each light (as far as possible). Note the position of the main switch, meter, and fuses. Read the meter regularly for six months, and with these readings check the bills sent by the electric light company.

CHAPTER XVIII

ELECTROPLATING

MANY household utensils are plated. For example, spoons, forks, and table dishes may be made of white metal, brass, or Britannia metal and covered or plated with silver, that is, silver plated. Other utensils, such as poker, stove lifters, teakettles, metallic lamps, etc., are frequently made of iron, steel, brass, or copper and covered or plated with nickel. Many pieces of jewelry are made of copper or brass, etc., and then plated with gold.

Objects are plated with copper, silver, gold, etc., by means of an electric current. To understand how this is done we must first study electrolysis.

Electrolysis. — It is found by experiment that organic liquids, such as gasoline, alcohol, kerosene, etc., do not conduct electricity, but that solutions of acids, bases, and salts do conduct electricity. It is found also that when an electric current passes through a solution of an acid, base, or salt, the substance in solution is decomposed. A solution which conducts electricity and is decomposed by the current is called an *electrolyte*. The process of decomposing a liquid by means of an electric current is called *electrolysis*.

Electrolysis of water. — In Fig. 146, the liquid *S* is water containing a small quantity of sulphuric acid. The current is passed through the water by means of strips of platinum attached to platinum wires sealed in the glass tubes *G*. After the current has passed through the liquid for some time, we find that hydrogen (*H*) has collected in one test tube and oxygen

(O) in the other. The volume of hydrogen is always twice that of the oxygen, that is, it is in the proportion in which these gases combine to form water, H_2O . It is found also that the H always moves in the direction the current moves, and is deposited on the platinum plate by which the current leaves the liquid. The O moves in the opposite direction and is deposited on the plate by which the current enters the liquid. The platinum plate by which the current enters the liquid is

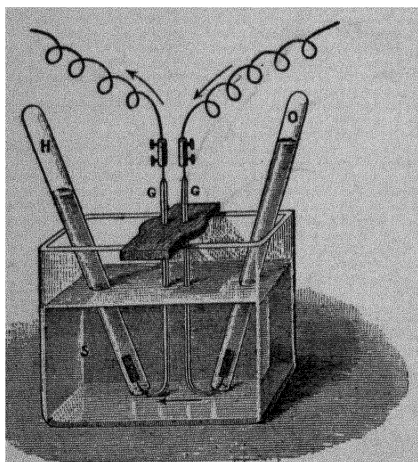

FIG. 140 — Electrolysis of water

called the *anode*, the plate by which it leaves the liquid is called the *cathode*.

If the liquid *S* is a solution of copper sulphate, $CuSO_4$, we find that oxygen is formed at the anode as above, but that copper is deposited on the cathode instead of hydrogen.

The explanation of electrolysis is as follows. When sulphuric acid is dissolved in water, it breaks up into positively charged H ions and negatively charged SO_4 ions. The SO_4 ions are attracted by the positively charged anode and give up their charge to the anode. They then unite with water to form sulphuric acid and oxygen. The H ions are attracted by the negatively charged cathode, and give up their charge to it. They then collect as hydrogen gas.

The same explanation holds for other acids, and for salts and bases. For example, when the salt $CuSO_4$ is dissolved in water, it breaks up into positively charged Cu ions and negatively charged SO_4 ions. The SO_4 ions are attracted by the

anode and form oxygen as above. The Cu ions are attracted by the cathode and form a deposit of copper on it.

When a current passes through a solution of any salt, acid, or base, the positive, metal or hydrogen, ions of the solution move with the current and are deposited on the cathode. The negative ions are deposited on the anode.

Electroplating. — We learn from our study of electrolysis that when an electric current is passed through a solution of a salt, the salt is decomposed, the metal part of the salt moves in the direction the current moves and is deposited on the cathode. This property of the electric current is used in electroplating.

Copperplating. — The arrangement of an electroplating outfit is shown in Fig. 147. Let us suppose that we wish to copperplate a medal. We proceed as follows: Make a solution of a

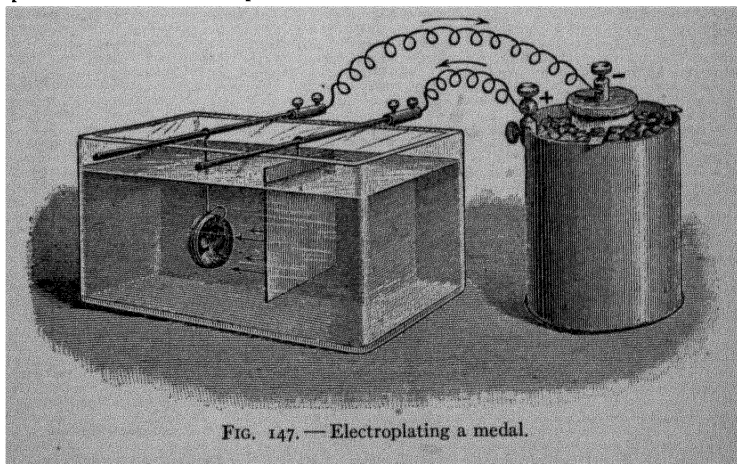
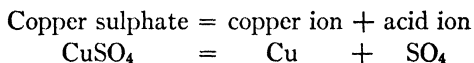

FIG. 147. — Electroplating a medal.

copper salt, say copper sulphate. Place in this solution a plate of pure copper and the medal to be plated. Then connect them with a battery in such a manner that the current flows, first to copper plate, then through the solution to the medal and back to the battery. The medal receives a coating of copper and the copper plate loses an equal weight of copper.

The action is as follows: The copper sulphate (CuSO_4) is decomposed into copper ion (Cu) and the acid ion (SO_4).



The copper is deposited upon the medal and plates it. The SO_4 is deposited upon the copper plate, and unites with the copper to form more copper sulphate.

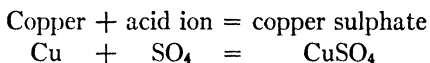

Thus, in the operation of plating, the medal receives a certain weight of copper, the copper plate loses the same weight of copper, and the copper sulphate solution remains at a constant strength.

Nickel plating. — If we wish to nickel plate the medal, we use a solution of a nickel salt and a plate of pure nickel; otherwise the arrangement of the apparatus is the same. Again the solution remains at a constant strength, and by weighing the medal and nickel plate before and after the plating, we find that the medal receives a certain weight of nickel and the plate loses the same weight.

Silver and gold plating. — In silver and gold plating the arrangement of the apparatus is the same, except that we use different solutions and plates. In silver plating we use a solution of a silver salt and lead the current into the solution by a plate of silver. In gold plating we use a solution of a gold salt, and lead the current into the solution by a plate of gold.

The solution used in silver plating is silver cyanide dissolved in potassium cyanide. In gold plating the solution is gold cyanide dissolved in potassium cyanide. In nickel plating the solution is a double salt of nickel sulphate and ammonium sulphate dissolved in water. The solution used in copper plating is copper sulphate dissolved in water.

Preparation of the object for plating. — In preparing for plating of any kind the greatest care must be taken to make the

object absolutely clean. First it is scoured and polished until it looks clean. Then it is attached to a wire and dipped into a hot solution of caustic potash or soda ; this takes off the grease. It is then washed in water, dipped into dilute acid, washed in water again, and then placed in the plating bath. An object should not be touched with the fingers after coming from the caustic potash solution because the points so touched are made greasy and the deposit does not "take."

The current used in plating is of low voltage, and the deposit is formed slowly, the usual time being from twenty-four to forty-eight hours. After the deposit is made, the last step is to polish the object by means of revolving wheels made of brass wire, leather, or canvas.

Laws of electrolysis. — The laws of electrolysis were discovered by Faraday. They are :

(1) *The weight of any substance liberated by a given quantity of electricity is proportional to the chemical equivalent of that substance, that is, to the weight in grams of that substance which will replace 1 g. of hydrogen, or which will combine with 1 g. of hydrogen to form a chemical compound.*

(2) *The weight of any substance liberated in a given time is proportional to the quantity of electricity which passes in that time.* That is, the weight liberated is proportional to, amperes \times seconds.

(3) *The energy of the electrolytic action is the same in all parts of the circuit.* For example, if a current passes in series through a silver-plating bath, a gold-plating bath, and a copper-plating bath, then the current which liberates one chemical equivalent of silver also liberates one chemical equivalent of gold, and one chemical equivalent of copper.

Storage cells. — A storage cell differs from the electric cells we studied in chapter XIV, in that the plates are both of the same metal, namely, lead. These lead plates are perforated and the holes are filled with compressed oxide of lead, Fig. 148. The liquid between the plates is dilute sulphuric acid. When a

urrent is passed through the cell, hydrogen is deposited on the athode and oxygen on the anode, just as they are in the electrolysis of water. The hydrogen acts on the lead oxide contained in the holes of the cathode, and reduces it to spongy lead. The oxygen oxidizes the lead oxide on the anode, and turns it into lead peroxide. When the storage cell is charged, we have in reality two different plates, one of lead, and one of lead per-

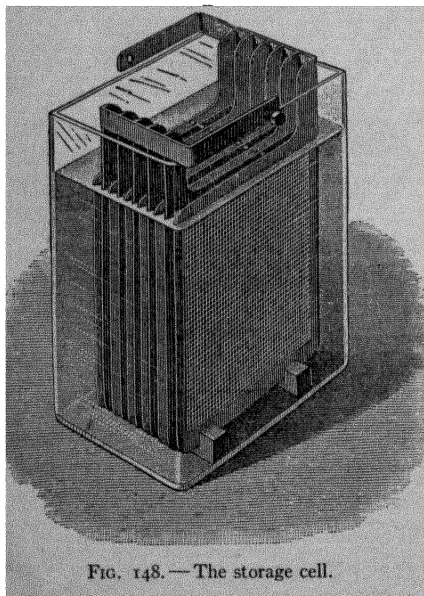

FIG. 148. — The storage cell.

oxide. If the cell now is connected with an electrical appliance, it gives an electric current in the opposite direction to the current which charged it. This current will continue until the lead plate is oxidized to lead oxide, and the lead peroxide plate is reduced to lead oxide. The plates are then identical, and the current ceases. The cell may then be recharged, when it will again give a current; and so on.

It will be noticed that the cell stores up not electricity but chemical energy.

The commercial storage cells are usually made up of a number of plates. For example, the cell, Fig. 148, has five negative plates and six positive plates. All the negative plates are joined to the negative terminal, and all the positive plates to the positive terminal. The storage cell gives an electromotive force (e. m. f.) of a little over two volts, and since the plates

are large and close together, the resistance is small and therefore the rate of flow of current in amperes is large. These cells have an efficiency of about 75 per cent, that is, they give back 75 per cent of the electrical energy used in charging them.

The action of the storage cell can be illustrated by a simple experiment as follows: Place two strips of sheet lead, *A* and *B* (Fig. 149), in a dilute solution of sulphuric acid (1 part acid to 40 parts water) and connect these with two storage cells joined in series.

It will be noticed that the plate on which the current enters, the anode *A*, becomes coated with a red substance, this is lead peroxide. Hydrogen bubbles rise from the cathode *B*. If after the charging current has been running for five or ten minutes the plates are connected with an electric bell, the storage cell rings the bell.

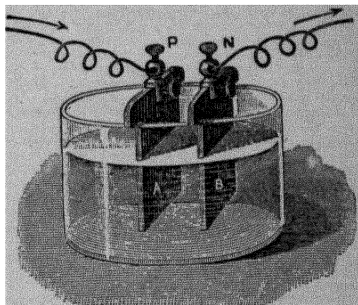

FIG. 149 — A simple storage cell

If the direction of the charging current and of the discharging current are determined by means of a galvanometer, it will be found that they flow in opposite directions.

EXERCISES

1. Define electrolysis, electrolyte, anode, cathode.
2. What liquids conduct electricity readily? What liquids do not?
3. Describe what happens when an electric current is passed between platinum plates dipped in a solution of H_2SO_4 , of $CuSO_4$.
4. Make a diagram illustrating the arrangement of apparatus for copper plating, for nickel plating. Describe what takes place in each.
5. What solution is used in silver plating, in gold plating, in nickel plating, in copper plating?
6. State the laws of electrolysis.
7. Describe the storage cell.

CHAPTER XIX

ELECTRICAL TERMS AND MEASURES

IN this chapter we shall study the meaning of such electrical terms as volt, ohm, ampere, watt, etc.

If we examine an electric iron, we notice a small metallic plate stamped something like this: 110 V, 4 A, 440 W, which means that the iron is to be used on a 110-volt circuit, that it uses 4 amperes current, and that the rate at which it uses electrical energy is 440 watts. An electric stove may be marked as follows: 110 V, 2 A, 220 W, which means that it is to be used on a 110-volt circuit, that it uses 2 amperes current, and that it uses electrical energy at the rate of 220 watts.

Practically every electrical appliance is stamped with similar letters and figures, and when we understand their meaning, we know at once the electrical conditions under which the appliance will work.

Common electrical terms. — The terms in most common use in connection with the electric current are *ampere*, *ohm*, *volt*, *watt*, *watt hour*, *kilowatt*, and *kilowatt hour*. Two other terms which we shall meet less frequently are *coulomb* and *joule*. These terms are all derived from the names of distinguished scientists, and, therefore, do not in themselves give us any hint of their meaning.

The ampere is the unit of current strength. It is the strength of current which when made to deposit silver by electrolysis will deposit .001118 g. of silver per second.

The ohm is the unit of resistance. It is defined as the resistance at 0° C. of a column of mercury 106.3 cm. long, and of uniform cross sectional area of 1 sq. mm.

The volt is the unit of electrical pressure or electromotive force. It is the electromotive force which will force a one ampere current through a circuit having a resistance of one ohm.

The watt is the unit of electrical power. It is the power or rate of working of a current of one ampere driven by an electromotive force of one volt.

RELATIONSHIPS AMONG ELECTRICAL UNITS

Ohm's law. — One of the most important laws relating to the electric current is *Ohm's law*. It is: *The current in any circuit is directly proportional to the electromotive force and inversely proportional to the resistance.*

A simpler way of stating the same thing is as follows: *Ohm's law* is:

$$\text{Current in amperes} = \frac{\text{e. m. f. in volts}}{\text{resistance in ohms}}$$

Or, if we let: C = current in amperes, E = the e. m. f. in volts, and R = the resistance in ohms, Ohm's law is:

$$C = \frac{E}{R}$$

Ohm's law states the relation which the ampere, volt, and ohm bear to one another.

The definition of the watt gives us the relation of the watt to the ampere, volt, and ohm. *The power of any current in watts is found by multiplying the current in amperes by the e. m. f. in volts.*

Power in watts = current in amperes \times electromotive force in volts.

Or if we let: W = watts, C = current in amperes, and E = e. m. f. in volts, we have the equation:

$$W = C \times E$$

This expresses the relation between watts, amperes, and volts.

We may find the relation between watts, amperes, and ohms, or between watts, ohms, and volts by means of Ohm's law and the equation $W = CE$.

By Ohm's law: $C = \frac{E}{R}$, or $CR = E$

If in the equation $W = CE$, we substitute for C , its value $\frac{E}{R}$, we obtain the equation:

$$W = \frac{E^2}{R}$$

which expresses the relation between watts, volts, and ohms.

If, in the equation $W = CE$ we substitute for E its value CR , we have the equation:

$$W = C^2R$$

which expresses the relation between watts, amperes, and ohms.

The heating effect of a current. Joule's law. — The heating effect of an electric current was carefully investigated by the English scientist Joule, who found that when the power of a current is 1 watt, and when all the electrical energy of the current is used to produce heat, .24 gram calories of heat are produced each second.

That is, a current with a power of 1 watt produces .24 gram calories of heat each second, or

$$\text{Calories} = \text{watts} \times .24 \times \text{time in seconds.}$$

In the last paragraph we found three equations, each of which describes a method of finding the power of a current in watts; namely,

$$W = CE$$

$$W = \frac{E^2}{R}$$

$$W = C^2R$$

We can calculate the heat produced in any electrical device when we know any two of the three quantities C , E , R , where C is the current in amperes which flows through the device,

E is the e. m. f. necessary to force the current C through it, and R is the resistance of the device.

If H = the heat produced in gram calories and t = the time in seconds,

$$H = CEt \times .24$$

or
$$H = \frac{E^2}{R} t \times .24$$

or
$$H = C^2Rt \times .24$$

Any one of these equations may be used to calculate the heat produced in any electrical device. Joule expressed the results of his experiments in the form

$$H = C^2Rt \times .24$$

This equation states that *the heat produced is proportional to the time, to the resistance, and to the square of the current.* This is known as *Joule's law.*

We have now learned a number of equations which state the relation between amperes, volts, ohms, watts, and gram calories. The three in most common use are

Ohm's law
$$C = \frac{E}{R}$$

Watts,
$$W = CE$$

Joule's law,
$$H = C^2Rt \times .24$$

ELECTRICAL TERMS APPLIED TO COMMON APPLIANCES

We shall be able to remember the terms, *ampere, volt, ohm,* and *watt* more readily if we associate them with electrical appliances with which we are familiar.

Volt. — The electromotive force of the Daniell cell is about 1 volt, of the dry cell 1.5 volts, and of the storage cell about 2 volts.

Until the dynamo was invented high voltages could be obtained only by connecting a number of cells in series. For example, 100 Daniell cells connected in series give an e. m. f. of 100 volts. With the dynamo, however, high voltages are

easily obtained. The lighting current in homes has usually an e. m. f. of 110 volts or 220 volts. The current used to drive street cars has usually an e. m. f. of 500 volts. These illustrations will help us to remember the meaning of the term *volt*.

Ampere. — The current strength obtained from a Daniell cell, when the copper and zinc plates are joined by a wire of small resistance, is about 1 ampere; from the ordinary dry cell about 15 amperes. The current used in an ordinary incandescent light on a 110-volt circuit is about $\frac{1}{2}$ ampere and on a 220-volt circuit about $\frac{1}{4}$ ampere. The motor used to run the sewing machine, washing machine, etc., uses about 1 ampere current. The current used in arc lighting is about 10 amperes.

The ohm. — The resistance of the ordinary Daniell cell is about 1 ohm, and of the dry cell about .1 ohm. The resistance of a 16 candle-power incandescent lamp constructed for use on a 110-volt circuit is about 220 ohms. The No. 22 copper wire which we use in the laboratory to connect battery with bell, etc., has a resistance of 1 ohm for every 62 ft.

Watt. — The Daniel cell has an e. m. f. of 1 volt and gives a current of about 1 ampere, therefore since watts = volts \times amperes, it works at the rate of $1 \times 1 = 1$ watt. A dry cell has an e. m. f. of 1.5 volts, and when it is giving a current of 15 amperes it is working at the rate of $1.5 \times 15 = 22.5$ watts. A 16 candle-power incandescent lamp on a 110-volt circuit uses $\frac{1}{2}$ ampere current. The rate at which it consumes electrical energy is $110 \times \frac{1}{2} = 55$ watts. An iron which uses 4 amperes current on a 110-volt circuit is using energy at the rate of 110×4 or 440 watts.

These examples will help us to understand the meaning of the four important electrical terms, *volt*, *ampere*, *ohm*, *watt*.

Kilowatt, watt hour, kilowatt hour, coulomb, joule. — The terms *kilowatt*, *watt hour*, and *kilowatt hour* are common electrical terms. The kilowatt simply means .1000 watts. An appliance which is using electrical energy at the rate of 1000 watts is said to be using it at the rate of 1 kilowatt. The

terms *watt hour* and *kilowatt hour* are used to denote the amount of energy used by an electrical appliance. An appliance which uses energy at the rate of 1 watt for one hour is said to use 1 watt hour of energy; if it uses energy at the rate of 1 kilowatt for one hour, it uses 1 kilowatt hour of energy.

The terms *coulomb* and *joule* are less often met. The coulomb is the unit of quantity of electricity. In a circuit in which a current of 1 ampere is flowing, 1 coulomb of electricity passes any point in the circuit in one second. The joule is the unit of electrical work. A current working at the rate of 1 watt does 1 joule of work per second.

ELECTRICAL CALCULATIONS

Ohm's law. — *Problem.* — A dry cell has an e. m. f. of 1.5 volts and gives a current of 15 amperes when its plates are joined by a wire of negligible resistance. What is the resistance of the cell?

Answer. — Ohm's law is $C = \frac{E}{R}$, that is

$$\text{Amperes} = \frac{\text{volts}}{\text{ohms}}$$

$$\therefore 15 = \frac{1.5}{R} \text{ or } 15 R = 1.5, \text{ or } R = \frac{1.5}{15}$$

$$\therefore R = .1$$

The resistance of the cell is .1 ohm.

Problem. — An incandescent lamp used on a 110-volt circuit has a resistance of 220 ohms. What current passes through the lamp?

$$\text{Ohm's law is, amperes} = \frac{\text{volts}}{\text{ohms}}$$

$$\therefore \text{amperes} = \frac{110}{220} = \frac{1}{2}$$

The current passing through the lamp is $\frac{1}{2}$ ampere.

Problem. — The heating element of an electric iron has a resistance of 110 ohms. What e. m. f. will be necessary to force a current of 2 amperes through the iron?

$$\text{Ohm's law is, amperes} = \frac{\text{volts}}{\text{ohms}}$$

$$2 = \frac{E}{110}, \text{ or } E = 220$$

The e. m. f. necessary is 220 volts.

Watts. — *Problem.* — An electric iron uses a current of 2 amperes on a 220-volt circuit. Find the rate in watts at which it uses electrical energy.

$$W = C \times E, \text{ or watts} = \text{amperes} \times \text{volts}$$

$$\therefore \text{watts} = 2 \times 220 = 440$$

The iron uses electrical energy at the rate of 440 watts.

Problem. — The metal plate on an electric stove is marked 110 V., 1100 W. Find the current it uses.

$$\text{Watts} = \text{amperes} \times \text{volts}$$

$$1100 = \text{amperes} \times 110$$

$$\therefore \text{amperes} = \frac{1100}{110} = 10$$

The stove uses 10 amperes current.

Problem. — An electric oven is marked 1100 W., 5 A. What e. m. f. is required?

$$\text{Watts} = \text{amperes} \times \text{volts}$$

$$1100 = 5 \times \text{volts, or volts} = 220$$

The e. m. f. required is 220 volts.

Joule's law. — *Problem.* — The heating element in an electric iron has a resistance of 110 ohms, and the current passing through the iron is 2 amperes. How much heat is produced in the iron in one minute?

Joule's law is $H = C^2Rt \times .24$, that is

$$\text{Gram calories} = (\text{amperes})^2 \times \text{ohms} \times \text{seconds} \times .24$$

$$\text{or } H = 4 \times 110 \times 60 \times .24.$$

$$H = 6336.$$

There are 6336 gram calories of heat produced in the iron in one minute.

A gram calorie is the amount of heat required to heat 1 g. of water 1° C. A kilogram calorie is the amount of heat required to heat 1 kg. (1000 g.) of water 1° C.

To find the number of kilogram calories of heat produced per second in any electrical device. Joule's law is expressed

$$H \text{ (kilogram calories)} = \frac{C^2Rt \times .24}{1000}$$

or

$$H = C^2Rt \times .00024$$

In English-speaking countries the common unit of heat is the British Thermal Unit (B. T. U.).

The British Thermal Unit is the amount of heat required to heat 1 lb. of water 1° F. It has been found that

$$1 \text{ watt} = .0009478 \text{ B. T. U. per second}$$

$$\therefore H \text{ (B. T. U.)} = C^2Rt \times .0009478$$

Problem. — The heating element of an electric iron has a resistance of 110 ohms. The current used is 4 amperes. How many kilogram calories of heat are produced per minute?

$$H \text{ (kilogram calories)} = 4 \times 110 \times 60 \times .00024 = 6.336$$

The heat produced in one minute is 6.336 kilogram calories.

Problem. — The heating element of an electric oven has a resistance of 44 ohms. The current is 5 amperes. How many B. T. U. of heat are produced in one minute?

$$\begin{aligned} H \text{ (B. T. U.)} &= C^2Rt. \times .0009478 \\ &= 25 \times 44 \times 60 \times .0009478 \\ &= 62.5 \end{aligned}$$

There are 62.5 British Thermal Units produced in one minute.

Electrical heating and cooking appliances are usually marked with the number of watts of energy they use. In this case the amount of heat produced may be calculated directly.

Problem. — An electric oven uses electrical energy at the rate of 1100 watts. How many gram calories of heat are produced in it per minute?

$$\begin{aligned} H \text{ (gram calories)} &= \text{Watts} \times \text{seconds} \times .24 \\ &= 1100 \times 60 \times .24 = 15,840 \end{aligned}$$

There are 15,840 gram calories of heat produced per minute.

Kilowatt hours. — *Problem.* — A 6-lb. electric iron is using 5 amperes current on 100-volt circuit. How many kilowatt hours of energy does it use in 8 hr.?

$$\begin{aligned} \text{Watts} &= \text{amperes} \times \text{volts} \\ W &= 5 \times 100 = 500 \end{aligned}$$

The iron is using energy at the rate of 500 watts.

A kilowatt is 1000 watts, therefore the iron is using energy at the rate of 500 divided by 1000 or $\frac{1}{2}$ kilowatt.

In 8 hr. the iron uses $8 \times \frac{1}{2} = 4$ kilowatt hours of energy.

Cost of electric heating. — *Problem.* — The cost of electric energy is usually about 10 ct. per kilowatt-hour. What is the cost of the current used in the iron above in 8 hr.?

The iron uses 4 kilowatt hours of energy in 8 hr. The cost of electric energy is 10 ct. per kilowatt hour, therefore the cost of the electric energy is $10 \times 4 = 40$ ct.

Problem. — An electric oven is marked 1500 watts. With electric energy at 10 ct. per kilowatt hour, what is the cost of baking for 2 hr.?

1500 watts = 1.5 kilowatts. In 2 hr. the oven uses $1.5 \times 2 = 3$ kilowatt hours of energy. The cost is $3 \times 10 = 30$ ct.

Horse power of an electric current. — In English-speaking countries we measure the power of engines, such as a steam engine, gasoline engine, etc., in horse power, and in order to compare the power of an electrical appliance, such as the motor, with these engines, we must know the relation between the watt and horse power. This has been determined, and it is found that

$$746 \text{ watts} = 1 \text{ horse power}$$

Knowing this relation, we can calculate the horse power of any motor. For example, a sewing machine motor on a 220-volt circuit uses about $\frac{1}{4}$ ampere.

$$\text{watts} = 220 \times \frac{1}{4} = 55 \text{ and the horse power} = \frac{55}{746} = .07 \text{ h. p.}$$

or about $\frac{1}{14}$ h. p.

EXERCISES

1. Define ampere, ohm, volt, watt.
2. State Ohm's law.
3. How is the power of a current determined in watts?
4. State Joule's law.
5. State the e. m. f. in volts of the current in some common appliances.
6. State the rate of current in amperes obtained from different cells, and of the current used in common appliances.
7. State the resistance in ohms of some common appliances.
8. State the power in watts of the current obtained from different cells, and of the current used in some common appliances.
9. Define kilowatt, watt hour, kilowatt hour, coulomb, and joule.
10. If a Daniell cell has an e. m. f. of 1 volt, and gives a current of $\frac{1}{2}$ ampere, when its plates are joined by a wire of negligible resistance, what is the resistance of the cell in ohms?
11. A tungsten lamp on a 110-volt circuit has a resistance of 440 ohms. What current does it use?
12. What e. m. f. will be necessary to force a current of 2 amperes through the heating element of an electric iron which has a resistance of 55 ohms?
13. An immersion coil is marked 500 watts. It is used on a 110-volt circuit. What current in amperes flows through it?
14. A curling iron heater on a 110-volt circuit uses $\frac{1}{2}$ ampere current. What is the rate in watts at which it uses electrical energy?
15. A coffee percolator is marked 350 watts; it is used on a 110-volt circuit. What current does it use?
16. A 1 h. p. motor (746 watts) is used on a 110-volt circuit. What current does it use?

17. An electric iron is marked 475 watts. If all this electrical energy is turned into heat, how many gram calories are developed per minute?

18. An electric toaster has a resistance of 40 ohms, and uses 3 amperes current. How many gram calories are produced in it per minute?

19. An immersion coil is marked 500 watts. How many British Thermal Units are produced in it per minute?

20. An immersion coil is marked 500 watts. How long will it take it to heat 1 imperial quart of water ($2\frac{1}{2}$ lb.) from 60° F. to 212° F.?

21. If electric energy costs 10 cents per kilowatt hour, what is the cost of using each of the following for 5 hr.: an iron marked 400 watts; a luminous radiator marked 500 watts; an oven marked 1500 watts; an air heater marked 2500 watts?

22. A sewing machine motor uses $\frac{1}{2}$ ampere current on a 110-volt circuit. What is the horse power of the motor?

23. If electrical energy costs 10 cents per kilowatt hour, what is the cost of the energy required to run the motor (Exercise 22), for 10 hours? for 1 hour?

24. A kitchen motor uses 1 ampere current on a 100-volt circuit. If electrical energy costs 10 cents per kilowatt hour, what is the cost of the energy required to run the motor for 1 hr.?

CHAPTER XX

MEASURING INSTRUMENTS. SERIES AND PARALLEL CONNECTIONS

Electrical measuring instruments.— Instruments used to measure electric current are called *galvanometers*. The first part of the name is from Galvani, the name of the Italian scientist who, in 1786, discovered that a continuous electric current could be produced by chemical action. For many years the electric current was called the galvanic current. The word “meter” means “to measure,” and galvanometer means a measurer of the electric current.

There are two types of galvanometers, each of which consists of a coil of wire and a magnet. In galvanometers of one type the magnet moves, and the coil remains stationary. In those of the other type, the coil moves, and the magnet remains stationary.

In our experiments on the magnetic effect of the electric current, page 175, we found that if a magnetic needle is placed near a piece of wire and a current is sent through the wire, the magnetic needle tends to turn at right angles to the wire. If the wire passes under and over the needle, the turning force is doubled; and if the magnetic needle is placed in the center of a coil of many turns of wire, the turning force is increased approximately in proportion to the number of turns of wire in the coil. Galvanometers of one type, Fig. 150, are made in this way: a small magnetic needle is suspended in the center of a coil of many turns of wire. When a current is sent through the wire, the magnetic needle is deflected and the

amount of the deflection is used to determine the strength of the current.

The second type of galvanometer, known as the D'Arsonval galvanometer, consists of a coil of insulated wire wound on a frame, about a piece of soft iron, and suspended between the poles of a permanent magnet, Fig. 151. A coil of insulated wire wound about a piece of soft iron is an electromagnet. This electromagnet is suspended so that

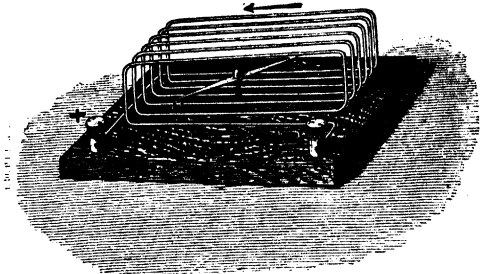

FIG. 150. — A galvanometer with fixed coil and movable magnet.

its poles are at right angles to those of the permanent magnet.

When a current is passed through the coil, it is magnetized, and tends to turn its poles toward the poles of the permanent magnet. The amount of this turning is a measure of the strength of the electric current. The coil is suspended by means of a fine ribbon of copper wire which leads the current into the coil. The current is led away from the coil by means of a fine metallic spring below the coil. When the coil turns, it twists the fine copper ribbon, and the elastic force tending to untwist the ribbon acts against the magnetic force turning the coil. The mirror attached to the coil is used to measure the current, as follows. A scale and telescope are so placed that an image

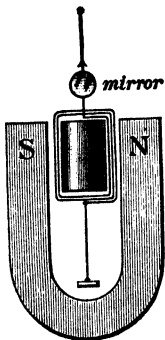

FIG. 151. — A D'Arsonval galvanometer with fixed magnet and movable coil.

of a small part of the scale can be seen in the mirror by means of the telescope. When the mirror moves, another part of the

scale is brought into view. The difference between the two scale readings serves as a measure of the current.

Commercial measuring instruments. — The **voltmeter**, Fig. 152, is used to measure the e m f of a current in volts. The

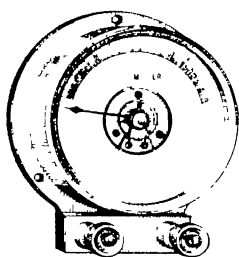

FIG. 152 — The voltmeter

ammeter, Fig. 153, is used to measure the strength of a current in amperes. These instruments are both D'Arsonval galvanometers. In each a coil of high resistance is wound on a frame about a piece of soft iron and placed between the poles of a strong permanent magnet. This coil is on pivots and is held in position by a fine spring. The current turns the coil against the force of this spring. In each there is a second coil through

which part of the current passes. In the ammeter this second coil has a low resistance and therefore carries the greater part of the current. In the voltmeter the coil has a high resistance.

If you use electricity in your homes, you will find an electric meter near the point at which the current enters the house. This meter measures the electrical energy used, in kilowatt hours, and it is called a kilowatt-hour meter. It is simply a small light-running motor which uses a small part of the current to turn the hands on the dial. This dial registers the number of kilowatt hours of energy used from one visit of the inspector to the next.

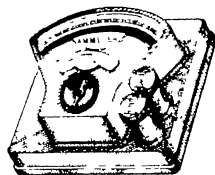

FIG. 153 — The ammeter

Service entrance, fuses, and meter connection. — In Fig. 154 is represented the method of bringing wires into the house, or the service entrance. The two wires from the poles are attached to the side of the house. The wires then form a drip loop and pass through the wall through two porcelain tubes sloping upward toward the inside. The loop allows rain water to drip from the wires, and the upward slant of the por-

celain tubes excludes water from the tubes. Sometimes, for convenience, the meter is placed in the cellar instead of the attic.

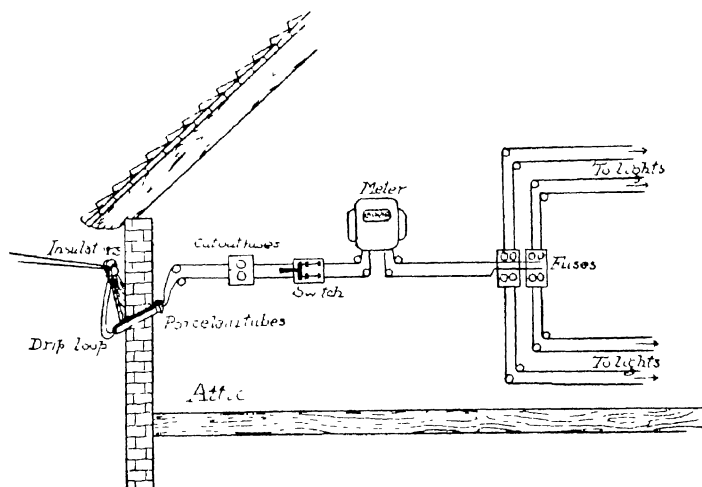

FIG. 154 - How the electric current is brought into the home

Inside the building the wires are joined in series to cut-out fuses, the switch, the meter, cut-out fuses, and the wires leading to the electric lights.

Fuse wire. — All electric house fixtures are protected from damage from an excess of current by a device known as a fuse. It is simply a piece of wire which melts when the current is too great. Fuse wire is made of an alloy which melts at a low temperature, it is made in different sizes, and the size used in any case depends upon the current strength which may be used in the appliance. For example, if the maximum current allowable in an electric device is three amperes, a three-ampere fuse is used to protect it. If the current goes above three amperes, the fuse melts and the current is stopped. The fuse wire is usually inclosed in a porcelain cylinder or other insulating device to avoid danger of fire from the melted metal. In Fig. 154

the first cut-out fuse protects all appliances in the house. If it is a lighting circuit and one of these fuses is melted, all the lights go out. The fuses on the branch lines protect the lights and other appliances on that particular branch.

The cut-out fuses and switch are placed in a cabinet lined with slate, marble, or asbestos, as a further protection against fire.

RESISTANCE, SERIES AND PARALLEL CONNECTIONS

Resistance. — All conductors of electricity offer some resistance to the passage of the electric current. The laws of this resistance are as follows :

The resistance of any substance

- (1) is directly proportional to its length ;
- (2) is inversely proportional to its area of cross section ;
- (3) varies with the nature of the substance ;
- (4) changes with the temperature.

To put these laws into simple language :

If two wires are the same, except that one is twice as long as the other, the longer wire will have twice the resistance of the shorter wire.

If two wires are the same in all respects, except that the area of cross section of one is twice that of the other, the resistance of the thicker wire is one-half that of the thinner wire.

The resistance depends upon the material of which the wire is made ; for example, if we compare the resistance of an iron wire with that of a copper wire of exactly the same dimensions, we find that the iron wire has about six times as much resistance as the copper wire.

The resistance varies with the temperature. The resistance of all metals increases as we increase the temperature ; the resistance of carbon and electrolytes decreases as we increase the temperature.

Series and parallel connection. — Wires joined end to end in such a way that all of the current passes through each wire are said to be joined *in series* (Fig. 155). In this case the total

resistance is equal to the sum of the two resistances. In Fig. 155, it is equal to $R_1 + R_2$.

Wires joined, as in Fig. 156, in such a way that only part of the current flows through each wire, are said to be joined in

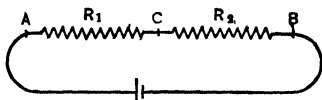

FIG. 155. — Wires joined in series.

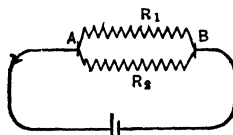

FIG. 156. — Wires joined in parallel.

parallel. If in this case the resistances are equal, the resistance of the combination is equal to one half that of each wire.

If we let R = the total resistance and E the e. m. f. between A and B, the total current C is equal to $\frac{E}{R}$ and is equal to the sum of the currents in each branch; that is, $C = C_1 + C_2$; that is,

$$\frac{E}{R} = \frac{E}{R_1} + \frac{E}{R_2} \text{ or } \frac{I}{R} = \frac{I}{R_1} + \frac{I}{R_2} \text{ or } \frac{I}{R} = \frac{R_2 + R_1}{R_1 R_2} \text{ or } R = \frac{R_1 R_2}{R_1 + R_2}$$

This is the formula for finding the total resistance of two wires joined in parallel.

Cells in series and parallel. — If we join N cells in series, we find the e. m. f. of the combination to be N times the e. m. f.

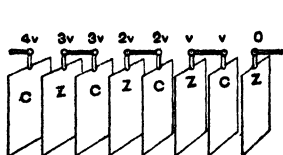

Cells in series.

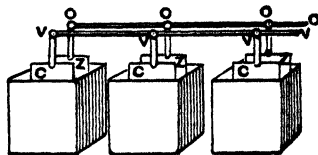

Cells in parallel.

FIG. 157. — Cells joined in series and in parallel.

of each cell. In Fig. 157, the e. m. f. of one cell is V , of 4 cells $4V$. We find also that the total resistance is N times the resistance of one cell.

If we let C = the current, E = e. m. f. of one cell, r = the resistance of one cell, and R = the external resistance, the current is found by the formula

$$C = \frac{N E}{N r + R}$$

If we join N cells in parallel, we find the total e. m. f. to be equal to that of one cell. In Fig. 157, the e. m. f. of three cells joined in parallel is V . We find also that the total resistance of the cells is $\frac{1}{N}$ times that of one cell.

We find the current in this case by the formula

$$C = \frac{E}{\frac{r}{N} + R}$$

When the external resistance is large, we join the cells in series; when the external resistance is small, we join them in parallel.

EXERCISES

1. Describe the two types of galvanometers.
2. Describe the voltmeter and ammeter.
3. What is a fuse wire?
4. State the laws of resistance.
5. Two wires are joined in series; the resistance of each is 3 ohms. What is the total resistance?
6. What is the total resistance if the wires in 5 are joined in parallel?
7. The e. m. f. of a dry cell is 1.5 volts; the internal resistance is .1 ohm. What current will 5 such cells joined in series send through a bell having a resistance of 7 ohms?

CHAPTER XXI

INDUCED CURRENTS THE DYNAMO

Private lighting plant -- A private lighting plant for country residences is shown in Fig. 158. The outfit consists of a gasoline engine, dynamo, switchboard, and storage battery. The gasoline engine runs the dynamo, the current from the dynamo

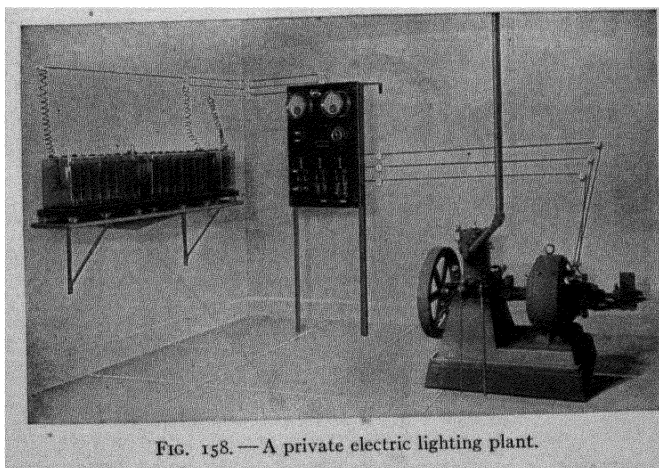

FIG. 158. -- A private electric lighting plant.

charges the storage cells, and the current from the storage cells is used in the lights as needed. The electric lights used are 32-volt tungsten lamps. Since a storage cell has a voltage of 2 volts, 16 storage cells are connected in series to make a 32-volt storage battery.

We have studied electric lights, the storage cell, and also the gasoline engine. We may now study the dynamo.

The dynamo. — There are two chief sources of the electric current, namely, the electric cell and the dynamo. The electric cell is used only when the electric power required is small; for example, to operate the electric bell. Where the electric power needed is comparatively large, the current is obtained from a dynamo; for example, to operate heating, cooking, and lighting appliances, and electric motors. The dynamo is the most important of electrical appliances, because it furnishes the current for nearly all other electrical devices. It is usually located at the power house of the electric light and power company, and is driven by a steam engine, gas engine, gasoline engine, or by water power. We study it because we wish to understand the source of the current used in those household appliances which use more power than can be supplied economically by electric cells.

Before we take up the study of the dynamo it will be necessary to learn something about *induced currents* because the dynamo produces induced currents.

Induced Currents. — In 1831, the English scientist, Michael Faraday, discovered that an electric current could be produced in a wire by means of a magnet. He called these currents *induced currents*.

We can illustrate the production of induced currents by means of the following experiment, Fig. 159.

If we connect the ends of a coil of wire with a galvanometer, and then plunge a magnet into the coil, we find that a momentary current is produced in the coil. If we lift the magnet out of the coil, a momentary current is produced in the opposite direction. This is a remarkable experiment. We take a coil which has no current in it, and a magnet which also has no current in it, and by pushing the magnet into the coil we obtain a momentary current. This is a very important discovery because it gives us another method of producing an electric current. It is the basis of the dynamo; and without the dynamo

the greater part of the modern electrical development would have been impossible.

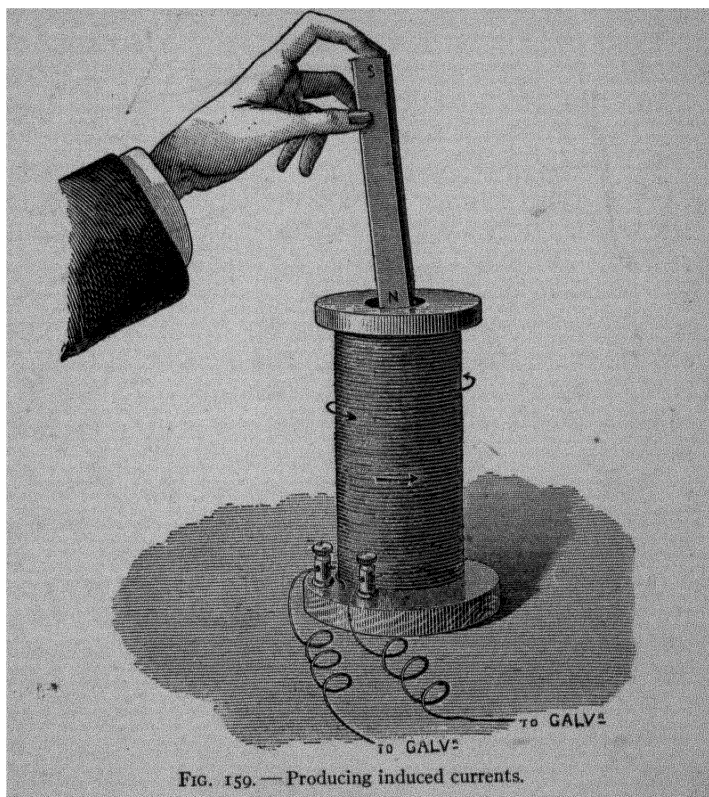

Magnetic lines of force are cut by the coil. — When the magnet enters or leaves the coil, the magnetic lines of force of the magnet are cut by each turn of wire of the coil. It is this operation which produces the current.

These experiments have been made many times with great care, and it has been learned that when magnetic lines of force are cut by any conductor, an electromotive force is set up in

the conductor; and that the direction of the electromotive force depends upon the direction in which the magnetic lines of force are cut. Let us put this into ordinary language.

In our experiments with magnets, pages 171-172, we placed a magnet under a piece of paper, and by dusting iron filings over the paper we traced out the magnetic lines of force of the magnet. Now copper wire is a conductor, and when we push a pole of a magnet into a coil of copper wire, each loop of the coil cuts many lines of force of the magnet, and an electromotive force is set up in the coil. When we allow the magnet to remain at rest, there are no magnetic lines of force being cut, and no electromotive force is set up in the coil. When the magnet pole is pulled out of the coil, the magnetic lines of force are cut in the opposite direction, and an electromotive force in the opposite direction is set up in the coil.

Strength of e. m. f. in coil. — If we push the magnet into the coil slowly and then rapidly, we notice that the e. m. f. produced is much greater when the motion is rapid.

If we hold the like poles of two magnets together, and push them into the coil, the number of magnetic lines of force cut is twice as great, and we find that the e. m. f. set up is twice as great.

If we join to the galvanometer a coil made of wire of the same size, but with more turns, and push the magnet pole into it, we find the e. m. f. to be greater.

After many experiments it has been learned that: "the strength of the electromotive force set up in a conductor depends upon *the number of magnetic lines of force cut per second.*" Or, in other words, the strength of the electromotive force set up in a coil depends upon: *the strength of the magnet, the number of turns of wire in the coil, and upon the speed with which the magnetic lines of force are cut.*

Direction of the induced current. — In the experiments above we have used the north pole of a permanent magnet. If we use the south pole, we find that when the south pole enters the

coils, it produces an induced current in the opposite direction to that of the current produced when the north pole enters.

When the south pole leaves the coil, it produces a current opposite in direction to that produced when a north pole leaves.

Similar results are obtained when an electromagnet is used instead of a permanent magnet. In this case, however, instead of moving the electromagnet into and out of the coil, we can place it in the coil and simply start and stop the current.

If, in each case, we find the direction of the induced current in the coil, we can find the direction of the magnetic field produced by it (by means of the rule given on page 178). We find that *the magnetic field produced in the coil by the induced current is opposite in direction to the magnetic field in the object which produces the induced current.* This is *Lenz's law*.

In other words, when a north pole enters a coil, the magnetic field produced in the coil is opposite to that in the magnet. Magnetic fields which are opposite in direction oppose each other. Thus the magnetic field produced in the coil always opposes the motion of the object which produces it.

We have learned, then,

- (1) that an electromotive force is set up in a conductor whenever it cuts magnetic lines of force ;
- (2) that the strength of the electromotive force depends upon the number of magnetic lines of force cut per second ;
- (3) that the direction of the induced current is always such that its magnetic field opposes the motion of that which produces it.

APPLICATIONS OF INDUCED CURRENTS

The dynamo. — The construction of the dynamo is based upon the laws stated above. The essential parts of a dynamo are a coil of wire and a magnet, Fig. 160. The coil of wire *AB* is so arranged that it can be revolved on the axis *CD* between the poles of the magnet. If we examine Fig. 160, the magnetic lines of force, represented by the long arrows, extend from the

north pole to the south pole of the magnet. Every time the coil makes one revolution, each side of the coil cuts the magnetic

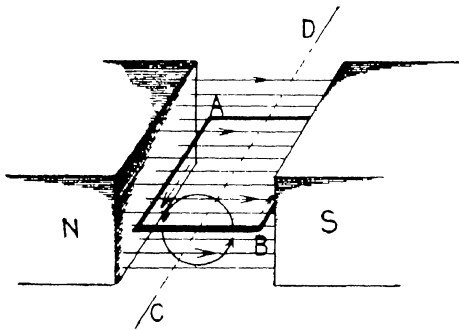

FIG. 100 -- Principle of the dynamo

lines of force twice, first in one direction and then in the other. There are thus two currents produced in the coil at each revolution: the first is set up during the first half revolution, and is in one direction, the second is set up during the

second half revolution, and is in the opposite direction. Thus if the coil makes five revolutions each second, there are ten separate currents set up each second, five in one direction, and five in the other. A current which is reversed in direction a number of times a second is called an *alternating current*.

The coil which revolves between the poles of the magnet is called the *armature* of the dynamo. It is always wound on a soft iron core because the magnetic lines of force pass through iron more readily than through air, and therefore the number of lines of force passing through the coil is increased. * The magnet is called the *field magnet* of the dynamo.

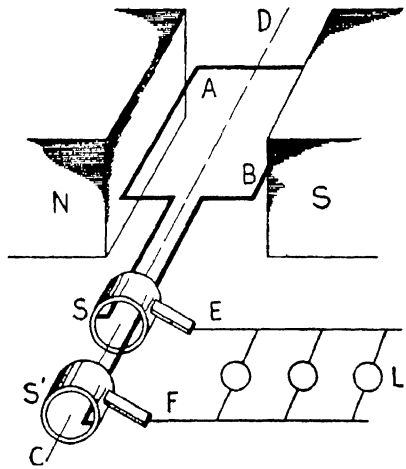

FIG. 101 -- Diagram of an alternating-current dynamo

The alternating-current dynamo. — The current is generated in the armature, and in order to make use of it, means must be provided to lead it out of the armature into an outer circuit. The chief difference between the alternating-current dynamo and direct-current dynamo is in the way in which this is done.

A simple diagram of the alternating-current dynamo is given in Fig. 161. The current is led out of the armature AB as follows: One end of the wire of the armature is joined to the metal ring S , the other to the metal ring S' . These rings are fastened to the axle CD , and revolve with it, they are insulated from each other and from the axle. Two metal or carbon strips E and F are so arranged that one touches one ring and the other the other. These strips are called *brushes*; they are stationary and the rings slide under them. The current is led out of the armature and into the outer circuit L through these brushes.

The current sent through the lights L is alternating because it comes out on one brush during one half revolution, and on the other during the other half revolution. A dynamo arranged in this way is called an *alternating-current dynamo*.

The direct-current dynamo. — The direct-current dynamo is the same as the alternating-current dynamo, except that it has a commutator instead of rings. The commutator is a ring split in sections as shown in Fig. 162. One end of

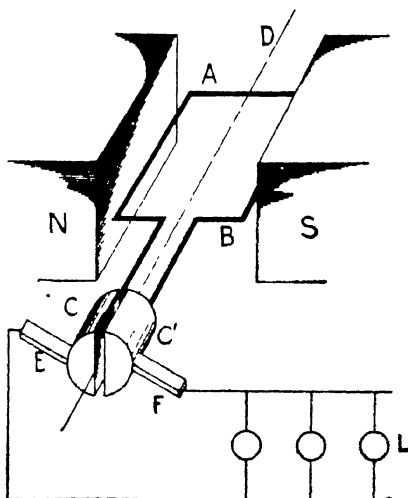

FIG. 162. — Diagram of a direct-current dynamo.

the coil of the armature is joined to one section C and the other to the other section C' . During one half revolution of the armature the current comes out on one section, and during the other half on the other, but since the commutator revolves with the armature, the current always comes out into the outer circuit from one brush and returns on the other. Thus the current in the outer circuit always flows in the same direction, that is, it is a *direct current*. Dynamos arranged in this way are called *direct-current dynamos*.

Dynamos and motor -- We can show that the dynamo and motor are the same in construction, as follows. Join two hand-

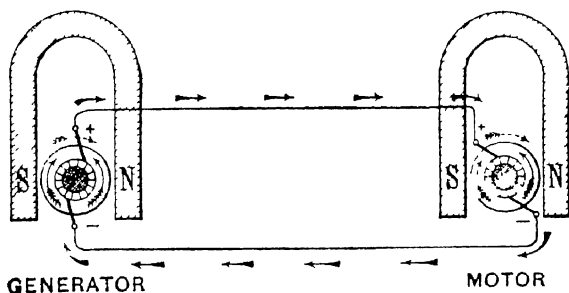

FIG. 163. -- The dynamo or generator and the motor

power dynamos by means of wires, Fig 163. Then turn the armature of the first dynamo by hand power and the current produced makes the armature of the second dynamo revolve. That is, the second dynamo acts as a motor. Now turn the armature of the second dynamo by hand power and the current produced makes the armature of the first dynamo revolve. That is, the first dynamo acts as a motor.

This shows that the dynamo and motor are the same in construction. A machine is acting as a dynamo when it turns mechanical energy into electrical energy; it is acting as a motor when it turns electrical energy into mechanical energy.

Armature and field magnets. -- The armatures of commercial dynamos consist of many separate coils wound on a soft iron

core. If the core is in the shape of a drum, the armature is called a *drum* armature. If the core is in the shape of a ring, the armature is called a *ring* armature.

The commutators of direct-current dynamos have as many sections as there are coils on the armature

The field magnet of a direct-current dynamo is energized by part of the current produced by the dynamo. The field magnet of an alternating-current dynamo is energized by a small separate direct-current dynamo.

Commercial dynamos. — A commercial direct-current dynamo is shown in Fig. 164. It will be noticed that the field magnet

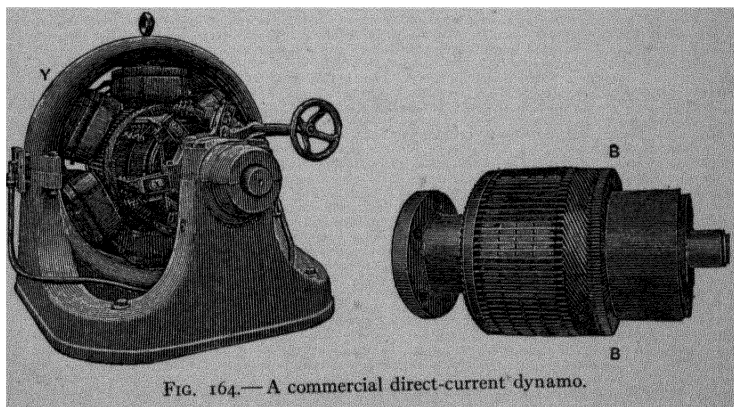
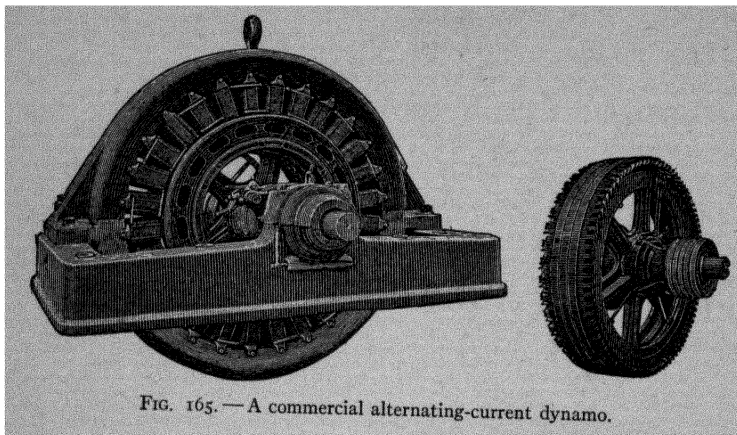

FIG. 164.— A commercial direct-current dynamo.

Y has six poles. These are alternately north and south poles. The armature *B B*, shown on the right, is a drum armature. It consists of many coils wound lengthwise on a soft iron drum. The coils are attached to the strips of the commutator in series.

A commercial alternating-current dynamo is shown in Fig. 165. The field magnet has many separate poles. The armature is of the ring type. There is no commutator, the alternating current being led from the armature by means of rings on the armature axle.



The sources of the electrical energy. — The electricity which we use in our homes comes from the power house of an electric power company, except that which we obtain from batteries. If the electric power company drive their dynamos by means of a steam engine, the following changes in energy take place. The coal burned under the boiler produces steam in the boiler, the steam drives the steam engine, and the steam engine drives the dynamo. The heat energy of coal is thus changed to mechanical energy in the boiler and engine, the mechanical energy is changed into electrical energy in the dynamo; and the electrical energy is turned into light and heat energy in the appliance. We see then that the electrical energy which we use in household appliances is in this case derived from the heat energy of the coal burned under the boiler.

In some power houses the dynamos are driven by a gas engine or a gasoline engine. In this case the electrical energy is obtained from the heat energy of the gas or gasoline which burns in the engine.

In other power houses the dynamos are driven by waterwheels. In this case the electrical energy is obtained from the mechanical energy of the falling water which passes through the waterwheel.

From the above we see that when we use an electrical appliance in our homes, a certain extra amount of coal, gas, gasoline, or water must be used in the power house to supply the necessary current. For example, when the current comes from a power house where coal is used, and we use an electric stove, iron, toaster, or motor in our homes, a certain extra amount of coal must be burned to supply the current. We see also that if we leave an electric light or other appliance "on" longer than it is needed, we really waste a certain amount of coal in the power house.

EXERCISES

1. Why is the dynamo an important electrical appliance?
2. Describe how induced currents are produced.
3. On what does the c. m. f. of an induced current depend?
4. State Lenz's law.
5. Make a simple diagram of an alternating-current dynamo.
6. Make a simple diagram of a direct-current dynamo.
7. How would you show that a dynamo and motor are the same in construction?
8. Name the changes in energy which occur when coal is used to produce electricity for lighting.

CHAPTER XXII

INDUCED CURRENTS (continued)

TRANSFORMER, INDUCTION COIL, AND TELEPHONE

The transformer. — In cities and towns, the current supplied for lighting purposes is alternating. A high voltage current is generated in an alternating-current dynamo at the power house. It is carried on wires to a transformer near the group of houses in which it is to be used. In the transformer it produces a new alternating current of lower voltage. This new current is then

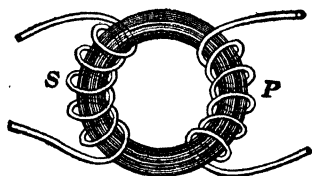

FIG. 166. — The transformer.

distributed to the houses. We will first study the transformer, and then take up its advantages.

A diagram of the transformer is given in Fig. 166. It consists of a ring of soft iron upon which are wound the two coils *P* and *S*.

The coil *P*, which receives the current from the dynamo, is called the *primary* coil. The coil *S*, in which the new current is produced, is called the secondary coil.

The action of the transformer is as follows. When the alternating current from the dynamo passes through the wire of the coil *P* in one direction, it makes the ring a magnet. This magnetism passes through the secondary coil *S* and produces an induced current. The next instant the direction of the current in *P* changes; this magnetizes the ring in the opposite direction, and produces an induced current in the opposite direction in the coil *S*. If, for example, the current from the

dynamo reverses its direction 50 times a second, the induced current produced in S also reverses 50 times a second.

The important feature of the transformer is that it takes an alternating current of one voltage and produces a new alternating current of a higher or lower voltage according to the ratio of the windings of the coils. For example, if the coil P (Fig. 166) has ten times as many turns of wire as the coil S , the new current produced in S has only $\frac{1}{10}$ the voltage of the current used in P . If, however, the current from the dynamo is sent into the coil S , the new induced current obtained from P has 10 times the voltage of the current used in S . If the windings are in any other ratio a corresponding change is produced.

In general, *the ratio of the voltages of the old and new currents is the same as the ratio of the number of turns of wire in the coils.*

When a transformer is used to take an alternating current of one voltage, and produce a new alternating current of a lower voltage, it is called a *step-down* transformer. When it is used to produce a current of a higher voltage, it is called a *step-up* transformer.

The power of a current is measured in watts, and is equal to volts \times amperes. This power is not altered by a transformer. For example, if the ratio of the windings of the coils is 10, a current of 1100 volts and 20 amperes is transformed to one of 110 volts and 200 amperes. That is, the amperage is changed in the opposite direction to the voltage, and the product, volts \times amperes, is constant, $1100 \times 20 = 110 \times 200$. This is true in general, if we neglect the small loss in the transformer.

Advantage of the transformer. — In city lighting circuits the current from the dynamo has usually a potential of 1100 volts. This is carried to the transformer where it produces a new current of 110 volts. The advantage of this arrangement is that the high voltage current can be carried on smaller wires because the amperage is lower. The size of wire needed for any current depends only upon the number of amperes. For example, the size of wire needed to carry 20 amperes is only one tenth

that required for 200 amperes. The wire is made of copper, and since copper is expensive, the saving in cost of copper, brought about by the use of the transformer, is a very important consideration.

The induction coil. — We have now studied two appliances which produce induced currents; namely, the dynamo and the transformer. In this paragraph we will take up another such appliance, the induction coil.

The induction coil is applied in a number of ways; for example, it is used as a jump spark coil on gasoline engines in automobiles,

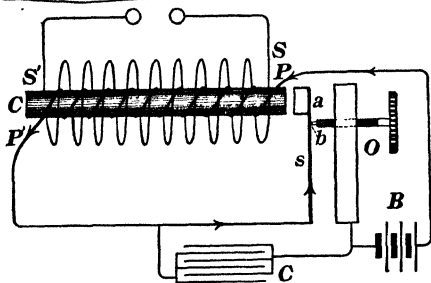

FIG. 167. — The induction coil.

motor boats, etc. It is used also to produce current for the X ray and wireless telegraph, which we will study later. It is also an important part of the telephone.

A diagram of the induction coil is shown in Fig. 167. It consists of a soft iron core C on which is wound a primary coil PP' consisting of a few turns of coarse wire. Outside of this is wound a secondary coil SS' , consisting of many turns of fine wire. The primary wire is connected with a battery and an interrupter, which consists of a piece of soft iron a on the end of a piece of spring steel s . The current from the battery B passes through the primary coil PP' , and to the steel spring s ; it then passes across to the large screw at the point b , and back to the battery through the metal post O . The interrupter "makes" and "breaks" the current at the point b . When the current is started, C becomes a magnet and draws a over, breaking the current at b . The core C then ceases to be a magnet and the spring s draws a back; this "makes" the current; and so on.

The action of the induction coil is as follows: When the current is started in the primary, an induced current is produced in the secondary, in a direction opposite to that in the primary. When the current is stopped in the primary, an induced current is produced in the secondary, in the same direction as that in the primary. Since the secondary has many more turns of wire than the primary, the induced current in the secondary has a much higher e. m. f. than that in the primary. If the e. m. f. is high enough, sparks pass between the secondary terminals.

The condenser *C*, shown at the bottom of the diagram, serves to make the "break" sharper. It consists of sheets of metal foil insulated from one another by paraffined paper. Its action is as follows: We know from our study of induced currents that the e. m. f. produced is greater the more rapidly the magnetic lines of force are cut. If the condenser is not used, the current in the primary forms a small arc at *b* on the "break," making the "break" slow. This arc is due to the current produced by induction in the primary coil. When a condenser is used, the current flows into the condenser and the arc is not formed. Thus the "break" is sharp and the e. m. f. produced in the secondary coil is high.

The telephone. — The telephone, as we all know, is a very important household electrical appliance. The chief parts of it are the transmitter and receiver. The part of the telephone into which we speak is the *transmitter*, and the part we place against the ear is the *receiver*.

The transmitter. — Behind the mouth piece of the transmitter, Fig. 168, is a thin, flexible sheet metal diaphragm *D*, fastened loosely around the edge in such a way that it vibrates when sound waves strike it. A small plate of carbon *C* is fastened to the back of this diaphragm, and vibrates with it. A second plate of carbon *C'* is fastened to the transmitter frame a short distance behind this, and the space between the two carbon plates is filled with carbon granules or carbon shot *g*. The

current from the battery flows in succession through the diaphragm, the first carbon plate, the carbon shot, and the second carbon plate. It then flows through the primary of induction coil, and back to the battery.

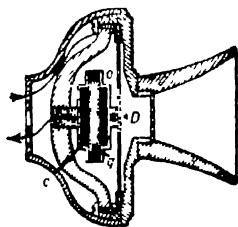

FIG. 168 — The transmitter

The action of the transmitter, illustrated in Fig. 169, is as follows: When a person speaks into the mouthpiece *T*, the sound waves, produced in the air, make the thin, flexible diaphragm vibrate, and with it the carbon plate fastened at the back. When the plate moves in,

the carbon granules are forced more closely together, and when it moves out, they are less closely compressed. When carbon granules are forced together, they conduct electricity better than they do when less closely compressed. Therefore, when the diaphragm moves in, the battery *B* sends a stronger

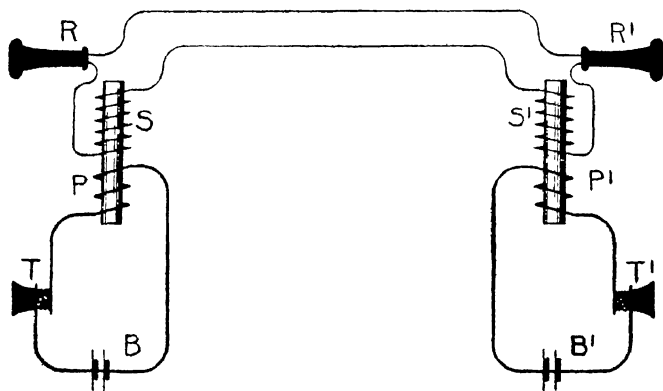

FIG. 169 — Diagram of two telephones connected

current through the primary coil *P* of the induction coil; and when it moves out, this current is decreased. When the current is increasing in the primary coil, an induced current

is produced in one direction in the secondary S of the induction coil, and when it is decreasing, another induced current is produced in the secondary but in the opposite direction to the first.

If the voice produces 200 sound waves per second, the thin, flexible diaphragm moves in and out 200 times each second, and thus there are 400 induced currents produced in the secondary of the induction coil each second, 200 in each direction. These induced currents pass through the receiver R of the telephone spoken into, and also through the receiver R' of the telephone at which the message is received. Let us see what happens in the receiver.

The receiver — If we unscrew the cap of the receiver of a telephone, we find a thin, flexible sheet iron plate D , and beneath it a magnet MM , Fig. 170. The plate is supported around the edge in such a way that it is close to the pole of the magnet, but does not touch it. The magnet is a permanent magnet with a coil of fine wire CC wound around one pole. The two end wires FF of the coil are joined to the secondary of the induction coil. The magnet then is really a *permanent magnet and also an electromagnet*. In modern receivers, a horseshoe magnet is used and both poles are placed beneath the plate D .

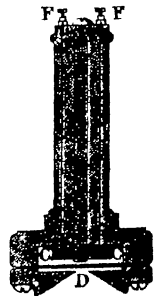

FIG. 170. — The receiver

The action of the receiver is as follows: The thin, flexible plate is bent in by the pull of the permanent magnet, and when an induced current passes around the coil in such a direction that it increases the strength of the permanent magnet pole, the flexible plate is bent in still farther. The next induced current being in the opposite direction decreases the strength of the permanent magnet pole, and allows the elasticity of the iron to bend the plate out. The next current bends it in, the next out, etc. If the voice produces 200 sound waves in the transmitter, the induced currents bend the flexible plate of the receiver in and out 200 times each

second. The plate thus produces 200 sound waves per second in the air in the cap of the receiver, and the ear hears a sound which is made up of 200 waves.

We notice, then, that the telephone wire carries not sound, but electricity. When a person speaks into a telephone the sound moves just about one inch, that is, to the flexible plate of the transmitter. After this it is all electric currents until we come to the receiver. The sound a person hears in the receiver is produced about one inch from the ear; it is produced by the movement of the flexible plate of the receiver.

EXERCISES

1. Make a diagram of the transformer. Describe what takes place in the transformer.
2. Make a diagram of an induction coil. Describe it.
3. Make a diagram of the telephone transmitter, and tell what takes place when a person speaks into it.
4. Make a diagram of a telephone receiver, describe it, and tell how sound is produced in it.
5. Make a diagram of two telephones connected. Describe it.

CHAPTER XXIII

WIRELESS TELEGRAPH, CATHODE RAYS, X RAYS, AND RADIUM

Wireless telegraphy.
— The telegraph and telephone transmit messages from one place to another by means of wires. The wireless telegraph, as its name indicates, transmits messages without the use of wires between stations. The essential parts of the wireless telegraph are the sending apparatus and the receiving apparatus.

Wireless sending apparatus. — A simple sending station is shown in Fig. 171. It consists of an induction coil *I* with one secondary terminal connected to the earth and the other

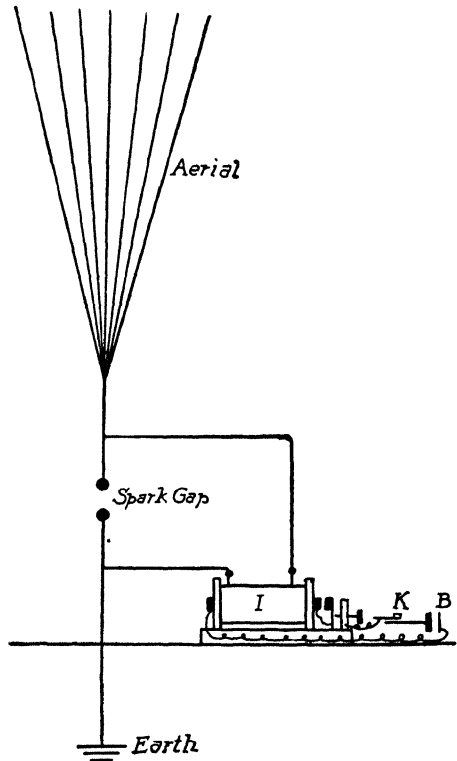

FIG. 171. — Wireless sending apparatus.

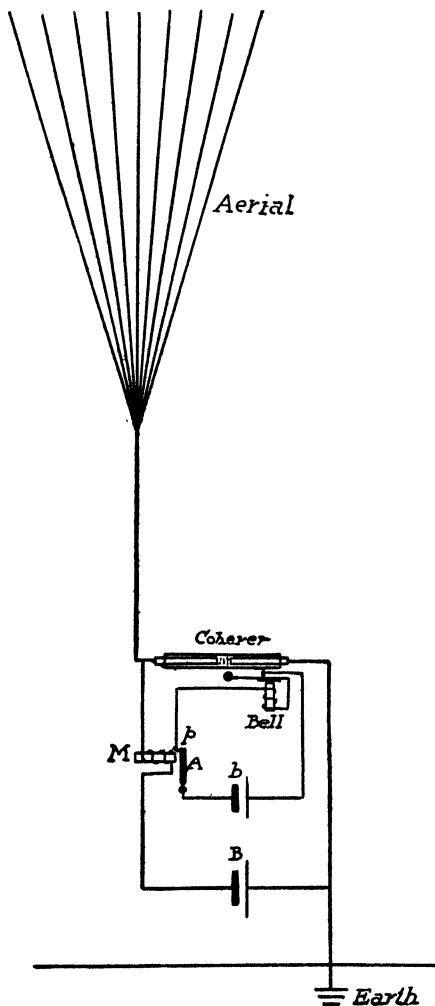

FIG. 172. — Wireless receiving apparatus.

connected with a group of wires suspended from insulators attached to a tall mast. This group of wires is called the *aërial*.

An electric spark which appears to the eye to be one single spark is really made up of from 10 to 30 separate sparks. This may be shown by looking at the image of a spark in a rapidly revolving mirror, when the image appears as a series of sparks side by side. It may be illustrated more simply by allowing an electric spark to penetrate a piece of cardboard; the rim of the hole will be rough on *both* sides, showing that the electricity must have passed through it in both directions.

When a spark is produced at the spark gap by the induction coil of the sending station, the electricity passes back and forth between the aërial and the earth a number of times. This surging of electricity up

and down produces a series of waves in the ether. These waves travel out in all directions, and are detected at the receiving station as explained below.

Wireless receiving station. — A simple receiving station is shown in Fig. 172. It is equipped with an aerial similar to that at the sending station. This is joined to one end of the coherer, which is the sensitive part of the receiving station. The other end of the coherer is connected with the ground.

The coherer. — The action of the coherer is based upon the following facts. Metal filings conduct electricity very poorly; but when an electric spark is passed through them, the filings cling together or cohere, and become a good conductor of electricity. If the filings are shaken up, they separate or decohere and again become a poor conductor of electricity.

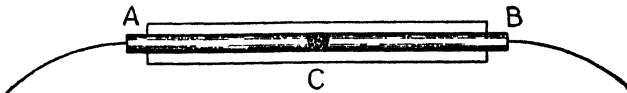

FIG. 173. — The coherer.

The coherer, Fig. 173, consists of a small glass tube in which two metal rods *A*, *B* are separated by a small quantity of loosely packed metal filings *C*.

The coherer, besides being connected with the aerial and the ground wire, is also connected in series with the battery *B*, and the relay magnet *M*. When the waves from the sending station fall upon the aerial, electrical surgings are set up between the aerial and the ground and a series of sparks pass through the metal filings in the coherer. The filings cohere and become a conductor, a current then flows from the battery *B*, through the coherer, and through the relay magnet *M*.

The bell battery *b* is connected with the electric bell through the relay armature *A*. When the current from the battery *B* flows through the relay magnet, the relay armature is drawn over. This closes the circuit of the bell battery *b*, at the point *p*, and the bell begins to ring.

The knob of the bell is so arranged that it strikes the coherer and shakes up the filings. This decoheres the filings, and they become a poor conductor, therefore the current through the relay magnet is stopped, the relay armature is released, the current from the bell battery is broken at the point p , and the bell stops ringing. As long as the waves are coming from the sending station the bell rings because the filings remain cohered in spite of the fact that the bell knob is shaking them up. When the waves stop coming the last stroke of the bell knob decoheres the filings, and the bell stops ringing.

In sending a message the operator at the sending station sends out long and short series of waves. These produce long and short rings of the bell, which correspond to the dash and dot of the telegraph code. An ordinary telegraph sounder may be used instead of the bell, and, with coherers which do not require tapping to decohere them, the telephone receiver may be used. Each station is equipped with both a sending and a receiving apparatus, which use the same aerial, one being disconnected while the other is in use.

Cathode rays, electrons. — An electric discharge passes through a partial vacuum much more readily than through air.



FIG. 174 — Electricity passing through a partial vacuum

This may be shown as follows. Connect the terminal of an induction coil with the two wires, sealed into the ends of a

glass tube, Fig. 174, attach an air pump to the small open tube shown near one end. Start the induction coil working and the spark passes between the terminals of the induction coil; but when the air pressure inside the tube is reduced to about $\frac{1}{10}$ of an atmosphere, the spark passes through the long tube, in the form of a colored band. That is, an electric discharge passes more readily through a partial vacuum than through air.

When the pressure is reduced to about $\frac{1}{10000}$ of an atmos-

sphere the nature of the discharge changes, and invisible radiations known as cathode rays are given off from the cathode.

The properties of these cathode rays are as follows :

- (1) They produce fluorescence in the glass walls of the tube.
- (2) When concentrated on a substance, they produce strong heating effects.
- (3) They make sharp shadows of objects placed in their path.
- (4) They give a negative charge of electricity to bodies they fall upon.
- (5) They are deflected by a magnet.
- (6) They are deflected by an electric charge.
- (7) When they penetrate a gas they make the gas a conductor of electricity. This is called ionization.

Nature of cathode rays. — The cathode rays have been the subject of much investigation, and it has been found that they consist of streams of very small particles which are called *electrons*. The electrons are isolated charges of negative electricity which travel with various velocities up to $\frac{1}{2}$ that of light. Also the two remarkable facts have been discovered: first, that all electrons are the same, no matter what metal is used as the cathode, or what gas remains in the tube; second, that the mass of the electron is electromagnetic in nature and thus depends on the velocity, but in certain cases is about $\frac{1}{1700}$ the mass of the hydrogen atom. In other words, it has been discovered that there are particles very much lighter than the lightest atom known, and that these particles are the same, no matter from what substance they are derived.

Electron theory of matter. — The discoveries mentioned in the last paragraph gave rise to the electron theory of matter developed by the English physicist, Sir. J. J. Thomson. This theory is that all atoms are made up of systems of positively and negatively charged particles in rapid motion, the negatively charged particles being electrons. According to this theory: light, heat, and electromagnetic waves are produced by the vibration of the electrons; a current of electricity consists of a stream

of electrons moving through the conductor, a negatively charged body contains an excess of electrons, and a positively charged body is deficient in electrons.

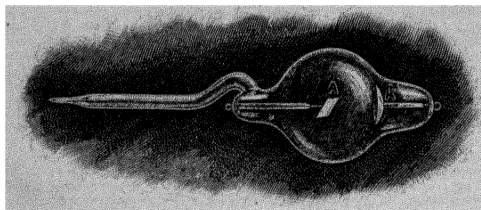

FIG. 175. — X ray tube. The cathode rays from *K* strike the metal anode *A* and produce X rays.

X rays — When the cathode rays fall upon a body such as a piece of metal or the walls of a tube, they set up another invisible radiation known as

the X ray. This was discovered by Rontgen in 1895. The X ray is different from the cathode rays in that it is not deflected by a magnet or by an electric charge, and it penetrates substances through which the cathode ray cannot pass.

X ray pictures. — The X ray is similar to light in that it affects a photographic plate and causes fluorescence in certain substances. The denser a substance the less readily the X rays penetrate it. If the hand is held over a photographic plate inclosed in a plate holder, and is exposed to the influence of the X ray for a short time, the plate on being de-



FIG. 176. — X ray photograph.

veloped shows the outline of the hand and of the bones of the hand. The bones are denser than the flesh, and the X rays penetrate them less readily; therefore the outline of the bones on the negative is lighter than that of the flesh. A picture printed from this negative shows the bones darker Fig. 176.

Similarly, if the hand is held between an X ray tube and a screen covered with a substance which is caused to fluoresce by X rays, the outline of the hand and of the bones of the hand may be seen on the screen. The fluoroscope, Fig. 177, is used for this purpose. The bottom of it is a fluorescent screen.

Nature of X rays. — X rays were called X rays because it was not known what they are. It has recently been shown that they are similar to light in that they can be reflected, refracted, and polarized. They are believed to be very thin pulses in the ether, set up by the impact of electrons upon solid bodies.

Radium. — X rays are produced by cathode rays which cause strong fluorescent and phosphorescent effects in various bodies. This led scientists to examine bodies which are made phosphorescent by sunlight to see whether they gave off X rays. In 1896 the French scientist, Henri Becquerel, investigated this with the phosphorescent substance uranium. He wrapped a photographic plate in opaque paper, placed a coin on the paper, and suspended a piece of uranium over the coin and plate. He allowed these to stand for a few days in a dark room, and on developing the plate found upon it an image of the coin similar to that formed by X rays. It has since been shown that there is no relation between phosphorescence and this effect; but Becquerel's experiment demonstrated that uranium sends out rays which have an effect similar to those produced by X rays.

Professor and Madame Curie then investigated many substances and found that the element thorium has a similar effect. During the investigation they discovered that pitchblende, an ore of uranium, has a greater effect than uranium



FIG. 177.—The fluoroscope.

They concluded that there must be in pitchblende some new substance producing this greater effect. They started in to separate this new substance, and after great labor succeeded in separating a few milligrams of it from tons of pitchblende. This new substance they called *radium*.

It has been shown by Rutherford that the rays given off by radium are of three kinds, which he named the alpha, beta, and gamma rays. The alpha rays are positively charged particles with a mass equal to four times that of the hydrogen atom and with a velocity of about 20,000 miles per second. It has recently been shown that they are positively charged atoms of helium. The beta rays are identical with cathode rays; they consist of streams of electrons with very high velocities. The gamma rays are supposed to be X rays produced by the impact of the electrons of the beta rays on surrounding substances.

Substances which have the property of sending out rays are known as *radioactive* substances; such are uranium, thorium, radium, actinium, and polonium.

It has been shown that the atoms of radioactive substances, besides giving off rays, also decompose and produce atoms of new substances. For example, uranium atoms decompose, and after the formation of two intermediate substances produce atoms of radium. Radium atoms in turn produce a series of new atoms, the final one at present known being lead. Similarly, thorium and actinium atoms decompose and each produce a series of new atoms.

Radioactive substances are intensely interesting because, first, their atoms change into atoms of new substances; second, the atoms in changing give off energy in the form of heat and of particles moving with great velocity. This energy is the internal energy of the atoms.

In radioactive substances we have for the first time examples of the change of one element into another, and of the release of the energy contained in the atom.

EXERCISES

1. Make a diagram of a wireless sending apparatus and describe it.
2. Make a diagram of a wireless receiving apparatus and describe it.
3. State the properties of cathode rays.
4. What are the properties of electrons?
5. State the electron theory of matter.
6. How are X rays produced. How are X ray photographs made?
7. What are the alpha, beta, and gamma rays?
8. Why are radioactive substances interesting?

CHAPTER XXIV

LIGHT IN THE HOME

How do we see? — We see any object by means of light which travels *from the object to the eye*. Light which enters a room from any source is reflected many times from the floor, ceiling, walls, and from objects in the room. That is, it is scattered or diffused in all directions and thus objects in the room are made visible. Any particular object, however, is seen only by means of the light which moves from that object to the eye.

Arrangement of lighting fixtures in the home. — The lighting fixtures in a home should be so arranged that the light is thrown upon the objects to be seen, and not into the eyes. To understand the reason for this we must understand the action of the pupil of the eye. The pupil is the opening in the colored part of the eye. Its function is to regulate the amount of light which enters the eye. When the light is strong, the pupil contracts; when the light is dim, it expands.

It is difficult to read while facing a strong light because the strong light causes the pupil to contract to such an extent that it does not admit sufficient light from the book or paper. It is easy to read with the back to the light, because the strong light does not fall upon the eye, and the pupil expands until it admits sufficient light from the book or paper.

In planning the arrangement of the lighting fixtures we must remember: first, that an object is seen by means of light which travels from the object to the eye; therefore, the fixtures should be so placed that they throw the light on the objects we wish to

see; second, the pupil adjusts itself to the light which falls on it; therefore, the fixtures should be so arranged that the direct light does not fall on the eyes. In short, the fixtures should be so arranged that the light is thrown on the objects to be seen and not into the eyes.

Keeping these facts in mind, we find the proper illumination for the different rooms in the home to be somewhat as follows. In the kitchen, separate lamps over the table, range, and sink, each lamp being so shaded that the light is thrown down upon the table, range, or sink and not into the eyes. If in addition, general illumination is desired, a separate light should be placed near the ceiling, well above the level of the eyes. Similarly in the dining room, it would seem that the lights should be well shaded and placed low over the table, in order to throw the light down upon the table and not into the eyes. In the halls, where general illumination is desired, the lights should be near the ceiling at a height well above the level of the eye. In the dressing rooms, lights should be placed on each side of the mirror and a sufficient distance in front of the mirror to throw the light on the sides of the face rather than into the eyes.

Intensity of light. — If we hold a book one foot from a lamp, it receives a certain amount of light; if we hold it two feet from the lamp, it receives only one fourth as much light; if we hold it three feet from the lamp, it receives only one ninth as much light; and so on. That is, *the intensity of the light on an object varies inversely as the square of the distance between the object and the source of light.*

We can show this nicely by means of the experiment illustrated in Fig. 178. The light from a lamp is allowed to pass through a small hole O , and fall upon a square hole $ABCD$ in a screen one foot from O . The light which passes through the square hole is caught on a second screen placed two feet from O . It covers an area $EFGH$ which has four times the area of the square hole. Since the light covers four times the area, it is only one fourth as intense on any one area. That is, the light

at a distance of two feet is only one fourth as intense as it is at a distance of one foot from the source.

If the second screen is placed three feet from O , the area covered is nine times as great, that is, the intensity is only one

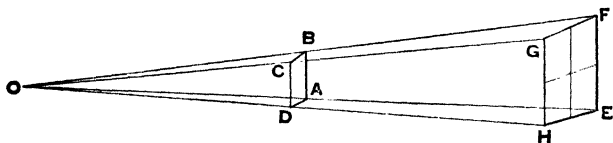

FIG. 178. — The intensity of light varies inversely as the square of the distance between the source of light and the object illuminated.

ninth as great. That is, the intensity of the light on an object varies inversely as the square of the distance between the object and the light.

Candle power of a light. — In the days of our great-grandparents, the common source of light in the home was the candle. Since that time the oil lamp has been perfected, and methods of lighting by means of gas and electricity have been introduced. With the introduction of each new source of light, the amount of light it gave was compared to the amount given by a candle. If, for example, the light gave five times as much light as a candle, it was called a five candle-power light. This is the common method still in use; for example, if we examine the common electric light bulb, we find it marked 16 c. p., which stands for 16 candle power and means that the electric light gives as much light as 16 standard candles or 16 times as much light as one standard candle.

The law stated above regarding the intensity of light is used in finding the candle power of a lamp. The apparatus used in measuring candle power is called a photometer. We shall study one of the simplest of these, namely, Bunsen's photometer.

Bunsen's photometer. — The arrangement of Bunsen's photometer is shown in Fig. 179. A sheet of paper A with a greased spot in the center is placed between a standard candle B and the

lamp to be tested, *C*. The standard candle is placed a certain distance from the screen, say one foot. The lamp is then moved back and forth until a position is found in which the greased spot is as bright as the remainder of the paper. If this distance is 3 ft., the lamp at 3 ft. is throwing as much light on the screen as the candle at 1 ft. Therefore, since the intensity of the light is inversely proportional to the square of the distance, the lamp is 9 candle power.

Let us explain this further. If a piece of paper with a greased spot is viewed by reflected light, the greased spot appears

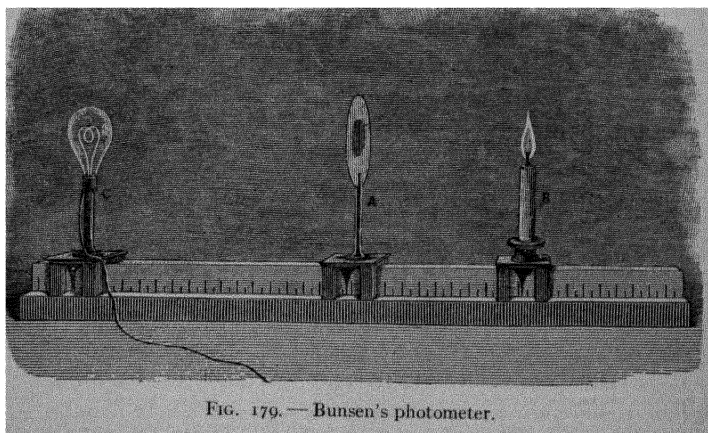

FIG. 179. — Bunsen's photometer.

darker than the remainder of the paper, because more light passes through the greased spot than through the paper. If it is viewed by transmitted light, the greased spot is brighter than the paper, for the same reason, that is, more light passes through the greased spot than through the paper.

The candle throws a certain amount of light on the screen of the photometer, and a certain amount passes through the greased spot. When the lamp is in such a position that it throws the same amount of light on the screen as the candle, the greased spot is as bright as the remainder of the paper, because the light

which passes through from one side is equal to that which passes through from the other side.

If the candle is placed 1 ft. from the screen and the lamp throws an equal amount of light on the screen when it is 3 ft. from the screen, it is a 9 candle-power lamp, because the intensity varies inversely as the square of the distance, and the lamp at 1 ft. from the screen would throw on the screen 9 times as much light as the candle. If other lamps at 4, 5, and 10 ft. throw as much light on the screen as the candle at 1 ft., they are 16, 25, and 100 candle-power lamps respectively.

Nature of light. — Light is that which produces the sensation of sight. The exact nature of light has long been a subject of investigation and at the present time scientists believe that light is *a transverse wave motion in the ether*. The ether is believed to be a medium which fills all space. It is believed to fill the space between the planets and also the space between the molecules and atoms of all substances. For example, it is believed to fill the space between the sun and the earth and also the space between the molecules and atoms of our bodies. It is believed that when any body is moved, the ether flows through the body just as water flows through a sieve.

A transverse wave motion is one in which the particles of the medium vibrate in a direction at right angles to the direction in which the wave moves. For example, water waves are transverse waves; the wave moves along the surface of the water, but any particle of water moves simply up and down in a direction at right angles to the surface. This can be illustrated by throwing a chip on the surface of water on which there are waves which do not break or form white caps. The wave moves along the surface, but, if there is no wind, the chip moves simply up and down at right angles to the surface.

Light waves are heat waves. — If the hand is held near a source of light, such as the flame of a candle, oil lamp, or gas jet, the hand is illuminated and also heated. All our common

sources of light send out thousands of streams of waves in the ether. Each stream consists of waves of one length, but the waves in one stream may differ in length from those of another. Therefore at any instant the hand is receiving waves of many different wave lengths. All the waves received give some heat; that is, they are all heat waves; a certain number also produce upon our eyes the sensation of sight, that is, they are light as well as heat waves. Light waves, then, are heat waves which produce upon our eyes the sensation of sight.

The process of transferring heat from one place to another by means of heat waves is known as *radiation*. We took up the question of radiation on page 104 above; we also learned there how heat and light waves are produced.

How heat and light waves are produced. — In the section on heat we learned that when a body is heated the particles comprising the body vibrate more rapidly. All our sources of light are heated bodies, for example, the sun, candle, oil lamp, gas jet, incandescent light, arc light, etc. At the present time scientists believe that heat and light waves are produced as follows. The molecules, atoms, and particularly the very small particles, known as electrons, of which the atoms are composed, vibrate rapidly in the luminous part of the source of light. Each vibrating particle sets up a stream of waves in the ether. These waves travel out in all directions and are the heat and light waves.

Velocity of heat and light waves. — The velocity of heat and light waves has been measured many times, and it has been found: first, that all heat and light waves travel in the ether with the same velocity, and second, that they travel with the enormous velocity of 186,000 miles per second. It is very hard to conceive such a velocity. Sound travels at a velocity of about $\frac{1}{2}$ mile per second, a high velocity bullet at the rate of about $\frac{1}{2}$ mile per second. These are the highest velocities with which we are familiar, but they are snail's paces compared to the velocity of light.

Wave front, ray, pencil, and beam. — Every point of a luminous body sends out waves in all directions in the ether. These waves travel with equal velocities. Each vibration of a particle sets up a wave which travels out from the particle in the form of a sphere of which the particle is the center. The surface of this sphere is called the *wave front*.

Lines drawn from the vibrating particle through the wave fronts are called *rays*. They show simply the directions in which the light is traveling. Since the vibrating particle is the center from which the wave fronts start, a ray is a radius of the sphere and therefore *a ray is always perpendicular to the wave fronts*.

When rays meet at a point or diverge from a point, they are known as a *pencil of light*.

When the source of light is at a great distance, the wave fronts are nearly parallel, and as a result the rays are nearly parallel. A collection of parallel rays is called a *beam of light*.

EXERCISES

1. How would you show that objects are seen by light which travels from the object to the eye?
2. Why is it more comfortable to read with the back to the source of light?
3. How should the lights be placed in a kitchen, dining room, hall, and dressing rooms? Why?
4. Describe an experiment to show that the intensity of illumination varies inversely as the square of the distance between the source of light and the object illuminated.
5. Describe the Bunsen photometer.
6. Lamps placed $3\frac{1}{2}$, 5, and 10 ft. from a Bunsen photometer screen give the same light as a standard candle placed 1 foot from the screen. What is the candle power of the lamp in each case?
7. What is light?
8. How do light waves differ from other heat waves?
9. Define wave front, ray, pencil, and beam.

CHAPTER XXV

REFLECTION AND REFRACTION OF LIGHT

Light travels in straight lines in a given medium. — That through which light travels is known as the *medium* through which it travels, examples, ether, air, water, and glass.

Light travels in a straight line through a given medium. This can be shown for the medium, air, by the experiment illustrated in Fig. 180. A hole is made in each of three cards,

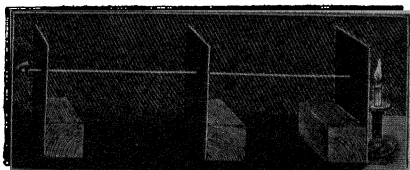

FIG. 180 — Light travels in a straight line.

placed in a row in front of a candle. The light of the candle can be seen only when the holes are in a straight line.

When light moving through one medium meets another medium, it is reflected or refracted or both. For example, when light moving

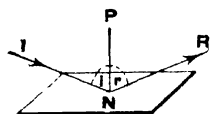

FIG. 181 — The angle of reflection is equal to the angle of incidence

through air strikes a mirror, it is reflected; when it strikes water, it is partly reflected and partly refracted.

Angle of reflection equals angle of incidence. — If a beam of sunlight is allowed to fall upon a mirror and the beam before and after reflection is made visible by means of chalk dust in the air, it is found that the beams make equal angles with a ruler held perpendicular to the mirror, Fig. 181.

The beam *I* which strikes the mirror is called the *incident beam* and the beam *R* which is reflected is called the *reflected*

beam. The angle i which the incident beam makes with the perpendicular PN is called the *angle of incidence*, and the angle r which the reflected beam makes with the perpendicular is called the *angle of reflection*. The experiment described above illustrates the *Law of Reflection*, which is, *The angle of reflection equals the angle of incidence.*

The location of the image seen in a mirror. — *The image seen in a mirror is always the same distance behind the mirror that the object is in front; also, the image is exactly opposite the object, that is, a line drawn from the object perpendicular to the mirror passes through the image.*

This can be shown as follows : Stand a pane of window glass in a perpendicular position on the table, place a lighted candle in front of it, and an unlighted candle of the same size behind it. Move the unlighted candle until it coincides with the image of the lighted candle, no matter from what position the eye views it from the front side of the glass. It is found by measurement that the image is opposite the candle, and at an equal distance from the mirror.

Since each point of an image is directly opposite the corresponding point of the object, the image formed in a mirror is reversed. For example, in a mirror, the right hand becomes the left hand and the left hand the right hand.

The reason the image appears the same distance behind the mirror that the object is in front is as follows : The eye estimates distance by the curvature of the wave fronts which fall upon it. If an object is near at hand, the wave fronts from it are much curved ; if the object is at a distance, the wave fronts from it are less curved when they reach the eye.

The wave fronts from an object which strike a mirror are changed in direction but not in curvature ; thus the image appears to be behind the mirror and at the same distance behind that the object is in front.

Refraction. — When light from any object passes in a slanting direction from one medium to another, for example, from water

to air or the reverse, the rays are bent at the surface separating the media. The bending of the rays of light is called *refraction*.

We can show the refraction of light rays when light passes from air into water by the experiment illustrated in Fig 182. A beam of light AB is allowed to pass through a shutter and fall upon the water in a glass trough. The light after it enters the water moves in the direction BD instead of in the direction BC . It will be noticed that the light is bent towards the line

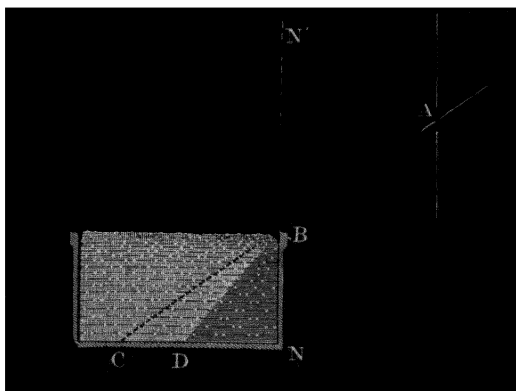

FIG. 182. — The beam of light is bent in passing from air into water.

NN' drawn perpendicular to the surface of the water at the point the light enters.

When light passes from water to air, the rays are bent in the opposite direction, that is, away from the line drawn perpendicular to the surface at the point the light leaves the water.

Laws of refraction. — The following laws of refraction have been discovered by experiment.

(1) When light rays pass in a slanting direction *from a rare medium to one more dense*, they are bent *towards* the line drawn perpendicular to the surface at the point they enter.

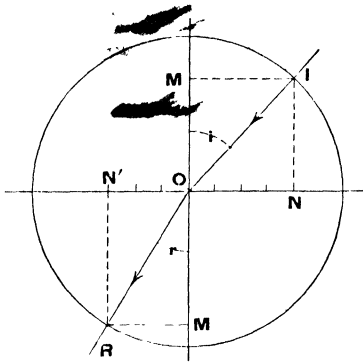

FIG. 183. — Light passing from air into water.

(2) When light rays pass in a slanting direction from a dense medium to one less dense, they are bent away from the line drawn perpendicular to the surface at the point they leave the surface.

These laws are illustrated in Figs. 183 and 184. In Fig. 183 the ray IOR passes from air into water and is bent towards the line MOM' drawn perpendicular to the surface at the point it enters.

In Fig. 184 the ray IOR passes from water to air and is bent away from the line drawn perpendicular to the surface at the point it leaves the water.

For any two media the ratio between the sines of the angles of incidence and refraction is constant. In Fig. 183,

$$\sin i = \frac{IM}{OI} = \frac{NO}{OI}; \quad \sin r = \frac{RM'}{RO} = \frac{N'O}{RO} \quad \text{and} \quad \frac{\sin i}{\sin r} = \frac{NO}{N'O} = \frac{4}{3}$$

This ratio is constant for all angles of incidence when light passes from air to water.

In Fig. 184,

$$\frac{\sin i}{\sin r} = \frac{NO}{N'O} = \frac{3}{4}$$

This ratio is constant for all angles of incidence when light passes from water to air.

Explanation of refraction. — When light passes from one medium to another of different density, the curvature of the wave fronts is altered, because the light travels at a different velocity in the second medium. Since the rays are always at right angles to the wave fronts, their direction is changed when the wave fronts change in curvature. This is the explanation of refraction.

We may illustrate this by an example. It is known that light travels faster in air than in water, and when we view an object in water, the light moves from the object to the eye, first through water and then through air. When a wave front reaches the surface, that part which arrives first moves faster in the air than the part which is still in water, thus the curvature of the wave fronts is increased and the object appears nearer than it really is. Thus the rays appear to come from the nearer point, and each slanting ray is bent away from the line drawn perpendicular to the surface at the point it leaves the surface.

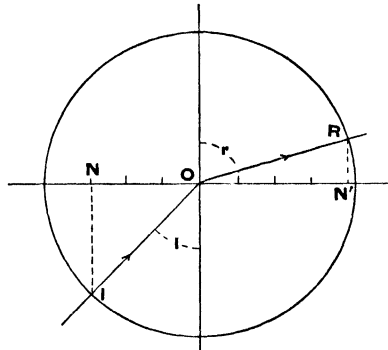

FIG. 184. — Light passing from water into air.

When light travels from air to water the reverse is true; the wave fronts become less curved, and each slanting ray is bent towards the perpendicular.

Media with parallel sides. — When an object is viewed in a slanting direction through a dense medium with parallel sides, it appears shifted to one side. The explanation is illustrated in Fig. 185. Light from *A* passes through a glass plate with parallel sides. As the light enters the glass it is bent *towards* the perpendicular *eg*.

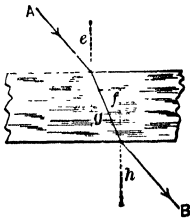

FIG. 185. — Light passing through a glass plate with parallel sides.

It travels in this new direction through the glass, and when it leaves it is bent *away from* the new perpendicular *fh*. The ray after it leaves the glass moves in a path parallel to the path in which it moved when it entered the glass.

Prism. — When an object is seen through a prism made of a dense medium it appears to be in an entirely different position. For example, in Fig. 186, the object L when seen through a glass prism appears to be at L' . The explanation is as follows: When the light from L enters the glass prism, it passes from a rare to a dense medium, and is bent *towards* the perpendicular n . It travels in this new direction through the prism. When it leaves the prism, it passes from a dense to a rare medium, and is bent *away from* the perpendicular n' .

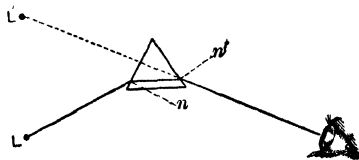

FIG. 186. — Light passing through a prism.

When the light from L enters the glass prism, it passes from a rare to a dense medium, and is bent *towards* the perpendicular n . It travels in this new direction through the prism. When it leaves the prism, it passes from a dense to a rare medium, and is bent *away from* the perpendicular n' .

Since the glass is in the form of a prism, these two bendings are in the same direction and the object appears to be in a position much removed from its actual position. It will be noticed that when light passes through a prism it is bent towards the thicker part of the prism.

EXERCISES

1. State the law of reflection.
2. How would you show by experiment that an object and its image are the same distance from a plane mirror?
3. Explain why the image of an object is the same distance behind a mirror that the object is in front.
4. Explain why a glass of water appears shallower than it is when viewed from above.
5. State the laws of refraction.
6. Make a drawing showing the path of a ray of light through water in a bottle with flat parallel sides; explain each change in direction of the ray.
7. Make a drawing showing the path of a ray of light through a prism. Explain each change in direction of the ray.

CHAPTER XXVI

LENSES AND OPTICAL INSTRUMENTS

Convex and concave lenses.—Lenses are of two kinds, convex and concave. Convex lenses are thicker in the center than at the edges. They cause the light to converge. Concave lenses are thinner at the center than at the edges. They cause the light to diverge.

To understand the action of lenses, we can think of them as made up of sections of prisms, the angles of the prisms being greater the nearer we approach the edge.

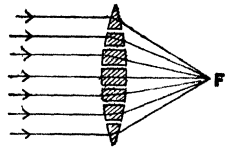

FIG. 187.—A convex lens.

In Fig. 187 a convex lens is shown built up in this way. A ray of light falling on one of the prism sections is bent towards the thicker part of the section. If the prism angles are properly chosen, the rays converge at some point F ; and if the incident rays are parallel, this point F is the principal focus of the lens.

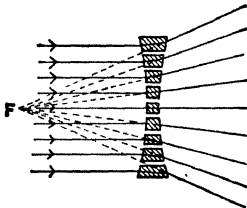

FIG. 188.—A concave lens.

In Fig. 188 is shown a concave lens made up of sections of prisms. In this case the thinner ends of the sections point towards the center. A ray of light falling on one of these sections is bent towards the thicker end of the section. Thus the rays diverge; and if the incident rays are parallel, the point F from which they *appear* to come is the principal focus of the concave lens.

Images. — Images are of two kinds, “real” and “virtual.” An image is “real” when the rays which produce it actually pass through the image. An image is “virtual” when the rays which produce it only *appear* to pass through the image. A real image can be produced on a screen; a virtual image cannot be produced on a screen.

Principal axis, principal focus, focal length. — A line drawn through the centers of curvature of the surfaces of a lens is called the *principal axis* of the lens. The point at which rays parallel to the principal axis converge (or from which they appear to diverge) is called the *principal focus* of the lens. The distance from the center of the lens to the principal focus is called the *focal length* of the lens.

Images formed by a convex lens. — A convex lens produces either real or virtual images. A concave lens produces only virtual images.

When an object is placed in front of a convex lens at a distance greater than the focal length, the lens produces a real

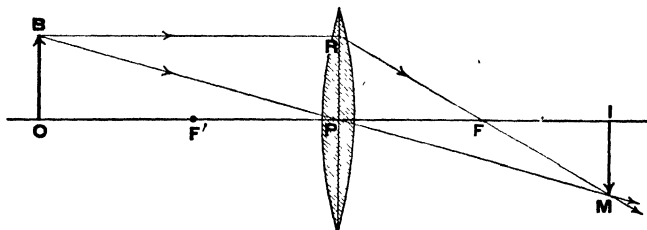

FIG. 189. — Real image formed by a convex lens.

image. This is illustrated in Fig. 189. The line OI is the principal axis. F and F' are the principal foci. The object is OB and the real image is IM . All the rays from B which fall on the lens converge at M . Thus M is the image of the point B . The rays which fall on the lens from a point just below B converge at a point just above M . Similarly rays from all points of OB converge at corresponding points along IM and form the real image.

We can trace readily the paths of two or three rays from any point, and two suffice to locate the image. We can trace the ray BR , which is parallel to the principal axis, because we know that it passes through the focus F after it leaves the lens. The ray BP passes through the center of the lens, and since the surfaces of the lens are nearly parallel at this point, the ray is shifted a little to one side. If the lens is thin, however, we make only a slight error if we assume that the ray passes through in a straight line. These two rays locate the position of M , the image of B ; similarly other points on IM are found to be images of points on OB . The image IM is real and inverted.

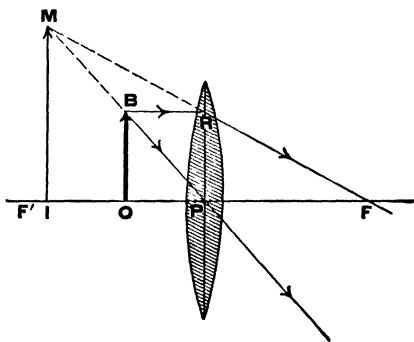

FIG. 190. — Virtual image formed by a convex lens.

If an object is placed in front of a convex lens, but at a distance less than the focal length, a virtual image is formed. This is illustrated in Fig. 190. The parallel ray BR from the point B passes through the focus F after leaving the lens. The ray BP passes through the center of the lens in a straight line. These rays are diverging after they leave the lens; thus they cannot meet to form a real image of B . If, however, they fall on the eye of an observer, they *appear* to come from M . Thus M is the *virtual* image of the point B , and the points along IM are virtual images of points along OB . The image IM is virtual, erect, and enlarged.

Images formed by a concave lens. — A concave lens produces reduced virtual images. This is illustrated in Fig. 191. OB is the object and IM the image. When the parallel ray BR leaves the lens, it moves in such a direction that it *appears* to

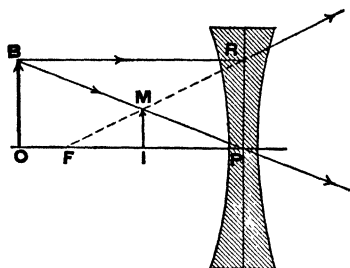

FIG. 191. — Virtual image formed by a concave lens.

come from the principal focus F . The ray BP passes through the center of the lens in a straight line. These rays diverge after passing through the lens and thus cannot form a real image. If, however, they fall on the eye of an observer they *appear* to come from M . Thus M is the virtual image of B . Similarly

IM is the virtual image of OB . The image is virtual, erect, and reduced.

OPTICAL INSTRUMENTS

The camera. — The photographic camera, Fig. 192, is simply a light-proof box, with a converging lens L , fixed in an opening on one side and a ground glass screen S at the opposite side. To focus the camera on any object AB , the lens is moved back and forth until a distinct inverted image ba is seen on the ground glass screen. In order to take a picture, the lens is covered, a photographic plate is substituted for the ground glass screen, and then the lens is uncovered for a certain time.

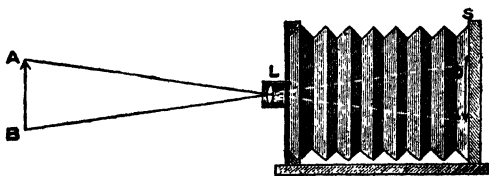

FIG. 192. — The camera.

The projecting lantern. — The projecting lantern consists of a light-proof box, a source of bright light, a condensing lens, the lantern slide, and a projection lens.

A bright light is produced by electricity, or gas, or, as in Fig. 193, by a lime light. The condenser consists of two large convex lenses. It causes the strong light to converge on the lan-

tern slide. The projecting lens is a system of convex lenses. It throws an image of the lantern slide on the screen.

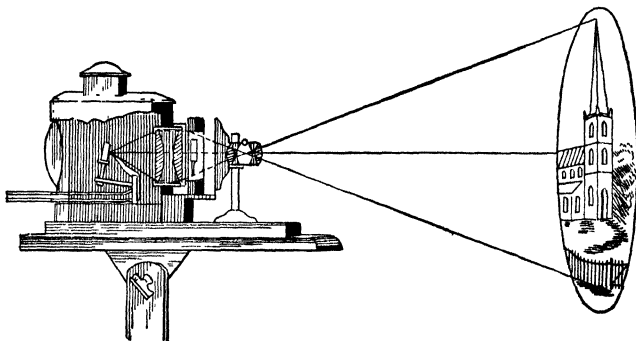

FIG. 193. — The projecting lantern.

The eye. — A horizontal section of the human eye is shown in Fig. 194. The covering of the front of the eye is a transparent membrane *c*, called the *cornea*. Behind this is a clear liquid *a*, called the *aqueous humor*. The colored part of the eye is the *iris*, *i*. It is a muscular tissue with a circular opening, the *pupil*, in the center. The iris has an involuntary motion which regulates the amount of light which enters the eye. It enlarges the pupil in a dim light and contracts it in a bright light. Behind the iris is a double convex transparent body *o*, the *crystalline lens*. The large cavity in the eye is filled with a jelly-like substance *v*, called the *vitreous humor*. The image is formed on the *retina r*, which is an expansion of the optic nerve. The *optic nerve n* carries the impression of light from the retina to the brain. Behind the retina is a black membrane called

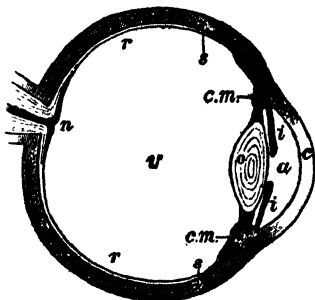

FIG. 194. — The eye.

the *retina r*, which is an expansion of the optic nerve. The *optic nerve n* carries the impression of light from the retina to the brain. Behind the retina is a black membrane called

the *choroid coat*, which incloses the interior cavity of the eye except for the opening, the pupil. It serves to keep all light out of the eye except that which enters through the pupil; it also prevents interior reflection of the light which enters through the pupil. The outer coating of the eye is called the *sclerotic*; it is the part commonly called "the white of the eye."

The eye resembles a camera; it is a light-proof cavity with a lens *o* in an opening in one side, and a screen, the retina, on the other side. When the eye is focused on an object, the light from the object is refracted by the crystalline lens, the aqueous humor, and the vitreous humor, and an inverted image is formed on the retina. The image on the retina is upside down and it would seem that we should see everything upside down. This idea comes from the conception that the brain is something which looks at the image on the retina from behind, whereas the light which falls upon the retina simply stimulates the optic nerve, and this stimulation when carried to the brain produces certain changes which give us the sensation of light. It is not known what changes are produced in the brain by the stimulus from the optic nerve nor how these changes produce the sensation of light.

There is one striking difference between the eye and the camera and that is in the method of focusing. The camera is focused by moving the lens back and forth, but the eye is focused by changing the shape of the lens. When the eye is viewing an object near at hand, the ciliary muscles *cm* of the eye contract the lens so that it is more convex. When it is viewing a distant object, the muscles extend the lens so that it is less convex. That is, when we look at an object near at hand, the lens of the eye is smaller and thicker; and when we look at a distant object, it is larger and thinner.

Spectacles. — Many people can see things at a distance but not those close at hand. In such cases the eyes are farsighted. The eye lens cannot be made thick enough to focus, on the retina, light from objects near at hand, and the image would be

formed behind the retina, as shown in *B*, Fig. 195. To overcome this difficulty spectacles with converging lenses are used, and the proper lens is one which will produce just enough convergence to enable the eye to focus the image on the retina.

Some people can see things near at hand but not those at a distance. In such cases the eyes are nearsighted. The eye lens cannot be made thin enough to focus, on the retina, light from a distant object, and the image is formed in front of the retina, see

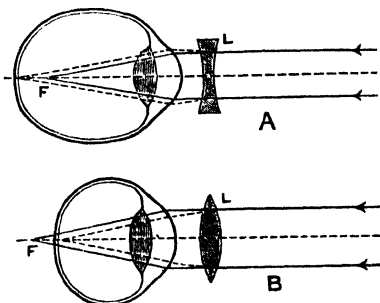

FIG. 195. — Spectacles.

A, Fig. 195. To overcome this difficulty, spectacles with diverging lenses are used, and the proper lens is one which will cause the light to diverge to such an extent that the eye can focus the image on the retina.

Magnifying glass. — The reading glass, magnifying glass, or simple microscope is a double convex lens. When it is held

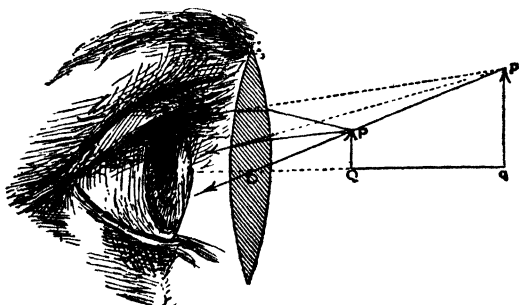

FIG. 196. — The simple microscope.

between an object and the eye, it enables the eye to see an enlarged erect image of the object. The object must be held at

a distance equal to or less than the focal length of the lens. Such an object is represented by the arrow PQ in Fig. 196. In this figure the paths of three rays from the top of the arrow are traced. It will be noticed that the rays are still diverging after they pass through the lens. The rays from P appear to the eye to come from p , those from Q from q , and the rays from points between P and Q appear to come from points between p and q . Thus the eye sees an enlarged image right side up. To the eye, the light appears to come from pq . The image pq is not a real image because no light comes from it. It is a virtual image.

The telescope. — The telescope is a combination of two double convex lenses. The lens nearest the object is called the

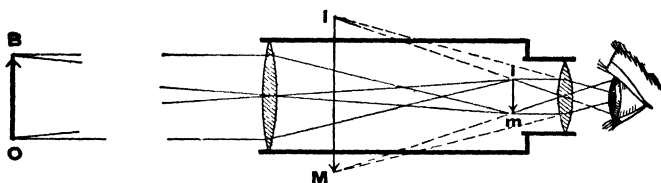

FIG. 197. — The telescope.

objective and the lens nearest the eye is called the *eyepiece*. The objective forms a real inverted image im of the object BO at or near its focus. The eyepiece is so placed that this image is closer to it than its focal length. It magnifies the image and the eye sees the enlarged virtual image IM . The telescope shown in Fig. 197 is of the type used in astronomical observations; in it the image is upside down. In the common terrestrial telescope the image is turned right side up by means of a lens or combination of lenses placed between the objective and eyepiece.

The compound microscope. — The compound microscope, Fig. 198, consists of two converging lenses, the objective and the eyepiece. The object BQ is placed just outside the focal length of the objective and thus a real enlarged image mi is

formed. This image is inside the focal length of the eyepiece, and thus the eyepiece forms an enlarged virtual image IM .

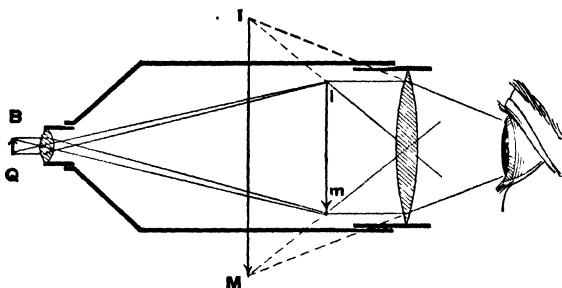

FIG. 198. — The compound microscope.

It will be noticed that the object is magnified twice: first, by the objective, and second, by the eyepiece.

The opera glass. — The opera glass is a combination of two lenses; the objective C is a double convex lens and the eyepiece c is a double concave lens. The eyepiece is placed nearer to the objective than the focal length of the objective,

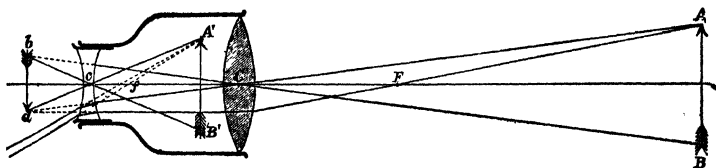

FIG. 199. — The opera glass.

see Fig. 199. AB is the object and if the eyepiece were absent, the objective would form an inverted image of AB at ab . With the eyepiece in place, the rays are refracted and diverged, and the rays which enter the eye appear to come from $A'B'$. $A'B'$ is a virtual erect image of AB .

The stereoscope. — The two pictures, placed side by side on the views used with the stereoscope, are taken by two cameras so placed, side by side, that the pictures are not quite the same.

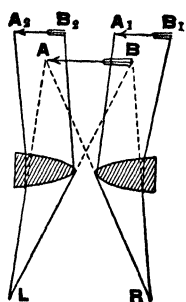

FIG. 200. — The stereoscope.

The glasses in the stereoscope are two prismatic lenses placed edge to edge (Fig. 200). From our study of prisms we can understand how the light which enters the eye *R* from the picture A_1B_1 or the eye *L* from A_2B_2 , is so bent by the prisms that it appears to come from *AB* between the two. Each eye receives a slightly different image, just as it does in looking at objects without the stereoscope, and for this reason the objects in the picture seem to stand out, just as objects do when we are looking at them without the stereoscope.

EXERCISES

1. How do convex and concave lenses differ in shape?
2. Define real image, virtual image, principal axis, principal focus, and focal length.
3. Show by a diagram how a convex lens produces a real image.
4. Show by a diagram how a convex lens produces a virtual enlarged image.
5. Show by a diagram how a concave lens produces a virtual reduced image.
6. Describe the camera; make a diagram.
7. Make a diagram of the projecting lantern and describe it.
8. Make a diagram of the eye and describe it.
9. Make a diagram illustrating longsighted and shortsighted eyes. Tell why they are longsighted or shortsighted and what spectacles are required.
10. Make a diagram showing how the virtual image is formed by a magnifying glass.
11. Make a diagram showing how the eye sees an image in a telescope.
12. Make a diagram showing how the eye sees an image in an opera glass.
13. Make a diagram showing the path of light in a stereoscope. Explain it.

CHAPTER XXVII

COLOR

Composite nature of white light. — We can show that white light is divisible into lights of different color by means of the experiment illustrated in Fig. 201. If we allow a beam of white light to fall on a glass prism, we find that the white light is broken up into lights of the colors red, orange, yellow, green, blue, indigo, and violet. This shows that white light is composed of these colors.

We can give further proof that white light is made up of these colors by the experiment illustrated in

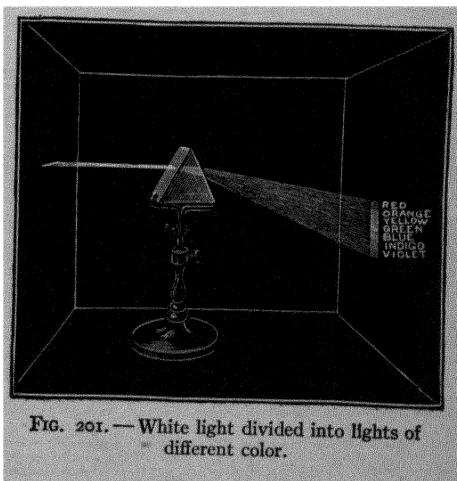

FIG. 201. — White light divided into lights of different color.

Fig. 202. A beam of white light is separated into its components by a glass prism. The resulting red, orange, yellow, etc., lights are allowed to fall on a second prism placed in the reverse position. The lights of different color are combined and produce white light. This shows again that white light is composed of lights of different color.

The colored band produced by passing a narrow beam of

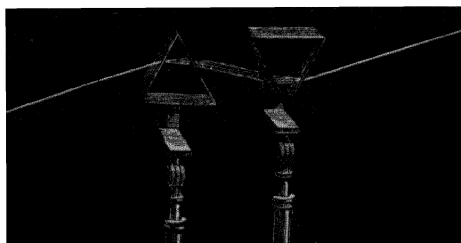

FIG. 202. — White light produced from lights of different color.

white light through a prism is called the *spectrum* of the white light.

Lights of different colors have different wave lengths. — It was stated above that scientists believe light to be a wave

motion in the ether. The lengths of the waves of light of different colors have been measured, and it has been found that they differ in length. The wave lengths of all colors are very short; for example, the wave length of red light is about $\frac{3}{80000}$ of an inch, and of violet at the other end of the spectrum, about half that of red, or $\frac{1}{80000}$ of an inch. The wave lengths of other colors fall between these. Waves a little shorter than red are orange, those a little shorter than orange are yellow, and the wave lengths of green, blue, indigo, and violet are each shorter in order. When we look at the spectrum, we find that one color merges into the next, and that it is impossible to tell the exact spot at which one color ends and the next begins. The reason for this is that there are in reality an infinite number of colors. For example, what we call red in the spectrum is in reality made up of very many wave lengths, some longer than $\frac{3}{80000}$ of an inch, and some shorter; and each wave length produces a shade of red. The same is true of the other colors.

Dispersion. — The bending of light when it passes from one medium to another is known as refraction. The spreading out of white light, due to the unequal bending of the colors which make up white light, is known as *dispersion*. What is the cause of dispersion?

The cause of refraction, as we learned above, is the difference in velocity of light in the two media. The cause of dispersion is

the difference in velocity of different colors in the same medium. As far as is known, all heat and light waves travel with the same velocity in the ether. It has been found by experiment, however, that this is not true in denser media, such as glass, water, etc. In these the long waves are less retarded than the short waves, and therefore the longer waves corresponding to red color travel faster than the shorter waves corresponding to violet; the other colors fall between these two.

All the waves travel more slowly in glass than in air, and therefore all are bent or refracted in passing from air to glass or the reverse. But in glass itself, the velocities are different, and therefore the amount of refraction is different, the violet travels more slowly than the red and therefore is more refracted than the red. This explains why the colors which make up white light are spread out or dispersed by a prism.

Why objects are colored. — Now that we know that white light is a mixture of colors, we are in a position to understand why objects are colored. Let us suppose that we are looking at a red dress in daylight. The dress is receiving light of all colors, that is, white light; but it sends to the eye only red light. Why is this? It has been found that the reason is, the dye in the cloth absorbs the colors which are *not* red, and therefore reflects only red. Similarly if we are looking at a blue dress in daylight, the cloth receives light of all colors but reflects to the eye only blue because the dye in the cloth absorbs the other colors. Similarly with other colors. An object seen in white light is colored, then, because it absorbs some of the colors of white light but not others.

Transparent substances. — We have learned that in general substances are colored because certain of the constituents of white light are absorbed. There are many substances, however, which allow light to pass through without absorption; these are said to be *transparent*; for example, glass, water, and air.

A pane of ordinary window glass is a very important house-

hold light appliance. It allows light to pass through, but keeps out wind, rain, dust, and insects. We should soon realize the importance of glass if we had to do without it. Before glass was invented, windows were sometimes covered with cloth, or with skins of animals. More often they were simply holes which were covered with shutters at night or when the weather was stormy.

Complementary colors. — If a beam of yellow light and a beam of blue light are made to fall upon a white screen at the same point, the resultant color is white. This is also true if the beams are red and bluish green, orange and greenish blue, or greenish yellow and violet. Colors which may be combined in this way to produce white light are called *complementary colors*.

Mixing of pigments. — From the fact that yellow and blue lights produce white, we might expect that if we mixed a yellow pigment with a blue pigment, we should get white pigment. The result, however, is a green pigment. The reason is, the yellow pigment absorbs red, blue, and violet from white light, and the blue pigment absorbs red, orange, and yellow from white light. Therefore, the only part of white light which is not absorbed by the mixture is green, and the mixture sends green light to the eye, that is, it is colored green.

The Young-Helmholtz theory of color vision. — The relation of the eye to color sensation has been the subject of much investigation, and the generally accepted theory of color vision is that proposed by Young and developed by Helmholtz. It is that there are three primary color sensations produced in the eye; namely, those of red, green, and violet. The theory is that the retina is made up of three sets of nerves, one sensitive to red, one sensitive to green, and one sensitive to violet. When all are stimulated at the same time, the result is the sensation of white light. When only one or two are stimulated, the result is colored light.

EXERCISES

1. Making a drawing showing how white light is spread out into a spectrum by a glass prism.
2. Tell how lights of different colors differ in wave lengths.
3. Explain why a prism spreads out the colors of white light.
4. Explain why a dress is red, blue, or yellow.
5. Explain why colored pigments mixed do not give the same color as lights of the same colors mixed.
6. State the Young-Helmholtz theory of color vision.

CHAPTER XXVIII

SOUND

How sound is produced. — In this chapter and the one following we shall study sound, particularly the sound obtained from musical instruments. Let us consider, first, how sound is produced.

In the stringed instruments, such as the banjo, guitar, violin, and piano, the vibrations of the strings set the body of the instrument or the sounding board in vibration, and this produces the sound.

In the wind instruments, such as the trumpet, cornet, and trombone, the vibration of the player's lips sets the air in the instrument in vibration, and this produces the sound.

In the case of the voice, the vibration of the vocal chords sets the air in the throat and mouth in vibration, and this produces the sound.

In fact, in every case, sound is produced *by the movement of some material body.*

Sound travels through gases, liquids, and solids. — A few simple experiments will demonstrate that sound travels through gases, liquids, and solids, as follows :

It is hardly necessary to make a special experiment to show that sound travels through air, since this is demonstrated every time we hear a person speak. Sound travels through all gases.

If you put your head under water and make a sound of some sort in the water, for example, by striking two stones together, you hear the sound very distinctly. This illustrates the fact that sound travels through liquids.

If a long piece of wood is held against the ear and a person scratches the other end lightly with a pin, the sound is heard very distinctly. Also, if a spoon is suspended from a string and the end of the string is wound around the finger placed against the ear, the sound heard when the spoon is struck is very distinct. These illustrate the fact that sound travels through solids.

Sound does not travel through a vacuum. — Suspend an electric bell in the bell jar of an air pump, Fig. 203, and pass an electric current through the bell while the jar is full of air; a loud sound is heard. Produce a vacuum in the jar and again pass the current through the bell; a very slight sound is heard, and the better the vacuum the less the sound. This illustrates the fact that sound does not travel through a vacuum. In this experiment a certain amount of sound is heard because the vibration of the bell is carried along the wires to the sides of the bell jar and thus to the outer air.

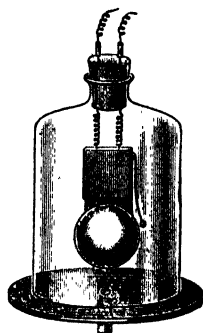

FIG. 203. — Sound does not travel through a vacuum.

The velocity of sound. — The velocity of sound in air is found to be 1087 ft. per second at 0° C., and 1126 ft. per second at 20° C. (68° F.). The velocity increases not quite 2 ft. per second for each increase in temperature of 1° C. (In our calculations we may use 1100 ft. per second for the velocity of sound in air.) In water the velocity of sound at 0° C. is 4590 ft. per second, and in iron 16,728 ft. per second.

How sound travels. — When a gun is discharged, the air nearest the muzzle is shoved out in all directions. This air pushes back the air farther away, and this air in turn moves air farther away, and so on. In this way a spherical compression wave is sent out in all directions.

Each particle of air moves only a short distance out and back

and then comes to rest, but the compression moves out indefinitely. This is true also when sound travels through solids or liquids.

When a gun is discharged, only one wave is produced, and therefore only one sound is heard. When, on the contrary, a bell is struck once by the clapper, it continues to vibrate and sends out a series of spherical waves (Fig. 204). These

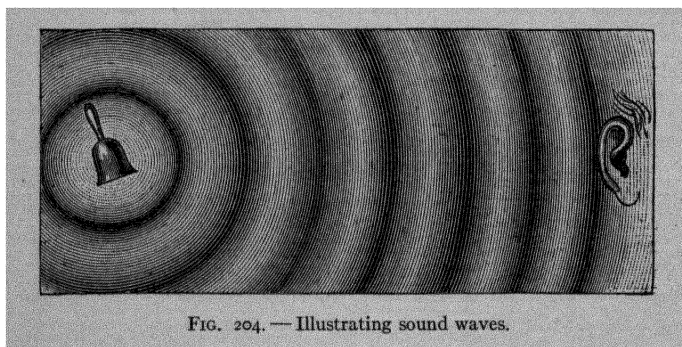

FIG. 204.— Illustrating sound waves.

waves travel out in all directions, and when they fall upon the ear produce a series of sounds

What is sound? — A sound, then, may be defined as *any vibration, in a solid, liquid, or gas, which has sufficient energy to affect the ear*

Nature of sound waves. — Each sound wave consists of a compression and a rarefaction. This is illustrated in Fig. 204; the dark circles represent the compressions and the lighter circles the rarefactions. The compressions are produced by the outward movement of the metal of the bell, the rarefactions by the inward movement of the metal.

If a line were drawn from the bell to the ear in this figure, it would pass through a rarefaction, a compression, a rarefaction, a compression, etc. The length of one rarefaction and one compression on such a line is one wave length. In Fig. 211 the distance bc is one wave length.

Wave length. — Sound travels at the rate of about 1100 ft. per second. If a bell makes 100 vibrations per second, it produces 100 waves per second and each wave is $\frac{1100}{100} = 11$ ft. long. If it makes 1000 vibrations per second, it produces 1000 waves and each wave is 1.1 ft. long.

If we let v = velocity of sound, n = the number of vibrations per second of the source of the sound, and l = the length of the sound waves produced by this source, then :

$$l = \frac{v}{n}$$

Noises and musical notes — The difference between noises and musical notes can be illustrated as follows: If a card is held against the teeth of a revolving toothed wheel, on which the teeth are placed at *irregular* intervals, the sound heard is disagreeable, that is, it is a *noise*. If the card is held against the teeth of a revolving toothed wheel on which the teeth are placed at *regular* intervals, the sound heard is a *musical note*.

This illustrates the difference between noises and musical notes. A *noise* is a single sound or succession of sounds at *irregular intervals*. A *musical note* is a series of sounds in rapid succession at *regular intervals*. If the sounds at regular intervals are less frequent than 40 per second, they are not musical and are classed as noise. The frequencies used in music are from about 40 to 4000 vibrations per second.

The pitch of a note depends on the number of waves per second — This can be shown by means of the disk, Fig. 205. The disk is perforated with holes at regular intervals. A blast of air is directed against the disk in such a way that a puff goes

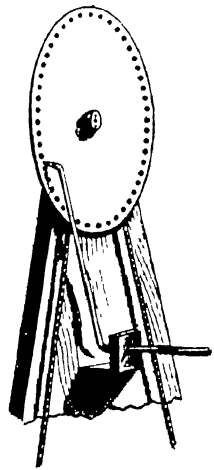

FIG. 205 — The pitch of a note depends upon the number of waves per second.

through each hole as it passes the tube. It is found that as the disk is revolved more and more rapidly the pitch of the note produced becomes higher. Since a wave is started by each puff and the greater the number of revolutions per second the greater the number of puffs per second, we conclude that *the greater the number of waves per second the higher is the pitch of the note produced.*

Loudness. — The loudness of a sound depends on the energy given to the air by the source of the sound, and upon the distance from the source. The sound from any given source decreases in loudness as we move away from the source. Sound waves are spherical and therefore at a distance of 10 ft. from the source, they cover four times the surface they do at a distance of 5 ft. from the source. Thus the sound at 10 ft. is only one fourth as loud as it is at 5 ft., that is, *the loudness varies inversely as the square of the distance from the source.*

Echo. — An echo is caused by sound waves reflected from some large object at a distance.

EXERCISES

1. How is sound produced?
2. Through what does sound travel?
3. Describe sound waves.
4. What is the length of the sound waves produced by a person whose vocal chords vibrate 200 times a second?
5. What is the difference between noise and music?
6. On what does the pitch of a note depend?
7. On what does the loudness of a sound depend?

CHAPTER XXIX

MUSIC AND MUSICAL INSTRUMENTS

Musical scale. — The disk shown in Fig. 206 has four rows of holes. The inside row has 24 holes, the next 30, the next 36, and the outside row 48. If this disk is revolved and a jet of air is directed against each row of holes in turn, beginning with the inside row, the notes *do*, *mi*, *sol*, *do'* are obtained.

When the air jet passes through a hole, it produces a wave in the air on the opposite side of the disk. We learn from this experiment that the number of waves per second which produce the notes *do*, *mi*, *sol*, *do'* are in the ratio 24, 30, 36, 48.

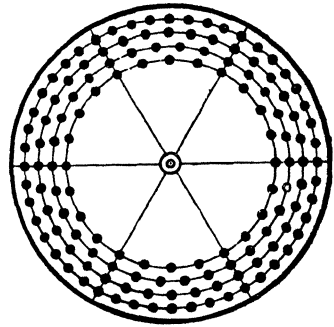

FIG. 206. — The notes *do*, *mi*, *sol*, *do'*.

We can produce the eight notes of the octave by using a disk with eight rows of holes, the numbers of holes being 24, 27, 30, 32, 36, 40, 45, and 48.

The notes, the corresponding number of holes, and their ratios are:

Notes	C	D	E	F	G	A	B	C
	<i>do</i>	<i>re</i>	<i>mi</i>	<i>fa</i>	<i>sol</i>	<i>la</i>	<i>si</i>	<i>do'</i>
ratio	24	27	30	32	36	40	45	48
ratio	1	$\frac{9}{8}$	$\frac{5}{4}$	$\frac{4}{3}$	$\frac{3}{2}$	$\frac{5}{3}$	$1\frac{1}{3}$	2

This means, not that the notes of a musical scale are produced by 24, 27, 30, etc., vibrations per second, but that the vibrations per second are in this ratio.

If we wish to determine the musical scale of a note of any frequency, we proceed as follows: call the note *do*, then *re* is produced by $\frac{9}{8}$ the frequency of *do*; *mi* by $\frac{3}{4}$; *fa* by $\frac{4}{3}$ the frequency of *do*, etc.

It will be noticed that the note one octave higher than any note *do* is produced by just twice as many waves per second as *do*.

Stringed instruments — Let us now use the knowledge we have gained of pitch and the musical scale to help us understand stringed instruments. Many of us have had experience with one or more of these instruments, for example, with the guitar, violin, banjo, or piano. We know that, in general, the short, light strings give notes of high pitch and the long, heavy

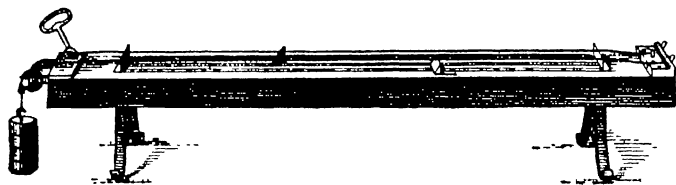

FIG. 207 — The sonometer.

strings notes of low pitch. We know also that tightening a string raises its pitch and loosening it lowers its pitch.

We can make an instructive experiment with any string of a banjo, guitar, or violin as follows: Measure the length of the string and sound it, call the note *do*. Then make the string in succession $\frac{3}{4}$, $\frac{2}{3}$ and $\frac{1}{2}$ as long and sound it. The notes produced are *fa*, *sol*, *do'*, which we know are produced by $\frac{4}{3}$, $\frac{3}{2}$, and 2 times as many vibrations per second as *do*. That is, the rate of vibration of a string varies inversely as the length of the string.

Vibrating strings are studied by means of the sonometer shown in Fig. 207. With this instrument the length and tension of the strings can be varied easily, and the following laws can be illustrated.

Laws of vibrating strings. — The rate of vibration of a string varies :

- (1) inversely as the length,
- (2) directly as the square root of the stretching force,
- (3) inversely as the thickness,
- (4) inversely as the square root of the density of the material.

Sounding board. — The sound produced by a piano comes from the sounding board. The strings set the sounding board in vibration and these vibrations give the sound. In the case of the guitar, violin, harp, the body of the instrument acts as the sounding board and produces the sound.

The action of a sounding board can be illustrated by means of a tuning fork. If a tuning fork is set in vibration and held in the hand, the sound produced is not great. If, however, the handle of the fork is placed against a large elastic surface, such as the panel of a door or the top of a table, the sound is much louder. The panel or table is set in vibration by the fork and, being much larger in area than the prongs of the fork, sets a much larger mass of air in vibration; thus it gives a louder sound. The sounding board is the important part of any stringed instrument; for example, one violin is more valuable than another, not because of any difference in the strings, but because the body of one gives out fuller, richer notes than that of the other.

Fundamental, octaves, and overtones. — The lowest note that can be produced by a vibrating body, such as a stretched string or an air column, is called the *fundamental* of the vibrating body.

A note one *octave* higher than the fundamental is made up of *twice* as many waves per second (see page 279). A note one octave higher still is made up of twice as many waves per second as the first octave, or four times as many waves as the fundamental. The note the third octave higher is made up of twice as many waves per second as the second octave, or eight times as many as the fundamental, and so on.

If we consider the fundamental note to be made up of 100 waves per second, then the number of waves in the octaves are in order as follows :

fundamental	1st octave	2d octave	3d octave	4th octave
100	200	400	800	1600

The *overtones* or harmonics of a fundamental are the notes produced by 2, 3, 4, 5, 6, etc., times as many waves per second as the fundamental. For example, if we consider the fundamental to be produced by 100 vibrations per second, the number of waves per second in the overtones are in order as follows :

fundamental	1st overtone	2d overtone	3d overtone	4th overtone
100	200	300	400	500

It will be noticed that all octaves are overtones, but that all overtones are not octaves. This will help us to distinguish between octaves and overtones, which are sometimes confused.

Quality. — We can readily distinguish a note played on one instrument from the same note played on any other instrument. For example, middle C on the piano is easily distinguished from middle C on the violin, organ, or flute, and each of these is easily distinguished from the others. Why is this? If they are the same note, why is there a difference? These notes are said to differ as to the *quality* of tone. In order to understand differences in quality it will be necessary to study fundamentals and overtones a little further.

When a wire vibrates as a whole as shown in *A*, Fig. 208, it produces its fundamental note. If each half of the wire vibrates as shown in *B*, it produces its first overtone, which has twice as many vibrations per second as the fundamental. If each third of the wire vibrates as shown in *C*, the note produced is the second overtone.

The actual vibrations of a wire are always complex. They are made up of those which produce the fundamental, and those which produce various overtones. Thus a fundamental tone is never pure, no matter what instrument produces it; it is

always accompanied by overtones. The overtones, however, differ in loudness according to the instrument. Every tone, then, is made up of a fundamental and many overtones, and *the same notes in different instruments differ in quality because the fundamental is accompanied by overtones which vary in number and loudness.*

Let us explain this a little further. The sound we hear from a violin, for example, really comes from the wood; the wood is forced to vibrate at the same rate as the string: these are called *forced vibrations*. However, each piece of wood vibrates more readily with certain tones than with others, so that when it is set vibrating by a string, those overtones which it produces most readily are louder than the others. The *quality* of the resulting tone depends upon which of the overtones happen to be loud. In a piano the sound we hear comes from the sounding board; in the guitar, mandolin, etc., from the wooden body; and in wind instruments from the vibrating air column. In each case certain overtones are produced more readily than others, and the *quality* of the resulting tones varies for this reason.

Wind instruments. — In wind instruments the air column in the instrument is set in vibration by some means, and these vibrations produce the musical note.

The pitch of the note produced depends on the strength of the air blast and on the length of the air column.

For a given air column, gentle blowing produces either the fundamental note or one of the low overtones; harder blowing produces the higher overtones.

For a given strength of air blast, the pitch varies inversely as the length of the air column.

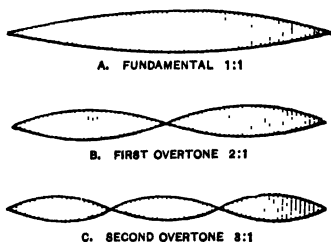

FIG. 208. — How overtones are produced.

We can illustrate this nicely with the common tin whistle or flageolet or with a fife. With all the holes closed, gentle blowing produces the fundamental, harder blowing the overtones. We can obtain the eight notes of the octave as follows. Start with the note given, when all the holes are closed and the air blast has a certain strength; call this note *do*. We obtain the next six notes by opening the holes in order, beginning at the lower end. Opening the holes shortens the length of the air column. The eighth note is obtained by closing all the holes and blowing a little harder.

How the sound is started. — The air column in a wind instrument is set in vibration in various ways: by the vibrations of the player's lips, by the vibrations of a reed, or by the vibrations of an air blast directed across a thin edge. The vibrations produced in these different ways are complex, that is, they are made up of vibrations of different frequencies. The air column, however, vibrates in unison with only one frequency, depending on its length and on the strength of the air blast.

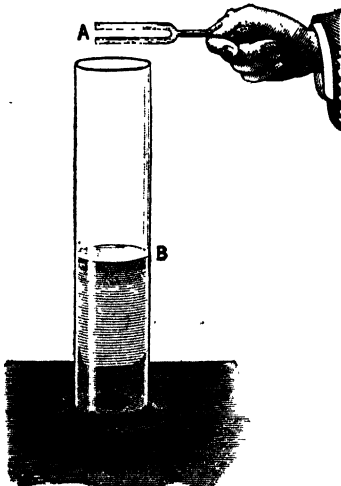

FIG. 209. — Resonance.

In the case of the fife, for example, the air blast is directed across the edge of a hole. This produces a fluttering which is made up of vibrations of different frequencies. The air column in the fife vibrates in unison with one of these frequencies, which frequency depends on the length of the air column and on the strength of the air blast.

Resonance. — If a tuning fork is sounded and held over a closed air column (*AB*, Fig. 209) which is just $\frac{1}{4}$ as long as the wave length produced by

the fork, a loud sound is heard. The fork sets the air-column in vibration and these vibrations produce the loud sound. This is an example of *resonance*.

We can explain resonance as follows: If we are swinging a person, we can keep the swing in motion with little effort if we give it gentle pushes at just the right time; that is, if the rate of vibration of the swing and the rate of applying the pushes are exactly the same.

Now the rate of vibration of the fork used above is exactly the same as the rate of vibration of the air column. The fork, therefore, gives impulses to the air column at just the right times and thus sets it in vibration.

Interference. — If we produce resonance as above, and then revolve the prongs of the fork slowly, we find that there is silence when the prongs are at an angle of 45° to the top of the air column. In this case the compression produced by one side of the prong is destroyed by the rarefaction produced by the other side, that is, the two sound waves produce silence. This is known as *interference*.

The explanation of this silence is illustrated in Fig. 210. *A* and *B* are the ends of the prongs of a

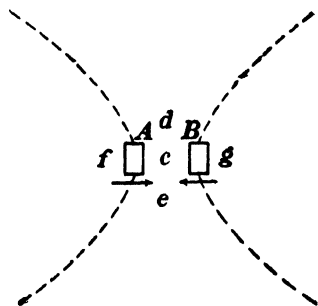

FIG. 210. — Interference.

tuning fork. These ends are moving in the direction shown by the arrows; they are producing compressions in the directions *cd* and *ce*, and rarefactions in the directions *f* and *g*.

Along the dotted lines the compressions and rarefactions touch. At any point on these lines, then, one wave is trying to compress the air, and the other is trying to rarefy it. The result is that there is neither compression nor rarefaction; that is, the air is still and there is no sound. This is an example of two series of sound waves which interfere and produce silence.

Harmony and discord. — Whether two notes are harmonious or discordant depends on how many *beats* they produce per second. To understand this it is necessary to understand beats. We can illustrate beats as follows.

Tune two strings of a guitar or other stringed instrument, to the same pitch, then change the pitch of one slightly and sound them together. It is found that the sound varies in loudness at short intervals (it sounds a little as though a person were saying wa, wa, wa, wa). These variations in sound are known as beats. These beats may be shown also as follows: Take two tuning forks of the same pitch; stick some wax on the prongs of one so that they are heavier and vibrate a little more slowly, then sound the forks together. It is found again that beats are produced.

Explanation of beats. — We can represent a sound wave by a curved line as shown in Fig. 211. Let the hills *a* represent the compressions, and the hollows *b*, *c*, etc., the rarefactions.

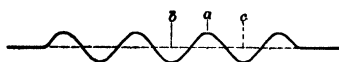

FIG. 211. — Representing sound waves.

Let us suppose that we are listening to two notes of nearly the same number of vibrations per second. Let us suppose, for simplicity, that one note makes just one vibration per second more than the other. The two series of waves can be represented as shown in Fig. 212. If at the beginning of a second the waves are both compressing or rarefying the air, we hear a sound twice as loud as that produced by one note. At the end of $\frac{1}{2}$ second, one note is compressing the air, while the other is rarefying it. The result is the air is neither compressed nor rarefied and there is silence. At the end of the second both notes are

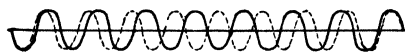

FIG. 212. — How beats are produced by interference.

again compressing or rarefying the air, and the sound is twice as loud as that produced by one note. Thus there is one **silence** and one loud sound each second, when one note makes

one vibration per second less than the other ; that is, there is one beat per second.

If one note makes two vibrations less per second than the other, there are two silences and two loud sounds per second; that is, there are two beats per second, etc. This shows how beats are produced by interference.

Two notes are discordant when they produce a certain number of beats per second. The discord is greatest when there are about 33 beats per second. When there are fewer than 6 or 8 or more than 70 or 80 the roughness disappears and the notes are harmonious. The beats may be produced by the fundamentals, or by the fundamental of one and an overtone of the other, or by an overtone of one and an overtone of the other. Whether notes are harmonious or discordant, then, depends upon the number of beats produced per second.

The phonograph. — One of the most wonderful of sound instruments is the phonograph, invented by Thomas A. Edison. The principle of the machine is simple. A small stylus *G* is attached to the center of a flexible disk *B*, Fig. 213, which is supported at the edge. The point of the stylus bears on the wax cylinder *C*.

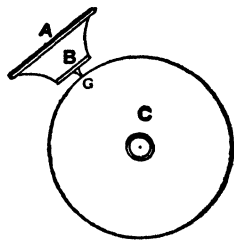

FIG. 213. — The phonograph.

In making a record a person speaks or plays an instrument, in front of the mouthpiece *A*. The sound waves set the disk in vibration, and the stylus under the disk digs into the wax cylinder.

The cylinder is kept revolving at a certain rate, and the disk and stylus move sidewise slowly; thus the stylus traces a spiral groove on the cylinder. Each wave of sound produces one vibration of the disk and stylus, and for each vibration the stylus makes a small hollow and hill in the groove. If the groove is examined with a magnifying glass it is found to consist of a series of irregular hills and hollows.

In reproducing the sound, the stylus is placed at the starting

point and the cylinder is revolved at the same rate as when the record was being made. The stylus traveling along the groove moves down into the hollows and up over the hills, and gives the disk this up and down motion, with the result that the disk makes the same vibrations that it did when the record was being made. These vibrations give the air in the mouthpiece the same vibration, and therefore the sounds heard are those which were used in making the record.

EXERCISES

1. State the ratios of the number of vibrations per second of the notes of the musical scale.
2. State the laws of vibrating strings.
3. What is the function of a sounding board?
4. Define fundamental, octave, and overtone.
5. Why do notes differ in quality?
6. Explain how beats are produced.
7. Why are notes discordant?
8. Describe the phonograph.

CHAPTER XXX

A FURTHER STUDY OF MECHANICS

GRAVITATION, COMPOSITION OF FORCES

Gravitation. — It was stated on page 28 that the weight of a body is the measure of the earth's attraction for it. Let us consider this a little further. If we hold in the hand an object such as a book, a stone, or a flatiron, we feel a certain pull towards the earth. If we release the object, it falls to the ground. We account for these facts by saying that the earth exerts an attractive force upon the object. We call this force *gravitation or gravity*.

Sir Isaac Newton studied the action of gravitation as shown by falling bodies and as shown by the motion of the planets. He was led to certain conclusions, which he stated as follows: "*Every particle of matter in the universe exerts an attraction on every other particle. This attraction varies directly as the product of the masses of the particles and inversely as the square of the distance between them.*" This is known as the *Law of Universal Gravitation*.

Center of gravity. — The earth exerts an attractive force upon every particle of a body and the sum of all these small attractive forces is the weight of the body. *It is possible to find one point such that if a force equal to the weight of the body is exerted upwards at that point, the body is in equilibrium.* This point is called the *center of gravity*.

Equilibrium. — A body may be in *stable, unstable, or neutral equilibrium*. A body is said to be in stable equilibrium if

it returns to its original position when slightly displaced (*A*, Fig. 214).

A body is said to be in unstable equilibrium if, after being slightly displaced, it tends to move farther from its original position (*B*, Fig. 214).

A body is said to be in neutral equilibrium if, when slightly displaced, it moves neither back to its original position nor farther away from it (*C*, Fig. 214).

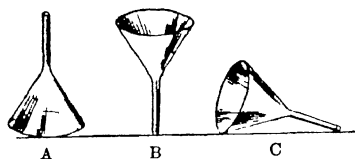

FIG. 214 — Examples of stable, unstable, and neutral equilibrium

A body will stand up as long as its center of gravity is supported; that is, as long as the line drawn vertically downwards through its center of gravity falls inside the base of the body

Composition of forces — The single force which has the same effect as two or more forces is called the *resultant* of these forces. The single force which keeps one or more forces in equilibrium is called the *equilibrant* of these forces.

If two or more forces are acting at the same point and in the same direction, the resultant is equal to the sum of the forces and it acts in the same direction, the equilibrant is equal to the sum of the forces and acts in the opposite direction.

Forces acting at an angle to each other. — If two forces are acting at the same point but at an angle to each other, their resultant and equilibrant are not equal to the sum of the two forces. There is, however, a simple rule by which these may be found.

The rule is as follows: "If two forces acting at an angle upon a point are represented in direction and amount by straight lines, the resultant of the two forces is exactly represented in direction and amount by the diagonal of the parallelogram of which the lines are the sides. The equilibrant is equal to the resultant but is in the opposite direction." This is known as the *Parallelogram Law of Forces*.

In Fig. 215, let the length of AC represent the amount of one force and the direction of AC the direction of this force, and let the length of AB and its direction represent the amount and direction of another force; then AD represents the resultant in amount and direction and AD' represents the equilibrant in amount and direction.

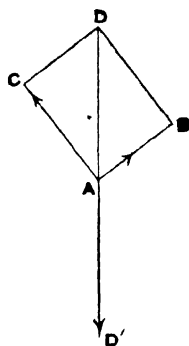

FIG. 215 — Illustrating the parallelogram law of forces

Parallel forces. — *If two forces are acting on a body at different points but in the same direction, the forces are parallel. The resultant is equal to the sum of the forces and acts in the same direction. The equilibrant is equal to the sum of the forces and acts in the opposite direction. The point of application of the resultant and equilibrant divides the line drawn perpendicular to the forces, inversely as the forces.*

In Fig. 216, P and Q are parallel forces. The resultant is a

force equal to $P + Q$ acting downward at C . The equilibrant is a force equal to $P + Q$ acting upward at C . The point of application C divides AB inversely as P and Q , that is, $AC : CB :: Q : P$.

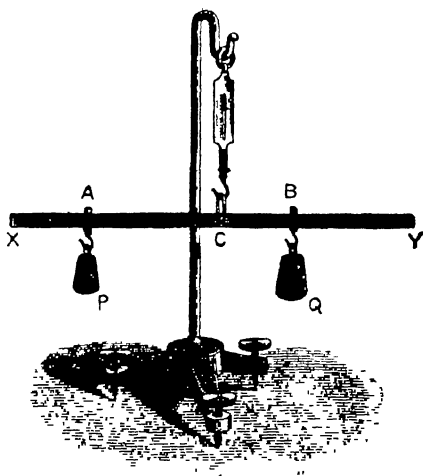

FIG. 216. — The rod XY is acted on by three parallel forces.

MOTION

Motion, velocity. — *A body is said to be in motion when its position is changing, and the velocity of a body is the rate at which its position*

is *changing*. Velocity is expressed in various ways, feet per second, centimeters per second, miles per hour, knots per hour, etc.

The space a body travels in a given time is equal to its average velocity multiplied by the time, that is:

$$\text{space} = \text{average velocity} \times \text{time}$$

Falling bodies, acceleration. — If a body falls vertically downward, its velocity increases uniformly. If it is thrown vertically upward, its velocity decreases uniformly until it ceases to rise. The rate of increase of velocity is called *acceleration*; the rate of decrease, *negative acceleration*.

Experiments with falling bodies. — Measure upward from the ground a vertical distance of 16 ft. Allow stones to drop this distance, and, with a stop watch, measure the time it takes them to fall. It will be found that the stones fall the 16 ft. in 1 sec.

Measure upward from the ground a vertical distance of 64 ft. Allow stones to fall this distance and find the time of fall. It will be found that the stones fall the 64 ft. in 2 sec.

If you have a place of sufficient height, measure upward from the ground a vertical distance of 144 ft. Drop stones down this distance and find the time it takes them to fall. It will be found that the stones fall 144 ft. in 3 sec.

By these experiments it is found that, on account of the attraction of the earth, a body falls 16 ft. in 1 sec., 4 times as far in 2 sec., and 9 times as far in 3 sec. In other words, the *distance* the body falls varies as the *square of the time*.

Bodies falling from rest. — If we let g equal the increase in velocity or acceleration of a falling body, then if the body falls from rest it has a velocity of g ft. per second at the end of 1 sec.; a velocity of $2g$ ft. per second at the end of 2 sec.; $5g$ ft. per second at the end of 5 sec., and so on. In general its final velocity v at the end of t seconds is gt , that is:

$$v = gt$$

The average velocity of a falling body for a given time is the average of its initial velocity and its final velocity. If the body falls from rest, its initial velocity is 0. In this case:

$$\text{Average velocity} = \frac{0 + gt}{2} = \frac{gt}{2}$$

The space any body travels in a given time is found by multiplying its average velocity by the time. In the case of a body falling from rest,

$$s = \text{average velocity} \times t = \frac{gt}{2} \times t = \frac{gt^2}{2}, \text{ that is, } s = \frac{1}{2} gt^2$$

It has been found that the increase in velocity per second (or acceleration) of a falling body is 980 cm. or 32.16 ft. (In our calculations we will use 32 ft. instead of 32.16 ft.)

A body falling from rest falls in 1 sec.:

$$s = \frac{1}{2} gt^2 = \frac{1}{2} \times 32 \times 1^2 = 16 \text{ ft.}$$

In two seconds it falls:

$$s = \frac{1}{2} gt^2 = \frac{1}{2} \times 32 \times 4 = 64 \text{ ft.}$$

These are the results we obtained in our experiment above.

If a body falls from rest for t seconds, its final velocity $v = gt$, then $t = \frac{v}{g}$. If we substitute this value of t in the formula $s = \frac{1}{2} gt^2$ we obtain the formula

$$s = \frac{v^2}{2g}$$

This gives the space a body falls from rest in terms of its final velocity.

Bodies given an initial velocity. — If a body is thrown vertically downward with a velocity of v ft. per second, its velocity increases at the rate of g ft. per second and at the end of t sec., it is $v + gt$.

Its average velocity for this time is $\frac{v + (v + gt)}{2} = v + \frac{1}{2} gt$.

The space this body travels in t sec. is :

$$s = \text{average velocity} \times t = (v + \frac{1}{2} gt) t$$

or
$$s = vt + \frac{1}{2} gt^2$$

If a body is thrown vertically upward with a velocity of v ft. per second, its velocity decreases at the rate of g ft. per second, and at the end of t sec. it is $v - gt$. Its average velocity for this time is

$$\frac{v + (v - gt)}{2} = v - \frac{1}{2} gt$$

The space this body travels in t seconds is :

$$s = \text{average velocity} \times t = (v - \frac{1}{2} gt) t$$

or
$$s = vt - \frac{1}{2} gt^2$$

If a body is thrown vertically upward with a velocity of v ft. per second, its velocity is decreased g ft. per second each second, therefore the time it rises is $\frac{v}{g}$, that is :

$$t = \frac{v}{g}$$

If we substitute this value for t in the formula, $s = vt - \frac{1}{2} gt$, we obtain the formula :

$$s = \frac{v^2}{2g}$$

This gives the height to which a body will rise when its initial velocity upward is v ft. per second.

It will be noticed that this is the same formula that we obtained above, but that s and v stand for different quantities in the two formulæ.

Acceleration in general. — The letter a is used to denote any uniform acceleration, the letter g is used to denote only the acceleration due to the force of gravity. If we substitute the letter a for the letter g in the formulæ derived above, we have formulæ which apply to any case in which the acceleration is uniform.

That is, $s = \frac{1}{2} at^2$ gives the space traveled by a body which starts from rest and travels for t seconds, the uniform acceleration being a feet or centimeters per second.

The formula $s = vt + \frac{1}{2} at^2$ gives the space traveled in t seconds by a body having an initial velocity v and an acceleration of a feet or centimeters per second.

The formula $s = vt - \frac{1}{2} at^2$ gives the space traveled in t seconds by a body having an initial velocity of v and a negative acceleration of a feet or centimeters per second.

The formula $s = \frac{v^2}{2a}$ gives: first, the space a body which starts from rest travels in acquiring a velocity v , the acceleration being a ; second, the space a body which has a velocity v travels in coming to rest, the negative acceleration being a .

FORCE

Newton's laws of motion. — The fundamental laws of motion were stated by Sir Isaac Newton over two centuries ago. They are as follows:

First Law. — *A body at rest remains at rest and a body in motion remains in motion with constant speed in a straight line, unless acted upon by some external force.*

Second Law. — *Change of momentum is in the direction of the impressed force and is proportional to it and to the time during which it acts.*

Third Law. — *To every action there is an equal and opposite reaction.*

First law. — The first law defines a general property of matter; namely, *inertia*. Inertia may be defined as *that property of matter in virtue of which a body at rest tends to remain at rest and a body in motion tends to remain in motion in a straight line*. All matter possesses the property of inertia. The examples of inertia are numerous; three familiar examples are:

1. When a car stops suddenly, a person standing in the car tends to fall forward because the inertia of his body tends to keep him going with the same velocity.

2. When a car starts suddenly, a person standing tends to fall backward because the inertia of his body tends to keep him at rest.

3. It is difficult for a boy to turn suddenly when running because the inertia of his body tends to keep him moving straight ahead.

Second law. — Change of momentum is in the direction of the impressed force and is proportional to it and to the time during which it acts. The *momentum* of a body is the quantity of motion possessed by a body, and it is defined as the product of the mass and the velocity of the body:

$$\text{Momentum} = \text{mass} \times \text{velocity}$$

Thus a mass of 10 lb. moving with a velocity of 20 ft. per second has a momentum of 200. A mass of 50 g. moving with a velocity of 100 cm. per second has a momentum of $50 \times 100 = 5000$.

In comparing the momentum of one body with that of another care must be taken to use the same system of measurement for both bodies, that is, pounds and feet or grams and centimeters.

The second law gives us a means of comparing forces. Forces are equal if they produce equal changes of momentum in the same time. One force is twice as great as another if it produces twice as great a change of momentum as the other in a given time.

Units of force. — The common units of force are the *pound* and the *gram*. These are called the gravitational units of force. A *pound of force* is a force equal to the force the earth exerts on a pound of mass. A *gram of force* is a force equal to the force the earth exerts on a gram of mass.

The pound of force and the gram of force vary with the dis-

tance of the body from the center of the earth. For scientific purposes it is desirable to have a constant unit of force.

In scientific work the units of force used are the *poundal* and the *dyne*. A *poundal* is that force which will give a mass of 1 lb. an acceleration of 1 ft. per second, in 1 sec. This unit is used to some extent in engineering. A *dyne* is that force which will give a mass of 1 g. an acceleration of 1 cm. per second in 1 sec. This is the unit used in scientific work.

From the second law we see that the change of momentum is proportional to the force impressed; that is,

$$\text{Force} = \text{rate of change of momentum}$$

The rate of change of momentum is found by multiplying the mass of the body by the change in velocity of the body in one second or by the acceleration, therefore

$$\text{Force} = \text{mass} \times \text{acceleration}$$

or
$$f = ma$$

This is a very important equation. It means that the force in *poundals* is equal to the mass in *pounds* multiplied by the acceleration in *feet per second*; or that the force in *dynes* is equal to the mass in *grams* multiplied by the acceleration in *centimeters per second*.

Pound and poundal. — We can find the relation between the pound and the poundal as follows. A pound of force is the force which the earth exerts on 1 pound of mass, and a poundal of force is the force which gives 1 lb. of mass an acceleration of 1 ft. per second.

We know from our experiments with falling bodies that when a pound of mass is allowed to fall, the 1 lb. of force which the earth exerts upon it gives it an acceleration of 32 ft. per second. Now from the equation $f = ma$ we learn that the force which gives 1 lb. of mass an acceleration of 32 ft. per second is 32 poundals; as follows,

$$\begin{aligned} f &= ma \text{ poundals} \\ f &= 1 \times 32 = 32 \text{ poundals} \end{aligned}$$

Since 1 lb. of force and 32 poundals of force each give to 1 lb. of mass an acceleration of 32 ft. per second, we see that *1 lb. of force is equal to 32 poundals of force.* Since $g = 32$ ft. per second, the acceleration due to gravity, we can say 1 lb. of force is equal to g poundals of force.

Gram and dyne. — We find the relation between the gram of force and the dyne of force in the same way.

A gram of force is the force which the earth exerts upon 1 g. of mass, and a dyne of force is the force which gives a mass of 1 g. an acceleration of 1 cm. per second.

When a gram of mass is allowed to fall, the force of 1 g. which the earth exerts upon it gives it an acceleration of 980 cm. per second. From the equation $f = ma$ we know that the force which gives 1 g. of mass an acceleration of 980 cm. per second is 980 dynes; as follows,

$$f = ma \text{ dynes}$$

$$f = 1 \times 980 = 980 \text{ dynes}$$

Since 1 g. of force and 980 dynes of force each give to 1 g. of mass an acceleration of 980 cm. per second, we see that *1 g. of force is equal to 980 dynes of force.* Since $g = 980$ cm. per second, the acceleration due to gravity, we can say 1 gram of force is equal to g dynes of force.

Third law. — Action and reaction are equal and opposite. This law expresses the fact that there are always two sides to the action of a force. If a rope is attached to a post and a man pulls on the rope with a force of 10 lb., the post resists with a force of 10 lb. If a man dives into the water from a boat, the man goes in one direction with a certain momentum and the boat goes in the opposite direction with a certain momentum. The third law states that the momentum of the boat backward is equal to the momentum of the man forward, etc.

WORK AND ENERGY

Work. — On page 20 we learned that work is done when a force is exerted through any distance. We learned there also that the units of work in common use are the foot pound and the gram centimeter.

A *foot pound* of work is done when 1 lb. of force is exerted through a distance of 1 ft.

A *gram centimeter* of work is done when 1 g. of force is exerted through a distance of 1 cm.

Since the pound of force and the gram of force vary with the distance of a body from the center of the earth, the foot pound and the gram centimeter are not quite constant. In scientific work the constant units of work, the *foot poundal* and the *erg*, are used. A *foot poundal of work* is the work done when a force of 1 poundal is exerted through a distance of 1 ft. An *erg of work* is done when a force of 1 dyne is exerted through a distance of 1 cm.

Since 1 pound is equal to 32 poundals, *1 foot pound of work is equal to 32 foot poundals of work*; and since 1 g. of force is equal to 980 dynes of force, *1 gram centimeter of work is equal to 980 ergs of work*.

Energy. — The energy of a body is defined as its *capacity for doing work*. Inanimate bodies possess energy only because work has been done upon them. There are two types of energy: *potential energy* and *kinetic energy*. The *potential energy* of a body is the energy which it possess by virtue of its position or condition. For example, a rock on top of a cliff possesses potential energy because it can do work in falling to the base of the cliff; a watch spring coiled up possesses potential energy because it can do work in uncoiling. The *kinetic energy* of a body is the energy it possesses by virtue of its mass and velocity. For example, a bullet or pile driver in motion possess energy because they do work when brought to rest.

To measure potential and kinetic energy. — The potential energy of a body raised above the earth is equal to its mass multiplied by its distance above the earth.

$$PE = mh \text{ foot pounds or gram centimeters}$$

$$PE = mgh \text{ foot poundals or ergs}$$

Examples. — A mass of 10 lb. 20 ft. above the earth has a potential energy of $10 \times 20 = 200$ foot pounds or $10 \times 32 \times 20 = 6400$ foot poundals. A mass of 10 g. 20 cm. above the earth has a potential energy of $10 \times 20 = 200$ gram centimeters or $10 \times 980 \times 20 = 196,000$ ergs.

The kinetic energy of a body is found as follows :

$$KE = \frac{mv^2}{2g} \text{ foot pounds or gram centimeters}$$

$$KE = \frac{mv^2}{2} \text{ foot poundals or ergs}$$

These equations are obtained as follows. When a moving body is brought to rest it does work. For example, when a moving bullet is brought to rest by an earth embankment it does work in moving a certain distance into the embankment. The work it does is equal to its kinetic energy. Let m = the mass of the moving body ; v , its velocity ; s , the distance it moves in being brought to rest ; f , the force it exerts while being brought to rest ; and a , the decrease in its velocity per second or its negative acceleration.

The kinetic energy of a moving body is equal to the work it does in being brought to rest.

$$KE = w = fs$$

but

$$f = ma \text{ and } s = \frac{v^2}{2a},$$

therefore

$$KE = fs = ma \times \frac{v^2}{2a} = \frac{mv^2}{2}$$

that is,

$$KE = \frac{mv^2}{2} \text{ foot poundals or ergs}$$

This equation gives the kinetic energy in foot poundals or ergs because in the equation $f = ma$, f is expressed in poundals or dynes.

Since 1 lb. is equal to g poundals and 1 g. is equal to g dynes, the kinetic energy of a moving body in foot pounds or gram centimeters is found by the equation

$$KE = \frac{mv^2}{2g} \text{ foot pounds or gram centimeters.}$$

Potential energy changes to kinetic energy. — A body at rest above the earth has potential energy. If the body is allowed to fall, the potential energy changes continuously to kinetic energy, and at the instant it strikes the ground its potential energy has been changed entirely to an equal amount of kinetic energy (neglecting the friction of the air). We can illustrate this best by means of an example.

A weight of 10 lb. 144 ft. above the earth has $10 \times 144 = 1440$ foot pounds of potential energy.

If this body is allowed to fall, its velocity when it strikes the ground is $s = \frac{v^2}{2g}$ or $144 = \frac{v^2}{2 \times 32}$ or $v^2 = 64 \times 144$ or $v = 8 \times 12 = 96$ ft. per second

Its kinetic energy is

$$KE = \frac{mv^2}{2g} = \frac{10 \times 96 \times 96}{2 \times 32} = 1440 \text{ foot pounds}$$

That is, its potential energy has been changed into an equal amount of kinetic energy.

When a body is shot upward, its kinetic energy changes continuously to potential energy and when it reaches its greatest height its potential energy is equal to the kinetic energy it had at the start.

The pendulum. — The pendulum is interesting for a number of reasons, (1) it gives us an example of potential energy changing to kinetic energy and the reverse; (2) any given pendulum makes its swings in equal times; (3) it is the regulating device of pendulum clocks.

When the pendulum is in the position *A*, Fig. 217, it has potential energy equal to the weight of the bob multiplied by the

distance AH . When it is in the position N all of this potential energy has been changed to kinetic energy. When it is in the

position A' its kinetic energy has been changed again to potential energy, etc.

If there were no friction, a pendulum once started would swing forever and these changes would be repeated for all time.

The time of swing of a given pendulum is approximately constant. It is expressed very closely by the formula

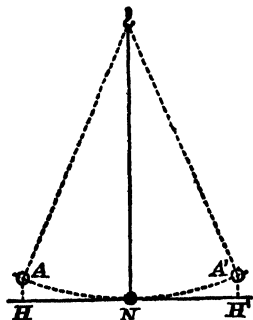

FIG. 217. — The pendulum.

$$t = \pi \sqrt{\frac{l}{g}}$$

The time t is the time in seconds it takes the pendulum to swing from one side to the other, for example, from A' to A or A to A' . l is the length of the pendulum from the point of support to the center of oscillation; g is the force of attraction of the earth. If l is expressed in feet, g is expressed in poundals, $g = 32$ poundals. If l is expressed in centimeters, g is expressed in dynes, $g = 980$ dynes.

EXERCISES

1. State the law of gravitation.
2. Define stable, unstable, and neutral equilibrium.
3. Define resultant and equilibrant.
4. State the parallelogram law.
5. How far will a body fall in 4 sec.; in 6 sec.?
6. A body is thrown upwards with a velocity of 160 ft. per second. How many seconds will it rise?
7. How high will the body in (6) rise?
8. State Newton's laws of motion.
9. Give examples of inertia.
10. Define poundal, dyne, erg, energy.
11. What is the potential energy of a 10-lb. body 200 ft. above the earth?
12. What is the kinetic energy of a 10-lb. body moving with a velocity of 160 ft. per second?

APPENDIX

Weights and Measures

Linear Measure

12 inches (in.)	= 1 foot (ft.)	320 rods	= 1 mile (mi.)
3 feet	= 1 yard (yd.)	1760 yards	= 1 mile
5.5 yards	= 1 rod (rd.)	5280 feet	= 1 mile
16.5 feet	= 1 rod	6 feet	= 1 fathom

Square Measure

144 square inches (sq. in.)	= 1 square foot (sq. ft.)
9 square feet	= 1 square yard (sq. yd.)
30 $\frac{1}{4}$ square yards	= 1 square rod (sq. rd.)
160 square rods	= 1 acre (A.)
640 acres	= 1 square mile (sq. mi.)
1 square mile	= 1 section
36 square miles	= 1 township

Cubic Measure

1728 cubic inches (cu. in.)	= 1 cubic foot (cu. ft.)
27 cubic feet	= 1 cubic yard (cu. yd.)

Wood Measure

16 cubic feet	= 1 cord foot (cd. ft.)
128 cubic feet	} = 1 cord (cd.)
8 cord feet	

Table of Counting

12 units = 1 dozen (doz.)	24 sheets of paper = 1 quire
12 dozen = 1 gross (gro.)	20 quires or 480 sheets = 1 ream
12 gross = 1 great gross (gt. gro.)	

Avoirdupois Weight

7000 grains (gr.)	= 1 pound (lb.)
16 ounces (oz.)	= 1 pound
100 pounds	= 1 hundredweight (cwt.)
2000 pounds	= 1 ton (T.)
2240 pounds	= 1 gross ton

*Troy Weight**For Precious Metals, Jewels, etc.*

24 grains	= 1 pennyweight (pwt.)
20 pennyweights	= 1 ounce
12 ounces	= 1 pound

437½ grains = 1 ounce	} Av.
7000 grains = 1 pound	
480 grains = 1 ounce	} Troy
5760 grains = 1 pound	

Apothecaries' Weight

20 grains	= 1 scruple (sc. or ℥)	
3 scruples	= 1 dram (dr. or ℥)	12 ounces
8 drams	= 1 ounce (oz. or ℥)	5760 grains
		} = 1 pound (lb. or ℔)

Apothecaries' Liquid Measure

60 minims	= 1 fluid dram (f ℥)
8 fluid drams	= 1 fluid ounce (f ℥)
16 fluid ounces	= 1 pint (O.)
8 pints	= 1 gallon (cong.)

Measure of Time

60 seconds (sec.)	= 1 minute (min.)
60 minutes	= 1 hour (hr.)
24 hours	= 1 day (da.)
7 days	= 1 week (wk.)
365 days or	} = 1 year (yr.)
12 months (mo.)	
10 years	= 1 decade
10 decades	= 1 century

Liquid Measure (U. S.)

4 gills (gi.) = 1 pint (pt.)	231 cu. in. = 1 gal.
2 pints = 1 quart (qt.)	31½ gal. = 1 bbl.
4 quarts = 1 gallon (gal.)	1 liquid quart = 57.7 cubic inches

Dry Measure (U. S.)

2 pints (pt.) = 1 quart (qt.)
8 quarts = 1 peck (pk.)
4 pecks = 1 bushel (bu.)
32 quarts = 1 bushel
2150.4 cu. in. = 1 bushel

Liquid and Dry Measure (British)

2 pints (pt.) = 1 quart (qt.)
4 quarts = 1 gallon (gal.)
2 gallons = 1 peck (pk.)
4 pecks = 1 bushel (bu.)
8 bushels = 1 quarter (qr.)
1 quart = 69.318 cubic inches
1 gallon = 277.274 cubic inches

Household Measures

1 teaspoon = 5 c.c.	16 tablespoons = 1 cup
3 teaspoons = 1 tablespoon	2 cups = 1 pint

Miscellaneous

1 (U. S.) gallon of water weighs 8.33 lb.
1 (British) gallon of water weighs 10 lb.
1 cubic foot of water weighs 62.3 lb.

The Metric System*Measures of Length*

10 millimeters (mm.) = 1 centimeter (cm.)
10 centimeters = 1 decimeter (dm.)
10 decimeters = 1 meter (m.)
10 meters = 1 dekameter (Dm.)
10 dekameters = 1 hektometer (Hm.)
10 hektometers = 1 kilometer (Km.)
10 kilometers = 1 myriameter (Mm.)

Measures of Surface

100 sq. millimeters (sq. mm.)	= 1 sq. centimeter (sq. cm.)
100 sq. centimeters	= 1 sq. decimeter (sq. dm.)
100 sq. decimeters	= 1 sq. meter (sq. m.)
100 sq. meters	= 1 sq. dekameter (sq. Dm.)
100 sq. dekameters	= 1 sq. hektometer (sq. Hm.)
100 sq. hektometers	= 1 sq. kilometer (sq. Km.)

Measures of Volume

1000 cu. millimeters (cu. mm.)	= 1 cu. centimeter (c.c.)
1000 cu. centimeters	= 1 cu. decimeter (cu. dm.)
1000 cu. decimeters	= 1 cu. meter (cu. m.)

Measures of Capacity

10 milliliters (ml.)	= 1 centiliter (cl.)
10 centiliters	= 1 deciliter (dl.)
10 deciliters	= 1 liter (l.)
10 liters	= 1 dekaliter (Dl.)
10 dekaliters	= 1 hekoliter (Hl.)
10 hekoliters	= 1 kiloliter (Kl.)

Measures of Weight

10 milligrams	= 1 centigram	10 dekagrams	= 1 hektogram
10 centigrams	= 1 decigram	10 hektograms	= 1 kilogram
10 decigrams	= 1 gram	1000 kilograms	= a metric ton
10 grams	= 1 dekagram		

Commit to Memory

1 meter (m.)	= 100 centimeters (cm.)
1 meter (m.)	= 1000 millimeters (mm.)
1 liter (l.)	= 1000 cubic centimeters (c.c.)
1 kilogram (kg.)	= 1000 grams (g.)
1 cubic centimeter of water at 4° C.	weighs 1 gram
1 liter of water at 4° C.	weighs 1 kilogram.

Equivalents

1 inch	= 2.54 centimeters
1 foot	= 30.48 centimeters
1 quart (U. S. liquid)	= .9464 liter
1 quart (U. S. dry)	= 1.101 liters
1 quart (British)	= 1.1351 liters
1 pound av.	= .4536 kilogram
1 centimeter	= .3937 inch
1 meter	= 39.37 inches
1 liter	= 1.051 quarts (U. S. liquid)
1 liter	= .9081 quart (U. S. dry)
1 liter	= .8809 quart (British)
1 kilogram	= 2.205 pounds

INDEX

- Acceleration**, 292-295
Advantage, 4
Aéroplanes, 75
Air, compressed, 57, 62, 64, 70, 73, 75;
 convection current, 90, 91, 94, 104,
 111-114; heater, electric, 190; weight
 of, 49; weight of hot, 90
Air brake, 76
Air chamber, of plumbing, 73; of pump,
 62; of ram, 64
Alternating-current dynamo, 225, 228
Ammeter, 214
Ampere, 167, 202, 206
Anode, 196
Appliances in the home, electrical, 163-
 167, 178-180, 182-192, 214-216,
 223-236; heat, 86-97, 107-114, 133-
 141, 151; light, 246, 262-268; me-
 chanical, 2, 6, 7, 9, 15, 31, 62, 63, 66-76;
 sound, 279-287
Arc light, 193
Archimedes, law of, 40, 56; explanation
 of law, 42
Armature, 183, 185, 224
Artesian well, 33
Artificial ice machine, 138
Atmosphere, pressure of, 50-55

Baking powder, 89
Balloon, 56, 74
Barometer, 53
Batteries, 162-167
Beats, 286
Bell, electric, 178; circuits, 179
Bellows, hydrostatic, 39
Boiler, double, 151; steam, 154
Boiling, applications of, 150; and evap-
 oration, 150
Boiling point, 148; variation of with
 pressure, 149
Bolt, 15
Boyle's law, 57
Bread, mixer, 9, 186; raising, 88
British thermal unit, 116

Broiler, electric, 190
Button, push, 179

Cake mixer, 186
Calorie, 116
Camera, 262
Can opener, 6
Capacity, heat, 126
Cathode, 196; rays, 240
Cells, electric, 162-167; simple, 162;
 storage, 199
Center of gravity, 289
Centigrade thermometers, 86
Chafing dish, electric, 189
Chimney, draft in, 92; location of, 93
Circulation, of air, 90; of water, 95
Clamp, 15
Clothes, 111; drying, 146
Clouds, 147
Coefficient of expansion, 83
Coffee mill, 9; percolator, electric, 189
Coherer, 239
Color, 269; complementary, 272; how
 produced, 270
Commutator, 183, 225
Compass, mariner's, 175
Compressed air appliances, 62, 64, 75,
 76
Conduction, of electricity, 168; of heat,
 102, 106
Conductivity, thermal, 106
Convection, in air, 90; in water, 95
Cooker, fireless, 108; steam, 140
Cooking, electric, appliances, 188; ex-
 pansion of gases in, 88; utensils, 107,
 118
Cooling, artificial, 137; effect of ice and
 ice water, 122
Copperplating, 197
Cost, of heat, 153; of work, 158
Coulomb, 206
Cup and cylinder, 41
Currents, convection, 90, 95; electric
 163 ff.

- Damper, in pipe, 92; in range, 93
 Daniell cell, 164
 Density, 43-47
 Dew, 147; point, 148
 Discord, 286
 Dispersion, 270
 Distillation, 140
 Diving bell, 75
 Draft, in grate, 91; in range, 93; in stove, 91
 Dry cell, 166
 Drying, explanation of, 146
 Dynamo, 220-288; alternating-current, 225; commercial, 227; direct-current, 225; and motor, 226
 Echo, 278
 Eggs, beating, 89; beater, 186
 Electric, air heater, 190; arc, 193; bell, 178; broiler, 190; cooking appliances, 188; coffee percolator, 189; chafing dish, 189; heating appliances, 187-190; iron, 187; luminous radiator, 189; light, arc, 193; light, incandescent, 191; motor, 181-186; oven, 189; stove, 189; telegraphy, 180; toaster, 190; warming pad, 189
 Electrical, calculations, 207; sources of, energy, 228; terms, 202
 Electricity, how produced, 162; in the home, 161 ff.; what is, 161
 Electrolysis, 195; laws of, 199
 Electromagnet, 175, 177; applications of, 178-186
 Electromotive force, 167
 Electron, 241; theory of matter, 241
 Electroplating, 195-199
 Energy, 290-301
 Engine, gasoline, 155; steam, 154
 Equilibrant, 290
 Equilibrium, 289
 Erg, 299
 Ether, 104, 250
 Evaporation, 144; cooling by, 145; in nature, 147
 Expansion, 80; applications of, 84, 88; coefficients of, 83
 Extinguisher, fire, 70
 Eye, 263
 Fahrenheit thermometers, 86
 Falling bodies, 292-295
 Faraday, 199, 220
 Faucet, 15
 Field, magnetic, 171
 Fire, extinguisher, 70; tongs, 7
 Fireless cooker, 108; comparing, 120
 Fires, comparing, 119
 Focal length, 260
 Fog, 147
 Foot warmers, comparing, 120
 Force, 2, 20, 295; arm, 2; units of, 296
 Forces, composition of, 290; parallel, 291; parallelogram law of, 290
 Fork and knife, 7
 Freezing mixtures, 135
 Friction, 22
 Fruit press, 6, 15
 Fuels, 152; comparison of, 153
 Fulcrum, 2
 Fundamental, 281; units, 28
 Fusion, heat of, 130
 Galvanometer, 213; D'Arsonval, 213
 Gases, expansion of, 88; laws of, 55-59
 Gas meter, 73
 Gasoline engine, 155
 Gold plating, 198
 Gram, 306
 Grass cutter, 7
 Grate shaker, 9
 Gravitation, law of, 289
 Gravity, cell, 165; center of, 289
 Hail, 147
 Handles, of cooking utensils, 108
 Harmony, 286
 Heat, appliances which control, 106; applications of latent, 133; capacity, 126; conduction of, 102; convection of, 104; engines, 154; from electricity, 152, 187, 204; in the home, 79; latent, 128; measurement of, 116; mechanical equivalent of, 158; movement of, 102; nature of, 99; radiation of, 104; sources of, 152; specific, 126; turned to work, 157; units of, 116
 Heating systems, hot-air, 95; hot-water, 96; steam, 139
 Henry's law, 59
 Home, arrangement of lighting fixtures in, 246; electricity in, 161; heat in the, 79; light in the, 246; motor in the, 182

- Horse power, 157; of electric current, 210
- Hot-air heating system, 95
- Hot-water, heating system, 96; tank, 97
- Household appliances, electrical, 161 ff.; heat, 79 ff.; light, 246 ff.; mechanical, 1 ff.; sound, 279 ff.
- Humidity, 148
- Hydraulic press, 39
- Hydraulic ram, 64
- Hydrostatic bellows, 39
- Hydrostatic paradox, 37
- Ice, 123; artificial, 137; and salt, 136; latent heat of, 128; machine, 138; water, 123
- Images, by concave lens, 262; by convex lens, 260; in mirror, 254; real, 260; virtual, 260
- Incandescent light, 191
- Induced currents, 219-223; application of, 223-235
- Induction coil, 232
- Inertia, 295
- Instruments, musical, 278-287; optical, 262-267; stringed, 280; wind, 283
- Insulators, electric, 168; heat, 106
- Interference, 285
- Iron, electric, 187
- Jack screw, 16
- Joule, 206
- Joule's law, 204, 208
- Key, telegraph, 180
- Kilogram, 27
- Kilowatt, 202, 206; hour, 202, 206, 209
- Kinetic energy, 299
- Kitchen, motor in, 185; power table in, 185
- Lamps, incandescent, 192; arc, 193
- Lantern, 263
- Latent heat, of ice, 128; of steam, 130
- Leclanché cell, 105
- Lemon squeezer, 6
- Lenses, 259-262
- Lenz law, 223
- Lever, 1; appliances, 2, 6, 7; classes of, 5; law of, 3
- Light, appliances, 262-268; candle power of, 248; electric, 192; in the home, 246; intensity of, 247; nature of, 250; reflection of, 253; refraction of, 253
- Lighting fixtures, arrangement of, 246
- Lines of force, magnetic, 171
- Liquids, 30; density of, 45; pressure in, 34-40
- Loudness of sound, 278
- Machines, artificial ice, 138; defined, 14; law of, 14
- Magdeburg hemispheres, 50
- Magnet, artificial, 169; bar, 171; electro, 175; horseshoe, 172; how made, 172; natural, 169; pole, 169; theory of molecular, 173.
- Magnetic field, 171; field about a current, 176; induction, 170; lines of force, 170, 176
- Magnifying glass, 265
- Mass and weight, 28
- Mastery, 4
- Measurement, 24; common system of, 25, 303; of heat, 116 ff.; metric system of, 27, 305
- Measuring instruments, electrical, 212
- Meat chopper, 15; grinder, 186
- Mechanical appliances, in the home, 1-19
- Mechanical equivalent of heat, 158
- Meter, 27
- Metric system, 305; advantages of, 27; history of, 26
- Microscope, compound, 266; simple, 265
- Mirror, 254
- Molecular magnets, theory of, 173
- Molecules, 99
- Moment, 2
- Momentum, 296
- Motion, 291; Newton's laws of, 295
- Motor, 182; how current runs, 183; in the home, 182
- Movement of heat, 102 ff.
- Music and musical instruments, 279
- Musical scale, 279
- Newton, law of gravitation, 289; laws of motion, 295
- Nickel plating, 198
- Noise and music, 277
- Nonconductors, of electricity, 168; of heat, 106
- Nut cracker, 6

- Octaves, 281
 Oersted's discovery, 175
 Ohm, 167, 202, 206
 Ohm's law, 203, 207
 Opera glass, 267
 Oven, electric, 189
 Overtones, 281
- Pad, electric warming, 189
 Paradox hydrostatic, 37
 Parallelogram law, 290
 Pascal, 53; law of, 37, 55
 Pendulum, 301
 Phonograph, 287
 Photometer, Bunsen's, 249
 Pirsch gas system, 77
 Pitch, 277
 Pliers, 2
 Pneumatic tank, 62; water supply system, 62
 Pneumatic tubes, 76
 Polarization, 164
 Power, horse, 157
 Pressure, atmosphere, 50-55; of gases, 55; in liquids, 34-40; in water pipes, 40
 Prism, 258
 Pulley, law of, 13; systems, 13
 Pump, air, 65; force, 61; handle, 2; lift, 61
- Quality, 282
- Radiation, 104, 251
 Radiator, hot water, 96; luminous, 189
 Radioactivity, 244
 Radium, 243
 Rain, 147
 Range, dampers in, 93; draft in, 93
 Rays, cathode, 240; light, 252; X, 242
 Reflection, 253; laws of, 253
 Refraction, 253, 254; explanation of, 256; laws of, 255
 Refrigerators, 109, 133; comparing, 135; temperature of air in, 134
 Relay, 180
 Resistance, 167, 216
 Resonance, 284
 Rheostat, 190
 Right-hand rules, 176, 178
- Saturated air, 145
 Scissors, 2
- Screw, 15; appliances, 15, 18; advantage of, 17; jack, 16; nail, 15
 Sealer, 15
 Series connection, 216, 217
 Service entrance, 215
 Sewing machine, motor driven, 182
 Silver plating, 198
 Siphon, 71
 Snow, 147
 Sonometer, 280
 Sound, 274; defined, 276; velocity of, 275; waves of, 276
 Sounder, telegraph, 180
 Sounding board, 281
 Specific heat, 126
 Spectacles, 265
 Spectrum, 269
 Steam, cooker, 140; engine, 154; heating effect of, 123; heating system, 139; latent heat of, 130
 Stereoscope, 267
 Still, domestic, 141
 Storage cell, 199
 Stove, draft in, 92; electric, 188; heating a room, 94
 Stringed instruments, 280
- Tack-lifter, 2
 Telegraph, key, 180; relay, 180; sounder, 180; wireless, 237
 Telephone, diagram of, 234; receiver, 235; transmitter, 233
 Telescope, 266
 Thermal units, British, 116; calorie, 116
 Thermometer, comparison of, 87; gas, 86; liquid, 85, 86; solid, 84
 Thermos bottle, 109
 Toaster, electric, 190
 Torricelli, 52
 Transformer, 230; advantages of, 231
 Transmitter, 233
 Transparent substances, 271
 Trap, 72
- Units, 28, 116, 202
- Vacuum, sound in, 275
 Vacuum cleaners, 66-70; air pump of, 68
 Velocity, 291; of light, 251; of sound, 275
 Ventilation, 111-113
 Volt, 167, 202, 205

- Voltmeter, 214
Volume, of irregular solids, 42
- Walls of houses, 111
Washing machine, motor driven, 182
Water, electrolysis of, 195; expansion of, 98; heating effect of boiling, 123; hot, lighter than cold, 90
Water supply, city, 30; for country homes, 31; pneumatic tank system of, 63
Watt, 202, 206, 208; hour, 202, 206
Wave, front, 252; lengths of light, 270; length of sound, 277
Wave theory of light, 250
Weight, 2; arm, 3
- Weights and measures, 24, 303 ff.
Wells, 32; artesian, 33; on hillside, 34
Wheel and axle, 7; appliances, 8
White light, nature of, 269
Wind instruments, 283; how sound is started in, 284
Wireless telegraph, 237
Work, cost of, 158; defined, 20; law of, 21; from heat, 158; units of, 20, 299
Wringer, 9; motor driven, 182
- X-ray, 242; nature of, 243; pictures, 242
- Yard, 28; stick as lever, 1
Young-Helmholtz theory, 272

