

ROORKEE TREATISE
ON
CIVIL ENGINEERING.

SECTION XIII.

DRAWING,

FOR ENGINEER STUDENTS & DRAFTSMEN.

SECOND EDITION.

170491

Major E. H. deV. ATKINSON, R.E.

Principal, Thomason Civil Engineering College, Roorkee.

PART II.

On sale in the Thomason College Book Depot, Roorkee.

ROORKEE :

PHOTO.-MACHL. AND LITHO. DEPARTMENT, THOMASON COLLEGE.

1927.

[All rights reserved by the Secretary of State for India in Council].

UNIVERSAL
LIBRARY

OU_170491

UNIVERSAL
LIBRARY

ROORKEE TREATISE
ON
CIVIL ENGINEERING.

SECTION XIII.

DRAWING,

FOR ENGINEER STUDENTS & DRAFTSMEN.

SECOND EDITION.

BY

Major E. H. deY. ATKINSON, R.E.,

Principal, Thomason Civil Engineering College, Roorkee.

PART II.

On sale in the Thomason College Book Depot, Roorkee.

ROORKEE :

PHOTO.-MECHL. AND LITHO. DEPARTMENT, THOMASON COLLEGE.

1927.

[All rights reserved by the Secretary of State for India in Council].

R O O R K E E :

PHOTO -MECHL. AND LITHO. DEPARTMENT, THOMASON COLLEGE.

1927.

PREFACE TO THE ROORKEE TREATISE ON CIVIL ENGINEERING IN INDIA.

THE Roorkee Treatise was originally compiled by Lieut.-Col. J. G. Medley, R.E., in 1866 and issued in two volumes.

The Treatise grew out of the various College Manuals, dealing for the most part with subjects which required special treatment to suit the climate and methods used in India, and has been constantly revised and re-written. It is found advisable now to publish the Treatise in separate Sections, so that each Section can be re-written or revised and brought up to date whenever opportunity occurs, to keep pace with modern methods and discoveries.

The Treatise now contains the following Sections :—

Section	I. Building Materials,...	...	1924
„	II. Masonry,	1924
„	III. Carpentry,	1926
„	IV. Earthwork,	1926
„	V. Estimating,	1926
„	VI. Building Construction,	1925
„	VII. Bridges,	1925
„	VIIA. Chapter on Steel Bridges,	1925
„	VIII. Roads,	In Press.
„	IX. Railways,	1925
„	X. { Irrigation Works, Vol. I.,	...	1924
„	„ „ „ II.,	...	1919
„	XI. Sanitary Engineering, Part I.,	...	1925
	(Water-Supply).		
„	XII. Sanitary Engineering, Part II.,	...	1926
	(Sewerage on Drainage Works).		
„	XIII. { Drawing Manual, Part I.,	...	1927
„	„ „ „ II.,	...	1927
„	XIV. { Surveying, Part I.,	...	1924
„	„ „ II.,	...	1926

PREFACE TO DRAWING.
FOR ENGINEER STUDENTS AND DRAFTSMEN
[PARTS I. & II.]

THE chief aim in compiling this Manual has been to include in it, only such information as is generally necessary to the various grades of Engineers educated in the College. It is divided into two parts. Part I. comprises the course for Lower Subordinates. Parts I. and II. comprise the course for Engineers, Upper Subordinates and Draftsmen.

Among the books consulted are—Pulford's Theory and Practice of Drawing, Chambers' Treatise on Civil Architecture, Leoni's Architecture of Palladio, Atkinson's Practical Solid Geometry and Watson's Descriptive Geometry.

February, 1904.

E. H. deV. A.

CONTENTS.

SECTION XIII.—DRAWING.

PART II.

CHAPTER XI.—FURTHER PROBLEMS IN THE PROJECTION OF LINES AND PLANES.

	PAGE.
Lines and Planes,	148
Case I.,	148
Case II.,	148
To find the length of the Minor Axis,	152
Exercises,	153

CHAPTER XII.—FURTHER PROBLEMS IN PRO- JECTION OF SOLIDS.

Case V.,	155
Case VI.,	156
Case VII.,	157
Exercises,	158

CHAPTER XIII.—INTERPENETRATION OF SOLIDS AND TANGENT PLANES.

Case I.,	161
Tangent Planes,	163
Case II.,	166
Exercises,	170

CHAPTER XIV.—DEVELOPMENT OF SOLIDS.

Development of Solids,	173
The Helix,	176
To determine the Development,	177
Exercises,	178

CHAPTER XV.—THE DETERMINATION OF SHADOWS AND SHADING.

	PAGE.
The determination of the shadow cast by an object on the Planes of Projection,	180
Case I.,	180
Case II.,	180
The determination of the shadow cast by an object on itself,	181
To determine the lines of separation of Light and Shade, ...	182
To determine the line of highest Light,	183
To determine the lines of separation of Light and Shade, ...	184
To determine the lines of separation of Light and Shade and the shadow cast on the Planes of Projection,	184
The determination of the shadow cast by one object on another, ...	186
Shading,	188
General Rules,	189
Shading by flat tints,	191
Shading by softened tints,	193
Elaboration of Shading and Shadows,	193
Shade lines,	197
Exercises,	198

CHAPTER XVI.—PERSPECTIVE PROJECTION.

Perspective Projection,	200
Perspective by Orthographic Projection,	201
Definitions of terms used in Perspective,	202
Definitions,	204
Visual rays,	204
Picture plane,	204
Station point,	204
Line of Sight,	204
Point of Sight,	205
The Horizontal plane,	205
Ground plane,	205
Ground line,	205
Central visual ray,	205

	PAGE.
Perspective by Measurement,	205
Perspective by Vanishing points,	209
Vanishing points of oblique lines,	213
Vanishing points beyond the paper,	214
Perspective by Points of Measurement,	214
Perspective by Local Scales of Measurement,	217
General,	219
Perspective as applied to Drawing from nature,	220
To find the Perspective of any Curve,	221
Shadows in Perspective,	222
Exercises,	227

PART II.

CHAPTER XI.

FURTHER PROBLEMS IN THE PROJECTION OF LINES AND PLANES.

The problems given in Chapter VIII., Part I., represent the more general and simpler problems in Lines and Planes. The further problems given in this Chapter must, however, be thoroughly grasped before the Student can work out the remaining Cases of the Projection of Solids which are given in Chapter XII.

Problem 211.—Through a given point to pass a plane ; (i), perpendicular to a given line ; (ii), perpendicular to a given plane. (Plate XXII., Figs. 1 and 2).

Let p_{12} be the given point and $b_3 c_7$ the given straight line.

Case 1. Make an elevation of the point p_{12} and the line $b_3 c_7$ on an XY line parallel to $b_3 c_7$. Through p' draw $p' d'$ perpendicular to $b' c'$, meeting the XY line in d' . Then p' and d' are the elevations of the 12 and 3 contours of the required plane. The contours can be drawn perpendicular to the XY line and the Scale figured.

Case 2. This Case is worked in the same way as Case 1, the elevation of the given plane P being drawn on an XY parallel to the Scale of Slope of the plane.

Problem 212.—To find the shortest distance from a given point to a given straight line. (Plate XXII., Fig. 3).

Let $b_3 c_7$ be the given straight line and p_{10} the given point. Make an elevation of the given straight line $b_3 c_7$ on an XY line parallel to itself. Then if the perpendicular drawn from the elevation of the given point meet the elevation of the given line as $p' d'$, then it is evident pd is the shortest distance from p_{10} to the line $b_3 c_7$. If the perpendicular from the given point will not meet the elevation of the given line, as in

the case of the perpendicular from r_{11} , then the given point must be joined to the nearest extremity of the line as rc .

Problem 213.—Through a given line to pass a plane parallel to another given line. (Plate XXII., Fig. 4).

Let $a_5 b_{12}$ and $c_3 d_7$ be the two given lines. It is required to pass through $a_5 b_{12}$ a plane parallel to $c_3 d_7$.

Through a_5 draw a line $a_5 e_9$ parallel to $c_3 d_7$ (Problem 196). Through $a_5 e_9 b_{12}$ pass a plane (Problem 197), then this plane is the required plane as it contains $a_5 e_9$ which is parallel to $c_3 d_7$, and therefore the plane itself is parallel to $c_3 d_7$.

Problem 214.—Through a given point to draw a line to meet two given lines which are not parallel. (Plate XXII., Figs. 5 and 6).

Let p_{10} be the given point and $a_5 b_{12}$ and $c_2 d_{12}$ be the two given lines.

Examine Fig. 6. If we take a plane M to contain the line AB and the point P and a plane N to contain the line CD and the point P, then it is apparent that the intersection of the planes M and N, as represented by the line TS, will be the required line.

In Fig. 5, through p_{10} a_5 and b_{12} pass a plane M (Problem 197), and through p_{10} c_2 d_{12} pass a plane N, then the intersection of these two planes will be the required line meeting the two given lines produced if necessary in t and s .

Problem 215.—To draw a line perpendicular to two given lines which are not parallel. (Plate XXII., Figs. 7 and 8).

Let $a_{10} b_{-3}$ and $c_{-6} d_1$ be the two given lines.

In Fig. 8, let AB and CD be the two given lines. Let M be a plane containing AB and parallel to CD. From any point in CD (say D) drop DI, a perpendicular to the plane. Draw the line IK, lying in the plane M and parallel to CD. This line will meet AB (produced if necessary) in the point K.

Draw KL parallel to DI. Then KL is the required line, being perpendicular to AB and also to CD (because CD is parallel to the plane M).

In Fig. 7, draw the plane M to contain $a_{10} b_{-3}$, and to be parallel to $c_{-6} d_4$ (Problem 213). From any point in $c_{-6} d_4$ (say d_4), draw $d_4 i$ perpendicular to the contours of the plane M. Make an elevation of the

Note.—Problems 211 to 218 are taken from Atkinson's Practical Solid Geometry by permission of Messrs. E. and F. N. Spon, Limited.

plane M and the line $d i$, and find i , the plan of their point of intersection. From i draw $i k$ parallel to $c d$, meeting $a b$ (produced if necessary) in k . From k draw $k l$ parallel to $d i$, meeting $c d$ (produced if necessary) in l . Then $k l$ is the required line, perpendicular to the two given lines.

Problem 216.—To measure the angle made by a given line with a given plane. (Plate XXII., Figs. 9 and 10).

When a line meets a plane, the angle between the line and the plane is the angle between the line and its projection on the plane. This is the smallest angle which can be measured between the given line and any line in the plane.

Let $a_5 b_9$ be the given line and M the given planè. It is required to measure the angle which the line AB makes with the plane M .

In *Fig. 10*, let the point I be the intersection of a line AB with a plane M . From any point in AB (say A) drop a perpendicular to the plane meeting it in T . Then TI is the plan on the plane M of a portion of AB , and the angle TIA (θ) is the angle which the line AB makes with the plane M .

Turn to *Fig. 9*. Make an elevation of the plane M and the line $a_5 b_9$. Find i the plan of their point of intersection. From any point in the line (say a_5) draw a perpendicular to the plane. Find t the plan of its point of intersection with the plane. Index $i_8 t_{17}$ from the elevation. Then $t_{17} i_8 a_5$ is the plan of the required angle. "Construct" this angle, and obtain the real angle TIA .

To "Construct" the angle. Pass a plane P through $t_{17} i_8 a_5$ (Problem 197). Using the (8) contour as an axis of rotation, make an elevation of the three points on an XY (8). "Construct" the points a_5 and t_{17} to A and T . The point i will remain stationary, and may be marked I , because the triangle $t i a$ has been "constructed" into an H. P. of level (8), which is also the level of i . Join AI and TI .

Problem 217.—Through a given line to draw a plane, making a given inclination with a given plane. (Plate XXII., Figs. 11 and 12).

Let M be the given plane and $a_{23} b_{20}$ the given line. It is required to draw a plane through $a b$ making an angle of 70° with the plane M . In *Fig. 12*, let a line AB intersect a plane M inclined to the H. P. in the point I . Erect a cone, the vertex of which is at A , the axis perpendicular to the plane M , and the generatrix making an angle of 70° with the

base. From I draw IF tangent to the base of the cone. It is evident from the figure that, if a plane V is passed through the points I, F and A, it will fulfil the required conditions. It contains the line AB, and being tangent to the cone, which makes an angle of 70° with the plane M, must itself be inclined at 70° to the plane M. Further, it is evident that two planes may be drawn to fulfil the conditions. Because another tangent IG can be drawn from I to the base of the cone, a plane passed through the points, I, G and A will also fulfil the conditions.

If the angle of inclination of the cone is less than the angle which the line AB makes with the plane M, the problem is evidently impossible.

Now refer to *Fig. 11*. Make an elevation of the plane M and the line $a_{23} b_{20}$. Find and index i_{21} , the plan of their point of intersection. Through a_{23} draw a line perpendicular to the plane M. Find the elevation c' of its intersection with the plane M. With a' as vertex and $a' c'$ as axis, draw the elevation $a' d' e'$ of a cone, the generatrix of which is inclined at 70° to the elevation of the plane M.

The problem may now be completed in two ways :—

1. This method is shown in *Fig. 11*, as it is more accurate. “Construct” i_{21} , the point of intersection of the line and plane to I.

Also “construct” the elevation of the base of the cone. The constructed plan will be the circle DFEG. Draw tangents IF and IG from the point I to the circle. “Reconstruct” the points F and G into the plane M, and obtain the points $f_{13} g_{10}$.

To “reconstruct” the point F.

From F draw a projector meeting the XY line in f'' . With centre o and radius o f'' , draw an arc cutting the elevation of the plane M in f' (thus rotating the point f'' up into the plane M). Project down from f' . Draw from F a line parallel to the XY line to meet this projector in f . Index f from the elevation. The point G is “reconstructed” in the same way.

The two planes V^1 and V^2 passed through $i_{21} f_{13} a_{22}$ and $i_{21} g_{10} a_{23}$ respectively are the required planes. The construction for drawing these planes has not been shown in *Fig. 11*.

2. Project down the plan of the cone. The plan of its base is an ellipse, the minor axis of which lies in a c (the plan of the axis of the cone), the point c being the centre of the ellipse. Draw tangents to this ellipse from i_{21} , obtaining the points f_{12} and g_{10} .

Problem 218.—Through a given point to draw a plane of proposed inclination to make a given angle with a given plane. (Plate XXIII., Figs. 1, 2, 3).

To draw through a point p_{20} a plane inclined at 70° to the H. P., and making 80° with a given plane M.

In *Fig. 2*, let P be the given point and M the given plane. With P as common vertex, erect two cones: one a right cone, with its axis perpendicular to the H. P. and its generatrix inclined at 70° ; the other an oblique cone, having its axis perpendicular to the plane M and its generatrix inclined at 80° to the plane M. From *Fig. 2*, it is evident that if a plane V is drawn tangent to the two cones it will fulfil the required conditions. Being tangent to the right cone it is inclined at 70° to the H. P., and being tangent to the oblique cone it is inclined at 80° to M. It also passes through the point P.

Further, it can be seen that four tangent planes may be drawn to fulfil the conditions: two outside the two cones, and two passing between the cones. If, however, the bases of the two cones touch each other externally, there will only be three planes possible. If the bases intersect, there will only be two planes possible.

Now turn to *Fig. 1*. Draw an elevation of the point p_{20} and the plane M. With p' as common vertex, draw the elevation of two cones: one with its axis perpendicular to the XY line, and its generatrix inclined at 70° to the XY line; the other with its axis perpendicular to the elevation of the plane M, and its generatrix inclined at 80° to the plane M. The elevation of this cone intersects the XY line in b' and c' .

Draw the plan of the two cones. The plan of the right cone is a circle, of which the point p_{20} is the centre. The plan of the common vertex is at p_{20} . The plan of the base of the oblique cone is an ellipse, of which the major axis lies on the plan of the axis of the cone—in other words, on the line $p_{20}c$. Project down the points b' and c' , obtaining b c the length of the major axis. Bisect $b'c'$ in a' . The plan of this point a is the centre of the ellipse. A line drawn perpendicular to bc through a is the *direction* of the minor axis.

TO FIND THE LENGTH OF THE MINOR AXIS.

Refer to *Fig. 3*. BSC is an ellipse showing the section of the cone made by a horizontal secant plane passing through the cone. (The lettered points correspond with those shown in *Fig. 1*). The major axis,

BC and the point A, the centre of the ellipse, have been obtained. It is required to find AS the semi-minor axis. Draw the section of the cone made by a plane *perpendicular to the axis, passing through A*, the centre of the ellipse.

This is the circle DSE, of which the centre is at O. A perpendicular to DE through A, cuts both the ellipse BSC and the circle DSE in their point of intersection. Then AS is the semi-minor axis, being perpendicular to BC, the major axis, and drawn through the point A, the centre of the ellipse.

Now refer again to *Fig. 1*. Draw $d' e'$ through the point a' perpendicular to the axis of the cone, meeting the axis in o . With centre o and radius $o d'$, describe a semicircle (representing half the circle DSE, *Fig. 3*). From a' draw $a' s$ perpendicular to $d' e'$ meeting the circumference of the semicircle in s . Then $a' s$ is the length of the semi-minor axis. Measure this off on each side of a , on the direction of the minor axis, which has already been found. Complete the ellipse. Draw the four tangents common to the ellipse and circle. These will be the (0) contours of the required planes. Draw parallels through p_{20} , and graduate the scales of slope of the four required planes $V_1 V_2 V_3 V_4$.

EXERCISES.

1. Five steps, rise and tread 1 foot, lead to a terrace. Two feet from the bottom of the lowest step rises one side of a plane wooden boarding inclined towards the steps at 80° to the ground which is horizontal. Through the edge of the top step show a second wooden boarding so inclined as to meet the first at right angles. What is the inclination of the second boarding to the ground?

2. Through a point p_8 draw a plane perpendicular to a given line $a_3 b_7$ two inches long.

3. Draw a square of two-inch side, and figure three of the corners $a_5 b_{17} c_{12}$. Find the length of the shortest line which can be drawn from c_{12} to the line $a_5 b_{17}$.

4. The 5 and 25 contours of a plane are represented by two parallel lines 2 inches apart. From a point p_{80} equidistant from the two lines, draw a perpendicular to the plane and measure its length in plan.

5. Two lines $a_5 b_{17}, c_{13} d_3$ are each two inches long in plan, and their extremities are one and one-and-a-half inches distant from each other. Through $a_5 b_{17}$ draw a plane parallel to $c_{13} d_3$.

6. Figure in rotation the angles of a regular hexagon ($1\frac{1}{2}$ -inch side) $a_0 b_{20} c_5 d_{10} e-15 f_{15}$. Draw parallel planes containing AB and CD, and find PQ the shortest distance between DE and AF.

7. A plane M is inclined at 50° to the H.P. In the plane place a line $a b$ inclined at 45° and through this line draw a plane N, making an angle of 40° with the plane M.

8. A plane M is inclined at 40° . A horizontal line (level 10) makes an angle of 35° with the contours of the plane M. Find the angle which it makes with the plane.

9. The plan of two lines AB and BC meet each other at an angle of 120° . The points A and C are on the same horizontal level. The line AB is inclined at 25° . What is the elevation of the line BC?

10. Two lines sloping at $\frac{1}{3}$ and $\frac{1}{4}$ meet, making an angle of 60° in plan. Measure the true angle between them.



CHAPTER XII.

FURTHER PROBLEMS IN PROJECTION OF SOLIDS.

The three remaining Cases detailed on page 110, Part I, now can be examined.

CASE V.

The inclination of one face and of a line in that face being given.

Problem 201 shows how to obtain the true form of any plane polygon. If we consider this plane figure as the side or base of a solid, by means of an elevation, the plan of the solid can be drawn with its side of base lying in a plane inclined to the H.P.

The levels of certain points in the base are, however, necessary to fix the position of the object in the plane; and the necessity of this additional condition is obviated in the case under consideration by the fact that the inclination of a line in the given face is fixed.

From the consideration of a model it will be obvious that if, in addition to the inclination of the plane, the inclination of any line belonging to the object and lying in that plane is given, then the exact position of the object is fixed.

Problem 219.—To draw a hexagonal pyramid (edge of base 1 inch, height 2 inches), the plane of the base being inclined at 55° to the H.P., and one edge of the base AB, inclined at 35° . (Plate XXIII, Fig. 4).

Draw the plan and elevation of the plane M inclined at 55° . In this plane at any point a , place a line ax inclined at 35° . (Problem 200).

“Construct” the line ax into the H.P. (Problem 201), by projecting the point x up to the elevation of the plane to the point x'' , and with centre a' and radius $a'x''$ bringing the point x'' down to the XY line, in the point x' . Then a line drawn from x' perpendicular to the XY line, to meet a line parallel to the XY line through x , will give the point X and AX will represent the line ax “constructed” into the H.P. On AX draw the hexagon (1-inch side) ABCDEF.

“Reconstruct” each of these points into the plane M and obtain the plan of the base of the pyramid $a b c d e f$ inclined at 55° to the H.P.

The process of “Reconstruction” is exactly opposite to that of “Construction” and consists of lifting a body out of the H.P. into any required plane. Thus the point D is projected up to d' in the XY line. With centre a' and radius $a' d'$ the point a' is lifted to d'' in the elevation of the plane M; the point d'' is then projected down till it meets a parallel to the XY line through D in the required point d .

To complete the figure find V the centre of the hexagon and “reconstruct” it into the plane M in the point v'' . At v'' erect $v'' v'''$ perpendicular to the plane M and 2 inches long. Project down the point v''' till it meets a parallel to the XY line drawn through V in the point v . Complete the figure.

CASE VI.

The inclination of two edges or diagonals being given.

In the last case the inclination of the plane in which one face lies was given. In this case the inclination of the plane has to be determined. The method employed will be best understood by a reference to *Fig. 5, Plate XXIII.*

Let AB and CB represent two adjoining edges of a face of a solid. Let AB be inclined at α degrees and CB at β degrees. Let H be a horizontal plane cutting AB and CB in the points F_1 and F_2 . Drop a perpendicular from B to the H.P. meeting it in b .

Then BF_1b is a right-angled triangle, of which the angle BF_1b is equal to α ; and BF_2b is a right-angled triangle, of which the angle BF_2b is equal to β . Also F_1b is the plan of F_1B and F_2b the plan of F_2B . Draw a perpendicular from b to F_1F_2 meeting it in O. Join OB. Then the angle $b OB$ is the angle of inclination of the plane in which the two lines AB and CB lie.

If the angle $F_1BF_2 + \alpha + \beta = 180^\circ$ the plane is vertical; if it exceeds 180° the problem is impossible.

Problem 220.—To draw a triangular pyramid (edge of base and height 2 inches) when two adjacent edges of the base are inclined at 30° and 40° . (*Plate XXIII., Fig. 6.*)

Draw ABC, the plan of the triangular base of the pyramid, lying in the H.P. At any convenient point in the side AB (say A), draw $A\delta_1$

making an angle of 30° with AB. From B draw Bb_1 perpendicular to Ab_1 . With centre B and radius Bb_1 describe an arc. Draw Fb_2 tangent to this arc, and making 40° with BC. The most convenient way is to draw any line making 40° with BC, and draw the tangent parallel to it. Draw the radius Bb_2 perpendicular to the tangent. Then since Bb_1 and Bb_2 are equal, the points A and F must be on the same level (representing F_1F_2 in Fig. 5). By joining F and A, a contour of the required plane M is obtained.

To obtain the elevation of the plane, draw an XY line perpendicular to the contour FA. Now the radius Bb_1 of the arc represents the actual height of the point B above the H.P. (of level equal to the level of the contour FA). Draw a line parallel to the XY line at a distance from it equal to Bb_1 . Project up B to the XY line and obtain the point b' . With centre o where the contour FA meets XY line and radius ob' draw an arc intersecting the "parallel line" in b'' . Join ob'' . Then ob'' (produced indefinitely both ways) is the elevation of the plane M, and contains the elevations of the edges AB and CB when lying in the plane M. Complete the problem by "reconstructing the points" in exactly the same way as the last problem.

CASE VII.

The inclination of two adjacent faces being given.

We may first consider the general case of any solid. It is evident that the solid angle between the two planes in which the two adjacent faces lie must first be found. We can then draw the two planes of given inclination making a given angle with each other (Problem 218), and obtain their intersection. This will give the indefinite plan of the edge common to the two faces. "Construct" this edge into the H.P. from the plane of one of the given sides. On the constructed line draw the plan of that side when lying in the H.P. "Reconstruct" this plan into the given plane, and obtain the plan of the side in the required position. Now "Construct" the line representing the plan of the common edge into the H.P. from the plane of the second face, and working in the same way as above, obtain the plan of the second face. Lines drawn parallel to the edges thus obtained will give the plan of the solid.

The general case will be best understood by a careful perusal of Problem 221.

There is, however, a much simpler method applicable to cubes and rectangular prisms. In these solids the edge of a face as well as the face itself is perpendicular to the plane of the adjacent face, and the method of working is shown in Problem 222.

Problem 221.—To draw the plan of a pentagonal pyramid (edge of base 1·8 inches, the sloping faces being inclined at 75° to the base) when two adjacent faces are inclined at 40° and 52° respectively. (Plate XXIV., Fig. 1).

Draw the plan and elevation of a plane M inclined at 40° . Through any convenient point p_{20} draw a plane N inclined at 52° and making an angle of 75° with M. (Problem 218). Find ap the intersection of the two planes. From the plane M. "Construct" ap into the H.P., and obtain ap_1 .

On any convenient part of ap_1 lay off AB_1 , 1·8 inches in length, and draw $A B_1 C_1 D_1 E_1$ the plane of the base of the solid. "Reconstruct" the five points $AB_1 C_1 D_1 E_1$ into the plane M, and obtain $a b c d e$ the plan of the face inclined at 40° . Now "Construct" the intersection line ap from the plane N into the H.P., and obtain ap_2 . On this line draw the plan of a face of the solid $AB_2 V_2$. "Reconstruct" the points $B_2 V_2$ into the plane N and obtain abv the plan of an adjacent face inclined at 52° . Complete the solid.

Problem 222.—To draw the plan of a cube ($1\frac{1}{2}$ inches side), two adjacent faces being inclined at 30° and 74° respectively. (Plate XXIV., Fig. 2).

Draw the plan and elevation of the plane M inclined at 30° . At r' erect $r'p'$ perpendicular to the elevation of the plane. Then rp is the indefinite direction of an edge of the cube perpendicular to the face lying in the plane M. Through rp draw a plane N inclined at 74° (Problem 194) and find rs the intersection of the plane M and N. "Construct" rs into the H.P. in rs_1 , and on this line draw a plane of one face of the cube $r ABC$. "Reconstruct" these points into the plane M and obtain the face $ra bc$. Make $r' p'$ equal in length to the edge of the cube and obtain the plan rp . The required plan may now be completed by drawing lines parallel to those already obtained.

EXERCISES.

1. A regular hexagon $A B C D E F$ lies in a plane M inclined at 35° . One side AF of the hexagon is inclined at 15° . Draw its plan.

2. The edge of a cube (2 inches square) is inclined at 35° . One of the faces containing that edge is inclined at 40° . Draw the plan of the cube.

3. Draw the plan of an equilateral triangle (2-inch side) when two adjacent edges are inclined at 30° and 40° respectively.

4. Draw the plan and elevation of a right hexagonal prism (side of base $1\frac{1}{2}$ inches, length $2\frac{1}{4}$ inches) when two adjacent edges are inclined at 35° and 27° respectively.

5. Draw the plan of an octahedron (2-inch side) when two adjacent faces are inclined at 30° and 40° respectively.

6. A cube ($2\frac{1}{2}$ inches edge) has one of its faces inclined at 45° , and a diagonal of that face at 20° . Draw its plan.

7. A right prism has for its base an equilateral triangle of $1\frac{1}{2}$ -inch side. Its height is 3 inches. Draw its plan when one face is inclined at 50° , and the intersection of that face with an adjacent face is inclined at 25° .

8. Draw the plan of a pyramid having a square base of 2 inches side and height of 3 inches, when the base is inclined at 50° , and one of the edges of the base at 40° .

9. Draw the plan of a square ABCD of $2\frac{1}{2}$ inches side, when the corner A is raised 1 inch, and the corner B $1\frac{1}{2}$ inches above the H.P.

10. Draw the plan of a tetrahedron of $2\frac{1}{2}$ inches edge, two adjacent edges being inclined at 30° and 40° .

11. A square prism (edge of base $1\frac{1}{2}$ inches height 3 inches) has a short edge inclined at 50° , and an adjacent long edge at 25° . Draw its plan.

12. A pyramid having a hexagonal base of $1\frac{1}{2}$ inches side, and height $2\frac{1}{2}$ inches, has two adjacent edges inclined at 50° and 20° (long edge at 50° , short edge at 20°). Draw its plan.

13. Draw the plan of an octahedron of $2\frac{1}{2}$ inches edge, when two edges of one face are inclined at 32° and 45° .

14. One diagonal of an octahedron of $2\frac{1}{2}$ inches edge is inclined at 25° ; a second diagonal is inclined at 30° . Draw the plan of the solid.

15. A cube of 2 inches edge has two adjacent faces inclined at 40° and 70° . Draw its plan.

16. A tetrahedron of $2\frac{1}{2}$ inches edge has two adjacent faces inclined at 50° and 70° . Draw its plan.

17. A letter T (3 inches high and $2\frac{1}{2}$ inches extreme width) is made of material $\frac{3}{4}$ -inch square in section. Draw its plan when lying on a plane inclined at 35° to the H.P., the natural base of the letter being inclined at 65° .

18. A pentagonal prism (edge of base $1\frac{1}{2}$ inches, height 3 inches) has two adjacent faces inclined at 40° and 55° . Draw its plan.

19. A right square pyramid (edge of base 2 inches, height $2\frac{1}{2}$ inches) has two adjacent faces inclined at 40° and 60° . Draw its plan.

20. The plans of three angles of a cube (length of diagonal 5.2 inches) meet in a point and make 115° , 110° and 130° with one another respectively. Complete the cube.

21. A box measures 3 inches by 2 inches by 1 inch when closed. The lid is $\frac{1}{2}$ -inch deep (the thickness to be neglected). One corner is in the H.P., one end inclined at 70° , and the bottom at 50° . Draw the plan of the box when the lid is opened to an angle of 30° .

22. Three corners of one face of a cube are respectively at the level -10 , 0 and $-2\frac{1}{2}$. Draw the cube, and find the level of its centre.

23. The lines ab and bc make an angle of 110° with each other in plan. AB is inclined at 40° , and ABC is a right angle. Find the inclination of BC .

24. Draw two planes perpendicular to one another, and inclined at 30° and 80° respectively.

25. The plane containing two diagonals of an octahedron (3 inches edge) is inclined at 27° . The plane containing one of these diagonals and the third diagonal is inclined at 80° . Draw the plan of the octahedron.

CHAPTER XIII.

INTERPENETRATION OF SOLIDS AND TANGENT PLANES.

The subject of Interpenetration of Solids is an important one to the Engineering Student, as it enables him to draw correctly the plans and elevations of roofs and buildings. The subject is obviously only a development of the intersection of planes with solids and the application of Problems 195 and 199.

The Chapter may be divided into two cases—

- I. The Interpenetration of Solids bounded by planes.
- II. The Interpenetration of Solids of Revolution.

CASE I.

The Interpenetration of Solids bounded by planes.

The general and most important method is the use of a series of equidistant parallel planes cutting both solids. The plans of these planes will be "contours" which will severally intersect in points on the plans of the intersections of the respective faces of the solids. All that is necessary, therefore, is to obtain the intersection of any two contours (produced if necessary) of a face of one solid with the corresponding contours of a face of the other solid. This intersection gives the plan of the intersection of the planes of those faces, hence, if any portion of this plan falls within the plans of *both of the faces in question*, that portion will be common to both solids, and will therefore be part of their common intersection. It is not necessary that the parallel planes should be horizontal, but it is obvious that planes should be used whose intersections with the solids can be most readily determined. It will be seen that this method is only a development of that used in Problem 204. A general example is now given in Problem 223 and a more complicated example in Problem 224.

Besides this general method, there are many devices which in certain

cases will simplify the working, and for which the Student must rely on his ingenuity.

Problem 223—An irregular pentagonal pyramid interpenetrates an irregular four-sided pyramid, as shown in Plate XXV., Fig. 1. Find the projections of their intersections.

Draw the elevations of four equidistant parallel planes I', II', III' and IV', intersecting the solids and project down their plans on to the plans of the two solids, obtaining a series of contours. Take each face separately and find the intersections of the contours, such as the intersection of the contours of the face $jp k$ with those of $d v c$, and the intersection of the contours of the face $jp k$ with those of $e v d$, and so on. Then such portions of the intersection lines as fall within the plans of both the faces in question will be part of their common intersection.

The elevation of the intersection is obtained by projecting up the plans of the points of intersection. In the figure only the elevation of the intersections which are visible are shown so as not to confuse the figure.

Problem 224.—Draw the projections of the interpenetration of the pentagonal and triangular pyramids as shown in Plate XXV., Fig. 2.

This is a more complicated figure, and it will be unnecessary to use more than two parallel planes I and II. Obtain the plans of these planes. The contours of plane I are drawn single chain-dotted, and those of plane II, double chain-dotted. In a complicated figure great care must be taken to go to work methodically and number each intersection systematically or the result will be hopeless confusion. Start with the intersection of the contours of the faces $av c$ and $p z t$, which gives the line 1, 2. Next in order comes the face $av c$ and $t s z$ giving the line 2, 3. To obtain the point 3, the II contour of the face $t s z$ must be continued till it cuts the II contour of the face $av c$. This point must be joined to 2 and the point 3 will be the point where this line is terminated in the face $t s z$. Then $av c$ and $s r z$ gives the line 3 and 4 and so on, till finally the last point 12 is joined up to 1, and completes the outline of the interpenetration.

The elevation is obtained by simply projecting up each of the points obtained in plan. All intersection lines which are not visible are shown very fine dotted.

Problem 225—Draw the plan and elevation of the interpenetration of a triangular equilateral prism and a square pyramid of the dimensions shown in Plate XXVI., Fig. 1. The pyramid rests on the H.P., and one face of the prism is inclined at 18° to the H.P. and one edge 18° with the V. P.

This problem could be worked out of course by the general method, but the following is a simpler method :—

Make an auxiliary elevation of the two solids on an X_1Y_1 line perpendicular to the edges of the prism. As before be systematic and work each point in sequence. In the auxiliary elevation, the edge $v''d''$ cuts the face $f''g''$ in the point $1''$. Project down $1''$ on to the plan vd and obtain the point 1 . Project this point up to the XY line and cut off the point $1'$ the same height above the XY line as $1''$ is above X_1Y_1 . Each of the points of interpenetration may be obtained in the same way—except 4 and 8. In their case the edge $v''a''$ does not cut the plane $f''g''$, so we must find the point k'' where it would cut it if the plane was produced, and project k'' on to the plan of va . Join the points $k1$ and $k3$ cutting the edge f in the required points 8 and 4.

Problem 226.—A four-sided prism (2 inches high) interpenetrates a pentagonal pyramid ($2\frac{1}{2}$ inches high) in the position shown in Plate XXVI, Fig. 2. Find the elevation of the intersection.

This problem shows another method of dealing with the problems that may arise. Working systematically from one edge, first find where the edge ve cuts the face $emnf$ in the point 1 , and projects up 1 to cut $e'v'$ in $1'$. The next point in sequence will be where the edge nm of the prism cuts the face evd of the pyramid. To obtain this through m draw vp project up the point p to p' and join $p'v'$. Then the point 2 where a projector from m cuts the line $p'v'$ is the required point of intersection of the edge mn and the face ved . Invisible intersection lines are shown very finely dotted.

TANGENT PLANES.

Before proceeding to investigate the subject of the interpenetration of curved surfaces, we must first consider that of tangent planes. The determination of these under given conditions is an important point in many questions of intersection of solids of revolution, and also in the determination of the shadows cast by them.

The following problems illustrate the method of finding the traces of planes tangential to the surface of solids of revolution such as the cone, cylinder and sphere. As there will be an infinite number of planes tangent to the surface of such solids we must always have another condition given, if we wish to determine completely the position of any tangent plane.

If a point on the surface at which the tangent plane is to touch that

surface is given, there can be only one plane. Tangent planes to all surfaces of revolution generated by curved lines can, if the point of contact is not given, be determined to contain two given points and touch the given surface. Tangent planes to all surfaces of revolution generated by straight lines can only be determined to contain one given point and touch the given cone or cylinder, since the tangent plane must, from the nature of the surface, contain one of the generatrices.

Since a representation on one plane of projection suffices to determine the problems, the system of indices adopted in this book is particularly well adapted for working out these problems.

Problem 227.—Given the plan and elevation of a right circular cylinder, through a given point p_1 to draw tangent planes to the cylinder. (Plate XXVII., Fig 1).

All planes tangent to a cylinder must be parallel to its axis. If we draw through p_7 a line ml parallel to the axis of the cylinder the required planes will contain this line. Further, if from the points where this line ml cuts the planes of the bases of the cylinder, tangents are drawn to those bases, the required planes must contain those tangents and must touch the cylinder in generatrices drawn through their points of contact.

Find the points lm where the line lm cuts the planes of the bases of the cylinder and figure those points from the elevation $l_{0.5} m_{1.5.5}$. From these points draw $l_{0.5} c_{13.5}$, $l_{0.5} f_{6.5}$, $m_{1.5.5} d_{28.5}$, $m_{1.5.5} g_9$ tangents to the plans of the bases of the cylinder and figure the points from the elevation. Then cd and fg are the generatrices along which the required planes touch the cylinder, and the planes may be drawn through $c_{13.5} d_{28.5} p_7$ and $f_{6.5} g_9 p_7$ respectively.

In the case of a cone the problem may be worked in the same way except that in this case the vertex of the cone must be joined to the given point p . The point where this line meets the plane of the base of the cone is the point from which tangents to the base must be drawn.

Problem 228.—Through a given point p_{10} to draw tangent planes to two given spheres. (Plate XXVII., Fig. 2).

If the spheres are external to each other it is evident four planes are possible; if they touch each other externally, three planes; if they cut each other, two planes; if they touch internally, one plane; if one sphere is wholly inside the other the problem is impossible.

Let a_0 and b_{10} be the centres of the two given spheres. If a cone is

drawn enveloping the two given spheres the tangent planes must touch this cone. Similarly, if two cones be drawn with p_{10} for vertex, one enveloping each sphere, the required tangent planes must touch these cones also. If, then, the circles of contact of each of these cones with the sphere are determined, the intersections of the circles of contact will be the points of contact of the required tangent planes and the spheres. Each plane, therefore, containing the vertices of the two cones and one of the points of intersection of the circles of contact, will fulfil the required condition. Draw elevations of the spheres on an XY line parallel to the line joining their centres and draw the plan and elevation of the enveloping cones. Then v is the vertex of these cones and can be figured $v_{3.5}$ from the elevation.

The plans of the circles of contact of these cones and the spheres are the ellipses cd and ef , the major axes of which are obtained from the plans and the minor axes are projected down from the elevations.

Draw now the plans of the enveloping cones with vertex p_{10} . As p_{10} is the same level as b_{10} , the line joining them, or the axis of the cone, will be horizontal, and the circle of contact of the cone and the larger sphere will be vertical and represented in plan by the straight line lm . The points of intersection of the two circles of contact on the larger sphere are r and s . The indices of these points are obtained as follows:—Suppose a great circle of the sphere passing through one of the points r to be rotated about its horizontal diameter till its plane is horizontal. This great circle will then coincide with the plan of the sphere. Draw rr' meeting the circumference in r' and perpendicular to br . The r' is the point r "constructed" into the H.P. The distance rr' is therefore the difference in level between b and r , and since r is above b , the index of r is $10 + rr' = 17$ units. Similarly the index of s is $10 - ss' = -2$ units. The plan of the circle of contact of the cone (with vertex p_{10}) enveloping the smaller sphere is an ellipse, the major axis of which can be obtained from the plan. To obtain the minor axis it is necessary to make an auxiliary elevation of the cone and sphere on an XY line at right angles to the major axis.

The points of intersection of the two ellipses t_7 and $u_{-3.5}$ can be obtained and indexed in the same way as r and s . The four tangent planes can now be drawn, each containing p_{10} , $v_{3.5}$ and one of the points $r, s,$

CASE. II.

Interpenetration of Solids of Revolution and Curved Surfaces.

The intersection of two curved surfaces may be either (a) a *straight line*, as in the case of two cylinders with parallel axes ; (b) 2 a *plane curve*, as in the case of a sphere and a right cone whose axis passes through its centre ; (c) a *curve of double curvature*, as in the case of two unequal cylinders whose axes are not parallel.

These intersections are most readily determined by means of auxiliary planes, their intersection with each of the intersecting solids can be found, and the points where these intersections cut one another, will be points common to both solids, and, therefore, points in the required intersection. Auxiliary planes, whose intersections with the solids are most easily determined, should of course be used. This condition will be fulfilled as a rule, if the intersestions of the auxiliary planes with the solids under considerations are generatrices of those solids. Thus, two conical surfaces with oblique axes and any bases, should be cut by a system of planes passing through both vertices. A conical and a cylindrical surface should be cut by a system of planes containing the vertex of the first surface and parallel to the axis of the second. Two surfaces of revolution whose axes intersect, should be cut by a system of concentric spheres whose common center is the point of intersection of the axes. Two surfaces of revolution whose axes are vertical, should be cut by a system of horizontal planes. The simpler cases in which the axes of the surface are perpendicular to each other or both horizontal will first be dealt with. We can then deal with the more complex problems in which the axes of the surfaces may be inclined at any angle to each other and to the vertical and horizontal planes, but in every case the principles laid down above are the same.

Problem 229.—To determine the intersection of a right cone with a right cylinder the axes being respectively at right angles, the axis of the cone being $1\frac{1}{2}$ inches above and parallel to the H.P. (Plate XXVIII., Fig. 1).

Let $a b c$ be the plan of the cone and the circle O the plan of the cylinder.

Nothing further is required in plan, and it will only be necessary to find the interpenetration curve in elevation.

Draw an elevation of the cylinder and cone. The elevation of the base of the cone is obtained by Problem 188.

According to the principles laid down we require a series of auxiliary planes passing through the vertex of the cone and parallel to the axis of the cylinder. These planes will consequently be vertical, and will be represented in plan by generatrices of the cone such as A, B, C, D, &c.

Now the plane A is tangent to the cone and cuts the plan of the cylinder in the point 1. The elevation of its intersection with the cone will be the line A' . Project up the point 1 to meet A' in $1'$, which gives a point on the required curve.

The plane B cuts the cylinder in the point 2 and the elevation of the cone in two lines B' and B'_1 . By projecting up the point 2 meet B' and B'_1 , we obtain two points $2'$ and $2'_1$ on the curve of interpenetration. Any amount of points may be obtained by using sufficient auxiliary planes. Only visible curves are shown in this example so as not to confuse the drawing.

Problem 230.—To determine the elevation of the intersection of a right cone and a sphere. The base of the cone rests on the H.P., and the centre of the sphere is $1\frac{1}{2}$ inches above the H.P. (Plate XXVIII., Fig. 2).

Carrying out the principles laid down the auxiliary planes in this case will be horizontal.

Take two horizontal planes represented in elevation by the lines I' and II'. The plans of the intersection of these planes with the plans of the sphere and cone will be the circles marked I and II, and the intersections of these circles will give points on the required curve of interpenetration.

For instance, take the two circles marked I. They intersect each other in the points marked 1 and 2. Project up these points to the elevation of the plane I and we obtain the points $1'$, $2'$ on the curve.

Any number of points can be obtained by increasing the number of auxiliary planes.

A simple method of obtaining the limiting points of the curves h' , k' is to make an auxiliary elevation of the cone and sphere on an XY line parallel to the line joining the centres of the solids from which the heights of h' and k' can be determined.

Problem 231.—To determine the intersections of two cylindrical surfaces whose axes are oblique to both planes of projection, and do not meet. (Plate XXVIII., Fig. 3).

The projections of the two cylindrical surfaces are given. The plans of the portions where these surfaces cut the XY line will be ellipses which, if not given, must first be determined. Then if the two surfaces are cut by a system of planes parallel to both axes, these planes will cut the surfaces in generatrices whose intersections will give points on the common intersection of the surfaces.

Take any point x' , and from it draw the elevation of two lines $x' y'$ and $x' z'$, each parallel to the axis of a cylinder. Draw their plans $x y$ and $x z$. Then the plane containing these two lines will be one of the required auxiliary planes; and the line joining y and z will be a contour of this plane of the same level as the XY line.

Draw any convenient lines $l m$ and $a d$ parallel to $y x$. Then these lines are contours of planes parallel to the first auxiliary plane, and the plans and elevations of their intersections with the cylinders are obtained by drawing lines parallel to the axes through the points l, e, f, m, a, b, z, d , and through the elevations of these points. The intersection of these lines with each other in plan and elevation gives points in the required intersection of the two cylinders.

The extreme points of the curves of intersection are determined by means of auxiliary planes which are tangent to one cylinder while cutting the other, in which case we shall have one generatrix intersecting two others; the two points thus determined will be limiting points of the curve; the generatrices determined by the intersection of the plane with one cylinder being tangents to the curve at these points.

Draw $q n$ and $s o$ parallel to $y x$ representing the contours of auxiliary planes which are tangents to the smaller cylinder, and draw their intersections with the cylinders. The points where these generatrices intersect are limiting points on the required curve of intersection.

It is best, however, in all complicated examples to work in a methodical way, taking one curve at a time. Begin with the generatrices traced by the plane $q n$, these intersect in the point 1. Those traced by the plane $l m$ intersect in 2 and 6; those traced by $a d$ in 3 and 5; and the limiting point 4 is obtained by the generatrices traced by $s o$. The other curve 7, 8, 9, 10, 11, 12 is obtained in the same manner.

The elevations of the curves are obtained by either projecting up the plans of the points till the projector cuts one of the parent generatrices, or making the intersection of a pair of generatrices by the same method as employed to obtain the plan.

Problem 232—To determine the interpenetration of a cylinder and a cone (Plate XXIX., Fig. 1).

Draw the plan and elevation of any cylinder and cone which interpenetrate.

Through v the vertex of the cone draw the plan and elevation of a line $v p$ parallel to the axis of the cylinder. Then all planes passing through this line and cutting both surfaces will cut those surfaces in generatrices of the cone and cylinder respectively.

Through p draw any number of lines, which for convenience we may call A, B, C, D and E, and regard these lines as O contours of planes containing the line $v p$. If through the points where these lines cut the bases of the cone and the cylinder we draw generatrices, these generatrices will be the lines in which each plane passing through $v p$ cuts the two surfaces, and their points of intersection will give us the outline of the intersection of the surfaces.

First regard the plan only. Let A and E be lines tangent to the base of the cylinder. All visible generatrices have been drawn in firm lines and all invisible ones in dotted lines, as this adds greatly in the clearness of the figure.

The line A is tangent to the base of the cylinder at a and cuts the base of the cone in c and d . Draw the generatrices (these will be all dotted) and mark their intersection in the points 1 and 9. The line B cuts the base of the cylinder in e and f and of the cone in g and h . In each case one generatrix is firm and one dotted. Mark the points of intersection, 2 and 8 and 10 and 16. It is easiest to take one intersection at a time, either the intersection made by the cylinder entering or leaving the cone and to work methodically round the base. We have obtained points 1 and 2 by the points a and e . Then the line C cuts the bases in j and k , draw the generatrices, and mark the point of intersection, 3. By going round the base of the cylinder in order, we obtain a series of points 1 to 8 and a closed curve. Proceed in the same manner to obtain the second curve of intersection, using the same points on the base of the cylinder, and the further points on the base of the cone such as a and d , e and h , j and l .

The elevation is obtained in exactly the same manner by drawing elevations of the generatrices and marking the points of intersection,

The Student will find no difficulty in noting which part of the curve is visible and which invisible if he starts by drawing all visible generatrices in firm lines and all invisible generatrices in dotted lines. Intersections given by visible generatrices will give a visible curve and by invisible generatrices an invisible curve.

As the lines A and E are tangent to the base of the cylinder, their generatrices are tangents to the curves of intersection at the points 1, 9, 5 and 13.

Problem 233.—To determine the interpenetration of two cones. (Plate XXIX. Fig. 2).

In this case we must join the vertices of the two cones $v' p'$. The point where $v' p'$ intersects the XY is too far distant to be shown in the drawing, but its plan and elevation must be obtained. From the plan of this point draw lines $A B C D$ cutting the plans of the bases of the two cones and representing O contours of auxiliary planes containing the line $v p$. The problem is then worked in exactly the same way as the last and is left as an exercise for the Student.

Problem 234.—Draw the plan and elevations of a roof, as shown on Plate XXX., with a hexagonal spire whose apex is 20 feet above a point on the ridge half way between m and n in plan, and with the side of its horizontal section at the level of the ridge 8 feet long. One of the angles of this section to be on the ridge. All slopes of the main roof to be $\frac{2}{3}$. Scale—12 feet=1 inch.

This is a simple example of the adaptation of the principles enunciated in this Chapter to the representation of a roof. All necessary dimensions and auxiliary elevations are given, and the methods of obtaining the intersections can be best followed by drawing the example.

EXERCISES.

1. Determine the intersection of two cylinders 3 inches and $2\frac{1}{2}$ inches long with radii 1 inch and $1\frac{1}{2}$ inches respectively. Their axes are horizontal and intersect at an angle of 35° .
2. A pentagonal prism (1 inch side and 3 inches high rests on its base in the H. P. It is penetrated by a square pyramid (1 inch base, 5 inches high). One face of the pyramid makes 25° with the H. P.
3. A hexagonal pyramid (height 3 inches, side 1 inch) and a pentagonal pyramid (height 4 inches, side $1\frac{1}{2}$ inches) rest on their bases in the H. P. One angle of the base of the former is at the centre of the base of the latter. Determine the projections of their intersections.

4. A vertical pentagonal right prism (base $1\frac{1}{2}$ inches, height 4 inches) penetrates through a sphere of 2 inches radius. The axis of the prism passes at a distance of $\frac{1}{4}$ -inch from the centre of the sphere. Draw the elevation of the intersection of the solids on a V. P. making 25° with one face of the prism.

5. A vertical right cone (radius of base $1\frac{1}{2}$ inches, height $4\frac{1}{2}$ inches) penetrates a sphere of $1\frac{3}{4}$ inches radius. The centre of the sphere is 2 inches above the base of the cone, and the latter touches the surface of the sphere. Determine the projections of the intersections.

6. The horizontal traces of two right cones are ellipses whose axes are 4 inches, $2\frac{1}{2}$ inches, and $3\frac{1}{2}$ inches, and $2\frac{1}{2}$ inches, respectively; the major axis of the former makes 25° and of the latter 35° with the XY line. These ellipses touch each other. Determine the projection of the intersections of the cones.

7. Two equal cylinders intersect; their diameters are $1\frac{1}{4}$ inches and their axes are horizontal and vertical respectively. The axis of the first cylinder makes 35° with the V. P., and its bounding generatrix on plan passes outside the circular plan of the vertical cylinder and $\frac{1}{4}$ -inch from it. Determine the elevation of the resulting intersections.

8. A hollow vertical right cylinder, external diameter $2\frac{1}{2}$ inches, thickness $\frac{1}{2}$ -inch is pierced by a horizontal right cone diameter of base $2\frac{1}{4}$ inches, height $4\frac{1}{2}$ inches. The axis of the cone makes 40° with the V. P., and the cone itself touches the internal cylindrical surface. Determine the projections of the intersection when the cone is removed.

9. A right prism, whose base is an equilateral triangle, 2-inch side, has its axis vertical and one face parallel to the vertical plane. A square prism, whose side is $1\frac{1}{2}$ inches, axis horizontal and $1\frac{1}{2}$ inches above the horizontal plane, and inclined at 40° to the vertical plane, penetrates the first prism so that the axes intersect. One face of the square prism is inclined at 60° to the horizontal plane. Show the elevation of the intersection of the solids.

10. A right prism, whose ends are isosceles (side $2\frac{1}{2}$ inches), height $1\frac{3}{4}$ inches, rests with a face on the horizontal plane, one edge being inclined at 15° to the vertical plane. The plan of the apex of a hexagonal prism, $\cdot 9$ -inch side, and $2\frac{1}{2}$ inches high, is situated $\frac{1}{4}$ -inch from the plan of the ridge of the prism, no one side of the base of the pyramid being parallel to the sides or ends of the prism. Show plan and elevation of intersection of the solids.

11. The base of a pyramid standing on the horizontal plane is an equilateral triangle of 2 inches side. The plan of the apex of the pyramid is at the centre of one side of its base. Altitude $2\frac{1}{2}$ inches. A sphere 2 inches in diameter rests on the horizontal plane, the plan of its centre falling on the centre of the base of the pyramid. Show plan and elevation of the intersection of the solids.

12. A right cone, base $2\frac{1}{2}$ inches diameter, axis $2\frac{1}{2}$ inches, has its base horizontal. A cylinder $1\frac{1}{2}$ inches diameter, whose axis is horizontal, penetrates the cone. The axis of the cylinder is 1 inch above the base of the cone, and its axis $\frac{1}{4}$ -inch distant from that of cone. Show plan and elevation of intersection of solids.

CHAPTER XIV.

DEVELOPMENT OF SOLIDS.

By this term is meant the unrolling, extending or flattening out upon a plane, of the covering of any solid body. A practical application of this is found in the work of tin and copper smiths, and boiler-makers, who have constantly to fashion out of thin sheets of metal, surfaces such as cones, cylinders, spheres, &c.

All surfaces generated by the motion of a straight line are developable if the generatrix in two successive positions always lies in one plane. Thus conical and cylindrical surfaces are always developable, while spherical, spheroidal, helicoidal and conoidal surfaces are incapable of development.

Surfaces generated by the motion of a straight line and incapable of development are termed "*twisted Surfaces.*"

In the case of the coverings of solid polyhedrons such as cubes, tetrahedrons, prisms, pyramids, &c., the determination of the development is simply an extension of the determination of the true shape of plane figures when given by their projections; the true shape of each face of the object can be found, and as two adjacent faces have one edge common to them, it is evident that the true shape of each face having been found, that of the development of the surface will be obtained by placing the different faces in succession according to their correct relative positions.

For instance if we wish to obtain the development of the surface of a prism, we know that it is made up of a number of parallelograms, and if the true form of these parallelograms be drawn and placed side by side, so that those angular points coincide which coincide in the prism, the resulting figure will be the development of the surface. The cylinder and cone are only particular cases of the prism and pyramid. Their surfaces being supposed to be composed of an infinite number of parallelograms or triangles.

Problem 235.—To determine the development of a right circular cone; also the development of the lower portion when it is cut by a plane *L M* making 35° with the *H. P.* (Plate XXXI., Figs. 1 and 2).

In whatever position the cone is given, its plan and elevation can be obtained when resting on its base in the H. P. So let $a' v' b'$ (*Fig. 1*) be the elevation of a given cone. Draw a half plan.

If we consider the cone is a pyramid with an indefinite number of equal sides, on unrolling it we shall evidently obtain a surface made up of a series of equal lines converging in a point. These lines are generatrices of the cone, and the point the apex. In other words the development of the cone will be a sector of a circle, the radius of which is equal to a generatrix of the cone.

The length of the arc bounding the sector will evidently be equal to the circumference of the base of the cone.

This measurement can either be set off along the arc of the sector by successive divisions taken from the base of the given cone between the compass points, or the angle of the sector can be calculated as follows :—

Suppose (R) to be the radius of the circular base of the given cone and (l) the length of a generatrix. Then the circumference of the base will be ($2\pi R$). The circumference of a circle described with (l) as radius will be ($2\pi l$), and this corresponds to 360° ; but as only a length of ($2\pi R$) is required to be taken along the circumference of the sector, $\frac{2\pi R}{2\pi l} \times 360^\circ = \frac{R}{l} \times 360^\circ$, will be the corresponding angle, which is therefore the angle of the sector. In the first case the length of arc obtained will not be truly the same as that of the circumference of the base of the cone, since the distances taken off by the compasses are the chords of the arcs, instead of the arcs themselves. By increasing the number of the divisions, however, the error can be reduced so as to be practically inappreciable.

In the example only eight divisions are taken for clearness sake.

To determine the development of the truncated cone, draw the plan and elevation of the section made by plane LM making 35° degrees with H. P. We have then only to find the "TRUE LENGTHS" of vc , vd , ve , &c., and mark them off from the point v_1 (*Fig. 2*) on the development of the cone along their corresponding generatrices. The simplest way of finding the true lengths of these lines is as follows :—Take for example the length ve . Make vh equal to ve and project up the point h to meet the line $v' a'$ in h' . Then $v' h'$ is the true length of ve and can be marked along $v_1 8_1$ and $v_1 7_1$.

Problem 236.—To determine the development of a right circular cylinder cut by a plane making 30° with its axis (Plate XXXI., Figs. 3 and 4).

Let LM (*Fig. 3*) be the elevation of the plane cutting the cylinder and making 30° with the axis. The problem may be treated in exactly the same way as the last. Divide the plan of the base of the cylinder (*Fig. 3*) into any number of parts, say eight, and project these up as generatrices on to the elevation. The base of the development (*Fig. 4*) will be equal to the circumference of the base of the cylinder. The height of each of the points on the outline of the development $a, b, c, d, \&c.$, may be obtained direct from the elevation, as in this case, the latter represent "true lengths."

If the cylinder is an oblique cylinder, the development can be obtained by cutting it by a plane perpendicular to its axis and then projecting down to the plane the base of the cylinder rests on.

Problem 237.—A horizontal cylinder penetrates a semi-cone. Determine the development of the curve of intersection both on the surface of the cone and of the cylinder. (Plate XXXI., Figs. 5, 6 and 7).

In *Fig. 5* draw the plan and elevation of the interpenetration of the cylinder and semi-cone.

First take the development of the curve of intersection on the surface of the cone. From v (*Fig. 5*) draw $v 5$ and $v 11$ generatrices of the cone tangent to the curve of intersection, and divide the arc $5, 11$ into any number of equal parts, say six. In *Fig. 6* draw the development of the semi-cone and insert the corresponding generatrices $v_1, 5_1$ to $5_1, 11_1$. We must then obtain the "TRUE LENGTHS" of the points where each of the generatrices in *Fig. 5* cuts the plan of the curve of intersection, and mark these true lengths along the corresponding lines in *Fig. 6* to obtain the development of the curve of intersection. For instance, $v7$ cuts the plan of the curve in h and g . Make $f' h_1$ equal to $v h$ and project up h_1 to meet the outer generatrix of the semi-cone in h' then $v' h'$ is the true length of $v h$ and may be marked off on *Fig. 6*.

To obtain the development of the curve of intersection on the surface of the cylinder, draw $k l$ (*Fig. 7*) equal to the circumference of the base of the cylinder and divide it into any number of equal parts, say twelve, and through these points draw parallel lines perpendicular to $k l$. Divide the plan of the base of the cylinder (*Fig. 5*) into the same number of parts, and through the points obtained draw generatrices cutting the curve of

intersection. Then the distances from the base of the cylinder of each of the points in which the generatrices cut the curve of intersection marked on the corresponding line in *Fig. 7*, will give the curve of development of the intersection of the surface of the cylinder. These distances are only "true lengths" because the cylinder is horizontal, if it was inclined to the H. P. the true lengths of each line would have to be obtained.

THE HELIX.

A screw surface is generated by a straight line moving with a uniform velocity along a fixed straight line with which it makes a constant angle, and at the same time has a uniform motion of rotation about that axis.

The intersection of a screw surface with the surface of a right vertical cylinder having the same axis, is a curve called a Helix; if it intersects with a right vertical cone it is called a conical Helix.

The axial pitch is the distance between one coil of a helix and the next, measured parallel to the axis.

A Helix may have an increasing instead of a uniform twist as in the rifling of some guns.

Problem 238.—Draw the projection and development of a rectangular screw thread ($\frac{3}{8}$ -inch deep $\frac{1}{4}$ -inch broad) pitch $1\frac{1}{2}$ inches, traced on a cylinder of $2\frac{1}{2}$ inches diameter. (Plate XXXII., Figs. 1 and 2).

Draw the elevation and half plan of a cylinder $2\frac{1}{2}$ inches diameter (*Fig. 1*). If with the same centre with which the plan of the cylinder is drawn, we draw a semicircle of 3 inches diameter, then the difference between the two circles will be $\frac{1}{4}$ -inch or the breadth of the screw thread. Through the extremities of the diameter of the larger semicircle draw lines parallel to the sides of the elevation of the cylinder.

Divide the plan of the base into any number of parts, say 12. Make $a' b'$ equal to the pitch $1\frac{1}{2}$ inches and divide it into 12 parts, and through the points thus obtained draw lines parallel to the base of the cylinder.

It is evident from the definition that for each fraction of the circle through which the generating point moves, it will rise the same fraction of the pitch. Thus if the generating point starting from a' , moves from 1 to 2 it will rise from 1 to 2' and attain the position c' , where the projector from 2 cuts the parallel through 2'. In this way any number of points may be obtained and a curve drawn through them. The height of the thread being $\frac{3}{8}$ -inch we can start from the point 4', and

using the same construction, obtain the upper curve. The intersection of the thread and the cylinder is obtained by using the points on the inner semicircle. If, instead of a rectangular thread, we have a circular spring, (*Fig. 2*), the curve is generated by a sphere whose centre moves along a helix which is the centre line of the spring. Draw first the projection of this helix, and then if the projection of the sphere be drawn in different positions, the curves drawn tangent to these spheres will be the projection of the spring.

To determine the Development.

In *Fig. 1*, let $a' d'$ equal the perimeter of the outer semicircle. Draw $d' e'$ at right angles equal to half the pitch of the thread, then e' represents the point 7, when the curve 1, 7' is developed on the V. P. As, however, the helix has a uniform twist, the ratio between the co-ordinates of the developed curve is constant, and the development is the straight line $a' e'$. Similarly, the development of the intersection of the thread and cylinder is the line $k' h'$. If the twist is not uniform, the development becomes a curve.

Problem 239.—Draw the projection of a helical curve on a cone (diameter of base 2 inches, height 2 inches) pitch 1 inch, and also determine the development of the curve. (Plate XXXII., *Fig. 3*).

Draw the plan and elevation of the cone and divide the circumference of the plan into any number of parts, say eight. Project up the points thus obtained to the XY line and draw generators through the elevations of these points. Divide the pitch (one inch) into eight parts and through each point of division draw lines parallel to the base of the cone. Then the point where one of the parallels cuts a generator drawn through a point of corresponding number is a point on the required curve in elevation, and the curve can be drawn by joining up the points so found.

To obtain the plan project down the point 1', representing the top of the pitch, on to the line $a b$ and obtain the point c . Divide $a c$ into eight parts, and with v as centre and each point of division as radius draw concentric circles. Then the points where each circle cuts the lines $v 2$, $v 3$, &c., in succession, give points on the required curve, which can be drawn.

To obtain the development of the curve draw the development of the cone and eight generatrices, then the points where concentric circles drawn

with v' as centre and $v' 2'$, $v' 3'$, &c., as radii, cut the development of the generatrices give points on the developed curve.

EXERCISES.

1. Determine the development of a hexagonal prism ; (base $\frac{3}{4}$ -inch side, height 2 inches).

2. A cylinder (2 inches diameter, 3 inches height) is cut into two parts by a plane making 40° with the axis at a point $\frac{1}{2}$ -inch from one end. Determine the development of the smaller portion.

3. A cone (radius of base $1\frac{1}{3}$ inches, height 2 inches) is cut by a plane passing through the centre of its axis and inclined at 30° to the H. P. Determine the development of the frustum.

4. Determine the development of the surfaces of each of two cylinders intersecting under the following conditions :—

Radii $\frac{5}{8}$ -inch, and $\frac{3}{8}$ -inch, length 6 inches and 4 inches. Angle between axes 45° .

5. A right vertical cone (radius of base $1\frac{1}{2}$ inches, height 4 inches) penetrates a sphere (radius $1\frac{3}{4}$ inches). The centre of the sphere is 2 inches above the base of the cone and the latter touches the surface of the sphere. Determine the development of the cone.

6. Determine the projection and development of a square screw thread ($\frac{1}{2}$ -inch square) pitch 1 inch, traced on a cylinder of 3 inches diameter.

7. Determine the projection of a helical spring of rectangular section ($\frac{7}{8}$ " \times $\frac{3}{8}$ "), external diameter of spring 3 inches, pitch 2 inches, number of turns, two.

8. Determine the projection of a helical spring of circular section ($\frac{1}{2}$ -inch diameter), external diameter of spring $3\frac{1}{4}$ inches, pitch $1\frac{1}{2}$ inches.

9. Determine the projection traced on a cylinder of a triangular screw thread ($2\frac{1}{2}$ inches diameter) pitch $\frac{3}{4}$ -inch, angle of the apex of the triangle being 60° .

10. Determine both projections and the development of a square-headed screw ($\frac{1}{2}$ -inch) traced on a cone (base 4 inches diameter, height $4\frac{1}{2}$ inches) pitch $1\frac{1}{2}$ inches.

CHAPTER XV.

THE DETERMINATION OF SHADOWS AND SHADING.

To the unpractised eye there is sometimes a certain amount of difficulty in reading orthographic projections and the delineation of the shadows cast by objects is often very useful in enabling a correct interpretation to be readily attained.

In all Geometrical and Architectural drawings the light is supposed to fall in parallel rays in a given direction. A certain portion of these rays will be intercepted by the object, and the outline traced on any surface by the rays tangential to the object will represent the shadow cast by it.

The date fixing the direction of the light can of course be altered at pleasure, but for the purposes of any particular shadow, it is always necessary to know the angles made by the projections of a ray with the ground line. There is, however, one Conventional direction for the rays used in Engineering and Architectural drawings: this is taken as parallel to one of the diagonals of a cube standing on the H. P. and having one face parallel to the V. P. Both projections of this diagonal will invariably make 45° with the XY line, or roughly speaking the ray is supposed to come over the left shoulder. The real inclination of the ray, however, is not 45° , and is found as follows:—

Problem 240.—To find the real angle of inclination to the planes of projection of the Conventional ray. (Plate XXXII., Fig. 4).

Let $a\ b$ and $a'\ b'$ represent the plan and elevation of the conventional ray each making 45° with the XY line.

Then to find the real angle of inclination to V. P., we require a right-angled triangle in which the real distance in space between A and B is the hypotenuse, the line $a\ b$ is the base, and the height of a' above the XY line is the perpendicular. With centre b and radius $b\ a$ describe an arc cutting the XY line in c . At c drop a perpendicular, and through a draw a A parallel to the XY line and cutting the perpendicular in A. Join $A\ b$. Then the triangle $A\ b\ c$ fulfils the above conditions, and the

angle $A b c$ is the true angle of inclination of the conventional ray to the V. P., and is about $35\frac{1}{4}^\circ$. In exactly the same manner the inclination of the ray to the H. P. may be obtained.

The determination of shadows may be conveniently divided under three heads—

- 1 The determination of the shadow cast by an object on the Planes of Projection.
- 2 The determination of the shadow cast by an object on itself.
- 3 The determination of the shadow cast by one object on another object.

The determination of the shadow cast by an object on the Planes of Projection.

It is obvious that the shadow cast by any object represented by orthographic projection may either fall only on one plane or on both planes according to the distance the object is supposed to be from the XY line. In any case, however, the outline of the shadow must be continuous.

In the following problems the Conventional direction of the ray is used, and all rays will be represented by double chain-dotted lines with arrow heads.

Problem 241.—To determine the shadow cast by a line on the planes of projection—

- (i) When the shadow only falls on one plane of projection. (Plate XXXIII., Fig. 1).
- (ii) When the shadow falls on both planes of projection. (Plate XXXIII., Fig. 2).

CASE I.

Let the projections of the given line $A B$ be drawn. Following the principles laid down above, we must draw projections of RAYS through the extremities of the line. As these projections of rays meet on the H. P., the shadow will lie wholly on the H. P. From the points where the projections of the RAYS in elevation cut the XY line, drop perpendiculars to meet the projection of the RAYS in plan in the points A and B . Then the line AB is the required shadow.

CASE II.

Draw projections of rays through the extremities of the projections of the given line. The projections of the RAYS drawn through a and a' meet

in the H. P., and the projections of the RAYS drawn through b and b' in the V. P. The shadow will therefore be partly on the H. P. and partly on the V. P. The points A and B can be obtained by the method shown in Case I., but as they are in different planes, the line joining them will not be the true projection of the required shadow. To find the direction of the shadow on the H. P., suppose the V. P. moved away, and find B_1 the point of intersection of the projections of the RAYS through the extremity b, b' with the H. P. Joining A and B_1 we obtain $\Delta O B_1$ of which the portion is the required portion of the shadow on the H. P., and OB will be that on the V. P.

Problem 242.—To determine the shadow cast on the planes of projection by a vertical circular plate. (Plate XXXIII., Fig. 3).

Draw the projections of the given plate and divide the plan into any number of points. Each of these points will represent two points in elevation and the points in plan must be therefore lettered $\frac{c}{d}, \frac{g}{h}, \frac{e}{f}$, &c. To fix the location of these points in elevation we must draw an auxiliary elevation of the plate on $X_1 Y_1$, which will give us the distances of each point from the elevation of the diameter $\frac{b'}{a'}$. Projections of Rays drawn through these points in plan and elevation, in the same manner as in the last two problems, give the required shadow which is an ellipse.

Problem 243.—To determine the shadow cast on the planes of projection by a circular plate which is in a plane perpendicular to the V. P. and inclined to the H. P. (Plate XXXIII., Fig. 4).

Draw the plan and elevation of the given plate and locate on the circumference any convenient number of points c, d, e, f, g, h , &c. Through these points draw the plans and elevations of "Rays" as usual. Some of these will meet in the H. P. and some in the V. P., so portions of each shadow must be drawn. The outline must, however, be continuous and the shadows must meet on the XY line.

The determination of the Shadow cast by an object on itself.

So far we have dealt with objects of two dimensions. It is obvious however that an object of three dimensions will, in addition to the shadow cast on the planes of projection, have a certain portion of its surface unilluminated and therefore in shade.

Problem 244.—To determine the shadow cast by a right hexagonal pyramid standing on the H. P. on the plane of projection, and to determine the line of separation of light and shade on the surface of the solid. (Plate XXXIII., Fig. 5).

Draw the projections of the solid. Then if vt and $v't'$, the projections of a ray through the vertex be drawn, the plan and elevations of all other rays will be parallel. The faces dve , evf and $fv a$ are evidently unilluminated, hence if the horizontal trace t of the ray through the vertex be determined, the outline of the shadow on the H. P. will be given by joining at and dt . The lines of separation of light and shade are in this case evident from inspection, and are dv and av .

Problem 245.—To determine the shadow cast on the planes of projection by a right cone the plane of the base of which is parallel to and $\frac{1}{2}$ -inch distant from the H. P., and to determine the lines of separation of light and shade. (Plate XXXIII., Fig. 6).

Draw the projection of the cone, and the projections of a ray $a'o'$ and ao , through the centre of the base of the cone. Then the horizontal trace of the ray, o , will be the centre of a circle representing the shadow cast by the base of the cone on the H. P. As the plane of the base is parallel to the H. P. the radius of this circle will be equal to the radius of the base of the cone.

Draw the projections of the ray through the vertex. As these intersect in the V. P., part of the shadow will be in the V. P.

From the point c where the elevation of the ray through the vertex v' cuts the XY line, erect a perpendicular to the XY line meeting the plan of the ray through v in d . Lines drawn from d , tangent to the circular outline of the shadow of the base, gives the outline of the shadow in the H. P. cutting the XY line in e and f . The vertical trace of the ray V may now be obtained by the same construction as was used in Problem 241 (2), and the outline of the shadow in the V. P. is obtained by joining eV and fV .

To determine the lines of separation of Light and Shade.

The lines of separation will be the generatrices along which planes containing the extreme rays of light touch the cone. These planes contain the vertex, and therefore tangents drawn from g the horizontal trace of the projection of the ray through the vertex of the cone when resting on

the H. P., to the base of the cone, will give the required point h and j . Generatrices drawn through h and j will give the lines of separation of light and shade.

Problem 246.—To determine the shadow cast on the plane of projection by a right cone whose axis is horizontal and inclined to the V. P. and to determine the lines of separation of light and shade. (Plate XXXIII., Fig. 7).

Draw the projections of the given right cone. Then if A, B, C and D are the horizontal traces of rays passing through the extremities of the horizontal and vertical diameters of the circular base of the cone, and V is the horizontal trace of the ray through the vertex vv' , and ellipse with AB and CD as conjugate diameters being described, tangents to the ellipse from V complete the outline of the shadow cast by the cone on the H. P.

To determine the lines of separation of Light and Shade.

If p and q are the points of contact of the tangents drawn from V to the ellipse $ABCD$ then the plans of the rays through p and q will cut the plan of the base of the cone in s and r . Generatrices drawn through s and r give the lines of separation of light and shade.

Problem 247.—To determine the line of highest light and the lines of separation of light and shade on the surface of any cylinder. (Plate XXXIV., Fig. 1).

This is a general case, so draw the projections of a cylinder the axis of which is inclined to both planes of projection.

To determine the line of highest Light.

Since the points of highest light on the surface of the cylinder will be those on which the rays of light fall normal to the surface, it follows that the lines of highest light will be determined by the intersection of a plane containing rays of light, and normal to the surface of the cylinder. Such a plane will evidently pass through the axis of the cylinder, and must contain all the rays, which, if produced, would pass through the axis. Hence the horizontal trace of this required plane must pass through the horizontal trace of the axis, or the point o . If we draw the projections of a ray through any point n on the axis and find its horizontal trace k , then it is evident that k is another point on the horizontal trace of the required plane which may be drawn through $k o$ and produced to

meet the circumference of the base in e . The generatrix drawn through e will give the required line of highest light ef .

To determine the lines of separation of Light and Shade.

The lines of separation will be the generatrices along which a plane containing the extreme rays will touch the cylinder. This plane will evidently be parallel to that through the axis, determined as above. Draw tangents to the base of the cylinder parallel to the line eo and touching the base at the points g and m . These represent the horizontal traces of the required tangent planes, and the generatrices gl and mp will, therefore, be the required lines of separation of light and shade.

In the cases of the vertical right cylinder the tangents will coincide with the plan of rays drawn tangential to the circular plan of the cylinder.

The general case of the cone is similar to the special case given in Problem 245.

Problem 248.—To determine the point of highest light and the lines of separation of light and shade on the surface of a sphere, and also the shadow cast by the sphere on the plane of projection. (Plate XXXIV., Fig. 2).

The determination of the point of highest light is the same problem as the determination of the shadow cast by a point on a sphere, and will be discussed in Problem 253, the only difference being that the given point will be any point on a ray passing through the centre of the sphere.

To determine the lines of separation of Light and Shade and the shadow cast on the Plane of Projection.

The rays intercepted by a sphere from a right cylinder and the outline of the shadow cast by the sphere on the plane of projection is that of the section of the cylinder by that plane. This outline is therefore an ellipse. Further, half the sphere will be in shade, and since the great circle which separates the light and shade is the circle of contact of the rays of the cylinder and the sphere, its plane is at right angles to the direction of the rays and its projections are both ellipses.

An auxiliary elevation of the cylinder of intercepted rays must be made on any XY line (X_1Y_1) parallel to the plans of the rays and touching the sphere. To save drawing we may place the new ground line X_1Y_1 in such a position that the given plan of the sphere becomes the required auxiliary elevation. Draw $m's'$, $n'l'$ touching the elevation of the sphere

and making an angle δ with $X_1 Y_1$ equal to the TRUE INCLINATION of the rays of light. Then $m's' n'l'$, is the elevation of the cylinder of intercepted rays on $X_1 Y_1$ and op' parallel to $m's'$ is the elevation of its axis. Further $m' n'$ is the elevation (on $X_1 Y_1$) of the circle of contact of the cylinder and the sphere. Now lines parallel to the rays in plan and touching the PLAN of the sphere in a and b , determine the plan of the cylinder. Hence $a b$, is the plan of the horizontal diameter of the great circle of contact and is therefore the major axis of the required ellipse. By projecting $m' n'$ to m and n the minor axis $m n$ is obtained. The elevation may now be drawn by projecting the points a, b which will be on the horizontal diameter of the ellipse in elevation. Project up from m and n and make $m'' n''$ the same height above the XY line as m' and n' are above $X_1 Y_1$. Lines projected from t and q to meet the circumference of the sphere in elevation will give more points on the ellipse which can be drawn in. There is no difficulty in deciding which portion is in shade.

2. It now remains to determine the shadow cast on the plane of projection.

The point p , obtained by projecting from p' is the horizontal trace of the axis of the cylinder of rays, and is therefore the centre of the ellipse in which the latter cuts the H. P. The major axis of this ellipse will coincide with the plan of the axis of the cylinder and the points l and s are the extremities. The minor axis is equal to the diameter of the sphere draw through p , and the ellipse can now be drawn.

Problem 249.—To determine the shadow cast in a hollow hemisphere when the circular end is horizontal. (Plate XXXIV., Fig. 3).

Draw the plan and elevation of the given hemisphere. We will first consider the ray, whose plan $a b$ passes through o , the centre of the hemisphere. To obtain the point where this ray intersects the hemisphere, make an auxiliary elevation of the hemisphere on $X_1 Y_1$ parallel to $a b$. Then, if we draw $a' A'$ making the TRUE INCLINATION of the ray with the $X_1 Y_1$ line, and project the point A' on to $a b$ we will get Λ the plane of the required point of intersection. The true angle of inclination may be obtained by Problem 240, or more simply by making $r' q' p' = 45^\circ$; $p' s' = r' q'$, then the angle $r' s' p' =$ the true angle of inclination of the conventional ray.

In the case of this particular ray the auxiliary elevation is the semi-circle drawn with the radius of the hemisphere as radius. Any number

of points C, D, &c., can be fixed by taking other rays and making auxiliary elevations of the sections of the hemisphere made by the vertical planes containing the rays.

The point P where a tangent ray touches the hemisphere is evidently the limit of shadow.

To find the corresponding points in elevation, the point a is fixed in elevation as a' . Through a' draw the elevation of a ray (at 45°) and projecting up from A we obtain A' . In the same way the other point C' , D' , &c., can be fixed, and the curve of the outline of the shadow drawn.

Problem 250.—To determine the shadow cast in a semi-cylinder standing on the H. P. (Plate XXXIV., Fig. 4).

Draw the projections of the semi-cylinder. Then the plan of the ray drawn through a determines one limit of the shadow as all the rays to the right are unintercepted.

The point A' is found in elevation by means of the projections of the ray through a' and a' . The tangent ray at d determines the point d' , the limit of shadow. Any number of points B' , C' , &c., may be obtained in the same manner as A' .

Problem 251.—To determine the shadow cast in a hollow hemisphere when the circular end is vertical. (Plate XXXIV., Fig. 5).

Draw the projections of the given hemisphere. In the same manner as in Problem 249, make an auxiliary plan of the sections of the hemisphere made by horizontal planes containing the rays, and through the points obtained a , b , &c., draw lines inclined at the true inclination of the conventional ray, obtaining the points A' , B' , on the curve of the outline of the shadow.

Problem 252.—To determine the shadow cast on a cylindrical column by a pentagonal cap. (Plate XXXIV., Fig. 6).

This is only given as a practical example of the use of shadows and offer no new feature in construction. The limit of shadow is obtained by the projection of the ray through k and the tangent ray at l . The outline of the shadow is obtained by taking any convenient rays as through f , b , g .

The determination of the Shadow cast by one object on another.

The determination of the shadow cast by an object on any figure bounded by plane surfaces offers no difficulty, and the determination of the

shadow cast by an object on a curved surface will be covered by the following two general cases.

Problem 253.—To determine the shadow cast by a point on a sphere. (Plate XXXV., Fig. 1).

Let a be the given point and o the given sphere. Draw their elevations. The problem amounts to finding the intersection of a ray through the point a with the sphere. Suppose a vertical plane containing the ray to cut the sphere. This plane will have for its horizontal trace ab , the plan of the ray, and its section with the sphere will be a vertical circle, the diameter of which will be equal to de , and the centre of which will be vertically above h , the centre of de , and at a height above the H. P. equal to the height of o .

Using b as a hinge construct this auxiliary plane into the V. P. The point b is stationary, h moves to h_1 and a to a_1 . Project up and obtain the points H. and A. Join Ab' and describe a circle with H as centre and radius he . Then P and R the points of intersection of this circle with Ab' , will be the real points of intersection of the ray with the given sphere when constructed into the V. P. To obtain the corresponding projections of these points, draw PP' and RR' parallel to the XY line cutting $a'b'$, the elevation of the ray, in P' and R' . Then these points will be the required elevations of the points of intersection, and $P_1 R_1$ obtained in the usual manner will be the plans.

Problem 254.—To determine the shadow cast by a point on a cone. (Plate XXXV., Fig. 2).

Draw the projections of the cone, the given point a , and the projections of a ray through a . Figure the XY line any convenient level, say (o), and figure a from it as $a_{12,5}$.

The first step is to find the generatrix on which the ray enters the cone, then the intersection of this with the given ray will be the required point: this will be found by supposing a plane to pass through the vertex of the cone, and to contain the ray; and then determining its intersection with the conical surface.

Find b the horizontal trace of the ray and the index of v which is 14. Through these three points pass the plane M. Find g the intersection of the o contour of the plane M and the base of the cone. Then gv is the plan and $g'v'$ the elevation of the required generatrix of intersection.

The intersection of this generatrix with the ray gives the point P, P' at which the ray intersects the cone. The verticality of the line P P' will be a test of the accuracy of the construction. By the aid of this problem the shadow of any object on a conical surface can be determined.

SHADING.

We have already seen that the amount of light reflected from any surface depends on the angle at which the illuminating rays strike it ; when they are normal to it, the surface will be pure white, and the shade of tint of the surface will become darker and darker, as the rays strike it more and more obliquely. Hence the first point to be determined in finding the light and shade to be applied to any object, is the portion of it which is in highest light, that is, the portion of the surface on which the rays fall most perpendicularly.

The next point will be to determine the line of separation of absolute light and shade, that is, the line on the surface of the object, beyond which the illuminating rays do not strike it, the portion thus determined being, therefore, unilluminated, save by whatever light may be reflected on to it.

The methods of obtaining these two points have already been discussed in the preceding pages.

The intensity of a shade or shadow, is modified by the various peculiarities in the form of the body, by the intensity of the light, and by the position which the object illuminated, has with regard to the illuminating rays.

Flat surfaces wholly exposed to the light, and on which the rays fall at right angles, are theoretically colorless and white, and will always in practice be left white, or receive a uniform wash of the lightest possible tint.

The tone of other surfaces on which the rays of light fall at angles less than a right angle, will vary in darkness from the lightest tint just mentioned, to whatever degree of shade may be desired, according to the angle between the plane in question and the rays of light. In curved surfaces, therefore, the shade will vary in every part, from pure white to extreme dark.

In geometrical drawings, the direction of the rays of light are determined by means of their two projections, which are each inclined at an angle of 45° to the ground line. By means of the plan and elevation, therefore, of any object, we can both determine the theoretical shape of the shade and shadows ; and also by means of the above-mentioned consideration, and the

conventional rules which we are about to give, determine the value of the tone for each portion of the surface of the object to be represented.

The following are some general rules for the tints to be applied to any given surface :—

Flat surfaces equidistant at all points from the eye, should receive a tint uniform in tone, the tone depending upon the angle at which the illuminating rays strike the surface in question.

In orthographic projection, where the visual rays are imagined parallel to the horizontal plane of projection, in the case of an elevation, and to the vertical plane in that of a plan, every surface parallel to either plane of projection is supposed to have all its parts at the same distance from the eye.

When two surfaces thus situated are parallel, the one nearer the eye should receive a lighter tint than the other.

Every surface exposed to the light, but not parallel to a plane of projection, and, therefore, having no two points equally distant from the eye, should receive an unequal tint. The tint should gradually increase in depth as the parts of such surface recede from the eye.

If two surfaces are unequally exposed to the light, the one which is more directly opposed to its rays should receive the fainter tint.

When a surface entirely in the shade is parallel to a plane of projection, it should receive a tint uniformly dark.

When two objects parallel to each other are in the shade, the one nearer the eye should receive the darker tint.

When a surface in the shade is inclined to the plane of projection, the part which is nearest the eye should receive the deepest tint.

If two surfaces exposed to the light, but unequally inclined to its rays have a shadow cast upon them, the shadow upon the lighter surface will be more intense than that on the darker surface.

Problem 225.—To determine the value of the shades on the faces of a prism. (Plate XXXV., Fig. 3).

Let it be proposed to shade the prism. According to the position of the prism, as shown by its plan, the face ($a' f'$) will be the lightest, the illuminating rays falling very nearly at right angles on its surface. As, however, this face is inclined to the plane of projection it will not be uniformly shaded, the darkest portion being that furthest away from the supposed point of the eye, *i.e.*, towards ($e' f'$), while the portion near ($a' d'$) will be the lightest.

The face ($a' c'$) is parallel to the vertical plane of projection, and, therefore, equidistant at all points from the eye. The angle at which the rays strike this face as compared with that at which they strike the face ($a' f'$), will evidently be measured by the angle ($P b a$) as compared with the angle ($m2e$). Though these angles may be used for the purpose of comparison, they are not, of course, the true angles of inclination of the rays to either face in question.

The strength of the tint, for the face ($a' c'$), should, therefore, be darker than the darkest part of the face ($a' f'$), but quite uniform.

The face ($g' c'$) will be entirely in shade, and being so, the strength of its tint will be greatest nearest the eye, that is at $b' c'$, and least at $y' h'$ the tint here being darker than the flat tint on the face $a' c'$. The practical method of obtaining these gradations of shade with the brush, will be considered further on.

Problem 256.—To determine the shading of a cylinder. (Plate XXXV., Fig. 4).

In the case of the cylinder, the depth of tint will vary for every generatrix of its surface.

In shading a cylinder it will be necessary to consider the difference in the tone proper to be maintained between the part in light, and that in shade. It should be remembered that the line of separation between the light and shade, is determined by the generatrix at (e), the position of which is determined by means of (R_1e) the plan of a ray drawn tangential to the plan of the cylinder, *vide* Problem 247. That part, therefore, of the cylinder, which is in shade, is comprised between the lines ($e' e'$) and ($b' b'$). This portion, then, should be shaded conformably to the rule previously laid down for treating surfaces in the shade, inclined to the plane of projection; all the remaining part of the cylinder which is visible presents itself to the light; but in consequence of its circular figure, the rays of light form angles varying at every part of its surface. In order to represent with effect the rotundity, it will be necessary to determine with precision the part of the surface where we shall have the highest light. This part is situated on the generatrix ($d' d'$), determined by the line ($R d$), the plan of a ray drawn through the centre of the cylinder, *vide* Problem 247. As the visual rays, however, are perpendicular to the vertical plane, and, therefore, parallel to $5 O$, drawn through the centre (O), of the plan of the cylinder, perpendicular to the XY line, it follows that

the part which appears clearest to the eye will be, by the previous rules, near this line. If, therefore, we bisect the angle (R O 5), by the line *Om*, we may consider that the lightest portion of the cylinder will be included between the generatrices at *2'* and *m'* equal to (*d 2*) being half (*d m*).

This part should have no tint upon it whatever, if the cylinder happen to be polished—a turned iron shaft, or a marble column for instance; but if the surface of the cylinder be rough, as in the case of a cast-iron pipe, then a very light tint—considerably lighter than on any other part—may be given it. The depth of shade will, therefore, be gradually reduced from (*e' e'*) to (*m' m'*), and again will be deepened from (*d' d'*) to (*a' a'*).

The portion immediately in the neighbourhood of the generatrix *e' e'* will be the darkest part of the cylinder, and the depth of shade will be toned down from this to *b' b'*, where, however, the tint must still be darker than the darkest portion of the surface which is in light.

Problem 257.—To determine the shading of a cone. (Plate XXXV., Fig. 5).

The considerations, just gone into, in the case of the cylinder, are likewise applicable to that of the cone. The line of highest light (*c' d'*) must first be determined, and then the line of separation of light and shade (*c' e'*). The triangle (*c' e' b'*) will be the dark portion of the cone, and the triangle (*c' 2 r'*), determined as for the cylinder, the portion which has the highest light. In shading the cone, the rules for shading surfaces at unequal distances from the eye must be adhered to; hence the darkest part of the cone will be the triangle (*c' 8' 9'*), immediately in the neighbourhood of the generatrix (*c' e'*), and this tint will gradually be toned down, till (*c' b'*), the edge of the cone, is reached, taking care, of course, that the lightest tint of a surface in shade, is darker than the darkest tint of a surface in light. The different shades are blended into each other by gradations, as will be explained further on.

SHADING BY FLAT TINTS.

We shall now proceed to give some directions for using the brush, and explain the usual methods employed in producing conventional tinting and shading.

The methods of shading most generally adopted are either by the superposition of any number of flat tints, or of tints softened off at their edges. The former method is the more simple of the two, and should be first attempted.

The process of laying on a flat tint is, of course, simple, and only requires a moist brush, and not too much color.

The process of laying on a graduated tint, by means of a sum of flat tints, is more complicated, and is as follows:—The prism before considered being taken as an example, let us commence to shade the side ($b' h'$) (*Plate XXXV., Fig. 3*).

First, divide the side into four equal parts by vertical lines. These lines should be drawn very lightly in pencil, as they merely serve to circumscribe the tints. A greyish tint is then spread over the first division, ($b' 4'$). When this is dry, a similar tint is laid on, extending over ($b' 5'$), *i.e.*, over the first and second divisions, when this is dry, a tint is laid over ($b' 6'$), and so on, till lastly, a tint covering the whole surface imparts the desired graduated shade to that side of the prism. The number of tints designed to express such a graduated shade depends upon the extent of the surface to be shaded, and the depth of tint must vary according to the number.

As the number of washes is increased, the whole shade gradually presents a softer appearance, and the lines which border the different tints become less harsh and perceptible. For this reason the foregoing method of representing a shade or graduated tint by washes successively passing over each other, is preferable to that sometimes employed, of first covering the whole surface, and then gradually narrowing the tint at each successive wash, because in this way the outline of each wash remains untouched, and presents, unavoidably, a harshness which, by the former method, is in a great measure subdued. Any cut shade which may arise during the above-mentioned process, must be counteracted, by stippling with a fine brush, on *each side of it*, the line itself must, on no account, be touched.

The face ($a' f'$) is treated in the same manner the tints being, however, much lighter.

The face ($a' c'$) is covered with a uniform flat wash of a medium tint.

Again, let us suppose the half plan of the cylinder (*Plate XXXV., Fig. 4*), to be divided into any number of equal parts; indicate these divisions upon the surface of the cylinder by faint pencil lines, and begin the shading by laying a light tint over all that part of the cylinder in shade, *i.e.*, over ($e' b'$). When this is dry, put on a second tint,

attending over that division which is to be deepest in color, *viz.*, ($e' 8'$), then spread a third tint over this division, and one on each side of it. Proceed in this way, until ($b' 6'$) is covered, then lay a tint [over ($b' 5'$), then a light tint over ($b' 4'$), and finally, a very light tint over $b' m'$. In the figure the quadrant ($5' b'$) is divided into five parts; the divisions on each side of the point (e') being $\frac{1}{5}$ of ($5' b'$), the others $\frac{2}{5}$ of ($5' b'$).

Treat in a similar manner the left-hand side, commencing with ($a' 1'$), then ($a' 2'$), &c., and complete the operation by covering the whole surface of the cylinder—excepting only the division in full light, *i.e.*, ($d' 3'$), with a very light tint.

The cone is to be treated in an exactly similar manner. The divisions are shown in (*Plate XXXV.*, *Fig. 5*).

SHADING BY SOFTENED TINTS.

The advantage which this method possesses over the one just described, consists in imparting to the shade a softer appearance, the limitations of the different tints being imperceptible. It is, however, more difficult.

Let it be proposed to shade by this method the example of a prism in *Fig. 3*.

Apply a narrow strip of tint to the nearest division of the shaded side, and then, qualifying the tint in the brush with a little water, join another lighter strip to this, and finally, by means of another clean brush moistened with water, soften off the edge of this second strip, which may be taken as the limit of the first tint.

When the first tint is dry, cover it with a second, which must be similarly treated, and extend beyond the first. Proceed in this manner with the other tints, until the whole face is shaded.

In the same way the left-hand face is to be covered, though with a tint considerably lighter, for the rays of light fall upon it almost perpendicularly.

A cylinder or cone can be shaded by means of softened tints, exactly in a similar manner to the above, the same divisional lines being made use of as in the case of shading by flat tints.

The shading of a sphere is noticed further on.

ELABORATION OF SHADING AND SHADOWS.

Having thus laid down the simplest primary rules for shading isolated

objects, and explained the easiest methods of carrying them into operation ; it is now proposed to illustrate their application to more complex forms, to show where the shading may be modified or exaggerated, to introduce additional rules, and to offer some observations and directions for shading architectural drawings.

Whatman's best rough-grained drawing-paper is better adapted for receiving color than any other. Of this paper, the *Double Elephant* size is preferable, as it possesses a peculiar consistency and grain. A larger paper is seldom required, and even for a small drawing, a *portion* of a Double Elephant sheet should be used.

The paper for a colored drawing ought always to be strained upon a board with glue, or by means of a straining frame. Before proceeding to lay on color, the *face* of the paper should be washed with a sponge well charged with water, to remove any impurities from its surface, and to prepare it for the better reception of the color. The whole of the surface is to be damped, that the paper may be subjected to a uniform degree of expansion. It should be only lightly touched by the sponge, and not rubbed. Submitted to this treatment, the sheet of paper will present, when thoroughly dry, a clean smooth surface, not only agreeable to work upon, but also in the best possible condition to take the color.

The size of the brushes to be used will, of course, depend upon the scale to which the drawing is made. Long thin brushes, however, should be avoided. Those possessing corpulent bodies and fine points are to be preferred, as they retain a greater quantity of color, and are more manageable.

During the process of laying on a flat tint, if the surface be large, the drawing may be slightly inclined, and the brush well charged with color, so that the edge of the tint may be kept in a moist state until the whole surface is covered. If in tinting a small surface the brush should be too fully charged with color, the surface will unavoidably present rugged edges and an uneven appearance throughout. A moderate quantity of color in the brush, well and expeditiously spread on the paper, is the only method of giving an even, close-grained aspect to the surface.

As an invariable rule let it be remembered, that no tint, shade, or shadow, is to be passed over or touched again *until it is quite dry*, and that the brush is not to be moved backwards and forwards through the color.

In the examples of shading which are given in this work, it may be observed, that all objects with curved outlines have a certain amount of reflected light imparted to them. It is true that all bodies, whatever may be their form, are affected by reflected light; but, with a few exceptions, this light is only appreciable on curved surfaces. The judicious degree and treatment of light is of considerable importance.

All bodies in the light reflect on the objects near them some of the rays they receive. The shaded side of an isolated object is lighted by rays reflected from the ground on which it rests, or from the air which surrounds it.

In proportion to the degree of polish, or brightness in the color of a body, is the amount of reflected light which it communicates to adjacent objects, and also its own susceptibility of illumination under the reflection from other bodies. A polished column, or a white porcelain vase, receives and imparts more reflected light than a rough casting, or a stone pitcher.

Shade, even the most inconsiderable, ought never to extend to the outline of any smooth circular body. On a polished sphere, for instance, the shade should be delicately softened off just before it meets the circumference, and when the shading is completed, the tint intended for the local color may be carried on to its outline. This will give transparency to that part of the sphere influenced by reflected light. Very little shade should reach the outlines even of rough circular bodies, lest the coloring look harsh and coarse. Shadows also become lighter as they recede from the bodies which cast them, owing to the increasing amount of reflection which falls on them from surrounding objects.

Shadows, too, are modified in intensity by the air, as they recede from the spectator; they thus appear to increase in depth as their distance from the spectator diminishes. In nature this difference in intensity is only appreciable at considerable distances. Even on extensive buildings inequalities in the depth of the shadows are hardly perceptible. It is most important, however, for the effective representation of architectural subjects drawn in plan and elevation, that the variation in the distance of each part of an object from the spectator should at once strike the eye; and, therefore, a conventional exaggeration is practised. The shadows on the nearest and most prominent parts are made very dark, to give scope for the due modification in intensity in those parts which recede. The same direction is applicable to shades. The shade on a cylinder, for instance, situated near the spectator, ought to be darker than on one more

remote. As a general rule, the color on an object, no matter what it may be intended to represent, should become lighter as the parts on which it is placed recede from the eye.

Plate XXXV presents some examples of finished shading. The remarks which we now propose to offer upon each of these figures are applicable alike to all forms of a similar character.

Fig. 6 exemplifies the complex appearance of shade and shadow presented on a concave surface. It is worthy of notice that the shadow on a concave surface is darkest towards its outlines, and becomes lighter as it nears the edge of the object. Reflection from that part of the surface on which the light falls, causes this gradual diminution in the depth of the shadow; the part most strongly illuminated by reflected light being opposite to that most strongly illuminated by direct light.

No brilliant or extreme lights should be left on concave surfaces, as they tend to render doubtful, at first sight, whether the objects represented are concave or convex. After the local color has been put on, a faint wash should be passed very lightly over the whole concavity. This will modify and subdue the light, and tend to soften the tinting.

The lightest part of a sphere (*Fig. 9*) is confined to a mere point around which the shade commences and gradually increases as it recedes. This point is not indicated on the figure, because the actual shade tint on a sphere ought not to be spread over a greater portion of its surface than is shown there. The very delicate and hardly perceptible progression of the shade in the immediate vicinity of the light point, should be effected by means of the local color of the sphere. In like manner, all polished or light colored curved surfaces should be treated; the part bordering upon the extreme light should be covered with a tint of local color somewhat fainter than that used for the flat surfaces. In curved unpolished surfaces, the local color should be gradually deepened as it recedes from that part of the surface most exposed to the light. In shading a sphere, the best way is to put on two or three softened-off tints in the form of crescents converging towards the light point, and superposed one over the other, the first one being carried over the part in deepest shade.

Figs. 7 and 8 show the peculiarities of the shadows cast by a cone on a sphere or cylinder. The actual shape of these cast shadows is determined by the ordinary processes of descriptive Geometry. They are simply the curves in which the tangent planes, used for fixing the line of separation of light and shade (*vide* Problem 247), intersect the object on

which the shadow is supposed to fall. The rule that the depth of a shadow on any object is in proportion to the degree of light which it encounters on the surface of the object, is in these figures very aptly illustrated. It will be seen, by referring to the plan (*Fig. 7*), that the shadow of the apex of the cone falls upon the lightest point of the sphere, and this is therefore the darkest part of the shadow. So also the deepest portion of the shadow of the cone on the cylinder, in the plan (*Fig. 8*), is where it comes in contact with the line of extreme light. Flat surfaces are similarly affected; the shadows thrown on them being less darkly expressed, according as their inclination to the plane of projection increases. The local color on a flat surface should, on the contrary, increase in depth as the surface becomes more inclined to this plane.

These figures also show that shadows, as well as shades, are affected by reflected light. This is very observable where the shadow of the cone falls upon the cylinder.

The student is recommended to copy carefully, in sepia or Indian ink, the illustrations in this *Plate*.

SHADE LINES.*

Shade lines, when properly placed, render a single view of an object intelligible by giving the appearance of relief to its parts.

In shade-lining a drawing the following rules should be strictly observed.

SHADE LINES denote the intersection of two surfaces, one of which is illuminated and the other in shade, and *the latter invisible*. Shade lines should, therefore, never be placed at the junction of two surfaces, both of which are visible up to their line of intersection. If the visible surface has a curved outline, the shade lines would begin at the points at which the projection of the ray touches this outline, and its full strength should be gradually gained, starting at those points. SHADE LINES should never be drawn to indicate the outline or "contour" of a curved surface. Thus the elevation of a vertical right cylinder would be a rectangle), and the only shade line in this elevation would be the line representing the base of the cylinder. On the other hand, the elevation of a vertical square prism, with one face parallel to the V. P., would be a rectangle also, but one of the sides as well as the base would be a shade line.

In SHADE-LINE drawing, the rays of light are supposed to take the

These rules are taken from Clarke's Practical Geometry.

conventional direction explained in this Chapter. Thus, if a plan and elevation of an object are to be shade-lined, the rays in the former will come from the left-hand bottom corner of the paper, and in the latter from the left-hand top corner, making 45° with the edges of the paper in each case. The directions of the rays for other elevations are those which would be apparent to a spectator facing the respective planes on which the elevation is made.

Never use SHADE LINES to a drawing on which cast shadows or shading are employed. Always place SHADE LINES so that their thickness is outside the outline of the object. SHADE LINES TO SECTIONS follow the above rules, the direction of the ray in any particular section depending on the position of the secant plane.

Plate XXXVI., Fig. 1, exemplifies the value of shade lines.

EXERCISES.

1. A point A is 1 inch from the V. P. and $\frac{3}{4}$ inch from the H. P. Determine the shadow it casts on the planes of projection.
2. A thin plate is shaped like a pentagon of $\frac{1}{2}$ inch side. It is in a plane perpendicular to the H. P. and one edge rests on it, and is $\frac{1}{2}$ inch distant from the V. P. Determine the shadow it casts on the planes of projection.
3. A circular disc of 1 inch diameter is in a plane parallel to and $\frac{1}{2}$ inch distant from the H. P. The centre of the disc is 1 inch distant from the V. P. Determine the shadow it casts on the planes of projection.
4. A rectangular prism ($2'' \times 1'' \times 3\frac{1}{4}''$) has two adjacent faces parallel to the planes of projection and distant $\frac{1}{2}$ inch from the V. P. and 1 inch from the H. P. Determine the shadow it casts on the planes of projection.
5. A cylinder (diameter of base $1\frac{1}{2}$ inches, height 2 inches) has its base parallel to and $\frac{1}{2}$ inch distant from the H. P. The axis is $1\frac{1}{2}$ inches distant from the V. P. Determine the shadow it casts on the planes of projection.
6. A semi-circular niche of 2 feet radius is 4 feet high to the springing of the dome. Determine the shadow cast in the interior of the niche. Scale $\frac{1}{12}$.
7. A rectangular prism ($2'' \times 1'' \times 1''$) rests on the H. P., one long side makes 35° with the V. P. and one corner touches the V. P. A cone

(base 1 inch radius, height 3 inches) rests on its base on the H. P. The centre of the base is 2 inches from the V. P. and $1\frac{1}{2}$ inches from the nearest point in the prism. Determine the shadow the cone casts on the prism.

8. A hexagonal pillar (side of hexagon 1 foot) is surmounted by a cylindrical cap of 4 feet diameter and 1 foot in thickness. Determine the shadow cast on the pillar. Scale $\frac{1}{2}$.

9. A cylindrical column ($1\frac{1}{2}$ feet diameter) is surmounted by a square cap ($2' \times 2' \times 1'$). Determine the shadow cast on the column. Scale $\frac{1}{2}$.

10. The axis of a cone (base 2 inches diameter, height 3 inches) is inclined at 45° to the H. P. and its plan is inclined at 60° to the V. P. Determine the line of highest light and the lines of separation of light and shade.

11. A vertical truncated cone (base $1\frac{1}{2}$ inches diameter, height 3 inches, height of section 2 inches), plane parallel to base stands on the H. P., its axis being 1 inch from the V. P. Determine the shadow cast on the planes of projection, and the shaded portion of the solid.

12. A right cone (base 1 inch diameter, height 2 inches) has its axis horizontal and inclined at 30° to the V. P. Determine the shadow cast on the H. P.

13. A right cone (base 2 inches diameter, height 3 inches) and a sphere $1\frac{1}{2}$ inches diameter, rest on the H. P. The axis of the cone is $2\frac{1}{2}$ inches and the center of the sphere $1\frac{1}{2}$ inches from the V. P. Determine the shadow cast by the cone on the sphere, the shadows cast by both solids on the planes of projection, and the shaded portion of the solids.

14. The vertex of an inverted right pentagonal pyramid (height 4 inches, side of base $1\frac{1}{4}$ inches) is in the H. P. One edge of the base is in the V. P. and the axis vertical. Determine the shadow cast on the planes of projection and the shaded portion of the solid.

15. An octahedron (2 inches edge) has one face parallel to and 1 inch above the H. P. The centre of this face is 2 inches from the V. P. and one of its edges makes 30° with the V. P. Determine the shadow cast on the planes of projection, and the shaded portion of the solid.

16. A hollow inverted truncated right cone (base 3 inches diameter, height 3 inches) has its axis vertical. Its section plane is parallel to the H. P. and $\frac{3}{4}$ -inch from it. Determine the shadow cast on its interior surface.

17. A square-threaded screw (diameter 3 inches, pitch 1 inch) stands vertically on the H. P. Determine the shaded portion of its elevation.

CHAPTER XVI.

PERSPECTIVE PROJECTION.

In Chapter V. we have shown that if objects are represented on paper exactly as the eye sees them, they would not be represented by their exact sizes owing to certain distortions which occur.

These distortions arise from the fact that in nature the rays of light from every point in the object converge to the eye. For the purposes of geometrical drawing this difficulty is overcome by the use of Orthographic Projection, in which the Eye is supposed to be at an infinite distance, and the converging rays become parallel rays.

It is, however, very often convenient, and from an artistic point of view necessary, when no actual measurements are required from the projection, to obtain a view of the object exactly as seen by the human eye. This view is obtained by Perspective Projection, or as it is more generally called by Perspective. Even from a Perspective Projection, however, if accurately drawn, measurements can be obtained by a certain amount of calculation as will be shown further on.

If we suppose ourselves to be looking through a glass window at any object such as a cube, building, &c., on the other side, and imagine the rays of light which pass from each point of the object to the eye, to be intercepted by the plane of the window, the figure traced out by the lines joining the points of intersection thus obtained, will form what is termed a perspective representation of the object in question.

In practice, the plane of the window may be considered to be represented by that of the paper on which we wish to delineate any object.

It is clear that the eye, the plane, and the object must occupy fixed positions with respect to each other. That is to say, that while the operation of tracing out the outline of the object on the glass is performed, neither the eye, the plane or object must move relatively to each other or the picture will be confused.

This may be proved by taking a pane of glass the size of your paper

and holding it upright before you, so as to see the view you wish to draw through it, the picture you wish to make will appear as if drawn on the glass. By moving the glass further away from the eye you will take into your picture fewer objects, which will be larger than before and *vice versa* by bringing the glass nearer you, you will take in a larger view, but on a smaller scale.

It is also evident that only one eye must be supposed to be used during the process otherwise each eye would have its own perspective, and the two views, unless the object were very distant would interlace and confuse each other. The eye must in fact be considered as a point. It is, therefore, evident that the perspective of an object cannot be obtained unless the relative positions of the eye, the pane of glass or picture plane and the object are known.

There are several methods of obtaining the desired projection, and experience can only tell the Student which is the quickest and most convenient method. This experience cannot be gained by sitting in an easy chair, and the Student is warned that he must be prepared to sit with paper and pencil, and draw the figures as explained, and see the drawing grow, as they will naturally be confused with the number of lines in a complete figure. The whole correctness of the picture depends on accuracy in the drawing, and too great care cannot be taken to fix the points correctly, and draw the construction lines finely through them.

There are several different methods of obtaining the Perspective projection of an object—

- (1) Perspective by Orthographic Projection.
- (2) Perspective by Measurement.
- (3) Perspective by Vanishing Points.
- (4) Perspective by Points of Measurements.
- (5) Perspective by Local Scales.

The general principles of each method will first be explained separately. When the Student has thoroughly grasped these, he must decide from experience which is the most convenient method to employ in each case as it arises.

PERSPECTIVE BY ORTHOGRAPHIC PROJECTION.

It is evident that the whole operation involved in perspective is really that of determining the intersection of a number of convergent lines with

a plane. This can obviously be worked by ordinary Orthographic Projection, but this method will, in most cases, prove too tedious, and can only conveniently be employed to obtain the perspective of a geometrical figure given by its projections. We will here give one example before going on to the more convenient methods of obtaining a Perspective Projection.

We will take exactly the same figure as shown on *Plate XX., Figs. 5 and 6*, to show the difference between an Isometric and a Perspective view of an object. As stated on page 200 the relative positions of the eye, the picture plane and the objects must be given.

Problem 258.—To draw the Perspective Projection of a pentagonal pyramid (1.1 inch edge of base, height 2 inches). The observer's eye being 1 inch above the plane on which the base of the pyramid rests, and 2 inches from the plane on which the picture is to be drawn, the nearest corner of the base of the pyramid touches this plane (*Plate XXXVI., Fig. 2*).

Let GL represent the line in which the picture plane, which is vertical, intersects the horizontal plane, on which the base of the pyramid rests. Then one corner of the pyramid is in GL. Draw a plan of the pyramid $a b c d f$ with one corner d in GL. Let E be the observer's eye 2 inches from GL. Then as no conditions are given for the exact position of E with regard to the pyramid, we may take it about opposite the centre of the pyramid, but we must note that as the point E is shifted right or left so will the perspective view of the pyramid change. Draw lines from each angular point of the pyramid to E, representing rays of light, cutting the plan of the picture plane GL in 1, 2, 3, 4, 5, 6. These points are the plans of the required perspectives F A B C D V, and it is only required to obtain their heights above the ground plane. Make an elevation of the pyramid and the point E on an XY line perpendicular to GL, and the elevations of the rays from $a' b'$, &c., to E' . Then the points $1', 2', \&c.$, in which these elevations cut GL evidently give the heights of the perspectives required.

To save confusion we will construct the perspective on one side of the picture on GL. Transfer the points 1, 2, 3, 4, 5, 6 with a slip of paper to a convenient place on GL. Then set off the perpendicular heights of $1', 2', \&c.$, above XY, and the figure A B C D F V is obtained which is the perspective of the pyramid under the given conditions.

Definitions of terms used in perspective.

For the sake of brevity, certain technical terms and definitions must first be given.

To explain the subject as lucidly as possible a general view of processes employed is given in *Plate XXXVII.*, and every operation will be shown pictorially on this plate. Then *Plate XXXVII.*, is in itself a picture, that is, it is a representation on the flat paper of an artist drawing a picture of an object. We are supposed to be standing to the artist's left with our eye at the same height as his. Thus *E* is *our* picture of his eye, *ANO* is our picture of his object, a long box of which he has drawn *his* picture on the sheet of glass held up between him and it. The heavy dotted lines - - - - - are our picture of this sheet of glass or artist's *plane of the picture*, and *ano* is our picture of the picture he has drawn on it. The other heavy dotted lines — — — represent a horizontal plane through *E*, and — — — — a ground plane which will be shown to be most important. Both these planes are really unlimited, but certain portions of each of breadths *HL*, and *GL*, are enclosed by lines so as to show them. All the various lines the artist imagines in the air, or uses on his picture plane to produce his picture, are also shown in perspective, that is, as a picture. The whole sheet is a picture of a view containing several objects—the box, the picture of the box, and the artist—no measurements are therefore possible on it. The Student is requested to study this plate carefully till he *sees* the picture as really representing the view containing several objects. The box, the sheet of glass with the artist's picture on it, the artist's eye and its retina behind it, and all the lines drawn between these are one and all pictures of the real objects. The sketch is exaggerated in the endeavour to keep the various lines clear, and not drawn with any attempt at real accuracy.

Any picture is really formed on the retina or back of the eye, as shown very much enlarged in *Plate XXXVII.*, by rays of light proceeding from each point of the object. Each point, of course, throws off these rays in all directions, but the only one we are concerned with is the one which happens to strike *E* and make the impression on the retina. This is called the *Visual Ray* of the point. Thus *AEa'* is the visual ray from point *A* of the object, and *a'* is its picture on the retina, and *ME m'* is the same for the point *M*. This gives *a' m'* as the picture of the line *AM* on the retina. It is really inverted on the retina, but, of course, the impression on the brain is not so.

NOTE.—Points in the object will always be denoted by capitals and their pictures by the same small letter where possible.

The method of drawing a picture, or making an enlarged copy of the one on the retina, is most easily understood by imagining a large sheet of glass placed between the eye and the object, as shown by the dotted lines in *Plate XXXVII.*; and then, if each point in the object, such as A, is represented on the glass by a point or mark *a*, where the visual ray cuts it, *a* will, as it were, hide A, and if A were removed the artist would not know it, as *a* would still give *a'* on his retina, hence *a* is the correct picture of A. Similarly for all other points, their pictures can be drawn on the glass at the points where their visual rays cut it, and the whole picture of the object made by lines connecting these points, as is roughly shown in *Plate XXXVII.* where *amno* is the picture of the real box AMNO.

The whole art of perspective, therefore, consists in placing *a, b, m, n, x,* &c., the pictures of the points A, B, M, N, X, of the object, correctly on the picture plane. Figures and solids are all represented by points at their corners, and straight or curved lines connecting these points. Therefore, if we can clearly understand how to draw the picture of *any point in any object*, we have learned the *whole*. To draw the picture of a curved line, of course, we require to find the pictures of a good many points in it; but for a straight line two points are enough. There are many draftsman's tricks and conveniences, but the whole art is comprised in drawing the picture of a point, that is, placing it in its correct position on the picture plane.

DEFINITIONS.

Visual Rays.—The lines or rays converging to the eye from every point of the object are termed visual rays, as AE, DE, &c., *Plate XXXVII.*

Picture Plane.—The plane which is supposed to be intersected by the visual rays, and on which, therefore, the perspective delineation must be constructed, is supposed to be vertical for convenience, and is termed the "picture plane."

Station Point.—The point to which the visual rays are supposed to be drawn, in other words, the observer's eye, is called the "station point" and is marked E in *Plate XXXVII.*

Line of Sight.—As the same object will give a different picture from each different point it is seen from, it is evident that to draw one picture we must have the conditions under which the objects are seen distinctly

fixed. This is done by the *line of sight*, which is a *horizontal line*, represented by ESFF' in *Plate XXXVII.*, straight to the artist's front ; but not necessarily the same as the visual ray to the centre of the picture, which may be either above or directly below it. Thus, *the line of sight* is a fixed line in all pictures and suitable for referring measurements to.

Point of Sight.—The point S (*Plate XXXVII.*), in which the line of sight cuts the picture plane is termed the "point of sight."

The horizontal plane.—It is supposed to pass through this horizontal *line of sight* ESF, and will cut the picture plane in a horizontal line HL, which is called the *Horizon* or *the horizontal line*. Thus E, H, L, F, A₁, F₁ K are all points in *the horizontal plane*, and every point in the *horizontal line* is in *both* the picture plane and the horizontal plane.

GROUND PLANE.

The plane on which the object rests is supposed to be horizontal, and is termed the "ground plane."

GROUND LINE.

The line marking the intersection of the picture plane with the ground plane, is termed the "ground line," and is marked GL in *Plate XXXVII.*

CENTRAL VISUAL RAY.

The Student may select any portion of the object or country visible from his position for his picture, and the line from the central point of this to his eye will be the *central visual ray*, and his eye will take in 30° equally all round this line.* The line of sight is, however, horizontal, so will not necessarily coincide with the central ray, but must evidently be directly either above or below it. In most landscapes, for example, the horizontal line HL is about one-third of the height of the picture above the bottom, but in views taken from a hill looking down on the plains, the horizontal line may not come into the 60° of the picture at all, but in all cases the horizontal line of sight is a fixed line, and therefore is taken as the basis of all measurements.

PERSPECTIVE BY MEASUREMENT.

We have now the simplest means of measuring the exact position of

* This is more clearly explained at the conclusion of the Chapter.

every point in the picture. For example, take the point A, *Plate XXXVII.*, AA_1 runs straight up to the horizontal plane, that is, the height of a point is measured by its distance below, or, as in the case of point P, above the horizontal plane. Then A_1F at right angles to the line of sight, or KF_1 for P, gives its position sideways from the base, and then FE or F_1E gives its distance from the eye. All measurements to points in the view on the picture plane will, therefore, be given in this way; and these three measurements will be called *forward*, as EF; or EF_1 ; *side*, as A_1F or F_1K ; and *vertical*, as A_1A or KP. All forward measurements are on the line of sight, side measurements are in the horizontal plane, but may be either to right or left, and vertical measurements may be either up or down.

We have already shown that *the size of the picture depends on the position of the picture plane.* This fact is one about which there is often much confusion, simple as it is. From *Plate XXXVII.* it will easily be seen that if the picture plane is placed half-way between E and the vertical line AM, then the picture *am* will be half the real size of AM, or, if we are drawing from a drawing of the box, half the size of AM in the drawing. Similarly, if the picture plane is placed one quarter of EF from E, the picture of AM will be one quarter size, and so on. Thus in a view containing many objects the artist decides what proportion of its real size he wishes to draw some principal object, and places his picture plane accordingly. If he is drawing from the real objects, it will be seen that to get them on to his paper he must reduce them very much, and therefore the picture plane would need to be placed very close to his eye, and all the objects he wishes to include in his picture would probably be beyond his picture plane. But in many, if not all, cases in which accurate perspective pictures are to be made, they are not made from the real objects, but from drawings which are already much reduced from the real size, and the picture plane may often be placed actually through the corner of the drawing of one object, in which case the picture of that corner will be the same size as in the drawing, and all objects between the picture plane and the eye will be drawn in the picture larger than their actual size in the drawing from which the picture is being made. This will be clear as we go on, but the Student must not imagine that any object, such as Y, this side of the picture plane, cannot be taken into his picture. *The placing of the picture plane is merely the method of arranging the scale of the picture,*

The slightest change in the position of the artist or distance of E from the view, or in the direction of the line of sight from E, instantly produces a fresh view, and a fresh picture; but from one point E and one direction of line of sight, there can only be one picture of the same object or view.

Now it is easy to see that gS , the picture of A_1F in *Plate XXXVII.*, is parallel to it, and bears the same proportion to A_1F , the real size, that ES does to EF ; and similarly ga is parallel to A_1A , and $ga : A_1A :: Eg : EA_1$, or as $ES : EF$, the same proportion as before; and as A_1F and A_1A may stand for *any* straight line parallel to the picture, we have the general rule below.

Rule I.—The picture of a straight line parallel to the picture plane is parallel to it and bears the same proportion to its real length that the distance of the picture plane from the eye does to the *forward measurement* to the line, or, taking A as example, as ES does to EF .

For lines which are not parallel to the picture plane, such as AB for example, as each little portion is at a different distance from the picture plane, the diminution will be different according to its distance: the picture of the further half, for example, will be smaller than that of the nearer half, hence there can be no rule of diminution, and we can only find the pictures of the two end points and join them. Curved lines also, whether parallel to picture plane or not, can only be drawn by finding the picture of a great number of points in the curve, and sketching the picture in through them.

We have now explained matters sufficiently to commence on the actual practical method of drawing the perspective projection of the box shown in *Plate XXXVII.*

Problem 259.—To draw the perspective projection of a box $10' \times 15' \times 10'$ high when its sides AB and AD make 40° and 50° with picture plane. The nearest corner of the box A is 48 feet from the station point E and 20 feet to the left of the line of sight and 25 feet below the horizontal plane. Scale $\frac{1}{100}$ (*Plate XXXVIII., Fig. 1.*)

Draw a line up the middle of the paper to represent the line of sight making E near the bottom of the sheet. Make EF 48 feet and FA at right angles to EF 20 feet. This fixes the position of one corner of the box, and the plan of the box may now be drawn. We must now place the picture plane, or in other words, decide on the size of the picture.

Let us say we desire the picture of AM , the nearest upright edge of the box, to be $\frac{3}{4}$ ths the size it is in reality. We must then place the point of sight, S , where the picture plane cuts the line of sight, at $\frac{3}{4}$ ths of EF , or as this is 48, at 36 feet from E . Draw the line HL through S . Then HL is *the* real horizontal line, as it is in both planes.

Students should compare this with *Plate XXXVII*.

The same letters have been used. The plate contains all that is in the horizontal plane, and above or below it. Thus for point P , the forward measurement might be 65 feet, the side 15 feet, and P will be above K , but equally represented by it as A is by A_1 .

Join AE . Then AE is the plan of the visual rays from A_1M , and A_1 . Let AE cut the picture plane or HL in g . Then this is really g of *Plate XXXVII*, and a and m are immediately below it.

The Student should carefully note the way the paper now represents the picture plane as well as the horizontal plane. Turn to *Plate XXXVII*, and we see both planes pass through HL , so imagine them hinged there and turned till they meet and lie one just on the other. No point in the line HL will be moved at all; but if we suppose the horizontal plane remains fixed and the picture plane turns round to it, we find that the picture of any *vertical measurement* line, as ga , turns up round HL , like the spoke of a wheel round the axle, and shows its full size in the sheet. We can thus use the paper for both planes, and draw our *picture* as well as our *plan* on it, being careful to keep them separate in our mind's eye, and to remember the capital letters are mostly in one sheet and the small ones in the other, and that we cannot draw lines from a capital to a small letter, unless both lie in the horizontal plane as A_1 , g , and E .

We know then that, taking the paper as the picture plane, m and a will lie in a perpendicular line to HL drawn from g , and in this case below the line HL .

From g drop gg_1 a perpendicular to HL .

The conditions given are that the bottom of the box is horizontal and 25 feet below the horizontal plane, and the box is 10 feet high. This is, that A_1A is 25 feet and AM_1 is 15 feet. Then draw a line from A perpendicular to HL , and make $AA_1 = 25$ feet and $AM_1 = 15$, on the given scale. Join A_1E and M_1E cutting gg_1 in a and m and we have am the perspective of AM .

For since AA_1 is perpendicular to the picture plane, to find the point a

we have only to make ga so that it bears the same proportion to AA_1 , that ES does to EF , or that Eg does to EA , and similarly for the point m , we must make gm in the same proportion to AM_1 , and the Student can see that it is really so, by similar triangles.

In the same way all the other corners of the box can be found. For instance join EB , and from where it cuts AL in B drop a perpendicular to HL . At B draw a line parallel to this perpendicular, and mark off 15 feet and 25 feet as in the case of A , and join these points to E obtaining the points n and b . Complete the Perspective. This sums up the whole case of Perspective by measurement.

The Student has drawn a whole box, and by a method which will enable him to draw *any* point or *any* line he has the conditions of. He may think that these lines are all horizontal and vertical, and so particular cases; but nothing in the method has been made dependent on this particular condition of the lines. For example, suppose AQ had been the line of which the picture was required. This is one which is in no sense a particular case, the only conditions given are that it has two ends, as all finite lines have, and given these ends we can draw them.

This method gives the required perspective in a simple manner, but there are other methods which are more convenient under certain conditions, and we will now proceed to discuss them.

PERSPECTIVE BY VANISHING POINTS.

We have already shown in Rule I., that an object diminishes in proportion to its distance from the spectator. The second Rule on which the art of Perspective depends is that all parallel lines appear to meet in a point.

Familiar examples of the first will readily present themselves—the rails of a railway, the sides of a long straight road, the corner lines of a long corridor, &c. But suppose a man to walk away from the artist in any direction so that he keeps in the same straight line, and that, like a spider, he leaves threads behind him from various corners of his body and limbs. These will all be parallel lines, and if the man goes far enough he will vanish as a speck, and so all these lines must appear to meet, as shown in *Plate XXXVI., Fig. 3*, and as you can conceive him any size, so that the threads could be any distance apart at starting, this is a proof that all parallel lines appear to vanish in a point.

The same could be said of planes, that they vanish in lines ; but beyond the familiar example of the plains of India, or the sea, which, when looked at, appear to vanish or end in the horizon, we will not say anything now.

As to perspective diminution, it will be readily seen that when the man has got halfway to vanishing altogether, he is half the size he was at first, and again when three-fourths the way or one-fourth from the end, he is one-quarter his size.

In *Plate XXXVII.* imagine a line MP, which is merely a line running through ANY two points M and P and not any special case, and produce it away to any distance ; and from E draw a line *parallel to it* till it meets the picture plane in W. Then this line may be called *the finder*, as it finds W, the V. P. for MP, and for all lines parallel to it. Now, when we say that W is the V. P. of MP, we mean that *mW* will be the picture of MP produced ever so far, *i.e.*, the picture, of the line MP produced, vanishes to W.

To prove this consider that the distance between MP and its finder EW, though, of course, always actually the same, will, as the lines get longer and longer, *appear* smaller and smaller to the artist, till it actually vanishes to nothing, and thus the lines will appear to him to meet, just as shown by *Plate XXXVI., Fig. 3.*

But consider again what is the *picture* of the finder. Nothing at all but the point W. Therefore the lines appear to meet in W.

Any other line parallel to MP will also go to W, for the finder is drawn parallel to it, and the explanation applies to it just as well as to MP. Hence we have the general rule.

Rule II.—All lines which are parallel in the view appear in the picture to vanish to one point, and that point is that in which a line parallel to them from the artist's eye meets the picture plane. This rule also gives the V. P. of lines parallel to the picture plane, for as the finders of such lines must also be parallel to the picture plane they can never meet it. Hence such lines have no V. P., *i.e.*, their pictures do not converge, and hence must be drawn parallel to the real lines themselves.

Having now shown the general rule, we will proceed to the particular case of horizontal lines. The finder for any horizontal line, being parallel to it, must be horizontal, and therefore must be in the horizontal plane, and so can be drawn on paper, and will meet the picture plane in the

horizontal line. Hence the V. P. of *any* horizontal line must be in the Horizontal line. Thus (*Plate XXXVII.*) for AB and all parallel to it the finder will be EV_1 drawn parallel to AB, and the V. P. will be V_1 where it meets it HL.

The point of sight is the V. P. of all horizontal line perpendicular to the picture plane, because ES is drawn perpendicular to the picture plane and is therefore the finder in this case.

The above reasoning will apply equally will if 'plane' is substituted for 'line' for 'line' for 'point.' Thus:—

Rule.—All parallel planes vanish in a line, and that line is that in which a plane parallel to them through the artist's eye meets the picture plane.

Thus the finder of any horizontal plane is *the* horizontal plane, and they will all vanish in the horizontal line; and this we know is the case in looking down on the plains of India or the sea, the surface ends at the horizon.

Similarly vertical planes will vanish in vertical lines, &c,

Limited planes, such, for example, as the floor, roof, and sides of a long corridor will, of course, vanish in the *point* in which their limiting lines vanish.

It is not strictly true that the horizon of the sea coincides with the horizontal line, and if the artist is on an elevated standpoint the difference may be perceptible. This will be clear if it is remembered that the horizon is the tangent to the earth's or sea's surface from the station point, and the sea is not a horizontal plane; but this and many other little points do not affect the drawing of pictures, and so are omitted.

We will first show how to obtain the perspective of any point and then we will draw the same box as given in Problem 259 under the same conditions by the aid of vanishing points.

Problem 260.—To draw the perspective of any point A of any vertical line AM (height = h). The point A is 2 inches from the Station point, 1.15 inches to the left of the line of sight, and 1 inch below the Horizontal plane. (*Plate XXXVIII., Fig. 2.*)

Draw E the station point; ES the line of sight; HL the horizon, and A the plan of the given point in accordance with the conditions.

We will now see the use of the ground plane as represented by the

ground line GL which must be drawn 1 inch below HL according to the given conditions. There are three simple methods of obtaining the perspective of A.

1st Method.—Through A draw any two lines meeting the HL in t and l . Assuming these to be lines in the ground plane, determine their vanishing points V_1 and V_2 . To do this we draw EV_1 parallel to At and EV_2 parallel to Al . According to the principles laid down the vanishing points for horizontal lines must be in the HL. Now find t_1 and l_1 the plans of t and l in the GL and joint $t_1 V_1$ and $l_1 V_2$. Then these two lines are the perspective of At and Al produced indefinitely. Hence a , their intersection, is the required perspective of A.

Now compare this with *Plate XXXVII*. Here the same letters are used except that A_1 represents the plan of A on the horizontal plane. Any two lines $A_1 l$ and $A_1 t$ are drawn meeting the HL in l and t and their plans on the GL are l_1 and t_1 . V_1 and V_2 are the vanishing points of the lines $A_1 t$ and $A_1 l$; the finder EV_1 being parallel to $A_1 t$ and the finder EV_2 parallel to $A_1 l$. By joining $l_1 V_2$ and $t_1 V_1$ the perspective a of the point A is found to lie on the intersection of these two lines.

2nd Method.—In *Plate XXXVIII*, *Fig. 2*, draw, as before, any line At through A and obtain its VP. EV_1 . Through A draw Ax perpendicular to HL. Then Ax is a horizontal line perpendicular to the picture plane and hence its VP. is S, the point of sight. Find x_1 the plan of the point x and join $x_1 S$ cutting $t_1 V_1$ in a . Now compare this with *Plate XXXVII*. Here $A_1 x$ is drawn perpendicular to HL, plan of x on the GL is x_1 . If x_1 is joined to S, it intersects $t_1 V_1$ in a .

3rd Method.—In *Plate XXXVIII*, *Fig. 2*, draw, as before, any line At through A, and find its perspective $t_1 V_1$. Join AE cutting HL in g . Then AE is the plan of the visual ray from A to E. Let fall a perpendicular from g to g_1 on the GL, then g_1 is the plan in perspective of A. The point where gg_1 cuts $t_1 V_1$ gives a the perspective of A.

Now compare this with *Plate XXXVII*, and we see exactly the same thing represented pictorially, A_1 being the plan of A on the horizontal plane.

To find the perspective of a vertical line AM of height h —

What we want to do here is to erect a perpendicular at a of which the real height is h .

Through a draw ANY line cutting HL in V_2 and GL in l_1 . At l_1 erect

a perpendicular lr equal to h . Join rV_2 and draw a vertical line through a , cutting rV_2 in m . Then am is the required perspective of a line AM (height = h) under the given conditions.

The reason of this construction is evident. Since $l_1 V_2$, rV_2 are lines which have V_2 a point in the horizon as a vanishing point, they are the perspective of parallel and horizontal lines, and therefore am is parallel and equal in perspective to $l_1 r$ which was made equal to h . Hence the height of am is h . It makes no difference where the line $l_1 V_2$ is drawn, any line through a terminating in the HL and GL will do. This is shown pictorially in *Plate XXXVII.*, where $l_1 r$ is made equal to AM , and the line rV_2 cuts off on the perpendicular through g_1 the line am which is the required perspective of AM .

Problem 261.—To draw the perspective of a box by means of vanishing points under the same conditions as given in Problem 259. Scale $\frac{1}{100}$. (*Plate XXXVIII.*, Fig. 3).

Draw HL, E, S, and the plan of the box as before. The bottom of the box by the conditions is 25 feet below the horizontal plane. Draw GL parallel to and 25 feet distant from HL.

We may now use any of the methods described in the last problem to obtain the perspective of A.

Join AE cutting HL in g and project g to the GL in g_1 . Produce BA to meet HL in t and find t_1 its plan. Find V_1 the V. P. of At . The point where tV_1 and gg_1 intersect gives a the perspective of A. Further, the perspective of the line AB lies in aV_1 , and the point b is obtained by joining BE and projecting down a perpendicular to HL from β where the plan of the ray BE cuts HL.

In the same way the point c and d may be obtained.

To find m , draw any line $V_2 l_1$ through a terminating in HL and GL. Erect a perpendicular at l_1 and make $l_1 r$ equal to 10 feet the height of the box. Join rV_2 cutting gg_1 in m . Complete the perspective of the box. Compare the working with *Plate XXXVII.*

VANISHING POINTS OF OBLIQUE LINES.

We have so far dealt with the V. P's. of horizontal lines which are necessarily in the HL. We will now show how to find the V. P. of an oblique line, that is, how to find the point in which it meets the picture plane.

This is quite clearly shown in *Plate XXXVII.* for MP. The finder is EW, drawn from E parallel to MP. to meet the picture plane in W, the plan of this EW is EQ in the horizontal plane, and QW is the height the line EW rises in the horizontal distance EQ, as EW slopes up just at the same slope as MP. We are not concerned with the line beyond the picture plane; we only want the point W.

NOTE.—EW is, of course, very much out of drawing, as it really should be parallel to MP, and would run away to the right out of the sheet of paper before it met the picture plane, but this does not affect the explanation.

In *Plate XXXVIII., Fig. 3*, let us take, as an example, the line AO. The plan of this line is AD. Draw EV_2 parallel to AD. This will be the plan of the finder, which must lie in a vertical plane parallel to the plane AMOD. We have now to find the height V_2W . We know that OD rises 10 feet, in 15 feet, or in other cases the number of degrees of inclination may be given. On EV_2 erect a right-angled triangle $V_1W'E$ the height of which is to the base as 10 is to 15. Make V_2W equal to V_2W' and perpendicular to HL. Then W is the V. P. for AO. It may be noted that we cannot join E and W as they are in different sheets of paper as is evident from *Plate XXXVII.*

To use W. Join aW , then this line is the indefinite perspective of AO and will cut mV_2 in o giving the perspective of the point O.

VANISHING POINTS BEYOND THE PAPER.

Very often the vanishing points required comes outside the paper. Take, for example, the line RB of *Plate XXXVIII., Fig. 3*. Draw EZ parallel to it, *i.e.*, its finder, as far as the paper will allow, and from any point on HL draw a line XZ parallel to ES. Now divide ES into any number of equal parts, and ZX into the same, and number them, say, from top to bottom. Then any line passing through the same figure on both scales must go to the V. P. of RB.

PERSPECTIVE BY POINTS OF MEASUREMENT.

This system has for its chief recommendation the fact that no plan is required if all dimensions are given, or the plan may be placed on a separate piece of paper for the purpose of taking measurements. On the other hand, this method is more liable to lead to confusion—it requires

more lines—and if a mistake is made it is not easy to trace or check. We will first take a simple example to explain the method, using a plan, and we will then find the perspective of the box under the conditions given in Problem 259, adding a lid to illustrate the use of points of measurement for oblique lines.

Problem 262.—To draw the perspective of a pyramid of shape shown in Plate XXXIX., Fig. 1, by the use of measurement points.

Draw the plan and elevation of the pyramid ABCD. Assume the conditions for and draw HL, GL, E and S.

Draw EV_1 and EV_2 the V.P.'s of AB and AD. Produce DA to l_1 and draw l_1V_2 the indefinite perspective of the line AD. With V_2 as centre and V_2E as radius, describe an arc cutting HL in M_2 . Along the GL set off l_11 equal to LA and join $1M_2$ cutting l_1V_2 in a . Then a is the perspective of A. Similarly, make l_12 equal to LD and join $2M_2$ cutting l_1V_2 in d . Then d is the perspective of D. To prove this, join EM_2 . Then it is clear that M_2 is the vanishing point for all lines parallel to EM_2 . But the angle V_2EM_2 is equal to the angle V_2M_2E , and, therefore, all lines parallel to EM_2 must cut GL and HL, and all lines parallel to V_2E at equal angles. Therefore, aM_2 cuts HL and l_1V_2 at equal angles, and the distance l_11 is equal in perspective to l_1a and l_12 to l_1d and 1, 2 to $a d$.

Conversely, if it were required to set off on the line aV_2 a distance equal to AD. Join M_2a and produce it to cut GL in 1. Make 1 2 equal to AD and join 2 M_2 cutting aV_2 in d . Every V. P. therefore, can have an M.P., and all M.P.'s for horizontal lines will be in the H.P. Find M_1 the M.P. for V_1 , and by the same method as explained above, find the point b . To use this method for an oblique line let us examine the case of the line AC. The perspective of the plan of AC is ad , and therefore EV_2 is the finder. On EV_2 erect a right-angled triangle of the same inclination as VC, and with the height V_2v' mark off V_3 perpendicularly above V_2 . Join aV_3 . To find the M. P. for V_3 , with centre V_3 and radius $v'E$, cut off M_3 perpendicularly below V_2 .

We will now show how to cut off any assigned length on an oblique line ac by the use of the M.P. Produce the perspective of the plan of ac , which is ad , to meet GL in l_1 . At l_1 erect a perpendicular to GL. Join M_3a and produce it to cut this perpendicular in p .

From p mark off on the perpendicular $p q$, equal to the assigned length,

which is Ac'' . Join $q M_3$ cutting $a V_3$ in c . As cd is vertical, this point can be checked by the ordinary method by erecting a perpendicular $2r$ at the point 2 , equal to $d'c'$, and joining 2 and r to M_2 , these lines will pass through d and c .

The above may be proved as follows:— $V_2 E$ is equal to $V_2 M_2$ and $V_2 v'$ to $V_2 V_3$ and $V_3 M_2$ is equal to $v' E$ and therefore to $V_3 M_2$ and the angle $V_3 M_2 M_3$ is equal to the angle $V_3 M_3 M_2$, and, therefore, M_3 would be the V. P. of a line in the same vertical plane as ac , and making the same angle with ac as it makes with a vertical line drawn through any point of its length. Hence $p q$ is equal in perspective to ac .

As this is not quite easy to understand, we can put it in another way.

We want an isosceles triangle, the sides of which are parallel to ac , and a perpendicular drawn at the point a . If we find the V. P. of its base or any line parallel to it, the base will cut off on the line ac a distance equal to that it cuts off on the perpendicular. Now produce ca to meet the perpendicular through l_1 in x . Then it is evident in xqc we have the required triangle, because the angle xqc equals the angle xcq , therefore, the side xq equals the side xc , and since $p M_3$ is perspectively parallel to $q M_2$, therefore $p q$ is equal ac . To show exactly how M_3 is obtained, let us consider a vertical plane through E parallel to the vertical plane containing xq and xc . This plane cuts the H. P. in EV_2 , and the finder will clearly be in this plane, so consider that while E remains fixed in the horizontal plane, the paper is turned round HL so as to represent the picture plane. The vertical plane, above mentioned, through Ev_2 , will cut the picture plane in a line perpendicular to HL through $V_2 V_3$, and the M. P. required will be in this line. If we take $V_3 M_3$ on this line equal to the real length of the line EV_2 , we will have an isosceles triangle $V_3 E M_3$ parallel to the one we require at x , and EM_3 will be the finder and M_3 the required measuring point. Now $V_3 M_2$ is equal to $v' E$, and, therefore, $V_3 M_2$ is equal to the real length of $V_2 E$, and so we can with centre V_3 and radius $V_3 M_2$ cut off the required point M_3 . We will now show how to draw a perspective without the aid of the plan.

Problem 263.—To draw the perspective of a box by means of points of measurement under the same conditions as given in Problem 259. Also to show a lid 2 feet high open at an angle of 30° . Scale $\frac{1}{100}$ (Plate XXXIX., Fig. 2).

Draw HL , GL , E and S and $V_1 V_2$ making 50° and 40° respectively

with the line of sight. The corner of the box is 20 feet to the left of the line of sight. So on GL take the point 1, 20 feet to the left. Join 1 S. Now the points will have two points of measurement, one on each side, and these points which are the points of measurement for all lines perpendicular to the picture plane are usually called Points of Distance and may be marked $DP_1 DP_2$. Then as the forward measurement from HL to A is 12 feet, lay off 12 feet along GL to one side of the point 1, obtain the point 2 and vanish to DP_2 . Then the point where $2DP_2$ and 1 S intersect gives a the perspective of A. Vanish from a to V_1 and V_2 . Then $a V_1$ and $a V_2$ are the indefinite perspectives of the sides of the box AB and AD. To cut off $a d$ we must use M_2 , because AD vanishes to V_2 . Through a draw $M_2 a 4$ and make 4 5 equal to AD. Vanish from 5 to M_2 cutting $a V_2$ in d .

In the same way, by using M_1 the point b is obtained, and the box can be completed in the same way as in Problem 259.

To obtain the lid of the box sloping at 30° we must obtain a V. P. for lines inclined at 30° . As $V_1 M_1$ is equal to $V_1 E$, to save further lines, draw at M_1 a line making 30° with HL, and cutting a perpendicular to HL through V_1 in V_3 . Then V_3 is the required V. P., and its M. P. may be got by using V_3 as centre, and with radius $V_3 M_1$ cutting off M_3 on $V_3 V_1$ produced.

Join V_3 with n and q . Produce these lines giving the indefinite perspective of the lower edges of the lid. To cut off the length NG draw M_3 through n cutting the perpendicular through 3 in x . Make $x y$ equal to NG and join $y M_3$ cutting $V_3 n$ produced in g . In the same way, the point e can be found. To find the point j we will find the V. P. an inconvenient distance off the paper, so we must think out some other method. Draw an auxiliary elevation of the box (*Fig. 3*), and from P' drop a perpendicular $P' Z'$ cutting the base of the box in Z' . On $a b$ by means of M_1 cut off a distance $a z$ equal to $A' Z'$. Then the perpendicular through z will contain p . On the perpendicular to GL through 3 make $3r$ equal to $P' Z'$ and vanish from r to V_1 . Then $r V_1$ will cut the perpendicular through z in p , and the other points in the lid can be obtained in the same manner.

PERSPECTIVE BY LOCAL SCALES OF MEASUREMENT.

This method is often of great value when a mass of details have to be

put in various planes parallel to but at various distances from the picture plane, such as the details of doors, windows, tracery, &c.

The method depends on Rule I.

“The picture of a straight line parallel to the picture plane is parallel to it, and bears the same proportion to its real length that the distance of the picture plane from the eye does to the FORWARD MEASUREMENT to the line.”

This method further enables us to draw the perspective without the aid of a plan which can be drawn if required on a separate piece of paper, and enables us to work on paper on which there is no room to obtain the station point or V. P. by actual measurement. The principles will be explained in the following problem in which the same box is drawn as before with the conditions slightly altered.

Problem 264.—To draw by local scales of measurement the perspective of a box $10' \times 15' \times 10'$ high, when its sides AB and AD make 40° and 50° with the picture plane. The nearest corner of the box A is in the picture plane, 20 feet to the left of the line of sight and 25 feet below the horizontal plane. On this box is placed a pyramid $10' \times 15' \times 20'$ high, and under the box is a rectangular block extending 5 feet beyond the box on all sides and 4 feet high. (Plate XXXIX, Fig. 4).

First draw in any convenient position a horizontal line to represent HL, and 25 feet below it and parallel to it draw GL. Scale $\frac{1}{100}$. Now draw a plan of the conditions carefully to a small scale, say $\frac{1}{4}$ of the given scale, putting in HL, ES, V_1 , V_2 , M_1 , M_2 . This can be done on another sheet of paper and is not shown here. Then transfer M_1 and M_2 on the full scale to our drawing, that is to say, they will be four times the distance from S on the full scale, as they are on the small scale.

On GL make a 20 feet to the left of the line of sight. At any convenient place on GL, say y , draw the scale of $\frac{1}{100}$ and vanish each division to S. Then this is the scale vanishing to nothing in the horizontal plane through a , and at any distance BACK TO FORWARD will give the diminished or enlarged scale due to that distance for the plane there parallel to the picture plane.

Now on the plan (Plate XXXVI., Fig. 4), drop perpendiculars BL, DU to HL and CG from C to a line drawn parallel to HL through D.

At a in (Plate XXXIX., Fig. 4) make $a1$ equal to 10 feet the length of AB and vanish from 1 to M_1 . Make $a2$ equal to AL and vanish from

2 to S. Then the intersection of these lines will give the point b . The point d may be obtained in exactly the same manner, making a 3 equal to 15 feet, a 4 equal to AU and vanishing to M_2 and S. To obtain c through d draw a line parallel to HL cutting the scale.

This will give us a proportional scale for all objects at d . Make d 6 on the LOCAL SCALE equal to 10 feet and d 5 equal to DG, also on the LOCAL SCALE, and vanish to M_1 and S obtaining the point c .

Now it is evident, and must be carefully borne in mind, that all measurements for any point, and consequently for the vertical plane containing that point, must be taken off the local scale obtained by running a line through the point, parallel to HL, to cut the scale. The height of 10 feet can now be set up at a , b , c , d , each being 10 feet on its own local scale, and the figure completed. To draw the pyramid, draw the diagonals bd and ac , and from their point of intersection j_1 , run a line to cut the scale parallel to HL. This will give the local scale for j_1 , and 30 feet must be measured perpendicularly to j_1 , to obtain j the apex of the pyramid.

To obtain the rectangular footing is a more difficult matter by local scales and would be much easier if the V. Ps. were available. In the plan (*Plate XXXVI., Fig. 4*) produce each side of the box to cut the edges of the footing in the points F, P, S, T, W, Y, X, K, and likewise produce perspectives of the edges of the bottom of the box. The perspective of each of these points can be obtained by cutting 5 feet off the perspectives of the edges of the bottom of the box produced. For instance, mark off $a7$ and $a8$ 5 feet on each side of a on GL. This will be the full scale, because the local scale at a is full scale, a being in the picture plane. Join M_17 and M_28 cutting the edges of the bottom of the box produced in p and f . In the same way, using the local scales, 5 feet can be cut off at each of the corners of the box, the points obtained joined up and the top of the footing drawn. The depth of the footing can now be put in at each corner on its local scale, and the perspective of the footing completed.

It should be noticed that z being in front of the picture plane, has a local scale larger than the full scale of the picture.

General.

We have now shown several methods of obtaining the perspective of an object, and it remains for the draftsman to decide as each case comes which

is the simplest method of procedure, which will give the squarest intersection and which will give the fewest lines.

It is obvious that though in questions, the object is given at one side or other of the line of sight, in nature the observer would certainly look straight at it. Hence, to obtain a natural view, E should always be in the vertical line through the centre of the object. The human eye can only take in about a maximum of 60° , hence the picture should be arranged to take in about 30° on each side of the central visual ray. If more is taken into the picture the perspective appears distorted and unnatural, as may be sometimes noticed in photographs of architectural subjects taken with a lens which has too wide an angle.

PERSPECTIVE AS APPLIED TO DRAWING FROM NATURE.

In making a drawing from nature, specially of a landscape, no measurements are possible, and, therefore, no accurate picture can be drawn by the rules of perspective. But the student will at once find the use of the general knowledge he has acquired of the way objects are correctly represented. In commencing his picture, he will at once locate his horizontal line HL across his paper, and will refer all he can to that. For example, suppose a large building is an object in his view. He will draw in its nearest vertical corner placed carefully above or below, or part above and below HL, and to scale, to the best of his ability, and for subsequent lines he will refer to this selected size and put them in in proportion to their distance.

He will then vanish away the two principal horizontal lines of one side of his building, guided by his knowledge that they must meet in HL, and this indeed may often be a useful check on the selection he has made for the position of HL. He will then remember that IIL once fixed, all other horizontal lines must vanish into it, and all those sloping upwards or downwards, above or below it, and so, as he constructs the outlines of his picture, he will find continual help if he remembers what he would do if he had the measurements, and tries to draw on the system, judging his points and scales to the best of his ability, and in all pictures containing architectural objects of any size he should not despise the use of the rule in getting in his outlines.

In figure-drawing even he will often find it the greatest assistance to imagine straight lines connecting the main points of the figure. The

back bone with the shoulders and thigh lines square to it. The legs in planes, through the hip joints and the arms similiary connected with the main planes. A sketch of this skeleton in perspective should be first made, and then the head and limbs built on. The body can be imagined by horizontal circles or ovals, and their main points sketched in—the oval of the chest, say, above HL,—and so drawn as it would appear so with the further points below the nearer, and the circle at the waist and oval at the hips perhaps the other way below HL. These would not be actually drawn perhaps; but in drawing, these points would be kept in mind as guides. A little attention will prevent the lamentably-twisted figures and objects, such as tables with one leg held up in the air, so common in amateur drawing, and in addition the knowledge of where all the lines should be drawn gives a wonderful confidence to the judgment in drawing by eye as it is called.

In any picture containing many figures the knowledge of the fact that if they were all on a horizontal plane, and of the same size, and HL ran through one man's chest or head say, so it must run through the chest or head of all the others, will be a great guide. Judging from this, allowance can be made rapidly for figures of different size, and they can be made to look different sizes from those on higher or lower ground.

Even in the little examples given in examination, say, a water jug, with the centre of its neck at the height of the eye, the knowledge of what the pictures of the circles, at any height on it will be cannot fail to be of great assistance.

So that, generally, if the Student acquires a clear understanding of his perspective, he will find it of the greatest assistance in his free-hand drawing.

TO FIND THE PERSPECTIVE OF ANY CURVE.

The method employed for finding the perspective representation of any given curve, is to find the perspectives of any number of points in its circumference, and to join these by means of a hand-drawn curve.

The only curve which we need however consider here, is the circle. This is the one most often met with in practice, and the method now made use of to determine its perspective is applicable in the most general manner to any curve whatever.

The perspective of a circle is a straight line if its plane passes through the station point. If its plane is parallel to the picture plane and its

centre at the same height as the eye, the perspective is a circle. In all other cases which occur in practice it is an ellipse. In general, the circle should be circumscribed by a square and the perspective of the square obtained. Draw the two diagonals of the square. If we obtain the perspectives of the four points of contact of the circle and the square, and of the four points in which the circle cuts the diagonals of the square, the curve can be drawn in by hand.

Problem 265.—To draw the perspective of two semi-circular arches of a road bridge. The width of roadway is 30 feet. The total height of masonry 40 feet, height to springing of arches 20 feet. Width of abutments 15 feet, width of arches 30 feet. The road makes 30° with the picture plane. The nearest corner is 20 feet to the right of the point of sight, and the ground plane 60 feet below the horizontal plane. Scale $\frac{1}{30}$. (Plate XL., Fig. 1).

Draw a plan and elevation from the conditions and find M the centre of an arch. In the elevation draw a line through P' parallel to the base to touch the top of the arches, cutting the sides of the openings prolonged in L' and G' . Join $M'L'$ and $M'G'$, and through K' and H' where these diagonals cut the arch, draw a second line parallel to the base. We now have five points of the curve $1', K', 2', H', 3'$ to obtain the perspective of.

The corner A being in the picture plane we obtain its perspective by dropping a perpendicular to GL cutting it in a . Vanish to V_1 and V_2 . On the perpendicular through a set up 40 feet the height of the masonry, obtain d and vanish to V_1, V_2 . The outline may be completed by drawing rays to E from every necessary point and where these rays cut HL , dropping perpendiculars to GL .

We will now consider the case of one arch, the other being worked in exactly the same way. On ad set off ar, aq, ap , equal to $A'R', A'Q', A'P'$ and vanish to V_2 , we thus obtain the perspectives of L', G' and M' . Join ml and mg , cutting qV_2 in k and h . We now have the points $1, k, 2, h, 3$, the perspectives of the five points mentioned above, and we can draw the necessary curve. To show the interior of the arch the point f is vanished to V_1 : the inner semi-circle does not come into this perspective view, but if it did, the points would be obtained in the same manner as above, by using the points on the further side of the plan.

SHADOWS IN PERSPECTIVE.

The direction and inclination of the parallel rays of light, given by the

plan and elevation of one of them, were sufficient data for determining the shadows in Chapter XV., but when the shadow of an object is required in perspective, the vanishing points of the parallel rays may be considered as the projection of the sun's centre, and is determined from the direction and inclination, or from the sun's azimuth and altitude, by the following construction (*Plate XL., Fig. 2*).

On the HL. make the angle $V_{\text{R}}zt$ equal to a the assumed or given azimuth, then a line through V_{R} , at right angles to HL, will be the vanishing line of vertical planes parallel to the rays. Make $V_{\text{R}}l$ equal to $V_{\text{R}}z$ and at l make θ equal to the altitude. The line ZV' then cuts the perpendicular in V'_{R} which will be the vanishing point required. If the station point be between the sun and the picture plane, V'_{R} will be below HL, and the shadow cast will be from the spectator. If the picture plane be between the spectator and the sun, then V'_{R} will be above HL, and the shadow will be cast towards the spectator.

Now the shadow of any point on any plane M must lie in the intersection with M of any plane N containing the ray of light which casts the shadow, it is, therefore, clear that by drawing a line through the point, and another parallel to it through the source of light, wherever, it may be, the shadow of the point will lie in the intersection of the plane containing those two parallels with that receiving the shadow. By assuming these parallel lines also parallel to the picture plane the construction is simplified, and when the plane receiving the shadow is horizontal or perpendicular to the picture plane and the shadow is cast by the sun, as in the present case, V_{R} will be the intersection with that plane of the perpendicular from the sun, since V_{R} is at an indefinite distance in the HP. as the foot of the perpendicular from the sun must be. Now turn to *Plate XL., Fig. 3*, which represents the perspective of a flight of steps. If the corner AB be taken as a general example of any vertical line standing on a horizontal plane, and V_{R} is the V. P. of the plan of the ray, and V'_{R} that of the ray itself, the picture of the ray from A will be AV'_{R} , and BV_{R} will be the picture of the intersection of a vertical plane through the ray with the plane on which B stands, or the shadow cast on the plane by AB. Hence the portion BS to the meeting of the two lines will be the shadow of the line AB on the plane through B, and S will be the shadow of A on that plane.

The shadow of any other point, as, for example, of C, can be found in the same way CV'_{R} and DV_{R} intersecting give it at S' ,

But we know that the shadow of the horizontal line AE on a horizontal plane must be parallel to AE , hence its picture will vanish to V' , the V.P. of AE , and $V'S$ produced to meet the picture of the ray from E , or EV'_R will be the picture of ΔE .

The picture of the upright line EF will vanish to V_R , just as that of AB and CD did, and so can be drawn to meet the ray from F , or the shadow of GF can be drawn, which contains it, and so on down to the bottom.

The shadow of the back line of the steps through A will be parallel to the line itself, and so will vanish from S to V , and thus the shadow on the ground is complete.

This was all on one plane, but the same procedure will give us the other shadow on the several steps. Thus the shadow of K on the plane of the second step from the top will be at N , where KV'_R and MV_R meet and the shadow of KP or part KO through it will vanish to V' . Where this cuts the bottom of the rise will give the limit of the possible shadow, which must be joined with K .

Similarly for the next step. The shadow of point P on its plane is at Q and the same process gives the actual shadow on the step: and similarly for the fourth step, the shadow on its plane is at U , and $V'U$ gives the shadow on the step shown dotted in part, because it takes a longer line than KO to throw it.

Commencing from the bottom, the shadow of RO goes to V_R , till it meets the vertical rise on which it is vertical, on next step again it goes to V_R , and so on, till it meets with the shadow brought down from the top in the picture of the ray from O to OV'_R .

In the above example, the shadows were on all horizontal or vertical planes. Now let us take a case, *Fig. 4* where the shadow of the walls $ABCD$, $ABRN$, falls on the roofs and walls of two houses, of which a portion is shown. Let V_R , V'_R be the V.P.'s of the ray, V , V' those of the houses, and V_w , V'_w those of the walls.

Then we should first find the point E on the corner AB at the same height as the eaves of the house. Then AV'_R and EV_R give S , the shadow of A on the horizontal plane at eave level, and FGK is the section of the half roof made by the vertical plane through the ray. Hence the intersection of AS and FK gives P , the shadow of A on the roof, and PF is the shadow of part of AB , *i.e.*, AE on the roof, the rest being evidently FLB on the wall and ground.

The shadow of AD , the top of the wall, will be parallel to AD , hence

$V'_w SM$ gives its picture on the cave plane, and PM will be the shadow on the roof.

To find it on the wall we must find it on the ground. Thus DV'_r and CV_r give O , the shadow of D on the ground, and $V'_w OQ$ will be the picture, and produced beyond Q will give it on the ground, while MQ will be the shadow on the wall.

The shadow on the second sloping roof shown in the example will be found in the same way. The student should note that all shadows cast by vertical lines on roofs of the same slope will be parallel and, therefore, will vanish to the same point, as this will often assist him in getting in the shadows.

We will now draw as a final example a School house.

Problem 266.—The plan and elevation of a school house are given on a scale of $\frac{1}{100}$. Draw the perspective view on a scale of 6 feet to 1 inch when the distance of the picture is 48 feet. The height of HL above GL is 7 feet, and the nearest corner A is in the picture plane. The side AM is inclined at 35° to the HL . Also give the shadows on the ground and building, taking V_r and V'_r as the V.P.'s of the ray. (Plate XLI., Fig 1).

Draw HL and fix S and set off $ES = 48$ on the scale of 6 feet to 1 inch, and find the vanishing and measuring points V_1, V_2, M_1, M_2 . Then lightly sketch in an outline plan of the building, on the 6 feet to inch scale, with the near corner at S , and laying the ruler from E to its several corners, lightly mark the intersections of the visual rays with HL . The upright corners of the house will then be in perpendiculars to HL through these points, and we have them very accurately, so that all work afterwards, being between them, cannot be far out.

We then set off 7 feet down from S , and 5 feet above S , for the bottom and top of the wall, and 12 feet above S for the gable top, and vanishing off the lines to V_1 and V_2 from these points, we get the three corners of the two gables on the verticals already put in, and from these again vanishing inwards the ridges and eaves of the masonry of the building. We should lightly mark in the meeting of the ridges on the plan, and run the visual ray down to E to check the meeting found in the picture, and now we have the main outline correct, and our working in of the details *inside* the various parts of this cannot be far out.

Another method would be to use GL . Then, as the two corners of the left-hand gable are 16 and 29 from A , we should set off these

distances on GL to the left of α , and from them vanish to V_2 cutting αV_1 in the points required for the corners of the gable on the ground, at which points perpendiculars can be set up. Similarly, a point on the GL $22\frac{1}{2}$ feet from α , or halfway between the two other points, will give the ridge of the gable, and the proper heights can be cut off the perpendiculars at these three points as before. Similarly, the other gable, or any other point required, can be put in.

The next part to get in will be the roof, and this had better be drawn in exactly the same way as the masonry already drawn, that is, we put in the corners of the roof in the plan, and bring down the visual rays and put in the verticals containing the corners.

To obtain the height on these verticals. The intersection of the ridge ones with the picture of ridge already obtained will give the ridge points, and in many small examples, it would be sufficient to draw the edges parallel to those of the masonry, but as they are not parallel in the picture as the pairs approach or recede from the picture plane, they must be put in correctly. The simplest way is to produce the plan lines of the roof edges of the two gables to the picture plane, and at these points set up the full height 4 feet above HL and vanish to V_1 and V_2 . The inward lines of the other two faces can then be vanished to meet in the re-entering corner.

All the details can now be filled in either from the plan or points of measurement.

The belfry can be put in best from the plan, in the manner shown for the roof, by putting in the verticals by the visual rays, and then producing the plan lines to the picture plane and setting up dimensions on full scale for heights, but it can also be done by the use of local scales.

Frist, to secure the position of the whole belfry on the house already drawn, we should bring down the vertical line of the nearest corner of the nearest post from the plan and set it up on the eave line of the masonry in the picture at c , we must drop a line from c to the ground under it, on which the vanishing scale is drawn, and from this point run a line parallel to HL across to our vanishing scale, on which it will be the scale for the point c , and all the details can be put in exactly as in the case of the main building. The details are shown on the plate, but it would be tedious to describe them over again.

The shadows cast on the building and ground have been shown taking the rays as vanishing to $V_R F'_R$. The working is exactly as shown for

the steps and house, but the lines of construction are not given to avoid confusion. The Student can work the case out and check by the figure. This example also can be varied infinitely by changing the positions of V_N , V'_R .

EXERCISES.

NOTE.—In all cases where exact conditions are not given, the eye is to be 12 feet by scale distant from the picture plane and 5 feet above the ground line.

1. A circle, 8 feet radius, touches the picture plane 1 foot to the left of the spectator. A hexagonal pyramid (edges of base 2 feet, height 6 feet) stands in the centre of this circle. Two sides are perpendicular to the picture plane. Scale $\frac{1}{4}$.

2. Two square prisms stand on the G.P. The axis and two faces of each prism are in vertical planes receding to the right at an angle of 35° . The prisms are 6 feet high and each side of base 2 feet. They are 6 feet apart. The nearest point of the nearer solid on the G.P. is 1 foot to left and 3 feet within the P.P.

Resting on these and projecting 1 foot at either end is a third prism 12 feet long, whose base is a square, each side 2 feet. Its axis lies in the same plane as that of the other prisms. Scale $\frac{1}{6}$.

3. Draw the perspective of the structure of which a sketch plan and elevation are furnished under the following conditions:—The side A to be nearest the picture plane, and inclined at an angle of 35° to it. The point A to be 10 feet to the left of a perpendicular drawn from the point of sight to the picture plane. The station point to be 30 feet from the picture plane, and 5 feet above the ground. Scale $\frac{1}{2}$.

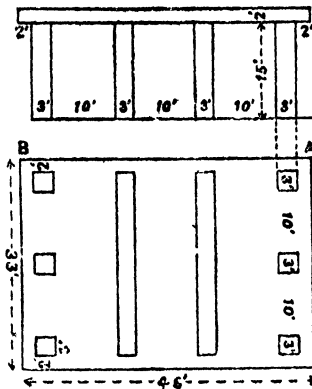

4. A pentagonal prism (edge of base 3 feet, height 2 feet) has the plane of its base vertical and inclined to the picture plane at 30° . Draw its perspective projection. Scale $\frac{1}{2}$.

5. Draw the perspective of a church shown in the accompanying plan and elevation. The point of sight is 80 feet from the picture plane and 25 feet above the ground plane. The nearest corner of the porch is in the picture plane, 20 feet to the right of the line of sight, and the wall containing the porch door makes 30° with the picture plane. Scale $\frac{1}{4}$.

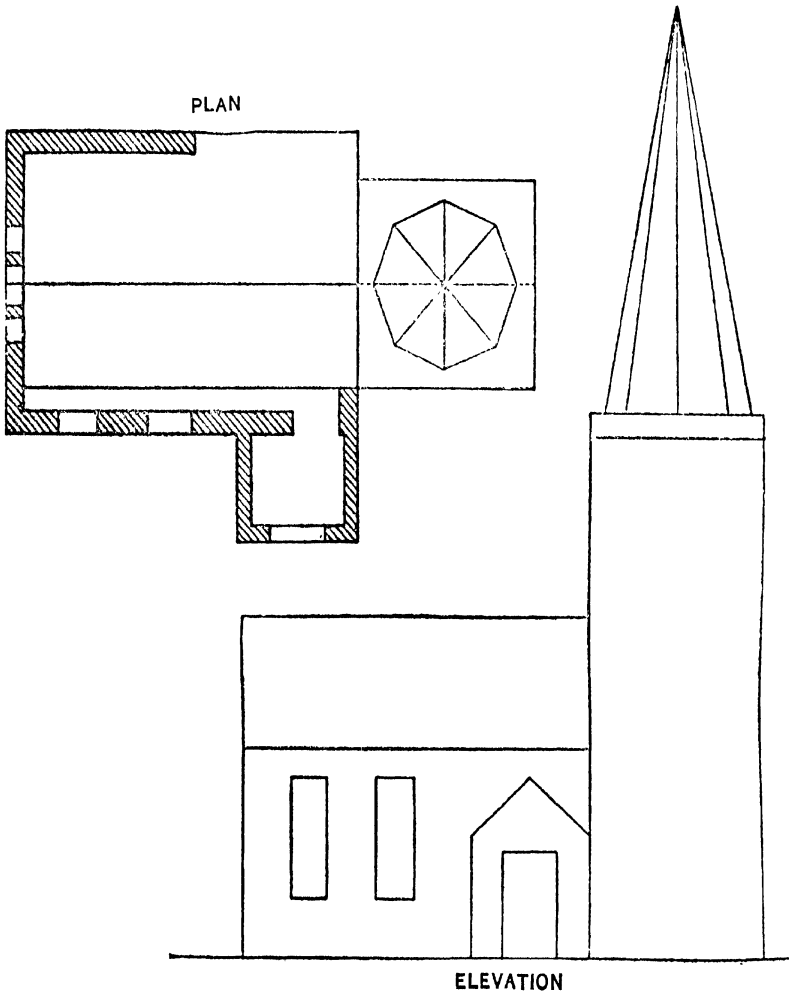

I N D E X .

PART II.

- C**entral Visual Ray, 205.
Contours, application to delineation of ground, 145.
Curve, perspective of, 221.
- D**efinition of terms used in Perspective, 202.
Delineation of ground by contours, 145.
Development of solids, 172.
- E**laboration of Shading and Shadows, 193.
- F**lat tints, shading by, 191.
- G**round Plane, 205.
———Line, 205.
- H**elix, 176
- I**nterpenetration of Solids of Revolution and Curved Surfaces, 166.
- L**ines and Planes, further problems, 148.
- O**blique Lines, Vanishing Points, 213.
- P**erspective by Local scales of measurement, 217.
———Measurement, 205.
———Orthographic Projection, 201.
———Points of measurement, 214.
———Vanishing Points, 209.
- S**hade Lines, 197.
Shading, 188.
Shading by Flat Tints, 191.
———softened Tints, 193.
Shadows in Perspective, 222.
———and Shading, 179.
- T**angent planes, 163.
- V**anishing Points of Oblique Lines, 213.
———beyond the paper, 214.

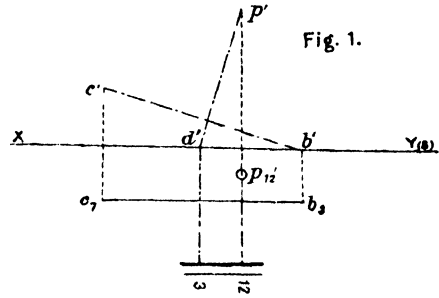

Fig. 4.

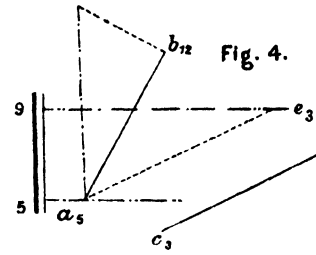

Fig. 5.

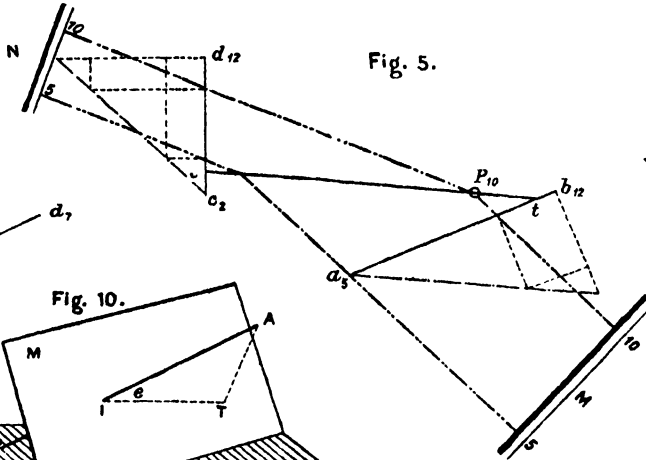

Fig. 6.

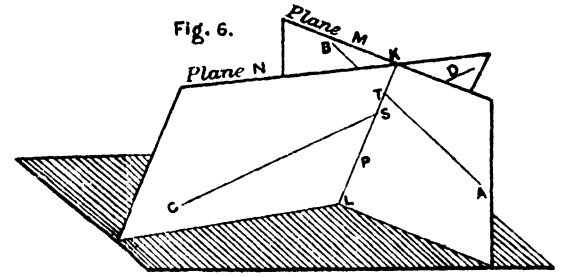

Fig. 2.

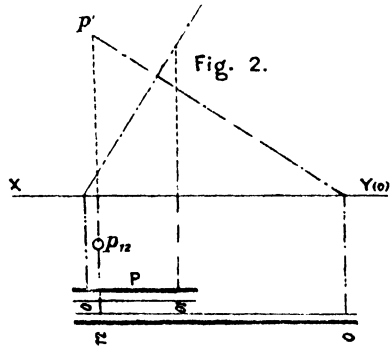

Fig. 3.

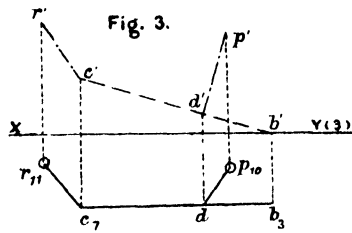

Fig. 10.

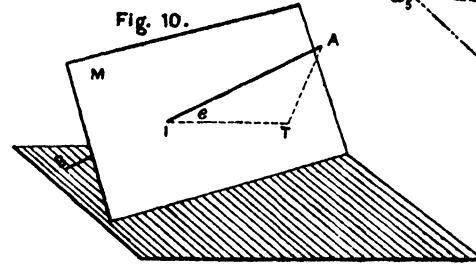

Fig. 12.

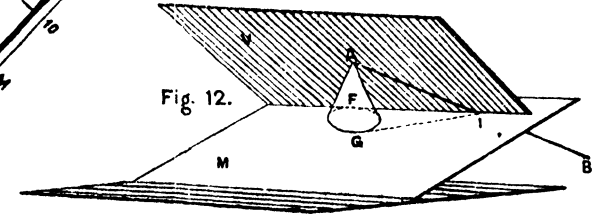

Fig. 9.

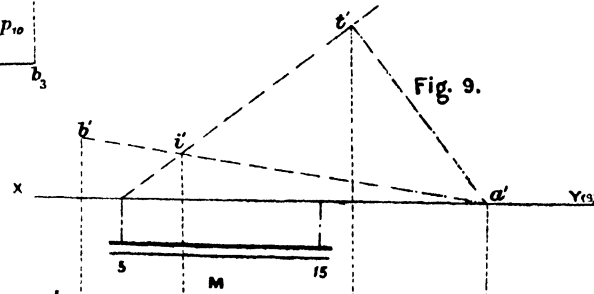

Fig. 7.

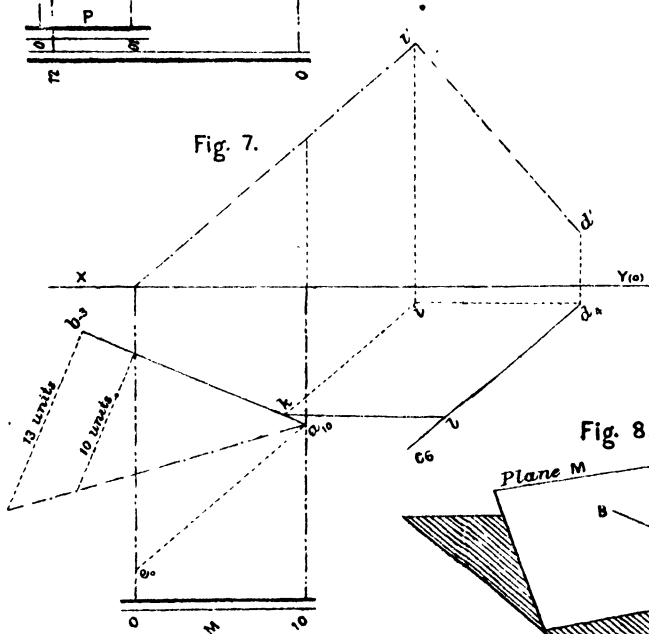

Fig. 8.

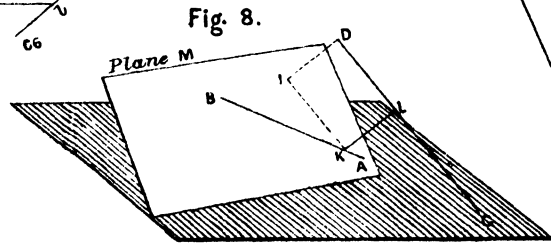
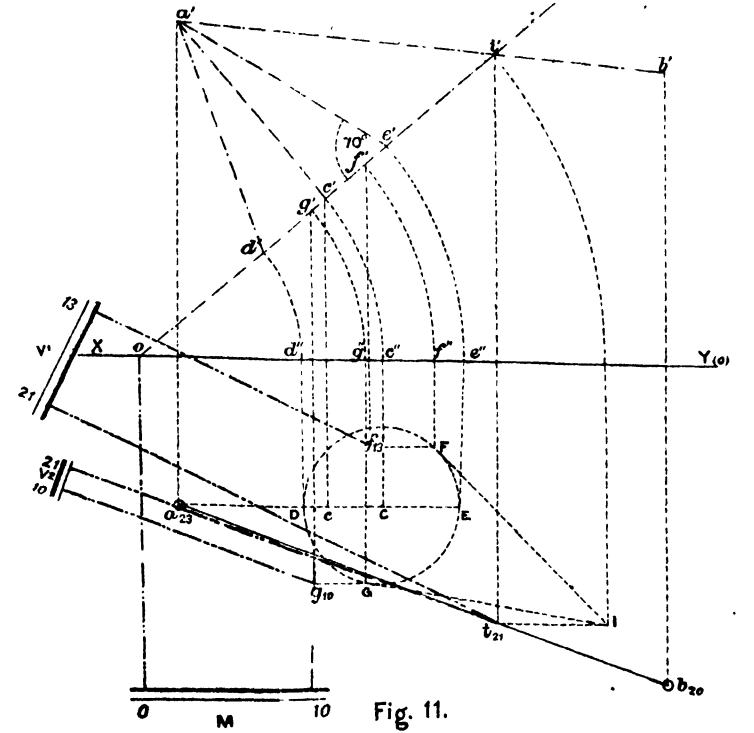

Fig. 11.



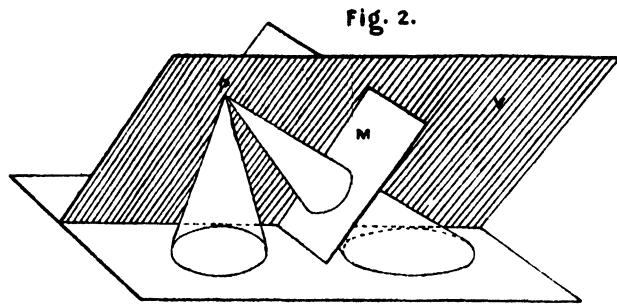

Fig. 2.

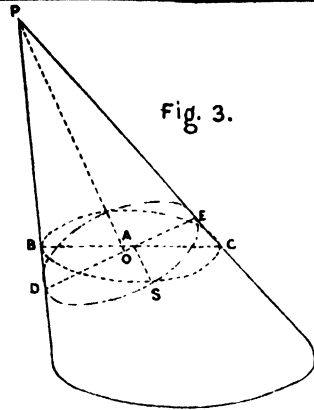

Fig. 3.

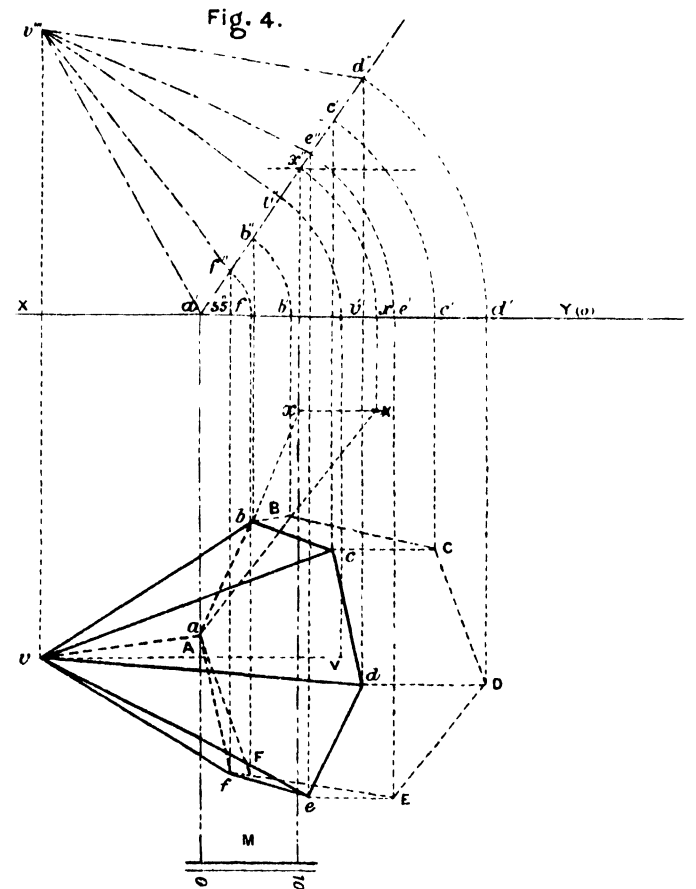

Fig. 4.

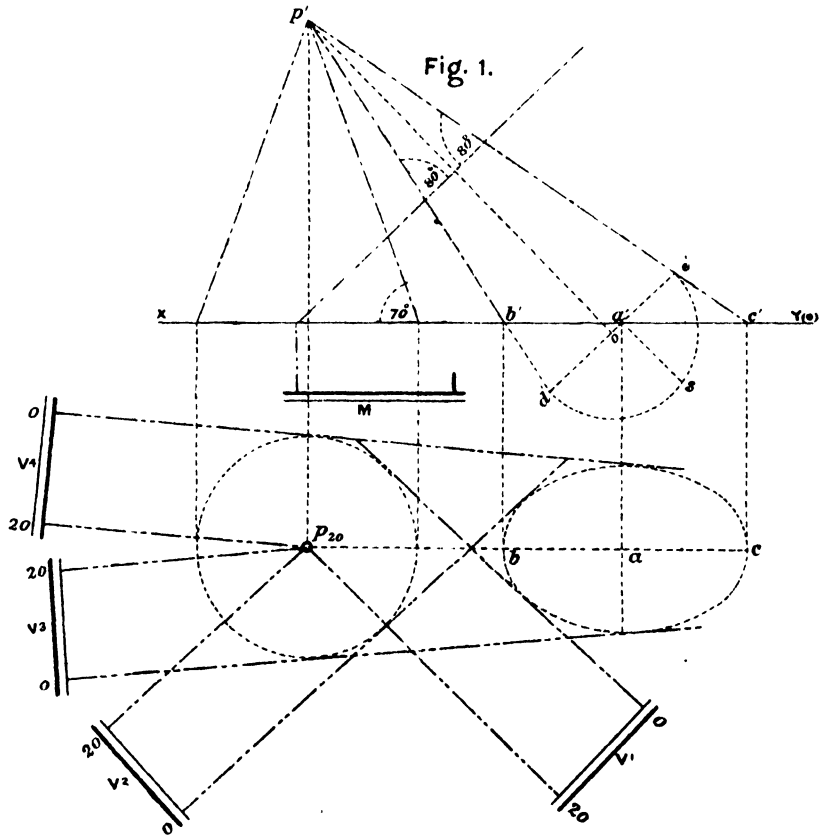

Fig. 1.

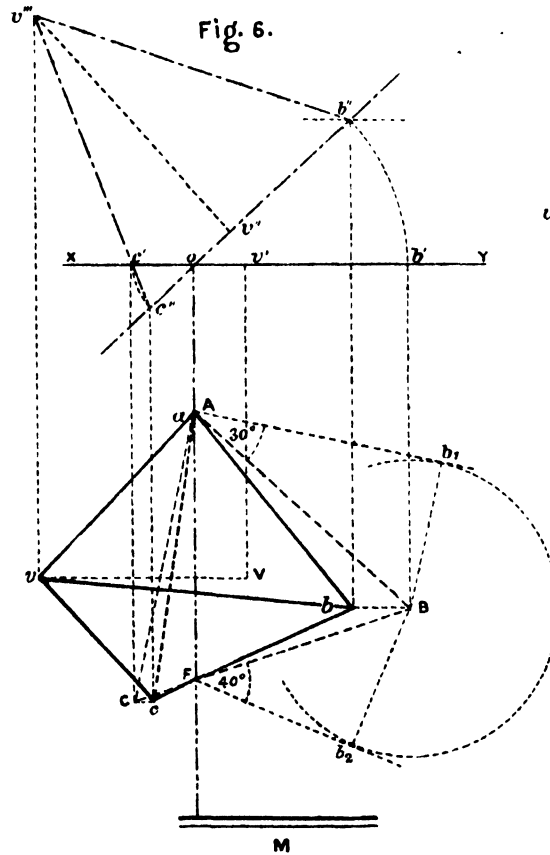

Fig. 6.

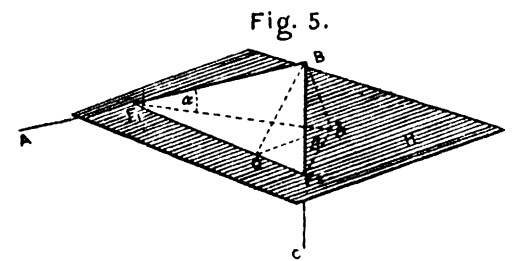

Fig. 5.

Fig. 1.

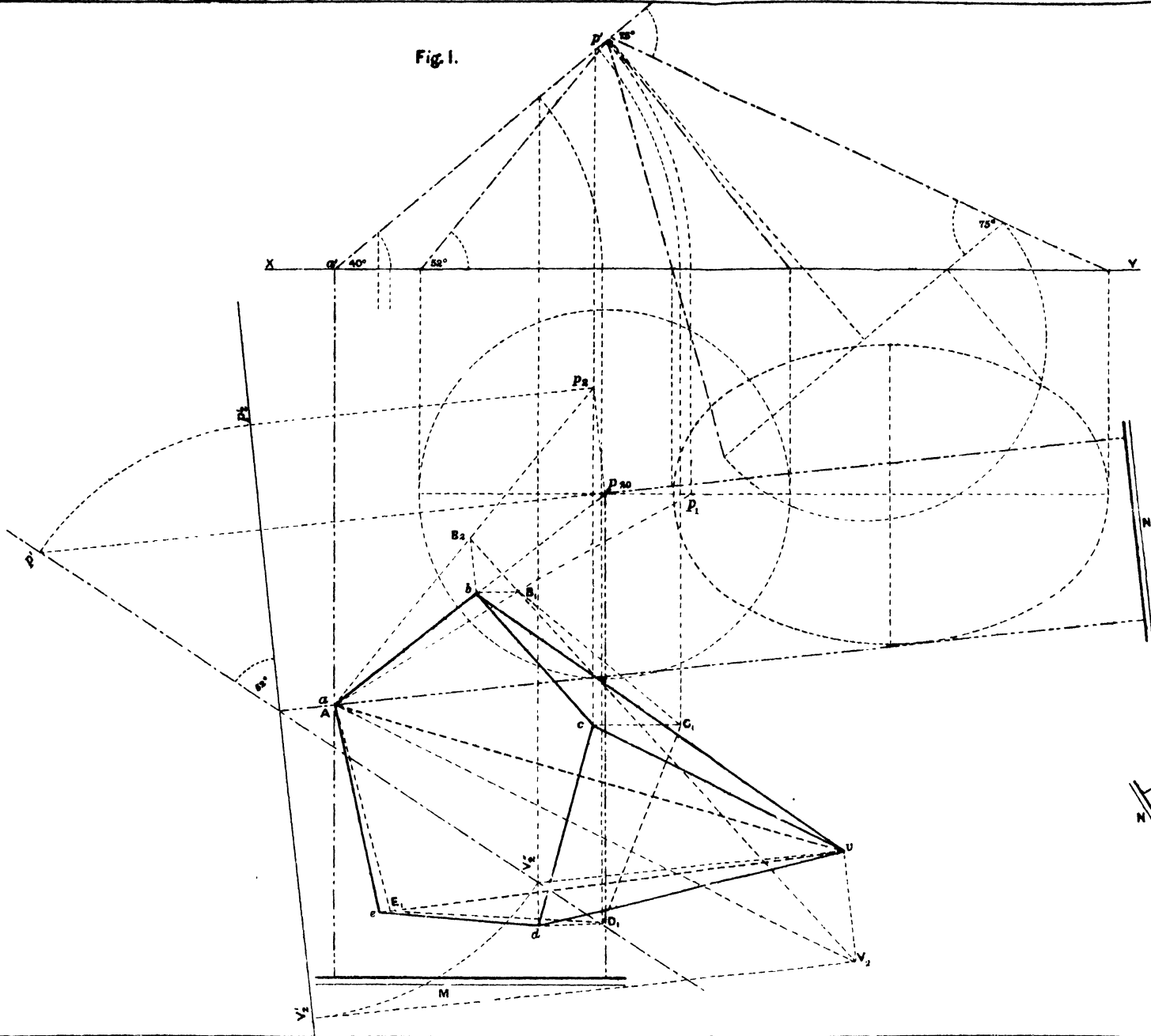

Fig. 2.

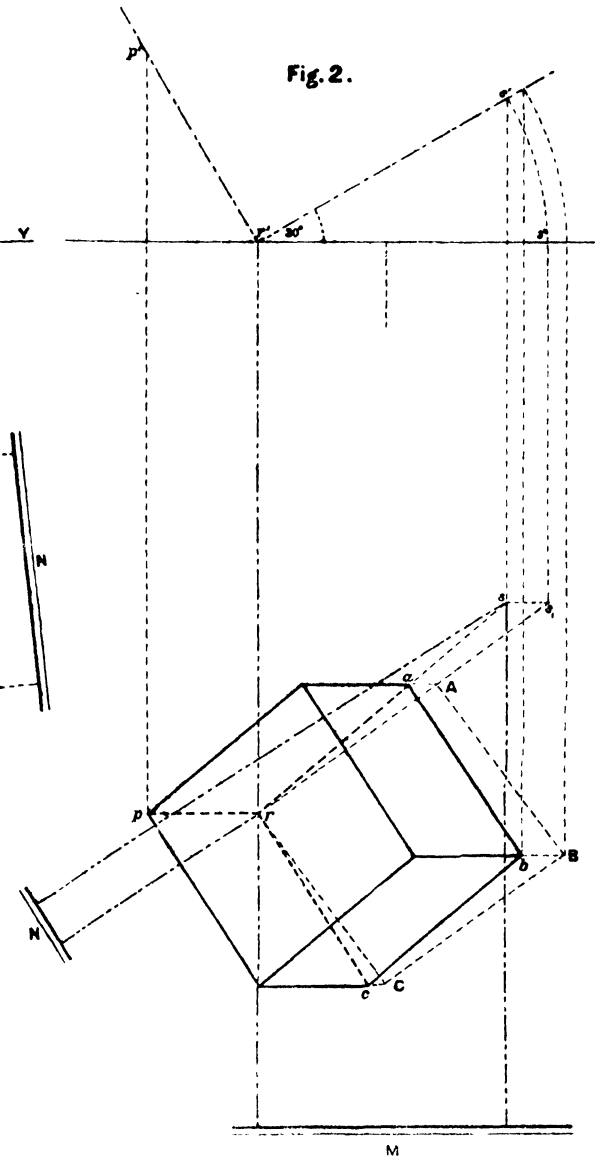

Fig. 1.

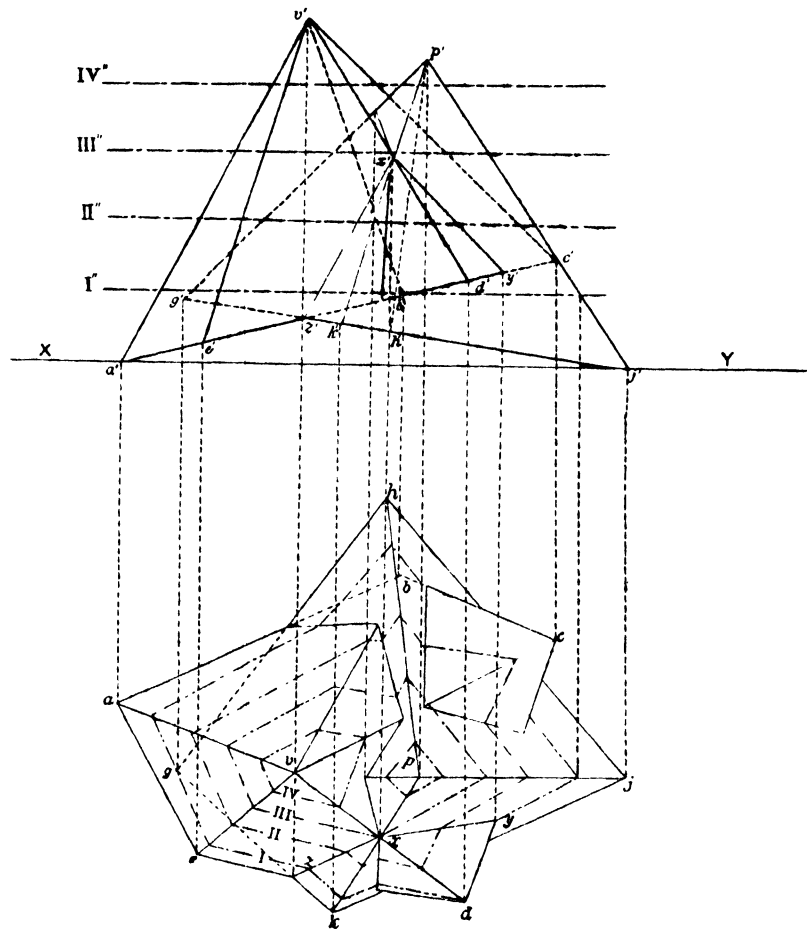

Fig. 2.

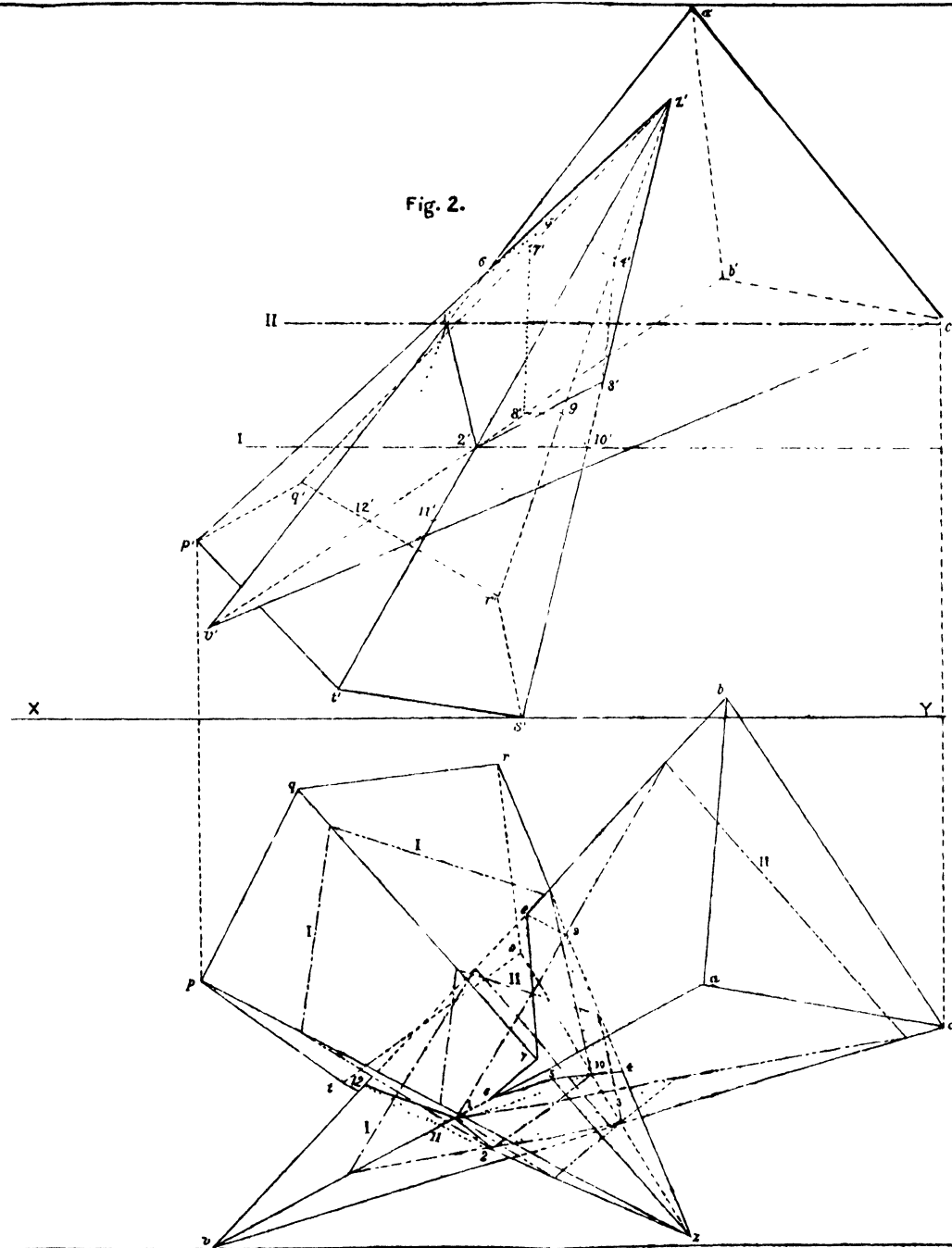

Fig. 1.

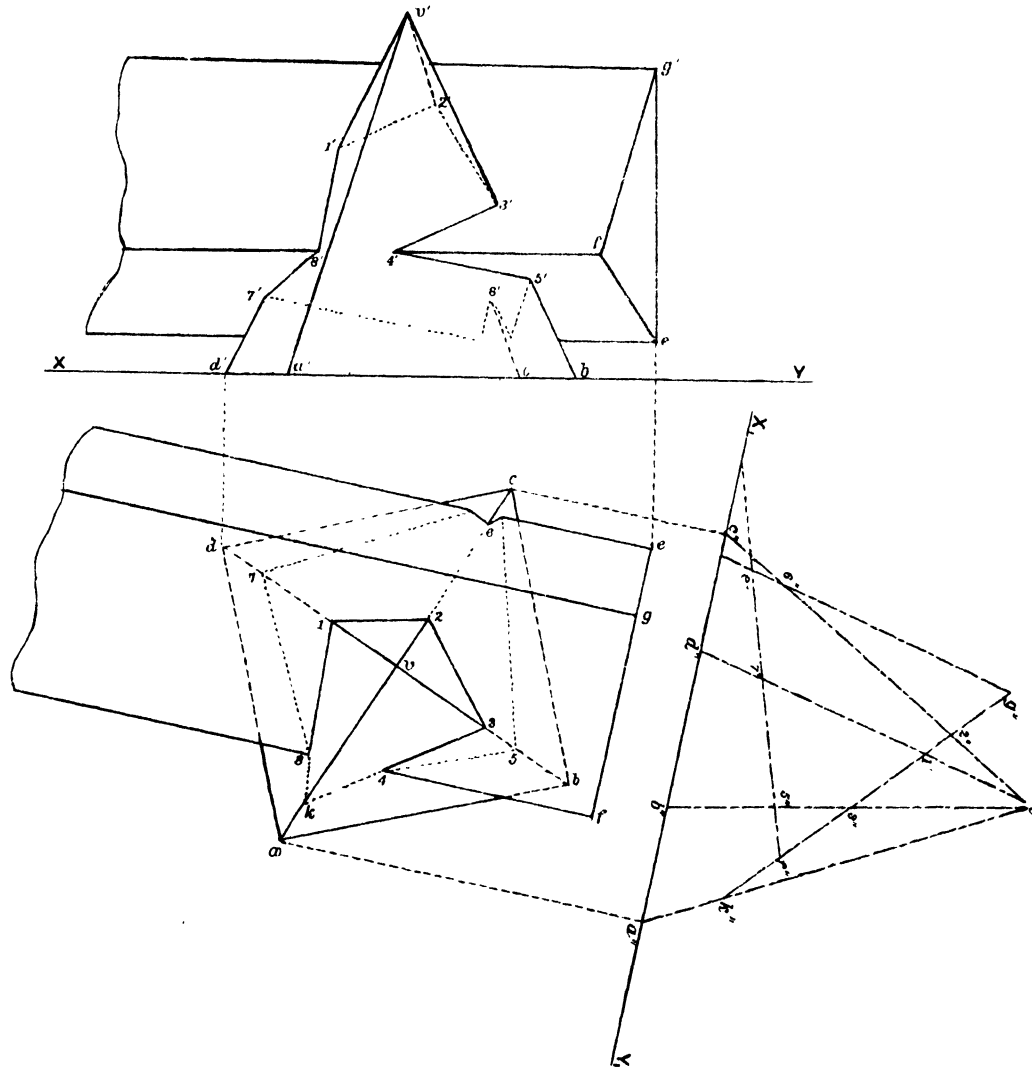

Fig. 2.

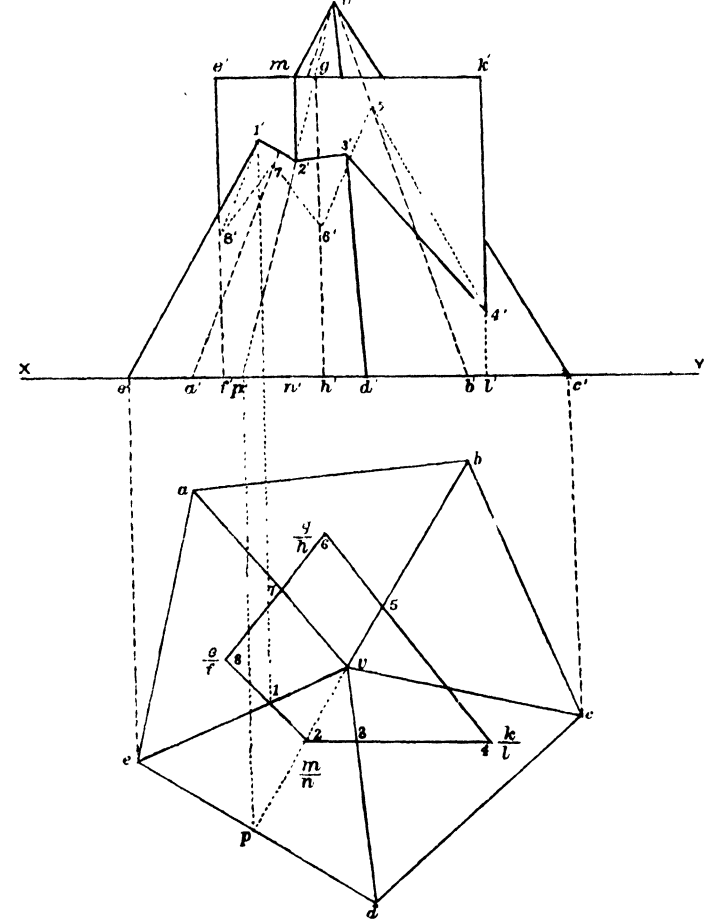

Fig. 1.

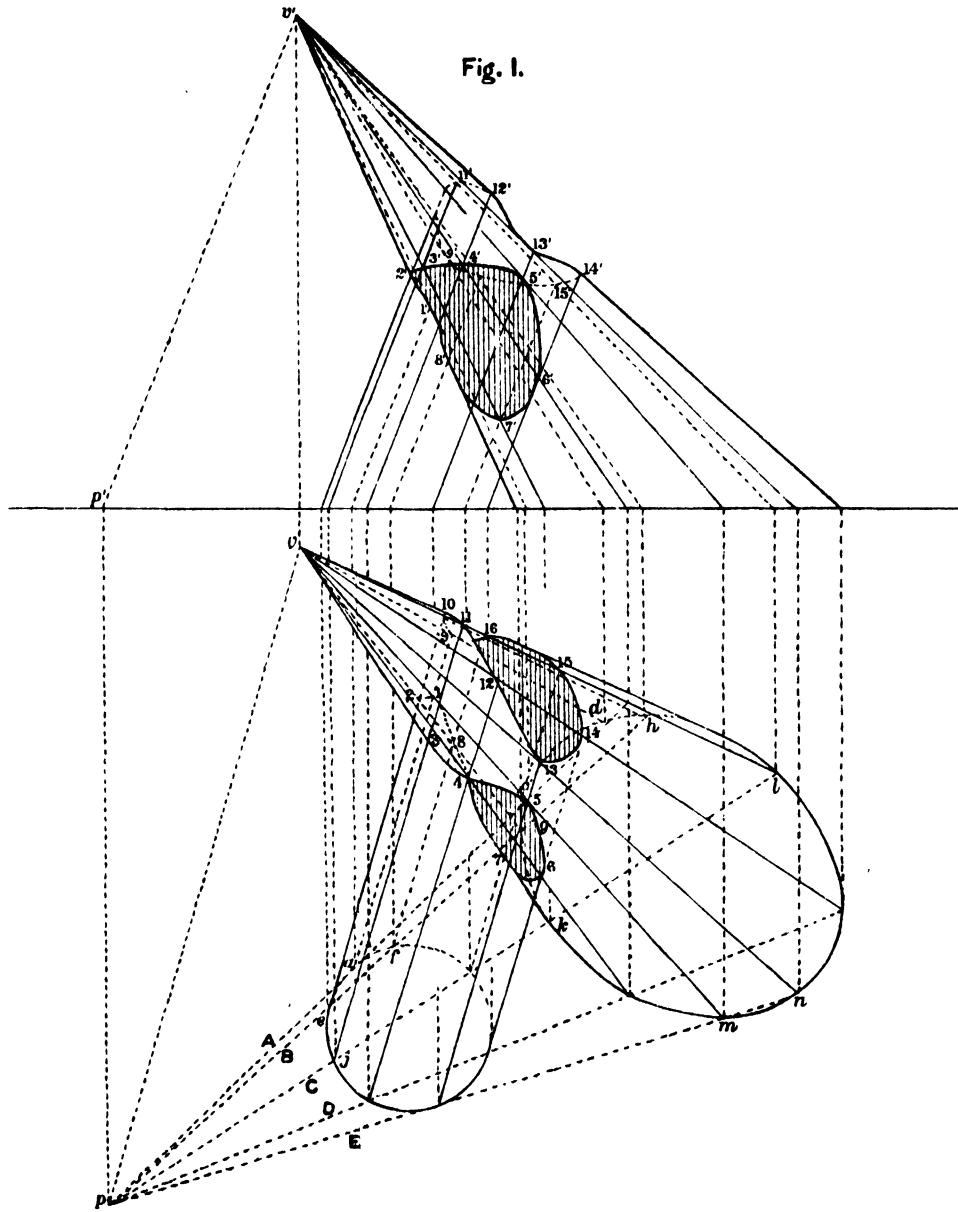

Fig. 2.

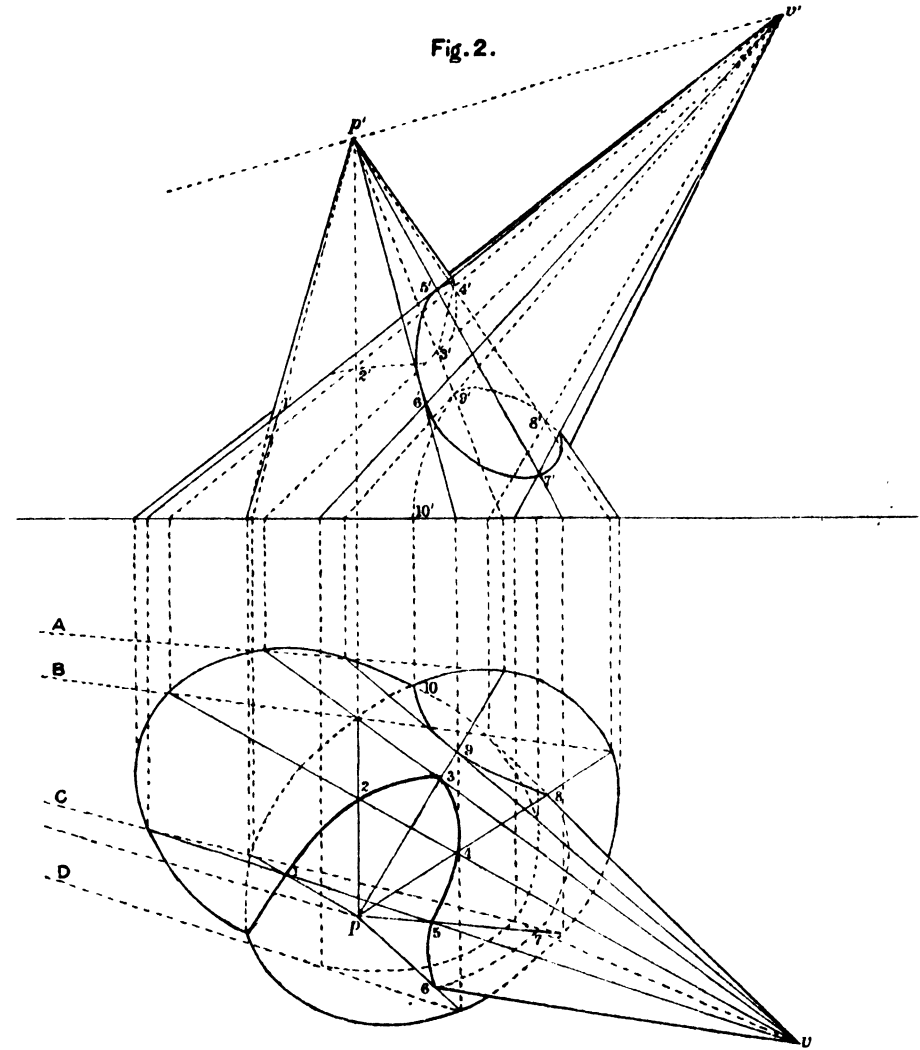

Fig. 7.

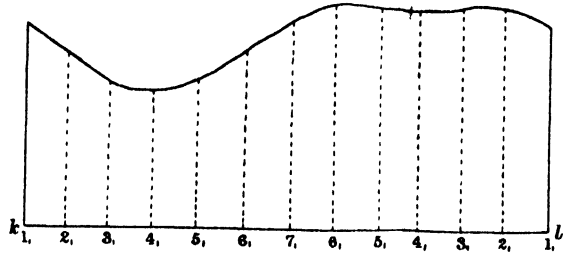

Fig. 5.

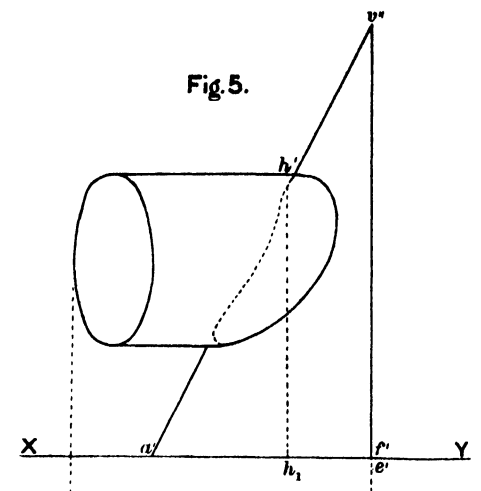

Fig. 6.

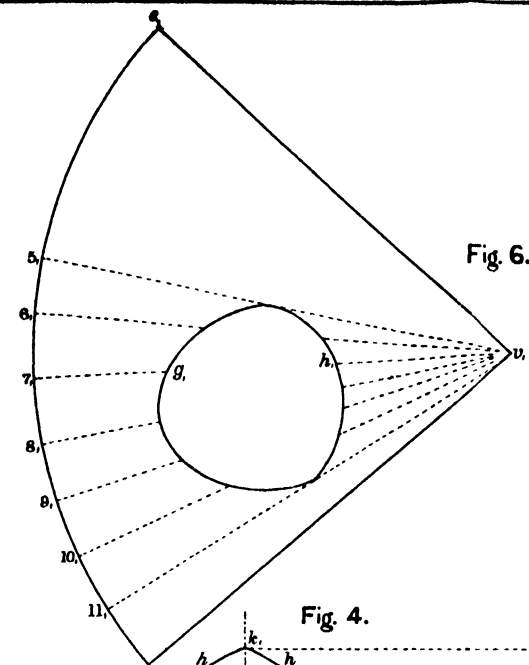

Fig. 1.

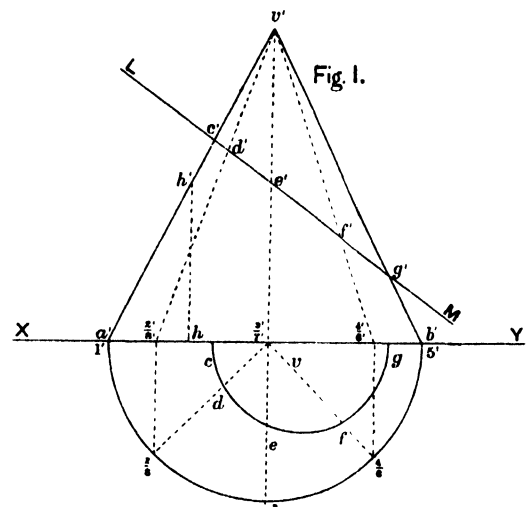

Fig. 4.

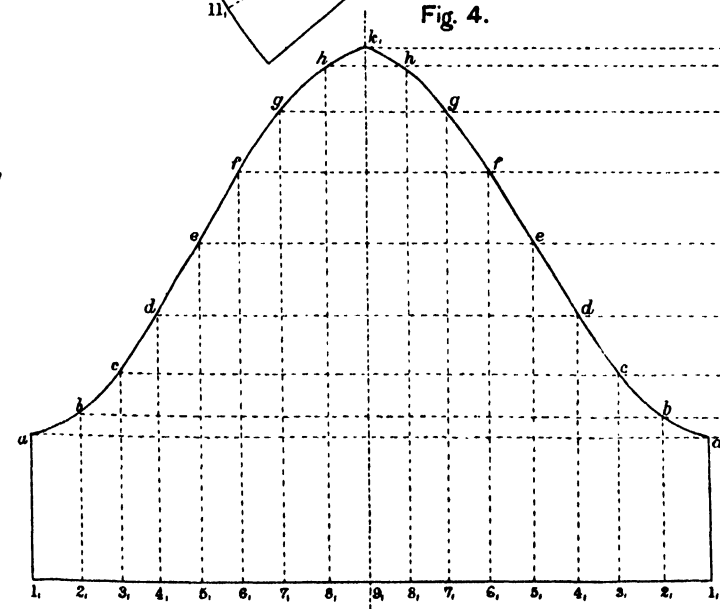

Fig. 3.

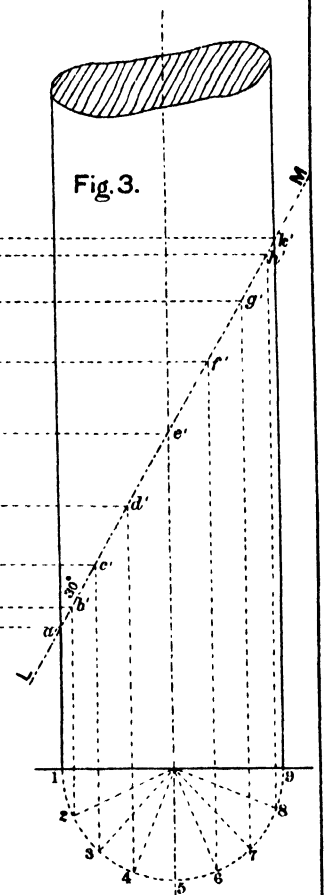
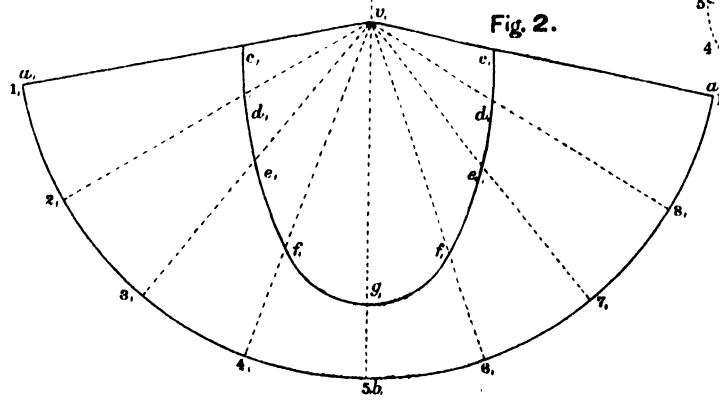

Fig. 2.



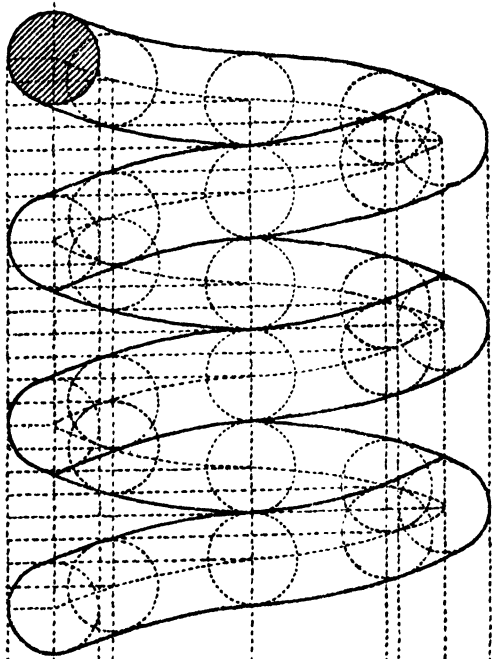

Fig. 2.

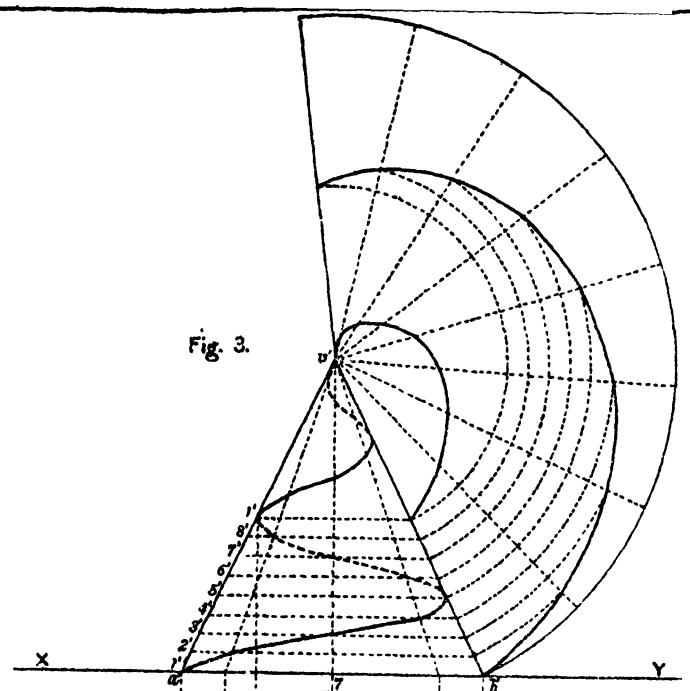
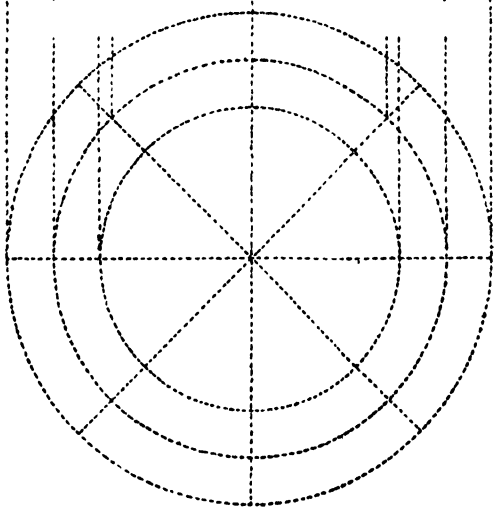

Fig. 3.

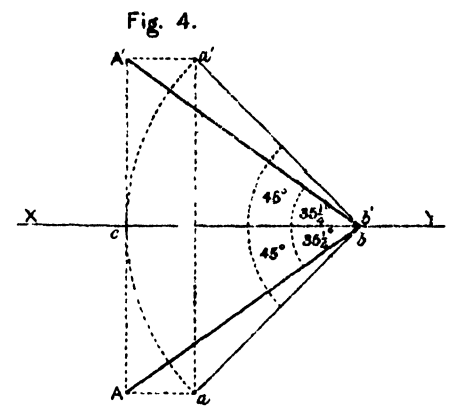

Fig. 4.

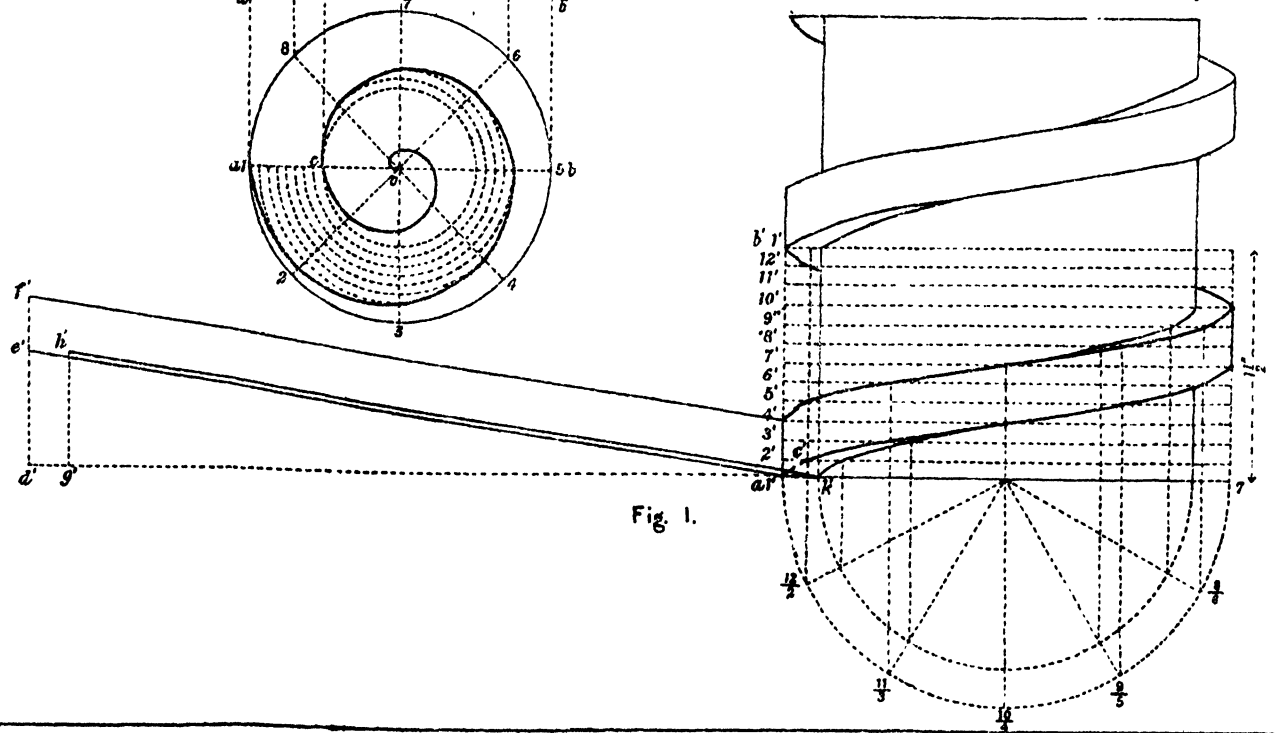

Fig. 1.

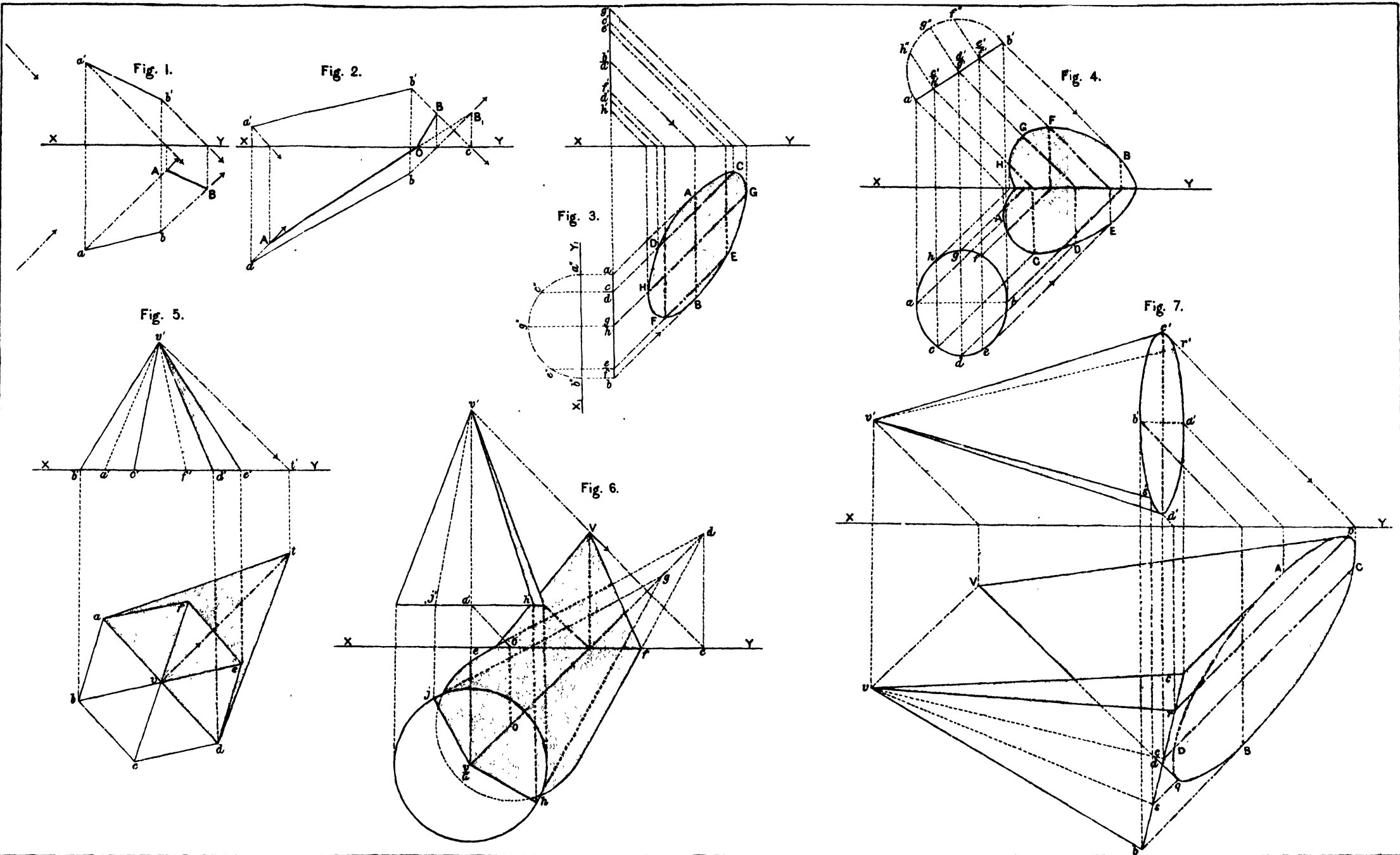

Fig. 3.

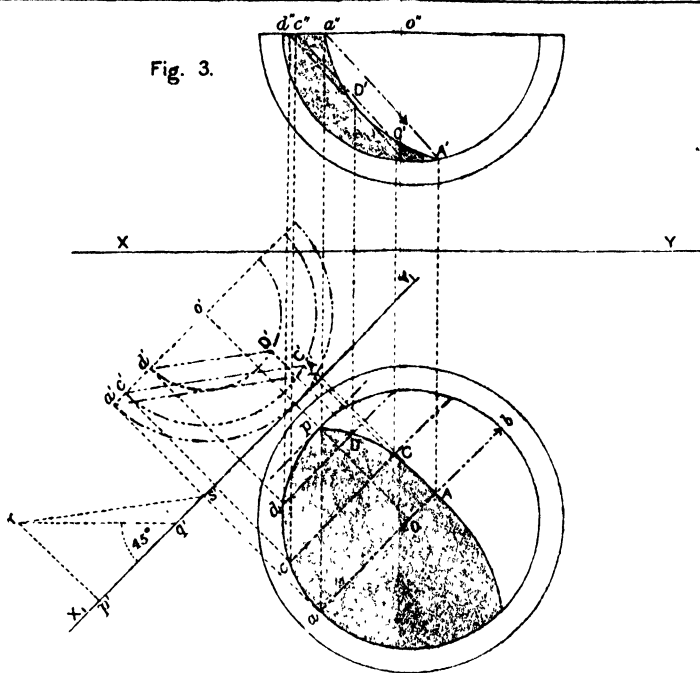

Fig. 4.

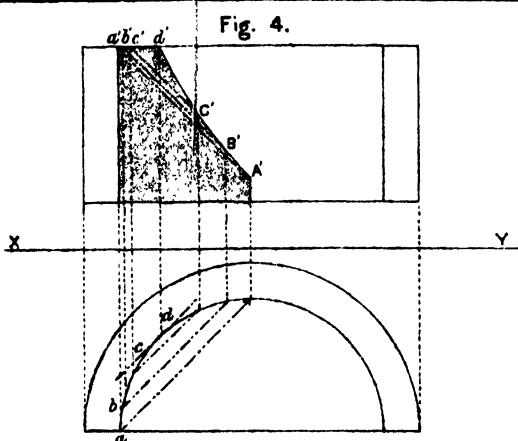

Fig. 5.

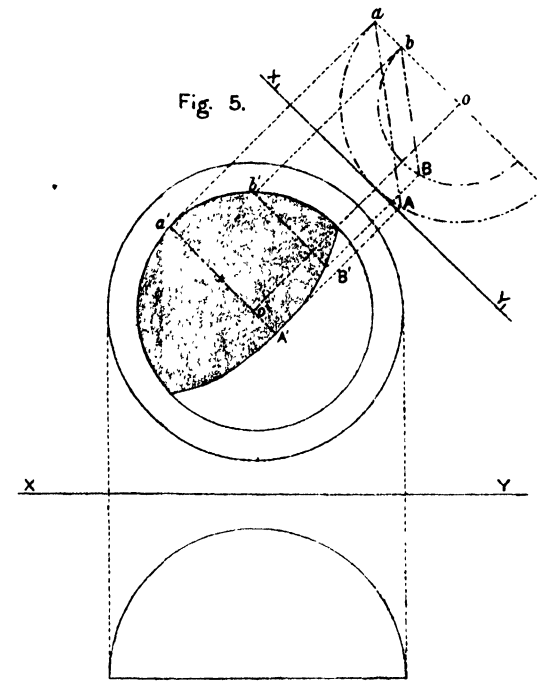

Fig. 6.

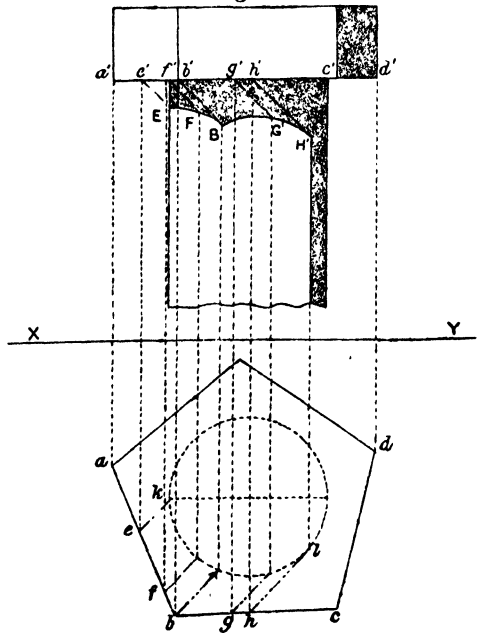

Fig. 2.

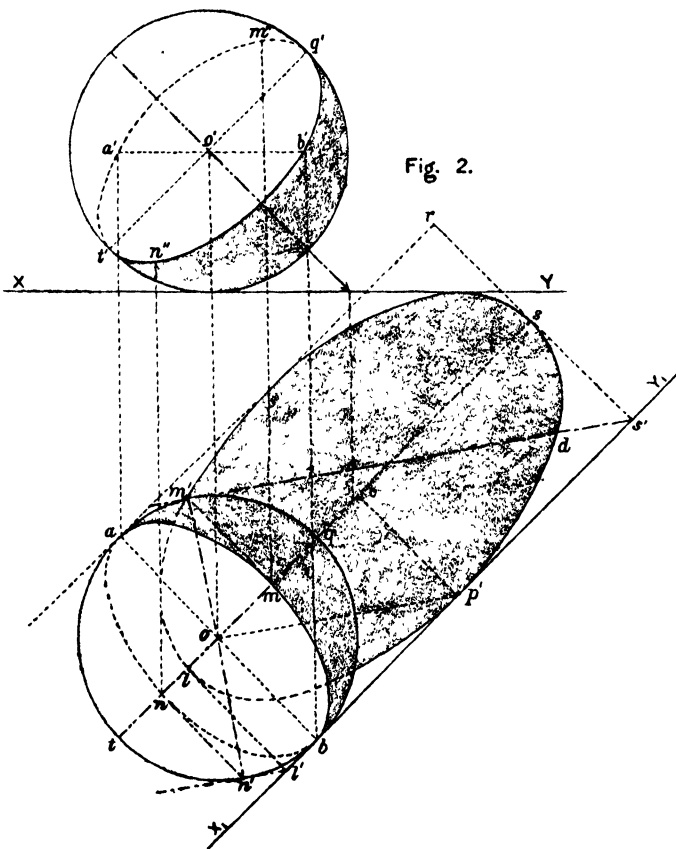
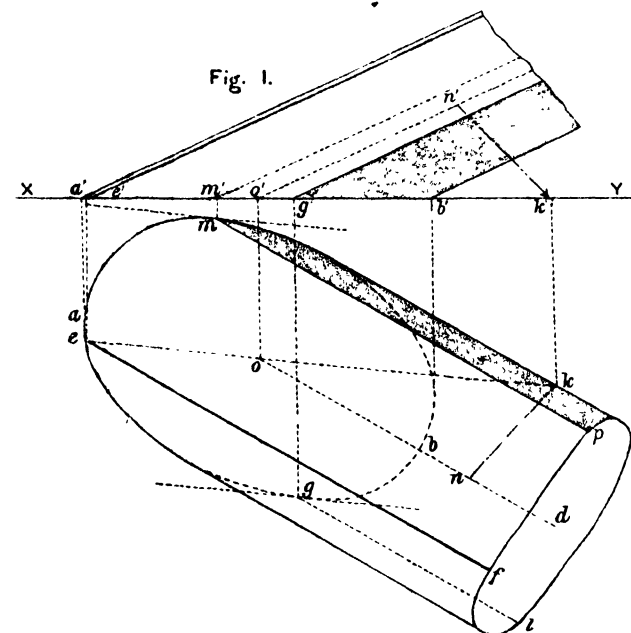

Fig. 1.



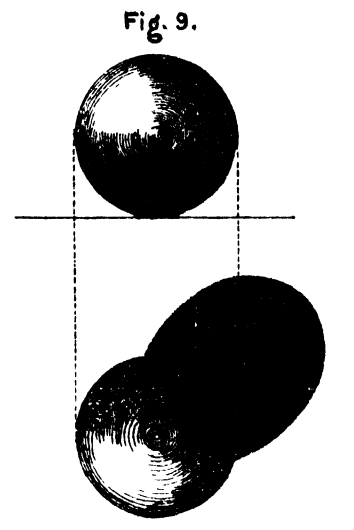
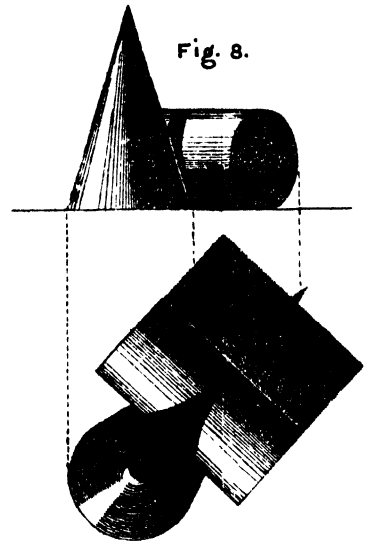
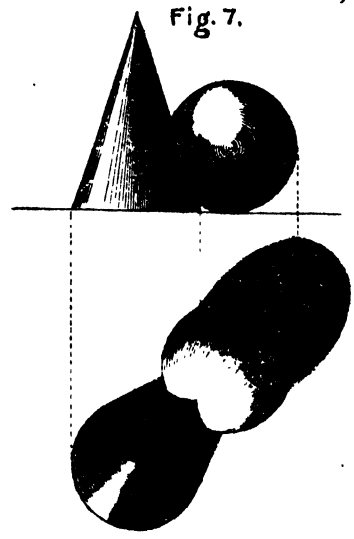
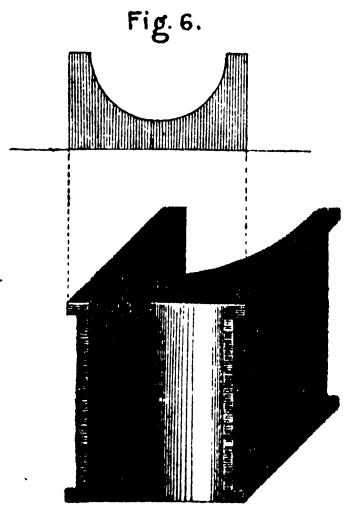
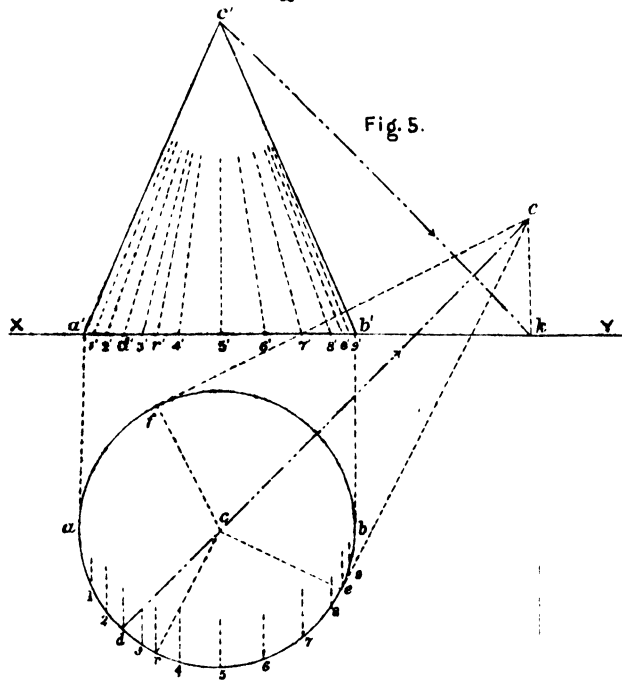
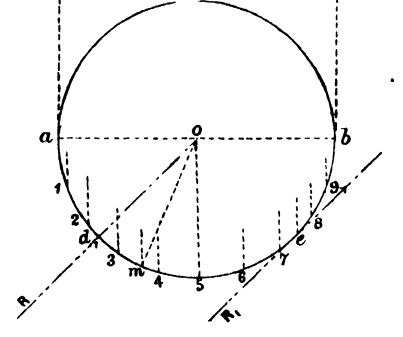
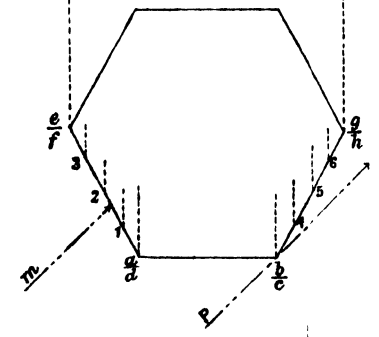
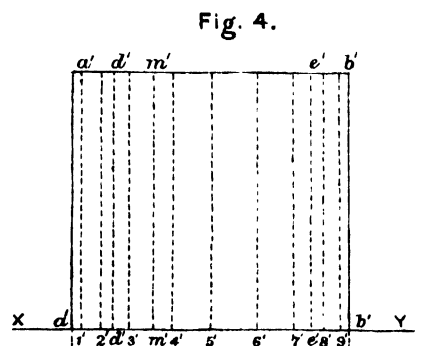
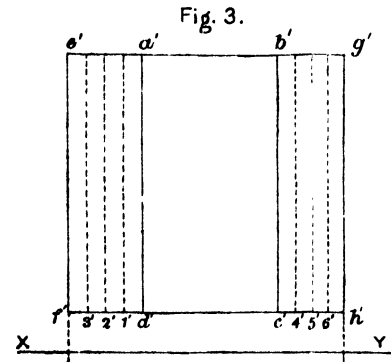
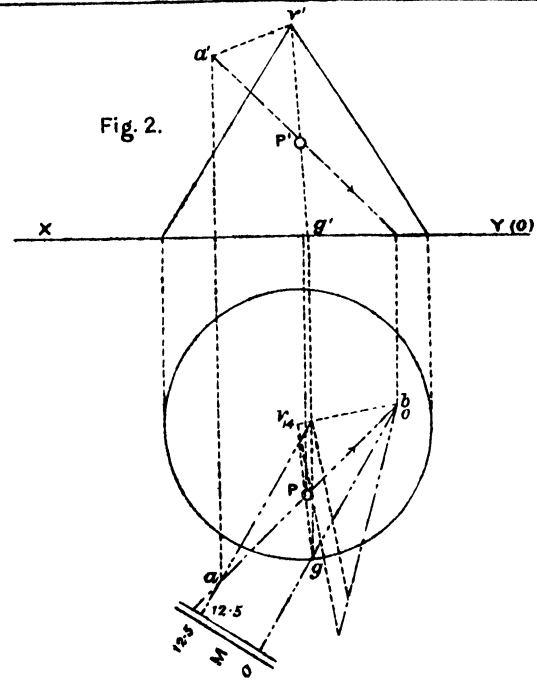
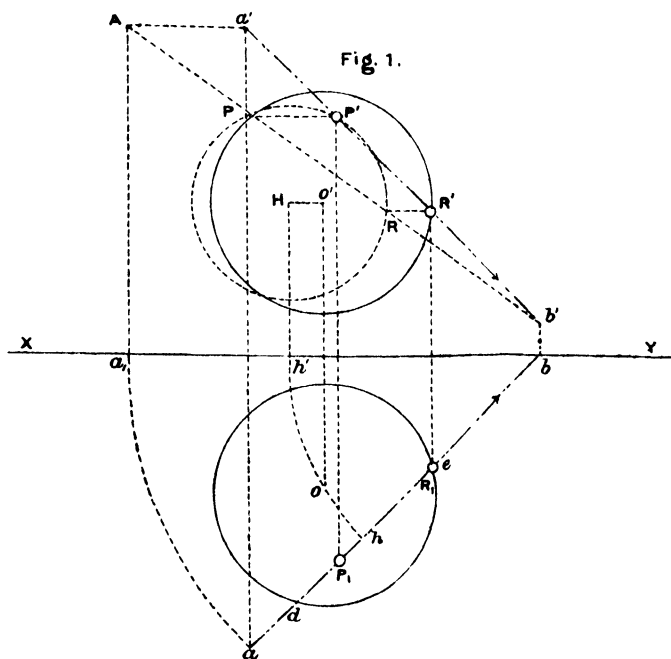

Fig. 1.

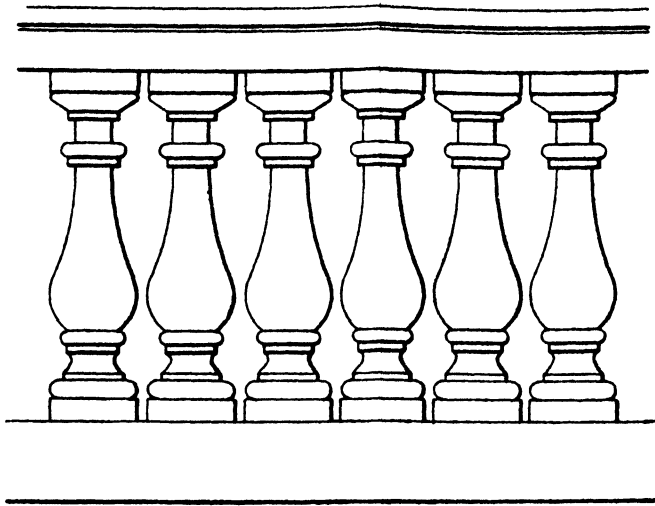

Fig. 4.

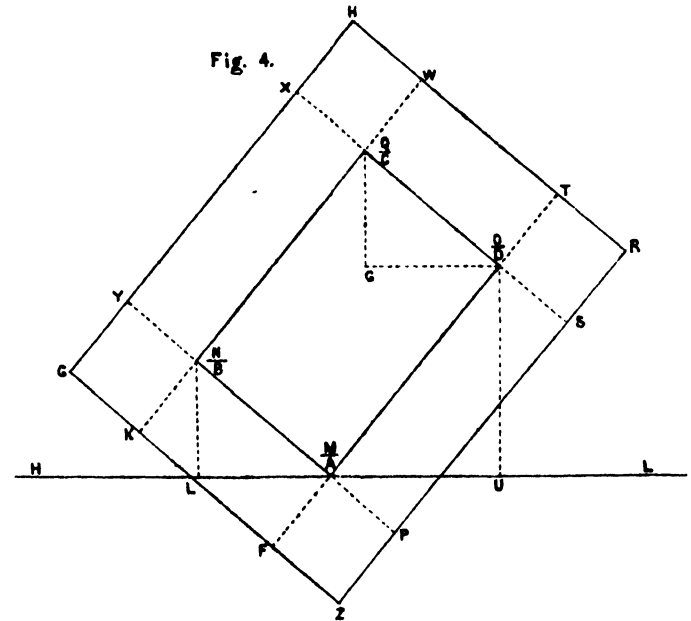

Fig. 2.

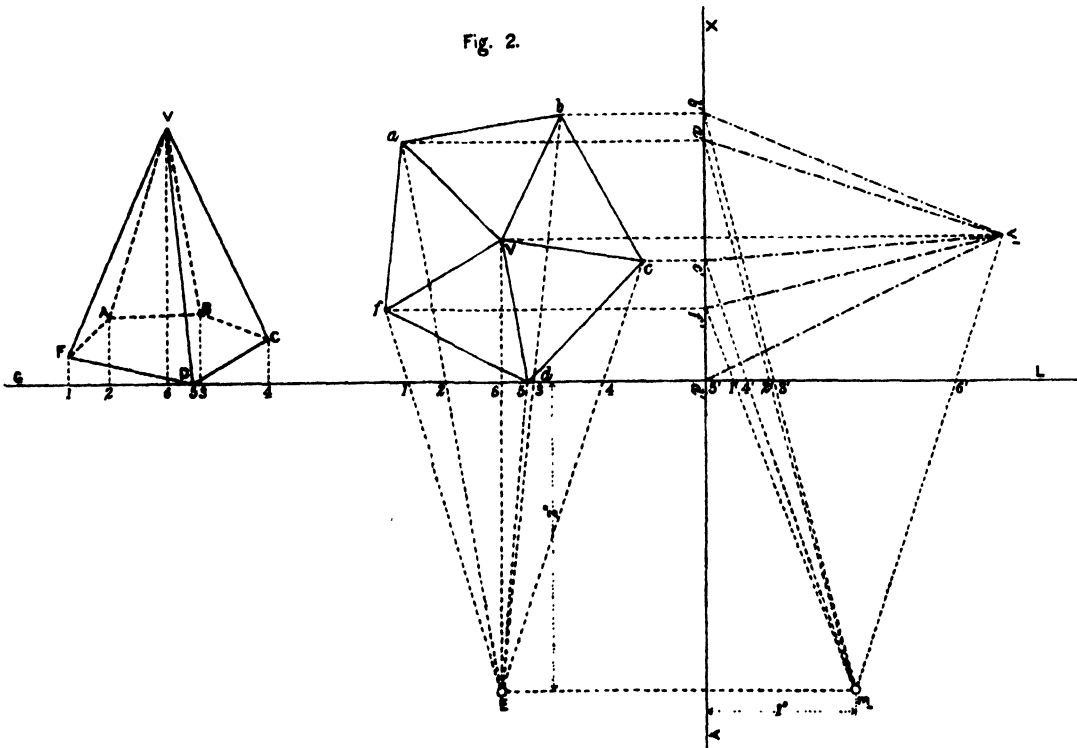
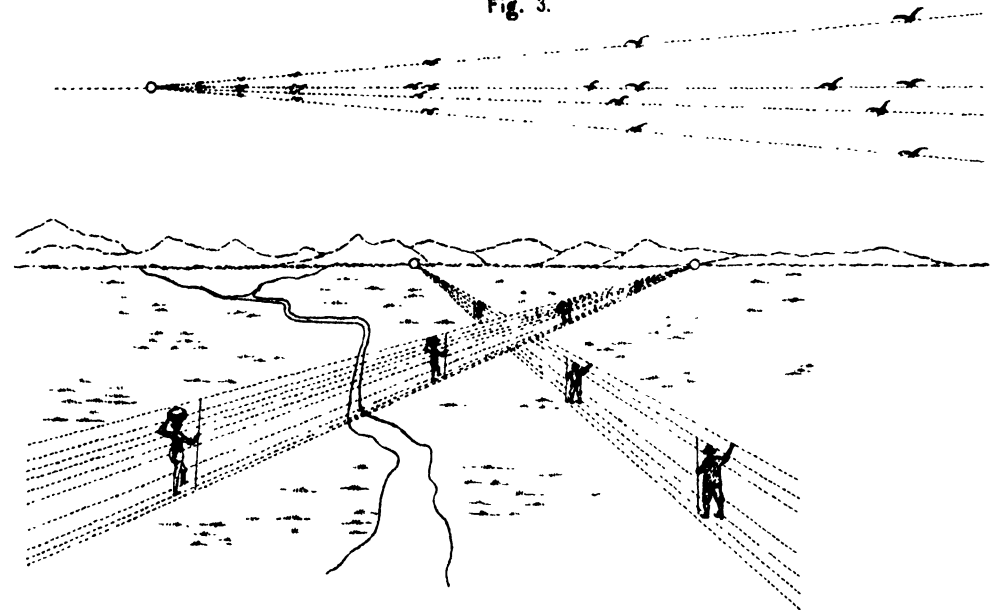
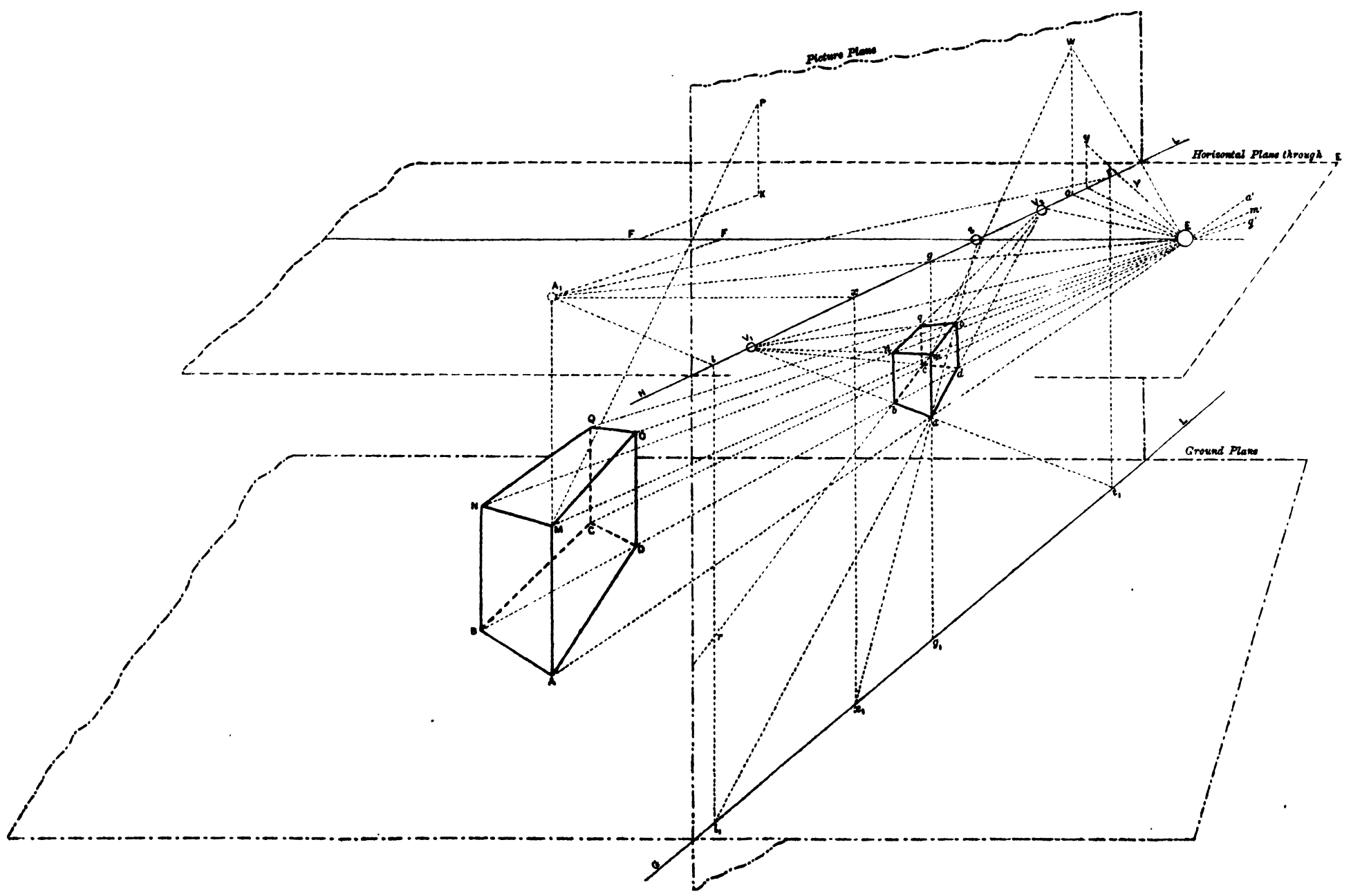
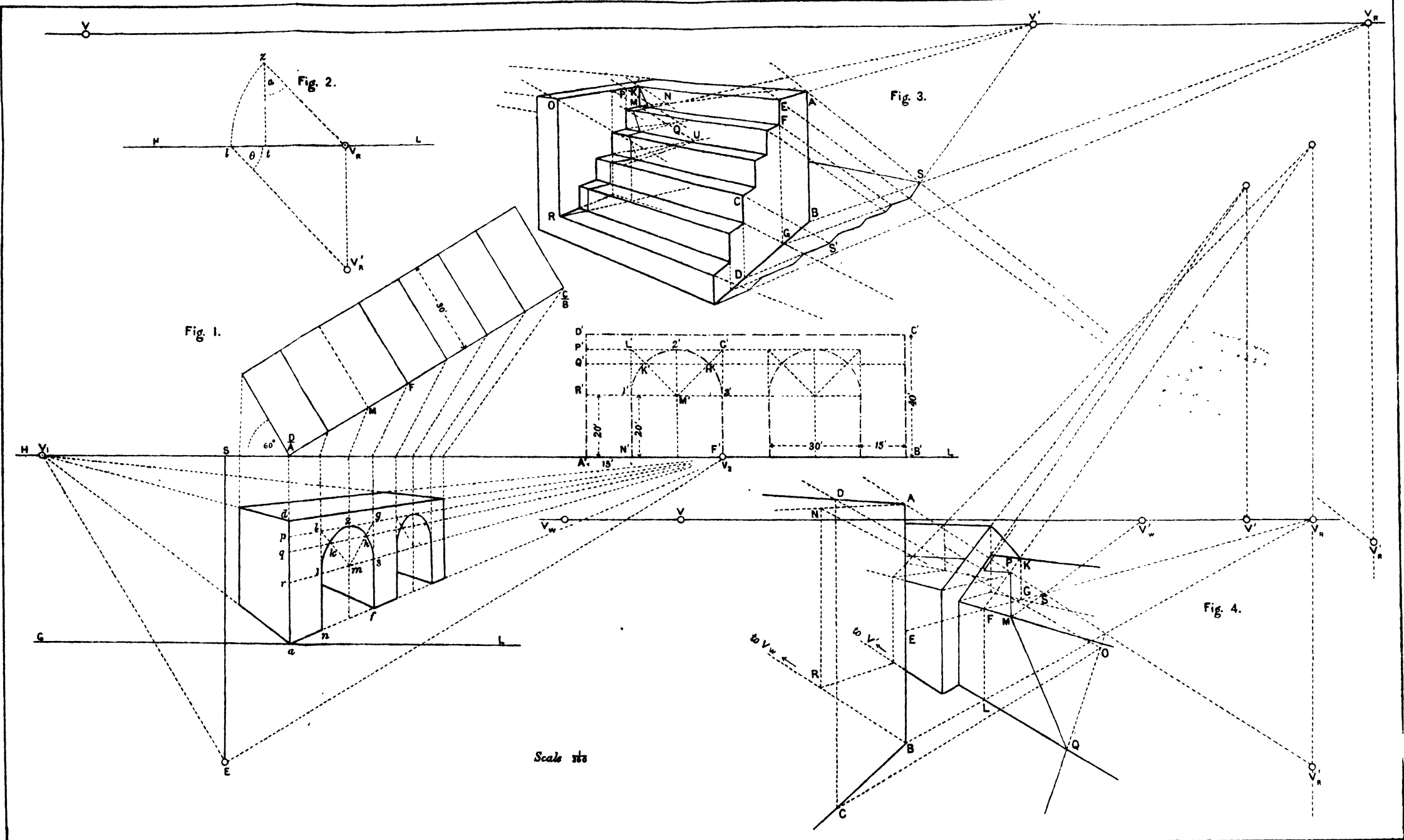

Fig. 3.







Scale 1/16

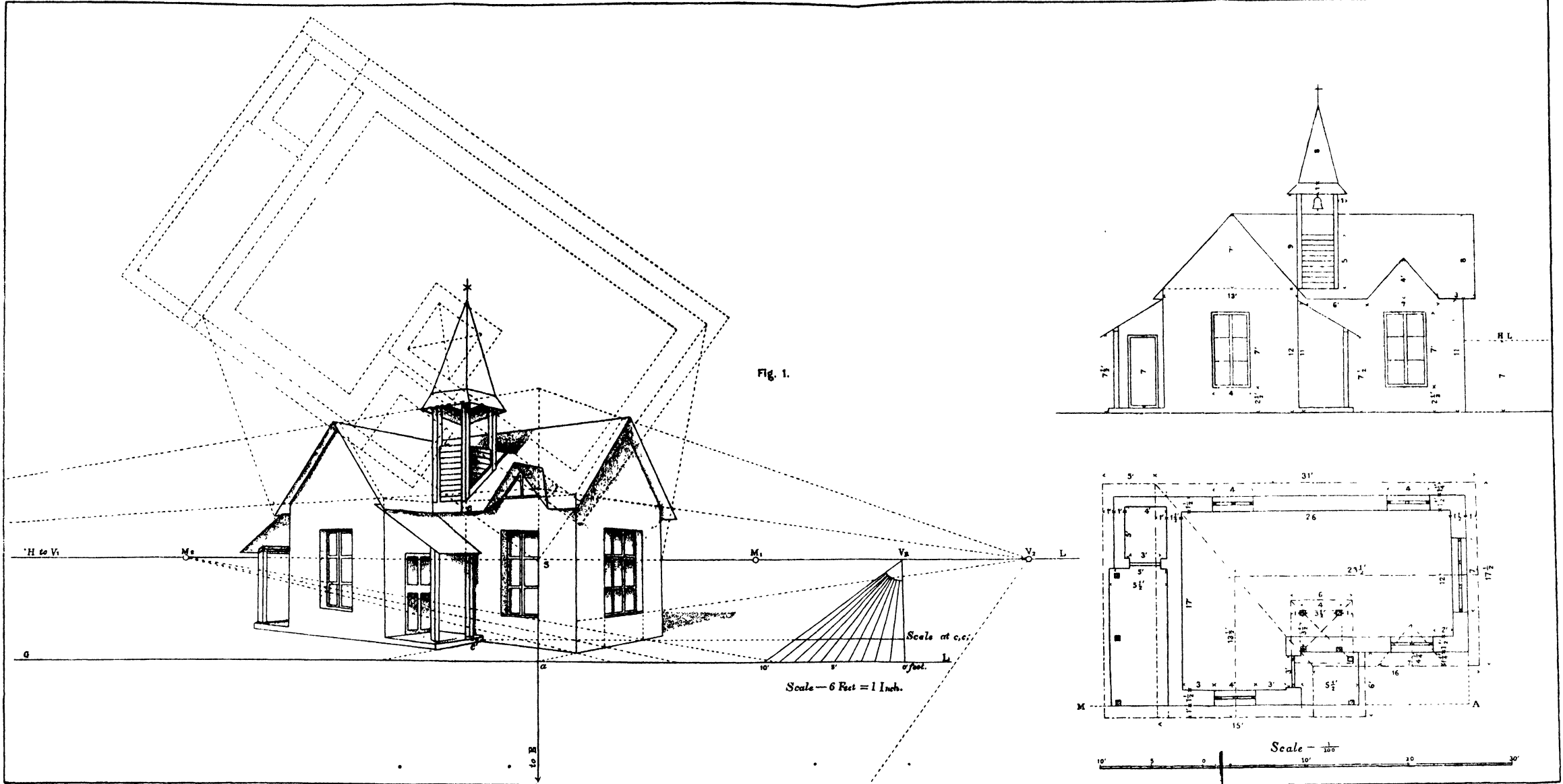

Fig. 1.

