

UNIVERSAL  
LIBRARY

**OU\_150252**

UNIVERSAL  
LIBRARY





**OSMANIA UNIVERSITY LIBRARY**

Call No. 532 / B 29 L Accession No. 367

Author Barton, E. H

Title Introduction - - - of which

This book should be returned on or before the date last marked



# **MECHANICS, DYNAMICS, STATICS, HYDROSTATICS, ETC.**

*WORKS BY S. DUNKERLEY, D.Sc., Assoc. M.Inst.C.E., M.Inst.M.E.*

**MECHANISM.** With 416 Diagrams. 8vo, 9s. net.

**HYDRAULICS.** With Numerous Diagrams. 2 vols. 8vo. (Sold separately.)

Vol. I.—Hydraulic Machinery. 10s. 6d. net.

Vol. II.—The Resistance and Propulsion of Ships. 10s. 6d. net.

*This work is designed to cover the Honours Course in Hydraulics at University, Engineering, and other Colleges.*

**ELEMENTARY APPLIED MECHANICS.** By ARTHUR MORLEY, M.Sc., M.I.Mech.E., Professor of Mechanical Engineering in University College, Nottingham, and WILLIAM INCHLEY, B.Sc., Lecturer and Demonstrator in Engineering in University College, Nottingham. With 285 Diagrams, numerous Examples and Answers. Crown 8vo, 3s. net.

*By the same Authors.*

**LABORATORY INSTRUCTION SHEETS IN ELEMENTARY APPLIED MECHANICS.** 8vo, 1s. 3d. net.

**HYDRAULIC TABLES AND DIAGRAMS FOR PRACTICAL ENGINEERS.** By Captain A. ff. GARRETT, R.E., Executive Engineer Indian Public Works Department. With 24 Diagrams. Oblong 4to, 15s. net.

**EXPERIMENTAL APPLIED MECHANICS FOR TECHNICAL STUDENTS.** By JAMES L. MAXIM, B.S., F.G.S. With Diagrams, Examination Questions, Tables of Logarithms, Constants, etc. Fcp. 8vo, 2s.

**MECHANICS FOR ENGINEERS: a Text-Book of Intermediate Standard.** By ARTHUR MORLEY, M.Sc., University Scholar (Vict.), Professor of Applied Mechanics at University College, Nottingham. With 200 Diagrams and numerous Examples. Crown 8vo, 4s. net.

**MECHANICS; Theoretical, Applied and Experimental.** By W. W. F. PULLEN, Wh.Sch., M.I.M.E., A.M.I.C.E. With 318 Diagrams and numerous Examples. Crown 8vo, 4s. 6d.

**ELEMENTS OF DYNAMICS (Kinetics and Statics).** With numerous Exercises. A Text-book for Junior Students. By the Rev. J. L. ROBINSON, M.A. Crown 8vo, 6s.

**APPLIED MECHANICS: Embracing Strength and Elasticity of Materials, Theory and Design of Structures, Theory of Machines and Hydraulics. A Text-book for Engineering Students.** By DAVID ALAN LOW, M.I.Mech.E., Professor of Engineering, East London College. With 850 Illustrations and 780 Exercises. 8vo, 7s. 6d. net.

**ELEMENTARY APPLIED MECHANICS (STATICS), INTRODUCING THE UNITARY SYSTEM.** By ALEXANDER NORWELL, B.Sc., C.E. With 218 Diagrams. Crown 8vo, 3s.

**ELEMENTS OF HYDROSTATICS.** By G. W. PARKER, M.A. With numerous Examples for use of Schools and Colleges. Crown 8vo, 2s. 6d.

**ELEMENTS OF MECHANICS.** By G. W. PARKER, M.A. With numerous Examples, for the use of Schools and Colleges. With 116 Diagrams and Answers to Examples. 8vo, 4s. 6d.

**ANALYTICAL MECHANICS.** Comprising the Kinetics and Statics of Solids and Fluids. By EDWIN H. BARTON, D.Sc. (Lond.), F.R.S.E., A.M.I.E.E., Professor of Experimental Physics, University College, Nottingham. 8vo, 10s. 6d. net.

**THEORETICAL MECHANICS—SOLIDS.** Including Kinematics, Statics and Kinetics. By ARTHUR THORNTON, M.A., F.R.A.S. With 200 Illustrations, 130 Worked Examples, and over 900 Examples from Examination Papers, etc. Crown 8vo, 4s. 6d.

**LONGMANS, GREEN AND CO.**

LONDON, NEW YORK, BOMBAY, CALCUTTA, AND MADRAS

# **MECHANICS, DYNAMICS, STATICS, HYDROSTATICS, ETC.**

**TABLES OF PHYSICAL AND CHEMICAL CONSTANTS, AND SOME MATHEMATICAL FUNCTIONS.** By G. W. C. KAYE, B.A. (Cantab.), D.Sc. (Lond.), A.R.C.Sc. (Lond.); and T. H. LABY, B.A. (Cantab.). Royal 8vo, 4s. 6d. net.

**AN INTRODUCTION TO THE MATHEMATICAL THEORY OF ATTRACTION.** By FRANCIS A. TARLETON, LL.D., Sc.D., Fellow of Trinity College, and Professor of Natural Philosophy in the University of Dublin. Crown 8vo, 10s. 6d.

**INTRODUCTION TO THE MATHEMATICAL THEORY OF THE STRESS AND STRAIN OF ELASTIC SOLIDS.** By BENJAMIN WILLIAMSON, D.Sc., F.R.S. Crown 8vo, 5s.

**AN ELEMENTARY TREATISE ON DYNAMICS.** Containing Applications to Thermodynamics, with numerous Examples. By BENJAMIN WILLIAMSON, D.Sc., F.R.S., and FRANCIS A. TARLETON, LL.D. Crown 8vo, 10s. 6d.

**DYNAMICS OF ROTATION: an Elementary Introduction to Rigid Dynamics.** By A. M. WORTHINGTON, C.B., F.R.S. Crown 8vo, 4s. 6d.

**A STUDY OF SPLASHES.** By A. M. WORTHINGTON, C.B., F.R.S. With 197 Illustrations from Instantaneous Photographs. Medium 8vo, 2s. 6d. net.

**AN INTRODUCTION TO MATHEMATICAL PHYSICS.** By R. A. HOUSTOUN, M.A., Ph.D., D.Sc. 8vo, 6s. net.

**A FIRST COURSE OF PHYSICAL LABORATORY PRACTICE.** Containing 264 Experiments. By A. M. WORTHINGTON, M.A., Head Master of the Royal Naval Engineering School, Devonport. With Illustrations. Crown 8vo, 4s. 6d.

**ELEMENTARY PHYSICS.** By MARK R. WRIGHT, M.A., Principal of the Normal Department, Armstrong College, Newcastle-on-Tyne. With Illustrations. Crown 8vo, 2s. 6d.

**ELEMENTARY PHYSICS.** By JOHN HENDERSON, B.Sc. (Edin.), A.I.E.E., Lecturer in Physics, Manchester Municipal Technical School. Crown 8vo, 2s. 6d.

**A TEXT-BOOK OF PHYSICS.** By W. WATSON, F.R.S., D.Sc., Professor of Physics in the Royal College of Science, London. With 579 Diagrams and Illustrations. Large crown 8vo, 10s. 6d.

**A TEXT-BOOK OF PRACTICAL PHYSICS.** By W. WATSON, D.Sc. With 278 Illustrations. Large crown 8vo, 9s.

**INTERMEDIATE PHYSICS.** By W. WATSON, D.Sc. With Diagrams. 8vo, 6s. net.

**ELEMENTARY PRACTICAL PHYSICS.** By W. WATSON, D.Sc. With 199 Illustrations and 193 Exercises. Crown 8vo, 2s. 6d.

## *WORKS BY J. HAMBLIN SMITH, M.A.*

**ELEMENTARY STATICS.** Crown 8vo, 3s.

**ELEMENTARY HYDROSTATICS.** Crown 8vo, 3s.

**KEY TO STATICS AND HYDROSTATICS.** Crown 8vo, 6s.

## *WORKS BY J. E. TAYLOR, M.A., B.Sc. (Lond.).*

**THEORETICAL MECHANICS,** including Hydrostatics and Pneumatics. With 175 Diagrams and Illustrations, and 522 Examination Questions and Answers. Crown 8vo, 2s. 6d.

**THEORETICAL MECHANICS—SOLIDS.** With 163 Illustrations, 120 Worked Examples, and over 500 Examples from Examination Papers, etc. Crown 8vo, 2s. 6d.

**THEORETICAL MECHANICS—FLUIDS.** With 122 Illustrations, numerous Worked Examples, and about 500 Examples from Examination Papers, etc. Crown 8vo, 2s. 6d.

**LONGMANS, GREEN AND CO.,**  
LONDON, NEW YORK, BOMBAY, CALCUTTA, AND MADRAS.

AN INTRODUCTION TO  
THE MECHANICS OF FLUIDS

BY THE SAME AUTHOR

**ANALYTICAL MECHANICS**

COMPRISING THE KINETICS AND  
STATICS OF SOLIDS AND FLUIDS

With 241 Diagrams.      8vo, 10s. 6d. net

LONGMANS, GREEN AND CO.  
LONDON, NEW YORK, BOMBAY, CALCUTTA, AND MADRAS

AN INTRODUCTION TO  
THE MECHANICS  
OF FLUIDS

BY  
EDWIN H. BARTON

D.Sc., F.R.S.E., A.M.I.E.E., F.P.S.L.  
PROFESSOR OF EXPERIMENTAL PHYSICS, UNIVERSITY COLLEGE  
NOTTINGHAM

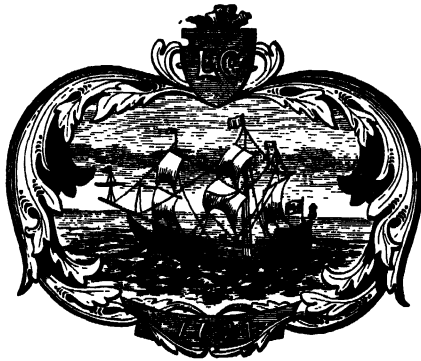

*WITH DIAGRAMS AND EXAMPLES*

LONGMANS, GREEN AND CO.  
39 PATERNOSTER ROW, LONDON  
FOURTH AVENUE & 30TH STREET, NEW YORK  
BOMBAY, CALCUTTA, AND MADRAS

1915

*All rights reserved*



## PREFACE

IN writing this book, while preserving the usual rigour, the endeavour has been made to impart to it by the character of the illustrations and examples, a modern and practical flavour which will render it more widely useful.

It is accordingly hoped that it will be found suitable for candidates for entrance scholarship and other university examinations, for naval and military preparation, for those technical students taking the Board of Education's lower examination in Theoretical Mechanics (Fluids), or any of a similar character held by the various provincial educational unions.

As to mathematical scope, the calculus is not used, but, in avoiding it, a summational formula is given, and, so far as may be, established. This obviates the necessity of recourse to a number of special devices and really forms an introduction to the calculus. It thus simplifies the work of the beginner and involves a minimum of change to those who pass to the calculus at a later stage.

Examples of an obvious character are freely sprinkled throughout the text ; additional ones, classified and miscellaneous, occurring at the end ; thus making a total of over 500 examples. These are followed by answers and a separate set of solutions and hints respecting those cases specially needing further elucidation.

For kindnesses extended in the preparation of the work, as to copyright, etc., thanks are hereby heartily tendered to the following gentlemen and bodies :—

1. The Controller of H.M. Stationery Office, for permission to include the Board of Education's Examination Papers and Mathematical Tables ;
2. Messrs. Macmillan & Co., Ltd., for permission with respect to the early part of the Logarithmic Tables ;
3. Mr. H. A. Humphrey, and
4. The Institution of Mechanical Engineers, for permission to give a diagram and description of the Humphrey Pump ;
5. Mr. Henry Fowler, for furnishing and allowing reproduction of diagram and description of the Midland Railway's Vacuum Brake ;

6. Various other firms, for similar permissions, and duly acknowledged in the text ;
7. Mr. W. H. White, for allowing copies to be made from the diagrams of the siphon barometer and barometer cistern in his "Handbook of Physics" ;
8. Mr. Cecil Hayes, for reading the proofs and checking the answers to examples.

It is hoped that few serious errors or obscurities now remain undetected ; but, if any readers finding such would kindly notify them, their services in this respect would be cordially welcomed.

NOTTINGHAM,

*July, 1915*

# CONTENTS

## PART I.—MECHANICAL BASIS

### CHAPTER I

#### PRELIMINARY

ART.		PAGE
1.	Fluids, Liquids and Gases . . . . .	I
2.	Object and Scope of Mechanics . . . . .	2
3.	Order of Treatment . . . . .	3
	EXAMPLES I. . . . .	3

### CHAPTER II

#### KINEMATICS

4.	Space and Position . . . . .	4
5.	Units . . . . .	4
	EXAMPLES II. . . . .	5
6.	Displacements . . . . .	5
7.	Scalars and Vectors . . . . .	6
8.	Composition of Displacements . . . . .	6
	EXAMPLES III. . . . .	7
9.	Time and Motion . . . . .	7
10.	Velocity and Speed . . . . .	8
11.	Space Graphs . . . . .	9
12.	Speed Graphs . . . . .	10
	EXAMPLES IV. . . . .	11
13.	Acceleration . . . . .	12
	EXAMPLES V. . . . .	13
14.	Dimensions of Mechanical Quantities . . . . .	13
15.	Fundamental and Derived Units . . . . .	14
	EXAMPLES VI. . . . .	15
16.	Composition of Velocities and Accelerations . . . . .	15
17.	Angular Velocity . . . . .	15
18.	Uniform Circular Motion . . . . .	16
	EXAMPLES VII. . . . .	17

## CHAPTER III

## KINETICS

ART.		PAGE
19.	Physical Basis: Motion, Mass, Force . . . . .	18
20.	Momentum and Impulse . . . . .	20
21.	Energy and Work . . . . .	20
	EXAMPLES VIII. . . . .	21
22.	Kinetical Units . . . . .	21
	EXAMPLES IX. . . . .	22
23.	Conservation of Energy . . . . .	24
24.	Activity: Horse-Power . . . . .	25
	EXAMPLES X. . . . .	25

## CHAPTER IV

## STATICS

25.	Forces at a Point . . . . .	26
	EXAMPLES XI. . . . .	27
26.	Parallel Forces . . . . .	27
	EXAMPLES XII. . . . .	29
27.	Moments . . . . .	29
28.	Couples . . . . .	30
29.	Reduction of Coplanar Forces . . . . .	31
30.	Equilibrium of Rigid Body . . . . .	33
	EXAMPLES XIII. . . . .	33
31.	Density and Specific Gravity . . . . .	34
	EXAMPLES XIV. . . . .	35
32.	Centres of Gravity and of Mass . . . . .	35
33.	Centroids of Simple Figures . . . . .	36
	EXAMPLES XV. . . . .	38
34.	Sum or Difference of Simple Figures . . . . .	38
35.	Rectangle and Triangle . . . . .	39
36.	Trapezoid . . . . .	39
37.	Frustum of a Pyramid . . . . .	40
	EXAMPLES XVI. . . . .	42

## CHAPTER V

## SUMMATIONS

38.	Work of a Variable Force . . . . .	43
39.	Simple Summations . . . . .	43
	EXAMPLES XVII. . . . .	45
40.	Summations of Powers of a Variable . . . . .	45
	EXAMPLES XVIII. . . . .	46

# CONTENTS

ix

ART.	PAGE
41. Summation of a Cosine . . . . .	46
42. Summation as Ordinate of Second Curve . . . . .	47
EXAMPLES XIX. . . . .	50
43. Centroid of Circular Arc . . . . .	51
44. Centroid of Sector of Circle . . . . .	51
45. Centroid of Segment of Circle . . . . .	52
EXAMPLES XX. . . . .	53
46. Centroid of a Hemisphere . . . . .	54
47. Centroid of a Spherical Zone . . . . .	54
48. Graphical Method for Centroid . . . . .	54
EXAMPLES XXI. . . . .	56
49. Moment of Inertia Introduced . . . . .	56
50. Moment of Inertia Theorems . . . . .	57
51. } Moments of Inertia of a Rectangle . . . . .	59
52. }	
EXAMPLES XXII. . . . .	59
53. Moment of Inertia of a Circle . . . . .	60
54. Triangle's Moment about a Side . . . . .	61
55. Triangle's Moment about a Perpendicular . . . . .	62
56. Graphical Method for Plane Area . . . . .	62
EXAMPLES XXIII. . . . .	63

## PART II.—HYDROSTATICS

### CHAPTER VI

#### LIQUIDS IN EQUILIBRIUM

57. Conception of Stress . . . . .	64
58. Normal and Tangential Stresses . . . . .	65
59. Hydrostatic Pressure independent of Direction . . . . .	65
60. Pressure same on given Level . . . . .	67
61. Pressure increases with Depth . . . . .	67
EXAMPLES XXIV. . . . .	69
62. Free Surface Horizontal . . . . .	69
63. Communicating Vessels . . . . .	70
64. Transmission of Pressure . . . . .	71
65. Hydraulic Press . . . . .	71
EXAMPLES XXV. . . . .	72
66. Superposition of Liquids . . . . .	73
67. Densities by U-tube . . . . .	74
68. Pressure Gauge or Manometer . . . . .	75
EXAMPLES XXVI. . . . .	76
69. Resultant Force on Immersed Plane Surface . . . . .	76
70. Whole Pressure on Immersed Surface . . . . .	79
EXAMPLES XXVII. . . . .	79
71. Centre of Pressure of Triangle . . . . .	80
72. Centre of Pressure: General Treatment . . . . .	81

CONTENTS

ART.	PAGE
73. Centre of Pressure by Centroid of Solid . . . . .	82
EXAMPLES XXVIII. . . . .	84
74. Any Triangle with Vertex at Surface . . . . .	84
75. Triangle wholly Submerged . . . . .	86
76. Particle Rule for Triangle . . . . .	87
77. Submerged Triangle by Radius of Gyration . . . . .	87
78. Graphical Method for Centres of Pressure . . . . .	88
EXAMPLES XXIX. . . . .	89

CHAPTER VII

FLOTATION

79. Resultant Force on Curved Surface . . . . .	90
80. Resultant Force on Closed Surface . . . . .	91
81. Resultant Force on Unclosed Surface . . . . .	93
EXAMPLES XXX. . . . .	94
82. Equilibrium of Floating Bodies . . . . .	94
83. Archimedes' Principles . . . . .	95
EXAMPLES XXXI. . . . .	96
84. Hydrometers of Variable Immersion for Liquids . . . . .	97
85. Hydrometer of Variable Immersion for Solids . . . . .	98
EXAMPLES XXXII. . . . .	99
86. Hydrometer of Fixed Immersion for Solids . . . . .	99
87. Hydrometer of Fixed Immersion for Liquids . . . . .	101
EXAMPLES XXXIII. . . . .	101
88. Hydrostatic Balance for Densities of Solids . . . . .	101
89. Do. do. do. Liquids . . . . .	102
EXAMPLES XXXIV. . . . .	103
90. Balance Work with Air Corrections . . . . .	103
91. Works of Emersion and Immersion . . . . .	105
EXAMPLES XXXV. . . . .	107
92. Stability of Floating Bodies : Metacentre . . . . .	108
93. Practical Location of Metacentre . . . . .	111
EXAMPLES XXXVI. . . . .	111
94. Tension of Vessels due to Fluid contained . . . . .	112
EXAMPLES XXXVII. . . . .	114

PART III.—HYDROKINETICS

CHAPTER VIII

STEADY FLOW

95. Steady Flow under Gravity . . . . .	115
96. Bernoulli's Theorem of Liquid Flow . . . . .	116
EXAMPLES XXXVIII. . . . .	118

# CONTENTS

xi

ART.	PAGE
97. Vena Contracta . . . . .	119
98. Torricelli's Theorem . . . . .	120
99. Discharge from an Orifice . . . . .	121
EXAMPLES XXXIX. . . . .	123
100. Mariotte's Bottle . . . . .	124
101. Hero's Fountain . . . . .	125
102. Uniform Rotation of Liquid . . . . .	126
EXAMPLES XL. . . . .	128

## PART IV.—PNEUMATICS

### CHAPTER IX

#### GASES

103. Thermometry . . . . .	129
EXAMPLES XLI. . . . .	130
104. The Ideal Gas . . . . .	131
105. Characteristic Equation of Ideal Gas . . . . .	131
106. Boyle's Law . . . . .	131
107. Compressed-Air Manometer . . . . .	134
EXAMPLES XLII. . . . .	135
108. Charles' Law . . . . .	135
EXAMPLES XLIII. . . . .	137
109. Increase of Pressure at Constant Volume . . . . .	138
110. Gas Thermometer . . . . .	139
EXAMPLES XLIV. . . . .	140
111. Values of Gas Constant R . . . . .	141
112. Work of Expanding Gas . . . . .	142
EXAMPLES XLV. . . . .	144
113. Isothermal Elasticity of a Gas . . . . .	145
114. Pressure of Mixed Gases . . . . .	145
EXAMPLES XLVI. . . . .	146

### CHAPTER X

#### HYGROMETRY

115. Ebullition : Vapour Pressure . . . . .	147
116. Saturation . . . . .	147
117. Dew Point . . . . .	150
118. Pressure of Atmospheric Vapour . . . . .	150
119. Humidity . . . . .	150
EXAMPLES XLVII. . . . .	151
120. Density of Atmospheric Vapour . . . . .	151
121. Density of Dry Air, etc. . . . .	152

ART.	PAGE
122. Moisture removed in Mine Ventilation . . . . .	152
EXAMPLES XLVIII. . . . .	153
123. Hygrometers . . . . .	153
124. Daniells' Hygrometer . . . . .	154
125. Dines' Hygrometer . . . . .	154
126. Regnault's Hygrometer . . . . .	155
127. Wet and Dry Bulb Hygrometer . . . . .	156
128. Graphs of Hygrometric Relations . . . . .	157
EXAMPLES XLIX. . . . .	158

## CHAPTER XI

## BAROMETRY

129. Torricelli's Experiment . . . . .	159
130. Cistern Barometer . . . . .	159
131. Kew Barometer . . . . .	160
132. Fortin's Barometer . . . . .	160
133. Siphon Barometer . . . . .	162
EXAMPLES L. . . . .	162
134. Temperature Corrections to Barometer . . . . .	162
135. Latitude and Altitude Corrections . . . . .	164
136. Vapour Pressure Corrections . . . . .	165
137. Examples of Barometer Corrections . . . . .	165
EXAMPLES LI. . . . .	166
138. Vitiated Vacuum of Barometer . . . . .	166
139. Height of Homogeneous Atmosphere . . . . .	167
EXAMPLES LII. . . . .	168
140. Heights determined by Barometer . . . . .	169
141. Alternative Proof for Heights . . . . .	170
142. Numerical Forms of Barometric Formula . . . . .	171
143. Aneroid Barometer . . . . .	172
143A. Millibar and Baromil . . . . .	173
EXAMPLES LIII. . . . .	173

## PART V.—APPLICATIONS.

## CHAPTER XII

## ILLUSTRATIVE APPARATUS

144. Classification of Hydraulic Appliances . . . . .	174
145. Primitive Water Lifters . . . . .	176
146. Lift Pump . . . . .	176
147. Force Pump . . . . .	177
148. Air Chamber ; Double and Triple Pumps . . . . .	178
EXAMPLES LIV. . . . .	178

# CONTENTS

xiii

ART.		PAGE
149.	Hydraulic Ram . . . . .	178
150.	Jet Pump . . . . .	179
151.	Venturi Water Meter . . . . .	179
	EXAMPLES LV. . . . .	180
152.	Diving Equipments . . . . .	181
153.	Siphons . . . . .	181
154.	Giffard's Injector . . . . .	182
155.	Pulsometer Steam Pump . . . . .	183
	EXAMPLES LVI. . . . .	185
156-159.	Humphrey's Internal-Combustion Pump . . . . .	{ 185 188
160.	Pumps for Hydraulic Power . . . . .	188
161.	Power Pump Electrically Driven . . . . .	189
162.	Hydraulic Accumulator . . . . .	190
163.	Intensifying Accumulator . . . . .	191
	EXAMPLES LVII. . . . .	191
164.	Torpedo Compressors . . . . .	191
165.	Bourdon Pressure Gauge . . . . .	192
166.	Differential Manometer . . . . .	193
	EXAMPLES LVIII. . . . .	195
167.	Early Air Pumps . . . . .	195
168.	Progressive Rarefaction by Air Pump . . . . .	196
169.	Jet Pumps for Exhaustion . . . . .	197
	EXAMPLES LIX. . . . .	197
170.	Geryk Vacuum Pump . . . . .	197
171.	Gaede's Piston Pump . . . . .	197
172.	Toepler Pump . . . . .	200
173.	Gaede's Molecular Pump . . . . .	200
174.	Exhaustion by Cooled Charcoal . . . . .	202
175.	Vacua Attainable . . . . .	202
176.	McLeod Gauge . . . . .	202
	EXAMPLES LX. . . . .	203
177.	Hydraulic Press . . . . .	203
178.	Hydraulic Lifts and Machines . . . . .	203
179.	Hydraulic Brakes . . . . .	204
	EXAMPLES LXI. . . . .	205
180.	Rock Drills, etc., . . . . .	206
181.	Turbines Classified . . . . .	206
182.	Parsons' Steam Turbine . . . . .	206
183.	Westinghouse Brake . . . . .	207
184.	Midland Vacuum Brake . . . . .	210
185.	Pelton Wheel . . . . .	211
186.	De Laval Steam Turbine . . . . .	212
	EXAMPLES LXII. . . . .	212

## ADDITIONAL EXERCISES

EXAMPLE		PAGE
LXIII.	On Kinematics . . . . .	213
LXIV.	On Kinetics . . . . .	213
LXV.	On Statics . . . . .	214

EXAMPLE	PAGE
LXVI. On Summations . . . . .	214
LXVII. On Liquids . . . . .	214
LXVIII. On Flotation . . . . .	215
LXIX. On Steady Flow . . . . .	216
LXX. On Gases . . . . .	216
LXXI. On Hygrometry . . . . .	217
LXXII. On Barometry . . . . .	217
LXXIII. On Apparatus . . . . .	218
LXXIV. Miscellaneous . . . . .	218
LXXV. Miscellaneous . . . . .	219
ANSWERS . . . . .	221
SOLUTIONS AND HINTS . . . . .	230
EXAMINATION PAPERS :	
Board of Education, Lower Grade, 1912 . . . . .	235
Board of Education, Lower Grade, 1913 . . . . .	236
Board of Education, Lower Grade, 1914 . . . . .	237
MATHEMATICAL TABLES . . . . .	239
INDEX . . . . .	245

# PART I.—MECHANICAL BASIS

## CHAPTER I

### PRELIMINARY

1. **Fluids, Liquids and Gases.**—As this little work treats the mechanics of fluids, we must obtain, at the outset, clear ideas about fluids and mechanics. These we now consider in the order named. A fluid consists of matter that can flow. The commonest examples are air and water. A formal definition is as follows.

DEFINITION.—A *fluid* consists of matter in such a state that it offers only very *small resistances* to changes in *shape*, however large, provided only that *time enough* is allowed in which those changes may occur.

This distinguishes fluids from *rigid solids*, which are supposed to retain their exact shape unchanged under all circumstances, and from *elastic solids*, any one of which exhibits a nearly constant ratio between its sudden small changes of shape and the external actions to which those changes are ascribed.

If the resistances offered by a fluid to very quick changes of shape are quite small, the fluid is said to be very mobile or of negligible *viscosity*. This last term denotes a property really possessed by all fluids to some large or small extent. In the case of very sluggish or *viscous* fluids in motion, this property would need taking into consideration. But it is evident that it need not enter into our account when considering any fluids at rest in equilibrium. And even in those cases of simple motion dealt with in this book the effects of viscosity will be regarded as negligible unless the contrary is stated.

We may now subdivide fluids into liquids and gases.

DEFINITION.—*Liquids* are fluids whose volumes per unit mass are practically independent of the pressures to which they are subjected.

Consequently, these volumes remain finite however small the pressure.

DEFINITION.—*Gases* are fluids whose volume per unit mass may become as large as we please by suitably reducing the pressure.

Thus, these volumes have no finite limit as the pressure is continually reduced.

We may accordingly sum up popularly as follows :—

A *solid* body has both *size* and *shape* ;

A given mass of *liquid* has *size* but *not shape* ;

A *gas* has neither *size* nor *shape*.

A rather fuller way of expressing these distinctions is the following :—

Solids have elasticity both of size and shape.

Fluids have elasticity of size only.

Liquids are almost incompressible.

Gases are highly compressible.

**2. Object and Scope of Mechanics.**—DEFINITION.—Mechanics is that branch of science which treats of the rest and motion of matter. For any given simple portion of matter or simple system, it determines

(i) the conditions of rest in equilibrium, and

(ii) the types of motion occurring under specified circumstances.

Thus, for each class of body or system of bodies studied in mechanics we are concerned with the problems of equilibrium and with the various problems of the possible motions. These two subdivisions of the subject are called *Statics* and *Kinetics* respectively.

But some of the motions occurring are of such intricate nature that it is highly desirable to study them apart from the conditions under which they occur. Thus, the study of pure motion, called *Kinematics*, is often regarded as a necessary preliminary to the study of kinetics.

Hence, for each form of matter treated we have the three subdivisions of kinematics, kinetics, and statics needing attention.

The chief divisions and subdivisions of elementary mechanics made on the above plan are exhibited in Table I.

TABLE I.—DIVISIONS AND SUBDIVISIONS OF ELEMENTARY MECHANICS.

States.	Systems.		
	Points and Particles.	Rigid Figures and Bodies.	Fluids.
Motion { Pure Actual	1. Kinematics of Points 2. Kinetics of Particles	{ Kinematics of Rigid Figures Kinetics of Rigid Bodies }	6. Hydrokinetics
Rest in Equilibrium	3. Statics of Particles	4. Statics of Rigid Bodies	5. Hydrostatics and 7. Pneumatics

3. **Order of Treatment.**—In the scheme of Table I. the motions of rigid bodies, enclosed in brackets, are outside the scope of the present work. The other subdivisions will be taken in the order of the numbers set against each. But, out of these seven parts, the first four are of the nature of preliminaries to the other three, which form the subject proper. Accordingly these earlier parts will receive a briefer treatment, suited for the revision work of a student already somewhat conversant with them. The fuller treatment is reserved for the later parts, which constitute the main body of the text and are supposed to cover ground new to the reader.

## EXAMPLES I.

1. Define *fluid*, *liquid*, *gas*, *rigid solid* and *elastic solid*. Also give in your own words some popular way of distinguishing between solids, liquids and gases.
2. Give a brief statement as to the object and scope of *mechanics*, and sketch a possible division of the subject.

## CHAPTER II

### KINEMATICS

4. **Space and Position.**—Since kinematics treats of pure motion or change of position with time, we need some convenient method of indicating the position of a point in space. If the point in question remains on a given plane it will suffice to take two lines at right angles in that plane, from which to measure. These are called coordinate axes and their intersection the origin, see OX, OY in Fig. 1.

The position of a point P in this plane is then indicated thus. Straight lines are drawn through P parallel to OY and to OX,

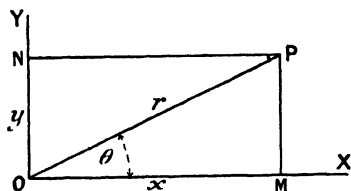

FIG. 1.—Position of a Point.

cutting the axes in M and N. Then the position of P is obviously specified by the lengths OM and ON, which are denoted by  $x$  and  $y$  and called respectively the *abscissa* and *ordinate* of P. The two values  $(x, y)$  are also spoken of as the *co-ordinates* of P.

The above method of specifying P's position uses *Cartesian* co-ordinates. We may also use instead the system called *polar* co-ordinates. In this case we join P to the origin O by a straight line, and state its length  $OP=r$  say, and the angle  $XOP=\theta$  say, which it makes with OX. Then the two quantities, or polar co-ordinates,  $r$  and  $\theta$  now locate P instead of the former two,  $x$  and  $y$ . Thus, in the former case the position of P was specified by two lengths, but in the latter by one length and one angle.

5. **Units.**—To express either lengths or angles in a manner amenable to calculation, we must use numbers (or symbols for them) proportional to their magnitudes. Such numbers accordingly express how *many times* the quantity in question contains some other quantity, or *unit*, of the *same kind*. Thus, for every quantity needing to be measured, we must have a unit of precisely the *same nature*, and a *number* showing how many times that unit is contained in the given quantity. The measure of a quantity accordingly consists of two factors, the number and the unit, and is incomplete if either factor is omitted. Thus, in the *answer* to any problem, the *units must be stated* as well as the numbers. Throughout

the numerical working of a problem, the units are often omitted, being stated only where exceptional or a change in them is being made. But at the end they should always be inserted. For, if the unit were *multiplied* by any factor, the number would need to be *divided* by the same factor to keep the product constant. Thus, the value of a quantity is not in general defined by a number alone, the statement of the units also being usually essential. For example, a length may be stated as 6 feet or 2 yards, and velocity as 15 miles per hour or 22 feet per second.

To preserve records, where possible or desirable, of any national or international units, *standards* are constructed in the best known way, and the relation between the unit and the standard in a particular state specified.

In this way the British yard, foot, inch, mile, etc., are defined; and, in like manner, the French metre, centimetre, millimetre, kilometre, etc., which are also cosmopolitan units. The relations between these and other units are shown in the tables at the end of the book.

The unit angle needs definition, but has no need of a standard. Thus we have the *degree*, of which 360 equal four right angles or one whole turn.

We have also the *radian*, or the angle whose arc equals the radius. But obviously neither unit needs the preservation of any standard to make the unit precise.

#### EXAMPLES II.

1. Make a diagram of a wall 12 feet wide and 9 feet high with picture nails A, B and C, whose co-ordinates are respectively (3, 7), (6, 8) and (9, 7). Find the distances AC and AB.
2. What are the *polar* co-ordinates of A, B and C in the previous example?
3. Draw a sketch of an equilateral triangular plate whose sides are 4 feet long, and give the co-ordinates of its corners and of the middle points of its sides taking the origin at one corner and the axis of  $x$  along a side.
4. In the previous example, shift the origin to the *centre* of the triangle and find the *polar* co-ordinates of the same points as before.
5. Draw a rectangular board 4 feet by 2 feet, set out upon it the eight points which trisect the diagonals of the two squares into which it may be divided. State the co-ordinates of these points, the axes being along adjacent sides of the board.
6. Express, both in right angles and in degrees, the smaller angles between the hands of a clock at 3, 12-30, 4.20, 6.15.

**6. Displacements.**—Let us now consider how we may specify any given change of position, or *displacement*, of a point. Suppose its magnitude to be 3 feet. We have here the two factors which measure the length to be passed over by the point in its displacement. But we have not yet fully specified the displacement, for obviously its *direction* needs stating also. Thus, if we simply state that a point shifts, or is displaced, 3 feet, it may then be anywhere on the surface of a sphere of radius 3 feet whose centre is the initial position of the point. Or, if confined to motions in a horizontal plane, then

the point is anywhere on the circumference of the horizontal circle of radius 3 feet whose centre is at the starting point.

Thus a length and an angle must be given to specify a displacement in the plane of the co-ordinates. These may conveniently be denoted by  $r$  and  $\theta$ , which are then the polar co-ordinates of the point after the given displacement from the origin.

Obviously we need also to know how the co-ordinates are directed, say OX horizontally to the east and OY vertically upwards.

The displacement may be graphically represented by OP, see Fig. 1.

7. **Scalars and Vectors.**—We are thus led to notice—

(1) that there are cases where a length may be thought of quite apart from direction, as when we say that this cricket ball is 2·9 inches diameter, or that bat is 37 inches long. But also,

(2) that there are other cases in which a length is insufficient without its direction being given, as when we say the encampment was shifted ten miles *due north*, or the climber *ascended* another hundred feet.

The above are very simple examples of the two classes of quantities, *scalars* and *vectors*. Scalars have magnitude (and may be of positive or negative sign), vectors have *direction* as well as magnitude. Examples of each class of quantity will occur as we proceed.

Vectors may also have various degrees of *localisation*. Thus if a number of articles are upon a table they may be all shifted a foot one way, or a single article may be so shifted. That is, the displacement in question may affect a certain region or be localised to a particular point. Important examples of this distinction will occur later.

8. **Composition of Displacements.**—Suppose a point to suffer the displacement represented by OP (Fig. 2) and then the displacement represented by OQ, and let it

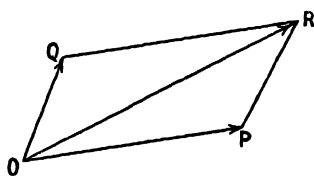

FIG. 2.—Composition of Displacement.

be required to find the final position or the *resultant* displacement. Obviously we have simply to make PR equal and parallel to OQ, then R is the final position of the point and OR the resultant displacement. In other words, the displacements OP and OQ *compound* to give the displacement OR, where OR is the diagonal of the parallelogram whose adjacent sides OP and OQ are the *component* displacements. The line QR is inserted in the figure to complete the parallelogram, but is evidently not actually needed. Neither, indeed, is OQ. Thus only OP and PR need have been drawn to represent the *successive component* displacements, OR being then drawn to represent the *final* or *resultant* displacement.

If the order of application of the component displacements were reversed, the sides OQ and QR would be traversed by the point and R, the final point, reached by this other path.

If, on the other hand, the component displacements occurred proportionately together, the point would actually traverse the line OR in passing from O to R.

The above is all on the supposition that the displacements are so localised as each to affect the point in spite of the other. That is, if the component displacements occur successively the operation of the first does not remove the point from the influence of the second.

We have thus a simple case of the compounding of directed quantities or the *addition of vectors*. It may be represented thus :

$$OP \hat{+} OQ = OR \quad . \quad . \quad . \quad . \quad . \quad (1)$$

where the circumflex accent over the sign of addition denotes that the addition is *vectorial*, or that of *directed* quantities and not mere arithmetical addition. The equation may be read as follows :—The *vector sum* of OP and OQ is OR.

### EXAMPLES III.

1. Give two or three examples of scalar and vector quantities and explain upon what the distinction depends.

2. A man goes north three miles, east 1 mile, north 2 miles, and then west 1 mile. How far has he travelled and what distance is he from his starting-point? What different kinds of addition have you to perform to obtain the two results?

3. A ship goes 14·14 miles south-east and then 10 miles due west. Draw to scale a map of its course and find how far it is from the starting-point and in which direction.

4. A cyclist rides 20 miles due east and then 34·64 miles north. Sketch his route and find his distance and direction from starting-point.

5. A boat sails 10 miles north-west and then sails due south for 20 miles. At what distance on its second course was the boat 10 miles from its starting point?

6. A man goes 12 miles east by train and then walks north till he is 13 miles from his starting-point. How far does he walk?

9. **Time and Motion.**—We have just referred to displacements without any consideration of the time in which they occurred or the state of the point while the displacement was occurring. By introducing this conception of time to those we already have of space, we obtain the idea of motion or change of position in time with which kinematics is concerned.

We may naturally ask whether time is a vector or a scalar. It is easy to see that the lapse of time between two events has magnitude and that from a given instant we may in imagination reckon forwards to the future or backwards into the past. This is something like going east from a point or going west. But, on the earth's surface, we may also go north or south, whereas in time there seems no possibility of this sidewise freedom. Time seems comparable to the space in a tube, allowing positive and negative displacements along its length, but nothing sideways or up and down. We accordingly class a period of *time* as a *scalar* quantity, since it has

a magnitude which may be positive or negative, but has nothing corresponding to direction in space.

To specify the magnitude we need a unit. This is usually the *second* of mean solar time, which is ascertained and recorded by astronomers and is available as *Greenwich mean time*. The associated larger units, minutes, hours, days, etc., may be used also whenever more convenient.

**10. Velocity and Speed.**—The *velocity* of a point is its *rate* of change of position, or its displacement *per* unit time. In other words, the velocity of a point is the *quotient*, its displacement divided by the time in which it occurred. The unit of velocity is accordingly (unit displacement divided by unit time). Thus, we may speak of *20 miles per hour* northwards or *10 cms. per second* vertically downwards, etc. Further, since displacement has direction, and time (being a scalar) has no power to remove it, velocity has direction also and is therefore a vector quantity. Hence the full specification of a velocity requires magnitude and direction. But often we may be concerned only with the magnitude of a velocity. For this, the word *speed* is used. Thus we may say that a particular make of motor bicycle is capable of a speed of 60 miles per hour under favourable conditions.

Suppose now that we are considering velocities along some given direction, we may then discriminate these velocities into various classes. Thus, let the total distance  $s$  feet be passed over in time  $t$  seconds. Then we may say that the velocity was  $v$  feet per second, where

$$v = \frac{s}{t} \quad . \quad . \quad . \quad . \quad . \quad . \quad (1)$$

Now imagine that we divide the distance up into a number of parts and ascertain the time over each part and take the quotients as at first. If all these quotients have the same value as that obtained for the total distance and time, we should say that the velocity in question was *uniform*.

If the quotients had different values we should say that the velocity was *variable*. If we only knew the total distance  $s$  and total time  $t$ , and nothing whatever of the intermediate positions and times, we should only be justified in saying that  $\frac{s}{t}$  was the *mean* velocity.

This shows us that when we had intermediate data and found various velocities for various parts of the course, even those values were only mean velocities for the corresponding smaller distances.

If we require the velocity at any instant called the *instantaneous* velocity, we may proceed as follows.

At time  $t$  let the co-ordinate of the point be  $s$ , and at a slightly later time  $t'$  let the co-ordinate be  $s'$ . Then take the quotient

$$\frac{s' - s}{t' - t}$$

This is evidently the mean velocity for the period in question. Next, suppose that corresponding values of  $t'$  and  $s'$  could be ascertained nearer to  $t$  and  $s$  respectively. And again take the new quotient. Its value might be slightly different from the former one. By proceeding in this way, continually decreasing the numerator ( $s' - s$ ) and the denominator ( $t' - t$ ) of the fraction, it would usually be found that the fraction itself tended towards a limiting value. This *limiting value*,  $u$  say, is called the *instantaneous velocity* at the instant  $t$  and position  $s$ . We may put this in symbols as follows:—

$$u = \text{the limit of } \frac{s' - s}{t' - t} \dots \dots \dots (2)$$

as the numerator and denominator of the fraction are taken smaller and smaller.

II. **Space Graphs.**—We may now with advantage note how the above points as to speeds may be represented graphically. Take

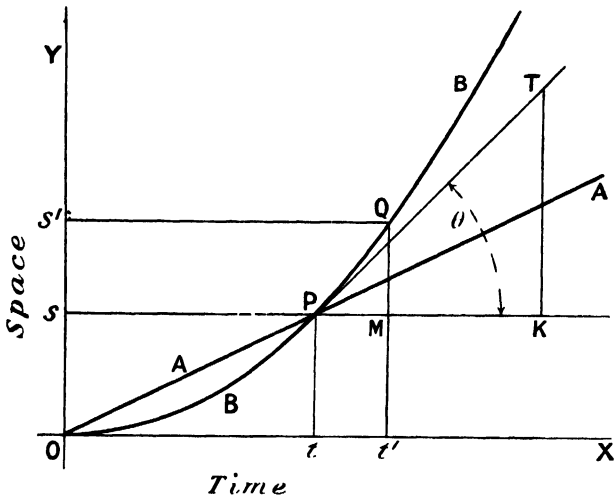

FIG. 3.—Space-Time Graphs.

two axes OX and OY, at right angles, plot times  $t$  upon the former and spaces  $s$  along the latter, as illustrated in Fig. 3.

Consider first the points O and P on the diagram, corresponding to the lapse of time  $t$  and the description of the space  $s$ . Then the quotient  $s/t$  gives a value for the velocity. If we know other pairs of values of  $s$  and  $t$  for the moving point and find that the corresponding places on the diagram all lie along the *straight* line OAPA, then evidently all such quotients  $s/t$  have the same value, and the velocity is *uniform*.

If, however, on obtaining further information about times and corresponding spaces and plotting them, we find that the *curved*

line OBPB is obtained on the diagram, then evidently the velocity is *variable*.

If we only knew the points O and P on the diagram, being ignorant of the other times and spaces, we could only state that the quotient  $s/t$  for these points expressed the *mean* velocity.

Suppose now that, for the motion illustrated by the curved line OBPB, the instantaneous velocity at P is required.

Then we take a near point Q on the curve, draw Qs' parallel to OX and QMt' parallel to OY, cutting OY and OX in s' and t' respectively, PMK being parallel to OX. Then, by the statement of the preceding article, the mean velocity from t to t' is

$$\frac{s' - s}{t' - t} = \frac{MQ}{PM}$$

And the instantaneous velocity at t is obtained as the limit of the above quotient when Q is taken nearer and nearer to P. But as Q is taken ever nearer and nearer to P, the straight line QP changes from a chord to the *tangent* to the curve at P. Hence the required limiting value of the quotients will be obtained by drawing the tangent PT at P, letting fall the perpendicular TK upon PK and taking the quotient  $KT \div PK$ . But this is the trigonometrical tangent of KPT, or is  $\tan \theta$  say.

We accordingly have for the *instantaneous* velocity at P

$$u = \text{limit of } \frac{s' - s}{t' - t} = \frac{KT}{PK} = \tan \theta \quad . \quad . \quad . \quad (3)$$

Here the  $KT \div PK$  or the corresponding  $\tan \theta$  must be interpreted according to the scales used for the space and time.

We thus see that the steeper the curve the greater the speed. Consequently the curved graph, having the same mean speed to P, but initially a less speed than the straight-line graph, has later a greater speed than it.

**12. Speed Graphs.**—We may now make graphs by plotting speeds as the ordinates instead of spaces, times still being used as the abscissæ. Fig. 4 illustrates this process applied to the two examples previously plotted, the letters AA and BB corresponding in the two figures.

The former inclined graph here becomes a horizontal one, as shown by APA. And the former curved graph reduces to a straight but inclined line OBPB.

For in the case of the A graph in Fig. 3 we had the relation

$$s = vt \quad . \quad . \quad . \quad . \quad . \quad . \quad (4)$$

where  $v$  was a constant. Consequently this constant  $v$  is here the constant ordinate of the A graph, which is therefore horizontal.

Again, for the B graph in Fig. 3 on examination it would be found that the value of  $\tan \theta$  for any point on the curve is proportional to the abscissa of that point. Accordingly the speed is proportional to the time, and in Fig. 4 the ordinate must be

proportional to the abscissa of the B graph. It is therefore an inclined straight line through the origin.

On a speed graph the area of the space below the graph has an important meaning. Thus, if we consider the space  $OvPt$  below the A graph, we see that the *area* of this rectangle is given by the product  $vt$ . But this is obviously the *space* passed over during the time  $t$  by the point to which the graph refers.

And if the graph, instead of being horizontal or slightly inclined, were wavy, still for each narrow vertical strip the area would be

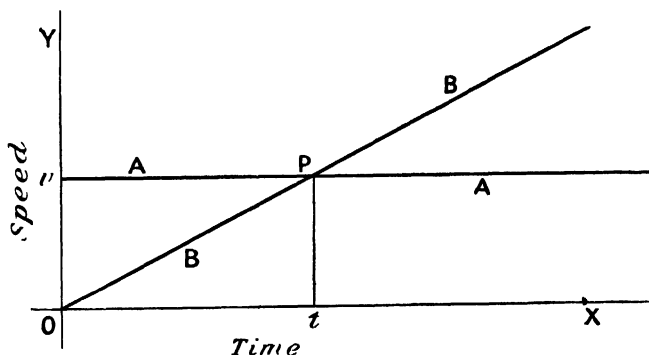

FIG. 4.—Speed-Time Graphs.

a speed multiplied by a time and therefore equal to the corresponding space. Thus the *total area* under any part of any graph would be the *total space* passed over in the corresponding time, for it would be the sum of small areas each of which represented the space for the small time in question.

#### EXAMPLES IV.

1. After 1, 2, 3, 4, 5, 6 and 7 minutes from rest a train is respectively  $\frac{1}{3}$ ,  $\frac{1}{2}$ ,  $1$ ,  $1\frac{1}{2}$ ,  $2\frac{1}{2}$ ,  $3$  and  $3\frac{1}{4}$  miles from its starting station. Plot a space-time graph of its journey.

2. From the graph for the previous question find the mean speeds (in miles per minute) for the *first* minute, the *second* minute, and the *last* minute. Also the instantaneous speed at the end of the *first* minute.

3. A ball rolling down a groove on a slope is observed at succeeding seconds to be at distances of 1, 4, 9, 16, 25, 36, 49, 64, 81 and 100 inches from its starting point. Plot a space-time graph of the motion and find the speeds after 2, 4, 6 and 8 seconds.

4. A train starts at 12 noon and at 1, 2, 3, 4, 5 and 6 minutes after has the speeds 30, 50, 60, 60, 60 miles per hour and zero respectively. Plot a graph for its motion and find the distance covered in this six-minute run.

5. In successive minutes from the start an aeroplane is observed to have covered  $\frac{3}{4}$ ,  $2$ ,  $3\frac{1}{4}$ ,  $5$ ,  $7$ ,  $9$ ,  $10$  miles. Plot the graph of its flight and find the mean speed and maximum speed.

6. A man walks 15 miles along a high-road and finds his times for the successive miles to be  $11\frac{1}{2}$ ,  $11$ ,  $11\frac{1}{4}$ ,  $10\frac{3}{4}$ ,  $11$ ,  $11$ ,  $10$ ,  $10$ ,  $10$ ,  $10$ ,  $10\frac{1}{2}$ ,  $11$ ,  $11$ ,  $11$ ,  $11\frac{1}{2}$ ,  $12\frac{1}{2}$  minutes. Plot a graph of the journey and find his mean and greatest speeds.

13. **Acceleration.**—We saw that in the space graph, slope meant speed, or magnitude of velocity. It is now necessary to note what meaning the slope may have on a speed graph. Obviously the slope here means rate of increase of speed. And this rate of increase is the *magnitude* of a quantity called *acceleration*, which includes the *direction* of this rate of increase as well as its magnitude.

This acceleration, like velocity, has both magnitude and direction, and, like velocity, may be uniform or variable. In the present work we shall usually confine attention to accelerations which are constant in magnitude or in direction or in both.

Let us now consider the last case, which is the simplest of all. Suppose a point with initial speed  $u$  to have an acceleration in the

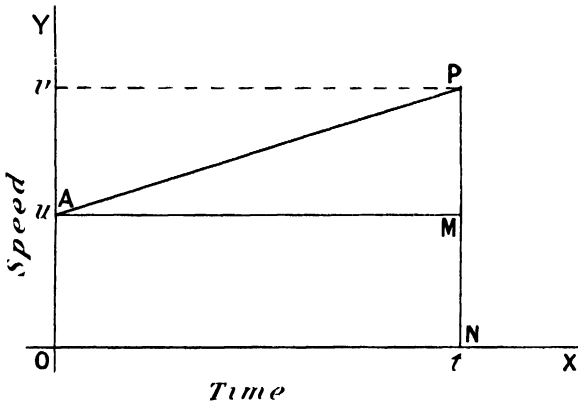

FIG. 5.—Uniform Acceleration.

same direction of constant value  $a$ , then at time  $t$  the speed  $v$  is given by

$$v = u + at \quad . . . . . (1)$$

For, by definition, the acceleration  $a$  is the speed added per second; thus, in  $t$  seconds the speed  $at$  must be added to the initial speed  $u$  to give the final speed  $v$ . This may be shown by a speed graph, in which the line is inclined to indicate the increase of speed at the rate  $a$  per second and is made to cut OY at the value  $u$  of the initial speed (see Fig. 5).

If we now inquire what space  $s$  is described in the above motion, we may obtain it from the area under the speed graph AP in Fig. 5. Thus, the area consists of the rectangle AMNO and the triangle APM. But the areas of these are respectively  $ut$  and

$$\frac{1}{2}(MP \times AM) = \frac{1}{2}(at \times t)$$

We accordingly find

$$s = ut + \frac{1}{2}at^2 \quad . . . . . (2)$$



Or, instead of using this fractional form, we may write the right side in the index form. Thus

$$v = s^{+1}t^{-1}$$

This gives rise to the statement that velocity is of *dimensions plus one in length and minus one in time.*

Similarly, we may write for acceleration

$$a = v/t = s^{+1}t^{-2}$$

Accordingly, acceleration is said to be of dimensions plus one in length and minus two in time.

It is seen that the term *dimensions* here applies to the *indices* of the various fundamental quantities which appear as factors in the expression for a derived quantity.

Thus, area is of two dimensions in length and volume of three, since the one involves length and breadth and the other thickness also.

**15. Fundamental and Derived Units.**—The consideration of the natures of the various quantities dealt with in mechanics naturally leads to that of the units in which they are expressed. And here the conception of dimensions is very useful. For it shows how a derived unit changes in size when the fundamental units involved by it are changed. It was pointed out in Art. 5 that if the unit in which a quantity is expressed is multiplied by any factor, the number expressing it is divided by the same factor. Hence, if the unit is a derived one, we must first find from dimensions how it changes when the fundamental units are changed. Then the number expressing the quantity in this new derived unit changes inversely as the unit does.

Thus, suppose we express an area as 432 square inches and it is required to change the linear unit from the inch to the foot = 12 inches. Then since the derived unit of square measure or area is length to the power *two*, it changes to  $12^2 = 144$  times the former unit. But the unit being multiplied by 144 the number must be divided by 144. Hence the area in question is 3 square feet. A compact way of working all such transformations is as follows :—

$$432 \text{ (inch)}^2 = \frac{432}{12^2} (12 \text{ inch})^2 = 3 \text{ sq. ft.}$$

This example is very simple, but it is well to note carefully the method in a case so familiar. Take next the change from second to minute as unit of time, the derived quantity being an acceleration. Then we may write

$$32 \frac{\text{ft.}}{\text{sec.}^2} = 32 \times 60^2 \left\{ \frac{\text{ft.}}{(60 \text{ sec.})^2} \right\} = 115,200 \frac{\text{ft.}}{\text{min.}^2}$$

Here it will be seen that the unit of time is increased sixty-fold, and yet the number expressing the acceleration is increased sixty

times sixty-fold. But this is because when the unit of time is *increased* by any factor the unit of acceleration is *decreased* by the *square* of that factor, and therefore the number *increased* by that *square* as shown numerically.

## EXAMPLES VI.

1. A railway carriage wheel running over rails 15 yards long gives 20 jolts at the joints in 10 seconds. Find the speed of the train in miles per hour.
2. A bicycle is geared up to 70 inches and the pedals make 20 revolutions in  $12\frac{1}{2}$  seconds: what is the rider's speed in miles per hour? (Take ratio of circumference of a circle to its diameter as  $22/7$ .)
3. If a train passes a quarter-mile post every 35 seconds, find its speed in miles per hour.
4. Show that a train at 60 miles per hour makes nearly 3 jolts per second on the joints of 10-yard rails. Hence frame an approximate rule for train speeds on such rails.
5. If a London tube train attains in half a minute from the start a speed of 30 miles an hour, what is its mean acceleration in foot-second units?
6. Transform a speed of 60 miles an hour and an acceleration of 32 feet per second per second to C.G.S. units.
7. Given that the speed of light is thirty thousand million centimetres per second, express it in feet per second and in miles per hour.
8. Taking the equatorial circumference of the earth to be 25,000 miles, what is the speed in feet per second of a place on the equator in consequence of the earth's diurnal rotation?
9. A certain part of a vibrating bar has at one instant a speed of 30 miles per hour and  $1/500$ th of a second later is momentarily at rest. What is its mean acceleration in foot-second units during that time?
10. If the acceleration due to gravity at some locality is 32.2 in foot-second units, what is its value in centimetre-second units and what in foot-minute units?

**16. Composition of Velocities and Accelerations.**—Since velocities have direction like displacements, it is obvious that two inclined velocities simultaneously possessed by any point may be compounded like displacements, as shown in Art. 8. The same remark applies to the compounding of accelerations with accelerations.

The composition of a velocity and constant acceleration along the same line has been dealt with in Art. 13.

The composition of a velocity and an acceleration *not* along the same line is reserved for a later article (18), as it involves new conceptions and requires special consideration.

**17. Angular Velocity.**—Suppose a point P is describing a circle of radius  $r$  at linear speed  $v$ , and let it be required to find the angle per second described by the radius CP. This is called the *angular velocity* of P about C.

Let the point pass over the arc  $s$  from P to Q in time  $t$  (see Fig. 6), the angle PCQ being called  $\theta$  radians. Also let us denote by  $\omega$  the angular velocity in radians per second. Then by definition we have

$$\omega = \frac{\theta}{t} = \frac{s/r}{t} = \frac{v}{r} \quad \dots \dots \dots (1)$$

We may also note that the linear velocity at P has the direction of the tangent there or is perpendicular to CP. Similarly the linear velocity at Q is perpendicular to CQ. Hence when a point is describing a curve of radius  $r$  with speed  $v$  its linear velocity is changing direction with angular velocity

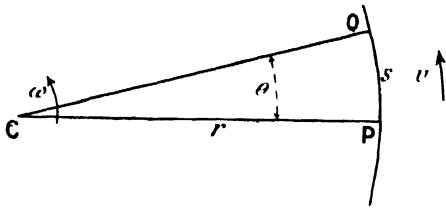

FIG. 6.—Angular Velocity.

$$v \div r = \omega, \text{ say } . \quad (2)$$

Conversely, if a linear velocity  $v$  is changing in direction only at angular velocity  $v \div r = \omega$ , the moving point describes a curve of radius

$$r = v \div \omega . . . . . (3)$$

18. **Uniform Circular Motion.**—We now consider the composition of a velocity  $v$  and an acceleration  $c$  constant in magnitude but varying in direction so as to be always at right angles to  $v$ .

The velocity  $v$  at a certain instant is denoted by OV in Fig. 7, and the acceleration  $c$  is at the same instant in the direction VR. Then in any very small time,  $t$  say, this acceleration will generate a velocity  $ct$ , as shown by VR in the figure. Thus, these two velocities,  $v$  and  $ct$  or OV and VR, compound to give the resultant OR. But since the acceleration was to be always perpendicular to the velocity, the time  $t$  must be taken so small that the angle VOR =  $\theta$  is very small. Hence (i) OR = OV nearly, *i.e.* the velocity  $v$  is unchanged in magnitude; and (ii)  $\tan \theta = \theta$  nearly. Thus we may write



$$\theta = \frac{ct}{v} \text{ or } \frac{\theta}{t} = \frac{c}{v} = \omega \text{ say } . . . . . (4)$$

where  $\omega$  is the angular velocity of the direction of the linear velocity.

Hence the velocity  $v$  changes its direction at the constant angular velocity given in (4). Therefore, the moving point describes a circle whose radius  $r$  is found from (3) and (4) to be

FIG. 7.—Circular Motion.

$$r = v \div \frac{c}{v} = \frac{v^2}{c} . . . . . (5)$$

Or, if a point moving with velocity  $v$  is to be made to describe a circle of radius  $r$  it needs, compounding with that velocity, a perpendicular acceleration  $c$  of magnitude

$$c = \frac{v^2}{r} . . . . . (6)$$

It is seen that Figs. 6 and 7 correspond; the first shows the actual path of the moving point described with velocity  $v$ . Fig. 7 shows by VR a portion of what is called the *hodograph*. This portion corresponds to PQ on the actual path. It is seen that the hodograph is described at a rate corresponding to the *acceleration* of the actual moving point. Also that the radii OV, OR from the *pole* O represent in magnitude and direction the velocities in the path. And this is the method of construction for any hodograph.

By using (4) in (5) and (6) we obtain the alternative expressions

$$r = \frac{c}{\omega^2} \text{ and } c = \omega^2 r \quad . \quad . \quad . \quad . \quad (7)$$

#### EXAMPLES VII.

1. While a boat is steaming due north at 12 miles an hour a passenger hurries across the deck at 5 miles an hour. What is his speed relative to the land?

2. A boat sails north-east at the speed of 10 knots,<sup>1</sup> and its vane makes the wind appear to come from due east; but it is known from boats in the harbour that the wind is really from the south-east. What is the *real* speed of the wind and its *apparent* speed to those on the boat?

3. A shot fired due south strikes a railway truck which is proceeding due west at 20 miles an hour. The truck is 6 feet wide and the shot holes left in the opposite sides are one in advance of the other by exactly an inch. What was the speed of the shot in feet per second?

4. From an aeroplane at a height of 1000 yards, while proceeding horizontally at 80 miles per hour, a bomb is let fall. Find the direction and speed with which it strikes the ground (take  $g = 32 \text{ ft./sec.}^2$ ).

5. A shaft runs at 80 revolutions per minute: what is its angular velocity in radians per second, and what is the linear velocity of the rim of a pulley 6 feet diameter fast on the shaft?

6. What are the angular velocities of the hour, minute and seconds hands of a watch in radians per second? What is the linear speed of the tip of the minute hand of the clock on the Houses of Parliament, taking its radius as 16 feet?

7. An emery wheel a foot diameter makes a thousand revolutions per minute. What is the acceleration of its periphery?

8. A train at 30 miles an hour takes a curve of radius 968 feet. What is its acceleration at right angles to the rails?

---

<sup>1</sup> A *knot* is a unit of speed, being 1 *nautical mile* (or 6080 feet) per hour.

## CHAPTER III

### KINETICS

19. **Physical Basis.**—To change from kinematics to kinetics we need the introduction of mass and force. For kinematics considers motions purely or in the abstract without regard to any actual body moving or the details of the conditions under which those motions might occur.

The principles of kinetics were enunciated in Latin by Newton in his celebrated definitions and laws of motion. The latter may be translated as follows.

**Newton's Laws of Motion.**—**LAW I.**—*Every body perseveres in its state of rest, or of uniform motion in a straight line, except in so far as it is compelled to change that state by forces impressed on it.*

**LAW II.**—*Change of motion is proportional to the moving force impressed, and takes place in the straight line in which that force is impressed.*

**LAW III.**—*An action is always opposed by an equal reaction; or, the mutual actions of two bodies are always equal and act in opposite directions.*

The wording of these laws and the accompanying definitions have been much criticised of late years. To a smaller extent their substance also has been disputed. Considerations of space, however, preclude any detailed discussion of the subject here. Perhaps the chief difference between the Newtonian and the modern views lies in the definition of mass. At the outset Newton had stated:—

**DEFINITION I.**—*Quantity of matter is the measure of it arising from its density and bulk conjointly.*

This quantity of matter is sometimes called the body or mass.

To this it has been objected that density should not have been used in defining mass, since it is itself defined as the quotient of mass and volume.

The present view about mass supposes particles to act upon each other (by attraction, repulsion, collision or any kind of spring connection) and so produce in each other *mutual accelerations*. Then the definition based upon this interaction may be stated as follows.

**Modern Definition of Mass.**—*The masses of particles are positive constants, inversely as their mutual accelerations.*

This may be put in symbols thus—

$$\frac{m}{m'} = -\frac{a'}{a} \dots \dots \dots (M)$$

where the *m*'s denote the masses and the *a*'s their mutual accelerations.

The next important difference between the classic and the modern view has reference to force. Newton may be said to have given a preliminary negative conception of force in his first law. He then offered a method of measuring force in his second law. But, if the definition of mass is unsound, anything based upon it may be unsound also.

The more recent view as to force may be expressed as follows.

**Modern Definition of Force.**—*Force is the product mass into acceleration, and has the direction of the acceleration,*

Or, in symbols,

$$F = ma \dots \dots \dots (N)$$

where *F* is the force, *m* the mass, and *a* the acceleration.

These definitions are based upon an acknowledged law of nature, which may be put thus:

**Modern Law of Motion.**—*Accelerations occur only in opposite pairs, whose ratios are constant for given particles.*

Or, in symbols—

$$-a \propto a' \dots \dots \dots (L)$$

where the *a*'s refer to the mutual accelerations of interacting particles.

On comparing these three modern statements, or their equivalent symbolic expressions in (L), (M), and (N), with Newton's laws of motion and his definition of mass, it will be seen that the new and the old cover practically the same ground. For (L) and (M) replace Newton's Law III. and Definition I., and (N) replaces Laws I. and II.

It is still, however, a matter of controversy as to whether the classic or the modern enunciations are on the whole preferable. Both may have to give place to something as yet unformulated. The reader may accordingly choose which he shall adopt. The matter is treated at some length in the author's *Analytical Mechanics*, chap. xi. (London, 1911), to which those interested are referred.

The student must specially seize the following fundamental points:—

(1) To every body may be assigned a *positive constant* which measures its *mass*, inertia, or sluggishness.

(2) When the body of a mass *m* has an acceleration *a*, the *force F* concerned is measured by the *product ma*; and at the same time—

(3) Some other body of mass *m'* has an acceleration *a'* such that *m'a' = -ma*, or *F' = -F*.

20. **Momentum and Impulse.**—On multiplying the kinematical equations for a point's motion by the mass  $m$  of a particle we transform it into a kinetical equation for the motion of this particle.

Thus, take first equation (1) from Art. 13, and write it in the form

$$v - u = at \quad . \quad . \quad . \quad . \quad . \quad (1)$$

Then, multiplying throughout by  $m$ , we obtain

$$mv - mu = mat = Ft \quad . \quad . \quad . \quad . \quad . \quad (2)$$

the expression on the extreme right following from the definition of force (N) in Art. 19.

But, just as it is convenient to have the name force and the symbol  $F$  for the product  $ma$ , so it is convenient to have names and symbols for the products  $mv$  and  $Ft$ . The names are respectively *momentum* and *impulse*, which we here denote by  $P$  and  $Q$  respectively. Thus (2) may be abbreviated to

$$P - P_0 = Q \quad . \quad . \quad . \quad . \quad . \quad (3)$$

where  $P_0 = mu$  is the initial momentum.

It will thus be seen that momentum and impulse are of the same nature, but the former term is used when we are thinking of the product mass and velocity actually possessed at any instant, the latter when we are thinking of the product force and time during which it acts. Further, this product called impulse is the addition to the momentum during the time in question.

21. **Energy and Work.**—We may now take equation (3) of Art. 13, write it in the form

$$\frac{1}{2}v^2 - \frac{1}{2}u^2 = as \quad . \quad . \quad . \quad . \quad . \quad (4)$$

and then multiply by  $m$ . We thus obtain

$$\frac{1}{2}mv^2 - \frac{1}{2}mu^2 = mas = Fs \quad . \quad . \quad . \quad . \quad (5)$$

But here again we have new products for which names and symbols are desirable. The product  $\frac{1}{2}mv^2$  is called the *kinetic energy* of the particle of mass  $m$  at speed  $v$ , and will be denoted by  $T$ . The product  $Fs$  is called the *work* done by the force  $F$  in the displacement  $s$  and will be denoted by  $W$ . Thus, using  $T_0$  for the initial value of  $T$ , (5) becomes

$$T - T_0 = W \quad . \quad . \quad . \quad . \quad . \quad (6)$$

an equation analogous to (3) of Art. 20.

Thus work and energy are of the same nature; but  $T$  and  $T_0$  denote the energies possessed at particular speeds and express them in terms of those speeds and the mass, whereas  $W$  denotes the difference of the energies and expresses that difference in terms of the force  $F$  and the displacement  $s$ .

We may sum up equations (3) and (6) by the statements—

(1) *Change of momentum equals impulse ;*

(2) *Change of kinetic energy equals work.*

Having regard to the meanings of impulse and work, we can derive from the foregoing the following statements, viz.—

(3) *Force is the time-rate of change of momentum ;*

(4) *Force is the space-rate of change of kinetic energy.*

These last might be put in equations thus—

$$F = \frac{P - P_0}{t} \quad . \quad . \quad . \quad . \quad . \quad . \quad (7)$$

$$F = \frac{T - T_0}{s} \quad . \quad . \quad . \quad . \quad . \quad . \quad (8)$$

EXAMPLES VIII.

1. Give Newton's three laws of motion and explain them as far as you can.
2. State Newton's definition of mass and also its modern substitute. Which seems to you preferable ?
3. Give in simple words a modern law of motion and definitions of mass and force. Illustrate by some concrete example the modern law of motion.
4. Explain what is meant by momentum and impulse, and show that the dimensions of each are the same. Illustrate the transformation of one of these quantities into the other by some simple experiment that any one could carry out.
5. From a kinematical equation derive another involving impulse and momentum.
6. By the introduction of mass into a well-known kinematical equation show that *work* equals the increase of *kinetic energy*.
7. Give a definition of force and then express it in two other ways involving respectively momentum and kinetic energy.

**22. Kinetical Units.**—We must now consider the units in which the various quantities just dealt with may be expressed. Now mass is the only new fundamental quantity which has been introduced, the others being all derived from it by taking products. Hence we only need one new fundamental unit, that for mass; the other units will then be derived from it on the principles of Art. 5, and in accordance with the relations developed in Arts. 20 and 21.

The units of mass that we are chiefly concerned with are the *pound* avoirdupois and the *gram*. The former, used in conjunction with the foot and second, gives the British (or *f.p.s.*) system of units. The latter, with the centimetre and second, gives the international (or *c.g.s.*) system of units.

The unit of force in the *c.g.s.* system is called the *dyne* and follows from the gram by the equation  $F = ma$ . In the British system, if we adhere to the same definition of force, the unit of force is called a *poundal* and is about half an ounce weight. For, a force equal to the weight of a pound gives to the mass of a pound the acceleration  $g (= 32.2 \text{ ft. per sec. per sec. nearly})$ , hence this force must

be called  $g$  poundals; therefore one poundal, corresponding to unit acceleration, is the weight of a pound  $\div g = \frac{1}{32}$  oz. wt. nearly.

In the engineers' system of British units the *pound weight*, or weight of one pound, in London, is taken as the unit force. The unit mass then becomes the *slug* of  $g$  lbs., if the relation  $F = ma$  is retained; or if the unit of mass is still the pound avoirdupois the relation  $F = Wa/g$  is then used for force, in which  $W$  is the weight of a body in pounds weight, and  $a$  the acceleration it experiences under the action of the force  $F$ .

It is well to note that the very fundamental relation

$$\frac{F}{W} = \frac{a}{g} \quad . \quad . \quad . \quad . \quad . \quad . \quad (1)$$

holds good for any of these systems;  $F$  and  $W$  being in any the same units of force,  $a$  and  $g$  being in any the same units of acceleration.

For equation (1) agrees with that given in the text just above for the British engineer's system; and for the *f.p.s.* or *c.g.s.* systems,  $W = mg$ , so (1) becomes  $F = ma$ .

The *c.g.s.* unit of energy or work is the *erg* and corresponds to one gram at a speed of one cm. per sec., or one dyne exerted through a centimetre.

The British units of energy and work are the *foot-poundal* and the *foot-pound weight* (usually called the *foot-pound*), corresponding to the two units of force previously noted.

The units of momentum and impulse in any system are the products of unit mass and unit velocity or of unit force and unit time in each such system. These units have not yet received any generally accepted names.

The foregoing relations are collected in Table II. with additional information as to the relative sizes of the British and *c.g.s.* units.

#### EXAMPLES IX.

1. Give the British unit of mass and, by using the relation  $F = ma$ , derive the corresponding unit of force, showing that it is rather less than half an ounce weight.
2. If the weight of one pound avoirdupois is taken as the unit of force, what must be the unit of mass if we adhere to  $F = ma$ ?
3. Suppose we take the pound as the unit of mass and its weight as the unit of force, what is then the relation between force  $F$  acting on a body, its weight  $W$  and its acceleration  $a$ ? Illustrate your answer by some numerical case.
4. Write a simple relation between force, weight, and acceleration which holds for any system of units. Use it to find the acceleration of 1 lb. which in descending vertically drags 3 lbs. along a smooth horizontal plane by a connecting cord which passes over a pulley.
5. A force of 1050 dynes acts upon a mass of 300 grams: find the acceleration which occurs.

TABLE II.—MECHANICAL UNITS.

Units in each System.						
Systems of Units.	Length.	Mass.	Time.	Force.	Energy and Work.	Momentum and Impulse.
International or C.G.S. ( $g=981$ nearly)	Centimetre = 0'032809 ft. nearly	Gram = 0'0022046 lb. nearly	Second of mean solar time	Dyne = 1 gm. cm./sec. <sup>2</sup> = $\frac{1}{g}$ of 1 gm. wt.	Erg = $\frac{1}{10}$ gm. cm. <sup>2</sup> /sec. <sup>2</sup> = 1 cm. dyne	A gram at a cm. per sec. = a dyne for a second.
British or F.P.S. ( $g=32\cdot2$ nearly)	Foot = 30'48 cm.	Pound ( <i>avoirdupois</i> ) = 453'59 gm. nearly	Second	<i>Poundal</i> = 1 lb. ft./sec. <sup>2</sup> = $\frac{1}{g}$ of 1 lb. wt.	Foot-poundal = $\frac{1}{16}$ lb. ft. <sup>2</sup> /sec. <sup>2</sup>	A pound at a foot per sec. = a poundal for a second.
Engineers' or F.S.S. ( $g=32\cdot1912$ at sea-level in London)	Foot = 30'48 cm.	<i>Slug</i> <sup>1</sup> = $g_0$ lbs.	Second	Weight of a pound at sea-level in London = $g_0$ poundals	Foot-pound (wt.) = $\frac{1}{16}$ slug ft. <sup>2</sup> /sec. <sup>2</sup>	A slug at a foot per sec. = a lb. wt. for a second.

<sup>1</sup> Or the *pound* may be used as the unit of mass, the unit force being then connected with the other quantities as follows:—

$$-F \text{ lbs. wt. at sea-level in London} = \frac{W \text{ lbs.} \times a \text{ ft. per sec. per sec.}}{32\cdot1912}$$

23. **Conservation of Energy.**—Let a particle of mass  $m$  be projected from a point P (see Fig. 8) near the earth's surface with an

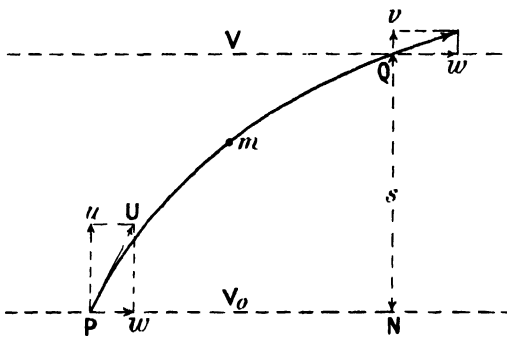

inclined velocity  $U$  whose components are  $u$  and  $w$  vertically and horizontally. Thus, its vertical acceleration is  $-g$  and its horizontal acceleration is zero. After time  $t$  let the particle be at  $Q$  at a level  $s$  higher than  $P$ . Then, we still have

FIG. 8.—Conservation of Energy.

$$\text{horizontal component of velocity} = w \quad \dots \quad (1)$$

Also, the vertical component of the velocity is given by

$$v = u - gt \quad \dots \quad (2)$$

Again, for the height risen, we have

$$s = ut - \frac{1}{2}gt^2 \quad \dots \quad (3)$$

Consider now the kinetic energy of the particle. Initially it was

$$T_0 = \frac{1}{2}mU^2 = \frac{1}{2}m(u^2 + w^2) \quad \dots \quad (4)$$

After time  $t$ , it is given by

$$T = \frac{1}{2}m(v^2 + w^2) \quad \dots \quad (5)$$

Hence, the loss of kinetic energy during time  $t$  while the particle passes from  $P$  to  $Q$ , is

$$T_0 - T = \frac{1}{2}m(u^2 - v^2) = \frac{1}{2}m(2gs) = mgs \quad \dots \quad (6)$$

and equals the work done against gravity, being the product of weight  $mg$  and height  $s$ .

But though the particle has lost kinetic energy it has obtained an equivalent advantage of position. For, by falling through the height in question, it could regain its original kinetic energy, as may be found by the ordinary equations of uniform acceleration. And the loss of kinetic energy depends only on the three factors at the right in (6), hence for the given body a value could be assigned for each level expressing its advantage of position there. The quantity thus expressed is called the *potential energy* of the body, and will be denoted by  $V$ . Since, as kinetic energy diminishes potential energy increases by an equal amount, their sum will remain constant. The present case is a simple example of the principle of the *conservation of energy*.

The matter may be put in equations as follows :—

$$V - V_0 = mgs = T_0 - T \quad . \quad . \quad . \quad (7)$$

$$T + V = T_0 + V_0 = \text{constant} \quad . \quad . \quad . \quad (8)$$

Or in words thus: The total energy of a system remains constant in spite of any transformations due to the interaction of its parts, provided that the system neither receives energy from nor gives energy to any other system outside itself.

It may be seen that only the law of *change* of potential energy with height is hereby settled, the *absolute* value assigned in a given position being arbitrary and usually chosen for convenience. For example, the potential energy of a projected particle may be called zero on the earth's surface, that of the bob of a pendulum may be called zero at the lowest point of its course, etc., etc.

The student should carefully notice that in (6) and (7) if the mass is in lbs. the kinetic energies are in foot-pounds.

**24. Activity : Horse-Power.**—The rate of doing work of any agent, engine or machine is called its *activity*. It may be measured by ergs per second, or foot-pounds per second, etc. It is, however, very frequently measured by the somewhat arbitrary unit called a *horse-power*, which is 550 ft.-lbs. weight per second, or 33,000 ft.-lbs. per minute.

Many of the statements about the horse-power of motor cars or cycles are misleading unless it be remembered that the engine can only develop the full power named at a certain fairly high speed. Thus when most is wanted of it, say, in starting uphill from rest, it may only be capable of a very small fraction of the nominal value.

#### EXAMPLES X.

1. A pendulum bob is one inch higher at the ends of its swing than at the middle point. What speed will it have there? Calculate also the kinetic energy of the bob at its lowest point if its mass is 3 lbs.

2. Explain carefully what you understand by the conservation of energy. Does it apply to the pendulum of an ordinary clock?

3. What kinetic energy will a 20-lb. body gain in falling from the top of a tower 300 ft. high? How far would it penetrate at the foot into material resisting it with a force of a ton weight?

4. A twelve-stone man ascends a 3000-ft. mountain in two hours and two minutes: at what mean horse-power did he work?

5. If in the ascent of the previous question part of the route was downhill, so that a gross rise of 3600 ft. occurs, and was made in an hour and three quarters, what was the mean horse-power during the ascending part of the route?

6. If a motor cycle weighing 200 lbs. carries a rider of 180 lbs. up a gradient of 1 in 12 at 25 miles an hour, what horse-power is it exerting apart from its own friction and the road and wind resistances?

7. What is the horse-power of a waterfall 100 ft. high which receives water of density  $62\frac{1}{2}$  lbs. per cubic foot, flowing at 1 mile an hour over a channel whose width is 100 yds. and its depth 20 ft.?

## CHAPTER IV

### STATICS

25. **Forces at a Point.**—It was shown in Arts. 7 and 8 that two displacements applied to a given point could be compounded by the parallelogram law or method. But we pass from displacements to velocities by dividing by time, then from velocities to accelerations by a second time division, and finally from accelerations to forces on multiplying by mass. Hence the construction that was established for the composition of displacements must be valid for that of forces also.

Thus let forces  $P$  and  $Q$  be applied to a point  $O$ , as represented in Fig. 9, by  $OP$  and  $OQ$  at an angle  $\alpha$ .

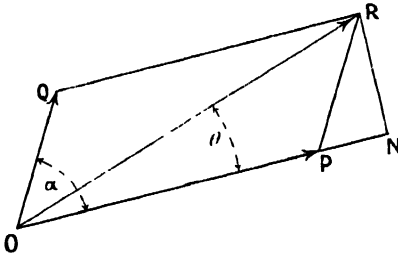

FIG. 9.—Composition of Forces.

Complete the parallelogram on  $OP$  and  $OQ$ , and draw from  $O$  the diagonal  $OR$ . Then this diagonal represents in magnitude and direction the resultant force obtained by compounding the two component forces given.

Let us now obtain analytically the magnitude  $R$  of this resultant and its direction, as specified by the angle  $\theta$  which it makes with  $OP$ . If necessary produce  $OP$  and let fall upon it from  $R$  the perpendicular  $RN$ .

Then we have from the figure,

$$\begin{aligned} OR^2 &= (OP + PN)^2 + NR^2 \\ &= OP^2 + 2 \cdot OP \cdot PN + PN^2 + NR^2 \\ &= OP^2 + 2 \cdot OP \cdot PR \cos \alpha + PR^2 \end{aligned}$$

or, using the single letters throughout for the components and resultant,

$$R^2 = P^2 + Q^2 + 2PQ \cos \alpha \quad \dots \quad (1)$$

Again, 
$$\tan \theta = \frac{NR}{OP + PN}$$

or 
$$\tan \theta = \frac{Q \sin \alpha}{P + Q \cos \alpha} \quad \dots \quad (2)$$

Let it now be required to resolve the force  $R$  along given directions specified by the angles  $\alpha$  and  $\theta$  as shown in the figure. We may then use for the triangle  $OPR$  the property that any side divided by the sine of the opposite angle gives the same quotient. This gives

$$\frac{P}{\sin(\alpha - \theta)} = \frac{Q}{\sin \theta} = \frac{R}{\sin \alpha} \dots \dots (3)$$

from which  $P$  and  $Q$  are calculable.

In the last quotient  $\sin \alpha$  is written for simplicity instead of  $\sin(90^\circ - \alpha)$ , as the values are the same.

Obviously if the angles  $\alpha$  and  $\theta$  had not been specified there would have been an infinite number of ways of resolving the given force into two others. When, without further explanation, the component of a force along a particular direction is spoken of, it is understood that the two components are taken at right angles. Thus if the northerly component of a wind is referred to, it would be on the supposition that the other component was along the east and west line.

EXAMPLES XI.

Find the magnitude and direction of the *resultant* obtained by compounding the components  $P$  and  $Q$  inclined at the angle  $\alpha$  for the values given in numbers 1 to 4.

P.	Q.	$\alpha$
1. 30 dynes.	20 dynes	60°
2. 40 lbs. wt.	40 lbs. wt.	120°
3. 60 tons wt.	25 tons wt.	45°
4. 50 oz. wt.	60 oz. wt.	30°

In numbers 5 to 8 determine the components  $P$  and  $Q$  into which the given  $R$  may be resolved along directions as there specified.

R.	$\alpha$ (between $P$ and $Q$ )	$\theta$ (between $R$ and $P$ )
5. 70 lbs. wt.	90°	30°
6. 85 dynes	60°	30°
7. 20 poundals	80°	25°
8. 50 oz. wt.	120°	60°

9. If forces of 70 and 30 lbs. wt. give a resultant of 80 lbs. wt., at what angle are they inclined ?

10. Forces of 40 and 30 dynes act horizontally and vertically on a particle, show on a diagram the magnitude and direction of the force which will balance them.

11. Establish the relations between the resultant and its inclined components acting on a given point.

26. **Parallel Forces.**—Suppose now that we have two parallel forces  $P$  and  $Q$  applied at points  $A$  and  $B$  in a rigid body, and are required to find their resultant. The forces are represented by  $AP$  and  $BQ$  in Fig. 10. Now, since the body is rigid, we may without

changing the resultant apply two opposite but equal forces, AF and BG.

But these compounded with P and Q give respectively P' and Q', which produced back meet in O. They may then be resolved into forces parallel to the original ones.

Thus from P and F we have a force P along OCR and OF' as shown; and from Q and G we have a force equal to Q along OCR and OG' opposite to OF' and equal to it. Thus OF' and OG' annul

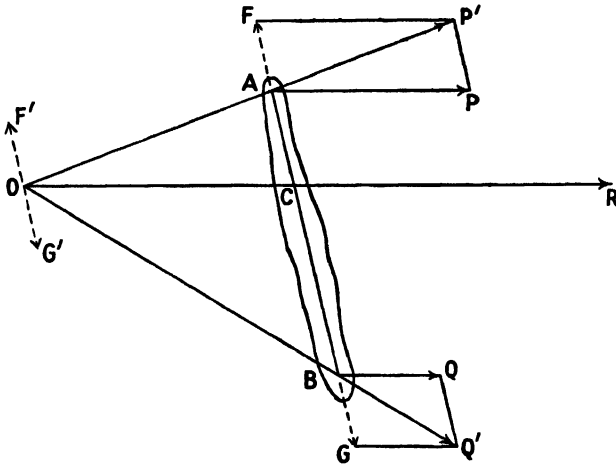

FIG. 10.—Parallel Forces.

one another, and we are left with the resultant along CR equal to the sum of P and Q, or

$$R = P + Q \dots \dots \dots (1)$$

The position of C may also be found from the geometry of the figure.

For

$$\frac{AC}{OC} = \frac{AF}{P} \quad \text{and} \quad \frac{CB}{OC} = \frac{BG}{Q}$$

Thus, since AF = BG, we find

$$P \cdot AC = Q \cdot CB$$

$$\text{or} \quad \frac{P}{CB} = \frac{Q}{AC} = \frac{R}{AB} \dots \dots \dots (2)$$

The last quotient in this series is obtained by adding numerators and denominators in the first and second.

The resultant R may be supposed as applied at any point of the body in the line OCR parallel to the forces P and Q. It should be noted that in equation (2) the orders of the letters indicate

lengths in the same directions; if any such length is negative, the length is in the opposite direction.

If the components act in opposite directions, they must have opposite signs, then the equations (1) and (2) still hold.

To picture the resultant in any case, as to position and direction, it is desirable to have in mind a set of three parallel forces in equilibrium. Then the resultant of any two is equal but opposite to the third and along the same line of action.

This is shown in Fig. 11, in which the three forces P, Q, S, applied at A, B, and C, are in equilibrium. Then the resultant of P and Q

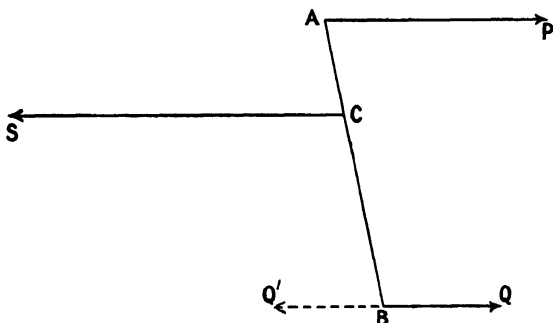

FIG. 11.—Equilibrating Parallel Forces.

is a force applied at C equal and opposite to S. Again the resultant of P and S is a force applied at B equal and opposite to Q as shown dotted by BQ'.

EXAMPLES XII.

1. Establish the formulæ that express the magnitude and position of the resultant of any two parallel forces.

2. Draw carefully a set of three parallel forces in equilibrium and then explain how to determine very simply the resultant of any two of these forces.

3. Forces of 3 and 6 lbs. wt. act vertically downwards at points 18 ins. apart. Find the magnitude and line of action of the resultant.

Find the magnitudes and positions of the resultants of the parallel forces specified in numbers 4 to 7.

At A.	At B	AB
4. 10 oz. wt. vertically up.	40 oz. wt. vertically up.	2 ft. 6 in.
5. 20 lbs. wt. northwards.	10 lbs. wt. southwards.	6 ft.
6. 400 dynes due east.	350 dynes due west.	10 cm.
7. 3 tons vertically down.	4 tons vertically down.	13 ft. 6 in.

8. What is the force which, with a vertically upward force of 20 lbs. wt., gives a downward force of 30 lbs. wt. five feet away? Also where does this force act?

27. **Moments.**—The moment of force about a point measures the twisting or turning effect of the force with respect to that point. It may be formally expressed thus.

**DEFINITION.**—The *moment* of a force with respect to a point is the *product of the force into the perpendicular* from that point upon the line of action of the force, and is reckoned *positive* when the direction of the force about the point is *counter-clockwise*.

**THEOREM.**—If two forces act at a point O, then the *algebraic sum of their moments* with respect to any point P in their plane is equal to the *moment of their resultant* about P.

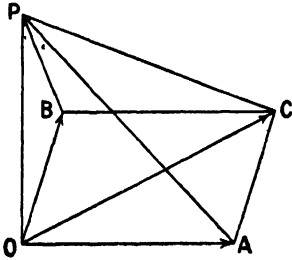

FIG. 12.—Theorem of Moments.

**PROOF.**—In Fig. 12 let the forces be at OA and OB and their resultant OC. Join O, A, B, and C to the point P about which the moments are to be taken. Then, on the figure the moment of OC about P is twice the area of the triangle OCP, and so for the other forces, we may thus write

$$\begin{aligned}
 \text{Half moment of OC} &= \text{area of } \triangle OCP \\
 &= \triangle OBP + \triangle OCB + \triangle BCP \\
 &= \triangle OBP + \triangle OAP^1 \\
 &= \text{half sum of moments of OB and OA.}
 \end{aligned}$$

When P is differently placed, the figure must be drawn accordingly, and then the proof follows in like manner, though it may involve differences instead of only sums.

Since parallel forces constitute a limiting case of inclined forces, where the angle between the forces vanishes, this theorem applies to them also.

It may be seen that the results obtained for parallel forces is in accordance with the present theorem, which indeed might have been used instead of the method of Art. 26.

**28. Couples.**—Let us now return to the parallel forces and suppose that we have two components in opposite directions but of equal magnitude. By equation (1) of Art. 26, the resultant has zero magnitude; and by equation (2) of the same article its point of application is at an infinite distance away.

Hence such a pair of forces cannot be reduced to a single equivalent force, but these forces must themselves be regarded as a new entity.

**DEFINITIONS.**—A pair of forces numerically equal and acting in opposite directions along parallel lines is called a *couple*. The plane containing these is the *plane* of the couple.

Any line perpendicular to this plane may be regarded as the *axis* of the couple.

The product, either force into their perpendicular distance apart, is called the *moment* of the couple.

<sup>1</sup> Because on equal base (OA=BC) and between the same total parallels (OA and parallel line through P) as the two triangles replaced by it.

Suppose a couple consists of forces of magnitude  $P$ , acting at a distance  $p$  apart. Consider their moments about a point whose perpendicular distance from the nearer force  $-P$  is  $r$ . The values are obviously

$$-Pr \text{ and } +P(p+r)$$

Hence, the algebraic sum of these moments is  $Pp$ , which is independent of  $r$ . Thus, the value which has been defined as the moment of the couple is the *algebraic sum of the moments* of its component forces with respect to *any point* in their plane. Hence, the axis of the couple (always perpendicular to its plane) may be taken as passing through any point in the plane without altering this moment.

**29. Reduction of Coplanar Forces.**—Suppose a number of forces in a given plane act in various directions at different points

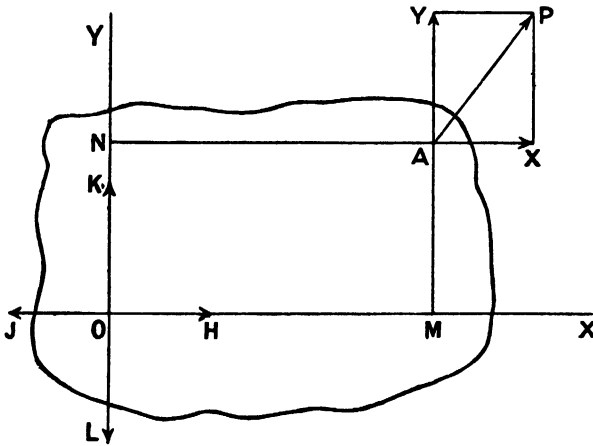

FIG. 13.—Reduction of Coplanar Forces.

of a rigid body. And let it be required to reduce them to their simplest equivalent. It will be found that this equivalent is, in general, a force applied at any prescribed point and a couple, and that these may then be further reduced to an equal force only, but applied along another line.

To establish this we may proceed as follows.

Let a force  $P$  of components  $X$  and  $Y$  act at a point  $A$  of coordinates  $x, y$ , as shown by  $AP, AX$ , and  $AY$  in Fig. 13, where  $OM = x$ , and  $ON = y$ . Then introduce at the origin  $O$  opposite forces,  $OH$  and  $OJ$ , parallel and equal to  $X$ . This will not alter the resultant of the system. But, taking  $OJ$  with  $AX$ , we obtain a couple in the plane of the diagram of value  $-X \cdot ON$ , since the direction is clockwise. This leaves  $OH$  at the origin. Hence the

component  $X$  at  $A$  reduces to  $X$  at  $O$  together with a couple of moment  $-Xy$ .

Similarly, to deal with the component  $AY$ , we introduce at the origin the opposite forces  $OK$  and  $OL$  each equal to  $Y$ . And, with the original  $AY$ , these give a force  $Y$  at the origin together with a couple  $+Yx$ .

But, as we have a number of forces distributed in the plane, we may distinguish them by the subscripts 1, 2, etc. What we have just proved for our force will accordingly apply to all. We thus obtain the scheme shown in Table III., in which  $U, V,$  and  $G$  are used for the sums of the force components along the axes and for the sum of the couples in their plane.

TABLE III.—REDUCTION OF COPLANAR FORCES.

Forces.	Coordinates of points of application.	Force components transferred to origin.		Couples in the plane of XOY.
		OX	OY	
$P_1$	$x_1, y_1$	$X_1$	$Y_1$	$Y_1x_1 - X_1y_1$
$P_2$	$x_2, y_2$	$X_2$	$Y_2$	$Y_2x_2 - X_2y_2$
...	...	...	...	...
$\Sigma P$		$\Sigma X = U$	$\Sigma Y = V$	$\Sigma(Yx - Xy) = G$

We may then further reduce the forces  $U$  and  $V$  to a resultant force of magnitude  $R$  and direction inclined  $\theta$  to  $OX$ , see Fig. 14, given by

$$R^2 = U^2 + V^2 \quad \dots \quad (1)$$

and  $\tan \theta = V \div U \quad \dots \quad (2)$

The couple still remains  $G = \Sigma(Yx - Xy) \quad \dots \quad (3)$

But we may finally reduce  $R$  and  $G$  to a force  $R'$  parallel and equal to  $R$  and which replaces both force and couple.

Thus, referring to Fig. 14, which shows  $U, V$  and their resultant  $R$ , let the couple  $G$  be formed of forces each equal to  $R$  and at a distance apart,  $r = G \div R$ , one of them being applied at  $O$  opposite to  $R$  as shown by  $OS$ , the other being  $O'R'$ . Then  $OS$  annuls  $OR$ , and we are left with the equal force  $O'R'$  parallel to  $OR$ , but transferred from  $OR$  by the perpendicular distance

$$r = G \div R \quad \dots \quad (4)$$

Equations (1) and (4) accordingly express the results obtained in the preliminary and final reductions of any set of coplanar forces acting on a rigid body. Of course, if either  $R$  or  $G$  vanish, no further reduction is possible.

30. **Equilibrium of Rigid Body under Coplanar Forces.**—Since force is the product of mass and acceleration, if any acceleration is to be zero, the corresponding force must be zero also. Hence,

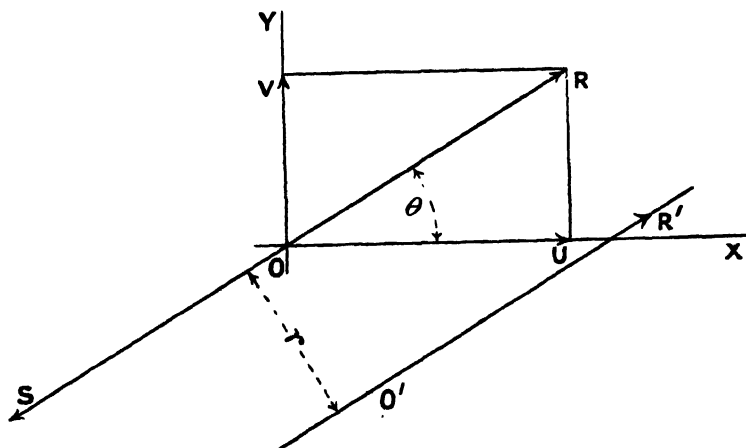

FIG. 14.—Reduction of Force and Couple.

for the condition of equilibrium of a rigid body under coplanar forces, we have

$$\Sigma X = 0, \Sigma Y = 0 \dots\dots\dots (5)$$

and  $\Sigma(Yx - Xy) = 0 \dots\dots\dots (6)$

or,  $U = V = G = 0 \dots\dots\dots (7)$

EXAMPLES XIII.

1. Define the *moment* of a force about a given point and show that the algebraic sum of the moments of two forces about any point equals that of their resultant about the same point.
2. Define a *couple* and show that the algebraic sum of the moments of its forces about any point in its plane is the same.
3. Explain carefully with diagrams, tables and equations, the method of reducing any coplanar forces to a single force acting at a given point and a single couple.
4. How may the reduction of the previous example be carried a stage further? When is this impossible?
5. Reduce the following system of coplanar forces to R and G:—

Components.		Co-ordinates.	
X	Y	x	y
dynes.	dynes.	cm.	cm.
4	3	1	2
2	6	5	8
7	9	4	6
8	5	7	3

6. A square ABCD of 8 ft. side has forces of 2, 3, 4, 5, and 6 lbs. wt. acting along the sides AB, BC, CD, DA and the diagonal AC respectively. Find the couple and the resultant at A and its angle with AB.

7. Along the sides AB, BC, and CA of an equilateral triangle of side 6 ft. forces of 3, 6 and 8 lbs. wt. act, also a force of 9 lbs. wt. along the median AD. Reduce this system to a single force, stating its magnitude, angle with AB, and the shortest distance from A to its line of action.

8. A figure ABCDE consists of a square ABCE of 4 ft. side and an equilateral triangle ECD. Forces act as follows: 4 lbs. wt. along AB, 2 along CE, 5 along AC, 6 along BE, and 7.72 along AD. Reduce the system to a force at A and a couple.

9. Along each side of a regular hexagon forces of 3 lbs. wt. act all counter clockwise, along the sides of the triangle whose corners are the alternate corners of the hexagon, forces of 2 lbs. wt. act all clockwise. Reduce the system as far as possible, given that the side of the hexagon is 4 ft.

**31. Density and Specific Gravity.**—The *density*  $d$  of any substance is the quotient, mass  $M$  of a portion of it divided by its volume  $V$ . The reciprocal of density, volume per unit mass, is called *specific volume*, and may be denoted by  $v$ . The *specific gravity*  $s$  of a substance is the ratio weight of a portion of it to the weight of the same volume of the standard substance. For solids and liquids the standard substance is water at  $4^{\circ}$  C. For gases, hydrogen at the standard temperature and pressure may be used as the standard substance. These statements may be put compactly in symbols as follows:—

$$d = \frac{M}{V}, v = \frac{V}{M}, s = \frac{w}{w_0} \quad . \quad . \quad . \quad . \quad . \quad (1)$$

It is thus seen that the specific gravity of any substance is the ratio of the density of that substance (in any units) to the density of the standard substance (in the same units).

Whatever units are in use the specific gravity of a given substance referred to a given standard substance is represented by the same number; for specific gravity is a pure ratio of like quantities and is therefore of *zero* dimensions, *i.e.* it is independent of the units of length, time, and mass in use. Density, on the other hand, is of the nature mass divided by volume, or of dimensions *plus one* in mass and *minus three* in length. Hence, the number expressing the density of a given substance varies with the units of length and mass in use, and the measure of a density is incomplete unless the units are stated, as well as the number. Thus, the specific gravity of water at  $4^{\circ}$  C. is unity simply, but its density is 1 gm. per c.c., 62.3 lbs. per cubic foot, and 0.03606 lb. per cubic inch.

The term *specific weight* is sometimes used for *weight per unit volume*.

One of the simplest methods of finding the density of a liquid is to weigh the quantity of liquid required to fill a *specific gravity bottle* and then weigh the water required to fill it. The quotient of the first weight by the second gives the density sought.

EXAMPLES XIV.

1. Define *density*, *specific volume* and *specific gravity*. Given that a cubic foot of water weighs 62·3 lbs. and that the specific gravity of a specimen of wrought iron is 7·77, what is its density in lb.-inch units ?

2. A given kind of timber has a specific gravity of one-half: what space will it occupy per ton ?

3. The specific gravity of sea water being 1·025 at a certain temperature, find the mass of it required to raise by 10 ft. the level in a rectangular lock 400 ft. by 50 ft.

4. A bottle weighs 40·38 gms. empty, then 81·88 gms. when full of spirit, and finally 90·38 gms. when filled with pure distilled water. What is the density of the spirit ?

5. A rectangular block weighs 8 lbs. 6 oz. and measures 6 ins. by 4 ins. by 1½ ins. What is its density in lb.-inch units ?

32. **Centres of Gravity and of Mass.**—The centre of mass of a number of particles of masses  $m_1, m_2, m_3$ , etc., at points  $(x_1, y_1), (x_2, y_2), (x_3, y_3)$ , etc., has co-ordinates given by  $\bar{x}$  and  $\bar{y}$ , where

$$\bar{x} = \frac{\Sigma mx}{\Sigma m} \text{ and } \bar{y} = \frac{\Sigma my}{\Sigma m} \dots \dots \dots (1)$$

This statement may be taken as a definition or its naturalness and simplicity may be traced out thus. For two particles of unit mass, the centre of mass is obviously the point of bisection of their joining line. Hence, in that case, we should have

$$\bar{x} = \frac{x_1 + x_2}{2} \text{ and } \bar{y} = \frac{y_1 + y_2}{2}$$

Then, extending to  $n$  particles, we should find next

$$\bar{x} = \frac{x_1 + x_2 + \dots + x_n}{n} \text{ and } \bar{y} = \frac{y_1 + y_2 + \dots + y_n}{n}$$

Now, if some of these unit particles had the same abscissæ, the above expressions could be slightly modified. Thus, if  $m_1$  unit particles, or a single particle of mass  $m_1$ , had the abscissa  $x_1$ , the corresponding term in the numerator would be  $m_1x_1$ , and that in the denominator  $m_1$ . We should accordingly find for the co-ordinates  $\bar{x}, \bar{y}$  of the centre of mass the following expressions:—

$$\bar{x} = \frac{m_1x_1 + m_2x_2 + \dots}{m_1 + m_2 + \dots}$$

$$\bar{y} = \frac{m_1y_1 + m_2y_2 + \dots}{m_1 + m_2 + \dots}$$

And these, when abbreviated, form the equations (1) with which we began.

If the co-ordinates of points with respect to the centre of mass are called  $a$  and  $b$ , we have

$$x = \bar{x} + a \text{ and } y = \bar{y} + b \dots \dots \dots (2)$$

And accordingly

$$\Sigma mx = \bar{x}\Sigma m + \Sigma ma \text{ and } \Sigma my = \bar{y}\Sigma m + \Sigma mb$$

But, using these values in the right sides of (1), we find

$$0 = \Sigma ma \text{ and } 0 = \Sigma mb . . . . (3)$$

as, of course, must be the case in accordance with the principles of (1). But equations (3) may be borne in mind as a convenient alternative expression instead of (1). Thus, if (1) is regarded as the definition of centre of mass, (3) may be taken as a result or property. If, on the other hand, (3) be taken as the definition of centre of mass, then (1) expresses the working rule for finding its position.

If we now pass from the masses of the particles to their weights, we may usually regard these weights as *parallel forces proportional* to those masses. It accordingly follows, from equations (1) and (2) of Art. 26, that the point through which the resultant of these parallel forces always passes is identical with their centre of mass. And this central point of these weights is called the *centre of gravity*. But, if our body is so large in comparison with the distance to the centre of attraction that the weights of the various particles form a set of *inclined forces* and of values *not proportional* to the masses, then the centre of gravity, if there is one, cannot be assumed to be identical with the centre of mass. Thus, the centre of mass is the simpler conception and its position is more easily determined. But, the term "centre of gravity" is of wider vogue and may be freely used alternatively with centre of mass in all ordinary cases of terrestrial mechanics, since the distinction between the two points then practically vanishes.

The term "centre of gravity" is often used in connection with purely geometrical figures, either solid, plane, or linear. The point in question is then identical with the centre of mass of a body of uniform density occupying the given figure. Thus the centre of gravity of a triangle is that of a piece of infinitely thin uniform material occupying that triangle. In cases like this, when neither gravity nor even mass is present, the purely neutral term *centroid* is really best.

**33. Centroids or Centres of Mass of Simple Figures.**—It is almost obvious that the centre of mass of a symmetrical figure of uniform material is at the geometrical centre or centre of symmetry. Thus, the centre of mass of a uniform straight wire is at the centre of its length, that of a right circular cylinder at the centre of its axis, that of a circle (or of a sphere) at its centre. But there are other important and simple cases which need determination, for the position of the centroids of triangles, pyramids, trapezoids, bent wires, parts of circles, and hemispheres are certainly not obvious.

*Triangle.*—Consider the surface of the triangle ABC, Fig. 15, as though it were of uniform material but infinitely thin, and draw the two medians AD and BE intersecting at G. Then, since each median bisects all elementary strips parallel to the corresponding base, each median contains the centroid of the whole triangle. Consequently it is at G, the intersection of the two medians. To find in the form of an equation the position of G, join DE and then note, by construction and the similarity of the triangles concerned, that

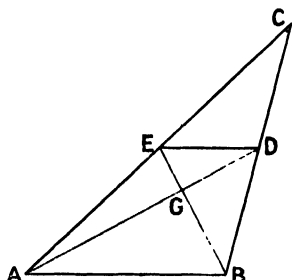

FIG. 15.—Centroid of Triangle.

$$\frac{1}{2} = \frac{CD}{CB} = \frac{CE}{CA} = \frac{ED}{AB} = \frac{DG}{AG}$$

Hence,  $AG = \text{two-thirds of } AD \dots \dots (4)$

That is, the centroid of a triangle is on any median and two-thirds of its length from the corresponding corner.

*Pyramid.*—Begin with a *tetrahedron* or pyramid on a *triangular* base as shown by ABCD in Fig. 16.

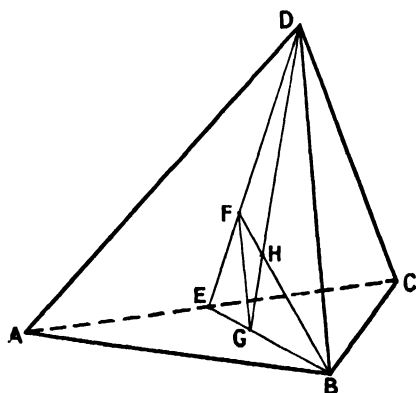

FIG. 16.—Centroid of Tetrahedron.

Bisect AC in E and draw the median plane BDE. Then, by symmetry, this plane contains the centroid of the tetrahedron. Take the centroids F and G of the faces CDA and ABC respectively, and join BF, DG, and FG. Then, by symmetry the centroid of the tetrahedron must be on BF, because it contains the centroid of every slice parallel to CDA. Similarly, it is on DG, consequently the centroid of the tetrahedron is at H, the intersection of BF and DG. To locate it, we have by construction and

similar triangles the following equal ratios:—

$$\frac{1}{3} = \frac{EF}{ED} = \frac{EG}{EB} = \frac{FG}{DB} = \frac{GH}{DH}$$

Hence  $DH = \text{three-fourths of } DG \dots \dots (5)$

And, if G is the centroid of the base of any *pyramid* or *conc*, and D its vertex, this relation will still define H, the centroid of that pyramid or cone. For obviously, DG still contains the centroids of

all slices parallel to the base, and therefore contains that of the whole figure ; further, H must be situated the same fractional distance along DG, because the law of increase of the slices is the same as before.

EXAMPLES XV.

1. Distinguish between the terms *centroid*, *centre of mass*, and *centre of gravity*. Give one example where the points coincide and one where they do not.
2. Derive expressions that locate the centre of mass of any number of particles distributed over a plane.
3. Masses of 1, 2, 3 and 4 lbs. are placed at the corners (taken in order) of a square of side 5 ft. How far is the centre of mass from the sides determined respectively by the 4 and 1 lbs. and the 1 and 2 lbs. ?
4. A regular hexagon of side 2 ft. has masses of 1, 3, 5, 7, 9 and 11 ounces placed at its corners taken in order. Locate their centre of mass with respect to the two sides which meet where the 1 oz. is.
5. At the corners of a regular octagon taken in order are placed weights of 1, 3, 5, 7, 33, 3, 5, 7 lbs. How far is the centre of mass of these eight weights from the centre of the octagon and towards which corner ?
6. Establish the position of the centroid of a triangle.
7. Draw carefully a pyramid upon a triangular base and determine its centroid.
8. Without assuming any formula for a solid figure, determine the centre of mass of a square pyramid.
9. Find the centroid of a right circular conc.
10. A capital letter W is marked out with strokes each 4 ft. long and angles of 60°. Beginning at one end, masses of 3, 7, 8, 7 and 3 are placed at its five corners. Find their centre of mass.

**34. Sum or Difference of Simple Figures.**—If a figure, though apparently complicated, consists of simple figures whose centroids are known, that of the whole is easily found.

Thus, use equation (1) of Art. 32 and distinguish the two parts of the system by the subscripts 1 and 2. We may then write

$$\bar{x} = \frac{\sum mx}{\sum m} = \frac{\sum m_1 x_1 + \sum m_2 x_2}{\sum (m_1 + m_2)} = \frac{\bar{x}_1 \sum m_1 + \bar{x}_2 \sum m_2}{\sum m_1 + \sum m_2}$$

or, (M<sub>1</sub> + M<sub>2</sub>) $\bar{x}$  = M<sub>1</sub> $\bar{x}_1$  + M<sub>2</sub> $\bar{x}_2$  }  
 Similarly (M<sub>1</sub> + M<sub>2</sub>) $\bar{y}$  = M<sub>1</sub> $\bar{y}_1$  + M<sub>2</sub> $\bar{y}_2$  } . . . . (6)

where the capitals denote the masses of the separate parts of the system.

Obviously this equation may be used to determine  $\bar{x}$ , the abscissa of the centroid of the *sum* of two figures, or to determine  $\bar{x}_1$ , the abscissa of the centroid of the *difference* of the whole figure and the other part. Indeed, the equation states that, for the purposes of finding the centroid of a compound figure, its component parts may be treated as *particles of corresponding masses* situated at the *centroids* of those parts. And this could be extended to apply to any number of parts.

From equation (6) we see that the centroid of a figure of two parts is situated on the line joining the centroids of the two parts, and divides that line inversely as the masses of those parts.

35. **Rectangle and Triangle.**—As an example of a figure which is the sum of two simpler ones, take that in Fig. 16A, compounded of an isosceles triangle ABC and rectangle CDEA, each of height  $a$  and on the same base  $b$ . Draw the median through B

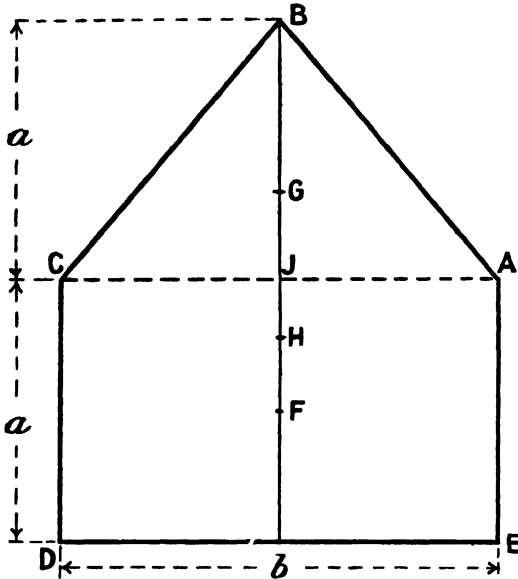

FIG. 16A.—Centroid of a Compound Figure.

and take on it the centroids F and G of the rectangle and triangle respectively. Then, since their areas are respectively  $ab$  and half that product, we can treat the case as though a particle of mass 1 were at G and one of mass 2 at F. Hence the centroid H of the whole figure is on FG at one-third of FG from F. Thus, if the median cuts AC in J, we have

$$FJ = \frac{a}{2}, \quad GJ = \frac{a}{3}, \quad FG = a\left(\frac{1}{2} + \frac{1}{3}\right) = \frac{5}{6}a, \quad FH = \frac{1}{3} \cdot \frac{5}{6}a = \frac{5}{18}a$$

and

$$JH = a\left(\frac{1}{2} - \frac{5}{18}\right) = \frac{2}{9}a \quad \dots \quad (7)$$

36. **Trapezoid.**—As an illustration of a figure which may be treated as the difference of two simple figures, take the trapezoid ABCD shown in Fig. 17 and regard it as the difference of the two triangles AED and BEC, with common vertex at E found by producing the inclined sides till they meet. Let the area (or mass) of EBC be

denoted by  $M_1$  and its centroid by F, that of the whole triangle AED by  $(M_1 + M_2)$  and its centroid by G. Thus the area (or mass) of the trapezoid will be denoted by  $M_2$  and its centroid is shown by H. Then, applying equation (6) to this case, we have

$$(M_1 + M_2)EG = (M_1)EF + (M_2)EH \dots (8)$$

But EF is known to be two-thirds of EJ and EG to be two-thirds of EK. So EH can be found if the relations of the M's is known.

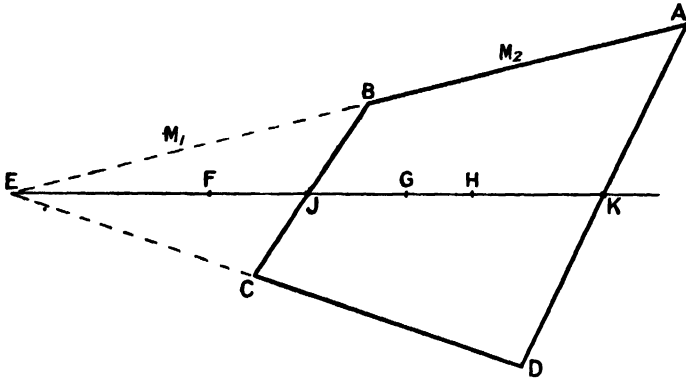

FIG. 17.—Centroid of Trapezoid.

From the geometry of the figure it is seen that the areas of the triangles are proportional to the squares of their corresponding sides. We accordingly have

$$\frac{M_1 + M_2}{M_1} = \frac{AD^2}{BC^2} = \frac{EK^2}{EJ^2} \dots (9)$$

This gives the relation needed, and makes EH calculable.

In the figure EJ is shown *half* EK, so that  $M_2 = 3M_1$ , and (8) becomes

$$\begin{aligned} 4EG &= EF + 3EH \\ \text{or} \quad 4\left(\frac{2}{3}EK\right) &= \frac{1}{3}EK + 3EH \\ \text{whence} \quad EH &= \frac{2}{5}EK, \\ \text{and} \quad HK &= \frac{3}{5}EK = \frac{4}{5}JK, \end{aligned}$$

in this case, where BC is *one-half* AD.

**37. Frustum of a Pyramid.**—Let us now treat the frustum of a pyramid (or cone) as the difference of the whole completed pyramid and the small completing portion. Then, referring to Fig. 18, the lettering being as in Art. 36, we must now remember that

$$\begin{aligned} EF &= \frac{1}{4}EJ, \quad EG = \frac{3}{4}EK \\ \text{and} \quad \frac{M_1 + M_2}{M_1} &= \frac{AD^3}{BC^3} = \frac{EK^3}{EJ^3} \dots (10) \end{aligned}$$

Putting these values in equation (8) of Art. 36, we have

$$EK^3 \cdot \frac{3}{4}EK - EJ^3 \cdot \frac{3}{4}EJ = (EK^3 - EJ^3)EH$$

or

$$EH = \frac{3}{4} \frac{EK^4 - EJ^4}{EK^3 - EJ^3} \dots \dots \dots (11)$$

This result expresses very compactly the distance of the centroid from the apex of the completed pyramid in terms of other distances from that apex. If we want the result in the form of the

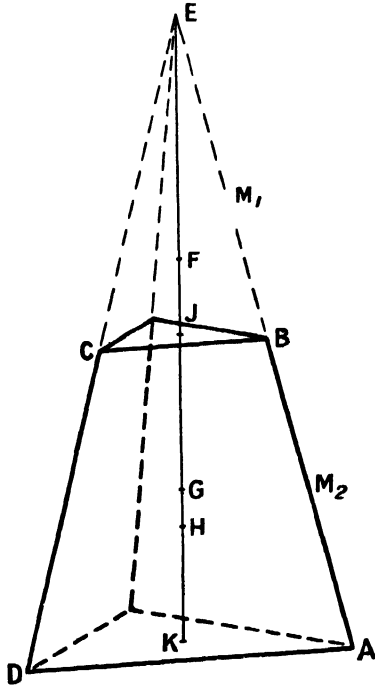

FIG. 18.—Centroid of Pyramid.

fraction  $(KH \div KJ)$  up the height of the frustum from the larger base, we may proceed as follows.

Let us put  $EK = a$  and  $EJ = b$ . Then

$$EH = \frac{3}{4} \frac{a^4 - b^4}{a^3 - b^3} = \frac{3}{4} \frac{a^3 + a^2b + ab^2 + b^3}{a^2 + ab + b^2}$$

$$KH = a - EH = \frac{a^3 + a^2b + ab^2 - 3b^3}{4(a^2 + ab + b^2)};$$

and

$$\frac{KH}{KJ} = \frac{a - EH}{a - b} = \frac{a^2 + 2ab + 3b^2}{4(a^2 + ab + b^2)} \dots \dots \dots (12)$$

It may be noticed that  $a^2$  and  $b^2$  are proportional to the areas of the larger and smaller bases respectively. These areas may accordingly be substituted for them if preferred.

#### EXAMPLES XVI.

1. Derive a formula for the location of the centroid of a figure compounded of simpler figures whose relative areas and centroids are known.

2. A capital letter L has a height of 6 ft. and a breadth of  $4\frac{1}{2}$  ft., the strokes being a foot and a half wide. Find its centroid.

3. The parallel sides of a trapezoid have lengths  $a$  and  $b$ , where  $a$  is the longer. Show that the distance from the middle point of the longer side to the centroid of the figure is

$$\frac{a+2b}{a+b} \cdot \frac{c}{3}$$

where  $c$  is the length of the line joining the middle points of the parallel sides.

4. Find the centroid of a trapezoid whose parallel sides are 6 and 4 ft., and length of line joining their centres 3 ft.

5. If the area of the base of a pyramid is  $P$  and that of its top  $Q$ , show that the height of its centroid divided by the height of the frustum is

$$\frac{P+2\sqrt{PQ}+3Q}{4(P+\sqrt{PQ}+Q)}$$

6. Determine the height of the centroid of a pyramidal frustum whose height is 8 ft. and its bases of areas as 4 to 1.

7. Upon a cube fits a square pyramid of height equal to that of the cube. If cube and pyramid are of the same uniform material find the height of their centre of mass.

## CHAPTER V

### SUMMATIONS

**38. Work of a Variable Force.**—We have seen that the work  $W$  done by a force of constant magnitude  $F$ , while the point of application moves through a distance  $s$  in the direction of the force, is given by the product  $Fs$ .

Thus, if the distances are laid off along the axis of  $x$  and the force at right angles to it, the line for a constant force would be parallel to the axis of  $x$  and the product, expressing the work for a given space, would be represented by the area of the rectangle under the force line for the space in question.

Suppose now that the force varies from instant to instant, then the line expressing it on the diagram will be a corresponding curve of variable ordinates. But,

for each small space, the corresponding strip of the area would correctly represent the work for that small space, its area being the product (mean ordinate) multiplied by (small space). This is shown in Fig. 19 by  $F$  and  $s$ . Thus the whole work is represented by the whole area under the curve, or may be denoted by the summation

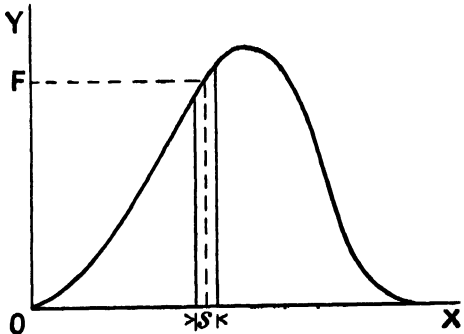

FIG. 19.—Work of a Variable Force.

$$W = F_1s_1 + F_2s_2 + F_3s_3 + \dots = \Sigma Fs \quad . \quad . \quad (1)$$

If the curve for  $F$  were precisely known and exactly plotted on squared paper, the area in question could be ascertained, to a certain degree of approximation, by counting the squares and parts of squares occupied by it. Or, any one of the various rules of mensuration applicable to an irregular area could be adopted.

**39. Simple Summations.**—But there are cases in which the bounding line is an inclined straight line, a circle or other simple

curve easily specified, and the area, or other summation, to be computed may be required for other purposes than the work of a force, and a precise result may be needed instead of any approximation.

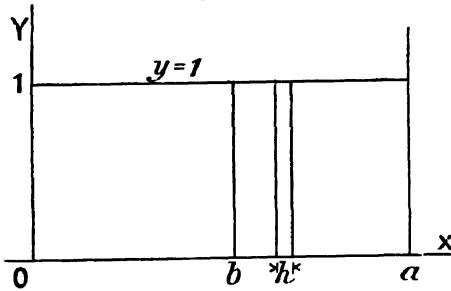

FIG. 20.

Thus, some definite but general method is desirable to obtain the summation of a series of products in which one factor varies according to some prescribed law and the other factor is a small increment of another quantity which has a certain specified range.

To introduce this aspect of the subject, consider first the very simple cases illustrated in Figs. 20 and 21.

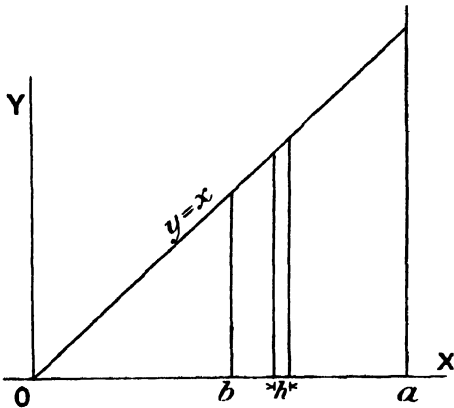

FIG. 21.—Simple Summations.

In Fig. 20, the ordinate has the constant value unity. In Fig. 21 the ordinate is expressed by  $y=x$ . Let the small increase of  $x$ , or width of the strip, be denoted by  $h$ . Then, in Fig. 20, if we extend the summation from  $x=0$  to  $x=a$ , we may write

$$\text{Area} = \sum_0^a 1h = a \dots \dots \dots (1)$$

In Fig. 21, taking the summation up to the same limits, we have

$$\text{Area} = \sum_0^a xh = \frac{a^2}{2} \dots \dots \dots (2)$$

The right sides are easily written in both these cases, since we are only concerned with a rectangle and a triangle.

When the line is a more complicated one than those just dealt with, the regular mode of summation is that of the integral calculus, which every mechanical student should learn as soon as possible. But, to avoid its use here, we shall now note the law which holds in the above cases and assume its extension to the other (although the proof of this extension will be one of the earlier parts of integration). See Art. 40.

EXAMPLES XVII.

1. A boat is towed by a force of 100 lbs. weight and a freight train is hauled by a force of 12,000 lbs. weight. Plot a force-space diagram for each and find the work done on the boat as it moves 120 ft. and the distance the train goes for the same work.

2. A tennis ball is struck by a racket, a cricket ball with a bat, and a cold rivet by a hammer. Suppose the work done to be the same in each case, draw three force-space diagrams to the same scale and representing the respective phenomena.

3. A long wire is stretched one inch and a half by a force which is proportional to the elongation, its final value being 24 lbs. wt. Plot a force-space diagram and calculate the work done.

4. A pyramid is pushed 3 ins. into a lump of clay, the force varying nearly as the square of the distance. The final force being 20 lbs. wt., plot a diagram on squared paper, and find the work done.

5. A wedge is pushed into some moist earth and meets a resistance proportional to its penetration. If the work done is 4.5 ft.-lbs. wt. for the first 6 ins., what is it for the next 4 ins., and what is the force with a penetration of 10 ins.?

**40. Summations of Powers of a Variable.**—Let it be required to effect the summation of any power of a variable between given limits. That is, the ordinate  $y$  of an area is any given power of  $x$  and the other factor of each product is  $h$ , a very small increase of  $x$ . Can we put the cases already noticed in this form? We can, as follows:—

$$\left. \begin{aligned} \sum_0^n x^0 h &= \frac{a^1}{1} \\ \sum_0^n x^1 h &= \frac{a^2}{2} \end{aligned} \right\} \dots \dots \dots (3)$$

We thus see that on the right sides we have the upper limit  $a$  (of the summation) raised to a power *one higher than that of  $x$*  on the left, and that it is divided by the *same number as its index*.

We are thus prepared to accept as probable, the *general* result established by the integral calculus, viz.—

$$\sum_0^n x^{n-1} h = \frac{a^n}{n} \dots \dots \dots (4)$$

This is a most important formula and will carry the reader through nearly all the summations required in the present text-book.

It has, however, one notable exception which occurs when  $n = 0$ . The result of the summation is then a Napierian logarithm or a logarithm to the natural base  $e$  whose value is 2.7183. Logarithms to this base are 2.3026 times those to the ordinary base 10.

If we now require the summation extending from the origin to any other value  $b$  of  $x$ , it is evident that  $b$  replaces  $a$  on both sides of equation (4), and that the corresponding area is shown in Fig. 20 and 21 up to the ordinate whose foot is marked  $b$ . But, if we wish

to extend our summation between the two ordinates at distances  $b$  and  $a$  from the origin, we should naturally indicate this by the symbol  $\Sigma_b^a$ , and it is evident from the figures that the value required will be the difference of the two previous summations to  $a$  and to  $b$  respectively. We may accordingly write (except for cases where  $n = 0$ )—

$$\Sigma_b^a x^{n-1} h = \frac{a^n - b^n}{n} = \Sigma_b^a r^{n-1} s \quad . \quad . \quad . \quad (5)$$

where  $r$  is a variable instead of  $x$ , and  $s$  is a small increase of  $r$ .

And for  $n = 0$ , we have

$$\Sigma_b^a \frac{h}{x} = 2.3026 \log_{10} \left( \frac{a}{b} \right) = \Sigma_b^a \frac{s}{r} \quad . \quad . \quad . \quad (5a)$$

The expressions on the extreme right are here introduced to remind the reader that since  $x$  and its small increase  $h$  on the left disappear from the result of the summation, any other quantity  $r$  and its small increase  $s$  might have been used if preferred. This is often a convenient notation when we are using a radius from a centre.

EXAMPLES XVIII.

1. If the ordinate of a curve is equal to the square of its abscissa, find the area under it from the origin to  $x = 6$  ins.
2. Effect the following summations:—

$$\Sigma_0^6 x^3 h, \quad \Sigma_1^6 x^{-1} h, \quad \Sigma_2^6 r^4 s.$$

3. Find the values of the areas to be obtained by the following expressions, the linear units being feet:—

$$\Sigma_2^4 x h, \quad \Sigma_3^6 x^2 h, \quad \Sigma_4^{10} x^3 h, \quad \Sigma_1^6 x^{-1} h$$

4. At the abscissæ 4, 5, 6 and 7 cm., the ordinates of a curve are 4, 6.25, 9, and 12.25 cm. respectively. Find the area between the portion of it named and the axis of abscissæ.
5. Plot a curve in which the ordinates are always one-fifth of the cube of the abscissæ, and find the area between it and the axis of abscissæ from the origin to  $x = 3$ , and from there to  $x = 6$  inches.

**41. Summation of a Cosine.**—Suppose now we wish to sum the products of a cosine of an angle  $\theta$  and the very small increases  $\delta$  of that angle. Then it is shown by the integral calculus that the result involves a sine of the same angle. What we have seen previously as to limits applies equally well here. We will accordingly write the complete expression for summation, between the limits  $\theta = \beta$  and  $\theta = \alpha$ , in the form

$$\Sigma_\beta^\alpha (\cos \theta) \delta = \sin \alpha - \sin \beta \quad . \quad . \quad . \quad (6)$$

This is illustrated in Fig. 22.

The Figs. 20-22 are drawn as though the summations were desired for the purpose of determining areas, but the summation formulæ apply equally well to any other problem involving the expressions in question.

We have thus the power to evaluate the summation between given limits of *any power* of a variable or the *cosine* of a variable for whatever purpose such summations may be required. And these two simple cases will suffice for all the problems of this kind likely to arise in the course covered by the present text-book.

**42. Summation as Ordinate of a Second Curve.**

The summation for a cosine was given in Art. 41 without any proof. An approximate check on any such rule is of course possible by the method of plotting the cosine graph on squared paper and counting the squares and parts of the squares included up to any given ordinate.

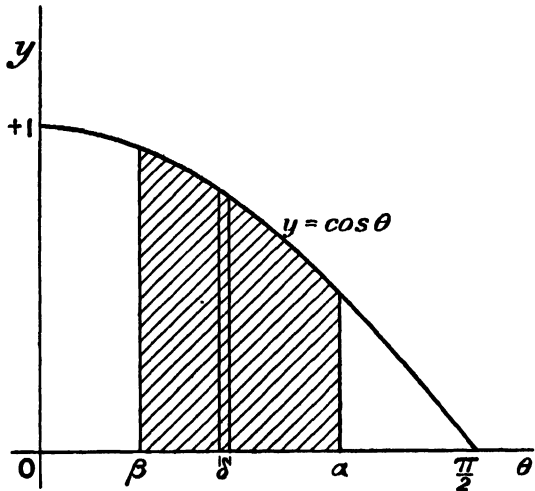

Fig. 22.—Summation of a Cosine.

And this check each student should apply for his own satisfaction. But it affords further support to the formula for cosine summation, and casts a welcome light on the whole subject, if we exhibit the result of *summation* for the area of one curve by the *ordinate* of another.

We may call these two curves the *original* and the *summational* curves.

For the cases already dealt with, in accordance with equations (1) to (6), it will be seen that we may write the equations for the ordinates as follows:—

<i>Original curve.</i>	<i>Summational curve</i>
$y = 1$	$y = x \dots \dots \dots (7)$
$y = x$	$y = \frac{x^2}{2} \dots \dots \dots (8)$
$y = x^{n-1}$	$y = \frac{x^n}{n} \dots \dots \dots (9)$
$y = \cos \theta$	$y = \sin \theta \dots \dots \dots (10)$

The cases expressed by equations (7), (8) and (10) are shown in Figs. 23, 24 and 25 respectively. In each of these figures the

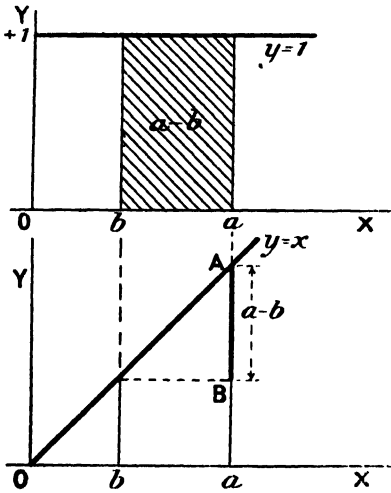

FIG. 23.—Summation of Rectangle.

Original Curve.  
Summational Curve.

upper part shows the original curve whose area is to be summed, while the lower part shows that curve whose ordinate at any place

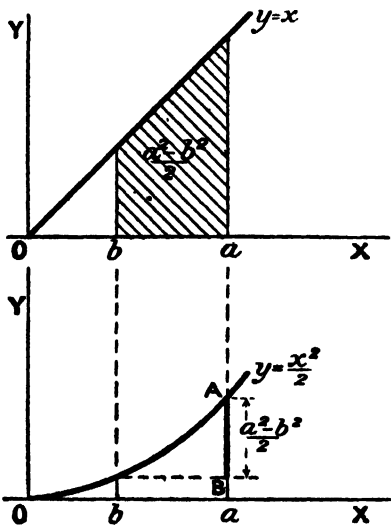

FIG. 24.—Summation of Triangle.

Original Curve.  
Summational Curve.

represents to scale the area of the original curve from the origin to the place in question. Thus, the shaded area of any original curve between the ordinates whose bases are marked  $a$  and  $b$  is given



the original curve, this slope must be equal to the corresponding ordinate of the original curve.

We might thus formulate the following direction for the construction of the summational curve corresponding to any original curve.

*The summational curve may begin at the origin and its slope must everywhere be equal to the corresponding ordinate of the original curve.*

We may now apply these observations to check the relation of the two curves, the cosine and sine in Fig. 25, the relation having been first given without any attempt at proof. Here the ordinate of the original curve is unity at the origin entailing a unit slope in the summational curve where it passes through the origin. Then as the ordinate of the original curve decreases gradually to zero, the slope of the summational one falls to zero also and in like manner.

It should be noted that the *unit slope* may not be exactly  $45^\circ$  on an actual diagram. This is a matter depending on the choice of scales for the abscissæ and ordinates. Thus in the lower curve of Fig. 23, the slope is unity and the angle  $45^\circ$ , because unity on each axis is made the same length. But in the lower part of Fig. 25, unit angle (the radian) along the horizontal is not represented by the same length as the unit ordinate. Hence the slope at the origin is *not*  $45^\circ$ , but it is *unit slope to scale*; that is, it rises at the rate of a *unit ordinate to scale* in the width of a *unit abscissa to scale*. And all slopes must be interpreted in this manner, then all is harmonised.

We have accordingly this double relation between the two curves, (i.) that the ordinate of the second represents to scale the area of the first; and (ii.) that the slope of the second (measured to *scale*) equals the ordinate of the first (to *scale*).

If these ideas are applied to the cosine and sine graph of Fig. 25, either generally or minutely by any measures however exact, it will be found that the relations stated are confirmed. The sine may accordingly be accepted as the summation of the cosine. (Very early in the student's work on the Integral Calculus this relation would be rigorously established.)

#### EXAMPLES XIX.

1. Find the values of the following summations:—

$$\sum_0^{\pi/2} (\cos \theta) \delta, \quad \sum_{\pi/4}^{\pi/2} (\cos \theta) \delta, \quad \sum_0^{\pi/4} (\cos \theta) \delta.$$

2. Effect the following summations, giving the answers in decimals:—

$$\sum_{15^\circ}^{45^\circ} (\cos \theta) \delta, \quad \sum_{90^\circ}^{60^\circ} (\cos \theta) \delta, \quad \sum_{20^\circ}^{80^\circ} (\cos \theta) \delta.$$

3. Write down a summation involving a cosine, evaluate it and make diagrams both for the original cosine and the summational curve.



finding the centroid. Let the plane sector be denoted by OACB, in Fig. 27, and take in it the very small elementary triangle OPQ. Then, the centroid of this triangle is at F, distant from O by *two-thirds* the radius of the sector. That is,  $OF = \frac{2}{3}OA$ . Through F draw the arc RFS with O as centre. Then on this arc must lie all the centroids of the small triangles like OPQ into which the whole sector OACB may be divided. But, in finding the centroid of any figure, we have seen that instead of taking every particle separately in the summation  $\Sigma mx$ , we may take any finite parts, each such part being supposed concentrated at its centroid (see Art. 34).

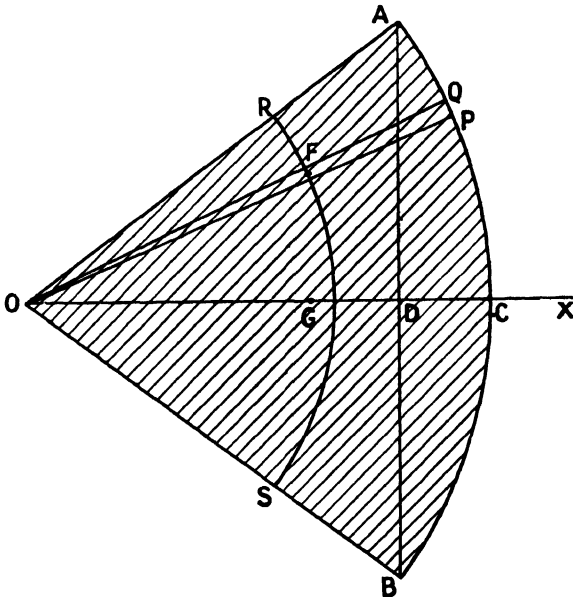

FIG. 27.—Centroid of a Sector.

Thus, the whole sector may be replaced by the uniform arc RFS of two-thirds the radius of the sector. But the position of the centroid of the arc is known from Art. 43. We may accordingly write for the sector

$$OG = \frac{2}{3} \frac{\text{chord}}{\text{arc}} \text{ radius of sector} \quad \dots \quad (2)$$

**45. Centroid of Segment of Circle.**—Let the segment be denoted by ACBD in Fig. 28, the centre of the circle being O, the radius  $r$ , and the half angle of the sector AOC being  $\alpha$ . Thus, we may treat the segment as the difference of the whole sector OACB and the triangle OADB, with centroids at G and F respectively, the centroid of the segment being at H on the centre line OC. Then, using the

principle of Art. 34, we may write the areas of the figures as though they were masses, and thus obtain

$$(OACB \times OG) = (OADB \times OF) + (ADBCA \times OH)$$

or,

$$\left( r^2 \alpha \times \frac{2r \sin \alpha}{3\alpha} \right) - (r^2 \sin \alpha \cos \alpha \times \frac{2}{3} r \cos \alpha) = r^2 (\alpha - \sin \alpha \cos \alpha) \times OH$$

whence 
$$OH = \frac{2}{3} OA \frac{\sin^3 \alpha}{\alpha - \sin \alpha \cos \alpha} \dots \dots (3)$$

Equations (2) and (3) may both be checked by taking the case

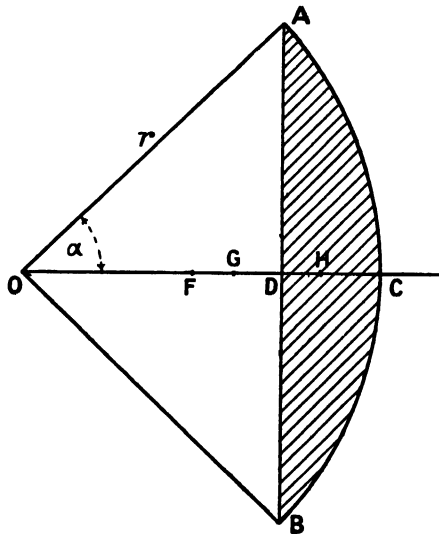

FIG. 28.—Centroid of a Segment of a Circle.

of a semicircle, which is at once a sector and a segment. By either expression we find,  $\bar{x} = (4 \div 3\pi)$  radius.

EXAMPLES XX.

1. Establish a general expression for the centroid of a circular arc or of a thin wire so bent.
2. Find the centroid of a wire bent into the quadrant of a circle.
3. Using the general expression, find the centroid of a semicircular wire and confirm it by considering the wire as consisting of its quadrantal halves.
4. Find the centre of mass of a fine wire bent into three-quarters of a circle, and check it by considering it as the whole circle less one quarter.
5. Obtain an expression for the centroid of the sector of a circle.
6. Calculate the position of the centre of mass of a quadrantal plate of radius 3 ft.

- 7. Derive an expression for the centroid of a segment of a circle.
- 8. Confirm the expressions for the centroids of sectors and segments of circles by consideration of a particular figure which is at once a sector and a segment.
- 9. Locate the centre of mass of one quarter (cut along the axes) of an elliptical plate 12 ins. by 18 ins.

46. **Centroid of a Hemisphere.**—To obtain the centroid of a hemisphere we may take a very thin slice parallel to the base as

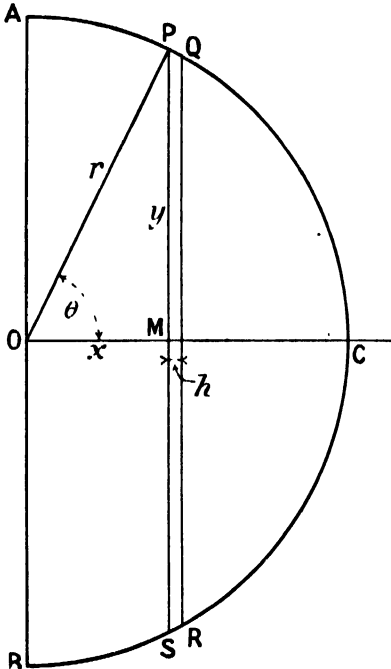

FIG. 29.—Centroid of a Hemisphere.

our elementary part, as shown by PQRS in Fig. 29, in which the radius OA is  $r$ . The abscissa OM of the slice will be denoted by  $x$ , its radius MP by  $y$ , and its thickness by  $h$ . Then the  $m$  for the slice is its volume  $\pi y^2 h$ . But  $y^2 = r^2 - x^2$ . We accordingly find, from the centroid rule, the equation

$$\bar{x} = \frac{\pi \int_0^r (xr^2 - x^3)h \div \pi \int_0^r (r^2 - x^2)h}{\left(\frac{r^4}{2} - \frac{r^4}{4}\right) \div \left(r^3 - \frac{r^3}{3}\right)}$$

or  $\bar{x} = \frac{3}{8}r \dots (4)$

47. **Centroid of a Spherical Zone.**—Referring again to Fig. 29, we see that for the surface of the sphere the very narrow band PQRS may be taken as the element. Then the  $m$  for this band is its area. Now  $h/PQ = \sin \theta = y/r$ ; and the circumference of the band is  $2\pi y$ . Hence its area is  $2\pi y PQ = 2\pi r h$ . But this is the same

as the area of the band cut by the same planes from the circumscribing cylinder. Thus, if the zone lies between the planes whose abscissæ are  $a$  and  $b$ , the centroid is midway, or

$$\bar{x} = \frac{a+b}{2} \dots \dots \dots (5)$$

48. **Centroid of any Plane Figure Graphically Determined.**—For any plane figure the position of the centroid may be seen to be related to the area of another figure graphically derived from the original figure as follows. In the original figure OPAQ of width  $OA = a$ , see Fig. 30, take the complete ordinate PQ; from its ends draw lines parallel to OX, meeting in  $p$  and  $q$  the line through A

parallel to OY. From  $p$  and  $q$  draw straight lines to the origin O, cutting the ordinate PQ in  $P'$  and  $Q'$ . Then  $P'$  and  $Q'$  are the points on the new figure corresponding to P and Q on the old one.

As we may for other purposes again derive another figure by repeating the above process, we shall distinguish those just dealt with as the *original* figure (OPAQ) and the *first derived* figure (OP'AQ'). All the necessary points are derived like  $P'$  and  $Q'$ , and the figure is drawn through them as shown shaded in Fig. 30.

Let the abscissa of  $PP'Q'Q$  be  $x$ , let  $PQ = y$ , and  $P'Q' = y'$ . Then, from the construction we have

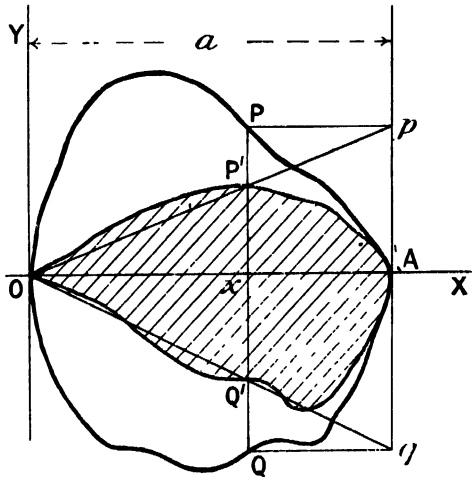

FIG. 30.—Centroid Graphically Determined.

$$\frac{y'}{y} = \frac{x}{a}, \text{ or } xy = ay' \dots \dots \dots (1)$$

Again, for the centroid of the original figure, we have

$$\bar{x} = \Sigma mx \div \Sigma m = \Sigma_0^a xy' h \div \Sigma_0^a y h \dots \dots \dots (2)$$

where, as usual,  $h$  is a very small increase of  $x$ .

Thus, substituting (1) in (2), and writing  $A$  and  $A'$  for the areas of the original and derived figures, we find

$$\bar{x} = a \Sigma_0^a y' h \div \Sigma_0^a y h = aA' \div A \dots \dots \dots (3)$$

or, in words—

$$\frac{\text{Abcissa of centroid}}{\text{Width of either figure}} = \frac{\text{Area of first derived figure}}{\text{Area of original figure}} \quad (3a)$$

Accordingly on finding the two areas by mensuration, counting squares, or any other device, we obtain the value of the abscissa sought.

The application of the same process parallel to the axis of  $y$ , then determines the ordinate  $\bar{y}$  of the centroid. Of course if the axis of  $x$  were an axis of symmetry, we should have  $\bar{y} = 0$ , so the value of  $\bar{x}$  would suffice to locate the centroid.



It is obvious that some length  $k$  could be taken such that the moment of inertia of the given body or figure would be equal to the total mass  $M$  or total area  $A$ , multiplied by  $k^2$ .

This length  $k$  is called the *radius of gyration* of the given body or figure for the axis in question.

Hence, for an abstract figure, we may write

$$I = Ak^2 \dots \dots \dots (3)$$

and

$$k^2 = \Sigma ar^2 \div \Sigma a \dots \dots \dots (4)$$

**50. Moment of Inertia Theorems.**—Before evaluating any moments of inertia we will first notice two theorems that will be useful.

*Parallel Axes Theorem.*—This theorem establishes a simple

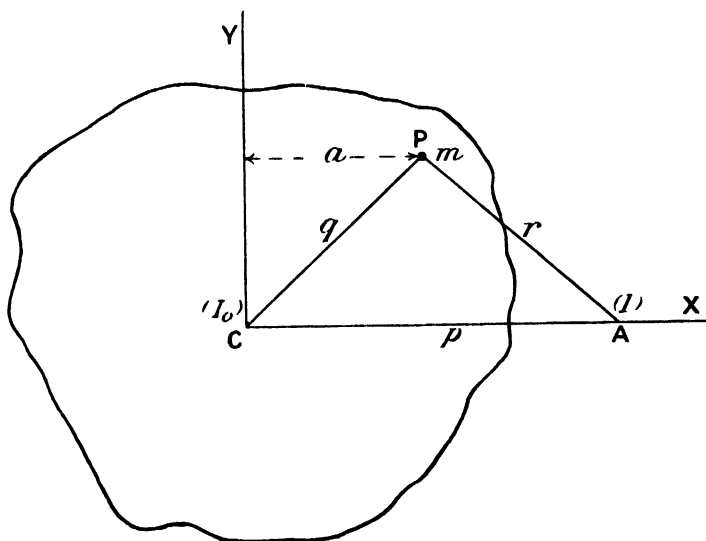

FIG. 31.—Parallel Axes Theorem.

relation between the moments of inertia of any body about any axis and about a parallel one through its centroid or centre of mass. Referring to Fig. 31, let the axes be perpendicular to the plane of the diagram and pass through A and the centre of mass C, where  $AC = p$ . And let the corresponding moments of inertia be denoted by  $I$  and  $I_0$  respectively, as shown in brackets. Take any point P, in the plane of the diagram, as the projection upon it of a point in the body at which a particle of mass  $m$  is situated. Join AP and CP and denote by  $p$ ,  $q$  and  $r$  the sides opposite to the angles P, A and C. Then the abscissa of P is  $a = q \cos C$ . Further, since C is the centre of mass, we have by equation (3) of Art. 32, that

$\Sigma ma = 0$ . We may accordingly write, from our definition of moment of inertia and the geometry of the triangle,

$$I = \Sigma mr^2 = \Sigma m(p^2 + q^2 - 2pq \cos C)$$

$$= \Sigma mp^2 + \Sigma mq^2 - 2p \Sigma ma.$$

or  $I = I_0 + Mp^2 \dots \dots \dots (5)$

If the actual body is replaced by a geometrical figure of area A, the corresponding relation may be written

$$I = I_0 + Ap^2 \dots \dots \dots (6)$$

This theorem thus enables us to pass from the moment of inertia about any axis through the centre of mass to a parallel one, or *vice versa*. The student is reminded that it *does not apply directly* to a pair of parallel axes *neither* of which passes through the *centre of mass*.

*Lamina Theorem.*— Take any two rectangular axes in the plane of any lamina, as OX, OY in Fig. 32, and let the corresponding

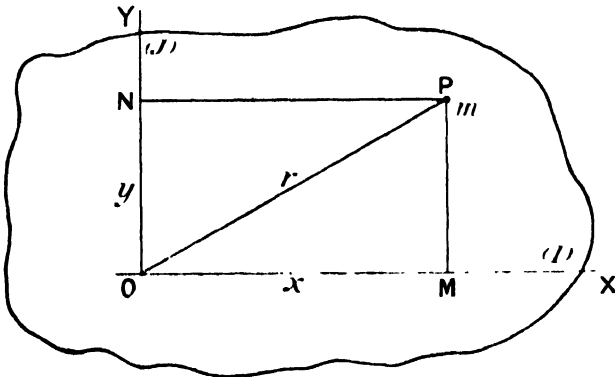

FIG. 32.—Lamina Theorem.

moments of inertia of the lamina be I and J. Also let K be the moment of inertia of the lamina about an axis through O, but perpendicular to its plane.

Take a point P in the lamina at a distance r from O and with co-ordinates x and y, and let there be a particle of mass m of the body at P. Then, by our definition and the geometry of the figure, we have

$$K = \Sigma mr^2$$

$$= \Sigma m(x^2 + y^2)$$

$$= \Sigma my^2 + \Sigma mx^2$$

or  $K = I + J \dots \dots \dots (7)$

expressing the simple relation which it was sought to establish.

51. **Moment of Inertia of a Rectangle about a Side.**—Let the rectangle have sides  $a$  and  $b$  and take the co-ordinate axes along adjacent sides, as in Fig. 33. Take points P and Q of abscissa  $x$  and  $x + h$  respectively, and take as element the very narrow strip cut off by ordinates through P and Q. Let the moments of inertia about OX and OY be denoted by I and J respectively. Then, by definition, we have

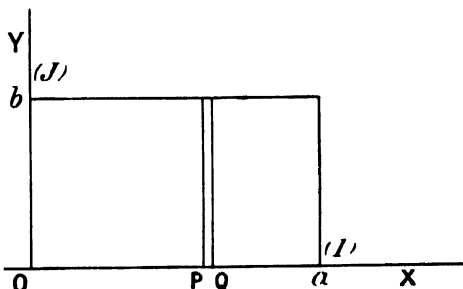

FIG. 33.—Moment of Inertia of Rectangle.

$$J = \sum_0^a b h x^2 = b \sum_0^a x^2 h = \frac{b a^3}{3}$$

or, writing A for the area  $ab$ ,

$$J = \frac{A}{3} a^2 \dots \dots \dots (8)$$

Thus, by symmetry of notation, we see that

$$I = \frac{A}{3} b^2 \dots \dots \dots (9)$$

52. **Moment of Inertia of Rectangle about Central Axis in its Plane.**—Denoting by  $I_0$  and  $J_0$  the moments of inertia about central axes parallel to OX and OY, and applying the parallel axes theorem, equation (6) of Art. 50, we have

$$I_0 = I - A \left(\frac{b}{2}\right)^2 = Ab^2 \left(\frac{1}{3} - \frac{1}{4}\right)$$

whence 
$$I_0 = \frac{A}{12} b^2 \dots \dots \dots (10)$$

And, by symmetry of notation,

$$J_0 = \frac{A}{12} a^2 \dots \dots \dots (11)$$

EXAMPLES XXII.

1. Give definitions of the moment of inertia as applied to solid bodies and to surfaces.
2. Establish the relation between moments of inertia about parallel axes. Through what special point must one of these axes pass?
3. Prove that the moment of inertia of a square is the same about any central axis in its plane.

4. What is the moment of inertia of a door about its hinges, if the mass is 54 lbs., height 6 ft. 8 ins., and width 2 ft. 8 ins. ?

5. Find the moment of inertia of a thin rod 2 ft. long and weighing a pound about a perpendicular axis through one end. If two such rods are joined end to end, what is their combined moment of inertia about perpendicular axes (a) through the middle, (b) through one end ?

6. A rectangular lamina is 4 ft. by 3 ft. Find its moments of inertia about its edges and about lines through the lamina parallel to the edges but a foot distant from them.

53. **Moment of Inertia of Circle.**—Let us now find the moment of inertia of the surface of a circle of radius  $a$  and first about an axis through the centre and *perpendicular* to its plane. In the circle take as the element a very narrow ring of radii  $r$  and  $r+s$ , as shown in Fig. 34. Then the circumference of this ring element

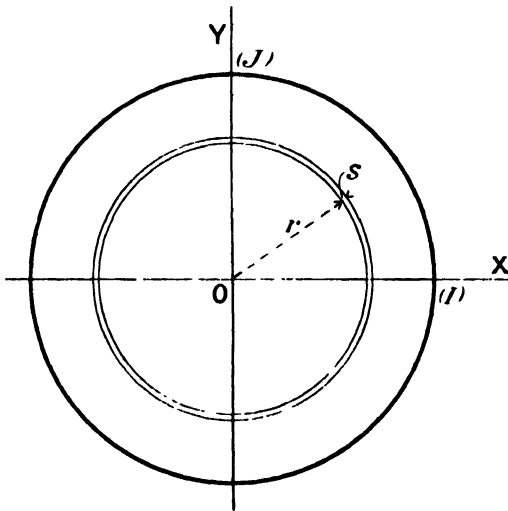

FIG. 34.—Moment of Inertia of Circular Area.

is  $2\pi r$  and its area  $2\pi r s$ . And, since it is equally disposed at a distance  $r$  from the axis of rotation, the moment of inertia of the ring will be  $2\pi r^3 s$ . This quantity must be accordingly summed for the moment of inertia  $K$  required. Hence

$$K = 2\pi \sum_0^a r^3 s = 2\pi \frac{a^4}{4}$$

or

$$K = \frac{1}{2} A a^2 \quad . . . . . (12)$$

where  $A$  is written for the area  $\pi a^2$  of the circle.

Writing  $I$  and  $J$  for the moments of inertia about the perpendicular diameters, we have by the lamina theorem that their sum

equals K. But, by symmetry, I and J must be equal. Thus, we have for the moment of inertia of the circle about a *diameter*

$$I = J = \frac{1}{4}Aa^2 \dots \dots \dots (13)$$

54. **Moments of Inertia of a Triangle about Axes Parallel to a Side.**—In the triangle ABC, Fig. 35, take the co-ordinate axes through B as shown, and consider first the moment of inertia J about the axis of Y parallel to the base CA. Let the elementary area be a strip parallel to OY of abscissa  $x$  and very small width  $h$ , as shown by PQ. Then, writing  $b$  for the length of the base CA and  $p$  for that

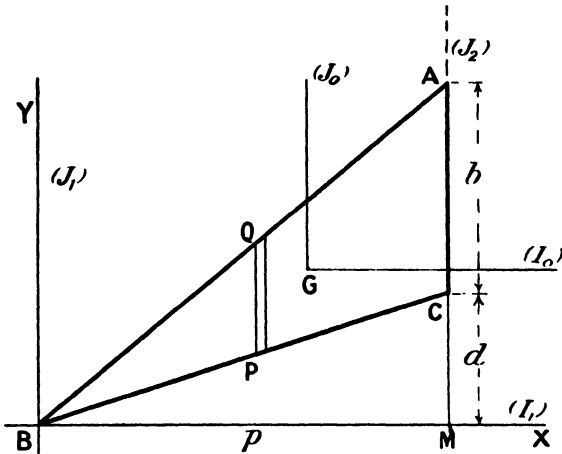

FIG. 35.—Moment of Inertia of a Triangle.

of the perpendicular BM upon it, the length PQ of the strip is  $\frac{bx}{p}$ . Its area is  $h$  times this, and its moment of inertia about BY is  $x^2$  times that. Hence, for the whole triangle of area  $A = \frac{bp}{2}$ , we have

(Axis through Vertex)  $J_1 = \frac{b}{p} \sum_0^p x^2 h = \frac{b}{p} \cdot \frac{p^3}{4} = \frac{1}{2}Ap^2 \dots \dots (14)$

By means of the parallel axes theorem, we can now pass from this result to the moment of inertia  $J_0$  about the axis through the centroid and still parallel to the base CA.

Then  $J_0 = J_1 - A(\frac{2}{3}p)^2 = Ap^2(\frac{1}{2} - \frac{4}{9})$  or,

(Axis through Centroid)  $J_0 = \frac{1}{18}Ap^2 \dots \dots \dots (15)$

Taking now the base CA as axis and writing  $J_2$  for the corresponding moment of inertia, we have

$$J_2 = J_0 + A(\frac{p}{3})^2 = Ap^2(\frac{1}{18} + \frac{1}{9}) \text{ or,}$$

(Axis along base)  $J_2 = \frac{1}{6}Ap^2 \dots \dots \dots (16)$

55. **Moments of Inertia of a Triangle about Axes Perpendicular to a Side.**—Still referring to Fig. 35, let us now determine the moment of inertia  $I_1$  about the axis BX perpendicular to the side CA. It will obviously be the difference between those of the triangles ABM and CMB, each about BX. But these values can be written down from the dimensions by application of equation (16). Thus, writing  $d$  for the length MC, we have

$$\begin{aligned} I_1 &= \frac{I}{6} \cdot \frac{p(b+d)}{2} \cdot (b+d)^2 - \frac{I}{6} \cdot \frac{pd}{2} \cdot d^2 \\ &= \frac{p}{12} \{ (b+d)^3 - d^3 \} \\ &= \frac{p}{12} (b^3 + 3b^2d + 3bd^2) \text{ or,} \end{aligned}$$

(Axis through Vertex)  $I_1 = \frac{A}{6} (b^2 + 3bd + 3d^2)$  . . . (17)

Then, writing  $I_0$  for the parallel axis through the centroid at a perpendicular distance  $(\frac{b}{3} + \frac{2d}{3})$  above, we find

$$\begin{aligned} I_0 &= A \left( \frac{b^2}{6} + \frac{bd}{2} + \frac{d^2}{2} \right) \\ &= A \left( \frac{b^2}{9} + \frac{4bd}{9} + \frac{4d^2}{9} \right), \text{ or,} \end{aligned}$$

(Axis through Centroid)  $I_0 = \frac{A}{18} (b^2 + 4bd + 4d^2)$  . . . (18)

It is noteworthy that the denominators of the fractions occurring in the moments of inertia are—

- 3 for *rectangular laminæ* about an edge,
- 4 for *circular laminæ* about a diameter,
- 2, 6 or 18 for *triangles* about axes in their plane.

56. **Graphical Method for Moment of Inertia of any Plane Area.**—Referring to Fig. 30, in Art. 48, we had in equation (1) the relation

$$\frac{y'}{y} = \frac{x}{a} \text{ . . . . . (1)}$$

Now let a *second derived figure*, characterised by the points P''Q'', be obtained from the first derived figure precisely as it was obtained from the original figure. And let P'''Q''' be denoted by  $y''$ . Then we have the extended relation

$$\frac{y''}{y'} = \frac{x}{a} = \frac{y'}{y} \text{ . . . . . (2)}$$

Thus  $\frac{y''}{y} = \frac{x^2}{a^2} \text{ . . . . . (3)}$

or,  $a^2 y'' = y x^2 \text{ . . . . . (4)}$

But, if  $J$  denote the moment of inertia of the original figure about  $OY$ , we see that it may be expressed by

$$J = \sum_0' yx^2h \dots \dots \dots (5)$$

Also for the area  $A''$  of the second derived figure, we should have

$$A'' = \sum_0' y''h \dots \dots \dots (6)$$

Accordingly, from (4), (5) and (6), we find

$$J = a^2A'' \dots \dots \dots (7)$$

which expresses the moment of inertia of the original figure in terms of the area of the second derived figure.

It is often convenient to introduce the radius of gyration, which we will denote by  $K$ . Then  $J = AK^2$ , and we see that

$$K^2 = a^2A'' \div A \dots \dots \dots (8)$$

EXAMPLES XXIII.

1. Establish the expression for the moment of inertia of a circular area of radius  $a$  about a diameter and thence find the moment of inertia about a tangent.
2. Derive expressions for the moments of inertia of a triangular area about a side and about axes parallel to a side but through the centroid and vertex respectively.
3. Obtain the moments of inertia of a triangle about axes through the centroid and through a vertex, in each case perpendicular to a side.
4. What is the moment of inertia about its diameter of a semicircle of 2 ft. radius?
5. Find the moment of inertia of a triangle 3 ft. high about its base, which is 4 ft. long.
6. Obtain by the graphical method the moment of inertia of a rectangle about a side, and check the result by calculation.
7. Determine graphically the moment of inertia of a semicircle about its base, and check by the ordinary method.
8. A plane figure consists of the square  $ABCD$  and the semicircle  $CED$ : find graphically its moment of inertia about  $AB$ .

## PART II.—HYDROSTATICS

### CHAPTER VI

#### LIQUIDS IN EQUILIBRIUM

57. **Conception of Stress.**—In dealing with problems as to the rest or motion of a given body we often think of a force acting on that body as though this single force were isolated. But this is never the case, and in certain problems it is imperative to bear this in mind and remember that when one body is under the action of a force  $F$ , some other body is under the action of the equal but opposite force *minus*  $F$ . Thus, if an engine hauls a truck along so that the truck is acted upon by a force  $F$ , the engine is acted on by the numerically equal but opposite force  $-F$ . (If there is acceleration, the above is strictly so only on the supposition that the coupling used to connect engine and truck is of negligible mass.) Now, when considering how the truck will behave we are concerned with the force  $F$  and the other forces on the truck. When considering how the engine will behave we are concerned with the force  $-F$  and any other forces acting on the engine. But if we are asked about the strength or possible elongation of the *coupling* we are concerned with the equal and opposite forces  $F$  and  $-F$  which constitute a *stress* or put the coupling in a *state of stress*. If either of these forces had been lacking, the coupling would have had an acceleration corresponding to the other force. The stress in the above case would be a *tension*, because the tendency of the forces was towards a *separation* of the substance lying on opposite sides of a cross section of the coupling.

On the other hand, if a vertical column of stone, say, is supporting a load, then the stress of the column is a *pressure or thrust*, because the parts of the column above and below a horizontal cross section are being forced together.

By the term stress some writers mean the set of forces in equilibrium applied to a body from outside, others mean the mutual forces occurring within the body itself. But, in most cases with which we are concerned in hydrostatics, the *measure* of the stress in *forces per unit area* would be the same in either interpretation.

It is well to note that in 1855 Kelvin gave the following definition and corollary:—

“DEFINITION.—A stress is an equilibrating application of force to a body.

“COROLLARY.—The stress on any part of a body in equilibrium will thus signify the force which it experiences from the matter touching that part all round, whether entirely homogeneous with itself, or only so across a part of its bounding surface.” (*Encyclopædia Britannica*, ninth edition, vol. vii. p. 819.)

The ordinary modern usage of the term *stress* may be thus expressed: *Stress* is the pair of forces per unit area constituting the intensity of the mutual interaction at or across a plane. Stress accordingly includes both the action and the reaction of which either single force is only one part.

58. **Normal Stress and Tangential Stress.**—The tensions and pressures just referred to are obviously perpendicular or *normal* to the cross sections at which they are estimated. But it is clear that the stress at a plane might be a *tangential* one; that is, the portions of substance on each side of it might be so circumstanced as to have a tendency to slide past each other. Thus, if a sheet of cardboard is held horizontally and cut by shears in a vertical plane, then the parts of the card on opposite sides of that vertical plane move past each other, showing that the forces were tangential to that plane. But in the case of liquids (or gases) such tangential stresses would produce relative motion, whether they were viscous or not. Hence, for fluids at rest in equilibrium, we may rule tangential stresses out of account, thus leaving for our present consideration *normal* stresses only. And since it is the property of a liquid at rest to produce this normal stress, it is often called a *hydrostatic* pressure.

59. **Hydrostatic Pressure Independent of Direction.**—We have now to show that the pressure of a fluid at rest upon a surface is the same however the surface is turned about, provided its centre is not shifted. Or, in other words, the pressure of a fluid *at a point is independent of direction*.

To establish this, consider the equilibrium of a small wedge-shaped portion of the fluid, as shown by OABCDE in Fig. 36. In this wedge the edges OA and OC are placed horizontally, and the edge OB vertically; the edges OA and CD have length  $a$ , the edges OC, AD and BE the length  $c$ , the vertical edges OB and CE the height  $b$ , the slant edges AB and DE inclined at  $\theta$  with the vertical have the length  $s$ . Then the normal pressure  $N$  on the slant face is inclined  $\theta$  with the horizontal. The pressure on the vertical rectangular face is denoted by  $P$ , and that on the base by  $Q$ , each normal to the face on which it acts. The weight of the fluid in the wedge is denoted by  $W$  and shown acting vertically down as applied at  $G$ , its centre of mass. Then this wedge-shaped portion of fluid is in equilibrium under the action of its weight and the forces expressed by the products of pressures into areas on which they act.

Hence, resolving horizontally parallel to P, we have

$$Pbc = Ncs \cos \theta = Ncb$$

or

$$P = N \dots \dots \dots (I)$$

Again, resolving vertically, we find

$$Qca - Ncs \sin \theta - \frac{1}{2}abcdg = 0,$$

where the third term gives the weight of the wedge of fluid of density  $d$ .

This equation cancels to

$$Q - N - \frac{1}{2}bdg = 0.$$

Now to have Q and N acting at the same point, O say, we may continually reduce our wedge in the dimensions  $a, b, c$  of its edges.

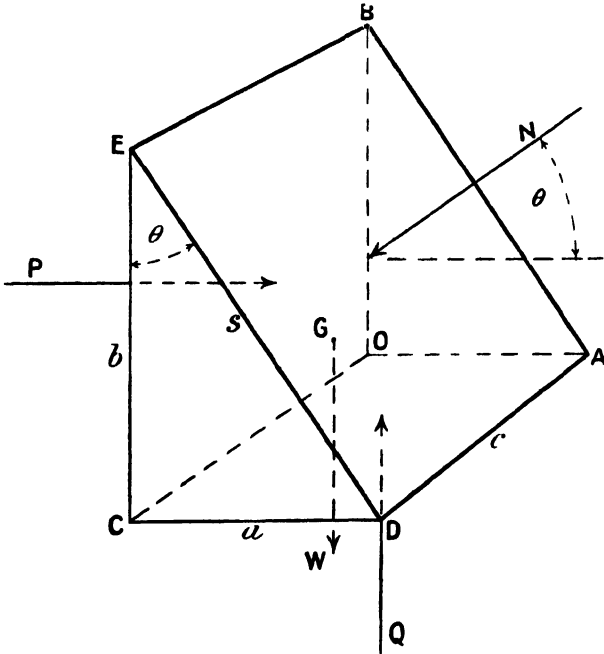

FIG. 36.—Hydrostatic Pressure Independent of Direction.

Thus the whole wedge shrinks to O, the forces P, Q, and N all act at the point O, and the third term in the equations vanishes in comparison with the others. That is to say, when the edges are very small, the volume involving the product of *three* edges is *negligibly* small compared with the areas of the faces involving the products of only two edges. Hence, in the limit in which the forces

can be said to really act *at a point*, the weight drops out of consideration in comparison with the pressure forces, and we find

$$Q = N \dots \dots \dots (2)$$

Thus, P, Q and N are all equal when they all act at the same point O. But N acts at any angle  $\theta$  with the horizontal, and in any vertical plane we choose, so what is true for this N, that it equals the horizontal pressure P and the vertical pressure Q, is true of the *pressure in any direction whatever*, provided that P, Q and N all act at the same point.

The pressures on the triangular ends of the wedge have not been mentioned, evidently they act on equal areas and must be equal since there are no other forces in that direction.

The experimental confirmation of the principle that the pressure at a point is the same in any direction, may be obtained by a chamber having pressure gauges on each face.

**60. Pressure the Same throughout a Given Level.**—Let us now compare the pressures

P and Q in a fluid at rest in equilibrium at two points A and B in a horizontal plane, as shown in Fig. 37. Take the points A and B as the centres of the bases of a right prism or cylinder of the fluid of small cross-sectional area  $a$ . Then resolving parallel to the axis of the prism, we have



FIG. 37.—Pressure same throughout given Level.

$$Pa - Qa = 0, \text{ or } Q = P \dots \dots \dots (3)$$

Now if the cross section of the prism is supposed made smaller and smaller, the centres of the ends being still at A and B, we see that equation (3) still holds and then establishes the following relation:—

In a fluid at rest in equilibrium the *pressure* is the *same* at all points in any *horizontal plane*.

**61. Pressure increases with Depth.**—Let us now consider the pressures P and P' at depths  $d$  and  $d'$  in a fluid at rest. Take a prism of the fluid, of cross-sectional area A with its axis vertical and extending between the levels in question, as shown in Fig. 38. Then, resolving vertically, we have

$$P'A - W - PA = 0$$

where W denotes the weight of the prism of fluid. Dividing out by A and transposing, we obtain

$$P' - P = \frac{W}{A} \dots \dots \dots (4)$$

This establishes a most important principle, which may be put in words as follows:—

The *increase of pressure with depth* in a fluid at rest in equilibrium equals the *weight of a prism of the fluid of unit cross-section extending between the levels in question.*

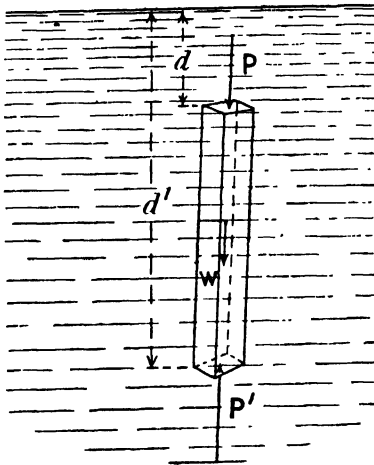

FIG. 38.—Pressure increases with Depth.

If the fluid is a liquid of moderate depth, the density is practically constant, and may be denoted by  $\rho$ . Thus

$$\frac{W}{A} = \frac{A(d' - d)\rho g}{A} = (d' - d)w$$

where  $w = \rho g$  is the weight of the liquid per unit volume, or its *specific weight*.

Hence, for the case of constant density, equation (4) becomes

$$P' - P = (d' - d)w \quad (5)$$

the weight of the unit prism being now expressed as the product of its height and weight per unit volume.

It is well to note here that equation (5) remains true whether the prism is very tall or very short, provided that  $w$  is the weight per unit volume of the fluid present in it. Thus, if the density were varying continuously in any way, and the prism were made very short indeed, we might write

$$\frac{P' - P}{d' - d} = w \quad \dots \quad (6)$$

This again is an important principle that we shall need later, and may be put in the following words:—

The *rate of increase of pressure with depth* anywhere in a fluid at rest in equilibrium equals the *weight of the fluid per unit volume at the place in question.*

A little reflection will probably convince the student that the principles of equations (3) to (6) may be included in a single statement as follows:—

The *rate of increase in any direction of the pressure* in a fluid at rest in equilibrium equals the *component in that direction of the forces acting upon it per unit volume.*

Thus, for the ordinary gravitating fluid, since no component of the weight is horizontal, there is no increase of pressure horizontally. The increase vertically is as stated in equation (6).

If, however, we have a magnetic liquid, like liquid oxygen, and a powerful magnet placed near so as to produce an attraction horizontally, then, when the liquid is at rest in equilibrium, the pressure will increase *horizontally in the direction of the attraction*.

## EXAMPLES XXIV.

1. Explain what you mean by stress, pressure, and tension, giving illustrations from everyday life.
2. Distinguish between normal and tangential stresses, and show that we cannot be concerned with the latter when dealing with liquids in equilibrium.
3. Make a careful diagram of a wedge-shaped figure and prove by it that the magnitude of the hydrostatic pressure *at a point* has the *same* value for *every direction* in space.
4. Prove that in a liquid in equilibrium the pressure is the same at all points in any given horizontal plane.
5. Establish an expression giving the pressure in a fluid at any depth when you know the pressure at some one level.
6. How much does the pressure increase on descending 250 ft. in a fresh-water lake?
7. What is the force due to liquid pressure on the horizontal base of a hollow cone filled with liquid? How do you account for this force exceeding the total weight of the liquid?

**62. Free Surface Horizontal.**—If we imagine a liquid at rest in equilibrium in a chamber, a vacuum existing over the liquid, it is easy to show that the free surface of the liquid will then be horizontal. For, in any horizontal plane below the surface, the pressure has everywhere a constant value (see equation (3) of Art. 59). Also the decrease of pressure as we approach the surface is proportional to the height passed through (see equation (5) of Art. 61). Hence these heights must be everywhere the same to reach a zero pressure from the given constant value. Or, we might have defined the surface in this case as the place of zero pressure, which is therefore horizontal because everywhere the pressure has the same value. The surface of water or mercury in a small trough can accordingly be used as a *level* surface.

Strictly speaking we cannot have a liquid devoid of its own vapour in the region above it in the chamber. But if the pressure of this has the small value  $p$ , say, then the free surface of the liquid, over which the pressure has this constant value, must be horizontal just as truly as if there were no pressure above it.

We have been, of course, thinking only of small surfaces, when we consider them horizontal planes. A large sheet of water like a lake has a *mean* surface which is approximately *spherical* like that of the earth. Here the pressure at the surface is that of the atmosphere at the place, which may be found by the barometer. And usually this atmospheric pressure will be practically the same over considerable areas. Should this pressure, however, be appreciably lower at one end of a lake, the mean level there would in consequence rise

to a corresponding amount in accordance with equation (5) of Art. 61.

63. **Communicating Vessels.**—We have now to notice that the separate free surfaces of a liquid in communicating vessels are at *one common level* when the liquid is in equilibrium.

This is illustrated in Fig. 39, which shows a number of variously shaped tubes fixed on the same vessel with liquid standing at the same level AB in all. The statement may be experimentally confirmed by the apparatus shown. That it is in accordance with the principles already developed may be shown as follows. Below the surface A in one tube take a point C in the vessel, then

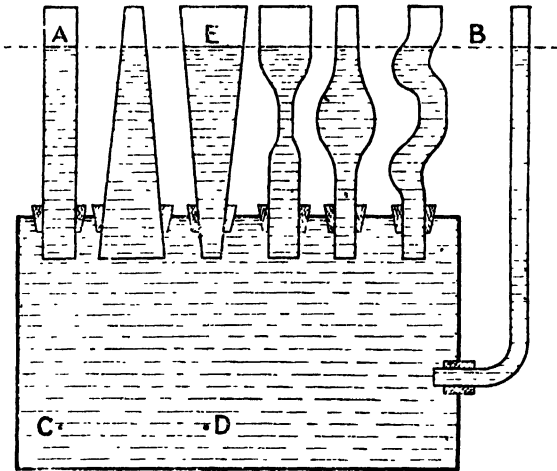

FIG. 39.—Common Level of Liquid Surfaces.

level with C take another point D below the surface E in another tube. Then the pressures are the same at C and D, because they are in the same horizontal plane. It accordingly follows that the pressure differences are the same between A and C and between E and D, since the pressures are the same at A and E. But we have seen that in liquids of the same density throughout pressure differences are proportional to differences of levels. Hence the two heights CA and DE are equal, or AE is a horizontal (see equations (3) of Art. 60 and (6) of Art. 61).

It should be noted that if any of the tubes in the apparatus are of *very narrow bore* at the place reached by the liquid, then (1) the level will be *raised* there, if the liquid *wets the tube* (like water in glass); but (2) will be *depressed* there, if the liquid does *not* wet the tube (like mercury in glass). These effects are due to the *surface tension* of the liquid where it meets the air.

For fairly broad tubes, say 3 cm. in diameter of bore, these disturbing effects will not be obtrusive.

64. **Transmission of Pressure.**—Equation (6) of Art. 61 may now be written

$$P' = P + (d' - d)w \quad . \quad . \quad . \quad . \quad (1)$$

This shows that whatever the pressure  $P$  may be at the depth  $d$ , the pressure  $P'$  at depth  $d'$  will exceed it by a certain amount proportional to the difference of depths and the density of the liquid.

Hence, if, by any means, the pressure  $P$  be increased, it follows that the pressure  $P'$  is increased also and by precisely the same amount. In other words, the additional pressure applied at one place is equally felt at another.

This result is known as Pascal's principle of *the equable transmission of fluid pressure*, having been enunciated by him in a somewhat different form in 1653 (*Equilibre des liqueurs*).

65. **Hydraulic Press.**—This principle has various most important applications. The one we notice here is embodied in the hydraulic press shown diagrammatically and partly in section in Fig. 40.

In this press the plunger  $P$  of the pump is of quite small diameter, the ram  $R$  of the press being much larger, say 12 times that diameter. Then the areas of plunger and ram are as 1 : 144. Now any pressure (force *per unit area*) applied to the liquid by the plunger is transmitted undiminished by the liquid to the ram. But the forces exerted on the plunger and by the ram are each obtained by multiplying the liquid pressure by the respective area. Hence, the ratio of forces on plunger and ram is the ratio of their areas. Or, in symbols, if  $P$  is the force applied to the plunger,  $a$  its cross-sectional area,  $R$  the force exerted by the ram, and  $b$  its cross-sectional area,  $p$  being the pressure of the liquid, we have

$$P = pa \text{ and } R = pb \quad . \quad . \quad . \quad . \quad (2)$$

so that

$$\left. \begin{aligned} P &= a \\ R &= b \end{aligned} \right\} \quad . \quad . \quad . \quad . \quad . \quad . \quad (3)$$

or

$$R = \frac{b}{a}P$$

Hence, with the numerical values named,  $R$  would be 144 $P$ . We have supposed in (2) that the end surfaces of the plunger and ram are on the same level. If they are at slightly different levels a correction would be needed in accordance with equation (1) at the beginning of this article. But, in any case, the *extra* pressure put on by the plunger and *its effect* on the ram would be correctly represented by equations (2) and (3) if the symbols were taken to refer to that extra pressure and its effect.

It is thus seen that any force however small applied to the plunger may be made to balance a very large one on the ram if the ratio of areas of ram and plunger be made large enough. This fact is often referred to as the *hydrostatic paradox*. There is nothing surprising in it if we note that any work done by the ram needs its full equivalent at the plunger. Thus, if the force at the plunger were only one-hundredth that at the ram, the plunger would have to move one hundred times as far as the ram. Thus many strokes of the

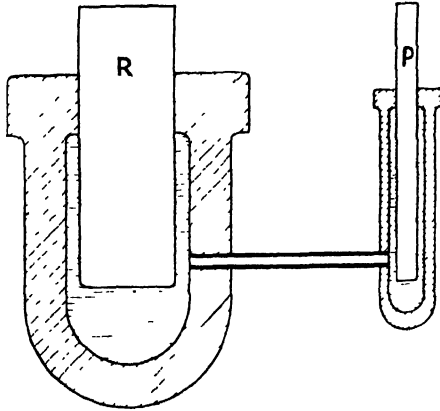

FIG. 40.—Diagram of Hydraulic Press.

plunger are required for a small motion of the ram. Strictly speaking, rather more motion than this is required for the plunger when reaching very high pressures (say 2 tons to the square inch), as the water then shrinks appreciably (one-seventieth of the volume).

The hydraulic press was made industrially applicable by the invention of the U-collar of leather due to Bramah (see Fig. 124 of Art. 177). It may be noted that the U-collar is indispensable at the ram because there is here a *large* circumference for leakage and exposed to the liquid pressure *continuously*. The plunger does not need this special device, although the pressure there is just as great when making a forward stroke, because immediately after that stroke the delivery valve closes and *relieves the pressure* on the plunger. Moreover, the circumference for leaks is *very small*.

#### EXAMPLES XXV.

1. Prove that the free surface of any moderate amount of liquid is approximately horizontal. How is this feature modified by the large extent of a lake and possible variations of atmospheric pressure?
2. Explain why the liquid stands at the same level in a teapot and its spout. How is this principle utilised in the gauge glasses of steam boilers? Sketch the arrangement.

3. What do you mean by the equable *transmission* of *fluid pressure*? Establish the principle and thus explain the so-called *hydrostatic paradox*.

4. The ram of a hydraulic press is 5 ins. diameter, the plunger is  $\frac{1}{2}$  in. and is worked by a point on a lever 2 ins. from the fulcrum. What force must be exerted on the lever at 2 ft. from the fulcrum in order to overcome a resistance of 30 tons weight by the ram?

5. In the previous question, if the stroke of the plunger were 2 ins., how many strokes would be required to shift the ram 1 in., even if there were no leakage at the valves? Also what work would be done on the plunger and by the ram?

66. **Superposition of Liquids.**—If two or more liquids which do not mix (say oil, water and mercury) are placed in the same vessel, they will obviously come to rest with the denser or densest below; the others being in order of density. After equilibrium is reached

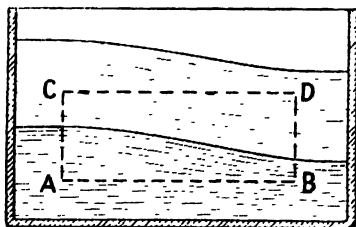

FIG. 41.

points A and B on the same level in the lowest liquid are at the same pressure. It accordingly follows that the surface of this liquid is level. For if above A the surface of the liquid were higher

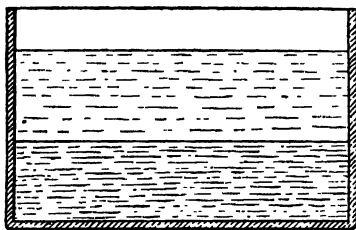

FIG. 42.—Interface of Liquids.

than above B, we should have in the next overlying liquid differing pressures at points on the same level like C and D (see Fig. 41), which is contrary to the result already established. Hence each interface of non-mixing liquids in equilibrium is a horizontal plane, as shown in Fig. 42. Obviously the same result applies if the upper substance is the atmosphere or other gas at rest in equilibrium.

The pressure  $P$  at a depth  $d_2$  in a liquid of density  $\rho_2$ , over which lies a layer of depth  $d_1$  of liquid of density  $\rho_1$ , is easily seen to be given by

$$P = g(\rho_1 d_1 + \rho_2 d_2) \dots \dots \dots (1)$$

In like manner the pressure may be written in the case of three or more liquids.

67. **Densities by U-Tube.**—We may conveniently use the fact of the level interface of {two liquids and the law of increase of

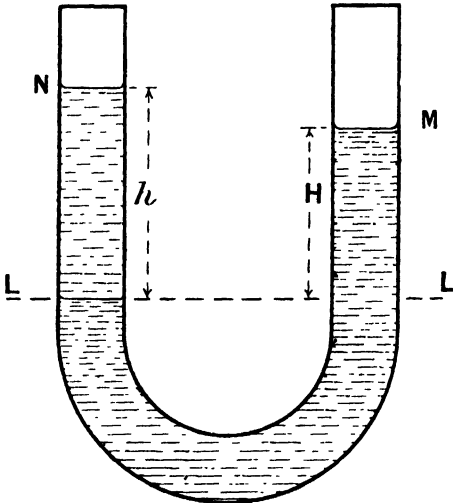

pressure with depth to find the relative density of one with respect to the other. For this purpose a U-tube may be used, with its limbs vertical and open ends at top, as shown in Fig. 43. Then, on introducing two liquids which do not mix, they will settle somewhat as shown if their densities differ slightly. The interface of the two liquids is at L on the left of the figure, and level with it at L on the right, the pressure must be the same,  $P$  say. Hence, in ascending from L to M in the one liquid of density  $D$ , say, the pressure falls to that of the atmosphere.

FIG. 43.—Density of U-Tube.

And, in ascending from L to N in the other liquid of density  $d$ , say, the pressure also falls through precisely the same range. But change of pressure is proportional to the product (depth  $\times$  density). Thus, calling these heights  $H$  and  $h$  respectively, we have

$$HD = hd$$

whence 
$$\frac{d}{D} = \frac{H}{h} \dots \dots \dots (1)$$

or 
$$d = \frac{HD}{h} \dots \dots \dots (2)$$

If the two liquids in the figure were water and oil, we might write  $D = 1$ , and thus find for the density of the oil

$$d = \frac{H}{h} \dots \dots \dots (3)$$

In performing the experiment the U-tube would be conveniently

held in a clip stand, and the heights of L, M and N measured from the table. If these were respectively  $a$ ,  $b$  and  $c$ , it is clear that we should have

$$H = b - a \text{ and } h = c - a . . . (4)$$

If the two liquids to be compared mix or pass into solution, like spirit and water, an *inverted* form of the U-tube is adopted. By an opening at the crown air is sucked out and the liquids drawn up the two limbs of the tube from the vessels into which they dip. Obviously, as before, the densities are inversely as the heights. The arrangement is shown in Fig. 43A.

If a liquid of known density were used and the air completely removed from the upper part of a *single* tube dipping in a liquid below, the height of the column would measure the *pressure of the atmosphere* and so illustrate the principle of the barometer.

68. **Pressure Gauge or Manometer.**—

Looking again at Fig. 43, we see that another way of regarding the matter would be expressed by saying that the height  $H$  of the denser liquid balanced the *excess of pressure* at the level L *over atmospheric pressure*. For this is true whether the pressure at L is due to the liquid column LN with the atmosphere above or due to any other liquid or gas pressing at the same place. A simple form of *pressure gauge* or manometer based on this principle is shown in Fig. 44. If the manometer is for reading the pressure of illuminating gas in buildings, the liquid may be water and the figures shown on each edge of the scale may be placed at *half* an inch apart. The gauge then reads *direct in inches of water*. If higher pressures were to be dealt with, the limbs might have lengths of half a metre and a metre respectively, and the liquid be mercury with a density 13.6 gm. per c.c.

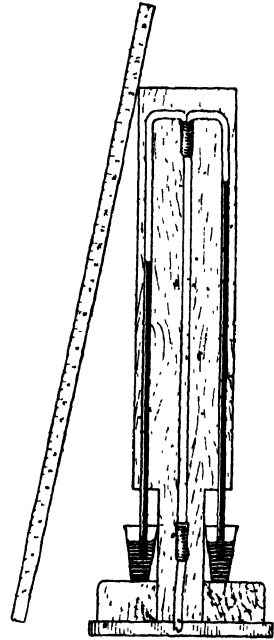

FIG. 43A.—Inverted U-Tube.

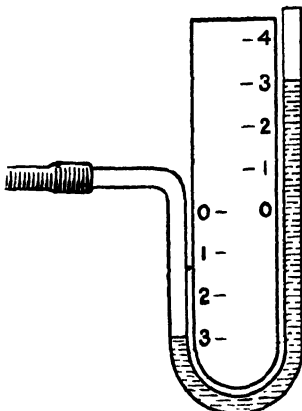

FIG. 44.—Simple Manometer.

EXAMPLES XXVI.

1. Water and oil are poured into a U-tube which is set with its limbs vertical. The levels are then found to be above the table by 15, 26, and 28·5 cm.; what is the density of the oil?

2. Water is drawn up one limb of an inverted U-tube, and spirit up the other, the successive heights of the columns being as follows:—

Water, 49·9, 48, 44, 42·7, 41·9, 39·8, 37·4, 34·3, 29·9, 26 cm.

Spirit, 60, 58, 53, 51·4, 50·5, 48, 45, 41·4, 36, 31 cm.

Calculate the density of the spirit.

3. A water manometer is put on the gas supply of a building, and the levels differ by 0·95 of an inch: find the excess of the gas pressure over the atmospheric in lbs. per square inch.

4. Gas in a chamber is found to give a difference of levels of 1·3 in. in a glycerine manometer. If you have a specimen of the same glycerine, explain how you would determine the pressure of the gas.

5. Suppose the gas in a gasometer shows a difference of levels of 7·3 cm. on a manometer in which the liquid had a density of 1·24 gm. per c.c., what is its pressure above atmospheric in gms. wt. per square centimetre, and in lbs. per square inch?

69. Resultant Force on Immersed Plane Surface.

*Case I. Surface Horizontal.*—Let the surface have an area  $A$  and be situated at depth  $d$  in a liquid of density  $\rho$ . Then, if the pressure at the free surface of the liquid is  $P_0$ , that at the depth  $d$  is  $P_0 + wd$ , where  $w = \rho g$  is the weight of the liquid per unit volume. Further, since the surface immersed is plane, all the liquid pressures are parallel and the resultant force is consequently their simple sum. Hence, we have for this resultant force

$$R = (P_0 + wd)A \dots \dots \dots (1)$$

*Case II. Vertical Rectangle with an Edge in Liquid Surface.*—Let the rectangle have breadth  $b$  and depth  $d$ . Take in it a horizontal strip at depth  $x$ , its width being the very small quantity  $h$ , as shown in Fig. 45. Then the pressure due to the liquid of depth  $x$  may be expressed by  $w x$ , and the area of the strip is  $b h$ . Accordingly the force on the strip is  $b w x h$ . Thus the resultant force on the rectangle is found by summing this quantity from  $x = 0$  to  $x = d$ . Hence we have

$$R = w \sum_0^d b x h = w b \frac{d^2}{2} \dots \dots \dots (2)$$

It may be noted that the quantity inside the sign of summation is an element of area  $b h$  multiplied by its distance from the level of the free liquid surface. Thus the summation of this must give the product—whole area multiplied by depth of its centroid or centre of gravity. Thus, if we write  $A$  for the area of the rectangle and  $G$  for the depth of its centroid, equation (2) takes the form

$$R = A w G \dots \dots \dots (3)$$

showing that the force may be regarded as being the product of the area into the pressure at the level of its centroid.

If the pressure on the free surface of the liquid (hitherto neglected

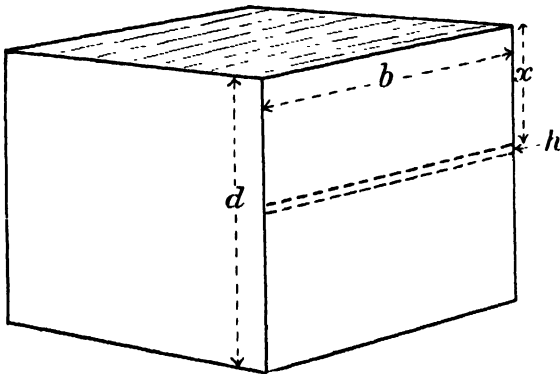

FIG. 45.—Force on Vertical Rectangle.

for the rectangle) were  $P_0$ , it is easy to see that the resultant force would then be increased by  $AP_0$ , the value being

$$R' = (P_0 + wG)A \quad \dots \dots \dots (4)$$

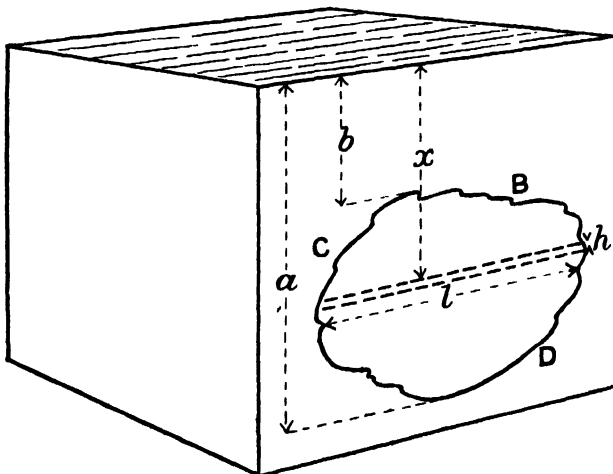

FIG. 46.—Any Plane Vertical Surface.

*Case III. Any Plane Vertical Surface.*—Let the surface be any prescribed plane figure BCD (Fig. 46), extending from the depth  $b$  to the depth  $a$ . In it, at the depth  $x$ , take a horizontal strip of very small vertical width  $h$ , let the length of this strip be  $l$ , as shown

in Fig. 46. Then its area is  $lh$  and the pressure at its level is  $w\bar{x}$ . Thus the resultant force on the surface of area  $A$  is given by

$$R = w \Sigma_i l x h = AwG \dots \dots \dots (5)$$

Or, if the pressure at the free surface of the liquid is  $P_0$ , then the force is

$$R' = (P_0 + wG)A \dots \dots \dots (6)$$

Of course, for any regular figure the value of  $l$  could be found in terms of  $x$ .

*Case IV. Any Plane Surface.*—Let the surface have area  $A$ , be inclined at  $\theta$  to the horizontal, and extend between the depths

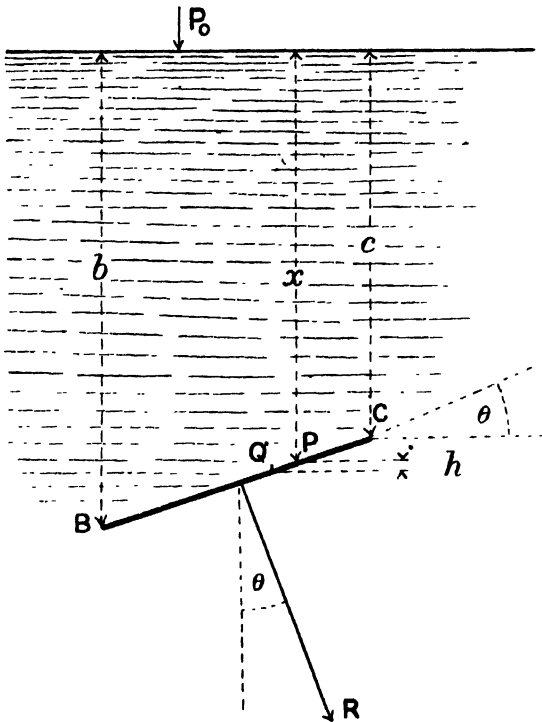

FIG. 47.—Any Plane Surface.

$b$  and  $c$  below the free surface of the liquid, as shown edgewise by  $BC$  in Fig. 47. Take in the area a narrow horizontal strip of width  $PQ$  whose edges are at depths  $x$  and  $x+h$  below the free surface of the liquid, so that  $h$  is very small, and call the length of this strip  $l$ . Then its area is  $l \times PQ = lh \div \sin \theta$ , and the pressure at its level is  $P_0 + wx$ , where  $P_0$  is the pressure at the free surface of the liquid, and  $w$  its weight per unit volume. Hence, summing over the

whole surface the products of pressure into area, we have the resultant pressure expressed by

$$R = \Sigma_r (P_0 + wx) \frac{l}{\sin \theta} h$$

$$= P_0 \Sigma_r \frac{lh}{\sin \theta} + w \Sigma_r \frac{lxh}{\sin \theta}$$

or  $R = P_0 A + wGA \dots \dots \dots (7)$

where, as before, G denotes the depth of the centroid of A.

If the surface pressure were absent, this would reduce to

$$R_0 = wGA \dots \dots \dots (8)$$

The vertical component of the resultant force is

$$R \cos \theta = (P_0 + wG) (A \cos \theta) \dots \dots \dots (9)$$

This evidently gives the *weights of the vertical columns of liquids or fluids resting on the area in question*, since  $A \cos \theta$  is the area of the horizontal projection of the inclined plane surface, and G is the depth of its centroid. And, on considering the equilibrium of the vertical columns resting on this inclined surface; since the pressures on the vertical sides are all horizontal, we see that the vertical component of the force on the base must equal the weights of the columns.

**70. Whole Pressure on an Immersed Surface.**—The *resultant* forces have just been found for various cases of immersed surfaces. A resultant force in such cases is always the resultant or *vector sum* of all the forces on the elements of the surface. But, since the surfaces considered were always plane, the vector sum and the arithmetical sum were accordingly identical. Now the arithmetical sum of all the forces on the elements of a surface due to fluid pressure is sometimes called the *whole pressure* of the fluid on the surface. It must be carefully noted that when the surface is not plane the whole pressure and the resultant force cannot be expected to be alike, and that it is only the resultant force that has any mechanical significance.

Thus, the *whole pressure* on a sphere of radius  $a$  under uniform pressure  $P$  is  $4\pi a^2 P$ . But the *resultant force* on it due to the pressure is *zero*, for the forces are equally distributed in space round the centre. The point is just referred to here that the student may have clear ideas upon the subject and not be troubled by any reference to whole pressures which he may meet. It is to be hoped that the term *whole pressure* will soon drop out of use.

EXAMPLES XXVII.

1. The sides of a tank slope outwards so that it is an inverted frustum of a pyramid. If its depth is  $d$  and its base has area  $A$ , what is the force on the base when the tank is full of a liquid of weight  $w$  per unit volume? If the

area of the upper part of the tank is B, what is the total weight of the liquid contained? Why does this differ from the force on the base?

2. A triangle has its plane vertical, its apex in the free surface of water, and its base horizontal of length  $b$  ft. and at depth  $d$  ft. Find the force on the triangle due to liquid pressure.

3. A circular hole 18 ins. diameter is cut in the vertical side of a tank filled with liquid of density 1.1 times that of water, the upper part of the circle being 2 ft. 3 in. below the free surface of the liquid. What force is needed to hold a plate on the side to cover the hole?

4. A casting is to be made resembling a table with its legs upwards. The main surface which is below is 5 ft. by 4 ft., and the legs project upwards 3 ft. If the specific gravity of the molten metal is 7.5, what load is needed to prevent the moulds separating at the time of casting?

5. A barrel is 2 ft. 6 ins. diameter at the ends, and 3 ft. deep inside; it is filled with sea water (specific gravity 1.025) and then slowly tilted to  $30^\circ$  from the vertical and held there. What is the force due to liquid pressures on its bottom?

6. On the vertical side of a tank filled with liquid a triangle is marked with its base in the free liquid surface. Where can this triangle be divided by a horizontal line so that the forces due to liquid pressure will be equal on its upper and lower portions?

7. On the plane end of a tank full of liquid a rectangle is marked with one side on the surface. It is then divided into equal parallel strips by equidistant horizontal lines. Find (a) the relative forces on the portions of the rectangle from the top to any one of these lines, and (b) the relative forces on the strips.

**71. Centre of Pressure of Triangle.**—The resultant force of all the pressures on the elements of an immersed surface has not only a magnitude and direction, but also a *line of action*. To determine this, we find the point P, called the *centre of pressure*, at which this line of action intersects the immersed surface. Let the distance OP of this point below the free level surface of the liquid be denoted by P also, the resultant force being as before denoted by R.

Consider first the vertical triangle ABC with apex B in the free liquid surface, and base  $CA = b$  horizontal, as shown in Fig. 48. Let the perpendicular height of the triangle be  $d$ , and take in it a horizontal strip element of width  $h$  at depth  $x$ . Then the length of this strip is seen to be  $bx/d$ , and the pressure at its level is  $wx$ . We accordingly have by summation

$$R = \rho g \sum_0^d \frac{b}{d} x^2 h = wb \frac{d^2}{3} \dots \dots \dots (1)$$

Let us now find the sum of the products—

(force on a strip  $\times$  depth of that strip below free liquid surface)

Obviously, this will be found by introducing into the previous summation another  $x$ , making  $x^3$  instead of  $x^2$ . Further this sum must equal the product PR, the moment of the resultant force R about the horizontal line DBE, where the plane of the triangle intersects the free liquid surface. Hence, we have

$$PR = w \sum_0^d \frac{b}{d} x^3 h = wb \frac{d^3}{4} \dots \dots \dots (2)$$

Then, by dividing (2) by (1), we find

$$P = \frac{3}{4}d \dots \dots \dots (3)$$

Showing that the depth of the centre of pressure below the surface is  $\frac{3}{4}$  that of the triangle. It is also situated on the median BPM of the triangle through B, as may be seen by symmetry.

72. **Centre of Pressure: General Treatment.**—Still referring to the triangle shown in Fig. 48, let us now see how the treatment may be generalised to suit the case of any vertical surface whatever.

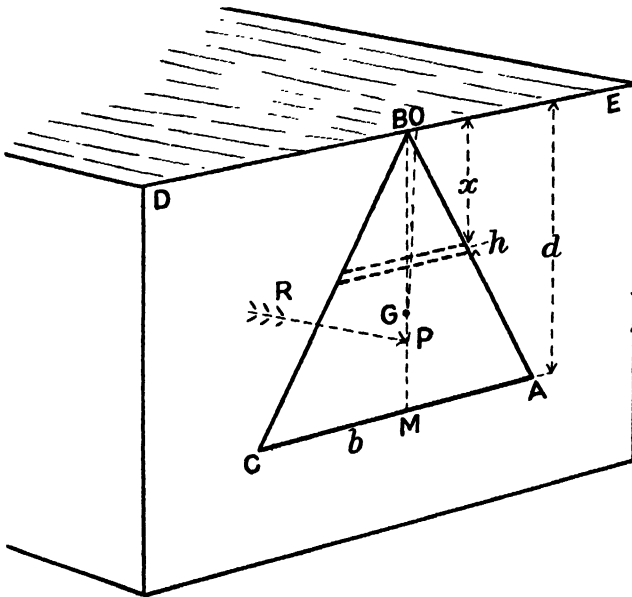

FIG. 48.—Centre of Pressure.

Let the area of the immersed surface be denoted by A, the depth of its centroid by G and that of its centre of pressure by P, both reckoned from the free level surface of the liquid. Let  $l$  be length of the horizontal strip element at depth  $x$ , and  $w$  the weight of the liquid per unit volume. Then for the resultant force we may write

$$R = w \sum_0^d lxh = wAG \dots \dots \dots (1)$$

Again, for the sum of the moments about DBE of the forces on the strips, we have

$$PR = w \sum_0^d lx^2h = wAK^2 \dots \dots \dots (2)$$

where K is the *radius of gyration*, about DBE, of the immersed surface.

Accordingly, dividing (2) by (1), we find

$$P = \frac{K^2}{G}, \text{ or } PG = K^2 \quad \dots \dots \dots (3)$$

Or, in words, the *product* of the depths of the *centre of pressure* and *centroid* of any immersed vertical surface equals the *square of its radius of gyration*, these depths and radius are to be taken from the intersection of the plane of the surface with the free liquid surface, which is understood to be free from pressure.

With some immersed surfaces, it is more convenient to use *k*, its radius of gyration about the horizontal line through its *centroid*. We then have

$$K^2 = G^2 + k^2 = PG \quad \dots \dots \dots (4)$$

Hence, in this case, (3) becomes

$$P = G + \frac{k^2}{G} \quad \dots \dots \dots (5)$$

For example, it is easily seen that this formula would facilitate the work for—

- (i.) A rectangle with edges horizontal and vertical but *not* reaching to the free surface of the liquid ; or for
- (ii.) A circle whether reaching the free surface or not.

On the other hand, a triangle with base in the free surface of the liquid, or a semicircle with base there would be more quickly solved by equation (3).

It may also be seen that for an inclined surface the *slant* depth *P'* of the centre of pressure is related to the *slant* depth *G'* of the centroid, and the radius of gyration *K'* of the surface about its intersection DE with the free liquid surface as follows :—

$$P' = \frac{K'^2}{G'} \quad \dots \dots \dots (6)$$

The slant depths *P'* and *G'* are each to be taken in the plane of the area and perpendicular to DE.

**73. Centre of Pressure by Centroid of Solid.**—To find the centre of pressure of an immersed plane surface we may sometimes with advantage draw to scale the forces representing the liquid pressures. Then the centroid of the solid figure, thus built up of all these forces will afford the clue sought for the centre of pressure. This, of course, obviates the necessity for a general summation when the solid figure is of a simple type whose centroid is known or easily found by elementary methods. Thus, let the immersed area be the vertical triangle ABC, shown in Fig. 49, with the vertex A in the free liquid surface and base BC horizontal. Then the liquid pressures on ABC, drawn to scale, would occupy the pyramid ABCDE. Now it is known that the centroid H of a pyramid is down from the

vertex by  $\frac{3}{4}$  of its height. Hence the centre of pressure P of ABC, level with H, is also down from A by  $\frac{3}{4}$  the height of the triangle. This agrees with equation (3) of Art. 71.

Again, consider the vertical triangle ABC with the base AB in

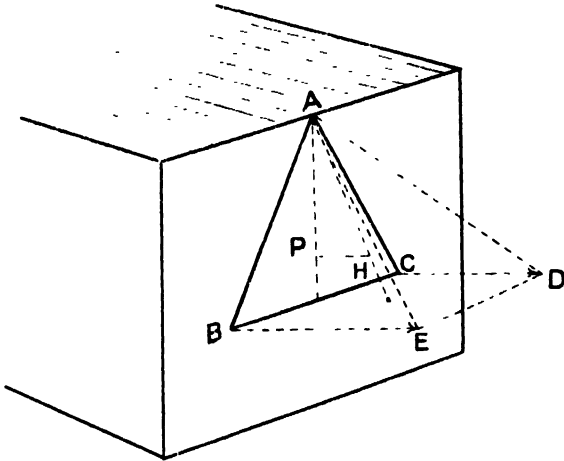

FIG. 49.

the free liquid surface, as shown in Fig. 50. Then, drawing to scale horizontally CD to represent the pressure at C, and joining AD

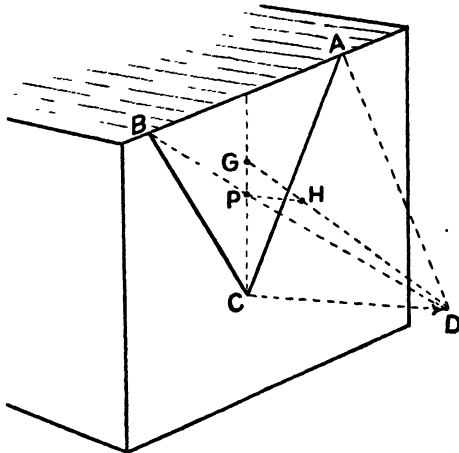

FIG. 50.—Centres of Pressures by Centroid of Solid.

and BD, we have the pyramid ABCD to represent the liquid pressures on ABC. Thus, taking first the centroid G of the triangle ABC, joining GD and finding in it the centroid H of the pyramid, we have,

level with H, the centre of pressure P sought. Further G is down below the free surface one-third of the depth of the triangle, and H is below G by one-fourth of the remaining two-thirds. Thus, H and P are each *half*-way down the depth of ABC.

Both these cases could, of course, be treated immediately by equation (3) of Art. 72.

For by equations (14) and (16) of Art. 54 we obtain for the cases under consideration the values of the moments of inertia of the triangle about the horizontal lines where their planes meet the free surface. These are respectively  $\frac{1}{2}Ap^2$  and  $\frac{1}{6}Ap^2$ , where A is the area of the triangle and  $p$  is the perpendicular height. Thus the values of  $K^2$  for the two are respectively  $\frac{1}{2}p^2$  and  $\frac{1}{6}p^2$ . Further, the depths G of the centroids of the triangles are respectively  $\frac{2}{3}p$  and  $\frac{1}{3}p$ . We thus have, for Fig. 49,

$$P = \frac{1}{2}p^2 \div \frac{2}{3}p = \frac{3}{4}p . . . . . (1)$$

and for Fig. 50

$$P = \frac{1}{6}p^2 \div \frac{1}{3}p = \frac{1}{2}p . . . . . (2)$$

in agreement with what was found before.

EXAMPLES XXVIII.

1. Find by two methods the centre of pressure of a triangle with its apex in the liquid surface.
2. Determine the depth of the centre of pressure of a vertical semicircle whose base is in the liquid surface.
3. A circle of 2 ft. diameter is marked on the plane vertical end of a tank which has liquid up to 3 ft. above the centre of this circle. At what depth is the centre of pressure of the circle ?
4. A rectangle on the vertical end of a tank has its upper and lower sides horizontal and 7 ft. and 9 ft. respectively below the liquid surface. Find the centre of pressure of the rectangle.
5. A rectangle has its upper side in the liquid surface and the lower one at a depth of 20 ins., the plane being vertical. Find where to divide the rectangle by a horizontal line so that the pressures on each part may be equal, and find the centres of pressure of each such part.

**74. Any Triangle with Vertex in Liquid Surface.**—Let us now find the depth of the centre of pressure of any oblique plane triangle ABC with one corner A in the liquid surface. Produce the side BC to meet the liquid surface in D, as shown in Fig. 51, and consider ABC as the difference of the two triangles ABD and ACD. Let the depths of B and C in the liquid be  $b$  and  $c$  respectively, and consider the moments about AD of the forces on each of the three triangles. Then we may apply the theorem as to the moment of resultant being equal to the algebraic sum of moments of components. Further, for any triangle, this moment will be proportional to the product of three quantities, viz.

- (i.) The *area* of the triangle,
- (ii.) The *depth* of its *centroid*, and
- (iii.) The *depth* of its *centre of pressure*.

It should be noted that the plane of the triangles under examination is not necessarily vertical, though that of the diagram is. Thus B and C may be supposed nearer to the observer than A and D, but A, B, C and D are, of course, all in one plane.

To construct the required moments, or rather quantities proportional to them, we may conveniently arrange the factors in a

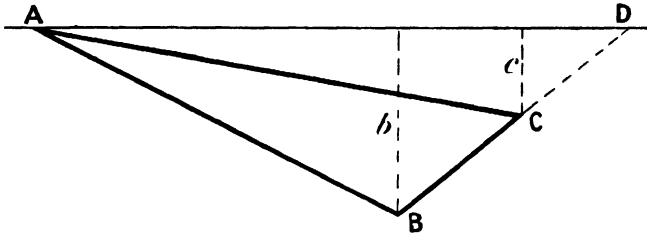

FIG. 51.—Centre of Pressure of Oblique Triangle.

tabular form, promptly discarding in the areas any factors which it is seen will occur alike in each line. The depths of the centroid and centre of pressure are correctly entered. These quantities and the numbers proportional to the moments are entered in Table IV., which should be verified by reading down the columns and then

TABLE IV.—MOMENTS FOR OBLIQUE TRIANGLE.

Triangles considered.	Areas are proportional to	Depths of centroids.	Depths of centres of pressure.	Moments of forces about AD are proportional to
ABD	$b$	$\frac{b}{3}$	$\frac{b}{2}$	$\frac{b^3}{6}$
ACD	$c$	$\frac{c}{3}$	$\frac{c}{2}$	$\frac{c^3}{6}$
ABC	$b - c$	$\frac{b + c}{3}$	P	$\frac{(b^3 - c^3)P}{3}$

along the lines. It must be remembered that any moment in the fourth column is the product of the quantities occurring on the same line in the three previous columns.

From the last column of this table, by equating the last moment to the difference of the others, we obtain

$$P = \frac{1}{2} \frac{b^3 - c^3}{b^2 - c^2} \dots \dots \dots (1)$$

75. **Any Triangle wholly Submerged.**—By making use of the result just obtained, and following the same method, we may find the depth  $P$  of the centre of pressure of any plane triangle  $ABC$  wholly submerged, the depths of its corners being  $a$ ,  $b$  and  $c$  respectively, as shown in Fig. 52.

We produce  $BC$  to meet the liquid surface in  $D$ , join  $AD$  and consider  $ABC$  as the difference of the triangles  $ABD$  and  $ACD$ ,

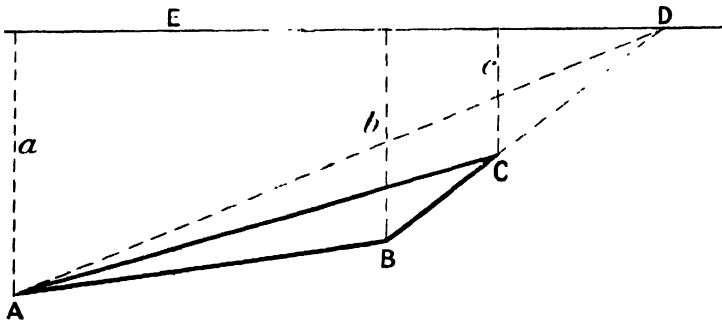

FIG. 52.—Centre of Pressure of Submerged Triangle.

taking moments about the intersection  $DE$  of their common plane with the liquid surface. We thus obtain the quantities in Table V. Since the triangles considered are all between the same parallels,

TABLE V.—MOMENTS FOR SUBMERGED TRIANGLE.

Triangles considered.	Areas are proportional to	Depths of centroids.	Depths of centres of pressure.	Moments about $DE$ are proportional to
ABD	$b$	$\frac{a+b}{3}$	$\frac{1}{2} \cdot \frac{a^3 - b^3}{a^2 - b^2}$	$\frac{b}{6} (a^2 + ab + b^2)$
ACD	$c$	$\frac{c+a}{3}$	$\frac{1}{2} \cdot \frac{c^3 - a^3}{c^2 - a^2}$	$\frac{c}{6} (c^2 + ca + a^2)$
ABC	$b - c$	$\frac{a+b+c}{3}$	$P$	$\frac{(b-c)(a+b+c)P}{3}$

their areas are proportional to their bases  $BD$ ,  $CD$  and  $BC$ , and therefore proportional to  $b$ ,  $c$  and  $b - c$ .

From the table, equating the third moment to the difference of first and second, we find

$$P = \frac{a^2 + b^2 + c^2 + bc + ca + ab}{2(a + b + c)} \dots \dots (2)$$

76. **Particle Rule for Centre of Pressure of any Triangle.**—Let us now suppose that the submerged triangle ABC of Fig. 52 is replaced by three particles at the middle points of its sides, their masses being proportional to their *depths* in the liquid. And let us find the depth H of the centre of *mass* of these particles. We have simply to apply the ordinary rule for any co-ordinate of a centre of mass, and we thus obtain

$$H = \frac{\left(\frac{b+c}{2}\right)^2 + \left(\frac{c+a}{2}\right)^2 + \left(\frac{a+b}{2}\right)^2}{\frac{b+c}{2} + \frac{c+a}{2} + \frac{a+b}{2}} \dots \dots (3)$$

But on simplifying the expression for H, we find it is that previously obtained for P.

If we draw in Figs. 51 and 52 a line DF in the common planes of the three triangles and at right angles to DA or DE, we may take the moments about DF and thus locate the position of the centre of pressure sideways. It would thus be found that in this respect also the centre of pressure agrees with the centre of mass of the three particles just referred to. We have accordingly the following rule which holds for all triangles:—

*Particle Rule.*—The centre of pressure of any plane triangle immersed in a liquid coincides with the centre of mass of three particles at the middle points of the sides and of masses proportional to their depths in the liquid.

This rule may, of course, be applied to plane figures with straight sides by dividing them into triangles.

*Atmosphere.*—In finding the depths of the centres of pressure we have hitherto neglected the atmospheric pressure, if any, on the liquids. We may allow for this influence, when necessary, by replacing the atmosphere by a layer of such thickness of the liquid as will produce the atmospheric pressure. We should thus obtain a new *imaginary* liquid surface from which to reckon our pressures on the plane areas properly situated with respect to the real and lower free surface of the liquid.

77. **Submerged Triangle by Radius of Gyration.**—For any plane triangle wholly submerged, we may readily find the depth P of the centre of pressure by the general formula expressed in equation (3) of Art. 72. For the depth of the centre of pressure is obviously not changed if we substitute for the given triangle its projection on a vertical plane. We may take the radius of gyration K of this vertical triangle about the intersection of its plane with the free surface of the liquid.

If the depths of its corners are *a*, *b*, and *c*, we then find, after reduction, that

$$K^2 = \frac{a^2 + b^2 + c^2 + bc + ca + ab}{6} \dots \dots (4)$$

Further, the depth of the centroid of the triangle is easily seen to be given by

$$G = \frac{a+b+c}{3} \dots \dots \dots (5)$$

Then, applying the formula, we have

$$P = \frac{K^2}{G} = \frac{a^2 + b^2 + c^2 + bc + ca + ab}{2(a+b+c)} \dots \dots (6)$$

in agreement with (2) and (3).

This method is not recommended for the sidewise location of the centre of pressure, as it leads to cumbersome expressions.

78. **Graphical Method for Centres of Pressure.**—This method is most useful for areas that are irregular or complicated in outline

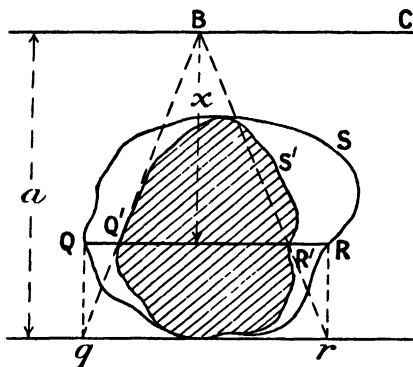

FIG. 53.—Graphical Method for Centre of Pressure.

as shown by the vertical area QRS in Fig. 53. It depends upon the principles already given in Arts. 48 and 56, together with the formula of equation (3) in Art. 72.

Let the free liquid surface be denoted by BC, the greatest depth of any point of the area by  $a$ , and the depth of any horizontal line QR in the figure QRS by  $x$ . Project QR by vertical lines to  $qr$  on the horizontal at depth  $a$ . Take any point B in the free surface and join

$qB$  and  $rB$ , cutting QR in  $Q'$  and  $R'$ . Then

$$\frac{Q'R'}{QR} = \frac{x}{a}$$

That is,  $Q'R'$  represents QR reduced so as to represent the pressure at its depth instead of at the extreme depth of the figure QRS. Hence, proceeding in this way, we might obtain the shaded figure shown, which has the property that each horizontal strip of it represents the *pressure on the corresponding strip of the original figure*.

Accordingly the centroid of this shaded, or first derived, figure  $Q'R'S'$  of area  $A'$ , say, is the centre of pressure of the original figure QRS of area  $A$ .

To obtain the depth  $P$  of this centroid we may refer to (3a) of Art. 48. Then calling the area of the second derived figure  $A''$ , we have

$$P = \frac{aA''}{A'} \dots \dots \dots (7)$$

And this agrees with equations (3) of Arts. 72 and 48, and equation (8) of Art. 56. For by these we find

$$P = \frac{K^2}{G} = \frac{a^2 A'' \div A}{a A' \div A} = \frac{a A''}{A'} \quad . \quad . \quad . \quad . \quad (8)$$

EXAMPLES XXIX.

1. Find the depth of the centre of pressure of a triangle with one corner in the liquid surface and the others at depths 5 ins. and 3 ins.
2. Establish the expression for the depth of the centre of pressure of an oblique triangle with one corner in the liquid surface.
3. Calculate the depth of the centre of pressure of a triangle whose corners are at depths of 2, 3 and 5 ft. below the liquid surface.
4. State the particle rule for the centre of pressure of any triangle.
5. Derive the expression for the depth of the centre of pressure of a wholly submerged triangle.
6. Treat the problem of depth of centre of pressure of a wholly submerged triangle by use of the radius of gyration.
7. Find by the graphical method the centre of pressure of a circle 4 ft. in diameter with centre 3 ft. below the liquid surface, and check by calculation.
8. At what depths are the centres of gravity and pressure of a triangle whose corners are at depths of 4, 6 and 7 ft. ?



the vertical through G, the centre of gravity of the liquid column in question.

Consider now the horizontal component S of the liquid pressure on ABCD. This component is taken parallel to *eba*, as shown in the figure. Project the curved surface in the opposite direction, *ab*, thus obtaining the figure *a'b'c'd'* on the end face of the vessel. Also isolate in thought any small prism of liquid with its axis parallel to *abe* and extending from the curved surface to its plane projection. Then on the sides of this prism all the liquid pressures are at right angles to its length and so contribute no component parallel to its axis. Hence the equilibrium of the prism requires the axial components at its ends to be equal and opposite. Thus, if the whole curved surface ABCD were supposed occupied by the bases of such prisms, we see that the horizontal component S of the liquid pressure on ABCD is equal and opposite to that on *a'b'c'd'*. Also, from the way this force is built up, it is obvious that its line of action must pass through P, the centre of pressure of *a'b'c'd'*.

If this horizontal through P cuts at I the vertical through G, then the resultant R of Q and S will evidently pass through I also. The magnitude and direction of R would be found in the usual way after Q and S were determined.

In the case just considered, the resultant R would represent the final resultant force on ABCD due to the liquid pressures, because the surface in question evidently receives no pressure component parallel to AD as it presents no area when projected in that direction.

If, however, the surface were of such form as to yield a projection in this direction, there would be a corresponding force, T say, which would need compounding with Q and S to form the final oblique resultant.

It is easy to see that the parallelogram law could be extended to a *parallelepiped* law for obtaining the resultant in this case. Thus, if the three forces Q, S and T were represented by adjacent edges of a parallelepiped, their resultant, R say, would be represented by that diagonal of the same figure drawn from the corner common to those edges.

In Fig. 54 the liquid pressures on the curved surface are down and to the left, because the liquid is inside. If the vessel shown were emptied and then pushed down into the same liquid till its top *abcdef* becomes just level with the free liquid surface, then it is obvious that the forces Q and S would be each exactly reversed in direction, but left the same in magnitude. (The thickness of the sides of the vessel are here neglected.)

**80. Forces and Resultant on a Closed Surface.**—Let us now find the distribution of the forces on any closed surface described entirely in a liquid and due to the liquid pressures all round it and acting inwards. We will first consider horizontal forces and afterwards vertical ones. In Fig. 55 a closed surface is indicated by the irregular

line passing through Q, S, P, T; the free liquid surface being at A, B, C. In the closed surface take a horizontal prism ST, and consider the horizontal forces parallel to its axis on the ends of the prism. By Art. 79, these axial components are obviously equal and opposite. And since this applies *all over* the closed surface and in *any* horizontal direction, we see that the pressures all over the closed surface yield no horizontal component.

Take now a vertical prism PQ and continue it to the free surface at B. Then, by Art. 69, we have the vertical component of the forces on the lower base at P equal to the weight of the prism PB of liquid. Again, the vertical component of the forces on the upper base Q equals the weight of the prism Q $\bar{B}$  of liquid. But the force

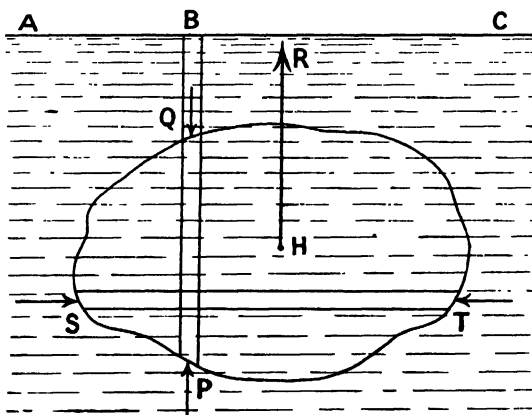

FIG. 55.—Forces on a Closed Surface.

inwards at the lower base was up, whereas the inward force at the upper base is down. Hence the resultant of the two forces at the bases P and Q acts upwards and equals their difference, which is the weight of the prism of liquid PQ. Accordingly, extending this examination throughout the closed surface, we see that the resultant vertical force due to liquid pressures all over the closed surface acts upwards and equals the *weight of the liquid inclosed by that surface*. Further, by the way this resultant is built up, it is clear that it must act through the *centre of gravity H of this inclosed liquid*.

But since all the pressures yielded no horizontal component, this vertical force is the sole and final resultant of all the pressures, and is shown by R in the figure.

If only the magnitude of the resultant were required, it could be obtained more quickly by consideration of the statical equilibrium of the liquid inclosed by the surface, under its own weight and the pressures round the surface. But the method first given shows in addition the exact distribution of the forces.

81. **Resultant Force on Unclosed Surface with a Plane Opening.**

—If it is required to find the resultant force of the liquid pressures on a curved surface not closed but closable by a plane, we may proceed as follows. Call the force required  $Q$ , and let  $S$  be that on the plane required to close the surface. Then their resultant,  $R$  say, will be the force on the now closed surface. Hence  $R$  and  $S$  being each calculable,  $Q$  follows by the parallelogram law. This treatment may be easily carried out for the curved surface of a hemisphere (or other portion of a sphere) or for the curved surface of a cone.

Let us take the curved surface of the cone  $CDE$ , as shown in

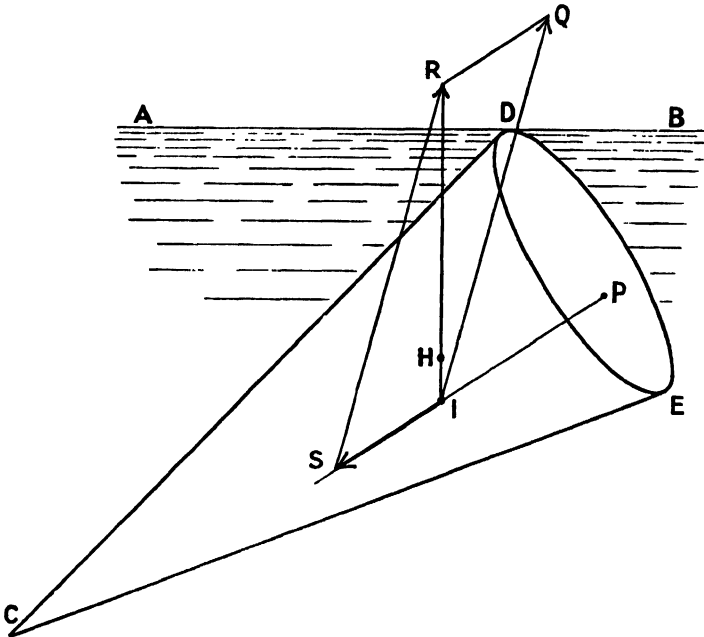

FIG. 56.—Resultant Force on Conical Surface.

Fig. 56, with axis inclined and one point  $D$  of the base in the free liquid surface  $ADB$ .

Then, by the previous articles we can find—

(1) The vertical force  $R$  due to the whole closed surface (obtained by adding the base) and passing through the centre of gravity  $H$  of the cone; and

(2) The force  $S$  perpendicular to the base  $DE$  and passing through  $P$ , its centre of pressure.

Let these two forces intersect at  $I$  and set them off to scale from  $I$ . Then  $IR$  represents in magnitude and direction the resultant of  $IS$  and the required force yet to be drawn,  $IQ$  say. Thus,  $IQ$  is parallel and equal to  $SR$ , as shown in the figure.

Accordingly, we have now found in magnitude and line of action the resultant force  $IQ$  due to the liquid pressures on the given conical surface  $CDE$  and closable by the plane base  $DE$ .

If the plane surface which closes the opening of an immersed unclosed curved surface is the free surface of the liquid itself, the corresponding force vanishes. It is thus evident that the resultant force of the liquid pressures on such a curved surface will equal the weight of the contained liquid and act vertically through its centre of gravity.

#### EXAMPLES XXX.

1. A tank is 3 ft. square in plan, has a semi-cylindrical bottom and contains water to a total depth of 4 ft. Find the component forces on one side of half the curved bottom, also the resultant.

2. A cylindrical tank, 2 ft. diameter and 5 ft. long, lies with its axis horizontal and is full of liquid of specific gravity 1.2. Find the component forces and resultant on the quarter of its curved surface bounded by the lowest horizontal line and that level with the axis.

3. A hemispherical tank 4 ft. diameter, placed with its diametral plane horizontal and uppermost, is filled with water. Find the component and resultant pressures on the quarter of its surface lying between two vertical planes which intersect at right angles in the axis.

4. Establish the expressions for the component forces and resultant on a curved surface exposed to liquid pressure.

5. Determine the resultant force on any closed surface exposed to liquid pressure.

6. A body of irregular shape is let down into a vessel full of water and causes 3 lbs. of water to run out. The body is now immersed in mercury (of specific gravity 13.6): what is the resultant force upon it due to liquid pressure?

7. A solid hemisphere 10 ins. diameter is immersed in water so that its base is inclined at  $30^\circ$  with the horizontal and just reaches the surface. Find the resultant force on the curved surface of the hemisphere.

**82. Equilibrium of Floating Bodies.**—Let us now suppose that a given closed surface in a liquid is the exterior surface of some body entirely immersed. Or, again, let us suppose that an unclosed surface whose plane opening is part of the free surface of the liquid is that of a body partly immersed. Then in either case, we see from the previous articles that the resultant force of all the liquid pressures, called the force of *buoyancy*, equals the weight of the liquid required to replace the immersed part of the body without disturbing the surrounding liquid and acts vertically upwards through the centre of gravity of this replacing liquid. This centre of gravity is termed the *centre of buoyancy* of the wholly or partially immersed body.

This replacing liquid is often for brevity spoken of as the liquid *displaced* by the body. It must, however, be noted that, in the case of a body floating in liquid contained in a vessel very little larger than the body itself, the liquid said to be displaced may be of a volume much in excess of all the liquid present.

For the equilibrium of a body wholly or partially immersed and

not in any other way supported, it is evident that the resultant force referred to must equal the weight of the body, and that the two must act in the same line. Hence we may state the case as follows:—

For the equilibrium of a body wholly or partially immersed it is necessary—

- (1) That the weight of the *replacing* (or *displaced*) liquid shall equal that of the body, and
- (2) That the centre of gravity (G) and centre of buoyancy (H) of the body shall be in the same vertical line.

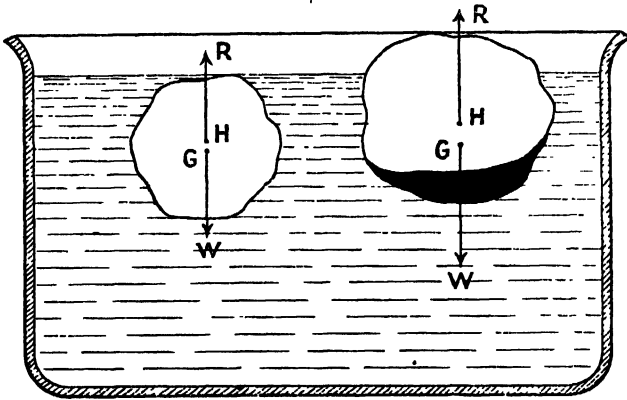

FIG. 57.—Floating Bodies.

Or, in symbols, denoting by R the resultant force of the liquid pressures, and by W the weight of the body, we have

$$R=W \dots \dots \dots (1)$$

and G and H are in the same vertical line. These conditions are illustrated for bodies wholly and partially immersed in Fig. 57.

It must be specially noted that the above expression for the upward force due to liquid pressures does not apply to a body which has settled into mud at the bottom and so *prevented the water from reaching its under surface*. Thus, in some cases, a boat left by the tide on certain mud flats must be rocked to and fro as the tide comes in to insure the entry of the water underneath, and so enable it to float again at high water.

**83. Archimedes' Principles.**—We have just seen what are the conditions for the free floating of a body, but have now to notice that when a body is not floated by immersion in a liquid it will still have *part* of its weight borne thereby. Thus, if a body weighing 11 lbs. displaces only 1 lb. of water on immersion, it will sink, but only exert on the bottom of the vessel a weight of 10 lbs. ; the other 1 lb. being supported by the liquid pressures.

The cases of floating and sinking bodies were both dealt with by Archimedes, the Sicilian, in the third century B.C. It must suffice to quote the six following propositions demonstrated by him.

“(a) The surface of any fluid at rest is the surface of a sphere whose centre is the same as that of the earth.

“(b) Of solids, those which, size for size, are of equal weight with a fluid will, if let down into the fluid, be immersed so that they do not project above the surface, but do not sink lower.

“(c) A solid lighter than a fluid will, if immersed in it, not be completely submerged, but part of it will project above the surface.

“(d) A solid lighter than a fluid will, if placed in the fluid, be so far immersed that the weight of the solid will be equal to the weight of the fluid displaced.

“(e) If a solid lighter than a fluid be forcibly immersed in it, the solid will be driven upwards by a force equal to the difference between its weight and the weight of the fluid displaced.

“(f) A solid heavier than a fluid will, if placed in it, descend to the bottom of the fluid, and the solid will, when weighed in the fluid, be lighter than its true weight by the weight of the fluid displaced.”

(*The Works of Archimedes, edited in Modern Notation*, by T. L. Heath, Cambridge, 1897, pp. 253-268, quoted by J. Y. Buchanan, *Trans. Roy. Soc. Edinburgh*, vol. xlix. Part I., 1912, p. 17.)

It is now customary to make a single statement embodying the substance of several of the foregoing propositions as to the effect of fluid pressures on bodies placed in them. We shall adopt the following form, which may be referred to as—

*The Principle of Archimedes.*—A body wholly or partially immersed in a fluid, at rest under gravity, is acted upon by fluid pressures whose resultant is a force equal to the weight of the fluid required to replace the immersed portion and acts vertically upwards through the centre of gravity of that supposed replacing fluid.

Archimedes only referred to a single fluid, but we may see, from the theory already developed, that it will apply equally to several. In this extended form the principle embraces the cases of fish wholly under water, of balloons wholly in the air, of ships partly in water and partly in the air, and lastly the cases of any bodies whatever surrounded by any liquid or liquids or fluids though not floating. Thus all bodies weighed in ordinary scales or balances, and also the weights used to weigh them, are alike buoyed up by the atmosphere to some extent, the results being thereby slightly vitiated. The principle is thus of widespread importance, as we shall see later.

#### EXAMPLES XXXI.

1. Derive the conditions for the equilibrium of floating bodies and illustrate them by sketches.
2. What do you know of the principles of Archimedes as to liquids at rest and bodies floating or submerged in them?
3. State what is now called the *Principle of Archimedes* and comment upon it.

4. Devise an experiment by which you could attempt to verify any of the principles of Archimedes.

5. A disc of wood of specific gravity 0.5 is thrown into water, also a ball of metal of specific gravity 7.5 and weight 15 lbs. How does the disc float, and what weight does the ball exert on the bottom and why?

6. If the disc and the ball of the previous question, when fastened together, neither sank nor rose in the water, what weight was the disc?

84. **Hydrometers of Variable Immersion for Liquids.**—We may now note a simple application of Archimedes' Principle in the common hydrometer, which indicates the density of the liquid in which it floats by the graduation to which it sinks.

Let us first discuss the theory of graduation of a uniform cylinder loaded at the bottom so as to float vertically. The cylinder is shown by OA, in Fig. 58, and sinks to W in water and to Q in a liquid of density D.

But the immersed volume in any case of free floating corresponds to a weight of the particular liquid equal to that of the instrument, which is constant. Hence, for the two cases named, since the volumes are proportional to the lengths immersed, we have

$$D \times OQ = 1 \times OW$$

Thus, 
$$D = \frac{OW}{OQ} \dots (1)$$

or 
$$OQ = \frac{OW}{D} \dots (2)$$

Equation (1) shows that if the *densities* increase in arithmetic progression, the *distances* OQ must *decrease* in *harmonic* progression. Similarly, equation (2) shows that if the *distances* OQ increase in arithmetic progression, the *densities* must *decrease* in *harmonic* progression.

Special hydrometers for industrial use have been employed with each of these types of graduation.

Since the ideal form shown would have to be extremely long to attain any delicacy in its indications, the lower part is made of much greater cross section and therefore shorter, as shown in Fig. 59. It is even then desirable and usual to have a set of hydrometers each having a limited range. Thus a set of four is very convenient, their ranges of specific gravity being respectively 0.7 to 1, 1 to 1.3, 1.3 to 1.6 and lastly 1.6 to 2.

It is easily seen that the bulbous portions of the hydrometer are equivalent in volume to a long extension of the stem to a point O

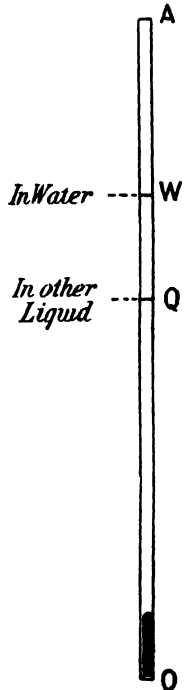

FIG. 58.—Principle of Variable-Immersion Hydrometer.

far beyond the edge of the page. Thus much greater sensitiveness is attained, as may be seen from equations (1) or (2).

85. **Hydrometer of Variable Immersion for Solids.**—We shall now notice a hydrometer made and used by Mr. J. Y. Buchanan for lecture demonstrations of the densities of solids (*Trans. Roy. Soc., Edin.*, vol. xlix., Part I., p. 18, 1912). Fig. 60 shows a sketch of it.

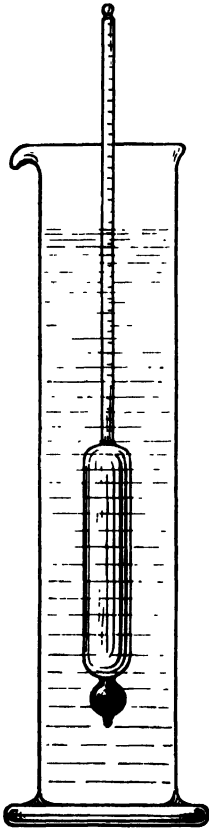

FIG. 59.—Common Hydrometer.

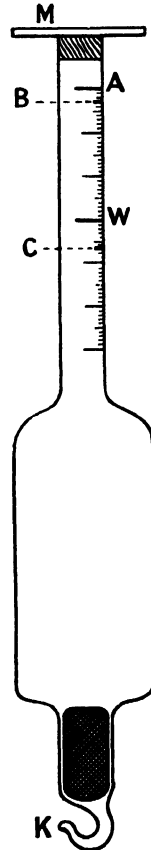

FIG. 60.—Buchanan's Hydrometer for Solids.

The stem of the instrument was of glass tube of about a centimetre diameter outside, of a truly circular section and uniform diameter. It has equidistant graduations of any convenient size, the numbers increasing upwards. It is ballasted with mercury or shot so as to sink to the middle of the scale (W say) when in water at the room temperature and with its scale pan M in place at the top. The hydrometer is finished with a hook K at the bottom.

To determine the density of a solid, a suitable fragment of it is placed on M, thereby sinking the hydrometer to the reading A. The solid is then transferred to the hook K, the hydrometer sinking to B say, if heavier than water ; or to C if lighter than water.

It then follows that the densities of the solids are given by the expressions

$$D = \frac{A-W}{A-B} \quad \text{or} \quad \frac{A-W}{A-C} \quad \dots \quad (3)$$

For the *weights in air* and *apparent losses of weights in water* (of density unity) are proportional to the numerators and denominators of the above fractions.

Of course, if the water was not pure distilled water, or if it was at such a temperature that the density was sensibly different from unity, the above expressions would not give the densities sought. They would then give only the relative densities (or specific gravities) of the solids with respect to the liquid in use of true density, *d* say. Then the real density of the solid would be expressed by the product *Dd*.

EXAMPLES XXXII.

1. A uniform rod of wood is varnished and fitted with a plug of lead at one end. When placed in water it floats with 8 ins. of its length submerged, but in another liquid has only 5 ins. submerged. What is the density of this liquid and to what depth would it be submerged if placed in a liquid of specific gravity 0.83 ?

2. A plain cylindrical hydrometer of variable immersion floats with a length of 10 ins. submerged in water: draw carefully to scale its graduations for liquids of specific gravities :—

0.7, 0.8, 0.9, 1.0, 1.1, 1.2, 1.3, 1.4, 1.5, 1.6.

How could the instrument be made shorter, and yet have the scale as above ?

3. Explain carefully the construction, graduation and use of the Buchanan Hydrometer of variable immersion for solids.

4. In a Buchanan hydrometer the presence of a bronze coin on the top depresses the instrument by 43.7 scale divisions in water, and the shift of the coin to the hook then raises the instrument by 5.1 divisions. What is the specific gravity of the coin ?

5. A piece of wax in air depresses a Buchanan hydrometer in pure water at 4° C. by 34.2 scale divisions, but on transferring the wax to the submerged position the hydrometer rises by 36.3 scale divisions. Find the density of the wax.

86. **Hydrometer of Fixed Immersion for Solids.**—The hydrometer we shall notice under this head is the well-known form due to Nicholson, who is stated to have produced it from an instrument due to Fahrenheit by adding the platform E for the body when under water, as shown in Fig. 61. The main displacements are due to the body BC and the lower piece E, the stem AB being slender to give sensitiveness to the instrument.

To make a determination of the density of a solid, weights  $P$  are placed on the upper platform  $A$  to sink the instrument to the standard immersion as indicated by the mark  $M$  on the stem. The same immersion is next secured by the body on the same platform + weights  $Q$ . Lastly, the body is placed in the lower platform

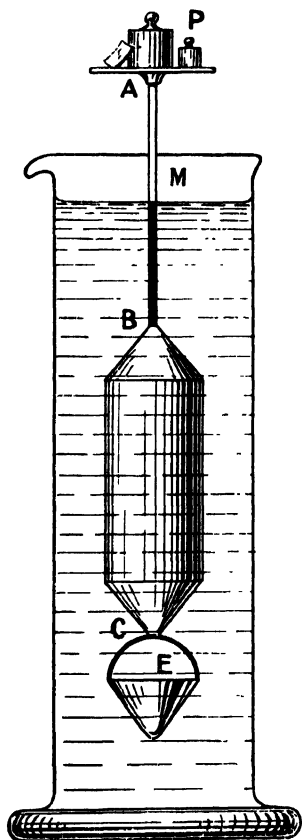

FIG. 61.—Nicholson's Hydrometer.

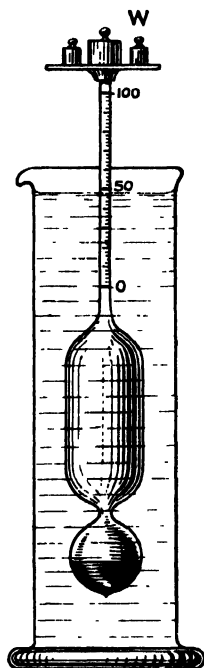

FIG. 62.—Buchanan's Closed Hydrometer for Liquids.

$E$  and the adjustment to  $M$  secured by weights  $R$  at  $A$ . Then the density  $D$  is given by

$$D = \frac{\text{weight of body in air}}{\text{apparent loss in water}} = \frac{P-Q}{R-Q} \dots (4)$$

If the solid used is lighter than water (like paraffin wax) it often can be placed at  $E$  so as to be held by the bow of wire above. Of course, in this case  $R$  exceeds  $P$  and the above equation brings the

density less than unity. But for a solid like bronze, the difference in the denominator is only about a ninth of that in the numerator.

**87. Hydrometer of Fixed Immersion for Liquids.**—We again notice a form of hydrometer used by Mr. J. Y. Buchanan (*Trans. Roy. Soc., Edin.*, vol. xlix., Part I., pp. 26–43, etc., 1912), and called by him a closed hydrometer because the instrument is sealed up and the internal ballast never altered in use. This hydrometer is shown in Fig. 62. It is of blown glass and ballasted to float in distilled water up to a mark a little above the zero when there is no platform or weight at the top. These are then added of such weight as to immerse the instrument exactly to the 50 mark, which is the centre of the 100 graduations on the stem. The graduations are useful in finding by proportion what weights would sink it to the 50 mark if none quite right are available. Let the weight of the hydrometer be  $H$ , and let  $W$  be the weight of the platform and other loads to immerse to the 50 mark in pure water. The hydrometer is then placed in the liquid to be tested and the weights,  $L$  say, found, which again immerse it to the 50 mark. Then the volume concerned is the same in each case, hence the densities are as the total loads in the two cases. Thus that of the liquid is given by

$$D = \frac{H+L}{H+W} \quad . . . . . (5)$$

For a good determination of density the water should be at such a temperature that its density is practically unity, the other liquid being at the same temperature. But, in any case, when the two liquids are at the same temperature, the above equation would give the relative density of the liquid to that of water at the temperature used. And the corresponding density  $d$  of water being found from tables, the true density of the liquid could be calculated, for it is obviously the product  $Dd$ .

EXAMPLES XXXIII.

1. Describe Nicholson's hydrometer and establish the theory of its use.
2. In a determination with the Nicholson hydrometer the instrument was successively immersed to the zero mark with loads as follows:—(1) 50·3 gms.; (2) the body in air and 9·6 gms., and (3) the body in water and 13·2 gms. in air. What was the density?
3. Find the specific gravity of a specimen of wax, if, in using a Nicholson hydrometer, it was sunk to the zero mark in water with the following loads:—(1) 25·6 gms., (2) the wax and 18·8 gms., and (3) the wax in water and 27·9 gms. in air.
4. A Buchanan hydrometer for liquids weighs 63·26 gms., and requires 25·16 gms. to sink it to the 50 mark in water. What is the density of a liquid in which it sinks to the same mark with a load of only 10·13 gms.?

**88. Hydrostatic Balance for Densities of Solids.**—The term “hydrostatic balance” may be applied to any sufficiently delicate balance when provided with a vessel of water suitably supported and



smooth solid which is not attacked by the liquids under test. Its apparent losses of weight on immersion in a liquid and in water are then found, and their quotient gives the density of the liquid in gms. per c.c.

The scheme of balancings is as follows:—

1. Counterpoise in left pan balanced by (sinker in *air* +  $w_1$  gms.)  
in right pan.
2. " " " " (sinker in *liquid* +  $w_2$  gms.)  
in right pan.
3. " " " " (sinker in *water* +  $w_3$  gms.)  
in right pan.

Then the density  $D$  of the liquid is given by

$$D = \frac{w_2 - w_1}{w_3 - w_1} \dots \dots \dots (2)$$

EXAMPLES XXXIV.

1. A body weighs 25.3 gms. in air and 22.1 gms. in water. Find its density, proving any equation you use.
2. A piece of coal (varnished over) weighs 10½ oz. in air and 2¾ oz. in water. What is its specific gravity?
3. A piece of wax weighs 5½ oz. in air, a wire cage weighs 2¼ oz. in water, and the wax in the cage weighs 1½ oz. in water. Find the specific gravity of the wax.
4. A block of wood (waxed over) weighs 35.4 gms. in air; when it is attached to a 20-gm. brass weight the two appear to weigh 6.4 gms. in water. Find the density of the wood and the brass if the weight alone appears to weigh 17.5 gms. in water.
5. In using a hydrostatic balance for the specific gravity of a piece of metal, a counterpoise in the left pan is balanced successively by the following in the right:—(a) 50.3 gms., (b) the metal and 6.8 gms., (c) the metal in water and 10.7 gms. in air. Find the density of the metal.
6. The counterpoise at one side of a balance is balanced by 16.5 gms. at the other side, then by a piece of wax and 5.3 gms., lastly by the wax in water and 17.7 gms. in air. What is the specific gravity of the wax?
7. A sinker of glass weighs 30.7 gms. in air, 22.9 gms. in water, and 24.3 gms. in some spirit. What is the specific gravity of the spirit?
8. A sinker weighs 23.6 gms. in air, 15.8 gms. in a salt solution, and 17.4 gms. in water. Find the density of the solution.

90. **Balance Work with Air Corrections.**—To illustrate the methods of allowing for the buoyancy of air, let us consider the following determinations.

It is required to ascertain the *true volume, density and mass* of a solid that sinks in water, allowances being made for the air displaced by the body and the weights and for the variation of density of water with temperature.

Let the body dealt with have mass, volume and density,  $M, V,$  and  $D$  respectively; and let the weights used have the corresponding quantities represented by  $m, v$  and  $d$ , subscripts being affixed to denote the particular values used in any given operation.

It should be noted that weights of brass, aluminium, and platinum are in common use and may be mingled in different ratios in the different weighings. Thus, if in any weighing the total mass is  $m$ , made up of weights of masses  $a$ ,  $b$  and  $c$  of respective densities  $\alpha$ ,  $\beta$ , and  $\gamma$ , we have

$$\left. \begin{aligned} m &= a + b + c, \\ v &= \frac{a}{\alpha} + \frac{b}{\beta} + \frac{c}{\gamma} \\ \text{and} \quad d &= \frac{m}{v} \end{aligned} \right\} \dots \dots \dots (1)$$

Hence, in the general case each set of weighings will be characterised by weights of a different *mean density* as well as of a different mass and volume.

Further, in the case of any body, whether in water or air, the effective mass must be written—

Volume of body  $\times$  *excess* of its density over *that* of the *fluid* in which it is *immersed*.

In these expressions  $W$  and  $A$  will be written for the densities of water and air respectively. The value of  $W$  must be ascertained for the temperature of the water used by reference to tables.

Then, following the usual procedure, the counterpoise in the left pan is balanced successively—

- (1) By (weights  $m_1$ ) on the right,
- (2) By (the body in air + weights  $m_2$ ) on the right,
- (3) By (the body in water + weights  $m_3$  in air), on the right.

Since the counterpoise remains unchanged in the left pan throughout, the effective masses in the right pan are the same in the three balancings. Hence, we have

$$v_1(d_1 - A) = V(D - A) + v_2(d_2 - A) = V(D - W) + v_3(d_3 - A)$$

From the first pair of equals, we may write

$$V(D - A) = v_1(d_1 - A) - v_2(d_2 - A) \dots \dots (2)$$

Similarly, for the last pair, we obtain

$$V(W - A) = v_3(d_3 - A) - v_2(d_2 - A) \dots \dots (3)$$

This last equation gives for the volume of the body

$$V = \frac{m_3(1 - A/d_3) - m_2(1 - A/d_2)}{W - A} \dots \dots (4)$$

Thus, if *only the volume* of the body were required, the balancing of the counterpoise by weights  $m_1$  is seen to be unnecessary.

Suppose now that in (4),  $d_3 = d_2 = d$ , say, the equation then reduces to the simpler form

$$V = \frac{m_3 - m_2}{W - A} \left( 1 - \frac{A}{d} \right) \dots \dots (4a)$$

To obtain an expression for the density of the body, divide (2) by (3). This gives

$$\frac{D-A}{W-A} = \frac{m_1(1-A/d_1) - m_2(1-A/d_2)}{m_3(1-A/d_3) - m_2(1-A/d_2)} \dots (5)$$

Here, again, if the *d*'s are all the same, the expression simplifies by their entire disappearance. We have then

$$\frac{D-A}{W-A} = \frac{m_1 - m_2}{m_3 - m_2} \dots (5a)$$

To obtain the mass of the body, put  $V = M \div D$  in (4) and substitute for *D* from (5). This gives

$$M = m_1\left(1 - \frac{A}{d_1}\right) - m_2\left(1 - \frac{A}{d_2}\right) + \frac{A}{W-A} \left\{ m_3\left(1 - \frac{A}{d_3}\right) - m_2\left(1 - \frac{A}{d_2}\right) \right\} (6)$$

Or, if the *d*'s are all alike, we may omit their subscripts and reduce the expression to

$$M = \left( m_1 - \frac{Wm_2 - Am_3}{W-A} \right) \left( 1 - \frac{A}{d} \right) \dots (6a)$$

which agrees with (4a) and (5a).

It should be noted that the adoption of the formulæ (4a), (5a) and (6a), where the weights are of various densities, mixed and in *different ratios* in the *several* weighings, is only an approximation and may in extreme cases involve errors corresponding to a third of a milligram in a gram. It would thus be useless to weigh to a tenth of a milligram in 100 gms. if such approximations were being made.

The density of the air, for the temperature of the room, may be found from the tabular density and the known expansion. For extreme accuracy this density should be corrected for humidity also.

If we wish simply to ascertain accurately the mass of a body whose density is approximately known, we derive from equation (2) the equation

$$M\left(1 - \frac{A}{D}\right) = m_1\left(1 - \frac{A}{d_1}\right) - m_2\left(1 - \frac{A}{d_2}\right) \dots (7)$$

which is all that is needed for this purpose.

**91. Works of Emersion and Immersion.**—In the case of a body of prismatic form floating freely with its axis vertical, the determinations of the mechanical works needed to raise it just clear of the liquid and to depress till wholly immersed form interesting problems.

Let the liquid have *weight w* per unit volume, be contained in a vessel with vertical sides and of horizontal area *B*, and let the depth of the liquid be *b* when the body is floating freely. Let the body have weight *sw* per unit volume, have a base of area  $A = rB$  and height *a*.

Then we have to consider the body in the three positions already referred to and illustrated in Figs. 64, 65, and 66, viz. freely floating, just clear, and wholly immersed.

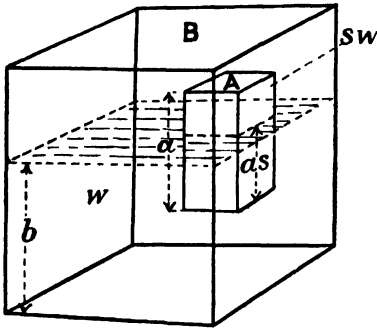

U  
FIG. 64.

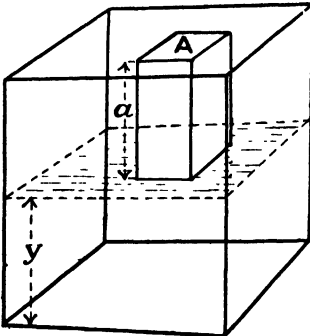

V  
FIG. 65.

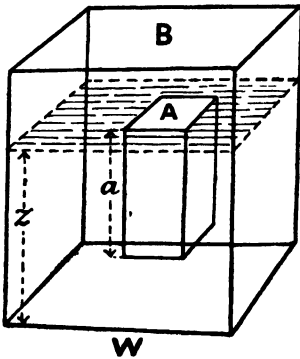

W  
FIG. 66.—Works of Emersion and

To obtain the works required it will be well to calculate the potential energy of liquid and body in each case. Then calling these  $U, V$  and  $W$ , their differences will express the works sought.

Further, it will be convenient to consider the liquid with the body wholly or partly immersed in it as made up of (i.) the whole volume of liquid as if the immersed part of the body were replaced by liquid added to that already there; (ii.) less this liquid supposed added. Then each volume is simple in form and its centre of gravity at its half height. We shall naturally reckon potential energies from the level of the bottom of the liquid.

Then, for the natural position of equilibrium, the depth immersed being  $as$ , we have

$$\frac{U}{w} = \frac{Bb^2}{2} - A(as)\left(b - \frac{as}{2}\right) + (Aa)s\left(b - as + \frac{a}{2}\right)$$

$$\text{or } \frac{2U}{w} = Bb^2 + Aa^2s(1-s) \quad (1)$$

To find the new depth  $y$  of the liquid when the body is raised clear, we equate volumes of the liquid in the two states. Thus

$$By = Bb - A(as)$$

$$\text{or } y = b - ars \quad (2)$$

Then, forming the expression

for the potential energy in this second state and using this value of  $y$ , we find

$$\frac{V}{w} = \frac{By^2}{2} + (Aa)s\left(y + \frac{a}{2}\right)$$

which may be reduced to

$$\frac{2V}{w} = Bb^2 + Aa^2s - Aa^2rs^2 \quad . \quad . \quad . \quad (3)$$

Hence, from (1) and (3), we have for the *work of emersion*

$$V - U = \frac{w}{2} Aa^2(1 - r)s^2 \quad . \quad . \quad . \quad (4)$$

For the depth  $z$  of the liquid in the third state, where the body is wholly immersed, we have the relation

$$Bz - Aa = Bb - A(as)$$

whence 
$$z = b + ar(1 - s) \quad . \quad . \quad . \quad (5)$$

Then, for the new value of the potential energy  $W$ , we find

$$\frac{W}{w} = \frac{Bz^2}{2} - Aa\left(z - \frac{a}{2}\right) + (Aa)s\left(z - \frac{a}{2}\right)$$

or by reduction

$$\frac{2W}{w} = Bb^2 + Aa^2(1 - s) - Aa^2r(1 - s)^2 \quad . \quad . \quad (6)$$

Hence, subtracting (1) from (6), we have for the *work of immersion*

$$W - U = \frac{w}{2} Aa^2(1 - r)(1 - s)^2 \quad . \quad . \quad . \quad (7)$$

It may easily be seen that equations (4) and (7) answer to the checks as to the simple values assumed for  $r = 0$  or  $r = 1$ .

If we wish to find the condition that the works of emersion and immersion shall be equal, a comparison of (4) and (7) shows it to be

$$s = \frac{1}{2} \quad . \quad . \quad . \quad (8)$$

EXAMPLES XXXV.

1. Explain the procedure for an accurate determination of density by the balance, and obtain an expression for it allowing for the density of the air and that of the water, but suppose the weights to be all of the same density.
2. Show how to obtain accurate determinations of the volume, density, and mass of a body by the hydrostatic balance, and derive the necessary expressions allowing for air displaced by body and weights, but taking the latter to be all of the same metal.
3. Derive quite general expressions for balance determinations of volume,

density, and mass, and show that they reduce to those of the previous question on assuming that all the weights have the same density.

4. Prove that in a determination of the density of a solid by the hydrostatic balance, allowing for air displaced by body and weights, the density of the weights, *if the same throughout*, has no influence on the result.

5. In careful balance work a counterpoise on the left side is successively balanced by the following loads on the right side :—

(i.) Weights 1·035 gm. of average density 7·8 gms. per c.c.

(ii.) Body in air and weights 0·865 gm. of average density 2·5 gms. per c.c.

(iii.) Body in water and weights in air of 0·889 gm. and of density 2·5 gm per c.c.

If the densities of the air and water are respectively 0·0012 and 0·9992 gm. per c.c., find as accurately as you can the volume, mass, and density of the body.

6. In the previous example, find the volume, density, and mass on the assumption that all the weights were brass of density 8 gms. per c.c.

7. Taking the densities of air and water as in example 5, find the density of the wax from the following observations with brass grams and platinum fractions (of densities 8 and 21 gms. per c.c.). Counterpoise at left side and sinker in water at right balanced successively the following loads on the right side :—

(i.) Weights, 22·132 gms.

(ii.) Wax and weights, 2·986 gms.

(iii.) Wax in water and weights, 23·937 gms. in air.

8. If all the weights were taken as brass in example 7, what value would be obtained for the density ?

9. A counterpoise at the left side of a balance is balanced successively on the right by 65 gms. in brass weights, and by a block of lead in air and brass weights 5·015 gms. If the density of air and lead be taken as 0·0012 and 11·4 gms. per c.c., what is the mass of the lead ?

10. Find the mass of a piece of wax of approximate density 0·9 gm./c.c. when its presence at one side of the balance involves the removal of platinum weights (density 21 gm./c.c.) 0·987 gm.

11. Obtain expressions for the potential energies of the liquid in a vessel and prism floating upright in it.

12. Find the work needed to lift a floating prism till none of it is immersed.

13. Determine the work needed to depress a floating prism till it is just entirely immersed.

**92. Stability of Floating Bodies : Metacentre.**—A very brief reflection suffices to show that for *vertical* displacements a body freely floating partly immersed is in stable equilibrium. For, on pushing it down, too much is immersed and the resultant force on it is upwards. Conversely, if we raise it from the position naturally assumed, too little is immersed, and it sinks again on being let go.

But the question of *angular* stability, that is, stability for *tilts* about *horizontal* axes, is not so easily solved. To treat it we proceed as follows.

Consider the stability of a body, a boat say, which floats freely with a volume  $V$  immersed in a liquid of weight  $w$  per unit volume. Let the boat tilt a *very small* angle  $\theta$  about its longitudinal axis  $CD$  (see Fig. 67), the centre of buoyancy thereby shifting from  $H$  to  $H'$  (see Fig. 68). Instead of redrawing the boat tilted, it is preferable to redraw the water line, which is then represented by  $A'OB'$ , whereas the original water line was  $AOB$ .

This shift  $HH'$  must be calculated from the wedges of emersion

and immersion  $AOA'$  and  $BOB'$  respectively. The calculation may be made by taking about an axis through  $O$  (perpendicular to the plane of Fig. 68) the moments of the weights of the liquids corresponding to the wedges and the whole volume immersed.

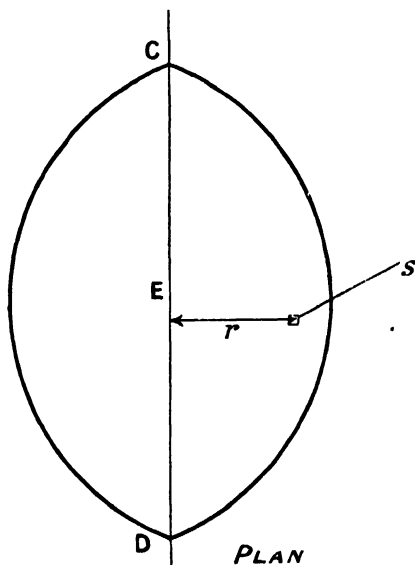

FIG. 67.

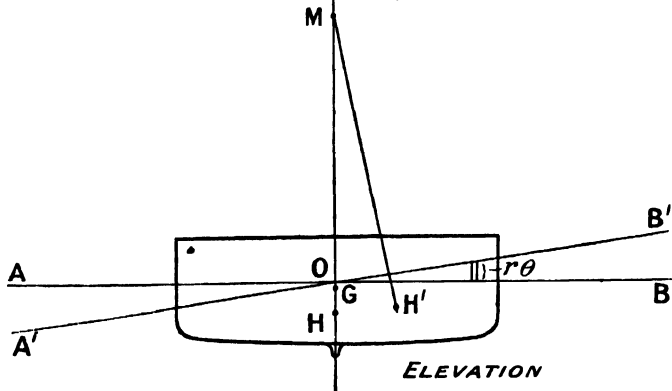

FIG. 68.

Figs. 67, 68.—Location of Metacentre.

The new volume displaced must be  $V$  like the old volume, since we are excluding all vertical displacements of the body as a whole and taking a tilt merely. Further, this new volume may be regarded as made up of—

The old volume— the wedge  $AOA'$  + the wedge  $BOB'$

But the moment of a resultant is equal to the algebraical sum of the moments of its components. To apply this to the present case we must form an expression for the moments of the forces corresponding to the wedges. For this, take at a horizontal distance  $r$  from the axis of tilt a small vertical prism of base  $s$ ; its height is accordingly  $r\theta$ . Thus the weight of the corresponding portion of liquid is  $\theta r s w$ , and the moment  $r$  times this. And summing all over the wedge gives the moment sought.

Hence, applying the moments theorem, with gravity parallel to MH, we find

$$Vw \times HH' = Vw \times \text{zero} - \theta w \Sigma_{\Delta}^0 (-r^2)s + \theta w \Sigma_0^B r^2 s,$$

or—

Moment for new volume

$$= \text{that of (old volume} - \text{wedge AOA}' + \text{wedge BOB')}$$

It is seen that the addition of the wedge AOA' would contribute a negative moment; thus its removal gives a positive term. The equation accordingly reduces to

$$V \cdot HH' = \theta \Sigma_{\Delta}^B r^2 s.$$

But the expression now under the sign of summation for both wedges is evidently the *moment of inertia*  $I$  of the *surface of flotation*, taken about the *axis of tilt* CED. We may accordingly write

$$HH' = \theta(I \div V) \dots \dots \dots (1)$$

Let us now take in the new or tilted position a vertical through the new centre of buoyancy  $H'$ , meeting in  $M$  the original vertical through  $H$ . Then  $M$  is called the *metacentre* of the body for the tilt in question, and is located by the height  $HM$ . Obviously

$$HH' = \theta(HM) \dots \dots \dots (2)$$

Thus, (1) reduces to

$$HM = I \div V \dots \dots \dots (3)$$

which fixes the position of the metacentre for rolling. That for pitching is given by

$$HM' = I' \div V \dots \dots \dots (3a)$$

where  $I'$  is the moment of inertia of the surface of flotation about a transverse axis through its centroid.

We may now easily show that the angular stability depends on the relative positions of the metacentre  $M$  and the centre of gravity  $G$  of the floating body.

Thus, if  $G$  (as shown in Fig. 68) is below  $M$ , then on the body being slightly tilted it is subjected to a *righting couple*.

This consists of the weight  $W$  acting vertically down through  $G$  and an equal force acting vertically up through  $M$ , and is seen to

act so as to reduce the tilt and bring the body back to its normal or upright position.

If, however, by the shape of the boat  $M$  is low and by the character of its lading  $G$  is so high as to be above  $M$ , then a slight tilt would bring into play a couple of the opposite sense or character, and the boat would be urged further from the vertical and would therefore upset. In other words, such a boat would be unstable and could not long remain floating erect.

93. **Practical Location of Metacentre.**—The practical test of the stability of a boat may be made by shifting a given weight across the deck and noting by a plumb line the angle of tilt thereby produced. From this experiment the height  $GM$  may be obtained if the total weight is also known.

Thus by shifting a weight  $w$  a distance  $b$  across the deck let the boat of total weight  $W$  be tilted through the very small angle shown by a plumb bob moving a distance  $s$  when the line has a length  $r$ .

Then, the tilting couple is balanced by the righting couple. Hence, writing these and equating, we have

$$wb = W(GM)\frac{s}{r}$$

or

$$GM = \frac{w}{W} b \frac{r}{s} \dots \dots \dots (4)$$

It should be noted that the theoretical method gives  $HM$ , while the practical gives  $GM$ . The former is a constant quantity for a given boat sunk to the same water line, independent of the particular distribution of its lading, which settles the position of  $G$ . On the other hand, it is the height  $GM$ , given by the practical method, which is of actual importance in settling the *stability* of the boat *whenever* it is loaded in the *same manner as when tested*.

Instead of moving a large solid weight across the deck of a ship, two boats a distance  $b$  apart may be alternately filled with the same weight  $w$  of water.

As a numerical example of this determination, suppose  $W = 1000$  tons,  $w = 5$  tons,  $b = 40$  feet,  $s = 1$  foot, and  $r = 25$  feet. Then, we have

$$GM = \frac{5}{1000} \times 40 \times 25 = 5 \text{ feet.}$$

The distance  $GM$  is sometimes called *metacentric height*, but the same term is also applied to the distance  $HM$  expressed by (3) in Art. 92. The phrase must therefore be used with caution, if at all.

EXAMPLES XXXVI.

1. Obtain an expression for the height of the metacentre above the centre of buoyancy.
2. Find the position of the metacentre of a wood disc, radius  $a$ , thickness  $b$ , floating in a liquid of double its own density.

3. Where is the metacentre for "pitching" of a cylindrical log 7 ft. long and 4 ins. diameter, floating half immersed in water?
4. Why does a disc float with its axis vertical, and a long cylinder float with its axis horizontal?
5. A uniform cylinder of length  $l$  and radius  $r$  has specific gravity  $s$  and floats in water. Find the relation between these quantities to insure its ability to float with its axis either vertical or horizontal.
6. If  $s = \frac{1}{2}$ , what is the ratio of diameter to length for the condition of example 5? Also what becomes of the relation if  $s > 1$ ?
7. Prove the equation used in the practical location of the metacentre and apply it to the following case. The ship displaces 3500 tons of water, and heels over 1 ft. in 30 ft. when a load of 10 tons shifted a distance of 50 ft. across the deck.
8. A 500-ton boat is tilted so that the bob on a 20-ft. plumb line moves 6 in. when 1 ton is shifted 20 ft. across the deck: where is its metacentre? On starting another trip, though drawing just the same water, it requires the shift of 2 tons to give the same tilt: how is this?

**94. Tension of Cylinder and Sphere due to Pressure of Contained Fluid.**—The pressures of a fluid on the sides of the containing vessel not only give a resultant force on them, but also, *when the sides are curved, produce a tension in them.* This effect we must now examine.

*Cylinder.*—Suppose we have a cylinder filled with a fluid at such high pressure that the changes in pressure due to the weight of the fluid are negligible over the space under notice. Consider a ring of the cylinder of unit width and imagine its internal radius to increase from its actual value  $r$  to a very slightly larger one  $r+s$ . Call the circumferential tension in the wall of the cylinder  $T$  *per unit width*, and let the excess of the internal pressure over the external be  $P$ . We can then determine  $T$  by forming two expressions for the work done in the imagined expansion. For in this expansion the work done by the pressure on any small area  $a$  would be given by

$$\text{Force} \times \text{distance} = Pa \times s$$

Hence, for the whole ring, we have

$$W = P2\pi rs = \text{pressure} \times (\text{volume described}) \quad \dots (1)$$

Again, this work may be regarded as done against the tension  $T$ , and, for the unit width, will be  $T \times$  increase of circumference. We thus find

$$W = T2\pi s \quad \dots \dots \dots (2)$$

But these two expressions for  $W$  are equal, so we obtain

$$\text{Circumferential tension} = T = Pr$$

or 
$$P = \frac{T}{r} \quad \dots \dots \dots (3)$$

which is the relation sought.

It must be remembered that this  $T$  is the force per unit width

## PART IV.—PNEUMATICS

### CHAPTER IX

#### GASES

103. **Thermometry.**—We saw at the outset that gases are highly compressible. But the actual diminution of volume produced by, say, doubling the pressure, depends on the original volume, and this again on the original pressure and *temperature*. The compressibility at a given volume is also affected by changes of temperature occurring during the compression. Hence the modes of measuring temperature, called thermometry, is an essential preliminary to the study of gases.

The instrument used to indicate temperatures is called a *thermometer*, the form in general use consisting of mercury in a glass bulb and graduated stem, as shown in Fig. 78. There are three modes of graduation with which the student should be familiar, viz. those called Centigrade, Fahrenheit and Réaumur. The clue to their respective graduations is given in Fig. 78, with their corresponding readings at room temperatures, at blood heat, and at the temperatures of melting ice and of steam from pure water boiling under the standard atmospheric pressure. These last two temperatures are called the *fixed points*, or may be referred to as the *ice point* and *steam point* respectively.

If we write  $C^{\circ}$ ,  $F^{\circ}$  and  $R^{\circ}$  for the measurements on the three systems of graduation of any one temperature, we have the relations :

$$\frac{C^{\circ}}{5} = \frac{(F - 32)^{\circ}}{9} = \frac{R^{\circ}}{4} = \frac{C^{\circ} + R^{\circ}}{9} \dots \dots (1)$$

The freezing or ice point is determined, or checked, by putting the thermometer in a clip stand with its bulb and part of the stem in clean moist ice shavings in a funnel, so that the top of the mercury can be just seen when it has settled.

The boiling or steam point is determined, or checked, by the use of a *hypsometer*, which is an apparatus for boiling water so arranged that the steam from the water passes up an inner tube and is kept dry by the steam descending in an outer jacket. The thermometer under test is placed with its bulb and stem in the inner tube and

is accordingly immersed in dry steam so far as the mercury extends. Every five minutes the thermometer may be raised a little for an instant so that the position of the mercury may be noted.

The barometer must also be read and a correction made if it is not at the standard height of 76 cm., after the necessary reductions

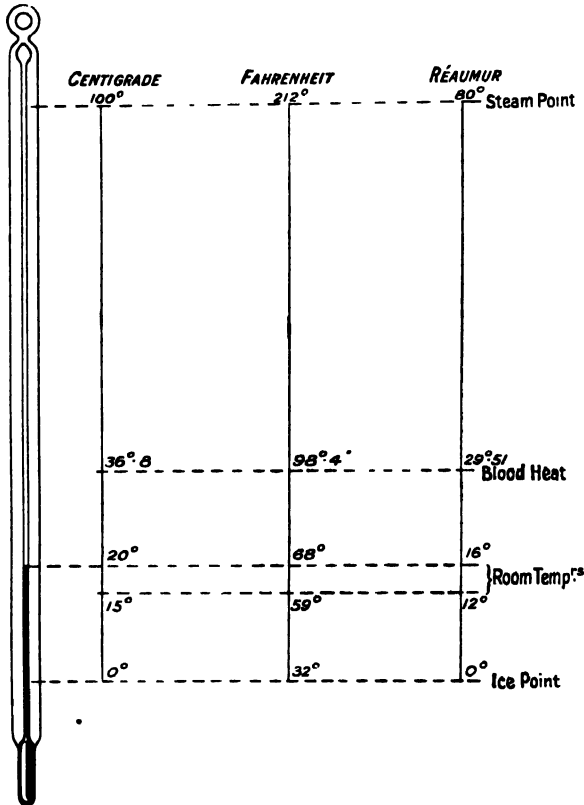

FIG. 78.—Thermometer Graduations.

have been made. These minor details will be dealt with in the chapter treating of the barometer.

Thus the mercury-in-glass thermometer acts by the excess of expansion of the mercury over that of the glass when the temperature rises, the rise being read off by the graduation on the stem reached by the mercury.

#### EXAMPLES XLI.

1. Describe the mercurial thermometer and its graduations.
2. Derive a formula connecting the readings of a centigrade thermometer with a Fahrenheit thermometer whose bulbs are placed in the same liquid.

3. Having found a few corresponding readings on centigrade and Fahrenheit thermometers, plot a graph whose abscissæ give the readings on one instrument and ordinates the readings on the other.

4. If it is 90° F. in the shade, what would be the readings on centigrade and Réaumur thermometers respectively?

5. Explain how the *fixed points* of a mercury thermometer are determined.

**104. The Ideal Gas.**—Some writers use the term *perfect gases*, and may thereby give the impression that there are others which refuse to behave as they should. But this cannot be true of any inanimate substances. Moreover, the so-called perfect gases exist only in the imagination.

The chief facts are as follows. For all gases the precise relations between pressure, volume and temperature are somewhat complicated. But for many gases, when far above their points of liquefaction, the relations holding differ but slightly from a certain simple standard form. This simple form can be easily expressed both in words and by equations. It is accordingly adopted as a *first approximation to the actual facts*, and is very useful when we are not anxious to enter into minute details.

We can therefore conveniently imagine an *ideal gas* whose properties are precisely expressed by that first approximation, though all actual gases behave in a slightly different way.

Indeed, the choice as to whether or not we shall adopt the simple relation often depends more upon the degree of accuracy required than upon the particular gas or special range of its variations contemplated.

**105. Characteristic Equation of the Ideal Gas.**—The simple standard form of the relations between the pressure  $P$ , the volume  $V$ , and the temperature  $T$ , reckoned from a zero about 273° C. below 0° C., may be expressed in symbols as follows:—

$$PV = RT \dots \dots \dots (1)$$

where  $R$  is a constant for the particular gas used, the mass of it taken and the units in which  $P$ ,  $V$ , and  $T$  are measured.

If we call  $T$  the *absolute* temperature, we may express (1) in words thus:—

The product of pressure and volume of a given mass of any gas is directly proportional to its absolute temperature. Equation (1) is called the *characteristic* equation of an *ideal gas*, or the *gas equation*.

Though this relation is very simple, it needs experimental examination by three methods for its verification. The methods involve the successive keeping of (i.)  $T$  constant; (ii.)  $P$  constant; and (iii.)  $V$  constant; the interdependent variations of the other two quantities being in each case investigated.

**106. Boyle's Law.**—On putting  $T$  constant in (1) we have the relation

$$PV = \text{const. for temperature constant} \dots \dots (2)$$

or, in words, the volume of a given mass of any gas varies inversely as its pressure, its temperature being maintained constant.

This is known as *Boyle's Law*, having been experimentally established by Boyle as a first approximation to the behaviour of gases at constant temperatures.

It may be illustrated in a very simple manner by the use of a straight glass tube, about 5 feet long and about a millimetre bore, into which a thread of mercury a foot or more in length is introduced. One end of the tube should be closed so as to have between it and

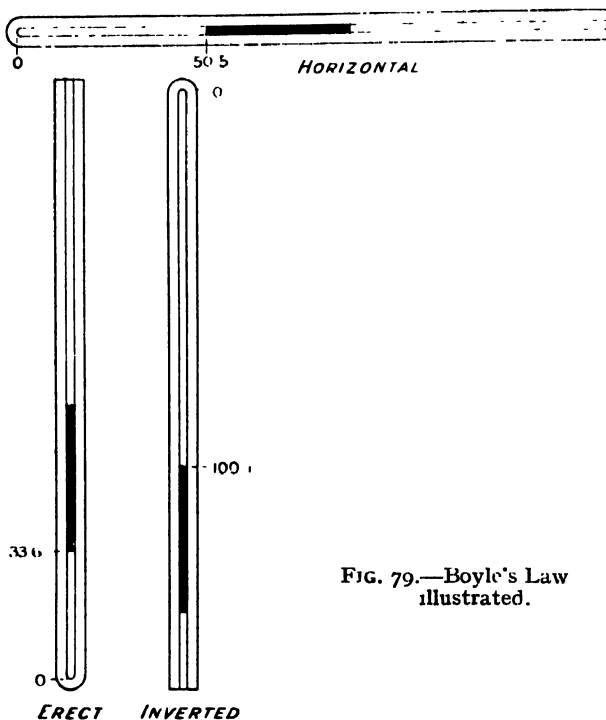

FIG. 79.—Boyle's Law illustrated.

the mercury a column of air whose length is 18 or 20 inches when the tube is horizontal.

The experiment is performed, as indicated in Fig. 79, by placing the tube successively erect, horizontal, and inverted, and measuring in each position the lengths of the air column and the thread of mercury. The length of the air column is a gauge of the volume of air if the bore of the tube is uniform. Any considerable deviation from uniformity of bore, as shown by lack of constancy of the length of the mercury thread, should cause the tube to be rejected.

The results of the observations may be arranged as shown in Table VII., the barometer being read (or for a very rough illustration

assumed to be as last seen or recorded in the newspaper). It is seen that the various positions of the thread of mercury affect the pressure and the volume varies accordingly.

TABLE VII.—ILLUSTRATION OF BOYLE'S LAW.

Length of Mercury Thread 37.5 cm., Barometer 76 cm.				
Position of Tube.	P.	V.	PV.	Difference of PV from Mean.
Erect . . . . .	$\left\{ \begin{array}{l} 76 + 37.5 \\ = 113.5 \end{array} \right\}$	33.6	3,814	- 21
Horizontal . . . . .	76	50.5	3,838	+ 3
Inverted . . . . .	$\left\{ \begin{array}{l} 76 - 37.5 \\ = 38.5 \end{array} \right\}$	100.1	3,854	+ 19
		Sum .	11,506	
		Mean product	3,835	

It is seen that with the figures given the greatest deviation of the product is only about *one-half per cent.* of its *mean value*, so that the law is illustrated and approximately confirmed.

A better confirmation may be obtained by using an apparatus of the style shown in Fig. 80.

In this arrangement the air (or other gas) is confined in the space AB, and its pressure is that of the atmosphere plus that due to the head of mercury BC. It is seen that the glass tube ABE is closed at A and that mercury extends from B through the indiarubber tube EF to C in the glass tube FCD, which is open at D, movable up and down the standard, and may be fixed in any desired position by the clamp G. Thus, having read the barometer, the pressure and volume of the gas in AB are easily ascertained by the readings A, B, and C, for any position in which the tube is clamped. From these one value of the product

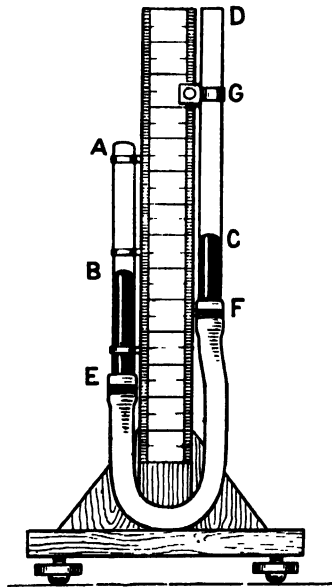

FIG. 80.—Boyle's Law Apparatus.

From these one value of the product

PV is derived and entered in the table. A new position is then used, new readings obtained, and a second value of the product derived, and so forth till 10 or 20 such products are calculated for the observations. Then a mean and deviations from it may be found as before. Thus the law is more fully and precisely confirmed.

In the figure the closed tube ABE is shown fixed; it is a further convenience if this moves down as the open tube FCD moves up. This may be easily arranged if the two tubes are connected by a cord passing over a pulley at the top of the apparatus (see Barton and Black's *Practical Physics*, Fig. 11, p. 37. London, 1912). Yet another form of apparatus is on the market, in which part of the indiarubber tube below EF passes under a board and may be squeezed by a screw. This sends the mercury columns up both at B and at C, and neither tube need be raised or lowered.

107. **Compressed-Air Manometer.**—An interesting application of Boyle's Law is presented by the compressed-air manometer shown in Fig. 81. In this instrument for measuring pressures the indication is given by the compression of the air in the closed end AB of the bent tube, whose open end D is in communication with the fluid whose pressure is to be ascertained, the separation being effected by the mercury BC in the dip of the tube.

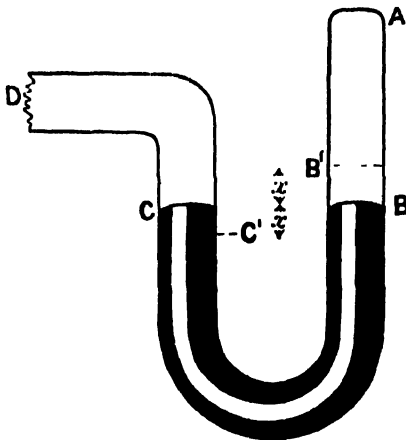

FIG. 81.—Compressed-Air Manometer.

Suppose it to be so arranged that the air in AB is at a pressure of one atmosphere when B and C are at the same level as shown, and denote by  $a$  the height AB. Next let the pressure at D drive the mercury round so as to depress C to C' and raise B to B' each by the length  $x$ . Then, if the pressure of the air in AB is now  $p$  atmospheres, we have by Boyle's Law

$$p(a - x) = 1a$$

or

$$p = \frac{a}{a - x} \dots \dots \dots (3)$$

But the pressure P at D and C is greater than  $p$  by that due to the head of mercury B'C' =  $2x$ . Suppose the height of the mercury barometer to be  $b$ . then the head  $2x$  corresponds to  $2x \div b$  of an

atmosphere. Hence, using (3), we find that the pressure to be measured is given in atmospheres by

$$P = \frac{a}{a-x} + \frac{2x}{b} \dots \dots \dots (4)$$

This gives the interpretation of the rise  $x$  and the rule for graduating AB if the manometer is to be made direct-reading in atmospheres. Of course, any other units of pressure may be adopted and the graduations made accordingly.

#### EXAMPLES XLII.

1. Explain what you mean by an ideal gas, and write an equation expressing its behaviour.
2. Give the characteristic equation of an ideal gas, and state what experiments are needed to verify it.
3. State Boyle's Law and show how it follows from the gas equation. If some gas occupies a volume of 20 c.c. at 35 cm. of mercury, what will be its volume at the same temperature when the pressure becomes 75 cm. ?
4. How may Boyle's Law be illustrated by a straight tube closed at one end and containing a thread of mercury ?
5. Describe a good apparatus for the confirmation of Boyle's Law, explaining how to conduct the experiment with it.
6. Give a set of ten specimen positions and twenty readings of mercury levels in a Boyle's Law apparatus, and work out the products, their mean, their individual and percentage deviations from the mean.
7. Make a sketch of a compressed-air manometer.
8. The air space in a manometer is 6 ins. high when the mercury in the limbs is level. What is the pressure when the mercury rises 1 in., the barometer being 30 ins. ?
9. A certain mass of gas fills a chamber whose volume is 2 litres and exerts a pressure of 75 cm. of mercury; if the vessel is put into communication with three other exhausted vessels whose volumes are 1, 3 and 5 litres, to what value will the pressure fall, the temperature remaining constant ?
10. A vessel of 300 cub. ins. capacity is filled with air at a pressure of 30 ins. of mercury: what sized exhausted vessel must it communicate with to let the pressure down to 24 ins. of mercury ? (The temperature is to be kept the same.)

108. **Charles' Law.**—Reverting again to the characteristic equation (1) of Art. 105, and putting  $P$  constant, we obtain

$$V \propto T \text{ for } P \text{ constant} \dots \dots \dots (5)$$

and this is one mathematical form of *Charles' Law*. We may put it in words as follows :—

The volume of a given mass of any gas, kept under constant pressure, is directly proportional to its absolute temperature.

It was the experimental discovery of this relation that led to the conception of the absolute temperature or temperature reckoned from a new or *gas zero*, which is practically  $-273^{\circ} \text{C}$ .

Thus, if the temperature of a mass of gas under constant pressure is made successively  $0^{\circ} \text{C}$ .,  $1^{\circ} \text{C}$ .,  $2^{\circ} \text{C}$ ., etc., *i.e.*  $273^{\circ}$ ,  $274^{\circ}$ ,  $275^{\circ}$ ,

etc., on the absolute or *gas scale* of temperatures, then we see that the corresponding volumes are as 273, 274, 275, etc.

Hence, it was the discovery that a gas under constant pressure expands per  $1^{\circ}$  C. by  $1/273$  (or  $0.003665$ ) of its volume at  $0^{\circ}$  C., that showed the convenience of taking a zero  $273^{\circ}$  (or  $1 \div 0.003665$ ) below  $0^{\circ}$  C., the freezing point of water. Denoting by  $T^{\circ}$  the temperatures on this gas or absolute scale, we evidently have the relation  $T^{\circ} = t + 273$ , where  $t$  is the temperature in Centigrade degrees.

But, if we are experimenting and using centigrade thermometers, we may put Charles' Law in the forms

$$\frac{V}{V_0} = \frac{t + 273}{273}$$

or  $V = V_0(1 + \alpha t)$  for pressure constant . . . (6)

where  $V_0$  is the volume of the given mass of gas at  $0^{\circ}$  C.,  $t$  is the temperature in centigrade degrees at which the volume is  $V$ , and  $\alpha$  (which equals  $1/273$ ) is called the *coefficient of expansion*.

Thus another way of expressing Charles' Law is to state that the coefficient of expansion has the same value, viz.  $1/273$ , for all gases, and at all temperatures.

To exhibit in a still clearer light the significance of the coefficient of expansion, we may transform (6) so as to give a mathematical definition of it. Thus

$$\alpha = \frac{V - V_0}{V_0 t} \text{ for pressure constant . . . (7)}$$

Or, in words, the coefficient of expansion is the quotient of the fractional increase of volume from  $0^{\circ}$  C. divided by the corresponding rise of temperature, the pressure being kept constant.

It may be noted here that in expressing absolute temperature it is customary to use degrees of the same size as centigrade degrees, and this practice will be followed in the present book unless the contrary is stated.

A very simple apparatus for confirming Charles' Law is shown in Fig. 82.

The air (or other gas) to be experimented upon is contained in the bulb and part of the graduated stem of the tube ABC and confined by the thread DE of mercury or sulphuric acid. Its temperature is regulated by the water bath in which the tube is immersed and read by the thermometer FG. The bulb tube and thermometer are both placed horizontally and at the same level, so that all parts of each may be at the same temperature when the bath is stirred. Let the volume of the bulb and stem to the zero mark be  $c$  times that of one division of the stem. (The value of  $c$  is ascertained by weighing the tube empty and filled to various graduations with water or mercury.) Then when the air extends to  $r$  divisions along the stem the volume may be represented

proportionally by  $(c + r)$ . Thus, if at the temperatures  $t_1$  and  $t_2$  the stem readings were respectively  $r_1$  and  $r_2$ , we should have

$$\frac{c + r_2}{c + r_1} = \frac{V_2}{V_1} = \frac{1 + at_2}{1 + at_1} \dots \dots \dots (8)$$

Hence, we could calculate  $a$ , the only unknown. A number of such pairs of readings for various gases over various ranges of temperature should give approximately the same value of  $a$  and thus confirm Charles' Law.

Another method would be to tabulate the values of  $r$ ,  $t$ ,  $c + r$ , and  $t + 273^\circ$  for any one gas, and then in another column enter the

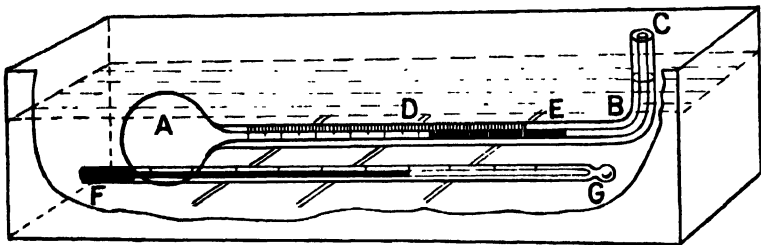

FIG. 82.—Charles' Law Apparatus.

values of the quotient  $(c + r) \div (t + 273)$ . This quotient should be *constant*, and then confirms Charles' Law in the form given in equation (5).

If, in any case, both pressure and temperature of a gas change, the new volume can obviously be found directly by use of the gas equation

$$PV = RT.$$

NOTE.—If the degrees in use are those on Fahrenheit's scale, the value 273 hitherto used will be changed accordingly, for the gas zero is  $273 \times 9 \div 5 = 491.4$  of Fahrenheit's degrees below freezing point, which is  $32^\circ$  F. Thus this gas zero is  $-459.4^\circ$  F.; consequently if F be written for temperatures in Fahrenheit's scale, the gas equation would be

$$PV = R(F + 459.4)$$

EXAMPLES XLIII.

1. Derive Charles' Law from the gas equation and explain the meaning and value of the coefficient of expansion per  $1^\circ$  C.
2. Sketch an apparatus suitable for experimentally verifying Charles' Law and describe the way to use it.
3. If gas in a cylinder with the piston midway has a temperature of  $80^\circ$  C.,

to what temperature must the gas be raised to double its volume, the pressure remaining constant ?

4. A certain mass of gas has a pressure of 70 cm. of mercury and a temperature of 10° C. To what temperature must it be raised in order that the pressure may be 75 cm. and the volume three halves of its former value ?

5. What pressure must be used to compress a mass of gas to half its volume if the temperature be also lowered from 100° to 15° C., the original pressure being 76 cm. of mercury ?

6. A gas originally at 30 ins. of mercury pressure at 20° C. is put under a pressure of 100 ins. of mercury and its temperature raised to 95° C. How is its volume thereby altered ?

109. **Increase of Pressure at Constant Volume.**—It is easy to see in several ways that for a gas regarded as obeying the laws of Boyle and Charles the coefficient of increase of pressure at constant volume is the same as that of increase of volume under constant pressure.

Thus, from the gas equation (1) of Art. 105, dividing by T we have

$$\frac{PV}{T} = R, \text{ a constant} \quad \dots \dots \dots (9)$$

showing that either P or V varies as T when the other is constant. Or, let P and V hold for our gas at 0° C. or T = 273, then change its temperature to t° C., keeping pressure constant, and afterwards restore its original volume by increasing its pressure at constant temperature. We thus obtain the following equations:—

$$\frac{PV}{273} = \frac{P\{V(1 + at)\}}{273 + t} = \frac{\{P(1 + at)\}V}{273 + t} \quad \dots \dots (10)$$

Increase of Pressure Law.

The laws which apply to each change are shown above and below the equations. It is thus seen that the pressure law may be written

$$P = P_0(1 + at) \text{ for volume constant} \quad \dots \dots (11)$$

in which a has the same value, 1/273, as in equation (6).

This law may, of course, be confirmed by direct experiment, and is an ordinary laboratory exercise. (See next article, also Barton and Black's *Practical Physics*, Expt. 45, pp. 62-63: London, 1912.)

Equations (10) may also be illustrated by a diagram, as shown in Fig. 83, in which pressures are plotted as ordinates and volumes as abscissæ, the higher pressure, volume, and temperature being indicated by accents. The three states shown in equations (10) are denoted in order by the points A, B and C on the diagram. It is then seen that Charles' Law applies to the operation shown by

line AB on the diagram; Boyle's Law applies to the operation shown by the line BC, while the pressure law applies to the operation shown by the line CA.

110. **Gas Thermometer.**—The simplicity of the laws to which the behaviour of gases closely approximates and the large expansion of gases makes them specially suitable for adoption as the thermometric substance in standard thermometers. In referring to such instruments the term *air thermometer* is often used, but hydrogen or nitrogen are sometimes preferred, so the term *gas thermometer* is really more appropriate.

It is obvious from what we have seen that a gas thermometer may be arranged to indicate by an increase of volume under constant

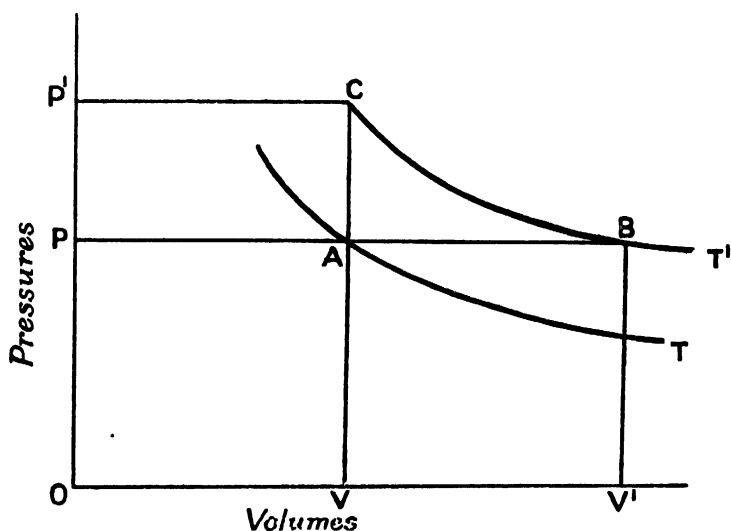

FIG. 83.—Increase of Pressure Law.

pressure or by an increase of pressure at constant volume. The latter arrangement, called the *constant-volume gas thermometer*, is found capable of greater accuracy. A simple laboratory copy in glass of such an instrument is shown in Fig. 84.

In this form the bulb, filled with pure dry gas, is represented at A and is connected by a capillary tube B to an upright tube C containing mercury, which is adjusted to the level D of the zero of the scale DE by means of the thistle funnel F. The pressure of the gas is then read directly from the scale as the height at which the mercury stands in the tube GH, for there is a Torricellian<sup>1</sup> vacuum at the upper part of this tube.

It is evident that by surrounding the bulb by a bath of water

<sup>1</sup> See explanation of the barometer in Chapter XI.

or other liquid, and varying its temperature, this apparatus would serve to verify directly the pressure law. Conversely the apparatus, shown in Fig. 82, for the verification of Charles' Law could be used as a rough form of constant-pressure gas thermometer.

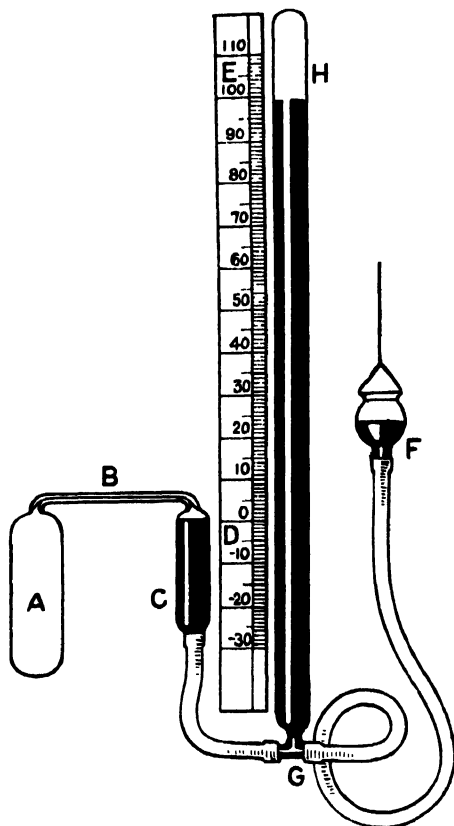

FIG. 84.—Constant-Volume Gas Thermometer.

#### EXAMPLES XLIV.

1. Show that for an ideal gas obeying the equation  $PV = RT$ , the coefficient of increase of pressure at constant volume equals that of increase of volume at constant pressure.

2. Make as correctly as you can a P-V diagram, indicating on it the increases of pressure for volume constant and of volume for pressure constant. Also describe how these changes could be actually made on gas in a glass bulb or metal cylinder.

3. Find the pressures of a mass of gas kept at constant volume when the temperature is raised to  $80^{\circ}\text{C}$ . and to  $180^{\circ}\text{F}$ . if it had 30 ins. of mercury pressure at  $15^{\circ}\text{C}$

4. If the pressure of the gas occupying a certain volume is 25 cm. of mercury at 10° C., to what temperature must it be raised to make the pressure 76 cm. of mercury, the volume remaining constant ?
5. If the volume of a given portion of gas is 49.3 c.c. at 12° C. and 75.6 cm. of mercury pressure, what would be its volume at 0° C. and 76 cm. pressure ?
6. Describe carefully, with an explanatory sketch, the construction and use of the constant-volume gas thermometer.
7. The pressure in a constant-volume air thermometer was 76.80 cm. of mercury when the bulb was in melting ice and 36.34 cm. when placed in solid carbon dioxide and ether. What was the temperature of the latter ?

**III. Numerical Values of the Gas Constant R.**—It is now desirable to calculate the numerical values which may be assigned to the gas constant. These obviously depend upon the quantity of the particular gas taken and the units adopted for the other quantities involved in the gas equation in which R occurs (see equation (1) of Art. 105). Thus, if the pressure be expressed in dynes per square centimetre, the volume in cubic centimetres, and the absolute temperature in centigrade degrees, we still have to choose a certain volume or mass of gas, and may have to state also what gas it is before the numerical value of R becomes determinate. The value of R is then expressed in ergs per degree of absolute temperature, and either per unit volume, or per unit mass, or per gram molecule as the case may be. Or, in symbols, to make R definite we may write the gas equation in any of the following three forms:—

$$\frac{PV}{V_0} = R_1 T \quad . \quad . \quad . \quad . \quad . \quad (1)$$

$$\frac{PV}{m} = R_2 T \quad . \quad . \quad . \quad . \quad . \quad (2)$$

or

$$\frac{PV}{M} = R_3 T \quad . \quad . \quad . \quad . \quad . \quad (3)$$

where  $V_0$  is the volume in c.c. of *any* gas under standard conditions,  $m$  gives the mass in grams of *some particular gas*, and  $M$  gives the mass in *gram-molecules of any gas*.

Let us now determine  $R_1$ ,  $R_2$  and  $R_3$  in order. Then, in (1), we may conveniently write for  $P$  the standard atmospheric pressure produced by a column 76 cm. high of mercury of density 13.6 gms. per c.c., and for  $T$  we will write 273°, which corresponds to 0° C. Then  $V \div V_0$  becomes unity. Hence

$$R_1 = \frac{PV}{TV_0} = \frac{76 \times 13.6 \times 981}{273} = \frac{1,013,962}{273} = 3,714.15 \text{ ergs per degree per c.c.} \quad (4)$$

The factor,  $981 = g$ , is introduced to convert the pressure from grams weight per square centimetre to dynes per square centimetre.

We will now find the value of  $R_2$  for oxygen. This gas, under standard conditions, occupies 699·7 c.c. per gram, so  $V \div m$  will be  $699\cdot7 \times V \times V_0$ . Accordingly  $R_2$  must be this number of times  $R_1$ . We thus have

$$R_2 \text{ for oxygen} = \frac{PV}{Tm} = \frac{1,013,962}{273} \times 699\cdot7 \\ = 2,598,791 \text{ ergs per degree per gm. of oxygen} \quad (5)$$

It may be noted that the value of  $R$  per gram of air is calculated in Art. 142, where required.

We will calculate finally the value of  $R$  per gram-molecule of a gas. This variable unit of mass equals the molecular weight in grams. This variable mass of gas has the advantage that the volume it occupies under standard conditions is the same for all gases. Taking the above value for the specific volume of oxygen and the international value 16 for its atomic weight, its molecular weight is 32, and the volume of 1 gram-molecule (or *mol*, as it is sometimes termed) is  $699\cdot7 \times 32$  c.c. under standard conditions. Thus,  $R_3$  for *any* gas will be 32 times  $R_2$  for oxygen. Or

$$R_3 = \frac{PV}{Tm} = 3\cdot714\cdot15 \times 22,390\cdot4 \\ = 83,161,304 \text{ ergs per degree per gram-molecule} \quad (6)$$

If we divide this last result by the mechanical equivalent of heat,  $J$ , in ergs per calorie,<sup>1</sup> we shall obtain  $R_4$ , the value of  $R_3$  with the energy expressed in calories instead of ergs. Now the value of  $J$  is  $4\cdot184 \times 10^7$  ergs per calorie. We accordingly obtain

$$R_4 = \frac{83,161,304}{41,840,000} = 1\cdot9876 \text{ calories per degree per gram-molecule} \quad (7)$$

Or, in words, this form of  $R$  is the *thermal capacity* of any gas per gram-molecule.

The value given in equation (7) is often erroneously quoted as " $R = 2$  calories," as though nothing else entered into the question, whereas the unit in question is calories per degree per gram-molecule. Neither is it allowable to say  $R$  has the value 2, for, as we have seen, it has values expressible by various numbers according to the amount of the gas taken and the units used.

**112. Work of Expanding Gas.**—The expansion of a gas may be exhibited graphically by a curve plotted with pressures as ordinates and volumes as abscissæ as was done in Fig. 83. And this is very useful if we wish to calculate the work done by the gas in such an expansion. For, since the work done is the product of force into

<sup>1</sup> A *calorie* is the quantity of heat required to raise 1 gm. of water 1° C.

distance or pressure into change of volume, it is evidently represented to scale by the *area* below the curve corresponding to the expansion in question. Thus, suppose the gas to expand in a cylinder of cross-sectional area  $A$ , so that the piston moves through a distance  $s' - s$ , the pressure remaining equal to  $P$  constant throughout. Then, denoting the work done by  $W$  and the force on the piston by  $F$ , we have

$$\begin{aligned} W &= F(s' - s) \\ &= PA(s' - s) \end{aligned}$$

or 
$$W = P(V' - V) \quad . . . . . (1)$$

where  $V$  and  $V'$  are the initial and final volumes of the gas in the cylinder.

Also the curve in this case reduces to a straight line parallel to the axis of volumes, and the area in question is that of a rectangle simply of height  $P$  and width  $V' - V$ .

If, however, the pressure is not constant, the expansion line is a curve or sloping line on the diagram, and the computation of the area may require special consideration.

But, whatever the conditions of expansion, if expressed on the diagram by a curve, the area could be found as mentioned in Art. 38. For each element of the expansion gives on the diagram a small vertical strip which, in the analysis, is the product of a certain finite pressure and a very small increase of volume.

The one case of variable pressure specially important to us here is that in which the *temperature is constant*, the expansion being then termed *isothermal*.

We accordingly now proceed to calculate the work done by a gas in an isothermal expansion over a *finite* range between given limits of volume  $V_1$  and  $V_2$ , the corresponding pressures being  $P_1$  and  $P_2$ .

Since the temperature is constant we may apply Boyle's Law, which shows that the product of pressure and volume remains constant during the expansion. Hence, if  $P$  and  $V$  are a pair of values corresponding to any intermediate point in the expansion, we may write

$$P_1 V_1 = PV = P_2 V_2 = C^2 \text{ say } . . . . . (2)$$

Thus 
$$P = C^2 \div V \quad . . . . . (3)$$

So, if  $V$  were represented by  $x$  and a very small increase of  $V$  by  $h$ , the work of expansion would be given by the summation of  $Ph$ , or

$$W = C^2 \sum_{V_1}^{V_2} x^{-1} h = P_1 V_1 2.3026 \log_{10} \frac{V_2}{V_1} \quad . . . (4)$$

It is seen that this is the special case of summation in which  $n = 0$ , and the ordinary rule does not apply (see Art. 40).

The expansion is shown on Fig. 85, the work being represented to scale by the shaded area below the curve  $A_1A_2$ , which is evidently the summation of strips such as that shown at  $AV$ .

By plotting the curve carefully on squared paper for any numerical example the area could be found with close approximation by

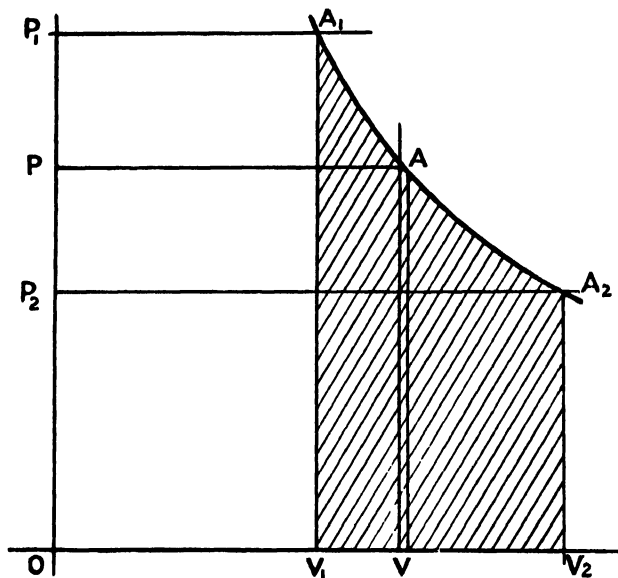

FIG. 85.—Work of Isothermal Expansion.

counting the squares, and thus the logarithmic rule would be confirmed.

#### EXAMPLES XLV.

1. Show that in the gas equation the constant  $R$  acquires a definite numerical value only when certain information is given as to the amount of the gas or its kind or both. Find the value  $R_1$  possessed by  $R$  when the equation refers to 1 c.c. of any gas at normal temperature and pressure.

2. Find the value  $R_h$  of the constant in the gas equation for a gram of hydrogen, taking its atomic weight as unity.

3. Show that the value assumed by  $R$  in the gas constant when referring to a gram-molecule of any gas is approximately  $R_g = 2$  calories per degree per gram-molecule.

4. Find the work done by a gas at constant temperature, starting at a pressure of 150 lbs. per square inch and expanding from 1 cub. ft. to a volume of 2 cub. ft.

5. Check the numerical result of example 4 by plotting a graph on squared paper and counting the squares.

6. A soap bubble 1 cm. diameter contains air at a pressure of 77 cm. of mercury. It is then caused to expand to 2 cm. diameter at constant temperature. Find the work done by the expanding gas.

113. **Isothermal Elasticity of a Gas.**—In the case of solids we have to recognise elasticities of size and shape. In the case of gases we are only concerned with elasticities of size or volume. Such an elasticity is the quotient of the small increase of pressure by the corresponding fractional decrease of volume. But the volume-changes for given increases of pressure depend upon the changes, if any, in the temperature.

The important case for us here is the elasticity when the temperature is constant, or the *isothermal elasticity*. This may be quantitatively defined as follows.

The isothermal elasticity of a gas is the limiting value of the ratio of an increase of pressure to the corresponding decrease of volume per unit volume at constant temperature when these changes are diminished indefinitely.

Thus, if the pressure and volume are initially  $P$  and  $V$ , and after a *very slight* change at constant temperature become  $(P + p)$  and  $(V - v)$ , we may write, by Boyle's Law,

$$(P + p)(V - v) = PV \quad . \quad . \quad . \quad . \quad (5)$$

And from this we may deduce a value of the isothermal elasticity, which we shall denote by  $E_t$ .

For, expanding the left side, we have

$$PV + pV - Pv - pv = PV \quad . \quad . \quad . \quad . \quad (6)$$

Then, removing the  $PV$  from each side and neglecting the product  $pv$  of two very small quantities, we have

$$E_t = \frac{p}{v/V} = P \quad . \quad . \quad . \quad . \quad (7)$$

Or, in words, the *isothermal elasticity of a gas is equal to its pressure* if its behaviour is sufficiently represented by Boyle's Law.

114. **Pressure of Mixed Gases.**—Two or more gases, between which no chemical action occurs, when placed in a chamber, form a mixture of uniform density. Each gas exerts its own or *partial* pressure, and the *total* pressure is the *sum* of these partial pressures. Moreover, each partial pressure depends on the mass of the particular gas present and the *whole* volume of the chamber open to it as though no other gas were present.

These facts were experimentally obtained and enunciated by Dalton in a compact form somewhat as follows and often referred to as—

*Dalton's Law.*—The pressure of a mixture of two or more gases is equal to the sum of the pressures that would be produced by each of the constituents of the mixture if the others were absent.

## EXAMPLES XLVI.

1. Define the isothermal elasticity of a gas, and show that it equals the pressure for a gas obeying Boyle's Law.
2. Show how to find, from a straight Boyle's Law tube (Fig. 79, Art. 106), the isothermal elasticity of the atmosphere.
3. There are three chambers of internal volumes 1, 2 and 3 cub. ft. and containing gases at temperatures  $0^{\circ}$  C.,  $10^{\circ}$  C. and  $15^{\circ}$  C., their pressures being respectively 40 cm., 65 cm., and 78 cm. of mercury. The gases are now all put together and forced into a vessel of 5 cub. ft. and reduced to  $0^{\circ}$  C. What are the separate pressures and their total, there being no chemical action between the gases?
4. A vessel of volume 500 c.c. is occupied by gas at  $25^{\circ}$  C. and 37 cm. of mercury pressure. What volume of gas at  $15^{\circ}$  C. and 75 cm. pressure must be forced into the vessel in order that the pressure of the whole at  $10^{\circ}$  C. shall be 60 cm. of mercury?
5. Gases of volumes 2 and 5 cub. ft., temperatures  $16^{\circ}$  and  $20^{\circ}$  C., and pressures 35 and 56 cm. of mercury respectively, are forced into a vessel of volume 3 cub. ft. To what temperature must the mixture be brought to make the pressure 75 cm. of mercury?

## CHAPTER X

### HYGROMETRY

115. **Ebullition: Vapour Pressure.**—It is a matter of common knowledge that water and other liquids, when sufficiently heated, boil. In other words, when their temperature is sufficiently raised they reach the state of *ebullition* or the giving off of bubbles of their vapour from within. The temperature at which this occurs for any liquid is called its *boiling point for the pressure* to which it is then exposed; or its boiling point simply if the pressure is that of a standard atmosphere.

The temperature of the boiling point is really *that of the vapour* escaping; that of the liquid may be slightly higher.

If the atmospheric pressure is higher than its standard value, the boiling of any given liquid occurs at a slightly higher temperature and *vice versa*.

And, if we artificially change the pressures throughout a much larger range than atmospheric, it is found that the boiling points suffer corresponding changes varying continuously with the pressure.

It may thus be noted that the underlying important fact is this intimate and continuous relation between *possible vapour pressure and temperature*. For, when we boil a given liquid under any pressure, natural or artificial, the boiling point for that pressure is simply the temperature at which its vapour can exert the pressure to which the liquid is then exposed.

Hence, while the liquid is being heated, its vapour pressure is continually rising until it reaches the external pressure. The state of ebullition announces that this equality is attained.

But before boiling is reached, indeed at any temperature whatever, liquids give off their own vapour *from their free surface, silently and often invisibly*, and this process is called *evaporation*. Thus, since the atmosphere is always exposed to sheets of water, seas, lakes and rivers, it always contains some aqueous vapour in consequence of their evaporation.

116. **Saturation.**—Suppose a quantity of vapour is introduced into an inclosed space previously vacuous. It expands to occupy this space and then exerts a certain definite pressure. Let more and more of the vapour be introduced into the chamber, its temperature being maintained constant. Then the pressure of the vapour rises, but not indefinitely. On the contrary, beyond a certain

point, depending on the vapour and its temperature, the pressure refuses to rise, the additional vapour introduced being immediately condensed to its liquid. At this point the vapour is said to be *saturated*, or the state of things where the liquid and vapour can exist in equilibrium is called *saturation*. If next some vapour were removed, a like quantity of vapour would be formed by evaporation of the liquid (if sufficient of it were present) so as to preserve the vapour at its full or *saturation* pressure corresponding to the temperature in question. This saturation pressure has previously been

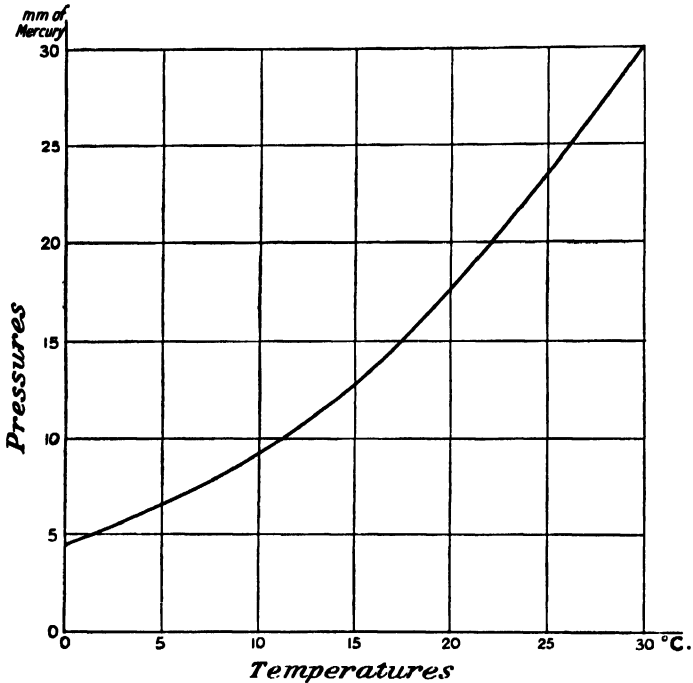

FIG. 86.—Saturation Pressures of Aqueous Vapour.

referred to as a possible pressure or a pressure which the vapour can exert at the given temperature.

Thus, if, without changing the quantity of the substance in the chamber, the temperature is raised, the pressure required for saturation is raised also, hence evaporation occurs until this new vapour pressure is reached. If, on the other hand, the temperature is lowered, some of the vapour usually condenses, as it is impossible for it to remain stably exerting a pressure exceeding that of saturation for the lowered temperature then obtaining.

We are, of course, most concerned here with aqueous vapour. The values of its saturation pressures at ordinary atmospheric temperatures are accordingly shown in Table VIII. and Fig. 86.

TABLE VIII.—SATURATION PRESSURES OF AQUEOUS VAPOUR.

Temperature in degrees centigrade.	Pressures in mm. of mercury.	Temperature in degrees centigrade.	Pressures in mm. of mercury.
0	4.5687	11	9.7671
1	4.9091	12	10.4322
2	5.2719	13	11.1370
3	5.6582	14	11.8835
4	6.0693	15	12.6739
5	6.5067	16	13.5103
6	6.9718	17	14.3950
7	7.4660	18	15.3304
8	7.9909	19	16.3189
9	8.5484	20	17.3632
10	9.1398	25	23.5172

These results are based on the determination of Regnault and others, with elaborate apparatus and most careful methods.

A simple laboratory apparatus for illustrating the pressure of aqueous or other vapours and their variation with temperature is shown in Fig. 87.

The apparatus consists essentially of two barometer tubes, each about 85 cm. long and a centimetre bore, closed at one end and open at the other, filled with clean mercury, inverted and mounted so that their open ends dip into a little vessel of clean mercury as shown. Into one tube a little of the liquid under test is introduced till a few mms. of it appear on the top of the mercury column. This is a proof that its vapour is saturated in the space above; or that the *space is saturated* by the vapour. The presence of the vapour, though invisible, is indicated by a fall of the mercury. The vapour pressure can therefore be measured by this fall, a suitable millimetre scale being used for the purpose.

In order to control the temperature of the vapour, the upper parts of both tubes are inclosed

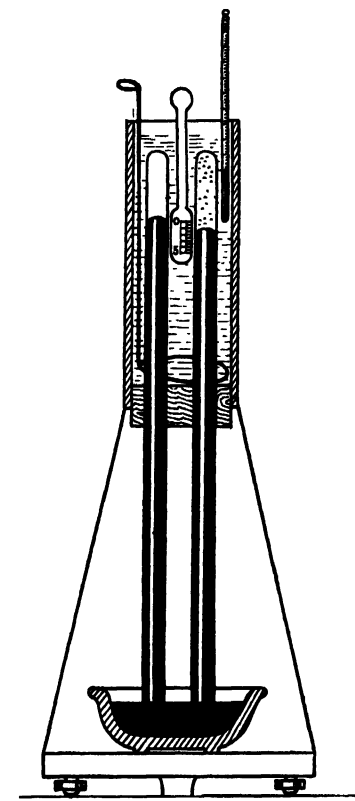

FIG. 87.—Laboratory Apparatus for Vapour Pressure.

in a water bath, which, by hot or cold water and stirring, may be adjusted to the desired point. The temperature is then read off by a thermometer.

**117. Dew Point.**—The temperature and pressure of the atmosphere at a particular place and time may of course be ascertained by the use of thermometer and barometer. But to determine its state as regards the moisture present in it, we must use a *hygrometer* or *moisture measurer*. Some forms of hygrometer enable the operator to find the *dew point* or the lowest temperature at which the aqueous vapour actually present in the atmosphere can exist stably without condensing. This is done by cooling a smooth surface until dew appears on it.

The dew point is specially valuable because (along with the temperature and pressure of the air) it furnishes the requisite clue to the calculation of the hygrometric state of the atmosphere in any of the forms in which it may be desired. This will be illustrated in the next article. The practical details of determining the dew point are deferred to Arts. 123–127.

**118. Pressure of Atmospheric Vapour.**—Let the total pressure of the atmosphere at a given time and place be  $H$  cm. of mercury, its temperature  $T^\circ C.$ , and its dew point  $t^\circ C.$  Let the saturation pressures of aqueous vapour corresponding to these temperatures be  $P$  and  $p$  cm. of mercury respectively, as found from Table VIII., Art. 116. But, in using the hygrometer to cool the atmosphere down to the dew point, no change has been made in its total pressure nor in the relative amounts of aqueous vapour and of dry air which it contains. Accordingly, the pressure  $p$  of saturation at the dew point  $t^\circ C.$  is that which existed in the atmosphere all along.

Thus, the use of any dew-point hygrometer, and reference to the table (or curve) of saturation pressures of aqueous vapour, determine the pressure of the vapour *actually present* in the atmosphere at the time and place of the experiment.

**119. Humidity.**—The *fractional saturation, relative humidity, or humidity* simply, is the ratio of the mass of vapour actually present in a given volume of the atmosphere to that needed in the same volume for saturation at the atmospheric temperature,  $T^\circ C.$  say. But the vapour in these two states exerts the pressures  $p$  and  $P$  respectively, and, at the given temperature, these pressures are practically proportional to the corresponding densities of the vapour, since Boyle's Law is nearly valid up to the point of saturation. Hence, if we write  $F$  for the fractional saturation or humidity, we have

$$F = \frac{p}{P} \dots \dots \dots (1)$$

The fractional saturation is, however, often expressed as a percentage. Thus, denoting this value of it by  $S$ , we obtain

$$S = 100F = \frac{100p}{P} \text{ per cent.} \dots \dots \dots (2)$$

These pressures and their corresponding temperatures are shown on Fig. 88, which may make the relations clearer.

If the temperature and dew point are respectively  $14^{\circ}$  and  $4^{\circ}$  C., then the humidity or fractional saturation is just over one-half, or 50 per cent. as shown in the figure. Whereas with a temperature of

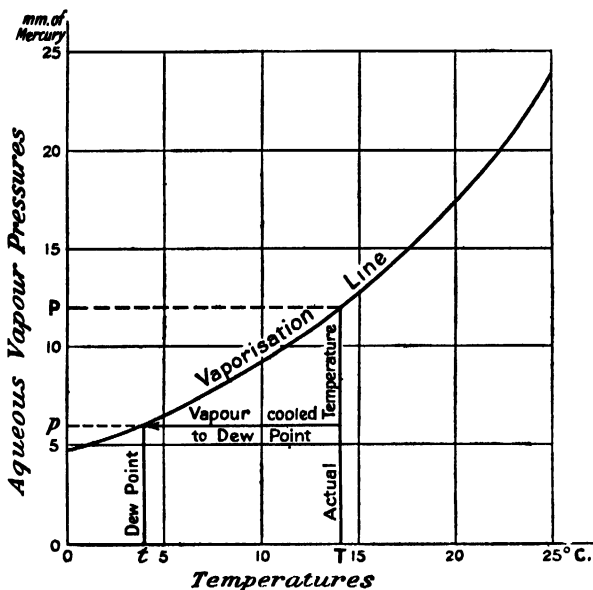

FIG. 88.—Dew Point and Humidity.

$7^{\circ}$  and dew point  $1^{\circ}$  C. it may be seen that the humidity would be about two-thirds, or 67 per cent.

### EXAMPLES XLVII.

1. Explain the terms evaporation, ebullition, vapour pressure, and boiling point.
2. State what you mean by saturation, and plot a graph giving the saturation pressures of aqueous vapour between  $0^{\circ}$  and  $25^{\circ}$  C.
3. Describe the construction and use of an apparatus to determine the relation between maximum vapour pressures and temperature for water or another substance.
4. Define the terms "dew point" and "fractional saturation." Make a graph of saturation pressures and mark on it a supposed state of the atmosphere showing the numerical values of the above quantities.
5. Do you think the atmosphere always contains more moisture per cubic foot when it feels moister? If not, explain the reasons for your view on the matter.

120. **Density of Atmospheric Vapour.**—We may now easily

calculate the density  $V$  of the aqueous vapour present in an atmosphere of total pressure  $H$  cm. of mercury, of temperature  $T^\circ \text{C.}$ , and of dew point  $t^\circ \text{C.}$ , the corresponding saturation pressures being  $P$  and  $p$  cm. of mercury.

For we know that the density of dry air at  $0^\circ \text{C.}$  and  $76$  cm. of mercury is  $0.00129$  gm. per c.c. Further, the density of aqueous vapour, at any temperature and pressure at which it exists as vapour, is  $0.623$  of that of dry air at the same temperature and pressure.

Thus, we have simply to find the density that dry air would have at  $T^\circ \text{C.}$  and  $p$  cm. of mercury pressure and then multiply this value by  $0.623$ .

Hence, we obtain the general expression,

$$V = 0.00129 \times \frac{273}{273 + T} \times \frac{p}{76} \times 0.623 \text{ gm. per c.c.} \quad (3)$$

It should be noticed that the value of  $V$  on a warm *dry* day in summer may much exceed that on a cold *damp* day in winter. For the dryness and dampness in each of these cases refers to the corresponding *fraction* of saturation and not to the *actual* density of vapour present. Thus, the higher temperature of summer may carry a greater mass of vapour with a smaller fraction of saturation.

**121. Density of Dry Air and whole Atmosphere.**—The density  $D$  of the dry air present in the atmosphere, as set out in Art. 120, is found by omitting the factor  $0.623$  and writing the appropriate value,  $H - p$ , for the pressure.

Thus, with these modifications of (3) we write

$$D = 0.00129 \times \frac{273}{273 + T} \times \frac{H - p}{76} \text{ gm. per c.c.} \quad (4)$$

The density of the atmosphere as a whole is obviously the sum of these two expressions. Hence,

$$D + V = \frac{0.00129 \times 273}{(273 + T)76} \{H - p + (0.623)p\} \text{ gm. per c.c.} \quad (5)$$

**122. Moisture removed by Mine Ventilation.**—The paramount importance sometimes attained by hygrometry may be shown by reference to a coal mine. Thus, to minimise the risk of explosion due to dry coal dust, the underground roads must be watered, and it becomes imperative to inquire how much of the moisture thus purposely introduced is unintentionally removed by the current of air in the upcast shaft which is essential for adequate ventilation.

Suppose the temperature of the air removed to be  $68^\circ \text{F.} = 20^\circ \text{C.}$ , and that its dew point is  $52.7^\circ \text{F.} = 11.5^\circ \text{C.}$  Then, the pressure  $p$

of its aqueous vapour is 10 mm. or 1 cm. of mercury. We accordingly find, by equation (3) of Art. 120,

$$\begin{aligned} V &= \frac{0.00129 \times 273 \times 1 \times 0.623}{293 \times 76} \text{ gm. per c.c.} \\ &= \frac{1}{100} \text{ kilogram per cubic metre} \\ &= 0.777 \text{ lb. per cubic foot nearly . . . . (6)} \end{aligned}$$

Now for satisfactory ventilation 40 men need about 100,000 cubic metres of air per 24 hours. Hence, for every 40 men working in the mine, the ventilation system would remove about *one ton of aqueous vapour every 24 hours!* and the excess of this over what was introduced by the cooler and perhaps drier air *must be supplied* by watering below, in order to settle the dust and make the workings safe.

#### EXAMPLES XLVIII.

1. Find the density of the vapour in the atmosphere when the temperature is  $17.6^{\circ}\text{C}$ ., and the dew point is  $8^{\circ}\text{C}$ .
2. If the density of the aqueous vapour in the atmosphere is  $5 \times 10^{-6}$  gm. per c.c. when the temperature is  $14.5^{\circ}\text{C}$ ., what is the vapour pressure and the dew point?
3. What are the fractional saturations in the two preceding examples?
4. The barometer stands at 75.7 cm., the temperature of the air is  $20^{\circ}\text{C}$ ., and the dew point is  $10^{\circ}\text{C}$ . Find the densities of the vapour, of the dry air, and of the whole atmosphere.
5. Explain carefully, with a numerical example, what an astounding weight of aqueous vapour may be removed from a mine every day by the ventilation system.

123. **Hygrometers.**—These instruments may be divided into three classes according to their modes of action, which are *absorption*, *condensation*, and *evaporation*.

To the first named belong the rough qualitative cottage models, or *hygrosopes*, in which a catgut or other absorbent substance takes in moisture and gives a corresponding indication by bringing a figure of a man or woman into view.

The chemical form of hygrometer also acts by absorption of the moisture in drying tubes through which the air is drawn. Thus, finding the gain of weight of the tubes and the volume of air drawn through, its pressure, and temperature, we may calculate the relative mass of aqueous vapour in it. But this method is obviously a slow and tedious one; we accordingly notice in more detail those acting by condensation (Daniells', Dines', and Regnault's) and that depending on evaporation (Mason's). The use of each of these instruments presents some advantage, but also involves some liability to error or other drawback. These will be noticed in turn as they are described.

124. **Daniells' Hygrometer.**—This form of dew-point instrument is very compact and easy to work if the dew point is high, but a large instrument gives trouble if the dew point is down nearly to  $0^{\circ}$  C., requiring considerable patience. Its construction and action may be readily understood by reference to Fig. 89.

The instrument consists of a double-bulbed tube twice bent at right angles and containing only ether and its vapour, the upper bulb being covered with muslin, the lower one dark (or gilded) and provided with an internal thermometer. An external thermometer

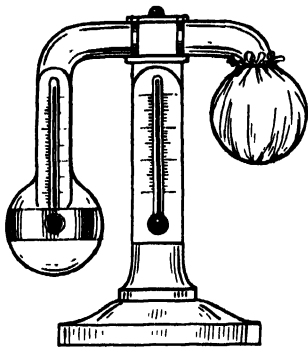

FIG. 89.—Daniells' Hygrometer.

is fixed on the stand. To use the hygrometer, the ether inside is poured into the lower bulb, and a little ether is poured on the muslin of the upper bulb. This quickly evaporates and so cools and condenses the ether vapour within the bulb. This in turn provokes evaporation of the ether in the lower bulb and so cools it. This process is continued till *dew just appears* on the outer surface of the bulb. The reading of the internal thermometer is then taken. But probably the surface was cooled a little *below* the dew point before the dew was seen, so this reading may be *too low*. The cooling is therefore

stopped and the dew watched till it just *begins to disappear* and the internal thermometer is again read. This reading is probably *too high*. When the dew point is roughly located, the cooling and stopping may be refined and the readings for appearance and disappearance obtained well within a degree of each other. Their mean is then taken for the dew point.

Sunshine, a draught, or the too near approach of the warm hands of the operator would each vitiate the action of the instrument and the results obtained.

The distance between the bulb of the internal thermometer and the cooled surface on which the dew is deposited may also introduce errors; further, it is sometimes difficult to catch sight of the first change of dewy appearance on the spherical surface of the bulb.

125. **Dines' Hygrometer.**—In this instrument the surface on which the dew is formed is flat and the bulb of the thermometer is close behind it. The cooling can also be effectively controlled and carried with ease almost to the freezing point. But it requires ice for its use, which forms a drawback. The horizontal form of the instrument is shown in section and perspective in Fig. 90.

The vessel A contains cold water and, when needed, ice also. Then, by opening the tap at B by the milled head C, the cold water flows through the chamber D and escapes by the overflow pipe E,

thus cooling the chamber and its cover. The plane surface of the glass F is watched for dew, and its temperature read on the stem G of the thermometer. The readings are then taken as in the case of Daniells' Hygrometer for the appearance of dew and its evaporation.

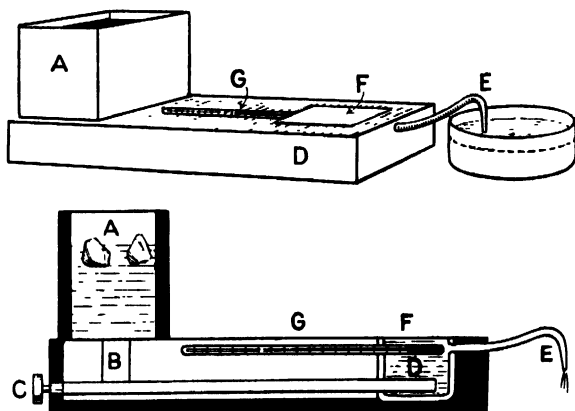

FIG. 90.—Dines' Hygrometer.

A vertical form of the instrument is also used, but with that form it is not so easy to detect the dew on the vertical surface.

126. **Regnault's Hygrometer.**—In this instrument the cooling is again by ether as in Daniells', but is very well controlled, and the

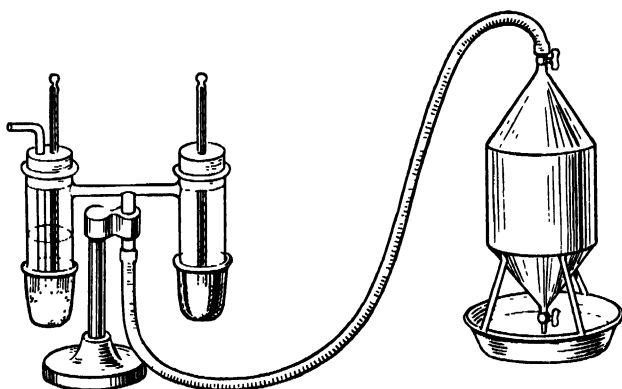

FIG. 91.—Regnault's Hygrometer.

operator should observe the dew and read the thermometers through a telescope so as to avoid moistening the air near them by his body. The cooling due to the evaporation of the ether is regulated by the aspirator as shown in Fig. 91. It is seen that the instrument has

two thermometers, each mounted in a tube whose lower part is a polished silver thimble. The aspirator is filled with water, and by its outflow draws air through both these tubes. But one tube is empty, and so its thermometer gives the air temperature and its thimble preserves its standard brightness for comparison. The other tube has ether covering the thermometer bulb, and the bubbling through the ether cools it till the thimble is bedewed. The

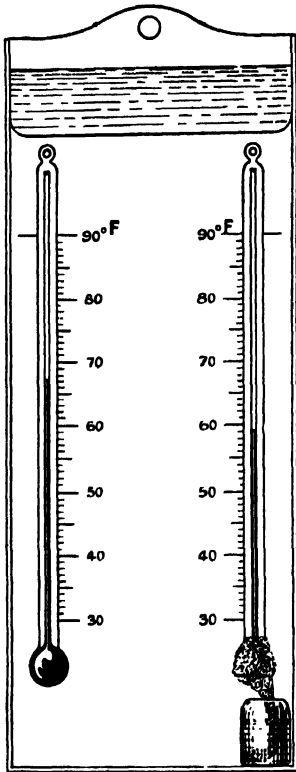

FIG. 92.—Wet and Dry Bulb Hygrometer.

thermometer is then read and the cooling stopped. The subsequent proceeding is as described with the other hygrometers. This instrument has the drawback of elaboration and costliness, but is capable of good work.

**127. Wet and Dry Bulb Hygrometer.**—This instrument, often called the wet and dry bulb thermometer, and sometimes Mason's hygrometer, is shown in Fig. 92.

It consists essentially of two thermometers, one of which has its bulb wrapped in muslin or old washed linen, kept wet by one end dipping in distilled water. In the best practice the air is blown past both bulbs at a slow standard speed. The dry bulb thermometer is quite ordinary and gives the atmospheric temperature,  $T^\circ$  say, while the wet bulb thermometer reads  $W^\circ$  say, which is lower than  $T$  unless the air is saturated. This difference ( $T - W$ ) of temperatures is found to be roughly proportional to the difference ( $P - p$ ), where  $p$  is the actual pressure of aqueous vapour present, and  $P$  is that for saturation at the temperature  $T$ . A nearer approximation is made by taking the quotient of this pressure difference and the total or barometric pressure

and equating this to the quotient of ( $T - W$ ) by a constant  $A$  for the given instrument under given conditions of use. Thus,

$$\frac{P - p}{H} = \frac{T - W}{A} \dots \dots \dots (7)$$

Hence, if the dew point  $t^\circ$  is found by another form of instrument and the two thermometers and the barometer are read, we find  $P$  and  $p$  from the table and so have everything in equation (7) except

the constant A, which may therefore be calculated. Then, having this constant, we may afterwards, by reading the two bulbs and the barometer and finding P from the table, determine  $p$ . This reduction may be performed more accurately and quickly by use of the special *hygrometric tables* which have been prepared to furnish the results on inspection (see Glaisher, 8th edition, 1893). This form of instrument is usually graduated in Fahrenheit degrees.

128. **Graphic Exhibition of Hygrometric Relations.**—The various data and other quantities used or required in hygrometry may be

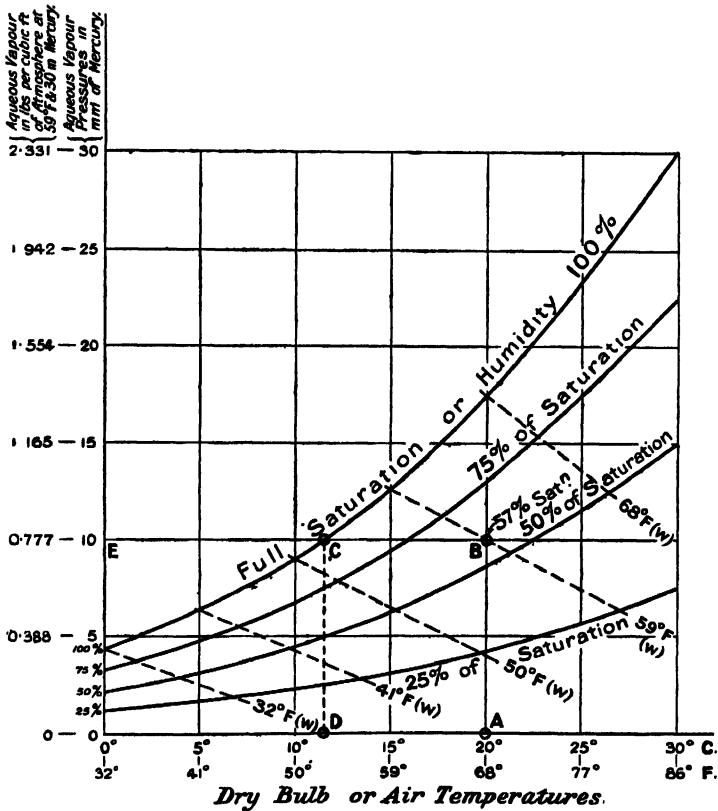

FIG. 93.—Hygrometric Relations.

usefully co-ordinated in a diagram as shown in Fig. 93, on the method devised and adopted by Professor McMillan.

The atmospheric temperatures (or dry bulb readings) are taken as abscissæ and the vapour pressures as ordinates. But, in addition to the ordinary vaporisation curve giving pressures for saturation (see Figs. 86 and 88), others are plotted showing 75 per cent., 50

per cent., and 25 per cent. of saturation, the pressures being the corresponding fractions of those for saturation. Then lines are added crossing these curves and indicating wet bulb temperatures, thus,  $59^{\circ}$  F. (W). These can only be taken as approximate, and would have to be ascertained for a given instrument used under given conditions. Along the ordinates another set of figures is marked, giving the approximate values of vapour density in lbs. per cubic foot. These figures are calculated for an air or dry bulb temperature of  $59^{\circ}$  F. and barometer reading of about 30 inches, or 76 cm.

As an illustration of the use of the diagram, suppose the wet and dry bulb temperatures to be  $59^{\circ}$  F. and  $68^{\circ}$  F. respectively, and the other hygrometric quantities are desired. Take on the abscissæ at A the temperature  $68^{\circ}$  F., follow up its ordinate till you reach at B the cross line marked  $59^{\circ}$  F. (W.). Then this point B is between the humidity lines 50 per cent. and 75 per cent. and corresponds to about 57 per cent. humidity. Follow the horizontal to the left from B till reaching the saturation curve at C, then drop along the ordinate to D, which shows the dew point  $52.7^{\circ}$  F. Reverting to C and continuing the horizontal line to the left to E, we have the pressure of the vapour actually present in the atmosphere given as 10 mm. of mercury. On the second set of figures still further to the left we see that the density of this vapour is approximately 0.777 lb. per cubic foot without correcting for the higher temperature  $68^{\circ}$  F. instead of  $59^{\circ}$  F. The correction for this would reduce the value to about 0.764 lb. per cubic foot.

#### EXAMPLES XLIX.

1. Describe the construction and use of a Daniells hygrometer.
2. Explain with sectional diagrams the working of a Dines hygrometer.
3. Give a careful sketch of the arrangement and action of a Regnault hygrometer.
4. Point out the advantages and disadvantages of the wet and dry bulb hygrometer, giving a diagram of the instrument.
5. Make a careful plot of graphs on squared paper showing in one diagram the temperatures, dew points, percentages of saturation, and densities of aqueous vapour.
6. On the diagram of example 5 take a numerical value representing a possible state of the atmosphere in a mine and find the density of the aqueous vapour, checking the result by actual calculation.

## CHAPTER XI

### BAROMETRY

129. **Torricelli's Experiment.**—The observation by Galileo that water would only rise about 32 feet in a suction pump led to the discovery of air pressure by his pupil Torricelli in 1643. For the latter said that if the atmospheric pressure could balance a column of water 32 feet high, it should balance a column of mercury about 30 inches high, the two being equivalent. And this he showed was the case by the celebrated experiment now known by his name.

Torricelli filled with mercury a tube about three feet long, closed at one end. The other end being also closed temporarily, the tube was inverted and its lower end immersed in a basin containing mercury and water. The lower end being then unclosed, the mercury descended a little way in the tube, remaining stationary at a height of thirty inches, about six inches of space apparently vacant being thus left at the top of the tube. This space is still referred to as presenting the *Torricellian vacuum*.

“On raising the open end of the tube above the level of the mercury, but still keeping it under the surface of the water, the mercury in the tube rushed rapidly out, its place being taken by the water, which completely filled the tube. Torricelli thus concluded that the elevation of the column of liquid which will stand in any tube is determined by the specific gravity of the liquid composing the column and by the atmospheric pressure. In 1648 Pascal of Clermont proved the accuracy of Torricelli's surmises by carrying a barometer from Clermont to the summit of the Puy de Dome, the mercury falling 3'33 in” (see *Encyclop. Brit.*, 10th ed., vol. iii., pp. 418-421; or the *Harmsworth Encyclop.*, vol. i., pp. 565-567).

130. **Cistern Barometer.**—The instrument devised and used by Torricelli in his classic experiment just referred to was what would now be called a *cistern barometer*, and though of the simplest form, it is still useful for some experiments. See *e.g.* Fig. 87 in Art. 116, in which the tube at the left dipping into the mercury in the cistern is merely a rough cistern barometer. To measure the actual height of the column at any time a scale would be needed extending from the level of the mercury in the cistern to that in the tube or beyond. Now it is easy to see that if the scale were *correctly graduated and*

*fixed* with its zero at the level of the mercury in the cistern at any one instant, this zero would be *wrong* when the mercury rose or fell in the tube, for this would involve a contrary and smaller motion of the level of the mercury in the cistern. This is referred to as the *error of capacity*, because its amount depends upon the relative areas of free surface in the tube and in the cistern, or on the capacity of the latter.

Thus, if these areas were as one to nine, the tube and cistern being each cylindrical, when the mercury rose *nine-tenths* of an inch in the tube it would fall one-tenth in the cistern, so the column would be *one inch* longer than before. Or the barometer would be said to have risen one inch.

**131. Kow Barometer.**—In this form of barometer the error of capacity is eliminated by using a scale of *contracted inches*. Thus, with the relations just cited, nine-tenths of an inch would be marked as an inch and be divided into twentieths. The vernier reads to a twenty-fifth of a division, and so corresponds to 0.002 of an inch change in the height of the column. See Fig. 94, which is reproduced by kind permission of Messrs. Negretti and Zambra.

A slight modification of this pattern constitutes the *marine* barometer. It is hung on a gymbal ring so that it may always remain in a vertical position. Further, lest the movement of the ship should cause the mercury column to oscillate, the bore of the tube is contracted near the cistern, thus making the action of the mercury slower and steadier.

Each form of instrument is provided with a thermometer at the middle.

**132. Fortin's Barometer.**—This form may be regarded as standard, for it is susceptible of very high accuracy. Its general appearance is shown in Fig. 95, which is reproduced here by kind permission of Messrs. Negretti and Zambra.

Its distinguishing feature is the provision of a cistern (see Fig. 96), which is *partially collapsible* and *may be set* by a screw till the mercury in it just touches the tip of an ivory stud. This marks the *fiducial point* or *zero* of the scales. These are accordingly graduated to their *true* values, since any slight rise or fall which may have occurred in the cistern since last reading the instrument is annulled by the new setting of the level to the ivory tip.

The instrument is usually provided with two scales: one in millimetres with a vernier reading to tenths of a millimetre, and one in inches and twentieths with a vernier reading to five-hundredths of an inch. The scales and verniers are shown in Fig. 97.

The verniers are brought down to the top of the mercury by turning a milled head. They are arranged with a front and back portion, so that the observer may be sure that his eye is exactly on a level with the top of the mercury column when setting for a reading.

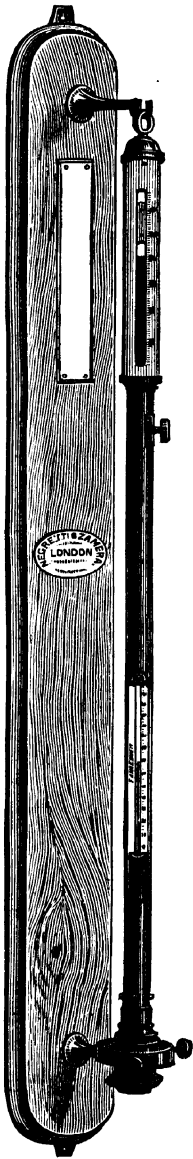

FIG. 94.—Kew Barometer.

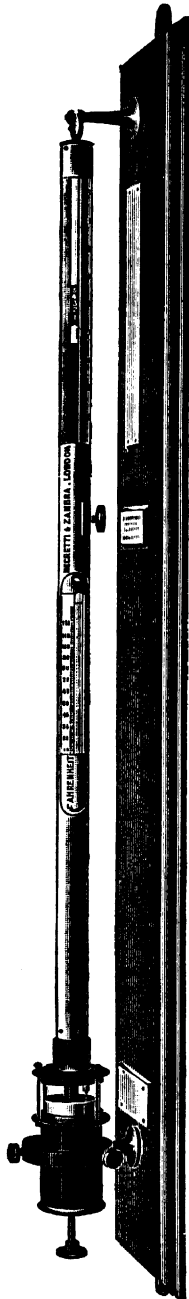

FIG. 95.—Fortin's Barometer.

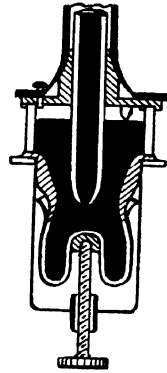

FIG. 96.—Cistern of Fortin's Barometer.

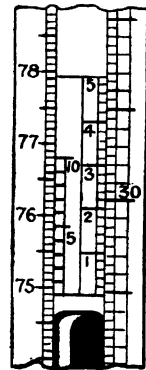

FIG. 97.—Scales and Verniers of Fortin's Barometer.

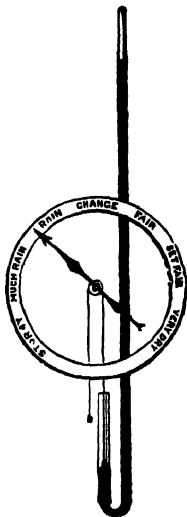

FIG. 98.—Siphon Barometer.

133. **Siphon Barometer.**—In this form of instrument the “error of capacity” involves a reduction of the motion to exactly one half. For, instead of using any cistern the lower end of the tube is bent round in a semicircle and then extends up a little, as shown in Fig. 98. On the lower surface of the mercury is a glass float from which a thread passes over a pulley to a balance weight. Thus, as the mercury rises or falls, the pulley turns and indicates by a pointer and graduated circle the height of the barometer. From the indicating arrangements this pattern is sometimes called the wheel barometer. It is a favourite type for domestic use. The indications tend to lag behind the true value, hence the need for tapping.

#### EXAMPLES L.

1. Describe Torricelli's experiment and the cistern barometer.
2. Explain what you mean by the error of capacity in a barometer and show how it is dealt with in the Kew type of instrument.
3. Give a sectional diagram of the cistern of Fortin's barometer and explain its object and mode of use.
4. Make an exact diagram of a scale and vernier reading to tenths of a division and explain how to use it.
5. Construct in cardboard a scale and vernier reading to fifths and twenty-fifths of a division.
6. Describe carefully the scales and verniers in use in the high-class barometers.
7. Draw a siphon barometer and explain its working. What becomes of the error of capacity in this form of instrument?

134. **Temperature Corrections to Barometer.**—Let us now revert to the Fortin barometer, and suppose that it is wished to compare the readings taken at the same time from two or more such instruments at different places. The temperatures, latitudes, altitudes, and other conditions may differ, hence the question arises will such readings be really comparable without allowances for these circumstances. They will not. If high accuracy is aimed at, a number of corrections must be applied.

We deal first with the corrections for temperature, as (for England) they are usually larger than all others put together.

In the best barometers the essential substances used are *brass* (for the scale), *glass* (for the tube), and the *mercury* itself. The mercury is pure and is carefully boiled in the tube to expel all moisture and air.

Suppose now such a barometer shows a height of 30 inches of

mercury, the temperature being 32° F. And let the temperature artificially change to 69° F. without any change occurring in the atmospheric pressure. Then the apparent height of the mercury column in the tube, as read by the brass scale, will be 30·10 inches. Thus a rise of a tenth of an inch has apparently occurred without any change in the pressure supporting the column. This may be explained hastily by saying that the mercury expands with temperature and expands more than the brass scale does. A closer examination shows that we are concerned

(1) With the *linear* expansion of the brass (or its increase of length per unit length per degree) ; but

(2) With the *volume* expansion of the mercury, or its increase of volume per unit volume per degree. For, with given pressure, the column has a height *inversely* as its density and therefore *directly* as the expanded *volume*.

The quantities expressing these increases are called *coefficients of expansion, linear or volume*, as the case may be.

The values for mercury and brass to the required accuracy, and the standard temperatures for each scale or substance, are as follows:—

Coefficient of Volume Expansion of Mercury = 0·000182 per 1° C.  
 = 0·000101 per 1° F.  
 „ Linear „ Brass = 0·000020 per 1° C.  
 = 0·000011 per 1° F.

Standard Temperature for Mercury and Metric Scales = 0° C. = 32° F.  
 „ „ English Yard and Inches = 62° F.

Let us now calculate the correction on the metric system for a barometer of observed height *h* mm. at temperature *t*° C.

For any length the temperature correction consists of three factors—the length in question, the coefficient concerned, and the change of temperature in question, with the right algebraic *sign* prefixed. Hence, to correct the observed height for the expansion of the mercury itself, we have

$$-h(0\cdot000182)t,$$

the minus sign being used because the warmer mercury is less dense and stands higher.

Similarly, to correct the brass scale for its own expansion (which makes it read a given length *less* than its true value), we have

$$+h(0\cdot000020)t.$$

Putting the two together, and calling the whole temperature correction *a*, we thus find

$$a = -h(0\cdot000162)t \quad . \quad . \quad . \quad . \quad (1)$$

Turning now to inches and degrees Fahrenheit, and using the

corresponding capital letters, we have as the corrections for the mercury and scale respectively—

$$-H(0\cdot000101)(T-32)$$

and

$$+H(0\cdot000011)(T-62).$$

Hence, taking as before, the algebraical sum for the whole temperature correction, we obtain,

$$A = -H(0\cdot000090T - 0\cdot00255) \quad . \quad . \quad (2)$$

Owing to the fact that 62° F. is the standard temperature for the inch scale and 32° F. that for the mercury, it will be found that the temperature of no correction is about 28½° F. instead of the freezing point.

**135. Latitude and Altitude Corrections to the Barometer.**—It must now be noted that for a given atmospheric pressure and temperature of the barometer, the height of the mercury column will depend on the apparent value of gravity at the place. Thus, if the value of gravity is less than its standard value at a given place, then the column of mercury will be a little higher in consequence. In that case, therefore, the correction to be applied to the reading would be negative.

The value of the apparent gravity at any place is the resultant of the earth's attraction there, and the centrifugal reaction due to the earth's rotation. Or, we might put it thus: a part of the earth's attraction is required to keep bodies moving in the circles described by them as the earth rotates, hence what is left and perceptible as gravity is usually smaller and slightly different in direction. This reduction is greatest at the equator and zero at the poles. But, in addition, the true gravity is greater at the poles than at the equator because the polar radius is less than the equatorial.

For the standard value of gravity the latitude of 45° and the sea-level<sup>1</sup> have been chosen. And apparent gravity increases with latitude, but decreases with altitude in the manner shown by the following formula published in Berlin, 1901, by Helmert (see *Landolt and Börnstein's physikalisch Tabellen*, p. 5):—

$$g = g_{45}(1 - 0\cdot002644 \cos 2l + 0\cdot000007 \cos^2 2l) - 0\cdot0003086m \quad . \quad (3)$$

where  $g_{45} = 980\cdot617$  cm./sec.<sup>2</sup> is gravity at sea-level in latitude 45°, and  $g$  is gravity in latitude  $l$  and at a height  $m$  metres above sea-level.

Applying the above to the barometer, we obtain with sufficient accuracy the corrections for gravity in the forms

$$b = -h(0\cdot0026 \cos 2l + 0\cdot000000031h) \quad . \quad (4)$$

and

$$B = -H(0\cdot0026 \cos 2l + 0\cdot0000000944K) \quad . \quad (5)$$

<sup>1</sup> For England this is taken as mean half-tide level at Liverpool.

where  $b$  is the correction in mm. to  $h$  mm. for a latitude  $l$  and height of  $h$  cm. above sea-level, and  $B$  is the correction in inches to  $H$  inches for a latitude  $l$  and height of  $K$  feet.

It is well to note here that a change of latitude from  $45^\circ$  to  $46^\circ$  necessitates a positive correction of about  $0.069$  mm. to the observed barometer height, while  $30,000$  cm. ( $300$  metres or  $984$  feet) above sea-level necessitates a negative correction of the order  $0.071$  mm.

**136. Corrections to Barometer for Vapour Pressure, etc.**—We have still to correct the barometer for the pressure of the mercury vapour above the liquid mercury in the tube. This pressure prevents the liquid column rising to the full theoretical height that would be attained in a vacuum. Hence the correction ( $c$  mm. or  $C$  inches) on account of it must be positive. The values of the vapour pressure at different temperatures have been variously determined. If we accept the work of Hertz in 1882, the values of the vapour pressure of mercury in mm. of mercury column are as follows:—

Temperature.	Pressure.
0° C.	0.00019 mm. = 0.0000748 inch
10° C.	0.00050 mm. = 0.0001970 inch
20° C.	0.00130 mm. = 0.0005120 inch

This correction is thus seen to be excessively minute, and is usually negligible.

The other possible errors of the barometer which may need correction are (1) that due to wrong relative positions of the scale and the ivory pointer, called the *zero error*, and (2) that due to *capillarity*, which may slightly change the height of the column. These errors, if existent, are corrected for in accordance with the certificate of the National Physical Laboratory supplied to order by the makers of any high-grade instrument.

**137. Examples of Barometer Corrections.**—Let the reading of a Fortin barometer be  $758.6$  mm. at a temperature of  $14.5^\circ$  C. in latitude  $53^\circ$  at  $58$  metres above sea-level, and suppose that the zero and capillarity errors are each negligible. We may then conveniently put positive corrections under the actual reading and negative corrections in a separate column, and then total as shown below.

Observed height	. . . . . $h = 758.6$ mm.																				
	Negative parts.																				
Corrections :	<table style="display: inline-table; border: none;"> <tr> <td style="border-left: 1px solid black; padding-left: 5px;"><math>a = -1.782</math></td> <td style="padding-left: 20px;"><math>+ 0.544</math></td> <td rowspan="3" style="font-size: 2em; vertical-align: middle;">}</td> <td rowspan="3" style="vertical-align: middle;">Positive parts.</td> </tr> <tr> <td style="border-left: 1px solid black; padding-left: 5px;"><math>b = -0.014</math></td> <td style="padding-left: 20px;"><math>+ 0.001</math></td> </tr> <tr> <td style="border-left: 1px solid black; padding-left: 5px;"><math>c =</math></td> <td></td> </tr> <tr> <td style="border-top: 1px solid black; text-align: right; padding-top: 5px;"><math>- 1.796</math></td> <td style="text-align: right; padding-right: 20px;"><math>+ 759.145</math></td> <td></td> <td></td> </tr> <tr> <td></td> <td style="text-align: right; padding-right: 20px;"><math>- 1.796</math></td> <td></td> <td></td> </tr> <tr> <td></td> <td style="border-top: 1px solid black; text-align: right; padding-top: 5px;"><math>+ 757.349</math></td> <td></td> <td></td> </tr> </table>	$a = -1.782$	$+ 0.544$	}	Positive parts.	$b = -0.014$	$+ 0.001$	$c =$		$- 1.796$	$+ 759.145$				$- 1.796$				$+ 757.349$		
$a = -1.782$	$+ 0.544$	}	Positive parts.																		
$b = -0.014$	$+ 0.001$																				
$c =$																					
$- 1.796$	$+ 759.145$																				
	$- 1.796$																				
	$+ 757.349$																				
Final result =	$757.35$ mm.																				

Take a second case in which the reading of the barometer is 29.126 inches at a temperature of 90° F. in latitude 30° and 800 feet above sea-level. Thus—

Observed height . . . .	$H = 29.126$	inches	
Corrections :	{	$A = -0.1617$	
		$B = -0.0401$	
		$C =$	$+ 0.0001$
		$- 0.2018$	$+ 29.1261$
			$- 0.2018$
			$+ 28.9243$

Final result, say 28.924 inches.

EXAMPLES LI.

1. A mercury barometer with a brass scale reads 76.3 cm. at 20° C., correct it for temperature.
2. What is the barometer corrected for temperature, if it reads 29.86 ins. at 61° F. ?
3. At station A the temperature is 12° C., and barometer reading 75.8 cm. ; at station B the temperature is observed to be 67° F., and barometer reading 29.7 ins. : reduce each for temperature and convert it to the scale used for the other.
4. If the barometer reduced for temperature is 76.05 cm., at latitude 40° and altitude 1400 metres, what is it reduced to 45° and sea level ?
5. Reduce to sea-level at latitude 45° the barometer height 29.77 ins. at altitude 4000 ft. and latitude 57°.
6. The Fortin barometer reads 761.5 mm. at 13.6° C. and 300 ft. above sea-level in latitude 51°. Reduce these observations, showing all the corrections separately.
7. State all the corrections and the reduced barometer height, if it reads 28.63 ins. at a temperature of 35° F. in latitude 42° and 600 ft. above sea-level.

**138. Vitiated Vacuum of Barometer Tube.**—If the space above the mercury in a cistern barometer is vitiated by the presence of air, this will be indicated by a change in the height of the mercury column on raising or lowering the tube and allowing the mercury to settle. But, by observing the heights *a* and *b* of the mercury columns in two such cases, and the lengths *u* and *v* of the corresponding spaces above, the actual barometer height *h* may be deduced. See Fig. 99.

For, by Boyle's Law, the pressures of air, *h* - *a* and *h* - *b*, in the two cases, are inversely as their volumes. We may thus write

$$(h - a)u = (h - b)v \quad \dots \quad (1)$$

or  $h(u - v) = au - bv$

So  $h = \frac{au - bv}{u - v} \quad \dots \quad (2)$

Having won this relation between the five quantities, it is evident that if any four of them were given the fifth could be calculated.

Also, having then the five quantities, we could write down the corrections  $h-a$  and  $h-b$  to be applied to the barometer in either state.

We have thus the key to the solution of any problems on a barometer with its vacuum vitiated instead of truly Torricellian.

In an actual case of this kind, of course the best procedure is to have the barometer made right as soon as possible. If of the Fortin type and received from the makers, it may suffice to invert the instrument and tap it gently.

A modified type of the vitiated vacuum problem occurs when  $a+u=b+v=c$  a constant, the  $a$  occurring for an actual barometer height  $h$  and the  $b$  for an actual barometer height  $k$ , say. Then,  $h$ ,  $a$ ,  $b$  and  $c$  being known, it is required to find the correction  $k-b$  to be applied to  $b$ . Then we have, for constant temperature throughout—

$$(h-a)(c-a) = (k-b)(c-b)$$

or 
$$k-b = \frac{(h-a)(c-a)}{(c-b)} \dots \dots \dots (3)$$

Thus, if  $c=33$  inches,  $a=29.5$  for  $h=30$  inches, the correction when  $b=29.2$  is

$$k-b = \frac{0.5(3.5)}{33-29.2} = 0.46,$$

so  $k=29.66$  inches.

It may also be noticed here that this method of calculation applies to problems on the diving bell, though at first sight the two cases may seem utterly unlike (see Art. 152).

139. **Height of Homogeneous Atmosphere.**—Knowing the pressure and density of the air near the earth's surface, we can calculate the height to which the atmosphere would extend if the density remained

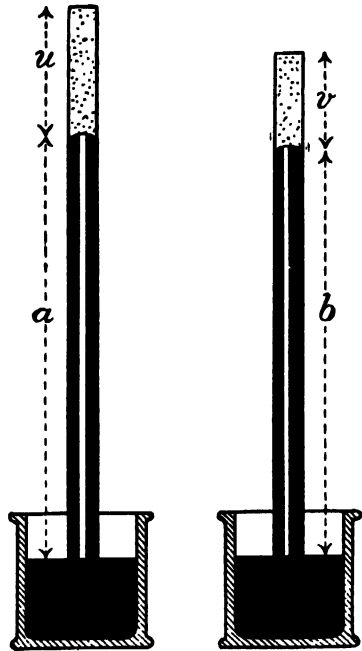

FIG. 99.—Vitiated Barometer Vacuum.

the same throughout. This is called *the height of the homogeneous atmosphere*.

Thus, if mercury of density 13·595 gm. per c.c. stands at a height of 76 cm. in a good barometer when the air is at 0° C. and has a density of 0·001293 gm. per c.c., then, neglecting the change of gravity as we ascend, the height of the homogeneous atmosphere is given by

$$k_0 = 76 \times 13\cdot595 \div 0\cdot001293 = 799,088 \text{ cm.} \quad (4)$$

or 8,000 metres nearly.

This height may be regarded as that of an *imaginary air barometer*. For a given air pressure the height of the homogeneous atmosphere varies with variations of temperature and gravity somewhat as the height of the mercury barometer does.

Thus, if the above height were for 0° C., then at  $t^\circ$  C. the height would become

$$k = k_0(1 + \alpha t) = k_0 \frac{273 + t}{273} \quad (5)$$

where  $\alpha$  is 0·003665 or  $1/273$  nearly, or say  $\alpha = 0\cdot004$ , since moisture is present, and this expands more than dry air.

Again, if with the same pressure the value of gravity is changed from  $g$  to  $g'$ , then the heights of the actual mercury barometer and of the homogeneous atmosphere are each changed in the ratio  $g' : g$ . That is, if gravity decreases, the height of the homogeneous atmosphere increases. It is thus evident that, since in the upper part of the height of the homogeneous atmosphere the value of  $g$  appreciably diminishes, this should be allowed for if we wish for more accuracy. We might, if we chose, take the value of  $g$  at the half-height of the homogeneous atmosphere as already found approximately.

Thus at the height of 4000 metres gravity is diminished by about 1 in 3220. Hence the 7991 metres is corrected to

$$k = 7993\cdot5 \text{ metres nearly} \quad (6)$$

#### EXAMPLES LII.

1. A faulty barometer reads 75 cm., with a space of 15 cm. above the mercury, when a neighbouring barometer known to be in good order reads 76 cm. Another day the faulty barometer reads 76 cm. What would the true barometer read?

2. A rough cistern barometer has been made, and the mercury in it stands at a height of 74 cm. when there is 8 cm. height above it, but at 75 cm. when the space above is 16 cm. What is the true barometer reading?

3. A rough cistern barometer reads 75 cm. when there is a height of 10 cm. above the mercury, but reads only 74·5 cm. when the height above is only 5 cm. The tube is then replaced and set in its first position. What are the true barometer heights when the instrument reads 73, 75 and 77 cm. respectively?

4. Explain what is meant by the height of the homogeneous atmosphere, and obtain an approximation to its value.

140. **Heights determined by the Barometer.**—If the temperature and humidity of the atmosphere do not vary much between two stations, then the difference of their heights may be simply expressed in terms of the corresponding barometer readings. If the temperature does vary slightly, the mean value may be taken and treated as constant over the range in question.

At height  $y$  let the density of the air be  $a$  and the pressure be  $p$ ,

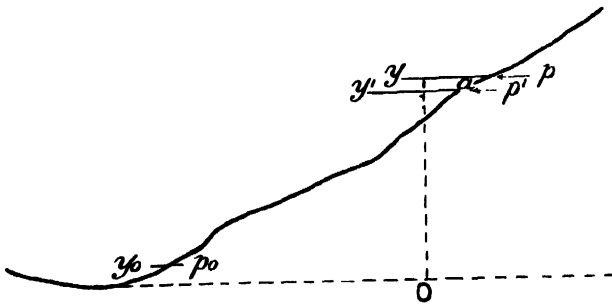

FIG. 100.—Heights by Barometer.

and at a very slightly lower height  $y'$  let the pressure be  $p'$  (see Fig. 100).

Then, by the hydrostatic equilibrium, we have

$$p' - p = ag(y - y') \quad \dots \quad (1)$$

Also, from Boyle's law, we may write

$$p = kag \quad \dots \quad (2)$$

where  $k$  is a constant, being the height of the *homogeneous atmosphere*.

By combining these two equations, we obtain

$$\frac{p'}{p} = 1 + \frac{y - y'}{k} \quad \dots \quad (3)$$

Each side of this simplifies if we take logarithms to the base  $e$ , where  $e = 2.7183$  and is the base of the Napierian logarithms.

The quotient at the left side becomes a difference, also the two terms at the right reduce to one, since  $\log_e(1 + x) = x - \frac{x^2}{2} + \frac{x^3}{3} \dots = x$  simply, when  $x$  is sufficiently small.

We then obtain

$$\log_e p' - \log_e p = \frac{y - y'}{k} \quad \dots \quad (4)$$

Now take a number of such small steps with pressures  $p'', p'''$ , etc., at heights  $y'', y'''$ , etc., ending with pressure  $p_0$  at height  $y_0$ . Then, if the corresponding equations were written and added together, all

the intermediate pressures and heights would cancel out leaving only the first and last values over the finite range in question.

We accordingly have the general expressions

$$\log_e p_0 - \log_e p = \frac{y - y_0}{k}$$

and 
$$y - y_0 = k \log_e \left( \frac{p_0}{p} \right) = k(2.3026) \log_{10} \left( \frac{p_0}{p} \right) \dots (5)$$

**141. Alternative Proof for Heights.**—Some readers may prefer the following proof, as it avoids the use of logarithms to the base  $e$ . We derive as before the first three equations, which are quoted here with their original numbers

$$p' - p = ag(y - y') \dots (1)$$

$$p = kag \dots (2)$$

$$\frac{p'}{p} = 1 + \frac{y - y'}{k} \dots (3)$$

Let us now notice that equation (3) shows that—

$$\left. \begin{array}{l} \text{as } y \text{ decreases by a given small constant difference} \\ p \text{ increases in a determinate constant ratio} \end{array} \right\} \dots (3a)$$

To some readers this might suggest that

$$y \text{ is proportional to the logarithm of } p \dots (3b)$$

But, whether this relation is foreseen or not, let us suppose it to hold between  $y$  and  $p$ , and then test its validity by ascertaining whether it satisfies the required condition as expressed in (3a).

Thus let

$$y = -c \log_{10} p, \text{ and } y' = -c \log_{10} p' \dots (6)$$

where  $c$  is some constant to be afterwards determined. Then, taking the difference of equations (6), we have

$$y - y' = c \log_{10} \left( \frac{p'}{p} \right) \dots (7)$$

It may now be seen that, although (7) differs in form from (3), yet it equally satisfies the condition (3a).

Hence, equation (6) is justified, and we may proceed to determine  $c$  by comparing equations (3) and (7).

Thus, writing

$$p = 10,000, \text{ and } p' = 10,001$$

we find 
$$\frac{10,001}{10,000} - 1 = \frac{y - y'}{k} = \frac{c}{k} (0.0000434)$$

so that 
$$c = \frac{k}{0.434} = 2.30 \times k \dots (8)$$

Hence, using (7) with this value of  $c$  and taking it over a range of height from  $y$  to  $y_0$ , the corresponding pressures being  $p$  and  $p_0$ , we have

$$y - y_0 = 2.30k \log_{10} \left( \frac{p_0}{p} \right), \quad \dots \quad (9)$$

which is in practical accord with equation (5) of the previous article.

The best method of obtaining this relation is by deriving the appropriate differential equation and solving it. Any mode of evading this higher branch of mathematics encounters obstacles and suffers from imperfections. The foregoing two methods are therefore not ideal but are offered with diffidence as honest attempts to present and solve the problem for students unacquainted with the calculus.

**142. Numerical Forms of Barometric Formula.**—Having obtained the general relation between heights and atmospheric pressures, we may now pass to its numerical interpretation. For this we must introduce the value of  $k$  which occurs in this relation. This may be quoted from Art. 139, equations (1) and (2), or may be found direct from the gas equation in the manner of Art. 111. Taking the latter plan, we have for the gas equation per gram of air

$$P \frac{V}{m} = R_a T, \text{ or } P = a R_a T \quad \dots \quad (10)$$

where  $a$  is the density of air and  $R_a$  is the value now assumed by  $R$ . Then, putting subscripts 0 for the standard values of  $P$ ,  $T$  and  $a$ , we have

$$R_a = \frac{P_0}{a_0 T_0} = \frac{76 \times 13.6 \times g}{0.00129 \times 273} \quad \dots \quad (11)$$

Again, comparing (10) with (2) of Arts. 140 and 141, we see that

$$k = \frac{R_a T}{g} = \frac{76 \times 13.6 (273 + t^\circ \text{ C.})}{0.00129 \times 273} \quad \dots \quad (12)$$

Thus, putting this value of  $k$  in (5) of Art. 140 or (9) of Art. 141, we find

$$(y - y_0)_{\text{cm.}} = \frac{76 \times 13.6 (273 + t^\circ \text{ C.})}{0.00129 \times 273} 2.3026 \log_{10} \left( \frac{p_0}{p} \right) \quad (13)$$

If we now denote by capital letters the heights in feet and temperatures in degrees Fahrenheit, we obtain

$$(Y - Y_0)_{\text{feet}} = \frac{76 \times 13.6 (459.4 + T^\circ \text{ F.})}{0.00129 \times 273} 2.3026 \log_{10} \left( \frac{p_0}{p} \right) \quad (14)$$

since a foot contains 30.48 cm. and the zero of the gas thermometer is 491.4 of Fahrenheit's degrees below the freezing point, or is  $-459.4^{\circ}$  F.

It should be noted that in each of these equations (13) and (14) the values of the  $p$ 's may be expressed in any units of pressure, provided that the same are used for  $p$  and  $p_0$  in the one equation.

It is well to notice that the mercury falls about 1 inch for an ascent of 1000 feet, or about 1 cm. for an ascent of 110 metres. These rough approximations will, of course, be modified by temperature.

The student should also be on his guard, if solving these numerical formulæ by logarithms, that the logarithm of a logarithm is required.

**143. Aneroid Barometer.**—As its name denotes, this instrument is devoid of liquid. It is therefore capable of use in any position, and may also be small and light. This form of barometer is accordingly specially suitable for use in the determinations of heights, and is in consequence described here.

Externally the aneroid barometer shows a cylindrical metal case with a dial graduated similarly to that of a syphon or wheel

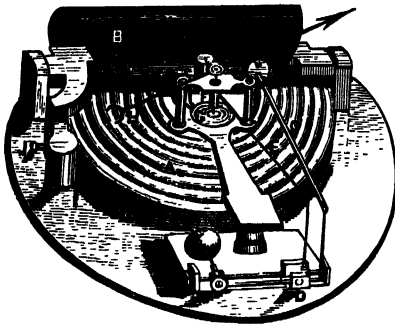

FIG. 101.—Aneroid Barometer.

barometer. Upon this dial a hand moves indicating the pressure in inches of mercury column. The internal construction and action may be understood by reference to Fig. 101, which is inserted here by kind permission of Messrs. Negretti and Zambra. The essential detector of the barometric pressure and its changes is a flat box A of thin metal corrugated in concentric circles. From this box the air and moisture are partially exhausted to form a sufficiently

good vacuum. The top of the box is elastic and would yield too much to the pressure, but for the strong spring B. It still yields slightly to the pressure, and this lowers or raises the lever C attached to the spring. This lever by a connecting link rocks the shaft D. The shaft in turn pulls or releases a cord or chain E which rotates the spindle at the centre of the dial and so moves the hand over the graduations.

Some aneroids have a second graduation on the dial, showing heights ascended in feet. These have the zero height at the highest pressure, viz., 31 inches, rising to say 10,000 feet at about 21.5 inches.

A second style of aneroid, graduated for heights, has only the pressures in inches of mercury on the dial, the heights being shown

round the cylindrical side of the case, one part of which, carrying a pointer, can be turned.

The height ascended is then determined as follows. At the low station, A say, at sea-level, the movable part of the case is set to zero on the scale of heights and the pressure, 30 inches say, is noted. Suppose an ascent is made involving a fall of the pressure to 26 inches. The movable part of the case is then turned until the original pressure reading is reproduced. The pointer on the movable part of the case then reads the required height on the scale of heights, in this case 3750 feet nearly.

**143A. New Barometric Units: Millibar and Baromil.**—The term *millibar* is accepted by the Director of the National Physical Laboratory "as meaning 1000 dynes per sq. cm. The word *baromil* is then employed to designate a unit of length, which is defined as equal to the height occupied by a column of pure mercury which, at  $0^{\circ}$  C. and at sea-level in latitude  $45^{\circ}$ , gives rise to a pressure of one millibar."

#### EXAMPLES LIII.

1. Obtain by any method known to you the relation between two heights and the corresponding barometer readings. State carefully the units in which each quantity is expressed.
2. Assuming the general form of the barometric formula for heights, derive the numerical values for centimetres and degrees centigrade.
3. Derive the numerical barometric formula for feet and degrees Fahrenheit, assuming the general form of the relation between heights and pressures.
4. In ascending a mountain, the barometer falls from 76.3 to 67.5 cm. The average temperature being  $12^{\circ}$  C., what is the difference of levels in metres?
5. At an average temperature of  $15^{\circ}$  C., a mountain ascent of 3000 ft. is made. If the barometer read 30 ins. at the foot, what would it read at the summit?
6. What is the height of a mountain in feet above sea-level, if the barometer stands at 21.4 ins. at the summit and 29.8 at a place 780 ft. above sea-level at the base? Take the average temperature as  $80^{\circ}$  F.
7. Describe the aneroid barometer, giving a diagram of its most important parts and explaining its advantages.

# PART V.—APPLICATIONS

## CHAPTER XII

### ILLUSTRATIVE APPARATUS

144. **Classification of Hydraulic and Kindred Appliances.**—The great number and widely-differing characters of the appliances in ordinary use in connection with liquids or gases in motion or under pressure are somewhat bewildering, and call for some clue as to their arrangement and treatment. This clue may be found in the fact that the energy of a fluid may consist of three terms, depending respectively on its position, velocity and pressure.

Thus, we may regard the main appliances as—

- (1) Those designed to *give* to fluids any desired *position, velocity, or pressure*; and
- (2) Those designed to *utilise* in various ways the energy of fluids due to their *position, velocity, or pressure*.

We also have subsidiary or accessory appliances, which either—

- (a) *Register a flow or pressure* of fluid which is natural or has been accomplished by one of the main appliances; or
- (b) In some other way *assist and promote* the realisation of the object of one of the main appliances.

Any such accessory may be considered along with the main appliance to which it is an auxiliary.

Such a classification as that just outlined cannot pretend to logical rigour; e.g. when removing from a chamber a portion of the gas in it, we may be changing the pressure of that portion which is left. Still it is a convenient practical distinction to regard certain appliances as chiefly controlling the *position* of fluids and others as chiefly controlling their pressure, for each such appliance is usually specialised for the end mainly in view.

Under the second heading of the main appliances, the utilisation of the energy of fluids is usually to be understood as the generation of power in a convenient way from the energy thus stored up in the fluid. But, occasionally, we have the reverse process, it being sometimes convenient to transform the energy of solid bodies into that of fluids which are then used as absorbers of energy instead of sources of it.

The typical classes of appliances arranged on the foregoing basis are collected in Table IX., and will be dealt with, where necessary, in that order. In this table the accessory appliances are shown in brackets, and those illustrating a reverse action are in italics.

TABLE IX.—HYDRAULIC AND KINDRED APPLIANCES.

Purposes.	Means employed.	Typical Examples.	
To control the Position or Velocity of Fluids by—	Solids	Centrifugal, Lift and Force Pumps; Fans	
	Liquids	Hydraulic Ram, Jet Pump (Water Meter)	
	Gases	Diving Equipment. Siphons, Steam and Explosion Pumps	
To control the Pressure of Fluids by—	Compression	Pumps for Hydraulic Pressure Systems (Accumulator), Tyre Pumps, Torpedo Compressors (Bourdon and Differential Gauges)	
	Rarefaction	Jet, Geryk, Toepler and Gaede Pumps (McLeod Gauge)	
To utilise the Energy of—	Position and weight of Liquid	Breast and Overshot Water Wheels	
	Pressure of—	Liquids	Hydraulic Presses, Lifts, Cranes and Riveters, Water Pressure Turbines, <i>Hydraulic Brakes</i>
		Gases	Rock Drills, Steam and Compressed Air Engines, Steam Pressure Turbines, <i>Air and Vacuum Brakes</i>
	Velocity of—	Liquids	Undershot Water Wheels, Impulse Water Turbines
		Gases	Wind Mills, Impulse Steam Turbines

**145. Primitive Water Lifters, etc.**—Various simple contrivances for raising water have been devised long ago; some one or more of them being still in use, others having chiefly an historic interest. The *Shadoof* has a long rod pivoted near one end which is weighted to counterpoise the longer arm at whose end is a bucket which is lowered into the water and then raised to the required level for delivery. The shadoof has been much used on the Nile for irrigation purposes. The so-called *Screw of Archimedes* (287–212 B.C.) consists of a tube or elongated chamber wound screw-wise round a central axis. The lower end of this tube dips into the water to be raised and the axis is set at such a slope that, on turning the screw, the water rises through the apparatus and is delivered at its upper end. The condition for this is obviously that the slope of the screw on the cylinder and the inclination of its axis should be so related that water may lodge in the lower part of each convolution of the screw when it is at rest. Thus, if the screw tube is inclined at an angle  $A$  to the horizontal when the axis is vertical, then, for proper working, the axis must be inclined *more than  $A$  from the vertical*. Some consider this device was first used in Egypt.

If the screw were set a little steeper than the slope derived from the above condition, by a very rapid rotation of the screw, water might still be forced up owing to its inertia causing it to refuse to rotate suddenly.

Utilising this principle, express trains have been fitted with an inclined *water scoop* which lifts water into the tender from a tank between the rails while the train is at full speed. Just after the beginning of the tank, a slight fall of the rails causes the lip of the scoop to dip into the water. Similarly, just before the end of the tank is reached, a rise of the rails lifts the scoop out of the water and clear of the tank end.

The *Chain Pump*, in which an endless chain carrying buckets passes over a rotating wheel, though crude, is still useful for sewage or other water holding in suspension various bodies which would prevent the proper working of valves. The *dredger* is similar in principle and arrangement.

*Centrifugal Pumps and Blowers* have rapidly rotating parts within a case and, so by the action of the atmospheric pressure, take in water or air at the centre and discharge it at the circumference.

**146. The Lift Pump.**—The contrivances just noticed were without valves and some had a continuous rotatory motion. The common suction or lift pump is the first example we take of a pump with *valves*, the action being to and fro or *reciprocating*. As is well known, a valve is some arrangement for allowing the free passage of a liquid, gas, etc., in one direction and refusing such passage in the contrary direction: As we are not here concerned with the details of constructional designs, the particular type of valve in use in each case will usually be sufficiently explained by its representation

in the diagram. When the water or gas is moved by a reciprocating piston it is clear that *two* valves are usually needed, one in the path of the fluid approaching the piston, and one in that of the fluid delivered by it. The action of the lift or suction pump is easily followed from Fig. 102, it being understood that the bucket AA is moved up and down the barrel and that the valves B and C open upwards only. The piston or bucket AA is shown ascending, valve B being open and C closed. When the bucket descends, B closes and C opens. It must, of course, be borne in mind that the pressure of the atmosphere is needed to force the water up to B when the first few ascents of the bucket makes a partial vacuum in the space AB. The height of the water barometer is about 34 feet,

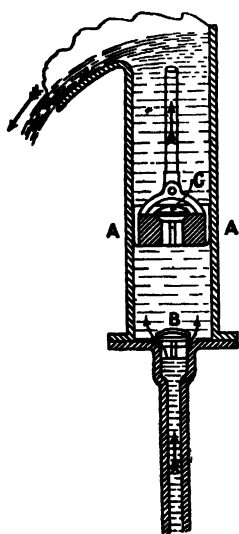

FIG. 102.—Lift Pump.

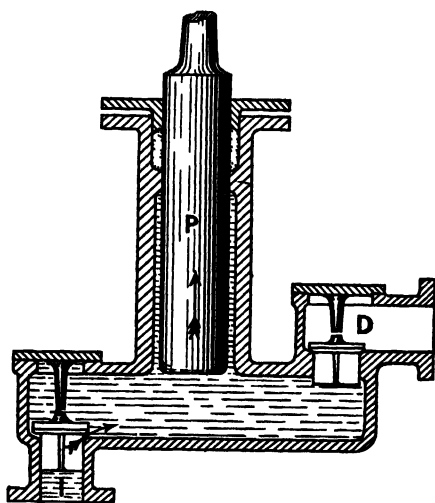

FIG. 103.—Force Pump.

but this type of pump will not work well if A is much over 26 feet above the level of the water to be lifted. It may also be noted that the action of the pump is intermittent, that is, it discharges water only during the up or delivery stroke.

147. **Force Pump.**—When it is desired to raise water to greater heights than those possible to the suction pump (or, to force the water against greater pressures than correspond to those heights), the *force pump* is employed. A simple form of it is shown in Fig. 103. In this case the plunger P is solid and moves up and down, the water never passing to its upper end, but simply entering by the inlet valve I during the up-stroke and passing out by the delivery valve D on the down stroke. This pump, being single-acting (*i.e.* having the water on *one* side only of *one* plunger), is intermittent in its

delivery. This matters but little if the pump is being used as a *feed pump* to force the water into a steam boiler, because the steam forms a sufficient cushion. But, if there is simply a long column of water on the delivery side which must be started and stopped at the beginning and end of each delivery stroke, this intermittence is a distinct and intolerable drawback. This is removed by the devices to be next noticed.

**148. Air Chamber; Double and Triple Pumps.**—To obviate this fluctuation, the delivery pipe of a force pump may be fitted with an *air chamber* (see E, Fig. 104). In the upper part of this chamber the air is compressed during the delivery stroke by the water below, then the subsequent expansion of the air maintains the flow of water during the suction stroke of the pump, while its delivery valve is closed.

To make the delivery still more regular we may have a double pump with its two plungers so arranged that one is delivering while the other is taking in. This form of double pump, combined with the air chamber, has been used for playing water on fires, and is often miscalled a *fire-engine*.

In some patterns of steam fire-engines the piston rod of the steam cylinder directly drives the piston of a double-acting force pump which, with its associated air chamber, thus maintains a continuous stream.

Where water under pressure is used for transmitting power to various appliances, a *triple-forcing* pump may be used with its three plungers worked from cranks at angles of  $120^\circ$ . Then, though each plunger is single-acting, the whole arrangement gives a tolerably regular delivery.

#### EXAMPLES LIV.

1. Give a scheme of classification of hydraulic machinery, name a dozen or more such appliances with which you are familiar, and assign them correctly to their approximate divisions.
2. Mention two or more primitive water lifters and explain their construction and use.
3. Make a sectional elevation of a lift pump and show how it works. What limit is there to its lift and why?
4. Describe, with sectional view, a force pump as used for feeding a steam boiler or raising water to heights of 100 ft. or more.
5. Explain two or more devices for rendering the delivery of pumps approximately uniform instead of intermittent.

**149. The Hydraulic Ram.**—This is an automatic device in which the kinetic energy acquired by water in descending along a gently sloping pipe is utilised for forcing a *part* of this water up to a level *above* that from which it started, the remainder running to waste. Its arrangement and action may be understood from Fig. 104.

The water from a spring or other natural source flows down the

slightly sloping pipe AA, and easily escapes by the large valve B, whose weight tends to open it. When sufficient velocity is attained, the rush of water is able to lift the valve B and close it. The momentum of the water thus receives a check which produces

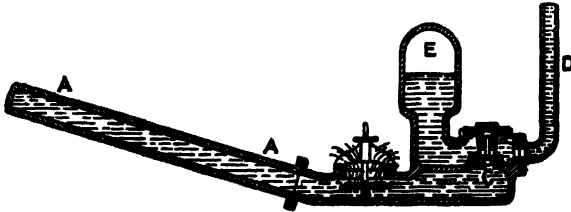

FIG. 104.—Hydraulic Ram.

sufficient pressure to open the valve C and drive some water up the delivery pipe D and so to a high-level tank, say at the top of a country house. The velocity of the water in the pipe AA accordingly falls off, the valve C closes and the valve B falls by its own weight, and the cycle of operations begins again. The air chamber E serves to maintain the flow in D after the valve C has closed, and thus moderate, if not remove, the intermittence of the discharge.

150. **Jet Pump.**—The principle and action of the jet pump may be seen from Fig. 105. When water (or air) is driven in at A, the contraction at B increases its velocity and so reduces its pressure, thus inducing a flow in at C from the lower level D, the two streams being discharged together at E. This is but one of many applications of the same principle. Other forms of pump involving this principle may be noticed later. (See Bernoulli's Theorem, Art. 96.)

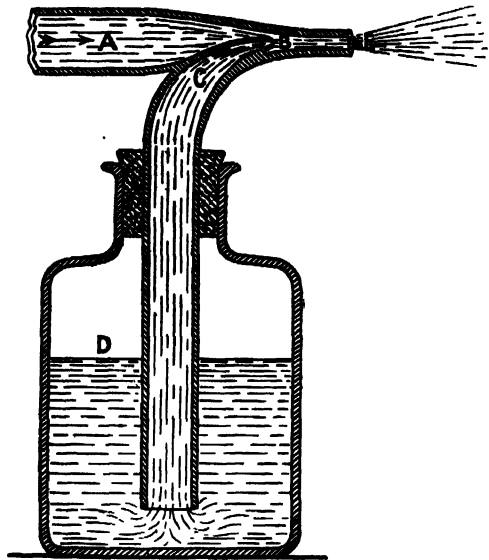

FIG. 105.—Jet Pump.

151. **Venturi Water Meter.**—This device, for measuring the volume of water passing a place in a given time, is a very interesting application of the principle that where the flow is quicker the pressure is

smaller, other things being equal. (See Bernoulli's Theorem, Art. 96, equation (5).)

In this meter the water is forced through a gently-sloping waist of cross-sectional area  $B$  in the pipe of area  $A$ , as shown in Fig. 106, and the pressures measured by mercury, water or other gauges at the largest and smallest sections.

Let the difference of the pressures in height of water column be

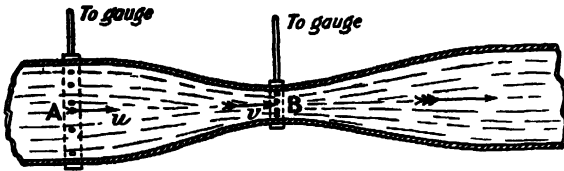

FIG. 106.—Venturi Water Meter.

$H$ , the velocities being denoted by  $u$  through  $A$ , and  $v$  through  $B$ . Then, if the axis of the pipe is horizontal, we have

$$v^2 - u^2 = 2gH \quad \dots \quad (1)$$

Also, if  $A = rB, u = \frac{v}{r} \quad \dots \quad (2)$

Hence, (2) in (1) gives  $v^2 \left(1 - \frac{1}{r^2}\right) = 2gH \quad \dots \quad (3)$

Or, if  $Q$  be the volume of water passing in time  $t$ ,

$$Q = Bvt = Bt \left( \frac{2gHr^2}{r^2 - 1} \right)^{\frac{1}{2}} = tC\sqrt{H} \quad \dots \quad (4)$$

where  $C = B \left( \frac{2gr^2}{r^2 - 1} \right)^{\frac{1}{2}} \quad \dots \quad (5)$

If  $B$  is in square feet,  $t$  in seconds,  $g$  in feet per sec. per sec.,  $H$  in feet, then  $Q$  will be in cubic feet.

The above is only the elementary theory, in practice friction must be allowed for.

EXAMPLES LV.

1. Explain the construction and action of the hydraulic ram. Does its working conflict with the principle of the conservation of energy?
2. Give a sketch of some simple form of jet pump or sprayer, and explain its action.
3. Explain carefully the principle of the Venturi water meter.
4. From the following data for a Venturi water meter find the volume of water passing per second and per hour.  
Cross-sectional area of waist, one-tenth of a square foot; cross-sectional area of rest of pipes, 1 sq. ft.; the difference of head at pipe and waist being 14 ft. of water.
5. Find, in gallons per 24 hours, the flow of water in a pipe 4 ins. diameter inside, if at a waist of 1.5 ins. diameter, the mercury pressure gauge differs from that in the pipe by a height of 1.6 ins.

152. **Diving Equipments.**—The old diving bell and the present diver's dress are examples of pushing aside water by means of air for the diver to breathe. In the bell the arrangement was static, only a limited amount of air being available. Its contraction in the bell at various depths may be found by Boyle's Law if the temperature is constant, or by the general gas equation if both pressure and temperature vary. (See also Art. 138.)

In the diving dress a supply of air is continually pumped to the helmet or chamber inclosing the diver's head, the air after respiration escaping in bubbles to the surface. (See Fig. 107.)

153. **Siphons.**—A siphon in its simplest form consists of an inverted U-tube of unequal limbs, the short limb dipping into the

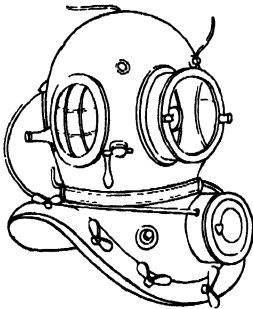

FIG. 107.—Diver's Helmet.

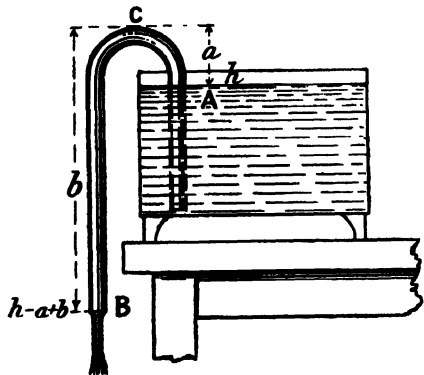

FIG. 108.—Common Siphon.

liquid to be drained away and the long limb outside and extending below the level to which it is desired to reduce that liquid.

Thus, in Fig. 108, the short limb dips into the liquid whose level is at A and the long limb reaches down to B, the bend of the siphon being at C. Let us denote by  $a$  and  $b$  the depths of A and B below C.

To understand the action of the siphon suppose it to be full of water and that the end B is closed, so that all the liquid is at rest. Then the pressure at B is given by

$$p = h - a + b \dots \dots \dots (1)$$

where  $h$  is the height of the barometer filled with the same liquid as that in the syphon. Then it is obvious that

$$p > h \text{ if } b > a \dots \dots \dots (2)$$

That is, when the siphon is filled and the end B opened, the liquid will flow while ever B is below A.

Sometimes it is desirable to have the siphon self-filling and

starting at regular intervals; such an arrangement is called an *intermittent* siphon. Perhaps the most familiar example is that of the washing trough in use for photographic plates. The principle of the device is shown in Fig. 109.

If water is set to trickle slowly into the trough it will, after a time, rise to the bend of the siphon and flow over. It then soon entangles the air present and sweeps it out of the long limb of the siphon, which then runs with its full bore occupied with water. If the rate of the siphon's discharge gains well on the trickle both at first and even when the water is quite low in the trough, the level will be reduced till air enters the bottom of the siphon's short limb, and so stop its working. The trickle then slowly refills the trough and restarts the siphon as before.

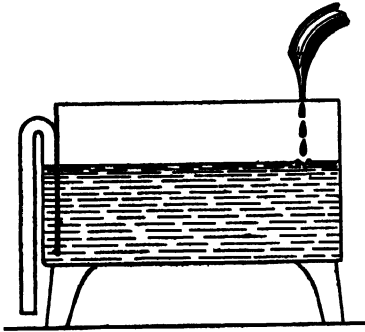

FIG. 109.—Intermittent Siphon.

The longer limb of the siphon is often arranged close to the end of the trough behind the ascending portion, but is shown outside in the diagram for clearness's sake.

**154. Giffard's Injector.**—Suppose that in a steam boiler we have nearly equal nozzles of cross-sections  $a$  and  $A$  from which issue steam and water of densities  $d$  and  $D$  respectively, the pressure above atmospheric being that of a column of water of height  $P$  (or a column of steam of height  $PD \div d$ ). Let the velocities of the jets of steam and water be  $v$  and  $V$  and the masses delivered per sec. of each be  $m$  and  $M$  respectively.

Then, using Torricelli's theorem, we obtain quite simply the following relations, as clearly set forth by Sir G. Greenhill (*Hydrostatics*, p. 465, London, 1894):—

$$\text{Ratio of velocities} = \frac{v}{V} = \frac{\sqrt{2gPD \div d}}{\sqrt{2gP}} = \sqrt{\frac{D}{d}} \dots \dots \dots (1)$$

$$\text{Ratio of masses delivered per second} \left. \vphantom{\frac{m}{M}} \right\} = \frac{m}{M} = \frac{vad}{VAD} = \frac{a}{A} \sqrt{\frac{d}{D}} \dots \dots \dots (2)$$

$$\text{Ratio of momenta} = \frac{mv}{MV} = \frac{a}{A} \dots \dots \dots (3)$$

$$\text{Ratio of energies or H.P.'s of jets} \left. \vphantom{\frac{1}{2}mv^2} \right\} = \frac{\frac{1}{2}mv^2}{\frac{1}{2}MV^2} = \frac{a}{A} \sqrt{\frac{D}{d}} \dots \dots \dots (4)$$

Hence, with a suitable apparatus, the greater energy of the steam enables it to overcome the water jet and to enter the boiler

even when mixed with the water and condensed by it. The maximum mass of water fed in per second would be the difference between the masses of water and steam blown out.

From equations (1) and (2) this difference is seen to be

$$VAD - vad = \sqrt{2gPD}(A\sqrt{D} - a\sqrt{d}) \dots (5)$$

In this way Greenhill popularly explains the action of *Giffard's injector* shown in Fig. 110. In such an injector a pound of steam may force in 15 lb. of water, but in a steam pump much more water may be forced in. The injector has, however, the advantages of working when the engine is still and of heating the feed water.

**155. The Pulsometer Steam Pump.**—This unique combination of steam power and pump is shown in section in Fig. 111. It has no pistons, rods or slide valves, but consists of a cast-iron body provided with two suction valves, E, E, and two delivery valves, F, F. The body is in one casting composed of two main chambers, A, A, joined together and communicating with the discharge box and the air vessel. Surmounting the body is the steam control valve, consisting of the neck J and the contained ball I of gun metal.

It is seen that the neck and ball control the admission of the steam from the pipe K to either the right or left of the two chambers A, A.

The action of the pump consists of two operations performed alternately, one being the driving of water out of a chamber A by the pressure of the steam on it, the other being the filling of that chamber by the subsequent condensation of the steam. 'The control of these alternations is automatically performed by the oscillation of the steam ball I in the following manner. Consider the state of things a little earlier than that shown in Fig. 111, viz. when the right-hand chamber A was full of water, but open to receive the steam. Then the steam passes by the ball into the chamber, and presses upon the small surface of water exposed, and depresses it *without agitation and therefore with little condensation*, and so drives it through the discharge valve F into the rising main. The moment, however, the water in the chamber falls to the level of the opening in the branch leading to the discharge box, the steam

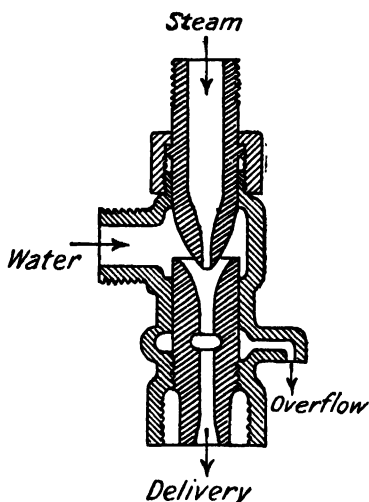

FIG. 110.—Giffard's Injector.

blows through with a *certain amount of violence*, and as it is brought into intimate contact with the water in the discharge box, an instantaneous condensation takes place, and the partial vacuum thus formed in the emptied chamber immediately pulls the control ball I over to the right and cuts off further admission of steam, allowing the vacuum to be completed. Water immediately enters

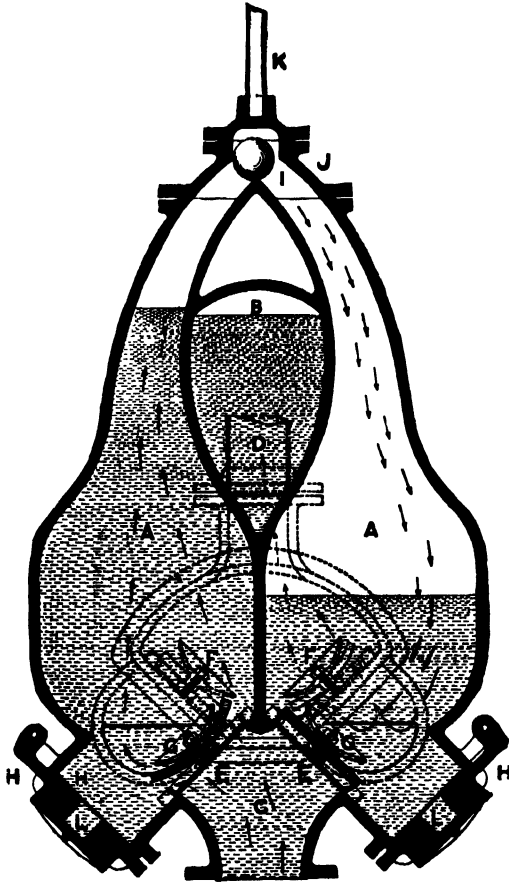

FIG. III.—Pulsometer.

through the suction pipe, and, lifting the rubber disc of the inlet valve F, rapidly fills the chamber again. We have thus traced through the cycle of two operations for the right-hand chamber A. But this is only half of the pump's work. For while the right chamber was emptying its water into the discharge pipe the left chamber was filling from the suction, and while the right chamber was filling from the suction the left chamber was discharging.

These alternations continue while the pump is supplied with steam and water, and follow with such regularity that the stream of water is practically continuous.

There are also air valves whose function is to introduce a small quantity of air at each stroke for the purpose of cushioning the ball when it changes position, and for separating the steam from the water by a non-conducting film so as to prevent loss by condensation during the explosive portion of the cycle. Air being lighter than water and heavier than steam, fulfils this duty admirably.

The foregoing figure and description are taken from publications kindly furnished for the purpose by the makers, the Pulsometer Engineering Co., Ltd., of London and Reading.

#### EXAMPLES LVI.

1. Explain the action of the diving bell and describe the arrangement by which it is now superseded.
2. Give a sketch of an ordinary siphon, explain its action, and show that it cannot deliver unless certain conditions are fulfilled.
3. Describe an intermittent siphon in common use. What condition is essential to the intermission of the action?
4. Explain how a Giffard's injector may be worked from steam in a boiler so as to force water into that same boiler against the very pressure that is driving it.
5. Give a sectional view of the pulsometer steam pump and describe its action.

**156. Humphrey's Internal-Combustion Pump.**—In 1909, H. A. Humphrey, of London, brought this novel invention before the notice of the Institution of Mechanical Engineers, from whose *Proceedings* the following account is taken by kind permission of the inventor and the Institution.

The inventor's aim was to produce a pump of great simplicity and strength, in which the explosive force is exerted directly upon the water, and in which no rotating parts nor any metal reciprocating parts were required beyond valves and their rods. This arrangement is often popularly referred to as an *explosion pump*.

"The idea of exploding a combustible mixture of gas and air to produce pressure on the surface of water to raise it, is not quite new, attempts to realise it dating back to 1868. But the old efforts in this direction involved the use of a non-return delivery valve past which the water was forced. And this valve proved a failure when the explosive force occurred behind it.

"In the types of pumps now invented there is, when the explosion occurs, a full-bore passage from the combustion chamber to the final outlet, also some of the water thus pumped to a high level is allowed to return to compress a fresh combustible charge. When sudden changes of velocity occur in masses of a heavy and incompressible liquid, like water, great difficulty is found in controlling the movement of the liquid. All such difficulties are removed in

the inventor's pumps by allowing the movements of liquid to control the pump, and by causing the mass of liquid moved to be sufficiently large, so that the velocities are never excessive. The mass of water forms a pendulum which swings between the high and low level, and, by its movement alone, serves to draw in fresh water, to exhaust the burnt products, to draw in a fresh combustible charge, and to compress the charge previous to ignition."

157. The construction and action of the first experimental four-cycle pump may be understood from Fig. 112, which shows one of the simplest forms. The combustion chamber is marked A, "and is fitted with an inlet valve B for the combustible mixture, and an exhaust valve C for the burnt products. A pipe D connects the bottom of the combustion chamber to a low-level tank E, and

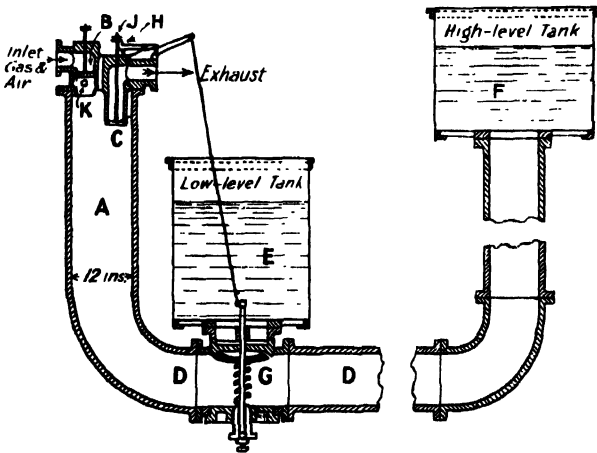

FIG. 112.—Humphrey's Internal Combustion Pump.

to a high-level tank F, and between this pipe and the former there is a water-valve G. The inlet valve B is normally kept shut by a spring, but the exhaust-valve C has no spring to hold it up, and falls by its own weight when the pawl H is removed from under a collar J on the exhaust-valve stem. This pawl is operated from the water-valve G, so that when the water-valve opens it releases the exhaust valve.

"Suppose all the valves shut, and a compressed combustible charge to exist in the top of the combustion chamber, the rest of the chamber and the pipe being full of water. Explosion occurs at a sparking-plug K, and the increase of pressure drives the water downwards in the chamber, and forces the column of water contained in the pipe to move towards the high-level tank so that a quantity of water is discharged into this tank. From the moment when ignition occurs to the time when expansion reaches a pressure

equivalent to the static head of the water in the high-level tank, the excess pressure in the combustion chamber has been increasing the velocity of flow towards the high-level tank, so that at the end of this period the column of water has a considerable velocity. The kinetic energy thus acquired causes the water to continue to flow in the same direction, until the pressure on the under side of the water-valve is less than that above it, and the difference of pressure causes this valve to open. This occurs when the products of combustion have expanded to about atmospheric pressure. The opening of the water-valve releases the exhaust valve, and now water from the low-level tank flows past the water-valve partly to follow the column of water still moving towards the high-level tank, and partly to flow into the combustion chamber to expel some of the exhaust gases. There is, of course, a tendency for the water to rise in the chamber to the same level as the water in the low-level tank, but usually a little before this level is quite reached the kinetic energy of the moving column has been expended in forcing more water into the high-level tank, and the column has therefore come to rest. At this point of the cycle the spring on the water-valve quietly closes this valve, and is assisted by the water now trying to flow back from the high-level tank to the chamber. It cannot flow back far, because there is already a considerable quantity of water in the chamber, and as the column rises further it reaches the exhaust-valve, and, striking against it, shuts it by impact. The exhaust valve is immediately locked shut by the pawl, and now that there is no longer any outlet for the small quantity of burnt products which remain, they are imprisoned in the top of the chamber and suffer compression as the water continues to rise, until the energy thus stored in the compressed elastic cushion is equivalent to the energy given out by the falling water. Thus the elastic cushion serves to bring the column of water again to rest, and as the compression pressure considerably exceeds the static head of the water column, a reverse flow is set up while this cushion expands again. If there were no friction losses the water column would be forced back by the cushion to the same point as that from which it started, namely, to a level in the combustion chamber a little below the level of the water in the low-level tank, but it actually does not move quite so far. However, when the water passes the level of the exhaust valve the elastic cushion is again at atmospheric pressure, and the further descent of the water in the combustion chamber tends to create a vacuum, but the inlet valve is only held shut by a light spring, and can therefore readily open to admit a fresh combustible charge during the rest of the descent, and until the water column is once more at rest. The state of affairs now reached is, of course, still unstable, because of the unbalanced pressure due to the head in the high-level tank, and this head produces a second return of the column, so that water ascends in the combustion chamber and compresses the fresh combustible charge. The explosion of the

charge by means of the ignition-plug now starts a fresh cycle. The operation of the apparatus is so simple that when an actual apparatus on these lines was first tried, it ran steadily at the very first attempt."

158.—Thus to sum up, starting with the charge under compression, we have

(1) The ignition and *power stroke* delivering water into the high-level tank.

(2) The *exhaust stroke* in which a return swing of some water drives out the burnt products and compresses a small cushion of gas.

(3) The *induction* in which the expansion of this cushion drives the water forward again so that by its momentum it continues and draws in a fresh combustible charge.

(4) The *compression*, in which a second return swing of the water compresses this charge ready for ignition.

We thus return to the state with which we started and so complete the four-stroke cycle of the pump.

The whole arrangement may be likened to the combination of a hydraulic ram and a gas engine, in which, however, the piston is water and so offers the advantages of automatic internal cooling and lubrication at no expense whatever.

159. Dr. W. Cawthorne Unwin tested one of Humphrey's pumps in Staffordshire, and found that the consumption of anthracite coal was 1.06 lb. per pump horse-power hour. With slack costing 6s. 9d. per ton delivered into the Mond gas producers at Dudley Port, the actual cost of slack to yield the 83 cubic feet of producer gas needed per pump horse-power hour is under 0.06d.

Many different forms of pump have been developed since that shown in Fig. 112, which gives but the germ of the invention. In 1913 eight Humphrey pumps were put in hand for the Egyptian Government, each to deliver a hundred million gallons a day through a lift of nineteen feet.

160. **Pumps for Hydraulic Power.**—We will now notice types of pumps used for delivering water at high pressure for purposes of hydraulic power (see Fig. 113).

This section shows an Admiralty pump in which the suction occurs only on the outstroke, when the plunger moves to the left, a half delivery occurring at the same time because the water is then driven out from the annular space round the piston rod. On the instroke, when the plunger moves to the right, all the water drawn in at the previous stroke passes through the intermediate valve, but of this only one half is delivered outright, the other half passing round into the annular space. This division into exact halves is, of course, secured by making the cross-sectional area of the piston rod just half that of the bore of the pump barrel. The delivery is thus very regular.

This pump is worked by a compound steam engine, the high

and low pressure cylinders being in tandem with the pump, so that the piston rods lie along the same line.

161. **Power Pump Electrically Driven.**—The type of pump shown in Fig. 114 is an example of a modern pump designed for hydraulic power, and is electrically driven. The illustrations and

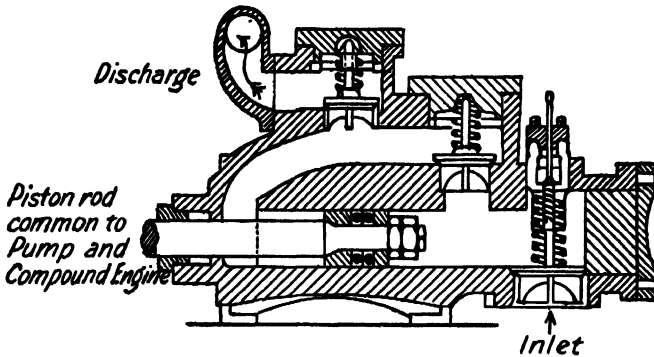

FIG. 113.—Admiralty Pump for Power.

description given are from material kindly supplied by the makers, the Worthington Pump Co., Ltd., of London, and are here reproduced by their permission. Fig. 114 is from a photograph of a horizontal duplex pump with four single-acting plungers each of 6 ins.

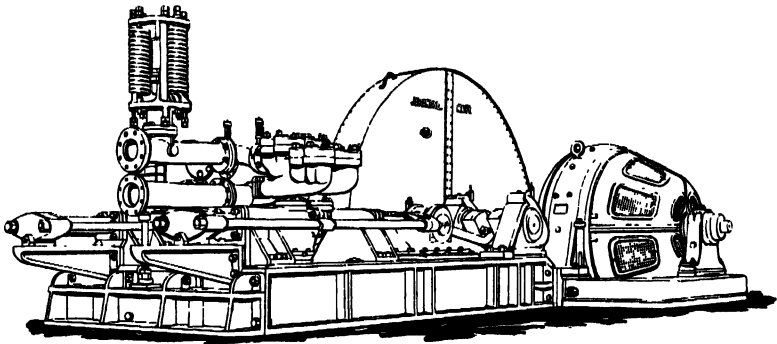

FIG. 114.—Worthington Power Pump.

diameter and 18 ins. stroke. This was built for purely hydraulic purposes for the Imperial Japanese Navy, and can deal with 286 gallons per minute against a pressure of 1,000 lbs. weight per sq. inch, when running at a speed of 40.5 revolutions per minute. It was driven by a British Westinghouse direct-current motor of 250 brake horse-power at 430 revolutions per minute. As may be inferred from the view in Fig. 114, the motor is geared down. This

is accomplished by steel wheels inclosed in the case. The two cranks are set at an angle of  $90^\circ$  to each other. One pair of single-acting plunger pumps are in a line and worked from one crank by the connecting rod, the two plungers being connected by the yoke rods and crossheads seen. The other pair of plungers is similarly worked from the other crank.

On each pump is mounted a valve box as shown in section in Fig. 115.

This box contains two suction valves at S, S, and at a higher level two discharge valves at D, D, covered by covers C, C, C, C, all similar, though only one of the four valves (with its cover) is shown in the diagram. The route of the water is shown by the arrows.

Pumps of this type have been supplied to iron works and mines, and for operating lifts, capstans and other hydraulic machinery.

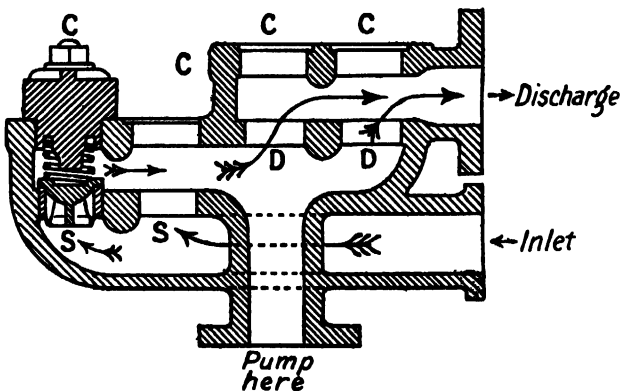

FIG. 115.—Section of Valve Box.

The valves differ slightly in different examples according as the water is clean or gritty.

The piece of apparatus standing up at the left side in Fig. 114, with vertical coiled springs, is called the alleviator. Its purpose is to provide a mechanical substitute for the air vessels commonly adopted on high-pressure pumps, but which give trouble for pressures exceeding 600 feet head of water. The ram of the alleviator, held down by the four springs, lifts slightly when necessary, and so takes up the pulsations of the water and thus relieves the shock on the pumps and motor. It is said to give no trouble in working, even with pressures up to three tons weight per square inch.

162. **Hydraulic Accumulator.**—Since the machines driven by hydraulic power may work intermittently, it is desirable during their cessation to store up the energy delivered by the pressure pumps and avoid their stoppage also. This is effected by the use of an *hydraulic accumulator*. It consists essentially of a vertical

hydraulic cylinder, connected both to the pumps and the machines, and provided with a weighted ram so as to deliver the water at a definite constant pressure. When the ram rises to its upper limit, it actuates a mechanism which stops the pumps. Power drawn from the stock of energy in the accumulator, by the starting of any machine, then lowers the ram and restarts the pumps.

163. **Intensifying Accumulator.**—In connection with an hydraulic pressure system an *intensifying accumulator* or *intensifier* may be used. In this device a piston works in the low-pressure cylinder and a connected piston rod, or ram, in the high-pressure cylinder, from which the hydraulic machines can draw their supply. Thus, the pressure is magnified in the ratio of the areas of ram and piston. An intensifier is shown diagrammatically in Fig. 116.

It is easily seen that the intensifier presents an analogy to the hydraulic press. For, in the press, the *forces* exerted by plunger and ram rise in the *direct* ratio of their areas, the *pressure* of the connecting *fluid* remaining constant. Whereas, in the intensifier, the *pressures* of the fluids in contact with piston and ram rise in the *inverse* ratio of their areas, the total *forces on ram and piston* being constant.

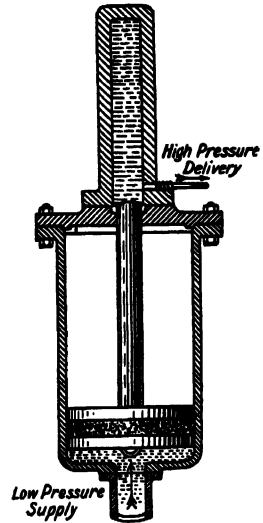

FIG. 116.—Intensifying Accumulator.

#### EXAMPLES LVII.

1. Give a diagram of Humphrey's four-cycle internal combustion pump and explain its working.
2. What advantages are claimed for Humphrey's explosion pump?
3. Describe some form of hydraulic power pump.
4. Give a general description of some electrically-driven pump with section showing its valve arrangements.
5. Explain carefully the object and construction of a hydraulic accumulator.
6. Make a sectional sketch of an intensifying accumulator and contrast its action with that of an hydraulic press.
7. In an intensifying accumulator, the piston is 8 ins. diameter and bears a pressure of 500 lbs. weight per square inch, and the ram is  $2\frac{1}{4}$  ins. diameter. At what pressure does the intensifier deliver the liquid?

164. **Torpedo Compressors.**—The commonest example of a pump for compressing air is the ordinary pattern for inflating cycle tyres and familiar to all.

An important type for high-pressure purposes is that used for imparting the charge of compressed air which supplies the motive

power to one form of torpedo. The same type of pump is also used for compressing the air in Hampson's liquefier for the wholesale liquefaction of air. As used for this purpose the pump is shown in Fig. 117. It is seen to consist of a large low-pressure cylinder A, and a small high-pressure one B. The first cylinder compresses the air to about 16 atmospheres, which then passes by the pipe C to the second cylinder, which compresses it to something exceeding 200 atmospheres, so that in normal working the gauge, some distance beyond the pumps, stands at 200 atmospheres.

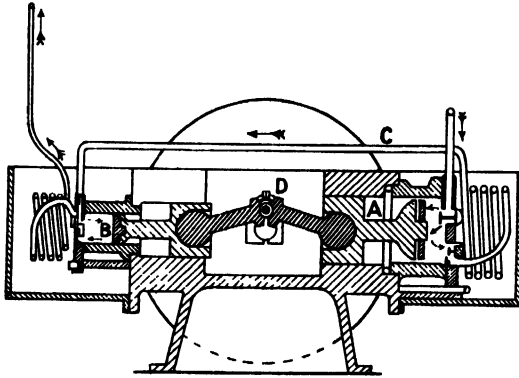

FIG. 117.—Torpedo Compressors.

It is seen that the one crank D works both pistons, one giving its power stroke while the other gives the back stroke. The whole is immersed in running water to keep the air cool in spite of the compression.

165. **Bourdon Pressure Gauge.**

—The principle of this instrument was discovered by its inventor in 1851, and is as follows. If a bent tube of elliptic cross section is exposed to a higher internal than external pressure, the cross section becomes more nearly circular and the bend in the length of the tube uncurls somewhat. If the pressure is decreased again the cross section and longitudinal curvature recover their original values.

The gauge is diagrammatically shown in Fig. 118. The bent tube PQ is, at its fixed end P, open to the pressure of the steam or other gas to be indicated. The other end Q is closed, but moves by the curling or uncurling of the tube under lower or higher pressures. It thus actuates the pointer T, by the link L, quadrant R, and pinion N, as shown. The pressures are

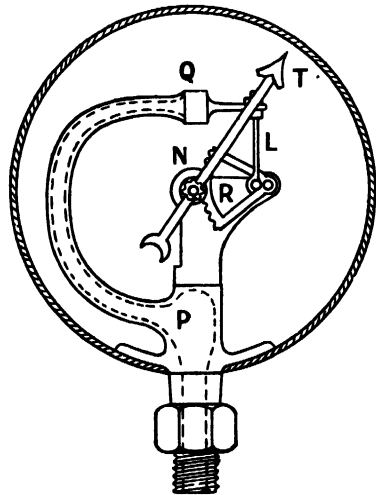

FIG. 118.—Bourdon Gauge.

then read on the dial which is graduated by the application of several known pressures.

166. **Differential Manometer.**—In the ordinary U-tube manometer (see Fig. 44 of Art. 68), though the difference of levels measures the pressure, the change from zero of either of these levels is only half the difference reached. Hence if one limb of the manometer is read by a microscope or optically projected on to a screen for an audience, this manometer *loses half* the motion.

But sometimes, for small changes of pressure, the very opposite effect, a magnification of the motion, is desirable. In these cases a differential hydrostatic principle may be used as follows, see Fig. 119.

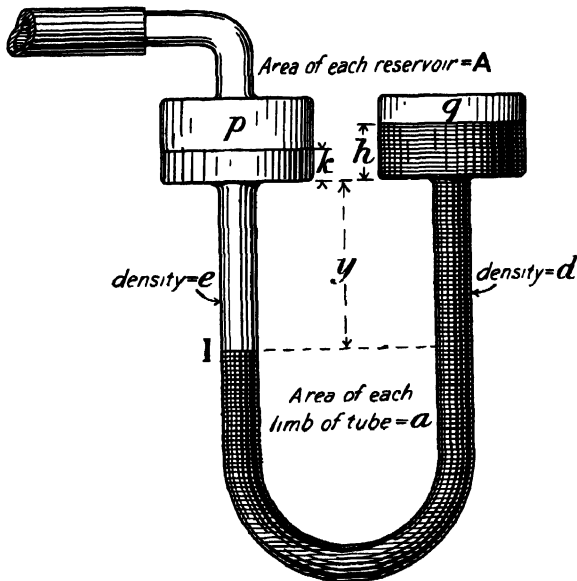

FIG. 119.—Differential Manometer.

In this arrangement we may first notice the reservoir at the top of the right limb. The effect of its larger cross-section is to reduce the rise of liquid level in it when the pressure  $p$  rises. Thus, if the vessel were made wider and wider, we should approach the case in which the other level of the liquid I, in the left limb, would give the *full* motion instead of only *half* as in a plain U-tube.

Let us note secondly the effect of introducing a lighter liquid between the main liquid and the gas whose pressure is to be ascertained. This lighter liquid rests upon the other at I and extends into the wide reservoir at the top of the left limb. Hence, it is almost as though this were air and the other liquid were of density equal to the difference of the actual densities of the two liquids.

Thus, if this difference were only one-fiftieth, a fifty-fold magnification would be approached if the reservoirs were very wide.

To deal with the case in detail we may proceed thus. Take the level of the bottoms of the reservoirs as zero, let the interface I of the two liquids in the left limb be  $y$  below, and the heights of the liquids in the two reservoirs be  $h$  and  $k$ , the densities of the corresponding liquids being  $d$  and  $e$ . Also let the inner cross-sectional areas of each of the reservoirs be  $A$  and of each limb of the tube be  $a$ , the pressure to be measured  $p$ , and that of the air  $q$ .

Then we must express the hydrostatic law of equilibrium as to pressure and depth, also the constancy of volume of each liquid. The hydrostatic principle gives

$$p + (k + y)e = q + (h + y)d \quad \dots \quad (1)$$

The constant volumes of the liquids give

$$Ah - ay = \text{a constant} = AB, \text{ say,}$$

and

$$Ak + ay = \text{a constant} = AC, \text{ say.}$$

Hence,

$$h = B + \frac{a}{A}y \quad \dots \quad (2)$$

and

$$k = C - \frac{a}{A}y \quad \dots \quad (3)$$

These in (1) give an equation which may be written

$$p - q = \left( B + \frac{A+a}{A}y \right) d - \left( C + \frac{A-a}{A}y \right) e \quad \dots \quad (4)$$

thus giving the gauge pressure,  $p - q$ , in terms of the quantities involved. We see that for  $p - q = \text{zero}$  the two terms on the right side are numerically equal.

Suppose now that the pressure  $p$  changes to  $p'$ , the interface I then moving to a new depth  $y'$ . Then, we have

$$p' - q = \left( B + \frac{A+a}{A}y' \right) d - \left( C + \frac{A-a}{A}y' \right) e \quad \dots \quad (5)$$

Subtract (4) from (5), collect the  $y' - y$ , and divide by  $p' - p$ . We then obtain

$$\frac{y' - y}{p' - p} = \frac{A}{(A+a)d - (A-a)e} \quad \dots \quad (6)$$

And this expresses what may be called the *sensitiveness* of the manometer or gauge, for it gives the ratio of the change of level of the interface I to the change of pressure which produces it.

We reduce this to the case of the plain U-tube manometer by putting  $A = a$ , and then find that

$$\frac{y' - y}{p' - p} = \frac{1}{2d} \quad \dots \quad (7)$$

Take now the other extreme, where  $a$  is negligible in comparison to  $A$ , *i.e.* the reservoirs are very wide indeed. Equation (6) then becomes

$$\frac{y' - y}{p' - p} = \frac{1}{d - e} \dots \dots \dots (8)$$

The comparison of (7) and (8) bears out what was mentioned at the outset that the differential gauge obviates the reduction of motion to a half as in the plain gauge and is equivalent to the use of a single liquid of density equal to the difference of the densities of the two actual liquids.

Thus the limiting advantage possible in the sensitiveness as compared with the plain manometer is given by (8) ÷ (7), or

$$\text{Ratio of sensibilities} = \frac{2d}{d - e} \dots \dots \dots (9)$$

To illustrate the exact gain for given values, let  $A = 30a$  and  $d$  and  $e$  be 0.81 and 0.80 respectively (obtained by paraffin and a mixture of water and spirit). Then, referring to (6), we find

$$\frac{y' - y}{p' - p} = \frac{30}{31(0.81) - 29(0.80)} = \frac{30}{1.91}$$

Whereas for the lighter liquid in a plain U-tube, the value from (7) would be

$$\frac{y' - y}{p' - p} = \frac{1}{2 \times 0.80} = \frac{1}{1.6}$$

Thus showing a 25-fold gain in sensitiveness !

EXAMPLES LVIII.

1. Make a sectional drawing of a pair of torpedo compressors and explain their action and result.
2. Explain, with diagram, the principle and action of a Bourdon pressure gauge.
3. Consider the motion of the liquid in one limb of an open manometer and show how its displacement may be nearly doubled if the open end is made very wide, and then still further increased if another liquid of slightly less density is interposed between the first liquid and the gas.
4. Derive a mathematical theory of the differential manometer in which two liquids are in wide reservoirs and meet in a communicating U-tube.
5. Give a numerical example of a differential gauge showing about a thirty-fold gain of sensitiveness.

167. **Early Air Pumps.**—Various forms of air pump have been devised to obtain partial vacua to different degrees of exhaustion in order to illustrate or utilise the effects of lessening the usual pressure and density of the atmosphere. As in modern practice the earlier forms are largely superseded, they will be but briefly noticed.

*Hawksbee's Air Pump* consisted of two suction pumps open at the top and mounted side by side, their piston rods having toothed racks which were actuated in opposite directions by a toothed wheel engaging in them. Thus, as the exhaustion proceeded, one piston rising against the atmospheric pressure was balanced by the other falling under the same pressure. This pump had the disadvantages (1) of valves that needed lifting, and (2) of clearance spaces.

*Smeaton's Air Pump* was a single suction or lift pump, the duplication being here unnecessary because the top of the pump was closed, and the atmospheric pressure thus shut off during the greater part of the stroke.

*Tate's Air Pump* was double-acting with a single horizontal barrel, at the *centre* of which is the connection to the receiver to be exhausted. The piston is nearly half the length of the barrel so as to just pass to the right or left of the inlet pipe from the receiver. Thus, in either extreme position of the piston, the other half of the barrel is open to the receiver; and this half-barrel of air is swept out on the return stroke and forced through a little valve consisting of a flap of oiled silk. And these outlet valves are the only ones required.

168. **Progressive Rarefaction by Air Pump.**—Let the receiver of an air pump have volume  $V$  and be put into communication with a volume  $v$  in the barrel. Then, by this single stroke, the original density  $d$  of the air is changed to a value  $d_1$ , where

$$Vd = (V + v)d_1 \dots \dots \dots (1)$$

The next operation of the pump ejects the volumes  $v$ , leaving in the receiver the volume  $V$  of air at density  $d_1$ . We may call this stroke and return stroke a cycle.

Thus, at the next opening of the receiver to the barrel, the density falls to  $d_2$  by its expansion from  $V$  to  $V + v$ . Accordingly, after two cycles,

$$Vd_1 = (V + v)d_2 \dots \dots \dots (2)$$

And generally, after  $n$  cycles,

$$Vd_{n-1} = (V + v)d_n \dots \dots \dots (3)$$

Hence, multiplying all such equations together, we see that after  $n$  cycles of the pump, the density  $d_n$  is given by

$$d_n = \left( \frac{V}{V + v} \right)^n d \dots \dots \dots (4)$$

That is, as the number of strokes increases in arithmetical progression the density diminishes in geometrical progression.

The above examination and result only hold for the ideal case of no clearance spaces, no leaks, no evolution of gas in the receiver, etc., etc.

**169. Jet Pumps for Exhaustion.**—For many purposes where only moderate exhaustions are required, various forms of jet pump made of glass or of metal are convenient and often used. The principle is explained in Art. 150, and one form for liquid suction shown in Fig. 105.

#### EXAMPLES LIX.

1. Give an account of some early forms of air pump, pointing out their faults and consequent inability to produce high vacua.
2. Show that it is impossible to obtain an absolute vacuum by any ordinary air pump, even if there were no leaks.
3. Prove that the pressure in the receiver of an air pump can at best only fall in a geometrical progression as the number of strokes increases in an arithmetical progression.
4. If the volume of pump barrel swept through by the piston of an air pump in each stroke is one-tenth that of the receiver, what fraction of the original pressure is that left in the receiver after twenty effective strokes?
5. Given that the receiver of an air pump is, at each effective stroke of the pump, put into communication with a volume one-fifth of its own, how many cycles of the pump must be performed to reduce the density in the receiver to one-fiftieth?

**170. Geryk Vacuum Pump.**—This modern pump is named after Otto von Guericke, and is made under Fleuss' patents by the Pulsometer Engineering Co., Ltd., who have kindly permitted the reproduction of the accompanying diagrammatic section, Fig. 120. Referring to the figure, A is the suction pipe, B the air port into the cylinder above the piston, C is the piston whose bucket leather is kept up to the cylinder wall by oil pressing in the annular space D. E is the piston valve, F an air pipe to relieve the piston on first few strokes, G, H and I collars and cover forming a good joint and delivery valve combined.

When the piston is at the bottom of its stroke as shown, there is a perfectly free opening from A to B. As the piston rises the port B is cut off and the cylinder full of air irresistibly carried up to the outlet valve G. No air can get back past the piston as it is covered with oil. When the piston approaches the top of its stroke, it lifts the valve G off its face and gives a free outlet for the air. The oil on the piston then mingles with that shown above G, but the right quantity returns with the piston on the closing of G. L is the plug for filling up with oil, which is very non-volatile, moistureless and non-solvent of air and fills all clearance spaces and seals the valves.

With a single-cylinder pump of this type it is claimed that a pressure as low as the quarter of a millimetre of mercury can readily be obtained.

**171. Gaede's Piston Pump.**—This patent high-vacuum pump is shown in section in Fig. 121. It is but one of a number of appliances for producing high exhaustions which are due to the same inventor, Dr. Gaede.

It is described somewhat as follows by the maker, E. Leybold's Nachfolger, of Cologne.

The piston rod *D* actuates the three pistons *A*, *B* and *C*. The stroke of the pistons is limited by the cover *a*, the fixed partitions *b*

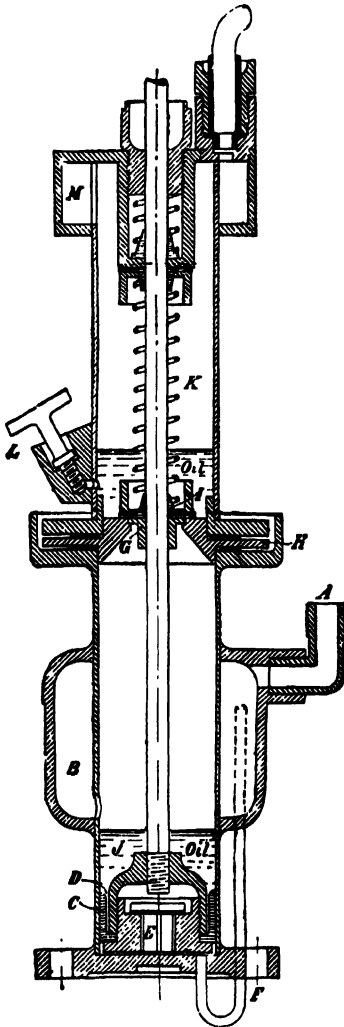

FIG. 120.—Geryk Pump.

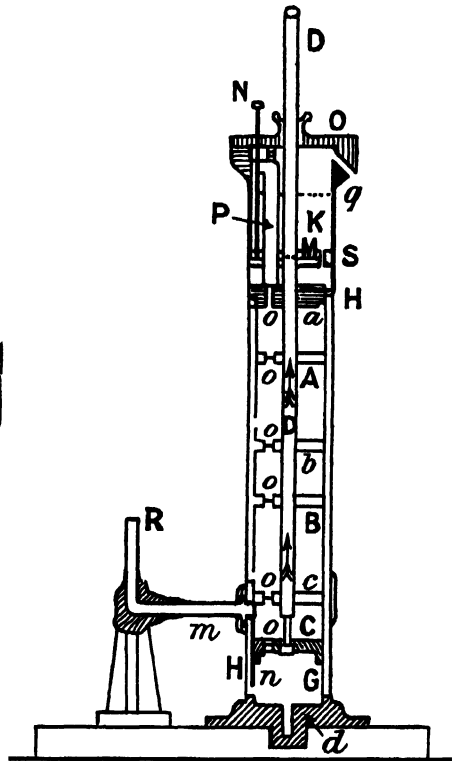

FIG. 121.—Gaede's Piston Pump.

and *c*, and the cylinder bottom *d*, all but this bottom being provided with small valves *o*. On the up stroke, the pistons force the air from the port *n* towards the valves in the partitions, thereby producing a vacuum in the bottom chamber. The vessel to be

exhausted is fitted on to the standard ground nozzle R, connected to the jacket H of the pump barrel by the tube *m*, after greasing.

The bottom position of the piston C is in contact with *d* and the thin end of the piston rod slides down into the recess in *d*. In this position the air from the receiver flows through the nozzle R, the tube *m*, the space between the jacket H and the pump barrel, and the port *n* into the lowest chamber, between the piston C and the partition *c*.

As the piston rod moves upwards its reduced end slides in the piston till the latter is carried up with it. Shortly before the end of the up stroke, with C nearly up to *c*, the air in the space above the piston passes through the annular opening left on the partition *c* by the reduced end portion of the piston rod, and thus enters the rough vacuum in the second chamber, above the partition *c*, produced there by the action of the auxiliary piston B.

The piston C is retained in its top position close against the partition *c* by the force of adhesion until the thicker part of the piston rod has again closed the opening in the partition wall and then carries the piston C along with it in its downward motion.

The air contained in the second chamber between the partitions *c* and *b* is not delivered directly into the atmosphere by the piston B, but into another rough vacuum formed between the partitions *b* and *a* by the action of the piston A.

The air is finally ejected by the piston A through the top valve *o*, and the vent *q*.

The oil, penetrating in a film along the piston rod into the space between the cover *a* and partition *b*, forms an emulsion of oil and water with the vapour condensed above the piston A at each compression stroke. This emulsion is forced, together with the air, through the valve *o* in the cover *a*, through the tube P above the valve, and thence into the chamber K. This chamber is filled with a fibrous mass by which the oil and water emulsion is separated into its components. In consequence of its greater density, the water collects on the bottom M of the chamber, and may be pumped off as often as necessary by means of a glass syringe and rubber tube connected to the tube N extending upwards out of the pump. The oil overflows through the tube S into the space between *a* and M, whence it re-enters the pump barrel to combine with fresh quantities of water vapour.

The pumping mechanism of Gaede's piston pump contains only the oil necessary for lubrication, and, owing to the peculiar action of the piston C, the gases and volatile components of the lubricating oil are soon expelled. Further, the pressure of the gases and vapours disengaged by the oil is lowered to such a degree as to make this pump compete with the *rotary mercury pump*, which was previously devised by Dr. Gaede. In this pump the compartments of a hollow cylinder or drum are filled in succession with rarefied air admitted through an axial pipe. They then plunge under mercury

and so expel their contents into the rough vacuum prepared by some other and more ordinary pump.

**172. Toepler Pump.**—In this classic device for obtaining the high vacua needed in many physical experiments, mercury forms the piston and also opens and closes certain ports, so that no valves are needed except one rough glass valve (G) to prevent the mercury entering the chamber which is being exhausted.

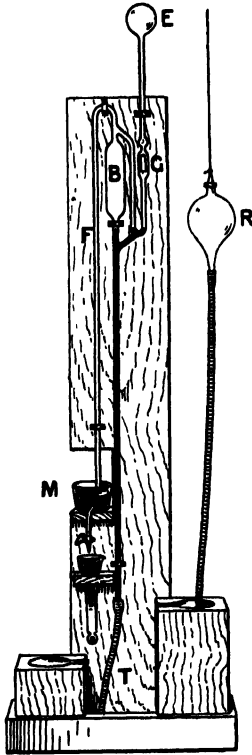

FIG. 122.—Toepler Pump.

As seen in the photographic reproduction of Fig. 122, the pump is chiefly of glass mounted on a wood stand, the exception being the rubber tube (T) connection with the reservoir (R), which is alternately raised and lowered by hand to work the pump.

When the reservoir is raised as shown, the mercury shuts off connection with the vessel (E) to be exhausted. A little further raising of the reservoir would then fill the bulb (B) with mercury and send a little down the fall tube (F), pushing the air or other gas before it. When the reservoir is lowered so as to re-open the connection between E and B, some gas passes in the direction named, thus producing a further exhaustion in E. Air cannot enter from the atmosphere into B, because the bottom of the fall tube dips into mercury in the bowl M and the height of the fall tube exceeds the height of the mercury barometer. Hence, the next raising of the reservoir expels the gas in the bulb B.

The alternate raisings and lowerings which constitute the strokes of the pump may be continued till the required exhaustion (or that of which the pump is capable) is reached.

**173. Gaede's Molecular Pump.**—This strikingly original pump, patented by Dr. Gaede and put on the market by E. Leybold's Nachfolger, will be described by abstracts from the maker's catalogue. Its working principle is illustrated by Fig. 123, in which A is the drum or cylinder fixed on the shaft *a* and inclosed in the casing B. A groove reaching from *n* to *m* is cut into the casing B. When the drum A is rotated clockwise, the air contained in the groove is entrained from *n* to *m* by friction. On connecting a gauge to the apertures *m* and *n* by pieces of rubber tubing S, it shows a difference of pressure between *m* and *n*. The mercury is depressed to *o* in the right limb of the gauge and rises to *p* in the left limb.

This difference of pressures is proportional to the number of revolutions of the cylinder A and the viscosity or internal friction of the gas.

“According to the kinetic theory of gases the internal friction is produced by the collisions continually occurring between the moving molecules of the gas. Maxwell found by calculation that the internal friction should remain the same independently of the pressure to which the gas is subjected. This theoretic inference may be proved to be correct by means of the arrangement shown in the figure. On connecting the casing B with an air pump the level of the mercury at  $o$  and  $p$ , indicating the difference of pressures produced by the molecular pump, will be seen to remain unchanged although the absolute pressure is lowered considerably by the action of an auxiliary or rough pump.

“From this experiment conclusions of practical importance may be drawn as to the action of the molecular air pump. Let the difference of pressure at  $n$  and  $m$  produced by friction (or viscosity) be equal to a column of mercury  $o$  to  $p$  of 10 mm.

As long as the casing is in communication with the atmosphere the pressure at  $m$  will be 760 mm. (say), and that at  $n$  750 mm., but on rarefying the air in the casing we obtain, say, 200 mm. at  $m$  and 190 mm. at  $n$ , or 50 mm. at  $m$  and 40 mm. at  $n$ .

“When the pressure at  $m$  is lowered to 10 mm., if the above rule held good, the pressure at  $n$  should become zero, and we should be able to produce an absolute vacuum by means of the arrangement described, which would thus be an ideal air pump.

“However, at extremely low pressures the above simple relation between the pressures at  $m$  and  $n$  gives place to a more complicated one. It is no longer *the difference* between the pressures at  $m$  and  $n$  but *their ratio* which is constant independently of the degree of rarefaction reached.

“The molecules of a gas move with a very high velocity in rectilinear paths, the direction of which is absolutely irregular, until they meet with other molecules. At ordinary pressures the result of this is an irregular zig-zag motion. At extremely low pressures, however, the collisions of molecules among each other become very rare, owing to the high degree of rarefaction, so that the molecules of the gas may be said to impinge exclusively on the walls of the vessel containing them. From the walls the molecules are reflected quite irregularly, the angle of reflection being independent of the angle of incidence.

“We may imagine the wall of the exhausted vessel to be covered

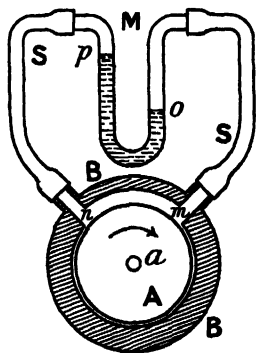

FIG. 123.—Diagram of Molecular Pump.

with a number of small guns out of which the molecules are projected in all possible directions with a certain mean velocity, the molecular velocity.

"If the surface of the cylinder A moves with a velocity higher than this molecular velocity, the guns move to the right with a higher velocity than that with which the molecules are projected out of them to the left, so that the molecules projected towards the point  $n$  are nevertheless entrained to the right in the direction of the arrow in the figure.

"Hence, no molecules reflected from the cylinder will reach the aperture  $n$ , and a region of fewer molecules, that is a higher vacuum, will be formed at  $n$ ."

In practice, the speed of the rotation of the cylinder is not so high as that of the molecules, further, the apparatus is much more complicated than is shown in the figure, which is diagrammatic only. It must also be remembered that this pump is effectual only in conjunction with an auxiliary or rough pump.

**174. Exhaustion by Cooled Charcoal.**—Sir James Dewar found that cocoa-nut charcoal, when cooled by immersion in liquid air, absorbs most of the traces of gas or vapour still present in an exhausted chamber. This method of finishing the exhaustion of any bulb is accordingly very valuable and in regular use. A side tube, hanging down and with the charcoal in it, is provided on the main chamber and then a vessel of liquid air can be raised into position and there supported, so as to immerse this side tube, cool the contained charcoal, and thus complete the exhaustion.

**175. Vacua Attainable.**—The following table gives the pressures of the rarefactions attainable by the various pumps noticed, together with references to the authorities for each.

TABLE X.—RAREFACTIONS ATTAINABLE.

Pump.	Pressure.	Authority.
	Mm. of Mercury.	
Jet Pump or Ejector (using water)	7	G. W. C. Kaye ( <i>X-Rays</i> )
Geryk Pumps (two in series) . . .	0'0002	Pulsometer Eng. Co., Ltd.
Gaede Piston Pump . . . . .	0'00005	E. Leybold's Nachfolger
Töpler Pump (improved) . . . . .	0'00001	G. W. C. Kaye ( <i>X-Rays</i> )
Gaede Rotary Mercury Pump . . . . .	0'00001	E. Leybold's Nachfolger
Gaede Molecular Pump . . . . .	0'00002	E. Leybold's Nachfolger

**176. McLeod Gauge.**—The higher vacua noted above were determined by the McLeod gauge. This device has a bulb B of total volume  $V$ , which is put in communication with the exhausted chamber C, whose pressure  $p$  is to be measured. Then, by raising a reservoir of mercury, the gas in B is cut off from C and compressed into the very small volume  $v$  of the upper part of B by one limb of

crane is less than the thrust on the ram, but rises proportionately quicker.

Additional cylinders, rams and tackles, may be provided for the swinging, traversing, or other motions of the crane.

Some hydraulic machines require small slow motions and high

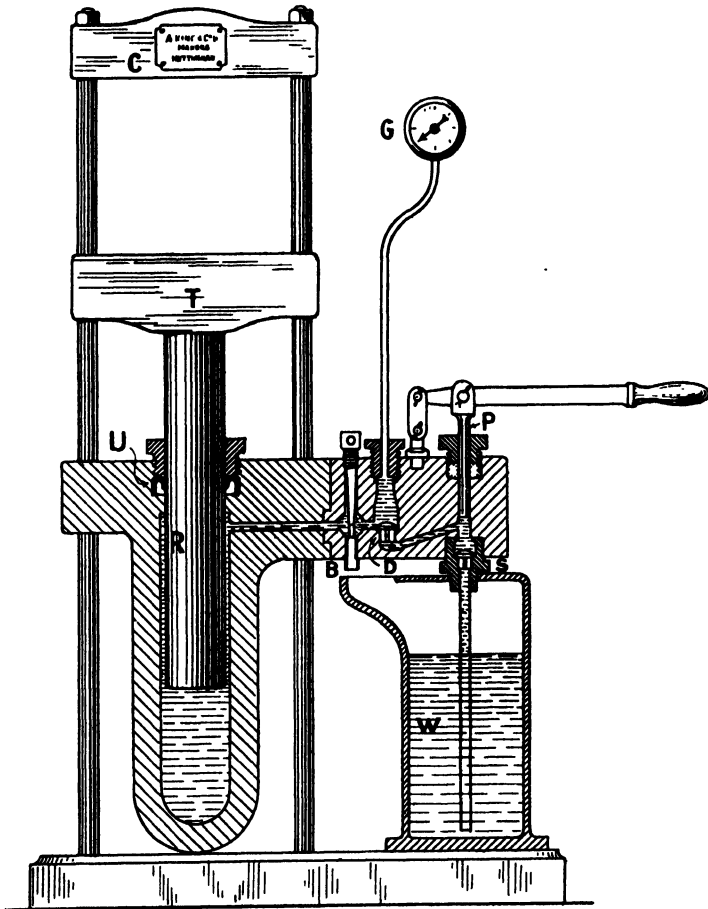

FIG. 124.—Hydraulic Press.

pressures, such as riveters. These, therefore, may be worked direct from a hydraulic ram and cylinder.

179. **Hydraulic Brakes.**—But hydraulic appliances may be used to check motions as well as originate them. Thus a hydraulic brake is used to check the recoil of guns. A more familiar example of this braking action is afforded by the Yale and Towne Co.'s *Blount door check*.

This device combines a powerful coil spring (which furnishes the motive power to close the door) and a metallic piston moving in a metallic cylinder against a non-freezing liquid (which furnishes the checking or controlling power). A simple regulating valve enables these two powers to be so adjusted, relatively to each other, as to give any desired action to the door, whereby it may be positively closed, but under a control which prevents slamming. Fig. 125 and the accompanying explanation references are reproduced by kind permission of the makers.

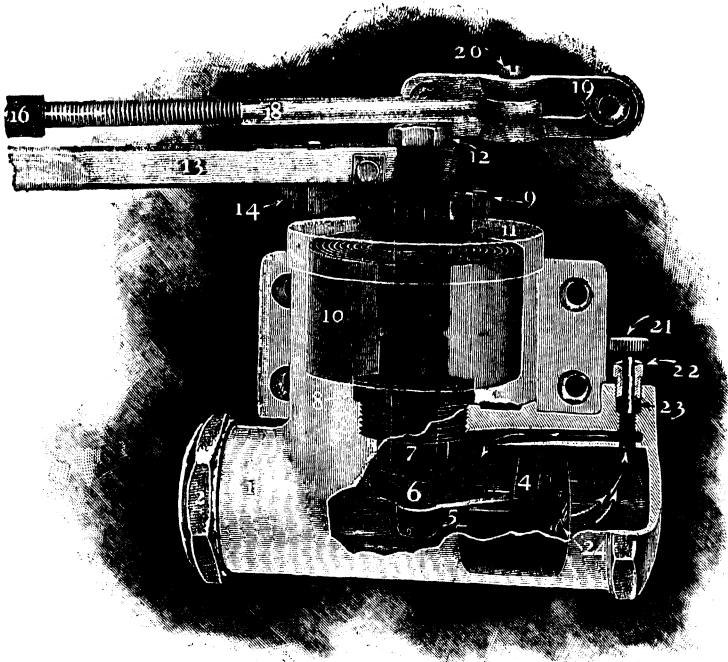

FIG. 125.—Blount Door Check.

EXPLANATION.—1, Case; 2, End Cap; 4, Piston; 5, Connecting Rod; 6, Crank; 7, Shaft; 9, Ratchet Sleeve; 10, Coil Spring; 11, Top Cap; 13, Main Arm; 14, Sliding Catch; 16, Forked Arm; 18, Screw for Forked Arm; 19, Jamb Plate; 20, Bracket Screw; 21, Regulating Screw; 22, Nut; 23, Washers; 24, Retainer for Ball Valve.

#### EXAMPLES LXI.

1. Explain in some detail the construction and arrangement of an hydraulic press. Why is the U-tube leather essential for the ram and not for the plunger?
2. How may an hydraulic lift be arranged and worked?
3. Sketch the arrangement of an hydraulic crane.
4. Describe that familiar hydraulic brake known as the Blount door check.

180. **Rock Drills, etc.**—This appliance forms a good example of the application of compressed air to a machine that needs to be moved about, as the flexible air pipe lends itself to such treatment. A rock drill has a tripod stand and is mounted over the place in a quarry or mine where a hole needs to be drilled. It has a plunger, carrying the drill in a socket below, and enlarged to a piston in the cylinder above. This plunger, by an arrangement of air ports, automatically opening and closing, receives a rapid reciprocating motion, thus striking a succession of blows on the rock with the star-faced drill. In addition, owing to a spiral guide rod, the plunger rotates slightly with each blow, just as a projectile turns as it advances along a rifled barrel.

*Steam and Compressed Air Engines* are of course examples of prime movers operated by fluids, but it would be out of place to enlarge upon them here.

181. **Turbines Classified.**—The term *turbine* was formerly used chiefly for a water wheel having a vertical axis. It is now extended to a variety of types of machine in which a wheel in various positions is driven by water or steam, the flow of the fluid being in various relations to the wheel, and the rotation effected by the velocity or pressure of that fluid.

This gives us the key to the classification of turbines when using the word in this extended sense. Thus, we may divide turbines into two classes according to the fluid used: I. *Water*, and II. *Steam*. We may divide each of these into two according as the effect of the fluid is derived chiefly from (a) its *Pressure*, or (b) its *Velocity*. Again, the varieties of turbines within each of the above four divisions differ in the relation of the flow of the fluid to the wheel. This flow may be either (1) *Axial*, (2) *Tangential*, (3) *Inward*, or (4) *Outward*.

We have thus the possibility of 16 varieties of turbine, apart from any admixture of the above types. But various mergings of these types actually occur and so still further extend the list. For example, the effect of the fluid may be at first due to its *velocity*, *action* or *impulse*, when striking the blades or vanes of the wheel; but afterwards due to its *pressure* or the *reaction*, when quitting the vanes. Similarly, the flow may be partly radial and partly tangential, or other combinations of the four directions may occur. In the case of steam turbines, thermodynamic effects obtain and lead to further varieties.

Of the types and admixtures thus sketched as possible, many have also been realised, but only a few of the most interesting can be noticed in this work. Thus, the water-pressure turbines have received no detailed notice.

182. **Parsons' Steam Turbine.**—The earliest recorded example of steam turbine seems to be that described about 120 B.C. by Hero of Alexandria. In this a pivoted sphere containing steam supplied through one of its trunnions, was made to rotate by the tangential

escape of the steam from two opposite jets. It thus worked by the reaction or pressure effect.

The other extreme is illustrated by the modern and highly elaborated steam turbines due to the Hon. C. A. Parsons, and first patented about 1884, and now used for marine and other purposes.

In this type the flow is chiefly axial and the velocity nearly uniform, the effect being derived from the pressure which falls as we advance along the line of flow. In the actual design are many complications into which we cannot enter here. The chief points to be noticed are as follows. The shaft is provided with a number of sets or rings of blades, the whole forming the wheel or *rotor*. These rings of blades alternate with blank spaces of similar size, and into these spaces sets of fixed blades project from the outer casing. Hence the steam moving axially encounters fixed and

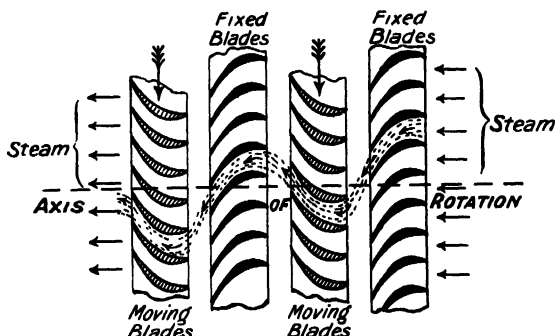

FIG. 126.—Diagram of Parsons' Turbine Blading.

movable blades alternately, each tending to deflect it tangentially, and so resulting in the rotation of the shaft. This action is shown diagrammatically in Fig. 126.

Much care has to be taken in designing the sizes of the various parts that as the pressure falls and the steam expands a proportionately larger space is open to it in order that the flow may be maintained practically constant.

183. **Westinghouse Brake.**—This brake, so largely used on railways, is here explained by extracts from the official instruction book, this quotation being kindly allowed by the makers.

“The Westinghouse Automatic Brake is continuous throughout the train and is operated by compressed air furnished by the pump and stored in the main reservoir on the engine. This compressed air is fed by the driver's brake valve into the train (main or brake) pipe, and, past the (special devices called) triple valves, into the auxiliary reservoir on each vehicle.

“The brake is applied by reducing the pressure in the train pipe, which causes the pistons of the triple valve to move and

permit some of the compressed air stored in the auxiliary reservoirs to pass to the brake cylinders, the pistons of which are forced outwards, applying the brake blocks to the wheels.

"The brake is released by restoring the air pressure in the train pipe, which causes the triple valves to close the communication between auxiliary reservoirs and brake cylinders and open a port from the brake cylinder to the atmosphere, through which the compressed air escapes from the cylinder. The spring in the cylinder can then push back the piston and withdraw the blocks from the wheels.

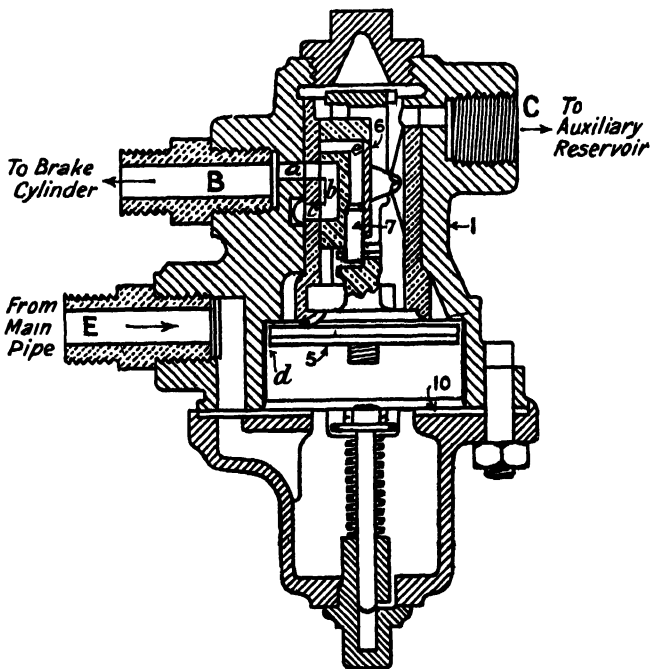

FIG. 127.—Westinghouse Triple Valve.

"The brakes are usually applied by the driver, or in cases of emergency by the guard, but a break-away, or rupture of a hose coupling, or other accident causing an escape of air from the train pipe, also immediately applies the brakes; hence the term 'automatic.'"

The special device called the *triple valve* now calls for more detailed consideration. The simplest type, called *ordinary*, is shown in Fig. 127. As before mentioned, the "triple valve is operated by the variations of pressure in the main pipe, in such a manner that it automatically admits compressed air from the corresponding reservoir to the brake cylinder whenever the pressure in the main

pipe is reduced ; and discharges the compressed air from the brake cylinder (and secures the recharging of the auxiliary reservoir) when the original pressure in the main pipe is restored.

“ The construction and mode of operation of this valve are as follows :—

“ Enclosed in a case 1 (see Fig. 127), is a piston 5, carrying with it a slide valve 6, which covers the port *a* to the brake cylinder, and in the position shown establishes a communication between port *a* and the atmosphere by the cavity *b* and exhaust passage *c*. Compressed air from the main pipe enters at E, and forcing up the piston 5, feeds past it through the groove *d* and passage C into the auxiliary reservoir, which is thus charged with an air pressure equal to that in the main pipe. The reservoir, triple valve, and main pipe then contain equal air pressures, and so long as this is maintained, the brake remains out of operation.

“ Upon a reduction of pressure being made in the main pipe, the piston 5 will be moved downwards owing to the excess of pressure now acting on its upper surface. The piston—having a limited movement without affecting the slide valve 6—closes the feed groove *d*, at the same time unseating the graduating valve 7, which thus opens the port *e*. The piston then also moves downwards the slide valve 6, which cuts off the communication from the cylinder to the exhaust port *c*, and opens the port *e* to the passage *a*, leading to the brake cylinder, into which compressed air from the auxiliary reservoir immediately flows and applies the brake. The further downward movement of the piston 5 and slide valve 6 is arrested by the decrease of pressure above the piston, caused by the air flowing into the brake cylinder. So soon as the pressure in the reservoir is thus reduced a little below that in the brake pipe, the piston 5 is moved up so far, that it closes the graduating valve 7, while the slide valve 6 retains its position. By simply producing further reductions of pressure in the main pipe, the motion of the piston 5 and graduating valve 7 may be repeated, and the driver can thus gradually introduce any desired pressure into the brake cylinder from zero up to full power.

“ When a considerable reduction of pressure in the main pipe is suddenly made, the piston 5 is at once forced down to the limit of its stroke, and seated on the leather gasket 10. The slide valve 6 then entirely uncovers the port *a*, so that the compressed air from the auxiliary reservoir flows into the brake cylinder with great rapidity, applying the brake with full force.

“ To release the brake, air is again admitted from the main reservoir to the brake pipe. The air pressure, acting against the reduced pressure in the auxiliary reservoir, forces the piston 5 and slide valve 6 into the positions shown in Fig. 127, thus permitting the air in the brake cylinder to exhaust through the port *c*, whilst at the same time the auxiliary reservoir is recharged through the feed groove *d*.”

Other patterns of the triple valve are also in use to attain quicker action or other improvements, but these are more complicated.

It is recommended that the pressure in the main reservoir should be 90 lbs. per square inch, and that in the train pipe 70 lbs. per square inch.

184. **Midland Vacuum Brake.**—In vacuum brakes a partial vacuum (instead of an extra pressure) is produced and maintained in the train pipe. And while the normal vacuum is present in the pipe, the same vacuum exists on each side of the piston in the brake cylinder. But when air is allowed to enter the train pipes or, by an accident, does enter, then this extra pressure is admitted to only one side of the piston and the brakes are applied. In the first case a valve allowed the exhaustion from both sides of the piston, in the second the valve stops the flow of air in the opposite direction.

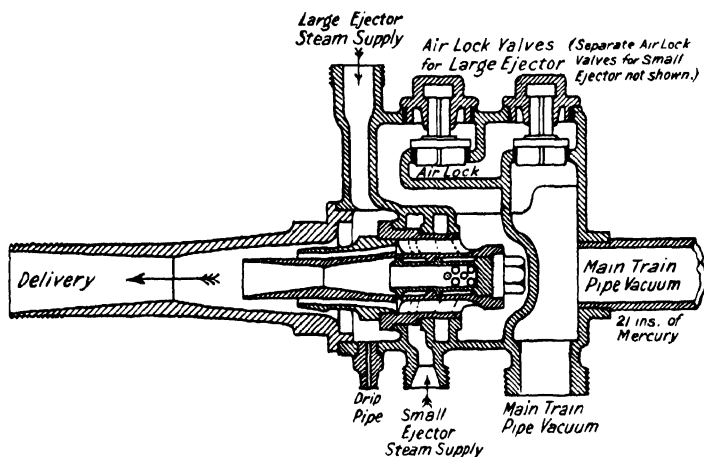

FIG. 128.—Midland Railway Company's Combined Ejector.

A large ejector is needed to produce the required vacuum, but only a small one is necessary for its maintenance.

As to the details of the Midland Railway Vacuum Brake, their chief mechanical engineer, Mr. Henry Fowler, has kindly permitted publication of the accompanying drawing, Fig. 128, of their combined ejector and the following official statement.

“The vacuum brake fittings on M.R. engines differ in arrangement and slightly in details from the standard automatic vacuum brake as more generally used, and as supplied by the Vacuum Brake Company.

“In the M.R. arrangement the large and small ejectors are combined and placed on the side of the boiler near the smoke box. The usual back stop valves and air-locks are provided in the ejector casting. The small ejector steam valve is placed in the engine cab

while the large ejector valve is worked by a rod and lever from the footplate. The driver's brake valve and vacuum regulating valve are separate and placed in the engine cab.

"The brake valve has the usual air disc, and the steam plug is controlled by the vacuum in the train pipe in the usual way. Drip valves are placed at the back and front ends of the engines and on the tender at the lowest position of the train pipe.

"It is the standard M.R. practice to fit steam brake, on engine and tender."

185. **Pelton Wheel.**—This is a good example of an impulse water turbine. The wheel is mounted on a horizontal axis and the jet plays tangentially at the under side of the wheel. It differs, however, from an ordinary undershot water wheel in the form of its blades or vanes. These are designed so as to obviate shock when the jet strikes and to reduce the velocity of the water to a minimum before it quits the vanes, thus extracting the kinetic energy from the jet as far as may be.

This action of the water jet on the vanes may be understood from Fig. 129, which gives an inverted sectional plan, *i.e.* the view looking upwards from below the wheel with the outer part of the vanes cut off.

It is of interest to inquire what relation the velocity  $v$  of the vane should bear to the velocity  $u$  of the jet for maximum efficiency. To obtain full efficiency we aim at extracting all the kinetic energy of the jet, *i.e.* reducing its *actual* velocity to zero. Now the *relative* velocity of a jet along a smooth curved vane remains unchanged in numerical value. Thus, in the present case, this value is  $u - v$  to the right, on striking the vanes and, after slipping along the semicircular cups, is the same but oppositely directed (or we might write it  $v - u$ ) on quitting the vanes. Accordingly, the actual velocity of the jet to the right is found by adding that of the vanes, and gives  $2v - u$ . But, for fullest effect on the wheel, this must be zero. Hence, for maximum efficiency, we have the condition

$$2v - u = 0, \text{ or } v = \frac{1}{2}u$$

Or, in other words, to get the best effect out of the water, the periphery of the wheel should have a velocity half that of the jet.

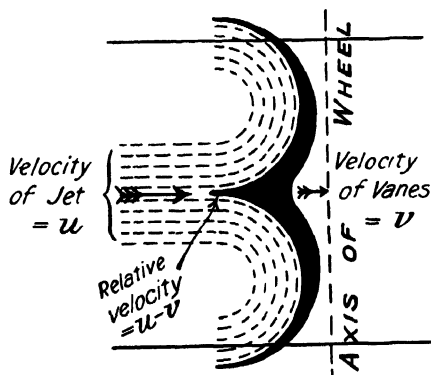

FIG. 129.—Vanes of Pelton Wheel.

But the various parts of the vanes describe circles of various sizes, and so move at slightly different linear speeds. Hence,  $v$  cannot be  $\frac{1}{2}u$  for every point of the vanes. This and other circumstances reduce the efficiency from the theoretical ideal to about 85 per cent.

It is clear that for  $v$  equal to zero or equal to  $u$ , then in either case the work would be zero. Hence it is not surprising that the maximum work is obtained for a value of  $v$  midway between these extreme limits.

186. **De Laval Steam Turbine.**—As an example of an impulse steam turbine we take that of De Laval patented in 1888. This consists of a disc with a number of curved blades fitted into its

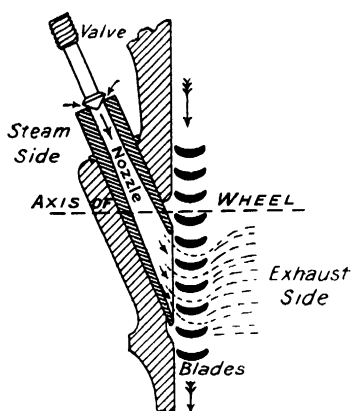

FIG. 130.—Action of De Laval Steam Turbine.

periphery so as to form a single ring, and admitting steam between them from several slightly oblique nozzles fixed at one side, the other side providing the exhaust. The wheel and nozzles are inclosed in a suitable casing. The action of the steam jets on the blades of the wheel may be understood from Fig. 130, which shows a section through one nozzle and a few of the blades which are projecting radially towards the reader. In a 300 horse-power turbine of this make the blades are only about  $1\frac{1}{2}$  inches in length by  $\frac{3}{8}$  inch wide, and weigh but little over half an ounce each. Yet, when running at the standard speed of 7,500

revolutions per minute, the centrifugal pull of a single blade is of the order 1000 lbs. weight!

For further information on turbines and hydraulic machinery in general references may be made to A. E. Tompkins' *Turbines* (London, 1908), J. Goodman's *Mechanics Applied to Engineering* (London, 1908), and S. Dunkerley's *Hydraulic Machinery* (London, 1907).

#### EXAMPLES LXII.

1. Explain the working of a rock drill.
2. Give some scheme of classifying turbines.
3. Describe some ancient type of direct steam-pressure engine or turbine and a modern application of the same principles.
4. Make a sketch of the blades used in a Parsons' steam turbine and explain the working of the appliance.
5. Give a general explanation of the construction and action of the Westinghouse brake as used on railway trains.

6. Explain the functions of the Westinghouse triple valve.
7. Describe the vacuum brake system in use on the Midland Railway.
8. Make a sectional view of the Midland Railway's combined ejector.
9. Explain with sketches the construction and action of a Pelton wheel.
10. Prove that, in a Pelton wheel, the peripheral velocity should be half that of the jet.
11. Describe the arrangement and working of the De Laval steam turbine,
12. If the blade of a De Laval steam turbine has a mass of half an ounce, and is set on a wheel 2 ft. radius making 7,000 revolutions per minute, what is its radial pull on the wheel ?

ADDITIONAL EXERCISES

EXAMPLES LXIII.

ON KINEMATICS.

1. A motor van proceeding at 15 miles per hour has both roof and floor pierced by a bomb. If the roof is 8 ft. above the floor and one hole was 8·8 inches ahead of the other, from what height did the bomb fall ?
2. If an aeroplane when starting runs a hundred yards in a quarter of a minute with uniform acceleration before leaving the ground, what was its speed at that instant and what was its previous acceleration ?
3. A train starts from one station, travels for five minutes with uniform acceleration, and then retards uniformly for two minutes and comes to rest in another station.  
If the stations are  $3\frac{1}{2}$  miles apart what was the maximum speed of the train ?
4. A train is 2 minutes late at a station A, travels at a uniform speed for 40 miles to a station B, which it passes 4 minutes late ; it then increases speed by 12 miles per hour and so arrives on time at the station C, which is 20 miles beyond B. At what uniform speed should it have travelled over the whole 60 miles ?
5. A disc with its axis vertical has its upper surface slightly conical so that the radii are inclined  $30^\circ$  to the horizontal. The disc is then spun about its axis and marbles are placed upon it. Account for the fact that marbles placed near the centre of the disc roll down inwards and those near the edge roll up outwards. Also find the diameter of the ring that separates the two behaviours when the disc is spinning at 60 revolutions per minute.

EXAMPLES LXIV.

ON KINETICS.

1. If a body of mass  $M$  moving at speed  $u$  is overtaken by another body and urged on in such a way that the speed of the first increases to  $v$  by uniform acceleration, show that the *work* done upon it equals the *impulse* it receives multiplied by the arithmetic mean of the two speeds named. Would this still be true if the acceleration were not uniform ?
2. A pile weighing 2 tons meets a resistance of 98 tons weight. How far will it descend each time a weight of half a ton is let fall upon it from a height of 16 ft., supposing the weight does not rebound off the pile ?
3. In the previous example what fraction of the energy expended in hoisting the weight is lost and what becomes of it ?
4. A motor cycle and rider weigh 250 lbs. and take a gradient of 1 in 3 at 15 miles per hour. If, allowing for friction, this is equivalent to a gradient of 1 in 2 (or  $30^\circ$ ), what horse power is being used ?
5. An aeroplane flies *through the air* at 60 miles an hour and is in a steady west wind of 30 miles an hour. How far may the aeroplane automatically rise each time it changes its course from east to west ?

## EXAMPLES LXV.

## ON STATICS.

1. In a wheel-barrow the horizontal distance from the handles to the centre of the wheel is 4 ft. The empty barrow weighs 40 lbs., half of which comes on the wheel. When a load of 200 lbs. is placed in the barrow with its centre of gravity 18 ins. from the wheel, what is the load on each handle?
2. Find in oz. per cubic inch the density of an alloy consisting of 40 oz. of copper of specific gravity  $8\frac{1}{2}$  and 60 oz. of silver of specific gravity  $10\frac{1}{2}$ .
3. Where is the centroid of a rectangle 5 ft. by 3 ft. with a circular hole 2 ft. diameter whose centre is equidistant from the sides and one end?
4. A kite-shaped figure consists of two isosceles triangles base to base, their heights being 2 and 4 ft. respectively. Find the centroid.
5. Find the height of the centre of gravity of a frustum of a pyramid 3 ft. high whose bases have areas 9 and 4 sq. ft.

## EXAMPLES LXVI.

## ON SUMMATIONS.

1. Find the work done in a displacement of 3 ft. if the resistance met with varies as the square of the displacement and has a final value of 18 lbs. weight.
2. Calculate the mass of a disc 4 ft. diameter whose mass per unit area at a radius  $r$  ft. is  $3r^2$  lbs. per sq. ft.
3. Liquid flows through a tube 2 mm. diameter inside, the speed being 6 mm. per second at the centre of the pore and nothing at the inner wall of the tube itself and varying uniformly with the radius simply at other places. Find the volume discharged by the tube per second.
4. An area extends along the axis of  $x$  from the origin to the point  $x=6$  ft., and is there terminated by a perpendicular line. The third side of the area is curved in such wise that the ordinate  $y$ =half the cube of  $x$ . Find the extreme ordinate, the area and the mean ordinate.
5. A conical vessel has its axis vertical and vertex uppermost and is filled with a liquid with solid matter in suspension which settles so that the density is proportional to depth. Determine the position of the centre of mass of this mixture.
6. Determine the moment of inertia of a semi-circular area about an axis through its centroid and parallel to its base.

## EXAMPLES LXVII.

## ON LIQUIDS IN EQUILIBRIUM.

1. Find the total pressure at a depth of 250 ft. in a Cumberland lake when the atmospheric pressure is equivalent to a layer of water 33 ft. deep, assuming the water to be incompressible.
2. In a hydraulic press the ram is 5 ins. diameter and the plunger  $\frac{1}{8}$  in. diameter. If the water is used at a pressure of 2 tons to the square inch, what force must be exerted on the plunger and what force will the ram give?
3. In a U-tube the junction of water and oil stands a foot above the table top, the upper surface of the oil at 23.7 ins. and the upper surface of the water in the other limb at 21.9 ins. Sketch the arrangement and calculate the specific gravity of the oil and its density in lbs. per cubic inch.
4. Describe a modification of the U-tube method for determining the specific gravity of a liquid which mixes with water. Give a specimen set of readings and show the value finally obtained from them.
5. Find the total force due to water pressure on the vertical triangular face of a dam of which the apex is 80 ft. deep and base at the surface 1000 ft. long.

6. Determine the depth of the centre of pressure of a vertical semicircular area whose base is 5 ft., and is set *vertically* with its centre 3 ft. below the water level.
7. Calculate the depth of the centre of pressure of a triangle two of whose corners are at depths of 3 and 4 ft., the third being in the liquid surface.
8. A submerged triangle has its corners at depths 2, 6 and 8 ft., find the depth of its centre of pressure.
9. A hollow pyramid stands on a square base and is filled with liquid, show that the pressure on the base is three times the weight of the contained liquid.

EXAMPLES LXVIII.

ON FLOTATION.

1. Find the resultant force due to liquid pressures when a wooden sphere 3 ft. diameter is held down so as to be half immersed in water.
2. A solid cone has a base 2 ft. diameter and a height of 3 ft. It is submerged in water with its axis at an angle of  $45^\circ$  and the vertex in the surface. Find the resultant force on its curved surface and represent its line of action on a diagram.
3. A hemisphere 4 ft. diameter has its centre at a depth of 5 ft. in water, its base upwards and inclined  $30^\circ$  with the horizontal. Find the magnitude of the resultant force on the spherical surface, also locate it on a diagram.
4. A vessel of water in one scale pan is balanced by weights in the other. A 1 lb. brass weight hanging on a thread is now lowered so as to be immersed in the water without touching the sides or bottom of the vessel and without causing any water to overflow. What happens to the equilibrium and why? If disturbed how would you propose to restore it?
5. Describe carefully with sketches and explanatory theory a hydrometer of variable immersion for densities of solids and one of fixed immersion for densities of liquids.
6. A vessel quite full of water hanging from one arm of a balance is just balanced by weights on the other arm. A glass tube with a bulb blown on the end is thrust into the water and held there so as not to touch the vessel, but be immersed and displace 24 c.c. of water which flows away. How is the balance affected by this change?  
The glass bulb is now removed and a lead ball weighing 220 gm. is lowered into the water so as to hang immersed but not touch the vessel. How does this affect the balance?
7. Find the density of zinc from the following data of weighings with a hydrostatic balance.  
Zinc in air weighs 24.36 gm., zinc in water apparently weighs 20.92 gm.
8. Calculate the specific gravity of a specimen of wood (varnished so as not to absorb water) which weighs 10 oz. in air and together with a half lb. brass weight appears to weigh 2 oz. in water.
9. Some nails which should be copper are suspected of being only zinc or iron and therefore tested as follows. A number of them weighing  $17\frac{1}{2}$  oz. are taken, and on putting them into a bottle full of water, the total weight of bottle and contents is less by 2 oz. than it was before the water was displaced by the nails. What is the specific gravity of the nails and what material do you suppose them to be?  
A second sample weighing 14 oz. in air displaced 2 oz. of water; what do you conclude as to them?
10. Pure gold and silver in accurately weighed quantities are served out to a jeweller to make a ring of 22-carat fine (*i.e.*,  $22/24$ ths pure gold); the ring and the returned quantities of gold and silver make up the original total, but it is wished to ascertain if the ring is of the right quality.  
Determine this from the following data. At  $15^\circ\text{C}$ . the ring in air balances brass weights to the value 22.015 gm., and the ring in water balances 20.834

gm. of brass weights in air. Take the densities of gold, silver and brass as 19·32, 10·50 and 8·00 gm. per c.c., those of the air and water as 0·0012 and 0·9992 gm. per c.c. respectively.

11. A sphere of wood a foot diameter floats freely in water so as to be just half immersed. The vessel containing the water has a horizontal area of 2 sq. ft., its walls being upright. Find the work required to lift the sphere just clear of the water.

12. Can a cube of wood of specific gravity one-half float in water with its faces vertical and horizontal? Work out results mathematically so as to prove your assertion.

13. Determine two limiting densities of a uniform cube to enable it to float in water with its edges horizontal and vertical.

14. For a uniform solid cube of edge  $a$  and density  $\kappa$  supposed floating in water with its faces vertical and horizontal, plot two graphs for the heights of the metacentre  $M$  and the centre of gravity  $G$  of the cube above its centre of buoyancy  $H$ , the density  $\kappa$  being the abscissæ. Show that these graphs confirm the result of the previous question as to the stability of the cube.

15. A rectangular landing stage is 20 ft. by 15 ft. by 2 ft., and with its load weighs 2 tons. When a 12-stone man shifts across by 10 ft. the stage draws half an inch more water on one side and half an inch less on the other. What are the heights of the metacentre above its centre of gravity and above its centre of buoyancy?

16. In a hydraulic service at a wharf the water is conveyed in pipes,  $\frac{3}{4}$  in. outside diameter and  $\frac{1}{4}$  an inch bore, at a pressure of 2 tons to the square inch; find the circumferential tension in the pipes per square inch of material.

17. In an experiment a glass tube of internal diameter a quarter of an inch and wall one-sixteenth of an inch thick is exposed to an internal pressure of 40 atmospheres. Calculate the circumferential tension per square inch of the glass.

#### EXAMPLES LXIX.

##### ON STEADY FLOW.

1. A boat has a sharp-edged hole 3 ins. diameter in her side at 10 ft. below the water line, how many tons of sea-water (sp. gr. = 1·025) will she "make" in an hour?

2. Two pith balls hang side by side from threads a yard long so that there is a clear space of about a quarter of an inch between them. A powerful blast of air is now directed on to this space; what will the balls do and why?

3. At what depth below the surface of still water in a reservoir may the water have a speed of 8 ft. per second and a pressure of 10 lbs. to the square inch above atmospheric?

4. Find the time required to lower by 12 ft. the level in a lock 80 ft. by 25 ft., if the sluice has an effective area of 16 sq. ft. situated at a mean depth of 20 ft. 3 ins., the coefficient of discharge being 0·6. Take  $g = 32$  ft./sec.<sup>2</sup>

#### EXAMPLES LXX.

##### ON GASES.

1. Explain how with a metre rule, some mercury and a straight tube closed at one end, a dozen or more observations may be made in confirmation of Boyle's law.

2. For use in a manometer explain the advantages of the various liquids commonly adopted, viz. : water, mercury, glycerine.

3. A bulb tube when empty weighs 26 gm., but weighs 76·3 and 96·5 gms. when filled with water to the graduations 3 and 205 respectively.

The tube is now emptied and dried, and a little thread of mercury introduced. It is then placed horizontally and heated to various temperatures in

a bath, the readings being 46, 75, 147 and 216 at  $0^{\circ}$  C.,  $14.9^{\circ}$  C.,  $50.1^{\circ}$  C., and  $85^{\circ}$  C. respectively. Determine the bulb constant  $c$  and the coefficient of expansion of the air.

4. What would be the volume under standard conditions of a mass of gas which occupies 120 c.c. at  $16^{\circ}$  C., and a pressure of 74 cm. of mercury?

5. Find the pressure of a mass of gas at  $57^{\circ}$  C. when occupying 125 c.c., if it exerted a pressure of 26 cm. of mercury at  $5^{\circ}$  C. in a volume of 236 c.c.

6. Some gas occupies a chamber of 80 c.c. and has a pressure of 130 cm. of mercury at  $12^{\circ}$  C., it is then allowed to expand to a volume of 150 c.c.; determine the temperature needed to give it a pressure of 76 cm. of mercury.

7. A cylinder is 75 mm. bore and the piston has a stroke of 90 mm., thereby compressing the gas to one-tenth. Find in ft.-lbs. weight the work done in such compression if done so quickly that the temperature rises and makes the work double that for isothermal compression. Take the initial pressure as atmospheric, viz. 14.7 lbs. per sq. in.

EXAMPLES LXXI.

ON HYGROMETRY.

1. What is meant by saying that the atmosphere has a humidity 50 per cent. of saturation? If this is true when the temperature is  $76.1^{\circ}$  F., what is the dew point?

2. If in the case of the previous question the barometer stood at 75.8 cm., what are the densities of the aqueous vapour and dry air present?

3. Write an explanatory and critical account of the various hygrometers in use.

4. Explain the terms *relative humidity* and *density of aqueous vapour* as applied to the atmosphere, showing by numerical examples that the former may increase while the latter decreases.

5. In the ventilation of a room 16 ft. by 14 ft. by 10 ft., three cubic feet of air per second pass out at a mean of  $77^{\circ}$  F. and dew point  $68^{\circ}$  F. Calculate in lbs. the moisture thus removed in six hours.

EXAMPLES LXXII.

ON BAROMETRY.

1. Describe the essential features of the various types of barometer you would choose (a) as a standard instrument, (b) for home use, and (c) for mountain ascents; justifying your choice in each case.

2. Explain carefully the need for temperature corrections to the mercury barometer and calculate the corrected value for an apparent height of 75.86 cm. at a temperature of  $16^{\circ}$  C. How is it you may call this height 76 cm. when calculating the correction but not when you are applying it?

3. To accommodate the men constructing the foundation of a bridge over an estuary a cylindrical vessel is let down, open at the bottom and closed at the top, its height being 25 ft. When the vessel entered the water the barometer stood at 30 ins. and the thermometer at  $50^{\circ}$  F., on reaching the bottom at a depth of 55 ft. the temperature was  $68^{\circ}$  F., and the compressed air machinery (whose exhaust was depended on for ventilation) failed to work. Calculate the pressure of the inclosed air and the height to which the water would rise in the vessel.

4. The barometer reads 29.76 ins. in latitude  $56^{\circ}$  at an altitude of 750 ft. above sea level, the temperature being  $53^{\circ}$  F. Correct it for temperature, latitude and altitude, working to a thousandth of an inch.

5. A mountain ascent is made in which the aneroid barometer carried falls from 30.1 ins. to 24.3 ins. Find the height of the ascent, taking the mean temperature at  $50^{\circ}$  F.

6. The mean temperature being  $30^{\circ}$  F., find the height ascended which causes the barometer to fall from 30.2 to 15.1 ins.

## EXAMPLES LXXIII.

## ON APPARATUS.

1. Describe several arrangements without valves still in use for lifting water or other liquids.
2. Write a short account of various devices for diminishing or removing the intermittent character of the delivery of a pump, stating under what circumstances such devices are most needed.
3. Sketch a form of Venturi water meter that you could easily make yourself, explaining the material used for each part and the observations you would take in using and testing it.
4. A cylindrical diving bell 18 ft. high is lowered 43 ft. in fresh water, how far does the water ascend in it if the barometer stands at 30 ins. and the temperature is the same in the water and out?
5. Show that the action of a Giffard's injector is in harmony with the principle of conservation of energy.
6. Give four examples from modern practice of pumps combined with some self-contained motor or prime mover.
7. Calculate the sensibility of a differential manometer using liquids of densities 0.805 and 0.800 gm. per c.c., the areas of the reservoirs being 40 times that of the bore of the limbs of the U-tube.
8. Write a short account of two modern appliances for producing high vacua, showing their superiority over the older arrangements for the same purpose.
9. Sketch any two pieces of hydraulic apparatus with which you are conversant and explain their working and advantages.
10. Write an account of any forms of turbine with which you are familiar, giving sketches of important details explanatory of the action between the blades and the water or steam in use for driving.

## EXAMPLES LXXIV.

## MISCELLANEOUS.

1. Two points M and N are fixed on a given circle on which the point O moves. Along OM and ON act forces P and Q of variable magnitude but constant ratio.  
Find a fixed point C through which the resultant OR of P and Q always passes.
2. Forces represented by the lines OP and OQ act at O and their resultant passes through a point K.  
Show that the resultant of the forces represented by KP and KQ passes through O.
3. A hollow cone has internal height 3 ft. and internal base 2 ft. diameter. It is set with its axis vertical and its vertex downwards and filled with spirit of specific gravity 0.83. At the vertex a hole of area 0.144 sq. in. is then opened. Find the time taken for the cone to empty if the coefficient of discharge is exactly one half.
4. A right circular cone made of uniform solid material is just able to float in water with its axis vertical and base up. Show that the specific gravity of the cone equals the sixth power of the cosine of its semi-vertical angle.
5. Water is flowing in a semi-circular channel 6 ins. diameter which it just fills. The speed is a yard per second at the centre of the semi-circle, but may be taken as falling off uniformly with radius to zero at the inner surface of the channel itself. How many gallons pass per minute?
6. A punt is 12 ft. by 3 ft. and, when laden with goods and a 12-stone man, draws 4 ins. of water. Take the centre of gravity of punt and luggage as being at the water level and that of the man 2 ft. 8 in. above. Calculate how

much one side is depressed when the man moves a distance of one foot across the punt.

7. A shallow cylindrical vessel with open top is set rotating uniformly about its axis which is vertical. It then has liquid poured in until it is just up to the outer edge, but has no liquid at all at the very centre.

Show that when all rotation has ceased the vessel will be found to be exactly half full.

8. A parallelogram has one side in the surface of a liquid and the other below. A line is then drawn from an upper corner to the middle of the lowest side; determine the fractions of the total force on each part into which the parallelogram is thus divided.

9. On the end of a tank a parallelogram is described with one side level with the liquid surface, from a point one-third the way down one side a line is drawn to the bottom of the opposite side. Find the ratio of the forces on the upper and lower parts of the parallelogram.

10. A triangle with its base in the liquid surface is marked on the side of a tank. A horizontal line in this triangle is then taken as the base of a second triangle whose apex is to be in the liquid surface. Determine the depth of the second triangle to secure the maximum force of liquid pressure upon it.

EXAMPLES LXXV.

MISCELLANEOUS.

1. A pair of gates closes a lock 25 ft. wide, the bottom being at the same level in the lock and out. When the water stands 21 ft. deep at one side and only 6 ft. the other what is the moment of the forces about the bottom tending to overturn the lock gates?

2. A hollow iron cone 6 ft. high inside is lowered by a chain at its vertex into a fresh-water lake till the water enters the cone to a height of 3 ft. If the barometer stood at 30 ins., calculate the depth to which the base of the cone is sunk in the water.

3. A number,  $n$ , of soap bubbles of equal size exist in a vacuum and then coalesce into a single bubble, the temperature remaining constant; show that the diameter of the new bubble is  $\sqrt{n}$  times that of the original bubbles.

4. A hollow tetrahedron (a figure with four equal triangular faces) is filled with liquid of total weight  $W$  and hung up by one corner. Find the pressures on base and the inclined faces, also their inclination, and thus harmonise the result.

5. In the vertical side of a tank is carefully fitted a disc pivoted on a horizontal axis, so that half the disc is in the liquid inside the tank.

Will the disc be set in rotation by the liquid pressures; if not, why not?

6. Find the total force on a sea wall due to a wave 100 yds. long and 12 ft. high in the middle, the shape of the wave being taken as a simple triangle and the salt water as 64 lbs. per cubic foot.

7. In a Mariotte's bottle, which is cylindrical and flat topped, the tube reaches down half way and the exit pipe is at the very bottom. If it takes 5 minutes to lower the level from the top to the tip of the tube, calculate how long it will take to discharge the remaining half-bottle full.

8. An express train while travelling at 60 miles per hour scoops up water from a tank between the rails. If the water is delivered at a height of 9 ft. through an opening 6 ins. diameter find the minimum length of the tank to enable the engine to take up 300 cubic feet of water.

9. The water in a reservoir is 25 ft. deep against the dam which is 220 yds. long. Find the moment about its bottom edge of the water pressure against the dam.

10. If the part of an iceberg above water is rectangular of size, 450 by 220 by 100 ft., find the total mass of the berg, on the assumption that its mean specific gravity is 0.92 and that of the sea-water 1.025.



# ANSWERS

## CHAPTER II

### EXAMPLES II (p. 5)

- |  |  |
|--|--|
| <p>(1) 6 ft. 3'16 ft.<br/>                 (2) A. 7'6 ft., 67° nearly.<br/>                 B. 10 ft., 53° nearly.<br/>                 C. 11'4 ft., 38° nearly.<br/>                 (3) Corners (0, 0), (4, 0), (2, 3'464)<br/>                 Middle points of sides (2, 0),<br/>                 (3, 1'732), (1, 1'732).<br/>                 (4) Corners 2'309 ft., 90°, 210° and<br/>                 330°.</p> | <p>Middle points of sides 1'55 ft.,<br/>                 30°, 150°, 270°.<br/>                 (5) Abscissæ, 8 in., 1 ft. 4 in.,<br/>                 2 ft. 8 in., 3 ft. 4 in.<br/>                 Ordinate 8 in. and 1 ft. 4 in.<br/>                 (6) 1 right angle, 1<math>\frac{1}{8}</math>, <math>\frac{1}{6}</math> and 1<math>\frac{1}{12}</math> right<br/>                 angle.<br/>                 90°, 165°, 10° and 97<math>\frac{1}{2}</math>°.</p> |
|--|--|

### EXAMPLES III (p. 7)

- |   |  |
|---|--|
| <p>(2) 7 miles, 5 miles north: Arith-<br/>                 metical and vectorial.<br/>                 (3) 10 miles south.<br/>                 (4) 40 miles in direction 60° north<br/>                 of east.</p> | <p>(5) 14'14 miles along its second<br/>                 course, or 5'86 miles from its<br/>                 goal.<br/>                 (6) 5 miles.</p> |
|---|--|

### EXAMPLES IV (p. 11)

- |  |   |
|--|---|
| <p>(2) One-eighth, three-eighths, and<br/>                 one-quarter of a mile per<br/>                 minute. About a quarter of a<br/>                 mile per minute.</p> | <p>(3) 4, 8, 12 and 16 in. per sec.<br/>                 (4) 4<math>\frac{1}{2}</math> miles.<br/>                 (5) 85<math>\frac{5}{8}</math> and 120 miles per hour.<br/>                 (6) 5'49 and 6 miles per hour.</p> |
|--|---|

### EXAMPLES V (p. 13)

- |  |  |
|--|--|
| <p>(2) 2, 8, 18, 32 and 18 ft.<br/>                 (6) 2'5 sec.</p> | <p>(7) 5 sec. 400 ft.<br/>                 (8) 3'5 ft. per sec. per sec.</p> |
|--|--|

### EXAMPLES VI (p. 15)

- |  |  |
|--|--|
| <p>(1) 61<math>\frac{4}{7}</math> miles per hour. Note the<br/>                 example means that 20 rails<br/>                 (not 19) are passed over in<br/>                 10 secs.<br/>                 (2) 20 miles per hour.<br/>                 (3) 25<math>\frac{5}{8}</math> miles per hour.<br/>                 (4) Speed in miles per hour equals<br/>                 number of jolts in 20 sec.<br/>                 (5) 1<math>\frac{7}{8}</math> ft./sec.<sup>2</sup></p> | <p>(6) 2,682'24 cm./sec., 975'36 cm./<br/>                 sec.<sup>2</sup><br/>                 (7) 984,200,000 ft./sec., 671,200,000<br/>                 miles per hour.<br/>                 (8) 1,527<math>\frac{7}{8}</math> ft./sec.<sup>2</sup><br/>                 (9) 22,000 ft./sec.<sup>2</sup><br/>                 (10) 981'456 cm./sec.<sup>2</sup>, 115,920<br/>                 ft./min.<sup>2</sup></p> |
|--|--|

## EXAMPLES VII (p. 17)

- |  |   |
|--|---|
| (1) 13 miles per hour.                   | (5) 8.38 radians/sec., 25.13 ft./sec.           |
| (2) 10 knots, 14.14 knots.               | (6) 0.0001454, 0.001745, 0.1047                 |
| (3) 2,112 ft./sec.                       | rad./sec., 0.0279 ft. per sec.                  |
| (4) 453.6 ft./sec. at 15° from vertical. | (7) 5,481 ft./sec. <sup>2</sup> towards centre. |
|  | (8) 2 ft. per sec. per sec.                     |

## CHAPTER III

## EXAMPLES IX (p. 22)

- |                           |                                |
|---------------------------|--------------------------------|
| (2) 32.2 lbs.             | (4) 8.05 ft./sec. <sup>2</sup> |
| (3) $F = \frac{W}{g} a$ . | (5) 3.5 cm./sec. <sup>2</sup>  |

## EXAMPLES X (p. 25)

- |  |                  |
|--|------------------|
| (1) 2.316 ft./sec., 8.05 ft.-poundals. | (5) 0.174 H.P.   |
| (2) 193, 200 ft.-poundals, 2.678 ft.   | (6) 2½ H.P.      |
| (4) Practically one-eighth H.P.        | (7) 100,000 H.P. |

## CHAPTER IV

## EXAMPLES XI (p. 27)

- |                                    |   |
|------------------------------------|---|
| (1) 43.6 dynes at 23° with P.      | (7) P = 16.630 and Q = 8.58   |
| (2) 40 lbs. wt. at 60° with P.     | poundals.   |
| (3) 79.66 tons wt. at 13° with P.  | (8) P = Q = 50 oz. wt.  |
| (4) 106.3 oz. wt. at 16.5° with P. | (9) $\cos \alpha = \frac{1}{2}$ or $\alpha = 81\frac{1}{2}^\circ$ . |
| (5) P = 60.62 and Q = 35 lbs. wt.  | (10) 50 dynes at 37° with horizontal.                               |
| (6) P = Q = 49.08 dynes.           |   |

## EXAMPLES XII (p. 29)

- |  |   |
|--|---|
| (3) 9 lbs. wt. down at 1 ft. from 3 lbs. wt. | (7) 7 tons wt. vertically down, CB = 5 ft. 9½ in. AC = 7 ft. 8½ in.       |
| (4) 50 oz. wt. CB = 6 in. AC = 2 ft.         | (8) 50 lbs. wt. down at 3 ft. from the 20 lbs. and 2 ft. from the 30 lbs. |
| (5) 10 lbs. wt. N. CB = 12 ft. AC = - 6 ft.  |   |
| (6) 50 dynes E. CB = 80 cm. AC = - 70 cm.    |   |

## EXAMPLES XIII (pp. 33-34)

- |   |  |
|---|--|
| (5) R = 31.145 dynes, $\theta = 47.5^\circ$ , G. = 14 dyne-cms. | (7) R = 4.7 lbs. wt. $\theta = 36^\circ$ , r = 6.634 ft. |
| (6) 56 ft. lbs. wt., 3.172 lbs. wt. at 45°.                     | (8) 15.68 lbs. wt. 24.97 ft.-lbs. wt.                    |
|   | (9) G = 50.35 ft.-lbs. wt. R = 0.                        |

## EXAMPLES XIV (p. 35)

- |                                       |                              |
|---------------------------------------|------------------------------|
| (1) 0.28 lbs. per cub. inch.          | (4) 0.83 gm. per cc.         |
| (2) 71.9 cub. ft. per ton.            | (5) 0.3102 lbs. per cub. in. |
| (3) 12,771,500 lbs. or 5,701,563 tons |                              |

## EXAMPLES XV (p. 38)

- |   |   |
|---|---|
| (3) 2'5 ft., 3'5 ft.  | (5) Midway between the 33 lbs. and the centre of the octagon. |
| (4) 8 ins. from line through 1 and 9 oz., 2 ft. 3'71 ins. from line through 1 and 3 oz. | (10) Halfway down the median of the centre triangle.          |

## EXAMPLES XVI (p. 42)

- |   |  |
|---|--|
| (2) 3 ft. 9 ins. down the inner edge of the down stroke.          | (6) $3\frac{1}{8}$ ft.                     |
| (4) 1'4 ft. from middle of longer side towards middle of shorter. | (7) $1\frac{1}{8}$ the height of the cube. |

## CHAPTER V

## EXAMPLES XVII (p. 45)

- |                                |                                 |
|--------------------------------|---------------------------------|
| (1) 12,000 ft. lbs. wt.; 1 ft. | (4) $1\frac{3}{8}$ ft. lbs. wt. |
| (3) 1'5 ft.-lbs. wt.           | (5) 8 ft. lbs. wt.; 30 lbs. wt. |

## EXAMPLES XVIII (p. 46)

- |   |                                  |
|---|----------------------------------|
| (1) 72 sq. ins. or 0'5 sq. ft.                                      | (4) 23'25 sq. cm.                |
| (2) 20'25; 0'6931; 618'6  | (5) 4'05 sq. ins.; 60'75 sq. in. |
| (3) 6 sq. ft.; $32\frac{1}{2}$ sq. ft.; 2,436 sq. ft.; 1'61 sq. ft. |                                  |

## EXAMPLES XIX (pp. 50-51)

- |                             |              |
|-----------------------------|--------------|
| (1) 1, 0'159, 0'707.        | (5) 2'5, 21. |
| (2) 0'4483, 0'3660, 0'6428. |              |

## EXAMPLES XX. (pp. 53-54)

- |  |  |
|--|--|
| (2) $\frac{2\sqrt{2}}{\pi}$ or 0'9 of radius from centre of circle.  | (6) $\frac{4\sqrt{2}}{\pi}$ or 1'8 ft., or 1 ft. 9'6 ins. from centre of circle.   |
| (3) $\frac{2}{\pi}$ or 0'637 of radius from centre of circle.        | (9) $\left\{ \begin{array}{l} \frac{12}{\pi} \text{ and } \frac{8}{\pi} \text{ or} \\ 3'82 \text{ and } 2'547 \text{ ins. from axes.} \end{array} \right.$ |
| (4) $\frac{2\sqrt{2}}{3\pi}$ or 0'3 of radius from centre of circle. |  |

## EXAMPLES XXI (p. 56)

- |  |  |
|--|--|
| (3) 11'84 ins.   | (6) $1\frac{1}{8}$ in. from centre of base nearly. |
| (4) 5'7 ins.   |  |
| (5) To the latitude whose cosine is 0'75, or say $41\frac{1}{2}^\circ$ . |  |

## EXAMPLES XXII (pp. 59-60)

- |  |   |
|--|---|
| (4) 128 lbs. ft. <sup>2</sup>  | (6) About long and short edges, 36 ft. <sup>4</sup> and 64 ft. <sup>4</sup> |
| (5) $\frac{1}{4}$ lb.-ft. <sup>2</sup> ; $\frac{3}{8}$ lb.-ft. <sup>2</sup> ; $\frac{1}{2}$ lb.-ft. <sup>2</sup> | About axes parallel to above, 12 ft. <sup>4</sup> and 28 ft. <sup>4</sup>   |

## EXAMPLES XXIII (p. 63)

- |   |   |
|---|---|
| (1) $0.7854a^4$ , $3.927a^4$<br>(4) $6.2832 \text{ ft.}^4$<br>(5) $9 \text{ ft.}^4$ | (6) One-third $ab^3$ if about side $a$ .<br>(8) $0.917 \times (AB)^4$ . |
|---|---|

## CHAPTER VI

## EXAMPLES XXIV (p. 69)

- |   |  |
|---|--|
| (6) 15,575 lbs. wt. per sq. ft., or<br>108.2 lbs. per sq. in.<br>(7) Three times the weight of the<br>liquid. The slant sides re- | ceive an upward component<br>equal to twice the weight of<br>the liquid. |
|---|--|

## EXAMPLES XXV (pp. 72-73)

- |                 |                                    |
|-----------------|------------------------------------|
| (4) 56 lbs. wt. | (5) 50 strokes, 5,600 ft.-lbs. wt. |
|-----------------|------------------------------------|

## EXAMPLES XXVI (p. 76)

- |   |  |
|---|--|
| (1) $0.815 \text{ gm./c.c.}$<br>(2) $0.830 \text{ gm./c.c.}$<br>(3) $0.0342 \text{ lbs. per sq. in.}$ | (5) $9.052 \text{ gm. wt. per sq. cm.}$<br>$0.128 \text{ lb. wt. per sq. in.}$ |
|---|--|

## EXAMPLES XXVII (pp. 79-80)

- |  |  |
|--|--|
| (1) $Awd$ , $\frac{A+B}{2} wd$ , because the<br>excess weight is borne by the<br>sloping sides.<br>(2) $20.77 bd^3 \text{ lbs. wt.}$<br>(3) $363.3 \text{ lbs. wt.}$ | (4) 12 tons 10 cwt. 1 qr. 7 lbs.<br>(5) 619 lbs. wt.<br>(6) At half its depth.<br>(7) (a) $1^2, 2^2, 3^2, 4^2, \dots$<br>(b) 1, 3, 5, 7, . . . |
|--|--|

## EXAMPLES XXVIII (p. 84)

- |  |  |
|--|--|
| (2) $0.589$ of the radius.<br>(3) One inch below centre of circle.<br>(4) Half an inch below centre of<br>rectangle. | (5) 14.14 ins. below liquid surface ;<br>at depths 9.427 and 17.237 ins. |
|--|--|

## EXAMPLES XXIX (p. 89)

- |   |  |
|---|--|
| (1) $3\frac{1}{8}$ ins.<br>(3) $3.45 \text{ ft.}$ | (7) 4 ins. below the centre.<br>(8) 5 ft. 8 ins. and 5 ft. $8\frac{1}{4}$ ins. |
|---|--|

## CHAPTER VII

## EXAMPLES XXX (p. 94)

- |  |  |
|--|--|
| (1) Components 1031.13 lbs. wt.<br>down and 911.14 lbs. wt.<br>sidewise.<br>Resultant 1376 lbs. wt. at $42^\circ$<br>with the vertical.<br>(2) Components 667.38 and 560.7<br>lbs. wt. down and sidewise.<br>Resultant 872.26 lbs. wt. at $40^\circ$<br>with the vertical.<br>(3) Components 260.97 lbs. wt.<br>down and two each of 166.1<br>lbs. wt. horizontal. | Resultant is square root of sum<br>of squares of foregoing three<br>components and equals<br>$309.34 \text{ lbs. wt.}$<br>(6) 40.8 lbs. wt. vertically up<br>through the centre of buoy-<br>ancy.<br>(7) 16.33 lbs. wt. obliquely up at<br>$13^\circ$ with vertical. |
|--|--|

## EXAMPLES XXXI (pp. 96-97)

- (5) Half submerged, 13 lbs. wt. | (6) 13 lbs. wt.

## EXAMPLES XXXII (p. 99)

- (1) 1'6 gm. per c.c.; 9'64 in. nearly. | (5) 0'942 gm./c.c.  
 (4) 8'57 nearly.

## EXAMPLES XXXIII (p. 101)

- (2) 11'3 gm./c.c. | (4) 0'83 gm./c.c.  
 (3) 0'747.

## EXAMPLES XXXIV (p. 103)

- (1) 7'9 gm./c.c. | (5) 11'15 gm./c.c.  
 (2) 1'37. | (6) 0'903.  
 (3) 0'88. | (7) 0'82.  
 (4) 0'76 gm./c.c. and 8 gm./c.c. | (8) 1'258 gm./c.c.

## EXAMPLES XXXV (pp. 107-108)

- (5) 0'024036 c.c., 0'17029 gm., | (7) 0'9131 gm./c.c.  
 7'0848 gm./c.c. | (8) 0'9131 gm./c.c.  
 (6) 0'024044 c.c., 0'169998 gm., | (9) 59'982 gm.  
 7'0703 gm./c.c. | (10) 0'98824 gm.

## EXAMPLES XXXVI (pp. 111-112)

- (2)  $HM = \frac{a^2}{2b}$ ,  $GM = \frac{a^2}{2b} - \frac{b}{4}$ . | (6)  $\sqrt{2}$ . The body sinks and the  
 relation does not apply.  
 (3)  $HM = 31\frac{3}{4}$  ft. | (7)  $GM = 4\frac{3}{4}$  ft.  
 (4) Because these positions put | (8)  $GM = 1\frac{3}{8}$  ft. G has been  
 M above G and so insure | lowered  $1\frac{3}{8}$  ft. by different  
 stability. | character or placing of cargo.  
 (5)  $\frac{r^2}{s} = 2s(1-s)$

## EXAMPLES XXXVII (p. 114)

- (2) 6,720 and 3,360 lbs. wt. per in., | (3) 54 dynes per cm.  
 7,168 and 3,584 lbs. wt. per | (4) 7787'5 lbs. wt. per ft.  
 sq. in. | (5) 52,332 lbs. wt. per ft.

## CHAPTER VIII

## EXAMPLES XXXVIII (pp. 118-119)

- (4) 13'9 ft. per sec. | at surface is 4,909 poundals  
 (5) 8'25 ft./sec., 21'26 ft./sec. | per sq. ft., or 1'06 lbs. wt.  
 (6) Increase of pressure over that | per sq. inch.

## EXAMPLES XXXIX (pp. 123-124)

- (5) 16'06 gals. per minute. | (6) 1'57 ins. diameter; 66'13 gals.  
 per minute

## EXAMPLES XL (p. 128)

- (3) The angular velocity appears | (4) 2'65 inches.  
 squared in the equation, | (5) 51'1 rev. per minute.  
 therefore a negative velocity  
 makes no change in the  
 curvature.

## CHAPTER IX

## EXAMPLES XLI (pp. 130-131)

- (4)
- $32\frac{3}{8}^{\circ}$
- C.,
- $25\frac{7}{8}^{\circ}$
- F.

## EXAMPLES XLII (p. 135)

- |                         |                                      |
|-------------------------|--------------------------------------|
| (3) $9\frac{1}{2}$ c.c. | (9) $13\frac{7}{11}$ cm. of mercury. |
| (8) 38 ins. of mercury. | (10) 75 cub. ins.                    |

## EXAMPLES XLIII (pp. 137-138)

- |                           |                                  |
|---------------------------|----------------------------------|
| (3) $433^{\circ}$ C.      | (6) It becomes 0.377 of original |
| (4) $181.8^{\circ}$ C.    | volume or diminishes in the      |
| (5) 117.4 cm. of mercury. | ratio 2.654 : 1                  |

## EXAMPLES XLIV (pp. 140-141)

- |   |   |
|---|---|
| (3) 36.77 ins. of mercury; 37 ins. of<br>mercury. | (5) 46.98 c.c.  |
| (4) $587.32^{\circ}$ C.                           | (7) $+129.2^{\circ}$ absolute, or $-143.8^{\circ}$ C. |

## EXAMPLES XLV (p. 144)

- |  |                         |
|--|-------------------------|
| (1) $R_1 = 3,714.15$ ergs per degree<br>per c.c.               | (4) 14,927 ft. lbs. wt. |
| (2) $R_h = 41,580,656$ ergs per degree<br>per gm. of hydrogen. | (6) 1,118,500 ergs.     |

## EXAMPLES XLVI (p. 146)

- |  |                        |
|--|------------------------|
| (3) Separate pressures 8, 25.09<br>and 44.37, giving a total of<br>77.46 cm. of mercury. | (4) $168.9^{\circ}$ C. |
|  | (5) $-85.1^{\circ}$ C. |

## CHAPTER X

## EXAMPLES XLVIII (p. 153)

- |  |   |
|--|---|
| (1) 0.0000079 gm./c.c.                     | (4) $9 \times 10^{-6}$ , $1183 \times 10^{-6}$ and<br>$1192 \times 10^{-6}$ all in gm./c.c. |
| (2) 4.98 mm. of mercury; $1.16^{\circ}$ C. |   |
| (3) 53.4 per cent. and 40.5 per cent.      |   |

## CHAPTER XI

## EXAMPLES LI (p. 166)

- |  |  |
|--|--|
| (1) 76.05 cm.  | (6) Corrections are :—<br>for temperature, $-1.678$ mm.<br>for latitude, $+0.410$ mm.<br>for altitude, $-0.021$ mm.<br>for vapour, $+0.001$ mm.<br>Reduced height, 760.212 mm. |
| (2) 29.77 ins.   | (7) Corrections are :—<br>for temperature, $-0.017$ in.<br>for latitude, $-0.008$ in.<br>for altitude, $-0.002$ in.<br>for vapour, negligible.<br>Reduced height, 28.603 ins.  |
| (3) At station A, 75.65 cm. or<br>29.783 ins.<br>At station B, 75.17 cm. or<br>29.597 ins. |  |
| (4) 759.83 mm.   |  |
| (5) 29.79 ins.   |  |

EXAMPLES LII (p. 168)

- |  |                                    |
|--|------------------------------------|
| (1) $77\frac{1}{4}$ cm.                                      | (4) 8000 nearly, or more strictly, |
| (2) 76 cm.   | 7993'5 metres.                     |
| (3) $73\frac{1}{2}$ , $75\frac{1}{10}$ , $77\frac{3}{8}$ cm. |                                    |

EXAMPLES LIII (p. 173)

- |                  |                                 |
|------------------|---------------------------------|
| (4) 1024 metres. | (6) 10,330 ft. above sea-level. |
| (5) 26'92 ins.   |                                 |

CHAPTER XII

EXAMPLES LV (p. 180)

- |   |                                |
|---|--------------------------------|
| (1) No.   | (5) 76,770 gals. per 24 hours. |
| (4) 3'01 cub. ft. per sec., or 10,836<br>cub. ft. per hour. |                                |

EXAMPLES LVI (p. 185)

- (3) The supply flow must be much less than the siphon flow.

EXAMPLES LVII (p. 191)

- (7) 6321 lbs. wt. per sq. in.

EXAMPLES LIX (p. 197)

- |                                  |                 |
|----------------------------------|-----------------|
| (4) 0'1486 or $\frac{1}{6'73}$ . | (5) 22 strokes. |
|----------------------------------|-----------------|

EXAMPLES LXII (pp. 212-213)

- (12) 1043'2 lbs. wt.

EXAMPLES LXIII (p. 213)

- |   |                          |
|---|--------------------------|
| (1) 900 ft. (taking $g$ as 32 ft. per sec.<br>per sec.  | (3) 60 miles per hour.   |
| (2) Speed $27\frac{3}{11}$ miles per hour.<br>Acceleration $2\frac{3}{8}$ ft. per sec. <sup>2</sup> | (4) 50 miles per hour.   |
|   | (5) 11'22 ins. diameter. |

EXAMPLES LXIV (p. 213)

- |  |                                    |
|--|------------------------------------|
| (2) One-fifth of an inch nearly<br>(taking $g=32$ ft. per sec. per<br>sec.). | and sound on striking the<br>pile. |
| (3) Four-fifths is lost in heat  | (4) Five horse-power.              |
|  | (5) 242 ft.                        |

EXAMPLES LXV (p. 214)

- |  |  |
|--|--|
| (1) 47'5 lbs. wt.                                      | (4) 8 ins. from the middle point of<br>common base towards vertex<br>of larger triangle. |
| (2) 0'346 lb. per cub. in. or 5'54 oz.<br>per cub. in. | (5) 15'63 ins.   |
| (3) 2'235 ft. from the other end.                      |  |

EXAMPLES LXVI (p. 214)

- |                                  |   |
|----------------------------------|---|
| (1) 18 ft.-lbs. wt.              | (5) At four-fifths the depth from<br>the vertex.              |
| (2) 75'3984 lbs.                 | (6) $0'072 \times \text{area} \times \text{radius squared}$ . |
| (3) 6'2832 c.mm. per sec.        |   |
| (4) 108 ft.; 162 sq. ft.; 27 ft. |   |

## EXAMPLES LXVII (pp. 214-215)

- |   |                     |
|---|---------------------|
| (1) 17,631 lbs. wt. per sq. ft., or<br>122.4 lbs. wt. per sq. in. | (5) 29,667 tons wt. |
| (2) 0.614 ton wt., 39.27 tons wt.                                 | (6) 3 ft. 6½ ins.   |
| (3) Specific gravity = 0.846; 0.0305<br>lb. per cubic inch.       | (7) 2.643 ft.       |
|   | (8) 5½ ft.          |

## EXAMPLES LXVIII (pp. 215-216)

- |  |  |
|--|--|
| (1) 440.2 lbs. wt.   | (10) Density should be 18.585<br>gm./c.c., but is 18.604 gm./c.c.<br>This makes it 22.052 carats<br>fine.                  |
| (2) Force required has components,<br>293.58 lbs. wt. horizontally,<br>and 97.86 lbs. wt. vertically<br>downwards.               | (11) 4.029 ft.-lbs. wt.  |
| (3) The force required is 4835 lbs.<br>wt. and with that on the base<br>(20π62.3) makes the verti-<br>cally upward force ½π62.3. | (12) No; because if it did HM =<br>one-sixth of edge, but HG =<br>one-quarter, so G would be<br>above M and body unstable. |
| (4) The vessel descends because the<br>water level is raised. Put<br>2 oz. in other pan.   | (13) 0.7886 and 0.2113.  |
| (6) The bulb does not change the<br>balance, the lead ball re-<br>quires about 20 gm. adding<br>to other arm.                    | (14) HG is $y = \frac{a}{2}(1-x)$ .<br><br>HM is $y = \frac{a}{12x}$ .   |
| (7) 7.08 gm. per c.c.  | (15) 67.5 ft. and 78.23 ft.  |
| (8) Two-thirds.  | (16) 4 tons wt. per sq. in.  |
| (9) 8½, copper; sp. gr. 7, zinc.   | (17) 117.68 lbs. wt. per sq. in.   |

## EXAMPLES LXIX (p. 216)

- |  |               |
|--|---------------|
| (1) 49.1614 lbs. per sec. or 79.01<br>tons per hour.                                   | (3) 24.11 ft. |
| (2) Approach and cling together<br>because where speed is higher<br>pressure is lower. | (4) 69½ sec.  |

## EXAMPLES LXX (pp. 216-217)

- |  |  |
|--|--|
| (1) Set the tube at various angles.  | (3) 500 and ½π nearly.   |
| (2) Mercury gives compactness for<br>high pressures, water greater<br>sensibility, glycerine is<br>valued because so slightly<br>volatile. | (4) 110.37 c.c.<br>(5) 58.28 cm. of mercury.<br>(6) 39.4° C.<br>(7) 152 ft.-lbs. wt. |

## EXAMPLES LXXI (p. 217)

- |  |                |
|--|----------------|
| (1) 13.4° C. or 56.1° F.   | (5) 68.16 lbs. |
| (2) Vapour 0.0000116 gm. per c.c.<br>Dry air 0.001163 gm. per c.c. |                |

## EXAMPLES LXXII (p. 217)

- |  |   |
|--|---|
| (2) 75.66 cm. Because the differ-<br>ence of 0.14 gives only a<br>fourth place decimal in the<br>correction. | 13.35 ft. leaving the air to<br>occupy 11.65 ft.              |
| (3) 55.6 ins. of mercury; it rises   | (4) 29.757 ins. of mercury.<br>(5) 5833 ft.<br>(6) 18,140 ft. |

## EXAMPLES LXXIII (p. 218)

- |           |   |
|-----------|---|
| (4) 9 ft. | (7) $22\frac{2}{3}$ is the value of the quotient :<br>(Shift of interface in cm.)<br>$\div$ (pressure in cm. of water). |
|-----------|---|

## EXAMPLES LXXIV (pp. 218-219)

- |                                |   |
|--------------------------------|---|
| (3) 544 sec., or 9 min. 4 sec. | (9) Upper to lower as 13 : 14.                      |
| (5) 36.7 gals. per min.        | (10) Two-thirds the depth of the<br>first triangle. |
| (6) 2.73 ins.                  |   |
| (8) One-third and two-thirds.  |   |

## EXAMPLES LXXV (p. 219)

- |  |   |
|--|---|
| (1) 1048 ft.-tons wt.  | through the axis and so have<br>no moment about it. |
| (2) 241 ft.  | (6) 411.43 tons.                                    |
| (4) On base $3W$ , on each slant face<br>$2W$ , giving an upward com-<br>ponent $\frac{2}{3}W$ . | (7) Ten minutes.<br>(8) 530 yds.                    |
| (5) No. All the normal pressures<br>on the curved surface pass                                   | (9) 47,803 ft.-tons wt.<br>(10) 2,473,000 tons.     |

## SOLUTIONS AND HINTS

Ex. III. 6. Let  $x$  miles be the required distance; then, since the two directions taken are at right angles, we have

$$12^2 + x^2 = 13^2,$$

whence

$$x = 5 \text{ miles.}$$

Ex. IV. 2. For the instantaneous speed, draw very carefully a tangent to the graph at the point in question, then measure the rise (or increase of ordinate) of this tangent *per unit of abscissæ*, i.e. the rate of increase of distance per unit time. And this is the speed required.

5. The maximum speed corresponds to the steepest part of the space-time graph.

Ex. v. 4. Find the distances described in 1, 2, 3, 4, etc., seconds, then by subtraction obtain those for any desired second.

Ex. VI. 1. Speed is expressed by

$$\begin{aligned} 20 \left( \frac{15 \text{ yards}}{10 \text{ seconds}} \right) &= \frac{20 \times 15 \times 3 \left( \frac{\text{feet}}{\text{sec.}} \right)}{10} = \frac{20 \times 45 \times 60 \times 60 \left( \frac{5280 \text{ ft.}}{60 \times 60 \text{ sec.}} \right)}{10 \times 5280} \\ &= 61.11 \left( \frac{\text{miles}}{\text{hour}} \right). \end{aligned}$$

2. A bicycle *geared* to 70 ins. travels the circumference of a circle of 70 ins. diameter for each revolution of the pedals.

Ex. VII. 1. Compound the boat's velocity and that of the man relative to the boat.

2. To find the apparent velocity of the wind relative to the boat, compound with the wind's velocity and the boat's a velocity equal and opposite to that of the boat. This brings the boat to rest and gives to the wind the appearance of coming from the east, i.e. it blows to the west. But this resultant velocity is compounded from the wind's real velocity to the north-west and the added velocity of 10 knots to the south-west. So the wind's real speed is 10 knots and its apparent speed is  $10\sqrt{2}$  knots.

Ex. xxvi. 5. Pressure required is expressed by

$$\begin{aligned} &7.3 \times 1.24 \left( \frac{\text{gms. wt.}}{\text{cm.}^2} \right) \\ &= \frac{7.3 \times 1.24 \times 2.54^2}{453.6} \left( \frac{453.6 \text{ gms. wt.}}{(2.54 \text{ cm.})^2} \right) \\ &= 0.128 \left( \frac{\text{lbs. wt.}}{\text{inch}^2} \right) \end{aligned}$$

Ex. xxvii. 4. Suppose the moulds to separate at the bottom of the legs. Hence the force tending to lift the upper mould is that due to the liquid pressure at a depth of 3 ft. and over the main surface 5 ft. by 4 ft.

- Ex. xxviii. 5. Find an expression for the pressure on the whole rectangle and then determine the depth  $x$  of the upper part upon which the pressure would be half.
- Ex. xlvi. 2. Assume Boyle's Law and so by use of the tube find the barometric pressure. Then this is the isothermal elasticity sought.
- Ex. lv. 1. Its working does not conflict with the conservation of energy; much water flows down the gentle incline and some runs to waste, only a small part of the water is forced up to the great height.
- Ex. lxxiii. 1. While the bomb falls 8 ft., the van (at 22 ft. per second) advances 8.8 ins., hence the time is  $8.8 \div (12 \times 22)$  sec. Thus the speed of the bomb is  $8 \div \{8.8 \div (12 \times 22)\}$ , and from this its height of fall may be calculated.
3. Since the train is always either uniformly accelerating from rest or retarding uniformly to rest, the maximum speed is double the mean speed, which is total distance divided by total time.
4. Let the speed the train should have had be  $v$  miles per hour. Then the scheduled times for the 40 and 20 miles runs are  $40 \div v$  and  $20 \div v$  respectively. Also the actual speeds of the train over these distances were accordingly

$$\frac{40}{\frac{40}{v} + \frac{2}{60}} \quad \text{and} \quad \frac{20}{\frac{20}{v} - \frac{4}{60}}$$

But the second speed exceeded the first by 12 miles per hour. Hence we obtain the equation,

$$\frac{20}{\frac{20}{v} - \frac{4}{60}} = \frac{40}{\frac{40}{v} + \frac{2}{60}} + 12.$$

This reduces to the quadratic

$$7v^2 + 50v - 20,000 = 0$$

or,

$$(v - 50)(7v + 400) = 0.$$

Hence the right speed was 50 miles per hour. (The actual speeds were 48 and 60 miles per hour respectively.)

5. It is evident from Art. 102 that, for equilibrium of the marbles *anywhere*, the upper surface should be concave and a paraboloid. Thus in comparison with this paraboloid the conical shape with straight radii inclined at a fixed angle may give too much slope near the centre and too little near the outer edge. The dividing circle is at the radius where the cone is tangential to the paraboloid; or, in other words, where the paraboloid has the same slope as the cone.
- Ex. lxxiv. 2. The weight in falling through 16 ft. acquires the velocity of 32 ft. per sec. Suppose the common velocity of weight and pile after impact to be  $v$  ft. per sec. Then, since the impulses on the pile and the weight are equal and opposite, the momentum gained by one will equal that lost by the other. Or,

$$2 \times v = \frac{1}{2}(32 - v),$$

whence

$$v = 32/5 \text{ ft. per sec.}$$

Accordingly at this speed the kinetic energy of weight and pile is

$$\frac{1}{2}(2 + \frac{1}{2})(\frac{32}{5})^2 \div g \text{ ft.-tons.}$$

But this equals the work done against the resistance, viz., force into distance through which it is overcome.

Now the total resistance is 98 tons weight, so, deducting the weights

of pile and the striking mass, we have a net resistance of  $95\frac{1}{2}$  tons. If the distance the pile sinks is  $s$  ins., we have

$$\frac{1}{2}(2 + \frac{1}{2})\left(\frac{32}{5}\right)^2 \div 32 = 95\frac{1}{2} \times \frac{s}{12}$$

5. A body of mass  $m$  and speed  $v$  has a kinetic energy  $\frac{1}{2}mv^2$  and by upward steering in *still* air may, apart from friction, rise to a height  $h$ , given by

$$\frac{1}{2}mv^2 = mgh$$

before its onward speed is exhausted.

But, if a bird or aeroplane is flying horizontally down wind, its speed with respect to the earth is the sum of the speed of the wind and that of the body through the air. In the present problem this is 90 *miles per hour*. Then, when it turns from east to west, it is going at 120 miles per hour through the air, because it meets the wind. Hence, we have to calculate the height it may rise before its speed of 120 is reduced to its normal 60 miles per hour through the air, *i.e.* 30 *miles per hour with respect to the earth*.

Accordingly, for this case, we have

$$h = \frac{(90^2 - 30^2)(22/15)^2}{2 \times 32} = 242 \text{ ft.}$$

- EX. LXVI. 2. Take a ring element of radius  $r$  and very small radial width  $s$ . Then its area is  $2\pi rs$ , its surface density  $3r^2$ , and its mass the product of these. Thus, the total mass of the disc is given by

$$6\pi \int_0^2 r^3 s = 6\pi \times \frac{2^4}{4} = 24\pi.$$

6. Find moment of inertia about diameter and then use the theorem of parallel axes.

- EX. LXXIV. 1. Draw the figure and add the line of action of the resultant R of the forces P and Q. Let this line cut the circle in C.

Then, because O moves on the circle on which M and N are fixed, the angle MON is constant. Further, because the ratio of P and Q is constant the ratio of the sines of opposite angles is constant. (See equation (3) of Art. 25.) Thus, each of the angles MOC and NOC is constant. That is, C is the fixed point required.

2. The resultant of the two inclined forces OP and OQ is the diagonal through O of the parallelogram on OP and OQ, and therefore its line of action bisects the other diagonal PQ. Let the middle point of PQ be M.

Then OK passes through M because it is the line of action of the resultant of forces represented by lines terminating in PQ whose middle point is M.

For the same reason the resultant of KP and KQ passes through M, and therefore also through O, as was to be shown, because by construction OMK is a straight line.

3. Consider the state of things when the spirit is at the height  $x$  ft. and let its level fall by the very small distance  $h$  ft. in the very small time  $s$  sec., the speed of outflow being theoretically  $v$  ft./sec. Then the radius at that level is  $x/3$  and the volume discharged is  $\pi x^2 h/3^2$ . But this has passed through the opening and equals half the product of the theoretical speed ( $v = \sqrt{2gx}$ ), the area of the opening and the time  $s$ . We thus obtain—

$$\frac{1}{2}\sqrt{2gx}\left(\frac{0.144}{144}\right)s = \pi\left(\frac{x}{3}\right)^2 h,$$

whence

$$s = \frac{2000\pi}{8 \times 9} x^{3/2} (-h)$$

Now  $t$ , the time required to empty the vessel is  $\Sigma s$ , from  $x=3$  to  $x=0$ . Hence, we find

$$t = \frac{2000\pi}{8 \times 9} \Sigma_3^0 x^{3/2} (-h) = 100\pi\sqrt{3} \text{ sec.}$$

4. Let the cone have height  $h$ , radius of base  $r$ , semi-vertical angle  $\alpha$ , and specific gravity  $s$ . Also, for convenience, write  $f^2 = s$ . Call the vertex of the cone A and let it be downwards, and denote its centre of buoyancy by H, its centre of gravity by G, and metacentre by M. Then to be just stable G and M coincide. Now the depth immersed is  $fh$ , and the radius here is  $f r$ , we thus have

$$AG = \frac{3}{4}h, \quad AH = \frac{3}{4}fh$$

and

$$HM = \frac{\pi f^2 r^2 \cdot \frac{1}{4} f^2 r^2}{\pi f^2 r^2 \cdot \frac{3}{4} fh} = \frac{3}{4} \frac{f r^2}{h}$$

But

$$AG = AH + HM,$$

or

$$\frac{3}{4}h = \frac{3}{4}fh + \frac{3}{4} \frac{f r^2}{h}$$

Thus

$$f = \frac{h^2}{h^2 + r^2} = \cos^2 \alpha$$

or

$$s = f^2 = \cos^4 \alpha$$

as was to be shown.

10. Let the base of the first triangle be  $b$  and its depth  $p$ , and take the base of the second triangle at depth  $x$ , then its length is

$$\frac{b}{p} (p-x)$$

Thus the area of this second triangle is  $\frac{b}{2p} x(p-x)$ , the depth of its centroid is  $\frac{2}{3}x$ , and the force upon it proportional to the product of these two, viz. :

$$\frac{2}{3} \cdot \frac{b}{2p} x^2 (p-x)$$

Hence to make this force a maximum, we must make

$$px^2 - x^3 = y, \text{ say,}$$

a maximum.

To find the value of  $x$ , which fulfils this condition, plot a graph with  $y$  as ordinates and  $x$  as abscissæ. For the highest point of the curve it will be found that

$$x = \frac{2}{3}p$$

which is the answer sought.

Ex. LXXV. 3. By Boyle's Law we have

$$np \frac{4}{3} \pi r^3 = q \frac{4}{3} \pi s^3$$

if  $p$  and  $r$  are the pressure and radius of original bubbles and  $q$  and  $s$  those of the final one. Also, if  $T$  is the surface tension, we have

$$p = \frac{4T}{r} \quad \text{and} \quad q = \frac{4T}{s}$$

Hence  $nr^3 = s^3$  as required.

7. By equation (11), p. 123, the time  $t$  required to empty the bottom half of depth  $b$  is given by

$$t = \frac{2\sqrt{b}}{h}$$

With the notation of equation (8), p. 122, it is seen that the time 5 minutes required to empty the top half is given by

$$5 \times 60 = \frac{Sb}{CVA\sqrt{2gb}} = \frac{\sqrt{b}}{k}$$

Thus  $t = 10$  minutes.

8. The still water in the tank has a *speed* of 60 miles an hour or 88 ft. per sec. *relative* to the train. If the relative speed on delivery is  $v$  ft. per sec., we may equate the loss of kinetic energy to the gain of potential energy. Thus—

$$\frac{1}{2}m88^2 - \frac{1}{2}mv^2 = mg \times 9$$

Whence

$$v = 84.7 \text{ ft. per sec.}$$

If the time for delivery of 300 cubic feet is  $t$  seconds, then, without any coefficient of discharge, we have as its minimum value

$$t = \frac{300}{84.7 \times (\frac{1}{2})^2 \times \frac{\pi}{4}} = 18.04 \text{ sec.}$$

Whence the distance as sought.

# EXAMINATION PAPERS

BOARD OF EDUCATION, 1912.

## Subject 5.—Theoretical Mechanics (Fluids).

### INSTRUCTIONS.

A full and correct answer to an easy question will in all cases secure a larger number of marks than an incomplete or inexact answer to a more difficult one.  
*The examination in this subject lasts for three hours.*

### LOWER EXAMINATION.

You are not permitted to answer more than *eight* questions.

1. Explain, with examples, the phrase "Equal transmission of fluid pressure."  
Draw carefully a diagram of a hydraulic press, and explain how it comes about that a small force is able to produce a large pressure. (15)
2. A vessel, in the shape of a frustum of a cone with the broader base downwards, is filled with water and then placed upon a table. Compare the pressure on the base of the vessel with the pressure of the vessel on the table, and explain the so-called "hydrostatic paradox." (20)
3. Show how, in general, to find the resultant pressure on a curved surface completely immersed in a liquid.  
A hemispherical vessel, with a plane base and full of liquid, is placed with its base vertical. Find the resultant horizontal and vertical pressures on the curved surface. (25)
4. Show in a diagram the forces which keep a floating body in equilibrium.  
Find the density of a solid cone which floats in water with axis vertical and one-half of its curved surface immersed. (20)
5. What is the "characteristic equation of a gas" ?  
Explain how variations of barometric height or of temperature will cause air to enter or leave a given space.  
Show that a room 12 m.  $\times$  5 m.  $\times$  5 m. will lose about  $6\frac{1}{2}$  per cent. of air if the barometer falls from 760 mm. to 750 mm., and the temperature rises from zero to  $15^{\circ}$  C. Calculate the weight of the air lost. (25)
6. State shortly the principle of construction of the mercury barometer.  
A barometer tube has 18 cub. cms. of air at atmospheric pressure above the mercury in the tube, which is then inverted in a mercury bath; it is found that the air now occupies 38 cub. cms. and the mercury 400 mm. of the tube above the surface of the bath. Find the atmospheric pressure in mm. of mercury. (30)
7. On what principle is the diving-bell constructed ?  
A wide tube, 10 inches long, open at both ends, is dipped vertically into mercury to a depth of  $5\frac{1}{2}$  inches at a time when the barometer stands at 30 inches; if the finger be then placed on the upper end and the tube raised, show that a column of mercury 5 inches long will be raised. (25)

8. What force is necessary to support a cylindrical bell-jar full of mercury immersed in mercury; its diameter is 12 cm.; its height above the mercury in which it is immersed, 25 cm., and the pressure of the atmosphere, 76 cm. ? (20)
9. Find the density of the air and the height of a mercury barometer at a given depth within the earth; gravity being supposed to vary as the distance from the earth's centre, and the temperature of the air from the surface to where the barometer stands to remain constant. (30)
10. State the law which governs the pressure of mixed gases.  
 Two litres of hydrogen at pressure  $3\frac{1}{2}$  atmospheres,  
 One litre of nitrogen " 5 " "  
 Three litres of carbonic acid "  $1\frac{1}{2}$  " "  
 are placed in a vessel whose capacity is 2.75 cubic decimetres. What is the final pressure of the mixture, the temperature remaining constant ? (25)
11. Describe, with a diagram, an ordinary air-pump.  
 The receiver has a capacity of 5 cubic decimetres: what is the capacity of the barrel in litres if the air is reduced to  $\frac{1}{2}$  of its density in 6 strokes ? (20)
12. Give a short rule for ascertaining the Centigrade temperature when that shown by the Fahrenheit thermometer is known.  
 Show that the reading Fahrenheit may be obtained by adding 32 to the sum of the Centigrade and Réaumur readings. (20)

## BOARD OF EDUCATION, 1913.

## Subject 5.—Theoretical Mechanics (Fluids).

## LOWER EXAMINATION.

You are not permitted to answer more than eight questions.

1. Explain, fully, the expressions—

- (i) poundals per square foot,  
 (ii) dynes per square centimetre.

Show how to convert a pressure of pounds weight per square inch into grammes weight per square centimetre. (15)

2. Show how to find the specific gravity of a mixture of given weights of two fluids of given specific gravities.

Find the specific gravity of a mixture formed of equal weights of water and of a fluid of specific gravity 0.9. (20)

3. Give a graphical construction for the centre of pressure of any plane area immersed in liquid.

A triangle is wholly immersed in a liquid with its base in the surface; show how to draw a horizontal straight line in its plane so as to divide it into two parts, the resultant pressures on which are equal. (20)

4. A spherical surface of radius  $r$  contains gas at a pressure  $p$ ; if the tension of the surface be  $t$ , find the relation between  $r$ ,  $p$  and  $t$ .

A thin india-rubber ball containing air has a radius  $a$  when the temperature is  $\tau^\circ$  C. If the tension of the rubber varies directly as the area of the surface of the ball, find the radius when the temperature is  $\theta^\circ$  C. (20)

5. What forces act upon a body which is wholly immersed in a fluid ?

A heavy cylinder of specific gravity 12.4 and 13 inches long floats wholly immersed with its axis vertical in a vessel filled with mercury (specific gravity, 13.6) and water. Find the length of the portion of the cylinder which is surrounded by the water. (20)

6. How could you determine the specific gravity of a piece of metal ?

An empty closed cubical vessel, having sides 1 inch in thickness, is

made of material whose specific gravity is  $2\frac{89}{127}$ . If the vessel can float in water, show that its internal volume must be at least a cubic foot. (20)

7. Show that when a body floats in water the centres of gravity of the body and of the displaced liquid are in the same vertical line.

If a weight of  $w$  kilogrammes floats in water with  $a$  cubic metres above the surface, find its volume in cubic metres. (20)

8. Describe the "Siphon" and explain its use.

State clearly the conditions necessary for the effective working of a siphon.

When the mercurial barometer stands at 29.5 inches, over what height can water be carried by a siphon?

[Specific gravity of mercury, 13.6.] (20)

9. What do you know about the pressure exerted by a mixture of gases? A cubic foot of a gas at a pressure of 30 inches of mercury is mixed with a cubic yard of another gas at a pressure of 29 inches of mercury and the mixture is placed in a vessel of volume 2 cubic feet; find the resulting pressure, the temperatures being constant. (25)

10. Give a statement of Boyle's Law and describe how it may be experimentally verified.

A cylindrical tube,  $25\frac{1}{2}$  inches in length, closed at one end, is immersed vertically in water so that the closed end is in the surface of the water. Show that the water will rise  $1\frac{1}{2}$  inches in the tube if the height of the water barometer be 32 feet. (30)

11. A barometer becomes faulty when a little air is introduced into the vacuum, explain why this is.

A barometer stands at 30 ins., the volume of the vacuum is  $\frac{7}{8}$  cubic inch, and the area of a cross section of the tube is  $\frac{3}{8}$  square inch; how much of the external air introduced into the vacuum will depress the mercury 5 inches? (30)

12. A gas at pressure  $p_0$  is enclosed in an envelope whose volume is  $v_0$  cubic centimetres, and expands isothermally until the volume is  $v_1$  cubic centimetres. Give the expression for the work done, and, if this be measured in ergs, state the units in which  $p_0$  is measured.

Is the work done by the pressure of an expanding gas on its envelope always equal to the work done against any external pressure which acts upon the surface of the envelope? (35)

BOARD OF EDUCATION, 1914.

Subject 5.—Theoretical Mechanics (Fluids).

LOWER EXAMINATION.

You are not permitted to answer more than eight questions.

1. Distinguish between "specific weight," "specific gravity" and "density."

Show that, in the C.G.S. system of units, the same number expresses both the specific gravity and density. (15)

2. A body of specific gravity  $\sigma$  when weighed against a weight of specific gravity  $\rho$  in water—the whole balance being immersed—appears to have a weight  $W$ . Show that its true weight is

$$\frac{\sigma}{\sigma - 1} \cdot \frac{\rho - 1}{\rho} W \quad (20)$$

3. If a plane area, occupying any position in a liquid, is lowered by a motion of translation unaccompanied by rotation, show that the point of application of the resultant pressure on one side of the area rises towards the centre of area the more the area is lowered.

A cube is filled with liquid and has one diagonal vertical; show that the pressure on one of the lower faces is  $\frac{2}{\sqrt{3}}$  of the whole weight of the liquid. (20)

4. What is the resultant vertical thrust of a liquid on a curved surface ?

A hemispherical bowl is filled with water and then closed by a plane disc ; if it be now placed with the base in contact with a horizontal table compare the resultant vertical thrust on the curved surface with the thrust upon the table. (20)

5. Investigate the position of the Centre of Pressure of an immersed plane area.

Has alteration of atmospheric pressure any effect upon the position ?

Find the position of the Centre of Pressure of a rhombus which is totally immersed with a diagonal (of length  $a$ ) vertical and its centre at a depth  $b$ . (25)

6. Discuss, shortly, the conditions of equilibrium of a body freely floating in a liquid.

A uniform log of square section floats in water with one angle below the surface ; prove that there are two unsymmetrical positions of equilibrium if the specific gravity of the log be less than  $\frac{3}{2}$ . (30)

7. How does the weight of air occupying a constant volume vary with the temperature and pressure ?

A room, not hermetically sealed, contains 150 lbs. of air when the temperature is  $10^{\circ}$  C. and the pressure equal to 29 inches of mercury. What is the weight of the air in the room when the temperature falls to  $0^{\circ}$  C. and the pressure rises to 30 inches of mercury ? (20)

8. Describe the construction of an ordinary mercury barometer. In a mercury barometer, the area of the cross-section of the tube is 4 square inches, the length of the Torricellian vacuum is 6 inches, and the mercury stands at a height of 30 inches. One cubic inch of the external air, the temperature being  $27^{\circ}$  C., is introduced into the vacuum, and then the temperature falls to  $7^{\circ}$  C. ; show that the height of the mercury column will now be 29 inches. (30)

9. Explain why the barometric height has to be considered in weighings of precision.

The weights of a body are found to be  $W$ ,  $W'$  when the barometric heights are  $h$ ,  $h'$  ; find the weight when the barometric height is  $h''$ . (25)

10. Describe some form of condensing air-pump. Show how to calculate the density of the air after a given number of strokes. (20)

11. State what you know concerning the pressure exerted by a mixture of gases.

Different gases have volumes 1 cubic foot and 1 cubic yard, and are at pressures of 29" and 30" of mercury respectively ; if they be mixed together and placed in a vessel of 5 cubic feet capacity, find the resultant pressure, the temperature remaining constant. (25)

12. Prove Torricelli's Law giving the velocity of discharge of a liquid from a small orifice.

A hemisphere a foot in diameter, with axis vertical, is filled with fluid. Find the time in which it will empty itself through a small orifice in its vertex, taking the area of the *vena contracta* to be  $\frac{1}{4}$  of a square inch. (25)

# MATHEMATICAL TABLES<sup>1</sup>

(Reproduced here by kind permission of the Controller of H.M. Stationery Office.)

*If any Examination Paper contains questions for the solution of which Useful Constants and Mathematical Tables are necessary, a copy of the Tables will be supplied to each candidate taking that paper.*

## USEFUL CONSTANTS.

(Many of the more fundamental data given here should become, by repeated use, part of the mental equipment of technical students. They are given in this place for convenience of reference.)

1 Inch = 25.40 millimetres. 1 mm. = 0.03937 inch.

1 Gallon = 0.1604 cubic foot = 10 lb. of water at 62° F.

1 Knot = 6080 feet per hour = 1 Nautical mile per hour.

Weight of 1 lb. in London = 445,000 dynes.

One pound avoirdupois = 7000 grains = 453.6 grammes.

1 Cubic foot of water weighs 62.3 lb.

1 Cubic foot of air at 0° C. and 1 atmosphere, weighs 0.0807 lb.

1 Cubic foot of Hydrogen at 0° C. and 1 atmosphere, weighs 0.00559 lb.

1 Foot-pound = 1.3562 × 10<sup>7</sup> ergs.

1 Horse-power-hour = 33000 × 60 foot-pounds.

1 Electrical unit = 1000 watt-hours = 1.34 horse-power-hours.

Joule's Equivalent to suit Regnault's H, is  $\begin{cases} 774 \text{ ft.-lb.} = 1 \text{ Fah. unit.} \\ 1393 \text{ ft.-lb.} = 1 \text{ Cent. } \end{cases}$  „

1 Horse-power = 33000 foot-pounds per minute = 746 watts.

Volts × ampères = watts.

1 Atmosphere = 14.7 lb. per square inch = 2116 lb. per square foot = 760 mm. of mercury = 10<sup>6</sup> dynes per sq. cm. nearly.

A column of water 2.3 feet high corresponds to a pressure of 1 lb. per sq. inch.

Absolute temp.,  $t = \theta^\circ \text{ C.} + 273^\circ$  or  $\theta^\circ \text{ F.} + 459.4^\circ$ .

Regnault's H = 606.5 + 0.305  $\theta^\circ \text{ C.} = 1082 + 0.305 \theta^\circ \text{ F.}$

[N.B.—Every student who studies the properties of steam should habitually use a Steam Table. Regnault's expression gives only approximately correct results, and students should be definitely told that it is not accurate, though by its means the quantities can be calculated with sufficient precision for most engineering problems.]

$p u^{1.0666} = 479.$

$\log_{10} p = 6.1007 - \frac{B}{t} - \frac{C}{t^2}$

where  $\log_{10} B = 3.1812$ ,  $\log_{10} C = 5.0882$ .

$p$  is in pounds per sq. inch,  $t$  is absolute temperature Centigrade.

$u$  is the volume in cubic feet per pound of steam.

$\pi = 3.1416.$

One radian = 57.30 degrees.

To convert common into Napierian logarithms, multiply by 2.3026.

The base of the Napierian logarithms is  $e = 2.7183.$

The value of  $g$  at London = 32.182 feet per sec. per sec.

<sup>1</sup> These "Useful Constant and Mathematical Tables" are also published separately, and may be purchased, either directly or through any Bookseller, from Wyman and Sons, Ltd., Fetter Lane, E.C., and 54, St. Mary Street, Cardiff; or H.M. Stationery Office (Scottish Branch), 23, Forth Street, Edinburgh; or E. Ponsonby, Ltd., 116, Grafton Street, Dublin. Price 1d., or 5s. per 100.

## LOGARITHMS

	0	1	2	3	4	5	6	7	8	9	1234	5	6789
10	0000	0043	0086	0128	0170	0212	0253	0294	0334	0374	4 9 13 17 4 8 12 16	21	26 30 34 38 24 28 32 37
11	0414	0453	0492	0531	0569	0607	0645	0682	0719	0755	4 8 12 15 4 7 11 15	19	23 27 31 35 22 26 30 33
12	0792	0828	0864	0899	0934	0969	1004	1038	1072	1106	3 7 11 14 3 7 10 14	18	21 25 28 32 20 24 27 31
13	1139	1173	1206	1239	1271	1303	1335	1367	1399	1430	3 7 10 13 3 7 10 12	16	20 23 26 30 19 22 25 29
14	1461	1492	1523	1553	1584	1614	1644	1673	1703	1732	3 6 9 12 3 6 9 12	15	18 21 24 28 17 20 23 26
15	1761	1790	1818	1847	1875	1903	1931	1959	1987	2014	3 6 9 11 3 5 8 11	14	17 20 23 26 16 19 22 25
16	2041	2068	2095	2122	2148	2176	2201	2227	2253	2279	3 5 8 11 3 5 8 10	13	16 19 22 24 15 18 21 23
17	2304	2330	2355	2380	2405	2430	2455	2480	2504	2529	3 5 8 10 2 5 7 10	13	15 18 20 23 15 17 19 22
18	2553	2577	2601	2625	2648	2672	2695	2718	2742	2765	2 5 7 9 2 5 7 9	12	14 16 19 21 14 16 18 21
19	2788	2810	2833	2856	2878	2900	2923	2945	2967	2989	2 4 7 9 2 4 6 8	11	13 16 18 20 13 15 17 19
20	3010	3032	3054	3075	3096	3118	3139	3160	3181	3201	2 4 6 8	11	13 15 17 19
21	3222	3243	3263	3284	3304	3324	3345	3365	3385	3404	2 4 6 8	10	12 14 16 18
22	3424	3444	3464	3483	3502	3522	3541	3560	3579	3598	2 4 6 8	10	12 14 15 17
23	3617	3636	3655	3674	3692	3711	3729	3747	3766	3784	2 4 6 7	9	11 13 15 17
24	3802	3820	3838	3856	3874	3892	3909	3927	3945	3962	2 4 5 7	9	11 12 14 16
25	3979	3997	4014	4031	4048	4065	4082	4099	4116	4133	2 3 5 7	9	10 12 14 15
26	4150	4166	4183	4200	4216	4232	4249	4265	4281	4298	2 3 5 7	8	10 11 13 15
27	4314	4330	4346	4362	4378	4393	4409	4425	4440	4456	2 3 5 6	8	9 11 13 14
28	4472	4487	4502	4518	4533	4548	4564	4579	4594	4609	2 3 5 6	8	9 11 12 14
29	4624	4639	4654	4669	4683	4698	4713	4728	4742	4757	1 3 4 6	7	9 10 12 13
30	4771	4786	4800	4814	4829	4843	4857	4871	4886	4900	1 3 4 6	7	9 10 11 13
31	4914	4928	4942	4955	4969	4983	4997	5011	5024	5038	1 3 4 6	7	8 10 11 12
32	5051	5065	5079	5092	5105	5119	5132	5145	5159	5172	1 3 4 5	7	8 9 11 12
33	5185	5198	5211	5224	5237	5250	5263	5276	5289	5302	1 3 4 5	6	8 9 10 12
34	5315	5328	5340	5353	5366	5378	5391	5403	5416	5428	1 3 4 5	6	8 9 10 11
35	5441	5453	5465	5478	5490	5502	5514	5527	5539	5551	1 2 4 5	6	7 9 10 11
36	5563	5575	5587	5599	5611	5623	5635	5647	5658	5670	1 2 4 5	6	7 8 10 11
37	5682	5694	5705	5717	5729	5740	5752	5763	5775	5786	1 2 3 5	6	7 8 9 10
38	5796	5809	5821	5832	5843	5855	5866	5877	5888	5899	1 2 3 5	6	7 8 9 10
39	5911	5922	5933	5944	5955	5966	5977	5988	5999	6010	1 2 3 4	5	7 8 9 10
40	6021	6031	6042	6053	6064	6075	6085	6096	6107	6117	1 2 3 4	5	6 8 9 10
41	6128	6138	6149	6160	6170	6180	6191	6201	6212	6222	1 2 3 4	5	6 7 8 9
42	6232	6243	6253	6263	6274	6284	6294	6304	6314	6325	1 2 3 4	5	6 7 8 9
43	6335	6345	6355	6365	6375	6385	6395	6405	6415	6425	1 2 3 4	5	6 7 8 9
44	6435	6444	6454	6464	6474	6484	6493	6503	6513	6522	1 2 3 4	5	6 7 8 9
45	6532	6542	6551	6561	6571	6580	6590	6599	6609	6618	1 2 3 4	5	6 7 8 9
46	6628	6637	6646	6655	6665	6675	6684	6693	6702	6712	1 2 3 4	5	6 7 7 8
47	6721	6730	6739	6749	6758	6767	6776	6785	6794	6803	1 2 3 4	5	5 6 7 8
48	6812	6821	6830	6839	6848	6857	6866	6875	6884	6893	1 2 3 4	4	5 6 7 8
49	6902	6911	6920	6928	6937	6946	6955	6964	6972	6981	1 2 3 4	4	5 6 7 8
50	6990	6998	7007	7016	7024	7033	7042	7050	7059	7067	1 2 3 3	4	5 6 7 8

The copyright of that portion of the above table which gives the logarithms of numbers from 1000 to 2000 is the property of Messrs. Macmillan and Company, Limited, who, however, have authorised the use of the form in any reprint published for educational purposes.

LOGARITHMS

	0	1	2	3	4	5	6	7	8	9	12345	6789
51	7076	7084	7093	7101	7110	7118	7126	7135	7143	7152	1 2 3 3	4 5 6 7 8
52	7160	7168	7177	7185	7193	7202	7210	7218	7226	7235	1 2 2 3	4 5 6 7 7
53	7243	7251	7259	7267	7275	7284	7292	7300	7308	7316	1 2 2 3	4 5 6 6 7
54	7324	7332	7340	7348	7356	7364	7372	7380	7388	7396	1 2 2 3	4 5 6 6 7
55	7404	7412	7419	7427	7435	7443	7451	7459	7466	7474	1 2 2 3	4 5 5 6 7
56	7482	7490	7497	7505	7513	7520	7528	7536	7543	7551	1 2 2 3	4 5 5 6 7
57	7559	7566	7574	7582	7589	7597	7604	7612	7619	7627	1 2 2 3	4 5 5 6 7
58	7634	7642	7649	7657	7664	7672	7679	7686	7694	7701	1 1 2 3	4 4 5 6 7
59	7709	7716	7723	7731	7738	7745	7752	7760	7767	7774	1 1 2 3	4 4 5 6 7
60	7782	7789	7796	7803	7810	7818	7825	7832	7839	7846	1 1 2 3	4 4 5 6 6
61	7853	7860	7868	7875	7882	7889	7896	7903	7910	7917	1 1 2 3	4 4 5 6 6
62	7924	7931	7938	7945	7952	7959	7966	7973	7980	7987	1 1 2 3	3 4 5 6 6
63	7993	8000	8007	8014	8021	8028	8035	8041	8048	8055	1 1 2 3	3 4 5 5 6
64	8062	8069	8075	8082	8089	8096	8102	8109	8116	8122	1 1 2 3	3 4 5 5 6
65	8129	8136	8142	8149	8156	8162	8169	8176	8182	8189	1 1 2 3	3 4 5 5 6
66	8195	8202	8209	8215	8222	8228	8235	8241	8248	8254	1 1 2 3	3 4 5 5 6
67	8261	8267	8274	8280	8287	8293	8299	8306	8312	8319	1 1 2 3	3 4 5 5 6
68	8325	8331	8338	8344	8351	8357	8363	8370	8376	8382	1 1 2 3	3 4 4 5 6
69	8388	8395	8401	8407	8414	8420	8426	8432	8437	8445	1 1 2 2	3 4 4 5 6
70	8451	8457	8463	8470	8476	8482	8488	8494	8500	8506	1 1 2 2	3 4 4 5 6
71	8513	8519	8525	8531	8537	8543	8549	8555	8561	8567	1 1 2 2	3 4 4 5 5
72	8573	8579	8585	8591	8597	8603	8609	8615	8621	8627	1 1 2 2	3 4 4 5 5
73	8633	8639	8645	8651	8657	8663	8669	8675	8681	8686	1 1 2 2	3 4 4 5 5
74	8692	8698	8704	8710	8716	8722	8727	8733	8739	8745	1 1 2 2	3 4 4 5 5
75	8751	8756	8762	8768	8774	8779	8785	8791	8797	8802	1 1 2 2	3 3 4 5 5
76	8808	8814	8820	8825	8831	8837	8842	8848	8854	8859	1 1 2 2	3 3 4 5 5
77	8865	8871	8876	8882	8887	8893	8899	8904	8910	8915	1 1 2 2	3 3 4 4 5
78	8921	8927	8932	8938	8943	8949	8954	8960	8965	8971	1 1 2 2	3 3 4 4 5
79	8976	8982	8987	8993	8998	9004	9009	9015	9020	9025	1 1 2 2	3 3 4 4 5
80	9031	9036	9042	9047	9053	9058	9063	9069	9074	9079	1 1 2 2	3 3 4 4 5
81	9085	9090	9096	9101	9106	9112	9117	9122	9128	9133	1 1 2 2	3 3 4 4 5
82	9138	9143	9149	9154	9159	9165	9170	9175	9180	9186	1 1 2 2	3 3 4 4 5
83	9191	9196	9201	9206	9212	9217	9222	9227	9232	9238	1 1 2 2	3 3 4 4 5
84	9243	9248	9253	9258	9263	9269	9274	9279	9284	9289	1 1 2 2	3 3 4 4 5
85	9294	9299	9304	9309	9315	9320	9325	9330	9335	9340	1 1 2 2	3 3 4 4 5
86	9345	9350	9355	9360	9365	9370	9375	9380	9385	9390	1 1 2 2	3 3 4 4 5
87	9395	9400	9405	9410	9415	9420	9425	9430	9435	9440	0 1 1 2	2 3 4 4 5
88	9445	9450	9455	9460	9465	9469	9474	9479	9484	9489	0 1 1 2	2 3 4 4 5
89	9494	9499	9504	9509	9513	9518	9523	9528	9533	9538	0 1 1 2	2 3 4 4 5
90	9542	9547	9552	9557	9562	9566	9571	9576	9581	9586	0 1 1 2	2 3 4 4 5
91	9590	9595	9600	9605	9609	9614	9619	9624	9628	9633	0 1 1 2	2 3 4 4 5
92	9638	9643	9647	9652	9657	9661	9666	9671	9675	9680	0 1 1 2	2 3 4 4 5
93	9685	9689	9694	9699	9703	9708	9713	9717	9722	9727	0 1 1 2	2 3 4 4 5
94	9731	9736	9741	9745	9750	9754	9759	9763	9768	9773	0 1 1 2	2 3 4 4 5
95	9777	9782	9786	9791	9795	9800	9805	9809	9814	9818	0 1 1 2	2 3 4 4 5
96	9823	9827	9832	9836	9841	9845	9850	9854	9859	9863	0 1 1 2	2 3 4 4 5
97	9868	9872	9877	9881	9886	9890	9894	9899	9903	9908	0 1 1 2	2 3 4 4 5
98	9912	9917	9921	9926	9930	9934	9939	9943	9948	9952	0 1 1 2	2 3 4 4 5
99	9956	9961	9965	9969	9974	9978	9983	9987	9991	9996	0 1 1 2	2 3 4 4 5

ANTILOGARITHMS

	0	1	2	3	4	5	6	7	8	9	1	2	3	4	5	6	7	8	9
00	1000	1002	1005	1007	1009	1012	1014	1016	1019	1021	0	0	1	1	1	1	2	2	2
01	1023	1026	1028	1030	1033	1035	1038	1040	1042	1045	0	0	1	1	1	1	1	2	2
02	1047	1050	1052	1054	1057	1059	1062	1064	1067	1069	0	0	1	1	1	1	1	1	2
03	1072	1074	1076	1079	1081	1084	1086	1089	1091	1094	0	0	1	1	1	1	1	1	2
04	1096	1099	1102	1104	1107	1109	1112	1114	1117	1119	0	1	1	1	1	1	1	1	2
05	1122	1125	1127	1130	1132	1135	1138	1140	1143	1146	0	1	1	1	1	1	1	1	2
06	1148	1151	1153	1156	1159	1161	1164	1167	1169	1172	0	1	1	1	1	1	1	1	2
07	1175	1178	1180	1183	1186	1189	1191	1194	1197	1199	0	1	1	1	1	1	1	1	2
08	1202	1205	1208	1211	1213	1216	1219	1222	1225	1227	0	1	1	1	1	1	1	1	2
09	1230	1233	1236	1239	1242	1245	1247	1250	1253	1256	0	1	1	1	1	1	1	1	2
10	1259	1262	1265	1268	1271	1274	1276	1279	1282	1285	0	1	1	1	1	1	1	1	2
11	1288	1291	1294	1297	1300	1303	1306	1309	1312	1315	0	1	1	1	1	2	2	2	3
12	1318	1321	1324	1327	1330	1334	1337	1340	1343	1346	0	1	1	1	1	2	2	2	3
13	1349	1352	1355	1358	1361	1365	1368	1371	1374	1377	0	1	1	1	1	2	2	2	3
14	1380	1384	1387	1390	1393	1396	1400	1403	1406	1409	0	1	1	1	1	2	2	2	3
15	1413	1416	1419	1422	1426	1429	1432	1435	1439	1442	0	1	1	1	1	2	2	2	3
16	1445	1449	1452	1455	1459	1462	1466	1469	1472	1476	0	1	1	1	1	2	2	2	3
17	1479	1483	1486	1489	1493	1496	1500	1503	1507	1510	0	1	1	1	1	2	2	2	3
18	1514	1517	1521	1524	1528	1531	1535	1538	1542	1545	0	1	1	1	1	2	2	2	3
19	1549	1552	1556	1560	1563	1567	1570	1574	1578	1581	0	1	1	1	1	2	2	2	3
20	1585	1589	1592	1596	1600	1603	1607	1611	1614	1618	0	1	1	1	1	2	2	2	3
21	1622	1626	1629	1633	1637	1641	1644	1648	1652	1656	0	1	1	2	2	2	2	3	3
22	1660	1663	1667	1671	1675	1679	1683	1687	1690	1694	0	1	1	2	2	2	2	3	3
23	1698	1702	1706	1710	1714	1718	1722	1726	1730	1734	0	1	1	2	2	2	2	3	3
24	1738	1742	1746	1750	1754	1758	1762	1766	1770	1774	0	1	1	2	2	2	2	3	3
25	1778	1782	1786	1791	1795	1799	1803	1807	1811	1816	0	1	1	2	2	2	2	3	3
26	1820	1824	1828	1832	1837	1841	1845	1849	1854	1858	0	1	1	2	2	2	2	3	3
27	1862	1866	1871	1875	1879	1884	1888	1892	1897	1901	0	1	1	2	2	2	2	3	3
28	1905	1910	1914	1919	1923	1928	1932	1936	1941	1945	0	1	1	2	2	2	2	3	3
29	1950	1954	1959	1963	1968	1972	1977	1982	1986	1991	0	1	1	2	2	2	2	3	3
30	1995	2000	2004	2009	2014	2018	2023	2028	2032	2037	0	1	1	2	2	2	2	3	3
	2046	2051	2056	2061	2065	2070	2075	2080	2084		0	1	1	2	2	2	2	3	3
	2094	2099	2104	2109	2113	2118	2123	2128	2133		0	1	1	2	2	2	2	3	3
	2143	2148	2153	2158	2163	2168	2173	2178	2183		0	1	1	2	2	2	2	3	3
	193	2198	2203	2208	2213	2218	2223	2228	2234		1	1	2	2	2	2	2	3	3
	2244	2249	2254	2259	2265	2270	2275	2280	2286		1	1	2	2	2	2	2	3	3
	2301	2307	2312	2317	2323	2328	2333	2339	2345		1	1	2	2	2	2	2	3	3
30	2355	2360	2366	2371	2377	2382	2388	2393	2399		1	1	2	2	2	2	2	3	3
04	2410	2415	2421	2427	2432	2438	2443	2449	2455		1	1	2	2	2	2	2	3	3
60	2466	2472	2477	2483	2489	2495	2500	2506			1	1	2	2	2	2	2	3	3
	2523	2529	2535	2541	2547	2553	2559	2564			1	1	2	2	2	2	2	3	3
	2582	2588	2594	2600	2606	2612	2618	2624			1	1	2	2	2	2	2	3	3
	2642	2649	2655	2661	2667	2673	2679	2685			1	1	2	2	2	2	2	3	3
	2704	2710	2716	2723	2729	2735	2742	2748			1	1	2	2	2	2	2	3	3
	2773	2780	2786	2793	2799	2805	2812				1	1	2	2	2	2	2	3	3
	2838	2844	2851	2858	2864	2871	2877				1	1	2	2	2	2	2	3	3
	2904	2911	2917	2924	2931	2938	2944				1	1	2	2	2	2	2	3	3
	2972	2979	2985	2992	2999	3006	3013				1	1	2	2	2	2	2	3	3
	3041	3048	3055	3062	3069	3076	3083				1	1	2	2	2	2	2	3	3
	3112	3119	3126	3133	3141	3148	3155				1	1	2	2	2	2	2	3	3

ANTILOGARITHMS

	0	1	2	3	4	5	6	7	8	9	1 2 3 4	5	6 7 8 9
50	3162	3170	3177	3184	3192	3199	3206	3214	3221	3228	1 1 2 3	4	4 5 6 7
51	3236	3243	3251	3258	3266	3273	3281	3289	3296	3304	1 2 2 3	4	5 5 6 7
52	3311	3319	3327	3334	3342	3350	3357	3365	3373	3381	1 2 2 3	4	5 5 6 7
53	3388	3396	3404	3412	3420	3428	3436	3443	3451	3459	1 2 2 3	4	5 6 6 7
54	3467	3475	3483	3491	3499	3508	3516	3524	3532	3540	1 2 2 3	4	5 6 6 7
55	3548	3556	3565	3573	3581	3589	3597	3606	3614	3622	1 2 2 3	4	5 6 7 7
56	3631	3639	3648	3656	3664	3673	3681	3690	3698	3707	1 2 3 3	4	5 6 7 8
57	3715	3724	3733	3741	3750	3758	3767	3776	3784	3793	1 2 3 3	4	5 6 7 8
58	3802	3811	3819	3828	3837	3846	3855	3864	3873	3882	1 2 3 4	4	5 6 7 8
59	3890	3899	3908	3917	3926	3936	3945	3954	3963	3972	1 2 3 4	5	5 6 7 8
60	3981	3990	3999	4009	4018	4027	4036	4046	4055	4064	1 2 3 4	5	6 6 7 8
61	4074	4083	4093	4102	4111	4121	4130	4140	4150	4159	1 2 3 4	5	6 7 8 9
62	4169	4178	4188	4198	4207	4217	4227	4236	4246	4256	1 2 3 4	5	6 7 8 9
63	4266	4276	4285	4295	4305	4315	4325	4335	4345	4355	1 2 3 4	5	6 7 8 9
64	4365	4375	4385	4395	4406	4416	4426	4436	4446	4457	1 2 3 4	5	6 7 8 9
65	4467	4477	4487	4498	4508	4519	4529	4539	4550	4560	1 2 3 4	5	6 7 8 9
66	4571	4581	4592	4603	4613	4624	4634	4645	4656	4667	1 2 3 4	5	6 7 9 10
67	4677	4688	4699	4710	4721	4732	4742	4753	4764	4775	1 2 3 4	5	7 8 9 10
68	4786	4797	4808	4819	4831	4842	4853	4864	4875	4887	1 2 3 4	6	7 8 9 10
69	4898	4909	4920	4932	4943	4955	4966	4977	4989	5000	1 2 3 5	6	7 8 9 10
70	5012	5023	5035	5047	5058	5070	5082	5093	5105	5117	1 2 4 5	6	7 8 9 11
71	5129	5140	5152	5164	5176	5188	5200	5212	5224	5236	1 2 4 5	6	7 8 10 11
72	5248	5260	5272	5284	5297	5309	5321	5333	5346	5358	1 2 4 5	6	7 9 10 11
73	5370	5383	5395	5408	5420	5433	5445	5458	5470	5483	1 3 4 5	6	8 9 10 11
74	5495	5508	5521	5534	5546	5559	5572	5585	5598	5610	1 3 4 5	6	8 9 10 12
75	5623	5636	5649	5662	5675	5689	5702	5715	5728	5741	1 3 4 5	7	8 9 10 12
76	5754	5768	5781	5794	5808	5821	5834	5848	5861	5875	1 3 4 5	7	8 9 11 12
77	5888	5902	5916	5929	5943	5957	5970	5984	5998	6012	1 3 4 5	7	8 10 11 12
78	6026	6039	6053	6067	6081	6095	6109	6124	6138	6152	1 3 4 6	7	8 10 11 13
79	6166	6180	6194	6209	6223	6237	6252	6266	6281	6295	1 3 4 6	7	9 10 11 13
80	6310	6324	6339	6353	6368	6383	6397	6412	6427	6442	1 3 4 6	7	9 10 12 13
81	6457	6471	6486	6501	6516	6531	6546	6561	6577	6592	2 3 5 6	8	9 11 12 14
82	6607	6622	6637	6653	6668	6683	6699	6714	6730	6745	2 3 5 6	8	9 11 12 14
83	6761	6776	6792	6808	6823	6839	6855	6871	6887	6902	2 3 5 6	8	9 11 13 14
84	6918	6934	6950	6966	6982	6998	7015	7031	7047	7063	2 3 5 6	8	10 11 13 15
85	7079	7096	7112	7129	7145	7161	7178	7194	7211	7228	2 3 5 7	8	10 12 13 15
86	7244	7261	7278	7295	7311	7328	7345	7362	7379	7396	2 3 5 7	8	10 12 13 15
87	7413	7430	7447	7464	7482	7499	7516	7534	7551	7568	2 3 5 7	9	10 12 14 16
88	7586	7603	7621	7638	7656	7674	7691	7709	7727	7745	2 4 5 7	9	11 12 14 16
89	7762	7780	7798	7816	7834	7852	7870	7889	7907	7925	2 4 5 7	9	11 13 14 16
90	7943	7962	7980	7998	8017	8035	8054	8072	8091	8110	2 4 6 7	9	11 13 15 17
91	8128	8147	8166	8185	8204	8222	8241	8260	8279	8299	2 4 6 8	9	11 13 15 17
92	8318	8337	8356	8375	8395	8414	8433	8453	8472	8492	2 4 6 8	10	12 14 15 17
93	8511	8531	8551	8570	8590	8610	8630	8650	8670	8690	2 4 6 8	10	12 14 16 18
94	8710	8730	8750	8770	8790	8810	8831	8851	8872	8892	2 4 6 8	10	12 14 16 18
95	8913	8933	8954	8974	8995	9016	9036	9057	9078	9099	2 4 6 8	10	12 15 17 19
96	9120	9141	9162	9183	9204	9226	9247	9268	9290	9311	2 4 6 8	11	13 15 17 19
97	9333	9354	9376	9397	9419	9441	9462	9484	9506	9528	2 4 7 9	11	13 15 17 20
98	9550	9572	9594	9616	9638	9661	9683	9705	9727	9750	2 4 7 9	11	13 16 18 20
99	9772	9795	9817	9840	9863	9886	9908	9931	9954	9977	2 5 7 9	11	14 16 18 20

Angle.		Chord.	Sine.	Tangent.	Co-tangent.	Cosine			
De-grees.	Radians.								
0°	0	0	0	0	∞	1	1·414	1·5708	90°
1	·0175	·017	·0175	·0175	57·2900	·9998	1·402	1·5533	89
2	·0349	·035	·0349	·0349	28·6363	·9994	1·389	1·5359	88
3	·0524	·052	·0523	·0524	19·0811	·9986	1·377	1·5184	87
4	·0698	·070	·0698	·0699	14·3007	·9976	1·364	1·5010	86
5	·0873	·087	·0872	·0875	11·4301	·9962	1·351	1·4835	85
6	·1047	·105	·1045	·1051	9·5144	·9945	1·338	1·4661	84
7	·1222	·122	·1219	·1228	8·1443	·9925	1·325	1·4486	83
8	·1396	·140	·1392	·1405	7·1154	·9903	1·312	1·4312	82
9	·1571	·157	·1564	·1584	6·3138	·9877	1·299	1·4137	81
10	·1745	·174	·1736	·1763	5·6713	·9848	1·286	1·3963	80
11	·1920	·192	·1908	·1944	5·1446	·9816	1·272	1·3788	79
12	·2094	·209	·2079	·2126	4·7046	·9781	1·259	1·3614	78
13	·2269	·226	·2250	·2309	4·3315	·9744	1·246	1·3439	77
14	·2443	·244	·2419	·2493	4·0108	·9703	1·231	1·3265	76
15	·2618	·261	·2588	·2679	3·7321	·9659	1·218	1·3090	75
16	·2793	·278	·2756	·2867	3·4874	·9613	1·204	1·2915	74
17	·2967	·296	·2924	·3057	3·2709	·9563	1·190	1·2741	73
18	·3142	·313	·3090	·3249	3·0777	·9511	1·176	1·2566	72
19	·3316	·330	·3256	·3443	2·9042	·9455	1·161	1·2392	71
20	·3491	·347	·3420	·3640	2·7475	·9397	1·147	1·2217	70
21	·3665	·364	·3584	·3839	2·6051	·9336	1·133	1·2043	69
22	·3840	·382	·3746	·4040	2·4751	·9272	1·118	1·1868	68
23	·4014	·399	·3907	·4245	2·3559	·9205	1·104	1·1694	67
24	·4189	·416	·4067	·4452	2·2460	·9135	1·089	1·1519	66
25	·4363	·433	·4226	·4663	2·1445	·9063	1·075	1·1345	65
26	·4538	·450	·4384	·4877	2·0503	·8988	1·060	1·1170	64
27	·4712	·467	·4540	·5095	1·9626	·8910	1·045	1·0996	63
28	·4887	·484	·4695	·5317	1·8807	·8829	1·030	1·0821	62
29	·5061	·501	·4848	·5543	1·8040	·8746	1·015	1·0647	61
30	·5236	·518	·5000	·5774	1·7321	·8660	1·000	1·0472	60
31	·5411	·534	·5150	·6009	1·6643	·8572	·985	1·0297	59
32	·5585	·551	·5299	·6249	1·6003	·8480	·970	1·0123	58
33	·5760	·568	·5446	·6494	1·5399	·8387	·954	·9948	57
34	·5934	·585	·5592	·6745	1·4826	·8290	·939	·9774	56
35	·6109	·601	·5736	·7002	1·4281	·8192	·923	·9599	55
36	·6283	·618	·5878	·7265	1·3764	·8090	·908	·9425	54
37	·6458	·635	·6018	·7536	1·3270	·7986	·892	·9250	53
38	·6632	·651	·6157	·7813	1·2799	·7880	·877	·9076	52
39	·6807	·668	·6293	·8098	1·2349	·7771	·861	·8901	51
40	·6981	·684	·6428	·8391	1·1918	·7660	·845	·8727	50
41	·7156	·700	·6561	·8693	1·1504	·7547	·829	·8552	49
42	·7330	·717	·6691	·9004	1·1106	·7431	·813	·8378	48
43	·7505	·733	·6820	·9325	1·0724	·7314	·797	·8203	47
44	·7679	·749	·6947	·9657	1·0355	·7193	·781	·8029	46
45°	·7854	·765	·7071	1·0000	1·0000	·7071	·765	·7854	45°
			Cosine.	Co-tangent.	Tangent.	Sine.	Chord.	Radians.	De-grees.
								Angle.	

# INDEX

References are to Pages

## A

Abscissa, 4  
Absolute temperature, 131  
Absorption hygrometers, 153  
Acceleration, 12  
Accumulator: hydraulic, 190; intensifying, 191  
Activity, 25.  
Additional exercises, 213.  
Addition of vectors, 7  
Admiralty pump, 188-190  
Air chamber for pumps, 178  
Air corrections to balance work, 103-105  
Air pumps: early, 195-196; *Fleuss'*, 197; *Gaede's*, 197-202; *Geryk*, 197; *Hauksbee's*, 196; molecular, 200-202; *Smeaton's*, 196; *Tate's*, 196; *Toepler*, 200  
Air thermometer, 139-140  
Altitude corrections to barometer, 164-166  
Aneroid barometer, 172-173  
Angular velocity, 15-16  
Answers, 221-229  
Aqueous vapour, 147-151, 157-158  
*Archimedes'* principles, 95-96  
*Archimedes'* screw, 176  
Atmosphere, density of, 152  
Atmospheric vapour, 147-151, 157-158

## B

Balance work with air corrections, 103-105  
Barometer: aneroid, 172-173; cistern, 158-159; corrections, 162-166; *Fortin's*, 160-161; *Kew*, 160-161; marine, 160; siphon, 162  
Barometric formula for heights, 169-172  
Baramil, 173  
*Bernoulli's* theorem, 116-118  
Blades of *De Laval* turbine, 212

*Blount* door check, 204-205  
Boiling point, 147  
*Borda's* mouthpiece, 121-122  
*Bourdon* pressure gauge, 192  
*Boyle's* law, 131-134; apparatus for, 132-133  
Brakes, hydraulic, 204-205  
*Byamah* press, 71-72; 203-204  
British Westinghouse motor for pumps, 189-190  
Buoyancy, centre of, 94, 108

## C

*Cartesian* co-ordinates, 4  
Centigrade thermometer, 129-130  
Centre of buoyancy, 94, 108  
Centre of gravity, 35-41  
Centre of mass, 35-41; of arc, 51; of any plane figure, 54-55; of frustum, 40; of hemisphere, 54; of pyramid, 37; of sector, 51-52; of segment, 52-53; of trapezoid, 39-40; of triangle, 37; of zone, 54  
Centres of Pressure, 80-89; by centroid of solid, 82-84; general treatment, 81-82; graphical method for, 88-89; of oblique triangles, 84-89; of vertical triangle, 80-81  
Centrifugal pump, 176  
Centroids, 35-41  
Chain pump, 176  
Characteristic equation of ideal gas, 131  
*Charles'* law, 135-137; apparatus for, 137  
Check for doors, 204-205  
Circular motion, 16-17  
Cistern barometer, 159-160  
Classification of appliances, 175  
Closed surface, resultant force on, 91-92  
Coefficient of expansion, 136  
Coefficients of contraction, discharge and velocity, 121  
Communicating vessels, liquid in, 70

Components, 6  
 Composition of displacements, 6; of forces, 26-29; of velocities and accelerations, 15  
 Compressors, 191-192  
 Condensation hygrometers, 153-156  
 Conservation of energy, 24-25  
 Constant-volume gas thermometer, 139-140  
 Contracted jet, 119-120  
 Contraction co-efficient, 121  
 Co-ordinates, 4  
 Coplanar forces, reduction of, 31-32  
 Corrections to barometer, 162-166  
 Couples, 30-31  
 Cranes, hydraulic, 203  
 Curved surface, resultant force on, 90-91

## D

*Dalton's law*, 145  
*Daniell's hygrometer*, 153, 154  
 Density, defined, 34; atmospheric, 152; of atmospheric vapour, 151-152; of liquids and solids: by hydrometers, 97-101; by hydrostatic balance, 101-103; of liquids by U-tubes, 74-75  
 Dew point, 150, 154-158  
 Differential manometer, 193-195  
 Dimensions of mechanical quantities, fundamental and derived, 13-14  
*Dines' hygrometer*, 153-155  
 Discharge coefficient, 121  
 Discharge from an orifice, 121-123  
 Displacements, 5  
 Diving bell and equipments, 181  
 Door check, 204-205  
 Double pumps, 178  
*Dunkerley, S.*, 212  
 Dynamical gravity, 126  
 Dyne, 21, 23

## E

Ebullition, 147  
 Effective gravity, 126  
 Egyptian Government, pumps for, 188  
 Elasticity of a gas, 145  
 Electrically driven pumps, 189-190  
 Emersion, work of, 105-107  
 Energy, 20-21; conservation of, 24-25  
 Equilibrium of floating bodies, 94-96  
 Equilibrium of rigid body, 33  
 Erg, 22, 23

Error of capacity in barometer, 160  
 Evaporation, 147  
 Evaporation hygrometers, 153, 156-157  
 Examination papers, 235-238  
 Exercises, additional, 213-219  
 Exhaustion by cooled charcoal, 202  
 Expansion coefficient, 136  
 Expansion of gas, work of, 142-144  
 Explosion pump, *Humphrey's*, 185-188

## F

*Fahrenheit thermometer*, 129-130  
 Fire engine, 178  
 Fixed points of thermometer, 129  
 Flotation, 94-114; stability of, 108-111  
 Flow, steady, 115-123  
 Fluid defined, 1  
 Foot-pound, 22-23  
 Force, 18-19  
 Force on any plane, 78-79; on any vertical plane, 77-78; on horizontal plane, 76; on immersed planes, 76-79; on vertical rectangle, 76-77  
 Force pump, 177-178  
*Fortin's barometer*, 160-161  
*Fowler, Henry*, 210  
 Fractional saturation, 150-151, 157-158  
 Free liquid surface horizontal, 69

## G

Gas constant R, 131, 141; numerical values of, 141-142  
 Gas equation, 131  
 Gases defined, 1-2; treated, 129-146  
 Gas thermometer, 139-140  
*Giffard's injector*, 182-183  
*Goodman, J.*, 212  
 Graphs, space, 9-10; speed, 10-11  
*Greenhill, Sir G.*, 182  
*Guericke, Otto von*, 197

## H

Heights by barometer, 169-172  
*Helmert's gravity formula*, 164  
*Hero's fountain*, 125-126  
*Hero's turbine*, 206  
 Hints and solutions, 230-234  
 Hodograph, 17  
 Homogeneous atmosphere, 167-168

Horse-power, 25  
 Humidity, 150-151, 157-158  
*Humphrey's* internal-combustion pump, 185-188  
 Hydrokinetics, 2, 115-128  
 Hydraulic accumulator, 190-191  
 Hydraulic appliances, 174, 212  
 Hydraulic brakes, 204-205; 207-211  
 Hydraulic cranes, 203  
 Hydraulic lifts, 203  
 Hydraulic power pump, 188-190  
 Hydraulic press, principle of, 71-72; practical example of, 203-204  
 Hydraulic ram, 178-179  
 Hydrometers, 97-101; *Buchanan's*, 98, 101; of fixed immersion for liquids, 101; and for solids, 99-101; *Nicholson's*, 99-100; of variable immersion for liquids, 97; and for solids, 98-99  
 Hydrostatic balance for densities, of liquids, and solids, 101-103  
 Hydrostatic pressure, increases with depth, 67-68; independent of direction, 65-67; the same on given level, 67; transmission of, 71  
 Hydrostatics, 2, 64-114  
 Hygrometers, 153-157  
 Hygrometric graphs, 157  
 Hygrometry, 147-158  
 Hygrosopes, 153  
 Hypsometer, 129

## I

Ice point, 129  
 Ideal gas, 131  
 Immersion, work of, 105-107  
 Impulse, 20-21  
 Injector, *Giffard's*, 182-183  
 Intensifying accumulator, 191  
 Internal-combustion pump, *Humphrey's*, 185-188  
 Inverted U-tube, 75  
 Isothermal elasticity of a gas, 145

## J

Japanese navy pump, 189-190  
 Jet pump, 179

## K

Kew barometer, 160-161  
 Kinematics, 2, 4-17  
 Kinetics, 2, 18-41

## L

*Landolt and Börnstein*, 164  
 Latitude corrections to barometer, 164-166  
 Lift pump, 176-177  
 Lifts, hydraulic, 203  
 Liquid defined, 1, 2  
 Localisation of vectors, 6

## M

*McLeod* gauge, 202-203  
 Manometer, compressed air, 134-135; differential, 193-195; open, 75  
 Marine barometer, 160  
*Mariotte's* bottle, 124-125  
*Mason's* hygrometer, 153, 156-157  
 Mass, 18-19  
 Mathematical tables, 239-244  
 Mechanics subdivided, 2  
 Metacentre, 108-111  
 Meter, venturi water, 179  
 Midland Railway vacuum brake, 210-211  
 Millibar, 173  
 Mixed gases, pressure of, 145  
 Modern views of mass, motion and force, 18-19  
 Moisture removed in ventilation of mine, 152-153, 157-158  
 Moment of inertia, 56-57; of any plane area, 62-63; of circle, 60; of rectangle, 59; of triangle, 61; theorems, 57-61  
 Moments, 29-30; theorem of, 30  
 Momentum, 20-21

## N

*Napierian* logarithms, 169  
*Negretti and Zambra*, 160-161, 172  
*Newton's* laws of motion, 18

## O

Ordinate, 4  
 Orifice, discharge of, 121-123

## P

Parabolic surface of rotating liquid, 127-128  
 Parallel forces, 27-31  
*Parsons, Hon. C. A.*, 207  
 Partial pressure of gases in mixture, 145

*Pelton* wheel, 211-212  
 Pneumatics, 2, 129-173  
 Polar co-ordinates, 4  
 Position in space, 4  
 Potential energy, 24  
 Poundal, 21-23  
 Power pumps, 188-190  
 Pulsometer steam-pump, 183-185  
 Pumps, Admiralty, 188-190; air chamber for, 178; centrifugal, 176; chain, 176; charcoal, 202; compression, 191-192; double, 178; Egyptian Government, 188; electrically driven, 189-190; explosion, 185-188; force, 177-178; *Fleuss's*, 197; *Gaede's*, 197-202; *Geryk's*, 197; *Hauksbee's*, 196; *Humphrey's*, 185-188; hydraulic, 188-190; Japanese navy, 189-190; jet, 179; lift, 176-177; molecular, 200-202; motor for, 189-190; power, 188-190; pulsometer, 183-185; *Smeaton's*, 196; steam, 183-185; *Tait's*, 196; *Toepler's*, 200; triple, 178; vacuum, 195-202; valve box for, 190; *Worthington*, 189-190  
 Pressure gauge, 75  
 Pressure head, 118  
 Pressure law for gases, 138  
 Pressure of mixed gases, 145

## R

Radius of gyration, 57  
*Réaumur* thermometer, 129-130  
 Re-entrant pipe, 121-122  
*Regnault's* hygrometer, 153, 155, 156  
 Relative humidity, 150-151, 157-158  
 Resultant, 6  
 Retardation, 13  
 Rock drills, 206  
 Rotation of liquid, 126-128

## S

Saturation, 146-150  
 Scalars, 6  
 Scoop for lifting water into locomotive tender, 176  
 Screw of *Archimedes*, 176  
 Shadoof, 176  
 Siphon barometer, 162  
 Siphon, common, 181; intermittent, 182  
 Slug, 22-23  
 Solids, elastic and rigid, 1, 2  
 Solutions and hints, 230-234

Space graphs, 9  
 Specific gravity, 34  
 Specific weight, 34  
 Speed graphs, 8-9  
 Stability of flotation, 108-111  
 Statics, 2, 26-42  
 Steady flow, 115-123  
 Steam point, 129  
 Steam pumps, 183-185  
 Stream line, 116-118  
 Stream tube, 116-118  
 Stress, conception of, 64; normal and tangential, 65  
 Summations, 43-50; of cosine, 46-47; of powers of a variable, 45-46; simple, 43-44  
 Superposition of liquids, 73-75  
 Surface tension, 70, 113-114

## T

Tables, mathematical, 239-244  
 Temperature corrections to barometer, 162-166  
 Tension of cylinder due to fluid pressure, 112-113; ditto of sphere, 113-114  
 Thermometry, 129-130  
 Time of emptying vessel, 122-123  
*Tompkins, A. E.*, 212  
 Torpedo compressors, 191-192  
*Torricelli's* experiment, 159; theorem, 120; vacuum, 139, 159  
 Transmission of pressure, 71  
 Triple pump, 178  
 Triple valve, 207-209  
 Turbines, 206-207, 211-212; *De Laval*, steam, 212; *Hero's*, 206; impulse water, 211-212; *Parsons's* steam, 206-207; *Pelton*, 211-212; pressure, 206-207

## U

U-collar of *Bramah* press, 72, 203-204  
 Unclosed surface, resultant force on, 93-94  
 Units for barometry, baromil, and millibar, 173  
 Units, 4; fundamental and derived, 14-15; kinetical, 21-23  
*Unwin, W. Cawthorne*, 188  
 U-tubes for densities, 74-75

## V

Vacua attainable, 202  
 Vacuo, weighings reduced to, 103-105  
 Valve box for power pumps, 190  
 Vanes of *Pelton* wheel, 211  
 Vapour pressure, 147, 150  
 Vapour pressure of mercury, corrections for, 165-166  
 Vectors, 6  
 Velocity co-efficient, 121  
 Velocity head, 118  
 Velocity, instantaneous, 8-9; mean, 8; uniform, 8; variable, 8  
 Vena contracta, 119-120  
 Venturi water meter, 179-180  
 Viscosity, 1  
 Vitiated vacuum, 166-167

## W

Water scoop, 176  
*Westinghouse* brake, 207-210  
 Wet and dry bulb hygrometer, 156-157  
 Whole pressure, 79  
 Work, 20-21; of expanding gas, 142-144; of variable force, 43  
*Worthington* power pump, 189-190

## Y

*Yale and Towne Co.'s* door check, 204-205

## Z

*Zambra, Negretti* and, 160-161, 172  
 Zero temperature, 131

THE END















