

**TEXT LITE
WITHIN THE
BOOK ONLY**

UNIVERSAL
LIBRARY

OU_214529

UNIVERSAL
LIBRARY

214529

OSMANIA UNIVERSITY LIBRARY

Call No. 538 Accession No. 32439

Author G67P

Gorter, C.J.

Title Paramagnetic Relaxation

This book should be returned on or before the date
last marked below.

PARAMAGNETIC RELAXATION

PARAMAGNETIC RELAXATION

BY

C. J. GORTER, Ph. D.

PROFESSOR OF EXPERIMENTAL PHYSICS
IN THE UNIVERSITY OF LEYDEN
(NETHERLANDS)

ELSEVIER PUBLISHING COMPANY, INC.

NEW YORK**,
AMSTERDAM



D O N
BRUSSELS

1947

Printed in the Netherlands by
Eduard IJdo N.V. — Leiden

P R E F A C E

The greater part of the present monograph was written during the winter of 1944-45 known in Holland as "starvation winter". At that time the densely populated Western part of the Netherlands was cut off from the South by the fighting-line and from the East by a broad zone of German military posts. Owing to the German drives for slave-workers it was often risky for men under forty to go about in the streets; only very urgent duties and the necessity to procure food or wood for fuel could induce them to leave their houses. In spite of this, however, scientific work was continued here and there. In the ZEEMAN Laboratory of the University of Amsterdam enough fuel was left for one room to still be heated, so that this building remained one of the few centres where research work was carried on. The news supplied clandestinely by the radio, run on the batteries of the laboratory, constituted also an attraction to the scientific and technical personnel. Owing to the absence of electricity and gas activities were mostly of a theoretical nature: writing theses, discussing theoretical problems, designing, calculating and working out previous observations. Though from an objective point of view the value of this work was perhaps not outstanding, it helped people to rid themselves for a time of the daily obsession and anxiety about food, warmth and the slow progress of the war and to hold their own as self-respecting scientific workers.

After the Liberation, there was so much other work to do that it took some time before the last chapter was written and the whole had been revised.

Paramagnetic relaxation is not an important chapter in modern physics. Nevertheless it contains a number of in-

teresting problems solved and unsolved and is closely connected with adiabatic demagnetisation, with the theories of paramagnetism and of the crystalline state and with dielectric relaxation. About one hundred papers have appeared so far in this field of research but many of those publications had a provisional character or gave only the result of one particular series of observations. The theses of F. BKJONIS (1938), P. TEUOTSSEN (1939), P. K. Du PNE (1940), L. J. DIJKSTRA (1943), L. J. F. BROER (1945), and J. VOLGER (1946) all dealt with part of the experimental and theoretical work and gave a more or less general survey of the problems involved. But they are all written in Dutch. It seemed worth while, however, to give a general survey in English too of the experiments and theories bearing on paramagnetic relaxation. I hope this survey will make it easier for fellow-scientists to enter this new but rather specialized field of research.

Though I do not stress it continually, I made most abundantly use of the theses mentioned and particularly of that of L. J. F. BROER, which gives an excellent survey of a large part of this field of research, and was of great value to me while writing this monograph.

C. J. GORTER

Leyden, November 1946.

CONTENTS

	Page
I. INTRODUCTORY CHAPTER.	1
§ 1. NORMAL PARAMAGNETISM	1
§ 2. THERMODYNAMICS	6
§ 3. CRYSTALLINE FIELDS AND INTERACTION BETWEEN MAGNETIC IONS	10
§ 4. THE VARIOUS MAGNETIC IONS	14
§ 5. PARAMAGNETIC? DISPERSION AND ABSORPTION	19
§ 6. HISTORICAL	25
II. EXPERIMENTAL METHODS.	29
§ 1. HETERODYNE BEAT METHOD	29
§ 2. CALORIMETRIC METHOD	36
§ 3. BRIDGE METHOD	46
III. RESULTS	49
§ 1. REVIEW OF THE SUBSTANCES INVESTIGATED	49
§ 2. RESULTS OF THE DISPERSION MEASUREMENTS BY THE HETERODYNE BEAT METHOD	51
§ 3. RESULTS OF THE ABSORPTION MEASUREMENTS BY THE CALORIMETRIC METHOD	67
§ 4. RESULTS OF THE χ MEASUREMENTS AT LIQUID HELIUM TEMPERATURES BY A BRIDGE METHOD	77
IV. THEORY.	83
§ 1. THE PROCESS OF MAGNETIZING	83
§ 2. THE THEORY OF LATTICE RELAXATION	87
§ 3. THE THEORY OF SPIN RELAXATION	94
V. DISCUSSION OF RESULTS.	103
§ 1. VALUES OF $6/0$	103
§ 2. VALUES OF p	116
§ 3. VALUES OF p'	120
§ 4. FINAL REMARKS	124

I. INTRODUCTORY CHAPTER

§ 1. NORMAL PARAMAGNETISM

If the magnetic susceptibility χ_0 of a substance is in a first approximation inversely proportional to the absolute temperature T , in other words, if it obeys CURIE'S law. $\chi_0 T = C$, we usually speak of *normal paramagnetism*. Normal paramagnetism occurs in many salts of the rare earths and of the iron group in which magnetic ions are diluted with large quantities of non-magnetic (diamagnetic) material. Typical examples are $\text{Gd}_2(\text{SO}_4)_3 \cdot 8 \text{H}_2\text{O}$, $\text{Cr}(\text{NO}_3)_3 \cdot 9 \text{H}_2\text{O}$, $\text{FeNH}_4(\text{SO}_4)_2 \cdot 12 \text{H}_2\text{O}$, $\text{MnSO}_4 \cdot 4 \text{H}_2\text{O}$, $\text{FeSO}_4 \cdot 7 \text{H}_2\text{O}$, $\text{NiSO}_4 \cdot 7 \text{H}_2\text{O}$, $\text{Cu}(\text{NH}_4)_2(\text{SO}_4)_2 \cdot 6 \text{H}_2\text{O}$.^x

At extremely low temperatures all these substances, however, lose their character of normal paramagnetic substances. They either show signs of ferromagnetism or their susceptibility tends to become independent of the temperature.

Examples of non-normal paramagnetism leading to susceptibilities independent of T are encountered in the alkali metals and in some complex salts containing atoms of the iron group or of other transitional elements such as $\text{K}_2\text{Cr}_2\text{O}_7$, KMnO_4 and $\text{K}_4\text{W}(\text{CN})_8$, etc.; oxides and anhydrous salts of the rare earths and the iron group often have susceptibilities which decrease slower with increasing T than is prescribed by CURIE'S law.

The molal susceptibility of normal paramagnetic salts of the type mentioned is almost independent of the anion and of the amount of crystal-water. This proves the ions of the rare earths and of the iron group to be the carriers of the paramagnetic properties. In accordance

i Oxygen gas, also, exhibits normal paramagnetism.

with a remark made by KOSSEL only the number of electrons in the magnetic ion matters; this is illustrated by the equality of the molal susceptibilities of hydrated manganous and ferric salts.

The ions of the rare earths and of the iron group contain a shell of electrons, respectively the 4f- and 3d-shell, which is only partly filled. The electrons in this shell arrange themselves in such ways that most of the energy levels are magnetic; that is to say, either split or are considerably displaced upon application of a magnetic field. In § 3 of this Chapter and in Ch. IV § 1, we shall discuss the influence of the surrounding non-magnetic material and of the interaction between different magnetic ions. In this paragraph we will for an introductory survey of the essential phenomena, neglect the interaction and will consider each separate magnetic ion to be exclusively under the influence of its non-magnetic surroundings and of an external magnetic field H_c .

Let us consider the spectroscopical energy $W(n)$ of one energy level of one ion, where n stands for a combination of quantum numbers and let us introduce a small change ΔH of the external magnetic field H_c . Developing $W(n)$ in a power series in ΔH we get:

$$W(n) = W_0(n) + W_1(n)\Delta H + W_2(n)(\Delta H)^2 + \dots, \quad 1$$

and the value of the magnetic moment of the ion in the direction of ΔH will be

$$M_{\Delta H}(n) = -\frac{\Delta W(n)}{\Delta H} = -W_1(n) - 2W_2(n)\Delta H - \dots \quad 2$$

According to the perturbational methods of the quantum theory we have:

$$W_1(n) = -M_{\Delta H}(nn), \quad 3$$

$$W_2(n) = -\sum_{n'} \frac{|M_{\Delta H}(nn')|^2}{W(n') - W(n)}, \quad 4$$

where $M_A // (nn')$ are the matrix elements of the magnetic moment of the ion in the direction of AH and the index at the summation sign indicates that in the summation over the different levels n' the original level n is excluded.

We see therefore, that the magnetic moment in the state n is the sum of a constant term $M_A // (nn)$ and of a term proportional to AH which is governed by the non-diagonal elements of the matrix of the magnetic moment. In general $M_A // (nn)$ and $M_A // (nn')$ will depend on the magnitude of H_c and its orientation with respect to AH as well as on the orientation of both with respect to the non-magnetic surroundings of the ion.

If we wish to find the total magnetic moment of a system of N atoms, where N is conveniently taken equal to AVOGADRO'S number, we have to sum over all energy levels which are occupied proportional to BOLTZMANN'S factor $\exp(-W(n)/kT)$. VAN VLECK¹ has pointed out that we shall then obtain in a first approximation CURIE'S law, if the energy levels are arranged in two groups, in one of which the energetical distances to the lowest level are small compared with kT (low frequency levels) while in the other these energetical distances to the lowest level are large compared with kT (high frequency levels). We shall characterize the first group of levels with n and n^* and the second group by n'' . It is very simple to obtain with VAN VLECK, for the molal susceptibility:

$$\chi_0 = \frac{N \Delta M_{\Delta H}}{\Delta H} = \frac{N \sum_n \sum_{n'} |M_{\Delta H}(nn')|^2}{kT \sum_n 1} + \frac{N \sum_n \sum_{n''} \frac{2 |M_{\Delta H}(nn'')|^2}{W(n'') - W(n)}}{\sum_n 1} + \dots \quad 5$$

It must be noted that the summation signs in the first
i J. H. VAN VLECK, *Thys. Bev.*, 31 (1928) 587 and: The Theory of electric and magnetic susceptibilities.

term on the right-hand side contain no index and that 2 l in the denominators is simply the number of (non-degenerate) low frequency levels.

The last term in (5) is responsible for the non-normal paramagnetism of the complex salts mentioned in the beginning of this paragraph, though in all normal paramagnetic substances it is, of course, small.

The double sum in the numerator of the first term on the right-hand side of (5) determines the value of CURIE'S constant C . Diagonal and non-diagonal elements of the magnetic moment appear together in this sum, but the physical significance of their contributions is quite different. The diagonal elements correspond to an energy shift which is proportional to AH . This shift necessitates a rearrangement of the BOLTZMANN-distribution between levels with different values of $M(nn)$. This rearrangement leads to a change of the average magnetic moment. The non-diagonal elements correspond to a magnetic polarisation by the field $A//$. A non-diagonal element $M(nn')$, according to (4) and (2), gives rise to a positive polarisation of the lower of the two levels and to a negative polarisation of the higher one. As the lower level, according to BOLTZMANN'S factor, is somewhat more frequently occupied, the positive magnetic polarisation preponderates. If the low frequency levels are perturbed in some way or other the double sum remains invariant in accordance with VAN VLECK'S well-known theorem of *spectroscopic stability*¹. For that reason perturbations leading to energy shifts which are small compared with kT , do not lead to any change of the susceptibility and this therefore remains simply determined by the number of electrons of the magnetic ion. This applies to perturbations by H_c (in orientation and magnitude) as well as by crystalline fields.

When the temperature is lowered so much that kT is

i J. H. VAN VLECK, *Phys.Rev.*, 29 (1927) 727 and: The Theory of electric and magnetic susceptibilities.

zio longer large compared with the differences between the low frequency levels, deviations from CURIE'S law will appear and the mentioned invariance will lose its simple consequences. If the energy shifts introduced by H_c become of the order of kT the so-called *paramagnetic saturation* will appear. If the splittings due to crystalline fields (ire small, though not very small, in comparison with kT , we can replace CURIE'S law by the CURIE-WEISS law:

$$\chi_0 (T - \theta) = C, \quad 6$$

where¹

$$\theta = \frac{\sum_n W(n)}{k \sum_n 1} - \frac{\sum_n \sum_{n'} W(n) |M(nn')|^2}{k \sum_n \sum_{n'} |M(nn')|^2}. \quad 7$$

It may be shown, however, that this becomes zero in isotropic substances as does also its average value in any powder¹. It is remarkable, however, that a BOLTZMANN-distribution over a number of levels often leads to the validity of the CURIE-WEISS law (6) in powders over a rather wide range of temperatures in which kT is of the order of the splittings. θ has then no simple meaning but if experimentally the CURIE-WEISS law is found, and if neither interaction between magnetic ions nor the last term in (5) can be of any importance, it is safe to conclude that splittings exist which are at least somewhat larger than θ .

If we have to deal with one degenerate low frequency level of a free ion, we have, in the absence of a constant field H_c

$$W = nij g/3 AH, \quad 8$$

where m_3 is the magnetic quantum number of a state, g is LANDES splitting factor and $\beta = (e/2 mc) (h/2 \pi)$ is BOHR'S magneton. The magnetic moment of this state is $-nijgp$ and its occupation is proportional to BOLTZMANN'S factor

i C. J. GORTER, *Phys. Z.*, 1-i (1932) 546.

exp— (*raj* $g/2 AH/kT$). Summing up over the $2J + 1$ possible values of m_J J being the total quantum number, one finds:

$$\chi_0 = \frac{C}{T} = \frac{Ng^2 J (J + 1) \beta^2}{3 kT}. \quad 9$$

Sometimes this is written:

$$\chi_0 = \frac{C}{T} = \frac{N p^2 \beta^2}{3 kT} \quad 10$$

where $p = g \sqrt{J (J + 1)}$ is then called the magnetic moment of the level expressed in *Boim-magnetons*. This designation reminds one of LANGEVIN'S classical formula:

$$\chi_0 = \frac{C}{T} = \frac{N \mu^2}{3 kT}, \quad 11$$

where μ is the permanent moment of a magnetic dipole. If CURIE'S law is valid, the value of the Curie-constant C is often characterized by p "the magnetic moment expressed in Bohr-magnetons", thus formally applying (10) though the substance does not consist of free ions at all.

§ 2. THERMODYNAMICS

In the literature on this subject two expressions are used for the work done by a magnetized substance when the external field H and (or) the magnetic moment M change. These expressions are $(M \cdot AH)$ and $-(H \cdot A \delta I)$. The first law of thermodynamics is accordingly written in two forms:

$$\Delta Q = \Delta U + (\vec{M} \cdot \Delta \vec{H}), \quad 12$$

or

$$\Delta Q = \Delta U' - (\vec{H} \cdot \Delta \vec{M}). \quad 12'$$

It is clear that the difference between the two expressions is essentially a difference between two definitions of the internal energy (V or W). All consequences of thermo-

dynamic treatments based on (12) or (12') are identical and one can pass from one treatment to the other by interchanging the internal energy with the enthalpy (heat content) and the free energy with the thermodynamic potential.

In § 1 we had to deal twice already with the spectroscopical energy W viz. in (1) and (2) where the well-known relation $M_A \# = -AW/AH$ was used, and in the BOLTZMANN factor used in the derivation of (5). In a system of independent atoms U contains the usual contributions to the energy of a mechanical or thermic nature plus the spectroscopical energies of the atoms. The relation between Z' and W is not so simple. In view of this it seems natural to accept the first alternative and to choose (12).

It may be instructive to point out that in the thermodynamics of dielectric phenomena it is more natural to choose the equivalent of the second alternative:

$$AQ = AU' - (F.AP). \quad 12'$$

A very close parallelism exists between a magnetic substance in a coil and a dielectric substance in a condenser and, as already pointed out, the thermodynamical consequences of the different choice are nil. It may be worth while, however, to stress with BROER¹ three differences between the two cases which are connected with this different choice.

a. The total field energy $(\iiint (H_x^2 + H_y^2 + H_z^2) dV/Srr)$ of a magnetic dipole in the field of a coil is equal to the field energy of the coil alone plus the field energy of the dipole alone plus (HM) . In the electric case we get the field energies of condenser and dipole alone minus (FP) . The difference is due to the different course of the lines of force "inside" the dipole.

b. A constant magnetic moment M has no influence on the inductivity of the coil, whereas a constant electric mo-

i L. J. F. BROER, *Physica*, 12 (1946) 49 and *Thesis* Amsterdam, 1945.

ment P attracts the charges on the condenser, thereby increasing its capacity.

c. If \vec{M} changes spontaneously by $\vec{A}if$, the current in the coil decreases by induction. It requires the work $\vec{H} \cdot \vec{A}M$ to bring the current (and therefore also the

field H) to its original value. The charge on the condenser (and therefore also the field F) is not influenced by a spontaneous change in P .

The usual thermodynamics of the textbooks, where the pressure P and the volume V are the coupled variables, can be completely taken over on substituting P by M and V by 77 . Instead of normal products we have, strictly speaking, always to take the scalar product of vectors. We quote a few of the well-known formulae with this substitution :

where $C_H = (dU/dT)_H$ is the specific heat at constant fieldstrength.

For the specific heat at constant magnetic moment C_M we get:

$$C_M = C_H + T \left(\frac{\partial M}{\partial T} \right)_H \left(\frac{\partial H}{\partial T} \right)_M, \quad 15$$

and

$$\left(\frac{\partial C_M}{\partial M} \right)_T = -T \left(\frac{\partial^2 H}{\partial T^2} \right)_M. \quad 16$$

Taking H and M as independent variables, (14) becomes :

$$\Delta Q = C_H \left(\frac{\partial T}{\partial M} \right)_H \Delta M + C_M \left(\frac{\partial T}{\partial H} \right)_M \Delta H. \quad 17$$

Putting $\Delta Q = 0$, we find for the adiabatic susceptibility¹

i P. DEBIJE, *Phys. Z.*, 39 (1938) 616.

$$xJ = (dM/dH)_S$$

$$\chi_{ad} = \frac{C_M}{C_H} \left(\frac{\partial M}{\partial H} \right)_T = \frac{C_M \chi_0}{C_H} \quad 18$$

and for the adiabatic rise of temperature we have, in view of (14) and (15):

$$\left(\frac{\partial T}{\partial H} \right)_S = \frac{T}{C_H} \left(\frac{\partial M}{\partial T} \right)_H = \left(\frac{\partial T}{\partial H} \right)_M \frac{C_H - C_M}{C_H}. \quad 19$$

It is sometimes easy to derive the required formulae from the free energy $F=U-TS$ and then use $S = -(dF/dT)_H$ and $M = -(dF/dH)_T$.

The formulae (12) to (19) may be used in two different senses. In one sense V is the sum of mechanical, thermal, and spectroscopical energy as mentioned before. Then, at all but extremely low temperatures, C_H and C_M are determined by the energy of the heat waves of the lattices; they are practically equal and $x \ll d \sim X_0 - I^{*1}$ the second sense, however, U includes the spectroscopical magnetic energy only. This sense becomes of importance when the system of elementary ionic magnets (often called spin system) is rather well isolated from the heat waves in the crystalline lattice. It is then possible to ascribe, as proposed by CASIMIR and van PRÉ¹ (compare Ch. IV § 2), a temperature T to this system of ionic magnets. It is in this latter sense that we shall use the formulae (12)—(19) in Ch. IV.

In normal paramagnetic substances we are concerned generally with the case considered by VAN VLECK in which we have only low-frequency and high-frequency levels and we have for $H=0$ in the second sense mentioned in the preceding alinea: $C_M = C_H = b/T^2$ where

$$b = \frac{N \sum_n \sum_{n'} (W(n') - W(n))^2}{2k \sum 1}, \quad 20$$

the summation extending over all low frequency levels,

i H. B. G. CASIMIR and F. K. Du PRO, *Physica*, 5 (1938) 507.

In view of (16) and (15) and of CURIE'S law $MT = CH$ we have for all values of //

$$C_M = \frac{b}{T^2} \text{ and } C_H = \frac{b + CH^2}{T^2}. \quad 21$$

Accordingly we have then

$$\chi_{ud} = \frac{b \chi_0}{b + CH^2}, \quad 22$$

$$\left(\frac{\partial T}{\partial H} \right)_S = \frac{H}{T} \frac{CH^2}{b + CH^2}, \quad 23$$

and

$$F = - \frac{b + CH^2}{2T} + AT + B.$$

where A and B are the usual two arbitrary constants in expressions for the free energy.

§ 3. CRYSTALLINE FIELDS AND INTERACTION BETWEEN MAGNETIC IONS

It has been stressed in § 1 that the ions in crystals or solutions are not free, but are subjected to inhomogeneous electric fields due to the (non-magnetic) surroundings. In normal paramagnetic substances the nearest surroundings often consist of a shell of (frequently 6) water dipoles. The magnitude of the fields is not known exactly but sometimes X-ray analysis of the crystal allows to draw conclusions concerning the symmetry of the fields. From this symmetry-character it is possible to deduce the number of energy levels into which a degenerate term is split by the fields. This has been done by BETHE¹ with the aid of group theoretical methods on which we cannot dwell here. Some of the results are given in Table I. The quantum number characterizing the degenerate level may be F . The degeneracy in the absence of a crystalline field is

i H. BETHE, *Ann. Phys.*, 3 (1929) 133.

TABLE I

REMOVAL OF AN $2F + 1$ -FOLD DEGENERACY BY FIELDS OF DIFFERENT SYMMETRY

F	Free	Cubic	Trigonal	Tetragonal	Rhombic
0	1	1	1	1	1
	2	2	2	2	2
Y	3	3	1, 2	1, 2	3-1
	4	4	2-2	2-2	2-2
2	5	2, 3	1 2-2	3-1, 2	5-1
$2\frac{1}{2}$	6	2, 4	3-2	3-2	3-2
3	7	1, 2-3	3-1, 2-2	3-1, 2-2	7-1
$3\frac{1}{2}$	S	2-2, 4	4-2	4-2	4-2

given in the second column; it is $2F + 1$. In the other columns the remaining degeneracies are given in fields of different symmetry. A level with $F = z3\frac{1}{2}$ splits, for instance, in a cubic field into one level of fourfold degeneracy and two double levels. A very important theorem has been found by KRAMERS¹, stating that, if the number of electrons of the system is odd, fields of an electrical nature will not remove the degeneracy completely as a twofold degeneracy of each level will remain. The splittings for $F = \frac{1}{2}, 1\frac{1}{2}, 2\frac{1}{2}$ and 3^{\wedge} in Table I leave as a matter of fact this KRAMERS-degeneracy. In some cases it is possible to say something about the relative energetical distances between the component levels. In the mentioned case of $F = 3\frac{1}{2}$ in a cubic field the fourfold level will be between the double levels and the ratio of the energy differences will be $5/3$.

The presence of crystalline fields leads to very different consequences for different groups of ions, the essential point being the ratio between the splittings due to the crystalline fields and the multiplet splitting. In the next paragraph we shall go further into this matter.

i H. A. KRAMERS, *Proc. Amsterdam*, 33 (1930) 959.

A remarkable theorem pronounced by JAHN and TETTER¹ for non-linear molecules is also of importance for crystals. Let us suppose that at a certain value x_0 of the distance-parameter x a twofold degeneracy exists, then it might be that in this point the energy curves either intersect or

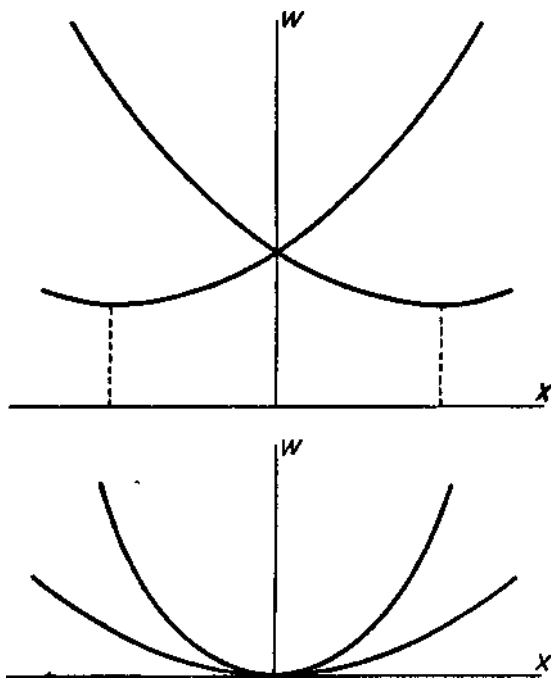

Fig. 1.

Energy levels TV as a function of the distance parameter x . According to JAHN and TELLER'S theorem the lower drawing cannot correspond to reality in non-linear molecules.

touch, or that they coincide for all values of x . The theorem states, that the second possibility (touching) does not

¹ H. A. JAHN and E. TELLER, *Proc. Roy. Soc.*, A 161 (1937) 220; J. H. VAN VLECK, *J. chem. Phys.*, 7 (1939) 72.

occur. If the curves intersect, however, the position at x_0 will not be stable. As a result a small displacement of the atoms or ions will always occur, which results in a field of lower symmetry removing the degeneracy. This applies also to higher degeneracies, but not to KRAMERS's degeneracy, as for this the two curves coincide.

A satisfactory treatment of the consequences of the magnetic interaction between different magnetic ions in a crystalline lattice is very difficult. VAN VLECK¹ has shown that in a first approximation this interaction is characterized by the so-called internal magnetic field Hi . Its square is the average square of the magnetic field in the place occupied by one magnetic ion due to the other ions. We have:

$$H_i^2 = 2 \mu^2 \sum_{p \neq q} r^{-6}, \quad 25$$

where q indicates an arbitrary ion and the summation over p has to be extended over all other ions in the whole crystal, $\overline{fx^2}$ is the average square of the magnetic moment of one ion. For a free ion $\overline{fi^2} = g^2 J(J-1) p^2$ and in general $\overline{fx^2} = p^2 \overline{fi^2}$ (see (10)). In a face-centered cubic lattice

$$\sum_{p \neq q} r^{-6} = 7.2 n^2 \quad 25a$$

where n is the number of ions per unit of volume. This expression is often used for an evaluation of Hi when the crystal structure is unknown, though in a simple cubic lattice the numerical factor is not 7.2 but 8.4 and in other lattices the factor may have still other values.

At temperatures for which $1/x Hi \ll kT$ the contribution to the specific heat due to the magnetic interaction is inversely proportional to T^2 . WALLER² and VAN VLECK find

$$C_M = \frac{CH_i^2}{2 T^2} = \frac{b_{magn}}{T^2}. \quad 26$$

i J. H. VAN VLECK, *J. chem. Phys.*, 6 (1937) 320.

2 I. WALLER, *Z. JPhys.*, 104 (1937) 132.

If we have to deal with splittings by a crystalline field as well as with magnetic interaction we are allowed, for a first approximation, simply to add the corresponding contributions to the specific heat. In this way we arrive again at the formulae (21)—(24), where, now, however

0 —belece "T" *O*magn*

§ 4. THE VARIOUS MAGNETIC IONS

Tables II and III contain a list of the various magnetic ions of the rare earths and of the iron group. The configuration of the electrons is given in the second column. As regards the rare earths, the completely filled 1s, 2s, 2p, 3s, 3p, 3d, 4s, 4p and 4d shells, and as regards the iron group, the completely filled 1s, 2s, 2p, 3s and 3p shells have been omitted according to usage.

TABLE II
THE RARE EARTHS

Ion	Con- figuration	I	Basic level	$jl/j(J+lj)$	$pexp$
Ce •••	$4f^1 5s^2 p^6$		2F	2.54	(2.4)
Pr •••	$4f^2$		$3H^{B/2}$	3.58	(3.6)
Nd •••	$4f^3$	19 "		3.62	(3.6)
61	$4f^3$	99 "	$9\ 2$	2.68	
Sm •••	$4f^4$			0.84	
Eu •••	$4f^5$		$7F$	0	
Gd •••	$4f^6$	" "		7.94	7.9
Tb •••	$4f^7$	" "	$7F$	9.72	9.7
Dy ••	$4f^8$	$11\ 11$	$8H_{15/2}$	10.63	10.5
Ho •••	$4f^9$	" "		10.60	10.5
Ez •••	$4f^{10}$	" "	F	9.59	9.4
Tin •••	$4f^{11}$	" "	41	7.57	(7.2)
Yb •••	$4f^{13}$	" "	.rf''	4.54	(4.5)
	$4f^{14}$	" "	$2F_{7/2}$		

TABLE III
THE IRON GROUP

Ion	Con- figuration	I	Basic level	$g\sqrt{j(j+1)}$	$2j/8$	$(8+1)$	P_{exp}
Ti---, V---	3d ¹		2D	1.55	1.73		1.7 ⁶
V -	3d ²			1.63	2.83		2.8
Cr---, V "	3d ³		3/2	0.77	3.87		3.8
MU---, Cr--	3d ⁴			0	4.90		4.9
Fe---, Mil--	3d ⁵			5.92	5.92		5.9
Fe--	3d ⁶			6.70	4.90		5.5
Co--	3d ⁷		⁴ F	6.54	3.87		4.4-5.3
Ni-	3d ⁸		*F ^{o12}	5.59	2.83		3.2
di-•	3d ⁹	"		3.55	1.73		1.9

As already mentioned in § 1 the incomplete 4f- or 3d-shells are responsible for the magnetic behaviour. RUSSELL and SAUNDERS'S scheme has proved to be valid for the ions, so that in a first approximation the spins of different electrons interact exclusively with each other, giving a resulting spin vector S . Similarly, the orbital movement of the electrons give the orbital vector L . The interaction between these two resulting vectors A ($L \cdot S$) is much smaller than the interaction between the individual spins or orbits and gives rise to the multiplet structure. The resulting J vector characterizing the moment of momentum of the whole ion may have $2L-1$ or $2S-1$ different values.

The number of electrons in the incomplete shell being given, HUND'S rules allow us to predict the S , L and J -values of the lowest level. According to these rules, S has the highest value allowed by PAULI'S principle. The L -value is the highest value then allowed and J is $L - S$, if the shell is less than half full and $L + S$ if the shell is more

than half occupied. Column 3 contains the values of this lowest level, while Column 4 gives $p = g J / J (J + 1)$ (compare (10)).

It is seen that a good agreement is found between the numbers in Column 4 and those of the last column which gives the experimental p values, deduced from (10) for those compounds, of which the susceptibilities are in agreement with CURIE'S law. This agreement for the rare earths ions was first noted by HUND. It means that the magnetic susceptibility is little influenced by the crystalline fields, for it has practically the same value as it would have for free ions. It must be noted, however, that the susceptibilities of Sm-JL* and Eu-;.* compounds deviate strongly from CURIE'S law and that the deviations of Ce •••, Pr.... Nd...Tm.... and Yb.... compounds from this law are not negligible.¹ Sometimes these deviations are described by the CURIE-WEISS law $\chi (T - \theta) = C$ but, in view of our remarks made on this matter in § 1, this has little sense. In these cases we prefer to derive an approximate value of p from the susceptibility at room-temperature only. This yields merely an "effective magneton number", and any different temperature would, of course, give a different magneton number. This is, however, not very serious, for if this temperature is not taken too low, the difference in p is confined to a few percent. The effective magneton numbers at room-temperature are placed in parentheses.

A rough analysis of the susceptibilities and absorption spectra leads to the conclusion that the splittings introduced by the crystalline fields are generally of the order of 10^2 or 10^3 cm⁻¹, while the multiplet separations are about a factor 10 higher. It is remarkable that, in spite of the fact that kT (at room-temperature 200 cm⁻¹) is of the same order as the crystalline splittings, the deviations from

i B. CABERA, *Eapport de la Reunion sar le Magnctisme*, Strassbourg, 1939.

CURIE'S law are usually small and that the magneton number is about the same as if the splittings had been very small. Calculation shows, however, that this in fact agrees with what was to be expected (compare § 1). The attempts to arrive at conclusions as to the value of the crystalline splittings from susceptibility measurements and to confront them with the absorption-spectra have met with rather little success.¹ The difficulty is, that the susceptibilities are not very sensitive to changes in the splittings and that the absolute values of the susceptibilities are often inaccurate and scarce, especially for single crystals. The provisional conclusion is that purely cubic crystalline fields will not do. In the case of Sm²⁺ and Eu²⁺ ions the state of affairs is complicated by the smallness of the multiplet splittings. These splittings are of the same order as the crystalline splitting and as kT at room temperature. Owing to the smallness of the denominators in (4) the non-diagonal elements of the magnetic moment between different multiplet terms are of importance here. According to PRANK and VAN VLECK² the experimental susceptibilities are in approximate agreement with the theoretical expectations for these ions too.

In the iron group there is no agreement between Column 4 of Table III and the last (experimental) column. The agreement between the fifth and the last one, however, is good in the first half of the group and moderate in the second half. This means, according to BOSE³ and STONEB⁴ that the susceptibility is chiefly due to the resulting electronic spin, the orbital magnetism being cancelled in

¹ F. H. SPEEDING, *Phys. Rev.*, 50 (1936) 574.

W. G. PENNEY and O. J. KYNCH, *Proc. Roy. Soc. A* 170 (1939) 112.

² A. F. PRANK, *Phys. Rev.*, 39 (1932) 119.

J. 11. VAN VLECK, *Bapport de la Reunion sur le Magnetisme*, Strassbourg 1939.

³ D. M. BOSE, *Z. Phys.* 43 (1927) 864.

⁴ E. C. STONER, *Phil. Mag.*, 8 (1929) 250.

some way or other. VAN VUSCK¹ has pointed out that this is exactly what a crystalline field of sufficiently low symmetry does if the splittings introduced by it are larger than the multiplet separations but smaller than the separations between different multiplets. If we neglect for a moment the coupling $A \begin{matrix} \rightarrow \\ \rightarrow \end{matrix} (\vec{L}, \vec{S})$ between orbits and spins, the orbital degeneracy will be completely removed by such a field and every resulting level will have only the $(2S + 1)$ -fold spin degeneracy. The susceptibility will be isotropic, will obey CURIE'S law and will be determined by the so-called spin-only magneton number $2 V S (S + T)$ given in Column 5 of Table III. If we now admit the spin-orbit interaction, splittings will arise of the order of $\lambda^2/\Delta W_{\text{cryst}}$, where ΔW_{cryst} denotes the crystalline splittings. If these first splittings are small compared with kT , CURIE'S law will still be valid, but the magneton number will differ somewhat from the spin-only value; the relative difference will be of the order $\lambda/\Delta W_{\text{cryst}}$. If the crystalline field is not cubic the magneton number may be dependent on the orientation in the crystal.

Because of the larger value of A the deviations from the spin-only value and the anisotropies are especially important at the end of the group. Assuming a predominantly cubic crystalline field, usually due to six water dipoles, it has been possible to describe the general magnetic behaviour of the magnetic ions. We shall return to this in Ch. V, § 1 and now, in Fig. 2, give only a sketch of the relative positions of the energy levels according to VAN VLECK and others.² We cannot conceal, however, that it is rather probable that the crystalline splittings are in general not small compared with the separation between the different multiplets. Several of the conclusions however will remain valid so long as they are small compared with the interval between levels of different S -values.

1 J. H. VAN VLECK, *Phys. Rev.*, 41 (1932) 208.

2 L. J. F. BROER, *Thesis*, Amsterdam, 1945.

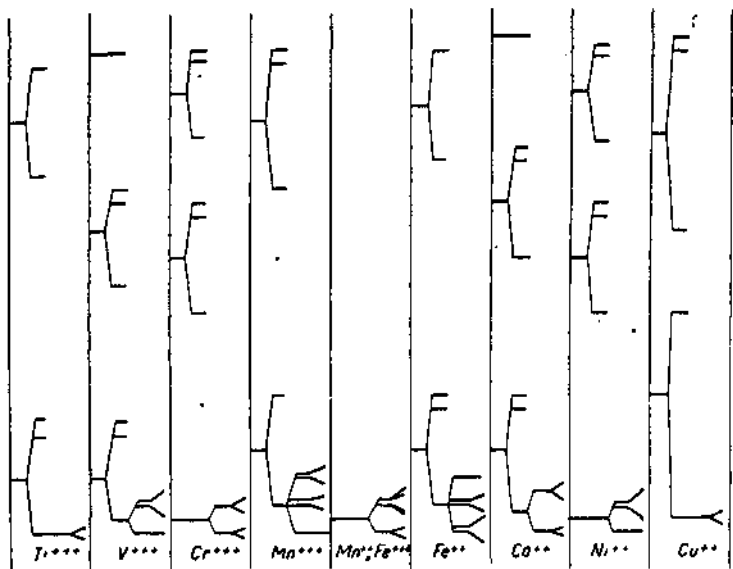

Sketch of the relative positions of the energy-levels in the iron group. We give for each ion: the levels in a cubic field, then those in a field of lower (rhombic) symmetry and for the lowest levels the influence of spin-orbit coupling and of an external magnetic field. If a level is split in a rhombic but not in a trigonal field the splitting is drawn to be email. The diagram is not at all according to scale.

§ 5. PARAMAGNETIC DISPERSION AND ABSORPTION

In § 1 we defined the static susceptibility χ_0 as the ratio $\Delta M_{\Delta H} / \Delta H$, where $\Delta M_{\Delta H}$ is the change of the magnetic moment in the direction of ΔH which accompanies a small change ΔH of the magnetic field. Concerning this definition we wish to make here a few fundamental remarks. Often the susceptibility is defined as M_H / H ; this agrees with our definition so long as M_H is proportional to H . At very low temperatures paramagnetic saturation occurs and then our

definition appears to be preferable. In a non-isotropic substance X_0 may be replaced by a tensor of the second degree which may be transformed by rotation of axes in such a way that three principle susceptibilities are obtained. If fixed directions of $H = H_c$ and of AH are accepted we may for most purposes ignore the component of the magnetic moment perpendicular to AH and retain our original definition of X_0 . But the value of X_0 is then dependent upon the orientation of both H_c and AH . In an isotropic substance (or powder) we must in any case distinguish between the cases where H_c and AH are parallel and where they are perpendicular to each other. In the first case we can define $\chi_{0//} = \Delta M_{//} / \Delta H_{//}$ and in the second one $\chi_{0\perp} = \Delta M_{\perp} / \Delta H_{\perp}$, where the signs // and \perp indicate parallelism or perpendicularity to H_c . So long as the magnetic moments are linear in the fields these two susceptibilities are equal.

If we now consider a magnetic field which varies harmonically the magnetic moment will also vary harmonically so long as the amplitude of the variation is not too large:

$$H = H_c + H_0 \cos 2\pi\nu t, \quad 27$$

$$M = M_c + M_0' \cos 2\pi\nu t + M_0'' \sin 2\pi\nu t, \quad 28$$

and in analogy to $\chi_0 = \Delta M_c / \Delta H_c$ we may put

$$\chi' = M_0' / H_0 \quad \text{and} \quad \chi'' = M_0'' / H_0 \quad 29$$

In reality F , H_c , H_0 , M , M_c , M_0' , M'' are all vectors and we obtain for χ' and χ'' two tensors of the second degree, which, moreover, are dependent on the orientation and magnitude of H_c . For many purposes, however, we may confine ourselves, as in (27), (28) and (29), to the component of M in the direction of H_0 . In isotropic substances (or powders) it is appropriate to decompose the harmonic variations in two components viz. parallel and perpendicular to H_c and to characterize the magnetic behaviour by two pairs of susceptibilities $\chi'_{//}$ and $\chi''_{//}$ and χ'_{\perp} and χ''_{\perp} .

Making use of complex notation, we can also write:

$$H = H_c + H_0 \exp 2 \pi j \nu t, \quad 27a$$

$$M = M_c + M_0 \exp 2 \pi j \nu t, \quad 28a$$

$$\chi = \frac{M_0}{H_0} = \chi' - j\chi'' \quad 29a$$

It must be borne in mind that χ' and χ'' (and also χ'_{\parallel} , χ''_{\parallel} , χ'_{\perp} , χ''_{\perp}) are not only functions of ν , but also of the magnitude of H_c .

χ' is for obvious reasons called: the high frequency magnetic susceptibility and its dependence on the frequency is called: paramagnetic dispersion, χ'' characterizes the paramagnetic absorption of energy from the high frequency magnetic field. As a matter of fact, this energy is per cycle (ef. (12))

$$-\oint M dH = \pi \chi'' H_0^2. \quad 30$$

Sometimes the absorption coefficient A_{sec} is defined as the amount of energy absorbed per second, divided by the average density of the magnetic energy $H_0^2/16\pi T$. We then have:

$$A_{sec} = 16 \pi^2 \nu \chi''. \quad 31$$

Sometimes also the product $A = \nu \chi''$ is called: absorption coefficient.

At very low frequencies χ' will be equal to the static susceptibility and χ'' will be zero. The course of χ' and χ'' as a function of ν will not be mutually independent since; they are joined by the so-called KRAMERIS-KRONIG¹ relations:

$$\chi'(\nu_1) = \frac{2}{\pi} \int_0^{\infty} \frac{\nu \chi''(\nu)}{\nu^2 - \nu_1^2} d\nu + C, \quad 32$$

i H. A. KRAMERS, *Atti Congr. Fis.*, Como (1927) 545.

R. KRONIG, *J. opt. Soc. Amer.*, 12 (1926) 547.

$$\chi''(\nu_1) = -\frac{2}{\pi} \int_0^{\infty} \frac{\nu_1 \chi'(\nu)}{\nu^2 - \nu_1^2} d\nu, \quad 33$$

where C is an arbitrary constant.

The condition for the validity of these formulae is that $X(\nu)$ is an analytic function of ν which has no poles in the lower half of the complex plane. J. P. SCHOUTEN¹ succeeded in deriving these formulae from the plausible assumption that if H is constant up till a certain moment and from then on has a slightly different value, the magnetic moment, also, will have a constant value up to that moment.

The dependence of x' and x'' on the frequency may differ. It may be that x'' has a sharp maximum at a certain frequency. Then x' changes steeply at that frequency. An example is furnished by a damped magnetic oscillator:

$$\chi = \frac{\chi_0 \nu_0^2}{\nu_0^2 - \nu^2 + j \kappa \nu}, \quad 34$$

which is equivalent to:

$$\chi' = \frac{\chi_0 \nu_0^2 (\nu_0^2 - \nu^2)}{(\nu_0^2 - \nu^2)^2 + \kappa^2 \nu^2}, \quad 35$$

$$\chi'' = \frac{\chi_0 \kappa \nu_0^2 \nu}{(\nu_0^2 - \nu^2)^2 + \kappa^2 \nu^2}. \quad 36$$

Another simple example is

$$\chi = \frac{\chi_0}{1 + j \rho \nu}, \quad 37$$

which is equivalent to

$$\chi' = \frac{\chi_0}{1 + \rho^2 \nu^2}; \quad 38$$

$$\chi'' = \frac{\chi_0 \rho \nu}{1 + \rho^2 \nu^2}. \quad 39$$

This function has been used by DEBIJE and others in the
i Cf. R. KRONIG, Ned. T. v. Nat., 9 (1942) 402.

description of dielectric relaxation and is often called: the DEBIJE-function. It is also of great importance in the theory of paramagnetic relaxation (compare Ch. III and IV).

Of course (35) and (36), as well as (38) and (39), obey the KRAMERS-KRONIG relations (32) and (33).

In order to represent results bearing on paramagnetic dispersion and absorption, two types of diagrams are in use. In the first type of diagram $\chi' > \chi''$ or $\chi' = \chi''$ are plotted against the logarithm of the frequency. Eq. (38),

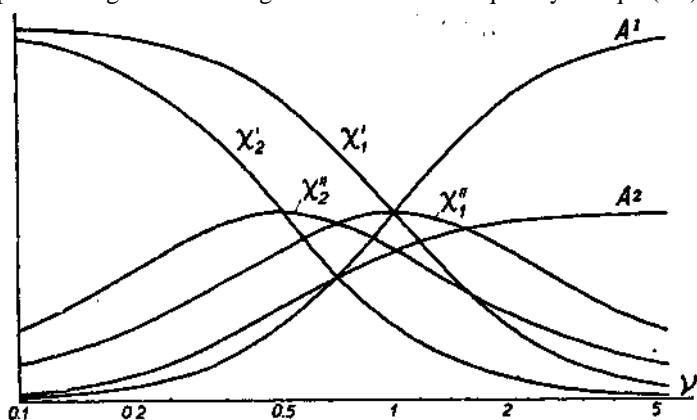

Fig. 3.

The graphic of (40), (41) and (42). ρ is taken equal to 1 and 2.

(39) and the corresponding expression for A then become

$$\chi' = \frac{\chi_0}{2} [1 - \operatorname{tgh}(\ln \nu + \ln \rho)], \quad 40$$

$$\chi'' = \frac{\chi_0}{2} \operatorname{sech}(\ln \nu + \ln \rho); \quad 41$$

$$A = \chi'' \nu = \frac{\chi_0}{2 \rho} [1 + \operatorname{tgh}(\ln \nu + \ln \rho)]. \quad 42$$

One of the advantages of plotting results in this way is, that if they follow DEBUE-curves, a change of the relaxation constant introduces only a shift of the curves for χ'

and x'' over in $(p_1/92)l$ as may be seen immediately from (40) and (41). The curve for A is not only shifted but also multiplied by p_1/p_2 , as may be seen from (42).

Another type of diagram often used, when x' and x'' are measured simultaneously at the same frequencies¹, is to plot x'' against x' . If x' and x'' behave according to a DEMJE-function, the points for different frequencies lie on a circle

$$\left(x' - \frac{x_0}{2}\right)^2 + x''^2 = \left(\frac{x_0}{2}\right)^2 \quad 43$$

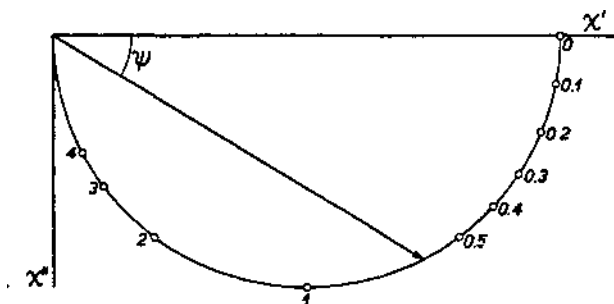

Fig. 4.

The graphic of (43). p is taken equal to 1. The frequencies corresponding to different points on the circle are given too.

Prom the position of each experimental point on the circle it is possible to derive the value of p . The simplest way is to consider $\text{tg } \psi = x''/V - 9^V$ which gives p if v is known.

It will be seen later that the experimental results often give a DEBIJE curve for x'' and a DEBIJE curve plus a constant term for x' . It is clear that then the curve for x' in Fig. 3 and the circle of Fig. 4 is shifted by this term in a vertical and a horizontal direction respectively.

i F. K. Du PR6, *Thesis*, Leiden, 1940.

§ 6. HISTORICAL.

The modern theory of the phenomena of dispersion and absorption in electric dipole substances is connected with DEBIJE'S name, but experimental researches in this domain go even back to DRUDE². It would seem rather obvious to search for the magnetic analogon of these well-known phenomena but the paramagnetic susceptibilities are a factor 10^3 — 10^4 smaller than the electric ones and therefore much less accessible by simple experimental techniques; on the other hand the theory of paramagnetism was for a long time a rather obscure chapter. In 1920 LENZ³ pointed out that the re-orientation of elementary magnetic moments which, according to LANGEVIN'S theory, should be responsible for the paramagnetic susceptibility, should take place in discrete elementary processes under the influence of the temperature of the crystalline lattice and he suggested that this re-orientation will take place the slower, the lower temperature. In the same year the problem was mentioned by EHRENFEST* and the author remembers having discussed in his college days in Leyden the possibility of relaxation phenomena in paramagnetics and the difference between isothermal and adiabatic susceptibilities, with his friend the late E. C. WIERSMA.

On PAULI'S suggestion WALLER⁵ in 1932 took up the problem and in an impressing paper laid a sound basis for the theory of paramagnetic relaxation. He distinguished between magnetic fields much weaker and much stronger than the internal magnetic field and came to the conclusion that in weak fields the relaxation time should be independent of the temperature, while in strong fields the interaction with the crystalline lattice should be essential, which would lead to a rapid dependence on the temperature.

i P. DEBIJE, *Polare Molekeln*, Leipzig (1929).

2 P. DRUDE, *Z. phys. Chemie*, 23 (1897) 267.

3 W. LENZ, *Phys. Z.*, 21 (1920) 613.

* P. EHRENFEST, *Comm.*, Leiden, 446 (1920).

s I. WALLER, *Z. Phys.*, 79 (1932) 370.

The first extensive experiments, after some incidental researches with bridge methods at relatively low frequencies, were carried out at RUTHERFORD'S suggestion by BELZ¹ in 1922. BELZ used the heterodyne beat method (compare Ch. II, § 1), and measured the high frequency susceptibility of a series of crystallized salts of the iron group and of their solutions at a frequency of about $0.8 \cdot 10^6$ Hz. Absolute measurements of this kind cannot be very accurate because of the uncertainty in the filling-factor (compare Ch. II, § 1) but the agreement with the static susceptibility was good in all cases. This did not astonish the writer, as "relaxation is not to be expected when the period is large compared with the relaxation time of the molecule". BELZ considered his arrangement more as a new installation for the measurement of susceptibilities than as one for the detection of relaxation phenomena.

BREIT and KAMERLINGH ONNES² following suggestions of LENZ and EHRENFEST, deliberately investigated whether at liquid hydrogen temperatures the susceptibilities of CrCl_3 and $\text{Gd}_2(\text{SO}_4)_3 \cdot 8\text{H}_2\text{O}$ differ at a frequency of $0.369 \cdot 10^9$ Hz from the static susceptibilities. Again the heterodyne beat method was used, but, because of the uncertainty in the filling factor, the accuracy was rather unsatisfactory. The result was that, though the high frequency susceptibility seemed somewhat lower than the static susceptibility, there was agreement so far as the order of magnitude was concerned. From our present knowledge we may conclude that the observed difference must have been spurious.

In 1935 and 1936 a series of investigations was started first at Haarlem and then, at low temperatures, at Leyden concerning the heat developed in paramagnetic substances under the influence of a high frequency alternating field of about 10^7 Hz.³ In accordance with WALLER'S expectation for weak fields, it was found that the results could be

i M. H. BELZ, *Phil Mag.*, 44 (1922) 479.

2 G. BREIT and H. KAMERLINGH ONNES, *Comm.*, Leiden, 168b. ,

« C. J. GORTER, *Physica*, 3 (1936) 503.

described by a relaxation constant which was of the order of 10^{-9} seconds independent of the temperature. With only short interruptions these measurements on paramagnetic absorption were continued and extended at Groningen and Amsterdam till 1944. Most observations were carried out by Dr F. BRONS, Dr L. J. DUKOTRA, Dr O. VAN PAEMEL, Dr J. VOLGER, and Mr F. W. DE VRIJER.

In 1937, following the example of BELZ and BREIT another series of measurements was started with the heterodyne beat method.¹ In the absence of a constant field the high frequency susceptibility is always practically equal to the static one, but in large parallel fields it often decreases considerably. This phenomenon was studied over a wide interval of frequencies on many substances at Groningen and Amsterdam. Most of the observations were carried out by Dr F. BRONS, Dr P. TEUNISSEN, Mr H. GROENDUK, Mr J. EISISES, Dr L. J. F. BROER and Mr D. C. SPHERING e.i.

In 1941 STARR² has been carrying out similar investigations at Cambridge (Mass.) with the aid of very strong constant fields.

Since 1938 a series of investigations is being carried out at Leyden under the direction of DE HAAS at the temperatures of liquid helium by bridge methods at audio frequencies. Most of the measurements were carried out by Dr F. K. Du PRE, Prof. H. B. G. CASIMIR, Mr D. DE KLERK and Mr D. BIJL.

In the meantime, WALLER's theory has been elaborated and extended by KRONIG, CASDVUR, DU PRE, DEBIJE, VAN VLECK, BROER and a number of other theoretical physicists.³

1 C. J. GORTER and F. BMONIS, *Physioa*, 4 (1937) 579.

2 C. STARR, *Phys. Bev.*, 60 (1941) 241.

3 C. J. GORTER and R. KRONIG, *Physica*, 3 (1936) 1009.

R. KRONIG, *Physica*, 5 (1938) 65 and 6 (1939) 33.

R. KRONIG and C. J. BOUWKAMP, *Physica*, 5 (1938) 521 and 6 (1939) 290.

H. B. G. CASIMIR and F. K. Du PRE, *Physica*, 5 (1938) 507.

P. DEBIJE, *Phys. Z.*, 39 (1938) 616.

P. T. O.

At a few tenths of a degree absolute gadolinium salts and iron alum show a considerable paramagnetic absorption. This effect was discovered by GIAUQUE and MAC DOUGALL in 1935 and it was later studied in Oxford, Cambridge and Leyden¹. It seems closely connected with the more or less ferromagnetic properties acquired by normally paramagnetic substances at those extremely low temperatures and we will not enter further into it in the present monograph.

J. H. VAN VLECK, *Phys. Rev.*, 57 (1940) 426 and 59 (1941) 724 and 780 and *Le MagnStisme*, Strassbourg, 1939.

L. J. F. BROER, *Physica*, 9 (1942) 547 and 10 (1943) 801.

L. J. F. BROER, *Thesis*, Amsterdam, 1945.

L. S. ORNISTEIN, *Physica*, 7 (1940) 205.

M. FEERZ, *Phytioa*, 5 (1938) 433.

H. BANZER, *Phys. Z.*, 40 (1939) 557.

H. N. V. TEMPERIEY, *Proc. Carnibr. Phil. Soc.*, 35 (1938) 256.

i W. F. GIAUQTJE and D. P. MAC DOUGALL, *Phys. Bev.*, 47 (1935) 885.

D. P. MAC DOUGALL and W. F. GIAUQUE, *J. Am. chem. Soc.*, 58 (1936) 1032.

A. H. OOOKE and R. A. HULL, *Proc. Boy. Soc.*, A 162 (1937) 404.

E. S. SHIRE and H. M. BARKLA, *Proc. Cambr. Phil. Soc.*, 35 (1939) 327.

H. B. G. CASIMIR, D. DE KLERK, and D. POLDER, *Physica*, 7 (1940) 737.

Note added in the proof

The very remarkable researches carried out in Russia by ZAVOISKY, FRENKEL and others came too late to my notice to be included. The same applies to more recent work of CUMMEROW and HALLIDAY at Pittsburgh.

II. EXPERIMENTAL METHODS

§ 1. HETERODYNE BEAT METHOD

The principle of this method is as follows. When a paramagnetic sample is moved into the coil of a high frequency oscillator circuit the generated frequency will vary owing to the high frequency-paramagnetic susceptibility of the sample. If the frequency is given by $\nu = 1/2 IT V LC$, a molal paramagnetic susceptibility x' will lead to a relative variation $2-K^q/V$, where V is the molal volume and q the so-called filling-factor which gives the fraction of the coil occupied by the sample (strictly speaking the volume in and around the coil must be weighed in proportion to jff_0^2). This variation is detected by mixing the measuring frequency with a slightly different constant frequency of a reference oscillator. The differential audiofrequency is measured; its change is equal to that of the measuring frequency.

An essential difficulty is, that in the region where x' varies as a function of the frequency, x'' differs from zero. Insertion of the sample into the measuring coil means, therefore, an increase in load and this causes a disturbing variation of the frequency. SCHERINO studied the influence of this varying load by connecting two multigrid tubes, the control bias of which could be changed, parallel to the measuring coil. With the aid of such a variable damping a circuit was developed which allowed an easy automatic compensation of the influence of varying load on the generated frequency¹. Fig. 5 is a diagram of the oscillator

i SCHERING also developed a circuit in which the frequency was very strongly dependent on x'' . By subtracting the variations in the two circuits x'' could be determined. This research has been interrupted in 1944 and has not yet been resumed.

circuit, used by BROER and SCHERING¹, in which the variable damping apparatus is built in.

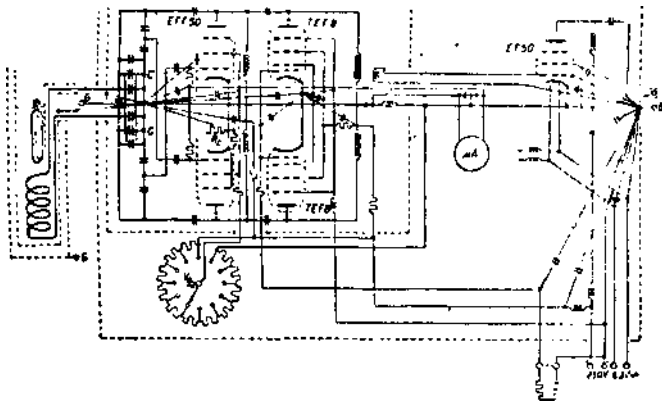

Fig. 5

Oscillator built by BROER and SCHERING. The required compensation for varying load can be obtained by adjusting B_c and V in such a way that change of the control grid bias of the EF 8-tubes (by switching in the small battery below at the right hand side) has no influence on the frequency.

Fig. 6 gives the electron-coupled reference oscillator which can be operated either with a quartz crystal (PIERCE circuit) or with a COLPITIS circuit, the buffer stage, which may act as a frequency multiplier, and a balanced additive mixer circuit. The resulting audio-frequency is amplified and, after passing a low-pass filter, measured by an A.E.G. direct reading frequency meter. Fig. 7 gives a functional block diagram of the whole assembly.

Most measurements have been performed at the boiling points of liquid nitrogen and oxygen under normal pressure (77° and 90°K). A few measurements have been carried

i L. J. F. BROER and D. C. SCHERING, *Physica*, 10 (1943) 631.

out in nitrogen at reduced pressure (64°K), with solid carbon dioxide in ether (195°K), and at room temper-

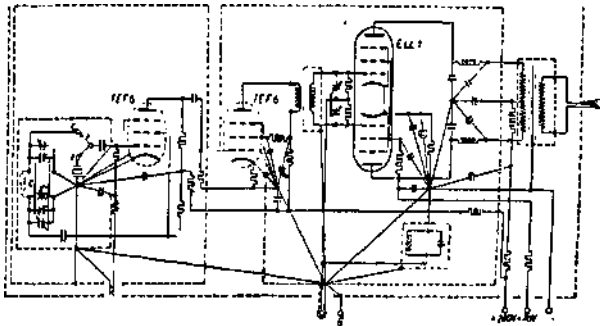

Fig. 6

Reference oscillator, bufferstage acting as frequency multiplier and mixer circuit used by BROER and SCHERING. The oscillator is entirely a.c. operated, the power supply being highly stabilized.

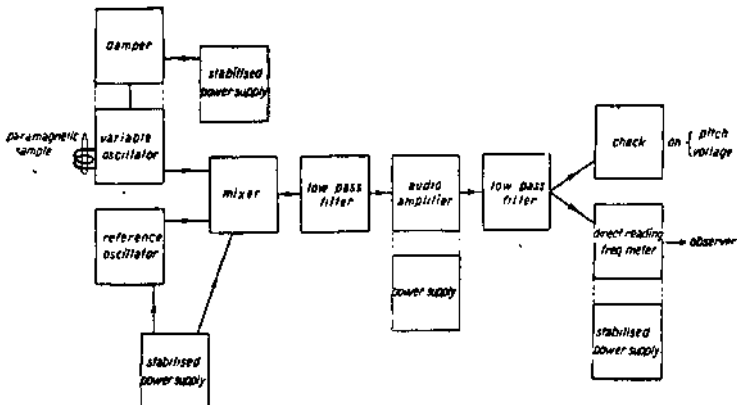

Fig. 7

Functional block diagram of BROER and SCHERING'S set up.

ature. The sample was placed inside a DEWAR vessel into which various cryostat liquids could be poured. In older researches the sample consisted of small crystals contained in a perforated paper tube into which the cryostat liquid could penetrate. In more recent researches the sample was contained in a sealed glass tube. In older researches the measuring coil was either placed around the DEWAR vessel or inserted into it, so that the cryostat liquid boiled inside as well as outside the coil. In the first case the filling factor is small while the second alternative led to irregular capacitive disturbances of the generated frequency by gas bubbles in the liquid. For that reason BBOER used in later researches¹ a small coil (Fig. 8), completely enclosed in a copper cylinder *H*. The thin glass tube containing the sample *O* approximately fits into the coil; it can be pulled out of the coil by means of the string *F*.

The cylinder is closed by the German silver lid *O*. The smallness of the hole, through which the string passes, and the German silver mantle *G* are sufficient to prevent condensation of liquid air inside the coil when this is cooled by liquid nitrogen. The whole cylinder is placed into the DEWAR vessel. Before inserting a new sample into the cylinder it is desirable to pre-cool the sample.

By various precautions the variation upon inserting the sample due to capacitive change is reduced to a few Hz. It is determined by performing the same measurement with a similar diamagnetic sample (compare also § 2). The reproducibility in the volume susceptibility χ/V of hydrated salts amounts to about 10^{-6} at frequencies ranging from $0.1 \cdot 10^6$ Hz to $14 \cdot 10^6$ Hz. In this connection we mention that the volume susceptibilities of iron ammonium alum and cupric Tutton salts are about $170 \cdot 10^{-6}$ and $25 \cdot 10^{-6}$ respectively at 90°K .

Because of the uncertainty in the filling factor q the high frequency susceptibilities are not determined ab-

i L. J. F. BKOER and D. C. SPHERING, *Physica*, 10 (1943) 631.

solutely but as a fraction of the static susceptibilities X_0 . This is possible because the high frequency susceptibility

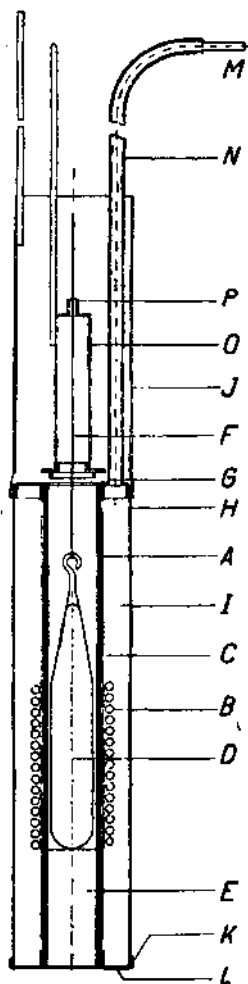

Fig. 8

Measuring coil enclosed in copper cylinder after BROER and SCHERING.

in the absence of a longitudinal field is always equal to the static susceptibility χ_0 -

Perpendicular fields have no detectable influence on the high frequency susceptibility; usually, therefore, all measurements are carried out in an iron-free cylindrical coil, the axis of which coincides with that of the measuring coil.

BRONS¹ has given a few fundamental considerations about the construction of such coils. The problem is how to obtain a magnetic field in a cylindrical space of radius d when a certain electrical power is at one's disposal. As these considerations may be of some interest to those wishing to construct such a coil for the study of paramagnetic relaxation or for other purposes, we will briefly summarize BRONS's conclusions. The magnetic field obtained in a homogeneously wound cylindrical coil is

$$H = 0.4 F \sqrt{\frac{\pi q A}{2 \rho d}} \quad 44$$

where q is the filling factor, being the ratio between the volume occupied by the metal (copper) wire carrying the current, and the total volume; A is the electric power dissipated as JOULE heat and p is the specific resistance of the metal (copper). The factor F depends on the shape of the coil. BRONS has calculated F for a few different shapes of the coil. His results are given in Fig. 9. The height of the coil is $2y$ its inner and outer radius are d and $d + x$ respectively. It is seen that the most favourable value $F \sim 0.36$ is reached when the outer radius is about three times the inner radius and the height is about four times that inner radius, but rather considerable deviations from this ideal shape are tolerable. If two or more different power supplies can be used together, it is advantageous to divide the coil in such a way that the current density decreases approximately in proportion to the minus three

i F. BRONS, *Thesis, Gronmgen*, 1938.

halves power of the distances to the axis. The filling factor q depends, chiefly on the system adopted for cooling. Most systems (coils wound on a cylinder in which water circulates, copper tubes carrying currents of electricity as well as of cooling liquid, wires alternating with tubes etc.) lead to rather unfavourable filling factors. A favourable construction is obtained by spiralling isolated copper wire, preferably of flat rectangular cross-section into flat discs

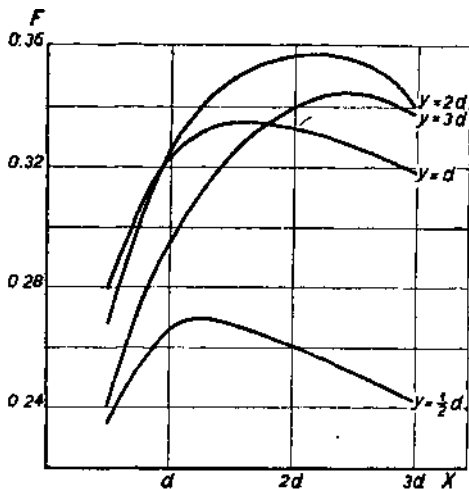

Fig. 9

BftONS's factor influencing the strength of the field obtained in an iron free cylindrical coil of height $2y$ and inner and outer radius d and $d + x$ respectively. The field is then given by (44).

and interleaving these with cooling discs in which a cooling liquid circulates between thin brass sheets; in this way a value of $g = 2/3$ may be reached comparatively easily. To give an example: if the available power is 20 kWh and the inner radius must be 5 cm, a field of about 7200 O is obtainable. It is evident that the cross-section of the copper wire must be chosen in such a way that the available power can be dissipated as JOULE heat.

The apparatus used by STARR¹ at Cambridge (Mass.) is, apparently, rather similar to BROER and SCHERING'S apparatus. One of the two differences is the method to measure the audio-frequency. In STARR'S arrangement this frequency feeds one set of plates of a cathode ray oscillograph, while the other set of plates is connected to a calibrated audio frequency generator, which then is adjusted so that a standing pattern on the screen is obtained. This same method has been used by BRONB and TEUNISSEN² in Groningen, but it has since been dropped in favour of the direct reading frequency meter which operates nearly twice as quickly. On account of frequency fluctuations of the oscillator this was of some importance but it is true that STARR can claim an unusually good constancy for his oscillator. The second difference concerns the coil, which brings about the constant field. This is a large BITTER magnet which gives fields up to 60000 O while in Holland the largest field regularly used is only 3200 O. Though STARR, apparently, also has an arrangement enabling him to insert and to remove the sample, he does not use it as it does not give sufficiently reproducible results. Instead, he leaves the sample in its place and determines the variation of the oscillator frequency when the constant field is changed by steps. He then, apparently, assumes x' to be zero in a field of 60000 O, an assumption which is not generally admissible. The uncertainty of the correction which therefore has to be applied is possibly responsible for serious discrepancies between his results and those obtained in Holland².

§ 2. CALORIMETRIC METHOD

In this method a small thermally isolated sample is subjected to a high frequency magnetic field, while its temperature is continuously observed.

¹ C. STARR, *Phys. Bev.*, 60 (1941) 241.

² L. J. F. BROER, *Thesis*, Amsterdam, 1945.

Fig. 10 shows the arrangement used by DIJKSTRA¹ at Amsterdam. The sample of the substance under investigation is contained in a thin-walled glass tube hanging from

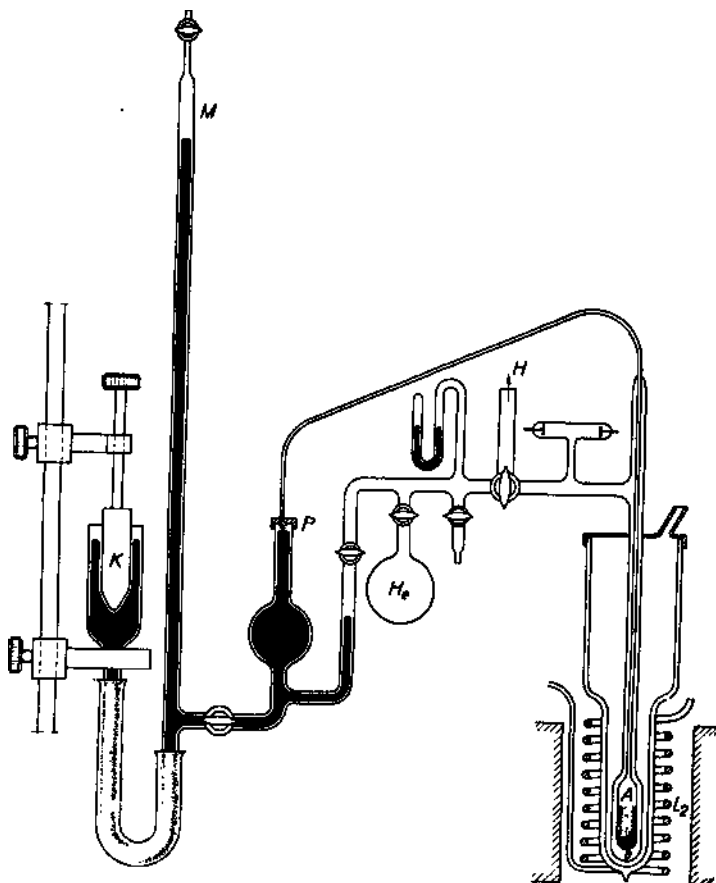

Fig. 10

Apparatus used by DIJKSTRA for researches on paramagnetic absorption by the calorimetric method.

i L. J. DIJKSTRA, *Thesis*, Amsterdam, 1943.

a long narrow glass capillary. The glass tube is filled with helium gas, the pressure of which can be observed by means of a manometer communicating by a steel capillary and the glass capillary with the space inside the glass tube. By this contrivance the glass tube serves as a calorimeter and at the same time as the reservoir of a gas thermometer. The measurements are usually performed at a constant volume of the gas, the wooden block K being screwed into the mercury -at such a rate that, in spite of the rise of pressure in the glass thermometer, the steel point at *P* remains very near to the surface of the mercury. The point *P* and the meniscus are observed with a microscope; it is essential that the regulation with the wooden block be not performed too abruptly, as then the helium gas would flow up and down the glass capillary, thereby causing a thermal leak. It is desirable to make the noxious volume around *P* small. The pressure of the helium gas is usually of the order of one atmosphere. If the glass capillary is too narrow, the pressure lags too much behind the temperature and if it is too wide, the thermal isolation of the calorimeter is affected.

The glass tube hangs in a wider glass vessel which can be evacuated or filled with air at a low pressure through JEL . The glass vessel is placed in a DEWAR vessel filled with some or other cryostat liquid. When the glass vessel is evacuated, the glass tube is thermally isolated from the surroundings. Radiation from above is reduced by a small metal screen in the glass vessel, which is in contact with the cryostat liquid; it is also necessary to screen off all visible light which might reach the glass tube. If these precautions are taken the radiation coming from room temperature is negligible compared with the conduction along the glass capillary.

The measurements proceed as follows. When the temperature in the glass tube is equal to that of the cryostat liquid, it is thermally isolated by evacuating the glass vessel, and the pressure of the helium gas is measured

at M every two minutes. Then the high frequency magnetic field is switched on and maintained constant during a few minutes and finally this is switched off. During the steep rise of temperature and the after-period the pressure is also observed. Fig. 11 gives a typical example of the rise in pressure during a measurement.

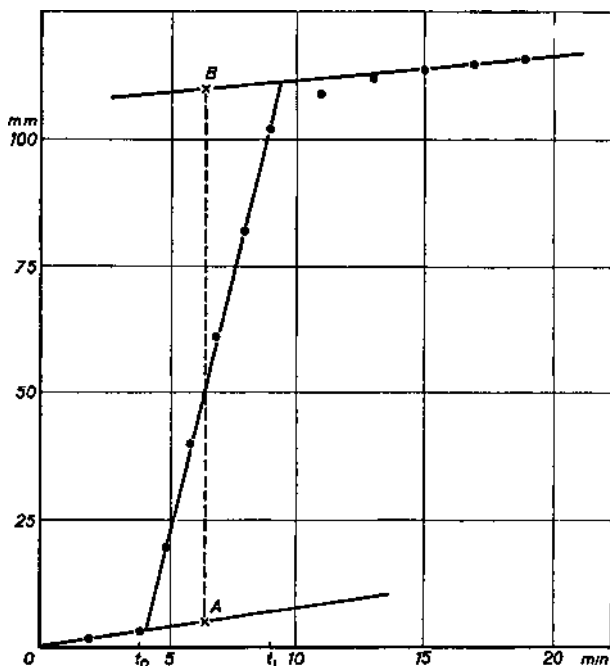

Fig. 11.

Rise of the pressure measured by the manometer. The high frequency magnetic field is switched on at t_0 and switched off at t_1 . The development of heat is approximately proportional to the distance AB taken at the time $(t_1 - t_0)/2$.

The presence of metal in the high frequency field has to be avoided most carefully, as this would lead to an enormous dissipation of heat. This was experienced a few

times when the sample contained a scarcely visible drop of mercury or a small chip of metal. Of course, the DEWAR vessel should not be silvered.

A high frequency magnetic field up to $10 \cdot 10^6$ Hz could easily be obtained by placing the coil of a resonant LC-circuit around the DEWAR vessel, as indicated in Fig. 10. A reasonable high frequency current in this coil is 20 ampere which brings about a high frequency field of the order of 200. It is very important that the vertical component of the high frequency electric field which may be several hundred volts per cm, be screened off. In spite of the low electric conductivity of glass and substance at low temperatures such a high oscillating electric field would give rise to a considerable development of heat. A layer of thin, mutually isolated, vertical aluminium strips on a pertinax cylinder around the DEWAR glass proved to be an excellent screen.

The high frequency current may be generated by any oscillator. Fig. 12 gives a diagram of the circuit used by DIJKSTRA for this purpose. DIJKSTRA worked with a Philips triode T.A. 12/10000 at an anode voltage of up to 5000 volts. In order to avoid harmonics the coupling between primary and secondary resonant circuit had to be rather loose. Later on VOIDER¹ introduced link coupling with very satisfactory results. The constancy of the high frequency current was controlled by means of an ultra high frequency amperemeter; it could be regulated by a large auto-transformer (type VARIAC) which varies the anode voltage in small steps. About the measurement of the high frequency magnetic field we shall speak later on.

At higher frequencies than about $10 \cdot 10^6$ the large triode had to be replaced by a compactly built Philips TB 2/500 which gave sufficiently large high frequency magnetic fields up to about $78 \cdot 10^6$ Hz. At the highest frequencies¹ the coil around the DEWAR glass had to be replaced by a

i J. VOIXJER, *Thesis*, Amsterdam, 1946.

LECHER system introduced into the DEWAR glass (see Fig. 13). The LECHER system had a wave resistance of about 300 O and was closed by a copper ring, the sample was placed immediately over this ring between the LECHER bands. A current of about 5 ampere gave a high frequency

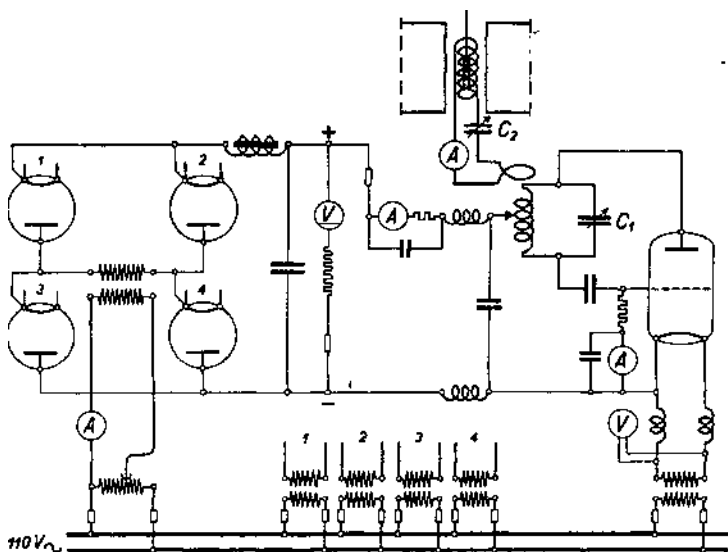

Fig. 12

Circuit used by DIJKSTRA for the generation of high frequency magnetic fields. By interchanging condensers and coils the frequency could be varied between about $0.2 \cdot 10^6$ and $10 \cdot 10^6$ Hz. The secondary coil L around the sample was, however, left the same, as far as possible. The high voltage condenser of SCHOTT'S minus glass proved to be very handy.

field of about 1.5 O. It was not possible to screen off effectively the high frequency electric field so that a considerable extra amount of heat was developed.

In all these measurements the development of heat is found in millimeters of mercury pressure per second at

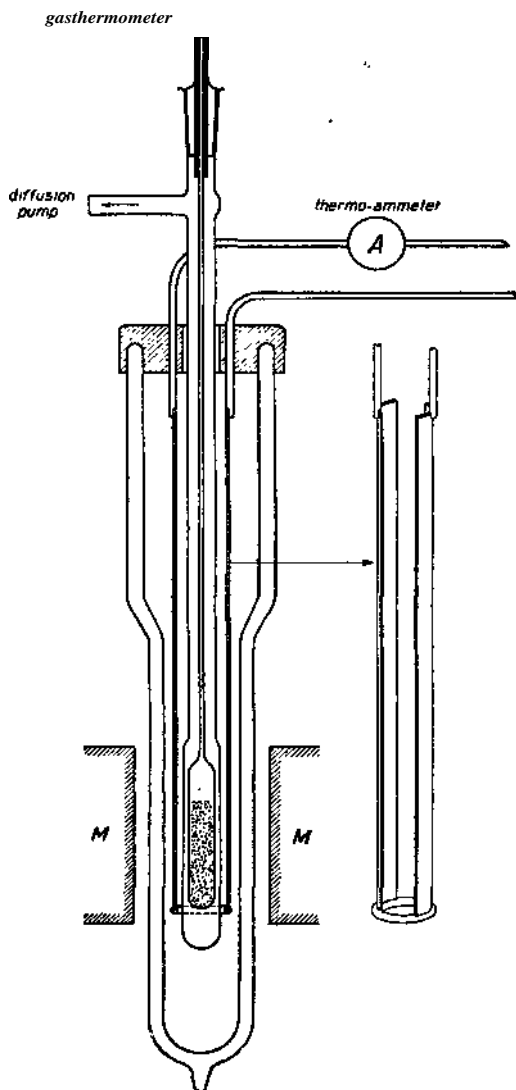

Fig. 13

End of LECHER system introduced into the DEWAR vessel
as used by VOIXIER.

a certain high frequency current registered by the ammeter. We may remark at once that the rise of pressure always proved to be proportional to the square of the readings on the ammeter, so that' reduction between different values of the current at the same-frequency did not give rise to any difficulties. If we wish to derive the absolute value of x'' we have to determine the amount of heat in calories corresponding to the differences in mercury pressure as well as the values of the high frequency magnetic field corresponding to the deflections of the ammeter.

The first problem, being essentially the determination of the heat capacity of the calorimeter, is relatively easy to solve by winding a resistance wire on the calorimeter and dissipating in it a known amount of JOULE heat. However, the introduction of the leads to the resistance wire without spoiling the thermal isolation is not easy at all and it would be an elaborate proceeding to do this for every sample. An alternative method proposed by VOLGER is to fix a somewhat elastic copper cylinder on the glass tube and to heat it in a reproducible way by induction in an alternating field of 50 Hz.

One of the best ways to determine the high frequency magnetic field is probably with the induction dynamometer that was proposed by HERTZ¹. Schematically the apparatus built by VOLGER for the purpose of determining horizontal high frequency fields (as obtained with the LECHER system just mentioned) is given in Fig. 14a. A small rectangular frame of copper wire hangs on a quartz fiber. The frame has about the same size as the paramagnetic sample and hangs in a glass vessel. If originally the angle between the direction of the high frequency field and the position of the frame is $7\pi/4$ this angle may be supposed to change by, say, a when a homogeneous field with amplitude H_0 is switched on. If we may neglect the ohmic resistance in comparison with the inductance aL , which in our example is allowed

i H. HERTZ, *Wied. Ann.*, 42 (1891) 407.

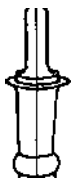

it)

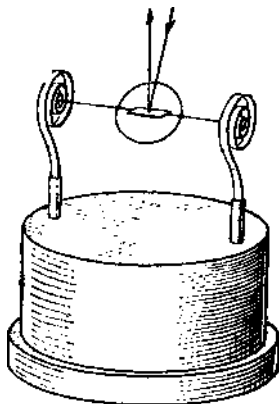

Fig. 14a
Apparatus to
measure horizontal
high frequency fields

Fig. 146
Apparatus to measure vertical
or horizontal
high frequency fields

over 10^6 Hz, the moment due to the LORENTZ force on the induced current is

where O is the surface of the frame. This moment is equal and opposite to Da , where D is the directional constant of the quartz fiber. If, therefore, we determine the dimensions of the frame (on which also L depends) and measure a we can calculate H_0 . A systematic error is made if the high frequency field is not quite homogeneous. A similar apparatus which may also be used for vertical fields constructed by VOLGER is shown in Fig. 14b.

In nearly all older researches however the heat capacity of the calorimeter and the amplitude of the high frequency field were not determined, but the absorption was given in arbitrary units (e.g., rise of 0.1 mm mercury pressure in five minutes at a deflection of the ammeter of 10 amperes). But then it was quite essential to check how far the ratio between high frequency magnetic field and ammeter deflection was independent of the frequency. This could be done by inserting a small test coil into L_2 ; this test coil was connected by a long double wire with a super high frequency milliammeter. If the resistance of the test circuit is negligible in comparison with its inductance $a \gg L$, the ratio between induced current and high frequency magnetic field is independent of the frequency. It was found, in fact, that at frequencies between 10^6 and $4 \cdot 10^6$ Hz the ratio between the deflections of the two high frequency instruments was constant. But at higher frequencies deviations occurred amounting to about 10% at $10 \cdot 10^6$ Hz. The corrections on the scale of the two high frequency instruments being small, a description of the deviations by a capacity of the order of 10^{-12} F in parallel to L_2 seems appropriate. In view of the presence of the vertical screening strips around the DEWAR glass and of the magnet for the constant fields this is quite a reason-

able result. In this way it was possible to derive the correction which had to be applied in order to ensure that the "absorption in arbitrary units" is proportional to v_x , the proportionality constant being independent of the frequency.

We have dwelt upon the custom of expressing the paramagnetic absorption in arbitrary units and upon the necessary accessory calibrations, not only because most older results have been presented in this way, but also because the relative accuracy of the numbers thus obtained is, as yet, better than the accuracy of absolute determinations involving determinations of heat capacity and amplitude of the high frequency field. In the older researches comparison with the theory required the adjustment of the arbitrary unit with the aid of the theory itself; it is certainly satisfactory, however, that this adjustment can now be dropped.

Finally, a few words must be added concerning the correction applied for the heating due to high frequency electric fields. It is sometimes determined by measuring the heat developed in similar samples not containing paramagnetic ions (e.g., aluminium alum for iron- and chromium alum, magnesium ammonium sulphate for copper, nickel and iron ammonium sulphate). At relatively low frequencies, where the electric field can be screened off efficiently, this correction is often of little importance, but at higher frequencies, and especially when the LECHER system is used, its uncertain nature is very awkward. Sometimes it has been found helpful to make use of the theoretical expectation that the paramagnetic absorption vanishes in a very-large perpendicular magnetic field.

§ 3. BRIDGE METHOD

At Leyden DE HAAS, DU PITE, CASOHR, DE KLERK, and BIJL carried out a series of observations with a bridge method in the frequency interval between 16 and 256 Hz. They

worked at the temperatures obtainable with liquid helium as the most interesting region for the relaxation, which for quite a number of substances lies at radio frequencies at liquid air temperatures, has shifted to audio frequencies at these very low temperatures. The employment of very low temperatures has also the advantage that, in accordance with CURIE'S law, the susceptibilities are much larger and that therefore a good relative accuracy may be obtained rather easily.

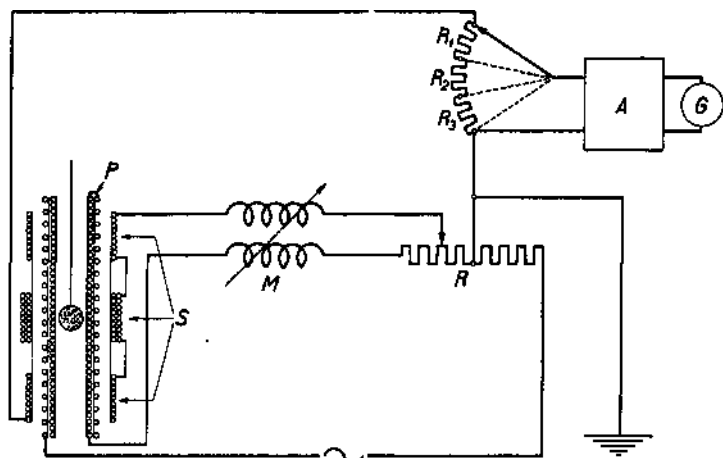

Fig. 15

Sketch of a HARTSHORN bridge used at Leyden for the simultaneous determination of paramagnetic dispersion and absorption.

A mutual induction bridge according to HARTSHORN was used.¹

As a rule a vibration galvanometer G with an, over a wide range, adjustable frequency was used, as null instrument of the bridge and was preceded by an audio frequency amplifier A^*

The mutual inductance between the primary coils P in Fig. 15 and the secondary coils S would be very small in
i F. K. DTJ PR6, *Thesis*, Leiden, 1940.

the absence of the sample. At "high" temperatures (e.g., in liquid air) it is also small because of the smallness of the susceptibility. But at liquid helium temperatures the mutual inductance is quite considerable. The difference can be compensated and measured by a change of the calibrated inductor M . Similarly, the difference in absorption due to the sample can be compensated and measured by a change of the variable resistance JR .

It is essential to reduce magnetic coupling of the coils P and S with the surroundings, as well as with each other, through intermediary of metal parts. The coil S is therefore wound in three sections, the upper and the lower Section each having half as many turns as the middle section. The three sections are connected in such a way that compensation exists for homogeneous fields. The sample is placed in the middle section. The shielding of the primary coil from the surroundings is more refined. This coil consists of two concentric separate coils of equal length the diameters of which are in the ratio $1: \sqrt{2}$, while the number of windings is in the ratio $2:1$. The circulation of the currents in the coils is in opposite directions. Under these conditions the resulting field vanishes very quickly with increasing distance from the coils; as a matter of fact, as quickly as that of a magnetic octopole, while the field produced in the inner coil by the current in this coil is only reduced to half its value by the current in the outer coil¹.

The bridge method has the advantage that the dispersion and the absorption can be measured simultaneously. Experience has taught that between different samples small differences usually exist, especially when they have been treated differently as regards their sealing and evacuating. Simultaneous measurement of x' and x'' eliminates this difficulty and makes thereby a more rigorous test of theoretical conceptions feasible.

¹ H. B. G. CASIMIR, D. BIJL and F. K. DU PRE, *Physica*, 8 (1941) 45S.

III. RESULTS

§ 1. SURVEY OF THE SUBSTANCES INVESTIGATED

The following list contains the pure substances about which experiments concerning the paramagnetic relaxation have been reported. If later experiments yielded more accurate results or were carried out over a wider range of variables only these later results are mentioned.

Substance	Method	Frequen- I	Temperature	Result
$Gd_2(SO_4)_3 \cdot 8H_2O$	I D	0.1-9	77; 90; 290	
	A, c, d	0.1-10; 78	77; 90	+
	A	10-20	14; 20; 77	+
	B	1 and 6-10-5	1.3-4.2	+
$Gd_2(C_2H_4)3 \cdot 10H_2O$	D	0.1-9	77; 90; 195	+
$Gd(C_2H_3O_2)_8 \cdot 4H_2O$	D	0.2-9	77; 90; 195; 290	
Gd_2O_3	D	9	77	
$Dy_2(8O_4) \cdot 8H_2O$	D	9	77	
$TiCs(SO_4)_2 \cdot 12H_2O$	D	3	77	
	A, c	6	77	
	A	10-20	14; 20	
	B	6-10-s	12	
$V(NH_4)(SO_4)_2 \cdot 12H_2O$	D	4	64	
	A	10-20	14; 20	+
$CrK(SO_4)_2 \cdot 12H_2O$	D	0.2-7	64; 77; 90	+
	A, c, d	0.2-78	77; 90	+
	A	10-20	14; 20	
	B	2.5-25-10-5	2.0	+
$CrNH_4(SO_4)_2 \cdot 12H_2O$	D	2-10	77	+
$CrK_2(C_2O_4)_3$	D	0.2-13	77; 90	+
[Cr. 6 11,0] 01,	D	0.2-9	90	+
[Cr. 4H ₂ O. 2Cl]Cl. 12H ₂ O	D	0.2-9	77; 90	+
	D	0.2-13	77; 90	+
[Cr. 2H ₂ O. 2NH ₃ . 2Cl]Cl	D	0.2-9	77; 90	+
[Cr. 6NH ₃]Cl ₁ . 2HgCl _a	D	0.2-9	77; 90	+

Substance	Method	Frequency X 10 ⁶	Temperature	Result
[Cr.SNH ₃ .Cl]Cl	D	9	77	
[Cr.3NH ₃ .3H ₂ O]Cl	D	9	77	
[Cr.5KH ₂ O]Cl	D	9	77	
Cr ₂ (SO ₄) ₃ .6H ₂ O	D	9	77	
CrK(8O ₄) ₂	A, c, d	34; 78	90	+
	D	4	64	
	A, c, d	78	77	+
Cr ₂ (SO ₄) ₃	A, c, d	78	77	+
Cr(NO ₃) ₃ .9H ₂ O	D	0.2-4	77; 90	+
K ₂ CrF ₆	D	0.2-13	77; 90	+
V(NH ₄) ₂ (SO ₄) ₂ .6H ₂ O	D	0.2-4	64; 77; 90	+
FeNH ₄ (SO ₄) ₂ .12H ₂ O	D	0.2-7	64; 77; 90	+
	A, c, d	0.2-78	77; 90	+
	A	10-20	14; 20; 77	
	B	4 and 6:1(M)	1.3-4.2	+
Fe(NO ₃) ₃ .9H ₂ O	D	0.2-4	64; 77; 90	
FeNH ₄ (SO ₄) ₂	D	4	64	+
	A, c, d	4	77; 90	+
K ₃ Fe(CN) ₆	D	4	64	
Fe ₂ (SO ₄) ₃ .9H ₂ O	D	9	77	
FeCl ₃ .6H ₂ O	D	9	77	
Fe ₂ (C ₂ O ₄) ₃	D	9	77	
FeCl ₃	D	10	77	
	D	0.1-4	54; 77; 195; 290	+
Mn(NH ₄) ₂ (SO ₄) ₂ .6H ₂ O	A, c, d	0.1-78	90; 195	+
	D	0.1-9	77; 90; 290	+
MnSO ₄ .4H ₂ O	A, c, d	78	77; 90	+
	D	0.2-7	64; 77; 90; 290	+
MnCl ₂ .4H ₂ O	D	0.2-9	290	+
MnO ₁ .2MgCl ₂ .12H ₂ O	D	4	64	
MnSO ₄	A, c	22	77; 90	+
	A, c, d	78	77; 90	+
MnCl ₂	D	4	64	
MnO	D	4	64	
MnCO ₈	D	10	77	
MnF ₂	D	10	77	
FeSO ₄ .7H ₂ O	D	4	64	
Fe(NH ₄) ₂ (SO ₄) ₂ .6H ₂ O	D	I 4	64	
	A, c	6	77	
	B	6-10-5	13	
CQS ₄ .7H ₂ O	D	i 4	64	I

Substance	Method	Fre- quencyXIOe	Temperature	Result
Co(NH ₄) ₂ (SO ₄) ₂ .6H ₂ O	D	4	64	
NiSO ₄ .7 Kfl	D	0,2-9	77; 90	+
	I A, c	2-10	I 77; 90	
Ni(NH ₄) ₂ (SO ₄) ₂ .6H ₂ O	D	0.2-9	77; 90	+
	A, c	2-6	77; 90	+•
Ni(NO ₃) ₅ .6H ₂ O	D	4	G4	+
		0.2-13	77; 90	+
Ou(NH ₄) ₈ (SO ₄) _a .6H ₂ O	A, c, d	78	77	+
	D	0.2-13	! 77; 90	+
CuSO ₄ . 5 H ₂ O	A, e, d	3-78	77; 90	+
	D	9	77	
Cu(BrO ₃) ₂ .6H ₂ O	A, c, d	78	90	+
	D	9	77	
Cu . 4 NH ₃ . SO ₄ . ILO	A, e, d	78	77; 90	+
CuSO ₄	A, c, d	78	I 77; 90	
CuCl ₂ . 2 H ₂ O				

D means: dispersion measurements by the heterodyne beat method. A means: absorption measurements by the calorimetric method. Later researches in which especially the dependence on longitudinal and transversal magnetic fields were studied (H_c and H_d) are denoted by A, c, d. B indicates measurements by the bridge method at Leyden. In most D and A, c, d researches the constant magnetic fields ranged up to 3200, 4000 or 4800 O. The measurements by STARR at 2—10·10⁶ Hz (chromium alums, iron alum, hydrated manganese sulphate, hydrated manganese chloride, ferric chloride, manganese carbonate, and manganese fluoride) ranged up to 60000 O, while those by the bridge method were usually extended up to 2300 O.

§ 2. RESULTS OF THE DISPERSION MEASUREMENTS BY THE HETERODYNE BEAT METHOD

The heterodyne beat method is convenient and quick when the experimental arrangement is in good working order; this appears also from § 1, where the measurements carried out by TEUNTSSSEN and BROER by this method are far more numerous than all measurements by other methods.

Figures 16a and 16b give the results on $\text{Gd}_2(\text{SO}_4)_3 \cdot 8 \text{H}_2\text{O}$ in graphic form (comp. Ch. I, § 5) as a typical example¹. The curves represent the equation

$$\chi' = \frac{\chi_0 F}{1 + p^2 \nu^2} + \chi_0 (1 - F) \quad 46$$

where F is given by the CASMIR-DU PRe relation (comp. Ch. IV, § 2)

$$F = \frac{CH_c^2}{b + CH_c^2} \quad 47$$

with $b/C = 3.9 \cdot 10^9 \text{ O}^2$; the values of p are given in Table IV.

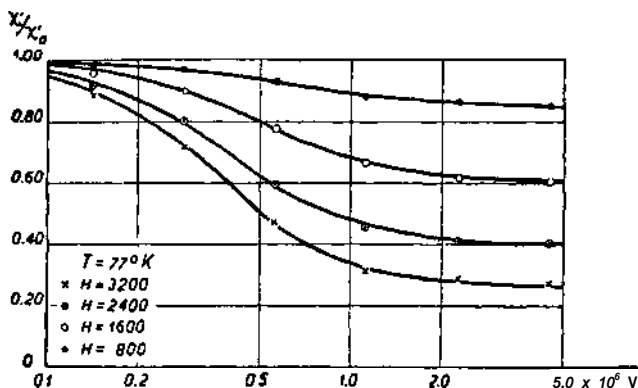

Fig. 16a.

Paramagnetic dispersion in $\text{Gd}_2(\text{SO}_4)_3 \cdot 8 \text{H}_2\text{O}$ at 77°K

As appears from the figures the agreement with the experimental curves is very good. It is possible to describe the dependence of p on H_c by the BRONS-VAN VLECK equation- (comp. § 3 and Ch. IV § 2)

$$p = p_0 \frac{b + CH_c^2}{b + pCH_c^2} \quad 48$$

¹ L. J. F. BROER and C. J. GOKTER, *Physica*, 10 (1943) 621.

2 F. BRONS, *Thesis*, Groningen, 1938.

J. H. VAN VLECK, *Phys. Rev.*, 57 (1940) 426.

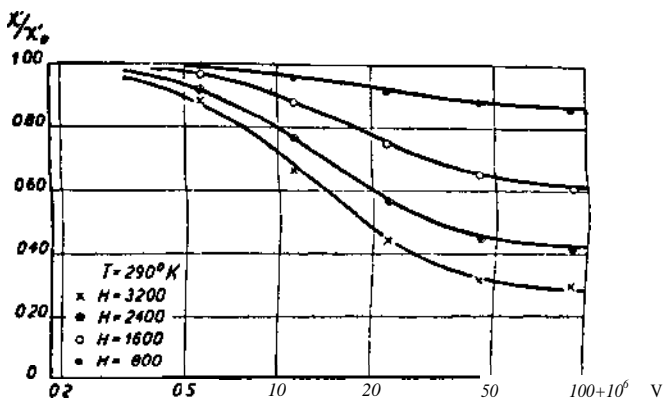

Fig. 166

Paramagnetic dispersion in $Gd_2(SO_4)_3 \cdot 8 H_2O$ at $290^\circ K$

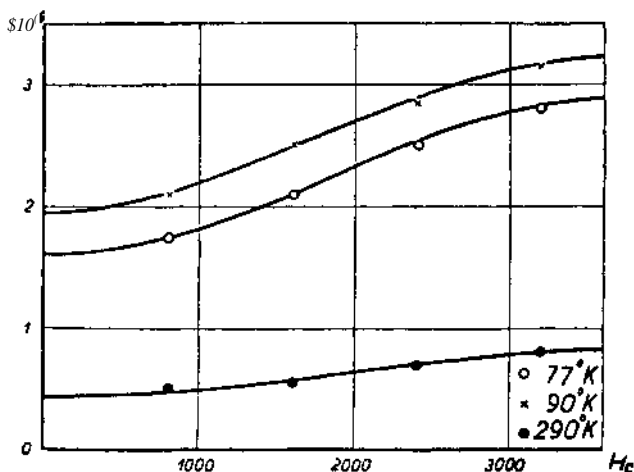

Fig. 17

p as a function of H_c in $Gd_2(SO_4)_3 \cdot 8 H_2O$

The theoretical results in the last columns of Table IV have been obtained by taking for p_0 the values $1.6 \cdot KH$ and $0.42 \cdot 10^{-6}$ and for p the values 0.40 and 0.36 respectively.

TABLE IV
p-VALUES IN $\text{Gd}_2(\text{SO}_4)_3 \cdot 8\text{H}_2\text{O}$

E_c	F	p-10 ⁵ (77°) L-10 ⁶ (290°)		P10 ⁶ (theor.)
800	0.14	1.7	0.50	1.7 ³ ; 0.46
1600	0.40	2.1	0.55	2.1 ; 0.56
2400	0.60	2.5	0.69	2.5 ; 0.68
3200	0.72	2.8	0.79	2.8 ; 0.78

Most values of p_0 and p have been borrowed from BROER'S thesis¹, which analyses quite a number of p-values in this way. We must stress, however, that the experimental inaccuracy leaves a wide margin in p_0 and p . For instance, the difference between the two values of p (0.40 and 0.36) is much smaller than the experimental uncertainty.

Before giving more detailed data we shall first mention a few investigations of a more or less fundamental character. Experiments have been carried out by TEUNISSEN² on solutions of MnSO_4 which are known to belong to the normal paramagnetic substances. No inhibition of the susceptibility could be observed at a frequency of $3.8 \cdot 10^6$ Hz and $H_c = 3200$ O, while in $\text{MnSO}_4 \cdot 4\text{H}_2\text{O}$ the high frequency susceptibility under these conditions was as low as about 0.5 Xo. When the temperature was lowered until ice and finally a solid salt crystallized out, there appeared at last a decrease of x' too.

TEUNISSEN^{5*} also carried out a few measurements on iron ammonium alum with different angles $\langle p$ between the constant and the high frequency field. He could verify the relation

$$x'_{\varphi} = x' \cos^2 \varphi + x_0 \sin^2 \varphi \quad 49$$

which means that we are allowed to decompose the high frequency field in the directions parallel and perpendicular

¹ L. J. F. BROER, *Thesis*, Amsterdam, 1945.

² P. TEUNISSEN and C. J. GORTER, *Physica*, 7 (1940) 33.

* P. TEUNISSEN and C. J. GORTER, *Physica*, 5 (1938) 483.

to H_c and add the varying magnetic moment caused by each of those two components individually.

TEUNXSSSEN¹ also experimented with a single crystal of the cubical iron ammonium alum. He failed to detect any anisotropy of χ' . His accuracy was about 2 % of χ_0 .

Finally, we mention that, though usually no constant fields over 3200 O have been used, a few measurements have been carried out with $\text{Mn}(\text{NH}_4)_2(\text{SO}_4)_2 \cdot 6 \text{H}_2\text{O}$ in the much stronger fields obtainable between the pole pieces of a WEISS magnet. As with such a magnet it is not possible to pull the sample quite away in the direction of the common axes of high frequency field and constant field, a special arrangement without a DEWAR vessel had to be made² which could only operate at room temperature. The result of the measurements up to 9000 O was that at high fields χ' does not show much further decrease. Measurements in still stronger fields carried out in a magnet coil by STARR (comp. Ch. III, § 1) led to the general result that there is not much further decrease of χ' when $H_c \gg (b/C)^{1/2}$. This is qualitatively in agreement with (48).

We shall now proceed to a review of the results of the measurements. In order to save space we will not give individual measurements on the many substances investigated, but refer, also for the deduced values of p , to the original publications. We shall only give the values of b/C deduced by the authors from their measurements and also the values of p_0 , p and $p = p_0/p$ derived by BROER in his thesis from the p -values given by the authors. Even in favourable cases the uncertainties in b/C , p_0 and p are of the order of 10%; in less favourable cases they are much larger. In § 3 we shall see that it is often possible to deduce values of b/C , p_0 and p from absorption measurements. For simplicity we mention these values already in the same list, though for a right understanding of the a[^]

1 P. TEIXNISSEN and C. J. GORTER, *Physica*, 5 (1938) 855

2 P. TEUNISSEN and C. J. GORTER, *Physica*, 7 (1940) 33

in which they are obtained reading of the next paragraph is necessary.

Gadolinium salts.

1. $Gd_2(SO_4)_3 \cdot 8H_2O$. The results obtained from dispersion¹ and absorption² measurements are summarized in Table V. The results from the dispersion measurements are printed over those from absorption measurements.

TABLE V
RESULTS ON $Gd_2(SO_4)_3 \cdot 8H_2O$. DISPERSION AND
ABSORPTION RESPECTIVELY.
 $b/C = 3.9 \cdot 10^6$ 02.

T		$P_0' \cdot 10^6$	$p \cdot 10^4$		V
77°		1.6	4.0	I	0.40
		1.1	4.0		0.28
90°	I	1.95	4.2	I	0.47
		1.4	4.4		0.32
290°	I	0.42	1.25	I	0.36

Table V shows that the values of p_0 , though remaining of the same order of magnitude, differ considerably in dispersion and absorption, and also the values of p , but it is remarkable that the values of $p_w = p_0/p$ differ much less than those of p_0 . This behaviour is often found when the results obtained from dispersion and absorption or obtained by the same method applied to two samples differ. We can, therefore, formulate what we shall call the *first empirical rule (about different samples)*: the variation in pa is smaller than that in p_0 . This substance is also an example of the *second empirical rule*: if p^{\wedge}/p_0 is not instant p^{\wedge} varies less with T than p_0 .

L., J. F. BOER and C. J. GORTER, *Physica*, 10 (1943) 621.

2 F\W. DE VRIEJER, J. VOLGER, and C. J. GORTER, *Physica*, 11 (1946)412

A very peculiar result concerning this substance is that, whereas p generally decreases with increase of T , p_0 at 90°K is doubtlessly larger than at 77°K .

2. $\text{Gd}_2(\text{C}_2\text{O}_4)_3 \cdot 10\text{H}_2\text{O}$. The results¹ are summarized in Table VI and in the figures 18 and 19.

TABLE VI
RESULTS FOB $\langle \text{M}_2(\text{C}_2\text{O}_4)_3 \cdot 10\text{H}_2\text{O} \rangle$.
 $b/C = 1.8.106 \text{ } 02$,

T	$\text{Po}'10^6$	$p \cdot 10$	ν
77°	1.5	3.6	0.42
90°	1.5	3.6	0.42
195°	0.24	1.5	0.16

At 290°K : $p < C \cdot 0.02 \cdot 10^{-e} \text{ sec}$.

At liquid -air temperatures p is very slightly dependent on the temperature, whereas at higher temperatures the dependence on T is decidedly pronounced. The variation

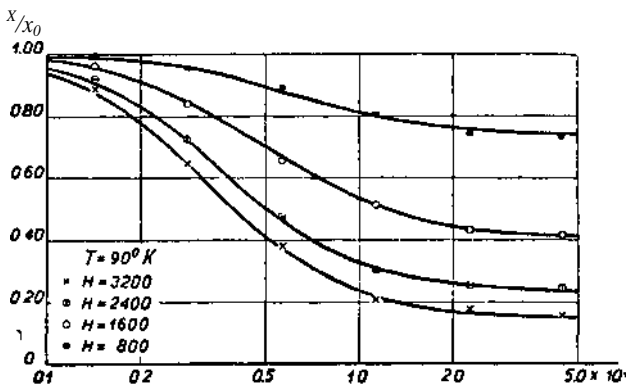

Fig. 18.

Paramagnetic dispersion in $\text{G-d}_2(\text{O}_2\text{O}_4)_3 \cdot 10 \text{H}_2\text{O}$ at 90°K .

i L. J. F. BEOER and C. J. GOETER, *Physica*, 10 (1943) 621.

of p is also certain and in agreement with the second empirical rule.

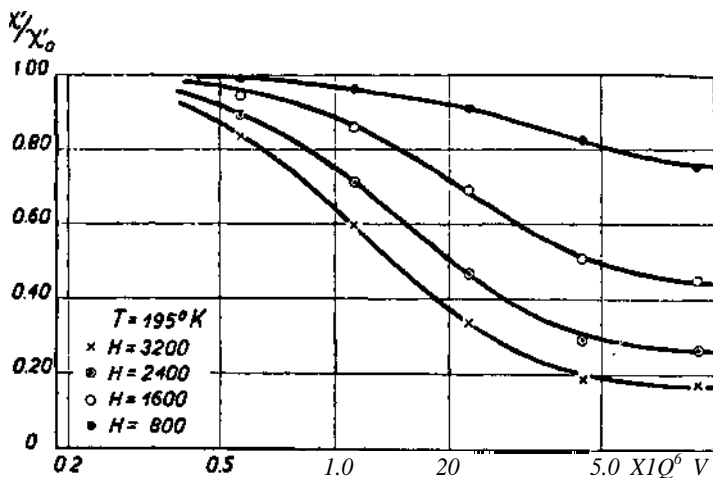

Fig. 19.

Paramagnetic dispersion in $Gd_2(O-Ai)_3 \cdot 10 H_2O$ at $195^\circ K$.

3. $Gd(C_2H_3O_2)_3 \cdot 4H_2O$. This substance has been investigated¹ at 77° , 90° , 195° and $290^\circ K$, but the results for the higher temperatures are few and $\chi V \chi_0$ differs little from 1. b/C is about $8.7 \cdot 10^6 O^2$. This is so high and the variation of p up to $H_c = 3200$ is so small that an accurate value for p cannot be deduced. Its order of magnitude is 0.6 at the two lower temperatures, p is about $0.7 \cdot 10^{-6}$, $0.5 \cdot 10^{-6}$, $0.3 \cdot 10^{-6}$ and $0.12 \cdot 10^{-6}$ sec at 77° , 90° , 195° and $290^\circ K$. The dependence of p on T has, therefore, the normal sign but is very small.

Chromic salts

4. $CrK(SO_4)_3 \cdot 12H_2O$. A large number of investigations have been carried out on this salt. In § 3 and § 4 we shall mention the results obtained from measurements of paramagnetic absorption and those obtained by the bridge

i L. J. F. BBOER and C. J. GORTER, *Physica*, 10 (1943) 621.

method at very low temperatures. Table VII summarizes the results obtained on three samples. Sample I was a Brocades preparation, while sample II was obtained from the same preparation by recrystallizing. BROER¹ studied the dispersion of both samples. Another part of this recrystallized substance was used by DIJKSTRA and VAN PAEMEL² in their absorption measurements. The three sets of values belonging to each value of T refer to sample I, sample II and the absorption measurement respectively. Earlier investigations of a provisional character by BRONS and by DIJKSTRA and GROENDIJK have been left aside.

TABLE VII
RESULTS FROM DISPERSION (2 SAMPLES) AND
ABSORPTION IN $\text{CrK}(\text{SO}_4)_2 \cdot 12 \text{H}_2\text{O}$.
 $b/C = 0.65 \cdot 106 \cdot 02$.

T	$P_0' 10^6$	$\epsilon \cdot 10^2$	V
77°	0.9	4.1	0.22
	0.7	2.8	0.25
	0.62	2.7	0.23
90°	0.33	2.1	0.16
	0.25	2.0	0.13
	0.23	1.8	0.12

As appears from this table the difference between the results about the dispersion in samples I and II in accordance with the first empirical rule at 90°K but *not* at 77°K. It is surprising that upon recrystallizing, p decreases. The difference of p at the two temperatures is considerable and in agreement with the second empirical rule.

STARR^H has determined b/C at 77°K; he finds $b/C =$

i L. J. F. BROER, *Thesis*, Amsterdam, 1945.

2 L. J. DIJKSTRA, C. J. GORTER, and O. VAN PAEMEL, *Physica*, 9 (1942) 673.

s C. STARR, *Phys. Bev.*, 60 (1941) 261.

$0.64 \cdot 10^{60^2}$ in excellent agreement with our result; he did not publish p -values.

5. $\text{Cr}(\text{NH}_3(\text{SO}_4)_2 \cdot 12\text{H}_2\text{O})$. STAEJR¹ determined b/C , and found $2.68 \cdot 10^6 \text{ } 0^2$.

6. $\text{CrK}_3(\text{C}_2\text{O}_4)_3$. The fc/C -value² is $27 \cdot 10^{60^2}$. This is so high that p cannot be deduced from the results. It seems to be rather small however. At 77° and 90°K p is of the order of $0.3 \cdot 10^{-6}$ sec and $0.2 \cdot 10^{-6}$ sec respectively.

7. $[\text{Cr} \cdot 6\text{H}_2\text{O}] \text{Cl}_3$. * This substance has only been investigated² at 90°K .

TABLE VIII
RESULTS FOR $[\text{Cr} \cdot 6 \text{HX}] \text{Cl}_8$.
 $b/C = 0.96 \cdot 10^6 \text{ } 0^2$.

T	$\text{Po}^* 10^-$	$p \cdot 10^6$	P
90°	2.5	5.0	0.50

8. $[\text{Cr} \cdot 4\text{H}_2\text{O} \cdot 2\text{Cl}] \text{Cl} \cdot 2\text{H}_2\text{O}$. Results²:

TABLE IX
RESULTS FOR $[\text{Cr} \cdot 4 \text{HX} \cdot 2 \text{Cl}] \text{Cl} \cdot 2 \text{H}_2\text{O}$.
 $b/C = 4.5 \cdot 10^6 \text{ } 0^2$.

T	$\text{Po} 10$	$P \cdot 10^6$	ν
77°	1.2	1.9	0.63
90°	1.05	1.5	0.72

The variation of p with T is within the limits of accuracy.

¹ C. STARR, *Phys. Rev.*, 60 (1941) 261.

² L. J. F. BKOER, *Thesis*, Amsterdam, 1945.

9. $[\text{Cr} \cdot 6\text{NH}_3] (\text{NO}_3)_3$. The b/C -value is $13 \cdot 10^6 \text{ } \text{O}^2$. No change in p with H_c was observed, which means that p does not differ much from unity. At 77° and 90°K p was $0.20 \cdot 10^{-6}$ sec and $0.18 \cdot 10^{-6}$ sec respectively.

10 and 11. In $[\text{Cr} \cdot 2 \text{H}_2\text{O} \cdot 2 \text{NH}_3 \cdot 2 \text{Cl}] \text{Cl}$ and $[\text{Cr} \cdot 6\text{NH}_3] \text{Cl}_3 \cdot 2 \text{HgCl}_2$ dispersion phenomena were observed¹ which could not be described by a single DEBYE curve plus a constant. There was reason however to doubt the purity and homogeneity of the samples investigated.

12. $\text{Cr}(\text{NO}_3)_3 \cdot 9 \text{H}_2\text{O}$. Results:

TABLE X
RESULTS FOR $\text{Cr}(\text{NO}_3)_3 \cdot 9 \text{H}_2\text{O}$.
 $b/C = 1.1 \cdot 10^6 \text{ } \text{O}^2$.

T	$p_0 \cdot 10^6$	$p \cdot 10^9$	V
77°	2.2	6.3	0.35
90°	0.7	3.2	0.22

The variation of p with T is in accordance with the second empirical rule.

13. Kr_3CrF_6 . The b/C -value¹ is $8 \cdot 10^6 \text{ } \text{O}^2$. This is too large to allow a precise determination of p . It may have been of the order of 0.4. p_0 was about $0.1940 \cdot 10^{-6}$ sec and $0.15 \cdot 10^{-6}$ sec at 77° and 90°K respectively.

Vanadous salts.

14. $\text{V}(\text{NH}_4)_2(\text{SO}_4)_2 \cdot 6 \text{H}_2\text{O}$. b/C is about $4.8 \cdot 10^6 \text{ } \text{O}^2$, while p is only slightly dependent on H_{Cl} which indicates that p was not far from unity². According to the pro-

1 L. J. F. BROER, *Thesis*, Amsterdam, 1945.

2 J. EISSES, H. GROENDUK and C. J. GORTER, *Physica*, 7 (1940) 865.

visional measurements p was about $15 \cdot 10^{-6}$, 6.510^{-6} and 310^{-6} sec at 64° , 77° and 90°K respectively.

Ferric salts.

15. $\text{FeNH}_4(\text{SO}_4)_2 \cdot 12\text{H}_2\text{O}$. This is the substance in which the phenomena of paramagnetic absorption and dispersion were discovered¹ and together with chromium potassium alum it is the most thoroughly investigated salt. The agreement between the p_0 and p -values of different samples in dispersion and absorption is quite satisfactory though differences in p of the order of 10% were found. Table XI summarizes the results.

TABLE XI
RESULTS FOR $\text{FeNH}_4(\text{SO}_4)_2 \cdot 12\text{H}_2\text{O}$.
 $b/C = 0.27 \cdot 10^6$

T		$p_0 \cdot 10^6$	$p \cdot 10^6$ *	p
64°		0.75	3.0	0.25
77°	I	0.25	2.1	0.12
90°	!	0.04	0.9	0.045

at 195°K $p < c$ $0.02 \cdot 10^{-6}$

It must be mentioned at once that the result obtained by STARR² for p_x at 77°K is widely different. His results for that temperature are: $p_0 = 0.25 \cdot 10^{-6}$ sec; $p_x = 1.010^{-6}$ sec; $p = 0.25$. However, in view of the agreement of three series of measurements on the dispersion and on the absorption with Table XI and because the calculation of p in strong fields by STARR seems open to serious criticism (ef. Ch. II, § 1) we cannot but keep to Table XI.

» C. J. GORTEB, *Physica*, 3 (1936) 503.

C. J. GORTER and F. BRONS, *Physica*, 4 (1937) 579. *

2 C. STARR, *Phys. Rev.*, 60 (1941) 241.

One sees that p_0 varies exceptionally fast as a function of the temperature. The variation of p_M is much more normal. This is in accordance with our second empirical rule. For that reason p is very strongly dependent on T and becomes very small at 90°K . But this low value of p (just as the low value of p_0) is rather uncertain, as it is merely founded upon the splitting of the experimental absorption in two terms (cf. § 3 (51)), which leaves an ample margin.

TEUNISSEN¹ has performed a series of experiments on a "heavy alum" in which 93% of the JBT-atoms had been replaced by deuterium. b/C did not change. The results on p are summarized in Table XII.

RESULTS FOR "HEAVY" IRON AMMONIUM ALUM

T			V	
64°		0.75	3.0	0.25
77°		0.32	2.2	0.14
90°	II	0.08	1.0	0.08

Table XII shows that at 64°K the results differ little from those in Table XI. The differences for p_y are also small. The difference for p_0 at 90°K , however, is quite large.

TEUNISSEN¹ performed also a series of experiments with alums in which 9% and 40% of the iron ions were replaced by the non-magnetic aluminium ions. The results could be described by the same $6/C$, the p -values, especially in weak fields, having decreased somewhat. Thus p_0 decreased considerably, whereas p hardly changed. The

i P. TEUNISSEN and C. J. GORTER, *Physica*, 6 (1939) 1113.

changes were relatively small at 64°K. The character of the changes is therefore very similar to that of the changes in "heavy" alum, but they are in opposite direction.

16. $\text{Pe}(\text{NO}_3)_3 \cdot 9\text{H}_2\text{O}$. $6/C$ was $19.51 \cdot 10^6$; that is too high for an accurate determination of p , which may have been of the order of 0.2. p_0 was about $1.0 \cdot 10^{-6}$, $0.7 \cdot 10^{-6}$ and $0.45 \cdot 10^{-6}$ sec at 64°, 77° and 90°K respectively.

Manganous salts.

17. $\text{Mn}(\text{NH}_4)_2(\text{SO}_4)_2 \cdot 6\text{H}_2\text{O}$. Results recently obtained by BROER¹:

TABLE XIII
RESULT® ON $\text{Mn}(\text{NH}_4)_2 \cdot 6\text{H}_2\text{O}$.
 $h/G = 0.64.106 \text{ } 02.$

T	$p_0 \cdot 10^6$		P
90°	5.5	1.1	0.50
195°	0.93	1.9	0.49
290°	0.40	0.8	0.50

Older, less accurate results of TEUNISSEN² led to $0.75 \cdot 10^6$. The absorption measurements, however, (comp. § 3) lead to the lower value $0.46 \cdot 10^6$. TEUNISSEN² also carried out measurements at 64°K.

BROER¹ performed a few experiments with the same salt where part of the Mn-ions had been substituted by Co-ions. It was found that a small amount of Co (1.5%) gave only a slight decrease of p . A larger amount (9%) exerted little influence at room temperature, somewhat more influence (a factor 2) at 195°K and a very large change

i L. J. F. BROER, *Thesis*, Amsterdam, 1945.

2 P. TEUNISSEN and C. J. GORTER, *Pfysisica*, 7 (1940) 33.

(a factor of the order of 50) at 90°K. This leads to the remarkable fact that the relaxation constants are smaller at liquid air temperature than at room temperature.

18. $\text{MnSO}_4 \cdot 4\text{H}_2\text{O}$. For b/C TEUNISSEN¹ gives $6.2 \cdot 10^6$ &² while STARR³ arrives at $4.2 \cdot 10^6$ 0². This considerable difference is not yet explained. TEUNISSEN'S p's do not seem to obey (48) but these values are very uncertain in the lowest field used. Neglecting the results at this lowest field of 8000 we arrive at about $p_0 e^{-4} L(H, 3.2 \cdot 10^{-6}$ and $0.3240 \cdot 10^{-6}$ sec and $p \sim 0.2$ at 77°, 90° and 290° respectively.

19. $\text{MnCl}_2 \cdot 4\text{H}_2\text{O}$. TEUNISSEN¹ and STARR give for b/C : $19.5 \cdot 10^6$ sec and $19.8 \cdot 10^6$ 0². This large value does not allow an accurate determination of p. It may have been relatively small. p_0 was about $1.0 \cdot 10^{-6}$, $0.8 \cdot 10^{-6}$, $0.5 \cdot 10^{-6}$ and $0.0940 \cdot 10^6$ sec at 64°, 77°, 90° and 290° respectively.

20. $\text{MnCl}_2 \cdot 2\text{MgCl}_2 \cdot 12\text{H}_2\text{O}$. BROER³ detected dispersion in this substance at room temperature but did not carry out further measurements.

Nickel salts.

21 and 22. $\text{NiSO}_4 \cdot 7\text{H}_2\text{O}$ and $\text{Ni}(\text{NH}_4)_2(\text{SO}_4)_2 \cdot 6\text{H}_2\text{O}$. Only at the highest frequencies (about 10^7 Hz) the difference between x' and X_0 is notable and as $p\nu$ apparently remains about 1 while F is quite small, it was not possible to derive F and p from dispersion measurements alone⁴. Making use of measurements of paramagnetic absorption and assuming the F - and p -values to be equal in both cases, it was possible to come to a conclusion about the order of magnitude. b/C was about $90 \cdot 10^6$ 0² for the Tutton salt while p was 0.14-KH and 0.11-KH sec at 77° and 90°K

i P. TBUNUSBEN and C. J. GORTER, *Physica*, 7 (1940) 33.

2 C. STARR, *Phys. Rev.*, 60 (1941) 241.

3 L. J. F. B'BOER, *Thesis*, Amsterdam, 1945. -

4 I. J. F. BROER, L. J. DUBSTRA and G. J. GORTER, *Physica*, 10 (1943) 324. f;

respectively. This result has however a provisional character **and** further researches at higher frequencies or lower temperatures are required to verify the conclusions. The results on the hydrated sulphate are so uncertain that we prefer to omit them.

Cupric salts.

23. $\text{Cu}(\text{NH}_4)_2(\text{SO}_4)_2 \cdot 6\text{H}_2\text{O}$. At Leyden it was discovered by Buii¹ that the corresponding potassium cupric Tutton salt shows dispersion in small parallel fields at liquid helium temperatures, and shortly afterwards the same conclusion was reached by GROENDIJK for the ammonium cupric Tutton salt at liquid air temperatures. But because of the small susceptibility the reproducibility was unsatisfactory. Later on BROER and KEMPERMAN succeeded in measuring reproducible dispersion curves. DIJKSTRA² carried out measurements on absorption. BROER and DuKSTRA arrived at about the same p-value, but DIJKSTRA's fr/O-value was about 25 % lower. We give an average result.

TABLE XIV
RESULTS ON $\text{Cu}(\text{NH}_4)_2(\text{SO}_4)_2 \cdot 6\text{H}_2\text{O}$.
 $b/C = 0.16.106 \text{ 02}$

T		$\text{Po}^* \cdot 10^{\text{II}}$	$p \cdot 10^6$		V
77°	I	0.35	0.7	I	0.5
90°		0.24	0.4		0.6

24. $\text{CuSO}_4 \cdot 5\text{H}_2\text{O}$. The results on this salt are somewhat similar to those on the nickel salts. BROER¹³ detected

i B. BWL, *Physica*, 8 (1941) 461.

2 L. J. DIJKSTRA., *Thesis*, Amsterdam, 1943.

» L. J. F. BROER, *Thesis*, Amsterdam, 1945.

a beginning of dispersion and VODGER and DE VRIJER' studied the absorption up to frequencies of $78 \cdot 10^6$ Hz. In spite of the wide range of the measurements it was not possible to determine b/C with certainty. It probably is a few times 10^7 O^2 . p is undoubtedly about $0.03 \cdot 10^{-6}$ sec at 77° as well as at 90° .

§ 3. RESUL/PS OF THE ABSORPTION MEASUREMENTS
BY THE CADORIMETRIC METHOD

a. *Without a constant magnetic field*

The first investigations of paramagnetic relaxation- were those carried out at Leyden on the absorption at liquid hydrogen temperatures in the absence of a constant magnetic field. The determination of the amplitude H_0 of the high frequency field and of the heat capacity of the sample were very rough, so that the results gave only the order of magnitude of x'' - Nevertheless, a few results of a rather essential nature could be obtained in those researches, viz.:

a. The development of heat is proportional to H_0^2 . This has repeatedly been verified in various substances, also in the presence of constant fields, even when a field H_c of the order of H_0 already has an appreciable influence on x'' . This means that up till now x'' is found to be independent of the amplitude H_0 .

b. The development of heat is inversely proportional to T . This result has been verified too for a number of normal paramagnetic substances, in the absence of a constant field or in a perpendicular field H_d . It usually does not apply in parallel fields H_c . As the static susceptibility X_0 is also inversely proportional to T in normal paramagnetic substances, this result means that $x'' \sim P^{ro} \sim$ portional to x_0 -

c. In chromium alum, iron alum, and gadolinium sulph-

i J. VODGER, *Thesis*, Leyden, 1946.

2 C. J. G-ORTER, *Physioa*, 3 (1936) 503.

ate octohydrate the development of heat is approximately proportional to the square of the frequency ν . This result seemed not to apply to vanadium alum and to a series of iron- and chromium alums in which part of the magnetic ions had been replaced by non-magnetic aluminium ions.

d. The development of heat in the "diluted" alums just mentioned, is much larger than in pure alums. This was particularly striking in a sample which contained 20% iron and 80% aluminium ions. The development of heat in this sample at $20 \cdot 10^6$ Hz was at 20°K twice that in pure iron alum, so that it was per iron ion ten times larger. Further decrease of the iron content did not lead to any further considerable increase of the absorption per ion.

The results *a*, *b* and *c* may be summed up by putting

$$\chi = \chi'' \nu = X \gg p \nu \quad 50$$

where p' is independent of H_0 , T and ν .

The results mentioned under *d* indicate an increase of p' upon diluting, though the apparent dependence of p' on ν (under *c*) sheds some doubt on the significance of p' in this case. The results on vanadium alum, mentioned under *c*, should also be regarded with some reserve. Later experiments on $\text{CuSO}_4 \cdot 5 \text{H}_2\text{O}$ at a frequency of $78 \cdot 10^6$ Hz showed that the absorption was only 82% of that deduced from the measurement at lower frequencies by means of (50)

The absolute values of p' are usually of the order of 10^{-9} sec.

The values¹ of p' obtained by VOMER given in the following list cannot claim a high accuracy. The uncertainties are at least of the order of 10%.

b. In a parallel field $\mathcal{H} \parallel \mathcal{C}$

In a parallel constant magnetic field the development of heat may increase enormously as was first noted by BRONS in 1938². Fig. 20 gives an example of this increase in

1 J. VOLGER, *Thesis*, Leyden, 1946.

2 F. BRONS and C. J. GORTER, *Physica*, 5 (1938) 599.

TABLE XV

Approximate p' values for various substances, the substances placed in parentheses are no normal paramagnetic substances as CURIE'S law does not apply to them. It is doubtful in how far p' will be independent of T in these substances.

Substance	$p' \cdot 10^9$	Substance	
$Gd_2(SO_4)_3 \cdot 8H_2O$	0.36	$MnSO_4$	(0.60)
$CrK(SO_4)_2 \cdot 12H_2O$	1.6	$Fe(NH_4)_2(SO_4)_2 \cdot 6H_2O$	<0.02
$Cr_2(SO_4)_3 \cdot 6H_2O$	(0.56)	$NiSO_4 \cdot 7H_2O$	<0.02
$Crk(SO_4)_2$	0.98	$Cu(NH_4)_2(SC_4)_2 \cdot 6H_2O$	5.7
$Cr_2(SO_4)_8$	(0.53)	$OuSO_4 \cdot 5H_2O$	4.2
$FeNH_4(SO_4)_2 \cdot 12H_2O$	0.7	$Cu(BrO_3)_2 \cdot 6H_2O$	7.1
$FeNH_4(SG_4)_a$	(0.85)	$CuSO_4$	(0.40)
$Mn(NH_4)_2(SO_4)_2 \cdot 6H_2O$	0.79	$CuCl_2 \cdot 2H_2O$	6.0
$MnSO_4 \cdot 4H_2O$	0.40		

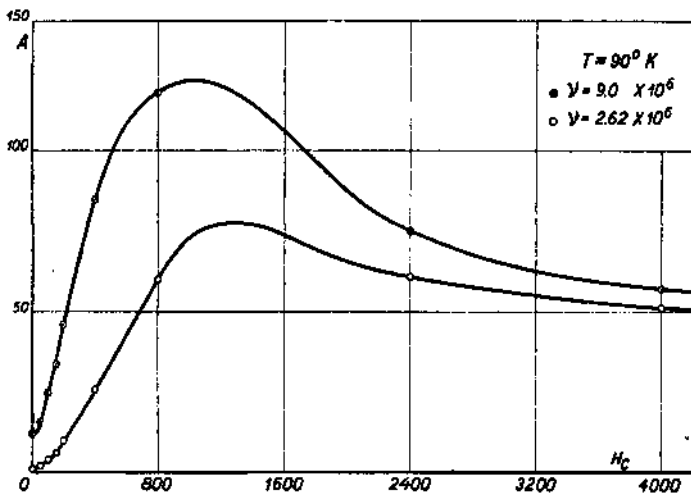

Fig. 20

Paramagnetic absorption at $90^\circ K$ in chromium alum as a function of the parallel field H_c

chromium alum. The relative increase is most pronounced at the lower frequency as the development in a zero field is usually proportional to ν^2 (comp. (50)), whereas that in parallel fields usually increases at a lower rate with ν .

Fig. 21 gives the absorption in gadolinium sulphate octohydrate at 77°K as a function of the frequency¹ and may serve as an example of the usual behaviour. Let us first

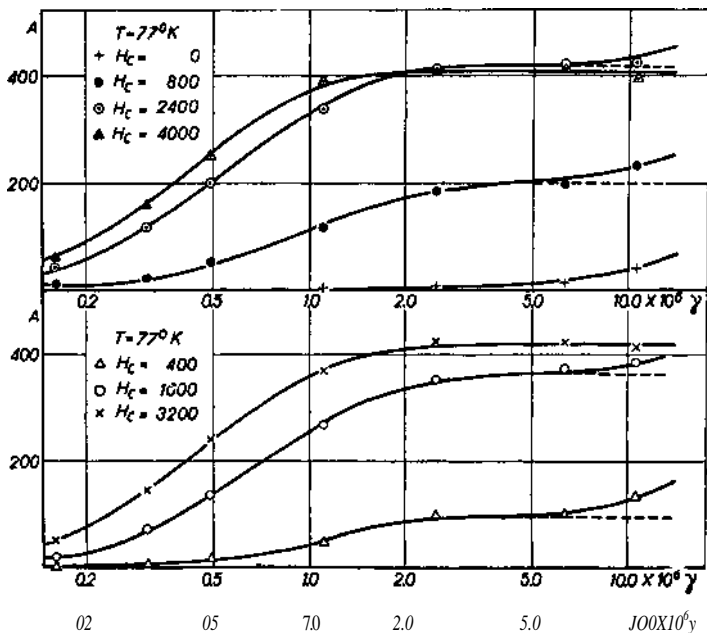

Fig. 21

Absorption in $\text{Gd}_2(\text{SO}_4)_3 \cdot 8 \text{H}_2\text{O}$ at 77°K expressed in arbitrary units

consider the absorption in the highest constant fields of 2400 O, 3200 O, and 4000 O. Within the limits of accuracy this absorption follows a simple DEBIJE curve:

¹ F. W. DE VRIJER, J. VODGER, and C. J. GORTER, *Physica*, 11 (1946) 412.

$$A = \chi''\nu = \frac{k\nu^2}{1 + \rho^2\nu^2}$$

where k and p are constants. At zero field the formula of the absorption is

$$A = \chi''\nu = \chi_0\rho'\nu^2 \quad 50$$

Inspection of the curves at low constant fields e.g., 400 and 800 0 shows that p' does not merge continuously into p , but that both types of dependence on ν appear to be superposed. For that reason it is plausible to try

$$A = \chi''\nu = \frac{\chi_0 F^2 \nu^2}{1 + \rho^2 \nu^2} + \chi_0 (1 - F^2) \rho' \nu^2 \quad 51$$

This formula is not only capable of describing the absorption in the present example, as is shown by the full-drawn lines in Fig. 21 calculated with (51), but also the great majority of the results obtained with other substances at all temperatures, p is usually strongly dependent on T , whereas p' is not.

Table XVI gives the F -, p - and p' -values used in our example.

TABLE XVI
 F , p AND p' FOR $(M_3(8O_4)_3 \cdot 8H_2O)$

	F	$p * 10^6$	$p \quad 10^6$	$p_{theor} * 10^6$
0	0		0.0003	1.1
400	0.05	1.0	0.0003	1.1
800	0.14	1.2	0.0003	1.2
1600	0.40	1.5	0.0003	1.5
2400	0.60	1.9	0.0003	1.9
3200	0.72	2.4		2.3
4000	0.80	I 2.6		2.6

$$F = \frac{CH_c^2}{b + CH_c^2} \quad 47$$

(comp. § 2 and Ch. IV, § 2). b/C is $3.9 \cdot 10^6 \text{O}^2$, that is the same value as that found from the dispersion measurements (cf. Table IV). The values of p are of the same order of magnitude as those found in the dispersion measurements, but substantially smaller, especially in small parallel fields. As was mentioned in § 3, somewhat different values are often found for p in different samples. In absorption measurements relatively small values are often found. The fact that the difference is smaller in high constant fields is in accordance with the "first empirical rule" given in § 2.

The last column of Table XVI shows that also these values of p are within the limits of accuracy, in agreement with the BRONS-VAN VLBECK formula

$$p = p_0 \frac{b + CH_c^2}{b + pCH_c^2} \quad 48$$

The experimental curves are therefore described by a set of p - and p' -values and a value of b/C , p' and b/C being independent of T . There are in this way quite a number of constants at our disposal, and especially if the interval of frequencies or the interval of fieldstrengths is not very large, there is considerable freedom to shift b/C and the p 's simultaneously. The uncertainty is especially large as regards p' , but also for p it is usually at least 10%. Assuming beforehand the validity of (48), it is possible to reduce the number of constants. This possibility, however, not yet been used in the discussion of the measuring points and for that reason no use has been made of (48) in the plotting of the "p-values".

On some substances, different series of measurements have been performed: first with rather provisional apparatus in rather small ranges of frequencies and later with improved methods and at other frequencies. In these

researches we have a sort of successive approximation to reality and sometimes conclusions made in the early stages of research had to be modified considerably. One of these substances is chromium potassium alum and even now its behaviour in paramagnetic relaxation is not quite clear. After a preliminary investigation by DIJKSTRA and GROENDIJK¹, DIJKSTRA and VAN PAEMEL² came to the conclusion that p' in a zero field was $0.0019 \cdot 10^{-6}$ sec, then increased with H_c up to 4000 where p' reached a maximum of about $0.006 \cdot 10^{-6}$ and then decreased again. Theoretically, this pronounced increase of p' was difficult to understand and therefore VOLGER³ performed new measurements at a much higher frequency. At the original relatively low frequencies (up to about $10 \cdot 10^6$ Hz) the term with p' in (51) is merely a correction to that with p . But at this higher frequency ($78.5 \cdot 10^6$ Hz) the term with p' is preponderant as it has increased in proportion to v^2 , whereas the other term has become constant as soon as $pv \gg 1$. Figure 22 gives the absorption in chromium alum at 90°K in a parallel as well as in a perpendicular field. The results in the perpendicular field were used to correct for dielectric loss (cf. c and Ch. II, § 2). The dotted curve was calculated with DIJKSTRA and VAN PAEMEL'S values of p and assuming p' to be independent of the parallel field H_c . It is true that the experimental points lie somewhat above the theoretical curve - at the lowest fields, but the difference is of the order of 20% rather than of 200%, so that the earlier interpretation of the results was not correct. But it is not easy to shift p and b/C in such a way that DIJKSTRA and VAN PAEMEL'S results are described by (51) with an approximately constant p' . An explanation of this discrepancy has not yet been found.

1 C. J. GORTER, L. J. DIJKSTRA, and H. GROENDIJK, *Physica*, 7 (1940) 625.

2 L. J. DIJKSTRA, C. J. GORTER, and O. VAN PAEMEL, *Physica*, 9 (1942) 673.

s J. VOLGER, *Thesis*, Leyden, 1946.

It may be that we have to deal with a spurious effect such as was also detected in $\text{Mn}(\text{NH}_4)_2(\text{SO}_4)_2 \cdot 6\text{H}_2\text{O}$.

It is possible to describe the results for $\text{Mn}(\text{NH}_4)_2(\text{SO}_4)_2 \cdot 6\text{H}_2\text{O}$ at frequencies under 310^6Hz by (51) in a satisfactory way¹, though b/C is found to be decidedly lower than was found in the researches on the dispersion (comp. § 2). But at frequencies between $3 \cdot 10^6$ and $11 \cdot 10^6$ Hz the value of A was not quite constant in high fields ($F \sim 1$)

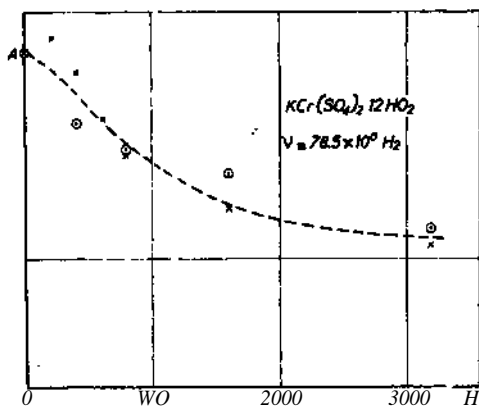

Fig. 22

Paramagnetic absorption in $\text{OK}(\text{SO}_4)_2 \cdot 12\text{H}_2\text{O}$ at 90°K at $78.5 \cdot 10\text{c Hz}$ in a parallel (X) and in a perpendicular (O) field. The dotted curve is drawn under the supposition that p' is independent of the parallel field JH'_C and that the drawn line gives the dielectric loss.

as it should be according to (51), but it increased slowly. The corresponding increase of x'' is merely of the order of $0.01 X x_0$ and the effect has provisionally to be considered as a relatively small spurious one.

We cannot discuss all the results in detail, but only state that the values of b/C are always the same as found from the investigations of the dispersion (apart from the man-

ganese ammonium sulphate), whereas the p -values, though always of the same order of magnitude in the two ways of research, are usually somewhat different (especially in weak constant fields).

p' is only found from absorption measurements. In general we may put $p' = p'_{0y}(H_c)$. In all experiments $p'(1 - F) = p \setminus (1 - F)_y(H_c)$ vanishes in strong fields when $H_c \gg 6/C$, but it is often not very clear whether it vanishes more rapidly than $1 - F^l$. It was mentioned that from the results on chromium alum at the highest frequency y seems to be somewhat larger than 1 in 2000 and 4000. On the other hand y seems to decrease by nearly 0.5 in iron ammonium alum in a field of 6000. Usually y remains approximately 1 for values of H_c up to about and it is difficult to say anything at all about its magnitude in much higher fields.

c. *In a perpendicular field H_d .*

Already in the very first investigation of paramagnetic relaxation it was found that the absorption existing in the absence of a magnetic field may decrease when a perpendicular magnetic field is applied. Later it was found that this result is quite general and that in a very strong field the absorption — in accordance with the theory (comp. Ch. IV, § 3) — even vanishes altogether. Often the absorption in a perpendicular field is proportional to the square of the frequency and then we may put

$$A = \chi'' \nu = \chi_0 \nu^2 \rho' = \chi_0 \nu^2 \rho'_0 \delta(H_d) \quad 52$$

where $S(H_d)$ is a function of H_d , which is analogous to $y(H_c)$ of b . As has been mentioned already a few times, it has become usual to choose the correction applied for dielectric losses in such a way that $p^f = 0$ for very large values of H_d . Sometimes the experimental fields are not strong enough for extrapolation. Then not only the δ -curve

will be uncertain, but also p_0' (called p' in (51)) will contain an unknown constant term.

It must be noted that the accuracy of the 8-curves is not very high. On the contrary, the margin of uncertainty is as a rule at least 0.1. Within this margin the 8-values are identical at 77°K and at 90°K. A very difficult substance is iron ammonium alum. The 8-curve begins rather steeply but it has a very long tail so that the extrapolation to very high fields is rather uncertain. If this is done as well as possible, the correction for dielectric losses is approximately equal to the development of heat found in diamagnetic samples at 77°K. But at 90°K this correction becomes more than twice as large, so that we come to the conclusion that at 90°K there exists a considerable absorption of an unknown nature in iron alum. This anomalous absorption which had already been discovered earlier at lower frequencies may have to do with the transition point which, according to GUILLIEN¹, the alums possess at these temperatures (ef. Ch. V).

The 8-curve at 90°K in $\text{CuSO}_4 \cdot 5 \text{H}_2\text{O}$ has a different shape at the highest frequency ($78.5 \cdot 10^6$ Hz) in comparison with that found at lower frequencies ($6 \cdot 10^6$ — $20 \cdot 10^6$ Hz). This anomaly certainly has to do with the mentioned dependence of p_0' on the frequency in this substance.

Fig. 23 gives a few S-curves² derived from measurements at $78.5 \cdot 10^6$ Hz.

i B. GUILLIEN, C.B., 209 (1939) 21.

2 J. VOLGER, *Thesis*, Leyden, 1946.

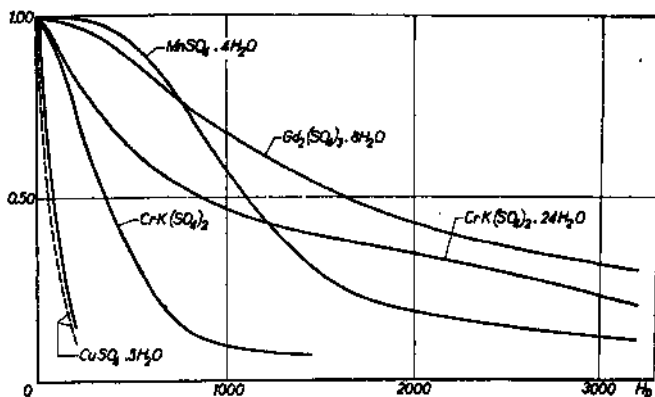

Fig. 23

p-curves for a number of salts measured at 78.5 .106 Hz. The dotted curve for $\text{CuSO}_4 \cdot 5 \text{H}_2\text{O}$ boars upon lower frequencies.

§ 4. RESULTS OF THE MEASUREMENTS AT LIQUID HELIUM TEMPERATURES BY A BRIDGE METHOD

The number of observations by the bridge method is not very large. In the earlier investigations the validity was assumed of the formulae following from CASIMIR and Du PRE's theory (ef. Ch. IV, § 2)¹ and from a series of measurements of x' at two or three frequencies a value of b/C and a rough value of p were obtained. The frequencies were usually not very different and this procedure was only possible because the accuracy of the measurements appeared to be high (a few promille). In later researches the scale of frequencies was extended and x' and x'' measured simultaneously. The results were plotted in the diagram of Fig. 4 (Ch. I, § 5) and lead to reliable values for b/C and p . There appears to be some difference in the b/C -

¹ In the case of paramagnetic saturation x is a function of H_c and the expression for F is somewhat different from (47) (comp. Ch. IV (65a)).

values obtained from different samples of the same substance and fairly large differences in p .

The substances investigated were: $Gd_2(SO_4)_3 \cdot 8 H_2O$, $FeNH_4(SO_4)_2 \cdot 12 H_2O$, $CrK(SO_4)_2 \cdot 12 H_2O$, $CuK_2(SO_4)_2 \cdot 6 H_2O$ and an alum in which the chromium had been diluted with aluminium ions. Negative results were obtained with $TiCs(SO_4)_2 \cdot 12 H_2O$ and $Fe(NH_4)_2(SO_4)_2 \cdot 6 H_2O$.

As an example we reproduce the results by CASDUR, BIJL, and Du Pile¹ at $2.04^\circ K$ at the H_c -values 456 0 and 1572 0 in the $x''-x'$ -diagram of Figure 4. A circle is drawn

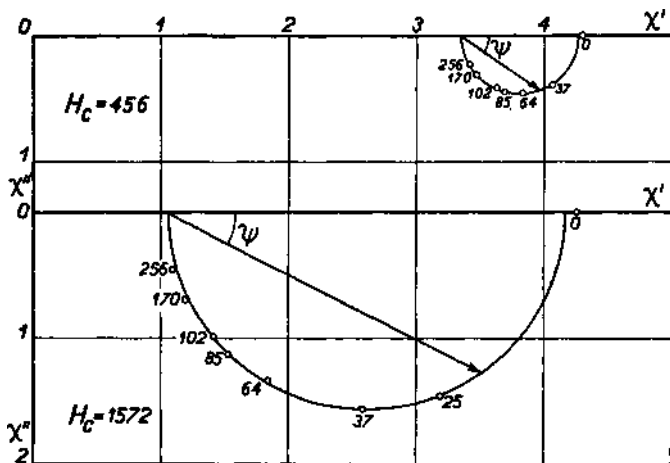

Fig. 24

Results of simultaneous measurements of % and x'' of $CTK(SO_4)_2 \cdot 12 H_2O$ at 2.04° and $H_c = 456$ and 1572 0 with various frequencies

through the observed points. From the value of $tg \psi$ at the frequency ν a value of $\sigma = \{tg \psi\} / \nu$ may be derived from each point. In our examples the result is given in Table XVII.

¹ H. B. G. CAISIMIR, O. BIJL, and F. K. Du PR6, *Physica*, 8 (1941) 449.

TABLE XVII
VALUES OF p DERIVED FROM FIGURE 24

ν	$p \cdot 456 \cdot 10^3$	$p1572 \cdot 10^3$
25.0		27.4
37.5	15.2	27.5
64.0	14.8	27.0
85.3	15.4	27.6
102.4	14.6	27.5
170.7	15.2	27.6
256.0	13.0	35.7

Table XVII shows that, apart from the results at the highest frequency, for which the accuracy of $tg \delta$ is not very high, the agreement with the theoretical formulae is satisfactory. It must, however, be noticed that the static susceptibilities were found to be a few percent higher than corresponds to the circles in Figure 24. The authors suggest that a ferromagnetic impurity or a slight mechanical vibration of the coil (?) is responsible for this latter discrepancy.

We shall, now, give a short summary of the various results.

$Gd_2(SO_4)_3 \cdot 8 H_2O$. Only χ' has been measured up to 18200 and the results have a provisional character¹, p is little dependent on H_c . See Table XVIII.

TABLE XVIII
EESUI/DS FOR $Od, (SO_4)_3 \cdot 8H_8O$.
 $b/C = 3.0 \cdot 106 \cdot 02$.

T	$p \cdot 10^3$
4.24	24
3.52	38
3.00	50

$FeNH_4(SO)_2 \cdot 12H_2O$. Only x' has been measured and the results have a provisional character, p increases slowly as a function of H_c the approximate result at 1350 0 is given in Table XIX.

TABLE XIX

$b/C = 0.24 \cdot 106 \ 02$
RESULTS FOR $FeNH_4(SO_4)_2 \cdot 12 \ H_2O$.

T	$p \cdot 10^8$
4.22	16
3.49	22

Du PRE has the impression that the purer the samples the lower b/C and the higher p .

$CrK(SOJ_2 \cdot 12 \ H_2O)$. This substance is best investigated at $2.04^\circ K$. We have already mentioned a few results. Table XX gives the resulting values². It may be mentioned, however, that in an earlier investigation Du PRE¹ found $p = 4A \cdot 10^{-3}$ sec at $3.50^\circ K$ and $p = 113 \cdot 10^3$ sec at $2.01^\circ K$ in $H_c = 1350 \ 0$. His result at $2.01^\circ K$ differs by a factor 4 or 5 from the later results at $2.04^\circ K$ (cf. Table XX).

$(Cr-Al)K(SOJ_2 \cdot 12H_2O \ (1:13))$. From a quantitative point of view the results on "diluted" paramagnetic substances are seldom very satisfactory but qualitatively they are, like those obtained on the absorption and dispersion of such salts, (comp. § 2 and. § 3) highly interesting. In

» P. K. Du PR6, *Physica*, 7 (1940) 79.

2 H. B. G. CASIMIR, D. BWL and F. K. Du PR6, *Physica*, 8 (1941) 449.

TABLE XX
RESULTS FOR $\text{CrK}(\text{SO}_4)_2 \cdot 12\text{H}_2\text{O}$ AT 2.04°K
 $h/C = 0.80 \cdot 106 \text{ O}2$

	$p' \cdot 10^2$
456	15
775	17 ⁷
1141	21 ⁵
1572	27 ⁸
2257	35

the diagram¹ the points lie fairly well on circles. The p -value varied very little between 900 and 2300 O at the highest temperature (4.04°K); it was about $55 \cdot 10^{-3}$ sec. At lower temperatures, however, a strong dependence on H_c appeared which, in contrast with the other substances investigated, consisted in a decrease of p with increasing H_c . At 1.21°K the result was: $p = 750 \cdot 10^{-3}$ sec at 9050 and $p = 320 \cdot 10^{-3}$ sec at 2290 O. These conclusions from the results seem to be very uncertain as pv was always larger than 20 at this temperature. A further anomaly is that the i^\wedge -values do not satisfy CASIMIR and Du PRS'S equation

$$F = \frac{CH_c^2}{b + CH_c^2} \quad 47$$

At low fields the results are in agreement with $b/C = 0.9 \cdot 10^6 \text{ O}^2$, but at 1.74°K the F -value at 1575 O is about 0.84, whereas the computed value is 0.74. A similar, and strangely enough, even more pronounced effect seems to exist at 2.04°K but it is absent at 2.53°K .

$\text{CuK}(\text{SO})_2 \cdot 12 \text{ H}_2\text{O}$. BUL'S measurements² on this substance were confined to two frequencies, namely 128 and 170.7 Hz. On the assumption that the experimental points

1 D. BUL, *Physica*, 8 (1941) 495.

2 D. BUL, *Physica*, 8 (1941) 461.

lie again on a circle in the $x''-x'$ diagram, it is possible to derive values for p and F . p increases considerably with increasing H_c . At 1.7°K it increases from about $30 \cdot 10^{-3}$ to about $170 \cdot 10^{-3}$ sec and at 3.0°K from about $12 \cdot 10^{-3}$ to about $60 \cdot 10^{-3}$ sec while H_c increases from 1190 till 2313 O. The fc/C -values derived from F appear to depend on the temperature; they increase from about $0.10 \cdot 10^6 \text{ O}^2$ at 1.7°K to about $0.13 \cdot 10^6 \text{ O}^2$ at 3.0°K .

IV. THEORY

§ 1. THE PROCESS OF MAGNETIZING

As a starting point for the theory of normal paramagnetism two different points of view can be chosen.

The first one, which was accepted in the introductory section Ch. I, § 1, considers the individual magnetic ion, its various states and the matrix of its magnetic moment. The statistical behaviour of a system of identical ions can be considered in a microcanonical ensemble and some of the results to which this treatment leads, characterized by a BOLTZMANN distribution over the different states, have been summarized in that section.

We may remind the reader of a few essential points and add a few remarks about these results. A diagonal term M_{nn} in the magnetic moment of the ion indicates the existence of a magnetic moment in the state under consideration from which a close parallelism to the permanent magnetic moments of LANGEVIN'S classical theory of paramagnetism results. The energy of the state varies by $-M_{nn}AH$ in an extra field AH and, owing to BOLTZMANN'S factor, a change in the distribution over the various levels and consequently of the average magnetic moment occurs¹. It is worth while to point out that this change of distribution requires some kind of interaction with either the electromagnetic field of radiation or with the surrounding atoms and ions. The interaction with the radiation field is, however, so weak that it is never of any importance. Small amounts of energy are given off to (or taken from) the surrounding atoms and

¹ In Ch. I, § 1a slightly different notation was used. In this Chapter we use M_n instead of M_{AH} (nn).

ions or the lattice as a whole. In this picture the heat of magnetisation (or the cold produced in demagnetisation) is simply the sum of these small amounts of energy.

The non-diagonal elements of the magnetic moment give rise to polarisability of the ion in the states concerned. The contribution to the polarisability, due to the element between two states, is positive for the lower state and negative for the higher one (comp. Ch. I (4)) and, owing to BOLTZMANN'S factor, the positive contribution preponderates. It is worth while to point out that, though the sum $\sum_n \sum_{n'} |M_{nn'}|^2$ is invariant with respect to small perturbations (comp. Ch. I, § 1), the values of the individual terms will not be invariant at all. In general they will be functions of H . If, in particular, we have a non-diagonal element M_{ni} , a magnetic moment $M_{ni} = 2AH/(W_n - W_i)$ will arise in the state n upon an increase of H by AH , so that M_{ni} will increase by the same amount if we compare its value at $H + AH$ with that at H .

According to the second point of view, first proposed by CASIMIR and Du Pffe¹ and later worked out by BROER², the system of all ionic moments — often called the *spin system* — is considered to be one entity which, in a first approximation, is isolated from the crystalline lattice. The statistical treatment now requires ensembles which can be called canonical. It is appropriate to ascribe a temperature — the so-called *spin temperature* T_s — to the system and in the static case a BOLTZMANN distribution will, on the average, exist over the enormously large number of states of the system. This time we have to consider diagonal and non-diagonal terms of the magnetic moment of the whole system, and the formulae (1)—(4) Of Ch. I are applicable in this new sense. Again, both sorts of terms contribute to the variation of the average total magnetic moment if the field is varied.

1 H. B. G. CASIMIR and F. K. Du Pffe, *Physica*, 5 (1938) 507.

2 L. J. F. BROER, *Physica*, 10 (1943) 801.

If, now, the field is varied quickly (non-adiabatically in EHRENFEST'S sense) there is a certain probability that the system will make a transition to a different state. Let us consider a variation which is periodical with frequency ν and suppose the system to be in the state h . The probability of finding the system after a certain number of cycles in the state h' , the energy of which is $h\nu$ larger, will be proportional to $|M_{hh'}|^2$ where $M_{hh'}$ is the non-diagonal element of the magnetic moment of the system. In this way energy is continuously transferred from the high frequency magnetic field to the spin system and we are used to speak in this case of *spin absorption* and, together with the corresponding dispersion, of *spin relaxation*. Here we have to add two remarks. In the first place, we have to deal as well with EINSTEIN'S stimulated emission as with absorption, the difference giving the net absorption. In the second place energy will in this way be stored up in the spin system and its spin temperature will rise if it is not carried off by some interaction with the surroundings. It appears, however, that we need not worry about this point as even a very weak interaction is sufficient to provide for this, so that the rise of spin temperature is always negligible (compare with the case of nuclear spins Ch. V, § 4).

The diagonal elements of the magnetic moment of the system give rise to a displacement — M_{hh} of every level h . If we suppose no transitions to occur, the pre-existing BOLTZMANN distribution will thereby be disturbed. Strictly speaking, there will then be no such thing as a new spin temperature, but BROER has shown that it is all the same possible to define an effective spin temperature. The differences between any property of the system and the property calculated with the aid of the effective spin temperature will remain of the order of the statistical fluctuations.

Accepting for a short moment our first point of view, it is easy to see that in very large magnetic fields the

spin temperature T_s will be proportional to H . For, if the occupation of the energy levels, and therefore also the BoLTZMANN-factors $\exp(-\Delta W/kT_s)$ remain unaltered, T_s has, just as AW_y to be proportional to H .

In Ch. I, § 2 a thermodynamical reasoning already gave us the value of the rise of the spin temperature. For the case of a normal paramagnetic substance we found in (19) and (23):

$$\left(\frac{\partial T}{\partial H}\right)_s = \left(\frac{\partial T}{\partial H}\right)_M \frac{C_H - C_M}{C_H} = \frac{T}{H} \frac{CH^2}{b + CH^2} \quad 23$$

and the solution of this equation is

$$T = y (b + CH^2)\%, \quad 54$$

where y is determined by the original values of T (T_s) and H . We see that, if H^2 is large compared with b/C , T will, of course, be proportional to H , whereas, if IP is small in comparison with b/C , a change in H will hardly produce any change at all in T .

The rise of T_s with increasing H will, in view of CURIE'S law, lead to a decreased susceptibility, if the variation and observation occur so quickly that no energy transfer to the crystalline lattice can take place. If we consider a periodical variation of H , however, the so-called *lattice relaxation* will occur, when this transfer of energy becomes of importance.

If both non-diagonal and diagonal elements of the total magnetic moment occur, we shall have both spin relaxation and lattice relaxation and the contributions of these two to x' and x'' may simply be added (cf. Ch. III (51)).

The second point of view mentioned in this section has certain advantages when we wish to treat the spin absorption. This point of view has, therefore, been accepted in § 3. In dealing with this spin absorption, one can very well start also from the first point of view. In that case the effect is considered on one single ion of the various

and varying magnetic fields due to the presence of the other magnetic ions, but in the application of this treatment one has to be very careful, as is demonstrated by KRONIG and BoxrWKAMP¹⁹'s theory on the influence of a constant magnetic field on the spin absorption, which later on proved to be incorrect.

In the treatment of the interaction between the magnetic ions and the crystalline lattice, a mixture of the two views seems advantageous. The second view with its notion of the spin temperature is generally accepted, but in order to evaluate the transfer of energy between spin system and crystalline lattice, one starts from the (interaction between the lattice and a single ion. This problem, leading to the so-called lattice absorption and lattice dispersion, will be treated in the next section.

§ 2. THE THEORY OF LATTICE RELAXATION

CASIMIR and Du PR6², who first noticed the importance of a spin temperature for the phenomena of paramagnetic relaxation, gave formula (22) for the adiabatic susceptibility. Later, DEBUE introduced the more general formula (18). At relatively low frequencies x' will be equal to the static susceptibility X_0 ; at very high frequencies it will be equal to x^\wedge . In these extreme cases x'' will be zero. In the transition region x' will depend on the frequency (dispersion), while x'' may reach values of the order of X_0 . Assuming the transfer of energy between spin system and lattice to be proportional to the difference AT between spin temperature and the constant lattice temperature, a very simple expression for the susceptibility in the transition region may be obtained.

Formula (17) leads on these assumptions to

i R. KRONIG and C. J. BOTJWKAMP, *Physioa*, 5 (1938) 521.

2 H. B. G. CASIMIR and F. K. Du PRO, *Physioa*, 5. (1938) 507.

P. DEBUE, *Phys. Z.*, 39 (1938) 616.

$$-\alpha \Delta T dt = C_H \left(\frac{\partial T}{\partial M} \right)_H \Delta M + C_M \left(\frac{\partial T}{\partial H} \right)_M \Delta H \quad 55$$

where a is the coefficient of thermal contact between spin system and lattice.

On the other hand we have

$$\Delta T = \left(\frac{\partial T}{\partial M} \right)_H \Delta M + \left(\frac{\partial T}{\partial H} \right)_M \Delta H \quad 56$$

and elimination of ΔT yields

$$(C_H + \alpha dt) \left(\frac{\partial T}{\partial M} \right)_H \Delta M + (C_M + \alpha dt) \left(\frac{\partial T}{\partial H} \right)_M \Delta H = 0 \quad 57$$

Putting

$$\Delta H = H_0 \exp 2\pi j vt \quad 58$$

$$\Delta M = M_0 \exp 2\pi j vt \quad 59$$

(ef. (27a) and (28a), we get

$$\chi = \frac{M_0}{H_0} = \frac{2\pi j v C_M + \alpha \left(\frac{\partial M}{\partial H} \right)_T}{2\pi j v C_H + \alpha \left(\frac{\partial M}{\partial H} \right)_T} \quad 60$$

We can also split χ into its real and imaginary components χ' and χ'' and as $\chi_0 \left(\frac{dM}{dH} \right)_T$,

$$\chi' = \frac{\chi_0 F^2}{1 + \rho^2 v^2} + \chi_0 (1 - F) \quad 61$$

$$\chi'' = \frac{\chi_0 F^2 \rho v}{1 + \rho^2 v^2} \quad 62$$

$$F = \frac{C_H - C_M}{C_H} \quad 3$$

$$\text{and } \rho = \frac{2\pi C_H}{\alpha} \quad 64$$

The result is therefore a simple DEBIJE curve for $\chi' >$ the maximum of which is equal to $\chi_0/2$, and a DEBIJE curve plus

i The numerical parameter F must not be confounded with the free energy F in (24).

a constant term for the high frequency susceptibility $x' \ll$ At very high frequencies we get $x' = X_0 (1 - F) = \chi_0 C_M / C_H$, the adiabatic susceptibility according to (18).

In the case of a normal paramagnetic substance we may put, according to (21),¹

$$F = \frac{CH^2}{b + CH^2} \quad 65$$

$$p = \frac{2\pi (b + CH^2)}{\alpha T^2} \quad 66$$

It is now worth while to remark that the formulae (61) and (62) are identical with the formulae (46) and (51) (limiting case for low frequencies). Also (65) is identical with (47) where, of course, H has been called H_c . In Ch. I 11 the conclusion was reached that these formulae give a satisfactory description of the experimental results at not too high frequencies.

A further analysis of the interaction between spin system and crystalline lattice is required in order to evaluate the coefficient of thermal contact a . We shall first show that, if this interaction causes the occurrence of a certain number of spontaneous transitions between the different energy levels of the spin system, it is possible to calculate a and therefore also p from the probabilities of those transitions.

Let us therefore suppose this transition probability from a level H_0 a level k to be A^{\wedge} . According to the principle of detailed balancing we shall have

$$N_h A_{hk} - N_k A_{kh} = 0 \quad 67$$

where the numbers N_h and N_k of the ions in the different states must obey the BOLTZMANN distribution. Hence

$$A_{hk} = \overline{A_{hk}} \exp \frac{W_h - W_k}{2 kT}$$

1 If we have to deal with very low temperatures and large constant fields so that paramagnetic saturation is of importance, the expression for F is somewhat different. In the case that $M = f(E/T)$ we get

$$F = fH^*/(b + fE.^*) \quad (65a)$$

$$A_{hk} = \overline{A_{hk}} \exp. \frac{W_k - W_h}{2kT} \quad 69$$

Now we assume that the temperature of this BOLTZMANN distribution is $T_g = T + \Delta T$ and we wish to find the surplus of the processes going from h to k . In stead of (67) we then get

$$N_h A_{hk} - N_k A_{kh} = \overline{N_{hk}} \overline{A_{hk}} \left\{ \exp \left(\frac{W_h - W_k}{2kT} \right) \left(\frac{1}{T} - \frac{1}{T + \Delta T} \right) \right. \\ \left. - \exp - \left(\frac{W_k - W_h}{2kT} \right) \left(\frac{1}{T} - \frac{1}{T + \Delta T} \right) \right\} \quad 70$$

Supposing $|W_h - W_k| \ll kT$ and developing the exponentials, and noticing that the total energy (heat) transmitted to the lattice is found by multiplying the surplus number by the energy difference $W_h - W_k$ and summing up over all values of h and k we get

$$\frac{dQ}{dt} = \frac{\Delta T}{2kT^2} \sum_h \sum_k \overline{N_{hk}} \overline{A_{hk}} (W_h - W_k)^2 \quad 71$$

so that

$$\alpha = \frac{1}{2kT^2} \sum_h \sum_k \overline{N_{hk}} \overline{A_{hk}} (W_h - W_k)^2 \quad 72$$

As we can put (compare (20))

$$C_H = \frac{1}{2kT^2} \sum_h \sum_k \overline{N_{hk}} (W_h - W_k)^2 \quad 73$$

and as $N_{hk} = (N_h^j r N_k)_j$ is independent of the choice of h and k , we can write for (64)

$$\rho = \frac{2\pi \sum_h \sum_k (W_h - W_k)^2}{\sum_h \sum_k \overline{A_{hk}} (W_h - W_k)^2}$$

Before discussing this formula we will first make a few remarks about the nature of the transition probabilities A_{hk} .

WALLER¹ pointed out already that the exchange of energy between the magnetic ions and the lattice will take place in two essentially different ways. In the first way a lattice vibration quantum is absorbed or emitted by the ions. In the second way, a vibration quantum is scattered non-elastically by the ions. These latter processes are a sort of RAMAN processes in which the light waves are replaced by lattice waves and the molecular energy levels by ionic energy levels. At first sight one would expect the former processes to be the more frequent ones as they are processes of the first order in contrast with the "RAMAN"-processes. But on the other hand all lattice waves can cause a certain transition by "RAMAN-effect", whereas the first order process requires a lattice wave of the right $h\nu$. The number of RAMAN-processes rises steeply with the temperature. According to FIERZ and KRONIG² it is proportional to T^2 for $T \gg 0$ and to T^7 for $T \ll 0$, where 0 is DEBIJE'S characteristic temperature of the lattice. The intensity of the lattice waves of low frequency which give rise to the first order process of absorption, is only proportional to T and this also applies to the number of emission processes. At very low temperatures, therefore, (those obtainable with liquid helium) the first order processes will preponderate but at higher temperatures (and certainly at liquid air temperatures) the "RAMAN"-processes will be the more frequent ones.

We shall now proceed to a qualitative discussion of (74). We observe that in the denominator the transition probabilities A are weighed in proportion to the square of the energy differences ($Wh - Wk$) so that chiefly transitions between levels with a relatively large difference are of importance. We may expect the transition probabilities between such levels to be only slightly influenced by a constant field H_c , so long as the shift it produces is small

i I. WALLER, *Z. Phys.*, 79 (1932) 370.

2 M. FIERZ, *Physica*, 5 (1938) 433.

R. KRONIG, *Physica*, 6 (1939) 33.

compared with the original energy difference. This leads us to expect a constant value of p so long as $H_c^2 \ll b/C$. If, now, we consider very large fields $H_c^2 \gg b/C$, all energy differences of importance will be proportional to H_c . As far as the "RAMAN"-processes are concerned the A 's will now be independent of the exact value of H_c , so that p will tend to another constant value and, when the A 's transform themselves in a way which is independent of the temperature, the ratio between the p 's in very small and very large fields will also be independent of the temperature. But, when the first order processes predominate, the A 's will not at all be independent of H_c ; they will on the contrary be proportional to the square of the energy differences. At very low temperatures, therefore, where those processes are predominant, p should become inversely proportional to H^2 .

As already mentioned in § 1, the consideration of the interaction between the lattice and one individual ion is the basis of the evaluations of the A 's and of p . This involves the supposition that only transitions in the spin system are of importance that can be specified as a transition of one individual ion between its own levels. As a matter of fact, TEMPERLEY¹ has suggested that the interaction between the ions might introduce transitions in which more than one ion are concerned. As the number of these transitions would decrease soon with increasing H_c this mechanism might for very low temperatures lead to a limited increase of p as a function of H_c before the decrease in proportion to H_c^{-2} sets in. VAN VLECK doubts however whether such transitions can play a role of any significance².

It was soon noticed that transitions induced by the variations of the internal magnetic field associated with the heat motion of the lattice are not numerous enough

i H. N. V. TEMPERLEY, *Proc. Cambr. PUI Soc*, 35 (1938) 256.

2 J. H. VAN VLECK, *Le Magnetisme*, Strassbourg, 1939.

to account for the p's found in the temperature regions of liquid air or liquid helium. KRONIG has pointed out that spin magnetism is always to a certain extent combined with a remains of orbital magnetism and that this is influenced by the electric fields associated with the heat motion of the lattice. KRONIG' arrived at the right order of magnitude in a very rough evaluation. VAN VLECK², independently, investigated the same problem much more in detail. He considered a specific model, analysing on the one hand the normal modes of vibration of a X. 6 H₂O-cluster, where X indicates the magnetic ion and the interaction between the magnetic moment of that ion and the normal vibrations of the cluster, while on the other hand the normal coordinates are expanded in terms of DEBIJE elastic waves. He considers the two specific cases of titanium alum (with $S = \frac{1}{2}$; $L = 2$) and of chromium alum (with $S = \frac{3}{2}$; $L = 3$).

In the case of the titanium alum a field of cubic symmetry does not remove the orbital degeneracy (ef. Fig. 2). This requires a field of lower symmetry and the corresponding splitting A is relatively small, though larger than kT at room temperature. VAN VLECK evaluates its order of magnitude at 10^3 cm^{-1} . At the temperatures of liquid air, where the "RAMAN"-processes preponderate, a will be proportional to AVA^6 , where A (ef. Ch. I, § 4) characterizes the spin-orbit coupling. At very low temperatures, where the first order processes dominate, a will be proportional to A^2/A^4 .

In the case of chromium alum the orbital degeneracy of the basic level is completely removed by a cubic field, so that merely the fourfold spin degeneracy remains. Fields of lower than cubic symmetry are required to split the fourfold basic level in two double levels, they will also decompose the higher levels, which are left degenerate by

i R. KRONIG, *Physica*, 6 (1939-) 33.

2 J. H. VAN VLECK, *Phys. Rev.*, 57 (1940) 426.

the cubic field. It appears that the lowest orders in the perturbation calculations do not give an appreciable contribution to a , so that higher orders come into account and the calculations are apt to become rather complicated and speculative. This time a turns out to be proportional to a high inverse power of the cubic term in the crystalline field, but it is not strongly dependent upon fields of lower symmetry.

For both substances at liquid air temperatures the dependence of p on the constant field H_c should be given by

$$p = p_0 \frac{b + CH_c^2}{b + pCH_c^2} \quad 48$$

where p should be independent of T , in agreement with the qualitative expectation given earlier in this section. p should be about 0.5 for both substances; in the case of iron ammonium alum p should be between 0.22 and 0.6. At very low temperatures p should decrease with increasing field and, in agreement with the qualitative expectation, be inversely proportional to H_c^2 in large fields.

It may be remembered here that, though (48) approximately represents the experimental values, the values of p do not agree with the expectations for the alums, while the experimental results at very low temperatures are widely at variance with VAN VLECK'S theoretical expectation. This latter discrepancy has brought him to a far-reaching theoretical investigation of abnormal conditions among the lattice vibrations, which have not yet led to definitive results¹ and upon which we shall not dwell here.

§ 3. THE THEORY OF SPIN* RELAXATION

The theory of spin relaxation was founded by WALLER² and was extended by BROER³. AS BROER'S treatment is

i J. H. VAN VLECK, *Phys. Bev.*, 59 (1941) 724 and 730.

2 I. WALLER, *Z. Phys.*, 79 (1932) 370.

a L. J. F. BROER, *Physica*, 10 (1943) 801.

more transparent and goes more into detail, we will follow his line of thought. The starting point is the "second view" of § 1 in which a canonical ensemble containing all possible states of the whole spin system is considered and in which the diagonal elements and non-diagonal elements of the magnetic moment of this system are placed in contrast. The diagonal elements lead to changes of the spin temperature and to lattice relaxation, as was discussed in § 2, while the non-diagonal elements lead to absorption of energy by the spin system (spin absorption). If the frequency of the oscillating magnetic field is ν , we have to deal with processes of absorption and stimulated emission. The surplus number of absorption processes will therefore be proportional to $h\nu/kT$ and the surplus absorption itself with $(h\nu)^2/kT$. Further, the absorption will be proportional to the average square of the non-diagonal magnetic moment with frequency difference ν . When ν is varied the absorption will vary continuously and the distribution function of the square of the non-diagonal magnetic moment over the frequency will be essential. We will call this distribution function $f(\nu)$.

We then have

$$A \quad \underline{\delta^* \gg \nu' / (\gamma)}$$

and correspondingly (ef. (31))

$$\chi'' = \frac{\pi \nu f(\nu)}{2 kT} \quad 76$$

This distribution function $f(\nu)$ has been normalized in such a way that

$$\int_0^{\infty} f(\nu) d\nu = \chi_{ad} kT$$

which means that the KRAMERS-KHONIG relation (32) is fulfilled for $\chi'(\infty) - \chi'(0) = \chi''^*$

The problem is now reduced, therefore, to the determination of $f(v)$. BROER has proposed two methods in order to obtain some idea about the course of $f(v)$ in a few special cases. The first method is that of the invariant diagonal sums which in principle allows to calculate the integrals

$$\int_0^{\infty} f(v) dv, \int_0^{\infty} f(v) v^2 dv, \text{ etc.}$$

The corresponding integrals with higher powers of v usually lead to very complicated calculations. The second method is a perturbation method in which we start from the (sharp) energy levels existing in the absence of all interaction and then introduce the magnetic interaction as a perturbation. Strictly speaking such a perturbation method is not correct, as the perturbation energy increases beyond all limits when the number of ions in the system increases, so that it becomes very much larger than the energy differences between the unperturbed levels. Stressing the fact that only perturbations of the order of pHi (ef. Ch. I, § 1 and § 3) are of importance, BROER has made it plausible that, all the same, this method leads to acceptable results so long as $H_c \gg Hi$.

BROER treats the following cases:

- a. No electric splittings (single spin; **Ti+++**, **Cu++**).
- b. Electric splittings removing all degeneracy (even number of electrons; **V+++**, **Fe++**, **Ni++**).
- c. Electric splittings which leave the KRAMERS degeneracy (odd number of electrons; **Cr+++**, **Mn++**, **Fe+++**, **Gd+++**)

and we shall summarize his results for $f(v)$ in the absence of a magnetic field (a), in a parallel magnetic field H_c (c), and in perpendicular field Ha (d).

a, a: No electric splittings, no magnetic field. The invariance of diagonal sum yields

$$\int_0^{\infty} f(\nu) d\nu = \frac{4}{3} N \beta^2 S(S+1) = \chi_0 kT, \quad 78$$

$$\int_0^{\infty} f(\nu) \nu^2 d\nu = \frac{4}{3} N \beta^2 S(S+1) \frac{4 \beta^2 H_i^2}{\hbar^2} = \chi_0 kT \nu_0^2, \quad 79$$

where S is the spin quantum number of the ions, while $H_i^2 = 8 \beta^2 S(S+1) \sum_{p \neq q} r_{pq}^{-6}$ is the internal magnetic field introduced in Ch. I, § 3 (25) and

$$\hbar \nu_0 = 2 \beta H_i. \quad 80$$

The LANDE splitting factor g has been taken to be 2.

We see from (78) and (79) that $f(\nu)$ becomes very small so soon as $\nu \gg \nu_0$. A DEBIJE curve ($f(0)/(1+pV)$) will not do for $f(\nu)$, because (79) would diverge. Tentatively, BROER proposes a GAUSS-curve

$$f(\nu) = \frac{\chi_0 kT \sqrt{2}}{\nu_0 \sqrt{\pi}} \exp - (\nu^2/2 \nu_0^2). \quad 81$$

This expression satisfies (78) and (79). It gives

$$\chi'' = \frac{\chi_0 \nu \sqrt{\pi}}{\nu_0 \sqrt{2}} \exp - (\nu^2/2 \nu_0^2), \quad 82$$

and, identifying this expression for low values of ν with (50),

$$\rho' = \sqrt{\frac{\pi}{2}} \frac{1}{\nu_0} = \sqrt{\frac{\pi}{2}} \frac{\hbar}{2\beta H_i} \quad 83$$

The result is essentially the same as that obtained earlier by WALLER. We must not forget, however, that the numerical factors ($\sqrt{\pi/2}$ etc) are due to the special assumption of a GAUSS-curve for the shape of $f(\nu)$.

a, c: N6 electric splittings, a parallel magnetic field.

We then have

$$\int_0^{\infty} f(v) dv = \frac{b \chi_0 kT}{CH_c^2} = \frac{H_i^2 \chi_0 kT}{2 H_c^2} \quad 84$$

$$\int_0^{\infty} f(v) v^2 dv = \chi_0 kT v_0^2. \quad 85$$

Whereas the area under the $1/(v)$ -curve vanishes, therefore, in proportion to H_e^{-2} the area under the $v^2/(v)$ -curve (which, in view of (75), is proportional to A_{sec}) remains constant. As a matter of fact

$$\frac{\int_0^{\infty} f(v) v^2 dv}{\int_0^{\infty} f(v) dv} = \frac{2 H_c^2 v_0^2}{H_i^2} = \frac{8 \beta^2 H_c^2}{h^2} \quad 86$$

so that the average value of v^2 increases in proportion to H_c^2 .

The method of the invariant diagonal sums does not give more particulars about the shape of the $1/(v)$ -curve, but a perturbation calculation, as mentioned before, can help in that respect for very large fields. If we neglect interaction between the ions we have a very large number of discrete equidistant highly degenerate levels with distances $2f/H_c$. The magnetic moment in the direction of H_c has only diagonal elements, but upon introducing magnetic interaction as a perturbation, non-diagonal elements arise between some of the levels with mutual distances $0, 2f/H_c$ and $4f/H_c$. In this way we get three absorption regions: at low frequencies, around $2\beta H/h$, and around $4fH_c/h$. Each region has a half width of the order of v_0 . The intensities ($\int f(v) dv$) of the peaks at $2fH_c/h$ and at $4\beta H/h$ are proportional to $(H_i/H_c)^2$, their ratio is about 2. The intensity of the peak at zero frequency is proportional to $(H_i/H_c)^4$. As the half width of this peak is not dependent on H_c , the contribution to x'' at the relatively low fre-

quencies, with which we are concerned experimentally, is also proportional to H_c^{-4} . As $1 - F$ is proportional to H_c^{-2} , $\gamma(H_c)$ (compare Ch. III, § 3) is therefore proportional to H_c^{-2} . Unfortunately the proportionality coefficient could not be calculated.

a, d: No electric splittings, a perpendicular magnetic field.

In this case we have

$$\int_0^{\infty} f(\nu) d\nu = \chi_0 kT \quad 78$$

$$\int_0^{\infty} f(\nu) \nu^2 d\nu = \chi_0 kT \left(\nu_0^2 + \frac{4\beta^2 H_d^2}{h^2} \right) \quad 79$$

Just as in the case of a parallel field, the average value of ν^2 increases therefore in proportion to the square of the large constant field, but this time the area; under the $f(\nu)$ -curve is constant.

Now the magnetic moment, in the absence of interaction, has only non-diagonal elements with frequency $2J3H/h$. The perturbation by the interaction broadens this "absorption line" to a half width of about ν_0 and introduces, moreover, absorption regions at zero frequency and at $4\beta H_d/h$. The intensities of these latter peaks are both proportional to H_d^{-2} . Again the proportionality constant could not be calculated.

6, a: Electric splittings removing all degeneracy, no magnetic field.

The expression

$$\int_0^{\infty} f(\nu) d\nu = \chi_0 kT \quad 78$$

is also valid in this case, but we have only non-diagonal elements of the total magnetic moment (between levels

lying AW apart) and no diagonal elements. The $I(\nu)$ -curve has therefore peaks at the frequencies $A W/h$, but not at zero frequency, so that we have no absorption at low frequencies so long as $h\nu_0$ is negligible in comparison with AW . In a following approximation we shall have absorption, $I(0)$ being of the order of $\chi_0 k T h^2 \nu_0 / (AW)^2$; that is to say very small in comparison with (81). I will also be approximatively reduced by the electric splitting in the ratio $(h\nu_0/AW)^2$.

b, c, d: Electric splittings removing all degeneracy, a magnetic field.

In the presence of a magnetic field the absorption will in general remain small. But at certain values of the magnetic field the energy levels of the individual ion may cross each other. We can expect in that case a rapid increase of the absorption at low frequencies. This effect, however, will presumably be anisotropic with respect to the crystalline axes, as the "critical" value of the constant field will be different for different directions. The absorption for a powder is for that reason likely to remain small.

c, a: Electric splittings not removing all degeneracy, no magnetic field.

Again (78) is valid, but now we shall have absorption peaks at the frequencies $A WA$ as well as at zero frequency. The ratios of the intensities of the different peaks will be the same as for one single ion, provided $h\nu_0 \ll AW$. Assuming a certain symmetry character of the electric field, it is often possible to calculate the intensities of the absorption lines at the various frequencies. These intensities are proportional to the squares of the corresponding non-diagonal elements of the magnetic moment of the single ion. The diagonal as well as the non-diagonal elements between degenerate levels (called semi-diagonal by BROER) give rise to the peak at zero frequency. The width of this

peak is presumably the same as in the absence of the electric field. It follows that the absorption at very low frequencies is only decreased because of the non-diagonal elements mentioned, so that we get instead of (83)

$$\rho' = \sqrt{\frac{\pi}{2} \frac{\sum_n \sum_{n'} |M_{n n'}|^2 - \sum_{(n d)} \sum_{n'} |M_{n n'}|^2}{\nu_0 \sum_n \sum_{n'} |M_{n n'}|^2}} \quad 88$$

where (n.d.) means that the summation extends only over those combinations of ionic levels, that have different energies.

c, c, d: Electric splittings not removing all degeneracy, a magnetic field.

Regarding this case not much more can be said than that the absorption will vanish with very large fields in proportion to $(\hbar\nu_0/2\beta H_c)^2$ or $(\hbar\nu_0/2\beta H_d)^2$. Unfortunately this is the case to which nearly all experimental researches are related. In intermediate fields the same phenomenon may occur as mentioned under 6, c, d and the crossing of energy levels may considerably increase the absorption at low frequencies. This increase must be very rapid and pronounced but it will again be anisotropic and obliterated in a powder.

Fig. 25 is due to BROER¹ and shows the curve for $f(\nu)$ and for $\nu^2/(\nu)$ as a function of ν in a few of the cases discussed.

i L. J. F. BROER, *Thesis*, Amsterdam, 1945.

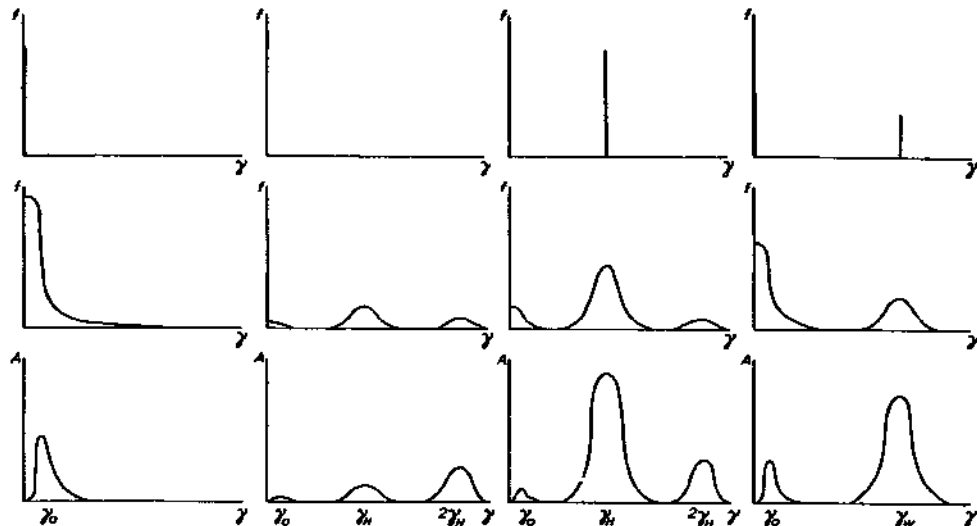

Fig. 25

Sketch of the results of the perturbation method. From left to right the following cases are given: *as*. (no electric splitting; no magnetic field), *ac* (no electric splitting; a large parallel magnetic field J^2_c), *ad* (no electric splitting; a large perpendicular field H_d) and *ca* (electric splitting not removing all degeneracy; no magnetic field). The first three cases are those of Ti^{+++} (or Cu^{+}), the last case that of Cr^{+++} . In the upper row magnetic interaction is not present, in the middle and lower row $I(v)$ and $A_{sec} \sim v^2/v$ are given when interaction is admitted.

$$\nu_H = 2\beta H_c/h \text{ or } = 2\beta H_d/h; \nu_0 = 2\beta H_l/h; \nu_w = \Delta W/h.$$

V. DISCUSSION OF RESULTS

§ 1. VALUES OF b/C

Describing the experimental results concerning the dispersion and on the absorption by (46) and (51) respectively, we find values of F for a series of parallel fields H_c . The dependence of F on H_c always satisfies the CASBUR-Du Pite relation

$$F = \frac{CH_c^2}{b + CH_c^2} \quad 47$$

and the values of b/C thus obtained have been given in Ch. III, § 2. The theoretical treatment of Ch. IV, § 2 yield these same relations for normally paramagnetic substances with $b = CMT^2$, where CM is the spectroscopical specific heat (comp. Ch. I, § 2) while C is the CURIE constant $C = x^T$. As the CURIE constant is usually known for the substances investigated, the determination of b/C is essentially a determination of the specific heat CM'

b/C was generally found to be independent of or at any rate only slightly dependent on the temperature. This means that in effect C_M appears to be inversely proportional to T^2 . Starting from the point of view of independent ions, it was found (comp. Ch. I, (20)) that C_M will be inversely proportional to T^2 as long as only low frequency levels (with distances $\ll kT$ to the lowest level) are occupied. This result is not altered if we allow for interactions with neighbouring ions as long as the energetical changes introduced by them are also much

i In the case of normal paramagnetic substances in not too strong fields, to which our formulae apply, C_M is independent of the value of M and therefore equal to the specific heat in the absence of an external field (ef. (21)).

smaller than kT . This is not quite evident in the case of magnetic interaction but VAN VLECK has shown that the same conclusion is valid in that case (comp. Ch. I, § 3). The theoretical expectation and the experimental results are therefore in perfect agreement in this respect.

With the exception of $\text{Mn}(\text{NHJ}_2(\text{SO}_4)_2 \cdot 6\text{H}_2\text{O})$ and of a few results at liquid helium temperatures b/C was found not to vary from sample to sample, which shows that the "spectroscopical" specific heat is less sensitive to small perturbations than the relaxation constants (comp. § 2).

We shall now proceed to a short discussion of the b/C -values found for the various substances and compare them with the values derived from investigations of another nature.

Gd-salts.

Table XXI gives a list of the experimental values for $\text{Gd}_2(\text{SOJ}_3 \cdot 8\text{H}_2\text{O})$. The last two investigations yield only fc , but as C is known, it was easy to derive the value of b/C .

TABLE XXI
 h/C -VALUES FOB $\text{Gd}_2(\text{SO}_4)_3 \cdot 8\text{H}_2\text{O}$.

Authors	b/C	r	i	Method
DE VRIJER, VOLGER and GORTERI	I $3.9 \cdot 10^6$	77; 90; 290		Absorption
BROER and GORTER2	$3.9 \cdot 10^6$	I 77; 90		Dispersion
DE HAAS and Du PRÉ3	$3.0 \cdot 10^6$	4.2; 3.5; 3.0		Dispersion
GIAUQUE and MAC DOUGALL*	$3.9 \cdot 10^6$	0.7-3.5		Adiab. demagn.
VAN DIJK and AUERS	$3.8 \cdot 10^6$	1-4		Bpec. heat

i W. F. DE VRIJER, J. VOLGER, and C. J. GORTER, *Physioa*, 11 (1946) 412.

2 L. J. F. BROER and C. J. GORTER, *Physioa*, 10 (1943) 621.

s W. J. DE HAAS and F. K. Du PRÉ, *Physioa*, 6 (1939) 705.

4 W. F. GIAUQUE and D. P. M. MAC DOUGALL, *J. Am. chem. Soc.*, 57 (1935) 1175.

s H. VAN DIJK and W. U. AUER, *Physioa*, 9 (1942) 785.

DE HAAS and Du Pite's value is somewhat low but the agreement between the other results is excellent.

For $Gd_2(C_2O_4)_3 \cdot 10H_2O$ and $Gd(C_2H_8O_2)_8 \cdot 4H_2O$ was found: $b/C = 1.8 \cdot 10^{60^2}$ and $8.7 \cdot 10^{60^2}$ respectively, but no other measurements have been published concerning these salts.

The spatial arrangement of the Gd-ions in these salts is unknown and therefore the contribution of magnetic interaction to b cannot be calculated with certainty. HEBB and PURCELL¹ and VAN DIJK obtain about $1.1 \cdot 10^{60^2}$ for the hydrated sulphate but the assumption of a face — or body — centered cubic lattice leads to a contribution 15% lower.

PENNEY and SCHLAPP- assume in their calculations a cubic symmetry around the magnetic ion, presumably due to six water dipoles. In such a field the basic level of the Gd-ion is split into two double levels and a fourfold level between them. The ratio of the distances is 3/5 (the results of HEBB and PURCELL as well as of VAN DIJK and AUER suggest that the smaller separation lies lowest). Assuming this pattern and applying a correction for magnetic interaction the over-all splitting is calculated to be about 1.0, 0.60 and 1.7 cm^{-1} respectively, in the hydrated sulphate, the oxalate and the acetate. From their data DE HAAS and Du Pite calculate 0.82 cm^{-1} in the hydrated sulphate.

Generally, from a theoretical point of view, not much can be said about the absolute value of the splittings. An evaluation of the splitting would not only require a knowledge of the crystalline field and of the radial distribution of the electrons in the lowest S-state, but also of the position and nature of the excited levels of Gd^{++} . The considerable difference in magnitude of the splittings in the three salts is somewhat unexpected, as the surroundings of the magnetic ions (six oxygens) are probably similar

i M. H. HEBB and E. M. PURCELL, *J. chem. Physics*, 5 (1937) 338.
2 W. F. PENNEY and B. SCHLAPP, *Phys. Rev.*, 41 (1932) 194.

and as, according to HEBB and PURCELL, the splittings in $\text{Gd}(\text{C}_6\text{H}_4\text{NO}_2\text{SO}_3)_3 \cdot 7\text{H}_2\text{O}$ is sensibly the same as in the hydrated sulphate. Perhaps this indicates that the higher b/C -values are due to deviations from the cubic symmetry.

Chromic and Vanadous salts.

Table XXII gives a list of the experimental values of b/C in $\text{CrK}(\text{SO}_4)_2 \cdot 12\text{H}_2\text{O}$. As in the case of the gadolinium sulphate, results for b obtained from experiments on adiabatic demagnetisation have been reduced to fc/C -values. It must be remarked that the value obtained from KUKTI and SIMON'S experiments at extremely low temperatures has been derived by HEBB and PUTCELL and that the

TABLE XXII
 b/C -VALUES FOR $\text{CrK}(\text{SO}_4)_2 \cdot 12\text{H}_2\text{O}$

Authors	b/C	T	Method
GORTER, DTJKSTRA, and VAN PAEMELI	0.65 $\cdot 10^6$	77; 90	Absorption
BROER ²	0.65 $\cdot 10^8$	77; 90	Dispersion
STARRS	0.64 $\cdot 10^8$	77	Dispersion
CASIMIR, BLJL, and Du PRE ⁴	0.80 $\cdot 10^9$	2.0	Disp. and abs.
CASIMIR, DE HAAS, and DE KLERKS	0.86 $\cdot 10^6$	106-0.9	Adiab. demagn.
KURTI and SIMONS	0.45 $\cdot 10^7$	3.03-0.15	Adiab. demagn.
RLEANNEY ⁷	0.69 $\cdot 10^8$		Adiab. demagn.

i C. J. GORTER, L. J. DUKSTRA, and O. VAN PAEMELI, *Physica*, 9 (1942) 673.

2 L. J. F. BROER, *Thesis*, Amsterdam, 1945.

a C. STARR, *Phys. Bev.*, 60 (1941) 241.

4 H. B. G. CASIMIR, D. BIJL, and F. K. Du PR6, *Physica*, 8 (1941) 449.

5 H. B. O. CASIMIR, W. J. DE HAAS, and D. DE KLERK, *Physioa*, 6 (1939) 365.

e See M. H. HEBB and E. M. PURCELL, *J. chem. Phys.*, 5 (1937) 338.

7 Quoted by J. H. VAN VIJDCCK, *Phys. Bev.*, 57 (1940) 426.

agreement between the experimental and their theoretical curves is only very moderate. The lack of agreement with the other results is therefore not serious. It is peculiar that all the Leyden results are high, but on the whole the agreement is not bad.

The results for other salts have all been obtained at liquid air temperatures¹ and Table XXIII gives the values of b/C .

TABLE XXIII

b/C -VALUES FOR DIFFERENT CHROMIC AND VANADOUS SALTS

Substance	b/C
$\text{CrNH}_4(\text{SO}_4)_3 \cdot 12\text{H}_2\text{O}$	$2.68 \cdot 10^6$
$\text{CrK}_3(\text{C}_2\text{O}_4)_3$	$27 \cdot 10^*$
$[\text{Cr} \cdot 6 \text{H}_2\text{O}]\text{Cl}_3$	$0.96 \cdot 10^6$
$[\text{Or} \cdot 4 \text{H}_2\text{O} \text{Cl}_2] \text{Cl} \cdot 2 \text{H}_2\text{O}$	$4.5 \cdot 10^6$
$[\text{Cr} \cdot 6\text{NH}_1](\text{NO}_2)_3$	$13 \cdot 10^6$
$\text{Cr}(\text{NO}_8)_3 \cdot 9\text{H}_2\text{O}$	$1.1 \cdot 10^6$
K, CrF .	$8 \cdot 10^e$
$\text{V}(\text{NH}_4)_a(6\text{O}_4)_2 \cdot 6\text{H}_2\text{O}$	$4.8 \cdot 10^6$

As VAN VLECK first pointed out, the orbital degeneracy of the lowest level of an ion with 21 electrons in a cubic field is completely removed (cf. Fig. 2), so that only the fourfold degeneracy due to the resulting spin vector ($8 = i$) remains. As may be seen from Table I, this basic level does not split in a purely cubic field if the spin-orbit coupling is taken into account. But in a field of lower symmetry (e.g., of trigonal symmetry⁹) the fourfold level will be split in two doubly degenerate levels with a

i L. J. F. BROER, *Thesis* 1945, Amsterdam.

2 Macroscopically the alums have cubic symmetry but the elementary cell contains four equivalent Cr-ions each being on a body diagonal. The symmetry of their surroundings is predominantly cubic but also contains a trigonal term.

separation of the order $\sqrt{AW_{tr}/(AW_{Cub})^2}$ where AW_{tr} and AW_{Cub} denote the order of magnitude of the separation which the trigonal field alone or the cubic field alone would bring about, while A is the constant of spin-orbit interaction (ef. Ch. I, § 4). The magneton number in the hydrated chromic salts is very near the spin-only value (ef. Table III) which indicates that $\sqrt{AW_{Cub}}$ is very small. The splitting already mentioned of the basic level is therefore very small compared with $fc1^7$, except at the temperatures obtainable by adiabatic demagnetisation. Nevertheless, the contribution of the magnetic interaction to b is still much smaller. And next to experiments concerning adiabatic demagnetisation, a determination of b/C is probably the best way to determine the splitting mentioned. Accepting $0.65 \cdot 10^{60^2}$ for b/C in the potassium alum, a splitting of 0.16 cm^{-1} is obtained while CASIMIR, BIJL and Du PRE arrive at 0.18 cm^{-1} .

The corresponding separations in the other salts may be calculated without difficulty; they are proportional to the square root of b/C . Increase of AW_{tr} as well as decrease of AW_{Cub} leads to increase of b/C . Generally, large differences in b/C are to be attributed to differences in AW_{tr} . The substances, in which the Cr-ions are doubtlessly surrounded by six water dipoles, have in fact rather low values of b/C , while substances for which the surroundings have a very low symmetry (e.g., five ammoniums and one chlorine or water; three ammoniums and three water), give negative results (comp. Ch. III, § 1) which is probably due to high b/C -values. Though in $[\text{Cr} \cdot 6 \text{NH}_3](\text{NO}_3)_3$ a good cubic symmetry probably exists around the magnetic ion and though it follows CURIE'S law well, its b/C is high. This may be due to a relatively low value of AW_{Cub} , as the surrounding NH_3 -dipoles have smaller moments than water-dipoles.

GUILLJEN¹ has discovered by observation of dielectric con-

i R. GUILLDSN, C.B., 209 (1939) 21.

stants and of dielectric losses that a series of alums have transition points at liquid air temperatures¹. In the case of chromium potassium alum the transition region lies between 77° and 90°K and shows a large thermic hysteresis. In view of this, it is peculiar that at both temperatures the same bl C-value is found.

The large difference between the b/C 's of the potassium and the ammonium alum at 77°K is rather astonishing as one would expect the crystalline fields to be more or less equal in the two compounds. STARR suggests that the transition points have something to do with this difference but it is not clear how this suggestion should be worked out.

Ferric and manganese mlts.

Table XXIV summarizes the experimental values of b/G for $\text{FeNH}_4(\text{SO}_4)_2 \cdot 12\text{H}_2\text{O}$. Apart from the result derived by HEBB and PURCELL from KURTI and SIMON'S measurements at very low temperatures the agreement between the various results is satisfactory. BROER'S value obtained from dispersion measurements is more accurate than the previous value obtained by TEUNISSEN and GORTER.

For $\text{Fe}(\text{NO}_3)_3 \cdot 9\text{H}_2\text{O}$ b/C is almost a hundred times larger than for the alum. It is $19.5 \cdot 10^{60^2}$.

In $\text{Mn}(\text{NH}_4)_2(\text{SO}_4)_2 \cdot 6\text{H}_2\text{O}$, $\text{MnSO}_4 \cdot 4\text{H}_2\text{O}$ and $\text{MnCl}_2 \cdot 4\text{H}_2\text{O}$ b/C , being 0.6440^6 , $6.2 \cdot 10^6$ and $19.5 \cdot 10^6$ respectively, also varies considerably.

It must be mentioned that for the TUTTON salt and for the hydrated sulphate, VOLGER' and STARR^H found b/C -values lying considerably lower ($0.46 \cdot 10^6$ and $4.2 \cdot 10^6$ respectively).

The basic level of a free ion with 23 electrons is a

i KRAUS and NUTTING find small changes in the absorption spectra between 20° and 85°K which they ascribe also to transitions.

, 2 j . VOLGER, *Thesis*, Leaden, 1946.

3 C. STARR, *Phys. Rev.*, 60 (1941) 241.

TABLE XXIV
b/C-VALUES FOR FeNH₄ (.SO₄)₂.12 H₂O

Authors	<i>b/C</i>	<i>T</i>	Method
DUKSTRA, GORTER, and VOLGERI	0.27 · 10 ⁵	77; 90	Absorption
TEUNISSEN and GORTER ²	0.25-10 ⁶	64; 77; 90	Dispersion
BROER ³	0.27-10* ⁶	77; 90	Dispersion
STARR ⁴	0.26-10 ^e	77	Dispersion
Du PRE ⁵	0.25 · 10* ⁶	3.5; 4.2	Dispersion
KURTI and SIMONS	0.31-10 ⁶	0.05-0.20	Adiab. demagn.
CASIMIR, DE HAAS, and DE KLERK ⁷	0.24-10 ⁶	0.27-1.2	Adiab. demagn.

⁶S_{5/2}-state and no crystalline field is required to quench orbital magnetism. In a first approximation, the basic level will not be split by crystalline fields but the higher levels, belonging to other multiplets, will, so that in a higher approximation the basic level, too, will undergo a slight splitting. Its character will be determined by the symmetry of the crystalline field, but without detailed knowledge of the many higher levels it is difficult to say anything as to its magnitude.

As in all the salts considered, the magnetic ion is surrounded by six oxygens it is plausible to assume a predominantly cubic symmetry. In a cubic field the basic level splits into a double level and a fourfold level and, taking b_{magn} into account, it is possible to calculate the

¹ L. J. DIJKSTRA, C. J. GORTER and J. VOLGER, *Physica*, 10 (1943) 337.

² P. TEUNJISEN and C. J. GORTER, *Physica*, 6 (1939) 1113.

³ L. J. F. BROER, *Thesis*, Amsterdam, 1945.

⁴ C. STARR, *Phys. Rev.*, 60 (1941) 241.

⁵ F. K. Du PRE, *Physica*, 7 (1940) 79.

⁶ M. H. HERB and E. M. PURCELL, *J. chem. Physics*, 5 (1937) 338.

⁷ H. B. G. CASIMIR, W. J. DE HAAS and D. DE KLERK, *Physica*, 6 (1939) 241.

separation between the levels. In iron alum the contribution of the magnetic interaction to b/C is relatively high ($0.10-10^{60^2}$). Accepting for the total b/C the value of DUKSTRA and BROER, the separation turns out to be 0.13^5 m^{-1} . It is known from the results on chromic alum that in the alum the crystalline field contains also a trigonal term but it is plausible that the separation due to this term is smaller than the broadening due to the magnetic interaction. The remarkable result that ferric alums contaminated with aluminium alum give about the same b/C as the pure ferric alum, may be explained along this line. For, this contamination will disturb the symmetry of the arrangement around the magnetic ions but it will only slightly affect the cubic term due to six water dipoles². Also the "heavy" alum, which was contaminated with a fair amount of hydrogen atoms gave the same b/C -value.

GXJILLIEN³ has discovered that ferric ammonium alum also has a transition point between 77 and 90°K. In view of this it is remarkable that here again this does not introduce a notable change in b/C .

In the highly hydrated nitrate a much higher value is found for b/C and the same applies to the hydrated manganese sulphate and chloride in comparison with the manganese TUTTON-salt. This suggests that the separation in those salts is mainly due to non-cubic fields.

Nickel salts.

The investigations on $\text{NiSO}_4 \cdot 7 \text{H}_2\text{O}$ and $\text{Ni}(\text{NH}_4)_2(\text{SO}_4)_2 \cdot 6 \text{H}_2\text{O}$ had only a provisional character. They led to a

i HEBB and PURCELL came to the conclusion that the double level lies lowest.

² On the other hand, the large influence of small contaminations observed at very low temperatures by CAISIMIR, DE HAAS, and DE KLERK is in disagreement with this explanation.

s R. GXJILLIEN, *C.B.*, 209 (19&9) 21.

b/C -value of about $90 \times 10^6 \text{ o}^2$ for the TuTTON-salt and a higher value for the hydrated sulphate.

The theory of normally paramagnetic nickel salts has been developed by SCHLAPP and PENKEY¹. It is very similar to that of chromium salts. The orbital degeneracy of the lowest level is completely removed by a cubic field. Just as in chromium salts the spin degeneracy (three-fold this time) is not removed by the spin orbit coupling in a purely cubic field. But in a field of rhombic symmetry the degeneracy is completely removed².

Discussion of the results concerning magnetic anisotropics by KRISHNAN, CHAKRAVORTY, and BANERJEE³ led to the conclusion that two of the three levels lie very near to each other. The overall splitting turns out to be about 5.3 and 3.4 cm^{-1} in hydrated sulphate and the TuTTON-salt respectively. Assuming these separations, very good agreement is obtained with the results concerning anisotropy and its dependence on the temperature and with the difference of the CuRiE-constant from the spin-only value. For the case of the TurroN-salt this separation would lead to $b/C = 400 \cdot 10^6 \text{ o}^2$, which is in disagreement with the results for the paramagnetic dispersion; evidently the last word about this problem has not yet been said.

Cupric salts.

At liquid air temperatures b/C was found to be $0.16 \cdot 10^6 \text{ o}^2$ for $\text{Cu}(\text{NH}_2(\text{SO}_4)_2 \cdot 6 \text{ H}_2\text{O})$. From recent measurements at liquid air temperatures on $\text{CuK}(\text{SQ}_4)_2 \cdot 6 \text{ H}_2\text{O}$ BROER and KEMPERMAN⁴ derive $b/C = 0.12 \cdot 10^6 \text{ o}^2$, while from DE KLERK'S⁵ results on the entropy of this salt at temperatures between 0.2 and 0.8°K exactly the same

i R. SCHLAPP and W. F. PENNEY, *Phys. Rev.*, 42 (1932) 6&Q.

2 This is possible because the number of electrons is even.

3 K. S. KRISHNAN, N. C. CHAKRAVORTY, and S. BANERJEE, *Phil. Tram.*, 232 (1933) 991.

4 L. J. F. BROER and J. H. KEMPERMAN, *Physica*, 13 (1947)

s D. DE KLERK, *Physica*, 12 (1946) 513.

value for b/C can be derived. We have therefore good reasons to doubt the validity of Bui/s conclusion that it should decrease from $0.13 \cdot 10^6$ to $0.10 \cdot 10^{602}$ between 3.0°K and 1.7°K .

The situation in the case of $\text{CuSO}_4 \cdot 5 \text{H}_2\text{O}$ is more obscure. Results of a provisional character lead to a value for b/C of the order of $10^7 0^2$.

AISHMEAD¹ has observed maxima in the specific heat of $\text{CuSO}_4 \cdot 5 \text{H}_2\text{O}$ at about 0.1 and 1.0°K while, according to REEKIE², the susceptibility of this substance shows large deviations from CURIE'S law at liquid helium temperatures which may be described by a value of -0.7° for θ in WEISS' law (comp. I, § 1).

Theoretical treatments of the copper salts have been presented by JORDAHL³ and by POLLER⁴. JORDAHL made use of erroneous experimental results for magnetic anisotropy but POLLER'S view is in agreement with KRISHNAN'S⁵ experimental and theoretical investigations as well as with the Leyden measurements of Mrs J. C. VAN DEN HANDEL-HUPISE⁶. The unit cell in $\text{CuSO}_4 \cdot 5 \text{H}_2\text{O}$ contains two clusters, each consisting of one copper ion surrounded by four water dipoles and two oxygens. The clusters have approximately tetragonal symmetry but, according to KRISHNAN and co-workers the angle between the axes of the two clusters is about 82° . POLDER supposes a similar arrangement of cupric ions and their surroundings in $\text{CuK}(\text{SO}_4)_2 \cdot 6 \text{H}_2\text{O}$ but the angle mentioned has to be about 40° . The splittings introduced by the tetragonal term of the crystalline field are of the same order as those due to the cubic term. The basic level has no orbital degeneracy and the next lowest level lies at a distance of about 12000 cm^{-1} .

i J. ASHMEAD, *Naxtwre*, 143 (1939) 853.

2 J. REEKIE, *Proo. Boy. Soc.*, A 173 (1939) 367.

a O. M. JOKDAHL, *Phys. Bev.*, 45 (1934) 87.

4 D. POLLER, *Physioa*, 9 (1942) 709.

o K. S. KRISHNAN and A. MOOKHERJI, *Phys. Bev.*, 50 (1936) 860 and 54 (1938) 533 and 841.

e J. C. HTJPSE, *Physioa*, 9 (1942) 633.

The basic level has, of course, the twofold spin degeneracy which, according to KRAMERS' theorem cannot be removed by purely electric fields. But because of the small magnetic moment of the Cu^{++} ions the magnetic interaction is also small. Its evaluation leads to $b/G = 0.025 \cdot 10^{60^2}$ and $0.0940 \cdot 60^2$ respectively, while the experimental values are at least five times as large. The KRAMERS degeneracy must therefore be removed by some other mechanism, possibly an exchange or superexchange coupling between the cupric ions. In $\text{CuSO}_4 \cdot 5 \text{H}_2\text{O}$ this coupling apparently leads already to considerable deviations in an anti-ferromagnetic sense of the susceptibility of $\text{CuSO}_4 \cdot 5 \text{H}_2\text{O}$ from CURIE'S law at normal helium temperatures. And DE KLERK'S recent investigations on adiabatic demagnetisation with $\text{CuK}_2(\text{SO}_4)_2 \cdot 6 \text{H}_2\text{O}$ have brought to light a much smaller deviation from CURIE'S law in a ferromagnetic sense with $\theta = 0.052^\circ\text{K}$. This value of θ is even in good agreement with the value of b/C , if both are ascribed to exchange coupling according to OPECHOWSKY¹.

Negative Results.

The many negative results obtained by TEUNISSEN, BROER, and STARR indicate that either b/C was too large or p was too small. In the first case the relative difference $(X_0 - x')/x_0$ is equal to CH_c^2/b , in the second case it is equal to pV , and when both CH_c^2/b and pV are relatively small, equal to the product $H_c^2 v^2 (p^2 C/b)$. A priori it may be expected that the θ 's depending on the separations of the basic levels are quite large. This is corroborated by the deviations from CURIE'S law which are often small at room temperatures but nevertheless quite certain. These cases will give negative results but it may be that at the same time p is also small so that both causes may collaborate.

In the following list a few values of θ are given, deter-

¹ W. OPECHOWSKY, *Physica*, 4 (1937) 181.

mined from deviations from CURIE'S law in the substances that gave a negative result. It must be mentioned beforehand that these values often have a rather arbitrary character, as WEISS' law $\chi(T - \theta) = C$ often applies only to a restricted region of temperatures, while often only the susceptibilities at 290°K and 90°K are known (from measurements in the Zeeman-laboratorium by VOLGER and DE VRIJER¹).

TABLE XXV

Substance	θ	Substance	θ
Gd ₂ O ₃	— 10	FeCl ₃	— 12
Dy ₂ (SO ₄) ₈ .8H ₂ O		MnSO ₄	— 28
TiCs(SO ₄) ₂ .12H ₂ O		MnCl ₂	— 3
VNH ₄ (iSO ₄) ₂ .12H ₂ O	— 4	MnO	— 610
[Cr. 5 NH ₃ . Cl]Cl	— 3	MnCO ₃	— 130
[Cr. 3NH ₃ . 3H ₂ O]Cl	— 13	MnF ₂	— 100
[Cr. 5NH ₃ . H ₂ O]Cl ₃	— 5	FeSO ₄ . 7 H ₂ O	— 1
Cr ₂ (SC ₄) ₈ .6H ₂ O	— 34	Fe(NH ₄) ₂ .(SO ₄) ₂ . 6H ₂ O	— 3
CrK(SO ₄) ₂	— 2	CoSO ₄ .7H ₂ O	— 14
FeNH ₄ (SO ₄) ₂	— 19	CoCNH.MSO ₄ ,. 6 H ₂ O	— 21
K ₈ Fe(CN) ₆	— 5.4	Ni(NO ₃) ₂ .6H ₂ O	
Fe(SO ₄) ₈ .9H ₂ O	— 40	Ou(BrO ₃) ₂ .6H ₂ O	— 15
FeCl ₃ . 6 H ₂ O		[Ou. 4NH ₃]SO ₄ .H ₂ O	— 15
Fe ₃ (C ₂ O ₄) ₂	— 9.5		

As the strongest fields used were usually 3200 O and the accuracy of the measurements of the order of 3 percent, a b/C -value of $3 \cdot 10^8$ O² or higher would account for the negative result. When θ is of the order of 3°K or more and if this is not chiefly due to YAN VLECK'S temperature-independent paramagnetism (which is very seldom large enough) such a high b/C -value, and thus a negative result, is to be expected. It is seen that this applies to most of

i J. VOLGER, *Thesis*, Leyden, 1946.

the salts investigated and also to MnCO_3 and MnF_2 investigated by STARR in much stronger fields.

On the other hand, smallness of $|\delta|$ by no means guarantees a small value of b/C . But it is quite possible that in substances that present small δ -value, like $\text{CrK}(\text{SO}_4)_2$, $\text{FeSO}_4 \cdot 7 \text{H}_2\text{O}$ and $\text{Cu}(\text{BrO}_3)_2 \cdot 6 \text{H}_2\text{O}$, the negative result is due to the smallness of p . This might be decided by experiments in very strong fields or — even better — at lower temperatures e.g. in the liquid hydrogen region. From our general knowledge about the energy levels in rare earth salts it is probable that in $\text{Dy}_2(\text{SO}_4)_3 \cdot 8 \text{H}_2\text{O}$, too, the value of b/C is high.

§ 2. VALUES OF p

Let us first consider the dependence of the relaxation constant p on the constant field H_c . In Ch. IV we have seen that VAN VLECK¹ expects this dependence to obey the relation

$$p = p_0 \frac{b + CH_c^2}{b + pCH_c^2} \quad 48$$

where p is independent of the temperature. But the data of Ch. III lead to the conclusion that, though it is nearly always possible to describe the dependence on H_c by (48), p is often not independent of T . The assumption of a p independent of T would lead to the conclusion that in going to a higher temperature all dispersion curves merely shift to higher frequencies by an equal amount (in the logarithmic scale for ν) and this is certainly not always true. This may be seen from the experimental curves for gadolinium oxalate at 90° and at 195°K (Figure 18 and 19). The separation between the curves for different constant fields is certainly smaller at 90°K than at 195°K . A similar difference of separation is also found for Cr-alum and, much more pronounced, for iron alum between 64°K and

i J. H. VAN VLECK, *Phys. Rev.*, 57 (1940) 426.

90°K. In $\text{Mn}(\text{NH}_4)_2(\text{SO}_4)_2 \cdot 6\text{H}_2\text{O}$ and $\text{Cu}(\text{NH}_4)_2(\text{SO}_4)_2 \cdot 6\text{H}_2\text{O}$ on the contrary, the ratio between the p -values at different temperatures is only very slightly dependent on the field and p is about 0.5. In a few other cases p seems to vary as a ; function of the temperature but the variation is not very certain.

For chromium alum VAN VLECK expects p to be 0.5 and for iron alum he expects p to lie between 0.22 and 0.6. It is clear that the experimental data are at variance with theory. But it is possible that the discrepancy as well as the strong dependence of p on T is related to the transition point of the alums at liquid air temperatures.

The two experimental rules (ef. Ch. III, § 2) governing the variation of p from sample to sample and from temperature to temperature, stating that the differences in p are smaller than those in p_0 remain also quite unexplained.

For the dependence of p on H_c at liquid helium temperature only few data are available. Apart from the case of diluted chromium alum they all point to an increase of p with H_c which, only by accepting TEMPERLEY'S multiple transitions, could be reconciled with the normal supposition that the first-order processes determine p at these very low temperatures (ef. Ch. IV, § 2).

Let us now consider the dependence of p on the temperature.

For chromium alum p_w , and of course also p_0 , should change by a factor 1.8 between the boiling points of nitrogen (77°K) and oxygen (90°K) and for other hydrated salts a factor of about the same magnitude may be expected. For most chromic salts the factor is, in fact, about 1.8. Only p_0 for chromic alum varies by a factor of about 3. The variation of p for iron alum is rather large (2.3) and of p_0 it is enormous (about 6). The variations in ferric nitrate are normal again and so are those in the cupric salts. The variation in the manganese and gadolinium salts is generally small. In most of the

investigated manganese and gadolinium salts, even at room temperature, quite strong dispersion appears at frequencies of a few megahertz. The dependence of the relaxation constants of gadolinium sulphate octohydrate is quite abnormal, and, to a lesser degree, also that of the oxalate. The dependence of p on T is inverse in the sulphate, the relaxation constant being larger at 90° than at 77°K .

In view of the large differences in the dependence of p on the temperature at liquid air temperature, it is surprising that the p 's of various substances (iron alum, chromium alum, gadolinium sulphate, cupric TUTTON salt) have all increased at liquid helium temperatures by a factor of the order 10^4 . This does not however necessarily mean that the dependence of p on T is approximately equal between the two regions of temperature, as the mechanism determining p may be different in the two energy regions, viz. a "RAMAN"-process and a first order absorption process.

At liquid helium temperatures the influence of impurities on p seems to be particularly large. From the few data, we may conclude that p changes less quickly with T than at liquid air temperatures: it is about proportional to a power of T between -1 and -2 . As for first order processes T^{-1} must be expected, this may indicate that the "RAMAN" processes still play a part at these temperatures.

The theoretical evaluations of the absolute value of p are hardly able to predict the order of magnitude even in favourable cases and the lack of agreement between theory and data, as regards the dependence of p on H_c and T , suggests that agreement in absolute value is as yet more or less accidental. Nevertheless, it must be admitted that in VAN VLECK'S calculations concerning chromium alum the right order of magnitude was obtained.

From the experimental point of view it is striking that p is more dependent on the nature of the ion — its number of electrons, but also its resulting electric charge — than on the structure of the individual salt. This even applies to the dependence of p on T . The dependence of p on T

is therefore relatively small in all Gd^{+++} - and Mn^{++} -salts, while this dependence is, for instance, much larger in the Fe^{+++} -salts, though the ferric ion is isoelectronic with the Mn^{++} -ion. The p 's in the salts of bivalent V^{++} and Mn^{++} are larger than those of the trivalent isoelectronic ions Cr^{+++} and Fe^{+++} .

If now we compare the relaxation constants and the b/C -values of different salts containing the same ion we often see that high values of b/C are accompanied by low values of p . As an example we mention $Mn(NH_4)_2(SO_4)_2 \cdot 6H_2O$, $MnSO_4 \cdot 4H_2O$ and $MnCl_2 \cdot 4H_2O$ with $b/C = 0.75 \cdot 10^6$, $6.2 \cdot 10^6$ and $19.5 \cdot 10^6$ while at $90^\circ K$: $p = 5.5$, 3.2 and 0.5×10^{-6} sec respectively. From a theoretical point of view this is understandable, as a large b/C -value indicates a strong coupling between spin and lattice. But it may be that crystalline fields of different symmetry have quite unequal influences on b/C and p . The b/C -value in chromic salts for instance will be proportional to the trigonal component of the fields and inversely proportional to the square of the cubical component, while according to VAN VLECK p increases with increasing cubical component but is little influenced by the trigonal field.

It is possible that anomalies such as in the combination $FeNH_4(SO_4)_2 \cdot 12H_2O - Fe(NO_3)_3 \cdot 9H_2O$, where b/C differs by a factor of the order 10^2 while p is about the same, may be explained in this way.

According to VAN VLECK'S calculations for titanium alum it must be expected that also in the cupric salts p will decrease with decreasing crystalline fields of low symmetry. This may account for the negative result in the cubic salt $Cu(BrO_3)_2 \cdot 6H_2O$, which according to Table XXV has a small θ and therefore possibly a low b/C -value.

It has been mentioned several times that the influence of impurities is not negligible. At liquid helium temperatures it appears even to be enormous. TEUNISSEN carried out a series of measurements on iron ammonium alum

in which part of the iron had been substituted by aluminium. The decrease of p generally was not so large as was expected and at 64°K the influence on p was even very small. It is possible that the larger influence p , at higher temperatures is connected with the transition point already mentioned so often. It is peculiar that the influence of substitution of 93% of the crystal water by heavy water which consists of an increase of p was also very small at 64°K .

BROER carried out another series of measurements on $\text{Mn}(\text{NH}_4)_2(\text{SO}_4)_2 \cdot 6\text{H}_2\text{O}$, where part of the Mn-ions were substituted by Co. The coupling of the spins of the Co-ions with the crystalline lattice is doubtlessly much stronger than that of the Mn-ions, but the influence of a small Co content on p was small and apparently did not lead to a short-circuit between spin system and lattice. Possibly the spins of the Co-ions do not become part of the spin system of the Mn-ions. Very peculiar however is the enormous influence of 9% Co on p at liquid air temperatures (a factor of about 50), while the influence at room temperature is very small.

Finally, we wish to remind the reader of the negative result in aqueous solutions of MnSO_4 . It is plausible that p has decreased because of the irregular and asymmetrical electrical fields around the Mn-ions.

§ 3. VALUES OF p'

In Table XXVI the experimental values of p_0' are compared with the values calculated from BROER'S formulae (83) and (88)^x. In the derivation of (83) it has been assumed that the decrease of x''/v with v^2 is exponential (cf. Ch. IV, § 3 (82)) and that no electric splittings exist. H_i does not merely depend on the ionic moment and the gram-ionic volume, but also somewhat on the spatial arrange-

i J. VOLGER, *Thesis*, Leyden, 1946.

TABLE XXVI

VALUES OF p_0' AND OF THE PERPENDICULAR FIELD H_d ($1/2$) IN WHICH p' HAS DECREASED TO $p_0'/2$. FOR COMPARISON WE ALSO GIVE THE THEORETICAL VALUES OF p_0 , NON CORRECTED (83) AND CORRECTED (88) FOR THE INTERNAL ELECTRIC FIELD, AS WELL AS AN APPROXIMATE VALUE OF THE INTERNAL MAGNETIC FIELD ff . AND $\sqrt{b/c}$ WHICH IS THE FIELD CHARACTERIZING THE SPECIFIC HEAT OF THE SPIN SYSTEM

Substance	$v_{exp'}$	$UA^{(88)} * 10^9$				$\sqrt{b/c}$ i d	
Gd ₂ (SO ₄) ₃ .8H ₂ O	0.36 I	0.3	0.13	1300	1380	1970	0
CrK(SO ₄) ₂ .12H ₂ O	1.6	1.5	0.9	870	310	810	0
Cr ₂ (SO ₄) ₃ .6H ₂ O	! 0.56			480 I	710		-34
OrK(SO ₄) ₂	I 0.98	0.6	0.3^s	350 I	790		I ~ 2
Cr ₂ (SO ₄) ₃	0.53			540	1300		
FeNH ₄ (SO ₄) ₂ .12H ₂ O	0.7	1.0	0.5	870	450	520	30
FeNH ₄ (SO ₄) ₂	0,85			280	1180		0
Mn(NH ₄) ₂ (SO ₄) ₂ . 6H ₂ O	0.79	0.8	0.4	800	590	870	-24
MnSO ₄ . 4 H ₂ O	0.40	0.4	0.2	1200	1200	2500	0
MnSO ₄	0.60			390	2700		0
Cu(NH ₄) ₂ (SO ₄) ₂ .6H ₂ O	5.7	2.8	1.8	85	200	375	-28
CuSO ₄ .5 H ₂ O	I 4.2	1.5	1.5	50	370	(4000)	0
Cu(BrO ₃) ₂ . 6 HO	7.1	2.2	2.2 I	75	250		0
CuSO ₄	! 0.40			380	910		0
CuCl ₂ .2 H ₂ O	6.0	0.9	0.9	72	590		-77
							- 5

VALUES OF p'

ment of the magnetic ions. We use the value valid for a face-centered or body-centered cubic lattice. In (88) the same value of p_0' has been reduced by a factor representing the intensity of the absorption near zero frequency divided by the total absorption including that part, which, by the presence of the electric field, has been shifted to relatively high frequencies. This factor depends on the character of the electric field but not on its magnitude. In the gadolinium-, ferric- and manganous-salts the electric field has been supposed to be cubic, in the chromic salts it has been supposed to have trigonal symmetry.

It is seen that the experimental values agree with the theoretical values as far as the order of magnitude is concerned. But in general the experimental values are larger by a factor of about 2; in the case of the hydrated cupric chloride this factor is even 6 or 7. This indicates that the dependence of x'' on ν differs from BROER'S assumption in such a way that the decrease of x'' at very high frequencies is less rapid than BROER supposes. The dependence of x'' on ν cannot be a DEBIJE function ($x'' \sim \nu/(1 + \rho_0'^2 \nu^2)$; cf. Ch. I, § 5) as (79) would then diverge, but if one supposes for instance x' to be proportional to $\nu/(1 + \rho_0'^2 \nu^2)^2$ one obtains instead of (83),

$$\rho' = \frac{2}{\nu_0} = \frac{h}{\beta H_i} \quad 75$$

by which all theoretical values of p' theor in Table XXVI would be increased by a factor 1.6, thus leading to a better agreement with the experimental values. The only information we have as to the dependence of p' on ν are a few earlier and not very reliable observations on vanadium alum and diluted iron and chromium alum, obtained at liquid hydrogen temperatures at frequencies of about $15 \cdot 10^6$ Hz, and the more recent result that the absorption in $\text{CuSO}_4 \cdot 5 \text{H}_2\text{O}$ at $78 \cdot 10^6$ Hz is about 82 % of what it would be if it were proportional to ν^2 . Now in this case $p'_{e(tpV)} = 0.33$ which would lead to a factor of 96 % or 94 %

if BROER'S dependence of x'' on v or the dependence leading to (75) are assumed. The order of magnitude seems right and it will not be difficult to obtain more experimental material bearing on this problem for other cupric salts which have high values of p' . In this connection it must be noted that the values of p'_{exp} for these salts given in the Tables XV and XXVI have been obtained at $78-10^6$ Hz, so that measurements at lower frequencies will probably lead to even somewhat higher values.

Comparing different salts of one ion, it is seen that the differences in p'_{th} , due to the difference in gramionic volume are somewhat reflected in the experimental values but $\text{CuCl}_2 \cdot 2\text{H}_2\text{O}$ with its small gramionic volume and very large absorption is a striking exception.

It is very remarkable that the salts showing large deviations from CURIE'S law (approximate values of θ obtained in the temperature interval between liquid air temperature and room temperature are given in the last column), and to which BROER'S theory therefore does not apply, show absorption of the same order of magnitude as the normal paramagnetic salts.

As regards the change of p' as a function of a parallel field H_{Cl} it is sometimes difficult to apply the right correction for the contribution of lattice relaxation. BROER expects that p' will vanish as soon as H_c becomes of the order of H_i but no clear example of this has been found experimentally. On the contrary, it is striking that in many cases p' is very slightly influenced even by large parallel fields. In some cases ($\text{Cr}_2(\text{SO}_4)_3 \cdot 6\text{H}_2\text{O}$, $\text{CrK}(\text{SO}_4)_2$) the absorption increases with H_c while there is no indication that this is due to lattice relaxation. In the case of $\text{Cr}_2(\text{SO}_4)_3 \cdot 6\text{H}_2\text{O}$ this leads us to a value of about 3 for y in a field of 4000 O.

It is possible to characterize the decrease of p' as a function of a perpendicular field by the field $H_{d(\frac{1}{2})}$ in which it has decreased to half its value. The values of this field are given in column 5 of Table XXVI. In the

two next columns the internal magnetic field H_i is given as well as $V b/C$ which characterizes the total (electric + magnetic) splitting of the basic level. According to BROER we should expect $H_d(i)$ and H_i to be of the same order of magnitude. This is what is actually found, though in most hydrated salts $H_d(i)$ is the larger of the two, while in the case of the anhydrous salts and of the cupric salts $H_d(i)$ is much smaller than H_i .

It is very remarkable that the salts showing large deviations from CURIE'S law have small values of $H_d(i)$. At first sight this is just the contrary of what one would expect. In these salts the interactions of the magnetic ion with its surroundings is very large and it seems peculiar that in these circumstances a very weak external field makes any difference at all. An explanation might perhaps be found in the following suggestion. BROER¹ has pointed out that exchange interaction will have no influence on p' , so that it seems possible that in spite of the very large interaction mentioned the magnitude of p' and its dependence on an external perpendicular field is conditioned by the magnetic interaction. The dependence on H_a in these anhydrous salts might then perhaps be considered as the normal case while in hydrated salts like gadolinium sulphate octohydrate, chromium alum, iron alum and manganese ammonium sulphate the absorption at very low frequencies in relatively high perpendicular fields might be enhanced by the crossing over of levels between which magnetic dipole transitions are not forbidden (cf. Ch. IV, § 3, c, c, d).

§ 4. FINAL REMARKS

A considerable amount of experimental and theoretical work has been carried out and a qualitative understanding of the phenomena involved is reached in some respects.

i L. J. F. BROER, *Thesis*, Amsterdam, 1945.

At several places in this monograph, and especially in this chapter, unsolved problems and questions have been pointed out and in this paragraph we intend to mention once more a few of the chief unsolved problems.

In general the relaxation phenomena can be described satisfactorily by three constants, χ/C , p and p' , of which p and p' are not really constants but are dependent on applied constant magnetic fields and of which p is also dependent on the temperature.

It has not been possible in any definite case to calculate the values of those constants from theoretical considerations and data about the ions and the crystals in which they are placed, but in general the values, as far as the order of magnitude is concerned, are not in disagreement with theoretical expectations.

The only χ/C -values which can be calculated from pure theory are those in the cupric salts, and these are much smaller, than the experimental values. The cause of this discrepancy must lie in some neglected interaction — possibly of the exchange character — between the cupric ions. Its nature has still to be investigated further both experimentally and theoretically and it has still to be ascertained whether the same interaction does or does not exist between other ions.

The magnitude of p in different substances has been studied as a function of constant magnetic fields and of T . But it will be worth while to extend the interval of temperature considerably for a number of substances and to see whether, when the temperature decreases, the role of "RAMAN" processes is really taken over by first order processes. Especially the dependence on constant parallel fields has to be compared for the two kinds of processes.

As regards the spin relaxation the theory of the dependence of p' on constant parallel and perpendicular fields should be considered more closely. Also the case of the anhydrous salts, which show large deviations from CURIE'S law should be investigated theoretically.

Experimentally it will be worth while to study the way in which the paramagnetic absorption at higher frequencies depends on the frequency. Already at frequencies of the order of 10^8 Hz this will be interesting in copper salts but using the microwave technique developed with so much success in the war years it will be possible to increase the interval of frequencies to 10^{10} Hz, thus carrying out the programme on which DIJKSTRA¹ and VOLGER² already embarked previously with insufficient means.

Since 1936 we tried to extend our investigations also to the magnetic moments of atomic nuclei⁵. Apparently observation of the absorption band to be expected at a frequency $g_v \beta H_a / h$, where g_v is the nuclear splitting factor, should be relatively easy with our techniques. But our experiments with the absorption method in 1936 and the dispersion method in 1942 had no success. It was at once understood that the reason of this failure was the very long relaxation time p of the nuclear magnetic moments. At our suggestion RABI⁴ substituted for our technique his very remarkable* and effective molecular beam technique and he and his co-workers succeeded in measuring g_v with very good accuracy for a number of nuclei to which the molecular beam technique could be applied. After the war BLOCH⁵ and PURCELL⁶ with their co-workers succeeded independently in measuring g_v in solids with methods rather similar to our dispersion technique. As the discussion of

i L. J. F. DIJKSTRA, *Thesis*, Amsterdam, 1943.

2 J. VODGER, *Thesis*, Leyden, 1946.

3 C. J. GORTER, *Physioa*, 3 (1936) 995.

C. J. GORTER, *Ned. T. v. Nat.*, 5 (1938) 97.

C. J. GORTER, *Ned. T. v. Nat.*, 9 (1942) 1.

c. J. GORTER and L. J. F. BROER, *Physioa*, 9 (1942) 591.

⁴ I. I. RABI, J. B. ZACHARIAS and P. KUSCH, *Phys. Rev.*, 53 (1939) 318 and 55 (1939) 526.

s F. BLOCH, W. W. HANSEN and M. PACKARD, *Phys. Rev.*, 69 (1946) 680.

e E. M. PURCELL, H. C. TORREY and R. V. POUND, *Phys. Rev.*, 69 (1936) 37.

these investigations lies outside the scope of the present monograph we shall not dwell upon the results obtained for atomic nuclei. We only remark that the difference between BUOCH'S and FUBCSEUL'S investigations and our previous attempts appears to lie chiefly in the higher temperature which apparently considerably decreases the relaxation times and perhaps also in an unfavourable choice of our substances (LiCl, KF and aluminium alum). It is obvious that the road now lies open for the investigation of the paramagnetic relaxation of the atomic nuclei, which probably will have many points of contact with the phenomena described in this monograph.

Note added in the proof.

The very remarkable researches carried out in Russia by ZAVOISKY, FRENKEL and others came too late to my notice to be included. The same applies to more recent work by CUMMEROW and HAIXIDAY at Pittsburgh.

