

UNIVERSAL
LIBRARY

OU_154837

UNIVERSAL
LIBRARY

OSMANIA UNIVERSITY LIBRARY

Call No.

Accession No.

Author

Title

This book should be returned on or before the date last/marked below.

THE FLYING-MACHINE

Printed in Great Britain.

PREFACE

The author's "James Forrest" Lecture, now presented in book form, was delivered before the Institution of Civil Engineers three months prior to the outbreak of war; it constituted an attempt to epitomise the state of scientific (aerodynamic) knowledge, and of the technical art of aeroplane construction at that time.

Since the outbreak of war, from considerations of national secrecy, very little, indeed, of a technical character has been added to the stock of public information, and thus the position existing immediately prior to the war has become a matter of more permanent interest than the author anticipated at the time his Lecture was prepared.

The present republication of the Lecture has been undertaken in order to meet the many applications for copies, which have been greatly in excess of those available.

In the revision of the proofs for the present publication the original text has been corrected only in substituting the *third person* for the *first person* wherever it appeared in the original. A new figure also has been substituted for Fig. 27; the original having been found to have been incorrectly drawn.

Incidentally the author has taken the opportunity of republishing a paper,¹ which was contributed by him to the 1915 International Engineering Congress, San Francisco, Cal. This paper was so badly edited by the Committee, and, as issued, contained so many errors and mistakes, that many of its passages were rendered meaningless. It is a paper bearing mainly on the more controversial points of aerodynamic theory, and will probably be read with interest by those to whom such points of controversy make an appeal. Perhaps the best excuse for giving this paper wider publication is that the accepted truth of the future may usually be sought amongst the matters of controversy of to-day; a statement which will, perhaps, find more ready acceptance if expressed in the converse form, the truths of to-day have been established by the controversy of the past.

F. W. LANCHESTER.

BIRMINGHAM,
August, 1916.

¹ "Concerning the Theory of Sustentation and Expenditure of Power in Flight"

CONTENTS

SECTION.	PAGE
INTRODUCTION	1
1. THE AIR CONSIDERED AS THE "PERMANENT WAY"	8
2. CATASTROPHIC INSTABILITY.	15
3. THE LAWS OF RESISTANCE	25
4. BODY-RESISTANCE	42
5. TOTAL RESISTANCE	47
6. PROPULSION	51
7. MOTIVE-POWER INSTALLATION	59
8. RELATING TO THE DESIGN OF THE AEROFOIL	66
9. RESISTANCE OF STRUTS, WIRES, WHEELS, ETC.	70
10. VERTICAL SURFACE	72
11. THE DYNAMIC LOAD-FACTOR AND FACTOR OF SAFETY	73
12. LANDING-GEAR	78
13. ACENTRIC TYPES OF MACHINE	85
14. STABILITY AND CONTROL	88
APPENDIX I. A DISCUSSION ON SKIN-FRICTION	93
APPENDIX II. A NOTE ON THE STABILITY OF THE FLYING-MACHINE AS AFFECTED BY CONSIDERATIONS RELATING TO PROPULSION	100
APPENDIX III. REPORT ON TEST OF AUTHOR'S AEROFOIL OF 1894	105
APPENDIX IV. PNEUMATIC AND HYDRAULIC ALIGHTING MECHANISMS FOR MESSRS. WHITE AND	106

A DISCUSSION CONCERNING THE THEORY OF
SUSTENTATION AND EXPENDITURE OF
POWER IN FLIGHT.

	PAGE
INTRODUCTORY	109
DIRECT RESISTANCE AS RELATED TO SKIN-FRICTION	115
SUSTENTATION IN FLIGHT. THE DYNAMIC SYSTEM	121

INDEX	131

THE FLYING-MACHINE

FROM AN ENGINEERING STANDPOINT

INTRODUCTION.

IN the present volume an endeavour is made to deal with those problems in mechanical flight which come more directly within the purview of the aeronautical constructor. Matters of essentially scientific interest, such as the theory of stability, longitudinal, lateral, and rotative (or asymmetric), have been in the main taken for granted; that is to say, the results of existing investigations have been assumed as established fact.

Although primarily the present discussion is addressed to those having some initial acquaintance with the subject, it is necessary to make allowance for the rate at which development has taken place of recent years. It may now be said (in contrast to the position of a few years ago) that the general disposition of the main functional organs of the flying-machine is definitely established. The diagrammatic elevation in Fig. 1 will probably be found of use to those not fully *au courant* with the anatomy of the modern machine,¹ and will in any case serve to define, for the present purpose, the nomenclature of the main components.

The flying-machine clearly has qualities which render it unique as an instrument of locomotion, although its capacity is, in certain directions, qualified by sharp limitations, the most serious of these being imposed by its high coefficient of resistance. This condition is roughly summarized in

¹ It is not intended to be taken as fully representative of every existing type of machine; for example, the arrangement shown in Fig. 1 is by no means universal; in machines for certain purposes, it is considered inadmissible.

THE FLYING-MACHINE

Table I., in which a comparison is instituted between most of the recognized methods of traction and locomotion in current or commercial use. The high coefficient of resistance

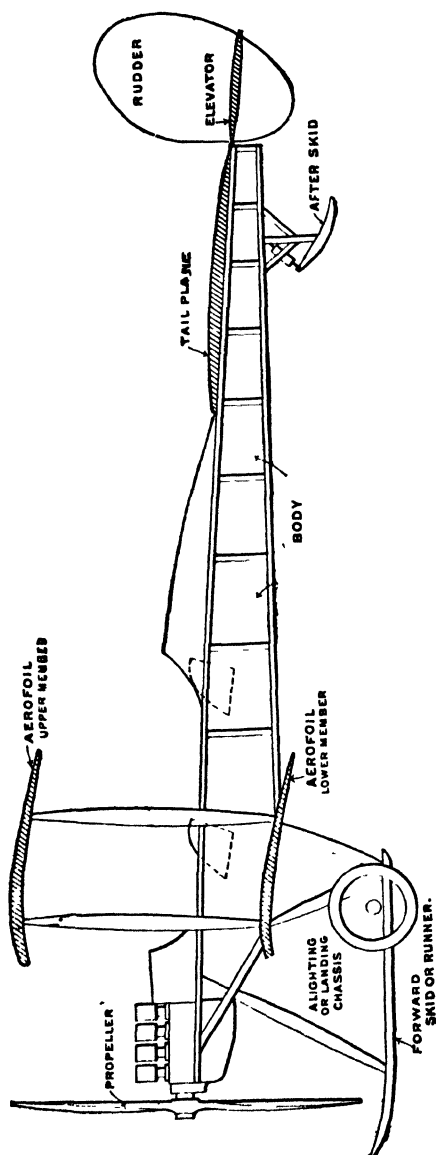

FIG 1.

to which the flying-machine is subject is inimical to high speed, and is restrictive of the available range or radius of action.

TABLE I.—COEFFICIENTS OF TRACTIVE RESISTANCE.

<i>Land.</i>	Resistance. Per cent.
Road vehicles—	
Pneumatic tire	2·00
Solid india-rubber tire	3·00
Iron tire—	
(a) On wood pavement	2·20
(b) On macadam	3·30
Sleigh (wooden runners)—	
Smooth ice	1·25
Snow-covered road in good condition	{ 1·50 to 3·00
Snow-covered cart-track	{ 3·00 to 6·00
Loose snow, fresh fallen, 6 inches deep (about)	25·00
Train on rails—	
Ordinary conditions	1·00
At low speeds (minimum)	0·25
<i>Water.</i>	
Ocean-going merchant vessels—	
Atlantic liner ("Lucania")	0·70
12-knot cargo-boat	0·25
8- " "	0·10
<i>Air.</i>	
Flying-machines—	
Voisin ¹	13·50
Wright ¹	12·00
<i>Airships.</i>	
Non-rigid—	
7 tons displacement at 40 m.p.h.	{ 6·0 to 7·0
Rigid—	
30 tons displacement at 50 m.p.h.	4·0

We are so accustomed to-day to consider aerial flight as an essentially rapid mode of locomotion, that it is necessary to emphasize the fact that the speed is obtained, not, as might

¹ The values given are probably too low; they

are estimated by the author in 1903, and are not fully representative of present-day practice.

readily be supposed, *by virtue of* any show of economy—as is true of the large steamship or railway train—but *in spite of* a coefficient of resistance and an expenditure of power of an altogether extravagant character. The flying-machine starts with a handicap on the score of efficiency equivalent to an adverse gradient of approximately 7 or 8 per cent., and on this it piles up a direct air or “wind” resistance, as in the case of a motor-car or railway train, and following the same V^2 law. The high speed associated with aerial flight is therefore in no wise promoted by economic considerations, but rather by questions of expediency; the main controlling factors are the desirability of limiting to reasonable proportions the wing-area employed, and the necessities imposed by the question of stability. Beyond the above, when once it is understood that flight cannot compete with the older modes of locomotion on the score of economy, it becomes evident that it will need to justify itself on other grounds, and it is both natural and logical to seek a compensating advantage in high speed. Finally, it may be pointed out that the reliability of the flying-machine, in whatever service it may be engaged, clearly depends upon having at command a speed of flight very much higher than the ordinary wind velocity; this condition alone will impose upon the designer for many years to come obligations of a most exacting kind, both as touching the speed to be obtained under flying conditions, and as concerning the provision of an appropriate and adequate landing chassis and gear.

The limitation imposed on the total range of flight is probably the most serious consequence of the high coefficient of traction with which we are confronted. The total available energy of petroleum fuel, employing existing methods, is round about 4,000,000 foot-pounds per pound of fuel, corresponding to a combined thermal and mechanical efficiency of approximately 27 per cent.; and, when allowance has been made for propeller loss, we cannot count on more than 3,200,000 foot-pounds as available, or say 600 “mile-pounds.” If we assume a traction coefficient of 10 per

cent. (a figure that has scarcely yet been reached), we find that for 10 per cent. of the weight of the machine carried as petrol the flight-range is 600 miles. An estimate was given on a similar basis by the author in 1907, but lower values were taken for the efficiency of both engine and propeller, the figure then given being 360 miles : this latter figure is not far from that of present-day achievement. The new estimate represents an attempt to forecast the limit of possibility, which it may be hoped may prove attainable by the gradual refinement of existing method. It may be considered fair to take about one-third of the total (mean) weight as reasonably representing the full charge of petrol for a machine specially designed for long-distance flying ; on this basis we have the possible range of flight represented by a distance of 2,000 miles, or, in the language of the Services, the radius of action is 1,000 miles.¹

The foregoing estimate has an intimate bearing on the possibility of crossing the Atlantic by air, a subject which is at the moment prominently before the public. The minimum distance to be traversed is in round figures 1,700 miles, and since it is impossible for the aeronaut to reckon definitely on being able to renew his petrol supply *en route*, the range limit must be legitimately considered as the decisive factor. It is evident that it is at present scarcely reasonable to regard a flight of 1,700 miles as possible ; with the best machine that could be turned out to-day, and with one-third of the total weight in fuel, a run of 1,400 miles is an outside estimate ; it would require a 40-per-cent. petrol load to enable the whole distance to be covered. The main hope of those who propose to take part in the forthcoming attempt lies in the fact that there is believed to exist a general eastward air-current at high altitude, sometimes estimated at 20 to 30 miles per hour ; if it exists, such a current might, in effect, reduce the distance to be covered by 400 or 500 miles, or thereabouts, leaving a net 1,200 or 1,300 miles as

¹ The radius of action is sometimes spoken of as the total range of flight. The matter is merely one of definition.

representing the actual distance to be flown. Evidently there is a possible chance of successful achievement.

The maximum speed for which a machine may be designed is (as in the case of maximum flight-range) likewise limited by the question of resistance; so far as the air considered as a track is concerned there is, within reason, no limit to the velocity that might otherwise be attained. In considering the question of maximum flight-speed, we find ourselves concerned with a higher coefficient of resistance than that which obtains under normal flight conditions, since at high speed the direct or body resistance of the machine becomes disproportionately high; the detail considerations governing the problem of maximum flight-speed are more fully discussed in the body of the work. The present-day position¹ may be summarized by saying that a maximum flight-speed *through* (i.e., *relatively to*) the air of about 120 miles per hour is one for which it is already possible to design, though it is likely that some years will elapse before speeds of design greatly in excess of this will be reached.

The direction in which advance is necessary before any great increase of speed can be realized is that of reduction in the weight per horse-power of the motor; it is difficult to believe that any great reduction in weight can be effected on the *best* figure available to-day without an undue sacrifice of reliability.²

There is, moreover, another factor (quite extraneous to flying conditions proper) which at present puts a definite handicap on high speed and prevents the aeronautical designer from doing himself justice in that direction; namely, the backward condition of existing accommodation in the way of alighting-grounds.³ Owing to quite well

¹ At the date of delivery of the lecture, May, 1914.

² About 3 pounds per b.h.p. In the generality of aero-motors the present-day weight per h.p. is more nearly 4 to 5 pounds.

³ The use of the word "aerodrome," introduced by the Press to denote a flight-ground, should be discouraged, inasmuch as that word had already taken its place in the English dictionary with the signification originally proposed by Langley to denote that which is to-day termed an aeroplane

understood conditions, it is necessary before rising to attain a speed on the ground not very much less than the normal flight-speed of the machine, and so, in the case of a machine designed for 120 miles per hour maximum flight-velocity, it would be necessary to acquire a speed round about 80 miles per hour before leaving the ground, which would necessitate a straight-line run of about 300 yards. To comply with this condition, and to give safe room otherwise for handling the machine, a flight-ground of at least half a mile length should be provided, having a surface far better than is now customary. Beyond this, since in bad weather it is undesirable either to start or to alight across the direction of the wind, it would appear that a ground of not less than some 100 or 150 acres in extent would be desirable. At the present time the author believes that the provision of well-appointed flight-grounds of the area stated in different parts of the country would do more to further the cause of aviation than an equal expenditure of money in any other direction.

It is possible that at some future time the landing-gear of machines may be so far improved that it will be found practicable to alight on the ordinary high road ; also it may be that sections of the high road will be specially widened and freed from adjacent obstruction to serve in case of emergency. It is clear, however, that the general use of the high road for this purpose would in any case be open to very grave objection.

It might be thought that the setting apart as flight-grounds of such considerable areas of land as above indicated would impose too serious a financial burden on flying, at least for some time to come, to be commercially possible. It is, however, to be borne in mind that with proper management such grounds could, especially if duplicated, be utilized for grazing purposes : thus, if an area of 200 acres were available, a herd of some few hundred head of cattle could be grazed,

or flying-machine. Compare Webster, 1907 edition ; supplement :—
“ Aerodrome (ā-er-o'-drōm), (aëro + Greek, *δρόμος*, a running), a flying machine composed of aéroplanes ; an aéroplane. (With illustration.) ”

being transferred from one section of the ground to another from time to time. It is therefore evident that, under favourable conditions, the commercial aspect of the problem is by no means outrageous, even during the period that must intervene before flying as a mode of locomotion can become in any sense popular. Beyond this, assuming that the flying-machine is able to justify its existence apart from its employment by the Services, there seems no reason to suppose that the returns of a well-equipped flying-ground might not easily become far greater than the agricultural value of the land concerned, which at the best is but a few pounds per annum per acre.

Without looking so far ahead as has been attempted in the preceding paragraph, it cannot to-day be disputed that the immediate future of the flying-machine is guaranteed by its employment by the Army and Navy. It is already admitted by military and naval authorities that for the purpose of reconnaissance an aeronautical machine of some kind is imperative, and its more active employment as a gun-carrying or bomb- (or torpedo-) bearing machine will without question follow : its utility in this direction has already been experimentally demonstrated. In the author's opinion, there is scarcely an operation of importance hitherto entrusted to cavalry that could not be executed as well or better by a squadron or fleet of aeronautical machines. If this should prove true, the number of flying-machines eventually to be utilized by any of the great military Powers will be counted not by hundreds but by thousands, and possibly by tens of thousands, and the issue of any great battle will be definitely determined by the efficiency of the Aeronautical Forces.

1. THE AIR CONSIDERED AS THE "PERMANENT WAY."

In approaching the subject of the flying-machine from the engineering standpoint, it is desirable to devote attention in the first instance to the air considered as the "permanent

way." When the atmosphere is quiescent a gliding model or a flying-machine carves its way through the air in rectilinear flight as if supported on a perfectly-laid track—a far more perfect track than the railway engineer has hitherto shown himself able to lay down. Under such conditions the aeronautical constructor requires to know the weight and coefficient of traction of the machine, the velocity of flight, and the maximum gradient it is required to climb, the problem then resolving itself into the provision of a screw-propeller of sufficient diameter and appropriate pitch to supply the necessary thrust-reaction, and the fitting of a motive-power engine (and, if necessary, gearing) to drive the propeller at its correct speed. The horse-power needed is calculated just as in any other case of propulsion or traction. In addition, the engineer needs to be able to calculate the stresses necessary to the design of his aerofoil and body structure, and to design a suitable alighting-chassis. For the present we shall assume that we have to deal with a machine in being, and devote our attention to the peculiarities and properties of the aerial highway to which the machine has to be adapted and to adapt itself. In Fig. 2 is represented the flight-path¹ of a hypothetical machine, plotted from a mathematical equation. The hypothetical machine differs from an actual flying-machine, or glider, inasmuch as it is assumed to be quite small in comparison to the minimum radius of curvature of its flight-path, its whole mass is taken as concentrated at its centre of gravity (consequently it has no moment of inertia about its transverse axis), and it is presumed to experience no resistance in flight, or, alternatively, it is supposed to have a propelling force constantly applied equal at every instant to its resistance. Referring to Fig. 2, it is seen that the straight-line flight-path is represented by a horizontal line, path No. 1; here the velocity of the machine is equal to that acquired by a body falling freely through a distance H_n , constituting the distance

¹ Reproduced from Fig. 42 of "Aerial Flight," by F. W. Lanchester, vol. ii., London, 1908.

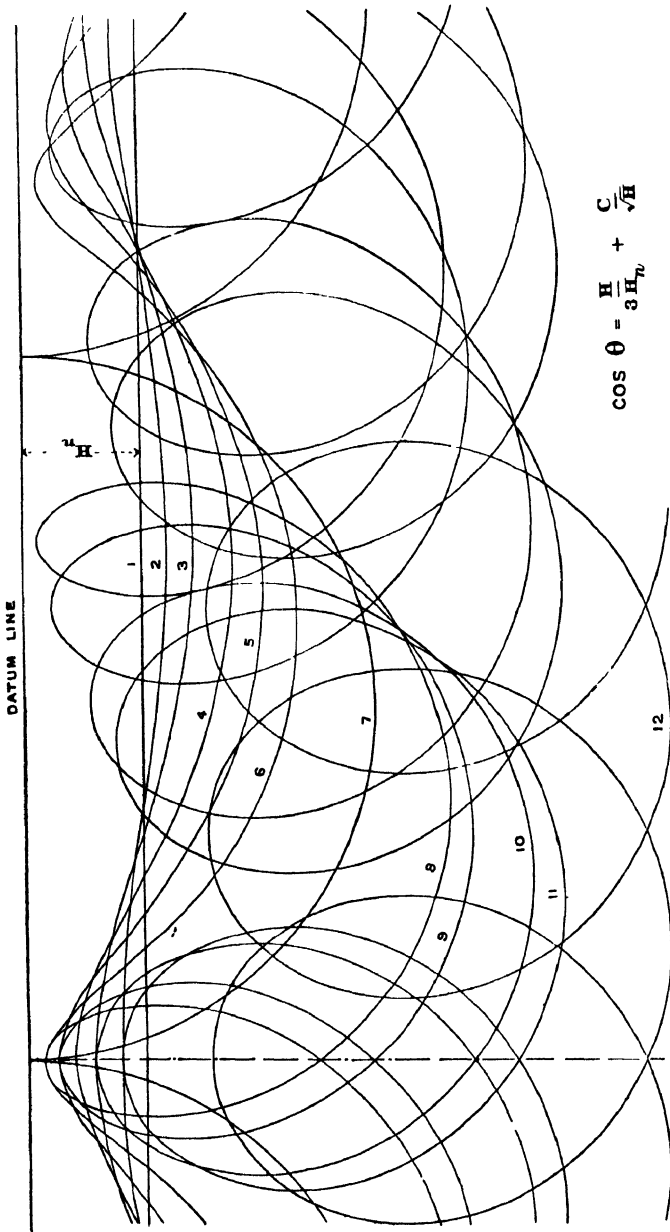

FIG. 2.

between flight-path No. 1 and the datum-line. For this hypothetical machine there is an infinite number of other possible flight-paths, the whole series being represented by the equation—

$$\cos \theta = \frac{H}{3\sqrt{H_n}} + \frac{C}{\sqrt{H}}$$

from which the samples given are plotted.

It will be seen that the series comprises two notable special cases,¹ first, we have the straight-line path No. 1, secondly, the exact semicircle No. 7.

The flight-paths, or phugoids, Nos. 1 to 6, of less amplitude than the semicircle, are those which are of chief concern from our present point of view; the cases beyond the semicircle, in which the curve has no point of inflection, and in which the machine "loops the loop," are in the main only interesting from the point of view of the mathematician and the student of "trick-flying." These inflected curves have been more fully plotted in Fig. 3. In both Figs. 2 and 3 the velocity at any point is that corresponding to a body falling freely from the datum-line. Thus, given the normal or natural flight velocity V_n , the scale of the chart is determined by the calculation of H_n from the equation of the falling body

$$H_n = \frac{V_n^2}{2g}.$$

Although, as already stated, the flight-paths given in Figs. 2 and 3 represent, strictly speaking, a hypothetical machine that only faintly resembles an actual machine, the difference has but little effect on the validity of these flight-path charts. The author has shown² that in the main the effect of moment of inertia about the transverse axis is to cause the amplitude of the oscillation to increase, so that the machine, or glider, will pass by imperceptible stages from one curve to another in the order they are numbered on the chart, eventually leading to instability. The author has also demon-

¹ There is a further special case when the value of H becomes infinite; the flight-path becomes a circle of radius = $2 H_n$.

² "Aerial Flight," vol. ii., §§ 52 *et seq.*

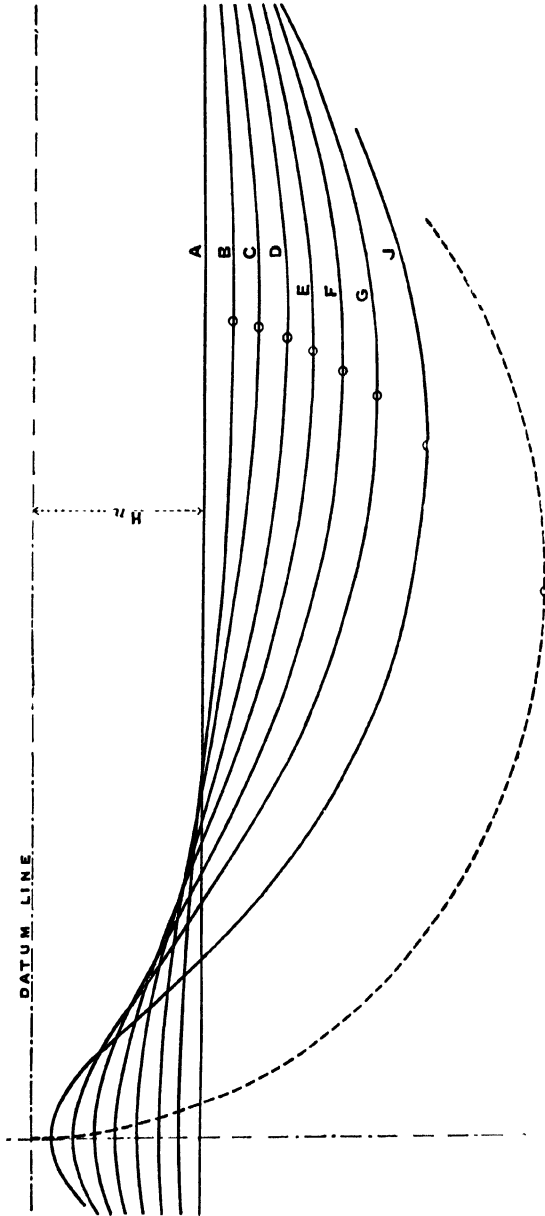

FIG. 3.

strated that the assumption of a constant horizontal propulsive force, in place of a force always in equilibrium with the resistance, has the reverse effect, and tends to damp out an oscillation and diminish the path amplitude. We may thus in any free-flight model, or glider, have the flight-path unstable, neutral, or stable,¹ according to which (if either) influence predominates. In an actual flying-machine we may also have the flight-path unstable, neutral, or stable, but here experience has shown that a skilled pilot is well able to handle a machine even though its natural flight-path may be unstable ; in spite of this, calculation shows that, speaking generally, machines as flown to-day are not far, one way or the other, from the neutral state. From the engineer's point of view it is unimportant whether the flight-path stability is inherent in the machine, or whether, so to speak, the finishing touches have to be given by the pilot himself.

The point to be made clear at the present juncture is that the curves, plotted from a mathematical equation, do actually apply with reasonable experimental exactitude to models and to machines in flight. Thus, a disturbance acting on any model in free flight will set up periodic undulations in the flight-path, and these have within the limits of experimental observation both the time-period and phase-length corresponding to their theoretical values in relation to the flight-velocity. Some experimental determinations,² showing the reality of this relation made with models in free flight, are given in Table II.

TABLE II.

	1	2	3
Flight-velocity . feet per second	14.0	14.0	10.0
Theoretical phase-length . feet	27.0	27.0	15.5
Measured " " . feet	26.0
Theoretical time-period second	1.93	1.93	1.55
Measured " " second	1.9	1.83	1.37

¹ This kind of stability is frequently termed *dynamic stability*.

² Tabulated from "Aerial Flight," vol. ii., § 69.

The phugoid, or flight-path, chart is capable of useful application in more ways than one. Any movement of the tail-plane or "elevator," for example, by altering the attitude of the main aerofoil causes the machine to become self-supporting at a lower or higher velocity, that is to say, alters its natural velocity, and we may thus represent such a change in the manner indicated in Fig. 4. Here a machine is presumed to be flying at a certain velocity corresponding to the height H_n , and at the point a its elevator is altered to correspond to a lower flight-velocity corresponding to a height h_n ; this is equivalent to altering the scale of the chart at that point, and the subsequent path of the machine is represented by the phugoid curve $a b$. This path may

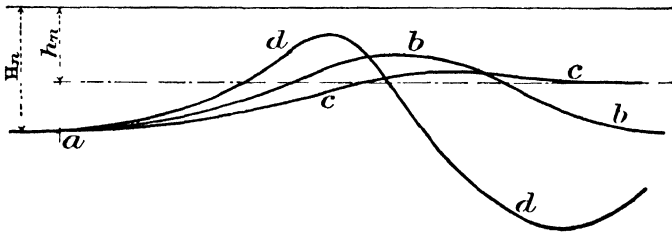

FIG. 4.

undergo damping, due either to the inherent stability of the flight-path or to the intervention of the pilot, as shown by the line $a c$. In the case of a model of unstable flight-path with no intervention from the pilot the flight-path becomes one of augmented amplitude, $a d$.

When a machine is fitted with an elevator (or adjustable tail-plane) of large surface, it is possible for the pilot to take such entire charge of his machine that he appears to be designing his own flight-path curves rather than modifying or damping the natural curves of the equation. It is quite true that this is one way to fly; it is, in fact, the old Wright method of flying, the original Wright machines having been furnished with a front elevator carrying little or no load. That type of machine, however, may be regarded as a thing of the past. The Wright machine could be "piled up" by

inattention or want of skill at any moment, and if once its flight-velocity fell below a certain value, either from want of attention on the part of the pilot, or from a wind gust from abaft or other cause, the pilot was definitely unable to restore his normal flight condition ; it is for this reason that the Wright type of machine has been abandoned.¹

2. CATASTROPHIC INSTABILITY.

Before entirely quitting this branch of the subject attention will be directed to a point first raised within the last 12 months under the title of Catastrophic Instability.² It is a curious fact that, although the author and other investigators had been studying the question of stability by various methods for some 20 years more or less, and such items as longitudinal stability, lateral stability, and a form known as asymmetric or "rotative" stability, had been "catalogued" and investigated, both theoretically and experimentally, a form of instability which may in practice be far more serious and deadly has until quite recently escaped notice. There are certain types of flight model, of which

¹ Practically the whole of the distinctive features of the early Wright machine have disappeared to-day ; for example, the tailless machine is a thing of the past, nearly every modern machine being fitted with a tail-plane. The forward elevator is obsolete or nearly so. The twin propeller has given place to the single propeller in almost every case ; there is a tendency, however, for the twin propeller to come again into favour in large machines. The chain-driven propeller also has been abandoned. The exposed position of the pilot, engine, etc., has gone, never to return. The Wright method of launching on runners and alighting on skids also is a thing of the past. The biplane construction and the fore-and-aft vertical surface have to some extent survived, but these features were in no wise new when adopted by the Wright brothers. The wing warping and vertical rudder (neither feature in itself new), operated by the Wright brothers from one control-lever in common, are nowadays operated from two entirely separate controls. A critical discussion of the main features and facts concerning the Wright machine will be found in a Paper by the author read before the Aeronautical Society, printed in full in *Engineering*, December 18th, 1908.

² British Association Meeting, Birmingham, September, 1913 (*vide Engineering*, October 24th, 1913).

the ordinary "ballasted plane" is an example, in which the flight-path is ambiguous. In the case of the ballasted plane¹ the position is quite simple; this type of model is symmetrical, it has no "upside down;" if launched at its correct flight-velocity to travel on flight-path No. 1 (Fig. 2) it is equally capable of travelling on an alternative flight-path intermediate to those numbered 11 and 12, the only determining factor being whether at the moment of launching the pressure reaction is in an upward or downward direction. A very slight want of skill in launching one of these ballasted

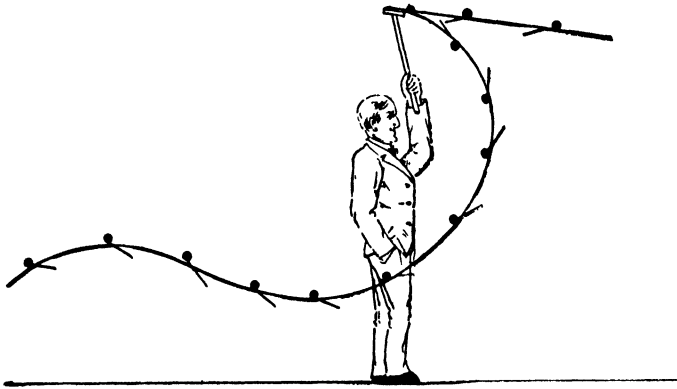

FIG. 5a.

planes gives at once the inverted flight-path (Fig. 5a); likewise a gust or disturbance acting on a model of this kind in flight may be sufficient to invert the flight-path and determine its downfall. In Fig. 5b the normal and inverted flight paths O A and O B are shown in their relation to the trajectory of an ordinary projectile O C. From our present point of view, regarding the air as the "permanent way," the position is as though the model, or machine, were continually crossing a number of facing points arranged, not quite as on a railway, but in a vertical sense (Fig. 6), so

¹ A rectangular plate of mica, conveniently 0.003 inch thick, 8 inches \times 2 inches, ballasted at the centre of the leading edge. Compare "Aerial Flight," vol. i., p. 231; vol. ii., p. 4.

that the machine is always in danger of being switched off on to an inverted flight-path *a a*, if an aerial disturbance of the right kind and of sufficient magnitude and duration happens to be encountered.¹

In the author's opinion the soundest way to avoid danger from this cause is to experiment in a wind channel with

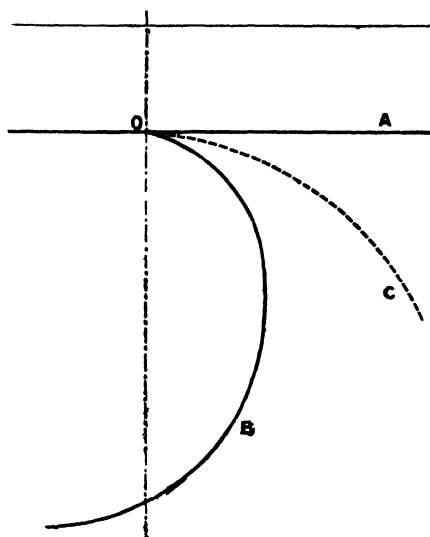

FIG. 5*b*.

scale models, both of the aerofoil and of the machine as a whole, prepared from the working drawings.

According to the evidence which has been collected up to the present, the lift-diagram for any machine passes without break of continuity from positive to negative values, and the angle

¹ The disastrous nature of this sudden inversion of the flight-path may be gauged from the fact that it represents in effect a complete reversal of gravity, the machine is accelerated downwards with a force comparable to that previously giving it support, and any loose tools, instruments, or fittings, as well as the pilot himself, are liable to be jettisoned by the machine, whose subsequent career is an upside-down flight carried out on its own account. The facts on record relating to the fatal accident to Major Merrick at the Central Flying School (October 3rd, 1913) point strongly to catastrophic instability as the cause.

of inclination (given by abscissa) is a single-valued function of the pressure-reaction $a a$, Figs. 7 and 8. The pitching moment

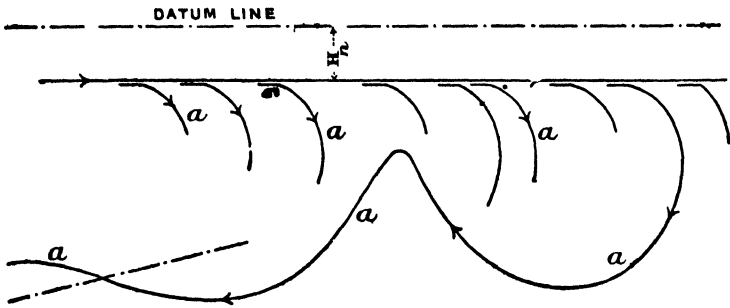

FIG. 6.

is in some cases a curve of similar character, $b b$, Fig. 7 ; in other cases it is of the form $b b$, Figs. 8a and 8b, the latter of

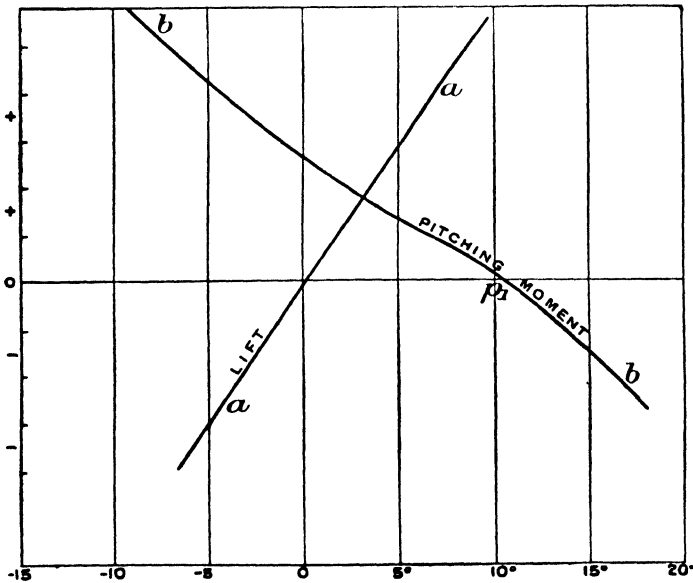

FIG. 7.

which represents the case of the ballasted plane. In Fig. 7 the model may be considered as catastrophically stable, but in Figs. 8a and 8b there is instability ; there are three positions,

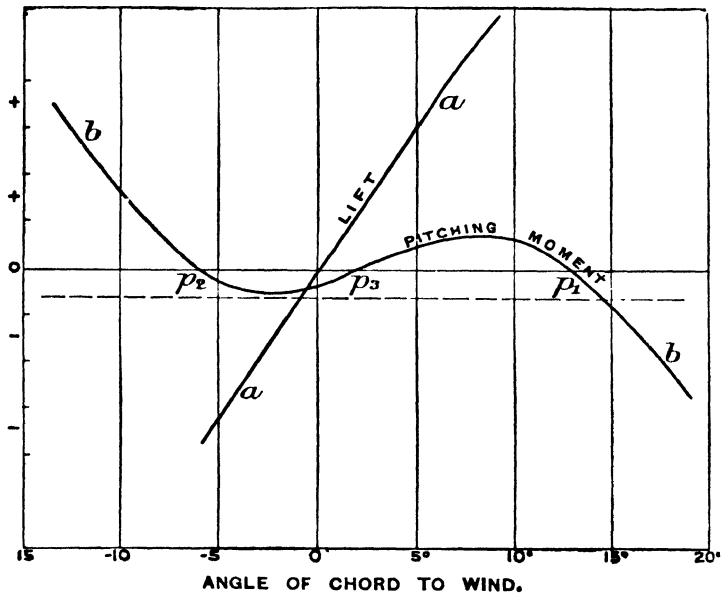

FIG. 8a.

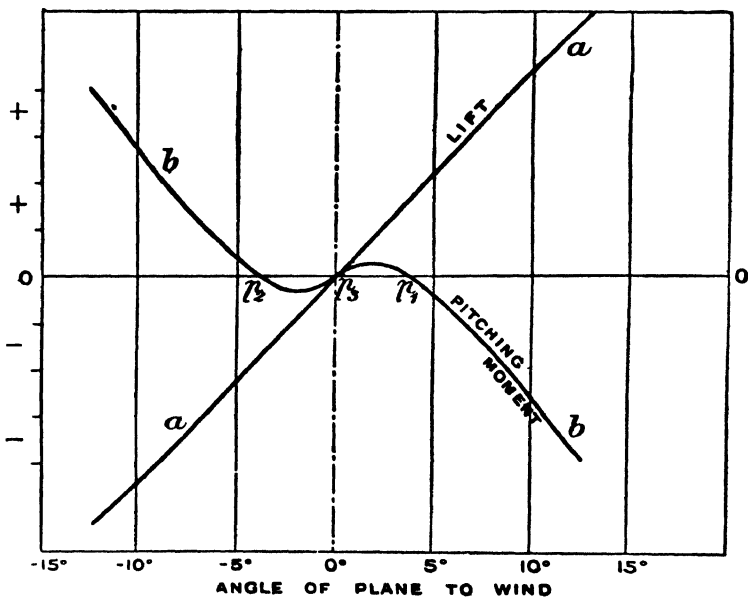

FIG. 8b.

or attitudes, of the machine, at which the pitching moment is zero, the outer two, p^1 and p^2 , defining respectively the stable positions of normal and upside-down flight, and p^3 marking the critical angle of unstable equilibrium when the machine passes from one state to the other.

In Table III. results are given of some experiments recently carried out with a model machine at the National Physical Laboratory. These were not directed to the point

TABLE III.

Angle of Pitch	Pitching Moment.	
Chord as Datum.		
- 14	+0.0264	
- 12	+0.0152	
- 10	+0.0063	< Angle of stable equilibrium upside down.
- 8	-0.0015	
- 6	-0.0059	
- 4	-0.0049	
- 2	-0.0014	
0	+0.0030	< Critical angle of catastrophic change of flight-path.
2	+0.0070	
4	+0.0102	
6	+0.0210	
8	+0.0218	
10	+0.0127	
12	+0.0072	
14	+0.0026	< Angle of stable equilibrium right way up.
16	-0.0043	
18	-0.0173	

in question, but serve incidentally as an apt illustration, and roughly form the basis of the plotting Fig. 8a.

In the experimental figures as tabulated, the evidence of catastrophic instability is seen in the column headed pitching moment; whenever there are three changes of sign the model is catastrophically unstable.

Referring to Fig. 8a, it may be observed that the character of the pitching-moment curve depends primarily upon the

form of the aerofoil, the position of the centre of gravity, and the effective area of the tail member. By altering the angle of the tail-plane (or by altering its effective angle by moving the flap known as the elevator) the datum-line of Fig. 8a is in effect raised or lowered, but the form of the curve itself is not materially changed. It is evident, therefore, that a given machine may be catastrophically stable within certain limits of the adjustment of its elevator; that is to say, referring to Fig. 8a, it will be seen that the datum-line may either

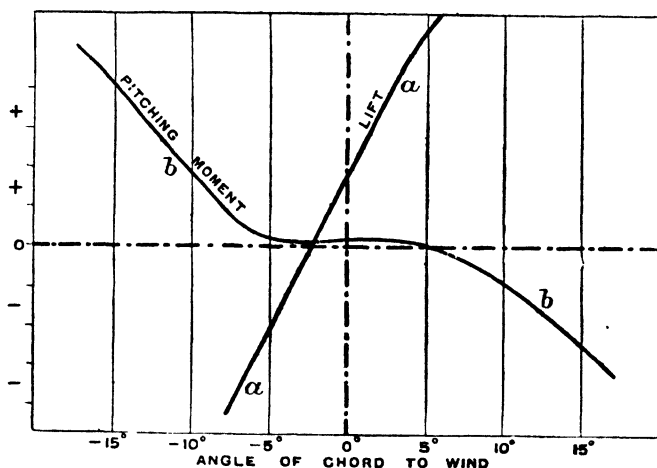

FIG. 9.

cut the curve once or three times; the range of adjustment of the elevator that results in cutting the curve once leaves the machine catastrophically stable, but when the elevator is adjusted so that the datum-line cuts the curve three times the machine is catastrophically unstable. In such a case as that shown by the dotted datum-line in Fig. 8a, in which the machine is catastrophically stable, the form of the pitching-moment curve is still open to objection. Not only is it always possible for the pilot to bring about catastrophic instability by an otherwise well-intentioned movement of his elevator, but the restoring couple for pitching beyond a small amplitude ceases to follow even approximately the

straight-line law, a fact that inevitably imperils the flight-path stability. Even when, as illustrated in Fig. 9, the pitching-moment curve $b b$ never passes the horizontal, and so catastrophic instability is no longer to be feared, the conditions are not satisfactory, since there may be a considerable change of attitude of the machine without giving rise to any commensurate restoring couple.

The undesirable kink in the pitching-moment curve, shown in Figs. 8*a*, 8*b*, and 9, is due to the movements of the centre of

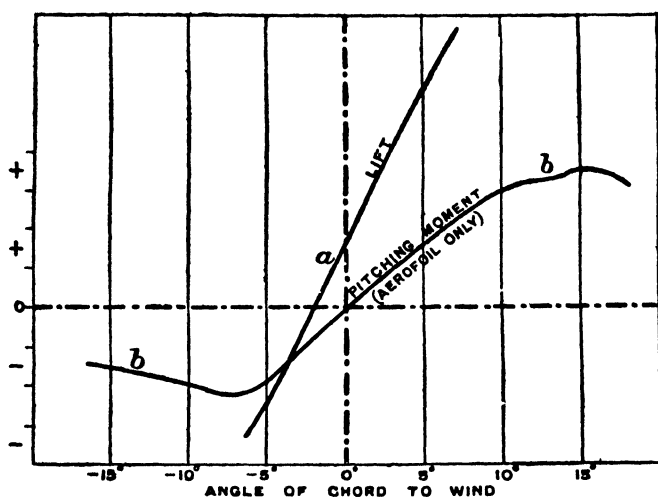

FIG. 10.

pressure of the aerofoil itself in relation to the position of the centre of gravity. The tail-plane alone will give a pitching-moment curve of the type illustrated in Fig. 7, but the fore-and-aft change of position of the centre of pressure of the aerofoil, at different angles of attack, gives rise to a pitching-moment curve whose exact character depends upon the position of the centre of gravity. Should this correspond to a positively loaded tail, a curve of the type $b b$, Fig. 10, will result; this, superposed on the tail component, imparts to the pitching-moment curve of the complete machine the kink shown in Fig. 8*a*.

In order to make definitely sure of a satisfactory pitching-moment curve for the complete machine, the pitching-moment curve of the aerofoil alone should, at no point, exhibit an inverse trend. To achieve this it is necessary to bring the centre of gravity appreciably in front of the most forward position of the centre of pressure of the aerofoil, so that the tail-plane will under all conditions carry a slight

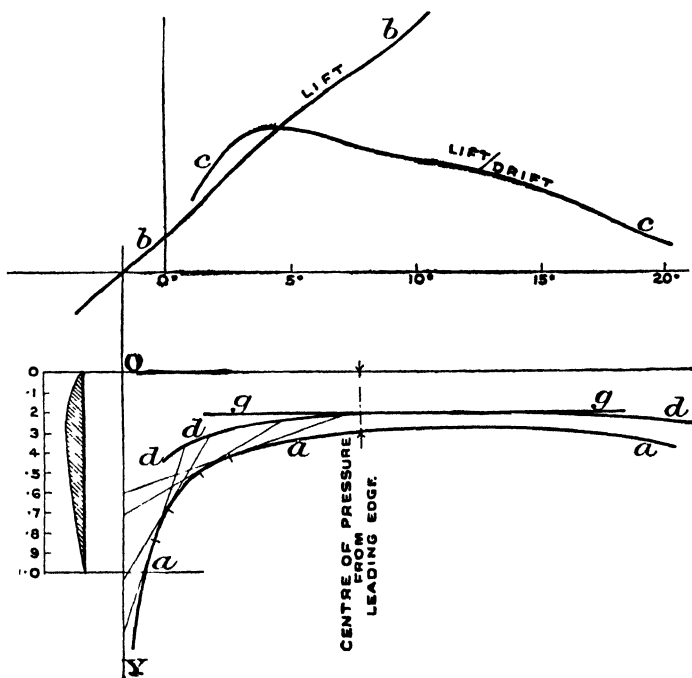

FIG. 11.

negative load. Taking it as a basis that at the worst point the pitching-moment curve for the aerofoil alone shall be horizontal (the form of curve shown in Fig. 9), the geometrical construction given in Fig. 11 may be employed to give a suitable location to the centre of gravity; here the locus of the centre of pressure (as experimentally determined) is given by the line *a a*, the pressure-reaction curve is shown by the line *b b*, the dynamic zero being on the line *O Y*. A

number of tangents to the pitching-moment curve are drawn at random from points on the axis OY , and are produced a distance equal to their own length beyond the point of contact, the extremities of these tangents defining a curve $d d d$. Draw $g g$ tangent to $d d d$, then the centre of gravity should be situated on, or forward of, the line $g g$. The location of the centre of gravity on this line gives a pitching-moment curve for the aerofoil alone whose point of inflection is horizontal (as in Fig. 9). If we assume the machine flown at a normal speed corresponding to the maximum lift/drift ratio of the aerofoil (curve $c c$), the centre of gravity in this particular case is one-eighth of the chord length in advance of the centre of pressure. Assuming that tail length equal to three times the chord, as in the "B.E.2." type of the Royal Aircraft Factory, whose outline elevation is given in Fig. 1, this is equivalent to a negative load on the tail equal to 0.04 (4 per cent.) of the weight of the machine.¹ A machine so ballasted may be regarded as absolutely secure from catastrophic instability and as having a pitching-moment curve of an adequate character.

In connection with the present subject it is worthy of remark that in a well-designed aerofoil the most forward position of the centre of pressure is never far removed from the point of maximum lift/drift ratio;² this fact is of

¹ A similar conclusion was reached by the author some 8 years ago, based on an entirely different method of investigation. For model experiment a negatively loaded tail was found to be advantageous; the figure 0.035 is given in "Aerial Flight," vol. ii, p. 335. It is desirable to work with a less proportion of negative load from the point of view of keeping the resistance low; evidently the matter is one for compromise. In any case the position of the point defined by the line $g g$ in Fig. 11, is an important landmark; it should be ascertained for every individual aerofoil and should form the datum in relation to which the position of the centre of gravity is specified.

² This is not in the nature of a coincidence: a well-designed aerofoil at its attitude of least resistance meets and leaves the stream-lines representing the relative air-flow (in the region of its mid-section) more or less conformably. Under these conditions small changes of attitude one way or the other do not cause any abrupt change in the aerodynamic system. Such expedients as flattening the extremities and giving a reflex curve to the trailing edge are

importance, inasmuch as it permits a considerable range of movement round about the attitude of normal flight without introducing grave irregularities in the pitching-moment curve. Were it not for this, the required conditions might frequently be far more difficult of fulfilment than is actually the case.

3. THE LAWS OF RESISTANCE.

Having established the general character of the airway, or track, on which the flying-machine is sustained, we pass directly to the consideration of the law of resistance, as determining the coefficient of traction, on which depends the power expenditure. It is customary and correct to regard the resistance encountered by a machine in flight as made up of two parts; first, the direct resistance common to flying-machines, dirigibles, motor-cars, ships, etc., in other words, the ordinary resistance experienced by any vessel or body in its passage through a fluid, which varies approximately¹ as the square of the velocity; and, secondly, the flight-resistance proper which follows an entirely different regime.

So far as the pilot or aviator himself is concerned, all the direct resistances may be regarded as of the same kind and grouped together, namely, the sum of the eddy-making and skin-frictional resistances due to the body, the alighting-chassis, and the various struts, stays and spars, whether belonging to the body of the machine or to the aerofoil; also the engine resistance (if exposed), the radiator, and the frictionally exposed surfaces of the rudders, fins (vertical

at the command of the designer as means by which movement of the centre of pressure may be controlled.

¹ The V^2 law, it would appear, in no case exactly represents the actual facts; the departures from this law occur in various and sometimes most unexpected directions. In the case of resistance due to skin-friction sufficient data exist to enable the degree of departure from the law to be computed: in other cases, as, for example, in the pressure reaction experienced by an inclined plane or aerofoil, departures of a different kind have been demonstrated, and are being gradually elucidated by experimental investigation. In spite of these shortcomings, the foundation theory of flight is to-day, and probably will continue to be, based on the V^2 law.

surface), and of the aerofoil itself. Resistance from all these causes varies approximately as V^2 , and so can be represented by an equivalent normal plane, which is one of the resistance constants of any given machine ; it may be represented by a parabolic curve *a a*, Fig. 12, covering the range of speed of which the machine is capable.

From the point of view of the pilot, the aerodynamic resist-

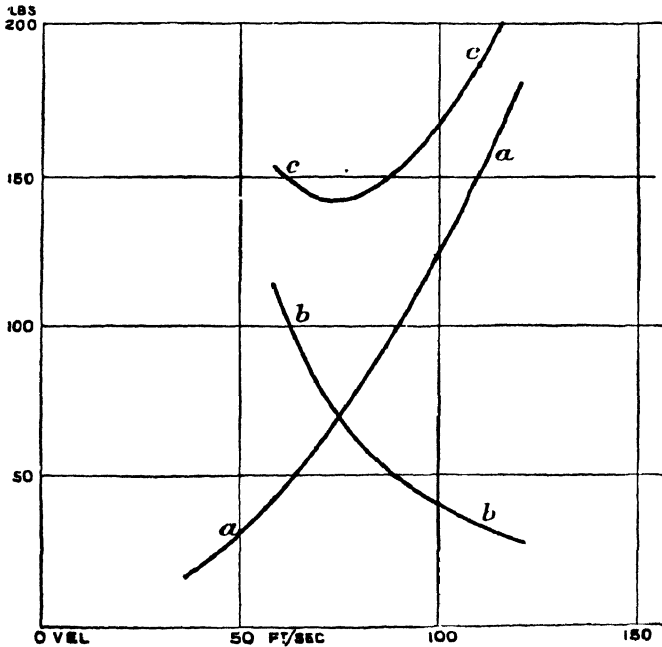

FIG. 12.

ance *b b*, which goes to make up the total *c c* (Fig. 12), follows, within limits, the inverse-square law, namely, varies as k/V^2 , where k is a constant determined by the design of the aerofoil ; there is a critical angle which defines the low-velocity limit of this law, and at best the inverse-square law is but an approximation ; it is the correct law to assume for an undefined form of aerofoil, but every individual design has its own particular manner of variation, which must be ascertained by experiment. The experimental

determinations for any aerofoil include, with the aerodynamic resistance, the skin-frictional resistance and a large amount of other inseparable direct resistance, so that if experimental values are taken these resistances should not be again included in the computation of the equivalent normal plane.

From the point of view of the designer things assume a somewhat different aspect, and a sharp line has to be drawn between two different classes of direct resistance. In the

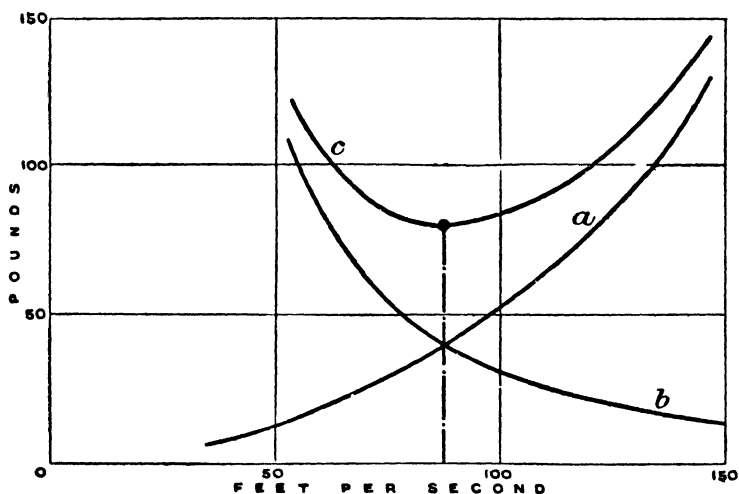

FIG. 13a.

first place there is the body resistance, which is taken to include the resistance of all those parts such as body, alighting-gear, etc., which is independent of the design of the aerofoil. In the second place there is the direct aerofoil resistance, including the skin-friction and strut and stay resistances, which are variables depending upon the area, span, and design of the aerofoil itself. By sufficiently extending the aerofoil the designer can reduce the aerodynamic resistance (as shown by Langley) to as low a value as he pleases, within the limit prescribed by the question of the added weight ; but this reduction in the aerodynamic

resistance is accompanied by an increase of skin-frictional and other direct aerofoil resistance, so that for any given machine and designed velocity there is an extent of aerofoil beyond which it does not pay to go ; there is definitely a design of least resistance.

Treating the matter from the broad standpoint of general theory, the author has shown that the condition of least resistance is reached when the aerodynamic and direct resistances of the aerofoil are equal to one another.¹ This is illustrated

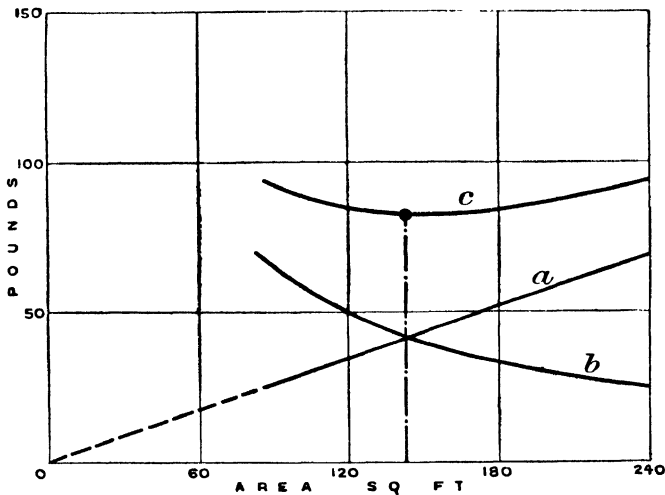

FIG. 13b.

by Fig. 13a, in which (as in Fig. 12) *a* represents the graph of the direct resistance ($R \propto V^2$), and *b* that of aerodynamic resistance ($R \propto 1/V^2$), and *c* is the total. In Fig. 13b a similar result is shown in which the plotting is given for constant velocity, as representing more literally the problem as presented to the designer.

In Fig. 14 we have, diagrammatically, the result of designing a number of aerofoils to the condition of least resistance. Each of the graphs shown represents the resistance of an

¹ "Aerial Flight," vol. i., 1st ed., ch. vii., London, 1907. (Later editions are textually identical.)

aerofoil designed to a different specified area to carry a given (constant) load W ; thus each curve is of the character of the curve c in Fig. 13a, and it is one of the results given by the theory in question that the *minima of all these curves is constant*. In other words, under the conditions of least resistance, the aerofoil resistance is independent of the velocity.

The general theory on which the foregoing result is based depends upon and is subject to the limitations of the $1/V^2$ law of aerodynamic resistance. This law corresponds to the

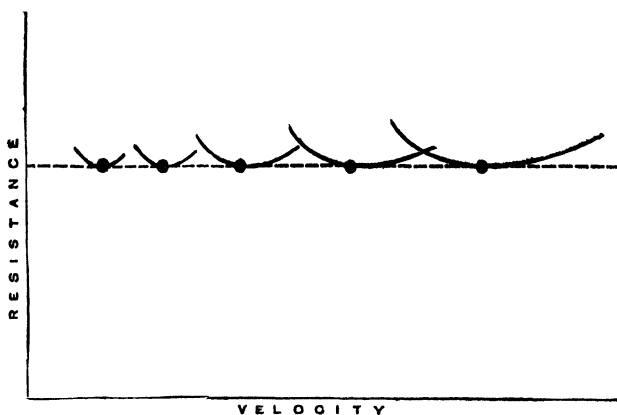

FIG. 14.

straight-line law as correlating pressure and angle, and is a close approximation between useful limits, but it breaks down at a certain critical maximum angle (depending mainly upon the aspect-ratio), as shown in the examples given in Figs. 15a and 15b. The square plane follows a straight-line law up to about 30° , whereas in the plane of aspect ratio = 6 the limit is about 12° . The breakdown of the law at these limiting angles puts a very definite limit to flying at low speed.

The author has further demonstrated¹ that the condition of least resistance implies, for an aerofoil of any given aspect-

¹ "Aerial Flight," vol. i., ch. viii.

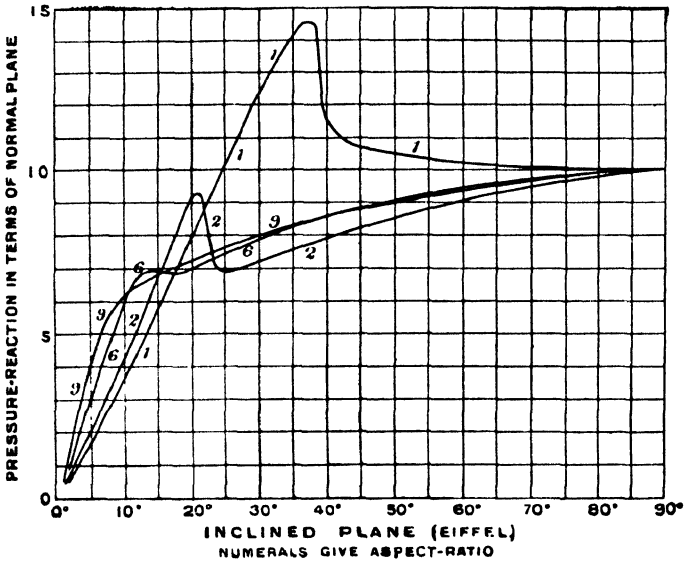

FIG. 15a.

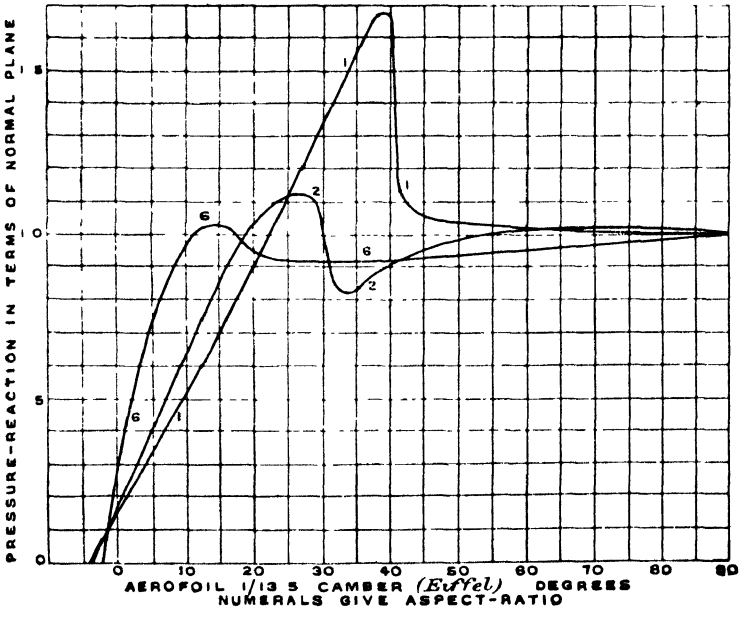

FIG. 15b.

ratio, a definite value of the angle of trail,¹ β , Fig. 16; the chord angle, except where a plane lamina is used, is an incidental, and not, as frequently supposed, a quantity of fundamental importance; calculated values of trail-angle β for least resistance are given in Table IV. Thus any aerofoil properly designed for least resistance for any given velocity of flight will be correctly designed for every other

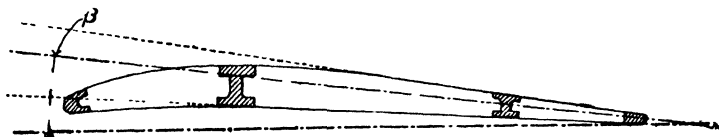

FIG. 16.

velocity provided that its load per unit area be varied as the square of the flight-velocity.

TABLE IV.—VALUES OF β (ANGLE OF TRAIL) FOR LEAST RESISTANCE.

Aspect-Ratio	$\xi = 0.020$	$\xi = 0.015$.	$\xi = 0.010$.
3	0.189 = 10.8°	0.163 = 9.3°	0.133 = 7.6°
4	0.196 = 11.2°	0.169 = 9.7°	0.138 = 7.9°
5	0.202 = 11.6°	0.174 = 10.0°	0.142 = 8.1°
6	0.206 = 11.8°	0.178 = 10.2°	0.145 = 8.3°
7	0.212 = 12.15°	0.183 = 10.5°	0.149 = 8.5°
8	0.218 = 12.5°	0.189 = 10.8°	0.154 = 8.8°

It thus becomes possible to prepare tables of mean pressure values corresponding to least resistance for different flight velocities and different values of aspect-ratio (Table V.). Tables IV. and V. are reproduced from "Aerial Flight," vol. i., pp. 261, 262 and 271, the variable factors in addition

¹ It is not easy to define the *angle of trail* of an aerofoil when the section is one of considerable body; clearly it is something intermediate between the upper and under surfaces, probably more nearly approximating to the former, as shown by the dotted line in Fig. 16.

to the flight-speed being the aspect-ratio, which is here shown as tabulated for values from 3 to 8, and the double-surface coefficient of skin-friction, values of which are taken from 0.01 to 0.02. These values for skin-friction are on the high side, but as an actual fact the values given do fairly represent the total direct resistance that in practice depends upon the area of the foil, and which requires to be included in the useful application of the theory ; the higher values, generally speaking, represent more closely biplane conditions, and the lower values are more applicable in the case of the monoplane.

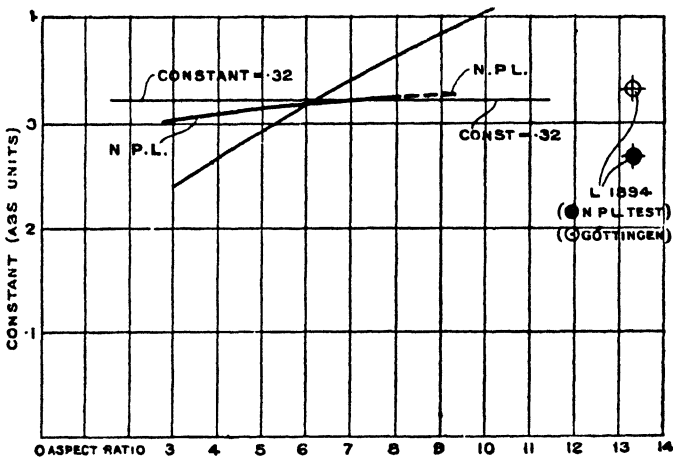

FIG. 17.

It would seem probable from recent experiment that the conclusions, as given in Tables IV. and V., though in the main correct, require revision—at least in a quantitative sense. Thus, plotting values of the pressure-constant, derived as from Table V., for $\xi = 0.015$, and different values of aspect-ratio, and also as determined for the condition of least resistance (max. lift/drift) by the National Physical Laboratory (Fig. 17), we find the two in perfect agreement for an aspect-ratio of 6 ; we also find that both graphs slope in the same direction, namely, they give a higher pressure-constant as appropriate to higher aspect-ratio. We do not, however,

find justification for the extent of the difference as given in the Table : the N.P.L. curve gives the effect as very slight indeed, in fact, almost negligible ; the pressure-constant for the aerofoil tested might be assumed as 0.32 for all values of aspect-ratio without serious error.¹

In Fig. 18, the N.P.L. curve from Fig. 17 has been plotted for comparison with the curve of the normal plane. It is well known that the pressure-constant of the normal plane is greater for planes of elongated form ; the normal-plane curves given in Fig. 18 are based on the determinations of Langley and Dines, as given in " Aerial Flight " (the upper curve), and the more recent determinations of Mr. Eiffel, the values according to this authority being very much lower. On the left, on the line aspect-ratio = 1, we have the value for the square plane as determined by the National Physical Laboratory, and a curve is shown (dotted) directed towards this point as being the nearest we can at present do towards a representation of the truth.

The relation of the normal-plane curve to the aforesaid N.P.L. curve is most suggestive ; it happens that the values of the constants are almost exactly in the relation of two to one. This is probably a mere coincidence ; a more important fact is that the increase of the pressure-constant of least resistance (touching changes of aspect-ratio) for the aerofoil is almost exactly proportional to the ordinary pressure-increase in the case of variations of proportion in the normal plane. This suggests that the increase in the two cases is

¹ The series of observations from which the curve marked N.P.L. in Fig. 17 was plotted are those given in Advisory Committee Report 1911-1912, Memorandum 60, § vi., Plate 3 ; the section of the form of aerofoil used is given in the Report, and is reproduced in section in Fig. 18. The value of the pressure-constant (at maximum lift/drift) evidently varies considerably for different forms of section. Rejecting forms that may be considered bad on account of their low maximum, we find :—In Report 72 (1912-1913) the fourth, fifth and sixth sections given in Fig. 1, constants 0.322, 0.334 and 0.334 respectively. In the same Report, section ii., figures are given of the tests of four aerofoils varied as to bluntness of leading edge. The three best of these each had a constant approximately 0.4. In the same Report an aerofoil corresponding in form to " R.A.F. 6 " gave a value almost exactly 0.3.

due to the same primary cause ; also that the coefficient of camber proper to least resistance is a quantity independent of the aspect-ratio. If this should turn out to be the case, the reduction of the resistance for aerofoils of high aspect-ratio may be regarded as due entirely to the fact that, where the

TABLE V.—PTERYGOID AEROFOIL.
Load (pounds) per Square Foot for Least Resistance.

	Flight-Velocity.	Values of Aspect-Ratio.					
	Feet per Second.	3	4	5	6	7	8
$\xi = 0.020$	5	0.017	0.018	0.020	0.022	0.023	0.025
	10	0.068	0.075	0.082	0.089	0.094	0.101
	15	0.152	0.169	0.186	0.200	0.213	0.228
	20	0.270	0.300	0.330	0.355	0.379	0.405
	25	0.390	0.433	0.475	0.511	0.545	0.582
	30	0.610	0.676	0.743	0.800	0.852	0.911
	35	0.830	0.920	1.01	1.08	1.16	1.24
	40	1.08	1.20	1.32	1.42	1.51	1.62
	50	1.69	1.88	2.06	2.22	2.37	2.53
	60	2.44	2.70	2.97	3.20	3.40	3.64
	70	3.32	3.68	4.05	4.35	4.64	4.96
	80	4.33	4.81	5.30	5.70	6.07	6.47
$\xi = 0.010$	5	0.012	0.013	0.014	0.015	0.016	0.018
	10	0.047	0.053	0.058	0.063	0.066	0.071
	15	0.107	0.119	0.131	0.142	0.150	0.161
	20	0.190	0.211	0.234	0.253	0.267	0.287
	25	0.298	0.331	0.366	0.396	0.418	0.450
	30	0.427	0.475	0.526	0.570	0.601	0.645
	35	0.582	0.647	0.717	0.777	0.820	0.880
	40	0.760	0.845	0.935	1.01	1.07	1.15
	50	1.18	1.32	1.46	1.58	1.67	1.79
	60	1.71	1.90	2.10	2.28	2.40	2.58
	70	2.32	2.58	2.86	3.10	3.27	3.51
	80	3.04	3.38	3.73	4.05	4.27	4.59

cyclic component is stronger, the dip of the leading edge can be increased at the expense of that of the trail, that is to say, the chord angle may be diminished with higher aspect-ratio, and with it the trail angle will be also diminished. This is contrary to the tabulated results of Table IV. : if true, it must lead to the reconsideration of some of the assumptions

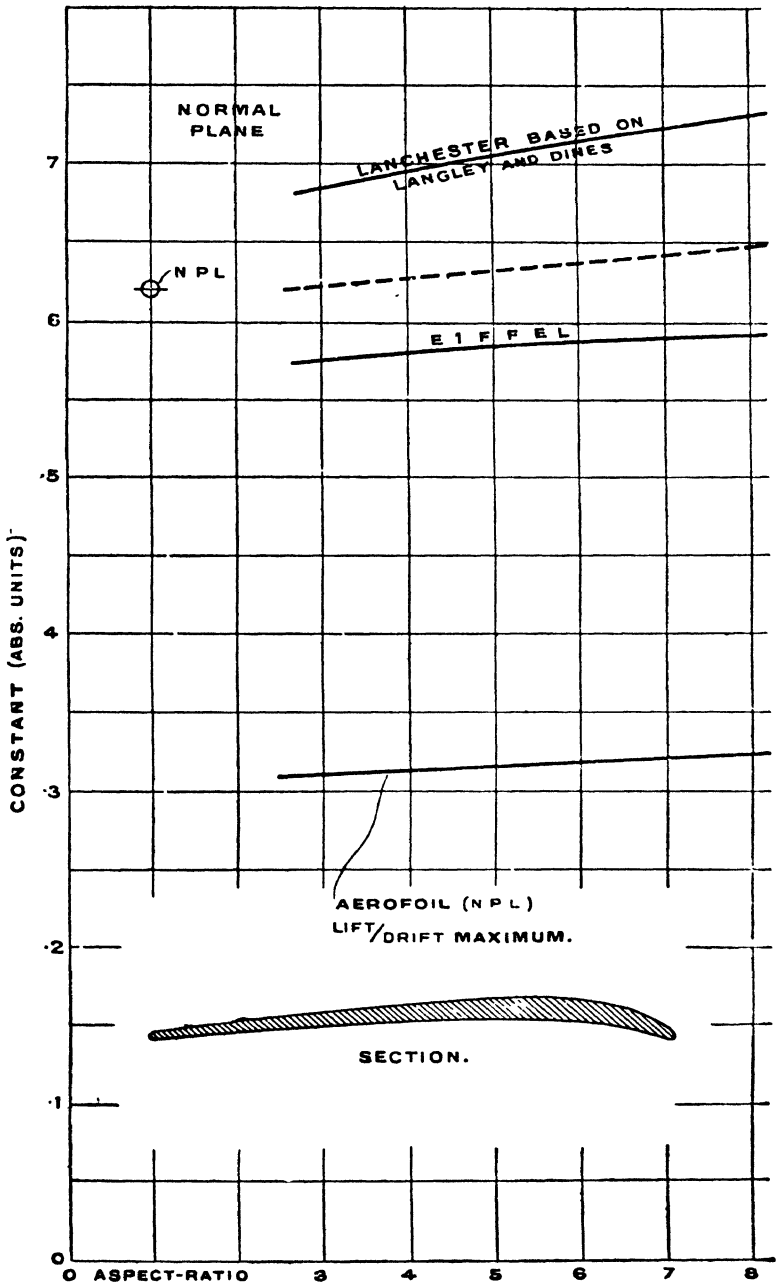

FIG. 18.

on which the author has based his theory, or at least in the revision of some of the values of the constants.

In spite of the evidence, it is by no means certain that the matter is quite as simple as it appears. It is to be observed that any investigation to determine the effect of aspect-ratio must of necessity involve a very complex experimental campaign, not merely a set of determinations with some half-dozen or so of models sawn off to length from a piece of Bleriot or de Havilland "moulding"; this is exactly what was done in the experiments forming the basis of the plotting given in Fig. 17, and any such method of investigation is liable to prove delusive.¹

In the first place, each aspect-ratio should be explored by means of a number of determinations using aerofoils of varying camber; secondly, the aerofoil section must not be uniform from end to end, the section must be "graded," or, as it is sometimes expressed, the camber must "wash out" at the extremities. Beyond this, not one series but a dozen or more must be tried. The best for each aspect-ratio is the aerofoil of greatest lift/drift.

In my opinion, in the present unsatisfactory state of things, it is best (so far as the pressure-constant is concerned) to assume as the initial basis of design a uniform value for all values of aspect-ratio, say that given as appropriate to aspect-ratio = 6 in Table V. Whether we consider the N.P.L. result as valid or not, the salient fact is that we have at present no sufficient evidence that there is any change in the pressure-constant worth taking into account. Alternatively, we are not going far astray if we design initially for aerofoil pressures equal to half the pressure on the normal plane, as shown in Fig. 18. The final selection

¹ It is an old axiom that in conducting a scientific research only one condition (when possible) should be changed at a time. In trying to adhere to this rule too literally it is easy to mistake the shadow for the substance; in the present example, to vary the length of an aerofoil of constant section may appear superficially to be "changing one condition," but in reality it is nothing of the kind.

of aerofoil is usually based on actual experimental determinations on scale models.

The most important fact with which we are immediately concerned in connection with the theory of least resistance is that the total aerofoil resistance for least value is almost constant in respect of velocity; in other words, provided that we design for least resistance, we know our traction coefficient in advance; it is virtually a constant, just as though the problem were that of an automobile required to ascend a hill of known gradient—an analogy which comprehends the fact that there is the direct wind-resistance or

TABLE VI.—LEAST GLIDING-ANGLE ($= \gamma_1$) (THEORETICAL).

n	$\xi = 0.025$		$\xi = 0.02$		$\xi = 0.015$		$\xi = 0.010$	
	Angle	Ratio	Angle	Ratio	Angle	Ratio	Angle	Ratio
3	6.25°	1: 9.2	5.6°	1: 10.2	4.8°	1: 12	3.95°	1: 14.5
4	5.75°	1: 10	5.15°	1: 11.1	4.4°	1: 13	3.65°	1: 15.7
5	5.3°	1: 10.8	4.75°	1: 12	4.1°	1: 14	3.4°	1: 16.8
6	5.0°	1: 11.5	4.5°	1: 12.8	3.9°	1: 14.7	3.2°	1: 17.9
7	4.7°	1: 12.2	4.25°	1: 13.5	3.6°	1: 15.9	3.0°	1: 19.1
8	4.5°	1: 12.8	4.0°	1: 14.4	3.4°	1: 16.8	2.8°	1: 20.5
10	4.1°	1: 14	3.65°	1: 15.8	3.2°	1: 17.9	2.6°	1: 22
12	3.8°	1: 15	3.42°	1: 16.8	3.0°	1: 19	2.4°	1: 23.9

body-resistance additional in both cases. This constant is only within control, inasmuch as, by careful design, the effective value of the coefficient of skin-friction ξ can be kept down and a high aspect-ratio adopted. Theoretical values of least gliding-angle (that is to say, resistance-coefficient), tabulated for values of ξ and aspect-ratio, are given in Table VI.¹ It is of some interest to inquire to what extent these results are in agreement with modern experiment.

Experimental data have been gathered from various sources:—A series of aerofoils of Bleriot section,² aspect-ratios vary from 3 to 8. Determinations of Voisin wing by Mr. Eiffel,

¹ From "Aerial Flight," vol. i., p. 262.

² Report of the Advisory Committee for Aeronautics, 1911-1912, p. 76

aspect-ratio 6.3. Aerofoil "R.A.F. 6" (Royal Aircraft Factory), aspect-ratio 6. Aerofoils from the author's 1894

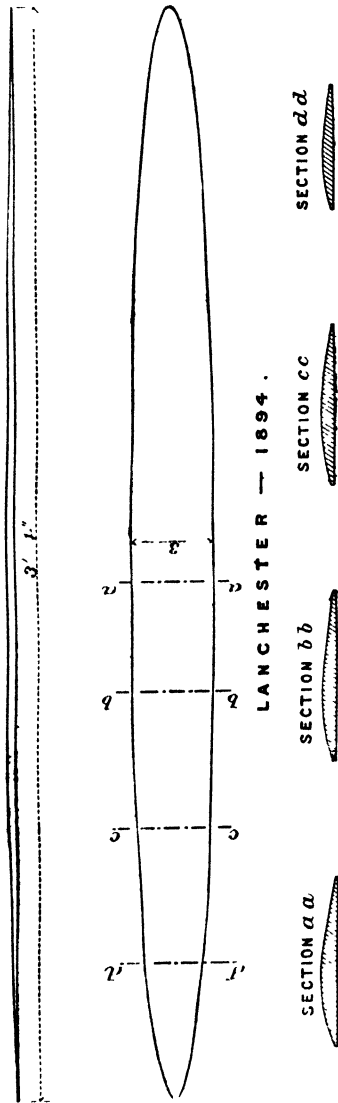

FIG. 19.

model (Fig. 19), aspect-ratio 13.3, independent determinations by the N.P.L. and the Göttingen Laboratory. The

above are given in Table VII. ; columns 1, 2, and 3 give the aspect-ratio, type, and authority, respectively ; column 4 gives the experimental determination, and theoretical values are given in columns 5 and 6 for values $\xi = 0.02$ and $\xi = 0.015$. Table VII. is shown plotted in Fig. 20, the relation of aspect-ratio to lift/drift being represented by curves drawn through the observed and calculated values.

It will be noted on referring to Table VII. and Fig. 20 that the agreement is almost complete. The two cases of the

TABLE VII.

1	2	3	4	5	6
Aspect-Ratio	Type	Determination by	Experimental.	Calculated $\xi = 0.02$	Calculated $\xi = 0.015$
3.0	Bleriot section	N.P.L.	10.1	10.2	12.0
4.0	"	"	11.5	11.1	13.0
5.0	"	"	12.9	12.0	14.0
6.0	"	"	14.0	12.8	14.8
6.0	R.A.F. 6	"	14.5
6.3	Voisin	Eiffel	14.0
7.0	Bleriot section	N.P.L.	15.1	13.5	15.9
8.0	"	"	15.5	14.4	16.8
10.0	15.8	17.9
12.0	16.8	19.0
		N.P.L. ¹	17.1
		" ¹	17.6
13.3	Author, 1894	" ²	20.0
		Göttingen ³	16.4
		" ³	17.3

Eiffel determination of the Voisin aerofoil and the "R.A.F. 6" aerofoil are shown as outlying points, not being fully in agreement with the main run of the remaining experimental determinations. It will be noted, however, that the whole of the experimental values lie between the two adjacent theoretical curves given, and the general form of the experimental curve corresponds to the curves given by the equa-

¹ Velocity, 30 feet per second.

² Value at 50 feet per second (computed by N.P.L.).

³ Velocity not stated.

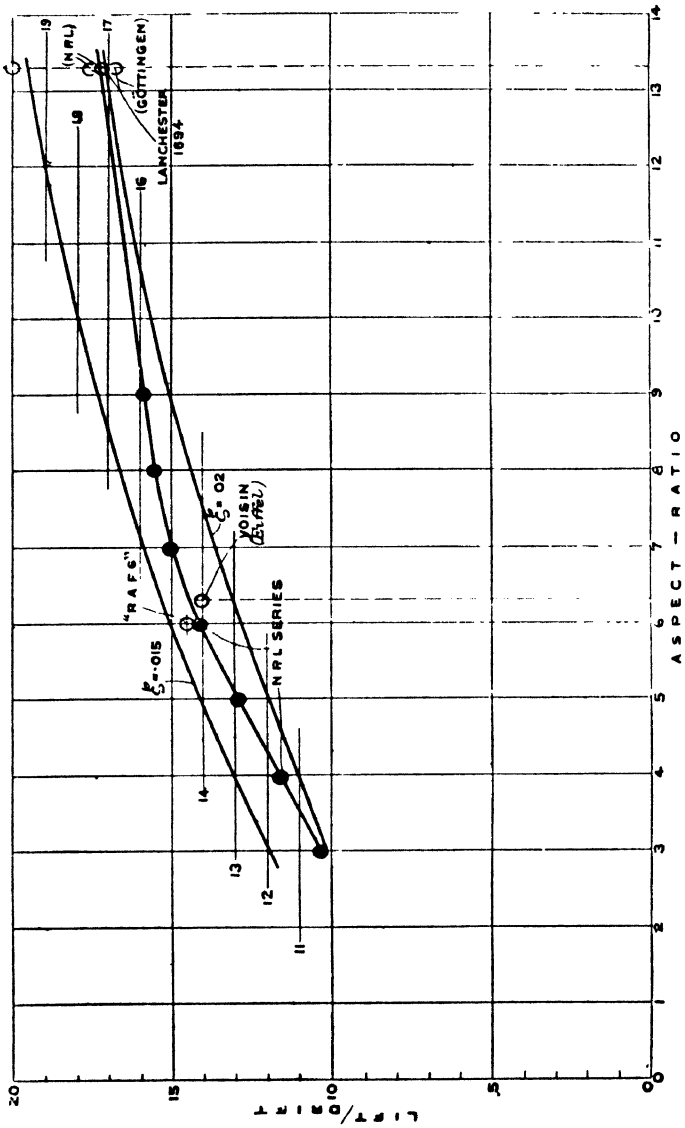

Fig. 20

tions. It is true that there is something in the nature of a hump on the experimental curve, the extremities of which correspond to a double-surface coefficient of skin-friction of 0.02, whereas the central part of the curve round about aspect-ratio = 6 rises nearly to the upper curve. This peculiarity of angular character of the curve may be a real feature, but the author is disposed to think that it is more probably due to the fact that a great deal more experimental work has been done in the region of the hump of the curve and so more highly perfected forms have been developed than for aspect-ratios of greater or less value. It would appear probable that if equal diligence were displayed in designing and testing forms of other aspect-ratios the upper theoretical curve ($\xi = 0.015$) would be found to be very close to the truth; some confirmation of this is found in the fact that the best value for the "R.A.F." aerofoil, a form that has been subject to considerable study both by the Royal Aircraft Factory and the National Physical Laboratory, lies considerably above the curve representing the run of other observations.

In the National Physical Laboratory report to the author on the tests of his 1894 model, it is stated that if it had been found possible to employ a velocity of 50 feet per second instead of 30 feet per second, the figure obtained would probably have reached the neighbourhood of 20. This value is also plotted as an outstanding point in Fig. 20.

Summarizing the position, it is clear that the tractive effort required to overcome flight-resistance proper, namely, the aerofoil resistance, need not exceed 1 in 12 to 1 in 14, that is, 7 or 8 per cent., using an aspect-ratio of about 6, and that values less than this are to-day actually reached in existing machines. It is also apparent that if it is found practicable to employ a really high aspect-ratio, such as in the author's early flight-models, there is every reason to suppose that a resistance coefficient as low as 6 per cent. or even 5 per cent. may prove to be attainable. This is

the magnitude of the "constant gradient" of the motor-car analogy. We now pass to the consideration of body-resistance.

4. BODY-RESISTANCE.

The body-resistance, as already stated, varies approximately as the square of the velocity. It is therefore evident that, with a machine of given weight, since the flight-resistance proper (the aerofoil resistance) is constant, the higher the flight-speed, the more serious does the question of body-resistance become relatively, and the design of the car or *fuselage* and its accessories, such as alighting-gear, etc., as to "fairing" is a matter of increasing importance as the contemplated flight-velocity becomes higher. The calculation of body-resistance involves the computation of the resistance of each individual element, and in some cases allowance for the interference or influence of one element or portion on another. Thus in the computation of body-resistance it is necessary to have at command tabulated results of the resistance of spars of various sections, wires, wheels, and the like, in addition to a sufficiency of known data as to stream-line forms of various degrees of perfection. A considerable amount of experimental data has now been collected in this direction, but a great deal yet remains to be done.¹

The resistance of the body is a factor on which at present the information available is the least satisfactory, since it is rarely possible for the designer to adopt a close approximation to a perfect stream-line form, or a form for which the resistance coefficient has been already determined; it is usually necessary to have recourse to model experiment in each individual case. This must be expected, in view of the fact that the same applies to the design of a ship's hull when any departure is made from existing practice.

¹ For the resistance coefficients of spars, wires, etc., reference should be made to the various reports of the Advisory Committee for Aeronautics and the work of Mr. Eiffel and others, also section 9 following.

A very few years ago little or nothing was known as to the resistance of the so-called stream-line or ichthyoid body. In 1908-9 the author made inquiries in the endeavour to obtain some figures on this subject. For bodies constituting a rough imitation of a good fish form, with a ratio of length to diameter of about 6 to 1, the figures given in Table VIII. were supplied by the different authorities named; the figures supplied in various forms are here reduced to represent the equivalent of normal plane in terms of the maximum cross section.

TABLE VIII.

Authority	Date.		Remarks.
Prandtl . . .	1908	0.125	Given as approximate only. ¹ { From rough experiments at the factory of Voisin Frères. } Given as an experimental deter- mination by the late Col. Renard. } Actual for water (ratio about 3 : 1). Probable for air.
Colliex . . .	1908	0.100	
Sureouf . . .	1908	0.031	
British Admiralty .	1909	{ 0.032 0.023	

It would appear from more recent experiments carried out at the Royal Aircraft Factory, and at the National Physical Laboratory, that for a well-designed stream-line form the best result so far recorded is approximately 0.07, the coefficient of fineness, length/diameter, being round about the value 3 or 4 : 1.

The plotting given in Fig. 21 is based on a series of determinations made at the Royal Aircraft Factory, with corrections (for which the author takes responsibility) to com-

¹ Professor Prandtl ("Zeitschrift für Flugtechnik und Motorluftschiffahrt") has more recently made some very complete and interesting investigations of the ichthyoid body. Basing his work on a length ratio 6 : 1, he has shown that about 60 per cent. of the total resistance is directly due to skin-friction, and the remaining 40 per cent. is due to a secondary effect; the skin-frictional wake current brings about a degeneration of the stream-line system which results in a loss of energy mainly due to a reduction of pressure in the region of the tail. It would appear that this indirect loss is proportionally greater the shorter the body relatively to its diameter.

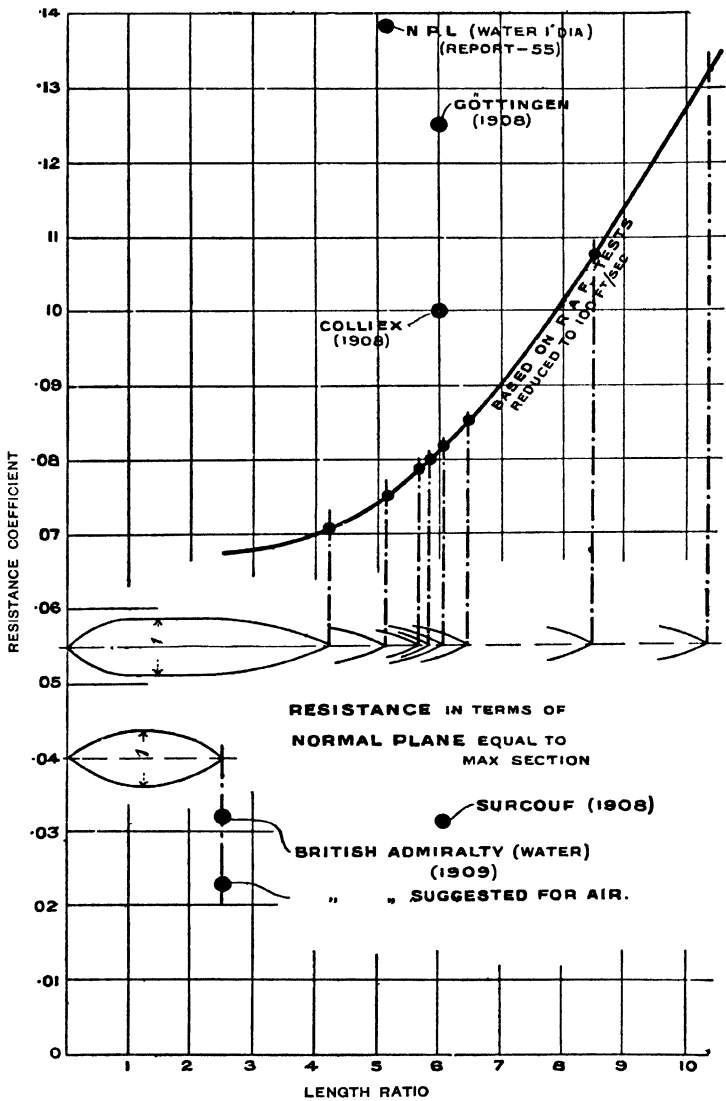

FIG. 21.

pensate for the difference in the coefficient of skin-friction between the velocity, 20 feet per second, actually employed, and an assumed flight-speed of 70 miles per hour. The plotting represents the resistance-coefficient for bodies of about 2 to 3 feet diameter.

When we turn our attention to the design of the body of machines as they exist to-day, we find that although it is becoming customary to give the body a distinct fish-like outline, it is rare that any real attempt is made to adopt a definitely stream-line or true ichthyoid form, such as employed in the experimental determinations already cited, and such as commonly used for dirigible balloons. It is not sufficient to give a rough general outline to the body if a material reduction in the resistance is required; it is necessary to go further and to avoid, as far as possible, corners and projections of every description. In many cases in the body-forms used to-day the resistance is nearly as great as that of a normal plane equal to the mid-section area, and a body with a coefficient of less than 0.5, in view of current practice, must be regarded as exceptionally good. As a consequence the resistance of the body and passengers alone is often equivalent to some 3 or 4 square feet, whereas an equivalent considerably less than 1 square foot ought to suffice. It is not only necessary to avoid up-standing projections such as wind-screens, etc., but even such things as longitudinal angles should be eliminated from the design: this latter point has been partially investigated by the National Physical Laboratory.

In the Paulhan-Tatin machine, mentioned in the researches of Mr. Eiffel, the question of body-form has been studied with extreme care, the form of body employed being substantially a solid of revolution, as illustrated in Fig. 22*a*. The only irregularity in the body is the aperture for the pilot which has clearly been reduced to the minimum. According to the results given in Fig. 21 it would be still better, from the point of view of resistance, to design the body on the lines shown in Fig. 22*b*, making it only of sufficient length to

contain the pilot, motor, etc., and carrying the tail organs from a tubular continuation. A model of this kind, made and tested at the N.P.L. (from designs of the Royal Aircraft Factory), gave a normal plane equivalent of about one-fifth of its maximum cross section. The form was imperfect as a stream-line body, and the small scale ($\frac{1}{25}$ full size) otherwise rendered the resistance higher than it would be in actuality (Advisory Committee Report 74, p. 177).

It is evident that with sufficient experience the body (fuselage) resistance of an ordinary two-seat machine should be capable of reduction to the equivalent of 1 square foot

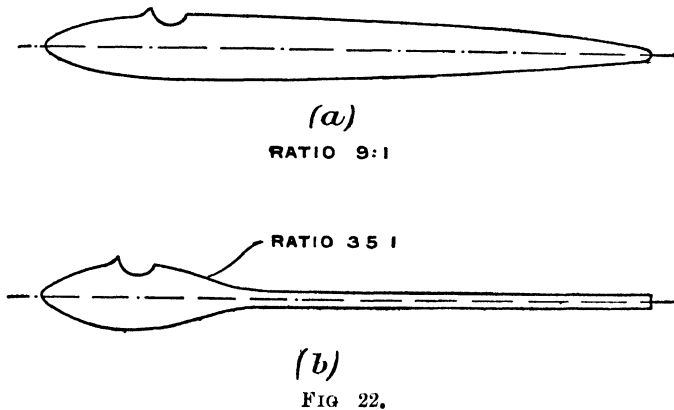

area of normal plane, since a good model of stream-line body of 5 square feet maximum section should in itself offer less than half this resistance. Added to this we have the alighting-chassis and auxiliary surfaces, the resistance of which should be capable of being reduced to an equivalent of 2 square feet if the design be studied in every detail, making 3 square feet in all. On the basis of a speed of 80 miles per hour the resistance will then amount to 60 lbs., or, say, approximately, 5 per cent. The body-resistance in the machines of to-day is very much higher; it is commonly the equivalent of at least some 5 square feet of normal plane: Mr. Eiffel has given 1 square metre ($= 10\frac{3}{4}$ square feet) as usual.

5. TOTAL RESISTANCE.

Fig. 23 represents graphically the position with which the designer has to cope ; the horizontal line A represents an aerofoil resistance coefficient of 7 per cent. The curves 1, 2, 3, 4, 5, 7, and 10, represent (from A as datum) the additional coefficient due to body-resistance on the assumption that we are dealing with a machine of 1,200 lbs. weight, in which the body-resistance has respectively the equivalent

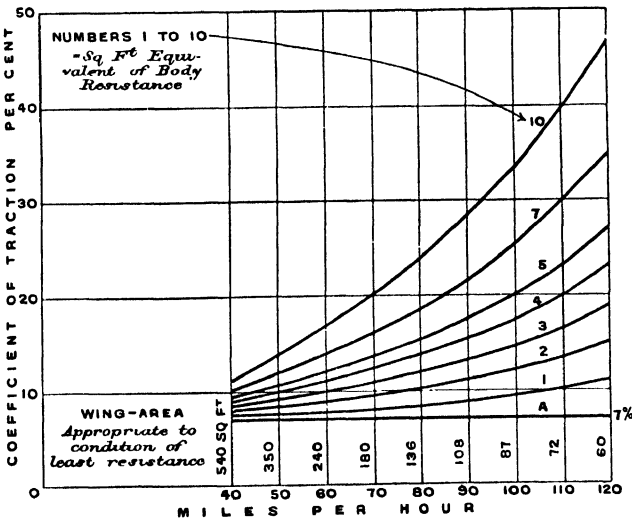

FIG. 23.

of 1, 2, 3, etc., square feet area of normal plane ; curve 5 may be taken roughly to represent the best present-day practice. It is evident that so long as flight-speeds were limited to 40 miles an hour or less, as was the case a few years ago, the body-resistance remained a matter of minor importance ; in fact, in the Wright machine, and in several other machines of that day, the pilot sat fully exposed, and little or no attempt was made to minimize resistance. With speeds of 80 miles per hour, however, unless great care is taken in the design, the body-resistance will considerably exceed the flight-resistance proper. Fig. 23 does not represent the

resistance of a given machine flown at different speeds, but rather the resistance of a series of machines of given weight, *each (aerofoil) designed for least resistance at its own particular speed*, and with body-resistance equivalent to the area indicated.

Referring to Fig. 23, it will be seen that the total traction coefficient in the case of curve 5 at 80 miles per hour is roughly 15 per cent., the gliding-angle consequently being 1 in 6.7; this is slightly better than the best figures actually obtained in the military trials of 1912. The highest speed at the military trials did not touch 70 miles per hour, so that on the basis given the gliding-angle should have been better than stated; no allowance was made for the drag of the propeller, and it is probable that the difference is due in part to this factor.

The question of body-resistance has for some time been a matter of careful study by the staff of the Royal Aircraft Factory, and it is understood that in some of the later models the equivalent normal plane area has been very considerably reduced. If we take an aerofoil coefficient of 7 per cent., and a curve representing 3 square feet equivalent normal plane, we find that at 80 miles per hour the gliding-angle, or the resistance-coefficient, should be approximately 12 per cent., and at 60 miles per hour 10 per cent.: I believe this figure to be in sight, though it may not yet have been actually reached.

As illustrating the extent to which the present-day results have been anticipated by theory: in 1907, dealing with the question of the power expended in flight, the author tabulated¹ the results of calculations for gliding-angles as for complete machines ranging from 12° (approximately 1 in 5) to 6° (approximately 1 in 10). In the military trials of 1912 the worst gliding-angle recorded was 1 in 5.3, and (as pointed out in the preceding paragraph), the present-day figure is gradually approaching 1 in 10.

If we try, in the light of present data, to look into the

¹ "Aerial Flight," vol. i., ch. ix, pp. 331, 332.

future, it seems probable that the limiting gliding-angle, or, rather, the minimum total coefficient of resistance, may even be materially less than 1 in 10 ; thus, if it is found possible, in spite of structural difficulties, to obtain in an actual machine results equal to those obtained in wind-channel model tests, namely, a coefficient of resistance for the aerofoil approximating to 5 per cent., and if the body area equivalent, for a machine of 1,200 lbs. gross weight, can eventually be reduced to 2 square feet, a total coefficient of resistance as low as 8 per cent. may prove well within reach. Whether the sacrifices necessary in order to achieve such results in practice would be justified, the future alone can decide.

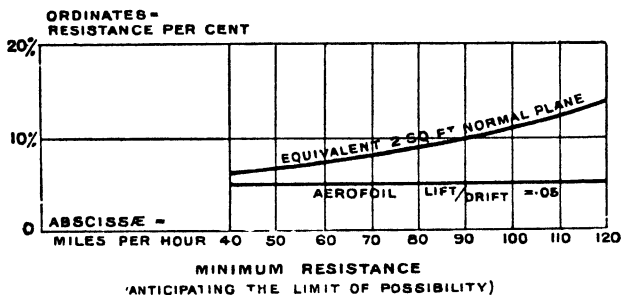

FIG 24.

The solution of an engineering problem is always to some degree a matter of compromise, and it would be rash to suggest that in the case of the flying-machine there are not considerations of sufficient importance to render it inadvisable to run after the last 1 per cent. reduction in tractive effort. A graph is given in Fig. 24 representing the coefficient of resistance on the basis of the present paragraph. The aerofoil coefficient of traction is taken at 5 per cent., the weight of the machine is assumed as before to be 1,200 lbs., and the suggested total of 8 per cent. corresponds to a flight-speed of nearly 80 miles per hour.

Before we have finished with the question of resistance we need to know something as to the gradient of ascent, or

climbing-power required. A machine that is capable only of horizontal flight is evidently quite unserviceable. It is well understood, too, that any machine with an insufficient rate of ascent is intrinsically dangerous ; not only does it remain too long at low altitudes where any " fluke " in the wind is liable to bring about disaster, but in bad weather when buffeted about by the wind a pilot may find himself incapable of making altitude altogether if his initial margin of power is insufficient.

The rate of ascent for which provision has to be made depends very much upon the service for which the machine is required ; for the ordinary needs of the aeronaut who wishes to make cross-country flights under fair-weather conditions, a margin of power representing an upgrade of 5 per cent. or 6 per cent. appears to be ample ; there is but a moderate advantage in any greater provision. For military or naval service, on the other hand, there are without doubt occasions when everything may depend upon the rapidity at which the machine can make altitude. The author feels that he cannot do better than quote from the specifications given by the Superintendent of the Royal Aircraft Factory for two types of machine, namely, R.E. 1. Reconnaissance aeroplane, and F.E. 3. Gun-carrying aeroplane.¹ For the first of these the rate of climbing demanded is 600 feet per minute, or, taking the normal flight-speed at 70 miles per hour (the specification gives maximum 78 miles per hour, and minimum 48), we have a climbing-gradient of approximately 10 per cent. For the gun-carrying machine the speed is given as 75 miles per hour, and the rate of climbing 350 feet per minute, which, expressed as climbing-gradient, is a trifle less than $5\frac{1}{2}$ per cent. Manifestly a machine carrying a gun of some kind (presumably a machine gun) and, we may assume, an adequate supply of ammunition, with perhaps a few square feet of bullet-proof armour-plate, needs to sacrifice something in the matter of climbing-power.

There is good reason to suppose that if a demand for higher

¹ Advisory Committee for Aeronautics, Report 1912-1913, p. 267.

speeds than those at present attained or contemplated is to be satisfied in the future, success will depend to some extent upon our ability to build larger and heavier machines. By reference to Figs. 23 and 24 it will be seen how soon, with increased flight-speeds, the question of body-resistance becomes a disproportionate factor. It is manifestly impossible in a machine of given size to reduce the equivalent normal plane area beyond a certain point; but it is evident that by increasing the weight and power of the machine the effect of such body-resistance may be rendered less important, since an increase in weight and power does not require a proportionately serious increase in the size of the members to which the body-resistance is due. Also since the square of the product of l and V varies directly as the weight (where l represents the linear size of the aerofoil), the value of ξ is also a function of the weight, and diminishes slightly as the weight is increased.¹

6. PROPULSION.

We are now in a position to consider the question of propulsion. Whether we appeal to experience or to theory, it would appear that there is only one method of propulsion available, namely, the screw-propeller.² The problem of propulsion, whether aeronautical or submarine, is essentially the same; the laws of dynamic similarity, with certain reservations, are strictly applicable. Roughly speaking the conditions of usage of propellers in water and air may be compared by merely taking cognizance of the relative densities of the two media—approximately 800 to 1. The laws of dynamic similarity indicate that this relation is not exact, but any refinement of theory on this score is of academic rather than of practical importance. Apart from

¹ Compare Appendix I. The weight taken for the purpose of illustration, *i.e.* 1,200 lbs., is far less than that of the ordinary service machine.

² Nature's method of propulsion—wing flapping—besides being very objectionable from a mechanical point of view, shows certainly no higher degree of mechanical efficiency than the screw-propeller (*Engineering*, 26th February, 1909).

fine points of this kind, there is a limitation that renders the air propeller and the marine propeller not strictly comparable; this limitation is due to the appearance of the phenomenon known to the naval engineer as cavitation. The law of the relation of pressure to velocity for least resistance applies to the blade of the screw-propeller precisely as it does to the aerofoil itself, so that if a propeller is being designed for least resistance the pressure per square foot at any point of the blade must bear its constant relation to the square of the velocity of the blade through the fluid at that point. In the case of the marine propeller this results in a speed being reached (at about 20 or 25 knots speed of vessel) at which the velocity of the blade-tips is such that the negative pressure (on the back of the blade), based on the law of least resistance, is greater than the hydrostatic (absolute) pressure. Under these conditions a vacuum is formed in the vicinity of the blade extremity, and the system of flow is impaired; this is the condition of incipient cavitation, and as the speed is progressively increased the vacuum invades more and more of the blade-area until the greater part of the propeller becomes ineffective. From the critical speed upwards the design of the marine propeller becomes a compromise. The extremity of the blade is first designed broader to avoid developing pressures sufficient to initiate cavitation, and then, owing to the additional skin-friction thereby involved, it is found desirable to adopt higher pitch/diameter ratio to prevent the extremities from cutting the water with excessive velocity. Eventually the propeller for high-speed craft becomes one of extremely coarse pitch, with blades of great width or of saucer-like form. No such thing as cavitation is experienced in the aeronautical propeller; if we should require to deal with propeller-blade speeds approaching the velocity of sound we might find something analogous, due to the high rarefaction of air; but at present the aeronautical designer can afford to ignore the question of cavitation.

It is frequently stated that the theory of the screw-propeller is entirely empirical and quite unsatisfactory; this

is not the author's opinion. The theory of the screw-propeller based on the theory of the aerofoil as laid down in "Aerodynamics,"¹ appears fully to meet the requirements of the aeronautical designer. According to this theory the propeller-blade is treated as an aerofoil, its P/V^2 ratio at every point of the blade being fixed by the same law as that of the aerofoil as given; following this the "gliding-angle" of the propeller-blade is constant from root to tip. The section of the blade at every point is designed as an aerofoil in which the true helical surface corresponds to the horizontal plane in flight.² Under these circumstances it is shown in my work that each point of the propeller-blade has efficiency proper to itself and is represented by a curve as plotted in Fig. 25, which corresponds to a gliding-angle of 6° , or approximately 10 per cent. Under these conditions it will be seen that in the region of maximum efficiency the efficiency is just over 81 per cent. Unfortunately we cannot use only the region of maximum efficiency; we have to employ a blade of considerable length, and consequently parts of the blade have an efficiency below the maximum. If we take a propeller of the usual proportions in which the pitch is about $1\frac{1}{2}$ times the diameter—such a blade as is represented in Fig. 25—we see that the marine engineer declines to employ any portion of the blade with an efficiency of less than about 92 per cent. of the maximum, that is to say, the efficiency of different points of the blade ranges from 74 to 81 per cent., or theoretically the limit of efficiency of such a propeller should be round about 78 per cent. Unfortunately an actual propeller cannot consist of blades alone; it requires a boss and a connection between the boss and the blades, and in driving these functionally useless parts through the water

¹ "Aerial Flight," vol. i., ch. ix. Compare also "The Screw Propeller," Proc. Inst. A. E., 1915; vol. ix., 263.

² There is one factor which affects the analogy between the aerofoil and the propeller-blade; the latter is not able to the same extent to hold or accumulate a *dead-water* wake, the propeller-blade sheds its dead water continuously by centrifugal force. The extent to which this affects the problem has yet to be determined.

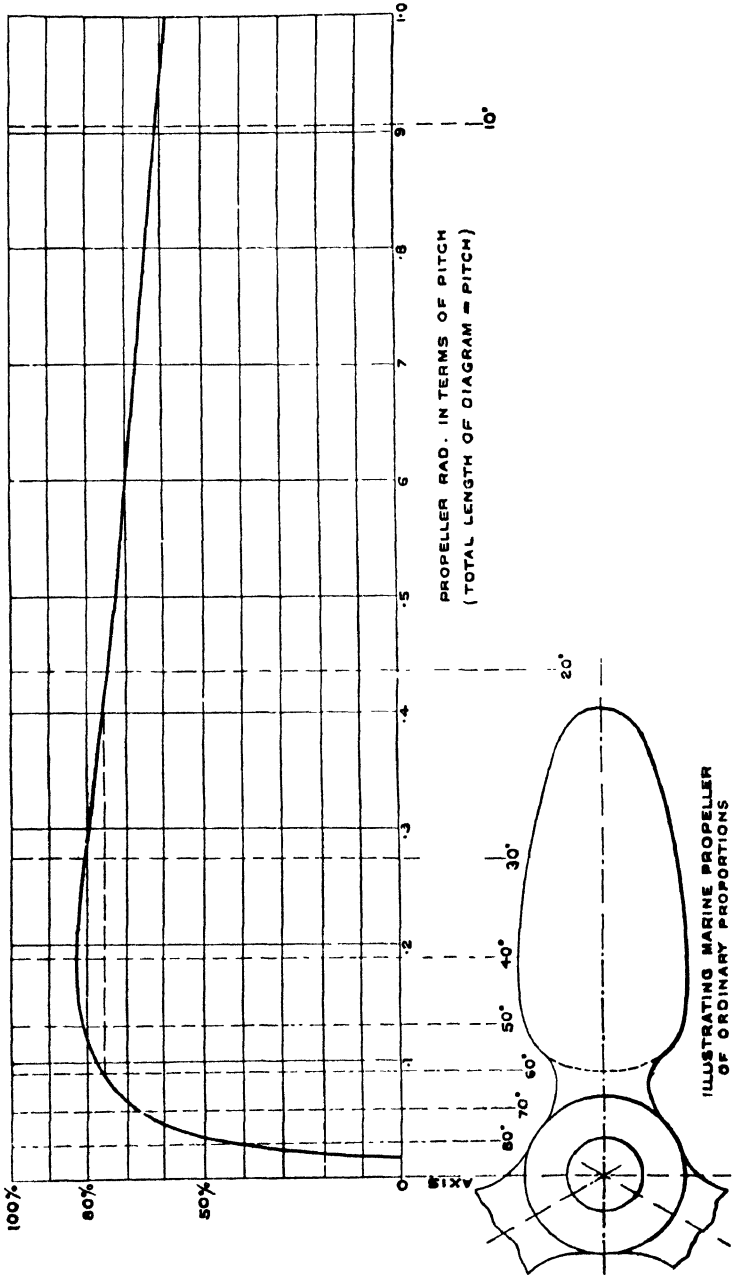

FIG. 25.

considerable further loss is inevitable. Probably it is for this reason that the actual efficiency of a marine propeller rarely exceeds 70 per cent. In the author's work a design is given of an aerial propeller based on theory alone, in which a very conservative estimate is taken of the gliding-angle. If in the light of present knowledge we assume the propeller-blades to be of an aspect-ratio corresponding to that of my 1894 gliding model, the gliding-angle or resistance-coefficient will be about 5 or 6 per cent., and we might anticipate a theoretical limit to the propeller-efficiency of 88 or 90 per cent. We have here, as in the marine propeller, to provide a boss and arms, and we require to take into account the fact that it never pays in practice to take the full diameter of the propeller that theory would indicate (it being better to sacrifice a few per cent. of efficiency to save weight and clearance diameter). Everything considered, the author is disposed to put the limit of efficiency of an aeronautical propeller at somewhat less than 85 per cent.; this is higher than has been found possible in marine engineering.¹

The author's method of propeller-design has been adopted

¹ There should be nothing to prevent the marine propeller (at speeds below the cavitation point) from giving as high an efficiency as the aeronautical propeller, were it not for the limit imposed by the strength of materials. To obtain the highest efficiency even in an air propeller it may be found necessary to abandon the wooden blade and substitute a solid nickel-steel blade of somewhat the sectional form given in Fig. 19; this, in the case of an 8-foot propeller, would mean a blade 4 feet long, the outer 3 feet of which would be the *effective* blade, the maximum width in the widest part being no more than 3 or 4 inches. If any attempt were made to design such a propeller for marine work, there is no material known at the present time that would stand the stress involved; the pressure-reaction, speed for speed, would be about 800 times greater in water than in air, and the aspect-ratio of the blade that can be utilized for marine work is strictly limited by this fact; even the softest of timber is relatively far stronger as a medium for the construction of an aeronautical propeller than any known material, even tempered tool-steel, would be for marine work. In the design of an aeronautical propeller advantage may be taken of the fact that a very slight *forward* slope of the blades relieves the blades of all bending stresses, the resultant of the centrifugal force and pressure-reaction being *in the line of the blade*, and the latter is consequently stressed in pure tension.

and employed for some years by the Superintendent and staff of the Royal Aircraft Factory, with satisfactory results ;¹ at present there is but little available information on the question of efficiency, owing to the fact that the arrangements up till now at the disposal of the Royal Aircraft Factory do not permit of the effective testing of full-sized propellers.²

Working-drawings of a propeller, designed at the Royal Aircraft Factory by this method, are given in Fig. 26. For the full exposition of the system of "lay-out," reference should be made to the work already cited.

As an alternative and purely empirical basis of treatment, we may fall back on our experience in marine propulsion. There is a practical rule which appears to be commonly adhered to in the design of marine propellers for sea-going craft of moderate speed. The area of the propeller-disk is approximately 1 per cent. of the total wetted surface. This rule has been found by the author to represent a rough average of the practice in various cases,³ but whether or not it is an accepted rule I do not know. Let us take the case of a flying-machine involving, say, a thrust of 200 lbs. at 80 feet per second ; at this speed the frictional air-resistance will be approximately 0.035 lb. per square foot of surface (0.07 lb. per square foot of lamina, i.e., double surface) ; thus the resistance of the machine is approximately represented by 6,000 square feet "wetted" surface, and, following the rule given in the case of water, the area of the propeller-disk should be 60 square feet ; this corresponds to a propeller-diameter of about 9 feet. In an actual machine of about this

¹ In a memorandum appearing in the Report of the Advisory Committee for Aeronautics, 1911-1912, p. 173, by H. Bolas, the method in question is described as due to Drzewieski, but both the terminology and method are those given by me in "Aerial Flight," vol. i., in 1907. Drzewieski's work cited by Mr. Bolas was published in 1909.

² At the date of writing (1914).

³ The average of a number of war-vessels, capable of about 18 to 20 knots speed, gave the figure 1.3 per cent. Two typical low-speed merchantmen (from particulars supplied by the builder) gave exactly 1 per cent.

FIG. 26

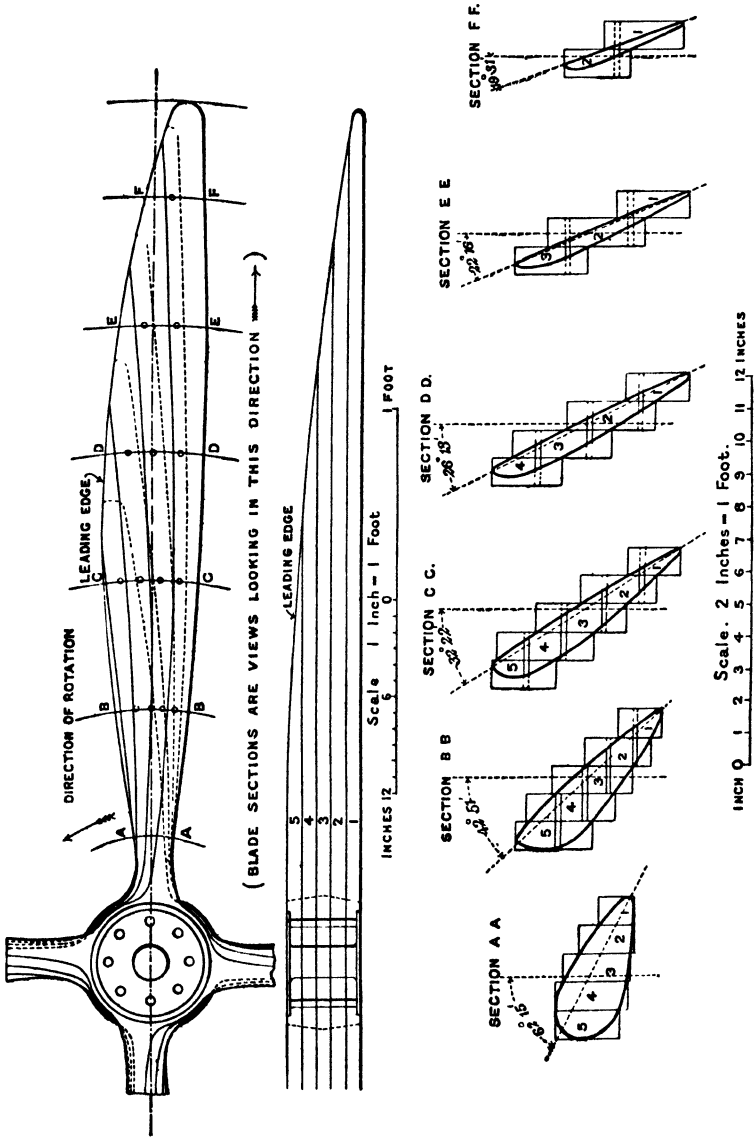

size the propeller is commonly about 7 to 8 feet in diameter, which, taking everything into account, is in substantial agreement. The propeller employed in flight is of necessity (from considerations of the speed revolution of the engine) of finer pitch than that of best efficiency. Under these conditions theory shows that the correct diameter is less than

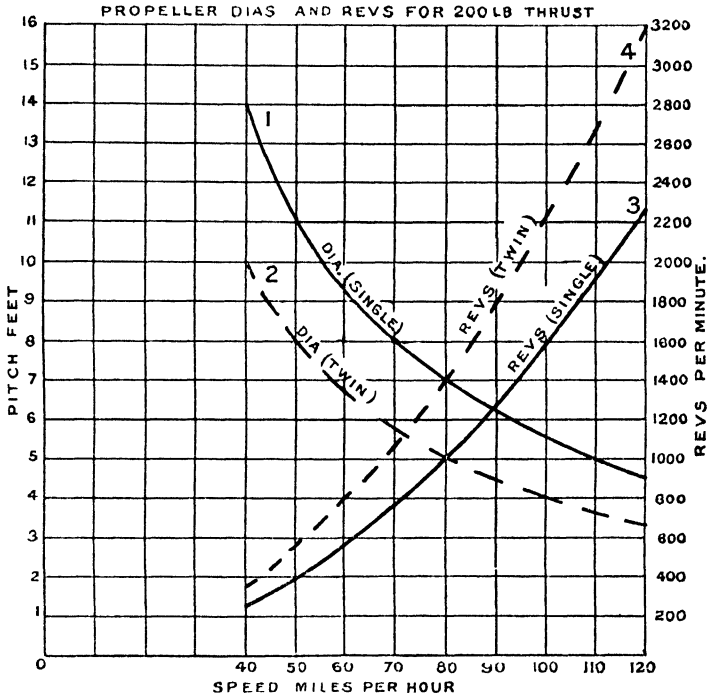

FIG. 27.

that of the propeller of best diameter/pitch ratio, such as is employed by the naval architect.¹

There are (in the present state of the art) two prominent reasons for the adoption for aeronautical machines of a propeller of finer pitch than that of greatest efficiency; first, there is the question of suiting the pitch of the propeller to the running-speed of the engine. For the power necessary

¹ Compare "The Screw Propeller," Proc. Inst. A. E., 1915; vol. ix., p. 263.

in a modern aeroplane (50 to 100 HP.) a stroke of about 5 inches is found suitable in proportioning the engine. Now it is uneconomical, from the point of view of both weight-saving and petrol-consumption, to employ too low a piston-speed; in fact, for any given dimensions of cylinder the power developed is, within limits, roughly proportional to the piston-speed. Taking a piston-speed of 1,000 feet per minute and 5-inch stroke, we require 1,200 revolutions per minute, or 20 revolutions per second. Assuming a velocity of flight of about 80 feet per second the effective pitch of the screw requires to be 4 feet, or approximately equal to half the diameter of the screw, instead of at least equal to the diameter, as in a good marine propeller.

Of course it is not difficult to gear down from the engine to the propeller, in fact this has been done frequently, but, since gearing involves a tax of approximately 4 per cent. of the power, it is evidently better to drive direct and sacrifice something in the efficiency of the propeller, especially as this course involves a far lower torque on the propeller-shaft, and consequently a lower recoil torque on the framework of the machine.

The relation between flight-speed and propeller is shown graphically in Fig. 27, to which further reference will be made. The graphs given represent a thrust of about 200 lbs. and may be looked upon as appropriate to a machine of 1,200 or 1,400 lbs. weight. The propeller is assumed to be of pitch equal to its diameter. Graphs are given both of propeller diameter and of appropriate revolution-speed.

7. MOTIVE-POWER INSTALLATION.

We are now faced with the consideration of the motive-power installation. At the present time, the internal-combustion engine—more definitely the petrol-motor—holds the field. No other prime mover is able to compete either on the score of weight per horse-power or weight of fuel; there is nothing in sight likely to oust the internal-combustion motor from its supreme position.

The relative importance of lightness and economy of fuel is determined by the class of service for which the motor is required. In Fig. 28 curves are given of *weight/horse-power* for various motors ; ordinates represent weight of motor plus fuel, abscissæ the duration of the run at full load. It can be seen at a glance from this diagram that for brief periods the weight per horse-power of the engine is the all-important factor, whereas for long runs this becomes relatively less important, the weight of petrol and lubricating-oil becoming the main item. It will be noted, taking the extremes, that the Gnome engine starts with a very considerable advance over the motor-car engine given for comparison, but after a run of 17 hours at full load, the motor-car engine (represented for the purpose of illustration by the Daimler), by its greater economy, has taken the lead. This diagram was prepared by the author some 3 or 4 years ago (see Report of the Advisory Committee for Aeronautics for 1909-1910). Many of the aeronautical motors of the present day combine with a *weight/horse-power* factor of about 4 (lbs. per HP.), a degree of economy which compares well with the best automobile practice.

Out of a great multiplicity of types of aeronautical engine now on the market there are two, namely, the rotating cylinder type on the one hand and the light-weight multi-cylinder Vee type on the other, which may be considered likely to survive. The rotating type of engine gives the possibility of very complete balance with simplicity of working parts, and so provides the aeronautical constructor with an engine especially serviceable where small machines are concerned and simplicity and upkeep¹ are of importance. The rotating engine is, at the present day, reasonably economical in petrol, but is grossly extravagant in lubricating oil, and consequently is at a disadvantage for long-distance work ; it will, however, probably hold its own for some time to come in machines for short-distance flying. The rotating engine, also, suffers from

¹ With the rotating engine in its present state of development, the question of upkeep is not its most satisfactory feature.

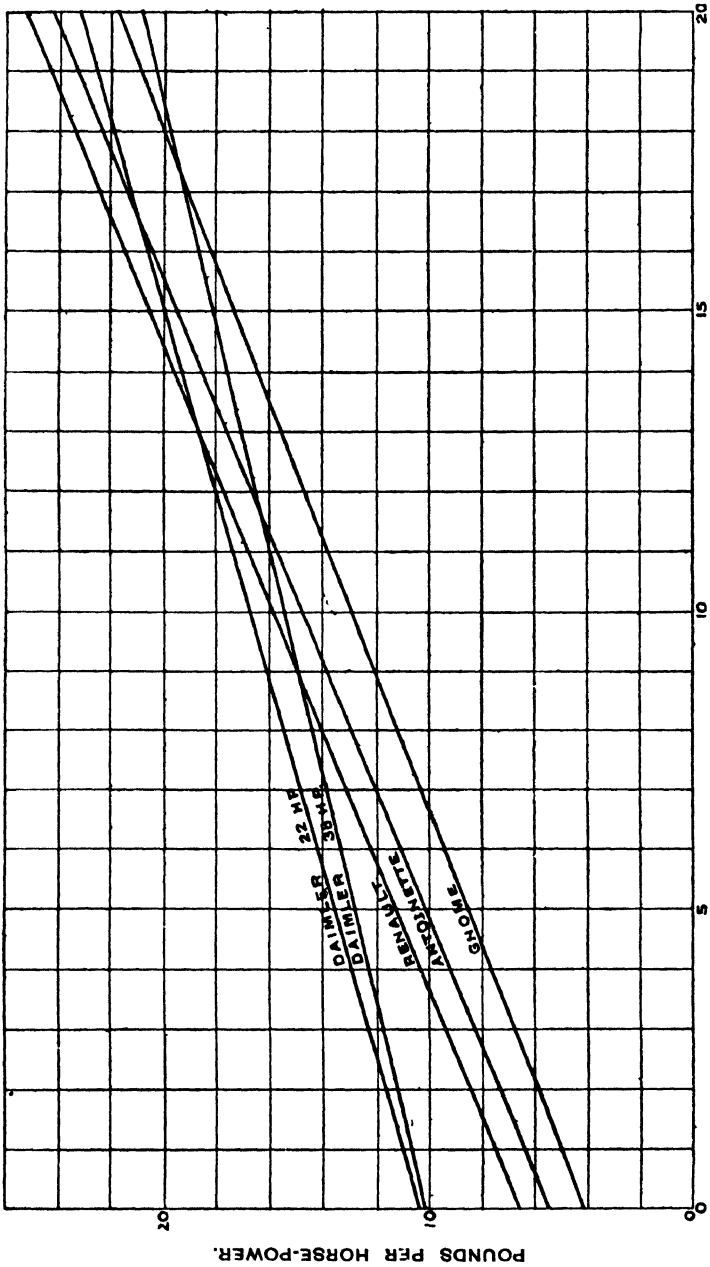

FIG 28.

some disadvantage on the score of exhaust silencing. The multi-cylinder Vee type, though ordinarily not so light, power for power, as the rotating engine, has many advantages, especially for high power and where long distances have to be negotiated.

It is customary in the rotating engine to employ direct air cooling ; it is, in fact, difficult to arrange such an engine with water cooling. The power absorbed in the Gnome engine *incidental to* air cooling is very great ; in the original so-called 50-HP. Gnome (which actually gives very little over 40 HP. in flight), the power consumed in wind-resistance, even on the test stand, amounts to fully 6 HP., and it may be materially greater under flying conditions.¹

In engines of the Vee type water cooling is in greater favour ; the Renault special aeronautical motor is an exception, being cooled by air-blast generated by a centrifugal fan. The weight of the water cooling-system, when fitted, amounts at the best to 0.6 lb. per horse-power (with water, nearly 1 lb. per horse-power), and thus constitutes a serious addition to the weight of the installation. Here again the class of service becomes important. It is evident that for short-distance flying, where engine-weight is of paramount importance, it may be better to employ direct air cooling ; when, however, a long-distance service is required, it may happen that the weight of the water-cooling system is justified by the saving in horse-power and better fuel-consumption.²

According to a recent investigation by the author,³ the minimum power expended in cooling, that is to say, the power *necessarily* expended in cooling, is a function of the area and

¹ It may be somewhat reduced by appropriate "cowling."

² Since the date of the lecture the question of cooling has been fully treated in a paper by the author, Proc. Inst. A. E., 1915.

³ Report of the Advisory Committee for Aeronautics, 1912-1913, p. 40. The basis on which the investigation in question is grounded is that the cooling (or heating) value of a surface may be expressed in terms of its skin-frictional resistance, a fact that may be independently deduced from the work of Professor Osborne Reynolds. The main result has been since verified at the National Physical Laboratory (see report).

temperature difference of the surface exposed, and there is some difficulty in providing an air-cooled engine-cylinder with sufficient gill surface to keep the power-loss as low as is desirable; when, on the other hand, water is used as a heat-carrier, the rigid limitation as to available surface no longer applies, but there is some disadvantage as to temperature-difference. Fig. 29 is a diagram showing the essential relations between horse-power equivalent of heat dissipated per square foot of surface¹ (abscissæ), tangential velocity of air (ordinates), temperature-difference, and power absorbed in skin-friction. It will be understood that the graphs represent the minimum power absorbed, based on the assumption that the air is traversing the surface along a stream-line path, and that there is no additional loss of power in eddy-making (other than that incidental to skin-friction). The honeycomb type of radiator most nearly complies with this condition.

We may now proceed to consider the interrelation and compatibility of engine and propeller. It has already been pointed out that in order to get the full output from a given engine (as is also well known to be the case in marine propulsion), a propeller-pitch has often to be selected far from that proper to highest efficiency. The difficulty has been met (as in the early Wright machine) by adopting a reduction-gear; alternatively (as also in the Wright machine) a multiplicity of propellers may be employed. It is evident, for example, that, if four propellers be used in place of one, the individual diameter may be halved, and consequently for a given pitch (and therefore revolution-speed) the pitch/diameter ratio doubled. The original Wright machine furnished a good example of a case in which the propeller

¹ It is of interest to point out the fact that the heat lost to the cylinder walls in an internal-combustion engine is commonly about equal to the heat equivalent of the power developed; thus in the case, for example, of a Daumler-Knight engine with the water-jacket surrounding a large part of the exhaust ports and giving 39.2 HP. on the brake, the heat absorbed by the jacket was found to be the equivalent of 41 HP. A similar engine, but with a minimum of water-cooling on the exhaust ports, at the same output, gave 27 HP. only as the equivalent of the heat absorbed.

pitch/diameter ratio was made approximately that of best efficiency, and this result was obtained, in spite of the low velocity of the Wright machine, by a combination of both methods: that is to say, two propellers were used instead of one, and these propellers were geared down from the engine in the relation 10 to 33.

The incompatibility at present existing between the engine-speed and the propeller-pitch becomes less as the flight-velocity is increased, so that, in the case of a machine of about 1,400 lbs. total weight, the propeller-speed (for best efficiency) for a single-screw machine becomes appropriate to the normal engine-speed at about 100 miles per hour. Since the loss of efficiency for a fine-pitch propeller, even down to half the pitch-ratio of best efficiency, is not great, it may be taken that for flight-speeds of 60 miles per hour and upwards the balance of advantage lies with the direct-coupled propeller; this agrees with experience.¹ A point of interest in connection with propellers of comparatively fine pitch and somewhat reduced diameter, such as are commonly used to-day, is the fact that, with the engine fully opened out, there is very little difference between the thrust and the speed of revolution whether the machine is standing or is in full flight—it is commonly reported that the revolution speed does not increase more than 10 per cent. from “standing” to full normal flight-speed—and the thrust variation also is slight. This fact constitutes the only justification for the so-called static test of aeronautical propellers, frequently resorted to when approximate data are required. There is no doubt that in a propeller of theoretically perfect proportion, or in an existing propeller, if fitted to a machine of less resistance, there would be a far greater response to flight-speed variations. Actually this is the case in marine propulsion (in which the propeller is usually of a diameter approximating to its optimum value), where the propeller

¹ In the Vee type of engine commonly adopted, the propeller shaft is, however, often geared down in the ratio of two to one.

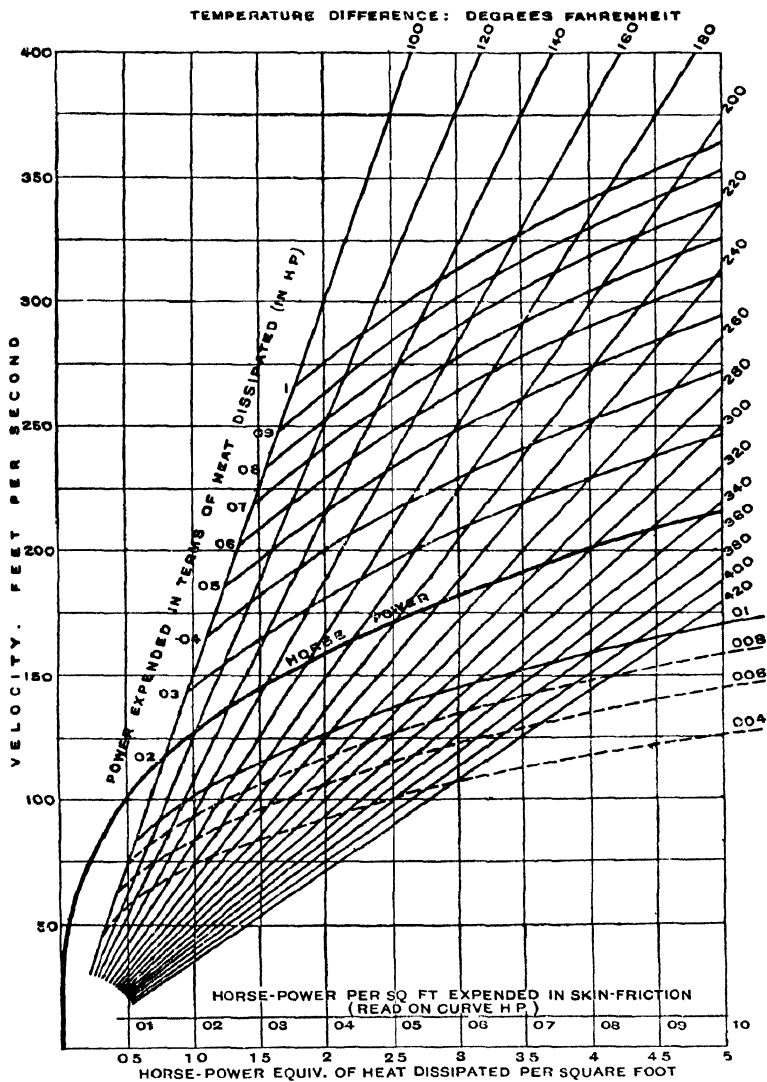

FIG. 29.

Formulae:—

$$(1) \frac{\theta V}{15,000} = \text{h.p. dissipated as heat per sq. ft.}$$

$$(2) \frac{V^3}{100,000,000} = \text{h.p. expended in skin friction per sq. ft.}$$

revolution-recorder is commonly found to give more reliable readings than the ship's log.

The question of compatibility of speed between engine and propeller is summarized by the graphs given in Fig. 27, to which reference has already been made. Here graphs are given for both single propellers (solid line) and twin propellers (dotted line) appropriate to a thrust of 200 lbs. ; ordinates represent diameter (which is to be read also as pitch) and appropriate speed of revolution ; abscissæ represent flight-velocity. Graphs 1 and 2 represent propeller-diameter for single and twin propellers respectively ; graphs 3 and 4 similarly give the speed of revolution, assuming *effective pitch* = *diameter*.

8. RELATING TO THE DESIGN OF THE AEROFOIL.

We shall now proceed to the discussion of the more detailed arrangements and structural features of the machine. First, the aerofoil. The pressure appropriate to least resistance we have already seen to be given as a general rough approximation by the expression¹ $0.32 \rho V^2$ in absolute units or $\frac{\rho V^2}{100}$ in pounds per square foot.

Consequently if w is the weight in pounds (in flying order) the area required is $\frac{100 w}{\rho V^2}$ as appropriate to least resistance.

The above is the whole basis of any initial "lay-out" ; there are many refinements, however, to be considered which enter into the complete problem. The principal of these are :—

The fact that part of w is a function of the aerofoil area—the quantity we are determining—means that the best area will be less than that given by the foregoing expression. This point has been dealt with by the author in "Aerial Flight," 1907, vol. 1., §§ 171, 194, 195, 196, and also more recently by the staff of the National Physical Laboratory.²

¹ Compare Figs. 17 and 18 and text. The constant 0.32 is empirical.

² Report of the Advisory Committee for Aeronautics, 1911–1912, p. 78.

Beyond the above, the specification of flight-velocity for any machine consists more often than not in the prescription of higher and lower limits, rather than of a fixed speed. Under these circumstances the final values and proportions are based on a "lay-out" of graphs of resistances, thrust, etc., on the lines of the diagrams already given (Figs. 12 and 13).

It is evident from the general character of the resistance-velocity curve as shown in Figs. 12 and 13 that whereas considerable departure may be permitted from the normal velocity of flight on either side of the minimum without incurring appreciable increase in resistance, at the limits of the flight-speed range the slope of the resistance-curve is considerable, and there will be sharply defined points at which the resistance is equal to the maximum propeller-thrust and no liberties can be taken. It is important to note that at the maximum limit of flight-speed the equilibrium of thrust and resistance is stable, whereas at the minimum limit the conditions are those of instability, so that should the machine at any time fall below the minimum, the aeronaut can only recover his power of flight by calling upon gravity to assist him, that is to say, by taking a downward course. If, as when near to the ground (or an obstacle), the downward course is not permissible, the machine will execute an undignified and dangerous descent, to which the verb "to pancake" has been applied. The critical speed at which this will take place is not necessarily related to the critical "least velocity" angle of the aerofoil.

Briefly, for a given machine the extent of the flight-speed variation is a function of the reserve of thrust over the minimum resistance value, the absolute value of the limits being fixed by the load that the aerofoil is called upon to sustain. In the case of a high-powered machine, however, the lower limit may be prescribed by the critical angle of the aerofoil.

The choice between monoplane and biplane is, in the main, a question of constructional engineering; there is not a great

deal to choose between the two from an aerodynamic standpoint, but with equally good design the monoplane gives a slightly better lift/drift ratio. The interference effect of the two members of a biplane aerofoil has been studied by many investigators. Professor Langley showed, about 1890, that with superposed planes (aspect-ratio = 4) the interference was not serious when separated by a distance equal to their smaller dimension, the "chord" according to present-day nomenclature. The results of a more recent investigation by the staff of the National Physical Laboratory are published in the report of the Advisory Committee for

TABLE IX.—TABLE OF MULTIPLYING FACTORS TO OBTAIN COEFFICIENTS FROM THE COEFFICIENTS FOR A SINGLE AEROFOIL.

Biplane Spacing, Gap/Chord.	Lift Coefficient			Lift/Drift.		
	6°.	8°.	10°.	6°.	8°.	10°.
0·4	0·61	0·62	0·63	0·75	0·81	0·81
0·8	0·76	0·77	0·78	0·79	0·82	0·86
1·0	0·81	0·82	0·82	0·81	0·84	0·87
1·2	0·86	0·86	0·87	0·84	0·85	0·88
1·6	0·89	0·89	0·90	0·88	0·89	0·91

Aeronautics for the year 1911–1912 (p. 73), from which Table IX. has been taken. In addition to obtaining quantitative data for the particular aerofoil chosen (Bleriot, aspect-ratio = 4), an investigation was also made on the effect of staggering the planes. It is shown to be advantageous to arrange the upper foil in advance of the lower; thus the combination *a b*, Fig. 30, is of the same efficiency as the combination *a c*.

Considering the aerofoil, whether monoplane or biplane, from a structural standpoint, and in investigating the strength of the aerofoil as a whole, it may be treated definitely as an inverted cantilever system. Thus, comparing the stresses

in an aeroplane with the stresses in a cantilever bridge, we have the weight of the body with its alighting-chassis, motor, passengers, etc., the inverted equivalent of the supporting reaction on the central pier of a cantilever girder. We have the air-pressure force, by which the said load is sustained, distributed along the aerofoil length, corresponding to the weights of the outstanding members of the cantilever. We

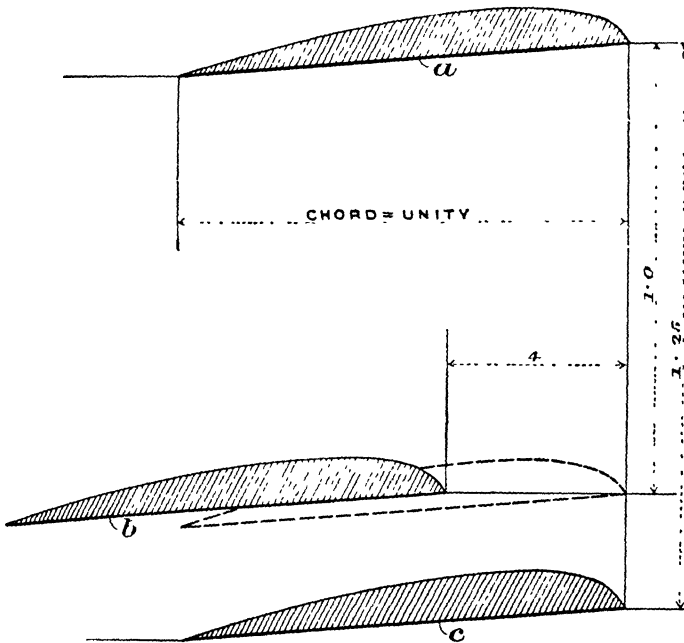

FIG. 30.

have a variation of pressure from point to point due to gusts, eddies, etc., corresponding in some degree to the movable loads representing traffic over the bridge. In the case of the aerofoil, we have in addition something not represented in the analogy of the cantilever girder, i.e., the weight of the aerofoil itself directly supported by the pressure reaction; we may, however, regard this equal and opposite distribution of weight and pressure as superposed on the main system, and as not contributing to the stresses in the aerofoil

members. So far as the analogy to the bridge holds good, it is evident we have a well-known engineering problem which is capable of being treated by well-known methods. In the calculation of stresses of the aerofoil members two alternative methods are in current use ; in the one the aerofoil struts are treated as pin-jointed members, by the usual truss-girder graphic construction ; according to the other method, in place of the hypothesis of the pin-joint, we have the hypothesis of continuity in the main longitudinals. The first and simpler method has been used by several firms for many years past, and gives results which, under ordinary conditions, are very much on the safe side ; the second method has been developed during the last few years by the National Physical Laboratory,¹ and has been to some extent used by the Royal Aircraft Factory, and by other manufacturers.

This alternative method is considerably more complex, and reference should be made to the report cited. It is well to remark that though the pin-joint hypothesis gives results usually on the safe side, the extent of the factor of safety so introduced is not one that can be relied upon, and may in special cases even be negative. It is hardly necessary to point out that the more important and vital the problem, the less appropriate become methods of an approximate and inexact character.

9. RESISTANCE OF STRUTS, WIRES, WHEELS, ETC.

The question of the resistance of components such as are commonly embodied in the design of existing machines has been studied experimentally at the National Physical Laboratory, at the Aerodynamic Laboratory at Göttingen, and by M. F. Eiffel, in Paris. A few results relating to strut sections are given in Fig. 31*a*. The graph *a a* is a plotting from National Physical Laboratory data,² relating to the section A,

¹ Report of the Advisory Committee for Aeronautics, 1912-1913, No. 83.

² Report of the Advisory Committee for Aeronautics, 1912-1913, p. 111.

representing one of the best forms tested, graphs *b* and *c* relating to sections B and C as determined by M. Eiffel.¹ In Fig. 31*a* ordinates represent resistance coefficient both in absolute units and in terms of normal plane (the normal plane unit being that of maximum section). In Fig. 31*b* are shown two strut-sections designed at the Royal Aircraft Factory. These were reported upon by the N.P.L. as giving less resistance *for given strength* than a number of others submitted. Approximately, strength for strength,

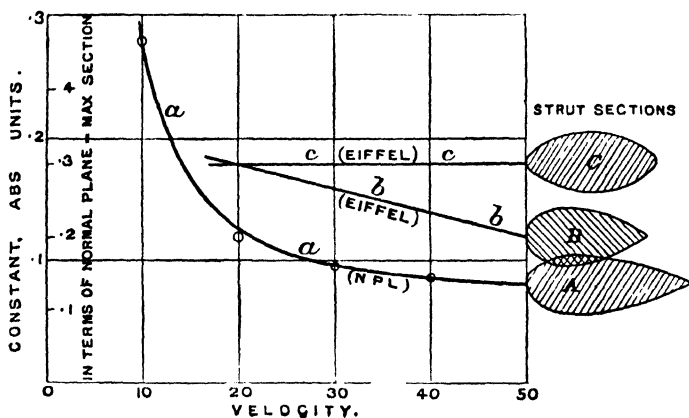
FIG. 31*a*.

these gave one-fourth the resistance of struts of circular section.²

The resistance of wires and ropes has been investigated both by the National Physical Laboratory and by Professor Prandtl of Göttingen. The position may be summarized here by saying that the resistance of a rope or stranded cable, at right angles to the direction of motion, is virtually equal to that of its area projected on a normal plane. The resistance of smooth wires is about 20 per cent. less. Both these results only hold good above a certain minimum value of LV , which may be taken at about 1.5; thus at 100 feet

¹ "Resistance of the Air and Aviation," p. 184.

² Report of the Advisory Committee for Aeronautics, 1911-1912, p. 95.

per second, the rule may be taken as applying to cables or wires down to about $\frac{3}{16}$ inch ($= 0.015$ foot) diameter.¹

Another interesting set of determinations, for which we are indebted to the National Physical Laboratory, is that relating to the resistance of alighting-wheels; these have been tested both in respect of resistance and lateral reaction.² The direct resistance of a 26-inch wheel fitted with a $2\frac{1}{2}$ -inch pneumatic tyre appears to be equal to about a third of its projected area in terms of equivalent normal plane, the projected area being taken to be that of the tyre itself. For

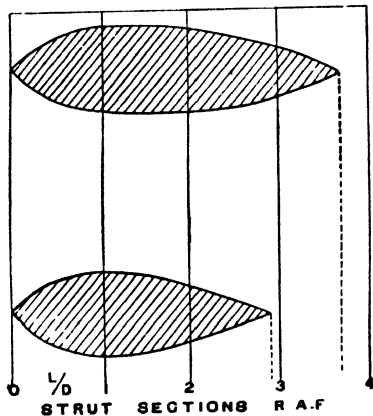

FIG. 31b.

fuller information reference should be made to the Memorandum cited.

10. VERTICAL SURFACE.

One of the quantities of moment in connection with the type of stability known as rotative or spiral stability is that of vertical surface. It is of great importance to be able to compute with accuracy the effective distribution of vertical surface in any machine, and of recent years considerable

¹ Compare Memoranda 40 and 75, Reports of the Advisory Committee for Aeronautics.

² Memorandum 74, Report of the Advisory Committee for Aeronautics, 1912-1913.

attention has been devoted to what we may term the "valuation" of accidental vertical surface. For example, every vertical or inclined strut has a certain directive value which may be expressed in terms of vertical surface; the alighting-wheels, especially if of disk form, represent considerable areas of equivalent vertical surface; even the stream-line body or car has its equivalent value considered as vertical surface. It was pointed out some years ago¹ that a screw-propeller moving other than axially gives rise to a considerable lateral force. More recently Mr. T. W. K. Clarke, Assoc. M. Inst.C.E., has called attention to this action and to the importance of considering the propeller in its capacity as effective vertical surface. It appears from Mr. Clarke's investigation² that the propeller equivalent in terms of vertical surface is a very large and serious factor, and one that under no circumstances should be ignored. The Memorandum in question is worthy of careful consideration by all engaged in the design or construction of flying-machines.

A point that should not be overlooked is that the propeller value, in the sense under discussion, may be different when under power and when dragging or stationary; this suggests the desirability of locating the propeller as near to the centre of gravity (in the fore-and-aft sense) of the machine as conveniently possible.

11. THE DYNAMIC LOAD-FACTOR AND FACTOR OF SAFETY.

A matter of importance, and one of a controversial nature, is the factor of safety necessary in order to take care of the many and varied conditions met with by a machine in flight. In the simple case of a machine in horizontal flight in calm weather we know that the load supported by the aerofoil

¹ *The Engineer*, 26th February, 1909.

² Presented to the Advisory Committee by Mr. Mervyn O'Gorman. Memorandum 80, March, 1913. Report, 1912-1913. The substantial accuracy of Mr. Clarke's investigation has been quite recently established experimentally at the N.P.L.

structures is the weight of the body of the machine and its associated parts, but not including the aerofoil itself, whose weight is directly distributed over the pressure-surface; also we know that in the various evolutions a machine is called upon to perform the stresses may considerably exceed the normal, and that variations of effective load are experienced, due to wind-gusts which it is quite out of the power of the pilot to prevent. Excluding the latter for the time being, we are clearly able to define the worst that the pilot is able to do and specify the factor by which the normal stresses must be multiplied in order to represent the actual stresses; conversely, we may specify arbitrarily a factor of safety, and we may tell the pilot just what he is permitted to do, and just what he cannot undertake without risk. Take in the first instance the assumption that the pilot is allowed to do his worst—he is to be allowed *to try to wreck his machine*. There are two ways in which he can operate; he can either drive his machine at the highest possible speed and suddenly alter his elevator to the position corresponding to the lowest possible speed, or he may take sharp turns involving heavy banking. Now the highest possible speed is the limit of velocity which the machine will acquire in falling head first vertically; this, in the generality of machines constructed at the present day, may be estimated at about 140 to 150 miles per hour. The lowest velocity in the present sense is the velocity at which the aerofoil is meeting the air at its critical angle (the lowest velocity capable of giving a pressure reaction equal to the weight); this may be taken for the purpose of our argument as 40 miles per hour. If, when falling vertically at 140 miles an hour, the pilot with absolute suddenness jerks his elevator into the position corresponding to 40 miles per hour, the reaction brought to bear on his aerofoil is $\left(\frac{140}{40}\right)^2 W$, that is to say, approximately, twelve times the weight of the machine. In practice, for the figures given, the maximum load would be diminished, since the elevator cannot be moved with absolute suddenness, and, if it were, the machine could

not answer the elevator and alter its attitude to the line of flight immediately. It is probable on the basis of the figures given that 10 W is the maximum effective load that could under any circumstances be brought to bear.

In the case of banking, if the machine be banked to an angle θ the resultant of the weight and the centrifugal force is of the value $W \sec \theta$. The author has frequently made estimates of the angle of banking when a pilot has been making a steep spiral dive; ¹ this angle rarely exceeds 60° or 70°. Taking 70° as the maximum the stresses in the machine will correspond to a load equal to 3 W.

From the foregoing it would appear almost certain that in calm weather the pilot, if asked to do his worst, cannot in any manner reach or exceed ten times the stresses due to the static load.

Now as to the effect of atmospheric disturbances. Let us take what may be considered an extreme gust. The machine enters air or is struck by a gust represented by a change of velocity equal to half the flight-speed. Assuming the machine has time to swing to its appropriate relative direction under the new conditions, a simple resolution of velocity shows that the worst condition is that in which the direction of motion of the gust is directly opposed to that of flight; in such a case the relative velocity of the machine becomes $1\frac{1}{2}$ times the normal, and the effective load on the aerofoil will be $1.5^2 = 2\frac{1}{4}$ times the normal. In case of the machine being struck by a *sudden* gust or squall, the load will be considerably higher, but still it can scarcely approach the figure 10 obtained on the basis of the pilot suddenly "flattening out" when at maximum speed.

It is evident from the foregoing that a flying-machine in the course of its normal usage is liable to stresses many times greater than that of its normal load, and the frequency

¹ When observing the banking angle of a machine in flight it is important not to be deceived by false banking, and in fact it is very difficult in any case to be certain of one's estimate. The assumption is here made that θ is the correct angle of bank, i.e., that at which the machine has no tendency to side-slip.

of these stresses, and the total number of times they occur in the life of the machine, will be related to their magnitude by some empirical law for any given class of service. In such a case it is evident that the term "factor of safety" does not carry its ordinary meaning; if, for example, in the lifetime of a fleet of 100 machines the stresses reach 6 times the normal once and 5 times the normal, say, 10 times, and 4 times the normal, say, 150 times, it will certainly be sufficient and proper if the designer works to 6 times the normal load for his elastic limit without using any factor of safety in the accepted sense at all; to do otherwise would be to burden the whole 100 machines with a weight of superfluous material without justification. Whether under these conditions we continue to employ the term "factor of safety" or not¹ the aeronautical designer must bear clearly in mind that in his particular case the factor has a double function, namely, to give the margin of strength and durability needed under ordinary conditions of flight, and to provide for abnormal conditions of stress, occasionally even almost to the theoretical limit of the strength of the structure.

In Memorandum No. 96 of the Advisory Committee (not yet included in an annual report) the matter is fully considered, and the extreme probable values are estimated as follows:—

Nature of Contingency.	Computed Dynamic Load-Factor.
Gusts	4·0
Banking	1·4
Flattening out	8·0
Looping ²	4 to 5

¹ This point may perhaps be dealt with by the use of some qualified expression such as *dynamic load-factor*.

² Estimated by the author; not in original report. The basis of this estimate is the phugoid chart, Fig. 2, the dynamic load-factor is given by the height H in terms of H_n , or in the case of looped paths numbered 8 to 12 the value of $\frac{H}{H_n}$ varies from 3·6 to 5·5. By skilful pilotage it is possible to execute a loop on a far lower factor.

In the report in question¹ the recommendation is made that a factor N , equal to not less than 5 or 6, be adopted in design, this being considered sufficient to take care of anything likely to happen to a machine with reasonable and proper pilotage. Tests and calculations of the wing spars of different existing machines gave the following results :—

Type	Value of N .	How Determined.
A	4	By experiment
B	4	By experiment
C	5	By calculation.
D	3	By calculation.
E	3	By calculation.
F	4	By experiment
G	7	By calculation

At the Royal Aircraft Factory a factor somewhat greater than that recommended in the memorandum in question has been adopted ; a machine (G in the above Table) whose aerofoil was tested to destruction actually recorded 8.4.

In connection with the subject of aerofoil structure it is to be observed that the stress-distribution varies considerably under different conditions, namely, at different angles of attack. Referring to Fig. 16, it will be noted that the aerofoil structure commonly includes two longitudinal members, front and rear respectively, and the proportion of the load borne by each depends upon the position of the centre of pressure and varies with its displacement, which can only be ascertained from experiments on a scale model of the aerofoil itself. This fact needs consideration when computing the maximum stress

¹ If this factor N cannot with propriety be termed a factor of safety, I suggest the term *factor of contingency*, i.e., the factor of contingency requires to be equal to or greater than the dynamic load-factor for which it makes provision.

in the members in question and in the aerofoil structure as a whole.¹

The calculation of the aerofoil structure not only comprises the resolution of the main lifting-force distribution, as already discussed, but also entails the calculation of the longitudinal stresses due to line-of-flight, or "drift" forces. These may be quite moderate under normal flight-conditions, but may become far more severe at abnormally high speeds.² The treatment of this problem does not offer any serious difficulty; it is to-day generally considered the best practice to provide for the edgewise strength of the wing by internal diagonal bracing.

12. LANDING-GEAR.

The details of the alighting-mechanism next claim our attention; this mechanism is necessarily of two distinct types, depending upon whether the machine is designed for land or for marine usage. Taking first the land or military type of machine, the essential features comprise ordinarily a pair (in some cases two pairs) of pneumatic-shod wheels arranged on a common axis somewhat forward of the centre of gravity of the machine, and supplied with a rudimentary elastic suspension of some kind, in addition to runners or skids to take the "bump" in emergency, and some kind of temporary tail-support, consisting of either a castor-pivoted wheel or, more generally, a simple spring-controlled skid. It was at one time believed to be essential that the alighting-wheels should be all castor-pivoted or *orientable*, the intention being to take care of the relative motion of the ground when alighting across the wind;³

¹ Reference should be made to the Report 96 cited.

² When a machine is diving head first downwards at or near its limiting velocity the drift load may be considerably greater than half the weight of the machine.

³ Messrs. Voisin Brothers, in the days of their pioneer work, attached great importance to this point. They attributed the early success of Farman (in his Voisin machine) largely to the fact that this feature was embodied in the design.

experience appears to show that with reasonably careful handling this provision is unnecessary. Two types of sus-

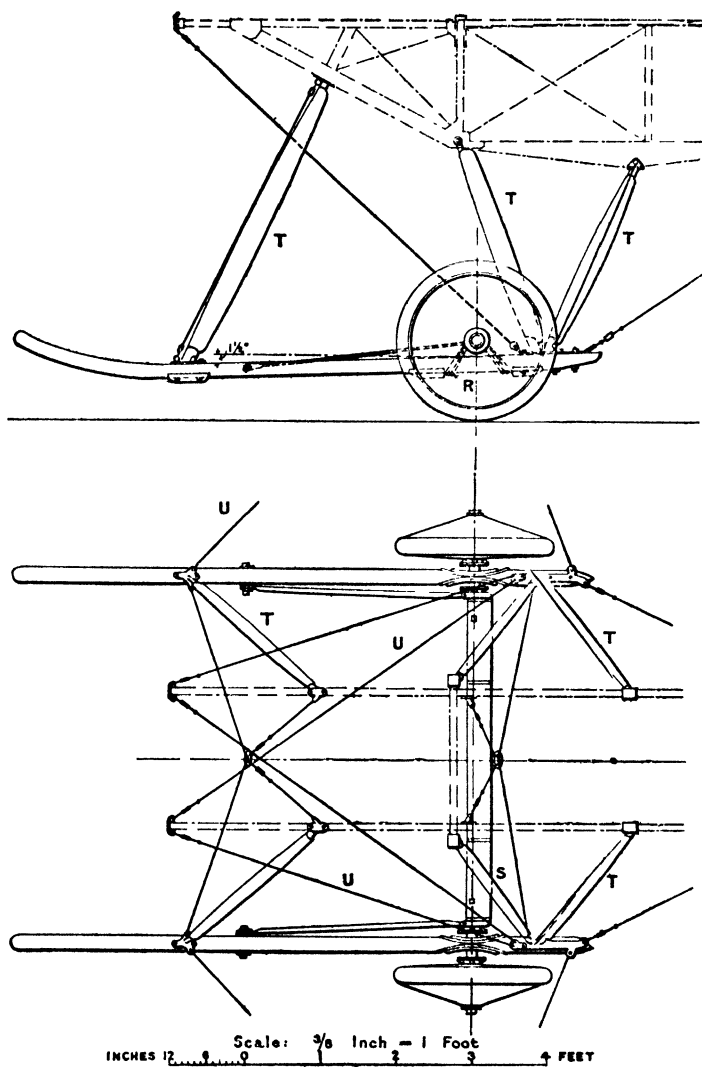

FIG. 32.

pension are illustrated in Fig. 32 (R.A.F.) and Fig. 33 (Bleriot); it will be noted that in both cases the medium

employed to absorb the shock is rubber ; this is preferable to steel (as universally employed on road-vehicles) for two reasons ; first, the energy that good vulcanized rubber will absorb is far greater than in the case of steel ; it runs to some 500 to 1,000 foot-lbs. per pound (10 to 20 foot-lbs. is

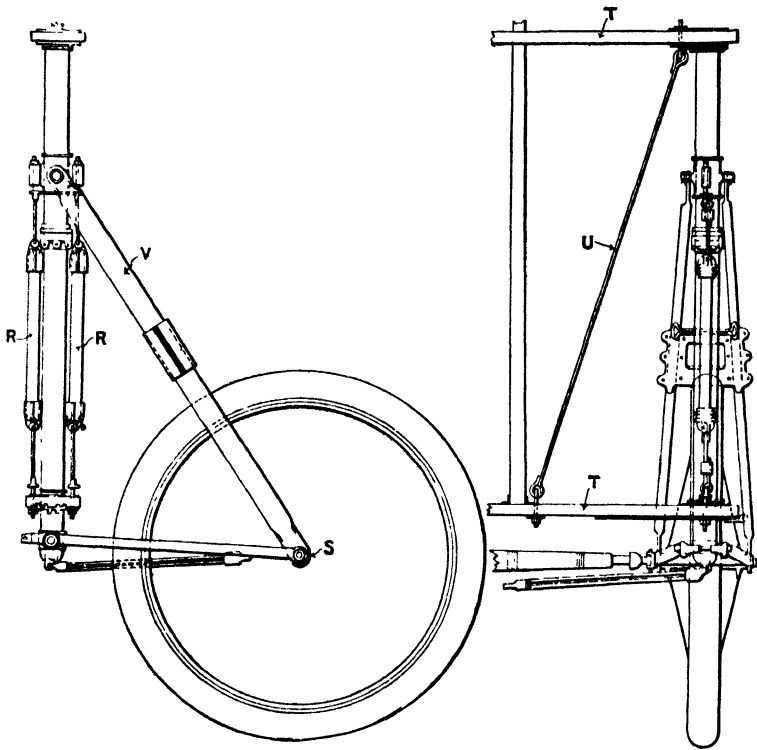

FIG. 33.

all that may be allowed for steel). Secondly, the signs of fatigue in rubber are evident to the most casual observer and the material is cheaply and easily replaced. The alighting-wheels, with their associated parts, are mounted on a structure commonly known as the landing-chassis, whose function is to raise the machine proper to a sufficient height above the ground to provide clearance for the

propeller, aerofoil, etc. Unless careful design and workmanship are put into the landing-chassis, its "spidery" proportions, necessary to give clearance, may, on the one hand, constitute a source of weakness, or, on the other, give rise to excessive resistance. Owing to the liability of the landing-chassis to injury, it is clearly desirable that its structure should be complete within itself, yet this is very difficult of achievement in actual design; more often than not there are members in common to the landing-chassis and the aerofoil structure or the body. This is considered a weak point in design, since it involves the risk that some organ essential to flight may be strained or otherwise injured on landing, or at least be stressed beyond the limit for which it has been designed. It is open to question whether, by making the landing-chassis integral with the wing structure, an actual weight saving could not be effected.

Referring to Fig. 32, it will be seen that the india-rubber suspension takes the form of a lashing, R, the two wheels being mounted on a single axle, S, formed of spar section; the connection between the body consists of six compression members or struts, T, T, T, and wire bracing, U, U, U.

In Fig. 33, which represents the Bleriot method, the wheels are mounted pivotally, after the manner of castors, on a vertical head carried by outriggers, T, T, from the body, diagonal wires, U, being fitted; the wheel-axle, S, is carried on a triangular system of linkwork, one member of which, V, is articulated to slide on the vertical head, the load being taken in tension by the rubber members, R, R.

In both Figs. 32 and 33 it will be observed that the alighting-chassis structure is, in the main, independent of the flight-organs proper, although it is not wholly self-contained, but rather forms an outgrowth from the body. In Fig. 32, however, there are actually guy wires or cables carried from the wing-structure to the runners; this may be regarded as a feature open to criticism, but one which in design it is extremely difficult to avoid.

In spite of all that has been done up to the present, the

landing-chassis is only able to take a very moderate " bump " with safety : 1 foot free fall on to a hard surface is as much as can be deemed safe in the best of existing machines ; a free fall of 4 or 5 feet would lead to almost certain failure. Hence, in landing, a machine should never under any circumstances be allowed to take the ground with a greater vertical velocity-component than 8 feet per second (corresponding to a one foot fall). Assuming a gliding-angle of $\frac{1}{4}$, this means that a machine, flying at 38 miles per hour (56 feet per second), could be allowed to take the ground (presuming the latter horizontal) without intervention of the pilot, but for any higher velocity of flight its course must be eased or flattened : in actual practice it is, of course, part of the art of flying to avoid all shock when alighting ; no pilot would think of taking the ground without at least making his best effort to flatten his angle of descent. There is probably a future for some form of hydraulic-pneumatic device ; already several attempts have been made in that direction.¹

Passing now to the marine type, we find in the earlier examples a landing-chassis of the ordinary pattern fitted with a pair of floats in place of wheels and skid, and a temporary tail-support in the form of a third float arranged aft under the tail member. In the earlier machines these floats were little more than boxes of rectangular section (Fig. 34) ; more recently there has been a tendency to give to the floats a more boat-like form,² surfaces of single or double curvature being adopted in place of flat surfaces, and so the liability to being " stove in " has been reduced to a minimum. The double-float support has proved itself suited to comparatively smooth water, but a strong feeling exists at the present time, for machines intended to serve on the high seas, that this construction will be abandoned

¹ See Appendix IV.

² An instructive series of trials have been made in the William Froude Tank at the National Physical Laboratory. Report Advisory Committee, 1912—1913, Memorandum No. 70 (Baker and Millar).

in favour of the single central boat, as already to be seen in the Curtis and Sopwith machines (Fig. 35) ; here auxiliary floats or bob-floats are fitted to the extremities of the aerofoil to give stability to the machine when resting on the water, and to avoid damage to the aerofoil when getting under way or when alighting.

The main floats, whether single or double, require to be constructed to rise in the water on the same principle as the so-called hydroplanes or skimmer craft, being designed with the usual stepped bottom. A single step is usually found to give the best results considered from the point of view of efficiency alone ; the multiple step appears to have some advantage in broken water. A deep ∇ form of hull, though not as yet employed, might be expected to prove

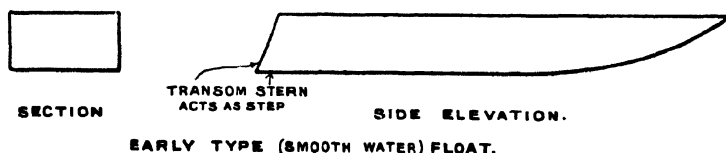
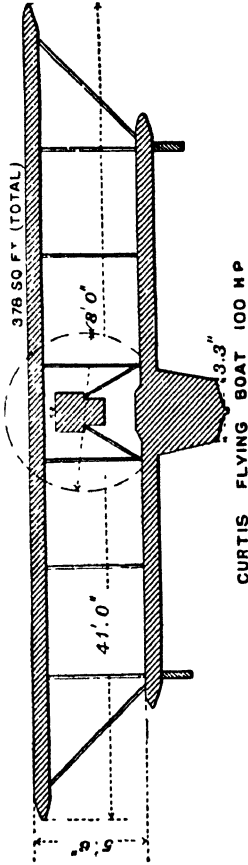

FIG. 31.

of great advantage in starting or alighting in a choppy sea ; in such a design the step would be made to follow the hull-section, and, though some sacrifice in lifting efficiency would undoubtedly be involved, this, with the horse-power now available, is not an overwhelming disadvantage.

The design of floats or hull for a marine machine must be regarded as still in an early stage of development, and much will depend in the future on the general evolution of the machine as to what form of float-gear will ultimately be found most appropriate. It would reasonably appear that as a development of the existing single-boat type it would be desirable to bring the motor or motors, and as far as possible other heavy parts, down into the hull, and design the boat as a thoroughly sea-worthy craft with proper metacentric height and fitted with its own (marine) screw-propeller so that it is capable of being navigated

FIG. 35.



NORMAL FLYING SPEED 70 MPH
 WEIGHT 3 TONS GROSS
 AEROFOIL 800 SQ FT TOTAL AREA

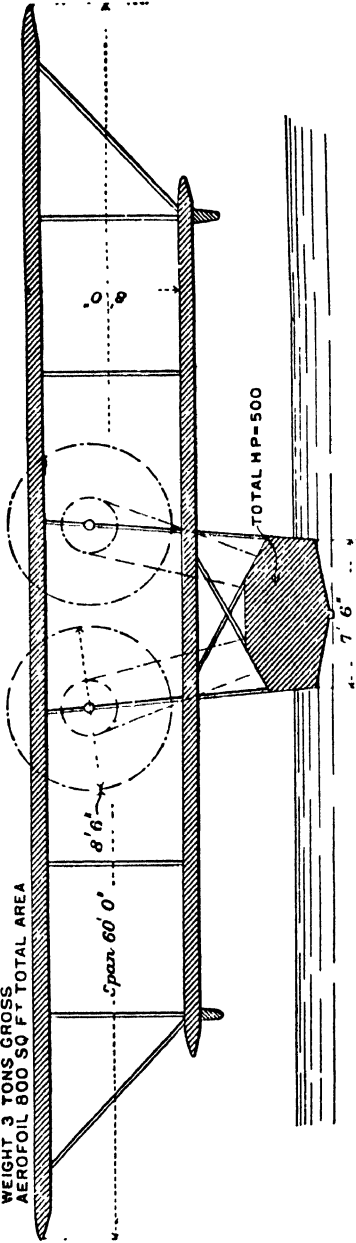

FIG. 36.

independently of its flight-organs (Fig. 36). In such a design it would evidently be necessary to drive the propellers through a belt, chain, or gear of some kind, and mechanism would be provided by which the pilot could jettison the superstructure in emergency. Such a machine would be essentially one of considerable size, and would probably be fitted with two, three, or even more engines, with a total of over 500 HP. The weight of such a machine would require to be 3 to 4 tons, and it would be capable of making port under its own power in the event of the flight-organs being abandoned.

13. ACENTRIC TYPES OF MACHINE.

The type of machine here suggested would be liable to certain objections on the ground that the line of the propeller-thrust is acentric, being situated considerably above the centre of gravity and probably also above the centre of resistance of the machine : conversely, the centre of gravity would be considerably below the centre of resistance. These are objections which have been raised with regard to some existing machines. It is undoubtedly desirable, when other considerations permit, to bring the centre of propulsion, centre of resistance, and centre of gravity, to approximately the same level. There is no fundamental difficulty in flying a machine in which this condition is not complied with, since any pitching moment that results from the want of concentricity can be corrected by suitably arranging the centre of gravity. Serious difficulty, however, is liable to arise in the event of a sudden change in the mode of flight, such as is brought about when the engine is cut out. Under these conditions, the machine being propelled in gliding flight by a component of gravity instead of by the propeller-thrust, a change of pitching moment takes place equivalent to the total resistance of the machine multiplied by the vertical distance between the line of propulsion and the centre of gravity. In a machine of the

type suggested above such a change of moment would be the equivalent of a movement of the centre of gravity through a distance of nearly 2 feet, a change which we may regard as of dangerous magnitude.

The position is that shown diagrammatically in Fig. 37, in which it will be seen that the resultant of gravity and the propeller-thrust passes some considerable distance in front of the centre of gravity, whereas in gliding flight the resultant of the lifting and propelling forces *is* the force of gravity, and so passes through the centre of gravity.

It has been suggested that by arranging the tail-plane (and elevator) in the wake, that is, in the propeller slip

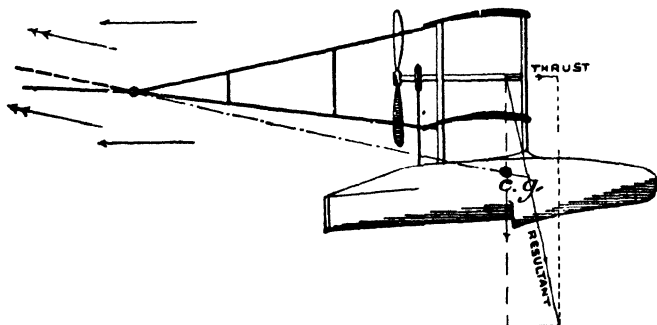

FIG. 37.

stream, and giving it an upward rake—in other words, by employing a negatively loaded tail—the tail may be made to supply a countervailing pitching moment when the propeller is at work; thus whilst the direct effect of the propeller is to tend to lift the tail and depress the nose of the machine, the indirect effect brought about by the action of the slip stream on the upturned tail will be the inverse. It might be possible in this way to correct a small want of concentricity of the propeller-axis, but such a method would scarcely be applicable to the case in point. In order that the method in question should be effective, the slip stream must be discharged radially from the centre of gravity of the machine, that is to say, the general body

of air discharged in the slip stream must be so deflected that its moment of momentum about the centre of gravity is zero. Roughly speaking, this means that the tail, as shown dotted in Fig. 37, must be set at such an angle that, if produced, it would pass through the centre of gravity of the machine; the double-headed arrows show the slip stream diverted as theory requires. The method is evidently impracticable; not only is the tail angle as necessitated

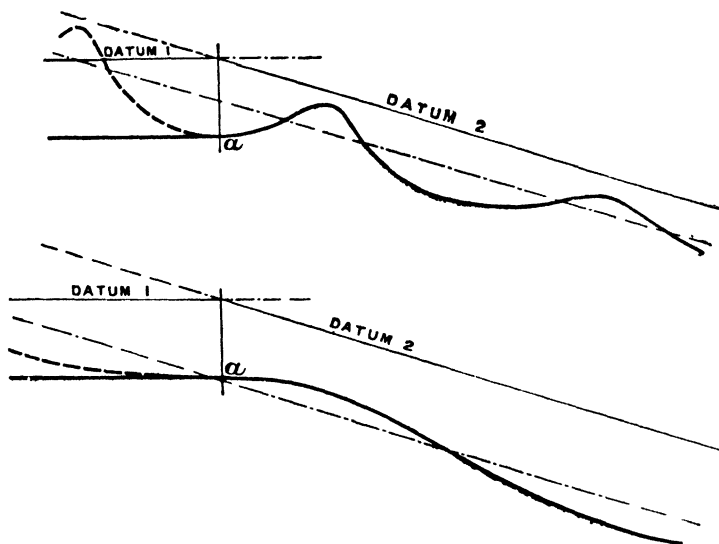

FIG. 38.

altogether excessive, but also the whole story has not been told—the tail would require to be “feathered” immediately the propeller ceases its function, otherwise it would continue to supply a moment of some magnitude when no longer required.

It is of interest to examine in greater detail the behaviour of a machine such as we are considering under flight conditions. It is clear that if at any instant the engine is switched off two things happen: First, as in a machine of the concentric type, the supply of energy being withdrawn the datum of the phugoid chart takes a downward trend,

its down slope being that of the gliding-angle (Fig. 38, datum 2). Secondly, since the withdrawal of the thrust reaction is in effect equivalent to a movement backward of the centre of gravity, the angle of attack of the aerofoil is increased, the natural velocity of the machines is reduced, and H_n is diminished to a corresponding degree. The conditions are thus represented by the upper diagram in Fig. 38; the reduction of H_n being calculated, we consult the phugoid chart and select the curve to correspond; as shown, this has been taken as curve G from Fig. 3 (p. 12). In the lower diagram (Fig. 38) a similar construction has been shown for a machine nearly concentric as to its thrust; the resulting phugoid here corresponds roughly to that labelled C in Fig. 3. The case of least disturbance is that in which the original flight-path picks up the new flight-path at its point of inflection; this is the case if the propeller-axis is slightly below the centre of gravity, since then, on cutting out the engine, the value of H_n is slightly increased; this is as actually represented on the lower diagram.

At present there are difficulties, of the character and extent outlined, standing in the way of development in the direction indicated; they are difficulties that will without doubt eventually be overcome.

14. STABILITY AND CONTROL.

In the foregoing discussion questions of stability in the ordinary sense have been taken for granted. The problems of longitudinal stability, lateral and directional stability, and spiral or rotative stability, though of vital import to the aeronautical engineer, are primarily matters for the physicist and mathematician; the engineer can well afford to leave questions of this character in the hands of the specialist—at least, so far as their scientific aspect is concerned.

There is perhaps less excuse for the absence of all mention of controlling mechanism. A great deal might be added on that subject without going beyond the scope of the title;

however, since the question of control is closely wrapped up with considerations relating to stability, and since it is necessary to draw a line at some point, the omission is one of expediency rather than logic.

The question of stability is not, as is frequently supposed, one that is in any sense obscure ; in fact, from the scientific point of view, the present position is at least satisfactory ; it can be said without exaggeration that we have a great deal more knowledge on the subject than we are at present able to utilize.

There is very little of importance, specifically relating to the stability of the flying-machine, that has been written, either before or since, that will not be found either in the work of Dr. Bryan¹ or in "Aerial Flight."² A few notes have appeared in the various reports of the Advisory Committee for Aeronautics, but not very much ; two short notes of a somewhat trivial character appear in the report of 1909-10, in addition to an excellent abstract of Mr. R. Soreau's "Etat actuel et avenir de l'Aviation."³ In the Reports for 1910-11 and 1911-12 there is nothing ; in the Report for 1912-13 there are two or three interesting communications, mainly due to the staff of the National Physical Laboratory, notably Memoranda Nos. 77, 78 and 79. No. 77 (L. Bairstow, Melville Jones, and A. W. H. Thompson) is, in the main, an examination and extension of existing theory following the methods initiated by Dr. Bryan ; No. 78 (L. Bairstow and L. A. MacLachlan) relates mainly to the determination of the various coefficients required for the application of Dr. Bryan's method of treatment ; and No. 79 (L. Bairstow) deals with the more detailed application of the same method. These communications

¹ G. H. Bryan, "Stability in Aviation." London, 1911. Also Bryan and Williams, Proc. Royal Soc., 1903.

² F. W. Lanchester, "Aerial Flight," vol. ii., London, 1908. A recent note communicated by the author to the Advisory Committee for Aeronautics as bearing on the relation between the results of his own investigations and those of Dr. Bryan will be found in Appendix II.

³ Mémoires, Société des Ingenieurs Civils de France.

are conspicuous by the fact that their authors appear to be really *au courant* with the previous literature of the subject.

The work that has been done on the Continent on the subject of stability does not in sum amount to much, and moreover it frequently appears to suggest complete ignorance of what has been done in this country; in this particular matter it would seem that the Continent has become insular and our island cosmopolitan. For example, we find the work of Mr. Georges de Bathezat¹ described by Mr. Painleve as "the first to give an exact and complete discussion of the stability of the aeroplane"; and when we examine the work so described we find the subject not more than half dealt with, and in so ineffective a manner that scarcely one of the conclusions can be regarded seriously. The works of Messrs. R. Knoller² and Reiszner,³ though interesting, do not materially advance the subject. Mr. R. Soreau deals with the subject of longitudinal stability under two distinct headings, *equilibrium* and *stability*; so far as the former is concerned, his conclusions, as formulated, will be found published by the author in their entirety in 1897, with the reasoning clearly set forth.⁴ Soreau, however, scarcely carries the matter as far as in this previous publication. Incidentally he gives two propositions, relating to minimum tractive force and minimum horse-power, which, except for differences of notation, appear to be identical with two propositions previously given by the author in "Aerodynamics," 1907, § 164. When we come to the question of stability it will suffice to state here that his conclusions on the subject of longitudinal stability are gravely at fault; briefly, he states that the moment of inertia must not be too small for fear of oscillations becoming

¹ "Etude de la Stabilité de l'Aeroplane." Dunod, Paris, 1911.

² "Über Langstabilität der Drachenflugzeuge," 1911.

³ "Einige Bemerkungen zur Seitenstabilität der Drachenflieger," 1912.

⁴ Patent Specification 3608, 1897, or compare also "Aerial Flight," vol. ii., p. 353.

too rapid, whereas the only oscillation of importance—the “phugoid oscillation”—is virtually independent for its period of the value of the moment of inertia. On the questions of lateral stability and directional stability, Mr. Soreau's views (as pointed out by Dr. Bryan) are entirely at fault; the whole question of asymmetric or rotative stability is lost sight of, and the fact that in directional stability the centre of gravity cannot be treated as a static pivot¹ is ignored.

The work of Captain G. A. Crocco² is of interest. In the main he follows established mathematical lines of treatment; the author has made no attempt to follow his work in detail. Captain Crocco's conclusions on the whole appear to be sounder than those of most Continental writers; his work is evidently worth careful study, although nowise beyond criticism.

The foregoing may be taken as a brief summary of the existing literature of the subject. Excellent abstracts of the work of the foreign authors cited will be found in the appendixes to the various reports of the Advisory Committee; except in the case of the French writers, which have been consulted in the original, I have relied on the abstracts in question for the summary here given.

In general the question of stability has, in the past, been treated too closely on mathematical lines to be of immediate service to the engineer; in many cases the writers have clearly suffered from their want of appreciation of the real conditions. It is the author's opinion that there is very little room for useful work to-day on the subject of stability unless it be rigidly and directly supported by experimental work, and from our standpoint as engineers I think we may

¹ Compare “Aerial Flight,” vol. ii., §§ 95 to 100; also Bryan, “Stability in Aviation,” ch. vii.

² “Sulla stabilita laterali degli aeroplani,” also “Perfezionamenti nella stabilita longitudinale degli aeroplani,” “Rendiconti delle Esperienze e degli Studi eseguiti nella Stabilimento di Costruzioni Aeronautiche del Genio, Anno II.”

in the future look confidently to the excellent work being accomplished at the National Physical Laboratory, and at the Royal Aircraft Factory, to keep us in touch with that which is essential in this important branch of the subject.

APPENDIXES.

APPENDIX I.

THE subject of skin-friction where air is concerned has been one of considerable controversy. The quantities to be measured are so small and the apparatus employed until recent years has been so insensitive that until the work of Zahm in 1904 very little was known on the subject. Langley in his "Experiments in Aerodynamics," 1891, asserted skin-friction to be a negligible factor in its relation to flight. Dines about the same date expressed the same view; in "Aerial Flight," vol. i., which appeared in 1907, the author (not aware of the work that had been done by Zahm) published some determinations of skin-friction and attacked Langley's views, pointing out that skin-friction is one of the controlling factors in the economics of flight. The author also introduced the practice of expressing it as a coefficient representing the resistance of a thin lamina in tangential motion in terms of its resistance at 90 degrees; the coefficient so expressed is the *double surface* coefficient, and in the work in question is represented by the symbol ξ . In the greater part of this experimental work planes or laminae of mica were employed of but a few square inches area; the largest area used in any of these determinations was approximately $\frac{1}{2}$ square foot. Now it is well established that the coefficient of skin-friction in a plane of small area is sensibly greater than in one of large area; consequently the author's values were on the whole considerably higher than those of experimenters working to a larger scale. However, the following passage may be cited as the summary of experiments made with planes of about $\frac{1}{2}$ square foot area and of smooth surface:—"It is therefore to be concluded that for a well-varnished surface or for polished metal, under the conditions of experiment, the effective value of ξ is approximately 0.009 with a probable error of less than 10 per cent., plus or minus."¹ According to the best estimate that can be made to-day the actual value of the double-surface coefficient under the conditions of the experiment in question should be 0.0081, showing an error of precisely the 10 per cent. stated.

It has been frequently stated that the author's results were in disagreement with those of Zahm; sometimes those making this

¹ "Aerial Flight," vol. i., p. 380.

statement ignored the author's lower values and took the highest, which admittedly were too high; in other cases they read the double-surface coefficient as a single-surface coefficient, and so made the author's values twice as great as they really are.

In a communication to the Advisory Committee for Aeronautics (Memorandum No. 15, June, 1909), the author has pointed out that his own results and those of Zahm for air, and the results obtained many years ago by W. Froude for water, are in substantial agreement—in fact, in very close agreement—provided that they are put in their proper perspective, with due consideration to the laws of dynamic similarity.¹ The final conclusion given in the memorandum under discussion is expressed in graphic form in Figs. 39*a* and 39*b*, in which abscissæ represent the quantity LV (the product of the linear dimension² in feet by the velocity in feet per second), and in which ordinates represent the coefficient of skin-friction. Three curves are shown: the upper curve is the double-surface coefficient for air, for which the author employs the symbol ξ ; the lower curve (solid line) is the single-surface coefficient (half the value of the former); the dotted curve is the coefficient for water. In Fig. 39*a*, LV values may be read from 20 to 1,400. In Fig. 39*b* is given a graph for lower values.

It is a point not without interest that, for geometrically similar aerofoils, the weight sustained varies as $(LV)^2$; consequently, for any given value of LV , the weight is constant. In other words, as already shown, for least resistance $P = C \rho V^2$, where C is a constant whose value is about 0.32, or if $n L^2$ represents the area, and $W =$ weight (poundals),

$$W = 0.32 n \rho (LV)^2,$$

$$\text{or } W \text{ (pounds)} = 0.01 n \rho (LV)^2.$$

Therefore, assuming good design (maximum lift/drift) and some definite value of aspect-ratio (the constant n), the coefficient of skin-friction is determined by the weight of the machine, and is the same

¹ Compare memorandum cited, also addendum to same by Lord Rayleigh.

² Ordinarily the *linear dimension*, represented in the laws of dynamic similarity by L , presupposes geometrical similarity, i.e., geometrical form as an invariable. In the present usage, owing to the thinness of the layer of air affected, L may be taken as the linear dimension of the plane in the direction of motion. In the case of a plane 1 foot square, for example, the total skin-frictional resistance (double surface) may be represented by the momentum of a layer of air only about 1 millimetre in thickness, or 0.5 millimetre on each surface. A rough computation shows that the thickness of the layer of air *sensibly* affected during the passage of the plane will not exceed say 10 millimetres, and therefore the *end effect* will be very slight; hence the coefficient is but little influenced by the lateral extent of the surface except in the case where the lateral dimension is relatively very small.

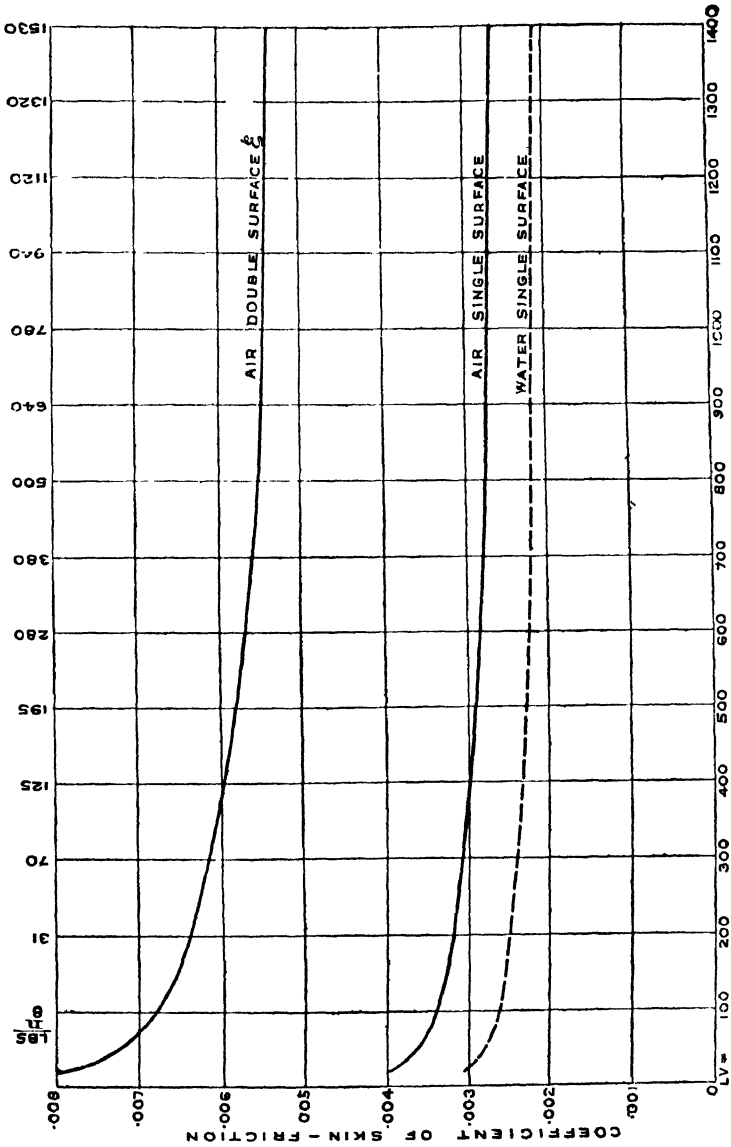

Fig. 39a.

whatever the designed velocity may be. In Figs. 39a and 39b values of weight in terms of aspect-ratio are indicated for the values of LV given by the scale. These figures multiplied by the aspect-ratio give the weight of the machine appropriate to the value of LV in question¹ as corresponding to the condition of least resistance, and enable the skin-friction coefficient to be read as the corresponding ordinate.

Skin-friction has a habit of playing an elusive part in actual resistance phenomena, and the subject in practice is full of pitfalls.

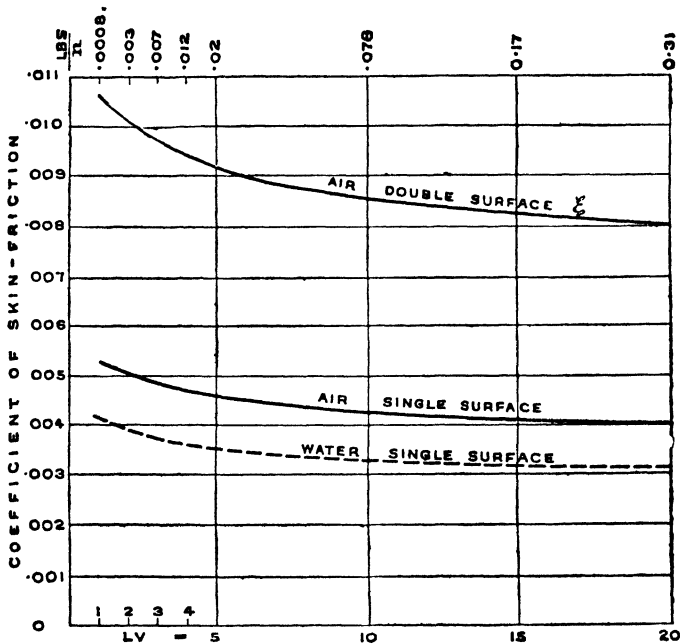

FIG. 39b.

In the case of a plane moving edgewise, it may frequently happen that skin-frictional resistance will virtually disappear: the leading edge of a plane such as used by the late Professor Langley will by its bluntness set in motion a certain quantity of air, and this moving air subsequently washing the surfaces of the plane will reduce the skin-frictional resistance to something immeasurably small. As pointed out in the author's discussions of Langley's work, this was one of the causes that led him into error.

¹ The product of the chord dimension of the aerofoil and the flight-velocity in feet.

Another case where the coefficient of skin-friction may be abnormally low is that of the inclined plane at a small angle of incidence. In "Aerial Flight," vol. i., the matter is dealt with on p. 264, § 182; it is pointed out that as a deduction from gliding experiments made with the ballasted plane, and calculations based thereon, the coefficient of skin-friction is in effect less than is ordinarily the case, and the explanation is offered that the upper

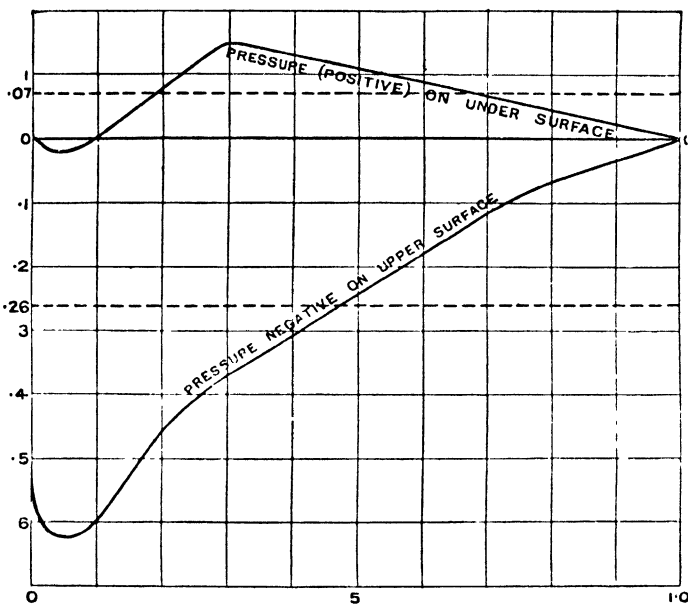

FIG. 40.

surface of the plane being to a certain degree a "dead-water region" the coefficient may in this case be only that of the single surface. This conclusion has received striking confirmation in connection with some experimental work carried out recently at the National Physical Laboratory.

It is probable that in the case of the pterygoid aerofoil, that is to say, the aerofoil of wing-like section, such as is shown at the foot of Fig. 40, the skin-friction may in effect be abnormally high owing to the augmented velocity with which the air flows over the

upper surface. This, speaking generally, is not altogether compensated by the lower velocity on the under side. The velocity of the air in the vicinity of the aerofoil can be deduced approximately by the ordinary laws of fluid motion from the local pressure. Now pressure-curves have been made for several different sections on aerofoil by the National Physical Laboratory; the curve shown in Fig. 40 may be taken as roughly typical of the pressure graph for

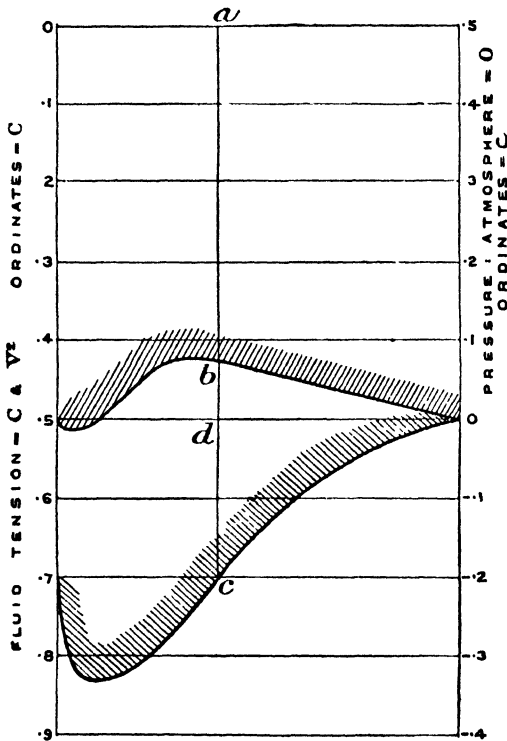

FIG. 41.

mid section of any well-shaped aerofoil at or about its angle of least resistance. The ordinates downwards from the zero datum-line are the negative pressures on the upper surface of the foil, and the ordinates measured upwards from the said datum-line are the positive pressures on the under surface, in both cases measured above and below atmosphere. Plotting the same curve in Fig. 41, and taking a datum-line corresponding to zero motion, ordinates will represent fluid tension (negative pressure) and the velocity at every

point is represented by the square root of its ordinate; hence the skin-friction will vary as the ordinate itself, and, referring to Fig 41, the effective coefficient of skin-friction will be greater than the normal in the relation of the mean of the ordinates ab , ac , to the ordinate ad . Referring again to Fig. 40, it may be observed that the mean pressure-increase on the under face is approximately one-fourth of the mean pressure-decrease on the upper face; taking this proportion as a basis, we have, in Fig. 42, graphs of the augmentation of the skin-friction as a function of the aerofoil pressure-constant; the normal coefficient proper to the LV value in question being read on the ordinate corresponding to pressure-constant = zero, on the left hand of the Figure. In the case, for example, of the

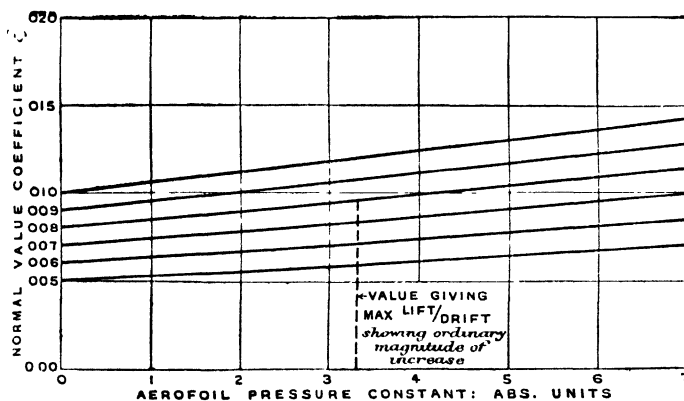

FIG. 42

normal value of the coefficient being 0.008, it will be seen that for a pressure-constant = 0.32 the augmented coefficient will be nearly 0.01.

We thus begin to obtain values approaching those that the author found to apply in connection with the theory of least resistance. If, in addition to the above, we allow an addendum to represent *form resistance*, as has been found by Prandtl in the case of the ichthyoid body, and which is due to the degeneration of the streamline system consequent on the appearance of the frictional wake, we might expect the effective direct resistance of the aerofoil expressed in terms of skin-friction equivalent to a coefficient of 0.017, which is in very fair agreement with experience. The assumption here is that the proportion of the added *form resistance*¹

¹ In the case of the aerofoil the *form resistance* includes the combined effect of thickness and camber.

bears the same ratio to the true skin-friction, approximately 0·7 : 1·0, as is commonly found in the case of the ichthyoid body, of 6 to 1 ratio. It is probably somewhat less in an aerofoil of good proportion; the effective total coefficient under the ordinary conditions of wind-channel experiment is more nearly 0·015.

APPENDIX II.

THE ADVISORY COMMITTEE FOR AERONAUTICS.

NOTE ON THE STABILITY OF THE FLYING-MACHINE AS AFFECTED
BY CONSIDERATIONS RELATING TO PROPULSION.

By Mr. F. W. LANCHESTER.

1. In the author's "Aerial Flight," vol. ii., p. 101, the results of an investigation are given in the form of an equation in which a quantity ϕ , a function of the constants of the machine, is given in the form of an expression which may be fully ascertained from the design of the machine and from observations of its velocity and gliding angle. The condition of flight path stability (or, as it is now termed, *dynamic stability*) is that this quantity shall be greater than unity.

2. The investigation in question strictly relates to a machine in horizontal flight propelled by a *constant* force whose magnitude is exactly equal to the mean resistance.

3. The result was subsequently taken, without sufficient scrutiny, to apply without qualification to the case of a machine or model in gliding flight, and later in the work (p. 115, section 70 *et seq.*), a number of experimental determinations were made with mica gliding models in order to verify the equation.

4. These results were, on the whole, considered satisfactory, and the disagreement (in view of the fact that no such work had previously been attempted) was not considered serious. The value of ϕ , as calculated for a number of models experimentally found to be *just stable*, were as follows :—

	ϕ .
12-gramme model	0·93
$\frac{4}{1}$ " "	0·95
$\frac{1}{4}$ " "	0·65
"One grain" " (=0·062 gramme) .	0·84

According to the equation the above should have been 1·00 in every case.

5. Later in the work (section 118 *et seq.*) the question of the mode of propulsion and its influence on stability is discussed, and special study is given to the particular case when the motor is working at *maximum output*, that is to say, at that point where the torque varies inversely as the revolution speed; and more generally it was shown that the conditions can be met by the introduction of a factor ψ and by representing the condition of stability thus—

$$\psi\phi > \text{unity};$$

the factor ψ was shown to depend upon the value of the slope of the torque curve (with some assumptions on the subject of the torque thrust relation of the propeller). In the particular case mentioned, with the motor under conditions of maximum horsepower, the quantity ψ was shown to have the value 1.5 (p. 210).

6. Dr. G. H. Bryan, in his "Stability in Aviation" amongst his more generalized theory, has incidentally touched upon the particular case represented by my own restricted hypothesis, and has in the main confirmed my result; he discusses the special case in question under the appellation "Lanchester's Condition." He also publishes a very important result, for which he gives the credit to Mr. Harper, that the stability is very greatly affected by the inclination of the flight path. In other words, it is shown that my own equation only applies with exactitude to the particular case of the horizontal flight path, and that it does not apply, as tacitly assumed in my work, without correction to the case of gliding flight; similarly, a correction is required in the opposite sense if the machine is climbing.

7. Briefly stated, the magnitude of the "*Harper Effect*" is such that for gliding flight the conditions of stability are satisfied if we have—

$$\phi > \frac{2}{3};$$

or, if we prefer to so write it—

$$1.5 \phi \text{ greater than unity.}$$

Also, if the machine be climbing at its gliding angle, we have—

$$0.5 \phi \text{ greater than unity};$$

and if climbing at twice the gliding angle the stability has gone, for at that flight path inclination the multiplier becomes zero; hence however great ϕ be made the conditions of stability cannot be complied with.

8. The author has re-examined the problem, using his own methods, with complete confirmation of Dr. Bryan's results; the Harper effect makes its appearance at once, the moment the conditions of the

inclined flight are critically examined. The omission to have located this in the first instance was due to the assumption (not definitely formulated) that the constant flight path component of gravity is the equivalent of a constant propulsive force (or a constant resistance in the case of climbing); this is true for the rectilinear flight path, and is approximately true for the phugoid of small amplitude, but the degree of approximation is only the same as that of the quantities forming the basis of investigation, and therefore must be taken into account. On introducing the flight path inclinations as a new factor, and on equating the change of scale of the phugoid chart in the same manner as in the case of the other quantities concerned, we obtain Mr. Harper's result as above stated. The approximate form of the graph representing the Harper factor is a straight line as given in Fig. 43.

9. It is of interest to re-examine the experimental values obtained (section 4, *ante*) from models computed to be *just stable*. These being gliding models, the calculation should have given $\phi = 0.66$. The two first, the 12-gramme and 4-gramme models, gave respectively 0.93 and 0.95; these were considered very satisfactory at the time, as the result then expected was 1.0; the $\frac{1}{4}$ -gramme model gave the result 0.65, which, in the light of present knowledge, is extremely good, but which at the time caused some misgiving. Commenting on the point at the time, the author wrote (p. 124):—

“In this case the agreement is not so close as in the preceding examples, the stability according to direct observation being apparently 50 per cent. better than as computed from the equation. Further trials of the model failed to show any error in the observation data. An inaccuracy of 10 per cent. in the velocity measurement would be required to account for the discrepancy; it is unlikely that an error of one-quarter this amount would have escaped notice.”

In the light of our present knowledge it is not surprising that all attempts to find an error in observation or data failed; it is rather in the case of the models that showed a higher reading that some explanation is due.

10. The item of data with regard to which the greatest doubt may be said to exist is the *correction for wash*. The basis on which this correction is founded is given in the final discussion of the equation itself,¹ and briefly depends upon the hypothesis that the tail is *long*; it is assumed to be acted upon by the *residuary motion* of the periphery only. In none of the examples in question could the tail be fairly considered to be beyond suspicion in the matter of length, and

¹ “Aerial Flight,” vol. ii., p. 100. Also Memorandum No. 161, 1914–15, Report Advisory Committee for Aeronautics; also Proc. Inst. A.E., vol. ix., pp. 209 *et seq.* and p. 239.

consequently the tail (wash) correction employed may be expected to be somewhat less than its actual value under the conditions of experiment. This will account for the values of ϕ as calculated being too high, and is the probable explanation; on referring to the drawings given of the models in question,¹ it will be seen that the tail of the $\frac{1}{4}$ -gramme model (in terms of the fore and aft dimension of the aerofoil) is relatively longer than either of the other two.²

11. From the foregoing *résumé* and discussion of the position it is evident that the "Harper Effect" is a real live fact, and one that will require to be taken into account, especially now that climbing angles as great and even in excess of the gliding angle have to be reckoned with. I do not go so far as Dr. Bryan when he says: "*It is not safe to draw inferences regarding the stability of motor-*

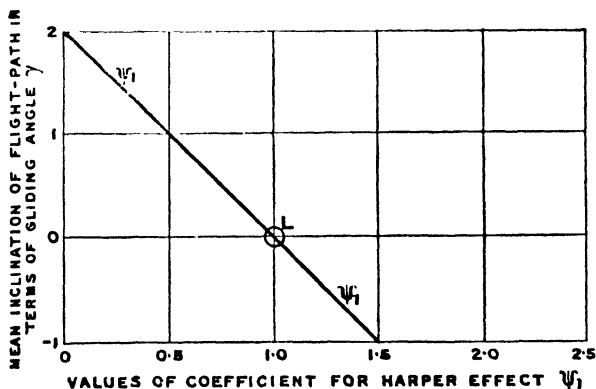

FIG. 43.

driven machines from experiments with gliders" (p. 89 of his work); a method of correction to enable such inferences to be correctly dealt with had already been worked out and published (cp. par. (5), *ante*); but it is clear that the Harper effect must be simultaneously taken into account, and to this extent Dr. Bryan's warning is quite to the point.

12. In Fig. 43 the Harper effect has been given in the form of a graph in which ordinates represent the mean flight path gradient in terms of the gliding angle and abscissæ the value of a factor or multiplier to be applied to the quantity ϕ of my equation. We

¹ "Aerodnetics," pp. 117, 121, 123.

² A suggested form of correction for *shortness* of tail has been given by the author (in reply to Mr. O'Gorman) in a recent paper on "The Aerofoil," Proc. I.A.E., vol. ix., p. 239.

will call this factor ψ_1 , and we will denote the propulsion factor by ψ_2 , the sum of these being a total correction factor ψ . Thus, in Fig. 44, the point L denotes what Dr. Bryan has termed "Lanchester's Condition," and the vertical through L is the value ψ presumably to be inferred from my original investigation as applying generally to the condition of constant force of propulsion. The correction for the Harper effect is given by the line ψ_1 and the correction for propulsion as given by me for engine at maximum output (torque \times velocity = constant) is given by the " ψ_2 No. 1." The algebraic sum of the two corrections is given by the vertical " ψ No. 1." This particular case is of great interest, inasmuch as the propulsion effect exactly neutralizes the Harper effect, and the stability factor is constant for all path inclinations.

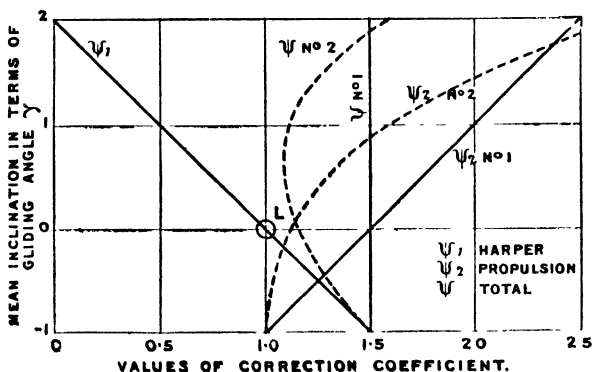

FIG. 44.

13. The particular case taken in the last section to correspond to the special case given in my "Aerodnetics" (p. 210), besides being of interest, as being an exact antidote to the loss of stability pointed out by Mr. Harper, is of value as defining for the engineer the character of the power curve that it is desirable to employ from the present standpoint, although it may not be one that altogether commends itself in other ways. It would in practice mean that the motor must be always run on the throttle to bring the maximum point of the power curve to correspond to the speed of revolution for the time being employed; this would not only be inconvenient, but also would be extravagant in fuel consumption; it would, at the best, mean working at about two-thirds full torque, with a corresponding loss of efficiency. One cannot frame the consequent *régime* with exactitude without first making thrust-revolution determinations of the propeller and taking actual power

curves of the engine, but given these in any particular case the matter becomes an ordinary one of graphic lay-out to determine the form of the correction graph. The usual character of this would be somewhat as depicted in " ψ_2 No. 2" and " ψ No. 2."

14. In the author's opinion the control of the motor-power curve opens the way to a practical solution of the problem of the increase in flight path stability under flight conditions. In view of the importance of avoiding excessive fuel consumption it would seem appropriate that the requisite character may be given to the power curve of the motor artificially by means of a governor; by this

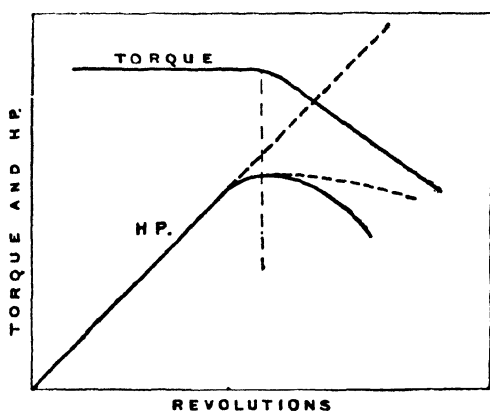

FIG. 45.

means the point of maximum horse-power may be arranged to be available without material loss of torque, as shown in Fig. 45, and if desired a comparatively flat top may be imparted to the power curve; any result of this kind may be obtained by suitably designing and proportioning the governor mechanism.

APPENDIX III.

In Section 3 of the present work reference has been made to the results obtained from recent tests of the author's 1894 aerofoil at the National Physical Laboratory and elsewhere. In view of the fact that no better results as to lift/drift ratio have been recorded up to the present¹ either at the National Physical Laboratory or at

¹ May, 1914.

Göttingen (or elsewhere to the author's knowledge), the matter has been deemed of sufficient interest to include the present Appendix embodying the Report in full.

A scale drawing of the aerofoil has already been given in Fig. 19.

REPORT ON TEST ON MR. LANCHESTER'S AEROFOIL OF 1894.

The actual aerofoil tested was a model to $\frac{3}{4}$ scale of that sent by Mr. Lanchester. The wind-speed was kept at 30 feet per second, and the inclination of the chord varied from -2° to $+18^\circ$. The lift and drift are given in the following Table :—

Angle of Incidence.	Lift Co-efficient Lbs on Model at 30 Feet per Second.	Lift/Drift.
-2	-0.015	..
0	0.066	6.3
2	0.143	13.0
4	0.234	17.1
6	0.305	15.2
8	0.366	11.7
10	0.399	8.1
12	0.401	6.4
14	0.387	4.2
16	0.362	3.4
18	0.352	3.0

If we take the increase of lift/drift to be the same as that for R.A.F. 6, Report T 234, the lift/drift at the top speed of the channel (50 feet per second) would be between 20 and 21 as against the 17.6 given in the Report.

LEONARD BAIRSTOW,
p.p. Director.

19th February, 1913.

APPENDIX IV.

In Section 12 of the present work reference has been made to the employment of hydraulic or pneumatic-hydraulic mechanism in connection with the landing-chassis. Many proposals and attempts have been made of recent years in this direction with more or less success; one of the earliest of these is described in the author's

specification [No. 18,384 of 1909. The apparatus in question was designed by the author and built by the Daimler Co., Ltd., for Messrs. White and Thompson, of Middleton, Sussex, in 1909-10. It was temporarily abandoned owing to the exigencies of an altera-

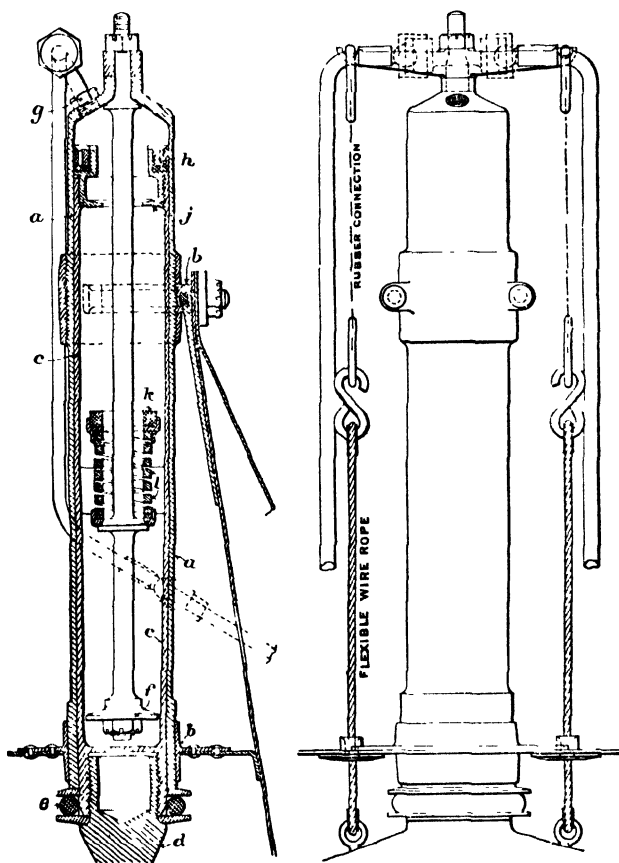

FIG. 46.

tion of design, and up to the present no opportunity has occurred of giving it a trial.

The apparatus in question is illustrated by the scale drawing, Fig. 46, in which a sleeve or cylinder *a* is mounted in a suitable bracket *b*, attached to the body. Inside this cylinder *a* is a further cylinder or hollow ram *c*, into which can be screwed at its base the fork lug *d*, which in turn carries an alighting wheel. The cylinder *c*

can move vertically within the cylinder *a*, and the Figure shows the two cylinders with cylinder *c* in its uppermost position, i.e., at the top of its stroke ; an india-rubber buffer *e* is provided to prevent shock.

The cylinder *c* is not internally of even diameter throughout its length, and is fitted with a fixed piston *f* carried rigidly from the head of the cylinder *a*. This inner cylinder is filled with oil, which acts as a hydraulic buffer when the machine takes the ground ; the vent being formed by leakage round the periphery of the piston *f*. The taper of the bore of the cylinder *c* is so designed that the escape of the oil is less restricted when the relative upward motion of the piston begins (and when its velocity is greatest), and the restriction becomes gradually greater as the motion is absorbed and the velocity becomes less. The grading of the taper is designed to calculated dimensions to ensure the approximate constancy of the pressure throughout the whole period of motion, this being the condition under which the vertical component of the flight-velocity can be taken up in the least distance with a minimum of stress on the landing gear.

Pneumatic pressure is admitted to the head of the cylinder *a* by the inlet *g*, furnished with a valve under the control of the pilot ; it is presumed that in its normal condition the machine is resting on skids or runners, which may act as a brake either when the machine is standing or when it is being brought to rest, and that it is lifted off the ground by the depression of the alighting wheels on the admission of air-pressure to the cylinder by the port *g* ; the free running or braking of the machine is therefore under the command of the pilot by virtue of his control of the pneumatic pressure valve.

The usual cup leather packing to prevent loss of air is arranged at *h*, and the check plate *j* is provided to arrest the downward motion of the plunger, a counterpart leather pad *k* and spring *l* begin fitted to the piston rod.

A DISCUSSION

CONCERNING THE THEORY OF SUSTENTATION AND EXPENDITURE OF POWER IN FLIGHT ¹

INTRODUCTORY

THE present communication is, in the main, a *résumé* and discussion of work and investigations relating to the theory of sustentation and the expenditure of power in flight. Attention is particularly given to the controversial points which at present undoubtedly exist; there still appears to be some divergence of view amongst different workers and writers on the subject.

The opening sections relate to the question of *direct resistance*, especially as concerning the wing member or aerofoil of a flying-machine; this is a matter on which authorities are, so far, by no means in agreement. Whereas the present writer has made it his practice to deal with the direct aerofoil resistance (varying approximately as V^2) on the basis of an *augmented coefficient of skin friction*, there are others, notably members of the staff of the National Physical Laboratory in this country,² who contest the validity of this procedure. The subject is one of great subtlety and full of pitfalls. The importance of the matter is due to the fact that the theoretical determination of the conditions of least resistance, and in fact the whole subject of the economics of flight, depends finally upon the correct expression of the *direct resistance*. The present writer based his work³ (published in 1907) on the hypothesis that the total resistance can be analysed or divided into two portions or component resistances: a *direct resistance*, which varies directly as V^2 , and termed the *x-resistance*; and an *aerodynamic resistance*, which varies inversely as V^2 , and termed the *y-resistance*: it is shown in the work in question that the condition of minimum resistance is that the direct or *x-resistance*, and the aerodynamic, or *y-resistance*, are equal to one another. On this foundation, together with the computation of direct resistance on the basis

¹ Paper contributed to the International Engineering Congress, San Francisco, Cal., 1915.

² Proc. Inst. A.E., vol. ix., pp. 229 *et seq.*

³ "Aerial Flight," vol. i., Aerodynamics, chap. vii.

of a *surface* or *skin-frictional* coefficient, a whole superstructure of theory has been established which accords well with experience,—even with the most modern experimental results,—including such facts as the $\frac{P}{\bar{v}^2}$ relation of least resistance; the approximate constancy of gliding angle for machines designed to different velocities; and the advantage to be derived from high aspect ratio. Not only were the general facts, as above, deduced from the premises stated, but coupled with an application of vortex theory (an application which the author actually employed as long ago as 1894), quantitative values were obtained and tabulated; and these tabulated values, whether for the $\frac{P}{\bar{v}^2}$ relation, the minimum gliding angle, or for the angles defining the form of camber, cannot be much improved upon even at the present day.

It is to be understood that two distinct issues are involved in this question of direct resistance: first, whether it is legitimately to be reckoned as an entity separable from the aerodynamic resistance; second, whether it is legitimately to be assessed, or we may say best assessed, on the basis of a surface or skin-frictional coefficient. It is evident that if the direct resistance is properly assessed on the basis of “wetted” surface, whether we call it a *surface* coefficient or a *skin-frictional* coefficient is merely a question of terminology; were the objection involved merely in the term used, it would be pure pedantry; it is not a question of the term, it is a question of fact. These matters are discussed in Sections I. to IV.

A later portion, Section V., deals with the author’s method of treatment of the dynamics of sustentation, as founded on vortex motion, both as given in his “Aerodynamics” in 1907 and in a recent paper read before the Institution of Automobile Engineers of London.¹ This theory was utilized by the author in the design of his early gliding models, 1894² (mainly directed to the investigation of stability), and formed the subject of a paper presented, in 1897, to the Physical Society of London but rejected. A theory having a similar basis has been developed independently by Kutta. In spite of the sluggishness with which this theory has been accepted by English physicists, there is to-day no question whatever of its truth; it is impossible to explain the facts known to us from experiment without taking vortex motion as the starting

¹ Proc. Inst. A.E., vol. ix., pp 176 *et seq.*

² The experiments in question formed also the main subject of a paper read at the Annual Meeting of the Birmingham Natural History and Philosophical Society, June 19th, 1894.

point. Those who still persist in denying the truth or utility of the cyclic or vortex theory have nothing to offer in its place, and have to confine themselves, to the assertion and classification of the empirical results obtained from wind-channel or whirling-arm experiments : experiments which are frequently ill-directed, owing to the lack of a true appreciation of the factors which are essential and those which are unimportant.

The author maintains that even at the present time, when very large sums of money have been expended in experimental apparatus and in experimental work, theory is still the most reliable guide where the problem is other than one of some specific performance. Speaking more generally, the value of existing determinations is many times enhanced when interpreted in the light of theory ; without such interpretation experimental results may actually prove misleading.¹

In the following discussion the main points are made and arguments presented as concisely as possible ; it is the author's intention that the references given should be consulted when the present *résumé* or abstract is found inadequate. The subject of skin-friction and direct resistance, however, is argued at some length.

I. CONCERNING SKIN-FRICTION.

The question of direct resistance and skin-friction and their interrelation is one of considerable complexity. So long as we are dealing with a plane lamina at zero angle, i.e., in tangential motion, authorities are now agreed that in different fluids, whether air or water, at variable velocities and for geometrically similar laminae of different sizes, skin-friction closely follows a law as expressed by the dimensional equation.

$$R = k\rho (LV)^n \nu^{2-n} \dots \dots \dots (1)$$

in which R is resistance ; L is a linear dimension defining the size of the lamina, V is velocity, and ν is kinematic viscosity, ρ is density, and k is a constant. This equation may be said to define the conditions of *dynamic similarity*. The index n is not of necessity constant ; thus, the foregoing equation may be looked upon as only literally true in its differential form. For any given point on the resistance velocity curve, it defines, locally, the rate of change for variations in any or all of the three variables concerned ; it does not mean that the curve of resistance for any considerable length is of the type suggested by the equation in its integral form.

¹ Proc. Inst. A.E., vol. ix., p. 250.

In view of the fact that in actual problems such as come within the range of ordinary experience, the index, n , is never far from 2, it is usual to regard skin-frictional resistance, along with other direct resistance, as following the ordinary V^2 law; it is thus expressed as a *coefficient* whose value depends, for any given fluid, i.e., air or water, upon the value of the product LV . Variations in this coefficient may be regarded as necessary to correct for the cumulative effect of considerable changes of LV . These variations may be graphically represented as in Fig. 47, in which a parabola drawn as a local approximation to an arbitrary curve, will require a different constant according to the point on the curve chosen.

Thus the constant, or coefficient of skin-friction, is commonly expressed either, as in the author's "Aerodynamics," as the resistance of a lamina in tangential motion in terms of the resistance of the same lamina moving normally, by the symbol ξ , or it is expressed by a constant C_0 in accordance with the equation

$$R = A \times C_0 \rho V^2,$$

in which A is the area of the lamina, and ρ the density of the fluid, C_0 being the constant for zero angle. When the coefficient ξ is employed, it is defined in the author's work to be the double-surface coefficient, namely, it relates to the resistance of a *lamina* rather than a *surface*. If the constant C_0 be taken, also, as that proper to a lamina, it is related to ξ by virtue of the usual equation of the normal plane,

$$P_{90} = C_{90} \rho V^2$$

thus,

$$C_0 = \xi C_{90}.$$

Or if the constant C_0 be taken to relate to a single surface (as is more usual), it is half this value. C_{90} may be taken as having a constant value 0.6 or 0.62 for the purpose of this relation; its variation as a function of aspect ratio may be ignored. When the author originally adopted his form of expression, i.e., that representing the skin-friction in terms of normal-plane resistance (many years before the publication of his work in 1907), the general perspective of the subject was not quite so clear as it is to-day; otherwise he would have given preference to the C_0 constant. The difference between the two modes of expression, however, is of no great importance once the position is clearly stated.

The author has given graphs for the value of ξ for variations of (LV) in his "James Forrest" Lecture, 1914,¹ these graphs, Figs. 39A and 39B, being founded on the assumption of a constant

¹ Proc. Inst. C.E., vol. cxviii., p. 327.

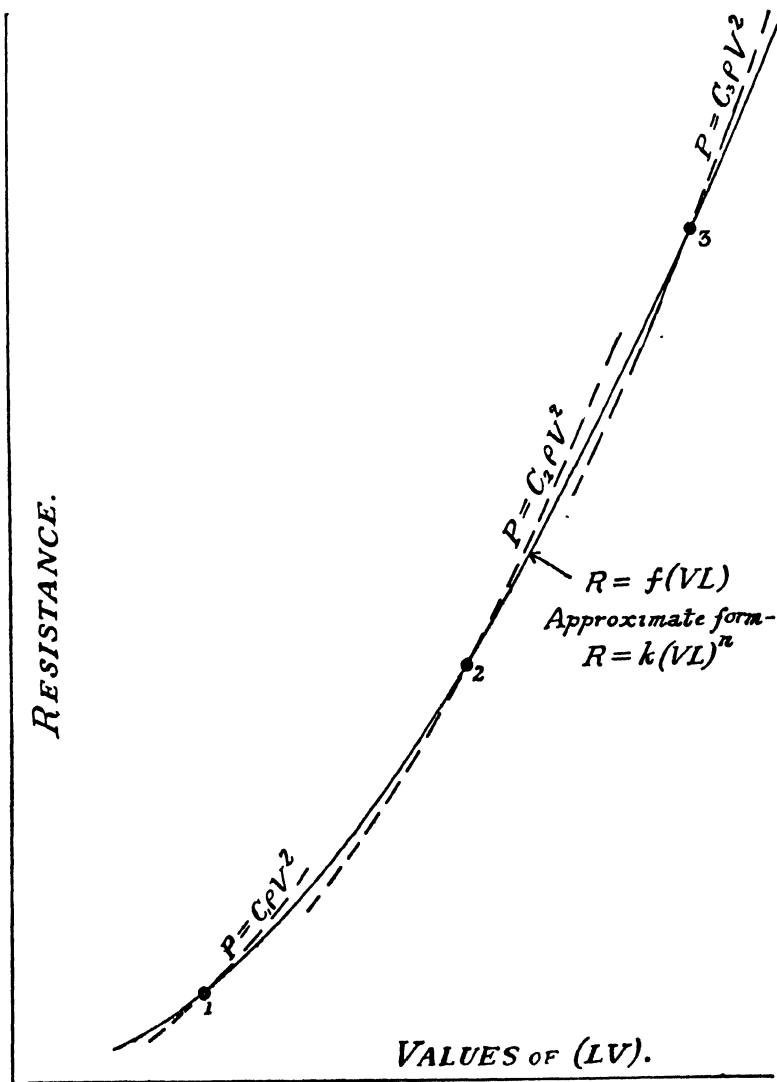

FIG. 47.

index, n , of 1.9, this probably is only a questionable approximation to the truth; the result, however, agrees fairly well with the determinations, both of Zahm and of the author, for air, and those of the late William Froude for water.

Incidentally, it is pointed out that since in the design of a flying machine (for the condition of least resistance) the linear size of the aerofoil varies inversely as the flight velocity, we have, for any given weight of machine, LV a constant; so that the coefficient of skin-friction depends primarily upon the weight of the machine. This fact is represented by the upper abscissa scale in the figure, the weight being given per unit of the aerofoil defined by the square of the chord, in other words, $weight/n$ (here n represents the aspect ratio); it is necessary to put the expression in this form to take account of different values of aspect ratio being employed. The assumption involved is that when the condition of geometrical similarity is departed from the fore-and-aft dimension fairly represents the L of the dimensional equation: the author believes this to be approximately true where skin-friction is in question.

It is impossible to harmonise the work of different writers on skin-friction as completely as one would wish, since the work has, in the past, been conducted in an entirely empirical manner. The law of dynamic similarity as defined by equation (1) was not made use of either by Froude or Zahm, and no attempt was consequently made by either of these investigators to establish its accuracy experimentally by the employment of geometrically similar planes, or to ascertain that which the present author believes to be approximately true, the relative negligibility of the width, and proximate identity, for practical purposes, of the fore-and-aft dimension and the L of equation (1). That the author's view is by no means the obvious or only view is evident from the fact that in a report contributed by the staff of the National Physical Laboratory to the proceedings of the Advisory Committee for Aeronautics (No. 54, March, 1912) the width of the plane is assumed to have the same importance as its length, and the square root of the area is taken as the equivalent of the L of the equation: the present author believes this view to be wrong, but there is no existing means of proving who is mistaken.¹

The problem which the author set himself, of bringing into line and harmonising his own results with those of Froude and Zahm, as

¹ In a more recent communication (May, 1915) to the Advisory Committee, the author has pointed out that the layer of air sensibly affected during the passage of a lamina is so thin that it is impossible that the influence of *width* should require consideration. The L of the dimensional equation is *virtually the length*.

given in Figs. 39a and 39b, involves the interpretation of the work of the latter in the light of the equation of dynamic similarity, and the value of the index n adopted, 1.9 was derived as a compromise¹; this compromise being, in part, based on the direct values suggested by both Zahm and Froude, as relating to velocity, and, in part, based on the relative values for air and water given, respectively, by these authorities, in view of the difference in the kinematic viscosity, that of air being taken as 14 times greater than that of water. The index 0.1 was found to be approximately applicable.

It cannot be too clearly stated that, broadly speaking, whenever the principle of dynamic similarity is employed or in question, the quantity L , which defines the linear size, may be *any* linear dimension, so long as it is the corresponding dimension in every case, because *dynamic similarity* presupposes *geometrical similarity*. Thus, if a cube be the subject of experiment, L may be chosen as an edge, or it may be a face diagonal, or it may be a trigonal diagonal; but whichever be initially taken must always be taken: L is then a true measure of linear size. Without the condition of geometrical similarity, it is clearly impossible to define variation of size by a single linear dimension; and it is then only possible to apply the principles of dynamic similarity when it can be otherwise demonstrated that some particular dimension or condition is unimportant owing to the special circumstances of the problem; under these circumstances the application will, at the best, be regarded by the physicist as somewhat loose. The problem of skin-friction, in the absence of experimental evidence to the contrary may be considered as a case in point.

II. DIRECT RESISTANCE AS RELATED TO SKIN-FRICTION.

Immediately we depart from the case of the plane lamina in tangential motion, all the simplicity of the problem disappears. The inclined lamina, for example, at small angles invariably shows a fictitiously low skin-frictional resistance; a flat plate of finite thickness, whether in tangential motion or inclined, also may show a fictitiously or apparently low coefficient. Again, in the case of an aerofoil of pterygoid (winglike) form, such as commonly adopted, we may likewise find apparently less skin-friction than would be calculated from its "wetted" surface.² An important point,

¹ Originally proposed by the author in Report 15, 1909, Adv. Comm. Aeronautics.

² If the skin-friction were not substituted by other forms of direct resistance, it would be greater rather than less under these conditions, owing to the higher mean square of the velocity. (Compare "James Forrest" Lecture, Proc. Inst. C.E., vol. cxviii., p. 328).

however, in all these and similar cases, is that although the skin-friction may be abnormally low, in *no case is the total resistance less than the skin-friction as ordinarily calculated*. In other words, in all the cases cited, the skin-frictional resistance is accompanied by resistance of other kinds, and these other kinds of resistance "mask" the skin-friction to a greater or lesser degree.¹

In endeavouring to analyse, experimentally, the total resistance, whether it be of a spar section, or an ichthyoid body, or an aerofoil, the accepted method is to determine the pressure distribution over a mapped-out series of sections by means of a number of small holes and tubes connecting to manometers or pressure gauges; the total pressure reaction in any direction is then obtained by integration, and the difference between this total and the actual resistance, as determined in the ordinary manner, is attributed to skin-friction. An investigation of this character was made by the staff of the National Physical Laboratory,² the result being that, in the case of a particular aerofoil, skin-friction was actually found to represent, at the most, about one sixth of the total resistance. Probably if the same method had been adopted in the case of the "planes" of rectangular section employed by the late Prof. Langley, the direct evidence of skin-friction would have been even less—possibly it would not have been detected at all. Now there is nothing really wrong with the method; it is in itself quite reasonably accurate. What is wrong is the interpretation which is too frequently put upon the results; for example, in the case of the planes of rectangular section employed by Langley it may have been literally true that, as Langley states, the resistance could be, practically speaking, accounted for by the edge effect, as separately computed; but to have built upon this fact, as demonstrating the negligibility of skin-friction, is to-day generally admitted to be quite without justification. The truth is, as pointed out in the author's "Aerodynamics," the edge effect merely serves to mask the skin-friction; both the edge and the faces of the planes are washed by the same air, and if this air is given a forward motion by the direct pressure on the edge, the faces of the plane are relieved of the greater part or the whole of their ordinary skin resistance. Similarly in other cases, as, for example, the aerofoil forming the basis of the investigation at the National Physical Laboratory, the edge effect—or, more generally expressed, the "bluffness" effect—is equally present and prevents the full influence of skin-friction from being developed. In all such cases the direct resistance is present and is

¹ "Aerodynamics," §§ 158, 182, 183, also Proc. Inst. A.E., vol. ix., pp. 246, 249.

² Report No. 73, March, 1913; Adv. Comm. Aeronautics.

at least as great as, and in practice greater than, the skin-friction which it masks. It is indeed possible that the skin-friction may be rendered *negative*; for example, if a lamina in tangential motion be preceded by a small normal plane or other bluff body, Fig. 48, the lamina, being wholly surrounded by the "dead-water" and situated where it is known the latter has a forward movement, may be actually *dragged forward* instead of being *resisted* by skin-friction.

The whole position is illustrated diagrammatically by Fig. 49; here ordinates represent resistance and abscissæ may be taken to be a measure of bluntness, on any basis we fancy. Now, when the bluntness is zero we have the case of a thin lamina in tangential motion, and the resistance is that due to skin-friction. When any degree of bluntness, whether by edge thickness or otherwise, is introduced, the resistance is increased, perhaps at first in very small degree and later more rapidly, as shown by a curve *a b*—this graph represents, in fact, the

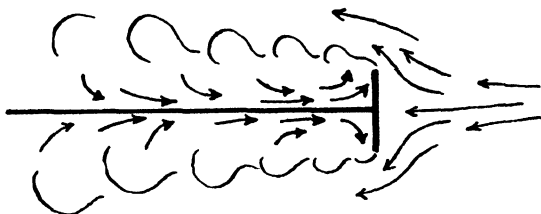

FIG. 48.

measure of the total *direct resistance*. From an engineering point of view, it is this total direct resistance and its measurement which concerns us; it matters not one iota whether as the resistance increases the skin-friction actually remains constant, as shown by the line *a a*, or whether it decreases, as shown by the line *a c*, or even if, as at *c d*, it becomes negative. One thing is clear, the skin-frictional resistance as based on a lamina of equal area (and the same plan form) gives us a *minimum value for direct resistance*.

Thus the propriety, or otherwise, of assessing the direct resistance of an aerofoil, or tail member, or fin, on the basis of skin-friction depends upon the extent of the bluntness with which, in practice, we may have to deal; upon the augmentation in resistance to which, following Fig. 49, this will give rise; and upon the possible alternative methods which may be open if the skin-frictional basis be rejected. On the other hand, it does not depend in the least degree upon the results of such experiments as those cited (Committee Report 73) or upon the presence, or otherwise, of actual skin-friction as determined by even the most scientifically exact methods or refined

apparatus. Evidently if we go to the extreme and think of the bluffness as comparable to that of a normal plane, such, for example, as in the case of a circular cylinder, all idea of founding an expression for the resistance on a basis of skin-friction must be abandoned; such a basis would be clearly inadmissible. So long, however, as we are dealing with forms which are admittedly designed on as fine lines as possible with the very idea of avoiding unnecessary direct resistance (which is true of any rationally designed aerofoil or fin),

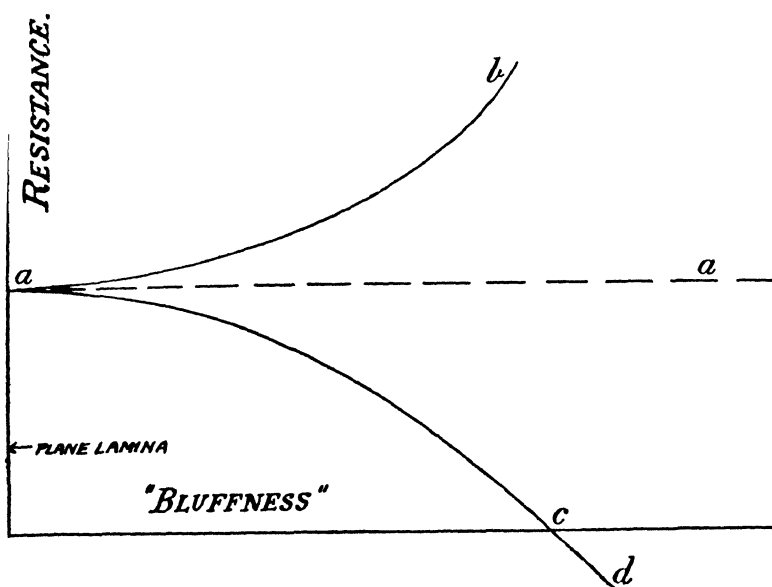

FIG. 49.

we are on precisely the same footing as obtains in the case of the hull form of a ship, in which the basis of skin-friction, with an augmentation variously assessed, is universally admitted.

The author has found a great tendency, amongst those occupied in aerodynamic laboratory research to deny the validity of these really most elementary considerations, and instead of assisting the theoretical understanding of the subject by determining the approximate augmented skin-friction values for different degrees of bluffness and camber, an enormous amount of time and money are being wasted in the vain endeavour to prove that skin-friction cannot have the importance attaching to it, because it is not really

there. If those in charge of our naval and other experimental tanks had shown no more perspicacity, our knowledge in matters pertaining to ship forms and resistance would not be where it is to-day.

In the author's opinion and experience the skin-frictional basis of computing the direct resistance is completely justified for fin or spar sections of good form up to a thickness whose maximum does not exceed about 0.13 or 0.14 of the fore-and-aft length—it may be justified even beyond this; with experimentally determined coefficients much more could of course be done. In the case of the pterygoid aerofoil—and it is here the greatest importance attaches to the method—it is probable that the “camber” effect and the “bluffness” effect have to be simultaneously taken into account. The author has found that with aerofoils carrying about half the pressure intensity proper to a normal plane at the same velocity (C in absolute units = 0.3), the ordinary coefficient of skin-friction requires to be augmented by about 60%; a portion of this, however,—about 10%—is calculable as due to the augmented mean square of the air velocity in the vicinity of the aerofoil, as deduced from the local pressure values. Thus, for models of a scale suited to wing channel experiment, the augmented coefficient ξ (double surface) is about 0.015 to 0.016 (corresponding to C_o (double surface) = 0.01), and for full-sized machines, $\xi = 0.01$ or $C_o = 0.006$.

III. THE TEST OF EXPERIENCE AS CONFIRMING THE SKIN-FRICTION BASIS OF DIRECT RESISTANCE.

Those responsible for the design of actual machines, in common with those engaged on aeronautical research, have continually in view the reduction of the resistance coefficient of the member of support—the aerofoil; consequently, in the results of recent experiment and in the forms developed we may fairly presume that we have some reasonable approximation to the best that can be done in this respect. Now, in the author's “Aerodynamics” (1907) tabulated theoretical values are given for the *least gliding angle* for aerofoils of different aspect ratio and for various values of skin-friction coefficient—it is of interest to compare these results. This has been done in the author's “James Forrest” Lecture, Fig. 20. Here we see two curves representing the theoretical values of the lift resistance (the converse, or reciprocal, of the gliding angle) plotted from the author's original tables, for values of aspect ratio varying from $n = 3$ to $n = 13$, the skin-friction coefficient (augmented values) being taken as $\xi = 0.015$ and $\xi = 0.02$ in the two curves.¹ On the same diagram are plotted

¹ See also Table VII., § 3; “James Forrest” Lecture, pp. 39, 40, *ante*.

various results, mainly quite recent determinations made at the National Physical Laboratory; these latter lie consistently between the two theoretical curves, and a point of great interest is that these values show (compared to the curves of theory) far better results at about an aspect ratio of $n = 6$ to 7 than for other values—there is, in fact, an appreciable “hump” in the experimental values about here. Now this is just the value of aspect ratio most commonly adopted in actual machines, and it is a value to which far the greater number of the investigations and determinations which have been made relate. Hence, we see that, assuming the theory as correct, the form of the experimental curve is just what we might anticipate; further, we may infer that were the other values of aspect ratio as carefully worked out as that in question, the curve would lie more nearly parallel to those of theory and correspond to an augmented coefficient of skin-friction of about 0.016 or 0.017.

As a confirmation of the author's view, the foregoing is little short of complete, especially when it is borne in mind that at the date of the publication of the table represented by the curves in Fig. 20, very little had been published on the subject of aerofoils of curved sectional form and that little highly misleading. As a matter of fact, the author relied exclusively on his own theoretical methods, with “constants” furnished by deduction from experimental determination with *planes*, as given in his work already cited.

The foregoing example is but one of many that might be given as demonstrating from experimental fact the truth of the skin-frictional basis. The pressure tables given in the author's “Aerodynamics,”¹ for instance, are in close agreement with present-day experience and depend upon the same foundation theory. Beyond this the difference known to experiment between the least gliding angle for high values and low values of (LV) is clearly to be explained as a result of the corresponding difference in the skin-friction coefficient.

The variations in the coefficient ξ , on which the tabulated figures, in the author's work are based, cover a range from 0.01 to 0.03. We have already seen that the first of these figures is that which roughly obtains in the case of a full-sized machine at ordinary speeds of flight—briefly, for a machine of about one ton weight. The higher limit, 0.03, may be taken as required to cover the conditions of extremely small-scale work such as indulged in by the author in his experiments and determinations with mica models; the lightest

¹ “Aerial Flight,” vol. i., pp. 270 and 271.

of these weighed approximately 1 grain (0.062 gram).¹ It is the author's opinion that the index diminishes rapidly for very small areas and low speeds, such as those in question, with a correspondingly more rapid increase in the coefficient.

IV. RESISTANCE OF THE INCLINED PLANE LAMINA.

The particular case of the inclined plane lamina is worthy of special note. It is sometimes assumed in the case of the inclined plane when used for experimental determinations or as a means of sustentation in flight, that the whole of the resistance component derived by a resolution of forces about the angle of inclination represents work done aerodynamically. In one sense this may be true; it is, however, as a matter of fact, possible to separate, analytically, the proportion of the energy so expended which is usefully employed in sustaining the load, from the proportion dissipated in useless eddy making. Assuming this analysis, it is clear that the useless eddy-making resistance may be regarded as direct resistance, and as such, it has been demonstrated, both by theory and by experiment that it is capable of masking at least half of the skin-friction as ordinarily computed—perhaps more than half. On the other hand, this kind of direct resistance does not follow the usual V^2 law, and it is just here that the special nature of the case becomes manifest. We have a form of direct resistance, which instead of varying directly as V^2 varies as part of the aerodynamic resistance and, within limits, may be regarded as proportional to the latter; so that from the point of view of the equation of least resistance, the whole of the resolved resistance component requires to be considered as y -resistance—that is to say, of aerodynamic origin. The position is admittedly complicated; but so far as the condition of least resistance is concerned, it is approximately reached if it be assumed that the upper surface of the plane is not subject to surface friction owing to its being situated in a “dead-water” region, and that the resolved resistance be taken as the aerodynamic resistance. In other words, the calculation is made in the usual manner, but the single-surface coefficient is made use of in place of that for double surface. For the fuller discussion of this case the references already given should be consulted.

V. SUSTENTATION IN FLIGHT. THE DYNAMIC SYSTEM.

The author's theory of sustentation in flight is based on the more general theory of vortex motion. The author believes he can claim priority as far as the discovery of the vortex or cyclic system sur-

¹ “Aerial Flight,” vol. ii., § 74.

rounding the aerofoil is concerned, this, as already stated, having been the basis of a paper read before the Birmingham Natural History and Philosophical Society in 1894, and a further paper submitted by him to the Physical Society of London in 1897. The theory in question, with the results of a considerable number of other investigations, eventually received full publication in the year 1907 in the author's "Aerial Flight."

The vortex or cyclic theory of sustentation in flight has been still further developed recently, the latest results being summarised in a paper contributed by the author to the Institution of Automobile Engineers¹ and the discussion on this paper conveys some impression of the extent to which the subject is one of controversy.

It is not only shown that a vortex system, comprising a cyclic component in the fluid surrounding the aerofoil, is necessary to account for known phenomena; but it is also demonstrated that a simple arithmetical solution to the problem of sustentation in flight follows immediately from the acceptance and application of vortex theory.

Expressed briefly, it may be stated that the aerofoil leaves in its wake a vortex pair, that is to say, the two-dimensional analogue of a vortex ring. The vortices forming this vortex pair are not simple vortices, but are complex, each vortex element comprising, generally speaking, filaments or individual vortices wrapped up and involved in the common cyclic motion. It is shown that the origin of these vortices at the after edge of the aerofoil is in part due to a Helmholtz "surface of gyration" resulting from the components of motion, towards and away from the axis of flight, impressed on the different parts of the air above and below in the vicinity of the aerofoil. Also a part of the vortex system arises from flow of the discontinuous type beyond the lateral extremities of the aerofoil. The two phenomena thus concerned in the generation of the trailing vortex pair are depicted diagrammatically in Fig. 50. It is shown in the author's recent paper that it is possible to assess with considerable accuracy the supporting reaction sustained by the aerofoil from the downward momentum equivalent of the trailing vortex pair.

Now a simple vortex pair may be generated by an impulse applied over the area included between the two focal filaments, and the momentum per unit area communicated by the said impulse is constant; a simple vortex pair, however, is not a possible system—the conditions in the vicinity of the foci or filaments are, from the standpoint of practice, indeterminate. In the case of a complex

¹ "The Aerofoil in the Light of Theory and Experiment," Proc. Inst. A.E., vol. ix., p. 171.

vortex pair, it is necessary to imagine that a number of impulses are applied simultaneously, an impulse system distributed, in fact, over a certain width or belt (represented by the track of the aerofoil), and thus the different longitudinal elements of the said belt, in respect of downward momentum per unit area, will vary amongst themselves. In order to obtain an arithmetical solution, it is necessary to ascertain or assume some definite form of distribution and, to a certain extent, to solve, the resulting hydrodynamic system.

In the paper in question, the author has shown that there is a particular system already to hand of which the mathematical solution is known. This system is depicted by its streamlines, plotted from the mathematical equation in Fig. 51—the diagram in question being found in any standard works on hydrodynamics. This streamline

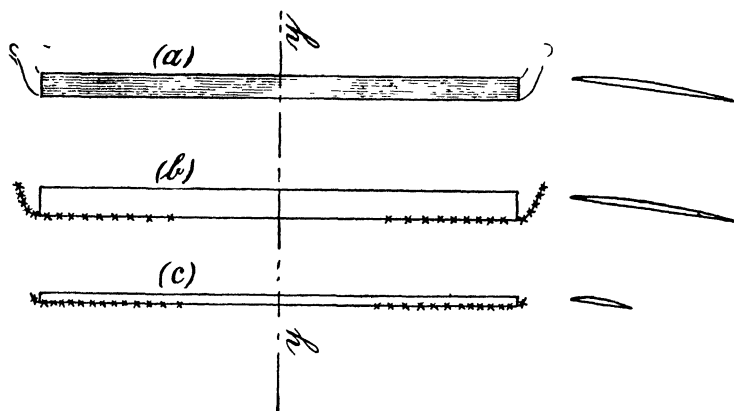

FIG. 50.

system corresponds to that of an elliptical cylinder in "broadside on" motion, the system being applicable to any ellipse of which the two extremities of the base line are the foci, and the base line itself represents a special case of such an ellipse; thus the streamlines shown are also those of a plane in broadside motion.

Now, it is an established fact that any elliptical cylinder set into broadside motion involves, in the air surrounding it, a movement whose energy and inertia are equal to that of a circular cylinder whose diameter is equal to the major axis of the ellipse.¹ Thus the whole motion depicted in Fig. 51 is the equivalent, both as to momentum and energy, of a circular cylindrical mass of the air whose diameter is equal to that of the base line.

¹ "Aerial Flight," vol. i., § 83.

Now, in the actual problem of flight, the force acting on the air is not an impulse distributed over an area; it is an impulse, if we may say so, *spread* by the advancing aerofoil. As a matter of fact, the force exerted by the aerofoil is not impulsive, inasmuch as it is a finite force acting through some finite time; but if we consider the load of an aerofoil as distributed along an axis parallel to its leading edge—otherwise, an axis at right angles to the line of

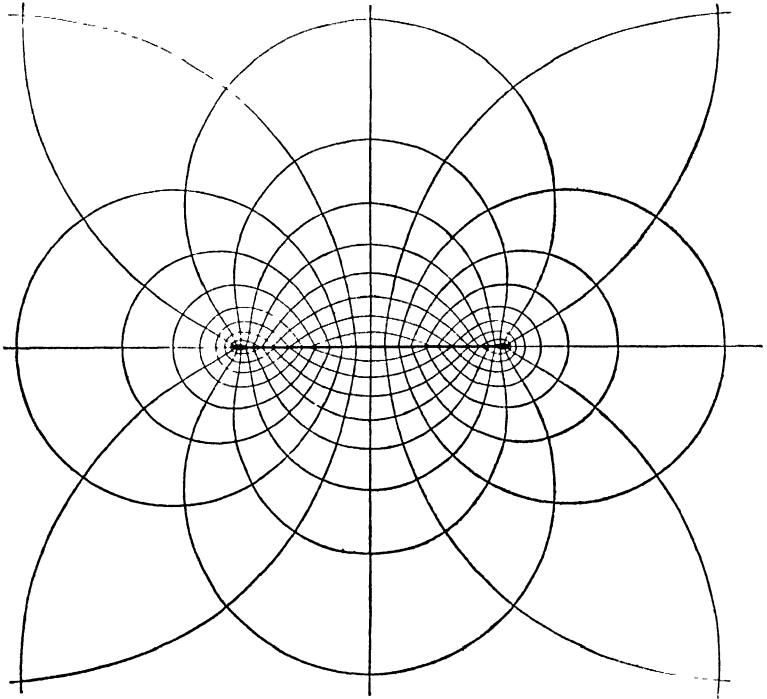

FIG. 51.

flight—we may imagine this application of force as representing an impulse on each two-dimensional vertical slice of the air through which it cuts. This, however, is not the whole story, since the air is not thus confined to two-dimensional motion, but if we consider also a vertical plane in the line of flight, we find that the movement of this impulse line is consistent with, and in fact implies, a cyclic motion in that plane superposed on that of translation. It is well known that cyclic motion thus superposed on translation actually involves a force at right angles to the line of flight, and so

the cyclic motion in the vertical plane of flight accounts definitely for the direct lateral reaction on the aerofoil. One method of demonstrating, quantitatively, the magnitude of this lateral reaction is to consider the movement of the central filament of a cyclic system as, of necessity, representing an extension of an impulse surface equal to the actual area swept by the filament, and so the movement of the filament will represent an amount of momentum whose measure is the momentum density of the impulse surface multiplied

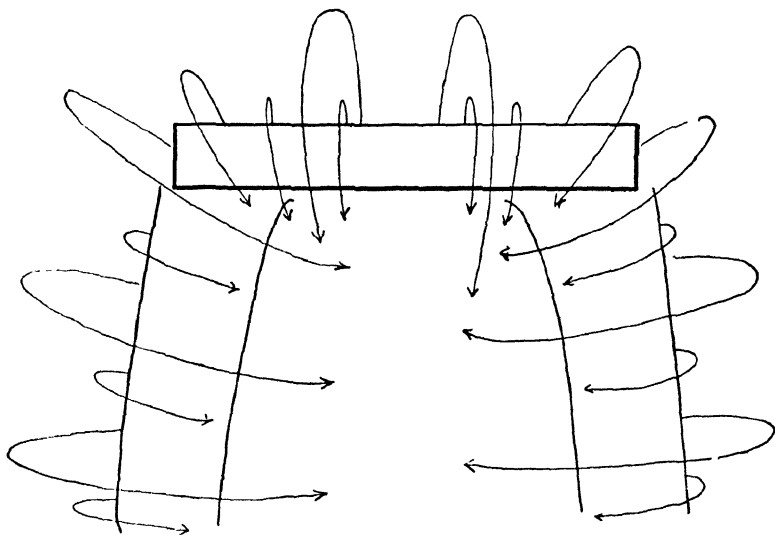

FIG. 52.

by the said area. This gives an accurate measure of the sustaining reaction.

The continuity of the whole system, the cyclic motion or "circulation" around the aerofoil, and the trailing complex vortex pair, are illustrated diagrammatically in Fig. 52.

It will thus be seen that, in the vortex theory of sustentation, we have two definite quantities, both representing a measure of the sustaining reaction. Firstly, we have a downward momentum of the ultimate or trailing vortex system, and secondly, we have the reaction as measured by the advance of the aerofoil and extension of the impulse surface as given by the cyclic component or "circulation" round the aerofoil. These two measures are essentially equal; they correspond respectively to the mass and motion in the peripteral area, and the mass and motion in the "sweep" area, as defined in

the author's original investigation. Further, in relation to the design of the aerofoil, they correspond respectively to "the *primary* and *secondary* camber," as defined in the author's recent paper. In the author's latest method of treatment, the primary camber is a hypothetical quantity which represents, in the curvature of an imaginary aerofoil, the change of motion from the initial state to the final state, and is best considered as the form which would be adopted for an actual aerofoil if the particles of the air were con-

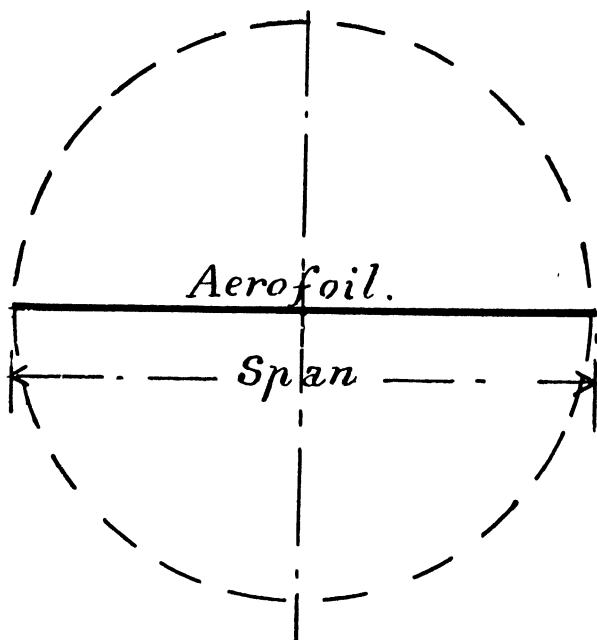

FIG. 53

strained to move only in planes at right angles to the axis of flight. The particular condition shown in Fig. 51 (the stream-lines of the elliptical cylinder) corresponds to a primary camber uniform from end to end of the aerofoil; the normal component of the motion imparted to the air is everywhere equal. Thus, the passage of the aerofoil through any given vertical plane is equivalent to a short movement of the normal plane, represented by the base line of Fig. 51, and the subsequent "solution" or disappearance of the plane from the vertical stratum in question. On the basis already discussed, the motion so left in the air will represent momentum and energy equivalent to that of a horizontal cylindrical column of

circular section in uniform motion, the diameter of the column being equal to the span of the aerofoil, Fig. 53.

Thus, we see, so far as our ultimate dealings with the air are concerned, that we have an arithmetical measure of the momentum communicated and energy expended for an aerofoil of uniform primary camber. The primary camber, however, is not the actual camber of the aerofoil; because, in the region of the aerofoil, it is shown that we have to deal with a cyclic component in the vertical plane of flight. The character of the streamlines, in such a case, shows that there is an up current in the region of the leading edge of the aerofoil, and a down current at the trailing edge; and this system superposed on that dealt with by the primary camber represents the actual flow with which the aerofoil has to deal. This is shown to require that the aerofoil will have an additional camber superposed on the primary camber, as depicted in Fig. 54, and this additional, or secondary, camber being everywhere proportional to the motions with which the aerofoil has to deal, will need to vary

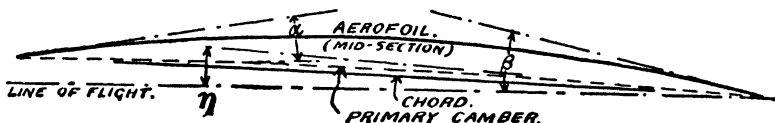

FIG. 54.

from point to point along the span of the aerofoil in accordance with the intensity distribution of the cyclic motion. The whole of this question is fully discussed in the author's work and paper to which reference has been made.

For the particular example in question—the streamlines of the elliptical cylinder—it appears probable that the secondary camber should be graded from maximum in the central plane to zero at the extremities of the aerofoil; the ordinates of the camber being those of an ellipse, or otherwise expressed, proportional to the ordinates of a circle, Fig. 55.¹

In the majority of flying machines, at the present day, the aerofoil does not differ greatly from that depicted in Fig. 55. In some cases, the actual camber, which represents the sum of the primary and secondary camber, is uniform from end to end, but more commonly there is a certain degree of "washout" which renders the form, on the whole, a close approximation to that of theory. In any case, the variation in the actual camber of the aerofoil,

¹ This solution is perhaps open to question; there is room for further investigation.

more especially at the extremities, results in comparatively small variations in the dynamic value of the resulting vortex system, so that we may expect that the result here given—viz., that the ultimate mass of air dealt with by an aerofoil may be measured by the content swept by a circle whose diameter is the span of the aerofoil itself—will apply with approximate exactitude to the general run of experience. Actual calculations given in the paper in question prove the soundness of this deduction.

In a further paper,¹ the bearing of the foregoing theory is dealt with as relating to the screw propeller. In the author's earlier work, the screw propeller had already been dealt with on the basis of vortex theory, and the conditions of maximum efficiency had been investigated.² The extension of propeller theory, in the paper now in question, carries the matter further and deals with the condition of maximum efficiency under restricted conditions, that is to say, under conditions in which the diameter or the pitch is so restricted artificially that the optimum condition is not available. An investigation of this kind has for some time been wanted by the aeronautical designer. It is frequently advantageous to restrict the propeller diameter for reasons concerning ground clearance, at other times it is desirable to limit the pitch in order to obtain the required speed of crank-shaft revolution. It is, in any case, desirable that the designer shall be in a position properly to weigh the pros and cons, or relative advantages, of a geared or a direct-driven propeller. When this choice exists, the advantage of the direct-driven propeller, and consequently finer pitch, consists, firstly, in the avoidance of gearing, which is objectionable from the point of efficiency loss, noise and weight; and secondly, in the

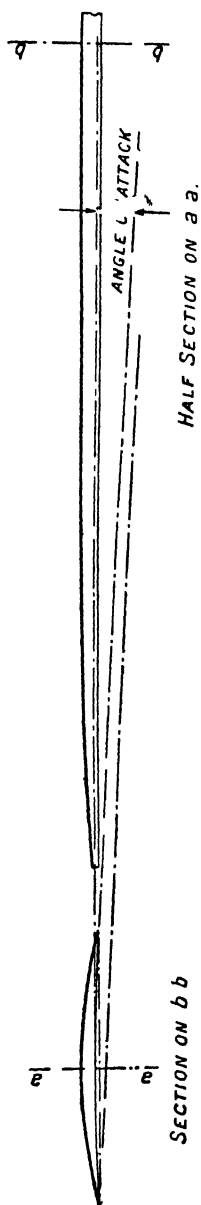

FIG. 5.

¹ "The Screw Propeller," Proc. Inst. A.E., vol. ix. p. 263.

² "Aerodynamics," chap. IX.

reduction of the recoil torque borne by the machine in flight. On the other hand, the disadvantage of a direct propeller, with its consequent fine pitch, is usually a measurable loss of efficiency; the appropriate system to adopt depends upon the balance of advantages and disadvantages. Hitherto the question has been usually settled by rule of thumb and trial and error; the designer, first, has not had theoretical guidance as to what pitch he should employ under an artificial restriction of diameter; neither has he had anything to tell him what a given pitch restriction necessarily means in the matter of lost efficiency. In the paper in question, the main conclusions are summarised in the diagram reproduced here in Fig. 56. For fuller information, and for details of the investigation on which this diagram is based, reference may be made to the paper. Incidentally, the paper includes an investigation on the stationary screw or helicopter, and a discussion of the previous work on the special case of the condition of maximum efficiency.

INDEX

- ACENTRIC types of machine, difficulties of, 86, 87
Advisory Committee, extract of Continental work, 91
Aerodrome, dictionary and popular meanings of, 5, n. *See also* FLIGHT-GROUND.
Aerofoil, Bleriot section, 36, 37 ; de Havilland section, 36 ; tabulated data, 39 ; Voisin wing (by M. Eiffel), 37-39 ; R.A.F. 6, 38, 39 ; graphic diagram, 40 ; design of, 66 *et seq.* ; Lanchester's model of 1894, 38 ; report by N.P.L. on Appendix III. ; pressure velocity relation, 66 ; primary and secondary camber of, 126 ; theoretical form deduced from vortex theory, 127, 128
Aerofoil structure, drift stresses, 78. *See also* WING STRUCTURE.
Aeronautical motor. *See* MOTORS, AERONAUTICAL.
Air, the, considered as the "permanent way," 8 *et seq.*
Alighting, possible use of high-road, 7
Alighting gear. *See* LANDING-GEAR.
Alighting grounds, insufficiency of, 5, 6 ; area desirable, 7
Alighting mechanism. *See* LANDING-GEAR.
Atlantic by air, possibility of, 5
- BAIRSTOW, L., contribution on stability, 89
Ballasted plane, the, as exemplifying catastrophic instability, 16
Banking, stresses due to, 74
Biplane and monoplane, a constructional question, 67, 68
Bluffness, as affecting validity of skin-frictional estimate of resistance, 117, 118
Body resistance, 42 *et seq.* . reliance on model experiment, 42 ; expressed as equivalent normal plane, 46-49
Bryan, G. H., work on stability, 89 ; the work of, "Lanchester condition," 101 ; reference to Mr. Harper, 101
- CATASTROPHIC instability, 15 *et seq.* : dangers of, 17
Cavitation. *See* SCREW PROPELLER.
Clarke, T. W. K., propeller equivalent in vertical surface, 73
Climbing, rates of, in machines of various types, 50 ; importance of sufficient, 49-50

- Coefficients of traction, table of, 3
 Cooling, air, *versus* water, 62; the Gnome engine, 62; author's investigation on, 62, 63; diagram of cooling data, 65; cooling system as appropriate to duty, 62
- DAMPING of flight-path amplitude, 13, 14
 Diagrams. *See* GRAPHS.
 Dynamic load factor, 73 *et seq.*; dynamic load factor tabulated, 76, 77
 Dynamic similarity, law of, not utilised by Froude or Zahm, 114; presupposes geometrical similarity, 115
- EFFICIENCY, thermal and mechanical, maximum estimate of, 4
 Elliptic cylinder, stream lines of, 123, 124
 Engine and propeller, compatibility of, 66
- FACTOR of safety and dynamic load factor, 73 *et seq.*
 "Fairing," importance of, 42
 "Flattening," stresses due to, 76
 Flight, coefficient of resistance, comparative table, 3; speed of, in relation to wind velocity, 4; range of, conditions determining, 4, 5; range of, estimates of maximum, 5
 Flight-ground, area desirable, 7; present insufficiency of, 6, 7; economic aspect, 7, 8. *See also* ALIGHTING GROUND.
 Flight-path, theoretically plotted, 10; equation to the, 11; theoretical basis of equation (hypothesis), 9; types of phugoid curve discussed, 11, 12; relation between velocity and period, 13; stable and unstable, 13; as modified by elevator, 14
 Flight resistance, the constant adverse gradient, 4
 Flight - speed, present - day maximum estimate of, 6; conditions governing, 3, 4
 Float, early type, 83; V type of section, advantage of, 83
 Flying-boat, Curtis and Sopwith types, 82, 83
 Flying-machine, general disposition of functional organs, 1; high coefficient of resistance, 1; its uses in warfare, 8; its future dependent upon Army and Navy, 8; numbers required, an anticipation, 8; acentric types, 85 *et seq.*; acentric type, flight-path deflection, 87, 88; marine type, suggested development, 83-85
 Form resistance, reference to Prandtl's result, 99
 Fuselage, design of, 42-45
- GNOME engine, cooling, consumption of power in, 62
 Gradient, equivalent representing constant resistance, 4

Graphs, resistance, 26-29; flight-path, 10; ichthyoid form, 44; of lift constant, 32, 35; of lift-drift ratio, 40; total resistance, 47 *et seq.*; propeller efficiency, 54; propeller diameters and speeds, 58; engine and fuel weights, 61; surface cooling temperature relation, 65; spar resistances, 71; skin-friction coefficient, 95, 96, 99, 113; stability (Harper effect), 103, 104; streamlines of elliptical cylinder, 124; propeller pitch diameter ratio, 130
Gravitational resistance, 50; in different types of machine, 50.
Gust, wind gust, stresses due to, 75

HARPER, the Harper effect, 101

ICHTHYOID body, resistance of, 43, 44

Instability. *See* STABILITY.

Inverted flight-path. *See* CATASTROPHIC INSTABILITY.

LANCHESTER'S Aerofoil of 1894, result of test, Appendix III., 106

Landing-gear, landing wheel pivoted and otherwise, 78; the tall support, 78; land type described, 79, 80, 81; steel *versus* rubber as shock absorber, 80; the absorption of the shock, 80; R.A.F. and Bleriot types, 79, 80; hydraulic pneumatic device, 82; height and velocity of fall permissible, 82; marine type, 82, 83; marine type, flying-boat *versus* double-float type, 83; pneumatic hydraulic mechanism, Appendix IV.

Langley's experiments on superposed planes, 68

Limit of flight-range, present and past estimates, 5

Looping, stresses due to, 76

MERRICK, Major, fatal accident, 17, n.

Monoplane and biplane, a constructional question, 67, 68

Motive-power installation, 59 *et seq.*

Motors, aeronautical, types of, 60; the weight factor, 60, 61

Motor, weight factor, importance of, 6

NATIONAL Physical Laboratory, experiments bearing on catastrophic instability, 20; data relating to superposed foils, 68; staff report on skin-friction, 114

"Negative tail," value of, stability due to, 23

Negative tail load, relation to centre of pressure, 23, 24; relative magnitude, 24

PAULHAN-TATIN machine, form of, 45, 46

Petrol and petroleum fuel, energy content and energy available, 4

Phugoid. *See* FLIGHT-PATH.

Phugoid Chart, application of, 14. *See also* FLIGHT-PATH.

- Pitching-moment curve, importance of, as bearing on catastrophic instability, 21-23
- Prandtl, work on resistance of ichthyoid bodies, 43, n.
- Pressure constant, values of, 32 *et seq.*; as related to aspect ratio, table of, 34; N.P.L. result discussed, 36; values for normal plane (diagram), 35
- Pressure reaction, on planes and aerofoils of different aspect ratios, 30; the straight-line law and its limiting values, 29, 30
- Propulsion, 51 *et seq.*; effect on stability, Appendix II.
- RANGE of flight, conditions determining, 4, 5; estimates of, maximum, 5
- Renault air-cooled V engine, 62
- Resistance, tractive, table of coefficients, 3; laws of, 25 *et seq.*; direct, classified, 25, 26; aerodynamic, law concerning, and graph, 26; theory of constant gradient, 28, 29; magnitude of constant gradient, 41; body, 42 *et seq.*, due to climbing, 50; direct, as related to skin-friction, 115; as based on skin-friction, evidences for and against, 116 *et seq.*
- Royal Aircraft Factory, work on resistance of ichthyoid bodies, 43-45
- SCREW PROPELLER, the P/V^2 relation applicable to the different blade elements, 53; the cavitation limit, 52; cavitation not encountered in the case of the air propeller, 52; modern theory of, 53; efficiency limits considered, 53-55; efficiency diagram, 54; author's method of design, 55; comparison between marine and aeronautical conditions, 55; Royal Aircraft Factory design, 56, 57; relation of propeller disc area to "wetted surface," 56; diagram of diameter and speed relation, 58; reasons for relatively fine pitch propellers in aeronautics, 58, 59; the only available implement of aeronautical propulsion, 51; compatibility between engine and propeller, 63; the static test, 64; appropriate diameters of, 66; application of vortex theory to, 129; diagram of best pitch diameter ratio and efficiencies available, 130; number of blades permissible, 130
- Skin-friction, Appendix I.; law of dynamic similarity in relation to, 94, n.; work of Zahn and Froude, 94; author's conclusions, 94; graph representing coefficient for air and water, 95, 96; anomalies relating to, 96, 97; augmented value, 98, 99; index proposed by author, 114; difficulty in harmonising work of different writers, 114; as basis of direct resistance, 115; anomalous condition, 116, 117; skin-friction and direct resistance in relation to bluntness, 117, 118; basis of augmented values, 119; computing direct resistance from, tested by experience, 119, 120
- Sopwith, flying-boat type, reference to, 83

- speed of flight, maximum estimate, 6 ; factors controlling, 6, 7
- stability, different kinds of, 1 ; flight-path stability, 13 ; catastrophic, 15 ; extent of our knowledge, 89 ; references to publication of, 89 ; discussion of Continental work, 90, 91 ; as affected by considerations relating to propulsion, Appendix II.
- Stream-line body. *See* ICHTHYOID BODY.
- stresses on structure due to banking and flattening out, 74, 75
- strut, resistance of, 70, 71, 72
- Superposed foils, advantage of staggered arrangement, 68 ; superposed foils, table of coefficients, 68
- Sustentation, the vortex theory of, 121 *et seq.* ; the peripteral area and the "Sweep" area, 125 ; two modes of computing sustaining reaction, 125
- Sustentation in flight, the cyclic component round the aerofoil, 124, 125
- TAIL, negative, advantage of, 23, 24
- Traction, table of coefficients, 3
- Trail, angle of, 31
- VELOCITY expressed or specified by higher and lower limits, 67
- Velocity of flight, limiting factor, 67 ; the critical lower limit, 67
- Vertical service, factors contributing to, 72, 73 ; computation of, 72, 73
- Vortex motion in sustentation, how generated, 122, 123 ; the typical system based on stream-line of elliptical cylinder, 123, 124
- Vortex theory of sustentation, 121 *et seq.*
- WASH, correction for, reference to author's work, 102
- Weight per horse power, 60 ; graphic representation of, 61
- Weight sustained in relation to area, 66
- Wheel, air resistance of, 72
- White and Thompson, design for alighting mechanism, 107
- Wind velocity as affecting the question of speed, 4
- Wing structure, comparable to cantilever bridge, 68, 69 ; calculation of, 69, 70 ; factor of safety explained, 76
- Wire, resistance of, 70-72
- Wright machine, propeller arrangement, 63 ; peculiarities of, 14 ; method of flying, 14, 15 ; reference to, concerning body resistance, 47
- Wright type, reason for abandonment, 15
- ZAIM, work on skin-friction, 93

BY THE SAME AUTHOR.

AERIAL FLIGHT.

VOL. I.

AERODYNAMICS

21/- net.

VOL. II.

AERODONETICS

21/- net.

Translated into French by COMMT. BENOIT: Gauthier Villars, Paris.

Translated into German by PROF. CARL RUNGE: Teubner, Leipzig.

The Times, November 4th, 1908.—“A distinct step forward in the campaign for the conquest of the air is marked by the publication of Mr. LANCHESTER'S two volumes.”

The Morning Post, October 27th, 1908.—“Mr. LANCHESTER seems to be the first man who has considered and mastered the fact and theory of every phase of the subject before sitting down to write.”

AIRCRAFT IN WARFARE.

THE DAWN OF THE FOURTH ARM.

By F. W. LANCHESTER, M.Inst.A.E.,

With Introductory Preface by

MAJOR-GENERAL SIR DAVID HENDERSON, K.C.B.,

Director-General of Military Aeronautics.

Engineering.—“The value of Mr. LANCHESTER'S book is that it is both interesting and informing, it appeals to the man in the street, it tends to the spread of correct judgment and it intimates progress on practical lines.”

Flight.—“. . . a highly valuable contribution to the science of aviation couched in non-technical language almost throughout.”

Medium 8vo.

Illustrated.

Price 12s. 6d. net.

CONSTABLE & COMPANY, LIMITED.

LIST OF PAPERS

PUBLISHED BY

THE INSTITUTION OF AUTOMOBILE ENGINEERS,

28, VICTORIA STREET, LONDON, S.W.

	PRICE	DATE.
“Horse Power of Petrol Motor in Relation to Bore Stroke and Weight.” Complete with Discussion	2/- net.	1906—7
“Some Problems Peculiar to the Design of the Automobile.” Complete with Discussion	2/- net.	1907—8
“Tractive Effort and Acceleration of Automobile Vehicles”	1/- net.	1909—10
“Presidential Address — Factors that have contributed to the Advance of Automobile Engineering, and which control the Development of the Self-propelled Vehicle”	1/- net.	1910—11
“Worm Gear.” Complete with Discussion ..	2/- net.	1912—13
“Engine Balancing.” Complete with Discussion ..	2/- net.	1913—14
“Two Papers on the Flying Machine— (A) The Aerofoil, (B) The Screw Propeller.”		
Bound in Cloth	3/6 net.	} 1914—15
Or separately, each	2/- net.	
“Cylinder Cooling of Internal Combustion Engines.” Complete with Discussion	2/- net.	1915

