

UNIVERSAL
LIBRARY

OU_148596

UNIVERSAL
LIBRARY

OSMANIA UNIVERSITY LIBRARY

Call No.

581.151252 / P 12 1/2

Accession No.

22557

Author

Darlington

Title

Handling of chromosomes

This book should be returned on or before the date last marked below.

THE HANDLING OF
CHROMOSOMES

By Dr. Darlington

Chromosomes and Plant Breeding

Macmillan, 1932

Recent Advances in Cytology

Churchill. 2nd edition. 1937

The Evolution of Genetic Systems

Cambridge University Press, 1939

THE HANDLING OF CHROMOSOMES

by
C. D. Darlington, F.R.S.
and
L. F. La Cour

London
George Allen & Unwin Ltd

First published in 1942

All rights reserved

PRINTED IN GREAT BRITAIN
in 11-Point Imprint Type
BY UNWIN BROTHERS LIMITED
WOKING

To
JOHN BELLING
1866-1933

*whose ingenious invention
brought the chromosomes within
reach of every enquirer*

PREFACE

The cells of all plants and animals, with a few obscure exceptions, are organized and controlled by a visible body, the nucleus. This nucleus consists of permanent hereditary structures, the chromosomes, which themselves can be made visible by simple treatments. Our purpose in this book is to describe such treatments. We have attempted to cover all the steps from dissecting the first animal or plant to drawing the last diagram. The result should in the first place serve teachers and students in school and university. But, since the methods we describe are mostly the fruit of the last ten years' ripening, they should not come amiss to workers in the many branches of research for which the handling of chromosomes has now become useful or perhaps even necessary.

4/16 We are particularly indebted to the following collaborators:

Dr. D. G. Catcheside, Botany School, Cambridge

Dr. P. C. Koller, Institute of Animal Genetics, Edinburgh

Dr. J. D. Macleod, Lambeth Hospital, London, S.E.

Dr. U. Philip. University College, London, W.

Mr. H. N. Barber, Mr. H. G. Callan, Dr. D. Lewis,

Dr. K. Mather and Dr. P. T. Thomas of this institution.

We also have to thank Mr. H. C. Osterstock for preparing the photographs and diagrams.

C. D. DARLINGTON

L. F. LA COUR

JOHN INNES HORTICULTURAL INSTITUTION

LONDON, S.W.19

CONTENTS

CHAPTER	PAGE
PREFACE	7
1 ORIGIN, SCOPE AND PURPOSE OF CHROMOSOME WORK	17
2 EQUIPMENT	21
<i>a. Microscopes</i>	
<i>b. Resolving Power and Magnification</i>	
<i>c. Lighting and Screens</i>	
<i>d. Oil and Lenses</i>	
<i>e. Camera Lucida</i>	
<i>f. Other Equipment</i>	
3 LIVING CHROMOSOMES	30
<i>a. Material</i>	
<i>b. Methods</i>	
<i>c. Vital Staining</i>	
<i>d. Chromosome Optics</i>	
4 BULK FIXATION	33
<i>a. Principles</i>	
<i>b. Practice</i>	
<i>c. Mordanting and Hydrolysis</i>	
<i>d. Penetration</i>	
<i>e. Condition of the Material</i>	
<i>f. Duration</i>	
5 SMEARS AND SQUASHES	40
<i>a. Material</i>	
<i>b. Smear Methods</i>	
<i>c. Acetic Squash Methods</i>	
<i>d. Maceration</i>	

CHAPTER	PAGE
6 PARAFFIN METHODS	45
<i>a. Value</i>	
<i>b. Fixation and Washing</i>	
<i>c. Dehydration and Infiltration</i>	
<i>d. Embedding</i>	
<i>e. Section Cutting</i>	
<i>f. Mounting Ribbons</i>	
7 STAINING AND MOUNTING	50
<i>a. Staining</i>	
<i>b. Mounting</i>	
<i>c. Fading</i>	
<i>d. Re-staining</i>	
8 SPECIAL TREATMENTS	56
<i>a. Pre-treatment for Structure</i>	
<i>b. Animal Eggs</i>	
<i>c. Salivary Glands</i>	
<i>d. Tadpole Tails</i>	
<i>e. Amphibian Testes</i>	
<i>f. Culex testes</i>	
<i>g. Embryo Sac and Endosperm</i>	
<i>h. Other Plant Tissues</i>	
9 THE CONTROL OF MITOSIS	64
<i>a. X-rays</i>	
<i>b. Drugs</i>	
<i>c. Temperature</i>	
<i>d. Centrifuging</i>	
<i>e. Various Genetical Devices</i>	
10 THE CONTROL OF FERTILIZATION	71
<i>a. Pollen Germination</i>	
<i>b. Tube Division</i>	
<i>c. Pollen Storage</i>	
<i>d. The Style</i>	
<i>e. Haploid Plants</i>	
<i>f. Haploid Animals</i>	

CHAPTER	PAGE
11 PHOTOGRAPHY	77
<i>a. Uses</i>	
<i>b. Cameras</i>	
<i>c. Taking the Photograph</i>	
<i>d. Developing</i>	
<i>e. Printing and Regulation of Contrast</i>	
<i>f. Preparing Photographs for Reproduction</i>	
<i>g. Screen Projection</i>	
12 DESCRIBING THE RESULTS	85
<i>a. Interpretation</i>	
<i>b. Illustration</i>	
<i>c. Description</i>	
APPENDIX	
1 SOURCES OF MATERIAL	97
<i>a. Natural Groups</i>	
<i>b. Chromosome Calendar</i>	
2 STANDARD SOLUTIONS	106
<i>a. Fixing Solutions</i>	
<i>b. Stains for Chromosomes</i>	
<i>c. Stains for Styles</i>	
<i>d. Various Fluids</i>	
<i>e. Drosophila Medium</i>	
<i>f. Photographic Solutions</i>	
3 SCHEDULES OF TREATMENT	116
4 CATALOGUE OF IMPLEMENTS	125
5 ABBREVIATIONS	129
REFERENCES	130
INDEX	157.

LIST OF TABLES

	PAGE
I. Approximate Capacities of Apochromatic Objectives	23
II. Refractive Indices (n) of Mounting Media, etc.	53
III. X-Raying of Chromosomes	66
IV. Effects of Drugs on Chromosomes	68
V. Methods of Regulating Contrast	81
VI. Chromosomes of Natural Groups	98
VII. Times for Obtaining Material	102
VIII. Properties of Reagents	106
IX. Composition of Compound Fixatives	108

LIST OF FIGURES

	PAGE
FIG. 1. Microscope Illuminated by Home Made Lamp	25
FIG. 2. <i>Drosophila</i> larva	60
FIG. 3. Home Made Box Cameras	78
FIG. 4. Compound Smear Schedule	118
FIG. 5. Metal Instruments	125
FIG. 6. Glass Instruments and Smearing Dish	126
FIG. 7. Glass Bottles and Spirit Lamp	127

The co-existence of the most wonderful success with the most profound ignorance is one of the characteristic features of present day biology.

Szent-Györgi (1940)

Chapter 1

ORIGIN, SCOPE AND PURPOSE OF CHROMOSOME WORK

In 1831 Robert Brown discovered and named the cell nucleus. He saw that it was important, but he did not know what it did or how it worked. He could not at that time realize the part it played in cells and in organisms and even in the whole unfolding of life. These things we have since learnt, and our knowledge may be framed in one sentence: *the nucleus is the chromosomes*. In the nucleus the apparatus of cell-government is at rest, in the chromosomes it is in movement.

But it was fifty years before the chromosomes themselves were seen. Their study sprang from the study of whole organisms, tissues and cells. Its methods and its ideas were at first derived from its larger scale origin. The subdivision of its teaching between botany and zoology and medicine still lives on to remind of this accident of birth. And the anatomist from long habit still attaches to them a value (as he believes) consistent with their size. As Robert Brown said: "The few indications of the presence of this nucleus, or areola, that I have hitherto met with in the publications of botanists, are chiefly in some figures of epidermis. . . . But so little importance seems to be attached to it, that the appearance is not always referred to in the explanations of the figures in which it is represented" (1833, p. 713).

Now, however, there is less danger of the nucleus being overlooked, and the chromosomes have become a study in themselves; a study, that is, with its own theory and its

own technique! They are amongst the largest molecules whose chemistry is pursued. They are also the smallest living structures whose movements and transformations can be seen and followed. And throughout living organisms they show a uniformity in chemistry and mechanics which we now know to be the foundation of their uniformity in physiology and genetics.

The similarities of mitosis in the simple filaments of *Chara* and in the staminal hairs of *Tradescantia*, of meiosis in the turbellarian testis and in the paeony anthers, of the nucleic acid cycle and its vagaries in maize and in the fruit fly—these things may still astonish us. But now we have also learnt to profit by them. They show us that we may turn from one to another in seeking material for experiment or demonstration. And in doing so we need consider only our own technical convenience. The lily can tell us what happens in the mouse. The fly can tell us what happens in man. We take whichever is largest, or easiest, or best known, or merely what is in season.

What purpose does this technical convenience serve? Our study of chromosomes has three aims within its compass:

First, we have to examine the chromosomes as chemical structures within the cell manifesting laws of behaviour peculiar to themselves, and fundamental to the reproduction of the cell and the organism.

Secondly, we have to examine them as the governing organs of cell life; that is to say, organs whose change underlies the variability or the constancy, the health or the disease, of animal or plant development. It is this function which makes their control the business of cancer research.

Thirdly, we have to examine them as the gene-strings,

bearers of heredity, whose laws their uniform movements express. It is this last function which has made their control necessary for the practice of plant and animal breeding; wherever to be sure this art has grown into a science.

These primary aims have thus beyond them an ultimate one, that of the control of life in its three aspects of reproduction, heredity and development. This control, as we shall see, has to be exerted through the agency of chromosomes by way of four processes: (i) mitosis and the reproduction of genes, (ii) meiosis and their recombination, (iii) fertilization and polyploidy, (iv) mutation, breakage and reunion of groups of genes. To have this power we must know all stages of chromosome life and know them in organisms chosen as most suitable for study, that is, once more, for their technical convenience.

These methods of teaching and research are possible, and even inevitable, simply because we are here dealing with an inductive-deductive branch of knowledge, that is, with a science, in a strict sense. This important fact has taken many of those who could best make use of the chromosomes—whether in systematics at one end or histology at the other—by surprise. They were unprepared for the eventuality and have failed to profit by it. They still, like the old chemists, speak of phlogiston twenty years after the discovery of oxygen.

At the root of the theoretical advances now being made is a rapid improvement in technique. Chromosome treatment has recently advanced by innumerable steps and strides; equally in fixation and in staining, in crude handling and in fine optics. The history of *Drosophila* is a pretty and special example of a collateral succession of developments. Breeding, chromosome counts, X-rays, salivary glands,

transplantation, these tricks and devices applied to this favoured fly, have broadened the basis of experiment and have finally joined genetics and cytology into one practice and one theory.

Many of the new chromosome methods that are most effective are also extremely simple. Others are as elaborate as you could wish. The student, the teacher and the research worker cannot at present get hold of the information they need from any single source, and much of what is needed has never been published. Reagent, technique, organism and problem are all bound up together, and their suitability for one another has to be set out in the light of what we know to-day. We shall now describe the simple methods fully for those who need to use them, and indicate how and why and when the elaborations and refinements of specialists need to be applied.

Chapter 2

EQUIPMENT

a. MICROSCOPES

The standard microscope for chromosome work must include the following components:

1. Two apochromatic objectives, (i) 16 mm. dry and (ii) 2 mm. or 1.5 mm. oil immersion (*cf.* Table I).
2. A condenser under the stage.
3. A plane mirror or prism.
4. Three eyepieces magnifying approximately 5, 15, and 30 times.
5. A mechanical stage.
6. A camera lucida.

In addition, an 8-mm. objective and 10 and 20 eyepieces will be useful for most workers and indispensable for some. For photographic work a revolving stage is convenient in adjusting the direction of the negative in relation to the field.

The use of a double, or binocular, as opposed to a single eyepiece is of no value for correct observation, it entails a loss of illumination and again a great waste of time if frequent drawings and photographs are made. Its use seems to be in enabling workers to carry out routine observations such as have now become superfluous for most purposes with the present technique.

Two other kinds of microscope are required for special purposes:

1. For watching and regulating the differentiation after staining: a low-power microscope with a concave mirror instead of a condenser and with 8-mm. and 16-mm. objectives,

which need not be apochromatic. Daylight is used for illumination.

2. For the dissection of embryo-sacs, testes and salivary glands and other special tissues: a Greenough binocular microscope. An opal electric lamp is used for illumination.

b. RESOLVING POWER AND MAGNIFICATION

Resolving power in the microscope is its capacity of producing a separate image of different parts of an object measured by their distance apart. It is limited by the angle of the cone of light illuminating the object and passing through the objective. Magnification on the other hand consists in the multiplication of the angle subtended by the image at the eye relative to that subtended by the object. Magnification, which derives from objective, tube-length and eyepiece (apart from resolving power) is necessary for providing an image large enough for the observer's eye to resolve and record its details. It is however valueless as a means of increasing resolving power, and the highest eyepieces are wasted unless used with a system providing the appropriate resolution. Excess of either magnification or resolution relative to the other can be spoken of as empty.

The observer's eye escapes the theory of pure microscopy in two ways. First, observers differ in their capacity of resolution. What is empty magnification for one may be necessary for another. Secondly, the resolving power of the eye varies as between different wave-lengths of light. Coles (1921) says that although the light best resolved by the microscope is blue, green is best resolved by the eye.

The maximum resolving power is obtained with (i) critical illumination, (ii) an oil-immersion achromatic condenser of numerical aperture (n.a.) 1.4, (iii) an oil-immersion

TABLE I
 APPROXIMATE CAPACITIES OF APOCHROMATIC OBJECTIVES
 (For use with compensating eyepieces only)

Focal Length f	Numerical Aperture $n.a.$	Magnification (with 160 mm. tube length) $m = \frac{t.l.}{f}$	Limit of Resolution* $h = \frac{0.61 \lambda}{n.a.}$	Depth of Focus† df	Object-Objective Distance‡
<i>dry</i>					
$\frac{3}{8}''-16$ mm.	0.25	10	1.51 μ	12.2 μ	8 mm.
$\frac{1}{6}''-4$ mm.	0.75	40	0.50 μ	1.3 μ	0.7 mm.
<i>oil</i>					
$\frac{1}{8}''-3$ mm.	0.90	53	0.44 μ	1.0 μ	0.47 mm.
$\frac{1}{2}''-2$ mm.	1.3	80	0.29 μ	0.4 μ	0.37 mm.
$\frac{1}{2}''-2$ mm.	1.4	80	0.27 μ	0.4 μ	0.22 mm.
$\frac{1}{6}''-1.5$ mm.	1.3	107	0.29 μ	0.4 μ	0.25 mm.

(*) Calculated for green light, $\lambda = 0.54 \mu$.

(†) In medium of refractive index 1.5 (from Martin and Johnson 1931).

(‡) Subtract about 0.17 mm. to give "working distance" above the cover slip.

Note.—Cover slip thicknesses are as follows: No. 0, 75-100 μ ; No. 1, 100-167 μ ; No. 2, 167-215 μ .

apochromatic objective of the same n.a. Whichever of these two has the lower n.a. necessarily limits the effective cone of light, and hence the resolving power of the whole system.

Most accounts of microscopy treat the microscope as an ideal optical instrument. It can however be treated as an instrument with two degrees of optical efficiency. The lower alone is necessary for routine examination, elementary teaching, and even for research on large chromosomes which are far above the limits of microscopic resolution. The higher degree is required for smaller scale examination and for photography. Some of the precautions necessary for the second are tedious and wasteful if applied to the first.

For most routine studies resolution up to 0.37μ is sufficient, it is unnecessary to go down to 0.27μ . Since oil on the condenser is always troublesome, a dry condenser can be used. This automatically limits its n.a. to 1.0. The whole system, with a 1.3 n.a. objective, will have an effective n.a. of 1.15 (*cf.* Coles 1921, Chamot and Mason 1938) and the limit of resolution will be about 0.33μ). If it is never intended to use oil then an aplanatic condenser of n.a. 1.2 will be enough. With any condenser water may be used instead of oil as a compromise between rigour and convenience (Belling 1930).

c. LIGHTING AND SCREENS

In practice the limiting factor in the efficiency of microscopes used for chromosome work is not usually the microscope but the lighting system. The simplest method of lighting for low powers is by a white sky with plane mirror and with the condenser focussing the beam at the level of the object on the slide and centred in the axis of the tube. The intensity of illumination produced in this way is of

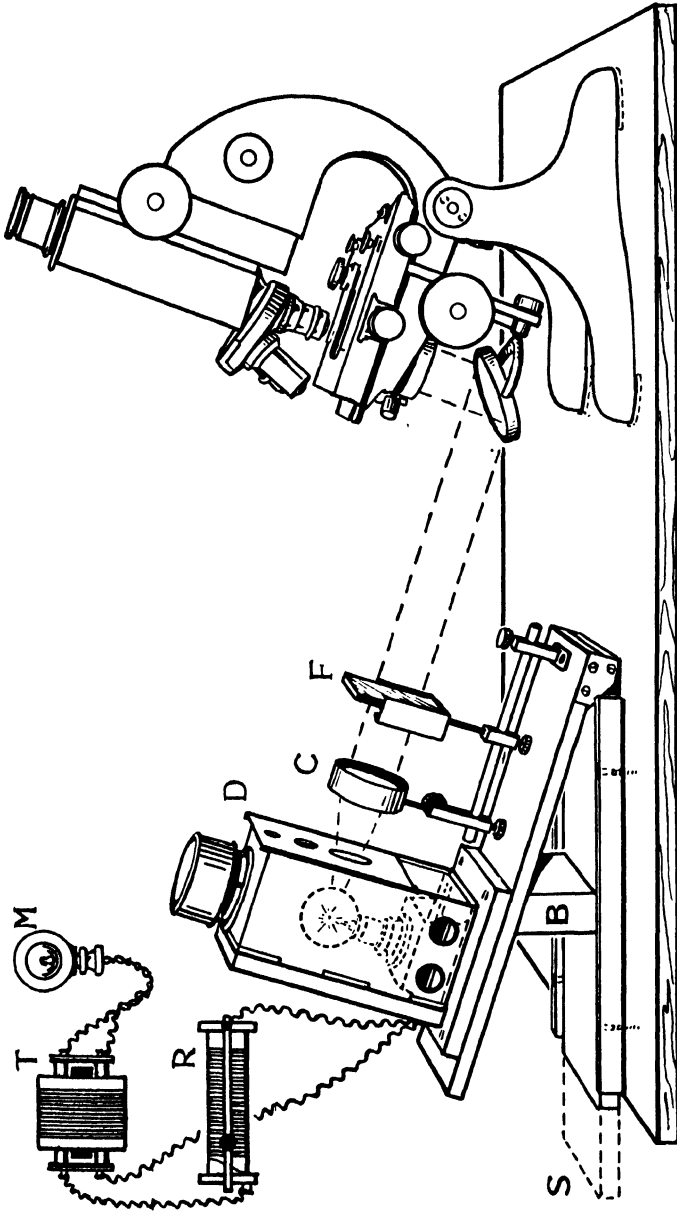

FIG. 1.—Microscope illuminated by home-made lamp described in the text. M, mains switch. T, 6 or 12 volt transformer. R, resistance. D, sliding diaphragm. C, condenser. F, colour filter. S, sliding lamp stand. B, movable wooden block for adjusting angle of beam. The ground glass mounted behind D is not shown.

course uncontrolled and its source is diffuse. It is the business of artificial lighting to produce an image of the light source that is at once precise, constant and undiffused, and focussed on the object; this constitutes critical illumination. The source must be small and uniform. If it shows any structure the condenser has to be put out of focus, with a slight loss of resolving power. Its radiation must be condensed by a convex lens into a nearly parallel beam filling the whole substage condenser.

The cheapest, and one of the most efficient, of lighting apparatuses can be constructed in the following way. A tight-coil filament headlight bulb, with screw base, of 6 or 12 volts and 30-40 watts is the source of light. This can be worked from a resistance with some wastage, but most economically of course with a transformer. Either method allows of adjustable intensity of illumination. Stout wiring must be used on account of the heat generated.

The bulb is enclosed in a black ventilated six-sided tin with a circular orifice varied if possible by a diaphragm, the source diaphragm, suitably mounted for adjustment in height and distance. A ground glass screen covers the orifice less than one inch from the bulb. A condenser, of 2-3 in. focal length, is mounted, separately or in adjustable connection, with the diaphragm at its principal focus (Fig. 1).

Of the more expensive lamps the ribbon-filament mercury arc and pointolite may be recommended.

If the intensity of illumination is not adjustable at the source it may be reduced by any of four methods:—

- (1) reducing the source diaphragm,
- (2) reducing the substage diaphragm,
- (3) putting the substage condenser out of focus,
- (4) inserting coloured screens, either substage or in front of the light.

For high powers, the first may already be reduced to a minimum needed for critical illumination. The second cuts down the cone of light, and so reduces the resolving power of the objective. The third method is only to be recommended for routine examination of under-stained or faded preparations with low eyepieces. The effect is produced by using the differential refractive index of cell walls and chromosomes to show them up. It is thus a kind of improvised dark-ground illumination (*q.v.*).

The last method is the best available for critical work. The choice of screens for eye work is governed by two considerations, the colour of the light and the colour of the stain. In general a weak screen should correct any colour in the light. A strong screen should be complementary to the stain: a blue screen for fuchsin and carmine, a yellow-green screen for gentian violet (*e.g.* Wratten filter 58 with a maximum transmission at $5,200 \text{ \AA}$). A merely reducing effect can be obtained by using a neutral grey screen. The loss of critical illumination from using ground glass in place of a screen is allowable for routine purposes.

A plane glass mirror is normally used for reflecting the beam of light into the axis of the microscope. Such a mirror produces slight secondary images of the source. To avoid these an aluminized mirror or prism can be used for reflection.

d. OIL AND LENSES

Purified cedarwood oil has now been replaced for immersion use by various non-drying mineral oils (liquid paraffins) which can be left on the lens indefinitely without damage. Cedarwood oil needs to be removed with a cloth or lens paper moistened with xylol. Mineral oils can be removed

without xylol and also without direct pressure on the face of the lens. If finger-tip pressure is applied to the conical mounting alone, the lens will be cleaned well enough. This is important, because it is impossible to ensure that, with the safest keeping, lens paper will be entirely free from grit.

Dry lenses should be dusted with a camel-hair brush, cleaned with xylol. Eyepieces and dry objectives can be dismantled for this purpose. Immersion lenses should be dismantled only by an expert.

e. CAMERA LUCIDA

For accurate drawing it is necessary to impose on the microscope image an image of the drawing paper of nearly equal intensity. This is done by the combination of a mirror and prism with an adjustable set of screens for reducing the strength of each beam to produce equality. A bench lamp beside the microscope is useful to maintain uniform lighting.

The Bristol board must be pinned on the drawing board, which must lie in a plane parallel to that of the microscope stage. A departure from this plane of 5° or 10° leads to a slight exaggeration of length; $\cos 5^\circ$ is 0.996 and $\cos 10^\circ$ is 0.985. A greater exaggeration of breadth, and one which is unequal for different parts of the drawing, results from the camera lucida mirror not being placed at 45° ; for then the different parts of the drawing will not be at a distance from the eye proportionate to the distances of the corresponding parts of the image. The design of the camera lucida allows of this false adjustment, but its convenience is a trap to be shy of, since measurement is one of the chief objects of drawing.

To obtain an accurate measurement of the magnification

of drawings the scale of a *stage-micrometer* should be drawn under the same conditions as those of the chromosome drawings.

For counting pollen grains and recording their germination a squared *micrometer-eyepiece* attachment is also necessary.

f. OTHER EQUIPMENT

A list of other equipment is given in Appendix 4. One word of comment is needed. Workmanlike handling of these implements depends first and last on being clean, neat and orderly. Slides must be clean, bottles must be stoppered, implements in the right order. At every stage we work by wit and not by witchcraft.

Chapter 3

LIVING CHROMOSOMES

a. MATERIAL

The observation of chromosomes in the living state is useful as an introduction to their study, and it also serves certain special purposes of physical research. The optical methods which were formerly of interest for showing that living chromosomes tallied with the appearance of fixed ones are now chiefly used for the study of fixed material.

The most suitable material for direct observation of cell division and chromosome movement is as follows (*cf.* Becker 1938):—

PLANT:

Staminal hairs and young petals, *Tradescantia*, diploid or tetraploid species. Belar 1929, Barber 1939, Kuwada and Nakamura 1940.

Pollen tubes, many plants. Wulff 1934.

Antheridial filaments, *Chara* and *Nitella*. Karling 1928; and rhizoids, *cf.* Becker 1938.

ANIMAL:

Salivary glands, Diptera, *Chironomus*. Bauer 1934; Poulson and Metz 1938.

Testes, Orthoptera (Meiosis). Belar 1929.

Tails of Urodela. Barber and Callan 1942.

b. METHODS

The mounting media for these tissues are in order of importance:—

- (1) Liquid paraffin (Schaede 1930).
- (2) Natural juices squeezed out of adjoining tissue.
- (3) Ringer or isotonic salt solution.
- (4) Sucrose solutions (especially for pollen tubes, *q.v.*).

Liquid paraffin may be used to ring the cover-slip and prevent evaporation even where it is not used for mounting. Its value depends on its capacity for dissolving five times as much oxygen as water will. In a class by itself is the examination of salivary glands in whole living larvae of *Drosophila* or *Sciara* in air or young *Chironomus* in water, ringed with vaseline to prevent squashing, and lightly pressed to show the gene bands (Buck and Boche 1938).

To exclude heat radiation from the source of light the beam should be passed through a water bath containing a weak aqueous solution of ferrous ammonium sulphate (Belar 1929a), as in the projection method (Fig. 3).

c. VITAL STAINING

The alleged vital staining of chromosomes by methylene blue is perhaps staining but scarcely vital, since this oxidizing agent certainly injures the chromosomes as soon as it becomes effective. The same applies to a number of other vital stains that are said to have been effective (Yamaha and Nomura 1939).

d. CHROMOSOME OPTICS

The chromosomes have three optical properties that make their observation possible without staining.

(1) For the first method of observation it is necessary to cut down the lighting so as to make use of the *differential refractivity* of the chromosomes and the spindle. The simplest method, used by Kuwada and Nakamura 1940, Wada 1932, is to restrict the cone of light passing through the condenser. Films of chromosome movement can be taken in this way (Barber 1939). For the study of the action

of fixatives dark ground illumination has been found useful (Strangeways and Canti 1927). The principle of this method is to illuminate the object from the edge of the normal cone so that the light entering the objective is chiefly that transmitted by differential refraction. It is not therefore reliable as a means of studying fine structure.

(2) The second method depends on their *differential absorption of ultra-violet light*. With an ultra-violet microscope, photographs of living chromosomes have accordingly been taken (Lucas and Stark 1931). The maximum absorption was found by Caspersson (1940) to be at 2,600 Å. The greatest value of this method lies in the higher resolving power of light with the shorter wavelength (*cf.* Table 1) which then can be applied to fixed chromosomes, stained or unstained (Ellenhorn *et al.* 1935).

(3) The third method is that of *rotation of polarized light*. It depends on their regular molecular orientation, especially when stretched naturally as in the filamentous grasshopper sperms, or artificially as in accidents of smearing. This property, which they share with the mitotic spindle, makes it possible for them to be seen between crossed Nicol's prisms by polarized light (Schmidt 1937). For this purpose, although living observation is possible, fixation in alcohol has been used since it is naturally more convenient for photographic purposes, and desiccation perhaps intensifies molecular orientation (Nakamura 1937).

All these three properties, like those of differential staining, are presumably due to the nucleic acid attached to the protein chain of the chromosome.

Chapter 4

BULK FIXATION

a. PRINCIPLES

The purpose of fixation is:—

(1) *Coagulation* of the constituents of the cell without solution, disintegration, or disturbance of their internal structure or external spacing. The curd must be life-size and it must contain the water, which makes up nine-tenths of the cell.

(2) *Mordanting*, in a broad sense, to produce surface conditions in the fixed structures that will enable them to hold the particular stains intended for making them visible.

(3) *Toughening* the curd so that it will resist embedding, or *softening* it so that it will not resist squashing.

The objects to be treated have certain invariable properties. The chromosomes are threads composed of fibrous protein. These threads are the most resistant material in the cell, and they are further strengthened during mitosis by being spirally coiled and covered with a sheath of nucleic acid. It is this uniform coat which makes the chromosomes stain with the same basic dyes in all organisms. Acetic acid swells them slightly, chromic and osmic acids contract them, but none of these reagents cause displacements.

The chromosomes themselves, therefore, present little difficulty and little variety in fixation. They exist, however, under various conditions of cell and tissue environment. The cell-environment is of two kinds: (i) The spindle and cytoplasm which, though more watery than the chromosomes, nevertheless support them well under all but the

worst conditions of fixation. (ii) The prophase nucleus, which is particularly fluid in the prophase of meiosis. Its coagulation without displacement by shrinkage requires rapid fixation and careful handling.

The tissue environment is of greater importance in plants than in animals for here the cell walls, and also hairs and wax on the epidermal surface, are an obstacle to mass fixation. They demand a special treatment for rapid penetration.

It is therefore in relation to the cytoplasm and the cell walls, on the one hand, and the after-treatment, especially the staining, on the other hand, that we have to consider the choice of fixing reagents for chromosomes.

b. PRACTICE

Coagulation can be brought about by boiling water, dilute sulphuric acid, absolute alcohol, and a hundred other agencies. The boiling water uncoils spiral chromosomes, and either water or alcohol will cause collapse of prophase nuclei. Single cells can even be fixed by drying. Smearcd pollen mother cells, for example, can be fixed in a desiccator. In this way separate punctured eggs of worms have shown excellent fixation (Ch. 8), and pollen grains from herbarium sheets have given satisfactory pictures of the nuclear conditions (Ch. 10).

Coagulation without disturbance can be brought about best by two single reagents: 45 % acetic acid as a fluid and osmic acid as a vapour.

Acetic acid, with its small ions, penetrates a tissue rapidly, but it swells the protoplasm and does not toughen it for later treatment, or at least not quickly enough. This difficulty may be got over either by combining the stain with

the acid for joint action, or by combining alcohol with the acid to fix and harden the protein, other than the chromosomes, in the cells so that the chromosomes may be contained and preserved for later staining.

Osmic acid vapour gives the best possible fixation, but without deep penetration, or indeed any penetration of cellulose walls. It can therefore be used only on animal cells, which should be smeared in a thin film and inverted over a chamber containing the 2 % solution for half a minute. Since the preparation must afterwards be stained and therefore subjected to either dehydration or maceration, it must be toughened after fixation. This can be done with 1 % *chromic acid* for 1 hour.

The combination of all these three acids has the necessary properties of penetration, coagulation and toughening. It was the foundation of the first effective fluid for fixation in bulk, which was the original method. This combination in weak concentration was first used by Flemming in 1882. Its variations have given rise to all the chief fixatives in use to-day. These variations have consisted in:

(1) Changes of concentration, *e.g.* strong Flemming, etc.

(2) Reduction in the acetic component, to preserve chondriosomes from solution, *e.g.* Benda, or for smear preparations where penetration is less important, *e.g.* La Cour's 2BE. The complete omission of acetic acid by Champy and Lewitsky is unreliable for plants on account of the cell walls, but Minouchi, Matthey and Koller find it useful for mammals.

(3) Replacement of osmic acid by less expensive reagents. This was done completely by Bouin in 1896 with picric acid for animal material and by S. Navashin in 1910 with formaldehyde for plant material. It has been done partially

in La Cour's series of fixatives with potassium dichromate. Picric acid, as well as other substitutions by platinic chloride, ruthenic acid, uranic acid and uranium salts we cannot recommend.

(4) Addition of reagents to reduce surface tension, or to raise the osmotic pressure, as discussed later.

A second line of development arose from the penetrating alcoholic fixatives first used by Carnoy in 1884. Their disadvantage lies in their unsuitability for embedding or for aqueous staining afterwards.

The aqueous fixatives harden a tissue for embedding. The alcoholic fixatives containing acetic acid soften cell walls and matrices conveniently for squashing, and by their lower surface tension allow of the penetration of resistant membranes such as eggshells.

Fixatives containing both oxidizing and reducing agents, such as the Navashin and Bouin series, must have the opposite components kept separate until they are used, and should be used immediately on mixing. It is also said that the Champy series should be fresh, on account, perhaps, of its high osmic content.

c. MORDANTING AND HYDROLYSIS

The essential step in the fixation-staining process is in general one of salt-formation of a non-specific character (Gulick 1941), and Feulgen's method of staining, which will be specially considered, gives a solitary example of a known chemical reaction being concerned.

In the salting process combination of stain and fixative is vital. Oxidizing agents, as well as strong acids, prepare the surface of chromosomes and other bodies for particular staining reactions. Thus a formalin fixative probably gives

a weaker nucleic acid reaction with crystal violet than does an osmic fixative. This difference shows only in nucleoli, the chromosomes being saturated after either fixation. Chromic acid, or some equally penetrating oxidizing agent, is a necessary component of any fixative for crystal violet. On the other hand it interferes with the action of any acetic stain.

With some stains, however, no fixation can provide a sufficient mordant for staining. Mordanting must be carried out afterwards. The function of the mordant is either as an iso-electric point modifier or as a chemical link between the stain and its recipient. Possibly chromic acid before crystal violet and alum before haematoxylin has the first effect, while hydrolysis before Feulgen staining is known to have the second. An after-mordant effect is produced by rinsing a slide in iodine or in chromic or picric acids after staining with crystal violet.

d. PENETRATION

Rapid penetration of the fixative is necessary for its uniform action. This is aided in five ways:

(1) Dissecting out small testes (under Ringer solution) or anthers, cutting up under the fixative, slitting root-tips or truncating anthers, or (see Ch. 5) smearing material before fixation. In addition:--

- (i) Animal eggs (Ch. 8) may be pricked to admit fixative.
- (ii) Pollen mother cells which hang together and are thus impossible to smear (*e.g.* in some lilies and cereals) can be squeezed out of cut anthers in four strings and fixed naked for embedding.

(2) Penetration of the surface by alcoholic fixatives is most

satisfactory, but they fail to harden the important cell structures. To remedy this they can be followed after one minute by rinsing and the use of an aqueous fixative (Kihara's Carnoy-Flemming method). This method is useful where flower-buds have to be fixed whole.

(3) Some fixatives, *e.g.* Allen's Bouin or acetic acid, can be used warm (36° – 40° C.). This increases the rapidity of penetration and it may increase the effectiveness of coagulation and hardening.

(4) After unheated aqueous fixation (but never after alcoholic treatment) the material should immediately be shaken and put under a water or hand vacuum pump to remove air bubbles which may delay penetration.

(5) Materials may be added to an aqueous fixative to lower its surface tension. This is the purpose of saponin in La Cour's fixatives.

(6) Maltose and urea have been used to adjust the osmotic pressure of fixation. The "effective" osmotic pressure is, however, that due to small ions in solution (*cf.* Young 1935) and these substances are relatively useless. Adjustment of the effective osmotic pressure to that of the tissue to be fixed is important in bulk fixations of animal material and can be achieved by making up the fixing solutions in normal saline.

e. CONDITION OF THE MATERIAL

Material before fixation must be healthy. Starvation with animals, drought with plants, have a disastrous effect on the fixation properties of both chromosomes and mitotic spindle. Root tips for mitosis are best either taken from pot plants where the ball of soil is neither too wet nor too dry, or from water-cultures. Testes for meiosis should

usually be from immature or young animals. Cold treatment is a palliative for poor condition in hot weather, and even the use of fixatives at freezing point.

f. DURATION

Owing to the absence of cellulose walls, animal tissues are fixed more rapidly than plant. The hardening process, however, requires several hours for either. The upper limit varies with the reagent as follows:

<i>Fixative Type</i>	<i>Limit of Safe Action</i>	<i>Effect of Excess</i>
Formalin	several weeks	—
Low Osmic	one week	—
Alcoholic	24 hours	reveals spindle structure
High Osmic	1 hour	damages chromosomes

Since animal cells are not hardened enough in one hour, their fixation in high-osmic types must be followed by 12–24 hours in 1% chromic acid.

Chapter 5

SMEARS AND SQUASHES

a. MATERIAL

Sections have now been largely replaced by smears and squashes for all but the smallest masses of material. The advantages of these methods are rapidity of fixation and rapidity of handling without embedding. In both respects rapidity means not only saving of time but also increased efficiency. Both methods enable us to examine single layers of large cells in their totality. This advantage is combined with the instantaneous fixation of smears and the rapid acetic fixation of squashes.

b. SMEAR METHODS

Where feasible, smearing is to be preferred to squashing for meiosis in anthers and soft testes. Smearing consists always (in the absence of pre-treatment) of the direct spreading of the cells in such a semi-fluid tissue over the surface of the slide with a flat-honed scalpel and the immediate inversion of the slide over a dish of fixative. The combinations of fixative and staining that are possible with smearing are shown in Schedule 2.

c. ACETIC SQUASH METHODS

The simplest of all chromosome treatments is to use a combined stain-fixative of the aceto-carmin type first used by Schneider and adapted for chromosome work by Belling in 1921. For this purpose inversion is unnecessary, since

the cells can be directly mounted and studied in the fixative. This makes acetic staining methods very convenient for determining stages of division in anthers and testes before fixing them by some other method.

The standard iron-aceto-carmin method was devised by Belling (1926) for the study of pollen mother cells, but it is now equally widely used for animals. It consists in teasing out the tissue in aceto-carmin with unplated iron needles and mounting directly under a cover slip. The iron acetate formed acts as a mordant for the carmin and gives a differentiation of chromosomes and cytoplasm which is usually good enough for the study of metaphases.

In many flowering plants, however, particularly where the chromosomes are small, the cytoplasm takes up too much of the stain. The following improvements and developments of the aceto-carmin technique are chiefly concerned with this difficulty.

(1) *Fixation*.—A prior fixation in 1-and-3 fresh acetic alcohol for 12–24 hours reduces the staining of the cytoplasm (McClintock 1929). Whether this effect is due to differential solution or change of pH is not known.

(2) *Storage of Material*.—If the material is not wanted for immediate staining, it can be stored in 70 % alcohol, but fixation and staining will suffer after two months or more. Long storage however can be used for the special purpose of exaggerating the differentiation of the spindle to facilitate the study of its development (Darlington and Thomas 1937).

(3) *Heating*.—Gentle heating of the slide over a spirit flame flattens the cells, sticks them to the slide and cover slip and spreads the chromosomes whether in prophase or metaphase (McClintock 1929). The degree of spreading is

due to the pressure of the cover slip, and this is controlled by the amount of stain-fixative used.

(4) *Pre-mordanting*.—The method of Thomas (1940) is perhaps the most satisfactory for small chromosomes. Iron acetate is introduced into the acetic alcohol. A weak stain is best, about $\frac{1}{3}$ strength aceto-carmin (diluted with 45 % acetic acid) and more iron is introduced at the time of teasing by using steel needles.

(5) *Acetic-Orcein*.—This new chromosome stain recommended by La Cour (1941), is more selective than carmin and for many organisms gives clearer permanent preparations. No iron mordant is needed. One special point: orcein should not be used on tissues that have been stored in 70 % alcohol.

(6) *Lacmoid indicator* (resorcin blue).—This reagent was first used in alkaline solution for staining cytoplasm (*v.* pollen tube technique). In acetic acid solution it stains only the chromosomes. Again no iron mordant is needed. Its colour remains red so long as the preparation remains acid and the mount is made in cedarwood oil. If the mount is made in neutral balsam the colour changes to blue. Lacmoid is most useful after maceration (see below, La Cour unpub.).

(7) *Bismarck Brown*.—Formerly used as an aqueous stain this reagent can likewise be substituted for carmin (Plate XII, 1).

(8) *Compound staining*.—Nebel (1940) has suggested the use of chlorazol black E as a combined stain with carmin for small chromosomes. Workable stains can also be made from all combinations of orcein, lacmoid and carmin.

(9) *Storage of Slides*.—Preparations are usually improved after keeping for a few days. The edges of the cover slip should be sealed with a rubber solution, or a mixture of

paraffin wax and gum mastic. They are best kept on ice (Belling 1929).

(10) *Permanent Method*.—There are a number of methods for making permanent preparations, the most notable being McClintock's (1929) and the vapour method of Bridges (1935). A modified form of McClintock's method is given in the schedule.

Combined fixing, staining and mounting methods developed by Zirkle (1940) can be used with water-soluble or fat-soluble mounting media (Appendix 3). The results are rapid and often satisfactory. Orcein and lacmoid can be used to replace the carmine in any of these formulae.

d. MACERATION

Soft fixations of soft tissues, *i.e.* alcoholic fixations of PMC or insect testes, need not, indeed should not, be macerated for squashing. All other material requires maceration, which must be so adjusted in plant tissues that solution of the pectic salt in the middle lamella of the cell walls is complete without the cell contents being unduly softened. There are four methods of maceration:—

- (1) Add N.HCl to (a) acetic orcein, or (b) acetic lacmoid (Schedule 3).
- (2) Extend Feulgen hydrolysis to 10 or 20 minutes (Heitz 1932).
- (3) Immerse in 4 % NH_4OH at 60° C. for 15 min. Wash 30 min. and hydrolyse 8 min. for Feulgen staining (Hillary 1940).
- (4) Immerse in equal parts of strong HCl and 95 % alcohol for 5 min. without warming. If after alcoholic fixation, the material should be hardened in Carnoy for 10 min. before staining (Warmke 1935).

Root Tips.—All these methods are suitable. There are some difficulties however in plants with small and numerous

chromosomes. Most of the metaphase plates are then found to be in side view, and the cells cannot be turned without damage. There are two methods of overcoming this difficulty by combined squashing and sectioning:—

- (i) *a.* Carnoy fixation. *b.* Transverse sectioning by the freezing microtome. *c.* Combined softening and staining in acetic-lacmoid (Schedule 3).
- (ii) *a.* Aqueous fixation. *b.* Transverse sectioning by the paraffin method. *c.* Feulgen staining with extended hydrolysis. *d.* Pressure applied after mounting in dioxan balsam (Warmke 1941).

Pollen-Grains.—All methods except (2) are suitable. Maceration allows the contents of the pollen-grain, whether large as in *Lilium* or small as in *Pyrus*, to escape from the thick wall which in these cases stands in the light of the chromosomes.

Embryo-Sacs.—Method (1*b*), not (1*a*), has a sufficiently hardening effect on the cytoplasm to preserve the embryo-sac entire.

Chapter 6

PARAFFIN METHODS

a. VALUE

Embedding may become necessary where, for one of several reasons, smears or squashes are impracticable. This is particularly so in the handling of very small organs, including all but the largest embryo-sacs, or even for larger bodies where mitoses are scarce. As an auxiliary method, embedding is also useful in showing the arrangement of cells in a tissue and the sequence of the stages of meiosis in a testis or an anther.

b. FIXATION AND WASHING

For material that is to be embedded, aqueous fixatives are necessary to protect the cells from maceration by water or collapse by loss of water. The precautions already described must be taken to ensure satisfactory penetration. A solution of at least 20 times the volume of the material to be fixed must be used to fix it, and bulk material in any case requires stronger fixatives than do smears.

It has recently been shown that long washing in water is unnecessary and even harmful. Indeed washing can be omitted altogether in preparing root tips for chromosome counts (Randolph 1935, Upcott and La Cour 1936). The root tips can be taken directly from the fixative into 75% alcohol. For more delicate tissues 2 or 3 changes of water are preferable before transference to alcohol.

c. DEHYDRATION AND INFILTRATION

Many tests have been made by various workers using new reagents as substitutes for ethyl alcohol and xylol, or ethyl alcohol and chloroform. The objects have been a speeding up of the process, an avoidance of excessive hardening and shrinkage of tissues, and the use of one fluid instead of two. The most important of these reagents are:

- (1) *Dioxan*: Graupner and Weisberger 1931, '33; Johansen 1940; Baird 1936 (animal tissues); La Cour 1937; Maheshwari 1939.
- (2) *Butyl alcohol*: Zirkle 1930, Randolph 1935.
- (3) *Tertiary butyl alcohol*: Johansen 1940.
- (4) *Iso-propyl alcohol*: Bradbury 1931.
- (5) *Methylal paraffin oil*: Dufrenoy 1935.

Of these new reagents, the first three have given the most promising results. Dioxan, however, has toxic properties and extreme care should be taken in its use. Johansen claims that his method is the least drastic and does not remove all the bound water from the tissues. It should therefore avoid collapse of delicate structures such as prophase chromosomes. All substitutes for chloroform are nevertheless poorer solvents of paraffin wax and for the infiltration of bulky material, such as flower buds, chloroform is to be preferred.

Special treatments are useful for small objects (Madge 1936). Eosin may be introduced in the 70 % alcohol, or fuchsin in the 1 : 3 alcohol-chloroform, to make them conspicuous in the wax.

d. EMBEDDING

The following precautions should be borne in mind:

- (1) Remove all traces of the solvent by evaporation, or by changing the molten wax.

(2) Avoid overheating. The oven temperature should never be more than 58°C .

(3) Choose wax of melting point suited to the tissues to be cut and the laboratory conditions. In a temperate climate use 50°C . M.P. wax for sections to be cut at $14\text{--}40\ \mu$ and 58°C . M.P. below $14\ \mu$. Waterman (1939) has described the preparation of hardened paraffin waxes having low melting points.

(4) Orientate root tips and anthers in rows in the wax for convenience in cutting. Randolph (1940) has suggested a method of card mounting which might be valuable for small root tips. The tips are mounted prior to fixation. Fabergé and La Cour (1936) have devised an electrically heated needle to facilitate orientation, avoiding the danger of damaging delicate tissues by overheating.

(5) Cool the block rapidly in water to avoid crystallization of the wax.

e. SECTION CUTTING

The first question to decide is the thickness at which the sections should be cut. Until recently, for heavy haematoxylin staining, sections had to be cut so thin that a large proportion of nuclei were injured. Indeed some microtomes are not adjusted to cut at more than $20\ \mu$. The best extend to $40\ \mu$. The following list shows how to adjust the thickness of the sections to the length of the chromosomes:

<i>Chromosomes</i>	<i>1-10 μ</i>	<i>15-40 μ</i>
RT	4-16 μ	20-40 μ
PMC	14-20 μ	30-40 μ
EMC	20-30 μ	40 μ
Testes and Eggs ..	4-10 μ	14-40 μ

(1) Keep the microtome knife sharp by correct honing and stropping. For a review of methods see Maheshwari (1939).

(2) To secure straight ribbons with a minimum of breaking, trim the block so that the wax is evenly distributed around the material. The sides must be parallel and mounted parallel to the razor edge.

(3) Mount the razor at the correct angle and screw it tight to keep it rigid.

(4) If there is difficulty in securing continuous ribbons of thick sections in cold weather, either warm the mounted block and holder in the oven, or warm the edge nearest the razor with a hot scalpel.

(5) For thin sections that wrinkle badly, owing to the wax having too low a melting point for the room temperature, cool the block on ice or use a hardened paraffin (see under embedding).

(6) To secure sections of hard material (animal eggs) expose one side of the material by trimming the block, and soak in water 12–24 hours. Waddington and Kriebel (1935) advise the use of a small amount of petroleum ceresin in the embedding wax.

(7) In dry climates the ribbons will be electrified. Hance (1937) has suggested air conditioning to avoid this. For other methods see Maheshwari (1939).

f. MOUNTING RIBBONS

Mayer's albumen is most commonly used for fixing ribbons to the slide. The film must be the thinnest obtainable by smearing with the finger. Even so, it will be well to avoid loss of thick sections through failure of drying, by heating the smeared slide gently over a spirit flame for 2–3 seconds.

The ribbons are cut into lengths shorter than the cover slip to allow for stretching.

The ribbons are floated on a few drops of water on the slide. A hot plate maintained at 45°C . is necessary for stretching and drying the ribbons. Avoid air bubbles under the sections. They arise from careless laying out or too sudden heating. Drying is completed in 4 to 12 hours according to thickness. It can be hastened by the use of 50% alcohol instead of water, or by placing the slide in the paraffin oven at a temperature of 58°C ., but only after all visible water has evaporated.

Chapter 7

STAINING AND MOUNTING

a. STAINING

Apart from the acetic stains which act as combined stain-fixatives, five basic dyes are suitable for aqueous staining of chromosomes, as follows:

(1) The *leuco-basic fuchsin* method was first developed by Feulgen and Rosenbeck (1924) as a microchemical test for the thymonucleic acid found in chromosomes (Gulick 1940). It depends on Schiff's aldehyde reaction, and gives a translucent but fairly permanent stain. The method consists of:

- (i) Liberation of the aldehyde groups of the nucleic acid by mild hydrolysis in normal hydrochloric acid at 60° C.
- (ii) Chemical reaction between the liberated aldehydes and the leuco-basic fuchsin, resulting in a violet coloration of the chromosomes.

Three types of substance in the cell are capable of giving the aldehyde reaction, (i) free *aldehydes* in lignified cell walls, (ii) *thymonucleic acid* after hydrolysis, (iii) *polysaccharides* after oxidation with chromic acid (Bauer 1933). (i) and (iii) thus require no hydrolysis but (i) is confined to the cell wall and (iii) is limited to the effects of chromic acid fixation. A specific diagnosis of thymonucleic acid in the cell should therefore always be possible by means of the Feulgen reaction.

The method is of wider application than crystal violet. Tissues can be stained in bulk (see squash methods), or as sections or smears. It can be used after alcoholic fixation,

and unlike most chromosome stains, it requires no differentiation.

Workers have been slow to make use of Feulgen's method owing to its occasional failure. This failure has been due to various causes:—

(i) Incorrect timing of hydrolysis. As to the minimum and optimum times of hydrolysis, Hillary (1939), using nucleic acid impregnated agar blocks and four different types of fixatives, has shown that two types of hydrolysis curve are possible. These depend on the presence or absence of chromic acid in the fixative. With fixatives containing chromic acid, maximum staining follows hydrolysis at 60° C. from 6 to 30 minutes; without chromic acid the maximum extends only from 4 to 8 minutes (*cf.* Bauer 1932).

(ii) Osmic acid unless carefully reduced by bleaching will similarly interfere with the Feulgen reaction. This is particularly serious with small chromosomes. Incomplete bleaching of the nucleolus has its use, however (see Plate XIV).

(iii) Formalin fixatives will lead to staining of the cytoplasm by the Feulgen reaction, if not washed out.

(iv) Poor samples of basic fuchsin, which fail to give completely decolorized solutions, will lead to stained cytoplasm, and sometimes weakly stained chromosomes. Coleman (1938) has suggested decolorizing carbon as a means of obtaining colourless solutions free from impurity (App. II).

(v) Finally, as experiments show (Ch. 9 *c*), the nucleic acid charge of chromosomes varies with temperature and other conditions. The specificity of the Feulgen reaction therefore makes it susceptible, as a stain, to changes in environmental conditions to which less discriminating reagents are indifferent. The coloration produced by the

reaction depends on the fixative used: violet after alcoholic fixatives, red after chromic.

(2) The *crystal violet* method (Newton 1927, La Cour 1937) is simple and rapid. It is possible to obtain sections up to 40 μ in thickness with well-stained chromosomes and clear cytoplasm. Also the intensity of the stain is easily reduced by differentiation, an important factor in the study of large chromosomes at meiosis. A weak stain, 0.1 %, recommended by Upcott and La Cour (1936), can be used for this purpose. Where the stain does not hold in small chromosomes the chromic acid method of La Cour (1937) or the picric acid method of Johansen (1932) can be used.

(3) *Haematoxylin* is now seldom used except where intense permanent staining is required. Particularly in plants, coloration of the cytoplasm is difficult to avoid, and this stain is therefore more easily applied to thin sections, or smears, of animal tissues. A more elaborate method than that given in Schedule 8 is recommended by Cole (1926).

(4) The *brazilin* method of Belling (1928) and Capinpin (1930) suffers from the same defects as haematoxylin, but it can be made to yield good results with pollen mother cells.

(5) *Giemsa* (Gelei's modification) has been recommended by Belar as a satisfactory stain for animal chromosomes after fixation by osmic vapour. Giemsa has also been used for staining mitosis in germinating spores of bacteria after fixation for 3-5 mins. in osmic vapour and for an indefinite time in 70% alcohol followed by hydrolysis for 7 mins. in N.HCl at 60° C. (Robinow 1941).

Light Green and Fast Green are suitable counter-stains to use for the nucleoli after the chromosomes have been stained by the Feulgen method. The light green method of Semmens and Bhaduri (1939) is unnecessarily compli-

cated. A simple fast green method for slide or bulk material (0.1 % aqueous solution for 2-12 hours) has been recommended by Hillary (1940) to be used after bleaching in SO₂ water and rinsing.

b. MOUNTING

Optically the soundest mounting medium is one whose refractive index lies between that of the glass slide and that of the tissues, which may be a little higher. Canada balsam

TABLE II
REFRACTIVE INDICES (*n*) OF MOUNTING MEDIA, ETC.

<i>Medium</i>	<i>n</i>	<i>Medium</i>	<i>n</i>
Distilled water ..	1.336	Crown glass	1.518
Sea Water	1.343	Cedarwood oil, thick	1.520
Liquid Paraffin ..	1.471	Balsam in xylol ..	1.524
Olive Oil	1.473	Clove oil	1.533
Glycerine, concentrated	1.473	Balsam, dry	1.535
"Euparal"	1.483	Gum damar	1.542
Xylol	1.497	"Clarite X"	1.567
Cedarwood oil, thin ..	1.510	(= "Nevillite No. 1")	

in general has the advantage on this ground. It is however acid, and causes certain stains to fade. To overcome this difficulty various neutral resins have been produced. Neutral balsam in sealed tubes and "clarite X" may be recommended, but clarite cannot be used for aceto-carmine preparations, and becomes milky with alcohol.

Xylol is the usual solvent for such resins, but toluene dries more quickly (Groat 1939). Soft tissues or squashes are liable to collapse in these petroleum distillates. To avoid this we may avail ourselves of two other methods:—

- (1) *Feulgen or aceto-carmine preparations*: Mount directly from absolute alcohol in euparal or balsam dissolved in alcohol. If the alcohol contains any water the balsam will become cloudy. Warm on the hot plate to get rid of this. Dioxan and dioxan-balsam are recommended by Hillary (1941).
- (2) *Orcein or lacmoid preparations*: Mount from thin cedarwood oil into oil thickened by exposure, or into xylol-balsam, *i.e.* without passing through xylol.

c. FADING

All stains can fade in certain circumstances, though what these circumstances are has not always been defined. The chief agents of fading seem to be (i) ultra-violet light (since it will happen rapidly from an arc lamp projector and gradually from daylight), (ii) acidity of the mounting medium, already referred to, and (iii) inclusion of reagents from earlier treatment, through careless mounting.

From all these causes crystal violet fades most easily (even in a few weeks), haematoxylin and carmine least easily. F. H. Smith (1934) claims that washing in saturated picric acid in absolute alcohol after staining makes crystal violet permanent. His method certainly delays fading. The chromic acid after-mordant would probably have the same effect. †

d. RE-STAINING

After fading or unsuccessful staining re-staining is possible with the same stain or with any other stain for which the original fixative was appropriate, *e.g.* a Flemming-crystal violet preparation can be re-stained in Feulgen. This is done by repeating the process after removing the cover slip and the mounting medium with xylol. To this rule there is one physical exception: an acetic smear is likely to collapse on removing the cover slip. And there is one

chemical exception: Feulgen preparations cannot be re-hydrolyzed for re-staining with leuco-basic fuchsin. They can however be re-stained, after acetic fixatives with an acetic stain (especially lacmoid), after aqueous fixatives with crystal violet and after alcoholic, with haematoxylin. Further, after acetic fixatives an ordinary Feulgen preparation which has turned out to be insufficiently stained may at once be brightened with carmine or lacmoid (2-5 min.).

Chapter 8

SPECIAL TREATMENTS

a. PRE-TREATMENT FOR STRUCTURE

Internal spirals, which appeared at metaphase by accidents of fixation, were first illustrated in *Tradescantia* by Baranetzky in 1880. Relic spirals have long been known in the resting and prophase nucleus. For a long time a relationship of the two was vaguely presumed. The general laws of chromosome structure were clarified only by the regular demonstration of internal spirals by pre-treatment of pollen mother cells (or testes in the few animals examined). This method derives from Sakamura (1927) who photographed major spirals in MI chromosomes of *Tradescantia* fixed in boiling water and unstained. A second step was the discovery by various workers that smears dried before chromic fixation (accidentally or otherwise) showed spiral structure. Diploid and tetraploid species of *Tradescantia* and many species of *Trillium* are convenient for the smear treatment of PMC necessary with all methods.

Some of the methods, such as heat and ammonia vapour, depend on uncoiling and can restore a resting nucleus condition. Others depend on dissolving the nucleic acid envelope of the chromosome thread. A third effect is swelling, which depends on increased hydration following a change in pH of the cytoplasm away from the I.E.P. of the chromosomes.

(1) *Meiosis*

(i) *Ammonia vapour* (PMC in 3% sucrose: 5-15 seconds before fixation.

(a) aceto-carmin (Kuwada and Nakamura 1934).

(b) 2BE-Crystal Violet or Feulgen (La Cour 1935).

- (ii) *Ammonia in 30 % alcohol* (6 drops in 50 c.c., 5–20 secs.). Flemming-Crystal Violet. Useful because alcohol attaches the cells to the slide (Sax and Humphrey 1934, Creighton 1938 on an amphibian, *Amblystoma*).
- (iii) *Weak alkaline solvents of nucleic acid* (Oura 1936, Kuwada *et al.* 1938, Hillary 1940). Smear is placed in solutions of NaCN, NaHCO₃ or even NaOH 1/100 gram molecular for 15 seconds to 3 minutes according to the material. Flemming with C.V. or Feulgen.
- (iv) *Acid fumes* (nitric, hydrochloric and acetic) followed by 2BE-C.V. (La Cour 1935).
- (v) *Precipitation and digestion of nucleic acid*: Hillary's modification, 1940, of Caspersson's method.
 - (a) pre-treatment as in (iii), 30 seconds 1/100 g.m. NaCN.
 - (b) Fixation in Flemming.
 - (c) Preparation left about 12 hours in 0.1 % lanthanum acetate to precipitate nucleic acid as lanthanum salt.
 - (d) 24 hours at 37° C. in 1 % solution of trypsin containing a trace of lanthanum acetate.
 - (e) Stain by Feulgen.

(2) *Mitosis*.—Ordinary methods of pre-treatment are unsatisfactory for chromosomes within a cell wall. As a first attempt an ammonia-thorium nitrate method was suggested for root tips by Nebel (1934). Three methods are now available to overcome this difficulty:

- (i) Pollen tube mitosis (Upcott 1936 on *Tulipa*). Aceto-carmine; penetration is easy on account of extremely thin cell wall.
- (ii) Pollen grain, first mitosis (Geitler 1938, *cf.* Darlington and Upcott 1941). Pressure in fixation with aceto-carmine.
- (iii) Root tip frozen, while growing, for four days to give nucleic acid starvation of heterochromatic segments, which then show their spiral structure (see Ch. 9 c).

Finally micro-incineration (Barigozzi 1937, Uber 1940) has been used as a method of showing chromosome structure.

b. ANIMAL EGGS

Three stages in the development of the egg concern us:

- (1) Prophase of meiosis: this begins in the young ovary and may last the greater part of its life.
- (2) The meiotic divisions: these are rapid and are usually set in motion by the entry of the sperm.
- (3) The cleavage divisions of the fertilized egg: these exceed in their rapidity all other mitoses and in consequence have a character of their own (see App. 1, index 10).

During the oögonial divisions and in early prophase neither yolk nor shell is present to hinder treatment, and the ovary can be treated like a testis. Where the shell is thin and the yolk deficient, squash preparations can still be made in all the later stages. This is true of the Annelida and Mollusca. For example in *Allolobophora* eggs, Foot and Strobell (1905) obtained their best preparations of meiosis by puncturing each egg in a very small drop of water. When the contents of the egg were dragged out of its membrane they dried so rapidly as to give admirable fixation of the nucleus in a self-flattened smear. Twenty such eggs were laid on a slide ruled in squares with a diamond and stained with aqueous Bismarck Brown.

Where the shells are thick, paraffin sections are necessary. The shells should then be punctured or removed if possible to aid infiltration of wax. Alcoholic fixatives, particularly Kahle's fluid or S. G. Smith's (1941) modification, are the best. Special methods of dehydration and infiltration are necessary for obtaining good sections, owing to the brittleness of the yolk. Smith's (1941) procedure is perhaps the most favourable (Schedule 1", v. Ch. 6 e). Haematoxylin or

crystal violet (chromic method) staining are preferable for meiosis, Feulgen for cleavage divisions.

c. SALIVARY GLANDS

Salivary glands and some other gland tissues of Diptera contain high-polyploid nuclei in a perpetual prophase. These were first described by Balbiani in 1880 but only understood fifty years later (Heitz and Bauer 1933, Painter 1934). Their chromosomes, when fully extended, are about 100 times as long as at metaphase of mitosis. The 128, 256 or 512 threads of each homologous type are associated in parallel; each gene therefore appears as a band which is visible in the living state (*cf.* Chapter 3). The fully developed banded chromosomes are as long as a quarter or half a millimetre and when stained are visible with a hand lens. Structural hybridity is shown by the same changes of partner as with pachytene pairing at meiosis. Salivary glands are important therefore both for study in combination with genetics and systematics and for micro-chemistry (*cf.* Caspersson 1940).

Larvae of the most suitable species may be obtained as follows:—

Chironomus (Poulson and Metz 1938) is the common blood-worm of ponds.

Bibio (Heitz and Bauer 1933) feeds on roots and leaf-mould.

Drosophila (Koller 1935; Kaufmann 1938), the fruit fly, may be trapped by a bait of over-ripe fruit, and the flies bred on a special pabulum (App. II e).

Sciara (Metz 1935), the dung fly, can be bred on mouldy *Drosophila* pabulum.

Well-fed larvae ready for pupation have the largest chromosomes. Each salivary gland contains 28–32 cells in *Sciara*, 28–44 in *Chironomus*, 100–120 in *Drosophila*. These

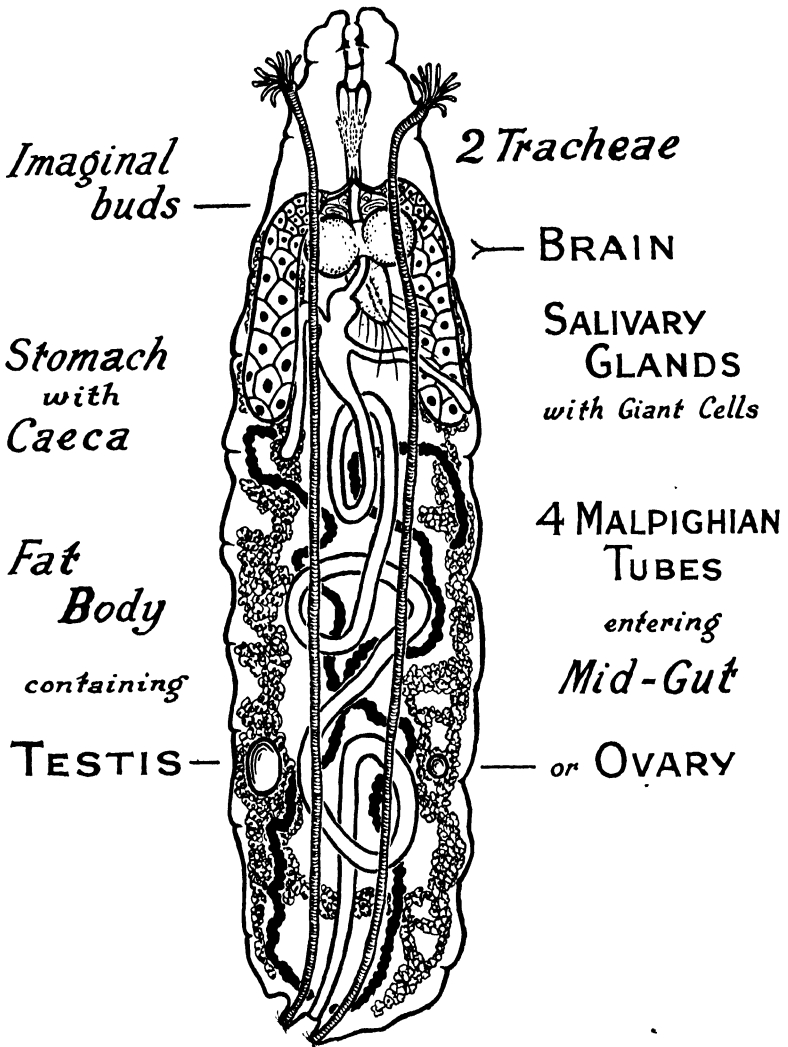

FIG. 2.—Dorsal view of six-day larva of *Drosophila melanogaster*, showing the tissues important for chromosome study in block capitals. Testis and ovary shown on opposite sides become connected with the ducts in the pupal stage. $\times 25$.

are in different stages of development—the largest in the middle or at the rear end (Fig. 2).

Dissection.—Take the full-grown larva, having established its sex if necessary, and place it on a slide in a large drop of isotonic Ringer solution. Cut off its head with a needle in the right hand while pressing the body with a needle in the left. When the pressure is released the salivary glands will float out and can then be fixed on another slide (Schedule 4). Separate preparations can be made of ganglia, guts, or gonads as required (Koller 1940).

d. TADPOLE TAILS

The epidermal cells of the tail in the urodele larva (*e.g.* *Triton*, the newt) are marked out for the study of mitosis. The cells are particularly favourable for prophase, since they are large and very flat. The best stage is when the tail fin is fully grown. Under natural conditions this stage is reached in May, June and July. In the laboratory the larvae can be partially starved and brought into condition when they are needed.

The tail should be cut off just behind the anus and fixed in acetic alcohol for 2 to 24 hours. Preparations can later be made in iron aceto-carmin or acetic lacmoid, or with Feulgen. Care should be exercised when using Feulgen not to press the preparation too hard lest the cells be crushed.

Larvae with amputated tails can be retained and used once more when the tail has regenerated. In Great Britain a vivisection licence is required for such operations.

e. AMPHIBIAN TESTES

To study meiosis in the newt, testes should be fixed about a month after the breeding season. They should be

cut into small pieces and fixed in acetic alcohol for 2 or 3 days. They should be stained with iron aceto-carmine or acetic lacmoid, not with Feulgen. Very small pieces, the size being accommodated to that of the cover slip, should be placed on a slide in a small drop of stain, tapped out lightly, and covered after the material has darkened with the stain. The cover slip should be pressed lightly in the middle under blotting paper, and suitable isolated cells will be found lying at the edges of the preparation.

f. Culex TESTES

The pupa is placed on a slide in Ringer solution A and examined by dissecting microscope. Needles are placed in the head and tail, and the larva broken in two as they are pulled apart. The testes with their small ducts attached, if the individual is male, are readily visible as small translucent egg-shaped bodies. They are removed with a fine needle to acetic alcohol, where they fix in 2 minutes. They should now be picked up by the needle and placed on a slide in a drop of iron aceto-carmine or acetic lacmoid. The preparations can be covered after about 1 minute's staining (the time should be adjusted to suit stain and material) and pressed lightly through blotting paper applied above the cover slip. Preparations can be made permanent. This method is suitable for most small insect testes.

An account of insect morphology may help in dissection, *e.g.* Imms 1925.

g. EMBRYO SAC AND ENDOSPERM

Meiosis in the embryo-sac may take place as long as two or three weeks after meiosis in the anther. In *Fritillaria*

and *Tulipa* it usually coincides with the pollen grain division (*cf.* Darlington and La Cour 1942).

Wherever possible the ovules should be removed from the ovary before fixation. In a number of Monocotyledons they come out in entire strings. Very large ovaries should have part of the ovary wall removed.

The squash method after acetic alcohol fixation, followed by acetic-lacmoid staining, is most suitable where cells and chromosomes are large. For small chromosomes and material difficult to handle the paraffin method has to be used, with a strong and penetrating aqueous fixative, *e.g.* 2BX.

Endosperm divisions are to be found a few days after pollination. In view of the difficulty of obtaining material at the right stage, the paraffin method is the least trouble for Angiosperms. The same care should be taken in fixation as with embryo sacs. In Coniferales it is possible to dissect out entire endosperms from female cones. They are then fixed in acetic alcohol and can be readily stained as squashes with acetic stains (Sax and Sax 1933).

h. OTHER PLANT TISSUES

Not only roots but any plant tissue which is undergoing cell division, such as leaves, petals, tendrils or glumes, can be fixed and treated as a squash for chromosome study (Baldwin 1939). This is especially useful where changes occur during development (Darlington and Thomas 1941).

Chapter 9

THE CONTROL OF MITOSIS

a. X-RAYS

The specific effect of X-rays on the cell in producing gene mutations and chromosome breakages was first shown by Muller in 1927 and by Stadler in 1928. It at once became the most important experimental method of handling chromosomes.

The apparatus required for studying qualitative effects of X-rays is of the simplest. For quantitative tests of effects of varying dosages, intensities, and wave-lengths, more elaborate equipment is necessary.

The minimum equipment consists of an X-ray tube together with the necessary rectifier, transformers and controls. The desired dosages can be obtained by trial and error, which indeed must be the basis of attack on any new material, for the effective dosage varies enormously between the highly susceptible pollen of *Tradescantia*, whose chromatids break frequently enough just before mitosis at 50 or 100 *r*, resting seeds which may resist 10,000 *r* without serious damage (*cf.* Gustafsson 1936), and the multinucleate conidia of *Neurospora* only half of which are killed by 500,000 *r*. Polyploids also show much less effect from mutation or chromosome breakage than do related diploids with the same dose (*cf.* Müntzing 1941).

A characteristic intensity shown by a Coolidge water-cooled tube is as follows:—

75 *r.p.m.* at 30 *cm.* target distance, with 72 *Kv.* mean *E.M.F.*
and 5 *ma.* current.

The material, methods, dosages and stages used for treatment vary according to its purpose (*cf.* Stadler 1930, Knapp 1935, Gustafsson 1936, Goodspeed and Uber 1939) as shown in Table III. But for the immediate study of mitosis with chromatid breakage we can recommend lower doses than have yet been used (50–100 r).

The immediate effects of X-rays depend on the stage of development treated. Resting seeds are delayed in germination. Nuclei in prophase of mitosis are set back into resting stage, to return later in a polyploid condition. Sperm nuclei of animals or plants can reveal no immediate effect. The delayed effects that are observed depend on the length of time after treatment during which the changed cells and changed chromosomes have to survive if they are to be observed. The more serious changes, especially in haploid pollen, kill the cell after mitosis has led to the loss of fragments without centromeres and the breakage of chromosomes with two centromeres (*cf.* Darlington 1937, Muller 1940, Darlington and Upcott 1941).

It will be seen that X-ray studies, as is proper in their initial stages, have been directed to organisms with large chromosomes capable of showing precise effects. There is another group of observations however which stand apart in this respect—X-ray work on human cancer. This work on the most difficult chromosomes, under abnormal and little understood conditions, has been carried out on a large scale by workers having no experience of normal chromosome behaviour, or even of X-ray treatment of normal tissues. Its theory and practice have therefore remained outside the boundaries of science longer than was to be hoped in such a field.

TABLE III—X-RAYING OF CHROMOSOMES

Organism and Part	Cells affected	Time of Observation	Dosage	Reference
FLOWERING PLANTS				
<i>Tradescantia</i> (2x = 12) flowers	PG after meiosis	First mitosis or later	100-800 r	Sax 1939
<i>Tulipa</i> , etc. (2x = 24)	PG after meiosis	First mitosis or later	100-800 r	Fabergé 1940 Newcombe 1942
<i>Tradescantia</i> (2x = 12) germinating pollen	PT	Mitosis of GN	150 r	Newcombe 1942
<i>Crocus biflorus</i> (2x = 8) root tips	Mitotic cells	3 days or later	500-1,000 r	Mather and Stone 1933
<i>Vicia Faba</i> (2x = 12) flowers	PMC	3 days or later	500-1,000 r	Mather 1934
<i>Hordeum sativum</i> (2x = 14) seeds, wet or dry	Growing points	Mitosis or meiosis, PMC	not given	Gustafsson 1936
<i>Zea Mays</i> (2x = 20)	Growing points	PMC	ca. 1,000 r	Anderson 1935
—Ripe pollen on slide	Sperm nuclei	PMC of F ₁	800-1,500 r	Catcheside 1938b
—Flowers	Single cell of pro-embryo	PMC of F ₁	not given	McClintock 1931
<i>Crepis capillaris</i> (2x = 6) seedlings	Growing points	RT of F ₁	not given	Lewitsky 1940
INSECTS				
<i>Drosophila</i> (2n = 6, 8, 10) adult males in capsules	Sperm	SG of F ₁ or breeding behaviour	1,000-5,000 r	Bauer, Demerec and Kaufmann 1938
adult females	Eggs	Cleavage	200-5,000 r	Catcheside 1938
<i>Locusta</i> (2n = 23) adult males	Spermatogonial cells	12 hrs.-14 days later	ca. 500 r	Sonnenblick 1940 White 1935
<i>Mecostethus</i> (2n = 23)	Young SMC	7 hrs. later	ca. 400 r.	White 1937
<i>Circotettix</i> (2n = 21)	Whole organism	Maturity, 6-8 weeks later, SMC	200-400 r	Helwig 1938
MAMMALS				
<i>Mus musculus</i> , adult males (2n = 40)	Whole animal	Fertility and F ₁	700-900 r (neutrons)	Snell 1939 Koller unpub.

b. DRUGS

Drugs are being used with success as spindle anaesthetics to suppress the division of nucleus and cell. The ulterior objects are (i) to produce polyploid tissues and organisms and (ii) to examine their mode of origin in the cell and show how the spindle works, and (iii) to suppress or modify chromosome pairing at meiosis. The swelling of the treated shoot (or tadpole) is often an index of the proportion of cells which have been arrested at metaphase.

Table IV gives some examples of the reagents, treatments and organisms that have been used for these purposes. It should be noted that drugs, unlike abnormal temperatures, continue their action long after treatment. For this reason prolonged treatment of seeds is often too effective and Thomas (unpub.) finds the maximum tetraploidy (80% of cells) in *Lolium* seedlings after 2 hours in 0.4% colchicine at 37° C. The action of the drug is more accurate and more rapid at the higher temperature.

c. TEMPERATURE

Low temperatures have an important effect on nuclear metabolism; they restrict the supply of nucleic acid available for the spiralized chromosomes. This renders heterochromatin visible on account of its lower control of its nucleic acid attachment (Darlington and La Cour 1938, 1940, 1941, on *Trillium*, etc.; Callan 1942 on *Triton*).

Spindle formation is stopped below a critical temperature characteristic of each plant or animal: 3° C. in *Triton*, 0° C. in *Trillium*, — 5° C. in *Fritillaria Meleagris* (cf. Barber and Callan 1942). Low temperature can therefore be used as a substitute for drugs for all the purposes mentioned (except

TABLE IV—EFFECTS OF DRUGS ON CHROMOSOMES

Reagent							
A. Production of polyploids							
Colchicine	0.1 % in 0.8 % agar	3 days	buds	<i>Datura</i>	Blakeslee and Avery 1937		
Colchicine	0.2-1.6 % aqueous	10 days	seeds	<i>Datura</i>	Blakeslee and Avery 1937		
Colchicine	1 % in lanolin	smear	buds	<i>Antirrhinum</i>	Nebel and Ruttle, 1939		
Colchicine	0.01-0.2 % aqueous	17 hours	runners	<i>Mentha</i>	Nebel and Ruttle 1939		
Colchicine	1 % in 1.5 % agar*	smear	buds	<i>Petunia</i>	Levan 1939		
Colchicine	0.125 % aqueous	20 hours†	seeds	<i>Petunia</i>	Levan 1939		
Colchicine	0.06 % aqueous	2 days	Germinating seeds	<i>Hordeum</i>	Karpechenko 1940		
Colchicine	0.05-0.1 % aqueous	12-24 hours	dry seeds†	<i>Gossypium</i>	Harland 1940		
Colchicine	0.05-0.1 % aqueous	12 hours	shoots	<i>Gossypium</i>	Harland 1940		
Acenaphthene	Satd. soln. on paper	2-7 days	shoots	<i>Antirrhinum</i>	Kostoff 1938		
B. Examination of mitosis							
Aurantia	0.01-0.1 % aqueous	1-6 days	roots	<i>Hordeum</i>	Favorsky 1940		
Tribromoaniline	powder	sprayed	roots	<i>Hordeum</i>	Favorsky 1940		
Colchicine	0.125-2 % aqueous	7 mins-72 hours	roots	<i>Allium</i>	Levan 1938		
Colchicine	0.1 % aqueous	to 2 days	larva	<i>Triton</i>	Barber and Callan 1942		
Heterauxin	1-10 p.p. million aqueous	4-6 days	roots	<i>Allium</i>	Levan 1939d		
C. Control of Meiosis							
Colchicine	0.5 % aqueous	from 7 days	flower buds	<i>Fritillaria</i>	Barber 1942		

* arm.

† Vacuum-pumped.

‡ Germinated afterwards at 30-35° C. (Harland).

in birds and mammals). Callan (1942) with *Triton* has shown how temperature manipulation can be used for the joint control of spindle development, spiralization and nucleic acid metabolism.

The same effect can be obtained by high temperatures (5 hours to 2 days at 30°–40° C.) at mitosis and meiosis, e.g. PMC of *Fritillaria* (Barber 1940) and of *Trillium* (Matsuura 1937). Barber's work shows that heat, like X-rays and growth hormones, can throw the prophase nucleus back into the resting stage and thus give rise to diplo-chromosomes at the next mitosis.

Higher temperatures (ca. 44° C.) for a short period have the same effect by shock and have been used on young embryos for producing polyploid cereals (Randolph 1932, Dorsey 1936) and *Linum* (Lutkov 1938). Before meiosis they reduce chromosome pairing (Straub 1937). Their detailed action on chromosomes and spindles has been analysed by Barber and Callan (1942).

d. CENTRIFUGING

Experiments have been made for various purposes by Beams and King (1935), Kostoff (1937) and Kawaguchi (1938).

e. VARIOUS GENETICAL DEVICES

Most combinations of chromosomes and breeding work are too obvious or too elaborate to be given here. Four intermediate hints may be mentioned.

(1) With plants it is usually easy to take out one anther and later examine or breed from another. Also to take roots of seedlings so as to decide which to breed from.

(2) In animals, special procedure is often necessary, *e.g.* in mammals to remove one testis for examination and leave the other for breeding.

(3) In *Drosophila* the progeny of an important parent are examined (in the salivary glands) while the parent is still alive, in order to discover its chromosome make-up before using it for experimental breeding. Where the presence of the Y chromosome is important, mitosis in the oesophageal ganglia must be used (acetic orcein smear).

Ganglia should be kept in 70 % alcohol for parallel test with salivary gland in case they are required in breeding experiments.

(4) The genetic activity of chromosomes can be studied most rapidly and most conveniently in pollen, for every anther of a hybrid plant contains a genetic experiment. A simple study of this kind is described by Levan (1939b), a more complicated one by Darlington and Thomas (1941). The genetic implications of embryo-sac studies are reviewed by Darlington and La Cour (1942).

Chapter 10

THE CONTROL OF FERTILIZATION

a. POLLEN GERMINATION

Artificial germination of pollen is necessary for two purposes: the measurement of fertility and the observation of the generative nucleus in the pollen tube. Free growth of pollen tubes demands special culture media with temperatures controlled at about 20° C. and humidity approaching saturation.

Culture Media :

- (1) Cane sugar solutions in water, 8 % for *Tradescantia*, 14 % for *Tulipa* and up to 25 %
- (2) The same (a) in agar (b) in 2 % agar, 2 % gelatin (Newcomer 1938).
- (3) The same with extract of style and placenta or stigmatic secretion (Yasuda 1934).
- (4) Stigmatic secretion alone (Lewis unpub. *Prunus*, *Pyrus*).

The first two simple methods are generally successful; for the tomato a slight acidification, *e.g.* with weak tartaric acid, is necessary (Sandsten 1909).

Observation with controlled humidity is simplest by the hanging drop method. A drop of the medium containing the pollen is placed on a cover slip which is inverted over a vaselined ring (Fig. 5h) to make a hanging drop chamber. The humidity can be increased by adding a drop of water on the slide, or by placing a drop of agar beside the hanging drop on the cover slip. A more accurate method is to leave the ring unsealed and place the slide in a desiccator with

glycerine in water, adjusted by trial to give the correct humidity: 80% glycerine gives 50% humidity at 15° C.

Rapid method for germination test.—Dust the dry pollen on a cover slip, invert over hanging drop chamber containing a small piece of wet filter paper. Adjust the size of the paper to give correct humidity (Thomas unpub.).

b. TUBE DIVISION

In Angiosperms (apart from Gramineae) the generative nucleus usually divides into the two sperm nuclei in the pollen tube. In *Tradescantia* and *Tulipa* the division is 12–24 hours after germination at room temperature. A cover slip with the pollen germinated as already described can then be stained and fixed either by a stain-fixative or by 2BE–C.V. (Upcott 1936).

Recent improvements make this mitosis one of the most favourable for the study of chromosome shape, structure and breakage, as follows:

- (1) The pollen is germinated on Newcomer's sugar-agar-gelatin medium.
- (2) The gelatin is added after the other constituents have been raised to boiling point and slightly cooled. The medium is smeared on 3–6 slides while still hot and the grains sown when cool by dusting with the burst anther.
- (3) The slides are placed in slotted staining jars with moist, but not wet, filter paper at top and bottom.
- (3a) In addition the chromosomes during mitosis can be contracted and retained at metaphase, to improve observation by scattering acenaphthene crystals on the bottom of the slotted jar. This method works with *Tradescantia* but will not work if the division takes place more quickly (Swanson 1940).
4. The slides are taken at the maximum period of division (which can be discovered by trial with acetic lacmoid) and fixed and stained by any smear method.

c. POLLEN STORAGE

For purposes of cross-fertilization it is often necessary to store pollen. Ripe anthers are allowed to burst in petri dishes and the pollen is stored in vials stoppered with cotton wool, which are placed in desiccators with humidity controlled at 50 % by using glycerine in water. A list of the storage capacities of 500 species, and of the sugar concentrations they require for germination, is given by Doroshenko (1928). Kept at 0-8° C. pollen has been found to maintain its capacity for germination for long periods. It does not however maintain its capacity for fertilization so long (Nebel and Ruttle 1939).

In this regard pollen seems to be of two kinds. In grasses the generative nucleus divides into two sperms before germination. This pollen loses its capacity for germination in about 40 days, for fertilization in about 1 day. In other plants whose generative nucleus divides after germination in the pollen tube, the pollen will germinate after two or three years, and it loses its capacity to fertilize only in 40-200 days. The failure of fertilizing power is probably due in grasses to the death of the sperm nuclei; elsewhere to the fusion of sister chromatids shown to occur in the generative nucleus after storage (Barber 1938).

Dead pollen such as that of old herbarium specimens can still be examined by acetic stains in order to discover its size and quality and the numbers and positions of the vegetative and generative nuclei (Darlington and Thomas 1941).

d. THE STYLE

Fertilization in plants is controlled in the first place by the style-pollen relationship, which has been the subject

of extensive genetic and cytological study in regard to both self- and cross-sterility. Styles examined from four hours to six days after pollination (according to the rate of growth) show differences in the progress of pollen-tubes according either to their absolute and relative genetic constitutions, or to the temperature, or to a special effect of irradiation. Thus X-rayed styles allow incompatible pollen to grow in species crosses of *Triticum* according to Tanaka (1937) and in self-pollination of *Oenothera* according to Lewis (unpub.).

Treatment depends on the size of the style. Large styles usually have thick central strands of conducting tissue. These strands contain all the pollen tubes and they can be removed intact with the stigma after the style is slit (*Datura*, Buchholz 1931; *Oenothera*, Emerson 1938).

In small styles the central strand is more fragile and special methods must be used to get at it, according to its size and shape:—

(1) *Material fresh or fixed 10 minutes in acetic alcohol and stored if necessary in 30 % alcohol to prevent hardening.*

- (i) Cut the style in half (*Pyrus*, *Prunus*, *Primula*, Lewis and Modlibowska 1942). Crush afterwards under the cover slip (*Tradescantia*, Anderson and Sax 1934; *Secale*, Sears 1937).
- (ii) Boil in 4 % sodium sulphite solution for about 3–10 minutes and press out the central strand under a cover slip (*Pelargonium*, *Petunia*, *Nicotiana*, etc., Sears 1937).
- (iii) Section on freezing microtome at 20 μ (plants with straight styles, e.g. *Prunus* and *Primula*, Lewis unpub.).

Stains for (I):

- (a) Acid-Fuchsin with Light-Green, 5 min. to 6 hr. at 55° C. (*Primula*, *Pyrus* and generally).
- (b) Cotton Blue, 5 min. to 6 hr. at 55° C. (*Cereals*, Watkins 1925, *Prunus*, *Oenothera*).
- (c) Lacmoid—Martius Yellow (*Pyrus*, Nebel 1931).

(2) *Material fixed in Medium Flemming*

(d) Embed and stain in Delafield's haematoxylin or (a) (b) (c).

e. HAPLOID PLANTS

Haploid plants are important for the light they throw on the genetic constitution of their parents; for the study of their chromosome pairing at meiosis; for the production of homozygous diploids by their later doubling; and for making species crosses possible.

Haploid parthenogenesis can probably be induced in most diploid and even-numbered polyploid plants (4x, 6x, etc.), inbred diploids being easier than outbred. Certain special conditions favour this development (*cf.* Darlington 1937):—

- (1) Pollination with another species (*Datura*, *Solanum*, *Nicotiana*).
- (2) Pollination with a plant of a different ploidy (*Zea*, *Campanula*, *Petunia*).
- (3) Delayed pollination giving rise to twins (*Triticum*, Kihara 1940).
- (4) Use of X-rayed pollen (*Triticum*, *Nicotiana*, Kihara and Yamashita 1938).

Amongst natural conditions, twinning has been found to lead to the development of haploids or triploids, or both, in *Triticum*, *Poa*, *Gossypium*, *Linum* and *Solanum* (*cf.* Harland 1936; Skovsted 1939).

f. HAPLOID ANIMALS

The development of haploid eggs following partial or complete suppression of doubling of fertilization has been studied chiefly in Echinoderms and Amphibia (*cf.* Wilson 1928). The object is to trace the relationships of chromosomes, mitotic spindles and general development.

Eggs can be made to undergo incomplete cleavage without fertilization or with multiple fertilization by (i) shaking or pricking, (ii) placing in hypertonic solution, (iii) treatment with drugs such as strychnine.

Development of egg fragments without egg nuclei can be induced in *Triton* by separating a part of an egg containing the sperm by ligature (Fankhauser 1937). Comparable experiments have been successful in studying fusion in *Paramecium* (Tartar and Chen 1941).

In the Hymenoptera, where the control of fertilization is a necessary part of the breeding system, many factors, internal and external, control it (*e.g.* temperature, R. L. Anderson 1936).

CHAPTER II

PHOTOGRAPHY

a. USES

Microphotos can show either less or more than drawings according to how they are chosen. If ill chosen they will certainly show less, and if they require arrows and signs to explain their meaning they must be regarded as ill-chosen. The first problem in microphotography is therefore to choose a subject capable of illustration in this way. Where the subject is unsuitable it can be made suitable in four ways:

- (1) By using flat smears and squashes instead of sections.
- (2) By adapting the method of fixation so as to give the flat subject required.
- (3) By using a deeper stain.
- (4) By using a lower objective to give great depth of focus.

The best general guide to microphotography is Hind and Randles (1927).

b. CAMERAS

Type A.—A simple and sufficient box camera designed by Mr. H. C. Osterstock, which may be made of cardboard, plywood, black paper and glue, is illustrated in Fig. 3. It may be made to give an eyepiece-plate distance varying from 6 to 9 in. (15 to 23 cm.) and giving a linear magnification directly proportionate to the object-plate distance. A 9 in. model designed for plates $3\frac{1}{2}$ in. \times $2\frac{1}{2}$ in. weighs 7 oz. (200 gm.) unloaded, $9\frac{1}{2}$ oz. when loaded with the plate.

Type B.—Where a large field is required, the camera

must be heavier and needs support from a separate stand. A field camera with extensible bellows can be readily adapted

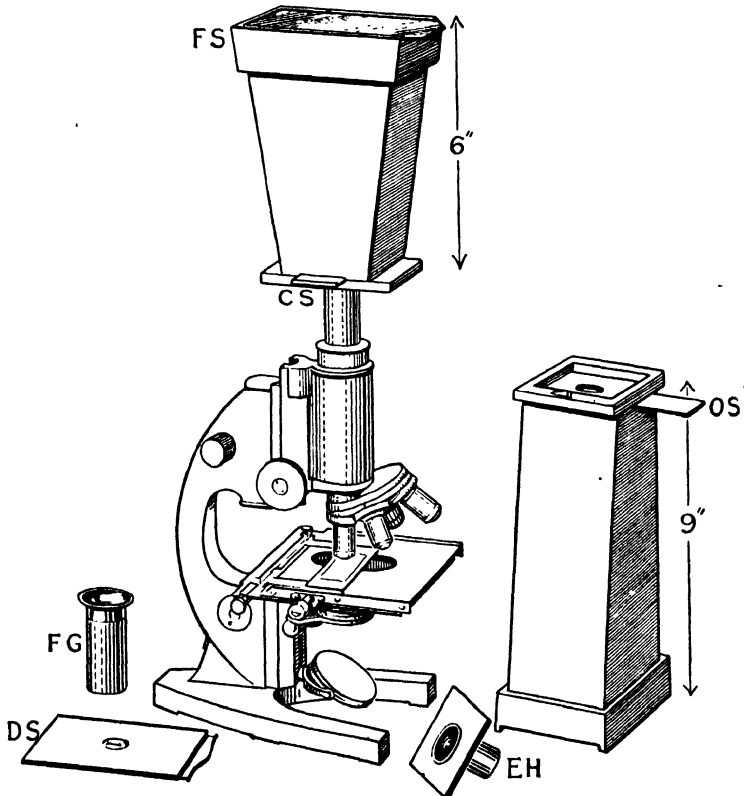

FIG. 3.—Home made box cameras, 9 in. model unmounted, 6 in. model mounted on microscope. FS, focussing screen. CS, closed shutter. OS, open shutter. FG, focussing glass. DS, dark slide. EH, eyepiece holder to be inserted in top of unmounted camera before mounting.

for this purpose. The greater distance of the plate makes it possible to use a lower eyepiece.

Type C.—A roll film or ciné camera can also be adapted

to take photographs which afterwards require strong enlargement (*cf.* Barber 1939).

c. TAKING THE PHOTOGRAPH

(1) *Preliminary*

- (i) The illumination and the cleanliness of the apparatus naturally require more attention for photography than for casual use. The extraneous window light must be cut off.
- (ii) The screens will depend on the type of plate used: for panchromatic plates green or yellow, or both, intensify the staining contrast. Ordinary plates can be used without any screen where the stain is red (carmine, fuchsin, etc.).
- (iii) For all purposes a partial cone of light is the best. The substage diaphragm should be cut down, but not to the point of producing refraction images or optifacts (Darlington and La Cour 1938).
- (iv) The bench must be set up to avoid vibration.
- (v) The slide can be tilted to flatten the object where a slight correction is needed (White unpub.). Pollen grains in liquid preparations may be rolled by sliding the cover slip.
- (vi) The eyepiece should be of suitable power for the object and plate. A special projection eyepiece is unnecessary.

(2) *Operative*

- (i) Fix eyepiece in holder and attach to camera.
- (ii) Insert eyepiece (with camera attached) in microscope.
- (iii) Restrict the cone of light, remove filters, focus the image on the focussing screen. A special lens is helpful in tracing the image on ground glass, and indispensable if a plain glass screen is used.
- (iv) Insert filters.
- (v) Remove eyepiece-with-camera very carefully and load with plate.
- (vi) Close the shutter and open the dark slide.
- (vii) Replace eyepiece-with-camera on microscope.
- (viii) Expose by opening the shutter. The correct length of the exposure will be .10 seconds to 3 minutes according to the illumination and the type of plate. It varies as the square of the linear magnification.

- (ix) Switch off the light; close the shutter; close the dark slide and remove the plate from the camera.

d. DEVELOPING

With box-camera plates it is convenient to be able to enlarge photographs up to twice for publication and up to ten times for demonstration pictures.

If the negative is to be used for enlargement more than twice it should be developed with a fine-grain developer (formula in App. 3).

Development is carried out with a red light for ordinary plates and in complete darkness or under a safe green light for panchromatic plates. It is complete with an ordinary plate as soon as the image appears satisfactorily, or with a panchromatic process plate as soon as the back of the plate turns light grey. With the optimum exposure, development should take 3-20 minutes, being longest with a fine-grain developer at a low temperature (see App. 3).

Over-developing (with a strong solution) can be used to correct for under-exposure, but this is not sound practice, because it coarsens the grain.

e. PRINTING AND REGULATION OF CONTRAST

The test of a good print is that it should show as much as the negative. The better the negative the easier this is.

Bromide paper is made in a series graduated in capacity between hard contrast and soft contrast. Your choice must depend on what you want to show.

For contact printing, artificial light is most satisfactory. Daylight is necessary for the enlargement of a hard negative,

since it gives a softer picture and blurs the grain. An under-exposed negative needs to be under-printed.

TABLE V
METHODS OF REGULATING CONTRAST

<i>Stage</i>	<i>Hard contrast</i>	<i>Soft contrast</i>
1. Type of plate	Process panchromatic	Panchromatic and ordinary
2. Screening	heavy	light
3. Length of exposure	correct	over-exposure
4. Developing plate	long development in weak solution	short development in strong solution
5. Developer	hydroquinone types	other types
5'. After-treatment of plate	intensification (after under-exposure)	reduction (after over-exposure)
6. Printing light*	yellow	blue
7. Printing paper (Bromide)	hard	soft
8. Enlargement	artificial light	daylight
9. Developing print	long development in weak solution	short development in strong solution

* For multigrade paper.

The technique of producing effective results largely depends on the correct adjustment of such compensating methods of intensifying and reducing contrast as are shown in Table V. Only as a makeshift should the after-treatment of the plate be used as a remedy.

Recently a new method of regulating contrast has been introduced by Messrs. Ilford. A single type of "multigrade" printing paper is used and the effect is obtained by varying the relative exposure under two screens: yellow for hardness is quicker, blue for softness is slower. This method is capable of giving the finest results.

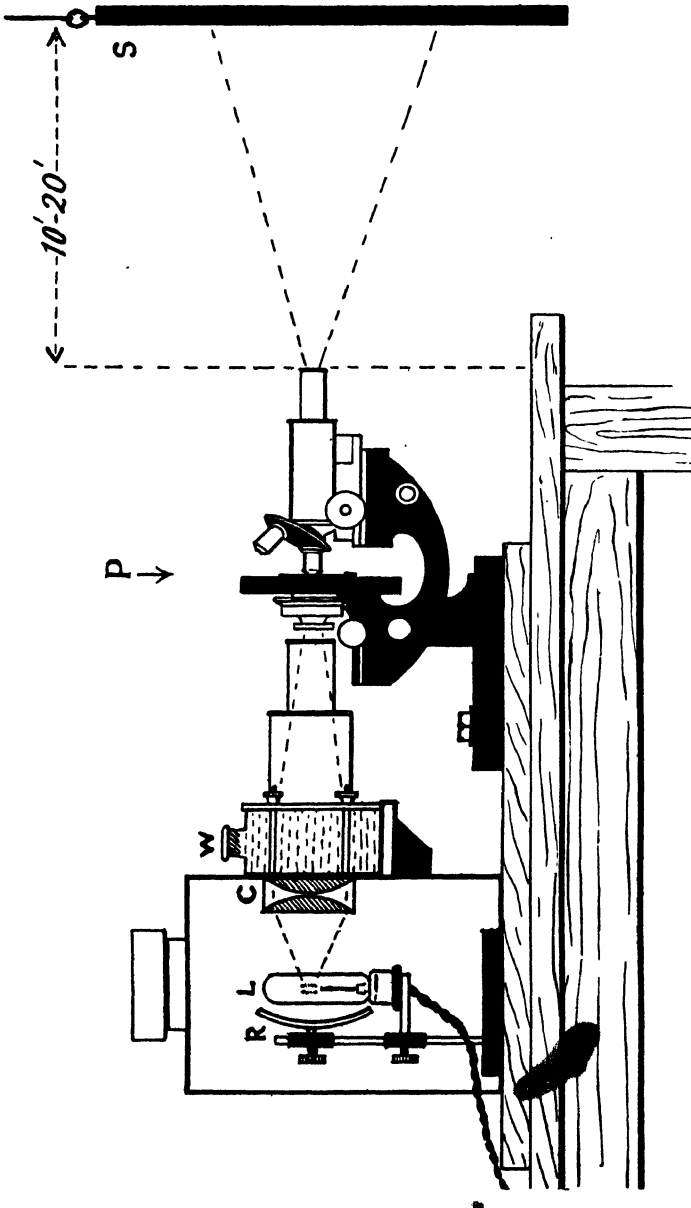

FIG. 4.—Microscope set up for screen projection. R, reflector. L, projector lamp. W, water cooler. C, condenser. P, preparation. S, screen.

f. PREPARING PHOTOGRAPHS FOR REPRODUCTION

Two methods of reproduction are in common use by scientific publishers: half-tone (as in this book) and collotype. Both these methods are more expensive than the zinc block used for line reproduction of pen-and-ink drawings.

For reproduction, glossy paper is necessary, and the prints are glazed by rolling and drying on plate glass cleaned and polished with french chalk or a proprietary substitute.

Since the photograph should, as far as possible, explain itself, irrelevant structures should be excluded by vignetting in printing.

Some publishers prefer photographs unmounted. If mounted, the photograph or group should leave no gaps or patches but should fill the whole plate as nearly as possible. In one plate all the photographs benefit by having a uniform intensity, background, and magnification.

g. SCREEN PROJECTION

For demonstration of chromosomes, in teaching, the simplest method is to project the image on a screen. Focus and position on the slide can then be varied while both demonstrator and audience have the image in view (Darlington and Osterstock 1936).

The diagram (Fig. 4) shows the way to set up such an apparatus. A 10 amp. arc lamp, a strong condenser, and a water-ammonia heat-absorbing tank allow a sufficient beam to be passed through a horizontal microscope with a balanced stand. With a 2 mm objective and $\times 5$ eyepiece an image magnified 5,000 diameters can be produced on a screen 4 ft. in diameter and 9 ft. from the microscope. The

beam is enclosed between the two condensers to avoid glare.

A solid slow-fading stain such as haematoxylin gives the best image, but we have had satisfactory results with crystal violet, fuchsin and carmine.

Chapter 12

DESCRIBING THE RESULTS

a. INTERPRETATION

When we have our preparations fixed and stained, how are we to know the value of what we see in them?

Clearly the first problem is the construction of a three-dimensional model in the mind's eye from a continuous series of focal projections seen by the physical eye. This is a question of training, and probably trainability. It must be left to practice, especially practice in drawing, to solve.

The second problem is more intellectual, that of validity. Obviously if we can compare fixed with living observations we have a direct test of validity. This test has now been greatly extended by the use of ultra-violet photography. But this method is restricted by the elaboration and costliness of the apparatus. It has therefore been applied so far only to special studies, which have shown the general soundness of the images obtained by what we earlier recognized as "good fixation." This recognition was made by comparisons of other kinds, namely:—

- (1) Of chromosome behaviour in similar cells of different species.
- (2) Of chromosome behaviour in the same cells with different treatments and
- (3) Of the succession of observations during development which provide a satisfactory basis of prediction.

Interpretation therefore depends on common sense and on taking into account all the relevant data. These data may now extend beyond the description of the chromosomes.

They include the results of the new methods of experiment already described. They include also considerations of genetical experiments and protein chemistry, reinforced by X-ray analysis (Bernal 1940). This extension of the critical apparatus of cytology has recently removed the main grounds of contention and has helped to establish a wide measure of agreement in the interpretation of chromosome behaviour.

b. ILLUSTRATION

Drawing is an integral part of chromosome research. It is doubtful whether good training or even good observation at all is compatible with bad drawing. But it is certain that its value is largely wasted if unsubstantiated by good drawing. In the past a large part of the cost of publication of chromosome studies has been frittered away by editors proud of the expensive reproduction of works which derived little from art and contributed nothing to science. The earliest error, now disappearing, lay in attempting to use a realistic imitation of perspective drawing with pencil or sepia wash to show light and shade. These drawings, expensively reproduced by lithograph or collotype, had the meretricious charm of blurring the uncertain edges of observation. What is needed, however, is a drawing which (i) can be reproduced cheaply, (ii) will show the reader, true or false, exactly what the draughtsman thought he saw. For these purposes pen-and-ink drawing alone is suitable.

As the needs of research change, the subjects and manner of illustration must change too, and a great deal will depend on their adaptability. For this everything hinges on the necessary detail of the subject in question. The original magnification of drawings should always be about half again as big as the smallest at which they will show this necessary

detail, and at which they should be reproduced. To allow for this reduction all lines and all spaces between lines should usually be bold, *i.e.* about 0.5 mm. thick.

Again, in different drawings of the same subject, the purpose and therefore the significant elements will change. Sometimes it is the arrangement of the chromosomes in the cell and sometimes the structure of individual chromosomes. In the first case the unit of drawing is the whole cell, in the second each chromosome can, and perhaps should, be drawn separately. Sections of course, where they can be complete, have the advantage, for the first, smears and squashes for the second. Particular chromosomes can be picked out by showing them solid or cross-hatched or stippled as against others in outline. Further, everything should be done in the way of lettering and marking special structures to enable the reader to see at once what is referred to in the text. Finally, where the case is novel and intricate, diagrams and graphs should be used to clarify the description or explain the hypothesis.

And as to good training, it means simply this: take care of the drawing at the beginning and in the end the drawing will take care of itself. A slovenly start cannot be made good.

c. DESCRIPTION

When the drawings and photographs are prepared, and the data of observation collected, the work is ready for description. Discoveries unpublished are discoveries wasted, and the author himself will increase the accuracy of his observation by submitting to the discipline of description no less than of illustration. This is a necessary part of technique, and one which has made some advances recently, habit and

tradition notwithstanding. Certain rules are therefore worth setting out:

First, assess your results in relation to the previous work of others. Consider everything that is relevant, whether or not it arises by similar methods or from similar organisms. For relevance arises in many ways, and how to discover them is all the more important in research for its being neglected. Never fear to make surprising conjunctions of plant and animal, of genetics and physiology, for it is of the nature of chromosome studies to bring such conjunctions about. Do not, on the other hand, quote papers which you believe to be worthless, unless you wish to prove them so. And in proving them so, never say that the proof is absolute or certain for that, as everyone knows, only time can show.

Secondly, be concise. This you can do in many ways:

§ Make your title short. Do not offer a "preliminary account," for all scientific work is preliminary. Do not put Linnaeus or Pallas in the title; leave them to enrich the text. State the specific and analytical result rather than the general and superficial class of your observations.

§ Convey information in your summary. Let it be exact without detail and general without vagueness. Do not say "A, B and C were discussed." Give your conclusion if you reached any. There are some who will tell you to arrive at no conclusion, for it will only "weaken your argument." Do not believe it. If you are unable to state any conclusion, leave out the discussion, for not even the professional abstractors will read it.

§ Obtain and give quantitative results where a sharp classification makes it possible: provided of course that some useful conclusion can be drawn from them. Never say merely that such an event was "frequent" or "very

frequent," since that means nothing to anyone else. If you do not know precisely, give an estimate.

§ Put all possible facts in tabular form since if you do not, your readers will have to do so, and their number will be fewer. On the other hand do not offer tables which mean nothing.

§ Use technical terms consistently and state your definitions of terms that have not been defined. Do not "furnish data"—just state the facts. Do not "describe phenomena"—just say what you saw. Avoid vocables like karyokinesis, arrhenotoky, megagametophyte, photomicrography. They exist only in books, and in the memories of over-learned men.

§ Omit personal matters. Let your results alone speak for your exertions. Especially take care not to explain why you failed to get results. The reader is selfish. He is interested only in your success.

In a word, pay attention to the reader if you wish him to pay attention to you.

LIST OF PLATES

PLATE I

Polar views of metaphase in the spermatogonial cells of the testes of insects

1 and 2, mitoses in young and old follicles in *Leptophyes punctatissima*, Orthoptera; 30 one-armed autosomes and one two-armed X (no Y).

3, *Tettix bipunctata*, Orthoptera; 12 autosomes and one indistinguishable X (no Y).

4, *Drosophila miranda*; the chromosomes in order of size are: X₁, Y, X₂ and three pairs of autosomes (*cf.* *D. melanogaster* on the cover).

1, 2 and 3, sections cut at 20 μ , fixed 2BD, stained CV.

4, acetic-lacmoid squash, prep. and photo by P. C. Koller.

1 and 2, $\times 3500$, 3, $\times 4000$, 4, $\times 10,000$

All photos taken with 2 mm. oil-immersion objective, green screen and panchromatic process plates, and printed on graded bromide paper, unless otherwise stated.

PLATE II

First P.G. mitosis in polar view

1, *Brodiaea uniflora*, Liliaceae, $n = 6$.

2, *Tradescantia virginiana*, Commelinaceae, $n = 9$ (from aberrant plant with 22 chromosomes).

2 BE — CV smears. 1, $\times 4000$. 2, $\times 1200$. 1, printed on multigrade paper.

PLATE III

First P.G. mitosis in *Paris quadrifolia*, Liliaceae, showing all stages from prophase to telophase. $n=10$ (*cf.* Darlington 1937, 1941)

2 BE — CV smear, 8 mm. objective. $\times 800$.

PLATE IV

Acetic smears of plants with small chromosomes

1, First PG mitosis in *Morus nigra*, the mulberry, $n = 154$.

2, First PMC metaphase in side view of *Prunus avium* "Duke Cherry," $4x = 32: 6IV, 2II, 1III, 1I$.

1 and 2. Thomas's method (weak carmine with high iron content), prep. and photo 1.5 mm. objective; 1, $\times 2000$; 2, $\times 2600$.

PLATE V

Root-tip squashes of *Trillium* spp., $x = 5$, showing metaphase chromosomes after nucleic acid starvation at 0°C .

1, *T. stylosum*, $2n = 10$, heterochromatin on 4 terminal and 4 intercalary segments, weakly stained but spirialized (cf. Darlington and La Cour 1940).

2, *T. Tschonokii*, $2n = 4x = 20$, heterochromatin on 2 large intercalary segments unspirialized.

2 BD — Feulgen. 1, $\times 1700$. 2, $\times 1300$.

PLATE VI

Root tip squashes showing anaphase separation

1, *Trillium stylosum*, starved heterochromatic segments still in contact (cf. Darlington and La Cour 1940).

2, *Fritillaria pudica*, $3x = 39$, spiral structure of chromatids revealed by pressure after cold treatment.

2 BD — Feulgen; 1, $\times 1700$. 2, $\times 3000$.

PLATE VII

Cleavage mitosis in the morula of a teleostean fish, *Coregonus clupeoides*, in the middle of anaphase. Spindle structure revealed by slow fixation

Section cut at $10\ \mu$. $\times 4000$. Strong Flemming, haematoxylin. Prep. and photo by P. C. Koller.

PLATE VIII

First metaphase in EMC of *Fritillaria pallidiflora*,
Liliaceae; the 12 bivalents have single chiasmata
close to the centromere (*cf.* Darlington and La Cour
1941)

2BX — CV, section 40 μ . 8 mm. objective. \times 1200.

PLATE IX

Living salivary gland nucleus of *Chironomus riparius*,
mounted in liquid paraffin. The nucleolus is at-
tached to the fourth and smallest pair of chromo-
somes

Prep. and photo by A. M. Melland. 8 mm. objective. \times 600.

PLATE X

Polytene chromosomes in the salivary glands of fly
larvae. 1, *Drosophila* sp., nucleus unbroken; 2, *D.*
melanogaster, nucleus broken

All chromosomes, and in (1) the nucleolus as well, are
attached to the fused body of heterochromatin.

1, acetic-orcein (La Cour 1941). \times 900. Process plate, no
screen.

2, aceto-carmin, \times 500(?) Prep. and photo by H. G.
Callan. 1 and 2, 8 mm. objective, multigrade paper.

PLATE XI

Spiral structure at first metaphase in *Tradescantia vir-*
giniana PMC, $4x = 24$

1, pre-treated with nitric acid vapour, medium Flemming
— CV. \times 2400.

2, hot aceto-carmin, prep. and photo by M. M. Richardson.
 \times 1500.

1, multigrade paper.

PLATE XII

First metaphase in PMC smears of *Tradescantia* and *Rhoco*

1, *T. virginiana*, $4x = 24 + 3$ fragments; 4^{IV} , 4^{II} (one with interstitial chiasma), 1 f^{III}.

2 and 3, *Rhoco discolor* with ring of 12, due to interchange hybridity: frozen to show heterochromatin near the centromere.

1, Acetic — Bismarck Brown. $\times 1800$.

2 and 3, Acetic-lacmoid, 3 mm. objective, $\times 2700$. Multigrade paper.

1, 2 and 3, Process plate without screen.

PLATE XIII

Polar view of first metaphase of meiosis, showing proximally localised chiasmata (*cf.* Plate VIII)

1, SMC of *Mecostethus grossus*, $n = 11$ (+ X, invisible).

2, PMC of *Fritillaria oranensis*, $n = 12$.

1, section at 30μ , 2BD — CV. $\times 2700$.

2, smear, 2BE — CV. $\times 1800$.

PLATE XIV

Prophase of meiosis (pachytene) of *Fritillaria*

1, *F. imperialis*, PMC, pairing of chromosomes attached to darkly stained nucleolus not complete (Darlington 1935). Smear, Medium Flemming — CV. $\times 3000$.

2, *F. pudica*, $3x$, ESMC, heterochromatin darkly stained, nucleolus darkened with osmic acid but unstained (Darlington and La Cour 1941a). Section at 40μ , 2BX — Feulgen. $\times 3400$.

1. multigrade paper.

PLATE XV

First metaphase in SMC of animals

1, *Chrysochraon dispar*, Orthoptera: 8^{II} + X.

2, *Triton vulgaris*, Urodela: 12^{II}.

1, aceto-carmin squash. Prep. and photo by H. Klingstedt.
× 1500.

2, Acetic-alcohol — Feulgen squash after nucleic acid starvation. Prep. and photo by H. G. Callan. × 2400.

PLATE XVI

Second metaphase in SMC of *Cimex rotundatus*,
Heteroptera, $n = 14 + X_1X_2Y$. Polar and side
views, show central co-orientation of the three
sex chromosomes (*cf.* Darlington 1939)

Section at 16 μ , 2 BD — CV. × 3000.

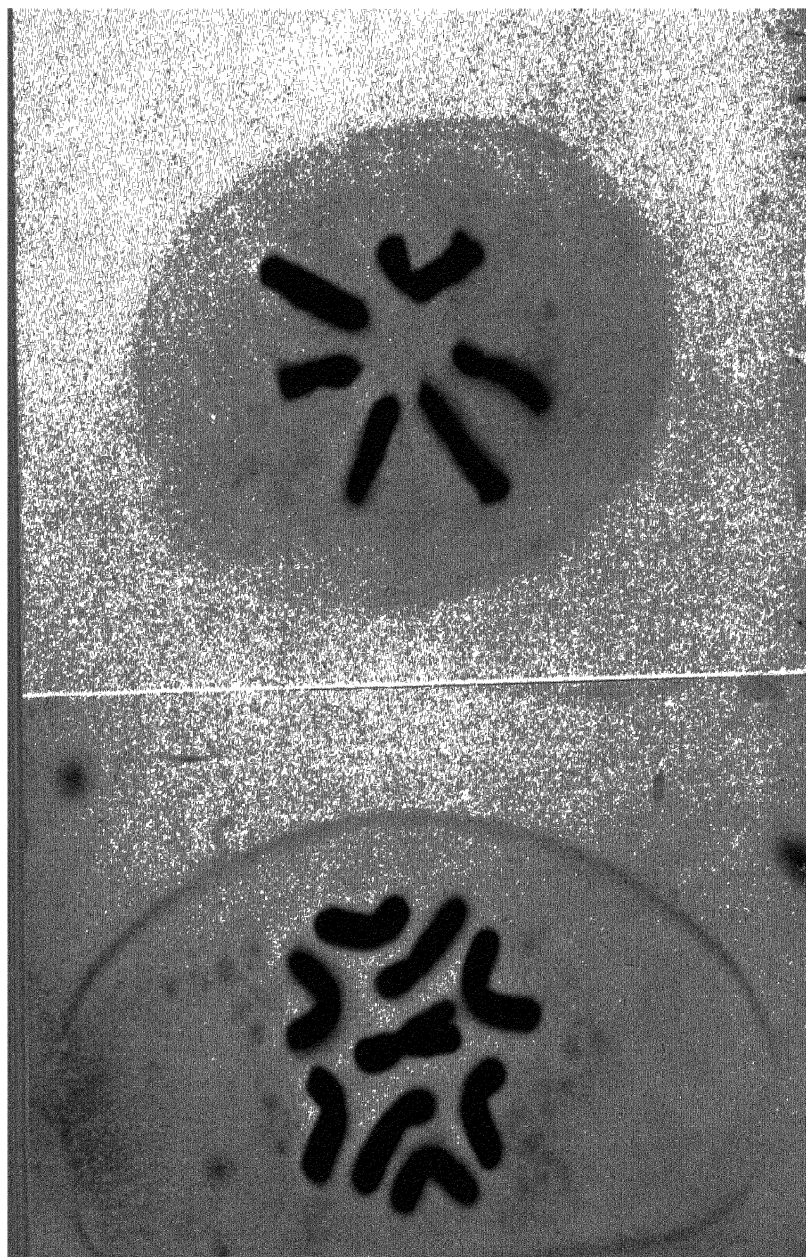

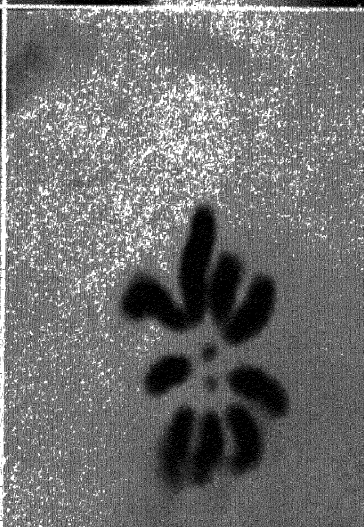
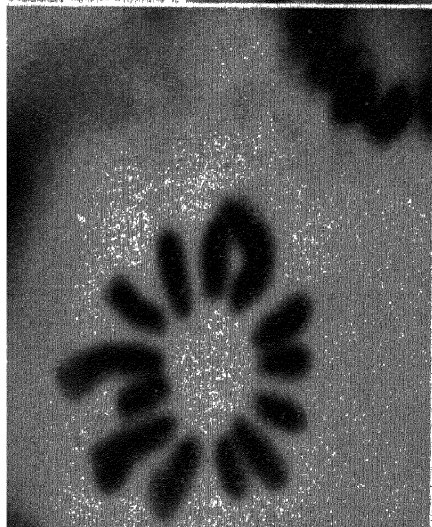
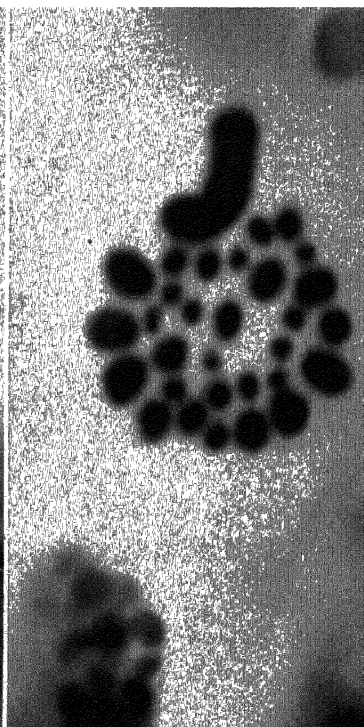
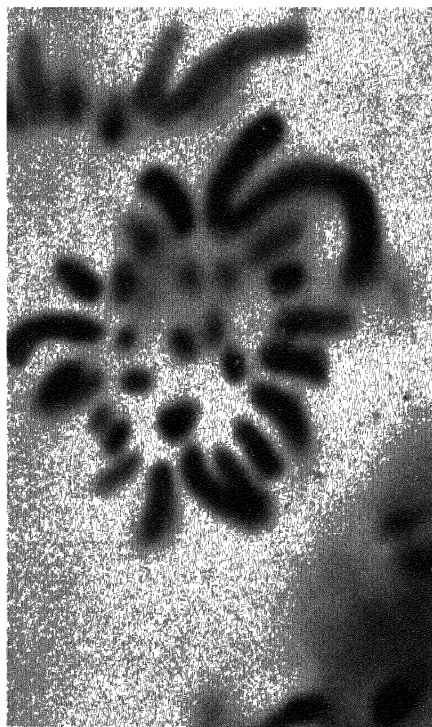

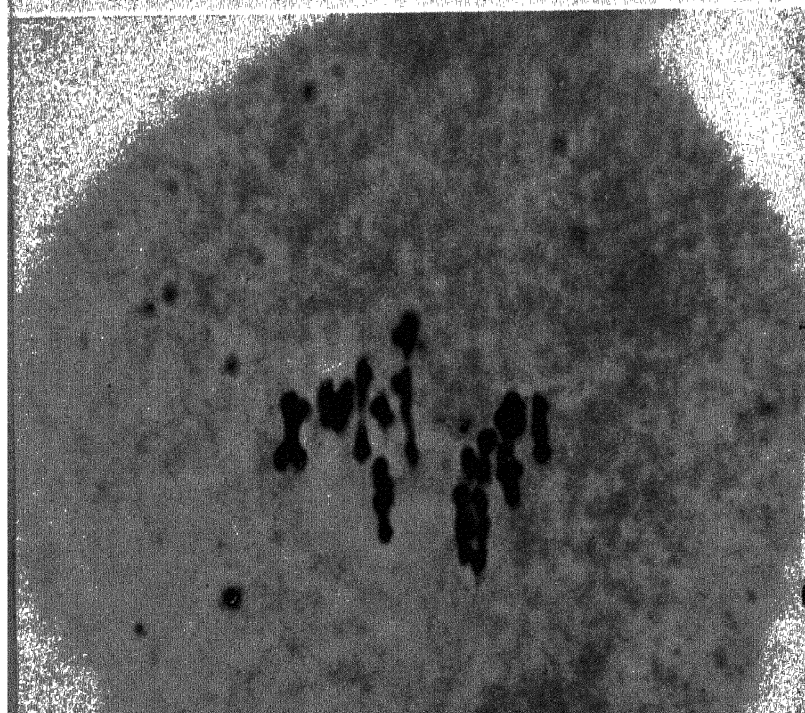
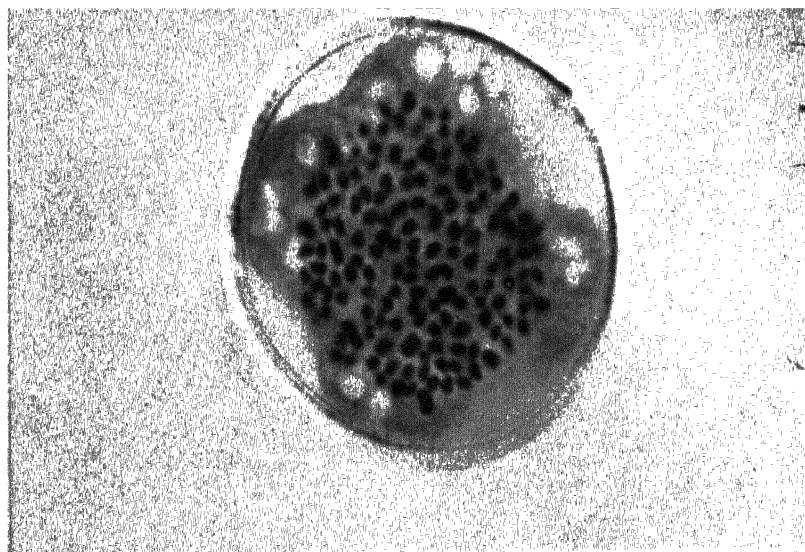

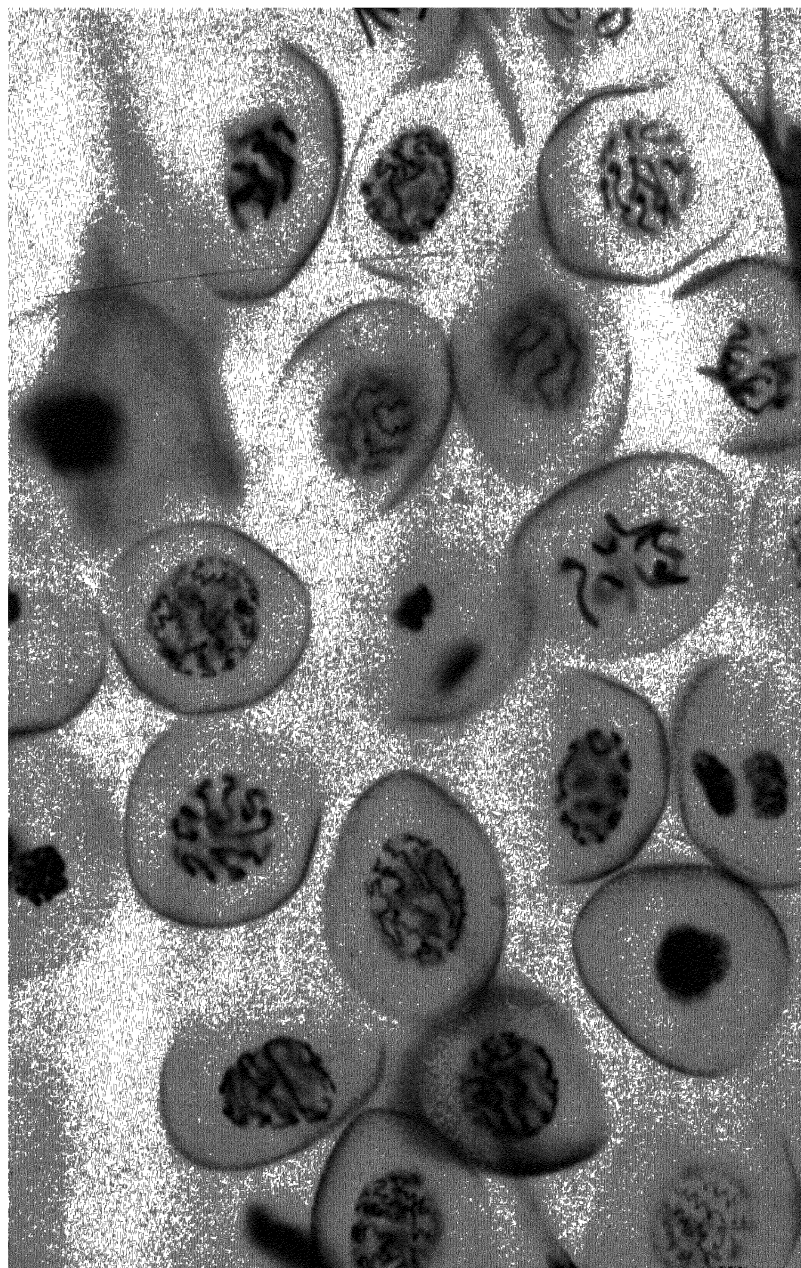

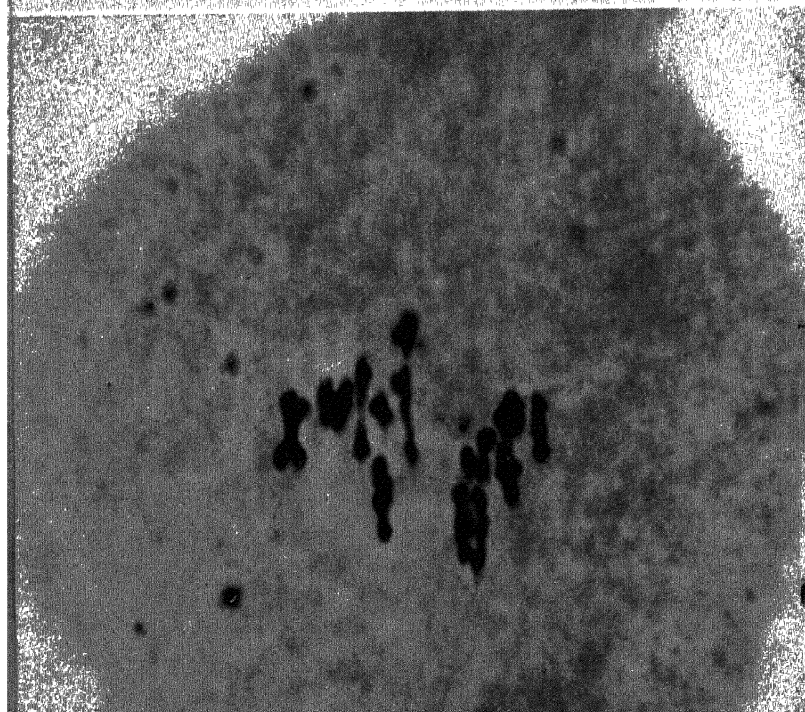
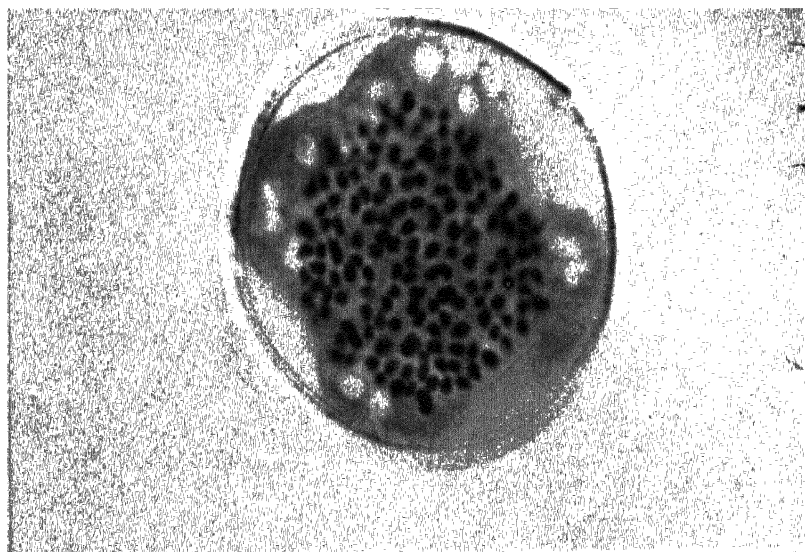

一
第
二
次

第
三
次
第
四
次
第
五
次

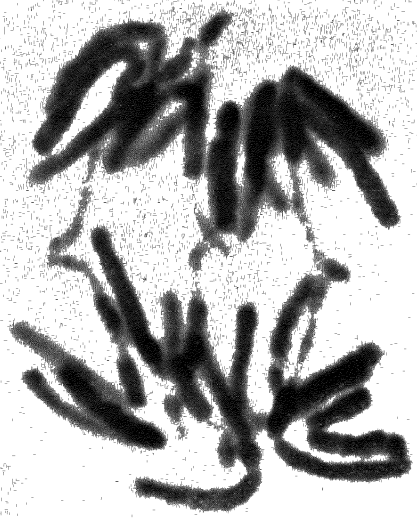

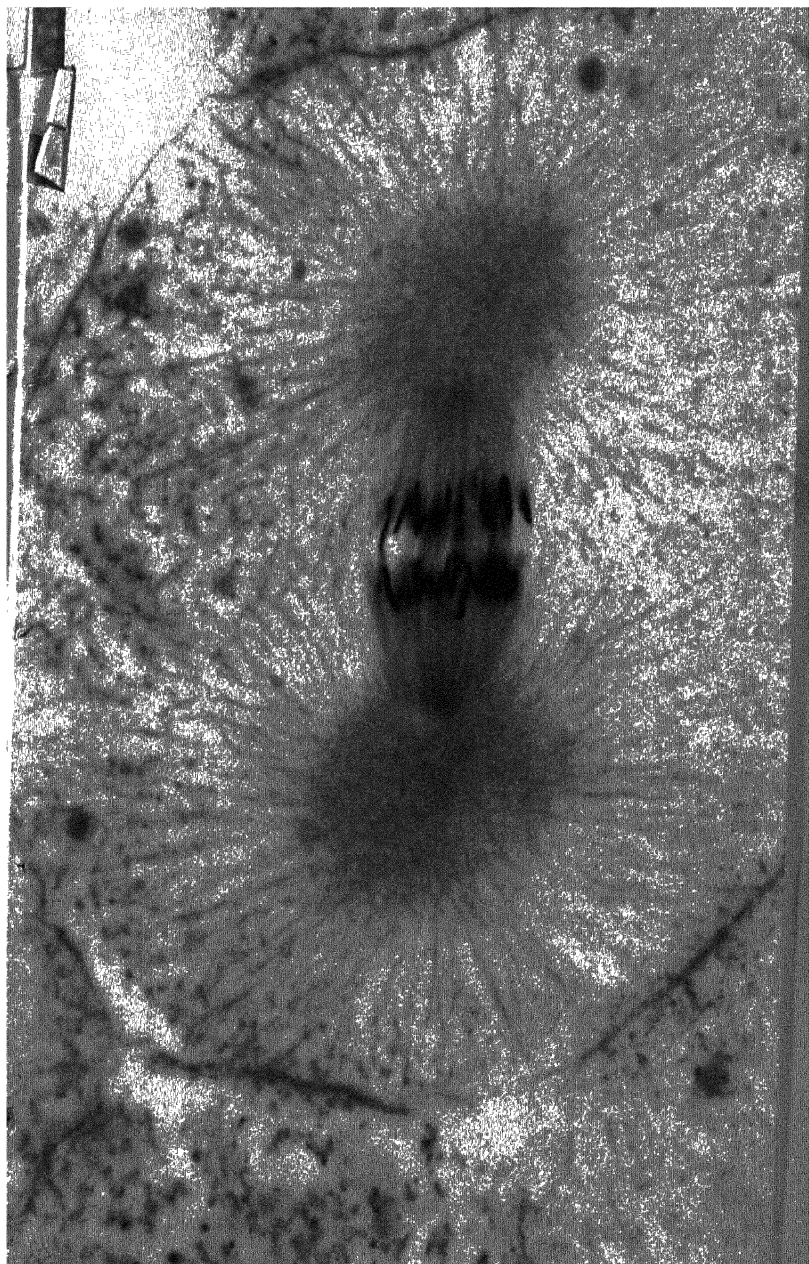

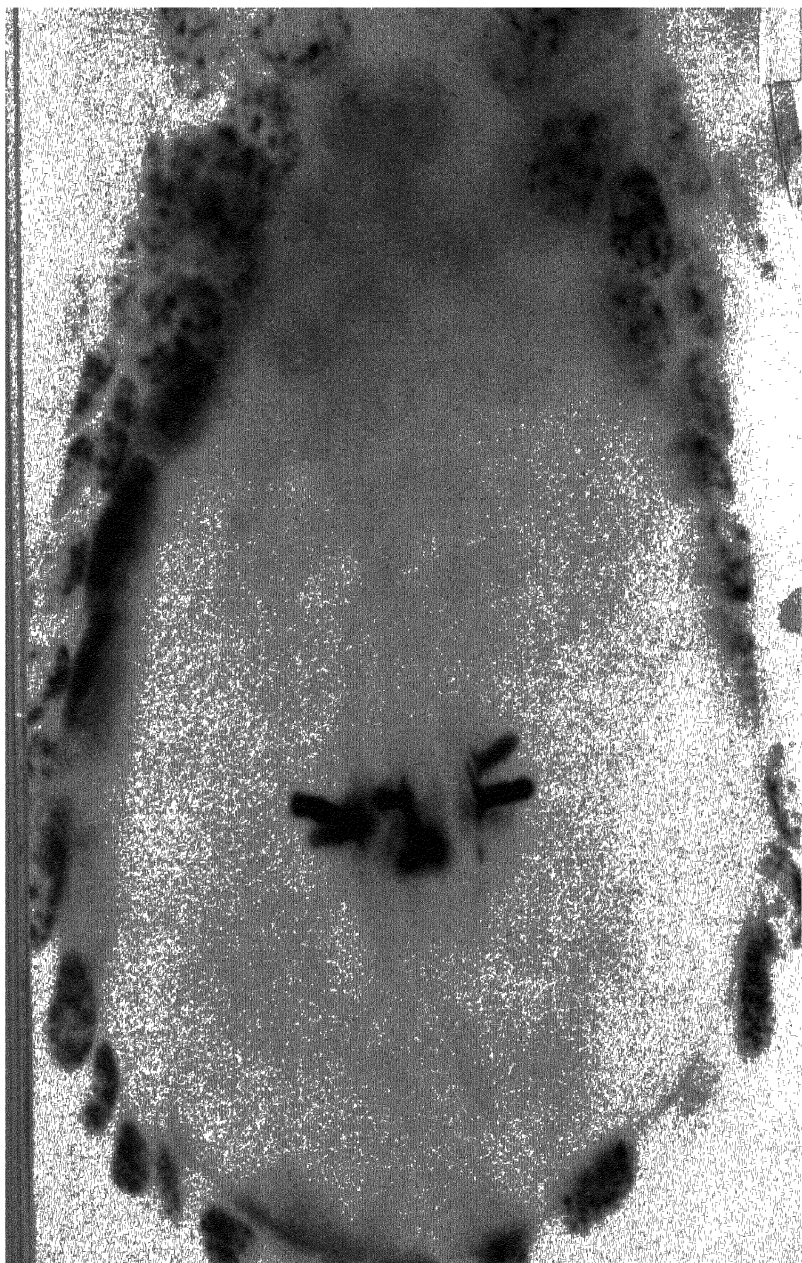



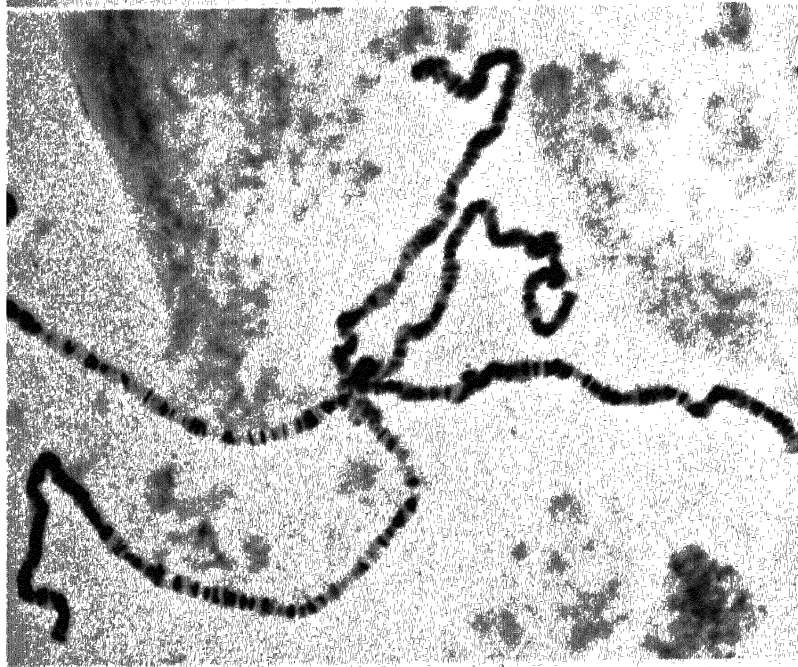
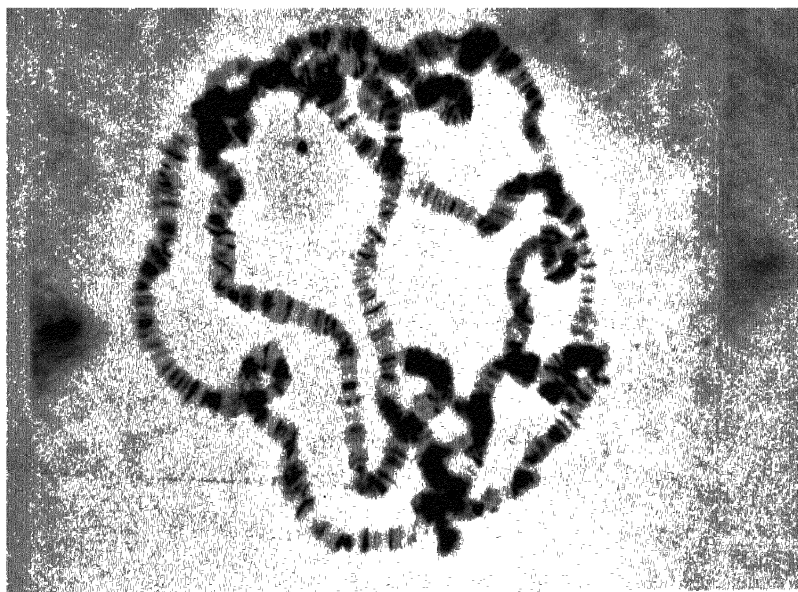

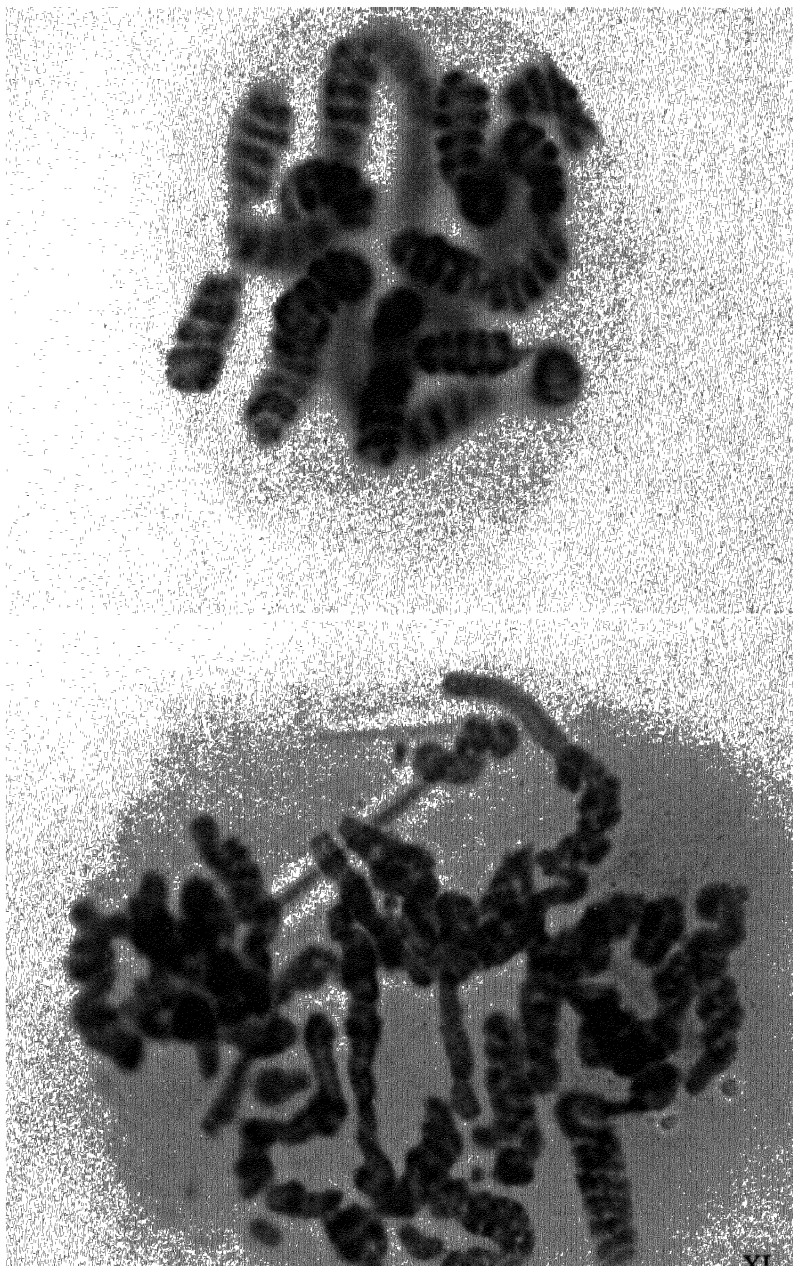

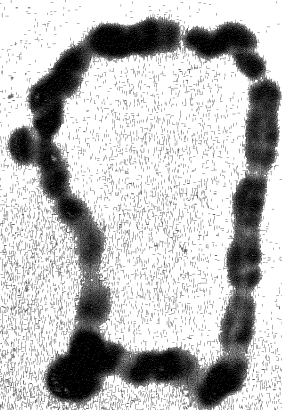
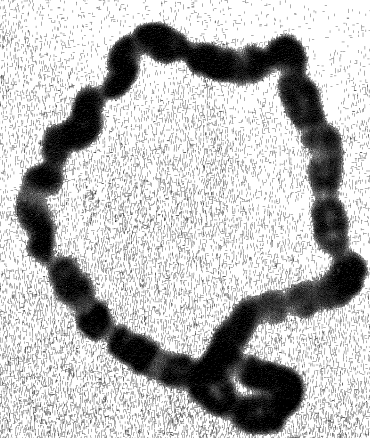
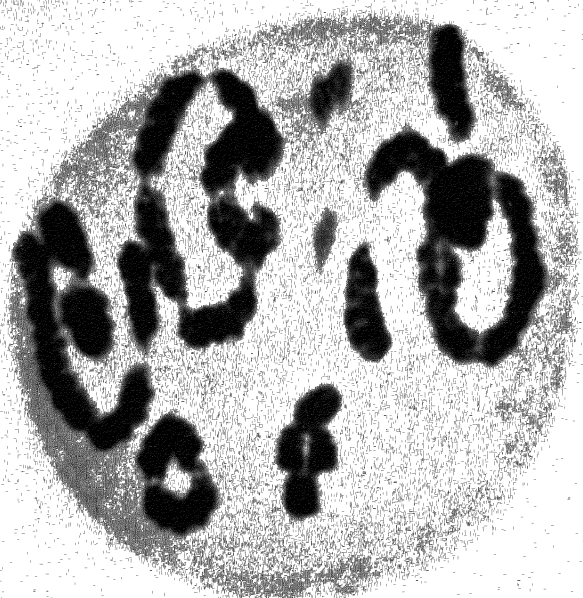



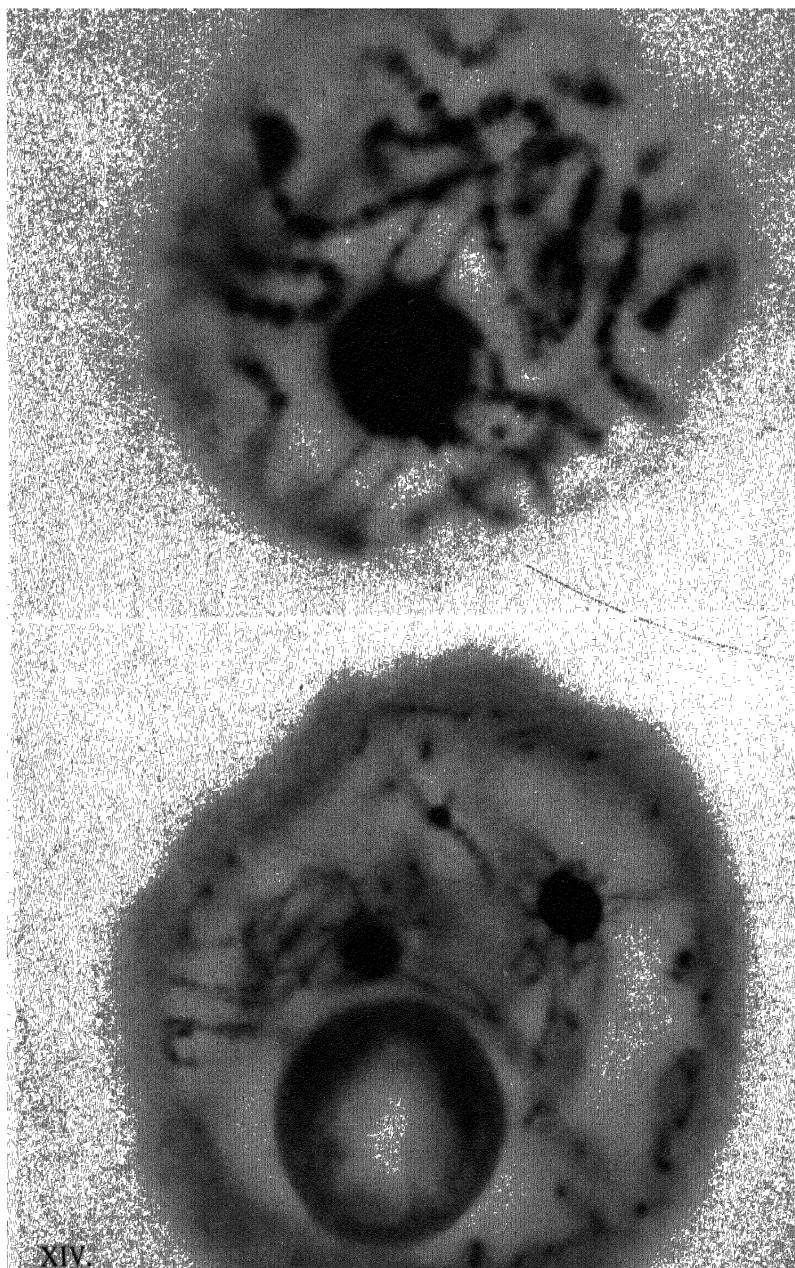

三十一

三十一

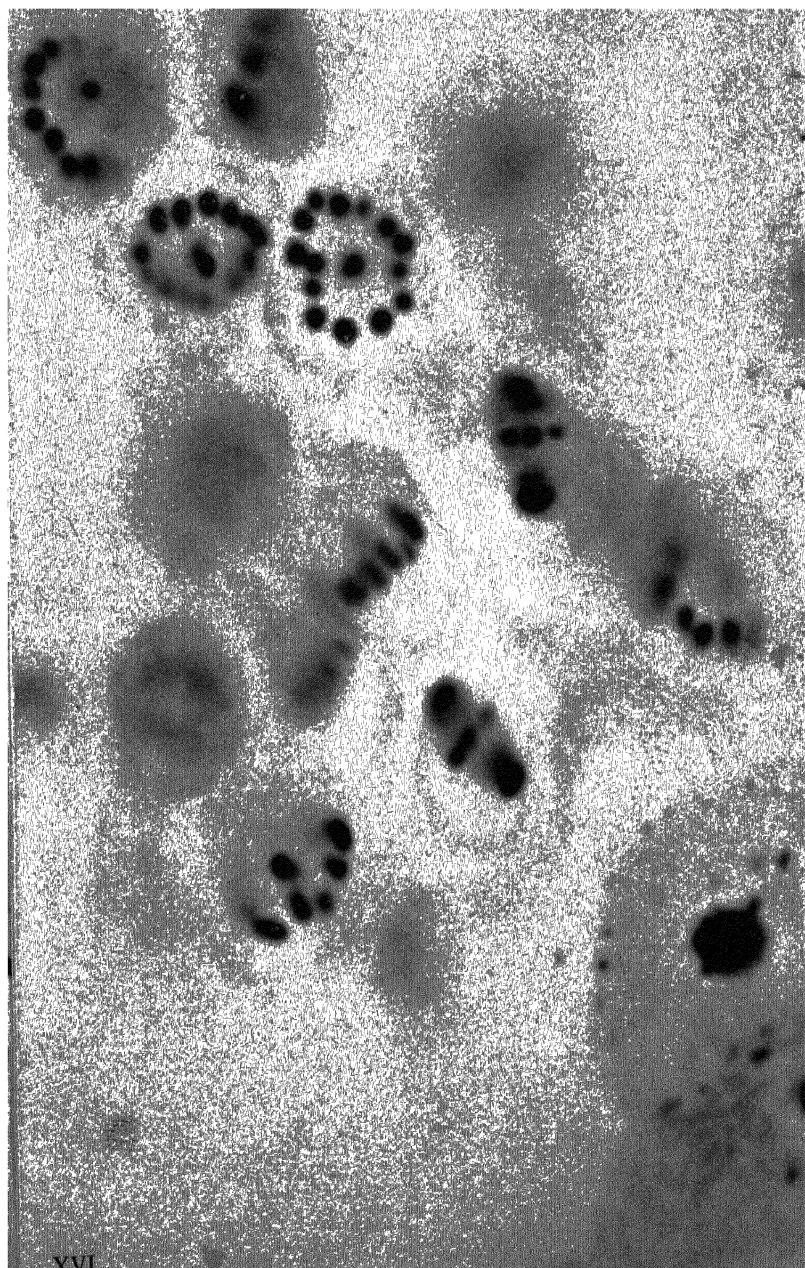

APPENDIX I

SOURCES OF MATERIAL

(a) NATURAL GROUPS

In order that the unity of chromosome behaviour can be turned to advantage we have collected the following references to the most recent papers describing the handling of chromosomes in various classes and families.

Indices of Subject Matter

1. <i>Mitosis</i> :	Chromosome form and number: diploid	A
	haploid	B
2. <i>Meiosis</i> :	chiasmata, free	A
	proximal	B
	terminal	C
	abnormal	D
3. <i>Spiral Structure</i> :	prophase	A
	metaphase	B
4. <i>Polyploidy</i> :	triploidy	A
	tetraploidy	B
	aneuploidy (odd numbers)	C
5. <i>Heterochromatin</i> :	resting stage	A
	metaphase	B
	inert chromosomes	C
	diminution	D
6. <i>Hybridity</i> :	inversions (bridges)	A
	interchanges (rings)	B
	non-pairing	C
7. <i>Nucleoli</i>			
8. <i>Sex</i> : X and Y	A
	haploid males	B
	apomixis	C
9. <i>Experimental</i> :	mitosis	A
	meiosis	B
	chromosome breakage	C
	breeding	D
10. <i>The Egg</i> :	prophase	A
	metaphase	B
	cleavage	C

TABLE VI
CHROMOSOMES OF NATURAL GROUPS

	Genus	Index	Author
PROTISTA (general)			
Flagellata	—	1-7	Belar 1926
Radiolaria	<i>Spirotrichonympha</i>	3 AB	Cleveland 1938
Ciliata	<i>Collozoum</i>	3 AB	Pátau 1937
	<i>Zelleriella</i>	7	Chen 1936 b
	<i>Paramecium</i>	4	Chen 1940
ANIMALS			
1. COELENTERATA	<i>Gonionemus</i>	1, 2, 10 ABC	Bigelow 1907
2. CHAETOGNATHA	<i>Sagitta</i>	1, 2, 10 A	Stevens 1911
3. PLATYHELMIA			
<i>Turbellaria</i>	<i>Dendrocoelum</i>	10 A	Gelei 1921
<i>Trematoda</i>	<i>Mesostoma</i>	2 C, 5 C	Husted <i>et al.</i> 1940
4. NEMATODA	<i>Schizostomum</i>	2 C	Ikeda and Makino 1936
	<i>Rhabditis</i>	2, 8 A, 10	Boveri 1911
	<i>Ascaris</i>	5 D, 10 C	White 1936
5. ANNELIDA	<i>Tomopteris</i>	2 A	Schreiners 1906
<i>Polychaeta</i>	<i>Allolobophora</i>	10 B	Foot and Strobell 1904
<i>Oligochaeta</i>	—	1, 10	<i>cf.</i> Vandell, 1938
<i>Hirudinea</i>	<i>Helix</i>	1 A	Perrots 1937
6. MOLLUSCA	<i>Vivipara</i>	2 D	Pollister 1939

7. ECHINODERMATA	<i>Urechis</i>	8 C, 9 A	Belar 1933
8. ARTICULATA			
<i>Crustacea</i>			
(1) Phyllopoda	<i>Artemia</i>	4 B, 8 C, 10 BC	Gross 1935
(2) Isopoda	<i>Daphnia</i>	4 B, 8 C, 10 B	Mortimer 1935
(3) Decapoda	<i>Anilocra</i>	2 BC	Callan 1940
(4) Ostracoda	<i>Plagusia</i>	2, 8 A	Niyama 1937
<i>Arachnida</i>	<i>Heterocypris</i>	4 B, 5 C, 8 C	Bauer 1940
(1) Acarina	<i>Pediculoides</i>	3 A, 8 BC	Pätäu 1936
(2) Phalangidea	<i>Pediculopsis</i>	2 B, 10 B	Cooper 1937
	Various	5 BD	Sokolow 1929
<i>Insecta</i>			
(1) Neuroptera	Various	2, 8 A	Naville <i>et al.</i> 1933
(2) Odonata	Various	2, 8 A	Asana <i>et al.</i> 1935
(3) Orthoptera	<i>Callimantis</i>	2 D	White 1938
	<i>Stenobothrus</i>	9 B	Belar 1929a
	Various	3 A, 8 A	White 1940
	Various	10 C	McNabb 1928
	<i>Saga</i>	10 AB	Matthey 1941
	<i>Gryllotalpa</i>	5 C	Asana <i>et al.</i> 1940
(4) Dermaptera	<i>Forficula</i>	8 A	Callan 1941
(5a) Heteroptera	<i>Cimex</i>	2 D, 5 C, 8 A	Darlington 1939
(5b) Homoptera	<i>Aphis</i>	8 C	Lawson 1936
(6) Trichoptera	Various	8 A	Klingstedt 1931
(7) Lepidoptera	<i>Bombyx</i>	10 B	Maeda 1939
(8) Coleoptera	<i>Micromalthus</i>	8 B	Scott 1936
	<i>Otiorrhynchus</i>	4 B, 8 C	Suomalainen 1940

TABLE VI—continued

	Genus	Index	Author
ANIMALS—continued			
8. ARTICULATA—continued			
<i>Insecta</i> —continued			
(9) Diptera	<i>Drosophila</i>	2 D, 6 C	Dobzhansky 1934
(cf. Ch. 8)	<i>Drosophila</i>	10 C	Sonnenblick 1940
	<i>Tipula</i>	5 C	Bauer 1931
	<i>Miasmor</i>	5 D	Kraczkiewicz 1937
	<i>Sciara</i>	10 C	Schmuck and Metz 1931
(10) Hymenoptera	<i>Habrobracon</i>	8 B, 9 D	R. L. Anderson 1936
	<i>Diprion</i>	8 B, 10 B	S. G. Smith 1940
9. CHORDATA	<i>Pristiurus</i>	10 A, B	Rückert 1892
Pisces	<i>Cyprinus</i>	2	Makino 1939
<i>Amphibia</i>	<i>Bufo</i>	2	Witschi 1933
(1) Anura	<i>Triturus</i> , etc.	8 C, 9 A	Fankhauser 1937
(2) Urodela	<i>Triton</i>	2, 5 B, 9 A	Callan 1942
(3) Gymnophiona	<i>Ichthyophis</i>	1 A	Seshachar 1937
<i>Reptilia</i>	Various	2	Matthey 1933
<i>Aves</i>	<i>Gallus</i>	10 A	White 1932, Koltzoff 1938
	Various	1 A	Oguma 1937
<i>Mammalia</i>	<i>Cairina</i> and <i>Anas</i>	2 D, 6 A	Crew and Koller 1936
	Marsupialia	2 A, 8 A	Koller 1936
	<i>Rattus</i>	5 B, 8 A	Koller <i>et al.</i> 1934
	<i>Mus</i>	10 AB	Makino 1941
	<i>Homo</i>	8 A	Koller 1937

PLANTS				
ALGAE				
<i>Rhodophyceae</i>	<i>Plumaria</i>	4 A	Drew 1939	
<i>Phaeophyceae</i>	<i>Sargassum</i>	2	Abe 1933	
<i>Chlorophyceae</i>	<i>Cladophora</i> , etc.	3 A	Geitler 1936	
<i>Cyanophyceae</i>	Various	—	Spearing 1937	
<i>Characeae</i>	<i>Nitella</i> , etc.	9 A	Karling 1928	
FUNGI				
<i>Ascomycetes</i>	" <i>Humaria</i> "	2 A	Fraser 1908	
	<i>Peziza</i>	2, 3 A	Wilson 1937	
BRYOPHYTA	Various	5 A, 8 A	Jachimsky 1935	
<i>Musci</i>	<i>Sphaerocarpus</i>	4	Allen 1935	
<i>Hepaticae</i>	<i>Sphaerocarpus</i>	5 A, 8 A	Knapp 1935	
	<i>Sphaerocarpus</i>	4 C	Mackay 1937	
	<i>Osmunda</i>	2 A, 3 B, 4 A	Manton 1939	
PTERIDOPHYTA	Various	1 A	Sax and Sax 1933	
GYMNOSPERMAE	Various	1 A	Sax and Beal 1934	
<i>Coniferae</i>	Various	5 A	Heitz 1931	
<i>Cycadales</i>	<i>Zea</i>	7	McClintock 1934	
ANGIOSPERMAE	<i>Taraxacum</i>	8 C	Gustafsson 1935	
(See next section)	<i>Allium</i>	6 ABC	Levan 1936	
	<i>Crepis</i>	8 C	Stebbins <i>et al.</i> 1939	
	<i>Tulipa</i>	3 B, 9 C	Darlington and Upcott 1941	
	<i>Melandrium</i>	2 C, 5 A, 4 AB, 8 A	Westergaard 1940	
	Orchidaceae	1 B	Barber 1941b.	

TABLE VII
TIMES FOR OBTAINING MATERIAL

PLANTS		
ALL THE YEAR ROUND		
<i>Vicia Faba</i>	RT	Lewitsky 1931
<i>Ranunculus</i> spp.	RT	Larter 1932
<i>Allium</i> spp.	RT	Levan 1931
<i>Crepis</i> spp.	RT	Babcock and Navashin 1930
<i>Rhoeo discolor</i> (6 B)	{ RT } { PMC } { PG }	Darlington 1929
<i>Secale cereale</i>	RT	Lewitsky 1931
JANUARY		
<i>Hyacinthus orientalis</i>	RT	Darlington 1926
<i>Scilla</i>	RT, PMC	Darlington 1926
FEBRUARY		
<i>Ueularia</i> spp.	PMC, PG	Barber 1941
MARCH		
<i>Fritillaria Meleagris</i> (4 B)	PMC	Darlington 1935, 1936
<i>F. imperialis</i> (4 A)	PMC	Darlington 1935, 1936

n = 7

n = 7, 8

n = 3

n = 6

n = 7 + B

2x = 16

3x = 24

n = 8

n = 7

n = 12

n = 12

APRIL	<i>Paeonia</i> spp. <i>Paris quadrifolia</i> (1 A) <i>Trillium</i> (5 A, B) (until Sept.)	PMC, PG PG RT	n = 5, 10 n = 10 n = 10	Dark 1933, Stebbins <i>et al.</i> 1939 Darlington 1941 D. and La Cour 1940
MAY	<i>Tradescantia</i> spp. (till October) <i>Chara</i> and <i>Nitella</i> <i>Allium</i> spp.	{ PMC PG PT } filaments and antheridia { RT PMC PG }	n = 6, 12 various	Many authors Karling 1928 Levan 1931
JUNE	<i>Secale</i> spp. (2 C, 4 C, 6ABC) <i>Lilium</i> spp. and hybrids (5 A) <i>Kniphofia</i> spp. <i>Eremurus</i> spp. (2 A) <i>Agapanthus</i> spp. (2 A) <i>Campanula persicifolia</i> (5 B)	PMC PMC, PT PMC PMC PMC (pachytene) PMC	n = 7(+ B) n = 12 n = 5 n = 7 n = 15 n = 8, 16	Müntzing <i>et al.</i> 1941 Richardson 1936 Darlington 1933 Upcott 1936 Darlington 1933 D. and Gairdner 1937
JULY	<i>Zea Mays</i> (3, 4 A)	PMC	n = 10	McClintock 1933-40
AUGUST	<i>Trillium grandiflorum</i> (4 A)	PMC	n = 5	La Cour unpub.

PLANTS—continued

	PMC	n = 12	Upcott 1937
SEPTEMBER <i>Tulipa Gesneriana</i> (2x)	PMC	n = 12	Upcott 1937
OCTOBER <i>Tulipa Gesneriana</i> (3x) <i>Hyacinthus</i> , var.—Yellow Hammer, Roi des Belges, Garibaldi, Gertrude <i>Narcissus Pseudo-Narcissus</i> (2x, 3x, 4x) <i>Galanthus</i> (until Feb.) <i>Crocus biflorus</i> (until Feb.)	RT, PMC PMC, PG RT, PMC RT, PMC RT	2n = 36 2x = 16 2n = 14, 21, 28 2n = 24, 48 2n = 8	Upcott 1937 Darlington 1926 Nagao 1933 La Cour unpub., Sato 1937 Mather 1932
NOVEMBER <i>Narcissus poeticus</i> <i>Hyacinthus</i> vars. — Grand Maître, King of the Blues, etc.	PMC, PG PG	2n = 14, 21, 28 3x = 24	Nagao 1933 Darlington 1926
DECEMBER <i>Trillium erectum</i> <i>Fritillaria pudica</i> <i>Narcissus Bulbocodium</i> <i>N. biflorus</i> <i>Aucuba japonica</i> (6 B) <i>Taxus baccata</i> ♂ <i>Helleborus foetidus</i>	PMC PMC, PG PMC and PG PMC and PG PMC PMC PMC	2x = 10 2x = 26 3x = 39 2x = 14 7II + 10I 4x = 24 2x = 24 4x = 32	Huskins <i>et al.</i> 1935 Darlington 1936 Nagao 1933 Meurman 1929 Maude 1939 Maude 1939

(b) CHROMOSOME CALENDAR

Plants show the following sequence of stages of division: 1, Pollen the mother cells (PMC); 2, embryo sac mother cells (EMC); 3, Pollen grain (PG) first mitosis.

PMC divisions (meiosis) take place when the anther is still translucent and about one-third of the length at maturity.

PG division may take place at any time, usually about half way, between meiosis and maturity, when the pollen is becoming dry and the anther is turning yellow (or the proper colour of ripeness).

For other conditions see Ch. 4 e.

ANIMALS

ALL THE YEAR ROUND		
Amphibia: tadpole's tails (if starved)	mitosis	{ Prokofeva 1933 Barber and Callan 1941 Koller and Darlington 1934 cf. Chap. 8
Mammalia: rat or mouse testis	mitosis and meiosis	
Diptera: <i>Drosophila</i> spp. salivary glands	polytene	
APRIL-SEPTEMBER		
<i>Culex</i> , <i>Chironomus</i> , testes	meiosis	} cf. Chap. 8
<i>Chironomus</i> , salivary gland	polytene	
MAY-SEPTEMBER		
Orthopteran testes	mitosis and meiosis	{ Darlington 1936 White 1934-40
JUNE-JULY		
Amphibian testes	mitosis and meiosis	Witschi 1933
AUGUST		
Oligochaetan eggs and testes	meiosis	Foot and Strobell 1904

APPENDIX II
STANDARD SOLUTIONS

(a) FIXING SOLUTIONS

TABLE VIII

PROPERTIES OF REAGENTS

<i>Reagent</i>	<i>Formula</i>	<i>M.W.</i>	<i>M.P.</i>	<i>B.P.</i>	<i>Saturated Soln. at 15° C.</i>	<i>O or R</i>	<i>S.T.</i>
1. Ethyl alcohol "absolute"	C_2H_5OH	46	—	78°	Aq. all propns.	—	22·3
2. Acetic acid "glacial"	CH_3COOH	60	17°	—	Aq. all propns.	—	27·6
3. Formaldehyde (Aq. formalin)	$HCHO$	30	—	— 20°	Aq. 35-40 %	R	—
4. Chloroform	$CHCl_3$	126·5	—	61°	Al. all propns.	—	27·1
5. Chromium trioxide (chromic acid)	CrO_3	118	196°	—	Aq. 62 %	O	—

6. Osmium tetroxide (Osmic Acid)	OsO_4	255	40°	—	Aq. 6 % g.p. 100 c.c.	0	—
7. Potassium dichromate	$\text{K}_2\text{Cr}_2\text{O}_7$	294	236°	—	Aq. 9 %	0	—
8. Picric acid	$\text{C}_6\text{H}_3(\text{NO}_2)_3\text{OH}$	229	122°	—	Aq. 1.4 %	0	—
9. Mercuric chloride (Corrosive sublimate)	HgCl_2	272	275°	—	Aq. 6 % Al. 30 %	(0)	—

NOTES ON TABLE VIII

1. O or R: Oxidising or reducing agent. Formaldehyde must not be mixed with chromic or osmic acids until immediately before use. Osmic acid solution on the other hand is unstable in light except in the presence of chromic acid or mercuric chloride.
2. Aq. = Aqueous. Al. = alcoholic.
3. S.T.: Surface tension, γ , in dynes per sq. cm. at 20°C . γ for water is 72.8, for its mixtures with 1 and 2 it is increased roughly proportionately (from Hodgman's *Handbook of Chemistry and Physics*, 22nd ed.).
4. Mercuric chloride is poisonous; osmic acid is also dangerous to the cornea.
5. Absolute alcohol is used only where water is to be excluded. Otherwise rectified spirit, 96 %, can take its place.

TABLE IX
COMPOSITION OF COMPOUND FIXATIVES
(Aqueous solutions by volume unless otherwise stated)

(1) *Osmic Fixatives*

Stock Solutions (Material)	Fleming 1882				La Cour 1931			Champy 1913	
	Strong Bulk	Medium Smear	Benda Chondrios	2BD General	2BE Plant	2BX Bulk	Minouchi		Koller
							Animal	Mammal	
Chromic acid 2 %	100	100	100	100	100	100	100	100	100
Pot. dichromate 2 %	—	—	—	100	100	100	300	—	—
Osmic acid 2 %	53	66	66	60	32	120	120	50	—
Acetic acid 10 %	133	80	15	30	12	60	—	—	—
Saponin 1 %	—	—	—	20	10	10	—	—	—
Water, distilled	—	190	120	210	90	50	—	—	125
Totals	286	436	301	520	344	440	520	275	—

(2) *Formalin Fixatives*

Solutions	S. Navashin 1910				Bouin 1896
	M. Navashin 1926 (RT)	Sanfelice White 1940 (Animal)	Randolph 1935 (Plant)	Karpechenko 1927 (PMC)	
Chromic acid 2 %	100	100	100	100	1.5 g.
Acetic acid 20 %	100	60	70	67	5.0 g.
Picric acid ..	—	—	—	—	1.0 g.
Urea ..	—	—	—	—	2.0 g.
Water, distilled ..	20	60	170	300	75 c.c.
Formaldehyde 40 %	80	100	60	11	25 c.c.
Totals ..	300	320	400	478	100 c.c.

(3) *Alcoholic Fixatives*

Components	Carnoy 1886				Carnoy-Lebrun
	Acetic alcohol	Kahle 1908	Smith 1940	Smith 1940	
Alcohol, abs. ..	100	100	100	100	100
Acetic acid, glac. ..	33	16	7	7	100
Chloroform, pure ..	—	50	—	—	100
Formaldehyde 40 % ..	—	—	40	40	—
Corr. sublimate ..	—	—	—	—	saturation
Water ..	—	—	200	—	—
Total ..	133	166	347	147	300

(b) STAINS FOR CHROMOSOMES

1. *Aceto-carmin* (after Belling 1926, 1928).

45 c.c. glacial acetic acid.

55 c.c. distilled water.

Heat to boiling and add 0.5 gm. of carmine.

Shake well and filter when cool.

A drop or two of 45 % acetic acid saturated with iron acetate can be added. Too much iron precipitates the carmine.

2. *Acetic-orcein* (after La Cour 1941)

The standard solution is 1 % orcein in 45 % acetic acid; modified solutions contain up to 70 % acetic acid and 0.5-2 % orcein.

Dissolve 1 gm. orcein in 45 c.c. of hot glacial acetic acid (near boiling). Cool, then add 55 c.c. distilled water.

Shake well and filter.

3. *Acetic-lacmoid* (La Cour, unpub.)

As for orcein.

4. *Leuco-basic fuchsin* (1st formula, after De Tomasi 1936)

Dissolve 0.5 gm. basic fuchsin by pouring over it 100 c.c. boiling distilled water.

Shake well and cool to 50° C.

Filter: Add 10 c.c. N.HCl to filtrate.

Add 0.5 gm. $K_2S_2O_5$.

Shake well and store in a tight-stoppered bottle for 12-18 hours before use. Keep in the cool and dark.

4' *Leuco-basic fuchsin* (2nd formula, after Coleman 1938)

Take

200 c.c. solution prepared by 1st formula.

10 c.c. normal HCl.

2 gm. $K_2S_2O_5$.

Allow solution to bleach for 24 hours; add 0.5 gm. of decolorizing carbon.*

Shake well for about a minute and filter rapidly through coarse filter paper.

* *Norit*, a proprietary vegetable carbon, is recommended.

4". *SO₂ water*

5 c.c. normal HCl.
 5 c.c. $K_2S_2O_5$ 10 %.
 100 c.c. distilled water.

5. *Crystal violet* (after Newton).

1. 1 % aqueous solution boiled and filtered.
 Also used as 0.5 % and 0.1 % solutions.
2. 1 % iodine, 1 % potassium iodide in 80 % alcohol.

6. *Heidenhain's haematoxylin*.

0.5 % aqueous solution, ripened for 1-2 months, or rapidly by Hance's method (1933).

(c) STAINS FOR STYLES

1. *Acid Fuchsin—Light Green*.

54 c.c. lactic acid.
 6 c.c. glycerine.
 1 c.c. acid fuchsin 1 %.
 1 c.c. light green 1 %.

2. *Cotton Blue—Lacto-Phenol*.

Equal Parts	{	lactic acid.
		phenol.
		glycerine.
		water.

0.08 % to 1 % cotton blue dissolved in the above.

3. *Lacmoid-Martius Yellow*.

0.005 gm. lacmoid (resorcin blue).
 0.005 gm. Martius yellow.
 10-15 c.c. water.
 Adjust to pH 8 by the addition of a few drops of 1 % ammonia.

4. *Delafield's haematoxylin*.

To 100 c.c. of a saturated solution of ammonium alum (containing about 10 gm.) add, slowly, a solution of 1 gm. of haematoxylin dissolved in 6 c.c. absolute alcohol. Expose to air and light for 1 week. Filter. Add 25 c.c. glycerine and 25 c.c. methyl alcohol.

Allow to stand (uncorked) until the colour darkens.
 Filter and keep in a tight-stoppered bottle.
 Allow the solution to ripen before use for a month.

(d) VARIOUS FLUIDS

1. *Physiological saline solution.*

0.67 % sodium chloride.

2. *Ringer solution A* (for cold-blooded animals).

0.65 gm. sodium chloride.

0.025 gm. potassium chloride.

0.03 gm. calcium chloride.

(0.02 gm. sodium bicarbonate, approximately, to give a
 pH 7.0-7.4)

100 c.c. distilled water.

2'. *Ringer Solution B* (for warm-blooded animals).

0.85 gm. sodium chloride.

0.025 gm. potassium chloride.

0.03 gm. calcium chloride.

100 c.c. distilled water.

3. *Cleaning Slides and Cover Slips.*

(1) Mixture for separating slides and cover slips (Carlson 1935)

1 part *n*-butyl alcohol.

9 parts xylol.

(2) to clean:

10 gm. potassium bichromate.

10 gm. sulphuric acid.

80-120 c.c. water.

(3) Wash in running water.

(4) Store in 70 % alcohol.

4. *Stain-fixative mounting media* (after Zirkle 1940).

No. 1.

10 gm. gelatin.

10 c.c. sorbitol.

50 c.c. glacial acetic acid.

60 c.c. distilled water.

0.5 gm. $\text{Fe}(\text{NO}_3)_3 \cdot 9\text{H}_2\text{O}$.

Carmine to saturation.

Orcein, 1 gm. or lacmoid, 0.5 gm. can be substituted for the carmine. The iron salt is then unnecessary.

No. 2.

- 20 c.c. venetian turpentine.
- 55 c.c. phenol (as loose crystals or 88 % liquid).
- 35 c.c. propionic acid.
- 10 or 15 c.c. glacial acetic acid.
- 25 c.c. distilled water.
- 0.5 gm. $\text{Fe}(\text{NO}_3)_3 \cdot 9\text{H}_2\text{O}$.
- Carmine to saturation.

Orcein or lacmoid can be used as above instead of carmine.

Mix in a graduated cylinder in the following order: Propionic acid, turpentine, mix thoroughly; phenol, acetic, water. The ferric nitrate should be dissolved before any carmine is added. Filter after 12 hours.

At no time should the mixture be heated.

Do not allow fluid to come into contact with the skin.

5. ✓ *Sealing medium for semi-permanent acetic squashes* (McClintock 1929).

Equal parts gum mastic and paraffin wax, heated and well mixed. To be applied with a heated wire.

An alternative mixture removable by alcohol is: 2 of beeswax to 1 of resin.

6. *Mayer's albumen slide fixative.* ✓

- 25 c.c. albumen (white of egg).
- 25 c.c. glycerine.
- 0.5 gm. sodium salicylate

Filter before use.

(e) DROSOPHILA MEDIUM ✓

Composition of Drosophila Food (Bridge's formula, for salivary glands. 1932. cf. *Dros. Inf. Service*, p. 62, 1936).

- Water, 75 c.c.
- Treacle, 13.5 c.c.
- Maize meal, 10 gm.
- Agar-agar, 1.5 gm.
- Nipagin or Moldex, trace.

This quantity is enough for three half-pint milk bottles. Fill 1 in. deep. The nipagin preserves the food from mould.

Soak the agar 12 hours in water, boil it until it dissolves, add treacle and cornmeal and stir.

When cool a small portion of food should be removed from one side and a piece of folded, sterilized crape paper inserted for the larvae to pupate on.

The medium should be yeasted by the addition of a few drops of yeast suspended in water (of a creamy consistency). Dried yeast is liable to become mouldy. Flies are mated for two days in 3" × 1" vials with a small wedge of food about 25° C. before moving to the bottles prepared as above. All bottles are stoppered with cotton wool.

D. melanogaster, as well as most of the larger species, can be kept at room temperature.

Fattening larvae for salivary glands.—To avoid overcrowding of larvae, from the laying of too many eggs, transfer parents after a day. As soon as the young larvae appear (in *melanogaster*, after about three days) the cultures should have a second yeasting. They should then be kept at about 18° C. until ready for the knife, to slow down growth. To do so, bottles can be placed in trays which are continuously flooded with tap water.

(f) PHOTOGRAPHIC SOLUTIONS

1. *Developers.*

- (i) *Metol Hydroquinone Developer, medium contrast* (plates and bromide paper)

1 gm. metol.
3·5 gm. hydroquinone.
37·5 gm. sodium sulphite.
37·5 gm. sodium carbonate.
Water to make up 500 c.c.

Development should be complete in 3–5 min. at 65° F. (18° C.). For harder contrast, add 3·5 c.c. potassium bromide 10% solution. For softer contrast, increase the sodium sulphite.

- (ii) *Ilford 13 Developer, Hard Contrast* (process, process panchromatic, and half-tone plates).

25 gm. hydroquinone	} Solution A.
25 gm. potassium metabisulphite	
25 gm. potassium bromide	
Water to make up 1,000 c.c.	
50 gm. potassium hydrate	} Solution B.
Water to make up 1,000 c.c.	

For use, mix equal parts of A and B.

Development should be complete in 2-3 min. at 65° F. (18° C.).

(iii) *Fine Grain Developer, Soft Contrast* (cf. McWhorter 1939).

1 gm. metol.
 50 gm. sodium sulphite.
 2.5 hydroquinone.
 1 gm. borax.
 Water to make up 500 c.c.

Development should be complete in 10-15 min. at 65° F. (18° C.).

Note.—(ii) and (iii) can be used only once; (i) can be used many times, but changes with use.

2. *Fixing Bath (acid).*

80 gm. sodium hyposulphite.
 5 gm. potassium metabisulphite.
 Water to make up 250 c.c.

3. *Intensifier* (after Ilford).

6 gm. mercuric chloride.
 6 gm. ammonium chloride.
 Water to make up 250 c.c.

Wash the hyposulphite thoroughly out of the plate, then bleach in the above solution and blacken in:

1 part 0.880 ammonia.
 100 parts water.

4. *Reducer.*

Potassium ferricyanide, 10 % solution.

For use, add a few drops of the above to a weak non-acid hyposulphite solution. The colour is a fair indication of the strength of the reducer; it should be a pale yellow colour. Wash the negative thoroughly after reducing.

APPENDIX III

SCHEDULES OF TREATMENT

SCHEDULE I.—PARAFFIN PREPARATION

- A. *Fixing*: 12–24 hours in 10 c.c. glass phial (aqueous fixation).
- B. *Washing*: 3 quick changes of water in phial.
- C. *Dehydration*: in water-alcohol mixtures by steps.

- 50 % 3 hours.
- 70 % overnight.
- 80 % 3 hours.
- 95 % 3 hours.
- 100 % overnight.

- D. *Transference*: by steps in alcohol-chloroform mixtures.

- 25 %, 50 %, 75 %, 2 hours in each,

followed by pure chloroform to which wax has been added.

- E. *Infiltration*: Place on oven top or hot plate at about 30° C. Add more wax at intervals for 2 days. Place in small watch-glass inside oven at 60° C., adding more wax, for 4 hours.

- F. *Embedding*: Transfer contents of watch-glass with more molten wax to a paper boat or flat-bottomed watch-glass smeared inside with glycerine. Orientate and group material. Allow skin to form on wax. Submerge carefully in cold water.

- G. Prepare block and cut sections on microtome.

- H. Lay ribboned sections shiny face downwards on filmed slide covered with water or 20 % alcohol.

- K. Stretch and straighten ribbon by placing slide on hot plate for 5 minutes.

- L. Drain water off slide and leave to dry on hot plate for 4–24 hours.

M. Xylol, 10-15 mins, to dissolve wax ribbon.

N. Absolute alcohol, 2 mins.

O. Bleach in 20 vol. H_2O_2 and 80 % alcohol, 1 : 3, 4-12 hours after osmic fixatives.

P. Pass quickly through alcohol series 80 %, 40 % to water.

SCHEDULE 1'. RAPID DIOXAN METHOD FOR ROOT TIPS (La Cour 1937).

C'. *Dehydration*: In water-dioxan mixtures by steps.

25 %, 50 %, 75 %, 2 hours in each. 100 % dioxan overnight.

E'. *Infiltration*: Place directly in oven, adding wax of low M.P. at intervals for 4 hours. Transfer to pure molten wax for 2 hours.

SCHEDULE 1''. SOFTENING METHOD FOR ANIMAL EGGS (after S. G. Smith 1940)

A''. *Fixation*: Kahle's Fluid without water, 2 hours (for Feulgen staining).

[B''. No washing.]

C''. *Dehydration*: By stages as follows:

	<i>Water</i>	<i>Ethyl alcohol</i>	<i>n-Butyl Alc.</i>	<i>Phenol</i>
(i) 1 hr.	30 %	50 %	20 %	—
(ii) 24 hrs.	11 %	50 %	35 %	4 %
(iii) 1 hr.	5 %	40 %	55 %	—
(iv) 1 hr.	—	25 %	75 %	—

follow by two changes of 4 % phenol in n-butyl alcohol.

E''. *Infiltration*: Place directly in oven with equal amount of solid paraffin. Change to solid paraffin after about 16 hours.

F''. *Embedding*: As usual. In preparing for sectioning cut down the block. Expose one side of the material and soak the block for 24 hours or more in water before cutting.

SCHEDULE 2.—SMEAR METHODS.

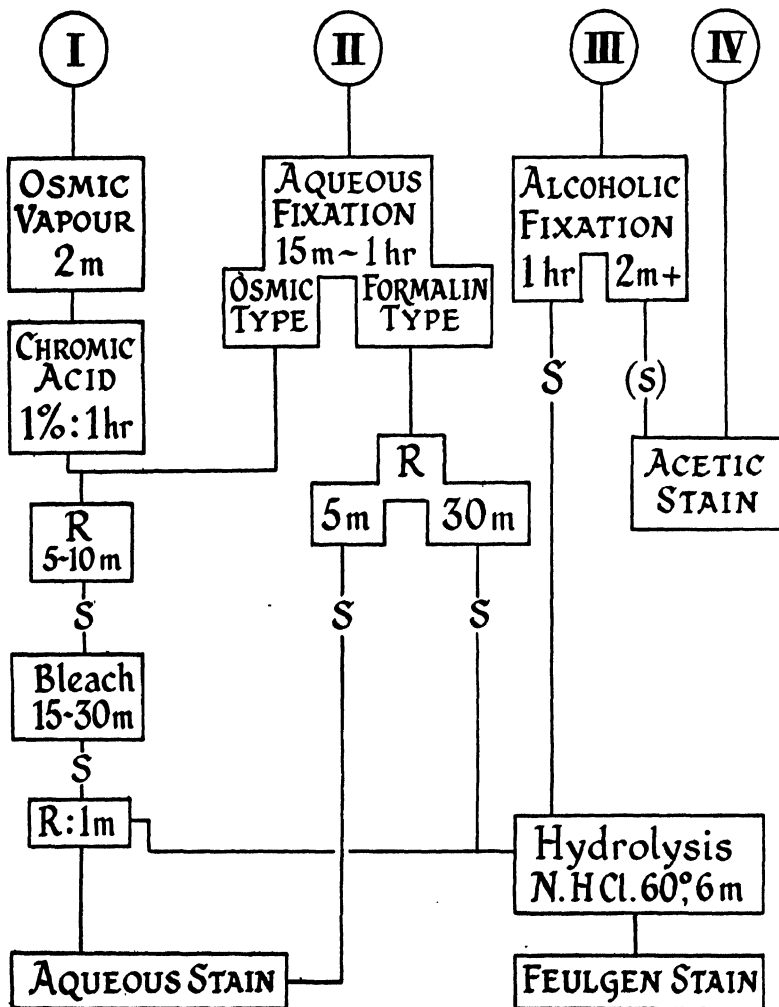

Schedule showing the general combinations of treatments possible in smear methods. R, rinse in running water. S, store if necessary in 70 % alcohol up to 2 months. (S) store only up to 48 hours. I, for animals and bacteria only. IV, stain-fixative method. III-IV, compare Schedule 2'.

SCHEDULE 2'.—PERMANENT STAIN-FIXATION.

Tissues: SMC, PMC, PG, PT, ganglia.

A. Dissect out small pieces of tissue from acetic alcohol and crush them in a drop of stain-fixative, on a very clean slide. The blunt end of a bone or aluminium needle holder is a suitable tool. Leave 1-2 mins.

B. Prepare cover slip by smearing thinly with Mayer's albumen and drying over spirit flame 1-3 secs.

C. Remove all but the smallest debris and place cover slip in position.

D. Pass the slide quickly over a spirit flame 5-6 times. The solution must not boil; judge the heat by passing the slide over the palm of the hand.

After aceto-carmine:

E'. Invert the slide in a smearing dish containing 10 % acetic acid. (The cover slip will separate from the slide after 5-15 minutes.)

F'. Take the slide and cover slip through:

1 in 3 acetic alcohol	2 mins.
Absolute alcohol, 2 changes	2 mins. each.

Mount in "Euparal."

After acetic-orcein or lacmoid:

E''. Invert slide in a covered smearing dish containing acetic alcohol.

F''. Pass through:

Absolute alcohol	2 mins.
Cedarwood oil, 2 changes	5 mins. in each

Recombine slide and cover slip by mounting in thick immersion oil, or balsam. Blot carefully to remove excess cedarwood oil.

Notes:

1. Use no more stain-fixative than will permit of the cover slip being placed in position without air bubbles.

2. Vary the amount of intermittent heating for different tissues and stages of division.

3. Mount the cover slip rapidly to avoid absorption of moisture. If cloudiness appears, place the slide on the hot plate for a short time and it will clear.

SCHEDULE 3.—ACETIC-LACMOID SQUASH METHOD.

Tissues: Root tips, embryo sacs, pollen grains.

[A. Fix in acetic alcohol 12–24 hrs.]

B. Stain by placing tissues in a watch-glass containing a few drops of: 10 c.c. standard acetic-lacmoid, plus 1 c.c. N.HCl.

C. Heat without boiling 2–3 times over a spirit flame. (Vary the amount of heating according to the hardness of the tissues.) Leave 10 mins.

D. Tease out the tissues on the slide in a drop of fresh standard solution.

E. Place filmed cover slip in position. Apply pressure under several thicknesses of blotting paper, allowing no sideways movement of the cover slip.

F. Mount as in Schedule 2'.

SCHEDULE 4.—ACETIC-ORCEIN SQUASH METHOD.

Tissue: Salivary glands, ganglia, *Drosophila*.

The best stain in general is: 1 % orcein in 45 % acetic acid. For *Drosophila melanogaster* use 2 % stain in 70 % acetic acid.

A. Dissect out glands in saline solution (on ice for preference).

B. Leave glands in a drop of stain on a well-slide 5–10 mins.

C. Film the cover slip.

D. Transfer to clean slide by fine pipette.

E. Flatten by applying slight pressure under blotting paper.

F. Seal, or make permanent as in Schedule 2'.

SCHEDULE 4'.—SCIARA.

The best stain is: 10 c.c. of 1 % orcein in 45 % acetic acid plus 1 c.c. chloroform.

A'. Dissect out glands in 45 % acetic acid.

B'. Stain 2–3 mins.

Subsequent treatment as above.

SCHEDULE 4''. CHIRONOMUS.

The best stain is: 2 % orcein in 50 % acetic acid.

A''. Dissect out glands in saline solution.

B''. Stain 3–5 mins.

Subsequent treatment as above.

SCHEDULE 5.—FEULGEN SQUASH METHOD (Heitz 1932, Darlington and La Cour 1937, Hillary 1940).

Tissues: All, except as a rule PMC and SMC.

A. Fixation: 12–24 hours (see Table VIII).

B. Rinse, 2–3 changes of water, more after formalin.

C. Macerate by hydrolysis in N.HCl at 60° C. for 6 min. or more as in Table VIII.

TABLE VIII

MACERATION METHODS FOR SCHEDULE 5

(H, hydrolysis; M₁ and M₂ as in directions, p. 43. Range of times according to hardness of tissue; m, minutes.)

<i>Fixative</i>	<i>Plant</i>	<i>Animal</i>
Alcoholic (hard tissues)	RT and ovaries 6 m. H	6 m. H
	PG M ₃ or M ₄ and 6 m. H	
Osmic	10–20 m. H	10 m. H
Formalin	M ₃ or M ₄ and 10 m. H	15 m. H

D. Stain in leuco-basic fuchsin: Animal 1–2 hours, plants 2–3 hours.

E. Tease out small pieces of tissue (root tips, thin slices of tip) on a slide with a drop of 45 % acetic, with the blunt end of a bone needle holder.

F. Film the cover slip, place it in position and apply pressure under several thicknesses of blotting paper, allowing no sideways movement of cover slip.

G. Heat the slide gently over a spirit flame 4 or 5 times, do not boil.

H. Separate the slide and cover slip by turning the slide face down in a smearing dish containing 10 % acetic acid; after 3–10 mins. the cover slip will fall off,

J. Pass the cover slip (and slide if necessary) through alcohols: 80 % 2 min. absolute 2 changes, 2 min. each.

K. Recombine slide and cover slip by mounting in "Euparal."

SCHEDULE 6.—FEULGEN METHOD FOR SECTIONS AND SMEARS.

A. Distilled water: rinse.

B. Hydrolyse in NHCl at 60°C ., 6 min.

C. Stain in leuco-basic fuchsin*. Plant tissues 2-3 hrs., animal 1-2 hrs.

D. Fresh SO_2 water* in stoppered jars, 3 changes of 10 min. each.

E. Distilled water, rinse.

F. Alcohol series, 20 %, 60 %, 80 %; rinse in each.

G. Absolute alcohol 2-3 min.

H. Mount in "Euparal."

SCHEDULE 7.—CRYSTAL VIOLET.

Material: Sections or smears after aqueous fixation.

A. Rinse.

B. Stain: $\left\{ \begin{array}{l} 0.5 \%, 3-10 \text{ min.} \\ 0.1 \%, 10 \text{ min}-1 \text{ hr.} \dagger \end{array} \right.$

C. Rinse.

D. 1 % I_2 , 1 % KI in 80 % alcohol, 30-45 sec.

E. 95 % alcohol, rinse.

F. Absolute alcohol. 4-10 sec.

G. Clove oil; differentiate under microscope about 30 secs.

H. Xylol; 3 changes, 10 min.

K. Neutral balsam or "Clarite," mount.

Notes.

1. The quickest staining and differentiation are best.

F. Fading is differential; the centromere is often the last structure to fade.

3. Faded or under-stained slides can be re-stained after removing cover slip in xylol and taking down through alcohol to water. Metaphase chromosomes may then show an additional contraction.

* See Formulae of Reagents.

† White, unpub., for orthopteran testes.

SCHEDULE 7'.—CHROMIC MODIFICATION FOR DEEPER STAINING
(La Cour 1937).

- A'. Rinse.
- B'. Stain. 10 min. in 0·5 %.
- C'. Water, rinse.
 - > Absolute alcohol, 2 sec.
- D'. I₂-KI in 80 % alcohol, 2 min.
 - > Absolute alcohol, 2 sec.
 - > Chromic acid 1 % aqueous solution, 15 sec.
 - > Absolute alcohol, 5 sec.
 - > Chromic acid 1 % aqueous solution, 15 sec.
- E/F'. Absolute alcohol, 10-15 sec.
- G/K. As before.

Note.—This is the only crystal violet method that gives passable results after alcoholic fixatives.

SCHEDULE 8.—HEIDENHAIN'S HAEMATOXYLIN (Short method).

Material: any smears or sections.

- A. Rinse.
- B. Mordant in 4 % alum, 10-30 min.
- C. Rinse in running water, 10-15 min.
- D. Stain in 0·5 % haematoxylin (ripened), 5-15 min.
- E. Rinse in water and de-stain 5-20 min. in saturated aqueous picric acid (Tuan 1930).
- F. Blue the stain in a jar of water containing 1 or 2 drops of 0·880 ammonia, 1 min.
- G. Rinse in running water, 30 min.
- H. Pass quickly through an alcohol series, 20 %, 60 %, 80 %, absolute.
- I. Examine in clove oil.
- J. Xylol, mount in balsam or "Clarite."

SCHEDULE 9.—GIEMSA METHOD (Gelei's modification for *Dendrocoelum* eggs).

Material: animal or bacterial, best after osmic vapour—chromic acid smears.

- Stain: $\left\{ \begin{array}{l} 10 \text{ drops Giemsa solution.} \\ 10 \text{ c.c. water.} \end{array} \right.$

- A. Mordant in 1-2 % ammonium molybdate, 5-15 min.
- B. Rinse in distilled water, 2-5 min.
- B. Rinse in distilled water, 2-5 min.
- C. Stain: 10-45 min.
- D. De-stain in 96 % alcohol.

The following means have been used to produce metaphases with super-contracted chromosomes; they all act by suppressing the spindle and permitting the chromosomes to continue contraction beyond metaphase:—

- (i) Freezing: *Crepis*, Delaunay, *cf.* Darlington 1937.
Triton, Barber and Callan 1942.
- (ii) Acenaphthene: *Tradescantia* (PT) Swanson 1940.
- (iii) Colchicine *Triton*, Barber and Callan 1942.

APPENDIX IV
CATALOGUE OF IMPLEMENTS

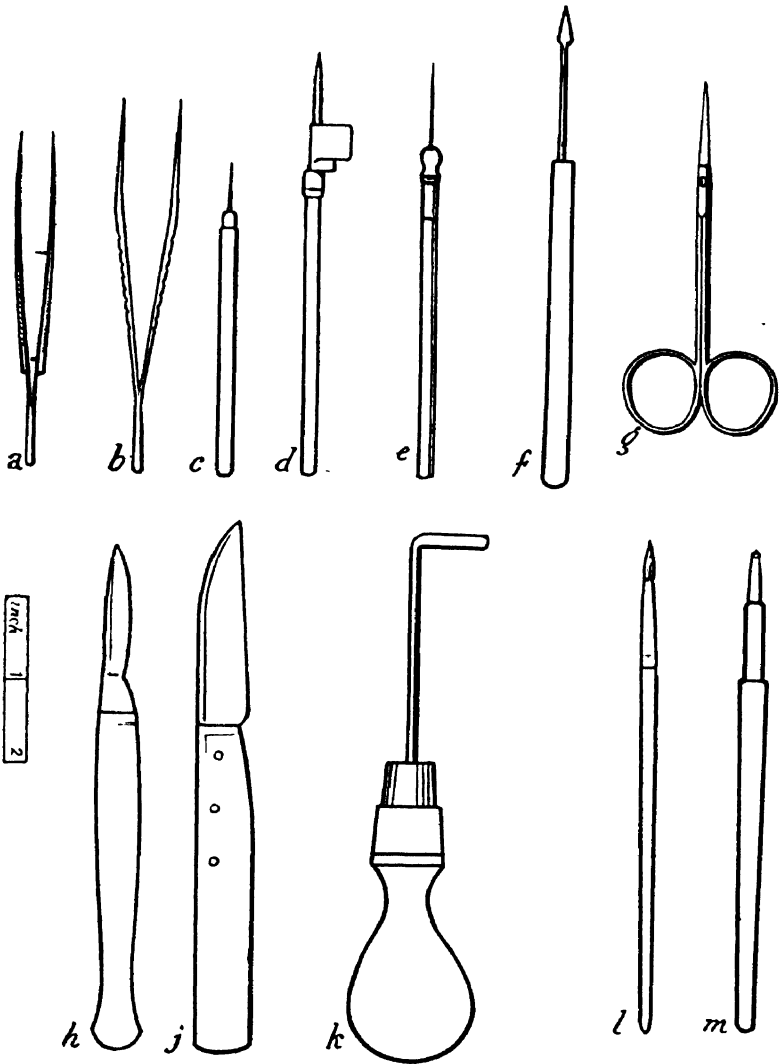

FIG. 5 — Metal Instruments (see text).

(i) *Metal instruments* (Fig. 5).

- (a) Fine forceps for cutting off root tips and dissection.
- (b) Coarse forceps for holding slides.
- (c) Bone needle holder for tapping out squashes (blunt end) and dissection (pointed end).
- (d) Aluminium mounted needle with lancet blade and soldered safety-razor blade attachment for cutting tissues or raising cover slips.
- (e) Plain mounted needles, one iron for teasing aceto-carmine, one nickel-plated for other purposes.
- (f) Spear-shaped mounted needle with two cutting edges for dissection and cutting of small tissues.
- (g) Fine scissors for animal dissection.
- (h) Scalpel.
- (j) Flat-honed potato-knife scalpel for smearing.
- (k) Mounted rimming-rod for sealing cover slips.
- (l) Camel-hair brush, one needed for holding microtome ribbons and transferring material from fixative, etc., another for cleaning eyepieces.
- (m) Diamond (or carborundum) pencil for engraving numbers on slides.

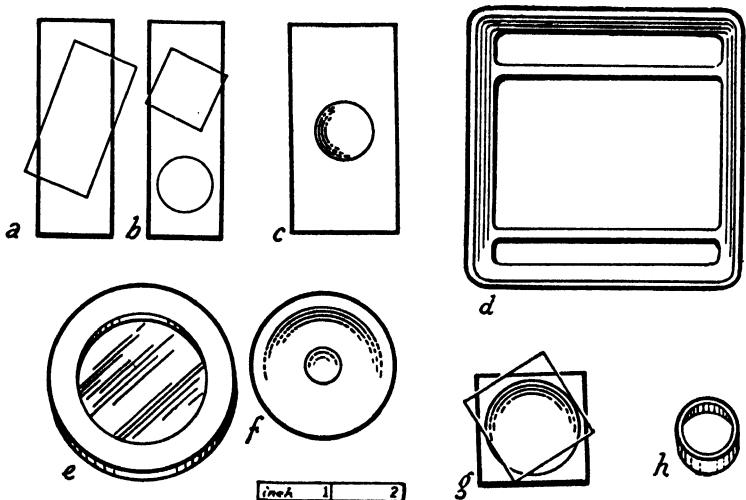

FIG. 6.—Glass instruments and smearing dish (see text).

(ii) *Glass and Earthenware Implements* (Fig. 6).

- (a) Slide and long cover slip for ribbons or smears. All slips should be grade 0 (0.075–0.1 mm. thick).
- (b) Slide and cover slips for squashes, etc.
- (c) Well-slide for warming fixative and tissues for maceration, or for fixation of very small objects.
- (d) Ridged smearing dish $3\frac{1}{2}$ in. square, earthenware, for fixation, bleaching and, if necessary, staining.
- (e) Solid, flat-bottomed watch-glass for embedding or for dissection of small animals in Ringer or wax.
- (f) Ordinary watch-glass for evaporation from wax, etc.
- (g) Solid watch-glass with cover for fixation, etc.
- (h) Glass ring, to make a “van Tieghem” cell for hanging drop preparations (Chaps. 2 and 10).

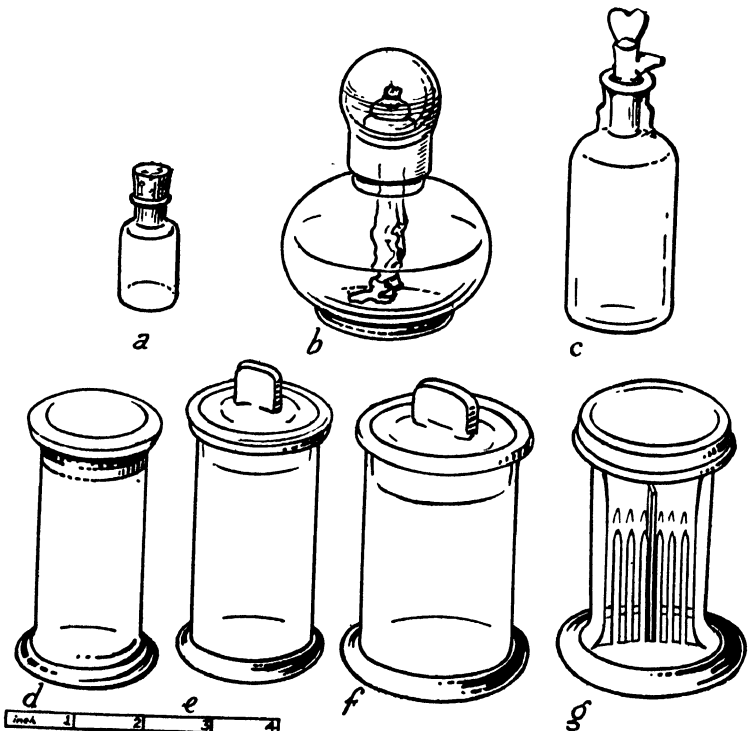

FIG. 7.—Glass bottles and spirit lamp (see text).

(iii) *Glass Bottles and Lamp* (Fig. 7).

- (a) Fixing bottle, corked.
- (b) Spirit lamp for heating acetic squashes and smears.
- (c) Dropping or pipette bottle for acetic stains, etc.
- (d)-(f) Jars, various, narrow types for taking up slides with cover slips in making squashes and smears permanent. Cover slip holders may be made of aluminium wire.
- (g) Ridged jars for crystal violet or haematoxylin.

(iv) *Other general items.*

- (a) Dark bottles, ground stoppered for H_2O_2 and OsO_4 .
- (b) Pipettes, graduated and ungraduated.
- (c) Measuring cylinders, 10-100 c.c.
- (d) Water vacuum pump.
- (e) Small hand pump for field work.
- (f) Dissecting pins, various.
- (g) Dissection board.
- (h) Small petri dishes for pollen germination.

(v) *Special Apparatus for Paraffin Sections.*

Sections demand the following extra apparatus:—

- (a) *A thermostatic oven* is needed for three purposes:
 - (i) Embedding material in paraffin wax, temp. 50° - 60° C.
 - (ii) Evaporating chloroform during penetration of material by wax, temp. 50° - 60° C.
 - (iii) Hydrolysis for Feulgen reaction, temp. 60° C.
- (b) *A thermostatic hot plate* is needed for stretching and drying paraffin ribbons and slides with cover slips mounted on balsam. The top of the oven can be used as a substitute.
- (c) *A microtome* is needed to cut sections ranging in thickness from 4 to $40\ \mu$.

(vi) *Drawing Implements*

- (a) H pencil, for drawing the outline by camera lucida.
- (b) Indian ink, fixed.
- (c) Pen nib, fine pointed; Brandauer 515 is the best design, 24 mm. long and 4 mm. broad, with a triangular tip 10 mm. long. With such a nib a line can be widened to a streak 5 mm. broad, the point making an accurate edge.
- (d) Bristol board; 3-ply is thick enough for handling and thin enough for cutting and mounting on thick squared paper.

APPENDIX V
ABBREVIATIONS

- PMC = pollen mother cell.
EMC = embryo-sac mother cell.
SMC = spermatocyte or sperm mother cell.
PT = pollen tube.
GN and VN = generative and vegetative nucleus of PG.
PG = pollen grain.
RT = root tip.
SG = salivary gland (with polytene nuclei).
X and Y = sex chromosomes.
MEIOSIS: The two mitoses by which a diploid mother cell gives four haploid spores or gametes.
I and II = univalents and bivalents at meiosis.
MI, MII and AI, AII, first and second metaphases and anaphases of meiosis.
X, Xta = chiasma, chiasmata, structures produced by crossing over.
C.V. = Crystal Violet.
x = basic chromosome number of a polyploid series.
n and 2n = gametic and zygotic chromosome numbers.
 μ = micron = 0.001 mm.
 \AA = Ångstrom unit, 0.0001 μ = 0.1 m μ .
I.E.P. = iso-electric point.
n.a. = numerical aperture.
pH = hydrogen ion concentration.
r = Röntgen unit.

REFERENCES

A. RECENT REVIEWS

Abbreviations: P., proceedings. S.T., Stain Technology.

- BAKER, J. R. 1933.
Cytological Technique.
London (Methuen). pp. 11 + 131.
- BECKER, W. A. 1938.
Struktur und Doppelbrechung der Chromosomen.
Arch. exp. Zelf. 22: 196-201.
- BELAR, K. 1926.
Der Formwechsel der Protistenkerne.
Ergebn. Zool. 6: 235-652.
- BELAR, K. 1929.
Die Technik der deskriptiven Zoologie.
Meth. wiss. Biol. 1: 638-735.
- BELLING, J. 1930.
The Use of the Microscope.
N.Y. (McGraw-Hill). pp. 315.
- BLAKESLEE, A. F. 1939.
The present and potential service of chemistry to plant breeding.
Amer. J. Bot. 26: 163-72.
- CHAMOT, E. M. & MASON, G. W. 1938.
Handbook of Chemical Microscopy. Wiley. N.Y.
- COLES, A. C. 1921.
Critical Microscopy. Churchill, London.
- CONN, H. J. 1940.
Biological Stains.
Geneva, N.Y. (Biotech. Pub.). 4th ed. pp. 308.
- DARLINGTON, C. D. 1937.
Recent Advances in Cytology.
London (Churchill). 2nd ed. pp. 16 + 671.
- DARLINGTON, C. D. and UPCOTT, M. B. 1939.
The measurement of packing and contraction in chromosomes.
Chromosoma 1: 23-32.
- GAGE, S. H. 1936.
The microscope.
Ithaca, N.Y. (Cornstock).

- GEITLER, L. 1938.
Chromosomenbau.
Berlin (Borntraeger). pp. 7 + 190.
- GOODSPEED, T. H. and UBER, F. M. 1939.
Radiation and plant cytogenetics.
Bot. Rev. 5: 1-48.
- GRAY, J. 1931.
Experimental Cytology.
Cambridge. pp. 10 + 516.
- HIND, H. L. & RANGLES, W. B. 1927.
Handbook of Photomicrography, 2nd. Edn.
London (Routledge) and New York (Dutton).
- IMMS, A. D. 1938.
A general textbook of entomology.
London (Methuen). 4th ed. pp. 12 + 727.
- JOHANSEN, D. A. 1940.
Plant microtechnique.
N.Y. (McGraw-Hill). pp. 531.
- LEE, BOLLES. 1937.
The microtome's vade-mecum.
(ed.) J. B. Gatenby and T. S. Painter.
London (Churchill). 10th ed. pp. 9 + 784.
- LEWITSKY, G. A. 1931.
The morphology of the chromosomes.
B. appl. Bot. 27 (1): 19-137.
- MCLLUNG, C. E. 1937.
Handbook of microscopical technique.
N.Y. (Hoerber). pp. 14 + 495. 2nd ed. 698.
- MCLLUNG, C. E. 1940.
Chromosome Numbers in Animals.
Tab. Biol. 18: 83-113.
- MAHESHWARI, P. 1937.
A critical review of the types of embryo-sacs in Angiosperms.
New Phyt. 36: 359-417.
- MARTIN, L. C. and JOHNSON, E. K. 1931.
Practical microscopy.
London (Blackie). 1931. pp. 116.
- MATSUURA, H. and SUTO, T. 1935.
Contributions to the idiogram study in phanerogamous plants. I.
J. F. Sci. Hokkaido. V. 5: 33-75.

- MAUDE, P. F. 1939.
The Merton Catalogue.
New Phyt. 38: 1-31.
- OGUMA, K. and MAKINO, S. 1937.
A new list of the chromosome numbers in Vertebrata.
J.F. Sci. Hokkaido. VI. 5: 297-356.
- RHOADES, M. M. and McCLINTOCK, B. 1935.
The cytogenetics of maize.
Bot. Rev. 1: 292-325.
- SCHRADER, F. 1928.
The sex chromosomes.
Berlin (Borntraeger). pp. 194.
- SCHRADER, F. and HUGHES-SCHRADER, S. 1931.
Haploidy in Metazoa.
Q. Rev. Biol. 6: 411-38.
- TISCHLER, G. 1936.
Pflanzliche Chromosomen-Zahlen.
Tab. Biol. Berl. 11: 281-304; 12: 1-115.
- UBER, F. M. 1940.
Microincineration and ash analysis.
Bot. Rev. 6: 204-26.
- VANDEL, A. 1938.
Chromosome number, polyploidy and sex in the animal kingdom.
P. zool. Soc. Lond. A, 107: 519-41.
- WHITE, M. J. D. 1937.
The Chromosomes.
London (Methuen). pp. 8 + 128.
- WHITE, M. J. D. 1940.
The origin and evolution of multiple sex-chromosome mechanisms.
J. Genet. 40: 303-36.
- ZEIGER, K. 1938.
Physikochemische Grundlagen der histologischen Methodik.
Wiss. Forsch. Ber. 48: 1-202.

B. SPECIAL ARTICLES

- ABE, K. 1933.
Mitosen in Antheridium von *Sargassum confusum* Ag.
Sci. Rep. Tohoku. 8: 259-62.
- ALLEN, C. E. 1935.
The occurrence of polyploidy in *Sphaerocarpos*.
Am. J. Bot. 22: 635-44.

- ANDERSON, E. and SAX, K. 1934.
A cytological analysis of sterility in *Tradescantia*.
Bot. Gaz. **43**: 609-21
- ANDERSON, E. G. 1935.
Chromosomal interchanges in maize.
Genetics **20**: 70-83.
- ANDERSON, R. L. 1936.
Effects of temperature on fertilisation in *Habrobracon*.
Genetics **21**: 467-72.
- ASANA, J. J. and MAKINO, S. 1935.
A comparative study of the chromosomes in the Indian dragonflies.
J.F. Sci. Hokkaido VI, **4**: 67-86.
- ASANA, J. J., MAKINO, S. and NIIYAMA, H. 1940.
Variations in the chromosome number of *Gryllotalpa africana*, etc.
J.F. Sci. Hokkaido. VI, **7**: 59-72.
- BABCOCK, E. B. and NAVASHIN, M. 1930.
The Genus *Crepis*. *Bibliogr. genet.* **6**: 1-90.
- BACKMAN, E. 1935.
A rapid combined fixing and staining method for plant chromosome counts.
S.T. **10**: 83-6.
- BAIRD, T. T. 1936.
Comparative study of dehydration.
S.T. **11**: 13-22.
- BALDWIN, J. T. 1939.
Chromosomes from leaves.
Science **90**: 240.
- BARBER, H. N. 1939.
The rate of movement of chromosomes on the spindle.
Chromosoma **1**: 33-50.
- BARBER, H. N. 1940.
The suppression of meiosis and the origin of diplochromosomes.
P.R.S. B, **128**: 170-85.
- BARBER, H. N. 1941a.
Chromosome Behaviour in *Uvularia*.
J. Genet. **42**: 223, 257.
- BARBER, H. N. 1941b.
Pollen-grain Division in the *Orchidaceae*.
J. Genet. **43** (press).
- BARBER, H. N. 1942.
The Experimental Control of Chromosome Pairing in *Fritillaria*.
J. Genet. (press).

- BARBER, H. N. and CALLAN, H. G. 1942.
The effects of cold and colchicine on mitosis in the newt.
J. Exp. Biol. (press).
- BARIGOZZI, C. 1937.
Lo studio degli spodiogrammi dei cromosomi.
Comment. pontif. Acad. **1**: 333-49.
- BAUER, H. 1931.
Die Chromosomen von *Tipula paludosa* Meig. in Eibildung und Spermatogenese.
Z. Zellf. **14**: 138-93.
- BAUER, H. 1932.
Die Feulgensche Nuklealfärbung in ihrer Anwendung auf cytologische Untersuchungen.
Z. Zellf. **15**: 225-47.
- BAUER, H. 1933.
Mikroskopisch-chemischer Nachweis von Glycogen und einigen anderen Polysacchariden.
Z. mik-anat. Forsch. **33**: 143-60.
- BECKER, W. A. 1938.
Recent Investigations in *in vivo* on the division of plant cells.
Bot. Rev. **4**: 446-72.
- BAUER, H. 1935.
Der Aufbau der Chromosomen aus den Speicheldrüsen von *Chironomus Thummi* Kiefer.
Z. Zellf. **23**: 280-313.
- BAUER, H. 1936
Structure and arrangement of salivary gland chromosomes in *Drosophila* species.
P.N.A.S. **22**: 216-22.
- BAUER, H. 1940.
Über die Chromosomen der bisexuellen und parthenogenetischen Rasse des *Ostracoden*, etc.
Chromosoma **1**: 620-37.
- BAUER, H., DEMEREC, H. and KAUFMANN, B. P. 1938.
X-ray induced chromosomal alterations in *Drosophila melanogaster*.
Genetics **23**: 610-30.
- BEAMS, H. W. and KING, R. L. 1935.
The effect of ultracentrifuging on the cells of the root tip of the bean (*Phaseolus vulgaris*).
P.R.S. B **118**: 264-76.
- BELAR, K. 1929a. Beiträge zur Kausalanalyse der Mitose II. Untersuchungen an den Spermatozyten von *Chorthippus* U.S.W.
Arch. EntMech. Org. **118**: 359-484.

- BELAR, K. 1929b. Beiträge zur Kausalanalyse der Mitose III. Untersuchungen an den Staubfäden, Haarzellen und Blattmeristemzellen von *Tradescantia virginica*.
Z. Zellf. **10**: 73-134.
- BELAR, K. 1933 (ed. W. Huth).
Zur Teilungsautonomie der Chromosomen.
Z. Zellf. **17**: 51-66.
- BELLING, J. 1926. The Iron-Acetocarmine Method of Fixing and Staining Chromosomes.
Biol. Bull. **50**: 160-2.
- BELLING, J. 1928.
A method for the study of chromosomes in pollen mother cells.
Univ. Calif. Pubn. Bot. **14**: 293-9.
- BERNAL, J. D. 1940.
Structural Units in Cellular Physiology in "The Cell and Protoplasm."
199-205. Washington.
- BIGELOW, H. B.
Studies on the Nuclear Cycle of *Gonionemus*, etc.
B.M. Comp. Zool. Harvard **48**: 287-399.
- BLAKESLEE, A. F. and AVERY, A. G. 1937.
Methods of inducing doubling of chromosomes in plants.
J. Hered. **28**: 392-411.
- BOVERI, T. 1911. Über das Verhalten der Geschlechtschromosomen bei Hermaphroditismus. Beobachtungen an *Rhabditis nigrovenosa*.
Verh. Phys.-Med. Ges. Würzburg **41**: 83-97.
- BRADBURY, Q. C. 1931.
A new dehydrating agent for histological technic.
Science **74**: 225.
- BRIDGES, C. B. 1932.
Apparatus and Methods for *Drosophila* culture.
Am. Nat. **66**: 251-73.
- BROWN, ROBERT. 1833.
On the Organs and Mode of Fecundtn. in Orchideae and Asclepiadeae.
Trans. Linn. Soc. **16**: 685-745.
- BRIDGES, C. B. 1935.
The vapor method of changing reagents, and of dehydration.
S.T. **12**: 51-2.
- BUCHHOLTZ, J. T. 1931.
The dissection, staining and mounting of styles in the study of pollen tube distribution.
S.T. **6**: 13-24.

- BUCK, J. B. and BOCHE, R. D. 1938.
Some properties of living chromosomes.
Anat. Record, **72**: abstr. 88.
- CALLAN, H. G. 1940.
The chromosomes of the cymothoid isopod *Anilocra*.
Q.J.M.S. **82**: 327-35.
- CALLAN, H. G. 1941.
The sex-determining mechanism of the earwig, *Forficula auricularia*.
J. Genet. **41**: 349-74.
- CALLAN, H. G. 1942.
Heterochromatin in *Triton*.
P.R.S., B. 132 (press).
- CAPINPIN, J. M. 1930.
Brazilin stain on smear preparations of *Oenothera* pollen mother cells.
Science **72**: 370-1.
- CARLSON, J. G. 1935.
A rapid method for removing cover glasses of microscope slides.
Science **81**: 365.
- CARPENTER, D. C. and NEBEL, B. R. 1931.
Ruthenium tetroxide as a fixative in cytology.
Science **74**: 225.
- CASPERSSON, T. 1940.
Methods for the determination of the absorption spectra of cell structures.
J.R.M.S. **60**: 8-25.
- CATCHESIDE, D. G. 1938a.
The effect of X-ray dosage upon the frequency of induced structural changes in the chromosomes of *Drosophila melanogaster*.
J. Genet. **36**: 307-20.
- CATCHESIDE, D. G. 1938b.
The bearing of the frequencies of X-ray induced interchanges in maize upon the mechanism of their induction.
J. Genet. **36**: 321-8.
- CHEN, TSE-TUAN. 1936a.
Observations on mitosis in opalinids (Protozoa, Ciliata). I.
P.N.A.S. **22**: 594-602.
- CHEN, TSE-TUAN. 1936b.
Observations on mitosis in Opalinids (Protozoa, Ciliata). II.
P.N.A.S. **22**: 602-7.
- CHEN, TSE-TUAN. 1940.
Polyploidy and its origin in *Paramecium*.
J. Hered. **31**: 175-84.

- CLEVELAND, L. R. 1938.
Longitudinal and transverse division in two closely related flagellates.
Biol. Bull. 74: 1-24.
- COLE, E. C. 1926.
A rapid iron haematoxylin technique.
Science 64: 452-3.
- COLEMAN, L. C. 1938.
Preparation of Leucobasic Fuchsin for use in the Feulgen reaction.
S.T. 13: 123-4.
- COOPER, K. W. 1937.
Reproductive behaviour and haploid parthenogenesis in the grass mite,
Pediculopsis graminum (Reut.) (Acarina, Tarsonemidae).
P.N.A.S. 23: 41-4.
- CREW, F. A. E. and KOLLER, P. C. 1936.
The Intergeneric Hybrid of *Cairina moschata* and *Anas platyrhyncha*.
P.R.S. Edin. 56: 210-41.
- DARK, S. O. S. 1936.
Meiosis in diploid and tetraploid *Paeonia* species.
J. Genet. 32: 353-72.
- DARLINGTON, C. B. 1926. Chromosome Studies in the Scilleae.
J. Genet. 16: 237-51.
- DARLINGTON, C. D. 1928. Studies in Prunus, I and II.
J. Genet. 19: 213-56.
- DARLINGTON, C. D. 1929a. Meiosis in Polyploids II.
J. Genet. 21: 17-56.
- DARLINGTON, C. D. 1929b. Chromosome Behaviour and Structural
Hybridity in the *Tradescantiae*.
J. Genet. 21: 207-86.
- DARLINGTON, C. D. 1933a.
Meiosis in *Agapanthus* and *Kniphofia*.
Cytologia 4: 229-40.
- DARLINGTON, C. D. 1935a.
The internal mechanics of the chromosomes. I-III.
P.R.S., B, 118: 33-96.
- DARLINGTON, C. D. 1936.
The external mechanics of the chromosomes. I-V.
P.R.S., B, 121: 264-319.
- DARLINGTON, C. D. 1939.
The genetical and mechanical properties of the sex chromosomes.
V. *Cimex* and the Heteroptera.
J. Genet. 39: 101-37.

- DARLINGTON, C. D. and LA COUR, L. 1938.
Differential reactivity of the Chromosomes.
Ann. Bot., N.S. 2: 615-25.
- DARLINGTON, C. D. and LA COUR, L. 1940.
Nucleic acid starvation in chromosomes of *Trillium*.
J. Genet. 40: 185-213.
- DARLINGTON, C. D. and LA COUR, L. 1941.
The Detection of Inert Genes.
J. Heredity. 32: 114-21.
- DARLINGTON, C. D. and LA COUR, L. 1942.
The Genetics of Embryo Sac Development.
Ann. Bot. (press).
- DARLINGTON, C. D. and OSTERSTOCK, H. C. 1936.
Projection method for demonstration of chromosomes in situ.
Nature 138: 79.
- DARLINGTON, C. D. and THOMAS, P. T. 1941.
Morbid Mitosis and the Activity of Inert Chromosomes in *Sorghum*.
P.R.S., B (press).
- DARLINGTON, C. D. and UPCOTT, M. B. 1941a.
The activity of inert chromosomes in *Zea Mays*.
J. Genet. 41: 275-96.
- DARLINGTON, C. D. and UPCOTT, M. B. 1941b.
Spontaneous Chromosome Change.
J. Genet. 41: 297-338.
- DE TOMASI, J. A. 1936.
Improving the technic of the Feulgen stain.
S.T. 11: 137-44.
- DOBZHANSKY, Th. 1934.
Studies on hybrid sterility. I. Spermatogenesis in pure and hybrid
Drosophila pseudoobscura.
Z. Zellf. 21: 169-223.
- DOROSHENKO, A. V. 1928.
Pollen physiology (in Russian).
Bull. appl. Bot. 18 (5): 217-344.
- DORSEY, E. 1936.
Induced polyploidy in wheat and rye.
J. Hered. 27: 154-60.
- DREW, K. M. 1939.
An investigation of *Plumaria elegans*, etc.
Ann. Bot. N.S. 3: 347-67.

- DUFRENOY, J. 1935.
A method for embedding plant tissues without dehydration.
Science **82**: 235.
- ELLENHORN, J. 1933.
Experimental-photographische Studien der lebenden Zelle.
Z. Zellf. **20**: 288-308.
- ELLENHORN, J., *et al.* 1935.
The optical dissociation of *Drosophila* chromomeres by means of ultraviolet light.
C.R. Acad. Sci. URSS 1935, **1** (4) 234: 242.
- EMERSON, S. 1938.
The genetics of self-incompatibility in *Oenothera organensis*.
Genetics, **23**: 190-202.
- FABERGÉ, A. C. 1940.
An experiment on chromosome fragmentation in *Tradescantia* by X-rays.
J. Genet. **39**: 229-48.
- FABERGÉ, A. C. and LA COUR, L. 1936.
An electrically heated needle for paraffin embedding.
Science **84**: 142.
- FANKHAUSER, G. 1937*a*.
The production and development of haploid salamander larvae.
J. Hered. **28**: 1-15.
- FANKHAUSER, G. 1937*b*.
The development of fragments of the fertilised *Triton* egg with the egg nucleus alone ('gyno-merogony').
J. exp. Zool. **75**: 413-70.
- FAVORSKY, M. V. 1939.
New polyploidy-inducing chemicals.
C.R. Acad. Sci. URSS **25**: 71-4.
- FERNANDES, A. 1939.
Sur le comportement d'un chromosome surnuméraire pendant la mitose.
Sci. genet. **1**: 141-67.
- FEULGEN, R. and IMHAÜSER, K. 1925.
Über die für Nuklealreaktion und Nuklealfärbung verantwortlich zu machenden Gruppen, etc. II.
Hoppe-Seyl Z. **148**: 1-16.
- FEULGEN, R. and ROSSENBECK, H. 1924.
Mikroskopisch-chemischer Nachweis einer Nucleinsäure vom Typus der Thymonucleinsäure. *Hoppe-Seyl Z.* **135**: 203-48.
- FOOT, K. and STROBELL, E. C. 1905. Prophases and metaphases of the first maturation spindle of *Allolobophora foetida*.
Am. J. Anat. **4**: 199-243.

- FRASER, H. C. I. 1908. Contributions to the Cytology of *Humaria rutilans*, Fries.
Ann. Bot. 22: 35-55.
- GEITLER, L. 1935a.
Der Spiralbau somatischer Chromosomen.
Z. Zellf. 23: 514-21.
- GEITLER, L. 1936.
Über den feineren Kern-und Chromosomenbau der Cladophoraceen.
Planta 25: 530-78.
- GELEI, J. 1921.
Weitere Studien über die Oogenese des *Dendrocoelum lacteum*. II.
Arch. Zellf. 16: 88-169.
- GRAUPNER, V. H. and WEISBERGER, A. 1933
Die Verwendung von Lösungen in Dioxan als Fixierungsmittel für Gefrierschnitte.
Zool. Anz. 102: 39-44.
- GROAT, R. A. 1939.
Two new mounting media superior to canada balsam and gum damar.
Anat. Rec. 74: 1 and Suppt. 1.
- GROSS, F. 1935.
Die Reifungs- and Furchungsteilungen von *Artemia salina*, etc.
Z. Zellf. 23: 522-65.
- GULICK, A. 1941.
The Chemistry of Chromosomes.
Bot. Rev. 7: 433-57.
- GUSTAFSSON, A. 1935.
Studies on the mechanism of parthenogenesis.
Hereditas 21: 1-112.
- GUSTAFSSON, A. 1936.
The different stability of chromosomes and the nature of mitosis.
Hereditas 22: 281-335.
- HANCE, R. T. 1933.
Improving the staining Action of Iron Haematoxylin.
Science 77: 287.
- HANCE, R. T. 1937.
Air conditioning for microtomes.
Science 86: 313.

- HARLAND, S. C. 1936.
Haploids in polyembryonic seeds of Sea Island Cotton.
J. Hered. **27**: 229-31.
- HARLAND, S. C. 1940.
New polyploids in cotton by the use of colchicine.
Trop. Agric., Trin. **17**: 53-4.
- HEARNE, E. M. and HUSKINS, C. L. 1935.
Chromosome pairing in *Melanoplus femur-rubrum*.
Cytologia **6**: 123-47.
- HEITZ, E. 1931. Die Ursache der gesetzmässigen Zahl, Lage, Form und Grösse pflanzlicher Nucleolen.
Planta **12**: 774-844.
- HEITZ, E. 1935.
Chromosomenstruktur und Gene.
Z.I.A.V. **70**: 402-47.
- HEITZ, E. 1963b.
Die Nucleal-Quetschmethode.
Ber. d. bot. Ges. **53**: 870-8.
- HEITZ, E. and BAUER, H. 1933.
Beweise für die Chromosomennatur der Kernschleifen in Knäuelkernen von *Bibio U.S.W.*
Z. Zellf. **17**: 67-82.
- HELWIG, E. R. 1938.
The frequency of reciprocal translocations in irradiated germ cells of *Circotettix verruculatus* (Orthoptera).
Arch. Biol. Paris **49**: 143-58.
- HILLARY, B. B. 1939a.
Use of the Feulgen reaction in cytology. I. Effect of fixatives on the reaction.
Bot. Gaz. **101**: 276-300.
- HILLARY, B. B. 1939b.
Improvements in the permanent root tip squash technique.
S.T. **14**: 97-9.
- HILLARY, B. B. 1940.
Uses of the Feulgen reaction in cytology. II.
Bot. Gaz. **102**: 225-35.
- HUSKINS, C. L. and SMITH, S. G. 1935.
Meiotic chromosome structure in *Trillium erectum* L.
Ann. Bot. **49**: 119-50.
- HUSTED, L. and RUEBUSH, T. K. 1940.
A comparative cytological and morphological study of *Mesostoma*, etc.
J. Morph. **67**: 387-410.

- IKEDA, K. and MAKINO, S. 1936.
Studies on the sex and chromosomes of the oriental human blood fluke,
Schistosomum japonicum Kats.
J.F. Sci. Hokkaido VI, 5: 57-71.
- JACHIMSKY, H. 1935.
Beitrag zur Kenntnis von Geschlechtschromosomen und Hetero-
chromatin bei Moosen.
Jb. wiss. Bot. 81: 203-38.
- JOHANSEN, D. A. 1935.
Dehydration and infiltration.
Science 82: 253-4.
- KARLING, J. S. 1928.
Nuclear and cell division in the antheridial filaments of the Characeae.
B. Torrey bot. Cl. 55: 11-39.
- KARPECHENKO, D. G. 1927.
Polyploid hybrids of *Raphanus sativus* x *Brassica oleracea*.
B. Appl. Bot. 17: (3), 305-410.
- KARPECHENKO, G. D. 1938.
New tetraploid barleys—the hulled and the naked.
C.R. Acad. Sci. URSS 21: 59-62.
- KARPECHENKO, G. D. 1940.
Tetraploid six-rowed barleys obtained by colchicine treatment.
C.R. Acad. Sci. URSS 27: 47-50.
- KATAYAMA, H. 1939.
The sex chromosomes of a may-fly, *Ameletus costalis* Mats. (Ephemera).
Jap. J. Genet. 15: 139-44.
- KAUFMANN, B. P. 1938.
Nucleolus-organising regions in salivary gland chromosomes of *Drosophila melanogaster*.
Z. Zellf. 28: 1-11.
- KAWAGUCHI, E. 1938.
Der Einfluss der Eierbehandlung mit Zentrifugierung auf die Vererbung
bei dem Seidenspinner. II.
Cytologia 9: 38-54.
- RIHARA, H. 1924.
Cytologische und genetische Studien bei wichtigen Getreidearten.
Mem. Coll. Sci. Kyoto B, 1: 1-200.
- RIHARA, H. 1927b. Über die Vorbehandlung einiger pflanzlicher
Objecte bei der Fixierung der Pollenmutterzellen
Bot. Mag. Tokyo 41: 124-28.

- KIHARA, H.
Formation of Haploids by means of delayed pollination in *Triticum monococcum*.
Bot. Mag. Tokyo. **54**: 178-85.
- KIHARA, H. and YAMASHITA, K. 1938.
Künstliche Erzeugung haploider und triploider Einkornweizen durch Bestäubung mit Röntgenbestrahlten Pollen.
Akemie Commem. Papers 9-20.
- KLINGSTEDT, H. 1931.
Digamete beim Weibchen der Trichoptere *Limnophilus decipiens* Kol.
Acta zool. fenn. **10**: 1-69.
- KNAPP, E. 1935.
Zur Frage der genetischen Aktivität des Heterochromatins, nach Untersuchungen am X-Chromosom von *Sphaerocarpus Donnellii*.
Ber. d. Bot. Ges. **53**: 751-60.
- KOLLER, P. C. 1935.
The internal mechanics of the chromosomes, IV. Pairing and coiling in salivary gland nuclei of *Drosophila*.
P.R.S., B: **810**: 371-97.
- KOLLER, P. C. 1936.
The origin and behaviour of chiasmata, XI. *Dasyurus* and *Sarcophilus*.
Cytologia **7**: 82-103.
- KOLLER, P. C. 1937.
The genetical and mechanical properties of Sex Chromosomes. III. Man.
P.R.S., *Edin.* **57**: 194-214.
- KOLLER, P. C. 1940.
Technique for staining mitotic chromosomes of *Drosophila*.
Dros. Inf. Service. **13**: 79-80.
- KOLTZOFF, N. K. 1938.
The structure of the chromosomes and their participation in cell-metabolism.
Biol. Zhur. **7**: 3-46.
- KOSTOFF, D. 1938a.
Polyploid plants produced by colchicine and acetonaphthene.
Curr. Sci. **7**: 108-10.
- KOSTOFF, D. 1938b.
The effect of centrifuging upon the germinated seeds of various plants.
Cytologia **8**: 420-42.
- KOSTOFF, D. 1938c.
Irregular meiosis and abnormal pollen-tube growth induced by acenaphthene.
Curr. Sci. **7**: 8-11.

KRACZKIEWICZ, Z. 1937.

Recherches cytologiques sur le cycle évolutif de *Miastor metraloas*.

Cellule 46: 55-74

KUWADA, Y. 1937.

The hydration and dehydration phenomena in mitosis.

Cytologia, Fujii Jub. Vol. 389-402.

KUWADA, Y. and NAKAMURA, T. 1934a.

Behaviour of chromonemata in mitosis, II.

Cytologia 5: 244-7.

KUWADA, Y. and NAKAMURA, T. 1940.

Behaviour of Chromonemata in Mitosis. IX. On the configurations assumed by the spirals of the chromonemata.

Cytologia 10: 492-515.

KUWADA, Y., SHINKE, N. and OURA, G. 1938.

Artificial uncoiling of the chromonema spirals as a method of investigation of the chromosome structure.

Z. wiss. Mikr. 55: 8-16.

LA COUR, L. 1931.

Improvements in everyday technique in plant cytology.

J.R.M.S. 51: 119-26.

LA COUR, L. 1935.

Technic for studying chromosome structure.

S.T. 10: 57-9.

LA COUR, L. 1937.

Improvements in plant cytological technique.

Bot. Rev. 5: 241-58.

LA-COUR, L. 1941. Acetic-Orcein.

S.T. 16: 169-74.

LARTER, L. N. H. 1932.

Chromosome variation and behaviour in *Ranunculus* L.

J. Genet. 26: 255-83.

LAWSON, C. A. 1936.

A chromosome study of the aphid *Macrosiphum solanifolii*.

Biol. Bull. 70: 288-307.

LEVAN, A. 1932.

Cytology studies in *Allium* II.

Hereditas 16: 257-94.

LEVAN, A. 1936.

Die Zytologie von *Allium Cepa* × *fistulosum*.

Hereditas 21: 195-214.

LEVAN, A. 1938.

The effect of colchicine on root mitoses in *Allium*.

Hereditas 24: 471-86.

- LEVAN, A. 1939a.
The effect of colchicine on meiosis in *Allium*.
Hereditas 25: 9-26.
- LEVAN, A. 1939b.
Amphibivalent formation in *Allium cernuum* and its consequences in the pollen.
Bot. Notiser 1939: 236-60.
- LEVAN A. 1939c.
Tetraploidy and octoploidy induced by colchicine in diploid *Petunia*.
Hereditas 25: 109-31.
- LEVAN. A. 1939d.
Cytological phenomena connected with the Root swelling caused by Growth Substance.
Hereditas 25: 87-96.
- LEWIS, D. and MODLIBOWSKA, I, (1942). Genetical studies in Pears, IV. Pollen tube growth and Incompatibility.
J. Genet. (press).
- LEWITSKY, G. A. 1931.
An essay on cytological analysis of the fixing action of the chrom-acetic formalin and the chromic formation.
B. appl. Bot. 27 (1): 176-85.
- LEWITSKY, G. A. 1934.
Fixation changes of the chromosome body.
C.R. Acad. Sci. URSS 4: 223-4.
- LEWITSKY, G. A. 1940.
The Progeny of X-rayed *Crepis capillaris*.
Cytologia 11: 1-29.
- LUCAS, F. F. and STARK, M. B. 1931. A Study of Living Sperm Cells of Certain Grasshoppers by means of the Ultraviolet Microscope.
J. Morph. 52: 91-107.
- LUTKOV, A. N. 1938.
Tetraploidy in *Linum* induced by high-temperature treatment of the zygote.
C.R. Acad. Sci. URSS. 19: 87-90.
- MCCLINTOCK, B. A. 1929
A method for making acetocarmine smears permanent.
S.T. 4: 53-6.
- MCCLINTOCK, B. 1931.
Cytological observations involving known genes, translocations and an inversion in *Zea Mays*.
B. Univ. Mo. Agr. Exp. Sta. 163: 1-30.

McCLINTOCK, B. 1933.

The association of non-homologous parts of chromosomes in the mid-prophase of meiosis *Zea mays*.

Z. Zellf. **19**: 191-237.

McCLINTOCK, B. 1934.

The relation of a particular chromosomal element to the development of the nucleoli in *Zea mays*.

Z. Zellf. **21**: 294-328.

MCNABB, J. W. 1928.

A study of the Chromosomes in meiosis, fertilisation and cleavage in the grasshopper egg.

J. Morph. **45**: 47-93.

MCWHORTER, F. P. 1939.

Application of fine grain processing and condenser illumination enlarging to photo-micrography.

S.T. **14**: 87-96.

MADGE, M. 1936.

The use of agar in embedding small or slender objects.

Ann. Bot. **50**: 677.

MAEDA, T. 1939.

Chiasma studies in the silkworm, *Bombyx mori* L.

Jap. J. Genet. **15**: 118-27.

MAHESHWARI, P. 1939.

Recent advances in microtechnique II. The paraffin method in plant cytology.

Cytologia **10**: 257-81.

MAKINO, S. 1939.

The chromosomes of the carp, *Cyprinus carpio*, etc.

Cytologia **9**: 430-40.

MAKINO, S. 1941.

Studies on the Murine Chromosomes I.

J.F. Sc. Hokkaido VI. Zoo. **7**: 305-80.

MANTON, I. 1939.

Evidence on spiral structure and chromosome pairing in *Osmunda regalis* L.

Phil. Trans. R.S. **230**: 179-215.

MATHER, K. 1932.

Chromosome variation in *Crocus*, I.

J. Genet. **26**: 129-42.

MATHER, K. 1934.

The behaviour of meiotic chromosomes after X-irradiation.

Hereditas **20**: 303-22.

- MATHER, K. 1935.
Meiosis in *Lilium*. *Cytologia* 6: 354-80.
- MATHER, K. and STONE, L. H. A. 1933.
The effect of X-radiation upon somatic chromosomes.
J. Genet 28: 1-24.
- MATSUURA, H. 1937.
Chromosome studies on *Trillium kamschaticum* Pall. V.
Cytologia, Fujii Jub. Vol. 20-34.
- MATHEY, R. 1933.
Nouvelle contribution a l'étude des chromosomes chez les Sauriens.
Rev. suisse Zool. 40: 281-316.
- MATHEY, R. 1941.
Etude biologique et cyt. de *Saga pedo* Pallas (Orthoptères-Tettigoniidae).
Rev. suisse zool. 48: 91-142.
- METZ, C. W. 1935.
Structure of the salivary gland chromosomes in *Sciara*.
J. Hered. 26: 177-88.
- MILOVIDOV, P. F. 1936.
Zur Theorie und Technik der Nuklealfärbung.
Protoplasma 25: 570-97.
- MORTIMER, C. H. 1935.
Untersuchungen über den Generationswechsel der Cladoceren.
Naturwiss. 23: 476-80.
- MULLER, H. J. 1940.
An analysis of the process of structural change in chromosomes of
Drosophila.
J. Genet. 40: 1-66.
- MÜNTZING, A. 1941.
Differential response to X-ray treatment of diploid and tetraploid
barley.
K. Fysiog. Sällsk. Lund. Förh. 11: 1-10.
- MÜNTZING, A. and PRAKKEN, R. 1941.
Chromosomal Aberrations in Rye Populations.
Hereditas. 27: 273-308.
- NAGAO, S. 1933.
Number and behaviour of chromosomes in the genus *Narcissus*.
Mem. Coll. Sci. Kyoto B, 8: 81-200.
- NAKAMURA, T. 1937.
Double refraction of the chromosomes in paraffin sections.
Cytologia, Fujii Jub. Vol. 482-93.

- NAVASHIN, M. 1926. Variabilität des Zellkerns bei Crepis-Arten in Bezug auf die Artbildung.
Z. Zellf. 4: 171-215.
- NAVASHIN, M. 1934.
Die Methodik der zytologischen Untersuchungen für züchterische Zwecke.
Z. Zücht, A, 19: 366-413.
- NAVILLE, A. and BEAUMONT, J. DE. 1933.
Recherches sur les Chromosomes des Neuroptères.
Arch. Anat. micr. 29: 119-243.
- NEBEL, B. R. 1931.
Lacmoid-Martius Yellow for Staining Pollen-Tubes in the Style.
S.T. 6: 27-9.
- NEBEL, R. 1932.
Chromosome structure in the Tradescantiae I.
Z. Zellf. 16: 252-84.
- NEBEL, B. R. 1939.
Chromosome structure.
Bot. Rev. 5: 563-626.
- NEBEL, B. R. 1940.
Chlorazol Black E as an aceto-carmin auxiliary stain.
S.T. 15: 69-72.
- NEBEL, B. R. and RUTTLE, M. L. 1939.
Colchicine and its place in fruit breeding.
Circ. N.Y. agr. Exp. Sta. 183: p. 19.
- NEWCOMBE, H. B. 1942. The Action of X-rays on the Cell I & II.
J. Genet. (press).
- NEWCOMER, E. H. 1938.
A procedure for growing, staining and making permanent slides of pollen tubes.
S.T. 13: 89-91.
- NEWTON, W. C. F. 1927. Chromosome Studies in *Tulipa* and Some Related Genera.
J. linn. Soc. (Bot.) 47: 336-54.
- NIIYAMA, H. 1937.
The problem of male heterogamety in the decapod Crustacea, etc.
J.F. Sci. Hokkaido VI, 5: 283-95.
- OGUMA, K. 1937.
Studies on Sauropsid chromosomes. IV.
J. Sci. Hokkaido VI, 5: 265-82.

- OURA, G. 1936.
A new method of unravelling the chrononema spirals.
Z. wiss. Mikr. **53**: 36-7.
- PAINTER, T. S. 1934.
A new method for the study of chromosome aberrations, etc.
Genetics **19**: 175-88.
- PÄTAU, K. 1936.
Cytologische Untersuchungen an der haploid-parthenogenetischen Milbe
Pediculoides ventricosus.
Zool. J. **56**: 277-322.
- PÄTAU, K. 1937.
SAT-Chromosom und Spiralstruktur der Chromosomen der extra-
kapsulären Körper (*Merodinium* sp) von *Collozoum inermis*.
Cytologia, Fujii, Jub. Vol. 667-80.
- PERROT, J-L. and PERROT, MAX. 1937.
La formule chromosomique de l'*Helix pomatia*.
Rev. suisse Zool. **44**: 201-7.
- PETO, F. H. 1935.
Associations of somatic chromosomes induced by heat and chloral
hydrate treatments.
Canad. J. Res. C, **13**: 301-14.
- POLLISTER, A. W. 1939.
Centrioles and chromosomes in the atypical spermatogenesis of *Vivipara*.
P.N.A.S. **25**: 189-95.
- POULSON, D. F. and METZ, C. W. 1938.
Studies on the structure of nucleolus-forming regions and related
structures in the giant salivary gland chromosomes of Diptera.
J. Morph. **63**: 363-95.
- PROKOFIEVA, ALEXANDRA. 1935.
On the chromosome morphology of certain Amphibia.
Cytologia **6**: 148-64.
- RANDOLPH, L. F. 1932.
Some effects of high temperature on polyploidy and other variations
in maize.
P.N.A.S. **18**: 222-9.
- RANDOLPH, L. F. 1935.
A new fixing fluid and a revised schedule for the paraffin method in
plant cytology.
S.T. **10**: 395-6.
- RANDOLPH, L. F. 1940.
Card Mounts for handling Root Tips in the paraffin method.
S.T. **15**: 45-8.

- RILEY, H. P. 1936. The effect of X-rays on the chromosomes of *Tradescantia gigantea*.
Cytologia 7: 131-42.
- ROBINOW, C. 1941.
A study of the nuclear apparatus of bacteria.
P.R.S. B., (press).
- RÜCKERT, J. 1892.
Zur Entwicklungsgeschichte des Ovarialeies bei Selachiern.
Anat. Anz. 7: 107-58
- SAKAMURA, T. 1927. Fixierung von Chromosomen mit siedendem Wasser. *Bot. Mag. Tokyo* 41: 59-64.
- SANDSTEN, E. P. 1909.
Some conditions which influence the germination and fertility of pollen.
Res. Bull. Wis. agric. Exp. Sta. 4.
- SATO, D. 1937.
Polymorphism of Karyotypes in *Galanthus* with special reference to the SAT-chromosome.
Bot. Mag., Tokyo 51: 242-50.
- SAX, KARL. 1938.
Chromosome aberrations induced by X-rays.
Genetics 23: 494-516.
- SAX, KARL. 1940.
An analysis of X-ray induced chromosomal aberrations in *Tradescantia*.
Genetics 25: 41-68.
- SAX, K. and BEAL, J. M. 1934.
Chromosomes of the Cycadales.
J. Arnold Arbor. 15: 255-8.
- SAX, K. and ENZMANN, E. V. 1939.
The effect of temperature on X-ray induced chromosome aberrations.
P.N.A.S. 25: 397-405.
- SAX, K. and HUMPHREY, L. M. 1934.
Structure of meiotic chromosomes in microsporogenesis of *Tradescantia*.
Bot. Gaz. 95: 353-61.
- SAX, K. and SAX, H. J. 1933.
Chromosome number and morphology in the conifers.
J. Arnold Arbor. 14: 356-75.
- SCHAEDE, R. 1930. Über die Struktur des ruhenden Kernes.
Ber. d. bot. Ges. 48: 342-8.
- SCHMUCK, M. L. and METZ, C. W. 1928.
A method for the study of chromosomes in entire insect eggs.
Science 74: 600-1.

- SCHREINER, A. and K. E. 1916a.
Neue Studien über die Chromatinreifung der Geschlechtszellen. I.
Arch. Biol. Paris **22**: 1-69.
- SCOTT, A. C. 1936.
Haploidy and aberrant spermatogenesis in a coleopteran, *Micromalthus debilis*.
J. Morph. **59**: 485-516.
- SEARS, E. R. 1937.
Cytological phenomena concerned with self-sterility in flowering plants.
Genetics **22**: 130-81.
- SEMMENS, C. S. and BHADURI, P. N. 1939.
A technique for differential staining of nucleoli and chromosomes.
S.T. **14** 1-5 (also 1941).
- SESHACHAR, B. R. 1937.
The chromosomes of *Ichthyophis glutinosus*.
Cytologia **8**: 327-30.
- SHIGENAGA, M. 1937b.
An experimental study of the abnormal nuclear and cell divisions in living cells.
Cytologia, Fujii Jub. Vol. 464-78.
- SHINKE, N. 1937a.
An experimental study on the structure of living nuclei in the resting stage.
Cytologia, Fujii Jub. Vol. 449-63.
- SKOVSTED, A. 1939.
Cytological studies in twin plants.
C.R. Lab. Carlsb. **22**: 427-45.
- SMITH, F. H. 1934.
The use of picric acid with the Gram stain in plant cytology.
S.T. **9**: 95-6.
- SMITH, S. G. 1940.
A new embedding schedule for insect cytology.
S.T. **15**: 175-6.
- SMITH, S. G. 1941.
A new form of spruce sawfly identified by means of its cytology and parthenogenesis.
Sci. Agric. **21**: 244-305.
- SNELL, G. D. 1939.
The Induction by irradiation with neutrons of hereditary changes in mice.
P.N.A.S. **25**: 11-14.

SOKOLOW, I. 1929.

Untersuchungen über die Spermatogenese bei den Arachniden IV.
Z. Zellf. 10: 164-94.

SONNENBLICK, B. P.

Cytology and development of the embryos of X-rayed adult *Drosophila melanogaster*.

P.N.A.S. 26: 373-81.

SPEARING, J. K. 1937.

Cytological studies of the Myxophyceae.
Arch. Protistenk. 89: 209-78.

STADLER, L. J. 1930.

Some genetic effects of X-rays in plants.

J. Hered. 21: 3-19.

STADLER, L. J. 1931.

The experimental modification of heredity in crop plants. I. Induced chromosomal irregularities.

Sci. Agric. 11: 557-72.

STEBBINS, G. L. and ELLERTON, S. 1939.

Structural Hybridity in *Paeonia californica*, etc.

J. Genet. 38: 1-36.

STEBBINS, G. L. and JENKINS, J. A. 1939.

Aposporic development in the North American species of *Crepis*.

Genetica 21: 191-224.

STEVENS, N. M. 1910.

Further Studies on Reproduction in *Sagittaria*.

J. Morph. 21: 279-319.

STONE, L. H. A. 1933.

The effect of X-radiation on the meiotic and mitotic divisions of certain plants.

Ann. Bot. 47: 815-26.

STRANGEWAYS, T. S. P. and CANTI, R. G. 1927.

The living cell in vitro as shown by dark ground illumination and the changes induced in such cells by fixing reagents.

Q.J.M.S. 71: 1-14.

SUOMALAINEN, E. 1940.

Polyploidy in parthenogenetic Curculionidae.

Hereditas 26: 51-64.

SWANSON, C. P. 1940.

The use of acenaphthene in pollen tube technic.

S.T. 15: 49-52.

- TANAKA, M. 1937.
A method of rendering difficult interspecific crossing successful by means of X-rays.
Bot. and Zool. 5: 1567.
- TARTAR, V. and CHEN, T-T. 1941.
Mating reactions of enucleate fragments in *Paramecium Bursaria*.
Biol. Bull. 80: 130-8.
- TAYLOR, W. R. 1924. The smear method for plant cytology.
Bot. Gaz. 78: 236-8.
- THOMAS, P. T. 1940.
The aceto-carmin method for fruit material.
S.T. 15: 167-72.
- TUAN, H. 1930.
Picric acid as a destaining agent for iron alum.
S.T. 5: 135-8.
- UPCOTT, M. B. 1936a.
The origin and behaviour of chiasmata, XII. *Eremurus spectabilis*.
Cytologia 7: 118-30.
- UPCOTT, M. B. 1936b.
The mechanics of mitosis in the pollen-tube of *Tulipa*.
P.R.S., B, 121: 207-20.
- UPCOTT, M. B. and LA COUR, L. 1936.
The genetic structure of *Tulipa*. I. A chromosome survey.
J. Genet. 33: 353-72.
- WADA, B. 1935.
Mikrurgische Untersuchungen lebender Zellen in der Teilung II.
Cytologia 6: 381-406.
- WADDINGTON, C. H. and KRIEBEL, T. 1935.
A "dope" for embedding wax.
Nature 136: 685.
- WARMKE, H. E. 1935.
A permanent root-tip smear method.
S.T. 10: 101-3.
- WARMKE, H. E. 1941.
A section-smear method for plant cytology.
S.T. 16: 9-12.
- WATERMAN, H. C. 1939.
The preparation of hardened embedding paraffins having low melting points.
S.T. 14: 55-62.

- WATKINS, A. E. 1925.
Genetical and Cytological Studies in Wheat, II.
J. Genet. 15: 323-66.
- WESTERGAARD, M. 1940.
Studies on Cytology and Sex Determination in Polyploid Forms of
Melandrium album.
Dansk. Bot. Ark. 10 (5).
- WHITAKER, W. 1939.
The use of the Feulgen technique with certain plant materials.
S.T. 14: 13-16.
- WHITE, M. J. D. 1932.
The chromosomes of the domestic chicken.
J. Genet. 26: 345-50.
- WHITE, M. J. D. 1935.
The effects of X-rays on mitosis in the spermatogonial divisions of
Locusta migratoria L.
P.R.S., B, 119: 61-84.
- WHITE, M. J. D. 1936.
The chromosome cycle of *Ascaris megalocephala*.
Nature 137: 783.
- WHITE, M. J. D. 1937.
The effect of X-rays on the first meiotic division in three species of
Orthoptera.
P.R.S., B, 124: 183-96.
- WHITE, M. J. D. 1938.
A new and anomalous type of meiosis in a mantid, *Callimantis antillarum*
Saussure.
P.R.S., B, 125: 516-23.
- WHITE, M. J. D. 1940.
The heteropycnosis of sex chromosomes and its interpretation in terms
of spiral structure.
J. Genet. 40: 67-82.
- WILSON, I. M. 1937.
A contribution to the study of the nuclei of *Peziza rutilans* Fries.
Ann. Bot. 1: 655-72.
- WITSCHI, E. 1933.
Contributions to the cytology of amphibian germ cells. I.
Cytologia 4: 174-81.
- YAMAHA, G. and NOMURA, K. 1939.
Über den Einfluss der Wasserstoffionenkonzentration der Neutralsalze
auf die Vitalfärbung. u.s.w.
Sc. Rep. Tokyo Univ. Lit. Sci. 4: 27-42.

- YASUDA, S. 1934.
Self-incompatibility in *Petunia violacea*.
Bull. Imp. Coll. Ag. Morika. 20: 1-95.
- YASUI, K. 1933.
Ethyl alcohol as a fixative for smear materials.
Cytologia 5: 140-5.
- YOUNG, J. Z. 1935.
Osmotic pressure of fixing solutions.
Nature 135: 823.
- ZIRKLE, C. 1930.
Use of N-butyl alcohol in dehydrating woody tissues for paraffin embedding.
Science 71: 103-4.
- ZIRKLE, C. 1940.
Combined fixing, staining and mounting media.
S.T. 15: 139-53.

INDEX

- Abstractors, 88
Acenaphthene, 68, 72, 124
Acetic acid, 33 *sqq.*, 106
Acetic-alcohol, 41, 61 *sqq.*, 74, 95,
109, 119
Acetic Stains, *see* Stain-fixatives
Aceto-carmine, *see* Carmine
Achromatic condenser, 22
Agapanthus, 103
Agar, 71, 113
Albumen, 48, 113
Alcohol—
butyl, 117
ethyl, 35, 46, 106
Algae, 101
Allen, 38, 101
Allium, 68, 102, 103
Allolobophora, 58
Alum, 37, 111, 123
Amblystoma, 57
Ammonium hydroxide (NH_4O_4),
43, 56, 57
Ammonium molybdate, 124
Amphibia, 61, 75, 100, 104
Anaesthetics, 67
Anaphase, 92
Anderson, 66, 76
Angström, 129
Animal—
breeding, 19
tissues, 39
Annelida, 58
Anthers, 37, 40
Antirrhinum, 68
Aplanatic condenser, 24
Apochromatic objectives, 21
Arachnida, 99
Arc-lamp, 54
"Arrhenotoky," 89
Artemia, 99
Ascomycetes, 101
Aucuba, 104
Aurantia, 68
Autosome, 91
Babcock, 102
Bacteria, 52, 118, 123
Baird, 46
Balbani, 59
Baldwin, 63
Balsam, 42
Baranetzky, 56
Barber, 67 *sqq.*, 79, 124
Barigozzi, 57
Basic dyes, 33
Bauer, 30, 50, 51, 59, 66
Beams and King, 68
Becker, 30
Beeswax, 113
Belar, 30, 52
Belling, 24, 40, 52
Benda, 35
Bernal, 86
Biblio, 59
Birefringence, 32
Bismarck Brown, 42, 58, 94
Bivalent, 93
Blakeslee, 68
Bleaching, 110, 117, 118
Boiling Points, 106
Bombyx, 99
Borax, 115
Bouin, 35
Boveri, 98
Bradbury, 46
Brazilin, 52
Breeding experiments, 19, 69
Bridges, 43, 113
Bristol board, 28, 128
Brodiaea, 91
Bromide paper, 91
Brown, Robert, 17
Bryophyta, 101
Buchholz, 74

- Buck, 31
 Bulk—
 fixation, 33
 staining, 50
 Butyl alcohol, 46
- Callan, 67, 68, 93, 100, 124
 Camera, 77 *sqq.*
 lucida, 21, 28
Campanula, 75, 103
 Canada Balsam, *see* Balsam
 Cancer, 65
 Cane sugar, *see* sucrose
 Canti, 32
 Carbon, 51, 110
 Carlson, 112
 Carmine, 41, 92, 93, 110, 112
 Carnoy, 36, 43, 109
 Caspersson, 32, 57
 Catcheside, 66
 Cedarwood oil, 27, 42, 53, 119
 Cell, 17
 anaesthesia, 67
 death, 65
 fixation, 33
 Cellulose, 35
 Cell-walls, 36, 43
 Centrifuging, 69
 Centromere, 65, 93, 122
 Cereals, 37
 Chaetognatha, 98
 Chamot, 24
 Champy, 35, 108
Chara, 18, 30, 107
 Chemical Formulae, 106
 Chemistry, 18, 36
 Chen, 76, 98
 Chiasma, 93, 94, 97, 129
Chironomus, 30, 59, 93, 104, 120
 Chlorazol Black, 42
 Chloroform, 46, 106, 120
 Chondriosomes, 35, 108
 Chromatid, 92
 Chromic acid, 33 *sqq.*, 53, 106, 118, 123
 Chromosome—
 breakage, 19, 64
- Chromosome—*continued*
 fragments, 94
 pairing, 67
 rings, 94
 size, 59
Chrysochraon, 95
 Ciliata, 98
Cimex, 95, 99
 Cinema Film, 31
Circotettix, 66
 Clarite, 53
 Classification, 98
 Cleavage, 58, 92
 Clove-oil, 53
 Coagulation, 33
 Coelenterata, 98
 Colchicine, 68, 124
 Cold treatment, *see* Temperature
 Coleman, 51, 110
 Coleoptera, 99
 Coles, 22
 Collotype, 83, 86
 Condenser, 21
 immersion, 24
 Conidia, 64
 Coniferales, 63
 Contrast, 81
 Cooper, 99
 Co-orientation, 95
Coregonus, 92
 Corrosive sublimate, 107
 Cotton Blue, 74, 111
 Counter-stains, 52
 Cover slip, 23, 41, 119
 sealing, 42
Crepis, 101, 102, 124
 Creighton, 57
 Critical illumination, 26
Crocus, 66, 104
 Crustacea, 99
 Crystal Violet (CV), 37, 52, 59, 111, 122
Culex, 62, 104
 Culture Media (*see* Ringer), 71
 Cyanophyceae, 101
 Cytoplasm, 33, 41, 42

- Dark ground, 27
 Darlington, 63
 Datura, 68, 75
 Dehydration, 116
 Delafield, 75
 Delaunay, 124
 Dermaptera, 99
 Desiccation, 32, 34, 71
 De Tomasi, 110
 Developer, 80, 114
 Development, 18, 19
 Diagrams, 93
 Diamond, 126
 Diaphragm, 25, 26
 Differentiation (in staining), 41
 Dioxan, 46, 54, 117
 Diplo-chromosomes, 69
Diprion, 100
 Diptera, 59, 100, 104
 Dissection, 22, 37, 60
 Dobzhansky, 100
 Doroshenko, 73
 Dorsey, 69
 Dosage, *see* X-rays, Drugs
 Drawing, 28, 92, 128
 Drew, 101
Drosophila, 19, 59, 66, 70, 91, 93,
 100, 113, 120
 Drugs, 67
 Dufrenoy, 46
 Dyes, *see* Stains
- Echinoderms, 75, 99
 Editors, 92
 Eggs, 37, 47, 58, 97, 117
 Eggshells, 36, 58
 Embedding, 37, 45, 116
 Embryo-Sac, 44 *sqq.*, 62, 70, 93,
 105
 Endosperm, 62
 Eosin, 46
Eremurus, 103
 Euparal, 53, 119, 122
 Exposure, 80
 Eyepieces, 21, 79
 micrometer, 29
- Fabergé, 47
 Fading, 53, 54, 122
 Fankhauser, 76
 Fast Green, 52
 Favorsky, 68
 Ferric nitrate, 112
 Fertility, 71
 Fertilization, 19, 58, 73
 Feulgen, 36, 50, 54, 59, 61, 92,
 117, 121
 Filter, *see* Screen
 Fish, 92
 Fixation, 33 *sqq.*, 41, 45, 91, 116
 Fixatives, 34, 91-95, 106, 118, 121
 warm, 38
 Flagellata, 98
 Flemming, 35, 92, 94, 108
 Flower-buds, 38, 46
 Foot and Strobell, 58
 Forceps, 126
Forficula, 99
 Formaldehyde (Formalin), 35 *sqq.*,
 51, 106, 118
 Freezing, *see* Temperature
 French chalk, 83
Fritillaria, 62, 67, 92, 93, 94, 102,
 104
 Fuchsin—
 acid, 74, 111
 basic, 50, 110, 121
 Fungi, 101
- Galanthus*, 104
 Ganglia, 61, 70, 119, 120
 Geitler, 57, 101
 Gelatin, 71, 113
 Gelei, 52, 123
 Gene, 18
 Generative Nucleus (GN), 71, 72,
 73
 Germination—
 pollen, 71 *sqq.*
 seeds, 68
 Giemsa, 52, 123
 Glands, *see* Salivary
 Glumes, 63

- Glycerine, 53, 72, 73, 111
 Goodspeed, 65
Gossypium, 68, 75
 Gramineae, 72, 73
 Graupner, 46
 Groat, 53
 Ground-glass, 25, 26
 Growth Hormone, 69
Gryllotalpa, 99
 Gulick, 36
 Gum damar, 53
 Gum mastic, 42, 113
 Gustafsson, 64, 66
Gymnophiona, 100
- Habrobracon*, 100
 Haematoxylin, 37, 47, 58, 75, 84,
 111, 123
 Half tone, 83
 Hance, 111
 Hanging drop, 71, 127
 Haploidy, 65, 75
 Hardening, 39
 Harland, 68
 Heating, 41
 Heidenhain, 111
 Heitz, 43, 59, 121
Helleborus, 104
 Hemiptera, 99
 Herbarium pollen, 73
 Heredity, 19
 Heterauxin, 68
 Heterochromatin, 57, 92, 93, 94,
 97
 See also Nucleic Acid and Tem-
 perature
 Heteroptera, 95
 Hillary, 43, 51, 121
 Hind, 77
 Hirudinea, 98
 Histology, 19
 Hodgman, 107
Homo, 100
 Honing, 48
Hordeum, 66, 68
 Hot plate, 49, 54, 128
- Humaria*, 101
 Humidity, 71
 Huskins, 104
 Husted, 98
Hyacinthus, 102, 104
 Hybridisation, 75
 Hybridity, 59, 94, 97
 Hydrochloric Acid (HCl), 43, 50^{sqq.}
 Hydrogen-ion Concentration (pH),
 41, 56
 Hydrogen peroxide, 117, 118
 Hydrolysis, 36, 43, 50, 118, 121
 Hydroquinone, 81, 114
 Hymenoptera, 76, 100
- Ilford, 81
 Illumination, 79
 critical, 22
 dark ground, 24
 Image, 22
 Immersion oil, 22, 24
 Imms, 62
 Inference, 85
 Infiltration, 46
 Intensifying, 115
 Interchange, 94
 Interpretation, 85
 Iodine, 37, 122
 Iron
 acetate, 41, 42
 alum, 34, 111, 123
 Iron-aceto-carmines, *see* Carmine
 Iso-electric Point (I.E.P.), 37, 56
 Iso-propyl alcohol, 46
 Isotonic solutions, 30
- Johansen, 46
- Kahle, 58, 109, 117
 Karling, 30
 Karpechenko, 68
 "Karyokinesis," 89
 Kaufmann, 59
 Kawaguchi, 69
 Kihara, 38, 75
 Klingstedt, 95

- Knapp, 65
Kniphofia, 103
 Koller, 59, 61, 91, 92, 100
 Koltzoff, 100
 Kostoff, 68, 69
 Kuwada, 30, 56

 Lacmoid, 42, 55, 61, 72, 94 *sqq.*,
 110 *sqq.*, 119, 120
 La Cour, 35, 38, 42, 52, 56, 67, 69,
 117
 Lactic Acid, 111
 Lamp, 25, 28
 Lanthanum, 57
 Larter, 102
 Lenses, 21
 Lepidoptera, 99
Leptophyes, 91
 Leuco-basic Fuchsin, 50
 Levan, 68, 70
 Lewis, 71, 74
 Lewitsky, 35, 66
 Light Green, 52, 111
 Lighting, 24
Lilium, 44, 103
 Linnaeus, 88
Linum, 69
 Lithograph, 86
 Living nuclei, 85, 93
Locusta, 66
Lolium, 67
 Lucas, 32
 Lutkov, 69

 McClintock, 41, 43, 66, 103, 113
 Maceration, 43, 121, 127
 See also Hardening
 Mackay, 101
 McWhorter, 115
 Madge, 46
 Magnification, 22, 86
 Maheshwari, 46, 48
 Malpighian Tube, 60
 Maltose, 38
 Mammals, 35, 69, 70, 104
 Manton, 101

 Marsupialia, 100
 Martius Yellow, 74, 111
 Mather, 66
 Matsuura, 69
 Matthey, 35
 Mayer, 48, 113, 119
Mecostethus, 66, 94
 "Megagametophyte," 89
 Meiosis, 94, 97
 See also PMC, ESMC, SMC
Melandrium, 101
 Melland, 93
 Melting Points, 106
 Mercuric chloride, 107, 115
 Mercury Arc, 26
Mesostoma, 98
 Methylal paraffin oil, 46
 Methylene Blue, 31
 Metol, 114, 115
 Metz, 59
Miastor, 100
 Micro-chemistry, 59
 Micro-incineration, 57
 Micrometer, 29
 Microphotography, 77
 Microscope, 21
 Microtome, 44, 47, 128
 Middle Lamella, 43
 Minouchi, 108
 Mirrors, 21
 Mitosis, 65, 91 *sqq.*, 97
 Moldex, 113
 Molecular Weights, 106
 Mollusca, 58
 Mordanting, 33, 36, 41, 124
 Morula, 92
Morus, 92
 Mounting media, 30, 41 *sqq.*, 53
 Muller, 64
 Multigrade paper, 81, 91
 Müntzing, 64
Mus musculus, 66
 Mutation, 19, 64

Narcissus, 104
 Navashin, 35, 109

- Nebel, 42, 57, 68, 73
 Needles, 41, 42, 126
 Nematoda, 98
 Neuroptera, 99
Neurospora, 64
 Nevillite, 53
 Newcombe, 66
 Newcomer, 71, 72
 Newt, 61
 Newton, 52
Nicotiana, 74, 75
 Nipagin, 113
Nitella, 30, 103
 Nitric Acid, 57, 93
 Norit, 110
 Nucleic Acid, 18, 32, 50, 57, 67, 92,
 95
 See also Heterochromatin
 Nucleolus, 37, 51, 93, 94, 97
 Nucleus, 17, 59, 73
 Numerical aperture (n.a.), 22, 23

 Objectives, 21 *sqq.*
 Odonata, 99
 Oenothera, 74
 Oil, immersion, 22, 24
 Oligochaeta, 98, 105
 Olive Oil, 53
 Oögonia, 58
 Optics, 22, 31
 Orcein, 42, 70, 93, 110, 113, 119,
 120
 Orchidaceae, 101
 Orthoptera, 91, 94, 95, 99
 Osmic Acid, 33 *sqq.*, 51, 94, 106,
 118, 123
 Osmotic Pressure, 36, 38
Osmunda, 101
 Osterstock, 77
 Ovary, 58, 63
 Oven, 46, 49, 128
 Oxidising Agents, 36, 106

 Pachytene, 94
Paeonia, 103
 Painter, 59

 Panchromatic plates, 79 *sqq.*
 Paraffin—
 liquid, 30, 53, 93, 113
 wax, 46, 47, 58, 116
Paramecium, 76, 98
Paris, 91, 103
 Parthenogenesis, 75
 Pectic Salt, 43
Pelargonium, 74
 Pencils, 86, 128
 Penetration (of fixative), 34 *sqq.*
 Pens, 86, 128
 Petals, 63
 Petri dish, 128
 Petroleum ceresin, 48
Petunia, 68, 75
Peziza, 101
 Phenol, 111, 117
 Phlogiston, 19
 Photography, 21, 32
 "Photomicrography," 89
 Physiological saline, 112
 Picric Acid, 37, 107
 Pipette, 120, 128
 Platinic chloride, 36
 Pointolite, 26
 Polarized light, 32
 Pollen—
 grain (PG), 44, 51, 57, 70, 71,
 91 *sqq.*
 herbarium, 73
 mother cell (PMC), 92
 storage, 73
 tube (PT), 30, 57, 72, 74
 Pollination, 74, 75
 Pollister, 98
 Polychaeta, 98
 Polyploidy, 19, 59, 64 *sqq.*, 97
 Polysaccharides, 50
 Polytene, 93, 129
 Potassium—
 bromide, 114, 115
 dichromate, 36, 107
 ferricyanide, 115
 iodide, 122
 metabisulphite, 115

- Potassium thiosulphate, 110
 Poulson, 30
 Pre-treatment, 56, 93
Primula, 74
 Prism, 27, 28
Pristiurus, 100
 Projection, 83
 Prophase, 65, 91
 Propionic Acid, 113
 Protista, 98
Prunus, 74, 92
 Publication, 86, 87
 Pupa, 59, 62
Pyrus, 71, 74

 Quantitative Method, 88

 Radiolaria, 98
 Randolph, 45, 47, 69
Ranunculus, 102
Rattus, 100
 Razor, 48
 Rectified Spirit, 107
 Reducing, 115
 agents, 36
 Refractive-index, 23, 27, 53
 Reptilia, 100
 Resolving power, 22
 Re-staining, 54
Rhoeo, 94, 102
 Ribbon (paraffin), 48
 Richardson, 93
 Ringer solution, 30, 37, 61, 112
 Robinow, 52
 Root-tip (RT), 38, 43, 45, 92
 Rubber solution, 42
 Ruthenic Acid, 36

 Sakamura, 56
 Salivary Glands, 59, 70
 Sandsten, 71
 Sanfelice, 109
 Saponin, 38, 108
 Sax, 57, 63, 66
 Scalpel, 40, 126
 Schiff, 50

 Schmidt, 32
 Schneider, 40
Sciara, 31, 59, 100, 120
Scilla, 102
 Scott, 99
 Screen, 24, 26, 79
 Sealing Medium, 113
 Sears, 74
Secale, 102, 103
 Sections, 47 *sqq.*
 Seeds, 64 *sqq.*
 Self-sterility, 74
 Semmens, 52
 Sex Chromosome, 91, 95, 97
 Skovsted, 75
 Smearing dish, 127
 Smears, 35, 40, 50 *sqq.*, 87, 91 *sqq.*,
 118
 Smith, F. H., 54
 Smith, S. G., 58, 109, 117
 Snell, 66
 Sodium—
 cyanide (NaCN), 57
 hyposulphite, 115
 salicylate, 113
 sulphite, 74, 114, 115
Solanum, 75
 Solubilities, 106
 Sonnenblick, 66
 Sorbitol, 112
 Spearling, 101
 Spectrophotometry, 32
 Sperm, 65
 Mother Cells (SMC), 95
 nuclei, 72, 73
 Spermatogonia, 91
Sphaerocarpus, 101
 Spindle, 32, 67, 69, 92
 Spiralization, 69
 Spiral Structure, 34, 92, 97
 Squashes, 40, 63, 87, 92 *sqq.*
 Stadler, 64
 Stain-fixatives, 40, 54, 110, 118
 Staining, 36, 42, 50, 91 *sqq.*
 Staminal hair, 30
 Stebbins, 101, 102

- Sterility, 74
 Stigma, 71
 Storage—
 of material, 41
 of pollen, 73
 Strangeways, 32
 Straub, 69
 Stropping, 48
 Strychnine, 76
 Style, 71, 73
 Sucrose, 56, 71
 Sulphur dioxide (SO₂) water, 53,
 111
 Sulphuric Acid, 34
 Surface tension, 36, 38, 106
 Swanson, 72, 124
 Szent-Györgi, 16

 Tables, 89
 Tadpoles, 61
 Tanaka, 74
Taraxacum, 101
 Tartar, 76
 Tartaric Acid, 71
Taxus, 104
 Telophase, 91
 Temperature, 39, 67
 treatment, 92, 94, 124
 Testes, 38, 40, 62
Tettix, 91
 Thomas, 41, 63, 67, 72, 92
 Thorium nitrate, 57
 Thymo-nucleic Acid, 50
Tipula, 100
 Tissues, 34, 38
 shrinkage of, 34, 46
 Titles, 88
 Toluene, 53
 Tomato, 71
Tomopteris, 99
Tradescantia, 30, 56, 66, 71, 72,
 91 *sqq.*, 124
 Transformer, 25, 26
 Trematoda, 98
 Tribromoaniline, 68
 Trichoptera, 99

Trillium, 56, 67, 69, 92, 103,
 104
 Triploids, 75
Triticum, 74, 75
Triton, 61, 67, 124
 Tuan, 123
 Tube-length, 22
Tulipa, 57, 66, 71, 72, 104
 Turbellaria, 98
 Turpentine, 113
 Twins, 75

 Uber, 57
 Ultra-violet, 32, 54, 85
 Upcott, 45, 52, 57, 72
 Uranium, 36
 Urea, 38
Uvularia, 102

 Vacuum pump, 38, 128
 Vandel, 98
 van Tieghem, 127
 Vaseline, 71
Vicia, 66, 102
 Vignetting, 83
 Vital Staining, 31
Vivipara, 99
 Vivisection, 61
 Vocables, 89

 Waddington, 48
 Warmke, 43
 Washing, 45
 Watch glass, 127
 Water—
 cooler, 82, 83
 pump, 128
 Water-cultures, 38
 Waterman, 47
 Watkins, 74
 Wave-lengths, 22, 64
 Wax, *see* Paraffin, Beeswax
 Well-slide, 120, 127
 White, 66
 Witschi, 100

Working distance, 23
Wratten filter, 27
Wulff, 30

X-chromosome, 91, 95, 97
X-rays, 19, 64, 74, 86
Xylol, 27, 46, 53

Yasuda, 71
Y chromosome, 70
Yeast, 114
Young, J. Z., 38

Zea, 66, 75, 103
Zinc block, 83
Zirkle, 43



GEORGE ALLEN & UNWIN LTD
LONDON: 40 MUSEUM STREET, W.C.1
CAPE TOWN: 58-60 LONG STREET
SYDNEY, N.S.W.: 65 YORK STREET
TORONTO: 91 WELLINGTON STREET WEST
BOMBAY: 15 GRAHAM ROAD, BALLARD ESTATE
WELLINGTON, N.Z.: 8 KINGS CRESCENT, LOWER HUTT

BAIRD & TATLOCK

— (LONDON) LTD —

Manufacturers and Suppliers of
**SCIENTIFIC APPARATUS . STAINS
REAGENTS AND FINE CHEMICALS**

Microscopes and Accessories . Microtomes . Embedding
Apparatus . Dissecting and Mounting Instruments .
Staining Requisites . Specimen Slides . Dyes
“Analar” Chemicals . Fixatives

Price Lists sent post free on request

14-17 ST. CROSS STREET, HATTON GARDEN,
LONDON, E.C.1

GURR'S

Standardized STAINS for Microscopy

are used in the principal laboratories of the Empire

**STAINS in Powder, Solution or Tablet Form
Mounting Media, Bacteriological Sugars,
Immersion Oils, Medicinal Dyes, Indicators,
Filtered Paraffin Wax, Microscopical Sundries,
etc.**

Price List and literature on application

GEORGE T. GURR

136 NEW KING'S ROAD - LONDON, S.W.6

Works: ELYSIUM PLACE, S.W.6

