

**THE BOOK WAS  
DRENCHED**

UNIVERSAL  
LIBRARY

**OU\_160402**

UNIVERSAL  
LIBRARY







# RESEARCHES IN EXPERIMENTAL PHONETICS.

## THE STUDY OF SPEECH CURVES.

BY

E. W. SCRIPTURE.

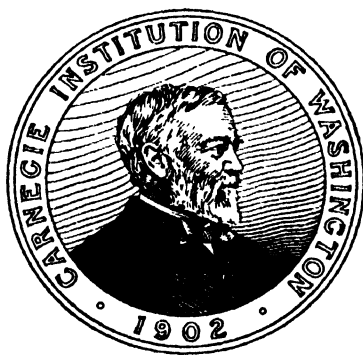

WASHINGTON, D. C. :  
Published by the Carnegie Institution of Washington  
November, 1906

**CARNEGIE INSTITUTION OF WASHINGTON**  
**PUBLICATION No. 44**

**PRESS OF GIBSON BROS.,**  
**WASHINGTON, D. C.**

## PREFACE.

---

These investigations had their origin in an attempt to use the methods of natural science in studying the nature of verse. The only true verse is that which flows from the mouth of the poet and which reaches the ears of the public; printed verse is only a makeshift for the verbal communication. It is evident that the only way to undertake a scientific study of verse is to get it directly as it is spoken and then to use the methods of analysis and measurement.

Three methods of studying verse suggest themselves. In the first place we may listen to the words of the poet as they are spoken, and may attempt to detect the laws of verse by the unaided ear. Some rough facts and many important suggestions have been gathered in this way. Such is the interesting hypothesis that each piece of verse has a specific melody which arises from the melodies of the words; this has led to the remarkable theory that the specific melody is so firmly fixed that different redactions may be picked out of a complex text (*e. g.*, the Nibelungenlied) merely by the different kinds of sentence melody that appear when the text is read. Yet there is always a distrust of results obtained by this method alone, perhaps more distrust than is actually justified. As everybody knows, the ear will hear what it expects to hear; a suggestion from a pet theory or even from some unconscious source is often sufficient to make us hear things that do not exist. The scientific man of to-day demands that work with the unaided senses be followed up by the methods of recording and measuring.

An advance in the methods of studying speech occurs when the words are registered automatically. This may be done by various instruments. Some of them give records from which data concerning melody, duration, and some other important details may be obtained.

Still another step in advance occurs when the words are registered on a phonograph or a gramophone. Such a record is at least as good as it sounds when reproduced. The speech curve is then traced off from the record with any desired magnification and submitted to analysis and measurement. The original record is always at hand to listen to for comparison and interpretation.

The last method is the one I have used for most of my work. An apparatus was devised for tracing off the curve from a gramophone plate; it is still the only one in existence. At a later date one was made for tracing phonograph records.

The expectation of at once obtaining results concerning the laws of verse proved to be illusory; the recorded curve of the spoken verse proved to be a problem in itself, and extensive researches had to be made before it could be understood. The record from the mouth of the poet is a speech vibration. The first thought is that such a vibration can be readily interpreted. Indeed, we would naturally expect to learn a kind of vibration alphabet by which we could read a curve into its elements. The first curve I obtained showed that every individual vowel had its peculiar curve. An attempt to classify them according to types indicated a far larger number of different typical vowels than was allowed for in the works of phoneticians. Again, the curve of a vowel changed with every shade of emotion; moreover, each curve changed more or less gradually from beginning to end in every individual vowel. Every single wave of a vowel was thus a problem that had to be investigated.

The fundamental problem to be attacked was, therefore, the analysis of each wave into its elements. To this I devoted a large part of my efforts. Previous investigators had confined themselves to vowels sung for a time at a constant pitch, that is, to purely mechanical performances totally devoid of expression. In spite of the schematic character of such curves the results had shown little but mutual disagreement. I tried to clear up the difficulties by analyzing large numbers of waves from spoken vowels obtained from many speakers, but I found within a single vowel more discordance than ever. It became evident that the fundamental suppositions concerning the vowels were inadequate, and that new views of their nature and modified methods of analysis were required.

Our views of the nature of speech are, in fact, so inadequate that even the very problems to be investigated can not be formulated in advance. "We stand at the limits of an unexplored world" (Professor Brandl). The one thing to do is to make a systematic study of speech curves of the most varied kinds. In this way we may expect to discover the fundamental facts concerning the elements of speech, physically, physiologically, and psychologically. We may learn for the first time the laws of combination of sounds and the laws of change, and may thus hope to advance beyond the elementary rules of the phonetics of to-day. We may establish theories of verse and prose that are more than pieces of typographical jugglery. This is the way the natural sciences have traveled, and it is the

way phonetics and philology must go. Automatic records, experimental analysis, and careful measurement must be the foundation of phonetics as a natural science.

My investigations were begun at Yale University.\* The special apparatus devised for obtaining speech curves had furnished a large amount of material for the study of which I had neither time nor assistance. The work was inspected by a committee from the Carnegie Institution of Washington (Dr. S. Weir Mitchell and Dr. John S. Billings) and judged worthy of support. In March the work was removed from Yale to Munich; here a laboratory of six rooms was installed. Valuable assistance was received from the Psychological Laboratory (Professor Th. Lipps, director) of the University. During the six months in Munich many computers were employed and the main conclusions were outlined.† In October, 1903, the work was moved to Berlin, where a small private computing bureau was opened. The tracing apparatus was set up in the Psychological Institute (Professor C. Stumpf, director) of the University of Berlin; this was made the occasion of a lecture before specially invited members of the faculty and of the Academy of Sciences, in which the methods and general conclusions were presented.‡ The apparatus was used by Professor Brandl (English Department) for tracing the curves from a specially made disc. The environment in Berlin was exceptionally favorable, and the work was continued there for a year and a half. On March 1, 1905, a new laboratory was opened in Zurich.

This volume gives an account of the methods used in obtaining and studying the curves.

The first chapter gives a sketch of the way in which sounds are recorded and reports some experiments on diaphragms. These experiments are, I believe, sufficient to do away with the notion that the vibrations of such diaphragms have any resemblance to those of plates that produce the Chladni figures. The theses maintained are: (1) that the diaphragms bend concentrically around the center; (2) that nodal lines are present only as disturbing factors and this to a small degree or not at all; (3) that the aim of the construction is to produce an air-tight, unbending piston which will accurately follow the phases of condensation and rarefaction of the air-wave. A further investigation might have important results in producing better telephone diaphragms as well as better talking machines,

\*Researches in Experimental Phonetics, Stud. Yale Psychol. Lab., 1899, vii, 14; 1902, x, 49; *Speech Curves*, 1, Mod. Lang. Notes, 1901, xvi, 72; *A New Machine for Tracing Speech Curves*, Amer. Jour. Sci., 1903, xv, 147.

†*Mechanics of the Voice*, Carnegie Year Book No. 2, 243, Washington, 1903.

‡*Ueber das Studium der Sprachkurven*, Annalen der Naturphilosophie, 1904-05, iv, 28

but the matter must be left to physicists, as it leads rather aside from the more strictly phonetic problems.

The second chapter gives an account of my method of obtaining speech curves. In addition to its accuracy, a special feature of the method is that the process is automatic and can go on day and night continuously. This is important for the more specially phonetic and psychological problems, for which whole speeches and conversations must be studied. When we consider that a moderate enlargement of the speech curve for a four-minute conversation requires a tracing a quarter of a mile long, and that to obtain each individual wave accurately the apparatus must run slowly, it is easy to understand why the apparatus must be automatic. The account of the apparatus is intended to be detailed enough to enable a skillful mechanic to construct duplicates; the methods of testing its accuracy are described.

The chapter on qualitative analysis indicates how phonetic facts can be read directly from the speech curves without measurement. This will probably be a new thought to philologists. Anyone with a knowledge of the principles of phonetics can in a short time acquire the art of reading curves. What he will find in them will surprise him. The speech curves present to the eye of the phonetician the flow of language as it is actually spoken. It is evident that the investigator can proceed on a much surer foundation than at present, where he uses only two methods; for modern languages he can do nothing but gather vague impressions by the ear, while for the ancient languages he must rely on the typographical representations, which give no details and which may be both erroneous in their origin and misunderstood by himself. The great need in phonetics at the present day is a supply of accurate speech curves of various languages published in the form of atlases for purposes of study by specialists.

In Chapter IV, I have explained how such fundamental factors of speech as melody, duration, and amplitude can be obtained from the curves by simple methods of measurement. The problems are of interest to the psychologist as well as the phonetician.

In Chapters V, VI, and VII some difficult but necessary problems are discussed. In the first place, the method of harmonic analysis is carefully considered, as it is the basis of all work on wave analysis. I have had the advantage of advice from Professor Weber, of the Swiss Polytechnicum (who was the first person, with Schneebeli, to apply the Fourier analysis to a vowel curve), and of Professor Wolfer, of the Swiss National Observatory at Zurich. Although Helmholtz had distinctly stated that the application of the harmonic analysis to a vowel wave is a purely

arbitrary procedure which gives no idea of the real composition until some physical hypothesis is introduced, later investigators have not hesitated to assume that the analysis proves the components of vowels to be reinforced overtones from the glottis. The unsatisfactory results of many hundreds of analyses made it evident that the simple harmonic analysis was not directly applicable to vowel curves. In fact, the vowel vibrations are not composed of simple sinusoids, but of sinusoids affected by factors of friction (logarithmic decrement). An analysis that does not provide for this gives incorrect results, as can be readily shown by analyzing frictional sinusoids whose equations are known. In Chapter VII, I have explained a method of analysis that provides for the introduction of a single factor of friction. I hope that some mathematician or physicist will devise a way to introduce two factors of friction, one of moderate size to represent the friction in the vocal cavities and one that may vary from 0 to very great values to represent the suddenness of the glottal vibrations.

Chapter VIII discusses the theories of vowel production. Professor Hermann (Königsberg) has given final proof of the incorrectness of the overtone theory (Wheatstone, Grassmann, Helmholtz). The two essentials of the theory of Willis and Hermann, namely, that the glottis emits puffs of greater or less sharpness and that the vowel tones are generally inharmonic to the glottal tone, can be considered as definitely established. The reason for the puff-character of the glottal action has been found by Professor Ewald (Strassburg) in the fact that the glottal lips are masses of muscle which yield by compression and do not vibrate like membranes. These facts have remained largely unknown, and we still find in the text-books the totally false theory that the vowels are produced by membrane-like vibrations in the larynx. I have adopted the Willis-Hermann theory and have taken into consideration some further elements also; namely, friction in the vocal cavities and associative formation of the vowel at the glottis. It is strange that the friction in the vocal cavities should have been so long overlooked; they have for the most part soft walls covered by a moist membrane and their laws of resonance must differ from those of brass or glass cavities. As I have shown with water resonators, the phenomena of resonance in soft cavities are quite different from those with resonators of metal. The other new element was suggested by experiments in making artificial vowels which led me to believe that the action of the glottal lips differs not only for each emotion but also for each vowel; I assume that the nervous impulses to the various portions of these muscles differ for the different vowels, with the result that the glottal lips contract differently for each typical vowel.

The wide prevalence of another Helmholtz theory, that of hearing, on which the use of the simple harmonic analysis was based and for which unthinking writers suppose the possibility of such an analysis to be a proof, makes it necessary to consider what form of analysis is appropriate to represent the process in the ear (Chapter IX). That Helmholtz supposed the simple harmonic analysis to correspond to his theory of hearing is an interesting case of *lapsus cogitationis* (if the term may be permitted); it is easily shown that the simple harmonic analysis can not give the tones corresponding to the resonating fibers.

Chapter XI gives detailed examples of vowel analysis; it is intended as a guide for the investigator, but it also shows clearly how false are the results obtained by improper methods.

The schedules at the end are to aid the investigator in preparing his patterns. With the advance in methods it becomes necessary to use more and more ordinates for an analysis. For the higher partials up to the thirty-sixth it is necessary to use seventy-two ordinates. As far as I am aware the schedules for seventy-two ordinates have never before been made. I hope that the great labor of preparing and testing them has been given to a worthy object. The schedules for thirty-six ordinates are also published for the first time.

Using the methods and fundamental principles explained in this volume, I have traced and studied a number of records of American speech; the results are nearly ready for publication. A large amount of material on rhythm and verse has also been collected and partly prepared for publication; the investigations thus return to the problems with which they began.

E. W. SCRIPTURE.

CARNEGIE INSTITUTION,  
*Washington, D. C.*

## CONTENTS.

---

	Page.
<b>CHAPTER I. Recording Speech Vibrations . . . . .</b>	<b>13</b>
II. Tracing Gramophone and Phonograph Records . . . . .	23
III. Qualitative Analysis . . . . .	39
IV. Quantitative Analysis: Apparatus, Methods . . . . .	57
V. Harmonic Analysis . . . . .	75
VI. Inharmonic Analysis . . . . .	99
VII. Analysis into Frictional Sinusoids . . . . .	101
VIII. Wave Analysis in Reference to Vocal Action . . . . .	107
IX. Wave Analysis in Reference to Action in the Ear . . . . .	125
X. Synthesis of Vibrations . . . . .	131
XI. Examples of Vowel Analysis . . . . .	137

## ILLUSTRATIONS.

PLATE.	FACING PAGE.
I. Phonograph and Gramophone Recorders (figs. 1-6).....	14
II. Tracing Machine for Gramophone Records (figs. 18 20).....	24
III. Details of Tracing and Recording Mechanisms (figs. 21-26).....	26
IV. Curves of Musical Sounds (figs. 28-32).....	32
V. Curves of Various Sounds (figs. 33-36).....	34
VI. Curves of Various Sounds (figs. 37-41).....	34
VII. Curves of Various Sounds.....	36
VIII. Portion of "Speech on Forefathers' Day," by Chauncey M. Depew.....	40
IX. Curves from "Cock Robin".....	44
X. Waves from Vowels by Joseph Jefferson.....	50
XI. Apparatus for Auditory Analysis.....	54
XII. Melody of Beginning of "Speech on Forefathers' Day".....	70
XIII. Synthesis of Vibrations (figs. 116-118).....	132

FIG.	PAGE.	FIG.	PAGE.
1. Phonograph recorder.....	14	26. Recording point, side view.....	26
2. Tracing from a phonograph groove.....	14	27. Pulleys and belt tightener.....	27
3. Gramophone recorder, section.....	14	28. Yodel.....	32
4. Gramophone recorder, front view.....	14	29. Piano with yodel.....	32
5. Casting from phonograph grooves.....	14	30. Trombone.....	32
6. Gramophone grooves.....	14	31. Band.....	32
7. Gramophone reproducer or sound box, section.....	16	32. Orchestra.....	32
8. Sound box repeating motion of a fork.....	16	33. Gong.....	34
9. Nodal figure from a diaphragm with free edge.....	18	34. Conductor's whistle.....	34
10. Circular distribution of light from a diaphragm with fixed edge.....	18	35. Locomotive whistle.....	34
11. Holes in shutter and their reflection by flat diaphragm.....	19	36. Three locomotive puffs.....	34
12. Reflection by bent diaphragm with vaseline fixation.....	19	37. Blocks.....	34
13. Reflection by bent diaphragm with metal fixation.....	19	38. Whistling.....	34
14. Method of obtaining curvature of diaphragm from the reflection of parallel rays.....	20	39. Whistling with piano.....	34
15. Curve of bending for vaseline fixation.....	20	40. Plucked string.....	34
16. Curve of bending for metal fixation.....	20	41. Curves from Graham record.....	34
17. Ideal of a sound box.....	20	42. Machine for tracing phonograph records, top view.....	37
18. Machine for transcribing gramophone records, top view.....	24	43. Piece of curve obtained with apparatus in figure 42.....	37
19. Side view of rotator.....	24	44. Sonant [h] in the Jefferson record.....	46
20. End view of rotator.....	24	45. Coordinate measurer.....	57
21. Tracing end of lever.....	26	46. Notes and their melody plot.....	60
22. Machine with compound lever.....	26	47. "Oh," sorrowfully.....	63
23. Gimbal joint.....	26	48. "Oh," admiringly.....	63
24. Joints for second lever.....	26	49. "Oh," questioningly.....	64
25. Recording point, top view.....	26	50. "Ah," sorrowfully.....	64
		51. "Oh dear," sorrowfully.....	65
		52. "Oh my," sorrowfully.....	65
		53. "Oh, not really?" questioningly.....	66
		54. Melody plot, beginning of [ai] "I," Depew.....	67
		55. Amplitude plot, beginning of [ai] "I," Depew.....	67
		56. Melody plot, beginning of [ɔ] "on," Depew.....	67

FIG.	PAGE.	FIG.	PAGE.
57. Amplitude plot, beginning of [ɔ] "on," De- pew.....	67	102. Ring frame for puff siren.....	112
58. Melody plot, beginning of [ə] "a," Mitchell	67	103. Disc for puff siren.....	112
59. Amplitude plot, beginning of [ɔ] "a," Mit- chell.....	67	104. Siren holes and hypothetical forms of puffs	113
60. Melody plot, beginning of [ɔ] "also," Mit- chell.....	68	105. Top view of glottis.....	115
61. Amplitude plot, beginning of [ɔ] "also," Mitchell.....	68	106. Method of vibration at the glottis.....	116
62. Melody plot, beginning of [æ] "America," Mitchell.....	68	107. Glottal lips with medial loading.....	116
63. Amplitude plot, beginning of [æ] "Amer- ica," Mitchell.....	68	108. Glottal lips with lateral loading.....	116
64. Melody plot, beginning of [ai] "ein," Brun- ner.....	69	109. Slant fibers of the M. vocalis.....	117
65. Musical notation to Plate XII.....	71	110. Hypothetical curves of puffs.....	117
66. Melody of beginning of "Der Fichtenbaum" v. Hagen.....	73	111. Sinusoid with large factor of decrement..	121
67. Simple sinusoid.....	76	112. Sinusoid with very large factor of decre- ment.....	121
68. Sinusoids of different amplitudes.....	76	113. Relative stimulation of acoustic fibers, first case.....	128
69. Sinusoid a quarter period ahead of that in figure 69.....	76	114. Relative stimulation of acoustic fibers, second case.....	128
70. Harmonic series of simple sinusoids.....	76	115. Relative stimulation of acoustic fibers by tones of different pitch, separately and simultaneously.....	129
71. Curve with its sinusoid components.....	77	116. Magnetic vibrating spring with adjustable damper.....	132
72. Harmonic plot to figure 71.....	77	117. Sinusoids with different factors of friction	132
73. Irregular curve.....	78	118. Frictional sinusoids aroused by impulses with steadily decreasing interval..	132
74. Harmonic plot to figure 73.....	78	119. Multiple pendulum.....	133
75. Sinusoid with $3\frac{1}{2}$ waves to fundamental..	78	120. Curve compounded of frictional sinusoids.	136
76. Harmonic plot to figure 75.....	78	121. Curve for analysis.....	137
77. Plot of five harmonics.....	79	122. Simple harmonic plot to figure 121.....	140
78. Plot of five harmonics with one inharmonic.	79	123. Plot of inharmonic components from fig- ure 122.....	140
79. Harmonic plot to figure 78.....	79	124. Curve of figure 121 with friction eliminated	141
80. Plot of five harmonics with one inharmonic.	79	125. Harmonic plot to figure 124, or frictional harmonic plot to figure 121.....	142
81. Harmonic plot to figure 80.....	79	126. Plot of inharmonic components from fig- ure 125.....	142
82. Wave from [a] in "Marshall".....	80	127. Actual components of figure 121.....	144
83. Harmonic plot to figure 82.....	80	128. Plot of actual components of figure 121...	145
84. Component plot from figure 83.....	80	129. Waves from [o] of "fourteenth".....	147
85. Wave from [ɔ] in "called".....	83	130. Group of waves from figure 129.....	147
86. Harmonic plot to figure 85.....	83	131. Simple harmonic plot to figure 130.....	150
87. Component plot from figure 86.....	83	132. Component curves of figure 130, according to simple harmonic analysis.....	150
88. Six successive waves used as a single wave for an inharmonic analysis.....	99	133. Plot of inharmonic component to figure 130.....	151
89. Clarinet.....	100	134. Component curve of figure 130, according to figure 133.....	152
90. Cornet.....	100	135. Curve of figure 130 with friction elimi- nated.....	154
91. Saxophone.....	100	136. Frictional harmonic plot to figure 130...	156
92. Sinusoid with different factors of friction.	101	137. Plot of inharmonic components from fig- ure 136.....	156
93. Frictional sinusoid showing logarithmic decrement.....	101	138. Component curves of figure 130.....	156
94. Curve compounded of frictional sinusoids.	101	Schedules for 12 ordinates.....	159
95. Harmonic plot to fig. 94 with $\epsilon = 0$ .....	103	Schedules for 24 ordinates.....	160, 161
96. Harmonic plot to fig. 94 with $\epsilon = 0.002$ ...	103	Schedules for 36 ordinates.....	162-165
97. Harmonic plot to fig. 94 with $\epsilon = 0.005$ ...	103	Schedules for 72 ordinates.....	166-201
98. Scheme of partial tones.....	109		
99. Scheme of reinforced partials.....	109		
100. Puff siren with resonator.....	112		
101. Blast tube for puff siren.....	112		

## PHONETIC SYMBOLS.

---

<p>[a], "yacht, ah."            [æ], "pat, pass."            [b], "bat."            [ɔ], "gnaw."            [ɾ], Germ. "Sage."            [d], "do."            [ð], "thine."            [e], "pane."            [ɛ], "pen."            [ə], "her."            [f], "fat."            [g], "go."</p>	<p>[h], "hat."            [i], "peet."            [ɪ], "pit."            [k], "keen."            [χ], Germ. "ach, Buch."            [j], Germ. "Jäger."            [l], "love."            [m], "mat."            [n], "no."            [ŋ], "singer."            [o], "no."            [p], "pat."</p>	<p>[r], trilled r.            [ɾ], untrilled r.            [s], "so."            [š], "show."            [t], "toe."            [θ], "thin."            [u], "do."            [v], "vat."            [ʌ], "such."            [w], "with."            [z], "zone."            [ž], "azure."</p>
--	---	--

## CHAPTER I.

### RECORDING SPEECH VIBRATIONS.

The term "speech vibration" is used here to indicate the movement of a particle of air a short distance in front of the mouth during speech. The short distance must be so selected as not to exclude the vibratory effects coming through the nose. The curve corresponding to a speech vibration is termed a "speech curve."

The vibration from the voice may be recorded by several methods. The earliest method was that of Scott's phonautograph (1856), wherein the air vibrations passed down a trumpet or tube to a thin, soft membrane; a light lever recorded its vibrations on a revolving cylinder coated with smoke. The phonautograph did not turn the curve back into sound again.

The phonautograph has been modified and improved in various ways by a series of investigators, but in spite of all improvements I doubt that it has at present any value for registering speech curves, although it is of great use in recording the melody of the voice.

The reasons for completely ruling out the phonautograph as a speech recorder are the following: First, there is no guarantee whatever that the apparatus records correctly. The curve can not be turned back into sound so that the success of the record can be judged by the ear. Second, experience in the development of talking machines has shown that crude recorders of any kind fail to give good reproducing records. It is only after some years of experience under control of the ear that the phonograph and the gramophone recorders have been developed to their present stage of success by careful elaboration of every detail in the construction. It makes, for example, a difference whether the glass diaphragm in a recorder is fastened to the box by dextrine or wax, whether the recording point has a base that is circular, elliptical, or oval, etc. Not one of these innumerable factors receives any attention in the phonautograph. Where large vibrations are requisite, as in the gramophone recorder, a hundred different glass diaphragms may be tried before one is found that records sounds satisfactorily. The reason why the particular one succeeds is not known. In the phonautograph a diaphragm of unknown peculiarities is used with no possibility of testing the results. I do not mean to say that the phonautograph records the vowel [a] with an [o]-

curve, or even that the pitch of the chief resonance tone is incorrectly given. The vowel curves obtained by investigators using the phonautograph may indicate correctly the pitch of one of the cavity tones in the vowel recorded, although there is no proof of this fact.

A phonautograph recorder could be trusted only if it could be proved that it gives the proper curves. This might be done by turning its curves back into speech or by comparing its curves with curves of known correctness. An apparatus that can be used for the former purpose will be described at the end of Chapter III. The latter method might be practically applied by using the phonautograph to record the tones of a series of good tuning-forks or of a series of other sounds whose true curves are known. Owing to the great convenience of the phonautograph it has a future before it when the proper principles of construction are found and followed, and when the tests are properly applied.

An improvement on the phonautograph is found in the instruments that not only record the speech vibrations but also turn them into sound again.

The first of these instruments was the phonograph of Edison; later the gramophone of Berliner was evolved. Most recently the telephonograph of Poulsen and the selenophotograph of Roumer have appeared, but neither of them has yet been used for phonetic researches; the photophonograph has not yet been made successful.

In the following account I shall do no more than call attention to some points that are usually known only to experts; it is unfortunately a fact that workers with recording apparatus, as well as students and critics of speech curves, are constantly led into failure and error by being unaware of many essential steps of the technique.

In the phonograph the sound wave passing down the receiving tube or trumpet reaches the "recorder." The best form of recorder at present is that shown in figure 1. A perfectly plane piece of thin glass is held by a thin rim of wax. The light aluminum arm carries a sapphire cutting tool, whose end is a plane making a certain angle with the axis. It is preferable to have the sapphire bored hollow, so that its end is a flat ring and not a plane surface. Many other details have to be regarded. The construction of a good recorder is the work of an expert; out of a large number made, only a few are found to give the best results. The "expert recorders" are never found in commerce; the ordinary ones that can be bought give very inferior results.

The recorder is placed against a moving wax surface, usually a cylinder, just as a tool in a lathe against a brass bar; a continuous groove is made in the wax. The vibrations of the diaphragm in response to the sound

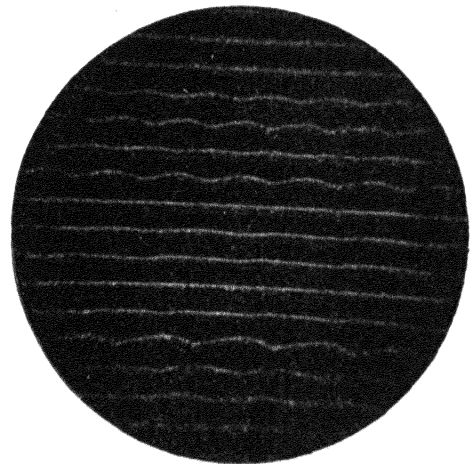
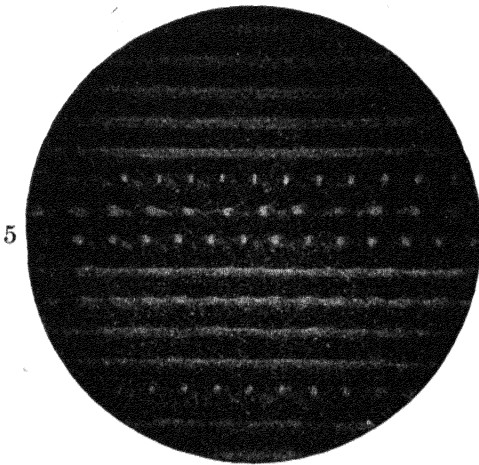
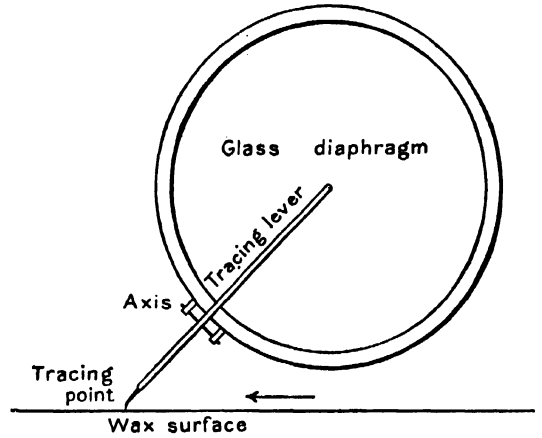
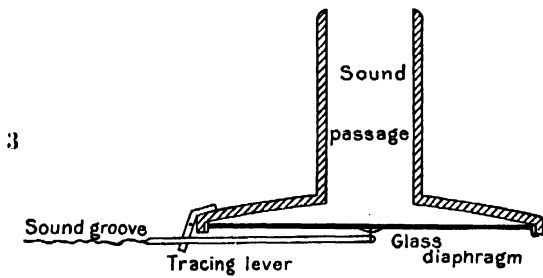
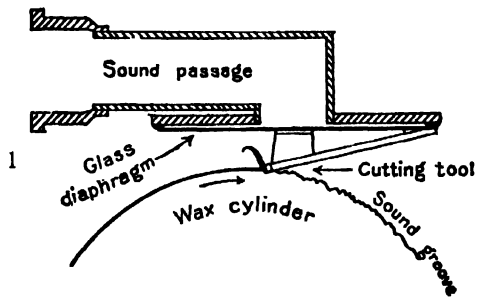

FIG. 1.—Phonograph recorder.

FIG. 2.—Tracing from a phonograph groove.

FIG. 3.—Gramophone recorder, section.

FIG. 4.—Gramophone recorder, front view.

FIG. 5.—Casting from phonograph grooves.

FIG. 6.—Gramophone grooves.

PHONOGRAPH AND GRAMOPHONE RECORDERS.



wave vary the depth of this groove. In an ideal recorder the depth of the groove would vary directly with the ordinate of the sound wave and a longitudinal cut along the middle of the groove would give the sound curve itself. The curves, however, are systematically distorted. The weight of the recorder rests on the engraving point and bends the diaphragm. In a condition of silence the diaphragm has therefore a curved surface and is in a state of tension; downward movement diminishes it, upward movement increases it; the movement in the two directions is not equal for the same force, the curve being systematically diminished on the upper side and magnified on the lower one. Opposed to this is the distortion due to the resistance of the wax. In a condition of rest the sapphire tool turns off a chip of a certain thickness; when vibrations act on the diaphragm the tool takes a thicker or a thinner chip according to the positive or negative phase of the vibration. The resistance, however, depends on the thickness of the chip; movement downward is thus systematically diminished in comparison with movement upward. This appears clearly in some of the phonograph tracings by Professor Hermann, of which a specimen is shown in figure 2.

The phonograph record may be made on a composition cylinder called the "wax" cylinder; the record is reproduced by exchanging the recorder with its cutting tool for a similarly made reproducer with a round sapphire or glass point. Wax records gradually wear out. The original record may be used to form a matrix by galvanoplasting; from the matrix a large number of copies may be obtained by casting in wax or in a much harder material or in celluloid. These are the so-called "molded" and "indestructible" records. Still another modification is the direct celluloid process of Lioret; the surface of a cylinder of celluloid is rendered soft at the moment of taking the record; it is afterwards hardened again. In another modification the phonograph record is made on a disc instead of a cylinder; a metal matrix is formed and is used as a die to stamp copies in cardboard.

To make a gramophone record, a recording lever turning on an axle is attached to the center of the diaphragm; its cutting end rests on a rotating disc of wax. The construction and action of the gramophone recorder are shown in figures 3 and 4. The groove made in the wax by the cutting end has sidewise deviations due to movements of the center of the diaphragm in response to the sound waves; the depth of the groove is constant. The wax plate containing the sound line is used to form a matrix by electroplating. From the matrix the black composition discs (called "rubber discs," although they contain no rubber) are produced by hydraulic pressure under heating. These black discs or

“records” are accurate copies of the wax original. To turn the gramophone record into sound its groove is made to pass under the needle point of a “reproducer” whose construction is similar to that of the recorder.

A photomicrograph from a phonograph record (matrix) showing the varying width and depth of the speech groove is given in figure 5. Being from the matrix, the figure shows the groove as a raised ridge. The photomicrograph, figure 6, shows the groove of constant depth but changing position on a gramophone disc.

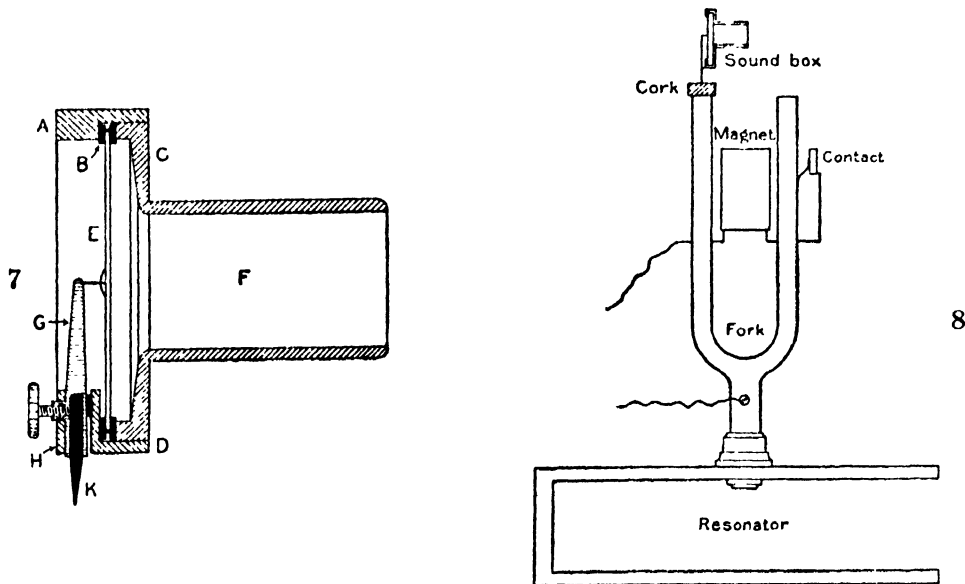

FIG. 7.—Gramophone reproducer or sound box, section.

FIG. 8.—Sound box repeating motion of a fork.

Some experiments made on gramophone sound boxes indicate the necessity of changing the prevalent view of such vibrating diaphragms. They indicate also the reasons for the phonograph or the gramophone twang to the records.

For these experiments the ordinary gramophone reproducing sound boxes with certain modifications were used. Part of the useless projecting metallic rim was cut away so that the mica diaphragm could be seen to its full extent. A section through such a reproducer is given in figure 7. The mica diaphragm *E* is connected at the center to the arm *G*, which holds the needle *K*. The arm *G* is held by a light spring at *H*. Around the edge of the diaphragm are the two rubber washers (or gaskets) tightly pressed by the metal ring *A* to the body of the box *CD*. The tube *F* is for connection to the trumpet. The needle *K* runs in the groove on the gramophone disc and transmits the vibratory movement to the diaphragm.

Six such reproducers were prepared with different forms of edge-fixation at *B*, namely: (1) with vaseline instead of gaskets; (2) with rubber gaskets; (3) with loosely pressed paper gaskets; (4) with dextrine instead of gaskets; (5) with tightly pressed paper gaskets; (6) with no gaskets, but with diaphragm held by direct pressure of the metal ring *A*. The reproducers in this order represent increasing degrees of tightness of fixation at the edges.

On the end of one prong of an electric fork of 517 complete vibrations a piece of cork was glued. The fork itself was mounted on a wooden resonator. The fork in vibration produced a loud, smooth tone; by closure of the opening of the resonator the tone became almost inaudible.

With the fork in vibration but with the resonator closed, the needle of the reproducer was placed on the cork at the end of the prong (figure 8); a tone was then heard directly from the reproducer. By opening the resonator the reproducer tone could at any moment be compared with the resonator tone.

None of the sound boxes reproduced the fork movement as a smooth tone; in every case the sound was more or less a "sharp, piercing" tone. The degree of "sharpness" was least with the vaseline box; it increased with the boxes in the order given above. We can thus conclude that the correctness with which a tuning-fork movement at the needle is reproduced by the diaphragm decreases as the stiffness of edge-fixation increases. When used with ordinary gramophone records the reproducers showed likewise that the sharpness of the tone increased with the firmness of the edge-fixation.

The following conclusions seemed justified: (1) The above gramophone reproducers are incapable of perfectly reproducing the fork vibration; (2) the distortion of the vibration imparted to the needle increases with the firmness of the edge-fixation; (3) the curve of a gramophone record is more truthful than that of the sound from the reproducer.

Similar conclusions may be drawn concerning the recording sound boxes. These, however, are more carefully constructed. The use of specially selected glass diaphragms (not one in a hundred is found to give the best results) and special methods of fixation render the distortion of the vibration much less.

The motion of the prong of the fork is represented by the simple sinusoid curve, which produces for the ear a simple smooth tone. The "sharper" tone indicates that the diaphragm changes this motion to one that can be represented by a sum of sinusoids. The increase of sharpness with increased firmness of edge-fixation indicates that the greater

stresses and strains favor the components of greater frequency. The problem of how this occurs still remains uninvestigated. The experiments of Bourget were confined to paper membranes glued to wooden frames; the analytical treatment by Rayleigh is confined to firm edge-fixation; the results are not applicable to the present case. It is natural to suppose that the change of the simple fork tone into a sharp tone occurs by vibration of the diaphragm in parts; as far as I am aware this is the thought in the minds of all who have discussed vibrating membranes. In the case of sound boxes from talking machines this view is erroneous, as the following experiments show.

To test the effect of the entire removal of the edge-fixation a reproducer was employed in which the diaphragm was not fastened at the edge at all, being supported only by the arm at the center. When set in vibra-

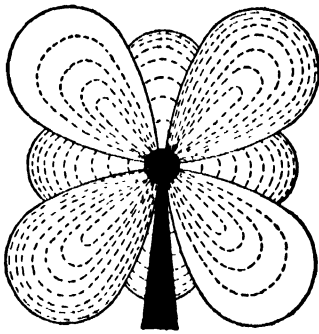

FIG. 9.—Nodal figure from a diaphragm with free edge.

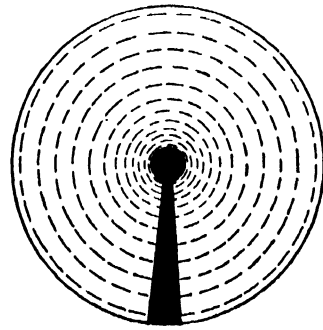

FIG. 10.—Circular distribution of light from a diaphragm with fixed edge.

tion by a gramophone record, the box gave forth only a very weak tone with occasional rattling. The edges of the diaphragm could be seen to be in strong vibration; this occasionally became so strong that the glass struck the metal. When water was placed round the edge, the result was not greatly altered, as the water was quickly blown away. As soon, however, as vaseline was applied, the sound came out strongly and clearly. We can thus conclude that the fixation at the edge has at least two purposes: (1) To produce an air-tight closure around the diaphragm, and (2) to hinder the edge from striking against the metal.

A third purpose of the fixation appears in the following experiments:

The light from an arc lamp was allowed to fall upon the diaphragm of a reproducer; the reflection was caught upon a white screen. When the diaphragm had been so inserted in the reproducer that its surface was flat, the reflection appeared as a white circle.

A reproducer with free edge was then used in a gramophone. The reflection on the screen showed a constantly changing figure with nodes; for example, as in figure 9. The figure changed its form with every tone. The dark portion was the shadow from the supporting lever and the joint in the center. When a reproducer with fixed edge was used, the reflection showed a circle of constantly changing diameter; the changes in the distribution of light over the circle were limited to concentric waves, as indicated in figure 10. We can thus conclude that an important function of the edge-fixation is to hinder the production of nodes.

An attempt was made to determine the nature of the bending of the diaphragm and its dependence on the edge-fixation. The arc light was

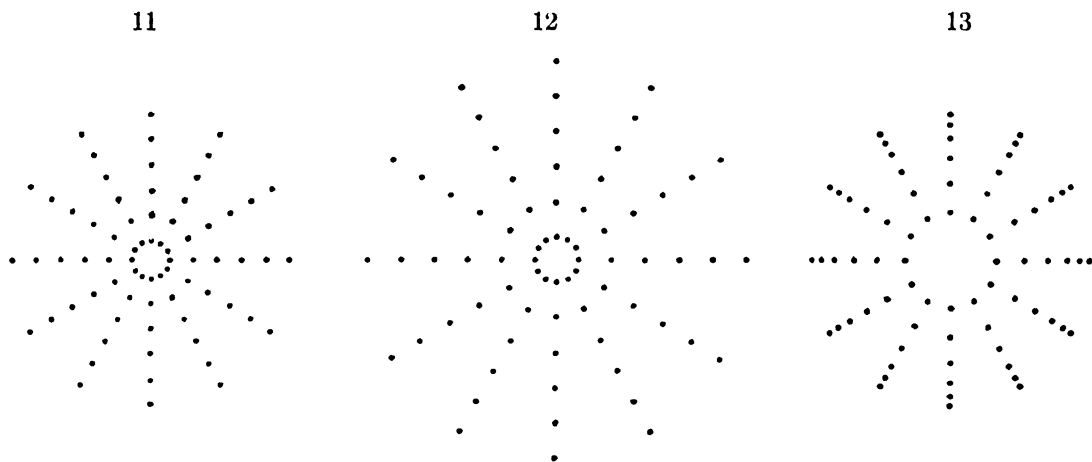

FIG. 11.—Holes in shutter and their reflection by flat diaphragm.

FIG. 12.—Reflection by bent diaphragm with vaseline fixation.

FIG. 13.—Reflection by bent diaphragm with metal fixation.

placed in a long box with a circular opening at one end. This opening was covered by a metal plate in which equidistant concentric circular series of holes were bored (figure 11). The reflection of these beams of light by the diaphragm showed a similar figure.

When a reproducer with free edge was used, pressure on the needle point moved the entire figure to one side without noticeably changing it. When a reproducer with vaseline fixation was used, pressure on the needle point enlarged all the circles (figure 12); the increase was approximately proportional to the diameter. A reproducer with metal fixation showed little or no enlargement of the inner circle, but enlargement of the others (figure 13). The other forms of fixation showed figures that lay between the vaseline and the metal types. The figure for loose paper fixation approached that for vaseline and rubber; those for tight paper and dextrine fixation approached that for metal.

The explanation of the results is simple. When the (approximately) parallel rays fall on a flat surface they are reflected back as they came (figure 14, A, B, C, D). When the surface is convexly curved, they will be bent outward from the center (figure 14, A', B', C', D'). From the movements of the points upon the screen it is possible to deduce the curve of the diaphragm. It is readily seen that the curve with vaseline fixation must be of the general form indicated by figure 15, while that for metal fixation must be of the form shown in figure 16.

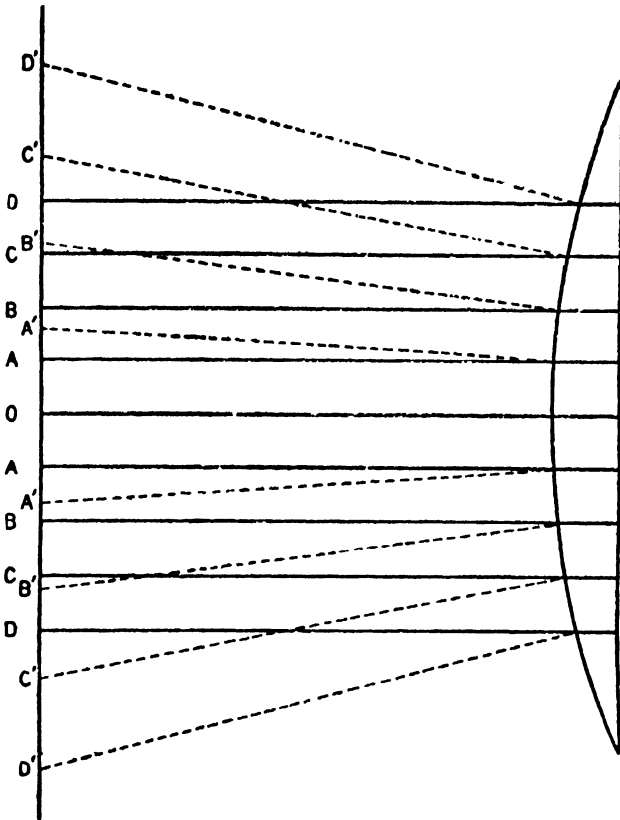

FIG. 14.—Method of obtaining curvature of diaphragm from the reflection of parallel rays.



FIG. 15.—Curve of bending for vaseline fixation.

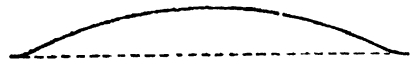

FIG. 16.—Curve of bending for metal fixation.

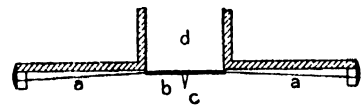

FIG. 17.—Ideal of a sound box.

In a further series of experiments a micrometer screw was pressed against the center of the diaphragm. In this way the relation could be established between the degree of movement at the center and the bending at each point of the diameter. It was my intention to investigate in this way the relation between the deviation at the center and the movements of the dots. The curve of bending for each degree of movement at the center could thus be established. As the first results were in the main the same as before, no quantitative work was done, although a completed

investigation would be a matter of importance in reference to the action of sound-receiving instruments such as talking-machine recorders, telephone transmitters and the human ear.

It is at present not my intention to pursue these investigations further. What has already been done indicates that the formation of nodes (Chladni figures), as in most vibrating plates, is a matter of no importance in the stiff diaphragms of talking machines. The essential factor is the curve of bending. This depends on the material and on the edge-fixation. In my opinion the aim should be to obtain a rigid diaphragm with liquid fixation. The diaphragm would yield to the vibration pressure like a piston in a cylinder. The distortion of the vibration would depend on the inertia and the friction.

The sound boxes now made for gramophones and phonographs are the results of experience without reasoning. According to the prevalent view of their action (as far as any view at all is prevalent) the diaphragms are regarded—without justification—as Chladni plates. The above experiments indicate the ideal toward which the constructors of sound boxes unconsciously strive. It comprises a stiff circle in the center *b*, figure 17, held in position by a ring, *a*, that acts as a spring and also as an air-tight closure. The tube *d* has the diameter of the stiff center. Over the ring *a* enough air space is left in the frame to allow free movement. The recording or reproducing link *c* acts like a piston-rod attached to the stiff center. It is essential that the stiff center *b* should have perfectly regular movement; therefore the spring ring *a* must be perfectly homogeneous. This can not at present be accomplished without making the diaphragm all in one piece. Consequently, in order to obtain springiness in the outer portion the stiffness must be yielded in the center; the glass or mica diaphragm thus bends at all points. A new model of box partly recovers the central stiffness by additional central layers of mica.

If we rule out any nodal action in the diaphragm, what is then the cause of the gramophone and phonograph twangs? The two are different from each other and from the natural sound. Let us put to one side the fact that the small diaphragm of the talking machine is physically incapable of creating such strong vibrations as those of a bass drum; we will also disregard further questions of loudness and the modification of the sound by the trumpet.

The falsification of natural sounds by the talking-machine recorders occurs, in my opinion, from a distortion of the waves by the bending of the diaphragm and not to nodal vibrations. The sinusoid movement imparted to the rod by the fork, as described above (p. 17), would, with

a perfectly stiff piston in an air-tight box with no friction, produce a sinusoid movement of the air and a smooth tone. The diaphragm of the sound box, however, bends so that there is more or less of yielding and side motion to the air behind it; this alters the form of the wave transmitted to the air. In both gramophone and phonograph the wave is distorted by the bending of the diaphragm in the manner just explained. It is also distorted by the friction in the wax, which, being proportional to the velocity, will diminish as the point departs from the position of equilibrium.

The reason for the difference between the phonograph twang and the gramophone twang lies apparently in the difference in tension of the diaphragms at the position of rest, and in the differences in friction in the two instruments. In the phonograph one diaphragm is already bent upward when at rest; as explained above (p. 15), the vibration is unequal on the two sides. In the gramophone the diaphragm is held without tension at rest; it vibrates equally to both sides. In the phonograph the friction in the wax increases as the point moves downward. In the gramophone recorder the needle vibrates always in the same thickness of wax; the element of friction which affects the vibration is that which opposes the deviation of the needle from its position of equilibrium; this is equal on both sides.

It must be added that the highly developed technique of the present day makes it possible occasionally to produce both phonograph and gramophone records that for the ear have absolutely no twang.

## CHAPTER II.

### TRACING GRAMOPHONE AND PHONOGRAPH RECORDS.

A phonograph record may be studied with a microscope, but finer analysis requires that the groove be traced off on paper in great enlargement. For a gramophone record the microscope is useless because the waves are so drawn out in length that the details are lost for the eye; tracing is always necessary.

The curves used for my investigations were traced by four pieces of apparatus which have undergone gradual improvement. It will be sufficient to describe only the latest forms. The gramophone tracing apparatus is first described because it was the first one made and also because it gave experience for the more difficult phonograph apparatus.

A top view of the gramophone apparatus is shown in figure 18. An electric motor turns a pulley connected to a series of countershafts by which the speed is reduced before being transmitted to a brass cylinder termed the "far drum." A band of paper of any desired length transmits the movement to the "near drum." The band of paper is coated with smoke. The axle of the near drum carries two pulleys which drive the "rotator." One pulley has a belt to slowly rotate a horizontal metal plate upon which a gramophone disc is fastened. A steel point fastened near the fulcrum in a very long lever rests in the groove of the gramophone disc. As the disc turns, the vibrations of the sound groove move the steel point back and forth sidewise and the recording point of the lever traces this movement as a white line in the smoke on the band of paper around the two drums. As the sound groove is a spiral running toward the center of the disc, the disc must be moved sidewise in order to have the groove pass continuously under the steel point. This is accomplished by a "screw for side movement"—run by belt from the second pulley on the axle of the near drum—which shoves the disc sidewise.

A side view of the rotator (figure 19) shows the metal disc turned by its belt. The disc itself runs on an axle which is fixed to a carriage. This carriage has two projections bored to receive the circular rod indicated as "rail" in the figure; the ends of these two projections are shown; one of them carries the "contact support." The other side of the carriage has a single projection which rests on a planed rail (not shown). The carriage is pushed along by the "screw" for side movement. It is held against the end of the screw by the "tension weight." This screw is

turned in the "revolving barrel" by means of the projecting screw-head in the slot; it feeds through a brass "nut" attached to the frame. The under side of the metal disc carries a hard rubber insulating plate through which 10 sets of metal pins have been driven into the metal disc; the sets of 2, 3, 4 pins are shown in the figure. On the carriage is the hard rubber "contact support" carrying a copper brush which rests against the hard rubber plate. The spring and the frame of the apparatus are placed in circuit with a battery and a magnetic marker (not shown); the marker is adjusted to record on the smoked paper beside the lever; as the disc turns, the pins make contact with a copper brush and a series of 1, 2, 3 . . . 10 checks is recorded for each revolution. The screw for side movement should have the same number of threads as the gramophone spiral; several interchangeable screws with their nuts are provided. Bevel gears can not be used in the rotator, as the unevenness of the teeth causes irregularity in the rotation. An end view of the rotator (figure 20) shows the metal plate with the gramophone disc on it and the rubber disc with the contact pins below. The thoroughly braced supporting arm carries the lever holder so that the tracing point rests in a groove on the gramophone disc.

A view of the tracing end of the lever is given in figure 21. The rotator has upon it the gramophone disc. The lever is carried by a metal piece containing a fixed steel center below and a pointed steel "center screw" above. The two points are inserted in a little "vertical axle." The center screw is turned until the movement of the lever on the axle is perfectly tight and yet perfectly loose; the screw is fixed by a little "jam nut." The fine "tracing point" rests in the groove; its side movements force the "tracing lever" to move. The adjustment of the lever on the vertical axle is a vital matter. The point of the center screw must be exactly in the center of its diameter, and the screw hole must be so placed that its center is exactly opposite the fixed center below. The holes in the vertical axle must also be exactly true. Any deviations of the centers or the holes from an exactly straight line produce differences in friction at different points of the movement. The surfaces of the centers and the holes must be true cones and rings. Differences in friction produce differences in the movement of the lever for the same movement in the speech groove. Defects in the construction thus falsify the curves.

The necessity for perfect tightness with perfect looseness arises from the length of the long arm of the lever as compared with that of the short arm. Any looseness allows the tracing point to make movements not recorded on the paper. Any stiffness causes the supports to bend, although they are made with such stoutness that bending seems impossible.

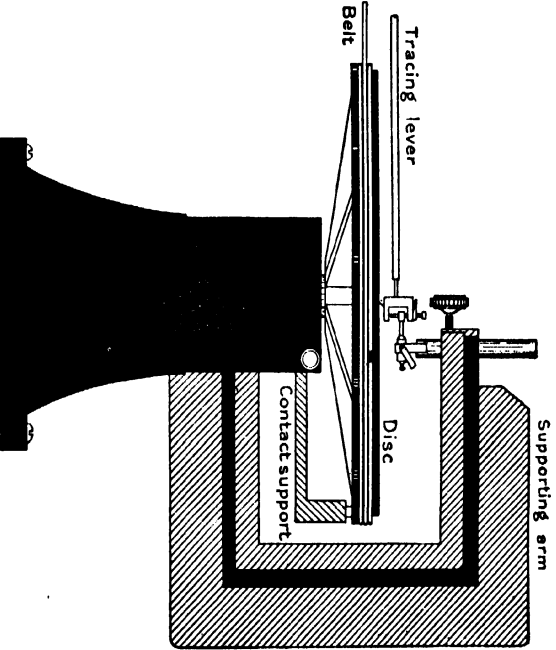
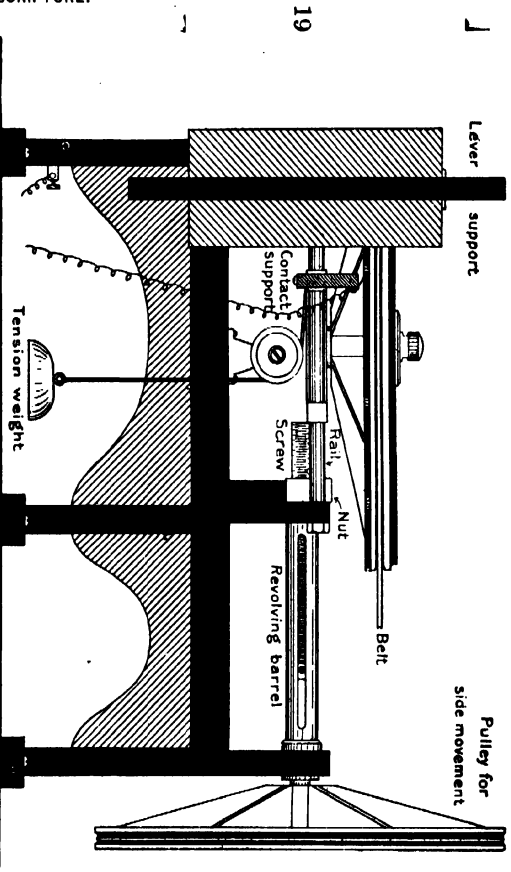
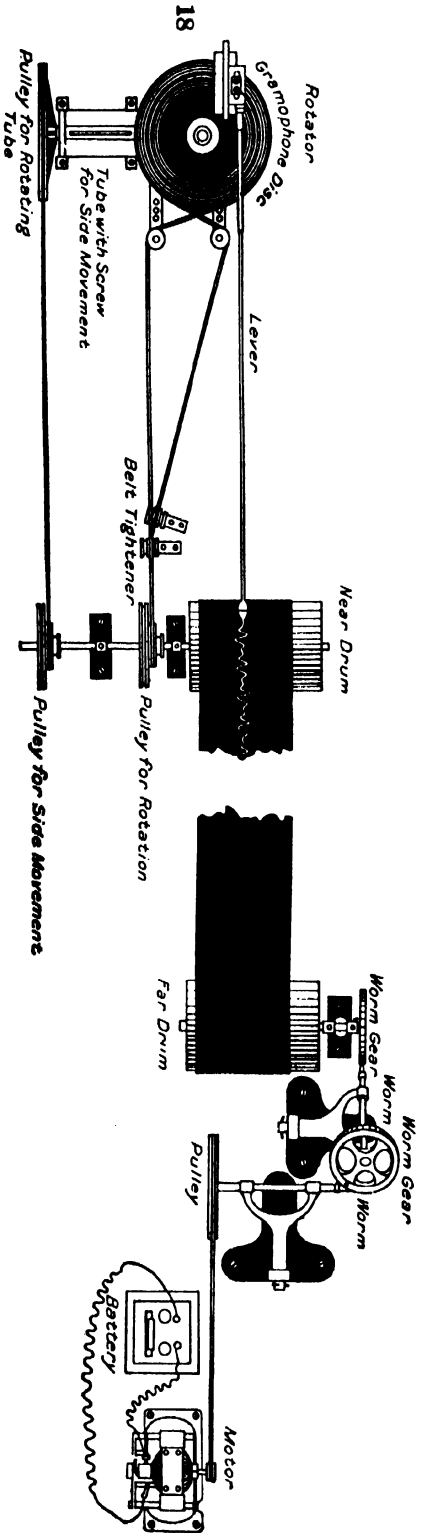

Fig. 18.—Machine for transcribing gramophone records, top view.

Fig. 19.—Side view of rotator.

Fig. 20.—End view of rotator.

TRACING MACHINE FOR GRAMOPHONE RECORDS.

19

20



To allow for variations in the thickness of the gramophone disc the axle of the tracing lever is borne by a short "vertical link." This is a metal bar held on an axle in the same way as the tracing lever. The axle is horizontal; any change in the thickness of the disc raises or lowers the tracing point around this axle. The magnification of this movement at the record is comparatively small, and as the discs are now made with great precision, the main purpose of the vertical link is to maintain constant friction at the tracing point. The axle for the vertical link is held on an adjustable "lever holder," which can be fastened by a "fixing screw" in the supporting arm.

The tracing point should lie in a radius of the gramophone disc perpendicular to the tracing ~~lever~~; ~~the lever is thus a tangent~~ to the groove being traced. This can be fixed once for all by a non-adjustable point and a hole in the supporting arm for the lever holder, as in figure 21. It is, however, often desirable to vary the magnification of the tracing by changing the distance of the point from the fulcrum; the position of the lever holder must then be changed also. A sliding brass block which can be securely fastened to the supporting arm is then used to carry the lever holder; this is the arrangement indicated in figure 22.

The gramophone disc must be level, otherwise the tracing point may run up the side of the groove. Considerable pressure is needed in order to make the tracing point remain in the bottom of the groove. A small weight is sometimes of advantage when placed just over it. A larger weight causes the supporting parts to bend and thus diminishes the amplitude of the movements, or, if very great, it causes the point to skip over the apexes of sharp waves.

Both single and compound levers have been used. The single lever is shown in figure 18. The lever itself must be very light and very rigid. In most cases the larger portion near the fulcrum was of Japanese reeds 4mm. in diameter, while the other half was of some 2mm. German straws ending in a very light 1mm. French straw.\* The tracing point was attached to the end. It was found possible by practice to construct these levers so lightly and rigidly and to adjust the recording point so delicately that a greater magnification could be obtained with the single lever than with a compound one.

The arrangement with the compound lever is shown in figure 22. The first lever is short; its end repeats the movement of the tracing point with small magnification. Its movement is communicated to the second

---

\*The French straws can be obtained of Ch. Verdin, Paris, Rue Linné 7, and the German ones of Wm. Petzold or E. Zimmermann, Leipzig. The Japanese reeds can be obtained in America by buying the very smallest Japanese brushes.

lever by a connecting link. Since it is desirable to have considerable weight to keep the tracing point at the bottom of the groove, the first lever can be made of a stout brass rod. The connections are made by gimbal joints.

The gimbal joint (figure 23) comprises a steel square at whose corners pivot holes are bored. Each fork carries a fixed and an adjustable pivot screw, the adjustable one having a jam nut. It is vitally important to have the axial lines correct and all pivots and pivot holes accurately round and central. The rod of one fork is inserted into a hole in the end of the first lever, that of the other fork into a hole in the connecting link. The connecting link is a tube of aluminum. The connecting link moves the second lever by a joint (figure 24) whose construction is the same as that of the gimbal joint, except that one fork carries a metal piece with a hole for the second lever.

The second lever must be light and stiff. The central portion is a piece of aluminum tubing; the other portion is a reed or stiff straw. The degree of amplification depends on the length of the lever and the nearness of the link to the fulcrum. The attachment to the support is by a fork with pivots working on an axle.

It would naturally be expected that the magnification of the speech vibrations could be carried to any desired extent by means of the compound lever. The difficulty lies in the making of the pivots at the joints and in adjusting them. The cones of the pivots and the centers of the bearings should be perfectly true to the desired axes; the joints should be perfectly tight and yet perfectly frictionless. The finest mechanics obtainable for making the joints have not succeeded in producing a compound lever that correctly enlarges more than 125 times. The best results have been obtained with the single lever with which correct tracings with a magnification of 300 times have been reached. The future of the method lies, however, in the development of a compound lever.

The recording point (figure 25) consists of a piece of thin card cut across and joined by the thinnest obtainable non-elastic membrane (gold-beater's skin); one piece is fastened to the lever, the other carries a fine glass rod with its end rounded by heat. This recorder is stiff in the direction of the movement, but highly flexible at the hinge. The critical part lies in the membrane; this must be so thin that its elasticity has no effect in pressing the glass point against the drum. The recording point is so adjusted that the minute glass knob is in a horizontal plane passing through the axis of the drum, and the hinge is almost but not quite under the knob (figure 26). If the angle of the glass rod with the surface of the drum is too great, the point will catch and move by jerks. The axis of

21

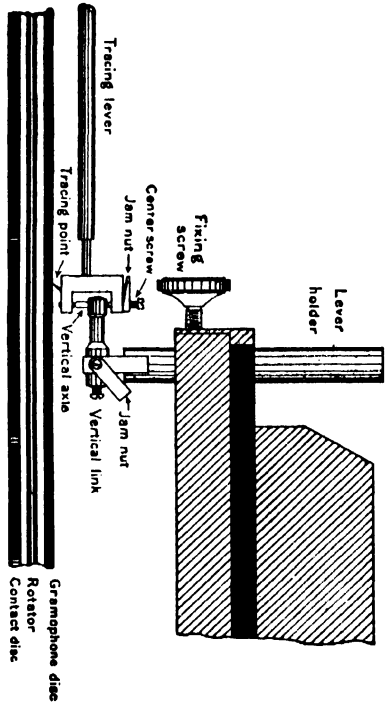

22

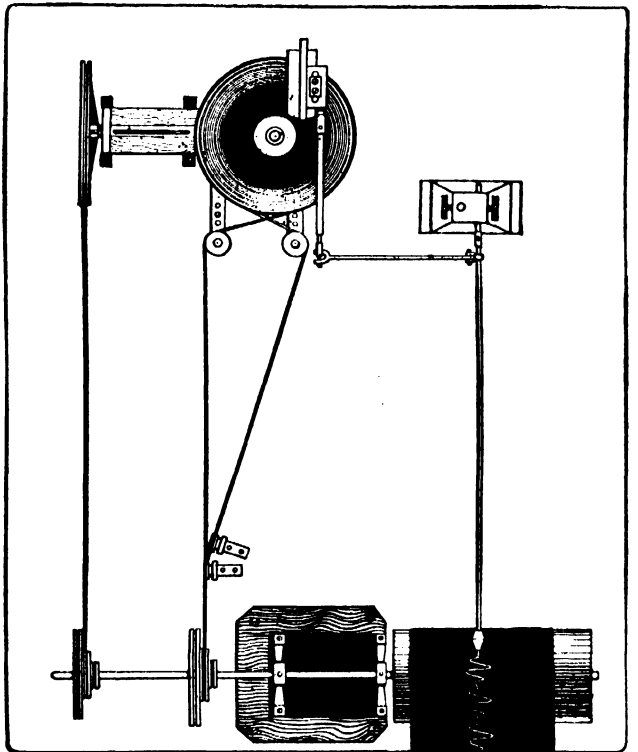

SCRIPTURE.

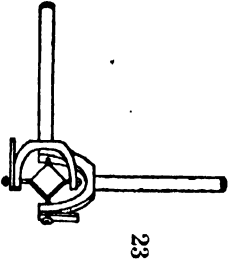

23

Fig. 21.—Tracing end of lever.

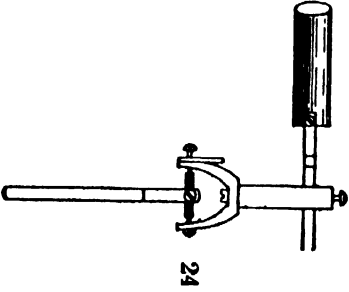

24

Fig. 22.—Machine with compound lever.

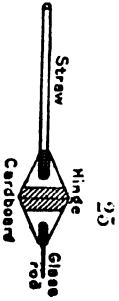

25

Fig. 23.—Gimbal joint.

Fig. 24.—Joints for second lever.

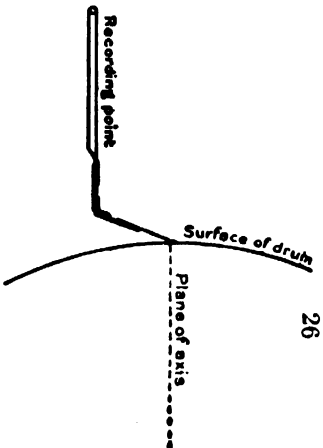

26

Fig. 25.—Recording point, top view.

Fig. 26.—Recording point, side view.

DETAILS OF TRACING AND RECORDING MECHANISMS.



the drum, the knob of the recording point, and the apex of the tracing point should be in the same plane.

If the glass point bears so lightly on the paper that the line traced by it is not white enough, it may be weighted by a piece of wax. When the tracing is to be reproduced by photography, the line must be whiter than is otherwise necessary.

The gramophone disc must be accurately centered on the rotator. The tracing point is placed in the groove and the position of the recording point is noticed. The disc is now turned; the point moves to one side, then to the other and back; the positions of extreme deviation are noted

and the disc is turned to one of them. It is then carefully shoved until the point takes the middle position. This is repeated until the point rests at the same place during one entire revolution.

The arrangement of the pulleys at the near drum is shown in figure 27; it is presumably clear without any description. The steps may be on either side; in figure 22 they are to the rear, in figure 27 to the front;

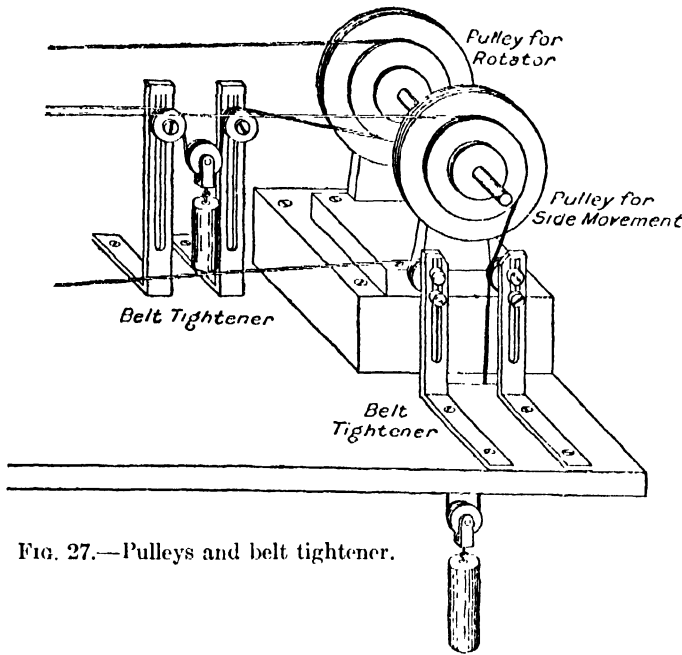

FIG. 27.—Pulleys and belt tightener.

an improvement has been recently introduced by having more steps to the pulleys. I have lately adopted the plan of replacing the weight belt tighteners by single pulleys carried by heavy supports. The pulley is adjusted till the belt gives a certain tone when snapped; the adjustment of the belt for side movement is made once for all and is tested occasionally; that for rotation must be made anew at intervals, as the side movement of the disc steadily stretches the belt. The standard of tension can be kept by comparison with a tuning-fork.

The arrangement shown in figure 18 for the far drum and countershafts is now modified by using much smaller worm gears. The reduction of speed can be made very great; with two worm gears of 164 teeth the speed of the drum axle is  $\frac{1}{164 \cdot 164} = \frac{1}{26896}$  of that of the first countershaft. By

using a pulley ten times the diameter of that on the motor the drum speed becomes  $\frac{1}{200000}$  of that of the motor.

The tracing paper must be of a durable white color, not turning yellow with exposure light. With the hinge recording point the glaze is not needed to reduce friction; some of my records were made with specially rough paper. This fact is readily explainable by the action of the recording point; there is so little pressure that the glass point drags over the smoke and not through it. Viewed under the microscope the point is seen to drag flakes of smoke from the glazed paper. On some unglazed paper it rolls the smoke up under it and then passes over the roll; on this paper the curve is a series of dots. Such unglazed paper takes the smoke evenly and makes a thinner line. Most rough papers, and some glazed ones, too, seize the smoke so tightly that a clear tracing can not be made. The long band of paper is pasted evenly at the joint; it should run true when the drums are rapidly turned.

The smoking may be done by an ordinary gas flame, provided it is sufficiently rich in carbon. A tube with a series of holes making a set of small flames is convenient; or a set of wax tapers may be used. Flames that deposit sticky smoke are to be avoided.

The best method to avoid jarring is to mount the apparatus on two tables standing on a cement floor. When this can not be done, the tracing portion may be mounted on a platform or table suspended by ropes and springs; the jarring of the floor is not transmitted to the apparatus; the jarring of the ceiling, however, may cause trouble. The method of resting the platform on rubber cushions that may be blown up is suggested. The far drum and the countershafts are placed on a table as far as space permits from the tracing portion; the motor may be placed on this table or on the floor. The motor should run with the minimum of jarring; if necessary, it may be placed in a box of sand.

The greater the distance between the two drums, the longer may be the strip of paper and the less often the necessity of changing it; my experience with distances up to 30 meters (100 feet) is that the longer the strip the easier is the manipulation in every way.

When a record is to be fixed, a solution of shellac is spread by a brush on the *back* of the paper before it is removed from the drums; this fastens the smoke from the back evenly to the paper and produces a dull surface. Most glazed papers keep the varnish from coming through, but some are perfectly porous.

The apparatus must run slowly enough to avoid any swing from the inertia of the lever when large curves are being registered. I have found

a rotation once in five hours to be perfectly safe with the most sensitive of levers. Vibrations of the lever itself do not occur unless the apparatus is jarred or the tracing point is so badly adjusted that it catches on the paper. The period of the lever is so short that its vibration appears in the former case as a white dot and in the latter as a cross line. The vibrations of the lever itself have no influence whatever on the movements for the curve traced; they can even be used to widen the tracing line by putting on the table some automatic jarring apparatus.

The tracing point must move without catching; this is tested by rapping on the near drum when it is recording a large side deviation. If it catches, it will move by jerks.

The tracing point must lie in the bottom of the groove; this is tested by rapping very gently on the gramophone disc. If the point is not at the bottom it will fall to it, and a sudden jerk of the lever will be seen. The trouble can be removed by weighting the lever.

The gramophone disc must turn evenly. The movement is best studied by mounting a piece of mirror over the center by a bit of wax, and reflecting a beam of light on the wall. With good lubrication and a non-stretching belt the beam will move evenly. Otherwise it will move with jerks that become less as the ideal conditions are approached. Raps on the table produce sudden jerks; these indicate how much the belt stretches. The evenness of rotation of the screw for side movement can be studied in a similar way.

It is necessary to keep a careful watch over these points at all times, because any irregularity of motion appears in the record with the same magnification as the speech curve. The belts should be very flexible, but non-stretching; certain threads and strings answer the requirements, but they can only be selected by careful tests. I have obtained the best results by using fine iron wire.

The hard rubber ring or "contact disc," referred to above (p. 24), serves two purposes. The ten sets of metal contact pins—the first containing one pin, the next two pins, etc.—pass over a copper brush in circuit with a battery and a magnetic time-marker, which writes on the strip of paper. As the rotator turns, the sets of pins pass in succession over the brush and make momentary contacts, whereby the time-marker registers successively 1, 2, 3, etc., checks. In this way it is possible to know the position of the disc at each point of the tracing. This convenient arrangement is not absolutely necessary, except for a few turns in order to establish the relation between the rate of rotation of the disc and the length of the curve, that is, the "time equation" (see below); it is useful, however, in

matching curves when the apparatus has been stopped, and it is desirable as a constant test of the rate of rotation.

It is necessary to know the relations of magnification between the traced curve and the vibration on the disc. For the X-axis of the tracing the distance corresponding to one revolution of the disc is found by measuring the distance on the tracing between any two corresponding checks of the time-marker. If the rate of rotation in the original recording machine is known (it is usually 75 per minute), the "time equation" for the tracing can be found. For example, if the distance between two like checks is 2024mm. and the disc made one revolution in  $\frac{1}{75}$  of a minute or in 0.8s., the time equation for the X-axis will be

$$1\text{mm.} = 0.8 \div 2024 = 0.000357\text{s.},$$

or, say,  $1\text{mm.} = 0.0004\text{s.}$  It is desirable to sound a tuning-fork just before and just after taking a record on a gramophone; the curve of the fork then gives the time equation directly.

To obtain the magnification sidewise the tracing point is placed in a groove and the apparatus is moved just enough to make a short line on the drum; the point is then lifted to the next groove and another short line is made; it is then lifted to the original groove to give a third line. The process is repeated a number of times, giving a series of short lines alternating from left to right. The distances between the successive ends of the lines are measured and averaged, whereby the variations due to the vibration are eliminated. Divided by the distance apart of the gramophone grooves this gives the magnification. To obtain the distance apart of the grooves a chalk line is made radially across the disc after the record has been traced off; it is placed on a gramophone and allowed to turn a large number of times; the distance over which the chalk has been scratched off divided by the number of turns gives the distance apart of the grooves. The distance apart can also be measured by a microscope with ocular micrometer.

The apparatus should be tested thoroughly. It is necessary, however, to first determine how precisely the records can be measured. For this, a piece of tracing has its amplitudes and wave-lengths measured in the manner to be adopted for the whole tracing; for example, with a scale in tenths of a millimeter read by a magnifying glass. The results are placed in the record book that belongs with the apparatus. After these results have been forgotten, the same tracing is again measured in the same way. The two sets of measurements are then compared and the degree of precision computed.

For example, the amplitudes of successive waves were twice independently measured with the following results:

First measurement. . . .	4.4	5.0	5.6	6.5	7.1	7.9	7.2	7.9	8.8	7.3	Average: 6.77
Second measurement. . .	4.3	5.0	5.7	6.4	7.1	7.9	7.3	7.8	8.8	7.3	....
Difference . . . . .	0.1	0.0	0.1	0.1	0.0	0.0	0.1	0.1	0.0	0.0	Average: 0.05

There was thus an average error of  $0.05 \div 6.77$  or 0.0074 of the average or, say, 0.7 per cent.

To determine how precisely the apparatus is working, the same piece of curve should be traced off twice independently. The corresponding waves are measured and the differences found. For example, a second tracing of the same curve as that just measured gave the amplitudes 4.6, 5.0, 5.7, 6.4, 7.1, 7.9, 7.3, 7.9, 8.9, 7.5. The differences from the corresponding waves in the first tracing were 0.2, 0.0, 0.1, 0.1, 0.0, 0.1, 0.0, 0.1, 0.2, and the average difference was 0.07, *i. e.*,  $0.07 \div 6.77$ , or 0.010, or 1 per cent of the average. This is the variation due to the apparatus and the measuring together. If this average difference be indicated by  $s$ , that for the measuring by  $p$ , and that for the apparatus alone by  $q$ , the relation is, by a well-known law,  $s^2 = q^2 + p^2$ . Consequently,

$$q = \sqrt{s^2 - p^2} = \sqrt{0.07^2 - 0.05^2} = 0.049;$$

this is  $0.049 \div 6.77$  or, say, 0.7 per cent of the average.

Whenever any alteration is made in the apparatus the precision should be again determined. For practical purposes I have assumed 1 per cent as the limit of error in the tracings.

The various factors in the process of tracing should be tested. Thus ten measurements of amplitudes for the same curve traced on certain glazed and unglazed papers showed a difference of 0.016 per cent in favor of the former, or practically zero. The particular kind of glazed paper thus offered no advantage over the particular unglazed paper. A test by comparing a record on lightly smoked paper with one on heavily smoked paper showed an average decrease in amplitude for 10 waves of 0.4 per cent on the heavily smoked paper. The addition of a small piece of wax to the hinge so as to make the glass knob trace a whiter line showed no diminution in amplitude.

The mounting of the curves on cardboard has to be systematically done. A good method is to draw a line each side of the curve and cut out the narrow strip with scissors. This strip is to be divided into portions as long as the mount which is to be made from it—the longer the strip, the less often a curve is cut. Each portion is numbered on the back before it is cut off; the angle at which the scissors cut the

portion off is changed each time to avoid getting the portions reversed. The portions are then pasted on pasteboard sheets of the required size.

For reproduction in the form of plates for printing, the curve has to be made somewhat whiter than is otherwise necessary. A small wax weight is added to the outer part of the recording point, so that the glass knob rests a little more heavily on the smoked paper. The danger lies in the bending of the lever due to the greater resistance of the smoke. A test of amplitudes is made before and after adding the wax; if the alteration falls within the limit of error (say 1 per cent) the wax is retained.

The only available processes of reproduction seem to be copper etching and zinc etching. The former gives excellent results, but is expensive. The latter is successful only when the engraver employs the best zinc. The mount is photographed by the engraver. Ordinarily the negative is then stripped from the glass; since the gelatine stretches and introduces errors, this process is avoided by mounting all the curves backwards (from right to left) on the pasteboard and instructing the engraver not to strip the glass plate. In the print the curves appear to read from left to right. With the usual construction of the apparatus used for taking records the phase of condensation of the original sound registers with an outward (centrifugal, away from the center) deviation of the sound groove. With the tracing point as shown in figure 21 this phase gives a deviation upward on the page. The curve as seen in the figure reads backward. When the strips are mounted backward, the blocks produced from them without stripping have the phase of condensation also upward.

Illustrations of the work done by the gramophone tracing apparatus are given in the accompanying figures and plates. The time equation for figures 28 to 40 is  $1\text{mm.} = 0.0004\text{s.}$  The curves in figures 28 and 29 were made by the apparatus with single lever as shown in figure 18; the pressure of the glass point against the paper was very light and the line—reproduced by zinc etching without retouching—appears like a series of dots. For the curve in figure 30 the glass point was weighted and the zinc etching—with no retouching—appears clearer. The curve in figure 31 was produced in the same way, but was retouched; the line is stronger, but is at a decided disadvantage on account of its raggedness and also because its width renders it difficult to measure. The curve for the yodel (figure 28) is a short portion out of a single note; it shows strong, smooth waves, each of which corresponds to one vibration of the voice. The short portion in figure 29 shows a softer yodel combined with piano vibrations. The trombone vibrations (figure 30) show considerable fluctuations in intensity even in the short time represented by the piece

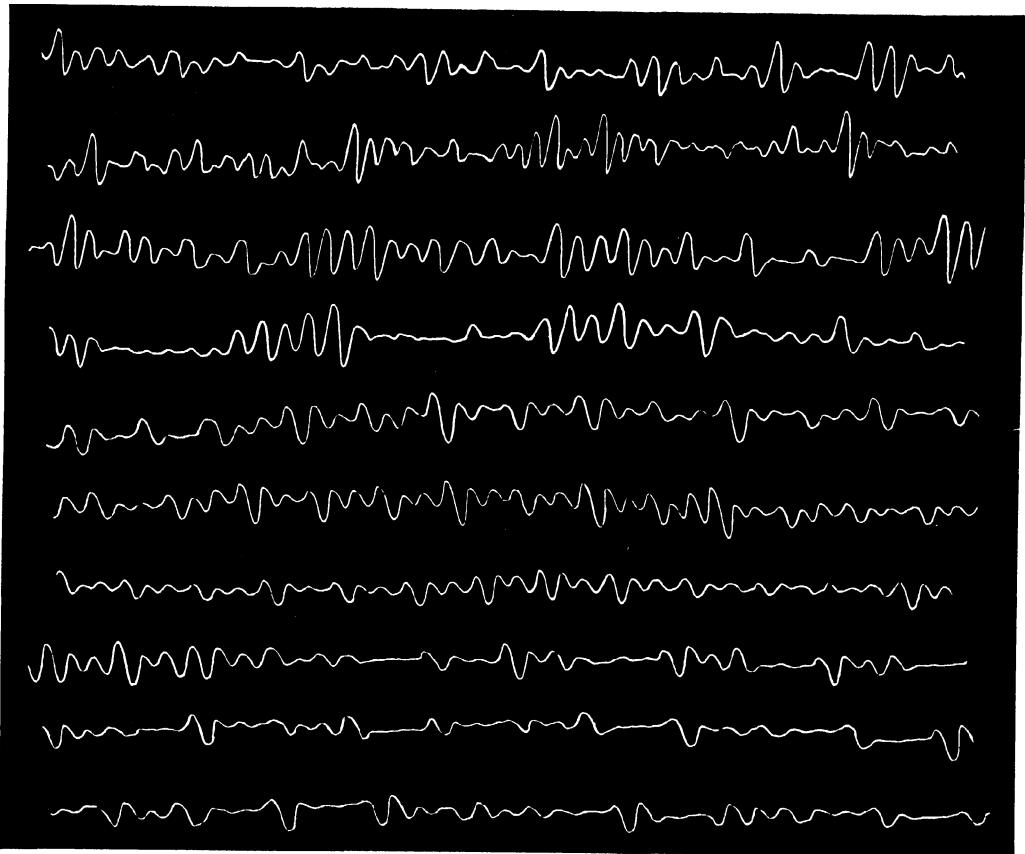
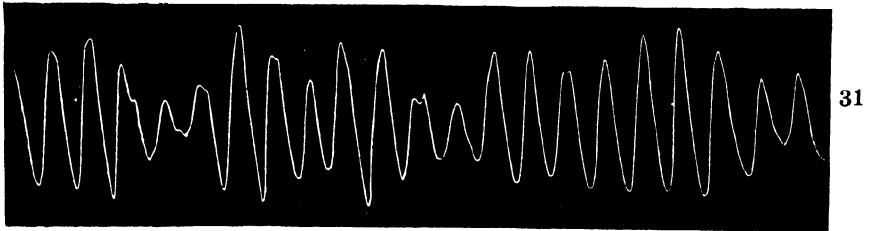

FIG. 28.—Yodel. FIG. 29.—Piano with yodel. FIG. 30.—Trombone. FIG. 31.—Band. FIG. 32.—Orchestra.



of curve in the figure; there is a curious resemblance of the vibrations to those of vowel curves. In the band curve (figure 31) we can pick out the strong vibrations for the note on which most of the instruments coincide. We notice that every fourth vibration is especially strong; it is from the bass instruments playing two octaves below. The very short vibrations, which can be detected best at a positive or negative apex, are from a piccolo. The curve in figure 32 is from the record of a note from an orchestra. The most prominent vibration is one whose wave-length is  $3\text{mm.} = 0.0012\text{s.}$ , that is about the note  $g^{2\sharp}$ . Another prominent feature is the grouping of these vibrations in threes, indicating a tone with a period of  $9\text{mm.} = 0.0036\text{s.}$ , or a note about  $c^{1\sharp}$ . The greater strength of certain vibrations indicates the presence of bass notes. There is one which reinforces every sixth vibration of the high note and another that coincides approximately with every ninth; the former would correspond to  $c^{0\sharp}$ , the latter to  $g^{-2\sharp}$ . The combination of all these notes—each comprising a fundamental with overtones—produces a very complicated curve. From such vibrations, however, the ear can pick out not only the component notes but also the characteristic tones of the piano, violin, etc.

The record of the gong in figure 33 shows the effect of a blow. It begins with a sudden upward deviation due to the blow of the hammer and an almost complete vibration of smooth form before the gong begins its special vibrations. The longer vibrations with a period of  $7\text{mm.} = 0.0024\text{s.}$ , or about  $g^{1\sharp}$ , correspond to the lower tone of the gong, the shorter ones with a period of  $1.3\text{mm.} = 0.0005\text{s.}$ , or about  $c^{\sharp}$ , to the higher tone. The form of the long wave shows that other prominent vibrations are present. The interference of the chief tones of the gong produces the beats seen in the weaker portions of the curve. These beats occur every  $60\text{mm.} = 0.0240\text{s.}$ , or about 40 times a second. Beats are heard in nearly all tones from bells and gongs, but here they are not audible; this is due to their frequency, which is sufficient to produce the impression of a low tone instead of beats.

The record of the conductor's whistle in figure 34 shows the very short vibrations for the high note and also the pseudobeats (periodic weakenings of the sound) that are produced by the rattling of the little ball in the whistle; only a very small portion of the long record is given.

Figure 35 gives a small piece out of the record of a European locomotive whistle; the tone is not excessively high; it has a hollow character, somewhat like that of a tuning-fork.

The first of the three locomotive puffs in figure 36 was soft and long; only a small piece is reproduced; its pitch was comparatively high and

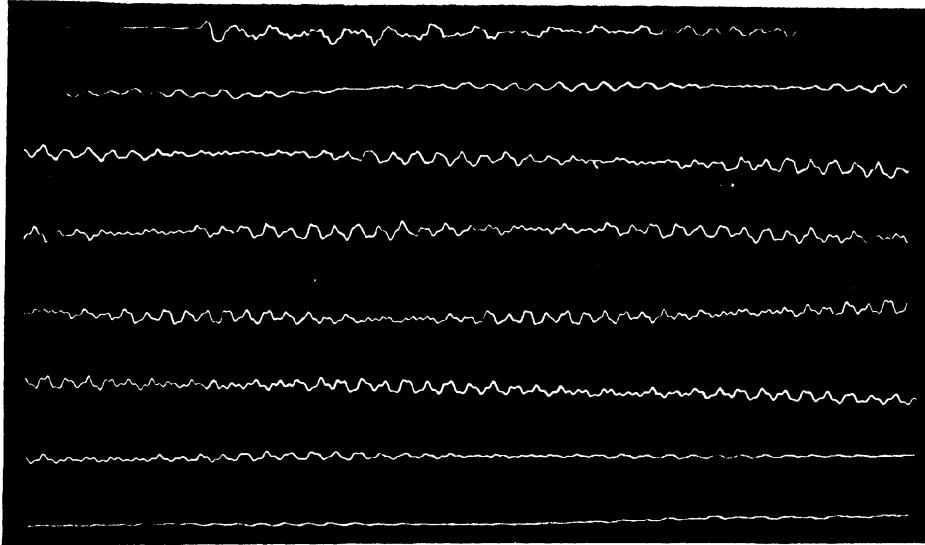

33



34

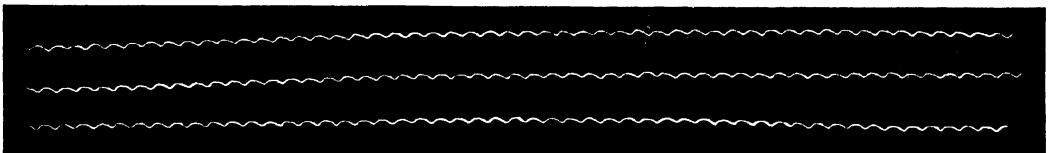

35

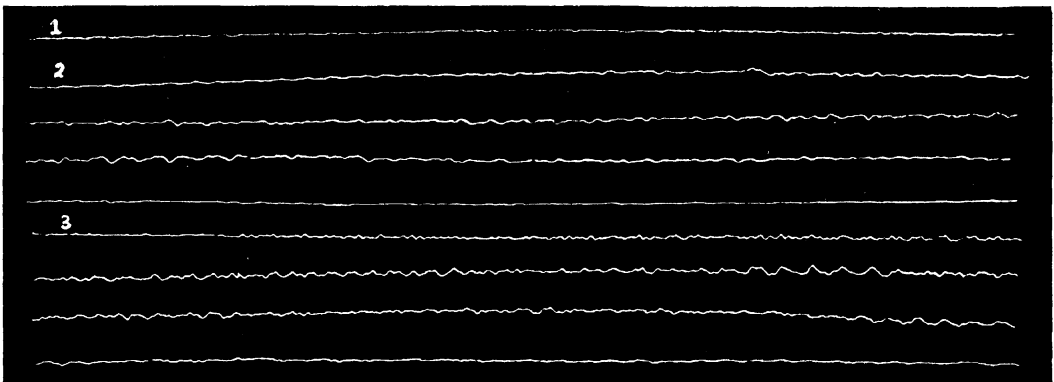

36

FIG. 33.—Gong. FIG. 34.—Conductor's whistle. FIG. 35.—Locomotive whistle. FIG. 36.—Three locomotive puffs.  
CURVES OF VARIOUS SOUNDS.



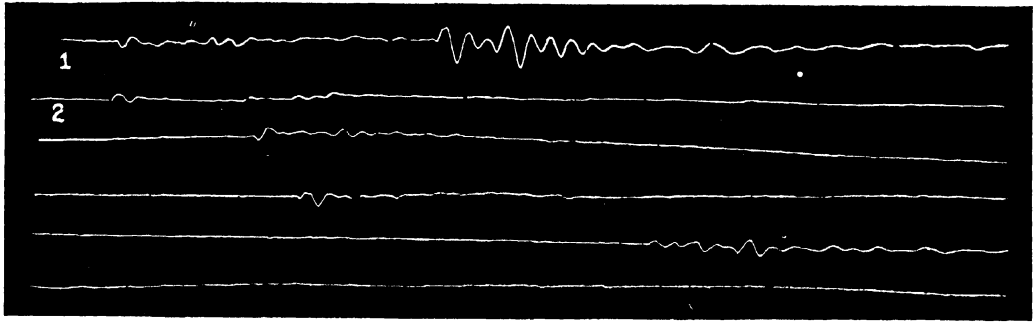

37



38

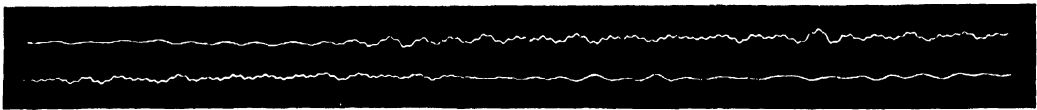

39



40

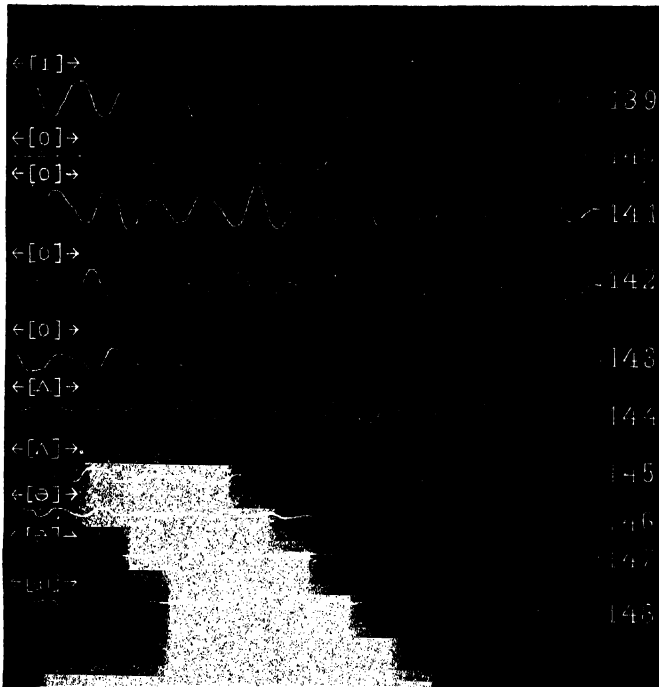

41

FIG. 37.—Blocks.    FIG. 38.—Whistling.    FIG. 39.—Whistling with piano.    FIG. 40.—Plucked string.  
 FIG. 41.—Curves from the Graham record.

CURVES OF VARIOUS SOUNDS



can not be detected by the ear. How a single vibrating string can produce such beats is a problem for investigation. Lack of homogeneity in the string may be the cause.

The curves in figure 41 are from the "Graham record"; they were made by a single lever and have a magnification of 124 and a time equation of 1mm. = 0.00022s. The figure reproduces a piece of a mount three times as wide; each line therefore shows the last third of the line on the mount. Line 139 gives the curve of [ɪ] in "before"; lines 140-143 give pieces out of beginning, middle, and end of [o] in the same word. Lines 144 and 145 give portions of the beginning and end of the vowel [ʌ] in "such." Lines 146 and 147 give waves from [ə] belonging to the article "a." Line 148 is from [ai] of "highly."

The first two specimens in plate VII are from a record by S. Weir Mitchell. The former gives one-fifth of the exclamation "oh" spoken sorrowfully. We observe the gradual change in the form of the waves throughout the "oh," indicating that the sound of the vowel changed slowly. The second specimen gives the last half of [ɔ̃] (not [ɛ]) followed by [ɹɪ] from the word "America." We note that the strong vibrations for [ɔ̃] become weaker as the sound glides into the "untrilled r." This "r" includes at least two wave-groups of small amplitude; the weakness of the vibrations indicates that it is a consonant "r" and not a vowel "r." The vibrations gradually increase in strength as the [ɪ] is produced; this is a very short sound fading away rather abruptly before the [k] which follows the last wave in the line. The third specimen on the plate is from a Chinese vowel; the type of the wave in the first portion of the record is far more constant than in American vowels, but the inevitable gradual change appears in the latter part. The next curve on the plate is a small portion of a trill by an Italian voice (Mme. Chalia) on a high note. We notice at once that the amplitude rises and falls, that is, that the intensity changes. This is the characteristic of a tremolo, not of a trill. These variations of intensity show indications of periodicity in time, but they are very irregular in amount and duration; the first line of the piece selected starts with a weak portion, a second one occurs in the middle of the same line, and a third at the end of it; the second one is weaker than the first and the third is still weaker. The third region of weakening is longer than the others, extending into the second line. The fourth weakening, which occurs in the second line, is most marked of all. A faint weakening occurs toward the end of the second line and irregular weakenings occur in the third line. The pitch of the tone—length of the waves—varies somewhat irregularly from vibration to vibration, but does not rise and fall as required in a correct trill, which is supposed to be an alternation

of two notes. The ostensible trill is therefore not a proper one, but merely a tremolo or quavering on a high note. The false nature of this trill is not apparent even to trained musical ears on first hearing the record, but by making the gramophone disc turn slowly the pitch of the tone is lowered and the tremolo becomes evident.

It would be interesting to investigate the nature of the mechanism of the tremolo and the reasons why it is substituted for a trill; some records and observations on these points will be reported in a future publication. Here I will only say that in my opinion the tremolo is often not produced by movements of the muscles of expiration, but by variations in the action of the larynx. The effect of any such variations in the adjustment of the larynx for a given tone—the pitch of the tone remaining unchanged—would be to modify the timbre of the tone in addition to the alterations of intensity; this would show itself in differences in the form of the waves in the loud and weak portions of the curve. This is apparent at once on close inspection of the curve given; the two portions have two typical forms, with gradual passage from one to the other. How this fluctuation in intensity is produced by the larynx is a matter for future investigation. Before leaving this curve we note that in some of the weaker portions the waves fall into groups of twos or threes or even fours; an explanation is suggested in the discussion of the curves of laughter in the chapter on Qualitative Analysis.

The next specimen on the plate is the curve of the first half of a piano chord with one note more prominent than the others. The curve shows great complexity, due to the summation of the different waves for the separate notes and to the fact that these die away at different rates. A detailed study of the curve requires mathematical methods; it will be given on a future occasion.

The curves of laughter give the last two of a set of laughs which may be indicated by "Ah, hah, hah, hah." These will be discussed in detail in the chapter on Qualitative Analysis.

The curves on this plate were made with a single lever. The time equation is  $1\text{mm.}=0.0004\text{s.}$ ; the magnification is 150. The curves on plates VIII and IX were made with the compound lever. The time equation for plate VIII is  $1\text{mm.}=0.0007\text{s.}$ ; that for plate IX,  $1\text{mm.}=0.0016\text{s.}$  The magnification in both cases is 150.

The phonograph tracing apparatus (figure 42) was constructed by a grant from the Elizabeth Thompson Science Fund.\* It is adapted solely for tracing celluloid cylinders of the Lioret type.

\* A New Machine for Tracing Speech Curves, *Amer. Jour. Sci.*, 1903, xv, 147.

Part of curve of [o]

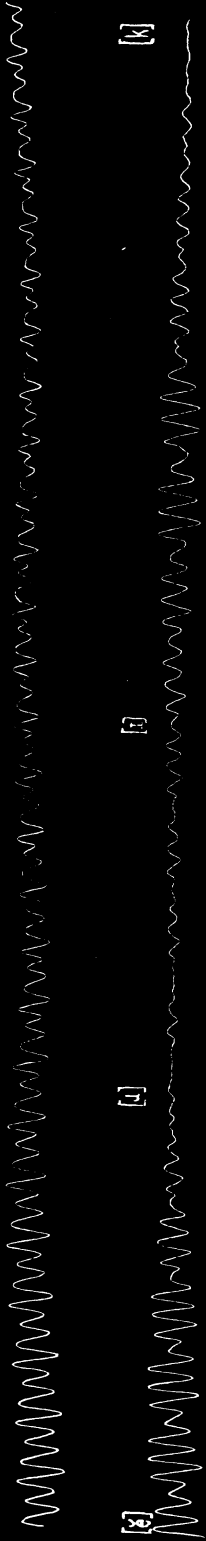

Part of curve of Chinese vowel

Part of a trill (tremolo).

Part of a chord from a piano.

Laughter.

164 mm



The celluloid cylinders are 55mm. in diameter and 43mm. in length. The speech groove consists of depressions just as in the ordinary wax phonograph. They reproduce the voice with great truthfulness. For tracing the speech groove the cylinder is removed from its brass frame and placed on the "rotator." This is a steel barrel having a tapered end for the cylinder. It is rotated by a motor. The speed of the motor is twice reduced to  $\frac{1}{100}$  and finally to  $\frac{1}{3}$  by the pulleys, giving a total reduction to  $\frac{1}{70000}$ . The speed of the motor is so adjusted that the cylinder turns once in  $4\frac{1}{2}$  hours.

As the barrel turns, it is made to move axially by a thread turning in a brass "nut." An additional "bearing" takes the strain of the pulleys and relieves the nut. The celluloid cylinder thus turns and moves axially in such a way that the speech groove passes under a sapphire point, which

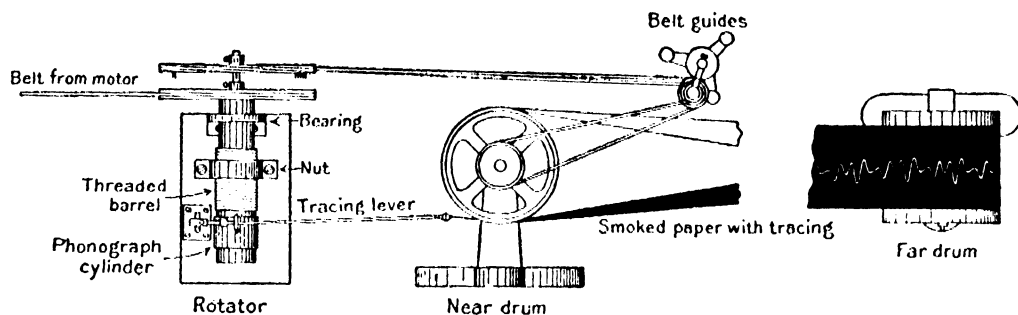

FIG. 42.—Machine for tracing phonograph records.

follows the rise and fall in the bottom of the groove and moves a light "tracing lever." The point of this lever records the movement on a long band of smoked paper passing over two drums. The vertical "near drum" is run by a belt from the rotator. The speech curves appear in great magnification on the band of smoked paper.

The tracing lever is the critical part of the apparatus. The sapphire at the end of a steel point follows the speech groove. The fulcrum of the lever to which it is attached is just to the left of it. The long arm is made of selected German straws of unusual lightness and rigidity. This is balanced by a weight. The end of the straw arm carries a somewhat modified hinge point.



FIG. 43.—Piece of curve obtained by apparatus in figure 42.

A piece of curve reduced to three-eighths size from tracings made by this apparatus is given in figure 43; it is from the record of the French poem "Le Roi d'Yvetot."

In the work of tracing, it is necessary to balance several factors. The enlargement chosen for the vowels will not give the curves of the consonants; that necessary for the consonants makes the vowel waves so high and steep that they lose all detail. In selecting the longitudinal magnification (time equation) such a balance must be kept with the vertical magnification that the waves come out properly for the purpose in hand. For studying curves with the eye it is desirable to condense them horizontally (as in the Cock Robin plate). For accurate measuring and analyzing, they must be more extended. Such an extension takes up too much room in printing, a single vowel being often a meter or two long. A convenient mean is that adopted for the curves shown in plate VII. The problem of cost in printing puts limits to the magnification, as will be readily understood from the following facts. The Mitchell vowel record, traced with the time equation  $1\text{mm.} = 0.0002\text{s.}$  and the magnification 258, gives a strip of tracing 717 meters long (nearly half a mile), which makes 104 plates of the size of plate VII, containing 1,938 lines, each 37cm. long.

### CHAPTER III.

#### QUALITATIVE ANALYSIS.

The entire intellectual and emotional impression conveyed by the voice from the speaker to the hearer is contained in the speech vibration and registered in the speech curve. Hardly any problem of greater interest could be proposed than that of discovering the manner of getting from a voice curve the data concerning the action of the vocal organs in such an exact and minute form that conclusions can be drawn concerning the variations in the voice as depending on every emotion, on every condition of health, on every step in voice culture, on every difference in vowels and consonants, on each change in dialect, etc. The problem, however, is too vast for solution in a short time.

The curve itself is at the outset as unintelligible as a mass of Chinese word-signs. The key to the outline features lies in comparing the curve with the original spoken record of the disc or cylinder; this work may be termed "translating the curve." The actual interpretation of the details of the curve is an art that requires extensive knowledge of phonetics, physics, physiology, and psychology; this art may be called "qualitative analysis." The full content of the curve is found by methods that may be termed "quantitative analysis" and "mathematical analysis."

To interpret a record the words are first written down exactly as spoken by the gramophone or the phonograph, the long and short pauses being indicated by rests. The long straight lines in the record are then assigned to the respective pauses; a portion of the record between two long straight lines thus corresponds to a phrase between two pauses. Each phrase is written in phonetic notation according to the ear. The interpretation of the curve for a phrase proceeds by assigning the short straight portions to the surds, and by picking out the curves for the various sonants. This latter work is sometimes very difficult, as the original division of the words into phonetic elements by the ear fails to take account of the details found in the curve; the ear is also easily deceived, and the usual phonetic transcriptions are often erroneous.

The fundamental supposition on which the interpretation depends is as follows: The record itself is at least as good as the sound which it can be made to give. Every technical expert knows that the record itself is far better than the sound it gives and that the difference between the original sound and the reproduced sound arises less from the recording

than from the reproducing; this is due to such facts as that the reproducers are less well made than the recorders, that the reproducer point does not have time to follow the details of the curve, that details are lost in multiplying records, etc. When a record is heard to say distinctly "Minots Ledge Lighthouse" we can feel sure that the curve traced from it contains the waves for [mainɔts], etc. We can also be sure that it contains many details more for these sounds and their glides than the ear can possibly detect, and that the departure of the waves from absolute accuracy is less than that of the sounds heard from the original sounds.

With the accurately traced record before us we can undertake the study of the curve by the unaided eye. For a phonetician accustomed to interpret curves, the results of such a "qualitative analysis" are so rich that they alone amply repay the cost and pains of tracing records. In this respect the method stands in strong contrast to "mathematical analysis." Here the expert gathers in a few hours a mass of facts of great importance, whereas the full mathematical analysis of a single wave of a vowel occupies days and furnishes only one minute fact; to be sure there is only one way to get facts of the latter kind, and the labor can not be avoided if certain problems are undertaken.

The best way of teaching qualitative analysis is to carry through in detail a few examples; I have selected for this purpose a plate from the Depew record and another from the Cock Robin record.

The Depew plate is number 6 of a series giving the curves of his "Speech on Forefathers' Day." Line 94 shows the weak vibrations for [w] followed by the stronger ones for [ɪ] ending with the first of the weaker ones for [ʃ]. The [ʃ] extends nearly to the middle of the line 95, the vibrations becoming steadily weaker. Here the [au] begins; it continues through line 96 until it glides into [t] in line 97. In line 97 a piece 205mm. long of straight line has been omitted. Let us examine the curve somewhat in detail.

To understand a vowel curve we note that the vibrations occur in groups; for example, in the middle of line 96, the vibrations fall into a series of wave groups. Each group represents the result of one puff (or vibration) from the glottis after acting on the set of vocal cavities. Since each group corresponds to one puff from the glottis, the length of the group can be used to give the period of the puff and consequently the pitch of the voice. Shorter groups represent higher tones, longer groups lower ones. Without making any measurements we can compare groups by means of dividers. We can at once make two observations. In the first place, the length of the groups is not constant; this means that the voice changes its pitch at each instant. This holds good of all speech

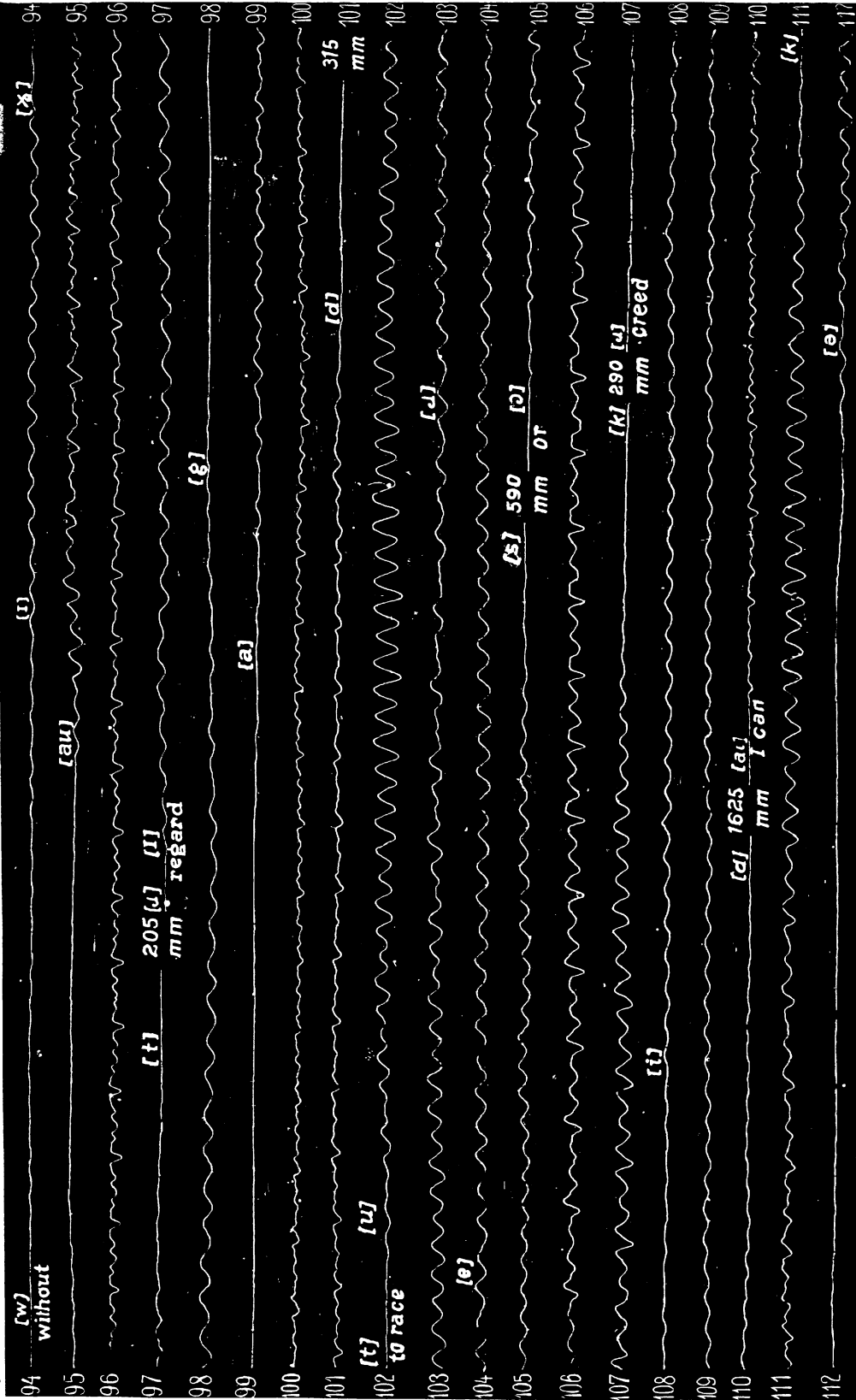

(1mm. = 0.0007s.)

PORTION OF 'SPEECH ON FOREFATHERS' DAY' BY CHAUNCEY M. DEPEW.



records; the glottal tone is never still, even within a very short vowel. Are there any laws governing the rise and fall of the voice within vowels? We will return to this problem later.

The second observation is that, although neighboring groups resemble each other, no two are exactly alike; we also note that the change is gradual as we pass along the series of groups. The vibrations within a group represent the action of the vocal cavities in response to the glottal puff; the form of the small vibrations depends on the sizes, connections and openings of these cavities. The gradual change is to be found not only in every curve in the plate but also in every speech curve. We draw the conclusion that the cavity tones in the spoken vowels are never constant. This fact, when thoroughly understood and recognized, must effect changes in the prevailing views of sounds found in the books on phonetics and the dictionaries. These are really written with notions of sounds that are derived from typography and not from actual speech; the conclusions often have little relation to the really spoken sounds. Attempts have been made to modify these views by concepts such as glides and the like, but the results have an artificiality that makes them of little use. Spoken sounds are phenomena whose very nature lies in their changes from instant to instant; and there is no possibility of getting any scientific information concerning them, except directly from the sounds themselves.

Another observation forces itself upon us in the curve for [aʊ]. Since the form steadily changes from beginning to end of [aʊ] we must conclude that this sound is not a diphthong composed of a sound [a] followed by a sound [ʊ], but is a single sound which begins in one way, passes gradually through various forms, and ends in another way. That we think we hear the two sounds [a] and [ʊ] is mainly a matter of suggestion from teaching. Many other so-called diphthongs show a structure like this one. Is it an illustration of a general law for all diphthongs? or are there different kinds of diphthongs? or is it an isolated fact? If the sound changes steadily from beginning to end, was any [a]-sound or [ʊ]-sound really present in the sound for which we have used the symbol [aʊ]? If vowels also show continuous change as a fundamental element, are all vowels really diphthongs? or are diphthongs really only long vowels? or, finally, are these concepts merely suggestions from type or illusions of the ear? These are problems whose solutions may be found in the study of speech curves.

Comparison of the curve for [a], lines 99–101, with that for [aʊ], lines 95–96, shows considerable resemblance of the middle portion (line 100 and first half of line 101) of [a] to the middle portion (first two-thirds of line 96)

of [au]. The two sounds in these portions are therefore similar although not identical; assuming that the [a] of "regard" is typical, we can say that most of the second vowel of "without" consists of [a]. We note next that the last portion of this vowel, line 96, shows a few waves that differ considerably from the [a] waves; this we expect, because we have been taught to consider this vowel as a diphthong, but what we do not expect is to find that this portion is exceedingly short, comprising not more than one-sixth of the whole vowel sound. The waves do not resemble the waves of the distinctly spoken short [u] in "to," line 102; the sound may be [ʊ] or [ə], but we do not have sufficient material on this plate for comparison; comparison with other curves indicates that it is [ʊ]. Quite unexpected is the fact that the first portion of this vowel, line 95, shows waves that differ from the [a]-waves. The vowel is therefore not a diphthong, but a triphthong. To judge from the resemblance of the waves in line 95 to those in line 106, the first portion is [ə]-like in sound. We have here, then, the triphthong [əau] in which the longest portion is [a] and the shortest [ʊ].

Going back now to line 94, we observe that every third wave of [ɪ] has a small, sharp corner; the waves thus fall into groups of three. The form of vibration is utterly different from any form seen in [au]. The cavity tones must be different. The groups are all longer than in [au]; the voice is consequently lower. The groups for the preceding [w], which can be readily distinguished, are still longer. We see at once that the voice begins low for [w], rises through [ɪ] and becomes still higher in [au]. We also note that internal changes take place during the [w] and during the [ɪ]. The change from [w] to [ɪ] is gradual. At the end of line 94 the vibrations weaken as the sound changes to [ʃ]; they become steadily weaker in line 95, till in the middle they change into [au]. There is no sharp limit between [w] and [ɪ], between [ɪ] and [ʃ] or even between [ʃ] and [au]. For example, the change from [ʃ] to [au] occupies at least two groups of vibrations in the middle of line 96. These might be reckoned to the beginning of the vowel, although the first of the groups is weak and in both the form is rather different from the typical form of the following vibrations. They can hardly be reckoned to [ʃ], for we define [ʃ] as a sonant fricative produced in a narrow passage between tongue and palate; here the tongue has begun to make a large opening. We may call them a "glide" from [ʃ] to [a] although it is difficult to say why the second wave is to be counted to the "glide" and the third to the vowel. A "glide" is, moreover, merely a makeshift to help us out of the difficulties introduced by the erroneous view that speech is made up of a series of independent elements. Not only must we say that every individual sound changes from beginning to end, but we must assert that each one develops out

of the preceding sound and into the following one. In speech there is a flow of sound which can not truthfully be represented by any spelling; there are no well-defined limits between neighboring sounds—not only because the limits are vague, but also because there are no independent sounds to be limited.

The [t] of “without” and the [ɹ] of “regard” are contained mainly in the 205mm. of straight line omitted. A characteristic phenomenon is shown by the curve at the beginning of line 97. The vowel vibrations diminish rapidly in the amplitude till they cease altogether, because the tongue is moving in the mouth to the [t] position. This may be considered as the glide from the vowel to the closure of the [t], or as the “implosion” of the [t]. We note here again that the change from one sound to another is gradual, that speech is a fusion and not an agglomeration.

In line 97 the vibrations for [ɹ] clearly fall into groups of two; the groups are of the same general form as those of [ɹ], line 94. This form occurs frequently for the vowel [ɹ] in the Depew speech.

In the middle of line 98 the [ɹ] vibrations weaken into [g] vibrations. For the latter part of [g] they are lacking or else they are too small to show with the degree of magnification used. This part of the [g] thus becomes (if the former is true) or approaches (if the latter) a surd [g], which differs little from [k]. This is a familiar phenomenon for final [g] with many Americans who pronounce “dog” as [dɔgk] rather than [dɔg].

Line 99 shows vibrations as the tongue changes from the [g]-closure to the open position of [a]. The vibrations of [a] show a steady change from beginning to end. The change is especially marked at the two ends, though not so great as in [aʊ], lines 96–97. A comparison of the two cases shows how little difference there may be in actual speech between what we have been taught to consider a diphthong—or triphthong—and what we believe to be a steady long vowel. A diphthong, in fact, is in many cases simply a long vowel in which the change is considerable. Here the change is not very great.

The 315mm. omitted include most of the [d] and [t]. As the [t]-closure is opened, the vibrations appear in line 102. Are these weak vibrations to be reckoned to the vowel vibrations that occupy the rest of the line? or are they to be treated as a “glide” from [t] to the vowel? I have placed the beginning of the vowel at the point where the vibrations reach half a millimeter amplitude. For the vowel the speaker uses here a distinct, short [u]. The [u]-vibrations fall into groups of three; the main cavity vibration for the [u] is thus about a duodecime above the tone of the voice. The form of the group begins to change early in line

103; beyond the middle it is already quite different. Somewhere here we must place the vowel-like "r." The change continues and a new type gradually arises in line 104 and lasts till the middle of line 105; this is the vowel [e]. Again we observe that nowhere in this whole sequence is there any sudden change, nowhere any possibility of assigning limits between the three vowels [uæ]. We must conclude that there are no such limits and that the sound changes gradually throughout. Another unexpected fact confronts us; very little change is found in the curve for [e] in lines 104, 105. The change can hardly be detected; it is far less than that for [a] in lines 99, 101, or, in fact, for most simple vowels. The prevailing view that "long a" in English is a diphthong [ei] is not correct for this example of American "a."

The vowel [ɔ] of "or" occupies nearly two lines of the record (105-107); its curve shows considerable resemblance to that of [a]. The changes in the latter part indicate the presence of some other sound, possibly [ə]. The [ɹ] in "creed" is weak; so is the vowel [i]. The [ai] in lines 110, 111, shows again a steady change from beginning to end. The group with a large number of short vibrations as in line 110 is quite different from that with three longer and stronger vibrations in line 111. These types are characteristic of most cases of [ai] (see the special study of [ai] in Appendix II of my "Elements of Experimental Phonetics"). This [ai] may quite properly be called a "diphthong" on the understanding that it does not consist of a separate [a] followed by a separate [i], but is a single long vowel sound (changing steadily from beginning to end) in which the first portion resembles [a] and the latter [i]. I have used [i] to indicate the latter part, although it is not the same sound as an independent [i]. The plate ends with a few vibrations of [ə] of "can" spoken as [kən].

Another illustration of qualitative analysis will now be given. Plate IX is from a record of "The Sad Story of the Death and the Burial of Poor Cock Robin." The weak vibrations of [w], line 1, are followed by strong ones of [r]; the change is gradual as usual. The [r] is followed by the weak vibrations of [ʒ] and [m] which can not be distinguished from each other. The [m] passes into [a] of [ai] in two vibrations; the first of these is weaker, the lips not having opened; the second is stronger, but the smaller vibrations are not those of the following [a], the mouth not yet having reached the [a] position. The following vibrations for [a] are quite characteristic; they rise steadily in pitch and amplitude. About the middle of [ai], line 3, the amplitude steadily falls, although the pitch continues to rise. The form of the curve steadily changes to the utterly different form for [i] in the latter half. The groups of two almost equal vibrations

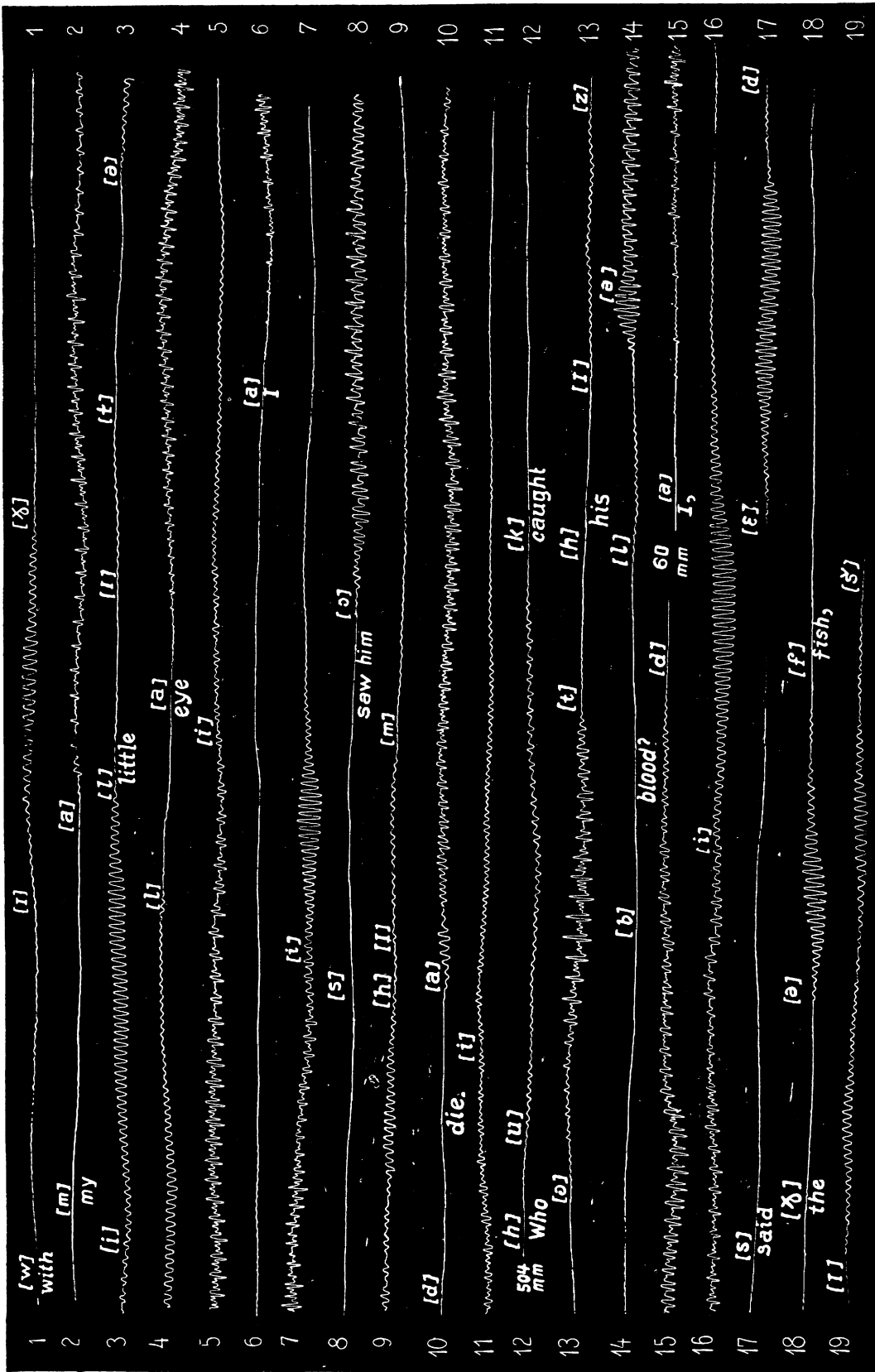



(the cavity tone being approximately the octave of the glottal tone) for [i] rise and then fall in amplitude. There are two maxima of amplitude in this vowel; it is therefore an intensity diphthong as well as a quality one. The vibrations of [i] pass rather abruptly into the weaker ones for [ɪ], line 3. The [ɪ] is followed by an extremely short [ɪ], which includes seven groups of vibrations. Then follows the plain line for [t], after which comes the rather long vowel [ə], line 4, followed by the weak vibrations for the final [l], line 4. As a phonetic spelling for this case we might use [l.təl], where the smallness of the [ɪ] indicates its weakness. The vibrations of the [l] pass into those of [ai] in "eye," line 4, without break. The form of the vibration for the first part resembles that in the [ai] of "my." The last part is quite different from those of the other [ai]s; the vibrations come in groups of five and are weak. My ear is unable to decide what the second element in the ordinarily spoken "I," "my," "die," etc., sounds like; it may be [i], [ɪ], or [ɛ]. No help is obtained by exaggerating the pronunciation of a certain speaker; in conversation he may speak otherwise. The curves on this plate show that the last parts of "my" and "I" are similar to each other, also those of "eye" and "die" to each other, but that the two types are different. In default of any means of decision with only these two plates I have indicated both types by [i]; further work in vowel analysis will show which sounds are most like [i], which like [ɪ] and which like [ɛ],—or perhaps that some of them are still different; the final decisions can be quickly and definitely made as soon as the sound can be acoustically reproduced from its curve and prolonged by the apparatus described at the close of this chapter. The [ai] in "eye" has one of the characteristic marks of an initial vowel, namely, the rise from a small amplitude; the other one—the rise from low pitch—is lacking, as would be expected from the fact that [l] passes without break into [a] whereby the glottis would hardly make any sudden jump in the pitch of its tone. The pitch of [ai] remains constant for a while and steadily falls; such a fall is characteristic at the end of a phrase. It is to be noted that there is not a break in the curve or in the action of the glottis except at [t], and that even here very weak vibrations appear. "With my little eye" is a single speech unit, the result of a single thought. A grammatical analysis into preposition, possessive pronoun, adjective, and noun has nothing whatever to do with what was said; the speaker had an impulse—perhaps a mental picture of a sparrow with his little eye—and expressed it as readily and as automatically by "with my little eye," as in another case he would have done by any other words or even a single sound associated to the picture. There was no separation into two or more ideas,

otherwise there would have been a break in the even course of the pitch of the glottal tone.

The short pause after "eye" is followed by an emphasized "I" which has all the characteristics of the initial vowel (see above); its latter portion has the same form of curve, but is louder and much shorter than that for the latter portion of "my." The sharp, quick fall at the end of "I" is a means of emphasis. There is a short pause after "I," followed by [s] of "saw him." The vibrations for [ə] of "saw him" show that the vowel action is similar to that for [a]; the curve passes into a curve which resembles something between that of the latter half of "my" and that of "die"; in fact we have here apparently the diphthong [əi] constructed like [ai].

The rather weak vibrations for [i] and the still weaker ones for [m] are distinctly seen in line 9. Is the breath-sound [h] lacking? We might suppose that the [h] was omitted, especially as this is generally the case in such phrases in England and as the same has been asserted to be true



FIG. 44.—Sonant [h] in the Jefferson record.

for America. But the record can be heard to distinctly pronounce "saw him" and not "saw 'im." The [h] is therefore present between [ə] and the following [i], although the vibrations of the glottis do not cease for an instant. We thus have here distinctly a sonant [h]—prescribed by the Sanskrit grammarians, long supposed to be non-existent in modern languages, and pronounced an impossibility by some phoneticians. The curve for this sonant [h] can be seen in the weakened vibrations after [ə] in line 9. Another case of sonant [h] was found in the other curve of "saw him" ("Who saw him die?") in the Cock Robin record. Still another was found in the Jefferson record (figure 44). The proof is the same in each case; the vibrations are continued without interruption between the two vowels, and yet the gramophone disc speaks a distinct [h].

How the breathy [h] is produced while the glottis is vibrating is a question to which a decisive answer can not be given at present. One view of the mechanism of sonant [h] is that the glottis opens while the glottal lips are vibrating and that this permits an escape of air with a rushing noise (this does not appear in my curves) while the vibration continues. This involves a fairly constant tension in the glottal lips, in spite of the opening of the glottis. The action is presumably like that of the sonant

whisper. This would probably be the action corresponding to Seelmann's view of the nature of the Greek spiritus asper and lenis as being the strong and weak breathy beginnings of vowels.

The speech curves suggest another view. This is that the glottal lips continue to vibrate during the intervocalic [h] with no disturbance, the glottis remaining closed as in the adjacent vowels, and that the [h] is produced by narrowing the air passage either by bringing the ventricular bands together or by partially closing the epiglottis down over the larynx. One can sing a breathy [a], [e], etc., indefinitely long with some closure that is behind and below the tongue. According to this view the sonant [h] would be a sonant fricative of the same class as [j] in North German "Jäger" or [ɣ] in North German "Sage," etc., with the passage narrowed in the mouth. It thus differs radically from the ordinary surd [h]. This view is in conflict with a fundamental psychological principle that I have felt obliged to assume as the basis of all deductions concerning sound change, namely, that where a person varies from one form to another—for example, surd to sonant [h]—in the same combinations of sounds used on different occasions without perceiving any difference, the two forms must be merely variations of the same articulation. In records from a person speaking continuously we find surd and sonant [h] used indiscriminately between vowels; exactly the same words are spoken on one occasion with a sonant [h] and on the next with a surd one. That in one the breathy sound should be produced by the ventricular bands and in the other at the glottis seems—from the psychological principle of performing the same act in the same way with a variation around a mean—to be improbable. The final decision must be left till definite experimental knowledge can be obtained. It is hardly profitable to go into discussion of the possible relations of the sonant [h] to the Arabic "ain." The physiology of neither sound has yet been established; what speculation can do is shown by Sweet's amusing supposition of a vibration occurring below the glottis (that is, in a wide open tube with walls of cartilage) for the Arabic "ain."

The [ɪ] in line 9 is short and weak, being almost lost before the [m], which is much longer. The vibrations of [m], like those of all sounds where the mouth is closed, are of much smaller amplitude than those of the vowels. The vibrations for the [d] are still weaker than those for the [m]; there is no break between the two, the sounds being run together. The explosion of the [d], line 10, and the large irregular vibrations as the [d] passes into the following vowel extend over an unusually long space. The curve for [a]—which may be made to include the irregular vibrations

or not, as the reader pleases—shows a long series of waves whose amplitude rises and falls, but whose pitch, as can be seen directly in the lengthening of the wave-groups, steadily falls. The latter part of [ai] falls steadily to a very low pitch, as is usual at the end of a phrase. The [i] is very weak.

After an interval of 504mm.=0.8s. the following stanza is begun with the curve for "Who." The weak vibrations for [u], line 12, fade in three groups into [k] of "caught," which extends to the first part of line 13. The unusually strong vibrations for [ɔ] change their form in the middle of line 13 and indicate slight diphthongization. The vowel fades in three or four groups of faint vibrations, which, in my opinion, are to be considered as a sonant beginning of [t]. The limits between [t] and [h] can not be given; the two sounds are very brief. The short [ɪ] of "his," line 13, is followed by vibrations for [z], lines 13 and 14; those for [b] of "blood" are too weak to be seen. The vibrations for [l], line 14, are weak. The [ə] of "blood" begins with very strong vibrations, line 14, which gradually become weaker in line 15, and fade into [d]. The 60mm. omitted belong partly to [d], but mostly to the pause. The curve for [ai] of "I," lines 15-16, resembles that for [ai] of "I," lines 6-7, above, but is longer. The [s] of "said" is represented by the straight line in line 17. The vowel [ɛ], line 17, is followed by weak vibrations for [d]. Then comes a line for [ʒ], followed by the vibrations of short [ə] of "the," in line 18. The [f] of "fish," line 18, is rather long; the vowel [ɪ] is shown in line 19.

Owing to the comparative condensation along the horizontal axis (1mm.=0.0016s.) the amplitudes of the vowels appear more characteristically to the eye than in the Depew plate (1mm.=0.0007s.). Several general characteristics of the American vowel can be at once established. We note first that all but one of the vowels on the Cock Robin plate is of circumflex amplitude, that is, the amplitude rises steadily to a maximum and then falls, in a regular crescendo-diminuendo. This is the fundamental form of amplitude in the American vowel; the variations in suddenness and extent of the circumflexion are elements of expression. The vowel [ɪ] in "fish," line 19, has a double circumflex; it should be perhaps treated as an intensity diphthong with two like elements, or as [ɪɪ]; if not so short, it would be heard as distinctly diphthongal as [ai].

It is to be noted that the two kinds of [ai] differ also in the course of amplitude; the [ai] of "I" and "my" is not only a quality diphthong with two different types of wave-group, but is also an intensity diphthong with two maxima of circumflexion; the [ai] of "eye" and "die" is a quality diphthong with only one circumflexion of amplitude. An investigation

is now being made to determine if this double diphthongization is a regular characteristic of the pronoun "I."

So much has been said of the complexity and the variability of the speech curves that the impression may have been produced that they are hopelessly irregular. This is not true. They are as irregular as the leaves of the trees; no two are exactly alike, yet the individuals of a variety resemble one another and differ from other varieties. The resemblance between two cases of [ɪ] and that between [a] and the first portions of [au] and [ai] in the Depew plate has been noticed. The conformity to type, with difference in each case, can be clearly seen in the several cases of [ai] on the Cock Robin plate and in the extended special study of [ai] above referred to. Moreover, resemblances are found between the corresponding sounds on the two plates, whereby it must be remembered that the horizontal magnification for the Depew plate is 1mm. = 0.0007s. and for the Cock Robin plate 1mm. = 0.0016s.

The curves in plate x show waves from various vowels spoken by Joseph Jefferson in "Rip Van Winkle's Toast." Each line contains only a few waves out of the curve for a vowel. The first line is from the beginning of the vowel [ə] in "Come"; we note that the amplitude increases steadily; in the latter portion of the vowel (not shown) it falls again. It is a general law for American vowels that their amplitudes are convex, or crescendo-diminuendo. Applying the dividers to the wave-groups, we find that the pitch of the glottal tone steadily rises. It is a general law that the pitch in an American vowel steadily rises and then falls, but this is modified greatly by the adjacent sounds. The form of the wave-group steadily changes, and we have here an illustration of a third fundamental law also, according to which the American vowel changes its sound constantly. These three laws might, perhaps, be deduced from one, namely, that every factor of muscular adjustment—respiratory pressure, glottal tension, and vowel configuration—is continually changing in an American vowel. The curve in the second line is from the first portion of [ɪ] in "Rip"; it likewise illustrates the three laws. The waves in the third line are from the latter half of the vowel in "what"; the amplitude does not fall gradually according to the first of the above laws, but diminishes suddenly beyond the piece here shown in three waves as the sound changes to [d], the words being spoken as [hwədəjə]. As the reason for this exception to the law of convex amplitude I can only suggest that possibly the following [d] (although a consonant) is treated by the speaker—unconsciously, of course—as unified with the vowel just as the latter portion of a diphthong to the first part; we have already seen how several sounds may be unified into one vowel stretch; and this may indicate the

extension of the principle. The next line contains a portion from the middle of [ə] in "do," comprising the top of the amplitude-convexity. The steady change in form is apparent. The eye tells at once whether the curves in the other lines are from beginning, middle, or end of a vowel simply by noting how the amplitude is changing.

A comparison of the curves for the different vowels is interesting. The vowel of "Come" is the one described by phoneticians as the indefinite vowel and indicated by [ə]. The waves show that—like all short vowels—it changes its character greatly within a short time; from such a changing sound the ear obtains only a general impression with no indication of the variations. If we select the waves at the right of the line as typical of this vowel, we find that somewhat similar waves occur for the vowel of "do"; as far as the ear can judge the two vowels sound alike. The ear is absolutely incapable of deciding what the vowel is in "what" in this record; I have indicated it by [ə], but its curve bears no resemblance to those of [ə] in the "Come" and "do." To the ear the vowel of "you" in the fifth line is also the indefinite one, but its wave shows that it is quite different from the vowels in "Come" and "do." The ear hears that these "indefinite vowels" differ from one another, but we can not state the distinctions because phonetics has not provided the means of specification. As the curves in plate x show, these vowels have sharply defined, characteristic curves; the indefiniteness does not lie in the vowels, but in our knowledge concerning them.

The vowel of "to" is distinctly heard to be a very short [u] and not [ə]; its waves are similar to those of "your" and "good." This "your" is spoken with [u] and not like the "you" in the fifth line. The writer is utterly unable to decide by the ear what vowel is used in "your" of the nineteenth line; it sometimes seems to sound rather like [o]; its curve resembles no other in the figure. The indefinite article "a" is pronounced with the vowel [ə]; the curve is somewhat like that of [ə] in "you." The waves for [æ] in "glass," "that," "schnapps," "and," and "family's" show little differences from one another, except in their amplitudes. The vowel in "pros-" shows waves that are not similar to those for the [a] in the last line; the vowel in this case is certainly not a "short a," although that would probably be the English pronunciation. I have indicated it by [ə], which seems to be the most common American pronunciation. Its latter part shows a slight similarity to the first portion of the vowel in "Come." The line for "per" shows only a few irregular vibrations; Jefferson was accustomed to speak this syllable practically as a surd.

The curve of laughter on plate VII presents some interesting problems. The vowel in these laughs is not the vowel [a] or [ə], although it seems

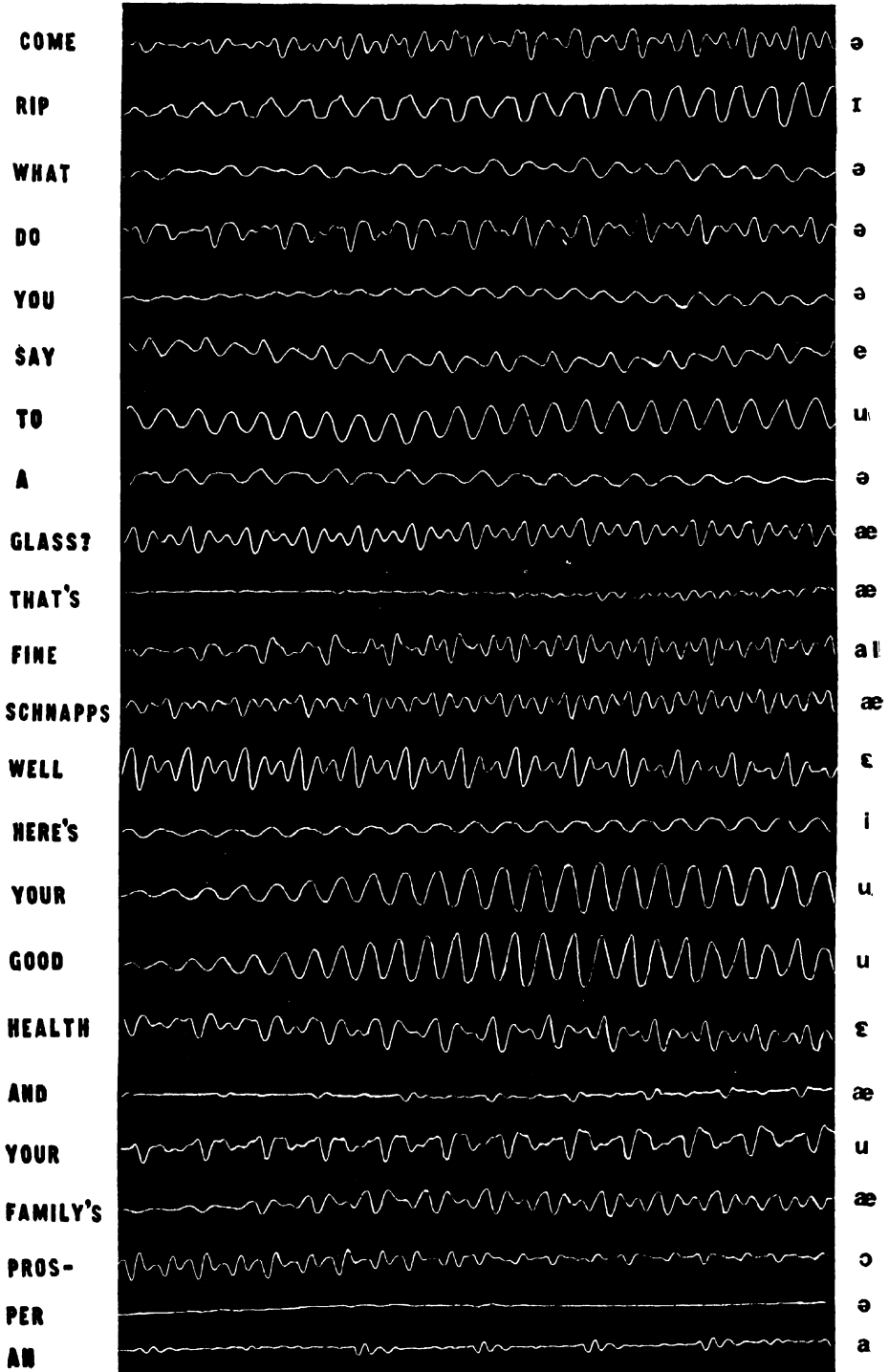

WAVES FROM VOWELS BY JOSEPH JEFFERSON.



to resemble them; it does not in any way resemble [o] or [i], but the ear fails to suggest anything more definite. The ear hears an [h] sound at the beginning of each of the two laughs, but although it is fairly clear that there is some sound after the vowel, at the end the ear can not decide whether it is [h] or not. The sounds of laughter are not so frequent as the words of ordinary speech and their characters are not so typically fixed; the ear is left, therefore, to judge from the sound itself with less suggestion from the context or past experience. It is legitimate to ask, If the ear fails us so when it receives no help from suggestion, does it not falsify when the suggestion is present? I must add that I submitted the record to five persons, who all showed the same indecision.

The curves themselves are surprising. In the middle of the first line the waves are characteristic vowel curves. Toward the right the form of the wave changes steadily—that is, gradually from wave to wave—but yet with such rapidity that there is as much change in five waves as in two or three times the number in the American vowels we have considered; between the middle and end of the vowel (last quarter of the line) there are at least three utterly different types. The portion just to the left of the middle exhibits a peculiar phenomenon; there is a tendency to weakness of the maximum amplitude in alternate wave-groups. If dividers are placed over the middle portion so as to include two waves it will be found that when applied to the earlier portion they will mark off vibrations that appear to be almost single wave-groups. They can not be single wave-groups, because they would then have an extremely low pitch, whereas the laugh is on a high pitch; also because if that were the case there would then be a sudden jump of an octave in the middle of the laugh—a jump that the glottis can not make from one vibration to the next, and finally because even in the middle of the laugh itself (but not in the latter half) there is a fainter indication of the same phenomenon.

Let us now consider the laugh from beginning to end. At 11mm. from the end of the first line there appear faint vibrations which become quite marked at about 40mm. further. They seem to fall into groups of two faint waves with two vibrations each, and then a stronger wave with likewise three subordinate divisions. Beyond this point the so-called subordinate vibrations can not be grouped satisfactorily. We might be inclined to take four subordinate groups for the fourth wave and two each for the six following ones; but this is not allowable, because such large groups would indicate a lower pitch of the voice than was present in this case, and because the pitch can not change suddenly from group to group. We are forced to conclude that each of the so-called subor-

dinate vibrations is one wave-group representing one puff from the glottis and that the systematic changes in amplitude have some special cause. I have no final explanation to offer for this phenomenon, but I venture the suggestion that the smaller groups arise from vibrations of the muscular glottis, while the larger groups come from vibrations of the whole mass, including the vocal muscles and the arytenoid cartilages; that is, of the entire glottis, cartilaginous as well as muscular. In an ordinary vowel the whole glottis is supposed to vibrate in the chest register and only the muscular glottis in the head register. Here, although the whole glottis may vibrate with a longer period, the muscular glottis vibrates in addition with a shorter period. Such a combination of two vibrations is not difficult to imitate mechanically. This action may perhaps arise on account of the preceding [h], which may be sonant in its latter portion. If this sonant portion is produced by the muscular glottis vibrating while the cartilaginous glottis is open for the air to pass with aspiration, the vowel might be produced by closing the latter somewhat more, whereby the entire mass might come into vibration without stopping the vibrations of the muscular glottis. In the last part of the line the vibrations die down rapidly; the pitch also falls. The smaller vibrations toward the end of the first line and in the second line show signs of conflicting grouping suggestive of conditions similar to those at the beginning; there is probably present some such sound as sonant [h], although the ear is quite unable to decide what the sound is. The curve of the second laugh shows vibrations in many respects similar; there is, however, a tendency to fall irregularly into groups of three instead of two, or even into groups of four, throughout the whole curve. We note far less change from wave to wave; in fact, not more than in vowels of ordinary speech. The unusual curves found for these laughs may have some other explanation than the one I have suggested; in particular, we may note the possibility of vibrations or flappings of other parts of the vocal apparatus, namely, the ventricular bands or the epiglottis. A somewhat similar phenomenon has been observed in the curve of "So," spoken by Jefferson (plate VII of "Elements of Experimental Phonetics"). This word was spoken after a toast and the sound is like that produced when a particle of liquid remains in the throat. It may have been produced in this case by some flapping of the ventricular bands or the epiglottis. Still another example of this grouping of waves occurs in the curve of the trill as already noted on p. 36.

The qualitative analysis in all these examples has been a purely descriptive one made by the eye, yet it advances far beyond the older

methods. The descriptions of speech sounds contained in the usual works on phonetics are careful and clever, but they go no further than unaided observation; the use of the method of registration and tracing is like introducing a phonetic microscope which from the start opens up a new field.

The qualitative analysis as already described in this section has been made without any experimental aids. There is a future, however, for the introduction of a system of "experimental analysis"; if such a system can be developed its results will certainly be as startling as the series of discoveries in chemistry resulting from the introduction of similar methods.

The experimental analysis of the action of the vocal organs in speech is already well developed and forms almost a science by itself. A first attempt at something different, namely, an experimental analysis of the sounds heard by the ear, will here be described.

As already repeatedly pointed out, no two waves of a vowel are alike; the differences are often so great that we may be sure that one part sounds utterly different from another, although the ear apparently gets only a single general impression. A method must be found whereby the ear can be enabled to hear the sound of each wave separately; for this purpose the apparatus illustrated in plate XI has been constructed.

A "zinc strip" with the etched curve—which may be a photographic copy of any speech curve or an arbitrary curve—is moved horizontally between guides by a "felt wheel." Resting in the etched groove on the strip there is a sharp steel "motor point" at the end of the "reducing lever"; this point follows the vibrations of the curve as the strip is moved. The movement imparted to the reducing lever is registered by a second steel point—the "recording point"—near the fulcrum. The registration is done on a rotating zinc "recording disc" coated with asphalt varnish or with wax, or on a wax disc. The relations of amplitude, that is, the degree of reduction, are arranged by adjustment of a little slide carrying the recording point. The horizontal axle in the reducing lever is to allow for differences in thickness of the recording disc.

To establish the necessary relations between the movement of the zinc strip and the rotation of the disc they are both moved from the same source. The motor belt turns an axle carrying a "spur driving gear"; this turns another "spur gear" which is attached to the "driving axle" for the two parts of the apparatus. This driving axle carries two worms. One "worm" rotates a "worm gear" on the axle with the felt wheel. The other "worm" rotates a "worm gear" on an axle with two pulleys; of

these only the "upper pulley" appears in the figure. A belt from the upper pulley turns the recording disc. A belt from the lower pulley turns a "rotating tube," in which there is a screw that moves the recording disc sidewise; in this way the recording point is made to trace a spiral line from the outside to the center. To permit the side-movement of the recording disc the belt passes through a "belt spanner" with weight, which allows the belt to lengthen and yet keeps it always at the same tension. The "belt tightener" for the belt from the lower pulley is provided with a spring that keeps the tension constant. For many purposes it is desirable to have the recording point trace one revolution in a circle and not make a spiral; for this the belt tightener is loosened so that the rotating tube remains still.

With this apparatus a single wave can be selected from the curve and can be repeated indefinitely on the zinc strip; the gramophone disc then produces continuously the sound of that wave. Beginning with the first wave, we thus make a disc, one line of which will produce indefinitely the sound of the first wave, another line the sound of the second wave, etc. In this way we have an acoustic analysis—for the ear!—of each element in the vowel. For example, we are thus able to hear separately the 25 different vowels that are present in the record of [ε] in "get" with 25 waves. Innumerable debated problems can in this way be settled immediately. For example, what is the vowel in "not" in the case of a certain speaker? The word is recorded on a gramophone disc in natural conversation, and the curve is traced off; then a single wave or a group of waves is etched on a zinc strip and traced repeatedly on the gramophone disc; the disc then speaks the vowel continuously as long as desired and affords an opportunity for deciding its resemblance to [ɔ], [ə], or [a]. When this has been done for a number of persons whose speech is recognized as having the standard pronunciation, the proper phonetic spelling of "not" can be settled. We are quite safe in asserting that very many—or most—of the short vowels are incorrectly indicated in the dictionaries. By the speech curves and by this apparatus it will be possible to settle the correct pronunciations.

There is still another application of interest, namely, an inquiry concerning the sounds of arbitrary curves. For example, what is the sound of a zigzag line or of a zigzag with one element shorter than the others? What is the sound of a curve composed of alternating positive and negative semi-circles? Just as each musical instrument and each vowel records its own peculiar curve, so each peculiar curve will produce a special sound; from curves not like those of known musical instruments or vowels we may expect sounds representing musical instruments that do not exist.

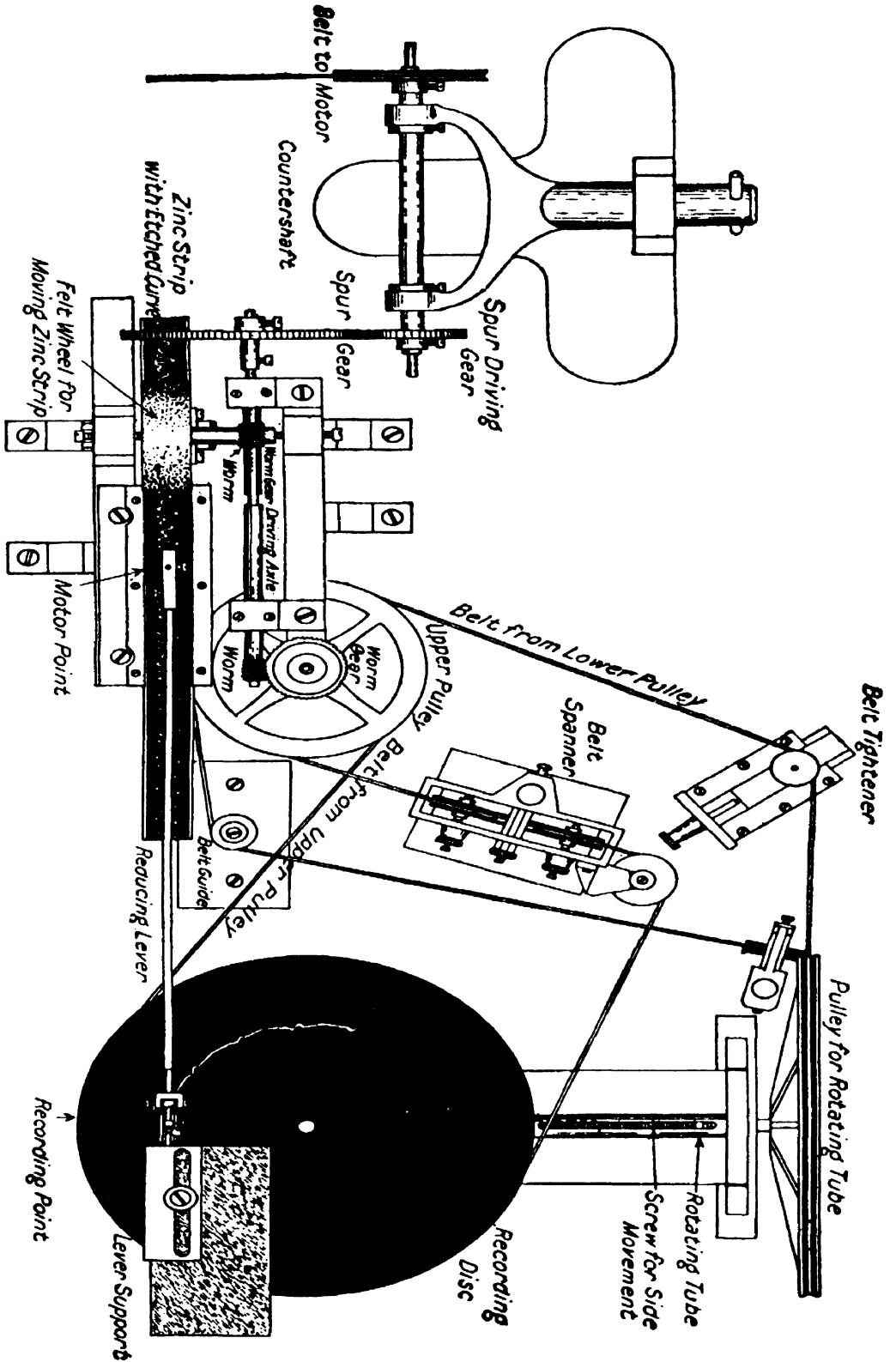

APPARATUS FOR AUDITORY ANALYSIS



The apparatus took its origin in a suggestion from Dr. Billings that it would be desirable to have a machine that would test the accuracy of the tracing of a curve by making a gramophone plate from it and comparing the sound with the original. For tracings like those of my last machine there is no necessity for such a test, as their accuracy can be readily proved in other ways. The test, however, is important for phon-autograph curves (p. 14), which are entitled to little credit until so tested. It is also important for curves that may be obtained where the apparatus has not been carefully tested and cared for. The special importance of the apparatus, however, lies in an utterly new field of research opening up by it, namely, the acoustic analysis of speech sounds.



## CHAPTER IV.

### QUANTITATIVE ANALYSIS: APPARATUS, METHODS.

The term "quantitative analysis" is used here to include such analysis of sound curves as may be obtained immediately by measurements. It is distinguished from more complicated methods—such as harmonic analysis—which are based on measurements, but which aim at both qualitative and quantitative distinctions.

For measurements the following pieces of apparatus have been found useful: For long pieces of curve a millimeter scale is advantageous; when tenths of a millimeter are required, they can be estimated by the eye. For the finer measurements either a metal scale in tenths of a millimeter read by a watchmaker's eyeglass or a low-power microscope with ocular micrometer, or a low-power microscope traveling on a millimeter thread with barrel reading in hundredths, may be used. Each of these methods has its special advantages and difficulties. The only convenient scale in tenths of a millimeter which the writer has been able to find is the "petite échelle en argentan divisé d'un côté en dixièmes de millimètres" for 20 francs from the Société genevoise, Geneva. It is 110mm. long. The measurements can be made quickly, but the work is fatiguing. Except in a very few cases the ordinary low-power microscope with micrometer ocular is not available, because the field is not large enough. To meet the needs of the work I have arranged a microscope as described in the following paragraphs.

The "coordinate measurer" shown in figure 45 comprises a microscope mounted on a car movable in two directions by micrometer screws. The microscope is held on a projecting arm, which can be replaced by other arms adapted to hold other microscopes or magnifying glasses; the sights in the posts are for adjusting the carrying arm in the plane of the horizontal screw. The screws must be accurately made and must not show any wobble or back-lash. The whole apparatus should be stoutly built; the rails shown in the figures should, in the future cases, be replaced by V-bearings. It is made rather small so that it can be readily placed anywhere on a plate of curves and clamped to the table or drawing-board. The ocular may have cross lines or a scale.

The apparatus is placed over the curve to be measured, with the horizontal screw parallel to the axis of the curve. This is accomplished by scratching beforehand on the celluloid covering of the plate a line that is

apparently the axis of several waves. The horizontal axis of the already adjusted ocular (upper lens focused on the cross lines) is then made to coincide with the axis seen through the microscope. When the microscope is moving horizontally the horizontal line of the ocular will remain in the axis if all adjustments are correct. A difficulty lies in the fact that the ocular scale has to be read over the dark surface of the smoked paper. An ordinary scale is hardly visible. Various means of producing a white scale and illuminating it in the ocular have been tried, but without success. A scale with thoroughly blackened lines (as in the Leitz ocular) works successfully when the plate is well illuminated. Each time before use the upper

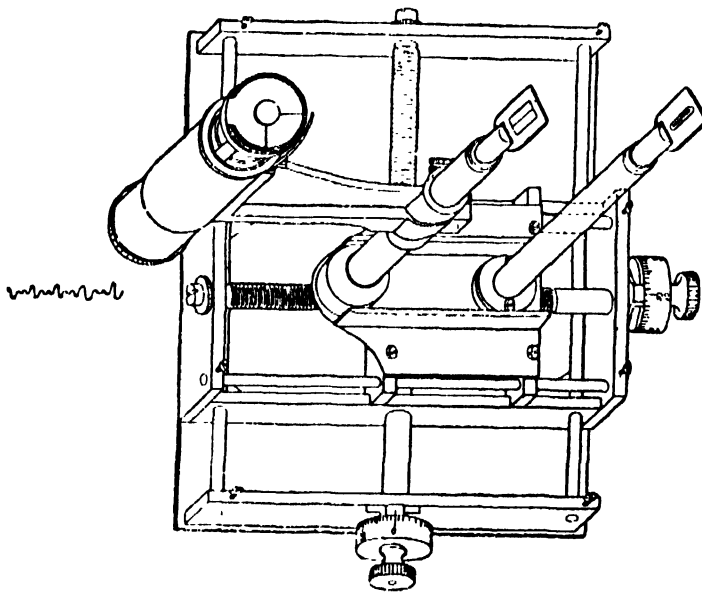

FIG. 45.—Coordinate measurer.

lens of the ocular is focused on its scale; the microscope is then focused on a millimeter scale. The relation between the scale of the ocular and the millimeter scale is then read off; for example, 50 divisions in the ocular = 10mm. If the two scales do not correspond in some simple relation—for example, if 50 divisions = 10.3mm.—the ocular is slightly drawn out or pushed in and the whole micro-

scope then refocused. This is repeated till some simple relation (1:10, 1:5, etc.) is obtained.

The simplest problems involving quantitative analysis are found in the studies of duration, amplitude and melody; the methods will now be described.

For a study of the duration of sounds a long millimeter scale is used. It is laid horizontally along the speech curve; the reading for the beginning of the sound is taken, then the reading for the end; the latter at the same time is the reading for the beginning of the next sound (or pause), etc. The scale should not be unnecessarily moved. The difficulty arises in assigning the limits between speech elements. This is due in the first place to the fact that speech elements have no absolutely definite limits. One sound shades off more or less gradually into the next one; even the passage

from a vowel to an occlusive is not sudden. Where is the limit to be set in the case—for example—of the succession indicated by [ap]? If we say “at the last vibration in the curve,” then we find that a rise in the curve clearly indicates the closing of the lips for the implosion of [p] while the vocal bands are still sounding for the vowel. If we say “at the beginning of the implosion,” then we have a sonant implosion for [p]. If we determine to place the end of [a] at the first indication of the implosion, and the beginning of [p] at the cessation of the vowel vibrations, and to call the sonant implosion a glide, we get out of the difficulty in this case fairly well. But in many other cases, particularly combinations of vowels and liquids, no such solution is possible; one sound changes gradually into another; thus in the whole vowel mass, in lines 102 to 105 of the Depew plate, there is not a single sudden change, and any assignment of limits would be a fiction. To the psychologist this condition is the only conceivable one. In “Elements of Experimental Phonetics,” Chapter XXX, the writer has sketched a centroid theory of speech utterance based on these observations; here it is necessary only to point out the technical difficulty in measuring.

The amplitude of a vibration is its maximum excursion from its position of equilibrium; when a simple vibration is evenly maintained the excursion is the same on both sides and the amplitude is half the distance between the two extremes. Although speech curves are not evenly maintained vibrations and are not simple in form, it is sufficient for many purposes to take half the vertical distance between the highest and lowest points in a wave-group; the results may be regarded as giving roughly the amplitudes of the vibrations forming the groups. The technique is evident; the “coordinate measurer” is specially adapted to this work. When different records are to be compared the results may be divided by the magnification of the tracing lever (p. 30); the results then refer to the gramophone grooves. Nothing is known of the relation to the amplitudes of the original air-vibrations.

The study of melody is the study of the fluctuations of the pitch of the tone from the glottal lips. Each explosion, puff, or vibration from the glottis arouses a vibratory movement that shows itself in the speech curve as a group of vibrations (p. 40); this we have called a “wave-group” or a “wave.” A “wave” thus means the whole complicated group of vibrations resulting from a single glottal movement. The study of melody has to do with these waves or wave-groups. Confusion seldom arises, except where the “wave” or “wave-group” is composed of two or three subordinate vibrations of nearly equal amplitude (Depew plate, line 102; Cock Robin plate, lines 1, 3, 7, 16); even here it is easy to pick out the stronger vibration that begins each group or to tell whether the groups are of twos or threes by following the curve from clearly marked groups.

In music the melody is supposed to proceed by the steps, the tone being constant in pitch for the time of each note; in figure 46 the melody indicated by notation is given by the plot below it. What is the nature of the melody in speech? Is the melody of actual song like the melody indicated by the notation?

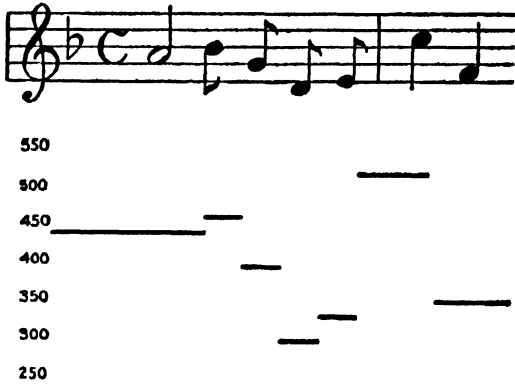

FIG. 46.—Notes and their melody plot.

For a study of the melody of a speech record the length of each wave-group is measured in tenths of a millimeter. When the waves are long—for example, in records where 1mm. is less than 0.0010s.—it is sufficient to use a millimeter scale and estimate the tenths of a millimeter by the eye. It is, in fact, preferable to using a scale in tenths of a milli-

meter and reading by a magnifying glass, because after a little practice the estimation of tenths is just as accurate as the reading of them, while the time and fatigue involved are far less. When the waves are short—for example, when 1mm. = more than 0.0010s.—it is desirable or necessary to use a scale finer than millimeters. In the results reported in this chapter the metal scale graduated directly in tenths of a millimeter and read by a magnifying glass has generally been used. Owing not only to the greatly increased accuracy but also to the saving in fatigue, the writer now often uses the coordinate measurer described above. The apparatus is placed over the plate, the ocular scale is brought accurately over the waves by the two micrometer screws, and the wave-lengths are read off and recorded. The microscope is then moved axially till a new set of waves is seen.

A record-book with the following columns is prepared:

Word.	Running measurement.	Wave-length in 0.1mm.	Frequency.	Remarks.

The scale is placed parallel to the axis of the curve, but below or above the highest points. Readings for the highest or lowest points of successive waves are taken. The results are written in the second column of the record book. The differences between successive results give the wave-lengths; these are written in the third column. For the straight-line portions with no waves the lengths are inserted. Since the waves are smoothly rounded, there will often be doubt as to where to locate the apex, but with running

measurements an error to one side will be compensated by a larger reading for the next measurement.

When desirable the measuring can be changed from bottoms to tops of the waves, or the reverse; the middle points or any characteristic features may be used. The reason is that, although each wave (that is, wave-group) is the result of one glottal vibration, the groups overlap, and there is no means of knowing exactly where each begins. In any case the best thing to do is to pick out some characteristic feature and follow it from group to group.

A special difficulty arises from the fact that the characteristic features gradually change; one fades away and another appears. For example, a set of waves beginning with a fairly sharp apex may gradually develop an accessory apex; the latter may finally become more prominent than the other, which often ultimately disappears. In all cases of doubt it is wise to measure the waves two or three times with different characteristic points.

The wave-lengths are to be multiplied by the time equation in order to obtain the period in seconds; the frequencies are found from a table of reciprocals. For example, a wave-group 23.6mm. in length in the Mitchell vowel record with a time equation of 1mm. = 0.0002s. indicates a period of  $23.6 \times 0.0002s. = 0.00472s.$ , or a frequency of  $1 \div 0.00472 = 212$ . Since each wave-group is the result of one vibration of the glottal lips, this gives the pitch of the tone from the larynx at that instant.

A table of periods and frequencies is prepared to fit the measurements. The first column contains the most frequent measurements in tenths of a millimeter, the second the product of these by the time equation, the third the reciprocals of the second. Thus for a wave-length of 50 tenths of a millimeter (first column) of a record whose time equation is 1mm. = 0.0007s., the second column will show the period  $50 \times 0.0007s. = 0.00350s.$ , the third column the frequency  $1 \div 0.0035 = 286$ . The products and reciprocals can be found in books of tables.\* Such a table would begin as follows:

Wave-length in 0.1mm.	Period.	Frequency.
50.....	0.00350	286
51.....	367	280
52.....	364	275
53.....	371	270
54.....	378	265
55.....	385	260
56.....	392	255
57.....	399	251
58.....	406	246
59.....	413	242
60.....	420	238

\*Zimmermann, Rechentafeln, Berlin, 1891; Ligowski, Taschenbuch der Mathematik, Berlin, 1893; Barlow, Tables, London, 1897.

For most melody work such a table will suffice, except when the waves are so long that a difference of 0.1mm. shows in the frequency column in tenths of a vibration. In these cases the results must be worked out in tenths; for example, a wave measuring 167 tenths of a millimeter has a period of 0.01167s. and a frequency of 85.5, while a wave 168 tenths long gives 0.01176s. and 85.0, etc.

For portions without waves the length is multiplied by the time equation and the result is written across both columns to show that the number does not indicate a wave-period, but another kind of duration (surd, pause, etc.).

To plot the melody curve some time equation is assigned to the X-axis of the plot. In order to have all curves uniform it would be well to adopt certain relations as standard ones: say for X, 1mm.=0.001s.; for Y, 1mm.=1 vibration. The speech curve may be supposed to be laid along the X-axis and stretched or contracted to suit the case. At the beginning of each wave an ordinate is erected proportional to the frequency.

To obtain the wave-lengths the period must be divided by the number of seconds per millimeter for the X-axis of the plot. Thus for a plot with 1mm.=0.0010s. the periods must be divided by 0.0010, for 1mm.=0.0005s. by 0.0005, etc. For example, let 1mm.=0.001s. for the X-axis and 1mm.=1 vibration for the Y-axis, and let the melody of the series of waves 50, 54, 55, 56, 59 tenths of a millimeter be plotted. At zero, a dot is placed 286mm. (see table on preceding page) above the X-axis. Then a distance along X is laid off equal to the length of the first wave in order to find the beginning of the second wave. The period or wave-length in seconds from the first wave is (see the table) 0.00350s.; for 1mm.=0.001s., this gives a wave-length of 3.5mm. The distance 3.5mm. is laid off to find the beginning of the second wave. Here a dot is placed at 265mm. above the X-axis. The length of the second wave 5.4mm. is then laid off to find the beginning of the third wave. Here a dot is placed 260mm. above, etc. In this way we proceed, placing a "frequency dot" over the beginning of each wave and laying off its length to find the beginning of the next wave, thus, frequency 255, length 5.6; frequency 242, length 5.9. The series of frequency dots thus obtained is the "melody plot."

The separate dots may be connected by straight lines, and a general smooth curve of melody may be drawn among them; in this way the demands of detailed study and also of general view are met. Where only a general view is wanted it is sufficient to draw the smooth curve.

To illustrate the methods to be followed in the study of melody I will show how the plots were interpreted in several investigations, namely, of

interjections, of initial vowels, of the first part of an oration, and of the first line of a poem.

According to the course of the melody plot when referred to the X-axis we can distinguish "convex," "straight," and "concave" plots; the inclination of the axis of the plot gives us "rising," "even," and "falling" melodies. The fundamental law of speech melody is, in my opinion, that each speech unit has a convex—that is, rising-falling (or circumflex)—melody.\* This is varied to produce effects of expression. Let us see how it is done.

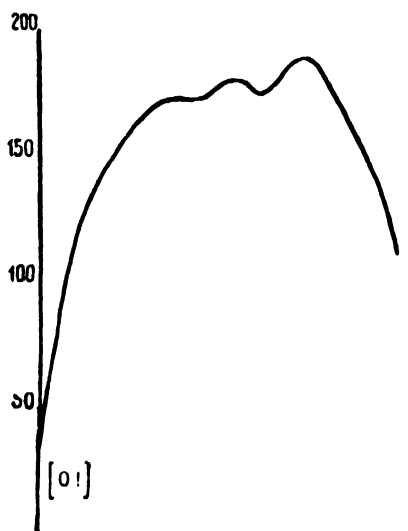

FIG. 47.—"Oh," sorrowfully.

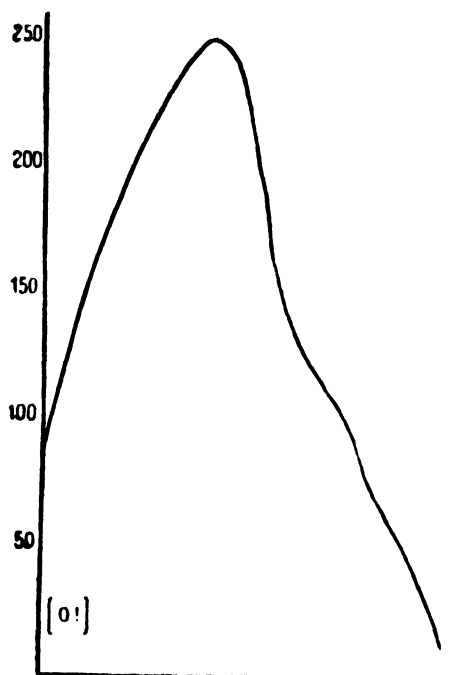

FIG. 48.—"Oh," admiringly.

A gramophone record of words spoken by Dr. S. Weir Mitchell comprised a number of interjections. The curve was traced off as described in Chapter II. The melody plots, obtained as just described, are given in figures 47 to 53 with a reduction to  $\frac{1}{3}$ .

The sorrowful "oh" (figure 47) has somewhat more than the usual vowel convexity, a general rising melody, and an average pitch that is lower than the general average for the discourse of the speaker. The admiration "oh" (figure 48) is characterized by a great amount of convexity; the degree of convexity is, in fact, a vital element in the expression of the emotions;

\* Studies of Melody in English Speech, *Philosophische Studien*, 1902, xix, 599; A Record of the Melody of the Lord's Prayer, *Neuere Sprachen*, 1903, x, 1; *Elements of Experimental Phonetics*, Chapter xxxii, New York, 1902.

religious and parenthetical phrases have comparatively little of it (see researches on melody above referred to). The dubitative or questioning "oh" (figure 49) is characterized by a high pitch throughout and a rising melody. This "oh," which seems to the ear to be simply a rise from beginning to end, nevertheless shows the fundamental convexity distinctly. The sorrowful or despairing "oh"s of "oh dear" (figure 51) and "oh my" (figure 52) are in general alike; they have less convexity than the other "oh"s.

The sorrowful "ah" (figure 50) has a very small amount of circumflexion, the pitch being almost monotonous; the main effect comes from the straightness and evenness of the melody. The sorrowful effect of the phrase "oh dear" and "oh my" is due largely to the sameness and the general lowness in each phrase, and also essentially

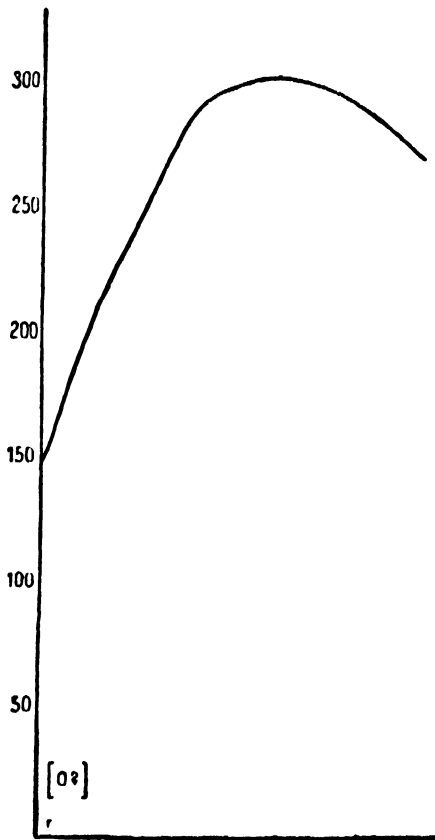

FIG. 49.—"Oh," questioningly.

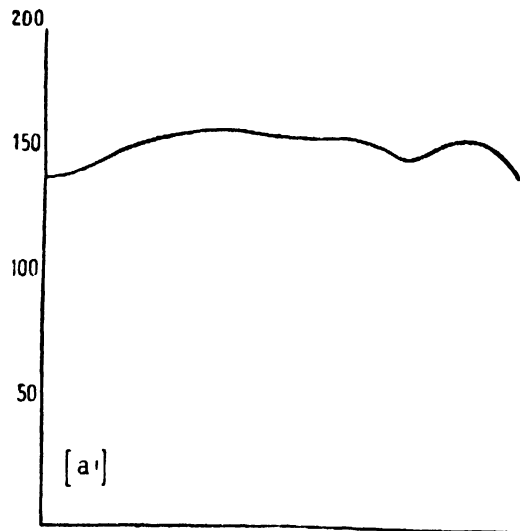

FIG. 50.—"Ah," sorrowfully.

to the lack of convexity. This is in strong contrast to the plot for "oh, not really" (figure 53), where the surprise and possible doubt appear in the lively circumflexion of the three vowel groups. It is easy to see how a change in the melody at any point would change the expression. For example, "oh" spoken with the melody of "ah" (figure 50) would still be sorrowful, but with quite a different shade of emotion from the "oh" in figure 47. It is interesting to note that the course of melody in the sorrowful interjection is not smooth, but shows minor fluctuations. These tremblings of the voice are vital elements of emotional expression that are

used by effective speakers particularly to excite sorrow, pity, and religious feelings.

This work on the interjections is now being extended to other speakers. Combined with the results from emotional sentences and discourse it furnishes systematic data concerning the expression of the emotions for the voice.

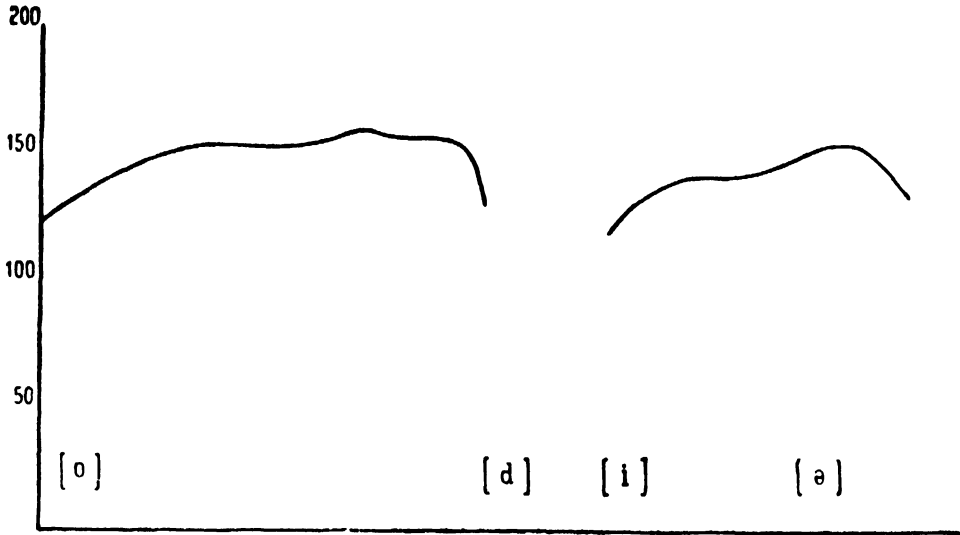

FIG. 51.—“Oh dear,” sorrowfully.

We will now illustrate the manner of investigating melody and amplitude in initial vowels. In the first part of [ai], Depew plate, line 110, the length of each group is measured, giving 16.9, 16.0, 16.7, 16.2, 16.1, 16.2,

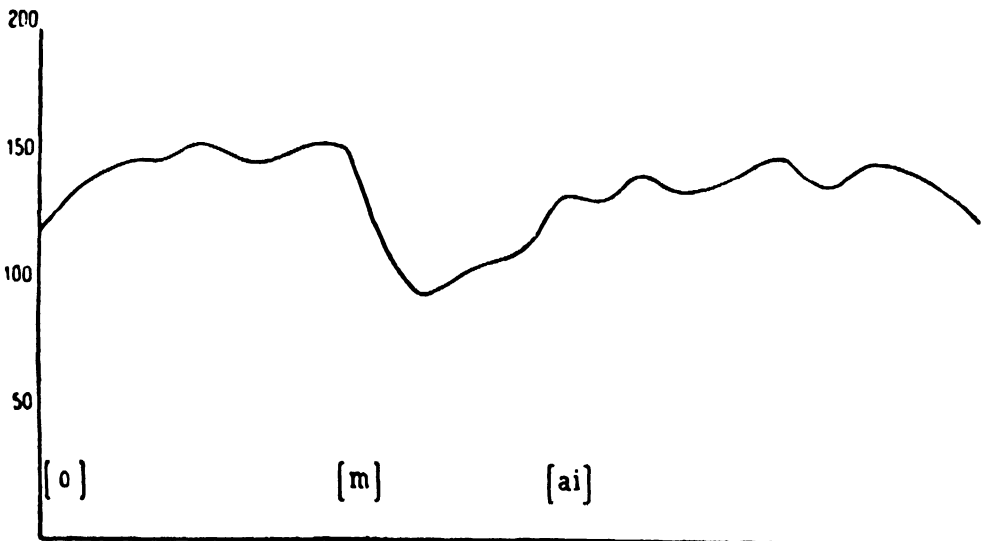

FIG. 52.—“Oh my,” sorrowfully.

15.9, 15.8, 15.7, 15.8mm. This gives the series of periods 0.01183, 0.01120, 0.01169, 0.01134, 0.01127, 0.01134, 0.01113, 0.01106, 0.01099, 0.01106s., and the frequencies 84.5, 89.3, 85.7, 88.2, 88.7, 88.3, 89.9, 90.4, 91.0, 90.4 in vibrations per second. Plotting the frequencies we have the "melody plot" in figure 54. This shows that the vowel begins low and steadily rises. (For figures 54 to 64 the equation for the X-axis was 1mm.= 0.0007s.; the drawings were then reduced to  $\frac{2}{3}$ .)

Let us now measure the amplitude, or maximum of vibration, for each group. For this we take half the distance between the extreme point below and the extreme point above. The results are 0.1, 0.4, 0.6, 1.1, 1.1, 1.1, 1.1, 1.1, 1.1, 1.1mm. Reduced to the size of the curves on the gramo-

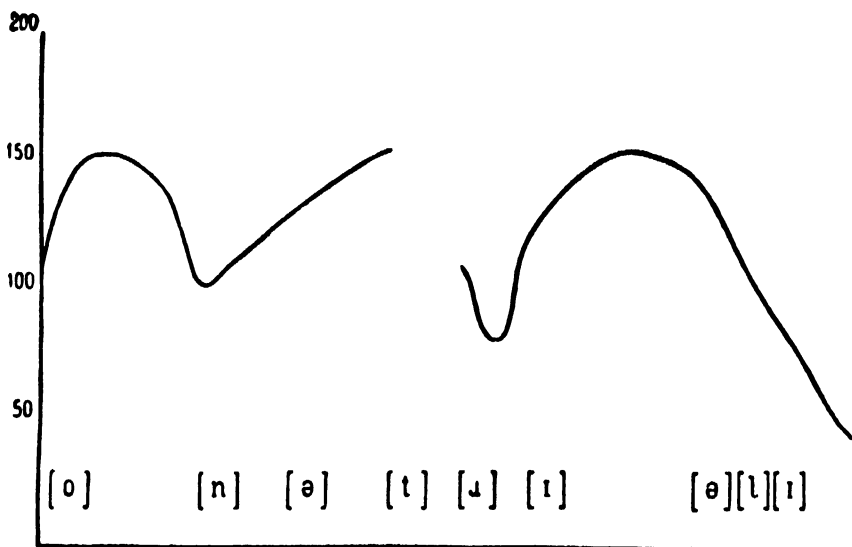

FIG. 53.—"Oh, not really?" questioningly.

phone plate ( $\pm 150$ ), these give 0.0007, 0.0027, 0.0040, 0.0073, etc., from which the amplitude plot in figure 55 is obtained. The plot shows that the [a] portion begins softly, but rises very rapidly to a considerable amplitude, at which it remains constant for a while.

Are these results indicative of general laws? Let us first compare them with other initial vowels in the Depew record. For the beginning of [ɔ] in "on" of the phrase "on the one side in New York," the melody and amplitude plots are shown in figures 56 and 57. The same general characteristics are found in other cases in the Depew record. Compare with them the melody and amplitude plots (figures 58-63) for the first ten vibrations of three initial vowels, [ɔ] in "a leaf," [ɔ] in "also," and [æ] in "America" (the word was so pronounced) of the Mitchell vowel record. Like the

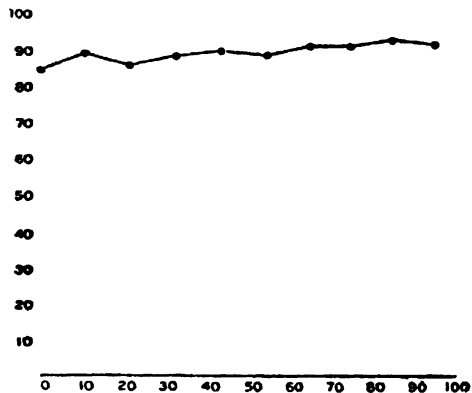

FIG. 54.—Melody plot. Beginning of [ai] "I." Depew.

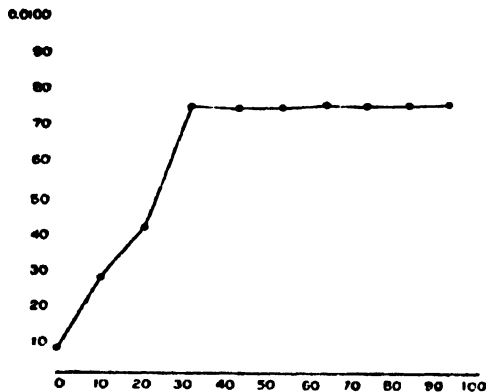

FIG. 55.—Amplitude plot. Beginning of [ai] "I." Depew.

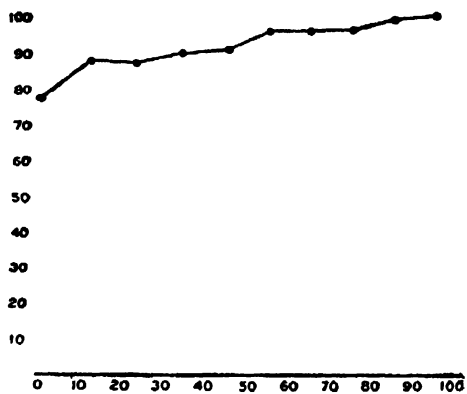

FIG. 56.—Melody plot. Beginning of [ə] "on." Depew.

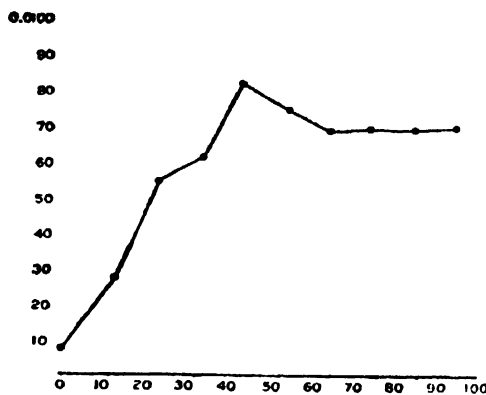

FIG. 57.—Amplitude plot. Beginning of [ə] "on." Depew.

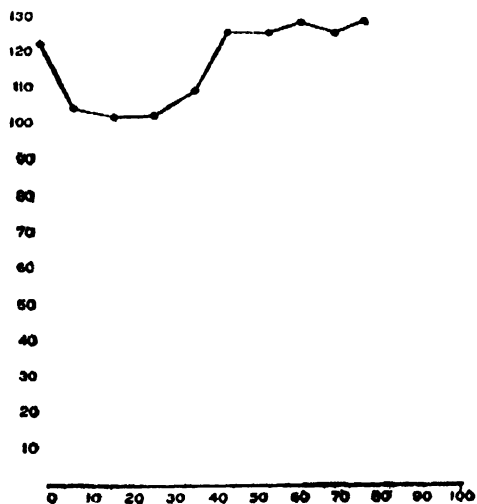

FIG. 58.—Melody plot. Beginning of [ə] "a." Mitchell.

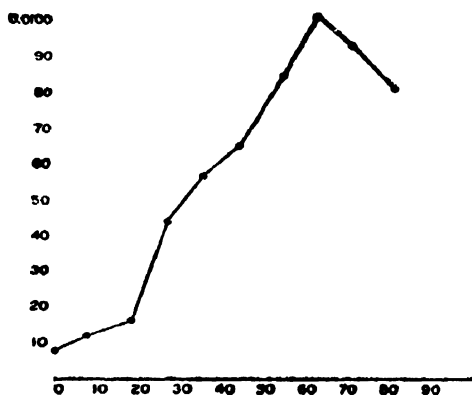

FIG. 59.—Amplitude plot. Beginning of [ə] "a." Mitchell.

Depew vowels they begin with rising pitch and rising amplitude. From these and from many other cases by different speakers we can deduce the general law that in American English an initial vowel begins with low pitch and very small amplitude, and steadily rises to a maximum. This is certainly different

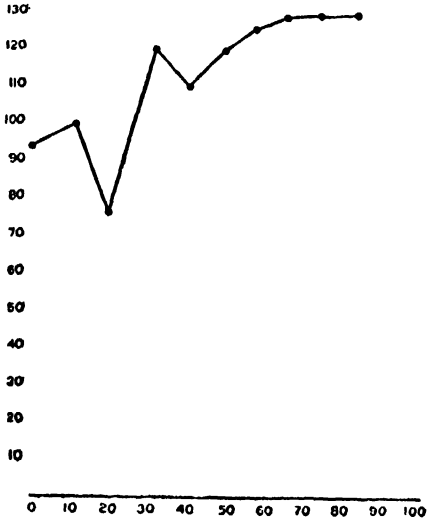

FIG. 60.—Melody plot. Beginning of [ə] "also." Mitchell.

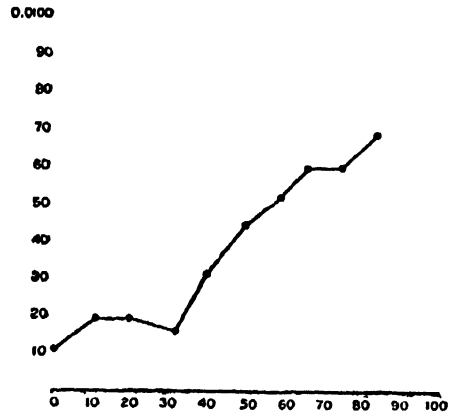

FIG. 61.—Amplitude plot. Beginning of [ə] "also." Mitchell.

from the case in German initial vowels, although not enough cases of German have been studied to make a definite conclusion possible for them. No curves of English or French speakers have been studied.

Another peculiarity of these plots is at once noticed; the vibrations begin irregularly in pitch. The irregularity is small in the Depew record and much larger in the Mitchell record. This is due

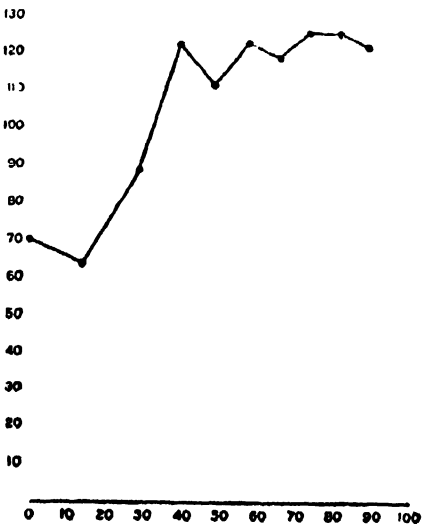

FIG. 62.—Melody plot. Beginning of [æ] "America." Mitchell.

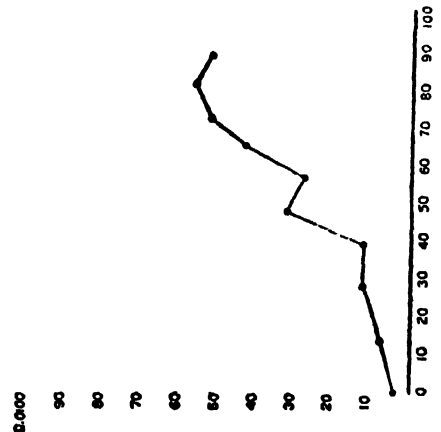

FIG. 63.—Amplitude plot. Beginning of [æ] "America." Mitchell.

to irregularity in adjusting the glottal lips. The variations in irregularity are personal characteristics of the speakers.

In this connection it may be interesting to report an observation on German initial vowels. A number of records were made of the glottal puffs

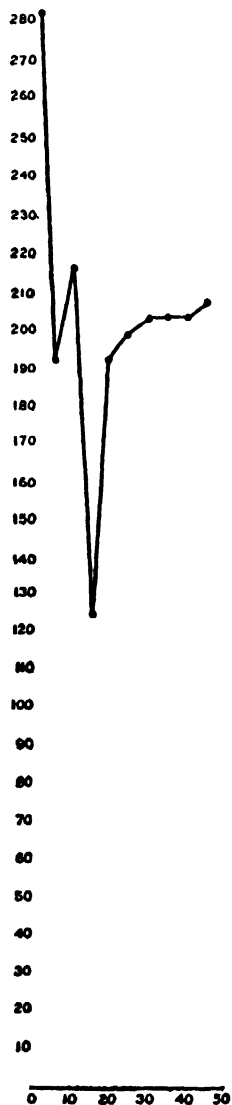

FIG. 64. —Melody plot. Beginning of [ai] "ein," Brunner.

during a recitation of "Ein Fichtenbaum." With one of the persons, a native of Lower Bavaria, 29 years of age, the initial vowels always showed unusual irregularity in the first few puffs; a specimen melody plot is given in figure 64. No such great irregularity was noticed in the records of the other persons. The glottal action in German initial vowels, however, is quite different from the American action; the glottal lips are closed tightly together across the larynx, shutting off the air completely before any vibration occurs, presumably before there is any rise in the breath pressure; the muscles of the glottal lips are then tensed, and the vowel starts usually with full height of pitch and nearly full intensity. In this particular person the action was irregular. Why? The answer depends on the nature of the glottal action. One might suppose that in the German initial vowel the glottal lips stopped the breath until it gained sufficient pressure to burst through and set them in vibration. Such an action would, in my opinion, be too crude for the accuracy of speech. The closure of the glottis can be assumed to occur by action of the constrictor muscles, mainly the transverse arytenoids; when the vibrations are to be begun the muscles are relaxed to the requisite degree. In watching the glottis with the laryngoscope while Germans say [a] we can see the glottal lips come together before vibration; in one case I have seen the two lips strike so tightly together that a ridge was formed for a moment along the edge of each before the relaxation occurred.

In this way the study of initial vowels may be pursued to determine the manner in which pitch and intensity act as elements of expression, with the variations for different persons, different emotions, different languages, etc.

The method of studying a complete melody plot will now be illustrated by two examples. As established in my previously published researches on speech melody, the fundamental form for the American sentence is the

convex melody, beginning low, rising steadily to a maximum, and then steadily falling. This form is varied for purposes of expression. For example, an interrogative sentence requiring the answer "yes" or "no" does not fall at the end, but rises higher than at the middle. Other interrogative sentences keep the convex form, unless there is some special change to produce expression. Exclamatory sentences retain in general the convex form. Religious speech is characterized by comparative evenness of melody, by small convexity, and by general low pitch. In conversation, characteristic variations are introduced to express irritation, sarcasm, solemnity, etc.

The melody plot for the beginning of the record of Depew's "Speech on Forefathers' Day" is given in plate XII. It contains the words "My ancestors, having arrived in this country among the early settlers, on the one side in New York, on the other in New England, and, having fallen in love and married in the old-fashioned way"; the sentence concludes "without regard to race or creed, I can claim the membership of nearly every one of the National Society." (The thought in the mind of the speaker was evidently "relationship of nearly every member," etc.)

The measurements and the plot were made as described above; the scale for the X-axis in plate XII is 1mm. = 0.025s. A small scale is desirable when the general course of melody is to be studied, as with the large scale the eye gets no definite picture from the plot; for the same reason a smooth line is drawn among the dots instead of a zigzag from dot to dot.

The first line of text in plate XII gives the phonetic letters, the left edge of each being placed under the point of the curve at which its sound began. The second line of text gives the words spoken; the third line gives the numbers of the lines in the original plates of the speech curve.

Confining ourselves on the present occasion to the general features of the melody, we note that in the first phrase the melody rises somewhat suddenly at the start according to the typical convex form for the American sentence. Instead, however, of completing the convexity it rises suddenly at the end. The average tone is rather low. This form of melody gives a special emotional character to the phrase, for which no appropriate terms exist. In fact, our language is almost totally deficient in terms for emotional expression, and we can define the expressive character of the melody here only by saying that it is the one appropriate for a solemn statement in an oration. The evenness of the melody gives it solemnity, the steady rise through the phrase gives it pomposity, the sudden rise at the end makes it somewhat brusque and challenging. As only a few researches on speech melody have been made, little can be said

SCRIPTURE.

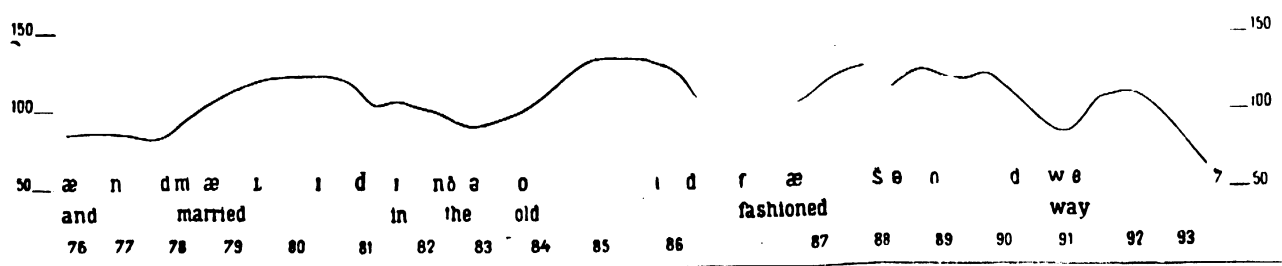
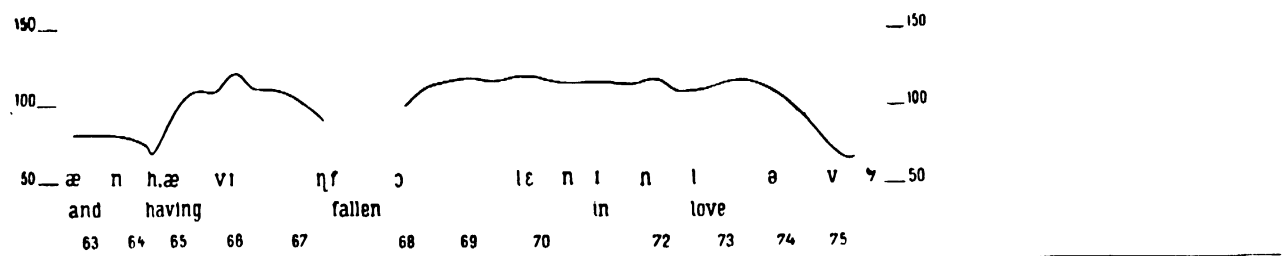
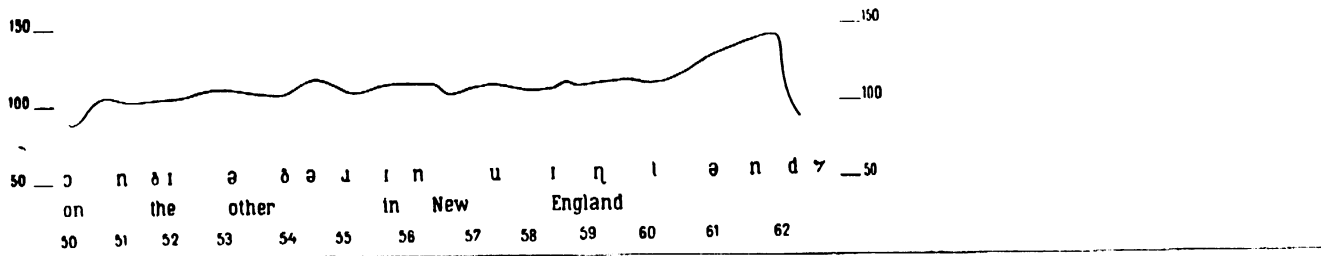
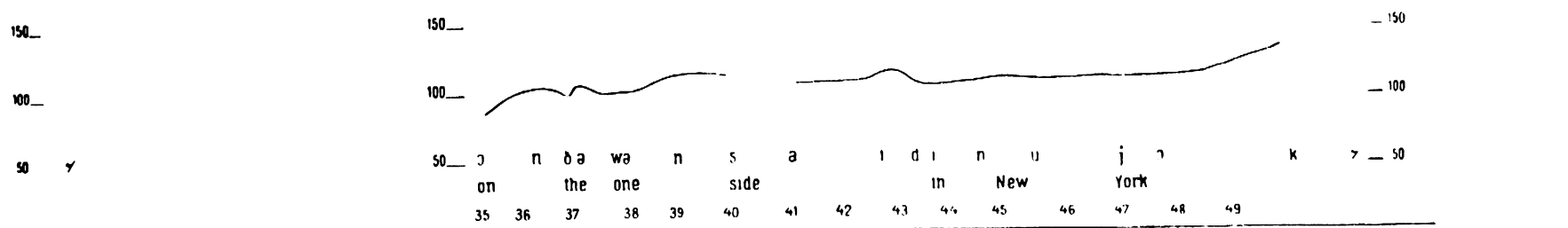
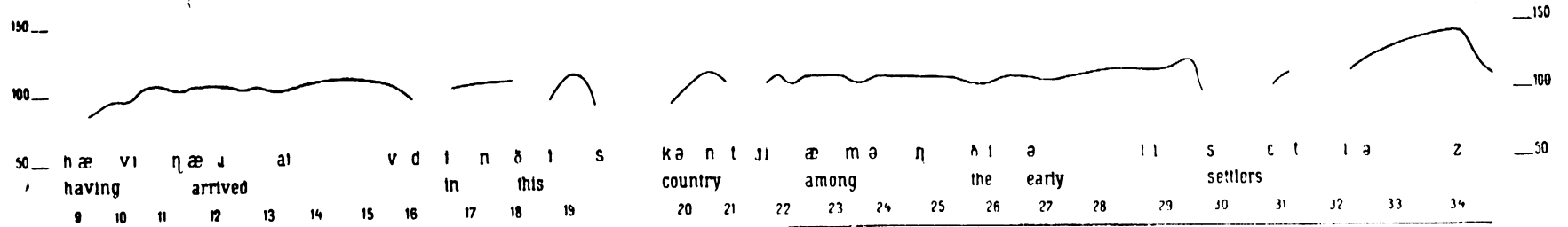
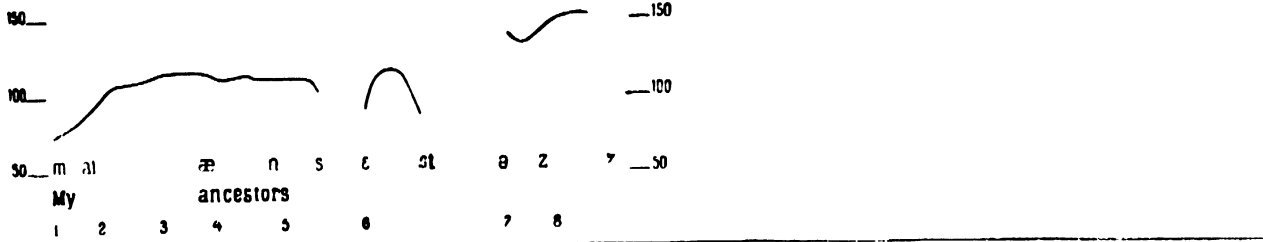

MELODY OF BEGINNING OF "SPEECH ON FOREFATHERS' DAY."



concerning the change in emotional effect which such a phrase would undergo with changes in the melody. We know, however, that if the even melody had not the steady rise and had fallen at the end, the phrase would have had a religious intonation (see the researches on the Lord's Prayer already referred to). If the evenness had been replaced by fluctuations, the melody would have lost its solemnity, even if it had retained the other characteristic of solemnity, namely, the general low pitch.

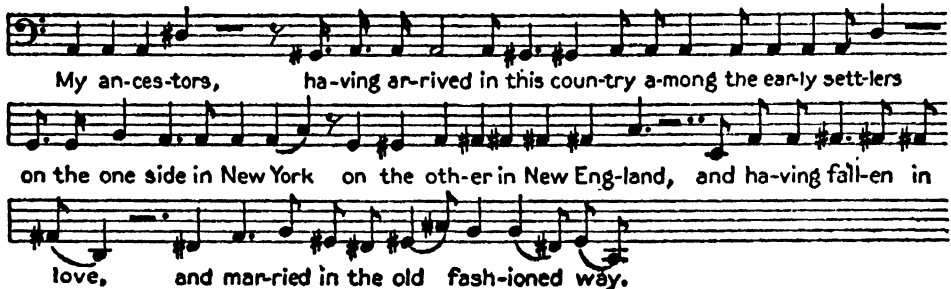

FIG. 65.—Musical notation for plate XII.

The phrase is followed by a considerable pause. As a peculiarity, we notice the sharp convexity for [ε], due presumably to its position between two surds.

The second line comprises a long phrase. There is the usual rather sudden rise at the beginning. Thereafter the pitch of the voice steadily ascends to the end. Minor fluctuations are seen, especially around surds. The second pause is indicated at the beginning of the third line. The third and fourth phrases show the same type of melody. The pause after the third phrase is very brief; that after the fourth is longer. The emotional effect of all four phrases is the same.

In the fifth phrase the melody is of a different kind. There is more flexibility and the convexity is completed by a low fall. In the sixth phrase there are four strong subordinate convexities for the four emphatic units, "married," "old," "fashioned," "way." These are fused to a phrase with very flexible melody. The phrase ends with a fall in melody and a pause, although it needs the words "without regard to race or creed" to complete it. The last two phrases are in contrast to the first four. The evenness is replaced by great flexibility, the rise at the end is replaced by an exaggerated fall. The entire effect of such a melody is distinctly humorous—an effect that is increased by the very low tones employed, especially at the end (going as low as nearly 50 vibrations a second). It is a common device of humor to imitate solemnity in its chief traits and to change one of them into an inconsistency. Here the effect is that of

a staid humor of a mild degree. Both these phrases might have been spoken with rising closure without destroying the general tenor of the impression, but the humorous turn and the contrast would have been lacking. Throughout the record the melody is one that is appropriate to ceremonial oration with a constant humorous twist to it. The unusually long pauses between the phrases, with the low and monotonous pitch, aid in the ceremonious expression. Some of the vowels are abnormally long for purposes of emphasis.

The melody of this portion of the Depew speech can be approximately represented in musical notation as in figure 65. There is no division by bars, as the prose accent is not so regular as the musical one. Nevertheless there is a decided rhythmical effect, and there is a division into phrases showing similarity and contrast.

It is often necessary to obtain on the spot the data for a melody plot; a method simpler than that of tracing gramophone curves must be used. A convenient method consists in placing a speaking tube before the mouth or over the larynx and recording the vibrations on a smoked drum by means of a very small tambour. The vibrations in such records are of the same pitch as the glottal tone, but the form of the waves is not that of a speech curve.

The melody plot of the beginning of a record obtained in this way of "Der Fichtenbaum" from a cultured Berliner (Baron von Hagen, a Prussian major) is given in figure 66. The poem begins

Ein Fichtenbaum steht einsam  
Im Norden auf kahler Höh'.

It was spoken from memory without any suggestion whatever.

The first line is evidently made up of two thought units, or two mental images, namely, the fir tree in its place ("Ein Fichtenbaum steht") and the loneliness ("einsam"). Using the terms proposed in "Elements of Experimental Phonetics," page 553, there are two centers of thought or two centroids. The fundamental law of melody seems to be that each thought unit is characterized by a convex melody; it appears here in the general rise and fall in each unit. The other laws of melody are also exemplified; thus, the initial vowel of a unit is rising ("ein," etc.), the final melody falling ("steht," etc.). The sudden fall at the end of [χ] in "Fichtenbaum" is presumably a matter of disturbance of articulation and has nothing to do with the intended melody. The double convexity in "einsam" I would explain as arising from a peculiar form of emphasis. The word might be spoken with prepondering stress on the first syllable, as would be the case in the midst of a prose sentence; here the melody would probably be a simple convexity. The word may also be spoken with two

emphatic syllables, the latter being long drawn out; this gives an emotional tinge appropriate to the thought. I assume that here the speaker felt the two syllables more or less separately and that each received its natural convex melody; since the whole was fused into one large unit which must have its own convexity, the two components become modified.

The second line is also made up of two thought units, namely, "Norden" and "kahler Höh'," each with its own general convex melody. The special minor convexity of "Höh'" may be due to a tendency to special emphasis or to the changes in articulation around [h]. The unimportant preposition "auf" seems to have its melody fitted to that of "Norden."

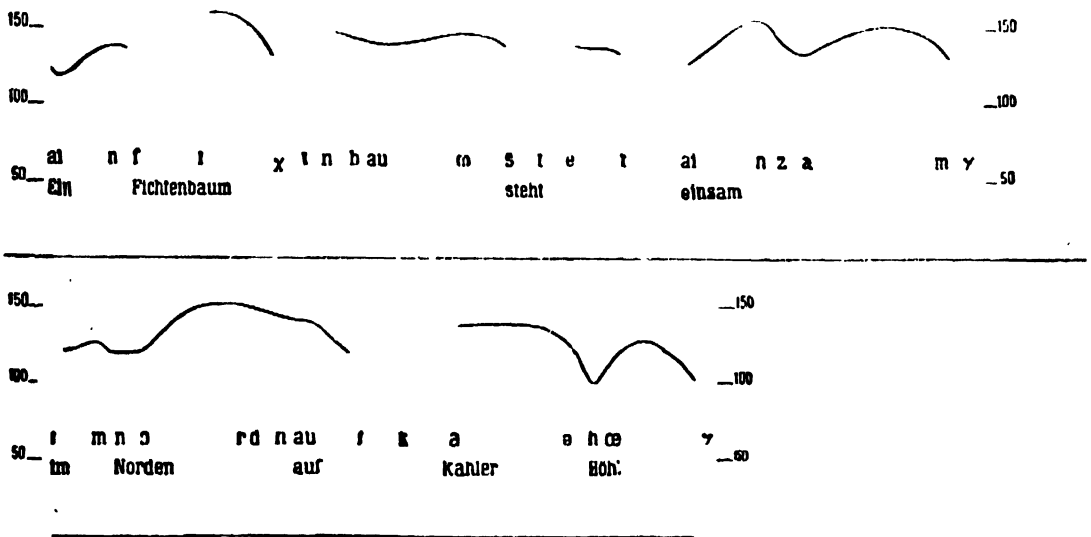

FIG. 66.—Melody of beginning of "Der Fichtenbaum," v. Hagen.

This melody plot agrees in a general way with those of the same poem by the other speakers, although some of them were from Southern Germany. The melody of conversation in Southern Germany is asserted to be the reverse of that of Northern Germany; since no records of German sentence melody have ever been published, the experimental proof is lacking. In spite of this direct reversal of high and low in ordinary speech, the records for "Der Fichtenbaum" agree in the general outline of melody; we can say, therefore, that "Der Fichtenbaum" has a "specific melody" of its own. This may be explained as follows. Owing to surroundings (family, school, etc.) each vowel, each word, each sentence, each combination is spoken with the same average forms of melody by the speakers of each dialect. The specific melodies for conversation differ greatly in various parts of Germany; a perfectly natural conversation would not show a specific melody for all Germany, but a set of specific melodies

different for each region. That "Der Fichtenbaum" does have a specific melody independent of dialect is due to the fact that it is literature and not conversation. The melody is always different the moment a speaker changes from conversation to recitation; that all speakers should change to approximately the same melody for a certain poem (even if they had never learned or heard it before) is probably due to their education in German literature. A poet can thus expect that the entire cultured public will respond to the melody he feels that he is putting into his verse. The uncultured mass, however, may have different standards of melody—a factor that may be of influence in distinguishing a local from a national poet.

## CHAPTER V.

### HARMONIC ANALYSIS.

When a well-made tuning-fork is set in vibration and a fine point at the end of one of its prongs is drawn over a piece of glass coated with smoke, it inscribes a curve of the form shown in figure 67. A curve of this character is known as a "simple sinusoid." The extent of the elongation to each side of the position of rest is called the "amplitude"  $a$ ; the time for one complete vibration is the "period"  $T$ . The number of vibrations per second is termed the "frequency"; the frequency is the reciprocal of the period, or  $n=1/T$  (for example, if a fork has a period of  $T=0.02s.$ , its frequency will be  $n=1/0.02=50$  per second).

Some elementary facts concerning simple sinusoids must be borne in mind; the tuning-fork vibration may be used to illustrate them. Since the fork may vibrate more or less strongly, its amplitude may vary (figure 68). The record of the fork may begin at some point of the vibration not on the axis. Figure 69 shows a record beginning at the extreme of positive elongation. The condition of the vibration at any moment is known as its "phase." The phase of the vibration in figure 69 is a quarter of a period more advanced than that in figure 67.

A series of vibrations whose periods have the relations  $1, \frac{1}{2}, \frac{1}{3}, \dots$  (that is, with frequencies in the relations  $1, 2, 3, \dots$ ) is termed a "harmonic series." The amplitudes and phases in the series may have any values. A harmonic series of simple sinusoids with the same amplitude and phase at the start is shown in figure 70.

According to Fourier's theorem\* a curve of any form—not only a complicated curve but even a straight line or a dot—may be expressed as the sum of a harmonic series of simple sinusoids, provided the series is sufficiently extended and the amplitudes and phases are properly adjusted. A practical method of deducing the necessary sinusoids from the original curve has been developed; the method is known as "simple harmonic analysis." Briefly stated, a simple harmonic analysis is made in the following way. A number—12, 24, 36, 72—of equidistant ordinates are measured from the axis of the curve or from a line parallel to it. These ordinates

---

\*Fourier, *Théorie Analytique de la Chaleur*, Ch. III, Paris, 1822. For complete account of work on this and similar problems see Burkhardt, *Entwickelungen nach oscillirenden Funktionen*, Jahresbericht d. deutschen Mathematiker-Vereinigung, 1901-02-03, x.

are multiplied by certain numbers and the results are written in a table. Special patterns with perforations marked + and - are laid over this table and the additions and subtractions are made as indicated by each pattern. There are as many patterns as there are ordinates; the designs for the patterns for 12, 24, 36, and 72 ordinates are given at the end of the volume. From the results for each pair of patterns we obtain the amplitude of one of the simple harmonics; thus with 12 ordinates we obtain the first six harmonics, with 24 ordinates the first twelve, etc. A detailed account of this method of analysis is given in the latter part of this chapter; complete examples are given in Chapter XI.

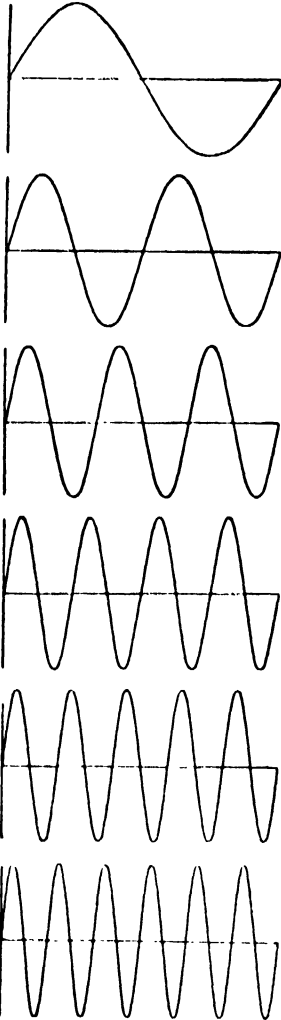

FIG. 70.—Harmonic series of simple sinusoids.

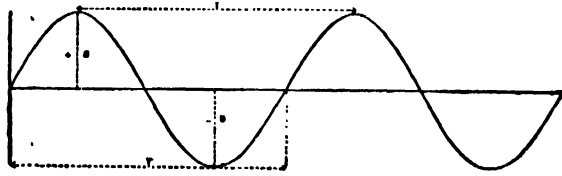

FIG. 67.—Simple sinusoid.

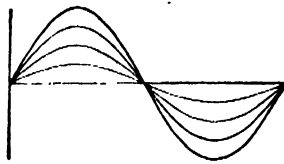

FIG. 68.—Sinusoids of different amplitudes.

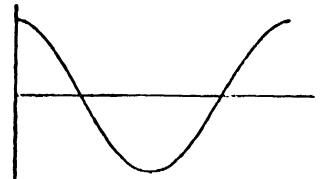

FIG. 69.—Sinusoid a quarter period ahead of that in figure 67.

The wave in the top line of figure 71, when analyzed, gives the simple sinusoids indicated below it. A plot showing the relations of amplitude among the harmonics is termed a "harmonic plot"; that for figure 71 is given in figure 72. The figures along the X-axis give the ordinal numbers of the harmonics. An ordinate is erected for each harmonic whose height is 10 times the amplitude of the harmonic. The accuracy of a harmonic analysis can be tested by combining the sinusoids and comparing the resulting curve with the original. The three simple sinusoids of fig. 71, when added, give the original curve in the top line exactly.

The irregular curve (figure 73) requires a large number of harmonic sinusoids to represent it with any approach to accuracy; if we are content with the accuracy obtained by an analysis into 12 harmonics, the result

is that shown in the harmonic plot in figure 74. A straight line or even a dot may be represented by the results of a harmonic analysis, but an infinite number of terms is required.

The harmonic analysis is a purely mathematical operation. Applied to a vibration it shows—provided it is sufficiently extended—how that vibration might have been produced, but not how it actually was produced. When a curve has been produced by adding a number of simple sinusoids with harmonic periods, the analysis will give as results the true amplitudes of the components actually used and 0 for the amplitudes of all other members.

What will be the results of analysis when simple sinusoids have been used for the composition whose periods do not belong in the harmonic series?

Curves whose periods do not coincide with any members of the harmonic series are said to be "inharmonic." It is important to inquire how an inharmonic sinusoid will show itself in the results of a harmonic analysis. The result is utterly different from that for a harmonic. For example, the sinusoid with the period  $\frac{1}{3}T$ , appears in the result only as a sinusoid with the period  $\frac{1}{3}T$ ; it does not appear at all in the other members of the series. Its harmonic plot shows a single ordinate. The sinusoid, however, with the period  $\frac{1}{33}T$ , having no place of its own in the results, appears in every member, more strongly in members whose periods are near its own, less strongly in members with periods that differ more. Such a simple sinusoid (figure 75) would appear in a harmonic analysis into 36 members as shown in figure 76.

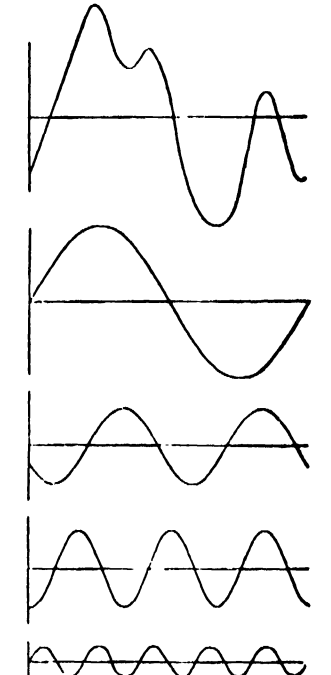

FIG. 71.—Curve with its sinusoid components.

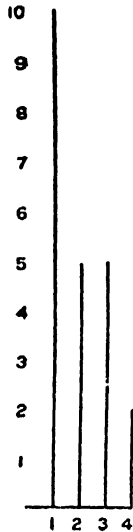

FIG. 72.—Harmonic plot to figure 71.

It is important to remember that an inharmonic in the midst of a number of harmonics as components of a curve appears in the results of a harmonic analysis only as an intensification of the harmonics. A curve composed of a series of sinusoids with the periods  $T, \frac{1}{2}T, \frac{1}{3}T, \frac{1}{4}T, \frac{1}{5}T$ , and the amplitudes 10, 5, 5, 5, 5 (actual plot in figure 77), gives, when analyzed, a harmonic plot which is identical with the actual plot. The harmonic analysis of a curve composed of simple sinusoids with the

periods  $T, \frac{1}{2}T, \frac{1}{3}T, \frac{1}{3\frac{1}{4}}T, \frac{1}{4}T, \frac{1}{5}T$ , and the amplitudes 10, 5, 5, 5, 5, 5 (actual plot in figure 78) gives the results shown in the harmonic plot in figure 79. It might be thought that, even if the composition of a curve is unknown, the presence of the inharmonic would indicate itself in the plot in figure 79, but there is nothing to distinguish it—or the original curve—from a curve with the first five harmonics and the amplitudes 12, 7.7, 11.9,



FIG. 73.—Irregular curve.

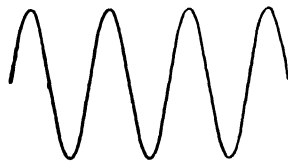

FIG. 75.—Sinusoid with  $3\frac{1}{2}$  waves to fundamental.

10.9, 6.8, for which both the actual and the harmonic plots would coincide with the plot in figure 79. In the case of a curve composed of simple sinusoids with the periods  $T, \frac{1}{2}T, \frac{1}{3}T, \frac{1}{3\frac{1}{4}}T, \frac{1}{4}T, \frac{1}{5}T$ , and the amplitudes 10, 5, 2, 2, 3, 5 (actual plot in figure 80), the harmonic analysis (plot in figure 81) does not furnish even a hint that an inharmonic is present.

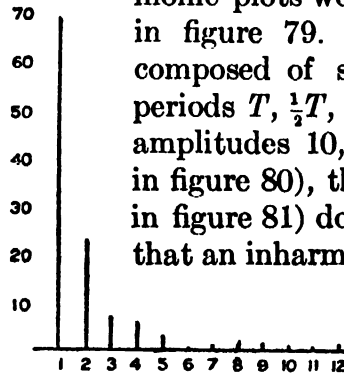

FIG. 74.—Harmonic plot to fig. 73.

We can thus draw the conclusion that, although the harmonic analysis represents the way in which the curve

may have been produced, it does not of itself give the actual way except in cases where only harmonic elements were used for the composition.

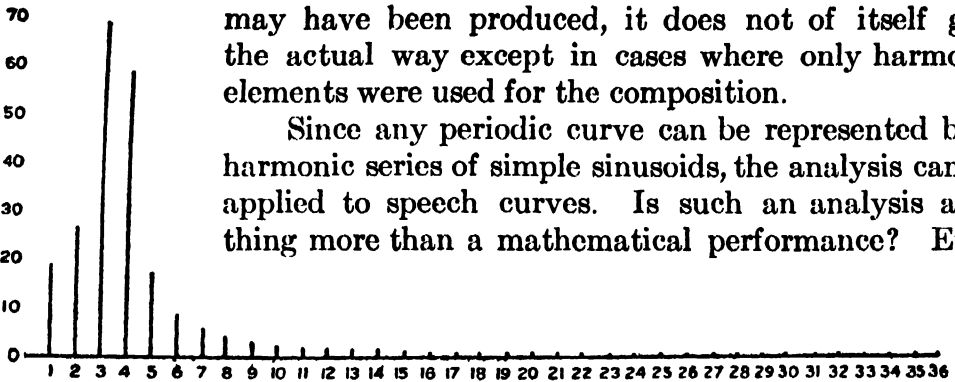

FIG. 76.—Harmonic plot to figure 75.

Since any periodic curve can be represented by a harmonic series of simple sinusoids, the analysis can be applied to speech curves. Is such an analysis anything more than a mathematical performance? Even

if it is nothing more, has it a value for the study of speech curves? To be anything more than a purely mathematical operation, the analysis must represent the way in which the vowel vibration is produced or perceived. If the vowel was actually produced by combining simple sinusoid vibrations in a harmonic series, then this form of analysis gives the elements directly. The sounds from the musical instruments are presumably produced in this way, but we dare not assume that the vowels are so produced until the fact has been proven.

If we suppose an actual vowel curve to have been produced by the addition of a number of harmonic and inharmonic sinusoids, we must

devise a method of separating them out of the mixed results of a harmonic analysis. Hermann\* gives the following rules: (1) When a harmonic of large amplitude appears with neighboring harmonics of very small amplitude, it may be considered alone as indicating approximately the partial. (2) When the strong harmonic is accompanied by two neighboring strong harmonics, all three should be considered. (3) When one of the neighbor-

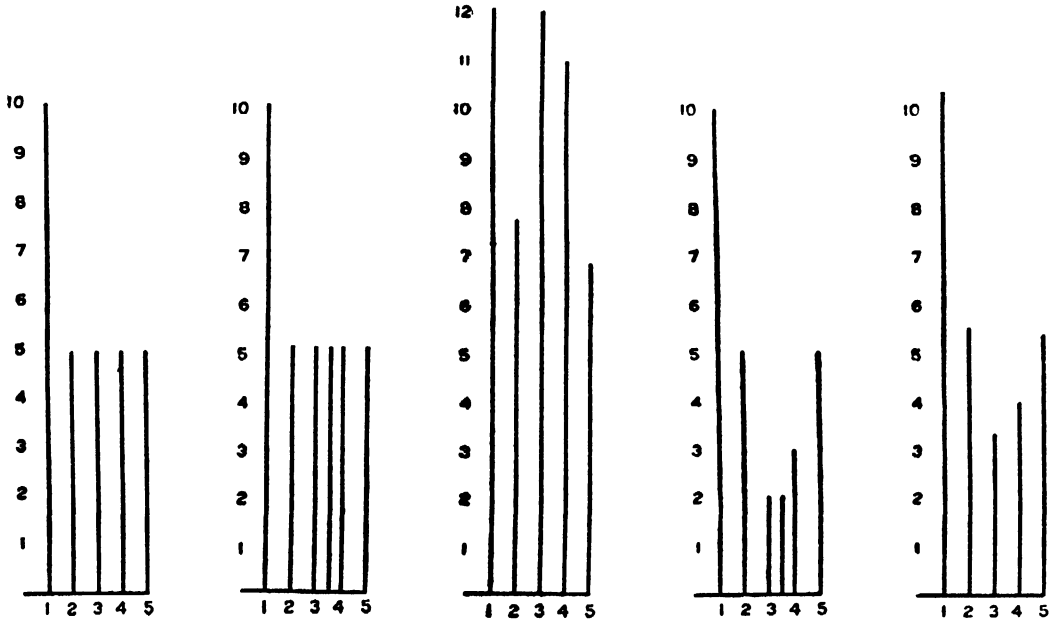

FIG. 77.—Plot of five harmonics. FIG. 78.—Plot of five harmonics with one inharmonic. FIG. 79.—Harmonic plot to figure 78. FIG. 80.—Plot of five harmonics with one inharmonic. FIG. 81.—Harmonic plot to figure 80.

ing harmonics is more than twice as great as the other, only the former should be considered with the strong harmonic. In the case, for example, where the first 10 sinusoids in the result have the relative amplitudes 4.2, 8.5, 3.2, 7.3, 2.2, 13.9, 44.7, 50.2, 13.6, 14.6, Hermann calculates the relative period of the upper inharmonics from the four strong harmonics. The weighted mean is

$$\frac{(13.9 \times 6) + (44.7 \times 7) + (50.2 \times 8) + (13.6 \times 9)}{13.9 + 44.7 + 50.2 + 13.6} = 7.53.$$

That is, the frequency of the inharmonic is 7.53 times that of the fundamental. In this particular case the latter was 98; consequently the frequency of the inharmonic was 737.

\* Hermann, Phonophotographische Untersuchungen, iv, Arch. f. d. ges. Physiol. (Pflüger), 1893, LIII, 50. A summary of Hermann's mathematical methods and of the discussion with Pipping is to be found in Burkhardt, Entwicklungen nach oscillirenden Funktionen, Jahresbericht d. deutschen Mathematiker-Vereinigung, 1901-02-03, x, 279-288.

When we consider how an inharmonic appears in a harmonic analysis (figure 76), the conclusion seems unavoidable that the members taken for the weighted mean should not be broken off so arbitrarily. In the example just given the results are cut off at the 10th harmonic; the strength of this harmonic makes it evident that at it or just above it another strong tone must be present. The amplitude of the 9th harmonic is due not only to the strong tone between the 7th and 8th but also to that at or above the 10th.

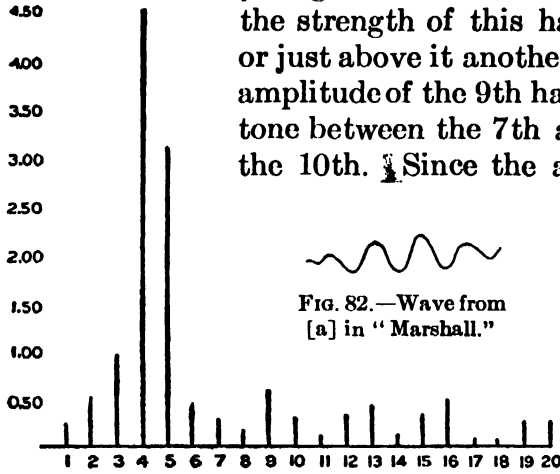
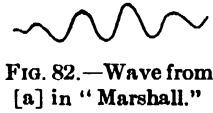

Fig. 83.—Harmonic plot to figure 82.



Since the amplitude for the 9th arose from at least two tones, one above and one below, it might, therefore, properly be divided between them. Divided in the ratio of the neighboring tones (50.2 : 14.6) the amplitude 13.6 gives 10.5 and 3.1. The amplitude 2.2 of the 5th harmonic might likewise be divided in the ratio of the two neighboring tones (13.9 : 7.3) giving 1.4 and 0.8.

For calculating the inharmonic between the 7th and the 8th, we may then use the neighboring parts of the 9th and 5th, giving

$$\frac{(1.4 \times 5) + (13.9 \times 6) + (44.7 \times 7) + (50.2 \times 8) + (10.5 \times 9)}{1.4 + 13.9 + 44.7 + 50.2 + 10.5} = 7.45.$$

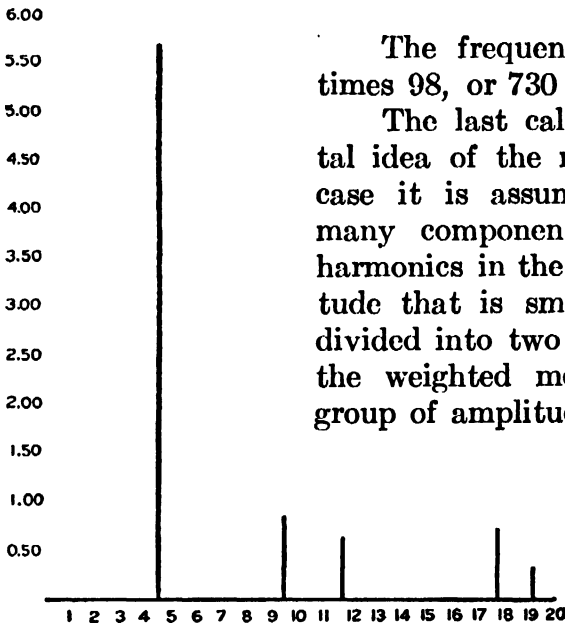

Fig. 84.—Component plot from figure 83.

The frequency of the inharmonic is thus 7.45 times 98, or 730 vibrations.

The last calculation indicates the fundamental idea of the method I have adopted. In each case it is assumed that there were present as many component tones as there are prominent harmonics in the harmonic plot; then every amplitude that is smaller than both its neighbors is divided into two parts proportional to their sizes; the weighted mean is then calculated for each group of amplitudes around a maximum, the calculation being extended to the parts of the minimum amplitudes. The following examples will illustrate how the component tones are obtained from the results of a harmonic analysis.

A harmonic analysis of a wave (figure 82) from [a] in "Marshall" gave the following result:

Partial .....	1	2	3	4	5	6	7	8	9	10	11	12	13	14	15	16	17	18	19	20
Amplitude.....	1.9	5.1	9.1	44.5	31.3	5.1	3.3	2.1	6.0	3.3	1.2	3.4	4.4	1.4	2.7	5.2	1.0	0.8	2.5	3.1

The harmonic plot is given in figure 83. There are minima at the 8th, 11th, 14th, and 18th partials. The amplitudes for each of these is to be divided proportionately between its two neighbors. For example, 2.1 is divided into two parts in the ratio of 3.3 to 6.0, that is, into 0.7 and 1.4. Similarly divided, the other numbers give 0.6, and 0.6; 0.9 and 0.5; 0.2 and 0.6 respectively. For the group around the first maximum we then have

$$\frac{(1 \times 1.9) + (2 \times 5.1) + (3 \times 9.1) + (4 \times 44.5) + (5 \times 31.3) + (6 \times 5.1) + (7 \times 3.3) + (8 \times 0.7)}{1.9 + 5.1 + 9.1 + 44.5 + 31.3 + 5.1 + 3.3 + 0.7} = 4.3$$

This means that the first component tone has the ordinal number 4.3 in the series of partials; its frequency is 4.3 times that of the fundamental, namely,  $144.5 \times 4.3 = 619.9$ . For the second component we find

$$\frac{(8 \times 1.4) + (9 \times 6.0) + (10 \times 3.3) + (11 \times 0.6)}{1.4 + 6.0 + 3.3 + 0.6} = 9.3.$$

Its frequency is, therefore,  $144.5 \times 9.3 = 1343.9$ . In the same way we find that the group of partials between the minima at 11 and 14 has a weighted mean of 11.5, giving a frequency of 1661.8, and the following group has a mean of 17.6, giving a frequency of 2543.2. For the last group the calculation becomes somewhat indefinite because the series is broken off at a partial which can not be a minimum; we can do no more than make a rough approximation to the tone which must lie somewhere between the 19th and 20th partial, let us say at

$$\frac{(19 \times 2.5) + (20 \times 3.1)}{2.5 + 3.1} = 19.5,$$

which gives the frequency  $144.5 \times 19.5 = 2817.8$ .

It is important to approximate the amplitudes of the components. This might perhaps be closely done by a complicated calculation, but as a practical rule I suggest the following one. When the inharmonic does not differ much from a harmonic the largest amplitude in the group is taken for that of the inharmonic. When it differs much (for example, when it lies about half-way between two harmonics),  $\frac{1}{3}$  of the amplitude of the largest harmonic in the group is taken. The suggestion for this rule arises from the fact that if an inharmonic is slightly changed so as to become a harmonic, its amplitude will coincide with that of the harmonic, and from the method of distribution of the harmonic results shown in figure 76. In the present case each inharmonic lies nearer the middle point between

two harmonics than it does to a harmonic, and  $\frac{4}{3}$  of the highest amplitude are taken. The results are thus:

Component.	Frequency.	Ratio.	Amplitude.
I	619.9	4.3	59.3
II	1343.9	9.3	8.0
III	1661.8	11.5	5.9
IV	2543.2	17.6	6.9
V	2817.8	19.5	4.1

The plot of components is given in figure 84.

Harmonic analysis of a wave from the vowel [ɔ] of "called" (figure 85) gives the results (figure 86):

Partial .....	1	2	3	4	5	6	7	8	9	10	11	12	13	14	15	16	17	18	19	20
Amplitude.....	6.0	4.1	16.9	47.6	5.7	10.4	26.6	5.1	5.8	2.6	4.6	1.7	2.2	2.7	2.7	1.6	1.8	0.9	1.2	1.0

Minima are found at the 2d, 5th, 8th, 10th, 12th, 16th, and 18th harmonics; the values are divided as before. Except for the first and the last components the calculation proceeds as in the previous case. For the first component we must consider that there is no probability that a wave was present where the period was just a little shorter than that of the fundamental; on the contrary we have every reason to believe that the fundamental was certainly present and we therefore assume it as the first component. For the last component we can perhaps best use only the last two numbers, obtaining

$$\frac{(19 \times 1.2) + (20 \times 1.0)}{1.2 + 1.0} = 19.2.$$

For the amplitudes we take those of the strongest harmonic in each group or  $\frac{4}{3}$  of it according to the rule just given. We thus obtain the set of partials as follows:

Component.	Frequency.	Ratio.	Amplitude.
I	134.8	1.0	6.0
II	498.8	3.7	63.5
III	916.6	6.8	35.5
IV	1226.7	9.1	5.8
V	1482.8	11.0	4.6
VI	1900.7	14.1	2.7
VII	2278.1	16.9	1.8
VIII	2588.6	19.2	1.2

The plot of components is given in figure 87.

A systematic accumulation of vowel analyses like these examples may be expected to answer such questions as the following ones: What is the nature of a vowel by which it is distinguished from the tones of musical instruments? How is one typical vowel distinguished from

another? Do these differences lie in the presence of certain tones of definite pitch (Helmholtz, Hermann)? If so, are these tones overtones of the glottal tone (Helmholtz), or inharmonic to it (Hermann)? Do the differences lie in the relations of the cavity tones to one another? On any of these principles what distinguishes [a] from [o], etc.? It is evident that a theory of the vowels is involved; whether the simple inharmonic analysis can give results reliable enough to furnish a decision is a matter for investigation. In the following chapters some modifications of this

FIG. 85.—Wave from [ɔ] in "called."

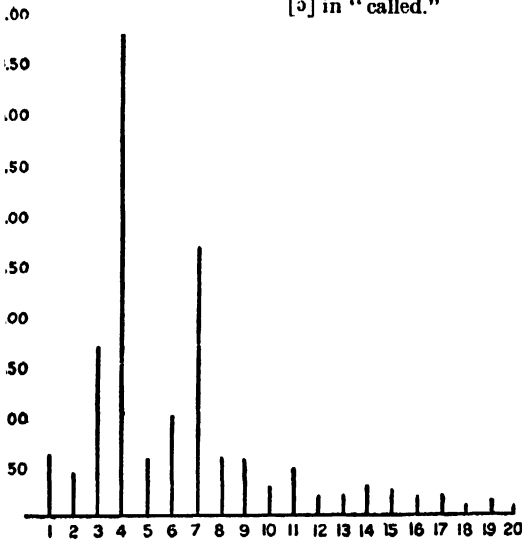

FIG. 86.—Harmonic plot to figure 85.

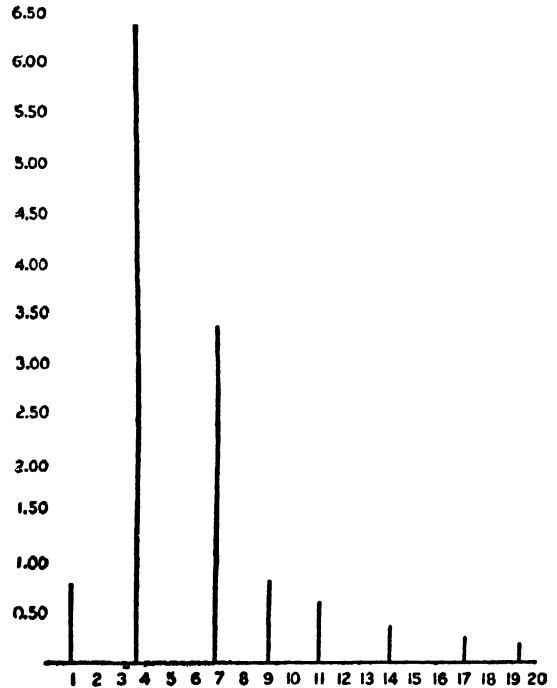

FIG. 87.—Component plot from figure 86.

method will be considered, after which will follow a discussion of the applicability of the different procedures.

We will now turn to a detailed treatment of the method of harmonic analysis; the reader who does not wish to follow it can proceed to the following chapter without interruption of the train of thought.

In a "simple sinusoid" function of the form

$$y = a \cdot \sin\left(\frac{2\pi}{T} t - q\right) \tag{1}$$

$y$  is the elongation at the moment  $t$ ,  $a$  is the amplitude or the maximum value of  $y$ ,  $T$  is the period, or the time of one complete cycle. The phase  $q$  depends on the moment from which  $t$  is calculated; if  $t$  is taken from the

moment at which  $y$  begins its positive values (indicated by  $y = +0$ ), then  $q = 0$ , and the equation becomes

$$y = a. \sin \frac{2\pi}{T} t. \quad (2)$$

If the distance from the origin of coordinates to  $y = +0$  be denoted by  $r$ , then

$$r = \frac{q}{2\pi} T. \quad (3)$$

A sine curve with the phase  $q = -\frac{\pi}{2}$  is the same as a cosine curve with the phase 0, or

$$y = a. \sin \left( \frac{2\pi}{T} t + \frac{\pi}{2} \right) = a. \cos \frac{2\pi}{T} t.$$

If the "frequency," or number of vibrations per second, is  $n = 1/T$ , then

$$y = a. \sin 2\pi n t. \quad (4)$$

If the number of vibrations in  $2\pi$  seconds is  $k$ , then

$$k = 2\pi n = \frac{2\pi}{T}, \quad (5)$$

$$y = a. \sin k t. \quad (6)$$

According to Fourier's theorem any periodic function of  $t$  may be expressed by a constant, plus the sum of a harmonic series of sines and cosines where the amplitudes receive the necessary values and the series is sufficiently extended. Thus,

$$\begin{aligned} y = C + a_1. \cos \frac{2\pi}{T} t + a_2. \cos \frac{2\pi}{\frac{1}{2}T} t + a_3. \cos \frac{2\pi}{\frac{1}{3}T} t + \dots \\ + b_1. \sin \frac{2\pi}{T} t + b_2. \sin \frac{2\pi}{\frac{1}{2}T} t + b_3. \sin \frac{2\pi}{\frac{1}{3}T} t + \dots \end{aligned} \quad (7)$$

Here  $C$  is the ordinate for the mean value of the function (height of the curve axis above the X-axis),  $T$  is the period of the function to be expressed,  $T, \frac{1}{2}T, \frac{1}{3}T, \dots$  are the harmonic series of periods, and  $a_1, a_2, a_3, \dots, b_1, b_2, b_3, \dots$  are the amplitudes of the sinusoids belonging to the series.

The values of the coefficients  $a_1, a_2, a_3, \dots b_1, b_2, b_3, \dots$  are given by

$$C = \frac{1}{T} \int_0^T y \cdot dt \tag{8}$$

$$a_i = \frac{2}{T} \int_0^T y \cdot \cos \left( i \frac{2\pi}{T} t \right) \cdot dt \tag{9}$$

$$b_i = \frac{2}{T} \int_0^T y \cdot \sin \left( i \frac{2\pi}{T} t \right) \cdot dt \tag{10}$$

$$(i = 1, 2, 3, \dots)$$

By using a sufficient number of terms any function whatever (straight line, irregular curve) of  $t$  within the period  $T$  can be represented by the series (7). The resolution into such a series is termed "harmonic analysis." The results of the analysis are applicable only to the curve within the period analyzed, that is, within  $T$ , unless the curve repeats itself exactly outside of  $T$ .

To obtain a more convenient form for (7) it is sufficient to put

$$\begin{aligned} a &= -c \cdot \sin q, & b &= c \cdot \cos q, \\ \text{that is,} & & & \\ c &= \sqrt{a^2 + b^2}, & \tan q &= -\frac{a}{b}; \end{aligned} \tag{11}$$

whence we have

$$y = C + c_1 \cdot \sin \left( \frac{2\pi}{T} t - q_1 \right) + c_2 \cdot \sin \left( \frac{2\pi}{T} t - q_2 \right) + c_3 \cdot \sin \left( \frac{2\pi}{T} t - q_3 \right) + \dots \tag{12}$$

It is often convenient to use the form (6), whereby the equations (7, 8, 9, 10) become

$$\begin{aligned} y &= C + a_1 \cdot \cos kt + a_2 \cdot \cos 2kt + a_3 \cdot \cos 3kt + \dots \\ &+ b_1 \cdot \sin kt + b_2 \cdot \sin 2kt + b_3 \cdot \sin 3kt + \dots \end{aligned} \tag{13}$$

$$C = \frac{k}{2\pi} \int_0^{\frac{2\pi}{k}} y \cdot dt \tag{14}$$

$$a_i = \frac{k}{\pi_0} \int_0^{\frac{2\pi}{k}} y \cdot \cos ikt \cdot dt \quad (15)$$

$$b_i = \frac{k}{\pi_0} \int_0^{\frac{2\pi}{k}} y \cdot \sin ikt \cdot dt \quad (16)$$

( $i = 1, 2, 3, \dots$ )

Equation (12) appears in this form as

$$y = C + c_1 \cdot \sin(kt - q_1) + c_2 \cdot \sin(2kt - q_2) + c_3 \cdot \sin(3kt - q_3) + \dots \quad (17)$$

To perform a harmonic analysis the wave-length  $T$  is divided into a number  $m$  of equal parts  $h$  (thus,  $T = mh$ ), giving along the time-axis the equidistant points  $t_0, t_1, t_2, t_3, \dots, t_j, \dots, t_{m-1} = 0, h, 2h, 3h, \dots, jh, \dots, (m-1)h$ . The ordinates at these points,  $y_0, y_1, y_2, y_3, \dots, y_j, \dots, y_{m-1}$ , are then measured. With these finite values ( $dt = h$ ), the coefficients (8, 9, 10) become

$$C = \frac{1}{m} \sum_{j=0}^{j=m-1} y_j \quad (18)$$

$$a_i = \frac{2}{m} \sum_{j=0}^{j=m-1} y_j \cdot \cos ijh \quad (19)$$

$$b_i = \frac{2}{m} \sum_{j=0}^{j=m-1} y_j \cdot \sin ijh \quad (20)$$

( $i = 1, 2, 3, \dots$ )

The coefficients are thus (21)

$$C = \frac{1}{m} (y_0 + y_1 + y_2 + y_3 + \dots + y_{m-1})$$

$$a_1 = \frac{2}{m} (y_0 \cdot \cos 0 + y_1 \cdot \cos h + y_2 \cdot \cos 2h + y_3 \cdot \cos 3h + \dots + y_{m-1} \cdot \cos [m-1]h)$$

$$b_1 = \frac{2}{m} (y_0 \cdot \sin 0 + y_1 \cdot \sin h + y_2 \cdot \sin 2h + y_3 \cdot \sin 3h + \dots + y_{m-1} \cdot \sin [m-1]h)$$

$$a_2 = \frac{2}{m} (y_0 \cdot \cos 0 + y_1 \cdot \cos 2h + y_2 \cdot \cos 4h + y_3 \cdot \cos 6h + \dots + y_{m-1} \cdot \cos 2[m-1]h)$$





We obtain likewise

$$b_1 = \frac{1}{8} (0 + 0.50y_1 + 0.87y_2 + y_3 + 0.87y_4 + 0.50y_5 + 0 - 0.50y_7 - 0.87y_8 - y_9 - 0.87y_{10} - 0.50y_{11}),$$

$$a_2 = \frac{1}{8} (y_0 + 0.50y_1 - 0.50y_2 - y_3 - 0.50y_4 + 0.50y_5 + y_6 + 0.50y_7 - 0.50y_8 - y_9 - 0.50y_{10} + 0.50y_{11}),$$

$$b_2 = \frac{1}{8} (y_0 + 0.87y_1 + 0.87y_2 + 0 - 0.87y_4 - 0.87y_5 - 0_6 - 0.87y_7 + 0.87y_8 + 0_9 - 0.87y_{10} - 0.87y_{11}),$$

and so forth.

For the entire set of coefficients it is necessary only to multiply each ordinate by 1.00, 0.87, 0.50, 0, and select the requisite values with the proper signs. The formulas show that the selection is to be made according to definite rules. When the values are written in 4 columns of 12 lines (see the schedules at end of volume) the selection for  $a$  always begins with + in the upper lefthand corner, and for  $b$  with + in the upper righthand corner. For  $a_1$  it proceeds continuously "1 to the right and down, 1 to the right and down," etc.; for  $a_2$ , "2 to the right and down, 2 to the right and down," etc. For  $b_1$  it proceeds "1 to the left and down, 1 to the left and down," etc.; for  $b_2$ , "2 to the left and down," etc. Whenever the count strikes the righthand edge, the sign changes from + to - or from - to +.

The labor of selecting the values according to these rules is largely avoided by using patterns that cover all except one set at a time, and at the same time indicate the signs. Thus a pattern is made for  $a_1$ , another for  $a_2$ , and so forth; the patterns for  $b_1$  and  $b_2$  . . . are obtained by turning those for the corresponding  $a$ 's over and marking the signs properly. Thus for 12 ordinates there will be 6 patterns, but each one is used on both sides. For 24 ordinates there will be 12 patterns, etc. It will be found that for the last  $b$  in each set the pattern indicates a sum of zeros; this can therefore be omitted. The corresponding pattern for the last  $a$  can also be omitted, if it is remembered that for this  $a$  the values of the first column are taken with alternate + and -. The simple zigzags for  $a_2$  and  $b_2$  are also readily memorized. Thus for 12 ordinates only 4 double-sided patterns are absolutely necessary.

At the end of this book the schedules for 12, 24, 36, and 72 ordinates are given. The labor of preparing such schedules is very great and the chances of mistakes are numerous. All the patterns given in this volume have been computed by at least three persons independently. They have also been subjected to a series of tests sufficiently detailed, it is hoped,

to insure their correctness. The patterns themselves may be prepared from these schedules by having a lithographer engrave a stone with rectangles 12mm. by 5mm. For a set of 12, 24, 36, and 72 patterns a total of 72 prints on cardboard is made; a supply of prints on paper is also required, one print for each analysis to be done.\*

To prepare a pattern the rectangles marked + and - are cut out; the holes for those with + are surrounded by a black line, those with - by a red line.

On the paper ruled in columns and lines the values of  $y$  are written in the first column. If 72 ordinates are used, each of these values of  $y$  is to be multiplied by 1.00000, 0.99619, 0.98481, 0.96593, 0.93969, 0.90631, 0.86603, 0.81915, 0.76604, 0.70711, 0.64279, 0.57358, 0.50000, 0.42262, 0.34202, 0.25882, 0.17365, 0.08715, 0. For 36 ordinates the multipliers are 1.00000, 0.98481, 0.93969, etc., namely, every second one of the above set for 72. For 24 ordinates they are 1.00000, 0.96593, 0.86603, 0.70711, 0.50000, 0.25882, 0. For 12 they are 1.0000, 0.86603, 0.50000, 0. Positive products are written with black ink, negative with red. These products may be taken from Crelle's Rechentafeln; this suffices for two or three places, but requires an extravagance of time for four or five places. When large numbers of waves are to be analyzed, it is well to prepare a table of products with a multiplying machine, using seven places and then condensing to five. The table should be made for 72 ordinates; for 72 ordinates each line is copied completely; for 36 ordinates every second column is used; for 24 ordinates every third column, and for 12 ordinates every sixth column. For much of the work it is not necessary to use more than two or three decimal places; a condensed table can be readily prepared.

To calculate a coefficient the requisite pattern is laid over the sheet with the products. All the figures seen through the holes are added; those whose color corresponds with that of the lines around the holes are positive, the others are negative. As this work—particularly with 72 ordinates—requires an enormous amount of time, and as it must be done over at least twice in order to insure against mistakes of addition, the use of adding machines is to be strongly recommended.† The result of each addition is divided by half the number of schedules. The values  $a$  and  $b$  thus obtained are used to calculate  $c = \sqrt{a^2 + b^2}$ .

When the analysis has been made, the serial numbers of the successive harmonics are laid off on the X-axis and ordinates proportional to the amplitudes  $c$  are erected as straight lines. The tops of the ordi-

\* Prints can be had by mail from G. Heinicke, Dorotheenstr. 39, Berlin, Germany, at 10 marks per hundred for cardboard and 6½ marks per hundred for paper.

† Burroughs, Felt and Tarrant, etc.

notes in such a "harmonic plot" should not be connected unless by straight lines to guide the eye. Smooth curves drawn through harmonic plots have led two investigators to discuss a "curve of resonance" for each vowel, whereas such a concept is absolute nonsense. To familiarize the mind with the practice of harmonic analysis I will give some elementary illustrations, using only 12 ordinates and one decimal place. By consulting the patterns at the back of the book the reader can readily perform the simple calculations mentally. Actual work with speech curves is, of course, much more laborious, requiring usually 36 or 72 ordinates and two to four decimal places; such an analysis of a single wave usually requires the work of one person for two or three days.

A curve with the ordinates 0.0, 5.0, 8.7, 10.0, 8.7, 5.0, 0.0, -5.0, -8.7, -10.0, -8.7, -5.0, 0.0 yields the neighboring table of products.

1.00	0.87	0.50	0
0	0	0	0
5.0	4.4	2.5	0
8.7	7.6	4.4	0
10.0	8.7	5.0	0
8.7	7.6	4.4	0
5.0	4.4	2.5	0
0	0	0	0
-5.0	-4.4	-2.5	0
-8.7	-7.6	-4.4	0
-10.0	-8.7	-5.0	0
-8.7	-7.6	-4.4	0
-5.0	-4.4	-2.5	0

The analysis gives  $a_1=0$ ,  $b_1=10.1$ , with the other coefficients = 0. The curve is therefore present only as the first harmonic in the sine series with a phase factor = 0. Assuming 36 as the length of the period and neglecting the tenths of a unit, we have as the equation of the curve  $y=10.\sin\frac{2\pi}{36}t$ , which is the equation according to

which the ordinates were calculated. The curve itself is given in figure 67.

A curve yields ordinates and products as in the adjacent table. The analysis gives  $C=12$ ,  $a_1=0$ ,  $b_1=10$ , and all other coefficients = 0. The curve is therefore the same as the preceding one except in having its axis at 12 above the X-axis. This illustrates the principle that the addition of a constant to the ordinates of the curve does not affect the coefficients for the sinusoids.

1.00	0.87	0.50	0
12.0	10.4	6.0	0
17.0	14.8	8.5	0
20.7	18.0	10.3	0
22.0	19.1	11.0	0
20.7	18.0	10.3	0
17.0	14.0	8.5	0
12.0	10.4	6.0	0
7.0	6.0	3.5	0
3.3	2.9	1.7	0
2.0	1.7	1.0	0
3.3	2.9	1.7	0
7.0	6.1	3.5	0

The curve in figure 69 yields a table of products like the first one given above, except that three values are removed from the beginning and placed at the end. The analysis gives  $a_1=10$  and all other coefficients=0. The curve is therefore

$$y=10.\cos\frac{2\pi}{36}t=10.\sin\left(\frac{2\pi}{36}t+\frac{\pi}{2}\right).$$

This case illustrates the fact that values can be transferred from one end of the table to the other without altering anything except the phase. It

may also readily be shown that when the curve consists of the same wave regularly repeated, the amplitude of the harmonic found is independent of the point at which the first ordinate is taken. That the result is not the same when the wave is not regularly repeated can be readily illustrated by replacing some of the end values of the table by others not from the table. This principle marks a fundamental distinction between musical curves and speech curves.

A curve yielding the adjacent table of products is analyzed into a series with  $a_1=0$ ,  $b_1=10$ ,  $a_2=0$ ,  $b_2=5$ ,  $a_3=0$ ,  $b_3=5$ , and all the other coefficients = 0. The equation of the curve (for  $T=36$ ) is therefore

1.00	0.87	0.50	0
0	0	0	0
14.3	12.4	7.2	0
13.0	11.3	6.5	0
5.0	4.4	2.5	0
4.3	3.7	2.2	0
5.7	5.0	2.9	0
0	0	0	0
-5.7	-5.0	-2.9	0
-4.3	-3.7	-2.2	0
-5.0	-4.4	-2.5	0
-13.0	-11.3	-6.5	0
-14.3	-12.4	-7.2	0

$$y = 10 \sin \frac{2\pi}{36}t + 5 \sin \frac{2\pi}{18}t + 5 \sin \frac{2\pi}{12}t.$$

A curve yields the ordinates 0, 73.4, 5.0, 17.1, 8.7, 3.4, 10.0, 2.0, 8.7, -2.9, 5.0, 1.3, 0, 1.3, -5.0, 2.9, -8.1, 2.0, -10.0, -3.4, 48.7, -17.1, -5.0, -73.4. The analysis with 24 ordinates gives  $b_1 = 10.1$ ,  $b_2 = 10.0$ ,  $b_3 = 10.0$ ,  $b_4 = 10.1$ ,  $b_5 = 10.0$ ,  $b_6 = 10.0$ ,  $b_7 = 10.1$ ,  $b_8 = 10.1$ ,  $b_9 = 10.1$ ,  $b_{10} = 10.0$ , and all other coefficients = 0. The equation (tenths of a unit being dropped) is therefore (for  $T=36$ )

$$y = 10 \sum_{i=1}^{i=10} \sin \frac{2\pi}{36} i t.$$

A curve yields the ordinates -7.50, -3.32, +1.00, +4.87, 9.43, +13.72, +10.97, +6.93, +6.55, +8.50, +8.06, +2.50, -5.31, -1.10, -13.53, -15.43, -13.72, -9.50, -2.31, +3.07, +2.21, -3.50, -8.06, at intervals of  $t = 5$ . The analysis gives  $C = 0$ ,  $a_1 = 0$ ,  $b_1 = 10.0$ ,  $a_2 = 2.5$ ,  $b_2 = 4.3$ ,  $a_3 = 5.0$ ,  $b_3 = 0$ ,  $a_4 = 0$ ,  $b_4 = 0$ ,  $a_5 = 0$ ,  $b_5 = 2.0$ ,  $a_6 = \dots = a_{12} = b_6 = \dots = b_{12} = 0$ . The curve thus has the equation:

$$y = 10 \sin \frac{2\pi}{36}t + 5 \sin \left( \frac{2\pi}{18}t - \frac{5\pi}{6} \right) + 5 \sin \left( \frac{2\pi}{12}t - \frac{\pi}{2} \right) + 2 \sin \frac{2\pi}{7.2}t.$$

The curve and its components are shown in figure 71.

In the examples hitherto considered, the period of the curve analyzed has coincided with that of one member of the harmonic series used for the analysis. The more general and more important problem is how a sinusoid curve of any period will show itself in a harmonic analysis.

The sinusoid  $a.\sin pt$  is expressed by the analysis as

$$a.\sin pt = C + a_1.\cos kt + a_2.\cos 2kt + \dots + b_1.\sin kt + b_2.\sin 2kt + \dots \quad (22)$$

where

$$C = \frac{ak}{2\pi_0} \int_0^{\frac{2\pi}{k}} \sin pt . dt, \quad (23)$$

$$a_i = \frac{ak}{\pi} \int_0^{\frac{2\pi}{k}} \sin pt . \cos ikt . dt, \quad (24)$$

$$b_i = \frac{ak}{\pi} \int_0^{\frac{2\pi}{k}} \sin pt . \sin ikt . dt, \quad (25)$$

$$(i = 1, 2, 3, \dots).$$

Integration gives

$$C = -\frac{akp}{2\pi} \left[ \cos pt \right]_0^{\frac{2\pi}{k}} = -\frac{akp}{2\pi} \left( \cos 2\pi \frac{p}{k} - 1 \right) = \frac{akp}{\pi} \sin^2 \pi \frac{p}{k}. \quad (26)$$

$$\begin{aligned} a_i &= -\frac{ak}{2\pi} \left[ \frac{\cos (p + ik)t}{p + ik} + \frac{\cos (p - ik)t}{p - ik} \right]_0^{\frac{2\pi}{k}} \\ &= -\frac{akp}{\pi(p^2 - i^2k^2)} (\cos 2\pi \frac{p}{k} - 1) = \frac{2akp}{\pi(p^2 - i^2k^2)} \sin^2 \pi \frac{p}{k}. \end{aligned} \quad (27)$$

$$b_i = -\frac{ak}{2\pi} \left[ \frac{\sin (p + ik)t}{p + ik} - \frac{\sin (p - ik)t}{p - ik} \right]_0^{\frac{2\pi}{k}} = \frac{aik^2}{\pi(p^2 + i^2k^2)} \sin 2\pi \frac{p}{k}. \quad (28)$$

Putting  $p = jk$ , we have, for  $a.\sin jkt$ ,

$$C = \frac{ajk^2 . \sin^2 \pi j}{\pi}, \quad (29)$$

$$a_i = \frac{2aj . \sin^2 \pi j}{\pi(j^2 - i^2)}, \quad (30)$$

$$b_i = \frac{aij . \sin 2\pi j}{\pi(j^2 - i^2)}, \quad (31)$$

$$c_i = \frac{2aj . \sin \pi j \sqrt{\sin^2 \pi j + i^2 . \cos^2 \pi j}}{\pi(j^2 - i^2)}. \quad (32)$$

When the period of the curve analyzed is found in the harmonic series,  $j$  is a whole number; the numerators of the fractions are in every case  $= 0$ ; the denominators are concrete numbers for all cases except  $j = i$ ; consequently the coefficients  $C, a_1, a_2, \dots b_1, b_2, \dots$  except  $a_i, b_i$ , are also  $= 0$ . For  $a_i$  and  $b_i$ , the denominators are  $= 0$ , and the fractions are indeterminate. We have, however,

$$a_i = \frac{a}{\pi j} \int_0^{\frac{2\pi}{k}} \sin jkt \cdot \cos jkt \cdot d(jkt) = \frac{a}{2\pi j} \left[ \sin^2 jkt \right]_0^{\frac{2\pi}{k}} = 0,$$

and

$$b_i = \frac{a}{\pi j} \int_0^{\frac{2\pi}{k}} \sin^2 jkt \cdot d(jkt) = a.$$

Thus the analyzed curve appears in the harmonic series with its full amplitude for the member having the same period and phase, and with zero for all other members. When the period of the curve analyzed is not to be found in the harmonic series,  $j$  is not a whole number. Here the vibration has a frequency that is not an even multiple of the lowest term of the series, that is, its period does not occur in the harmonic series. Such a curve is "inharmonic" to the series used for the analysis. The harmonic coefficients are given by the formulas (27, 28). For example, the curve  $a \cdot \sin pt$ , where  $p = 3\frac{1}{2}k$ , will appear in the analysis with the coefficients,

$$C = \frac{3\frac{1}{2} ak^2}{\pi} = 1.1141 ak^2,$$

$$a_i = \frac{7a \cdot \sin^2 3\frac{1}{2}\pi}{\pi | (3\frac{1}{2})^2 - i^2 |} = \frac{a}{5.4978 - 0.4488 i^2},$$

$$b_i = \frac{aik^2 \cdot \sin 7\pi}{\pi | (3\frac{1}{2})^2 - i^2 |} = 0.$$

Expressed as a harmonic series of sines the curve has the coefficients

$$c_1 = \frac{a}{5.0490}, c_2 = \frac{a}{3.7026}, c_3 = \frac{a}{1.4576}, c_4 = \frac{a}{-1.6830}, c_5 = \frac{a}{-5.7222},$$

and so forth, with the factors of phase

$$q_1 = q_2 = q_3 = \frac{3\pi}{2}, q_4 = q_5 = \dots = \frac{\pi}{2}.$$

If, for illustration, we have  $a = 10$ , then  $c_1 = 1.98$ ,  $c_2 = 2.70$ ,  $c_3 = 6.85$ ,  $c_4 = 5.94$ ,  $c_5 = 1.75$ ,  $c_6 = 0.94$ ,  $c_7 = 0.61$ ,  $c_8 = 0.43$ ,  $c_9 = 0.32$ ,  $c_{10} = 0.24$ ,  $c_{11} = 0.20$ ,  $c_{12} = 0.16$ ,  $c_{13} = 0.14$ ,  $c_{14} = 0.12$ ,  $c_{15} = 0.10$ ,  $c_{16} = 0.09$ ,  $c_{17} = 0.08$ ,  $c_{18} = 0.07$ ,  $c_{19} = 0.06$ ,  $c_{20} = 0.06$ ,  $c_{21} = 0.05$ ,  $c_{22} = 0.05$ ,  $c_{23} = 0.04$ ,  $c_{24} = 0.04$ ,  $c_{25} = 0.04$ ,  $c_{26} = 0.03$ ,  $c_{27} = 0.03$ ,  $c_{28} = 0.03$ ,  $c_{29} = 0.03$ ,  $c_{30} = 0.03$ ,  $c_{31} = 0.02$ ,  $c_{32} = 0.02$ ,  $c_{33} = 0.02$ ,  $c_{34} = 0.02$ ,  $c_{35} = 0.01$ ,  $c_{36} = 0.01$ , and so forth. These values are shown in figure 76.

The way in which an inharmonic appears in the results of a harmonic analysis is thus utterly different from that for a harmonic. The third harmonic,  $p=3k$ , for example, appears in the analysis with different values for  $a_3$  and  $b_3$  (depending on the phase), but with 0 for every other  $a$  and  $b$ ; it thus appears in its proper place with its full value and has no influence anywhere else. The inharmonic, however, has no place of its own in the series, but appears in every element. The average ordinate  $C$  for a harmonic gives the height of the axis of the curve; for an inharmonic it depends not only on the height of the axis but also on the fractional part of a wave included in the fundamental.

When several inharmonic sinusoids coexist, the curve of their sum will when analyzed yield a harmonic series of sinusoids whose amplitudes are the same as the amplitudes of the original components. Thus for the curve  $a'.\sin p't + a''.\sin p''t$ , we have

$$a'.\sin p't + a''.\sin p''t = C + a_1.\cos kt + a_2.\cos 2kt + \dots + b_1.\sin kt + b_2.\sin 2kt + \dots$$

where

$$C = \frac{a'k}{2\pi} \int_0^{\frac{2\pi}{k}} \sin p't . dt + \frac{a''k}{2\pi} \int_0^{\frac{2\pi}{k}} \sin p''t . dt = C' + C'',$$

$$a_i = \frac{a'k}{\pi} \int_0^{\frac{2\pi}{k}} \sin p't . \cos ikt . dt + \frac{a''k}{\pi} \int_0^{\frac{2\pi}{k}} \sin p''t . \cos ikt . dt = a_i' + a_i'',$$

$$b_i = \frac{a'k}{\pi} \int_0^{\frac{2\pi}{k}} \sin p't . \sin ikt . dt + \frac{a''k}{\pi} \int_0^{\frac{2\pi}{k}} \sin p''t . \sin ikt . dt = b_i' + b_i''.$$

$$(i = 1, 2, 3, \dots)$$

From these equations the values of the coefficients can be calculated as above.

It is necessary to have some idea of the accuracy with which an actual analysis gives the values required by the formulas. The result depends on the number of members used and on the number of significant figures. With four significant figures used in the analysis of  $y = 10. \sin 3\frac{1}{2}t$ , the results rounded off to two decimal places give: for 6 members (12 ordinates) 1.43, 2.12, 6.22, 6.68, 2.65, 2.17; for 12 members (24 ordinates) 1.85, 2.57, 6.72, 6.08, 1.89, 1.09, 0.76, 0.60, 0.50, 0.45, 0.42, 0.41; for 18 members (36 ordinates) 1.92, 2.64, 6.80, 6.00, 1.81, 1.00, 0.67, 0.49, 0.39, 0.32, 0.27, 0.24, 0.22, 0.20, 0.19, 0.18, 0.18, 0.18; for 36 members (72 ordinates) 1.97, 2.69, 6.81, 5.96, 1.76, 0.95, 0.65, 0.47, 0.34, 0.27, 0.22, 0.18, 0.16, 0.14, 0.12, 0.11, 0.10, 0.09, 0.09, 0.07, 0.07, 0.06, 0.06, 0.06, 0.05, 0.05, 0.05, 0.05, 0.05, 0.05, 0.04, 0.04, 0.04, 0.04, 0.04, 0.04. A comparison of these figures with those obtained above by calculation shows some inaccuracy for the analysis into 6 members, and a steady increase of accuracy as the number of members is increased.

Helmholtz and Hermann suggest an analogy between the results of a harmonic analysis and the effect of a maintained sinusoid vibration (such as produced by a steadily vibrating fork) on a harmonic series of resonators. As explained in works on mathematical physics and acoustics, the resonators will respond to the vibration  $a \sin pt$  with the amplitudes

$$c_1 = \frac{a}{m_1 \sqrt{(k^2 - p^2)^2 + 4p^2 \epsilon_1^2}}, \quad c_2 = \frac{a}{m_2 \sqrt{(4k^2 - p^2)^2 + 4p^2 \epsilon_2^2}}, \quad \dots \quad (33)$$

$$c_i = \frac{a}{m_i \sqrt{(i^2 k^2 - p^2)^2 + 4p^2 \epsilon_i^2}}, \quad \dots$$

where  $m$  is the vibrating mass of the resonator and  $\epsilon$  is the factor of friction. If we consider the factor of friction to be so small as to be negligible and the resonators to all have the same mass, unity, we obtain as the general formula

$$c_i = \frac{a}{|i^2 k^2 - p^2|}, \quad (34)$$

or, if we put  $j = \frac{p}{k}$ , then

$$c_i = \frac{a}{k^2 |i^2 - j^2|}. \quad (35)$$

The amplitudes of the responses thus depend on the frequency of the fundamental. When the experiment is repeated with a higher set of resonators and with a maintained sinusoid proportionately higher, the

results will differ although the relation of the sinusoid to the resonators is the same as before. This is different from the mathematical analysis, where the results always remain the same whatever the period of the fundamental, provided the harmonic vibration has the same relation to it. The relation of the two cases is shown by a comparison of the formulas for the vibration  $a.\sin jkt$ ; the harmonic  $i$  has an amplitude given by  $a$ , in (30); the resonator  $i$  responds with the amplitude given by  $c$ , in (35). The two agree only when

$$k = \sqrt{\frac{\pi}{7 \sin^2 j\pi}}. \quad (36)$$

The analogy is therefore not a valid one. In Chapters VIII and IX we shall consider Helmholtz's theory of the vowels, which was based entirely on this analogy.

We have now to face the problem of deducing the pitch and amplitude of the inharmonic sinusoid vibration from the results of a harmonic analysis.

In the case of a single vibration  $a.\sin pt$ , the values  $a$  and  $p$  are to be found when the coefficients  $a_1, a_2, \dots b_1, b_2, \dots$  in a harmonic analysis with the fundamental  $k$  are known. For this calculation any two values of  $a$  or of  $b$  will suffice.

Thus from

$$a_1 = \frac{2 akp. \sin^2 \pi \frac{p}{k}}{\pi (p^2 - k^2)}$$

$$a_2 = \frac{2 akp. \sin^2 \pi \frac{p}{k}}{\pi (p^2 - k^2)}$$

we obtain

$$p = k \sqrt{\frac{a_1 - 4a_2}{a_1 - a_2}},$$

from which  $a$  can be calculated by substitution. Since the values  $a_1, a_2, \dots b_1, b_2, \dots$  were obtained from the ordinates  $y_0, y_1, y_2, \dots$  which are contaminated by the errors of measurement, the values of  $p$  from different pairs of coefficients will not exactly agree; the method of least squares requires that their average be taken. The matter is of no practical importance because we never have to deal with a vibration composed of a single element.

When the vibration has several harmonic and inharmonic elements, the harmonic analysis does not give the components. As indicated above, the curve that furnishes the harmonic plot in figure 81 may have been produced by a set of simple sinusoids whose amplitudes are given in figure 80, or by a set with the amplitudes given in figure 81; in the former five harmonics and one inharmonic were used; in the latter, only five harmonics. The same curve could be just as well produced by any other inharmonic below 5 in connection with 5 harmonics, the amplitudes being appropriately selected. In every case the harmonic analysis would give the result in figure 81.

No matter how a curve was produced, the harmonic analysis will always give the same result. When the possibility of the presence of inharmonic components is admitted, the harmonic analysis of the curve gives no conclusion, and the problem of its composition becomes indeterminate unless some limiting suppositions are made. If we assume that the vowel curve had as many chief components as there are maxima in the harmonic plot, we can proceed to calculate these components as indicated above (p. 79).

## CHAPTER VI

### INHARMONIC ANALYSIS.

When inharmonic sinusoids are present in a vibration, as illustrated by the case of  $3\frac{1}{2}T$  in the preceding section, several successive waves may be treated as a single wave of correspondingly long period (figure 88). In this way the inharmonic of the single wave may be made a harmonic of the multiple wave, if the latter is sufficiently long. Thus by repeating the wave  $T$  once, the new double wave  $V = 2T$  is the fundamental of the series of harmonics:

$$\begin{array}{cccccccccccc}
 V & \frac{1}{2}V & \frac{1}{3}V & \frac{1}{4}V & \frac{1}{5}V & \frac{1}{6}V & \frac{1}{7}V & \frac{1}{8}V & \frac{1}{9}V & \frac{1}{10}V & \frac{1}{11}V & \frac{1}{12}V \\
 2T & T & \frac{2}{3}T & \frac{1}{2}T & \frac{2}{5}T & \frac{1}{3}T & \frac{2}{7}T & \frac{1}{4}T & \frac{2}{9}T & \frac{1}{5}T & \frac{2}{11}T & \frac{1}{6}T.
 \end{array}$$

The inharmonics  $\frac{2}{3}T, \frac{2}{5}T, \frac{2}{7}T, \frac{2}{9}T, \frac{2}{11}T$  are all found as harmonics of the double wave. A harmonic analysis of the double wave will yield these inharmonics of the original wave directly as its own harmonics. Such a modification of the method of the preceding section may be termed an "inharmonic analysis."

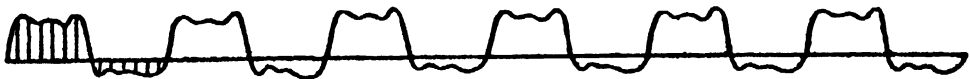

FIG. 88. — Six successive waves used as a single wave for an inharmonic analysis.

This method needs little special explanation. What can be accomplished by using  $V = 6T$  with only 12 ordinates in measuring the original wave is worth considering. We have the harmonic set

$$\begin{array}{cccccccccccc}
 V & \frac{1}{2}V & \frac{1}{3}V & \frac{1}{4}V & \frac{1}{5}V & \frac{1}{6}V & \frac{1}{7}V & \frac{1}{8}V & \frac{1}{9}V & \frac{1}{10}V & \frac{1}{11}V & \frac{1}{12}V & \frac{1}{13}V & \frac{1}{14}V & \frac{1}{15}V & \frac{1}{16}V & \frac{1}{17}V & \frac{1}{18}V \\
 6T & 3T & 2T & \frac{3}{2}T & \frac{6}{5}T & T & \frac{6}{7}T & \frac{3}{4}T & \frac{2}{3}T & \frac{3}{5}T & \frac{6}{11}T & \frac{1}{2}T & \frac{6}{13}T & \frac{8}{7}T & \frac{2}{5}T & \frac{3}{8}T & \frac{6}{17}T & \frac{1}{3}T \\
 \frac{1}{19}V & \frac{1}{20}V & \frac{1}{21}V & \frac{1}{22}V & \frac{1}{23}V & \frac{1}{24}V & \frac{1}{25}V & \frac{1}{26}V & \frac{1}{27}V & \frac{1}{28}V & \frac{1}{29}V & \frac{1}{30}V & \frac{1}{31}V & \frac{1}{32}V & \frac{1}{33}V & \frac{1}{34}V & \frac{1}{35}V & \frac{1}{36}V & \frac{1}{36}V \\
 \frac{6}{19}T & \frac{3}{10}T & \frac{2}{7}T & \frac{3}{11}T & \frac{6}{23}T & \frac{1}{4}T & \frac{6}{25}T & \frac{3}{13}T & \frac{2}{9}T & \frac{3}{14}T & \frac{6}{29}T & \frac{1}{5}T & \frac{6}{31}T & \frac{3}{16}T & \frac{2}{11}T & \frac{3}{17}T & \frac{6}{35}T & \frac{1}{6}T
 \end{array}$$

in which a large number of inharmonics appear. Such an analysis requires the use of schedules with 72 ordinates, but only 12 multiplications are to be made; these are then simply written over six times. If 24 ordinates had been measured, an analysis with  $V = 6T$  would require schedules for 144 ordinates; if 36 had been done, then schedules for 216; if 72,

then schedules for 432. For  $V = 3T$ , just half as many would be required in each case; for  $V = mT$ , then  $m$  times as many. If  $r$  is the number of ordinates measured and  $V = mT$  the form of the analysis, the number of the schedules will be  $mr$ .

The method is evidently of some importance. Thus a curve consisting of an inharmonic with the period  $\frac{2}{3}T = \frac{1}{3}T$ —which was used as an example to show the application of the harmonic analysis to an inharmonic (p. 77)—would be found at once with its exact period and amplitude by an inharmonic analysis where  $V = 2T$ ; the labor required would not be greater than that involved in the harmonic analysis with the subsequent calculations (p. 79). To obtain the higher inharmonics the analysis must be more extended and a considerable number of ordinates must be measured.

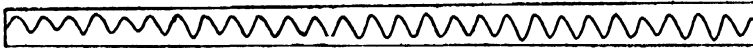

FIG. 89.—Clarinet.



FIG. 90.—Cornet.

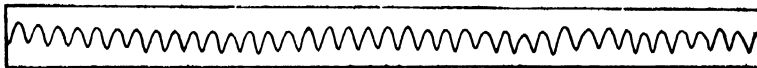

FIG. 91.—Saxophone.

This method is applicable only when the vibration is maintained unchanged for several waves. Such is undoubtedly the case in many musical instruments, for example, the clarinet (figure 89), the cornet (figure 90), and the saxophone (figure 91); it is sometimes approximated in singing. It is never the case in speech; not only does the wave-length (period of the tone from the glottis) change at every wave (it always rises, falls, or wavers, p. 40), but the adjustments of the mouth and other vocal cavities also change at every instant (p. 41). The conditions in two successive waves are therefore different, and each wave must be treated by itself. It will not do to simply repeat the ordinates of a single wave in order to obtain a multiple one. This breaks the inharmonics off at odd points and begins them at the same point for each wave; the results of repeating the ordinates and then analyzing such a multiple wave are identical with those furnished by the analysis of a single wave.

## CHAPTER VII.

### ANALYSIS INTO FRICTIONAL SINUSOIDS.

When the finger is laid softly against the side of the prong of a vibrating fork the movement dies away with a rapidity depending on the amount of friction of the prong against the finger. The curve traced in such a way may be called a "frictional sinusoid"; curves with the same period, amplitude, and phase, but with different degrees of friction, are shown in figure 92.

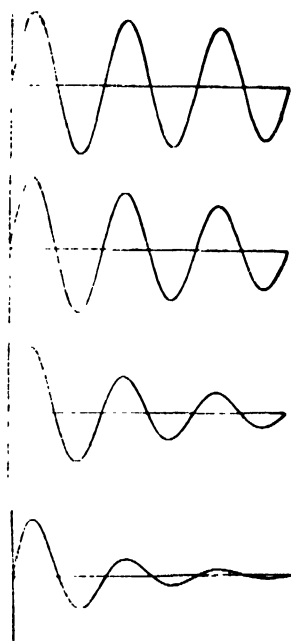

FIG. 92.--Sinusoid with different factors of friction.



FIG. 93.--Frictional sinusoid showing logarithmic decrement.



FIG. 94.--Curve compounded of frictional sinusoids.

The vibrations of the voice in speech are—as will be conclusively shown in the following chapters—composed exclusively of frictional sinusoids and not of simple sinusoids, as has hitherto been assumed. Can a method of analysis into frictional sinusoids be found? Does an analysis into simple sinusoids give false results for the vowel curves? The purpose of this chapter is to answer these two questions.

When a line is drawn along the tops of the vibrations of such a tuning-fork curve (figure 93) it is found to bend downward with greater or less rapidity and to gradually approach the zero line. This curve—which we may call the "curve of friction"—has a definite form indicated by the expression  $a.e^{-\epsilon t}$  where  $a$  is the amplitude of the vibration without friction,  $e = 2.71828$ ,  $\epsilon$  is a figure indicating the amount of friction, and  $t$  is the time from the start. The number  $\epsilon$  may be called the factor of friction (it is not the same as the coefficient of friction used in physics, but depends directly on it). The entire expression  $e^{-\epsilon t}$ , which modifies the amplitude, may be termed the frictional element of the curve.

Figure 67 is the same curve as that in figure 93 without friction. It is evident that if we know the factor of friction  $\epsilon$  we can calculate the frictional element  $e^{-t}$  for each value of  $t$ ; then by multiplying each ordinate of the curve in figure 95 by  $e^{-t}$  we shall obtain the ordinates of the curve in figure 67. In other words, to turn the simple sinusoid into the frictional sinusoid we multiply each ordinate by  $e^{-t} = \frac{1}{e^t}$  (or divide by  $e^t$ ); to turn the frictional sinusoid into a simple one, we reverse the process and divide by  $e^{-t}$  (or multiply by  $e^t$ ).

Suppose now that we have a wave concerning which we know only the period  $T$  and the factor of friction  $\epsilon$ , and that it was produced by one or more frictional sinusoids, for example, the wave in figure 94. To obtain its elements we must analyze it into a series of frictional sinusoids.

Har- monic	$\epsilon = 0$			$\epsilon = 0.002$			$\epsilon = 0.005$			$\epsilon = 0.010$		
	12	24	36	12	24	36	12	24	36	12	24	36
1	4.64	4.62	4.57	6.09	5.69	6.12	10.00	10.01	10.00	24.96	27.80	27.69
2	0.89	0.85	0.83	0.78	0.85	1.02	0.00	0.02	0.04	5.35	5.16	5.05
3	0.39	0.34	0.37	0.28	0.44	0.59	0.06	0.04	0.04	2.32	2.10	1.93
4	0.25	0.19	0.18	0.22	0.21	0.45	0.07	0.00	0.03	1.51	1.14	1.08
5	0.20	0.10	0.18	0.20	0.09	0.36	0.15	0.07	0.01	1.24	0.82	0.79
6	0.17	0.08	0.09	0.20	0.04	0.34	0.08	0.04	0.04	1.18	0.59	0.54
7	....	0.10	0.05	....	0.11	0.32	....	0.09	0.04	....	0.42	0.47
8	....	0.05	0.03	....	0.03	0.23	....	0.07	0.06	....	0.38	0.34
9	....	0.05	0.04	....	0.05	0.31	....	0.06	0.04	....	0.29	0.25
10	....	0.05	0.03	....	0.08	0.31	....	0.04	0.05	....	0.28	0.30
11	....	0.04	0.03	....	0.05	0.30	....	0.07	0.04	....	0.39	0.31
12	....	0.04	0.01	....	0.03	0.33	....	0.08	0.07	....	0.30	0.24
13	....	....	0.05	....	....	0.28	....	....	0.02	....	....	0.08
14	....	....	0.04	....	....	0.26	....	....	0.02	....	....	0.03
15	....	....	0.03	....	....	0.30	....	....	0.03	....	....	0.19
16	....	....	0.02	....	....	0.28	....	....	0.01	....	....	0.19
17	....	....	0.02	....	....	0.25	....	....	0.09	....	....	0.06
18	....	....	0.03	....	....	0.27	....	....	0.00	....	....	0.08

By multiplying each of the ordinates of the curve by the appropriate value of  $e^t$  we turn the curve into the corresponding simple sinusoid with the friction eliminated. The new curve is then the sum of a number of simple sinusoids, and we can use the harmonic or the inharmonic analysis to find its elements.

This analysis presupposes that the factor of friction  $\epsilon$  is known; in the case of a curve resulting from a single element, as in figure 93, it can be obtained by measuring the successive amplitudes and performing a simple calculation in the manner indicated at the end of this chapter. In more complicated curves it can often be approximated when one of the components is much stronger than the others; an illustration will be given in Chapter XI.

To get some idea of the degree of accuracy of the results of harmonic analysis applied to a frictional sinusoid, and also of the error introduced by using the wrong factor of friction, the curve in figure 94 was submitted

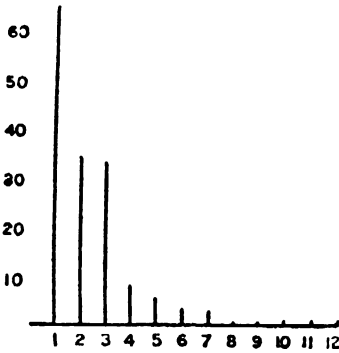

FIG. 95.—Harmonic plot to figure 94 with  $\epsilon = 0$ .

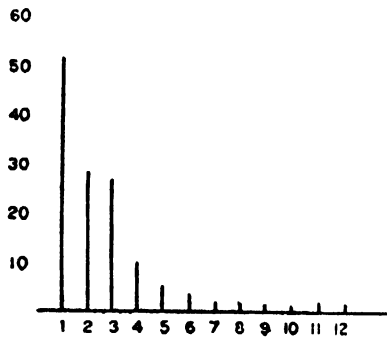

FIG. 96.—Harmonic plot to figure 94 with  $\epsilon = 0.002$ .

to harmonic analysis into simple sinusoids ( $\epsilon = 0$ ) and into various systems of frictional sinusoids with  $\epsilon = 0.002, 0.005, 0.010$ . The results are given in detail in the table on page 102. The numbers 12, 24, 36 give the number

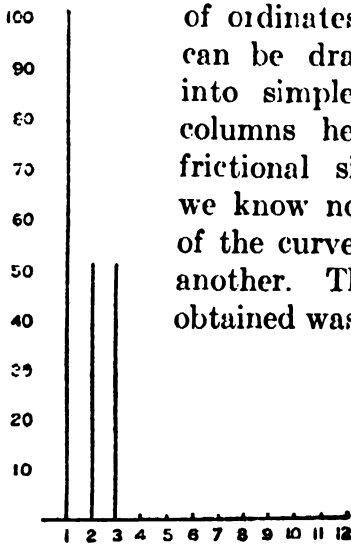

FIG. 97.—Harmonic plot to figure 94 with  $\epsilon = 0.005$ .

of ordinates used. From these results several conclusions can be drawn. The curve in figure 94 can be analyzed into simple sinusoids with the amplitudes given in the columns headed  $\epsilon = 0$ ; or it can also be analyzed into frictional sinusoids with various factors of friction. If we know nothing whatever about the original composition of the curve, one mode of analysis will be just as good as another. The equation according to which the curve was obtained was

$$y = 10 \cdot e^{-0.005t} \cdot \sin \frac{2\pi}{36}t.$$

We find that analysis with any other factor than  $\epsilon = 0.005$  gives results that differ widely from the original equation. The difference increases with the divergence in the factor of friction. We therefore conclude that the analysis must be made with the appropriate factor of friction if it is to give the way in which the curve was obtained.

These considerations are of great practical importance. As will be shown in the following sections, the vibrations in speech always have large factors of friction. The treatment of the curves by simple harmonic analysis—the only method that has hitherto been tried—furnishes results that are so wrong as to be utterly misleading when used to indicate the manner in which the vibrations were produced. In such a case the

analysis must be made with the appropriate factor of friction if it is to give the way in which the curve was obtained. These considerations are of great practical importance. As will be shown in the following sections, the vibrations in speech always have large factors of friction. The treatment of the curves by simple harmonic analysis—the only method that has hitherto been tried—furnishes results that are so wrong as to be utterly misleading when used to indicate the manner in which the vibrations were produced. In such a case the

use of a large number of members—as the table clearly shows—involves merely an increase of labor without any essential increase in correctness. The only advantage of a large number of members occurs when the correct factor is used; then the number of members is settled by the number of tones to be found.

To show the application to a compound curve, the wave in figure 94 was analyzed with the assumptions  $\epsilon = 0.000, 0.002, 0.005$ . The results are given in the harmonic plots in figures 95, 96, 97 with the ordinates ten times enlarged. It is clear that the curve is most simply represented by the results of the analysis with  $\epsilon = 0.005$ , according to which its equation is

$$y = 10.e^{-0.005t} \cdot \sin \frac{2\pi}{36}t + 5.e^{-0.005t} \cdot \sin \frac{2\pi}{18}t + 5.e^{-0.005t} \cdot \sin \frac{2\pi}{12}t.$$

This is the equation according to which the curve was obtained. The reader who does not wish to go into the detailed treatment may pass to the following chapter.

In a frictional sinusoid

$$y = a.e^{-\epsilon t} \cdot \sin\left(\frac{2\pi}{T'}t - q\right), \quad (1)$$

$y$  is the elongation at the moment  $t$ ,  $T'$  is the period,  $a$  the amplitude which would be present in the case of no friction, and  $\epsilon$  is a factor depending on friction. The actual amplitude  $a.e^{-\epsilon t} = a/e^{\epsilon t}$  steadily decreases. The period  $T'$  is longer than  $T$  for the same curve without friction; the relation is

$$T' = \frac{2\pi T}{\sqrt{4\pi^2 - \epsilon^2 T^2}}. \quad (2)$$

The difference is so small that in practical work  $T$  may be used for  $T'$ . Using the form of equation (6) of Chapter V the frictional sinusoid is

$$y = a.e^{-\epsilon t} \cdot \sin(\sqrt{k^2 - \epsilon^2} \cdot t). \quad (3)$$

Let the function  $y$  be built up of a harmonic series of frictional sinusoids with the same factor of friction, thus,

$$y = a_1.e^{-\epsilon t} \cdot \cos \frac{2\pi}{T'}t + a_2.e^{-\epsilon t} \cdot \cos \frac{2\pi}{\frac{1}{2}T'}t + \dots \quad (4)$$

$$+ b_1.e^{-\epsilon t} \cdot \sin \frac{2\pi}{T'}t + b_2.e^{-\epsilon t} \cdot \sin \frac{2\pi}{\frac{1}{2}T'}t + \dots$$

The equation can be written

$$e^{it}.y = a_1.\cos\frac{2\pi}{T'}t + a_2.\cos\frac{2\pi}{\frac{1}{2}T'}t + \dots \tag{5}$$

$$+ b_1.\sin\frac{2\pi}{T'}t + b_2.\sin\frac{2\pi}{\frac{1}{2}T'}t + \dots$$

From this the coefficients  $a_1, a_2, \dots, b_1, b_2, \dots$  can be obtained by considering  $e^{it}.y$  as a curve to be subjected to the harmonic analysis. The coefficients are therefore

$$a_i = \frac{2}{T'} \int_0^{T'} e^{it}.y.\cos\left(i\frac{2\pi}{T'}t\right).dt \tag{6}$$

$$b_i = \frac{2}{T'} \int_0^{T'} e^{it}.y.\sin\left(i\frac{2\pi}{T'}t\right).dt \tag{7}$$

$$(i = 1, 2, 3, \dots)$$

A convenient form of (5) is

$$e^{it}.y = c_1.\sin\left(\frac{2\pi}{T'}t - q_1\right) + c_2.\sin\left(\frac{2\pi}{\frac{1}{2}T'}t - q_2\right) + \dots \tag{8}$$

where

$$c = \sqrt{a^2 + b^2} \text{ and } \tan q = -\frac{a}{b}. \tag{9}$$

When the wave length is divided into  $m$  equal parts  $h$  (that is,  $T' = mh$ ), the time axis has the equidistant points

$$t_0, t_1, t_2, \dots, t_j, \dots, t_{m-1} = 0, h, 2h, \dots, jh, \dots, (m-1)h,$$

for which the ordinates multiplied by the respective elements of friction become

$$e^{it_0}.y_0, e^{it_1}.y_1, e^{it_2}.y_2, \dots, e^{it_j}.y_j, \dots, e^{it_{m-1}}.y_{m-1}.$$

With these finite values the coefficients become

$$a_i = \frac{2}{m} \sum_{j=0}^{j=m-1} e^{it_j}.y_j.\cos ijh, \tag{10}$$

$$b_i = \frac{2}{m} \sum_{j=0}^{j=m-1} e^{it_j}.y_j.\sin ijh.$$

The coefficients are thus analogous to those given in equations (18, 19, 20) of Chapter V. The method of procedure is at once apparent. The ordinates of  $y_0, y_1, y_2, \dots, y_{m-1}$  are to be multiplied by  $1, e^{h\epsilon}, e^{2h\epsilon}, e^{(m-1)h\epsilon}, \dots$  respectively. The results are then treated just as the original ordinates in the simple sinusoid analysis.

For this, from a frictional sinusoid, equation (1) above, the value of  $\epsilon$  can be calculated if the successive amplitudes are known. It is readily shown that the successive maximum amplitudes  $a_1, a_2, a_3, \dots$  in such a curve bear the relations ( $+$  and  $--$  disregarded)

$$\frac{a_2}{a_1} = \frac{a_3}{a_2} = \dots = e^{-r\frac{T}{2}},$$

or

$$\log_e a_2 - \log_e a_1 = \log_e a_3 - \log_e a_2 = \dots = -\epsilon\frac{T}{2} = -d. \quad (11)$$

The value  $d$  is called the logarithmic decrement; when it has been obtained, the factor of friction  $\epsilon$  can be calculated. It is not necessary to measure from the axis of the curve; the successive points are more conveniently measured from a line parallel to the axis; the results  $s_1, s_2, s_3, \dots$  yield likewise  $\log_e s_2 = \log_e s_1 = \log_e s_2 = \dots = -d$ .

The calculation according to the method of least squares gives the familiar formula

$$d = \frac{(n-1)(\log_e s_1 - \log_e s_n) + (n-3)(\log_e s_2 - \log_e s_{n-1}) + (n-5)(\log_e s_3 - \log_e s_{n-2}) + \dots}{n(n^2-1)} \quad (12)$$

from which we obtain

$$\epsilon = \frac{2d}{T}.$$

Examples will be given in the last chapter.

## CHAPTER VIII.

### WAVE ANALYSIS IN REFERENCE TO VOCAL ACTION.

An element of speech may be "physically" defined by the properties of the vibrations transmitted through the air. It may be "physiologically" defined by a description of the action of the vocal organs producing it, or of the ear in receiving it. Or, finally, it may be "psychologically" defined by a description of the hearer's or speaker's perception of the sound as heard or spoken.

A vowel analysis may be physical, physiological, or psychological. The physical analysis may follow different methods; for example, it may be an analysis of the vibration in the air by means of resonating instruments, or an analysis of the record of vibration. The present researches are concerned only with the analysis of the records of the physical vibration, the data and references up to 1902 for the other forms of analysis are given in my *Elements of Experimental Phonetics*.

The complete analysis of a vowel curve includes a description of its characteristics (Chapter III), the measurements and plots for its duration, melody and intensity (Chapter IV), and the mathematical analysis of each wave. This latter step requires special consideration.

The physical analysis of a wave may take different forms. The wave may be analyzed into (1) an arbitrary set of vibrations, (2) a set of vibrations corresponding to the physiological action that produced it, (3) a set of vibrations corresponding to the action in the ear, (4) a set of vibrations corresponding to the elements of the sound heard.

In the present chapter, I will attempt to show how the analysis of a wave is to be made in order to correspond to the vocal action by which it was produced; the following chapter will discuss similar problems for the physiological process in the ear and for the mental act of perception.

The method to be selected in order to analyze a vowel into the elements out of which it was built up will depend on the nature of the action of the vocal organs. The prevailing views have now to be discussed.

The "overtone theory" arose from supposing the vowels to be produced like the tones of some musical instruments. When a musical string is snapped, its vibration as a whole produces a strong tone, the "first partial" (or "fundamental"). When it is snapped and then touched at the middle, it continues to vibrate in halves, and the octave or "second partial"

("first overtone") is heard; it is weaker than the tone of the whole string. When it is touched at one-third of its length instead of half, it vibrates in thirds and the "third partial" ("second overtone") appears. The fourth, fifth, and higher partials can be likewise obtained. The tone of the string when vibrating freely is thus proved to consist of a series of partials. That the series is a harmonic one can be proved by determining the pitch of each partial by comparison with tones of known pitch. The sound curve of such a string would be the sum of the curves for each partial, that for the first partial being the predominant one because—as even the eye can see and the ear can hear—that vibration is strongest in the string. It would naturally be treated by harmonic analysis to obtain the partials and their amplitudes. The harmonic analysis would here be not only a mathematical operation but also a true physical analysis. In this case the analysis would not have to be a frictional one, because the sound dies away so slowly in stringed instruments that the factor of friction would hardly show itself within a single wave. In the case of a maintained tone, as from a violin, the bow keeps the string in continual vibration and the tone registered by the curve would also be subjected to a harmonic analysis into simple sinusoids.

Suppose, now, a glass or metal resonator to be set up close to a string. When the string is plucked it produces its usual complex tone, consisting of a series of partials of which the first is the loudest. If the natural period of the resonator happens to coincide with that of any one of the partials, that partial will be "reinforced" and will appear louder than otherwise. To reinforce a partial the natural period of the resonator must therefore be harmonic to the fundamental tone of the string. If the resonator is inharmonic to the string, no partial will be reinforced. The sound curve in the case of a string with a harmonic resonator will contain the sum of the curves of each of the partials of the string; the curve of the fundamental may be strong and predominating as before (because that element of the tone may still be the loudest), but the curve for the reinforced partial will be stronger than in the case of the string without a resonator. If the resonator is inharmonic to the string, no partial is reinforced; the tone remains the same as without a resonator, and the sound curve will also be the same. In either of these cases the method of harmonic analysis into simple sinusoids will be appropriate because such an analysis corresponds to the way in which the sound is built up. The character of the tone produced will depend on what size of resonator is used, that is, on which partial is reinforced. By reinforcing several partials in different degrees of intensity a large number of different sounds can be made.

According to Wheatstone, Grassmann and Helmholtz the glottal lips vibrate after the manner of strings and produce a series of partials of which the first (or fundamental)—that is, the tone of the voice—is the strongest. The series of cavities above the glottis reinforce certain of these partials; for each vowel the cavities are readjusted and a different set of partials is reinforced. The curve of a vowel is therefore the sum of the curves for the series of the partials of the voice, some of these partials being reinforced by the resonance. The curve will contain the first partial (fundamental) as the strongest element, because the glottal tone is in every case by far the loudest; whatever we may lose of a sung or a spoken vowel by deafness or distance, we always hear the glottal tone if we hear anything. For example, let us suppose the glottis to emit a tone whose partials are in the relations of strength indicated by the sizes of the numbers in figure 98. A vowel would increase the strength of some of the partials, for example, as indicated in figure 99.

1 2 3 4 5 6 7 8 9 10

FIG. 98.—Scheme of partial tones.

1 2 3 4 5 6 7 8 9 10

FIG. 99.—Scheme of reinforced partials.

The overtone theory of the vowels can not be correct. The following reasons seem conclusive.

If the theory were correct, the harmonic analysis into a series of simple sinusoids would be the proper one, and its results would give the series of partials with their proper amplitudes. The analyses made by various investigators show that in most cases the first partial is very weak or entirely lacking, that is, it gives a result that is known to be false because the ear hears just this partial as by far the strongest of all. Either the theory is incorrect or the method of obtaining the curve introduces a falsification. As long as the curves were obtainable only by the phonautograph, the latter might be supposed to be the case. With the curves obtained by the tracing methods from phonograph and gramophone records a new test can be made. The chief tone of the voice, the glottal tone or first partial, is present in the records and can be heard as distinctly as in the original voice; in fact, as long as anything can be heard from a record—whether weakened by distance or by wear—just this tone remains. Yet a harmonic analysis of the curve of such a record usually shows the absence of this tone. One investigator was led to the remark that “the phonograph must be deaf to the glottal tone” and failed to see that this must be absurd because as long as the phonograph

does anything it registers that tone and reproduces it; even in a record so bad that the vowels can not be distinguished from one another the tone of the voice can be heard. In any case, the theory requires a strong first partial in the results of the analysis; since such a partial usually does not occur, the theory must be incorrect or inadequate.

An inspection of the curve by the eye shows that it falls into groups of small waves, the entire group corresponding to the period of one vibration of the glottal tone (p. 40). The eye notes at once that in most cases a sinusoid of the length of the groups is lacking. We have here apparently a demonstration directly to the eye that the glottal tone is weak or lacking. Yet the glottal tone—the first partial or fundamental—is the strongest of all in the sound itself; we may not be able to decide whether a voice sings [o] or [a], but we certainly hear the tone on which it is sung and know whether it is a bass or treble note. Since the fundamental simple sinusoid is indicated as wholly or partly lacking in the curve, the theory can not be correct and there must be present some other form of vibration than the simple sinusoid.

Another reason for rejecting the overtone theory is that the harmonic plots do not indicate the reinforcement of certain overtones with total absence of others, but generally show that several neighboring overtones are reinforced (p. 83). Such results indicate rather that the tones reinforced in the vocal cavities are not harmonic overtones, but inharmonics of the fundamental; the reason that they do not appear in the plot is that the analysis provides only for harmonics (p. 77).

Still another reason for rejecting the overtone theory lies in the fact that it is based on views of resonance which are not valid for the voice. Helmholtz supposed the vocal cavities to act as a series of resonators which respond to definite overtones in the glottal tone. Such a supposition would be appropriate if the cavities were made of metal or other hard substances. The vocal cavities have, however, soft or moderately hard walls lined with moist membranes. The laws of resonance for soft cavities are different from those for brass resonators. The experiments on resonance summarized at the close of this chapter show that cavities with soft walls will respond to a range of tone which increases as the softness; for example, a cavity with walls of water will respond to any tone, a cavity with flesh walls to a considerable range of tone, etc. The same conclusion can be deduced theoretically. The process of vowel production must therefore differ completely from the theory that compares it to the response of hard resonators to overtones.

Wheatstone and Helmholtz were apparently led to the overtone theory by the utterly erroneous supposition that the glottal lips act like rubber membranes with freely swinging edges. How misleading this notion

was, can be seen from the statement of Helmholtz that, when the edges strike together, the sound must be sharp as from striking musical reeds.\* The stroboscopic observations of Rethi, however, show that in the male glottis the edges usually strike. Krause reports the case of a tenor whose glottal lips looked like two ridges of red flesh and whose tones appeared nevertheless unusually sweet and soft. Imhofer† observed a singer with hypertrophy of one of the ventricular bands so that the glottal lip appeared as only a small edge beneath the heavy mass of the ventricular band resting upon it; with this apparently unavailable organ he is a successful tenor on one of the largest German stages. Both these cases can be understood on the puff theory, according to which the glottal lips in most cases come together at each vibration and open only to emit the puff of air. This theory will now be discussed.

According to the "puff theory" of Willis and Hermann the glottis emits a series of more or less sharp puffs; each puff, striking a vocal cavity, produces a vibration whose period is that of the cavity; a single wave-group shows the sum of these vibrations from all the cavities; the periods of these vibrations may stand in any relation to the interval at which the puffs come, that is, to the fundamental.

This theory is certainly correct in asserting that the glottal tone (the fundamental) consists of a series of more or less sharp puffs. Many of the vowel curves (see [a] and [ɔ] in the Depew and Cock Robin plates) show groups of vibrations of which the first is slightly larger, as if it had resulted from a sudden impulse. The vowel curves can be counterfeited by apparatus built to apply sharp puffs to damped springs; some experiments in this direction will be described in Chapter X below. The puff action of the vocal lips has, moreover, been directly observed for male bass voices by the laryngo-stroboscope.

The more sudden the puffs the more unlike they are to a simple sinusoid and the more completely they will fail to appear as a fundamental in a simple harmonic analysis. The relation between the amplitude of the chief cavity tone and that of the fundamental indicated by a simple harmonic analysis can be used directly as an index of the sharpness of the puffs; a weak first harmonic with a strong higher one indicates a strong sharp puff; a strong first harmonic indicates either a smooth puff or the presence of a cavity tone of the same period as the puffs.

As shown by the hundreds of analyses made by Hermann and myself, the theory is also correct in asserting that the pitch of a cavity tone is to a great extent independent of the interval of the puffs. A sharp puff acting on a cavity will arouse a vibration whose period is that natural

\* Helmholtz, *Lehre v. d. Tonempfindungen*, 5. Aufl., 169, Leipzig, 1896.

† Imhofer, *Die Krankheiten der Singstimme*, 25, Berlin, 1904.

to the cavity. When the puffs are far enough apart, the vibration will consist of a series of groups with decreasing amplitudes, and the vibration within a group will be independent of the interval at which the puffs come.

This theory was made the basis of some experiments on resonance. A siren (figure 100) was devised to blow resonators by series of puffs. The blast tube was cut entirely across and the two parts were mounted

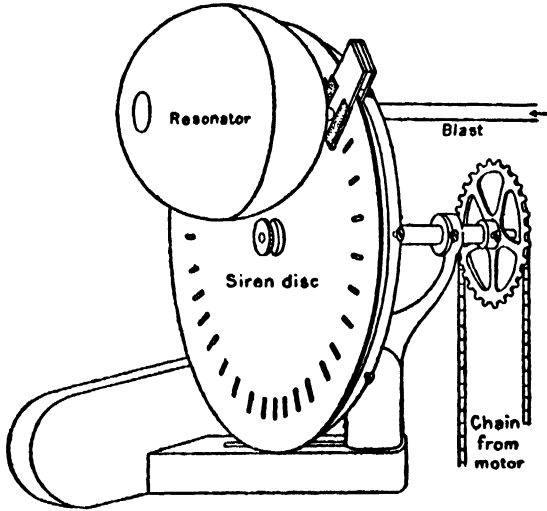

FIG. 100.—Puff siren with resonator.

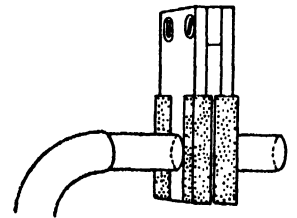

FIG. 101.—Blast tube for puff siren.

in a holder (figure 101) and packed with felt so that the disc would pass tightly between the two parts. Such an arrangement was necessary in order to obtain sufficient blast to arouse the resonators without being disturbed

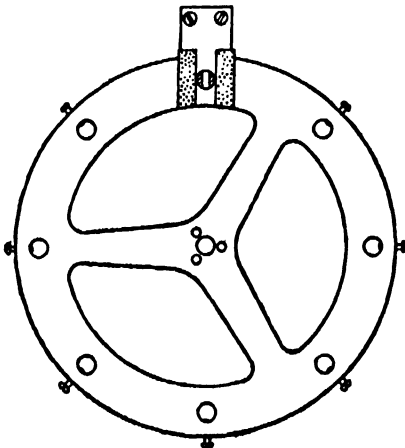

FIG. 102.—Ring frame for puff siren.

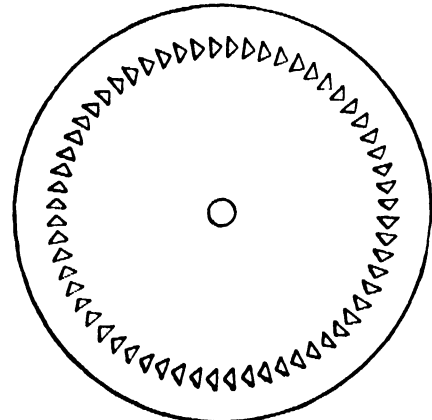

FIG. 103.—Disc for puff siren.

by the rushing noise of lost air. The inner opening of the blast tube was made into a slit in order to make the puffs of definite forms. The tube was held by a ring frame (figure 102) arranged to take eight blasts, the object being to provide for blowing several resonators at the same time

in order to build up the vowels. One of the discs is shown in figure 103. The form of the puff depended on the width and shape of the slits; the frequency was determined by the number of slits that passed across the blast. Resonators were held to the blast-pipe and the frequency was varied by altering the speed of the motor.

Four typical discs were used with openings of the forms indicated by *A*, *B*, *C*, and *D* in figure 104. The puffs produced by them are of increasing sharpness from *A* to *D*; their forms have not been mathematically determined, but we may assume that they resemble somewhat those indicated by the curves shown beside them in the figure.

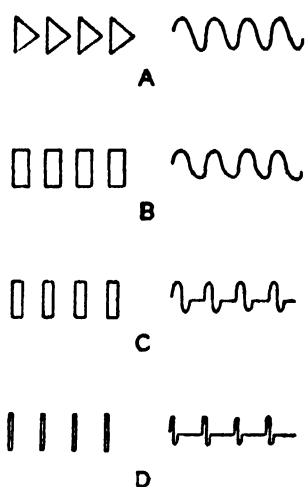

Fig. 104.—Siren holes and hypothetical forms of puffs.

Various kinds of resonators were used, including spherical brass resonators, cubical wooden resonators, resonators lined with felt, resonators with walls of flesh, with walls of water, etc. The water resonators were made by spreading absorbent cotton inside or outside hemispheres made of wire netting and uniting the two halves. Flesh resonators were made by spreading layers of meat over cubical wire frames; the same frames could be used also for water resonators.

For illustration a series of experiments with cubical wooden boxes, each having a circular opening on one side, will be described. When disc *B* was speeded up and down to produce puffs of different frequencies, the resonators attached would respond loudly at a certain frequency; this frequency was different for each resonator. The loud response was not sharply confined, but was spread over a considerable range of frequency. With disc *A* (smoother puffs) the range of response became much smaller, with disc *C* (sharper puffs) the range became greater, with disc *D* (very sharp puffs) it was quite broad. At frequencies where there was no loud response, there was nevertheless a peculiar quality added to the tone; the sharper the puff the more strongly this quality appeared; it differed for each resonator. With disc *D* this quality was distinctly vowel-like. With a resonator of absorbent cotton soaked in water, little or no special resonance effect could be noticed with any of the discs, but the vocal quality appeared at all times.

It was observed that the audibility of the puff tone increased with the sharpness of the puff. Smooth puffs sounded weak unless a resonator was attached; then they became loud, with a soft vowel-like character. With sharp puffs the puff tone appeared at all times.

The results of this investigation—as far as they are applicable here—may be summarized as follows:

A spherical brass resonator blown by a series of smooth puffs responds loudly when the period of the puffs is the same as that of the resonator. A very soft resonator, for example, a water resonator, responds practically alike to all frequencies of the puffs within a large range. This response, however, appears partly as an increase in the loudness of the puff tone, but mainly as an addition of a peculiar vowel tinge. The effect becomes less prominent as the softness of the resonator diminishes.

The resonance effect depends also on the form of the puff. It is well known that to a perfectly smooth puff, as from a tuning-fork ( $a.\sin pt$ ), a spherical resonator with hard walls will respond only when its period coincides with that of the puffs. As the puff becomes sharper the required coincidence changes from a point to a range. To moderately sharp puffs a resonator with hard walls will respond not only when the puff period is the same as its own but also when it is nearly the same—the effect diminishing with the difference between the periods. For very sharp puffs my experience is that hard walls respond in two ways, with a loud tone when the periods correspond and with a modification of tone at all times.

The principles involved in these experiments can be directly applied in a vowel theory. Thus the loudness of the tones with sharp puffs explains the loudness of the glottal tone although the simple harmonic analysis indicates a weak sinusoid of that period. The prominence of the cavity vibration in the curve over the glottal vibration is also explained.

With funds from the Smithsonian Institution\* I made an attempt to construct a musical instrument to produce the vowels. Any attempt to build up the vowels by adding sinusoids (tuning-fork tones), whether harmonic or inharmonic, can not succeed, because the curves of the vowels—even sung vowels—are of an utterly different character. Helmholtz seems to have satisfactorily produced [u], [o], and [a] in this way, but there is much doubt whether his reported success with [e], [i], etc., was a close one. No one else ever seems to have succeeded with the same method. Experiments were begun on the basis of the Willis-Hermann theory that a vowel is produced by the action of a series of puffs on a resonating cavity. For the source of tone, striking reeds of metal, wood, etc., in vox humana pipes were used; for the cavities gelatin and water resonators singly, doubly, and triply, also gelatin copies of the mouth, also a skull fitted with gelatin instead of flesh and with exchangeable gelatin tongues; flesh

\* Scripture, Report on the Construction of a Vowel Organ (Hodgkins Fund), Smithsonian Miscellaneous Collections, 1905, XLVII (3), 360.

cavities were made by spreading meat over wire frames. Innumerable varieties of [u], [o], and [a] could be made with a wooden reed and soft resonators. They were of a smoothness and beauty rarely attained by the human voice. All attempts at vowels like [e] and [i] failed, no matter how small the resonators were. This led to the supposition that different vowels require different glottal action. Instead of reeds, rubber membranes, rubber cushions, etc., were used, whose mode of vibration would depend on the action of the air in the cavities above them. Even with hard resonators it was possible to get almost any sort of tone out of the membranes. Through a hole in the resonator they could be seen to change their vibrations as the cavity was changed. All the vowels could

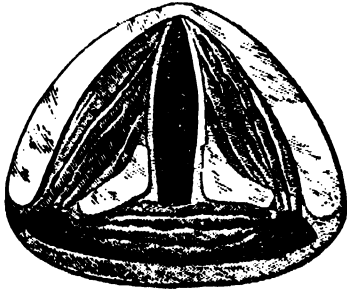

FIG. 105.—Top view of glottis.

be imitated by building up the resonators in sets of two or three below and above the vibrating membrane. This is a support for my supposition that the glottal lips vibrate differently for the different vowels, but here the difference was brought about by reaction of the rubber glottis to the tones of hard cavities, whereas in the larynx it presumably occurs by nervously aroused contractions of the fibers of the muscles in the glottal lips.

Let us now attempt a complete statement of the puff theory.

Physiologically stated, the action for a vowel is as follows: Each glottal lip consists mainly of a mass of muscle supported at the ends and along the lateral side (figure 105). It bears no resemblance to a membrane or a string. The two lips come together at their front ends, but diverge to the rear. The rear ends are attached to the arytenoid cartilages. When the ends are brought together by rotation of these cartilages, the medial surfaces touch. At the same time they are stretched by the action of the cricothyroid muscles, which pull apart the points of support at the ends.

In this way the two masses of muscle close the air passage. To produce a vowel such a relation of air-pressure and glottal tension is arranged that the air from the trachea bursts the muscles apart for a moment, after which they close again; the release of the puff of air reduces the pressure in the trachea and they remain closed until the pressure is again sufficient to burst them apart. With appropriate adjustments of the laryngeal muscles and air-pressure this is kept up indefinitely, and a series of puffs from the larynx is produced. The glottal lips open partly by yielding sidewise—that is, they are compressed—and partly by being shoved

upward and outward (fig. 106). The form of the puff—sharp or smooth—is determined by the way in which the glottal lips yield; the mode of yielding depends on the way in which the separate fibers of the muscles are contracted. When contracted along the medial edge (or edge of the glottis) as indicated in figure 107, the action may approach that of a stretched string loaded with a soft mass along its middle portion or along its entire length. When contracted more laterally (figure 108), the action may approach that of a soft mass flapping in a current of air, or of two soft cushions striking together. These two forms of contraction correspond to

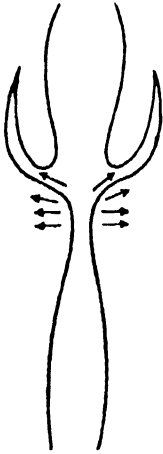

FIG. 106.—Method of vibration at the glottis.

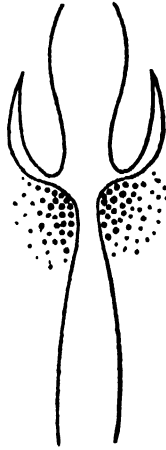

FIG. 107.—Glottal lips with medial loading.

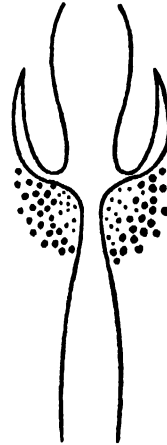

FIG. 108.—Glottal lips with lateral loading.

separate action of the *M. vocalis* and the *M. thyreoarytenoideus* (*externus*). When the slant fibers which insert along the medial edge of the glottal lips (figure 109) are contracted, there will be nodal points similar to those of stretched strings.

These differences produce differences in the forms of the puffs. We can thus explain the forms of puffs in the different types of vowels by differences in the action of the muscles of the glottal lips. We may assume that these muscles contract differently for the different vowels, the vowel being formed at the glottis as well as in the mouth. This phenomenon can be explained by supposing that certain sets of innervations to the fibers of the glottal muscles as well as to the cavity muscles are associated with the sound of each vowel.

Physically stated, a vowel consists of a series of explosive puffs of air from the glottis acting on a complicated cavity with considerable friction. The puffs of air may be very brief and may be separated by comparatively long intervals of rest; or they may be of smoother form,

even resembling a tuning-fork vibration. The period from one puff to the next determines the pitch of the voice; the form of the puff determines the musical timbre. Some purely hypothetical curves to indicate puffs of different forms are given in figure 110; they all have the same amplitude, phase, and period, but the upper one is sharpest and the lower one is smoothest.

These puffs act on the vocal cavity, that is, on a complicated system of cavities (trachea, larynx, pharynx, mouth, nose) with variable shapes, sizes and openings. The effect of the puff on each element of the vocal cavity is double: first, to arouse in it a vibration with a period depending on the cavity; second, to force on it a vibration of the same period as

that of the set of puffs. The prevalence of one of the factors over the other depends on the form of the puff, the walls of the cavities, etc. Some vowels include the puff element as an important component, others consist almost entirely of the cavity vibrations.

The vowel curve—according to this theory—contains the record of the glottal puffs and of the set of

cavity tones aroused by it. The glottal puff is of the form of a frictional sinusoid (p. 101) with very large amplitude and very large coefficient of friction; the cavity vibrations are also of the frictional sinusoid form. In a single wave there is not only a record of one glottal puff and of the cavity tones for one vibration, but also of what is left over from the fading vibrations of the preceding wave.

Curves of vibration resulting from a single puff are found when the interval between the puffs is so large that the vibrations die away before the next puff occurs, as in the curve at the beginning of [ai] "I" in line 110 of the Depew plate. In speech the pitch of the glottal tone changes continually; the effects may be seen in the same vowel curve. As the pitch of the tone from the glottis rises, the group of cavity vibrations come closer and finally overlap. This produces very complicated forms, but when the period of the puff becomes an even multiple of that of the cavity the waves sum up in like phases and strong, smooth vibrations result. For example, when the puffs occur at exactly twice the period of the cavity, each arouses a vibratory movement whose phase coincides with that of the others; the vibratory movement going on in the cavity may

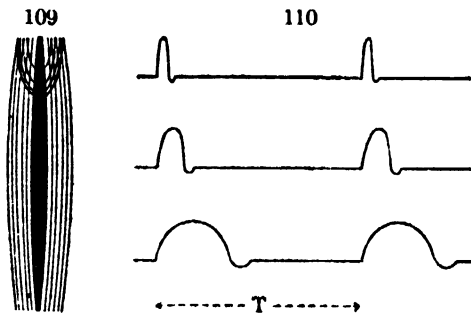

FIG. 109.—Slant fibers of the *M. vocalis*.  
FIG. 110.—Hypothetical curves of puffs.

be said to have received an added impulse at every second vibration. Speech curves are continually found whose alternate vibrations are a trifle stronger; we know at once that the vibrations occur in groups of two, that the frequency of the cavity tone is twice that of the glottal tone, and that the puffs are very sharp; such curves are to be seen for [ɪ] line 96, [e] line 104 of the Depew plate, and [i] line 3, [i] line 7, [i] line 16, [ə] line 18 of the Cock Robin plate. Similar conditions where the vibrations occur in groups of three—the cavity tone having a frequency of three times that of the glottal tone—are seen in [u] line 102, [i] of [ai] line 111 of the Depew plate and [ɛ] line 17 of Cock Robin plate. In [i] line 11 of the Cock Robin plate groups of four are found. It is a curious fact that this condition seems to be characteristic of certain vowels and not of others.

The speech curves also indicate not only that different sets of the cavity tones are present for each kind of vowel, but also that different types of puff forms are used for different vowels. Thus [u] shows a smooth puff, [i] a very sharp one, etc. The vowel character is therefore found in the puff itself as well as in the cavity tones.

For the ear the succession of puffs produces the tone of the voice, that is, the pitch of the sound heard depends on the interval at which the puff comes. The form of the wave impresses the ear with the effect of timbre, that is, with its character as more or less musical and also with its vowel character.

Returning, now, to the question of what method of analysis is to be adopted for vowel curves, we must conclude that a frictional analysis is required by the only theory of vocal action which we can accept. The simple harmonic analysis can lead only to false conclusions.

The reader who does not wish to go into the following more precise statement of the principles involved in the theory of vocal action may pass to the next chapter.

A vowel consists physically of a series of impulses from the glottis impressed on a set of resonating systems, namely, the air in the vocal cavities. For simplicity each resonance system may be considered to be of one degree of freedom, with the coefficient of elasticity  $s$  and the coefficient of friction  $b$ . If the friction is neglected or compensated the equation of motion is

$$m \frac{d^2y}{dt^2} = -sy \quad (1)$$

of which the solution is

$$y = a \sin \left( \sqrt{\frac{s}{m}} t - q \right).$$

Here the amplitude  $a$  depends on the energy received by the system; the period

$$T = \frac{2\pi}{\sqrt{\frac{s}{m}}} \tag{2}$$

depends exclusively on the elasticity and the mass of the system itself; the factor of phase  $q$  can be made zero by proper choice of coordinates. Putting

$$k = \sqrt{\frac{s}{m}} \text{ and } q = 0,$$

we have

$$y = a.\sin kt. \tag{3}$$

This is the simple sinusoid discussed above (p. 84).

In speech vibrations the friction can not be neglected. For small movements the friction may be considered as proportional to the velocity and opposed to the movement. Adding the term for friction the equation of motion becomes

$$m \frac{d^2y}{dt^2} = -sy - b \frac{dy}{dt},$$

of which the solution is

$$y = a.e^{-\frac{bt}{2m}} .\sin \left( \sqrt{\frac{s}{m} - \frac{b^2}{4m^2}} .t - q \right). \tag{4}$$

The period

$$T' = \frac{2\pi}{\sqrt{\frac{s}{m} - \frac{b^2}{4m^2}}} \tag{5}$$

is thus dependent not only on the elasticity and the mass, but also on the friction; it is longer than the period without friction. The amplitude  $a$  depends on the energy imparted to the system. The frictional element  $e^{-\frac{bt}{2m}}$  acts to steadily decrease the amplitude.

For

$$k = \sqrt{\frac{s}{m}}, \quad \epsilon = \frac{b}{2m}, \quad \text{and } q' = 0, \tag{6}$$

we have

$$y = a.e^{-\epsilon t} .\sin (\sqrt{k^2 - \epsilon^2} .t). \tag{7}$$

This is the frictional sinusoid considered above (p. 104).

When vibrations are aroused in the vocal cavities by a sudden blow, they can be treated as if aroused by a momentary impulse and then left to themselves. The equation of motion is then for each cavity the one just considered. For a system of cavities struck by a sudden blow we may treat the effect as the sum of the effects on each element of the system, whereby the constants for each element are determined while it is in connection with the other elements and not alone. The result is then a vibration of the form

$$y = \sum a.e^{-\epsilon t} . \sin (\sqrt{k^2 - \epsilon^2} . t - q_1) \quad (8)$$

The amplitudes  $a_1, a_2, a_3, \dots$ , the factors of friction  $\epsilon_1, \epsilon_2, \epsilon_3, \dots$ , the factors of system  $k_1, k_2, k_3, \dots$ , and the phases  $q_1, q_2, q_3, \dots$ , have to be determined for each cavity, not as an isolated one but in connection with the rest of the system.

Let us suppose, now, the glottis to produce sinusoidal vibrations in the air current. When the resonating cavity is acted upon by a maintained force of the character  $a.\sin pt$ , the equation of motion becomes

$$m \frac{d^2y}{dt^2} = -sy - b \frac{dy}{dt} + a.\sin pt.$$

of which the solution—after substituting  $\epsilon$  and  $k$  as in (6)—becomes

$$y = \frac{a}{m \sqrt{(k^2 - p^2)^2 + 4p^2 \epsilon^2}} . \sin (pt - q) + R.e^{-\epsilon t} . \sin (\sqrt{k^2 - \epsilon^2} . t - q'). \quad (9)$$

The first element is the "forced vibration"; it has the frequency of the glottal vibration impressed on the resonating cavity and the amplitude

$$c = \frac{a}{m \sqrt{(k^2 - p^2)^2 + 4p^2 \epsilon^2}}, \quad (10)$$

which depends on the amplitude  $a$  of the glottal vibration, on the mass  $m$  of the air in the cavity, on the friction  $\epsilon$ , on the frequency  $p$  of the glottal vibration, and on the difference between the frequency  $k$  of the cavity and that of the glottal vibration.

The second element is the vibration of the air in the cavity aroused and left to itself; its frequency has no relation to that of the glottal vibration, but depends solely on the cavity and the friction.

Owing to the factor of friction in the second element, it rapidly dies away, leaving only the first element. The curve, when this occurs, is a simple sinusoid indefinitely maintained. The case may be illustrated by the vibration of a brass resonator responding to a tuning-fork indefinitely kept in vibration.

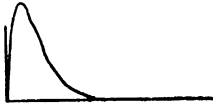

FIG. 111.—Sinusoid with large factor of decrement.



FIG. 112.—Sinusoid with very large factor of decrement.

As we have already seen (p. 111), the vibrations produced in the glottis are puff-like and only rarely approach the simple sinusoid form. We can conveniently represent a puff as a simple sinusoid modified by a large factor of friction, that is, by the equation

$$y = a.e^{-\theta t}.\sin pt. \tag{11}$$

The quantity  $\theta$  is analogous to the factor of friction  $\epsilon$ ; it may be called the “factor of suddenness” or “factor of decrement,” as we are not at present concerned as to how the force acquired this characteristic form. Figures 111 and 112 show curves with  $a = 100$ ,  $T = 36$ , and  $\theta = 0.050$  and  $0.100$  respectively; the curve without the factor of suddenness has the same period as the curve in figure 67, but an amplitude ten times as great.

We have now to consider the effect of a single element (11) of a puff on a single vocal cavity.

The effect of a force of this kind (11) on a vibrating system with one degree of freedom is given by

$$m \frac{d^2y}{dt^2} = -sy - p \frac{dy}{dt} + a.e^{-\theta t}.\sin pt$$

of which the solution—after substituting  $k$  and  $\epsilon$  as in (6)—is

$$y = \frac{a}{m \sqrt{(k^2 - p^2 + \theta^2 - 2\theta\epsilon)^2 + 4p^2(\theta - \epsilon)^2}} .e^{-\theta t}.\sin (pt - q) + R.e^{-\theta t}.\sin (\sqrt{k^2 - \epsilon^2}. t - q'). \tag{12}$$

The first element is the impressed vibration; it has the frequency  $p$  of the impressed force (that is, the period of the glottal puff) and an amplitude depending on the amplitude  $a$  of the impressing vibration, on the mass  $m$  of the system, on the periods  $p$  and  $k$ , on the suddenness of the impressing vibration, on the friction of the system and on the difference between the last two factors. The amplitude at the start

decreases more or less rapidly according to  $\theta$ , the factor of suddenness. When the puff is very sharp ( $\theta$  large) this element will not be prominent in the result and the impressing vibration will appear as a momentary modification of the second element at the start.

The second element is the vibration of the cavity aroused by the puff and left to itself; its period does not depend on that of the puff. When the first element fades, this alone is left.

The two extremes of the predominance of the impressed (or glottal) period or of the natural period of the cavity are found in the curves of some musical instruments and of some vowels. In musical instruments whose source of tone consists of smooth puffs (3) continued for some time, the vibrations are given by equation (9); but the second element is present only at the very beginning of each tone and generally can not be detected in the curve; the tone then consists exclusively of vibrations represented by the first element. Such are the curves for the clarinet, cornet, and saxophone given in figures 89, 90, 91. The other extreme appears strikingly at the beginnings of some vowels where the puffs are sudden (11) and so far apart that the effect of one dies away before the next occurs, as in the curve for [ai] "I," Depew, line 110; here the solution is given by equation (12), but the first member hardly appears, and the curve seems to consist solely of the second element with the period of the resonance cavity.

The equation (12) is sufficient to express the action of a single glottal puff of greater or less sharpness on a single vocal cavity; for the action of the puff on a system of cavities we would have to take the sum of a set of such equations where the factor of system (period), the mass, and the friction for each one is considered. When the complicated structure of the glottal lips is considered, we must admit that the puff may be of such a form that  $\theta$ , the factor of suddenness, has to be replaced by a more complicated expression, or that the puff is to be expressed by a sum of frictional sinusoids with various values for  $a$ ,  $\theta$ ,  $p$ , and  $q$ . In the absence of any definite information we may, however, for the following remarks use  $\theta$  as in (12). The complete expression for the action of a single puff on the set of vocal cavities then becomes

$$y = \sum \frac{a}{m \sqrt{(k^2 - p^2 + \theta^2 - 2\theta\epsilon)^2 + 4p^2(\theta - \epsilon)^2}} \cdot e^{-a} \cdot \sin(pt - q) \\ + \sum R \cdot e^{-a} \cdot \sin(\sqrt{k^2 - \epsilon^2} \cdot t - q') \quad (13)$$

where the sum is to be taken over as many elements as required. This is the fundamental equation for each wave of a vowel curve. The various waves differ in the values given to the different letters.

If this theory of the vowels is valid, it is the object of the analysis of a vowel curve to pick out the elements indicated by this equation. With the present methods it is impossible to do so completely, but some of them may be approximated.

When the puff is very sharp the forced vibration will vanish quickly, leaving only the second element which expresses the free vibrations of the cavities. The curve in such a case is mainly a "cavity curve," because its components are the vibrations of the cavities. Since the differences in combining the cavity vibrations furnish the distinctions between the vowels of the language, the second element of equation (13) may be termed the "vowel component." When the puff is moderately smooth ( $\theta$  of the same grade as  $\epsilon$ ), the two elements will be nearly evenly balanced. A perfectly smooth puff  $\theta = 0$  gives the result previously considered where the acting force was  $a.\sin pt$  (p. 120); both elements must be considered at the start, afterwards only the first is present. This last condition never occurs in speech, because it never happens that a constant series of smooth puffs acts upon a fixed set of cavities. In song, however, it does sometimes happen that the glottis emits such a series of vibrations and that the cavities are fixed for a time. In such cases, where the first element is the more prominent, the sound acquires less a vowel character than a personal one, that is, the vowels of a person differ less from one another than the sounds of different persons for the same vowel. Since the first member of equation (13) is determined mainly by the character of the action at the glottis, it may be termed the "glottal component," or—since this is the governing factor in the musicalness of the voice—the "musical component."

In speech curves both the vowel and the musical components are present at each vibration. No method exists that will perform the analysis completely.

When the glottal puffs are not sharp, the curve contains all the elements indicated by (13). The expression can be simplified by writing the two sums as

$$y = A_1.e^{-\epsilon t}.\sin\left(\frac{2\pi}{P_1}t - q_1\right) + A_2.e^{-\epsilon t}.\sin\left(\frac{2\pi}{P_2}t - q_2\right) + \dots \\ + R_1.e^{-\epsilon t}.\sin\left(\frac{2\pi}{Q_1}t - q'_1\right) + R_2.e^{-\epsilon t}.\sin\left(\frac{2\pi}{Q_2}t - q'_2\right) + \dots \quad (14)$$

All that our methods of analysis can do is to represent such a curve by the harmonic series:

$$y = c_1.e^{-\epsilon t}.\sin\left(\frac{2\pi}{T}t - q''_1\right) + c_2.e^{-\epsilon t}.\sin\left(\frac{2\pi}{\frac{1}{2}T}t - q''_2\right) + \dots \quad (15)$$

Only by careful adaptation can such a representation avoid being utterly false. The same coefficient of friction (or suddenness) is used throughout; although this is only an approximation, it brings us far nearer the truth than the clearly false assumption that  $\epsilon=0$ . We can assume that the fundamental  $T$  of the analysis arises from the glottal tone  $P_1$ , that is, that the element with  $T$  coincides with the element  $P$ . There may possibly have been some reinforcement by cavity resonance; such a condition will reveal itself in a speech curve by a strong vibration throughout the whole wave—a case that is very rare in the curves I have collected. We can also assume that the main higher tones come from the cavities, and can take one such tone for each maximum as indicated above (p. 80). That is, we assign the centroid for a group such as  $\frac{1}{3}T$ ,  $\frac{1}{4}T$ ,  $\frac{1}{6}T$ , etc., to some one cavity element, for example,  $Q_3$ , etc.

When the glottal puff is very sharp, it is approximately the effect of an instantaneous impulse and the curve itself is composed practically of the second member of (13). This gives us

$$y = R_1 \cdot e^{-at} \cdot \sin \left( \frac{2\pi}{Q_1} t - q_1' \right) + R_2 \cdot e^{-at} \cdot \sin \left( \frac{2\pi}{Q_2} t - q_2' \right) + \dots \quad (16)$$

for the curve. The analysis gives the results in (15) for which the means are calculated (p. 79), the lowest being assigned to the vibration with  $Q_1$ , the next to  $Q_2$ , etc.

The supposition that the friction in all the cavities is the same has some justification as far as the vowel elements are concerned; the various cavities are parts of a complicated one—thorax, larynx, pharynx, mouth, nose—having walls of flesh, cartilage or bone covered with moist membrane. The application to the glottal elements is made also because no better assumption suggests itself.

## CHAPTER IX.

### WAVE ANALYSIS IN REFERENCE TO ACTION IN THE EAR.

It can be safely assumed that the vibration in the air is transmitted through the middle ear without any essential change of form to the fluid of the labyrinth. What then occurs is still a matter of conjecture.

The prevailing hypothesis is the one known as the Helmholtz theory. The fibers of the basilar membrane in the cochlea have different lengths. Each can vibrate independently of its neighbors. A sinusoid vibration arriving in the labyrinth would set in vibration that fiber whose natural period agrees with that of the vibration. The vibration of a fiber arouses the nerve connected with it. If the vibration arriving in the labyrinth has a period to which there is no corresponding fiber, it will arouse the two fibers whose periods are just above and just below it with amplitudes corresponding to its relation to each. When a complex of vibrations reaches the labyrinth, those fibers will respond whose periods correspond to the components of the vibration. "Here we find an explanation why the ear analyzes the vibration of the air into sinusoid vibrations. Any particular particle of air can, of course, at any time perform only one movement. That we consider such movement to be mathematically a sum of sinusoid vibrations is at first an arbitrary fiction introduced for theoretical convenience and without a real meaning. Such a meaning, however, is found for this analysis in the consideration of the laws of resonance, since a periodic movement that is not sinusoid can arouse to resonance bodies of different periods in the harmonic series. We have, however, by our hypothesis reduced the phenomena of hearing to phenomena of resonance, and we find therein the reason why an originally merely periodic vibration in the air produces a sum of different sensations, and therefore appears compound for perception."\*

As an analogy we might have several thousand brass resonators tuned to vibration from 16 to 30,000 per second. When a vibration strikes the resonators, that one will respond whose period is the same. If no resonator has the exact period, the two neighboring ones will respond. To find what resonators will respond we have—according to Helmholtz—to perform a harmonic analysis of the vibration.

---

\*Helmholtz, *Lehre v. d. Tonempfindungen*, 5 Aufl., 243, Leipzig, 1896.

To this last conclusion we have to object that it is inconsistent with the Helmholtz theory.

For the sake of completeness let us assume that the ear contains fibers tuned from one vibration per second to 30,000, all being harmonic to the first. That the fibers of the ear may not be tuned exactly as harmonics to the lowest one or that the lowest may have a frequency greater than one per second, are secondary conditions.

Let a vowel sung on the tone 200 reach the ear. A harmonic analysis of a single wave provides for the tones 200, 400, 600, 800, etc., but it does not provide for the tones 201, 202, 203, etc. Nevertheless these tones are harmonic to the lowest fiber of the ear. The ear, in fact, provides for an inharmonic analysis of the sound on the basis of a very low fundamental. The simple harmonic analysis with the fundamental 200 can not possibly give the inharmonic tones of the vowel, although the ear will do so. How investigators can have supposed for many decades that the harmonic analysis of a single vibration in any way represents the action in the ear or gives the components as perceived by it on the Helmholtz theory is absolutely unintelligible.

It is remarkable that Helmholtz says: "Willis's description of the vibratory movement in the vowels certainly comes close to the reality, but it describes only the way in which the vibrations take place in the air and not the reaction of the ear to these vibrations."\* In spite of thus admitting the puff theory to be correct, Helmholtz develops a directly opposed one wherein the glottal lips act like membranes† and the vocal cavities respond like resonators with hard walls.‡ This he did because he believed that such a theory was required by his theory of hearing, the thought being first that the ear performs a harmonic analysis of all sounds and then that vowel vibrations must be built up of harmonics. As has just been shown, Helmholtz should have pointed out that the ear provides for an analysis on the basis of a deep fundamental, and the harmonic analysis where the fundamental is the lowest tone of the wave is utterly inadequate to represent the action in the ear. He should then have repeated that the harmonic analysis thus "remains an arbitrary fiction without a real meaning." As explained in a previous chapter, the harmonic analysis can be applied to any curve and gives no indication of the manner in which it was actually produced.

The usual version of the Helmholtz theory overlooks several important facts of resonance. The fibers of the ear are strongly damped, not

---

\* Helmholtz, as before, 191.

† Helmholtz, as before, 162.

‡ Helmholtz, as before, 186.

only by being in a liquid and by the tectorial membrane, but also by their structure. They are soft strings or bands loaded with various cells and connected with each other, or, rather, they are merely thickened fibers of a membrane. It is quite impossible that they should resonate like brass globes; they are rather to be compared to the water resonators described above (p. 113). We have, therefore, to reckon with the highly significant fact that the ear resonators respond to a range of tone whose extent depends on the amount of damping. A single vibration arriving in the ear will arouse a whole group of fibers. Another vibration of a different pitch will arouse a different group. Helmholtz himself recognized this fact,\* but did not see that here again not even the remotest analogy could be drawn between the process in the ear and the simple harmonic analysis.

How are the sensations of tone to be accounted for on the basis of the vibration of the fibers in groups?

Concerning the physiological process in the ear the following may be accepted as facts. Owing to the friction in the ear, each vibration—even a simple sinusoid—arouses a set of fibers. Each fiber has its special nerve which sends a stimulus to the brain whenever it is aroused. Just how this is done and what kind of nerve current passes are matters concerning which nothing need be said. What happens further in the brain is absolutely unknown.

The following psychophysical facts are recognized. A periodic series of impulses reaching the ear is heard as a single tone with a specific musical timbre. For example, the vibrations from a fork of 100 per second are heard as a tone of a certain pitch with the smooth "fork-timbre," or "u-timbre." The puffs from a siren of the same number per second are heard as a tone of the same pitch, but with different timbre, depending on the form of the puffs. The vibrations of a labial pipe, of the various musical instruments with the same frequency, etc., are heard as tones of the same pitch, but with different timbres. Physically the tones of the musical instruments may be analyzed into series of partials and the puffs may be likewise represented, but mentally there is at the outset no such analysis. It is a fundamental principle of mental life that groups of stimuli, even for several sense organs at once, may appear mentally as single impressions; these single impressions may be experimentally analyzed into simpler groups, but the mind does not perform such an analysis without help. The timbre of a tone is not analyzed directly by the mind.

From those two sets of facts we are forced to conclude that a group of nerve impulses aroused by the set of fibers produces mentally the

---

\*Helmholtz, as before, 243.

impression of a tone whose pitch is the mean for the group, and whose timbre is the result of the distribution of the stimulation within the group. For example, let us suppose that a tuning-fork of 100 vibrations per second arouses a set of fibers with the relative strengths shown in figure 113; the mental response is a tone of a certain pitch with the tuning-fork timbre. We will suppose likewise a set of siren puffs to arouse fibers in the relations shown in figure 114; the mental response will be a tone of the same pitch as the fork, but with the puff timbre.

These facts I would account for on the centroid principle. The complex of nerve currents produces mental results which are fused into a single tone, whose period is the mean of the lot. The mode of distribution of the mental impression around the mean is what we feel as the timbre of the tone.

The term "mean" is purposely used. Although we have at present no method for measuring the amplitudes of the vibrations of the fibers in the ear or the intensities of the mental elements composing the impression, it is presumably true that the pitch of the tone as perceived is a mean

of the group. Whether it is a simple average, or the weighted mean, or some other mean, must be left for the future to decide.

When two vibrations stimulate overlapping groups of fibers, some of them must respond to the



FIGS. 113, 114.—Relative stimulations of acoustic fibers, first and second cases.

sum of the impulses, and their nerves must likewise carry greater currents than for each case separately. We must assume that the mental effect is similarly composed of the overlapping impressions, and that the two centroids with their timbres are resolved out of the group. Figure 115 illustrates the stimulation of the fibers of three tones singly, and, in the lowest line, by the same three simultaneously; the complex stimulation in the last case produces the mental impression of three tones.

A detailed treatment would need to consider the natural tone of each fiber. As explained previously (p. 120) a vibration reaching a resonator arouses two responses, one with the period of the vibration itself and one with the period of the resonator. Each fiber of the ear must therefore perform—like every other resonator at the first instant—the sum of two vibrations, one with the period of the impressed force and one with its own period. For musical tones where the same vibration is maintained, the first component is of no importance because it rapidly disappears,

leaving after a vibration or two only the element with the period of the fiber. This is the case contemplated in discussing resonance theories of the ear. For spoken sounds the case is different. The sound changes from vibration to vibration, never remaining constant. A fiber in the ear must, therefore, perform a movement representing the sum of two elements, one with the period of the speech wave and the other with the period of the fiber itself. This is probably one of the sources of the peculiar mental impression of speech by which it is distinguished from all other sounds.

The question of what method of analysis is to be applied to a sound curve in order to represent the action of the ear is not an easy one. For a curve known to be composed of harmonic elements—as the curves of

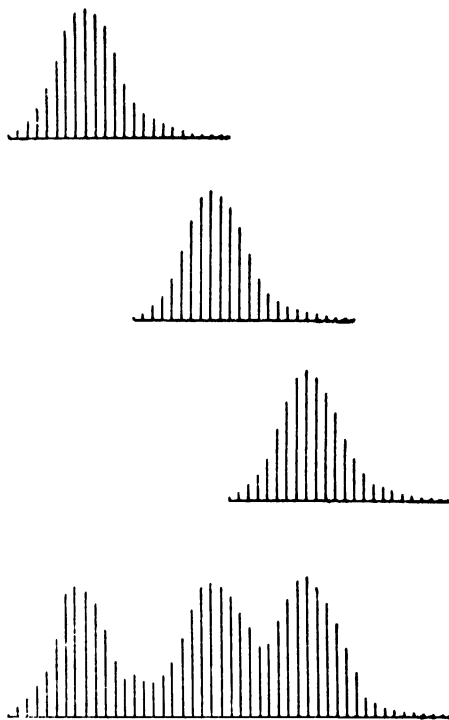

FIG. 115.—Relative stimulation of acoustic fibers by tones of different pitch, separately and simultaneously.

some musical instruments—the simple harmonic analysis is evidently to be used. When the nature of the curve is unknown, but its form is maintained unchanged from wave to wave, an inharmonic analysis is in place. For the sounds of speech we can not use the inharmonic analysis because each wave is different from the next (p. 100), and we know that the harmonic analysis without further treatment gives absolutely false results because it does not provide for the inharmonics. The best we can do is to apply the frictional harmonic analysis and pick out the elements on the centroid principle (p. 80). To be sure even this does not provide for the double nature of the vibratory movement of each fiber, as just considered. It is self-evident that the analysis must be a frictional one (Chapter VIII), but we have no means of obtaining the coefficients of friction in the ear. The difficulties are not insurmountable, but more of the action of the ear must be learned before we can adopt a method of analysis to represent it.

The negative conclusion just reached has a definite bearing. Of all the methods yet proposed for the curves of speech, the simple harmonic analysis is certainly the least applicable. It was originally introduced into the study of vowel curves because it was supposed to represent the

The negative conclusion just reached has a definite bearing. Of all the methods yet proposed for the curves of speech, the simple harmonic analysis is certainly the least applicable. It was originally introduced into the study of vowel curves because it was supposed to represent the

action of the ear. All previous investigations have been made on song, and it is quite conceivable that the tones of a vowel in song may be maintained with sufficient constancy through several vibrations to make it possible to use a number of successive waves for the inharmonic analysis. A harmonic analysis of a single wave can be used only to obtain the inharmonics on the centroid principle. The friction would probably have to be considered also. Thus for song an inharmonic frictional analysis offers a prospect of obtaining results that correspond to the action of the ear. For really spoken sounds there is no such possibility at present, and the one claim put forward by investigators to support their use of the simple harmonic analysis—namely, that it agrees with the action in the ear—has not the slightest justification.

## CHAPTER X.

### SYNTHESIS OF VIBRATIONS.

An excellent way to determine the composition of anything is to build it up out of elements with known characters. Applied to speech curves the method of synthesis would have to compose curves that resemble vowel curves.

The synthesis of simple sinusoids in harmonic relations (Preece and Stroh, Michelson and Stratton) can be made to furnish curves that resemble those from some musical instruments, but it can not furnish curves that resemble vowel curves unless an inordinately great number of elements is used. To have any meaning for vowel analysis, however, the number of elements must be small. Since vowel curves can not be counterfeited by adding any reasonable number of harmonic simple sinusoids, we must conclude that the vowels themselves were not produced by vibrating bodies whose periods form a harmonic series. In other words, the overtone theory of the vowels (p. 107) is not valid because curves produced by a small number of elements adjusted according to that theory do not resemble vowel curves.

The entirely different assumption that a vowel is the effect of sharp glottal puffs acting on the vocal cavities was used as the basis for the construction of a vibration apparatus. The apparatus was made to record the effects of sudden magnetic impulses on a steel spring; this was to represent the sharp glottal puffs acting upon the lowest vibratory element of the vocal cavity. An early form of this apparatus was described in "Elements of Experimental Phonetics" (Chapter I); the improved form is shown in figure 116.

A steel "vibrating spring" of any desired stiffness is held with any desired length in a "clamp"; it is free and carries a writing point which records its vibrations on a smoked surface. An "electromagnet" is placed so that a current sent through it will pull the spring down; the "magnet holder" permits adjustment at any point along the length of the spring and at any distance from it; an extra steel cap on the core makes it possible to allow for the bend of the spring. The "felt damper" is cemented to a strip of steel fixed in a "damper holder" that permits adjustment of the felt to any place on the spring; the "damper regulator" is a screw which bends the steel strip in the middle and presses the felt against the spring with any desired force.

When a single sharp electric impulse is sent through the magnet while the damper is out of contact, the spring vibrates for a long time. When the damper is applied, the same impulse produces a vibration whose amplitude steadily decreases; the rate of decrease depends on the degree of friction. Three specimen curves with increasing degrees of friction are shown in figure 117; the amplitude steadily decreases in each case, but more rapidly as the friction is greater. Such curves represent approximately the equation of the frictional sinusoid, discussed above (p. 104).

From the values of successive amplitudes in the same curve the degree of friction can be calculated (p. 106). The sharp electric impulse represents the glottal puff, the vibrating spring with much friction represents the vocal resonance with its poorly reflecting walls (p. 110). If such an apparatus can be made to produce curves resembling the vowel curves, it furnishes proof of the correctness of the puff theory of vocal action.

The curve in figure 118 looks like the curve of an initial vowel with some of the minor irregularities smoothed off; in fact, it is the type of an initial vowel curve after elimination of the peculiarities due to the specific vowels. It was made by a series of magnetic impulses acting on the spring, the impulses being at first far apart and then gradually closer. While the impulses are far apart, the vibration of the spring from each impulse dies away and is followed by a straight line; as the impulses come faster the vibration for one has not time to die away and its effect is united to the following one. A little later the period of the impulses approaches more nearly the period of the spring and a resonance effect begins to show itself. This is exactly the case with the action of the glottal puffs on the largest element of the vocal cavity in the initial vowel.

It is also possible to obtain curves like those for [ɪ] and [u] in the Depew plate by using a contact apparatus (described in "Elements of Experimental Phonetics," Chapter I), and adjusting the period of the contact to an octave below that of the spring; the minor fluctuations and deformations of the vowel curves—due to the higher tones—are lacking in these curves, but to the eye they often appear exactly like vowel curves.

That such close similarities to vowel curves can be obtained from a single vibrating spring is due to the shortness of the magnetic impulse (whereby the suddenness of the glottal puff is counterfeited), to the high degree of friction (as in the vocal cavity), and to the fact that all vowels contain one very strong cavity tone in comparison with which the other tones do not show prominently in the curve.

This apparatus is adapted to the study of the general vowel type of vocal action under variations in the suddenness and pitch of the glottal puffs and in the change of the main vocal cavity. The attempt was made

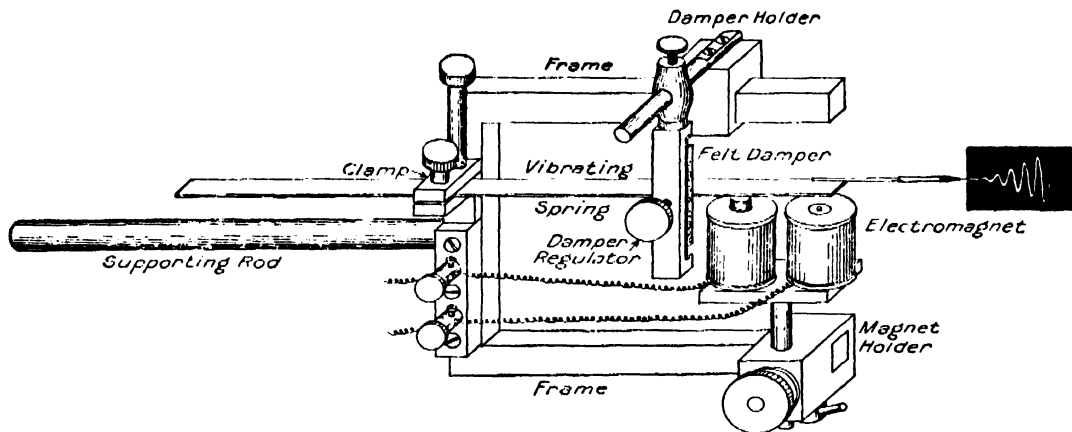

FIG. 116. — Magnetic vibrating spring with adjustable damper.

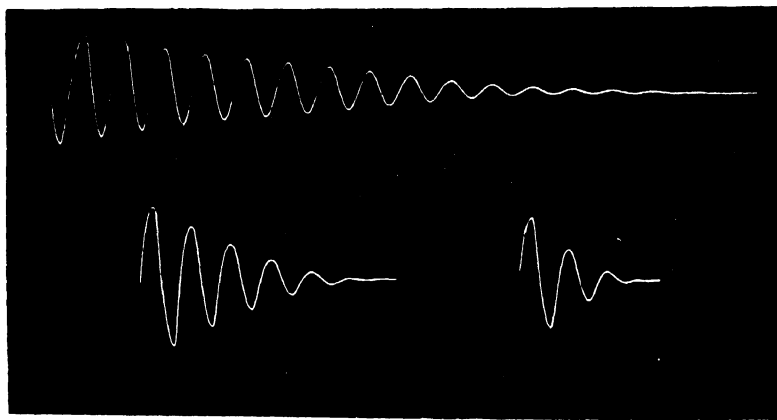

FIG. 117. — Sinusoids with different factors of friction.



FIG. 118. — Frictional sinusoids aroused by impulses with steadily decreasing interval.

SYNTHESIS OF VIBRATIONS.



to add another vibrating reed with magnet to the end of the first one (see "Elements of Experimental Phonetics," p. 70), but the additional weight on the end of the spring made the apparatus difficult to manage; a multiple pendulum was therefore tried.

The multiple pendulum is shown in figure 119. The frame carries a projecting half circle with bearings for the knife edges of the longest pendulum. This pendulum is held by a screw in a metal block; the position of its point of support may be adjusted, or it can be replaced by a shorter pendulum; in this way its period may be varied. It carries an adjustable half ring with bearings for the knife edges of the second pendulum. The second pendulum is held in a similar metal block with knife edges; it carries an adjustable bearing for the third pendulum, etc. In this way the vibrations of three pendulums may be compounded and the period of each may be varied at will. The pendulums are set in motion by a sharp blow from a felt hammer, or by a puff of air; these blows are repeated at intervals. The period of the blows and those of the pendulums can be varied at will. The sharp blows represent the glottal puffs and the various pendulums the vibratory elements of the vocal cavity. Vari-

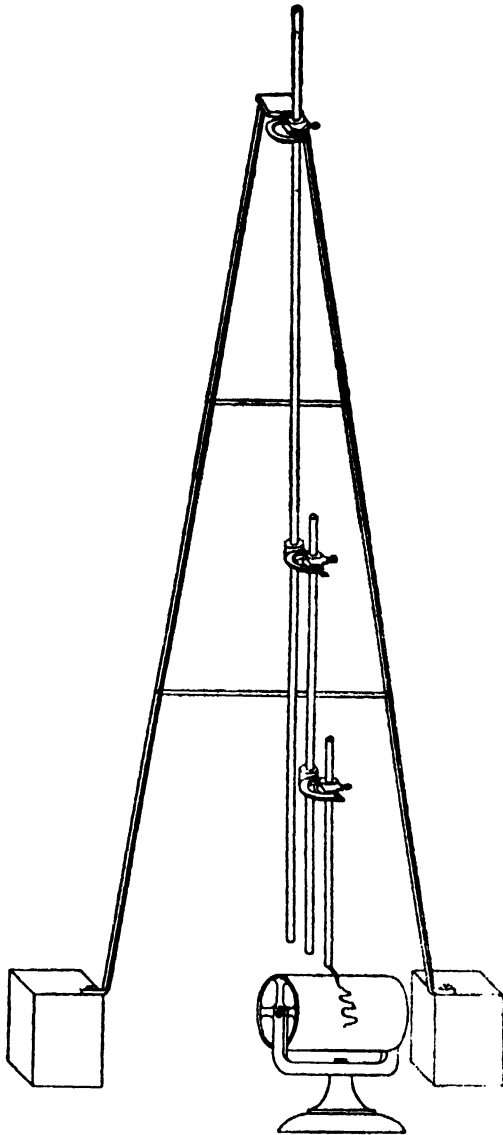

FIG. 119.—Multiple pendulum.

ous degrees of friction are introduced by adding wind vanes to the pendulums. The principle is capable of extension to more than three pendulums.

If the vowel vibrations are the results of puffs of various sharpness acting on a series of cavities, the analogy of this apparatus to the vocal vibratory system is very close. It must be possible to obtain curves that

can not be distinguished from vocal curves; indeed, it can be expected to counterfeit every curve of a vowel or a musical instrument blown by the lips.

The results from the pendulum apparatus make clear from the start that—as the construction of the apparatus indicates—the vibrations are interdependent. When the pendulums are fastened together by clamps at the bottom, they all trace the same curve. When they are allowed to swing freely, the bottom of the longest pendulum does not trace a sinusoid, but a curve depending on the vibrations of the other pendulums; this curve thus depends essentially not only on the length of the longest pendulum, but also on the lengths, weights, and periods of the smaller ones and on the degree of friction. Applied to the voice, this indicates that the vibrations of the largest element of the vocal cavity are determined not only by its size, its openings, and its internal friction, but also by the sizes, openings, and friction of the connecting cavities; moreover, not only the form of the vibration but its very period are thus dependent. We can reject as absolutely worthless a long English investigation in which the ton *s* of the vowels are calculated merely from the size of one large cavity, because the tone of any one cavity depends on all the others and on the openings.

Another line of work closely connected with these experiments is the computing and plotting of compound curves. Curves are calculated and plotted on different assumptions until those are found which resemble the curves obtained in the speech tracings.

This method has the advantage that each factor is accurately known from the start. It has the disadvantage that until the leading principles are discovered, the work requires an incredible amount of time. The method, however, is the only one that leads to a solution of some of the vowel problems.

The work was conducted on the following plan. A table was computed for a set of "simple sinusoids,"

$$y = a \cdot \sin \frac{2\pi}{T} t,$$

for  $a = 100$ ,  $T = 360, 180, 120, \dots, 36$ , and  $t = 5, 10, 15, \dots, 360$ . The values of the elements depending on friction  $e^{-\epsilon t}$  for  $\epsilon = 0.001, 0.002, 0.050, \dots, t = 5, 10, 15, \dots, 360$  were then computed, each set of  $\epsilon$  being written on a separate "friction slip." A friction slip was then laid beside each of the "simple sinusoids" in succession and a table for the "frictional sinusoids"

$$y = a \cdot e^{-\epsilon t} \cdot \sin \frac{2\pi}{T} t$$

was obtained for each value of  $\epsilon$ . This set of tables formed the basis of the investigation.

Combinations of the frictional sinusoids in twos, threes, etc., were made, and the results were plotted and compared with speech curves.

It was of course impossible to think of carrying out this whole plan up to 10 or 20 components, as the number of curves to be made was unattainable. One assumption after another was made and a few curves calculated for each. When the results showed incompatibility with the vowel curves, the assumption was abandoned and that line of computation was dropped. Thus the assumption that vowel curves are composed of simple sinusoids ( $\epsilon=0$ ) in a harmonic series could be ruled out at the start, because all such combinations (when all waves begin with the same phase) produce curves symmetrical to the X-axis, whereas vowel curves are never symmetrical. Of course, vowel curves could be counterfeited by adding harmonic simple sinusoids with differences of phase just as any curve can be analyzed into a harmonic series, but the number of elements would be large and the objections to the simple harmonic analysis are also valid against such a synthesis. The assumption that the friction is the same in all harmonics of a compound (that is, that  $\epsilon_1 = \epsilon_2 = \epsilon_3$ , etc.) produced curves that showed what might be called a distorted "symmetry" with the second half of the wave a dwindling reverse of the first. Vowel curves do not show this phenomenon.

Results closely resembling vowel curves were obtained, however, when a comparatively large value was given to  $\epsilon_1$ , and much smaller values to  $\epsilon_2$ ,  $\epsilon_3$ , etc. For example, the equation

$$y = 100.e^{-0.100t}.\sin \frac{2\pi}{36}t + 20.e^{-0.005t}.\sin \frac{2\pi}{12}t + 20.e^{-0.005t}.\sin \frac{2\pi}{7.2}t$$

gives the curve in figure 120, which appears to the eye exactly like a vowel curve. The peculiarity of the equation lies in the comparatively large factor of friction of the first element. What does this fact mean? We may suppose that  $\epsilon_1$  is not a factor of friction at all, but is the factor of suddenness  $\theta$  in the glottal puff (p. 121). The first element in the compound curve is—in the writer's opinion—approximately the curve of the glottal puff; the other elements are mainly cavity vibrations. By using equations of the form just given, and by varying the amplitudes and periods we can hope to imitate not only the different typical vowel forms but also the personal peculiarities of the speakers.

This work of producing curves by synthesis is of special importance, not only because it can be used as the test of any theory of the vowels,

but also because it constantly furnishes new suggestions for the perplexing phenomena found in the actual speech curves.

It is interesting to consider what such synthetic work may ultimately lead to. A successful synthetic apparatus or system of computing would be able to counterfeit the curve of any vowel; inscribed on a gramophone disc such a curve would produce a vowel sound that had never been produced by the vocal organs. New vowels could be produced that have not been—and perhaps never will be—present in any language.

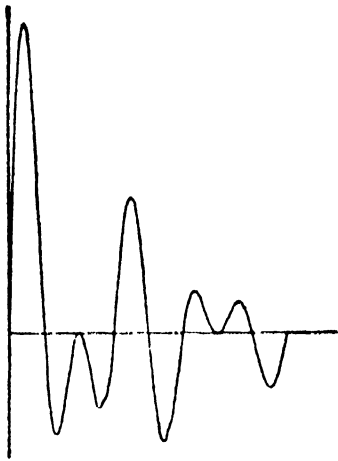

FIG. 120.—Curve compounded of frictional sinusoids.

The development of the method of synthesis will lead ultimately to systematized collections of curves which will include all the usual forms found in speech curves. When this has been accomplished, the collection can be used as an index for analyses. When a curve is found to coincide with a synthetic curve, the formula of synthesis can at once be used as the result without performing the actual analysis. Although such an index would be of almost incredible utility—furnishing an analysis after a few minutes' search instead of the 10 or 12 hours' minimum of labor regularly required for each wave—it is unfortunately not to be hoped for in the near future. The

curve of a frictional sinusoid (regardless of phase) contains three arguments to be varied: period, amplitude, and factor of friction. A moderately thorough treatment would require perhaps 100 variations of each argument. This would require tables for 300 fundamental curves, and additions for 50,000 curves. Such an undertaking is at present out of reach.

## CHAPTER XI.

### EXAMPLES OF VOWEL ANALYSIS.

To illustrate the methods used in vowel analysis and give some idea of their accuracy an artificial curve whose composition is known will first be used. Thereafter an example will be taken from an actual vowel curve.

The vibrations in figure 121 represent one wave-group of a speech curve, corresponding to the vibrations aroused by one puff from the glottis (p. 40). We have first to find the axis of the curve. This is best done while the vibrations are still in the continuous speech curve. It often happens that successive wave-groups begin with vibrations of the same

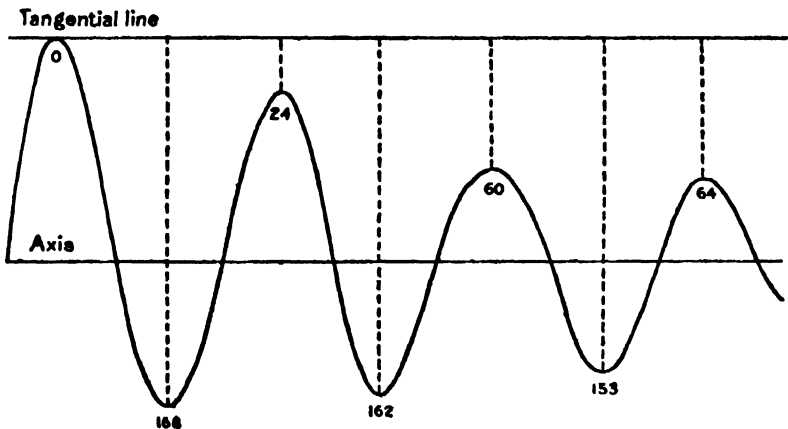

FIG. 121.—Curve for analysis.

height. We draw a line along the tops of these highest vibrations and get a "tangential line," as indicated in the figure.

The distance of the maxima and minima of the vibrations from this line are found to be 0, 168, 24, 162, 60, 153, 64. The vibrations start strong and gradually die away. If the vibrations were of the nature of those of a tuning-fork or a pendulum, the successive maxima and minima would occur at equidistant intervals. In such a case the position of the axis can be found by taking the average of the maxima and that of the minima and averaging the two results.

Although we have no proof that this curve is of the same character as the pendulum curve with a vibration dying away, we can use the method

as an approximation. We have thus  $\frac{1}{2} \{ \frac{1}{4}(0 + 24 + 60 + 64) + \frac{1}{3}(166 + 162 + 153) \} = 100$  as the distance of the axis below the tangential line. The curve is also found to cut the axis at intervals of approximately 100.

The analysis is to be made with 36 ordinates. The length of the wave-group is 360mm.; the ordinates therefore occur at intervals of 10mm. The ordinates are given in the first column of the adjacent table. They are then multiplied by the cosines for the 36 schedules (p. 90).

THIRTY-SIX ORDINATES FROM FIGURE 121, MULTIPLIED BY THE COSINES.

	1.000	0.985	0.940	0.866	0.766	0.643	0.500	0.342	0 174	0
0	0	0	0	0	0	0	0	0	0	0
1	+67.1	+66.1	+63.0	+58.2	+51.4	+43.1	+33.6	+22.9	+11.7	0
2	+101.0	+99.5	+94.9	+87.5	+77.4	+64.9	+50.5	+34.5	+17.6	0
3	+91.3	+89.9	+85.8	+79.1	+69.9	+58.7	+45.7	+31.2	+15.9	0
4	+50.1	+49.3	+47.1	+43.4	+38.4	+32.2	+25.1	+17.1	+ 8.7	0
5	- 0.9	- 0.9	- 0.8	- 0.8	- 0.7	- 0.6	- 0.5	- 0.3	- 0.2	0
6	-41.9	-41.3	-39.4	-36.3	-32.1	-26.9	-21.0	-14.3	- 7.3	0
7	-62.4	-61.5	-58.7	-54.0	-47.8	-40.1	-31.2	-21.3	-10.9	0
8	-60.3	-59.4	-56.7	-52.2	-46.2	-38.8	-31.2	-20.6	-10.5	0
9	-37.3	-36.7	-35.1	-32.3	-28.6	-24.0	-18.7	-12.8	- 6.5	0
10	+ 0.9	+ 0.9	+ 0.8	+ 0.8	+ 0.7	+ 0.6	+ 0.5	+ 0.3	+ 0.2	0
11	+42.9	+42.3	+40.3	+37.2	+32.9	+27.6	+21.5	+14.7	+ 7.5	0
12	+73.5	+72.4	+69.1	+63.7	+56.3	+47.3	+36.8	+25.1	+12.8	0
13	+75.4	+74.3	+70.9	+65.3	+57.8	+48.5	+37.7	+25.8	+13.1	0
14	+48.5	+47.8	+45.6	+42.0	+37.2	+31.2	+24.3	+16.6	+ 8.4	0
15	+ 3.2	+ 3.2	+ 3.0	+ 2.8	+ 2.5	+ 2.1	+ 1.6	+ 1.1	+ 0.6	0
16	-39.6	-39.0	-37.2	-34.3	-30.3	-25.5	-19.8	-13.5	- 6.9	0
17	-61.6	-60.7	-57.9	-53.3	-47.2	-39.6	-30.8	-21.1	-10.7	0
18	-55.4	-54.6	-52.1	-48.0	-42.4	-35.6	-27.7	-18.9	- 9.6	0
19	-29.4	-29.0	-27.6	-25.5	-22.5	-18.9	-14.7	-10.1	- 5.1	0
20	+ 2.9	+ 2.9	+ 2.7	+ 2.5	+ 2.2	+ 1.9	+ 1.5	+ 1.0	+ 0.5	0
21	+28.6	+28.2	+26.9	+24.8	+21.9	+18.4	+14.3	+ 9.8	+ 5.0	0
22	+41.5	+40.9	+39.0	+35.9	+31.8	+26.7	+20.8	+14.2	+ 7.2	0
23	+39.5	+38.9	+37.1	+34.2	+30.3	+25.4	+19.8	+13.5	+ 6.9	0
24	+24.4	+24.0	+22.9	+21.1	+18.7	+15.7	+12.2	+ 8.3	+ 4.2	0
25	- 0.3	- 0.3	- 0.3	- 0.3	- 0.2	- 0.2	- 0.2	- 0.1	- 0.1	0
26	-27.5	-27.1	-25.9	-23.8	-21.1	-17.7	-13.8	- 9.4	- 4.8	0
27	-46.8	-46.1	-44.0	-40.5	-35.9	-30.1	-23.4	-16.0	- 8.1	0
28	-49.1	-48.4	-46.2	-42.5	-37.6	-31.6	-24.6	-16.8	- 8.5	0
29	-42.2	-41.6	-39.7	-36.5	-32.3	-27.1	-21.1	-14.4	- 7.3	0
30	- 3.5	- 3.4	- 3.3	- 3.0	- 2.7	- 2.3	- 1.8	- 1.2	- 0.6	0
31	+23.6	+23.2	+22.2	+20.4	+18.1	+15.2	+11.8	+ 8.1	+ 4.1	0
32	+37.3	+36.7	+35.1	+32.3	+28.6	+24.0	+18.7	+12.8	+ 6.5	0
33	+33.5	+33.0	+31.5	+29.0	+25.7	+21.5	+16.8	+11.5	+ 5.8	0
34	+16.9	+16.6	+15.9	+14.6	+12.4	+10.9	+ 8.5	+ 5.8	+ 2.9	0
35	- 3.6	- 3.5	- 3.4	- 3.1	- 2.8	- 2.3	- 1.8	- 1.2	- 0.6	0

The 36 patterns (see schedules at end of this volume) with perforations and indications of + and - are now applied. After a pattern has been laid over the table all the figures seen through the perforations are added; those for which the sign of the pattern coincides with that of the table being taken as plus, the others as minus (p. 90). For example, let us suppose the schedule for  $a_1$  to be laid over the table. The values for which the signs coincide are 66.1, 95.0, 79.1, 38.4, 37.2, 60.7,

55.4, 29.0, 0.1, 4.8, 15.2, 28.6, 29.0, 15.9; those for which they differ are 0.6, 21.0, 21.3, 10.5, 0.2, 14.7, 36.8, 48.5, 37.2, 2.8, 2.7, 24.8, 31.8, 25.4, 12.2, 8.5, 14.4, 1.8, 3.5. Taking the former as plus and the latter as minus, we obtain + 235.8. Divided by half the number of ordinates used, namely, by 18, this gives + 13.1, as the value for  $a_1$ . Using the pattern for  $b_1$  in the same way, we obtain + 6.4. The amplitude of the first partial, or fundamental, is therefore  $c_1 = \sqrt{a^2 + b^2} = 14.6$ .

The phase of a component may be calculated in two ways. By equation (11) on page 85 we have directly  $\tan q = -\frac{a}{b}$ , from which we obtain  $q$  by means of a table of tangents. A method that is often more convenient is the following one. The curve for a component may be represented as the sum of a cosine and a sine curve, or

$$y = c \cdot \sin \left( \frac{2\pi}{\tau} t - q \right) = a \cdot \cos \frac{2\pi}{\tau} t + b \cdot \sin \frac{2\pi}{\tau} t.$$

For  $t=0$ ,

$$y = c \cdot \sin (-q) = a.$$

This gives

$$q = -\frac{a}{c}.$$

Since  $\tan x = \tan (180^\circ + x)$  and  $\sin x = \sin (180^\circ - x)$ , there will always be two values obtained for  $q$  by the above equations. The required one can be found by considering that

$$c \cdot \sin (-q) = -c \cdot \sin q = a.$$

Since  $c$  is always positive,  $\sin q$  must have the sign opposite to that of  $a$ . We thus have the following rule: When  $a$  is positive,  $q$  must lie between  $180^\circ$  and  $360^\circ$ ; when  $a$  is negative  $q$  must lie between  $0^\circ$  and  $180^\circ$ . From  $q$  we obtain  $r = \frac{q}{2\pi} T$  and  $r = \frac{q}{2\pi} \lambda$  (p. 84), where  $T$  is the period of the vibration and  $\lambda$  its length.

For the first component we have  $a_1 = + 13.1$ ,  $b_1 = + 6.4$ , whence  $\tan q_1 = -2.1$ ,  $q_1 = 295^\circ$ . Since the wave-length for the first partial is 360mm.,  $r = \frac{q}{2\pi} = \frac{295}{360} \cdot 360 = 295\text{mm.}$

In the adjacent table of results the first column gives the serial number of each partial. Its wave-length is obtained from the wave-length of the fundamental 360mm. by dividing by 1, 2, 3, etc. The coefficients  $a$  and  $b$  give the amplitudes of the cosine and the sine series respectively

when the curve is expressed as a sum of cosines and sines (p. 84);  $c$  gives the amplitude when the curve is expressed as a series of sines alone. The values  $q$  and  $r$  are obtained as just explained. The harmonic plot is given in figure 122.

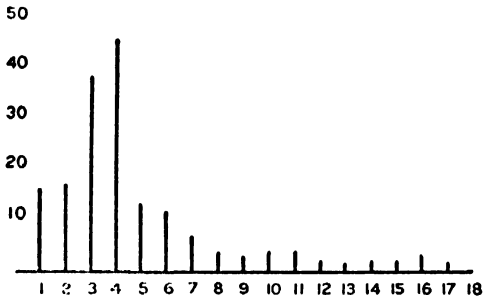

FIG. 122.—Simple harmonic plot to figure 121.

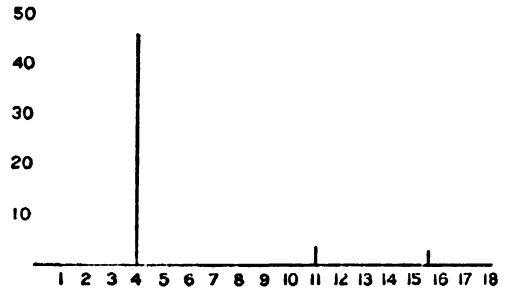

FIG. 123.—Plot of inharmonic components from figure 122.

TABLE OF RESULTS OF SIMPLE HARMONIC ANALYSIS OF FIGURE 121.

Partial.	$\lambda$	$a$	$b$	$c$	$q$	$r$
1	360mm.	+13.1	+ 6.9	15.5	298	298
2	180	+16.2	+ 0.3	16.2	271	136
3	120	+36.7	+ 4.1	36.9	277½	93
4	90	-36.6	+25.0	44.3	56	14
5	72	-11.1	+ 4.1	11.8	69½	14
6	60	- 6.3	+ 8.7	10.7	35	6
7	52	- 4.5	+ 2.0	4.9	114	15
8	45	- 2.7	+ 0.8	2.8	73½	9
9	40	- 2.3	+ 0.2	2.3	85	9
10	36	- 2.4	- 0.5	2.5	102	10
11	33	- 1.3	+ 0.8	1.5	58	5
12	30	- 0.9	+ 0.9	1.3	45	4
13	28	- 0.5	+ 0.2	0.5	68	5
14	26	- 0.8	- 0.4	0.9	116½	8
15	24	- 1.2	- 0.1	1.2	95	6
16	22	- 1.6	+ 0.5	1.7	72½	5
17	21	- 0.6	+ 0.5	0.8	50½	3
18	20	0.0	0.0	0.0	...	...

The simple harmonic analysis has not provided for the possible presence of inharmonics (p. 77). If we suppose that inharmonics are present and assume as many as there are maxima in the harmonic plot we find that there are three. The two minima 2.3 and 0.5 are then divided in the ratios of their neighbors according to the rule given on p. 81. The weighted mean of the first group is thus

$$\frac{(1 \times 15.5) + (2 \times 16.2) + (3 \times 36.9) + (4 \times 44.3) + (5 \times 11.8) + (6 \times 10.7) + (7 \times 4.9) + (8 \times 2.8) + (9 \times 1.2)}{15.5 + 16.2 + 36.9 + 44.3 + 11.8 + 10.7 + 5.1 + 2.8 + 1.2} = 3.6;$$

that is, the inharmonic has a wave-length 1/3.6 that of the fundamental, or 100.0mm. The other two inharmonics have wave-lengths 1/10.6 and

1/15.5 that of the fundamental, or 34.0 and 23.2mm. Taking the maximum ordinate as the amplitude of the inharmonic we have as a result the three sinusoids with the wave-lengths 100.0, 34.0, 23.2mm. and the amplitudes 44.3, 2.5, 1.7mm. These inharmonic components are given in figure 122.

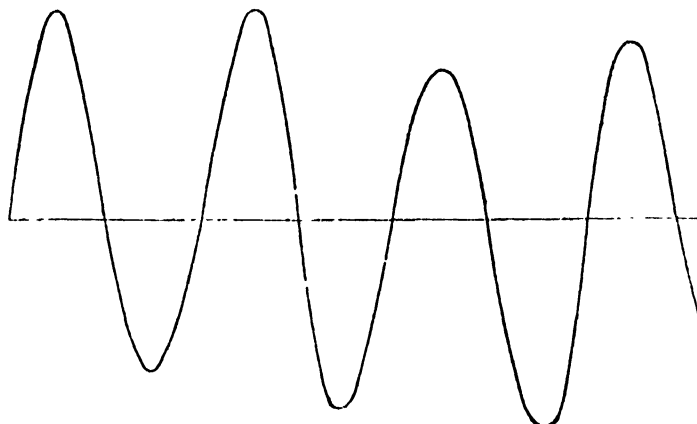

FIG. 124. —Curve of figure 121 with friction eliminated.

For an analysis into frictional sinusoids (Chapter VII) the factor of friction (p. 106) must be found. Using the maxima and minima we perform the adjacent calculation. The first column contains the maxima and minima, the second the differences between successive values. The third gives the natural logarithms. From the last column we have to calculate

Observed values.	s	log <sub>e</sub> s
0		
168	168	5.1240
24	144	4.9698
162	142	4.9558
60	102	4.6250
153	93	4.5326
64	89	4.4886

$$d = 6 \frac{5(5.1240 - 4.4886) + 3(4.9698 - 4.5326) + (4.9558 - 4.6250)}{6 \times 35} = 0.1377.$$

Since the period  $T$  of the vibration from which we calculate  $d$  is very closely 100 we have

$$\epsilon = \frac{2d}{T} = 0.0028.$$

The calculation rests on the assumption that for this purpose we can treat the given curve like a single frictional sinusoid. If it were such a curve the differences between the successive maxima and minima would have a constant relation. In the given curve the differences are 168, 144, 138, 102, 93, 89; the relation of each to the following one is 1.17, 1.05, 1.36, 1.10, 1.05 respectively. Instead of being constant the relation varies considerably. It is due to the fact that the curve is compounded of several simpler curves and the maxima and minima result from their

addition. In the present case we have no further information concerning the curve and as the best approximation we must use the maxima and minima as we find them.

We now propose to multiply the ordinates of the curve by  $e^{+0.0028t}$  and then to perform a simple harmonic analysis of the new curve, as indicated by the principles of the frictional analysis (Chapter VII). We expect thereby to obtain the frictional sinusoids out of which the curve was originally composed.

Since each of the ordinates is to be multiplied by the corresponding value of  $e^{+0.0028t}$ , we have first to calculate this quantity for the 36 ordinates. We first obtain  $\epsilon.\log e = 0.0028 \times 0.4343 = 0.00122$ . The 36 abscissas have

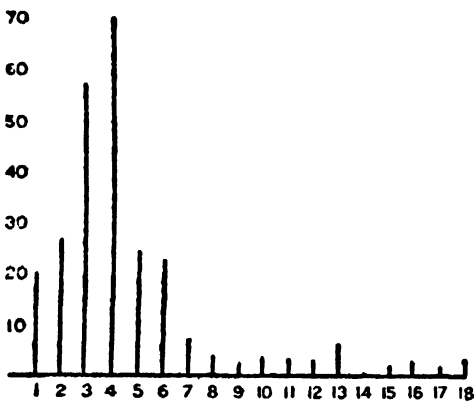

FIG. 125.—Harmonic plot to figure 124, or frictional harmonic plot to figure 121.

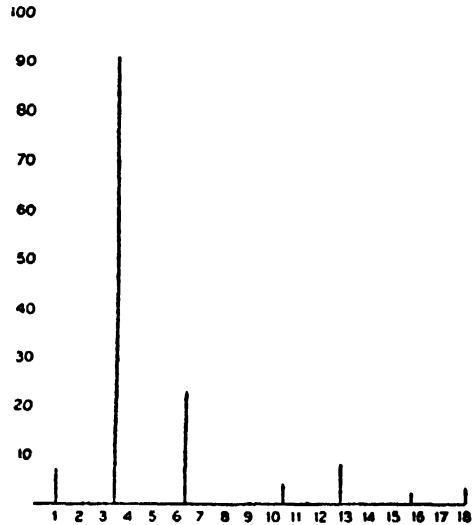

FIG. 126.—Plot of inharmonic components from figure 125.

the values 0, 10, 20, 30, . . . ; we have therefore only to find  $\epsilon t_{10}.\log e = 0.00122 \times 10 = 0.0122$ , and then to multiply this by 0, 1, 2, 3, . . . 35. The results are given in the first column of the adjacent table. For each of these values we find the numerus (from a table of logarithms). The values of  $e^{0.0028t}$  thus obtained are given in the second column. The third column gives the values of  $y$  in the original curve; the last column gives the product  $y.e^{0.0028t}$ . These are the ordinates of the new curve (figure 124) from which the frictional element has been removed.

The new ordinates are multiplied by the cosines as indicated in the adjacent table. With the schedules we obtain  $a$  and  $b$  as usual. These are used to give  $c$ ,  $g$ , and  $r$  as before. The results give the simple harmonic analysis of figure 124, or the frictional harmonic analysis of figure 121.

TABLE SHOWING HOW THE FRICTIONAL MULTIPLICATION IS PERFORMED.

t	et loge.	e <sup>st</sup>	y	y. e <sup>st</sup>	t	et loge.	e <sup>st</sup>	y	y. e <sup>st</sup>
0	0	1.03	0	0	180	0.2196	1.66	-55.4	-92.0
10	0.0122	1.03	+ 67.1	+ 69.1	190	0.2318	1.71	-29.4	-50.3
20	0.0244	1.06	+101.0	+107.1	200	0.2440	1.75	+ 2.9	+ 5.1
30	0.0366	1.09	+ 91.3	+ 99.5	210	0.2562	1.80	+28.6	+51.5
40	0.0488	1.12	+ 50.1	+ 56.1	220	0.2684	1.86	+41.5	+77.2
50	0.0610	1.15	- 0.9	- 1.0	230	0.2806	1.91	+39.5	+75.4
60	0.0732	1.18	- 41.9	- 49.4	240	0.2928	1.96	+24.4	+47.8
70	0.0854	1.22	- 62.4	- 76.1	250	0.3056	2.02	- 0.3	- 0.6
80	0.0976	1.25	- 60.3	- 75.3	260	0.3172	2.08	-27.5	-57.2
90	0.1098	1.29	- 37.3	- 47.4	270	0.3294	2.14	-46.8	-100.2
100	0.1220	1.33	+ 0.9	+ 1.2	280	0.3416	2.20	-49.1	-108.0
110	0.1342	1.36	+ 42.9	+ 58.3	290	0.3528	2.25	-42.2	-95.0
120	0.1464	1.40	+ 73.5	+102.9	300	0.3660	2.32	- 3.5	- 8.1
130	0.1586	1.44	+ 75.4	+108.9	310	0.3782	2.39	+23.6	+56.4
140	0.1708	1.48	+ 48.5	+ 71.8	320	0.3904	2.46	+37.3	+91.8
150	0.1830	1.53	+ 3.2	+ 4.9	330	0.4026	2.53	+33.5	+84.8
160	0.1952	1.57	- 39.6	- 62.2	340	0.4148	2.60	+16.9	+43.9
170	0.2074	1.61	- 61.6	- 99.2	350	0.4270	2.67	- 3.6	- 9.6

THIRTY-SIX ORDINATES FOR FIGURE 121 MULTIPLIED BY THE FACTOR OF FRICTION AND THE COSINES.

t	1.000	0.985	0.940	0.866	0.766	0.643	500	0.342	0.174	-
0	0	0	0	0	0	0	0	0	0	0
10	+ 69.1	+ 68.1	+ 65.0	+59.8	+52.9	+44.4	+34.6	+23.6	+12.0	0
20	+107.1	+105.5	+100.7	+92.7	+82.0	+68.9	+53.6	+36.6	+18.6	0
30	+ 99.5	+ 98.0	+ 93.5	+86.2	+76.2	+64.0	+49.8	+34.0	+17.3	0
40	+ 56.1	+ 55.3	+ 52.7	+48.6	+43.0	+36.1	+28.1	+19.2	+ 9.8	0
50	- 1.0	- 1.0	- 0.9	- 0.9	- 0.8	- 0.6	- 0.5	- 0.3	- 0.2	0
60	- 49.4	- 48.7	- 46.4	-42.8	-37.8	-31.8	-24.7	-16.9	- 8.6	0
70	- 76.1	- 75.0	- 71.5	-65.9	-58.3	-48.9	-38.1	-26.0	-13.2	0
80	- 75.3	- 74.2	- 70.8	-65.2	-57.7	-48.4	-37.7	-25.8	-13.1	0
90	- 47.4	- 46.7	- 44.6	-41.0	-36.3	-30.5	-23.7	-16.2	- 8.2	0
100	+ 1.2	+ 1.2	+ 1.1	+ 1.0	+ 0.9	+ 0.8	+ 0.6	+ 0.4	+ 0.2	0
110	+ 58.3	+ 57.4	+ 54.8	+50.5	+44.7	+37.5	+29.2	+19.9	+10.1	0
120	+102.9	+101.4	+ 96.7	+89.1	+78.8	+66.2	+51.5	+35.2	+17.9	0
130	+108.9	+107.3	+102.4	+94.3	+83.4	+70.0	+54.5	+37.2	+18.9	0
140	+ 71.8	+ 70.7	+ 67.5	+62.2	+55.0	+46.2	+35.9	+24.6	+12.5	0
150	+ 4.9	+ 4.8	+ 4.6	+ 4.2	+ 3.8	+ 3.2	+ 2.5	+ 1.7	+ 0.9	0
160	- 62.2	- 61.3	- 58.5	-53.9	-47.6	-40.0	-31.1	-21.3	-10.8	0
170	- 99.2	- 97.7	- 93.2	-85.9	-76.0	-63.8	-49.6	-33.9	-17.3	0
180	- 92.0	- 90.6	- 86.5	-79.7	-70.5	-59.2	-46.0	-31.5	-16.0	0
190	- 50.3	- 49.5	- 47.3	-43.6	-38.5	-32.3	-25.2	-17.2	- 8.8	0
200	+ 5.1	+ 5.0	+ 4.8	+ 4.4	+ 3.9	+ 3.3	+ 2.6	+ 1.7	+ 0.9	0
210	+ 51.5	+ 50.7	+ 48.4	+44.6	+39.4	+33.1	+25.8	+17.6	+ 9.0	0
220	+ 77.2	+ 76.0	+ 72.6	+66.9	+59.1	+49.6	+38.6	+26.4	+13.4	0
230	+ 75.4	+ 74.3	+ 70.9	+65.3	+57.8	+42.1	+37.7	+25.8	+13.1	0
240	+ 47.8	+ 47.1	+ 44.9	+41.4	+36.6	+30.7	+23.9	+16.3	+ 8.3	0
250	- 0.6	- 0.6	- 0.6	- 0.5	- 0.5	- 0.4	- 0.3	- 0.2	- 0.1	0
260	- 57.2	- 56.3	- 53.3	-49.5	-43.8	-36.8	-28.6	-19.6	-10.0	0
270	-100.2	- 98.7	- 94.2	-86.9	-76.8	-64.4	-50.1	-34.3	-17.4	0
280	-108.0	-106.4	-101.5	-93.5	-82.7	-69.4	-54.0	-36.9	-18.8	0
290	- 95.0	- 93.6	- 89.3	-82.3	-72.8	-61.1	-47.5	-32.5	-16.5	0
300	- 8.1	- 8.0	- 7.6	- 7.0	- 6.2	- 5.2	- 4.1	- 2.8	- 1.4	0
310	+ 56.4	+ 55.6	+ 53.0	+48.8	+43.2	+36.3	+28.2	+19.3	+ 9.8	0
320	+ 91.8	+ 90.4	+ 86.3	+79.5	+70.3	+59.0	+45.9	+31.4	+16.0	0
330	+ 84.8	+ 83.5	+ 79.7	+73.4	+65.0	+54.5	+42.4	+29.0	+14.8	0
340	+ 43.9	+ 43.2	+ 41.3	+38.0	+33.6	+28.2	+22.0	+15.0	+ 7.6	0
350	- 9.6	- 9.5	- 9.0	- 8.3	- 7.4	- 6.2	- 4.8	- 3.3	- 1.7	0

TABLE OF RESULTS OF FRICTIONAL ANALYSIS OF FIGURE 121.

Partial.	a	b	c	q	r	Partial.	a	b	c	q	r
1	+16.9	+7.3	18.4	294	294	10	-2.6	+0.9	2.7	71	7
2	+24.4	-3.2	24.6	262	131	11	-1.8	+2.0	2.7	42	4
3	+53.3	-13.3	54.9	256	85	12	0	+2.6	2.6	0	0
4	-64.3	+23.6	68.5	69	17	13	+5.7	+0.7	5.7	257	20
5	-16.8	+7.0	18.2	68	14	14	-0.1	-0.4	0.4	166	12
6	+8.3	+15.1	17.2	329	55	15	-1.2	-0.1	1.2	95	6
7	-4.0	+4.1	5.7	45	6	16	-1.1	+1.1	1.6	45	3
8	-1.9	+1.5	2.4	53	7	17	-0.1	+1.3	1.3	6	0
9	-2.1	+0.7	2.2	72	8	18	+2.4	0	2.4	276	15

To calculate the inharmonics we may follow the rule given above (p. 81) as a first suggestion. We find minima at 2.2, 2.6, 0.4, and 1.3, which we divide in the usual way. For the first group we have

$$\frac{(1 \times 18.4) + (2 \times 24.6) + (3 \times 54.9) + (4 \times 68.5) + (5 \times 18.2) + (6 \times 17.2) + (7 \times 5.7) + (8 \times 2.4) + (9 \times 1.0)}{18.4 + 24.6 + 54.9 + 68.5 + 18.2 + 17.2 + 5.7 + 2.4 + 1.0} = 3.6,$$

indicating a component with wave-length  $360\text{mm.} \div 3.6 = 100.0\text{mm.}$  For the other groups we find in like manner 10.4, 12.8, 15.7, and (since the series is cut off at a rise) 18.0. Taking  $\frac{1}{3}$  of the maximum as the

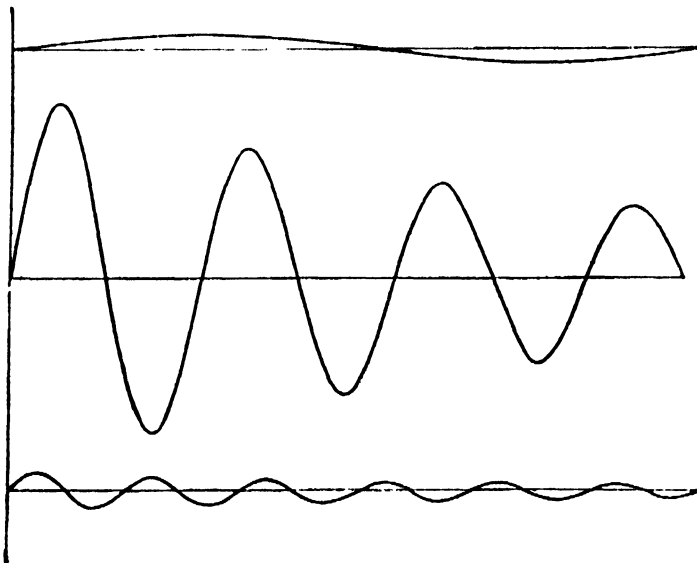

FIG. 127.—Actual components of figure 121.

amplitude of each component we have 91.4, 3.6, 7.6, 2.1, and 3.2 as the set of amplitudes.

Two modifications suggest themselves. As indicated by figure 76, the harmonic elements that are produced by an inharmonic fall off steadily according to a definite law. We can not attempt to apply the law here, but we see at once that the series of amplitudes fails to

fall from beyond 18.2 as it must do if only the inharmonic 3.69 is present; there must be another tone at or near the 6th harmonic with the amplitude 17.2 for the 6th partial. We can therefore treat 18.2 as a minimum and divide it in the ratio of its neighbors. We then have the component 6.3 with the wave-length 57.2mm. and the assumed amplitude 22.9mm. We also observe that the amplitude falls from 54.9 to 24.6,

but fails to continue the rapid fall for the first partial. We may suspect that the first partial is also present. We have no means of treating it as a minimum, but we can continue the fall proportionately from 54.9 to 24.6 and then to 11.0. We then assume a first component with the wave-length 360 and the amplitude  $18.4 - 11.0 = 7.4$ mm. The large component must now be recalculated. We have

$$\frac{(1 \times 11.0) + (2 \times 24.6) + (3 \times 54.9) + (4 \times 68.5) + (5 \times 14.1)}{11.0 + 24.6 + 54.9 + 68.5 + 14.1} = 3.39$$

with the wave-length 106.2mm. and the amplitude 91.4. The plot of inharmonics is given in figure 125.

We are now in position to discuss the accuracy of the results. The curve in figure 121 was obtained by adding the three curves

$$y' = 10.e^{-0.003t}.\sin\frac{2\pi}{360}t, \quad y'' = 100.e^{-0.003t}.\sin\frac{2\pi}{100}t, \quad y''' = 10.e^{-0.003t}.\sin\frac{2\pi}{60}t.$$

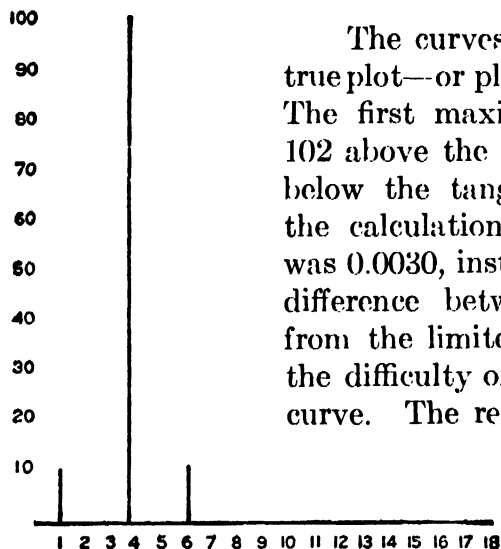

FIG. 128.—Plot of actual components of figure 121.

The curves themselves are given in figure 127; the true plot—or plot of components—is given in figure 128. The first maximum of the compound curves lay at 102 above the axis; the true axis is therefore at 102 below the tangential line and not 100, as found by the calculation on p. 141. The coefficient of friction was 0.0030, instead of 0.0028, as found on p. 141. The difference between these two values does not arise from the limited number of decimal places, but from the difficulty of obtaining the necessary data from the curve. The results of the various methods of analysis are given in the “comparative table of results.” It is at once evident that the only method that approaches the truth is the frictional analysis with the subsequent deduction of the inharmonics.

Purely as a matter of curve analysis, without any consideration of the processes in the vocal organs, we are forced to conclude that the simple harmonic analysis—into harmonics or inharmonics—does not give even an inkling of the true composition of such a curve as that in figure 121. As explained above (p. 77) the curve in figure 121 may be represented by the results of the simple harmonic analysis, but that may just as truly be done by any other analysis. A mere representation of the curve, how-

ever, is of no use to us; we must know how it was actually produced. Now we know that all speech curves are frictional ones; we have seen here and before that a simple harmonic analysis of such curves gives results that are utterly different from the truth. We are forced to the conclusion that this kind of analysis—into harmonics or inharmonics—is not merely inapplicable, but also distinctly misleading. It must cause some regret to find this conclusion forced upon us. The various investigators of speech curves in Germany, France, and America have, without hesitation or critique, always applied the simple harmonic analysis to vocal curves, and, as explained above, have assumed a totally false theory of vocal action on its suggestion. In fact, this theory—the overtone theory—must be

COMPARATIVE TABLE OF RESULTS OF ANALYSIS OF FIGURE 121.

Actual Composition.		Results of Analysis.							
		Simple Harmonics.		Simple Inharmonics.		Frictional Harmonics.		Frictional Inharmonics.	
$\lambda$	$c$	$\lambda$	$c$	$\lambda$	$c$	$\lambda$	$c$	$\lambda$	$c$
360	10	360	15	.....	.....	360	18	360	10
.....	.....	180	16	.....	.....	180	25	.....	.....
.....	.....	120	37	.....	.....	120	54	.....	.....
100	100	90	44	100	59	90	69	106	91
.....	.....	72	12	.....	.....	72	18	.....	.....
60	10	60	11	.....	.....	60	17	57	23
.....	.....	51	5	.....	.....	51	6	.....	.....
.....	.....	45	3	.....	.....	45	2	.....	.....
.....	.....	40	2	.....	.....	40	2	.....	.....
.....	.....	36	3	.....	.....	36	3	35	3
.....	.....	33	2	32	3	33	3	.....	.....
.....	.....	30	1	.....	.....	30	3	.....	.....
.....	.....	28	1	.....	.....	28	6	28	6
.....	.....	26	1	.....	.....	26	0	.....	.....
.....	.....	24	1	.....	.....	24	1	.....	.....
.....	.....	22	2	23	2	22	2	23	1
.....	.....	21	1	.....	.....	21	1	.....	.....
.....	.....	20	0	.....	.....	20	2	20	2

assumed in order to justify the analysis. For two years of the writer's own work he employed the simple harmonic analysis with subsequent calculation of the inharmonics, expecting that the discrepancies and inconsistencies that appeared in the results would disappear as more material was accumulated. This did not occur. It was found that the results for the same vowel under similar conditions differed often more than the results for utterly different vowels. The untrustworthiness of the methods did not become apparent until plotted artificial curves were computed, whereby the results could be compared with the truth—a method of procedure that every investigator ought to have used and still ought to use parallel with his work on speech curves. The self-evident fact that all vocal vibrations must have high coefficients of friction—

which ought to have been considered by investigators many decades ago—led to a hunt for a method of introducing it into the analysis. Only a method in which one factor of friction is used was developed; the method of approximating the value of this factor is, moreover, rather crude. As shown in Chapter VIII, provision should be made for at least two factors, one to represent the suddenness (p. 121) of the puff from the glottis and the other to represent the average friction in the vocal cavities. Even in its present condition, however, the method gives fair approximations to the truth instead of the absolutely false results given by the other methods.

We will now analyze an actual vowel curve; the task is a more difficult one because the real composition is unknown, and there is no test of the accuracy of the results. Figure 129 gives a piece of curve from the middle of the vowel [o] in "fourteenth" of the Mitchell vowel record.



FIG. 129.—Waves from [o] of "fourteenth."

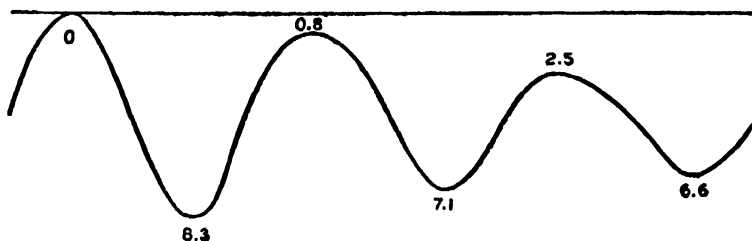

FIG. 130.—Group of waves from figure 129.

In the first place it is evident that the curve consists of a series of waves (or wave-groups, p. 40), each of which comprises three vibrations of different heights. The object of the analysis is to find how such a group was produced. We might begin the analysis at any point—as most investigators have done—and include one group of three vibrations. Such a procedure would be justified by the overtone theory of the vowels, according to which it would be indifferent where the beginning of a wave is placed. Quite aside from the manifest incorrectness of this theory, it is sufficient to find by trial that the results of the analysis of speech curves (not musical curves) differ radically with any change in the point of beginning. We must therefore determine how the vibrations are arranged within a group, whether a large one is followed by two smaller ones, or is preceded by them, or lies between them. According to the theory maintained in Chapter VIII, a vowel consists of a puff from the glottis which sets the air in the vocal cavities in vibration; the cavity vibrations thus occur in

groups, the first being largest and the others decreasing steadily owing to the friction. A single wave in this case therefore consists of a large vibration followed by two smaller ones. Of several such groups in the figure we will select the one reproduced on a large scale in figure 130.

The next step is to find the axis of the curve. This is not difficult in the present case, because the successive large vibrations that begin each wave are of the same height. A tangential line is drawn along the tops of the two large vibrations that bound the wave to be studied. The distances of the maxima and minima from this line are now to be measured. For this purpose let us use the coordinate measurer (p. 57). The mount is fastened to a board. The coordinate measurer is brought over it; its axis is made parallel to the tangential line, and the apparatus is also fastened to the board. The distances of the successive maxima and minima from the tangential line are found to be 0, 8.3, 0.8, 7.1, 2.5, 6.6mm. The wave represents a vibration which starts strong and gradually dies away. Although the successive maxima and minima in this wave are not at exactly

THIRTY-SIX ORDINATES FROM FIGURE 130, MULTIPLIED BY THE COSINES.

$t$	1.000	0.985	0.940	0.866	0.766	0.643	0.500	0.342	0.174	0
0	0	0	0	0	0	0	0	0	0	0
1	+2.20	+2.17	+2.07	+1.91	+1.69	+1.41	+1.10	+0.75	+0.38	0
2	+3.70	+3.64	+3.48	+3.20	+2.83	+2.38	+1.85	+1.27	+0.64	0
3	+4.20	+4.14	+3.95	+3.64	+3.22	+2.70	+2.10	+1.41	+0.73	0
4	+3.20	+3.15	+3.01	+2.77	+2.45	+2.06	+1.60	+1.09	+0.56	0
5	+1.80	+1.77	+1.69	+1.56	+1.38	+1.16	+0.90	+0.62	+0.31	0
6	-0.30	-0.30	-0.28	-0.26	-0.23	-0.19	-0.15	-0.10	-0.05	0
7	-2.10	-2.07	-1.97	-1.82	-1.61	-1.35	-1.05	-0.72	-0.36	0
8	-3.70	-3.64	-3.48	-3.20	-2.83	-2.38	-1.85	-1.27	-0.64	0
9	-4.10	-4.04	-3.85	-3.55	-3.14	-2.64	-2.05	-1.40	-0.71	0
10	-3.40	-3.35	-3.19	-2.94	-2.60	-2.19	-1.70	-1.16	-0.59	0
11	-1.40	-1.38	-1.32	-1.21	-1.07	-0.90	-0.70	-0.48	-0.24	0
12	+0.90	+0.89	+0.85	+0.78	+0.69	+0.58	+0.45	+0.31	+0.16	0
13	+2.20	+2.17	+2.07	+1.91	+1.69	+1.41	+1.10	+0.75	+0.38	0
14	+3.20	+3.15	+3.01	+2.77	+2.45	+2.06	+1.60	+1.09	+0.56	0
15	+3.20	+3.15	+3.01	+2.77	+2.45	+2.06	+1.60	+1.09	+0.56	0
16	+2.80	+2.76	+2.63	+2.42	+2.14	+1.80	+1.40	+0.96	+0.49	0
17	+2.00	+1.97	+1.88	+1.73	+1.53	+1.29	+1.00	+0.68	+0.35	0
18	+0.60	+0.59	+0.56	+0.52	+0.46	+0.39	+0.30	+0.21	+0.10	0
19	-0.80	-0.79	-0.75	-0.69	-0.61	-0.51	-0.40	-0.27	-0.14	0
20	-2.20	-2.17	-2.07	-1.91	-1.69	-1.41	-1.10	-0.75	-0.38	0
21	-2.90	-2.86	-2.73	-2.51	-2.22	-1.86	-1.45	-0.99	-0.50	0
22	-2.70	-2.66	-2.54	-2.34	-2.07	-1.74	-1.35	-0.92	-0.47	0
23	-1.70	-1.67	-1.60	-1.47	-1.30	-1.09	-0.85	-0.58	-0.30	0
24	-0.20	-0.20	-0.19	-0.17	-0.15	-0.13	-0.10	-0.07	-0.03	0
25	+1.00	+0.98	+0.94	+0.87	+0.77	+0.64	+0.50	+0.34	+0.17	0
26	+1.60	+1.58	+1.50	+1.39	+1.23	+1.03	+0.80	+0.55	+0.28	0
27	+1.60	+1.58	+1.50	+1.39	+1.23	+1.03	+0.80	+0.55	+0.28	0
28	+1.30	+1.28	+1.22	+1.13	+1.00	+0.84	+0.65	+0.44	+0.23	0
29	+0.70	+0.69	+0.66	+0.61	+0.54	+0.45	+0.35	+0.24	+0.12	0
30	0	0	0	0	0	0	0	0	0	0
31	-0.90	-0.89	-0.85	-0.78	-0.69	-0.58	-0.45	-0.31	-0.16	0
32	-1.80	-1.77	-1.69	-1.56	-1.38	-1.16	-0.90	-0.62	-0.31	0
33	-2.40	-2.36	-2.26	-2.08	-1.84	-1.54	-1.20	-0.82	-0.42	0
34	-2.30	-2.27	-2.16	-1.99	-1.76	-1.48	-1.15	-0.79	-0.40	0
35	-1.60	-1.58	-1.50	-1.39	-1.23	-1.03	-0.80	-0.55	-0.28	0

the same distance apart (the horizontal distances being 4.7, 4.6, 4.9, 4.4, 5.3, 4.1), we can perhaps neglect the small divergence and apply the rule given on page 137, finding that the axis lies at 4.2mm. below the tangential line. The axis need not be drawn; it is sufficient to make all measurements from the tangential line and subtract 4.2mm.

To analyze the curve a number of ordinates must be measured. The decision concerning the number should be intelligently made. With 12 ordinates only 6 partials are obtained, with 24 only 12, with 36 only 18, etc. The choice of the number of ordinates is determined by the number of partials which it is desired to obtain, or which the curve is accurate enough to justify. The evident smoothness of the curve indicates that if very high partials are present they must be of such small amplitude that they can hardly be detected. We will therefore not undertake the very great labor (at least two days of work) involved in using 72 ordinates, but will confine ourselves to 36. We shall then obtain the first 18 partials.

The third step is to measure the length of the wave. The ocular scale is moved till its vertical line is cut by the curve at 4.2; the reading of the horizontal micrometer screw is noted. The vertical line is then made to traverse the whole length of the wave until the curve again for the last time cuts it at 4.2. The length of the wave in this case was found to be 28.4mm. Since the time equation for this record is 1mm. = 0.0002s., the period of the wave is 0.00568s., and its frequency 176.1.

Since the length of the wave is 28.4mm., the 36 equidistant ordinates must be at 0.79mm. apart. We place the vertical line of the scale at the beginning of the wave and note the reading. The horizontal micrometer screw is then moved 0.79mm. and the reading is again taken, etc. In this way the 36 readings are obtained from which the ordinates are obtained by subtracting the reading of the axis, namely, 4.2. The ordinates in the present case are 0, 2.2, 3.7, 4.2, 3.2, 1.8, -0.3, -2.1, -3.7, -4.1, -3.4, -1.4, 0.9, 2.2, 3.2, 3.2, 2.8, 2.0, 0.6, -0.8, -2.2, -2.9, -2.7, -1.7, -0.2, 1.0, 1.6, 1.6, 1.3, 0.7, 0.0, -0.9, -1.8, -2.4, -2.3, -1.6mm. Adding these ordinates and dividing by 36 we obtain  $\frac{0.70}{36} = 0.02$ , that is, the axis

of the curve practically coincides with the axis found by using the maxima and minima; it lies, namely, at 4.2mm. below the tangential line. To detect mistakes in measurement the 36 values are plotted on millimeter paper; the resulting curve is found to agree with the original.

To perform a simple harmonic analysis the 36 values are written in the first column of the analysis sheet and are then multiplied by the cosines (p. 90). This gives the table found on page 148. It is convenient to write + values in black and - values in red.

Applying the 36 patterns we obtain the following table of results. In this table  $\tau$  gives the period of the harmonic,  $\mu$  its frequency,  $\lambda$  its wavelength,  $a$  and  $b$  the sine and cosine elements,  $c$  the amplitude,  $q$  the phase,  $r^s$  and  $r^{mm}$  the phase distances in seconds and millimeters (p. 139).

TABLE OF RESULTS OF SIMPLE HARMONIC ANALYSIS OF FIGURE 130.

	$\tau$	$\mu$	$\lambda$	$a$	$b$	$c$	$q$	$r^s$	$r^{mm}$
1	0.00568	176	28.4	+0.05	+0.20	0.21	346	0.00546	27.3
2	284	352	14.2	+0.70	-0.12	0.71	260	205	10.3
3	189	528	9.5	+0.04	+3.17	3.07	0	95	0
4	142	704	7.1	-0.45	+0.21	0.50	65	26	1.3
5	114	881	5.7	-0.30	+0.09	0.30	73	23	1.2
6	95	1057	4.7	+0.13	+0.18	0.22	324	88	4.3
7	81	1233	4.1	-0.08	+0.05	0.09	58	13	0.7
8	71	1409	3.5	-0.07	-0.02	0.07	106	21	1.0
9	65	1585	3.2	+0.01	0	0.01	359	65	3.2
10	57	1761	2.8	-0.02	+0.01	0.02	1	1	0
11	56	1937	2.6	-0.03	0	0.03	2	3	0
12	47	2113	2.4	0	0	0	0	0	0
13	44	2289	2.2	+0.02	+0.02	0.02	181	22	1.1
14	41	2465	2.0	-0.03	0	0.03	2	2	0
15	37	2642	1.9	+0.04	0	0.04	358	37	1.3
16	36	2816	1.8	-0.01	+0.04	0.04	2	2	0.1
17	33	2994	1.7	-0.02	+0.02	0.02	1	1	0
18	32	3170	1.6	-0.02	0	0.02	1	1	0

The harmonic plot is given in figure 131. The first six of the series of harmonics into which the wave has been analyzed is given in figure 132.

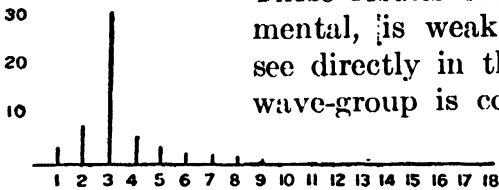

FIG. 131.—Simple harmonic plot to figure 130.

These results indicate that the first partial, or fundamental, is weak or practically lacking. The eye can see directly in the curve itself (figure 129) that each wave-group is composed mainly of a strong vibration with a period one-third of that of the group, and that a vibration of the whole period is lacking. Yet

the one thing that is heard above all others is the vibration from the glottis, namely, the note on which the vowel is spoken; this tone has the period of the fundamental. The second partial is indicated as present. The third partial is, as the curve itself makes evident, very prominent. The partials above the sixth are practically lacking.

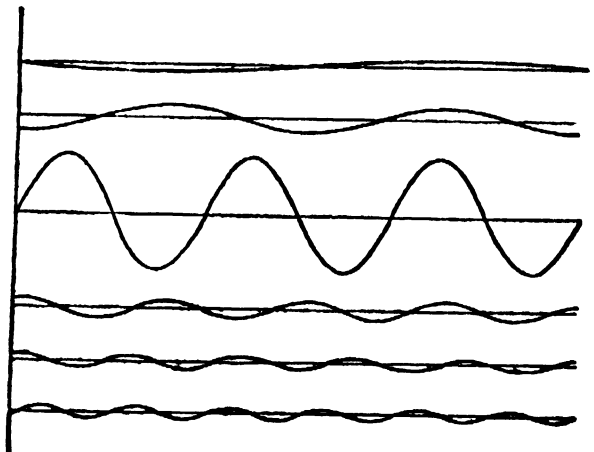

FIG. 132.—Component curves of figure 130 according to simple harmonic analysis.

What do these results mean? In the first place they mean that the curve in figure

130 can be mathematically analyzed into the series of simple sinusoids whose amplitudes and phases are given in the table and in figures 131 and 132. The original curve can be produced by calculating the ordinates from the table or by adding the ordinates of the components in figure 132. In itself the analysis means nothing more than this; it is a purely formal procedure devoid of physical or physiological meaning.

A physical interpretation can be given to the results by accepting the fact that the sound which gave the original wave can be closely imitated by adding sounds which would separately give the waves in figure 132, the phases being properly adjusted. We might presumably reproduce the original sound by maintaining a set of tuning-forks in vibration with the periods, amplitudes, and phases indicated by the curves in figure 132.

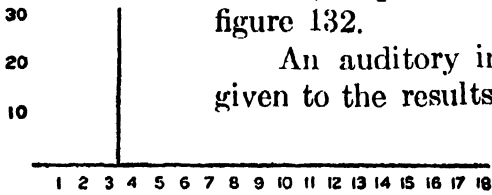

FIG. 133.—Plot of inharmonic component to figure 130.

An auditory interpretation is often supposed to be given to the results if we accept the Helmholtz theory of hearing (p. 125), according to which the ear physically analyzes a vibration into its harmonic components, just as we have here analyzed it mathematically, but the supposition

rests on a misunderstanding (p. 126).

A vowel interpretation must be given if we accept the overtone theory of the voice, according to which the vocal cavities reinforce overtones of the tone from the glottis (p. 109). The vocal cavities then vibrate with the relations of amplitude in column *c*. This theory we have been forced to reject (Chapter VIII).

If we take into consideration that the vocal tones may just as well be inharmonic to the fundamental, we have the problem of calculating the inharmonics from the set of harmonic results. Proceeding on the principle (p. 81) that there are as many components present as there are apexes in the harmonic plot, we have to calculate the inharmonic that lies around 3; the results for the higher harmonics are so small as to be practically 0. Taking the weighted mean for the first 8 results we have

$$\frac{(1 \times 0.21) + (2 \times 0.71) + (3 \times 3.07) + (4 \times 0.50) + (5 \times 0.30) + (6 \times 0.22) + (7 \times 0.09) + (8 \times 0.07)}{0.21 + 0.71 + 3.07 + 0.50 + 0.30 + 0.22 + 0.09 + 0.07} = 3.21$$

as the ordinal number of the inharmonic. The characteristic of the wave is thus a tone that has a frequency of 3.21 times the fundamental, or 565.3. The amplitude of this harmonic we can approximate (p. 81) by taking the largest amplitude of the group; we obtain 3.07. The composition of the vowel wave is thus given by the plot in figure 133 and the curve in figure 134.

The two presentations of results are directly opposed to each other; according to one the vowel wave, figure 130, is composed of a set of harmonics (figure 132); according to the other it is composed of the single inharmonic (figure 134).

Both presentations fail in two respects. In the first place no account is taken of the friction, which is known to be present in vowel vibrations, and which is so evident in the curve itself. The first example in this chapter and the simpler cases discussed above (p. 102) have shown that the neglect of friction produces erroneous results. In the second place we know (p. 109) that the strongest tone of the vowel is always the glottal tone, or the fundamental. In the wave just analyzed the harmonic interpretation represents it as very weak, and the inharmonic one represents it as entirely lacking. We will first consider the method of analysis that

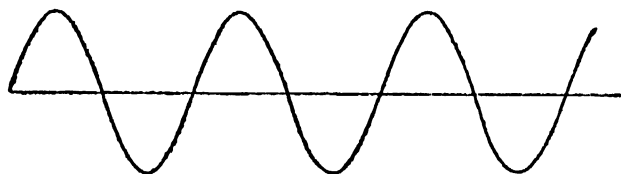

FIG. 134. Component curve of figure 130 according to figure 133.

takes account of the friction, and will then discuss the problem of the fundamental.

For an analysis into frictional sinusoids the factor of friction must be found. Using the maxima and minima we perform the adjacent calculation.

The first column contains the maxima and minima, the second column gives the differences between the successive ones. To find the natural logarithms each of these values must be multiplied by such a power of 10 that the result falls between 0 and 1000, in this case by 100. The natural logarithm is then taken from a table (*e. g.*, Ligowski, Taschenbuch der Mathematik). Since we can use only an even number of values for this computation, we must omit one of the five of the list. Omitting the last one, we have  $n=4$ , and (since  $\log_e s_1 - \log_e s_n = \log_e 100s_1 - \log_e 100s_n$ )

Observed values.	Values of $s$ .	100s	$\log_e 100s$
0			
8.3	8.3	830	6.7214
0.8	7.5	750	6.6201
7.1	6.3	630	6.4457
2.5	4.6	460	6.1312
6.6	4.1	410	6.0162

$$d=6 \frac{3(6.7214 - 6.1312) + (6.6201 - 6.4457)}{4 \times 15} = 0.19450.$$

Omitting each of the values in succession and computing the factor of friction from the four others, we obtain the five values: 0.19450, 0.22900, 0.26045, 0.24301, 0.21262, of which we take the average 0.22792 as the value for  $d$ .

Although the three vibrations used for this calculation have not exactly the same length, we can for the present purpose use one-third of their combined length, namely, one-third of 28.4 for the calculation of  $\epsilon$ . We have then

$$\epsilon = \frac{2d}{T} = \frac{0.45584}{9.5} = 0.0480.$$

The calculation being made on the assumption that for this purpose the wave can be considered as a single frictional sinusoid (p. 141), the quotients of the successive differences between the maxima and minima must be approximately constant. The differences for the wave in figure 130 are 8.3, 7.1, 6.3, 4.6, 4.1, and the quotients are 1.17, 1.13, 1.37, 1.12 respectively. The variation is great, but in the present case we have the means of getting a more general average for the factor of friction. The successive maxima and minima for the four wave-groups of the original curve of figure 129 are 8.3, 1.1, 6.0, 2.3, 6.3, 9.0, 1.2, 6.8, 2.3, 6.1, 8.3, 2.0, 6.5, 1.7, 6.3, 8.3, 0.8, 7.1, 2.5, 6.6. The ratios of successive differences vary around 1.20 irregularly; we therefore assume that the variations in a single set can be eliminated by taking the averages. The averages for the four sets of differences are 8.5, 7.2, 5.3, 4.4, 4.1, and the ratios are 1.18, 1.36, 1.20, 1.07. Calculating the factor of friction in the way just illustrated we obtain  $\epsilon=0.0492$ , a result so close to that for the original single wave that we retain the original calculation for the further computation.

TABLE SHOWING HOW THE FRICTIONAL MULTIPLICATION IS PERFORMED.

$t$	$\epsilon t \log e$	$e^{\epsilon t}$	$y$	$y.e^{\epsilon t}$	$t$	$\epsilon t \log e$	$e^{\epsilon t}$	$y$	$y.e^{\epsilon t}$
0	0	1.00	0	0	180	0.2970	1.98	+0.60	+1.19
10	0.0165	1.04	+2.20	+2.28	190	0.3135	2.06	-0.80	-1.65
20	0.0330	1.08	+3.70	+4.00	200	0.3300	2.14	-2.20	-4.71
30	0.0495	1.12	+4.20	+4.70	210	0.3465	2.22	-2.90	-6.44
40	0.0660	1.16	+3.20	+3.71	220	0.3630	2.31	-2.70	-6.24
50	0.0825	1.21	+1.80	+2.18	230	0.3795	2.40	-1.70	-4.08
60	0.0990	1.26	-0.30	-0.38	240	0.3960	2.49	-0.20	-0.50
70	0.1155	1.30	-2.10	-2.73	250	0.4125	2.59	+1.00	+2.59
80	0.1320	1.36	-3.70	-5.03	260	0.4290	2.69	+1.60	+4.30
90	0.1485	1.41	-4.10	-5.78	270	0.4455	2.79	+1.60	+4.46
100	0.1650	1.46	-3.40	-4.96	280	0.4620	2.90	+1.30	+3.77
110	0.1815	1.52	-1.40	-2.13	290	0.4785	3.01	+0.70	+2.11
120	0.1980	1.58	+0.90	+1.42	300	0.4950	3.13	0	0
130	0.2145	1.64	+2.20	+3.61	310	0.5115	3.25	-0.90	-2.93
140	0.2310	1.70	+3.20	+5.44	320	0.5280	3.37	-1.80	-6.07
150	0.2475	1.77	+3.20	+5.66	330	0.5445	3.50	-2.10	-8.40
160	0.2640	1.84	+2.80	+5.15	340	0.5610	3.61	-2.30	-8.37
170	0.2805	1.91	+2.00	+3.82	350	0.5775	3.78	-1.60	-6.05

Since each of the ordinates is to be multiplied by the corresponding value of  $e^{\epsilon t}$  (p. 142), we have to perform the calculation which is indicated in the adjacent table. We first obtain  $\epsilon \cdot \log e = 0.0480 \times 0.4343 = 0.0208$ .

This multiplied by  $t=0.79$  gives 0.0165. Since the successive values of  $t_0, t_{10}, t_{20}, \dots, t_{35}$ , namely, 0, 0.79, 1.58, . . . 27.65, are derived by multiplying 0.79 by 0, 1, 2, . . . 35, we obtain the first column

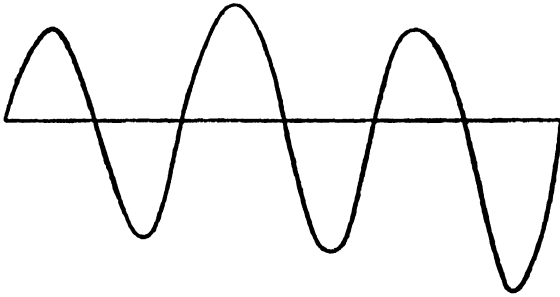

of the table by multiplying 0.0165 by these numbers. The numeri (from a table of logarithms) for this column give the values of  $e^u$  in the next one. The column  $y$  contains the original 36 ordinates. The last column is the product of the two preceding ones. This last column, when plotted, gives the curve of figure 130 with the friction eliminated (figure 135).

FIG. 135.—Curve of figure 130 with friction eliminated.

THIRTY-SIX ORDINATES OF FIGURE 130, MULTIPLIED BY THE FACTOR OF FRICTION AND THE COSINES.

$t$	1.000	0.985	0.940	0.866	0.766	0.643	0.500	0.342	0.174	0
0	0	0	0	0	0	0	0	0	0	0
1	+2.28	+2.25	+2.14	+1.97	+1.75	+1.47	+1.14	+0.78	+0.40	0
2	+4.00	+3.95	+3.76	+3.47	+3.07	+2.58	+2.01	+1.37	+0.70	0
3	+4.70	+4.63	+4.41	+4.07	+3.60	+3.02	+2.35	+1.61	+0.82	0
4	+3.71	+3.65	+3.48	+3.21	+2.84	+2.39	+1.86	+1.27	+0.65	0
5	+2.18	+2.15	+2.05	+1.89	+1.67	+1.40	+1.09	+0.75	+0.38	0
6	-0.38	-0.37	-0.36	-0.33	-0.29	-0.24	-0.19	-0.13	-0.06	0
7	-2.73	-2.69	-2.57	-2.36	-2.09	-1.76	-1.37	-0.93	-0.48	0
8	-5.03	-4.95	-4.73	-4.36	-3.86	-3.23	-2.52	-1.72	-0.88	0
9	-5.78	-5.69	-5.43	-5.01	-4.43	-3.72	-2.89	-1.98	-1.01	0
10	-4.96	-4.89	-4.60	-4.30	-3.80	-3.19	-2.48	-1.70	-0.86	0
11	-2.13	-2.10	-2.00	-1.84	-1.63	-1.37	-1.07	-0.73	-0.37	0
12	+1.42	+1.40	+1.33	+1.23	+1.09	+0.91	+0.71	+0.49	+0.25	0
13	+3.61	+3.56	+3.39	+3.13	+2.77	+2.32	+1.81	+1.23	+0.63	0
14	+5.44	+5.36	+5.11	+4.71	+4.17	+3.50	+2.72	+1.86	+0.95	0
15	+5.66	+5.58	+5.32	+4.90	+4.34	+3.64	+2.83	+1.94	+0.98	0
16	+5.15	+5.07	+4.84	+4.46	+3.94	+3.31	+2.58	+1.76	+0.90	0
17	+3.82	+3.76	+3.59	+3.31	+2.93	+2.46	+1.91	+1.31	+0.66	0
18	+1.19	+1.17	+1.12	+1.03	+0.91	+0.77	+0.60	+0.41	+0.21	0
19	-1.05	-1.03	-1.00	-0.93	-0.83	-0.71	-0.56	-0.36	-0.18	0
20	-4.71	-4.64	-4.43	-4.08	-3.61	-3.03	-2.36	-1.61	-0.82	0
21	-6.44	-6.34	-6.05	-5.58	-4.93	-4.14	-3.22	-2.20	-1.12	0
22	-6.24	-6.15	-5.87	-5.40	-4.78	-4.01	-3.12	-2.13	-1.09	0
23	-4.08	-4.02	-3.84	-3.40	-3.13	-2.62	-2.04	-1.40	-0.71	0
24	-0.50	-0.49	-0.47	-0.43	-0.38	-0.32	-0.25	-0.17	-0.09	0
25	+2.59	+2.55	+2.43	+2.24	+1.98	+1.67	+1.30	+0.89	+0.45	0
26	+4.30	+4.24	+4.04	+3.72	+3.29	+2.76	+2.15	+1.47	+0.75	0
27	+4.46	+4.39	+4.19	+3.86	+3.42	+2.87	+2.23	+1.53	+0.78	0
28	+3.77	+3.71	+3.54	+3.26	+2.89	+2.42	+1.89	+1.29	+0.66	0
29	+2.11	+2.08	+1.98	+1.83	+1.62	+1.36	+1.06	+0.72	+0.37	0
30	0	0	0	0	0	0	0	0	0	0
31	-2.93	-2.89	-2.75	-2.54	-2.24	-1.88	-1.47	-1.00	-0.51	0
32	-6.07	-5.98	-5.71	-5.26	-4.65	-3.90	-3.04	-2.08	-1.06	0
33	-8.40	-8.27	-7.90	-7.27	-6.43	-5.40	-4.20	-2.87	-1.46	0
34	-8.37	-8.24	-7.87	-7.25	-6.41	-5.38	-4.19	-2.86	-1.46	0
35	-6.05	-5.96	-5.69	-5.24	-4.63	-3.89	-3.03	-2.07	-1.05	0

The new ordinates are multiplied by the cosines as usual; the results are given in the table on p. 154.

The results of applying the schedules to the table are the values given as *a* and *b* in the table of results of frictional analysis. The values *a* and *b* are here the amplitudes of the cosine and sine series; the values of  $c = \sqrt{a^2 + b^2}$  are the amplitudes of the single sine series. In the same way as above (p. 139) *q* and *r* are computed. The plot of results is given in figure 136.

TABLE OF RESULTS OF FRICTIONAL ANALYSIS OF FIGURE 130.

Partial.	<i>a</i>	<i>b</i>	<i>c</i>	<i>q</i>	<i>r</i> <sup>s</sup>	<i>rmm</i>
1	-0.92	+0.59	1.09	57	0.00090	4.5
2	-0.22	-0.10	0.24	114	0.00090	4.5
3	-0.28	+6.11	6.12	3	0.00002	0.1
4	+0.11	+0.40	0.41	344	0.00136	6.8
5	-0.13	+0.23	0.26	30	0.00010	4.8
6	+1.14	+0.46	1.23	292	0.00077	3.8
7	+0.17	+0.10	0.20	275	0.00062	3.1
8	+0.09	0	0.09	270	0.00053	2.6
9	+0.15	+0.04	0.16	285	0.00051	2.5
10	+0.11	+0.04	0.12	290	0.00046	2.3
11	+0.08	+0.02	0.08	284	0.00044	2.1
12	+0.11	+0.01	0.11	275	0.00036	1.8
13	+0.13	+0.02	0.13	279	0.00034	1.7
14	+0.05	+0.01	0.05	281	0.00032	1.6
15	+0.15	0	0.15	270	0.00028	1.4
16	+0.32	+0.13	0.35	292	0.00029	1.5
17	-0.21	-0.02	0.21	95	0.00009	0.4
18	+0.08	0	0.08	270	0.00024	1.2

We now have to calculate the inharmonic components from the table of results. We find the ordinal numbers of the inharmonics for the curve without friction, figure 135, from the values in column *c*. The groups of ordinates are clearly marked off by minima at 0.24, 0.26, 0.09, 0.08, 0.05, and 0.08. Dividing each of these in the ratio of its neighbors we have for the highest component

$$\frac{(14 \times 0.03) + (15 \times 0.15) + (16 \times 0.35) + (17 \times 0.21) + (18 \times 0.08)}{0.03 + 0.05 + 0.35 + 0.21 + 0.08} = 16.2.$$

For the next highest component we have

$$\frac{(11 \times 0.04) + (12 \times 0.11) + (13 \times 0.13) + (14 \times 0.02)}{0.04 + 0.11 + 0.13 + 0.02} = 12.4.$$

Proceeding in this way we get the entire series of components above the fundamental: 3.0, 5.3, 9.5, 12.4, 16.2. The fundamental we know to be always present; it must therefore be added to the set. As approxi-

mations to the amplitudes we take the highest ordinate for the 1st, 2d, and 6th component, and  $\frac{4}{3}$  of it for the others. We thus obtain the final results (figure 137):

Component . . . . .	I.	II.	III.	IV.	V.	VI.
Ratio . . . . .	1	3.0	5.3	9.5	12.4	16.2
Frequency . . . . .	176	528	933	1,672	2,182	2,851
Amplitude . . . . .	1.09	6.12	1.64	0.24	0.17	0.35

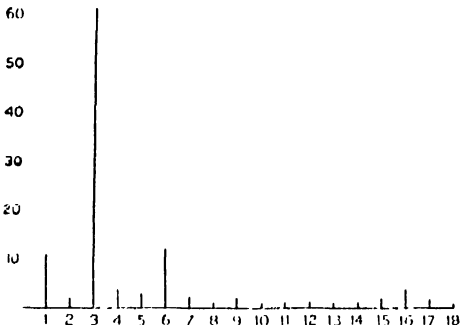

FIG. 136.—Frictional harmonic plot to figure 130.

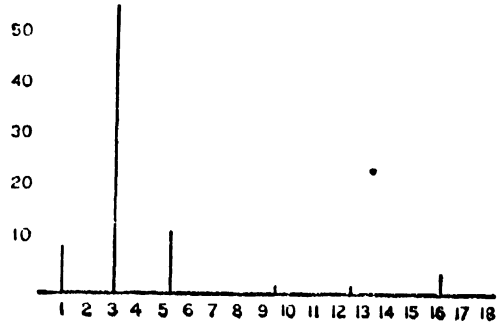

FIG. 137.—Plot of inharmonic components from figure 136.

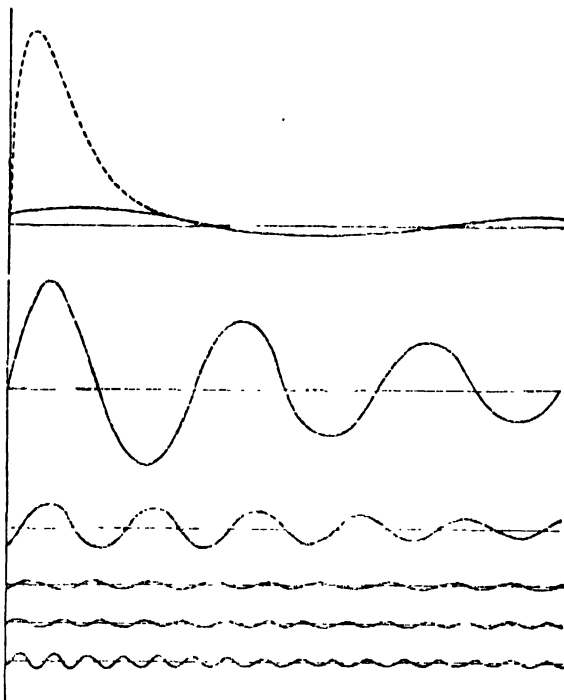

FIG. 138.—Component curves of figure 130.

The curves of the components are given in figure 138.

In spite of the amplitude given to the fundamental, it is evident that this tone should be much more strongly represented, for the reason so often repeated that this tone is heard to be the strongest of all and that the series of puffs from the glottis is the most energetic part of the vocal action. The glottal puffs may—as in this case—have a great degree of suddenness (p. 116). The suddenness will show itself in the curve in the same way as friction. We would be quite justified not simply in exaggerating

the component found for the fundamental but also in changing its form. This is indicated by the dotted line in figure 138.

COMPARATIVE TABLE OF RESULTS OF ANALYSIS OF FIGURE 130.

Simple Harmonics.			Simple Inharmonics.			Frictional Harmonics.			Frictional Inharmonics.		
Ratio.	$\mu$	$c$	Ratio.	$\mu$	$c$	Ratio.	$\mu$	$f$	Ratio.	$\mu$	$f$
1	176	0.21	3.2	565	4.08	1	176	0.77	1	176	1.03
2	352	0.71	....	....	....	2	352	0.20	3.0	528	7.28
3	528	3.07	....	....	....	3	528	5.46	5.3	933	1.55
4	704	0.50	....	....	....	4	704	0.38	9.5	1672	0.20
5	881	0.30	....	....	....	5	881	0.24	12.4	2182	0.16
6	1056	0.22	....	....	....	6	1056	1.16	16.2	2851	0.45
....	....	....	....	....	....	7	1232	0.19	....	....	....
....	....	....	....	....	....	8	1408	0.09	....	....	....
....	....	....	....	....	....	9	1584	0.15	....	....	....
....	....	....	....	....	....	10	1760	0.12	....	....	....
....	....	....	....	....	....	11	1936	0.08	....	....	....
....	....	....	....	....	....	12	2112	0.11	....	....	....
....	....	....	....	....	....	13	2289	0.12	....	....	....
....	....	....	....	....	....	14	2464	0.05	....	....	....
....	....	....	....	....	....	15	2640	0.15	....	....	....
....	....	....	....	....	....	16	2816	0.34	....	....	....
....	....	....	....	....	....	17	2992	0.21	....	....	....
....	....	....	....	....	....	18	3168	0.08	....	....	....

The above table gives the results of the different analyses.

It is evident that the complete analysis of a vowel wave is not a light undertaking. We can not escape from it, if the work is to have scientific value; any defect or laxity in the method is liable to lead to confusion and error. On the other hand a single trustworthy analysis is an achievement; it gives a new result which can be used as the basis for investigations. In this way it furnishes something that can never be obtained by mere observation with the ear. When many such analyses have been accumulated, we can hope for correct views of the physical and physiological nature of the vowels and reliable data concerning the vowels of a language; we can ultimately expect in this way to have accurate knowledge with which to replace the vagueness and error prevalent at the present day.



# SCHEDULES.

## SCHEDULES FOR 12 ORDINATES.

MULTIPLIERS:

1, 0.86603, 0.50000, 0.

$a_1$

0	+		
1	+		
2		+	
3			-
4			
5	-		
6	-		
7			
8			
9			+
10		+	
11	+		

$a_2$

0	+		
1		+	
2			-
3	-		
4			
5		+	
6	+		
7		+	
8			-
9	-		
10			-
11		+	

$a_3$

0	+		
1			-
2			
3			+
4	+		
5			-
6	-		
7			+
8	+		
9			-
10	-		
11			+

$a_4$

0	+		
1			-
2			
3	+		
4			-
5			
6	+		
7			-
8			
9	+		
10			-
11			

$a_5$

0	+		
1			-
2		+	
3			-
4			
5		+	
6	+		
7		+	
8			-
9			+
10			-
11		-	

$a_6$

0	+		
1			-
2	+		
3			
4	+		
5			-
6	+		
7			-
8	+		
9			-
10	+		
11			-

$b_1$

0			+
1		+	
2		+	
3	+		
4		+	
5		+	
6			-
7			-
8			
9			
10			-
11			-

$b_2$

0			+
1		+	
2		+	
3			-
4			
5			
6		+	
7	+		
8		+	
9			-
10			-
11			-

$b_3$

0			+
1	+		
2		-	
3			-
4			
5	+		
6			-
7			
8			+
9	+		
10			-
11			-

$b_4$

0			+
1		+	
2		-	
3			+
4		+	
5			
6			+
7		+	
8			
9			+
10		+	
11			-

$b_5$

0			+
1			+
2			-
3	+		
4			-
5		+	
6			-
7			
8		+	
9		-	
10		+	
11			-

$b_6$

0			+
1			+
2			+
3			+
4			+
5			+
6			+
7			+
8			+
9			+
10			+
11			+

SCHEDULES FOR 24 ORDINATES.

MULTIPLIERS:

1, 0.96593, 0.86603, 0.70711, 0.5000, 0.25882, 0.

$a_1$

0	+				
1		+			
2			+		
3				+	
4					+
5					
6					
7					
8					
9					
10					
11					
12					
13					
14					
15					
16					
17					
18					
19					
20					
21					
22					
23					

$a_2$

0	+				
1		+			
2			+		
3				+	
4					+
5					
6					
7					
8					
9					
10					
11					
12					
13					
14					
15					
16					
17					
18					
19					
20					
21					
22					
23					

$a_3$

0	+				
1		+			
2			+		
3				+	
4					+
5					
6					
7					
8					
9					
10					
11					
12					
13					
14					
15					
16					
17					
18					
19					
20					
21					
22					
23					

$a_4$

0	+				
1		+			
2			+		
3				+	
4					+
5					
6					
7					
8					
9					
10					
11					
12					
13					
14					
15					
16					
17					
18					
19					
20					
21					
22					
23					

$a_5$

0	+				
1		+			
2			+		
3				+	
4					+
5					
6					
7					
8					
9					
10					
11					
12					
13					
14					
15					
16					
17					
18					
19					
20					
21					
22					
23					

$a_6$

0	+				
1		+			
2			+		
3				+	
4					+
5					
6					
7					
8					
9					
10					
11					
12					
13					
14					
15					
16					
17					
18					
19					
20					
21					
22					
23					

$a_7$

0	+				
1		+			
2			+		
3				+	
4					+
5					
6					
7					
8					
9					
10					
11					
12					
13					
14					
15					
16					
17					
18					
19					
20					
21					
22					
23					

$a_8$

0	+				
1		+			
2			+		
3				+	
4					+
5					
6					
7					
8					
9					
10					
11					
12					
13					
14					
15					
16					
17					
18					
19					
20					
21					
22					
23					

$a_9$

0	+				
1		+			
2			+		
3				+	
4					+
5					
6					
7					
8					
9					
10					
11					
12					
13					
14					
15					
16					
17					
18					
19					
20					
21					
22					
23					

$a_{10}$

0	+				
1		+			
2			+		
3				+	
4					+
5					
6					
7					
8					
9					
10					
11					
12					
13					
14					
15					
16					
17					
18					
19					
20					
21					
22					
23					

$a_{11}$

0	+				
1		+			
2			+		
3				+	
4					+
5					
6					
7					
8					
9					
10					
11					
12					
13					
14					
15					
16					
17					
18					
19					
20					
21					
22					
23					

$a_{12}$

0	+				
1		+			
2			+		
3				+	
4					+
5					
6					
7					
8					
9					
10					
11					
12					
13					
14					
15					
16					
17					
18					
19					
20					
21					
22					
23					











SCHEDULES FOR 72 ORDINATES.

MULTIPLIERS:

1, 0.99619, 0.98481, 0.96593, 0.93969, 0.90631, 0.86603, 0.81915, 0.76604, 0.70711, 0.64279,  
0.57358, 0.50000, 0.42262, 0.34202, 0.25882, 0.17365, 0.08715, 0.

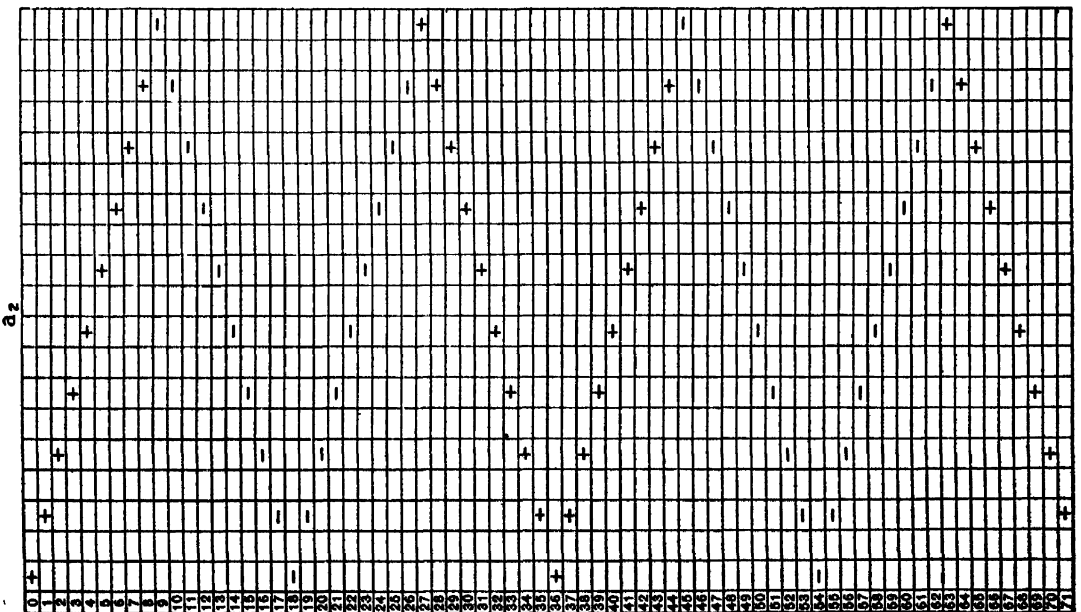
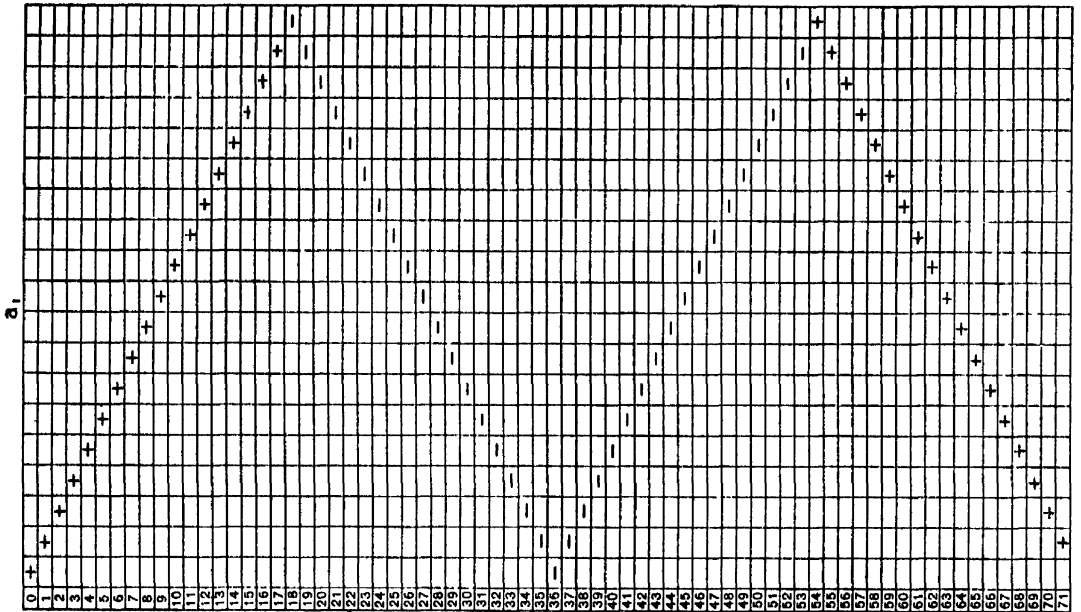



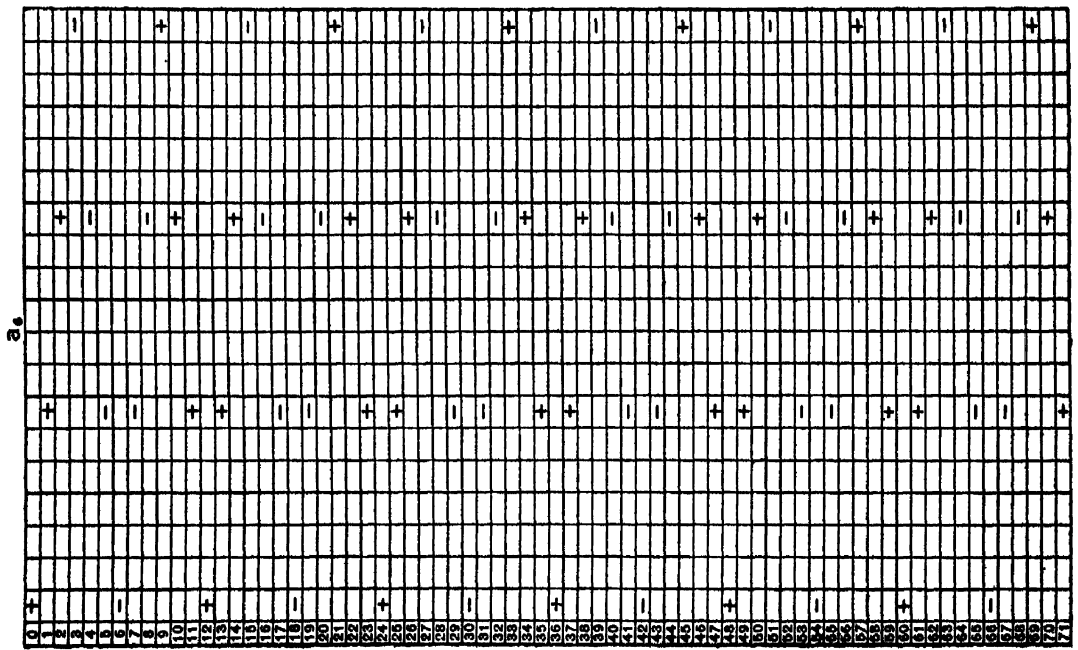
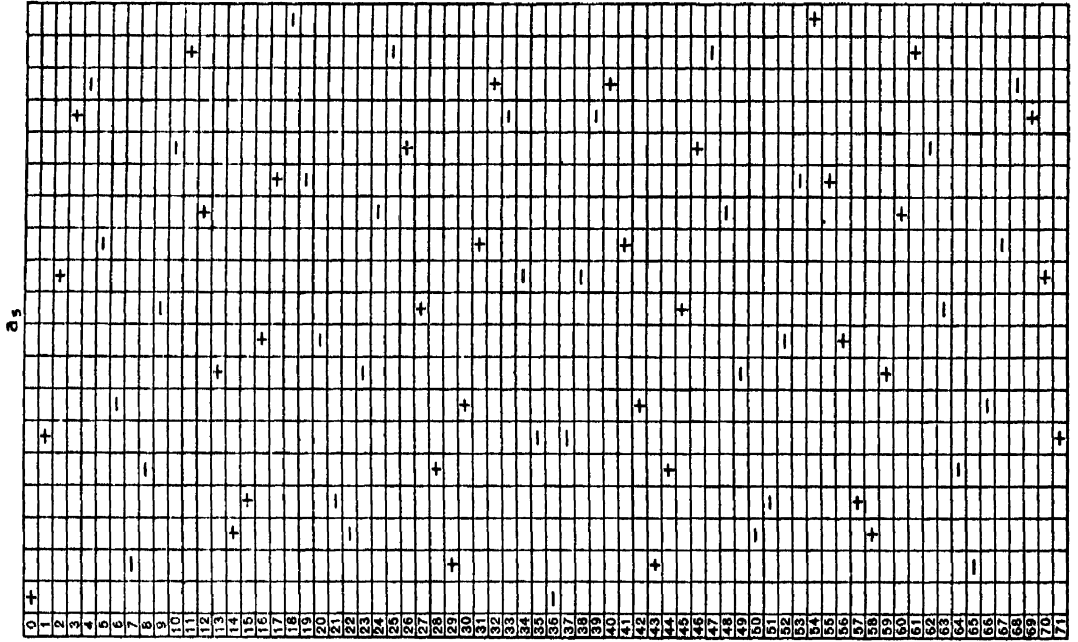







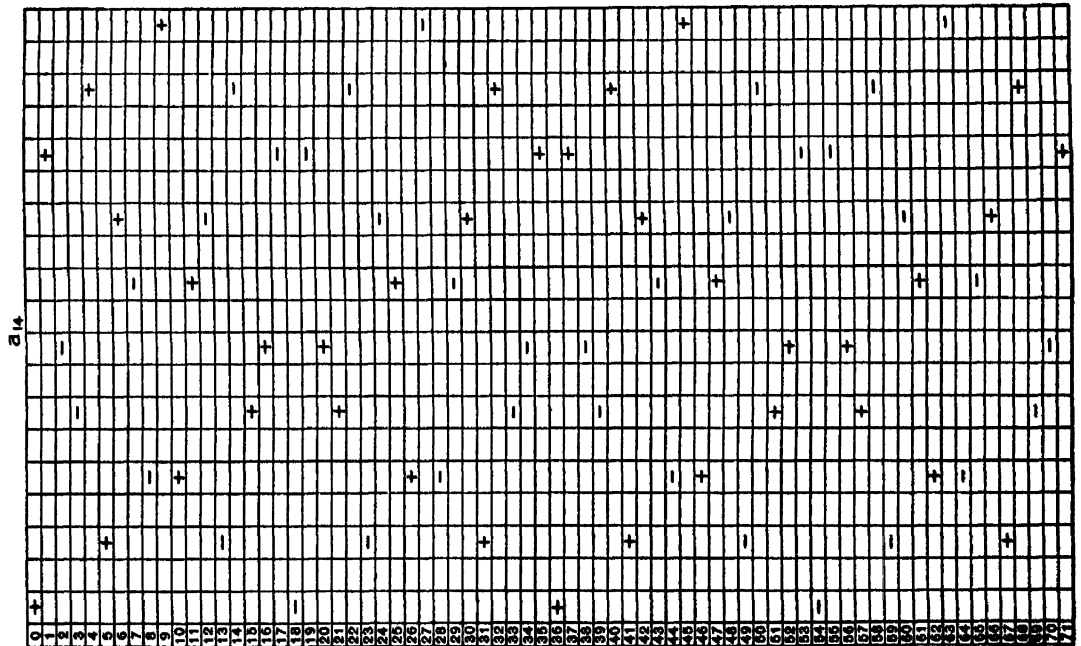
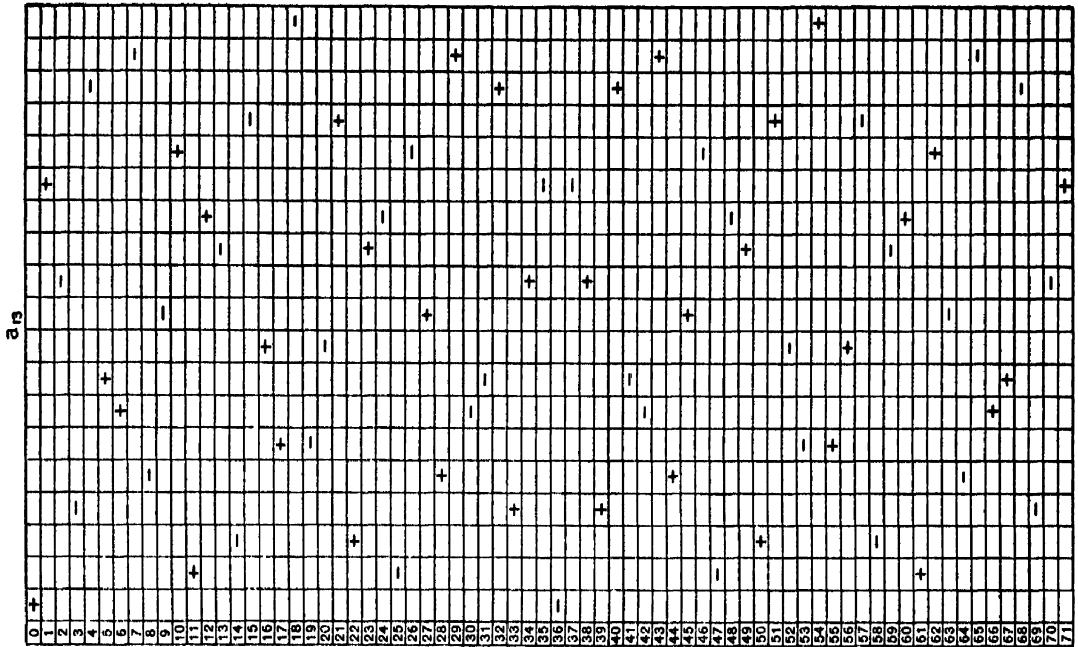















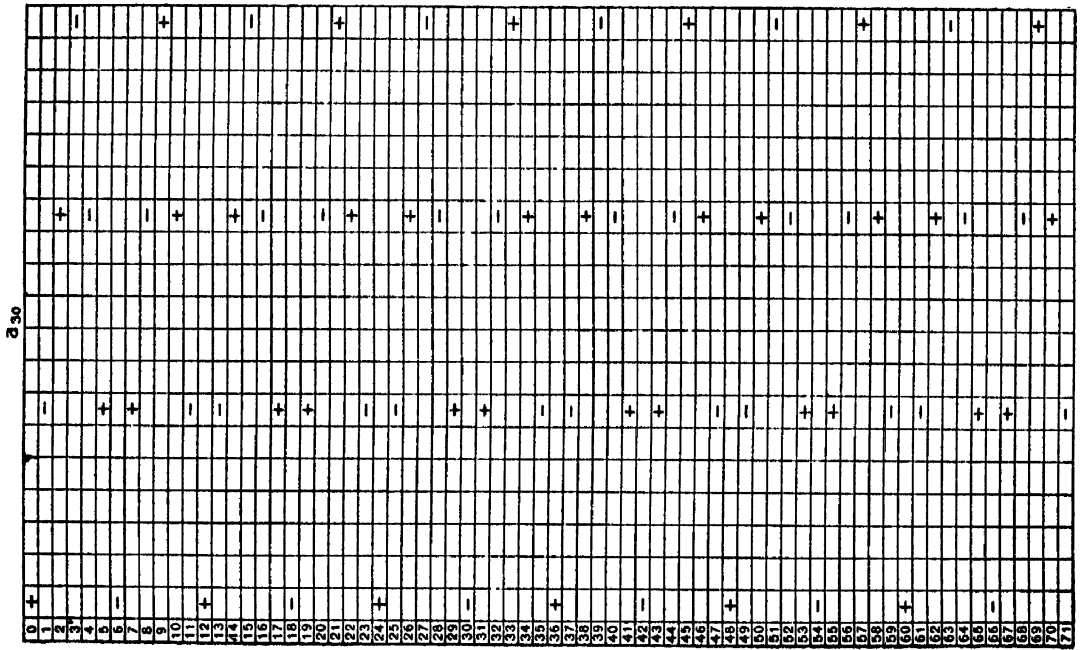
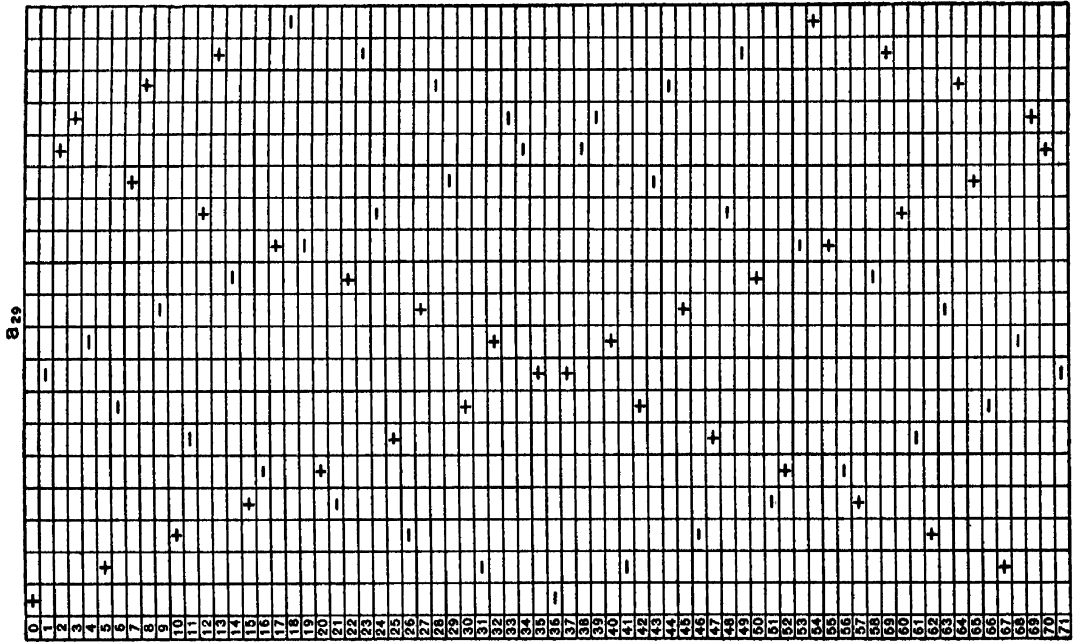



































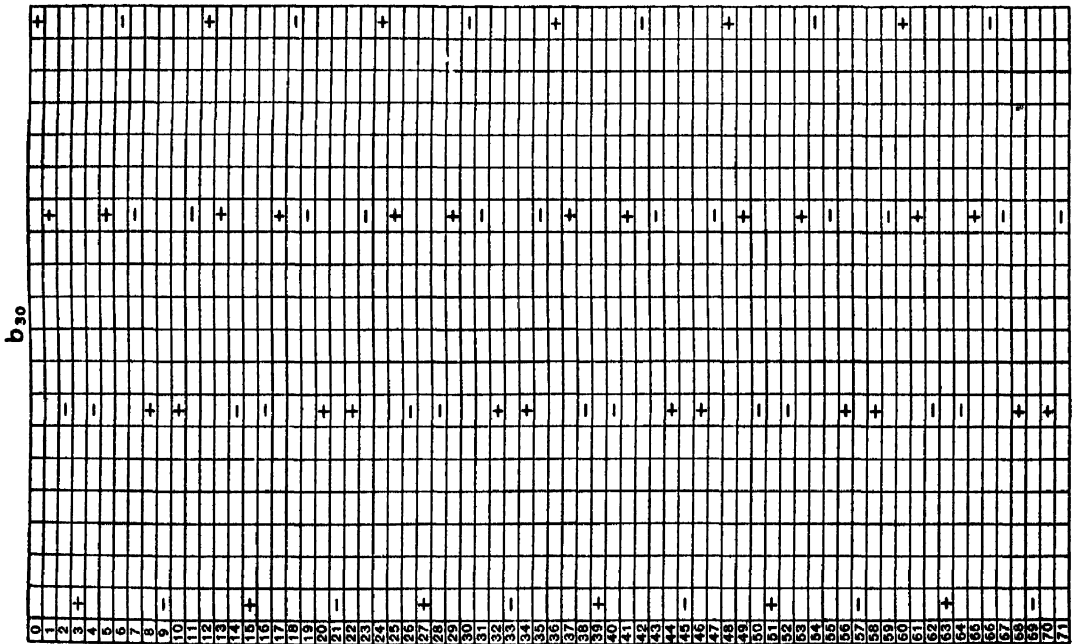
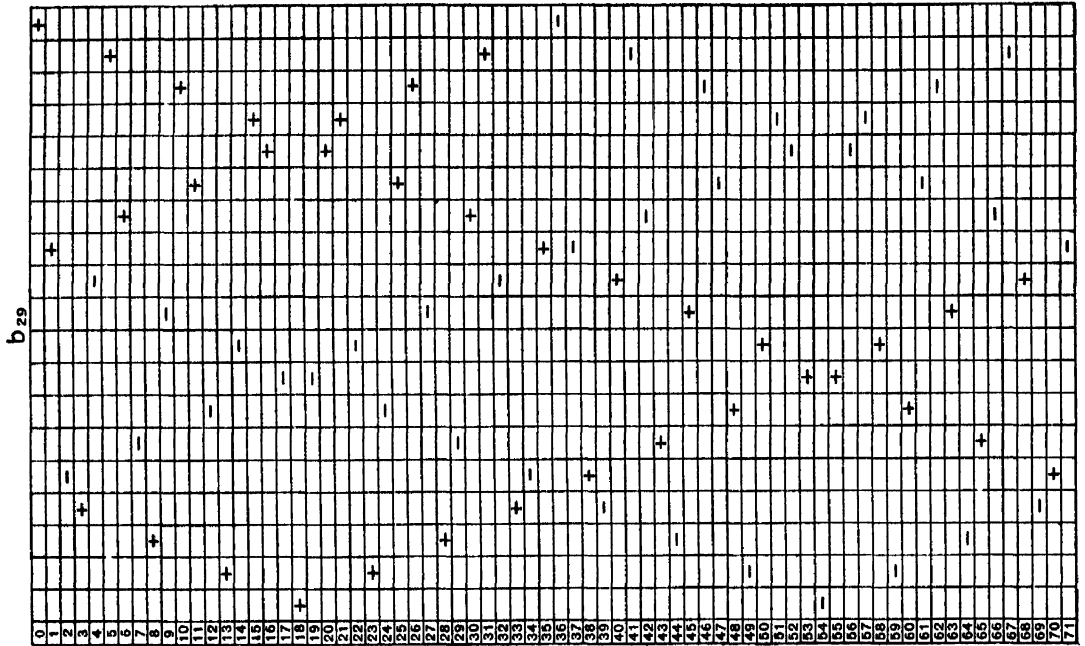









## INDEX.

(Phonetic letters are inclosed in [ ], words treated in " ")

- [a], 41, 43, 47, 81.  
 [æ], 50, 68.  
 [ai], 35, 44, 45, 47, 48, 65, 67, 69, 117.  
 [au], 40, 41.  
 "a," 35, 50, 67.  
 "America," 35, 68.  
 "and," 50.  
 Amplitude, defined, 59, 75, 83; of American vowels, 48.  
 Analysis, qualitative, 39; auditory, 53; quantitative, 57; harmonic, 75; inharmonic, 99; frictional, 101; in reference to vocal action, 107; in reference to action in the ear, 125.  
 Apparatus for tracing gramophone records, 23; for tracing phonograph records, 36; for analysis by the ear, 53; for producing vowels, 114; for synthesis of vibrations, 131.  
 Auditory analysis, 53.
- [b], 48.  
 "before," 35.  
 "blood," 48.  
 Band, 33.  
 Beats, 34.  
 Berliner, 14.  
 Bessel, 87.  
 Blocks, 34.
- [ɔ], 44, 46, 48, 50, 67, 68, 82.  
 [ɔi], 46.  
 "called," 82.  
 "can," 44.  
 "caught," 48.  
 "come," 49, 50.  
 "creed," 44.  
 Cavity vibrations, 41.  
 Celluloid phonograph, 15, 36.  
 Change of one sound into another, 58.
- Chinese musical instrument, 34.  
 Chinese vowel, 35.  
 Chord of piano, 36.  
 Circumflexion, 48.  
 Clarionet, 100.  
 Cornet, 100.  
 Cock Robin record, 38, 44.  
 Coefficient of friction, 101.  
 Coordinate measures, 57.  
 Curves, see the special subjects, *e. g.*, yodel, gallop, [a], [o], etc.
- [d], 47, 48.  
 "die," 47.  
 "do," 50.  
 Depew record, 40.  
 Diaphragms, experiments on, 16; method of vibration, 18.  
 Diphthongs, 41, 44, 48.
- [ð], 40, 42, 44, 48.
- [e], 35, 44.  
 [ɛ], 35, 48.  
 [ə], 35, 44, 45, 48, 49, 50, 67.  
 "ein," 69.  
 "eye," 45.  
 Ear, action in, 125; analysis by, 53.  
 Edison, 14.  
 Elizabeth Thompson Science Fund, 36.  
 Emotional expression, melody of, 64.  
 Examples of vowel analysis, 137.  
 Experiments, on sound boxes, 16; on vowels, 114.  
 Expression of emotions in melody, 63.
- [f], 48.  
 "family's," 50.  
 "fish," 48.  
 "fourteenth," 147.  
 Factor of friction, 101.  
 Fixation of diaphragms, 18.
- Fourier, 75, 84.  
 Frequency dot, 62, 75.  
 Frictional analysis, 101.  
 Frictional sinusoids, 101.  
 Fundamental, 107.
- [g], 43.  
 "glass," 50.  
 Gallop, 34.  
 German initial vowels, their melody, 69.  
 Glide, 42.  
 Glottal lips, method of vibration, 109, 116.  
 Gong, 33.  
 Graham record, 35.  
 Gramophone, 15.  
 Grassmann, 109.
- [h], 46.  
 "highly," 35.  
 "his," 48.  
 Harmonic analysis, 75, 85.  
 Harmonic plot, 76, 91.  
 Harmonic series, 75.  
 Helmholtz, 96, 125.  
 Hermann, 79, 96, 111.  
 Horse galloping, 34.
- [i], 44.  
 [i], 35, 40, 42, 43, 44, 45, 47, 48, 49.  
 "I," 44, 46, 48, 65, 67, 117.  
 Inharmonic analysis, 99.  
 Inharmonic components, 81.  
 Inharmonics, 77.  
 Initial vowels, 65.  
 Interjections, melody of, 63.  
 Intensity diphthong, 48.  
 Interpreting curves, 39.
- Jefferson record, 46, 49.
- [k], 48.
- [l], 45, 48.  
 "little," 45.  
 Laughter, 36, 50.

- Limits between sounds, 58.  
 Lioret, 15, 36.  
 Locomotive puffs, 33.  
 Locomotive whistle, 33.  
 Logarithmic decrement, 106.
- [m], 44, 46, 47.  
 "Marshall," 81.  
 "my," 44.  
 Matrix, 15.  
 Melody, defined, 59; in music, 60; in speech, 60; of interjections, 63; its fundamental law in speech, 63; in emotional expression, 63; in initial vowels, 65; of sentences, 70; of Speech on Forefathers' Day, 70; of Der Fichtenbaum, 72.  
 Melody plot, 62.  
 Mitchell record, 35, 38, 63.  
 Mounting curves, 31.  
 Multiple pendulum, 133.
- [o], 35, 147.  
 "oh," 35, 63.  
 "oh dear," 64.  
 "oh my," 64.  
 "on," 67.  
 "or," 44.  
 Orchestra, 33.  
 Overtone theory, 107.
- "prosper," 50.  
 Partial tones, 107.  
 Pendulum, multiple, 133.  
 Period, 75, 83.  
 Phase, 75, 83.  
 Phonautograph, 13.  
 Phonograph, 14.  
 Phonograph tracing apparatus, 36.  
 Photomicrograph, 16.  
 Piano, 32, 34, 36.
- Plucked string, 34.  
 Pseudo-beats, 34.  
 Puff siren, 112.  
 Puffs, locomotive, 33; from the glottis, 40.  
 Puff theory of the vowels, 111, 115.
- Qualitative analysis, 39.  
 Quality diphthong, 48.  
 Quantitative analysis, 57.
- [ɹ], 44.  
 "r," 35.  
 "race," 44.  
 "regard," 42.  
 "Rip," 49.  
 Recorder, 14, 15.  
 Recording point, 26.  
 Reproducer, 16.  
 Reproduction of curves, 32.  
 Resonance, 108.  
 Rip Van Winkle's Toast, 49.
- [s], 48.  
 "said," 48.  
 "saw him," 46.  
 "schnapps," 50.  
 "so," 52.  
 "such," 35.  
 Saxophone, 100.  
 Schedules for harmonic analysis, 89.  
 Seelmann, 46.  
 Simple sinusoid, 75, 83.  
 Siren, 112.  
 Smithsonian Institution, 114.  
 Smoking paper, 28.  
 Sonant [h], 46.  
 Sound box, 16.  
 Specific melody, 73.  
 Speed curve, 13.  
 Speech on Forefathers' Day, 40.  
 Speech vibration, 13.  
 String, 34.
- Sweet, 47.  
 Synthesis of vibrations, 131.
- [t], 43, 45, 48.  
 "that," 50.  
 "the," 48.  
 "to," 42, 50.  
 Time equation, 30.  
 Tracing machine, for gramophone records, 23; for phonograph records, 36.  
 Translating the curve, 39.  
 Tremolo, 35.  
 Trill, 35.  
 Trombone, 32.  
 Twang, 21.
- [u], 42, 43, 50.  
 Untrilled r, 35.
- Varnishing, 28.  
 Vibration apparatus, 131.  
 Vocal action, 107.  
 Voice, pitch of, 40.  
 Vowel analysis, 107.  
 Vowel apparatus, 114.  
 Vowels, kinds of analysis, 107; overtone theory, 107; puff theory, 111; the theory in detail, 118.
- [w], 40, 42, 44.  
 "who," 48.  
 "with," 44.  
 "without," 40.  
 Wave, defined, 59.  
 Wave group, defined, 59.  
 Wheatstone, 109.  
 Whistle, 33.  
 Whistling, 34.  
 Willis, 111.
- "your," 50.  
 Yodel, 32.
- [z], 48.

















