

**TEXT FLY WITHIN THE
BOOK ONLY**

UNIVERSAL
LIBRARY

OU_216303

UNIVERSAL
LIBRARY

Heroes of the Nations

EDITED BY

Evelyn Abbott, M.A.

FELLOW OF BALLIOL COLLEGE, OXFORD

FACTA SUUS VIVUNT, OPEROSIQUE
GLORIA SERVAT. — QVINTUS, DE LYLIAN, VII.
THE HERO'S DEEDS AND HARD-FIGHT
FORGEE SHALL LIVE.

NELSON







NELSON'S SIGNAL AT TRAPALGAR.

HORATIO NELSON

AND

THE NAVAL SUPREMACY OF ENGLAND

BY

W. CLARK RUSSELL

AUTHOR OF "THE WRECK OF THE GROSVENOR," "THE LIFE OF WILLIAM
DAMPIER," ETC.

WITH THE COLLABORATION OF WILLIAM H. JAQUES

LATE UNITED STATES NAVY, M. I. AND S. INST. M. P., ASSOC. INST. C. E.
ASSOC. I. N. A.

G. P. PUTNAM'S SONS
NEW YORK AND LONDON
The Knickerbocker Press

COPYRIGHT, 1890, BY
G. P. PUTNAM'S SONS
Entered at Stationers' Hall, London
BY G. P. PUTNAM'S SONS

The Knickerbocker Press, New York

CHAPTER V.

PAGE

Attack on Calvi—Nelson's eye hurt—Genoa—Newspaper lies— A cottage ashore—Money-loss through services—Action with French fleet—The <i>Agamemnon</i> and the <i>Ca Ira</i> —Nelson made Colonel of Marines—Action with the French fleet— General de Vins —A scandalous accusation—A seat in Parlia- ment offered—Evacuation of Corsica—Action with the <i>Santa Sabina</i>	53
--	----

CHAPTER VI.

Arrival at Gibraltar—Chased by two Spanish liners—Narrow escape—In the thick of the Spanish fleet—Anecdote of Jervis—Battle of St. Vincent—The <i>San Josef</i> and the <i>San Nicolas</i> —Their capture by Nelson—Nelson's explanation of his proceeding—The action considered	66
---	----

CHAPTER VII.

Rewards—Nelson's Popularity amongst sailors—Cause of it— Hand-to-hand fight off Cadiz—Project against Teneriffe— A disastrous blunder—Loss of his arm—Courage under suf- fering—Anecdotes of the surgical operation—Troubridge at Santa Cruz—Nelson sails for England—Lady Nelson—An- ecdotes belonging to this time—Character of his wife— Memorializes the King—St. Vincent's letter to Lady Ham- ilton—Nelson proceeds to the Mediterranean—A heavy gale of wind—Public opinion on St. Vincent's choice	76
--	----

CHAPTER VIII.

Pursuit of the French fleet—Anecdote of Lady Hamilton—The fleet weighs from Syracuse—Discovery of French fleet— Plans of attack—Nelson's policy of instant fighting—Battle of the Nile—Death of Admiral Brueys—Explosion of <i>L' Ori- ent</i> —Anecdotes of rescued Frenchmen—The <i>Culloden</i> ashore —Nelson wounded—Louis of the <i>Minotaur</i>	93
--	----

CHAPTER IX.

Comparative force of the two fleets—Signal but extraordinary triumph—French Remarks on the battle—Captain Hallo-	
---	--



PREFACE

IT

is hard to tell what has or has not been issued in the shape of literature during the past forty or fifty years, and therefore one may not say positively that there has been no life of Nelson produced since the publication of the first volume of "Nelson's Dispatches and Letters" by Sir N. Harris Nicolas in 1845.

If a strong, well-written book on Nelson's career, embodying all distinctive and important points in Nicolas and Pettigrew, is in existence in the English tongue, it is unknown to me. In my hunt after materials for this volume I have met with the following: the rude and primitive biographies of White, Charnock, and Churchill, written very shortly after Nelson's death, crowded with inaccuracies conveyed in the diction of Grub Street, and plainly designed at the time to serve as catch-pennies; the volumes of Clarke and M'Arthur, which, though it be necessary to refer to them in writing about Nelson, have long since ceased to be valued as authoritative; the "Life" by Harrison, that is no better than a romantic view of the Hero from a Della-Cruscan or Rosa-Matilda standpoint, a book inspired

Contents.

IX

	PAGE
well's gift—Consequences of the battle of the Nile—Honours and gifts—Reception of the news at Naples—Nelson's dislike of Naples—His arrival and reception by the King of the Two Sicilies—Anecdote of the <i>Vanguard</i> —The Hamiltons' House—Festivities at Naples—Lady Nelson's uneasiness	108

CHAPTER X.

State of the Kingdom of Naples—Precious time wasted—Malta taken by the French—Saumarez at Valetta—General Mack—Treachery of Neapolitan officers—Flight of the King and Queen from Naples—The voyage to Palermo—Influence of Lady Hamilton over Nelson—The Vesuvian Republic—Captain Foote and the rebel capitulation—Cardinal Ruffo .	122
---	-----

CHAPTER XI.

Caracciolo—His trial and execution—Reappearance of the body—Nelson's gifts to his family—Festivities—Nelson's adhesion to the Sicilian Court—Sir Sidney Smith—Captain Ball at Malta—Troubridge's hatred of the Court of Naples	137
--	-----

CHAPTER XII.

Action with <i>Le Ge'n/reux</i> —Lieutenant Parsons's description of the fight—Lord Cochrane on Nelson—Capture of <i>Le Guillaume Tell</i> —Life on board the <i>Foudroyant</i> —Insurrection at Leghorn—Incidents of Nelson's journey home—Arrival in London—Quarrel with Lady Nelson—His separation from her .	
--	--

CHAPTER XIII.

Honours—St. Vincent's Concern—Surrender of Malta—Case of the <i>Freya</i> —Attitude of Northern powers—British fleets sent to Copenhagen—The Danish defences—Anecdote of the Prince of Denmark's <i>aide-de-camp</i> —Nelson at Admiral Parker's council—Eve of the action .	166
--	-----

CHAPTER XIV.

The night before the battle—Order of sailing—Stations of the British ships—Remarkable instance of heroism—Parker's signal and its reception by Nelson—The battle described—A	
--	--

	PAGE
flag of truce—The <i>Elephant</i> ashore—Nelson's poetry—Story of the <i>Zealand</i> —Visit to the Danish prince—Danish losses—Young Welmoes—Departure of the fleet	178

CHAPTER XV.

Pursuit of the fleet in a boat—Blind Mrs. Nelson—Nelson at Revel—Personal habits—Investiture of Rear-Admiral Graves—Rev. W. Nelson—No medals for Copenhagen—Return to England—Fears of invasion—In the Downs—Purchase of Merton Place—Death of Captain Parker—Nelson's irritability	199
---	-----

CHAPTER XVI.

Political speeches—St. Vincent on Canada—Death of Rev. E. Nelson—Nelson and the Hamiltons—Visit to Wales—War with France—Buonaparte and Lord Whitworth—Nelson's income—Death of Sir Wm. Hamilton—Appointed Commander-in-chief on the Mediterranean station—Letter from the King of Naples—Blockading—A revolution in sea-affairs—Crazy ships—Fears for his eyesight—Bay of Palmas	217
---	-----

CHAPTER XVII.

Recollections of Rev. A. J. Scott—The leathern arm-chairs—Anecdote of a midshipman—La Touche-Tre'ville—Continued illness—Ambition to be Lord High Admiral—Anecdote—Tedious blockading—Spanish menace—Rich capture—Sir John Orde—Injurious treatment of Nelson—French fleet—Daring navigation—Pursuit of the French across the Atlantic—Misled by Brereton—The American schooner—Two years all but ten days of shipboard—Romantic incident	235
---	-----

CHAPTER XVIII.

Arrival in England—Sir Arthur Wellesley—George III.—Lord Sidmouth's story—Keats's ¹ ; anecdote of Nelson—Interview with Blackwood—Lady Hamilton's fanciful story—At Portsmouth—Junction at Cadiz—Strength of British fleet—The combined fleets—Beatty's account of Nelson—Blackwood to his wife—Nelson to his child—Weighing of the enemy	257
--	-----

CHAPTER XIX.

	PAGE
A grand picture—Nelson's men—His dress before the battle— His prayer—Blackwood's suggestion—The famous signal— Collingwood—The <i>Royal Sovereign</i> —Anecdote of Rotheram —The <i>Victory</i> in action — Overwhelming fire — Nelson wounded—Scene of the cockpit—Nature of the wound— Hardy— Tenderness of nature in last moments—** Anchor, Hardy, Anchor 1"—Nelson's death	276

CHAPTER XX.

After the battle—Cape Trafalgar—Anecdote of <i>the Achille</i> —Fate of the <i>Santissima Trinidad</i> —Fate of the <i>Redoubtable</i> — Effects of the battle—Ney on the invasion of England— Nelson's remains—Arrival at Spithead—Appearance of the body—National mourning—St. Vincent's grief—Honours to Nelson's family—Lady Hamilton's claims—Her death— Nelson's funeral—Conclusion	300
APPENDIX	317
INDEX	337

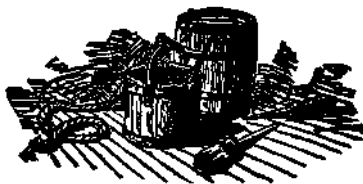



ILLUSTRATIONS.

	FAQS
NELSON'S SIGNAL AT TRAFALGAR (AFTER THE ORIGINALS IN THE UNITED SERVICE INSTITUTE, WHITEHALL, LONDON) <i>FrOntisj.</i>	
DEATH OF NELSON, 1805 (FROM THE PAINTING BY ERNEST SLINGENEYER)	1
BURNHAM THORPE, NELSON'S BIRTHPLACE	2
CAPTAIN MAURICE SUCKLING, R. N. (FROM AN OLD STEEL ENGRAVING BY RIDLEY)	12
SIR WILLIAM HAMILTON	
EMMA, LADY HAMILTON (AFTER A PAINTING BY ROMNEY)	44
VIEW OF BASTIA, ISLAND OF CORSICA	5°
LORD HOTHAM'S ACTION, MARCH, 1795.	60
THE "VICTORY" AND THE ^U SALVADOR DEL MUNDO." ACTION OFF CAPE ST. VINCENT, 1797	70
NELSON'S ENCOUNTER WITH A SPANISH LAUNCH	73
VIEW OF SANTA CRUZ, ISLAND OF TENERIFFE	80
THE BATTLE OF THE NILE, 1798	100
NELSON'S MONUMENT, ST. PAUL'S, LONDON	124
CAPTURE OF " LE GUILLAUME TELL," 1800	154
NELSON'S COLUMN, TRAFALGAR SQUARE, LONDON	160
THE BATTLE OF COPENHAGEN, 1801	180
LORD NELSON, K.B. (AFTER A PAINTING BY A. W. DEVIS).	20a

	PAGE
FAOSIMILE OF LORD NELSON'S FIRST LETTER AS " A PEER I	204
FAC-SIMILE OF LADY HAMILTON'S ATTESTATIC OF IT. J	
SNUFF-BOX MADE FROM THE WOOD OF "L'ORIEI) MEDAL FOR THE BATTLE OF THE NILE .)	220
FAC-SIMILE OF LORD NELSON'S AUTOGRAPH AT VARIOUS PERIODS OF HIS LIFE	234
NELSON'S MONUMENT AT LIVERPOOL (FROM AN OLD ENGRAVING)	254
THE " VICTORY " BREAKING THROUGH THE ENEMY'S LINE AT THE BATTLE OF TRAFALGAR, 1805 .	288
THE BATTLE OF TRAFALGAR, 1805. (FROM THE PAINTING BY C. STANFIELD)	290
SIR THOMAS MASTERMAN HARDY, BART., G.C.B. .	298
NELSON'S WATCH AND SEAL WORN AT TRAFALGAR .	299
FAC-SIMILE OF LORD NELSON'S STATEMENT OF HIS WOUNDS	302
NELSON'S PILLAR, SACKVILLE STREET, DUBLIN	310
H. M. S. " TRAFALGAR ".	318
SECTION OF FRIGATE	319
SECTION OF A FLUSH-DECK CORVETTE	322
COEHORN HOWITZER, 1805—WEIGHT, 2½CWT.	323
CARRONADE, THIRTY-TWO POUND, 1779—WEIGHT, 17 CWT.	325
H. M. S. " VICTORY ".	332





THE DEATH OF NELSON.

ENGRAVED FOR RUSSELL'S "NELSON" FROM THE PAINTING BY ERNEST BLINGSBYERL.

HORATIO NELSON.



CHAPTER I.

Birth—Rev. Edmund Nelson—Education—First going to sea—The sailor of the last century—Jervis and Collingwood—Dislike of the navy—West Indian voyage—Polar experiences—East India voyage—Impulse of patriotism.



o^

HORATIO NELSON was born on the 29th of September, 1758, at Burnham Thorpe, Norfolk, of which place his father, the Reverend Edmund Nelson, was rector. A singular interest inevitably attaches to the parents of great men. What was their character? what their talents, disposition, tastes? to what degree are their illustrious children indebted to them for the qualities which rendered them great? There is nothing in Nelson's genius and spirit that can be traced to his father. The Reverend Edmund appears to have been a plain country parson, overwhelmed with children,

and **poor**. He was a man of a heavy cast of piety, ponderous in opinion and sentiment, constantly pursuing his son with unnecessary admonitions, and taxing the gravity of posterity by a style of correspondence curiously in keeping with the well-like pews, the Georgian wigs, and the drowsy, insipid, hour-and-a-half's sermons of the days of Porteus and Hurd.

He was of a weak and sickly constitution, and this he seems to have bequeathed to Horatio. But the influence of the parson's cottage-home was always strong upon Nelson. "He was a thorough clergyman's son," his chaplain, Dr. Scott, would in after years say of him a little ambiguously. "I should think he never went to bed or got up without kneeling down and saying his prayers." * His mother was a daughter of Maurice Suckling, a Prebendary of Westminster, whose grandmother, as Nelson tells us himself in his "Memoir of his Services," was sister to Sir Robert Walpole, Earl of Orford. There was some fighting spirit on his mother's side. Galfridus Walpole commanded the *Lion*, of sixty guns, in a gallant action in the Mediterranean in 1711, and his sword came to Horatio Nelson from his uncle, Captain Suckling. Mrs. Nelson died when her son was nine. It is scarcely to be supposed that the memory of such influence as she might have exerted was of much account in the formation of his character. The Nelson Correspondence is very voluminous, as all know who have had occasion to refer to the Nicolas Collection; but nowhere that I can remember does he speak of his mother, save in that brief

* 'Recollections of the Life of the Rev. A. J. Scott, D.D.," p. igi,

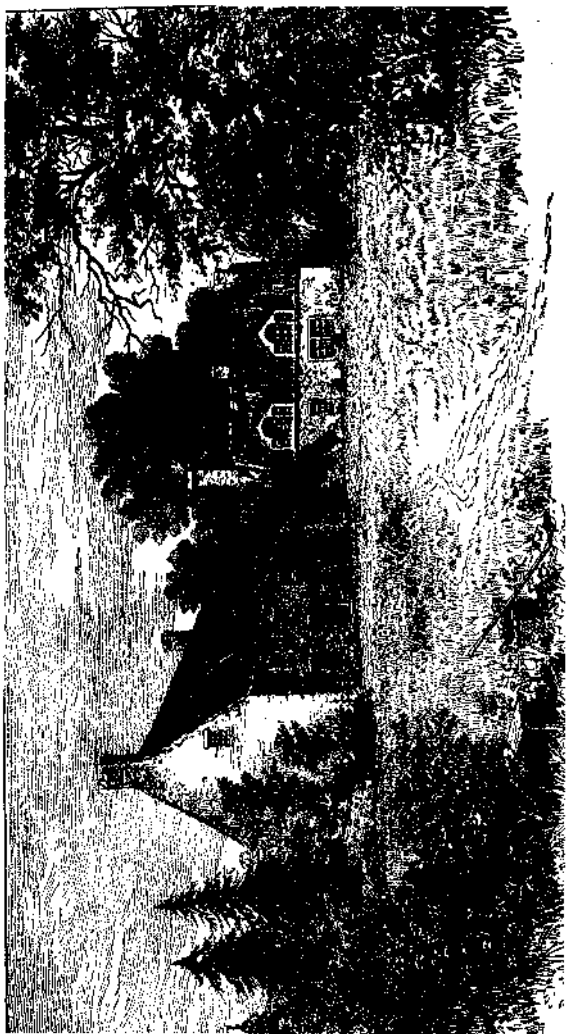

BURNHAM THORPE, NELSON'S BIRTHPLACE.

mention of her name in the sketch of his life which he sent in 1799 to John M'Arthur.*

Nelson's biographers have collected little as to his early education. He was at the High School at Norwich, and afterwards went to a school at North Walsham; but what he knew he seems to have himself wholly acquired, as may be gathered from a statement made by the Duke of Clarence long years afterwards, when in comparing Nelson with Collingwood, he spoke of the former as being entirely self-taught, whereas Collingwood, the Prince said, entered the Service well equipped by the school-master. The few anecdotes of the lad belonging to this period were years ago worn threadbare. Who has not heard how he told his grandmother, when she expressed wonder that fear did not drive him home, that "Fear never came near him"? how he plundered a pear-tree without partaking of the booty, entering upon the adventure only because every other boy was afraid? These and one or two other like stories are recorded by all Nelson's biographers with a striking unanimity of complacent approval. One wishes them true if merely as curiosities of biographic literature; but unhappily they are so varied in the telling that it is difficult not to suspect their authenticity. Much has been put into

* And (though it is not to the point) in a letter to Dr. Allott, Dean of Raphoe, 14th May, 1804: "Most probably I shall never see dear, dear Burnham again; but I have a satisfaction in thinking that my bones will probably be laid with my father's in the village that gave me birth. Pardon this digression; but the thought of former days brings all my mother into my heart, which shows itself in my eyes." — "Dispatches and Letters," vol. vi., p. 18.

Nelson's mouth which no man who has any acquaintance with the nautical character, but must feel convinced this Hero, who was a Sailor before all things, never could have uttered.* From the period of his school-days down to Trafalgar and the cockpit of the *Victory* he has been melodramatised, from White to Pettigrew, and from Charnock to Lieutenant Parsons.

Captain Manby, well known in his time for various nautical inventions, was at school with Nelson at Downham Market, and he would speak of him as a lad who wore a green coat and who set the market pump going that he might launch paper boats in the gutter. An instance of his extreme sensibility as a child is given. One day on entering a shoemaker's shop he accidentally jammed a pet lamb in thrusting open the door and cried bitterly at the pain he had caused the little animal. A Mr. Levett Hanson, writing to Nelson from Hamburg in 1802, embodies in an odd, flippant letter some recollections of Horatio as a schoolboy. "I well remember," he says, "where you sat in the school-room. Your station was against the wall between the parlour door and the chimney: the latter to your right. From 1769 to 1771 we were opposites. Nor do I forget that we were under the lash of Classic Jones, as arrant a Welshman as Rees-ap-Griffith, and as keen a flogger as Merciless Busby of birch-loving memory!" † This school thus referred to was at North Walsham, where Nelson

* See in particular Harrison's "Life of Nelson."

† Pettigrew. Vol. ii., p. 363.

remained until the Spring of 1771. Towards the close of the previous year he had read in a county paper that his mother's brother, Captain Maurice Suckling, was appointed to the *Raisonnable* of sixty-four guns. The lad had asked his brother William to write to his father at Bath and obtain his permission to go to sea with Uncle Maurice. Gruff Captain Suckling, on receiving the Reverend Edmund Nelson's letter, answered thus: "What has poor Horace done, who is so weak, that he above all the rest should be sent to rough it out at sea? But let him come; and the first time we go into action, a cannon-ball may knock off his head, and provide for him at once."

The *Raisonnable* was not ready for sea until the Spring of 1771. Young Nelson had returned to school with his brother William, and there he stayed; until one cold, dark morning there arrived a servant from the Reverend Mr. Nelson to bring him home that he might be got ready to start as a sailor. He was provided with a slender outfit, and was then accompanied by his father to London, where he was left to make the best of his way to the sixty-four-gun ship lying off Chatham. Nelson in after times would often recall the wretchedness of his childish heart as he wandered about in search of the ship. It was a grey, melancholy day, sharp with the frost of an expiring Winter. As the little fellow roamed here and there, shivering in his jacket and bewildered by the novelty of the scene of shipping, and darkling river, and noisy, bawling Jacks, and the many delectable sights and smells of **the**

dockyard, he was observed by a naval officer, who, happening to know Captain Suckling, took him home and gave the hungry little fellow some dinner. The captain did not arrive until several days after his nephew had joined the ship, and the lad found himself in his floating home without a soul who knew him to offer him a word of sympathy or to do him a single kindness.

Shipboard life in the days of the beginning of Nelson's career was very much as it was when Roderick Random was being poisoned by the fumes of the sick quarters of his man-of-war, and when his associate was being driven by famine to rob his Welsh colleague of his onions and bread. Little Nelson, fresh from school or the pastoral simplicity of his father's rectorial cottage, might well gaze with amazement round upon the scene into which Captain Suckling had been solicited to introduce him. There would be all the smartness of almond-white decks, the imposing grimness of lines of black and grinning ordnance, the beauty of airy heights of an exquisitely symmetrical fabric of spars and sails and rigging; there would also be no lack of delight to the boy's eyes in the spectacle of the red muzzles of the guns, in the white tompions, in the petticoat trousers of the sailors, in the long tails tied down their backs; but below—at least in that part of the ship which was the destined habitation of the boy—everything was dirt and gloom, smell and misery. The English sailor was in those days at the very height of his roughness and brutality. His back was scored with the lash; his skull

was in holes from the bludgeons of the pressgang; the salt beef of the service had penetrated his soul, and his sensibilities were as hard as the most fossilised of the contents of the harness-cask. No fancy could be more impressive to the imagination than the picture of the little lonely child Nelson, emaciated by repeated attacks of ague, his heart yearning towards his far-off inland home, friendlessly pacing the broad quarter-deck of the lumbering sixty-four-gun ship, directing his eyes brilliant with intellect and astonishment at the novel sights which lay about him. "The filial tenderness of his heart," one of his biographers says, "at first required a solace which it did not find." *

It is noteworthy that the introduction to the sea-life of two other boys who subsequently rose to very nearly the level of Nelson as great sea-captains, was as damping and killing to the spirits as that of Horatio. John Jervis, the famous Earl of St. Vincent, gave such an account to Captain Brenton of his first reception on board ship that his biographer owns himself incapable of repeating it. "I have too much respect/' he says, "for my readers, to describe the scene which his Lordship presented to me, in a very few words, but in his clear and emphatic manner. Suffice it to say, that in point of gross immorality and vice, it equalled or outdid anything described by Smollett in his 'Roderick Random.'" † It is told of Lord Collingwood that when he first went to sea he sat down crying bitterly over his separation

* Clarke and M'Arthur. Vol. i., p. 16.

† Brenton's "Life of St. Vincent," vol. i., p. 19.

from home, and such was his childish misery and his desire for compassion and sympathy that, on the first lieutenant accosting him with some little show of kindness, he was so affected that in his gratitude he invited the officer to accompany him to his sea-chest, out of which he took a large piece of plurru cake which he presented to the lieutenant.*

Nelson saw very little of sea-life aboard the *Raisonnable*. She remained but a short time in commission, and Suckling was then appointed to the *Triumph*, of seventy-four guns, stationed as a guard-ship in the Medway. Here was a condition of inactivity that was little likely to suit the restless spirit of young Nelson; and whether through his own importunity or through the judgment of his father or of Captain Suckling, he went on a West Indian voyage in a small ship in command of Mr. John Rathbone, who had served as master's mate under Captain Suckling. Referring to this voyage, Nelson himself says: "If I did not improve in my education, I came back a practical seaman, with a horror of the Royal Navy and with a saying then constant with a seaman, 'Aft the most honour, forward the better man!' It was many weeks before I got in the least reconciled to a man-of-war, so deep was the prejudice rooted; and what pains were taken to instil this erroneous principle in a young mind!" In truth the Navy was never a popular service with sailors. In Nelson's time particularly, the discipline was atrociously taut, the punishments cruel above expression, the food infamously bad; and there was no better

* "Collingwood's Correspondence," p. 6.

temptation to enter than prize-money, of which **the seamen** were remorselessly plundered by **the agents**. **In** the Merchant Service there was freedom. A man **signed** for a voyage and then he was his own master again. Those amongst Nelson's biographers who were not sailors are astonished that he should for one instant have formed a higher opinion of the Merchant Service than the Royal Navy. The real wonder would have been had his taste inclined the other way, seeing that everything agreeable to the sailor was on the side of the Red Flag, difference of wages being foremost.

Although it is certain that Nelson knew how to miss stays in putting a ship about,* there can be no question that this West Indian voyage made a thorough sailor of him. A little West Indiaman of those days provided such an ocean-school as even the fore-castle of a North Country collier could not supply. He arrived home a brown and tarry lad, ¹¹ "every hair a rope-yarn, every finger a fish-hook," and repaired on board his uncle's ship, the *Triumph* (July, 1772). Suckling finding him full of prejudices against the Navy, sought to coax him into a regard for it by giving him plenty of small but interesting work to do, with promise of a sort of promotion, such as making one of the crew of the cutter and decked long-boat, provided, as Nelson himself says, "he attended well to his navigation." Thus he spent the time in learning the trick of piloting from

* " Dispatches and Letters," vol. iv., p. 299. By "missing stays " is signified a posture of a ship in the act of tacking : instead of coming **round into the** wind, she halts, or falls off.

Chatham to the North Foreland till the year 1773, when there was set on foot a scheme, due to an application from the Royal Society, to equip and despatch a couple of vessels on a Polar voyage. The two craft were the *Racehorse*, Captain Constantine John Phipps, and the *Carcass*, Skeffington Ludwidge. Nelson went as coxswain to Ludwidge. He could obtain a footing in no other station, boys being prohibited by the Admiralty from serving in the voyage to the North Pole. He would hardly be sensible of any degradation in this, however, after having been rated as " Captain's servant " for above a year aboard the *Triumph*; though to be sure in the same ship he was raised to midshipman, which position Pettigrew is careful to tell us he filled for ten months, one week, and five days.

Nelson's Polar experiences are of little interest; they contributed, however, to the formation of his unparalleled sea character. It was a wide range in those ambling limited days from the fiery suns of the Antilles to the frozen silence of the Northern lights. Here occurred the well-known incident of his wandering from the ship in pursuit of a bear, that he might obtain the skin of the animal for his father. But it needed Aboukir and Copenhagen and Trafalgar to render this illustration of the character of a sailor lad in the least degree significant.

The *Racehorse* and *Carcass* returned to England and were paid off in October, 1773. Horatio was now fifteen years old, but he was already possessed of the complete knowledge of an able seaman, and needed nothing but a course of active service to

qualify him in almost every experience that was in those days to be got out of the ocean. Suckling, always his warm well-wisher and friend, recommended him to Captain Farmer, of the *Seahorse*, twenty guns, belonging to the squadron about to sail for the East Indies under Admiral Hughes. Naval ratings in those days were a little perplexing. Clarke and M'Arthur inform us that Nelson was stationed in the foretop of the *Seahorse* at watch and watch, as it is termed, by which we are to take it that he embarked as a foremast hand. It was not long before Farmer noticed the lad's smartness and attention to his duties, and during the voyage out he called him on to the quarter-deck and rated him as midshipman. He was now a naval officer, and was frequently suffered by the lieutenant of the watch to manoeuvre the ship even to the extent of putting her about, and in other ways he was allowed to give orders as though indeed he were himself a lieutenant.* By this time all the effects of his frequent attacks of ague had disappeared; he was no longer the meagre, sickly lad that had wandered about in search of his ship at Chatham, but a boy of a florid countenance, stout and athletic, with a deep sea-roll in his gait and the liveliest of hearties aloft.

His East India experiences were wide; they ranged from Bengal to Bassorah; but eighteen months of that climate proved too much for him. He was seized with a malignant disorder which reduced him to a mere skeleton and brought him very near to his grave. Admiral Hughes, the Commander-in

* Clarke and M'Arthur. Vol. i., p. 23.

chief, believing the lad to be dying, sent him home in the *Dolphin*, which sailed from India in 1776. By Hughes the life of Nelson was undoubtedly saved. The ship doctors could do nothing for him, and England in the hour of her need must have been without the greatest of her sea-captains but for this timely, compassionate act of Sir Richard Hughes. The passage home was long and tedious. Sickness, the uncertainty of his future, the sense of his friendlessness, in a professional sense, weighed heavily upon young Nelson's mind, and for days at a time he was bowed down by fits of crushing despondency. "I felt impressed," he says, "with an idea that I should never rise in my profession. My mind was staggered with a view of the difficulties I had to surmount and the little interest I possessed. I could discover no means of reaching the object of my ambition. After a long and gloomy reverie, in which I almost wished myself overboard, a sudden flow of patriotism was kindled within me and presented my king and country as my patrons. My mind exulted in the idea. * Well then,' I exclaimed, 'I will be a hero, and, confiding in Providence, I will brave every danger.' " This resolution to *do*, begotten in a moment of wretchedness, became the noble, animating, enduring impulse of his glorious mind. It never failed him. It was an ever-growing passion. Nay, to his fervid imagination it seemed a thing embodied, indeed; for he would often declare to his friend Hardy, that from that hour there was suspended before his mind's eye a radiant orb that courted him onward to renown.



CAPTAIN MAURICE SUCKLING, R.N.

FROM AN OLD STEEL ENGRAVING BY RIDLEY.

CHAPTER II.

Confidence in young Nelson—Examination for lieutenant—Captain William Locker—Sickly constitution—Capture of an American letter-of-marque—Career in the West Indies—Prince William—Nicaragua expedition—Residence at Bath—A Baltic cruise—Anecdote of the *Harmony*—Lord Hood.

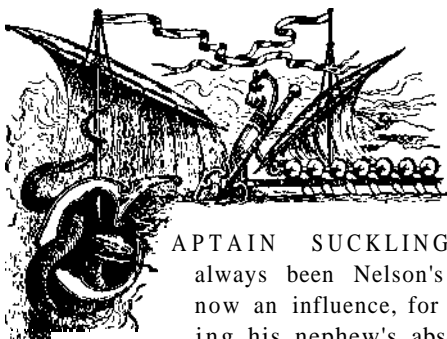

APTAIN SUCKLING, who had always been Nelson's friend, was now an influence, for in 1775, during his nephew's absence, he had succeeded Sir Hugh Palisser as Comptroller of the Navy, and thanks to his uncle's generous offices, young Nelson, after the *Dolphin* had been paid off, found immediate employment as Fourth Lieutenant of the *Worcester*, a ship of sixty-four guns, commanded by Mark Robinson.*

* The fact indicated in the following anecdote belongs to this period, though I am unable to fit it: "Lord Nelson says that when he was seventeen years of age, he won £300 at a gaming-table; but he was so shocked on reflecting that, had he lost them, he should not have known how to pay them, that from that time to this (1799) he has never played again."—"Autobiography of Miss **Cornelia Knight**," vol. ii., p. 286.

In this vessel he went to Gibraltar, and there was none of his early voyages which he recalled with more pleasure. Mark Robinson was a kind and a wise captain; he saw much in young Nelson that pleased and impressed him ; he gave all possible encouragement to his youthful abilities, and Nelson afterwards proudly recorded the confidence that the commander reposed in him. " Although my age might have been a sufficient cause for not entrusting me with the charge of a watch, yet Captain Robinson used to say he felt as easy when I was up on deck as any Officer *in* the ship."

He passed his examination for lieutenant on the 9th of April, 1777, being then nineteen years of age. Captain Suckling was at the head of the Board before which the young man appeared. Nelson entered the room nervously, but answered the questions put to him rapidly and with great intelligence. When the examination was ended, Captain Suckling rose and introduced the youth to his brother examiners as his nephew. " Why did not you tell us this before ? " was asked. " Because," answered the honest old sailor, " I did not wish the youngster to be favoured ; I felt convinced that he would pass a good examination and, gentlemen, you see I have not been disappointed." The result of this examination was his prompt appointment next day as Second Lieutenant to the *Lowestoffe* frigate, thirty-two guns, of which William Locker was the captain.

Of all Nelson's professional friends, Locker was the most valued. The hearty qualities, the fine, **genial, manly** character of this seaman are visible in

the round, large-eyed face that looks out from his well known printed likeness. Nelson was never weary of declaring that he owed his advancement, his glorious successes, indeed, to the training he received from William Locker, to his association with him, to his repeated advice, admonitions, instruction in all that his large experience qualified him to communicate.

The ill-health that harassed without ever hindering him throughout his life pressed at this time heavily on Nelson. Having joined the *Lowestoffe*, he was ordered to take the place of the first lieutenant (who was absent) at the rendezvous for pressed men, that was at that time near the Tower. His friend Lieutenant Bromwich, then a midshipman, would afterwards tell that Nelson was so extremely ill, that one cold night whilst they were on duty together at the Tower, he had to take him on his back and carry him to the rendezvous, and it was sometime doubtful whether he would recover from the swoon into which he had fallen.* His West Indian career begins with his arrival in the *Lowestoffe*, on the 4th of July, 1777, at Carlisle Bay, Barbadoes. He is said to have first won Locker's heart by an instance of intrepid resolution which is thus related. The *Lowestoffe* fell in with an American letter-of-marque. The first lieutenant was ordered aboard her, "but the sea ran so high," says Pettigrew, "that he was unable to reach her, and he returned to the frigate." Locker warmly inquired whether there was not an officer on board his ship capable of taking possession

* Clarke and M'Arthur. Vol. i., p. 25.

of the prize. The Master offered, but Nelson, pushing forward, exclaimed: "No, it is my turn now. If I come back it will be yours." He jumped into the boat, and after a hard tussle got aboard, but the sea was so heavy and the prize lay so deep that his boat was washed right over the Yankee, and it was some time before he could make good his entrance. Bromwich, however, who told the story, declared that the first lieutenant never left the frigate. He had gone below for his hanger, which he could not immediately find, and Locker, losing patience, cried out as we have read. Be this as it may, the achievement was Nelson's; but it is scarcely reasonable to suppose that long prior to this Captain Locker had not witnessed enough in the bearing, the conversation, the professional alertness and enthusiasm of his second lieutenant to endear the young man to him as a naval officer whose future was charged with brilliant possibilities.*

It would be impossible in a brief survey of such a life as Nelson's to find space for the recital of all that he did in the West Indies at this time. Locker appointed him to the command of one of the *Lowestoffe's* tenders, a little schooner in which, as he himself tells us, "he made himself a complete pilot of all the passages through the (Keys) Islands situated on the north side Hispaniola." Through the influence of Locker he was appointed by Ad-

* It is worth noting, however, that Sir James Mackintosh (see his *Life*, vol. ii., p. 135) says: "Windham, certainly, and perhaps P>x, met Captain Nelson at Holkham without suspecting **that he was more than a lively and gallant officer.**"

miral Sir Peter Parker third of the flag-ship *Bristol* and his place in the *Lowestoffe* was taken by Cuthbert Collingwood, who, in a brief account of his own life which he communicated to the *Naval Chronicle** wrote : " Whenever Lord Nelson got a step in rank I succeeded him, first in the *Lowestoffe*, then in the *Badger*, into which ship I was made a Commander in 1779, and afterwards the *Hinchinbrook*, a twenty-eight-gun frigate, which made us both Post-Captains." The *Bristol* cruised in company with other ships until the 17th of October. In this time seventeen sail of French merchantmen were captured. Two months later Nelson was promoted to the rank of Commander, and in the *Badger* brig was sent to protect the Mosquito coast and the Bay of Honduras from the American privateersmen who swarmed in those waters. He is described at this period as of a figure that might readily have passed for what it is customary to call " a common sailor." He was careless in his dress, blunt in speech, frank and off-hand in manner. There is little to surprise one in this. So far as he had now used the sea, he had endured the hardest part of its life in a vocational sense. He was a thorough-bred seaman at this period, but it needed the keen and affectionate penetration of a William Locker to perceive more in him than fore-castle and quarter-deck capacities somewhat above the average.

In 1779 England was at war with France and Spain. There was much anxiety felt in Great Britain ; for our naval force had been represented

* Vol. xxiii., p. 330.

by Lord Chatham as unequal to the needs of the nation. Further, ships were short-handed in consequence of the supplies of American seamen being stopped. King George, with the design of popularising the Service, entered his third son, Prince William Henry, as midshipman. So far as the quarter-deck was concerned the result was successful. The ships of war were promptly filled with sprigs of the nobility.* It was long a popular story in the Navy that soon after Prince William had become a midshipman a lieutenant of a man-of-war hailing the mizzen-topsail yard, shouted out : " My lords and gentlemen, and all you right honourable lubbers, bear a hand and roll up that sail and lay down ! " Three days earlier than the entering of the future King of England as a midshipman on board the *Prince George*, Nelson had been made Post into the *Hinchinbrook*. He was at sea when news of the arrival of Count D'Estaing at Hispaniola reached him. The enemy's powerful fleet and army threatened the safety of Jamaica. Nelson immediately offered his services to the Admiralty and to the Governor, General Dalling, and was appointed to command the batteries at Port Royal. This was the most important post in the whole island. Nothing, however, was done by D'Estaing, and General Dalling thereupon went to work to execute a plan originated by himself—*i. e.*, to take the fort of San Juan on the river that runs from Nicaragua into the Atlantic, and so capture Granada and Leon, that communication might be effectually cut off between

* *Naval Chronicle*, vol. xii., p. 335.

the northern and southern dominions of the Spaniards in America.

In this service Nelson was foremost. He conveyed the handful of troops which were sent, headed them in their landings, and may be said really to have shown them how to fight. The expedition was distressing and disgusting; the climate an intolerable one; the prospects poor, and even if achievable, of little worth; the seat of war a bed of mud; the river to be navigated rapid and difficult, soil and air swarming with venomous things and poisonous with the pestiferous exhalations of centuries of tropical rot. Nelson might easily have backed out of this cheap, mean, and idle contest, since his instructions from Sir Peter Parker were that the services of the *Hinchinbrook* should terminate with the landing of her soldiers. But he found that there was not a man of the whole company who had ever been up the river, or who had an idea of the distance of any fortification from its mouth.* He thereupon manned the Mosquito shore-craft with his own sailors, and carried the soldiers up to the castle of San Juan. His extraordinary energy is conspicuously manifested in this passage of his career. There was scarcely a gun fired which was not pointed by him. He himself, at the head of a few seamen, "boarded," as he called it, the St. Bartholomew battery, and the Spaniards fled in terror before the hurricane rush of the Jacks. That a single man of the expedition should have survived General Dalling's scheme is perhaps the most extraordinary part of this busi-

* Lord Nelson's "Memoir of his Services," part 2.

ness. Nelson was barely saved from being stung to death by a serpent. He narrowly escaped being poisoned through drinking at a spring in which some branches of the manchineel apple had been thrown. Men dropped dead during the march, and their bodies became putrid corpses within half an hour. They were without provisions, and were forced to subsist on a broth formed by boiling monkeys, a sort of food which Nelson often declared nothing could induce him to touch after a glance at the brutes simmering in the copper.*

His life was saved by Sir Peter Parker's appointment of him to the command of the *Janus* of forty-four guns. He returned to Jamaica to take possession of her, but was nearly dead of dysentery and fatigue. On his arrival he was conveyed on shore in his cot and attended by a black nurse named Cuba Cornwallis, from whose lodging-house he was removed to the residence of the Admiral, and tenderly nursed by Lady Parker and her housekeeper, Sir Peter himself often keeping watch by the young captain's bedside. It is told that such was his aversion from taking medicine that the only method which could be devised to induce him to swallow it was to send it to him by the Admiral's little girl, whom Nelson afterwards always spoke of as his nurse.f

* Yet Sir Sidney Smith ate rats with avidity! He "asserted that rats fed cleaner, and were better eating than pigs or ducks, and agreeably to his wish, a dish of these beautiful vermin were caught daily with fish-hooks, well baited, in the provision hold, for the ship was infested with them, and served up at the captain's table. The sight of them alone took off the keen edge of my appetite."—"Nelsonian Reminiscences," by G. S. Parsons, R. N., p. 275.

f Clarke and M' Arthur. Vol. i., p. 61.

His illness increased upon him. The West Indian climate was killing him ; there was no remedy but an immediate return to Europe, and on the first of September, 1780, he sailed for England in the *Lion*, commanded by Captain William Cornwallis, " whose care and attention," he says, "again saved my life."

For nearly a year he resided at Bath under the advice of Dr. Woodward, a celebrated physician, of whom Lady Nelson afterwards would tell this story: that when Nelson expressed surprise at the smallness of the fees charged and desired to increase them, Dr. Woodward answered : " Pray, Captain Nelson, allow me to follow what I consider to be my professional duty. Your illness, sir, has been brought on by serving your king and country, and believe me, I love both too well to be able to receive any more." His health improved, and he made earnest application for employment, but for a long time without result. On the 16th of August, 1781, he was appointed to command the *Albemarle* frigate, twenty-eight guns, and was despatched in October, along with two other vessels, to Elsineur to protect the homeward trade. This commission greatly irritated Nelson. He felt that his gallant services deserved a more generous recognition than his dispatch on a winter's cruise into the bleak North Sea, enfeebled as **he** was after a long course of the fever-breeding **parallels** of the West Indies. On his arrival at **Elsineur** the Danish admiral sent a midshipman to **the Albemarle** **that** he might be informed of the **names and** force of the ships. **The** visit of **the little creature** was felt as an indignity by Nelson. " **The**

*Albemarle*** said he to the midshipman, " is one of his Britannic Majesty's ships ; you are at liberty to count her guns as you go down the side ; and you may assure the Danish admiral that, if necessary, they shall all be well served." The midshipman carried this message ashore, and later on Nelson sent to say that the English squadron would salute the castle of Kronenburg with nineteen guns provided an equal number were returned. This was done, a few civilities were exchanged, and the Dane's discourtesy pardoned.

The cruise was uneventful, but it stored the mind of Nelson with memories which subsequently proved of inestimable value to his country. In April, 1782, his ship still being the *Albemarle*, he sailed in company with Captain Thomas Pringle with a convoy for Newfoundland and Quebec. Two months later, whilst cruising off Boston, he was chased by three French ships of the line and a frigate. The four ships outsailed him, and to save himself from being taken he ran amongst the numerous and dangerous shoals of St. George's Bank. The coolness which at such a moment as this springs from a long experience in the business of pilotage, where every instinct must be on the alert, and where a man needs as many eyes in his head as a peacock has in its tail, was Nelson's now ; and he saved his ship by it. The liners shifted their helm ; but the frigate continued to warily follow with a leadsman on either side of her ; whereupon the *Albemarle* shortened sail meaning to fight her ; but Monsieur happened to be without appetite just then

for the encounter, and taking advantage of the evening that had drawn down, he braced his yards up and staggered off in search of his consorts.

During this cruise Nelson captured a small Cape Cod-man called the *Harmony*. All that her owner, a poor fisherman, had in the world was aboard of his little craft. Nelson employed him for a while as a pilot. The poor fellow served him very faithfully; on which, first taking the judgment of his officers and ship's company, Nelson called to the man, whose name was Carver, to approach him and said: "You have rendered me a very essential service and it is not the custom of English seamen to be ungrateful. In the name therefore, and with the approbation of the officers of this ship, I return your schooner and with it this certificate of your good conduct. Farewell, and may God bless you." There can be no question that Nelson acted as is here recorded; proof of it may yet be extant in the original manuscript of the certificate that was framed and hung up in the house of Isaac Davis of Boston; but it is difficult to believe that he made the above speech to Carver. It is not the language of a bluff sailor; it is too melodramatic; it sounds, in short, as though written for a stage Nelson. Anyway, Carver was so grateful for the act, that he came off to the ship at the hazard of his life with a most useful and timely gift of sheep, poultry, and provisions, which Nelson insisted upon paying for.

Whilst at Quebec Nelson fell in love with an American lady. The *Albemarle* was ready for sea when Alexander Davison, whose name is intimately asso-

dated with that of Nelson in his life and correspondence, met the frigate's captain as he sprang from a boat on to the beach. Davison eagerly asked him the occasion of his return. "Walk up to your house," replied Nelson, "and you shall be acquainted with the cause. I find it utterly impossible to leave this place without again waiting on her whose society has so much added to its charms and laying myself and my fortunes at her feet." "Your utter ruin," cried Davison, "situated as you are at present, must inevitably follow." "Then let it follow!" exclaimed Nelson, "for I am resolved to do it." Davison, however, managed to blandly but firmly convey Nelson back into his boat and saw him safely off, perhaps watching from the beach until the *Albemarle* had got her anchor and was blowing out to sea.*

In October he sailed with a convoy to New York, where he found the fleet under the command of Lord Hood, namely the *Barfleur* with twelve sail-of-the-line, part of Lord Rodney's victorious ships of the 12th of April. Nelson waited on Admiral Digby on his arrival and Lord Hood was present. "You are come," said Digby, "on a fine station for making prize-money." "Yes, sir," replied Nelson, "but the West Indies is the station for honour." Lord Hood seems to have noted this speech. "He has honoured me highly by a letter," Nelson writes to Captain Locker, November 17, 1782, "for wishing to go off this station to a station of service, and has promised me his friendship."

* Clarke and M'Arthur. Vol. i., p. 77.

Prince William Henry, Duke of Clarence, afterwards William IV., had quitted Admiral Digby, under whom he had been serving as midshipman, for the *Barfleur*, on Lord Hood's arrival. He was on board that vessel when Nelson came off in his barge, and he afterwards described him as the merest boy of a captain he had ever beheld. His dress, he said, was worthy of attention. He had on a full-laced uniform; his lank, unpowdered hair was tied in a stiff Hessian tail of an extraordinary length; the old-fashioned flaps of his waistcoat added to the general quaintness of his figure. The Prince could not keep his eyes off him. He had never before viewed so singular a sailor. He could not imagine who he was nor what he came about, but on Lord Hood introducing him, the Prince found something irresistibly pleasing in his address and conversation, and an enthusiasm when speaking on professional subjects that showed he was no common being. There was something certainly very grotesque in the old naval costumes. Many of the noblest of the old sea-captains must have shown wonderfully like scarecrows in their day. When St. Vincent first went to sea his dress was formed of a coat that had been made for him to grow up to. It reached down to his heels and was "full large" in the sleeves. The dirk and gold-laced hat could but heighten the absurdity of such a figure. * Jervis, however, learnt to respect dress and to insist upon it. A story is told of Commodore Thompson, who, being one day clad in a purser's duck frock and a common

•Brenton's 'Life of St. Vincent,' vol. i., p. 17.

straw hat, passed in his boat under the stern of the flag-ship. Jervis, viewing the Commodore with astonishment, hailed the boat. " In the barge there! Go and assist in towing that transport." The Commodore, fully appreciating the significance of this rebuke, stood up, and taking off his hat, answered with Jack's customary cry of " Aye, aye, sir," and proceeded to execute the order.*

* *Quarterly Review* | 1844, p. 432.

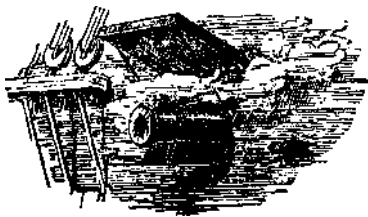

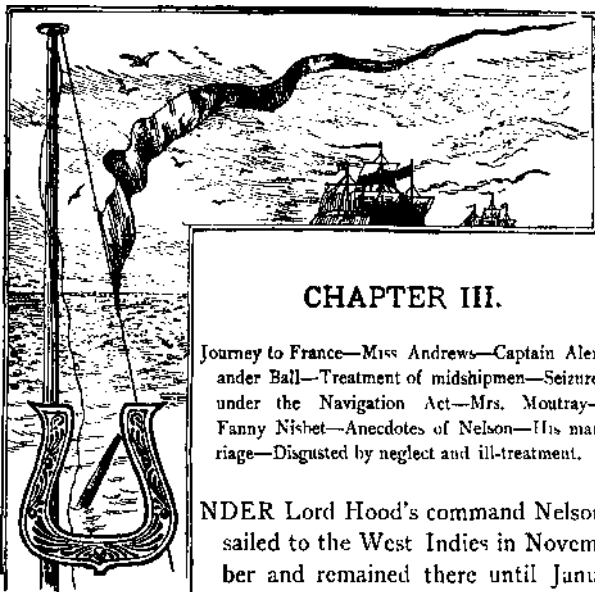

CHAPTER III.

Journey to France—Miss Andrews—Captain Alexander Ball—Treatment of midshipmen—Seizure under the Navigation Act—Mrs. Moutray—Fanny Nisbet—Anecdotes of Nelson—His marriage—Disgusted by neglect and ill-treatment.

UNDER Lord Hood's command Nelson sailed to the West Indies in November and remained there until January, 1783, when peace with France was concluded. Little that is worth noting occurred whilst he was on this station. He took a French brig, and made captive an illustrious foreigner and several French scientific gentlemen, whom he quickly, however, set at liberty. The *Albemarle* was paid off at Portsmouth July 3, 1783, and Nelson was placed on half-pay. On the 11th of the month Lord Hood carried him to St. James's Palace, and Pettigrew tells us that the King was very attentive to Nelson, perhaps on the recommendation of his son, Prince William, who was now able to state from personal experience that there was no man at that time afloat in the King's navy better able to give most

valuable information on naval tactics. It is said that when he left St. James's he dined with his Quebec friend Davison at Lincoln's Inn. "On his arrival he immediately threw off what he called his 'iron-bound coat,' and having procured a dressing-gown spent the evening in talking over the various occurrences of the interval that had elapsed since they last parted on the beach of the River St. Lawrence." * His talk would naturally concern his passion for the beautiful American lady whom Davison had obliged him to turn his back upon. Nelson's devotion to the ladies, however, like his ambition, was not to be restricted. In the Autumn of 1783, he went to France with Captain Macnamara, mainly with the intention of learning French, and at St. Omer met and fell in love with Miss Andrews, one of the three daughters of an English clergyman. How much in earnest he was may be gathered from his letter to his uncle, William Suckling, in which he tells him that the critical moment of his life is now arrived, that it depends entirely upon him, namely, his uncle, whether he is to be miserable or happy: in other words, as his income does not exceed £130 a year, will his uncle allow him £100 a year to enable him to get married? Suckling very handsomely complied; Nelson, however, did not marry Miss Andrews. Pettigrew believes he was rejected by her. What Nelson thought of her may be gathered from a letter which he wrote to his brother William. "She has such accomplishments

•Clarke and M'Arthur. Vol. i., p. 84.

that had I a million of money I am sure I should at this moment make her an offer of them." * Probably, £230 a year did not suggest an alliance sufficiently alluring to Miss Andrews, who had but a thousand pounds for her fortune. There could have been no ill feeling, however, for the girl had a brother in the Navy who subsequently became the friend and follower of Nelson.

Two naval officers were at St. Omer when Nelson was there. He thought them great coxcombs, chiefly because they wore epaulets, which was a French fashion that Nelson detested, though eleven years later the epaulet was ordered to be worn as part of the British naval uniform. One of these "coxcombs" was Captain, afterwards Sir, Alexander Ball, who had gone to sea in 1768 through reading "Robinson Crusoe." That Nelson's instant dislike of Ball was reciprocated does not appear, but it is remarkable that fourteen years later they came together at sea in a violent storm, when Ball rendered Nelson such services as caused the *Hero* to embrace him as his deliverer, and for the remainder of their lives they were intimate and even affectionate friends.

In March he was appointed to the *Boreas*, of twenty-eight guns, and sailed for the Leeward Islands, having with him Lady Hughes, the wife of Sir Richard, Commander-in-chief on that station. With him, as chaplain, went his brother, the Rev. William, afterwards the first Earl Nelson, a man

* "Dispatches and Letters," vol. i., p. 91. Miss Andrews married first a clergyman of the name of Farrer and second Col. Warneof the E. I. C. S.

whose character is warmly attacked by Pettigrew and pleasantly defended in our day by Mr. J. C. JeafTreson.* There were thirty midshipmen in the *BoreaSy* and Nelson's treatment of them was observed and recorded by Lady Hughes. The tenderness of his noble nature is finely illustrated by the lady's description. There were timid spirits amongst the lads, little creatures who gazed with affright at the towering masts it was their duty to climb. Nelson, to encourage them, would say, "I am going a race to the masthead, and beg I may meet you there," then would spring into the lee shrouds whilst the nervous little middy crawled up to windward; and Lady Hughes tells us that when they met in the top he would speak in the most cheerful way to the boy, and observe: "How much any person was to be pitied who could fancy there was any danger, or even anything disagreeable in the attempt." It was such traits as these that made Nelson loved as never was naval hero loved by sailors. His example, too, was of incomparable service, a life-long influence to the youths of his quarter-deck. He was always the first to arrive with his quadrant to take sights at noon. Regularly every day he would enter the school-room and stand listening and looking on whilst the boys buzzed through their nautical studies. "I make it a rule," he said, speaking of his midshipmen, "to introduce them to all the good company I can, as they have few to look up to, besides myself, during the time they are at sea."

*See "*Lady Humilton and Lord Nelson*," by J. C. Jeaffreson, *Passim*.

The *Boreas* reached Barbadoes on the 26th of June, and for nine months Nelson was occupied in suppressing the illegal traffic that was carried on in those islands. The trade with the West Indies had been almost entirely in the hands of the Americans, but they had ceased to be colonists and were now foreigners, and under our Navigation Laws had no right to trade in British colonies. Nelson found Sir Richard Hughes indifferent to British interests, perhaps secretly conniving at what was going forward. He seized many vessels which he knew were not privileged to trade, and for simply doing his duty was, as he himself says, "persecuted from one island to another." His zeal was very little relished. It was his opinion that men-of-war were sent abroad for other purposes than to be made a show of; he recommended Sir Richard Hughes to study the Navigation Act; and he hauled down a broad pennant that had been hoisted on board the *Latona* by order of the Resident Commissioner Moutray, on the ground that he, Nelson, knew of no superior officers besides the Lord Commissioners of the Admiralty and his seniors in active service on the post. The splenetic governor of the Leeward Islands, Sir Thomas Shirley, fell into a passion on finding his opinions firmly objected to by Nelson, and told him hotly that old generals were not in the habit of taking advice from young gentlemen. "Sir," answered Nelson, contemptuously, "I am as old as the Prime-Minister of England, and think myself as capable of commanding one of his Majesty's ships as that minister is of governing the State."

In a letter to Captain Locker Nelson briefly explained this difficulty of illicit traffic thus: "An American arrives; he has sprung a leak, or a mast; he makes a protest, he gets admittance, sells the cargo for any money, goes to Martinico, buys molasses, and so round and round; but I hate them all." On his arrival at Nevis he found four American vessels lying there deeply laden and flying the island colours, white with the red cross. They were required to hoist the American flag and leave in forty-eight hours. The masters denied that they were Americans, and refused to obey Nelson's orders. The crews were thereupon summoned to the cabin of the *Boreas* and examined by the Judge of the Admiralty, who happened to be on board, and after a little coaxing they all confessed they were Americans, and that their vessels and cargoes were wholly American property. On being proceeded against the four vessels with their cargoes were condemned as legal prizes to the *Boreas*. A rascally attorney got hold of the American masters and induced them to swear that their own and the depositions of their crews had been extorted from them by bodily fear. An actiort for damages—Pettigrew says £4,000, but Clarke and M'Arthur call it £40,000, Nelson himself talking of it as "the enormous sum of forty thousand pounds sterling"—was immediately commenced, against Nelson, and for many weeks he had to keep in hiding in his cabin, the ingenuity of his first lieutenant, Wallis, alone preserving him from arrest. One of his officers referring to this restraint used the word pity. Nelson was on **fire in an instant**. "Pity, did you say?" he **cried**: "I shall live,

sir, to be envied! And to that point I shall always direct my course." At the expiration of eight weeks the trial came on ; he pleaded his own cause, and his statements were so perfectly clear that the four American vessels were condemned. He memorialised the Government, and was ordered to be defended at the expense of the Crown. But the Commander-in-chief alone received thanks from the Treasury for the work that Nelson had done. " I feel much hurt," wrote Nelson to his friend Locker, " that after the loss of health and risk of fortune another should be thanked for what I did and against his orders." That Sir Richard should have coolly accepted those thanks, must justify to every reader of the life of Nelson the contempt with which our Hero regarded the Commander-in-chief, whom he would scornfully speak of as " that fiddler."

Amidst all his many varieties of occupations, however, and in defiance of the menaces of attorneys, and the abuse and hatred of Yankees and West Indian settlers, Nelson could find leisure to fall in love and marry. Possibly he would have laid his heart and fortune at the feet of Mrs. Moutray, the wife of the Commissioner of Antigua, had she been a widow. He writes of her as having been " *very, very good* ' to him; declares that but for her he must almost have hanged himself " at this infernal hole." She appears to have been a very charming woman. Collingwood loved her and wrote thus of her:

*' To you belongs the wondrous **art**,
To shed around you pleasure ;
New worth to best of things impart,
And make of trifles—treasure."

It was at the Island of Nevis, however, that Nelson "met his fate," as the novelists of his age would have said. Mrs. Fanny Nisbet, whose husband, Josiah Nisbet, a medical man, had died insane eighteen months after his marriage, was at St. Kitt's when Nelson paid his first visit to her uncle, Mr. Herbert, then President of Nevis.* A lady who was at the house when Nelson arrived, thought to amuse Mrs. Nisbet by describing to her in a letter "the little captain of the *Boreas*" as she called him. She told Fanny how he came up just before dinner, much heated, and that he was very silent, though he seemed to think the more. He drank no wine till the toasts of the King, the Queen, the Royal Family, and Lord Hood were given, and then "this strange man," wrote the lady, "regularly filled his glass and observed that those were always bumper toasts with him." But when he had passed the bottle he was silent again. The lady was much puzzled; she could not make out the little man's real character. His behaviour was one of sternness and reserve, but when he at long intervals uttered himself there was the hint of a very superior mind in what he said. "If you, Fanny, had been there you would have made something of him; for you have been in the habit of attending to these odd sort of people."

Six months after this Nelson was again at Nevis. Mr. Herbert on hearing of his arrival hastened

* This gentleman offered to become bail for Nelson, if he chose to suffer an arrest, to the amount of ;£10,000, observing that ^{4k} the captain had done no more than his duty, though he was one of the **greatest** sufferers by it.—Churchill's • Life of Nelson," p. 22.

to receive him and found him playing at hide-and-seek under the dining-room table with Mrs. Nisbet's child, Josiah, then three years old. A few days after, Mrs. Nisbet met Nelson and thanked him for his kindness to her little boy. He fell in love with her, found her indeed even more attractive than Miss Andrews had proved, spoke of her in a letter to William Suckling as twenty-two years old, "and her personal accomplishments, you will suppose, I think equal to any person's I ever saw." There can be no question as to the ardency of his love and of the sincerity of his devotion as a husband down to the time when Lady Hamilton was nursing him at Naples into a passion for her own beautiful and fascinating self. His union was delayed by his professional duties. Prince William warmly encouraged the match, promised to be present at the wedding and *give* away the bride. Nelson's letters to Fanny Nisbet at this time are full of delightful gossip about himself, and her, and his hopes and prospects; and nowhere else in his correspondence is the tenderness of his heart, the manliness of his beautiful, touching, sailorly character more visible. They were married on the 12th of March, 1787. Prince William kept his promise, but the marriage appears to have been quite private. Many of his professional friends considered he had made a sad blunder in burthening himself with a wife. "The Navy, sir," exclaimed Captain Pringle to a brother officer on the day after the wedding, "yesterday lost one of its greatest ornaments by Nelson's marriage. It is a national loss, that such an officer should **marry**; had it **not**

been for that circumstance I foresaw that Nelson would become the greatest man in the service."

Such foresight is not a little diverting in retrospect. Assuredly his marriage did not hinder him in his prosecution of services which rendered him in the highest degree obnoxious to the numberless rogues of the West Indies of those days. He detected and exposed the nefarious proceedings of contractors and prize-agents; he supplied the Admiralty with statements of fraud upon the Government amounting to a million sterling. It was all thankless work to him. "My activity of mind is too much for my puny constitution," he wrote to his uncle; "I am worn to a skeleton." Nevertheless his efforts in the public interest were unremitting down to the hour of his weighing anchor for home, his maxim being that it was better for a man to serve an ungrateful country than to give up his fame.

The *Boreas* sailed for England in June, 1787, and arrived at Spithead on the 4th of July. She was not paid off until the end of November. In the previous October he applied to Lord Howe for a ship of the line but was told that as the *Boreas* was victualled for three months and ready for sea he must hold himself prepared to sail at a moment's notice. No orders were received, however, and the disheartening condition of uncertainty induced emotions of disgust and irritation. The *Boreas* was kept at the Nore until the 30th of November as a slop and receiving ship! The claims which Nelson had upon the attention of the Admiralty deeply underscored, to his sensitive mind, this stroke of insulting neglect. It is

said that had he possessed the means of living independently on shore he would never have gone to sea again. When his ship was at last paid off he declared to the senior officer in command in the Medway, " That it was his firm and unalterable determination never again to set foot on board a King's ship." The senior officer was patriotic enough to understand that such a man as Nelson must on no account be lost to the country. He swiftly and secretly communicated with the Admiralty, with the result that before Nelson went ashore with the intention of resigning his commission he received a kind letter from Lord Howe, who expressed a wish to see him on his arrival in town. Nelson called upon Howe, talked to him about the West Indies and what he had done there, and so pleased him that he offered to present him to the King on the first levee day. Nelson's disgust was appeased by his reception at Court. The monarch's graciousness reanimated the sailor's loyalty, which it is very certain the contemptuous coldness of the Admiralty had gone very near to extinguish.

Meanwhile his health was extremely bad, and, to mitigate the consequences of an English winter upon a constitution that was now in some degree acclimatised to the high temperatures of the West Indies, he resolved to visit Bath. He afterwards retired with his wife to Burnham Thorpe. His intention had been to go to France, to acquire the language with the help of his wife who spoke it fluently, but his father begged him to remain at the parsonage. " Horace," the old Rector is made to exclaim

by Clarke and M'Arthur, " it would have been better that I had not been thus cheered if I am so soon to be bereaved of you again. Let me, my good son, see you whilst I can; my age and infirmities increase and I shall not last long/'

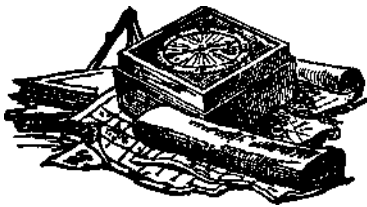

CHAPTER IV.

Long period of inactivity—Vain application for employment—Life in the country—Asks for command of a *cockle-boat*—Commissioned to the *Agamemnon*—Sails with Lord Hood's fleet—Sir William and Lady Hamilton—Anecdotes—Action off Sardinia—

Services on the coast of Corsica—Confidence reposed in Nelson—Cession of Corsica to Great Britain—Rastia.

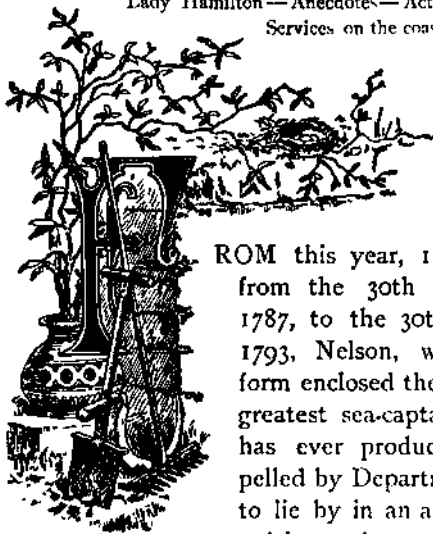

FROM this year, 1788, or rather from the 30th of November, 1787, to the 30th of January, 1793, Nelson, whose delicate form enclosed the genius of the greatest sea-captain the world has ever produced, was compelled by Departmental neglect to lie by in an almost poverty-stricken retirement. John Jervis had been even worse used. The gallant associate of Wolfe was neglected and unemployed for nearly twenty years.* Honourables and Right Honourables, Lordlings, Lords* toadies, led Captains' favourites,—these and the like of these obtained recognition, encouragement, employment; but the son of an

* *Edinburgh Review*, 1839, p. 40.

humble country parson must be without influence; his valuable West Indian services spoke for him, but unfortunately to ears which were unwilling to *listen*. That he could have gone fresh to the command of a ship of war, equal to every requirement of sea manoeuvre and of naval and military tactic, after his five years of bucolic rust, shows how thoroughly the ocean had done its work with him, how every fibre in him had been laid up into the true marine strands of the British nautical character.

Those five years of inactivity must have been a terrible penance to his eager spirit. He sought to kill the time by digging in his father's garden. He and his wife would go birds'-nesting. He studied charts, read the periodical works of the day, wrote, and drew plans. His favourite amusement was coursing. One of his biographers tells us he once shot a partridge, but his manner of holding a gun was so awkward—keeping the piece always cocked as though he were about to board an enemy, and letting fly when a bird appeared without taking aim or putting the fowling-piece to his shoulder—that any one who attended him went in fear of his life. He was sensible, however, of his imperfection as a sportsman: "Shoot I cannot, and therefore I have not taken out a licence." * One day he went to the fair to buy a pony. Whilst he was gone two rough fellows arrived at the parsonage and asked for CaptairWNelson. Mrs. Nelson was at home. They carefully ascertained that she was veritably Nelson's wife, and then presented her with a writ on the part

*/' *Dispatches and Correspondence*,' vol. i., p. 282.

of the American captains who had laid their damages at ,£20,000. Nelson's rage on his return may be imagined. *His* was the constitutional irritability of genius at all times, and we may suppose that his temper had not been sweetened by his long spell of half-pay obscurity, which yet promised no end, and by the cold-blooded replies he had received from the Admiralty in response to his entreaties for a ship. "If the Government will not support me," he exclaimed, "I will leave the country!" He wrote to the Treasury and promised that if a satisfactory answer were not sent him by return of post he would take refuge in France. In fact he made every arrangement for executing his threat even whilst he was despatching it. He was to go first, and ten days later Mrs. Nelson was to follow him under the care of his elder brother, Maurice.

Happily his friend Captain Pringle came to the rescue. He was to be supported by the Treasury. "Captain Nelson is a very good officer and need be under no apprehension." All this while he was corresponding with Prince William Henry, who was now commander of the *Andromeda* frigate, whilst the Admiralty would not give the future victor of Trafalgar the command of a cock-boat. The Prince did his best, spoke of him everywhere in warm terms of admiration, recommended him to Lord Chatham, who was first Lord of the Admiralty in July, 1788; but to no purpose. On the 5th of December, 1792, Nelson wrote: "If your Lordships should be pleased to appoint me to a *cockle-boat* I

should feel grateful." This letter, Sir Harris Nicolas says, is not to be found ; but that it was written, that at all events an application by Nelson was made, may be gathered from the subjoined response, couched in the traditional British Departmental tongue, originally designed, no doubt, for the production and encouragement of a race of great naval officers for the defence of the country. " Admiralty Office, 12 December, 1792. Sir: I have received your letter of the 5th instant expressing your readiness to serve, and I have read the same to my Lords Commissioners of the Admiralty." *

After five years of unendurable inactivity, when hope was almost dead in him, he was commissioned to the *Agamemnon*, a very fine ship of sixty-four guns. "*Post nubila Phæbus!*" he joyfully wrote to his wife; "after clouds come sunshine. The Admiralty so smile upon me that really I am as much surprised as when they frowned." But then everything now was indicating war. An English ship looking into Brest had been fired at. The pacific intentions of the British Government had proved of no avail, and there was nothing for it but to fight. Lord Hood was well acquainted with Nelson's character; so too was Prince William; the services of such a man at such a moment must be had; and so on the 27th of June, we find the *Agamemnon* sailing for Gibraltar with Lord Hood's fleet, nineteen sail-of-the-line, and a convoy of merchant-ships.

Nelson is now in high spirits. "We are all well,"

* "Dispatches and Letters," vol. i.. p. 201.



SIR WILLIAM HAMILTON.

he wrote to his wife in the previous month ; " indeed, nobody could be ill with my ship's company, they are so fine a set. Don't mind what newspapers say about us." " I not only like the ship," he tells his brother, " but think I am well appointed in officers, and we are manned exceedingly well; therefore have no doubt that we shall acquit ourselves well, should the French give us a meeting." On Lord Hood's arrival in the Mediterranean, he stationed his ships at Toulon, and after some negotiations it was agreed by some of the members of the Provisional Government to deliver up the town, arsenal, ships, forts, etc., to the British forces in the name of Louis XVII. After this surrender, Nelson was ordered to Naples with dispatches for Sir William Hamilton, the British Minister. On the 31st of August the *Agamemnon* fell in with the *Tartar* with Lord Hugh Seymour Conway on board, who sent a note by boat to him in which he gave him news of what had happened at Toulon subsequent to his sailing. " Our fleet and that of Spain are now anchored," wrote his Lordship ; " our squadron landed fifteen hundred men on the 28th, and the day following we anchored in the outer road." Nelson's astonishment is expressed in a letter to his wife, which he began on the 7th and closed on the 14th of September. " What an event," he exclaimed, " this has been for Lord Hood ! Such an one as history cannot produce its equal; that the strongest place in Europe and twenty-two sail-of-the-line, etc., should be given up without firing a shot! It is not to be credited."

On his arrival at Naples he called on Sir William

Hamilton, and Sir John Francis Acton, the Prime-Minister, a man of English origin, born in 1736 in France, whose spelling in his English letters is only a little less illiterate than Lady Hamilton's.* He was introduced to the King and the Court, and overwhelmingly welcomed with every effusion of Italian emotion as the representative of "the saviours of Italy," as the English were called. The plain sailor was much affected by the King's marked attention and condescension, and received from him, written by his Majesty's own hand, "the handsomest letter that can be penned" to Lord Hood, offering six thousand troops to assist in the preservation of Toulon, though Hood's demand was for ten thousand.

Now it was that he was first introduced to Lady Hamilton, "the bewitching siren," as she is again and again called by Nelson's earlier biographers,—a woman whose influence over the Hero in the years of his greatness and his glory imparts such an element of romance to his story that the like of it must be sought for in vain in the annals of the great men of the world. It is unnecessary to trace her career in these pages. Enough if it be said that she was born in 1763 ; that she served in the capacity of nursemaid to Mr. Thomas, of Hawarden, and to Dr. Budd, physician ; that she worked for a time as servant in the family of a tradesman in St. James's Mar-

* March 11, 1800, Nelson wrote to Admiral Goodhall: "Acton is married to his niece, not fourteen years of age: so you hear it is never too late to do well. He is only sixty-seven." There were three children by this marriage.



EMMA, LADY HAMILTON.

AFTER A PAINTING BY ROMNEY.

ket; that she had as friends several men of fashion and disrepute; that she was the "goddess of Health" of the notorious Graham's Temple; that Romney, the painter, thought her the most adorably beautiful woman he had ever beheld; that in 1786 she became intimate with Sir William Hamilton, whom she married in London on the 6th of September, 1791. Mr. Jeaffreson thus describes her (*circa* 1786): "She was still a lithe, lissom, agile, slim girl, with a waist none too small for health and classic grace, but looking somewhat less than its actual girth by reason of the boldness of her figure's upper and lower contours, which, even in the season of her bodily slighthness, betokened that in middle age her figure would be less remarkable for elegance than for stately dignity. . . . Some biographers have preferred to speak of her chestnut hair, but in doing so they were thinking of the deepest colour of the chestnut's rind—of a deep brown, toned with scarcely perceptible redness. Though they lacked the feathery softness of the Byronic curls, Emma's tresses in their colour resembled Byron's hair so closely that three inches snipped from the end of one of her ringlets might be used to give greater volume to a relic taken from the poet's head." * To beauties of face and form she united talents of an alluring sort. She was a sweet singer; she played the harp agreeably, and Lieutenant Parsons is never more effusive than when he describes her bending her lovely figure over that instrument; she was an excellent actress,

* "*Lady Hamilton and Lord Nelson*," vol. i., p. 145.

with great command over her face, and she was a mistress of postures. *

The manner and circumstance of her meeting with Nelson were, it may be supposed, related by herself to Harrison, whose life of the Hero was written under her eye. Nearly everything she delivers is highly coloured, but there is probably truth in her account of Nelson's introduction to her. Sir William, after a short conversation with the Captain of the *Agamemnon*, told Lady Hamilton that he would introduce her to a little man who was not indeed handsome, but who would become the greatest man that England ever produced. "I know it," he exclaimed, "from the very few words of conversation I have already had with him. I pronounce that he will one day astonish the world. I have never entertained any officer at my house, but I am determined to bring him here; let him be put in the room prepared for Prince Augustus." Nelson is reported to have said to Sir William towards the close of their first conference: "You are a man after my own heart; you do business in my own way; I am now only captain, but if I live I will be at the top of the tree." All through his life Nelson is made, by his biographers, to boast and brag of what he has done and will do. Yet conspicuous amongst his finest qualities was his modesty. We may be quite sure that he said but very little of what has been put into his mouth.

Of Lady Hamilton he wrote thus briefly and drily to his wife: "She is a young woman **of amiable**

* Pettigrew. Vol. i., p. 407; ii., p. 599.

manners and who does honour to the station in which she is raised." He is content to claim his wife's regard for her by saying that "Lady Hamilton has been wonderfully good and kind to Josiah,"—that is to say, to Mrs. Nelson's son by her first husband, now in his step-father's ship.

He returned to the fleet, and on the 9th of October received from Lord Hood sealed orders, which subsequently despatched him to Cagliari, where he placed himself under the direction of Commodore Linzee. On the 22d, when off the Island of Sardinia, having only three hundred and forty-five men at quarters, he fell in with and chased four French frigates and a brig. One of them, the *Melpomene*, he disabled; the other ships declined to bring the *Agamemnon* again to action, and hauled from her to look to their sinking consort. Nelson's ship was so cut to pieces aloft that she was unable to brace up to pursue. "Captain Nelson," wrote young William Hoste, then a midshipman on board the *Agamemnon*, in an account of this conflict sent to his father, "is acknowledged to be one of the first characters in the Service, and is universally beloved by his men and officers." There could have been nothing as yet, however, but a personal superiority in conversation, in theories of discipline, and in professional opinions to compel such a judgment as this. He had spent *five* years in obscurity. His West Indian services were hardly of a sort to be highly valued by his sea-brethren as illustrations of a heroic character. Little had come to his hand to do since he had taken command of the *Agamemnon*;

yet already everybody was talking of him as one of the first characters in the Service. The compelling strength of the individualism this indicates is extraordinary, particularly if we consider how bitter were the vocational jealousies of those times, "when," as the old saying used to go, "if there was ever a naval officer to be roasted there was always a naval officer close by ready to turn the spit."

It would need a stout volume to contain the services of Nelson whilst on the coast of Corsica. Lord Hood gave him the command of a squadron of frigates to protect British trade, and to preserve that of the Grand Duke of Tuscany. Nelson always regarded Lord Hood as the greatest sea-officer he had ever met. Yet of this fine old Admiral's conduct at Toulon, Sheridan, in 1804, ^m the debate on the prizes taken at Toulon, could say, "he was entitled to the strongest reprobation"!* His discernment of Nelson's genius was prompt and decisive. When the Hero received his appointment to the command of a squadron, there were five captains his seniors in the fleet. But the Commanders-in-chief under which he served seemed always to know their man. In 1796 he wrote to his wife: "One captain told me: 'You did just as you pleased in Lord Hood's time, the same in Admiral Hotham's, and now again with Sir John Jervis; it makes no difference to you who is Commander-in-chief.' I returned," he adds, "a pretty strong answer to this speech." It was true

* *Naval Chronicle* | vol. ii., p. 485. The virulence of party feeling that the whole debate exhibits seems incredible even in this age of abusive ranting "politicians."

nevertheless, and the truth of it was the secret of St. Vincent and Copenhagen, if not of Aboukir and Trafalgar.

It was held as a matter of the first consequence after the evacuation of Toulon, that Corsica should be in the hands of the British. Paoli, a name familiar to all readers of Boswell's "Life of Johnson/" was the leader of the insurgents. He desired the assistance of the English, and the island was ceded to Great Britain. Sir Gilbert Elliot was appointed Viceroy. Nelson meanwhile was cruising off the island, actively engaged in annoying the French and in preventing any supplies from reaching them. In the "Dispatches and Letters" is an abstract of his services,* in which we find him landing four miles from St. Fiorenzo, and burning the only water-mill in that part of the country; then burning four polacres loaded with wine for the French; then burning eight sail of vessels and destroying a thousand tons of wine; then attacking a French courier boat; cannonading Bastia and so on: all the dates very rapid,—February 6th, 8th, 12th, 19th, 24th, 26th. He furnished Lord Hood with an intelligent and valuable report on Bastia and its defences. "It is a beautiful place," he writes to his wife under date of May 4th, "and the environs delightful, with the most romantic views I ever beheld. This island is to belong to England, to be governed by its own laws as Ireland, and a Viceroy placed here, with free ports. Italy and Spain are jealous of our obtaining possession - it will command the

* Vol. i., p. 349.

Mediterranean." He was certain that if Bastia were attacked it would fall. Sir David Dundas, the commander of the forces thought otherwise, though Lord Hood agreed with the little Captain of the *Agamemnon*. Nelson had a poor opinion of soldiers. They were too slow for his headlong mind. His prejudices dated from 1780, the year of the expedition against San Juan, when he had himself to lead the troops and show them what to do. And now off Corsica he writes to his wife: "If I had carried with me five hundred troops, to a certainty I should have stormed the town and I believe it might have been carried. Armies go so slow that seamen think they never mean to get forward, but I dare say they act on a surer principle, although we seldom fail." In his own sailors he had the most unbounded confidence. He considered them invincible, and under him assuredly they proved so. "They really mind shot no more than peas," he proudly tells Mrs. Nelson.

Troops, marines, and seamen were disembarked for the siege on the 3d of April. The English batteries did not open until the nth, on which day Lord Hood had sent a flag of truce and a summons to surrender. "I have hot shot," was the answer; "for your ships, and bayonets for your troops. When two thirds of our men are killed I will then trust to the generosity of the English." On which the batteries let fly. Bastia was taken possession of on the 22d. At six in the morning the troops marched from their posts, the band playing "God **save the King.**" At seven the tri-colour to right **and**

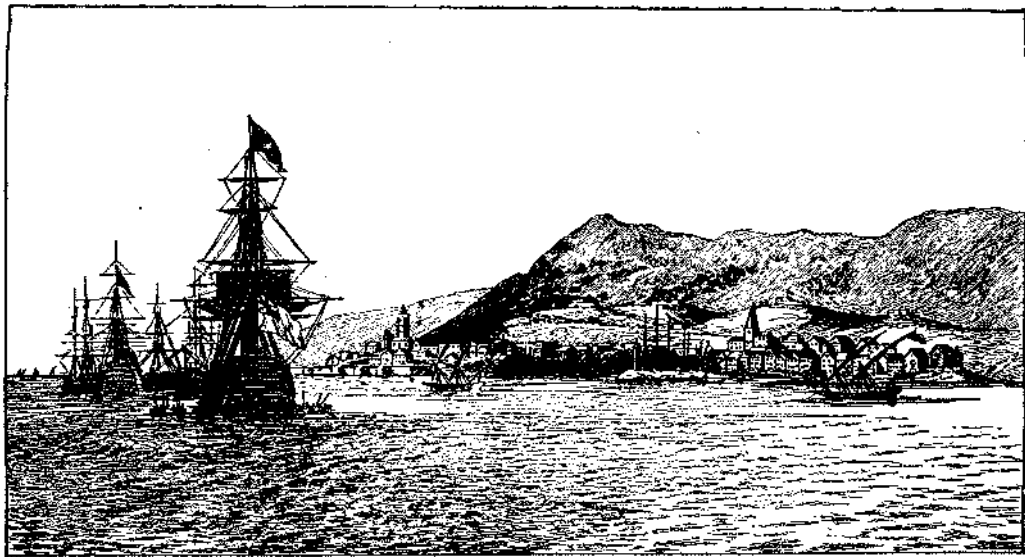

BASTIA, ISLAND OF CORSICA—1799. "VICTORY" AND FLEET AT ANCHOR.

FROM A DRAWING BY N. POCOCK.

left was hauled down and the British colours hoisted amid the cheers of the soldiers and sailors. Nelson called it "the most glorious sight that an Englishman could experience and which I believe none but an Englishman could bring about," and adds, "four thousand five hundred men laying down their arms to less than one thousand British soldiers who were serving as marines! "

During this siege he was hurt in the back: he speaks of it as a cut. The capture of Bastia was largely—indeed if we look closely into the narrative of it we might think almost wholly—owing to Nelson. He rightly conceived that his services were not fairly represented, nor justly emphasised in Hood's dispatch. The old Admiral might have written hurriedly, yet he could find leisure to heap praise upon a Royal Artillery officer. "When I reflect," Nelson wrote to William Suckling, February 7, 1795, "that I was the cause of re-attacking Bastia, after our *wise* generals gave it over from not knowing the force, fancying it two thousand men; that it was I who landed, joined the Corsicans, and with only my ship's party of marines, drove the French under the walls of Bastia; that it was I who knowing the force in Bastia to be upwards of four thousand men, as I have now only ventured to tell Lord Hood, landed with only twelve hundred men, and kept the secret to within this week past;—what I must have felt during the whole siege may be easily conceived. Yet I am scarcely mentioned. I freely forgive, but cannot forget." * However, in

* Quoted by Pettigrew from the *Athenaum* for 1834.

the previous July he had written to the same correspondent that Lord Hood and himself were never better friends, and adds: "Nor, although his letter does, did he wish to put me where I never was—in the rear'

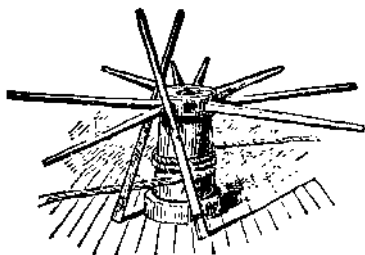

CHAPTER V.

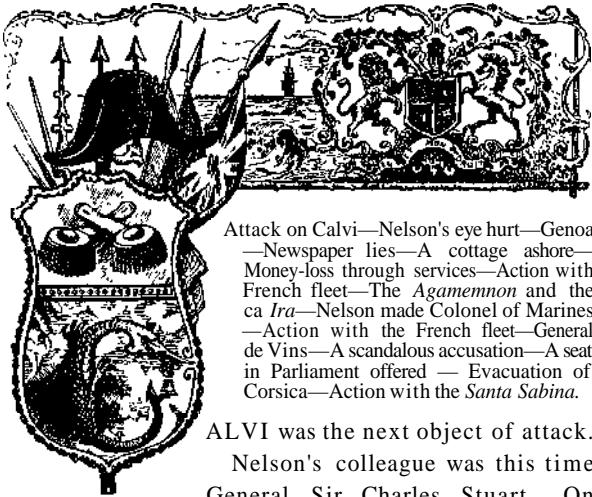

Attack on Calvi—Nelson's eye hurt—Genoa—Newspaper lies—A cottage ashore—Money-loss through services—Action with French fleet—The *Agamemnon* and the *ca Ira*—Nelson made Colonel of Marines—Action with the French fleet—General de Vins—A scandalous accusation—A seat in Parliament offered — Evacuation of Corsica—Action with the *Santa Sabina*.

ALVI was the next object of attack.

Nelson's colleague was this time General Sir Charles Stuart. On the 19th of June, 1794, the troops, consisting of 1,450 men, were disembarked at Port Agro. The service was extraordinarily laborious. The guns had to be dragged up acclivities, often steep, and to a distance of not less than a mile and a half. It was on the 12th of July that the enemy suddenly opened a heavy fire from San Francesco. A military officer named Anderson, with two others of the 51st Regiment, were standing with Nelson in his battery when a shell fell upon the ramparts, from which they were taking a view of the structure the enemy had erected opposite. They instantly flung themselves down on their faces, and the shell burst in the sand-bags of which the battery was composed.

Nelson, on rising, exclaimed that there was something in his eye. The officers examined it, said they could see nothing but a little sand, and advised him to wash it. The sight of the eye did not immediately fail him, but he ultimately lost it. He described the disaster to his wife thus, in a letter dated August 18th: "As it is all past I may now tell you that on the 10th of July [so in Clarke and MARTHUR, but the date is the 12th],* a shot having hit our battery, the splinters and stones from it struck me with great violence in the face and breast. Although the blow was so severe as to occasion a great flow of blood from my head, yet I most fortunately escaped, having only my right eye nearly deprived of its sight."

After the capture of Calvi, Nelson was sent to the Mole of Genoa with dispatches to Mr. Drake, the Minister there. He found Genoa a magnificent city of palaces, and wrote of it with such enthusiasm of poetic delight as is very rarely indeed to be found in his plain, straightforward, sailorly correspondence. The Doge received him with some sort of state, was full of civilities and courtesies, and was satisfied by Nelson's assurance that the strictest attention should be paid to the neutrality of Genoa. In November he was sent to look after the French fleet, and found sixteen sail-of-the-line, and several frigates at Toulon. A report which he calls "diabolical" was at this time current that the *Agamemnon* had been captured by the French. Nelson wrote indignantly to his wife: "Never believe any thing you may see in the

* See "Dispatches and Letters," vol. i., p. 435.

papers about us, and rest assured that *Agamemnon* is not to be taken easily : no two-deck ship in the world, we flatter ourselves, is able to do it." He loved his ship as if she were his wife : she grew in his affection in proportion as she was cut up and maimed by the balls of the enemy. He declared that she was the finest ship he had ever sailed in, and protested that were she a seventy-four nothing could induce him to leave her whilst the war lasted.

About this time his mind was much fixed on the fancy of a cottage ashore. One thinks of it as a sailor's dream and idealism, the growth out of many a lonely quarter-deck reverie in distant seas of the picture of a little roof nestling red amid the branches of trees, with the scent of the honeysuckle sweet upon the air, and all about a pleasant summer noise of bees and the songs of birds, and the lowing of cattle knee-deep amidst the buttercups. His hope is to live with his wife for many happy years in this cottage, which he is determined to purchase " if we can bring ,£2,000 round." So far the war had done considerably less than nothing for him. The taking of Corsica, he tells Suckling, like the taking of San Juan, cost him money: San Juan some £500; Corsica, £300, together with an eye and a cut across his back. Nothing but his determined resolution to serve his country enabled him to support the neglect he was at this time experiencing.

March 10, 1795, brought intelligence to Admiral Hotham that the French fleet had been seen off the Isle of Marguerite. Nelson, in full expectation of a general action, writes thus to his wife whilst the

signal is flying for a general chase: " My character and good name are in my own keeping. Life with disgrace is dreadful. A glorious death is to be envied; and if anything happens to me, recollect that death is a debt we must all pay, and whether now or a few years hence can be but of little consequence." But spite of this philosophical view a few years proved of great consequence to him, and of greater consequence yet to the nation he served as never before was nation served by a sea-captain of her breeding. Hotham was a respectable sailor, representing a school of which Gambier was another example. A very little in the shape of victory went a long way with him. Sir William Hamilton, sitting snug amidst his collection of art curiosities in his pleasant home overlooking the beautiful Bay of Naples, could write to Nelson that, "*entre nous*" his " old friend Hotham is not quite awake enough for such a command as that of the British fleet in the Mediterranean, although he is the best creature imaginable." * Had Nelson been in Hotham's place, the naval historian would have had to tell of this conflict with the French fleet a story very different indeed from what Hotham obliges him to recite. First the signal was made for eighteen sail of Frenchmen, then for twenty-five sail. March the nth the British were in order of battle with light draughts of variable wind brushing the heavy swell running from the south-west. Next day the two fleets were close, the wind still all round the compass, and the English almost becalmed. So it goes on till the 13th, when

* Southey.

a fresh breeze comes on to blow, and the English pursue the French, who are some three or four leagues distant. A French liner carries away her fore- and main-topmasts; the frigate *Inconstant* plumps a broadside into her, but the big Frenchman's shot obliges her to stagger away.* The disabled vessel proves to be the *fa Ira*, of 84 guns; there are two others hard by, the *Sans Culotte*, 120 guns, and the *Jean Barras*, 74 guns. Nelson heads for the *Qa Ira*, whose hawser is now aboard a frigate. The *Qa Ira* lets fly her stern-chasers, and so well directed are the guns that not a shot misses. On this the *Agamemnon* starboards her helm, and as she falls off, gives the *ca Ira* her whole broadside, each gun double-shotted. This manoeuvre is practised until one o'clock, the Frenchman meanwhile never being able to bring a broadside gun to bear upon his opponent. At dark, the *Agamemnon* takes her station, and the combat is over till daylight. The *Agamemnon* is then at the *Ca Ira* again, now in tow of *Le Censeur*, and at five minutes past ten she and *Le Censeur* strike to Nelson.† His manoeuvring in this affair is extraordinarily masterful. The captured vessels fought more gallantly than all the others of the French, owing, it is said, to a belief amongst the crews that no quarter would be given if they were taken. They discharged red-hot shot and used a sort of Greek fire. When these vessels had

* James says the frigate " gave her (*Ca Ira*) a broadside and stood on."

† From Nelson's own account. James's slightly differs. " Nav. His.," vol. i., pp. 286, 287.

struck, Nelson went on board Admiral Hotham and proposed that the two crippled British ships,* the two prizes, and four frigates should be left to themselves, that the enemy, who were heading under a press for the Isles of Hieres, might be pursued; but the Admiral answered: "No, we must be contented, we have done very well." "Now," says Nelson in a letter to his wife [April 1st], "had we taken ten sail and had allowed the eleventh to escape when it had been possible to have got at her, I could never have called it well done." He is of opinion that it was in the Admiral's power to have had such a day as was not to be met with in the annals of England. His theory, the determining impulse of his whole career in his relation with the French as foes, is strong here: "I verily think, if the Admiral can get hold of them once more, *and he does but get us close enough*, that we shall have the whole fleet. Nothing can stop the courage of English seamen."

He returned to St. Fiorenzo, and there remained until the 16th of April, on which day he wrote to Sir Gilbert Elliot, the Viceroy of Corsica, offering his own services and the command besides of such seamen as might be landed should the island be attacked. Then for ten days we hear of him beating to the westward, with the idea of joining expected reinforcements from England. He considered that the fleet had been forgotten by the people at home. More ships and men were badly needed; the French were in great force; and he

* *Illustrious and Courageux*,

wrote to Captain Locker that, -had the British vessels " not, fortunately, so much crippled the masts of the enemy in the action, we should have been left here in a very inferior state." He was astonished to learn that the store-ships and victuallers from Gibraltar had arrived in the fleet; their escape from the enemy he considered wonderful, and significantly adds: " Had we lost them our game was up here." * Lord Hood had himself remonstrated with the Admiralty on the smallness of the reinforcement which he was ordered to take out to the Mediterranean. The resignation of his command excited great regret. Nelson in particular held that had Hood remained in the Mediterranean the British might have regained Toulon, the Royalists then (August) being much more numerous at that place than they were when possession was first taken of it.

There was a promotion of flag-officers on the 1st of June, designed by the King to increase the significance of the commemoration of Howe's victory over the French in the preceding year. The epaulet was on this occasion for the first time introduced into the British Navy. Nelson was made a Colonel of Marines. The appointment was valuable to him as an honour, and it added to his pay. The Colonelcy was that of the Chatham Division. On the 4th of July Nelson, still in command of the *Agamemnon*, accompanied by a small squadron of frigates, was despatched to co-operate with the Austrian General de Vins in driving the French out of the Riviera of Genoa. He was chased for twenty-four hours by the **French**

• Clarke and M'Arthur. Vol. 1., p. 308.

fleet of seventeen liners and six frigates, and ran close to St. Fiorenzo, the enemy in hot pursuit; but though the breeze was variable, it was an inshore wind for the most part, and the English fleet could not get out to his assistance. He ascribed his salvation to the enemy being neither seamen nor officers.

On the 13th Admiral Hotham weighed with twenty-three sail-of-the-line, and on the 14th, according to Nelson, got sight of the French fleet. The weak west wind died away, a light easterly ail followed, and the French reached their own coast. This is Nelson's account, communicated in a letter to Captain Locker. James's version, however, represents that during the night of the 12th there was a heavy gale from the west-north-west, which split the main top-sails of six of the British ships; and that next day at daybreak it was still blowing strong, with a high swell. The enemy was then in sight. At half-past noon the wind suddenly shifted into the north, which enabled the rearmost of the French ships to bring their guns to bear upon the British van. *LAlcide*, seventy-four, after some brisk cannonading, struck to the *Cumberland*; but about a quarter of an hour after her surrender she caught fire in the fore-top, and was speedily in a blaze fore and aft. There were six hundred and fifteen souls aboard, of whom three hundred only were saved by the boats of the nearest British ships.* Nelson wrote contemptuously of the behaviour of the French, and spoke of the conflict as "a miserable action.*"

His co-operation with General de Vins must be

•James. Vol. i., p. ^96.

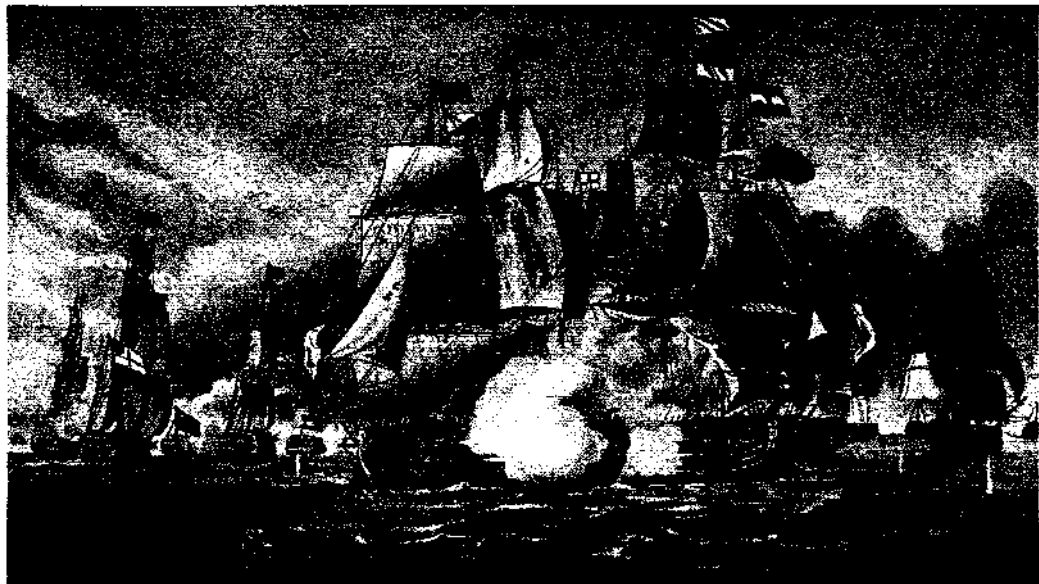

LORD HOTHAM'S ACTION, MARCH, 1796.

briefly dealt with. Austria had engaged in May, 1795, to provide two hundred thousand effective men in the different armies in the campaign of the year, on condition that England supplied £4,600,000. De Vins appears to have been another Mack "Everything done/" Nelson wrote to his wife, "was slow beyond description.*" He sought to hasten the Austrian general into measures which should have some correspondence with his own eager desires, but De Vins was not apparently very grateful for his proposals. Nelson's services and experiences in connection with the Austrian chief excited in him an immovable disgust to all Continental alliances. The behaviour of De Vins forced the conclusion upon him that the whole policy of the Emperor of Austria was simply directed to obtain another four millions of English money.

A scandalous accusation about this time filled Nelson with resentment, and confirmed his dislike and distrust of England's Austrian allies. He and other naval officers were charged with secretly permitting the enemy to land their cargoes for the supply of the French army on the Riviera of Genoa. The King of Sardinia credited the report Nelson, burning with indignation, addressed a letter to Lord Grenville, demanding a rigorous inquiry on behalf of himself and his brother officers. "For myself," he exclaimed, "from my earliest youth I have been in the naval service ; and (in two wars) have been in more than one hundred and forty skirmishes at sea and on shore ; have lost an eye and otherwise blood in fighting the enemies of

my king and country ; and God knows, instead of riches, my little fortune has been diminished in the service." His noble, dignified, affecting protest concluded with a pathetic lament that one who deserved of his country as he did should be libelled by an accusation " of a most traitorous nature.* The outrageous charge originated with Austrian officers, and is ascribed less to malice than to their ignorance of naval affairs.

In this year he was offered a seat in Parliament. He declined to enter the House save in the Whig interest, and proposed that the Duke of Portland should be applied to through Lord and Lady Walpole, " for," he adds, " although I have so often seen the French shot, yet truly I have seen little of their money." Towards the close of 1795, Sir John Jervis, afterwards Earl of St. Vincent, arrived at St. Fiorenzo (November 29th) and took command of the fleet. The *Agamemnon* went to Leghorn to refit. Her condition curiously illustrated the services of her commander in her. Charnock tells us * that there was not a yard, mast, or sail, nor any part of her rigging, but needed repair, owing to the shot she received ; and her hull was kept together by cables, which frapped or woolded the fabric from stem to stern. His duties and performances down to the day of the battle of St. Vincent were minute, laborious, of inestimable value to his country and to the security of those whom it was the business of our fleet to protect, but of little interest as a narrative. He boarded vessels, captured transports,

* Charnock's "Life of Nelson," p. 31.

made fiery proposals in respect to Vado Bay and the pursuit of enemy's ships-of-war and convoys. "Had all my actions," he wrote to his wife, August 2, 1796, "been gazetted, not one fortnight would have passed during the whole war without a letter from me ; one day or other I will have a long gazette to myself."

On the 11th of June * he hoisted his commodore's pennant on board the *Captain*, of seventy-four guns. The *Agamemnon*, a ship he had rendered the most famous of all then in the Royal Navy, was sent home with a convoy. A defensive alliance with Spain, entered into by the French Directory, rendered expedient the evacuation of Corsica. The Corsicans had from the beginning looked coldly upon the English ; the instant the enemy landed in force it was felt that every man in the interior would take part with him, and Sir John Jervis blessed himself that the evacuation had taken place before he received orders to maintain the Viceroy in the sovereignty of the island. Nelson superintended the evacuation. The partisans of France rendered this service a difficult one. British property was sequestered, and a plan was laid for seizing the Viceroy. Conspiracies of this sort Nelson terminated by threatening to batter down the town of Bastia. The guns of a privateer moored across the Mole head were levelled at Captain Sutton, who had been despatched with Nelson's message; whereupon Sutton, pulling

* Pettigrew ; Clarke and M'Arthur say : "On the 15th of August Nelson received an order which established him commodore," vol. i . , P. 450.

out his watch, said he would give the committee a quarter of an hour to arrive at a decision, at the expiration of which time the ships would open fire. It is said that the very sentinels, on hearing this, rushed away, and every vessel came out of the Mole. The embarkation occupied five days, and the value of the public stores saved amounted to ,£200,000, irrespective of private property.

Hoisting his broad pennant on board the frigate *Minerve*, Nelson proceeded with the *Blanche* to Porto Ferrajo to take command of the naval force there. Off Carthagená he fell in with a Spanish frigate, the *Santa Sabina*. This was on the 19th of December, at which time there was in force a treaty between the Court of Madrid and the French Directory, stipulating that either power requiring the help of the other should be assisted to the extent of thirteen sail-of-the-line and ten large frigates or corvettes. The treaty had been ratified at Paris on the 12th of September, and on receiving news of it the British Government had seized every Spanish ship then in an English port. This embargo had been responded to by a declaration of war by Spain, and such was the posture of affairs when Nelson fell in with the *Santa Sabina*. He hailed the Don, as he himself wrote in his private journal, told him his was an English frigate, and demanded his surrender, or he would fire into him. The Spanish captain, Don Jacobo Stuart, answered : " This is a Spanish frigate, and you may begin as soon as you please ! " He proved a tough morsel even for Nelson. The ships were of the same force to a gun, and the number of

the crews nearly alike. Again and again Nelson hailed Don Jacobo to haul down his colours, but the valiant Spaniard's answer was: " No, sir, not whilst I have the means of fighting left." He surrendered only when all his officers were killed. The *Santa Sabina* was retaken, and Nelson narrowly escaped capture through pursuit of two Spanish ship of the line and two frigates. His admiration of the heroic conduct of Don Jacobo borrowed something of its animation from the discovery that his prisoner was descended from the Duke of Berwick, son of James II. " I have returned him his sword," he wrote to his father, " and sent him in a flag of truce to Spain. I felt it consonant to the dignity of my country, and I always act as I feel right, without regard to custom." *

* " Dispatches and Letters," vol. ii. f p. 325.

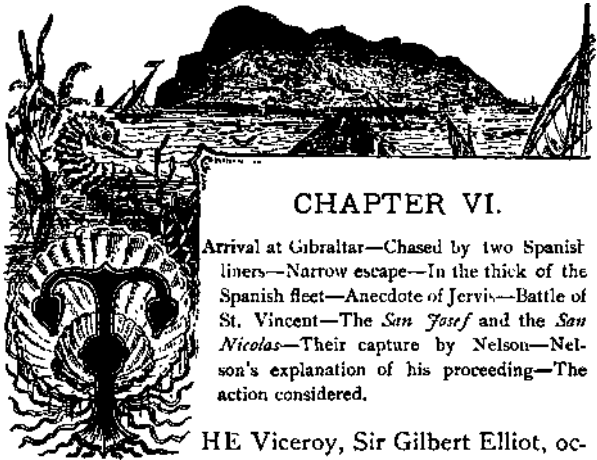

CHAPTER VI.

Arrival at Gibraltar—Chased by two Spanish liners—Narrow escape—In the thick of the Spanish fleet—Anecdote of Jervis—Battle of St. Vincent—The *San Josef* and the *San Nicolas*—Their capture by Nelson—Nelson's explanation of his proceeding—The action considered.

HE Viceroy, Sir Gilbert Elliot, occupied Porto Ferrajo in Elba after the evacuation of Corsica. To this fortress Nelson escorted Sir Gilbert and troops from Bastia. On the 27th of December he was again at Porto Ferrajo.' Sir Gilbert Elliot was in Italy, but returned to Elba on hearing of Nelson's arrival at the island. There was a conference, and it was decided that the British troops should remain at Elba, and, shortly after, Sir Gilbert Elliot embarked with Nelson in the *Minerve* to consult with the British Admiral, Sir John Jervis, then cruising with the fleet off St. Vincent.

After much reconnoitring and many peeps at a number of the enemy's harbours, Nelson headed for Gibraltar, at which place he arrived on the 9th of February in company with the *Romulus*. Lieutenants Culverhouse and Hardy, who had been on board the *Santa Sabina* when she was recaptured,

were exchanged and received by Nelson, who on the nth weighed. Scarcely were the frigate's top-sails sheeted home when two Spanish line-of-battle ships, which had been watching Nelson's movements, were seen to be getting their anchors and making sail. The *Minerve* entered the Strait, the Dons in hot pursuit. The headmost ship of the chase gained on the British frigate, which cleared for action, and Sir Gilbert Elliot saw all ready for heaving his public papers overboard. Nelson, who was walking the deck with Colonel Bethune (or Drinkwater as he was then called), owned that he thought an engagement possible, "but" he exclaimed, looking up at his broad pennant, "before the Dons get hold of that bit of bunting I will have a struggle with them, and sooner than give up the frigate I 'll run her ashore." * They went below to dinner ; on a sudden a cry of "Man overboard !" was heard, and there was instantly a rush on deck. Lieutenant Hardy and a body of sailors sprang into the jolly-boat. The strong current of the Strait in a few minutes carried the little fabric far astern of the *Minerve*, in the direction of the chasing Spaniard. Meanwhile the man that was to be rescued had sunk and Hardy endeavoured to regain the frigate. The boat's crew, however, were unable to make headway. Suddenly Nelson exclaimed : "By G— I 'll not lose Hardy ! Back the mizzen top-sail." It now seemed certain that an action must take place; but to the astonishment of all hands aboard the British frigate,

* "Narrative of the Battle of St. Vincent," by Col. Drinkwater Bethune, 1840, p. 13.

the pursuing Don suddenly shortened sail with every manifestation of alarm in his eager manner of clewing up and letting go. It was plain that the commander did not consider a Spanish ship of the line an equal match for an English frigate with Nelson on board her. The *Minerve* picked up her jolly-boat and stood on. Studding-sails were piled upon her; the helm was shifted so as to quarter the wind, her best point of sailing, and at sunset the two huge Spaniards were out of sight astern.

The night following that day was thick. Colonel Bethune, who shared a cabin with Sir Gilbert, was lying awake in his cot when by the light burning in the fore cabin he observed a figure standing in the doorway. It was Nelson. On learning that Sir Gilbert was asleep he softly stole to the Colonel's side and whispered that he believed the *Minerve* was at that very moment in the midst of the Spanish fleet. He was sure, by the signals of the phantom craft looming large in the thickness, that they were not Jervis's ships. All next day a bright look-out was kept, but no more ships hove into view, and Nelson, firmly persuaded that he had sailed in those hours of darkness through the Spaniards' grand fleet, grew exceedingly anxious to join Jervis, whose cruising rendezvous was now close at hand. Early next day the British frigate *Lively* was spoken, and a little later on the *Minerve* joined the Admiral's fleet. Nelson then quitted the *Minerve* and resumed the command of the *Captain*.

At daybreak on the 14th of February the **British fleet, formed in two divisions, were standing on a**

wind heading to the southward and westward. The dawn broke thick and the sea lay shrouded to a near horizon, but at about a quarter past eight o'clock the fog lifted and disclosed the Spanish fleet on the weather-bow, a noble spectacle of huge ships, one of them a four-decker, the largest vessel then afloat; their milk-white canvas towering in spires, their sides grinning with battery upon battery, and the light of the misty sun coming off in wet sparkles from their leviathan sides as they rolled. An eye-witness says: "They made the most awkward attempt to form their line-of-battle, and they looked a complete forest huddled together."* The British Admiral Jervis made the signal to prepare for battle. As he walked the quarter-deck the hostile numbers were reported to him as they appeared by signal. "There are eight sail-of-the-line, Sir John."—"Very well, sir."—"There are twenty sail-of-the-line, Sir John."—"Very well, sir."—"There are twenty-five sail-of-the-line."—"Very well, sir."—"There are twenty-seven sail, Sir John," and this was accompanied by some remark on the great disparity of the forces. "Enough, sir, no more of that; the die is cast; and if there were fifty sail I would go through them." Captain Hallowell, who was at Jervis's side when he thus spoke, was so delighted by this determined answer that, gently clapping the old Admiral on his back, he cried out: "That 's right, Sir John, that 's right; by G— we shall give them a d—d good licking." † At close upon half-past

•Parsons. P. 323.

†*Edinburgh Review*, 1844, p. 424.

eleven o'clock Jervis hoisted his large flag and ensign, and, announcing his intention to pass through the enemy's line, ran aloft the signal to engage. The action was soon general. The Spaniards were unable to unite their divided ships, and those to leeward presently put about and went stretching away in search of safety. Jervis, having effected his first purpose, signalled for the British fleet to tack in succession. It was then seen that the Spanish Admiral's plan was to join his leeward ships by wearing round under the sterns of the rearward of the British line. Nelson's genius penetrated the Don's intention, and, putting the *Captains* helm hard-a-weather, he steered a course for the enemy. The sixth ship from the Spaniard's rear was that towering four-decker, the *Santissima Trinidad*, of one hundred and thirty-six guns. Nelson got alongside of her, but ahead and astern of him were the Don's seconds of three decks each. Troubridge, in the *Culloden*, headed with all possible speed to his assistance, and was presently followed by Frederick in the *Blenheim*, Nelson's instant, intrepid resolution staggered the Spanish Admiral. The fire of the British was overwhelming, and such was its effect on the enemy's ships that the little crowd of onlookers on board the *Lively*, even in an early moment of the conflict, foresaw a glorious termination to the battle.

Nelson is the one conspicuous figure in that scene of roaring ordnance, of banks of powder smoke smitten by the red flashes of murderously plied batteries, of falling spars, of the shrieks of the dying and the wounded, and the stormy huzzas of the English

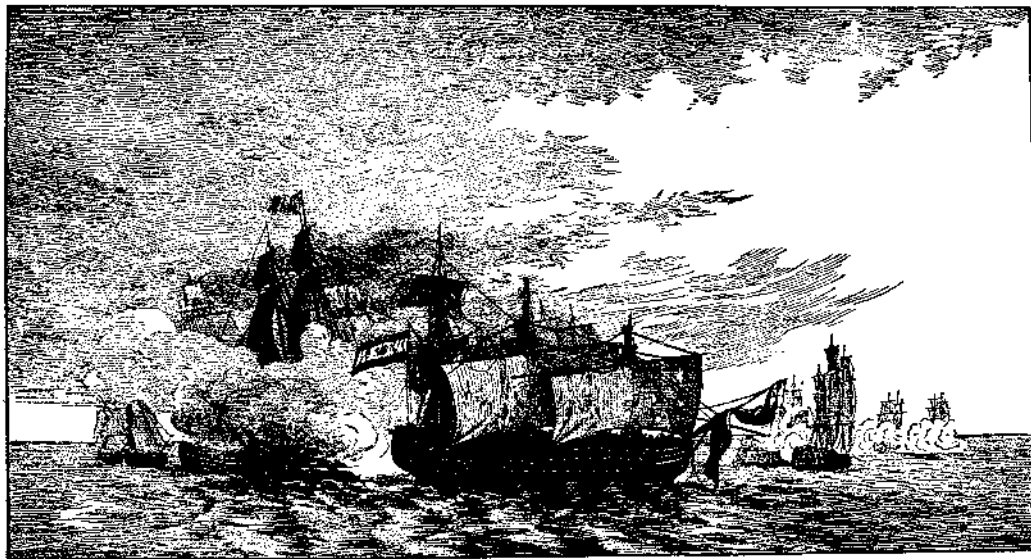

THE "VICTORY" AND THE "SALVADOR DEL MUNDO."

ACTION OFF CAPE ST. VINCENT, 1782.

sailors wrestling half-naked at their guns. At one moment the *Captain* was engaged with no less than nine line-of-battle ships. A little later on, she was hammering at the *San Josef* and the *San Nicolas*. The latter luffed, the *San Josef* fell aboard her, the *Captain* being abreast of them and close alongside. Her foretopmast was gone, her wheel was shot away, her running-rigging was in pieces, and Nelson, perceiving that she was no longer manageable, manoeuvred so as to foul the *San Nicolas*. This he contrived. His sprit-sail yard hooked the *San Nicolas*'s rigging. There were a number of the 69th regiment on board, and they were amongst the first who sprang into the *Don*—no easy task to landsmen encumbered with weapons, with the long Atlantic swell besides to create swift abysses between the roaring and flaming fabrics as they rolled. A soldier broke a window in the Spaniard's upper quarter-gallery, jumped in, and Nelson and others followed. The cabin doors were secured ; the Spanish officers on the quarter-deck snapped pistols at their boarders through the windows; but in a breath the doors were burst open, the soldiers fired, the Spanish brigadier (a commodore) fell, and Nelson, rushing out, found Berry, his first lieutenant, in possession of the poop and the Spanish ensign hauling down. Followed by his men, Nelson ran to the forecastle and received the swords of two or three Spanish officers; but a moment later a smart fire of pistols or muskets was opened from the *San Josefs* stern-gallery that towered within a jump of the *San Nicolas*. Instantly seeing what must be done, the

English seamen being now in full possession of every part of the *San Nicolas*, Nelson ordered sentinels to be placed at different ladders to guard the prisoners, and calling to Captain Miller on board the *Captain* to send more men into the *San Nicolas*, he sprang into the main-chains of the *San Josef*, followed by his brave fellows. As he did so, a Spanish officer looked over the quarter-deck rail and called out that the ship had surrendered. The Captain of the vessel, dropping on his knee, presented his sword, and said that the Admiral was dying of his wounds below. Nelson asked him on his honour if the ship had surrendered. He declared she had. "On which," says Nelson in the account of the action he sent to the Duke of Clarence, "I gave him my hand, and desired him to call to his officers and ship's company and tell them of it—which he did; and on the quarter-deck of a Spanish first-rate, extravagant as the story may seem, did I receive the swords of vanquished Spaniards; which, as I received, I gave to William Fearney, one of my bargemen, who put them with the greatest *sangfroid* under his arm." "The *Victory* and every Ship of the Fleet, passing the glorious group, gave me three cheers," he wrote to William Suckling. He received a blow in the side or stomach, but spoke of the hurt at the moment as nothing.*

Collingwood in the *Excellent* fought magnificently,

* When news of this victory came to Mrs. Nelson she wrote with wifely anxiety: "What can I attempt to say to you about Boarding? You have been most wonderfully protected: you have done desperate actions enough. Now may I—indeed I do—beg that you will never Board again. *Leave it for Captains*"—"Dispatches and Letters." vol. ii., p. 359.

and provided Nelson with the chance which his genius and courage rendered glorious. " My good friend the Commodore," Collingwood wrote to his wife, " had been long engaged with those ships, and I came happily to his relief before he was dreadfully mauled." * Colonel Bethune, after the action, had a chat with Nelson, and asked : " How came you to get into that singular and perilous situation ? " " I 'll tell you how it happened," he answered. " The Admiral's intention I saw was to cut off the detached squadron of light sail, and afterwards attack the main body, weakened by the separation. Observing, however, as our squadron advanced and became engaged with the enemy's ships, that the main body of the enemy were pushing to join their friends to leeward, by passing in the rear of our squadron, I thought, unless by some prompt and extraordinary measure, the main body could be diverted from this course until Sir John (at that time in action in the *Victory*) could see their plan, his well-arranged designs on the enemy would be frustrated." His resolution was immediately formed, with what success we have seen.

He was not, however, even named by Jervis in his dispatch. Sir John Barrow declares that the Admiral was prevailed on by Sir Robert Calder, the Captain of the Fleet, to omit Nelson's name, *on* the ground that he had disobeyed the signal of recall. " The surprise is," says Barrow, " that a man of Lord St. Vincent's sagacity should not have detected the lurking jealousy that gave rise to such

* Collingwood's Correspondence," p. 36.

a recommendation.* * Nelson, however, does not appear to have heard of this signal of recall. Writing to his father, April 6, 1797, he says: "An anecdote in the action is honorable to the Admiral and to Troubridge and myself. Calder said: 'Sir, the *Captain* and *Culloden* are separated from the Fleet, and unsupported; shall we recall them?' 'I will not have them recalled. I put my faith in those ships; it is a disgrace that they are separated and unsupported.'"

The figure that Nelson made in this conflict was extraordinarily great; but it is impossible not to agree with the exact, acid, and grudging James, who affirms that a deal more was made of the battle of St. Vincent than the victory merited. The Spanish crews and officers were, beyond expression, contemptible. There was no organization amongst them, no perception of the significance of signals, and there was scarcely a ship that would not have run if she could. When the *San Josef* was captured several tompions were found still fixed in the guns on the side that had been engaged! It is believed that the pieces were never loaded. It is quite certain, at all events, that the officers could not get their men to fire them. The panic-stricken wretches who manned the Spanish fleet refused to go aloft to repair the rigging. The officers shot some of them as an example, but to no purpose; the sailors, crossing themselves and falling upon their knees, piteously entreated, with tears in their eyes, not to be forced up the rigging. Over such opponents it would be ab-

* • Life of Howe," p. 249.

surd to call the most decisive victory "glorious." The relief of men's minds at home made the battle greatly talked of, and furnished it with a splendour it certainly did not possess. The union of the French and Spanish fleets had been despairingly regarded as an accomplished fact, and before news of the victory reached London, in the beginning of March, it had been decided at a Privy Council meeting that the Bank of England should suspend cash payment until the sense of Parliament had been taken as to the "public and commercial credit of the kingdom at this important conjuncture."*

* *Annual Register, 1797.*



CHAPTER VII.

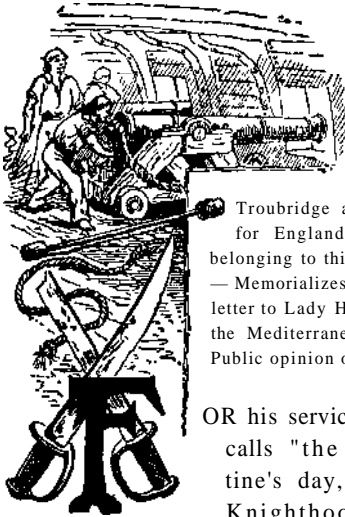

Rewards—Nelson's popularity amongst sailors—Cause of it—Hand-to-hand fight off Cadiz—Project against Teneriffe—A disastrous blunder—Loss of his arm—Courage under suffering—Anecdotes of the surgical operation—

Troubridge at Santa Cruz—Nelson sails for England—Lady Nelson—Anecdotes belonging to this time—Character of his wife—Memorializes the King—St. Vincent's letter to Lady Hamilton—Nelson proceeds to the Mediterranean—A heavy gale of wind—Public opinion on St. Vincent's choice.

OR his services, on what he himself calls "the most glorious Valentine's day," Nelson received the Knighthood and Order of the

Bath, and was promoted to the rank of Rear-Admiral of the Blue. Bethune says: "The King would have created the hero a baronet, but when it was suggested to Nelson that this honour would in all probability be conferred, he exclaimed, earnestly: 'No, no, if they want to mark my services, it must not be in that manner'; whence Bethune inferred that he desired to bear about his person some honorary distinction to attract the public eye.* The sword of the Spanish

* Bethune. P. 88

Admiral, received by him on board the *San Josef* Jervis, after taking him in his arms and thanking him for what he had done, insisted on his keeping. This sword Nelson presented to the city of Norwich.

Before he was acquainted with his promotion, he hoisted his pennant on board the *Irresistible*, the *Captain* having been rendered almost useless during the conflict. In this ship he went with the squadron to cruise off Cadiz, to keep an eye upon the Spanish fleet, and intercept the Viceroy of Mexico, one of whose vessels was a galleon full of dollars. He afterwards went aboard the *Theseus*, and in that ship watched every movement of the enemy; for, if the fleets combined, it was believed they would amount to forty sail-of-the-line.

The affection of his people for him was about this time illustrated by a paper, dropped on the quarter-deck, on which was written: "Success attend Admiral Nelson! God bless Captain Miller! We thank them for the officers they have placed over us. We are happy and comfortable, and will shed every drop of blood in our veins to support them, and the name of the *Theseus* shall be immortalized as high as the *Captains*.—SHIP'S COMPANY." The main significance of this testimony must be sought in the mutinous spirit that was then active in the British Navy. Never was there a commander who exhibited a tenderer and wiser interest in the seamen under him than Nelson. He knew what the fore-castle life was, recalled his own experiences, and was influenced by them. He abhorred punishment. He **had** always a kindly word for his Jacks. He

Admiral, received by him on board the *San Josef* Jervis, after taking him in his arms and thanking him for what he had done, insisted on his keeping. This sword Nelson presented to the city of Norwich.

Before he was acquainted with his promotion, he hoisted his pennant on board the *Irresistible*, the *Captain* having been rendered almost useless during the conflict. In this ship he went with the squadron to cruise off Cadiz, to keep an eye upon the Spanish fleet, and intercept the Viceroy of Mexico, one of whose vessels was a galleon full of dollars. He afterwards went aboard the *Theseus*, and in that ship watched every movement of the enemy; for, if the fleets combined, it was believed they would amount to forty sail-of-the-line.

The affection of his people for him was about this time illustrated by a paper, dropped on the quarter-deck, on which was written: "Success attend Admiral Nelson! God bless Captain Miller! We thank them for the officers they have placed over us. We are happy and comfortable, and will shed every drop of blood in our veins to support them, and the name of the *Theseus* shall be immortalized as high as the *Captain s—SHIP'S COMPANY.*" The main significance of this testimony must be sought in the mutinous spirit that was then active in the British Navy. Never was there a commander who exhibited a tenderer and wiser interest in the seamen under him than Nelson. He knew what the fore-castle life was, recalled his own experiences, and was influenced by them. He abhorred punishment. He had always a kindly word for his Jacks. He

licensed handsomely when no point of discipline was involved. Some of his crew had become Methodists, and, offended with the oaths and conversation of their shipmates, desired a separate mess. Nelson instantly consented.* When he quitted the *Foudroyant* (June, 1800), the crew of his barge sent him a touching letter, expressing their deep grief at his leaving them. They entreated permission to accompany him, go where he might, and be his ship what she would. " Pardon the rude style of seamen," the poor fellows wrote.† He was entirely with the mutineers of the Fleet in their first complaint. " We are a neglected set," he wrote, " and when peace comes are shamefully treated." The health of his seamen was always the first essential consideration with him. In 1803 he was writing that the squadron had been " within ten days of five months at sea, and we have not a man confined to his bed." He was the nation's pride indeed, but pre-eminently was he the sailors' darling.

The night of the 3d of July, 1797, witnessed the bombardment of Cadiz. Nelson was in his barge with, what he terms, " a common crew of ten men," besides the coxswain, Captain Fremantle, and himself, when he was boarded by the commander of the Spanish gunboats in a barge that rowed twenty-six oars, and numbered in all thirty of a crew. The hand-to-hand fight that followed is assuredly the most memorable of the thrilling incidents of Nelson's career. The Spanish commander was taken, eighteen

* *Blackwood's Magazine*, 1848, p. 598.

† " Dispatches and Letters," vol. iv., p. 263.



NELSON'S ENCOUNTER WITH A SPANISH LAUNCH, JULY, 1797.
AFTER A DRAWING BY G. KING.

of his men killed, and a number wounded. Nelson's coxswain, John Sykes, twice saved the Hero's life. Already Nelson had exhausted in his friend John Jervis the language of eulogy. All that St. Vincent could say of him in reference to this hand-to-hand fight was "that his actions speak for themselves; any praise of mine would fall very short of his merit." One follows with pain the narrative of this bombardment. The Spaniards, yielding to French influence, were nevertheless our friends at heart. There might have been fear, but there was certainly friendship in the reluctance with which they fought us. The bombardment barbarously injured the beautiful town; it was on fire in three places, and the houses of the inhabitants were plundered by the villains among them—"a glorious scene of confusion," Nelson calls it. A shell struck a convent and killed several priests—"that 's no harm," he says drily, "they will never be missed."

The next step was a disastrous blunder. There was scarcely ever executed a more ill-advised adventure than the Teneriffe expedition. News had come that the rich Manila ship, which Nelson was on the look-out for, had arrived at Santa Cruz. His head was full of a plan that could not fail of success, that was to immortalise the undertakers, that was to ruin Spain, and raise Great Britain to a higher pitch of wealth than she had ever yet attained. In a word, Santa Cruz was to be captured, good terms with the town made, and nothing but the delivery of public stores and foreign merchandise demanded. **The** value of the galleon is not stated; Nelson talked

of six or seven millions sterling. *' If this sum were thrown into circulation in England, what might not be done?" he says in his letter to Lord St. Vincent.

On July 15th he sailed for Teneriffe. The squadron appointed consisted of the *Theseus*, *Culloden*, and *Zealous*, each of seventy-four guns ; the *Leander*, *Seahorse*, *Emerald*, and *Terpsichore*, from fifty to thirty-two guns ; and the little *Fox* cutter of twelve guns. The ships were discovered before the men could be landed. Even the daring genius of a Nelson might have been mockingly set at defiance by the inaccessible heights and the numerous and powerful fortifications of the place. But the Spaniards must be made to understand that when the Briton strikes, he commonly strikes home ; and Nelson, with but little hope in the issue, determined upon a night attack on the garrison of Santa Cruz itself. At 8 P. M., July 24th, he wrote to St. Vincent—the last letter he ever penned with his right hand. He tells him that by to-morrow his head will be crowned with either laurel or cypress, and commends his step-son, Josiah Nisbet, to him and to his country. Before starting to row ashore, he entered his cabin and called to Nisbet, then a lieutenant in the *Theseus*, to help him to arrange and burn Mrs. Nelson's letters. He observed that the young man was armed and begged him to remain in the ship, saying: "Should we both fall, Josiah, what would become of your poor mother ? The care of the *Theseus* falls to you ; stay, therefore, and take charge of her' " The ship must take care of herself," answered young Nisbet; " I will go with you to-night, if I never **go again.**"



VIEW OF SANTA CRUZ, ISLAND OF TENERIFFE.

A thousand seamen and marines were to be thrown ashore under cover of the darkness. All the boats of the squadron were lowered, and filled with men and artillery. The *Fox* cutter, in command of the gallant Lieutenant Gibson, was crowded with about a hundred men. The force was formed into six divisions, having the *Fox* cutter in tow, the whole preceded by Nelson in his gig accompanied by three or four other boats. It was a very dark night; the wind too, much about this hour, breezed up into a fresh gale, and the high Atlantic sea washed in thunder to the base of the iron-bound rock of Teneriffe. Warily as the expedition advanced, the headmost boats were discovered by the sentinels. In an instant the strong wind was clamorous with the ringing of bells; the dark scene of shore flashed out into lights; the confused shouts of men could be heard with the rattling of carriages followed by the blaze and roar of upwards of thirty pieces of cannon.* The *Fox* cutter was struck by a shot and foundered out of hand, drowning many of her people. Most of the boats missed the pier. As Nelson stepped ashore, his boat being one of the very few which had struck the surfless side of the Mole, he was in the act of drawing his sword when his right elbow was hit by a grape-shot. "I am shot through the arm, I am a dead man!" he exclaimed. Young Nisbet was by his side; he caught him as he was falling, and laying him in the bottom of the boat, took a silk handkerchief from his neck and bound it tightly above the lacerated

* *Blackwood's Magaxim*, 1852 p. 508.

vessels, whilst one of Nelson's bargemen, a man named Lovel, tore his own shirt into shreds to form a sling for the wounded arm. Nisbet would have rowed him aboard the *Seahorse*, but Nelson insisted upon being carried to his own ship, lest Mrs. Fremantle, whose husband was Captain of the *Seahorse* should be terrified by the sight of his wound and his inability to give her any tidings of Captain Fremantle. On the boat getting alongside the *Theseus* he peremptorily declined to be helped on board. "Let me alone," he cried, "I have yet my legs left and one arm. Tell the surgeon to make haste and get his instruments. I know I must lose my right arm; so the sooner it 's off the better." Young Hoste, who was at the gangway of the *Theseus*, in describing the attack on Santa Cruz in a letter to his father, speaks of Nelson with his right arm dangling by his side, astonishing everyone with the spirit with which he helped himself to scale the labouring vessel. It is indeed an instance of human endurance and resolution scarcely credible. One stands amazed at that picture of a sickly and delicate human form filled with the anguish of a dreadful wound, with the deep mental distress moreover begotten of the conviction that his right arm was gone from him forever, spiritedly swinging by his remaining limb against the heeling side of the tall fabric, and clearing the bulwark only to demand the instant services of the surgeon with such coolness as his noble and beautiful nature would have been incapable of in asking a like operation for the very humblest boy of his squadron.

When his arm was cut off the surgeon asked if he wished it embalmed that he might send it to England to be buried; he answered: "Throw it into the hammock with the brave fellow that was killed beside me," referring to the body of a seaman that was about to be dropped overboard. * The operation was clumsily performed. Magrath who was Nelson's surgeon in the *Victory* (1803-4) attributed much of his irritability and derangement in other ways to this clumsy amputation. "Of all the sufferings of the operation," he told Sir N. Harris Nicolas, "and its subsequent facts so strongly pressed upon his (Nelson's) mind, he complained most of * the coldness of the knife' in making the first circular cut through the integuments and muscles. So painfully and deeply was the recollection ingrafted upon his feelings that I had general instructions in consequence, whenever there was a prospect of coming to action, to have a hanging-stove kept in the galley for the purpose of heating water in which to immerse the knife in the event of his being the subject of operation, and on which he always calculated." †

The Santa Cruz attack was a complete failure.

* ** Autobiography of Miss Cornelia Knight," vol. ii., p. 286.

f "Dispatches and Letters," vol. ii., p. 444. Colonel Bethune relates the following anecdote referring to the loss of Nelson's arm. Just before the victory of Camperdown, Bethune called upon Nelson, who asked him if there was news of Duncan's fleet. Then starting up in his peculiar energetic manner, notwithstanding Lady Nelson's attempts to quiet him, and stretching out his unwounded arm he exclaimed: "I would give this other arm to be with Duncan at this moment." Bethune. P. 97. This gentleman afterwards took the **name of Bethune**: by all Nelson's biographers **he** is called Drink' water.

Troubridge, who commanded the *Culloden*, on landing, collected his forces in a convent, and though without ammunition, demanded the surrender of the citadel. In the presence of a number of priests he set his people to make torches, fire-balls, and the like, to burn down the town with. The priests rushed to the Governor and begged him to offer terms to the "mad Englishman." The Governor was a person of good sense and kindness of heart, and his proposals ended in the British party marching with colours flying to the Mole, where they embarked in boats for the ships, every man receiving from the Spaniards a loaf and a pint of wine before starting.

Nelson in a fit of depression wrote on the 27th to Sir John Jervis that he was become a burthen to his friends and useless to his country, and that his one anxiety now was to see his step-son promoted. "When I leave your command," he wrote, "I become dead to the world ; I go hence and am no more seen." He asked the Admiral for a frigate to convey "the remains of my carcass to England," and on the 20th of August, 1797, hoisted his flag aboard the *Seahorse*, and proceeded home. On arriving at Spithead (September 1st) he struck his flag and journeyed to Bath where Lady Nelson and his father were. His arm had dreadfully tormented him during the passage. He had written to his wife with his left hand to announce his intention to return home, and his letter had not long preceded his landing. Lady Nelson had not heard of his desperate wound ; rumours only of the Teneriffe affair had reached **her**; she was puzzled by the handwriting in

which her husband had addressed her, and it was some time before she would allow herself to be persuaded that the letter was written by him. There is pathos and pain in the narrative of this lady's devotion to her husband at this and at other times, read by the light of what happened a few years later on. Lady Nelson at her husband's own earnest request attended to the dressing of his arm until she had acquired skill and resolution to deal with it herself, after which she continually nursed him. His anguish was unintermittently keen, owing to the ligature which had been affixed to the humeral artery involving a branch of nerve. It was in contemplation to cut down upon this ligature, but on a sudden it separated of itself and he was instantly relieved. His pious gratitude took the form of a thanksgiving, recited, as delivered by himself, by the clergyman officiating at St. George's, Ilanover Square: "An officer desires to return thanks to Almighty God for his perfect recovery from a severe wound, and also for the many mercies bestowed on him." This was dated December 8, 1797, "for next Sunday."

It is told that during the previous October, whilst he lay in suffering at his lodgings in Bond Street, he took some laudanum in the hope of obtaining rest. The news of Admiral Duncan's victory at that time reached London, and the streets were crowded with huzzaing mobs. The house in which Nelson lodged had not been illuminated. A crowd assembled to inquire the cause of the darkness and silence at such a time of rejoicing, and every window would have

been promptly smashed ; but on the servant of the lodgings informing them that Sir Horatio Nelson lay within badly wounded and endeavouring to sleep, a leader of the mob cried out: " You will hear no more from us to-night," and the whole rabble moved off.

Southey preserves an anecdote of Nelson that belongs to this period. Considering he was entitled to smart money for the loss of his eye, he went to receive a year's pay, but could not obtain the money because he had neglected to procure a certificate from a surgeon that the sight was actually destroyed. Though the loss of vision might not be apparent, it was at all events as a fact notorious enough, and Nelson was not a little irritated that this form should be insisted upon. However, he got his certificate for his eye, and took care that the loss of his arm should be mentioned, since the one injury was as likely to be doubted as the other! The idea put him in a good temper with himself and with the offending clerk. On his return to the orifice the clerk, finding it was only the annual pay of a captain, said that he thought it had been more. " Oh," exclaimed Nelson, " this is only for an eye. In a few days I shall come for an arm ; and in a little time longer, God knows, most probably for a leg." Soon afterward he applied on account of the arm, and, says Southey, with perfect good-humour exhibited his certificate of the loss of it.

Whilst Nelson was at this time in England he realised his quarter-deck dream by purchasing a cottage and a few acres of ground called Round-

Wood, near Ipswich. It does not appear, however, that he ever himself occupied it. When he was in search of the French fleet, Lady Nelson wrote to him : " On Sunday, the 20th of May, we arrived at Round-Wood. The satisfaction I felt was very great on being under your own roof. No thanks to any earthly being." * The " love-in-a-cottage " fancy was to prove but the idlest of dreams after all. It has been represented that Lady Nelson was inattentive to his personal comforts, that she alienated him by lack of that sort of homely sympathy which makes good husbands of men of even lukewarm natures. It is true that we read of Nelson complaining in his letters to his dear Fanny, that he finds but one pair of raw-silk stockings in his trunk ; that " I have not got, I assure you," (this to Lady Hamilton) " scarcely a comfort about me except the two chairs which you ordered of Mr. Foxhall ; I have wrote her (Lady N.) a letter of truths about my outfit " : and so on, and so on. But to this inattention there was surely the noble set-off of a most devoted and single-hearted spell of nursing, during the long days of torment he endured from the stump of his arm, and through tedious hours rendered wretched to her by his irritability and the constant spectacle of his anguish.

Her life was one almost of widowhood after he had sailed in the *Agamemnon* ; yet her pure heart was always with him, loving, passionately solicitous, profoundly admiring. His father was " our father " to her ; she lived with the old man, she cherished him,

* " Dispatches and Letters," vol. iii., p. 12.

and he loved her. The marriage had been one of affection, and their loyalty to each other, their faith, their high belief in each other, is unquestionable down to the year of the battle of the Nile. But how effectually Nelson's love was afterwards sundered, we may gather by these sentences from a letter to Lady Hamilton, dated September 17, 1805—words which one transcribes with a grief, and with a sense of shame, which must be proportioned to one's love for, and pride in, the character and the greatness of the immortal Hero: "I entreat, my dear Emma, that you will cheer up; and we will look forward to many, many happy years, and be surrounded by our children's children. God Almighty can, when he pleases, remove the impediment." *

But to return. In October, 1797, it was proposed to settle a pension of a thousand a year upon Nelson for his services. The demon of red tape demanded the usual Memorial, in which Nelson stated that during the war he had fought in four actions with the enemy's fleets, in three actions with frigates, in six engagements against batteries, in ten actions in boats. He enumerated his services at Bastia and Calvi, the number of the captures he had assisted in, and how he had lost his right eye and his right arm, not to mention minor injuries during the *one hundred and twenty times* he had fought against the enemy. In September he attended at St. James's Palace, and was invested with the insignia of Knight Companion of the Bath. The freedom of the City of London was conferred upon him in December, **and**

* Lady Nelson died, aged sixty-eight, on the 4th of May, 1831.

with it a gold box worth one hundred guineas. By this time his health was sufficiently good to enable him to go to sea again, and on the 19th of December he was appointed to the *Vanguard*, of seventy-four guns, in which ship he sailed on the 1st of April, 1798, from Portsmouth, arriving on the 23d with a convoy at Lisbon, whence a week later he weighed to join Lord St. Vincent and the fleet off Cadiz.

Nothing of special moment happened till near the close of the following month, when, on the 22d, Lord St. Vincent wrote a letter to Lady Hamilton, couched in terms which suggest but little of the salt beef and nor'-westers of the Service. "I am bound," says he, "by my oath of chivalry to protect all who are persecuted and distressed, and I would fly to the succour of their Sicilian Majesties was I not positively forbid to quit my post before Cadiz. I am happy, however, to have a knight of superior prowess in my train, who is charged with this enterprise at the head of as gallant a band as ever drew sword or trailed pike." This knight was Nelson. The day prior to the date of St. Vincent's letter to Lady Hamilton, Nelson had received his instructions from the Commander-in-chief. An armament had been preparing by the enemy at Toulon and Genoa, the object of which, it was assumed, was either an attack upon Naples or Sicily, the conveyance of an army to some part of the coast of Spain or Portugal, or the invasion of Ireland. Nelson was to seek this armament, and on falling in with it to use his utmost endeavours to *take, sink, burn, and destroy it*. With

respect to supplies, he was to *extract* whatever he required from the territories of the Grand Duke of Tuscany, the King of the Two Sicilies, the Ottoman territory, Malta, and the *ci-devant* Venetian dominions. All this is explicit enough, and effectually disposes of Lady Hamilton's claim to having helped Nelson to win the battle of the Nile, by enabling him, by a strategy of her own, to obtain supplies at Syracuse in defiance of the obligation of neutrality. For it is specially to be noticed that Nelson's instructions were to treat as hostile any ports within the Mediterranean, those of Sardinia excepted, when provisions, or other articles he might be in need of, should be refused.

He arrived at Gibraltar on the 4th of May. In the Gulf of Lyons he encountered a gale of wind that very nearly foundered his ship out of hand. "Figure to yourself," he wrote to his wife, "a vain man on Sunday evening at sunset walking in his cabin with his squadron about him, who looked up to their chief to lead them to glory, and in whom this chief placed the firmest reliance, that the proudest ships, in equal numbers, belonging to France, would have bowed their flags, and with a very rich prize lying by him. Figure to yourself this proud, conceited man when the sun rose on Monday morning, his ship dismasted, his fleet dispersed, and himself in such distress that the meanest frigate out of France would have been a very unwelcome guest!" The preservation of the *Vanguard* was owing mainly to Captain Ball, of the *Alexander*. We have seen that Nelson in 1783 had met Ball at St. Omer, and

taken a strong dislike to him, possibly because of his epaulets. When Ball went on board the *Vanguard*, to pay his respects to the Rear-Admiral, Nelson said to him, with an off-hand, contemptuous air: "What! Are you come to have your bones broken?" Ball responded, with much moderation of temper, that he did not intend to spare his bones in the performance of his duty. In the gale of the 20th, the *Vanguard* was almost completely wrecked. Ball, in the *Alexander*, took her in tow, but Nelson, fearing that both ships would founder if thus linked, hailed Ball to let go the hawser, and to leave the *Vanguard* to her fate. Ball, however, resolved to persevere, and successfully conveyed the *Vanguard* to St. Pierre. Nelson went on board him, and, straining the gallant commander to his breast with his one arm, exclaimed: "A friend in need is a friend indeed.*" From that moment they were warm friends.

In four days' time the *Vanguard* was equipped and at sea again, thanks to the extraordinary efforts of her carpenter, Morrison. On the 7th of June Nelson was joined by a squadron of ten sail-of-the-line, and the *Leander*, of fifty guns, and started in force in search of the French fleet. There was earnest remonstrance from Sir William Parker and Sir John Orde, who were both of them Nelson's seniors in the Service, on this command of a detachment being given to him. The ill-blood excited resulted in Orde sending Lord St. Vincent a challenge, but there was no duel. Orde gave much trouble, hard

* Communicated by Ball himself, and quoted by Sir H. Nicolas.

ened into the condition of a man with a grievance, and printed a long letter addressed to Nelson. Brenton, who gives full particulars of this affair in his life of St. Vincent, says that the Earl, when Nelson was objected to as a junior officer to take the command, replied: "That those who were responsible for measures had a right to choose their men." How very wise the veteran was in this case the battle of the Nile abundantly proved. The opposition to Nelson's appointment, even in the higher departments of government, was scandalously bitter. It will scarcely be credited that a letter from one of the puisne Lords of the Admiralty, in which Lord St. Vincent was insolently denounced for having sent so young a flag-officer as Nelson to seek the French fleet, was read publicly on board Sir William Parker's ship, the *Prince George*. Had the *Hero* failed, his impeachment would have been demanded, and perhaps obtained, in spite of the battle of St. Vincent, and all that he had done before and after it.



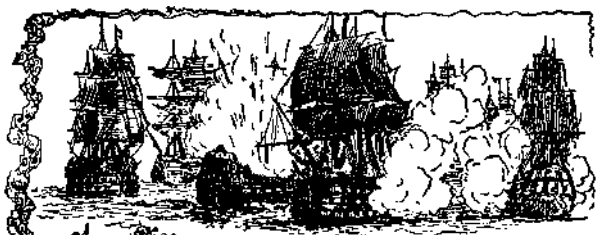

CHAPTER VIII.

Pursuit of the French fleet—Anecdote of Lady Hamilton—The fleet weighs from Syracuse—Discovery of French fleet—Plans of attack—Nelson's policy of instant fighting—Battle of the Nile—Death of Admiral Brueys—Explosion of *L'Orient*—Anecdotes of rescued Frenchmen—The *Culloden* ashore—Nelson wounded—Louts of the *Minotaur*.

THE Mediterranean was now to be hunted for the French fleet. The enemy had had a long start, and all that Nelson could at this period promise was that he would fight him the moment he could reach him, be he at anchor or be he under sail. The French had been sighted, on the 4th of June, off Trapani in Sicily, steering to the eastward; then Troubridge heard that they had gone towards Malta. Nelson sailed for that place, and on the 18th went away for Alexandria, where Captain Hardy reported he could obtain no intelligence. The British Admiral then skirted the coast of Asia, arriving on the 20th of July at Syracuse, to obtain a supply of fresh provisions. There was in force a treaty between Naples and France, a clause of which provided that no more than two English ships of war should enter into any of the Neapolitan or Sicilian ports. Nelson de*

spatched Captain Troubridge to Naples to obtain permission for his ships to water at Syracuse and take in other supplies. The romantic story goes that Troubridge arrived at the British Embassy at about six o'clock in the morning. Sir William Hamilton came hurriedly from his bed to receive him, and on hearing what he had to say, communicated with Sir John Acton, who at once convened a Council at which the King was present. Nelson's application was refused by the alarmed King, whereupon Lady Hamilton, rushing to the Queen's chamber where her Majesty lay in bed, went down upon her knees to implore her to authorise the required assistance or the Sicilies must be lost. The Queen consented; Lady Hamilton dictated; and Nelson obtained what he required. All this is most pleasantly but convincingly disposed of by Mr. J. C. Jeaffreson, who shows that Maria Caroline was a member of the Council, and possessed of the rights and powers that position conferred; that she was infinitely more sensible than her husband of the menaces of France to the country over which she, and perhaps she alone, virtually ruled; that she needed no Lady Hamilton with long hair to go down upon her knees to her, but as an intrepid, self-dependent, resolute woman, was perfectly happy to render quietly all needful assistance to that British Admiral in whom only she could find hope in this time of enormous difficulty and insecurity.* Indeed, all the Queen's affectionate attentions to **Lady Hamilton** were paid with a **strict eye to business**

* "Lady Hamilton and Lord Nelson," vol. i.

and to Sir William as the British Minister. Lady Hamilton wrote in Nelson's Letter-Book: "The Queen's letter, privately got by me, got him his fleet victualled and watered in a few days.—Emma Hamilton." She doubtless believed this, though not perhaps until after years of telling it. Nelson never doubted it from the beginning, as we may gather from the last solemn desire he wrote down on the eve of Trafalgar.

Having laid in a stock of water, wine, lemons, and bullocks at Syracuse, the squadron under Nelson weighed. He wrote to Lady Nelson: "I have not been able to find the French fleet. . . . I yet live in hopes of meeting these fellows; but it would have been my delight to have tried Buona-parté on a bowline, for he commands the fleet as well as the army. Glory is my object and that alone." He was sadly delayed by want of frigates, "the eyes of a fleet," as he called them. The French were insolently exultant. "I arrived," wrote Admiral Brueys at Aboukir Bay, "in the afternoon (July 7th) and formed a line of battle at two thirds of a cable's length. . . . I have heard nothing further of the English. They are gone perhaps to look for us in the west of Syria; or rather, and this is my private opinion, they have not so many as fourteen sail-of-the-line, and not finding themselves sufficiently numerous, do not judge it *apropos* to measure themselves with us." "We are now moored in such a manner," wrote Jaubert, Commissary of the Fleet (8th July) "as to bid defiance to a force more than double our own." *

* Clarke and M'Arthur. IL, pp. 106, 107.

On the morning of the 1st of August Nelson's squadron was off the city of Alexandria. The harbour was full of transports, and from many flag-posts the French tri-colour was floating. At four o'clock the *Zealous*, Captain Samuel Hood, made the signal of the French fleet. The force under Nelson amounted to thirteen 74-gun ships, and one 50, with one brig sloop only. The French fleet consisted of one 120-gun ship, three 80's, nine 74's, two 40's, two 36's, two brigs, and several bomb vessels and gunboats.* Before taking up his anchorage in Aboukir Bay, Vice-Admiral Brueys had called a council of his flag-officers and captains to determine whether the ships should engage at anchor or under canvas. Blanquet, rear-Admiral, alone of them all, disapproved of the fleet remaining at anchor. The ships were thereupon formed in line ahead, occupying a curve a mile and five eighths in extent.

The keenest delight was felt throughout the British ships at sight of the enemy. The sailors' appetites had been extraordinarily whetted by their long, tedious scouring of the Mediterranean. Nelson himself for days had hardly eaten or slept; but now that the Frenchmen he had been so long in search of were to be seen, he ordered his dinner to be served whilst the *Vanguard* was filled with the hurry and bustle of the preparation for battle, and on rising from table he is said to have exclaimed to his officers: "Before this time to-morrow I shall have gained a Peerage or Westminster Abbey." † The French account represents the

* See Appendix,

† These gasconades, as Sir H. Nicolas calls them, about Weit-

wind as light, but in the offing at all events it was blowing what seamen call a topgallant breeze, so that when Nelson hauled upon a wind most of the ships had to take in their royals. It had been the Hero's practice, so Sir Edward Berry tells us, * during the whole of the cruise, to take every opportunity of weather to bring together the captains of his ships aboard the *Vanguard*, when he would fully explain to them his own ideas of the different and best modes of attack. He assumed every imaginable situation for the enemy's fleet, and provided for dealing with it in that situation. The commanders, therefore, on beholding the French fleet at anchor in Aboukir Bay, knew exactly what Nelson intended; very few signals were needed, and thus was saved all the delay consequent upon the obligation of communicating strategic measures by message and by flags. It has been denied that Nelson's plans were preconcerted ; but what is not denied ? General Sir Charles Napier † preposterously claims for Captain Foley the merit of this great victory ! " Lord Nelson was not the man who proved the adventure," he says. And why ? Because Foley's ship, as Captain S. Hood attested, not having her ground tackle ready, brought up abreast of the second ship of the enemy inside of her. Brenton also states on the authority of Saumarez, who was second in command, that the plan of placing

minster Abbey and Glorious Victory and Peerages and the like which Bethune, Clarke and M'Arthur, and others put into Nelson's mouth, are to be received with distrust.

* " An Authentic Narrative," etc., 1798.

† *United Service Journal*, 1837.

the enemy between two fires was *not* preconcerted. Nelson's genius was instant in its perception and resolution. He could not indeed have prophetically provided for the exact conditions under which he now found the French fleet ; but it is ridiculous to suppose that amidst his numberless anticipations he had not foreseen some such a disposition of the enemy's forces as was now discovered, and pre-arranged with his captains for it. One difficulty his lightning-like mind witnessed and extinguished. He perceived that where there was room for an enemy's ship to swing there was room for one of his own squadron to anchor. The rest merely signified the use of the lead-line and all possible precaution in entering the shoaling water and taking up the retired positions.

Most sailors will probably consider this battle of the Nile the most triumphant in skill and daring of Nelson's achievements. As sea-manceuvrers the French were but poor hands at the best; but now they were in a situation that made no demands upon them as sailors. There were no braces to handle, no wheels to turn ; their ships lay motionless upon the smooth waters of Aboukir Bay, and were as fortresses for their people to let fly their ordnance from. In gunnery they were superb as precisionists, and now in this science of taking aim and firing they were to have it all their own way. We must realise every condition of this wonderful fight to appreciate its performance and its issue : the **superior** force of the enemy,—the darkness of the night **drawing round**,—the penetration of a space of water of

which there was not a man aboard the English squadron who knew anything. What, may be asked, would have been the decision of any other mind than that of Nelson? The French were trapped; they would probably remain where they were till daybreak; the safety of the British squadron would be imperilled by entering that uncertain, that unknown bay in the gloom of the evening. Therefore the one practicable expedient must be to heave to and wait for the sun to rise and attack the enemy as he lay at anchor or receive him as he got underway and came out. The seminal principle of all Nelson's tactics was to have at the foe at once. Wait for nothing! shift your helm, and *go* for him! get alongside as nimbly as your keel will carry you, and then *fight*! He was Commander-in-chief now; *now* had come his first magnificent opportunity. Heretofore he had been acting under the eye of others, a Hero to be controlled in a degree by the irresolution or the easily appeased ambition of a senior. But this was to be a Nelson fight, all his own! and with six ensigns, and flags red, white, and blue flying in his rigging, he hauled upon a bowline for Aboukir Bay, his squadron of ships swelling like white clouds upon the afternoon waters of the Mediterranean as they floated in their majesty of chequered sides and heights of gleaming rounded canvas down upon the enemy.

The *Goliath* and *Zealous* led the way. They were followed by the *Orion*, *Audacious*, and *Theseus*. The vessels entered the bay in grim silence—hands in the channels heaving the lead, hands aloft furling the canvas as sail was shortened from the deck, hands

ranged alongside overhauling lengths of cable ready to anchor by the stern. The signal was for "the headmost ship to bear down and engage as she reached the van of the enemy; the next ship to pass by and engage the second ship of the line; and so on." One after another the British battle-ships took up their positions, receiving broadsides plump into their bows from the enemy, with a simultaneous flying of colours on both sides streaming like flames of fire amid the satin-white bodies of powder-smoke floating up from the tall and bristling sides of the Frenchmen. At thirty-one minutes past six the sun was setting and the action had begun. At seven it was as black as midnight, without any gleam of moon as yet. But the incessant flashings of the guns made crimson the heavens, and amid the blood-red dimness of the smoke of the conflict the towering fabrics of the contending vessels loomed in giant proportions. When the sun sank every British ship had hoisted at her mizzen peak four horizontal lights. In less than twelve minutes the van ship of the enemy—*Le Guerrier*—was dismasted; ten minutes later *Le Conquerant*, and almost at the same instant *Le Spariate*, were almost wholly wrecked aloft. At half-past eight *LAquilon* and *Le Souverain Peuple*, the fourth and fifth ships of the enemy's line surrendered. Even at this early hour it seemed that the victory was with the British, for although the huge *L Orient*, *L'Heureux*, and *Tonnant* were not taken possession of, they were regarded as good as captured.

It was about ten minutes after nine, that *L Orient* was observed to be on fire. She was the flag-ship of



THE BATTLE OF THE NILE, 1798.

FROM AN OLD STEEL ENGRAVING.

the Admiral de Brueys. This gallant sailor had previously been wounded in the head and arm, but shortly after eight o'clock, according to the French account, two British ships* having anchored, one on *L^y Orient*s* starboard bow, and the other on her larboard or port quarter, the French Admiral was almost cut in two by a shot. He requested to be left to lie upon the deck and expired a quarter of an hour afterwards. Rear-Admiral Blanquet, in the *Franklin*, was soon afterwards wounded in the face and carried away senseless.

The burning of *L'Orient* forms the most terrific incident of that savage and tremendous scene of battle. The explosion of the huge fabric was inevitable, and the crews of the warships in the immediate neighbourhood of her went to work in red-hot haste to clear their decks of all combustibles, and to wet their sails, whilst men were stationed in all directions with buckets of water in their hands. Such was the temper, however, of the crew of *L'Orient*, that even when her lower deck was in flames, her men continued to fire the guns on the upper decks. An officer who was on board the *Leander* frigate describes the scene as it showed at ten o'clock: fore and aft the flames were waving in forks and living sheets and leaping on high, as though from the heart of some mighty volcano. She had ceased to fire; her sprit-sail yard and bowsprit were crowded with men who continued to crawl out, blackening those spars like flies, as the raging fire grew. By the wild, mast-high flames the whole scene of battle was as visi-

* The *Swiftsure* and the *Alexander* are probably referred to.

ble as by the light of the noontide sun. The colours of the flags of the ships could be easily distinguished—Every rope, every spar, the forms of the half-naked crews, smoke-blackened and in active motion, the land beyond with all details of the island fortress and of the distant rearmost ships, were startlingly visible by the glow of the burning ship, the brilliance of which was that of the conflagration of a city. At Rosetta, many miles distant from Aboukir, the roar of the battle was audible, and the scarlet of the atmosphere about the flaming *Orient* clearly witnessed. The dark figures of bodies of Arabs were to be seen upon the shore gazing in motionless postures at the awful sight.* Shortly after ten the great ship blew up. The explosion was that of an earthquake. The concussion swept through every seam, timber, and joint of the nearest ships, with the sensation as though the solid fabrics were crumbling into staves under the feet of the seamen. The air was filled with blazing masses of rigging and timber, shot to an immense height, descending in gigantic javelins of flame and piercing the water with the hissing as of an electric storm of hail followed by blinding clouds of steam. The sight was blackened as by a lightning stroke, and the instant the prodigious glare of the explosion had passed, the darkness of the night seemed to roll down in folds of ink upon the vision of the seamen. All was hushed ; every man in both fleets appeared paralysed ; and for nearly a quarter of an hour it is said no gun was fired, no movement was perceptible.

* Charnock's " Life of Nelson," p. 108.

From the deck of the *Leander* a number of the survivors of the miserable crowds which had filled the decks and 'tween decks of *L'Orient* were observed to be swimming towards the frigate. " The piercing cries of these unfortunate men/' wrote one who was present, " seem still to vibrate on my ear, as some of them approaching near the *Lcandcr*, cried out: * Bon John, give rop-e!—Oh, bon John, give rop-e, give rop-e!' As many of them as possible, we rescued from a watery grave, though some of them, after all our endeavours, sunk to rise no more. It was wonderful to observe, notwithstanding the deplorable circumstances in which these poor fellows were placed, what strength the *amor patriæ*, or reluctance to acknowledge defeat, exerted in them. To one of these forlorn creatures drenched with water and exhausted with fatigue, I said: 'Well, Monsieur, what think you now of your Buonaparte?' To which, the hapless man summoning the little energy which remained in him, replied: ' Oh, Monsieur John Bull, dis nothing, dis nothing; vivc Napoleon!' "*

The French account fixes the blowing up of *L'Orient* at a quarter to eleven. The great mass of her people who were swimming about in the water near her at the time were instantly destroyed; amongst those who perished were Commodore Casabianca, and his son, a little fellow ten years old, who during the action had behaved with astonishing bravery and intelligence, and the memory of whose sad death must long be perpetuated by Mrs. Hemans's moving verses. Nelson's force was weakened, and his victory conse-

* *Blackwood's Magazine*, 1832, p. 574.

quently heightened by the *Culloden* going ashore at a distance from the combatants, which rendered her useless. Captain Troubridge had been detained by the towing of a prize; he cast her off and advanced cautiously, sounding as he did so. The afternoon was darkening into night, when on a sudden the *Culloden* grounded on the tail of a shoal that ran from the Island of Bequicres. Every thing was done to warp her off, but she remained immovably fixed. Troubridge's anguish of mind was acute. Miss Knight says that after the battle he wrote to condole with Captain Darby of the *Bellcrophon*, who was badly wounded, and had also lost a number of his people; "but added that, had his sufferings been fifty times as much, *lie* had rather been in his place, than have borne the anguish he felt from running aground and being kept out of the Action—that he had found great difficulty in keeping from shooting himself, and that he even then frequently shed tears. Captain Darby and Captain Gould, who was present when he received the letter, both wept."*

After the blowing up of *L'orient* the firing was recommenced by a French ship, the *Franklin*, and the action raged afresh for twenty minutes, when there came a dead pause that lasted nearly a quarter of an hour. The battle was then renewed and continued until three in the morning, when it again ceased. The van of the enemy having been conquered, such British ships as were in a condition to move dropped down upon the fresh, untouched French vessels in the rear, and again the bay was

*' Autobiography of Miss Cornelia Knight." vol. ii., p. 287,

full of thunder and conflict. A few minutes past five in the morning the only two rear ships of the line of the enemy which had their colours flying were *Le Guillaume Tell* and *Le Gc'ne'reux*. Both these vessels at eleven o'clock, with two frigates, cut their cables and stood out to sea pursued by the *Zealous*, Captain Hood, who, as it was impossible to support him, was recalled after a short chase.

Nelson had been wounded some time before *L Orient* blew up. The hour is believed to have been about half-past eight. It is said that he was looking over a rough sketch of the Bay of Aboukir, which had been taken out of a French ship by Captain Hallowell a few days before the action, when he was struck in the forehead by a langridge shot or some such missile; the skin was cut at right angles, and hanging over his eye utterly blinded him. Captain Berry caught him as he reeled. He cried out: " I am killed; remember mc to my wife." He was carried below into the cockpit, and Jefferson, the *Vanguard's* surgeon, went immediately to attend him, but he exclaimed: " No, I will take my turn with my brave followers." So intense was the pain that he had no doubt whatever his end was at hand. The surgeon having probed the wound assured him there was no danger; but this he refused to believe, and calling Mr. Comyn, the chaplain, to his side, he asked him to convey his dying remembrance to Lady Nelson, and then ordered the *Minotaur* to be hailed that he might thank Captain Louis, her commander, for his noble support of the *Vanguard*. The story of this interview has been related by an officer who

was in the action. * It seems that when the *Vanguard* anchored alongside *Le Spartiate* she was exposed to the raking fire of *LAquilon*, the next ship in the enemy's line. In a few minutes fifty or sixty men of the *Vanguard* were killed or disabled. Louis in the *Minotaur* stationed himself ahead of Nelson and effectually relieved the Admiral's ship by overpowering the Frenchman. " While yet the combat was raging with the utmost fury, and he himself was suffering severely in the cockpit from the dreadful wound in his head, he sent for his first lieutenant, Mr. Capel, and ordered him to go on board the *Minotaur* in the jolly-boat to desire Captain Louis to come to him, for that he could not have a moment's peace until he had thanked him for his conduct; adding: '*This is the hundreth and twenty-fourth time that I have been engaged\ but I believe it is now nearly over with me*' The subsequent meeting which took place between the Admiral and Captain Louis was affecting in the extreme. The latter hung over his bleeding friend in silent sorrow. ' Farewell, dear Louis,' said the Admiral, * I shall never forget the obligation I am under to you for your brave and generous conduct; and now whatever may become of me my mind is at peace.' "†

* *Naval Chronicle*, vol. i., p. 287.

† Sir Harris Nicolas seems to doubt this story because he finds no mention in the *Vanguard's* log of any communication having taken place, during the battle, with the *Minotaur*. But what is to become of history if the assertions of contemporaries and of eye-witnesses are to be rejected? It is not because a comparatively trifling detail of a **vast scene** of battle is omitted in a log-book amid the hurry and

When the wound had been dressed, Nelson was requested to remain quiet in the bread-room ; but he was too eager to write a dispatch to the Admiralty to obey the surgeon's orders. He sent for his secretary, Mr. Campbell, who himself was wounded, and who, on beholding the suffering of the blinded Admiral was so much affected that he could not write. The chaplain was then summoned, but such was Nelson's impatience that groping himself for the pen he proceeded to trace some words expressive of the emotions inspired in him by the course of the conflict. Presently Captain Berry came below to tell him that *L'Orient* was on fire. It is said that he was led on deck to witness the conflagration, which is indeed irreconcilable with the statement that he lay blind in the bread-room—so blind and suffering, as we have seen, that his secretary was too overcome to do his business. After the Frenchman had blown up, Nelson was persuaded to go to bed, but he was so restless that he insisted upon again getting up that he might sign Mr. Capel's commission to the *Mutine* and Captain Hardy's commission to the *Vanguard* in the room of Captain Berry, who was to go home with the dispatches.

uproar of the strife that it must necessarily be false. Nelson was a regular reader of the *Naval Chronicle* ; he must have seen this anecdote which Nicolas doubts ; and had he contradicted it we may depend that somebody would have overheard and repeated the contradiction. In the *Naval Chronicle*, vol. iii., p. 183, it is stated in reference to this story of Captain Louis : " The anecdote inserted at this page is perfectly correct except in what relates to a boat being hoisted out from the *Vanguard*. Captain Berry hailed the *Minotaur* as she passed."

CHAPTER IX.

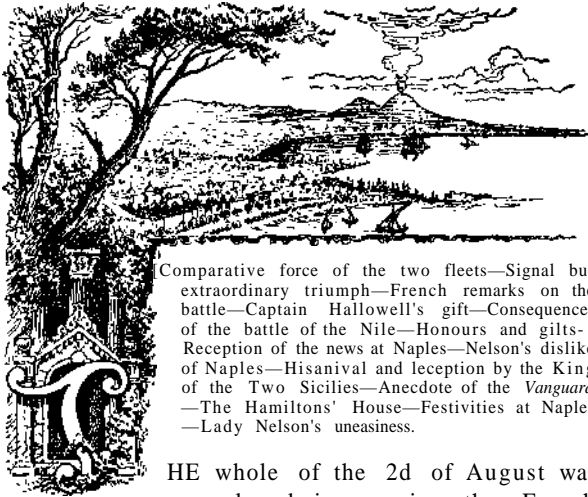

Comparative force of the two fleets—Signal but extraordinary triumph—French remarks on the battle—Captain Hallowell's gift—Consequence of the battle of the Nile—Honours and gilts—Reception of the news at Naples—Nelson's dislike of Naples—His arrival and reception by the King of the Two Sicilies—Anecdote of the *Vanguard*—The Hamiltons' House—Festivities at Naples—Lady Nelson's uneasiness.

THE whole of the 2d of August was employed in securing the French ships that had struck. Early that day Nelson issued the following memorandum: "Almighty God having blessed His Majesty's Arms with Victory, the Admiral intends returning Public Thanksgiving for the same at two o'clock this day; and he recommends every Ship doing the same as soon as convenient." On this morning the *Culloden* was floated off with the loss of her rudder, and such damage besides that her crew could scarcely keep her from foundering with all the pumps going; but within four days Troubridge contrived and shipped a new rudder, and the line-of-battle ship, though very leaky, was again fit for service. The Arabs and Mamelukes who had witnessed the battle from the shore illumi*

nated the coast and country for several nights in celebration of the British victory. There had never to that hour been a more decisive battle at sea. The comparative force of the two fleets is thus stated :

ENGLISH.			FRENCH.		
Ships.	Guns.	Men.	Ships.	Guns.	Men.
14 *	1,012	8,068	19	1,196	i l 230

The number of the enemy taken, drowned, burnt, and missing, was 5,225. On the English side 218 men were killed and 677 wounded.

This overwhelming defeat of the French must always rank amongst the most astonishing achievements in the catalogue of the battles of the world, by reason of the situation and disposition of the opposing forces. It was simply a conflict of bombardment ; the issue was wholly an affair of the cannon's mouth. There was no boarding; that all-conquering weapon in the British sailor's hands, the pike, was not employed ; there was no manoeuvring ; no demand upon the skilful seamanship of the British commanders, outside the judgment exhibited in taking up a position. The ships lay at anchor and fired into one another, and it never yet has been explained how it was that the French should have suffered so incredibly more than the English. Was

* Of those the *Culloden* was never in the action, and another, **the leander**, was a **small frigate**, though she did some noble work.

it that the firing of Nelson's squadron was fiercer, swifter, more furious than that of the French? When he captured the *Santa Sabina* the Spaniards declared that, such was the ferociousness of the *Minerves* fire, *it was like being in Hell* aboard their own ship. One witnesses this same almost preternatural capacity of rapid and overwhelming firing amongst the English seamen at Copenhagen and at Trafalgar.

The French at the Nile attributed their defeat to two causes: first, a deficiency in the number of good seamen; and second, a neglect on the part of many of the ships to obey the Admiral's signal to send a stream cable to the vessel astern for a hawser to be made fast to, that a spring might be obtained. The vessels in the rear could only look idly on whilst their van was being battered to pieces. The destruction of *L'Orient* was a tremendous loss, and the death of Brueys an overwhelming discouragement.

The fabric of *V'Orient* is still, it is said, to be seen peacefully resting in green and sandy repose under the glass-clear surface of the water of Aboukir Bay, whilst the Conqueror reposes in a relic of the great ship under the dome of St. Paul's Cathedral. When she blew up, a portion of her mainmast was taken on board the *Swiftsure*. The praise lavished on Nelson determined Captain Hallowell in May, 1799, to blandly remind the Hero that he was mortal. Nothing he thought could be fitter to produce the impression he desired to make than the gift of a coffin! He ordered one to be fashioned out of a part of *L'Orient's*

mast, and took particular care that everything used in its construction should be manufactured out of that spar. The very staples were formed of the spikes drawn from the cheeks of the mast, and when the coffin lid was closed toggles were employed to keep it down, to render nails or screws unnecessary. A paper was pasted on the bottom of the coffin on which was written : " I do hereby certify that every part of this Coffin is made of the wood and iron of *LOrient*, most of which was picked up by His Majesty's Ship, under my command, in the Bay of Aboukir. *Swiftsure*, May 23, 1799. Ben. Hallowell." When this singular gift was despatched to Nelson the following letter accompanied it: " My Lord, Herewith I send you a Coffin made of part of *U Orient's* mainmast, that when you are tired of this life you may be buried in one of your own Trophies—but may that period be far distant, is the sincere wish of your obedient and much obliged servant, Ben. Hallowell." Nicolas says that when this coffin was received aboard Nelson's ship the sailors talked about it with amazement and even alarm. " We shall have hot work of it indeed! " cried one of them ; " you see the Admiral intends to fight till he 's killed, and there he 's to be buried." One would give much to know in what terms Nelson answered Hallowell's letter. His reply—if indeed he ever replied by pen—has never been found. That he highly appreciated the gift is certain. He ordered it to be placed upright with the lid on, against the cabin bulkhead in the wake of his chair on which he sat at dinner, until Tom Allen, his servant, probably

compassionating the emotions of visitors, induced him to allow this very unpleasant piece of furniture to be carried below. One day observing the eyes of his officers to be directed at it whilst it was in his cabin, he exclaimed: " You may look at it, gentlemen, as long as you please ; but depend upon it none of you shall have it." Needless perhaps to state that Nelson was actually buried in this coffin.

The effects of the battle of the Nile are felicitously exhibited in the following sentences by la Graviere: " It was this battle which for two years delivered up the Mediterranean to the power of England ; summoned thither the Russian squadrons; left the French army isolated amidst a hostile population ; decided the Porte in declaring against it; saved India from French enterprise ; and brought France within a hair's breadth of her ruin by reviving the smouldering flames of war with Austria and bringing Suwarrow and the Austro-Russians to the French frontiers." *

On the 6th of October the *London Gazette* announced Nelson's elevation to the dignity of a Baron. A nation that would have been clamorous for the Hero's impeachment had he missed the French or been beaten by them, now considered a barony as a very mean recognition of the claims of the Victor of the Nile. Jervis had been made an Earl, and Duncan a Viscount for successes incomparably smaller, or at least of less significance, than that achieved in Aboukir Bay. It was said, in response to the wide-spread dissatisfaction, that

* Quoted by Pettigrew from Plunkett's " Last Naval War."

Nelson had acted as subordinate to Earl St. Vincent,—who, to be sure, had no more to do with the battle of the Nile than with the battle of Camperdown,—and that his claims, therefore, were not those of Jervis or of Duncan. It is much too old a matter to debate at this time of day, but there can be no question that Nelson was shabbily treated. Parliament voted him and his next two heirs male a pension of two thousand pounds a year, and he and his captains received a gold medal. The presents were rich and numerous. By the Emperor Paul of Russia he was presented with a gold box set with diamonds; from the Grand Signior came a magnificent diamond aigrette and a pelisse of sable fur; from the Grand Signior's mother, a box set with diamonds, valued at a thousand pounds; from the King of the two Sicilies, a sword of great historic interest, which had been given to the King of Naples by Charles III.; from other sources, a gold-headed cane, another diamond-mounted box, a gold box and chain, a piece of plate, five hundred pounds to purchase a piece of plate, and a gift of ten thousand pounds from the East India Company. His old friend, Alexander Davison, struck a medal in gold, silver, and copper for the Admiral, officers, and men of the squadron, at a cost to himself of two thousand pounds; but it is hard to see what particular honour was to be associated with a medal presented by a private individual.

When the news reached Naples the Queen fainted away. Lady Hamilton likewise conceived it her duty to swoon. Her Majesty cried, laughed, danced,

and kissed everybody within reach of her. " *Hip ! Hip !* " she writes to Lady Hamilton, September 3d, " I am wild with joy." Her children were mad with joy. She asks Heaven to prosper a nation so great, so magnanimous, so courageous. Meanwhile, the ships at anchor in Aboukir Bay had been repairing their damages with all possible expedition. The little island fortress was dismantled and the spot christened Nelson's Island. It was not until the morning of the 14th that the injured English vessels with their prizes were in a condition to start. They got under weigh in command of Sir James Saumarez, but the prizes being rigged with jury-masts, were worked with incredible difficulty out of the bay. After a very struggling passage, which lasted to the middle of September, they and their escort arrived at Gibraltar. On the road they fell in with the Portuguese squadron,—four ships of seventy-four guns, and one of sixty-four (British), with an English fire-ship, and a Portuguese brig,—under the command of **the** Marquis de Niza—that had been detached by Earl St. Vincent, off Cadiz, to reinforce Nelson, but that, happily for his glory, had been unable to join in time to participate in the battle. Read by this light, there is something of irony surely in Nelson's letter to De Niza, dated the 8th of September, in which he said : " It >* a matter of regret to me, and I am sure it must be to your Excellency, that your squadron **did** not join me before the 1st of August, when **not** a single French ship would have escaped us."

It was not until **the 19th** that Nelson, in **the Vanguard**, accompanied by **the Culloden and Alexander**

sailed for Naples. It has been thought remarkable that he should have abhorred this obligation of refitting his ships at Naples, as though he were being advised by some secret warning to guard himself against what was to follow this new visit to the Hamiltons. But the truth was that Nelson, in common with most sailors who had served in the Mediterranean, disliked the Italians, though they fought for them. Nelson, in an especial degree, hated all foreigners. Collingwood in a letter to his wife, in speaking of the Queen of Naples, says: "Her lot also has been cast awry, or in the distribution of stations for this world so loose a morality and such depravity of manners would never have been found perched upon the throne, from whence should issue the bright example of all that is good and great."* The gallant, honest Troubridge abhorred the Court of Naples. "You must excuse me," he writes to Lady Hamilton; "I trust nothing there, nor do I, or ever shall I, ask from the Court of Naples anything but for their service, and the just demands I have on them. I feel their ill-treatment and deep intrigues too much ever to forget or forgive them."† Nelson wrote to Lord St. Vincent that he detested the prospect of the voyage to Naples, and that nothing but absolute necessity could force him to the measure. He had

*"Collingwood's Public and Private Correspondence," p. 499. July 1, 1804, Nelson wrote to Lady Hamilton of the Queen of Naples: "I doubt much, my dear Emma, even her constancy of **real** friendship to you."—"Dispatches and **Letters**," vol. vi., p. 95.

† **Pettigrew. Vol. i., p. 339.**

been and still was seriously ill, spoke of his head as ready to split, complained of incessant sickness, also of a fever which he said had very nearly done his business. " For eighteen hours my life was thought to be past hope," he wrote.

At Naples all was expectation and excitement. On two ships of the line heaving into view, a great number of boats went out to meet them. The King himself was in his barge followed by a boat full of fiddlers. There also went Sir William and Lady Hamilton in a barge of their own, likewise followed by a band of musicians. It is pitiful to contrast these cheap buffoon effusions of gingerbread Neapolitan sentiment with the two line-of-battle ships grim with their realities of recent magnificent conflict. They were the *Culloden* (Troubridge), and the *Alexander* (Ball). On board the *Alexander* were several French personages, amongst them Admiral Blanquet.* The King of Naples declined to enter the ships, but from his barge saluted the officers. A number of British seamen were staring out of the portholes at his Sicilian Majesty, and at the boats with their cargoes of fiddlers, and at Lady Hamilton. Sir William exclaimed to them: " My lads, that is the King whom you have saved, with his family and kingdom." The Jacks, caring little about the matter, turned

* It is recorded of Blanquet that on leaving the *Alexander* at Naples he called on the French Consul, who exclaimed: " Oh, how delighted I am, my dear Admiral, to see you out of the hands of those abominable Englishmen." Blanquet answered: " Say nothing against the English, Consul. They fight like lions, and they have treated me and my officers and men most kindly."—Miss Knight. I., 122.

their quids, and rumbled out awkwardly: "Very glad of it, sir—very glad of it."

The *Vanguard* did not arrive until the 22d. This was to be a gala day, and the beautiful Bay of Naples was radiant and flashful with innumerable barges and boats, with gaudy uniforms, with flags and banners, whilst numberless bands of music played "God save the King!" and "Rule Britannia!" and "See the Conquering Hero Comes!" Nelson himself has told the story, and his own language in a life of him must always be chosen in preference to the descriptions of others. "I must endeavour," he wrote to Lady Nelson, "to convey to you something of what passed; but if it were so affecting to those who were only united to me by bonds of friendship, what must it be to my dearest wife, my friend, my everything which is most dear to me in this world? Sir William and Lady Hamilton came out to sea, attended by numerous boats with emblems, etc. They, my most respectable friends, had nearly been laid up and seriously ill; first from anxiety and then from joy. It was imprudently told Lady Hamilton, in a moment, and the effect was like a shot; she fell apparently dead, and is not yet perfectly recovered from severe bruises. Alongside came my honoured friends: the scene in the boat was terribly affecting; up flew her Ladyship, and exclaiming 'O God! is it possible?' she fell into my arm more dead than alive. Tears, however, soon set matters to rights; when alongside came the King. The scene was in its way as interesting; he took me by the hand, calling me his * Deliverer **and**

Preserver/ with every other expression of kindness. In short, all Naples calls me 'Nostro Liberatore'; my greeting from the lower classes was truly affecting. I hope some day to have the pleasure of introducing you to Lady Hamilton ; she is one of the very best women in this world ; she is an honour to her sex."

Mistress as she was of attitudes, it is here manifest that Emma Hamilton did not possess the art of falling down in a faint without hurting herself. When Nelson writes of her "as an honour to her sex," are we to conceive that he had any knowledge of her past years, unless possibly her relations, before marriage, with old Sir William? It was at least certain that, down to the hour of his death, he believed that Horatia was her only child.*

Miss Knight, who went on board the *Vanguard* on her arrival, relates the following interesting anecdote. Nelson, having conducted the King over every part of the ship, led the way to the cabin, where a handsome breakfast was prepared. "I remarked," says she, "a little bird hopping about on the table. This bird had come on board the *Vanguard* the evening before the action, and had remained in her ever since. The Admiral's cabin was its chief residence, but it was fed and petted by all who came near it, for sailors regard the arrival of a bird as a promise of victory, or at least as an excellent omen.

* See Nelson's letter to Lady Hamilton, March 1, 1801. Pettigrew. IL, 652.

It flew away, I believe, soon after the ship reached Naples." *

Nelson went to the Hamiltons* house, and was nursed by Lady Hamilton. Her tender solicitude, sweetened yet by her admiration, was doubtless exceedingly grateful to Nelson after a spell of rough doctoring aboard a man-of-war. Before the windows of Sir William's house stretched the magnificent scene of the Bay. At night the full moon seemed to rise from the crater of Mount Vesuvius. Amid the soft haze of moonshine, filling the atmosphere over the tranquil waters, the lights of the boats employed in the tunny fishery sparkled like constellations of fireflies, and the ships of war hung in shadowy groups on the calm surface. There was much also to delight in Sir William's house in collections of pictures and of objects of beauty and rarity and value. One room was filled with mirrors so disposed as to reflect the Bay in a broad expanse upon the walls. "I am in their house," Nelson wrote to his wife, "and I may now tell you it required all the kindness of my friends to set me up."

The flattery and honours heaped upon him at Naples were not wanting in a quality of buffoonery, due not a little perhaps to the animating influence of Lady Hamilton, whose taste carried her to the length of parading the streets with a bandeau on her forehead, on which were the words "Nelson and

* "Autobiography," i., 116. "Admiral Nelson is little," Miss Knight writes, September 22, 1798, "and not remarkable in his person either way; but he has great animation of countenance and activity in his appearance; his manners are unaffectedly simple and modest."—"Autobiography," ii., 259.

Victory." Bonfires and illuminations blazed in every part of the town. Lady Hamilton undertook the celebration of Nelson's birthday on the 29th of September. Eighteen hundred people were entertained. There was a rostral column erected under a magnificent canopy, and on it were inscribed the words : " Veni ; Vidi ; Vici." The cost of this entertainment was two thousand ducats. Nelson wrote to his wife about Lady Hamilton's preparations with almost childish glee. " The preparations of Lady Hamilton," he says, " for celebrating my birthday to-morrow are enough to fill me with vanity ; every ribband, every button has ' Nelson/ etc. The whole service is marked ' H. N. Glorious 1st of August ! ' Songs and sonnetti are numerous beyond what I ever could have deserved." The Court of Naples was in mourning at this time, but the crape was laid aside in honour of Nelson. The fete, however, was slightly marred by the behaviour of Josiah Nisbet. It is said that he was intoxicated ; his behaviour, at all events, to Nelson was so very offensive that Troubridge and another officer put him out of the room. Pettigrew says that Nelson was afterwards reconciled to his step-son by the intervention of Sir William and Lady Hamilton. The occasion of his insolence, perhaps, was rather Lady Hamilton than wine. Viewing her ladyship with his mother's eyes, he might have resented the amiable, admiring glances old Sir William's wife bestowed upon the Hero of the Nile, and the ill-dissembled delight the Hero felt in receiving or returning them. Nelson had already made too much of these "respectable" friends, and more **par-**

ticularly of the woman who " is an honour to her sex,* to please either Josiah or Josiah's mother. In the beginning of October he tells his wife : " The Grand Signior has ordered me a valuable diamond ; if it were worth a million, my pleasure would be to see it in your possession. My pride is being your husband, the son of my dear father, and in having Sir William and Lady Hamilton for my friends." Lady Nelson, to whom Lady Hamilton's antecedents were doubtless known, might reasonably wonder at the bracketing of Sir William and his wife with herself and the Reverend Edmund. There was also Josiah at Naples to give her the news ; yet it is not until the 7th of December this year, that we hear of Lady Nelson's uneasiness. It is conveyed in a letter from Alexander Davison to Nelson : " Your valuable better-half writes to you. She is in good health, but very uneasy and anxious, which is not to be wondered at. She sets off with the good old man to-morrow for Bath. . . . Lady Nelson this moment calls and *is* with my wife. She bids me say that unless you return home *in* a few months she will join the Standard at Naples. Excuse a woman's tender feelings—they are too acute to be expressed." * Yet, in spite of fetes and bandeaux and buttons and rostral columns, Nelson, on the day following his birthday, could write thus to Lord St. Vincent: " I am very unwell, and the miserable conduct of the Court is not likely to cool my irritable temper. It is a country of fiddlers and poets,——— and scoundrels." f

* " *Dispatches and Letters,*" iii., 138.

† *Clarke and M'Arthur.* I L , 151.

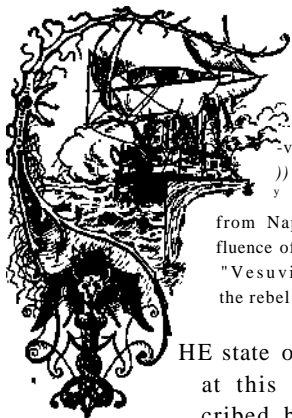

CHAPTER X.

State of the Kingdom of **Naples**—
Precious time wasted — Malta
taken by the French—Saumarez
at Valetta — General Mack —
)) Treachery of Neapolitan officers
y —Flight of (he King and Queen
from Naples—The voyage to Palermo—In-
fluence of Lady Hamilton over Nelson—The
"Vesuvian" Republic—Captain Foote and
the rebel capitulation—Cardinal Ruffo.

HE state of the Kingdom of Naples at this time has been happily described by Southey. He shows us a King with an Irish squireen's love of field-sports, and without taste for or interest in anything else; a Queen possessed of all the vices of the House of Austria, concerned alone in her pleasures, which must be supported, no matter how the revenue was **raised or** administered; and a Court filled with knaves and intriguers. The mass of the people believed that outside of France there was no hope for their country. No government they thought, could be worse than their own, and any sort of change, no matter how contrived, must prove beneficial. A revolution was desired by many even of the nobles, who wished for the power to which they thought themselves entitled; but there were others who joined in **the** cause of liberty from the purest and noblest mo-

tives. It was England's misfortune that it should fall to her lot to bolster up one of the most abominable of European governments. But hatred is a stronger emotion than contempt. The French were first of all to be abhorred, and their project for revolutionising Naples must be thwarted if there was any virtue left in the language of British cannon. All, however, that had to be done was to be the work of the British only. The King of Naples was scarcely to be insulted into defiance or resentment. Nelson told him to draw his sword and lead the way, or remain quiet and be kicked out of his kingdom. "The King," says Southey, "made answer he would go on and trust in God and Nelson; and Nelson, who would have else returned to Egypt for the purpose of destroying the French shipping in Alexandria, gave up his intention at the desire of the Neapolitan Court, and resolved to remain on that station in the hope that he might be useful to the movements of the army." *

It was the intolerable procrastination of the Court of Naples that enraged Nelson. He believed that amongst the Sicilians there were a very great number loyal to their sovereign, animated besides by a passionate eagerness for war against the French; and understanding that the King had an army of soldiers ready to march into a country anxious to receive them, he was astonished and indignant that week after week should be suffered to roll by without anything being done. "What precious moments," he writes, in a letter to Lord St. Vincent, "the two Courts are losing! Three months would

* Southey's "Life of Nelson."

liberate Italy; this Court is so enervated that the happy moment will be lost." Malta, by deputation, was offered to the King, but, as Nelson complains, the Government would not stir. It was expected that the English would take the island for the King of Naples, and the Neapolitans, in that sure conviction, were quite satisfied to go on dancing and fiddling and sunning themselves. The instructions at this time coming to Nelson through Lord St. Vincent from the Admiralty were : that the objects to be held in view by the squadron comprise, *inter alia*, the protection of the coasts of Sicily, Naples, and the Adriatic ; an active co-operation with the Austrian and Neapolitan armies should war be renewed in Italy; and the blockading of Malta to prevent provisions from being sent into it. It was to Malta that Nelson now addressed himself. In 1792 the French Government had decreed that the Order of St. John at Malta should be annulled, and its property annexed. The estates were immediately seized, many of the Knights imprisoned, and those who escaped were proscribed. On the 6th of June, 1798, a division of the French fleet, consisting of a few frigates and a number of transports, arrived off Malta, and the commodore in command, professing neutrality, asked and obtained such assistance as he required. But three days later the rest of the Toulon fleet approached. Buonaparte, who was in command, demanded that the whole fleet and convoy should have free entry to all the ports. This was refused by the Grand Master, whereupon the French landed 15,000 troops at St. George's Bay, to the



NELSON'S MONUMENT, ST. PAUL'S, LONDON

northwest of Valetta, and took possession of the place after a single shot had been fired. Before Buonaparte sailed on the 19th Malta was in possession of the French.

In September came news to the island of Nelson's victory at Aboukir. The Maltese rose against their despoilers, but the insurrection was suppressed. They then appealed to the King of the Two Sicilies as their sovereign for protection. On the 18th of September Valetta was blockaded by four Portuguese men-of-war and two frigates under the command of the Marquis de Niza, the Sicilian Admiral, with whom was Captain Ball in the *Alexander*. It was not, however, until the middle of the following month that Nelson sailed for Malta from Naples. On the 25th he addressed a letter to the French general commanding in the town of Valetta, in which he put the situation and his own demands thus: " That the inhabitants are in possession of all the Island except the town of Valetta, which is in your possession; that the islanders are in arms against you ; and that the Port is blockaded by a Squadron belonging to His Britannic Majesty. My objects are to assist the good People of Malta in forcing you to abandon the Island, that it may be delivered into the hands of its Sovereign, and to get possession of *Le Gviliaume Tell, Diane, and Justice*" He added that, on the delivery of the ships to him, the troops and seamen would be landed in France without being regarded as prisoners of war. On the 30th the little island of Gozo capitulated to Captain Ball. Meanwhile the French under General Vaubois held the town of

Valetta and port of Malta. But for Saumarez the Maltese would have been without arms and ammunition. On the passage to Gibraltar with the prizes captured at the battle of the Nile, Saumarez, whilst becalmed off Malta, supplied the islanders with twelve hundred stands of arms, ball-cartridges, and cartouche boxes. He had also summoned the French garrison in Valetta to surrender, but after three hours' consideration the General had sent word that "they are Frenchmen who are at Malta," adding "*Quant a votre sommation, les Francois Ventendentpas ce style.*" Nelson was filled with indignation on finding that the Sicilian Government had failed to keep a promise emphatically made to him, that supplies of arms, etc., should be sent to the Maltese, and wrote warmly to Sir William Hamilton: "The total neglect and indifference with which they (the islanders) have been treated appear to me *cruel* in the extreme." He had, however, promised the King of Naples to return in the first week in November. The Court trembled during his absence. At any moment might come the obligation of precipitate flight, and the King, Queen, and the others of the Royal Family could not enjoy an easy moment unless Nelson's colours were flying at his mast-head within reach of a few strokes of the oar from Naples.

But now the King was to draw his sword! **When** Ferdinand went on board the *Vanguard*, on her return from the Nile, he told Nelson **that he heartily wished he had been at the battle of Aboukir that he might have fought under him.** An opportunity had come to enable him to justify his **pretensions as a man of courage.** **Thirty-five thousand brill-**

iantly accoutred men of the Sicilies had been raised, and the King was himself to lead the glittering army against the French. It had been as well had he stopped at home. He entered Rome in triumph—a cheap triumph!—but very swiftly news arrived of the foe's return—and his Majesty fled! Mack, the Austrian general, was in command. Of this man Southey says that "all that is now doubtful concerning him is whether he was a coward or a traitor." Nelson thoroughly distrusted him. "General Mack," he says, "cannot move without five carriages. I have formed my opinion. I heartily pray I may be mistaken." Mack was probably more fool than either coward or traitor. Hoste declares that most of his officers had been bribed by the French, and that the Neapolitan soldiers, finding themselves betrayed on all sides, disgusted and disheartened, threw down their arms to a man.* He tells us that General St. Philip, commanding a division of nineteen thousand men, fell in with three thousand of the enemy and deserted to them. As the villain galloped off a Neapolitan soldier shot at and wounded him in the arm; but the injury was not severe enough to prevent him from joining with the French in pursuit of his own countrymen!

The King returned to Naples, and the story that follows is one of riot and assassination. Captain Ball had been left to blockade Malta by Nelson, who, on the 28th of November, arrived off Leghorn with a small squadron, accompanied by some Portuguese ships. On his summoning the town it

* Sir William Hoste's "Memoirs and Letters," vol. i., p. 113.

yielded, but the Neapolitan fiasco rendered this naval expedition entirely fruitless. He returned to Naples on the 5th of December, and a few days later the King arrived. On the 20th certain "most secret" orders were issued by Nelson respecting the evacuation of Naples. Three barges and a small cutter, armed with cutlasses only, were to be at "The Victoria" at half-past seven precisely. One barge was to be at the wharf, the rest to lie on their oars hard by. Other boats of the *Vanguard* and *Alcmena*, under the direction of Captain Hardy, armed with cutlasses and carronades, were to put off from the flagship at half-past eight, each boat having four or six soldiers in her. This flight of their Sicilian Majesties is one of the most romantic passages in the Nelson annals. Southey claims for Lady Hamilton that she had the chief hand in the business, and worked like a heroine in a novel. She assisted, indeed, but she contrived or dictated nothing. The neatest stroke of her share in the escape, she herself communicated: "I had, on the night of our embarkation, to attend the party given by Kelim Effendi, who was sent by the Grand Signior to Naples to present Nelson with a *chelongh* or Plume of Triumph! I had to steal from the party, leaving our carriages and equipage waiting at his house, and in about fifteen minutes to be at my post, where it was my task to conduct the Royal Family through the subterraneous passage to Nelson's boats, by that *moment* waiting for us on the shore."* Precipitate as was the Royal flight, the fugitives managed to heap his Britannic Majesty's

*Pettigrew. II., 619.

ship *Vanguard* with bullion, antiquities, works of art and the like, to the value of twenty million ducats. King Ferdinand and his Queen and family arrived on board Nelson's ship at nine P.M. on the 21st of December. With them were Sir William and Lady Hamilton, a number of the Neapolitan nobility and their servants, and several English gentlemen. When all were safe on board, Nelson gave notice that British residents would be protected on English vessels, and that French emigrants would find an asylum in two ships hired by Sir William Hamilton. All the Neapolitan vessels were ordered out of the Mole, and instructions given for certain ships of war to be burned, that they might not fall into the hands of the enemy.

The story of the voyage to Palermo was long afterwards related by Captain, subsequently Admiral, W. H. Smyth, known as the author of a voluminous dictionary of the marine. "The *Vanguard*" he says "weighed on the evening of Monday the 24th [23d ?] and was followed by the *Archimedes*, a Neapolitan 74, a corvette, and about twenty sail of merchantmen." On board all was confusion and wretchedness. The wind at the start was easterly, but hardly had the island of Capri been cleared when it came on to blow heavily from the westwards. A high sea was set running, and the *Vanguard* labored as a ship of her beam and length and general craziness would know how. The Italians and foreigners exhausted their throats in lamentations and in appeals to the Virgin and saints. At half-past one in the morning a blast of wind blew the

liner's close-reefed topsails out of the bolt-ropes. The consternation was universal. The Royal Party now persuaded themselves that they had only escaped butchery on shore to perish miserably of drowning at sea. Etiquette decreased as fear rose, and in the Admiral's crowded cabin all distinction was at an end. Nelson, who constantly suffered from nausea in heavy weather, was exceedingly perplexed to know what to do. Lady Hamilton, who was apparently a good sailor, was of much use in soothing and waiting. Her old instincts as a nursemaid were no doubt lively in her, when, later on, she hung over the little Prince Albert, who, having been taken ill in the morning, died in her arms on the evening of the 25th. "During the height of the gale," says Smyth, "when Lady Hamilton could think of nothing more wherewith to console the desponding Queen, she looked around for Sir William, who was not to be found. At length it was discovered that he had withdrawn to his sleeping cabin and was sitting there with a loaded pistol in each hand. In answer to her ladyship's exclamation of surprise, he calmly told her that he was resolved not to die with a 'guggle—guggle—guggle' of the salt water in his throat; and therefore he was prepared as soon as he felt the ship sinking to shoot himself."

It scarcely needed the affliction of the death of a child to heighten the misery of the King and Queen. Palermo was reached on the 26th, and at five A.M. Nelson attended the Queen and Princesses on shore. The Queen's grief would not suffer her to leave the

ship publicly, but Ferdinand's sensibility was less keen; and after a substantial breakfast, he landed at nine o'clock amid the cheers of an apparently well-meaning crowd.

The biographer of Nelson must needs dwell upon these Mediterranean experiences of the Hero at this time ; but the task is not an agreeable one. To English sympathies nothing in history can be much more distressing than the spectacle of Britain's noble, generous, simple, and single-hearted Sailor associated with the Court of Naples, living in an atmosphere of lies and deceit, hating and yet enduring his obligation of protection largely for the sake, it must inevitably be admitted, of Lady Hamilton. Nelson's Sicilian zeal was her anxiety, and her anxiety was the cheap ambition of a vain, low-born, unprincipled woman, to maintain her connection with the "adorable" Queen, who perfectly understood her, who merely employed her as a tool, and who, as her subsequent treatment of her proved, despised her all the while she was writing to her as "my dear friend," pledging herself to love her forever, and so on. St. Vincent wrote of this Queen in the language of an old man who labours hard in the direction of admiration and who says too much to render his sincerity convincing; but Lord Keith, when he took St. Vincent's place, sent a shrewd Scotch glance at their Sicilian Majesties, and formed the conclusion which assuredly had been come to by others in the Service, by Troubridge certainly, and by the gentlemanly Ball also: namely, that Nelson was much too enthusiastic in the interpretation of his instruc-

tions with regard to the Court of Naples, and that he was disposed to employ his Majesty's ships much more than the occasions might demand in the service of the Queen.

Whilst Nelson was at Palermo he urged the Sicilian Government to place the island in as complete a state of defence as was practicable. Troops were assembled, and Nelson himself superintended the fitting out of some gunboats and the mounting of batteries with guns which had been brought from Naples. In March he detached Troubridge with a squadron of four 74's, a frigate, and some bomb-vessels, together with a Portuguese 74 to blockade the port of Naples. Troubridge took possession of Procida and the Sicilian King's colours were hoisted by the inhabitants. Next day the same colours were hoisted at Ischia and Capri; and the rest of the Ponza Islands followed the example of Procida.* Meanwhile at Naples there had been a desperate slaughter of the loyal, or at least French-hating, *lazzaroni*, who in the conflicts of January had been butchered in thousands by those French who approached them only to furnish them with liberty and to establish their happiness! By the 23d of that month Naples was held by Championet's troops. A provisional government was established to administer the affairs of what was to be named the Parthenopeian Republic. Nelson happily termed it the "Vesuvian Republic." But discontents swiftly followed; the rapacity of the French grew hourly more and more unendurable.

* James. II., 306.

There were at first a few fruitless risings; but the revolts in Calabria and Apulia brought prominently on the stage Cardinal Ruffo, who, in command of 15,000 men, dealt some desperate blows to the disciplined troops of the Parthenopeian Republic. Meanwhile the French were suffering reverses in the north of Italy, and orders were received by Macdonald, who had succeeded Championet, to withdraw from Naples into Lombardy.

It was on the 12th of May, whilst Nelson was lying at Palermo, that news reached him of thirty-five sail of French men-of-war having passed the Straits. He immediately sent for Troubridge, who was in Naples Bay, to come to Palermo with the whole of his line-of-battle ships. He also communicated with Captain Ball, who was at Malta with the *Alexander* and *Goliath*. "Should you come upwards without a battle," he wrote to Lord St. Vincent, "I hope in that case you will afford me an opportunity of joining you; for my heart would break to be near my commander-in-chief and not assisting him at such a time." With such force as he could assemble, he got under way and cruised for several days. He then returned to Palermo, and having mustered a fleet of sixteen sail-of-the-line, he sailed for a cruise on and off the coast of Sicily; but neither the French nor the Spanish fleets were to be met with.

When Troubridge had been withdrawn, the blockade of the port of Naples devolved upon Captain Foote of the *Seahorse*, a thirty-eight gun frigate. The defeat of the French by Cardinal Ruffo, on the

5th of June, led to the capitulation to the *Seahorse* and squadron of the fortified rock of Rivigliano and of Castel-a-Mare. On the 17th, Foote proceeded to attack Castel-derUovo, which, with Castel Nuovo, formed the principal sea defence of the capital. St. Elmo and these two forts were now the only strongholds possessed by the French in that neighbourhood. On the 18th, Captain Foote offered to the commandant and garrison of the Castel-derUovo an asylum under the British flag. An insolent reply was returned—insolent in terms at least: " We desire the Republic one and indivisible: we will die for it. There is your answer. Away with you, citizen ; quick, quick ! " On this, Foote communicated to Cardinal Ruffo his intention of immediately attacking the fort. The Cardinal acquiesced, but on the 19th, when the naval attack had begun, he sent a letter to Foote asking him to cease hostilities. Next day a plan of capitulation, signed by the Cardinal and the chief of the Russians, then serving with the Neapolitan Royalists, was sent to Foote with the request that he would affix his signature to it. Two days later the capitulation for the forts of Nuovo and del' Uovo was formally signed by Ruffo, by the Russian as well as Turkish commanders, and by Foote as representing the British. The terms were, that the two garrisons, formed mainly of Neapolitan Revolutionists, should march out with the honours of war, and that private property should be respected. There were also minor conditions.*

On the morning of the 24th, Nelson sailed into

the bay in the *Foudroyant*, in which vessel were the Hereditary Prince, and Sir William and Lady Hamilton. With him were sixteen sail-of-the-line and a reduced sixty-four-gun ship. He had heard of the capitulation of the two castles whilst off Ischia, and now entered the bay flying signals intimating the annulment of the truce. The flag was at once hauled down aboard the *Seahorse*. On the following day the rebel garrisons were informed by Nelson that he would not permit them to quit the castles: " They must surrender themselves to his Majesty's Royal mercy." On the 26th, he took possession of the forts, and the soldiers were detained as prisoners until the arrival of King Ferdinand on the 9th of July, when they were given up to the Neapolitan Government.

Whether Nelson was justified in annulling the capitulation entered into by Ruffo, who commanded the Royalist forces, and by Foote, who acted as the representative of the British, is much too stale and worn-out a topic to be here considered. There must always be many who will hold with the lawyers that a man is bound by the acts of his own agent. Nor should it be forgotten that Nelson held the word of a British captain an inviolable thing. " I can assure you, Sir," he wrote to a Spanish nobleman, "that the word of honour of every Captain of a British man-of-war is equal, not only to mine, but to that of any person in Europe, however elevated his rank."* Cardinal Ruffo went on board the *Foudroyant* to a salute of thirteen guns to reason and remonstrate.

* " **Dispatches and Letters,**" vol. vi., p. 46.

Nelson could not communicate his mind in Italian, and the Cardinal had no English. Sir William Hamilton interpreted till he nearly fainted with fatigue, but the voluble Cardinal was not to be convinced, and Sir William, worn out, flung himself into a chair, filled with disgust and distress. Lady Hamilton then undertook the laborious work of translating, but to no purpose. Like Johnson's "female atheist," Ruffo was the man to "talk you dead." At last Nelson gave up, and seizing a pen wrote the following: "Rear-Admiral Lord Nelson, who arrived in the Bay of Naples on the 24th of June with the British fleet, found a treaty entered into with the rebels, which he is of opinion ought not to be carried into execution without the approbation of his Sicilian Majesty—the Earl of St. Vincent—Lord Keith." This decisive scrawl terminated the interview with the Cardinal, whom Nelson used to call "the **Great Devil** who commanded the Christian army."



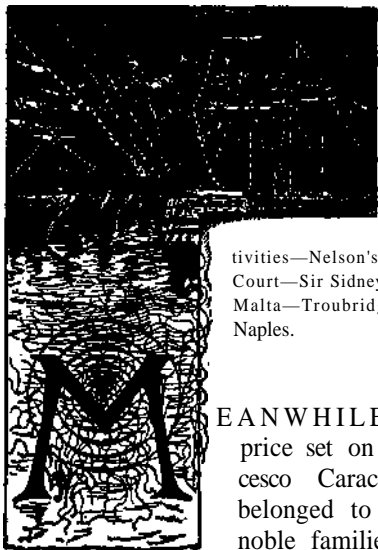

CHAPTER XL

Caracciolo—His trial and execution—Re-appearance of the body—Nelson's gifts to his family—Festivities—Nelson's devotion to the Sicilian Court—Sir Sidney Smith—Captain Ball at Malta—Troubridge's hatred of the Court of Naples.

MEANWHILE there had been a price set on the head of Francesco Caracciolo. This man belonged to one of the most noble families in Naples. He had been a Commodore in the

Neapolitan navy, and had honourably served against the French. On the establishment of the short-lived Parthenopeian Republic an edict was published that the estates of all persons who did not return to Naples would be forfeited. Caracciolo was then at Palermo ; he obtained the King's permission to return, and shortly afterwards joined the Republican naval forces acting against the King and his allies. On **the** recovery of Naples he applied to Cardinal Ruffo **for** protection, claiming it on the ground of

forty years of faithful services. This being refused him, he fled to the mountains, but was captured disguised as a peasant, and on the 29th of June, early in the morning, was brought alongside the *Foudroyant*.

Parsons has described the scene.* He was signal mate to Nelson, and Caracciolo was placed under his charge. "He was a short, thick-set man of apparent strength, but haggard with misery and want; his clothing in wretched condition, but his countenance denoting stern resolution to endure that misery like a man. He spoke a short sentence to me in pure English as if perfectly master of the language." Clarke and M'Arthur represent the unfortunate man as arriving on deck with his hands bound behind him, and Captain Hardy had "the utmost difficulty in restraining the insults and violence of the Neapolitan Royalists towards him." Hardy ordered him to be unbound and treated with the attention his rank entitled him to. Caracciolo arrived alongside the *Foudroyant* at nine A.M. By ten o'clock there had assembled in the British flagship a court-martial composed of Neapolitan naval officers with Commodore Count Thurn at their head, and Caracciolo was at once put upon his trial. Within two hours sentence of death was passed upon him, and Nelson issued an order for him to be executed by hanging at the yard-arm that day on board the Neapolitan frigate *Minerva*, Count Thurn's ship. Death the unhappy man did not fear, but the disgrace of being hanged was dreadful to him. He implored Lieutenant Parkinson of the *Foudroyant* to entreat Nelson to grant

* "Nelsonian Reminiscences."

him a second trial, or, failing this, that he might be shot. Nelson replied that Caracciolo had been fairly tried by the officers of his own country and that he could not therefore interfere. He was approached a second time by Parkinson, whose humane heart was moved by the misery of the poor man, but Nelson's rejoinder, delivered with agitation, was simply: "Go, sir, and attend to your duty." "At two o'clock in the afternoon," says Parsons, "the veteran,* with a firm step, walked into Lord Nelson's barge, and with a party of thirty of our seamen under one of our lieutenants was taken to his flagship, the gun fired, and the brave old man launched into eternity at the expiration of the two hours from the time the sentence had passed.^f The seamen of our fleet, who clustered on the rigging like bees, consoled themselves that it was only an Italian Prince and the Admiral of Naples that was hanging—a person of very light estimation compared to the lowest man in a British ship."

The story of the rising of Caracciolo's body has been variously told. Parsons fixes the time at "some days" after the execution. The King was then living on board the *Foudroyant*. Parsons went

* "To provoke pity for Caracciolo, it was the practice of the false scribes to represent that he was an *old* man—seventy or over seventy years *old*. His age at the time of his death was forty-seven."—"Lady Hamilton and Lord Nelson," vol. ii., p. 82. Miss H. M. Williams, in her "Sketches," says "he appeared to be about seventy, of a commanding figure, and with a dark, expressive countenance."—Vol. i., pp. 210, 211.

^f Clarke and M'Arthur give the hour of his removal from the *Foudroyant* as 5 P.M.

on deck and observed his Majesty gazing intently through his spy-glass at some object out upon the water. Suddenly the King turned pale, and with an exclamation of horror, let fall the glass. On Parsons directing his eyes over the "larboard" quarter, he perceived the body of Caracciolo. The face was "much swollen and discolored by the water, and the orbs of sight started from their sockets by strangulation." There were a number of priests on board, one of whom told the King that the spirit of his unfortunate admiral could not rest without his forgiveness. Nelson ordered a boat to get hold of the corpse, and tow it ashore.* Various as this anecdote has been related, there seems no good reason why it should not be received. Southey found the story in Clarke and M'Arthur, whose version is different indeed from Parsons'. The body is said to have been sunk by three double-headed Neapolitan shot, weighing in all two hundred and fifty pounds; yet it rose with the shot still attached! Nicolas, *in* a note, says that Dr. Clarke in a letter to Captain Foote, dated January, 1809, wrote: "Hardy told me that Caraccioli † floated, notwithstanding that three double-headed shot had been tied to his legs, and that these shot, on being weighed, were two hundred and fifty pounds! How can three double shot weigh so much? I have made it one hundred and fifty. I will write to Hardy, and, if wrong, mark it in the Appendix." Foote's reply was that the weight of a double-headed shot depended

* "Nelsonian Reminiscences," 6.

† Thus spelt; but Caracciolo wrote his name with an "o."

on the bore of the gun, and he supposed that three such shot belonging to a thirty-two pounder would weigh two hundred and fifty pounds.* But this does not answer the question, how a human body is to rise to the surface of the sea with two hundred and fifty pounds of iron attached to it.

The generosity of Nelson's character is at no time more conspicuous than during this period of Palermo and Naples experiences. On learning that the East India Company had voted him a gift of ten thousand pounds, he wrote to his wife that five hundred pounds should be given to his father ; five hundred to his brother-in-law, Mr. Bolton, " and let it be a *God-send* without any restriction " ; and five hundred each to his brothers Maurice and William. A like sum was to be given to his sister, Mrs. Matcham. " If I were rich I would do more," he says. " To my father say every thing which is kind. I love, honour, and respect him as a father and as a man, and as the very best man I ever saw. May God Almighty bless you, my dear father, and all my brothers and sisters, is the fervent prayer of your affectionate——Nelson." When the King of the Two Sicilies granted him the Dukedom and feud of Bronte, he wrote to tell his father that the value of it was about three thousand a year, which, " for your natural life, shall be taxed with five hundred a year." It must be admitted that the King liberally rewarded the services done him. A thousand ounces of silver were divided amongst the officers, seamen, and marines of the *Vanguard*. Troubridge received the

* * Dispatches and Letters," vol. iii., p. 506.

King's miniature set in diamonds, and a valuable ring*; Hardy and Hood somewhat similar gifts. The presents were numerous; they were most of them costly, and many of them princely.

Nelson was much feted at this time ; there was a great deal of celebration and merry-making. On the 1st of August, the anniversary of the battle of the Nile, the King dined on board the *Foudroyant*, then in the Bay of Naples. When he drank Nelson's health a royal salute of twenty-one guns was fired from his Majesty's ships of war and from all the castles. At night there was a general illumination. Amongst other representations was a large vessel equipped like a Roman galley, with lamps fixed to her oars, amidships a rostral column inscribed with Nelson's name, at the stern two angels supporting his picture. Nelson writes enthusiastically to his wife of two thousand variegated lamps; and of music and singers in galore. A little more than a month later we find him magnificently entertained in the Royal gardens at Palermo by Prince Leopold in commemoration of the day on which the news from Aboukir had reached Naples. The fireworks were very grand; there was a representation of the blowing up of *VOrient*; the Queen of Naples conducted the company into the richly illuminated gardens, where there were separate pavilions for the use of the English, Portuguese, Turkish, and Russian guests. As the company entered a band of musicians from the opera sang " God Save the King." In the vestibule of a Grecian temple

* In 1800 he was created Commander of the Order of St. Ferdinand, and a pension of £500 a year was settled on him.

superbly illuminated was a statue of Lord Nelson as large as life. The four Princesses having arranged themselves at the foot of the throne, Prince Leopold placed a crown of laurel on the statue, whilst the band played "Rule Britannia." Nelson, with tears in his eyes, saluted the Prince, who immediately embraced him. There is too much simplicity in all this for cynicism. To Nelson it was enjoyment at least, and it made the powder-blackened, hearts-of-oak who were associated with him happy. The soul of the sailor is that of the child. The student may smile at the character of these plaster-of-Paris celebrations; but to the mariner the fireworks, the variegated lamps, the Grecian temples, the devices, and the compliments were very fine things. As much as possible was to be made of them after the junk and rum of shipboard; they were professional garnishings, to be tasted once perhaps in a lifetime ere a round shot did for the seaman, or Peace drove him into some obscure cottage in England to nurse his wounds in poverty and live forgotten.

On the 9th of July a powerful Spanish fleet, followed, at an interval of a few hours only, by the French fleet—in all sixty-five sail—passed through the Strait. Lord Keith, at this time second in command under Earl St. Vincent, whose health was very bad, immediately requested the presence of Nelson and his ships for the protection of Minorca. Nelson, however, could think of nothing but the re-establishment of the Royal Authority at Naples. Troubridge was ashore attacking Capua with a large number of sailors and marines. Nelson, under **the**

circumstances, refused to budge. His acceptance of Lord Keith's orders went no further than his sending Admiral Duckworth with some ships to Minorca. "I am fully aware of the act I have committed," he wrote to Earl Spencer July 13th, "but, sensible of my loyal intentions, I am prepared for any fate which may await my disobedience." Capua and Gaeta he believed must speedily fall, and when the "scoundrels of French" had been thrashed out of the country he would send eight or nine ships of the line to Minorca. The Admiralty disapproved of his conduct in not obeying the Commander-in-chief's instructions. It was particularly objected that upwards of one thousand of the best men of Nelson's squadron should have been sent on shore at a time when the enemy's fleet were abroad and might at any moment heave in sight. And here "my lords" for once in a while appeared to form a correct opinion, for certainly the employment ashore at a distance of a large force of the crews of a squadron must necessarily leave the ships defective and even defenceless.

The appointment of Sir Sidney Smith in October, 1798, to act as Plenipotentiary to the Ottoman Court at Constantinople greatly irritated Nelson, and was regarded as an affront by Lord St. Vincent. They both held that it was a direct neglect of the claims of the lion-hearted captains who had fought at the battle of the Nile to place a portion of the command in other and junior hands. Nelson's indignation went to the length of asking St. Vincent's leave to withdraw from the command, which he begged should be given to Captain Troubridge, or, as he signifi-

cantly adds, "to some other of my brave friends who so gloriously fought at the battle of the Nile." All was astonishment and resentment with Nelson and indeed with St. Vincent too. There never was a more gallant officer than Sir Sidney Smith, but to his professional virtues he united several disagreeable qualities, of a very teasing and irritating sort, such as pertness, cocksureness, and self-complacency often accentuated into positive absurdity. At the very onset he contrived to outrage British sensibility in the Mediterranean by deliberately stating that, as he presumed all the ships in the Levant were junior to him, he had a right to take them under his command. St. Vincent ended this by requiring Sir Sidney to put himself under Nelson. He proved, however, a refractory junior, persisted in acting independently of Nelson, and provoked the Hero into writing some strong letters to him. Especially was Nelson annoyed by learning that Sir Sidney, in direct opposition to his commander's opinion, was drawing up a form of passport with the avowed intention of enabling all French ships in Alexandria to pass to France. "I . . . *strictly charge and command you*" writes Nelson, angrily underscoring his words, "never to give any French ship or man leave to quit Egypt." Sir Sidney's policy was entirely opposed to keeping the enemy "*dammed up* in Egypt," as he called it; his desire was that they should be allowed to evacuate the territory by all means, except that of permission to retire with arms in their hands. "Talents," wrote St. Vincent jocularly of him to Lady Hamilton, "he certainly pos-

esses, with a sufficient degree of enterprise; but his military merits appear to me rather problematical, and I must resort to a French phrase, *soi-disant*, to designate his character." *

Acre however considerably altered Lord Nelson's opinion. On the 25th of July he wrote to Sir Sidney's brother, Spencer Smith, that no one could admire his (Sir Sidney's) gallantry and judgment more than himself. The siege of Acre was raised on the 21st of May. It had lasted sixty days. The enemy's flotilla was destroyed, and extraordinary skill and bravery were exhibited by Sir Sidney Smith, who had little more than a body of undisciplined troops to oppose to the trained and desperate regulars of Buonaparte. "As an individual," wrote Nelson to him August 20th, "and as an Admiral, will you accept my feeble tribute of praise and admiration, and make them acceptable to all under your command."

Meanwhile to Captain Ball had been entrusted by Nelson the taking of Malta from the French. It was proposed that when the island surrendered, Ball should be governor as representing the King of Naples and the King of England. Nelson's concern in the feelings and the sensibilities of the Court of Naples is illustrated by his recommendation to Ball: "In case of the surrender of Malta I beg you will not do anything which can hurt the feelings of their Majesties. Unite their flag with England's if it cannot, from the disposition of the islanders, fly alone." All this to us at a dis-

* Pettigrew. I., 197.

tance surely seems a little *de trop*. Here was this country expending blood and treasure in the protection of a Court rotten to the heart, and doing work which those who desired to benefit b) it were too cowardly or too lazy to perform for themselves. Lady Hamilton and the Queen of Naples between them were fast impairing in Nelson the most sailorly of his characteristics: his swift capacity of penetrating to all that might be behind the foreigner's grimacings and posturings and politesse, and his quarter-deck trick of bluntly delivering what was in his heart.

Ball's duty was distracting and arduous. The blockade of Valetta had been conducted at a cost of £15,000 a month; the garrison was mutinous; the scurvy was raging; the Maltese were starving, and Ball was in despair how to obtain supplies for them. Even if money were to be raised, provisions were not to be had. What was the behaviour of that Naples Court whose sensibilities Nelson was so anxious not to vex? Coleridge, in his oft-quoted notice of his friend Sir Alexander Ball, answers the question: "Though the very existence of Naples and Sicily, as a nation, depended wholly and exclusively on British support; though the Royal Family owed their safety to the British fleet, though not only their dominions and their rank, but the liberty and even lives of Ferdinand and his family were interwoven with our success; yet, with an infatuation scarcely credible, the most affecting representations of the distress of the besiegers and of the utter insecurity of Sicily, if the French remained

possessors of Malta, were treated with neglect; and the urgent remonstrances, for the permission of importing corn from Messina were answered only by sanguinary edicts precluding all supply." * There was but one course for Ball to adopt: food must be obtained or the Maltese must starve; and the British captain ordered his lieutenant to proceed to Messina and seize the ships laden with corn there. This was done; it removed the necessity of raising the siege, but in consequence of this act, as Coleridge tells us, Ball became an especial object of the hatred and fear, and perhaps the respect, of the Court of Naples.

Troubridge arrived off Malta on the 9th of December, Nelson's hope being to bring the long blockade to a close. The devotion of this officer (who, in September, had been made a baronet by the King of Great Britain) to the service of his country, finds remarkable expression in his offer to assist the intended reinforcement, whose operations were delayed by want of money, with a considerable sum out of his own pocket. His love for Nelson is also strongly illustrated by his letters dated during the month of December from Malta. The Hero's health was bad; he undoubtedly required rest, but such rest as he could not obtain at Palermo. James cynically says: "Lord Nelson being indisposed (mentally if not corporeally)," etc.† But his illness was something more than mental. His temper had been affected by the wound he had received in the head at the battle of the Nile; his **having to**

* "The Friend," by S. T. Coleridge. Bohn's ed.

† James. II., 440.

return to Syracuse after the fruitless search for the French fleet, had then and there, he was wont to say, broken his heart; and he was now suffering from violent pains in his chest, which he would speak of as though a ligature tightly and tormentingly girdled him. Troubridge, gravely concerned for the health of his glorious chief, entreated him to act with prudence. "I know," he says, "you can have no pleasure sitting up all night at cards; why then sacrifice your health, comfort, purse, ease, everything to the customs of a country where your stay cannot be long? I would not, my Lord, reside in this country for all Sicily. . . . If you knew what your friends feel for you, I am sure you would cut all the nocturnal parties." Troubridge's detestation of the Kingdom of Naples and everybody in it and belonging to it again and again breaks forth amid the conjurations he addresses to his beloved chief. "I curse the day I ever served the Neapolitan Government." "For my own part, I look on the Neapolitans as the worst of intriguing enemies. Every hour shows me their infamy and duplicity."* There is a significant stroke in a letter that Nelson received towards the close of 1799 from his friend Admiral Goodall, then in England: "They say here, my good Lord, that you are Rinaldo in the arms of Armida, and that it requires the firmness of a Ubaldo and his brother knight to draw you from the enchantress."

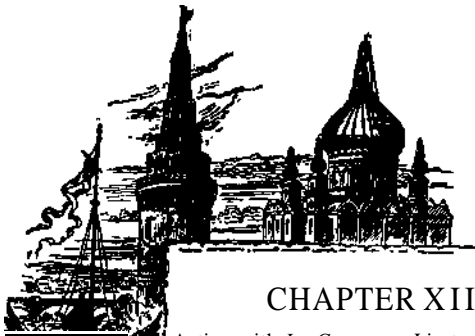

CHAPTER XII.

Action with *Le Genereux*—Lieutenant Parsons* description of the fight—Lord Cochrane on Nelson—Capture of *Le Guillaume Tell*—Life on board the *Fondroyant*—Insurrection at Leghorn—Incidents of Nelson's journey home—Arrival in London—Quarrel with Lady Nelson—His separation from her.



EARLY in January, 1800, Nelson sent Troubridge word that he would shortly join him at Malta. His position as Acting Commander-in-chief in the Mediterranean terminated on the 6th of January, when he learnt that Lord Keith had received orders to resume the command in that sea. Hoisting his flag on board the *Foudroyant*, he joined Lord Keith in the Leghorn Roads, and on the 3d of February sailed for Malta. Whilst off Cape Passaro, in Sicily, he fell in with a French squadron under Rear-Admiral Perree in *Le Gdne'reux*, 74, one of the vessels that had escaped at the battle of the Nile. This squadron had some 3,000 troops on board, to intercept the disembarkation of which Lord Keith, who had sailed with Nelson, kept as close to the entrance of Valetta in his 100-gun ship, the *Queen Charlotte*,

as the batteries would allow him. With Nelson's ship were the *Audacious* and the *Northumberland*; a fourth ship, *the Alexander*, was down on the south-east side of the island. This vessel on the 18th at daylight sighted PerreVs squadron, and a little later on fired at and brought to an armed storeship. The smaller of the Frenchmen tacked; the *Ge'nireux*, that could not have done so without coming to an action with the *Alexander*, bore up. The little *Success* frigate, that was to leeward, placed herself athwart the hawse of the French seventy-four, and raked her with several broadsides. At half-past four the *Foudroyant*, followed by the *Northumberland*, got near enough to plump two shots into the Frenchman, and the *Gdntreux*, after firing the usual ceremonious broadside, struck her colours.

Parsons, who was on board the *Foudroyant*, gives a lively account of the chase of the Frenchman. We see Nelson himself in this picture, hear him speak, and watch his motions. The deck is hailed from aloft and a man-of-war reported—a line-of-battle ship, apparently, going large on the starboard tack. " Ah, an enemy, Mr. Staines! " exclaimed Nelson. " I pray God it may be *Le Ge'ne'reux*. The signal for a general chase, Sir Ed'ard [the Nelsonian pronunciation for Sir Edward, addressed to Sir Edward Berry]. Make the *Foudroyant* fly ! " The *Northumberland* was now taking the lead, with the flag-ship close on her quarter. " This will not do, Sir Ed'ard ! " cried Nelson ; " it is certainly *Le Ge'ne'reux*, and to my flag-ship she can alone surrender. Sir Ed'ard, we must and shall beat the *Northumber-*

land! " Every effort was made, Parsons tells us. " I will do the utmost, my Lord," answered Sir Edward Berry, and gives the following orders: " Get the engine to work on the sails—hang butts of water to the stays—pipe the hammocks down and each man place shot in them—slack the stays, knock up the wedges, and give the masts play—start off the water, Mr. James, and pump the ship! " Then addressing whom it may concern, Sir Edward exclaims: " The Admiral is working his fin [the stump of his right arm] ; do not cross his hawse, I advise you ! " The advice was good, for at that moment Nelson opened furiously on the quartermaster at the wheel: " I 'll knock you off your perch, you rascal, if you are so inattentive! Sir Ed'ard, send your best quartermaster to the weather-wheel! "—" A strange sail ahead of the chase ! " called the lookout-man.—" Youngster, to the masthead !—What ! going without your glass, and be d——d to you ! Let me know what she is immediately!"—" A sloop-of-war or frigate, my Lord ! " shouted the young signal midshipman.—" Demand her number ? "—" The *Success*, my Lord, Captain Peard."—" Signal to cut off the flying enemy! Great odds, though—thirty-two small guns to eighty large ones."—" The *Success* has hove-to athwart hawse with the *Gdndrcnx*, and is firing her larboard broadside ! The Frenchman has hoisted his tri-colour with the Rear-Admiral's flag! "—" Bravo! *Success*, at her again !"—" She has wore round, my Lord, and firing her starboard broadside. It has winged her, my Lord, her flying-kites are flying away altogether. The enemy is close on **the**

Success, who must receive her tremendous broadside ! " The *Ge'ne'reux* opens her fire on her little enemy, and every person stands aghast, afraid of the consequences. The smoke clears away, and there is the *Success*, crippled, it is true, but, bull-dog-like, bearing up after the enemy. " Signal for the *Success* to discontinue the action and come under my stern," said Lord Nelson. " She has done well for her size. Try a shot from the lower deck at her, Sir Ed'ard."—" It goes over her."—" Beat to quarters and fire coolly and deliberately at her masts and yards." At this moment, Parsons goes on to tell us in this lively sketch, which may be accepted as a very real and correct portrait, a shot from the *Ge'ne'reux* passed through the mizzen staysail. Nelson, patting one of the little midshipmen on the head, asked him jocularly how he relished the music. The lad was pale and alarmed, and, observing this, Nelson told him that Charles XII. ran away from the first shot he heard, though he was afterwards called " The Great " because of his bravery. " I therefore," said Nelson, " hope much from you in future." Shortly after this the enemy hauled down his colours, and Sir Edward Berry was sent on board the prize, where he found Rear-Admiral Perree dying on his quarter-deck, having had both his legs shot off by the raking broadsides of the little *Success*. Nelson, who appears to have been incessantly in spirit with the Court of Naples, sent the French Admiral's flag as a gift to young Prince Leopold.

Lord Keith entrusted the command of the squadron that was blockading Valetta to Nelson ; but the

Hero's health, if not his energies, were exhausted. Nearly three months earlier he had written pathetically to Commissioner Inglefield: " You must make allowances for a worn-out, blind, left-handed man." Yet he was then but forty-one years of age ! He entreated Lord Keith to give the command of the squadron off Malta to Troubridge, and on the 16th of March he returned to Palermo. It was at Palermo that Lord Cochrane, afterwards Earl of Dundonald, met Nelson. There never was a finer sea-officer than Cochrane, despite his eccentricities as a man, and the opinion he formed by personal knowledge of the Hero of the Nile cannot but prove interesting. " It was never," he says, " my good fortune to serve under his Lordship either at that or any subsequent period. During our stay at Palermo I had, however, opportunities of personal conversation with him, and from one of his frequent injunctions, * Never mind manoeuvres; always go at them,' I had subsequently reason to consider myself indebted for successful attacks under apparently difficult circumstances. The impression left on my mind during these opportunities of association with Nelson was that of his being an embodiment of dashing courage, which would not take much trouble to circumvent an enemy, but being confronted with one would regard victory so much a matter of course as hardly to deem the chance of defeat worth consideration. This was in fact the case; for though the enemy's ships were for the most part superior to ours in build, the discipline and seamanship of their crews were in that

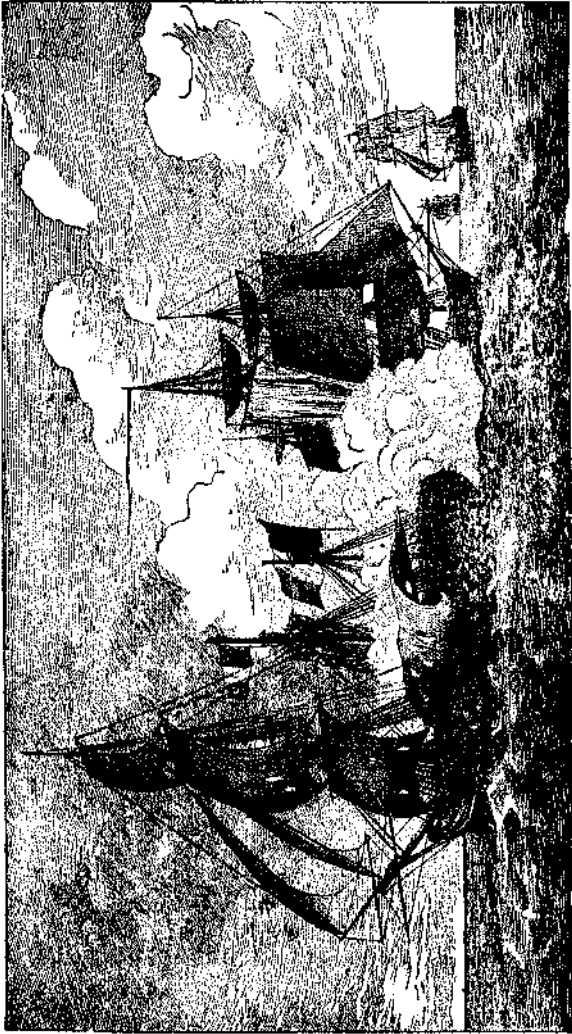

CAPTURE OF "LE GUILLAUME TELL," 1800

day so inferior as to leave little room for doubt of victory on our part." *

Another distinguished naval officer, Sir Jahleel Brenton, preserves a characteristic story of Nelson, which also belongs to this period. Brenton had command of a sloop-of-war, and was ordered with a convoy of Neapolitan vessels to Cagliari, where they were to load with corn and return to the ports of Italy. Brenton, then a very young man, sensible of the importance of his trust, and aware that the policy of the British Government towards the States of Barbary was one of extreme caution, asked Nelson what he should do in the event of the Algerines attacking his convoy. " Let them *sink you*" answered the Hero ; " but do not let them touch the hair of the head of one of your convoy. ALWAYS FIGHT AND YOU ARE SURE TO BE RIGHT."

Nelson was cheered on the 30th by the capture of *Le Guillaume Tell*, eighty-four guns, the remaining ship that had escaped at the battle of the Nile. She surrendered to Sir Edward Berry in the *Foudroyant*. Captain Manley Dixon of the *Lion* sent Sir Thomas Troubridge a graphic, detailed account of the action. The *Guillaume Tell* had a thousand men on board, and mounted eighty-six guns, according to Dixon's statement, and bore the flag of Contre-Amiral Decres. The English ships engaged were the *Foudroyant*, *Lion*, and *Penelope*. Signal rockets and the discharge of guns from the English batteries at Malta, on the midnight of the 30th of March, had

" Autobiography of a Seaman," p. 55.

announced her escape. Captain Blackwood, in the *Penelope*, descried her in the dark, with other escaped ships in company. Instantly Captain Dixon made the signal for the squadron to cut or slip, and gave chase under a press of canvas, steering his course by help of the flashes of the *Penelope's* guns, whilst he himself signalled the direction to be taken by rockets and blue-lights to the squadron in his wake. At daybreak the *Lion* was within gunshot of the chase, and the *Penelope* within musket-shot. It was a yard-arm to yard-arm action, with great confusion aboard the Frenchman owing to her wreckage aloft. "I was not in the least solicitous," writes Captain Manley Dixon, "either to board or to be boarded, as the enemy appeared of immense bulk and full of men, keeping up a prodigious fire of musketry." Seemingly the "Nelson touch" is wanting in this admission. The *Foudroyant* dived alongside under a press, hailing the enemy to strike as she passed, which she eventually did after the hottest action, so Captain Dixon terms it, that was ever maintained by an enemy's ship opposed to British vessels. The *Guillaume Tell* was a giantess of those days. It is said that the *Foudroyant* alone in this engagement expended 162 barrels of powder, 1,200 thirty-two-pound shot, 1,240 twenty-pound ditto, 100 eighteen-pound ditto, and 200 twelve-pound ditto.* Add to this the fire of the *Penelope* and the *Lion*, and we may realise the character of the ploughing suffered by the gallant Frenchmen in this desperate conflict.

Nelson's satisfaction was scarcely to be expressed.

* *Naval Chronicle*, vol. Hi., p. 508.

" My task is done," he wrote to Sir Edward Berry, " my health is lost, and the orders of the great Earl St. Vincent are completely fulfilled—thanks, ten thousand thanks to my brave friends." He refers to the then Commander-in-chief's instructions to him to *take, sink, bum,* and destroy the French armament, a command which this capture of the last of the enemy's liners that had fought at the Nile completely fulfilled.

The *Foudroyant* returned to Palermo, and on the 24th of April Nelson sailed in her for Syracuse. Little of interest attends his movements until the 18th of June, on which date he received a communication from Lord Keith, acquainting him with the capitulation between the Imperial and French armies, and of the proposed evacuation of the Genoese territories, and he was ordered to proceed with all the ships at Leghorn to the Gulf of St. Especia to obtain possession of certain garrisons there. It is noticeable that Lord Keith, in these directions, seems to anticipate an objection by speaking of the order given as " not a matter of caprice, but of actual duty and necessity," and adds : " I must desire to be final." Next day he directed that no line-of-battle ships should be employed to convey the Queen of Naples to Palermo, should she decide upon not going to Vienna, and Nelson was authorised to strike his flag and proceed to England either by *land*, or in the *Princess Charlotte*, or in the troopship at Mahon, or in the *Seahorse*. He struck his flag on the 11th of July.

Miss Knight, in her "Autobiography," * admits us

*Vol. i., p. 146.

to a close view of what may be termed Nelson's inner and private life at this period. It is by such glimpses as these that we are enabled to figure the Hero as he showed to those who lived in intimate association with him. Sir William Hamilton had been succeeded in his post as Minister at Naples by the Hon. Arthur Paget. The party that sailed in the *Foudroyant* from Palermo in April,* 1800, consisted of Sir William and Lady Hamilton, an English lady and gentleman, an old Maltese nobleman, and Miss Knight. Nelson's cabin, or his living-room as it may be called, is represented as being decorated with a carving in wood of an immense three-coloured plume of feathers, which had been a portion of the figure-head of the *Guillaume Tell*; four muskets that had been taken from the *San Josef*' in the battle off Cape St. Vincent; and the flag-staff of *L'Orient*, saved from the flames when that ship was blown up. The famous coffin, as we may suppose, had some time before this been removed. The table was good; there was plenty, without ostentation; Nelson, however, ate little—the wing of a fowl and a glass or two of champagne often served him for a dinner. Lady Hamilton was exceedingly miserable through leaving Sicily and her "adorable" Queen, and by way of consoling her, Miss Knight composed some verses to the tune of "Hearts of Oak," in the chorus of which Nelson would join with heartiness. After visiting Syracuse and Malta, the *Foudroyant* returned to Palermo, whence she sailed for Leghorn, with the Queen of Naples, her three

* Miss Knight gives the date as the 23d.

unmarried daughters, and Prince Leopold on board. The Queen was now on her way to Vienna, and Nelson, by accompanying her, was keeping a promise he had long before made. On the arrival of the ship at Leghorn, June 16th, the Queen presented to Nelson a rich picture of the King; to Sir William Hamilton she gave a gold snuff-box, with a picture of the King and herself in diamonds; and to Lady Hamilton a diamond necklace, with ciphers of all the children's names, ornamented by locks of their hair.*

Whilst the Royal Party were at Leghorn there was an insurrection of the people. The French army was about twenty-four miles distant, and the populace sought to secure the persons of the Queen and Royal Family and to detain Nelson that he might lead them against the abhorred foe. The Queen and her family escaped from the palace in which they were residing, and got on board the *Alexander*, in which ship Nelson had hoisted his flag after the departure of the *Foudroyant* to Minorca for repairs. It was Nelson's intention to convey the Queen to Trieste; instead of which she started for Florence and Ancona, and on the following day Nelson, Sir William and Lady Hamilton, and Miss Knight followed her. Florence was reached on the 12th of July, despite desperate risks; for the route of the Nelson party had obliged them to pass within a mile of the advance posts of the French, and Miss Knight assures us that even the officers and crew of the *Alexander* were shocked at the idea of the danger to

which their Admiral was exposing himself. When they reached Ancona they found a Russian squadron about to sail to Corfu. The commanding officer, however, consented to take the Queen and all her party to Trieste, at which port Nelson landed with the others on the 2d of August. He had met with several unpleasant adventures: for instance, at Castel San Giovanni the coach in which he, Sir William and Lady Hamilton were travelling was overturned. The wheel was repaired, but farther on the crazy vehicle broke down again at a moment when news had reached them that the French army was rapidly advancing. On board the Russian Commodore's ship Nelson is said to have suffered miserably. The Commodore himself was sick in his cot; and the vessel was in charge of the first lieutenant, a Neapolitan, who is described as the most insolent and ignorant of beings. Nelson declared that had the ship encountered a gale of wind she must have sunk.* At every place at which they arrived crowds assembled to behold the Hero of the Nile. At Vienna, his name figured on hundreds of signboards, and the very *modistes* went to work to celebrate him *In* costumes and dresses called after him. Amongst those whom Nelson met whilst on his travels home was Haydn. Prince and Princess Esterhazy feasted him at a table where the waiters were a hundred grenadiers, most of whom were above six feet tall. "Count Batthyany's contribution to the series of Nelson celebrations was the aquatic fete on the Danube, with his **experiments**

* " **Dispatches and Letters,**" vol. iv., p. 264.

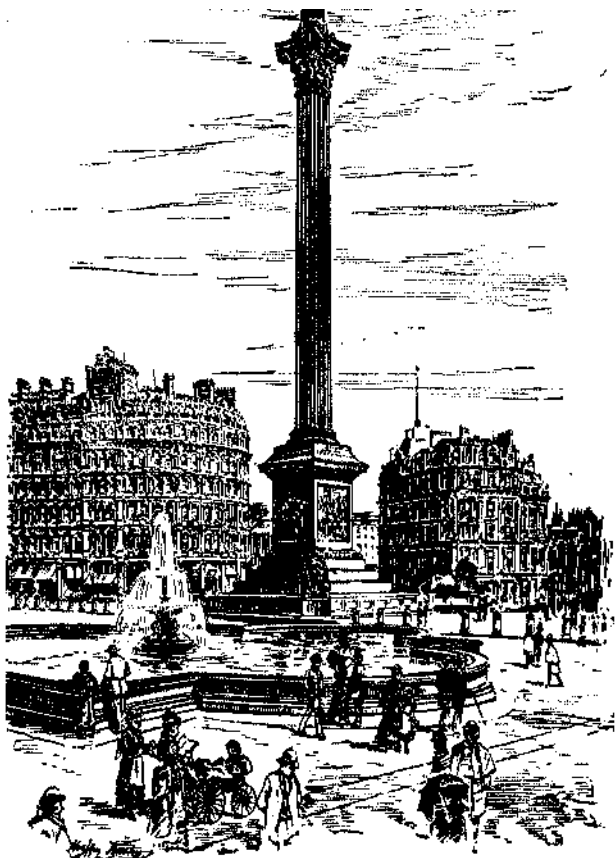

NELSON'S COLUMN, TRAFALGAR SQUARE, LONDON.

of vessels especially constructed to resist the torrents of the mighty river." *

At Prague occurred an incident characteristic of Continental travel: The hotel at which Nelson stopped was splendidly illuminated in honour of him; and when mine host sent in his bill it was observed that he had charged for every candle! At Hamburg Nelson called upon the poet Klopstock. During the visit the door was opened and an old man in canonicals, holding a Bible in his hand, was ushered in. He walked up to Nelson, and, bowing low, stated that he was between seventy and eighty years of age, and had travelled forty miles with the Bible of his parish church to obtain Nelson's signature "on the first leaf of it. Nelson willingly complied, and the clergyman, giving him his blessing, withdrew. Another anecdote belonging to this journey is told. The English merchants at Hamburg invited Nelson and his friends to a grand fete. He wore the magnificent sword that had been given to him by the King of Naples, and on examining it afterwards, found that one of the large diamonds which encrusted the hilt was missing. Search was made, but the diamond was irrecoverably lost. The merchants were desirous of replacing it, at a cost of £800, but the gift was declined.

On the 31st of October he and his companions went on board the *King George* mail packet, and arrived at Yarmouth on the 6th of November, after a stormy passage. The weather was so bad, indeed, that nothing but the determined spirit of Nelson,

" **Lady Hamilton** and Lord Nelson," vol. 11., p. 172.

supplemented by a strong glass of grog, could have induced the pilot to make the attempt to land. When the party entered the carriage that waited on the beach, the horses were taken from it, and it was dragged by the huzzaing crowd to the Wrestlers' Inn. The harbour was radiant with bunting; the freedom of the town was presented to him; the troops paraded before the inn, and their bands saluted the conquering Hero. Accompanied by the Corporation he went in solemn procession to church to offer up thanks on his safe return to his country, Illuminations and bonfires completed the day's rejoicings.

The party arrived in London on the 7th of November, 1800. Sir William and his wife accompanied Nelson to dine with his father and Lady Nelson. The Hero had been absent two years and seven months, and that his wife, after this long lapse of time, during which he had rendered his name immortal, should not have met him at Yarmouth, instead of coldly awaiting his arrival in London, is apparently to be explained only by her jealousy and dislike of Lady Hamilton, and by the stories which had reached her of her husband's relations with that woman. This connection indeed appears to have been the cause of the coolness of his reception at Court. Collingwood, writing under date of January 25, 1801, says: "Lord Nelson is here. . . . He gave me an account of his reception at Court, which was not very flattering after having been the adoration of that of Naples. His Majesty merely asked him if he had recovered his health, and

then, without waiting for an answer, turned to General——, and talked to him near half an hour in great good-humour. It could not be about his *successes*" This, after the battle of the Nile! It should have gone far to correct in Nelson his idolatrous theories of princes and potentates.

He and Lady Nelson lived together very unhappily for about two months after his return. The story of their separation has been related by an eyewitness.* Lord and Lady Nelson were at breakfast at their lodgings in Arlington Street in the winter of 1801 ; there was some cheerful conversation, when incidentally Nelson referred to something which had been said or done by " dear Lady Hamilton." Lady Nelson at once rose and exclaimed with some heat: " I am sick of hearing of *dear* Lady Hamilton, and am resolved that you shall give up either her or me." Nelson calmly answered : " Take care, Fanny, what you say. I love you sincerely, but I cannot forget my obligations to Lady Hamilton or speak of her otherwise than with affection and admiration." Muttering something about her " mind being made up," Lady Nelson left the room and shortly after drove from the house. This was followed by a separation, and they never afterwards lived together. Miss Knight, referring to this period, says : " I dined one day with Sir William and Lady Hamilton in Grosvenor Square. Lord and Lady Nelson were of the party, and the Duke of Sussex and Lady Augusta Murray

* W. Haslewood to Nicolas. " *Dispatches and Letters,*" vol. vii., p. 393.

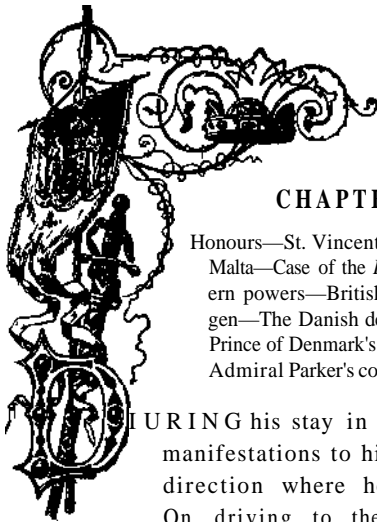

CHAPTER XIII.

Honours—St. Vincent's Concern—Surrender of Malta—Case of the *Freya*—Attitude of Northern powers—British fleets sent to Copenhagen—The Danish defences—Anecdote of the Prince of Denmark's *aide-de-camp*—Nelson at Admiral Parker's council—Eve of the action.

DURING his stay in England there were manifestations to his honour in every direction where he showed himself.

On driving to the Installation Dinner of the Lord Mayor of London in the Guildhall, he was recognised in Ludgate Hill, the horses were taken from his carriage, and he was triumphantly drawn to the banquet, where a magnificent sword voted by the City was presented to him. He received it standing under a triumphal arch. He accepted an invitation from Beckford, the well-known author of "Vathek," to visit him at Fonthill, and at Salisbury the Yeomanry Cavalry turned out to meet and escort him for a distance of twelve miles ; he was then conducted in state to the Council House and presented with the freedom of the City. In **the crowd** stood a sailor whom Nelson immediately rec-

ognised as one who had fought with him at the battle of the Nile. He called him forward, greeted, and dismissed him with a handsome gift. He also observed another man who had been at his side when his arm was amputated. The honest Tar was loudly huzzaing. Nelson beckoned to him and made him a present, and the poor fellow on withdrawing took from his breast a piece of laoe which he had torn from the shirt sleeve of Nelson's excised limb, and declared he should preserve it till the latest period of his life as a memorial of the beloved Hero. At Foothill Nelson was received by the Volunteers, headed by a band of music. The splendour of the hospitality was honourable to the imagination of the inventor of the "Hall of Eblis." Lady Hamilton with her husband was of the party, and she is said to have enchanted the company with one of her remarkable personations. In one scene her dumb show was so moving that a number of the spectators wept.

All this feting and feeding and movement caused St. Vincent to fear for his friend. "My dear Lord," he wrote, "I wish you had done with this City feasting, for there is much risk of illness in going out of smoking hot rooms into the damp air of putrid London streets." Yet his health had been undoubtedly benefited by his overland trip and return to England. Even on the day of his landing at Yarmouth he conveyed to the Admiralty his wish to serve immediately, and on the 21st of November, 1800, we find him writing to a friend that the *San Josef* is to be his flag-ship.

The fortress of Valetta and the island of Malta had surrendered on the 5th of September to the troops under General Pigott (an officer of whose behaviour Ball bitterly complained to Nelson) and to the blockading squadron under the command of Captain Martin in the *Nortk7imberla?id*. The terms of capitulation were that the troops should march out with the honours of war and lay down their arms ; the officers and non-commissioned officers to retain their swords ; and the garrison to be sent to France at the expense of the British Government, and not to serve against Great Britain until regularly exchanged. Eight hundred pieces of ordnance were found mounted on the fortifications. In the harbour was a Maltese sixty-four-gun ship of a very beautiful model. It is believed that not less than twenty thousand persons perished from famine, disease, and hardships during the blockade.

On the previous 25th of July, a British squadron had fallen in with a Danish forty-gun frigate convoying two ships. The senior British officer hailed the Dane to say he should send his boat on board the convoy, designing to exercise the unquestioned right of searching the ships of neutrals for contraband of war. The Dane threatened to fire into the boat; an action followed, and the *Freya*, the name of the Danish ship, was brought with her convoy to the Downs. The British Government hastily despatched Lord Whitworth to the Court of Denmark to adjust as best he could the very grave difficulty that had arisen. Conferences resulted in the agreement that **the** *Freya* and convoy should be repaired at **the cost**

of the English, **and** released; and the right of the British to search was to be discussed at a future day. Russia, deemed to be an ally of England at that time, resented the attack upon the *Freya*, and particularly took offence at the passage through the Sound of the squadron that had accompanied Lord Whitworth. The first act of the Emperor Paul, a brutal madman, was to sequester all British property in his dominions; the next to place his army and navy upon a war establishment. After three weeks the sequestration was removed, but news of the capture of Malta was now to hand, and the Emperor Paul, in his anger that the English flag alone should have been hoisted on the island contrary to treaties concluded in 1798, laid (5th November) an embargo on all the British shipping in his ports, numbering two hundred sail. The men belonging to the vessels, amounting nearly to two thousand, were marched away in the dead of winter to different villages and towns in the interior, as far as the confines of Siberia. This was followed (in December) by the re-establishment of an armed neutrality between Russia and Sweden ; a confederacy that was presently rendered more menacing by the junction of Denmark at the instigation of Russia and of Prussia. Thus briefly may be summarised the *motif* of that great Baltic drama, whose central brilliant feature was the battle of Copenhagen.

There was nothing for Great Britain to do but to assume the menacing posture adopted by the Northern nations, and on the 12th of March, 1801, **there** was despatched from Yarmouth Roads, under

the command of Admiral Sir Hyde Parker in the *London*, 98, with Nelson in the *St. George*, 98, as his second, a fleet of fifteen, afterwards increased to eighteen sail-of-the-line, with a large number of frigates, bombs, and other craft. In this fleet there had been embarked the 49th Regiment under Colonel Isaac Brock, two companies of the Rifle Corps, and a detachment of Artillery under the command of Colonel Stewart. The British force, however, was weakened on the 16th by the loss of the *Invincible*, of seventy-four guns, bearing the flag of Rear-Admiral Thomas Totty. She struck on a sandbank called Hammond's Knowl, where she lay for three hours, then afterwards floated into deep water and went down, taking with her four hundred people. Of her commander, Captain Rennie, Schomberg says that "after severe exertion, he had swum close to the launch, when, exhausted with fatigue, he resigned himself to his fate, lifting up his hands as if to implore the blessing of Heaven, and immediately placing them upon his face, he went directly down without a struggle." Admiral Totty and one hundred and ninety-six persons were saved.*

The ship which Nelson had exchanged for the *San Josef* seemed, at the outset of this expedition, about as fit for service as the *Agamemnon* was after his long employment of her. "You cannot think," he writes, February 9th, "how dirty the *St. George* is . . . the ship is not fitted for a flag,—her decks leaky, and is truly uncomfortable, but," he suggestively adds—he is writing to Lady Hamilton,—"it

*Schomberg's "Naval Chronology," vol. iii., p. 496.

suits exactly my present feelings." He had hoisted his flag on the 12th of February, but until the 19th had been unable to get aboard, owing to the violence of the weather. When he sailed from Portsmouth she was filled with caulkers and painters preparing her for sea! The achievements of British ships and British commanders would be found a very great deal more brilliant and astonishing than the annals express them, if the supineness, the gross indifference and neglect of the Admiralty officials were to be exhibited and illustrated side by side with the performances which have made Great Britain the country she is.

It is related that Nelson, prior to his departure for Copenhagen, whilst at the house of his friend Davison, spoke of what he would do had the command of this Baltic expedition been given to him instead of to Sir Hyde Parker, and during the course of his conversation he desired that a chart of the Cattegat should be purchased that he might have a look at it, as his memory or knowledge of those waters was imperfect. He hung over the chart for a little while in a posture of considering, then saying that he believed the Government could spare only twelve ships, he marked their situation upon the chart—a prophetic indication that was afterwards exactly fulfilled. There is, perhaps, a no more extraordinary instance of his surprising swiftness of perception, his instant power of coming to a conclusion and forming his plans.

His eager spirit was greatly fretted on understanding that the fleet was to anchor outside of Kronen-

burg Castle to enable the British Minister at Copenhagen to negotiate. "To keep us out of sight," he wrote, "is to seduce Denmark into a war." "I hate your pen-and-ink men; a fleet of British ships-of-war are the best negotiators in Europe; they always speak to be understood, and generally gain their point; their arguments carry conviction to the hearts of our enemies." The Dane, he tells Davison, should see the British flag waving every moment he lifted up his head. Already he considered there had been too much delay. Colonel Stewart, who printed a lively account of the battle, says that Nelson's plan on his arrival at Yarmouth would have been to start at once for the mouth of Copenhagen Harbour with such ships as were in readiness, leaving the rest to follow as rapidly as could be contrived. Such celerity would have rendered it impossible on the part of the Danes to have provided against the attack by preparations which British procrastination was now suffering them to render formidable. On the 29th of March, he changed his flag from the *St. George* to the *Elephant*, a lighter and handier ship.* Much loss of

* Colonel Stewart relates the following: Nelson, he says, "was rather too apt to interfere in the working of the ship (the *St. George*), and not always with the best success or judgment. The wind, when off Dungeness, was scanty, and the ship must be put about; Lord Nelson would give the orders, and caused her to miss stays. Upon this he said, rather peevishly, to the Master or Officer of the Watch (I forget which): 'Well, now see what we have done. Well, sir, what mean you to do now?' The officer saying, with hesitation: 'I don't exactly know, my Lord, I fear she won't do,' Lord Nelson turned sharply towards the cabin, and replied • 'Well, I am sure if you do not know what to do with her, no more do I either.' He went in, leaving the officer to work the ship as he liked."—Stewart's "Narrative."

valuable time was caused by the pilots, who made all they possibly could of the dangers of the expedition. When off Elsinour Admiral Parker sent a flag of truce to inquire of the Governor if he meant to oppose the passage of the fleet through the Sound. The Governor answered that he would fire at the ships if they approached. Despite this threat, the British fleet, on the 30th, early in the morning, weighed, and, with a fine sailing breeze, swept through the Sound in line ahead, with Nelson commanding the van division, Parker the centre, and Rear-Admiral Graves the rear. The Elsinour batteries opened, but not a shot hit the ships.

It was somewhere about noon that the fleet anchored a little way above the Island of Huen, fifteen miles distant from Copenhagen, and Nelson, accompanied by Admiral Graves, Colonel Stewart, and others, entered a lugger called the *Lark* to reconnoitre the enemy's defences. Nothing could well look more formidable, as armaments went in those times. Eighteen vessels, comprising hulks and full-rigged ships, were moored in a line occupying hard upon a mile and a half, flanked on the north by two artificial islands called the Trekroner batteries, mounting between them sixty-eight guns, 24- and 36-pounders, with furnaces for heating shot, and close beside them were two large two-deck block-ships. The entrance to the harbour and docks was protected by a chain; there were also batteries on the northern shore which commanded that channel. In excellent positions off the harbour's mouth were two 74-gun ships, a 40-gun

frigate, two brigs, and some xebecs. Upon Amag Island, to the south of the floating line of hulks and ships, were several gun and mortar batteries, so that seawards the city of Copenhagen was protected by defences which from end to end stretched a distance of nearly four miles. But additional security of infinite significance was furnished to the Danes by the dangers of the navigation. All the buoys had been removed or misplaced. Even Nelson was astonished by the commanding and threatening appearance of the enemy's preparations. His own sketch of the Danish hulks and battle-ships exhibits a very extraordinary armament: lumps of two-deck hulks, each with a pole-mast amidships, their sides bristling with the mouths of cannon; tall full-rigged ships, little gun-brigs, and in the distance the Crown battery, looking, with the vessels moored within it, like a small dock above which soar the three towering masts of a large ship-of-war, whose hull is hidden behind the embankment.

An *aide-de-camp* of the Prince of Denmark had come aboard Sir Hyde Parker's ship when the fleet was at anchor off Kronenburg. Nelson describes him as a young coxcomb about twenty-three. In writing a note in the Admiral's cabin the pen sputtered, and the little creature called out: "Admiral, if your guns are no better than your pens you may as well return to England." He asked who commanded the different ships, and on Nelson's name being pronounced he exclaimed: "What, is *he* here? I would give a hundred guineas to see him, Then I suppose it is no joke if *he* has come! You

will pass Kronenburg," he continued; "that we expect. But we are well prepared at Copenhagen. There you will find a hard nut to crack." This anecdote Nelson relates to Lady Hamilton, laughing over it as he sits in his cabin in the *Elephant* writing.

On the 31st Admiral Parker called a council of war, mainly to consider the best mode of attack. Nelson offered his services, asking for ten line-of-battle ships and the whole of the smaller craft. Very wisely the Commander-in-chief accepted, and not only left every thing to Nelson, so far, at least, as this detached service was concerned, but gave him two more line-of-battle ships than he had demanded. All the while the council was being held Nelson was pacing the cabin, working the stump of his arm, as was his habit when excited or irritated, and turning a countenance dark with mortification upon any man who ventured an observation that savoured in the least degree of alarm or doubt. It was suggested that the three powers which had combined might prove too many for the British. "So much the better!" was Nelson's impatient remark; "I wish there were twice as many. The easier the victory, depend on 't." He had long before prepared his plans, basing them on keen appreciation of the want of *tactique* amongst the northern fleets; and now, whilst on the eve of a desperate and bloody conflict with the Danes, he carried in his mind a perfect scheme for the defeat or annihilation of the Swedes or Russians later on.

It was he who, on the night of the day on which **the** council had been held, readjusted the **buoyage**

of the outer channel. He went in his boat, accompanied by Captain Brisbane of the *Cruiser*, and foot by foot groped his way over the dark waters through the biting March air and ice of that northern clime. How many admirals then afloat would have undertaken this duty for themselves? Most of them, possibly, would have applied to such a task Lady Nelson's theory of boarding, and "left it to the captains."

On the morning of the 1st of April the whole fleet sailed to within two leagues of the town of Copenhagen. Nelson had gone aboard the *Amazon*, in order to take a final view of the surroundings, and 'returning to the *Elephant* at one o'clock, ordered the signal to be made to weigh. At sight of the colours, there arose from the ships of the division he commanded a hurricane shout that was heard at a long distance. The channel was narrow; the wind a small air, though happily favourable; but the buoys had been laid down with such accuracy that the congregation of ships went smoothly and steadily on, led by the "gallant good" Riou in the *Amazon*, a thirty-eight-gun frigate. The detachment under Nelson consisted of seven 74's, three 64's, a 54 and a 50; five frigates, from 38 to 24; two ship-sloops and two brig sloops, together with seven bomb-vessels, two fire-ships, and a few small craft; thirty-six sail in all. Admiral Parker remained at anchor with two ships of 98 guns, three of 74, and two of 64. When Nelson's detachment weighed, the Commander-in-chief's eight ships also lifted their anchors and floated **a little closer towards the mouth of the harbour, but**

wind and current were against them, and throughout the action they continued at too great a distance to render any service. At dusk Nelson's division anchored off Draco Point. The headmost of the enemy's line was then two miles off. The narrowness of the waters as an anchoring ground brought the ships into a huddle, and infinite mischief might have been done the British had the Danes thought proper to shell the crowded vessels. Down to a late hour English guard-boats were out stealthily sounding; and Captain Hardy rowed to within the very shadow of the Danes' leading ship, round which he felt for the bottom of the water with a pole, that he might not be heard.

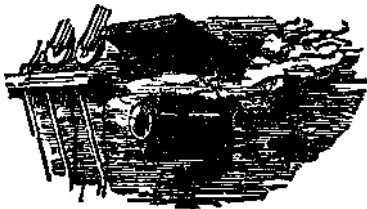

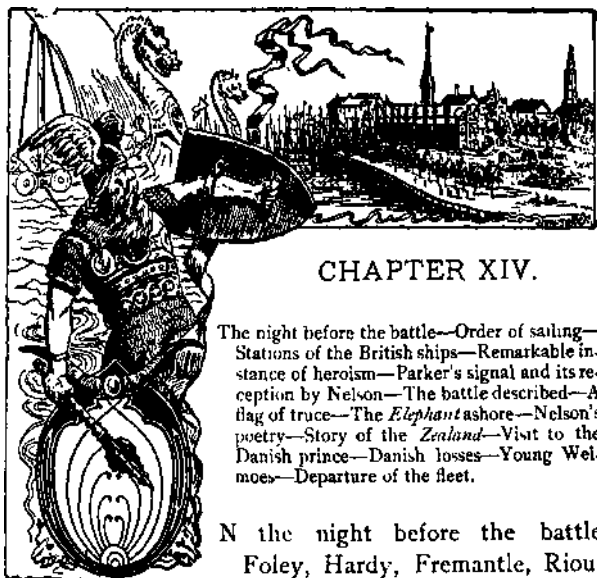

CHAPTER XIV.

The night before the battle—Order of sailing—Stations of the British ships—Remarkable instance of heroism—Parker's signal and its reception by Nelson—The battle described—A flag of truce—The *Elephant* ashore—Nelson's poetry—Story of the *Zealand*—Visit to the Danish prince—Danish losses—Young Welmoes—Departure of the fleet.

ON the night before the battle Foley, Hardy, Fremantle, Riou, Admiral Graves, and a few others dined with Nelson on board the *Elephant*. The Hero was in high spirits, and drank to a leading wind and to the success of the ensuing day; and the captains retired to their respective ships full of profound admiration for their great leader, and eagerly impatient to follow him to the approaching battle. Riou and Foley remained in the *Elephant* to arrange the order of the conflict, and prepare instructions to be issued next day. Nelson, who was greatly fatigued by his incessant labours, was so much exhausted while dictating his instructions that, yielding to the entreaties of his companions, or perhaps to the determined request of Alien,

his servant, who had the reputation of exactly knowing how to manage his master, consented to lie in his cot that was placed upon the deck; but he persisted, nevertheless, in dictating his orders. By one o'clock the necessary instructions were completed, and half a dozen clerks went to work to transcribe them. Nelson could not sleep; every half-hour he called from his cot to the clerks to bid them make haste, and throughout the night he was constantly receiving reports of the direction of the wind. By six he was up, dressed, and had breakfasted; and at seven made the signal for "All Captains."

Riou, a name that no Englishman can pronounce without emotions of reverence and affection as one of the most gallant and noble of the many gallant and noble men of that day of marine giants, was specially commanded to act as circumstances might require. The land forces and five hundred seamen under Fremantle and Colonel Stewart were to storm the Crown battery when its fire had been silenced; whilst the division under Admiral Parker was to menace the ships at the entrance of the harbour. The pilots then assembled on board the *Elephant*. They were chiefly mates of English and Scottish trading vessels, and when the question as to the bearing of the east end of the Middle Ground arose there was a very uncomfortable hesitation amongst them. Nelson, who was on fire with impatience, demanded that they should be resolute, steady, and decide at once. Still they paused, until Briarly, the mate of the *Bellona*, exclaimed that he was pre-

pared to lead the fleet. On this the pilots returned to their ships, and at half-past nine the signal was given to weigh in succession.

The *Edgar* led, but was for some time unsupported. The block-ship *Provesteen*, of 56 guns and 515 men, let fly at her when she was within range; but she "kept all fast" until nearly opposite the craft that was destined for her by the instructions, and then poured in a tremendous broadside. The *Polyphemus* was followed by the *Isis*, *Bellona*, and *Russell*, but the two latter ships in going down the channel ran aground. It was now the *Elephant's* turn; and Nelson, ignorant that the *Bellona* and *Russell* were ashore, signalled to them to close with the enemy. As this was not done he guessed the reason, and instantly quitted the intended order of sailing by starboarding his helm. The succeeding ships imitated the manoeuvre, which in all probability saved all or the majority of them from stranding. One by one the ships took up their positions, each anchoring by the stern abreast of her indicated opponent, with her broadside to the enemy. The action began at five minutes past ten, and in half an hour the battle was general.

Nelson's station was in the centre abreast of the *Dannebrog*, of 62 guns and 336 men, with Commodore Fischer in command on board. The distance between the *Elephant* and the *Dannebrog* was about a cable's length, 720 feet,* and this Stewart says was the average distance at which the action was fought. Nelson wished to get nearer; but the master and

* The hemp cable was 120 fathoms.



THE BATTLE OF COPENHAGEN, 1801.

pilots were afraid of shoaling their water, and when the lead was a quarter less five insisted on the anchor being let go. Yet it was afterwards found that the water from the point where the *Elephant* lay deepened from four fathoms to the enemy's very line. "I hope," Nelson had written to Sir Edward Berry from Yarmouth on March the 9th, "we shall be able as usual to get so close to our Enemies that our shot cannot miss their object, and that we shall again give our Northern Enemies that hailstorm of bullets which is so emphatically described in the *Naval Chronicle*, and which gives our dear Country the Dominion of the Seas. We have it, and all the Devils in Hell cannot take it from us, if our wooden walls have fair play."* A cable's length was too far for him, and Colonel Stewart was himself of opinion that the distance between the contending vessels was the cause of the long duration of the battle.

Immediately astern of Nelson was the *Glatton*; ahead of her the *Ganges*, *Monarch*, and *Defiance*; and betwixt these ships the distance did not exceed 350 feet. Never had British seamanship found finer illustration of its capacity of daring and skill than in the manner in which the vessels of the Division calculated their stations in a channel bewildering with its complicated and perilous navigation. Yet there were three of the ships aground, representing the force that was to have been opposed to the Crown or Tre Kroner battery; but the glory of the issue gains by a disaster that gravely weakened **the**

* " **Dispatches and Letters,**" vol. iv., p. 292,

original plan of attack, leaving the conquest to be achieved practically by fewer ships than even Nelson, with the utmost spirit of his sublime daring, had thought fit to demand.

Amongst the noblest instance of courage, on a day that was charged with heroisms on both sides, was one that occurred on the deck of the *Elephant*. The use of the lead and line for sounding the depth of water over the ship's side was confided to the Master; but two officers had to take their stations, one in each channel or chains,* to watch the heaving of the lead; and it is recorded that the competition between these men for the larboard side of the ship, where all the danger was, delighted Nelson as he paced the quarter-deck. Riou in the *Amazon* endeavoured to supply the blank in the plan of attack on the Crown battery, and proceeded down the line with his little squadron of frigates; but sting as these vessels might, they wanted the crushing weight of the liner's broadside, and their heroic efforts were of little or no use. At one o'clock no apparent impression had been produced upon the enemy, whose hulks and batteries and towering block-ships continued to blaze and roar with swiftly-fired artillery. The *Isis* was barely saved from destruction by the *Provesteeris* fire by the *Polyphemus* and *Desire'e*. The combined fire of the *Holstein* and *Zealand* was imperilling the *Monarch*, and only two of the British bomb-vessels had managed to get to their station, where they were throwing their shells at the Arsenal over both fleets. Of the gun

* Platforms affixed to the ship's side for spreading the lower rigging.

brigs one alone could manage to come into action. Parker's Division lay idle and helpless in the distance. The *Elephant* had not only the guns of the *Dannebrog* to contend with; two heavy praams were hammering at her, one on the bow and one on the quarter. Signals of distress were flying aboard the *Bellona* and *Russell* and the *Agamemnon*, with similar tokens, was indicating her inability to render the service expected of her.

Admiral Parker, aboard the *London*, viewing the scene from a distance, was alarmed for the result. The Danes' broadsides were incessant and furious; nothing seemed to have been silenced; from every point of the ponderous, looming line of defence flames were spitting, and the smoke of the cannon rising. Parker considered the fire too hot for Nelson to oppose. A retreat must be made, cruelly mortifying and disappointing as was such an alternative to the British Commander-in-chief. But there was the honour of the high-spirited gentleman in his motive: "He was aware of the consequences," he said, "to his own personal reputation; but it would be cowardly in him to leave Nelson to bear the whole shame of the failure, if shame it should be deemed." * Accordingly, at about one o'clock, the signal was thrown out on board the *London* for the action to cease.

Throughout the battle down to this time Nelson had been pacing the starboard side of the quarter-deck. He was dressed in a sort of blue greatcoat,

* **Southey** gives this "upon **the** highest and most unquestionable authority."

epaulets of gold lace, and a plain cocked-hat, and there were several Orders on his breast. He was full of animation, "and," Colonel Stewart says, "heroically fine in his observations." A shot struck the mainmast and scattered a few splinters, on which, looking at Colonel Stewart with a smile, he exclaimed: "It is warm work, and this day may be the last to any of us at a moment. But," added he, stopping short at the gangway, and speaking with emotion, "mark you, I would not be elsewhere for thousands!" Just then the signal aboard the *London* was observed. It was reported to Nelson, who, feigning not to hear or perhaps not hearing, as might well be the case amid such a cannonading as was then thundering, continued to stump the deck without speaking. The Signal Lieutenant, waiting till the turn of the deck brought Nelson back, asked if he should repeat the signal. "No; acknowledge it," said Nelson. As the officer was returning to the poop, Nelson called to him: "Is No. 16 still hoisted?"—this being the signal for "Close Action" that was flying aboard the *Elephant*. The Lieutenant replied that it was. "Mind you keep it so," said Nelson. His irritation was now great; he walked the deck with agitation, working the stump of his arm. Suddenly, addressing Colonel Stewart, he exclaimed: "Do you know what 's shown on board the Commander-in-chief, No. 39?" "What does 39 mean?" inquired the Colonel. "Why, to leave off action," answered Nelson; "Leave off action!" he repeated, "now, damn me if I do!" Captain Foley stood near. "You know, Foley," he went

on, " I have only one eye—I have a right to be blind sometimes," and lifting the glass to the eye whose sight was gone, and levelling it at the *London*, he exclaimed, with an archness that certainly was not wanting in scorn: " I really do not see the signal." It was therefore merely acknowledged on board the *Elephant*, not repeated. The gallant Rear-Admiral Graves, aboard the *Defiance*, repeated it, but took care to send it no higher than the lee main-topsail yard-arm, where it would scarcely be visible amidst the smoke, whilst streaming high aloft at the main-royalmast-head was the signal for " Close Action," clear to every man's sight as a star in the sky.*

The squadron of frigates, however, obeyed and hauled off. They were being hammered to pieces; their services were profitless, and they were wise to retreat. Captain Riou (in the *Amazon*) who had been wounded in the head by a splinter, sat on a gun encouraging his men. " What will Nelson think of us?" he exclaimed, with bitter grief at having to withdraw. A raking shot from the Tre Kroner battery killed his clerk who stood by his side, and a second shot laid low a number of marines who were rounding in on the main-brace. The frigate's stern was upon the fort when Riou was heard to exclaim: " Come then, my boys, let us die all together!" As he pronounced these words a shot cut him in halves, and " thus in

* The Rev. Dr. Scott was Sir Hyde Parker's chaplain in the *London*, and he distinctly affirms that " It had been arranged between the Admirals (Parker and Nelson) that, should it appear that the ships which were engaged were suffering too severely, the signal for retreat should be made, to give Lord Nelson the option of retiring if he thought fit."—" Recollections," p. 70.

an instant," says Colonel Stewart "was the British service deprived of one of its greatest honours, and society of a character of singular worth, resembling the heroes of romance."

For another long half-hour the contest continued to rage, but somewhere before 2 P.M. the Danish fire slackened, and a little later on ceased altogether along the greater part of the line. Some of the lighter vessels were adrift through their cables having been parted by the cannon-shot. The carnage on board the enemy is described as terrible, owing to fresh crews coming off from the shore to fight knee-deep amongst the dead upon decks which the British guns had transformed into shambles. There was much difficulty in taking possession of the ships which had struck, partly because of the fire of the Amag batteries, and partly because of the shot discharged at the boats of the captors by the fresh drafts, who seemed not to know that the ships which they reinforced had hauled down their colours. This was particularly the case with the *Dannebrog*. She was on fire and had hauled down her flag; the Commodore had removed his pennant and deserted her; yet new hands clambered over her side and, in ignorance of every right and law and custom of war, fired at the boats which approached to take possession. It needed a renewed attack by the *Elephant* and *Glatton* to silence her. As the smoke of these ships* guns cleared away the *Dannebrog* was seen to be drifting in flames before the wind, with her miserable crew throwing themselves overboard from every port-hole.

It was at about half-past two that Nelson sent a flag of truce ashore. He was determined to this step by the behaviour of the enemy's reinforcements. Walking right aft to the casing of the rudder-head, he wrote the celebrated note addressed "To the brothers of Englishmen, the Danes." In this communication he threatened to set fire to all the floating batteries he had taken unless the enemy discontinued hostilities. The letter was written and carefully folded. Mr. Wallis, the *Elephant's* purser, was for securing it with a wafer; but Nelson would not allow this to be done, and sent for a stick of sealing-wax. The man who went on this errand had his head taken off by a cannon-ball; this was reported to Nelson, who simply said: "Send another messenger for the wax." It was respectfully submitted that there were wafers at hand. "Send for the sealing-wax!" he roared. The letter was thereupon sealed with a great quantity of wax, which was very carefully impressed with the Nelson arms. He was asked why, at such a time, he attached so much importance to a circumstance apparently trifling. His answer was: "Had I made use of a wafer it would have been still wet when the letter was presented to the Crown Prince; he would have inferred that the letter was sent off in a hurry, and that we had some very pressing reasons for being in a hurry. The wax told no tales." * The

•Sir N. H. Nicolas finds this anecdote (given in Clarke and M'Arthur) corroborated by a letter from Wallis, the then purser of the *Elephant*, addressed to Haydon the painter, October n, 1843.—"Dispatches and Letters," vol. iv., p. 310.

letter was taken ashore by Captain Thesiger, who spoke fluently the Danish language.

Whilst the boat was absent the remainder of the enemy's line to the eastward of the *Trekroner* struck to the furious broadsides of the ships ahead of the *Elephant*; their surrender was, however, probably hastened by the approach of the *Ramilies* and *Defence*, belonging to Admiral Parker's Division. Meanwhile the firing from the Crown battery continued, but this was silenced by direction of the Danish Adjutant-General Lindholm, who arrived with a flag of truce. "The action," Colonel Stewart says, "lasted five hours," four of which were fiercely contested. The Crown Prince's message was to inquire the purport of Nelson's, whose reply ran thus; "Lord Nelson's object in sending *on* shore a Flag of Truce is humanity; he therefore consents that hostilities shall cease till Lord Nelson can take his prisoners out of the prizes, and he consents to land all the wounded Danes and to burn or remove his prizes." The letter concluded with some sentences of empty civility. To provide against a refusal of his offer, he had decided, after consulting Foley and Fremantle, to remove the fleet from the intricate channel whilst the wind held fair, that the ships might be ready to act afresh. Lindholm *on* his arrival was referred to Admiral Parker in the *London*, and whilst he was gone a signal was made for the *Glatton*, *Elephant*, *Ganges*, *Defiance*, and *Monarch* to weigh in succession. The *Monarch* grounded, but the *Ganges* fouled her amidships and floated her off. The *Glatton* went clear; but the

Defiance and *Elephant* ran aground at a distance of a mile from the Crown battery and there they stuck. Hostilities had ceased, otherwise these vessels must have been in extreme danger from the adjacency of the Crown battery, though it is confidently stated that had the battle begun anew, measures easily within the power of the British would have been adopted for destroying the formidable battery. These measures, according to Mr. Ferguson, the surgeon of the *Elephant* were: as the flag of truce left Nelson's ship, 1,500 of the choicest boarders of the fleet entered fifty boats under the command of Stewart and Fremantle. "The moment it could be known that the flag of truce had been refused, the boats were to have pushed for the batteries, and the fire of every gun in the fleet would have covered their approach." *

Nelson, leaving his stranded liner at four o'clock, followed Lindholm to the *London*. His spirits were depressed; he appears to have been shocked by the explosion of the *Dannebrog* and the dreadful slaughter of the four or five hours of conflict. "Well," he exclaimed, "I have fought contrary to orders and I shall perhaps be hanged; never mind, let them." It was agreed that there should be a suspension of hostilities for twenty-four hours, that all the prizes should be surrendered, and the whole of the Danish wounded sent on shore.

The *Elephant* went afloat at eight that night. Nelson, in ignorance of this, remained on board the *St. George*. At the very time when the crew of the

* Clarke and M'Arthur. IL, 420.

ship in which he had commanded at the battle were pumping, warping, straining every nerve to scrape clear of the sand, Nelson in the cabin of the *St. George* was writing a letter to Lady Hamilton and composing verses to her. " My dearest friend/' he says, " that same Deity who has on many occasions protected Nelson, has once more crowned his endeavours with complete success. The difficulty of getting at the Danes from sandbanks was our greatest enemy, for, from that event it took us between four and five hours to take all their floating batteries—this made the battle severe. The Prince Royal of Denmark was a spectator and nearly killed." This letter ended, he went to work to produce some verses. There has yet to be painted a picture of this glorious Sailor of imperishable renown, seated in the cabin of the *St. George* on the night of the day of the fierce and bloody battle of the Baltic, biting the feather of his pen whilst he labours in search of rhymes. The night is still; the dark, ice-cold waters ripple stealthily along the bends; the loud thunders of the cannon, which sent a note of storm for miles around, are now but a memory that yet makes deeper the hush of night. What are the verses which he produces ? They are thus headed :

" LORD NELSON TO HIS GUARDIAN ANGEL.

From my best cable tho' I 'm forced to part,
 I leave my Anchor in my Angel's heart:
 Love, like a pilot, shall the pledge defend,
 And for a prong his happiest quiver lend.

ANSWER OF LORD NELSON'S GUARDIAN ANGEL.

Go where you list, each thought of Angel's (Emma's) soul
 Shall follow you from Indus to the Pole :
 East, west, north, south, our minds shall never part,
 Your Angel's loadstone shall be Nelson's heart.
 Farewell, and o'er the wide, wide sea,
 Bright glory's course pursue,
 And adverse winds to love and me
 Prove fair to fame and you ;
 And when the dreaded hour of battle 's nigh,
 Your Angel's heart, which trembles at a sigh,
 By your superior danger, bolder grown,
 Shall dauntless place itself before your own,
 Happy, thrice happy, should her fond heart provo
 A shield to Valour, Constancy, and Love.

" *St. George, April 2nd, 1801, 9 o'clock at night: very tired after a hard-fought battle.*"

He writes to her and of her as his Guardian Angel. He had two pictures of her with him ; they were in the *St. George*, but when he shifted his flag to the *Elephant* they were placed in his cabin on board that ship; and so he says to her on April the 5th : " You must know you have been in the battle, for your two pictures, one done by Miss Knight crowning the Rostral Column, the other done at Dresden (I call them my Guardian Angels; and I believe there would be more virtue in the prayers of Santa Emma than of any saint in the whole calendar of Rome), I carried on board the *Elephant* with me, and they are safe, and so am I, not a scratch." His adoration even begets emotions of superstition, for some time later on we find him writing: "I have, my dear Friend, taken it into my head that within these few days

your picture has turned much paler than it used to be ; it has made me quite uneasy. I hope to God you have not been unwell, or any thing happened which could make you look differently on me." *

Early next day (April 3d) as dawn was breaking, he went in his gig to the *Elephant*, imagining the ship to be still aground. Finding her waterborne, he hastily breakfasted, and then made a tour of the prizes. It was reported to him that the *Zealand*, a Danish line-of-battle ship that had been the last to strike and that still lay under the guns of the *Trekroner*, had refused to acknowledge herself captured, quibbling about the colours and the pennant not having been hauled down. Nelson went on board the *Elephanten*, whose commander proved an old acquaintance whom he had known in the West Indies. His courtesy, the fascination which his magnificent records communicated to his least gesture, look, or word, his bland but convincing arguments, were such that he not only gained the point in dispute about the *Zealand*, but left the ship " as much admired by his enemies as he had long been by those who were his intimate friends/' †

Brenton, in his account of the battle of Copenhagen, has a curious story which must not be omitted, though one could wish it based on a higher authority. Apparently it was of the *Zealand* he was thinking when he wrote, though he calls her the *Holstein*. Be this as it may, he says: " She had ceased firing long before the action was discon-

* Pettigrew. II., 60.

f Colonel Stewart.

tinued in other parts of the line—her colours were down,—and she was, at the conclusion of the day, claimed as prize, and refused by the Danish officers to be given up to us, her pennant being still at the mast-head. Two British captains had been sent to demand her, but both returned without effecting their purpose. Nelson requested Sir Hyde Parker would send Captain R. W. Otway on this service, and he was despatched accordingly. As he went alongside the ship he ordered the coxswain of his boat, a bold, brazen-faced, impudent fellow, to go up into the maintop of the *Holstein* and bring away the pennant with him while Captain Otway was talking with the commanding officer. The man punctually executed his order, coming down from the mast-head with the pennant in his bosom, and placing himself in his boat with the most perfect composure. The mission having again failed, Captain Otway repeated that the ship had struck her colours, and was a prize ; it was at length agreed to refer the question to the Danish Commodore, then in the Arsenal and close to the *Holstein*, The Commodore, in reply to Captain Otway's demand, said that the ship had not struck her colours, that her ensign had been shot away, but that her pennant was still flying, and begged Captain Otway to look *at it*. Captain Otway soon convinced the mortified and astonished Commodore that the pennant was not flying, and he was compelled to own that the ship was British property. Otway lost not a moment, but with the assistance of the *Ealing* schooner cut the cables, and towed her out from under the Crown batteries

where she lay. The Danes found out the trick of the pennant, and were very indignant ; but the ship having struck in the action, the conduct of Captain Otway and his coxswain was highly applauded." *

On the 4th of April, Nelson, accompanied by Captains Hardy and Fremantle, visited the Prince of Denmark ashore. It is said by some that he was received by the populace with demonstrations of respect and admiration, but Colonel Stewart, whose accuracy in all other details of this passage of history is unimpeachable, affirms that it needed a strong guard to secure Nelson's safety. Negotiations lasted from the 4th till the 9th, during which the fleet were actively occupied in refitting and making ready to bombard Copenhagen should hostilities be renewed. On the 9th, Nelson again landed, and the crowd this time was much more orderly. There was still a difficulty; the Danish commissioners honestly avowed their apprehension of the Court of Russia. Nelson bluntly informed them that his reason for demanding a sixteen weeks' armistice was that he might have time to deal with the Russian fleet and then return to them, the Danes! There was much argument and hesitation, and one of the commissioners, speaking in French, hinted at a renewal of hostilities. Nelson, catching at the words, turned to a friend and exclaimed, with heat: "Renew hostilities! Tell him that we are ready in a moment ; ready to bombard this very night!" The commissioner apologised. Nevertheless, the duration of the armistice could not be settled, and the conference broke up that the

* Brenton's "Naval History," vol. i. , p. 533.

Crown Prince might be consulted. A grand dinner had been prepared, and the Prince led the way to the apartment in which the banquet was to be held. All the state-rooms had been denuded of their furniture in anticipation of the bombardment; Nelson, leaning on the arm of a friend as he went upstairs, and glancing round him, dryly whispered: " Though I Ve only one eye I see all this will burn very well." He sat on the right of the Prince, and there was much apparent cordiality. They were afterwards closeted, and eventually the Prince agreed to an armistice of fourteen weeks' duration.

The damage done the enemy's defences amounted very nearly to annihilation. Most of the floating hulks were literally cannonaded into staves. James is of Colonel Stewart's opinion, that the ships would have been knocked to pieces in much less time than four hours had Nelson been suffered by his hesitating and misgiving North Country pilots to occupy a closer position. Commodore Fischer reckoned the loss on his, the Danish, side at about 1,800 men. In the British fleet the killed numbered 253 and the wounded 688. The Danish hulks and block-ships were thus disposed of: the *Provesteen*, *Wagner*, *Jutland*, *Suersishen*, *Cronburg*, and *Hajen* were taken and burnt; the *Rensburg* drove on the shoals and was burnt; the *Nyburg* and the *Aggerstans* sank; the *Zealand* was burnt; the *Charlotte-Amelia* was burnt along with the *Sohesten*; the *Indosforethen* was also burnt, but the *Holstein* was re-equipped and carried away.

The Danes fought nobly, but it is idle to attempt

any comparison between their courage and the intrepidity of the British. Their line of defence might have been deemed impregnable of itself, seeing that the bulk of their vessels were mere floating batteries, bristling with ordnance, and filled with men ; without spars to fall, or manoeuvres to execute. To this must be added the navigation of waters unknown to the British, and rendered inexpressibly complicated and perilous by shoals. But there was no sea difficulty that the genius of Nelson was unable to surmount. By the help of the lead he felt his way to the enemy's side, with just such patience as a Channel pilot would exhibit off the Goodwin Sands in thick weather. His war programme was perfect ; he knew his captains and his men ; he had confidence in them, and their faith in him was a magnificent enthusiasm. The glory of the issue is the more remarkable because of the sort of half-heartedness with which the conflict was entered into. The Danes were in truth the brothers of the English, as they still are ; it was the wish of the British Court, and the Admiralty instructions accentuated it, that Sir Hyde Parker's posture should be one of conciliation, down to the moment when the Danes should render a friendly attitude no longer possible. Yet there was nothing in the peaceful disposition of the British to weaken or in any way impair their extraordinary prowess the instant hostilities began. It cannot be said that they fought the Danes as they fought the French. There was no burning hate, *no* consuming desire to extinguish. But whatever the sentiment of **the**

occasion might be, before all things Victory must be with the British flag! and Nelson and his men contrived that it should be so.

Yet, as has been said, the Danes proved foes worthy of the conquering nation which they opposed. An instance of individual courage and devotion must find a place here. A mere lad named Welmoes, not yet seventeen, had the command of a praam, a kind of raft, armed with six small cannon, with a crew of twenty-four men. He pushed or "poled" off from the shore to under the stern of the *Elephant*, Nelson's ship, and attacked her. The marines aboard the flag-vessel let fly amongst the gallant little band, and the slaughter was terrible. Twenty of the twenty-four courageous fellows fell, killed or wounded by the leaden storm, but their boy-commander, standing up to his waist amongst the dead, remained at his post until the truce was proclaimed. Nelson could not view such heroism in one so young without admiration. At the banquet at the palace, he is recorded to have spoken in raptures of the bravery of the Danes, and particularly requested the Prince to introduce him to young Welmoes. This was done; he embraced the lad, and turning to the Prince said that the young fellow deserved to be made an admiral of. "If, my Lord," was the answer, "I were to make all my brave officers admirals, I should have no captains or lieutenants in my service."

On the 12th of April, Admiral Parker sailed from Copenhagen road, leaving behind him the *St. George* and one or two frigates. The difficult channel

of the Grounds had to be passed through, and to manage this most of the men-of-war transshipped their guns into merchant vessels. Many of them went ashore, but all eventually contrived to go clear, and to the amazement of Danes, Swedes, Russians, and Prussians, the fleet entered the Baltic by a channel that had been thought impracticable.



CHAPTER XV.

Pursuit of the fleet in a boat—Blind Mrs. Nelson—Nelson at Revel—Personal habits—Investiture of Rear-Admiral Graves—Rev. W. Nelson—No medals for Copenhagen—Return to England—Fears of invasion—In the Downs—Purchase of Merton Place—Death of Capt. Parker—Nelson's irritability.

ON the 18th of April the *St. George* discharged her guns into a Yankee vessel and was ready to follow Sir Hyde; but on a sudden the wind came ahead. Nelson, who was on board the *St. George*, received notice next day that the Swedish fleet had been sighted by a look-out frigate. His plans were not to be dominated by the winds. He ordered a cutter to be lowered, and with Briarly, the mate of the *Bellona*, started with six oars to join the Commander-in-chief, in defiance of an adverse breeze and strong current, and of a distance of twenty-four miles to be measured. The air was "nipping and eager" but Nelson refused to wait even for a boat-cloak. He jumped into the cutter, calling for Briarly to accompany him. "All I had ever seen or heard of him could not," says Briarly who relates the story,

" half so clearly prove to me the singular and unbounded zeal of this truly great man. His anxiety in the boat for nearly six hours lest the fleet should have sailed before he got on board one of them, and lest we should not catch the Swedish squadron, is beyond all conception. I will quote some expressions in his own words. It was extremely cold and I wished him to put on a great-coat of mine which was in the boat: 'No, I am not cold. My anxiety for my country will keep me warm. Do you think the fleet has sailed?'—'I should suppose not, my Lord.'—'If they have we will follow them to Carlsrona in the boat, by God!'" This place was fifty leagues distant! He reached the *Elephant* at midnight and Briarley returned to the *St. George*.

He could not, however, with impunity thus risk his health. This five hours' row in a bitter cold night in an open boat nearly drove him into a decline. A week later he was seized with a terrible spasm of the heart that almost killed him. "From that time," he writes to Lady Hamilton under date of June, "to the end of May I brought up what everyone thought was my lungs, and I was emaciated more than you can conceive." To this period belongs an illustration of his fine nature. His brother Maurice died on the 24th of April. Nelson had been in ignorance of his home life; in other words he did not know that the woman who passed as Mrs. Maurice Nelson was not his brother's wife. Her name was Ford; she had lived with Maurice many years, lost her sight and become a cripple. On hearing of his brother's death, he at once wrote to Davison to do "every thing which is

right for his (brother's) poor blind wife." And thus he addresses the afflicted lady himself: " My dear Mrs. Nelson, you are and ever shall be considered by me as the honoured widow of my dear brother; and before I knew in what circumstances he had left you I had desired our good friend, Mr. Davison, to take care of you in every manner which could make you comfortable ; and I can assure you that I consider myself as only a faithful steward, and that if any more income is wanted than the interest of my brother's little fortune, that I shall have great pleasure in supplying it, for he was too generous to be rich." *

On the 23d of April Sir Hyde Parker received dispatches from the Russian Ambassador at Copenhagen, containing proposals of a pacific character from Alexander I., who had succeeded the Czar Paul. The fleet, on this, returned to Kiøge Bay, and shortly afterwards Sir Hyde sailed for England, leaving the command in the Baltic to Nelson. His first act was to make the signal to hoist in all launches and prepare to weigh. This was on the 7th of May. The ships now numbered seventeen sail-of-the-[^]ne, a 54- and a 50-gun ship, with a few frigates and smaller vessels. Of these, eight were left to cruise off Carlscrona under Captain Murray, and Nelson, with the remainder, headed with all dispatch for the Gulf of Finland. Revel Roads was reached on the 12th, but there was no Russian fleet to be seen; it had, indeed, been liberated by the

* The poor blind lady received an annuity of one hundred pounds a year from Nelson until his death. She was afterwards assisted by **Lady Hamilton**, and died about 1811.

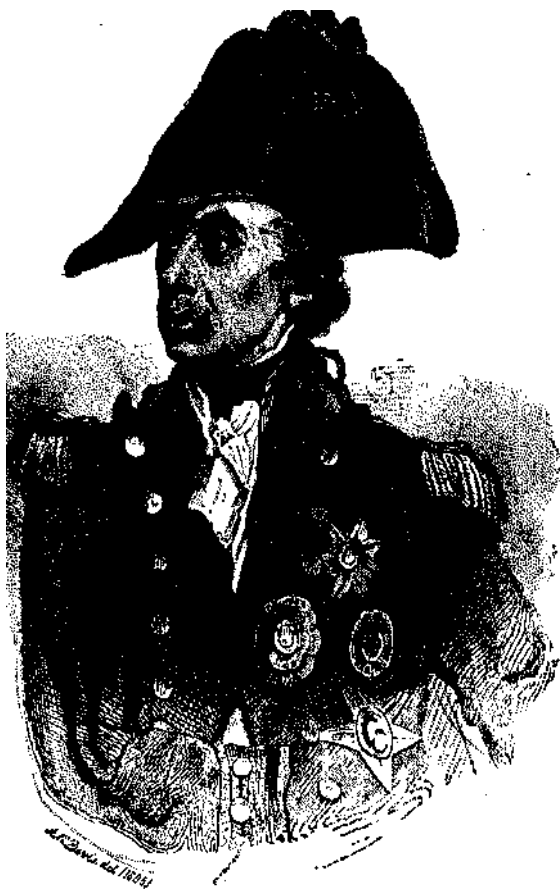

LORD NELSON, K. B.

AFTER A PAINTING BY A. W. DEVIE.

of Nelson's personal habits at this time. He rose every morning between four and five o'clock, breakfasted at six, sometimes much earlier, and was in bed by ten. The breakfast-party always included one or two midshipmen, and he would often, during the middle-watch—that is, between twelve and four o'clock,—send the little fellows an invitation to breakfast after they should come off duty at four o'clock. A treat indeed for the lads to look forward to! At table he would joke with the merriest of them and be the most youthful of the party. At dinner every officer of the ship was his guest in turn, and Colonel Stewart describes him as a host in an eminent degree polished and hospitable. The whole business of the fleet was invariably despatched before eight o'clock. No man ever more keenly appreciated the value of time. In conversing once with General Twiss, Nelson exclaimed: "Time, Twiss—time is everything. Five minutes make the difference between a victory and a defeat." His example in this respect communicated such a spirit of alertness throughout his ships as could only be thoroughly understood by those who bore a part in the discipline and routine of the fleet.

At Rostock he was received with the utmost veneration. Deputations from distant inland towns came aboard the *St. George* to request that he would write his name in the public books of record they

water's "St. Vincent," than Cooper Wylliam's "Nile," or than Stewart's "Copenhagen." Dr. Scott, the chaplain of Nelson, missed a magnificent opportunity at Trafalgar. Probably because throughout the battle he was, for the most part, in the cockpit.

brought with them. Boats hung about the flagship filled with people eager to catch a glimpse of him. But he did not again land; his mind was ill at ease, and when there was anxiety with him his health invariably suffered.

The *St. George* made her last cruise with Nelson's flag flying off Bornholm between the 9th and 13th of June, on which day he received the official sanction to return to England, together with instructions from the King to invest Rear-Admiral Graves with the Order of the Bath. There is a description of this investiture in the *Naval Chronicle*.* A chair was placed on the grating of the skylight on the quarter-deck, with the Royal Standard suspended over it; a guard was ranged on each side. Nelson came up the ladder first, and made three reverences to the chair, which represented the Throne. Captain Parker bore the sword of state—the sword that had been presented to Nelson by the captains who had fought under him at the Nile; all the captains of the fleet in full-dress uniforms attended. On Rear-Admiral Graves being introduced, he bowed thrice to the Throne and once to Nelson, then knelt, and Nelson laid the sword upon him, afterwards placing the Riband on the new knight's shoulder, and the Star on his left breast. After a short speech from Nelson the whole fleet fired a salute of twenty-one guns, and the Standard was hauled down.

Nelson was made a Viscount for the battle of Copenhagen. The patent of entail of his rank was announced in August, 1801, though the creation,

*Vol. v., 532.

My Dear Madam,

I honor and respect you

and my Dear friend Sir Will^m Hamilton

and Believe me ever
your faithful & affectionate

Wilson

5

The first letter written by
our noble & immortal Nelson
after his dignity to the people
may see step 2 measure him & long
may he live to enjoy the honors
he so deservedly won says his true
friend: Emma Hamilton

according to Nicolas, dated from May 22d. The preface to the patent ran thus: " His Majesty is graciously pleased, in consideration of the great and important services that Renowned Man, Horatio Viscount Nelson, hath rendered to his King and Country; and in order to perpetuate to the latest posterity the remembrance of his Glorious Actions, and to incite others to imitate his Example, to grant the dignity of a Baron of his United Kingdom of Great Britain and Ireland to the said Horatio Viscount Nelson, K.B., and Vice-Admiral of the Blue Squadron of His Majesty's Fleet, &c, &c, &c, by the name, style, and title of Baron Nelson of the Nile and of Hilborough, in his County of Norfolk." By this patent of entail the extinction of the Barony from failure of heirs male was provided against. It was to go to his father; failing him or male issue of his body, it was to extend to the heirs male of Nelson's sisters, Mrs. Bolton, and next Mrs, Matcham.

The Rev. William Nelson, of whom the Hero would sometimes write to Lady Hamilton in somewhat contemptuous terms,*—this gentleman who had a deal of the prig in him, who sat at Lady Hamilton's feet when he believed she had influence enough to obtain preferment for him, and who neglected and wronged her after Nelson's death—

* " My brother has a bluntness, and a want of fine feelings, which we are not used to ; but he means nothing." (Feb. 16, 1801.)—" Reverend Sir you will find a great bore at times, therefore he ought to amuse himself all the mornings, and not always to dine with you, as Sir **William may not like it.**" (March 1, 1801.)—Pettigrew. 1., 426-434.

this Rev. William Nelson, who makes the very shabbiest of figures in the books which have been written about his brother, and who, after Trafalgar, became the first Earl Nelson, was not a little astonished by the family behaviour when news came of the honours to be conferred on Horatio. "My dear Lady Hamilton," he writes on August 6, 1801, dating his letter at Hilborough, "you can easily conceive what joy your letter gave me this morning; thank God our great, glorious, and invincible friend is safe. I was at Swaffham when I received it, and read the *Gazette* honours to my father. He made but little observation upon it, only said he liked him as well *plai?i Horace* as with all these high-sounding titles; that may be true, but still I could have wished him to have appeared pleased with the prospect of his family honours descending to his posterity, and I could not help remarking to him, that we ought not to be like the selfish man, who is reported to have said: * Why should I care for posterity, for posterity never cared for me ? ' Mrs. Bolton made no remarks, nor seemed in the least elated or pleased; indeed, to say the truth, there appears a gloom about them all, for what reason I cannot devise, unless they are uneasy." They were probably uneasy at the prospect of the Rev. William one day inheriting honours which he could not but deform. Yet the title came ultimately, in the shape of an Earldom, to the posterity of that same Mrs. Bolton, who was one of the uneasy ones.

There were no medals given for Copenhagen. Nelson felt this bitterly down to the latest hour of his life. For himself he was sensible with most

men that the title of Viscount was an inadequate recognition of the magnificent services he had done his country. But he felt also yet more bitterly that his own honours were attended with but the scantiest inclusion of the claims of those who had enabled him to achieve a glorious and all-important victory. So late as June, 1804, the King's neglect of the officers and men of the fleet who had won the battle of Copenhagen was pressing with heavy vexation upon his loyal, generous heart. "I am aware," he wrote to Lord Melville, at this date, "that his Majesty has the most undisputed right to bestow Medals, or to withhold them as he pleases. No man admits it more fully than myself; but, my Lord, I turn back to the 1st of June, 1794; from that moment I have ever considered that his Majesty, by implication, pronounced these words to his fleet, holding forth the Medal: 'This, my Fleet, is the great reward which I will bestow for great and important victories like the present!' Considering this as a solemn pledge, his Majesty gave it as a reward for the Battles of St. Vincent, of Camperdown, and the Nile: then comes the most difficult achievement, the hardest fought battle, the most glorious result that ever graced the Naval Annals of our Country: the Medal is withheld, for what reason Lord St. Vincent best knows." The reason probably was, the King was opposed to the memorialisation of a passage in his reign which he desired to see buried in oblivion. Yet this battle, for which no medals were given, broke up the menacing Northern Confederation, defeated the subtle policy of France, caused the Russians and the Swedes to take off the embargo

that had been laid on British vessels in their ports, and re-established amicable relations between Great Britain and the three Northern Powers.

Nelson left the Baltic in a small brig, the *Kite*, on the 19th of June, and arrived at Yarmouth on the 1st of July. A paragraph in the *Naval Chronicle* of 1801, announcing his return to England, states that immediately on landing he went to the hospital to visit the sick and wounded men who had been brought there after the battle of Copenhagen. The Wrestlers' Inn, made famous by his visits to it, was now called Nelson's Hotel; having taken some refreshment at that house he left Yarmouth at *five* o'clock in the afternoon, and was accompanied as far as Lowestoft by a troop of cavalry. On his arrival in London he took up his residence at Sir William Hamilton's, in Piccadilly. A party consisting of the Rev. William and Mrs. Nelson, their son and daughter, and Nelson's favourite, Captain E. T. Parker, had assembled to meet him. London was hot and deserted; Sir William Hamilton was fond of fishing; Lady Hamilton considered a frequent change of air necessary to Nelson's health; so the whole party went to Box Hill, and afterwards to the Bush Inn, at Staines. The members of the party were described with some humour by Lord William Gordon in a copy of verses addressed to Lady Hamilton. He laments his inability to join them at the Bush Inn:

" There to have witnessed Father Thames's **pride**
While Anthony by Cleopatra's side—
While you, I mean, and Henry,—in a wherry,
Are cheek by jole afloat there, making **merry.**"

" Henry " was, of course, Nelson. The holiday was of short duration. Alarming rumours of the intended invasion of England by France had been for some time current. There was great activity along the Dutch, French, and Flemish shores. Camps had been formed at Ostend, at Boulogne, and between Gravelines and Dunkirk; and more significant yet was the assurance that the naval force of France combined with that of Spain represented a fleet of fifty-two ships of the line lying in the harbour of Brest. It is pretended that the alarm in this country was not very great, but it is certain that ministers considered it sufficiently lively to be worth allaying. There was but one remedy, and that must be Nelson. Yet the command that was now given to him was unworthy of his genius and fame—far fitter, indeed, for an Orde, a Calder, or a Ludwidge than for the Hero of the Nile and of Copenhagen. He was appointed by a Commission, bearing date the 24th of July, Commander-in-chief of a squadron of the king's ships to be employed in the defence of the mouths of the Thames and Medway, and of the coasts of Sussex, Kent, and Essex. The *Amazon* was to be prepared for his reception; but meanwhile he was to hoist his flag aboard any ship he might choose of his squadron, and to cruise off the districts named and watch the coast.

On the 27th of July his flag was flying on board the *Unitf* frigate at Sheerness. He wrote, under this date, humorously to his dearest Emma: " To-day I dined with Admiral* Graeme, who has also lost **his right arm**, and as **the Commander of the Troops**

has lost his leg, I expect we shall be caricatured as the *lame* defenders of England." Captain Parker, who was with him, describes Nelson's health as at this time extremely good. He was received at Sheerness " by the acclamations of the people, who looked with wild and most affectionate amazement at him, who was once more going to step forward in defence of his country." * With wonderful rapidity he gave orders, dealing with thirty of the ships under his command. The moment he appeared, everything was in motion. His movements may be followed, to an extent, in his correspondence with Lady Hamilton. On July 29th he left Sheerness for Deal, halting on his way at Faversham to examine into the state of a 'longshore force, called the Sea Fencibles, which had been raised by Captain, afterwards Sir, Home Popham in 1799 for ^{the} defence of the coast. He arrived at Deal at nine o'clock, and went to the house of his old friend, Admiral Ludwidge, where he supped, not having tasted a morsel since seven in the morning. Next morning he hoisted his flag aboard the *Leyden*, 64; but, meanwhile, he had sent for the *Medusa* frigate, in which ship, he tells Lady Hamilton, he means to go over to the coast of France.

On the 3d of August his flag was flying aboard the *Medusa*. There were about thirty vessels, great and small, under his charge, and with this force he weighed for Boulogne—the central *rendezvous* of the grand flotilla,—where was to be assembled, ac-

* E. T. Parker to Lady Hamilton. " Parker," writes Nelson, " sits **next me** to cut my meat when I want it done."—Pettigrew, II., 135.

According to Buonaparte's order, dated 12th of July, nine divisions of gun-vessels, nine battalions of troops, with several detachments of artillery, under the command of Rear-Admiral La Touche-TreVille. This flotilla was bombarded by Nelson on the 4th of August. The craft consisted of twenty-four brigs, lugger-rigged flats, and a schooner; of which three flats and a brig were sunk, and others driven on shore. The French represent the damage as much smaller than this. It was, in any case, inconsiderable. On the 15th there was another attempt. The armed boats of Nelson's squadron were formed into four divisions, and at half-past eleven o'clock at night put off from the *Medusa* in excellent order; but the tide completed the work of the obscurity of the hour, and the boats separated. The first division, under Captain Somerville, was swept to the eastward of Boulogne. A brig was attacked and carried, but she was secured by a chain, and nothing could be done with her. In this affair, eighteen of the English were killed and fifty-five wounded. The second division, under Captain Parker, impetuously boarded an enemy's brig, but were repulsed, with the loss of twenty-one killed and forty-two wounded, amongst the latter being Parker, whose wound proved fatal. The attempts of the third division, under Captain Cotgrave, were equally fruitless, and the loss amongst them was five killed and twenty-nine wounded. The fourth division, under Captain Jones, was carried so far to the eastward by the tide that it was unable to co-operate, and returned profitlessly to the Squadron.

Amidst all the anxieties, however, of his Downs' command, Nelson could find leisure to give expression to a wish that had been uppermost for some time ; namely, that Lady Hamilton should purchase for him a good, comfortable house. Upon this subject he writes to her on August the 15th, heading his letter " Medusa, off Boulogne." The commission was accepted by his " Guardian Angel," and it resulted in her choosing for him what Mr. J. C. Jeaffreson calls " a cheery, well-built, homely villa, skirted with shrubberies, nestled in finely timbered paddocks, and within an easy drive from Hyde Park Corner." * The property was called Merton Place. Sir William Hamilton, on the 16th of October, wrote thus of his wife's investment of Nelson's money : " I have lived with our dear Emma several years. I know her merit, have a great opinion of the head and heart that God Almighty has been pleased to give her, but a seaman alone could have given a fine woman full power to choose and fit up a residence for him without seeing it himself." But Merton Place was merely another form of Nelson's old quarter-deck dream of a cottage; only instead of Fanny it was to be Emma. " It would make you laugh," Sir William goes on in this same letter, " to see Emma and her mother † fitting up pig-stys and hen-coops, and already the canal is enlivened with ducks, and the cock is strutting with his hens about the walks." %

Meanwhile he had been grieved to the heart by

* " Lady Hamilton and Lord Nelson," vol. ii., p. 237.

† She was called " Mrs. Cadogan."

‡ Pettigrew. I I . . 224.

the death of his favourite little Parker, his "gallant good friend and able assistant/" as he called him. He had been shot in the thigh, and the bone was broken in three places. He died on the 27th of September, after languishing in great suffering, sometimes inspiring hope, but most often despaired of. "Dear Parker," writes Nelson to Lady Hamilton, "left this world for a better at nine o'clock; I believe we ought to thank God. He suffered much, and can suffer no more. I have no one to comfort me." And in a postscript to the letter he exclaims: "My heart is almost broke, and I see I have wrote nonsense; I know not what T am doing." The remains of the gallant fellow—and gallant and good we may be sure he was, to have won the love of Nelson—were interred at Deal in the burial-ground of St. George's Church. Nelson took care that the funeral should be conducted with all the honours which were due to his deceased friend's rank and admirable character. He attended as chief mourner. The ships in the Downs flew their pennants at half-mast high; their yards were cock-billed as an expression of mourning, and until the hour of noon minute guns were fired from the *Amazon* and the shore alternately. The cost of the burial Nelson himself defrayed. "The Admiralty," he tells Lady Hamilton (September 20th), "have refused to bury Captain Parker. He might have stunk above ground, or been thrown in a ditch; the expense of that and lodging, etc., has cost me near £200, and I have taken, poor fellow, all his debts on myself, if the creditors will give me a little time to find the money."

In September, whilst still wearily holding his command in the Downs, in bad health and suffering much from mental depression, he was attacked by a rogue named Hill in a pamphlet or paper which professed to consist of remarks on the Boulogne affair. The fellow, who called himself "a seaman," impudently forwarded his little bundle of trash to Nelson with a note in which he said that if the Admiral desired the "enclosed not to be inserted in the newspapers, he will please to *inclose by return of post a banknote of £100* to Mr. Hill, to be left at the Post Office till called for, London." Nelson wrote to the Secretary of the Admiralty to request their Lordships to send proper people "to take up whoever comes for Mr. Hill's letter." A porter applied and was seized, but the fellow either did not or would not know his employer. In spite of the Admiralty's action, however, Nelson thought proper to write to the villain as follows: "Mr. Hill,—Very likely I am unfit for my present command, and whenever Government change me, I hope they will find no difficulty in selecting an officer of greater abilities; but you will, I trust, be punished for threatening my character. But I have not been brought up in the school of fear, and therefore care not what you do. I defy you and your malice.—Nelson and Bronte."

His command in the Downs was of a kind to fill him with disgust. "I own, my dear Lord," he writes to St. Vincent (August 13th), "that this Boat-warfare is not exactly congenial to my feelings, and I find I get laughed at for my puny mode of attack." Day

after day he lay rolling in that famous roadstead, as seasick as a young lady, divorced from his friends, ill of a bowel complaint, and without an opportunity of further distinction. Little wonder that he felt sore and wrote sorely, with the memories of St. Vincent, and the Nile, and Copenhagen fresh in him. The contrast established by this bleak, bare, uncomfortable duty of sentinelling could not but prove fruitful of mortification and angry reflection. He found Deal the coldest place in the world. Of Troubridge, who was now one of " My Lords," he cannot speak with too much anger. " Troubridge writes me," he exclaims, " that as the weather is set in fine again he hopes I shall get walks on shore! He is, I suppose, laughing at me." " I believe the fault is all his," he writes again (October 14th) of his old friend, " and he ought to have recollected that I got him the medal of the Nile. Who upheld him when he would have sunk under grief and mortification? Who placed him in such a situation in the Kingdom of Naples that he got, by my public letter, *titles, the Colonelcy of Marines, diamond-boxes*, from the King of Naples, 1,000 ounces in money, for *no* expenses that I know of? Who got him £500 a year from the King of Naples? And however much he may abuse him, his pension will be regularly paid. Who brought his character into notice? Look at my public letters. *Nelson*, that Nelson that he now *Lords* it over. So much for gratitude. I forgive him, but, by God, I shall not forget it! He enjoys showing his power over me. Nevermind; altogether it will shorten my days. The day is very bad—

blows, rains, and a great sea; my complaint is returned from absolutely fretting; and was it not for the kindness of all about me, they, damn them, would have done me up long ago."

Sir Harris Nicolas suggests, and probably with justice, that much of this irritability in Nelson was owing to the wound that he had received in the head at the Nile. Certainly he had no rational reason to doubt Troubridge's love for and loyalty to him.

But, as has been said, his melancholy situation in the Downs would also account for many effusions of temper. To be lying at anchor for days at a time, restlessly tossed by the short staggering run of the Foreland seas; to be nipped by the advanced autumn winds of an exposed roadstead; to hold within view for weeks nothing gayer than the flat foreshore of the Sandwich district and the small sea-fronting structures of the town of Deal, with its stretch of shingle and depressing play of surf; to be so much the sport of the capricious weather of that part of the British coast as often to be unable to send a letter ashore, and when on shore to be hindered by the breakers foaming upon the beach from regaining the ship: this was Nelson's life at this time, and it needs but a very small appreciation of the character of these tedious, uneventful experiences of his to sympathise with the irritability that possessed him when he directed his thoughts to "My Lords."

CHAPTER XVI.



Political speeches—St. Vincent on Canada—Death of Rev. E. Nelson—Nelson and the Hamiltons—Visit to Wales—War with France—Buonaparte and Lord Whitworth—Nelson's income—Death of Sir Wm. Hamilton—Appointed Commander-in-chief on the Mediterranean station—Letter from the King of Naples—Blockading—A revolution in sea-affairs—Crazy ships—Fears for his eyesight—Bay of Palmas.

He was released on leave, and on the 22d of October went to Merton, his own property, which he had not before visited. On the 29th he took his seat in the House of Lords, his introducers being Viscounts Sydney and Hood. Of the few speeches he delivered there is not much to be said beyond that they have every characteristic of a plain, honest, sagacious, sailorly mind. In that of the 3d of November, however, it is remarkable to find Nelson, who was eminent before all things for foresight, ridiculing the possession of the Cape of Good Hope by the British. He contemptuously described Table Bay as a tavern, useful merely for ships to look into during the voyage to India. When the

Dutch, he said, had it, a cabbage was to be bought for twopence, but since the settlement had come into English hands the price of a cabbage was a shilling. It was only to be held at an enormous expense, and it was without usefulness to justify the cost it put the country to. This may be paralleled by Lord St. Vincent's prophecy respecting Canada. When, in 1783, Lord Shelburne's peace was signed, Jervis was sent for, that his opinion might be taken. "There is a great omission!" he exclaimed.—"In what?"—"In leaving Canada as a British province."—"How could we possibly give it up?" asked Lord Shelburne.—"How can you hope to keep it?" rejoined the Admiral. "With an English Republic just established on the side of Canada, and with a handful of English settled among a body of hereditary Frenchmen—it is impossible: and rely on it, you only retain a running sore, the source of endless disquiet and expense."—"Would the country bear it? Have you forgotten Wolfe and Quebec?" asked Lord Shelburne.—"Forgotten Wolfe and Quebec?" cried the Admiral, "No! it is because I remember both! I served with Wolfe at Quebec; having lived so long I have had full time for reflection on this matter, and my clear opinion is that if this fair occasion for giving up Canada is neglected nothing but difficulty in either keeping or resigning it will ever after be known." * It is well for Britons that their history is something more than the outcome of prophecy.

The character of Nelson's relations with Lady Hamilton was seemingly unsuspected even **by those**

* *Edinburgh Review*, vol. lxi., 41.

who lived in intimate association with them. Sir William certainly saw nothing. The Rev. William thought her ladyship very good company for his wife. The Rev. Edmund, Nelson's father, was willing, and indeed anxious, to live with his son and the Hamiltons at Merton Place. It was intended that he should take up his abode there in May of 1802, after wintering at Bath, but his death ended the project. He died at Bath on the 26th of April, aged seventy-nine, and was buried at Burnham Thorpe. Nelson was ill at the time, and deeply felt the loss of a parent whom, spite of a quality of cold, formal, and insipid piety of a sort to excite the disgust of those who follow its expressions in books or in letters, he loved, honoured, and dutifully cherished to the end.

Though we find Nelson in 1802 living at Merton with Sir William and Lady Hamilton, he was still in command between Orfordness and Beachy Head, and therefore on leave only; nor did he strike his flag until the 10th of April. His resentment of the neglect of the claims of those who had fought with him at Copenhagen was vehement at this time. He declined to receive a vote of thanks from the London Court of Common Council for his conduct in the Downs and off Boulogne, because the City had not approvingly and formally recognised the battle of Copenhagen. He refused for this reason to publicly dine with the Lord Mayor. His loyalty to his comrades, no matter where they had fought together, was constant, and in its efforts on their behalf unwearied. Never was chief more beloved by

those who served with and under him, nor did the veneration and awe his extraordinary character excited impair the simplicity of the whole-hearted sailorly affection with which he was followed by shipmate and by messmate.

In July he proceeded to Wales in company with the Hamiltons and the Rev. William Nelson, Mrs. Nelson, and son. The object of this excursion was to view Milford Haven and observe the improvements made by Mr. C. F. Greville upon the estate of his uncle Sir William Hamilton. At Oxford Nelson was presented with the Freedom of the City in a gold box. Blenheim was visited, but the Duke of Marlborough declined to receive the party. Refreshments were sent to them as they might be sent to a set of Cockney excursionists on a holiday jaunt by a considerate but exclusive proprietor of a spot ranking among the local sights ; but the Nelson party refused to partake of his Grace's hospitality thus proffered. Pettigrew endeavours to account for this act of singular incivility to the renowned naval warrior by speaking of the Duke's shy and retiring habits and of the absence of the usual ceremonials of introductory etiquette ; but Mr. J. C. Jeaffreson more correctly surmises that the ladies of the Marlborough family did not desire the honour of Lady Hamilton's acquaintance. Wherever they went bells were rung, the streets were filled with huzzaing crowds, **guns** were fired, militiamen turned out, and bands **of music** played martial strains. At Breckon **and at Milford** his reception was especially enthusiastic. At this last-named place Mr. Greville (**choosing the**



SNUFF-BOX MADE FROM THE WOOD OF 'L'ORIENT."

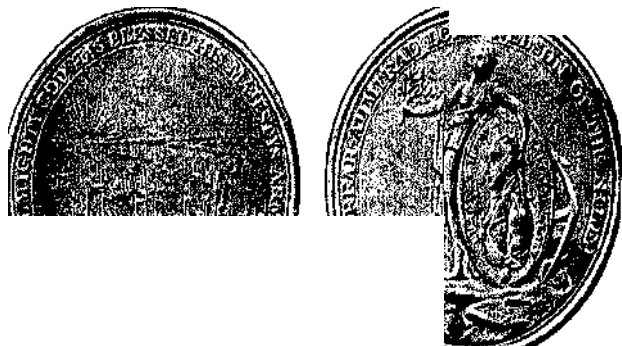

MEDAL FOR THE BATTLE OF THE NILE.

1st of August) invited all the nobility and gentry of the district to a fete in commemoration of Nelson's visit and the victory of the Nile. At Haverford West the crowd drew his carriage through the streets, and at Swansea he was dragged in triumph by a body of sailors. The tour was rather a royal progress than an excursion. He passed under triumphal arches; bishops carried him to view the cathedrals; freedoms were showered upon him; medals were struck to commemorate his visits, and dense throngs carrying hundreds of lighted torches escorted him from the theatre to his hotel. The journey greatly improved his health, and on the 5th of September he returned to Merton in the highest degree delighted by the often magnificent and always affectionate reception he had met with.

Preliminaries of peace were agreed upon, October the 1st, 1801 ; but the Treaty was not signed till seven months later, namely, March the 27th, 1802. The embers of the bonfires kindled in celebration of the peace of Amiens were still hot, when war with France was again imminent. It would unnecessarily crowd a limited space to enter into an account of the causes of the war that was declared by England against France on the 16th of May, 1803 ; that being the date on which letters-of-marque were issued and general reprisals ordered. It was at least very clear to all thinking Englishmen that Buonaparte—even when the preliminaries of peace were being signed by Lord Hawkesbury and Citizen Otto—was contemplating an early renewal of hostilities against England. He did not, indeed, anticipate a rupture before **the**

month of September; but the policy of Great Britain, in those times at all events, was not to await the attack, but to deliver the blow.

The decision and promptitude of the British astonished Buonaparte. A conversation between him and the English Ambassador, Lord Whitworth, at the Tuilleries, on the 13th of March, 1803, is printed by Clarke and McArthur.* "We have already had war," said Buonaparte, "for fifteen years." He seemed to pause for a reply, and Lord Whitworth exclaimed: "That is already too much." Buonaparte said: "But you would make another fifteen years of war, and are forcing me to it." He added: "You may be able perhaps to kill France, but you can never intimidate her."—"Neither one nor the other is wanted," responded Lord Whitworth, speaking assuredly not out of his conscience so far as Buonaparte and his government were concerned. "We simply desire to live on good terms with her," meaning France.

The speech from the throne, delivered November the 16th, 1802, was significant of war. "It is nevertheless impossible for me," King George was made to say, "to lose sight of that established and wise system of policy by which the interests of other States are connected with our own." The Address was seconded by Nelson, November the 23d, in the best, perhaps, of the few speeches he made: "I, my Lords, have in different countries seen much of the miseries of war. I am therefore in my inmost soul a man of peace. Yet I would not, for the sake

* Vol. ii., p. 464.

of any peace, however fortunate, consent to sacrifice one jot of England's honour. Our honour is inseparably combined with our genuine interest. Hitherto there has been nothing greater known on the Continent than the fame, the untainted honour, the generous public sympathies, the high diplomatic influence, the commerce, the grandeur, the resistless power, the unconquerable valour of the British nation." He added, that he rejoiced that the King intended to have due regard to the preservation of the liberties of Europe, and that preparations to maintain the dignity of Great Britain were not to be neglected.

Meanwhile he continued to reside at Merton. In March he devoted some time to looking into his pecuniary affairs, and forwarded to the Right Honourable Henry Addington a statement that cannot be perused without interest and surprise. It represented that his whole real property was under £10,000, and that when all the charitable and other charges he had voluntarily and nobly imposed upon it were deducted he had only £768 a year left to answer all demands made upon him. He was fond of quoting the old sailor's saying, *that his money never cost the widow a tear nor the nation a farthing.* " I got what I have with my pure blood from the Enemies of my Country."

On the 9th of March he attended a debate in the House of Lords, on the King's message, that dealt with the armaments preparing at the French ports, but did not speak. Before leaving he wrote as follows to the Premier, Addington :

" HOUSE OF LORDS, 4 o'clock, March 9th, 1803.

" Whenever it is necessary I am *your* Admiral.

"NELSON AND BRONTE."

Early in April he was distressed by the **death** of Sir William Hamilton. He and Lady Hamilton had sat up together for six nights running by the bedside of the sick man, who expired holding his wife's and Nelson's hands. Sir William's remarkable letter to his wife, concluding with " For God's sake," must convincingly assure the reader of it that, however well informed he was of her past, his confidence in her fidelity since she had been wedded to him was entirely unshaken. His belief in Nelson's purity and disinterestedness as a friend was equal to his admiration of him as a hero and a leader of men. The grief felt by Nelson on the death of his old, genial, trusting, and profoundly admiring companion and friend must, if the great Admiral's nature be visible to us at all on the surface of that literature in which posterity has to seek it, have been sorely increased by the voice of his conscience. " The world," he wrote of Sir William to the Duke of Clarence, " never lost a more upright and accomplished gentleman." Lady Hamilton, on the other hand, a mistress of postures, must needs pose upon her husband's remains. She writes : "*April 6th.* Unhappy day for the forlorn Emma. **Ten**

* ' * I have no complaint to **make**, but **I** feel **that** the whole **attention** of my wife is given to Lord Nelson and his interest at Merton. I well know the purity of Lord Nelson's friendship for **Emma and me**. And I know how very uncomfortable it wou'd **make** his **Lordship**, our best Friend, if a **separation** shou'd take **place**," etc.

minutes past ten, dear, blessed Sir William left me." That her grief went no deeper than this expression of it we have every right to believe. Puritanical as may seem the twang of Robert Southey's lament over this blot upon Nelson's otherwise spotless character as a gentleman, as an officer, and as a man, the world will go on agreeing in the spirit of the poet's words, despite the eloquence of Lady Hamilton's apologists, and of writers whose merit, higher than eloquence, is the effort to lighten in the portrait of Britain's Darling the shadow or the stain of a Wrong.

He was appointed Commander-in-chief on the Mediterranean station on the 16th of May, 1803, though his orders for departure came to him on the 6th. He went to Merton to settle his affairs, and on the 18th proceeded to Portsmouth, where he hoisted his flag on board the *Victory*. He sailed from Spithead on the 20th, at five o'clock in the afternoon, accompanied by the *Amphion*, a 32-gun frigate, commanded by Captain Thomas Masterman Hardy. His intention was to speak the fleet under Admiral Cornwallis, but the British ships had been blown from their station by a severe gale of wind, and, after a brief hunt for them, Nelson shifted his flag to the *Amphion* and made sail, leaving the *Victory* to follow him should Cornwallis not desire her as an addition to the Channel fleet. Nelson had no particular appetite for the sweets of a small frigate. When in sight of Ushant, he was writing to Lady Hamilton at eight o'clock in the morning to tell her that he is fretting under the idea that

Cornwallis may keep the *Victory*, and turn him **bag** and baggage into the *Amphion*.

On May the 25th he begins a sort of journal-letter, addressed to Emma, that contains in brief the story of his passage to Gibraltar in the *Amphion*, which vessel did not prove so uncomfortable as he had feared. "Here we are," he says, "in the middle of the Bay of Biscay—nothing to be seen but the sky and water. I left the *Victory* at eight o'clock last night. . . . Hardy takes good care of us, and the *Amphion* is very comfortable." His impatience almost rages at times. A foul wind and head sea kept the *Amphion* labouring off Finisterre, and Nelson could think of nothing but the time that was being lost, and of the likelihood of Sicily—the Neapolitan Court is still first with him, at all events, in his communications with Emma—being overrun by the French before he could get to work. "But," says he, "we are carrying sail, doing our utmost. Patience is a virtue at sea. Your dear picture and Horatia's are hung up; it revives **me** even to look upon them."

On the 2d of June he was passing the rock at Lisbon, with a gentle fair wind, and on the 3d arrived at Gibraltar, having made a run of one hundred leagues in eighteen hours,—that is to say, from eight o'clock on the previous morning down to two o'clock of the 3d, at which hour he wrote this entry. If there be no inaccuracy here, the time shows an average speed of a full ten knots an hour, which proves the old *Amphion* to have been **possessed of a very nimble keel, as clippers then went.**

Malta was reached on the 15th and Naples on the 25th, where Nelson expected to find the squadron under the command of Rear-Admiral Sir Richard Bickerton in the *Kent*, 74. But the ships had gone to Toulon. His anxiety for the preservation of the Two Sicilies was as enthusiastic as ever it had been in the days of the *Agamemnon* and the *Foudroyant*. "If I know myself," he wrote to Sir John Acton, "it is to know that the more my friends are in distress the more I am anxious to save them. A mouse assisted a lion, which is the only comparison I can make in arrogating to myself the power of assisting a King of the house of Bourbon." This King of the House of Bourbon seemed quite sensible of what was being done for him. "The hand of Providence again weighs on me and on my people," he wrote to Nelson, probably confounding the hand of Providence with his own or his wife's. "I see no hope or consolation but in the friendship of your august Sovereign, who was always my faithful and sincere ally. His support is certain since he has appointed you to the command in these seas. . . . I must solicit your immediate consideration of my position." * Again we find Nelson anxious to provide for the personal safety of the Neapolitan Royal Family by proposing to Sir John Acton to keep either a ship of the line or a frigate constantly at Naples, and before quitting Capri he directed the senior captain of the British ships in Naples Bay to receive, on his signed order being presented by the British

* Pettigrew. I I . , 315.

Minister, the King, Queen, and *Royal Family*, and convey them wherever *they wished to go*.

It was not until *the 8th of July* that he succeeded in joining Sir *Richard Bickerton*, who was cruising off Toulon with the following ships; *Gibraltar*, 80; *Kent*, *Donegal*, *Superb*, *Belleisle*, and *Renown*, all 74's; *Monmouth* and *Agincourt*, 64's; and two frigates, the *Amphion* making a third. The French force preparing for sea in Toulon under Vice-Admiral La Touche-Treville, consisted of seven line-of-battle ships almost in readiness to go afloat, two repairing at the Arsenal, and five on the stocks. All these vessels were craft of great weight of broadsides, 80's and 74's.

Forty-eight hours after Nelson had left the *Victory*, she fell in with the Channel fleet, and two hours later was suffered to proceed to the Mediterranean. She joined the squadron on the 30th of July, and Nelson at once shifted his flag to her, taking with him Captain George Murray as his first, and Captain Hardy as his second, captain.

In these days of steam much that went to render the business of blockading in olden times in the highest degree wretched and even unendurable, must be softened or extinguished. The propeller enables a ship to keep her station. She roams at will; for her the wind is without caprice, and it needs little short of a hurricane to divert her resolutions. All this was very different in the times of tacks and sheets. A long, strong squall would blow a blockading squadron out of sight, and hours and days might be expended in the task of "reaching" up against a strong off-shore wind to the old cruising station.

Expectation, long-strained and ever on the alert, became a sickness of heart; the enemy continued motionless; nothing was to be done but to continue sailing up and down, first on one tack then on the other, staring at the foe, whose masthead with heavy yards across towered above the line of docks and fortresses and pier heads. "The happiness," writes Nelson, "of keeping a station is always to have a foul wind, and never to hear the delightful sound, *steady*." In such work he would humorously say there was little more to be earned than salt-beef and honour; but unhappily the honour counted for nothing, whilst the salt-beef ate steadily into the constitution.

Early in August the French force at Toulon had risen by the launch of the *Neptune* to eight sail-of-the-line, as against Nelson's six; namely, the *Victory*, *Belleisle*, *Kent*, *Renown*, *Superb*, and *Triumph*—the *Canopus* and *Monmouth* having been detached.

The movements of Nelson whilst blockading Toulon must be followed, though they are without interest. Minute details of operations lose their power of detaining the attention in proportion as they are removed by time. This is specially true of the sea, and the truer still in these days because of the radical change, continuously active, that has been brought about by steam and the use of metal. Fifty years ago a naval officer would probably watch with profound interest Nelson's manoeuvrings off Toulon as they are described by his biographers and in his own dispatches and letters. But the seamanship of those days, the strategies, the devices, the expedients, are no longer of the least value voca-

tionally. A pity indeed that this should be so! The breed of men whom Nelson headed is by no means as yet extinct; but science has placed the Jacks of all the nations upon a level platform; one set of sailors must needs be as good as another set *if naval warfare is to consist of firing at league-long distances and if the ships employed are to be merely floating batteries, more or less submerged, propelled by steam, armed with leviathan ordnance, and filled with men who, as no calls upon their qualities as mariners can possibly be made owing to the character of the structures they float in and to the nature of the services required, must hardly, in spite of their dress, be regarded as much more than sea-going soldiers.* The pike has been *removed from the hands of the seamen*; the cutlass can be *little better than a tradition*; there can be no more yard-arm to yard-arm engagements; we may take it that the boarding-party is quite among the marine details of the dead past. Yet it was by the thrust of the pike, the deadly swing of the tomahawk or the cutlass, the daring hurricane-leap from bulwark to bulwark, the impetuous and irresistible rush along the enemy's deck, the red-hot hand-to-hand conflict swiftly terminated,—by these means it was, the British sailor achieved those issues which the true-born Englishman has a right to boast of and to proudly recall. In this century, however, has happened a very revolution in sea affairs; the manoeuvres of Nelson are to be followed as historic studies; but professionally they are of no worth.

On the 24th of October, the squadron under Nel-

son being short of water made for a newly discovered anchorage among the Magdalena Islands, leaving two frigates to watch the French force. For a whole week the ships were fighting with heavy gales, through nights of blackness made horribly perilous by a navigation of rocks and shoals in those days uncharted. The anchorage, however, was safely reached, and, having obtained the refreshments he required for his ships, Nelson sailed again on the 9th of November, and was off Toulon by the 23d. He was thoroughly satisfied with his crews. "We are healthy beyond example," he wrote to his friend Davison on October 4th, "and in great good humour with ourselves, and so sharp-set that I would not be a French Admiral in the way of any of our ships for something. I believe we are in the right fighting trim, let them come as soon as they please. I never saw a Fleet altogether so well officered and manned."

But the ships he declared crazy. To the Duke of Clarence he could write in language that was not to be interpreted into the faintest echo of the sailor's proverbial "growl": "I have the happiness," he says, "of commanding the finest squadron in the world—*Victory, Kent, Superb, Triumph, Belleisle, and Renown.*" But to his friend Davison he can find it in his heart to be candid: "If I am to watch the French I must be at sea, and if at sea must have bad weather; and if the ships are not fit to stand bad weather they are useless. I do not say much, but I do not believe that Lord St. Vincent would have kept the sea with such ships." The anxiety the

condition of the squadron gave him may be judged from this and other like passages in his correspondence. The Mediterranean weather, too, appeared to have changed its character, as though to complicate his worries. It was incessantly blowing hard Levanters, and nothing but his extraordinary foresight enabled him to hold his own in those waters. The Admiralty then, as always, needed warm and frequent promptings to keep alive in them a recognition of the needs of distant fleets. It seemed scarcely credible that Nelson should have found it necessary to point out to a body of officials who numbered old and seasoned sea-officers amongst them, that the Gulf of Lyons was notorious, wherever the mariner floated, for the number and severity and suddenness of its gales, and that as the fleet would be at sea, in all probability, during the whole of the winter, it was necessary to supply the ship with plenty of spare top-masts, top-sail yards, and extra suits of canvas.

But there was a deeper and a darker anxiety on his mind at this time than any trouble it was in the power of the French or of the weather or of the British Admiralty to create for him. "My dear friend," he wrote to Davison, "my eyesight fails me most dreadfully. I firmly believe that in a very few years I shall be stone blind. It is this only of all my maladies that makes me unhappy; but God's will be done." And to his brother, Edmund, he also writes: "The mind and body both wear out, and my eye is every month visibly getting worse, and I much fear it will end in total blindness. The moment the

battle is over, if I am victorious, I shall ask **for my** retreat—if, **unfortunately**, the contrary, I hope **never** to live to see it."

Incessant gales of wind, combined with the defective state of his ships, all whose running rigging, with the exception of the *Victory's*, was condemned, whilst some of them, such as the *Excellent* and *Kent*, had to be refitted with new main and mizzen shrouds, to the disgrace of the Portsmouth Dockyard people who had thus sent the ships to sea, compelled Nelson to withdraw to the shelter of the Bay of Palmas, where he lingered until the want of fresh water drove him once more to the anchorage amongst **the** Magdalena Islands.



11. April. 1777

Horatio Nelson,

*From Oath of Allegiance
in the Admiralty Records.*

Horatio Nelson

Admiralty Records.

Horatio Nelson

Letter in the Author's possession.

Nelson

Letter in the Author's possession.

Oronte Nelson of the Nile

Admiralty Records.

Nelson's Oronte Oct. 20th

Letter in the Author's possession

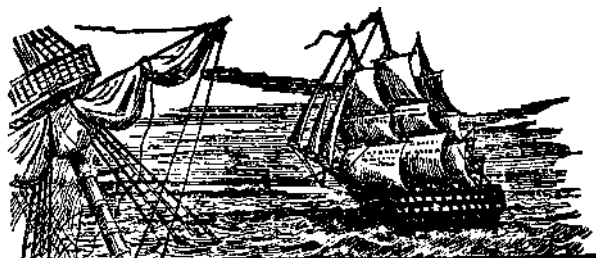

CHAPTER XVII.

Recollections of Rev. A. J. Scott—The leathern arm-chairs—Anecdote of a midshipman—La Touche-Tréville—Continued illness—Ambition to be Lord High Admiral—Anecdote—Tedious blockading—Spanish menace—Rich capture—Sir John Orde—Injurious treatment of Nelson—French fleet—Daring navigation—Pursuit of the French across the Atlantic—Misled by Brereton—The American schooner—Two years all but ten days of shipboard—Romantic incident.



SOME interesting recollections of Nelson by his chaplain in the *Victory*,

the Rev. A. J. Scott, belong to this period. It was a point of etiquette with him to transmit letters addressed to foreign Courts in his own tongue, with duplicates in the respective languages of those Courts; and this labour of translation was his chaplain's, who also read aloud to him all the French, Italian, Spanish, and other foreign newspapers which were sent to the ship. Nelson likewise obliged Scott to read through every twopenny-halfpenny pamphlet that came to hand, his notion being that no man ever put his hand to paper who had not something to tell worth knowing. The great Admiral appears to have possessed Dr. Samuel Johnson's capacity of

tearing the heart out of a book. A swift glance at a page or two enabled him to gather the writer's object. Day after day he and his chaplain and a secretary sat poring upon the papers which loaded the table. The cabin was furnished with two black leather arm-chairs, each with capacious pockets, and Scott, exhausted by the labour of translating, would sometimes sneak into one of these pockets some score or so of unopened private letters found in captured ships; but such was Nelson's restless solicitude that he was uneasy if even a single document was unexamined. These leathern chairs, with the help of an ottoman, when lashed together, formed a couch on which he would often snatch a few winks of sleep, which supplied him with as much refreshment as an ordinary mortal might obtain from a long night's rest.

No human being, according to Scott, ever possessed so remarkably as Lord Nelson the power of exciting affection for his nature and admiration for his genius. Sir Pultney Malcolm, who was intimately acquainted with Buonaparte, the Duke of Wellington, and our Hero, used to say that "Nelson was the man to *love!*" He found a very great delight in studying the characters of those who were about him; and at table would provoke arguments that he might draw out the thoughts and opinions of his companions. He abhorred all stiffness and formality, and when an hour arrived for debating the most important naval business he chose a turn on the quarter-deck with his captains, whom he would coax by his own frankness into free confessions of opinion, in prefer-

ence to the ceremonious solemnities of the council of war.

Scott was a man of talent and a scholar, and Nelson would often slyly amuse himself by provoking the chaplain into arguments on literature, politics, and even naval affairs. On one occasion he teased him into delivering a lecture on navigation to the no small diversion of Admiral Murray, Captain Hardy, and other officers who were present. The following story is related by the writer of Scott's life: One fine morning when the *Victory* was floating quietly along at some four knots in the hour there was a sudden cry of "Man overboard!" A midshipman named Flinn, who was sketching on deck, sprang to his feet, and looking over the quarter saw his own servant, who could not swim, drowning in the ship's wake. The lad whipped off his jacket at the instant that the Captain of Marines had thrown the sinking fellow a chair; but this did not hinder Flinn from leaping overboard. The lad, the man, and the chair were recovered and hauled on deck. Neteon, who stood looking on, was so pleased with Flinn's behaviour that he called the lad up to him and made him a lieutenant on the spot. A crowd of youngsters sent up a loud cheer whilst they tossed their hats in honour of their messmate Flinn's good-fortune. Nelson seemed to find something significant in the tone of their hurrahs, and putting up his hand for silence, whilst he inclined his body over the rail towards the lads, he said with a smile: "Stop, young gentlemen! Mr. Flinn has done a gallant thing to-day—and he has done many gallant things before—

for which he has got his reward; but mind! *l'il have no more making lieutenants for servants falling over-board!* " *

Nothing very material happened until the 13th of June, on which date Nelson was off Hyeres in the *Victory*, along with the *Canopus*, *Belleisle*, *Donegal*, and *Excellent*. Sir Richard Bickerton, with a division of five sail, was cruising at a distance of some sixty miles from the land. Two strange ships had been signalled off the east end of the island of Porquerolles, and the frigates *Amazon* and *Phoebe* were sent in chase. The light airs made the manoeuvring very slow; and it was not until next day that Nelson gathered that the strangers were two French frigates. The *Amazon* and *Phoebe* cleared for action; but they had scarcely done so when the whole of the French fleet in Toulon Road got under-way and stood in pursuit. There were fourteen sail of ships, but this powerful force seemed to have no other object in quitting what Nelson called their "nest" than to put the English frigates to flight, for when this had been done they returned to their quarters, out of which Nelson, by every species of strategy and defiance, had in vain for weeks and weeks been attempting to lure them. La Touche-Treville, the French Admiral, in an official communication to his government, reported of this profoundly insignificant business that Nelson *ran away*.

* "Scott's Recollections," p. 127. Mr. Flin (with one *n*) died a Post Captain and Companion of the Bath in 1819. Nelson's marginal note to his official letter on this subject tells the story very differently "Appointed in consequence of his having **jumped overboard on the night of nth inst., then very dark,**" etc.

There was never an insult and never a lie levelled at Nelson in all his career that he resented more bitterly than this. It is impossible not to agree with James, the historian, that he made a very great deal too much of the hectoring French coxcomb's gasconade. He even condescended to communicate on the subject with the Secretary of the Admiralty. "Although I most certainly never thought of writing a line of Mons. Touche's having cut a caper a few miles outside of Toulon, on the 14th of June, when he well knew I could not get at him without placing the ships under the batteries which surrounded that port ; and that, had I attacked him in that position, he could retire into his secure nest whenever he pleased ; yet, as the gentleman has thought proper to write a letter, stating that the fleet under my command ran away and that he pursued it, perhaps it may be thought necessary for me to say something. But I do assure you, sir, that I know not what to say except by a flat contradiction, for if my character is not established by this time for not being apt to run away, *t is not worth my time to attempt to put the world right." * He was less reserved in the expression of his indignation to friends. "I have kept M. La Touche's letter," he writes to Mr. Davison, "and if I take him I shall never see him ; or, if I do, *make him eat* his letter—perhaps sovereign contempt is the best." So also to Sir Alexander Ball: "Such a ilar is below my notice, except to thrash him."

La Touche, however, died before Nelson could

* " Dispatches and Letters," vi., 150.

get at him. He expired aboard the *Bucentaure* on the 18th of August, 1804. "He is gone," wrote Nelson, "and all his lies with him. The French papers say he died in consequence of walking so often up to the signal-post, upon Sepet, to watch us; I always pronounced that that would be his death."

The French papers, however, could lie about this man as freely and coolly as he could lie about Nelson. A sketch of his life appeared in the *Moniteur*, of the 1st of September, 1804, in which his behaviour at Boulogne is thus recounted: "He was soon sent to Boulogne, where he prepared the first elements of that Flotilla which has now grown to such a size; and every one remembers the glorious contests which he sustained on the 17th and 27th Thermidor in the year 9 against Admiral Nelson." Again, speaking of this man's command in the Mediterranean, the *Moniteur* says: "Since that epoch he has not ceased to be in sight of a superior force, which has in vain endeavoured to block up the port of Toulon. The activity which he had given to the ships of his squadron, and the strict discipline which he had established, did not permit an enemy's vessel to appear before the Road without being instantly pursued, harassed, and forced to quit the coast." * It is in this fashion that French naval history is written. Yet, a little before the period of the death of this same La Touche, who was "af-frighting the English" away from the French coast, Nelson was acknowledging to the Lord Mayor of London a vote of thanks, passed by the Corporation

* *Naval Chronicle*, xii., 301.

for his services off Toulon : " I beg to inform your Lordship that the port of Toulon has never been blockaded by me; quite the reverse ; every opportunity has been offered the enemy to put to sea, for it is there that we hope to realise the hopes and expectations of our country, and I trust that they will not be disappointed."

He was now suffering again in health, and particularly dreaded the gales and frosts of such another winter as he had passed. He communicated with the Admiralty to request leave to return to England, and asked that their consent might reach him soon, as his application had already been deferred too long. This permission he was anticipating eagerly in September, when writing to Lady Hamilton : " I shall not stay three minutes at Portsmouth, but fly to dear Merton, where all in this world that is dearest to me resides ; and, therefore, I would have you remain at Merton, being assured I shall lose no time in coming to you." But both his health and patience were to be heavily taxed before Merton could be visited. His sufferings took the form of great pains in his right side ; the sight of his remaining eye was also fast failing him. His burning ambition was to meet the French and defeat them, after which he seemed to count upon being made Lord High Admiral, with the whole management of the Naval Service of Great Britain in his hands. His dreams ran all that way, and in conversing with his intimate friends he would repeatedly tell them what he would do if he were in **power.**

By November in this year, however, he had abandoned his intention of going to England. "I shall not go yet," he told Mr. Lambton Este, in conversation; "and when I may go is quite uncertain—must depend upon events and upon my own precarious health."

Mr. Este tells a story belonging to this period, and Sir H. Nicolas cites it as an illustration of the character of Nelson. The fleet had been many months afloat, and Mr. Este judged that Nelson and his associates must be in want of naval stores. It was in his power to supply certain articles which he knew would be acceptable as delicacies, and he accordingly sent by the *Phoebe* frigate, as presents for the *Victory*, two large tierces of the finest English porter, together with a quantity of hams, tongues, pickles, and so on. When Nelson saw the baggage he exclaimed: "What \s all this lumber? What the devil have you got here?" He seemed hurt at Mr. Este's explanation that it was "only a little ammunition for the fleet, my Lord." But nevertheless he directed that the goods should be carefully stored away. Days and weeks passed, but none of Mr. Este's delicacies were served, either at the Admiral's table or in the wardroom of the *Victory*. Mr. Este thought this very odd, but nothing was said. When he left the ship a letter from Nelson was put into his hand: "I have tasted and reserved some of your princely and delicious presents. Had we returned together in the *Superb*, these should **have** afforded consolation to all on board that **ship on our homeward voyage**. As **our destinies are altered**

I have taken the liberty of sending them to Captain Pettet, to whom they will prove highly acceptable ; and before you have been long on board I trust you will think with me, that they could not have been more worthily bestowed. I have added a few bottles of fine Marsala, lately sent me by Woodhouse from Sicily, that you may have the pleasure of drinking my health in my absence."* All well-authenticated anecdotes of Nelson abound in interest: the more so as they are few. Yet it is not very easy to find in Mr. Este's story that illustration of Nelson's character which we are invited to observe. Better surely that the delicacies should have been eaten by the officers of the *Victory*—who had passed and were yet to pass a long and dreary spell of cruising,—than given to those who were sailing direct for England.

During the greater part of the month of July gales of wind were incessant, and Nelson had the utmost difficulty in keeping his station in the almost unseaworthy ships under his command. Towards the close of the month he sheltered his fleet in the Gulf of Palmas, where were eight transports with cargoes to be discharged. The *Belleisle*, the *Fisgard*, and the *Niger* were left off Toulon to cruise and watch the enemy. On the 2d of August, these vessels having been blown away out of sight of the shore, five French sail of the line and six frigates came out of Toulon, but on sighting the *Belleisle* and her consorts they instantly shifted their helm and returned to Toulon. This sort of thing had been now going on for months with exasperating regularity. **The**

•"Dispatches and Letters," vi., 258.

French Commander-in-chief seemed to desire nothing better than a chance to sneak out when no Englishman was in view, and then hurry in again like a hare with a hound after it, that he might communicate official lies to Napoleon. Yet he was in strong force, for when Nelson again reconnoitred Toulon on the 26th he counted twenty ship-rigged vessels, of which ten were sail-of-the-line, in the outer harbour; and in the inner harbour, a formidable line-of-battle ship and a frigate.

On the death of La Touche-Treville, Admiral Dumanoir-le-Pelley was appointed to the command of the French fleet, but on the 6th of November the gallant and unfortunate Villeneuve succeeded him, and hoisted his flag aboard the *Bucentaure*. Yet was nothing done. The business of waiting on one hand and of watching on the other went on. By the first day of the year 1805 the French fleet had risen to eleven sail-of-the-line, and eight frigates, on board of which a large number of troops had embarked, and nothing hindered Villeneuve from sailing but the presence of the British.

Meanwhile—that is to say, on the preceding 5th of October, 1804—there had occurred an incident that proved of extraordinary significance. In the declaration of war against France by the British Government, Holland was included, but not Spain. News, however, later *on* came to hand that a large Spanish force was collected in the port of Ferrol, and that a junction with the French was to be expected. Nelson received a secret Admiralty letter, in which were enclosed instructions to Admiral

Cornwallis to continue the blockade of Ferrol and to resist or deal with any hostile attempts on the part of Spain against the King of Great Britain's dominions. On this Captain Sir Richard Strachan, of the *Donegal*, was instructed to proceed immediately outside the Strait of Gibraltar, with the *Medusa*, *Amphion*, *Sophia*, and *Halcyon*, to intercept four Spanish frigates laden with specie and bound to Ferrol from Monte Video. They were fallen in with and hailed, and as the answers returned were not satisfactory, they were fired into. One of them blew up, the other three surrendered. Their value amounted to about a million of money. "The frigate," wrote Captain Sutton, of the *Amphion*, to Lady Hamilton on his arrival at Plymouth, "I was opposed to, took fire and blew up in action. I could only save one officer and forty-four men. Thirteen ladies, passengers from South America, were lost in the ship." The Spanish Government at once gave orders to make reprisals on English property, but it was not until the 12th of December that the King of Spain formally declared war against Great Britain.

Some time before this formal declaration of war, Vice-Admiral Sir John Orde was sent out as Commander-in-chief of a squadron off Cadiz. Nelson at this time had received no intelligence of the British Government's resolution to commence hostilities against Spain, and it was five weeks after Sir John Orde had been stationed before Cadiz that Nelson heard of his being in those seas. The prizes taken by Orde and his ships were rich and numerous. In a month the money thus earned enriched the Ad-

miral and *his officers for life*. Never could a greater wrong have been *done* to any man *in* Nelson's position. It is indeed one of the few insufferable passages of British maritime annals. If anything could have crushed the spirit *of this great* man, impaired his magnificent patriotism, weakened his superb quality of dutifulness to his King and to his Country, it was this. "Surely," he exclaims to Lady Hamilton, writing under the belief that Orde (a person he strongly disliked, and with good reason) had been sent out to take the command from him, "I never served faithfully, I have only dreamt I have done my duty to the advantage of my country." But his noble heart rises above all considerations of self. "The world," he says, in the same letter, "will see what a sacrifice I am ready to make for the service of my King and Country, for what greater sacrifice could I make than serving for a moment under Sir John Orde?" Coleridge has eloquently commented on this wretched business. "It was indeed an unexampled circumstance that a small squadron should be sent to the station which had been long occupied by a large fleet, commanded by the Darling of the Navy and the glory of the British Empire ; to the station where this fleet had for years been wearing away in the most barren, repulsive, and spirit-trying service in which the Navy can be employed ! And that this minor squadron should be sent independent of, and without any communication with, the commander of the former fleet, for the express and solitary purpose of stepping between it and the

Spanish prizes, and, as soon as this short and pleasant service was performed, of bringing home the unshared booty with all possible caution and dispatch. ^H And he quotes Nelson's affecting sentences: "It was not enough to have robbed me once before of my West-India harvest—now they have taken away the Spanish,—and under what circumstances, and with what pointed aggravation! Yet, if I know my own thoughts, it is not for myself or on my own account chiefly that I feel the sting and the disappointment: no! It is for my brave officers; for my noble-minded friends and commanders—such a gallant set of fellows! Such a band of brothers! My heart swells at the thought of them." *

He was again off Toulon, in the early part of January, 1805. On the nth the fleet anchored in Agincourt Sound, Nelson's baiting-haunt in the Magdalena Islands, leaving the frigates *Active* and *Seahorse* to watch the enemy's port. His force at this time consisted of eleven sail-of-the-line. On the 17th the French fleet put to sea from Toulon. It consisted of four 80's and seven 74's, together with seven frigates and two brigs; the whole under the command of Vice-Admiral Villeneuve, amongst whose ships there was also distributed a body of 3,500 troops, under General Lauriston. The enemy was descried by the *Active* and the *Seahorse*, and these frigates by carrying a press of sail were by about two o'clock on the 19th able by a distant signal to notify to Nelson that the French were

* "The Friend," Bonn's edition.

at sea. At half-past four the English fleet were under sail. It was almost dark, and a strong breeze of wind was blowing from the westward, against which the ships could not work. The alternative then must be a choice of the complex eastern passages, which open into the Tuscan Sea. The night had settled down black, but Nelson did not hesitate. The *Victory* took the lead with a light on her stern, and led the way in safety through a channel, whose breadth was less than a quarter of a mile. This is a picture to remember: the sullen loom of the Biocian and Sardinian rocks, on either hand; the narrow space of dark waters, flashful with leaps of pallid froth to the whipping of the strong wind howling through the channel; the towering forms of the British ships in line ahead, sweeping in a phantom-like procession after that heap of windy faintness of lofty canvas denoting the *Victory*, upon whose quarter-deck paces the restless figure of Nelson!

His progress was arrested by a heavy gale on the 20th. He despatched frigates, but could obtain no information. "What would I give to know where they are bound to, or to see them!" he says, in a letter to Sir Alexander Ball. "The result of meeting I should be a wretch to doubt." His conviction was, that the enemy's destination was Egypt. He was now renewing an old and bitter experience of anxiety; once again scouring the Mediterranean for the French, as he had before swept those blue waters ere lighting on the foe in Aboukir Bay. On February the 18th he tells Lady Hamilton that he has already traversed one thousand leagues of sea

after the French. Then for three weeks came a succession of gales, the worst weather, he declared, he had ever seen, and on the 8th of March he was at anchor again in the Gulf of Palmas.

In the meantime the French, after quitting Toulon, encountered much the same sort of weather that had distracted Nelson, and most of them had been driven, on or about the 20th of February, back to their port with much damage to their masts and rigging. Villeneuve lost no time in refitting. By the time he was ready to sail, his force consisted of eleven line-of-battle ships, six frigates, and two brigs. On the 15th Nelson was again in his old winter station to the eastward of Cape San Sebastian, and on the 27th returned to the Gulf of Palmas, where the victuallers and store-ships were lying. Two days later Villeneuve once more set sail from Toulon Road with the whole of his fleet.

The Rev. Dr. Scott's diary briefly hints at Nelson's movements during this harassing period. On April the 27th he writes that he has just come on board his sea-house, the *Victory* (he is speaking of himself), and that the latest news is that the French have sailed from Toulon. On April the 28th the British are off Alicante; on May the 4th they are in Tetuan Bay, and on the 6th in the harbor of Gibraltar. An instance of Nelson's sagacity and alertness is given when the ships were still refitting in Mazari Bay.* The officers and men had gone ashore, and the linen was landed to be washed. Nelson, ever on the look-out for a fair wind, per-

* According to James, though Scott says Gibraltar.

ceived indications of a change. A gun was fired from the *Victory*[^] and Blue Peter sent aloft, whilst Nelson hurriedly paced the deck, full of temper and impatient of a moment's delay. The officers who were ashore exclaimed, "Here is one of Nelson's mad pranks," but he proved right nevertheless; a fair wind blew, the linen was left on shore, and the ships sailed away.*

By this time Nelson was persuaded that the French had sailed to the West Indies, and he resolved at all risks to follow them. His chaplain tells us that there was a variety of opinion as to the route the enemy had taken, many believing that he had gone to Ireland. "If I fail," said Nelson to Dr. Scott,— "if they are not gone to the West Indies, I shall be blamed; to be burnt in *efhgy* or Westminster Abbey is my alternative!" At six o'clock on the evening of the 7th of May he weighed from Rozia Bay, Gibraltar, and went away through the Gut with a fine easterly wind. On the 10th he anchored in Lagos Bay, where he took in five months' provisions, and sailed again on the nth with ten ships of the line and three frigates in chase of the enemy's fleet, which he knew consisted of eighteen ships of the line and at least three times his number of frigates.

Nothing of moment happened during the run across the Atlantic. It is characteristic of Nelson that having to take a large land-force afloat he would not suffer any distinction in the allowance between soldiers and sailors. The custom was to serve out

* "Recollections," 171.

one pound of meat a *day* to the seamen and three quarters of a pound only to the soldiers, but Nelson's orders were that so long as the troops were under his command the rations to the two services should be equal. The fleet anchored in Carlisle Bay, Barbadoes, on the 4th of June. His pursuit of the enemy was a succession of disappointments. He heard of the French as bound to Tobago and Trinidad, took on board two thousand troops, and weighed, only to learn that he had been misled. For this disappointment he had to thank General Brereton, who had communicated to him the emphatic assurance "that twenty-eight sail of the enemy's fleet had passed to windward of Gros Islet."

On the 6th of June the English fleet arrived off Great Courland Bay, Tobago, where all was bustle and distress. One of the merchants, desperately anxious to ascertain whether the congregation of ships which had hove in sight were a friend or enemy, despatched his clerk in a small schooner with instructions to reconnoitre the men-of-war. As extraordinary a coincidence as ever happened at sea followed; the signal made by the clerk exactly corresponded with the affirmative signal which had been agreed on to inform the British of the enemy being at Trinidad. The evening was closing round, and the mistake was not discovered. The news flew throughout the British ships, every vessel was ready for action by daybreak, and Nelson confidently anticipated a second Aboukir in the Bay of Paria. Clarke and M'Arthur, who tell this story, add that **Nelson and** his officers were almost persuaded to

doubt the evidence of their senses when on entering the Gulf of Paria they not only saw there was no enemy, but learned that the French fleet had never been there.* Nelson's irritation was extreme, and the name of Brereton haunted his mind like a malediction. "If either General Brereton," he tells Lord Robert Fitzgerald, "could not have wrote or his look-out man had been blind nothing could have prevented my fighting them on June the 6th; but such information and from such a quarter close to the enemy could not be doubted."

In the first week of June Villeneuve had learnt that Nelson had arrived in the West Indies in search of him. The force under the British Admiral was greatly exaggerated, and Villeneuve, much alarmed, on the 9th or 10th of the month, hastily embarked all the troops which had been withdrawn from Martinique and Guadaloupe, and shortly afterwards, with the combined squadrons, set sail for Europe. Nelson pursued him. A fragmentary narrative of the chase may be obtained from his correspondence and dispatches. It was on June the 13th that he came to the conclusion the enemy was on his way home. He followed, but never came within sight of the foe. Indeed the information he obtained was of the scantiest. He flattered himself that he was within eighty leagues of the two squadrons and kept thrashing his ships through it, whilst the wind continued to blow, under every stitch that could be stretched upon their yards. On the 18th a little American schooner called the *Sally* was spoken

*Vol. ii., p. 409.

and afterwards boarded. She had apparently news of importance to communicate ; an entry in her log-book, dated two days previously, stated that twenty-two sail of large ships had been sighted to the eastward standing on a northerly course, and the Yankee skipper wrote down that he supposed them to be the French fleet from Martinique going home. Both he and his mate went to the mast-head of the schooner to take a view of the distant clouds of canvas, and were positive that they were men-of-war having royals, stay-sails, and all sails set, showing as low as the heads of the courses. But the wind slackened ; Nelson's squadron was bothered with light and variable airs. On the 21st he wrote in his private diary: "Midnight, nearly calm, saw three planks, which I think come from the French Fleet. Very miserable, which is very foolish." So for days: nothing but light breezes. He writes to the captains of his ships to come and dine with him, " For I 've too much fear that we shall not have a wind to move us faster than Boats can pass." We can figure the mortification and bitterness with which he writes down in his private diary on the 8th of July: " We crawled 35 miles the last 24 hours; my only hope is that the Enemy's Fleet are near us and in the same situation." The day before Cape Spartel hove in sight he notes that the whole run " from Barbuda day by day was 3459 miles," and that the average per day was thirty-four leagues, wanting nine miles.

On the day following the date of this entry the combined squadrons arrived off Cape Finisterre, and on the 19th the British fleet arrived in Gibraltar

Bay. " I went on shore," writes Nelson in his private diary on the 20th, " for the first time since the 16th of June, 1803 ; and from having my foot out of the *Victory* two years wanting ten days." One cannot but muse a moment on such a statement as this. Two years all but ten days of shipboard, and of such shipboard as was then afloat! Except the instance of Collingwood, and what is there in the annals that can be found in any degree to correspond with the marvellous spirit of devotion exhibited in this long term of voluntary imprisonment ? To appreciate the magnanimous patriotism which inspired and governed him, we should read his correspondence with Lady Hamilton during those two years; remember the fascination the beautiful woman had for him, how his heart yearned to return to her, with what passionate eagerness he desired a sight of his beloved little Horatia; and we must contrast what he knew awaited him at Merton with the dull and grinding routine of the blockading life. His bad health, too, is to be remembered; and the wound that had been dealt his pride and his affection for his shipmates and companions, through Sir John Orde, was a constant pain. Add the bitter anxieties of the period of the Toulon blockade to the yet bitterer anxieties which followed upon the escape of the French fleet, and the prodigious weight of responsibility which must attend his determination to measure **the** breadth of the Atlantic in pursuit of the recreant foe. Noble as Nelson always was, never in **the** glorious hour of decisive victory does he show **more** nobly than during **those two years of hard servi-**



NELSON'S MONUMENT AT LIVERPOOL.

(FROM AN OLD ENGRAVING.)

tude, of trials, disappointments, worries, injurious usage, and of absention from all the comforts, refinements, and elegancies of the life he might have led ashore.

An incident that has the character of a passage in a marine romance occurred during this great ocean chase. Much about the 3d of August, after having passed the Straits for Cape St. Vincent, the fleet fell in with an American merchant ship, the captain of which possessed a log-book that he had removed from an abandoned and fire-blackened hulk. There were also found a few seamen's jackets in the cabin. Nelson inspected the things, and observed that the last entry of the log-book contained these words: "Two large vessels in the W. N. W.," from which he inferred that the derelict had been a Liverpool privateer, cruising off the Western Islands. Whilst the log-book was being handled, a scrap of dirty paper covered with figures fell out of it. "These are French figures," exclaimed Nelson, and presently added: "I can explain the whole! The jackets are of French manufacture, and prove that the privateer was in possession of the enemy. She had been chased and taken by the two ships that were seen in the W. N. W. The prizemaster, going on board in a hurry, forgot to take with him his reckoning; there is none in the log-book, and the dirty paper contains his work for the number of days since the privateer left Corvo, with an unaccounted-for run, which I take to have been the chase, in his endeavour to find out his situation by back-reckoning. By some mismanagement, I conclude she was run on board by one of

the enemy's ships and dismasted. Not liking delay—for I am satisfied that those two ships were the advanced ones of the French squadron—and fancying we were close at their heels, they set fire to the vessel, and abandoned her in a hurry." The sagacity of this speculation finds confirmation in the conjecture of the historian : that the log-book was that of the Liverpool privateer *Mars*, which had been captured, and that the scrap of paper was in the handwriting of a Spaniard. " Whichever way it was, the inference remained just as the Vice-Admiral had drawn it, that the capturing fleet had steered to the northward.*

*James. III., 355.

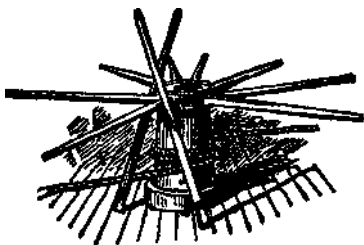



CHAPTER XVIII.

Arrival in England—Sir Arthur Wellesley—George III.—Lord Sidmouth's story—Keats's anecdote of Nelson—Interview with Blackwood—Lady Hamilton's fanciful story—At Portsmouth—Junction at Cadiz—Strength of British fleet—The combined fleets—Beatty's account of Nelson—Blackwood to his wife—Nelson to his child—The enemy sails.

IN the 15th of August, Nelson joined Admiral Cornwallis off Ushant, and on the same evening resumed his passage to Portsmouth in the *Victory*, accompanied by the *Superb*. On the 18th he anchored at Spithead and after a brief term of quarantine struck his flag. He arrived at Merton on the morning of the 20th, and remained there till the 13th of the following month. There are but few memorials of this brief holiday. It is stated that before he quitted London to rejoin the fleet he called at Mr. Peddieson's, an upholsterer, in Brewer Street, who had charge of the coffin formed out of the wood of *L'Orient*, and with an air of gaiety and good temper requested that an attestation of its identity should be engraved on the lid, adding, "I

think it highly probable that I may want it on my return." Three days after his arrival at Merton, a meeting of West India merchants was convened, and it was agreed that a deputation should wait upon the Admiral to express the grateful acknowledgments of every individual connected with the West Indian colonies for his prompt determination to quit the Mediterranean in search of the French fleet, for his sagacity in ascertaining their course, and for his bold and unwearied pursuit of the enemy, by which the safety of the West India Islands in general was secured.

It was during this period that Nelson is said to have met the Duke of Wellington, then Sir Arthur Wellesley. Sir Arthur had recently returned from his campaign in India. Nelson was in the waiting-room of the Secretary of State when Wellesley entered. The Admiral did not know him, but the numerous portraits of Nelson would have long before rendered his features familiar to the future great Field-Marshal. They had some time to wait, and were soon engaged in conversation. The news of Sir Robert Calder's action had just been received—an action disastrous to the career, though not to the reputation, of Sir Robert, but of immeasurable importance to the security of our coasts *—and Sir Arthur Wellesley said to Nelson: "This measure of success won't do nowadays—for your Lordship has taught the public to expect something more brill-

* It diverted the enemy from the Channel to Cadiz, out of which **they** were starved into hostilities. But for Calder, Trafalgar never **would have** been fought—whatever else might have happened.

iant." Shortly after this Nelsoji left the room, presumably to ascertain who his new friend was; but quickly returned and started the conversation on a fresh footing. He had some project in his mind for occupying Sardinia, and he wanted Sir Arthur to take charge of the troops on that occasion, but Wellesley replied that he would rather not—that he had just returned from India,—in short he did not enter into Nelson's view. Soon after this the Hero sailed, and needless to say these two great men—the one Buonaparte's destroyer by sea, the other his extinguisher by land—never met again.*

We have it, on the authority of Brenton, that the last interview between George III. and Nelson "was anything but satisfactory to the latter." He asserts that the King never exchanged a word with Nelson at the levee at Buckingham House after the affair at Boulogne. Whether it was the death of Caracciolo or Nelson's relations with Lady Hamilton which displeased his Majesty, Brenton is unable to decide, but the fact is certain. "The King wished to have seen him, and sent a message to him to that effect

* *Edinburgh Review*, 1838, 331, 332. The passage occurs in a review of Barrow's "Life of Earl Howe," and the writer adds: "How gratifying and instructive would it not be if we could obtain an account of the whole of the conversation, of which we have gathered merely the above small but authentic particulars!" Wellington, in referring to this meeting (at Walmer, in October, 1834), spoke of Nelson's conversation as all about himself, "and in really a style so vain and so silly as to surprise me. I suppose something that I happened to say made him guess that I was somebody, and he went out of the room for a moment, I have no doubt to ask the office-keeper *who I was*, for when he came back he was altogether a **different** man, both in manner and matter."

just before Nelson sailed from England to take the command of the fleet off Cadiz ; but the letter never reached him till he arrived on the last scene of his earthly glory." *

It is remarkable that long before Nelson sailed he should have thoroughly digested those very manoeuvres which subsequently resulted in the overwhelming defeat of the combined fleets of France and Spain. He had, no doubt—true to his old custom,—reviewed in his mind, during the many lonely hours he had spent in blockading and in chasing, every imaginable posture in which the enemy could offer himself; but it is astonishing to find human sagacity rising into absolute prophecy, as assuredly happened in the case of Nelson, who appears to have anticipated the exact order in which the confederated foe would appear. It is told in Dean Pellew's " Life of Lord Sidmouth " that, shortly before Nelson's departure, Lord Sidmouth wrote to ask him to take Richmond Park, on his way from Merton to London. Nelson sent this answer: " On Tuesday forenoon, if Superior Powers do not prevent me, I will be in Richmond Park, and shall be happy in taking you by the hand and to wish you a most perfect restoration to health." This was the last letter Lord Sidmouth ever received from his illustrious friend ; he cherished it greatly, and wrote thus at

* " Life of St. Vincent," vol. ii . , p. 48. Much that Brenton tells he collects from loose naval talk. Yet there is a foundation for most of his statements, and he is worth attention for that reason. It is doubtful whether he is not confusing the King with the Prince of Wales. The latter certainly invited Nelson to Carlton House, **before he sailed, to bid him farewell.**

the foot of it: " Lord Nelson came on that day, and passed some hours at Richmond Park. This was our last meeting." In after years he used to relate to his friends the particulars of this interview. There was a little study-table in the room ; Nelson went to it and scored diagrams upon it with his finger, to explain the manner in which, if the combined fleets offered to fight him, he proposed to attack them. " Rodney," he said, " broke the line in one point; I will break it in two."—" There," Lord Sidmouth said,— " There is the table on which he drew the plan of the battle of Trafalgar, but five weeks before his death. It is strange that I should have used this valued relic for above thirty years without having once thought of recording upon it a fact so interesting. Now I have perpetuated it by this brief record: —

" ' On the 10th day of September, 1805, Vice-Admiral Lord Viscount Nelson described to Lord Sidmouth, upon this table, the manner in which he intended to engage the combined Fleets of France and Spain, which he expected shortly to meet. He stated that he should attack them in two lines, led by himself and Admiral Collingwood, and felt confident that he should capture either their van and centre, or their centre and rear. This he successfully effected, on the 21st of October, following, in the glorious Battle of Trafalgar"

There is another anecdote which illustrates his far-sightedness. In the few brief days he spent at Merton he was visited by his friend Keats (afterwards Admiral Sir Richard Keats) and whilst they were walking in the grounds talking on naval mat-

ters he exclaimed : " No day can be long enough to arrange a couple of Fleets and fight a decisive Battle according to the old system. When *we* meet them (Keats was to have been with him), for meet them we shall, I 'll tell you how I shall fight. I shall form the Fleet into three Divisions in three Lines. One Division shall be composed of twelve or fourteen of the fastest two-decked ships, which I shall keep always to windward, or in a situation of advantage; and I shall put them under an Officer who I am sure would employ them in the manner I wish, if possible. I consider it will always be in my power to throw them into Battle in any part I may choose ; but if circumstances prevent their being carried against the Enemy where I desire, I shall feel certain he will employ them effectually, and perhaps in a more advantageous manner than if he could have followed my orders. With the remaining part of the fleet formed in two lines, I shall *go* at them at once if I can, about one third of their line from their leading ship. What do you think of it ? " His companion paused. " But I 'll tell you what I think of it," broke in Nelson, " I think it will surprise and confound the enemy. They won't know what I am about. It will bring forward a pell-mell Battle, and **that** is what I want."*

On the 2d of September, Captain Henry Blackwood arrived in London with important news for the Admiralty. He had been despatched from **the** Irish station by Admiral Drury, with **instructions to**

* Quoted by Nicolas. Vol. vii., p. 241.

trace the movements of the combined fleets under Villeneuve and Gravina, who had put to sea from Ferrol after the action with Sir Robert Calder off Finisterre. Blackwood watched them into Cadiz, then after a passage of five days arrived in England to report the fact. On his way to London he called at Merton. The hour was about *five* in the morning, but Nelson was already up. He instantly exclaimed to Blackwood: "I am sure you bring me news of the French and Spanish fleets and I think I shall yet have to meet them." He followed Blackwood to London and several times said to him when they again met, on speaking of the operations he contemplated on returning to the Mediterranean: "Depend on it, Blackwood, I shall yet give Mr. Villeneuve a drubbing."*

In Harrison's "Life of Lord Nelson" this anecdote, which is unquestionably authentic, is very dramatically amplified. It is there related that Captain Blackwood's account of the enemy's fleet "was nothing to Nelson, who exclaimed: "*Let the man trudge it, who has lost his budget!*" But though he said this gaily, Lady Hamilton observed that his countenance fell and wore an air of gloom. He went for a walk with her in one of the paths of Merton Garden, which he always called the Quarter-deck, and she told him that she perceived he was low and uneasy. "No," he answered with a smile, "I am as happy as possible," adding "that he saw himself

* *Blackwood's Magazine*, 1833. All that relates to Blackwood in these pages is quoted from the memoir of him and his letters in that journal, with Nicolas's corrections of the correspondence.

surrounded by his family; that he found his health better since he had been at Merton; and that he would not give a sixpence to call the King his uncle/' To this Lady Hamilton replied: "That she did not believe what he said, and that she would tell him what was the matter with him; that he was longing to get at these French and Spanish fleets; that he considered them as his own property, and would be miserable if any other man than himself did the business; that he must have them, as the price and reward of his long watching, and two years' uncomfortable situation in the Mediterranean." And she finished by saying: "Nelson, however we may lament your absence, and your so speedily leaving us, offer your services, immediately, to go off Cadiz; they will be accepted, and you will gain a quiet heart by it. You will have a glorious victory; and then you may come here, have your *otium cum dignitate*, and be happy." He looked at her for some moments in silence, and then, with tears in his eyes, exclaimed: "Brave Emma! Good Emma! If there were more Emmas there would be more Nelsons; you have penetrated my thoughts. I wish all you say, but was afraid to trust even myself with reflecting on the subject. However, I will go to town."

The reader must exert his *own* judgment *In accepting* this. It was dictated to Harrison by Lady **Hamilton** some time after Lord Nelson's death, **when** she was sparing no effort to obtain from an **ungrateful** country those rewards which she professed to consider she had as fully earned as Nelson **himself**.

Whether because of, or in spite of, his "Guardian

Angel," Nelson was now all eagerness to get at the combined fleets. He was apprehensive of nothing but an insufficiency of ships; concerned lest the Admiralty should supply him with a force within at least fifteen or sixteen sail-of-the-line of the enemy; so that if every British ship took her opponent there would be still a fleet of fifteen or sixteen sail-of-the-line fresh and untouched to fight. "But I will do my best," he wrote to Mr. Davison, "and I hope God Almighty will go with me. I have much to lose, but little to gain; and I go because it is right, and I will serve the country faithfully." He left Merton on the night of Friday, September the 13th, at half-past ten; but before quitting the house he went to the bedroom in which his child Horatia lay sleeping, and kneeling down by the little girl's bedside, earnestly prayed that God would bless and protect her. He then bade Lady Hamilton farewell, entered the post-chaise, and started for Portsmouth. His private diary contained this entry: "Friday, Sept. 13th, 1805. Friday night, at half-past ten drove from dear dear Merton, where I left all which I hold dear in this world, to go to serve my King and Country. May the great God whom I adore, enable me to fulfil the expectations of my country, and if it is His good Pleasure that I should return, my thanks will never cease being offered up to the throne of His Mercy. If it is His good providence to cut short my days upon earth, I bow with the greatest submission, relying that He will protect those so dear to me that I may leave behind. His **will be done.** Amen, Amen, Amen."

He arrived at the George Inn, Portsmouth—the room may be seen where he breakfasted before going on board the *Victory*—at six o'clock on the morning of September the 14th. There is a tradition that, to escape the crowd which filled the street in front of the inn, he made his way out through a back door. It is certain, at all events, if Southey is to be credited, that crowds were waiting on the beach to witness his embarkation. They followed him to the very wash of the water, "pressing forward to obtain sight of his face: many were in tears, and many knelt down before him, and blessed him as he passed. England," continues Southey, "has had many heroes, but never one who so entirely possessed the love of his fellow-countrymen as Nelson. All men knew that his heart was as humane as it was fearless; that there was not in his nature the slightest alloy of selfishness or cupidity; but that with perfect and entire devotion he served his country with all his heart and with all his soul, and with all his strength: and therefore they loved him as truly and as fervidly as he loved England." The behaviour of the crowd caused him to say to Captain Hardy: "I had their huzzas before—I have their hearts now."

On the 18th, the *Victory* was joined by the *Ajax* and the *Thunderer*, and on the 26th, Nelson despatched Blackwood in the *Euryalus* to inform Lord Collingwood of his approach, and to direct that when he joined the fleet and assumed command there should be no demonstration of salutes or of flags, that the enemy might be kept in ignorance of the arrival of a reinforcement. According to the log of

the *Victory*, she joined the fleet off Cadiz on the evening of the 28th of September. Though there were no salutes and no rejoicing colours flown, Nelson's reception by the people under him was one of such demonstrative enthusiasm as keenly delighted him. It caused him, to use his own words, " the sweetest sensation of my life. The officers who came on board to welcome my return forgot my rank as Commander-in-chief in the enthusiasm with which they greeted me. As soon as these emotions were passed, I laid before them the plan I had previously arranged for attacking the enemy ; and it was not only my pleasure to find it generally approved, but clearly perceived and understood." He also wrote to Lady Hamilton about the welcome he received from Collingwood—his old friend Coll—down to the humblest individual in the ships. " When," he says, " I came to explain to them the '*Nelson Touchy*' it was like an electric shock. Some shed tears, all approved — * It was new — it was singular—it was simple !' and, from Admirals downwards it was repeated—' It must succeed, if ever they will allow us to get at them ! You are, my Lord, surrounded by friends whom you inspire with confidence.' " *

The force under him consisted of twenty-seven sail-of-the-line, twenty-two of which were cruising about fifteen miles off Cadiz ; the remaining five, under Rear-Admiral Louis in the *Canopus*, were stationed close off the harbour, where they watched the motions of the combined forces. Such was the

* " *Dispatches and Letters*," vol. vii., p. 60.

disposition of the fleet at this time. But Nelson's object was to court Villeneuve and Gravina out of their nest by leading them to suppose his force much weaker than theirs. He therefore withdrew to a distance of about eighteen leagues west of Cadiz, leaving the task of watching the enemy to the two frigates Euryalus and Hydra, between which and the main body of the fleet, out of sight below the horizon, were stationed three or four sail-of-the-line at distances which enabled them to transmit the signals made by the inshore frigates.

On the 1st of October it was communicated to Nelson that there were thirty-four ships of the line (eighteen French and sixteen Spanish), with four frigates and two brigs, lying ready for sea in the outer harbour of Cadiz. Next day Blackwood was able to send word that there had been a great deal of bustle and movement among the enemy ; that all capable of serving had been sent on board the ships, and that the French troops which had landed were re-embarked. On the 4th, the two British frigates were attacked by some Spanish gun-boats which came sweeping out over the almost breathless water, but they made haste to retire after a few useless shots had been exchanged. Blackwood's duties were extraordinarily tedious, exacting, and anxious, but he discharged them magnificently. His gaze at the enemy was of a lynx-eyed steadfastness. Every motion was perceived and reported. " I rely on you," wrote Nelson to him on the 10th, " that we can't miss getting hold of them, and I will give them such a shaking as they never yet experienced;

at least, I will lay down my life in the attempt." It was felt, however, that the combined fleets could not much longer remain in port. The crews of so many ships made a huge crowd to feed, and the stock of provisions at Cadiz was rapidly failing. Buonaparte, in anticipation of some such a heavy demand as this upon the stores of the place, had ordered shipments to be made at Nantes, Bordeaux, and several Biscayan ports. The carriers sailed under Danish colours, and landed their cargoes at little places betwixt Algecir.is and Santa-Maria, whence they were uninterruptedly conveyed to Cadiz. This was a traffic to be checked, that hunger might provide the French and Spanish with stomach enough for a fight. A reinforcement of five British frigates rendered blockading easy and incessant, and the conveyance of stores to Cadiz, if not entirely stopped, was so far interrupted as to yield good assurance to Nelson that the enemy must soon show himself.*

Dr., afterwards Sir William, Beatty, who was surgeon in the *Victory*, has a good deal to tell about Nelson's personal habits and characteristics, referable, in the main, to this time when he was cruising off Cape Trafalgar. He seems to have been very strongly persuaded that he would be killed if there was a battle, and on several occasions told Captain Hardy that he wished, if his body were conveyed to England to be buried at the public expense, to lie in St. Paul's Cathedral rather than in Westminster

* 4¹ The stoppage of these supplies by the extension of the blockade left the combined fleets in a state of privation, which at last compelled them to put to sea."—"Memoir of Collingwood," p. i n .

Abbey. He had a somewhat odd reason to give for this choice : namely, that when he was a boy he used to hear it talked of as an old tradition that Westminster Abbey was built on land which was once a deep morass, and he considered it very likely that the soil, in the course of ages, would again become a swamp, into which the Abbey would sink without leaving a trace behind it. Failing a public funeral, it was his wish to be buried by the side of his father at Burnham Thorpe. Beatty tells us that Nelson took much exercise, generally walking the deck for six or seven hours in the day. He rose and breakfasted very early, and when on deck, if a thought suddenly occurred to him, he would at once go to his cabin to commit it to paper lest his memory should lose it. Dinner on board the *Victory* was served at half-past two, and the company consisted of seldom less than eight or nine persons,—officers of the ship; but when the weather permitted, the admirals and captains of the fleet were invited by signal to join the party, the invitations being governed by rotation of seniority. Beatty found Nelson as a host as affable, courteous, and laughter-loving as Colonel Stewart had; attentive to every one, but a sparing eater himself, often dining off a fragment of fowl and a plate of macaroni. His drink appears to have been champagne, but he never exceeded four glasses, which he would sometimes dilute with mineral or common water. Such was the wonderful activity of his mind that he rarely slept uninterruptedly for more than two hours at a time. Again and again he would spring from his cot to

make inquiries and learn what was going on above him and around in the fleet, and on several occasions he would mount on deck and remain there, pacing it the whole night through. Yet, sufferer as he was in health, he was at no pains whatever to cherish himself; he would quit his cabin on a wet night with only a thin coat on, and when soaked through and through he would refuse to allow his clothes to be changed, asserting that the leather waistcoat which he wore over his flannel one would protect him from all effects of damp. He objected to boots, and was repeatedly getting his feet wet. At such times he would enter his cabin, kick his shoes off, and walk on the carpet in his stockings to dry them. This he did rather than give his servants the trouble of drawing on clean stockings; for it must be remembered that Nelson had but one hand and could but assist himself in part only.

It is by personal descriptions of this kind that one gets to see and know the man as he showed and was known to those who beheld him in the flesh.

The combined fleet started to unmoor at seven o'clock in the morning, on Saturday, the 19th of October, but the wind was weak and twelve ships only succeeded in floating out of the harbour on that day. Blackwood, watching them from the deck of the *Euryalus*, can yet find a spare five minutes to write a letter to his wife. "What think you, my own dearest love?" he exclaims with a sort of joyous enthusiasm in the ring of the sentences he scores down. "At this moment the enemy are coming out, and as if determined to have a fair fight; all

night they have been making signals, and the morning showed them to us getting under way. . . . You see also, my Harriett, I have time to write to you. . . . It is very odd how I have been dreaming all night of my carrying home dispatches. God send so much good luck!"* It was signalled that the enemy were coming out of port. The *Victory* was at that time with the main body of the fleet some fifty miles W.S.W. of Cadiz; the wind a light air, and southerly. Instantly flew a signal for a "General Chase S.E."—that is, towards the Strait of Gibraltar, for at all costs the enemy must be hindered from entering the Mediterranean.

The universal impression was that there would be a battle that day, and Nelson, entering his cabin, wrote two letters; one to Lady Hamilton, and the other to his child Horatia. He addresses the little girl as "my dearest angel," tells her that the combined fleets of the enemy are coming out of Cadiz, says he is sure of her prayers for his safety, conquest, and speedy return, and bids her be a good girl. To Lady Hamilton he writes: "My dearest beloved Emma, the dear friend of my bosom. The signal has been made that the enemy's Combined Fleet are coming out of Port. We have very little wind, so that I have no hopes of seeing them before to-morrow.

*Blackwood was not the only dreamer in that fleet. "There is a thing," wrote Lord Collingwood to his wife, December the 6th, 1805, "which has made a considerable impression upon me. A week before the war, at Morpeth, I dreamt distinctly many of the circumstances of our late battle off the enemy's port, and I believe I told you of it at the time . but I never dreamt that I was to be a **Peer** of the Realm."—"Collingwood's Correspondence," p. 161.

May the God of Battles crown my endeavours with success; at all events, I will take care that my name shall ever be most dear to you and Horatia, both of whom I love as much as my own life. And as my last writing before the battle will be to you, so I hope in God that I shall live to finish my letter after the Battle. May Heaven bless you, prays your Nelson and Bronte."

It is not in human nature to repress an emotion of bitterness on thinking of the unworthiness of the recipient of these noble, touching, beautiful words. Deeply could one have wished for the survival into this hour of the eve of conflict and victory, of the affection that had been his before the battle of the Nile, that the final utterances of the great heart which was soon to cease to beat should have been for the wife of his choice, for his early love, for her and her only!

After writing these letters Nelson went on deck, and at three o'clock the *Colossus* signalled that the enemy's fleet was at sea. An instance of the Hero's prevision here occurs. He knew that the hoops round the masts of the enemy's ships were painted black, whereas the lower masts of his own vessels were painted yellow, excepting only those of the *Belleisle* and *Polyphemus*, which had recently joined. There could be no better distinguishing mark amid the smoke and confusion of battle than black circles on masts, and the *Belleisle* and *Polyphemus* were at once instructed by telegraph to paint over the hoops, that their masts might be of a uniform colour and in correspondence with those of the rest of the British

ships.* A light breeze sprang up in the evening, and the twelve sail of the enemy bracing up stood away to the northward, with the two British frigates *Euryalus* and *Sirius* to windward of them following and watching.

The 20th of October was a Sunday, and at break of day that morning all the others of the combined fleet then in Cadiz weighed and put to sea with a light breeze from the south-east, and by three P.M. the whole mass of shipping had united and formed in *five* columns. Twenty-seven sail-of-the-line, distinctively termed the Line of Battle, were subdivided into three squadrons of seven ships each, the centre commanded by Villeneuve, the rear by Dumanoir, and the van by the Spanish Vice-Admiral Alava. The second or reserve body were divided into two squadrons of six ships each, the first under Gravina and the second under Magon. The British were out of sight, having approached close to the mouth of the Strait of Gibraltar; but at seven in the morning the *Phoebe* signalled the enemy as bearing north, and by noon the fleet were to the south-west of Cadiz, about twenty-five miles distant from it. Shortly afterwards the wind headed the ships, which at four o'clock put their helms up and came round on the port or larboard tack with their heads at about north. It seemed very evident that the enemy's emergence was a half-hearted affair, and

* "Painting ship *a la* Nelson" was a saying among the officers of the fleet. It was Nelson, I believe, who first introduced the black ports to break what were then the *yelloiv* bands along the ship's sides. At what period white took the place of yellow I do not know.

that the French and Spaniards were immovably fixed in their resolution to keep the port of Cadiz close aboard ; and Nelson, feverishly anxious to get at them and to intercept all possibility of a recoil on their part from his "Touch," telegraphed to the *Euryalus* that he relied upon Blackwood keeping sight of the enemy all night. So excellent was his arrangement of night signals, and so thoroughly were they understood by his captains, that throughout the long hours of darkness the movements of the combined fleet were as clearly followed on board the British ships as though they had been interpreted by telescopes in the daylight. Twice they wore as though in doubt, and Nelson's apprehension, lest they should effect a retreat before he could bring them to a general engagement, caused him to hold his ships well aloof, that the foe should not perceive them before daybreak, when escape might be difficult, if not impossible.





CHAPTER XIX.

A grand picture—Nelson's men—His dress before the battle—His prayer—Blackwood's suggestion—The famous signal—Collingwood—The *Royal Sovereign*—Anecdote of Rotheram—The *Victory* in action—Overwhelming fire—Nelson wounded—Scene of the cockpit—Nature of the wound—Hardy—Tenderness of nature in last moments—"Anchor, Hardy, Anchor!"—Nelson's death.

[HEN the dawn of Monday, the 21st of October, threw out the dark line of sea in the eastward, the Franco-Spanish fleet were to be seen in a close line of battle on the starboard tack, standing to the southward. The sun never rose upon a grander and more impressive ocean-picture. As the courses and hulls of the hindmost of the British vessels floated up the sea-line the blue girdle of the deep became a field of ships : giant structures bristling with guns, canvas swelling in clouds to the heavens from their tall black sides crowned with grim and formidable defences, crowds of sailors motionless in expectation, quarter-decks glittering with uniforms, sterns sparkling with gilt and the flash of great cabin windows, and a deep stillness everywhere, broken to the ears aboard the British only by the creaming wash of the bow-surge, shouldered off into yeast by

the thrust of the cut-water, as the towering liners, brave with bunting, rolled majestically onwards towards the concourse of giantesses awaiting them in the east. The horizon *there* seemed filled with the white spires of men-of-war. Towering amidst them was the huge fabric of the *Santissvna Trinidad* of a hundred and thirty guns. She had escaped the British grasp at St. Vincent, and there she loomed again, but now with the very blackest of fates awaiting her. There, too, were the *Principe de Asturias* and the *Santa Ana*, vast structures, grinning with the teeth of a hundred and twelve guns each, with crosses ready to dangle at their spanker-boom ends, and priests in plenty to exhort, to confess, and to offer the saints every encouragement of candle, and perhaps of dollars, to assist in the fight with those Heretics in the west, whose manner of approach was even now weakening the pulse of the gallant, honourable Villeneuve.

Little need to hold an Englishman vain-glorious, for supposing that there could have been no lack of misgiving and of apprehension amongst those Frenchmen and Spaniards as Nelson's fleet came lifting from royals to courses, and from courses to the water-line into the open morning of that famous October day. The approaching Admiral was one whose name had long become a terror to the enemies of his country. His captains were men of splendid record, of admirable seamanship, of unparalleled daring. His seamen were the children of a nation whose offspring were the finest breed of sailors **the** world had ever produced. There were

twenty-seven liners, three of one hundred guns, most of the rest of them of seventy-four; they were united by one common spirit; they were combined under one flag; they were about to fight for one cause—a great and a good cause—for their country and against tyranny, oppression, and wrong! They were as one ship and as one crew in sympathy, faith, enthusiasm, and resolution. But amongst the Dons, as their behaviour after defeat proved, there was no love for the French; and amongst the French there was but very little confidence in the Dons. No further spirit of unanimity was to be found amongst them than such as the law of self-defence and the desire to come off at all events with their lives would provide. Who can wonder that Villeneuve's heart sickened in him when he sent his glance from the British ships to the hulking craft on either hand, rolling under the ensigns of two nationalities, his own vessels filled with crews whose impiety and infidelity had extinguished in the devout and superstitious Spaniards even such poor sympathy for purposes of battle as might be found in a common faith?

Shortly after daybreak on the morning of the 21st, Nelson came on deck dressed in his Admiral's frock-coat, on the left breast of which were embroidered the orders he was privileged to wear. He was in excellent spirits, had been so indeed throughout the previous day, when, so it is recorded of him, being on the poop of the *Victory*, where a group of midshipmen were assembled, he addressed them with a smile: "This day or to-morrow will be *a*, fortunate **one** for you, young men," refer-

ring to their promotion. Beatty says he did not wear his sword, and that Trafalgar was the only action in which he ever appeared without one. "I will not be contented with capturing less than twenty sail-of-the-line," he told Hardy, and added, addressing others, that "the 21st of October was the happiest day in the year amongst his family," meaning by this that on that day of the month, in 1757, his uncle, Captain Suckling, was attacked by an overwhelming French force, and gallantly beat it off. Several times he had said to Hardy and his chaplain, Scott, that "the 21st of October will be our day." Almost as soon as he had left his cabin a signal was made on board the *Victory* for the captains of the frigates to come on board, and when Blackwood arrived Nelson's remark to him was, "I mean to bleed the captains of the frigates, so I shall keep you on board until the very last minute." After the signal had been made for bearing down upon the enemy in two lines, Nelson mounted the poop, where he could obtain a clear view of his fleet, and while there gave particular directions for the removal of his cabin fixtures. Amongst the furniture was a portrait of Lady Hamilton. "Take care of my guardian angel," he said to the persons employed in this work.

Shortly after this—at about eleven o'clock in the morning—he quitted the poop to withdraw to his cabin for a few minutes. Whilst he was below, Lieutenant Pasco, who, though senior lieutenant, acted as signal-lieutenant on board the *Victory*, went to Nelson's cabin to make a report, and also

to prefer a complaint, namely, that at the moment of so glorious an opportunity, he, despite his seniority, should be doing duty in an inferior station. On entering the cabin the Lieutenant found Nelson on his knees writing. This is what he was composing at that moment: "At daylight saw the Enemy's Combined Fleet from East to E. S. E.; bore away; made the signal for Order of Sailing, and to Prepare for Battle, the Enemy with their heads to the Southward, at Seven the Enemy wearing in succession. May the Great God, whom I worship, grant to my country, and for the benefit of Europe in general, a great and glorious Victory; and may no misconduct in any one tarnish it; and humanity after Victory be the predominant feature in the British fleet. For myself, individually, I commit my life to him who made me, and may His blessing light upon my endeavours for serving my Country faithfully. To Him I resign myself, and the just cause which is entrusted to me to defend. Amen. Amen. Amen." "He was then penning that beautiful prayer," said Lieutenant, afterwards Captain, Pasco. "I waited until he rose and communicated what I had to report, but could not at such moment disturb his mind with any grievances of mine."* Either before or immediately after Pasco's visit Nelson added that famous Codicil to his will, in which, after stating the services he truly believed that Lady Hamilton had rendered to Great Britain, he bequeathed her and Horatia as a legacy to his King and Country.

His anxiety to close with the enemy was consum-

* Communicated by Captain Pasco to Sir W. H. Nicolas.

ing. He admired in the combined fleet what he termed "the good face" they put upon it, but several times exclaimed: "I'll give them such a dressing as they never had before." The British fleet were now heading direct for the foe. The breeze was light, a long Atlantic swell was rolling in, and the enemy's line was somewhat disordered by it, insomuch that instead of being straight, it formed a curve or crescent. Their ships were under top-sails and top-gallant-sails, and lay with the weather leeches "lifting." The weak wind made the interval between the moment of sighting and the moment of conflict long, for the British vessels, even with studding-sails set, were scarcely moving at three knots in the hour. As the two forces slowly closed, Captain Blackwood, appreciating the value of such a life as Nelson's, suggested that he should go aboard the *Euryalus*, where he would be better able to see what was going forward. Nelson would not hear of it. Blackwood then suggested that one or two ships of the line should go ahead of the *Victory*, and lead her into action, that the enemy's attention might in some measure be withdrawn from the flag-ship. Nelson, smiling significantly as he looked at Hardy, exclaimed (referring to the *Tfinfraire* that was then close to the *Victory*), "Oh, yes, let her go ahead." The *T&niraire* was thereupon hailed to take her station in advance of the flag-ship. At that moment the lieutenant who commanded upon the *Victory's* fore-castle observed something wrong in the hoist or set of the lee-lower studding-sail, and ordered it to be hauled in that it might be hoisted afresh.

Nelson, perceiving this, imagined that the lieutenant's intention was to shorten sail, and running forward rated him severely for acting without orders. The studding-sail was immediately run up afresh, and the *Victory*, as Nelson had all along intended, continued to lead the column.*

It was some little time after Nelson had come up from his cabin, where he had been writing his Prayer and the Codicil to his Will which Blackwood and Hardy witnessed, that he ordered the famous Signal to the fleet to be made.† The hour by the *Naiad's* log is given as thirty-five minutes past eleven. The story has been variously told, but Pasco's may be accepted as the truest. He was on the poop when Nelson approached him, and after ordering certain signals to be flown, the Admiral exclaimed: "Mr. Pasco, I wish to say to the Fleet, ENGLAND CONFIDES THAT EVERY MAN WILL DO HIS DUTY." And he added: "You must be quick, for I have one more to make, which is for close action." Lieutenant Pasco replied: "If your Lordship will permit me to substitute the *expects* for *confides* the signal will soon be completed, because the word *expects* is in the vocabulary, and *confides* must be spelt." Nelson hastily, but with an air of satisfaction, said: "That

*This is given on the authority of James, who differs, but not very materially, from Beatty's and Blackwood's version of the incident.

† The Signal was by Sir Home Popham's Telegraphic Code, and ran thus:

Nos. 253 269 863 261 471 958 220 374 4 21 19 24.
England Expects That Every **Man** Will Do His D U T Y.

will do, Pasco, make it directly." * The colours conveying this sentiment were hoisted, and Captain Blackwood relates that the shout with which the memorable, noble signal was received throughout the fleet when its signification became fully known, was truly sublime. " Now," exclaimed Nelson, turning to Blackwood, " I can do no more. We must trust to the great Disposer of all events, and the justice of our cause. I thank God for this great opportunity of doing my duty."

The position of the two fleets about this time may be thus stated : the enemy's ships were lying-to with their heads to the north in two irregular lines, the vessels being mingled without regard to the nationalities. The British ships were sailing into the combined fleet in two columns, the one to windward led by Nelson in the *Victory*, the one to leeward by Collingwood in the *Royal Sovereign*. Next to the great Admiral at this moment Collingwood must needs be the most interesting figure in the fleet. His servant, a man named Smith, stated that he entered the Admiral's cabin at about daylight, and found him already up and dressing. " He asked if I had seen the French fleet; and on my replying that I had not, he told me to look out at them, adding that in a very short time we should see a very great deal more of them. I then observed a crowd of ships to leeward ; but I could not help looking with still greater interest at the Admiral, who during all this time was shaving

* " Letters and Dispatches," vol. vii., p. 150. James says that the signal first ordered by Nelson, was " *Nelson* expects every man to do his duty."—" *Naval History*," vol. iii., p. 392,

himself with a composure that quite astonished me." Collingwood is said to have dressed himself that morning with peculiar care. On meeting Lieutenant Claveli he advised him to pull off his boots. "You had better," he said, "put on silk stockings as I have done; for if one should get a shot in the leg they would be so much more manageable for the surgeon." He then made the rounds of the decks to encourage the men to the discharge of their duty, and addressing his officers, said to them: "Now, gentlemen, let us do something to-day which the world may talk of hereafter." Shortly after this the grand telegraphic signal to the fleet was flown aboard the *Victory*. Collingwood, not knowing at first what it meant, said, after glancing at it, that he wished Nelson would make *no* more signals, for they all understood what they were to do. But on the signal being interpreted to him, he expressed the highest delight and admiration of it, and desired that it should instantly be made known to the officers and ship's company.*

The *Royal Sovereign* led a mile in advance of the rest of the fleet, owing to the superior nimbleness of her heels, due probably to her copper being clean, as she had but lately returned from England. She was in consequence the first to get into action. All the men were ordered to lie down upon the decks as she swept under studding-sails into the foe. The signal for her was to pass through the enemy's line at the twelfth ship from the rear; but this vessel happened to be a two-deck ship, whilst the one ahead was a

* "Collingwood's Correspondence," 124.

first-rate with Admiral Alava's flag flying on board, and Collingwood went for her. The *Fougueux*, that was astern of the great Spanish *Santa Ana*, closed up to prevent the *Royal Sovereign* from going through the line; on which Collingwood told his captain (Rotheram*) to steer for the Frenchman and carry-away his bowsprit. To escape such a disaster the *Fougueux* backed her maintop-sail, but let fly some cannons as the *Royal Sovereign* swept past—the first thunder of the action! but with the exception of a gun or two to conceal his ship with smoke, Collingwood held the batteries of the *Royal Sovereign* silent until she had ranged abreast of the stern of the *Santa Ana*, when she discharged her whole broadside of double-shotted guns with such terrific effect that the Don's stern was beaten in and four hundred of her men killed and wounded! At the same moment she sent her starboard broadside, similarly double-shotted, into the *Fougueux*, receiving as she did so the whole weight of the *Santa Anas* metal, the furious storm of which caused the English battleship to heel two streaks out of the water,

Collingwood was at least twenty minutes in action alone before another English ship could support him. When Nelson saw the first of the battle-smoke rising from the contending craft he is said to have struck his hand on his thigh whilst he exclaimed: "Bravo!"

*The following story of Rotheram is told: A heavy shower of musketry nearly swept the deck of the *Royal Sovereign*. Some of the officers begged Rotheram not to expose himself so recklessly to the enemy's sharpshooters by wearing a gold-laced hat and his epaulets. *' Let me alone," answered Rotheram, " I have always fought in a **cocked hat and always will!**"

three times, adding, " What a glorious salute the *Royal Sovereign* is in ! " It was at this time that Collingwood said to his captain : " Rotheram, what would Nelson give to be here ? " whilst Nelson, on board the *Victory*, almost, as it is stated, at the moment of Collingwood's utterance, cried : " See how that noble fellow, Collingwood, carries his ship into action ! "

Captain Blackwood remained on board the *Victory* till a shot from the enemy flew over her. He was then, with Captain Prowse of the *Sirius*, requested to leave, and on his way to his frigate to tell all the captains of line-of-battle ships that Nelson depended on their exertions. " He then again desired me to go away," says Blackwood; " and as we were standing on the front of the poop I took his hand and said : * I trust, my Lord, that on my return to the *Victory*, which will be as soon as possible, I shall find your Lordship well and in possession of twenty prizes ' ; on which he made this reply: ' God bless you, Blackwood, I shall never speak to you again. "

With ensigns and jacks distributed about her rigging, and with the signal " *Engage the enemy more closely*," flying at her fore-royalmast-head,—two flags quarter red and white over white with the blue cross, signifying number 16,—the *Victory*, with studding-sails out on either side at the fore, slowly floated down upon the enemy, whose ensigns were now hoisted, whilst by this time at the spanker boom end of every Spanish ship there was dangling a great wooden cross. Nelson seemed to be heading direct for that huge four-decker, the *Santissima Trinidad*, but not with the intention of attacking her. A

Spanish Rear-Admiral was a comparatively insignificant object, to be dealt with leisurely and by-and-bye, whilst there was a French Vice-Admiral in command to be got at. Yet where Villeneuve was could not be ascertained; the four-decker's flag at the mizzen was visible enough, but there was no French flag at the fore; nevertheless Nelson was persuaded that the French Admiral was in one of two or three ships which lay astern of the *Santissima Trinidad*, and for this reason he steered straight for that immense bristling castle.

The first shot that was aimed at the *Victory* came from the *Bucentaure* ; the ball fell short. There was a pause ; then followed a second shot, and the leap of the white water as the cannon-ball struck the sea was this time close alongside the British flag-ship. The range was again tried by a third shot, which flew over the ship, and then it was that Blackwood and Prowse bade Nelson farewell. There was a fourth and then a fifth shot, and a rent in the *Victory's* main-topgallant-sail was perceptible. The enemy now knew that the British ship was within reach of his guns. Yet another minute or two of silence, breathless and terrible! then to a signal from the French Admiral the whole artillery of the enemy's van, formed at least of seven or eight of the weathermost ships, opened upon the *Victory*. Never perhaps before in all maritime warfare had so tremendous a fire been directed at a single ship. John Scott, Nelson's public secretary, fell dead, killed by a round shot whilst he was conversing with Captain Hardy. The furious cannonading utterly stagnated

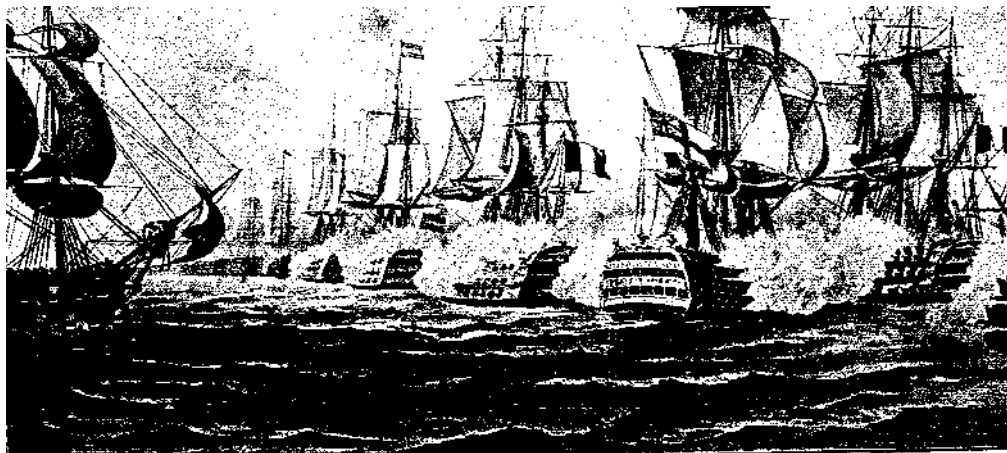

. VICTORY • BREAKING THROUGH THE ENEMY-S LINE, AT THE COMMENCEMENT OF THE BATTLE OF TRAFALGAR, 1805.

FROM A PAINTING BY WHITECOMBI

" This is too warm work, Hardy, to last long," said Nelson with a smile, adding that, often as he had been engaged in conflict, he never remembered the like of the coolness and courage which the men of the *Victory* were showing. The *Bucentaure* slowly forged ahead, disclosing a large French ship on her lee-quarter, with another ship yet, looming amid the fog of white powder-smoke, reaching in with the intention of closing the space over the *Victory's* bow. Hardy represented that it was impossible to pass through the enemy's line without running aboard one of those ships which were coming together ahead of her in a huddle. " I cannot help it," exclaimed Nelson ; " it does not signify which we run on board of. Go on board which you please ; take your choice."

At this time the loss in the *Victory* amounted to twenty killed, and there were thirty wounded besides ; her studding-sail booms had been shot off at the yard-arms ; every sail was like a grating, and her brand new fore-course gaped in an enormous rent.* But it was now the grand old ship's turn. All had been quiet on board of her saving the accidental explosion of a forward gun. But at this hour—about half-past twelve, though the exact time is of course disputed,—she discharged at the *Bucentaure* a sixty-eight-pounder carronade, loaded with a round shot and a keg filled with five hundred musket-balls. The dose was slapped right into the Frenchman's

* James calls it from eighty to a hundred yards, but a length of three hundred feet, either athwartships or up and down, is impossible, and the statement must therefore be a misprint.

cabin windows; and then, as the *Victory* slowly forged ahead, the remaining guns of the broadside, all of them double- and some of them treble-shotted, were deliberately fired, one after another. The men serving the guns in the *Victory* were nearly suffocated by the black clouds of smoke which entered the port-holes, and Nelson and all others then on the quarter-deck were begrimed by the dust of the crumbled woodwork of the *Bucen-taures* stern. This furious raking of the Frenchman was only a little less destructive to him than had been the *Royal Sovereign's* broadside to the *Santa Ana*. Twenty of the *Bucen-taure's* guns were dismounted by it, and her officers afterward said that the loss in killed and wounded reached nearly to four hundred men.

The French ship *Neptune*, that had been valiantly supporting the *Bucen-taure*, fearing to be run aboard of by the *Victory*, hoisted her jib and shifted her helm to forge ahead. Captain Hardy, who had decided to run aboard the ship that was to starboard, ported his helm and drove towards the *Redoubtable*, whose men, having discharged a broadside, promptly closed their lower-deck ports and fired from them no more.

Beatty and, after him, Southey say that, because there was danger that the *Redoubtable* might take fire from the *Victory's* guns, whose muzzles, when the pieces were run out, touched her sides, the fireman of each gun stood ready with a bucket of water to slap into the hole after the shot had been fired. James, however, convincingly disproves this

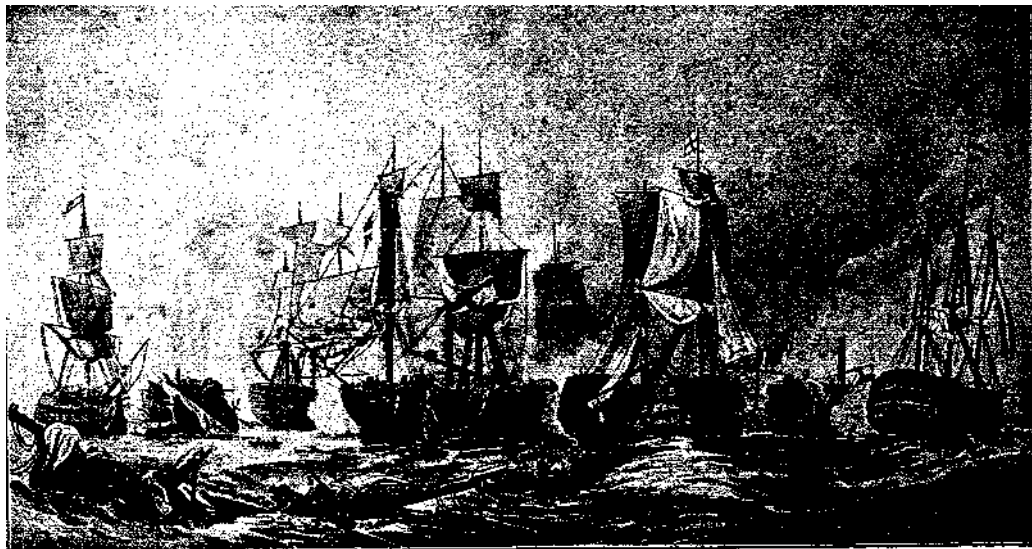

THE BATTLE OF TRAFALGAR, 1805.

FROM THE PAINTING BY C STANFIELD. IN THE VERNON GALLERY.

by exhibiting the situation of the combatants; nor, indeed, even if it were a practicable, is it at all a very credible, manoeuvre.

When the *Victory* had been fitted to receive Nelson's flag, a large skylight over the Admiral's cabin was removed, and planks let into the space so as to enable him to walk amidships clear of the guns and gear. The length of this walk was about twenty-one feet, the stanchion of the wheel ending it aft, and the coverings of the hatch which led to the cabin bounding it forward.

Nelson was pacing this promenade with Captain Hardy somewhere about half-past one o'clock, and having arrived at the cabin hatch, suddenly faced left about. Hardy, who had taken the further and final step, rounded to re-measure this pendulum walk. As he did so he observed Nelson in the act of falling. Before he could spring forward, the Hero had dropped with his face on the deck. The spot was exactly where his secretary Scott had been killed, and the blood of the poor fellow, yet fresh, stained Nelson's clothes. "They have done for me at last, Hardy," Nelson exclaimed. "I hope not," answered the Captain. "Yes," said* Nelson, "my backbone is shot through." He was lifted and carried below to the cockpit. On the way, with his one hand he drew his handkerchief over his face, that his sailors might not know who it was that was being conveyed below. Already the scene of the cockpit was that of a shambles. The gloomy depths were dimly illuminated by the feeble light of smoking oil flames, and all about lay the dead and the

dying, forms motionless or writhing in anguish. The atmosphere was insufferable with nauseating smells; and the dusky cavern resounded with the groans of suffering and with the volcanic-like notes of the artillery thundering above. The surgeon, Dr. Beatty, was bending over the forms of two officers—already corpses—when he heard several of the wounded calling to him: "Mr. Beatty, Lord Nelson is here. Mr. Beatty, the Admiral is wounded." He instantly looked in the direction indicated, and as he did so the handkerchief fell from Nelson's face and the decorations on his coat appeared. Beatty and the purser, Mr. Burke, ran hastily to assist, and received the dying Hero from the arms of the men who had brought him below. Nelson feebly asked whose were the arms which supported him, and, on being answered, he exclaimed: "Ah, Mr. Beatty, you can do nothing for me; I have but a short time to live; my back is shot through."

The Reverend Dr. Scott, the chaplain, had been some little while earlier ministering to the wounded in various parts of the cockpit. Moment after moment men horribly mutilated, screaming in their anguish, or expiring with a groan even as they were handed down the hatch, were arriving, and Scott was half maddened by the horrible scene. He persevered, however, until a fine young fellow, a lieutenant, was brought down desperately wounded. How bad his hurt was, the poor young officer did not apparently know until the surgeon had examined it; when, waiting until Beatty's back was turned, he tore off with his own hand the liga-

tures which had been applied, and bled to death ! Scott, almost frenzied by the sight, fled to the deck for relief. He rushed to the companion-ladder,—the steps were slippery with blood,—all was confusion, cries, the roar of ordnance, an endless storming noise of crashing timber and of splitting spar. Then it was that he heard Nelson had fallen, and instantly hastened to his side, wringing his hands with grief as he turned to the surgeon to say: " Alas, Beatty, how prophetic you were ! " referring to the fear that had been expressed lest Nelson's decorations should unnecessarily expose him on deck to the French sharpshooters. That same coat, which was claimed as the cause of the Hero's death, when removed from him, was hastily rolled up to serve as a pillow for Lieutenant Westphal, whose wound was bleeding freely ; and when the battle was over, and an attempt was made to remove the coat, several of the bullions of the epaulets were found to be so firmly glued into the Lieutenant's hair by the coagulated blood from his wound, that four or five of them were cut off and left in his hair, one of which he afterwards told Sir Harry Nicolas—in 1844*—he still possessed.

Nelson was laid upon a bed, and, his clothes being removed, he was covered with a sheet. Whilst this was being done he said to Scott in a hurried, agitated manner : " Doctor, I told you so. Doctor, I am gone." Adding a little later in a subdued voice : " Remember me to Lady Hamilton ! Remember me to Horatia ! Remember me to all my friends^f

* He was then Captain Sir George Westphal.

Doctor, remember me to Mr. Rose ; tell him I have made a will, and left Lady Hamilton and Horatia to my country." * The wound was probed, and the surgeon was of opinion that the ball had lodged in the spine. " Yes," exclaimed Nelson, " I am confident that my back is shot through " ; and on being asked to express his sensations, he said that he felt a rush of blood every minute within his breast; that he had no feeling in the lower part of his body, and that his breathing was difficult, with keen pain about that part of the spine where he had been hit. These were symptoms which persuaded Beatty that the case was hopeless, but the deadly character of the wound was kept secret from all, with the exception of Hardy, Scott, and one or two others, until the victory over the combined fleet was assured and declared.

Meanwhile, without, the battle was furiously raging. Such was the destructive effect of the *Redoubtable's* fire that most of the effective men left upon the *Victory's* upper deck were employed in carrying their wounded shipmates to the cockpit. Indeed the only occupants of the flagship's quarter-deck at that time were Captain Hardy, Captain Adair, of the marines, and one or two other officers. The sharpshooters in the *Redoubtable's* mizzen-top—whence had come the shot that had struck Nelson—hailed their officers below and communicated the seemingly deserted condition of the *Victory*, upon which an attempt was made to board ; but whilst the Frenchmen were scrambling into the chains and along the gang-

* From Dr. Scott's own account.

way of their ship there was a rush of men from the *Victory's* lower decks, and the assault was magnificently repulsed—but at a desperate cost to the English ; for in this affair alone Captain Adair and eighteen men were killed, Lieutenant Ram and one midshipman mortally wounded, and twenty men seriously hurt. Soon afterwards hostilities aboard the *Redoubtable* ceased ; but it does not appear that she was immediately taken possession of.

Down in the cockpit could be clearly heard the cheers given by the *Victory's* crew whenever they saw that their own shot told heavily, or whenever they observed an enemy's ship surrender. Once Nelson asked the meaning of the huzzas, and Lieutenant Pasco, who lay wounded near him, answered that another ship had struck. Nelson smiled ; but he was now suffering from thirst, and repeatedly called for drink and to be fanned with paper, crying " Fan, fan ; drink, drink ! " They gave him lemonade and wine and water. His utterances proved that he could think of little more than the event of the battle, and the safety of his friend, Captain Hardy, whom he loved, and for whose life he was fearing. He was told that the enemy were decisively defeated, and hope was expressed that he would live to be himself the bearer of the grand tidings to his country. " It is all over ; it is all over ! " was his reply. His anxiety to see Hardy was very great. " Will no one bring Hardy to me ? " he continued to exclaim ; " he must be killed ; he is surely destroyed ! " After a little the *aide-de-camp* came below to report that the situation of the fleet rendered it impossible for Cap-

tain Hardy to leave the deck ; but that he would descend the instant a chance offered. " Who is that ? " asked Nelson. The purser answered : " It is Mr. Bulkeley, my Lord." " It is his voice," exclaimed Nelson, and then, without turning his head, he said to Bulkeley: " Remember me to your father."

All that was beautiful in him of goodness, of gentleness, of thoughtfulness, of tenderness ; all that was noble in him of greatness of soul, of magnanimity of mind, of devotion to the country that he had been stricken to death in serving, showed with an incomparable sweetness and shone with a particular splendour in these, his last hours. A wounded seaman lay near waiting for the surgeon to amputate a limb ; he was struck, perhaps hurt, by some one passing; weak as he was, scarcely able to articulate, indeed, yet Nelson indignantly turned his head and reprimanded the man for his carelessness or his inhumanity. Still was the great battle without being furiously fought. The *Victory* was almost wrecked aloft; her rigging was cut to pieces; a score of details of the grand old fabric were shot away; her decks were running with blood ; but she still maintained her terrible play of artillery. When she opened her larboard guns on Dumanoir's squadron, the concussion of the firing so affected Nelson that, apostrophising his ship, he called out: " Oh, *Victory*, *Victory*, how you distract my poor brain!" then added, after a pause : " How dear is life to all men ! " He had been lying in the cockpit an hour and ten minutes before Hardy came to him. They shook

hands affectionately, and Nelson said : " Well, Hardy, how goes the battle?—how goes the day with us? " " Very well, my Lord. We have got twelve or fourteen of the enemy's ships in our possession." " I hope," said Nelson, "that none of our ships have struck, Hardy? " " No, my Lord," replied Hardy, " there is no fear of that." Nelson then said: " I am a dead man, Hardy. I am going fast; it will be all over with me soon. Come nearer to me. Pray let my dear Lady Hamilton have my hair, and all other things belonging to inc."

Hardy soon after this returned on deck. Beatty anxiously hung about the dying Hero, who begged him to attend to the wounded, " for," said he, " you can do nothing for me." The surgeon assured him that his assistants were doing all that was possible, but Nelson insisted, and Beatty withdrew. Shortly afterwards, however, he was summoned afresh, and after learning the symptoms that Nelson himself described, and being urged to speak the truth, he exclaimed : ^{4<} My Lord, unhappily for our country, nothing can be done for you," and, having said this, as he himself tells us, he turned round and walked a few paces away to conceal his grief. From time to time Nelson would exclaim: " God be praised, I have done my duty! " Once so exquisite was his pain, he said he wished he was dead, " yet," he added, in a voice a little above a whisper, " one would like to live a little longer too."

Captain Hardy came again after an interval of about fifty minutes. A second time they pressed each other's hand. The Captain was unable to report

how many ships were captured, but he had no doubt they amounted to fourteen or fifteen sail. Nelson exclaimed : " That is well, but I bargained for twenty " ; and with emphasis said : " Anchor, Hardy, anchor ! " The Captain replied : " I suppose, my Lord, Admiral Collingwood will now take upon himself the direction of affairs ? "—" Not while I live, I hope, Hardy," cried Nelson, struggling, but ineffectually, to raise himself ; " No ! Do *you* anchor, Hardy."—" Shall *we* make the signal, sir ? "asked Hardy. "Yes," answered Nelson, " for if I live I 'll anchor." A little later on he said he felt that in a few minutes he should be no more, and in a low voice exclaimed, " Don't throw me overboard, Hardy."—" Oh, no, certainly not," the Captain answered. " Then," said Nelson, " you know what to do. Take care of my dear Lady Hamilton, Hardy : take care of poor Lady Hamilton. Kiss me, Hardy." The Captain knelt and pressed his lips to his cheek. " Now I am satisfied," said Nelson, " thank God, I have done my duty." Hardy stood with his eyes fixed upon him, silent in contemplation ; then, kneeling, again kissed his beloved chiefs forehead. Nelson said, " Who is that ? " The Captain answered, " It is Hardy,"—" God bless you, Hardy," said Nelson. The Captain then went on deck. Nelson became speechless a little before four o'clock in the afternoon. Almost the last words he said to his chaplain, Scott, were, " Doctor, I have *not* been a *great* sinner," and his latest utterance was, " Thank God, I have done my duty." For a long while Dr. Scott and Mr. Burke had been supporting the bed under

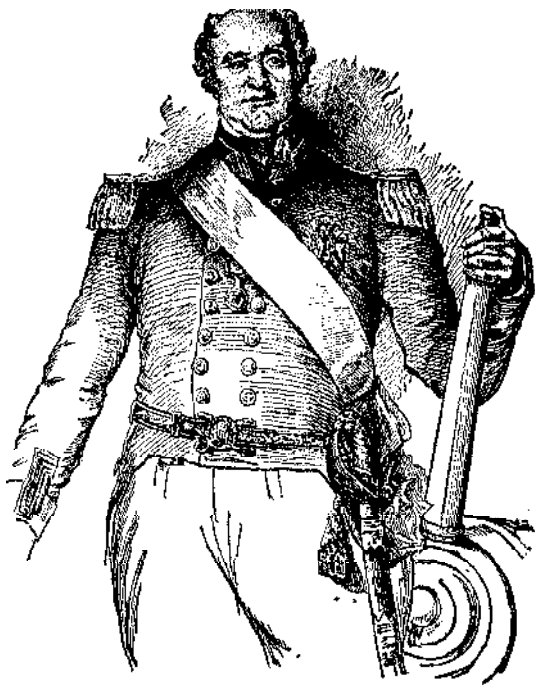

SIR THOMAS MASTERMAN HARDY, BART., G.C.B.

FROM THE PAINTING BY R. EVANS.

his shoulders that he might obtain some little ease **from a** semi-recumbent posture. It is recorded in the memoirs **of** Dr. Scott that Nelson, "passed so quietly out of life that Scott, who had been occupied ever since he was brought below in all the offices of the most tender nurse, was still rubbing his stomach when the surgeon perceived that all was over." Beatty knelt by the Hero's side and took his hand ; it was ice-cold, and the wrist pulseless. He felt his forehead, and Nelson opened his eyes but closed them instantly. Beatty withdrew to attend to the wounded, but had not been absent five minutes when he was told that Nelson **was dead.** **He returned** and found that it was so.

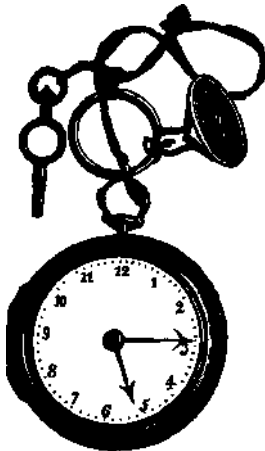

NELSON'S WATCH AND SEAL WORN AT TRAFALGAR.

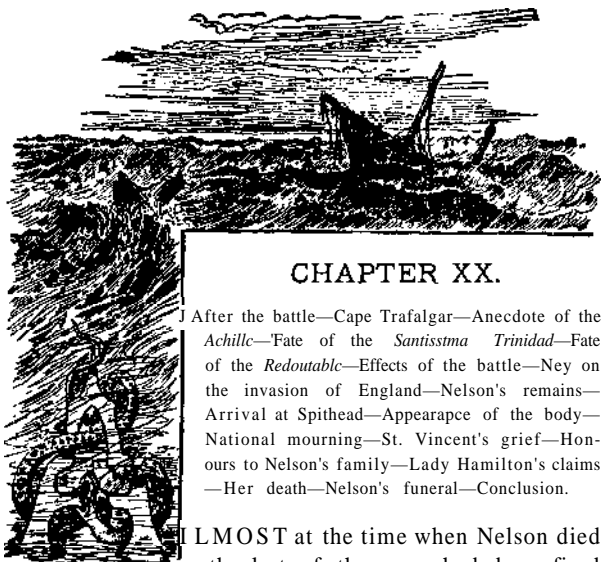

CHAPTER XX.

After the battle—Cape Trafalgar—Anecdote of the *Achille*—Fate of the *Santissima Trinidad*—Fate of the *Redoubtable*—Effects of the battle—Ney on the invasion of England—Nelson's remains—Arrival at Spithead—Appearance of the body—National mourning—St. Vincent's grief—Honours to Nelson's family—Lady Hamilton's claims—Her death—Nelson's funeral—Conclusion.

ALMOST at the time when Nelson died the last of the guns had been fired and the silence of the cockpit was disturbed only by the moans of the wounded. The cannonading had ceased ; a hush had fallen upon the floating armaments. The greatest sea victory that the world had ever known was won ; but at such a cost that there was no man throughout the British fleet—there was no man, indeed, in all England—but would have welcomed defeat sooner than have paid the price of this wonderful conquest. The scene of havoc was one of terrible sublimity on that October afternoon whilst the *Victor* lay below, motionless in death. In all directions mutilated ships lifted their sides, like castles upon the water—many of them with their masts gone, their bulwarks

trailing long serpentine lengths of severed rigging, the British colours flying upon stumps and staffs, scupper-holes gushing water tinged with red, masses of wreckage, seared, withered, blackened as by the electric bolt, lifting and falling upon the Atlantic swell. Eastwards a long, fog-coloured body of powder smoke was settling slowly towards the land, and in the dimness of the vaporous wing in the south there were faintly visible the hulls and white canvas of Dumanoir's squadron flying for safety, whilst in the north-east, with the wind fresh off their beam, were to be seen eleven French and Spanish ships of the line, and other smaller vessels, Gravina's flag blowing out amongst them, thrashing through it as fast as a press of canvas could carry them for the security of Cadiz or Rota. Almost in the heart of the huddle of ships and prizes, some of which yet lifted their royals to the sky, though many of them were sheer hulks rolling like drowning structures upon the run of the sea, was the French *Achille* 74, on fire, with the tri-colour upon her ensign staff fluttering, in a very mockery of triumph, against the dense black clouds of smoke rising from the hull. The action had begun at noon ; it was at its height at about half-past one ; at three o'clock in the afternoon the firing began to slacken, and at five o'clock it had wholly ceased. Almost as the last of the guns were thundering, the headland of Cape Trafalgar was seen from the *Royal Sovereign* bearing south-east by east, distant eight miles, and thus it was that the famous fight came to be called the Battle of Trafalgar.

The immediate result of the action was the capture of seventeen French and Spanish ships and one ship (*Achille*) burnt. This was Nelson's victory. It was made very much completer afterwards; but this was the conquest upon which it may be said that Nelson had closed his eyes,—which was veritably his—achieved before his heart had ceased to beat—whilst his flag was still flying at the mast-head, and whilst he was yet the Commander-in-chief of the grim and intrepid armament which had helped him to this crowning, this most glorious triumph !

Joshua White, in an account of the battle in his "Life of Nelson," prints a romantic detail on the authority of one of the officers of the *Revenge*. The story relates to the burning of the *Achille*. On board of that vessel there was a young woman, who, during the action, had been stationed below to assist in handing up powder. When the ship took fire, such of the people as could swim sprang overboard. The woman descended to the lower deck and remained there till the guns began to fall through the charred planks above. She then got out of the gun-room port on to the back of the rudder, where she undressed ; but she would not trust herself to the water till the melted lead from the taffrail obliged her to jump. She got hold of a piece of plank, and after being an hour and a half in the water she was picked up by one of the *Belleisles* boats and subsequently put on board the *Pickle* schooner, where she found her husband, who had likewise escaped. They were afterwards landed at Algebras, after she had been fitted out by the British officers as suitably as

LORD NELSON'S STATEMENT OF HIS WOUNDS.

*From Peltigrew's " Life of Nelson."**

their wardrobes would admit. She was described as young, handsome, and very intelligent, a native of French Flanders, and her name Jeannette.

The fate of two of the enemy's ships may be given, both of them being intimately associated with Nelson; the one as playing a part in the first of the most brilliant achievements of his career, the other as causing his death. The *Santissima Trinidad* had escaped him and Jervis at St. Vincent only to be hammered into a sheer hulk at Trafalgar. A gale of wind arose after the battle; a heavy sea was running; even the least injured of the British line-of-battle ships were in no condition to tow their monster prizes in the face of such weather as had now set in; and Collingwood gave orders that the leewardmost of the captured ships should be destroyed. One of these was Nelson's "old friend," the *Santissima Trinidad*. James says that she was cleared, scuttled, and sunk by the *Neptune* and *Prince*, but that in spite of every care being taken to remove the wounded, twenty-eight persons perished. Brenton tells the story differently. "The officers of the *Prince* and *Neptune*" he says, "by the most persevering efforts, had nearly got all the wounded men out of her by lowering them down in cots from the stern and quarter-gallery windows. We trust and hope that none of these unfortunate people were left behind, but a doubt seems to exist. Night came on; the swell ran high; *three* lower-deck ports on each side were open, and in a few minutes the tremendous ruins of the largest ship in the world were buried in the deep." *

**Naval History," vol. ii., p. 89.

information of a friend, who was first lieutenant and acting captain of the *Ajax* in the battle, that no one was suffered to perish in the *Santissima Trinidad*. The lieutenant (Pilfold) was in the last boat which left the huge ship. As the crew shoved off from the starboard quarter, a cat ran out on to the muzzle of one of the lower-deck guns, and by a plaintive mew seemed to beg for assistance. The boat returned and took her in, which proves that there was no hurry. The *Redoubtable*, a less romantic ship, met a very miserable end. She was amongst the most furiously mauled of the Franco-Spanish craft ; her main- and mizzen-masts, fore-topmast, and bowsprit were gone, her rudder destroyed, her stern swept in by the storms of cannon-balls, her hull pierced in all directions, and every timber in her veritably armour-clad with the studding of shot. Twenty of her guns on the side on which Nelson had engaged her lay dismounted ; of her crew of six hundred and forty-three, three hundred were killed and two hundred and twenty-two wounded. Vengefully indeed had the *Victory* dealt with her! Taken in tow by the *Swiftsure* at five o'clock, she was actually sinking at that hour, with the signal of distress flying at the stump of her foremast. The *Swiftsure* sent boats and brought off part of the prize-crew and about a hundred and twenty Frenchmen, as heavy a freight as the boats could receive. Before eleven o'clock that night the *Redoubtable's* stern was under water, and the *Swiftsure* cut herself clear. At half-past three in the morning, in the height of a heavy gale of wind, with lightning and sheets of rain, cries were

heard, and the *Swiftsure* was just in time to rescue fifty more of the *Redoutables* people, who had contrived to construct a raft from the spars of their sunken ship. Such was the end of the *Redoutable*,

The battle of Trafalgar fixed the destinies of Britain; but to appreciate all its significance it is necessary to turn to French history. There can be little question that Napoleon's intention to invade England was a very passionately earnest one. Bourrienne affirmed that he really never meditated the descent, and it was thought by many that his preparations in the Channel were designed merely to furnish occupation to his troops and to cover other designs. But then Napoleon himself insisted upon his having been in earnest, and claimed that the best combined plan he had ever laid during his whole career was defeated by Sir Robert Calder's action with the combined fleet. This plan is detailed in most of the naval histories. His instructions to Villeneuve were to have proceeded with the Franco-Spanish fleet to the West Indies to draw Nelson after him; then to immediately return, and after raising the blockade of Ferrol and Corunna, to join the forces at Rochelle and Brest and bring the whole of the ships into the Channel to cover the embarkation of the army. He thus calculated upon a naval force of seventy sail-of-the-line, an armament which, in the absence of Nelson's fleet, the British could have but ill opposed. Marshal Ney is express on this point. Speaking of Villeneuve, he says: "He left Toulon on the 30th March, and on the 23d June he was at the Azores on his return to Europe, leav-

ing Nelson still in the West Indies, but at the very moment when every one flattered himself that our vessels would speedily arrive to protect the embarkation of the army, we learnt that, deterred by a cannonade of a few hours and the loss of two ships [the battle with Calder is here referred to], he had taken refuge in Ferrol. A mournful feeling took possession of our minds ; everyone complained that a man should be so immeasurably beneath his destiny. All hope, however, was not lost. The Emperor still retained it. He continued his dispositions, and incessantly urged the advance of the marine. Every one flattered himself that Villeneuve, penetrated with the greatness of his mission, would at length put to sea, join Gantheaume, disperse the fleet of Cornwallis, and at length make his appearance in the Channel . . . Nothing could succeed for want of the covering squadron ; and soon the battle of Trafalgar and the Austrian war postponed the conquest of England to another age." *

It was not until the day after the battle that the surgeon of the *Victory* could find leisure to give his attention to the remains of the Hero. There was no lead on board to make a coffin of; a large cask called a leaguer had to serve as a shell; the hair was cut off the head of the body, which was stripped of all clothes except the shirt; the corpse was then put into the cask, which was filled with brandy and closed. During the heavy weather that followed, Nelson's remains were placed under the charge of a sentinel on the middle deck.

* "Memoirs of Marshal Ney," vol. ii., p. 262.

The cask stood on end having a closed aperture at its top and another below that the spirit might be withdrawn and renewed without disturbing the body. On the 24th there was such a disengagement of air that the head of the cask was lifted, and the sentinel much alarmed instantly reported the circumstance to the officers. The cask was thereupon spiled and the air freed.

On the 28th the *Victory*, in tow of the *Neptune*, arrived at Gibraltar, and next day all the dangerously wounded of the seamen and marines were sent ashore to the hospital. By the 2d of November, the grand old ship, refitted with jury-masts, was ready to sail to England. She was five weeks in making the passage to Spithead, and on the 12th of December she anchored in Dover Roads, whence she made several attempts to proceed, but was forced to bring up again; and even when she had managed to get her anchor on the 17th she had shortly afterwards to come to a stand in the Downs.

On the day on which she had left Spithead Nelson's body was taken from the cask in which it had been kept since the 22d of October. It was now that the ball was discovered; it had passed through the spine—verifying Nelson's repeated assurance that his back was broken—and was lodged in the muscles of the back. It had embedded with itself a considerable portion of the gold lace, pad, and lining of the epaulet, and the lace adhered to the lead as firmly as if it had been fused with the metal in a molten state. The body was wrapped in cotten vestments and placed in a leaden coffin, filled with brandy con-

taining camphor and myrrh. This coffin was then enclosed in one of wood, and deposited in the cabin that Nelson had occupied. There it remained till the 22d of December, when an order was received from the Admiralty for the removal of the body. The *Victory* was then anchored in the Swin with Commissioner Grey's yacht from Sheerness alongside of her. Apparently this yacht had brought with her the coffin that Captain Hallowell had presented to Nelson, for Beatty speaks of it as "being then received on board," though Pettigrew says that *L'Orient* memorial was shipped in the *Victory* when Nelson sailed for the last time. Be this as it may, on the arrival of the ghastly Nile relic the leaden coffin was opened and the body taken out. All the officers of the ship, and many of Nelson's and some of Captain Hardy's friends were present and viewed the corpse. All were astonished by the little evidence of decay it exhibited after the many weeks that had passed since death. The features were somewhat tumid but on being gently rubbed resumed in a great degree their natural character. For the last time the remains of the great Sailor were viewed by mortal eyes. Then completely apparelled, the body was placed in the shell made from *L'Orient's* mast, which in its turn was enclosed in the leaden coffin. This on being soldered was put into another wooden shell, and in this form the remains were conveyed into the Commissioner's yacht. As the coffin was lowered the *Victory* struck Lord Nelson's flag at the fore, and the same was hoisted half-mast high on board the yacht.

The yacht, having reached Gravesend, anchored, but on the 23d weighed, and then began those military honours which were paid to the dead Hero throughout the remainder of the passage. The shore was lined with Volunteers underarms; minute-guns were fired; every ship dipped her flag in a funeral salute as the yacht went by. For a mile below the Arsenal at Woolwich troops were drawn up in a line with arms reversed; so in the Arsenal and Dockyard, the soldiers stood in ranks, expressing the universal grief by their postures and manner of holding their weapons; every flag flew half-mast high, and the solemn sound of tolling bells was accentuated by dirges played by the bands, intermingled with the rolling note of the minute-guns. At seven o'clock the body was landed at Greenwich and carried to the Record Room, where it was to remain until the Painted Hall could be prepared for its reception. On Sunday, the 5th of January, it lay in public state.

Even at a distance of eighty-four years it is not difficult to realise the emotions which filled the country when the news came of the battle of Trafalgar and of the death of Nelson. That news had been received at the Admiralty at one o'clock on the morning of the 6th of November, having been brought by the *Pickle* schooner; and Collingwood's dispatch was at once printed in a London Gazette Extraordinary. The Park and Tower guns thundered the announcement of the glorious conquest; but every sensation of triumph and rejoicing which they inspired was tempered, subdued, almost extin-

gushed indeed by thoughts of the loss which the nation had sustained. When the announcement was made to the King he was so deeply affected that for some minutes he was unable to speak. The Queen called her daughters to her and wept with them as Collingwood's noble dispatch was read aloud. Pitt was aroused in the night to hear the news, and he told Lord Malmesbury that though he had been awakened at various hours by the arrival of all sorts of intelligence, he had always been able to lay his head on his pillow and fall asleep again; but on this occasion, the great event announced brought with it so much to weep over as well as to rejoice at, that he could not calm his thoughts, but at length got up, though it was three in the morning. Coleridge declared that when Nelson died it seemed as if no man was a stranger to another; all were made acquaintances by the rights of a common anguish. He was at Naples, he says, when the tidings came, and he adds: "Never can I forget the sorrow and consternation that lay on every countenance. Even to this day there are times when I seem to see, as in a vision, separate groups and individual faces of the picture. Numbers stopped and shook hands with me because they had seen the tears on my cheek and conjectured that I was an Englishman; and several as they held my hand burst themselves into tears." * The whole Navy wept their loss; but the affliction of few equalled that of the lion-hearted sea-chieftain, St. Vincent. It was Nelson who had added the brightest of the rays to the glory of old John Jervis's

* "The Friend."



NELSON'S PILLAR, SACKVILLE STREET, DUBLIN.

memorable St. Valentine's Day. Their love was as that of brothers. To St. Vincent Nelson owed the opportunity he had found or made in Aboukir Bay, and there was profound gratitude as well as veneration in him, whilst in the other were deep delight in, and purest admiration of, the transcendent qualities of the victor of Copenhagen and Trafalgar. "On board his flag-ship," says a writer, speaking of St. Vincent, "on all those great occasions when he entertained his numerous followers, *Nelson's dirge* was solemnly performed while they yet surrounded the table; and it was not difficult to perceive that the great warrior's usual contempt for displays of feeling here forsook him, and yielded to the impulse of nature and of friendship." *

The honours and emoluments to the Nelson family following upon Trafalgar were these: An Earldom was conferred upon the Rev. William Nelson, to which was attached a pension of £5,000 a year; a sum of £120,000 was voted to enable him to purchase an estate to be named after the famous victory; £20,000, however, of this money was to be divided between Nelson's sisters, Mrs. Bolton and Mrs. Matcham; and £320,000 were voted to the victors of Trafalgar as compensation for the prizes which

* *Edinburgh Review*, 1839, 45. It ought not to be forgotten of Lord St. Vincent that hearing by chance that Dibdin, the composer of "Tom Bowling," was in distress, he at once sent him one hundred pounds and requested his secretary, Mr. Tucker, to inquire into the real state of the case; "for," said he, "it would indeed be a shame that the man who has whiled away the mid-watch and softened the hardships of war should be in need while a seaman enjoys an abundance."—Tucker's "Life of Earl of St. Vincent."

had been lost in the hard weather that followed the action. Collingwood was made a peer ; he was without sons, and sought to get the title rendered hereditary in the female succession, but the favour was denied him, despite his services ranking next to those of Nelson himself at Trafalgar, and despite his magnificent spirit of dutifulness that held him for years absent from his fondly loved wife and daughters, and that finally killed him whilst still afloat.*

Lady Hamilton's " claims," emphasised as they had been by Nelson's last solemn appeal to his King and Country, remained without recognition. The Prince of Wales was amongst her few well-wishers; but nothing was done. Perhaps it was considered that she was left very much better off than she deserved. Her income, drawn mainly from money left by Nelson and Sir William Hamilton, amounted to about $\text{^}1,500$ a year, and the estate at Merton was her own property besides. Her extravagance plunged her into difficulties, and her vanity and shiftlessness disgusted those who had been willing to assist her. Mr. J. C. Jeaffreson satisfactorily disposes of the extraordinary stories told of this beautiful woman's closing days, such as Brenton's tale of

* " The length and hardship of Lord Collingwood's service are without any parallel. Of fifty years during which he continued in the Navy, about forty-four were passed in active employment abroad ; and in the eventful times from 1793 till his death in 1810 he was only for one year in England, and for the remainder was principally engaged in tedious blockades, rarely visiting a port; and on one occasion actually kept the sea for the almost incredible space of twenty-two months, without once dropping his anchor."—^{4c} *Memoirs.* II .

her constantly being haunted by the shade of Caracciolo, and shrieking aloud in her agonies of terror, and such as that still more startling statement of her body after death being popped into a bag and buried like a dog. She died in January, 1815, aged fifty-one, at Calais. She had found a friend in a Mrs. Hunter, who, when the unfortunate Emma had breathed her last, placed the dead woman in a cheap deal coffin covered by a pall formed of a white curtain and a black silk petticoat. A piece of ground just outside Calais had been consecrated, but there was no English Protestant clergyman to be found, and the funeral service was read, at Mrs. Hunter's request, by an Irish half-pay officer ! Not a vestige of the grave existed in 1833. The late Dr. Doran in that year sought for it, and found its locality entirely traditional.

Nelson's funeral was one of great magnificence. The Scots Greys led the procession; other regiments followed, their bands playing solemn music, and the military array was closed by eleven pieces of cannon and some companies of Grenadiers. Then came lines of carriages of commoners and of peers, pensioners of Greenwich Hospital, seamen and marines of the *Victory* bearing the Admiral's flag, whose folds were sieve-like with the balls which had passed through it; heralds in gauntlet and spur, in helm and crest, and target and sword; naval lieutenants and admirals bearing the canopy and supporting the pall, with the coffin, on a car formed of four columns resembling palm-trees, and having on its front and back a carved representation of the head and stern

of the *Victory*. The expense of this public funeral amounted to ;£ 14,000. The Duke of Clarence shed tears, and we may well suppose them to be genuine in the eyes of one who not only remembered the dead as an old shipmate and an affectionate friend, **but** who would also think of him as the Admiral to whom the very throne owed its preservation.

There is nothing in words to deal with such a character as this of Nelson. The enumeration of his qualities is the best eloquence that can express them. And yet to say that he was the greatest sea-officer Britain had ever produced ; to repeat, in the language of his own sailors, that he had the heart of the lion and the gentleness of the lamb; to declare that he was as good as a man as he was great as an ocean-warrior, affectionate, bountiful, without further weakness than is to be witnessed in a thirst for earthly distinction, always a sailor first of all, yet of a sagacity that was not to be paralleled by the intelligence of the ablest politician of his times ; clear and instant in his perceptions, daring and dominating in his actions, unerring and triumphant beyond anything that history can tell of other men in his achievements ; to say this is to say what ? Yet the heart must speak the rest. " I have him now before me," wrote Scott to Lady Hamilton, referring to Nelson, whose body the Chaplain was then watching ; " here lies Bayard—but Bayard victorious—*sans peur et sans reproche*. . . . So help me God, as I think he was a true knight and worthy the age of chivalry—one may say—*lui mime fait le siecle*—for where shall we see another? When I think, setting aside his heroism,

what an affectionate, fascinating little fellow he was, how dignified and pure his mind, how kind and condescending his manners, I become stupid with grief for what I have lost." Thus were all men thinking and saying. It is eighty-five years since he died; yet still is his name the one of all earthly names to work most magically in the thoughts of Englishmen. His example as a strategist is of no use now; it would be the idlest waste of time to enter, in this iron-armoured age, into a discourse upon his proceedings : how superior he was as an ocean-leader of men to Jervis, as Jervis was to Howe, as Howe was to that earlier race of admirals who may be traced back through the dim pages of Campbell and Burchett, fighting most valiantly yet with circumspection off the coast of the English Channel and down amongst the shoaling waters of the Dutch shore. It can profit us nothing, in a material sense, to know that his great theory of warfare consisted in swiftness of resolution, in dashing at the enemy, in getting alongside of him, as close as channels or yard-arms would permit and in firing until he struck or was annihilated. There are no longer channels; there are no longer yard-arms ; lines ahead may be formed, but if they are to be broken no hints of the manoeuvres to be employed are likely to be found in the most voluminous and minute accounts of the Nelsonian victories. But if his genius as an Admiral of the days of tacks and sheets can no longer be serviceable in suggestion to a posterity whose hopes are lodged in steel plates of twenty inches in thickness, in engines of ten thousand-horse power, in

ordnance big enough to berth the crew of a brig of Nelson's day, his example as an English sailor must, whilst there remains a British keel afloat, be as potent in all seafaring aspirations and resolutions as ever it was at any moment in his devoted and glorious life.

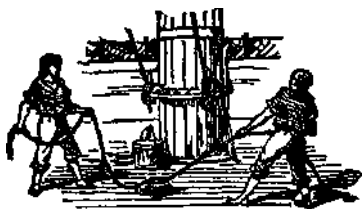



APPENDIX.

IN these days of struggle for the mastery between guns * and armor and the most efficient methods of applying and using them, when 2,000 yards constitutes a fighting range in place of the hand-to-hand conflicts that characterized the encounters of our Hero's period, when ranges of fourteen miles are attained, when tons of shot and hundreds of pounds of powder are expended in a single discharge from a single gun, in what manner can we best make a comparison that will enable us to estimate the comparative strength of the ships and batteries engaged in the naval wars of a century ago, and at the same time contrast them with the ships and cannon of to-day ?

Where, then, individual prowess and endurance and heroism backed bold and daring tactics ; where the object to be secured was to board the enemy's ship for a hand-to-hand contest; where, as Nelson himself expressed it, " I hope we shall as usual be able to get so close to our enemies that our shot cannot miss their object" ; now, scientific inventions and intricate mechanical instruments call for as much coolness and vigilance and nerve, if our commanders are ever to approach the records of the mastersailor whose history we have striven to narrate.

But, even with his desire for the means of wider action, and his ability to adequately estimate the value of the advantages of the great battle-ships *Nile* and *Trafalgar*, named after his memorable victories, his spirit tells us that he would have given them all for one action aboard his *Victory*, one chance to scale the side of his enemy, or one word from his beloved Hardy.

The various descriptions of ships and batteries engaged in the battles of the last of the eighteenth century and beginning of the nineteenth differ so widely from each other that it will often be interesting to compare with the individual authorities the batteries or armaments of the various classes of ships, as built or designed, with their actual fighting strength as engaged in the several actions. The following arrangement, based upon data obtained from James's "Naval History," will facilitate such comparison. Very little change was made from 1798 to 1805, or the period between Nelson's two greatest victories.

Class.	No. of Decks.	Rate.	Tonnage.	Armament.	Remarks.
120-Gun ship	3	First	2508	18 pdrs. to long 32's	
112 " "	3	"	2351	18 pdrs.	
112 " "	3	"	2457	12 "	
100 " "	3	"	2286	18 "	
100 " "	3	"	2175	12 "	
98 " "	3	"	2121	18 "	Small
98 " "	3	"	1869	12 "	
90 " "	3	"	1814	12 "	
80 " "	2	Third	2143	18 "	
74 " "	2	"	1889	24 "	
74 " "	2	"	1887	18 "	Large
74 " "	2	"	1778	18 "	Middling
74 " "	2	"	1614	18 "	Small
64 " "	2	"	1342	18 and 24 pdrs.	
60 " "	2	Fourth	1226	18 " 24 "	
56 " "	2	"	1341	Long 9-pdrs. and carronades.	Flush
54 " "	2	"	1182	Long 9-pdrs. and carronades.	"
50 " "	2	"	1060	18 and 24 pdrs.	Common, or quarter-decked
50 " "	2	"	911	24 pounders	Flush
44 " "	2	Fifth	882	"	
44-Gun frigate	1	"	1376	18 and 24 pdrs.	
40 " "	1	"	1258	24 pounders	
40 " "	1	"	1172	18 "	
38 " "	1	"	1064		Large

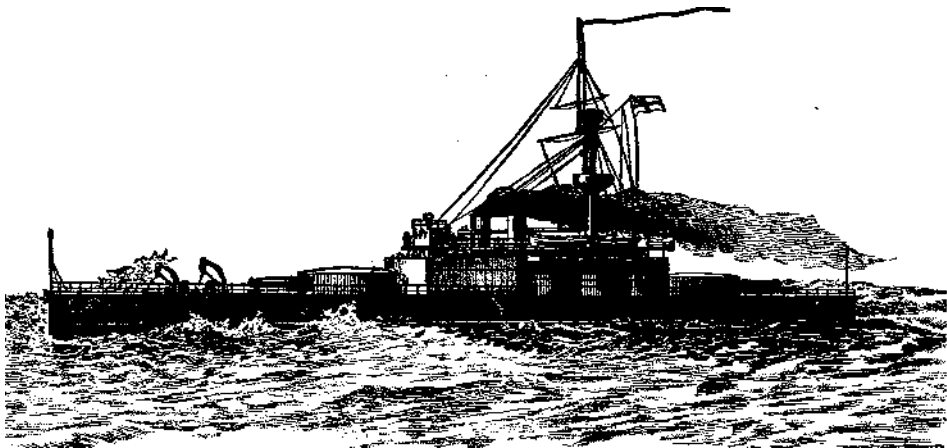

H. M. S. " TRAFALGAR. "

FROM BRASSEY'S " NAVAL ANNUAL. "

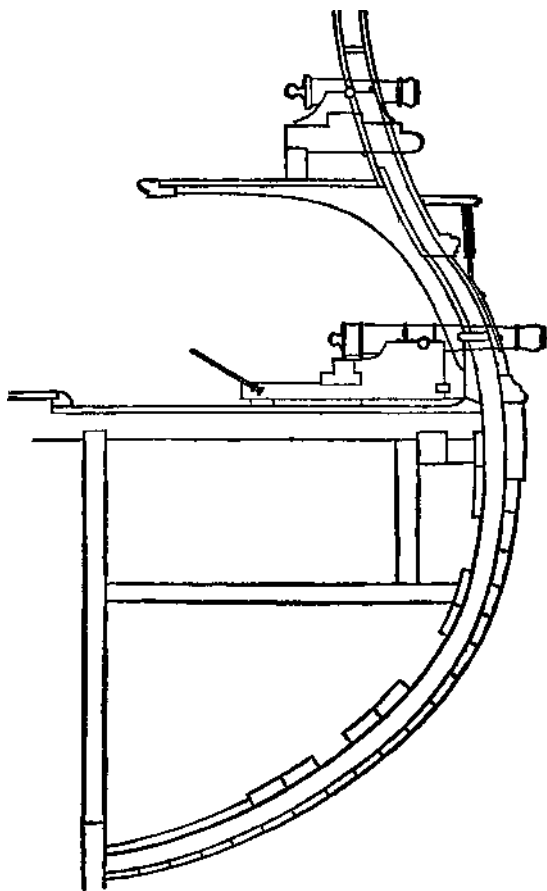

Section of frigate, with long gun on main-deck and carronade on spar-deck. Taken from "The American Artillerist's Companion," by Louis de Toussard (Philadelphia, 1811).

Class.	II f j v	Rate.	H ↑	Armament.	Remarks.
38-Gun frigate	I	Fifth	941		Small
36 " "	I	"	1030	18 pounders	Large
36 » "	I	**	890	18 "	Small
36 " "	il	"	939	12 "	
32 44 "	I	"	914	18 "	Large
32 44 "	I	"	801	18 "	Small
32 44 "	I	"	777	12 "	Large
32 " "	I	**	704	12 "	Small
28 " "	I	Sixth	610		
24-Gun post ship	I	"	524		Quarter-decked
24 " "	I	"	528		
22 " "	I	"	532		Flush
20 " "	I	"	432		Quarter-decked
20 " "	I	"	530		Flush
28 Carronade	I	Sloops	386	Carronades	
18-Gunship sloop	I	"	465		Quarter-decked
18 " "	I	"	312		Flush
16 " "			345		Quarter-decked, large
16 " "			319		Quarter-decked, small
16 " "	I	"	327		Flush
14 " "	il	"	304;		Quarter-decked,
"14 «	l	"	230		Flush
18-Gun brig sloop	il	"	384!		Large
18 " "	l	"	325!		Small
16 4l	l	"	310		
14 " "			202		
Bombs			320	8 guns, 2 mortars	
Fire-ships			423	14 guns	
Gun-brig			202	14 "	
			147	12 "	
			170	10 "	
Cutters			181	14 "	
			137	12 *	
			117	10 "	
			110	8 "	j
			90	6 "	
			88	4 "	
	I	Fourth	1249	26 "	
	I	Fifth	899	24 "	
			697	18 "	
Floating battery			1373	46 and 48 guns	
			372	20 guns and under	
Gun-vessels			75	1 to 4 guns	

Authorities generally agree that the French and Spanish ships of similar classes carried heavier batteries than the British. James, in comparing a British three-decker of the 98-gun class with a French 80—the *Franklin*,—gives :

Decks.	British 98.		French 80.		Weight of Each of the <i>Franklin's</i> Guns.		
First or lower	No. 28	Pdrs. long 32	No. 30	Pdrs. long 36 iron	cwt. 73	qrs. 2	lbs. 18
Second.	30	" 18	2	" 3 6 brass	51	0	14
Third.	30	" 12	32	" 24 iron			
Quarter-deck	8	" 12	2	4 4 24 brass	33	1	16
Forecastle.	2	" 12	12	" 12 iron			
Poop.	6	carrs. 18	2	" 12 brass			
			6	" 12 iron			
			6	carrs. 36 brass			
		104		92			
Broadside guns.	j No. 52		J 46				
	\ lbs. 1,012		\ 1,287				

The *Santissima Trinidad* and her class of gun-ships were built to mount 126 guns, distributed as follows : On the lower gun-deck, 30 long 36-pounders ; on the second deck, 32 long 18's ; on the third deck, 32 long 12's ; and on the spar-deck, 32 8-pounders.* James, in his " Naval History," describes them as 130-gun ships, and some British authorities place the *Santissima Trinidad's* strength in the battle of Trafalgar at 140 ; and, although the Spanish gun-ships generally mounted a greater number of guns than the British, the weight of metal thrown at a

* Simpson, 1859.

single broadside was about the same : as, for example, that of the *Santissima Trinidad* was 1,190 pounds to 1,180 pounds from the *Victory*, the former with a battery of 130 guns, the latter 100.

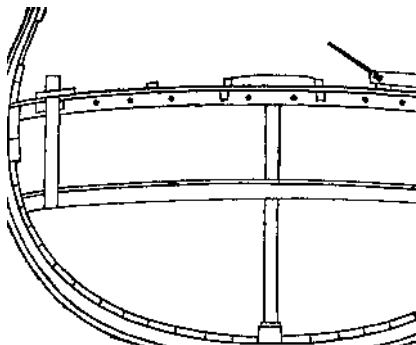

Section of a flush-deck corvette or sloop, carrying long guns.

Graviere gives the Spaniards a larger complement of guns than any other authority :

Name of Ship.	Number of Guns.	
	James.	Graviere.
Principe de Asturias.	112	118
Santa Ana	112	120
Santissima Trinidad .	130	136
Argonauta	80	92
San Augustine.	74	80
San Justo	74	76
San Leandro	64	74

The guns of the 74's were distributed as follows :

Gun-deck, 58 long 24's.
 < , , j 10 carronades 36-pounders.
 " P , ' (4 long 8-pounders.
 Poop-deck, 6 carronades 24-pounders.

These were probably supplemented by coehorns mounted in the tops, and a few smaller pieces movable about the decks. The coehorn was a very light mortar, discharging a large projectile with a small charge of powder ; it is probable that its projectile was intended to operate by means of the force of gravity when the ships would be within its short range. A heavy projectile falling from a great height and landing on a ship's deck might do much damage.*

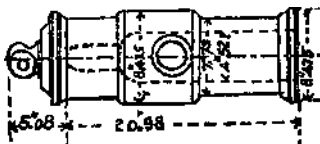

Coehorn Howitzer, 1805.—Weight, 2½ cwt.

French shot was heavier than the nominal weight of corresponding English shot, viz.: †

Nominal Weight of French Shot in English Pounds.	Actual Weight of Same Shot in English Pounds.
36-pounders.	43 lbs. 4 (
24 "	28 " 8¾
18 "	21 " 4½
12 "	14 " 7

There was very little alteration in the batteries of ships for a long period previous to the year 1806. Car-

* Simpson, 1859.

†

Simmons, 1837.

ronades of small weight and large calibre **took** the **place** in many cases of the 9- and 12-pounder long guns. Carronades were short, without trunnions, having a loop on the outside which set between lugs on the bed, a bolt passing through the lugs and the loop ; the bed was mounted on a slide. The name was derived from the Carron factory in Scotland, the first pieces of the kind having been made there in 1779 ; they were of large calibre and of light proportional weight. The powder charge was small, but at close quarters they were very effective.

One great objection to the batteries of the age was the variety of calibres crowded together in the same ship and sometimes on the same deck. Each calibre had to have its own ammunition which greatly multiplied difficulties of storage and complication of distribution. The introduction of carronades assisted very much in meeting some of these difficulties. In order to combine a gun which was too light for effect with one that was too heavy for convenient manoeuvring and rapid manipulation, the 18-pounder came into use as a favored battering-piece. The next higher calibre was used occasionally on the lower decks against antagonists having sides which required shot of greater penetration than the 18-pounder. For the upper decks of ships, however, this gun was found too heavy and occupied too much room ; 9-pounders therefore were substituted on these decks ; that calibre, however, not giving enough weight of blow, the carronade was introduced. The 32-pound carronade and carriage weighed about the same as that of the long 9. By this substitution, therefore, no weight was added, but much was gained in effect, especially at short range, the 32-pound shot having almost double **the** percussive force. The carronades had **from sixty to eighty pounds of metal for every pound of shot.** Few

guns now are made with less than one hundred pounds of metal to one of shot, and the heaviest average about one hundred and twenty-three pounds of metal to one of shot. If the superiority of the longer guns were taken into consideration the comparative force would differ somewhat from the universally accepted comparisons.*

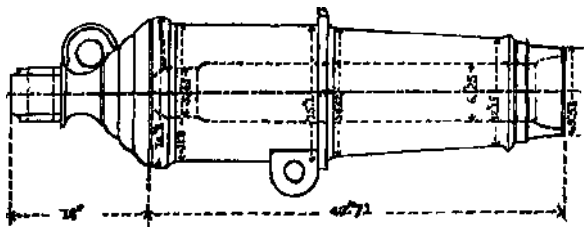

32-Pound Carronade, 1779.—Weight, 17 cwt.

The following tables give the officially authorized armaments of the periods indicated in each table:

SCALE FOR ARMING THE DIFFERENT RATES IN THE BRITISH NAVY WITH CARRONADES, . . . AS DRAWN UP BY ORDER OF THE BOARD OF ADMIRALTY, JULY 13, 1779 †

Rate.	Class.	Quarter-deck.		Forecastle.		Poop.		Total] number of carriage guns.
		No.	Pdrs.	No.	Pdrs.	No.	Pdrs.	
First.	100-gun ship.			2	12	8	12	110
Second.	90 or 98 "			4	12	6	12	100 or 108
Third.	74			2	12	6	12	82
	64			2	12	6	12	72
Fourth.	50	2	24	2	24	6	12	60
	(44)	8	18	2	18			54
Fifth.	38	6	18	4	18			48
	1 36	4	18	4	18			44
	132	6	18	2	18			40
Sixth.	(28)	4	18	2	18			34
	24	6	12	4	12			34
Sloops.	f 20 "	6	12	2	12			28
	j 18 , 16, and 14 I ship-rigged.	6	12	2	12			j 26 , 24 , (and 22

* Simpson, 1859.

f James.

TABLE OF THE ESTABLISHED ARMAMENTS OF FRENCH SHIPS AT THE
END OF THE EIGHTEENTH CENTURY.*

Class.	First or main deck.		Second deck.		Third deck.		Quarter-deck				Forecastle.		Poop.		Total No.	Comple- ment.	
	Brass		Brass		Brass		Brass				Brass		Brass				
	No.	Pdrs.	No.	Pdrs.	No.	Pdrs.	No.	Pdrs.	No.	Pdrs.	No.	Pdrs.	No.	Pdrs.			
120-gun ship.	32	36	34	24	34	12	14	8				6	8	4	36	124,1098	
110 "	30	36	32	24	32	12	12	8				4	8	4	36	114	1037
80 "	30	36	32	24			12	12				6	12	6	36	86	840
74 "	28	36	30	24			12	8				4	8	4	36	78	690
40-gun frig.	28	18					10	8	2	36		2	8	2	36	44	33 ⁰
38	26	18					10	8	2	36		2	8	2	36	42	32(7)
36	26	12					8	6	2	36		2	6	2	36	40	300
32	26	12					4	6	2	36		2	6	2	36	36	275
28	24	8					6	36				2	6			32	200)

In the battle of the Nile, it is probable that the actual number of guns approximated closely to the nominal, and that the following tables, taken principally from James's " Naval History," are correct:

LIST OF SHIPS ENGAGED IN THE BATTLE OF THE NILE (ABOUKIR),
AUGUST 1 AND 2, 1798. ENGLISH FLEET.

Class	No.	Number of Guns.		Command.	
		Nominal.	Actual.		
Gun- ship	Vanguard	74		(Rear-Adm. (b.) Sir Ho- • j ratio Nelson, K. B. (Captain Edward Berry	
	Orion	74		Captain Sir James Saumarez	
	Culloden	74		" Thomas Troubridge	
	Bellerophon	74		" Henry D'Ebterre Darby	
	Minotaur	74		" Thomas Louis	
	Defence	74		" John Peyton	
	Alexander	74		" Alexander John Ball	
	Zealous	74		" Samuel Hood	
	Audacious	74		" Davidge Gould	
	Goliath	74		" Thomas* Foley	
	Majestic	74		" George Blagden Westcott	
	Swiftsure	74		" Benjamin Hall iowell	
	Theseus	74		" Ralph Willett Mil- ler	
	Leander	50		" Thomas Boulden Thompson	
			1,012		

* James.

LIST OF SHIPS ENGAGED IN THE BATTLE OF THE NILE (ABOUKIR),
AUGUST 1 AND 2, 1798. FRENCH FLEET.

Class.	Name.	Number of Guns.		Command.
		Nominal.	Actual.	
Gun-ship	Orient	120		Vice-Adm.—Brueys Rear-Adm. Honore Gaulteaume < Commodore—Casa- [Bianca (Rear-Adm. Armand- •< Sim.-Mar Blanquet (Captain Maurice Gillet (Rear-Adm. P.-C.-J.-Bap. Silv. Villeneuve (Captain—Saulnier
	Franklin	80		Commodore Arist.-Aub. du Petit-Thouars
	Guillaume Tell	80		Commodore Henri-Alexan- dre Thevenard
	Tonnant	80		Captain—Le Joille
	Aquilon	74		" Etienne Dalbarade
	Genereux	74		" Jean-Pierre Etienne
	Conquerant	74		* Jean-F.-Timothee Trullet, sen.
	Heureux	74		*—Cambon.
	Guerrier	74		" Pierre - Paul Ra- cord
	Mercure	74		* Maurice - Julien Emeriau
	Souverain Peuple	74		Jean-Fr.-Timothe'e Trullet, jun.
	Spartiate	74		C Rear-Adm. Denis Decres I Captain Eleonore-Jean • (Nic. Soleil
	Timole*on	74		Captain—Villeneuve " Pierre-Jean-Stande- let
Frigate	Diane	40		1 " Claude Jean Martin
	Justice	40		
	Artemise	36		
Brig	Se'rieuse	36		
	Alerte	18		
Bomb	Railleur	14		
	Hercule	8		
	Salamine	8		
		1	1,226	

COMPARATIVE FORCE AND LOSS AT THE BATTLE OF THE NILE
(ABOUKIR).*

Fleet.	Number of guns.	Loss.	
		Killed.	Wounded.
English.	1,012.	218.	678.
French.	1,226.	2,000.	

In the battle of Trafalgar James considers twenty-seven and thirty-three a fair criterion of the relative forces, and that 2,148 and 2,626 represent the aggregate number of rated guns on each side. The following tables are based upon James, but certain modifications have been made to conform to some of the figures found in his text.

LIST OF SHIPS ENGAGED IN THE BATTLE OF TRAFALGAR, OCTOBER
21, 1805. ENGLISH FLEET.

Class.	Name.	Number of Guns.		Command.
		Nominal.	Actual.	
Gun-ship.	Victory	100	102	f Vice-Adm. (w.) Lord Nelson, K. B. J Captain Thomas Masterman Hardy Vice-Adm. (b.) Cuthbert I Collingwood J Captain Edward Roth- [eram (Rear-Adm. (w.) the Earl < of Northesk (Captain Charles Bullen Captain Eliab Harvey
	Royal Sovereign	100	112	" Richard Grindall
	Britannia	100	108	" Thomas Francis Fremantle
	Temeraire	98	102	
	Prince Neptune	98	104	

* James.

Class.	Name.	Number of Guns.		Command.
		Nominal.	Actual.	
Gun-ship	Dread-nought	98	104	Captain John Conn
	Tonnant	80	90	Charles Tyler
	Belleisle	74	90	" William Hargood
	Revenge	74	82	" Robert Moorsom
	Mars	74	82	" George Duff
	Spartiate	74	82	" Sir Francis Laforey, Bart.
	Defiance	74	82	" Philip Charles Durham
	Conqueror	74	82	" Israel Pellew
	Defence	74	82	" George Hope
	Colossus	74	82	" James Nicoll Morris
	Leviathan	74	82	" Henry William Bayntun
	Achille	74	82	" Richard King
	Bellerophon	74	82	" John Cooke
	Minotaur	74	82	" Charles John Moore Mansfield
	Orion	74	82	4. Edward Codrington
	Swiftsure	74	82	William George Rutherford
	Ajax	74	82	Lieut. John Pilfold
	Tnunderer	74	82	" John Stockham
	Polyphemus	64	68	Captain Robert Redmill
	Africa	64	68	" Henry Digby
Agamemnon	64	68	" Sir Edward Berry	
Frigate	Euryalus	40	40	" Hon. Henry Blackwood
	Naiad	40	40	" Thomas Dundas
	Phcebe	40	40	" Hon. Thomas Bladen Capel
Schooner	Sirius	40	40	" William Prowse
	Pickle	16	18	Lieut. John Richards Lapenotiere
Cutter	Entrepreneurante	12	14	" John Puer
		2,336	2,542	

LIST OF SHIPS ENGAGED IN THE BATTLE OF TRAFALGAR, OCTOBER 21, 1805. FRENCH FLEET.

Name.	No. Guns. Nom. Act	Command.
Gunship Bucentaure	80 86	(Vice-Ad. P.-Ch.-J.-B.-S. Ville* ^ neuve Capt. Jean-Jacques Magendie Rear-Ad. P.-R.-M.-E. Duma- noir-le-Pelley (Capt. Jean-Marie Letellier
Formidable	80 86	< Comm. Esprit-Tranquille Maistral
Neptune	80 84	Comm. Jean-Joseph Hubert
Indomptable	80 80	
Algeciras	74 78'	j Rear-Ad. Charles Magon Capt. Gabriel-Auguste Brouard
Pluton	74 78	Comm. Julien-Marie Cosmao-Ker- julien
Mount Blanc	74 78	Comm. Guill.-Jean-Noel La Ville- gris
Intrepide	74 78	Comm. Louis-Antoine-Cyprien Infernet
[Swiftsure	74 78	Capt. C.-E.-L'Hospitalier-Ville* madrin
Aigle	74 78	Pierre-Paul Gourrege
(Scipion	74 78	Charles Berengerf
[Duguay-Trouin]	74 78	Claude Touffet
Berwick	74 78	Jean-Gilles Filhol-Camas
Argonaute	74 78	Jacques Epron
Achille	74 78	Gabriel Denieport
Redoutable	74 78	Jean-Jacques-Etienne Lucas
Fougueux	74 78	Louis Alexis Beaudouin †
Heros	74 78	Jean-Bap.-Jos.-Remi FouUin
ICorne'lie	40 44	Martinea
Hermione	40 44	Mahe
Hortense	40 44	Lameillerie
Rhin	40 44	Chesneau
Themis	40 44	Jugan
Argus	40 44	Tallard
Furet	40 44	Demay
	1,636	1,736

* James in his text estimates the armaments of the 74's in this action to have been from 82 to 84 guns.

f Gravicre states that the *Snpion* was commanded by Captain Bel-langer and the *Fougueux* by Louis Alexis Baudouin.

LIST OF SHIPS ENGAGED IN THE BATTLE OF TRAFALGAR, OCTOBER 21, 1805. SPANISH FLEET.

Class.	Name	Number of Guns.		Command.
		Nominal.	Actual.	
Gun-ship	Santissima Trinidad	130	126	fRear-Adm. Don B. Hidalgo Cisneros j Commod. Don Francisco de Uriarte j Admiral Don Frederico Gravina
	Principe de Asturias	112	112	j Rear-Adm. Don Antonio Escano [Vice-Adm. Don Ign. Maria de Alava
	Santa Ana	112	112	j Captain Don Josef Gardoqui
	Rayo	100	100	Commod. Don Enrique Macdonel
	Neptuno	80	82	" Don Cayetano Valdes
	Argonauta	80	82	" Don Antonio Parejas
	Bahama	74	78	Captain Don Dionisio Galiano
	Montanez	74	78	" Don Josef Salzedo
	San Augustin	74	78	" Don Felipe Xado Cagigal
	San Ildefonso	74	78	" Don Josef Bargas
	S. Juan Nepomuceno	74	78	" Don Cosme Churruca
	Monaica	74	78	" Don Teodoro Argumosa
	S. Francisco de Asis	74	78	" Don Luis de Flores
	San Justo	74	78	" Miguel Gaston
	San Leandro	64	68	" Josef Quevedo
		1,270	1,306	

Napoleon's estimate of the value of the Spanish fleet is best described in his letter to Admiral Decres, August 13, 1805, viz. : " Villeneuve will notice in my calcula-

tions that I wish him to attack every time that he is superior in number, *counting two Spanish ships only as one.*"*

Of the thirty-three ships that composed the combined fleets of France and Spain in the action of the 21st of October, 1805, off Cape Trafalgar (exclusive of the French frigates and brigs), four were sent to Gibraltar, sixteen were destroyed, nine returned to Cadiz (but four of these were serviceable), and four escaped to the southward. Captain the Hon. Henry Blackwood, commanding the English frigate *Euryalus*, stated that the actual number of ships taken and destroyed was nineteen sail-of-the-line.f

Graviere gives the following figures relating to the battle of Trafalgar:

Fleet.	Number of Guns.	Killed.	Wounded.
English	2,148	4494	1241§
French	1,356	2,313†	
Spanish	1,270	1,000	1,383

The man who shot Nelson has been discovered, through his own memoirs, to have been Sergeant Robert Guillemard. He was stationed in the rigging of the *Redoutable*, and busied himself in picking off men on the *Victory*. He writes : " In the stern of the *Victory* stood an officer covered with decorations, who had only one arm. From what I had heard of Nelson, I had no doubt that it was he. As I had received no command to come down out of the rigging, and found myself forgotten in the top, I deemed it my duty to fire into the stern of the English ship, which I saw unprotected and quite near. I might have aimed at particular individuals, but I pre-

* Graviere.

†

" Nelson's Dispatches."

%

James.

§ Accounted for, but loss much greater.

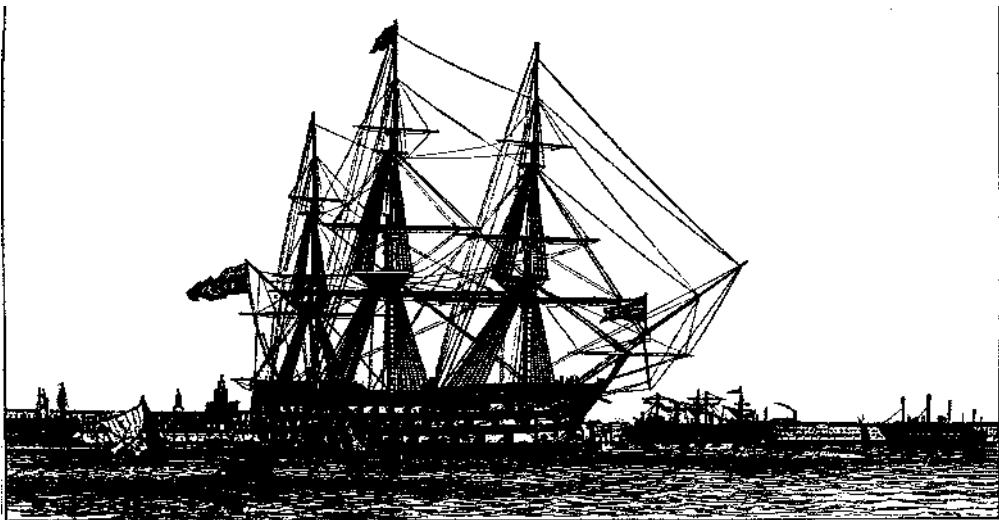

H. M. S. VICTORY," FIRST RATE, 104 GUNS, LYING IN PORTSMOUTH HARBOUR.

THE FLAG SHIP OF LORD NELSON ON BOARD OF WHICH HE WAS KILLED OFF TRAFALGAR, OCTOBER 21, 1

ferred to fire into the separate groups which surrounded the different officers. All at once I perceived a great commotion on board the *Victory*. The people crowded around the officer in whom I believed I had recognized Lord Nelson. He had fallen to the deck, and they carried him away at once, covered with a mantle. The excitement among the *Victory's* crew confirmed me in the belief that I had not been deceived, and that it was indeed the English Admiral. A moment later the *Victory* ceased firing."

To contrast the Navy of to-day with that of the time of Nelson, look at the *Victory* as she lies at her moorings in Portsmouth Dock-Yard, combined with her surroundings of scientific accessories of modern naval warfare.

If her dimensions alone and those of the magnificent battle-ships named in commemoration of the Hero's great victories at Aboukir and Trafalgar are compared, no startling difference will appear. The *Victory* has an extreme length of 226 feet ; three gun-decks of 186 feet, mounting 30 guns each ; a beam of 52 feet, and 2 feet depth of hold. But, being built of wood, her displacement, when fully equipped and manned, was only 2,200 tons. The *Nile* and *Trafalgar* have a length of 345 feet ; a beam of 73 feet, with a draught of 27½ feet. Fully equipped and manned, each will displace 12,500 tons. But while the battle-ship carries but four (4) guns in her main battery and but 26 more in the auxiliary, the *Victory* carried 102 guns into action at Trafalgar. The weight of metal in her entire broadside, however, amounted to but 1,180 pounds, while one alone of the heaviest guns of the *Nile* and *Trafalgar* will throw a shell of 1,250 pounds' weight, which will penetrate 29 inches of iron, and their individual broadsides

will aggregate more than 5,000 pounds. Built of steel, these battle-ships are without masts (except a military one), and are driven by high-pressure steam at a speed of 16½ knots, while the *Victory* was of wood and driven by sails.

*Nelson*s Visit to Portsmouth, 1798.*

SIR: — I have just read your interesting "Life of Nelson" in the "Heroes Series," and think you may feel interested in what I have to tell you, in reference to a possible second edition.

You quote Southey, in a rather doubtful way, in reference to Nelson's embarkation for his last voyage. I think I can give you positive information and somewhat interesting details even at this distant point of time.

An uncle of my own died here December 9, 1878, aged 81. He used to relate what was probably more a family tradition, or rather what he had heard from his father, than a matter of certain memory of his own, in all its details, the following:

On the day to which you refer, Mr. Samuel Price, of Warblington Street, Portsmouth, a pawnbroker there, took his young son, Matthew Porter Price, to join the crowds of people who went to get a sight of Nelson, but finding the street in the neighbourhood of the George Hotel so full of people that there was small chance of seeing anything, and having regard to the safety of his son, he made his way to Southsea Beach, whence he might get a distant view of the exciting event and see the boat as it passed through Spithead. While on the beach Mr. Price was much surprised to see Nelson approach from the town with one or two companions, and **told** his lad to take off his cap when the gentleman

who was approaching came near, and have him take notice of him, for he was the great Lord Nelson. The Admiral's barge or boat was on the beach at the spot where afterwards Hollingsworth's Assembly Rooms were built. As Nelson was about to embark, he beckoned to Mr. Price, requesting him to return to the town and make known to the waiting crowd at the George Hotel that he was already embarked and on his way to his ship. Mr. Price spoke to him a little, and in the conversation asked to be excused for the liberty, but, as a humble but Christian man he ventured to remind his Lordship that he was going on a dangerous expedition, from which he might never return, and that he ought to think of the concerns of his soul. Nelson thanked him for his freedom in speaking on the subject, and said that life on board ship was not favourable to piety, but he added " I think more of those things than people will give me credit for."

My uncle was standing, in the meantime, cap in hand, looking up at the great man, who then patted his head, and said to his father that, if he ever thought of sending his little fellow to sea, he would be glad to be of service to him, if Mr. Price applied to him.

As described in Southey, Nelson, with one or two attendants, he desiring to shun the deep excitement of the crowded street, and possibly under great tension of feeling from having so recently parted from Lady Hamilton and his daughter, passed by the back of the inn into Penny Street, and so by Green Row and the gate leading to Southsea reached Southsea Beach, where his barge was in waiting.

Portsmouth people of the present day would possibly fail to comprehend how Nelson would be likely to be at **the** George, as all great people embark from the Dock-

yard now. But in my young days the place of embarkation and landing for the Royal Navy was at some stairs close to the High Street semaphore, on the harbour side. The Port-Admiral's headquarters or offices being in an old house opposite the George Hotel, this hotel was frequented by the superior officers, the Fountain Hotel by lieutenants and midshipmen.

My uncle's credibility was of a high order, his mind being remarkable for clearness up to the time of his death. He was brought up as a printer, and afterwards became "reader," and was employed by Charles Knight, then in Ludgate Hill, and for him "read" the *Penny Cyclopaedia* and many other noted publications of the time ; finally, on Knight's failure, passing to Clowes's Sons, with whom he remained until his inability to pass a first-class proof to press with one reading, as younger men then undertook to do, gave him his signal to retire upon his savings and a small patrimony which had come to him while at Clowes's. I have heard him relate that he had "read" the *Nautical Almanack* on one occasion when, from some unusual circumstances, it had to be reprinted in a week. He was often upon the *Quarterly Review*, and told of his detecting Wilson Croker, the editor, in blunders from time to time. Though my uncle was remarkably free from conceit, he referred to this fact with some enjoyment.

I am, Sir,

Yours truly,

S. PRICE.

INDEX.

- Aboukir Bay, the French fleet in, 95 ; Nelson enters, 99 ; battle of, see battle of the Nile.
- Achille*, the, on fire at Trafalgar, 301 ; romantic story, 302
- Acre, siege of, raised, 146
- Active*, the, watches Toulon, 247 ; notifies Nelson of the sailing of the French fleet, 247
- Acton, Sir John Francis, Prime-Minister of Naples, 44 ; convenes a council, 94 ; letter from Nelson, 227
- Adair, Captain, marine officer on the *Victory*, 294 ; killed at Trafalgar, 295
- Addington, Right Honourable Henry, Nelson forwards him a statement of accounts, 223 ; letter from Nelson, 224
- Agamemnon*, the Nelson in command of, 42 ; sails from Gibraltar, 42 ; meets the *Tartar*, 43 ; in action off Sardinia, 47 ; reported capture of, 54 ; captures the *Qua Ira* and *Le Censeur*, 57 ; goes to Leghorn to refit, 62 ; her battered condition, 62 ; rendered famous by Nelson, is sent home, 63 ; flies signal of distress at Copenhagen, 183
- Aggerstans*, the, sunk at Copenhagen, 195
- Agincourt*, the, cruises off Toulon, 228
- Agincourt Sound, in the **Magdalena Islands**, 247
- A/ax*, the, at the battle of Trafalgar, 304
- Alava, Vice-Admiral, commands the van of the combined fleet, 274 ; Collingwood goes for him, 285
- Albemarle* the, Nelson commands, 21 ; arrival of, at Elsinour, 21 ; paid off, 27
- Albert, Prince, dies at sea, **130**
- l'Alcide*, surrendered and destroyed by fire, 60
- Alcmena*, the, her boats at the evacuation of Naples, 128
- Alexander*, the, in the Gulf of Lyons, 90 ; sails for Naples, 114 ; reception at Naples, 116 ; at the blockade of Valetta, 125 ; at Malta, 133 ; in the action off Valetta, 151 ; Nelson's flagship, 159
- Alexander I. sends pacific proposals, 201
- Alexandria, Nelson seeks the French fleet at, 93 ; arrives off, 96
- Alicante, British fleet off, 249
- Allen, Nelson's servant, insists on his taking rest, 178
- Alliance, a defensive, **between Spain and the French Directory**, 63
- Allott, Dr., Dean of Raphoe, **letter from Nelson to, 3 (note)**

- Amag Island, one of the defences of Copenhagen, 177
- Amazon*, the, Nelson on board of, 176; leads the fleet at Copenhagen, 176; prepares to receive Nelson, 209; chases French frigates, 238
- Amiens, peace of, 221
- Amphion*, the, Nelson shifts his flag to, 225; a fast ship, 226; cruises off Toulon, 228; intercepts the Spanish frigates, 245
- Ancona, Russian squadron at, 160
- Andrews, Miss, Nelson in love with, 28
- Andromeda*, the, Prince William Henry in command of, 41
- IJAquilon* surrenders at battle of the Nile, 100
- Apulia in revolt, 133
- Archimedes*, the, a Neapolitan corvette, 129
- Armaments, comparison of (Appendix), 318; table of (Appendix), 325
- Audacious*, the, in the advance at Aboukir, 99; off Valetta, 151
- B
- Badger*, Nelson commands the, 17
- Ball, Captain Sir Alexander, with Nelson at St. Omer, 29; assists Nelson in the Gulf of Lyons, 90; on board the *Vanguard*, 91; at the blockade of Valetta, 125; forces Gozo to capitulate, 125; at Malta, 133; instructions from Nelson, 146; arduous duty, 147; seizes corn at Messina, 148; complains of General Pigott, 168; Nelson's letter to, 239
- Barbadoes, Nelson at, 31
- Barjieur*, the, at New York, 24
- Barrow, Sir John, surprised at Lord St. Vincent, 73
- Bastia, Nelson's report on, 49; Lord Hood demands the surrender of, 50; capture of, 51
- Bath, Nelson resides at, 21; Nelson again at, 37
- Batteries, French and Spanish heavier than the British (Appendix), 321; comparison between the *Santissima Trinidad* and *Victory* (Appendix), 322
- Batthyany, Count, aquatic fete, 160
- Beatty, Dr., surgeon III the *Victory*, 269; on the personal habits of Nelson, 270; assists Nelson when wounded, 292
- Beckford entertains Nelson, 166
- Belleisle*, the, cruises off Toulon, 228; opposed to the Toulon fleet, 229; off Hyeres, 238; left off Toulon, 243; Nelson orders her masts painted, 273
- Bellerophon*, the, at the battle of the Nile, 104
- Bellona*, the, with Nelson at Copenhagen, 179; luns aground, 180; flies signal of distress, 183
- Bequieres, island of, in Aboukir Bay, 104
- Berry, Lieutenant, in possession of the *San Nicolas*, 71
- Berry, Sir Edward, Nelson's practice during the cruise, 97; catches Nelson when wounded, 105; tells Nelson *L'Orient* is on fire, 107; boards *Le G'nJ-reux*, 153; captures/*? *Guillaume Tell*, 155
- Bethune, Colonel, on board the *Minerve*, 67
- Bickerton, Rear-Admiral Sir Richard, Nelson in search of, 227; Nelson joins, 228; cruising off Toulon, 228
- Blackwood, Captain, commands the *Penelope*, 156; arrives in London, 262; calls on Nelson, 263; despatched to Collingwood, 266; sends word to Nelson, 268; exacting duties, 268; letter to his wife, 271; Nelson's remark to, 279; suggestions to Nelson, 281; witnesses

- Nelson's will, 282 ; leaves the *Victory*, 286
- Blanche*, the, accompanies the *Minerve* to Porto Ferrajo, 64
- Blanquet, Rear-Admiral, disappears of Bruey's plans, 96 ; wounded, 101 ; arrives at Naples, 116
- Blenheim, Nelson visits, 220
- Blenheim*, the, at the battle of St. Vincent, 70
- Bolton, Mrs., presented by Nelson with a gift of money, 141 ; money voted her in honor of Trafalgar, 311
- Boreas*, the Nelson in command of, 29 ; midshipmen on board of, 30 ; reaches Barbadoes, 31 ; examination in the cabin of, 32 ; sails for England, 36 ; receiving ship at the Nore, 36
- Bornholm, Nelson makes his last cruise in the *Si. George* off, 204
- Boulogne, the central *rendezvous* of the French flotilla, 210 ; Nelson repulsed off, 211
- Box Hill, Nelson and party at, 208
- Breckon, Nelson's reception at, **220**
- Brenton, Captain, 7 ; story of Nelson, 155 ; story of the flag, 192
- Brereton, General, false information to Nelson, 251 ; Nelson's irritation at, 252
- Brest, English ship fired at from, 42
- Briarly, master of the *Bellona*, offers to pilot Nelson, 179 , accompanies Nelson, 199
- Brisbane, Captain, accompanies Nelson, 176
- Bristol*, the, Nelson appointed to, 17
- British, the, their intrepidity, 196
- British Navy, mutinous spirit in, 77
- Brock, Colonel Isaac, commands the 49th Regiment, 170
- Bromwich, Lieutenant, with Nelson at the Tower, 15
- Brueys, Admiral, insolently exultant, 95 ; calls a council of officers, 96 ; killed, 101
- Bucenlaure*, the, La Touche-Treville dies on board of, 240 , flag-ship of Villeneuve, 244 ; fires the first shot at the *Victory*, 287 ; raked by the / victory, 289 ; effect of the *Victory's* guns, 290
- Budd, Dr., 44
- Bulkeley, *auit-de-camp* on the *Victory*, 296
- Buonaparte, arrives off Malta, 124 ; orders flotilla to assemble at Boulogne, 211 ; contemplates war while negotiating the treaty of Amiens, 221 ; astonished at the promptitude of the British, 222 ; intended to invade England, 305
- Burke, purser of the *Victory*, assists Nelson wounded, 292
- Burnham Thorpe, birthplace of Nelson, 1 ; Nelson retires to, **37**

C

- Cadiz, bombardment of, 78 ; British fleet off, 245 ; strength of the combined fleet at, 268 ; provisions growing scarce at, 269 ; blockaded, 269 ; the combined fleet put to sea from, 274
- Cagliari, Nelson at, 47
- Qa Ira*, the, attacked by the *Inconstant*, 57 ; captured by Nelson in the *Agamemnon*, 57
- Calabria in revolt, 133
- Calais, Lady Hamilton dies at, 313
- Calder, Sir Robert, prevails with Sir John Jervis to omit Nelson's name from the dispatch, 73 ; news of his action, 258 ; defeats Napoleon's plan, 305

- Calvi, attack on, 53 ; capture of, 54
- Campbell, Nelson's secretary on the *Vanguard*, 107
- Canada, Lord St. Vincent's prophecy respecting, 218
- Canopus*, the, detached from Nelson's fleet, 229 ; with Nelson off Hyeres, 238
- Capel, Lieutenant, goes on board the *Minotaur*, 106 ; Nelson signs his commission to the *Mutine*, 107
- Cape of Good Hope, the possession of, ridiculed by Nelson, 217
- Capri hoists Sicilian colors, 132
- Capua attacked by Troubridge, 143
- Captain*, the, Nelson in command of, 63 ; in the battle of Cape St. Vincent, 70 ; engaged with nine line-of-battle ships, 71 ; captures the *San Nicolas*, 71 ; captures the *San Josef*, 72
- Caracciolo, Francesco, history of, 137 ; trial of, 138 ; execution, 139 ; the rising of his body, 140
- Carcass*, the Arctic voyage of, 10 ; Nelson as coxswain of, 10 ; returns to England, 10
- Carlisle Bay (Barbadoes), Nelson arrives at, 15 ; Nelson again at, 251
- Carlsrona, British fleet cruises off, 201
- Carronades (Appendix), 324
- Carthage, action off, 64
- Castel-li-Mare capitulates, 134
- Castel-del'Uovo capitulates, 134
- Castel Nuovo capitulates, 134
- Castel San Giovanni, mishap at, 160
- Championet holds Naples, 132 ; succeeded by Macdonald, 133
- Charlotte-Amelia*, the, burnt at Copenhagen, 195
- Chatham, Nelson at, 5
- Chatham, Lord, on the British Navy, 18 ; neglects Nelson, 41 , receives news of Trafalgar and of Nelson's death, 310
- Clarence, Duke of, see Prince William Henry
- Clavell, Lieutenant, advised by Collingwood, 284
- Cochrane, Lord, impression of Nelson, 154
- Coehorn (Appendix), 323
- Coleridge, in defence of Captain Ball, 148 ; affected by news of Nelson's death, 310
- Collingwood, Lord Cuthbert, compared with Nelson, 3 ; first sea experience, 7 ; succeeds Nelson in the *Loioestoffe*, 17 ; averse to Mrs. Moutray, 33 ; at the battle of St. Vincent, 73 ; account of the Queen of Naples, 115 ; on Nelson's reception at Court, 162 ; leads the leeward column at Trafalgar, 283 ; Smith's account of, 283 ; orders part of the prizes to be destroyed, 303 ; his Trafalgar dispatch published, 309 ; made a peer, 312 ; his services (note), 312
- Colossus*, the, signals that the enemy's fleet is at sea, 273
- Comyn, chaplain on the *Vanguard*, 105
- Conqufrant, Le*, cut up at battle of the Nile, 100
- Conway, Lord Hugh Seymour, on board the *Tartar*, 43
- Copenhagen, fortifications of, 173 ; the British fleet off, 176 ; battle of, 180 ; damage to, 195 ; results of the battle of, 207
- Cornwallis, Cuba, nurses Nelson, 20
- Cornwallis, Admiral Sir William, saves Nelson's life, 21 ; instructions from the Admiralty, 245 ; Nelson joins, 257
- Corsica, island of, necessary to the British, 49 ; coast ravaged

- by Nelson, 49 ; evacuation of, 63
- Cotgrave, Captain, fails in the attack off Boulogne, 211
- Cronburg*, the, taken and burnt, 195
- Crown battery, the, see *Trekroner*
- Cruiser*, the, with Nelson at Copenhagen, 176
- Culloden*, the, hastens to Nelson's assistance, 70 ; sails for Teneriffe, 80 ; goes ashore in Aboukir Bay, 104 ; floated off, 108 ; sails for Naples, 114 ; reception at Naples, 116
- Culverhouse, Lieutenant, exchanged, 66
- Cumberland*, the, captures *L'Alcide*, 60
- D
- Dalling, General, Governor of Jamaica, appoints Nelson to command batteries at Port Royal, 18
- Danes, the, courage of, 196 ; brothers of the English, 196 ; worthy foes, 197
- Danish fleet, destruction of, at Copenhagen, 195
- Dannebrog*, the, opposed to Nelson at Copenhagen, 180 ; surrendered and in flames, 186 ; destruction of, 189
- Darby, Captain, wounded at battle of the Nile, 104
- Davis, Isaac, possessed Nelson's certificate to Carver, 23
- Davison, Alexander, intimate association with Nelson, 24 ; dines with Nelson, 28 ; strikes a medal in honor of battle of the Nile, 113 ; writes to Nelson, 121 ; instructed by Nelson regarding Lady Nelson, 165 ; instructions to, regarding Mrs. Maurice Nelson, 200 ; Nelson's letter to, threatening La Touche-Treville, 239
- Deal, Nelson arrives at, 210 ; Parker buried at, 213
- Decres, Contre-Admiral, surrenders *Le Guillaume Tell*, 155
- Defence*, the, hastens the surrender of the Danish ships, 188
- Defiance*, the, at the battle of Copenhagen, 185 ; aground, 189
- Denmark, Lord Whitworth despatched to the Court of, 168 ; menacing attitude of, 169 ; agrees to an armistice, 195
- Desir'e*, the, assists to save the *Isis*, 182
- D'Estaing, Count, arrives at Ilispaniola, 18
- De Vins, General, 59 ; his tardiness, 61
- Digby, Admiral, Nelson waits on, 24
- Dixon, Captain Manley, account of capture of *Le Guillaume Tell*, 155
- Dolphin*, Nelson leaves the East Indies in the, 12
- Donegal*, the, cruises off Toulon, 228 ; with Nelson off Hyeres, 238 ; intercepts the Spanish frigates, 245
- Draco Point, Nelson anchors off, 177
- Drake, Mr., British Minister at Genoa, 54
- Drury, Admiral, despatches Captain Blackwood from the Irish station, 262
- Duckworth, Admiral, sent to Minorca, 144
- Dumanoir-le-Pelley, Admiral, succeeds La Touche-Treville, and is succeeded by Villeneuve, 244 ; commands the rear of the combined fleet, 274 ; flies from Trafalgar, 301
- Dundas, Sir David, doubts the probability of the fall of *Bastia*, 50

E

- Ealing*, the, assists in towing the *Zealand*, 193
- East India Company presents Nelson with ten thousand pounds, 113
- Edgar*, the, first in action at Copenhagen, 180
- Elephant*, the, the signal to weigh from, 176; Nelson dines the captains on board, 178; Nelson assembles the pilots on board, 179; in the battle of Copenhagen, 180; attacks the *Dannebrog*, 180; instance of courage on board, 182; surrounded by the enemy, 183; renews the attack on the *Dannebrog*, 186; aground and floated off, 189; Lady Hamilton's pictures on board, 191
- Elephanten*, the, Nelson on board, 192
- Elliot, Sir Gilbert, appointed Viceroy of Corsica, 49; occupies Porto Ferrajo, in Elba, 66; embarks with Nelson, 66; arrives at Gibraltar, 66; chased in the *Miner ve*, 67
- Elsineur, Nelson arrives at, 21; Admiral Parker off, 173
- Emerald* the, sails for Teneriffe, 80
- England, at war with France and Spain, 17; declares war with France, 221
- Epaulet, the, introduction of, in the British Navy, 59
- Este Lambton, story of Nelson, 242
- Esterhazy, Prince and Princess, feast Nelson, 160
- Euryalus*, the, sent to Collingwood, 266; watches the enemy, 268
- Excellent*, the, with Nelson off Hyeres., 238

F

- Farmer, Captain, commands the *Sea Horse*, 11
- Faversham, Nelson halts at, 210
- Fearney, William, on board the *San Josef*, 72
- Featherstonehaugh, Sir Harry, 45
- Ferguson, surgeon of the *Elephant*, 189
- Ferrol, Spanish force collected at, 245; blockaded by Admiral Cornwallis, 245
- Finisterre, Cape, the combined squadron reaches, 253
- Fischer, Commodore, commands the *Dannebrog*, 180; sums up the loss of the Danes, 195
- Fisgard*, the, left off Toulon, 243
- Florence, the Royal party at, 159
- Foley, Captain, Napier's claim for, 97; dines on board the *Elephant*, 178; consulted by Nelson, 188
- Fonthill, residence of Beckford, 166; reception of Nelson at, 167
- Foote, Captain, commands the *Sea Horse*, 133; attacks the sea defences of Naples, 134; signs terms of capitulation, 134
- Foreigners, hated by Nelson, 115
- Foudroyant*, the, arrives at Naples, 135; Cardinal Ruffo on board, 135; trial of Caracciolo on board, 138; the King of Naples dines on board, 142; Nelson hoists his flag on board, 150; captures *Le Guillaume Tell*, 155; returns to Palermo, 157; Nelson's quarters onboard, 158; carries the Royal family to Leghorn, 158; sails for Minorca, 159
- Fougueux*, the, attempts to prevent the *Royal Sovereign* from breaking the line, 285; fires the first guns at Trafalgar,

- 285; receives the broadside of the *Royal Sovereign*, 285
- Fox*, the, on the Teneriffe expedition, 80; founders at Santa Cruz, 81
- France, at war with England, 17; peace concluded with, 27; sense of treaty with Naples, 93; war with, imminent, 221
- Franklin*, the, at the battle of the Nile, 101; recommences the action, 104
- Frederick, Captain, hastens in the *Blenheim* to Nelson's assistance, 70
- Fremantle, Captain, in a desperate light, 78; dines on board the *Elephant*, 178; his orders at Copenhagen, 179; consulted by Nelson, 188; accompanies Nelson to visit the Crown Prince of Denmark, 194
- French, the, poor sailors, but fine gunners, 98; trapped in Aboukir Bay, 99; overwhelmingly defeated at battle of the Nile, 109; defeated in Italy, 133
- Freya*, the, captured by a British squadron, 168; restored to Denmark, 168
- G**
- Ganges*, the, at the battle of Copenhagen, 181; fouls the *Monarch*, 188
- Gn/reux*, *Le*, escapes from Aboukir Bay, 105; flag-ship of Rear-Admiral Perree, 150; surrenders to Nelson, 151
- Genoa, Nelson at, 54
- George III., King of England, popularizes the navy, 18
- Gibraltar, Nelson at, 14; Nelson sails from, 42; the *Minerve* arrives at, 66; Nelson arrives at, 90; Saumarez, with prizes from Aboukir Bay, arrives at, 114; the *Victory*, with Lord Nelson's body, arrives at, 307
- Gibraltar*, the, cruises of Toulon, 228
- Gibson, Lieutenant, commands the *Fox* at Santa Cruz, 81
- Glation*, the, at the battle of Copenhagen, 181; renews the attack on the *Dannebrog*, 186
- Goliath*, the, leads the way at Aboukir, 99; at Malta, 133
- Goodall, Admiral, letter to Nelson, 149
- Gordon, Lord William, verses to Lady Hamilton, 208
- Gould, Captain, with Captain Darby on the *Bellerophon*, 104
- Gozo, capitulates to Captain Ball, 125
- Graeme, Admiral, Nelson dines with, 209
- Grand Signior, presents from the, and from his mother, to Nelson, 113
- Graves, Rear-Admiral, passes the Elsinour batteries, 173; reconnoitres the enemy, 173; on board the *Defiance* at Copenhagen, 185; invested by Nelson with the Order of the Bath, 204
- Gravina, Admiral, arrives at Cadiz, 263; commands the first reserve squadron of the combined fleet, 274; flies from Trafalgar, 301
- Great Britain, policy of, 222
- Great Courland Bay, Tobago, Nelson arrives at, 251
- Greenwich, Nelson's body in public state at, 309
- Grenville, Lord, Nelson demands an inquiry of, 61
- Greville, Mr. C. F., gives a fete in honour of Nelson, 221
- Greville, Honourable Charles, 45
- Grey, Commissioner, Nelson's body received on board his yacht, 308

- Guerrier, Le*, dismasted at battle of the Nile, 100
- Guillaume 7*ell, Le*, escapes from Aboukir Bay, 105 ; captured by Sir Edward Berry, 155
- Guillemard, Sergeant Robert, claims to have shot Nelson, (Appendix) 332
- Guns varieties of, (Appendix) 119 ; on the voyage to Palermo, 130; interprets for Cardinal Ruffo, 136; succeeded by Hon. Arthur Paget, 158; Nelson resides with, 208 ; fond of fishing, 208 ; death of, 224; character, of 224
- Hammond's Knowl, the *Invincible* lost on, 170
- Hanson, Levett, letter to Nelson, 4
- Hardy, Captain, reports on the French fleet, 93; commissioned to the *Vanguard*, 107 ; commands⁷ onts at the evacuation of Naples, 128 ; preserves Caracciolo from insult, 138 ; receives present from the King of Naples, 142; his daring, 177 ; dines with Nelson, 178 ; accompanies Nelson to visit the Prince of Denmark, 194 ; Nelson's second captain, 228 ; witnesses Nelson's will, 282; drives the *Victory* into the *Redoutable*, 290; at Nelson's side when he was wounded, 291; on the deck of the *Victory*, 294; Nelson's anxiety for, 295 ; visits Nelson in the cockpit of the *Victory*, 296; again reports to Nelson, 297 ; at Nelson's side, 298
- Hardy, Lieutenant, exchanged, 66 ; rescued by the *Minerve*, 68
- Harmony*, the, anecdote of, 23
- Haverford, West, Nelson at, 221
- Hawkesbury, Lord, signs the preliminaries of peace, 221
- Haydn, meets Nelson, 160
- Herbert, Mr., President of Nevis, 34
- L'Heureux* at the battle of the Nile, 100
- Hill attempts to blackmail Nelson, 214
- Hinchinbrook*, Nelson commands the, 18
- Hajen*, the, taken and burnt, 195
- Halcyon*, the, intercepts the Spanish frigates, 245
- Hallowell, Captain, delighted with Jervis, 69 ; singular gift to Nelson, no
- Hamburg, Nelson at, 161
- Hamilton, Lady, her career, 44 ; her appearance, 45; her meeting with Nelson, 46 ; intercession with the Court of Naples, 94 ; swoons on hearing of the battle of the Nile, 113 ; reception of Nelson, 117; celebrates Nelson's birthday, 120 ; share in the evacuation of Naples, 128 ; in the voyage to Palermo, 130 ; interprets for Cardinal Ruffo, 136 ; evil influence on Nelson, 147 ; cause of the separation of Lord and Lady Nelson, 163; Nelson's letter to, 190; buys Merton Place for Nelson, 212 ; at the bedside of her dying husband, 224 ; letter from Nelson, 226 ; advises Nelson, 264 ; bids Nelson farewell, 265 ; her claims not recognized, 312 ; death of, 313
- Hamilton, Sir William, British Minister at Naples, 43; receives Nelson, 44 ; marries his nephew's mistress, 45 ; opinion of Admiral Hotham, 56; receives Captain Troubridge, 94 ; goes to meet Nelson, 117 ; receives Nelson as a guest,

- Holland, Great Britain declares war against, 244
- Holstein*, the, a Danish ship, at the battle of Copenhagen, 182 ; story of, by Brenton, 192
- Hood, Captain Samuel, signals the French fleet, 96 ; quoted by Napier, 97 ; pursues the French, 105
- Hood, Lord, at New York, 24 ; at interview between Digby and Nelson, 24 ; presents Nelson to the King, 27 ; sails from Gibraltar, 42 ; receives the surrender of Toulon, 43 ; despatches Nelson under sealed orders, 47 ; Nelson's opinion of, 48 ; summons Bastia to surrender, 50 ; neglects Nelson in his dispatches, 51 ; remonstrates with the Admiralty, 59 ; resigns his command, 59 ; introduces Nelson to House of Lords, 217
- Hoste, William, opinion of Nelson, 47 ; on the Neapolitan army, 127
- Hotham, Admiral, 48 ; receives news of the French fleet, 55 ; prepares for action, 55 ; Sir William Hamilton's opinion of, 55 ; chases the French, 57 ; action with the French, 60
- Howe, Lord, applied to by Nelson for a ship, 36 ; encourages Nelson, 37
- Huen, island of, the British fleet anchor near the, 173
- Hughes, Admiral Sir Richard, sends Nelson home, 12 ; indifference to Navigation Act, 31 ; accepts thanks due Nelson, 33
- Hughes, Lady, sails with Nelson on the *Boreas*, 29
- Hunter, Mrs., buries Lady Hamilton, 313
- Hydra*, the, watches the enemy, 268
- Hyeres, Nelson off, 238
- |
- Inconstant*, the, fires into the ca Ira, 57
- Indosforethen*, the, burnt at Copenhagen, 195
- Inglefield, Commissioner, letter from Nelson to, 154
- Invincible*, the, loss of, 170
- Irresistible*, Nelson on board of the, 77
- Ischia, Troubridge hoists the Sicilian colors on, 132
- Isis*, the, in the battle of Copenhagen, 180 ; saved by the *Polyphemus*, 182
- Italians, dislike of, 115
- j
- Jaubert, Commissary, defies the British, 95
- Jeaffreson, J. C., opinion of Merlon Place, 212
- Jean Barras*, the, pursued by Admiral Hotham's fleet, 57
- Jefferson, surgeon on the *Vanguard*, attends Nelson, 105
- Jervis, John, Earl of St. Vincent, reception on shipboard, 7 ; his sea dress, 25 ; anecdote of, 25 ; neglected by the Admiralty, 39 ; arrives at St. Fiorenzo, 62 ; meets the Spanish fleet, 69 ; prepares for action, 69 ; battle of St. Vincent, 70 ; anecdote of, 74 \ gives Nelson the Spanish admiral's sword, 77 ; joined by Nelson off Cadiz, 89 ; challenged by Sir John Orde, 91 ; detaches Portuguese squadron to Nelson's assistance, 114 ; in ill-health, 143 ; affronted, 144 ; opinion of Sir Sidney Smith, 146 ; fears for Nelson, 167 ; prophecy respecting Canada, 218 ; grief at Nelson's death, 310

Jones, Captain, fails in the attack off Boulogne, 211
Jutland, the, taken and burnt, 195

K

Keats, Admiral Sir Richard, visits Nelson, 261
 Keith, Lord, opinion of Nelson's zeal, 131 ; sends for Nelson, 143 ; Commander-in-chief in the Mediterranean, 150 ; orders to Nelson, 157
 Kelim Effendi sent with present to Nelson, 128
Kent, the, Bickerton's flag-ship, 227 ; cruises off Toulon, 228 ; opposed to the Toulon fleet, 229
 King George, speech of, November 16, 1802, 222
King George, the, carries Nelson to Yarmouth, 161
 Kioge Bay, the British fleet at, 201
Kite, the, carries Nelson to Yarmouth, 208
 Klopstock visited by Nelson, 161
 Knight, Miss, Nelson's inner life, 158 ; follows the Queen of Naples, 159 ; account of the trouble between Lord and Lady Nelson, 164
 Kronenburg, castle of, saluted, 22 ; incident off, 174

L

Lagos Bay, Nelson provisions his fleet at, 250
Lark, the, used by Nelson at Copenhagen, 173
Latona, the, Nelson hauls down her broad pennant, 31
 Lauriston, General, commands the troops in Villeneuve's squadron, 247
LeancUr, the, sails for Teneriffe,

80 ; joins Nelson, 91 ; at the battle of the Nile, 101 ; receives the survivors of *JO Orient*, 102
 Leeward Islands, Sir Thomas Shirley governor of the, 31
 Leghorn Roads, Nelson joins Lord Keith in the, 150
 Leghorn, the *Agamemnon* goes to, to refit, 62 ; insurrection of the people at, 159
 Leopold, Prince, entertains Nelson, 142
Leyden, the, Nelson hoists his flag on board, 210
 Lindholm, Adjutant-General, arrives with flag of truce, 188 ; referred to Admiral Parker, 188
 Linzee, Commodore, Nelson serves under, 47
Lion, Nelson sails for England in the, 21 ; chases *Le Guillaume Tell*, 156
Lively, the, spoken, 68 ; at the battle of St. Vincent, 70
 Locker, William, commands the *Lowestoffe*, 14 ; kindness to Nelson, 14 ; letter from Nelson, 32
 London, City of, confers freedom on Nelson, 88 ; Nelson arrives at, 162 ; Nelson met by a party of relatives and friends at, 208
London, the, Sir Hyde Parker's flag-ship, 170 ; flies signal to cease action at Copenhagen, 183 ; Nelson follows Lindholm on board, 189
 Louis, Captain, assists Nelson at battle of the Nile, 106 ; thanked by Nelson, 106 ; commands the *Canopus*, 267
Lowestoffe, Nelson appointed Second Lieutenant of the, 14 ; Collingwood succeeds Nelson in the, 17
 Ludwidge, Skeffington, commands the *Carcass*, 10 ; entertains Nelson, 2x0

Lyons, Gulf of, Nelson nearly founders in the, 90; notorious for its gales, 232

M

Macdonald succeeds Championet, 133

Mack, General, commands the Sicilian army, 127

Macnamara, Captain, accompanies Nelson to France, 28

Magdalena Islands, Nelson waters his fleet at, 231

Magon, Rear-Admiral, commands the second reserve squadron of the combined fleet, 274

Malta, Nelson sails for, 92; Order of St. John at, annulled by French Government, 124; French fleet arrives off, 124; in possession of the French, 125; insurrection at, suppressed, 125; Nelson at, 227

Manby, Captain, anecdote of Nelson, 4

Marguerite, isle of, French fleet seen off, 55

Marlborough, Duke of, declines to receive Nelson and party, 220

Mars, the, a Liverpool privateer, 256

Martin, Captain, receives surrender of Malta, 168

Matcham, Mrs., presented with money, 141; money voted her in honour of Trafalgar, 311

Mazari Bay, Nelson refits at, 249

Mediterranean, the, hunted for the French fleet, 93

Medusa, the, Nelson hoists his flag on board, 210; intercepts the Spanish frigates, 245

Melpomene, the, disabled by the *Agamemnon*, 47

Melville, Lord, Nelson's letter to, 207

Merton Place, bought by Lady

Hamilton for Nelson, 212; first visited by Nelson, 217; his brief holiday at, 257

Messina, Captain Ball seizes corn at, 148

Middle Ground, the, in Copenhagen Harbour, 179

Milford, Nelson's reception at, 220

Miller, Captain, reinforces Nelson at the battle of St. Vincent, 72; affection of the crew for, 77

Minerva, the, a Neapolitan frigate, 138

Minerve, the, Nelson proceeds in, to Porto Ferrajo, 64; arrives at Gibraltar, 66; chased by the Spanish, 67; in the midst of the Spanish fleet, 68

Minotaur, the, hailed from the *Vanguard*, 105; assists Nelson at the battle of the Nile, 106

Monarch, the, at the battle of Copenhagen, 181; in peril, 182; grounded and is floated off, 188

Monmouth, the, cruises off Toulon, 228; detached from Nelson's fleet, 229

Morrison, extraordinary efforts to equip the *Vanguard*, 91

Moutray, Mrs., admired by Nelson, 33

Moutray, Resident Commissioner, 31

Murray, Captain George, commands British fleet off Carls-crona, 201; Nelson's first captain, 228

Mutine, the, Nelson signs Capel's commission to, 107

N

Naiad, the, the hour of Nelson's famous signal by her log, 282

Napier, General Sir Charles, his preposterous claim for Captain **Foley**, 97

- Naples, Nelson at, 43 ; sense of treaty with France, 93 ; the Court of, abhorred by Troubridge, 115 ; the Queen of, denounced by Collingwood, 115 ; excitement at, 116 ; Nelson's reception at, 117 ; Kingdom of, described by Southey, 122 ; the King of, on board the *Vanguard*, 126 ; the King of, enters Rome and returns to Naples, 127 ; flight of the Royal Family of, 128 ; voyage of the Royal Family to Palermo, 129 ; desperate slaughter at, 132 ; held by Championet's troops, 132 ; a provisional government established at, 132 ; blockaded by Captain Foote, 133
- Naval warfare, changes in, (Appendix) 317
- Navigation laws neglected by Sir Richard Hughes and enforced by Nelson, 31
- Navy, contrast between that of the time of Nelson and that of to-day, (Appendix) 333
- Nelson, Earl, see Reverend William Nelson
- Nelson, Horatio, birth, 1 ; parents, 2 ; education 3 ; goes to sea, 5 ; voyage to West Indies, 8 ; returns a sailor, 9 ; a Polar voyage, 10 ; promoted to midshipman, 11 ; East Indian voyage II : severe illness, 10 ; despondency, 12 ; appointed lieutenant, 14 ; ill-health, 15 ; boards a prize, 16 ; West Indian experiences, 16 ; promoted to Commander, 17 ; made Post-Captain, 18 ; on the Mosquito Coast, 19 ; commands the *Janus*, 20 ; at Bath, 21 ; a Baltic cruise, 21 ; sails for North America, 22 ; behaviour to Carver, 23 ; meets the Duke of Clarence, 25 ; on half-pay, 27 ; presented at St. James's, 27 ; journey to France, 28 ; appointed to the *Boreas*, 29 ; treatment of midshipmen, 30 ; arrives at Barbadoes, 31 ; enforces the Navigation Act, 31 ; quarrel with Sir Thomas Shirley, 31 ; affair at Nevis, 32 ; "meets his fate," 34 ; marries Mrs. Nisbet, 35 ; arrives in England, 36 ; neglected by the Admiralty, 36 ; resolution to resign, 37 ; his loyalty reanimated, 37 ; continued ill-health, 37 ; long period of neglect, 39 ; country pursuits, 40 ; resolves to leave the country, 41 ; applies for a *cockle-boat*, 41 ; appointed to the *Agamemnon*, 42 ; sails from Gibraltar, 42 ; at the surrender of Toulon, 43 ; sent to Naples with dispatches, 43 ; introduced at the Court of Naples, 44 ; meets Lady Hamilton, 44 ; rejoins the fleet, 47 ; action off Sardinia, 47 ; in command of a squadron, 48 ; on the coast of Corsica, 49 ; urges an attack on Bastia, 50 ; captures Bastia, 51 ; attacks Calvi, 53 ; wounded in the eye, 54 ; captures Calvi, 54 ; reception at Genoa, 54 • love for the *Agamemnon*, 55 ; longings for a country home, 55 ; money losses, 55 ; action with the French fleet, 57 ; captures the (*O Ira* and *Le Censeur*), 57 ; advises Admiral Hotham, 58 ; returns to St. Fiorenzo, 58 ; made Colonel of Marines, 59 ; ordered to co-operate with General de Vins, 59 ; chased by the French fleet, 60 ; disgust at the Austrians, 61 ; an indignant demand, 61 ; offered a seat in Parliament, 62 ; his numerous performances, 62 ; hoists his Commodore's pennant on the *Captain*,

Nelson (*continued*).

63 ; superintends the evacuation of Corsica, 63 ; proceeds to Porto Ferrajo in the *Minerve*, 64 ; captures the *Santa Sabina*, 65 ; arrives at Gibraltar, 66 ; sails to join Jervis, 67 ; chased by the Spanish, 67 ; will not lose Hardy, 67 ; sails through the Spanish fleet, 68 ; resumes command of the *Captain*, 68 ; at the battle of St. Vincent, 70 ; frustrates the Spaniards' plan, 70 ; attacks the four-decker, 70 ; the conspicuous figure in the battle, 70 ; engages nine line-of-battle ships at once, 71 ; captures the *San Nicolas*, 71 ; captures the *San Josef*, 72 ; cheered by the fleet, 72 ; not named in the Admiral's dispatch, 73 ; knighted, and promoted to Admiral, 76 ; affection of his crew, 77 ; at the bombardment of Cadi7, 78 ; sails for Teneriffe, 80 ; attacks Santa Cruz, 81 ; wounded, 81 ; his great endurance, 82 ; loses his arm, 83 ; failure of the expedition, 83 ; return home, 84 ; nursed by Lady Nelson, 85 ; anecdote of, 86 ; complains of his wife, 87 ; his memorial, 88 ; appointed to the *Vanguard*, 89 ; arrives at Gibraltar, 90 ; in great peril, 91 ; remonstrances against his command, 92 ; at Syracuse, 95 ; finds the French fleet, 96 ; instructions to his commanders, 97 ; his tactics, 99 ; battle of the Nile, 100 ; burning of L' *Orient*, 101 ; L' *Orient* blows up, 102 ; victory of the English, 105 ; Nelson wounded, 106 ; his restlessness, 107 ; his thanksgiving for victory, 108 ; receives a sin-

gular gift, in ; made a Baron, 112 ; honours and presents, 113 ; arrives at Gibraltar with his prizes, 114 ; dislike of the Italians, 115 ; reception at Naples, 117 ; at the Hamiltons' home, 119 ; celebration of his birthday, 120 ; and the King of Naples, 123 ; instructions from the Admiralty, 124 ; letter to the commander of Valetta, 125 ; indignant at the Sicilian Government, 126 ; distrust of General Mack, 127 ; directs the evacuation of Naples, 128 ; sails for Palermo, 129 ; attends the Royal Family on shore, 130 ; Mediterranean experiences, 131 ; assists in the defences of Palermo, 132 ; sails for a cruise, 133 ; sails into Naples, 133 ; annuls the truce, 134 ; interview with Cardinal Ruffo, 135 ; orders the execution of Caracciolo, 138 ; refuses to interfere in Caracciolo's behalf, 139 ; orders the body of Caracciolo towed ashore, 140 ; generosity to his family, 141 ; feted, 142 ; refuses to obey Lord Keith's orders, 143 ; sends ships to Minorca, 144 ; his conduct disapproved by the Admiralty, 144 ; irritated and indignant, 144 ; provoked by Sir Sidney Smith, 145 ; alters opinion of Sir Sidney Smith, 146 ; concern for the feelings of the Court of Naples, 146 ; bad influence of Lady Hamilton and the Queen of Naples, 147 ; his bad health, 148 ; joins Lord Keith, 150 ; falls in with a French squadron, 150 ; at the capture of *Le Genereux*, 151 ; sends a flag to Leopold, 153 ; in command of squadron off Valetta, 153 ; **health exhausted**,

Nelson (continued).

154 ; meets Lord Cochrane, 154 ; anecdote of, 155 ; satisfaction at capture of *Le Guillaume Tell*, 156 ; sails for Syracuse, 157 ; strikes his flag, 157 ; his quarters on the *Foudroyant*, 158 ; accompanies the Royal Family to Vienna, 159 ; unpleasant adventures, 160 ; incident at Prague, 161 ; arrives at Yarmouth, 161 ; at London, 162 ; cool reception at Court, 162 ; unhappy married life, 163 ; separates from Lady Nelson, 163 ; final interview with his wife, 164 ; honours in England, 166 ; health benefited, 167 ; commands the *St. George*, 170 ; poor condition of the *St. George*, 170 ; conversation with Davison, 171 ; hoists his flag on the *Elephant*, 172 ; passes through the Sound, 173 ; reconnoitres the enemy, 173 ; astonished at their preparations, 174 ; offers his services, and is accepted, 175 ; his excitement, 175 ; marks out the channel, 176 ; the force under his command, 176 ; anchors off Draco Point, 177 ; his incessant labors, 178 ; his sleeplessness and impatience, 179 ; signals for close action, 180 ; opposed to the *Dannebrog*, 180 ; in the battle of Copenhagen, 183 ; anecdote of, 184 ; does not see the signal to cease fighting, 185 ; sends a flag of truce ashore, 187 ; anecdote of the sealing-wax, 187 ; follows Lindholm to the *London*, 189 ; depression of spirits, 189 ; letter to Lady Hamilton, 190 ; verses to his guardian angel, 190 ; returns to the *Elephant*, 192 ; visits the prize, 192 ; visits the Prince of Denmark, 194 ;

dines with Crown Prince, 195 ; his genius at Copenhagen, 196 ; in pursuit of Parker, 199 ; sickness brought on by exposure, 200 ; instructs Davison to assist Mrs. Maurice Nelson, 201 ; in command in the Baltic, 201 ; at Revel Roads, 201 ; correspondence with St. Petersburg, 202 ; personal habits, 203 ; reception at Rostock, 203 ; invests Graves with the Order of the Bath, 204 ; created a Viscount, 204 ; disappointed at his reward, 207 ; bitter vexation that no medals were given for battle of Copenhagen, 207 ; arrives at Yarmouth, 208 ; at London 208 ; his holiday, 208 ; appointed Commander-in-chief, 209 ; reception at Sheerness, 210 ; hoists his flag on the *Medusa*, 210 ; bombards the French flotilla, 211 ; failure of attempt to destroy French flotilla, 211 ; buys Merton Place, 212 ; grief at the death of Parker, 213 ; buries Parker at his own expense, 213 ; attempt to blackmail, 214 ; angry at Troubridge, 215 ; cause of his irritability, 216 ; visits Merton, 217 ; takes his seat in the House of Lords, 217 ; relations with Lady Hamilton, 218 ; loyalty to his comrades, 219 ; journey to Wales, 220 ; a royal progress, 221 ; seconds the address, 222 ; his pecuniary affairs, 223 ; attends a debate in the House of Lords, 223 ; grief at the death of Sir William Hamilton, 224 ; appointed Commander-in-chief on the Mediterranean station, 225 ; hoists his flag on board the *Victory*, 225 ; sails from Spithead, 225 ; shifts his flag to

Nelson (*continued*).

the *Amphion*, 225 ; quick run from off Lisbon to Gibraltar, 226 ; at Naples, 227 ; anxious to preserve the two Sicilies and the Royal Family, 227 ; joins Sir Richard Bickerton, 228 ; movements while blockading Toulon, 229 ; off for the Magdalena Islands, 231 ; opinion of his fleet; 231 ; failing eyesight, 232 ; Scott's recollections of, 235 ; the French fleet make a demonstration, 238 ; resentment against La Touche-Treville, 239 ; denies the blockade of Toulon, 241 ; desire to return to England, 241 ; story illustrating the character of, 242 ; difficulty in holding his station, 243 ; in the Gulf of Palmas, 243 ; again off Toulon, 244 ; receives a secret Admiralty letter, 244 ; ignorant of war with Spain, 245 ; a great wrong to, 246 ; in Agincourt Sound, 247 ; his force, 247 ; notified of the sailing of the French fleet, 247 ; a striking picture, 248 ; scours the Mediterranean for the French fleet, 248 ; sails for the West Indies, 250 ; orders regarding rations, 251 ; arrives at Barbadoes, 251 ; irritation at Brereton's false information, 251 ; pursues the French fleet back to Europe, 252 ; slow progress, 253 ; arrives at Gibraltar, 253 ; two years on board the *Victory*, 254 ; an explanation, 255 ; arrives in England, 257 ; meets the Duke of Wellington, 258 ; last interview with George III., 259 ; resolves on his manoeuvres, 260 ; Lord Sidmouth's table, 261 ; explains his plans to Keats, 262 ; receives news of the French fleet, 263 ; re-

solves to offer his services, 264 ; farewell to Merton, 265 ; arrival at Portsmouth, 266 ; an affecting scene, 266 ; despatches Blackwood to Lord Collingwood, 266 ; reception by the fleet, 267 ; the " Nelson touch," 267 ; force under his command, 267 ; plan to draw-out the enemy, 268 ; presentiment of death, 269 ; chooses a burial-place, 270 ; an affable host, 270 ; letter-writing, 272 ; instance of his prevision, 273 ; excellent arrangements, 275 ; approach of his fleet, 277 ; on deck, 278 ; signals for the captains to come on board, 279 ; his prayer, 280 ; declines Blackwood's suggestions, 281 ; leads the column, 282 ; famous signal, 282 ; farewell to Blackwood, 286 ; seeks the French admiral, 287 ; indifference to personal risk, 288 ; " Warm work, Hardy!" 289 ; in the thick of the fight, 290 ; wounded, 291 ; carried below, 291 ; suffering, 295 ; " Kiss me, Hardy," 298 ; dead, 299 ; his body placed in a cask of brandy, 307 ; coffined and taken from the *Victory*, 308 ; honours paid to Nelson's body, 309 ; how England received the news of Trafalgar and of Nelson's death, 309 ; grief of the Earl of St. Vincent, 310 ; honours and emoluments to his family, 311 ; his funeral, 313 ; his character, 314

Nelson's Island, in Aboukir Bay,

114

Nelson, Maurice, death of, 200
 Nelson, Mrs., on boarding (note), 72 ; nurses her husband, 85 ; uneasiness regarding her husband, 121 ; dislike of Lady Hamilton, 162 ; unhappy life,

- 163 ; quarrel with Nelson, 163 ; separation, 164
- Nelson, Mrs. Maurice, blind and cripple, 200; Nelson's letter to, 201
- Nelson, Rev. Edmund, rector of Burnham Thorpe, 1 ; Captain Suckling's reply to, 5 ; death of, 219
- Nelson, Rev. William, intercedes for Horatio, 5 ; returns to school with his brother, 5 ; letter from Horatio, 29; sails with Horatio on the *Boreas*, 29 ; Nelson's opinion of, 205 ; letter to Lady Hamilton, 206 ; meets Nelson in London, 208 ; created an Earl and granted a pension, 311
- " Nelson touch," the, 267
- Neptune*, the, a French liner, 229 ; supports the *Bucefante*, 290
- Neptune*, the, with Nelson at Trafalgar, 303 ; tows the *Victory* to Gibraltar, 307
- Nevis, difficulty at, 32; Nelson married at, 35
- New York, Nelson at, 24
- Nicholas, Sir Harris, on Nelson's letter, 42 ; on Nelson's irritability, 216
- Niger*, the, off Toulon, 243
- Nile, battle of the, 100 ; a decisive British victory, 109 ; comparative strength of British and French at, 109 ; effects of the, 112 ; list of ships engaged in (Appendix), 326, 327 ; comparative force of the two squadrons (Appendix), 328
- Nile*, the, a battle-ship of to-day (Appendix), 317 ; compared with the *Victory* (Appendix), 333
- Nisbet, Josiah, a lieutenant on the *Theseus*, 80; with Nelson at Santa Cruz, 81 ; creates a disturbance, 120
- Nisbet, Mrs. Fanny, married to Nelson, 35
- Niza, Marquis de, commands Portuguese squadron, 114 ; letter from Nelson to, 114 ; blockades Valetta, 125
- Northumberland*, the, off **Valetta**, 151 ; attacks the *GInfreux*, 151; under command of Captain Martin, 168
- North Walsham, Nelson at school at, 3
- Norwich, Nelson at high-school at, 3 ; presented with a sword by Nelson, 77
- Nyburg*, the, sunk at Copenhagen, 195

O

- Orde, Sir John, remonstrates against Nelson's appointment, 91 ; challenges Lord St. Vincent, 91 ; commands a squadron off Cadiz, 245 ; takes numerous prizes, 245
- Order of St. John at Malta, annulled by French Government, 124 ; Grand Master of, refuses French demands, 124
- Order of the Bath, Nelson invests Rear-Admiral Graves with, 204
- ORient*, at battle of the Nile, 100 ; between two fires, 101 ; in flames, 101 ; blows up, 102
- Orion*, the, in the advance at Aboukir, 99
- Otto, Citizen, signs the preliminaries of peace, 221
- Otway, Captain R. W., demands the surrender of the *Zealand*, 193
- Oxford, Nelson presented with the freedom of the city of, **220**

P

- Paget, Hon. Arthur, succeeds Sir William **Hamilton**, **158**

Index,

- talermo, flight of the Royal Family to, 129 ; receives the King of Naples, 131 ; Nelson entertained at, 142
- Palisser, Sir Hugh, succeeded by Captain Suckling, 13
- Palmas, Gulf of, Nelson shelters his fleet in 243 ; returns to, 249
- Paoli, a Corsican leader, 49
- Paria, Gulf of, Nelson at, 252
- Parker, Captain E. T., assists at the investment of Graves, 204 ; meets Nelson in London, 208 ; account of Nelson's health, 210 ; repulsed at Boulogne, 211 ; fatally wounded, 211 ; Nelson's grief at the death of, 213 ; buried at Nelson's cost, 213
- Parker, Lady, nurses Nelson, 20
- Parker, Sir Hyde, commands British fleet, 170 ; communicates with Elsieur, 173 ; passes the Sound, 173 ; calls a council of war, 175 ; remains at anchor, 176 ; his part at the battle of Copenhagen, 179 ; unable to help Nelson, 183 ; signals to cease action, 183 ; sails for the Baltic, 197 ; receives pacific proposals, 201 ; returns to England, 201
- Parker, Sir Peter, appoints Nelson to the *Bristol*, 17 ; appoints Nelson to the *Janus*, 20
- Parker, Sir William, remonstrates against Nelson's appointment, 91 ; commands the *Prince George*, 92
- Parkinson, Lieutenant, intercedes with Nelson, 139
- Parsons, describes Caracciolo, 138 ; story of the rising of Caracciolo's body, 140 ; account of the action off Valetta, 151
- Parthenopeian Republic, 132 ; .
defeat of the troops of the, 133
- Pasco, Lieutenant, Signal Lieutenant on the *Victory*, 279 ; story of the famous signal, 282 ; wounded at Trafalgar, 295
- Passaro, Cape (Sicily), Nelson falls in with French squadron off, 150
- Paul, Emperor of Russia, present to Nelson, 113 ; sequesters British property, 169
- Peddieson has charge of Nelson's coffin, 257
- Penelope*, the, chases *Le Guillaume Tell*, 156
- Perree, Rear-Admiral, commands a French squadron, 150
- Phipps, Captain Constantino John, commands the *Racehorse*, 10
- Phoebe*, the, chases French frigates, 238 ; signals the enemy's course, 274
- Pickle*, the, brings the news of Trafalgar and of the death of Nelson, 309
- Pigott, General, captures island of Malta, 168
- Pilfold, Lieutenant, in the last boat leaving the *Santissima Trinidad*, 304
- Polyphemus*, the, in the battle of Copenhagen, 180 ; saves the */sis* from the *Provesteen's* fire, 182 ; Nelson orders her masts painted, 273
- Ponza Islands hoist Sicilian colors, 132
- Popham, Sir Home, raises the Sea Fencibles, 210
- Porquerolles, island of, French ships signalled off, 238
- Port Agro, troops **disembarked** at, 53
- Portland, Duke of, 62
- Porto Ferrajo, Nelson proceeds to, 64 ; occupied by Sir Gilbert Elliot, 66
- Port Royal (Jamaica), Nelson **commands batteries at, 18**

Portsmouth, Nelson sails from, in the *Vanguard*, 89 ; Nelson at, 225
 Portuguese squadron, the, too late to join Nelson at battle of Nile, 114; blockades Valetta, 125
 Prague, incident at, 161
Prince, the, assists in destroying the *Santissima Trinidad*, 303
Prince George, Prince William Henry a midshipman on board the, 18 ; Nelson denounced on board of the, 92
Principe de Asturias, the, at Trafalgar, 277
 Pringle, Captain Thomas, sails in company with Nelson, 22 ; his prediction on Nelson's marriage, 35 ; aids Nelson, 41
 Procida taken possession of, 132
Proves teen, the, opens the battle of Copenhagen, 180 ; nearly destroys the *J sis*, 182 ; taken and burnt, 195
 Prowse, Captain, leaves the *Victory*, 287
 Prussia instigates Denmark, 169

Q

Queen Charlotte, Lord Keith's flag-ship, 150

R

Racehorse, the Arctic voyage of, 10 ; returns to England, 10
Raisonnable, the, Captain Suckling appointed to, 5 ; Nelson joins, 6 ; out of commission, 8
 Ram, Lieutenant, desperately wounded at Trafalgar, 292 ; bleeds to death, 293
Ramilies, the, hastens the surrender of the Danish ships, 188
 Rathbone, John, 8
RedoutabU, the, at Trafalgar, 288 ; **destructive fire of, 294 ;** attempts to board the *Victory*, 294 ; knocked to pieces and sunk, 304
 Rennie, Captain, goes down in the *Invincible*, 170
Renozyvn, the, cruises off Toulon, 228 ; opposed to the Toulon fleet, 229
Rensburg, the, aground and burnt, 195
 Revel Roads, Nelson at, 201 ; ordered to leave, 202 ; sails from, 202
 Richmond Park, Nelson visits Lord Sidmouth at, 261
 Riou, Captain, dines with Nelson, 178; character of, 179; attacks the Tre Kroner battery, 182; wounded, 185; dies, 185
 Riviera, the, of Genoa, Nelson despatched to, 59
 Rivighano capitulates, 134
 Robinson, Mark, commands the *Worcester*, 13
 Rodney, Lord, part of his fleet at New York, 24
Romulus, the, arrives at Gibraltar, 66
 Rosetta, roar of battle of the Nile heard at, 102
 Rostock, Nelson's reception at, 203
 Rotherham, Captain, ordered to carry away the bowsprit of the *Fougueux*, 285
 Round-Wood purchased by Nelson, 87
Royal Sovereign, the, under Collingwood's command, 283 ; leads the fleet at Trafalgar, 284; attacks the *Santa Ana*, 285; unsupported, 285 ; Caps Trafalgar seen from, 301
 Ruffo, Cardinal, becomes prominent, 133; defeats the French, 134; signs the capitulation of Castel Nuovo, 135 ; interview with Nelson, 136
 Russell, the, aground at Copen-

- hagen, 180 ; flies signal of distress, 183
- Russian fleet, sought for by Nelson, 201 ; sailed for Cronstadt, 202
- Russia resents British proceedings, 169
- Salisbury, reception of Nelson at, 166
- Sally*, the, gives Nelson news of the French fleet, 253
- San Josef* the, attacked by the *Captain*, 71 ; surrenders, 72
- San Nicolas*, the, attacked and captured by the *Captain*, 71
- Sans Culotte* pursued by Admiral Hotham's fleet, 57
- Santa Ana*, the, at Trafalgar, 277 ; receives the broadside of the *Royal Sovereign* and returns her fire, 285
- Santa Cruz, attacked by Nelson, 81 ; failure of the attack on, 83
- Santa Sabina*, the, Nelson's action with, 64 ; capture of, 65 ; retaken, 65
- Santissima Trinidad*, the largest vessel afloat, 69 ; attacked by Nelson in the *Captain*, 70 ; at Trafalgar, 277 ; captured, scuttled, and sunk, 303 ; her strength at Trafalgar (Appendix), 321 ; compared with the *Victory* (Appendix), 322
- Sardinia, island of, action off the, 47
- Sardinia, King of, credits a scandalous report, 61
- Saumarez, Sir James, second in command at battle of the Nile, 97 ; leaves Aboukir Bay in command, 114 ; supplies the Maltese with arms, 126 ; summons the French to surrender, 126
- Scott, John, Nelson's official secretary, killed at Trafalgar, 287
- Scott, Rev. A. J., D.D., 2 ; recollections of Nelson, 235 ; extracts from diary of, 249 ; chaplain on the *Victory*, 292 ; distress during the battle of Trafalgar, 293 ; account of Nelson's death, 299
- Seahorse*, the, Nelson joins, 11 ; forms one of the Teneriffe expedition, 80 ; carries Nelson home, 84 ; under command of Captain Foote, 133 ; hauls down her flag of truce, 135 ; watches off Toulon, 247 ; notifies Nelson of the sailing of the French fleet, 247
- Sheerness, the *Unite'* at, 209 ; Nelson's reception at, 210 ; Nelson leaves, for Deal, 210
- Sheridan rebukes Lord Hood's conduct, 48
- Shirley, Sir Thomas, his anger at Nelson, 31
- Shot, French heavier than nominal weight of corresponding English (Appendix), 323
- Siberia, British merchant seamen transported to confines of, 169
- Sicilies, King of the two, presents a sword to Nelson, 113
- Sidmouth, Lord, asks Nelson to visit him, 260
- Sinus*, the, at Trafalgar, 286
- Smith, Collingwood's servant, 283 ; account of his master, 284
- Smith, Sir Sidney, his opinion of rats (note), 20 ; appointed to the Ottoman Court, 144 ; differs from Nelson, 145 ; bravery at Acre, 146
- Smith, Spencer, letter from Nelson, 146
- Smyth, Admiral W. H., story of the voyage to Palermo, 129
- Sohesten*, the, burnt at Copenhagen, 195
- Somerville, Captain, fails in the attack on the French flotilla, 211

- Sophia*, the, intercepts the Spanish frigates, 245
- Southey, Robert, opinion of General Mack, 127 ; on the flight of their Sicilian Majesties, 128
- Souverain Peuple, Le*, surrenders at battle of the Nile, 100
- Spain, at war with England, 17 ; enters into an alliance with the French Directory, 63 ; assembles a large force at Ferrol, 244 ; declares war against Great Britain, 245
- Spartiate, Le*, cut up at battle of the Nile, 100 ; attacked by the *Vanguard*, 106
- Spencer, Earl, Nelson's letter to, 144
- Spithead, Nelson sails from, 225 ; Nelson returns to, 257 ; the *Victory* with Lord Nelson's body arrives at, 307
- Staines, Nelson and party at, 208
- St. Elmo, held by the French, 134
- Stewart, Colonel, commands the artillery and rifles at Copenhagen, 170 ; reconnoitres the enemy, 173 ; commands the land forces at Copenhagen, 179 ; account of Nelson's personal habits, 203
- St. Fiorenzo, Nelson returns to, 58 ; arrival of Sir John Jervis at, 62
- St. George*, the, Nelson's flag-ship, 170 ; her poor condition, 170 ; Nelson on board of, 190 ; left at Copenhagen, 197 ; discharges her guns, 199 ; at Rostock, 203 ; last cruise under Nelson's flag, 204
- St. George's Bay, French troops landed at, 124
- St. Omer (France), Nelson at, 28
- St. Philip, General, deserts to the French, 127
- St. Pierre, the *Vanguard* with Nelson sale at, 91
- Strachan, Captain Sir Richard, ordered to intercept Spanish frigates, 245
- Stuart, Don Jacobo, commands the *Santa Sabina*, 64 ; his gallant fight, 65
- Stuart, Sir Charles, with Nelson at Calvi, 53
- St. Vincent, battle of, 70 ; effect of, in England, 75
- St. Vincent, Earl of, see John Jervis
- Success*, the, attacks the *G/nereux*, 151
- Suckling, Captain Maurice, 2 ; appointed to the *Raisonnaable*, 3 ; permits Nelson to sail with him, 3 ; appointed to the *Triumph*, 8 ; Comptroller of the Navy, 13 ; at Nelson's examination, 14
- Suckling, William, grants Nelson's request, 28 ; Nelson praises Mrs. Nisbet to, 34 ; Nelson's letter to, regarding Bastia, 51
- Suersishen*, the, taken and burnt, 195
- Superb*, the, cruises off Toulon, 228 ; opposed to the Toulon fleet, 229 ; accompanies the *Victory* to Portsmouth, 257
- Sutton, Captain, his coolness, 63 ; letter to Lady Hamilton, 245
- Swansea, Nelson dragged in triumph at, 221
- Swiftsure*, the, at battle of the Nile, 110 ; tows the *Redoutable* after Trafalgar, 304
- Sydney, Viscount, introduces Nelson to House of Lords, 217
- Sykes, John, saves Nelson's life, 79
- Syracuse, the British fleet at, 93 ; Nelson visits, 158

T

Table Bay, Nelson's description of, 217

- Tables, 318, 320-23, 325-33
- Tartar*, the, falls in with the *Agamemnon*, 43
- Tem'raire*, the, ordered to take station in advance of the *Victory*, 281
- Tenerifle, expedition to, 79
- Terpsichore*, the, sails for Teneriffe, 80
- Tetuan Bay, Nelson at, 249
- Theseus*, the, Nelson aboard of 77 ; sails for Teneriffe, 80 ; in the van at Aboukir, 99
- Thesiger, Captain, goes ashore with Nelson's letter, 188
- Thomas, Mr. (of Hawarden), 44
- Thompson, Commodore, rebuked by Jervis, 26
- Thurn, Count, a Neapolitan commodore, 138
- Tonnant*, at battle of the Nile, 100
- Totty, Rear-Admiral Thomas, saved at loss of the *Invincible*, 170
- La Touche-Tre'veille, Rear-Admiral, commands French flotilla, 211 ; commands French fleet at Toulon, 228 ; reports Nelson's flight, 238 ; death of, 240 ; French eulogy of, 240
- Toulon, surrender of, 43 ; British fleet off, 228 ; French fleet at, reinforced, 229 ; French fleet sails from, 247
- Trafalgar, battle of, 285 ; the greatest and most costly sea victory, 300 ; origin of the name of the battle, 301 ; the immediate result of, 302 ; importance of the victory, 305 ; how England received the news of, 309 ; the victors at, voted a money compensation for prizes destroyed, 311 ; list of ships engaged (Appendix), 328-331
- Trafalgar Cape, gives the name to Nelson's victory, 301
- Trafalgar*, the, a modern battleship (Appendix), 317 ; compared with the *Victory* (Appendix), 333
- Trapani, the French fleet sighted off, 93
- Treaty, between Court of Madrid and French Directory, 64 ; between Naples and France, 93 ; of Amiens, 221
- Trekroner battery, the, attacked by the British, 181 ; its guns rake the *Amazon*, 185 ; its fire silenced, 188
- Triumph*, the, Captain Suckling appointed to, 8 ; Nelson joins the, 9 ; opposed to the Toulon fleet, 229
- Troubridge, hastens in the *Culloden* to Nelson's assistance, 79 ; at the attack on Santa Cruz, 84 ; reports the whereabouts of the French fleet, 93 ; despatched to Naples, 94 ; distress at grounding of the *Culloden*, 104 ; fits his ship for service, 108 ; sent to blockade Naples, 132 ; takes possession of the Ponza Islands, 132 ; ordered to Palermo, 133 ; presented with a miniature, 142 ; attacks Capua, 143 ; arrives off Malta, 148 ; concern for Nelson's health, 149 ; hatred of Neapolitans, 149 ; ordered to join Nelson, 150 ; commands squadron off Malta, 154 ; Nelson angry with, 215
- Twiss, General, Nelson's conversation with, 203

U

Unite', the, Nelson's flag-ship, 209

V

Vado Bay, Nelson's fiery proposals respecting, 63

Valetta, action off, 151 ; block-

- aded by Nelson, 153; surrenders to the British, 168
- Vanguard*, the Nelson appointed to command of, 89; in distress, 90; Captain Ball on board of, 91; ready for sea, 91; preparation on board, 96; meeting of captains on board, 97; Nelson wounded on board 105; in the battle of the Nile, 106; sails for Naples, 114; reception at, 117; her boats at the evacuation of Naples, 128, carries the royal treasure, 129; sails for Palermo, 129; her crew receive a present from the King of Naples, 141
- Vaubois, General, commands the French at Valetta, 125
- "Vesuvian Republic," 132
- Victory*, the, cheers Nelson at the battle of St. Vincent, 72; Nelson hoists his flag on board of, 225; shifts his flag from, 225; falls in with Channel fleet, 228; Nelson shifts his flag to, 228; opposed to the Toulon fleet, 229; off Hyeres, 238; proceeds to Portsmouth, 257; Nelson goes aboard, 266; joined by the *A fax* and *Thunderer*, 266; joins the fleet off Cadiz, 267; Nelson addresses the midshipmen on board, 278; the captains signalled to come on board, 279; leads the column, 282; flies the famous signal, 282; floats down upon the enemy, 286; the *Buceniaure* fires the first shot at, 287; under a tremendous fire, 287; unable to return the fire, 288; coolness and courage of her crew, 289; rakes the *Bucentaure*, 289; effect of her guns, 290; attacks the *Redoubtable*, 290; attempt to board, 294; repulses the French, 295; her condition, 296; arrives at Gibraltar, 307; arrives at Spithead, 307; Lord Nelson's flag struck on board, 308; comparison of her armament with that of the *Santissima Trinidad*(Appendix), 322; compared with the armored ships of today (Appendix), 333
- Vienna, Nelson at, 160
- Villeneuve, Vice-Admiral, commands the French fleet, 244; puts to sea from Toulon, 247; driven back to Toulon, 249; again sets sail from Toulon, 249; learns of Nelson's arrival in the West Indies, 252; sets sail for Europe, 252; reaches Cape Finisterre, 253; his movements followed, 263; commands the centre of the combined fleets, 274; immeasurably beneath his destiny, 306

W

- Wagner*, the, taken and burnt, 195
- Wallise purser of the *Elephani*, 187
- Walpole, Lady, 62
- Walpole, Lord, 62
- Walpole, Sir Robert, 2
- Walpole, Galfridus, 2
- Wellesley, Sir Arthur, see Duke of Wellington
- Wellington, Duke of, meets Nelson, 258
- Welmoes, his bravery at Copenhagen, 197
- Westphal, Lieutenant, wounded at Trafalgar, 293
- Whitworth, Lord, despatched to Court of Denmark, 168; conversation with Buonaparte, 222
- William Henry, Prince, Duke of Clarence, comparison of Nelson with Collingwood, 3; enters the navy, 18; meets with and describes Nelson, 25;

encourages Nelson's marriage,
35 ; commands the *Andromeda*,
41 ; sheds tears at Nelson's
funeral, 314
Woodward, Dr., anecdote of, 21
Worcester, the, Nelson as Fourth
Lieutenant of, 13

Y

Yarmouth, Nelson arrives at, 161
Yarmouth Roads, British fleet
sail from, 169

Z

Zealand, the, a Danish ship, at
the battle of Copenhagen, 182 ;
story of the flag of, 193 ; burnt,
195

Zealous, the, forms one of the
Teneriffe expedition, 80 ; Cap-
tain Hood, of the, signals the
French fleet, 96 ; in the van at
Aboukir, 99 ; pursues the flying
French, 105



Heroes of the Nations

A SERIES of biographical studies of the lives and work of a number of representative historical characters about whom have gathered the great traditions of the Nations to which they belonged, and who have been accepted, in many instances, as types of the several National ideals. With the life of each typical character is presented a picture of the National conditions surrounding him during his career.

The narratives are the work of writers who are recognized authorities on their several subjects, and while thoroughly trustworthy as history, present picturesque and dramatic "stories" of the Men and of the events connected with them.

To the Life of each "Hero" is given one duodecimo volume, handsomely printed in large type, provided with maps and adequately illustrated according to the special requirements of the several subjects.

For full list of volumes see next page.

HEROES OF THE NATIONS

- NELSON. By W. Clark Russell.
GUSTAVUS ADOLPHUS. By C. R. L. Fletcher.
PERICLES. By Evelyn Abbott.
THEODORIC THE GOTH. By Thomas Hodgkin.
SIR PHILIP SIDNEY. By H. R. Fox-Bourne.
JULIUS CESAR. By W. Warde Fowler.
WYCLIF. By Lewis Sergeant.
NAPOLEON. By W. O'Connor Morris.
HENRY OF NAVARRE. By P. F. Willert.
CICERO. By J. L. Strachan-Davidson.
ABRAHAM LINCOLN. By Noah Brooks.
PRINCE HENRY (OF PORTUGAL) THE NAVIGATOR. By C. R. Beazley.
JULIAN THE PHILOSOPHER. By Alice Gardner.
LOUIS XIV. By Arthur HassaU.
CHARLES XII. By R. Nisbet Bain.
LORENZO DE' MEDICI. By Edward Armstrong.
JEANNE D'ARC. By Mrs. Ouphant.
CHRISTOPHER COLUMBUS. By Washington Irvine.
ROBERT THE BRUCE. By Sii Herbert Maxwell.
HANNIBAL. By W. O'Conno* Morris.
ULYSSES S. GRANT. By William Conant Church.
ROBERT E. LEE. By Henry Alexander White.
THE CID CAMPEADOR. By H. Butler Clarke.
SALADIN. By Stanley Lane Poole.
BISMARCK. By J. W. Headlam.
ALEXANDER THE GREAT. By Benjamin I. Wheeler.
CHARLEMAGNE. By H. W. C Davis.
OLIVER CROMWELL. By Charles Firth.
RICHELIEU. By James B. Perkins.
DANIEL O'CONNELL. By Robert Dunlop.
SAINT LOUIS (Louis IX. of France). By Frederick Perry.
LORD CHATHAM. By Walford Davis Green.
OWEN GLYNDWR. By Arthur G. Bradley.
HENRY V. By Charles L. Kin*s-ford.
EDWARD I. By Edward Jenka.
AUGUSTUS CESAR. By J. & Firth.

HEROES OF THE NATIONS

- FREDERICK THE GREAT. By W. F. Reddaway.
WELLINGTON. By W. O'Connor Morris.
CONSTANTINE THE GREAT. By J. B. Firth.
MOHAMMED. By D.S. Margoliouth.
CHARLES THE BOLD. By Ruth Putnam.
WASHINGTON. By J. A. Harrison.
- WILLIAM THE CONQUERER. By F. B. Stanton.
FERNANDO CORTES. By F. A. MacNutt.
WILLIAM THE SILENT. By Ruth Putnam.
BLUCHER. By E. F. Henderson.
ROGER THE GREAT OF SICILY. By E. Curtis.
CANUTE THE GREAT. By L. M. Larson.

Other volumes in preparation are:

- MARLBOROUGH. By C. T. Atkinson.
MOLTKE. By James Wardell.
ALFRED THE GREAT. By Bertha Lees,
GREGORY VII. By F. Urquhart.
JUDAS MACCABÆUS. By Israel Abrahams.
FREDERICK II. By A. L. Smith.
- New York-G. P. PUTNAM'S SONS, PUBLISHERS—London



The Story of the Nations

IN the story form the current of each National life is distinctly indicated, and its picturesque and noteworthy periods and episodes are presented for the reader in their philosophical relation to each other as well as to universal history.

It is the plan of the writers of the different volumes to enter into the real life of the peoples, and to bring them before the reader as they actually lived, labored, and struggled—as they studied and wrote, and as they amused themselves. In carrying out this plan, the myths, with which the history of all lands begins, will not be overlooked, though these will be carefully distinguished from the actual history, so far as the labors of the accepted historical authorities have resulted in definite conclusions.

The subjects of the different volumes have been planned to cover connecting and, as far as possible, consecutive epochs or periods, so that the set when completed will present in a comprehensive narrative the chief events in the great STORY OF THE NATIONS: but it is, of course, not always practicable to issue **the** several volumes in their chronological order.

For list of volumes see next page.

THE STORY OF THE NATIONS

- GREECE. Prof. Jas. A. Harrison. | THE HANSA TOWNS. Helen
 ROME. Arthur Gilman. Zimmern.
 THE JEWS. Prof. James K. Hos- | EARLY BRITAIN. Prof. Alfred
 mer. J. Church.
 CHALDEA. Z. A. Ragozin. | THE BARBARY CORSAIRS.
 GERMANY. S. Baring-Gould. Stanley Lane-Poole.
 NORWAY. Hjalmar H. Boyesen. | RUSSIA. W. R. Morfill.
 SPAIN. Rev. E. E. and Susan | THE JEWS UNDER ROME. W.
 Hale. D. Morrison.
 HUNGARY. Prof. A. Vambery. | SCOTLAND. John Mackintosh.
 CARTHAGE. Prof. Alfred J. | SWITZERLAND. R. Stead and
 Church. Mrs. A. Hug.
 THE SARACENS. Arthur Gil- | PORTUGAL. H. Morse-Stephea.
 man. | THE BYZANTINE EMPIRE. C.
 THE MOORS IN SPAIN. Stanley | W. C. Oman.
 Lane-Poole. | SICILY. E. A. Freeman.
 THE NORMANS. Sarah Orne | THE TUSCAN REPUBLICS. Bella
 Jewett. Duffy.
 PERSIA. S. G. W. Benjamin. | POLAND. W. R. Morfill.
 ANCIENT EGYPT. Prof. Geo. | PARTHIA. Geo. Rawlinson.
 Kawlinson. | JAPAN. David Murray.
 ALEXANDER'S EMPIRE. Prof. | THE CHRISTIAN RECOVERY
 J. P. Mahaify. OF SPAIN. H. E. Watts.
 ASSYRIA. Z. A. Ragozin. | AUSTRALASIA. Greville Tregar
 THE G a m s . Henry Bradley. | then.
 IRELAND. Hon. Emily Lawless. | SOUTHERN AFRICA. Geo. M.
 TURKEY. Stanley Lane-Poole. Theal.
 MEDIA, BABYLON, AND PER- | VENICE. Alethea Weii.
 SIA. Z. A. Ragozin. | THE CRUSADES. T. S. Axchet
 I and C. L. Kingsford.
 I MEDIEVAL FRANCE. Prof, Gus-
 tave Masson. | VEDIC INDIA. Z. A. Ragoain.
 | BOHEMIA. C. E. Maurice.
 HOLLAND. Prot. J- Thorold | CANADA. J. G. Bourinot.
 Rogers. | THE BALKAN STATES. WUUMI
 MEXICO. Susan Hale. i Millar.
 PHOENICIA George Rawtioaon.

THE STORY OF THE NATIONS

- BRITISH RULE IN INDIA.** R. W. Frazer.
- MODERN FRANCE.** AndreLeBon.
- THE BRITISH EMPIRE.** Alfred T. Story. Two vols.
- THE FRANKS.** Lewis Sergeant.
- THE WEST INDIES.** Amos K. Fiske.
- THE PEOPLE OF ENGLAND.** Justin McCarthy, M.P. Two vols.
- AUSTRIA.** Sidney Whitman.
- CHINA.** Robt. K. Douglass.
- MODERN SPAIN.** Major Martin A. S. Hume.
- MODERN ITALY.** Pietro Orsi.
- THE THIRTEEN COLONIES.** Helen A. Smith. Two vols.
- WALES AND CORNWALL.** Owen M. Edwards.
- HBDLEVAL POME.** Wm. Miller.
- THE PAPAL MONARCHY.** Wxa, Barry.
- MEDIAEVAL INDIA.** Stanley Lane-Poole.
- BUDDHIST INDIA.** T. W. Rhys-Davids.
- THE SOUTH AMERICAN RE. PUBLICS.** Thomas C. Dawson. Two vols.
- PARLIAMENTARY ENGLANU** Edward Jenks.
- MEDIAEVAL ENGLAND.** Mary Bateson.
- THE UNITED STATES.** Edward Earle Sparks. Two vols
- ENGLAND, THE COMING OF PARLIAMENT.** L. Cecil Jane.
- GREECE—EARLIEST TIMES—** AD. 14. E. S. Shuckburgh.
- ROMAN EMPIRE, B.C. 29-A.i:** 476. N. Stuart Jones.

