

**TEXT FLY WITHIN
THE BOOK ONLY**

UNIVERSAL
LIBRARY

OU_164899

UNIVERSAL
LIBRARY

ld be returned on o1

HOUSECRAFT SCIENCE

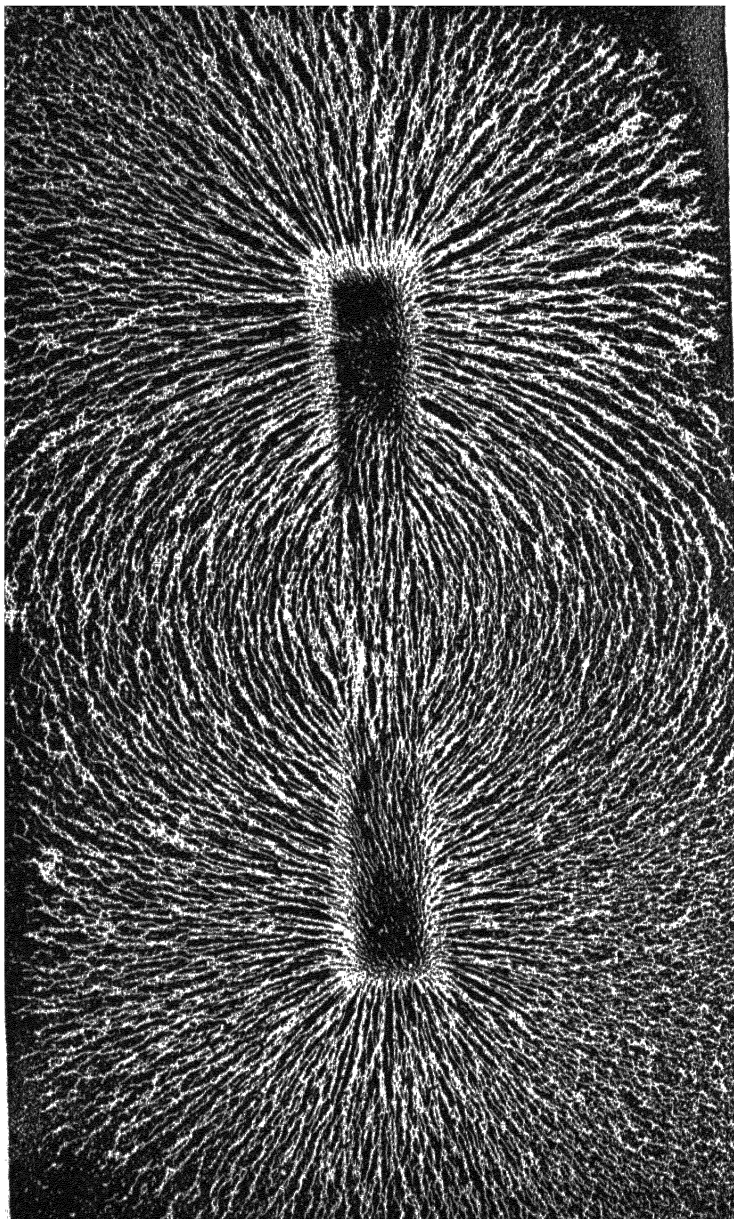

Lines of Magnetic Force (see p. 173).

Plate I shows by a photograph of iron filings scattered on white paper how two powerful unlike magnetic poles, such as the ends of a large horse-shoe magnet, placed just beneath the paper, cause the filings to form curves or lines of magnetic force, between the two poles.

HOUSECRAFT SCIENCE

BY

E. D. GRIFFITHS, B.Sc., F.R.G.S., F.C.S.

LICENTIATE OF THE COLLEGE OF PRECEPTORS
SCIENCE MASTER, EAST HAM TECHNICAL COLLEGE

WITH ONE HUNDRED AND SIX DIAGRAMS

METHUEN & CO. LTD.
36 ESSEX STREET W.C.
LONDON

First Published in 1917

PREFACE

THIS book is intended to stimulate independent investigation of those facts of elementary physics which explain everyday happenings in the home, and are capable of being established on an experimental basis. Measuring and weighing include plenty of household applications, while ventilation and warming are fully dealt with in the section on heat, and suggestions are made for promoting efficiency. Lubricants and anti-lubricants with the care and treatment of machinery are supplementary to the understanding of the six simple machines. The treatment of light includes all the common optical instruments, and under magnetism and electricity, wiring, dry batteries, electric meters, lamps, and fuses in common use are fully described.

The author has endeavoured to overcome difficulties in understanding the presentation of facts, and the consequent lack of interest, by simplicity of statement, by avoiding mathematical formulæ, by explaining all technical terms used, and by illustrating with clear sectional diagrams the working of apparatus and appliances in everyday use.

The author's grateful acknowledgments are due to Mr. W. T. Clough, A.R.C.Sc., and to Dr. A. E.

Dunstan, for permission to use certain diagrams from their books, and for valuable assistance. He is also greatly indebted to Mr. H. H. Green, B.Sc., who has revised the proof, to Principal Barker for useful suggestions, and to Messrs. Baird & Tatlock who have lent blocks.

E. D. G.

TECHNICAL COLLEGE,
EAST HAM.

CONTENTS

CHAPTER	PAGE
I. MEASURING	1
II. MEASURING AREAS	8
III. MEASURING VOLUMES	13
IV. MEASURING MASS OR WEIGHT	22
V. PROPERTIES OF MATTER	28
VI. DENSITY AND SPECIFIC GRAVITY	33
VII. SIMPLE MACHINES	40
VIII. FRICTION	51
IX. MEASURING FORCES	55
X. MEASURING TIME	61
XI. LIQUID PRESSURE	65
XII. AIR PRESSURE	73
XIII. COMPRESSION AND EXTENSION	78
XIV. APPLIANCES WORKED BY FLUID PRESSURE	82
XV. DIFFUSION OF LIQUIDS AND GASES	90
XVI. CAPILLARITY	94
XVII. HEAT AND TEMPERATURE	100
XVIII. CALORIMETRY—SPECIFIC HEAT	109
XIX. EXPANSION AND CONTRACTION	113
XX. CHANGE OF STATE; DEW POINT	122
XXI. LATENT HEAT	132
XXII. METHODS OF TRANSMISSION OF HEAT	137
XXIII. WARMING, COOKING, AND VENTILATION	142
XXIV. NATURE OF LIGHT, PIN-HOLE CAMERA, PHOTO- METRY	149
XXV. REFLECTION—REFRACTION—LENSES	157
XXVI. FAMILIAR OPTICAL INSTRUMENTS	164
XXVII. MAGNETISM	169
XXVIII. ELECTRO-MAGNETS AND ELECTRIC BELLS	174
XXIX. ELECTRIC LIGHTING—ELECTROLYSIS—ELECTRO- PLATING	178
INDEX	181

HOUSECRAFT SCIENCE

CHAPTER I

MEASURING

MEASUREMENT plays a large part in the business of life. If a building is to be constructed, all the lengths, thicknesses, and heights of the various walls have to be determined before the actual building is commenced. .

The areas of floors, corridors, walls, and roofs must also be calculated. The cubic material necessary to be dug out for the foundation, with the cubic air space of each room, is all worked out before building.

In buying canvas or calico, the price is so much a yard or metre; the length of a railway journey or tram ride determines the fare paid; while floor coverings are sold by the square yard or square metre.

Milk, oil, spirit, turpentine, are all sold by volume, and certain solids, like stone, gravel, or timber, by cubic measure, e.g. by the cubic yard or cubic foot.

Many articles are commonly sold by weight, and in cooking, ingredients are given partly by weight and partly by volume.

Besides measuring lengths, areas, volumes, and weights we frequently make use of other measurements, e.g. an interval of time in years, the size of

an angle in degrees, the pressure of the air in inches of mercury, or the temperature of a room by degrees on the thermometer.

In scientific work the *metric system* is almost universally adopted on account of its simplicity.

This is because the units of length, area, volume, and weight are closely related to each other; and each unit may be readily converted into a different unit of its own class by multiplication or division by a power of ten, i.e. by merely shifting a decimal point.

Measurement of Length.

The unit of *length* in the metric system is the *metre*.

1 metre		= 39·37 inches	1 m.
1 decimetre	= $\frac{1}{10}$ metre	= '1 metre	1 dm.
1 centimetre	= $\frac{1}{100}$ „	= '01 „	1 cm.
1 millimetre	= $\frac{1}{1000}$ „	= '001 „	1 mm.
1 Dekametre		= 10 metres	1 Dm.
1 Hectometre		= 100 „	1 Hm.
1 Kilometre		= 1000 „	1 Km.

The *Latin* prefixes deci, centi, milli are used for sub-multiples, while the *Greek* prefixes Deka, Hecto, and Kilo stand for multiples.

EXERCISE 1.—*To express a length in different metric units.*—

N.B.—The decimal point is placed immediately to the *right* of the figure standing under the unit of measurement required:

	Km.	Hm.	Dm.	m.	dm.	cm.	mm.
(a)	4	3	8	7	0	2	6
(b)	0	0	0	6	5	0	3

Length (a) = 4387·026 m. or 438702·6 cm. or 43·87026 Hm.

Length (b) = 0·006503 Km. or 6503 mm. or 0·6503 Dm.

EXERCISE 2.—Draw a straight line AB by using a boxwood scale or ruler, and a sharp lead pencil with a hard point.

Let the first line be 2 inches long. Draw a second straight line CD 3 inches long, and a third EF 5 inches long.

Check your measurements by holding your scale on edge against the paper and *bringing the marks on the scale in contact with the paper and the lines you have drawn.*

Do not measure from the extreme end of the scale because the end division may be inaccurate. Find by repeated experiment how many centimetres are contained in one inch, using a table of results like the one drawn below.

Line measured.	Length in inches.	Length in cm.	No. of cm. in 1 inch.
PQ	4	10·15	2·54

It will be found that 2·54 cm. are almost exactly 1 inch. Compare 1 cm. with half an inch on your boxwood scale. Using a metre or half metre scale determine the length of the bench or table in the room, the height of the doorway, the width of your desk or bench and the height of the bench top from the floor.

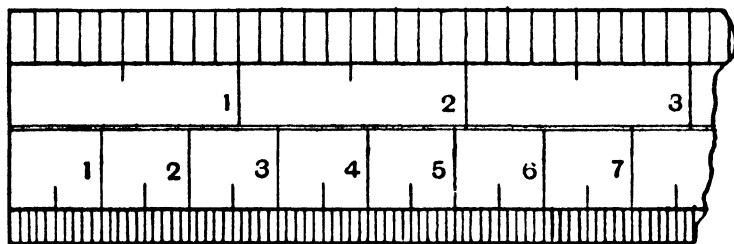

FIG. 1.

All these measurements should be entered neatly in metres; decimetres, centimetres, and millimetres expressed in decimal notation. Thus 1·735 m. represents a length of 1 metre, 7 decimetres, 3 centimetres, 5 millimetres.

Measure also the straight edges of rectangular wooden blocks and prisms. These measurements will be best expressed in centimetres followed by two decimal places to denote millimetres and estimated fractions of a milli-

metre. Thus 5.95 cm. represents 5 centimetres, 9 millimetres, and .5 or half a millimetre.

Measurement of Curves, Map Routes, Coast-lines, etc.

If we regard a curve as a line, which constantly changes its direction, we may consider all curves to be built up of a great many very short straight lines placed end to end. If we could measure all these very short straight lines their total length would represent the length of the curve.

EXERCISE 3.—Draw a circle of 3 cms. radius and using a pair of compasses with a hard chisel pencil point, or better still, dividers (Fig. 2), set exactly to 1 cm. space, measure the distance round the circumference in centimetres. The result does not *accurately* represent the length of the circumference because—

- (a) it is very difficult to get the compass points *exactly* 1 cm. apart.
- (b) the straight line distance from point to point may be 1 cm., but then the curve between those two points is *greater than* 1 cm.

Measure the circumference of the same circle of 3 cms. radius with a piece of damp cotton, laying it carefully over the curve and then transferring the cotton measure to a scale.

The effect of damping the cotton is to make it less springy.

This does not *accurately* represent the length of the circumference because—

- (a) the damp thread may slip during the measuring.
- (b) the thread will shrink when wet, and stretch when dried or pulled.

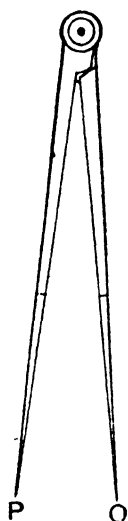

FIG. 2.

The Opisometer.

This instrument is used for measuring curved lines and is sometimes called a map measurer. It consists of a metal frame with a handle, supporting

a screw-threaded bar upon which a milled wheel travels. At one end of the frame is a *pointer*, from which the wheel is started, being run along the curve and then *back* to the pointer over a scale. This forms the most convenient method for measuring curves, map routes, or coast-lines because the wheel may readily be made to follow the curve, and the distance can be transferred to the scale of centimetres, or perhaps a scale of miles on the map.

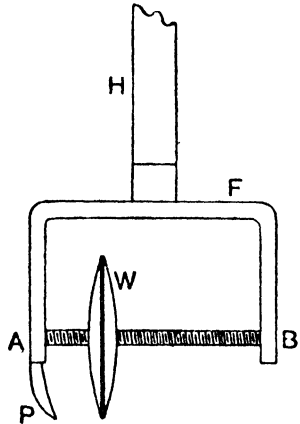

FIG. 3.

EXERCISE 4.—Trace an unworn penny with a sharp hard pencil, keeping as close to the metal edge as possible. Make a mark on the circle and measure the curve in centimetres by opisometer and scale.

Make a small blot on the metal edge of the penny and then let the coin roll down a sloping card. The distance from centre to centre of two consecutive blots will give the circumference. Record your measurements neatly in a notebook, and compare the results obtained by these two different methods.

The Calipers.

This instrument is used for finding the external or internal diameters of pipes, cylinders, or other round objects. The points of the calipers are placed in contact with the outside or the inside surface of the object *across a diameter*, and the distance between the points is then transferred to a scale. Note that in Fig. 4 the external diameter AB is the *same* as the internal diameter DE, while S is a screw which fixes the position for measuring. Use the calipers in the next exercise to measure the diameters of coins, and make a simple sketch of calipers,

using X as construction lines, and compasses for drawing the curved sides.

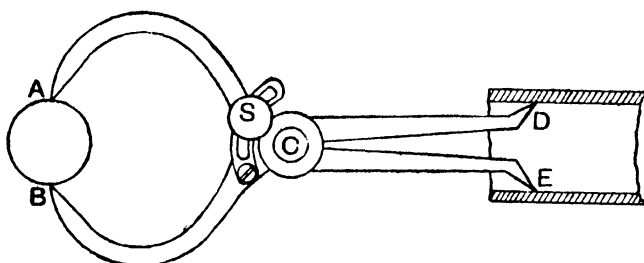

FIG. 4.

To Find the Relation or Ratio $\frac{\text{Circumference}}{\text{Diameter}}$ for any Circle.

EXERCISE 5.—Use a penny and a halfpenny to represent circles, and let them be as new and unworn as possible. Measure their diameters in inches and in centimetres. Find the length of the circumference of each coin in inches and also in centimetres by rolling down a sloping card as in the last exercise. Tabulate your results thus :—

Coin Used.	Diameter.	Circumference.	Ratio $\frac{\text{Circumference}}{\text{Diameter}}$.
penny	1.2 inches	3.85 inches	$\frac{3.85}{1.2} = \frac{38.5}{12} = 3.21$
penny	3.05 cms.	9.75 cms.	$\frac{9.75}{3.05} = \frac{975}{305} = 3.19$
halfpenny	1 inch	3.14 inches	$\frac{3.14}{1} = 3.14$
halfpenny	2.55 cms.	8.06 cms.	$\frac{8.06}{2.55} = \frac{806}{255} = 3.16$

The results in the last column should closely agree. Those set down in the above table are not to be regarded as accurate but merely as a guide to the method of working out.

The ratio $\frac{\text{circumference}}{\text{diameter}}$ accurately worked out is the same for every circle and is equal to 3·14159 or more briefly though less accurately, 3·14 or $3\frac{1}{7}$. This ratio is usually denoted by the Greek letter π . Since the diameter is twice the radius of any circle, when r is the radius, the circumference = $2\pi r$.

- EXAMPLES.—1. The diameter of a cycle wheel is 28 inches, what is the circumference of the tyre ($\pi = 3\frac{1}{7}$).
2. How many times does such a wheel revolve in 88 yards?
 3. How many revolutions does it make in 1 mile?
 4. What is the diameter of a circular tree-trunk 22 feet in circumference?
 5. What does the Greek letter π represent? Give its value numerically.

CHAPTER II

MEASURING AREAS

THE unit of *area* in the metric system is a square, each side of which is 1 metre. This is called a *square metre*, and similarly a square with 1 cm. side is called a *square centimetre*.

EXERCISE 6.—Draw a square with 1 cm. side and a second square having a side of 2 cms. Compare the areas covered by both. How many of the smaller squares are contained in the larger one ?

Count up the number of square millimetres in a square centimetre, using a squared page of your practical notebook.

Draw a rectangle 5 cms. long by 4 cms. wide on centimetre squared paper, and count up the number of square centimetres covered.

It will be seen that while in considering a *length* 10 mms. are equal to 1 cm., in considering an *area* 100 sq. mms. are equal to 1 sq. cm.

When we multiply a number by itself, we are said to *square* the number ; so that $2 \times 2 = 2^2$ or 4 and $3 \times 3 = 3^2$ or 9.

In square measure, using metric units, each unit contains 10 *squared* or 100 of the next lower unit.

EXAMPLE.—Find the area of a sheet of paper in square centimetres which measures 19 cms. by 20 cms. Express your result also in square millimetres and in square decimetres. Multiplying length by breadth we get 380 sq. cms. 380 sq. cms. = 38,000 sq. mms. = 3.80 sq. decimetres.

Area of any Triangle.

EXERCISE 7.—Fold a piece of scrap paper exactly in quarters and separate the four rectangles. Place one over the other to see if all are the same size. This is called *superposition*. Draw the diagonal across one rectangle and cut the figure through along the diagonal. Observe that two equal right-angled triangles are formed (Fig. 5). Prove them equal by superposition. Similarly make isosceles and scalene triangles, as in Figs. 6 and 7, and by superposing the waste pieces on the triangles prove that the area of these several triangles is in each case *half* the corresponding rectangle or half the base times the height. By choosing suitable rectangles, equilateral and also obtuse-angled

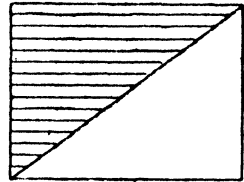

FIG. 5.

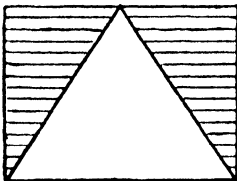

FIG. 6.

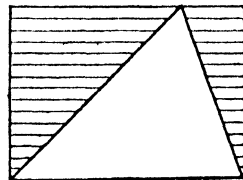

FIG. 7.

triangles can be cut out, and their areas also proved to be half the base times the height.

EXERCISE 8.—Trace your set squares on paper and calculate the areas of the triangles thus obtained.

Area of any Straight-sided Plane Figure.

Since we can divide up any straight-sided plane figure into triangles, we can then find the total area of the figure by adding together the areas of all the triangles.

Simpler methods can also be used in some cases, e.g. :—

A parallelogram has an area equal to base times

vertical height. Prove this by cutting a rectangle

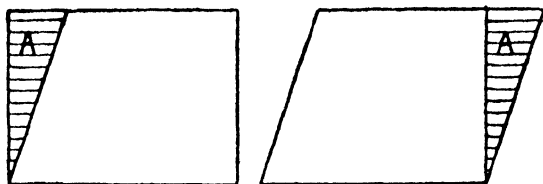

FIG. 8.

as in Fig 8, and then converting it into a parallelogram as shown.

Area of an Irregular Plane Figure or of a Curved Plane Figure.

The method of dividing into triangles may be used, or the figure may be traced on squared paper, and the squares covered counted to find the total area.

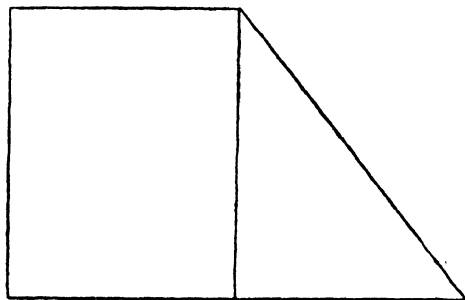

FIG. 9.

EXERCISE 9.—Draw Fig. 9, on squared paper, doubling the length of every bounding line and keeping the angles the same. Find the area by dividing into a rectangle and a triangle, and check your result by counting the squares covered.

Area of a Circle.

Any circle, by drawing innumerable radii, may be divided into an infinite number of triangles.

The bases of these triangles make up the circumference ($2\pi r$) and the height of each triangle is r , where r stands for the radius of the circle. The area of the circle is therefore the sum of the areas of all these triangles. Since the area of any triangle = half height times base, the area of all these triangles = half height times total length of bases.

$$= \frac{1}{2} \cdot r \cdot 2\pi r = \pi r^2.$$

If we know therefore the radius of a circle, by squaring this value and multiplying by π , we find the area of the circle *by calculation*.

EXERCISE 10.—Draw circles of 2 cms. radius and 6 cms. diameter. Find the area of each by calculation and state the results in square centimetres. Check your results by drawing similar circles on millimetre squared paper and counting the squares covered.

Note.—In a regular figure like a circle it is not necessary to count *all* the squares covered. Divide the circle into exact quadrants or quarters; find the area of a quadrant and multiply by four.

Area of an Ellipse.

Take a sheet of paper and fix it on a drawing-board. Draw a line half an inch long, in the centre, and insert two drawing-pins firmly at each end of the line. Make a loop of thread, and, passing it over the pins, keep it tightly stretched by a pencil point. Move the pencil in the stretched loop and it will be found that an ellipse can be traced. Each of the pin points is called a focus of the ellipse.

Produce the half-inch line joining the pin points both ways until it meets the curve of the ellipse. This line is the *major axis* and the line bisecting it at right angles is the *minor axis*.

The area of an ellipse = π times the product of the semi-axes.

EXERCISE 11.—Find the area of an ellipse which is 8 cms. along the major axis, and 6 cms. along the minor axis.

$$\begin{aligned}\text{Area of ellipse} &= \pi \text{ times product of semi-axes.} \\ &= 3.14 \times 3 \text{ cms.} \times 4 \text{ cms.} \\ &= 37.68 \text{ sq. cms.}\end{aligned}$$

The area of an ellipse may also be found by tracing it on squared paper and counting the squares covered.

CHAPTER III

MEASURING VOLUMES

THE unit of *volume* in the metric system is the *cubic decimetre* which is roughly equal to $1\frac{1}{4}$ pints. This unit is also called a *litre*.

EXERCISE 12.—Take a sheet of stiff cartridge paper rather more than 32 cms. long, and over 22 cms. in width.

Carefully rule decimetre squares on it, as in Fig. 10, three such squares along one long side of the paper and three others opposite, with a centimetre margin all round. The right angles should be made by using a set-square and each square should be divided up into 100 sq. cms.

Cut out the two rectangles of three squares each, leaving a centimetre margin round one rectangle. The margin

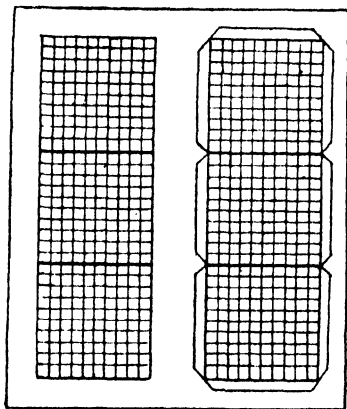

FIG. 10.

should be cut away at the corners of each of the squares, and by gumming the flaps formed in this way, the two rectangles of three squares each may be fastened together to form a cube. A cubic inch and a cubic centimetre should also be constructed of cartridge paper in a similar way.

It will be readily seen that since it requires 10 cubic centimetre cubes placed in line to make

1 decimetre, which is the length of the edge of the litre cube, that the number of cubic centimetres in a cubic decimetre or litre is $10 \times 10 \times 10$ or $10^3 = 1000$. In cubic measure each unit therefore contains 10 *cubed* or 1000 units of the next lower order, e.g. 1 cubic metre contains 1000 cubic decimetres.

Volumes of Regular Solids.

A *rectangular block* is a solid which has six faces, the same number as a cube has, but each face is a rectangle and therefore only opposite faces are equal in area. Since all the angles of the rectangles are right angles, the volume of such a block = length \times width \times depth.

EXERCISE 13.—Find the volume of a wooden rectangular block and the total area of all the faces. Find the *capacity* of a cardboard box without a lid, and the area of the cardboard used in making it.

A *prism* is a solid with two parallel ends, both of similar shape and of equal area. The faces of the prism, which are the same in number as the number of sides in one end of the prism, are usually at *right angles* to the ends. When they are at right angles the prism is a right prism [A, Fig. 11], but if they are not it is called an oblique prism [B, Fig. 11].

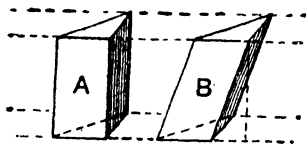

FIG. 11.

EXERCISE 14.—Make some cubes in soap, clay, or plasticine and cut them in the ways shown in Figs. 12-15.

Find what fraction of the volume of the cube each prism contains and observe that the volume of any right prism = area of end \times length.

The volume of any prism = area of end \times vertical height or length.

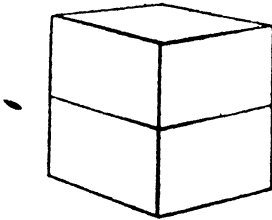

FIG. 12.

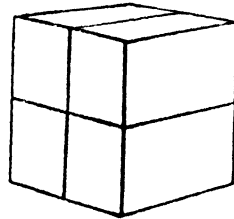

FIG. 13.

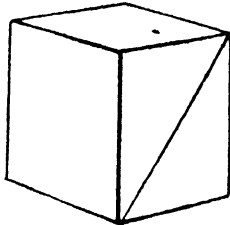

FIG. 14.

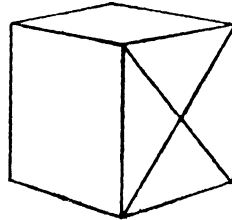

FIG. 15.

EXERCISE 15.—Find the volume of wooden prisms supplied, in each case working out the area of one end and multiplying by the length.

A *pyramid* is a solid with an apex or point which is situated upon a line which passes through the centre of the base, and which cuts the base usually at right angles. If the apex is not vertically over the centre of the base, the pyramid is oblique.

EXERCISE 16.—Take the four triangular prisms formed in Exercise 14, Fig. 15, and note that one side of each is a square, being one of the original faces of the cube. Standing each prism upon its square face, find the middle point of the top edge and cut two slant faces from this point so as to produce a pyramid. Each of the four prisms may be treated in this way, and the eight waste pieces produced will be found

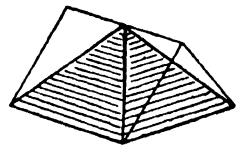

FIG. 16.

to fit together to form two other pyramids of the same size. Hence a cube may be divided up into six equal pyramids. The volume of each pyramid is $\frac{1}{6}$ of the cube or $\frac{1}{3}$ of half the cube. But half the cube has the same base and same height as one of the pyramids, so that the volume of a pyramid is $\frac{1}{3}$ area of base times height.

The volume of any pyramid = $\frac{1}{3}$ area of base times vertical height.

EXERCISE 17.—Find the volume of wooden pyramids supplied, in each case working out the area of the base, and multiplying by $\frac{1}{3}$ vertical height as measured by a set-square sliding up a vertical scale.

The Cylinder and the Cone.

A *cylinder* may be regarded as a prism with circular ends. Hence the volume of a cylinder is area of end \times length. We have previously found that the area of a circle is πr^2 when r = radius of the circle, so that if l = length of cylinder, volume of a cylinder = $\pi r^2 l$.

The *total surface* of a cylinder is evidently the two ends each = πr^2 , and the *curved surface* which = $2\pi r l$.

EXERCISE 18.—Cut a rectangle exactly as wide as the length of a wooden cylinder and roll the cylinder inside the

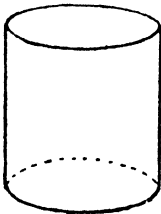

FIG. 17.

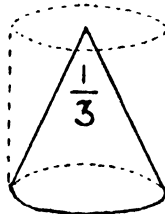

FIG. 18.

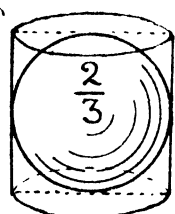

FIG. 19.

paper strip. Mark carefully the length of paper which just covers the curved surface, and then unroll the paper and cut off the surplus. We have now a rectangle with the long side = $2\pi r$, the circumference of the circular end

of the cylinder, and the short side = l , the length of the cylinder. The area of this rectangle which is evidently the *same* as that of the curved surface of the cylinder = $2\pi rl$.

A *cone* may be regarded as a pyramid with a circular base, and its volume is therefore = $\frac{1}{3}$ area of base times vertical height. The *sphere* or ball has a volume = $\frac{2}{3}$ of the corresponding cylinder, which is easily proved in the following way:—

EXERCISE 19.—Take a tennis ball or ordinary rubber ball and find a tin canister into which the ball just slips. Measure the diameter of the ball or that of the circular canister into which it fits closely and which therefore is approximately the same. Mark this distance off on the side of the canister in several places and draw a circle round the canister through the marks. Two or three small holes should then be made through the sheet metal of the sides of the canister on this circle, or the tin can be carefully cut round on the marked circle. By filling the canister with water up to the marked circle and then pushing the ball down into the water, it will be found that the ball displaces $\frac{2}{3}$ of the water previously held in the cylinder.

The volume of a ball or sphere is $\frac{4}{3}\pi r^3$ because the volume of the cylinder which just contains it, is area of base \times height = $\pi r^2 \times 2r = 2\pi r^3$. Hence in order

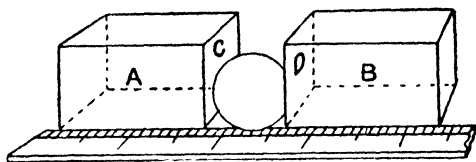

FIG. 20.

to find the volume of a ball, measure the diameter by calipers and scale (Fig. 4), or by rectangular blocks and scale (Fig. 20), and remembering that r or radius is half the diameter, *cube the radius* and multiply by $\frac{4}{3}\pi$.

Finding Volumes by Displacement of Water.

The last exercise suggests that the volume of an solid may be found by displacement, provided the

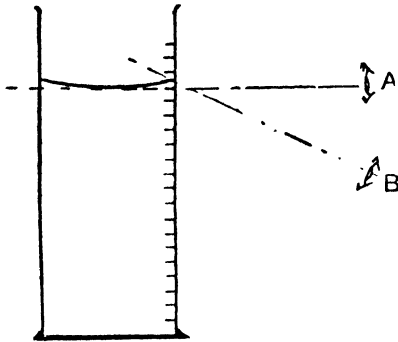

FIG. 21.

A, correct position ; B, incorrect position.

water does not spoil nor dissolve the solid. For this purpose a measuring jar is generally used (Fig. 21)

The Measuring Jar, or Graduated Cylinder or Jar

In the metric system the graduations show cubic centimetres. Frequently the smallest space marked stands for 2 or perhaps 5 c.c. Only the smallest measuring jars are marked in single c.cs. Sometimes the marks are numbered from the bottom upwards *and* also from the top downwards. This enables either the quantity poured out from the top mark or the quantity remaining in the jar to be read at a glance. Always let the jar stand on the bench while reading the level, and keep the eye in a horizontal line with the liquid surface, taking as the level the lowest point of the liquid curve or *meniscus* every time.

Finding the Volume of Solids by Using a Measuring Jar.

EXERCISE 20.—Determine by displacement of water, the volume of a quantity of sand ; of a number of lead shot

and therefore of one shot by division ; of an uncut lead pencil or short stick, either of which must be thrust below the water by a long wire or a hat-pin ; of an irregular stone or piece of metal ; of a teaspoon or a thimble.

Enter your notes as follows :—

- (a) Title of experiment followed by sketch and brief description of the method of using the apparatus, e.g. meniscus reading, how to drop in the solid, etc.
- (b) Volume of water taken in the jar c.c.
Increased volume after dropping in the solid . . . c.c.
 Volume of the solid by displacement c.c.

Testing the Capacity of Vessels by the Measuring Jar.

EXERCISE 21.—Find the number of c.c. contained in a test tube, a tablespoon, a teaspoon, entering in your notebook for each.

- Volume of water taken in the jar c.c.
- Decreased* volume after filling vessel c.c.
- Internal volume or capacity of the vessel c.c.

The Burette.

Note that this instrument holds 50 c.c. as a rule *between the graduated marks*. The jet, or tap at the bottom, must be filled before any measurements are made, and it is convenient to adjust the level by the tap or jet to the first mark before starting to measure. Each cubic centimetre is divided into tenths, so that much more accurate work can be done by this instrument than by the measuring jar.

EXERCISE 22.—Repeat the capacity experiments performed with the measuring jar, using the burette instead, and note the added degree of accuracy obtained by the latter.

The Pipette.

This holds a fixed quantity of liquid like a teaspoon, and is useful to measure small quantities of liquid. The pipette is filled by cautiously sucking out air from the upper end while the pointed jet is

held in the liquid. The rising surface of the liquid in the pipette should be watched all the time, or some liquid may be drawn into the mouth. The forefinger should be moistened and placed rapidly over the upper end, and by a gentle *rolling* motion of

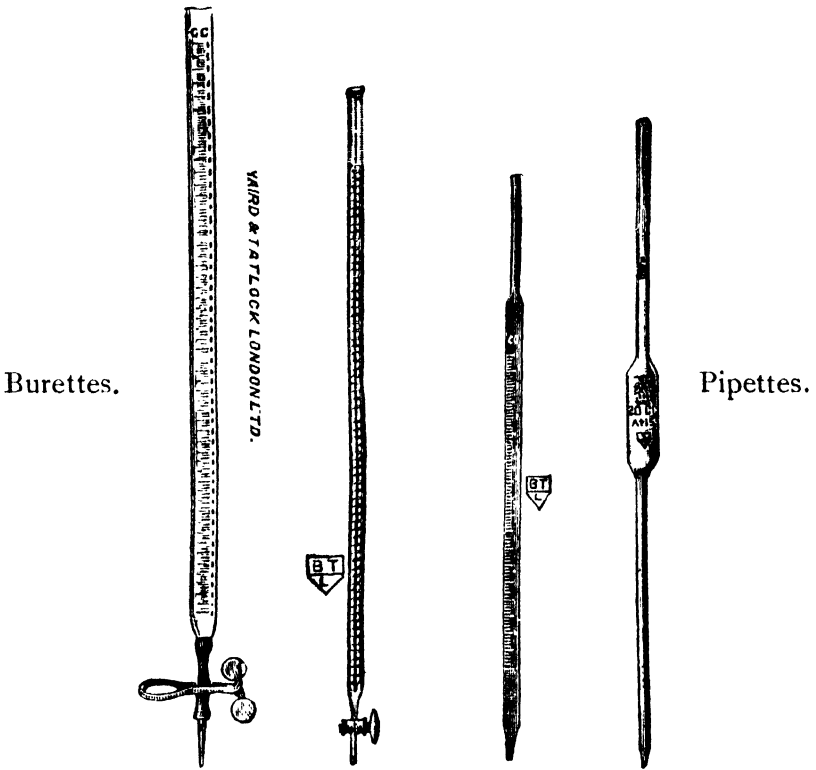

FIG. 22.

the finger, air should be slowly admitted in order to let the level fall to the etched mark just above the bulb. The measured quantity is then transferred to the required vessel.

EXERCISE 23.—Measure out 10 c.c. and 25 c.c. by pipettes of different sizes, and find the capacity of a tablespoon by a pipette.

The Canula or Fountain Pen Filler and the Dropping Tube.

This is a kind of ungraduated pipette with a rubber bulb at the top for transferring small quantities of liquid. A clean tube of this kind will measure out single drops of liquid very conveniently, and hence is useful for dropping alcohol or oil into the ear or measuring drops medicinally. A short length of quill glass tube forms a convenient dropping tube for taking up very small quantities of liquid, for microscope work, etc., and should be rounded at both ends.

EXERCISE 24.—Make a dropping tube by cutting a 4-inch length of quill glass tube. This is done by making a file scratch and then snapping the glass tube at the scratch. The ends should be rounded by heating until just red hot in the flame of a bunsen burner.

EXERCISE 25.—Find the number of drops in a teaspoon by means of a pen filler or dropping tube.

CHAPTER IV

MEASURING MASS OR WEIGHT

THE difference between mass and weight is explained in the next two chapters, but since mass is usually measured by weight, the units for both are the same. The unit of mass in the metric system is the weight of 1 cubic centimetre of water at 4° Centigrade, and is called a *gram*.

Balances and Weights.

The common balance for laboratory use is made of brass with a wooden base or sole. A central pillar supports the beam, from the ends of which hang the balance pans. The turning-points are made of hard agate, to avoid friction as far as possible, and a lever at the base of the central pillar puts the pans on or off the swing.

The pans must not be touched while swinging and must not be left on the swing. All weights should be lifted by the forceps except the heavier brass ones, which may be carefully handled with dry, clean fingers.

Usually there are eight small weights less than 1 gram, which are stamped in milligrams, and have special shapes to avoid confusing one with another (see opposite page).

Sometimes only the first four of these weights are supplied and weights less than 1 gm. are determined by a wire *rider*, a horse-shoe shaped

piece of wire weighing .1 gm., which can be slid along half the balance beam which is marked like a scale. For more accurate work the eight weights are supplied, together with a light wire rider .01

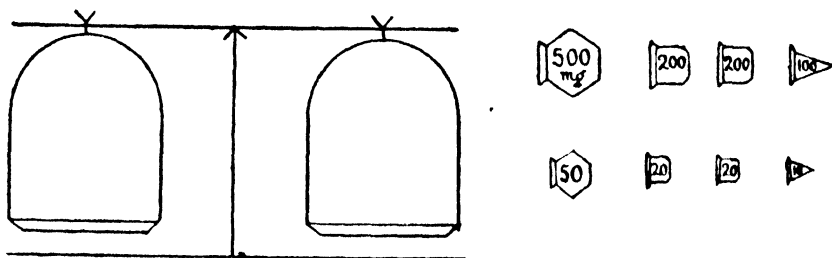

FIG. 23.

gm. which is used to determine the very small fractions of a gram. A sliding hook is used to move the light wire rider in a delicate balance, so that the final adjustment in weighing is made inside a closed glass case out of disturbance by air draughts.

Method of Using the Common Balance.

In order to weigh something *directly*, e.g. a small wooden block, the balance must first be properly adjusted. The wooden sole is supported on three brass feet, those in front having screws for raising or lowering. Like a camera tripod these three feet ensure a firm and level support. A silk cord and small brass weight, hung directly over a small spike fastened to the pillar, show when the pillar is quite upright. Small weights at either end of the beam travel along brass screws to secure equal turning forces on either side of the central pivot, and a pointer fastened just above the central pivot swings over an index at the base of the pillar and shows when the turning forces are equal. After checking the adjustment of the balance and

seeing the balance pans swing freely and are quite clean and free from dust, the box of weights should be examined to see that none are missing and that the forceps are in good condition.

Commencing with a weight *heavier* than the object to be weighed, every smaller weight in the box in turn should be placed on the pan while *off* the swing, the lever moved to put the pans *on* the swing, the weight being left on if insufficient, but removed after the pans have been placed *off* the swing if found to be in excess.

When the pointer swings equally on each side of the central mark or zero on the index, the weighing is correct.

To Find Correct Weight by an Ill-adjusted Balance.

1. The adjustment may be put right by using scrap paper, fragments of wire, etc., and the weighing carried out as before.

2. A rather heavier object than the substance to be weighed may be placed in one pan, counterpoised by weights and then the actual substance to be weighed may be placed in the *same pan as the weights*, the weights being taken off to make room for it. Weights are added to counterpoise the heavier object as before, and by comparing the first lot of weights with the second, the weight of the substance to be weighed is found by the *method of substitution*.

3. Weighing by *difference*. This method is invariably adopted in chemistry where a powdered or liquid substance must not touch the balance pan and must therefore be weighed in *some containing vessel*. A clean watch glass, test tube, basin, or flask is counterpoised and a second weighing is then made after placing the substance in the vessel. It will readily be seen that since the true weight

of the substance is found by *subtraction*, any error of adjustment in the balance will not affect the weight of the substance, but only the weight of the containing vessel, which does not matter. Sometimes the vessel and substance are weighed, some substance is shaken or poured out, and a second weighing is made, the *difference* representing the amount of substance used. This enables several different amounts of substance to be taken in consecutive experiments, with a minimum of weighing. Hence in weighing by difference, provided the balance pans swing freely, we need not adjust the balance before weighing; but it is absolutely necessary to use the same balance each time, and the same pan must carry the substance to be weighed every time.

The Spring Balance.

This is a convenient instrument for finding the *approximate* weight of a letter, parcel, fish, meat-carcase, etc.

Advantages as Compared with the Common Balance.

Cheap, and light in weight, it is easily carried about without getting out of order. It is quicker to work by, since there are no weights to handle.

Disadvantages as Compared with the Common Balance.

The spring balance is not nearly so sensitive and cannot show small differences of weight. This is mainly due to friction, which in time wears the spring, and causes it to stretch more easily. The spring varies slightly from time to time both on account of heat and cold, and because the attractive force of the earth or gravitation varies slightly from

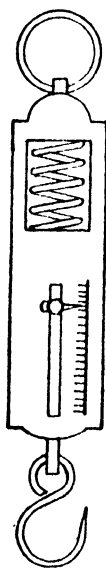

FIG. 24.

place to place ; e.g. at the geographical poles a body should weigh *more* on a spring balance than nearer the equator on this account, because the flattening of the surface curvature of the earth at the poles brings them nearer the centre of the earth than places more remote from the poles.

Exercises in Weighing (No. 26 to No. 40).

Using a common balance and carefully following out "method of using the common balance," weigh directly a wooden block, a small metal cube, and your watch or penknife. Take a clean post-card and draw upon it a rectangle of 10 sq. cms. and a circle of 3 cms. radius side by side. Cut each out carefully and weigh each figure in turn. If the rectangle weighs 1 gram and the circle 2.83 grams how could you compare the areas? Areas cut from precisely similar material are directly proportional to their weights, so that this method of finding area is *by proportional weights*. If you have a prism and a pyramid of similar material, e.g. the same kind of wood, or a cone and a cylinder of similar wood *of the same base area and of equal height*, weigh prism and pyramid separately, compare their weights and hence their volumes. Areas or volumes by proportionate weights are only approximate—cardboard or wood is not uniform but variable material. Using a spring balance, weigh the block of wood, cube, penknife or watch used, previously suspending each by a piece of thread. Compare your results with those obtained by using the common balance and decide which are likely to be more accurate. Weigh a large iron nail 5 inches long in air, and then immersed in a known volume of water in a measuring jar. Note that the loss of weight when weighed in water, expressed in grams, is approximately equal to the number of c.cs. of water displaced by the nail. We shall explain this fully in Chapter VI.

Weigh by difference 20 c.cs. of water measured into a beaker from a measuring jar. The result should be approximately 20 grams, because 1 c.c. of water (at 4° C.) weighs 1 gram. Weigh by difference various seeds, and assuming the material of the mustard-seed, pea-seed, and bean-seed

to be similar, compare the relative size of each seed. Thus if an *ounce* of each seed is taken and weighed, it would include 400 to 450 pea-seeds, a great many more mustard-seeds, and many less bean-seeds.

Find by experiment the number of grams in an ounce. Calculate and verify the number of seeds of each of the three kinds that weigh 1 gram.

CHAPTER V

PROPERTIES OF MATTER

MATTER is anything which gives rise to sense impressions. Our senses of *touch, sight, hearing, taste, and smell* make us aware of our surroundings. Touch serves to tell us of the presence of solid bodies, e.g. the floor, a table, a pencil, etc., also of liquids like water, and of gases in motion like a draught of air. Similarly our other senses receive many impressions from different forms of matter. We *smell* escaping coal-gas, we *taste* dissolved salt or sugar, we *hear* the pattering of unseen rain, we *see* the sun or moon.

Matter exists in the form of a solid, of a liquid, or of a gas. Many substances are known to assume all three of these forms or states, e.g. ice, water, steam. Liquids and gases *flow* and are therefore *fluids*. All forms of matter *have weight and occupy space*. They also require the application of a force to produce *motion* from a state of *rest* or to produce *rest* from a state of *motion*; in other words, all forms of matter possess the property of *inertia*.

It is easy to show that *solids* and *liquids* have weight, occupy space, and possess inertia. The inertia of a solid is shown in the fact that force is required to move it, or to stop it if it is already moving. The inertia of water is felt in swimming or in rowing. Muscular effort is required to force the body or the boat through the water.

To prove that a *gas*, such as air, possesses *weight*, a stout glass globe fitted with a brass tap is weighed full of air, and then again after exhausting the air from it by means of an air-pump. A *loss* of weight is observed when the air is withdrawn. To prove that a *gas*, such as air, occupies space, an ordinary glass tumbler or glass jam-pot may be pushed mouth downwards into a bowl of water. The water only rises a little way inside the glass because the air inside *occupies space* and resists the entry of the water. It is possible to make the air take up less space by compression, but even under great compression a volume of air still takes up some space.

To prove that air possesses *inertia*, hang a heavy ball or weight by a strong thread and set it swinging like a pendulum. After a time it comes to rest, chiefly because the air resists the passage of the ball through it, i.e. it offers resistance to the continual setting in motion of the air particles as the ball moves. A clock pendulum is kept swinging by the action of the spring or driving weight, and stops when this ceases, i.e. if the clock is allowed to "run down".

Porosity.

All forms of matter are more or less porous, that is, the minute particles or molecules of which they are composed have spaces between them. These pores are very variable in size. Gases are very porous, liquids only very slightly so. Solids vary in porosity. Certain metals are easily porous to gases at red heat, while practically non-porous to them when cold. Sponge, cork, coke, brick, calico, bread are solids with visible pores.

Compressibility.

This property of being able to be made smaller

by pressure is possessed to a very great extent by gases, to a much smaller extent by solids, and to a very slight extent indeed by liquids. Solids which have visible pores are more easily compressed than those with smaller pores. Gases are very easily compressed because their particles are very loosely packed together.

Elasticity.

Many substances when compressed try to regain their original volume because they possess elasticity. Certain solids also resist change of shape besides resisting change of volume. A solid which resists change of shape is said to be *rigid*, and so we speak of a rigid bar when we mean a bar that does not bend or change its shape under an ordinary strain. Gases are very elastic, liquids very slightly so, solids vary in elasticity. Rubber, steel, and glass are solids possessing considerable elasticity.

Indestructibility of Matter.

Many substances, e.g. water, may be readily obtained in both solid, liquid, and gaseous forms, and just as we can convert a solid to a liquid by heating, and by further heating to a gas, so by certain processes, e.g. burning or combustion, we can convert one kind of matter to a totally different kind. A solid wax candle on burning becomes various gases. We cannot actually *destroy* matter or *create* it, though the term destruction is frequently used when a thing is rendered unfit for a certain use.

Experiment on Indestructibility of Matter.

Take a small beaker containing about 20 c.cs. of dilute sulphuric acid and a little black copper oxide upon a piece of scrap paper. Place a piece of glass rod in the beaker for a stirring rod, weigh the acid, beaker, and rod together, and also the copper oxide on the scrap paper. Tip the oxide into the acid and stir. The black

oxide dissolves and forms a new substance which gives a *blue* colour to the contents of the beaker. There is no change of weight so that nothing has been created, though a new substance has been formed from the old one.

Solids, liquids, and gases possess distinctive properties which enable them to be readily distinguished from each other.

Solids have their own *size* and *shape*; liquids have their own *size* but take the shape of the vessel which holds them; gases have no shape nor size of their own, but only that of the containing vessel which must completely enclose them, or otherwise gas will escape. Solids possess the property of *cohesion* which makes the particles cling tightly together, liquids have little cohesion and gases none at all. The *diffusion* of liquids and gases resulting in two gases or two liquids becoming mingled, is due to the passage of one fluid through the pores of another. Solids as a class are heavier than liquids, though there are plenty of exceptions to this rule; gases are much lighter than either liquids or solids.

Hardness.

This property is possessed by solids in a varying degree, and the particles of hard bodies resist change of position, or being forced apart by the edge of a cutting instrument.

The diamond is the hardest known substance, and diamond drills will bore holes in the hardest rocks.

Ductility

is a property possessed by metals enabling them to be drawn out into a wire. Gold, silver, and copper are very ductile metals.

Malleability

is a property possessed by metals which enables them to be flattened into thin sheets. Gold-leaf is well known for its extreme thinness (up to $\frac{1}{300000}$ of an inch). Silver, platinum, lead, and tin are also very malleable. (So-called silver-paper is really thin tinfoil.)

CHAPTER VI

DENSITY AND SPECIFIC GRAVITY

WE have already considered the meaning of the word "matter" as being anything which gives sense impressions; the quantity of matter contained in a body is the *mass* of that body.

Equal sized blocks of lead and cork have very different weights, because the lead contains about fifty times more matter than the cork.

Difference between Mass and Weight.

The force of *gravity* or *gravitation* which attracts all bodies on the surface of the earth towards its centre, is generally used to measure the mass of a body. Mass and weight, however, have different and distinct meanings. The mass or quantity of matter in a body does not vary, but the attractive force of gravity varies slightly from place to place. Gravitation appears to act from the centre of the earth, and owing to the oblateness of the earth, this force has a greater effect on the same mass in polar regions than in equatorial regions. A delicate spring balance shows this, but an ordinary balance cannot show it, because both weights and object weighed are equally affected.

The *density* of a substance is mass per unit volume, and is useful for purposes of comparison. Thus a block of wood may be considerably heavier

than an iron weight of smaller size, but the density of wood is always less than that of iron, because it is only fair to compare the weights of *equal volumes* of wood and iron. The weights of a cubic centimetre, cubic inch, or some other unit volume should be found and the density of each expressed in grams per cubic centimetre, or ounces per cubic inch. Hence the density of any substance in grams per cubic centimetre can always be found by dividing the *mass in grams* by the *volume in cubic centimetres*.

Since 1 gram of water occupies 1 c.c., the density of pure water (at 4° C.) is 1 gram per c.c.

Specific Gravity is density relative to that of water, so that when we say that lead has a specific gravity of 11.4, we mean that lead is 11.4 times as heavy as water, bulk for bulk, or in other words, the density of lead is 11.4 grams per c.c.

To Find the Density of a Wooden Block.

EXERCISE 41.—The mass in grams is carefully found by weighing.

The volume in c.cs. is found by measurement and calculation.

$$\text{Density of the wood} = \frac{\text{mass in grams}}{\text{volume in c.cs.}} = x \text{ grams per c.c.}$$

To Find the Density of a Large Iron Nail.

EXERCISE 42.—The mass in grams is found by weighing.

The volume in c.cs. is found by displacement of water, using a measuring jar.

$$\text{Density of the iron nail} = \frac{\text{mass in grams}}{\text{volume in c.cs.}} = y \text{ grams per c.c.}$$

To Find the Density of a Liquid.

EXERCISE 43.—A small bottle fitted with a hollow stopper is used (Fig. 25). This is called a specific gravity bottle.

The hollow stopper is provided in order that the same amount of liquid may be taken every time the bottle is filled, i.e. the capacity of the bottle does not vary on account of a loose or tight cork, etc. In order to fill the

bottle, it should first be filled to the *brim*, and after blowing through the hollow stopper to ensure a clear passage of air the stopper is slowly inserted in the neck so that the liquid rises right through the stopper. All moisture is then carefully wiped off the outside of the bottle. The capacity of the bottle is found by weighing empty, then full of water, and the number of grams of water contained in the bottle represents the capacity in c.cs. The bottle is then filled with the liquid of which the density is required, and by subtracting the weight of the empty bottle the weight of the liquid is obtained. Since the volume of the liquid is the same as the capacity of the bottle previously found, the density of the liquid can be found.

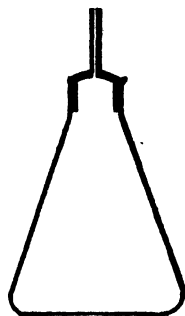

FIG. 25.

$$\text{Density of the liquid} = \frac{\text{mass in grams}}{\text{volume in c.cs.}} = z \text{ grams per c.c.}$$

or,

$$\text{Specific gravity of liquid} = \frac{\text{weight of liquid filling the bottle}}{\text{weight of water filling the bottle}}$$

The specific gravity is an abstract value and therefore *does not require* "grams per c.c." written after it.

To Find the Density of Sand or of a Heavy Powder.

EXERCISE 44.—The specific gravity bottle is used and its capacity in c.cs. is found as in the last experiment. The bottle is emptied and dried, about half-filled with the dry sand and the weight of the sand found. The bottle is now *filled up* with water and the amount of water *filling up the bottle* is determined first in grams, and then in c.cs. By subtracting this value from the capacity of the bottle, the volume of the sand is found.

$$\text{Density of sand} = \frac{\text{mass in grams}}{\text{volume in c.cs.}} = x \text{ grams per c.c.}$$

Write down the weighings for this experiment as follows :—

	Weight of bottle full of water	gms.
	Weight of bottle empty	gms.
	Weight of water contained	gms.
A.	Capacity of bottle	c.cs.
	Weight of bottle half-full of sand	gms.
	Weight of bottle empty	gms.
	Weight of sand	gms.
	Weight of bottle + sand filled up with water	gms.
	Weight of bottle + sand	gms.
	Weight of water <i>filling up the bottle</i>	gms.
B.	Volume of water filling up the bottle	c.cs.
	Volume of the sand (A—B)	c cs.

$$\text{Density of sand} = \frac{\text{gms.}}{\text{c.cs.}}$$

$$= x \text{ grams per c.c.}$$

Principle of Archimedes.

It is a well-known fact that water exerts an upward pressure on bodies placed in it, this pressure being often called the *buoyancy* of the water. Thus it is possible for a person to float in water, the whole of that person's weight being supported by the buoyancy of the water. In a similar manner a balloon filled with coal gas is pushed upward by atmospheric pressure, and floats high up in the air.

We have learned previously that the term *fluids* includes both liquids and gases, and since air and water are the most common fluids, we may consider the forces acting upon a body when *immersed in a fluid* such as air or water.

We found when weighing a large iron nail in air and then in water that there was a loss of weight when the nail was weighed in water. [See exercises in weighing, Nos. 26 to 40.] Archimedes (250 B.C.) found that this loss of weight was *equal to the weight of the fluid displaced*, and this may be proved by the bucket and cylinder experiment.

The apparatus used is shown in Fig. 26.

The cylinder *exactly fits* the bucket, i.e. the capacity of the bucket is equal to the volume of the cylinder.

Both bucket and cylinder are weighed together in air.

The cylinder is then immersed in water and a *loss of weight* is observed. Without disturbing any weights, the bucket is filled with water and the level of the balance is restored.

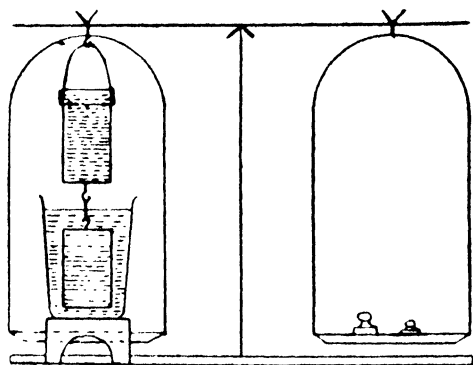

FIG. 26.

The Principle of Archimedes may now be stated as follows :—

If a solid is immersed in a fluid, it loses a portion of its weight, equal to the weight of the fluid displaced.

Since a solid always displaces its own volume of fluid, we have, by applying this principle, a ready means of comparing the weight of any heavy insoluble solid with the *weight of an equal volume of water*.

This comparison will give us the specific gravity of the solid, i.e. its density relative to that of water.

We may also prove that this principle applies to *any* insoluble solid which sinks in a fluid, e.g. a

stone or a potato, by using the apparatus shown in

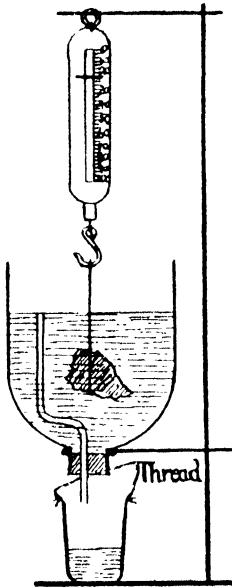

FIG. 27.

Fig. 27. The glass bell jar is filled with water to the level of the out-flow pipe, so that when a solid is lowered carefully into the water, it displaces its own volume of water, which overflows into the beaker below. The spring balance shows the weights of the solid *a* in air, and *b* in water; also the weights of the beaker *c* empty, *d* containing the water displaced by the solid; the beaker being suspended by thread for weighing. The decrease from *a* to *b* is found to be the same as the increase from *c* to *d*.

To Find the Specific Gravity of a Metal.

EXERCISE 45.—Take any solid metal object, e.g. a brass knob, an iron screw, a copper strip or small coil of copper wire, a leaden ball or weight, and by means of thread suspend it from the hook over a balance pan, to swing freely above a small wooden bridge which is used later on to support a small beaker of water. Weigh the metal in air and then in water. The loss of weight represents the weight of water displaced, i.e. the weight of a volume of water equal to the volume of the solid metal object.

Enter your results thus:—

- | | | | | | |
|----------------------------------|---|---|---|---|------|
| A. Weight of the metal in air | . | . | . | . | gms. |
| Weight of the metal in water | . | . | . | . | gms. |
| B. Weight of the water displaced | . | . | . | . | gms. |
| Specific gravity of the metal | | | | | |

$$= \frac{\text{weight of the metal in air A}}{\text{weight of an equal volume of water B}}$$

To Find the Specific Gravity of Cork or Wood.

EXERCISE 46.—Use the heavy metal object of the last experiment as a *sinker*. Three weighings only are necessary.

Take a clean cork and a foot length of cotton. Weigh the cork and cotton in air. Suspend the sinker in water with the cotton and weigh it in water, leaving a loose end of cotton about 3 inches long in the water. Tie the cork to the metal with the loose cotton and weigh both together in water. It will be noticed that the cork and metal together weigh *less* immersed in water than the metal alone when weighed in water, or in other words, the cork has a negative or minus weight in water. The speci-

fic gravity of cork = $\frac{\text{weight of the cork in air}}{\text{weight of an equal volume of water}}$.

Enter your results as follows :—

- A. Weight of the cork in air . . . = gms.
- B. Weight of the sinker in water . . . = gms.
- C. Weight of cork + sinker in water . . . = gms.

Specific gravity of cork = $\frac{A}{A + (B - C)}$.

B - C is the negative or minus weight of the cork in water which, *added on* to its weight in air, gives the weight of a volume of water equal to the volume of the cork.

CHAPTER VII

SIMPLE MACHINES: LEVERS, THE WHEEL AND AXLE, PULLEYS, INCLINED PLANE AND WEDGE, SCREWS, THE SCREW GAUGE

Levers.

A STIFF rigid rod or bar, either straight or curved, may be used as a lever. When we use a lever in applying force, one point in the lever does not change its position but is the turning-point, pivot, or *fulcrum*.

The *effort applied* to the lever overcomes a *weight or resistance* in such a manner that the turning effects of the two about the fulcrum are equal and balance each other.

In the common balance the beam is a simple lever, and the weight applied in one pan overcomes the resistance of gravity acting upon the mass to be weighed in the other.

In this case the arms of the balance are equal, but a balance may be used with unequal arms like the steelyard (see Fig. 28). Here a sliding weight moves along a scale and does duty for many different weighings.

Let us suppose that in an ordinary weighing machine with a sliding weight and extra slotted weights for large quantities, the metal scale arm is fourteen times as long as the arm supporting the foot-plate. A slotted weight of 1 lb. placed on the end of the scale arm will support 14 lb. or one stone

on the foot-plate. A sliding weight of $\frac{1}{14}$ lb. or a little over an ounce will give weighings to the nearest pound, half pound, or quarter pound if the scale is divided into exact fourteenths, and each division again subdivided into halves and quarters.

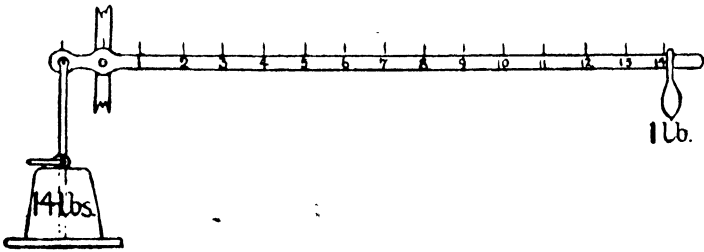

FIG. 28.

The same principle as that of the steelyard is used on ordinary balances having a wire rider and graduated beam, in order to determine the smallest fractions of a gram.

There are three orders or classes of levers. Suppose P stands for effort applied, F for fulcrum or turning-point, W for weight or resistance overcome.

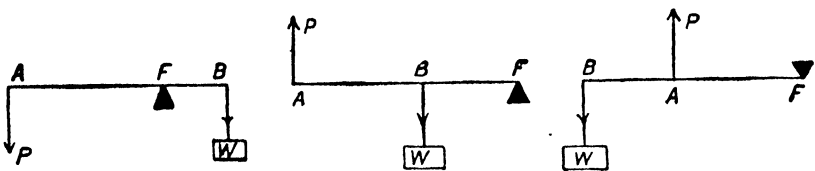

FIG. 29.

If we arrange these letters round a circle, or in cyclic order, keeping the same direction of rotation, they can only be arranged as PFW , FWP , WPF , representing the first, second, and third orders of levers. Fig. 29 represents levers of the first, second, and third classes respectively.

A poker raising coals through fire-bars, or a tin-opener in use, where the handle goes *down* while

the point goes *up*, a see-saw, the balance, and the steelyard all belong to the first order in which the fulcrum is *between the effort applied and the resistance*. There are many examples of a *pair of levers* of this order, e.g. scissors, pincers, pruning or metal-cutting "snips," pliers, etc.

The second order, where the weight is *between the fulcrum and the effort applied*, includes the wheelbarrow, an oar *when in use with the blade in the water*, a lifting action tin-opener in use. Double levers of the second order include nut-crackers, a pair of bellows, etc.

The third order, in which the effort applied is *between the resistance and the fulcrum*, is well illustrated by the human forearm when a weight is held in the palm of the hand and the forearm moved upwards, while the elbow remains stationary. The tendon which joins the biceps muscle to the bone just below the elbow-joint can be felt on the inside of the arm, and transmits the effort applied. The action of the jaw in biting is similar. Sugar-tongs, spring and ordinary coal-tongs, spring shears used for sheep-shearing or for grass-cutting, are examples of double levers of the third order.

EXERCISE 47.—Sketch a tin-opener in use, or give a simple drawing of a tin-opener, marking upon it the letters E for effort applied, F for turning-point or fulcrum, W for weight or resistance overcome at the corresponding points.

EXERCISE 48.—Sketch a wheelbarrow in use, or give a simple diagram of a wheelbarrow with the letters E, F, W marked in their correct positions.

EXERCISE 49.—Sketch a pair of sugar-tongs, marking the letters E, F, W opposite the right positions; or give a simple diagram of the human forearm, wrist, and hand, with a weight in the hand and the biceps tendon properly inserted and marked E for effort applied, F to be at the turning-point.

EXERCISE 50.—Label your three drawings as first, second,

or third order of levers, and state beneath each whether there is a gain of power, or a loss of power, by the form of leverage in question, when work is done on it.

In mechanics, *work* is done in producing motion against a resistance, so that a *foot-pound* of work means raising a mass of 1 lb. 1 ft. vertically against the resistance of the earth's gravitation.

The Wheel and Axle.

The crank of a cycle to which the pedal is attached is a lever of the second order. The effort applied follows a circular movement at one end of the lever or crank. The fulcrum is at the other end, while the resistance overcome, transmitted through the chain of the cycle, acts over a circle of smaller radius than the length of the crank.

A similar circular leverage is obtained in the windlass, in a wringer or mangle, and in a capstan. Fig. 30 illustrates a wheel and axle, the two cords being wound in opposite directions so that one is wound up as the other is unwound.

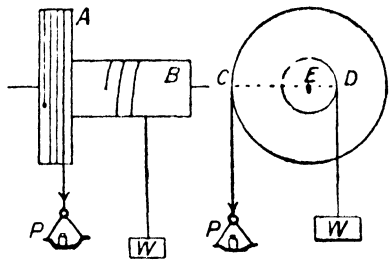

FIG. 30.

If two cog-wheels are of similar size and have

the same number of teeth, when in mesh either directly or if connected by a chain like that of a cycle, they revolve at the *same rate*.

If one has 24 teeth and the other has 8, then the smaller revolves three times more rapidly than the larger.

This method of transforming slow forceful motion into quicker but less powerful movement, or vice versa, is known as *gearing*. Compare the opposite methods of gearing in an ordinary bicycle and in a

motor cycle, the effect in the former being to *increase* the number of revolutions of the back wheel as compared with the number of revolutions of the pedals, while in the latter the engine pulley or driving-wheel makes a great many revolutions to one revolution of the back-wheel.

In a watch or clock, a spring or driving weight pulls a cog-wheel round, which through a train of toothed wheels drives the hands of the watch or clock round at the proper relative speeds for seconds, minutes, and hours.

In an ordinary wringer or mangle, it will be observed that the wheel to which the handle is attached revolves more rapidly than the lower wooden roller which is *on the same axle*. This is because the power is transmitted through cog-wheels which serve to *reduce the driving speed but increase the power*. Observe also that while the roller is *fixed* on the axle the driving-wheel is not, but *turns* on the same axle.

A similar arrangement enables the hour and minute hands of a clock to move at different rates, the hour hand being fixed to a hollow metal tube or sleeve through which passes the axle of the minute hand.

In an electric supply meter or in a gas meter, a train of wheels operates small hands on various dials showing the amount of current or of gas consumed. The setting of an alarm clock, and the working of a cyclometer depend upon a metal pin which *at one point* only in a complete revolution releases a brake on the alarm spring, or pushes the first cog of the train of wheels one tooth on.

Gas companies provide users of ordinary meters with a card on which a quarterly record is kept of the gas burnt. Full directions are given on the card how to check the meter reading. The right-hand

dial is usually marked to show hundreds of cubic feet, a complete revolution of the pointer on this dial registering a thousand feet. The next dial is marked in thousands of cubic feet, one revolution registering ten thousand cubic feet.

We are now in a position to understand the meaning of the term *machine*. **Any arrangement or contrivance by which an effort applied at one point is exerted at another under different conditions of direction or of magnitude is a machine.** In a frictionless machine the *work done on the machine*, i.e. the effort put into it, is equal to the *work done by the machine*, i.e. the force exerted by the machine; and this statement is known as the Principle of Work. The frictionless machine does not exist, so that the *efficiency* of a machine or $\frac{\text{work done by the machine}}{\text{work done on the machine}}$ in practice is always less than unity, i.e. some work is always lost through friction. The mechanical advantage of a machine

$$= \frac{\text{weight or resistance overcome}}{\text{effort applied or force used}}$$

The lever and the wheel and axle are examples of simple machines, because an effort applied through a lever or through a wheel and axle at one point overcomes a resistance which differs in magnitude or direction, or in both, acting at some other point. Other examples of simple machines are the pulley, the inclined plane, the wedge, the screw.

In an ordinary pulley such as that of a sash-line or of a blind cord, there is no mechanical advantage but merely change of direction (Fig. 31). The case surrounding the pulley-wheel is called the *block*, and in a fixed pulley such as we have just mentioned the block *does not move*. A movable pulley is one in which the block moves when the pulley is in use. Fig.

32 shows a single movable pulley in use with one fixed pulley. This arrangement gives a mechanical advantage of 2, i.e. only half the weight raised is needed as the lifting force, but while the weight is raised 1 foot the effort applied must act through 2 feet. Fig. 33 shows a *movable* block which contains three pulleys connected to a similar *fixed* block with three pulleys. If we count up the strings between the two pulleys, all being portions of the one long string or rope which goes round each wheel in turn, we find 6 portions. An effort of 1 lb. weight applied at

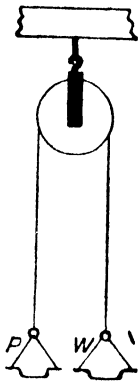

FIG. 31.

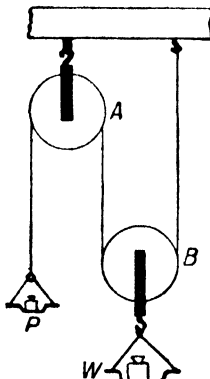

FIG. 32.

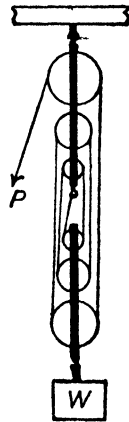

FIG. 33.

the free end of the rope is felt equally throughout the rope, so that each of the 6 portions has a tension of 1 lb. The mechanical advantage is 6, because a weight of 1 lb. supports 6 lb. weight attached to the hook of the movable block. At the same time the 1 lb. weight must act through a distance of 6 inches in order to raise the 6 lb. weight through 1 inch.

A machine which combines the features of a movable pulley with two different sized fixed pulleys above, is called the chain hoist, and is used for lifting heavy machinery, etc. An endless chain passes

round the movable pulley and over each of the fixed pulleys. On hauling at one side of the free loop of chain which hangs down, the movable pulley can be raised at a very slow rate but with very great force. Brakes act on the chain links and automatically hold the chain in position as soon as the lifting effort is removed.

The Inclined Plane.

An ordinary flight of steps, stair-way, or ladder is a contrivance or machine by which we raise our own weight; and in the simplest form, e.g. a sloping broad plank or gangway, communicating between a ship or boat and a landing-stage, is called an *inclined plane*. It is a matter of common experience that a steep slope is tiring to climb, while a gentle slope requires far less effort. When cycling up a hill, work is done against the force of gravity; on level ground no work is done against the force of gravity but only in overcoming friction; while in cycling down hill no work or effort is required because the force of gravity urges the cycle and rider down hill, and as a rule overcomes both friction and wind resistance.

The inclined plane therefore is a contrivance which assists in overcoming the force of gravity, enabling a small force operating over a long slope to raise a heavy weight to a vertical height that would be difficult to reach by any other method. It can be proved experimentally that the mechanical advantage of an inclined plane, where the effort applied acts parallel to the slope, is equal to $\frac{\text{length of slope}}{\text{vertical height}}$.

Heavy barrels are often drawn up or let down along a stout inclined ladder, while cliff railways, etc., make use of the inclined plane.

The Wedge.

A chisel, axe, or knife, when forced into wood so as to split the fibres, illustrates the wedge or double inclined plane. A blow from a hammer on the end of a wedge drives the wedge into the wood and separates the fibres with great force. The wedge is an example of a simple machine because the effort applied is transformed into a more powerful force acting through a lesser distance, e.g. when the wedge is driven in 3 inches perhaps the fibres are only separated to the extent of quarter of an inch, and hence a large mechanical advantage is obtained.

The Screw.

The screw is a *spiral inclined plane*.

EXERCISE 51.—Take a sheet of paper and cut from it a right-angled triangle having a base about six times as long as the height. Place the short perpendicular height parallel to a round ruler and roll the paper round the ruler. The hypotenuse or longest side of the right-angled triangle will form a spiral curve or *screw* round the ruler.

The perpendicular distance between one screw thread and the next, i.e. the distance the screw advances or recedes in one complete turn, is called the *pitch* of the screw. Examine ordinary carpenters' screws, also a metal screw *bolt*, and note that screws used in wood have a large or *coarse* pitch, while those used in metal have a small or *fine* pitch. Nearly all screws are right-handed or advance with a clockwise rotation. A hollow cylinder with an internal screw thread is called a *nut*. Gas and hot-water pipe fitters bring machine-made nuts and bends with them, and cut and thread lengths of iron pipe as required. The mechanical advantage of a screw is found in the same manner as that of the inclined plane, and by using a lever to turn the

screw great pressure can be obtained. A wringer or mangle is fitted with one or more screws which put great pressure on the rollers by compressing or flattening very powerful springs. These screws should always be raised when the machine is not in use, because they exert great pressure on the rollers. A copying or screw press, the screw-jack which is used to raise a railway truck, motor-car body or heavy wagon in order to replace a wheel, and the blacksmith's vice which grasps metal tightly while it is being cut or filed, are further illustrations of machines having screws.

Other important applications of the screw are seen in the propeller of an aeroplane or of a steamship, and in ventilating fans, frequently seen in shops and in public buildings.

The Micrometer Screw Gauge.

This instrument is used for measuring the thickness of sheet metal, wire, etc., and consists of a screw of 1 mm. pitch which can be screwed up until it touches the flat end of a fixed screw. The small

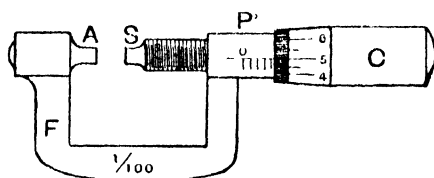

FIG. 34.

object to be measured is placed between the fixed and movable screws, and the handle screwed round until the object is just grasped. Markings on the handle of the screw enable readings to be taken representing $\frac{1}{100}$ of a complete turn, i.e. $\frac{1}{100}$ of a millimetre, a degree of accuracy which falls within $\frac{1}{2500}$ of an inch (Fig. 34).

EXERCISE 52.—Measure the thickness of a wire nail or of a copper wire with the micrometer screw gauge. The gauge should not be screwed up *tightly* but only sufficiently to grasp the object lightly, and before placing the object between the jaws the reading should be taken when the faces of the two screws are touching, because, often, owing to wear or over-screwing, the actual zero when the jaws touch is not true 0, and must be taken into account in finding the correct measurement.

EXERCISE 53.—Measure and compare the thicknesses of several coins, e.g. halfpenny, penny, shilling, etc.

CHAPTER VIII

FRICTION

ON a perfectly horizontal and smooth surface, such as a large sheet of clean ice, a body once set in motion continues to move or slide in a straight line for a very considerable distance.

There is so little friction on ice that skating and sliding are possible, while slipping is so easy that it is difficult to walk with smooth soles.

Other surfaces, e.g. a wooden floor, linoleum, carpet, the roadway, are far less slippery, i.e. there is more friction between them and the sole of the boot. However, a polished linoleum or wood floor, or a muddy pathway, may be sufficiently slippery to cause a fall.

Friction is the force which retards motion and produces most of the "wear and tear" of substances and fabrics. A polishing cloth soon wears into a hole, brake-blocks and boot soles need replacing from time to time, and though a well-oiled steel bearing lasts a long time, yet in process of time the operation of friction wears it out.

EXERCISE 54.—Lay a cast-iron weight with a ring upon its side on a horizontal bench top, and passing the hook of a spring balance through the ring, steadily drag the weight along horizontally without attempting to lift it at all.

After the weight has begun to move, the spring balance will show the force required to overcome the friction acting between the weight and the bench top.

EXERCISE 55.—Scatter a little sand on the bench top and repeat. The friction is now *greater* than before. Carefully remove all the sand by a duster and rub on some wax polish or a little linseed oil and repeat the experiment. The friction is now *less* than it was on the unpolished bench top.

EXERCISE 56.—Place a number of short lengths of glass tubing, all cut from the same length of tubing, beneath the weight, and note that *rolling friction* is less than *sliding friction*. This is because as a wheel rolls, it lifts the projections on its rim *over* those of the surface upon which it travels, but in sliding the projections of both surfaces rub against each other.

Substances which fill up the unevenness or roughness of a surface, e.g. oil or black-lead, are called *lubricants*, and lessen friction considerably. The opposite effect was seen when sand was used, and sand pipes are fitted to electric cars in order to scatter sand immediately under the wheels on the smooth rails, when it is necessary to apply the brakes and stop the car suddenly.

We shall now consider the application of lubricants and anti-lubricants in common instances.

Use of Lubricants.

All moving metal parts of machinery require oil or black-lead. Too much oil should not be used, as it leaks out and makes a mess. A small feather with part of the plume cut off on both sides of the shaft or quill, is a good means of applying oil to a sewing-machine, stiff lock, gate, bolt, or door-hinge. A mixture of black-lead and oil about the consistency of paint is a very good lubricant for an outside bolt, gate, or for a cycle-chain, because black-lead resists rusting, and does not collect dust like a wet lubricant. In oiling the hinge of a door it is a good plan nearly to shut the door on a wedge placed on the floor almost below the hinges. This lifts the

door slightly and enables an oiled feather to introduce oil between the parts of the hinge. Any excess of oil should be carefully wiped off with a clean piece of rag. French chalk or boracic acid powder are both dry greasy powders, useful for placing between inner tube and outer cover of a cycle or for lubricating a stiff wooden drawer. Casters beneath heavy furniture, and also sash-line pulleys, should be oiled occasionally, by means of an oiled feather.

Use of Anti-lubricants.

During a spell of severe frost, a little sand should be scattered over smooth, tiled outdoor paths, as a thin layer of ice over tiles makes a slippery and dangerous surface.

A resin or hardened gum is rubbed upon the horsehair bow of a violin to increase the friction, and smooth wooden pegs in a musical instrument become less likely to slip if treated with resin.

In unscrewing a fountain pen, a rubber band held between finger and thumb assists in gripping the nib section firmly. Rubber covers, or layers of twine or wash leather, similarly afford a firm grasp of a bat or racquet.

Care of Common Domestic Machines.

It should be remembered that machinery requires protecting against friction and also against rust. Paraffin oil is too thin for a lubricant, for being light and mobile, it speedily drains away from the wearing surfaces. This makes it suitable for cleaning clogged bearings from greasy dirt, but after drying off the excess of paraffin, proper lubricating oil should always be used. Linseed and olive oil are unsuitable because they dry up and clog the bearing, though they are useful for softening leather straps, etc.

A wringer or mangle, sewing-machine, lawn-mower, cycle, should have the bearings regularly

oiled with good lubricating oil. Vaseline is a good lubricant for cog-wheels, cycle-chains, etc., and preserves the cutting knives of a lawn-mower from rust. When a cycle is put away for winter, or any bright steel-ware, such as knives, a film of vaseline rubbed on the bright parts will prevent rust.

Only enough lubricant should be used to make an oil *film*, and not enough to run out or spill over. It is particularly desirable not to have excess of oil running out of a sewing-machine, and in order to avoid this the following method of lubricating is a good one. Place a penny tin of vaseline on the stove to melt the vaseline, and after clearing out the oil-holes of the machine with clean match sticks, oil the bearings with melted vaseline dropped in by the aid of a match stick or a cut feather. On cooling, the vaseline being semi-solid, is not likely to run out of the bearings. Mutton fat might also be used.

Nails and Screws.

These are held tightly in wood by friction, and since their insertion wedges the wood fibres apart, and is liable to produce splitting, a hole should always be bored first by a bradawl. Screws are easier to insert and to withdraw than nails, and should be greased with vaseline before being screwed into the wood. Screw eyes are very useful, as they can be inserted or withdrawn with the fingers after previously boring a hole. They can be used to attach picture-cord to pictures, to fasten a cord or light rope to woodwork, and to support wooden shelves for books, especially where the height of the shelf may have to be changed to suit the size of the books. If two strong screw eyes are fixed in the upper half of a sash window frame inside, so that they can be used in opening the window, they prevent accidents and breakage due to broken sash lines, and safeguard from burglarious entry.

CHAPTER IX

MEASURING FORCES

FORCE suggests the idea of *movement* or of *arresting movement*. We use muscular force in order to open or close a door or window, to propel a cycle, or to strike, or stop, a hockey ball. Similarly we use the words *effort* or *power* in a general way, with the same meaning as force, so that steam-power, water-power, conveys the idea of forceful movement. **Force is that which changes, or tends to change, the state of rest, or the state of uniform motion of a body.** The application of force does not always produce the desired result; e.g. one may fail to open a window against considerable friction even though a good deal of force be used. In this case the force used *tends* to open the window and would undoubtedly do so, but for the fact that it is opposed by a greater force, and so prevented from producing motion. In catching a cricket ball considerable force has to be used to bring the body to rest if it is moving rapidly.

It is very convenient to represent a force by a straight line, because *the length of the line* can express the magnitude or strength of the force; *the slope of the line*, the direction in which the force acts, and *the starting-point of the line drawn*, the point of application of the force.

The force of gravity, or the attractive force of the earth acting upon a body, enables us to express the

magnitude of a force as so many pounds weight or grams weight, so that the gravitational unit of force is a pound weight, or a gram weight, according to whether we use British or metric units.

EXERCISE 57.—Suspend a metre scale from two spring balances so that the scale is supported horizontally from the balance hooks fastened to each end of the scale. Hang masses of 100 gms., 50 gms., 20 gms. at various points along the scale and observe that as the weights are increased, the same increase is shown *as a total* on the spring balances, but the load is not equally shared between the spring balances.

EXERCISE 58.—Pass the ash map-pole through the ring of a 14 lb. weight, hold one end of the pole and get your friend to hold the other end, keeping the pole horizontal. Shift the position of the weight several times and it will be found that the weight is only shared equally when it is at an equal distance from both points of support. If nearer one support, that support bears a larger portion of the weight.

The Moment of a Force measures the turning effect of the force with regard to a certain point. In raising a trap-door or in opening the hinged lid of a large wooden box or travelling trunk, the best position to apply the lifting force is as far away from the hinge as the lid permits.

EXERCISE 59.—Suspend a metre scale by a wire loop from its centre or in a pivoted wooden stirrup so that it hangs horizontally. Hang a 100 gm. weight at a distance of 20 cms. from the centre. Fasten on a 50 gm. weight at 40 cms. from the centre on the other side to balance the 100 gm. weight. It will be seen that each weight has an equal and opposite turning effect about the central point of support (Fig. 35).

From this experiment we see that the moment of a force about a point, i.e. the turning effect of the force at that point, is the product of the force and

the perpendicular distance of the point from the line of action of the force. Thus 100 gms. weight acting at a perpendicular distance of 20 cms. from the turning-point has the same turning effect as 50 gms. weight acting at a perpendicular distance of 40 cms. from the turning-point; because these two different forces at different distances from the turning-point

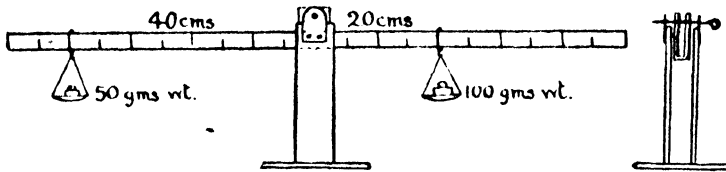

FIG. 35.

have equal and opposite effects. Of course the heavier weight only moves through *half* the distance in producing the same turning effect as the lighter weight. As in the case of the simple machines described in chapter vii., a small force acting through a greater distance balances a large force acting through a smaller distance.

EXERCISE 60.—Using the same scale and weights as in the previous exercise, hang the scale by a wire loop from its centre to the hook of a spring balance. Note the weight of the wooden scale, without the weights.

If the scale balances horizontally about its centre, we may represent a number of parallel forces acting vertically downwards from each particle of wood in the scale having its own weight. But the moments of the parallel forces acting on one side of the wire loop are balanced by the moments of the parallel forces acting on the other side of the loop. We may therefore suppose the point of support in this case to be vertically above the point where the whole weight of the body may be supposed to act. This latter point is called the **Centre of Gravity**.

EXERCISE 61.—Place the 100 gms. weight and the 50 gms. weight at the same distances from the centre as before, and note that the centre of gravity remains below the point of support, because the moments of the forces acting on either side of this point are equal and opposite. Note also that the spring balance indicates an *increase* of 150 gms. downwards.

To Find the Centre of Gravity of a Metal Plate or of a Piece of Cardboard.

EXERCISE 62.—Suspend the cardboard or plate from any point near the edge, first making a small hole through which to pass a thread. Holding the edge of a half-metre scale against the thread support, which should be several inches long and forms a plumb-line or vertical line, continue the line of the supporting thread across the plate by drawing a vertical lead pencil line, or a small weight or lead bob **L** may be hung on a thread as a plumb-line. Repeat the process using another point of support, and where the two vertical lines cross each other is the centre of gravity **G** (Fig. 36). Test this by experiment, balancing the plate or card upon the point of a pencil touching the point found as the centre of gravity. It will be found that the card or plate balances about this point.

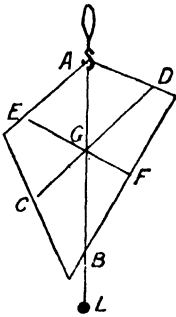

FIG. 36.

The centre of gravity is that point at which the whole weight of the body may be supposed to act.

EXERCISES 63 to 76.—Find by similar methods to those of the last experiment the centre of gravity of each of the following figures cut from cardboard or stiff paper:—

- (a) Triangle. C.G. is on the line joining the mid point of any side to the opposite angle, $\frac{1}{3}$ along this line from the side.
 - (b) Parallelogram, rhombus, rectangle, square. C.G. of each of these is at the intersection of the diagonals.
 - (c) Circle. C.G. is at the centre.
 - (d) Ellipse. C.G. is at intersection of major and minor axes.
- By using a fine pin and soft wooden models, forcing the pin

into the wood, and suspending by cotton from the pin, the following centres of gravity may be checked for various solids :—

- (e) Rectangular block, cube, sphere. C.G. of each is at the centre.
- (f) Cylinder or right prism. C.G. is at middle point of central axis.
- (g) Pyramid or cone. C.G. is $\frac{1}{4}$ distance along line joining vertex to centre of base.

Plasticine, clay, or potato models may be used, and the line of suspension continued vertically through the solid by a long pin. The intersection of two suspension lines can be found by slicing, and this is the centre of gravity of the solid.

Familiar Applications of the Centre of Gravity.

From our previous observations we see that the point of support for any body must be either vertically *above* or *below* its centre of gravity, otherwise the body will swing or topple.

The centre of gravity of a lifeboat is near the centre of the heavy keel, so that if the boat is overturned by a wave it rights itself; in other words, it is compelled to float right side up. Large airtight chambers at either end make it so buoyant that the floor level where the men sit, is *above* the water level outside the boat, and open pipes continually carry away any water that splashes in. A motor bus or an electric tramcar has its heavy framing and machinery placed as low as possible in order that the centre of gravity, even when the top is full of passengers, may not rise much above the wheels. This ensures stable or safe equilibrium. A wagonette with its passengers and chief weight above the wheels is far more unstable than a motor bus, and much more likely to upset. A person riding a cycle is in a position of unstable equilibrium, and cannot sway from side to side without upsetting. This is because the centre of gravity of the person

and machine together must be vertically over a broad line drawn from front to back tyre, as otherwise side-slip occurs. It is dangerous to stand up in a small boat for the same reason, as in a narrow boat it is quite easy to "side-slip". A punt or a sea-going row-boat is built much broader in order to avoid risk of upsetting sideways, and there is little danger of such a boat being upset, though it is quite likely that a person standing up in it may be jerked over the side. Vases and tumblers have broad or heavy bases, in order to lessen the risk of overturning them.

CHAPTER X

MEASURING TIME

The Pendulum.

A SIMPLE pendulum consists of a small heavy weight suspended by a light strong thread from a fixed support (Fig. 37).

EXERCISE 78.—Suspend a small lead bob by thread from the clamp of a retort stand, placing two small flat pieces of wood between the jaws of the clamp to grip the thread firmly. The lower edges of the pieces of wood should be level, and the length of the pendulum should be measured from this point where the thread is gripped to the *centre* of the lead bob. The *amplitude* is the distance through which the pendulum swings measured from the *vertical* or *place of rest*.

Verify by experiment that the amplitude of the swing does not affect the time of the swing, also that pendulums having the same length but with bobs of different material are found to beat at the same rate.

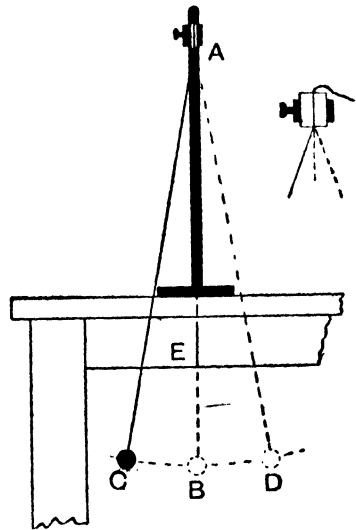

FIG. 37.

The time taken for *one complete swing*, i.e. from the starting-point across to the other side and back to

the starting-point again, is called the *periodic time* of the pendulum. Observe that a short pendulum swings more rapidly than a long one; and then, varying the length of your pendulum, as indicated in the following table, prove for yourself that the *periodic time* is directly proportional to the square root of the length.

It is best for some one to hold a watch which marks seconds, or if possible a stop watch or chronometer which registers fifths of seconds. The signal "Ready, go!" should be given finishing with "Time, up!" so that the interval between *go* and *up* is as nearly as possible exactly 60 seconds. The number of oscillations in 60 seconds can then be entered in the second column. The periodic time is found by dividing the number of oscillations into 60 seconds.

Length of Pendulum in Centimetres.	No. of Oscillations in 60 Seconds.	Periodic Time in Seconds.	Square Root of Length in cms.	Periodic Time \div $\sqrt{\text{Length}}$
100	30	2	10	'20
81	32	1'81	9	'20
64	37	1'57	8	'19
49	42	1'43	7	'20
36	50	1'2	6	'20
25	60	1'0	5	'20
16	73	'83	4	'20

Note that the pendulum 100 cms. long being *four* times that 25 cms. long, beats *twice* as slowly; also that the results in the last column agree very closely.

What is commonly called the seconds-pendulum is one that has a periodic time of *two seconds*, and therefore takes *one second* in swinging from *side to*

side. Such a pendulum regulates the works of a "grandfather" clock. A pendulum which beats twice in a second, or has a periodic time of one second, is often used on mantelpiece clocks. Compare the lengths of a seconds and half seconds-pendulum with the 100 cms. and 25 cms. pendulums given in the table above.

The seconds-pendulum is approximately a metre long.

In regulating a clock having a pendulum, the pendulum must be shortened to make the clock go faster, and lengthened to make it go slower. A small nut at the lower end of the pendulum rod allows for such regulation to be made.

If it were not for the spring of a clock or the descending weights which drive the hands round, after a time the pendulum would stop swinging as it does when the weight of the clock has "run down". We use the same term to describe the condition of any clock which requires winding, whether it works by a spring or by weights. In many clocks, and in all watches, the pendulum is replaced by a balance-wheel, which continually reverses its movement, being controlled by a fine or "hair" spring which coils and uncoils as the balance-wheel revolves first one way and then the other.

Attached to this balance-wheel or to the upper end of the pendulum rod, two metal teeth or "pallets," some distance apart, come in contact with a toothed wheel called the escapement-wheel of the clock or watch (Fig. 38). This is because the rocking motion of the two pallets only allows the cog-wheel to escape or pass them *one cog at a time*, and the regular tick-tack of a clock is due to the escapement cogs striking first one pallet and then the other.

The slight shock or push at every tick, communicated through the train of wheels from the main-spring or descending weight, keeps the pendulum or balance-wheel on the swing, as long as the clock is not run down.

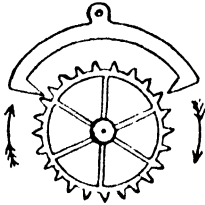

FIG. 38.

The striking of a clock or of an alarum has a separate spring or weight, and train of cog-wheels. A "snail" or comma-shaped piece of metal or a spiral, like one turn of a screw thread, regulates the number of hours struck on the gong, or the precise moment at which the alarum sounds. The hands of a striking clock or of an alarum clock *should never be turned backwards*, as there is considerable risk of injury to the striking control. Note the saw-like teeth and small catch which together ensure that a clock can only be wound one way.

The mechanism of the striking part of a clock is similar, in that it only operates during the ordinary clockwise rotation, and not with a backward movement. It does not injure a clock to set the hands with a clockwise movement, though it throws some strain on the works, because an axle which works stiffly inside a metal sleeve must be moved and friction overcome.

CHAPTER XI

LIQUID PRESSURE

IT is a well-known fact that pressure applied to a liquid is exerted equally in all directions. Water forced through a hose-pipe will come out forcibly at the other end, but will also be forced out through any leaks in the pipe wherever they may be. Since there is so little cohesion between water particles, they readily roll over one another, and hence water at rest always has a level surface, all hollows in the surface having been filled by the particles moving downwards under the force of gravity, and so distributing themselves evenly.

EXERCISE 79.—Take 6 inches of soft rubber tubing used for connecting small glass tubing. Tie one end up tightly with strong thread and stretch the other end over the water tap. Allow water to enter and distend the tubing to about six times its usual diameter. Tie the upper end tightly and remove from the tap. If the water tap cannot be directly connected with the tubing, sufficient pressure may be obtained by attaching a funnel to a long length of rubber tubing and only tying off the lower 6 inches, or a long length of glass tubing may be used, held vertically and connected to the funnel and the 6 inches of rubber tube. Place the rubber “sausage” in the sink, press it between the fingers and note the uniform resistance, then rapidly prick several holes with a pin near one end, and holding it up by the other observe how water is forced out equally in all directions, proving that pressure applied to a liquid is transmitted equally in every direction.

To Make a Spirit Level.

EXERCISE 80.—Take a piece of glass tubing 4 inches long and warm the centre in a bunsen flame by rapidly rotating the ends between fingers and thumbs. When the centre is nearly red hot bend the glass *very slightly*. Allow to cool and then seal one end by heating it strongly. After cooling, fill the tube almost full with coloured alcohol or methylated spirit, and close the open end with a suitable well-softened cork boring which fits tightly. Take a small flat piece of wood, an old flat ruler will do,



FIG. 39.

and fasten the tube at each end on to the wood by sealing wax or by gluing on pieces of cork previously cut to fit the tube so that the curve in the glass stands up in the centre, as in Fig. 39. This will act as a spirit level, since the air bubble left in will rest at the highest part of the curve when the instrument is placed on a level surface.

Why is spirit better than water or glycerine, and why is a camera fitted with a spirit level?

Reservoirs and Water Supply.

A lofty situation is chosen where possible for a reservoir. Many of the Welsh mountain lakes are used to supply water to towns at great distances, and where it is impossible to secure a natural reservoir at a hundred feet or more above sea level, a water tower has to be built and the water is pumped into a large cistern at the top of the tower so that the pressure obtained in this way may drive the water through the water mains and up through the pipes into the houses where the water is used. Hydraulic pressure is frequently obtained in this way, e.g. the lofty towers of the Tower Bridge have water cisterns which are kept full by pumps, and the pressure so obtained operates the powerful

machinery which raises and lowers the bascules or drawbridges. Hydraulic lifts are worked similarly. Fountains, like those of the Crystal Palace, are worked by water towers or lofty tanks, and water released from a jet many feet below the water level in the tanks, rises in an effort to find its own level and forms a fountain.

EXERCISE 81.—Fill a long piece of rubber tubing with water, and holding the two ends at the same level allow the tube to sag in the centre into the form of a U tube. Notice that immediately one end is lowered, water flows from that end. Close one end by pressure and bring it down several feet below the other end. On releasing the pressure a fountain is produced at the lower end.

EXERCISE 82.—Take a wide-mouthed bottle and bore two holes in a tightly fitting cork. Fit one with a large glass funnel and place a bent glass tube in the other, as in Fig. 40. Observe that the water level in both funnel and tube is the same when the bottle is full. This proves that water finds its own level even when carried through pipes for a distance. Hence a water pipe may be carried under any obstruction and the water will rise to the same level at both ends of the pipe. Since water transmits pressure equally in all directions, *the size of the pipe* does not affect the pressure transmitted.

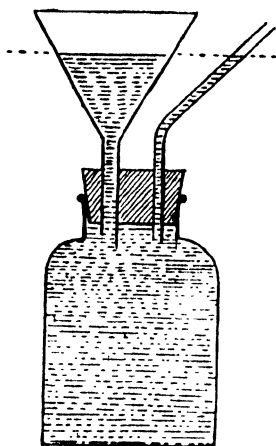

FIG. 40.

EXERCISE 83.—Make a U tube by joining two pieces of glass tubing of *unequal bore* by means of a short length of rubber tubing. Pour water down the wider tube and observe that the water stands at the same level in both tubes.

A modification of the unequal U tube fitted with plungers or pistons, and having valves, is known as

the Bramah press. The small limb of the U tube has a powerful piston fitted with a long lever, and on working this, water is slowly forced into the larger limb of the U tube, where it raises a much larger piston very slowly but with great hydraulic force. The hydraulic lift is another modification of the U tube.

Flotation.

Any substance which is lighter than water, bulk for bulk, will float in water. The average human being with the lungs full of air is of slightly less density than fresh water, and therefore floats in water. In swimming, the action of the arms and legs propels the body through the water and to a certain extent supports the body, since a swimmer by treading water with vigour may raise himself out of the water a few inches higher than usual. It should be observed that water resists the passage of a body through it far more than air, and hence the recovery of both arm and leg stroke, i.e. the bringing of the limbs forward for a fresh stroke, as in rowing, should be through the air rather than through the water. The "crawl" stroke practised by fast swimmers illustrates this point. The ball tap of a cistern is so arranged that the buoyancy of the water in lifting a hollow copper ball attached to the end of a long lever, forces a rubber-capped stopper into a hole like the neck of a bottle and so cuts off the water supply as the cistern fills.

To Make a Simple Model of a Hydrometer.

EXERCISE 84.—Take a test tube and load it with small lead shot or sand so that it floats upright in a beaker of water. Cut a slip of card the same length as the test tube, and after marking it in numbered half centimetres, place the slip in the test tube with the mark 1 touching the lower end. Note the mark opposite the water level. Place the same loaded test tube in methylated spirit, and in strong salt water.

Note the mark opposite the surface of the liquid used in each case. Since the weight of the loaded tube remains the *same* in every case, and a different fraction of the tube is immersed in the various liquids, we have a means of comparing the densities of the liquids.

Every floating body displaces its own weight of liquid, just as a heavy solid totally immersed loses a *portion* of its weight (cf. Principle of Archimedes). The liquid which pushes the tube upwards to the greatest extent, and in consequence has its surface level opposite a low mark on the scale, is the heaviest and most buoyant.

That which allows the tube to sink in most deeply, and has its surface opposite a high mark on the scale, is the lightest and least buoyant.

The Common Hydrometer.

An instrument like a glass float with marks on the stem corresponding to liquids of different densities is called a *hydrometer* (Fig. 41). A special form used for testing the purity of milk is called a *lactometer*. Milk is a denser liquid than water, so that the mark M for milk is lower on the stem than the mark W for water. The instrument usually has a small glass jar constructed just conveniently to hold the lactometer, so that very little milk is required to make this density test.

Nicholson's Hydrometer.

This form of hydrometer is a hollow metal float with a loaded cone attached, the base of which forms a pan in which solids can be weighed *under water*. An upper scale pan is

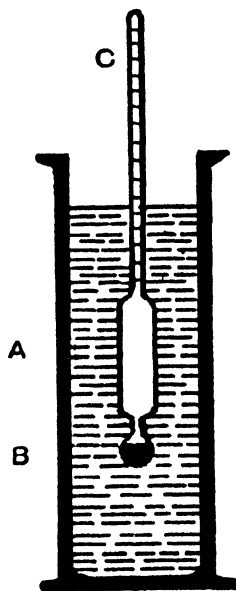

FIG. 41.

fitted on a wire, soldered to the metal float, and the wire has a mark about half-way between the pan and the float (Fig. 42).

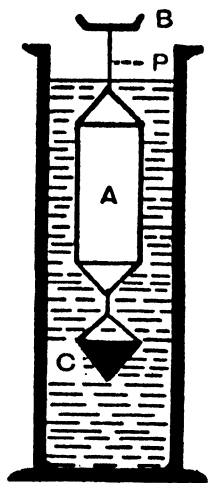

FIG. 42.

Sufficient weights are placed in the upper pan to sink the hydrometer to the mark in water. Any small insoluble solid may be put on the pan in place of some of the weights, and its weight found in air by subtraction. On transferring the solid to the lower pan under water—if *lighter* than water it must be tied by fine cotton—the *additional* weights required to sink it to the mark represent the *loss of weight* of the solid in water.

The loss of weight is equal to the weight of an equal volume of water, so that the specific gravity

$$\text{of the solid} = \frac{\text{weight of the solid in air}}{\text{weight of an equal volume of water}}$$

The densities of two *liquids* may also be compared by Nicholson's Hydrometer by first weighing the hydrometer and then *adding* the weights required to sink the hydrometer to the mark in the respective liquids. Since the volume of the hydrometer below the mark does not vary, and the weight of the fluid displaced in each case is equal to that of the weight of the floating body, assuming the liquids are A and B,

$$\frac{\text{Density of liquid A}}{\text{Density of liquid B}} = \frac{\text{Weight of the floating body in A}}{\text{Weight of the floating body in B}}$$

Comparing Densities of Two Liquids by the U Tube.

If liquids are taken *which do not mix*, or if a little mercury be poured in *first* to separate the two liquids

which are to be compared, the densities of the liquids are inversely proportional to the heights of their columns above the separating surface. [N.B. — If mercury is used the mercury columns on either side of the bend must be exactly the same height.] Thus in Fig. 43 an 8-inch column of water has a downward pressure in one limb which is balanced by a 10-inch column of methylated spirit. Hence the density of the spirit relative to that of water is $\frac{8}{10}$ or .8.

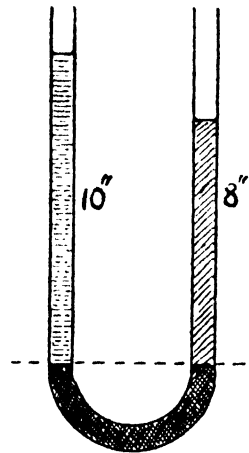

FIG. 43.

Comparing Densities of two Liquids by Hare's Apparatus.

This apparatus is like an inverted U tube, a T joint at the bend enabling air to be withdrawn by suction through a spring clip on a rubber pipe. Air pressure forces the liquids in the beakers partly to fill the tubes (Fig. 44). In the next chapter we shall learn that air pressure, like liquid pressure, is exerted equally in all directions so that the columns of liquids in the two tubes, being supported by equal pressure, must be of equal weight.

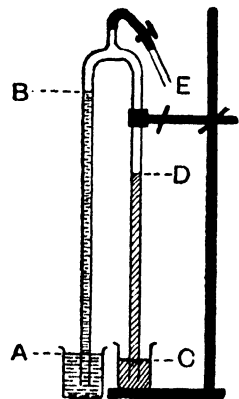

FIG. 44.

As in the U tube, the densities of the two liquids compared are inversely proportional to the heights of their columns (measured from lower surface to upper surface).

$$\frac{\text{Density of liquid in AB}}{\text{Density of liquid in CD}} = \frac{\text{Height of column CD}}{\text{Height of column AB}}$$

EXERCISE 85.—Fit up a Hare's apparatus (see Fig. 44).

Measurements of the heights of columns of liquid must be made from the lower surface to the upper surface.

Using blue copper sulphate solution and water, take readings at six different heights, tabulate, and compare results :—

Height of Blue Solution in Centimetres.	Height of Water Column in Centimetres.	Ratio = $\frac{\text{Height of Blue Solution Column.}}{\text{Height of Water Column.}}$

Observe that the results in the last column agree closely, and taking the average result, calculate the density of copper sulphate solution in grams per c.c.

Note that in the U tube or in Hare's apparatus, unequal bores in the two limbs make no difference, unless the bores are *very small* (Chap. XVI). *Vertical height* from surface to surface must be measured, and if the limb slopes we must *not* measure slant height. Make U tubes and Hare's apparatus with unequal bored glass tubes connected by rubber tubing and a T glass joint in the Hare's apparatus. Let one or both limbs be oblique instead of vertical and verify the fact that the vertical height of the column remains the same, as the slope of the limb is altered. Hare's apparatus may also be used to illustrate the *siphon*.

EXERCISE 86.—Fit up Hare's apparatus with the limbs dipping into two beakers of equal size. Nearly fill one beaker with water, and place only a depth of an inch of water in the other. Draw the water up both limbs until the columns meet at the bend, and close the clip. Observe that air pressure forces water over the bend towards the side with the greater fall, and that this goes on until the levels in both beakers are the same. A bent tube used in this way is called a siphon.

CHAPTER XII

AIR PRESSURE

The Barometer.

EXERCISE 87.—Take a glass jar, fill it with water, and after placing a ground glass plate on top, invert the jar and remove the hand from the loose plate. *The pressure of the air supports the plate* (see Fig. 45).

EXERCISE 88.—Take a tinned flask of thin sheet metal holding about a pint. [An old varnish tin or an oil flask will do.] Boil a *little* water in it, and while steam is issuing freely, remove the burner and force a softened cork tightly into the neck. As the flask cools and the steam condenses to water, a partial vacuum is created inside the flask. This is because the steam drove the air out of the flask while the water was boiling. *The pressure of the air forces in the sides of the metal flask.*

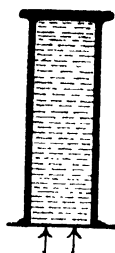

FIG. 45.

AN earthenware hot-water bottle need not be entirely filled because its thick sides withstand considerable pressure. Why does air rush in when the stopper is loosened after cooling? A rubber hot-water bottle should not be entirely filled, but should, when three-quarters full, be squeezed to bring the water up to the top before inserting the screw cap. How does this relieve internal pressure on the elastic sides of the bottle? An aluminium or copper hot-water bottle must be filled *to the brim*

before screwing in the stopper, otherwise on cooling the sides collapse under atmospheric pressure.

The Barometer.

The mercury barometer consists of a vertical glass tube closed at the upper end, about 33 inches long, which has been filled with mercury and inverted in a vessel containing mercury. The lower end is sometimes bent into the form of a U tube in order to dispense with the lower vessel containing mercury (Fig. 46).

EXERCISE 89.—Hold such a straight tube over a mercury tray, and using a small funnel drawn out into a narrow bore, entirely fill the tube with mercury. Placing the finger firmly over the open end, invert the tube and bring the open end beneath the surface of mercury contained in a basin. Remove the finger and fix the tube upright. Some of the mercury flows out until the column is about 30 inches high. The empty space above the mercury is airless, and except for traces of mercury vapour is a complete vacuum. Tilt the tube so as to bring the *vertical* height within 30 inches and mercury again fills the whole of the tube (Fig. 47).

In using Hare's apparatus we observed that by sucking out *some of the air* in the inverted U tube the two liquids were forced into the limbs by air pressure. In the case of the barometer the weight of a 30-inch column of mercury measures the *total* atmospheric pressure.

The height of the mercury column, generally described as the height of the barometer, varies day by day. This is because the atmospheric pressure in a district varies day by day according to the moisture present as vapour in the air. So-called steam from a kettle, which is really condensing into minute drops of water (true steam is invisible), is always observed to *rise*, showing that

it is lighter than air. True steam or invisible water vapour which is always present in air is lighter than air, and therefore as the quantity of water vapour increases, the atmospheric pressure diminishes. Hence on the approach of wet weather, when the air becomes saturated with water vapour, the barometer falls to perhaps 29 inches or even lower. Very dry cold air will send the barometer up to 31 inches or over.

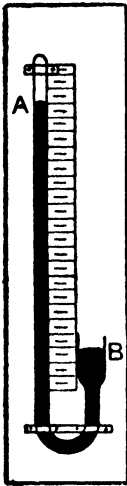

FIG. 46.

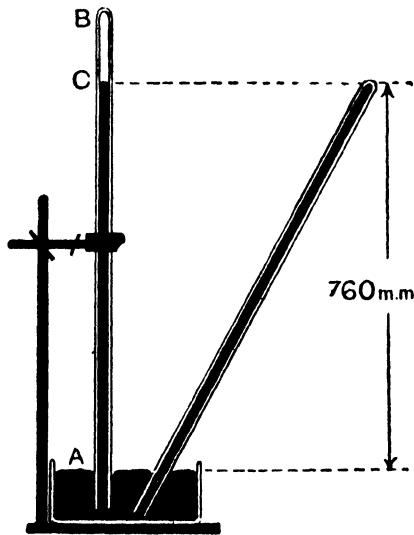

FIG. 47.

Fine weather is therefore dry weather, and the absence of much cloud and water vapour brings sunshine. Thirty inches is approximately equal to 76 centimetres or 760 millimetres, so that normal atmospheric pressure is 760 millimetres according to metric units. In a U tube or siphon barometer (Fig. 46), the long and closed limb is not under atmospheric pressure from above, but the mercury column of 30 inches or 760 millimetres is supported by atmospheric pressure acting vertically down-

wards on the surface of the mercury in the short open limb. Since whatever mercury column there is below this surface in the short limb is balanced by a column of equal height in the long limb, the height of the barometer must be measured *from the lower surface to the upper surface*.

The *aneroid* ("without liquid") barometer has a nickelled or white-metal box from which air has been exhausted. Air pressure keeps the sides of this box forced in to a certain extent, the balance between the springy sides of the box and the air pressure being so delicate, that variations

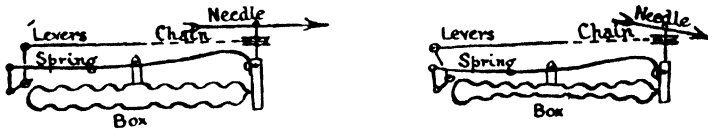

FIG. 48.

of air pressure cause the sides of the box to move in and out. A pillar soldered to the side of the box moves a hand over a dial, as in the old-fashioned mercury barometer (Fig. 48). The aneroid barometer is set by comparison with a standard mercury barometer, and like a watch will work in any position. A mercury barometer must be kept upright and is fitted with a spirit level or suspended vertically.

Barometric Readings Day by Day.

Certain kinds of aneroid barometers, commonly called "Barograph" or self-recording barometers, are so arranged that the end of the moving arm marks by means of pen or pencil, variations of barometric pressure upon squared paper. The squared paper charts are fixed on a drum which revolves by clockwork, and each chart thus records a graph of the barometric variations for one week.

Comparison of Barometer with U Tube.

We previously used the U tube to compare the densities of two *liquids*, and have also observed that a siphon is an *inverted* U tube in which air pressure forces a liquid over the bend towards the side with the greater "drop" or pull.

A siphon barometer illustrates the *balance of pressure* between a column of liquid mercury confined in a tube in such a way that there is no pressure on

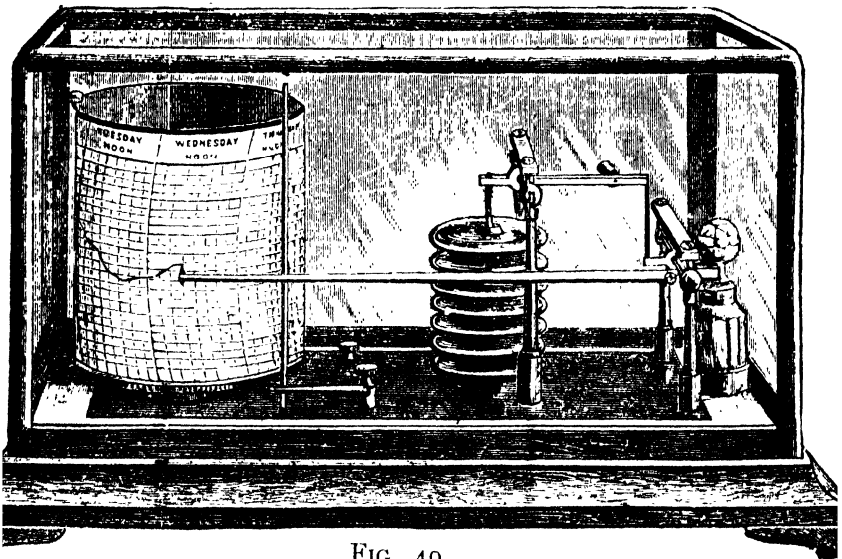

FIG. 49.

the upper end of the column, and the column of fluid air, which, assuming that the barometer is in the open air, rests upon the lower surface of the mercury in the barometer and extends upwards to the limit of the atmosphere, some 200 miles in thickness.

[*N.B.*—The lower *half* of the atmosphere is within $3\frac{1}{2}$ miles of the sea level, because at this height the barometric pressure becomes only half that at sea level.]

CHAPTER XIII

COMPRESSION AND EXTENSION

Boyle's Law.

WE have seen that a column of mercury may be used to measure the pressure of the atmosphere, and that as the air pressure varies, so the height of the barometer varies. It is equally possible to compress a gas by a pressure exerted by a column of mercury, and to do this conveniently a Boyle's tube may be used.

EXERCISE 90.—Take a piece of glass tubing of small bore, and about 4 feet long. Seal one end and then, using a flat flame burner, soften the tubing about 6 inches distant from the sealed end and bend the tube into a U loop. Fig. 41 represents such a tube which should be fixed vertically against a metre scale. Using a pointed funnel, pour in about 4 inches of mercury, and tilt the tube so as to allow some of the air to escape round the bend from the closed limb. Carefully adjust the mercury until the surfaces in both limbs are level at A and B. Cut two small rings from narrow rubber tubing and slip them on to mark A, the level of the mercury in the closed limb, C, the half-way mark between the first ring and the closed end (Fig. 50).

Note that though some air is now enclosed in the short limb, it is at the same pressure as the air outside, since the mercury in both limbs is at the same level at A and B. Now pour mercury into the long limb until the air in the closed limb has been compressed to one half. Measure the height of the column of mercury from the lower to the

upper surface, C to D. It is about 30 inches or the atmospheric pressure for the day. The enclosed air is now therefore under a pressure of *two* atmospheres, i.e. the original atmospheric pressure (one atmosphere) plus the weight of



FIG. 50.

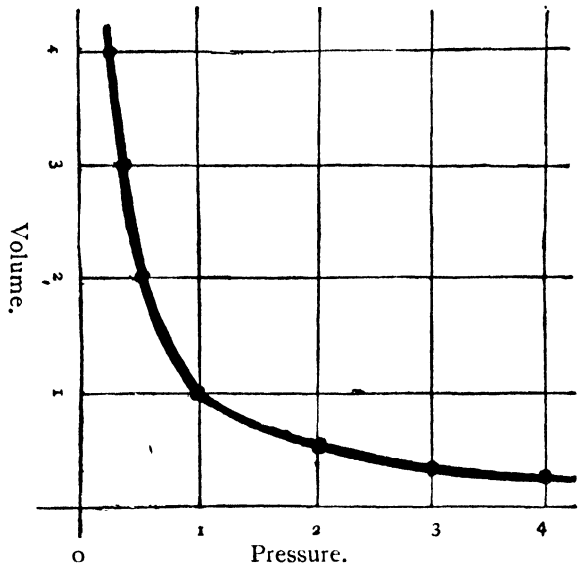

FIG. 51.

a 30-inch column of mercury (one atmosphere). We have now found that *double* the pressure gives *half* the volume. EXERCISE 91.—Repeat the experiment with the mercury in the long limb at various heights, measure the corresponding volume in the short limb and tabulate the results, e.g.

"Head" of Mercury, i.e. Vertical Distance C to D.	Atmospheric Pressure.	Total Pressure.	Volume of Gas Enclosed in Short Column as shown by Height.	Pressure × Volume.
23·1 cms.	76 cms.	99·1 cms.	7·6 cms.	753·16
27·2 "	76 "	103·2 "	7·3 "	753·36
33·2 "	76 "	109·2 "	6·9 "	753·48
51·7 "	76 "	127·7 "	5·9 "	753·43

The results in the last column agree closely, proving that "the volume of a gas (*at constant temperature*) is inversely proportional to the pressure". This is called Boyle's Law, after Sir Robert Boyle who discovered it. Using the results obtained from your table construct a graph similar to Fig. 51, to illustrate your figures and to enable you to calculate any intermediate values between those found.

Extension of a Spiral Spring.

EXERCISE 92.—Fix up a wire spring with a light scale pan and fine wire pointer moving over a scale, as in Fig. 44. Note the scale-reading opposite the wire pointer. Place 20 gms. in the scale pan and note the amount of stretch. Continue adding 20 gms. weight at a time up to 200 gms. Tabulate your results as follows and draw a graph to illustrate your figures:—

Load in Pan in gm.	Scale-reading.	Amount of Extension in cm., i.e. Scale-reading - 9·2 cm.
0	9·2	0
20	10·1	0·9
40	11·1	1·9
60	12·0	2·8
80	12·9	3·7
100	13·8	4·6
120	14·9	5·7
140	15·7	6·5
⋮		
⋮		
300	⋯⋯⋯	⋯⋯⋯

Compare the two graphs and note that they are very unlike. That illustrating pressures and volumes is a *curve*, and that connecting the stretch

of a spiral spring with the load is approximately a *straight line*. Deduce if possible from the graph

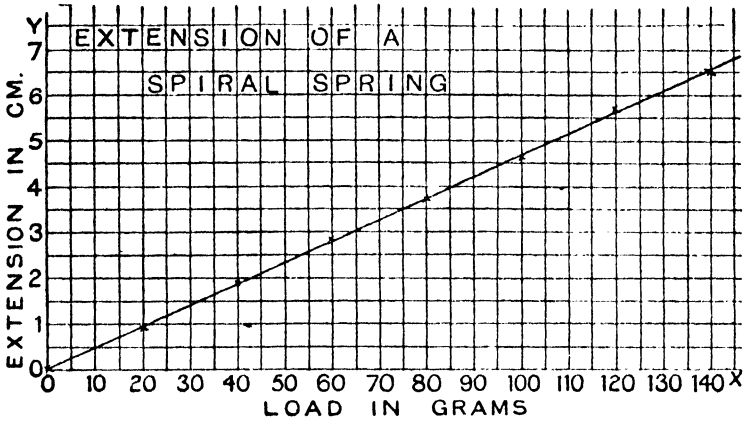

FIG. 52.

the law that governs the extension of a spiral spring within ordinary limits.

CHAPTER XIV

COMMON APPLIANCES WORKED BY FLUID PRESSURE

Syringe.

MAKE a model glass syringe as follows :—
Take a *stout* test tube, heat the closed end at the tip, draw out with a piece of wire when hot, and thus make a small hole. Find a soft cork which fits the tube loosely, i.e. would go right in if forced. Bore this cork and pass a piece of glass rod through tightly. Fasten the rod and cork together by liquid glue, seccotine, etc., and then heat and flatten the end of the rod like a button. Fig. 53 shows the model syringe. Grease the cork piston with vaseline, and work it up and down a few times before using in water. On lifting the piston when water surrounds the only opening, air pressure forces some water in through the hole. The return of the piston squirts water out through the hole.

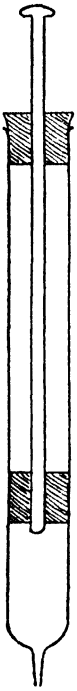

FIG. 53. wave of the report.

The pop-gun is simply an air syringe, though the friction between the cork stopper and the tube is suddenly overcome by the elasticity of the compressed air, the shock of which projects both the cork and sound

The bellows, football inflator, and bicycle pump are air syringes which take the air in at a

different place from that at which it is discharged. In the bellows, the inlet valve is visible. In the football or bicycle pump, the piston is a leather cup which allows air to pass one way only, admitting air as the piston is drawn out, but retaining it on the return stroke. Such pumps may have a nozzle or outlet valve also, preventing any return of air from football or tyre; but since the tyre always has a valve, most cycle pumps rely on the tyre valve, and have no nozzle valve. Football bladders have no valve and so a football inflator has a nozzle or outlet valve.

The Gas Blowpipe with Blacksmith's Bellows.

In this appliance double bellows are fitted, so that one acts as a holder, rising with a jerky motion as air is pumped in from the other, and, being subject to continuous pressure, sends out a steady stream of air, instead of the jerky blasts of an ordinary pair of bellows. The ordinary laboratory bellows frequently has a rubber air bag to serve as a gas holder, and by the pressure of its elastic covering the steady flow of air is maintained to the blowpipe.

The Vacuum Cleaner.

This is merely a type of double or multiple bellows in which the valves are directly opposite to those of ordinary bellows, so that it *exhausts* through the nozzle instead of forcing air out. Usually the bellows or pumps make alternate strokes and so keep up a steady exhaust. It is a very useful way of removing dust from all thick fabrics, when the machine is motor or electrically driven. Hand-worked machines are very fatiguing to use.

The Siphon.

[Refer back to Hare's apparatus used as a siphon.] This may be regarded as an inverted U tube in which air pressure forces the liquid up over the bend because there is a greater drop or "pull" on the further side.

Note that a "siphon" of soda-water does *not* work by atmospheric pressure, but by gas pressure from within the bottle.

EXERCISE 93.—Take a piece of glass tubing and bend it into a U tube with one limb 3 inches longer than the other. Place the shorter end in a vessel of water and observe that no flow takes place until the siphon or bent tube is entirely filled with water [which can be done by suction]. The water then flows over the bend because the heavier column of water is on the outside of the vessel. As this column falls out of the open end, it would produce a vacuum unless air pressure forced in water from the vessel to take its place.

The Common Pump, Force-Pump, and Fire-Engine.

The common pump has a barrel like a syringe, and a valve over the inlet tube, so that water may *enter* by it, but cannot escape (cf. the leather flap valve of bellows). The piston is usually attached to the piston rod by an arched piece of metal, and the centre of the piston is hollow and fitted on the upper side with a flap valve. Pump valves are like trap-doors and only open one way—pressure from beneath lifts the valve, but pressure from above closes it tightly (see Fig. 54).

The first stroke of the pump is like the first stroke of a syringe, but the return stroke passes the water into the barrel *through the piston*. Every upward stroke of the piston then serves *two* purposes: (a) The water already above the piston is lifted up and flows out; (b) More water is drawn in below the

piston, being forced in from the well by air pressure, as the piston is raised.

Note that the handle of a common pump is a lever of the first order, and the *downward* pull of the handle corresponds to the *upward* stroke of the piston. It is on this stroke that force must be expended; the return stroke, which lowers the piston, requires very little effort. Since both the common pump and the siphon depend upon atmospheric

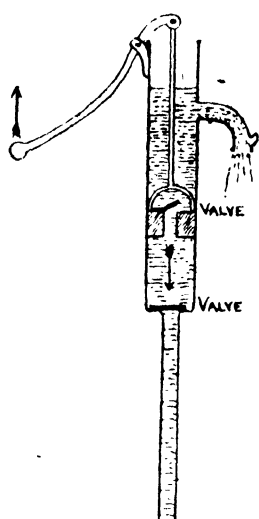

FIG. 54.

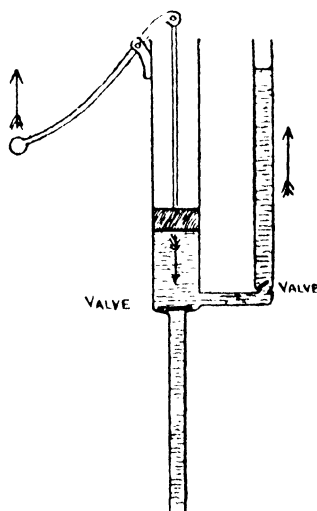

FIG. 55.

pressure, water can only be raised to a certain limit by such means.

Let us work out this limit for water under ordinary atmospheric conditions.

Atmospheric pressure normally supports a column of mercury 30 inches high, and mercury is 13.6 times as heavy as water. The height of the *water barometer* [one may actually be seen at South Kensington Museum, Western Science Galleries] which corresponds to 30 inches of mercury is $30 \times 13.6 = 408$ inches = 34 feet.

Hence, owing to leakage of air through pistons and valves, it is found impossible to raise water by the common pump more than about 30 feet.

The **force-pump** has a barrel and inlet tube with valve like that of the common pump. This part depends on air pressure to raise water to the barrel, and hence must be within 30 feet of the water level in the supply well. The piston is solid and an outlet tube fitted with a valve conveys water from the barrel, when it is forced out by the downward stroke of the piston (see Fig. 55). The height to which water is raised by this outlet tube depends on the pressure used and the force-pumps of a fire-engine can usually throw a jet of at least 60 feet high. A fire-engine has usually a pair of force-pumps making alternate strokes, and the water is forced into a strong vessel containing air which is compressed by the water being forced in, and in consequence exerts a powerful and steady return pressure. By this means the jerky action of the force-pumps is converted into a steady, continuous, and powerful outflow.

In raising water from a great depth, e.g. from a boring several hundred feet deep, a metal pipe is driven down into the boring and a smaller pipe is carried down inside the larger one, leaving a ring space or annular space between the two. A powerful air compressor forces air down the smaller pipe. This air ascends the annular space as an air *cushion* or very large bubble every few seconds, pushing water in front of it as it rises.

This type of valveless pump is very efficient and works by air pressure though *not* by atmospheric pressure.

The Air-Pump, Sucker, Balloon, Parachute.

The air-pump is really a reversed bicycle-pump. When the piston is drawn back, air can only enter

from the receiver or glass bell-jar through a valve. The return stroke shuts this valve and expels the air from the barrel. Hence it is impossible to withdraw *all* the air from the receiver or bell-jar, because only a fraction of the amount is removed at each stroke. The best air-pumps are mercury-pumps which exhaust by the action of gravity.

The **sucker** is a soft *wet leather or rubber* disc which adheres to a smooth surface by air pressure. Many of the lower forms of life cling to surfaces by suckers, e.g. limpets and anemones to wet rocks.

A **balloon** is a light bag filled with some light gas such as hydrogen or coal gas. Just as a cork floats in water so a balloon floats in the air.

The **parachute** is an umbrella-like device which acts as an "air brake" to a falling body. Cases are known of balloons having burst and the lower half of the balloon envelope having been forced tightly by air pressure into the upper half as the balloon fell. The "parachute" thus formed was the means of saving the lives of the æronauts.

EXERCISE 94.—Cut a round disc of soft leather about 3 inches diameter. Make a small hole centrally just large enough to allow a strong cord to pass. Pass the cord through and make a knot on the "coarse" side of the leather. Cut off any extra cord below the knot. Wet the disc thoroughly and test the "*sucker*" on any smooth hard surface.

EXERCISE 95.—Take a rubber ring from the screw stopper of a mineral water bottle. Choose a new cork over which it will stretch tightly. Wet the cork to make sure of an airtight joint, and force the cork into the ring a short distance leaving a projecting rubber "lip" all round the end of the cork. This rubber sucker will readily stick to glass.

EXERCISE 96.—Make some hot strong soap "suds," and using a new clay pipe or a glass thistle funnel blow a few soap bubbles. Each tends to rise but soon falls. Con-

nect the pipe with the gas tap by means of rubber tube. By turning the gas gently on and off blow some gas-filled bubbles. These rise rapidly and burst against the ceiling.

EXERCISE 97.—A square of material like a handkerchief has four short strings tied to each corner and each of these strings knotted together. Where the strings join each other, a small stone or weight is attached. If the material be loosely rolled into a ball with the stone touching it but not wrapped in it, on flinging it up in the air, preferably outdoors, it will descend gracefully and slowly as a parachute.

Rocket, Spray-Producer, Revolving Sprinkler.

The great philosopher Newton was the first to state as a law of motion that "*action and reaction are equal and opposite*".

This explains why a gun "*kicks*" when it is fired, while a cannon "*runs back*," or if it is fixed, swings on a pivoting arrangement; so that the *recoil* of a gun has given us a much-used figure of speech.

A vigorous swipe with hockey stick or bat generally brings a sensible "*recoil*" in the "*jar*" or shock of reaction from the ball struck. The recoil of the fiery comēt-like tail of a rocket sends the case spinning on its way, and such a rocket may be used to carry a light cord over a wreck to establish communication.

The *spray-producer* is another instance of reaction. Just as a glass ball coming in violent contact with an obstruction is dashed to pieces, so a fine jet of water meeting the obstruction of the air is broken up into spray. In a scent spray, nasal syringe, etc., air is driven into the bottle by a rubber bulb, plunger, etc., and this forces the liquid out in a fine jet. A soda-water siphon is a good spray-producer and a valuable emergency fire extinguisher.

In a revolving sprinkler the jets all point the same way, i.e. if it has a clockwise movement, all the jets spirt out in an *anti-clockwise* direction, and vice versa. The reaction of the water jets is used in driving the *sprinkler in the opposite direction*. This reaction is well illustrated in using a hose-pipe, especially fire-hose, for the recoil experienced from a powerful jet of water is very considerable indeed. Powerful fire-hose is often provided with crutch holders for the metal nozzles, so that the recoil of the jet may be supported largely by the crutch resting on the ground.

CHAPTER XV

DIFFUSION OF LIQUIDS AND GASES

WE have previously seen that all forms of matter, whether solids, liquids, or gases, are more or less porous, and when liquids or gases come in contact, they possess the property of mingling or mixing to a certain extent, the particles of each penetrating the pores of the other. This is known as *diffusion*.

Experiment on Diffusion of Liquids.

EXERCISE 98.—Take 6 inches of rubber gas piping and two lengths of glass tubing about 1 cm. bore and a foot in length. Make a U tube with the upright sides of glass tubing and the bend of rubber tubing which should be fitted with a spring clip. Fill one limb with a highly coloured solution, e.g. permanganate solution, copper sulphate solution, or red ink, and then fill the other limb with water and adjust the upper surfaces of the two liquids to the same level.

Squeeze all air bubbles out of the rubber tubing by pressing it with the fingers, and then carefully remove the spring clip so as to allow the two liquids to come in contact. After a time the coloured solution will gradually diffuse into the water, and the liquid in both limbs will become coloured.

Diffusion of Gases.

—It is a well-known fact that if a gas tap be turned on for a few seconds, to allow a little gas to escape into the room, gas can be smelt all over the room

very shortly afterwards. All gases are able to spread themselves abroad or diffuse in this way. Lighter gases diffuse more quickly than heavy ones. All gases have large intra-molecular spaces or pores, and hence the molecules or tiny particles of one gas are able to pass rapidly between the molecules of another. Gases pass rapidly through minute holes in solids, e.g. unglazed earthenware, such as clay pipe stem, flower-pot, or porous electric battery cell, much more rapidly than liquids do. The minute blood-vessels in the lungs retain the blood within their walls of thin membrane, but gases diffuse readily through such membrane, so that oxygen is absorbed and carbonic acid gas is expelled from the blood by diffusion through the walls of the blood-vessels.

Experiment on Diffusion of Gases.

EXERCISE 99.—A small, round porous pot, such as is used for electric battery inner cells, is fitted with a rubber stopper through the centre of which passes a short straight glass tube. The tube is joined to another piece of narrow width glass tubing by a short length of rubber tubing. The lower end of the narrow tube stands in a beaker of coloured water. This apparatus can be used to compare the diffusion of (a) light gases; (b) heavy gases as compared with that of the air.

(a) Take a large beaker or a large glass jam jar and fill it with coal gas by holding it for a few seconds *above* a turned on, unlit gas jet. This is called collecting a gas by *upward displacement*. Hold the jar or beaker, mouth downwards, over the porous pot, as in Fig. 56.

The light gas diffuses *inwards* more quickly than the heavier air inside the pot diffuses *outwards*, *through the sides of the porous pot*. This results in an *increase of pressure* inside the pot, and bubbles are forced out of the lower end of the tube, because the mixed gases inside the pot require *more room*. On removing the jar or beaker the light gas escapes rapidly from inside the porous pot and the liquid

in the beaker rises in the tube. Ammonia gas may be tested in the same way as coal gas.

EXERCISE 100.—(b) The same apparatus may be used for showing diffusion of a heavy gas or vapour, as compared with that of air. Carbonic acid gas, ether vapour, or bromine vapour, may be collected by *downward displacement* in a large beaker or jar, i.e. simply poured into the vessel like so much water.

The apparatus must now be fixed as in Fig. 57.

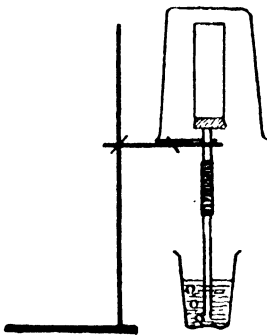

FIG. 56.

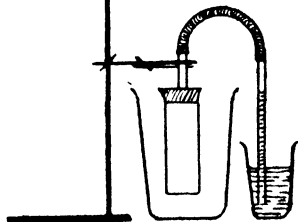

FIG. 57.

This time the lighter air *within* the porous pot diffuses *outwards* more quickly than the heavier gas or vapour surrounding the pot diffuses *inwards*. Consequently there is a *decrease of pressure* inside the pot, as shown by the liquid in the tube rising towards the rubber junction as the mixed gases inside the pot require *less room*. On removing the jar or beaker, the heavy gas or vapour inside the porous pot escapes slowly, while air enters from the outside more rapidly so that the liquid sinks back into the beaker.

Gases possess the property of diffusion to a much greater extent than liquids. Steam or water vapour, the gaseous form of water, is found everywhere in the earth's atmosphere, which though a *mixture* of gases, chiefly of nitrogen, oxygen, water vapour, and carbonic acid gas, has an almost constant aver-

age in the proportions of these gases present, owing to continual diffusion, which ensures uniformity in the mixing.

The diffusion of liquids, particularly of solutions, is very important in maintaining uniformity in the sap of a plant or in the blood of an animal.

Water in liquid form diffuses through porous soil and makes invisible films round particles of apparently dry soil. This moisture is extracted by root hairs of plants.

Gases dissolve in liquids, e.g. carbonic acid gas in water, and by diffusion become uniformly spread in solution throughout the entire mass of liquid.

CHAPTER XVI

CAPILLARITY

POROUS solids, e.g. sugar in lumps, blotting-paper, sponge, cotton wick, wood, etc., are able to soak up moisture into their pores. The attractive force which holds *unlike* particles together is *adhesion*, as distinct from *cohesion* which binds *similar* particles. Water *adheres* to almost everything with which it comes in contact, except oily, greasy surfaces. A finger placed in water is withdrawn wet, but if placed in mercury it is withdrawn clean and dry. The cohesion of mercury is very much greater than that of water and causes it to cling in little balls when spilt. Pour

some mercury into a clean test tube, or better still, into a burette. Pour water into a similar vessel. Note how the surface of the mercury curves *downwards* at the edges, but that of the water curves *upwards*.

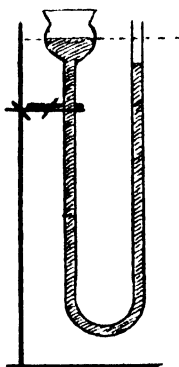

FIG. 58.

If water be used, the level in the narrower tube is *higher* than that in the funnel.

EXERCISE 101.—Take a thistle funnel and bend the long stem in the form of a U by using an ordinary flat flame burner and rotating the glass tube in the flame until it is quite soft. On pouring mercury into the funnel (see Fig. 58) the level in the narrower tube is *lower* than that in the

Water exhibits *capillary attraction* while mercury shows *capillary repulsion*. This is because water *adheres* to or wets almost any surface presented to it, and climbs up such a surface or through pores in order to do so; while mercury recoils from, or is repulsed from, most surfaces or pores.

To Show that a Flat Glass Surface Exhibits Capillarity.

EXERCISE 102.—Take two small clean sheets of glass of equal size. Two spoilt photographic glass negatives will do very well if cleaned in hot water. The glass sheets or plates should be wetted before use. Place the sheets one over the other with a short piece of rubber tubing between two of the edges, as in Fig. 59.

Two spring letter clips or spring clothes pegs should be placed at the upright edges to keep the plates close to-

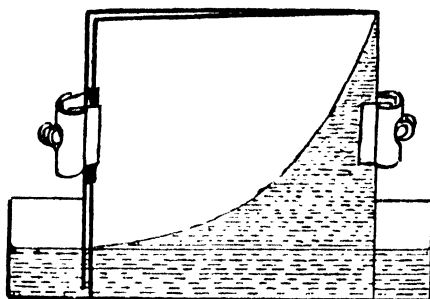

FIG. 59.

gether. On placing the plates upright in a shallow dish of water, a *curve of capillarity* will be seen, proving that while water climbs to a small extent by capillarity up almost any vertical surface, in a narrow space or crack it climbs considerably.

The more confined the space becomes, the greater the capillary attraction, within limits. It is thought that sap ascends to the top of high trees largely through this, climbing by capillary attraction.

What would be the effect of placing a similar double plate in mercury, and why? Verify your answer by performing the actual experiment.

A Capillary Siphon.

EXERCISE 103.—Take two small beakers, glasses or cups. Place one at a higher level than the other and fill the upper one with water. Connect the upper cup to the lower one by a piece of clean lamp wick or a skein of coarse cotton. The cotton acts as a siphon and conveys water from the upper to the lower level.

Why should we avoid placing cut flowers with drooping stems or leaves, in a vase of water upon a polished table top, piano, or valuable table cover? Capillary attraction may cause water to rise from the vase over the hairy surface of leaves or stems, and continually collecting in this way, it may drip from the drooping lower ends of leaves or stems on to the surface below.

Films or Liquid Skins, Drops.

The outside of a liquid, or a liquid surface, behaves like an elastic skin, stretched taut, with a definite and measurable force.

EXERCISE 104.—Obtain a camel-hair brush and a white fibre-bristle cheap gum brush; both should be clean and dry. The separate hairs or bristles stand apart and do not cling together. Wet each brush by placing them in a small beaker of clean water and by looking through the side of the beaker notice that the bristles or hairs still stand apart *while in the water*. On withdrawing the wet brushes, the camel hairs all cling together closely and form a brush point, while the white, stiffer bristles of the gum brush do not cling in the same manner. The elastic film or skin of water draws the soft camel hairs together, but the more springy white bristles of the gum brush successfully resist this elastic pressure.

EXERCISE 105.—Fix two precisely similar burettes with glass taps in wooden stands over small clean beakers.

Fill one burette with clean water and the other with methylated spirit. Open the taps slightly so as to allow the liquids to escape drop by drop into the beakers below. The water forms larger drops which consequently fall at longer intervals than the spirit drops. Notice that the drops are at first globe-shaped and then pear-shaped as the weight of the liquid tears through the elastic skin which holds up the drop as it forms.

There is such an exact balance between the weight of the drop, depending on its size, and the limit of the elastic stretch of the liquid skin, that the drops fall with exact regularity and were used to measure time in the *clepsydra* or water-clock, referred to by Julius Cæsar, which later on was replaced by the hour-glass of running sand, and still later by the pendulum. The surface tension, or elastic skin stretch limit of water, is evidently more than that of methylated spirit, because water forms larger drops.

Small lead "duck shot" are formed by allowing drops of molten lead to fall from a great height down a shot tower into a large vessel of cold water. Of course the size of shot made in this way is limited by the surface tension of molten lead.

A soap bubble is apparently a perfect sphere, though it can readily be distorted. In this case the weight is so small that the force of gravity has but little effect in distorting the spherical shape. In blowing bubbles one often observes a drop of superfluous liquid hanging on the bottom of a bubble and distorting it. The soap in solution strengthens the elastic skin or liquid surface. Similarly grease dissolved in benzine forms a stronger skin than pure benzine. Hence to remove a grease spot with benzine, make a ring of pure benzine round the spot without touching the spot. Now apply benzine to the spot itself, and the greasy benzine can readily

be soaked up by applying a cloth, because the stronger skin of greasy benzine continually draws the weaker surrounding skin of purer benzine towards it. If benzine is applied to a grease spot without "ringing" the spot, the effect is merely to spread the grease.

EXERCISE 106.—Take a gum or paste brush from the bottle of adhesive and wash it thoroughly in hot water. Observe how much water the brush will lift, and then how much gum or paste. Which has the greater surface tension, i.e. which liquid can form the largest brush drop?

A house decorator in applying whitewash or distemper carefully mixes his whiting or colours with a gum or glue solution called "size". If it is oil-paint, he uses linseed oil and turpentine. In both cases he aims at obtaining a creamy material that will cling to the brush by strong surface tension, and yet be sufficiently liquid to flow freely from the brush over the surface to be covered, without leaving streaks or brush marks.

EXERCISE 107.—Take a fine needle about an inch and a quarter long. Fill a beaker or cup with water almost to the brim, and then holding the needle between the finger and thumb, bring it horizontally as near the water surface as possible and then drop it. The needle will "float" on the elastic skin of the water. Another similar experiment can be carried out with an ordinary pin, if the pin is previously greased with vaseline, because a greasy surface is "water-proof" and repulses water capillarity.

As soon as a substance is wetted all over or right through, there is no "water-skin" below it, and no surface tension support. The so-called "stilt flies" which skate about on the surface of stagnant ponds do not get wet, but like the needle are supported by the "water-skin". Obviously therefore we greased the pin to prevent it getting wet.

A piece of thin blotting or tissue-paper will float on the surface of water for some time, but when it gets thoroughly sodden, i.e. when the water comes right through it and all air in the paper is displaced, it generally sinks.

CHAPTER XVII

HEAT AND TEMPERATURE

ACCORDING to the molecular theory all substances, whether solids, liquids, or gases, are made up of molecules. *A molecule is the smallest particle of a substance which can exist*, i.e. a particle which cannot be again divided, so small that if a single drop of water were magnified to the size of the earth, the molecules in it might be represented by the size of a cricket ball. No microscope therefore can distinguish a molecule, and these molecules are all supposed to be in a state of *molecular vibration*. *Heat* is the name given to this molecular vibration, so that as a body gets hotter, it possesses greater molecular vibration, and if the molecules are caused to vibrate more slowly, the body cools and loses heat.

Heat is therefore a form of molecular vibration or a form of energy.

Just as we can measure a *degree* of strength as between one man and another, and an *amount* of strength as between an army of 5000 men and an army of 25,000 men, so we can measure *degree of heat* and *amount of heat*. Water in a tea-cup, just poured out from a kettle of boiling water, is at a higher *degree* of heat than water in a pail, just poured out from a hot-water tap. In this case we are not considering *how much water* at all, but the *temperature* (= due measure) or *degree of heat* in water.

The pailful of hot water would be of more use to wash a floor than the tea-cup full of boiling water, partly because there is *more water in it*, and partly because there is *more heat in it*, i.e. a greater amount of heat owing to the very much larger quantity of water in the pail.

In order to measure *temperature, heat-level, or degree of heat*, a *thermometer* is employed (Gk. *thermos* = warm) while *quantities or amounts of heat* are measured by a *calorimeter* (Lat. *calor* = heat).

A thermometer consists of a glass bulb continued upwards into a narrow tube and containing mercury or coloured alcohol. The tube is marked in equal spaces or degrees. The tube is sealed up when *full* at a high temperature, so that the space above the liquid in the tube contains no air. In very cold weather the mercury shrinks almost entirely into the bulb, but in hot weather it expands, rising into the stem. All kinds of thermometers have *two fixed points*, the boiling-point (B.P.) and freezing-point (F.P.) of pure water. (See Fig. 60.)

A calorimeter consists of a vessel, usually of copper, surrounded by some kind of jacket, often of felt, to prevent the passage of heat through the sides of the copper vessel. (See Fig. 61.) By mixing liquids at different temperatures, or dropping a hot solid into a cooler liquid, the *amount* of heat given out by one and absorbed by the other may be found. *The quantity of heat*

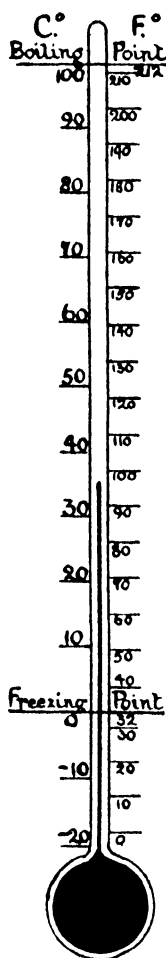

FIG. 60.

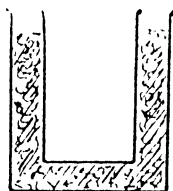

FIG. 61.

required to raise the temperature of 1 gram of water through 1 degree Centigrade is adopted as a convenient unit of heat and is called a calorie.

Examination and Comparison of Alcohol and Mercury Thermometers.

Take an ordinary household or classroom thermometer which has a wooden support with the scale marked on the wood. Two scales may be given, one on each side of the glass stem, the Centigrade and the Fahrenheit—these scales are explained in the next paragraph. The classroom thermometer does not give the boiling-point of water, but stops at about 120° Fah., because the temperature of a room never reaches more than about half-way to boiling-point.

The bulb may be filled with coloured alcohol or with mercury. Both liquids expand uniformly and do not absorb much heat. Alcohol is cheaper and has a very low freezing-point, but since it has a lower boiling-point than water, alcohol thermometers cannot be used for even moderately high temperatures. Mercury is the best liquid for thermometers used for general purposes.

Compare your classroom thermometer with an all-glass and mercury chemical thermometer, which has the degrees etched on the glass stem, and will read any temperatures from -15° C. to 110° C., or possibly higher still. The wooden Fahrenheit scale may have "Hospital Temperature" or "Temperate" marked at 60° (this is just above 15° C.); "Blood Heat" at 99° ; "Summer Heat" at 75° ; and "Freezing" at 32° .

Thermometric Scales and their Conversion.

The most sensible thermometer in use is the Centigrade, which has 100 equal spaces or degrees between the two fixed points, so that 0° C. represents

freezing-point and 100° C. boiling-point of pure water. The Fahrenheit thermometer commonly used in Britain has 180 equal spaces between these two fixed points. It is obvious, therefore, that 9° Fah. is equivalent to 5° C., but there is another fact which complicates the conversion of one scale into the other. Fahrenheit took the lowest temperature he could obtain by mixing ice and salt as his starting-point or zero, and this was 32° below freezing-point according to his scale.

In converting one scale into the other, first state clearly *how many degrees above or below freezing-point*, then multiply by the fraction necessary ($\frac{5}{9}$ or $\frac{9}{5}$) and the result is degrees above or below freezing-point on the other scale. The 32° Fah. which are *below* freezing-point must be *subtracted* in the first instance if converting degrees Fah. into degrees C., and *added* in the last instance if converting degrees C. into degrees Fah.

Examples.

- (1) Convert 55° C. to Fah. scale.

$$\begin{aligned} 55^{\circ} \text{ C.} &= 55^{\circ} \text{ C. above freezing-point} \\ &= \frac{55}{1} \times \frac{9}{5} \text{ Fah. above freezing-point} \\ &= 99^{\circ} \text{ Fah. above freezing-point} \\ &= 99^{\circ} + 32^{\circ} \text{ or } 131^{\circ} \text{ Fah.} \end{aligned}$$

- (2) Convert 90° C. to Fah. scale.

$$\begin{aligned} 90^{\circ} \text{ C.} &= 90^{\circ} \text{ C. above freezing-point} \\ &= \frac{90}{1} \times \frac{9}{5} \text{ or } 162^{\circ} \text{ Fah. above freezing-point} \\ &= 162^{\circ} + 32^{\circ} \text{ or } 194^{\circ} \text{ Fah.} \end{aligned}$$

- (3) Convert 86° Fah. to Centigrade scale.

$$\begin{aligned} 86^{\circ} \text{ Fah.} &= 54^{\circ} \text{ Fah. above freezing-point} \\ &= \frac{54}{9} \times \frac{5}{1} \text{ C. or } 30^{\circ} \text{ C.} \end{aligned}$$

(4) Convert -40° Fah. to Centigrade scale.

$$\begin{aligned} -40^{\circ} \text{ Fah.} &= 72^{\circ} \text{ F. below freezing-point} \\ &= \frac{72^{\circ} \times 5}{9} \text{ or } 40^{\circ} \text{ C. below freezing-point} \\ &= -40^{\circ} \text{ C.} \end{aligned}$$

A graph may be drawn on squared paper, and used for converting thermometric scales. Mark -40° against the left-hand bottom corner of the squared sheet. This is the *same point* on *both* scales (Ex. 4), 252 units should be marked off along the longer side of the paper, as -30° , -20° , -10° , 0° , 10° , 20° , etc., for Fah. scale, and 140 units along the shorter side, as -30° , -20° , etc., for Centigrade scale. Mark the positions on both scales of F.P. and B.P. and the values given in (1), (2), (3) above. The six points marked are on a straight line (cf. Fig. 52), and when joined up form a useful graph for converting scales at a glance.

Every house should possess two thermometers—one preferably with a metal scale, rather than wooden, which will serve to test the temperature of a sickroom or of a bath—and an ordinary clinical thermometer used to test the temperature of a person's blood. A clinical thermometer has a short

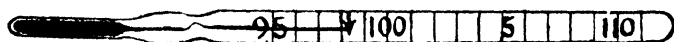

FIG. 62.

scale from about 95° Fah. to 110° Fah. and a constriction just above the bulb which breaks the mercury thread as it cools, so that the mercury must be shaken down each time before use. This enables the highest temperature of the blood to be recorded permanently by the instrument *until the mercury is shaken down*. Normal blood temperature is 98.4° Fah. and any temperature up to 100° Fah. is not

alarming. A sick person whose temperature is over 100° Fah. should be kept in bed. Both the thermometers described are quite inexpensive and can be purchased for about a shilling each.

Maximum and Minimum Thermometers.

A *maximum thermometer* contains *mercury* which, on expanding, pushes an iron index shaped like a double-headed pin along a horizontal tube. This index is always *outside the liquid*, and when the mercury contracts, it is left behind so that the end of the index next to the mercury gives the *maximum temperature* reached. This instrument is set by sloping it so as to slide the index back.

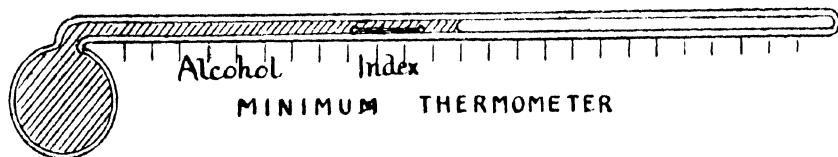
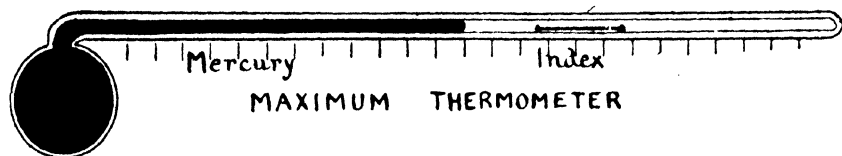

FIG. 63.

A *minimum thermometer* contains *alcohol* and has a similar glass-covered index always *inside the liquid*. With a rise of temperature, the alcohol flows past the index without disturbing it, but on contracting as far as the index, the alcohol surface drags the index back with it. Thus the end of the index next to the alcohol surface indicates the *minimum temperature* reached, and to set the instrument the index should be slid forward by sloping.

Combined Maximum and Minimum Thermometer.

This is an alcohol thermometer, but a U thread of mercury is introduced into the instrument, and the ends of the U serve to operate both indexes by pushing them upwards according as the alcohol expands or contracts, and the vertical sides of the U become of unequal length. Each index is of iron and has a hair spring which prevents the dropping of the index when left unsupported by the mercury. The lower ends of the indexes show the highest and lowest temperature reached during any period. The instrument is set by means of a small horseshoe magnet which acts through the glass and draws the indexes down.

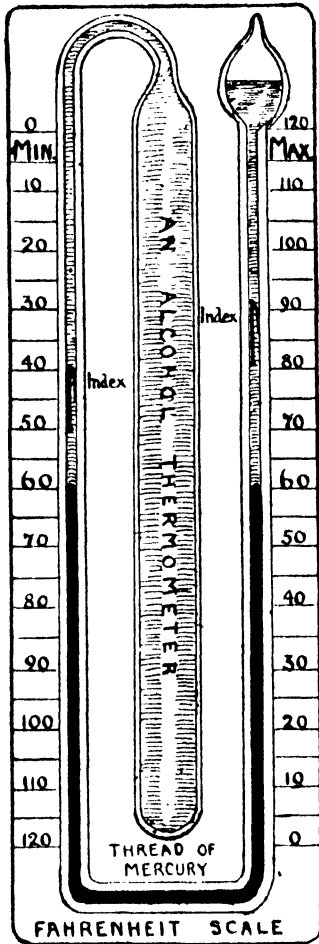

FIG. 64.

the sole of the foot, using some pressure; or it may be pressed in a cork press if one is available. Choose a foot length of narrow bored quill glass tubing and carefully bore the cork half-way through from the centre

Making and Using a Model of the Thermometer.

EXERCISE 108.—Take a strong glass test tube holding about 30 c.c. and fit it with a good soft cork by twisting the cork gently in. A cork should be chosen that is rather large for the tube, and it should then be rolled on the floor under

of each end, pushing out the bored core, and after rounding the sharp edges of the glass tube in a bunsen flame, pass the tube through the cork so that the end just shows at the narrow end of the cork. The test tube should then be held over a sink and filled almost full with clean methylated spirit, which is alcohol with about 10 per cent. of added impurity to render it unfit to drink or use in any alcoholic beverage. Insert the cork and tube so that the spirit is forced to rise just above the cork and shows in the tube. Methylated spirit is very inflammable and should not be brought near a flame, and care should be taken not to spill any on the bench or on clothing. A small rubber ring or a tiny strip of paper should be placed on the tube at the original spirit level. Now observe what happens when (a) the test tube is held in the warm hand; (b) when the test tube is placed in a freshly made solution of photographer's "hypo," a cheap salt used for fixing negatives; (c) when the test tube is placed in a freshly made dilute solution of caustic soda.

The rise or fall of the liquid in the tube attached to the test tube of methylated spirit shows the *degree of heat* reached in each case.

Coloured alcohol and mercury are common liquids used in the construction of thermometers, largely because they expand *regularly*.

To Find the Rate of Expansion of Alcohol.

EXERCISE 109.—Place your test tube of methylated spirit in a beaker of tap water, and after a few minutes, mark the level of the alcohol which must be adjusted in the lower part of the tube. Now place a proper Centigrade thermometer in the beaker of water and heat gently, using the proper thermometer as a stirrer, until the spirit has risen exactly half the length of the glass tube taken. Note the rise in degrees Centigrade. Empty both test tube and narrow tube of spirit over a large funnel, which should return the spirit to its proper bottle, and then wash both glass and tube with water.

Fill a burette with clean water to the zero mark, and after taking the precautions mentioned in Exercise 22, calibrate the test tube and the narrow glass tube separately. A

convenient method for the latter is to fill it entirely with water by placing it under water, then holding the cork between thumb and second finger, place the first finger over the open end of the tube and lift the tube out full of water. Bring the other end of the tube over a burette, and by raising the first finger allow the contents of the tube to fall into the burette, noting the *rise* in the burette. If the test tube held 30 c.c. and the narrow tube held 3 c.c. a rise of liquid to the extent of half the tube would mean a rise of 1.5 c.c. Suppose this increase occurred during a rise of 50° Centigrade as shown by the proper thermometer. 1° C. corresponds to a rise of .03 c.c. on the volume of 30 c.c. taken in the test tube. Hence the coefficient of expansion of alcohol is .001, or 1 volume expands $\frac{1}{1000}$ of its bulk for every degree Centigrade rise of temperature.

CHAPTER XVIII

CALORIMETRY—SPECIFIC HEAT

Making and Using a Model Calorimeter.

EXERCISE 110.—Obtain two small tin canisters which are bright or polished, and of which one is about an inch greater in diameter than the other, the smaller being quite watertight. Two sizes of condensed milk tins are excellent for this purpose. The larger canister is merely a case for the smaller, and the space between them should be packed with dry cotton wool, felt, cloth or any other good non-conductor of heat. (See Fig. 61.)

The inner vessel must *always* be kept in the outer protective jacket except while being weighed.

Effect of Mixing Known Weights of Hot and Cold Water.

Weigh the empty, clean, dry inner vessel. Fill to about $\frac{1}{3}$ with cold water and weigh again. The increase in grams gives the weight of cold water. Place the inner vessel in its protective case and carefully note the temperature of the cold water. Heat about a gallon of water in a clean bucket or pail to about 80° C., keeping it well stirred with a thermometer. Using an enamel cup with a handle, or a metal soup ladle as a dipper, after carefully noting the temperature of the hot water, rapidly transfer about the same amount of hot water as the cold water previously taken from the bucket to the jacketed inner vessel, and immediately stir the mixture of hot and cold water, and note the highest temperature the mixture reaches. Finally weigh the inner vessel. The further increase of weight represents the weight of hot water taken. Now investigate the truth or otherwise of the following statement:—

Heat lost by hot water = Heat gained by cold water, i.e.
 Weight of hot water \times its *fall* in temperature = Weight
 of cold water \times its *rise* in temperature.

On substituting the necessary figures and working out, it will be found that the number of calories on the *left*-hand side of the equation is rather *more* than the number of calories on the *right*-hand side of the equation. Evidently there is some wastage of heat somewhere, and obviously this is due to the fact that the inner vessel has used up some heat in becoming warmer when the hot water was poured in.

The water equivalent of any vessel is the weight of water that would be raised 1° C. by the amount of heat necessary to raise the temperature of the vessel 1° C. Find (a) the number of calories of heat used up in warming the inner canister used in the last exercise; (b) the water equivalent of it. As we shall see in dealing with specific heat later on in this chapter, the water equivalent of any vessel = mass \times specific heat.

Capacity for Heat.

The capacity for heat of anything, e.g. a bucket of water, a common brick, the volume of air contained in a room, is the amount of heat required to raise the temperature of that mass of material 1° Centigrade. Water has the greatest capacity for heat of any substance, i.e. more heat is required to raise the temperature of a mass of water 1° C. than is required to raise the temperature of an equal mass of any other substance 1° C.

EXERCISE III.—Take two small beakers of equal size and counterpoise them on a balance, adding a few weights to the side that happens to be lighter. Fill one beaker half full of turpentine, paraffin oil, or methylated spirit, and then pour into the other beaker an equal weight of water, using a pipette to add or withdraw water in adjusting weights. Take the temperature of each, and then stand both beakers in a bowl or dish of hot water and stir the contents of each with separate thermometers. The liquid

in the first beaker warms up more quickly than the water in the second beaker, proving that water requires more heat to raise its temperature to a given point than the other liquid used for comparison.

Water "holds the heat" longer than any other substance, for a substance that is quickly warmed is found to cool quickly also. Hence a hot brick cools much more rapidly than an equal weight of hot water, so that a hot-water bottle is the most common article in use for warming a bed or supplying warmth to a sick person.

Specific Heat.

In stating the specific heat of any substance, we really compare the capacity for heat of that substance with the capacity for heat of an equal weight of water. This is a *ratio*; and since water has the greatest capacity for heat, the value of this ratio must be always less than unity.

Specific heat = $\frac{\text{Amt. of heat required to raise 1 gm. of substance } 1^{\circ}\text{C.}}{\text{Amt. of heat required to raise 1 gm. of water } 1^{\circ}\text{C.}}$

If we know the specific heat of a substance, we can readily calculate the heat absorbed by a given mass of it, and evidently the water equivalent of any mass of it = mass \times specific heat.

To Find the Specific Heat of Copper.

EXERCISE 112.—Use a copper calorimeter for this purpose well cleaned and dry. Weigh it empty, then $\frac{1}{3}$ filled with cold tap water at an observed temperature. Add about an equal amount of nearly boiling water after previously noting the exact temperature and obtain the temperature of the mixture. Then by making a third weighing obtain the weight of hot water taken.

Enter your notes and weighings as follows:—

Weight of empty copper calorimeter (inner vessel only)	gms.
„ cold water taken at $^{\circ}\text{C.}$	gms.
„ hot water taken at $^{\circ}\text{C.}$	gms.
Temperature of mixture of hot and cold water	$^{\circ}\text{C.}$

CHAPTER XIX

EXPANSION AND CONTRACTION

IT is a matter of common observation that solids, such as metals, expand or get larger on heating.

Experiments on Expansion of Solids.

The Ball and Ring.—A metal ball is made to slip

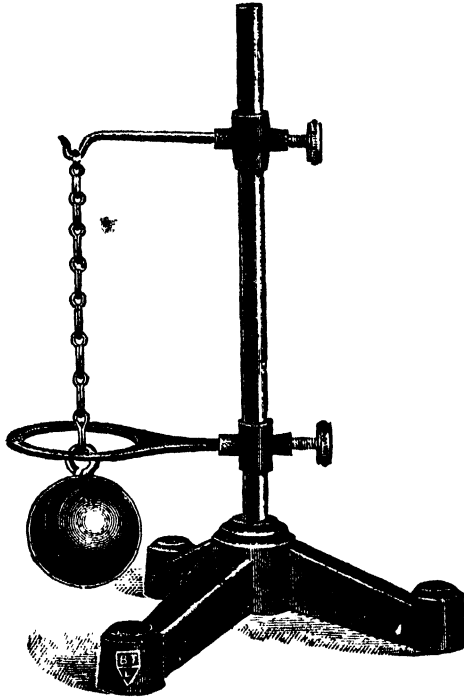

FIG. 65.

easily through a ring. On heating the ball, it is no longer possible to pass it through the ring (Fig. 65).

The Rod and Gauge.—The gauge accurately records both the length and the thickness of the rod.

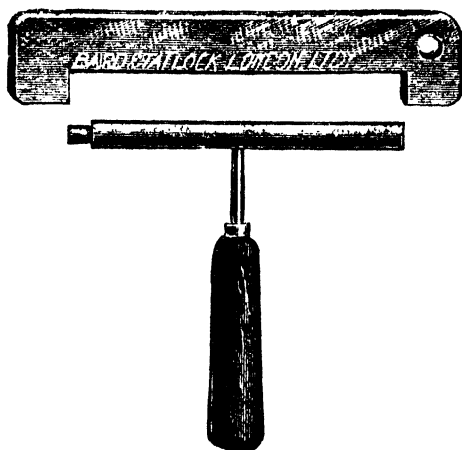

FIG. 66.

On heating the rod, both the length and the thickness are found to have increased (Fig. 66).

The Pyrometer.—This instrument shows the expansion in length of a metal bar when it is heated.

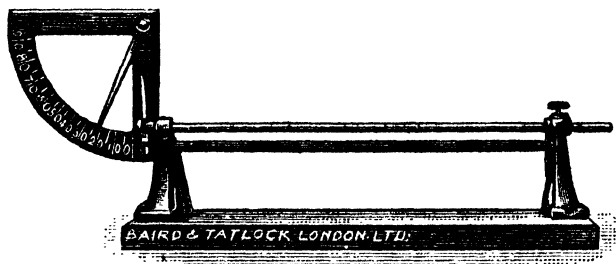

FIG. 67.

One end of the bar is fixed, while the other presses against a needle which as the rod lengthens, travels over a scale (Fig. 67).

Experiment on Contraction of an Iron Bar.

A strong wrought-iron bar about 2 cms. diameter has a coarse screw-thread cut on one end which is

fitted with a large nut. The other end is flattened, and has a hole bored through the flattened part, through which a cast-iron peg about as thick as a pen-holder is passed. A very strong cast-iron frame enables the nut to be screwed up tightly against the resistance of the peg while the bar is *hot* (Fig. 68).

As the bar slowly cools and becomes *shorter*, the cast-iron pin is broken by the force due to contraction. Note that the *cast-iron* frame and *cast-iron* pin cannot *bend* and so allow for the contraction of

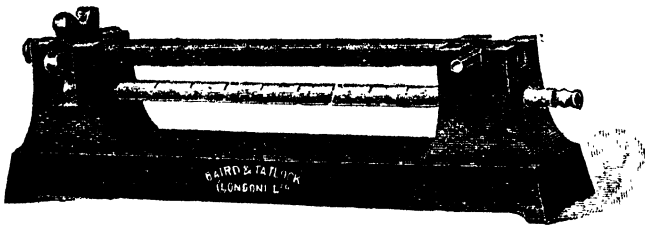

FIG. 68.

the bar, and that the bar is wrought iron which is tough and fibrous and not brittle like cast iron.

To Show that Solids Expand at Different Rates.

A strip of sheet brass is firmly riveted in several places to a similar strip of sheet iron. When the double strip is heated, it rapidly becomes curved because one metal expands more than the other. Which metal is then on the *outside* of the curve, and which therefore expands to the greater extent? (see Fig. 69).



FIG. 69.

Coefficient of Expansion.

Since we have proved that a metal bar increases in *length* when heated, we may express as a *ratio* the average increase of length of a bar of that metal for 1° C. rise of temperature to the length of the

same bar at 0° C. This is its *coefficient of linear expansion*. Similarly, if we measure expansion of *volume*, we have a *coefficient of cubical expansion*.

To Show that Liquids Expand at Different Rates.

EXERCISE 114.—Take two small flasks of equal size and calibrate both by means of the burette. A mark should be made within an inch of the top of each flask to show the upper limit of the same definite volume. A length of glass quill tubing about a yard long should be cut in half, and each half passed through a softened cork, which should be pressed into the flask neck until its lower edge comes to the mark on the neck of the flask. The two flasks should now be filled with different liquids up to the mark, and the corks with the glass tubes, exactly flush

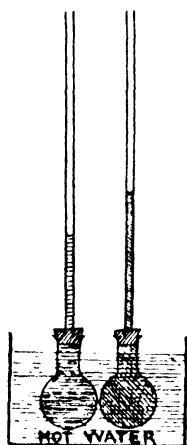

FIG. 70.

with the narrow ends of each, should be pressed in so that no air remains in the flasks above the liquids. We may now consider that for all practical purposes we have equal volumes of different liquids for comparison. Place the two flasks in a pan or bowl of water which can be heated from below and apply heat. The two liquids rise in the tubes at different rates, proving that liquids expand at different rates. Suitable liquids for comparison are water,

turpentine, methylated spirit, and they may be coloured if desired by the addition of a little dye, coloured ink, or permanganate of potash (see Fig. 70).

To Show that all Gases Expand at the Same Rate.

EXERCISE 115.—A long length of glass tubing should be cut exactly in half so as to ensure two *equal* tubes. Each should be sealed at one end in a bunsen burner. A length of wider glass tubing should be fitted over the two equal tubes as a steam jacket A (see Fig. 71). Fill the jacketed

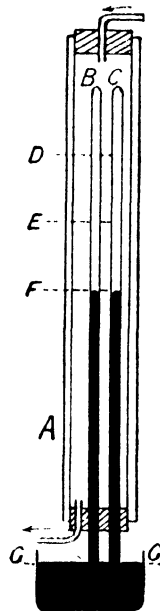

FIG. 71.

tubes with coloured water and invert them in a bowl or trough of coloured water. Now by means of a piece of glass tubing drawn to a point like a pen filler fastened to rubber tubing, fill the equal tubes say half full of two different gases, such as coal gas and air. Pass steam through the jacket and the two equal columns of imprisoned gases will *expand at the same rate*, and also on cooling, will *contract at the same rate*. D, E, F represent three positions of the liquid columns in the tubes B and C.

Expansion and Contraction Accompanying Change of State in Solids, Liquids, and Gases.

Change of state is accompanied by expansion or by contraction. A vapour or gas always takes up less room when it condenses into a liquid, and conversely a liquid must expand in becoming a vapour or a gas. The working of the steam engine depends upon this, one volume of water at 100° C. becoming 1728 volumes of steam at 100° C. The expansive force of steam admitted into a cylinder forces out the piston or movable end of the cylinder, and so through the piston rod drives the cranks. Steam, as steam, behaves as a gas, expanding like other gases, but immediately it condenses and forms minute drops of water, it contracts very considerably in the *change of state*.

When a solid becomes a liquid, or vice versa, either expansion or contraction occurs, but no definite rule can be laid down. Thus ice floats on water, proving that water on solidifying *expands*. This fact is also borne out by the bursting of water pipes in winter when exposed to severe frost, which produces the expansion due to change of state.

Type metal, used for making printers' type, has the same peculiarity, and hence makes sharp castings.

Cast iron shrinks as it solidifies, and hence the pattern for the casting is always made rather larger than the actual casting required.

Gold and silver contract during solidification, and as sharp castings cannot be obtained on account of this contraction, gold and silver coins and medals are stamped or struck from a "die," which is a hardened impression of the pattern to be imprinted.

Experiments on Expansion and Contraction Accompanying Change of State.

EXERCISE 116.—Take a test tube, which should be clean and dry, and put into it several pieces of candle wax or

paraffin wax. Have some more pieces of the same wax in reserve. Gently warm the test tube and its contents until the wax melts into a clear liquid like water. Remove the liquid wax from the source of heat, and drop in a few pieces of solid wax. Does the solid wax float or sink in the liquid wax? Deduce the fact that wax, like cast iron, gold, and silver, contracts on solidification. Allow the tube to cool in an upright position and observe the funnel-like depression in the centre of the wax due to contraction in solidifying. The same fact may be observed in an ordinary candle, or in a freshly opened tin of wax boot-polish, both of which show a central depression.

EXERCISE 117.—Fit up a simple barometer, and by means of a clean fountain pen filler, introduce a drop of ether into the barometer tube. There will be an immediate drop in the mercury column due to the pressure of the ether vapour. The single drop of ether takes up much more room, or expands considerably when changed from the liquid to the gaseous state. Ether is a highly inflammable liquid, and its heavy vapour can flow along a bench top, and become fired by a gas light or burner some distance away.

Expansion and Contraction of Solids, Liquids, and Gases in Everyday Life—Familiar Applications.

1. *Weathering of Rocks and of Stone Buildings, Mortar, etc.*—Unequal expansion due to changes of temperature, and particularly the expansion due to freezing when water turns to ice, causes splitting in rocks and mortar, and hence an old wall requires “re-pointing”.

2. All structural iron work—girders of bridges, railway lines, hot-water piping, etc., must be so constructed as to allow for expansion and contraction. Iron rails have small spaces left between consecutive rails, and the side plates and iron bolts which connect them allow for slight movement.

3. A wooden table top is "hooked" to the lower framework by wooden projections fitting into slots, so that the table top has a certain amount of "play," as it is called.

4. The contraction of iron is made use of in riveting boiler plates with red-hot rivets which, on cooling, draw the separate plates very closely together.

5. Old bulging walls are sometimes drawn together by passing iron bars through the building and screwing up large plates or cross pieces on the outside, while the bars are made hot. The great force exerted by the contracting iron bars pulls the walls slightly together.

6. Every hot-water tank must be fitted with an expansion pipe (see Fig. 83, p. 145).

7. Heated air rapidly rises, proving that it is lighter bulk for bulk than cooler air. A tall chimney creates a powerful upward draught, if a fire is burning below it, and it may be used as a valuable means of ventilation.

8. Land and sea breezes are produced by differences in temperature over the land and sea. In the sun's rays the land rapidly becomes hotter than the sea, and heats the air above it, which streams upwards, causing a sea breeze *towards the land*. The reverse happens at night when the cooler *land breeze* blows towards the sea. This reversing of the breeze at evening is well known by both sailors and cyclists.

9. Winds are due to differences of temperature on a larger scale, producing unequal expansion of air. A physical geography book will explain how great desert areas, such as Tibet or Central Australia, become centres of low pressure or of high pressure according to the season, and so induce inflowing or outflowing winds.

10. A *thin* glass vessel, such as a test tube or a beaker, may have boiling water poured into it without risk of breakage, but a thick glass or earthenware vessel may be broken by such treatment because unequal expansion occurs. Hence a thermometer should not be transferred from ice cold to boiling water, or vice versa. Hot-water bottles, jugs, and teapots should be warmed before boiling water is poured into them.

Glass dishes should not have hot liquids poured into them, and cut glass should not be suddenly plunged into very hot water. Common moulded glass will stand much greater changes of temperature than cut glass.

11. *How to Remove a Tightly-fixed Stopper from a Bottle.*—Since a stopper is cone-shaped, a smart tap with a wooden handle or stout piece of firewood will often dislodge the stopper, or the neck of the bottle may be cautiously heated, thereby expanding the neck more than the stopper, and so allowing the removal of the stopper. A bottle with inflammable or explosive contents should not be heated in this way for obvious reasons. Glass taps and stoppers should be slightly greased with vaseline. Caustic alkalies which attack glass and “set” stoppers, should either have rubber-stoppered bottles, or else have a rubber ring fitted on the glass stopper.

CHAPTER XX

CHANGE OF STATE—MELTING-POINT, BOILING-POINT, DEW-POINT

Melting-Point and Boiling-Point.

A PURE solid or liquid has a definite melting-point and boiling-point unless it decomposes on being heated. Hence a very common test of purity is the determination of melting-point or boiling-point.

To Check the Freezing-Point on a Centigrade Thermometer.

EXERCISE 118.—Fill a large glass funnel with ice broken into small pieces and place a small beaker below it to catch the water formed by the melting ice. Several thermometers can be placed in the melting ice and should register 0° C. *Melting ice* is always at 0° C., so that if the thermometer gives a different reading the instrument is at fault (see Fig. 72).

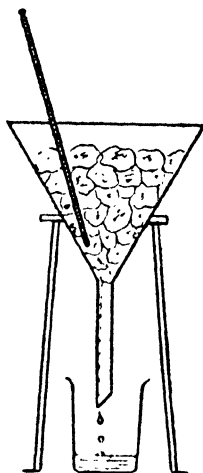

FIG. 72.

Effect of an Impurity on the Melting-Point.

EXERCISE 119.—Add a large handful of powdered salt to the ice in the funnel and mix it with the ice. The temperature rapidly drops to about -10° C. and a thick coating of white hoar frost forms on the outside of the funnel. Such a mixture of ice and salt is commonly used as a freezing mixture.

Inference.—Added salt lowers the melting-point of ice.

To Check the Boiling-Point on a Centigrade Thermometer.

EXERCISE 120.—Take a clean litre flask and fit it with a two-holed rubber stopper which will allow an ordinary Centigrade thermometer to slide easily through one hole. Fit the other hole of the rubber stopper with a right-angled bend of rather wide-bored tube. Pour in as pure a sample of water as possible to a depth of 2 inches, and adjust the thermometer so that the bulb is in the liquid. Heat the water to boiling-point, and when steam is issuing freely from the right-angled bend, take the temperature of the boiling water, which should be 100° C. Now raise the thermometer so that the bulb is 2 inches above the boiling water, and the temperature of the steam will be found to be *the same* as that of the boiling water (see Fig. 73).

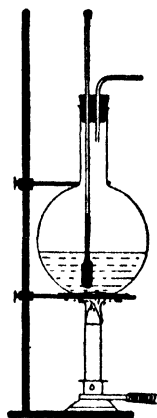

FIG. 73.

Effect of Dissolved Impurity on the Boiling-Point.

EXERCISE 121.—Add a large handful of powdered salt to the hot water in the flask and heat it up again until the salt solution boils. Take the temperature of the boiling liquid, *and of the vapour* at a point about 2 inches above the boiling liquid. The temperature of the boiling liquid is *above* that of boiling water, but that of the vapour is *the same* as that of steam or of boiling water.

Inference.—Added salt raises the boiling-point of water.

Effect of Pressure on the Freezing-Point of Water.

The melting of ice by pressure, and the subsequent re-freezing when the pressure is removed, is called *regelation*.

Experiment to Show Regelation.

EXERCISE 122.—A large block of ice about a foot long and 6 inches thick is supported on two wooden blocks over a

sink or large earthen trough to catch the water produced by melting. A heavy weight (28 lb.) is slung from a thin copper wire loop which passes round the ice "bridge". It is observed that the wire slowly cuts

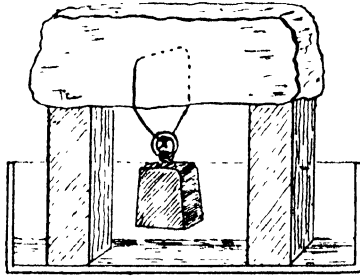

FIG. 74.

through the ice, but the cut surfaces become joined together again after the wire has passed through.

Inference.—Pressure produces melting of ice, or lowers the freezing-point of ice.

Ice-flow in Glaciers.

Regelation plays a large part in consolidating the material of glaciers and ice fields. Pieces of ice when pressed firmly together become welded or joined by pressure, just as snow may be made to bind into a hard snow or ice ball, by repeated pressure and removal of pressure.

Effect of Pressure on the Boiling-Point of Water.

EXERCISE 123.—Using the same apparatus as in Exercise 120, place 2 inches of clean water in the flask and connect the right-angled bend by rubber tubing to another right-angled bend which has one long arm about the length of a tall (250 c.c.) measuring jar. Heat to boiling-point and allow the escaping steam to bubble through about 2 inches of water contained in the measuring jar. Gradually pour water into the measuring jar so that the steam is forced out against the pressure of at

least a foot of water. Note the corresponding *rise* of the boiling-point (see Fig. 75).

EXERCISE 124.—Using a stout round glass flask with a short neck, fitted with a sound cork carrying a short length of glass tubing having a 3-inch length of rubber tubing and spring clip (see Fig. 76), fill the flask one-third full of water and boil the water, allowing the steam to escape through the rubber tubing. When steam has issued freely

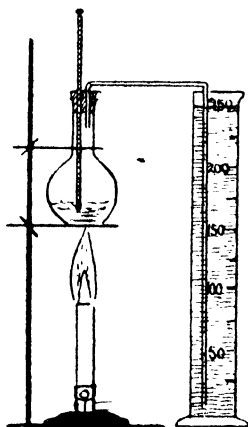

FIG. 75.

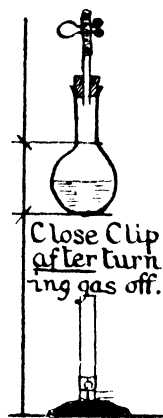

FIG. 76.

for a few minutes, remove the burner and then close the rubber pipe by means of the clip. On cooling the upper part of the flask by applying a wet cloth to the neck portion, and thereby diminishing the pressure inside the flask by condensing some of the steam, the water *continues to boil* for several minutes without being heated externally.

Inferences.—Increase of pressure raises the boiling-point, while decrease of pressure diminishes or lowers the boiling-point.

Everyday Applications of the Effect of Pressure on Boiling-Point.

1. A "double" cooking vessel, containing water in the outer vessel which does not allow the steam

to escape *except through a brass spring safety valve*, can be easily adjusted by regulating the gas flame beneath it so that it does not boil dry for many hours, and the increased pressure due to the action of the valve raises the boiling-point in the outer vessel so that the food in the inner vessel is actually raised above ordinary boiling-point. Such a contrivance will cook meat quite as well as an oven, and cannot dry up the juices nor burn outlying portions.

2. At high elevations, owing to the diminution of atmospheric pressure, cooking by boiling is unsuccessful, since water boils under such conditions at a lower temperature.

Melting Points of Wax, Butter, Margarine.

EXERCISE 125.—Where only a small sample of the substance is available, a little is introduced into a capillary tube made by drawing out a short piece of glass tubing into a yard length or more and then cutting off 3-inch lengths. It is best to melt the substance in a spoon, crucible, etc., and then insert one end of the capillary when the liquid will rise by capillary attraction. The lower end of the capillary is then sealed. This tube is then fastened to the lower end of a thermometer so that the sealed end of the capillary is level with the bulb (see Fig. 77). A small beaker is half-filled with a clear liquid—water will do for the substances given above, but sulphuric acid is required for substances with high melting-points. The bulb and capillary are placed in the liquid, which is then gently heated with a small flame. The temperature at which the solid melts is noted, and also that at which it again solidifies. The melting-point is the mean of these two values.



FIG.
77.

Boiling-Points of Alcohol, Milk, Paraffin Oil.

EXERCISE 126.—A test tube, or if, say, 10 c.c. of the sample are available, a boiling tube, is fitted with a cork having a thermometer and outlet tube. The bulb of the

thermometer should dip into the liquid which should be slowly heated until it boils. If a pure liquid, the boiling-point remains steady (see Fig. 78).

Distinction Between Ebullition or Boiling and Evaporation.

A volatile substance, such as camphor, ether, chloroform, water, etc., gives off vapour at ordinary temperatures from *any exposed surface*. Thus, a piece of camphor slowly disappears, and a puddle of water dries up. When a liquid passes into a gas in this way at ordinary temperatures, it is said to *evaporate*. When *the whole mass*

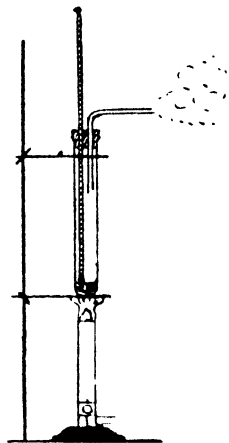

FIG. 78.

of liquid is changing into gas at a definite temperature, we have boiling or ebullition.

Humidity of the Atmosphere, Dew, and Dew-Point.

When there is a visible mist or damp fog, it is evident that the air is *saturated* with water vapour. Mists are more usual at night, early morning, or evening than they are during the rest of the day. It is commonly observed that the warmth of the sun dispels mists.

Dew-point is that point of temperature at which the water vapour present in the air locally saturates it, and forms a visible mist or dew.

The tiny drops of water condense on any points or surfaces which are sufficiently cool, hence grass, twigs, fences, wire-netting may be covered with dew drops, but the flagstones lying upon earth, or the slates or tiles of a house roof warmed from inside will scarcely show any deposit of dew, because they readily conduct heat through them, and are kept warmer than the air above them by being

warmed from below. Calm clear nights are most favourable to the deposit of dew, because clouds reflect the escaping heat of the earth back again, and winds keep the air on the move and prevent the lowest layer of air in contact with the earth being cooled down to dew-point.

Finding the Dew-Point Experimentally.

It is a fact of common observation that a liquid on evaporating takes up heat. Wet hands produce a sensation of cold. A classroom on a hot summer day may be considerably cooled by sprinkling water on the floor.

Experiment to Show that Heat is Absorbed when a Liquid Evaporates.

EXERCISE 127.—Pour out a few drops of ether into the palm of the hand. The ether evaporates rapidly and produces a sensation of cold in doing so. This is because the heat necessary to evaporate it has been absorbed from the hand.

The absorption of heat which accompanies the evaporation of ether is made use of in Daniell's hygrometer (hygros = moist), (see Fig. 79). The bulb at the higher level is surrounded by a muslin bag which is soaked with ether. The evaporation of this ether cools the liquid inside the bulb which is also ether. Hence ether vapour inside the instrument continually condenses in the upper bulb, and so lowers the vapour pressure inside the instrument.

We have previously found (see Fig. 76) that a decrease of pressure diminishes the boiling-point, and so we should expect that by diminishing the vapour pressure in the lower bulb, we should cause further evaporation of the liquid in that bulb. This actually occurs, and as the ether slowly evaporates in the lower bulb, the absorption of heat, which

occurs gradually, lowers the temperature of the bulb until a mist or water film forms on the outside of this bulb. A gilt or silvered band on the glass assists to show up the fine dew deposit, and the temperature at which the dew begins to form is shown by the small thermometer *inside* the bulb and stem.

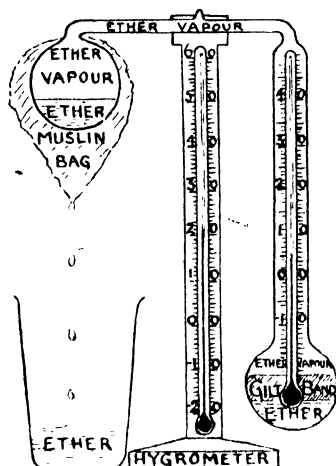

FIG. 79.

The dew-point can also be found by using wet and dry bulb thermometers, which consist of *two* similar thermometers side by side, one of which has its bulb surrounded by cotton fabric kept moist with clean water (see Fig. 80). The evaporation of the water from the fabric lowers the temperature of the bulb which it surrounds, and hence, unless the atmosphere is locally *saturated* with water vapour, in which case there can be no evaporation from the fabric and both thermometers read the same, the temperature indicated by the wet bulb thermometer is *lower* than that indicated by the dry bulb thermometer.

The difference of temperature between the two thermometers will be greatest when evaporation is going on rapidly, i.e. when the air is dry, and there will only be a slight difference when the air is moist or nearly saturated with water vapour. By refer-

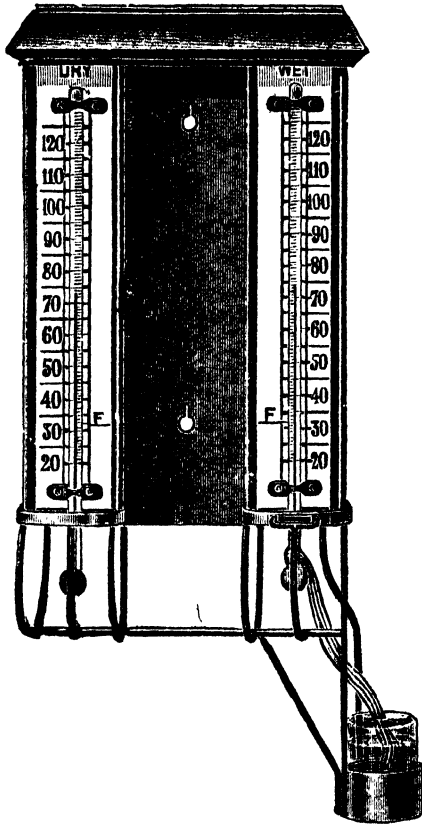

FIG. 80.

ence to a table of differences specially made for wet and dry bulb thermometers, the dew-point can be calculated.

The higher the atmospheric temperature, the greater will be the possibility of absorbing water vapour, i.e. the saturation-point rises with the corre-

sponding rise of temperature. Wind also greatly assists evaporation by continually bringing fresh particles of air in contact with the liquid surface. Hence in drying wet clothes, a sunny bright day when there is a breeze, gives a good drying day; while a misty calm day is not a good day for drying clothes.

Damp clothing, in evaporating moisture, absorbs heat from the body, and hence produces chills. This is particularly observed in the case of damp foot coverings, because the extremities of the body are more easily chilled and are usually more exposed to draughts.

Similarly, the evaporation of perspiration from the skin cools the skin, and the evaporation of water sprinkled on a hot pavement, or on a garden, cools the ground and the air above it. Most fabrics and paper can absorb moisture from the air, and this is the reason that sheets, underclothes, etc., that have been put away for a time should be "aired" or warmed before use.

CHAPTER XXI

LATENT HEAT

H EAT is used up in changing a solid into a liquid, and also in changing a liquid into a gas. Thus if ice at 0° C. is warmed, it is slowly converted into water at 0° C. The temperature of the water so formed, does not rise above 0° C. until all the ice is melted. We used a mixture of ice and water, or melting ice, to check the lower fixed point of a thermometer for this reason, because melting ice is always at 0° C. if the ice is pure. Similarly, when steam condenses to water, it gives out heat, and when water freezes to ice, it gives out heat.

Latent Heat is the stored or hidden heat which is either taken up or given out during a physical change of state, the substance remaining at the same temperature until the change is completed.

To Find the Latent Heat of Fusion of Ice.

EXERCISE 128.—Take a calorimeter which will hold about 300 grams of water when half-full. Weigh the inner vessel of the calorimeter, and then add about 300 grams of water at from 18° C. to 20° C. Weigh the water and vessel together, and carefully note the temperature of the water correct to $.1^{\circ}$ C. if possible. Small pieces of ice should then be dried, one at a time, on a clean cotton cloth, dropped in and stirred up with the thermometer until they melt. About 30 grams of ice should be added in this way, and the temperature should be taken as soon as the ice has melted. The inner vessel should then be weighed

again with its contents, in order to find how much ice was taken.

The heat absorbed by the ice, first in melting and then in bringing the ice-cold water formed by the melting ice up to the temperature of the resulting mixture, is derived from the water and its containing vessel.

We require to calculate the quantity of heat required (in calories) to melt 1 gram of ice *without* raising the temperature of the ice-cold water formed. Hence, if we know the number of calories required to melt 1 gram of ice and *in addition* to raise the 1 gram of ice-cold water so formed to, say, 10° C., the latent heat of fusion of 1 gram of ice alone would be the total value found, minus the heat absorbed in raising the water formed by 1 gram of melted ice from 0° C. to 10° C. In this experiment, for the sake of simplicity, we may neglect the water equivalent of the calorimeter.

EXAMPLE.

Mass of calorimeter	55 gms.
" " + water	315 gms.
" water taken . . . M	260 gms.
" calorimeter + water + ice	342.5 gms.
" ice taken . . . m	27.5 gms.
Temperature of water at first . . . T°	19.5° C.
" after adding ice . . . t°	10.5° C.

$$\begin{aligned}
 \text{Latent heat of fusion} &= \frac{M(T^\circ - t^\circ)}{m} - t^\circ \\
 \text{for 1 gram of ice} &= \frac{260 \times 9}{27.5} - 10.5 \\
 &= 77.4 \text{ calories.}
 \end{aligned}$$

The correct value to the nearest integer for latent heat of fusion of ice is 80 calories.

To Find the Latent Heat of Vaporization of Steam.

EXERCISE 129.—Take the same calorimeter used in the last experiment, or a similar one. Weigh the calorimeter, adding about 300 grams of tap water, and find the exact weight and temperature of this mass of water.

Steam at 100° should now be passed in from a boiler, for

2 or 3 minutes, and the temperature of the mass of water in the calorimeter is found to rise rapidly. The rise in temperature is observed and the mass of steam condensed is found. The heat absorbed by the tap water and its containing vessel is derived from the condensation of the steam, and from the cooling of the condensed steam, originally at 100°C ., down to the resulting final temperature.

EXAMPLE.

Mass of calorimeter	55 gms.
„ „ + water	353.4 gms.
„ water taken	298.4 gms.
„ calorimeter + water + steam	360.84 gms.
„ steam used	7.44 gms.
Temperature of water at first	20.5°C .
„ after passing steam	35.5°C .

Let L stand for latent heat of vaporization of water.

Total heat lost = Heat gained by water and containing vessel.

$$L \times 7.44 + 7.44 \times (100^{\circ} - 35.5^{\circ}) = (35.5^{\circ} - 20.5^{\circ}) \times 298.4.$$

$$L \times 7.44 + 479.88 = 4476$$

$$L = \frac{3996.12}{7.44}$$

$$= 537.1$$

The latent heat of vaporization of water is 537.

The chief difficulty in the last experiment is in getting "dry steam," i.e. steam which has not already partly condensed into water before being condensed in the calorimeter. Frequently a steam trap is used (Fig. 81) in which any condensed water is trapped a few inches above the calorimeter.

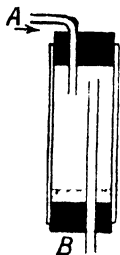

FIG. 81.

Another method (Fig. 82) is to use a 2 lb. syrup tin with a lever lid as a boiler, having previously soldered a piece of narrow bore copper tubing in the position shown in the sectional diagram. The tinned boiler is sup-

ported on a gas ring, the copper tube projecting about 4 inches below the gas ring and being attached by a 2-inch length of rubber tubing to a 3-inch length of glass tubing, which prevents heat being conducted into the calorimeter to any appreciable extent.

When the boiler is properly working with the lid tightly fixed, and steam is issuing freely from the glass tube, any number of calorimeters, up to a dozen or so, may be brought in turn beneath the glass tube, the rubber connexion being pinched for a second or two while inserting and withdrawing the glass tube in each calorimeter. It is best for the teacher to control the supply of steam to each calorimeter in turn, to ensure a suitable rise of temperature, and a trial experiment, to judge the time, should be made first.

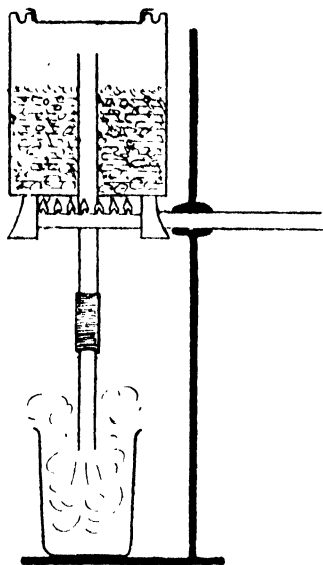

FIG. 82.

Everyday Applications of Latent Heat.

In the section on warming by steam, mention is made of the large amount of heat given out by steam in condensing to water, and the use of steam radiators and pipes in warming buildings, ships, railway trains, and public baths.

After a fall of rain, a rise in temperature is commonly observed, because heat is given out as the water vapour condenses, and becomes rain.

A heavy deposit of dew produces similar effects.

A fall of snow produces a rise in temperature,

though to a lesser extent, since the latent heat of condensation of steam or of vaporization of water is nearly eight times as much as that of freezing of water or of fusion of ice.

The most common application of latent heat is the absorption of heat produced by evaporating a liquid. This has already been considered in connexion with dew-point, and very low temperatures are secured in this way. Thus combined cold and pressure liquefies ammonia gas, and this liquid ammonia [*N.B.* *not* a solution of the gas in water] if exposed to the air, rapidly evaporates in part, withdrawing heat from its surroundings in order to do so, to such an extent, that it is a most powerful refrigerating agent.

It is evident that the part of the liquid ammonia which does *not* evaporate, is rendered intensely cold by the rapid evaporation of the rest, so much so that it may become frozen by the extreme withdrawal of heat.

In this way the low temperatures necessary to produce liquid air, etc., are reached, while compression and expansion play an important part also.

Great compression tends to liquefy a gas, but the temperature must be reduced also below a certain point called the "critical temperature" for that gas; for no amount of compression alone will liquefy a gas, unless below its critical temperature.

CHAPTER XXII

METHODS OF TRANSMISSION OF HEAT

CONDUCTION transmits heat between particle and particle in *contact*, whether of the same or of different substances. A kettle lid becomes hot by conduction in this way, partly through conduction from the metal surrounding the lid, and partly by conduction between steam and metal.

Radiation

transmits heat from the sun, from a fire, from a hot body, such as a radiator or flat-iron, without appreciably warming the medium, e.g. air, through which the heat rays travel. A night watchman sitting in the open air on a cold night, receives a great deal of warmth from his "bucket" fire in this way.

Convection

transmits heat by means of the moving particles of a *fluid*. Hot air or hot smoke ascends, and a lighted fire creates a powerful upward draught in the chimney above it. Similarly, if a kettle of cold water is heated from below, the hot metal of the kettle *conducts* heat to the water inside. The warmed water expands, becomes lighter bulk for bulk than the surrounding cold water, and streams upwards, while the colder water flows downwards to take its place. In this way heat causes *convection currents* and produces land and sea breezes, winds and

draughts. These are all due to local differences of temperature.

Experiments on Conduction, Radiation, and Convection.

EXERCISE 130.—Take a piece of glass tubing or of glass rod about 3 inches long, and a similar length of metal tubing or metal rod. Heat one end of each in a bunsen burner, and observe which of the two conducts the heat more rapidly to the fingers.

EXERCISE 131.—Fit a piece of wood, such as a penholder, into the metal tube at one end, and use it as a handle while holding the metal in the flame.

EXERCISE 132.—Use a holder for the metal tube, made of one thickness of calico, and a holder made of one thickness of flannel.

EXERCISE 133.—Fit a thermometer into a small flask, so that the bulb is in the centre of the flask, and cut a channel in the cork to allow air to pass into or out of the flask. Thrust the body of the flask into boiling water and observe the temperature recorded by the thermometer.

EXERCISE 134.—Wrap a small piece of ice round with some soft lead fuse wire or some soft copper wire, and drop it into a test tube half-full of water. The weighted ice sinks to the bottom. Now, holding the tube at an angle of 45° , heat the upper half of the water until it boils. The ice still remains unmelted, although the boiling water is only a short distance above it.

Carefully write down your conclusions or inferences from each experiment.

Metals conduct heat readily; glass and wood are poor conductors of heat compared with metals. Calico is a better conductor of heat than flannel. Air and water are bad conductors of heat.

After careful deliberation answer the following questions:—

1. Why does a copper soldering-iron when hot, rapidly melt solder if touched against it?

2. Why is a blanket a warmer covering than a closely woven cloth rug of the same weight?
3. Why are blankets used to cover ice on ice carts?
4. Why does a bird puff out its feathers when at rest during cold weather?
5. Why are irons and metal teapots often fitted with wooden handles?
6. Why does the surrounding sea temper the climate of an island?

Effect of Good Conductors of Heat in Contact with a Flame or in Contact with a Hot Liquid.

If a poker be placed in a fire, it conducts away some of the heat of the fire, and hence tends to deaden the fire. Heating flat-irons or soldering-irons has a marked effect of this kind upon a fire. A hot liquid is rapidly cooled if poured into a large cold basin which conducts away much of the heat. Similarly, it is difficult to light a fire in cold weather in an absolutely cold kitchen range, because the large masses of cold iron absorb a lot of heat by conduction.

Experiments on the Effect of Conductivity.

EXERCISE 135.—Light a bunsen burner and lower a square of fine wire gauze on to the flame. The flame will not pass through the gauze, though coal gas passes readily through it. Repeat the experiment under slightly different conditions, placing the gauze touching the burner, then lighting the gas above the gauze and lifting the gauze to a height of 2 inches above the burner.

EXERCISE 136.—Make a spiral of thick copper wire by winding some round a piece of glass tubing about a centimetre in diameter. Place the *cold* spiral over a candle flame which immediately goes out. Heat the spiral in a bunsen burner and place the *hot* spiral over a candle flame. The hot spiral has no effect on the flame. Repeat the

last two experiments, using a cold flat-iron and a hot flat-iron instead of the copper spiral.

Inferences.—A mass of cold metal can put out a flame by withdrawing heat from it. Hot metal does not put out a flame in this way.

The Davy safety-lamp, used by coal-miners, but now being supplanted by electric lamps, has a covered wire gauze chimney above the light, often forming an extension to a short glass chimney. No flame can pass through the gauze to fire inflammable gases in the mine, though air and the products of combustion pass freely through gauze.

EXERCISE 137.—Place a teacup full of boiling water in each of the following vessels: (*a*) a large stoneware jug; (*b*) a large cast-iron saucepan; (*c*) a tinned can standing on a stone slab or concrete floor; (*d*) a tinned can standing on felt. After five minutes' interval test the temperature of the water in each vessel and account for the varying temperatures.

Tea required for a picnic, may be made beforehand and poured while boiling hot into previously warmed bottles, which should then be tightly corked and wrapped in flannel, towelling, etc. Under these conditions the tea will keep quite hot for about three hours—a corkscrew should be taken to withdraw the forced-in corks. A thermos flask is still better, being a double bottle having the ring-like or annular space exhausted of air. This vacuous surrounding is the best non-conductor of heat known, and enables the hot liquid to retain nearly all its heat for many hours—even for as much as twenty-four hours. Similarly, of course, ice-cold liquids in a thermos flask remain ice-cold for days.

It will have been observed, that a boiled egg if wrapped whilst hot in a serviette, continues to cook and usually becomes "hard-boiled". If the shell

be cracked at one end, the hot imprisoned gases immediately escape, and the egg does not go on cooking. Various "cooking-boxes" are in use throughout the world which conserve or store up the heat in the hot food put into them, so that it goes on slowly cooking, or at least remains warm. Hay, sawdust, or other non-conducting material is used to surround the cooking pots. A brightly polished surface does not lose heat as rapidly, nor absorb heat as quickly, as a dull surface. Hence, it is an advantage to keep the sides of a kettle bright, and allow the bottom to get black.

EXERCISE 138.—Take a brightly polished tinned can or a new tinned kettle. Measure out an exact quantity of water by measuring jar from a bucket full of cold water, into the tinned can or kettle—sufficient to half-fill it. Place the vessel and its contents over a bunsen burner or gas-ring, and check the time required to raise the water to boiling-point. Repeat the experiment with another equal amount of water from the same bucket, using the same burner with the gas supply unaltered, only before putting in the second lot of water, black the bottom of the vessel with soot from a candle flame, or a mixture of lamp-black and oil. If the vessel is partly filled with cold water to keep the metal cool, a candle flame will rapidly deposit a coating of soot over the bottom. When blackened underneath, the vessel gets hot more rapidly, i.e. it becomes a better absorber of heat.

Good absorbers are good radiators, and hence we notice that steam or hot-water radiators in public buildings are generally painted black, or some colour which is nearly black.

CHAPTER XXIII

WARMING, COOKING, AND VENTILATION

The Warming of Buildings—Cooking-Stoves.

OPEN fire-places are the commonest means of warming the rooms of houses, the fuel being either coal, wood, peat, or specially prepared fuel derived from them. The chief essentials of a good fire-grate for warming a room should be, (*a*) a shallow fire-basket with a closed ash-pan below, in order that the ashes should automatically collect without scattering dust; (*b*) fire-bars should be thin and vertical, to avoid shading part of the fire and the dropping of live coals through the bars on to the hearth. (the best grates being bar-less); (*c*) some means for regulating the draught should be fitted, and over-hanging fire-bricks to economize the heat and burn the fuel to the best advantage.

Kitchen-ranges are frequently most inefficient, both for cooking and for heating water. It is best to study the advantages of a cooking-range at a reputable maker's. Modern types are now available which combine the advantages of an open fire-place suitable for a sitting-room, and a cooking-stove, being convertible at will. An oven should always be *above* the level of the fire, as it economizes heat and flues, and avoids a lot of stooping down to the oven.

Gas-Fires and Gas-Stoves.

Gas-fires are a great convenience for rooms which are occasionally used, and for bedrooms. In

districts where gas is cheap, they are not much more expensive than coal-fires, and save much dirt and labour. In lighting a gas-fire, turn the tap on a second or two to allow the gas to displace the air from the pipe beyond the gas tap, turn off, and then, bringing a lighted match or taper over the burners, turn on the gas which should light quietly. The flame should be blue and crackle slightly, like the flame of a bunsen when the inner cone shows clearly.

Gas-stoves and gas-rings are very useful for cooking, because the heat can be regulated exactly. The same precautions should be taken in lighting a gas-stove or a gas-ring as in lighting a gas-fire. The gas should never be turned on while the gas-oven door is shut. Most gas-stoves, rings, and fires can be readily taken to pieces, and all gas fittings work much more efficiently if kept clean and free from dust. A gas-fire should be disconnected from the floor junction once a year, and the fuel, flue, burners, etc., freed from dust, which should also be removed from the space behind the gas-fire.

Steam Heating.

Steam heating is suitable for public buildings, public baths, railway carriages, etc., where it is economical to employ an engineer to look after the necessary furnace. On board ship, on trains, and at public baths "dead" steam, i.e. steam which has passed through engines, may be profitably turned to account for warming purposes.

One advantage of steam heating is that much smaller pipes and radiators may be used, but the internal pressure is more likely to produce leaks, the system is more noisy in working, and the radiators become scalding hot to the touch, whereas hot-water radiators rarely burn the hand.

Hot-Water Warming.

This is the cheapest form of warming in up-keep, though the original cost of the installation is fairly expensive, but not more so than the cost of the ordinary fire-places and chimneys necessary in building the coal-fire warmed house.

Fig. 83 illustrates an ordinary domestic hot-water apparatus with two radiators, 60 feet of pipe, and a 25-gallon hot-water tank in circuit. Such a system enables the largest room and the hall and staircase of an eight-roomed house to be kept above 50° Fah. in cold weather, and supplemented by two or three gas-fires for occasional use, ensures a pleasant temperature throughout the house and a plentiful supply of hot water, for a minimum of labour and expense.

Only one fire is required, the boiler being constructed to burn coke, the cheapest fuel obtainable, and to burn for eight hours without going out if properly charged and regulated.

Such a boiler is very clean in use, being entirely closed in, and is absolutely safe to leave unattended, since it is impossible for a red-hot cinder to jump out of the fire and set the room on fire.

Electric Heating.

Though extremely convenient, electric heating is the most expensive form of heating in general use, and is only adopted as a rule in small rooms, offices, etc., where the use is only occasional.

Temperature of Rooms.

The temperature of a living-room should not fall below 50° Fah. In a sick-room it should be 60° Fah., and a room is too hot if above 75° Fah. (summer heat).

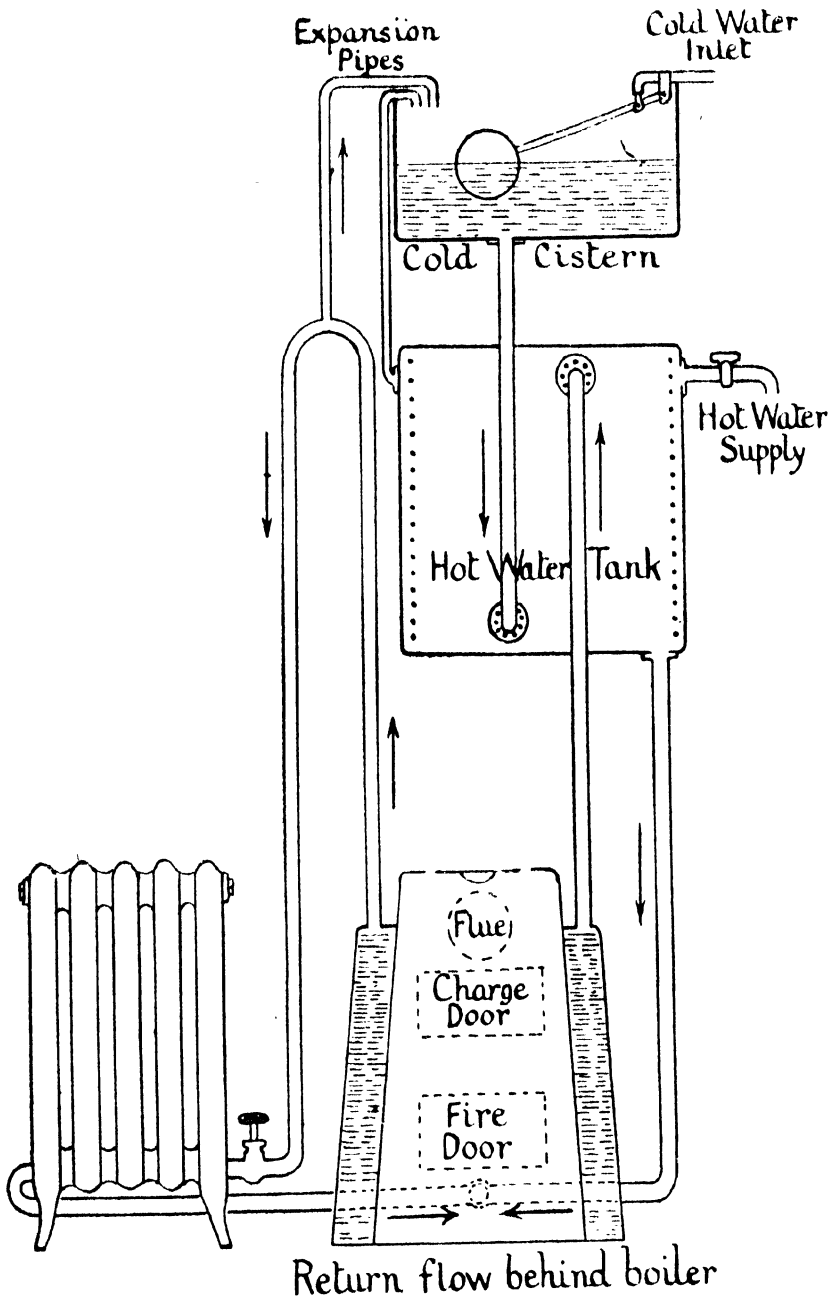

FIG. 83.

Ventilation of Rooms.

In the section on elementary chemistry, we shall consider how the atmosphere becomes unfit to breathe through the action of animal life, fires and combustion, decomposition and decay, and injurious fumes of all kinds. Vegetable life, sunlight, and certain scavenging agents of nature, restore the purity of the atmosphere, and it is a well-known fact that fresh air from outside is beneficial, while foul air which has been confined in crowded rooms, mines, sewers, etc., is harmful. In order to secure a continual changing of the air in a room, ventilation is necessary, and it should allow for a gentle current of air in continual motion, rather than admitting draughts.

Many rooms, houses, and buildings are badly ventilated through structural faults, but these can often be remedied by a little ingenuity.

Every room should have a window which opens to the outside air. The window should open high up if possible, because the warm, breathed out, or expired air rises, and flows naturally upwards. Chimneys are good for ventilation *when there is a fire burning* to send the air *up* the chimney. Otherwise a chimney, unless it communicates directly to the outer air through a short flue, should be closed because down-draughts are unpleasant, often smoky, and soot-tainted.

There should be a ventilator in every bedroom, and this is best secured by having a "fanlight" or hinged window above the door. Where rooms are fitted with casement windows instead of the ordinary sash windows, hinged fanlights should be fitted above the casement windows to allow of ventilation without draughts.

It often becomes necessary to consider inexpensive means of improving defective ventilation. A

good device to adopt with the ordinary sash window, is to have a length of wood $1\frac{1}{2}$ inches square section cut to fit at either end into the grooves in which the lower half of the window slides, so as to lie flat on the wooden sill and prevent the window being closed. This ensures ventilation at the overlapping of the top and bottom halves of the window, where rain cannot beat in, and direct-down draught is impossible. The same effect can be secured with a fanlight over a casement window by fitting wedges of wood on either side to prevent the window quite closing. Where a small bedroom has a window at one end and the door at the opposite end, and ventilation is required between the door and the window, a hook-

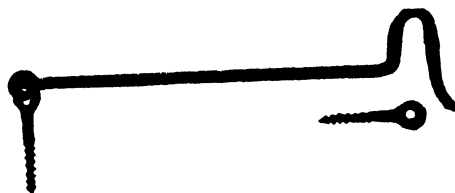

FIG. 84.

wire latch, costing a penny, is useful (Fig. 84). The hook, with screw-eye attachment, should be fixed high up in the door *frame* on the lock side of the door, with the other screw-eye an inch in from the edge of the door, fixed on the door itself. The swinging hook cannot rattle when the door is opened or shut in the ordinary way; the catch, when fastened, sets the door permanently "ajar" without the possibility of it being shut by a draught. A coat hung over the screw-eye, before the catch is slipped in, ensures privacy and freedom from draught, while ventilation proceeds over the top of the door. A small scullery where cooking is done by gas, should have an "air-brick," i.e. an iron grating of the same size, to replace one or two

bricks in the wall as high up as the roof will allow, so that gas fumes and cooking vapours may escape.

Strong screw-eyes, such as are used for hanging large pictures, when screwed into the upper frame of a sash window about 6 inches above the window catch on either side, are of great assistance in opening or closing a window, and in preventing accidents from broken sash cords. Small wooden wedges may be hung from them by fine string, and used to prevent the windows rattling in windy weather.

CHAPTER XXIV

NATURE OF LIGHT—PIN-HOLE CAMERA—PHOTOMETRY

Light.

LIGHT is the external physical cause which produces the sense impressions of sight. This means that without *some* light it is impossible to see at all. It is not correct to say that a cat can see in total darkness, though animals and birds which hunt at night have eyes that are specially suitable for seeing in dusk or in twilight, or even by starlight or a glimmer of moonlight.

EXERCISE 139.—Enter a dark room, a cellar, or a large dark cupboard carrying a sheet of white paper or a white handkerchief. If any light enters, the paper or handkerchief will be dimly visible as a dark grey object. If no light enters, the object *cannot be seen at all*. After the eyes have become accustomed to the gloom, if it is during the hours of daylight, some light will probably be detected entering through a crack or a grating. The same retreat at dusk will probably appear quite dark owing to the very small amount of light which is then able to enter.

All surfaces reflect light to some extent, and also absorb some of the light which falls on them.

Objects which are seen by means of the light which they receive and reflect, are called non-luminous or illuminated bodies, while those which actually emit light themselves, such as the sun, a flame, or a fixed star, are called self-luminous bodies.

The moon and the planets shine by reflected light, and are therefore non-luminous or illuminated bodies. Polished smooth surfaces are good reflectors, and absorb but little light, e.g. metals, silvered mirrors or painted-glass mirrors, i.e. glass with a dark background painted on one side. Dull-roughened surfaces, e.g. black cloth, velvet, or a soot-coated surface, absorb more light and reflect less than good reflectors. We are only able to see objects that either emit light themselves, or else reflect light from another source. If a substance allows light to pass through it, it is called a *medium*. The air, glass, water, oiled silk or paper, porcelain, are examples of *mediums*. A *transparent medium* allows light to pass *freely*, while a *translucent medium*, such as ground glass, only allows *some* light to pass. An *opaque* body, e.g. metal, does not allow light to pass, and is therefore not a medium.

Light travels in straight lines through the same medium if the medium is uniform. A *ray of light* is a mathematical line of light, a *beam* is a collection of parallel rays, while a very narrow beam is often called a *pencil of light*. The velocity of light, or the speed at which it travels, is about 186,000 miles in a second, about eight minutes being occupied in reaching the earth from the sun, a distance of about 93,000,000 miles.

The Pin-Hole Camera.

EXERCISE 140.—Obtain a short length of cardboard tube about 2 inches internal diameter. An upright incandescent mantle box is suitable, or a length of postal tube. Such a tube may be made by wrapping a piece of stiff, dark brown paper round a piece of broom handle and gluing the layers together. A similar short length should be made of brown paper to slide either outside or inside the first.

Both tubes should be from 4 to 6 inches long, and slide

within each other like the tubes of a telescope. Cover one end of the larger with a paper cap, or with the cardboard cap supplied with the incandescent mantle box. Glue the cap on light-tight, and make a central hole, not more than 1 mm. across, with a red-hot hat pin or a needle. Cover one end of the smaller tube with a similar cap of thin tissue paper—a smooth piece stretched tightly over, and the pasted edges held in position by cotton tied round, until the paste has set. When both tubes are dry, slide the tissue-paper covered end into the open end of the larger tube, and look through the tissue paper and pin-hole at a bright object, e.g. an electric or gas light. Slide the inner tube backwards and forwards until a clear image is obtained on the tissue-paper. The image will be found to be *upside down*.

The image or likeness obtained on the tissue paper screen, is produced by a great number of rays of light which have all come through the pin-hole. The rays have converged or come to a point at the pin-hole, and have afterwards diverged or spread out.

Experiment to Illustrate Inversion of the Image.

EXERCISE 141.—Take a small piece of scrap paper and a new coin or one of recent issue. Place the coin exactly upright *beneath* the paper, and by rubbing a blacklead

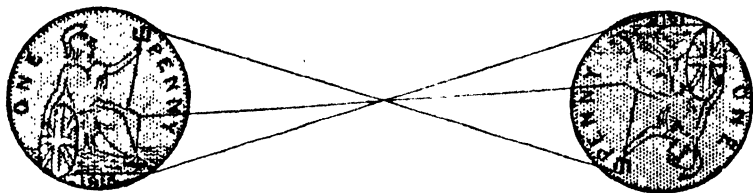

FIG. 85.

pencil on the *upper* side of the paper obtain a tracing of the coin. Now place the coin exactly upside down beneath the paper, at a distance of about 3 inches from the first tracing, and obtain a second tracing. Two impressions will then have been obtained, as in Fig. 85.

Using a ruler and a hard, sharp-pointed pencil, join up several of the corresponding points on the two impressions, and it will be observed that the lines all cross at one point. Repeat the experiment with two different-sized coins similarly marked, e.g. a penny and a halfpenny, and the same effect is observed.

In a pin-hole camera or in a photographic camera, whether the image is of the same or of different size from the object, it always appears *inverted*, because the rays which form it have passed through a common point or a *focus* as it is usually called.

The Reading-Glass or Burning-Glass.

Examine an ordinary reading-glass fitted in a metal rim with a wooden handle. Such a magnifying-glass, about $2\frac{1}{2}$ inches diameter, of ordinary quality, costs about 1s. 6d. A botany hand magnifying-glass could be used.

These glasses are bi-convex or double convex, i.e. they bulge outwards in the centre on both sides, and a piece of glass of this shape is described as a double convex *lens*. The "bull's-eye" of a cycle lamp is generally a plano-convex lens, i.e. flat or plane on the side next the flame, and convex or bulged outwards in the centre on the outside of the lamp.

Hold the bi-convex lens between the back of your left hand and a source of light, and move the lens toward or away from your hand until a bright spot about $\frac{1}{4}$ inch in diameter appears on your hand. This should be done cautiously in sunlight, because a bi-convex lens concentrates or brings to a point or focus, both light and heat rays. Paper may be set on fire by such a "burning-glass".

The Photographic Camera.

This consists of a dark box with the sides made of leather in folds, so that the front may be brought

nearer or further from the back when required for focussing, i.e. obtaining clear detail of the object. The lens in front is bi-convex, like a reading-glass, and collects all the rays which fall upon it, bringing them to a point or focus, much better than a pin-hole (see Fig. 86).

A diaphragm, similar to the coloured part of the eye or *iris*, regulates the amount of light passing through the lens. The aperture used is commonly called the *stop* in photography, because the iris diaphragm is used in partially stopping up the lens.

At the back of the camera is a screen of ground glass which receives the *inverted* image from the lens. When the image is focussed in clear detail on

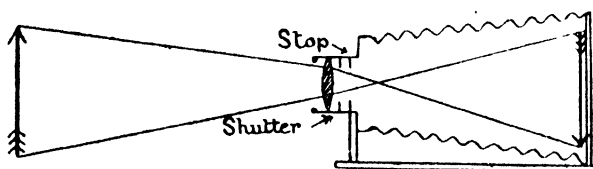

FIG. 86.

the ground glass, the shutter is closed, or the lens is covered by a cap, and a sensitive plate or film is substituted for the screen. An exposure of the plate or film is then made, regulated by the shutter which works to definite intervals of time, e.g. $\frac{1}{100}$, $\frac{1}{50}$, $\frac{1}{25}$, $\frac{1}{15}$, $\frac{1}{10}$, $\frac{1}{5}$, 1 second, etc. The plate, or film, after developing in a dark-room or covered tank is "fixed," i.e. rendered permanent, and then becomes the *negative* from which photographs are printed. It is so called because the light part of the object appears black, and the dark part light. A transparent photograph on glass may be used as a lantern slide.

Intensity of Light,—Photometry.

The intensity of the illumination produced by a source of light is inversely proportional to the

square of the distance from the source, e.g. at twice the distance the same sized area receives $(\frac{1}{2})^2$ or $\frac{1}{4}$ of the light.

Experiment on Intensity of Illumination.

EXERCISE 142.—Take an ordinary plain post-card $3\frac{1}{2}$ inches by $5\frac{1}{2}$ inches. Pin a sheet of drawing-paper on a drawing-board, and fix the board upright on the bench by means of a retort stand and clamp. Place a lighted candle exactly a metre distant, measured by a metre scale. A glass ink-well, or a flat cork with a pin pushed right through from below so as to stick into the lower end of the candle, will do for a temporary candlestick.

Holding the post-card exactly over the 50 cm. mark, i.e. *half-way* between the candle flame and the drawing-board, let the entire shadow of the card fall on the drawing-paper. The shadow is found to be *twice as wide and twice as long* as the post-card, or *four times the area* of the post-card; i.e. the same area as the post-card, at twice the distance, receives only $(\frac{1}{2})^2$ or $\frac{1}{4}$ of the light which falls on the card at the original distance.

The Grease-Spot Photometer.

EXERCISE 143.—Take the lid of a cardboard box about 12 inches by 6 inches or larger, and cut out a 4-inch square in the centre of the lid. Paste a piece of thin white paper

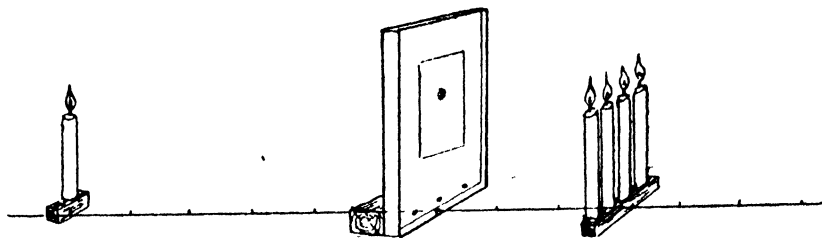

FIG. 87.

over the hole, common notepaper or typewriting paper is suitable (Fig. 87).

The paper should be stretched tightly. If it is previously wetted and pressed between blotting-paper, it will have

stretched sufficiently to become tight when it shrinks in drying. The cardboard lid may be fastened by tacks to a piece of wood of square section as shown in the figure. When the paper is quite dry, melt a little lard in a teaspoon, and by touching the melted lard with the tip of the little finger, transfer a drop of melted lard to the centre of the white paper. The grease-spot so obtained should be about $\frac{3}{4}$ inch in diameter.

Rule a straight chalk line, a metre long, on your bench. Using a flat tin lid or small piece of flat wood about 4 inches square, fix four candles upright close together, i.e. about an inch apart, at the corners of a square or touching one another in a straight line, and similarly fix one candle upright by itself.

The room must now be darkened and the candles lit, the cluster of four being placed on one side of the grease-spot, on the chalk line, and the single candle on the other side, also on the chalk line, which should pass immediately below the centre of the grease-spot.

By moving the candles or grease-spot photometer, a position will be obtained in which the grease-spot, viewed from either side, is practically invisible. This is because the light from both sources is so arranged that an equal amount passes through in opposite directions from both sides. The paper surrounding the grease-spot transmits *less* light than the grease-spot, but reflects *more*. Hence, when there is apparently no difference in appearance between the grease-spot and the surrounding paper, it is evident that the paper with its grease-spot is equally illuminated on both sides. Chalk marks should now be made round the bases of the photometer and candlesticks, and it will be found that when the illumination is equal on both sides, the four candles are twice the distance from the grease-spot that the one candle must be, proving that the intensity of illumination is inversely proportional to the square of the distance from the source of light.

The grease-spot photometer is useful for comparing the illuminating power of any source of light with that of a standard candle, and so we describe a light as being of so many candle-power. A steady

light is of greater value than a flickering light, and some brilliant lights, such as the electric arc lamp, flicker too much for reading or writing by, while suitable to illuminate streets, railway yards, etc. Flares of various types used for night signalling, and by contractors doing all-night open-air work, are flickering, though brilliant, illuminants.

CHAPTER XXV

REFLECTION—REFRACTION—LENSES

The Reflection of Light.

IT has already been shown that non-luminous bodies become absolutely invisible in total darkness, and are only visible when they are able to reflect light.

Experiments on Reflection of Light.

EXERCISE 144.—Pin a sheet of drawing-paper on a half imperial board. Rule a straight line centrally across the width of the paper, and place a strip of mirror glass upright, with the silver surface over the line drawn. Usually a block of wood is glued to the back of the mirror to keep it upright, or an upright pin can be placed behind it, with two others in front at the extreme ends of the strip. Rule a line at right-angles, using a set square, from the centre of the bottom edge of the mirror about 6 inches long. This line is a *normal* to the mirror, and any line drawn at right-angles to a mirror surface is a normal (see Fig. 88).

Fix a pin upright on the normal about 6 inches distant. On looking into the mirror along the normal, a likeness of the pin called an *image* is seen in the mirror. Now place several other pins along the same line nearer the mirror. On looking along the row of pins, a series of corresponding *images* may be seen in the mirror *in the same straight line*. This proves that when a ray of light, represented by the line joining the pins, strikes the mirror as a *normal*, i.e. at right-angles to it, the reflected ray, represented by the ray in line with the images, emerges from the mirror at the same angle, i.e. it is not deflected at all.

Now remove all the pins and place one pin upright, touching the glass on the normal. It may be necessary to shift the mirror strip, which can then be replaced over the original line drawn, and touching the pin. Place two pins A and B in a line with the first, in the position shown in Fig. 88. Remove the pin which is touching the glass, and place two other pins C and D, as shown in Fig. 88, in a line with the *images* of A and B. Now take away the pins and join up the pinholes left by A and B, continuing the line to the

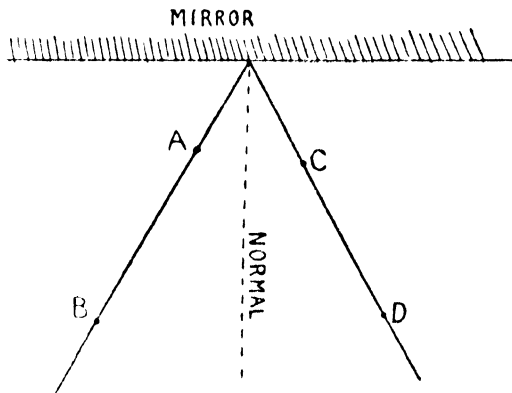

FIG. 88.

normal. Similarly, join up the pinholes left by C and D. Measure the angles made by the two lines with the normal, and it will be found that they are equal.

The line joining the first set of pins represents the *incident ray*. This makes the same angle with the normal as the line joining the second set, which being in the same straight line with the images of the first set represents the *reflected ray*. The *point of incidence* is where the incident ray strikes the mirror.

Laws of Reflection.

1. The incident ray, the reflected ray, and the normal at the point of incidence are in the same plane.
2. The angle of incidence is equal to the angle of reflection.

Mirrors at an Angle.

If two mirrors be placed at right-angles to each other, and an object be placed between them, three images may readily be distinguished. Two of these are just ordinary images and the third is a *reflection of an image*. It is easy to stand in front of a dressing-table mirror with a hand mirror, and by holding the hand mirror at a suitable angle behind the head, to examine the reflection of the back of the head shown by the hand mirror as a reflection in the dressing-table mirror.

Similarly, the inner side of the front teeth in the upper jaw may be viewed by means of a small mirror placed in the mouth, or partly in the mouth, and the image reflected into a larger mirror.

Both the dentist and the doctor use small mirrors for viewing the teeth, throat, and eyes. Silvered glass reflectors are used above electric lights in lighthouse reflectors, etc., and polished metal reflectors are used in cycle and carriage lamps.

The Periscope.

This instrument, in its simplest form, consists of two parallel mirrors, each sloping at *half a right-angle* or 45° to the horizontal. The upper mirror reflects a horizontal ray *vertically downwards* on to the lower mirror, which reflects it horizontally again, but at a lower level.

The periscope is used in submarines, and in trench warfare, for observation purposes.

Refraction.

In examining the reading-glass, we found that a double convex or bi-convex lens bends the rays which pass through it, bringing them to a point or focus. The bending of a ray of light in passing from one medium to another is called *refraction*.

Experiments on Refraction of Light.

EXERCISE 145.—*Refraction through a Glass Prism.*—Place a glass prism with one of its triangular ends resting centrally on a sheet of paper, and trace round the glass prism in order to mark its exact position. Place two pins in the positions of A and B (Fig. 89), each touching the glass. It may be necessary to remove the prism while A and B are inserted, and in this case the prism should be replaced in the original position. On looking at A in the direction CA, a position will be found in which the two pins A, B

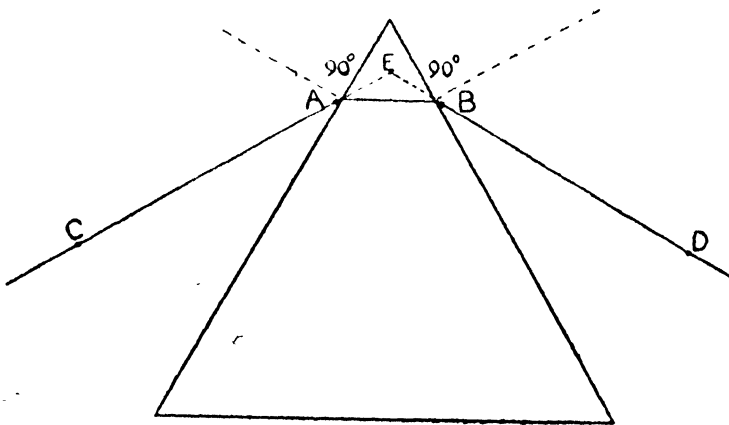

FIG. 89.

appear in a straight line. Place the pin C in this straight line. On looking at B in the direction DB, a position will be found in which B, A, and C appear in one straight line. Place the pin D in this straight line. Remove the prism and pins, and join up CA, AB, BD. Produce CA and DB to meet at E, and draw lines at right-angles to the prism at A and B as *normals*. CA represents the incident ray, the angle CED the angle of *deviation*, BD the emergent ray.

The ray of light is bent at A and again at B. Repeat the experiment using a rectangular glass block instead of a glass prism. The ray is twice bent as before, but the emergent ray is *parallel* to the incident ray.

Laws of Refraction.

1. The incident ray, the refracted ray, and the normal are all in one plane.

2. The incident and refracted rays are on opposite sides of the normal.

Apparent Depth of Water.

EXERCISE 146.—Obtain a large white enamelled bowl about 12 or 14 inches diameter. Fill it to within an inch of the top with water, and then hold an ordinary flat foot-rule or a half-metre scale at a slope of about 30° , half in and half out of the water. Look at the rule or scale from above, viewing it as you would view your pen in your hand whilst writing. Where the rule passes through the

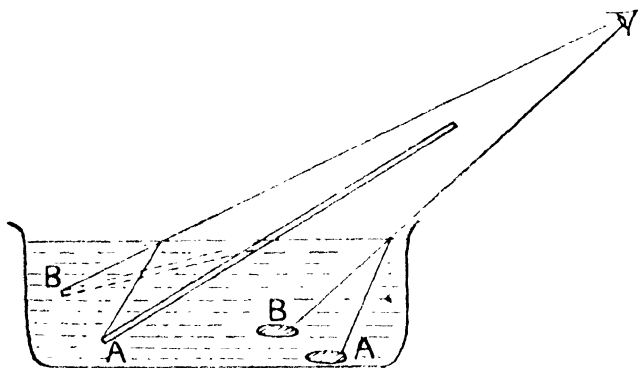

FIG. 90.

water surface, it appears to be *bent* so that the lower portion does not appear in the same straight line as the upper portion. The effect of this bending is to bring the lower end of the rule apparently nearer to the surface, and is due to refraction of light.

Empty the water out of the basin and place a penny on the bottom of the empty basin. Stand so that you can only just see the edge of the penny over the rim of the basin, and so that most of the coin is hidden by the rim of the basin. Get somebody else to pour water gently into the basin to a depth of several inches without disturbing the coin, and you will find that the coin is quite easily seen.

Fig. 90 shows the effect of the water in bending the rays as they reach the surface from the submerged object so that a ray which comes from A really *appears* to come from B.

Hence the depth of clear water cannot be judged by the eye on account of refraction.

Lenses.

We shall only briefly refer to ordinary glass or rock-crystal lenses in common use in optical instruments, spectacles, etc. The bi-convex and plano-convex lenses have already been illustrated (see A, B, Fig. 91). The meniscus curve of water in a measuring jar is similar to section C of a *converging meniscus*, D being a diverging meniscus, E and F double concave and plano-concave lenses respectively.

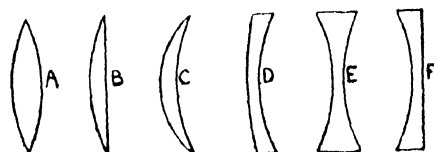

FIG. 91.

A bi-convex lens drawn in section, is somewhat similar to the section of two triangular prisms drawn base to base.

A double concave lens drawn in section, is somewhat similar to the section of two triangular prisms drawn point to point.

We found in our examination of the reading-glass, that a bi-convex lens brings rays which fall upon it to a point or focus. The effect of refraction in this kind of lens is to cause rays which pass through it to converge.

It will be readily seen by comparison with the action of a triangular prism, that the double concave lens causes rays which pass through it to diverge by refraction.

Spectacles and Defects of Vision.

Short sight or Myopia is defective for distant objects. This is due to excessive refraction of the crystalline lens of the eye, and is therefore corrected by *concave* glasses.

Long sight or Hypermetropia is defective for near objects, due to insufficient refraction of the crystalline lens of the eye and is therefore corrected by *convex* glasses.

Astigmatism is a defect due to light entering the eye from a horizontal direction, being refracted to a different degree from light entering vertically. Lenses of cylindrical curvature are needed to correct astigmatism.

To preserve the eyesight, objects, writing or print, should never be viewed *nearer* than ten inches distant. The light should fall on the object from above the eye-level, and when writing, from the left.

CHAPTER XXVI

FAMILIAR OPTICAL INSTRUMENTS

WE have already studied the photographic camera, and will now briefly discuss the magic lantern or optical lantern, the telescope, the opera glass, and the microscope.

The Magic Lantern.

A bright light, within the body of the lantern, is passed through a condenser, which acts like a reading-glass in collecting the light and concentrating it upon the transparent glass slide. The slide holder is placed between the condensing lenses, and the

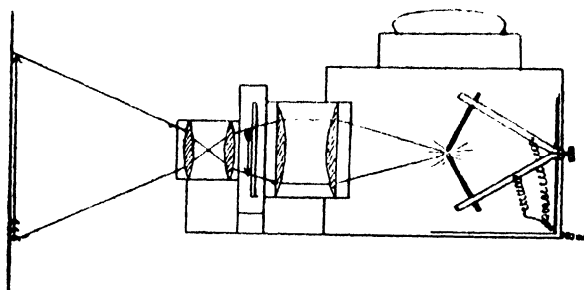

FIG. 92.

“objective” or projecting lenses which throw an *inverted* magnified image of the slide on the screen. Hence the operator must put the slides into the slide carrier *upside down*. If a tightly stretched thin sheet is used the picture shows *through* the screen also (Fig. 92).

The Astronomical Telescope.

This differs from the ordinary landscape telescope in giving an inverted image. An extra set of lenses in the latter restores the correct position of the object as seen by the unaided eye.

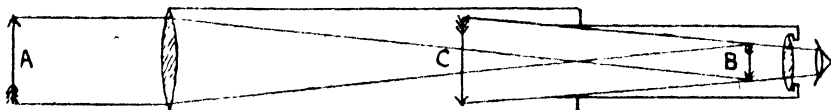

FIG. 93.

The object glass is a lens of considerable focal length and forms an inverted image B of the object A. The eyepiece magnifies this image so that it appears to be larger and situated at C.

The Opera Glass.

This is really a double telescope to be used by both eyes together and generally for a rather short range. As in the telescope the object glass alone would produce an inverted image; but the eyepiece,



FIG. 94.

which is a *double concave lens*, is so placed that the rays from the object lens converge on the eyepiece which makes them appear to diverge to the eye. The image seen by the eye, therefore, is correct as regards position, and is magnified by the eyepiece.

The Compound Microscope.

In principle this instrument is similar to the astronomical telescope, except that the "objective," or

lens near the object, is of very short focal length, i.e. it rapidly brings the rays to a focus. The eyepiece

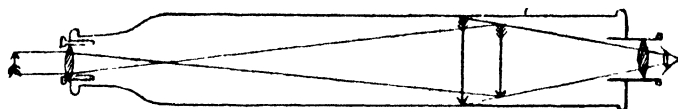

FIG. 95.

of the instrument is a powerful magnifier, and as in the astronomical telescope the image is inverted (Fig. 95).

EXERCISE 147.—Look through the eyepiece of a compound microscope and adjust the reflecting mirror below the slide carrier, so that the brightest circle of light possible is obtained. Place a simple slide, such as a stem section, under the objective, and focus until clear detail is obtained. Move the slide slightly, and notice that as the slide moves from left to right, the image in the microscope appears to move from right to left.

The Spectrum.

A ray of sunlight passing through a prism may produce a coloured rainbow band or a "spectrum". This is because sunlight consists of coloured rays blended together. The three primary colours are red, yellow, and blue, and seven colours of the rainbow are produced by the gradations and admixtures of the primary colours. Starting with a very deep shade of blue, we have violet, indigo, blue, green, yellow, orange, red. It will be readily seen that violet and indigo are shades of blue, while green and orange are intermediate compared with the primary colours between which they are found. It is desirable to memorize VIBGYOR and also *infra-red* and *ultra-violet*. The violet rays are refracted *most*. The red rays are refracted *least*, and are the least chemically active.

N.B.—Sensitive plates are developed, packed, etc., in red or orange light.

EXERCISE 148.—When a bright sunny day is available, place a glass triangular prism on a triangular end over a sheet of white paper and gradually rotate it in sunlight until a

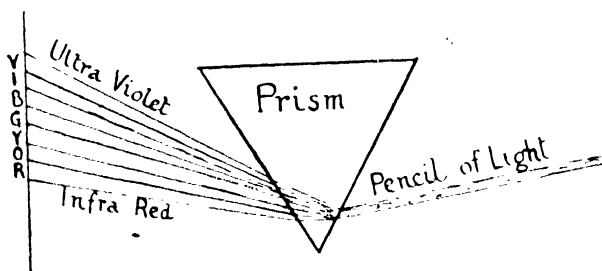

FIG. 96.

rainbow band is formed on the paper. Note the *order* of the colours in the band, and which colour has been refracted most in coming through the prism (see Fig. 96).

Sunlight is *composite* as distinct from *mono-chromatic* light, the former being a blend of coloured rays, the latter one colour only.

Refraction by raindrops occurs under certain conditions in nature and forms the rainbow, and a miniature rainbow may often be seen on a bright day, just by a waterfall, or over the paddle-box of a steamboat when water spray is continuously thrown up.

The Spectroscope.

This instrument, often conveniently in pocket form, may consist of a brass tube about 6 inches long containing several prisms and an eyepiece with a small slit at one end. A narrow band of sunlight comes through the slit, is refracted by each prism in turn, and as observed through the eyepiece, appears as a clear rainbow spectrum

crossed by many fine black lines. These lines denote the presence of certain elements in the sun.

Colour.

Colour is due to the nature of the light which falls upon a body, as well as upon the kind of body itself.

Blue glass *absorbs* the coloured rays of composite light except blue, red glass absorbs all but red, etc. Red cloth reflects red rays, and absorbs the others if it is sufficiently thick to prevent light passing through it. Red cellular or semi-transparent underclothing is frequently used in the tropics, because the orange and red rays do not have any harmful effect on the body, whereas the blue rays or "actinic" rays are those which produce sunstroke and injurious heat effects. Red cellular material, or red-glazed linen used for blinds, allows red rays to pass.

Colour Blindness.

Certain primary sensations of sight apparently convey the impression of colour. Thus a normal vision will detect red in any shade of red-brown or purple. Just as the crystalline lenses of the eyes may be defective and require correction by suitable spectacles, so one or more of the impressions of colour may be defective, e.g. the red sensation may be wanting or red may be confused with yellow. Shades of grey, brown, and green are most restful to the eyes, and these are the colours which nature so frequently repeats in great masses.

CHAPTER XXVII

MAGNETISM

IN very ancient times a certain kind of iron ore was discovered to act as a magnet, i.e. it attracted iron or steel. Later on it was found that iron, and especially steel, when rubbed with this natural magnetic iron ore, also became magnetic.

The Chinese then discovered that a needle-shaped magnet when freely suspended, pointed almost due north and south. This enabled them to pilot caravans across deserts, and gave the name "*lodestone*," or leading-stone, to the natural magnet.

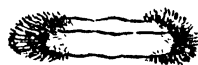

FIG. 97.

EXERCISE 149.—Take a knitting-needle or a piece of clock-spring and a strong horse-shoe magnet. Stroke the needle or the clock-spring, *in one direction* only, with the magnet. Test the magnetization of the needle or clock-spring by placing it in contact with a steel pen-nib or iron filings. Where does the magnetization appear strongest? Does the middle of the needle or spring have much magnetism? Break the spring or needle in two, and test again. Note that the ends of the broken pieces are strongly magnetic, whereas those portions, when joined, showed very little magnetism.

Make two paper stirrups and hang two magnetized needles in them, each suspended by a single silk thread. Do both needles point the same way? Find out the direction in which the needles point by reference to a pocket compass,

to the sun, or to your knowledge of the direction of streets, etc., in your neighbourhood. Bring the two needles near each other so that their ends which point in the same

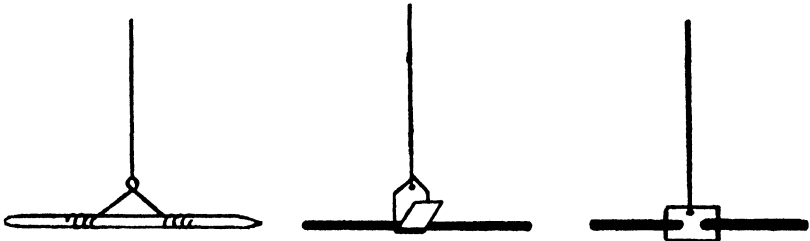

FIG. 98.

direction approach each other. These ends repel or repulse each other. Now bring ends pointing in *opposite* directions near each other, when they are seen to attract each other.

Two *points* near the ends of a magnetic needle where the magnetic power acts most strongly are called *poles*; one is the north-pointing pole and the other the south-pointing pole.

Like Poles Repel while Unlike Poles Attract.

It therefore follows that the earth, which is a huge magnet, has the magnetism of its north magnetic pole of the opposite kind to that of the north-pointing pole of a magnetic needle, otherwise they could not attract each other. The north pole of a magnetic or compass needle is of course the north-pointing pole. It is generally coloured blue in a compass to distinguish it, and points not to the true north or geographical north, but to the north magnetic pole, situated in North America about midway between the Arctic circle and the geographical north pole. Its position varies slightly in the course of years, as the magnetism of the earth slowly changes.

The Molecular Theory of Magnetism.

We previously found that heat is supposed to be a form of molecular vibration, because this theory of heat best explains the known facts about heat. In the same way the magnetic properties of any substance are best understood by supposing that the separate molecules are each magnets having a north-pointing and south-pointing pole. It depends on the arrangement of these molecular magnets, whether the substance as a whole acts as a magnet. Now the same horse-shoe magnet may be used to magnetize any number of knitting-needles without appreciably becoming any weaker in its own magnetism. Hence it does not share its magnetism, or part with some of it to each needle, but apparently



FIG. 99.

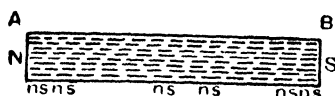

FIG. 100.

exerts a directive effect upon the molecules of the knitting-needles, so that all of one kind of magnetic pole point one way, while all of the other kind of magnetic pole point the other way.

Suppose Fig. 99 represents the haphazard arrangement of molecular magnets in a piece of steel like a needle.

Fig. 100 shows another arrangement in which, after being magnetized by a horse-shoe magnet, the molecular magnets are arranged in parallel rows so that unlike poles NS neutralize each other to a great extent, but *free* or un-neutralized magnetic poles are found at either end of the piece of steel NS.

This explains why the magnetism of a steel needle is strongest near the ends of the needle.

Fig. 101 shows another possible arrangement of

the molecules in a piece of steel after being magnetized, which gives free magnetic poles at the ends and also along the sides near the ends.

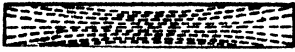

FIG. 101.

This arrangement is more in accordance with the observed facts than that of Fig. 100.

EXERCISE 150.—Fix a bar magnet horizontally, as in Fig. 102, and having magnetized a short sewing-needle, suspend

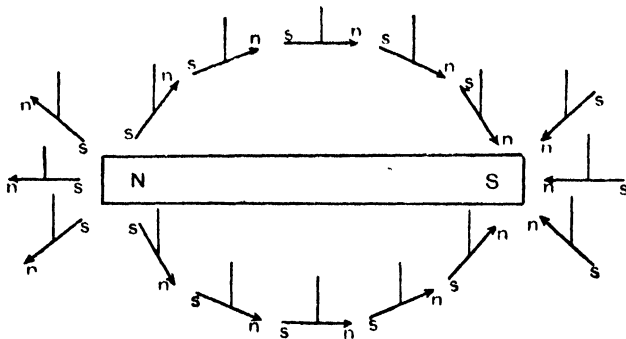

FIG. 102.

the needle horizontally by a silk thread. On slowly moving the suspended needle over, below, and around the bar magnet, it takes up positions as shown in the figure.

The space around the magnet in which its mag-

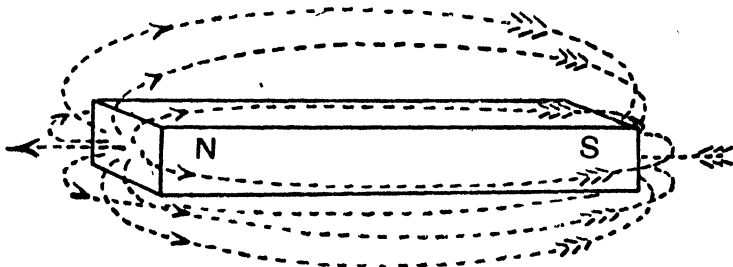

FIG. 103.

netic force is exerted is called its **magnetic field**, and

any line of force in the magnetic field shows one direction of the magnetic force traversing the field.

Fig. 103 gives an idea of the magnetic field surrounding a bar magnet, the dotted lines being lines of force similar to the curves traced by the needle in Fig. 102.

Plate I, facing the title-page, shows by a photograph of iron filings scattered on white paper, how two powerful unlike magnetic poles, such as the ends of a large horse-shoe magnet, placed just beneath the paper, cause the filings to form curves or lines of magnetic force, between the two poles.

CHAPTER XXVIII

ELECTRO-MAGNETS AND ELECTRIC BELLS

Electrical Attraction and Repulsion.

EXERCISE 151.—Rub a vulcanite rod or a fountain pen with a soft piece of woollen material, e.g. on the sleeve of your coat. It will now attract small pieces of tissue-paper, placed as small shreds upon a table, if held over them. Similarly, rub a piece of stout glass rod or tube with silk, and the same attraction towards shreds of tissue-paper may be observed.

EXERCISE 152.—Now take a small ball of dry pith, or a small ball of dry, crumpled tissue-paper, and suspend it from a retort stand by a dry silk thread about 6 inches long. Electrify the vulcanite rod, or a stick of sealing-wax, by rubbing it with a dry woollen cloth, and bring it near to the suspended pith ball.

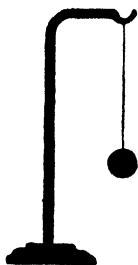

FIG. 104.

Note that it attracts the ball, which, after *touching* the electrified body, is immediately repelled or repulsed. This is because the ball becomes charged with the same kind of electricity as the rod possesses, on touching the rod, and is then repelled because, as in magnetism, *like kinds of electricity repel*.

EXERCISE 153.—Now electrify a glass rod with a silk rubber, and bring the electrified glass rod near the electrified pith ball. The glass rod *attracts* the ball, and this proves that the glass rod is charged with a different kind of electricity from that on the vulcanite rod.

FOR convenience we call the electrification of glass by silk *positive*, and that of vulcanite by flannel *negative* electricity, and denote them fre-

quently by the mathematical signs + and -. As in magnetism, like kinds of electricity repel, while unlike kinds attract.

A pith ball, or any similar instrument used to detect electrification, is called an *electroscope*.

Examination of a Simple Battery.

When we place two different substances in a jar of weak acid, or in a solution of certain salts like sal-ammoniac, chemical action may occur and result in an electric current being produced.

Examine an ordinary "wet" cell used for an

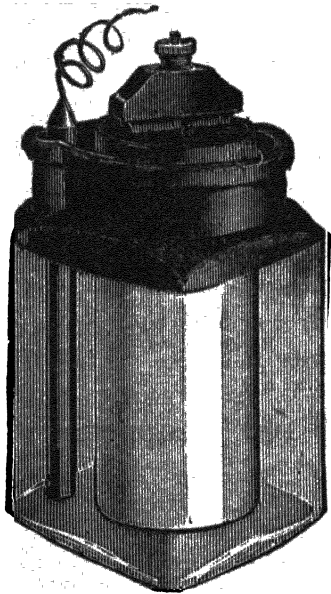

FIG. 105.

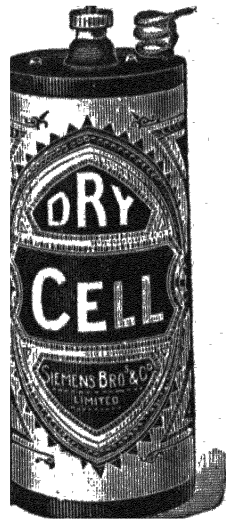

FIG. 106.

electric bell (Fig. 105). In this the solution must be renewed occasionally, as it is used up in generating the electricity. Examine also a so-called dry cell (Fig. 106) for the same purpose. In this the solution is rendered sufficiently pasty by being treated with absorbents so that the paste will not

spill. There is no chemical action going on unless the two different substances (in this case zinc and carbon) are connected by a wire, and in that case the electricity formed passes from the carbon along the wire to the zinc; and so the carbon is called the *positive pole* of the battery, and the zinc the *negative pole*.

Effect of an Electric Current Flowing Spirally Round a Bar of Soft Iron.

EXERCISE 154.—Wind a close spiral of cotton-covered copper wire round a stout glass test tube, and attach the ends of the wires to the carbon and zinc terminals of the battery, previously examined. Bring each end of the spiral in turn near the north-pointing pole of a compass needle, and notice it behaves like a bar magnet, having a north and a south pole, repelling and attracting like a bar magnet. Place a soft iron rod inside the test tube—a short length of gas pipe or a large iron wire nail would be suitable—and note the effect.

The soft iron becomes magnetized, and hence reinforces or increases the magnetic power of the spiral. Place the end of the soft iron projecting from the tube into some iron filings. The filings are attracted *while the current is passing*, but the magnetism of the soft iron rod disappears when the current is stopped.

Electro-Magnets.

are produced in this way. When a coil of insulated wire is revolved between the poles of an electro-magnet (of horse-shoe type generally) by mechanical means, we have very powerful electrification produced, and a machine constructed to do this is a *dynamo*; which thus converts mechanical power into electrical energy. Dynamos are in general use to supply the powerful currents required for electric lighting and power, and as these currents are danger-

ous to human life, and magnetize the steel-work of watches permanently, it is wise to adopt extreme caution when approaching a powerful dynamo.

Small electro-magnets are used in electric bells. The hammer of the bell is attached to a spring which is attracted by an electro-magnet, but on approaching the electro-magnet, it leaves the adjustable pin against which it previously rested, and so breaks the electric current which was flowing from the pin into the spring while the spring touched it. The "break" destroys the magnetism of the electro-magnet, the spring jumps back and the current again flows, only to be again broken as the spring is attracted away from the pin. Thus the oscillation of the hammer rings the bell.

Bell Wiring and Bell-Pushes.

It has been mentioned in connexion with the electric battery cell, used for ringing an electric bell, that the current is only developed by chemical action, when the zinc and carbon are connected by a wire. *Insulated* wire is commonly used, i.e. wire covered with waxed cotton, etc., to prevent the current escaping through the metal wire accidentally touching a good conductor. Frequently a twin strand or double strand of wire is used, of separately insulated wires in the same outer casing. The weak current in a bell circuit is absolutely harmless, and cannot cause either fire or shock. A bell-push contains a spring, usually part of a flat spiral, which on being pressed down, touches another flat piece of metal and makes the circuit complete, which was previously broken by a gap between the two metal surfaces.

CHAPTER XXIX

ELECTRIC LIGHTING—ELECTROLYSIS— ELECTRO-PLATING

Electric Lighting.

IF a powerful electric current is passed through a fine wire or a carbon thread or filament, it meets such a resistance to its passage that much of the electric energy is converted into heat energy, and the wire or filament is made white-hot or incandescent, just as a blue gas flame of the bunsen or gas-stove type supplies the necessary heat "energy" when inside an incandescent mantle to give a brilliant light. The wire or filament is enclosed in a vacuous bulb to prevent the oxidation or burning away of the filament. Another type of electric light is the arc lamp, used in street lighting, in which a brilliant electric spark between carbon rods, produces a glaring though somewhat unsteady light.

The current for the incandescent electric lamp bulbs used in houses is brought along stout copper wires, insulated, and fitted generally in a wooden casing.

Just as we talk of gas *pressure* and the *amount* of gas we burn, we can express the pressure of the electricity supplied in *volts*, and the amount of current used in *amperes*.

The electric light meter for an ordinary eight to ten-roomed house would show by four dials, very

similar to those on a gas meter, the amount of current used in units. It would probably be stamped 3 amperes and 240 volts, showing its *capacity* and the *pressure of the current*.

A *switch* is similar in principle to a bell-push. By moving a knob, two pieces of metal come in contact, and the circuit is completed, so that the current flows through the lamp or lamps. Unlike the bell-push, however, which springs back when released, the switch is constructed to stay either "on" or "off".

A *fuse* is a piece of lead or tin wire placed somewhere in the circuit, usually near the meter where the outgoing circuits for lighting are led off. In the event of the current becoming too powerful for the wire, the lead wire, like the filament of a lamp, would offer resistance to such an extent, that the heat energy produced would melt the wire, and destroy the circuit.

Electrolysis and Electroplating.

A powerful current of electricity when passed through acidulated water (the acid being added to enable the current to pass), decomposes the water into its two constituent gaseous elements, oxygen and hydrogen. For details, see any good chemical text-book. Similarly, solutions of metallic salts may be decomposed and their elements set free, either wholly or in part. Solutions of copper or silver salts can thus be made to deposit copper or silver on metal articles, placed in those solutions in the path of the electric current.

Lightning Conductors, Dangers of Lightning.

Electricity developed in the clouds, frequently seeks the earth, and a so-called lightning discharge takes place. This discharge will pass through any conductor that offers, and will select a good con-

ductor in preference to a poor one. A stout copper strip carried from the top of a tower, spire, or chimney, to the earth, will protect the building, because the electric discharge will flow along it and not through the building. When lightning strikes a tree, house, etc., the resistance encountered produces so much heat energy, that substances split and liquids boil.

Never stand under walls, trees, etc., in a thunder-storm; wet clothes are a protection, and there is no risk of being struck in the open, if you keep low down, e.g. a man in a cart should get out and walk by his horse, rather than stand up high in his cart.

Electrical Failures and Remedies: Electric Bells.

If the action of an electric bell suddenly fails, look out for a break in the wire, a corrosion where wire joins battery, a rusty electro-magnet in the bell, or a spent battery.

Electric Wiring and Lighting.

Keep a supply of fuse wires of the right size; electric pressure varies at times, and a fuse will "go" every now and then. In replacing a fuse, turn off the main switch, stand on a rubber mat, or wear dry rubber-soled shoes, rubber gloves if possible. When dusting or cleaning electric lamps, have the light turned on as there is then less chance of breaking the delicate filament or wire inside the lamp.

In buying new lamps, see that they are for the right voltage, i.e. the same as the old lamp they replace, and have them placed on circuit, or examine them carefully to see that the filament or wire is intact. Get the salesman to show you how to insert a lamp in its spring socket if you do not know.

INDEX

- Air-pressure, 73.
air-pump, 86.
amplitude, 61.
anti-lubricants, 53.
apparent depth of water, 61.
Archimedes, 36.
areas, 8.
- Balance, 22.
balloon, 86.
barometer, 73.
barometric readings, 76.
bellows, 82.
bicycle pump, 83.
blacksmith's bellows, 83.
boiling-point, 122, 126.
Boyle's Law, 78.
bucket and cylinder, 37.
burette, 19.
- Calipers, 5.
calorimeter, 101, 109.
camera, 152.
canula, 20.
capacity for heat, 110.
capillarity, 94.
capillary attraction and repulsion,
95.
capstan, 43.
casters, 53.
centre of gravity, 57.
chain hoist, 46.
change of state, 118.
circle, 6.
clepsydra, 97.
clinical thermometer, 104.
- coefficient of expansion, 116.
cohesion, 31.
colour, 168.
— blindness, 168.
common pump, 84.
compressibility, 29.
compression, 78.
conduction, 137.
conductivity, 139.
cone, 16.
contraction, 114.
cooking-stoves, 142.
- Damp clothing, 131.
defects of vision, 163.
density, 33, 71.
dew-point, 127.
diffusion, 31.
dividers, 4.
drops, 96.
dry steam, 134.
ductility, 31.
dynamamos, 176.
- Ebullition, 127.
efficiency of a machine, 45.
elasticity, 30.
electric battery, 175.
— bells, 177.
— fuses, 179.
— heating, 144.
— lighting, 178.
— wiring, 177.
electrical failures, 180.
electrolysis, 179.
electro-magnets, 174, 176.

electroplating, 179.
 ellipse, 11.
 evaporation, 127.
 expansion of alcohol, 107.
 — — gases, 117.
 — — liquids, 117.
 — — solids, 113.
 extension, 78.

 Films, 96.
 fire-engine, 84.
 floating needles, 98.
 flotation, 68.
 football inflator, 82.
 force, 55.
 force-pump, 84.
 fountains, 67.
 freezing-point, 122.
 friction, 50.
 fulcrum, 40.

 Gas blowpipe, 83.
 — fires, 143.
 — stoves, 143.
 gases, 28.
 gearing, 43.
 glaciers, 124.
 gram, 22.
 gravitation, 33.

 Hardness, 31.
 Hare's apparatus, 71.
 hay-box, 141.
 heat, 100.
 — latent, 132.
 — specific, 111.
 hot-water heating, 144.
 humidity, 127.
 hydraulic pressure, 66.
 hydrometer, common, 69.
 — model, 68.
 — Nicholson's, 69.
 hygrometer, 128.

 Inclined plane, 47.
 indestructibility of matter, 30.

inertia, 28.
 intensity of light, 155.
 inversion of image, 151.

 Land and sea breezes, 120.
 latent heat, 132.
 — — of fusion of ice, 133.
 — — — vaporization of steam,
 133.
 laws of reflection, 158.
 — — refraction, 161.
 lenses, 162.
 levers, 40.
 lifeboat, 59.
 light, 149.
 lightning, 179.
 liquid pressure, 65.
 — skins, 96.
 liquids, 28.
 litre, 13.
 lubricants, 52.

 Machine, 40, 44, 53.
 magic lantern, 164.
 magnetic field, 172.
 magnetism, 169.
 malleability, 31.
 mangle, 44.
 mass, 22, 33.
 matter, 28.
 maximum thermometer, 105, 106.
 measuring jar, 18.
 mechanical advantage, 45.
 mediums, 150.
 melting-point, 122, 126.
 meters, 44, 178.
 metric system, 2.
 micrometer, 49.
 microscope, 166.
 minimum thermometer, 105, 106.
 mirrors, 159.
 molecule, 100.
 moment of a force, 56.

 Nails, 54.
 nuts, 48.

- Opera glass, 165.
 opisometer, 4.
 oscillation, 62.
- Pallets, 63.
 parachute, 87.
 parallelogram, 10.
 pendulum, 61.
 periodic time, 62.
 periscope, 159.
 photometry, 153.
 pin-hole camera, 150.
 pipette, 20.
 poles of a magnet, 170.
 pop-gun, 82.
 porosity, 29.
 pressure and boiling-point, 124.
 principle of Archimedes, 37.
 — — work, 45.
 prism, 14.
 propeller, 49.
 pulleys, 46.
 pumps, 84.
 pyramid, 15.
 pyrometer, 114.
- Radiation, 137.
 reading-glass, 152.
 reflection, 157.
 refraction, 159.
 regelation, 123.
 removing fixed stoppers, 121.
 reservoirs, 66.
 revolving sprinkler, 88.
 rocket, 88.
 rod and gauge, 114.
- Screw-jack, 49.
 — pitch, 48.
 — press, 49.
 screws, 48, 54.
 seconds-pendulum, 62.
 sinker, 38.
 siphon, 84, 72.
- solids, 28.
 specific gravity, 34.
 — heat, 111.
 spectacles, 163.
 spectroscope, 167.
 spectrum, 166.
 sphere, 17.
 spiral spring, 80.
 spirit level, 66.
 spray producer, 88.
 spring balance, 25.
 steam heating, 143.
 steelyard, 41.
 sucker, 87.
 syringe, 82.
 switches, 179.
- Telescope, 165.
 thermometer, 101.
 thermometric scales, 103.
 transmission of heat, 137.
 triangles, 9.
- U tube, 71.
 unstable equilibrium, 59.
- Vacuum cleaner, 83.
 ventilation, 146.
 vice, 49.
- Warming buildings, 143.
 water equivalent, 110.
 — level, 67.
 — supply, 66.
 weathering of rocks, 119.
 wedge, 48.
 weight, 22, 33.
 wet and dry bulb thermometers,
 129.
 wheel and axle, 43.
 windlass, 43.
 winds, 120.
 work, 43.
 wringer, 44.

PRINTED IN GREAT BRITAIN AT THE UNIVERSITY PRESS, ABERDEEN

