

UNIVERSAL
LIBRARY

OU_160748

UNIVERSAL
LIBRARY

Methuen's Monographs on Physical Subjects

General Editor: B. L. WORSNOP, B.Sc., Ph.D.

ELECTRON DIFFRACTION

METHUEN'S MONOGRAPHS ON PHYSICAL SUBJECTS

General Editor: B. L. WORSNOP, B.Sc., Ph.D.

F^ocap 8vo, 2s. 6d. net (except where otherwise stated)

- Spectra.** By R. C. JOHNSON, D.Sc. *Second Edition, Revised.*
- Wave Mechanics.** By H. T. FLINT, D.Sc. *Second Edition, Revised and Enlarged.* 3s. 6d. net.
- The Physical Principles of Wireless.** By J. A. RATCLIFFE, M.A. *Third Edition, Revised and Enlarged.*
- The Conduction of Electricity through Gases.** By Prof. K. G. EMELÉUS, M.A., Ph.D.
- Magnetism.** By E. C. STONER, Ph.D. *Second Edition, Revised and Enlarged.* 3s. net.
- X-Rays.** By B. L. WORSNOP, B.Sc., Ph.D.
- X-Ray Crystallography.** By R. W. JAMES, M.A., B.Sc.
- The Commutator Motor.** By Prof. F. J. TEAGO, D.Sc.
- Applications of Interferometry.** By W. E. WILLIAMS, M.Sc.
- Photochemistry.** By D. W. G. STYLE, B.Sc., Ph.D.
- Thermodynamics.** By Prof. A. W. PORTER, D.Sc., F.R.S.
- Thermionic Vacuum Tubes.** By Prof. E. V. APPLETON, M.A., D.Sc. *Second Edition, Revised.* 3s. net.
- Wireless Receivers.** By C. W. OATLEY, M.A., M.Sc.
- Atmospheric Electricity.** By B. F. J. SCHONLAND, M.A.
- The Method of Dimensions.** By Prof. A. W. PORTER, D.Sc.
- Collision Processes in Gases.** By F. L. ARNOT, B.Sc., Ph.D. (Camb.), F.R.S.E. 3s. net.
- Physical Constants.** By W. H. J. CHILDS, B.Sc., Ph.D.
- Electromagnetic Waves.** By F. W. G. WHITE, M.Sc. 3s. net.
- The General Principles of Quantum Theory.** By Prof. G. TEMPLE, Ph.D., D.Sc. 3s. net.
- The Kinetic Theory of Gases.** By Prof. MARTIN KNUDSEN.
- Low Temperature Physics.** By L. C. JACKSON, M.Sc. (Lond), Doct. Wis. Nat. (Leiden). 3s. net. ●
- High Voltage Physics.** By L. JACOB, M.Sc. 3s. net.
- Relativity Physics.** By Prof. W. H. MCCREA, M.A.
- Fine Structure in Line Spectra and Nuclear Spin.** By S. TOLANSKY, Ph.D., D.I.C., A.Inst.P. 3s. net.
- Infra-Red and Raman Spectra.** By G. B. B. M. SUTHERLAND, M.A., Ph.D. 3s. net.
- Electron Diffraction.** By R. BEECHING, A.R.C.S., B.Sc. 3s. net.
- Thermionic Emission.** By T. J. JONES, M.Sc. 3s. net.

In Preparation

- Surface Tension.** By ALLAN FERGUSON, M.A., D.Sc.
- The Nucleus.** By Prof. J. A. CROWTHER, M.A., Sc.D.

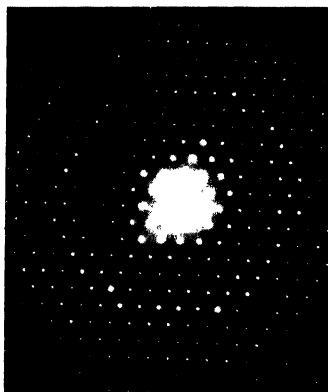

1. Kikuchi "N pattern" for mica (*G. J. Finch*). The film is of such a thickness that the "L pattern" is just beginning to develop.

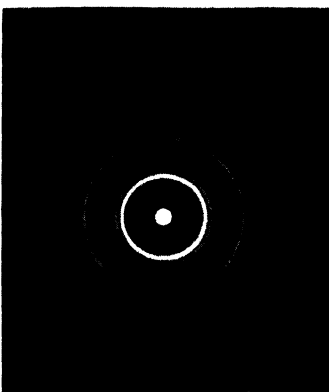

2. Transmission through a polycrystalline gold film (*G. P. Thomson*).

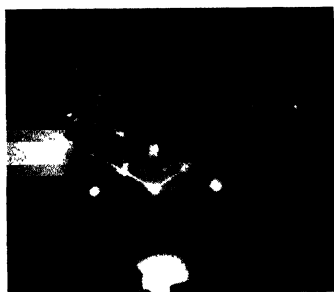

3. Reflection pattern from a cleavage face of zinc blende (*J. R. Tillman*).

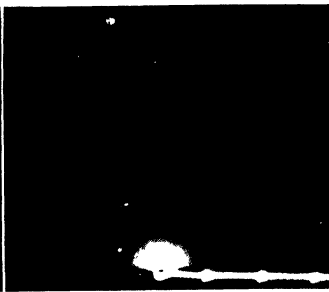

4. Etched single crystal of copper (111) face (*W. Cochran*).

ELECTRON DIFFRACTION

by

R. BEECHING, A.R.C.S., B.Sc.

DEMONSTRATOR IN PHYSICS AT THE IMPERIAL COLLEGE OF
SCIENCE AND TECHNOLOGY

with a Preface by

G. P. THOMSON, F.R.S.

PROFESSOR OF PHYSICS AT THE IMPERIAL COLLEGE OF
SCIENCE AND TECHNOLOGY

WITH A HALF-TONE FRONTISPIECE
AND 39 DIAGRAMS IN THE TEXT



METHUEN & CO. LTD.

36 ESSEX STREET, W.C.

London

First published in 1936

PRINTED IN GREAT BRITAIN

PREFACE

ALTHOUGH electron diffraction is a comparatively recent branch of physics, it is easy to justify its inclusion in this series of monographs. Its interest is twofold. On the one hand, it supplies by far the most direct evidence for the principles of wave-mechanics on which the whole of atomic physics is now based, on the other, its applications provide one of the most promising lines of approach to the study of surfaces, of molecular structure and of crystal growth. Electron diffraction can supply the same information about the arrangement of atoms in a surface that the diffraction of X-rays gives about their arrangement in bulk. Problems of surface and molecular structure, which now form part of the no-man's-land between physics and chemistry, seem likely to be studied increasingly during the next few years, and it is probable that their solution will provide the most important contributions of physical science to industry of the immediate future. It is therefore most desirable that the possibilities of the method should be presented clearly to as wide a circle of scientific workers as possible, and for this purpose the present book is admirably suited.

It is greatly to be hoped that the clear account here given of some of the results already obtained may induce many workers to try their luck with this fascinating new tool. If they do so they will find the account which Mr. Beeching has given of the technical

methods most valuable. He has used many of them himself, and has had opportunities of seeing most of the others in use and discussing their merits with those who are developing them.

The technique of electron diffraction is often supposed to be a difficult one. As regards the examination of surfaces by fast electrons this belief is mistaken, except in so far as any method used for the study of surfaces involves the difficulty of preparing surfaces under conditions which shall be truly reproducible and standard. The difficulties inherent in the vacuum technique have been much reduced by modern pumps and the use of ground and greased metal to metal joints, and are no longer really serious.

The book is well adapted for those also, no doubt the majority, who do not intend to use these methods themselves, but who are interested in the far-reaching theoretical implications of the wave character of electrons, or who wish to be able to appreciate the conclusions reached by means of this new technique.

G. P. THOMSON

August, 1935

CONTENTS

CHAPTER	PAGE
I. THE WAVE PROPERTIES OF THE ELECTRON, AND THE CRYSTAL AS A GRATING	1
De Broglie's Theory. Group Velocity. A Crystal as a Grating. Laue's Conditions. Bragg's Law. Structure Factor.	
II. THE EARLY EXPERIMENTAL WORK	12
Davisson and Germer's Experiments. G. P. Thomson's Work. Kikuchi's Mica Patterns. Origin of Kikuchi Lines. Further Verification of de Broglie's Law.	
III. DIFFRACTION BY TRANSMISSION THROUGH THIN FILMS	28
Single Crystal Films. A Small Crystal Block considered as a Cross Grating. Effect of Crystal Size. Orientation. Atomic Scattering Factor. Determination of Atomic Scattering Factor. Scattering in Monatomic Gases. Scattering by Free Molecules. Mark and Wierl's Method.	
IV. DIFFRACTION BY REFLECTION	49
Single Crystal Cleavage Face. Kirchner's Method of considering the Conditions for Diffraction. Inner Potential. Variation of the Apparent Inner Potential with Angle of Incidence. Diffraction of Slow Electrons. Dispersion Theory of Electron Diffraction. Kikuchi Lines and the Related Bands. Envelope of Kikuchi Lines. Etched Single Crystal. Reciprocal Lattice. Polycrystalline Block.	

CHAPTER	PAGE
V. APPARATUS AND TECHNIQUE	77
Production of a Homogeneous Beam. Filters. Saturated Diode. The Hot Cathode Tube. Mag- netic Focussing. Finch's Camera. The Compari- son Shutter. A Double Acceleration Apparatus. General Considerations of Speed and Convenience of Operation. Apparatus for Slow Electrons.	
VI. APPLICATIONS	93
Type of Problem suited to Examination by Electron Diffraction. Graphite Lubrication. Oil and Grease Films. Molecular Layers of Grease. Oxides on Metals. Further Applications. Surface Structure.	
SUBJECT INDEX	105
NAME INDEX	107

Fig. 15 is reproduced by kind permission of the Editor of *Nature*; Figs. 16 and 17 by kind permission of the Editor of the *Proceedings of the Royal Society*; and Figs. 34-38 by kind permission of the Secretary of the Faraday Society.

CHAPTER I

ELECTRONS AS WAVES, AND THE CRYSTAL AS A GRATING

WAVE properties were first attributed to the electron as a result of de Broglie's efforts to reconcile the wave and particle properties of light. In work on black body radiation, he was led to regard light as quanta controlled by waves. Later, he extended the theory to cover material particles, largely as a result of the close analogy between geometrical optics and classical dynamics.

A brief outline of de Broglie's method of developing the wave equation will be given here. The argument is not absolutely rigid, but, being less abstract, it is more easily understood than methods which have since been adopted by Schroedinger and others. No matter how the equation be derived, it depends upon a number of arbitrary postulates, the justification for which lies in the wide range of results correctly predicted.

De Broglie¹ in his original argument, regards the connection between energy and frequency as fundamental, and he therefore associates a frequency ν_0 with the rest energy of the particle

$$h\nu_0 = m_0c^2, \quad . \quad . \quad . \quad (1)$$

where h is Plank's constant, m_0 the rest mass of the particle, and c the velocity of light.

The actual nature of this frequency is not specified, but it may be represented in the form

$$\Psi = f(x_0y_0z_0) \sin 2\pi\nu_0t_0. \quad . \quad . \quad (2)$$

If this is submitted to a Lorentz transformation, for axes moving with velocity v in the z direction,

then
$$z_0 = \frac{z - vt}{\sqrt{1 - \beta^2}} \quad . \quad . \quad . \quad (3)$$

$$t_0 = \frac{t - \frac{\beta z}{c}}{\sqrt{1 - \beta^2}}, \quad . \quad . \quad . \quad (4)$$

where $\beta = \frac{v}{c}$ as is usual in relativity theory.

Thus the expression for Ψ becomes

$$\Psi = f\left(xy \frac{z - vt}{\sqrt{1 - \beta^2}}\right) \sin \left\{ \frac{2\pi\nu_0}{\sqrt{1 - \beta^2}} \left(t - \frac{\beta z}{c}\right) \right\} \quad . \quad (5)$$

This is an expression of the form

$$\Psi = A \sin 2\pi\nu \left(t - \frac{z}{V}\right) \quad . \quad . \quad (6)$$

which represents a wave along the z axis, and is one solution of a wave equation of the type

$$\nabla^2 \Psi - \frac{1}{V^2} \frac{\partial^2 \Psi}{\partial t^2} = 0 \quad . \quad . \quad . \quad (7)$$

provided A is a constant or $\nabla^2 A = 0$, where V is the velocity of the wave.

By analogy, we see that the velocity of the wave represented by expression (5) is given by

$$V = \frac{c}{\beta} = \frac{c^2}{v} \quad . \quad . \quad . \quad (8)$$

while the frequency ν is given by ,

$$\nu = \frac{\nu_0}{\sqrt{1 - \beta^2}} \quad . \quad . \quad . \quad (9)$$

The wave-length λ becomes less as v increases. Thus

$$\lambda = \frac{V}{v} = \frac{c^2 \sqrt{1 - \beta^2}}{v \nu_0} = \frac{h}{m_0 v} \sqrt{1 - \beta^2} = \frac{h}{mv},$$

$$\lambda = \frac{h}{\text{momentum}}. \quad (10)$$

The energy W of the particle, when moving with velocity v , can be shown to equal $h\nu$:—

$$W = \frac{m_0 c^2}{\sqrt{1 - \beta^2}} = \frac{h\nu_0}{\sqrt{1 - \beta^2}} = h\nu. \quad (11)$$

The wave equation, of which (5) is one solution provided the amplitude is constant, is of the form

$$\nabla^2 \Psi - \frac{1}{V^2} \frac{\partial^2 \Psi}{\partial t^2} = 0,$$

which becomes

$$\nabla^2 \Psi - \frac{v^2}{c^4} \frac{\partial^2 \Psi}{\partial t^2} = 0. \quad (12)$$

If the electron has total energy E and potential energy V , its kinetic energy is

$$\frac{1}{2} m v^2 = E - V,$$

$$v^2 = \frac{2}{m} (E - V). \quad (13)$$

Substituting this in (12) we get

$$\nabla^2 \Psi - \frac{2}{m c^4} (E - V) \frac{\partial^2 \Psi}{\partial t^2} = 0.$$

If (5) is a solution, we know that

$$\frac{\partial^2 \Psi}{\partial t^2} = - \Psi \frac{4\pi^2 \nu_0^2}{1 - \beta^2}.$$

Therefore the amplitude equation may be written in the form

$$\nabla^2 \psi + \frac{4\pi^2 \nu_0^2}{1 - \beta^2} \frac{2}{m c^4} (E - V) \psi = 0.$$

Substituting for $\frac{v_0^2}{1 - \beta^2}$ we get

$$\nabla^2\psi + \frac{8\pi^2m(E - V)}{h^2}\psi = 0, \quad . \quad . \quad (14)$$

which is the form of the wave equation usually used.

The Particles in the Waves.—So far, we have considered only a train of plane waves, and with regard to the particle, we know only that it is moving in the same direction as the waves. In order to define its position further, de Broglie associates with the particle a wave packet, made up of a group of waves with frequencies very close to one another. The resulting amplitude may then be regarded as showing a pronounced maximum at the point occupied by the material particle.

This way of looking at the matter is suggested by the fact that, in classical mechanics, the velocity of the particle is the differential coefficient of the kinetic energy with respect to the momentum.

For Newtonian mechanics

$$\frac{1}{2} \frac{d(mv^2)}{d(mv)} = v,$$

while according to the wave theory this becomes, from (10) and (11),

$$v = \frac{dW}{d(mv)} = \frac{d(h\nu)}{d(h/\lambda)} = \frac{d\nu}{d\left(\frac{\nu}{V}\right)}. \quad . \quad . \quad (15)$$

It may be shown that expression (15) is the same as the expression for the velocity of a group of waves of frequencies differing only infinitesimally from ν .

Since $\lambda = \frac{h}{mv}$ and $V = \frac{c^2}{v}$

the waves of the group will suffer dispersion, as the waves of greater wave-length move faster.

Group Velocity.—Consider two waves of slightly different wave-length, and suppose them to be in phase

at some point in space, as shown in the diagram (Fig. 1). The heavy line indicates the resulting amplitude. As the wave advances, the point of maximum amplitude will, if the waves suffer dispersion of the type under consideration, move backwards with respect to any one peak of either wave taken as origin. With reference to a fixed origin, the group will move forward with a velocity v , known as the group velocity, which is less than the velocity of either wave.

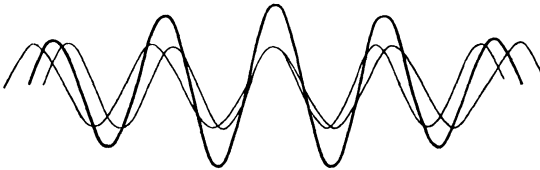

FIG. 1.—Wave group.

Suppose the sum of the two waves to be represented by

$$\begin{aligned} A &= \cos 2\pi\nu\left(t - \frac{z}{V}\right) + \cos 2\pi\nu'\left(t - \frac{z}{V'}\right) \\ &= 2 \cos 2\pi\left\{\frac{\nu + \nu'}{2}t - \frac{z}{2}\left(\frac{\nu}{V} + \frac{\nu'}{V'}\right)\right\} \\ &\quad \cos 2\pi\left\{\frac{\nu - \nu'}{2}t - \frac{z}{2}\left(\frac{\nu}{V} - \frac{\nu'}{V'}\right)\right\}. \end{aligned}$$

In the limit, as $\nu \rightarrow \nu'$, this becomes

$$A = 2 \cos 2\pi\left\{vt - z\frac{\nu}{V}\right\} \cos 2\pi\left\{\frac{dv}{2}t - \frac{z}{2}d\left(\frac{\nu}{V}\right)\right\}.$$

The second term in the expression represents a variation of amplitude, moving in the direction of the wave with a velocity

$$v = \frac{dv}{d\left(\frac{\nu}{V}\right)}.$$

Thus we see that the expression for the velocity of a group of waves, such as we have considered, is the same as the expression (15) for the velocity of the particle.

In order to make the theory complete, it is necessary to add one more postulate, namely, that the probability of a particle appearing at any point is proportional to the intensity of the waves at that point. This view is necessary also in the case of light, to reconcile the wave and quantum theories.

It is worthy of note that the velocity of the de Broglie waves is greater than the velocity of light,

$$V = \frac{c^2}{v} > c.$$

This is not, as it may appear, in conflict with the theory of relativity on which this theory is based, since the waves have no material existence. In the case of light, v must be equal to c , which means that the quanta move with the same velocity as the waves. This necessitates the assumption that the quanta have infinitesimally small rest mass.

Such, then, are the ideas which de Broglie put forward in 1924, and which in 1926 Schrodinger applied to the atom. As a result of his work, the appearance of $\sqrt{n(n+1)}$ in place of the integral quantum number of Bohr's theory was adequately explained. In 1928 de Broglie's theory received direct confirmation as a result of experiments carried out almost simultaneously by Davisson and Germer in America, and G. P. Thomson in Aberdeen. The critical test for a wave motion is an interference experiment and these investigators succeeded in diffracting beams of electrons by means of crystals acting as three dimensional gratings.

The Crystal as a Grating.—Some years before it was first suspected that electrons might possess wave properties, v. Laue had suggested that a crystal might be used to diffract X-rays, and as a result the very extensive subject of X-ray crystallography had grown up. Thus there was already to hand much information concerning

the behaviour of the crystal as a grating. It will be interesting to consider some of these ideas here, as it was upon them that the early work on electron diffraction was based.

In crystals the structure repeats itself periodically in each of three dimensions. Suppose we consider corresponding points in each repetition of the structure, then these points will themselves form a regular pattern called the "crystal lattice." If we join these points by any three sets of parallel straight lines, the result will be an array of parallelopipeds. Such a parallelopiped is known as the "unit cell," since it is the smallest element from which the whole structure may be built by repetition.

The parallelopipeds may be formed in an infinite number of ways, since they may be bounded by any three sets of parallel lines through the lattice points, but in each case the volume of the cell is the same.

For reference, directions parallel to three intersecting edges of the unit cell are called the crystal axes, and the lengths of these edges are known as the lengths of the axes. Consider a plane passing through a set of lattice points, such a plane being known as a "net plane." If the axes have lengths a , b , c , and if the plane passes through the axes at lattice points l , m , n units away from some lattice point chosen as origin, then the equation of the plane is

$$\frac{x}{al} + \frac{y}{bm} + \frac{z}{cn} = 1. \quad . \quad . \quad (1)$$

Suppose $x' = \frac{x}{a}, \quad y' = \frac{y}{b}, \quad z' = \frac{z}{c},$

then $\frac{x'}{l} + \frac{y'}{m} + \frac{z'}{n} = 1,$

and $x'mn + y'nl + z'lm = lmn;$

this becomes

$$hx' + jy' + kz' = N = (\text{an integer}) \quad . \quad (2)$$

where h, j, k have no common factors. Then h, j, k are known as the Miller indices of the set of planes parallel

to this one, and actually represent the number of sections into which the x , y , and z edges of the unit cell are divided by the set of planes. It may be shown that such a set of planes includes all the lattice points. Those sets which are widely spaced include many points per unit area, while those which are closely spaced include only a few. Also, the planes for successive values of N will be equally spaced.

The Diffraction of Waves.—In considering the diffraction of waves by the crystal, we need to find the condition that all the wavelets scattered from all the lattice points shall reinforce. Suppose we consider a simple cell, in

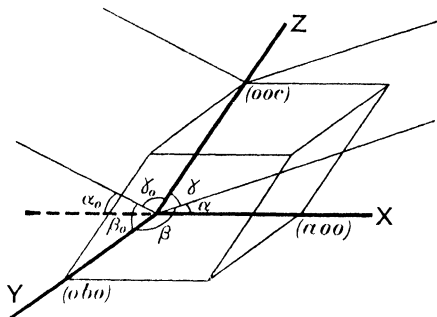

FIG. 2.—Diffraction condition for a single cell.

which there are only scattering points at the corners, which is equivalent to assuming only one point per cell, and allow plane waves to fall upon it. Suppose the normal to the incident wave front makes angles $\alpha_0, \beta_0, \gamma_0$ with the three axes, and consider the condition for reinforcement of parallel scattered rays, making angles α, β, γ with the axes, as shown in Fig. 2.

In order that a ray scattered from the origin and one scattered from the point $(a, 0, 0)$ shall reinforce, the path difference between the two rays $a(\cos \alpha_0 - \cos \alpha)$ must be equal to an integral number of wave-lengths. Similar conditions hold for points $(0, b, 0)$ and $(0, 0, c)$.

If, then, the conditions

$$\left. \begin{aligned} a(\cos \alpha_0 - \cos \alpha) &= l\lambda \\ b(\cos \beta_0 - \cos \beta) &= m\lambda \\ c(\cos \gamma_0 - \cos \gamma) &= n\lambda \end{aligned} \right\} \quad . \quad . \quad (3)$$

are all fulfilled simultaneously, the scattered waves from all the lattice points of the crystal will reinforce, since any point may be arrived at by an integral number of steps, each of which corresponds to a path difference of an integral number of wave-lengths. The scattered waves are considered parallel, since the effects are observed at a large distance from the crystal.

As α , β , γ are interdependent, there will not in general be a solution of the above equations for given values of $\alpha_0\beta_0\gamma_0$ and the wave-length λ . The indices l , m , n corresponding to any maximum are known as the Laue numbers.

W. L. Bragg has expressed the condition for a diffracted beam in a very simple manner. Consider a point $x'y'z'$ such that there is no path difference between rays scattered from it in the direction α , β , γ , and those scattered from the origin in the same direction.

Then

$$x'a(\cos \alpha_0 - \cos \alpha) + y'b(\cos \beta_0 - \cos \beta) + z'c(\cos \gamma_0 - \cos \gamma) = 0,$$

or $\lambda(lx' + my' + nz') = 0$.

This represents a net plane. If we apply Huygen's construction to a plane containing a finite number of points, the reflected ray will be such that the rays from various points have no path difference. Thus for any one plane the scattered wavelets from all points will reinforce in the direction corresponding to the reflected ray, and this condition will be satisfied also for any parallel plane. The condition that all the wavelets shall reinforce in such a direction therefore reduces to the condition that reflections from successive parallel planes shall reinforce each other.

This condition is easily found.

In Fig. 3 let AB and $A'B'$ be normals to the incident wave front AA' , and let BC and $B''C'$ be normals to the reflected wave front. If B and D are corresponding points on two neighbouring planes, then the path difference between the rays ABC and $A'B'DB''C'$ must be an integral number of wave-lengths.

$$\text{Thus} \quad B'D + DB'' = 2d \sin \theta = N\lambda.$$

Therefore, the condition that the reflected rays from successive planes shall reinforce is that

$$2d \sin \theta = N\lambda. \quad . \quad . \quad . \quad (4)$$

By analogy with the line grating in optics N is known as the "order of reflection".

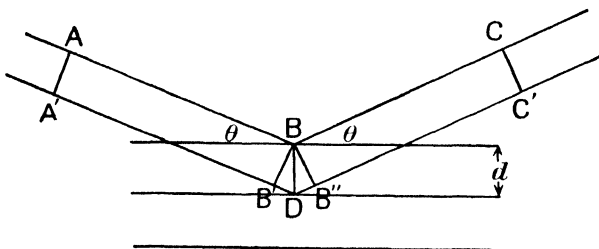

FIG. 3.—Bragg condition.

In order that expression (4), known as "Bragg's Law," may be applied, it is necessary to know d , the spacing between the planes. In general

$$d^2 = \frac{1 - \cos^2 \lambda - \cos^2 \mu - \cos^2 \nu + 2 \cos \lambda \cos \mu \cos \nu}{\left\{ \frac{h^2}{a^2} \sin^2 \lambda + \frac{j^2}{b^2} \sin^2 \mu + \frac{k^2}{c^2} \sin^2 \nu + \frac{2hj}{ab} (\cos \mu \cos \lambda - \cos \nu) \right.} \\ \left. + \frac{2jk}{bc} (\cos \nu \cos \mu - \cos \lambda) + \frac{2kh}{ca} (\cos \lambda \cos \nu - \cos \mu) \right\}} \quad (5)$$

where λ , μ and ν are the angles between the axes.

In the case of rectangular axes, Bragg's Law becomes

$$2 \sin \theta = \lambda \sqrt{\frac{l^2}{a^2} + \frac{m^2}{b^2} + \frac{n^2}{c^2}}, \quad . \quad . \quad . \quad (6)$$

while for cubic axes,

$$2a \sin \theta = \lambda \sqrt{l^2 + m^2 + n^2}. \quad (7)$$

Structure Factor.—So far, we have only considered a cell containing one scattering point. When there are many points in the cell, the above analysis gives only the condition for the reinforcement of the wavelets from corresponding points in each cell. There will also be interference between wavelets from the different parts of the same cell, and this results in a modification of the intensity of the various orders of the pattern. In some cases, orders are completely suppressed by this effect.

To illustrate the point, let us consider the case of a crystal of the body-centred cubic type. The unit cell of such a crystal is not a cube, but the lattice may be regarded as being built up of cells of the type shown in Fig. 4. At the centre of the cell is a scattering centre exactly the same as those at the corners. It will be seen at once that odd orders of reflection, from planes parallel to the cube face, will be destroyed, since the spacing of the planes will be half the cube edge. In general, if l, m, n are the Laue numbers satisfying equations (3), the path difference between the rays from opposite ends of the diagonal will be $\lambda(l + m + n)$, and that between rays from the origin and the centre $\frac{1}{2}\lambda(l + m + n)$. Thus, if the centre point is to be in phase with the corners, $l + m + n$ must be even. The diffraction maxima, for which this condition is not fulfilled, will be destroyed.

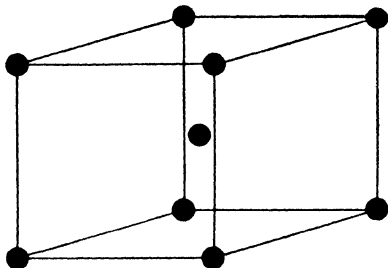

FIG. 4.—Body-centred cube.

REFERENCE

¹ L. de Broglie, "Dissertation" (Masson, Paris, 1924); *Phil. Mag.*, **47**, 446, 1924; *Ann. Phys.*, **3**, 22, 1925.

CHAPTER II

THE EARLY EXPERIMENTAL WORK

THE first experimental work to be published was that of Davisson and Germer.¹ They fired a homogeneous beam of slow electrons normally upon a (111) face of a single crystal of nickel, and observed the intensities of the scattered rays by means of a collector of the Faraday cylinder type, connected to a sensitive galvanometer. Although this work is of great interest, it will only be considered very briefly here, as most of the subsequent development of the subject has been concerned with fast electrons, rather than with electron beams as slow as those used by Davisson. The whole apparatus was completely enclosed, highly evacuated and degassed. Electrons from a tungsten filament were accelerated by an electrostatic field, maintained between a number of plates each pierced with a fine hole which served to define a narrow beam. The electrons impinged upon the face of the crystal, which could be rotated about an axis parallel to the beam. The voltages used ranged from about 30-600 volts, and a back potential of nine-tenths of the voltage on the gun was applied between the inner and outer cases of the collector, to exclude electrons which had lost more than one-tenth of their energy. Only those electrons which had not lost energy, and therefore had not changed in wave-length, were of interest in this work. The collector could be adjusted to receive electrons scattered through varying angles, simply by tilting the tube containing the apparatus,

while rotation of the crystal in azimuth was performed in a similar manner.

The method of procedure consisted of plotting curves showing intensity against voltage, for some one setting of the crystal and collector. A number of curves of this sort were plotted for various positions of the collector, and from these, co-latitude curves showing intensity

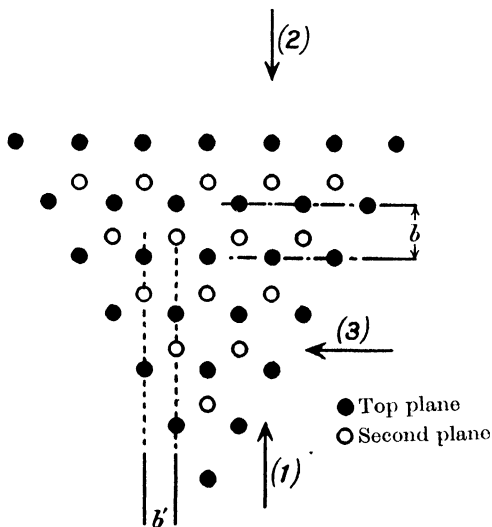

FIG. 5.—View of a (111) face of a nickel crystal.

against angle of scattering at constant voltages were plotted.

Before discussing the results obtained let us consider the crystal used. Nickel forms face-centred cubes, so that the (111) face presents the appearance shown in Fig. 5. The atoms in the net planes parallel to the surface are arranged at the corners of equilateral triangles, and each successive plane is displaced with respect to the one above, so that the atoms in one plane

are vertically below the centroid of the triangles of atoms in the plane above.

There are three azimuths showing specially symmetrical arrangements of the atoms. These are shown in Fig. 5, marked (1), (2), (3), the arrows indicating the direction in which the collector lay with respect to the incident beam. (1) and (2), the difference between which is due to the displacement of the successive planes through $\frac{1}{3}$ of the spacing between the atoms in the planes, each occur three times in 360° rotation, while (3) occurs six times. In general it was found that the intensity of scattered electrons increased steadily towards the normal, but with the crystal set in azimuth (1) a pronounced spur developed in the 54-volt co-latitude curve at an angle of 50° . If the crystal was then rotated in azimuth through 360° , this peak appeared in three positions, corresponding to the three occurrences of setting (1), while three subsidiary peaks appeared corresponding to azimuth (2). When the crystal was set initially in azimuth (2) a spur was found to develop at about 50 volts at an angle of 44° with the normal. Rotation of the crystal in this case again gave rise to three main peaks, and to three subsidiary peaks which this time corresponded to azimuth (1). When the initial setting was in azimuth (3), rotation of the crystal produced six peaks. As the voltage was further increased, other peaks appeared in each azimuth. The appearance of these maxima was in itself an indication of diffraction, but Davisson and Germer were able to go further.

The condition that the wavelets from the various atoms shall reinforce may be resolved into two conditions. For the azimuths considered, we may regard each plane as a line grating, the spacings of the lines being indicated in Fig. 5. Waves incident normally on such a grating will give rise to several orders of diffracted beam, obeying the condition (A) $b \sin \theta = n\lambda$ for settings (1) and (2), and (B) $b' \sin \theta = n\lambda$ for (3). If de Broglie's law is true, λ is given by

$$\lambda = \frac{h}{\text{momentum}} = \frac{h}{mv} = \frac{h}{\frac{\sqrt{2mPe}}{300}},$$

where P is the voltage on the gun, and the other symbols have their usual meaning. After putting in the values for the constants, this expression becomes

$$\lambda = \sqrt{\frac{150}{P}} 10^{-8} \text{ cms.} \quad . \quad . \quad (1)$$

The values of b and b' were known from X-ray work, and Davisson and Germer found that the values of the wave-length given by substituting their experimental values for θ , in expressions (A) and (B), were in agreement with those given by de Broglie's law.

If now we consider the second diffraction condition, which is that wavelets from corresponding points in successive planes shall reinforce, we get the following conditions for the three azimuths used:—

$$\text{Azimuth (1)} \quad a \cos \theta - \frac{b}{3} \sin \theta = n'\lambda.$$

$$\text{Azimuth (2)} \quad a \cos \theta + \frac{b}{3} \sin \theta = n'\lambda.$$

$$\text{Azimuth (3)} \quad a \cos \theta = n'\lambda.$$

It was found that while the peaks obeyed the first condition, the second condition was not satisfied.

In subsequent work Davisson and Germer used angles of incidence other than normal incidence. The collector was adjusted to receive the specularly reflected beam, and the voltage on the gun was varied. Again, a series of peaks was obtained, and these should have corresponded to the various orders of Bragg reflection. In this case, also, there was a discrepancy, and the beams did not occur exactly in the positions predicted by theory. The maxima occurred at voltages which corresponded with wave-lengths a little greater than those expected to give strong reflections.

The greater part of this disagreement between theory and experiment has since been explained in terms of a refractive index effect, due to the fact that the mean potential within the bulk of the crystal is not the same as that in free space. Even when this has been taken into account, there still remains a small disagreement, but it seems that this might be overcome by considering the crystal as an alternating potential field, instead of idealising it, first as a number of scattering points and then as a uniform distribution of potential. This has in fact been done by Morse² who treats the crystal as a medium in which the potential is of the form

$$V = \sum_l A_l e^{\frac{i l 2 \pi x}{a}} + \sum_m B_m e^{\frac{i m 2 \pi y}{b}} + \sum_n C_n e^{\frac{i n 2 \pi z}{c}},$$

where a , b , and c are the lattice spacings. Such a treatment yields results which are in good agreement with those of Davisson and Germer.

Diffraction by Transmission through Thin Films.—Shortly after the publication of the work of Davisson and Germer, an account was given of a series of experiments carried out by A. Reid³ at the suggestion of Prof. G. P. Thomson. In these experiments a beam of fast electrons, from a gas discharge tube, passed through a fine tube. It was then deflected by an electrostatic field so that the electrons passed through a small hole, .25 mm. in diameter, in a diaphragm. Immediately behind the hole was placed a thin film of celluloid of the order of 10^{-6} cms. thick, prepared by spreading a drop of a solution of celluloid in amyl acetate upon a clean water surface. The patterns formed by the passage of the rays through the film were recorded on a photographic plate, normal to the beam, and 20 cms. beyond the diaphragm. Beside the intense central spot, some of the plates showed one, two, or three fairly diffuse rings. This result would be explained if we supposed that the waves passed through a cloud of scattering centres, in which

some one distance of separation predominated. The diameters of the rings were approximately in the ratio 1 : 2 : 3, which suggested that they were three successive orders of diffraction, corresponding to one spacing. The crystal structure of celluloid not being known, it was impossible to calculate the actual wave-length, but it was estimated to be of the order required by de Broglie's formula. The experimenters showed that for any one ring $D\sqrt{P}$ was a constant, D being the diameter of the ring and P the voltage of the electrons. This is in agreement with theory.

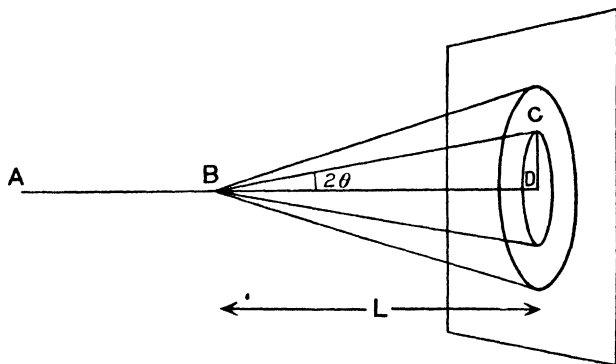

FIG. 6.—Transmission through a thin film.

Metal Films.—Following upon the work with celluloid films, G. P. Thomson⁴ performed similar experiments with metal films of known crystal structure. Before considering this work, it will be advantageous to consider what we should expect to happen when de Broglie waves pass through a polycrystalline film. As with the Debye-Scherrer powder method with X-rays, in the polycrystalline film there will be some crystals set at the correct angle to give a Bragg reflection from some set of planes. If there are enough crystals distributed at random, the result of such reflections will be a series

of rings. In Fig. 6, let AB be the incident beam, passing through the film at B , and let BC be a beam which has suffered a Bragg reflection in some small crystal in the film. The angle DBC will be 2θ , where θ is such that $n\lambda = 2d \sin \theta$, where n is the order of the reflection, and d the spacing of the planes producing the reflection. In the case of electrons, as θ is very small, we may write $n\lambda = 2d\theta$, and $2\theta = \frac{D}{L}$ where D is the diameter of the ring, and L is the distance from the film to the plate. Thus $D = \frac{Ln\lambda}{d}$.

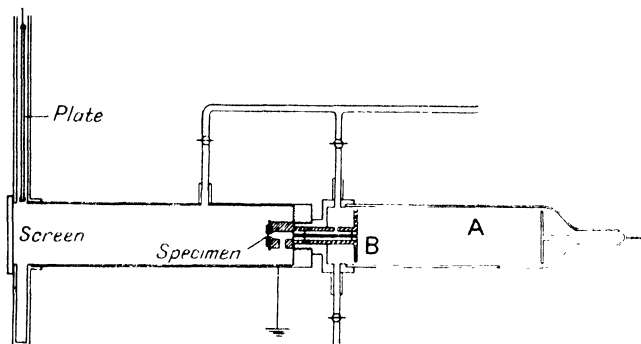

FIG. 7.—G. P. Thomson's early apparatus.

Thomson used films of many different metals, prepared in a variety of ways. Some were obtained by thinning down commercial foil by means of suitable solvents, while other films were made by sputtering the metals on to a base of rock salt or collodion, and then dissolving away the base.

The electron diffraction apparatus used is shown diagrammatically in Fig. 7. A beam of cathode rays was generated in the gas discharge tube by means of an induction coil, and a pencil of rays passed through the fine tube B , which was surrounded by a magnetic

shield of soft iron. After leaving the tube, the pencil of electrons passed through the film, and the pattern recorded upon a photographic plate at a distance of about 30 cms. beyond the film. The plate could be lowered in two stages by means of a magnetic release, thus enabling two exposures to be made on one plate. Beyond, was a fluorescent screen of willemite on glass, which enabled the pattern to be examined visually, before the plate was lowered. The camera was exhausted to a high vacuum, and air was allowed to leak into the discharge tube through a needle valve. Since the only connection between the camera and the discharge tube was through the fine tube B, it was possible to have the camera at a low pressure and yet have the discharge tube sufficiently soft to give a beam of the required voltage. The voltages used varied from 10-40 kv. and were measured by means of a spark gap. The current from the induction coil was rectified by a valve and in the later experiments, several smoothing condensers were connected in parallel with the discharge tube.

In all cases, the general effect in the patterns was a series of rings concentric with the undiffracted spot. In many of the patterns the intensity was uniform all round the rings, but in others the rings were divided up into a number of arcs. Also, in some cases, rings which were to be expected from a knowledge of the crystal structure, as shown by X-rays, were found to be missing or very faint. These peculiarities were all successfully accounted for by considerations of the crystal size and orientation, the effects of which will be dealt with in the next chapter.

It was shown, by deflecting the rays by means of a magnetic field, that the pattern was due to cathode rays. Thus, when the field was applied, the pattern as a whole moved to one side and the rings remained concentric with the spot due to the undiffracted beam. It was also shown that the voltage of the electrons forming the rings was the same as that of those in the

central spot, to within the experimental error, which was less than 1 per cent.

De Broglie's law was verified by calculating the size of the crystal axes, in the case of the various metals, and comparing these lengths with those found by means of X-rays. The different values were found to agree within the limits of the experimental error, which was about 2.3 per cent. Some results are shown in the table :—

Metal.	X-ray Spacing.	Cathode Ray Spacing.
Aluminium . . .	4.046×10^{-8} cms.	4.03×10^{-8} cms.
Gold	4.06×10^{-8} „	4.09×10^{-8} „
Platinum . . .	3.91×10^{-8} „	3.89×10^{-8} „

It was necessary, in these experiments, to calculate the kinetic energy by relativity mechanics, since the velocity of the electrons used was comparable with that of light.

Suppose P to be the potential drop across the discharge tube, then

$$\frac{eP}{300} = \frac{m_0c^2}{\sqrt{1-\beta^2}} - m_0c^2$$

and
$$\lambda = \frac{h\sqrt{1-\beta^2}}{m_0v}, \text{ where } \beta = \frac{v}{c}.$$

By eliminating v , approximating, and substituting the values for the constants we get

$$\lambda = h \sqrt{\frac{150}{ePm_0}} \left(1 + \frac{eP}{1200m_0c^2} \right).$$

This is the expression which was used in calculating the wave-length, for the purpose of determining the lattice spacings given in the table above.

Diffraction at Glancing Incidence.—Realising the limitation to the use of electron diffraction, imposed by the necessity for using thin films, G. P. Thomson⁵ endeavoured to obtain diffraction patterns, with fast

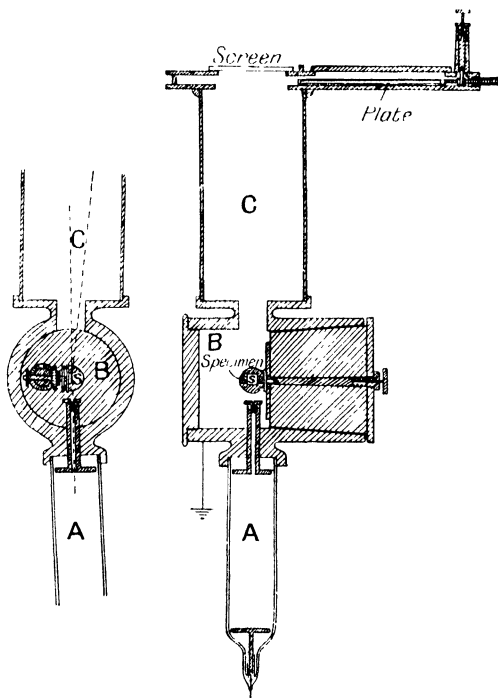

FIG. 8.—Showing the type of apparatus used by G. P. Thomson for diffracting electrons by reflection at glancing incidence. The pump tubes are omitted for the sake of clarity.

electrons, by reflection both from single crystals and from polycrystalline surfaces. The main features of the apparatus used are shown diagrammatically in Fig. 8. A was a gas discharge tube operated by an induction coil, the current being rectified by a valve

and smoothed by a condenser. The electrons passed through a fine tube and then struck the specimen. After diffraction the rays struck a willemite screen, or a photographic plate, which could be moved in front of the screen by means of a rack and pinion operated through a ground joint. The specimen could be moved in a direction perpendicular to the beam, and also rotated about an axis perpendicular to this direction and to the direction of the beam. A third ground joint allowed the specimen to be rotated about an axis perpendicular to the reflecting face.

In general, the patterns obtained by allowing a beam of fast electrons to strike a single crystal face at glancing incidence, showed a number of separate spots, and in some cases a few straight black lines also appeared on the plates. These lines were similar to those obtained by Kikuchi, whose work is described in the next section, and were undoubtedly of the same origin. In the case of the polycrystalline surfaces, patterns of rings, similar to those obtained by transmission, were observed, except that rather more than half of each ring was cut off by the shadow of the specimen. These patterns will be considered further in Chapter IV.

Kikuchi's Transmission Experiments.—Using the apparatus shown in Fig. 9, S. Kikuchi⁶ obtained diffraction patterns by transmission through thin films of mica. Cathode rays, generated in the discharge tube A, were deflected by a magnetic field in B, so that a thin pencil of homogeneous rays passed through the slits S_1 and S_2 . The mica specimen was situated at T, and could be rotated about an axis perpendicular to the plane of the paper by a ground joint G. The pattern was recorded on a photographic plate P.

The voltage of the rays, which varied from 10-85 kv. was determined from the current in the coils producing the deflecting field. Kikuchi showed that the product of the current in the coils times the wave-length of the cathode rays was equal to a constant. By using an aluminium film of known structure as a specimen, the

wave-length corresponding to any given coil current was determined.

Three types of pattern were found, depending upon the thickness of the mica film. With films of the order of 10^{-6} cms. thick, the pattern obtained was an extended pattern of spots, arranged in three sets of parallel rows making angles of 60° with each other. This pattern, which Kikuchi called the "N pattern," was shown to be a pattern the same as that which would be produced by a plane grating, such as that formed by the atoms in one lattice plane of the mica. (See Frontispiece, Fig. 1.)

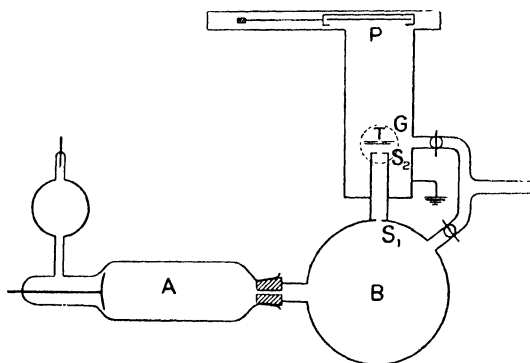

FIG. 9.—Kikuchi's apparatus.

With films thick enough to show interference colours, the "N pattern" was replaced by the "L pattern" consisting of a number of spots lying on circles, resembling Laue spots, and also a number of black and white lines. The lines persisted when the thickness of the film was still further increased, even after the central spot had disappeared. This is known as the "P pattern." The most interesting features of the patterns are the appearance of the array of spots corresponding to a two-dimensional grating, and the appearance of the black and white lines. An explanation of the former will be

given in the next chapter, but it will be convenient to consider the latter at this stage.

Formation of the Kikuchi Lines.—The black and white lines appear in pairs, being parallel to one another. The black line, black here referring to the photographic plate, often passes through a spot, and is then perpendicular to the line joining the spot to the origin.

Kikuchi's explanation of the occurrence of the lines, which is the generally accepted one, is as follows. When the beam enters the crystal, there will be a certain amount of diffuse scattering. The scattered rays will be reflected from various sets of planes with which they make the Bragg angle. Thus in Fig. 10, suppose AA' and BB' to

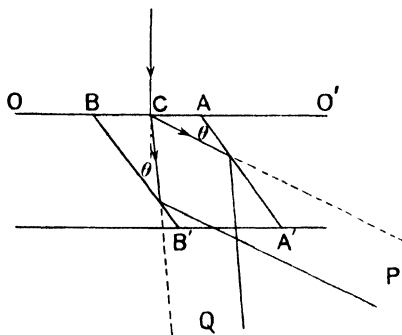

FIG. 10.—Production of Kikuchi lines.

be crystal planes, and suppose the incident ray to be diffusely scattered at C , then AA' reflects towards Q rays which would have gone to P , while BB' reflects towards P rays which would have reached Q . The intensity of the rays scattered towards Q will presumably be greater than the intensity of those scattered towards P , since the angle of scattering is less. Thus, as a result of the reflection at BB' , Q will lose more than it gains from the reflection from AA' . Thus Q will lose intensity, while P will gain. It is worthy of note that the white

line must always be nearer the central spot than the black line.

Although this theory affords a qualitative explanation of the appearance of the Kikuchi lines, it is not altogether complete, in so far as it does not account for the production of the diffuse scattering. If we consider the electrons concerned to have lost no energy, that is, to have been elastically scattered, then we are really considering a plane wave incident upon the crystal. In such a case, theory as it stands at present predicts nothing in the nature of diffuse radiation. If, on the other hand, the electrons are considered to be inelastically scattered, there will be diffuse radiation, but it is difficult in this case to account for the observed interaction between the lines and the spots. In some cases, when Kikuchi lines intersect near a spot, the spot is partially suppressed. This suggests an interference between the rays forming the spots and those forming the lines. If the diffuse radiation producing the Kikuchi lines is due to inelastic scattering, while the spots are due to electrons which have been elastically scattered, such an interference would be impossible, on account of the wave-length change which occurs at an inelastic scattering. It seems probable, therefore, that the lines are, at least partly, due to elastically scattered electrons.

Further Verification of de Broglie's Law.—In addition to the experiments already described, which served to verify de Broglie's law for electrons of energies ranging from 50-1000 volts, and from 10,000-85,000 volts, a great deal of other work has been done, in which connection it is necessary to mention the name of M. Ponte,⁷ who verified de Broglie's law to within three parts in a thousand for fast electrons, using a specimen of powdered zinc oxide. Rupp⁸ obtained effects by transmission of 150-300 volt electrons through thin metal films. He also succeeded in diffracting electrons of about the same voltage by means of a ruled grating, with 1300 lines per centimetre. The wave-length necessary to explain his results agreed, within close limits, with that predicted

by de Broglie's theory. B. L. Worsnop⁹ performed a similar experiment. Many other workers have verified de Broglie's law for slow electrons. Tillman, in some work on the inner potential of crystals, used a voltage range of 3-6 kv. over which de Broglie's law was shown to hold. Rupp and G. P. Thomson have each used voltages of the order of 200 kv. in work on the polarisation of electrons, and both found that de Broglie's law held.

Quite recently, J. V. Hughes¹⁰ has succeeded in verifying the law for electrons with velocities comparable with that of light. The apparatus used consisted essentially of a tube about 2 metres long, which could be highly evacuated, and which was adjusted to be in the direction of the earth's magnetic field. The source of electrons, a small, thin-walled tube of radon in equilibrium with its products, was placed at the lower end. At the middle of the tube, and co-axial with it, was a long cylindrical lead stop, which prevented the γ rays from fogging the plate, which was at the upper end of the tube. By means of a large focussing coil, wound about the middle of the tube, one or another of the characteristic β radiations was focussed to a spot on the plate. More will be said about focussing in the last chapter. The β rays left the source and passed between the stop and the walls of the tube, and were then converged to form a spot by means of the coil. The energy of the particular radiation focussed was known from consideration of the dimensions of the apparatus and the focussing current. The specimen in the form of a thin film of gold, sputtered on to a film of gelatine mounted on nickel gauze, was placed inside the tube, above the focussing coil. All the electrons passing the spot had to pass through this film before striking the screen. A number of photographs were obtained, with voltages ranging from 250 to 1000 kv., and these showed, one, two and sometimes three fairly sharp rings. The wave-length calculated from the size of these rings agreed with the de Broglie wave-length, within the experimental error.

REFERENCES

- ¹ C. Davisson and L. H. Germer, *Phys. Rev.*, **30**, 707, 1927.
- ² P. M. Morse, *Phys. Rev.*, **35**, 1310, 1930.
- ³ G. P. Thomson and A. Reid, *Nature*, **119**, 890, 1927.
- ⁴ G. P. Thomson, *Proc. Roy. Soc.*, **117A**, 600, 1928.
- ⁵ G. P. Thomson, *Proc. Roy. Soc.*, **128A**, 641, 1930.
- ⁶ S. Kikuchi, *Proc. Imp. Acad. Jap.*, **4**, 271, 275, 354, 471, 1928; *Jap. Journ. of Phys.*, **5**, 83, 1928.
- ⁷ M. Ponte, *Ann. de Phys.*, **13**, 395, 1930.
- ⁸ E. Rupp, *Ann. Phys.*, **85**, 981, 1928; *Z. Phys.*, **52**, 8, 1929.
- ⁹ B. L. Worsnop, *Nature*, **123**, 164, 1929.
- ¹⁰ J. V. Hughes, *Phil. Mag.*, **19**, 129, 1935.

CHAPTER III
DIFFRACTION BY TRANSMISSION
THROUGH THIN FILMS

Transmission through a Single Crystal.—Mention has been made, in the previous chapter, of the results of Kikuchi, who obtained diffraction patterns by transmission through a thin film of mica. When the film was of the order of 10^{-6} cms. thick, an extended pattern of spots was obtained, and it has already been pointed out that this would be accounted for if we considered the diffraction to be caused by a cross grating, such as one of the net planes of the crystal. Cross grating patterns of this type occur very frequently in electron diffraction, and the question arising is, "How can a three-dimensional crystal act as a two-dimensional grating?"

W. L. Bragg¹ put forward an explanation of this pattern, based upon the assumption of a small distortion of the crystal. Suppose some "zone axis," that is an axis common to a number of planes, makes a small angle with the beam. Viewed along the axis, the planes will be seen on edge, and will therefore appear as lines. The diagram (Fig. II) represents a cubic structure viewed along a zone axis, in this case a cube edge. Some of the principal planes are marked. The lines must be imagined to represent sets of parallel lines, and it will then be seen that the lines resemble the pattern of a cross grating. If the beam makes a suitable angle with any set of these planes, there will be a corresponding spot in the pattern. To account for the simultaneous appearance of spots

from so many sets of planes, Bragg considers the zone axis to be slightly curved, as a result of distortion of the crystal. Thus, at some part or other, all sets of planes will make the necessary angle with the beam, since, for electrons of the voltage employed, the angles of reflection are of the order of 1-2 degrees.

Although this explanation certainly accounts for the appearance of the cross grating in some cases, the alternative explanation given below has more general application.

Suppose a zone axis is in the direction of the beam, and suppose the sheet of crystal to be so thin that there are only a few scattering points on the axis. We may regard the condition for a diffracted beam to be made up of two parts. First, there is the condition that the wavelets, from the scattering points in each plane, at right angles to the axis, shall reinforce. This condition alone would produce a cross grating

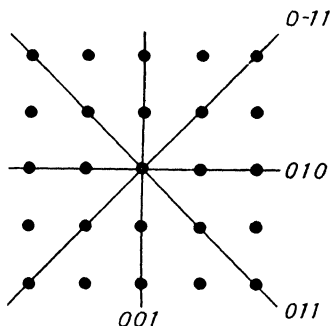

FIG. 11.—Showing a cubic structure viewed along a cube edge.

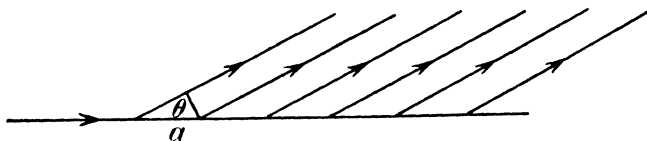

FIG. 12.—Showing the diffraction condition for a row of equally spaced atoms.

pattern. The second condition is that wavelets from successive points along the zone axis shall be in phase. The spots in the two-dimensional pattern will be strong where this condition is satisfied, and weak, or missing, where it is not. As will be seen from the diagram (Fig. 12),

the path difference δ between wavelets scattered from neighbouring points, in a direction θ , is given by

$$\delta = a(1 - \cos \theta). \quad (1)$$

The amplitude of the wave scattered in any direction θ will be given by the expression

$$A = A_0 \sin n \frac{\epsilon}{2} / \sin \frac{\epsilon}{2} \quad (2)$$

where n is the number of points scattering and ϵ is the phase difference between wavelets from successive points.

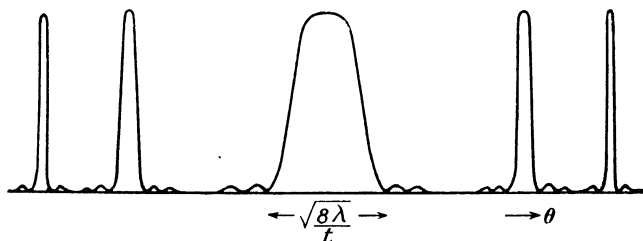

FIG. 13.—Showing the form of the function

$$A = A_0 \sin \frac{\pi n a \theta^2}{2\lambda} / \sin \frac{\pi a \theta^2}{2\lambda}.$$

From (1) we get

$$\begin{aligned} \epsilon &= \frac{2\pi\delta}{\lambda} = \frac{2\pi}{\lambda} a(1 - \cos \theta) \\ &= \frac{2\pi a}{\lambda} 2 \sin^2 \frac{\theta}{2} = \frac{\pi a \theta^2}{\lambda}. \end{aligned}$$

Thus
$$A = A_0 \sin \frac{\pi n a \theta^2}{2\lambda} / \sin \frac{\pi a \theta^2}{2\lambda}. \quad (3)$$

The expression is shown plotted in Fig. 13. The central maximum has an angular width of $\sqrt{\frac{8\lambda}{t}}$, and inside this angle the waves from the points in the row are approximately in phase, and, therefore, the spots

which occur within this angle are strong. The central maximum is surrounded by a series of narrowing circular fringes, for which wavelets from successive points have a phase difference 2π , 4π , etc. Between the peaks the cross grating spots are weak or missing.

In the case of Kikuchi's "N pattern" the spots were found to be intense over a greater area of the plate than was to be expected from a knowledge of the thickness of the film. It was this which led Bragg to suggest his theory based upon distortion of the crystal. As the crystal is made thicker the distortion becomes less, and the second explanation of the pattern holds. As the thickness of the crystal is increased, the central maximum of expression (3) becomes sharper, as also do the surrounding rings. As a result the "L pattern" is produced, only those spots appearing which occur on, or very close to, the circular maxima represented by expression (3).

If instead of being in the direction of the incident beam, an important zone axis makes a small angle with it, the second diffraction condition is such that the spots lying on a series of concentric circular fringes have maximum intensity, the zero order fringe passing through the central spot.

A Small Crystal Block as a Cross Grating.—Let us now consider the case of a small block of crystal, about 20 atoms thick each way. For a row of points at right angles to the beam, the path difference between successive points for rays scattered through an angle θ , is $a \sin \theta$, if a is the distance between the points, and is therefore much greater than that for a corresponding row in the direction of the beam. Therefore, a cross grating 20 points square will produce sharp spots, while a thickness of about 20 atoms will not be sufficient to make the second diffraction condition at all rigid in the case of electrons of the usual velocities. The small block of crystal will, therefore, act as a cross grating. As the crystal is rotated, a two-dimensional pattern will appear whenever an important zone axis comes parallel, or nearly parallel to the beam. If an electron beam

passes through a film in which small crystals are distributed at random, the resulting pattern will be a series of rings. We may imagine these to be produced by the rotation of the cross grating patterns, corresponding to important zones, about the central spot. The pattern does not blur out, as might be imagined, as a result of the random angle made by the cross gratings with the incident beam. This results from the fact that the deviation produced by a plane grating is constant if the angles of incidence and diffraction are small.

Thus $b(\sin \theta_1 - \sin \theta_2) = n\lambda$, where θ_1 and θ_2 are the angles of incidence and diffraction measured from the normal.

For θ_1 and θ_2 small, this becomes

$$b(\theta_1 - \theta_2) = n\lambda.$$

$\theta_1 - \theta_2$ is the deviation produced, and this is seen to be constant.

This provides us with an alternative explanation of the ring patterns produced by various films, such as those used by G. P. Thomson.

Crystal Size.—From the appearance of the rings obtained in this way, an estimate may be made of the size of the crystals in the film. If they are very small indeed, a few atoms square only, they will behave as cross gratings of poor resolving power, and as a result the rings will broaden and in some cases overlap. If, on the other hand, the crystals are large from the point of view of the electron beam, the beam may only cover a few of them. As a result, the circles will become broken up into spots. In the extreme case, when the part of the film covered by the beam is a single crystal, results similar to those of Kikuchi appear.

The Effects of Orientation.—So far we have considered the crystallites in the polycrystalline film to be disposed at random, but in practice, the small crystals are quite frequently orientated in some way or other, as a result of the method of preparation of the film. Thus, for example, cold working of a foil will often cause orientation.

It is quite common for crystals to be set with one axis perpendicular to the plane of the film. In a case of this sort, the ring pattern would be such as would be produced by the rotation of the cross grating patterns due to those planes, perpendicular or nearly perpendicular to this axis. For example, suppose we consider a film composed of simple cubic crystals, orientated with their (1 0 0) axis perpendicular to the plane of the film. Then, rings will appear corresponding to the various spacings in the (1 0 0) plane, that is, to the cube edge, the diagonal of the cube face, etc. No rings will appear corresponding to spacings between planes making a large angle with the cube face, and consequently, with the specimen surface. For this reason, rings corresponding to the spacing between the (1 1 1) planes will not appear.

Reference to Fig. 14 makes this clear. The diagram shows the cubic structure viewed along the diagonal of the cube face. The lines show the direction of the (1 1 1) planes, while the

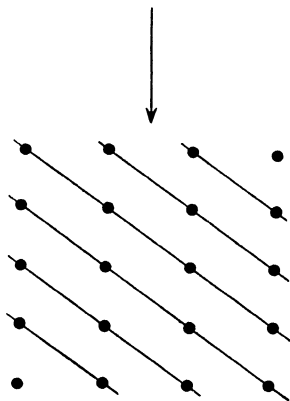

FIG. 14. — Cubic structure viewed along the diagonal of the cube face.

arrow indicates the direction of the incident electron beam. It is clear that only very high orders of reflection can take place at these planes, since the angle between them and the beam is about 40° . Such high orders would be very weak, and in any case would not fall on the photographic plate in the ordinary camera.

This kind of orientation, therefore, results in the disappearance of some of the rings which are to be expected from considerations of the structure factor only. In cases where the orientation is not complete, all the rings

may appear, but the intensity distribution among the rings will be altered. When the pattern is not well known, it is difficult to detect such orientation from consideration of missing or weakened rings, and some other test is necessary.

The Effect of Tilting the Film.—If the crystals are distributed at random, there should be no change in the pattern when the film is inclined to the beam. If the crystals are set in preferred directions with respect to the plane of the film, there will be a redistribution of intensity in different parts of the same ring, and between different rings as a whole, when the film is tilted. In general, rings which are present at full intensity when the film is perpendicular to the beam, will show the same intensity in arcs at the end of the diameter parallel to the axis of rotation, but will be weakened elsewhere. Corresponding to rings which do not appear, or are weaker than they should be when the film is normal to the beam, arcs will appear when the angle of tilt has a suitable value.

“Extra” Rings.—Several experimenters have observed “extra” rings in electron diffraction patterns obtained by transmission. These rings, which appear in addition to those to be expected from a knowledge of the normal crystal structure of the material of the specimen, usually occur inside the normal rings. Various explanations of their appearance have been advanced, including those based upon the supposition of impurities and also upon half order diffraction. More recently, Finch and C. H. Sun, working with electro-deposited metal films, have found patterns showing many “extra” rings, and also some circular bands, about 2-3 mms. wide, with a camera length of about 30 cms. Finch² suggests that the bands are due to penetration of gas into the metal, resulting in a distortion of the lattice. He suggests that the bands are due to the gradual expansion of the lattice, while the sharp rings are due to those parts which are uniformly distorted. The theory is based upon the fact that the

rings appear when the film is heated in a suitable gas, and disappear after prolonged heating of the film *in vacuo*. The rings disappear more rapidly if the heating is carried out in a gas which will tend to extract the gas already in the lattice (e.g. hydrogen to extract oxygen, and vice versa). Finch considers the evidence in favour of this theory to be conclusive in the case of the films which he examined, but it would be unsafe to suppose that this explanation holds in all cases. An alternative cause of extra rings will be explained in the last chapter.

Extinction Rings.—Finch has observed an absorption ring in the pattern from mica dust. This ring appeared white on the photographic plate. The suggestion is that the ring owes its origin to an extinction effect, similar to that which produces the Kikuchi lines.

The Atomic Scattering Factor.—We have so far taken no account of the interaction between the electron and the different parts of the atom in the crystal structure, but have only considered the result of diffraction of the electron waves by an array of points. It has been assumed that any one of these points will give rise to a secondary spherical wavelet, whose amplitude is independent of the angle of scattering, when a plane wave falls upon it. This way of looking at the problem is only an approximation to the truth. Since the atomic size and the wave-length of the electrons in the beam are of the same order of magnitude, it is to be expected that there will be interference between the wavelets scattered from various parts of the atom itself. At certain angles these will tend to interfere.

The expression for the amplitude of the wave scattered through a given angle was first calculated by Born,³ and subsequently in a somewhat simplified form by Mott.⁴

Consider the wave equation

$$\nabla^2\psi + 8\frac{\pi^2m}{h^2}(E - V)\psi = 0 \quad . \quad . \quad (4)$$

as derived in the first chapter. The solution of the equation, which we are looking for, must represent a plane incident wave and a scattered wave leaving the atom. Suppose we consider the incident wave to travel

along the x axis, then it will have the form $e^{2\pi i\left(\nu t - \frac{x}{\lambda}\right)}$,

and the scattered wave will have the form $r^{-1}f(\theta\phi)e^{2\pi i\left(\nu t - \frac{r}{\lambda}\right)}$, where $f(\theta, \phi)$ is the amplitude of the wave in a direction specified by the polar angles θ, ϕ .

It can be shown quite generally, that if ξ is any function, a solution of the equation

$$\nabla^2\psi + k^2\psi = \xi(x, y, z)$$

$$\text{is } \psi = \frac{1}{4\pi} \iiint \frac{e^{-ik|\mathbf{r}-\mathbf{r}'|}}{|\mathbf{r}-\mathbf{r}'|} \xi(x'y'z') dx'dy'dz', \quad (5)$$

where \mathbf{r} is the vector xyz and \mathbf{r}' the vector $x'y'z'$. This function represents wavelets of amplitude $\frac{1}{4\pi} \frac{\xi(xyz) dx dy dz}{R}$ spreading from each element of volume.

The equation (4) may be written in the form

$$(\nabla^2 + k^2)\psi = \frac{8\pi^2m}{h^2} V\psi.$$

It follows, therefore, that

$$\psi = \psi_0 + \iiint \frac{2\pi m}{h^2} V(x'y'z') \frac{e^{-ik|\mathbf{r}-\mathbf{r}'|}}{|\mathbf{r}-\mathbf{r}'|} \psi(x'y'z') dx'dy'dz' \quad (6)$$

is the most general solution of the equation, since the general solution is obtained by adding to the particular solution the most general solution of $(\nabla^2 + k^2)\psi = 0$, which we have called ψ_0 . If we put ψ_0 equal to e^{-ikx} , the right-hand side of expression (6) represents an incident wave, together with a scattered wave. The expression for the scattered wave in (6) is the same as that which would be obtained if we considered each element of volume as scattering a wavelet of amplitude

$$\frac{2\pi m}{h^2} V(xyz)\psi(xyz) dx dy dz / R. \quad (7)$$

Although it is theoretically possible to find a solution to equation (6), it is found necessary, in practice, to assume that the wave is little distorted inside the atom, and all the scattered wavelets therefore start in phase. This is equivalent to putting ψ in (7) equal to ψ_0 , that is e^{-ikz} .

Suppose we call the amplitude of the wavelet scattered per unit volume, when the amplitude of the incident wave is unity, $P(r)$. Suppose O to be the centre of the scattering medium, and consider a plane Ox such that the incident and scattered rays make equal angles θ with it. Consider a parallel plane, distant y from it. Then the phase difference between wavelets scattered by the two planes will be μy , where $\mu = \frac{4\pi}{\lambda} \sin \theta$. The resultant amplitude $\frac{E(\theta)}{R}$ of the scattered wavelets at a large distance R will therefore be

$$\frac{E(\theta)}{R} = \frac{1}{R} \iiint e^{i\mu y} P(r) dx dy dz.$$

In polar co-ordinates this becomes

$$\frac{1}{R} \int_0^\infty \int_0^\pi e^{i\mu r \cos \theta} R(r) r^2 dr \sin \theta d\theta.$$

Integrating over θ we get

$$\frac{1}{R} 4\pi \int_0^\infty \frac{\sin \mu r}{\mu r} P(r) r^2 dr.$$

From (7) $P(r)$ is $\frac{2\pi m}{h^2} V(xyz)$,

so that the amplitude is

$$\frac{8\pi^2 m}{Rh^2} \int_0^\infty \frac{\sin \mu r}{\mu r} V(r) r^2 dr. \quad . \quad . \quad (8)$$

Since we have assumed a spherically symmetrical distribution, we know from Gauss' theorem that

$$\nabla^2 V = \frac{1}{r^2} \frac{\partial}{\partial r} \left(r^2 \frac{\partial V}{\partial r} \right) = 4\pi \rho.$$

One partial integration of (8) gives

$$E(\theta) = \frac{8\pi^2 m}{h^2} \int_0^\infty \left[\frac{r \cos \mu r}{\mu^2} - \frac{\sin \mu r}{\mu^3} \right] \frac{\partial V}{\partial r} dr,$$

while a second gives

$$E(\theta) = \frac{8\pi^2 m}{h^2} \left[\left[\frac{r \sin \mu r}{\mu^3} \frac{\partial V}{\partial r} \right]_0^\infty - \int_0^\infty \frac{\sin \mu r}{\mu^3 r} 4\pi \rho(r) r^2 dr \right],$$

which reduces to

$$E(\theta) = \frac{8\pi^2 m e^2}{h^2} (Z - F) / \mu^2 \quad . \quad . \quad (9)$$

since $V \sim \frac{2e^2}{r}$ at the origin. F is the atomic scattering factor for X-rays.

The expression (9) may be written in the form

$$E(\theta) = \frac{m e^2}{2h^2} (Z - F) \frac{\lambda^2}{\sin^2 \theta} \quad . \quad . \quad (10)$$

Experimental Determination of the Atomic Scattering Factor.—The expression for the atomic scattering factor derived above holds strictly only for a free atom, and then only with the assumption that the incident wave is not deformed inside the atom. This approximation is justified only in the case of fast electrons, and it has been shown that the expression is approximately correct for an atom in a crystal provided the electrons considered are fast enough. In such a case, however, the assumption that the atom is spherically symmetrical is obviously untrue. Both G. P. Thomson⁵ and Mark and Wierl⁶ have determined the "E" factor, as expression (10) is called, by intensity measurements of the patterns obtained by transmission of fast electrons through polycrystalline metallic films.

A brief outline of Thomson's method will be given here. He used a thin gold film, and photographs of the diffraction pattern were taken with two different exposure times, in a known ratio, and with equal development. The patterns were then photometered

along corresponding radii, and two curves were plotted, showing optical densities against distance from the central spot. From these, a curve showing the relation between $\log (It)$ and the density was plotted, I being the electron intensity and t the exposure time. From this, a curve showing It against optical density was plotted, and this was used to convert measured densities to intensity of electrons striking any part of the plate. It was assumed that It always appears as a product in

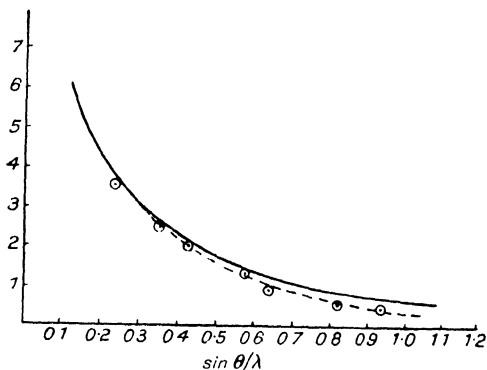

FIG. 15.—Electrons scattered by a gold atom. Number scattered per unit solid angle given by square of the ordinate. Full line, calculated curve; dotted line, curve corrected for heat motion in the crystal; circles, experimental readings, from G. P. Thomson's paper.

the expression for the density of blackening of the plate. This has been shown to hold in the case of electrons.

In determining the "E" curve from the result, it was necessary to allow for two factors not already mentioned. The relative number of planes contributing to a ring had to be taken into account. Thus, the ring, corresponding to a spacing equal to the cube edge divided by $\sqrt{3}$, might be formed by reflection from the sets of planes parallel to planes having indices (1 1 1) (1 1 -1) (1 -1 1) (-1 1 1) (1 -1 -1) (-1 1 -1) (-1 -1 1) or (-1 -1 -1).

Also, since the outer rings have a larger circumference, they are less intense for this reason alone. Both these factors were taken into consideration. In Fig. 15 the theoretical and experimental curves are shown plotted together. Allowance was made for the thermal agitation of the atoms. The full line is $\frac{Z - F}{\sin^2 \theta} \lambda$ plotted in arbitrary units, while the circles are the experimental points with the scale adjusted so that they fit the theoretical

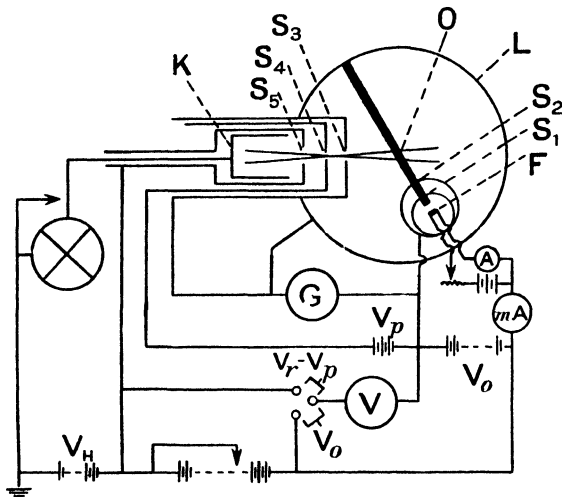

FIG. 16.—Arnot's apparatus for electron scattering.

curve at one point. The agreement is as close as could be expected.

Mark and Wierl obtained similar results with silver and aluminium films.

Scattering in Monatomic Gases.—As early as 1921, Ramsauer⁷ discovered that when a beam of electrons is fired through argon, the effective cross-section of the atoms varies in a curious way with the voltage of the electrons. It rises to a value several times greater than

the cross-section predicted by the kinetic theory, and then at even lower voltages falls considerably below the kinetic theory value. Subsequently, this effect was observed for other gases. It was not until 1928 that observations were made on the angle of deflection of the scattered electrons. In that year Dymond and Watson⁸ made experiments of this sort, and they were followed by a number of other workers. All the early work was confined to small angles of scattering, but in 1930 Bullard and Massey,⁹ and Arnot,¹⁰ carried out independent experiments, with angles of scattering measured up to 125° . The type of apparatus used by Arnot for his work on mercury vapour is illustrated diagrammatically in Fig. 16. F was a heated filament, and electrons from it were accelerated through slits S_1 and S_2 to form a narrow beam. These were scattered in the chamber A, the gas in which was at a sufficiently low pressure to prevent multiple scattering. The electrons scattered from a short length of the beam at a certain angle, passed through slits S_3 and S_4 and were collected in a Faraday cylinder connected to an electrometer. Retarding potentials were applied to S_3 , S_4 , and S_5 to prevent the admission of electrons which had lost more than 3 volts energy, which is less than the resonance potential for mercury vapour. This ensured that the electrons collected had been elastically scattered.

Curves were plotted showing scattering per unit solid angle, against angle of scattering. These were of the form shown in Fig. 17.

The interesting feature of the curves is the maxima which occur at certain angles for the lower voltages. Arnot and others have treated a number of gases in this way, and the monatomic gases show results similar to those obtained with mercury vapour. For the higher values of the voltages, the curves show a steady falling off in the scattering, with angle, and agree well with Born's theory.

It has already been pointed out that Born's theory, both in its original form and as modified by Mott, is

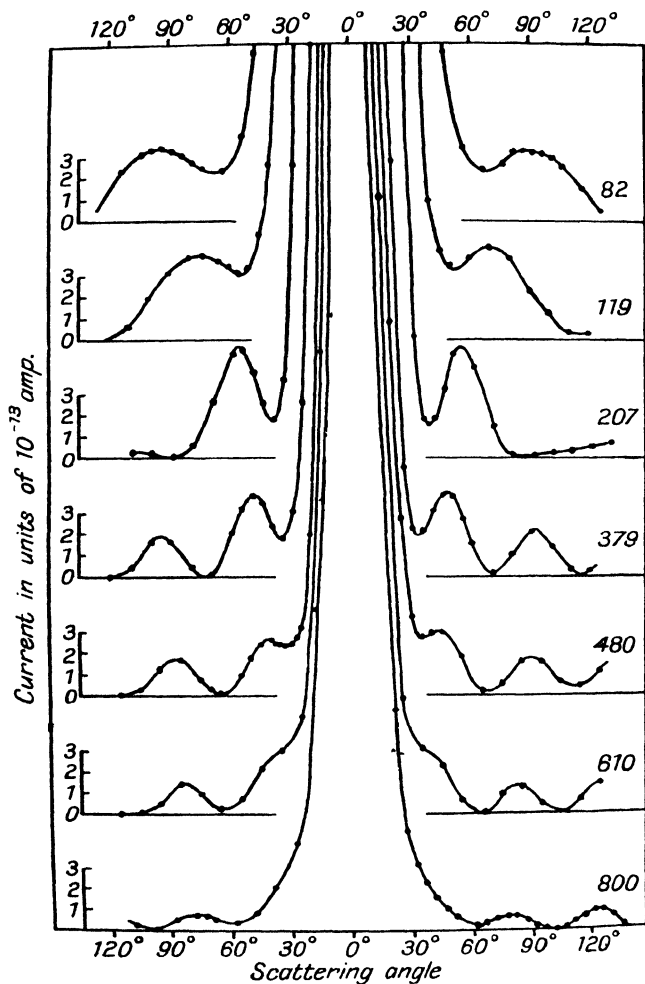

FIG. 17.—The angular distribution of elastically scattered electrons in mercury vapour. Curves for 82, 119, 207, 379, 480, 610, and 800 volt electrons.

based upon two assumptions. It is supposed that the atom behaves as a static distribution of charge, and that the oncoming wave is not distorted by the atomic field. Although these approximations are satisfactory for fast electrons, they are not justifiable for electrons of low voltage. It is for this reason that Born's theory fails to predict the humps found in the low voltage curves. Faxen and Holtsmark¹¹ have taken into account the refractive index due to the atomic field, and have calculated the scattering for spherically symmetrical potential fields. The results predicted by this theory show good agreement with the values found by Bullard and Massey for 6, 12, and 30 volt electrons in argon, and by Arnot for 54 volt electrons in krypton.

Diffraction of Electrons by Free Molecules.—A very important application of electron diffraction is to the examination of substances in the gaseous or vapour state. The method of deducing the distances between the atoms in a molecule, from X-ray interference patterns, was first developed theoretically by Debye,¹² and the theory may be adapted for use with electrons.

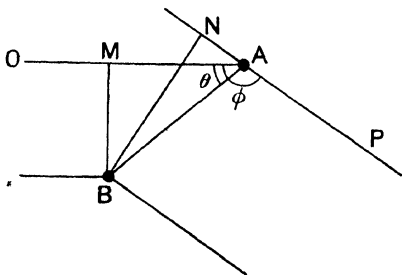

FIG. 18.—Showing the scattering of a plane wave by a diatomic molecule.

Consider a plane wave falling upon a diatomic molecule. In Fig. 18, let A and B represent the two atoms, and let d be the distance between them. If OA and AP are the directions of the incident and scattered rays respectively, then the path difference between rays scattered from A and B, in that direction, is $AM - AN$, where AM and AN are the projections of AB on OA and AP respectively. If θ and ϕ are the angles \widehat{MAB} and

\widehat{MAP} , then the path difference

$$\begin{aligned} &= AB \cos \theta - AB \cos (\theta + 180^\circ - \phi) \\ &= d(\cos \theta + \cos(\phi - \theta)) = d(\cos \theta(1 + \cos \phi) - \sin \theta \sin \phi) \\ &= 2d \cos \frac{\phi}{2} \cos \left(\theta + \frac{\phi}{2} \right). \quad . \quad . \quad (11) \end{aligned}$$

Consider now a polyatomic molecule, the atoms not necessarily being the same. Let us consider the amplitude of the scattered wave in a direction ϕ . Suppose $E_1, E_2, \text{etc.}$, are the amplitudes of the waves scattered in a direction ϕ , by the different atoms, and let the phase difference between the scattered wavelets be $r_{12}, r_{23}, \text{etc.}$ The resultant amplitude, at a large distance, will be represented by the closing side of a polygon with sides $E_1, E_2, \text{etc.}$, and external angles $r_{12}, r_{23}, \text{etc.}$ Therefore, the resulting intensity for any one molecule is given by

$$I = K \sum_1^n \sum_j^n E_i E_j \cos r_{ij}. \quad . \quad . \quad (12)$$

Since the molecules will be distributed at random, with respect to the incident beam, the mean value of $\cos r$ for all values of θ from 0 to π must be found.

$$\text{From (11)} \quad r = \frac{4\pi d}{\lambda} \cos \frac{\phi}{2} \cos \left(\theta + \frac{\phi}{2} \right).$$

We wish to find $\int \cos r \, dr / \int dr$ between such limits that θ goes from 0 to π .

This is given by

$$\begin{aligned} &\frac{\int_0^\pi \cos \left\{ \frac{4\pi d}{\lambda} \cos \frac{\phi}{2} \cos \left(\theta + \frac{\phi}{2} \right) \right\} \sin \left(\theta + \frac{\phi}{2} \right) d\theta}{\int_0^\pi \sin \left(\theta + \frac{\phi}{2} \right) d\theta} \\ &= \frac{\sin \left(\frac{4\pi d}{\lambda} \cos^2 \frac{\phi}{2} \right)}{\frac{4\pi d}{\lambda} \cos^2 \frac{\phi}{2}}. \end{aligned}$$

Thus the intensity of scattering, at an angle ϕ , due to a small cloud of molecules, is given by

$$I(\phi) = \sum_1^n \sum_1^n E_i E_j \frac{\sin x}{x},$$

where
$$x = \frac{4\pi d}{\lambda} \cos^2 \frac{\phi}{2}.$$

In order to apply the theory experimentally, a certain amount of tedious calculation has to be made, although the work is by no means as great as that involved in determinations of the positions of atoms in molecules, in the crystal state, by Bragg's X-ray method. Certain atomic spacings are assumed, and then these are adjusted until the theoretical curves fit the experimental ones.

Experimental Methods.—Mark and Wierl¹³ were the first to make use of this extremely powerful method of

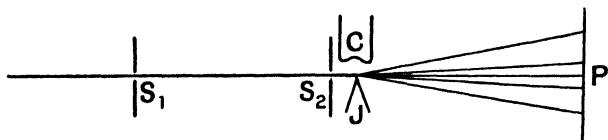

FIG. 19.—Diagrammatic representation of Wierl's apparatus.

analysis. Their first apparatus was quite simple, consisting essentially of a discharge tube, from which a fine beam of electrons passed through a long narrow tube. At the far end of the tube was a jet, from which the vapour was allowed to stream into the beam. The pattern was recorded on a photographic plate, or viewed on a fluorescent screen placed perpendicular to the beam, and about 20 cms. from the jet. In order that the vapour should not spread throughout the highly evacuated camera, the stream was made to impinge on a liquid air-cooled surface. The arrangement is shown diagrammatically in Fig. 19. Generally speaking, the vapour pressure of liquids is sufficient to give an intense stream of vapour, on account of the high vacuum in the

camera, but solids were heated in a small oven. By means of a magnetic trapping device, worked by a clock-

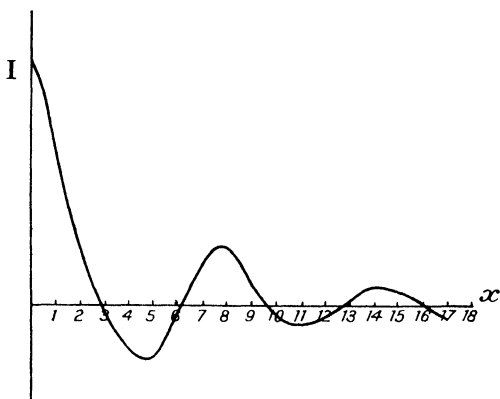

FIG. 20.—Showing the form of the function $I = \sin x/x$.

work relay, the exposure was made at the same time as the vapour was released from the jet. Only short exposure times, of the order of half a second, were necessary

on account of the readiness with which electrons are scattered. This makes the method much more convenient and rapid than the corresponding X-ray method.

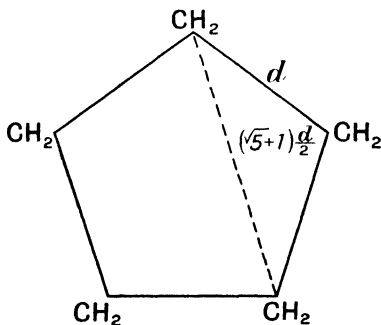

FIG. 21.—Cyclopentane.

The first substance investigated in this way was carbon tetrachloride, which gave, in some cases, as many as seven

maxima. In order to explain the results, the molecule was assumed to be tetrahedral, and the scatter-

ing due to the light carbon atom at the centre was neglected. The spacings between the chlorine atoms, which were assumed to be equal, were then the only ones to be considered. Thus, if the E terms are neglected, the intensity distribution in the haloes should be of the form $\frac{\sin x}{x}$. This function is shown plotted in Fig. 20,

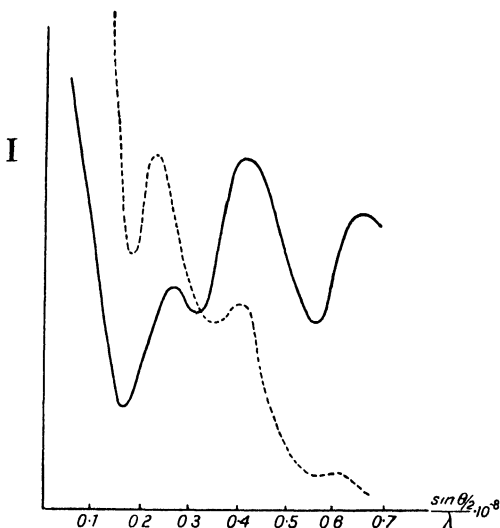

FIG. 22.—Curve showing the theoretical intensity distribution of electrons scattered in cyclopentane.

and it may be seen that maxima occur at 7.73 and 14. Thus $7.73 = \frac{4\pi d}{\lambda} \frac{\sin \phi}{2}$ and d may be deduced from a knowledge of the wave-length, and the angle ϕ at which the first maximum occurs.

In general, the intensity curve is by no means as simple as this. In Fig. 22 is shown the theoretical intensity distribution for scattering by cyclopentane.

The molecular model assumed is a plane pentagon, which leads to the formula

$$I(\phi) = 5KE_c^2 \left(1 + \frac{2 \sin x}{x} + 2 \sin \frac{(\sqrt{5} + 1)\frac{x}{2}}{(\sqrt{5} + 1)\frac{x}{2}} \right).$$

If E is regarded as a constant, the distribution of intensity resulting from the superposition of the various components is shown by the heavy line in Fig. 22. The dotted line shows the form of the intensity curve when the variation of E , which is the atomic scattering factor, is taken into account. Regarding E as a constant leads to only a slight change in the position of the maxima, but, generally speaking, gives completely wrong values of the relative intensities of the various haloes.

This method has been applied to the determination of atomic sizes, and also to such problems as the difference in spacing in the case of an aliphatic or an aromatic bond, and the free mobility of atoms in molecules.

REFERENCES

- ¹ W. L. Bragg, *Nature*, **124**, 125, 1929.
- ² G. I. Finch, *Trans. Faraday Soc.*, Sept. 1935.
- ³ M. Born, *Nachr. Ges. Wiss. Göttingen, Math.-physik. Klasse*, **146**, 1926; *Z. Phys.*, **38**, 803, 1926.
- ⁴ N. F. Mott, *Proc. Roy. Soc.*, **127A**, 685, 1930.
- ⁵ G. P. Thomson, *Proc. Roy. Soc.*, **125**, 352, 1929.
- ⁶ H. Mark and R. Wierl, *Z. Phys.*, **60**, 741, 1930.
- ⁷ Ramsauer, *Ann. de Phys.*, **64**, 513, 1921; **66**, 546, 1921.
- ⁸ E. G. Dymond and E. E. Watson, *Proc. Roy. Soc.*, **122**, 571, 1929.
- ⁹ E. C. Bullard and H. S. W. Massey, *Proc. Roy. Soc.*, **130**, 579, 1931; **133**, 637, 1931.
- ¹⁰ F. L. Arnot, *Proc. Roy. Soc.*, **129**, 361, 1930; **130**, 655, 1931; **133**, 615, 1931.
- ¹¹ H. Faxen and J. Holtsmark, *Z. Phys.*, **45**, 307, 1927.
- ¹² P. Debye, *Ann. de Phys.*, **46**, 809, 1915.
- ¹³ R. Wierl, *Ann. de Phys.*, **8**, 453, 1932; **8**, 521, 1931.

CHAPTER IV

DIFFRACTION BY REFLECTION

Diffraction by Reflection from a Cleavage Face of a Single Crystal.—As has been mentioned in Chapter II, patterns may be obtained by allowing an electron beam to impinge, at a small glancing angle, on a crystal face. By analogy with the X-ray case, this is usually referred to as a reflection pattern, but this is not strictly correct. In the cases of X-rays, only one spot appears at any one time, and that only when the crystal is set at exactly the right angle to the beam. In the case of electrons this is not so, and as a result, it is dangerous to press the analogy between the two effects too far. It is partly because this has been done so persistently that the diffraction of electrons by single crystals is by no means fully understood. Since atoms are so much more effective in scattering electrons than X-rays, fewer crystal planes take part in the scattering, and, as a result, the Bragg condition (Equation (4), Chapter I) is much relaxed. As a consequence of this, several diffracted spots frequently appear at the same time, and for nearly all settings of the crystal there is one spot visible, in addition to the Kikuchi lines which are always present with a good specimen.

Kirchner's Method of Regarding the Diffraction Conditions.—In order to make it easier to take into account the various effects of relaxation of the conditions for reinforcement of the wavelets from different atoms in the crystal, Kirchner¹ has expressed the conditions in a very

convenient form. In Fig. 23, AB represents an electron beam impinging at a small angle on a crystal cleavage face. The atoms in the crystal may be regarded as arranged in planes parallel to this face. The condition that the scattered wavelets from any line of atoms shall be in phase, is that the scattered ray shall lie on one of a series of cones with the particular line of atoms as axis. The atoms in each plane may be regarded as occurring at the intersections of two sets of parallel lines, and, for any setting of the crystal, it will be possible to choose two such sets of lines, one approximately in the same direction as the beam, and the other perpendicular to it. Corresponding to each of these sets of rows of

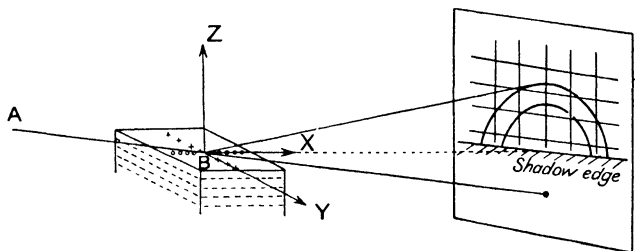

FIG. 23.—Showing the conditions necessary for a strong diffracted ray.

atoms, the condition for diffraction will be that the beam shall lie on a series of cones, which will intersect the plate in a series of circles in the case of the rows parallel to the beam, and as a series of parallel straight lines perpendicular to the crystal face, in the case of the rows perpendicular to the beam. (More strictly speaking, the latter condition will result in hyperbolæ, but over the extent of the plate these may be considered as straight lines.) The third diffraction condition, resulting from the interference of scattered wavelets from atoms in successive planes, will give rise to a third set of parallel straight lines parallel to the shadow edge. Only where all three of these conditions are satisfied will a strong diffracted beam occur.

It will be of interest at this stage to consider the effects of relaxation of these conditions in turn. The axes referred to are those marked in Fig. 23. The x axis is in the direction of the rows nearly parallel to the beam, the y axis is parallel to the rows perpendicular to the beam, and z is perpendicular to the crystal face.

(a) The condition which is most commonly relaxed is the z condition, and it is always assumed that this results from lack of penetration of the electron beam. As a consequence, the horizontal line condition degenerates into a number of broad bands, the spread of which depends upon the amount of penetration. In such a case, several intersections of the circles and vertical lines may occur on the wide bands, and all of these will give spots. The spots will be sharp for any setting of the crystal, but as the angle of incidence is altered, they will persist over a considerable range of angle of incidence. This is accounted for by the fact that, while the two sets of straight line maxima remain stationary for small angles of rotation, the circular maxima move as though rigidly fixed to the crystal.* The type of pattern resulting from relaxation of the z condition is shown in Fig. 24 (a). In the case of many crystals, the depth condition is so far relaxed that two spots appear on the central line, as shown in the diagram, and in some settings two or more circles of spots may be obtained, the spots occurring where the circular maxima cut the vertical line maxima. Such a pattern is often referred to as a surface pattern.

(b) Let us next consider the case where the x condition is relaxed. Such a relaxation arises if the extent of the crystal in the direction of the beam is very small, of the order of 50 atoms or so. As has been pointed out in connection with transmission through thin crystals, in Chapter II, the resolving power of a row of atoms in the direction of the beam is very much smaller than

* It should be realised, that although the circles and lines are spoken of as real things, they are in fact only theoretical abstractions.

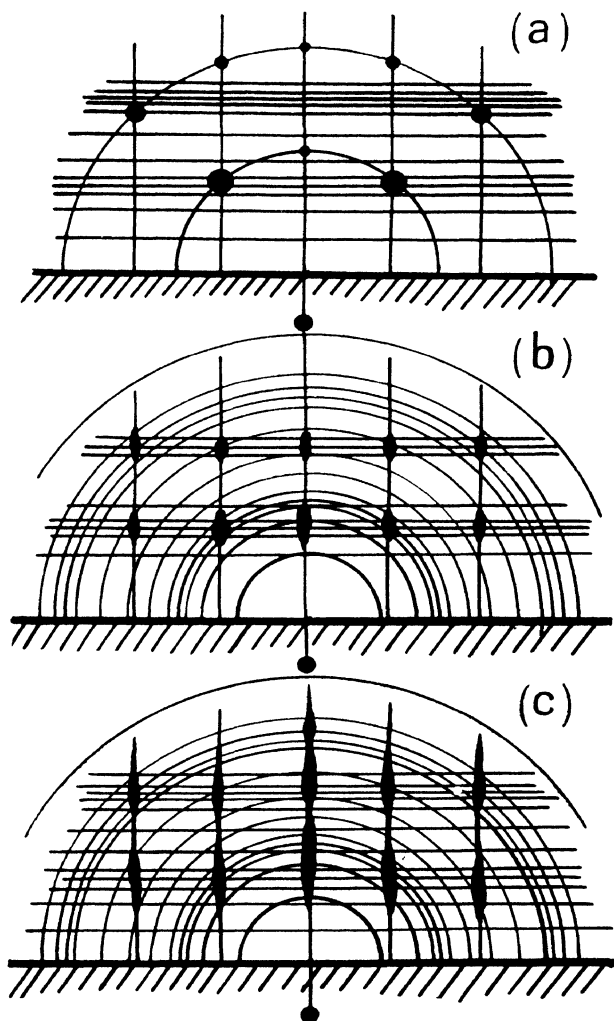

FIG. 24.—Types of pattern resulting from relaxation of the various diffraction conditions.

that of a corresponding row perpendicular to the beam. Thus a small square crystal face may give a pattern in which the x condition is very much relaxed, while the y condition is still quite rigid. Patterns of the kind about to be described would, therefore, be expected in the case of an imperfect crystal, the surface of which was broken up into blocks, the blocks not having lost their alignment. Such patterns are often found in practice.

If the z condition is quite rigid, sharp spots will occur wherever the verticle lines intersect the horizontal ones, the intensity of the spots being governed by the hypothetical intensity of the x condition at the point. In nearly all cases, the z condition is somewhat relaxed, and therefore the spots are slightly drawn out into short lines perpendicular to the line of intersection of the crystal surface with the plate. This line is usually referred to as the shadow edge since the plate is almost unaffected between it and the position of the undeflected spot. The type of pattern is shown in Fig. 24 (*b*).

(*c*) The third type of pattern results from the relaxation of both the x and z conditions. The circles and horizontal lines then become broad bands. As a result of this, the spots are drawn out into lines perpendicular to the shadow edge, the main intensity occurring where the circular bands intersect the horizontal ones. The type of pattern is shown in Fig. 24 (*c*) and is very similar to that which results from the rotation of a crystal, giving a pattern of type (*a*), about an axis perpendicular to the beam, and in the crystal face.

It should be noted that the conditions become more rigid at the larger angles of incidence and reflection.

Considerations of this sort allow us to account for the appearance of the spots, even though the crystal is not set at the appropriate Bragg angle, but allowance should be made for the effect of the inner potential of the crystal. This has been mentioned already in connection with diffraction of slow electrons, and the way in which it gives rise to a refractive index will now be considered.

The Effect of the Inner Potential.—Bethe² first suggested that the discrepancy between the observed positions of the maxima and those predicted by theory might be due to the effect of a refractive index, due to a mean inner potential in the crystal. It may seem at first that, since the crystal as a whole is made up of equal positive and negative charges, it cannot have a potential differing from that of free space. This would be so if the charges were uniformly distributed throughout the space, but as a result of the atomic arrangement, the mean potential of the space within the crystal is above that of the surrounding vacuum. Sommerfeld has derived an expression showing the relation between this inner potential and the thermionic work function.

It may be shown quite simply that the effect of the inner potential is to give a refractive index. Thus, the wave-length of the electron waves in free space is given by

$$\lambda = \frac{h}{mv}, \quad \text{where } \frac{1}{2}mv^2 = eP$$

and

$$v = \sqrt{\frac{2eP}{m}}.$$

If the electrons enter a region of positive potential V_0 , they have a potential energy of $-eV_0$. Therefore, since their total energy must be constant, their new velocity v' must be such that

$$\frac{1}{2}mv'^2 = e(P + V_0),$$

so that

$$v' = \sqrt{\frac{2e}{m}(P + V_0)}.$$

Thus the wave-length λ , in a space at a potential V_0 , is given by

$$\lambda = \frac{h}{\sqrt{2me(P + V_0)}}.$$

The refractive index μ is therefore given by the expression

$$\mu = \sqrt{\frac{P + V_0}{P}} = \sqrt{1 + \frac{V_0}{P}}. \quad (1)$$

It is immediately obvious that the refractive index varies with the voltage of the incident electrons. In the case of slow electrons its effects are very large. For electrons of 30,000 volts and upwards, the refractive index is very small, but its effects are still quite easily detectable as a change in position of the maxima, all of which are moved in towards the shadow edge.

Measurement of Inner Potential.—Measurements of inner potential have been made at low voltage by Davisson and Germer, Rupp, Farnsworth, and others. The work has been mainly concerned with metals, and it has been found, in general, that there is a constant inner potential, independent of the voltage of the electron beam. Farnsworth,³ however, finds values for copper which show a marked variation with the voltage of the electrons used. This and other effects with slow electrons, which will be considered later, have not been fully accounted for, although it has been suggested that they may be due to anomalous dispersion, or surface contamination. Certain negative values for the inner potential which have been found, may probably be accounted for by the accumulation of a surface charge on the specimen, as a result of the electron bombardment.

At high voltages, measurements of V_0 have been made by Shinohara,⁴ Yamaguti,⁶ Darbyshire, Dixit, Tillman,⁵ and others. Tillman has also made measurements with voltages between 3.5 kv. for rock salt, zinc blende, galena, pyrites, stibnite, fluorspar, calcite, and gypsum, and the results have been compared with values determined by means of electrons of voltage 20-40 kv., and are found to agree quite well. A table of the results obtained by various experimenters is shown on next page.

Specimen.	Yamaguti.	Shinohara.	Tillman.		Mean.
					volts.
Rock salt .	7.7	6.3	7.2 ^H	6.0 ^L	7.0
Calcite .	12.4	13.8	12.9	12.5	12.9
Mica .	10.6	10.4	--	--	10.5
Zinc blende	12.2	(12.2 Miyake) (12.2 Kikuchi and Nakagawa)	12.6	12.1	12.3
Galena .	(12.5 Dixit)	--	14.1	13.1	13.2
Stibnite .	11.9	--	14.7	--	13.3
Gypsum .	9.1	--	7.9	8.5	8.5
Fluorspar .	--	(15 Raether)	11.9	13.3	12.6
Graphite .	11.5	(10.7 Jenkins)	--	--	11.1

H and L refer to the high and low voltage ranges mentioned above.

Experimental Methods.—The method of determining the inner potential experimentally, which is most commonly used for fast electrons, depends upon measurements of the positions of the different orders of the spot produced by reflection from planes parallel to the cleavage face of the specimen. In order that this may be done conveniently, it is usual to take what is referred to as a "rotation picture." In order to do this, the plate is exposed and the specimen is slowly rotated about an axis, perpendicular to the beam and lying in the crystal face, so that the angle of incidence is varied from zero up to some angle large enough to bring in the highest order that will fall on the plate. Generally speaking, the spots will be somewhat elongated as a result of relaxation of the depth condition, but, as a rule, the spacings between the central spot and the various maxima may be determined to within about 1 per cent. Sometimes the measurements are made on the screen.

Let us consider how the refractive index affects the positions of the spots. This may be determined quite simply in the following way. Suppose a beam

of electrons makes an angle θ with the crystal face, and suppose the refracted ray in the crystal makes an angle θ' .

Then the refractive index μ is given by

$$\mu = \sin\left(\frac{\pi}{2} - \theta\right) / \sin\left(\frac{\pi}{2} - \theta'\right).$$

Hence $\mu^2 - 1 = (\cos^2 \theta - \cos^2 \theta') / (1 - \sin^2 \theta')$.

Since $\mu = \sqrt{1 + \frac{V_0}{P}}$,

$$\frac{V_0}{P} = (\sin^2 \theta' - \sin^2 \theta) / (1 - \sin^2 \theta'). \quad (2)$$

If θ corresponds to a diffraction maximum, we know that $2d \sin \theta' = n\lambda$ if the change in wave-length is neglected.

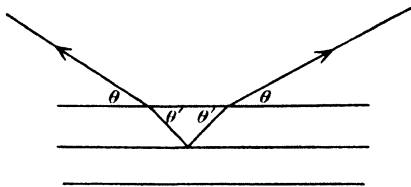

FIG. 25.—Showing the effect of inner potential.

So that $\sin^2 \theta' = \frac{n^2 \lambda^2}{4d^2} = \frac{150n^2}{4d^2 P}$.

Substituting in equation (2) we get

$$\frac{V_0}{P} = \left(\frac{150n^2}{4d^2 P} - \sin^2 \theta\right) (1 - \sin^2 \theta').$$

Since θ' is always small $(1 - \sin^2 \theta')$ may be taken as unity.

Thus $P \sin^2 \theta = \frac{150n^2}{4d^2} - V_0$. . . (3)

where P and V_0 are both expressed in volts and d is in angstroms. The inner potential may, therefore, be

deduced from a knowledge of the positions of the various orders of reflection on a rotation photograph, by plotting $P \sin^2 \theta$ against the squares of the order numbers n . The intercept on the $P \sin^2 \theta$ axis gives V_0 , and the spacing between the planes may be deduced from the slope of the line ϕ , which is given by $\phi = \frac{150}{4d^2}$.

In order to obtain accurate values, a relativity correction should be applied. The effect of this is to change the value of P to $P(1 + eP/600 m_0 c^2)$. It should be noted that if V_0 is large enough, some values of n do not satisfy the equation, and these orders do not appear in the pattern.

This method has been employed by most of the workers at high voltages, although some have determined the inner potential for each order separately, by substituting for n and θ in equation (3). A very similar method is employed at low voltages, except that θ is usually constant and P is varied.

A second method of measuring the mean inner potential, at high voltages, has been used by Shinohara. This depends upon the effect of refraction on the Kikuchi lines, especially those parallel to the shadow edge. Equation (3) holds for such a case. The angle θ may be determined by measuring the distance between the Kikuchi line and the shadow edge, and dividing it by the distance from the specimen to the photographic plate. Shinohara determined the position of the shadow edge by observations on those parts of oblique lines which were only slightly affected by refraction, but Tillman, who subsequently used the method, determined its position in an easier and more direct manner. In nearly all cases a spot was visible on the central line of the pattern, and whether there is refraction or not, the shadow edge must always be half-way between this spot and the spot due to the undiffracted beam. The agreement between values of the inner potential determined by this method and that previously described is very close.

The Decrease of the Inner Potential at the Crystal Surface.—In a paper published recently, Yamaguti gives an account of the measurement of the inner potential for natural crystal faces of pyrites. The method used was the rotation method, the specimen arrangement being slightly modified to give a pattern on either side of the central spot. In order to determine the positions of the maxima more accurately, microphotometer curves were taken, and the inner potential was determined separately for each order. It was found that for low order numbers, the value of the inner potential was less than for the high ones. Also, it was observed that the spots spread over quite a considerable range of angle of incidence, and the spread was not symmetrical, the intensity falling off more rapidly on the side of large angle. The probability of the inner potential being less for small angles is suggested by Bethe's dynamical theory, which will be discussed later, and has been treated theoretically by Lasckarew.⁷ In order to explain his results, Yamaguti assumed a simple crystal model, similar to that used by Lasckarew, such as that shown in Fig. 26 (a). He assumes that regions of high potential occur in the crystal in plane slabs parallel to the crystal face. Suppose the spacing between the slabs to be d , and their width α . The path of a ray inside the crystal will then be of the shape shown in Fig. 26 (b).

If the incident ray makes an angle θ with the surface, and the ray inside the regions of high potential makes an angle θ' , then, if μ is the refractive index in these regions, the equation

$$\mu^2 - 1 = \sin^2 \theta' - \sin^2 \theta$$

will hold.

If V_0 is the mean inner potential, and V the potential in the high potential regions,

$$dV_0 = \alpha V,$$

which gives $(\mu^2 - 1)\alpha = (\mu_0^2 - 1)d$,

where μ_0 is the measured refractive index. If the angle θ corresponds to a diffracted beam, the path difference between two adjacent layers is given by

$$n\lambda = 2\alpha \sin \theta' + 2(d - \alpha) \sin \theta,$$

provided the small change in wave-length is neglected.

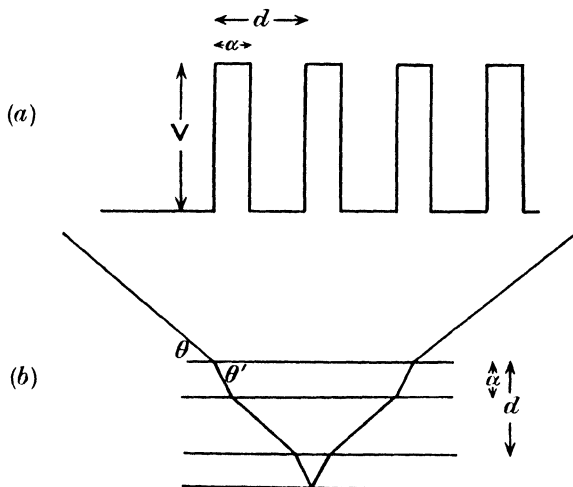

FIG. 26.—Showing the crystal model upon which Yamaguti bases his explanation of the change of the apparent inner potential with angle of incidence.

$$\begin{aligned} \text{Thus} \quad \sin^2 \theta' &= \left(\frac{n\lambda - 2(d - \alpha) \sin \theta}{2\alpha} \right)^2 \\ (\mu_0^2 - 1) &= \frac{\alpha}{d}(\mu^2 - 1) = \frac{\alpha}{d} \sin^2 \theta + \frac{n^2 \lambda^2}{4\alpha d} \\ &\quad - \frac{\alpha}{d} \left(\frac{d - \alpha}{\alpha} \right) \frac{n\lambda}{\alpha} \sin \theta + \left(\frac{d - \alpha}{\alpha} \right)^2 \sin^2 \theta \\ &= \frac{n^2 \lambda^2}{4d^2} \left(1 + \left(\frac{d - \alpha}{\alpha} \right) \right) - \sin^2 \theta \left(1 + \left(\frac{d - \alpha}{d} \right) \right) \\ &\quad - \frac{d - \alpha}{d\alpha} n\lambda \sin \theta + \left(\frac{d - \alpha}{\alpha} \right)^2 \sin^2 \theta \end{aligned}$$

$$\begin{aligned} & \frac{n^2\lambda^2}{4d^2} - \sin^2 \theta + \frac{d - \alpha}{\alpha} \frac{n^2\lambda^2}{4d^2} - \frac{d - \alpha}{d\alpha} n\lambda \sin \theta \\ & \quad + (d - \alpha) \left(\frac{1}{d} + \frac{d - \alpha}{\alpha d} \right) \sin^2 \theta \\ \frac{V_0}{P} = & \frac{n^2\lambda^2}{4d^2} - \sin^2 \theta + \frac{d - \alpha}{\alpha} \left(\frac{n\lambda}{2d} - \sin \theta \right)^2. \quad (4) \end{aligned}$$

It may be seen by comparing this with equation (3) that $\frac{d - \alpha}{\alpha} \left(\sin \theta - \frac{n\lambda}{\alpha} \right)^2$ is the only correcting term.

Yamaguti finds that by choosing a suitable value of α , fair agreement between the theoretical and experimental values for μ_0 may be obtained.

In addition to the variation of the apparent inner potential at small angles of incidence, Yamaguti finds that different specimens give differences in the values for V_0 , which are much too big to be attributed to experimental error. This variation was only observed with natural faces of pyrites, and not with cleavage faces, although the falling off of inner potential at small angles is observed with both types of crystal surface. No completely satisfactory explanation of the differences observed with different natural faces has yet been given, but Yamaguti suggests that it may be due to surface contamination which cannot be removed by washing.

Effect of Inner Potential in Other Cases.—Above, the effect of inner potential upon the reflection pattern has been considered. Although it does not rightly come under the heading of this chapter, another case will be considered here. In Chapter III, dealing with transmission through thin films, it will be remembered that

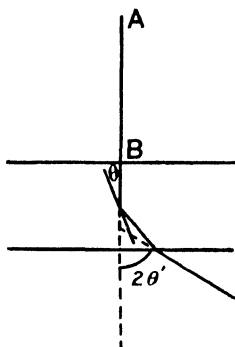

FIG. 27.

no mention was made of the effect of refractive index upon the pattern. This was because there is no observable effect in the case of electrons of the energies used. In Fig. 27, let AB be an incident beam of electrons falling on a metal film, and let reflection occur at a set of crystal planes inside the metal. Suppose the angle of reflection is θ , and that the deviation between the incident and emergent beams is $2\theta'$, we then have

$$2d \sin \theta = n\lambda' = \frac{n\lambda}{\mu}.$$

Also

$$\mu \sin 2\theta = \sin 2\theta'.$$

Hence $\sin 2\theta' = 2\mu \sin \theta \cos \theta = \frac{2n\lambda}{d} \cos \theta.$

When θ is small, as it is for fast electrons, this becomes

$$\sin 2\theta' = 2\theta\mu.$$

Within the limits of experimental error, μ is equal to unity, on account of the small value of $\frac{V_0}{P}$. Therefore, the pattern is not appreciably affected.

Diffraction of Slow Electrons with Reference to Inner Potential Measurement.—Several references have already been made to the difficulties of measuring inner potential by means of slow electrons, and the reason for these difficulties will now be considered in connection with the work of Farnsworth. Most of the work with slow electrons has been carried out with metals, and since it is impossible to obtain satisfactory cleavage faces with most metallic crystals, a face parallel to one of the principal sets of planes is cut and then etched. Farnsworth³ used copper, silver, and gold crystals, and for the purpose of determining the inner potential, the collector and the electron gun were adjusted so that the angles of incidence and reflection were equal. The voltage of the incident beam was then varied, as in the experiments of Davisson and Germer, and curves were plotted showing the Faraday cylinder current against the

square root of the voltage. In determining the inner potential from such a curve, the trouble which arises is mainly due to the difficulty of ordering the maxima. This is very much complicated by the presence of many extra diffraction maxima, which cannot be accounted for in terms of the ordinary space lattice of the crystal. That is, maxima which would not occur with X-rays of the same wave-length.

These maxima, which are of a varying nature, may be classed as due to one of the following causes:—

(1) Reflection from the surface grating.

(2) Maxima which occur in positions indicated by the simple theory with zero inner potential. These are considered to be due to interference between wavelets reflected from steps on the surface.

(3) Maxima prohibited by the structure factor, half orders, etc.

(4) Fine structure.

Beams of type (1) and (2) are usually weak, since they arise from the surface only.

Prohibited maxima may often be attributed to a layer of gas on the crystal, or to gas which has penetrated the lattice. In this case, the orders usually weaken or disappear on heating the specimen. This explanation, however, appears not to hold in all cases, and it is not yet fully understood why some of the forbidden orders appear.

The effect referred to as fine structure was first noticed by Farnsworth. In the curve showing intensity of reflection against the square root of the voltage, subsidiary peaks appear close to the maxima. Curves plotted for two slightly different angles of incidence are found to show quite a different arrangement of peaks.

Lasckarew⁷ has advanced an explanation, based on the dynamical theory, which accounts for the fine-structure effect. As the voltage of the incident beam is changed, other maxima, from crystal planes not parallel to the surface, will occur. The appearance of these maxima will result in a weakening of the centre line

maximum which is being observed. This causes a dip in the peak, of the type shown in Fig. 28. The full line shows the peak as observed, and the dotted line shows the shape it would be if no other maximum had appeared. It will be seen that the position of the maximum is altered. Following this idea, Lasckarew has redetermined the inner potential for copper from Farnsworth's results, after having drawn the maxima as he imagined they would be had no other orders appeared. When this has been done, he finds that the inner potential follows a smooth curve, when plotted against angle, and does not vary irregularly as Farnsworth suggested.

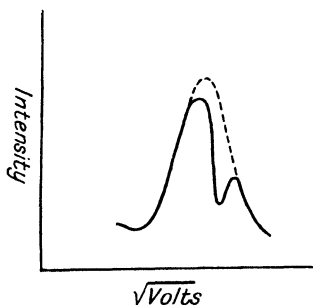

FIG. 28.—Fine structure.

Farnsworth also observed considerable differences in the position and structure of the various maxima for gold and silver crystals, using the same angles of incidence and reflection. Since the two crystals have the same structure, and the same lattice constants to within 0.4 per cent., these differ-

ences must be attributed either to surface differences or to atomic differences. The pattern obtained from a thin layer of silver, deposited on the gold crystal, was in general the same as that obtained from a solid block of silver. Farnsworth suggests that the thin silver film has probably the same type of surface as the gold block, and, since it gives the same pattern as a solid block of silver, he considers this to be evidence against the theory that the differences between the gold and silver patterns are due to surface effects. He points out, however, that the evidence is not conclusive. If this difference between the patterns from the two metals is not due to a surface effect, it must be due to some atomic effect not taken into account in the explanation of fine structure given above.

The Dispersion Theory of Electron Diffraction.—It will be seen from the foregoing account that, for fast electrons at least, the pattern obtained by reflection from a single crystal cleavage face may be accounted for quantitatively, but there is not as yet a theory which adequately explains the observed intensity distribution. In order to form a theory which will give some account of the intensity distribution to be expected, it is necessary to take into account the interchange of energy between the primary and diffracted beams. A similar problem arises in the case of X-ray diffraction, and Darwin and Ewald have each developed a dispersion theory which predicts the intensity distribution in the different orders. The theoretical results show good agreement with those found in practice.

Bethe ² has produced a dynamical theory for electrons, which is closely related to the X-ray dispersion theory. He considers the propagation of the de Broglie waves in a crystal, which he regards as a potential distribution represented by a triple Fourier series. The expression for the potential is included in the wave equation, and a solution in the form of a Fourier series is obtained. This represents a series of plane waves, whose directions are all the possible directions of the diffracted beams, and whose intensities are interdependent. In the case of slow electrons, the weak beams have a considerable effect on the intensity of the strong one, but for fast electrons, the number of weak beams should be small, and their effect negligible. Bethe has worked out the case when only one strong diffracted beam appears, and finds that, over a small range of angle of incidence the reflection is total, and outside this range it falls off very rapidly indeed. This prediction is exactly similar to the predictions of Darwin's theory in the case of X-rays, but, whereas for X-rays the agreement between theory and experiment is good, for electrons the observed spread is far greater than that predicted by theory. For example, in the case of the (3 3 3) reflection from diamond, the theoretical spread for 30,000 volt electrons is of the

order of $2'$, while the value found by the author is of the order of $30'$. In this particular case, the theory predicts that at the Bragg angle the de Broglie waves will penetrate about 20 planes before being damped down to half amplitude, and at angles other than the Bragg angle the beam is transmitted without damping. If the observed spread of the spots is to be attributed to lack of penetration, it means that only three or four planes can be effective at the small glancing angles used. In support of this, it must be pointed out that Bethe's theory neglects the absorption of the electrons (e.g. inelastic scattering), and this will play an important part in limiting the effective depth of penetration.

The great objection to any explanation of the persistence of the maxima over a wide range of angle, in terms of lack of penetration, is the sharpness of the Kikuchi lines. If the main beam penetrates only a few planes, there is no reason for supposing that the diffuse radiation will penetrate much more. The Kikuchi lines should, therefore, show the same angular spread as the range of angle of incidence over which spots appear in a rotation pattern. In practice, they are quite sharp, and measurements made by the author show that their spread is of the order predicted by Bethe's theory.

The frequent appearance of a strong surface pattern, such as that referred to on page 51, suggests that there is either small penetration or some marked difference between the surface layers and the bulk of the crystal. The evidence against the first assumption makes it necessary to pay attention to the second possibility.

J. W. Harding has suggested that the effect may be due to a contraction or expansion of the spacing between the surface planes, and he is working further upon this idea. Until the theory has been fully worked out, it is impossible to say with certainty whether it will explain the observed effects in full, but it promises to do so. Suppose the top few planes to be expanded or contracted slightly, so that the spacings between them are not uniform, then the wavelets scattered from these planes

will never be all in phase together, neither will they ever be completely out of phase. Thus there will be a reflected spot at all angles of incidence, although it will vary in intensity. At the true Bragg angle for the crystal, the part of the beam which passes through the top planes will also be reflected in the main bulk of the crystal where the spacing is regular, and Bethe's theory will apply. As well as offering a possible explanation of the spread of the spots over a considerable range of angle, this theory may account for the elastically scattered diffuse radiation, the selective reflection of which in the main bulk of the crystal will produce the sharp Kikuchi lines.

At the Bragg angle, Bethe's theory predicts that the reflection will be total. This is not in agreement with experiment. For slow electrons, Ehrenberg estimates that the intensity of the reflected beams is between 10^{-2} and 10^{-4} times the intensity of the incident beam, while the author finds that for 40 kv. electrons the ratio of the intensity of the incident beam to that of the diffracted beam is about 100 : 1. In determining this ratio, no account has been taken of the fact that the incident beam was not strictly parallel, but had a spread of the order of $5'$. This would have the effect of reducing the intensity of the diffracted beam, since not all the electrons would be incident at the correct Bragg angle, but this would not account for the marked difference between the observed intensity and that predicted by theory, more especially as Bethe's theory predicts that the reflection will be total over a range of angle of several minutes of arc. The discrepancy is undoubtedly largely due to the fact that Bethe's theory takes no account of absorption, and it has already been pointed out that this is an important factor.

Kikuchi Lines.—As was mentioned at the beginning of this chapter, the diffraction pattern obtained by reflection from a cleavage face of a single crystal is always crossed by a number of fine black and white lines, of the same type as those first observed by Kikuchi in his transmission

experiments with mica, and which undoubtedly originate in the same way. Black and white, as used here, refer to the photographic plate, so that a black line is a line of higher electron intensity than the background, while a white line has lower intensity. As in the case of transmission patterns, the black and white lines always appear in pairs, as indeed they must if the theory with regard to their production is correct, and the white line is always nearer the undeflected beam. The separation between the corresponding black and white lines is equal to the deflection which would be produced by a Bragg reflection from the set of planes which produces the lines, and to which the lines are parallel. In the case of most crystals, at any angle of incidence, several orders of the black lines parallel to the shadow edge

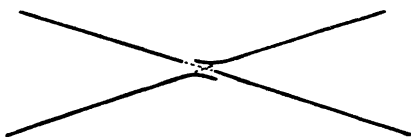

FIG. 29.—Showing the manner in which Kikuchi lines intersect.

are visible. These are produced by reflection from the cleavage planes, and it is these lines which were used by Shinohara to determine the inner potential. In addition to these, there are diagonal lines which produce very complicated patterns, especially at certain symmetrical settings of the crystal, as will be seen from Fig. 3, Frontispiece. Not only does confusion arise as a result of the wealth of lines present, but also because they interfere with each other where they intersect. When two lines cross, they do so in the manner indicated in Fig. 29, and a probable explanation of this, based on Bethe's theory, has been advanced by Shinohara.⁸ In view of the mutual interference of the Kikuchi lines, we are forced to assume that the last of the multiple scatterings is elastic, even if the first are inelastic. (See Frontispiece, Fig. 3.)

Another notable feature is the pattern produced when the crystal is set with a set of planes parallel, or nearly parallel, to the plane of incidence. In such a case, we might expect a pair of coincident black and white lines on either side of the central line, which would cancel each other, so leaving uniform background. Actually, the space between the positions where the lines would occur is occupied by a dark band. Photometer curves, taken across such bands, show their structure to be of the form shown in Fig. 30, while their width is equal to the displacement which would be produced by a Bragg reflection from the appropriate planes. Several orders of these vertical bands are often superimposed one upon the other, their widths increasing in arithmetic progression. Diagonal pairs of



FIG. 30.—Showing the intensity distribution across a band.

black and white lines, due to planes through a zone axis in the cleavage face, and in the plane of incidence, present very much the same appearance as the bands, except that the boundary on the side remote from the central spot is decidedly darker than that on the near side. (See Frontispiece, Fig. 3.)

No completely satisfactory explanation of the appearance of these bands has yet been advanced, although Shinohara⁹ has advanced a possible explanation based on Bethe's theory.

One-Dimensional Pattern.—Attention was first drawn to the possibility of one-dimensional electron diffraction by Emslie.¹⁰ With certain settings of the (0 1 0) face of a stibnite crystal, he obtained a diffraction pattern which showed two fine semicircular black lines. In the particular setting producing this effect, a row of

widely spaced antimony atoms in the crystal surface was in the plane of incidence, and the circles were found to be concentric with the point where this row would have intersected the plate.

To explain the effect, Emslie assumed that, after an inelastic collision, an electron had its wave packet confined chiefly to the single row of atoms in the plane of incidence, entrapped in a kind of potential tube. It would then be scattered by the potential variations along the tube.

Let us now consider the condition for diffraction, by a single row of regularly spaced atoms, of an electron

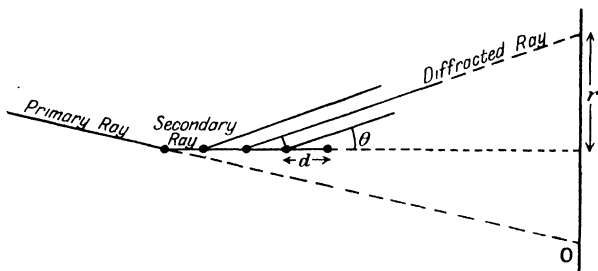

FIG. 31.—Illustrating the way in which a circle might be produced by one-dimensional diffraction.

wave packet travelling along the row. Fig. 31 shows the directions of the primary, secondary, and diffracted rays. Suppose λ to be the wave-length of the electron *in vacuo*, and λ' in the potential tube. The condition for a diffraction maximum, at an angle θ , then becomes

$$\frac{2\pi d}{\lambda'} - \frac{2\pi d \cos \theta}{\lambda} = 2\pi n,$$

where d is the spacing between neighbouring atoms. Now $\lambda = \lambda' \sqrt{1 + \frac{V}{P}}$ where V is the potential difference between the tube and free space, and P the voltage of

the incident electrons, so that the above equation becomes

$$\frac{V}{P} = \frac{2n\lambda}{d} \left(\cos \theta + \frac{n\lambda}{2d} \right) - \sin^2 \theta.$$

This relation enables V to be calculated, since the values of θ may be determined by measuring the radii of the circles. If we neglect $\frac{V}{P}$, which is small, we get

$$\sin^2 \theta = \frac{2\lambda n}{d} \left(\cos \theta + \frac{n\lambda}{2d} \right),$$

from which it is obvious that the radius of the second order circle will be approximately $\sqrt{2}$ times the radius of the first order.

Emslie supported his theory by measurements of the radii of the circles, and showed that the mean potential inside the tube was of the order of 26 volts. Subsequently Tillman¹¹ made a number of measurements of similar circles obtained by reflection from the (110) cleavage face of zinc blende. He was able to obtain circles from four different azimuth settings of the crystal, although, as a result of the comparatively small spacing, he was only able to get one circle corresponding to each position. The value of the inner potential, determined from these circles, showed a variation with azimuth. A simple crystal model was assumed, and values of the mean inner potential along the rows of zinc and sulphur atoms in the four directions considered were determined. These values showed sufficient agreement with those measured to lend a considerable support to the view that the circles were due to a one-dimensional diffraction effect. (See Frontispiece, Fig. 3.)

As Tillman has pointed out, the rather artificial assumption which Emslie has made about the electron wave packet being confined to a potential tube is not an essential part of the theory. An electron, having lost energy to a certain atom, will spread out as a spherical wave, the intensity of the wave being a maximum

in the direction of the incident beam. The intensity of the wave travelling along the row of atoms in the plane of incidence will, therefore, be quite appreciable. At suitable angles, the wavelets scattered from successive atoms in this row will reinforce. The wavelets from successive atoms in parallel rows will not be in phase with each other, since the distances of the atoms from the point of scattering of the primary electron will not be in arithmetic progression. Hence, the effect of these rows may be neglected.

In a recent paper, Finch, Quarrell and Wilman¹² suggest that these circles may be envelopes of Kikuchi lines. It may be shown that the Kikuchi lines, from planes common to a zone axis, form parabolic envelopes, and that the envelopes of these parabolæ are a series of circles of various order, the radii being proportional to \sqrt{n} , where n is the order number. Thus, to the first degree of approximation, this theory also would account for the appearance of the circular rings. It does not, however, predict any variation of the inner potential with azimuth, as measured from the rings. Recently, Shinohara¹³ has suggested that part of the observed displacement of the rings may be due to the interference of the Kikuchi lines between themselves, and not to inner potential. At present it is difficult to decide which of these theories is the true explanation of the effect.

Etched Single Crystal.—An account has already been given of the diffraction of slow electrons by etched single crystals. As a result of the many extra and unexplained orders obtained in these experiments, G. P. Thomson¹⁴ was led to examine etched crystals of silver and copper, with fast electrons, to see whether similar anomalies were found. The crystals were cut to approximately the correct face with a fine saw, and were then ground and etched. In the first place, the correcting of the angle of the face was carried out by an optical method due to Farnsworth. In later experiments the electron diffraction pattern from the etched

face was used to determine the change in angle necessary to make the face parallel to a certain set of planes.

The pattern resulting from the diffraction of a beam of fast electrons, at glancing incidence, by such a crystal surface, is an extended pattern of spots, very similar to that obtained by transmission through a thin film of crystal, except that part of it is cut off by the shadow of the specimen. The patterns were shown to have all the characteristics of cross grating patterns. All the spots could be accounted for by reflections from planes belonging to a single zone, and there were no extra orders. Thomson suggested that the patterns were formed by the electron beam passing through fine projections on the etched surface, and this theory is now generally accepted. Germer,¹⁵ however, thought that, after etching, the crystal surface might consist of a number of small crystal blocks set at varying angles to the surface. He suggested that the cross grating effect might be produced by the reflection of the beam from the surface of these crystallites. This idea cannot be correct, since, in some cases, Kikuchi lines have been observed as well as the spot pattern and such lines can only be produced if the crystal is sensibly perfect. Also, if the pattern was produced by reflection from exposed faces, an inner potential effect would appear, and this is not observed in the case of etched crystal patterns. Some crystal cleavage faces, which are probably imperfect in the way which Germer suggests, do give a cross grating type of pattern, which shows an inner potential effect, but the spots are usually very blurred, due to relaxation of the diffraction conditions on account of the small size of the crystal blocks. (See Frontispiece, Fig. 4.)

“Reciprocal Lattice.”—The cross grating type of pattern may very easily be interpreted in terms of the “reciprocal lattice” of the crystal producing it.

Suppose we take some point, corresponding to a lattice point in the crystal, as origin, and draw through it lines normal to all the sets of lattice planes in the

crystal. Suppose we then mark off on these lines a series of equally spaced points, the spacing between the points being the reciprocal of the spacing between the planes to which the particular line is normal. These points will then themselves form a space lattice, and this is known as the "reciprocal lattice" of the crystal. If a plane section is taken through this lattice, through the origin, then the points of the reciprocal lattice, lying on the plane, represent the arrangement of the diffraction spots in the cross grating pattern which would be produced if an electron beam of infinitely short wave-length were fired through the crystal in a direction normal to this plane section. In practice, the effect of finite wave-length is offset by the spreading of the reciprocal lattice points, when the crystal is thin in the direction of the beam.

Reflection from a Polycrystalline Surface.—When an electron beam is incident upon a polycrystalline surface, the diffraction pattern most commonly produced is a set of circular rings concentric with the undeflected spot. Rather more than half of each of these circles is cut off by the shadow of the surface, and so does not appear on the plate. Such a pattern as this must be due to the penetration of the electron beam through the small projections on the surface. Each little projection will produce a cross grating pattern and, if the crystals are distributed at random, the resulting pattern will be that produced by the rotation of all possible cross grating patterns about the central spot. The pattern will, in fact, be the same as that produced by transmission through a thin film, of the same constitution as the reflecting face, except that part of the circles will be cut off by the shadow of the specimen.

The only alternative explanation of the ring pattern observed is that the beam is reflected from the facets of crystallites in the surface. Such a theory would not account for the sharpness of the rings observed. The rings would be blurred because of the relaxation of the diffraction conditions on account of lack of

penetration and small crystal size. Also, the inner potential of the crystallites would cause a refractive index effect which would reduce the size of the rings. In general, this is not observed, although in a few special cases broadening of the rings, accompanied by a decrease in size, suggests that the second mode of production may sometimes be operative.

Orientation.—In many cases the rings are not of uniform intensity over their whole length, but are divided up into one or more strong arcs. This arcing of the rings is due to the orientation of the crystallites with respect to the surface of the specimen. The type of orientation most commonly observed is due to the setting of the crystals with one face approximately parallel to the reflecting surface.

We will consider what happens in the case of simple cubic crystals orientated in this way, with a cube face parallel to the specimen surface. The small crystal blocks will behave as cross gratings, so that, in the case of a beam at grazing incidence, the planes parallel to this cube face will produce a series of equally spaced spots in the plane of incidence, whatever the azimuth setting of the crystallite with respect to the beam may be. These spots are therefore strong. Reflections from the (011) planes, on the other hand, can only occur when the cube edge is set approximately parallel to the beam. These planes will then produce a series of spots, equally spaced along lines at an angle of 45° with the shadow edge. The (101) (110) $(0\bar{1}1)$ $(01\bar{1})$ $(\bar{1}0\bar{1})$ $(10\bar{1})$ $(\bar{1}10)$ and $(1\bar{1}0)$ planes will produce the same series of spots. Consideration of other sets of planes will enable us to decide where the corresponding spots will occur for any particular type of orientation, even for crystals of a more complicated structure than simple cubic. Usually the orientation is not complete and the spots become arcs.

In some cases the crystals are not only orientated with one set of planes parallel to the surface, but also with one axis in a preferred direction in the surface. In

this case, some of the arcs will not appear at any one particular setting of the specimen, and the pattern then approaches an etched single crystal pattern.

It is quite commonly observed that rings which show no sign of arcing are sharper where they approach the shadow edge. This can be accounted for by consideration of the resolving power of the cross gratings formed by the small projections. The part of the projection presented to the electron beam is probably wider than it is high. The resolving power of this grating is, therefore, greater in a direction parallel to the shadow edge than in a direction at right angles to it.

REFERENCES

- ¹ F. Kirchner and H. Raether, *Phys. Zeit.*, **30**, 510, 1932.
- ² H. Bethe, *Ann. de Phys.*, **87**, 555, 1928.
- ³ H. E. Farnsworth, *Phys. Rev.*, **40**, 684, 1932; **43**, 900, 1933.
- ⁴ K. Shinohara, *Sci. Pap. I.P.C.R., Tokio*, **18**, 315, 1932.
- ⁵ J. R. Tillman, *Phil. Mag.*, **18**, 656, 1934.
- ⁶ T. Yamaguti, *Proc. Math. Phys. Soc. Jap.*, **16**, 95, 1934; **17**, 58, 1935.
- ⁷ W. E. Lasekarew, *Zeit. Phys.*, **86**, 697, 1933; **89**, 820, 1934; *Trans. Faraday Soc.*, Sept. 1935.
- ⁸ K. Shinohara, *Sci. Pap. I.P.C.R., Tokio*, **20**, 39, 1932.
- ⁹ K. Shinohara, *Sci. Pap. I.P.C.R., Tokio*, **18**, 223, 1932.
- ¹⁰ A. G. Emslie, *Phys. Rev.*, **45**, 43, 1934.
- ¹¹ J. R. Tillman, *Phil. Mag.*, **14**, 485, 1935.
- ¹² G. I. Finch, A. G. Quarrell and H. Wilman, *Trans. Faraday Soc.*, Sept. 1935.
- ¹³ K. Shinohara, *Phys. Rev.*, **47**, 732, 1935.
- ¹⁴ G. P. Thomson, *Proc. Roy. Soc.*, **133**, 1, 1931.
- ¹⁵ L. H. Germer, *Phys. Rev.*, **44**, 1012, 1933.

CHAPTER V

APPARATUS AND TECHNIQUE

SEVERAL of the earlier types of apparatus for the diffraction of fast electrons have already been described. The main requirements are the production of a beam of electrons of uniform and constant velocity, together with an arrangement for giving the specimen the necessary degrees of movement inside an evacuated chamber. All the forms of apparatus at present used are the same in general principle as the diffraction camera originally designed by Thomson and Fraser,¹ but

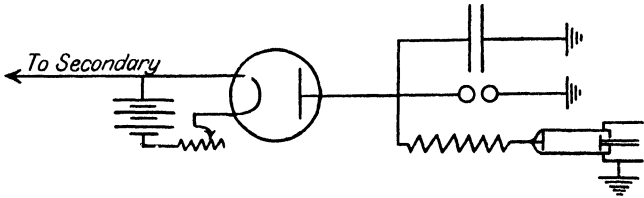

FIG. 32.—G. P. Thomson's H.T. supply.

in the last few years many improvements have been made.

The Production of a Homogeneous Electron Beam.—The high-tension current supply circuit used by G. P. Thomson has already been referred to. The arrangement is shown in Fig. 32. The output from the secondary of an induction coil, worked by a rotary mercury break, is fed through a rectifying valve. The rectified current is then passed through a gas discharge tube, the pressure

in which is controlled by a leak. The current is reduced to a suitable value by a resistance of the order of 10^5 ohms in series with the tube, and is smoothed by a condenser, of about $\cdot 01$ microfarad capacity, connected in parallel with the discharge tube. The voltage is measured by means of a spark gap, also in parallel with the tube. With such an arrangement it is possible to produce a beam of 40 kv. electrons which shows no sign of spreading when deflected through about ten degrees by

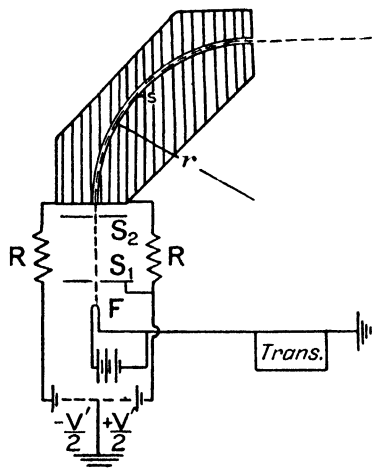

FIG. 33. — Yamaguti's arrangement for the production of a homogeneous beam of electrons.

homogeneous beam have already been described. Reid used an induction coil to run a gas discharge tube, and selected one component by means of an electrostatic deflecting field perpendicular to the initial direction of the electrons. Kikuchi produced a beam of electrons in a similar manner, and selected one component from it by allowing the beam to pass through a uniform magnetic field. More recently, Yamaguti² has used

a magnetic field. This form of high-tension apparatus has several disadvantages. At low voltages the current carried by the discharge is so large that the condensers do not smooth sufficiently. Above about 50 kv. the discharge tends to cut out, but over the range of voltage which is most commonly used it provides a satisfactory beam.

Filters. — Two methods of selecting electrons of a given energy from a heterogeneous

an arrangement which in some ways resembles both of the above methods. His apparatus is shown in Fig. 33. Electrons, from the hot filament F , are accelerated by a potential drop between the two plates S_1 and S_2 . This potential is maintained by a high-tension transformer. After passing through a hole in the second plate S_2 , the electrons enter a small channel between two metal blocks. The channel has a width of 2 mms. and is uniformly curved with a radius of 10 cms. A potential difference V' is applied between the two sides of this curved path, by means of a battery. Suppose the electrons entering the channel have an energy of V volts. If they follow the curve of the channel, the radial force acting will be mv^2/r , where m is the mass of the electron and v its velocity, while r is the radius of curvature of the path. This must be equal to the force exerted on the electron by the electrostatic field between the walls of the channel.

Therefore $\frac{mv^2}{r} = \frac{eV'}{S}$ where S is the width of the channel, but

$$eV = \frac{1}{2}mv^2.$$

Therefore $V = \frac{rV'}{2S} = 25V'$.

With such an arrangement as this, the velocity of the electron beam selected may easily be varied, and the voltage found at once, in terms of the potential difference applied to the metal blocks.

Use of a Saturated Diode.—A very efficient form of high-tension supply is used by Finch.³ The circuit is shown in Fig. 34. One end of the secondary of a 50-cycle, high-tension transformer, capable of giving an output at 120 kv., is earthed, and the output is rectified by a diode. The rectified current charges a condenser of suitable capacity, which is protected by a spill-over spark gap set at 110 kv. Current flows to the discharge tube through a 120 kv. diode, which is run under

conditions of saturation. The capacity of the condenser is large enough to maintain a current, sufficient to saturate the second valve, during the idle half cycle. With such an arrangement the current in the discharge is under complete control, being dependent upon the filament current in the saturated diode. Hence, if the resistance of the discharge is kept constant, the voltage drop across the tube will be constant. This system, in common with some others, depends upon the maintaining of a certain steady pressure in the discharge tube. In order that this may be done, the tube is continuously evacuated and, at the same time, air is allowed to leak in slowly.

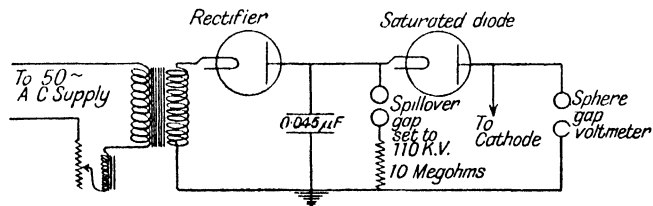

FIG. 34.—G. I. Finch's H.T. supply.

Various forms of leak are in use. A narrow capillary tube, connecting the discharge tube to a low-pressure gas chamber, is quite a common and satisfactory form of pressure control. The pressure in the gas chamber may be regulated to give the required leak. Alternatively, the capillary may be replaced by a needle valve leading either to a low-pressure gas reservoir, or in some cases to the open air. When the leak communicates directly with the atmosphere, a carefully designed valve is necessary, but when a low-pressure chamber is used, almost any common form of needle valve is sufficiently good to give a leak which is slow enough.

The Hot Cathode Tube.—If instead of a gas discharge tube a hot cathode tube is used, the current may be controlled by varying the filament current, but in order

to obtain a homogeneous beam of electrons, a constant voltage must be maintained across the tube. Where such a supply is available, a hot cathode tube is a very convenient source of electrons for diffraction purposes.

Magnetic Focussing.—Before going on to describe the more recent forms of electron diffraction camera, it is necessary to consider the magnetic focussing of an electron beam. It has already been mentioned, in connection with the work of Hughes on β -rays, that a beam of electrons diverging from a point may be converged to a focus by means of a coil carrying a suitable current, and the application of this to electron diffraction work was first suggested by Lebedeff.⁴

In 1926 Busch⁵ worked out the effect of a short, radially symmetrical magnetic field on the path of an electron. Before considering the mathematical aspect of this problem, let us consider it physically. It is well known that an electron passing through a magnetic field, perpendicular to its path, experiences a force in a direction mutually perpendicular to the path and to the direction of the field. If a moving electron enters a magnetic field, which has an axis of symmetry in the direction of motion of the electron, the radial component of the field will cause it to follow a spiral path round the axis. As a result of the angular motion of the electron about the axis, the axial component of the field will exert a force on the electron, and cause it to approach the axis.

Busch based his treatment on considerations such as these. The following analysis is a modification of Busch's general method, due to Martin,⁶ and valid only for paraxial rays. Suppose we consider a field in which the components at any point are H_r , H_ϕ and H_z corresponding to cylindrical co-ordinates r , ϕ and z . If the space is free of magnetic material, we know, from Laplace's equation, that

$$\frac{1}{r} \frac{\partial}{\partial r} (r H_r) + \frac{1}{r} \frac{\partial H_\phi}{\partial \phi} + \frac{\partial H_z}{\partial z} = 0. \quad (1)$$

If the field is symmetrical about the z axis,

$$\frac{\partial H_\phi}{\partial \phi} = 0. \quad \text{Hence } \frac{\partial}{\partial r}(rH_r) = -r \frac{\partial H_z}{\partial z}.$$

Integrating with respect to r , we find that the radial component at a radius r is given by

$$H_r = -\frac{r}{2} \frac{\partial H_z}{\partial z} \quad . \quad . \quad . \quad (2)$$

provided $\frac{\partial H_z}{\partial z}$ may be regarded as constant over a small change of r .

For a point near the axis

$$H_r = -\frac{r}{2} \frac{\partial H_z}{\partial z}.$$

If we consider an electron, of velocity v , entering such a field along a paraxial path, it will experience a tangential force $H_r e v_z$, due to the radial component of the field. Let the ϕ direction in which this force acts be considered positive.

$$\text{Thus} \quad mr\ddot{\phi} = H_r e v_z = -\frac{r}{2} \frac{\partial H_z}{\partial z} e v_z,$$

$$\ddot{\phi} = -\frac{1}{2} \frac{e}{m} \frac{\partial H_z}{\partial z} \frac{dz}{dt}.$$

Integrating, we get

$$\phi = \frac{1}{2} \frac{e}{m} \int_{-\infty}^{+\infty} \frac{\partial H_z}{\partial z} \frac{dz}{dt} dt = -\frac{1}{2} \frac{e}{m} H_z, \quad . \quad (3)$$

where the field grows from zero. Thus at any point z , the angular velocity depends only upon the magnetic field at that point.

This transverse velocity, across the axial component of the field, results in a radial force. If the velocity of the electron in this direction is v_ϕ , the centrifugal force is mv_ϕ^2/r , and the force due to the field will be $H_z e v_\phi$, where $v_\phi = r\dot{\phi}$.

The total radial acceleration is therefore

$$\ddot{r} = \frac{H_z e r \dot{\phi}}{m} + r \dot{\phi}^2,$$

hence

$$\begin{aligned} \dot{r} &= \frac{H_z e}{m} \left(-\frac{r}{2} \frac{e}{m} H \right) + \frac{r}{4} \left(\frac{e}{m} \right)^2 H_z^2 \\ &= -\frac{r}{4} H_z^2 \left(\frac{e}{m} \right)^2. \end{aligned} \quad (4)$$

If we assume that r remains sensibly unchanged as the electron passes through the field, the integration gives

$$\dot{r} - \dot{r}_0 = -\frac{r}{4} \left(\frac{e}{m} \right)^2 \int_{-\alpha}^z H_z^2 dt.$$

For the whole lens

$$\dot{r} - \dot{r}_0 = -\frac{r}{4} \left(\frac{e}{m} \right)^2 \int_{-\alpha}^{+\alpha} H_z^2 dt. \quad (5)$$

If α is the angle which the incident beam makes with the axis, and α' the angle between the emerging beam and the axis, then

$$\begin{aligned} \dot{r} &= v' \alpha', \\ \dot{r}_0 &= v \alpha, \end{aligned}$$

where the usual optical sign convention is used.

Thus

$$v' \alpha' - v \alpha = \frac{r}{4} \left(\frac{e}{m} \right)^2 \int_{-\alpha}^{+\alpha} \frac{H_z^2}{v_z} dz.$$

To the necessary degree of approximation $v = v_z = v'$.

Therefore

$$\alpha' - \alpha = \frac{r}{8} \frac{e}{m} \frac{1}{V} \int_{-\alpha}^{+\alpha} H_z^2 dz, \quad (6)$$

where V is the voltage of the incident electrons.

By analogy with the optical relation, the focal length of the magnetic lens thus formed is given by

$$\frac{1}{f'} = \frac{1}{8} \frac{e}{m} \frac{1}{V} \int_{-\alpha}^{+\alpha} H_z^2 dz. \quad (7)$$

The image formed will be rotated with respect to the object. The angle through which the image is twisted may be arrived at quite simply.

From equation (3)

$$\phi = \frac{1}{2} \left(\frac{e}{m} \right) H_z.$$

Therefore the total angle Φ , through which the image is twisted, is given by

$$\Phi = \frac{1}{2} \frac{e}{m} \int_{-\infty}^{+\infty} \frac{H_z}{v_z} dz.$$

From the point of view of electron diffraction, the rotation of the image is of no importance, as the magnetic lens is used to focus a thin pencil of rays from a small circular aperture.

The Finch Form of Camera.—A form of electron diffraction camera, capable of giving very precise results, has been designed and used extensively by

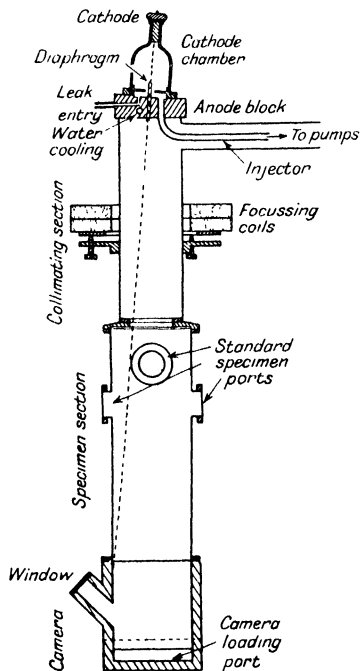

FIG. 35.—Finch type of camera.

Finch,⁷ in conjunction with the high-tension supply already described. The general form of the camera is shown in Fig. 35. The discharge tube consists of a glass wine bottle, with the base cut off, the base and neck apertures being ground flat and normal to the axis of the tube. The tube thus formed is sealed with picein wax into a groove in a brass block, the lower face of which is ground flat to make a vacuum-tight joint, when suitably greased, with the flat upper face of the

anode block. The cathode is a thick, polished aluminium rod which fits into the neck, and is screwed into a brass block at the upper end. The tube is evacuated by a pipe, which passes some way down the pump tube from the camera end of the apparatus, thus serving as an injector, and preventing mercury vapour, from the pump, diffusing into the camera. The pressure in the cathode chamber is controlled by a leak of gas through a fine capillary tube, connected to a gas reservoir.

A fine beam of cathode rays, from the discharge tube, passes through a narrow brass tube in the anode block. The upper end of this tube is spun down and drilled with a 0.1 mm. diameter hole. By having a sloping upper face to the anode block, the axis of the discharge tube is made to point to one side of the fluorescent screen, at the lower end of the apparatus. The slightly divergent beam of electrons is focussed by the magnetic lens, and also deflected slightly by tilting the coils, so that an image of the hole in the brass tube is formed on the screen. In connection with focussing, it is interesting to note that, just as in the case of light, the magnification produced is V/U , where U and V are the object and image distances. The spot formed on the screen is, therefore, about 0.2 mm. in diameter in the case of this particular camera.

As a result of the biasing and deviation of the beam by the magnetic lens, the slower electrons form a tail to the spot and may be cut out by a diaphragm just above the specimen. The other components in the beam from the discharge tube, namely, light rays and negative ions, do not strike the screen. The light is not affected by the coil, and the negative ions are not appreciably deflected, so that these components remain trapped.

The specimen carrier, which is shown in detail in Fig. 36, may be used in any of the four ports of the specimen chamber, each of which has a standard ground surface. By inverting the whole specimen chamber the effective camera length may be halved, and is then

about 25 cms. The specimen carrier allows four independent motions of the specimen. By means of the two control heads, shown on the left of Fig. 36, the specimen may be advanced into the beam, and rotated in azimuth. Motion across the beam, and adjustment of the angle of inclination to the beam, are obtained by suitable compression of the flexible bellows by means of the adjusting screws.

The Comparison Shutter.—The recording section of the camera consists of a hollow, cubical, bronze casting, fitted to the lower end of the specimen chamber by a

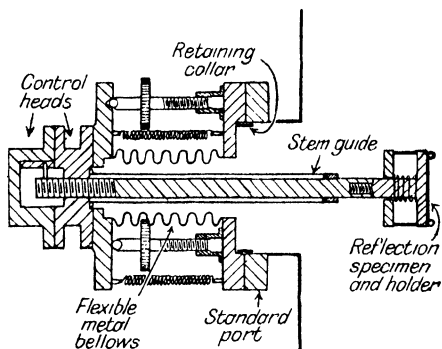

FIG. 36.—Specimen holder.

ground joint. At the bottom of one side of this casting is a rectangular port, with a ground surface, which may be closed by a brass plate, carrying a degassed rubber gasket, to make a vacuum-tight joint. On the inside of the brass plate is mounted the plate holder and the special shutter mechanism, shown in plan and elevation in Fig. 37. The photographic plate is held in a shallow recess in the brass frame K, and immediately above it is the shutter, which rotates about an axis OO' . The shutter is divided into two halves, A and B, either or both of which may be raised by the control heads F and E. A fluorescent screen covers both halves of the

shutter, and is loosely pivoted about OO' , so that it rises with either A or B.

By means of this comparison shutter, it is possible to make two exposures on one plate, one from the specimen under examination, and one from a standard specimen of known structure, both of which may be

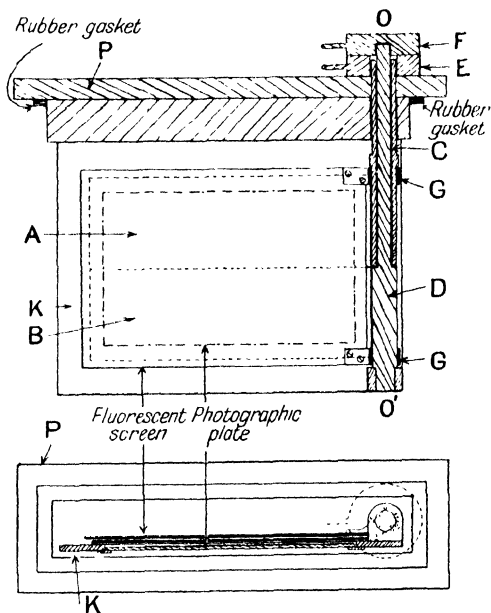

FIG. 37.—Comparison shutter in plan and elevation.

mounted on the same specimen holder and brought into the beam in turn. In this way the wave-length of the electrons used may be determined to within about 0.25 per cent.

For work requiring less accurate measurement, a smaller, somewhat modified form of this apparatus is used. The main point of difference is the omission

of the comparison shutter, the voltage being measured by a spark gap in the usual way.

A Double Acceleration Apparatus.—G. P. Thomson⁸ has recently designed an apparatus for use at voltages rather higher than are commonly used in electron diffraction work. By subjecting the electrons to a double acceleration, he has overcome the trouble caused by the cutting out of the ordinary gas discharge at voltages above about 80 kv.

The camera section of the apparatus is the same as the Thomson-Fraser type described previously, but

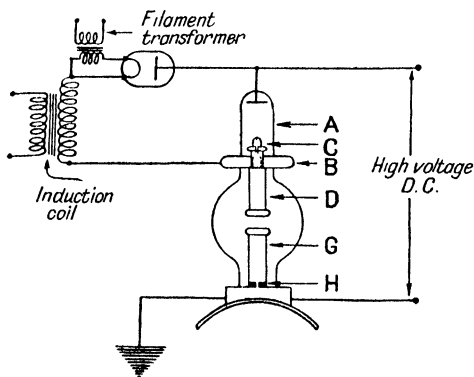

FIG. 38.—Double acceleration apparatus.

the discharge tube is replaced by an arrangement which is shown diagrammatically in Fig. 38. A discharge is passed in the upper tube A, the pressure in which is regulated by the ordinary type of leak to give a voltage drop across the tube of the order of 1000 volts. The supply for this discharge is obtained from an induction coil, and rectified by a valve. A fine pencil of cathode rays passes through a small hole C in the conical anode, and then through a copper tube D. The anode is mounted on an air-cooled copper block B. A high potential difference is maintained between the copper

tubes D and G, by means of a suitable high-tension supply. As the current which is taken from the smoothing condensers need be no greater than that carried by the fine beam of electrons passing through the hole C, a very constant voltage may be maintained. The beam which finally enters the specimen chamber is limited by a second hole H, 0.2 mm. in diameter. Owing to the fact that the block B is at high potential, it is necessary to insulate the pump which evacuates the discharge tube. This is done by mounting it on insulating pillars, and using a long leather belt between the pump and the driving motor.

General Considerations.—It would not be possible, nor is it desirable, to describe here all the different forms of camera at present used. Those that have been given are representative, and incorporate all the usual requirements. It will, however, be advantageous to consider the general conditions leading to accuracy and speed of operation.

The main sources of error in measurements of lattice spacings, by electron diffraction, are due to the following causes :—

- (a) Uncertainty in the voltage measurements.
- (b) Uncertainty in the effective camera length (i.e. the distance from the specimen to the plate).
- (c) Lack of sharpness in the rings or spots of the pattern.

The first of these difficulties may be overcome by use of some filtering device such as has already been described, or by use of a comparison shutter.

The actual distance from the screen or plate, to any known point on the specimen holder, may be determined very accurately by taking a series of transmission patterns from a film of known structure. The voltage of the electrons being known, it is an easy matter to calculate the distance from the film to the plate. A difficulty arises when a reflection specimen is used. Such specimens commonly have a length, in the direction

of the beam of about 1 cm., and the beam may be striking any part of the surface. Errors due to this may be diminished by using a smaller specimen, although this is not always convenient. Alternatively, a method which was first used for X-rays may be employed. A knife edge is adjusted over the crystal face, and perpendicular to the beam. By a suitable arrangement, it is possible to reduce the gap between the knife edge and the specimen to about 0.02 mm. At the small glancing angles used, this reduces the effective length of the specimen to about 2 mms.

The third source of inaccuracy, lack of resolution, may be due to the specimen itself, but it may also be caused by lack of homogeneity, or lack of definition in the beam. Homogeneity of the beam may be attained by one of the methods already mentioned. In order to produce a sharp pattern, the spot made by the main beam must be well defined and small. Such a beam may be produced by using very small anode holes, separated by a considerable distance, or, possibly rather more satisfactorily, by using a focussing coil in conjunction with one small anode hole. By suitably arranging the distance from this hole to the coil, and from the coil to the plate, the magnification may be made small. In connection with the use of such a coil, it should be noted that the specimen must be placed after the coil, and clear of the magnetic field, otherwise distortion or complete disappearance of the pattern will result.

The Speed of Operation.—With normal beam intensity, the exposure time required to obtain a diffraction photograph from any of a wide range of specimens, varies from a fraction of a second up to two or three seconds. Before exposing, however, it is necessary to evacuate the camera, and this process takes much more time (from 10 minutes up to about 40 minutes, depending upon the type of apparatus). The problem of increasing the speed at which photographs may be taken, therefore, largely resolves itself into a question

of vacuum technique. Rapidity of working may best be attained by high pumping speed, but may also be obtained by devices which enable several plates to be taken each time the apparatus is evacuated. Where this is done, several plates are usually mounted on a drum inside the apparatus, and may be brought into position in turn. In order to use such a device to the best advantage, it is necessary to have a specimen holder which carries several specimens, so that they may be brought into the beam in turn.

Apparatus for Use with Slow Electrons.—Owing to the technical difficulties and the unsatisfactory state of the theory connected with slow electrons, they have been very little used as a weapon for practical research. The apparatus usually employed is the same in principle as that of Davisson and Germer. The beam is produced by acceleration of a stream of electrons from a hot filament, and the diffraction pattern is investigated by a Faraday cylinder collector, connected to a galvanometer or electrometer. Owing to the slow speed of the electrons, and the necessity for preventing all contamination of the specimen, it is necessary to have the highest possible vacuum conditions. The whole apparatus has, therefore, to be enclosed in a sealed vessel, and all adjustments are made from outside, either magnetically or by tilting the container. Thus, even if the theory were satisfactory, the method would prove very tedious.

A form of apparatus, recently designed by Ehrenberg,⁹ greatly reduces the difficulties of observations with slow electrons. Instead of using an electrical detection method, the pattern is viewed on a fluorescent screen. The electron beam is produced by a gun of the usual type, and impinges on the specimen at a variable angle. Two cylindrical metal diaphragms, with slits in them in the plane of incidence, are arranged concentrically about an axis in the crystal face and perpendicular to the electron beam. Outside, and concentric with them, is the fluorescent screen, which is made of a

flexible material, mounted on a wire grid. A retarding potential, nearly equal to the initial voltage, is applied between the first two cylinders, the slits in which are covered with gauze. This field stops electrons which have lost energy by inelastic collisions. A high accelerating potential is applied between the outer diaphragm and the screen to make the electrons fast enough to cause fluorescence. The diffracted beams in the plane of incidence are not distorted, since all the fields are radial, and only these beams are observed. By means of such apparatus as this, more rapid advances in our knowledge of the diffraction of slow electrons are likely.

REFERENCES

- ¹ G. P. Thomson and C. G. Fraser, *Proc. Roy. Soc.*, **128**, 641, 1930.
- ² T. Yamaguti, *Proc. Phys. Math. Soc. Jap.*, **16**, 95, 1934.
- ³ G. I. Finch and A. G. Quarrell, *Proc. Roy. Soc.*, **141**, 398, 1933.
- ⁴ A. A. Lebedeff, *Nature*, Sept. 1931.
- ⁵ Busch, *Ann. de Phys.*, **81**, 974, 1926.
- ⁶ L. C. Martin, *Journ. Telev. Soc.*, **1**, 377, 1934.
- ⁷ G. I. Finch and A. G. Quarrell, *Proc. Phys. Soc.*, **46**, 148, 1934.
- ⁸ G. P. Thomson, *Trans. Faraday Soc.*, Sept. 1935.
- ⁹ W. Ehrenberg, *Phil. Mag.*, **18**, 878, 1934.

CHAPTER VI

APPLICATIONS

IN order fully to appreciate the usefulness of electron diffraction as an instrument of research, it is necessary to understand the type of problem which may most readily be investigated by this means. Such an understanding is, perhaps, best arrived at by consideration of the special features distinguishing X-ray and electron diffraction. The outstanding difference between the two cases is the very small penetrating power of even the fastest electrons used in diffraction work, which results from the readiness with which they are scattered and absorbed (i.e. inelastically scattered) by the atoms of the crystal lattice. In the case of electrons of the voltage usually used (~ 40 kv.), the atom scatters elastically about 10^7 times as efficiently as for X-rays, while the mean free path in a crystal, before inelastic scattering occurs, is of the order of 500 Å. At normal incidence the depth of penetration of fast electrons is of the order of 200 lattice planes, while at the small glancing angles employed in so-called reflection work, the penetration of the beam, normal to the surface, is of the order of 10 planes. As a result of this slight depth of penetration, electrons provide a very useful and convenient tool for the investigation of surface phenomena. X-ray crystal analysis and electron diffraction should be regarded as complementary, the first is unrivalled for the examination of material in bulk, while the latter has marked advantages for the investigation of surface structure, thin films and free

molecules. A further advantage of electron diffraction, which has already been mentioned in connection with scattering in vapours, is that owing to the ease with which electrons are scattered, the intensity of the diffraction pattern is high, so that only very short exposure times are necessary for photographic purposes. As compared with the exposure time necessary with X-rays, which may be of the order of hours, the few seconds required with electrons represents a considerable saving of time. This is partly offset by the necessity for evacuating the apparatus, as has been pointed out in the previous chapter.

Special Applications of Electron Diffraction.—A few references to the applications of electron diffraction have already been made in earlier parts of the book. Its use to determine the interatomic distances, and the molecular form of substances in the vapour state has been described, and also the way in which the inner potential of crystals may be deduced from electron diffraction patterns. In this section a few of the more practical applications will be explained, since these will have a greater appeal to the general reader, and are just as useful for demonstrating the principles of the subject.

Lubrication by Graphite.—Jenkins¹ used electron diffraction to study the mechanism of graphite lubrication and to compare the properties of graphite with those of amorphous carbon. In preliminary experiments, diffraction patterns were produced by reflection from a polycrystalline graphite surface and from a single crystal cleavage face. The polycrystalline surfaces were prepared by depositing fine graphite powder, from alcoholic suspension, on a ground glass specimen. Similar specimens were prepared, using Aquadag (a suspension of colloidal graphite in water prepared by E. G. Acheson Ltd.). Both these types of specimen gave a ring pattern, in agreement with those obtained by Hull with X-rays, the only difference being that the specimens prepared with colloidal graphite gave

rather more diffuse rings than the other specimens, indicating that the crystal size was less in this case. The single crystal cleavage faces produced a pattern of spots. Several orders of the spot from the cleavage face appeared along the centre line of the pattern, on account of the slight curvature of the crystals used. This has the effect of producing a rotation pattern. These spots showed the effect of inner potential, and this was measured in the usual way.

The polycrystalline specimens mentioned above were then polished by rubbing gently with a pad of cotton wool. As a result of this, the diffraction pattern was completely altered. The rings almost disappeared, leaving a central row of diffuse spots, or short arcs, corresponding to the various orders of reflection from the cleavage plane, and also two faint rows of side spots. The central row of spots corresponded with the central row in the single crystal pattern, while the rows of side spots were analogous to rows of side spots obtained with the single crystal in certain azimuths. This pattern was due to the orientation of all the small crystals into a setting with the main cleavage plane parallel to the specimen surface. Also it was apparent, from the diffuseness of the spots, that the crystal size had been still further reduced by the polishing. Other polished specimens, prepared in a variety of ways, showed the same type of pattern.

A specimen of amorphous carbon was prepared by rubbing an amorphous arc carbon on a piece of ground glass. A flat mirror-like surface was produced, although it was not as bright as graphite. The diffraction pattern from this specimen consisted of three strong diffuse rings, corresponding with the strongest rings in the graphite pattern, but showed practically no sign of orientation such as is shown by graphite treated in the same way.

Prolonged polishing of such a specimen caused it to show signs of orientation, but produced no apparent reduction in crystal size. The suggested explanation

is that amorphous carbon consists of aggregates of very small graphite crystals tightly bound together. The first polish smooths the surface without producing orientation, while subsequent polishing breaks up the aggregates and produces orientation without reducing the crystal size.

A final experiment was carried out to see whether a metal bearing surface, lubricated with oil containing colloidal graphite, would become coated with an adsorbed film of graphite. A flat, polished specimen of Swedish iron was rubbed for three hours on a flat iron table, the surfaces being lubricated with Oildag. The surface of the specimen was then washed several times in benzene, and swabbed with cotton wool. Diffraction patterns showed both graphite and iron rings. Further washing failed to remove the graphite film. When the specimen was rubbed hard on a pad of cotton wool, the pattern showed that the crystals had started to orientate and become smaller. Also, the rings due to the metal were almost suppressed, which seemed to indicate that the graphite film had spread over the whole surface.

More recently Finch has studied the same problem. He finds that very thin films of graphite, deposited by evaporating Aquadag, show orientation even before polishing. He also finds that a specimen of cast iron polished on emery paper yields a graphite pattern showing partial orientation. Mild steel treated in the same way gives the ordinary α iron pattern. This ability to coat itself with a graphite film is undoubtedly the source of the so-called self-lubricating properties of cast iron.

Oils and Greases.—Another problem in lubrication, of a rather different nature, has been studied by Murison.² Adam, Langmuir, Rideal and others have shown from their study of monomolecular films of long chain compounds on water, that, if the molecules are long and have a water-attracting group at one end, then they pack together closely side by side, and orientate with

their long axes at a steep angle to the water surface. If, on the other hand, they are short and have a water attracting group at both ends, then they lie flat on the water, and move about freely. X-ray examination of thicker films of the first type shows that the molecules are arranged so that their ends lie in sheets parallel to the surface. The X-ray patterns obtained from such films are easily explained by considering the molecule to contain uniform density of scattering matter along its length. The gap between the sheets of molecules is then the periodic discontinuity which gives rise to the diffraction pattern. If similar films are examined by electron diffraction by reflection, the spacing corresponding to the length of the molecule is so great that the diffraction pattern produced by it will lie too close to the central spot to be distinguishable.

Various types of pattern were actually obtained, with electrons, from oils and greases, and these were explained in terms of scattering by successive carbon atoms in the long chain. The patterns obtained were classified by Murison in the following way :—

- (a) A pattern of straight lines, parallel to the shadow edge.
- (b) A straight line pattern similar to the above, but with spots on the lines (Fig. 39).
- (c) Sharp rings.
- (d) Diffuse rings, or lines curved at the ends.
- (e) Diffuse rings.
- (f) Diffuse rings with one spot inside the second ring.

The first two types of pattern were produced mainly by greases and very heavy oils. The spacing between the lines was not uniform, on account of inner potential, but when this was allowed for, it was found that the spacing corresponding to the distance between the lines agreed with the value of 2.54 \AA , found by X-rays for the distance between alternate carbon atoms in the flat zigzag structure of the carbon chain. The patterns

may be explained if it is assumed that the chains are perpendicular to the surface. Suppose the molecules are orientated in this way, but otherwise at random. The electron beam is incident almost normal to the length of the molecules, so that the intensity of scattering will be a maximum over a series of cones with the molecule as axis. The cones will intersect the plate in hyperbolæ, but owing to the large semi-vertical angle of the cones corresponding to the low diffraction orders, these will appear as straight lines on the plate. This accounts for pattern (a). If, now, some of the molecules are packed closely side by side in small groups, the

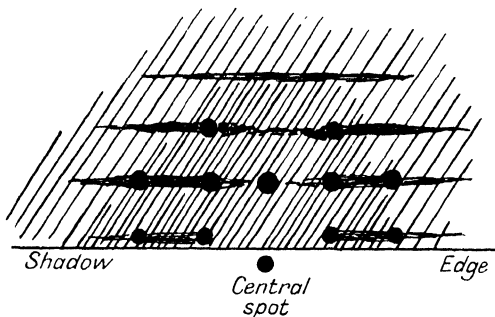

FIG. 39.—A grease pattern.

stronger spots corresponding to the side spacings of the chains will appear. As the grouping continues, the spots become more marked, and the lines tend to disappear, although they never go completely, showing that not all the molecules form close packed groups. This is the way in which pattern (b) is produced. It was found that mixtures of hydrocarbons showed more tendency to orientate than pure substances, and it is suggested that this is due to the tendency of the latter to form small crystalline lumps, disposed at random. The sharp ring patterns were produced mainly by pure substances, which were known to crystallise readily, and were

undoubtedly due to a random distribution of small crystals.

The (*d*) type of pattern was produced mostly by fatty acids and alcohols, and may be explained as being due to the scattering of the beam by molecules making a definite angle with the specimen surface, but otherwise distributed at random.

The last two types of pattern was produced by oils. It has been shown by Trillat with X-rays, and by Rupp with slow electrons, that the top layer of molecules on an oil film is orientated with the long axes perpendicular to the surface. The diffuse ring patterns obtained by Murison are similar to those obtained by Mark and Wierl with vapours, and may be interpreted in the same way. More recently, Maxwell, in America, has obtained similar haloes by transmission through thin oil films. When the films were very thin, some of the oils gave the pattern showing one spot inside the second ring. This spot was analogous to the strong spot, on the second line of the grease pattern, and showed that the oil was beginning to orientate.

Murison was able to draw very definite and useful conclusions about the lubricating properties of various oils. He concluded¹ that orientation is more likely to occur with impure rather than pure substances, the latter tending to form polycrystalline layers. In the case of grease, some free molecules are always present, and these facilitate the sliding of the packed groups parallel to each other. Further, the orientation of the molecules indicates a strong attractive force between the substrate and the grease, so that the oils and greases showing the most marked orientation are least likely to be squeezed out from the bearing surfaces by pressure. It was found that the higher the molecular weight the more likely was the oil to orientate, so that it may be concluded that the lubricating power will increase with molecular weight. This is in agreement with the work of Sir Wm. Hardy on the lubricating properties of pure liquid long chain compounds.

Molecular Layers of Grease.—Trillat³ has examined many organic substances, in the form of thin films, by electron diffraction. The patterns obtained are in most cases those which would be expected from the known X-ray structure of the substances producing them, but some specimens produce a pattern not in accordance with X-ray measurements, while others give extra spots and rings in addition to the expected pattern. Similar extra rings, obtained with inorganic films, have been mentioned in Chapter III, where the explanation of them suggested by Finch has been given. Trillat has advanced another theory, and his work would seem to show that, in some cases at least, this must be the true one. He suggests that the extra or spurious rings and spots are due to a very thin (possibly monomolecular) layer of grease on the specimen. If the grease molecules are orientated perpendicular to the film, and closely packed, they will appear as a cross grating, when viewed normally to the film. If the film is covered by many such groups of molecules, distributed at random on the surface, a typical sharp ring pattern will be produced when an electron beam is fired through the film. If, on the other hand, the groups are all packed together, they will form a pseudo single crystal film and produce a typical cross grating pattern, consisting of an array of spots. Trillat has shown that the first type of pattern slowly gives place to the second type, if the film is kept long enough, thus indicating that the orientation of the groups becomes more complete as time passes.

Even more recently, Lark-Horovitz, Yearian and Howe⁶ have performed experiments somewhat similar to those of Trillat, and they also have been led to attribute the extra rings to thin layers of organic impurities.

Oxide Layers on Metals.—As a result of electron diffraction examination of a film of zinc oxide, formed by exposing a polycrystalline zinc surface in oxygen at room temperature, Finch and Quarrell⁴ have been able to throw considerable light on the way in which the oxide layer is formed. They found that the oxide which, like

the zinc itself, is hexagonal in structure, appeared in a modified form when prepared as described. The basal plane of the unit cell is contracted so that it conforms to the zinc spacing, while the hexagonal axis of the cell is increased to keep the volume of the cell constant. When such a film is heated, the modified oxide breaks up into smaller crystals of the normal zinc oxide, thus exposing the zinc surface afresh, and allowing more of the abnormal oxide to form.

Oxides on Molten Metals.—Jenkins⁵ has examined the oxide films formed on several of the metals having low melting-points. He melted the metals *in vacuo*, scraped the surface clean, and then examined it by electron diffraction. The resulting patterns showed that in all cases oxides were present in the form of very small crystals, orientated with one particular face parallel to the metal surface. When the metals were allowed to solidify slowly, large crystals of the metal formed, and the oxide layer on these gave a single crystal pattern.

Further Applications.—A few of the other problems that have been investigated by electron diffraction may only be briefly mentioned here. The method has been used to examine the structure and poisoning of oxide coated filaments, the catalytic activity of platinum films, and the nature of the platinum deposit on platinised asbestos. Much light has been thrown on the interesting question of the formation of a liquid or amorphous layer on the surface of polished metals. The existence of such a layer was first suggested by Beilby, as a result of his microscopic examination of various polished surfaces. Its existence was not universally accepted, but recently the considerable research which has been carried out on this problem, by means of electron diffraction methods, would seem to show that such a layer does exist. The pattern from a polished metal consists of two diffuse rings, these being two orders of diffraction due to a predominating spacing, namely the least distance of approach of the atoms, which is found to be roughly the same for all metals.

Surface Structure.—As a conclusion to this chapter, it will be suitable to summarise the ways in which electron diffraction may be used to gain information about the small scale structure of surfaces, i.e. about those features of the surface which are submicroscopic, yet not necessarily so fine as the structure of the crystal lattice itself.

Let us consider first of all what may be learnt about the nature of single crystal cleavage faces. At the beginning of Chapter IV we have discussed Kirchner's method of regarding the diffraction conditions for a cleavage face, and also the way in which relaxation of these conditions affects the pattern. We have shown that the Bragg condition is usually more or less relaxed, for a reason which is not yet completely understood, but which is tentatively attributed to lack of penetration. The second condition, resulting from the interference of wavelets from successive atoms in the direction of the beam, which we will call the circle condition, is frequently relaxed on account of imperfection of the crystal face. The third condition is very seldom relaxed, since it is less affected by crystal imperfection. Therefore, for our present purpose, it is the relaxation of the circle condition which will afford most information. If the crystal face is broken into very small blocks, of the order of 20 atoms square, this diffraction condition will be relaxed. As a result, since we may assume the first condition to be partially relaxed, the spots will be spread out into short lines, perpendicular to the shadow edge. The length of the lines will afford a rough indication of the size of the crystal blocks, but, as the extent to which the Bragg condition is relaxed is not known, this estimate can only be very approximate. If the limitation of the spread were due to the circle condition only, i.e. if the Bragg condition were completely relaxed, it would be possible to form a close estimate of the crystal size.

There is another way in which a very similar pattern may be produced. Suppose a crystal face is broken into blocks, which, though small, are large enough to make the circle condition rigid, but which are tilted

through a few degrees, one with respect to another. The spots would then become lines perpendicular to the shadow edge. Apart from a slight sideways spread of the spots in this case, the pattern produced would be very similar to the one described above. It is possible to distinguish between the two cases, however, by observing the Kikuchi lines. In the first case, sharp Kikuchi lines should appear, while in the second case, the lines would be very blurred, or would disappear entirely. It is necessary to remember that, although the Bragg condition is relaxed for the spots, it remains rigid in the case of the Kikuchi lines. Thus by means of the spot and Kikuchi line pattern, we may decide whether a cleavage face is perfect over areas of more than about 10^{-5} cms. square or not, and if it is not perfect, we can get some idea of the type of imperfection present.

As has been explained, etched single crystals give a cross grating pattern, due to the penetration of the beam through small projections on the crystal surface. From consideration of the radius of the zone over which the cross grating spots are intense, it is possible to form a rough estimate of the thickness of the lumps by using the expression (3) of Chapter III. Any estimate of the thickness of the lumps arrived at in this way, depends upon the assumption that the crystal is undistorted, since distortion will increase the radius of the zone, thus making the apparent thickness of the projections less. Kikuchi lines again form a criterion of perfection. If sharp lines are present, the crystal must be sensibly perfect. The dimensions of the areas of the projections presented to the beam may be estimated roughly from the sharpness of the individual spots of the pattern. The angular half width of any spot will be approximately given by the expression $\phi = \lambda/x$, where ϕ is the half width and x is the extent of the lumps in a direction parallel to the direction in which the spread of the spot is measured.

The structure of polycrystalline surfaces may be examined by similar methods. The width of the diffraction rings gives information about the crystal size, although

it is necessary to be very careful in drawing conclusions from such measurements. Very small crystals, less than 20 atoms square, cannot give rise to sharp rings, but it does not necessarily follow that diffuse rings are due to small crystals. Where the crystals are fairly large, it is possible for the beam to enter and leave some crystal by the same face, at glancing angles. A diffracted spot will be produced, which will be, more or less, pulled in towards the central spot by refraction. If this occurs in the case of many crystals distributed at random, rings will be formed which will be diffuse on the inside. The outsides of the rings will be sharp, being due to electrons which have penetrated the finer projections. Several cases where this effect seems to be operative have been observed.

REFERENCES

- ¹ R. O. Jenkins, *Phil. Mag.*, **17**, 457, 1934.
- ² C. A. Murison, *Phil. Mag.*, **17**, 201, 1934.
- ³ Trillat, *Trans. Faraday Soc.*, Sept. 1935.
- ⁴ G. I. Finch and A. G. Quarrell, *Proc. Roy. Soc.*, **141**, 398, 1933 ;
A. G. Quarrell, *Proc. Phys. Soc.*, **46**, 148, 1934.
- ⁵ R. O. Jenkins, *Proc. Phys. Soc.*, **47**, 1934.
- ⁶ Lark-Horovitz, Yearian and Howe, *Phys. Rev.*, July 1935.

SUBJECT INDEX

- | | |
|--|--|
| <p>Absorption, 66, 67</p> <p>Atomic scattering factor, 35</p> <p style="padding-left: 2em;">" " " experimental determination of, 38</p> <p>Bands, 69</p> <p>Body-centred cubic structure, 11</p> <p>Bragg condition, 9</p> <p>de Broglie, law, 3, 15, 25</p> <p style="padding-left: 2em;">" wave-length, 3</p> <p>Celluloid, 16</p> <p>Comparison shutter, 86</p> <p>Conditions for diffraction, 9, 50</p> <p style="padding-left: 2em;">" relaxation of, 51</p> <p>Cross grating, pattern from, 23, 29</p> <p style="padding-left: 2em;">" " small crystal block as a, 31</p> <p>Crystal, as a grating, 6, 29</p> <p style="padding-left: 2em;">" lattice, 7</p> <p style="padding-left: 2em;">" size, effect of, 32</p> <p>Diffraction cameras, 21, 84</p> <p style="padding-left: 2em;">" by a nickel crystal, 12</p> <p style="padding-left: 2em;">" by a ruled grating, 25</p> <p style="padding-left: 2em;">" of β-rays, 26</p> <p style="padding-left: 2em;">" of slow electrons, 12, 62, 91</p> <p>Dispersion theory of diffraction, 65</p> <p>Double acceleration apparatus, 88</p> | <p>Extra rings, 34, 100</p> <p>Face-centred cubic structure, 13</p> <p>Fine structure, 63</p> <p>Forbidden orders, 63</p> <p>Free molecules, scattering by, 43</p> <p>Gases, scattering in, 40</p> <p>Graphite, 94</p> <p>Greases, 96</p> <p style="padding-left: 2em;">" molecular layers of, 100</p> <p>Group velocity, 5</p> <p>High-tension supply, 77, 79, 88</p> <p style="padding-left: 2em;">" " filters, 78</p> <p style="padding-left: 2em;">" " measurement of, 19, 23, 78, 86</p> <p>Hot cathode tube, 80</p> <p>Inelastic scattering, 25, 68</p> <p>Inner potential, 16</p> <p style="padding-left: 2em;">" " apparent variation of, 59</p> <p style="padding-left: 2em;">" " effects of, 54</p> <p style="padding-left: 2em;">" " measurement of, 55</p> <p style="padding-left: 2em;">" " measurement by slow electrons, 16, 62</p> <p>Kikuchi lines, 24, 67</p> <p style="padding-left: 2em;">" " envelope of, 69</p> <p style="padding-left: 2em;">" " intersection of, 68</p> <p style="padding-left: 2em;">" " production of, 24</p> <p>Laue number, 9</p> <p>Lubrication, 94, 97</p> |
|--|--|

- | | |
|-----------------------------------|----------------------------------|
| Magnetic focussing, 26, 81 | Single crystal, etched, 72 |
| Metal films, 17, 34 | " " reflection by, 22, |
| Mica, 22 | 49 |
| Miller indices, 7 | " " transmission |
| Multiple scattering, 25, 68 | through a, 22, |
| | 29 |
| Net plane, 7 | Structure factor, 11 |
| Oils, 96 | Surface, pattern, 51, 66 |
| One-dimensional diffraction, 69 | " structure, 102 |
| Orientation, effects of, 32, 75 | |
| Oxides on metals, 100 | Transmission through thin films, |
| | 16, 22, 29 |
| Particle velocity, 3, 4, 6 | |
| Penetration, 51, 66 | Unit cell, 7 |
| Polycrystalline block, reflection | |
| from, 22, 74 | Wave equation, 4 |
| Reciprocal lattice, 73 | |
| Relativity correction, 20, 58 | Zone axis, 28 |

NAME INDEX

- Arnot, F. L., 41
 Bethe, H., 54, 65
 Born, M., 35
 Bragg, W. L., 9, 28
 Broglie, L. de, 1
 Bullard, E. C., 41
 Busch, H., 81

 Darbyshire, J. A., 55
 Darwin, C. G., 65
 Davisson, C., 12, 15, 55
 Debye, P., 17, 45
 Dixit, K. R., 55
 Dymond, E. G., 41

 Ehrenberg, W., 91
 Emslie, A. G., 69
 Ewald, P. P., 65

 Farnsworth, H. C., 55, 62
 Faxen, H., 43
 Finch, G. I., 34, 72, 79, 84, 100
 Fraser, C. G., 77

 Germer, L. H., 12, 55, 73

 Harding, J. W., 66
 Holtsmark, J., 43
 Howe, J. D., 100
 Hughes, J. V., 26

 Jenkins, R. O., 94, 101

 Kikuchi, S., 22
 Kirchner, F., 49

 Lark-Horovitz, K., 100
 Lasckarew, W. E., 59, 63
 Laue, M. v., 6
 Lebedeff, A. A., 81

 Mark, H., 38, 45
 Martin, L. C., 81
 Massey, H. W. S., 41
 Morse, P. M., 16
 Mott, N. F., 35, 39
 Murison, C. A., 96

 Ponte, M., 25

 Quarrell, A. G., 72, 100

 Ramsauer, C., 40
 Reid, A., 16
 Rupp, E., 25, 26, 55

 Scherrer, P., 17
 Shinohara, K., 55, 58, 68, 69,
 72
 Sommerfeld, A., 54

 Thomson, G. P., 16, 26, 38, 72,
 77, 88
 Tillman, J. R., 26, 55, 71
 Trillat, J. J., 99, 100

 Watson, E. E., 41
 Wierl, R., 38, 45
 Wilman, H., 72
 Worsnop, B. L., 26

 Yamaguti, T., 55, 59, 78
 Yearian, H. J., 100

PRINTED IN GREAT BRITAIN AT
THE UNIVERSITY PRESS, ABERDEEN

METHUEN

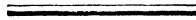

Books on
PHYSICS & CHEMISTRY

A SELECTION OF BOOKS ON PHYSICS AND CHEMISTRY

PHYSICS

GENERAL PHYSICS

- GRADED EXAMPLES IN PHYSICS.** By R. L. CHEETHAM. With 5 Diagrams. *Fcap. 8vo.* 1s. 9d. (Up to School Certificate Standard.)
- A PHYSICS NOTEBOOK: HEAT, LIGHT AND SOUND.** By E. W. TAPPER. With 53 Diagrams. *Fcap. 8vo.* 2s.
- TEST EXAMINATIONS IN PHYSICS.** By A. W. ANSCOMBE. *Third Edition.* 1s. 3d.
- HIGHER CERTIFICATE PHYSICS TEST PAPERS.** By A. H. COOPER, M.Sc., B.A. With Answers. *Fourth Edition.* *Fcap. 8vo.* 1s. 6d.
- EXAMPLES IN PHYSICS.** By C. E. JACKSON, M.A. With Answers. *Tenth Edition.* *Crown 8vo.* 3s. Also Part I (Secondary Course), 1s. 6d.; Part II (Scholarship Course), 1s. 9d.
- THE PROPERTIES OF MATTER.** By A. E. GODDARD and H. F. BOULIND, M.A. With 115 Diagrams. *Crown 8vo.* 4s. Also in two parts, 2s. 6d. each.
- A TEXTBOOK OF INTERMEDIATE PHYSICS.** By H. MOORE, D.Sc., A.R.C.Sc., F.Inst.P. With 560 Diagrams. *Fourth Edition.* *Demy 8vo.* 18s. net.
- ADVANCED PRACTICAL PHYSICS FOR STUDENTS.** By B. L. WORSNOP, B.Sc., Ph.D., and H. T. FLINT, M.Sc., Ph.D. With 404 Diagrams and Illustrations. *Third Edition.* *Demy 8vo.* 21s. net.
- THE KINETIC THEORY OF GASES.** By EUGÈNE BLOCH, Professor at the Lycée St. Louis. Translated by P. A. SMITH, B.A. *Second Edition, Revised.* *Crown 8vo.* 7s. net.
- THERMIONIC PHENOMENA.** By EUGÈNE BLOCH. Translated by J. R. CLARKE, M.Sc., F.Inst.P. With 24 Diagrams. *Crown 8vo.* 7s. 6d. net.
- MODERN PHYSICS.** A General Survey of its Principles. By THEODOR WULF, S.J. Translated from the German by C. J. SMITH, Ph.D., M.Sc., A.R.C.S. With 202 Diagrams. *Royal 8vo.* 35s. net.
- CRYSTALS AND THE FINE-STRUCTURE OF MATTER.** By FRIEDRICH RINNE. Translated by WALTER S. STILES, B.Sc. With a Drawing by A. DÜRER, and Portraits of the leading investigators, and 203 Figures. *Demy 8vo.* 10s. 6d. net.
- OPTICS.** By H. T. FLINT, Ph.D. With 130 Diagrams. *Crown 8vo.* 7s. 6d.
- THE PRINCIPLES OF PHYSICAL OPTICS.** By ERNST MACH. Translated by JOHN S. ANDERSON, M.A., D.Sc., Ph.D., and A. F. A. YOUNG, B.Sc., Ph.D. With 290 Illustrations. *Demy 8vo.* 21s. net.

BOOKS ON PHYSICS AND CHEMISTRY

- MODERN MAGNETICS.** By FELIX AUERBACH. Translated by H. C. BOOTH, A.R.C.Sc. With 167 Diagrams. *Demy 8vo.* 15s. *net.*
- RADIOACTIVITY: AND THE LATEST DEVELOPMENTS IN THE STUDY OF THE CHEMICAL ELEMENTS.** By K. FAJANS. Translated by T. S. WHEELER, B.Sc.(Lond.), A.R.C.Sc.I., A.I.C.; and W. G. KING. With 25 Diagrams and Tables. *Demy 8vo.* 8s. 6d. *net.*
- X-RAYS.** By MAURICE DE BROGLIE. Translated by J. R. CLARKE, M.Sc., F.Inst.P. With 7 Illustrations and 39 Diagrams. *Demy 8vo.* 12s. 6d. *net.*
- THE NEW HEAT THEOREM: ITS FOUNDATIONS IN THEORY AND EXPERIMENT.** By W. NERNST. Translated by GUY BARR, B.A., D.Sc. With 21 Diagrams. *Demy 8vo.* 12s. 6d. *net.*
- THEORETICAL PHYSICS.** By W. WILSON, F.R.S. In Three Volumes. *Demy 8vo.* Vol. I. MECHANICS AND HEAT (Newton—Carnot). With 80 Diagrams. 21s. *net.* Vol. II. ELECTROMAGNETISM AND OPTICS (Maxwell—Lorentz). With 78 Diagrams. 18s. *net.*
- MODERN THERMODYNAMICS BY THE METHODS OF WILLARD GIBBS.** By E. A. GUGGENHEIM, M.A. With 10 Diagrams. *Demy 8vo.* 10s. 6d. *net.*

METHUEN'S MONOGRAPHS ON PHYSICAL SUBJECTS

General Editor: B. L. WORSNOP, B.Sc., Ph.D.

Illustrated. *Fcap.* 8vo. Each 2s. 6d. *net* except where otherwise stated.

- SPECTRA.** By R. C. JOHNSON, M.A. (Oxon.). *Second Edition, Revised.*
- WAVE MECHANICS.** By H. T. FLINT, D.Sc., Ph.D. *Second Edition, Revised and Enlarged.* 3s. 6d. *net.*
- THE PHYSICAL PRINCIPLES OF WIRELESS.** By J. A. RATCLIFFE, M.A. *Third Edition, Revised and Enlarged.*
- THE CONDUCTION OF ELECTRICITY THROUGH GASES.** By Prof. K. G. EMELÉUS, M.A., Ph.D.
- MAGNETISM.** By E. C. STONER, Ph.D. *Second Edition, Revised and Enlarged.* 3s. *net.*
- X-RAYS.** By B. L. WORSNOP, B.Sc., Ph.D.
- X-RAY CRYSTALLOGRAPHY.** By R. W. JAMES, M.A., B.Sc.
- THE COMMUTATOR MOTOR.** By Prof. F. J. TEAGO, D.Sc.
- THE APPLICATIONS OF INTERFEROMETRY.** By W. EWART WILLIAMS, M.Sc.
- PHOTOCHEMISTRY.** By D. W. G. STYLE, B.Sc., Ph.D.
- THERMODYNAMICS.** By Prof. A. W. PORTER, D.Sc., F.R.S.
- THERMIONIC VACUUM TUBES.** By Prof. E. V. APPLETON, M.A., D.Sc., F.R.S. *Second Edition, Revised.* 3s. *net.*
- WIRELESS RECEIVERS.** By C. W. OATLEY, M.A., M.Sc.
- ATMOSPHERIC ELECTRICITY.** By B. F. J. SCHONLAND, M.A.
- THE METHOD OF DIMENSIONS.** By Prof. A. W. PORTER, D.Sc.
- COLLISION PROCESSES IN GASES.** By F. L. ARNOT, B.Sc. 3s. *net.*

METHUEN'S BOOKS ON

- ELECTROMAGNETIC WAVES.** By F. W. G. WHITE, M.Sc. 3s. net.
PHYSICAL CONSTANTS. By W. H. J. CHILDS, B.Sc., Ph.D.
THE GENERAL PRINCIPLES OF QUANTUM THEORY. By Prof. G. TEMPLE, Ph.D., D.Sc. 3s. net.
THE KINETIC THEORY OF GASES. By Prof. MARTIN KNUDSEN.
LOW TEMPERATURE PHYSICS. By L. C. JACKSON, M.Sc. 3s. net.
HIGH VOLTAGE PHYSICS. By L. JACOB, M.Sc. 3s. net.
RELATIVITY PHYSICS. By W. H. McCREA, M.A., B.Sc.
FINE STRUCTURE IN LINE SPECTRA AND NUCLEAR SPIN. By S. TOLANSKY, B.Sc., Ph.D. 3s. net.
INFRA-RED AND RAMAN SPECTRA. By Dr. G. B. B. M. SUTHERLAND, M.A. 3s. net.
THERMIONIC EMISSION. By T. J. JONES, M.Sc. 3s. net.
ELECTRON DIFFRACTION. By R. BEECHING, B.Sc. 3s. net.
THE EARTH'S MAGNETISM. By S. CHAPMAN, M.A. 3s. 6d. net.

In Preparation

- SURFACE TENSION.** By ALLAN FERGUSON, M.A., D.Sc.
THE NUCLEUS. By Prof. J. A. CROWTHER, M.A., D.Sc.
TELEVISION. By A. G. D. WEST, M.A., B.Sc.
MERCURY ARCS. By Prof. F. J. TEAGO, D.Sc.

ATOMIC AND QUANTUM THEORIES

- MAGNETISM AND MATTER.** By EDMUND C. STONER, Ph.D. With 87 Diagrams. *Demy 8vo.* 21s. net.
AN INTRODUCTION TO ATOMIC PHYSICS. By JOHN THOMSON. With 36 Diagrams. *Demy 8vo.* 10s. 6d. net.
THE STRUCTURE OF SPECTRAL TERMS. By W. M. HICKS, Sc.D. With 6 Diagrams. *Demy 8vo.* 10s. 6d. net.
THE BASIS OF MODERN ATOMIC THEORY. By C. H. DOUGLAS CLARK, B.Sc., D.I.C. With 44 Diagrams. *Crown 8vo.* 8s. 6d. net.
THE CHEMICAL ELEMENTS. By F. H. LORING. *Demy 8vo.* 8s. 6d. net.
ATOMIC THEORIES. By F. H. LORING. With 67 Figures. *Second Edition, Revised.* *Demy 8vo.* 12s. 6d. net.
ATOMIC STRUCTURE AND SPECTRAL LINES. By ARNOLD SOMMERFELD. Translated by HENRY L. BROSE, D.Sc. With 151 Diagrams. *Third Edition, Revised.* In two volumes. *Demy 8vo.* Vol. I. 35s. net.
WAVE-MECHANICS. By ARNOLD SOMMERFELD. Translated by HENRY L. BROSE. With 33 Diagrams. *Demy 8vo.* 21s. net.
THREE LECTURES ON ATOMIC PHYSICS. By ARNOLD SOMMERFELD. Translated by HENRY L. BROSE. With 8 Diagrams. *Cr. 8vo.* 2s. 6d. net.
AN INTRODUCTION TO THE STUDY OF WAVE MECHANICS. By LOUIS DE BROGLIE. Translated by H. T. FLINT. *Demy 8vo.* 12s. 6d. net.
THE THEORY OF THE BROWNIAN MOVEMENT. By ALBERT EINSTEIN. Translated by A. D. COWPER, M.Sc. *Crown 8vo.* 5s. net.
THE NEW PHYSICS. By ARTHUR HAAS, Ph.D. Translated by R. W. LAWSON, D.Sc. *Third Edition, Revised and Enlarged.* *Crown 8vo.* 6s. net.

PHYSICS AND CHEMISTRY

- THE QUANTUM THEORY.** By FRITZ REICHF. Translated by H. S. HATFIELD and H. L. BROSE. *Third Edition, Revised.* Crown 8vo 6s. net.
- THE QUANTUM AND ITS INTERPRETATION.** By H. STANLEY ALLEN, M.A., D.Sc. With 30 Diagrams. Demy 8vo. 12s. 6d. net.
- THE ELEMENTS OF THE NEW QUANTUM MECHANICS.** By OTTO HALPERN and HANS THIRRING. Translated by H. L. BROSE, M.A., D.Phil. With 13 Diagrams. Demy 8vo. 12s. 6d. net.
- THE THEORY OF GROUPS AND QUANTUM MECHANICS.** By H. WEYL. Translated by H. P. ROBERTSON. Demy 8vo. 21s. net.

RELATIVITY

- AN INTRODUCTION TO THE THEORY OF RELATIVITY.** By LYNDON BOLTON, M.A. With 38 Diagrams. *Second Edition, Revised.* Crown 8vo. 5s. net.
- RELATIVITY: THE SPECIAL AND THE GENERAL THEORY.** A Popular Exposition. By ALBERT EINSTEIN, Ph.D. Authorized Translation by ROBERT W. LAWSON, D.Sc. With 5 Diagrams and a Portrait of the Author. *Eleventh Edition.* Crown 8vo. 5s. net.
- SIDELIGHTS ON RELATIVITY: I. ETHER AND RELATIVITY; II. GEOMETRY AND EXPERIENCE.** By ALBERT EINSTEIN. Translated by G. B. JEFFERY, D.Sc., and W. PERRETT, Ph.D. Crown 8vo. 3s. 6d. net.
- THE MEANING OF RELATIVITY.** By ALBERT EINSTEIN. Translated by E. P. ADAMS. With 4 Diagrams. *Second Edition.* Crown 8vo. 5s. net.
- RELATIVITY FOR PHYSICS STUDENTS.** By G. B. JEFFERY, M.A., D.Sc. With 4 Diagrams. Crown 8vo. 6s. net.
- THE PRINCIPLE OF RELATIVITY.** By ALBERT EINSTEIN, H. A. LORENTZ, H. MINKOWSKI, and H. WEYL. With Notes by A. SOMMERFELD. Translated by W. PERRETT, Ph.D., and G. B. JEFFERY, D.Sc. With 8 Diagrams. Demy 8vo. 12s. 6d. net.
- THE FOUNDATIONS OF EINSTEIN'S THEORY OF GRAVITATION.** By ERWIN FREUNDLICH. Translated by HENRY L. BROSE, M.A. Crown 8vo. 6s. net.
- THE THEORY OF RELATIVITY.** By ERWIN FREUNDLICH. Translated by HENRY L. BROSE, M.A. Crown 8vo. 5s. net.

CHEMISTRY

METHUEN'S MONOGRAPHS ON CHEMICAL SUBJECTS

General Editor: C. S. SALMON, M.Sc.

Illustrated. Fcap. 8vo. Each 2s. 6d. net except where otherwise stated.

- THE ADSORPTION OF GASES BY SOLIDS.** By S. J. GREGG, B.Sc.
- THE CHEMISTRY OF RUBBER.** By Prof. H. FREUNDLICH, Ph.D.
- THE QUANTUM THEORY OF VALENCY.** By W. G. PENNEY, M.A.
- FLAME.** By O. C. DE C. ELLIS, M.Sc., and W. A. KIRBY, M.Sc. 3s. net.
- DISTILLATION.** By JOSEPH REILLY, M.A., D.Sc. 3s. net.
- THE GALVANIC CELL AND ELECTROLYSIS.** By J. A. V. BUTLER.

METHUEN'S BOOKS ON

INORGANIC CHEMISTRY

- THE COMPLETE SCHOOL CHEMISTRY.** By F. M. OLDHAM, M.A.
With 128 Diagrams. *Twenty-sixth Edition.* Crown 8vo. 6s.
- TEST EXAMINATIONS IN CHEMISTRY.** By F. M. OLDHAM, M.A.
Second Edition. With Answers. *Fcap.* 8vo. 1s. 3d.
Examination Papers of Matriculation and School Certificate standard.
- HIGHER CERTIFICATE CHEMISTRY TEST PAPERS.** By J. MORRIS, M.A. *Fourth Edition.* With Answers. *Fcap.* 8vo. 1s. 6d.
- OUTLINES OF INORGANIC CHEMISTRY.** By J. MORRIS, M.A. (Oxon.).
With 129 Diagrams. *Second Edition.* Crown 8vo. 7s. 6d.
Also in Two Parts: I. NON-METALS AND SOME COMMON METALS. For Matriculation Students. 4s. II. METALS AND PHYSICAL CHEMISTRY. For Intermediate Students. 4s.
- ELEMENTARY CHEMICAL THEORY.** By J. M. WADMORE, M.A. With 16 Diagrams. *Second Edition.* Crown 8vo. 5s.
- A SENIOR EXPERIMENTAL CHEMISTRY.** By A. E. DUNSTAN, D.Sc., F.I.C., and F. B. THOLE, D.Sc. With 125 Diagrams by E. D. GRIFFITHS, B.Sc. *Third Edition.* Crown 8vo. 7s. 6d.
- A TEXTBOOK OF INORGANIC CHEMISTRY.** By GEORGE SENTER, D.Sc., Ph.D., F.I.C., Principal, Birkbeck College. With 90 Diagrams, Questions and Answers. *Fourteenth Edition, Revised.* Crown 8vo. 7s. 6d.
- CHEMICAL SYMBOLS, FORMULAE, AND CALCULATIONS.** By A. W. WELLINGS, B.Sc. With Logarithmic Tables. *Second Edition, Revised.* Crown 8vo. 3s.
- AN INTRODUCTION TO QUANTITATIVE ANALYSIS.** By S. J. M. AULD, D.Sc.(Lond.), Ph.D.(Wurzburg), F.I.C., F.C.S. With 74 Diagrams and an Appendix. *Crown 8vo.* 6s.
- QUALITATIVE INORGANIC ANALYSIS.** By T. R. SNELGROVE, Ph.D., A.I.C., and J. L. WHITE, D.Sc. With 14 Diagrams. *Crown 8vo.* 7s. 6d.
- VOLUMETRIC ANALYSIS.** By A. W. WELLINGS, B.Sc. With 6 Diagrams. *Crown 8vo.* 5s.

ORGANIC CHEMISTRY

- A CONCISE SUMMARY OF ELEMENTARY ORGANIC CHEMISTRY.**
By F. H. CONSTABLE, M.A., D.Sc., Ph.D., F.I.C., Fellow of St. John's College, Cambridge. *Crown 8vo.* 4s. 6d.
- QUALITATIVE ORGANIC ANALYSIS.** By F. B. THOLE, D.Sc. With an Introduction by A. E. DUNSTAN, D.Sc., F.I.C. *Crown 8vo.* 2s. 6d.
- NATURAL TERPENES.** By J. W. BAKER, D.Sc., Ph.D., A.R.C.S., A.I.C. *Crown 8vo.* 6s.

PHYSICS AND CHEMISTRY

PHYSICAL CHEMISTRY

- A FIRST YEAR PHYSICAL CHEMISTRY.** By T. P. HILDITCH, D.Sc., F.I.C. With 58 Diagrams and an Appendix. *Crown 8vo.* 2s. 6d.
- OUTLINES OF PHYSICAL CHEMISTRY.** By GEORGE SENTER, D.Sc., Ph.D., Principal, Birkbeck College. With 46 Diagrams, Problems, and Questions, and Appendix. *Seventeenth Edition. Crown 8vo.* 7s. 6d.
- PRACTICAL PHYSICAL CHEMISTRY.** By J. B. FIRTH, D.Sc., F.I.C. With 74 Diagrams and an Appendix. *Crown 8vo.* 4s. 6d.
- A TEXTBOOK OF PRACTICAL PHYSICAL CHEMISTRY.** By K. FAJANS and J. WUST. Translated by BRYAN TOPLEY, M.A. With a Preface by F. G. DONNAN, F.R.S. With 74 Diagrams. *Demy 8vo.* 15s. net.
- PHYSICO-CHEMICAL CALCULATIONS.** By JOSEPH KNOX, D.Sc. Containing 365 Problems, with Answers and (in many cases) full Solutions. *Tenth Edition. Crown 8vo.* 4s. 6d.
- A SUMMARY OF PHYSICAL CHEMISTRY.** By K. ARNDT. Translated by W. H. PATTERSON. *Fcap. 8vo.* 3s. 6d. net.
- PHYSICO-CHEMICAL METHODS.** By JOSEPH REILLY, M.A. (Cantab.), D.Sc., Sc.D., D. ès Sc, F.Inst P, F.I.C., National University of Ireland; and WILLIAM NORMAN RAE, M.A. (Cantab.), F.I.C., University College, Colombo. With 586 Diagrams. *Second Edition, Revised and Enlarged. Royal 8vo.* 42s. net.
- PHYSICO-CHEMICAL PRACTICAL EXERCISES.** By WILLIAM NORMAN RAE and JOSEPH REILLY. With 74 Diagrams. *Crown 8vo.* 7s. 6d. net.
- THERMODYNAMICS FOR STUDENTS OF CHEMISTRY.** By C. N. HINSHELWOOD, M.A. With 11 Diagrams. *Crown 8vo.* 6s. net.
- THE ELECTROCHEMISTRY OF SOLUTIONS.** By S. GLASSTONE, D.Sc., Ph.D., F.I.C. With 38 Diagrams. *Demy 8vo.* 21s. net.

COLLOIDAL CHEMISTRY

- THE ELEMENTS OF COLLOIDAL CHEMISTRY.** By HERBERT FREUNDLICH. With Diagrams. Translated by G. BARGER, F.R.S. *Crown 8vo.* 7s. 6d. net.
- COLLOID AND CAPILLARY CHEMISTRY.** By HERBERT FREUNDLICH. Translated by H. S. HATFIELD, Ph.D. With 157 Diagrams. *Royal 8vo.* 50s. net.
- NEW CONCEPTIONS IN COLLOIDAL CHEMISTRY.** By HERBERT FREUNDLICH. With 47 Diagrams and 20 Tables. *Crown 8vo.* 6s. net.
- PRACTICAL COLLOID CHEMISTRY.** By WOLFGANG OSTWALD, Ph.D. With the collaboration of Dr. P. WOLSKI and Dr. A. KUHN. Translated by NEWTON KUGELMASS, M.D., Ph.D., Sc.D., and THEODORE K. CLEVELAND, Ph.D. With 22 Illustrations. *Crown 8vo.* 7s. 6d. net.

HISTORY AND PHILOSOPHY OF SCIENCE

HISTORY OF THE SCIENCES IN GRECO-ROMAN ANTIQUITY.

By Professor ARNOLD REYMOND. Translated by R. GHEURY DE BRAY.
With 40 Diagrams. *Crown 8vo.* 7s. 6d. net.

THE TECHNICAL ARTS AND SCIENCES OF THE ANCIENTS.

By ALBERT NEUBURGER. Translated by H. L. BROSE, M.A., D.Phil. With
676 Illustrations. *Special Royal 8vo.* 42s. net.

A CONCISE HISTORY OF CHEMISTRY.

By T. P. HILDITCH, D.Sc.,
F.I.C. With 16 Diagrams. *Second Edition, Revised. Crown 8vo.* 6s.

CHEMISTRY IN DAILY LIFE.

By S. GLASSTONE, D.Sc., Ph.D., F.I.C.
With 21 Diagrams. *Second Edition. Crown 8vo.* 6s. net.

A SHORT HISTORY OF PHYSICS.

By H. BUCKLEY, M.Sc., F.Inst.P.
Second Edition. Crown 8vo. 7s. 6d. net.

NEW WORLDS FOR OLD : THE REALM OF MODERN PHYSICS.

By R. G. LUNNON, M.A., M.Sc. *Fcap. 8vo.* 2s. 6d. net.

MODERN SCIENCE : A GENERAL INTRODUCTION.

By Sir J. ARTHUR THOMSON, M.A., LL.D. Illustrated. *Second Edition. Crown 8vo.* 3s. 6d. *Gift Edition* 6s. net.

SIR ISAAC NEWTON. A Brief Account of his Life and Work.

By S. BRODETSKY, M.A., F.R.A.S. With a Portrait, a Map, and 10 Diagrams.
Second Edition. Crown 8vo. 5s. net.

PHYSICO-CHEMICAL EVOLUTION.

By CHARLES E. GUYE. Translated by J. R. CLARKE, M.Sc., F.Inst.P. With 4 Diagrams. *Crown 8vo.* 6s. net.

THE PIONEERS OF WIRELESS.

By ELLISON HAWKS, F.R.A.S. With
24 Plates and 45 Diagrams. *Demy 8vo.* 12s. 6d. net.

SCIENCE AND RELIGION.

By Sir J. ARTHUR THOMSON, M.A., LL.D.
Third Edition. Crown 8vo. 7s. 6d. net.

THE GREAT SCIENTISTS

Each Volume Fcap. 8vo, 3s. 6d. net. School Edition, 2s. 6d.

THE GREAT PHYSICISTS. By IVOR B. HART, O.B.E., Ph.D., B.Sc.

THE GREAT CHEMISTS. By E. J. HOLMYARD, M.A., M.Sc.

THE GREAT ENGINEERS. By IVOR B. HART, O.B.E., Ph.D., B.Sc.

THE GREAT MATHEMATICIANS. By H. W. TURNBULL, M.A.

THE GREAT BIOLOGISTS. By Sir J. ARTHUR THOMSON, M.A., LL.D.

This catalogue contains only a selection of our Scientific Works.

A complete list can be obtained on application to

MESSRS. METHUEN & CO., LTD.,

36 ESSEX STREET, LONDON, W.C.2

