

**PAGES MISSING  
WITHIN THE  
BOOK ONLY**

UNIVERSAL  
LIBRARY

**OU\_156654**

UNIVERSAL  
LIBRARY



OSMANIA UNIVERSITY LIBRARY

540/ W 58 G

Accession No. 20820

White. A. S.

General science Chemistry 19

book should be returned on or before the date last marked below.



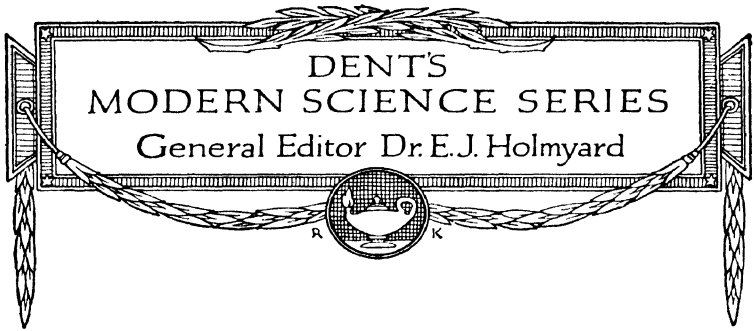

GENERAL SCIENCE  
CHEMISTRY

*By the same Author*

GENERAL SCIENCE  
PHYSICS

368 PAGES      4s. 0d.

# GENERAL SCIENCE CHEMISTRY

BY

A. SPENCER WHITE

B.Sc., L.C.P.

*Bournemouth School*

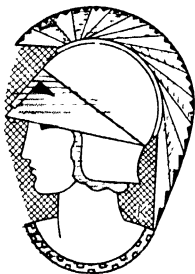

ILLUSTRATED WITH  
124 DIAGRAMS

J. M. DENT AND SONS LTD.  
BEDFORD ST. LONDON W.C.2

ALL RIGHTS RESERVED  
MADE IN GREAT BRITAIN BY  
BUTLER AND TANNER LTD., FROME AND LONDON  
FIRST PUBLISHED 1938

# CONTENTS

CHAP.	PAGE
PREFACE . . . . .	vii
I. AIR . . . . .	I
II. OXYGEN . . . . .	11
III. WATER AND HYDROGEN . . . . .	18
IV. CHALK, LIME, AND CARBON DIOXIDE . . . . .	30
V. MORE ABOUT COMBUSTION . . . . .	48
VI. SOLUTION AND OTHER PROCESSES . . . . .	67
VII. THE COMMON ACIDS . . . . .	77
VIII. QUANTITATIVE CHEMISTRY . . . . .	84
IX. SALTS . . . . .	99
X. MORE QUANTITATIVE CHEMISTRY . . . . .	122
XI. SOME IMPORTANT NITROGEN COMPOUNDS. . . . .	138
XII. CHLORINE AND ITS RELATIONS. THE HALOGEN FAMILY . . . . .	153
XIII. SULPHUR AND SULPHUR DIOXIDE . . . . .	159
XIV. CARBON COMPOUNDS . . . . .	167
XV. GAY-LUSSAC AND AVOGADRO . . . . .	174
XVI. UNCLASSIFIED TOPICS . . . . .	181
QUESTIONS . . . . .	194
TABLE OF LOGARITHMS . . . . .	204
INDEX . . . . .	211



## PREFACE

THE present volume deals with as much of the Chemistry of daily life as the non-specialist can be expected to digest. The content is rather more than that required for *General Science* at School Certificate and roughly corresponds with the chemistry of *Physics-with-Chemistry* or with the chemistry set at examinations for Clerical Classes of the Civil Service.

An attempt is made to keep up the interest of the pupil by the inclusion of numerous experiments with such careful directions that success should be certain.

Formulae are first introduced in Chapter VIII, and this arrangement has been found quite suitable for ordinary classes over a number of years. If, however, it is desired to proceed rapidly to formulae, it is suggested that the following sequence be adopted: pages 1-29, 60-2, then Chapter VIII as far as page 92.

With regard to the history of combustion, the recommendation of the Sub-Committee of the S.M.A. on the Teaching of General Science has been adopted; Lavoisier and 'phlogiston' are postponed until the facts of combustion are well known. If desired, these historical details may even be left until the rest of the book has been read, without violation of the sequence.

A representative set of questions will be found at the end of the book, and amongst these are several printed by kind permission of the Joint Matriculation Board of the Universities of Manchester, Liverpool, Leeds, Sheffield, and Birmingham; the University of London; the Oxford and Cambridge Schools Examination Board; and the Central Welsh Board.

I am indebted to the following industrial firms for their ready help—The British Oxygen Co., Messrs. Siebe, Gorman & Co., London, and Messrs. Pilkington Bros. of St. Helens, glass manufacturers.

My best thanks are also due to the General Editor of this series, Dr. E. J. Holmyard, for much valuable advice, and to the publishers for their perfect co-operation.

A SPENCER WHITE.

BOURNEMOUTH SCHOOL,  
*January* 1938.

## CHAPTER I

### AIR

#### **Air is Necessary for Burning.**

*Experiment.* Place a few chips of wood in a porcelain crucible. Put the lid on and heat strongly for about 10 minutes on a pipe-clay triangle and tripod over a Bunsen burner (Fig. 1). Allow to cool, then remove the lid and pour out the residue on to a sand tray. What does the residue look like? Replace it in the crucible with the lid off and heat again. What happens now?

*Experiment.* Repeat the previous experiment but this time cover

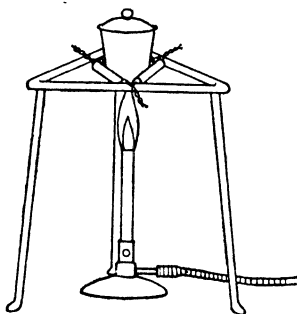

FIG. 1.

the chips with sand until the crucible is nearly full. What is the residue like? Put the residue back into the crucible without the sand and heat again in the open crucible.

*Experiment.* Repeat the previous experiments exactly but this time use small bits of coal instead of wood chips. Record your observations.

These experiments show that if there is little or no air available, wood changes to charcoal and coal to coke when heat is

applied. When there is a free supply of air, wood and coal, burn completely to form a light ash.

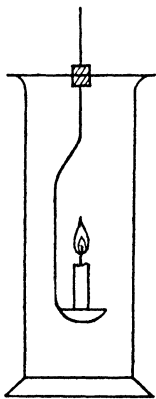

FIG. 2.

*Experiment.* Plunge a lighted candle on a burning-spoon into a jar of air (Fig. 2). The candle soon goes out because there is only a limited amount of air in the gas jar.

### Phosphorus and Magnesium.

So far we have dealt with the burning of very familiar substances. It will be convenient here to introduce two other substances which burn very readily, namely phosphorus and magnesium ribbon.

Phosphorus must be treated with very great respect. It is better not to touch it at all, but if it must be touched the fingers should be wet. On account of its readiness to take fire it is always kept in a bottle of water.

*Experiment (Demonstration).* Take a piece of phosphorus about half the size of a pea and dry it by moving it about on a filter paper with a knife. Place it in a crucible on a vaselined gas-jar cover. Touch it with a hot wire and place a gas jar over it. When the phosphorus stops burning, take off the jar. The phosphorus probably takes fire again, but if not, a hot wire will show that some phosphorus is left, because there was only a limited amount of air in the jar.

*Experiment.* Coil about two feet of magnesium ribbon and fasten it to a burning-spoon fitted with a lid. Ignite it and dip it into a gas jar. When the ribbon stops burning there will still be unburnt magnesium on the spoon unless the jar was very large.

These experiments with phosphorus and magnesium, as in the case of wood coal and candle, show that air is necessary for burning.

### Increase in Weight during Burning.

In our periodic efforts to 'tidy up the garden' or 'spring-clean the home' we constantly resort to the process of burning to get rid of unwanted rubbish. After the fire we are left with a *small* amount of ash and we are well satisfied with our effort. But the rubbish was mainly converted into gases which passed

off into the air. If we could catch all these gases and weigh them with the ash, we should find that there was an increase in weight. This, however, is hardly a laboratory experiment. We shall have to be content with testing the proposition in simpler cases, and perhaps the simplest is the burning of magnesium.

*Experiment.* On the left-hand pan of a chemical balance place a crucible with lid and about a yard of magnesium ribbon divided

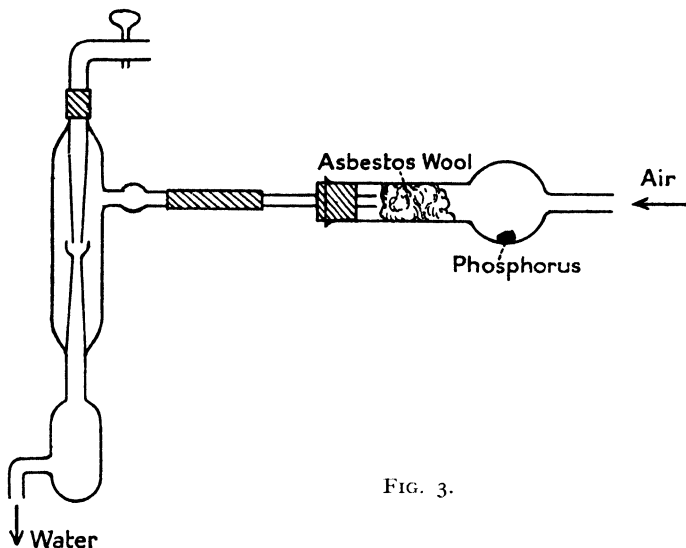

FIG. 3.

into half a dozen loose coils. Weigh. *Caution*: While the pans are swinging they must not be touched. Place one of the coils in the crucible, put on the lid, and heat on tripod and triangle with a Bunsen burner. After about a minute lift the lid with tongs, drop in another coil, and replace the lid. Repeat until all the coils have been used. Allow to cool, then weigh.

*Experiment* (Demonstration). Place a small fragment of phosphorus in the bulb of the tube (Fig. 3). Pack the straight portion of the tube with asbestos wool. Fit a cork and delivery tube and weigh. Attach the tube to a filter pump and adjust the latter so that a slow current of air is drawn through. Heat the phosphorus

gently with a Bunsen. When the phosphorus is burnt, allow to cool, detach tube, and weigh.

*Experiment.* The U-tube illustrated in Fig. 4 contains a substance which will absorb the gases given off by a burning candle. This substance is called soda-lime. The charged U-tube and the attached funnel with a short piece of candle are weighed on a chemical balance.

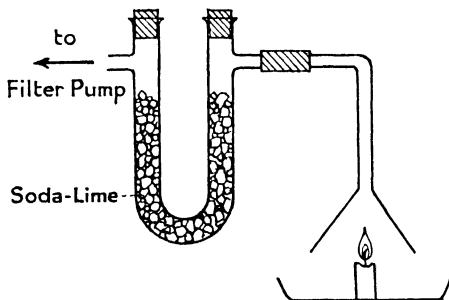

FIG. 4.

The pan is then removed from the balance and used to support the candle. The apparatus is suitably supported and joined to a filter pump set for a slow current of air. The candle is lighted and allowed to burn for some time. After the burning, the same items of apparatus are weighed again.

### Slow Burning without Flame.

*Experiment.* Weigh a crucible containing copper turnings. Heat for about 15 minutes without lid. Allow to cool, then weigh. Repeat with lead shot or foil.

### Rusting of Iron.

*Experiment.* Weigh a porcelain basin containing clean 'French' nails. Moisten with water, cover with a filter paper, and set aside for a few days. Remove excess water by gently heating. Cool and weigh. There is an increase in weight.

It may seem here that moisture is the essential condition for rusting, but the fact that air is also necessary can be proved by the following experiment.

*Experiment.* Half fill a flask with water. Add some clean 'French' nails. Boil for about a minute to drive out any air which

may be dissolved in the water. Remove the burner, fill up with boiled water from another flask, cork, and set aside for a few days. The nails will not rust because there is no air present.

### Some Air disappears during Burning and Rusting.

We have seen that during burning and rusting there is an increase in weight. It is natural to inquire from where this increase comes. We have a clue to the mystery when we remember that these processes do not go on in the absence of air. We will now carry out experiments to see if anything happens to the air itself during burning and rusting.

*Experiment.* Place a small lighted candle in a porcelain basin. Float it on water in a trough of water. Remove the stopper from a

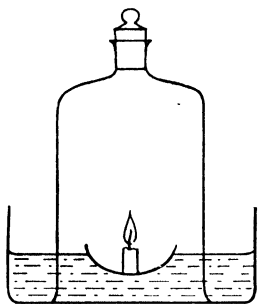

FIG. 5.

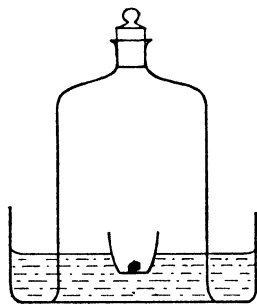

FIG. 6.

bell-jar. Place the jar over the candle so that it rests on the bottom of the trough and quickly insert the stopper previously well vaselined (Fig. 5). The candle soon goes out, the water rises inside the jar and sinks outside. A lighted taper or match plunged into the jar is extinguished.

*Experiment (Demonstration).* Dry a small piece of phosphorus on filter paper. Place the phosphorus in a dry crucible floating on water in a trough. Remove the stopper from a bell-jar. Place the jar over the crucible so that it rests on the bottom of the trough. Touch the phosphorus with a hot wire inserted through the neck of the jar. Quickly put in the stopper (Fig. 6). The phosphorus burns vigorously and the water rises inside and sinks outside. After the fumes have disappeared, test the air as before with a taper or match. Examine the contents of the crucible; heat over a Bunsen

in the fume chamber. There will probably be some phosphorus left showing that the burning did not stop through lack of phosphorus.

*Experiment (Demonstration).* Two identical thermometers are taken and a glass tube a little longer than the thermometers with a diameter of about 1 inch. One thermometer is fastened by rubber bands to the glass tube and separated from it by slips of cork. The other thermometer is lightly wedged into the tube with a piece of phosphorus at the closed end and a piece of cork at the open end. As soon as this is accomplished, the tube is immediately inverted in a beaker of water and supported on a burette-stand (Fig. 7). Readings of both thermometers are taken for about

10 minutes. The inside one should show a reading 5 or 6 degrees higher than the outside one, and water will rise in the tube about one-fifth of the original length. Air therefore disappears in slow burning as well as in rapid burning.

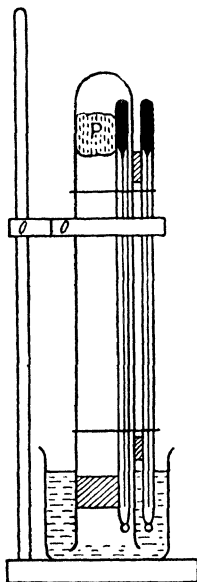

FIG. 7.

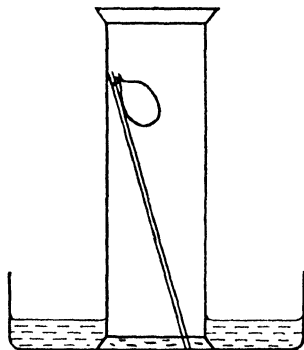

FIG. 8.

*Experiment.* Into a piece of muslin put iron filings or small clean 'French' nails. Gather the ends together so as to form a bag. Tie the bag to a glass rod or tube and arrange this and a gas jar in a trough containing a shallow layer of water as shown in Fig. 8. Set aside for a few days. The water will rise inside the jar and sink outside. The filings or nails will be rusty and the air left will extinguish a lighted taper or match. In the rusting of iron some of the air disappears.

Our experiments have shown that in burning (or combustion) one-fifth of the air is used up and never more. This is true whether the combustion is rapid or slow and the same disappearance of one-fifth of the air occurs also during rusting. The burning or rusting substance gains in weight. It is therefore highly probable that the increase in weight is caused by the absorption of some of the air.

But the fact that air *has* any weight may seem doubtful to some readers. The old philosophers had similar doubts. They thought that air was not a form of matter at all. One of them weighed a collapsed bladder and then weighed the same bladder inflated. The weight was just the same, and for some time this was regarded as proof that air had no weight. Actually the method is useless unless the weighings are carried out in a vacuum. The question was only definitely settled when another investigator weighed a *rigid* container full of air and then full of *compressed* air. The second weighing was greater. We need not trouble to repeat this experiment. We will ask our doubters to run with an open umbrella or try to get up a good speed on a bicycle with a large sheet of plywood fastened on the front. He (or she) will readily agree that air exerts a pressure and therefore presumably must have weight.

We will now look for additional proof of our belief that a burning substance increases in weight because it absorbs some of the air.

*Experiment (Demonstration).* Take a dry flask and drop into it a dry piece of phosphorus. Fit a rubber stopper carrying a glass tube, rubber tube, and clip (Fig. 9). Weigh. Wrap the hand in a duster, and gently warm the flask, keeping the phosphorus moving all the time. When burning ceases, allow to cool, then weigh. Open the clip, listen, then weigh again. The experiment gives strong support to the idea that a burning substance increases in weight by absorbing some of the air.

The experiment may be repeated without weighings to confirm the fact that only one-fifth of the air is active in supporting combustion. After the burning is over and the flask has



FIG. 9.

cooled, the stopper is removed under water (Fig. 10). The volume of the water which passes in can be measured with a graduated cylinder, and the volume of the whole flask found in the same way.

We now have considerable evidence to show that air contains two different kinds of air, an active portion (one-fifth) and an inactive portion (four-fifths). The active air is called oxygen and the inactive air nitrogen.

Now a burnt substance is often called a *calx* (plural, *calces*). Thus we have prepared magnesium calx, lead calx, copper calx, and phosphorus calx. If these substances are produced by adding on active air or oxygen to the original substance it might be possible to make the calx give back the oxygen. Unfortunately, none of the calces we have made can be induced to split up in this way. There is, however, another calx which will do this obliging trick. When mercury or quicksilver is heated for several days at a temperature just below its boiling point, it slowly unites with the oxygen of the air to form a red calx. When this red calx is heated strongly, oxygen comes off.

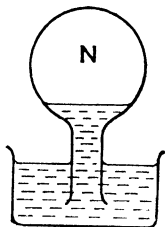
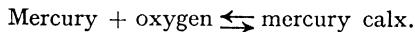

FIG. 10.

*Experiment.* Drop a little red calx to the bottom of a test-tube. Hold the tube almost horizontally over a Bunsen flame and rotate it so that the end of the tube is heated uniformly. Hold a glowing splint or a glowing piece of string in the mouth of the tube. The splint or string relights. A mirror forms on the upper part of the tube which later develops into a number of globules. When the calx has disappeared, allow the tube to cool and scrape out the globules into a porcelain basin.



We have now arrived at a working knowledge of combustion and the composition of ordinary air. When a substance burns, it unites with oxygen to form a new substance. This process is called **oxidation** and the original substance is said to have been **oxidized**. The oxidation may be slow or it may be rapid. In both cases heat is given out. In slow oxidation the heat passes off as fast, or almost as fast, as it is formed. But in rapid oxidation, heat may be generated so quickly that the sub-

stance gets hot enough to burst into flame. The inactive part of the air, nitrogen, has a slowing-down effect on its violent partner oxygen.

Our next experiment has nothing to do with combustion, but it provides a very neat method of illustrating the fact that air consists of 1 part by volume of oxygen and 4 parts by volume of nitrogen. The experiment is described here for convenience but may be postponed until later. We shall be using two substances which are probably quite new to you. The first is a white crystalline substance called pyrogallol, much used by professional photographers in developing. The other substance is caustic soda or sodium hydroxide, sometimes recommended for removing paint from wood and metal surfaces, but in unskilled hands it has less effect on the painted surface than on the operator's skin! This substance comes on the market in the form of white cylindrical sticks. When pyrogallol and caustic soda are dissolved together in water, the mixture absorbs oxygen from any gaseous mixture containing that gas.<sup>1</sup>

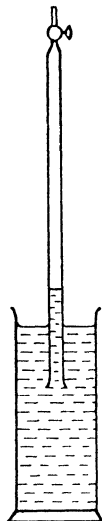

FIG. 11.

*Experiment.* 120 grams of caustic soda are dissolved in water and then made up to 200 c.c. 10 grams of pyrogallol are added and the mixture stored in a stoppered bottle. About 5 c.c. of the mixture are poured into a burette, which is immediately closed with a rubber stopper or by the thumb, protected by a square inch of rubber cut from tubing and opened out. The air column is measured in centimetres of tube with a ruler. The burette is now inverted several times and finally opened under water in a gas jar (Fig. 11). Water runs in and the new air column is measured after levelling.

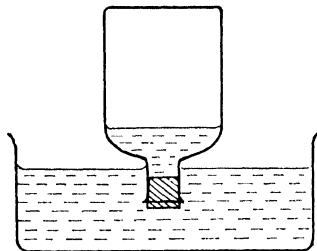

FIG. 12.

The experiment may now be repeated with a bottle having a fairly wide neck. The bottle is opened under water then closed again (Fig. 12) and the residual

<sup>1</sup> It absorbs many other gases besides oxygen, however.

air tested with a lighted match. The match is extinguished, showing that the mixture absorbed the same gas that a burning substance absorbs.

### Water Vapour in the Air.

Air also contains a little water vapour even in the dryest weather. This can be proved by using a substance called calcium chloride, which absorbs moisture very readily.

*Experiment* (Demonstration). Air is drawn through a weighed U-tube containing calcium chloride (Fig. 13). The first aspirator

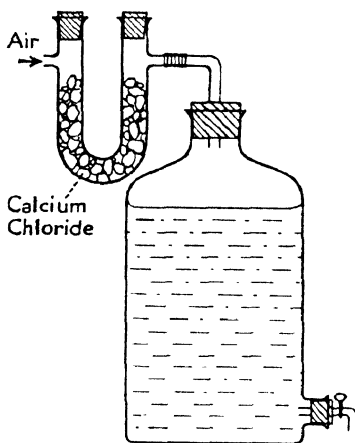

FIG. 13.

full is measured by running the water into a measuring jar. The aspirator is then refilled and the operation repeated three or four times. The U-tube is then reweighed.

This experiment is often done in physics and the result is stated in grams per 1,000 litres.

It is interesting to take a deep breath and then breathe through the U-tube containing the calcium chloride. A weighable increase will be noticed; exhaled air contains much more moisture than ordinary air.

## CHAPTER II

### OXYGEN

WE have seen that air consists of one volume of oxygen and four volumes of nitrogen. It would be very convenient if we could get some of this oxygen from the air. One method was indicated in the last chapter—we may heat mercury for several days just below boiling point and then split up the red scales by heating more strongly. This, however, is rather troublesome and the manufacturer has a much better method which we will now proceed to explain.

#### The Manufacture of Oxygen.

You will remember that water can exist as solid, liquid, or gas. This is also true for air and we can have air as a gas, a liquid or even a solid. Liquid air is very interesting in many ways. Its temperature is in the neighbourhood of *minus*  $200^{\circ}$  C. and it is constantly boiling. If a grape is immersed for half a minute in liquid air, it comes out as a hard brittle solid. You may smash it with a hammer and eat a piece, but you must be careful to prevent it clinging to your tongue. Experiments with liquid air must always be done in vessels like thermos flasks to stop it boiling off too rapidly. Pouring liquid air into an ordinary beaker would be somewhat like putting water into a red-hot saucepan. You may dip your finger into liquid air for a second or two, but if you leave it there you become frost-bitten. The warmth of the finger converts some of the liquid into gaseous air and this for a time serves as a cushion to protect the finger, but in a very short time this air cushion also becomes cold enough to do damage. Mercury can easily be frozen with liquid air.

In the manufacture of oxygen the first step is to make liquid air. The temperature of the liquid air is then allowed to rise. At  $-196^{\circ}$  C. the nitrogen boils off and at  $-183^{\circ}$  C. the oxygen

boils off. The oxygen gas is compressed into steel cylinders. Remember that these cylinders contain gaseous oxygen, not liquid oxygen. Neither liquid oxygen nor liquid air can be permanently confined in any sort of closed vessel at ordinary temperatures.

You will probably be curious to know how liquid air is made. A full explanation demands a knowledge of really advanced physics, but a few of the ideas will be quite familiar. When you

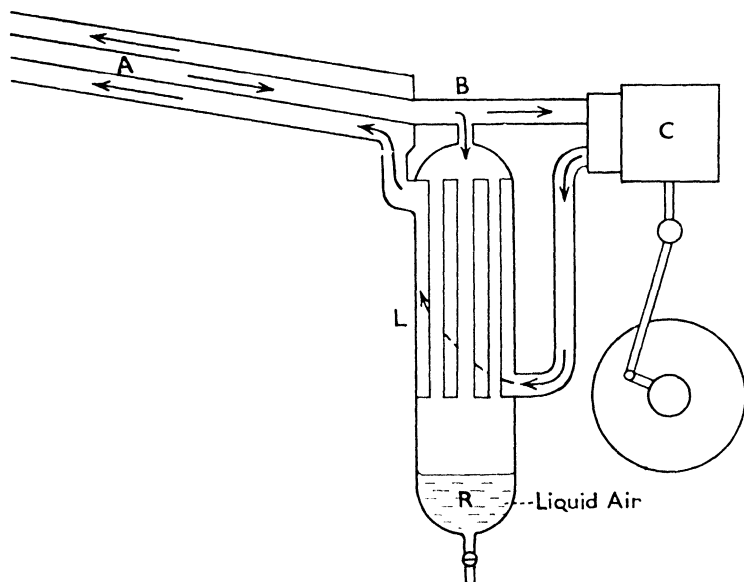

FIG. 14.

pump up a bicycle tyre quickly, the bottom of the pump gets hot. The heat is generated because a gas is being suddenly compressed. The opposite idea may be new to you, but it is nevertheless true that *when a gas suddenly expands it gets cooler*.

One of the methods used for liquefying air is shown in Fig. 14. It was invented by Georges Claude of the Société l'Air Liquide, a company working at Boulogne, one of the Paris suburbs. The method is also used by the British Oxygen Company.

The air is first compressed to about 45 atmospheres and passed

through purifiers to remove water vapour and carbon dioxide. (Why is this necessary?) The air then passes down the tube A. At B the air divides, some going through the tubes of the lique-

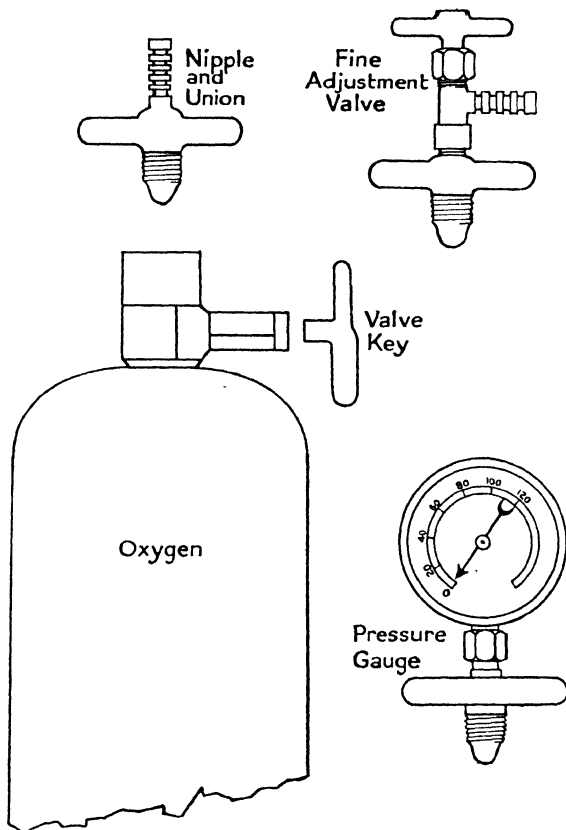

FIG. 15.

fier L and some to an expansion engine C. The inlet valve of the engine opens and the compressed air drives the piston down through a part of its stroke. The inlet valve then closes and the imprisoned air completes the stroke by expanding. *The air*

is thereby cooled and after escaping through the exhaust valve it passes up round the tubes of the liquefier L, cooling the air travelling down inside them. It now passes out through a tube which surrounds the inlet tube A. Thus the entering air is also

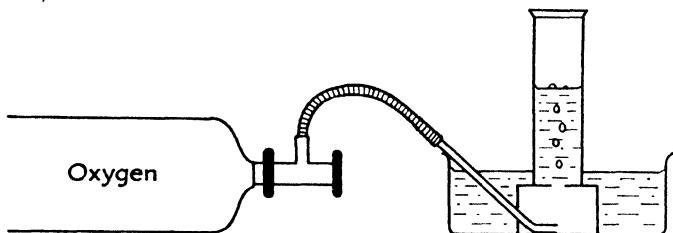

FIG. 16.

cooled. Very soon liquid air collects in the reservoir R. The expansion engine C helps to drive the compressor which produces the 45 atmospheres pressure.

**The Use of Manufactured Oxygen.** Oxygen is put on the

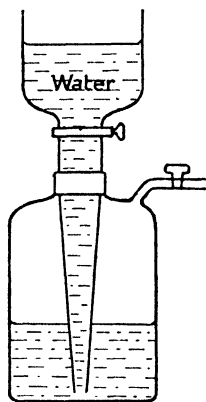

FIG. 17.

market in black steel cylinders having right-hand valves (Fig. 15). Inflammable gases are put in red steel cylinders with left-hand valves. The length of the cylinder ranges from 19 inches to 49 inches, the diameter from 4 inches to 7 inches and the capacity from 10 cubic feet to 100 cubic feet. In addition to these there are 'outsizes' going up to 150 cubic feet. The 19-inch by 4-inch cylinder will give 10 cubic feet or 283 litres of oxygen at atmospheric pressure. The gas is compressed to 120 atmospheres. A pressure gauge may be connected to the cylinder and when this reads '60 atm.' the cylinder is half full, '30 atm.' means one-quarter full and so on. Oxygen costs about 4*d.* per cubic foot when supplied in the company's cylinder and about 3*d.* per cubic

foot if you have your own cylinder.

If the school has anywhere on the premises a cylinder of oxygen, it can be used to collect jars of oxygen either directly as in Fig. 16 or by first filling a small gasometer (Fig. 17). Alterna-

tively we may prepare our own oxygen as explained in the next section.

**Laboratory Preparation of Oxygen.** Chlorate of potash or potassium chlorate is a white crystalline substance sometimes dissolved in water to make a gargle or mouth-wash. It does not occur in nature but is a product of the chemical works.

Manganese dioxide is a black substance found as an ore called pyrolusite in India, Brazil, Chile, Spain, and the Caucasus. It is much used in the making of alloys, especially hard steel.

When enough manganese dioxide is added to potassium chlorate to make the mixture black, we have what is sometimes known as 'oxygen mixture.'

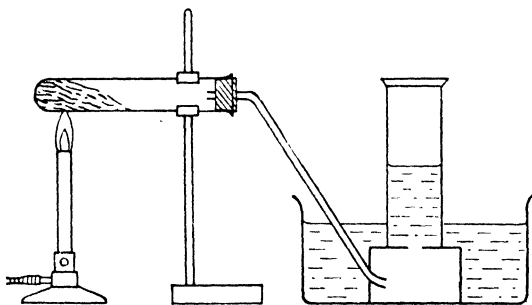

FIG. 18.

*Experiment.* Half fill a test-tube with 'oxygen mixture' and fix up the apparatus shown in Fig. 18. With gentle heat it is easy to get half a dozen jars full of oxygen. It is just as well to stop filling each jar when there is still an inch of water in it.

### Combustions in Oxygen.

(a) Dry a piece of phosphorus about one-quarter the size of a pea on filter paper (Caution!). Place it in a burning-spoon. Kindle the phosphorus over the Bunsen and quickly transfer to a jar of oxygen. Remove the spoon and cover the jar with a glass plate. Shake up and when the fumes have dissolved in the inch of water left in the jar, add some *blue litmus* solution. The litmus turns red, showing that an acid has been formed. (Litmus is a colouring matter prepared from lichens.)

(b) Having burnt away the excess phosphorus on the spoon in the fume chamber, kindle a little sulphur on the spoon and quickly transfer to another jar of oxygen. Again shake up the fumes with water and add blue litmus. The litmus turns red.

(c) After cleaning the spoon by burning off the excess sulphur, add a piece of charcoal (chemical name 'carbon'). Heat until one corner glows, then plunge the spoon into a new jar of oxygen. Shake up the product of burning with water and divide into two portions. To one portion add blue litmus—it goes red. To the other portion add limewater, a liquid made by adding a small quantity of builder's lime to a very large quantity of water. The limewater goes milky.

**Phosphorus, sulphur, and carbon give acid-forming products when burnt in oxygen.**

(d) Hold about 6 inches of magnesium ribbon with tongs and kindle it over a Bunsen. Plunge the ribbon into a jar of oxygen. Boil the ash with water and add *red* litmus. It goes blue, showing that an *alkali* has been formed.

(e) Sodium is a soft metal always kept under naphtha or paraffin. **It must never be touched with wet fingers or used at all without permission.** With a knife cut a piece of the metal about one-quarter the size of a pea; note the lustre. Transfer to a burning-spoon. Heat over a Bunsen until the sodium melts, then plunge into oxygen. When the burning is over, hold a book between your face and the jar and push the spoon down into the water. Add *red* litmus. It goes blue, showing that an *alkali* is present.

(f) Calcium is another metal generally kept immersed in naphtha or paraffin. Unlike sodium it is very hard and has to be cut with a chisel or hacksaw. Heat a little on the spoon until it glows at a corner or edge and plunge into oxygen. Allow to cool, then push spoon into the water. Test with *red* litmus. An *alkali* is again formed.

*Caution!* This combustion and that of sodium often burn part of the spoon away.

**Magnesium, sodium, and calcium give alkaline products when burnt in oxygen.**

(g) Coil a double spiral of piano wire on a pencil. Attach the iron wire to a spoon. Heat until the iron glows, dip into sulphur, and quickly plunge into a jar of oxygen, which **must** have water in the bottom. Globules of molten iron form as well as iron

calx. There is no action on red or blue litmus, because the substance will not dissolve in water.

**Summary.** In Chapter I we showed how lead, copper, mercury, magnesium, and phosphorus could be *oxidized* by heating in air and we came to the conclusion that in each case oxygen had been added on. We called the new substance a *calx* but a more usual name is **oxide**. Moreover, the word 'calx' generally refers to a solid while the new substance is frequently a gas.

In the present chapter we have oxidized substances by means of oxygen itself and we may sum up our results thus :

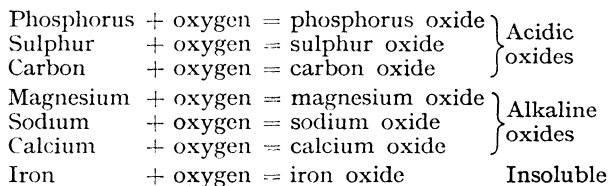

The substances on the left of the equations are called **elements**. Those on the right are **compounds**. *An element is a substance which has never been split up into simpler parts.* In other words, we cannot **analyse** an element. The only way to make a new substance from an element is to add something on. This we call **synthesis**. Thus we have

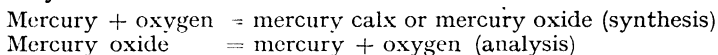

Elements can be divided into two classes—**Metals** and **Non-metals**. Magnesium, sodium, calcium, iron, and mercury are metals and their oxides are described as 'metallic oxides.' If a metallic oxide *does* dissolve in water, it gives an alkaline solution. Phosphorus, sulphur, and carbon are known as non-metals, their oxides being called non-metallic oxides. These oxides are acidic.

## CHAPTER III

### WATER AND HYDROGEN

NEXT to air the most important substance in our universe is water, so we will now carry out some experiments with the object of finding out whether it is an element or whether it consists of more than one kind of matter.

In Fig. 19 we have an apparatus adapted for passing an electric current through water. We shall need a battery of three accumulator cells, a plug key, and a vessel holding the water. This vessel is called a Hofmann voltameter. The electric current enters the liquid by way of a platinum wire sealed in glass at one end and carrying a piece of platinum foil at the other. The current leaves the water by way of another foil and wire. The platinum foils are called 'electrodes,' the one joined to the positive pole of the battery being called the positive electrode or anode, the other joined to the negative pole being the negative electrode or kathode.

Before filling the vessel it is necessary to add a little sulphuric acid to the water to make it a conductor of electricity. This is the acid used in the ordinary accumulator cell.

It will soon be noticed that one tube is collecting more gas than the other. When this tube contains about 20 c.c. of gas, run the gas off into a test-tube placed over the jet. Quickly hold the test-tube to a Bunsen burner, keeping the mouth of the tube down. The gas burns with a slight pop. This gas is called **hydrogen**. Run the other gas off similarly and test with a glowing splint. It is **oxygen**.

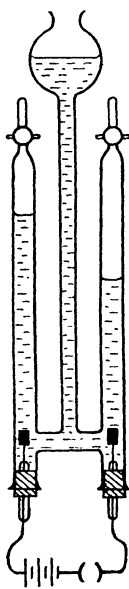

FIG. 19.

There was probably more than twice as much hydrogen as oxygen. Repeat the experiment using the same liquid in the voltameter. We now notice that the volumes are accurately 2 to 1. The reason for this slight change in the ratio is that oxygen is more soluble in water than hydrogen, but in the second case the water had become saturated with both gases. Note that **oxygen** comes off at the **positive** electrode.

One possible explanation of the above result is that water consists of 2 volumes of hydrogen and 1 volume of oxygen. Beware of saying that the experiment *proves* this fact. Later experiments, however, will amply support this explanation.

An interesting variation of the experiment is to reverse the current when the hydrogen tube has about 12 c.c. of gas and the oxygen tube 6 c.c. The two volumes will now soon be equal and each tube contains both gases. When the mixed gas is drawn off from either tube into a test-tube and fired there is a very definite explosion. The mixed gas is called **electrolytic gas**.

#### Action of Metals on Cold Water.

(a) A piece of **calcium** is placed in a small trough of water and a gas jar of water inverted over it (Fig. 20). Very soon

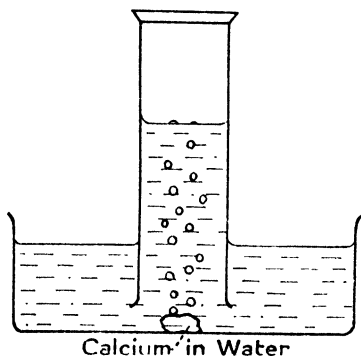

FIG. 20.

enough hydrogen will be collected to be tested with a flame. Test the water left with litmus. It is alkaline.

(b)(Demonstration). A piece of **sodium** about the size of a pea is cut into about eight pieces. A little dry mercury is placed

in a mortar and the pieces of sodium squeezed one by one under the mercury with a pestle. Occasionally there is a small flash and finally we have a pasty mass of **sodium amalgam**. This is

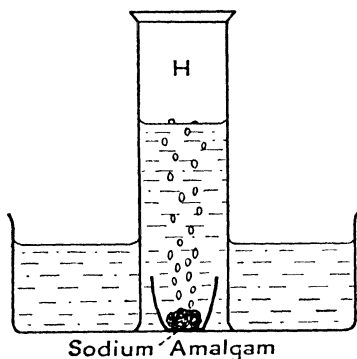

FIG. 21.

placed in a crucible in a trough of water and a jar of water inverted over it (Fig. 21). Hydrogen comes off. When the reaction is complete the mercury can be dried and returned to the store bottle. Test the water left with litmus. It is alkaline.

#### Action of Metals on Steam.

(a) **Magnesium.** Water is boiled in a conical flask. A piece of magnesium ribbon is held by tongs, ignited, and immersed in the steam. The ribbon continues to burn brilliantly and **hydrogen** burns at the mouth of the flask. The ash falls into the water and soon enough of it will dissolve to give an alkaline reaction to litmus.

The burning of magnesium in steam may be *demonstrated* more strikingly by the apparatus illustrated in Fig. 22. A coil of magnesium is pushed into a reduction bulb or a piece of combustion tubing about 9 inches long set to slope upwards from the water trap. The tube is kept fairly hot to prevent vapour condensing in it. As soon as steam issues freely the magnesium is heated strongly until it glows, when the heating is at once stopped. The tube generally cracks after the experiment owing to chemical action between the magnesium and the glass, but with care this does not happen until the magnesium burns and

the hydrogen is evolved. The ash boiled in water gives the usual alkaline reaction with litmus.

**Magnesium, sodium, and calcium turn out hydrogen from water**

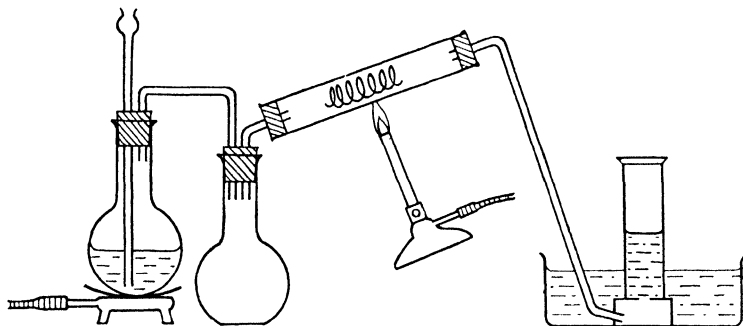

FIG. 22.

and combine with the oxygen to form alkaline oxides. (Compare with the results of the last chapter.)

(b) **Iron.** The oxidation of iron in steam may be demonstrated

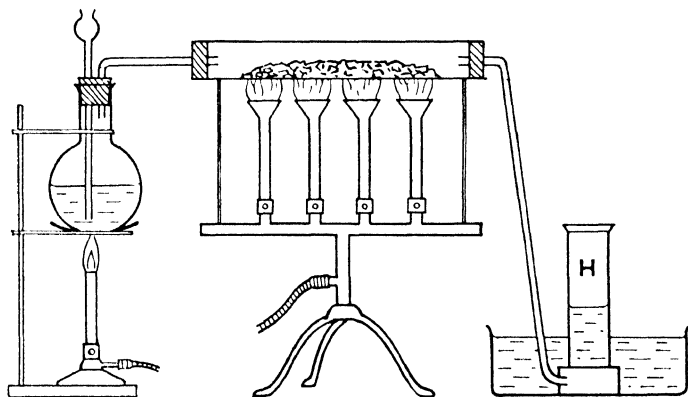

FIG. 23.

by means of the apparatus shown in Fig. 23. Iron filings or small clean 'French' nails are placed in a piece of iron gas-pipe, water-pipe, or combustion tubing about 18 inches long. This is

heated strongly with a small furnace or a few Bunsens fitted with 'spreaders.' Steam is then passed through. **Hydrogen** comes off and **iron oxide** is left in the tube. This is found to have no action on red or blue litmus, because it is insoluble in water.

**Hydrogen from an Acid.** In Chapter II we learned how to make three acids by burning phosphorus, sulphur, and carbon in oxygen and dissolving the products in water. In the laboratory you will find other acids and with one of these we will now make a closer acquaintance.

We occasionally see an expert at soldering dropping bits of zinc into a liquid which he calls 'spirit of salt.' He is making 'killed spirit' to use as a *flux* to clean the soldering bit and the parts to be joined. We can repeat this.

*Experiment.* Place a few pieces of granulated zinc in a porcelain basin. Add water to a depth of about one-third. Add strong

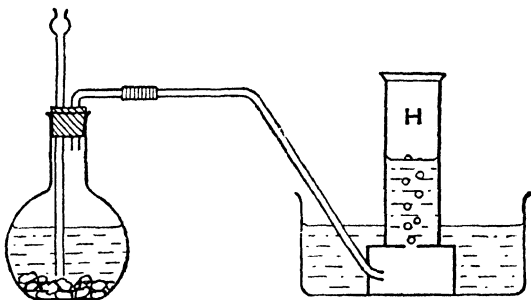

FIG. 24.

hydrochloric acid or spirit of salt. When bubbles issue freely, hold a match to them. There will be a series of small explosions. The gas is hydrogen and it came from the acid. When no more bubbles come off the 'spirit is killed.'

*Experiment.* The apparatus shown in Fig. 24 is suitable for preparing a large quantity of hydrogen. The flask is held in a sloping position and granulated zinc is gently slipped in. Water is then added to a depth of about an inch. When inserting the cork and thistle funnel, the flask is again sloped and care taken not to push the stem of the funnel against the bottom. *Small* quantities of strong hydrochloric acid are added as required and the hydrogen

collected over water. A test-tube is first filled with the gas, closed

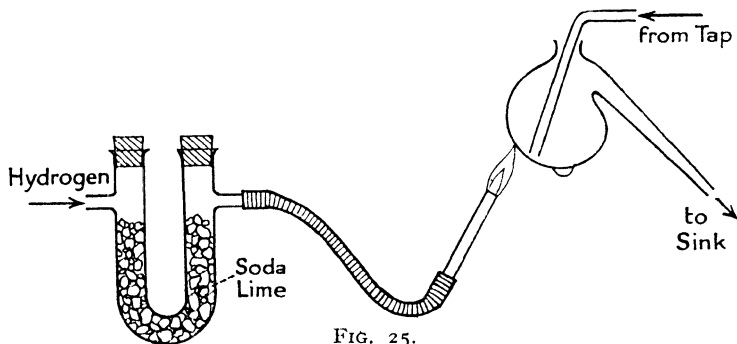

FIG. 25.

with the thumb and carried to a Bunsen 2 feet away from the apparatus. If the gas burns peacefully, jars of gas may be collected and the following experiments tried :

(a) Pour a jar of hydrogen *upwards* into a jar of air. Then test both jars at the Bunsen.

(b) Plunge a lighted taper into a jar of the gas.

(c) Replace the delivery tube by a right-angled bend and pass the gas *upwards* into a dry gas jar. When the jar is judged to be full, carry it mouth downwards to a distant Bunsen. After ignition note the *dew* on the sides of the jar.

(d) Fill a U-tube with granular soda-lime. This is a substance looking rather like 'grape-nuts.' It has the power of absorbing water vapour and acid fumes. To one end of the U-tube connect a rubber tube carrying the stem of a clay pipe (Fig. 25). Pass hydrogen through and fill a test-tube with the gas. Carry the test-tube to a Bunsen, then back to the pipe stem—the hydrogen catches alight. Allow the flame to impinge on a retort cooled by a stream of water. Drops of liquid will collect on the outside of the retort. Catch the liquid in a test-tube. When enough has been collected to cover the bulb of a thermometer, add a few grains of sand to promote smooth boiling and heat *gently* on a gauze having an asbestos centre (Fig. 26).

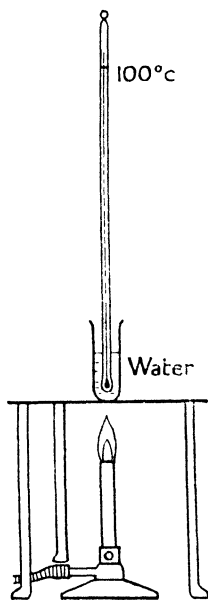

FIG. 26.

The liquid will boil at, or very close to,  $100^{\circ}\text{C}$ . If the test-tube had been immersed in a mixture of ice and salt, we should have found that the freezing point of this liquid was  $0^{\circ}\text{C}$ . A determination of the density would show this to be 1 gram per c.c. The liquid is certainly **water** and from the method of preparation we can infer that

### Water is hydrogen oxide.

In the electrolysis experiment we *analysed* water into its elements. In the last experiment we *synthesized* water from its elements.

### Volumetric Composition of Water.

We may synthesize water in another way, using the apparatus

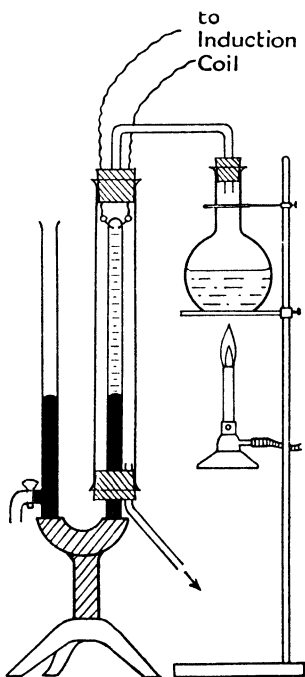

FIG. 27.

shown in Fig. 27, which consists of a eudiometer containing mercury, one limb of which is surrounded by a heating jacket. The closed end of the eudiometer has platinum wires sealed into it and these are connected by copper leads to an induction coil. Either electrolytic gas or two volumes of hydrogen and one volume of oxygen are passed down the open end of the eudiometer by means of a glass tube carrying enough rubber tubing to pass round the bend.

While the spark is passed, the open end of the eudiometer is closed with the thumb or a cork and the apparatus held down to prevent it jumping up with the force of the explosion. It is found that 2 vols. of hydrogen + 1 vol. of oxygen form a minute quantity of water and the mercury runs up to fill the tube.

We next use a heating flask containing water boiling briskly or amyl alcohol, a liquid which boils

at  $131^{\circ}\text{C}$ . On repeating the experiment, the water formed will be in the form of steam and we shall find that

2 vols. of hydrogen + 1 vol. of oxygen = 2 vols. of steam.

The above is the modern form of an experiment first performed by Henry Cavendish (1731-1810).

### Mixtures and Compounds.

We have now come across an illustration of the strangest fact in chemistry, namely, that *a compound is generally quite unlike its constituents*. No one could guess that the liquid, which we drink and use for all sorts of purposes, is a compound of an inflammable gas and a gas which relights a glowing splint! There is all the difference in the world between a **mixture** of two elements and a **compound** of the same two elements, thus,

Electrolytic gas is a **mixture** of hydrogen and oxygen.

Water is a **compound** of hydrogen and oxygen.

A mixture does what you would expect it to do, but a compound has very surprising properties. Here we may point out the difference in meaning between the word 'constituents' and the word 'properties.'

The *constituents* of water are hydrogen and oxygen. The *properties* of water are (a) it is wet, i.e. it clings to most surfaces, (b) it dissolves many substances like sugar and salt, (c) it is colourless, tasteless, and odourless, (d) it boils at 100° C., (e) it freezes at 0° C., (f) it has a density of 1 gram per c.c.

A good example of a mixture is **air**. Its constituents are nitrogen and oxygen. Now nitrogen does not allow things to burn in it, while oxygen supports combustion vigorously. The mixture of the two does what you would expect—air supports combustion moderately well.

Later on we shall deal with other differences between mixtures and compounds, but this one difference will do for the present. It will enable you to class as 'mixture' or 'compound' any substance you will meet in chemistry. We may state the test thus, *the properties of a mixture are the average of the properties of its constituents, in other words, no new substance was formed during the mixing.*

*The properties of a compound are entirely different from the properties of its constituents, in other words, a new substance has been formed.*

**Hydrogen from other Acids.** Another acid which you will frequently meet in the laboratory is sulphuric. We used a few drops of it in the electrolysis experiment. **Sulphuric acid must be classed with phosphorus and sodium as a dangerous chemical.**

If you examine the effect of one drop of the strong acid on a duster, you will realize the danger of getting it on your clothes. Strong sulphuric acid spilt on the hands or bench should immediately be washed off with much water.

For ordinary laboratory use it is diluted with ten times its own volume of water, *the acid being added to the water and not vice versa*. For accumulators it is diluted with three to four times its volume of distilled water.

Dilute sulphuric acid on the elements zinc, iron, or magnesium will give hydrogen. The use of zinc and dilute sulphuric acid is in fact a regular laboratory method of making hydrogen. The use of iron has the objection that other gases are also formed owing to impurities in the iron filings generally supplied to schools.

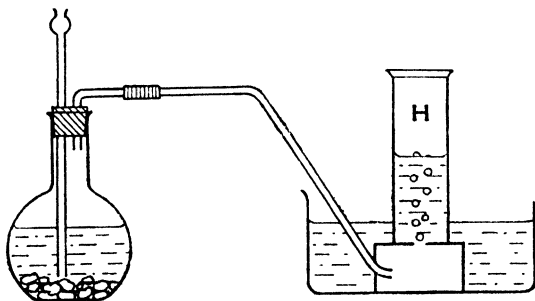

FIG. 28.

Magnesium is rather too expensive for making large quantities of hydrogen.

*Experiment.* Prepare hydrogen from dilute sulphuric acid and zinc, using the usual flask fitted with thistle funnel and delivery tube (Fig. 28). When the action stops, filter the contents of the flask into a porcelain dish. Evaporate slowly on tripod and gauze, from time to time cooling samples in a test-tube under the tap. When crystals form in the test-tube, set the dish aside to cool.

The crystals are zinc sulphate or white vitriol. Heat a sample, at first gently then strongly, in a dish or crucible. A substance is left which is yellow when hot and white on cooling. This is zinc oxide. If this is dissolved in dilute sulphuric acid, zinc sulphate is again formed and can be crystallized as before.

Another common acid is **nitric**, which you will see prepared later by the action of sulphuric acid on nitre or saltpetre. **Strong nitric acid is destructive to clothes and benches and makes unpleasant stains on fingers.**

If a coil of magnesium ribbon is added to a test-tube one-third full of water, nothing happens. But if dilute nitric acid is now added drop by drop to the water, hydrogen gas soon comes off.

We have now learnt that the three common acids of the laboratory, hydrochloric, sulphuric, and nitric, all contain hydrogen as one of their constituents. This is a perfectly general rule and we may define an **acid** as a substance which (a) has a sour taste, (b) turns blue litmus red, and (c) contains hydrogen as one of its constituents.

**The Lightness of Hydrogen.** Our experiments with hydrogen showed that this gas is much lighter than air. It is in fact the lightest substance known. For this reason it is used in balloons and airships. We can easily illustrate this use of hydrogen by the apparatus shown in Fig. 29. Hydrogen is generated in a thick-walled bottle fitted with a good rubber stopper and a 'drying-tube' containing lumps of quicklime or granular soda-lime kept in position by loose wads of cotton-wool. A toy balloon is stretched over the wide mouth of the drying-tube and tied or held in that position. After a time the balloon becomes fully inflated. The neck may then be tied and the balloon released. The method is quite effective even with really strong balloons which are difficult to blow up with the mouth.

Balloons and airships are often filled with ordinary coal gas which contains about 50% of hydrogen.

The lightness of hydrogen and coal gas is beautifully demonstrated by blowing soap bubbles with these gases. A few fragments of ordinary soap are stirred up for a few minutes with

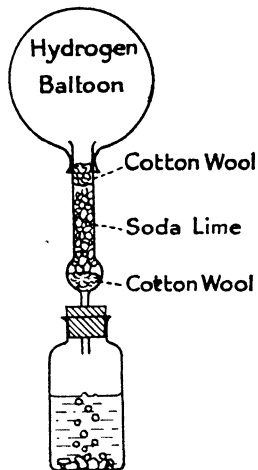

FIG. 29.

a mixture of four parts of water and one part of glycerine in a dish or beaker. Bubbles can then easily be blown by connecting to the gas supply or hydrogen generator a clay pipe, thistle funnel, or 'drying tube.' In the case of hydrogen it is as well to allow the gas to pass through soda-lime first, to remove acid fumes.

The fact that coal gas and hydrogen are inflammable is of course a great disadvantage when these gases are used for inflating balloons and airships. There is another gas, helium, which may be used instead. This gas is not inflammable but unfortunately the amount of helium so far discovered in the

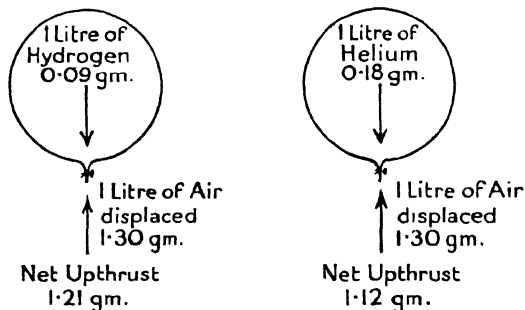

FIG. 30.

world is comparatively small. It occurs in gas wells in U.S.A. and Canada, and also in certain minerals from which it may be driven out by heating. Traces also occur in the atmosphere. Helium is exactly twice as dense as hydrogen, but we shall see that this is no great disadvantage.

Concerning the lifting power of a balloon there is a striking misconception in many a pupil's mind. He has a fixed idea that it is the hydrogen which does the lifting! This is not entirely his fault. It is at least partly due to the fact that we always speak of the lifting power 'of the balloon.' But imagine a swimmer dropping feet first into the deep end of the baths. He comes to the surface again, because his weight is less than the weight of the water he displaces. In other words, the water displaced lifts him. In the same way it is the air displaced which really lifts the balloon.

Let us now try to get clear ideas of the relative lifting power of hydrogen and helium balloons. Suppose that our toy balloon contains 1 litre (1,000 c.c.) of hydrogen.

1 litre of hydrogen at normal temperature and pressure weighs 0.09 gram. The air displaced weighs 14.4 times this, say, 1.30 gram. There is thus a nett upthrust of  $1.30 - 0.09$  gram, or 1.21 gram. One litre of helium weighs 0.18 gram. The nett upthrust will therefore be  $1.30 - 0.18$  gram, or 1.12 gram (Fig. 30). Therefore

$$\frac{\text{The lifting power of air on a hydrogen balloon}}{\text{The lifting power of air on a helium balloon}} = \frac{12}{11} \text{ approx.}$$

### Other uses of Hydrogen.

When hydrogen is driven through cotton-seed oil or palm oil containing fine nickel powder and heated to about  $200^{\circ}$  C., the hydrogen is absorbed. If the oil is now filtered and allowed to cool, all the nickel is recovered and the oil becomes a solid fat. This is the **fat hardening process** discovered by a French scientist called Sabatier. It is used in the manufacture of margarine and soap. The nickel helps the chemical change but is not itself used up. We shall find many similar cases in chemistry.

Further uses of hydrogen will be learnt on pages 145 and 171.

## CHAPTER IV

### CHALK, LIME, AND CARBON DIOXIDE

WHEN carbon was burnt in oxygen, we obtained a gas which turned limewater milky. At the time we called this gas 'carbon oxide,' but its full title is carbon *dioxide*. The reason for this slight addition to the name will appear later. In the present chapter we shall prepare this gas by other methods and study its properties more carefully.

Limewater, you will remember, was described as a liquid prepared by shaking up a small quantity of builder's lime with a large quantity of water. In the present chapter we shall also make a closer acquaintance with limewater.

#### **Heating Chalk.**

*Experiment.* Put some powdered cliff chalk into a hard glass tube. Fit a cork and delivery tube dipping into limewater. Heat the chalk strongly. The limewater goes milky. After allowing the tube to cool, pour the powder into a porcelain dish and add a few drops of water. The dish gets hot and steam is given off. Test the mixture with a red litmus paper. It goes blue.

On a pipe-clay triangle and tripod place a fair-sized piece of chalk and heat strongly for half an hour. Allow to cool, then add a small quantity of water. The solid swells, cracks, and steams. Test the solid with damp red litmus paper. It goes blue. Shake a little of the solid with a large quantity of water. Filter, and pass carbon dioxide through the filtrate. It turns milky.

We have produced from chalk some builder's lime, or quicklime, and carbon dioxide. We must now inquire whether the process was an adding on of oxygen from the air or whether chalk contains quicklime and carbon dioxide. In other words, was the process a synthesis or an analysis?

*Experiment.* Weigh a crucible without lid. Add a few grams of

powdered chalk and weigh again. Heat in a muffle furnace or over a Meker burner or large blowpipe for half an hour. Allow to cool and weigh again. There is a 44% loss of weight.

This seems to support the idea that the heating of chalk is a case of analysis. But we must seek further evidence.

### Acids on Chalk.

*Experiment.* Put some powdered chalk into a test-tube. Add dilute hydrochloric acid or dilute nitric acid. Arrange a second test-tube containing an inch of limewater with its lip under the lip of the first tube. Shake the limewater tube occasionally. The limewater turns milky.

*Experiment.* Put a few grams of chalk into the conical flask shown in Fig. 31. Add about 40 c.c. of water. Put about 10 c.c. of strong hydrochloric acid in the test-tube and suspend it inside the flask with thread. Close the flask with a rubber stopper fitted with tubes as shown. The drying-tube contains recently heated calcium chloride kept in place by cotton-wool plugs. Weigh the whole apparatus. Tilt the acid on to the chalk. Carbon dioxide comes out but moisture is retained by the calcium chloride. When the chalk has disappeared, the flask will be full of carbon dioxide, whereas the apparatus was weighed full of air. Gently blow air into the flask by means of a bellows connected to the right-angled tube. Weigh the whole apparatus. There is a loss of weight equal to 44% of the chalk put in.

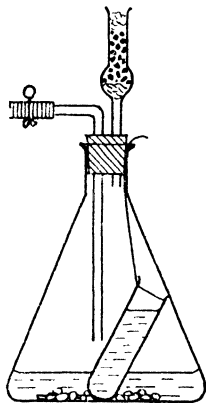
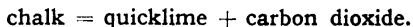

FIG. 31.

Thus acid turns out from chalk the same gas, and the same quantity of it, that we obtained by the action of heat on chalk. This is additional evidence that the heating of chalk is a case of analysis and we may say



### What is Quicklime ?

We will now study more carefully the chemical nature of quicklime. Let us first sum up what we know about it. It is a white alkaline solid which swells, cracks, and steams when water is put on it. A little of it dissolves in a large quantity of water to

produce limewater. For convenience we will put some of this in the form of verbal equation

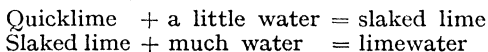

or, adding, we get

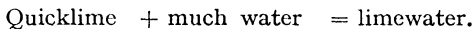

*Experiment.* Heat a piece of calcium strongly for half an hour on pipe-clay triangle and tripod. (Caution! This should be done on a metal table or a sheet of asbestos since the calcium sometimes burns rather vigorously and drops on the table.) Calcium oxide will of course be left. Or: Repeat the burning of calcium in oxygen, as on p. 16. Allow the calcium oxide to cool. It was previously shown that this substance is alkaline. Add a few drops of water to it. It swells, cracks, and steams. Add much water, shake, and filter. Pass carbon dioxide through the filtrate. It goes milky. There is considerable evidence here for believing that

**quicklime is calcium oxide.**

Therefore chalk = calcium oxide + carbon dioxide.

It is interesting to remember that everything said above concerning chalk applies also to marble and limestone. These three substances all have the same chemical composition and only differ in hardness and mode of formation in nature.

Chalk, marble, or limestone = quicklime + carbon dioxide.

Chalk, marble, or limestone + acid will give carbon dioxide.

**Properties of Carbon Dioxide.** To obtain large quantities of the gas, we may use marble chips and dilute hydrochloric acid in a Woulfe's bottle (Fig. 32). This generating bottle has the advantage over the ordinary flask that it is not easily broken by the marble chips.

We may also use a Kipp's apparatus (Fig. 33). This well-known feature of the chemical laboratory was invented by a Dutch instrument maker, Petrus Jacobus Kipp (1808-64). His firm, P. J. Kipp & Zonen, is still in existence at Delft in Holland.

The 'Kipp' is a combined generator and gasometer. Carbon dioxide is liberated in the centre chamber, and if the tap is closed, the gas pressure drives the acid down off the marble and up into the top chamber. Carbon dioxide is thus 'on tap.' Using large pieces of zinc and dilute sulphuric or hydrochloric acid in the Kipp, we can also have hydrogen 'on tap.' The conditions for

using a Kipp are (1) the gas must be generated by the action of a liquid on a solid in big lumps, and (2) no heat must be necessary.

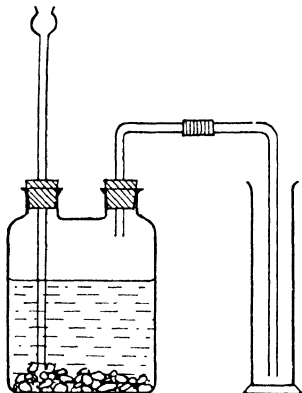

FIG. 32.

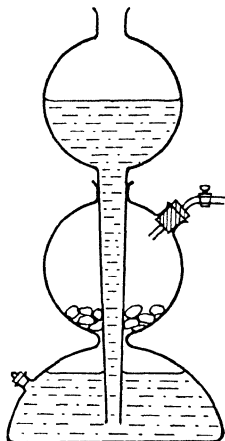

FIG. 33.

(a) Pass carbon dioxide from the Woulfe's bottle or the Kipp *downwards* into a gas jar. Test the gas with a lighted match. Fill another jar, cover it with a glass plate, then pour the gas over a lighted candle (Fig. 34). The candle goes out. The gas is heavier than air and puts out ordinary flames.

(b) Hold a piece of burning magnesium ribbon in the gas. The ribbon continues to burn, forming magnesium oxide. Black specks are seen on the sides of the jar. Wash the jar out with a little dilute sulphuric acid. The magnesium oxide dissolves, but the black specks float in the acid and do not dissolve. They are particles of carbon.

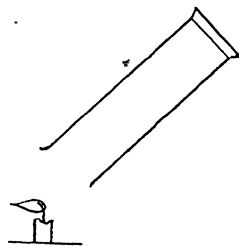
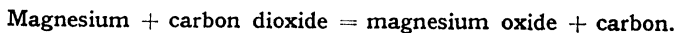

FIG. 34.



(c) Half fill two conical flasks with water. Colour both with blue litmus. Pass carbon dioxide into one of them and shake  
g.s.c.

well. Compare the colours of the two liquids. Carbon dioxide makes an acid with water.

(d) Pass the gas through a gas jar full of limewater. The limewater goes milky then clear again! This mystery will be cleared up later (p. 117).

(e) Repeat (d) but stop when the limewater is thoroughly milky. Allow to settle. Pour off as much of the clear liquid as possible, then filter the remainder. Dry the residue on the filter paper and heat strongly in a test-tube. Carbon dioxide comes off and quicklime is left. The milkiness was therefore chalk. When we pass carbon dioxide into limewater we are really synthesizing chalk.

Limewater, as we have seen, is a solution of quicklime or calcium oxide in water. Therefore we may say

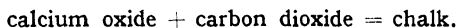

When a powder suddenly forms in a clear liquid and falls to the bottom in this way, it is called a *precipitate*, and this finely powdered chalk is often referred to as *precipitated chalk* (compare *precipice*—a sudden fall in the land).

(f) Pass the gas into water in a pneumatic trough. Invert a test-tube full of water over the delivery tube. When the tube is half full, close with the thumb and shake vigorously. Invert again in water and remove the thumb. The water rises, showing that, although carbon dioxide can be collected over water, it is fairly soluble in that liquid.

(g) Fill a test-tube quite full of the gas. Close with the thumb and remove it from the water. Quickly add a few drops of sodium hydroxide, close again with the thumb, and shake vigorously. Invert in water and remove the thumb. Carbon dioxide is extremely soluble in sodium hydroxide.

### Another Method of obtaining Carbon Dioxide.

*Experiment.* Pour a few c.c. of limewater into a test-tube. Breathe into it and shake well. The limewater goes milky.

Is there carbon dioxide in ordinary air or only in air which we breathe out?

*Experiment.* Leave a dish of limewater open to the air for a few hours. Pour into a test-tube. The limewater is slightly milky.

*Experiment.* Fix up the apparatus shown in Fig. 35. The test-tube contains a few c.c. of limewater. Connect the apparatus to a

filter pump and draw a slow current of air through. The limewater goes milky but only very slowly.

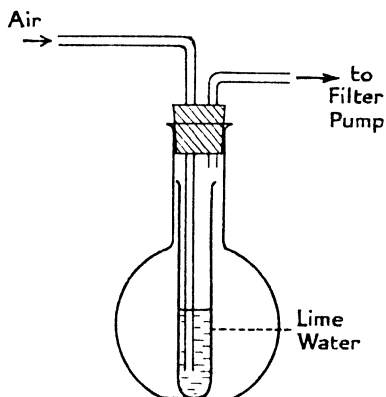

FIG. 35.

There is more carbon dioxide in air breathed out than in ordinary air.

Does air breathed out by other animals contain carbon dioxide or is this result peculiar to man?

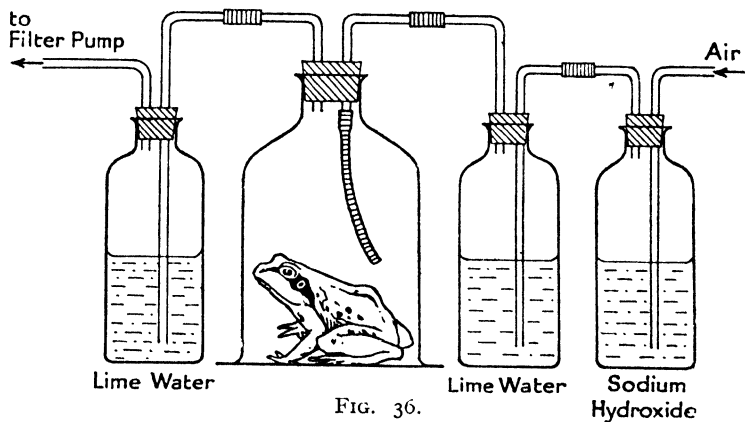

FIG. 36.

*Experiment.* By means of a filter pump a slow current of air is drawn through the apparatus shown in Fig. 36. The first wash-

bottle contains sodium hydroxide solution to remove carbon dioxide from the incoming air. The second wash-bottle contains limewater to prove that this has been accomplished. The bell jar rests on a glass plate and is made airtight with vaseline or plasticine. The air enters the bell jar by way of a *rubber* tube since this is safer for the tenant. The third wash-bottle contains limewater which should go milky.

If a frog is not available, beetles or worms can be used, a flask replacing the bell jar and glass plate since these will not now be necessary. If a potted plant or a plant supported in a small bowl of water is used in place of the frog, the limewater also goes milky. The bell jar must be covered with a dark cloth if a plant is used.

**The air breathed out by animals and plants contains carbon dioxide.**

This curious fact will be investigated more fully later, but before leaving the subject we will inquire how much carbon dioxide there is in the expired air of a human.

*Experiment.* Fill a gas jar with expired air as in Fig. 37. Plunge

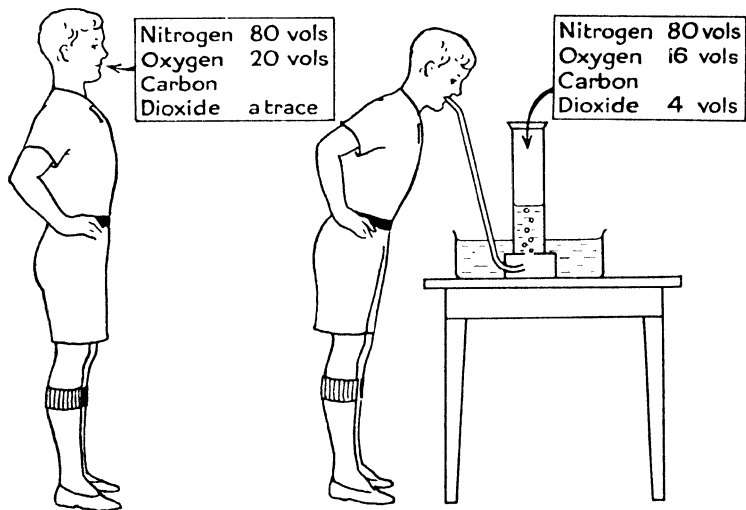

FIG. 37.

a lighted match into the gas jar. The match goes on burning quite well. There is still a good deal of oxygen in expired air. Roughly

speaking, 4% of the oxygen was used up and replaced by 4% of carbon dioxide.

*Experiment.* Using a rubber tube, breathe into a burette full of water inverted in a gas jar of water, stopping when there is still about 2 inches of water in the burette (Fig. 38). Insert a piece of sodium hydroxide in the burette, then close with a cork. Remove the burette and invert a few times. Dip the burette into the gas jar and loosen the cork. The liquid rises a little way because *sodium hydroxide absorbs carbon dioxide from a gas mixture.*

Place a little pyrogallol in a spill of paper. Quickly insert this and replace the cork. Remove the burette and invert several times. Dip the burette in the gas jar and again loosen the cork. The water rises considerably because *sodium hydroxide and pyrogallol mixture removes oxygen from a gas mixture.* Compare p. 9.

You have just done a very rough *gas analysis*. Try to point out some of the weaknesses in the experiment.

**Mine Rescue Work.** The fact that the lungs only use 4% of the oxygen taken in, is used in a very ingenious way in the 'Proto' Self-Contained Breathing Apparatus worn by rescue workers after a colliery explosion.

The combustion which takes place during the explosion removes much of the oxygen, replacing this by carbon dioxide and a still more dangerous gas called carbon monoxide. The mixture of nitrogen, carbon dioxide, and carbon monoxide left after the explosion is called *after-damp* (German *dampf*, vapour) and is responsible for at least as many deaths as the explosion itself.

Rescue workers wearing the 'Proto' apparatus (Fig. 39) can work in this bad atmosphere for about two hours. They breathe



FIG. 39.

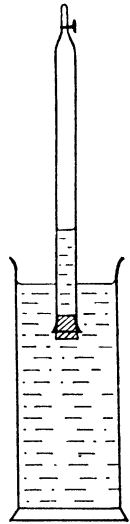

FIG. 38.

the same air over and over again, but the 4% carbon dioxide is removed by an apparatus on the chest containing sodium hydroxide and coke. At the same time a little cylinder of compressed oxygen on the back is adjusted so that it passes in 4% of oxygen.

**Carbonates.** We have already learnt that chalk is a compound of calcium oxide and carbon dioxide. Such a compound of a metallic oxide and carbon dioxide is known as a **carbonate**. Chalk is calcium carbonate, and we notice that, like all compounds, it is quite unlike its constituents in many ways.

In the laboratory you will find many other carbonates.

Magnesium carbonate is a compound of magnesium oxide and carbon dioxide.

Zinc carbonate           ,,   ,,   ,, zinc oxide and carbon dioxide.

Barium carbonate       ,,   ,,   ,, barium oxide and carbon dioxide.

Sodium carbonate       ,,   ,,   ,, sodium oxide and carbon dioxide.

*All carbonates when treated with dilute acid give carbon dioxide.*

*Some carbonates when heated give off carbon dioxide and leave the metallic oxide.* Chalk does this.

*Experiment.* Heat magnesium carbonate in a test-tube. If one of the powdered forms is used, it is apt to shoot out of the tube, so care must be taken. Allow the carbon dioxide to pass into a second test-tube containing a little limewater with its lip under that of the first tube. Test the residue. It is alkaline and has the same composition as the residue from burning magnesium in oxygen and in steam. It is, in fact, magnesium oxide.

*Experiment.* Heat zinc carbonate as in the last experiment. Carbon dioxide comes off and a residue is left which is yellow when hot and white on cooling (see also p. 26). This is zinc oxide. It can also be made by heating zinc strongly in a crucible. It then has a woolly appearance and was known to the early chemists as 'philosophers' wool.'

You have probably seen a nasty-looking green deposit on copper or brass fittings which have been exposed to a damp atmosphere. If you scrape some of this off and heat it in a test-tube, carbon dioxide comes off and black copper oxide is left. This green deposit is also a carbonate, but in ordinary language it is generally called 'verdigris' (i.e. Grecian green).

Many carbonates occur in nature, but some are produced only

in man's laboratory. Can we make carbon dioxide unite with a metallic oxide to form a carbonate? This is rather difficult, as direct synthesis generally is, but we can often make carbon dioxide react with a metallic **hydroxide** to form a carbonate. This is what we really did when we prepared precipitated chalk from limewater. Limewater may be looked upon as a solution of quicklime (calcium oxide) in water, or a solution of slaked lime (calcium hydroxide) in water. A metallic hydroxide is simply a compound of the metallic oxide with water.

Another important metallic hydroxide which you will continually meet is *sodium* hydroxide. When sodium was burnt in oxygen and the product dissolved in water (p. 16), the alkaline substance in solution was sodium hydroxide. Again, when sodium was put in water to get hydrogen (p. 20), this same alkaline substance was formed. Let us repeat the latter experiment in a rather different way.

*Experiment (Dangerous).* Take a piece of sodium about the size of a pea. Cut it into about 16 pieces. Add these *one by one* to a few c.c. of water in a dish. The water gets warm, soapy, and alkaline. Evaporate to a very small bulk and allow to cool in a desiccator.

We do not recover the sodium, because there has been a *chemical change*. If we dissolve salt in water and evaporate to dryness, we get salt back. This is called a *physical change*; no new substance is formed.

The residue after the solution of sodium in water is an entirely new substance, sodium hydroxide or caustic soda, as it is sometimes called. You will already be familiar with it in the form of white sticks.

*Experiment.* Either repeat the last experiment to get a solution of sodium hydroxide or use part of one of the white sticks and make a strong solution in a boiling-tube (say 5 grams in 20 c.c. water). Pass carbon dioxide through for about three-quarters of an hour. Set aside to cool. After a time a crystalline substance separates out. Pour off the liquid and dry the crystals between filter papers.

*Experiment.* Add a little hydrochloric acid to a sample of the crystals. Carbon dioxide comes off. *The crystalline substance is a carbonate.*

*Experiment.* Heat some of the crystals in a test-tube fixed up as in Fig. 40. The solid melts. Be careful that it does not run over into the receiving-tube. Find the boiling point of the liquid in the

receiving-tube. It turns out to be **water**. The heating-tube now contains a dead white powder. When it is cool, add acid to it. Carbon dioxide comes off. *The white powder is also a carbonate.*

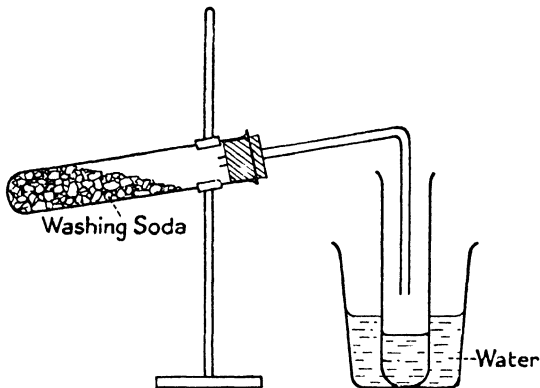

FIG. 40.

The white powder is **sodium carbonate**. The crystalline substance is **sodium carbonate combined with water**. It is the well-known substance called washing soda. When heated it gives off its water and loses its crystalline form. It is then described as *anhydrous* or 'without water.' Such water is known as **water of crystallization**. Observe too that the crystals although they contain water are perfectly dry to the touch. The water is *combined* water.

**Washing soda = sodium carbonate + water.**

The old chemists made a curious mistake in connection with washing soda. When washing soda crystals are left in a dry place for some time, a white powder forms on the surface. This was thought to be a kind of *growth* like mould growing on bread, cheese, or damp leather. In youthful parlance the substance appeared to be 'growing whiskers.' The old chemists invented a name for this. They said that washing soda was an *efflorescent* substance since it was apparently 'flowering' or 'blossoming.' Actually the washing soda is *losing water* on the surface and tending to become anhydrous.

If we pass carbon dioxide for a very long time through cold

concentrated caustic soda solution a different carbonate will separate out. This is sodium bicarbonate, the prefix *bi* indicating that there is a double dose of carbon dioxide present. This white powder is a well-known household substance. An 8% solution is often used for treating burns.

*Experiment.* Heat a little sodium bicarbonate in a test-tube. Moisture and carbon dioxide come off. When no more gas is evolved, allow the tube to cool and add a little hydrochloric acid. Carbon dioxide again comes off.

Sodium bicarbonate = sodium carbonate + water + carbon dioxide.

Sodium bicarbonate gives up half its carbon dioxide on heating, but no amount of heating will drive out the other half. In other words, sodium carbonate, unlike calcium carbonate, does not split up on heating.

The last experiment has an important application in cookery. Sodium bicarbonate is mixed with flour and water to form dough. When this is put in the oven, the bicarbonate decomposes and the carbon dioxide puffs out the dough, making it 'light.' For this reason sodium bicarbonate is sometimes called 'baking soda.'

A variation of this method is to mix sodium bicarbonate with tartaric acid. This is the so-called 'baking powder.' When this is wetted we have the ordinary action of an acid on a carbonate. Carbon dioxide comes off and the pastry is puffed out as before.

We have the same mixture, plus some medicinal substance, in Seidlitz powders, and health salts. As long as the mixture is dry nothing happens, but as soon as water is added we have a fizzy drink which masks the taste of the medicine.

*Experiment.* Thoroughly mix 2 grams of sodium bicarbonate, 2 grams of tartaric acid (powder form, not crystals), and 4 grams of icing sugar. Taste the mixture. Put some in water and taste it. Put some in a dry test-tube, add water, and test for carbon dioxide.

**Sodium's Relations.** We shall find as we go on that the 90-odd elements in the universe can be divided into families. Thus sodium is one of five—lithium, sodium, potassium, rubidium, and caesium. The last two you may never meet, for they have not much to do with daily life at present. All of them form similar compounds; thus lithia water, which was formerly used in gout and rheumatism, is a solution of lithium bicarbonate. Other compounds of lithium are still used for the same purpose. All

five decompose water, liberating hydrogen. Lithium does it peacefully, sodium dangerously and the others so violently that the hydrogen catches alight. In the ordinary laboratory you will only meet sodium and potassium. The behaviour of sodium is already known to you. We will now make a closer but cautious acquaintance with potassium.

*Experiment (Great Caution).* Potassium, like sodium, is kept under paraffin or naphtha. Cut one of the metal balls and notice the lustre which grows dim more quickly than in the case of sodium. Throw a **minute fragment** into a few c.c. of water in a dish. There is a quick lilac-coloured flash. This colour is characteristic of potassium and its compounds. When several fragments have been thrown in **one by one**, feel the liquid and test with red litmus paper. The liquid is warm, soapy, and alkaline.

The solution is caustic potash or potassium hydroxide and it has properties similar to those of sodium hydroxide. The solid substance comes on the market in similar white sticks. Potassium also forms a carbonate and a bicarbonate. The ordinary potassium carbonate is sometimes prepared from wood ashes. The ashes are washed with water and the solution evaporated in iron pots. The product is called 'pot-ash,' hence the names potash and potassium.

It is an interesting fact that while the ash of a land plant contains potassium carbonate, the ash of a plant growing near the sea contains more sodium carbonate. One plant growing in salt-marshes is specially noted for this. It is *Salicornia* or glasswort. This plant received its second name because the sodium carbonate was extracted for *glass* making. If you live near an estuary, it is worth while collecting some of this succulent plant, drying it in an oven, and then heating strongly in a large crucible. The residue when treated with acid should give carbon dioxide.

#### **Other Contacts of Carbon Dioxide with Daily Life.**

We saw that carbon dioxide is fairly soluble in water. Actually at ordinary temperature and pressure a litre of water will dissolve about a litre of gas. If the pressure is doubled, the litre of gas becomes half a litre (Boyle's Law). But the litre of water will still take a whole litre of the compressed gas. If the pressure is trebled, the water will still take the same volume of gas. In other words, *water dissolves the same volume of a compressed gas as of gas under ordinary pressure.* This fact is used in filling the

common soda-water syphon. Soda water is simply carbonic acid. Carbon dioxide is driven into water at a pressure of about 5 atmospheres. When the lever is depressed, the great pressure forces liquid out, and this liquid effervesces strongly because it contains more carbon dioxide than it can hold under ordinary pressure.

The actual pressure in a soda-water syphon can be determined

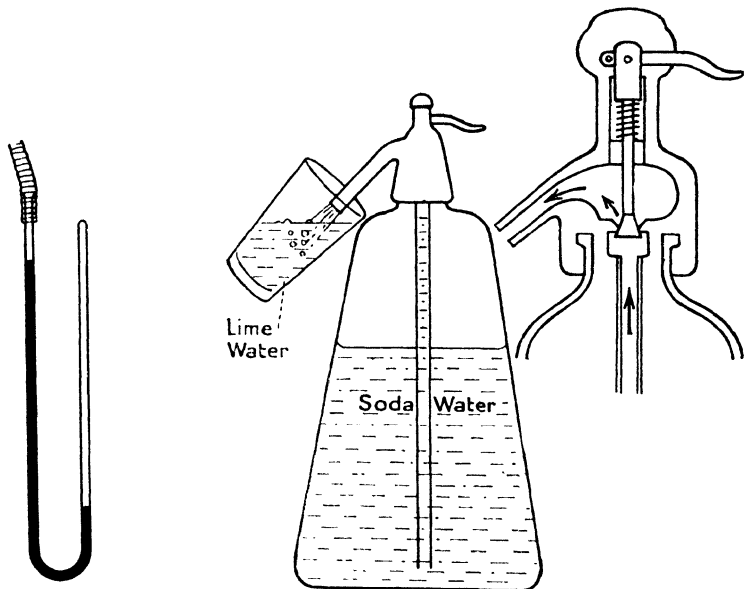

FIG. 41.

FIG. 42.

by connecting the glass U-tube containing mercury (Fig. 41) to a syphon. The connection is made with stout Bunsen tubing, wiring this on to the syphon and to the glass tube, which may advantageously have a lip. Another length of wire is then wound round the whole length of the tubing. On slowly depressing the lever, the mercury is driven round the bend and the enclosed air is compressed.

An interesting experiment which looks like a conjuring trick can be done with a soda-water syphon. A little soda water is squirted into a tumbler three-quarters full of limewater (Fig. 42).

It then looks like a glass of milk and will certainly astonish anyone unacquainted with chemistry.

If the syphon is inverted and the lever depressed, gas only comes off and this can be collected over water in gas jars. The soda water is of course useless afterwards and this method of making carbon dioxide is somewhat expensive, but as a novelty it is worth doing once in a while.

### Solid Carbon Dioxide.

In Chapter II we spoke of liquefying air by means of cold and pressure. This can also be done with carbon dioxide. Actually it is rather easier, and it is found that if the temperature of the gas is below  $31^{\circ}$  C., pressure will liquefy it. But if the temperature is above  $31^{\circ}$  C., no pressure on earth will do the trick. This temperature is called the *critical temperature* for carbon dioxide. Every gas has a critical temperature above which no pressure, however great, will liquefy it.

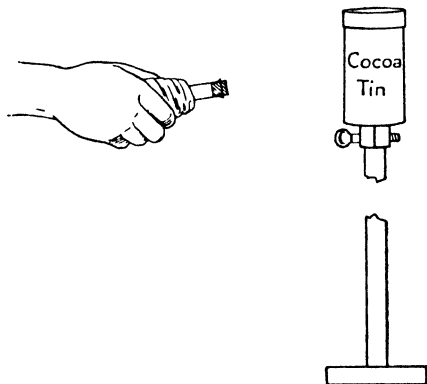

FIG. 43.

Carbon dioxide was first liquefied by Faraday. About 1835 a Frenchman, Thirlorier, solidified it and called it 'carbonic acid snow.' About 1928 it began to be used by ice-cream vendors and a Sunday newspaper came out with a heading *Wonderful new refrigerating agent*. The ice-cream vendor puts a package of solid carbon dioxide amongst his ice-cream packets and this prevents their melting.

The temperature of the snow is  $-79^{\circ}$  C. It must not be handled very much or painful sores may be formed. The surgeon uses this fact; he applies a pencil of snow to warts or moles on the skin. The snow can be safely handled with gloves or a duster.

#### Experiments with Solid Carbon Dioxide.

(1) Put a fragment in a gas jar. After a few minutes pour the gas over a lighted candle.

(2) Drop a piece into half a beaker of limewater.

(3) Place a lump in a dish in a desiccator. The solid only 'smokes' in a damp atmosphere.

(4) Lay a steel ruler on a block of the solid or put a small piece on an alarm bell. The metal vibrates.

(5) Put a small piece in a hard test-tube. Stop the tube with a rubber stopper. Wrap a duster round the tube, point it at the ceiling or some safe object and wait a minute (Fig. 43).

Thirlorier discovered that if the snow is mixed with a little ether, an excellent freezing mixture is obtained.

#### Experiments with Thirlorier's Mixture.

(1) Crush some solid carbon dioxide with pestle and mortar. Add ether and mix with a wooden ruler. Pour in a little mercury, then lift it out with the ruler. Immerse a test-tube containing mercury in the mixture, then invert it. Immerse a tiny hollow

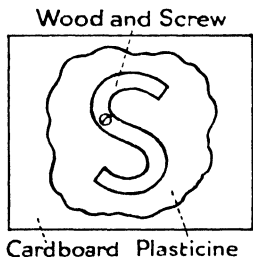

FIG. 44.

rubber ball for a few minutes, then throw it against the wall. Immerse a grape, an orange section, a soft rubber, or a piece of meat in the mixture. Take them out after a few minutes, and hammer them with a heavy pestle.

(2) Cut a letter **S** out of plywood 1 cm. thick and drive a stout screw into the middle of it. Hammer the **S** into a thick layer of plasticine placed on a sheet of cardboard (Fig. 44). Lift out the

S and fill the groove with mercury. Scoop up some mixture with a ruler and cover the mercury. In a minute or two a solid mercury S can be dug out and hung on a piece of copper wire. The plasticine mould can be preserved for future use.

(3) Dip a soap bubble into a large mortar containing the mixture. A fragile frozen bubble is obtained.

(4) Fill a small flask with bromine vapour (*Caution!*) by warming a little liquid bromine in it. The flask fills with red vapour. Cool a spot on the flask with a little of the mixture or stand the flask in a mortar containing the mixture. The bromine freezes and the atmosphere clears.

(Solid carbon dioxide for school use can be obtained during the summer months at about 4*d.* per lb. from the local depots of ice-cream vendors. It keeps well if buried in sawdust. Most of the experiments usually carried out with the aid of liquid air can be done with Thirlorier's mixture.)

### Fire Extinguishers.

Some fire extinguishers depend on the fact that when an acid acts on a carbonate, carbon dioxide is liberated. One of these contains a solution of sodium carbonate in which is a glass tube of sulphuric acid. The striking of a knob on the outside breaks the tube and a mixture of liquid and gas is expelled with great force.

### The Sparklet Syphon.

The fact that carbon dioxide can be so easily liquefied is used in the **Sparklet Syphon**. A small steel bulb full of liquid carbon dioxide can be attached to the syphon and this carries a piercing device. When the bulb is pierced, the liquid gasifies and passes into the water in the syphon, thus producing soda water at home.

### A Medical Use of Carbon Dioxide.

Carbon dioxide must not be regarded as a poisonous gas. If it were, we should not survive our first drink of lemonade or soda water. If, however, an animal is placed in an atmosphere containing a high percentage of carbon dioxide, it dies from suffocation. But within recent years a curious fact has been discovered. An average adult breathes in 7 litres of air per minute, but if the air contains 5% of carbon dioxide his breathing becomes much deeper and he will take in 30 litres of air per minute. A small addition of carbon dioxide thus stimulates the breathing.

This fact is found useful in surgical operations where ether is being administered, for the necessary ether is now more diluted and has less irritating action on the lungs and throat. Further, when the operation is over, the ether is more quickly got rid of. The same lung stimulation is also possible in the apparently drowned and those suffering from various kinds of gas poisoning.

Sometimes the stimulating carbon dioxide is administered from a special apparatus containing a sparklet bulb, but in drowning and poisoning cases a more drastic method is often necessary and the patient is made to breathe a mixture of 93% oxygen and 7% carbon dioxide. The apparatus for this purpose is called Novox and is made by Messrs. Siebe, Gorman & Co., London.

### **Brewing and Bread-making.**

*Experiment.* Put 50 gm. of sugar, 15 gm. of brewer's yeast and 500 c. c. of water in a large flask fitted with a delivery tube dipping into limewater. Place the apparatus on a radiator or in any other warm situation. In a few hours the mixture froths and bubbles, giving off **carbon dioxide**. After a couple of days filter and, if time allows, distil with the apparatus shown on p. 68. Collect the first 50 c. c. and re-distil. The new distillate should burn—it contains **alcohol**.

The yeast plant grows and multiplies by using the sugar, and in the process carbon dioxide and alcohol are formed. The process is called **fermentation**. In brewing, the alcohol is the main object. In bread-making the carbon dioxide puffs out the dough and makes it more digestible. The alcohol passes off during the baking.

## CHAPTER V

### MORE ABOUT COMBUSTION

We shall begin this chapter with two experiments which at first sight seem to have very little to do with combustion. Their bearing on combustion will, however, very soon be evident.

*Experiment.* Heat a little powdered bluestone in a test-tube as shown in Fig. 45. It is important that the test-tube should slope as shown. The bluestone loses its blue colour and becomes almost white. A liquid will collect in the second test-tube. A determination of its boiling point, freezing point or density will show that it

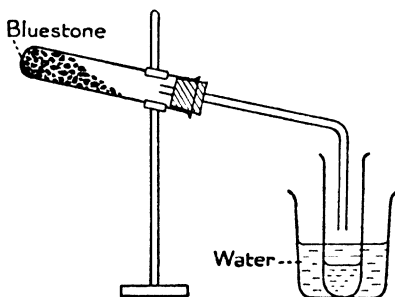

FIG. 45.

is water. Having allowed the white powder to cool, pour the water back on to it. Feel the tube while doing this. **The powder regains its blue colour and heat is given out.** This evolution of heat is a sign of chemical action or the formation of a compound. This is worth remembering as a second difference between mixtures and compounds.

Our experiment is somewhat similar to the heating of washing soda on p. 40. Here again *water of crystallization* comes off and

an *anhydrous substance* is left. In the present case it is **anhydrous bluestone**. Note that bluestone has two other names, 'blue vitriol' and 'copper sulphate.' The former name was given to it because the large crystals look like blue glass (Lat. *vitrum*—glass).

*Experiment.* Gently heat about half a teaspoonful of powdered bluestone in a porcelain dish. When the powder has gone white, allow to cool. Try various liquids, which you know to contain water, on samples of the powder. The samples go blue and the substance is therefore very useful to *prove the presence of water*. A sample left exposed also goes blue showing the presence of water vapour in the air.

### Heating Coal and Wood in Absence of Air.

*Experiment.* Heat some powdered coal in a hard glass tube and pass the gases coming off through a boiling-tube immersed in a

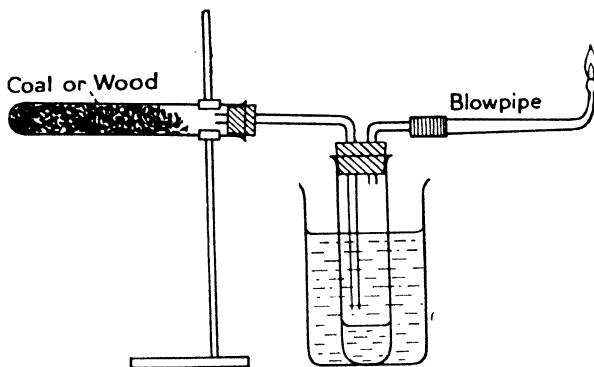

FIG. 46.

beaker of cold water (Fig. 46). After a time a smoky vapour issues from the blowpipe. The smell is rather unpleasant and suggests bad eggs. Hold a filter paper soaked in lead acetate solution in the issuing smoke. The paper goes black. This shows the presence of **sulphur compounds** (see p. 109). Set a light to the smoke. It burns with a long luminous flame. When the flame goes out, allow the apparatus to cool. The hard glass tube is now full of **coke**. The boiling-tube contains **tar** and a **liquid alkaline to litmus paper**. Put a drop of this liquid on anhydrous bluestone. The powder goes blue. Therefore the liquid contains **water**.

We have imitated the gas industry and this process of heating coal in the absence of air is known as the **Destructive Distillation** of coal.

*Experiment.* Clean out the boiling-tube from the last experiment with caustic soda solution. Put a few chips of the driest wood you can find into a new hard glass tube. Heat the wood exactly as in the last experiment. The **gas** coming off contains no sulphur compounds. It will burn at the blowpipe, but the flame is not nearly so steady; a good deal of the carbon and hydrogen in wood is already united with oxygen and this combined carbon and hydrogen cannot burn. When the gas will no longer burn, allow the apparatus to cool. The hard glass tube is full of **charcoal**. The boiling-tube contains **tar** and a liquid which is acid to litmus. This liquid is called 'wood spirit.' The word 'spirit' is popularly applied to any liquid or vapour prepared by distillation. The boiling-tube should be immediately cleaned out with caustic soda solution.

We have just carried out the **destructive** distillation of wood. We may sum up our results thus:

**Coal** → coal gas + an alkaline liquid + coal tar + coke.

**Wood** → wood gas + an acid liquid + wood tar + charcoal.

### Common Combustible Substances.

*Experiment.* Hold a *dry* gas jar over a burning spill of paper (Fig. 47). The gas jar goes misty. Sprinkle a little anhydrous bluestone into the damp jar. It goes blue. *Water has been formed.* Wash out the jar and again hold it over a burning spill of paper. Put a glass plate over the mouth of the jar, then pour in a little limewater. The limewater goes milky. *Carbon dioxide has been produced.*

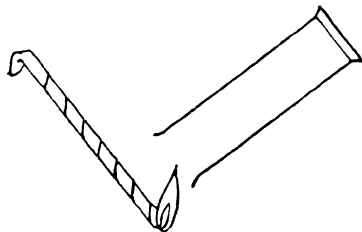

FIG. 47.



FIG. 48.

The experiment may also be carried out with the jar in the position shown in Fig. 48. The same results are obtained.

Put wood, a candle, methylated spirit, petrol, turpentine,

sugar, or starch in a burning-spoon and repeat the last experiment. *In all cases water and carbon dioxide are formed and heat is given out.*

Attach a bent glass jet tube to a Bunsen tube (Fig. 49). If the tubing does not make a tight joint, turn it back on itself as in turned-up trousers. Turn the gas on so as to have a small flame at the jet. Now repeat the previous experiment. Again water and carbon dioxide are formed. Water can also be readily produced by replacing the glass tube with a mouth blowpipe

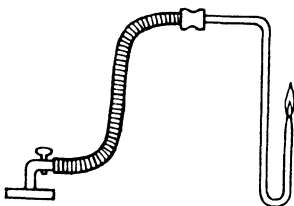

FIG. 49

and allowing the flame to strike against a cooled retort as in the hydrogen experiment on p. 23.

It is important to realize what the above experiment proves and what it does not prove. The experiment certainly shows that all the combustible substances we used contain carbon and hydrogen because these could not have come from the air. The experiment does **not** show that the burning substance contained carbon dioxide and water. Nor does the experiment show that the substances contained oxygen because this could have come from the air during the burning. We only know for certain that **the substances burnt contained carbon and hydrogen**. Actually a few of the substances do contain oxygen, but the experiment does not prove this.

The destructive distillation of coal and wood showed that these two contain oxygen as well as carbon and hydrogen because water was produced even when they were heated out of contact with air. We can also prove that starch and sugar contain oxygen as well as carbon and hydrogen.

*Experiment (Demonstration).* A small retort is nearly filled with starch or sugar and heated, the vapours given off being passed

through a Liebig condenser (Fig. 50). When no more vapours come off, the retort is allowed to cool. It is now full of carbon and will be of no further use. The receiving flask contains a brown tarry liquid.

The centre tube of the condenser is now cleaned in the usual way with a wad of cotton-wool tied in the middle of a piece of copper wire. The tarry liquid is distilled through the Liebig from a small distilling flask fitted with a thermometer. Although the liquid has a brown colour and a burnt smell, the boiling point will be approximately  $100^{\circ}\text{C}$ ., showing that most of the liquid is probably water. The second distillate can also be tested with

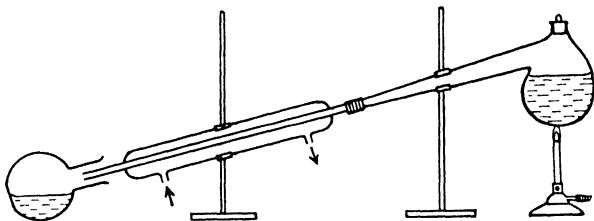

FIG. 50.

anhydrous bluestone. The distilling flask is then cleaned out with caustic soda solution.

Although we have obtained carbon and water from starch, the sceptic might contend that the oxygen in the water was not actually in the starch but came from the air in the retort. In answer to this we may explain that to produce the water we obtained would require much more air than was present in the retort. Actually to produce even 1 c.c. of water we should require the oxygen from about 3,000 c.c. of air. We may therefore take it as proved that starch (or sugar) contains carbon, hydrogen, and oxygen. In more advanced work it is shown that the hydrogen and oxygen in starch are present in the same proportions as in water. The same is true for sugar. For this reason starch and sugar are called **carbohydrates**.

### The Indestructibility of Matter.

In all our combustions we found that water and carbon dioxide are formed. Sometimes there is an ash as well. When

we have a fire in the garden we produce smoke and ashes. Smoke is a mixture of fine particles of unburnt carbon, water vapour, carbon dioxide and other acid gases.

Now if all these products of combustion were caught and weighed, we should find that we had more matter after than before. The increase is of course due to the oxygen taken from the air. We cannot really destroy anything. All we do is to change the substance into other forms of matter. These new forms of matter may of course be quite useless.

The fact applies not only to burnings but to any kind of change whether physical or chemical. We say '*Matter cannot be created or destroyed,*' or in more scientific language, *In any change whether physical or chemical the total weight of the substances after the change will be the same as the total weight before the change.*

This fact is called the Law of Indestructibility of Matter or the Law of Conservation of Mass. It is regarded as the fundamental law of Chemistry.

We had a very good illustration of the Law on p. 7 when we burnt a piece of phosphorus in a corked flask; the weight was the same after as before until the flask was opened to let air in to replace the oxygen which had been used up.

**Combustion and Energy.** We are constantly burning wood, coal, coal gas, and petrol and producing as a result carbon dioxide and water vapour. Why do we do this? Certainly not for the sake of getting the carbon dioxide and water vapour. We do it because we know that when carbon is burnt or oxidized to carbon dioxide or hydrogen to water, *heat is given out.* This heat we use in two ways. Either the heat is produced in an engine to do work for us, or the fuel is burnt in some contrivance to keep us warm. We learn in physics that heat is energy, so we may say that we burn fuels to produce energy.

**Animal and Plant Energy.** On p. 36 we saw that the air breathed out by animals and plants contains carbon dioxide. Is this also a liberation of energy? We know that animals work and many of them are warm. But can plants work and do they ever get warmer than their surroundings? A plant does a considerable amount of work during growth in overcoming gravity; consider the weight of an oak or elm. It has also to push its roots down against the resistance of the soil. Water has to be carried up from the soil to all parts of the organism. A plant works very slowly, but it certainly works.

A very young plant is sometimes warmer than its surroundings. Thus the temperature of soaked peas or barley may rise several degrees during germination.

*Experiment.* Soak some peas for 24 hours, drain off the water and pour the peas into a thermos flask. Close the flask with a wad of cotton wool through which passes a thermometer. Hang up the flask in an inverted position until the following day (Fig. 51). The temperature rises 5 or 6° C. If another thermos flask is set up at the same time containing peas which have been killed by boiling, no rise of temperature will occur.

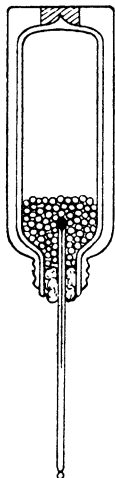

FIG. 51.

If an apple and a test-tube of limewater are placed in a gas jar with a greased plate on the top and left for a day, we shall find that the limewater goes milky and the air left will not support combustion because the oxygen has been used up.

Experiments such as these lead us to the conclusion that the breathing of animals and plants is simply a case of supplying oxygen to a slow combustion which continues as long as the animal or plant lives. Thus we have **an intake of oxygen, a slow oxidation and an output of carbon dioxide and energy.** This is the process known as **breathing or respiration.**

In the animal, respiration is necessarily a more vigorous process than in the plant. The plant does not need to wander round looking for food, nor does it chase and eat other plants. In an animal it is the food which is oxidized to provide energy. We ourselves put fuel on to this slow fire three or four times a day. But what is burnt or oxidized in a plant? The answer is *sugar*.

How does a plant breathe? It breathes all over the body but especially by pores called stomata (sing. *stoma*), which are chiefly to be found on the underside of the leaf.

*Experiment.* Cut across the leaf of a lily, daffodil, snowdrop, hyacinth or similar plant. Work a needle into the cut edge so as to loosen the colourless surface skin on the underside. Stretch this over a cover slip, mount in water and examine under the microscope.

There will be seen long cells with wavy cell walls, also pairs of

cells like small sausages enclosing a mouth (Fig. 52). This mouth is the stoma and it is through the stoma that the plant takes in oxygen and sends out carbon dioxide.

**The Water Animal and Plant.** How does a fish or a submerged water plant manage to get oxygen for respiration, surrounded as they are by water? They cannot of course split up the water into hydrogen and oxygen. They do not carry a little voltmeter round with them. Combined oxygen is perfectly useless to the fish, as you would quickly find if you immersed the fish in cold boiled water. It would soon drown! Why does boiled water taste flat while spring water or even tap water is quite pleasant to taste? It is because spring water and tap water contain **dissolved air**. It is from this that the water organism gets the necessary oxygen. We can easily show that tap water contains dissolved air.

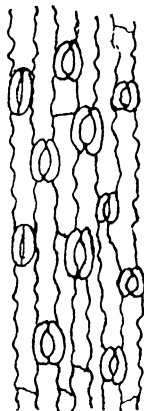

FIG. 52

*Experiment.* Fill the largest available flask with tap water. Fit a delivery tube to a rubber stopper so that it is just flush with the stopper. On squeezing the stopper into position in the neck of the

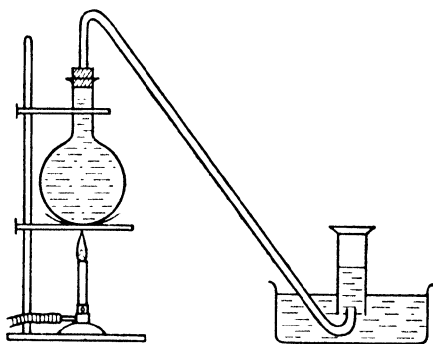

FIG. 53.

flask, the delivery tube should fill with water so that no air is enclosed. Boil the water and collect any gas which ~~comes off~~ ~~comes off~~ (Fig. 53).

20820

Test the gas with a glowing splint. It will continue to glow or may even glow more brightly since oxygen is about twice as soluble in water as nitrogen, therefore the air driven out of water contains more oxygen than ordinary air. Thus while ordinary air contains four volumes of nitrogen and one of oxygen, dissolved air contains about two volumes of nitrogen to one of oxygen.

**The Carbon Cycle.** It would seem at first sight that animals, plants and fires are in a sort of conspiracy to render the air unfit for breathing by using up the oxygen and replacing it by carbon dioxide.

But there are at least three influences acting to prevent this : (a) a good deal of the carbon dioxide is dissolved by rivers, lakes, and seas ; (b) some of the carbon dioxide is used up in the process known as the **weathering of rocks**. Granite is a mixture of quartz, mica, and felspar. Now felspar contains potassium oxide as one of its constituents. The carbon dioxide in the air dissolves in the rain and this solution of carbonic acid attacks the felspar producing potassium carbonate which dissolves and china clay which is left behind. This causes the granite to break up. Here is an example of weathering which has been going on for ages and is the cause of the china clay deposits in Cornwall. The Cornish industry consists largely in separating the china clay from the quartz and mica. Another example of weathering occurs in limestone districts. Here the carbonic acid slowly dissolves the limestone and produces hard water.

But more important than either of these influences is

(c) **The Feeding of Green Plants.** The green plant is able to take carbon dioxide from the air through its stomata and water from the soil to make sugar and oxygen.

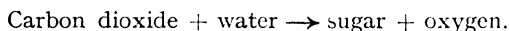

But when sugar burns in oxygen to form carbon dioxide and water, heat is given out.

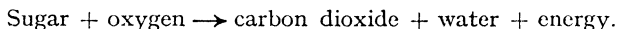

In other words (sugar + oxygen) has more energy than (carbon dioxide + water). The green plant must therefore be able to put energy in from somewhere and our first equation should read

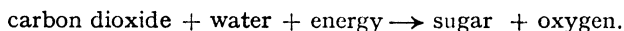

The energy is got from sunlight. You will already know that

sunlight consists of red, orange, yellow, green, blue, indigo, and violet light. The green leaf contains a green pigment called **chlorophyll** which enables it to absorb and make use of the red light as energy in its 'sugar factory.' We can easily obtain a sample of chlorophyll.

*Experiment.* Boil some green leaves in water. Pour off the water and add enough alcohol to cover the leaves in a test-tube. Warm the test-tube by immersion in warm water. Pour off the green liquid into a clean test-tube. It is an alcoholic solution of chlorophyll. If this solution is examined by sunlight through a spectroscope, dark bands will be seen, especially one very strong one in the red.

The plant, as we have seen, uses a little of its sugar to provide energy for its own work, but much the greater part is used to build its tissues, for the plant is able to convert sugar into starch and even into wood. This wood may be burnt and the carbon dioxide returned to the air. Thus we have a **carbon cycle**. But there are far more striking carbon cycles than this. When the plant is eaten by an animal, those complex substances, sugar and starch, will be slowly oxidized and the carbon dioxide is once more returned to the air. Again, the plant may be eaten by a herbivorous animal which in turn is eaten by a carnivorous one and the carbon dioxide is again returned to the air.

The plant thus builds up from simple compounds the complex substances which animals need in order to live and do work. It will therefore be seen that we and all animals are absolutely dependent on that dark absorption band in the red part of the spectrum.

This *building* up of complex substances with the aid of *light* energy is known as **photosynthesis**, or, since it consists largely of *adding carbon* to the plant tissues, it is sometimes called **carbon assimilation**.

The same process has been going on for countless centuries and the coal we burn to-day was formed by photosynthesis in the primeval forest. We are now returning the carbon dioxide to the air to complete yet another carbon cycle.

The fact that the green plant gives off **oxygen** in sunlight can best be illustrated with a plant which can live under water, and make use of dissolved carbon dioxide.

*Experiment.* Fix up the apparatus shown in Fig. 54. Suitable

plants are Canadian Pondweed, Potamogeton, Nitella, Mint, Watercress. Set the apparatus in sunlight. In May or June enough oxygen to test may be collected in a few hours. To make sure that the water contains dissolved carbon dioxide, we may breathe into it for a minute or two, or add a pinch of sodium bicarbonate, or use pond water which will contain carbon dioxide resulting from the decay of dead plants.

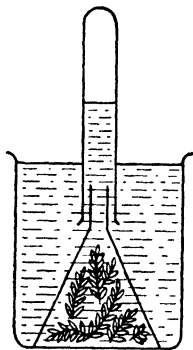

FIG. 54.

We may sum up the life of plants and animals thus :

*Plant :*

Simple substances  $\rightarrow$  complex substances  
+ oxygen (Energy stored).

*Animal :*

Complex substances + oxygen  $\rightarrow$  simple  
substances (Energy released).

### Reduction with Carbon.

We saw on p. 4 that we could make lead calx or lead oxide by heating lead shot or foil in the air. Another name for this calx is *litharge*. If this yellow calx is heated for some hours at a moderate temperature, it takes up a further quantity of oxygen and becomes changed to *red lead* or *minium*, a substance much used by painters and plumbers. If red lead is now heated to a still higher temperature, the second quantity of oxygen comes off and we obtain litharge once more.

But no matter how strongly we heat the litharge we cannot drive out the oxygen and get back to lead. There seems to be a very strong attraction or *chemical affinity* between these two elements. If we merely want the lead back, we can manage this by using something which has a still greater chemical affinity for oxygen, namely, the element carbon. We can bring about this chemical change.

Litharge or lead oxide + carbon  $\rightarrow$  lead + carbon dioxide.

*Experiment.* Mix litharge and powdered charcoal and heat in a test-tube. Note the metallic lustre forming in the tube and test for carbon dioxide coming off (Fig. 55).

*Experiment.* With the handle of a knife or the ends of a pair of crucible tongs, grind a shallow depression in a carbon block. Put

in a little litharge. Turn down the luminous Bunsen flame to a height of about three inches. Blow the flame down with a mouth blowpipe until there are two well-marked cones in the flame (Fig.

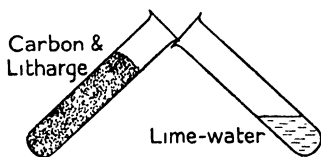

FIG. 55.

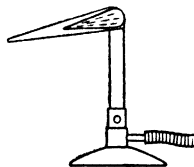

FIG. 56.

56). Bring up the litharge into the inner cone. After a time there will be a *bead of lead which is malleable and marks paper*.

**The carbon reduces the lead oxide to lead and is itself oxidized to carbon dioxide.**

*Experiment.* Heat ferric oxide on charcoal with the blowpipe flame and test the residue with a magnet.

*Experiment.* In the same way heat black copper oxide until brown particles appear. Transfer these to a test-tube and add about a c.c. of strong nitric acid. Brown fumes and a green solution will prove that the residue is *copper*.

*Experiment.* Place a little tin oxide in a crucible. Add a large quantity of powdered wood charcoal. Heat strongly with the Bunsen for ten minutes. Allow to cool, then pour out the excess charcoal. Metallic beads will be left which are malleable but do not mark paper. They are beads of metallic *tin*.

We have now **reduced** several metallic oxides to metals, the **reducing agent** being carbon. The reason for using the *inner* blowpipe flame will appear very soon. We noticed that the reducing agent, carbon, was oxidized to carbon dioxide.

The above experiments have an important application in the **winning of metals** from their ores. Many of our important metals occur in nature in the form of oxides, and it is by reduction with carbon in the form of coal or coke that these metals are produced on a large scale. Some metals occur uncombined in nature, or, as it is called, 'in the native state.' Examples of these are gold, silver, mercury, and copper. It is interesting to notice that the earliest known metals were either those which occur in the

native state or those which could be obtained by some simple reduction process. Of the latter iron, lead, and tin are good examples.

### Reduction with Hydrogen.

*Experiment.* Fix up the apparatus shown in Fig. 57. Hydrogen is prepared by the action of dilute sulphuric or hydrochloric acid on

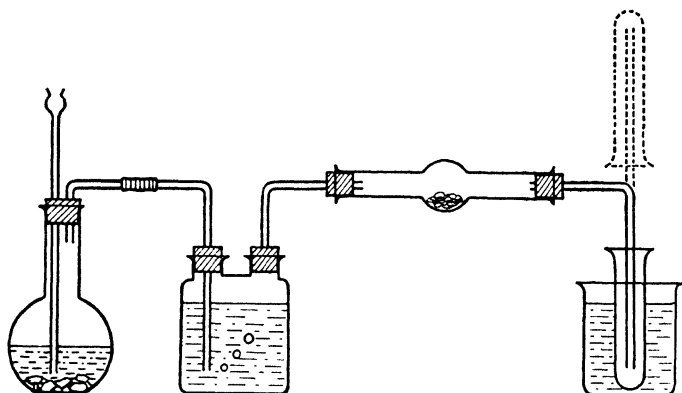
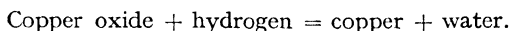

FIG. 57.

zinc. The hydrogen is dried by passing through strong sulphuric acid in a Woulfe's bottle. It is then passed through a bulb tube containing black copper oxide and collected in a test-tube by upward displacement. When the test-tube of gas burns peacefully at the Bunsen, the apparatus is judged to be free from air. The delivery tube and test-tube are then turned through  $180^\circ$  into a beaker of water and the copper oxide is heated.

Very soon the copper oxide is reduced to copper and water appears in the receiving tube.



Thus *hydrogen reduces copper oxide to copper and is itself oxidized to water.*

Since coal gas contains about 50% by volume of hydrogen, it is a very convenient reducing agent.

*Experiment.* Draw out the end of a test-tube (Fig. 58). Arrange a layer of copper oxide inside, pass coal gas through and after about

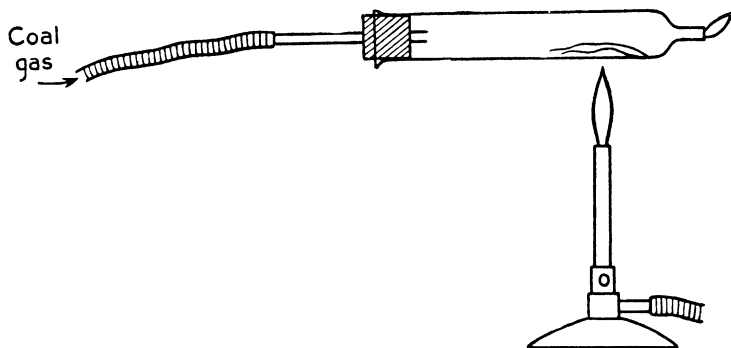

FIG. 58.

ten seconds heat the copper oxide. The oxide is quickly reduced to copper.

### The Dumas Experiment.

In 1842 a very important experiment was carried out by the French scientist, J. B. A. Dumas. Hydrogen was prepared by the action of dilute sulphuric acid on zinc. It was then passed through eight **U**-tubes containing various substances to remove moisture and other impurities. The hydrogen then passed over black copper oxide heated by a spirit lamp. The water formed was collected in a receiver followed by four **U**-tubes, one containing solid potassium hydroxide the others phosphorus pentoxide. These collected every trace of water formed. A simplified form of the apparatus is shown in Fig. 59.

The copper oxide and tube were weighed before and after the experiment. This gave **weight of oxygen used**. The water-collecting apparatus was weighed before and after. This gave **weight of water formed**. The **weight of hydrogen used** was then found by difference.

Dumas found that 7.98 wt. units of oxygen combined with 1 wt. unit of hydrogen to form water.

In 1895 an American scientist, E. W. Morley, carried out an

elaborate research and found the ratio to be 7.9395 to 1, and this is now accepted by the whole scientific world.

For elementary purposes the approximate ratio 8 to 1 will be

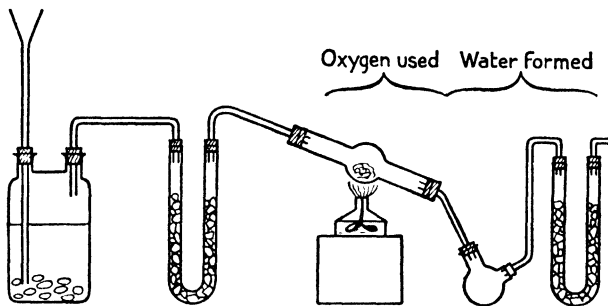

FIG. 59.

good enough and we may say 9 wt. units of water contain 8 of oxygen and 1 of hydrogen, or, in other words :

8 wt. units of oxygen combine with 1 wt. unit of hydrogen.

We shall find later that these facts are extremely important.

### Phlogiston.

Oxygen was discovered independently by Scheele, a Swedish apothecary, about 1770, and by Priestley, a Nonconformist minister, in 1774. It is interesting to inquire how combustion was explained before that time.

The most striking thing about a substance burning vigorously is the flame. It looks as if something is leaving the burning substance. The residue or ash will not burn because this mysterious something is apparently all gone. The old scientists said that a fire element which they called 'phlogiston' (Gk. *phlox*, flame) was leaving the burning body. The fire element, phlogiston, was a constituent of every combustible body and only when it had all escaped would a substance stop burning. This element could not be obtained pure, but substances like coal, peat, and charcoal were considered to be very rich in it.

When lead was heated for some hours in the open air a red calx was formed. This was because the phlogiston had left it,

but the loss had been so gradual that the lead did not burst into flame. Thus

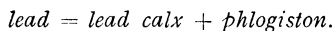

The lead calx could be turned back into lead by putting the phlogiston back. One had simply to heat the lead calx with coal, peat, or charcoal. Thus

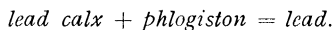

The same reasoning applied to tin and its calx. The ordinary method of obtaining tin was to heat the tin ore or calx with carbon. Thus

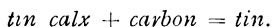

It was well known that the ash was always heavier than the original substance. 'Naturally,' said the phlogistonist, 'the fire element phlogiston is lighter than air. That is why it rushes off so readily. Before the burning, the substance is buoyed up by it. When the burning is over, the ash or calx is no longer buoyed up, so it is bound to be heavier.'

Thus the scientist of those days invented the idea of phlogiston to explain combustion. But we must not laugh; the physicist of to-day explains the transference of energy from the sun through space and the passage of wireless waves by inventing a mysterious medium called *ether*.

When Henry Cavendish in 1766 discovered hydrogen by treating zinc with dilute sulphuric acid, the phlogistonists felt that they were really getting on. This 'inflammable air' was considered to be almost pure phlogiston. It was lighter than air, as they had predicted, and would convert a calx to a metal. Thus



The Phlogiston Theory was seen at its best when explaining the chemistry of *zinc*. Zinc burnt with a brilliant flame to form a calx called philosophers' wool.

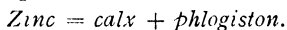

When zinc calx was heated with a substance like carbon rich in phlogiston the metal zinc came off as a vapour which could be condensed to the solid form.

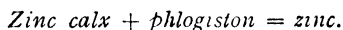

When zinc was treated with sulphuric acid, white vitriol and inflammable air were obtained.

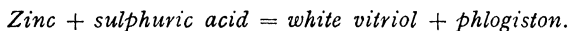

When white vitriol was strongly heated, zinc calx was obtained and this readily dissolved in sulphuric acid giving white vitriol and *no phlogiston*. Thus

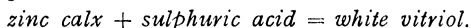

This was to be expected since zinc contained phlogiston but zinc calx did not.

The phlogistonists thought the hydrogen or inflammable air came out of the zinc. But we can excuse that. Try it again yourself. It certainly looks as if the hydrogen is coming from the zinc.

When Priestley discovered oxygen he found that substances would burn much longer in a closed space containing this new gas than in a closed air space. He explained this quite easily. Ordinary air contained a fair amount of phlogiston from previous burnings, but this new gas contained none, therefore it absorbed it greedily. He therefore called his gas *dephlogisticated air*.

The Phlogiston Theory was first put forward in detail by two German scientists, Becher (1635-82) and Stahl (1660-1734), and it must be admitted that it explained all the known facts fairly well.

Although Priestley was a confirmed phlogistonist, it was his discovery of oxygen which really started the downfall of the theory. The French scientist, Lavoisier (1743-94), became interested in Priestley's discovery of oxygen and as a result of a number of experiments showed that there was really no need to assume the existence of a fire element at all; combustion could be explained more simply without it.

The two weak spots in the phlogiston argument were the explanations put forward to account for

(1) The fact that a substance very quickly stopped burning in a closed air space.

(2) The fact that the calx weighed more than the metal.

Now even before Priestley's discovery of oxygen, Lavoisier had, in 1772, carried out a very illuminating experiment with tin. He converted tin into tin calx and found that a certain weight of air was absorbed. Moreover, the weight of air absorbed

was the same as the increase in the weight of the tin. Further experiments showed that when the tin was heated in a closed vessel containing air, it did not absorb all the air, but there seemed to be at least two different kinds of air and the tin only absorbed one sort.

When Priestley, dining with Lavoisier in Paris, mentioned his discovery of a new gas which he had prepared by heating mercury calx, Lavoisier had a sudden 'brainwave'—Priestley's gas might be the very gas which heated metals absorbed from the air. Lavoisier then carried out his historic experiment with mercury (Fig. 60).

Mercury was heated in a retort over a charcoal furnace for

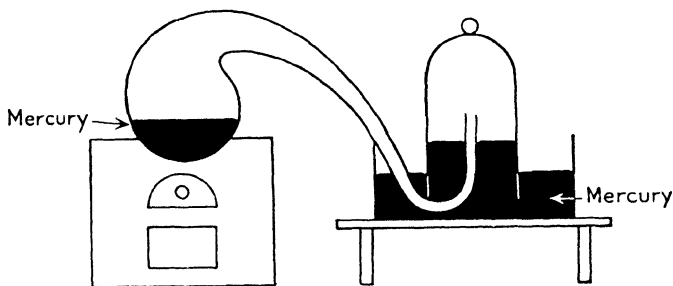

FIG. 60.

12 days. The air in the retort communicated with the air in the bell jar but was cut off from the outside air by the mercury in the trough. Lavoisier found that *8 cubic inches of air* had disappeared and that the mercury in the retort was covered with red scales. The air left would not support burning nor could a mouse live in it. He called this air 'azote' or 'without life.' He removed and heated the red scales strongly, thereby obtaining *8 cubic inches of Priestley's gas*. When this was mixed with the azote, ordinary air was obtained again.

When Lavoisier burnt phosphorus, sulphur, and carbon in Priestley's gas he obtained acid products as we ourselves did in Chapter II. He accordingly gave it the name *oxygen* or *acid producer*. At this time the elements magnesium and sodium were unknown, otherwise Lavoisier would have found that oxygen is not always an acid producer.

Lavoisier's explanation of combustion was now complete. The formation of a calx was an adding on of oxygen. It was a synthesis not an analysis. The rival combustion theories may be put thus—

Metal = calx + phlogiston (Old Theory) } Oxidation.  
 Metal + oxygen = calx (Oxygen Theory) }

Calx + carbon = metal (Old Theory) } Reduc-  
 Calx + carbon = metal + carbon dioxide (Oxygen Theory) } tion.

The oxygen theory seems to us now so simple and obvious that it may surprise you to hear that it was not immediately accepted. The chief trouble was that although combustion was explained perfectly, the evolution of hydrogen (phlogiston) from zinc and sulphuric acid could not be explained. The phlogiston theory seemed to explain this and it was still thought that the hydrogen came from the zinc. But when Cavendish proved that water consisted of hydrogen and oxygen, this paved the way to a better understanding of the composition of acids. When it was realized that all acids contain hydrogen, the only excuse for the phlogiston theory disappeared and the theory then died a natural death.

## CHAPTER VI

### SOLUTION AND OTHER PROCESSES

EVERYONE is familiar with the fact that when salt is put in water, the salt disappears from view. We say the salt has *dissolved* in the water. Water is said to be a *solvent* for salt and the salt itself is called the *solute*.

Sometimes one liquid dissolves in another liquid and then it is rather difficult to say which is the solvent and which the solute, but the difficulty is got over in this way. If 30 c.c. of alcohol are mixed with 70 c.c. of water, we say that the alcohol is dissolved in the water or that alcohol is the solute. But if 70 c.c. of alcohol are mixed with 30 c.c. of water, then water is the solute.

We have also met two cases where *gases* were dissolved in water. Thus it has been shown that tap water contains dissolved air and soda water contains dissolved carbon dioxide.

#### Solution and Suspension.

*Experiment.* Pour half an inch of distilled water into a beaker. Add enough salt to give the water a pronounced taste. The salt disappears. Fold a filter paper into semicircles and then into quadrants. Open the paper out in a funnel so that there are three thicknesses on one side and one on the other. Moisten the paper under the tap and make it cling to the funnel. Filter the salt solution into a porcelain dish. Taste the *filtrate*. It is still salty. *Matter in solution cannot be removed by filtration.*

Heat the filtrate on a sand-bath. As soon as there is any tendency to spit, stir well and only heat occasionally. *The salt is recovered by evaporation.*

*Experiment.* Pour half an inch of distilled water into a beaker. Add a little powdered blackboard chalk. The chalk remains visible ; it either falls to the bottom or 'hangs about' in the liquid. We say the chalk is 'suspended' in the liquid or the chalk is 'in suspension.' Filter and evaporate as before. The chalk remains on the filter paper. Little or none dissolved in the water.

### Separation of Salt and Sand from a Mixture.

*Experiment.* Add a little of the mixture to half an inch of water in a beaker. Stir and heat a little, then filter into a dish. The heating hastens solution and filtration. Evaporate the filtrate to recover the salt. Transfer the sand to a clean, dry dish and warm gently with constant stirring.

### To Recover the Solvent.

*Experiment.* Half fill a distilling flask with salt solution and connect up with a Liebig condenser. Note that the cooling water must enter the condenser jacket at the bottom. Taste the distillate. It is quite free from salt. Do not carry on the distillation until the flask is dry. (Why?)

We may use the same process to separate alcohol from water, but this time a thermometer must pass through the cork of the distilling flask (Fig. 61). We shall be able to separate the mix-

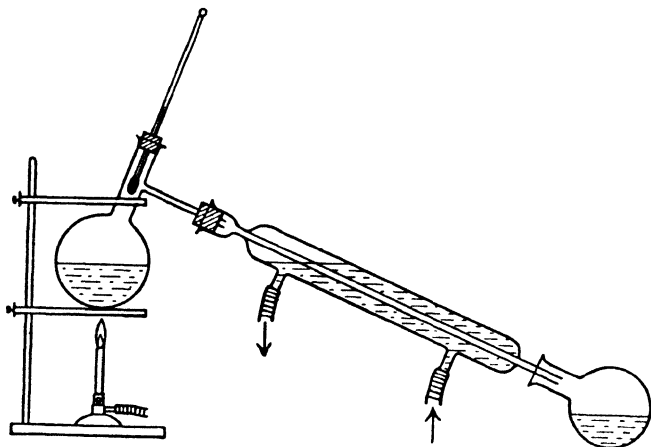

FIG. 61.

ture into two fractions, one boiling round about  $78^{\circ}\text{C}$ ., the other at or just below  $100^{\circ}\text{C}$ . The former is mainly alcohol, the latter chiefly water. The alcohol fraction can be distilled again and the best fraction finally dehydrated with the metal calcium.

This method of **fractional distillation** is often used in industry. One important example is the separation of crude petroleum into petrol, paraffin oil, lubricating oil, vaseline and paraffin-wax.

Ordinary petrol consists of the early fractions which distil between  $40^{\circ}\text{C}$ . and  $120^{\circ}\text{C}$ .

Ordinary distillation is carried out in nature. The sun causes sea-water to evaporate; the dissolved solids are left behind and the rain which falls is pure water.

**Saturated and Unsaturated.** If we continue to add salt to water, there comes a time when the water will take no more. It is a *saturated* solution. Before this point was reached, the liquid was an *unsaturated* solution. Soda water is a saturated solution of carbon dioxide.

### Effect of Temperature.

*Experiment.* Add about half a teaspoonful of powdered saltpetre to half an inch of water in a beaker. Stir and when the powder disappears continue to add small quantities with constant stirring until there is a residue at the bottom. Now warm gently on a sand-bath. The residue disappears. Add about half a teaspoonful again. When this disappears, cool the beaker under the tap. What do you observe? Dry the outside of the beaker and warm until the liquid is again clear. Filter hot into a watch glass or clock glass and allow to stand until cold.

We have learnt that saltpetre is more soluble in hot water than in cold. When a hot, strong solution is cooled down, some of the substance is deposited. The deposit is not, however, in the original powder form but in *pieces which have a definite geometrical form with plane faces*. Such pieces of matter, when formed naturally, are called **crystals**. If cooled still more the solution deposits a further crop of crystals. In fact, there is for each temperature a certain definite weight of solid which the liquid can hold in solution. Thus we say *the Solubility of a substance in a given solvent at a particular temperature is the number of grams of the substance which can be dissolved in 100 grams of the solvent at that temperature*.

The last experiment can be repeated with alum, copper sulphate, or washing soda. Saltpetre differs from these in one important detail—it contains no water of crystallization (compare p. 48). This can be proved by heating the dry crystals.

A solution from which we can obtain crystals by progressive cooling is often spoken of as the *mother liquor*.

Most solids are, like saltpetre, more soluble in hot water than in cold. But in some cases heating makes very little difference to the solubility, e.g. common salt. Again, a few solids are

less soluble in hot water than in cold ; slaked lime is an example of these. On the other hand, gases are always driven out of solution by heating.

The following table gives the solubility of saltpetre in water at different temperatures.

Temperature in °C. . . . .	0	10	15	20	40	60	80
Solubility in gm. per 100 gm. of water . . . . .	13	21	26	32	64	110	170

These results may be plotted on a graph and we then have

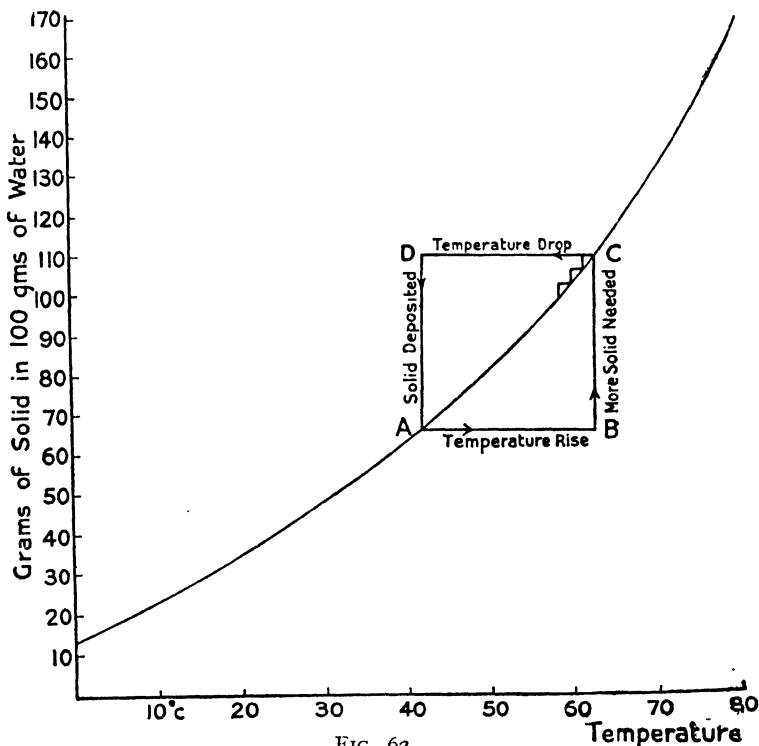

FIG. 62.

what is known as a *solubility curve* (Fig. 62). How does this curve illustrate the facts? Consider a point A on the curve. Draw a line horizontally to B. This means a rise in temperature and we are off the curve. To get back on to the curve at C more solid is needed. Draw a horizontal line to D. This is a drop in temperature and to get back on to the curve, solid must be deposited. This temperature drop and deposit of solid generally take place in little steps, but there are some cases where there is a big drop in temperature and then a sudden large deposit of solid. An interesting example of this is shown by photographer's 'hypo' (sodium thiosulphate).

*Experiment.* Nearly fill a test-tube with hypo. Hold the test-tube with a strip of folded paper (Fig. 63) and warm. The substance

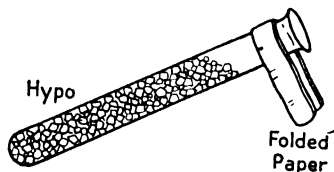

FIG. 63.

melts and dissolves in its own water of crystallization. When there is *no particle of solid left*, plug the tube with cotton-wool and set aside.

If this is done carefully, crystals will not form for *years*. We have what is known as a **supersaturated solution**. If the tube is shaken or a small crystal added, the whole mass crystallizes with evolution of heat. If desired, the experiment can be done on a larger scale with a conical flask fitted with cotton-wool plug and a *clean* thermometer. The temperature may rise as much as  $35^{\circ}\text{C}$ !

*Experiment.* To find the solubility of nitre in water at room temperature. Make a saturated solution by shaking powdered nitre with water in a flask for about a quarter of an hour. Meanwhile weigh a dish and short glass rod. With a pipette take out about 10 c.c. of the solution without powder and transfer to the dish. Weigh. Evaporate the water on a sand-bath, stirring towards

the end to avoid loss of solid by spitting. When the solid is cool and dry, weigh again. Record your weighings thus—

Dish + rod =  $a$  gm.

Dish + rod + solution =  $b$  gm.

Dish + rod + solid =  $c$  gm.

∴ wt. of water =  $(b - c)$  gm.

wt. of solid =  $(c - a)$  gm.

Then  $(b - c)$  gm. of water dissolve  $(c - a)$  gm. of nitre.

∴ 100 " " "  $\frac{c - a}{b - c} \times 100$  gm. of nitre.

Take the room temperature and see if your result agrees with the solubility curve (Fig. 62).

**Growth of Crystals.** Very large crystals can be obtained by slow cooling of a saturated solution. Thus a thread can be fastened to a glass plate by means of plasticine and suspended in a beaker containing a saturated solution of alum, copper sulphate or cane sugar (Fig. 64). In the last case, large crystals of sugar candy are obtained. The glass plate prevents dust falling in.

Glass plate and Plasticine

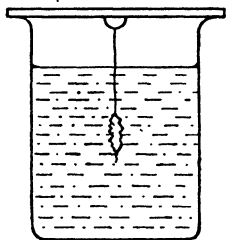

FIG. 64.

If a drop of a strong solution of nitre or Epsom salt is placed on a microscope slide, the formation of crystals can be watched with microscope or microprojector. Epsom salt solution may also be painted on

an ordinary piece of glass and the result examined with a lens.

**Other Solvents.** Water dissolves more different substances than any other liquid. For this reason it is very difficult to get absolutely pure water for delicate research work in chemistry. Even when the water is distilled, it starts dissolving the cooling-pipes and receiving-vessel very slightly.

But there are many substances which water will not dissolve, and if these are required in solution, other solvents have to be used.

*Turpentine* dissolves phosphorus, sulphur, and iodine, but more important is its power to dissolve resins and oils, and for this reason it is used in making varnishes and paints. Varnish is generally a suspension of a resin in linseed oil. Paint is a

suspension of some colouring matter in linseed oil. Since turpentine dissolves linseed oil, it can be used to thin the varnish or paint. When the varnish or paint has been applied to the required surface, the turpentine and the linseed oil gradually absorb oxygen from the air, thus drying and hardening to form a glossy surface. Linseed oil and turpentine are called 'drying oils.'

Its ability to dissolve oil is used in the making of microscope slides. The specimen is often made clear with clove oil and then mounted in Canada balsam. But if the clove oil is not removed, the balsam goes yellow and does not harden. So turpentine is often used to dissolve out the clove oil.

One gram of camphor will just dissolve in 700 grams of water, but turpentine dissolves it readily. This fact is used in making embrocations.

In more advanced work you will find that turpentine, resin, and camphor are close chemical relations. The fact that turpentine will dissolve the other two affords an excellent example of the rule that 'like dissolves like.'

*Alcohol*, like turpentine, will readily dissolve resins to make varnishes. We have an application of this in French polishing.

Alcohol also dissolves iodine very readily; the well-known *tincture of iodine* is a mixture of alcohol, water, iodine, and potassium iodide.

Ordinary alcohol is only one of a large number of alcohols. Its full title is *ethyl alcohol*. There is a heavy duty on this when it is used in the form of alcoholic drinks but not when it is used for industrial purposes. To prevent the industrial alcohol being used as a beverage, a little of another alcohol called *methyl alcohol* is added to make it poisonous and to spoil the taste. It is then called 'methylated spirit.' To make it still more unpleasant, paraffin, bone oil, and a blue dye are also added. For many industrial purposes the methylated spirit is just as good as the pure ethyl alcohol.

*Ether* is another important solvent. It dissolves resins, fats, and oils. You can try the effect on butter or lard, but while doing so **no flame must be near**. It has also the valuable property of being able to dissolve out many substances from an aqueous (*watery*) solution of these substances.

Sometimes too we have an oil scattered through water in small globules and it is necessary to obtain the oil. When ether is

shaken up with the mixture in a tap-funnel (Fig. 65), the ether dissolves the oil and comes to the top. The water is then run out at the bottom and the ether solution poured out *through the top*. The ether is then distilled off or evaporated and the oil is recovered. This can be tried with olive oil.

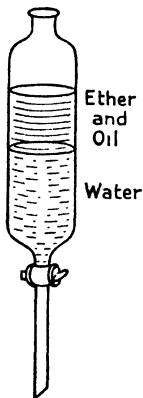

FIG. 65.

*Benzene and Petrol.* The fact that these will dissolve grease can be shown with butter or lard. A mixture of benzene and carbon tetrachloride is often used in dry cleaning.

Benzene and petrol will also dissolve rubber, forming 'puncture solution.' Put bits of red rubber into petrol and try sticking two pieces of 'inner tube' with the solution obtained. A similar rubber solution is used in making mackintoshes. The solution is painted on the fabric and allowed to dry. The material is then waterproof.

*Mercury* dissolves certain metals to form 'amalgams.' We met one case in the preparation of sodium amalgam (p. 20). It is also used to extract silver and gold from their ores. The ore is crushed and mercury added. The resulting slime contains silver or gold amalgam. The mercury is recovered by distillation and the silver or gold is left.

**Emulsions.** Alcohol and water will mix in all proportions. In other words, one dissolves the other. But oil and water do not mix in this way. It is, however, possible in certain cases to make a uniform mixture of the two. The result is a milky liquid called an 'emulsion.'

The word 'emulsion' comes from a Latin word meaning milk. It simply means 'like milk.' The milk of the female mammal is thus a typical emulsion. It consists of fat or oil globules suspended in water and prevented from joining together by the other substances present—albumen, casein (*kay'-se-in*), sugar, and mineral salts. It is only when the milk is allowed to stand for some time that the light fat globules manage to come to the top and form a layer called 'cream.' In a cream separator the milk is whirled round so that the heavier skim-milk flies to the outside while the lighter cream collects at the centre. The skim-milk and cream then emerge from two different outlets.

Examine a drop of ordinary milk and a drop of skim-milk under the microscope.

An *emulsion* may be defined as a *uniform mixture of water and tiny fat globules suspended in the liquid; these globules are prevented from joining together by the presence of some third substance which forms a coating round each globule.*

Another well-known example is cod-liver oil emulsion. The oil is extracted from the fresh liver of the cod by pressure and gentle heat. It is mixed with water, yolk of egg, and a gummy substance called tragacanth. The last two prevent the oily drops from joining together to form a layer. Small quantities of other substances are added as well, but these are only mentioned here to satisfy the curious—saccharin, benzoin, alcohol, chloroform, and oil of bitter almonds.

The cleansing action of soap is also due to the formation of an emulsion of fat, oil, or grease globules with water. Here it is the soap dissolved in the water which surrounds the globules and prevents their uniting. The globules can then easily be washed away with much water. A favourite way of removing tar from hands or clothes is to apply lard, butter or olive oil to dissolve the tar. Soap and water then form an emulsion with the oily mixture.

*Experiment.* Cut up some yellow soap into small particles and allow to stand in a bottle of rainwater or distilled water until the following day. Put a small quantity of olive oil or lubricating oil into each of three test-tubes. To one add some water and shake. To the second add some of your soap solution and shake. To the third add some washing soda solution and shake. Record any differences you may notice.

**Sublimation.** Some solids when heated do not melt but change directly to gas. On cooling, the gas becomes solid again. This direct conversion of a solid into its vapour is known as sublimation and we may sum the effects of heating and cooling thus—

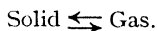

Two substances which behave in this way are solid carbon dioxide (see p. 44) and sal ammoniac (ammonium chloride).

*Experiment.* Heat a very small quantity of sal ammoniac in a test-tube, holding the tube horizontally and constantly rotating it. The sal ammoniac *sublimes* or *forms a sublimate*. When the tube is cool, wash it out with water.

Some substances do not quite miss the liquid state, but their vapours may very easily be produced and cooled to re-form the solid. Examples are naphthalene (moth balls), sulphur, and iodine.

*Experiment.* Repeat the last experiment with a few flakes of iodine. You can wash out the tube with a little water, methylated spirit, and a crystal of potassium iodide. What is the name of the resulting solution?

This easy formation of the vapour and re-formation of the solid are very important in separating these substances from their impurities. The method is actually used in the purification of naphthalene, sulphur, sal ammoniac, and iodine.

*Experiment.* Mix a little iodine with sand in a dish. Cover the dish with a filter paper and place a filter funnel on the paper. Heat gently for 15 minutes on a sand-bath. Good crystals of iodine should form on the inside of the funnel. If you get your fingers stained with the iodine, do not imitate the proverbial Scotchman who is said to have cut his fingers to avoid wasting the iodine, but wash the stain off with a solution of photographer's hypo.

When you see a bottle labelled 'Iodine Resub.' you will now readily guess the meaning of the label.

## CHAPTER VII

### THE COMMON ACIDS

#### Sulphuric Acid.

THE most important acid in existence and indeed the most important chemical is undoubtedly **sulphuric acid**. When we burnt sulphur in oxygen (p. 16) we obtained a gaseous oxide of sulphur which dissolved in water to form an acid. The full title of the oxide is *sulphur dioxide* and the acid is called *sulphurous acid*—

sulphur dioxide + water = sulphurous acid.

If sulphurous acid is left exposed to the air, it unites with oxygen forming *sulphuric acid*—

sulphurous acid + oxygen = sulphuric acid.

But this process is very slow and the method is not suitable for making sulphuric acid in quantity. We can however by a special method make sulphur *dioxide* unite with more oxygen to form sulphur *trioxide*. When this new oxide is dissolved in water, we have sulphuric acid.

Sulphur dioxide + oxygen = sulphur trioxide.

Sulphur trioxide + water = sulphuric acid.

Sulphur dioxide is manufactured on a large scale by burning sulphur in air. The gas can easily be liquefied and stored in thick glass syphons (Fig. 66). It might be thought quite simple to put the two gases, sulphur dioxide and oxygen, together and thus get sulphur trioxide. But this is not so, and we have to call in the aid of another strange substance called 'platinized asbestos.'

Platinized asbestos is prepared by dipping



FIG. 66.

some asbestos wool into platinic chloride solution and then heating the asbestos in the Bunsen flame. We then have platinum in a finely divided condition scattered throughout the asbestos. In other words, we have a large area of platinum although the actual weight of platinum present is very small.

### Preparation of Sulphuric Acid (The Contact Process).

Sulphur dioxide and oxygen are bubbled through bottles of strong sulphuric acid, two bubbles of the first to one of the second. The mixed gases now pass over the platinized asbestos heated to  $400^{\circ}\text{C}$ . in a hard glass tube (Fig. 67). Dense white

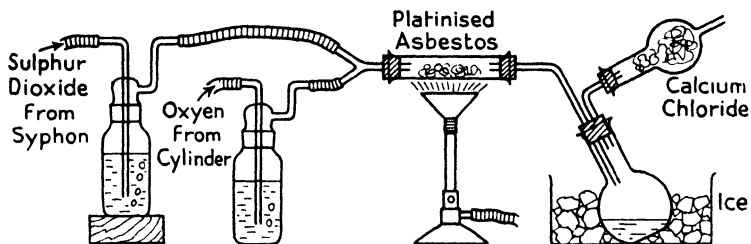

FIG. 67.

fumes of sulphur trioxide are produced. If these are passed into water, sulphuric acid is obtained. But it is also possible to obtain the sulphur trioxide in beautiful silky needles. The fumes are condensed to a liquid in a *dry* flask surrounded by ice. A tube of calcium chloride prevents the entry of moisture from the air. The flask is finally sealed off and the liquid then slowly changes to silky needles.

But we have still to deal with the part played by the platinized asbestos. After the experiment the platinized asbestos is left behind unchanged in any way. Its purpose was to speed up the chemical reaction between the oxygen and sulphur dioxide. **A substance which alters the rate of a chemical reaction but is left behind unchanged in any way is called a Catalyst or Catalytic Agent.**

We have met catalysts before; when we prepared oxygen from potassium chlorate and manganese dioxide (p. 15), the manganese dioxide speeded up the reaction but was itself unchanged at the end. The oxygen came off at a much lower

temperature in presence of the manganese dioxide but all the oxygen came from the potassium chlorate and none from the manganese dioxide. This is not saying that oxygen cannot be obtained from manganese dioxide. Oxygen *can* be obtained from manganese dioxide but only at a temperature much higher than when potassium chlorate and manganese dioxide were heated together. We heard of nickel as a catalyst on p. 29.

In the course of your chemical studies you will meet many catalysts, and in the libraries you can find whole books on the same subject. The industrial chemist is constantly on the look-out for substances which speed up or slow down chemical changes without being changed themselves at the end.

### Properties and Uses of Strong Sulphuric Acid.

As previously mentioned on p. 25, great caution is needed in using strong sulphuric acid. If any is spilt on hands, clothes, or bench, it should be immediately washed off with much water. This is much quicker than looking round for an alkali to neutralize it.

The most important property of strong sulphuric acid is its great chemical affinity for water. This is why it damages wood, paper, cloth, and the skin. Its effect on cloth has already been demonstrated (p. 26).

*Experiment.* Put a little powdered bluestone in a test-tube. Cover the powder with strong sulphuric acid. Set aside for a quarter of an hour. The powder is now white. It has been dehydrated by the acid.

*Experiment.* In a porcelain dish place about half a teaspoonful of ordinary sugar. Moisten with water. Add a little strong sulphuric acid. Stir with a glass rod and wait half a minute. The acid dehydrates the sugar, leaving a large bulk of carbon. Note the burnt toffee smell. Repeat the experiment in a test-tube.

*Experiment.* Write a word on paper with a glass rod dipped in dilute sulphuric acid. Put the paper on a piece of wire gauze and hold with tongs about a foot above the Bunsen flame. When the water in the acid evaporates, the strong acid left corrodes the paper and the word stands out in black letters.

There are countless uses of strong sulphuric acid in daily life and industry, but only two will be mentioned here. Every motor-car has its **accumulator**. Accumulator acid is made by adding the strong acid to three or four times its volume of

distilled water (Note: acid to water). Sulphuric acid is used in **making all other acids** and in particular hydrochloric and nitric.

How is the strong acid transported from the factory to the consumer? It may surprise you to hear that it often travels in *iron* tanks! This would be impossible with dilute sulphuric acid, but the strong acid has very little action on iron.

### Uses of Dilute Sulphuric Acid.

We have already learnt that dilute sulphuric acid on zinc, iron, or magnesium gives hydrogen.

Like all other acids, it gives carbon dioxide when added to a carbonate. But there is a slight complication when the carbonate chosen is marble.

*Experiment.* Put a few marble chips in a porcelain basin. Cover the chips with dilute sulphuric acid. Bubbles of carbon dioxide come off but the reaction soon stops. Wash off the acid and rub the chips with a brush. Again cover with acid. Bubbles come off again but only for a time.

The explanation is that a layer of calcium sulphate, insoluble in water, forms on the marble. This protects the marble from the further action of the acid.

### Hydrochloric Acid Gas.

Fit a conical flask with a cork, tap funnel, and delivery tube (Fig. 68). Put common salt in the flask and strong sulphuric acid in the tap funnel. Add small quantities of the acid as required. A fuming gas comes off. Carry out the following experiments.

(a) Fill a dry test-tube by downward displacement. Close the test-tube with the thumb, invert in water, and allow a few drops only to enter. Shake the test-tube. It sticks to the thumb. Again invert in water and remove the thumb. The water fills the test-tube. *The gas is very soluble in water.*

(b) Fill a dry flask with the gas (Fig. 69). Insert a rubber stopper carrying a jet tube and invert in water coloured with blue litmus (Fig. 70). This is the so-called 'fountain experiment.' *The gas is very soluble in water and acid to litmus.*

(c) [The gas which comes off a smelling salts bottle is called *ammonia*. Water dissolves about 1,000 times its own volume of this gas at ordinary temperatures. The resulting liquid is

called *ammonium hydroxide*. If you smell it, do so with great caution.] Hold the stopper of this bottle near the delivery tube of the hydrochloric acid gas. A very dense white fume is formed.

(d) Collect a dry test-tube full of the acid gas. Put one drop of ammonium hydroxide into another dry tube. Invert the first over the second and hold the mouths together. Allow the dense fume to settle to a white powder. Heat the test-tube

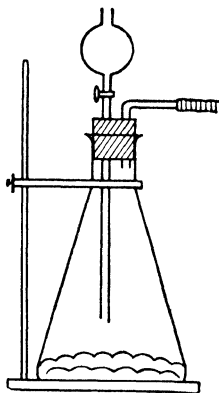

FIG. 68.

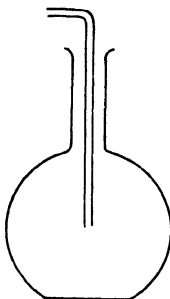

FIG. 69.

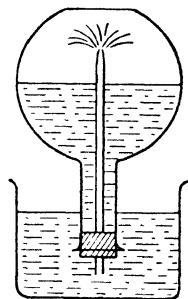

FIG. 70.

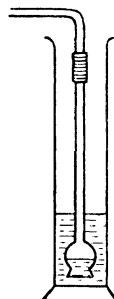

FIG. 71.

which contains more powder. The solid sublimes. It is *sal ammoniac*.

Ammonia + hydrochloric acid gas = sal ammoniac.

(e) Pass the acid gas for some time through a thistle funnel into about an inch of water in a gas jar (Fig. 71). Add some of the liquid obtained to (1) zinc, (2) marble, (3) manganese dioxide.

Hydrogen, carbon dioxide, and chlorine respectively are evolved. In the case of chlorine warm the test-tube gently and **very cautiously** smell the gas. Put a damp red or blue litmus paper across the mouth of the test-tube. The paper is *bleached*.

*When hydrochloric acid gas dissolves in water, the reagent hydrochloric acid is obtained.* Because it is prepared by a distillation process it is sometimes called 'spirit of salt.' The early scientists used sea salt, so they called it muriatic acid (from Lat. *muria*, brine).

**Nitric Acid, 'Aqua Fortis' or 'Spirit of Nitre.'**

Into a retort put some nitre or potassium nitrate and make sure that you do not use potassium *chlorate* by mistake. [The demonstrator may show you the effect of putting strong sulphuric acid on potassium chlorate in a test-tube and heating it. It can be done safely in a *closed* fume chamber.]

Add some strong sulphuric acid to the nitre, using a funnel. The acid should be just sufficient to cover the nitre. Fix up the apparatus as shown in Fig. 72. Heat gently, cooling the receiving flask by pouring water over it in a trough. Nitric acid distils

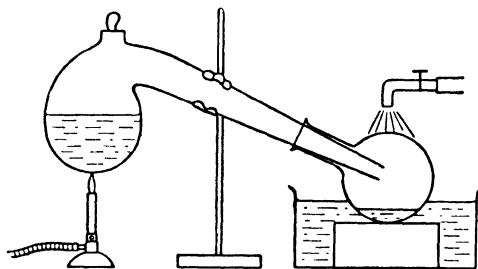

FIG. 72.

over as a golden yellow liquid. *Caution!* The acid is very corrosive and must be classed as a dangerous chemical.

Put copper turnings in a test-tube and add some of the nitric acid. *Poisonous brown fumes and a green solution* are obtained. This is the simplest test for nitric acid.

Nitric acid is a compound of the elements hydrogen, nitrogen, and oxygen. The presence of hydrogen in this acid was proved on p. 27. The nitrogen is difficult to prove by simple experiments, so at present it will have to be taken on trust. The presence of oxygen can be proved as follows—

*Experiment.* The apparatus illustrated in Fig 73 consists of a thistle funnel bent and drawn out to a jet then joined to a length of combustion tube by a piece of Bunsen tubing. The combustion tube is first heated with a wide flame or a Bunsen kept on the move. *Two or three drops* of strong nitric acid are then poured into the thistle funnel. The nitric acid is decomposed by the heat, a brown gas appears in the combustion tube and a smoky gas in the test-tube.

The next few drops of acid are only added when the first drops have disappeared.

When the gas in the test-tube is shaken up, the smoke disappears and the remaining gas will relight a glowing splint. It is *oxygen*.

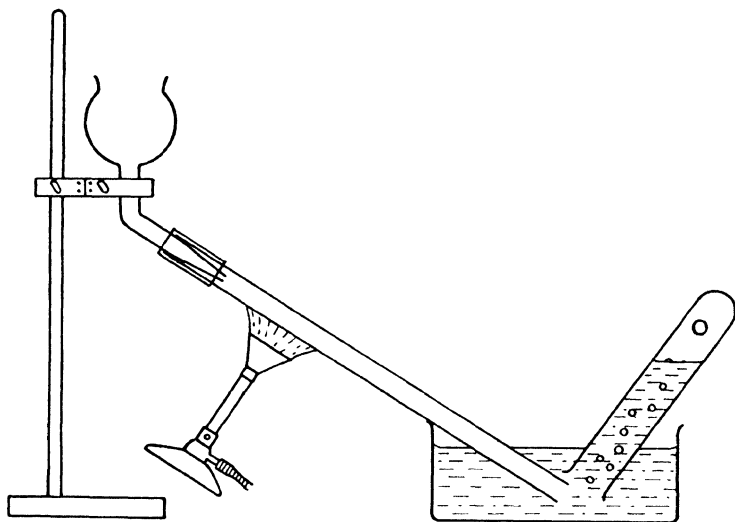

FIG. 73.

Instead of the thistle funnel and combustion tube a churchwarden pipe may be used, or two ordinary clay pipes may be joined together by rubber tube and the bowl smashed off one of them. It is quite easy to avoid burning the rubber.

A mixture of hydrochloric acid and nitric acid is called 'aqua regia' because it will dissolve the 'noble' metal gold. It will also dissolve platinum (but not silver). In each case the chloride of the metal is formed.

## CHAPTER VIII

### QUANTITATIVE CHEMISTRY

FROM time to time we have come across the fact that when elements combine together to form compounds, they do not do so in any chance proportions. Thus 8 grams of oxygen always combine with 1 gram of hydrogen to form water. Water always contains two volumes of hydrogen and one volume of oxygen. Chalk we found to be a compound of two compounds, quicklime and carbon dioxide. We found that there was always 56% of the quicklime and 44% of the carbon dioxide. These facts are illustrations of an important law of chemistry.

The **Law of Constant or Definite Proportions** states that *a Chemical Compound, however it is prepared, always contains the same elements in the same proportions.*

The following experiment illustrates the same law—

*Experiment.* Weigh a crucible without lid. Add a few grams of powdered bluestone and weigh again. Heat *gently* on tripod and pipeclay triangle until the powder is white. Allow to cool, then weigh again. Repeat until the weight is constant. Set out your results thus—

Crucible	= $a$ gm.
Crucible + bluestone	= $b$ gm.
Bluestone	= $(b - a)$ gm.
Crucible + anhydrous bluestone	= $c$ gm.
Anhydrous bluestone	= $(c - a)$ gm.
Water of crystallization	= $(b - c)$ gm.

Then  $c - a$  gm. of bluestone gave  $(b - c)$  gm. of water.

$$\therefore 100 \text{ ,, ,, ,, ,, } \frac{b - c}{c - a} \times 100 \text{ gm. of water.}$$

The result should be 36.1% of water.

Now add, say, six drops of water to the white powder in the crucible. Feel the bottom of the crucible. Heat is given out

because water and anhydrous bluestone are re-forming the original blue compound.

When we carry out weighings and measurements, we are said to be doing **quantitative** work as distinct from **qualitative** work. The more we deal with quantitative work, the more it will be realized that chemistry is not just a matter of smells, bangs, and precipitates. There is, in fact, a good deal of order and exactness in the subject.

It will be convenient now to sum up the knowledge we have gained here and in earlier chapters concerning mixtures and compounds.

A **mixture** consists of two or more elements put together in no very definite proportions. No heat is given out during the making of the mixture. The properties are the same as the properties of the constituents; in other words, no new substance has been formed. The constituents are often easily separated by physical methods like solution or distillation.

A **compound** consists of two or more elements put together in a definite proportion. Heat is given out during the process of making the compound. The properties are generally entirely different from the properties of the constituents; in other words, a new substance has been formed. The constituents cannot be separated by physical methods.

There is an experiment which has been used for at least a hundred years to illustrate the difference between a mixture of two elements and a compound of the same two elements.

*Experiment.* Intimately mix roughly equal bulks of iron filings and flowers of sulphur. Heat half the mixture in a test-tube held horizontally in the Bunsen by means of a strip of folded paper (Fig. 74). After heating the whole length a little, heat the end of the tube until it glows, then remove from the flame. The glow spreads along the tube. *Heat is being given out and a compound is forming.*

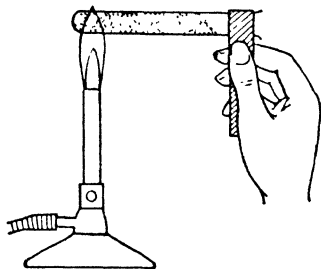

FIG. 74.

Break the tube to get the compound out. Examine the

mixture and compound and verify the following statements—

(a) The particles of iron and sulphur can be seen in the mixture but not in the compound.

(b) Carbon disulphide (a highly inflammable liquid which, when impure, smells like bad cabbage) dissolves sulphur out of the mixture but not out of the compound.

(c) A magnet removes all the iron from the mixture but only uncombined iron out of the compound.

(d) Hydrochloric acid acting on iron filings alone gives hydrogen and a smell of acetylene. (The acetylene is due to impurities in the iron filings.)

(e) Hydrochloric acid acting on sulphur alone gives no result.

(f) Hydrochloric acid acting on the mixture gives what one would expect—hydrogen and acetylene on account of the iron, while the sulphur plays no part.

(g) Hydrochloric acid on the compound gives a gas which smells like bad eggs and blackens filter paper which has been soaked in lead acetate (compare p. 49).

The compound which we have just prepared is called *ferrous sulphide*. More elaborate experiments would show that it contains 56 wt. units of iron and 32 wt. units of sulphur. If more iron is used, it is left uncombined. If too much sulphur is used, the excess burns off. It is impossible to use any proportions other than 56 of iron and 32 of sulphur. Heat was given out during its formation. Its properties are quite different from those of iron and sulphur. It is, in fact, a new substance. It could not be separated into its parts by physical methods. By all the tests it is, therefore, a fully qualified compound.

The evil-smelling liquid, carbon disulphide, is also a good example of a compound. It consists of exactly 12 wt. units of carbon and 64 wt. units of sulphur. Its properties are certainly surprising and it cannot be separated into its constituents by any physical methods. Its inflammable nature is easily demonstrated. Pour a little into an iron tray. Remove the bottle to a safe distance and set light to the liquid in the tray.

Carbon disulphide is prepared on the large scale by passing sulphur vapour over red-hot carbon in an electric furnace. It is used as a solvent for sulphur, phosphorus, rubber, camphor and fats, as an insecticide and in the artificial silk industry.

**Air is a Mixture.**

The fact that air is a mixture is very obvious from the following facts.

(a) If we mixed

1 vol. of oxygen with, say,  $4\frac{1}{2}$  vols. of nitrogen ;

or

$1\frac{1}{2}$  vols. of oxygen with, say, 4 vols. of nitrogen,

the mixture would in each case be quite breathable and would support combustion.

(b) No heat would be given out during the mixing.

(c) Air behaves exactly as we should expect from its composition, the oxygen supporting combustion and the nitrogen slowing it down.

(d) The oxygen and the nitrogen can be separated, at any rate partially, by physical methods like solution and distillation. Thus air driven out from its solution in water is richer in oxygen than ordinary air (see p. 56). Again, when the temperature of liquid air is allowed to rise, the air does not come off as a single substance ; the nitrogen comes off at  $-196^{\circ}$  C. and the oxygen at  $-184^{\circ}$  C. Air behaves, in fact, just like a mixture of alcohol and water.

**The Atomic Theory.**

You will often meet people who are very scornful about *theories*. 'Ah,' they say, 'there's a lot of difference between theory and practice.' We see the same attitude in those notices '*John Brown, Practical Tailor*' or '*William Binks, Practical Chimney Sweep*.' Nobody would ever advertise himself as a *theoretical* tailor or chimney sweep. But the ideal is to be practical *and* theoretical, for the theoretical man, when he meets unusual circumstances, is able to think logically and alter his practice to suit the circumstances.

To theorize is to use observed facts to arrive at a new fact. These severely practical people are constantly theorizing without knowing it. A man visits our practical tailor to be measured for a new suit. The tailor observes dust on the customer's coat but not much on the trousers. He thinks, "This man works in his coat in some dusty job. He certainly ought not to wear blue serge ; a grey would suit him better. I think I'll advise it." As the man is about to leave he takes out a tobacco pouch

and drops a piece of chalk. 'Ah!' says our practical tailor, 'a schoolmaster.'

When scientists had found out certain facts about water, it was quite natural for them to think out a possible explanation or theory to account for the facts. Let us gather these facts together.

(a) Water consists of 8 wt. units of oxygen and 1 wt. unit of hydrogen (the Dumas experiment, p. 61).

(b) Water consists of 2 volumes of hydrogen and 1 volume of oxygen (the Electrolysis experiment, p. 18, and the Cavendish experiment, p. 24).

(c) When the element sodium acts on water it displaces hydrogen and forms an alkali, caustic soda—

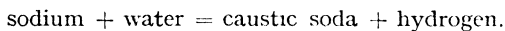

But if solid caustic soda is heated with iron filings in a test-tube, hydrogen comes off and may be ignited at the mouth of the tube. (Try this.) Therefore the sodium only displaced *part* of the hydrogen.

We will now consider the scientific explanation of these facts. All matter consists of tiny masses called *molecules* (Lat. *moles*, mass; *culum*, tiny). In Biology we meet *animalcules*, tiny animals which can only be seen with a microscope. But molecules are smaller still, for they cannot be seen even with a microscope. A lump of ferrous sulphide consists of a vast number of these molecules and each molecule consists of a little bit of iron and a little bit of sulphur. These still tinier bits are called *atoms*.

*A molecule is the smallest particle of a substance which can exist by itself.*

*An atom is the smallest particle of an element which can take part in a chemical change.*

Now the case of water was a little more difficult and at first the scientist went slightly astray.

The first idea was this. A tumbler of water consists of millions of molecules each consisting of one hydrogen atom and one oxygen atom. They represented a hydrogen atom by  $\odot$ , an oxygen atom by  $\bigcirc$ , and a molecule of water was  $\odot\bigcirc$  (Fig. 75). They said that the oxygen atom weighed 8 times more than the hydrogen atom, and since hydrogen is the lightest substance known, they decided to call the weight of its atom 1. This

meant that the oxygen atom weighed 8. They called 1 and 8 the *atomic weights* of hydrogen and oxygen respectively.

Now this idea fitted in with the Dumas experiment perfectly, for if each molecule of water contained 8 wt. units of oxygen and one weight of hydrogen, then any larger quantity of water would contain oxygen and hydrogen in the same proportion. But when you electrolysed the water, you would not expect 2 volumes of hydrogen and 1 volume of oxygen.

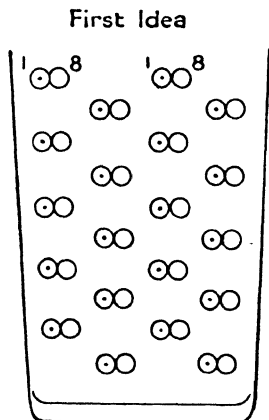

FIG. 75.

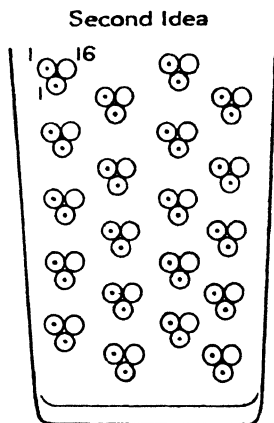





FIG. 76.

Further, if a single atom of sodium attacked a single molecule of water, how could it turn out *part* of the hydrogen?

The idea was thus found to be unsatisfactory. When good detectives find that their theory does not fit in with the facts, they scrap the theory and try another. So did our scientists.

The new idea was this. A water molecule must contain two hydrogen atoms and one oxygen atom and the atomic weight of oxygen must be 16 (Fig. 76). This you will find fits in quite well with all three facts. Thus when an atom of sodium (or, to give it its international name, *natrium*) acts on a molecule of water  it displaces one of the hydrogen atoms and goes

into the molecule itself to form caustic soda . We now see why caustic soda is called sodium *hydroxide*. Thus the *formula* for a molecule of water was shown to be , or H<sub>2</sub>O, while the formula for a molecule of caustic soda was , or NaOH.

There are altogether 92 elements. Each has a *symbol* and an *atomic weight*. The atomic weights have been determined with much labour by the scientists of many nations. So far you have seen how the atomic weight of oxygen was arrived at. Later you will learn how a few more were fixed, but the majority you will be allowed to take on trust. You will not be expected even to learn the list of atomic weights.

But what you must remember is that O is not merely a short-hand sign for oxygen; O stands for 16 wt. units of oxygen, N stands for 14 wt. units of nitrogen, Na means 23 wt. units of sodium, and so on.

Here are a few of the elements, their symbols and atomic weights.

		<i>Atomic Weight.</i>
Hydrogen . . . . .	H	1
Oxygen . . . . .	O	16
Nitrogen . . . . .	N	14
Chlorine . . . . .	Cl	35.5
Iodine . . . . .	I	127
Phosphorus . . . . .	P	31
Sulphur . . . . .	S	32
Carbon . . . . .	C	12
Magnesium . . . . .	Mg	24
Manganese . . . . .	Mn	55
Calcium . . . . .	Ca	40
Zinc . . . . .	Zn	65

There are some elements which have a Latin name. Sometimes this name was actually the name used by the Romans, but often it is only a name invented by modern scientists

for convenience and given to elements not known in Roman times.

		<i>Atomic Weight.</i>
Iron (Ferrum) . . . .	Fe	56
Copper (Cuprum) . . . .	Cu	63.6
Silver (Argentum) . . . .	Ag	108
Mercury (Hydrargyrum) . . . .	Hg	200
Lead (Plumbum) . . . .	Pb	207
Sodium (Natrium) . . . .	Na	23
Potassium (Kalium) . . . .	K	39

**Note :** Whenever the symbol for an element consists of two letters, the second letter is always a small letter. Abominations like *FE*, *NA* and *HG* have no meaning.

The Atomic Theory was founded by a Manchester schoolmaster and scientist, John Dalton (1766-1844). Dalton always represented atoms by circles, either plain as in the case of oxygen, or containing some design as in the case of sulphur  $\oplus$ . When he had exhausted his designs he put letters in the circles.



To represent the molecule of a compound, he put these circles together to make *formulae*.

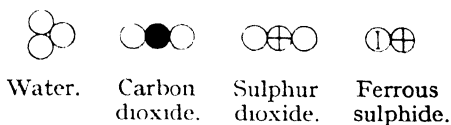

Such formulae were put into the modern form



by the Swedish chemist Berzelius (1779-1848). Other scientists who helped to establish the Atomic Theory were Gay-Lussac (1778-1850) and Dumas (1800-84) in France and Avogadro (1776-1856) in Italy.

The following are the formulae of some well-known substances which you have already met. It is a useful exercise to work out the molecular weights.

Sulphuric acid . . .	H <sub>2</sub> SO <sub>4</sub>	Manganese dioxide . . .	MnO <sub>2</sub>
Hydrochloric acid . . .	HCl	Copper oxide . . .	CuO
Nitric acid . . .	HNO <sub>3</sub>	Litharge . . .	PbO
Caustic potash . . .	KOH	Chalk . . .	CaCO <sub>3</sub>
Quicklime . . .	CaO	Mercuric oxide . . .	HgO
Slaked lime .	CaO <sub>2</sub> H <sub>2</sub> or Ca(OH) <sub>2</sub>	Copper sulphate . . .	CuSO <sub>4</sub> , 5H <sub>2</sub> O
Common salt . . .	NaCl	Washing soda . . .	Na <sub>2</sub> CO <sub>3</sub> , 10H <sub>2</sub> O
Magnesium oxide . . .	MgO		

### Chemical Equations.

We may represent the action of sodium on water by means of an equation thus—



This equation is not quite true to the facts, for it is known that hydrogen atoms do not exist singly but in pairs. It is as if hydrogen were a shy little atom; it waits for another to keep it company. Putting the equation into modern symbols, we have—

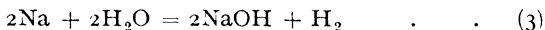
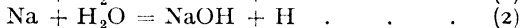
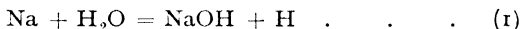

(1) and (2) are called *atomic* equations because single free hydrogen atoms are assumed to be present. Equation (3) is a *molecular* equation. In a similar way we always write O<sub>2</sub>, N<sub>2</sub>, Cl<sub>2</sub>. Thus the molecules of hydrogen, oxygen, nitrogen, and chlorine consist of two atoms.

Why do we not write Na<sub>2</sub>? Because we do not know how many sodium atoms join together to form a molecule, but if we put Na<sub>2</sub> we should be pretending that we did.

Note that a chemical equation must balance, otherwise it contradicts the Fundamental Law of Chemistry—The Law of Indestructibility of Matter. All the atoms taking part on the left must reappear on the right. Thus in the equation

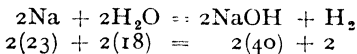

we have 2 sodium atoms, 4 hydrogen atoms and 2 oxygen atoms on each side. Again, we have 82 wt. units on the left, so we must have 82 wt. units on the right.

*Problem :* Calculate the percentage of water of crystallization in copper sulphate crystals.

Method :

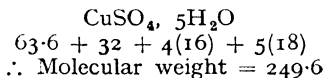

$\therefore$  249.6 wt. units of crystals contain 90 wt. units of water

$$\therefore 100 \quad \text{''} \quad \text{''} \quad \text{''} \quad \text{''} \quad \frac{90 \times 100}{249.6} \quad \text{''} \quad \text{''}$$

$$= 36\%$$

*Problem :* 10 grams of sodium cut into small fragments are added to water one by one. What weight of caustic soda could be obtained on evaporation ?

Method :

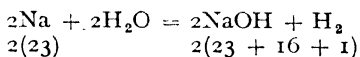

$\therefore$  46 wt. units of sodium produce 80 wt. units of caustic soda

$$\therefore 10 \quad \text{''} \quad \text{''} \quad \text{''} \quad \text{''} \quad \frac{80 \times 10}{46} \quad \text{''} \quad \text{''} \quad \text{''}$$

$$= 17.4.$$

*Problem :* How much quicklime would be produced by heating 40 tons of limestone ?

Method :

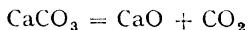

Your answer should be 22.4 tons.

*Problem :* Calculate the percentage composition of ferrous sulphide, FeS.

Method :



88 wt. units of the compound contain 56 wt. units of iron

$$\therefore 100 \quad \text{''} \quad \text{''} \quad \text{''} \quad \text{''} \quad \frac{56 \times 100}{88} \text{ wt. units of iron}$$

$$= 63.6\%.$$

Then by difference or further calculation % of S = 36.4.

*Problem :* A certain gas has the following percentage composition : C 27.3%, O 72.7%. Calculate the simplest formula for this gas.

Method: Let the formula be  $C_xO_y$ .

$$\begin{aligned} \text{Then} \quad x : y &= \frac{27.3}{12} : \frac{72.7}{16} \\ &= 2.27 : 4.54 \\ &= \frac{2.27}{2.27} : \frac{4.54}{2.27} \\ &= 1 : 2. \end{aligned}$$

Therefore the simplest formula is  $CO_2$ .

### A few more Equations and a Warning.

When we dissolved zinc in dilute sulphuric acid, we obtained zinc sulphate and hydrogen. The equation for this reaction is

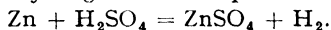

Note that we represent the reaction as if we had used *strong* sulphuric acid, while we actually used dilute acid. Strictly we should put



But it is customary to leave out the  $xH_2O$  from both sides. We should however always state in the account of an experiment whether we used strong or dilute acid.

Again we have

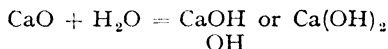

OH  
Quicklime + water = slaked lime

Slaked lime dissolves in a large quantity of water forming lime-water, and when carbon dioxide is bubbled in, the limewater goes milky.

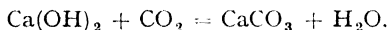

Here again there is a large quantity of water present but it is left out from both sides of the equation. Note that when reading out  $Ca(OH)_2$  we say

See ay oh aitch twice  
*not* See ay oh aitch two

The latter would mean  $CaOH_2$ , and to adapt the words of a Charles Dickens character, 'There ain't no sich thing.'

When steam passes over heated magnesium we obtain magnesium oxide and hydrogen (see p. 21).

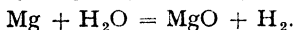

What happens if steam is passed over heated copper? The enterprising beginner thinks this an easy one and writes

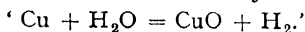

But alas ! **It does not happen.** Steam does not act on heated copper. Now try the reverse reaction

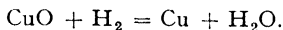

This is quite all right ; it is the Dumas experiment. Now reverse the magnesium equation



**This does not happen ;** the equation contradicts the facts. We must therefore remember that although we may be able to write a nice-looking equation, the reaction is not necessarily possible. An equation must (1) balance, (2) be molecular, (3) be true to the facts.

Here is another example. What is the action of sulphuric acid on copper? The beginner knowing the equation



thinks that copper will do the same and writes

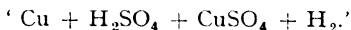

You can easily convince yourself that **this equation contradicts the facts** by gently heating a little copper turnings and strong sulphuric acid in a test-tube. Smell the gas **very cautiously**. You will detect the suffocating odour of sulphur dioxide. Hold the tube near the Bunsen flame. There is no sign of hydrogen coming off. What actually happens is that hydrogen is formed but does not come off because it is immediately acted upon by another molecule of sulphuric acid, thus—

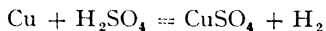

By addition  $\text{Cu + 2H}_2\text{SO}_4 = \text{CuSO}_4 + 2\text{H}_2\text{O} + \text{SO}_2$ .

The final equation gives the true picture of the facts (see p. 103).

### A Defence of Molecules.

' Well, John, what is your favourite subject at school ? '

' Oh, Chemistry, Grandad. '

' Humph ! all about smells, explosions, atoms, and molecules, isn't it ? '

The chemist certainly gets all the blame for atoms and mole-

cules but we shall see that although he is guilty of inventing 'atoms,' the physicist and biologist are not quite innocent with regard to molecules.

When the **temperature** of a body rises, the physicist says that its molecules are moving faster. If you touch a hot iron bar with your finger, you are burnt because the fast-moving iron molecules suddenly speed up the slow-moving skin molecules. As the temperature of a body falls, the molecules slow down and at  $-273^{\circ}\text{C}$ . they would stop altogether. Scientists call  $-273^{\circ}\text{C}$ . the *absolute zero*, and counting from this point they have invented a new scale of temperatures called *the absolute scale*. Corresponding temperatures on this scale and the Centigrade scale are :

$-273^{\circ}\text{C}$ .	$-173^{\circ}\text{C}$ .	$0^{\circ}\text{C}$ .	$20^{\circ}\text{C}$ .	$100^{\circ}\text{C}$ .
$0^{\circ}\text{Abs}$ .	$100^{\circ}\text{A}$ .	$273^{\circ}\text{A}$ .	$293^{\circ}\text{A}$ .	$373^{\circ}\text{A}$ .

For fuller detail on this point see *General Science Physics*, pp. 86, 87.

**Gas pressure** is explained by the constant bumping of the gas molecules against the enclosure. But hydrogen molecules are very light and carbon dioxide molecules are very heavy, yet under similar conditions they exert the same pressure. This is because the hydrogen molecules move much faster. It is quite conceivable that a fast-moving small car would do as much damage as a slow-moving lorry.

The fact that hydrogen molecules move faster than heavier gas molecules is shown in **gaseous diffusion** experiments, one of which is illustrated in Fig. 77.

The short limb of the **U-tube** has two holes blown in it. This does not need any special skill. A rubber teat is used to close the short arm. A small area of the tube is then heated with a blowpipe and gently blown out. This hole is then stopped with a tiny cork made out of a boring from an ordinary cork. The second hole is then blown.

Copper leads are then soldered to two ordinary pins and these are pushed through the corks. The leads are taken to a dry cell or accumulator, a lamp, and a bell. Mercury is put into the bend, so as to make contact with the lower pin but not with the upper one. An alternative arrangement is that shown at B, where a **loose-fitting** cork carries the two leads.

When a jar of hydrogen or coal gas is held over the porous

pot, the light hydrogen molecules get in more frequently than air molecules get out. The excess pressure in the long tube drives mercury round the bend to complete the circuit.

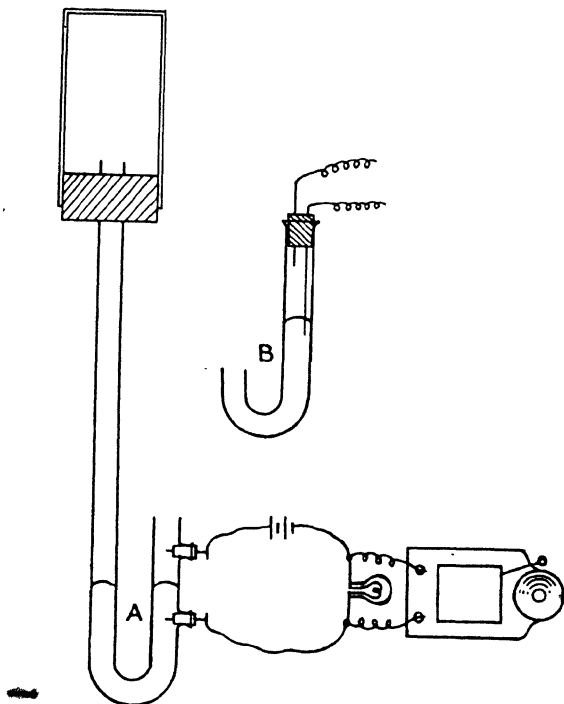

FIG. 77.

We also have an example of moving molecules in the following experiment illustrating *osmosis*.

An animal bladder is blown up and left to dry for a week or two. A piece large enough to cover the mouth of a thistle funnel is then cut out and soaked in water. It is then tied securely on to the thistle funnel.<sup>1</sup> A 10% sugar solution coloured with red ink is poured down the stem of the funnel until it fills

<sup>1</sup> Cellophane may be used instead of bladder.

the bulb and about an inch of the stem. The funnel is then immersed in water to the same level and clamped (Fig. 78).

Water molecules diffuse through the bladder until there is a considerable column of liquid pressing on it. The final pressure

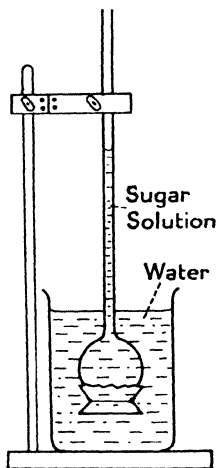

FIG. 78.

set up is called the *osmotic pressure* of the sugar solution. The experiment can be reversed, sugar solution being placed in the beaker and a column of water in the thistle funnel. Water now passes out and the column falls. This *passing of water through a membrane to dilute a solution on the other side is called osmosis*. You will meet osmosis frequently during your study of plant life.

The above account shows that the idea of moving molecules is used to explain temperature, gas pressure, diffusion, and osmosis. In fact, although no one has ever seen a moving molecule, the idea is accepted by the chemist, the physicist and the biologist.

## CHAPTER IX

### SALTS

#### Base + Acid.

*Experiment.* Take about half an inch of a stick of caustic soda, NaOH. Divide this into approximately equal parts. Dissolve one of these in water in a porcelain dish. Add dilute hydrochloric acid until the liquid is neutral. This can be tested with bits of red and blue litmus paper on a gas-jar cover. When a drop of the liquid has no effect on red or blue litmus paper, evaporate on a gauze or sand-bath. Towards the end **slow down the heating and stir constantly**. In this way you will prevent the substance sticking to the dish.

You should now have a dry white solid. If you are *quite sure that your liquid was neutral*, taste a little of the solid about the size of a pin's head. As an additional safeguard you may, before tasting, rub a little of the solid with water between the fingers and *make sure that it does not feel soapy*. The solid is common salt or sodium chloride and the experiment can be represented by an equation



Put the salt in a test-tube and add a little strong sulphuric acid. There should be acid fumes which go denser when the ammonia stopper is held near. Add a little manganese dioxide and put a damp litmus paper across the mouth of the tube. Refer back to p. 81.

These tests are additional evidence that the solid prepared is common salt. It was prepared by neutralizing hydrochloric acid.

Whenever a new substance is prepared by neutralizing an acid the product is called a **salt**, after common salt. Let us try another.

*Experiment.* Take about the same bulk of stick caustic potash (KOH). Dissolve in water as before and add dilute nitric acid until the liquid is neutral. Evaporate to dryness with stirring but

do not taste the new substance. It is *saltpetre* or *nitre* or *potassium nitrate*.

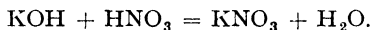

Add strong sulphuric acid to a little of the powder in a test-tube. Warm. What comes off? Add a few copper turnings. What comes off now? Refer back to p. 82.

Melt a little of the powder in a test-tube. When the molten salt-petre boils, test with a glowing splint. Oxygen comes off.

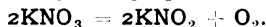

It was in this way that oxygen was discovered by the Swedish apothecary, Scheele. Add a fragment of carbon or sulphur to the boiling salt-petre. Each element burns brilliantly, obtaining the necessary oxygen not from the air but from the salt-petre. This is another sort of combustion and explains the working of gun-powder.

Gunpowder is a *mixture* of potassium nitrate, sulphur, and carbon in the proportions 75%, 13%, and 12% respectively, but since it is a mixture these proportions may be varied slightly. When gunpowder explodes, a large volume of nitrogen and carbon dioxide is formed, and it is because these hot gases require much more room than the original powder that the damage is done.

The explosion is approximately represented by the equation



$\text{K}_2\text{S}$  is potassium sulphide and this acted upon by water vapour in the air gives the smell.

Potassium nitrate is also a salt, because it was prepared by neutralizing an acid. How could sodium nitrate,  $\text{NaNO}_3$ , and potassium chloride,  $\text{KCl}$ , be prepared?

There is another alkaline substance well known to you, namely, slaked lime,  $\text{Ca(OH)}_2$ . We can neutralize hydrochloric acid with limewater and produce a salt. But this case is slightly complicated by the fact that 700 c.c. of limewater only contain about 1 gram of the actual slaked lime. This would entail a long evaporation, so we must alter the method slightly.

*Experiment.* Half fill a dish with dilute hydrochloric acid. Warm the acid, then add quicklime or slaked lime *until no more will dissolve*. Filter hot and evaporate down as before. Our salt is *calcium chloride*.



Leave a little of the solid in a dish exposed to the air for a few days. Put another portion in a dish in a desiccator (Fig. 79). This apparatus contains strong sulphuric acid or pumice stone soaked in strong sulphuric acid to maintain a dry atmosphere.

The exposed solid will be found to have absorbed enough water from the air to dissolve itself. Calcium chloride is said to be *deliquescent* or 'becoming liquid.' You have previously met calcium chloride as a drying agent. It is often used in a desiccator instead of sulphuric acid. Other deliquescent solids are caustic soda and caustic potash.

Substances which absorb water but not so vigorously as to dissolve themselves are spoken of as *hygroscopic* or 'water detecting' (compare *microscope*, *electroscope*). Anhydrous bluestone and

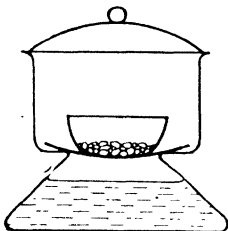

FIG. 79.

black copper oxide are hygroscopic. *Liquids* which absorb water are also known as hygroscopic, e.g. absolute alcohol and strong sulphuric acid.

*Experiment.* Add magnesium oxide to warm sulphuric acid of medium strength until no more dissolves. Filter hot and cool a sample in a test-tube under the tap. It crystals do not appear, continue evaporation until a sample crystallizes on cooling.



The same method can be used to make zinc sulphate crystals or white vitriol,  $\text{ZnSO}_4 \cdot 7\text{H}_2\text{O}$ , and copper sulphate, blue vitriol, or bluestone,  $\text{CuSO}_4 \cdot 5\text{H}_2\text{O}$ . What substances would you use to neutralize the acid?

We have now prepared a number of salts by neutralizing acids:

Salts of nitric acid are called Nitrates.

Salts of sulphuric acid are called Sulphates.

Salts of hydrochloric acid are called Chlorides.

The substance used to neutralize the acid was always either a metallic oxide or a metallic hydroxide. The neutralizing agent is called a **base**. In each case water was formed as well as the salt.

The formation of water can best be illustrated when the acid is hydrochloric because it can easily be obtained dry. If hydrochloric acid gas is passed over gently heated calcium oxide in the apparatus shown in Fig. 80, calcium chloride will be formed in the first bulb and water in the second. This can be tested with anhydrous bluestone. The excess hydrochloric acid gas is passed into water by means of a thistle funnel.

**A base is a substance which neutralizes an acid to form a salt**

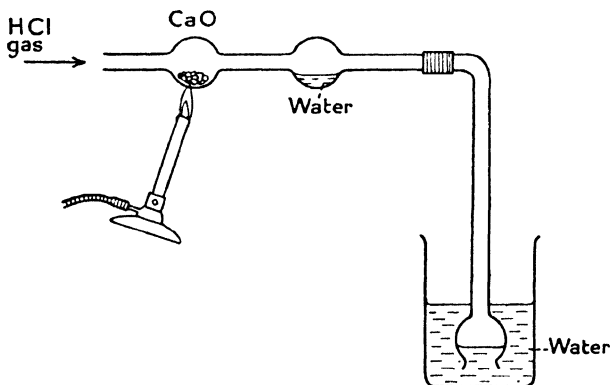

FIG. 80.

and water only. A base is nearly always a metallic oxide or a metallic hydroxide.

If the base is soluble in water we call it an **alkali** and the end-point can be found with litmus. But if the base is insoluble in water, then we add an excess of it to the acid and filter hot.

We now have the real difference between metals and non-metals. A **metal** forms a basic oxide, a **non-metal** forms an acidic oxide. The basic oxide may or may not dissolve in water to form an alkali, but it will always neutralize an acid to form a salt and water.

**A salt is the product of neutralizing an acid with a base, or**

**A salt is the result of replacing the hydrogen in an acid by a metal.**

A salt is composed of two parts, one metallic the other acidic. Thus in potassium nitrate potassium (K) is the metallic part and nitrate ( $\text{NO}_3$ ) is the acidic part. The  $\text{NO}_3$  group of atoms is often called the **acid radical**. Every nitrate has in its molecule the radical  $\text{NO}_3$ . Every sulphate has the radical  $\text{SO}_4$ .

Any given base can form as large a number of salts as there are acids available; thus potassium hydroxide can form a whole series of potassium salts, e.g. potassium nitrate, potassium sulphate, potassium chloride, etc. Note that in these names 'potassium' is an adjective, just as in 'iron saucepan' the word 'iron' is an adjective.

### Metal + Acid.

In the preparation of hydrogen on p. 26, we obtained the salt zinc sulphate.



This salt crystallizes with seven molecules of water of crystallization

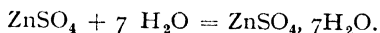

In a similar way we could prepare Epsom salt  $\text{MgSO}_4 \cdot 7\text{H}_2\text{O}$  and green vitriol or ferrous sulphate  $\text{FeSO}_4 \cdot 7\text{H}_2\text{O}$ .

If the object is to obtain the salt rather than the hydrogen, we can save evaporation by using rather stronger acid, say twice the strength of the ordinary dilute acid. Excess of zinc dust, iron filings, or magnesium is added to the acid in a flask and the flask allowed to stand until action ceases. On filtering, crystals should be obtained with very little evaporation.

To make copper sulphate, copper turnings are put into a flask and covered with strong sulphuric acid. The mixture is gently warmed in the fume chamber until a reaction starts. The flame is then removed and when the reaction has ceased and the flask is cool the mixture is diluted with an equal volume of water in **small doses with shaking**. The mixture is then warmed, filtered, and evaporated to crystallizing point, then set aside. Compare p. 95.

Here we may point out that 'Metal + Acid' is quite a good method of making a salt, but we have to use our discretion. We have just made copper sulphate by this method, but you already knew a better method, namely, adding black copper oxide to dilute sulphuric acid. Sometimes this method of adding metal to acid is not merely inferior but absolutely useless. For instance,

you will be well advised to avoid it in making potassium nitrate. This is an ancient 'howler' well known to all chemistry teachers.

### Base + Acidic Oxide.

This is well exemplified when we pass carbon dioxide through limewater.

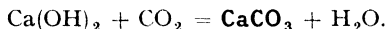

The salt is calcium carbonate. This reaction also takes place during the hardening of mortar in a wall. The fact that old mortar contains a carbonate is evident when acid is added to it.

On p. 39 we prepared sodium carbonate by passing carbon dioxide through sodium hydroxide solution

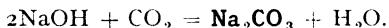

Potassium carbonate can be similarly prepared.



If we use sulphur dioxide,  $\text{SO}_2$ , instead of carbon dioxide, we obtain another series of salts called *sulphites*. One of these, sodium sulphite,  $\text{Na}_2\text{SO}_3$ , when boiled with sulphur, gives photographer's hypo,  $\text{Na}_2\text{S}_2\text{O}_3 \cdot 5\text{H}_2\text{O}$ .

Actually this method is almost the same as the first method, 'Base + Acid,' for the carbon dioxide dissolves in the water to form carbonic acid, and the sulphur dioxide forms sulphurous acid. The acid in each case is then neutralized by the base.

### Metal + Chlorine or Iodine.

Chlorides can often be prepared by passing dry chlorine gas over the metal, e.g. sodium chloride,  $\text{NaCl}$ , aluminium chloride,  $\text{AlCl}_3$ , and ferric chloride,  $\text{FeCl}_3$ , but these are strictly demonstration experiments.

*Experiment.* (a) Grind in a mortar 2 grams of mercury and 1.27 grams of iodine, moistening with a little alcohol. A greenish powder is formed—mercurous iodide,  $\text{HgI}$ .

(b) Add another 1.27 grams of iodine and a little alcohol and grind again. A red powder, mercuric iodide,  $\text{HgI}_2$ , is formed. Gently heat a little of this in a test-tube. Some of it changes to yellow, but on cooling most of it becomes red again. Scratch any remaining yellow powder with a glass rod. It changes to red again. Mercuric iodide can exist in two forms, red and yellow.

**Another Salt + An Acid.**

Sodium carbonate was prepared above by neutralizing carbonic acid with sodium hydroxide. Now sodium hydroxide is a very strong alkali, while carbonic acid is only a weak acid, so weak in fact that the salt sodium carbonate is alkaline to litmus paper.

*Experiment.* Take some solid sodium carbonate and dissolve in water in a dish or use some of the bench solution. Warm the solution, then add bench hydrochloric acid, occasionally boiling the liquid to get rid of carbon dioxide because it will act on litmus. Test drops of the liquid with bits of litmus paper on a gas-jar cover glass. When neutral, evaporate to dryness, stirring well towards the end. The solid left will be *common salt*.

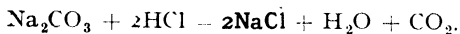

*Experiment.* Neutralization by the *titration* method. Fill a burette with bench hydrochloric acid, adjusting the bottom of the meniscus to the zero mark (note Greek *meniskos*, a little moon). Make sure that the jet is also full of acid. A sliding filter paper enables one to see the meniscus more easily (Fig. 81). In taking burette readings keep the eye on a level with the meniscus. Suck up 25 c.c. of bench sodium carbonate solution in a pipette. Caution! Do not suck the liquid into your mouth. This is generally caused by trying to suck up 25 c.c. from a vessel containing 20 c.c. or less (Fig. 82). Make sure that the lower end of the pipette is well covered with liquid. Run it into a conical flask, touching the bottom end of the pipette against the inside of the flask. Add a few drops of *methyl orange*. Run the acid into the soda solution 1 c.c. at a time until the indicator just changes from yellow to pink. The end point is more easily seen if a piece of white paper is placed on the baseboard, but the baseboard must be kept dry. Take the rough reading, then fill up to the zero mark with acid and start

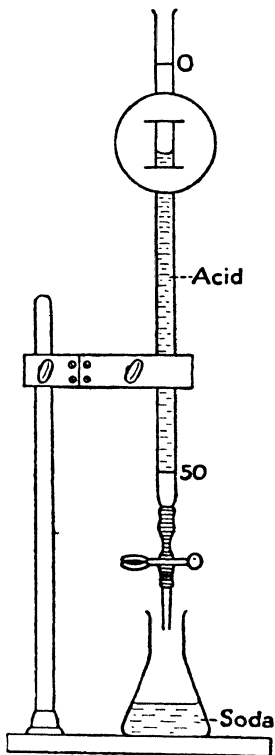

FIG. 81.

again with a fresh quantity of soda. This time add most of the acid at once and shake gently, then add drop by drop until the end point is reached. Now titrate a fresh quantity of soda without the methyl orange and evaporate the neutral liquid to dryness. Taste

the solid left. It is common salt.

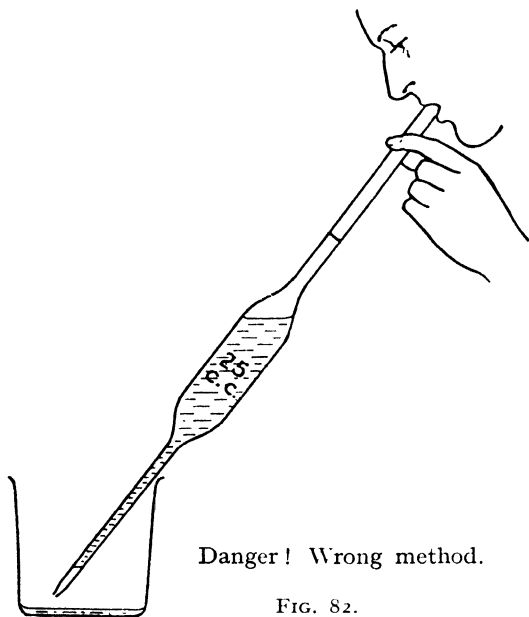

FIG. 82.

If litmus is used instead of methyl orange, the liquid must be boiled occasionally. Why?

You have now met two indicators, litmus and methyl orange. Phenolphthalein is another well-known one. They are all dyes which change their colour *very suddenly* according to whether the liquid is acid or alkaline.

Indicator.	Colour.		
	In Acid Solution.	In Alkaline Solution.	In Neutral Solution.
Litmus . . . . .	Red	Blue	Purple
Methyl Orange . . . . .	Red	Yellow	Orange
Phenolphthalein . . . . .	Colourless	Red	Colourless

These indicators provide interesting conjuring tricks.

*Experiment.* In Fig. 83 beaker (1) contains water and a few drops of phenolphthalein, beaker (2) has been rinsed with an alkali, and

beaker (3) with an acid. The colourless liquid from (1) is poured into (2). The liquid goes red, but a red litmus paper dipped into this red liquid goes blue. The liquid is then poured into (3). The liquid now goes colourless, but a blue litmus paper dipped in this colourless liquid goes red.

In applying the method 'Another Salt + An Acid,' we have so

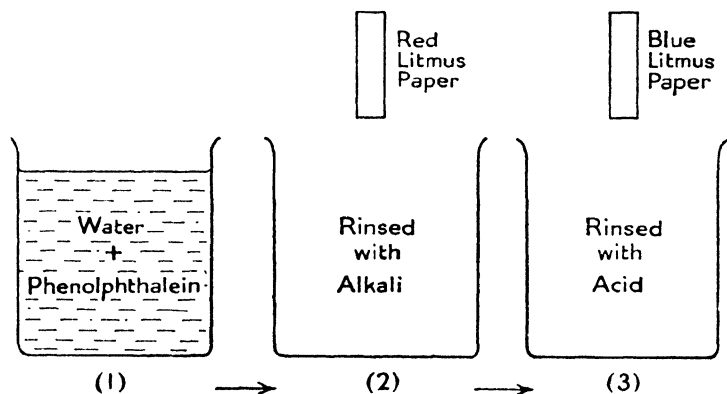
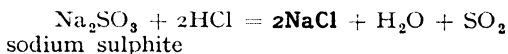

FIG. 83.

far only used sodium carbonate and hydrochloric acid. But we can use any carbonate and any acid. There is probably on your bench a bottle labelled 'Lead acetate.' This is generally made by dissolving lead carbonate in acetic acid. Acetic is the acid present in vinegar.

'Another salt' can also be a sulphite; thus—



But the chemist has one very strange way of using this method. As soon as he has prepared the salt he throws it away! The acid he uses is well known to you, but you probably do not know it as an acid. This acid has a foul smell and is made in the laboratory in a small compartment all to itself. Its proper name is sulphuretted hydrogen or hydrogen sulphide, but it is known in all countries as  $\text{H}_2\text{S}$  (*aitch too ess*).

*Lady from the Continent visiting English chemical laboratory:*  
Show me, please, zee machine zat make zee bad smell.

*Chemistry Master*: I expect you mean the apparatus for making hydrogen sulphide.

*Lady*: Ah, no. I know not zat name. We call it 'ahsh too ess.'

Hydrogen sulphide is prepared in a Kipp's apparatus using fer-

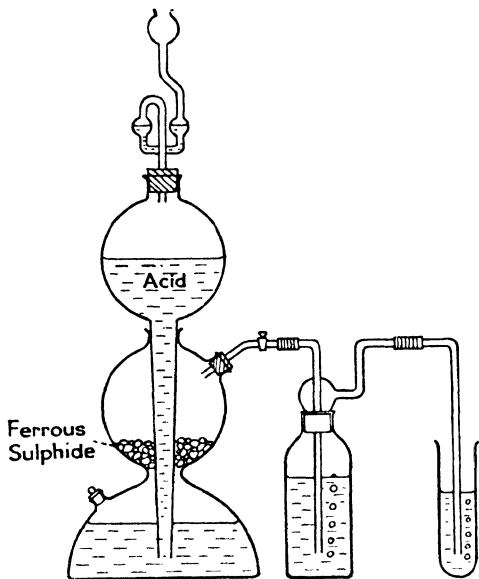
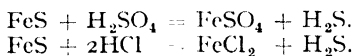

FIG. 84.

rous sulphide with either sulphuric or hydrochloric acid (Fig. 84).



When using the Kipp for making carbon dioxide (p. 32), we used marble in big lumps. Here too the ferrous sulphide must be in big lumps for the same reason.

When the gas is passed through copper sulphate solution, a black precipitate of *copper sulphide* is formed.

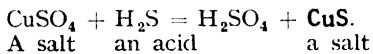



nothing can prevent puffs of contaminated air escaping while the liquid is rising into the top chamber. Watch the trap when the Kipp is turned on, then off.

If the gas is passed over heated tin or copper, the corresponding sulphide is formed and hydrogen is given off.

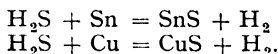

If a mouth blowpipe is connected to the Kipp, the gas can be ignited; it burns completely.



But if a jar of the gas is ignited, some of the sulphur does not burn. Why?

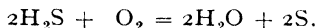

It will now be readily understood why hydrogen sulphide is regarded as **an acid**; it contains hydrogen replaceable by a metal and is acid to litmus. The old name for the gas was 'hydro-sulphuric acid,' but the most reasonable name is 'hydrogen sulphide' because it brings out the fact that it is the *parent* sulphide. For the same reason nitric, sulphuric, and hydrochloric acids are sometimes called hydrogen nitrate, hydrogen sulphate, and hydrogen chloride respectively.

Many metallic sulphides occur in nature. *Cinnabar*,  $\text{HgS}$ , is the chief ore of mercury. It is found mainly at Almaden (Spain) and Idria (E. Italy). To obtain the mercury, the ore is roasted in air.

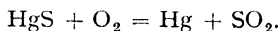

*Galena*,  $\text{PbS}$ , is the chief ore of lead. The metal is extracted by roasting, but the reactions are rather involved.

*Zinc blende*,  $\text{ZnS}$ , is the chief ore of zinc. The ore is roasted to form zinc oxide,  $\text{ZnO}$ , and this is then heated with carbon. The carbon reduces the oxide and zinc distils off. See also p. 59 on the **Winning of Metals**.

*Antimony sulphide*,  $\text{Sb}_2\text{S}_3$ , occurs native and is also made in the laboratory. This substance is one of the ingredients used in making safety matches.

### Double Decomposition.

*Experiment.* (a) Add some lead acetate solution to potassium

iodide solution in a beaker (demonstration) or test-tube (individuals). Note: potassium iodide is fairly expensive. A golden yellow precipitate of *lead iodide* is formed (Fig. 85).

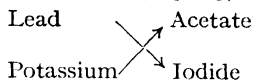

(b) Add potassium iodide solution to mercuric chloride solution. A precipitate changing rapidly from yellow to scarlet is formed. This is *mercuric iodide*.



(c) Add barium chloride solution to sodium carbonate solution. A white precipitate of barium carbonate is formed.



We have here another method of making a salt. It is called

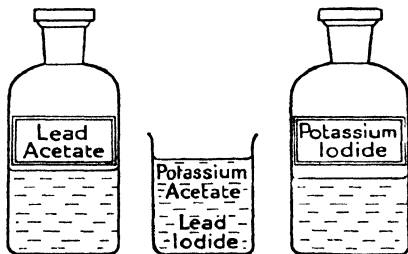
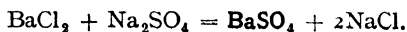

FIG. 85.

'double decomposition.' Both compounds split up and exchange acid radicals forming two new salts, one in solution, the other in suspension.

*If two solutions are mixed and there is any possibility of an insoluble compound being formed, then that compound certainly will form in preference to the formation of a mixed solution.* We shall meet many examples of double decomposition as we go along. Here are some of them.

*Test for a Sulphate.* Add barium chloride solution to the unknown solution—white precipitate *insoluble in hydrochloric acid*. Try this.



Compare with the equation from above—

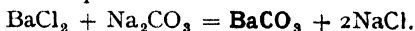

Barium sulphate and barium carbonate are both white, but the latter, like all carbonates, is soluble in hydrochloric acid, while the former is not. Hence the reason for the italicized phrase.

*Test for a Chloride.* Add silver nitrate solution to the unknown solution—white precipitate insoluble in nitric acid soluble in ammonium hydroxide.

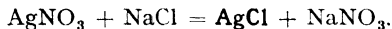

The white precipitate is silver chloride. Try this.

*Making Sodium Hydroxide.* This is not quite a double decomposition of two salts, but it is very similar. Add limewater to a solution of sodium carbonate. Chalk is precipitated and a solution of sodium hydroxide is formed.



The disadvantage of this simple method is that the limewater contains so little of the actual slaked lime.

The difficulty is got over by adding an excess of solid slaked lime to a strong solution of sodium carbonate. Then on filtering, the solution of caustic soda will be quite strong.

Caustic soda is now also manufactured by electrolysing brine, NaCl. Chlorine goes to the anode while sodium decomposes

water at the kathode, forming hydrogen and caustic soda.

**The Silica Garden.** There is a viscous liquid called 'water-glass' which is often used for preserving eggs. Its chemical name is sodium silicate,  $\text{Na}_2\text{SiO}_3$ . A two-pound jam jar is filled to within an inch or two of the top with water (Fig. 86). Two good teaspoonfuls of water glass are then stirred in. If any other vessel is used, a suitable proportion is one good teaspoonful to about 300 c.c. of water.

Various crystals are now dropped in so as to rest at different spots on the bottom. The jar is left undisturbed until the following day, when peculiar plant-like growths will be seen. It is really an excellent illustration of **double decomposition**, e.g.

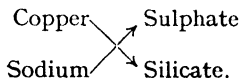

The sodium sulphate goes into solution while the insoluble copper

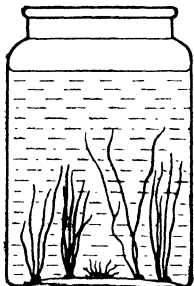

FIG. 86.

silicate forms a little tree. Suitable crystals and the 'plants' they form are detailed below.

Cadmium nitrate or bromide	. . . . .	White straggling growth.
Cobalt nitrate	. . . . .	Blue erect.
Copper sulphate	. . . . .	Very short branches.
Ferrous sulphate	. . . . .	Green erect.
Manganese sulphate	. . . . .	Yellowish brown erect.
Nickel sulphate	. . . . .	Stumpy.
Zinc sulphate	. . . . .	Tall white.

### A Digression on Silicon.

In the last paragraph we made a nodding acquaintance with an element not previously mentioned. Silicon, Si, is a non-metal (at. wt. 28) and silica, SiO<sub>2</sub>, is its oxide. Silicon is the second most prevalent element in the earth's crust. The order is O, Si, Al, Fe, Ca, Na, K, Mg, H. Yet you have probably never seen silicon and perhaps never will. It is manufactured as a grey crystalline substance or a brown amorphous substance and used in certain alloys and the hard grinding material, carborundum, SiC. It is because of its few uses that we rarely see it.

But although we are not well acquainted with silicon, its oxide silica was one of our earliest joys. We all of us at one time or another shovelled it into little buckets or made castles with it; **sand** is simply silica coloured with a little iron oxide. When we got older we possibly pulled sharp bits of silica out of bicycle or car tyres; **quartz** and **flints** are natural forms of silica. Some of you may one day wear silica as a decoration in the form of **opals** and **amethysts**.

You will be surprised to hear that silica is regarded as an acidic oxide although it does not dissolve in water to form an acid. But silica has the other qualification possessed by acidic oxides—it will dissolve in alkalis to form salts.

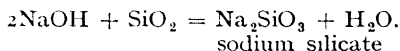

Compare

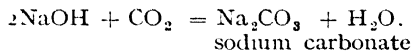

Now Na<sub>2</sub>SiO<sub>3</sub> can be written Na<sub>2</sub>O.SiO<sub>2</sub>, sodium silicate being regarded as a compound of a basic oxide and an acidic oxide just as Na<sub>2</sub>CO<sub>3</sub> can be looked upon as Na<sub>2</sub>O.CO<sub>2</sub>. This method

of writing the formula of a salt is frequently used with silicon compounds because they are generally very complex. The chief constituent of clay is aluminium silicate<sup>1</sup> (aluminium oxide + silica). Felspar, one of the constituents of granite, is potassium aluminium silicate<sup>2</sup> (potassium oxide + aluminium oxide + silica). Asbestos is magnesium calcium silicate. Thus many of the rocks in the earth's crust are complex compounds of silica.

These complex silicates are also extremely important in daily life. We frequently look through panes of sodium calcium silicate. When using a microscope we are gazing through a potassium lead silicate. The hard glass tubes of the laboratory are made of potassium calcium silicate.

Ordinary window glass is made by fusing together sodium carbonate, calcium carbonate, and sand. If the glass is to be coloured, a small quantity of some metallic oxide is added; manganese dioxide gives violet, while glass is always slightly green owing to iron oxide in the sand unless precautions are taken to get rid of it.

Lens glass is made by fusing potassium carbonate, litharge and sand. Although it is very soft and easily scratched, it is called flint glass, but this name comes from the ground flints which were originally used instead of sand. The same kind of glass is used in making 'cut glass' and the 'paste' diamonds of the detective stories.

Now glass could be made from quartz alone or even sand, and such glass would have some very definite advantages. It would have a high tensile strength, which means that the particles hold together strongly; it would therefore not readily smash when dropped. When ordinary glass is suddenly heated, one surface tries to expand before the other with disastrous results, but the coefficient of expansion of quartz is about sixteen times less than that of glass. Quartz, therefore, does not expand much at all, so a quartz vessel can be safely heated to redness, then plunged into cold water. Again, ordinary window glass stops that portion of sunlight called the 'ultra violet,' while quartz is transparent to most of it.

Why then do we not use quartz by itself? Simply because it needs a temperature of about 1,760° C. to make it soft and workable. When the various bases like lime, potash, soda, and litharge are added, silicates are formed which melt at a much

<sup>1</sup>  $\text{Al}_2\text{O}_3 \cdot 2\text{SiO}_2 \cdot 2\text{H}_2\text{O}$ .

<sup>2</sup>  $\text{K}_2\text{O} \cdot \text{Al}_2\text{O}_3 \cdot 6\text{SiO}_2$ .

lower temperature, but the disadvantages mentioned above are added at the same time.

Since ultra-violet radiation has been found beneficial to general health, scientists have tried to make a glass which would be transparent to it. This was found to be fairly easy, but such glass would not stand the weather. The best result so far was achieved in 1924 by Mr. F. E. Lamplough. He found that the addition of 2% boric oxide and the rigid exclusion of iron produced a glass which was transparent to a large proportion of the



FIG. 87.

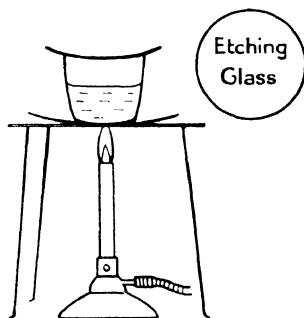

FIG. 88.

ultra-violet yet was unaffected by the weather. This 'Vita' glass is now manufactured by Messrs. Pilkington Bros. at St. Helens.

A neat little stencil made by this firm illustrates the properties of 'Vita' glass (Fig. 87). The stencil is made partly of 'vita' glass and partly of ordinary glass. It is strapped on the bare arm for an hour in strong sunlight or two minutes at a distance of 18 inches from a mercury vapour lamp, then removed. After some hours the word 'vita' is seen on the skin, but the word 'glass' never appears. If a mercury vapour lamp is used, the eyes should be protected with dark sun glasses.

*Etching Glass.* Glass will resist the action of most chemicals except fused alkalis, but we are sometimes inclined to forget

that glass is a chemical itself and not some supernatural material specially provided for chemical work.

Glass can be etched by means of hydrofluoric acid, HF. This acid comes on the market in hard rubber bottles. But to illustrate glass etching on a small scale we may gently heat a little calcium fluoride and strong sulphuric acid in a crucible (Fig. 88).

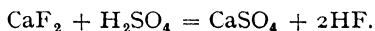

The watch glass is dipped into molten paraffin wax and allowed to cool. Writing is then scratched in the wax down to the glass surface with, say, a 'French' nail. When little puffs of the acid gas come off, the watch glass is placed on the crucible, precautions being taken against melting the wax. The wax is finally melted off in hot water. How would you etch copper?

#### 'Bi' Salts or Acid Salts.

We have seen that if we pass carbon dioxide through sodium hydroxide, we obtain sodium carbonate.



If we continue to pass the gas through, a second dose will be absorbed and we get sodium bicarbonate (see also p. 41).

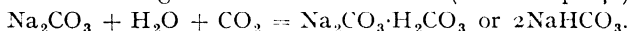

Sodium bicarbonate contains *twice* as much of the carbonate radical as ordinary or 'normal' sodium carbonate. Hence the name *bicarbonate*.

On p. 42 we also met normal potassium carbonate,  $\text{K}_2\text{CO}_3$ , and potassium *bicarbonate*.

There is always this possibility where a molecule of the acid contains two replaceable hydrogen atoms as  $\text{H}_2\text{CO}_3$  does. Such an acid is said to be **dibasic** because one molecule will react with one or *two* molecules of caustic soda forming two different salts, the acid salt and the normal salt. On the other hand, hydrochloric acid is **monobasic**; we can only get one sodium chloride. Sulphuric acid is another dibasic acid. From it we can obtain acid salts and normal salts. Potassium bisulphate was the substance left when nitric acid was prepared on p. 82.

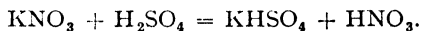

The manufacturer uses *sodium* nitrate to make nitric acid, and the sodium bisulphate formed is the chief constituent of 'Harpic.'

Again, when hydrochloric acid was prepared on p. 80, sodium bisulphate was left—

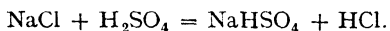

We can also make these bisulphates in another way.

*Experiment.* Titrate caustic soda solution in a conical flask with sulphuric acid from a burette. Make sure you can use a pipette before sucking up the alkali and see the caution on p. 105. When the alkali is neutralized, note the volume of acid used. If we evaporate now we shall get the normal salt  $\text{Na}_2\text{SO}_4$ . But instead of this add the same volume of acid used to the neutral solution. On evaporating to dryness we have what is known as sodium bisulphate or sodium hydrogen sulphate or acid sodium sulphate.

Using caustic potash, we can also prepare the corresponding potassium bisulphate.

Since sodium bisulphate is half-neutralized sulphuric acid, it will do most of the things which sulphuric acid itself will do. Since it is also a solid, it is generally put into little boys' 'Chemistry Sets' instead of the ordinary liquid acids.

Sodium bisulphate + saltpetre + a little water will serve the purpose of nitric acid. Thus this mixture + a little copper will give dense brown fumes.

Sodium bisulphate + common salt + a little water will serve instead of hydrochloric acid. This mixture + manganese dioxide will give chlorine.

Sodium bisulphate + ferrous sulphide will give 'H<sub>2</sub>S.' Sodium bisulphate + Hypo will give a precipitate of sulphur and the suffocating gas, sulphur dioxide.

So everybody is happy except mother and perhaps sister!

### Another 'Bi' Salt.

On p. 34 we came up against a slight mystery. When carbon dioxide was passed through limewater it went milky, but when an excess of carbon dioxide was passed through, the limewater went clear again. We shall find that here again a 'bi' salt is formed.

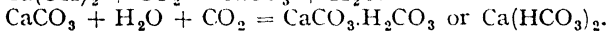
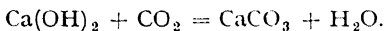

Chalk,  $\text{CaCO}_3$ , is insoluble in water, but calcium bicarbonate is soluble, so the liquid goes clear. If the liquid is now boiled

the last equation is reversed, the bicarbonate splits up, carbon dioxide comes off and chalk is left in suspension.

These facts have important applications in daily life. When rain falls through the air, it picks up carbon dioxide. If this carbonic acid now falls on chalk or limestone hills, the spring water will have calcium bicarbonate in solution. Caves form in these districts and from the roof hang drops of water holding calcium bicarbonate in solution. Water and carbon dioxide pass off and a residue of chalk is left. This through the centuries grows down into a **stalactite**. Occasionally drops fall on the floor and **stalagmites** grow up.

### Temporary Hardness.

Such water feels **hard**, that is, it is hard to form a lather with it. But if the water is just raised to the boiling point, the bicarbonate decomposes, chalk is deposited on the kettle or boiler as **fur**, and the water is now soft. If you have tea in a café in a hard-water district you may see particles suspended in the hot-water jug. Do not complain, remember your chemistry and geography. Hardness which can be removed by boiling is called **temporary hardness**.

Temporary hardness can also be removed by adding slaked lime. At first sight the remedy seems at least as bad as the disease, but actually it is quite effective.

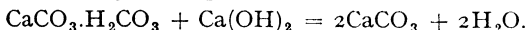

This is Clark's process. It must, of course, be based on a careful preliminary analysis of the water so that the correct weight of slaked lime can be added.

### Permanent Hardness.

Water containing calcium sulphate,  $\text{CaSO}_4$ , or calcium chloride,  $\text{CaCl}_2$ , is also hard. Boiling and the addition of slaked lime are both useless for this so-called permanent hardness. It is, however, only 'permanent' as far as these methods are concerned.

If washing soda is added we have a **double decomposition**—

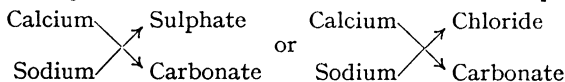

Calcium carbonate is precipitated and sodium sulphate or sodium chloride is left in solution. These do not cause hardness.

The most modern way of softening water is by using **sodium permutite**. Actually it is another of those complex silicates—sodium aluminium silicate. A cylinder is charged with this granular substance and the water which comes through is soft.

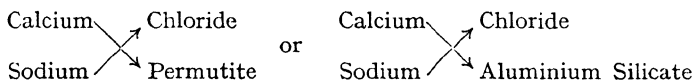

Calcium permutite is left in the cylinder and sodium chloride is left in the water. But there is not enough of this to give the water a taste.

After a time the sodium permutite is all changed to calcium permutite, but it can easily be regenerated. It is only necessary to run salt water through it for a short time.

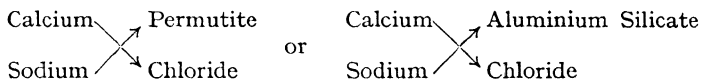

We have in the use of permutite two excellent examples of *double decomposition* and a first-class illustration of a *reversible reaction*. The method is often called the **Base Exchange** process.

There is still another method of softening water, but it is far too expensive for ordinary use—distillation. You will readily understand that distillation is much more expensive than mere boiling. Distilled water is absolutely essential for making up standard chemical reagents and for 'topping up' accumulators.

All the methods for removing permanent hardness, namely washing soda, permutite, and distillation, are also effective in dealing with temporary hardness. Boiling and Clark's process are of use in temporary hardness only.

In temporary hardness we only mentioned one culprit, calcium bicarbonate, but there is another—magnesium bicarbonate  $\text{Mg}(\text{HCO}_3)_2$ . This also responds to the same treatment.

Permanent hardness can also be caused by magnesium sulphate and magnesium chloride, but all that was said above concerning calcium salts will apply equally to these.

What happens if we *must* wash in hard water? After the wash, the water looks surprisingly dirty, but what you see is not all dirt. It is a new compound formed from the soap and the calcium sulphate or one of its fellow-culprits. Soap is a sodium

or potassium salt of oleic, palmitic, or stearic acid. Suppose our soap is sodium oleate.

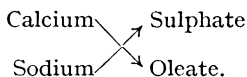

Here is another double decomposition and calcium oleate is precipitated as a scum.

### Relative Hardness.

*Experiment.* 10 grams of hard yellow soap are scraped off a lump and dissolved in 650 c.c. of distilled water and 350 c.c. of alcohol or methylated spirit. This liquid is put into a burette and used to titrate, say, 20 c.c. of (a) tap water, (b) spring water, (c) rainwater, (d) distilled water, (e) water made hard by the addition of a *little* calcium chloride. The soap solution is added 1 c.c. at a time until on shaking, a lather persists for 1 minute or any other fixed time.

The relative hardness of these five sample waters can then be found.

So far we have only spoken of hard water from the point of view of personal washing. But the matter is of still greater importance in laundries and in any industry where steam power is used. In the former, hard water causes a large rise in the soap bill. In the latter, the formation of *boiler scale* or *fur* increases the fuel bill because the fur is a poor conductor of heat, besides increasing the risk of burst boilers through unequal expansion.

### Double Salts.

Sometimes two salts combine together to form a *double salt*. The best examples of these double salts are the *alums*.

*Experiment.* Dissolve

10 grams of aluminium sulphate,  $\text{Al}_2(\text{SO}_4)_3 \cdot 12\text{H}_2\text{O}$   
and 1.8 grams of potassium sulphate,  $\text{K}_2\text{SO}_4$

together in 35 c.c. of hot water. Filter hot and set aside to cool. Octahedral (double pyramid) crystals will form. These are potassium alum or common alum,

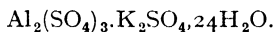

Alum is sometimes used to stop bleeding, but its most important use is to fix dyes in cloth.

In addition to common alum there are numerous others having the general formula  $T_2(SO_4)_3 \cdot U_2SO_4 \cdot 24H_2O$ ,

where T = Al, Fe, or Cr trivalent  
and U = Na, K, or  $NH_4$  univalent.

### Basic Salts.

Just as there are acid salts in which there is an excess of the acid, so there are basic salts in which there is an excess of the base. Thus verdigris, the deposit on copper and brass fittings, is generally basic copper carbonate,  $CuCO_3 \cdot Cu(OH)_2$ . White lead is basic lead carbonate,  $Pb(OH)_2 \cdot 2PbCO_3$ . This is used as a white paint and has the best covering power of all white paints. But workers have to be careful in using it and in making it, as it causes lead-poisoning. It is also blackened in any atmosphere containing 'H<sub>2</sub>S.'

## CHAPTER X

### MORE QUANTITATIVE CHEMISTRY

WHEN we speak of a litre of water or a pint of milk, these quantities are quite definite. But if we start talking about a 'litre of oxygen' or any other gas, the gas in question may be highly compressed gas or it may be very much heated gas. In the first case there would be a large quantity of gas present, and in the second there might be very little present.

Scientists have therefore agreed that when gases are measured it shall be done at a standard temperature and a standard pressure. The agreed temperature is  $0^{\circ}\text{C.}$ , while the agreed pressure is the usual atmospheric pressure at sea level on a normal day, in other words, a pressure of 30 inches or 760 mm. of mercury.

But suppose we have 380 c.c. of oxygen at a temperature of  $14^{\circ}\text{C.}$  and the pressure happens to be 750 mm. How can we calculate the volume under standard conditions? We shall need to know exactly how pressure affects the volume of a gas and how temperature alters it. The first difficulty was settled by Robert Boyle (1627-91).

**Boyle's Law** states that if the temperature is constant, the volume of a given mass of gas is inversely proportional to the pressure.

Let us use this law on our problem.

$$\begin{array}{l} \text{Vol. of gas at } 18^{\circ}\text{C. and } 750 \text{ mm.} = 380 \text{ c.c.} \\ \text{'' '' '' '' 1 mm.} = 380 \times 750 \\ \text{'' '' '' '' 760 mm.} = \frac{380 \times 750}{760} \\ \phantom{\text{'' '' '' '' 760 mm.}} = 375 \text{ c.c.} \end{array}$$

Notice that we kept the temperature constant.

The effect of temperature on the volume of a gas was discovered by Dalton in England, Charles and Gay-Lussac in France.

The conclusion they all came to independently is generally called by the name of Charles. **Charles's Law** states that **if the pressure remains constant, the volume of a given mass of gas is directly proportional to the absolute temperature.**

You will have learnt on p. 96 how to convert Centigrade temperatures into Absolute temperatures, so we can now finish off our problem.

$$\begin{aligned} \text{Vol. of gas at 760 mm. and } (273 + 21)^\circ \text{ A} &= 375 \text{ c.c.} \\ \text{'' '' '' '' } 1^\circ \text{ A} &= \frac{375}{294} \text{ ''} \\ \text{'' '' '' '' } 273^\circ \text{ A} &= \frac{375 \times 273}{294} \text{ c.c.} \\ &= 348 \text{ c.c.} \end{aligned}$$

Let us now try another problem and see if we can do it in one effort.

*Problem.* 250 c.c. of hydrogen are measured at  $20^\circ \text{ C.}$  and 750 mm. What will be the volume at **Normal Temperature and Pressure or Standard Temperature and Pressure**?

Method: Old temperature  $293^\circ \text{ A}$  Old pressure 750 mm.  
 New temperature  $273^\circ \text{ A}$  New pressure 760 mm.

The drop in temperature will diminish the volume, so we must multiply by  $\frac{273}{293}$  (not  $\frac{293}{273}$ ). The increase in pressure will also diminish the volume, therefore we multiply by  $\frac{750}{760}$  (not  $\frac{760}{750}$ ).

$$\text{Hence volume at N.T.P. or S.T.P.} = \frac{250}{1} \times \frac{273}{293} \times \frac{750}{760} = 230 \text{ c.c.}$$

*Another Problem.* What is the **weight** of the hydrogen in the last problem?

1 litre of hydrogen at N.T.P. weighs 0.09 gm. (p. 29)  
 $\therefore$  1 c.c. " " " " 0.0009 gm.  
 $\therefore$  230 c.c. " " " "  $230 \times 0.0009$  gm.  
 0.207 gm.

### More about Definite Proportions.

In Chapter VIII we learnt that elements do not combine in any haphazard proportions, but that they always do so in very definite proportions. In the same chapter we learnt how the atomic weight of oxygen and the formula for water were fixed. In the present chapter we shall learn still more about these definite proportions and incidentally how other atomic weights and formulae are decided.

We already know that magnesium turns out hydrogen from acids, and our first problem will be to find out whether a given weight of magnesium always turns out the same weight of hydrogen, and if so, how many weight units of magnesium will turn out one weight unit of hydrogen.

*Experiment.* [To save time it is recommended that the demonstrator should weigh out a few yards of magnesium ribbon and give each pupil or group a foot which generally weighs about 0.17 gram. Some pupils then use dilute sulphuric acid, others hydro-

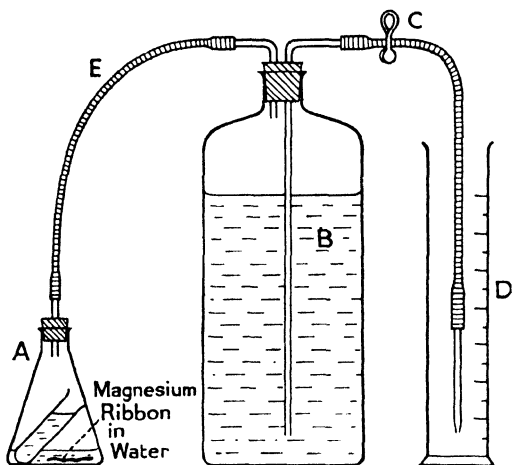

FIG. 89.

chloric acid.] Fit up the apparatus shown in Fig. 89. The conical flask contains the magnesium ribbon and a little water to slow down the reaction. The test-tube contains dilute acid. Nearly fill the Winchester quart bottle B with water. Blow through the rubber tube E until the syphon C is full of water and the measuring jar D contains about an inch. Pinch the tube E. If the water stops running, connect the flask A and watch the water. If it stops running, the apparatus is airtight. Raise D until its water is on a level with that in B. Close clip C and note how much water is in D and roughly what length of delivery tube is immersed. Tilt A so that only a little acid runs out and the reaction is kept under control. Then open clip.

When the reaction is over, allow the flask A to cool while you are reading the barometer. Raise or lower D until its water is level



do not happen in a haphazard way in Chemistry. Now look at these striking results :

- 1 gram of hydrogen is displaced by 12 grams of magnesium.
- 1 gram of hydrogen combines with 8 grams of oxygen (Dumas).
- 8 grams of oxygen combine with 12 grams of magnesium.

If time allowed, we could show experimentally that :

- 1 gram of hydrogen combines with 35.5 grams of chlorine.
- 1 gram of hydrogen is displaced by 12 grams of magnesium.
- 12 grams of magnesium unite with 35.5 grams of chlorine.

Again :

- 1 gram of hydrogen unites with 35.5 grams of chlorine.
- 1 gram of hydrogen is displaced by 20 grams of calcium.
- 20 grams of calcium combine with 35.5 grams of chlorine.

Again :

- 1 gram of hydrogen unites with 8 grams of oxygen.
  - 1 gram of hydrogen unites with 3 grams of carbon.
  - 3 grams of carbon unite with 8 grams of oxygen
- or 6 grams of carbon unite with 8 grams of oxygen.

The striking fact that emerges from all this is that each element has a certain definite number connected with it. This number is called the equivalent or combining weight of the element. It is defined as follows :

**The equivalent or combining weight of an element is the number of weight units of the element which will combine with or displace one weight unit of hydrogen.**

The orderly way in which elements combine with one another or displace one another is expressed in a law called the **Law of Combining Weights or Reciprocal Proportions**, which says, **When elements combine together or displace one another to form compounds, they do so in weights which are proportional to their equivalents.**

Let us now try to remember how we fixed the atomic weight of oxygen. We knew the equivalent of oxygen to be 8. We wondered whether the atomic weight should be 8 or 16, in other words, whether to multiply the equivalent weight by 1 or 2. After considering all the facts we knew about water, we finally decided to multiply the equivalent by 2 and make the atomic weight 16.

Scientists have given a name to that multiplier ; they call it



a strong case. So we will search for fresh evidence that the atomic weight of magnesium must be 24.

### The Periodic Classification of the Elements.

There is no need for panic at the sound of this title. The general idea is quite simple.

An English scientist, Newlands, a German, Lothar Meyer, and a Russian, Mendelejeff, about 1870 pointed out that if all the elements were arranged in the order of their atomic weights, they grouped themselves nicely into families. This arrangement is called the Periodic Classification. It was finally cleared of all difficulties by the work of H. G. J. Moseley. The first two 'periods' of the classification will be enough for our purpose.

He	Li	Be	B	C	N	O	F
4	7	9	11	12	14	16	19
Ne	Na	Mg	Al	Si	P	S	Cl
20	23	24	27	28	31	32	35.5

Now if magnesium is to fit into this scheme, its atomic weight cannot possibly be 12. But if the atomic weight is 24, it fits in quite well and helps to form a *family* with other elements like it.

Incidentally we may notice that this classification enabled scientists to say *how many* elements there were in the universe. In certain families there were gaps and the scientists of many nations engaged in little 'treasure hunts' to find these.

**Dulong and Petit's Law.** These two French scientists in 1819 found that if the atomic weight of a solid element is multiplied by its specific heat, the product is about 6.3.

Now the specific heat of magnesium is 0.25.

$$\text{Atomic Weight} \times \text{Specific Heat} = 6.3 \text{ approx.}$$

$$\therefore \text{Atomic Weight} = \frac{6.3}{.25} = 25 \text{ approx.}$$

This number 25 is sufficiently accurate to decide against 12 and in favour of 24 as the atomic weight of magnesium.

You will now probably agree that we are entitled to write the magic initials Q.E.D. to our proof that the atomic weight of magnesium is 24.

It is interesting to test out Dulong and Petit's Law on some

of the other elements. Here are some data which will enable this to be done :

	Ag	Cu	Pb	Fe	Ca	Hg	Zn
At. Wt.	108	63.6	207	56	40	100	65
S.H.	0.056	0.095	0.03	0.114	0.157	0.033	0.095

It must be mentioned in passing that there are a few exceptions to the law, but in the majority of cases it is very useful in helping to fix atomic weights.

### The Fixing of Formulae.

We have seen that once the atomic weight of magnesium is fixed as 24, then the formula of magnesium oxide must be  $MgO$ . But there are some substances which form complex molecules. Thus the brown fumes given off when nitric acid acts on copper are given the simple or 'empirical' formula  $NO_2$ , but at low temperatures two molecules bunch together to form the complex molecule  $N_2O_4$ .

This tendency is most marked in that part of chemistry called 'organic.' Here simple molecules often bunch together to form an entirely different substance. Thus formaldehyde, a substance often used in preserving biological specimens, has the formula  $CH_2O$ , but when six of these molecules bunch together, we have grape sugar or glucose,  $C_6H_{12}O_6$ . Thus the 'empirical' formula would be  $CH_2O$ , but the molecular formula is  $C_6H_{12}O_6$ . When we know the empirical formula but do not know the molecular formula we use an  $x$ , thus  $(C_6H_{10}O_5)_x$  is starch.

When the atomic weights and the formulae of simple substances are fixed, most of the others are quite easy because they are often made up of two simple ones. Thus chalk is a compound of quicklime,  $CaO$ , and carbon dioxide,  $CO_2$ ; its formula is  $CaCO_3$ . Sulphuric acid is a compound of sulphur trioxide,  $SO_3$ , and water,  $H_2O$ ; its formula is  $H_2SO_4$ . If we are in any doubt, a simple analysis will generally settle the matter.

*Problem : A white substance on heating gives off 52.4% of carbon dioxide and leaves 47.6% of magnesium oxide. What is the formula of the white substance ?*

Method: Let the formula be  $(\text{MgO})_x(\text{CO}_2)_y$ . Compare p. 94.

$$\begin{aligned}\text{Then } x : y &= \frac{47.6}{40} : \frac{52.4}{44} \\ &= 1.19 : 1.19 \\ &= 1 : 1\end{aligned}$$

Therefore the empirical formula is  $\text{MgO} \cdot \text{CO}_2$  or  $\text{MgCO}_3$ .

### Other Methods of Finding Equivalents.

*Experiment.* [In finding the equivalent of zinc it is recommended that the demonstrator should weigh a known rectangular area of zinc foil and cut it into square inches, one for each pupil or group.] The equivalent of zinc is then found by displacement of hydrogen from dilute hydrochloric or sulphuric acid, using a Winchester quart as in the magnesium experiment. It is however much slower than that experiment.

### Metal displacing Metal.

Some elements will not replace hydrogen from acids and when they combine with oxygen they may only do so very slowly. Copper is one of these, but we can proceed as follows:

$$\begin{aligned}1 \text{ gm. hydrogen} &\equiv 32.5 \text{ gm. zinc.} \\ 1 \text{ gm. hydrogen} &\equiv x \text{ gm. copper.}\end{aligned}$$

We can find out what weight of copper is turned out of copper sulphate solution by 32.5 gm. of zinc.

*Experiment.* [Same recommendation regarding square inches of zinc.] Put about a teaspoonful of powdered copper sulphate in a small flask containing about 50 c.c. of water. Add the zinc foil and gently shake. Make sure that the liquid remains blue to the end of the experiment, if necessary adding more copper sulphate. (Why?) Filter and wash the precipitate with a little water from a wash-bottle (Fig. 90). Spread the filter paper on a piece of gauze by supporting it on a radiator or about a foot above a Bunsen or in a steam oven. If the Bunsen is used, care must be taken not to oxidize the precipitated copper. Weigh the filter paper and copper, using another filter paper as a counterpoise.

Many similar displacements can be carried out. The following list of elements is called an **electro-chemical series**: magnesium, aluminium, zinc, iron, nickel, tin, lead, hydrogen, copper, mercury, silver, gold. If an electric cell is made with any two of these as poles, the early one is always negative and the later one positive. Thus in the Daniell (Copper-Zinc) cell and the

Nickel-Iron accumulator, copper and nickel are positive. The list is important from the present point of view because an early element displaces all later ones from their salts. The position of hydrogen in front of copper is interesting, for we know that magnesium, zinc and iron will replace hydrogen from its

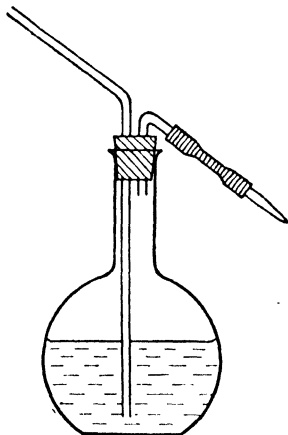

FIG. 90.

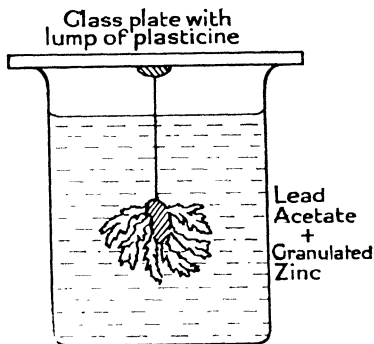

FIG. 91.

'salts' but copper will not. (What are the 'salts' of hydrogen?) In the extraction of silver and lead from their ores, iron is often used to displace the former and zinc the latter.

The displacement of lead from lead acetate solution by a piece of granulated zinc is often shown qualitatively by means of the 'lead tree' experiment (Fig. 91).

### Equivalent of Copper Electrically.

Faraday's second Law of Electrolysis says, 'If the same quantity of electricity passes through various electrolytes, then the weights of the elements liberated will be in the same proportion as their chemical equivalents.'

We may use this Law to determine the equivalent of copper, for we only need to find what weight of copper is liberated when 1 gram of hydrogen is liberated.

A Hofmann voltameter is connected in series with an electro-

lytic bath containing a double anode and a cathode, an ammeter, a rheostat, and a 6-volt battery. The double anode should be connected through the voltmeter to the + pole of the battery (Fig. 92). The copper sulphate in the electrolytic bath is a 15% solution containing 3 c.c. of strong sulphuric acid per litre. The acid in the voltmeter should be sulphuric diluted 1 to 6. By means of the rheostat the current is adjusted to a value of 1 ampere per 50 sq. cm. of cathode.

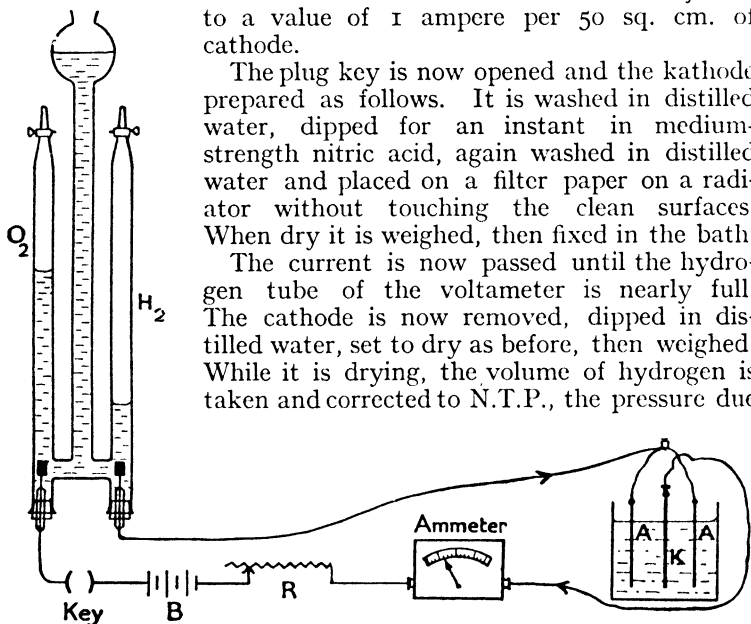

FIG. 92.

to the liquid in the reservoir tube being taken into account by multiplying its length by 13.6 and dividing by 1.2 the S.G. of the acid.

*Example.* Wt. of copper = 0.141 gm.  
 Vol. of hydrogen = 50 c.c.  
 Temp. = 19° C.  
 Total Pressure = 801 mm.

Calculate Equivalent of copper.

*Ans.* 31.8.

**Elements with More than One Equivalent.**

There are two oxides of copper, a black one and a red one. Coal gas or hydrogen will reduce both to copper. To make sure that these oxides are dry before we start, especially the black one, which you will remember is hygroscopic, we will gently heat enough for several pupils in two dishes over gauze with constant stirring for a few minutes. The dishes are then allowed to cool in a desiccator.

*Experiment.* With a piece of glass rod draw out an ordinary test-tube as shown in Fig. 93. Allow to cool, then weigh. Put in

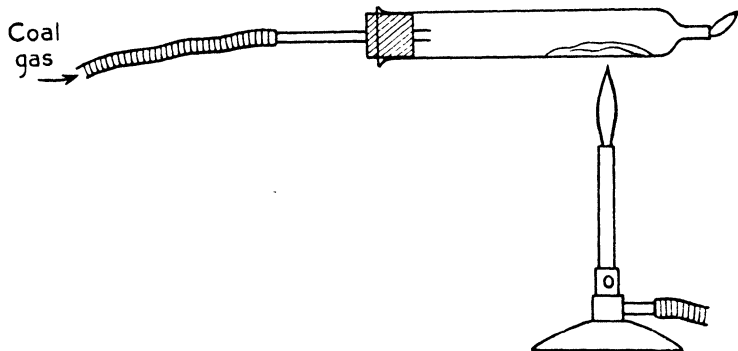

FIG. 93.

about 2 grams of either oxide and weigh again. Pass<sup>r</sup> in a slow current of coal gas and after half a minute heat the tube gently, keeping the Bunsen on the move. After a few minutes allow to cool, then weigh.

Appended are some results you may get if you are careful. Set down your own results in similar style and calculate what weight of copper was united with 8 grams of oxygen in each case.

Black oxide	{	Copper	1.60	32	64	Equivalent of Copper 32
		Oxygen	0.40	8	16	
Red oxide	{	Copper	1.78	64	128	Equivalent of Copper 64
		Oxygen	0.22	8	16	

These results are yet another illustration of the orderliness which we find in chemistry. They provide a good example of the **Law of Multiple Proportions**, which says, 'If a fixed weight of an element A combines with different weights of an element B to form different compounds, then the weights of the element B will be in a simple ratio.'

Do these results fit in with the Atomic Theory? They certainly do. The only simple explanation of the results is that in the black oxide one atom of oxygen is united with one atom of copper and in the red oxide with two atoms of copper.

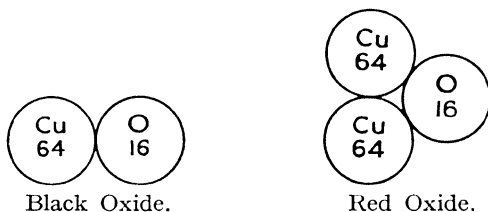

Dalton did several experiments like this with other pairs of elements and showed that the results of all such experiments fitted in quite nicely with his Atomic Theory. In fact, it is difficult to say whether his discovery of the Law of Multiple Proportions helped him to invent the Atomic Theory or whether the Atomic Theory led him to experiment and discover the Law of Multiple Proportions. It really does not matter at all. What *does* matter is that the two fit in so thoroughly.

We will deal with one more illustration of the Law of Multiple Proportions. Mercury forms two chlorides, called corrosive sublimate and calomel (Danger : Poison !). Both these chlorides can be reduced to mercury by means of a substance called hypophosphorous acid.

*Experiment.*<sup>1</sup> Weigh accurately about 5 grams of either chloride into a previously weighed beaker. Heat on a water bath with about 30 c.c. of water and 5-10 c.c. of syrupy hypophosphorous acid (or about 3 times the volume of commercial acid S.G. 1.136). The chloride is soon reduced to the metal, which, on further heating, collects into one or more large globules. Wash by decantation with water, alcohol, and ether in succession, removing the last drops of

<sup>1</sup> E. J. WILLIAMS, *School Science Review*, XII, 74.

each liquid with filter paper. Dry for five minutes in a steam oven cool, and weigh.

With perfect chemicals and perfect skill we should get the following results :

Mercuric chloride or corrosive sublimate	Hg	3.690	100	Equivalent of mercury 100 Valency 2
	Cl	1.310	35.5	
Mercurous chloride or calomel	Hg	4.245	200	Equivalent of mercury 200 Valency 1
	Cl	0.755	35.5	

Older pupils may do this experiment for themselves, but all should at least do it qualitatively on a small scale. The production of a globule of mercury from a white powder is a striking chemical change.

The results illustrate the Law of Multiple Proportions and also fit in perfectly with the Atomic Theory.

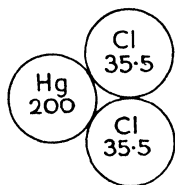

Mercuric Chloride.

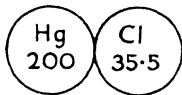

Mercurous Chloride.

### Oxidation and Reduction.

In very elementary chemistry, oxidation means adding on oxygen, while reduction means taking away oxygen. But in the last experiment we used the term reduction in describing the change from  $\text{HgCl}_2$  to  $\text{Hg}$ . What actually happened in that experiment was that the hypophosphorous acid took oxygen from the water to oxidize itself into phosphoric acid, the unattached hydrogen then took chlorine from the mercuric chloride to form hydrochloric acid and mercury was left. Expressed as an equation it would be—

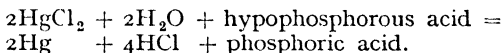

At this stage in your study of chemistry we may introduce the more general definition of oxidation and reduction used in advanced work.

**Oxidation** is an increase in the proportion of the electronegative or non-metallic part of the molecule. **Reduction** is a decrease in the proportion of the electronegative or non-metallic part of the molecule.

In our experiment the non-metallic part of the molecule of mercuric chloride was certainly decreased. In an experiment on p. 104 we changed mercury to mercurous iodide and then to mercuric iodide. Here we have two oxidations, and the iodine is said to have oxidized (a) mercury to mercurous iodide, (b) mercurous iodide to mercuric iodide. Note that the change in the name from *ous* to *ic* indicates oxidation. Similarly iron forms two sulphates,  $\text{FeSO}_4$  and  $\text{Fe}_2(\text{SO}_4)_3$ , and two chlorides,  $\text{FeCl}_2$  and  $\text{FeCl}_3$ . Can you name them?

**Electrolysis.** In our definition of 'oxidation' the term 'electronegative' came in. To understand the meaning of it we shall have to revise and extend our knowledge of electrolysis.

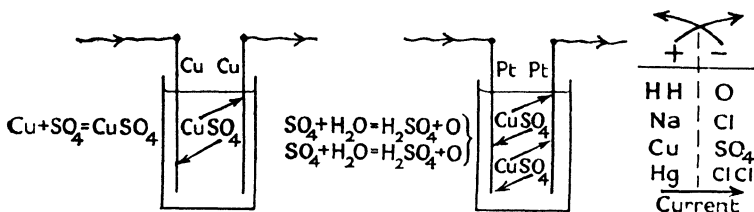

FIG. 94.

When we electrolysed water (p. 18) we found that hydrogen 'wandered' to the negative pole, while oxygen 'wandered' to the positive. When we electrolysed copper sulphate solution (p. 132) copper 'wandered' to the negative, while 'SO<sub>4</sub>' 'wandered' to the positive, where it acted on the copper to form copper sulphate. It was Faraday who first described this as 'wandering' and he called the wanderers 'ions' from a Greek word with the same meaning. The ion which wanders to the cathode is the *cation*, that which goes to the anode the *anion*.

Consider what would happen if the poles in that experiment had been made of platinum. The copper ion would still have been deposited on the negative, but the SO<sub>4</sub> going to the positive would have received no welcome from the platinum. The

$\text{SO}_4$  ion would then act on a molecule of water and liberate oxygen.

The ions which travel to the positive pole are attracted there because they carry a negative charge—they are *electronegative*. Similarly, those ions which go to the negative do so because they carry a positive charge—they are *electropositive*. These ideas are summarized in Fig. 94. We note that it is the non-metallic part of the molecule which is electronegative.

## CHAPTER XI

### SOME IMPORTANT NITROGEN COMPOUNDS

In Chapter VII we studied one very important compound of nitrogen, namely, **nitric acid**. Another equally important from all points of view is

#### AMMONIA, $\text{NH}_3$ .

In dealing with the destructive distillation of coal (p. 49), we found that one of the *by-products* in the manufacture of coal gas was an alkaline liquid. This alkaline liquid is known in the trade as 'ammoniacal liquor.' It is really a solution of ammonia,  $\text{NH}_3$ , in water. Sometimes the gas manufacturer converts the gas into *sulphate of ammonia* and puts it on the market as a fertilizer. Many fertilizers have a strong smell, but this one is quite innocent. The ammoniacal liquor is often passed on to the chemical industry, and here it becomes the starting-point in the production of many other chemicals. If the ammoniacal liquor is boiled, ammonia comes off. If it is treated with hydrochloric acid, sal ammoniac is formed.

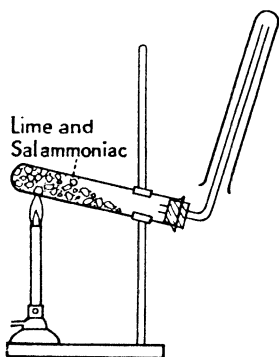
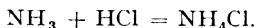
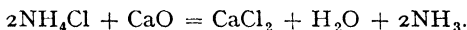

FIG. 95.

*Experiment.* Heat a dry mixture of quicklime or dry slaked lime and sal ammoniac in a sloping test-tube as shown in Fig 95. Note *moisture* coming off. Collect a test-tube full of ammonia. Close the tube with the thumb, open for an instant under water, then quickly replace the thumb. Shake the tube. A vacuum forms because the gas is very soluble in water. Open the tube under water. The tube almost fills with water. (Why not quite?) Blow fumes from the strong hydrochloric acid

bottle towards the delivery tube. Put 3 drops of the acid into a test-tube and mix with a tube of ammonia gas as in experiment (d) on p. 81. Mix what remains in the generating-tube with a little water, filter, evaporate filtrate and leave residue for a day or two. It gets damp. It is *calcium chloride*.

The complete reaction is represented thus—



When ammonia dissolves in water we have

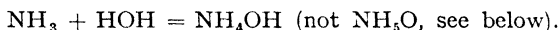

This is the reagent known as ammonium hydroxide—the ‘Liquor Ammoniae Fortis’ of commerce. It will neutralize acids to form salts.

*Experiment.* Add dilute ammonium hydroxide to dilute hydrochloric acid in a dish until the mixture is neutral to litmus paper. Evaporate down until a white powder is obtained. Heat a little of this in a test-tube—it sublimes. Mix a little with quicklime—ammonia comes off. The white powder is a salt—*ammonium chloride* or *sal ammoniac*.

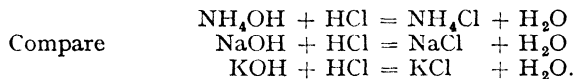

*Ammonia and Ammonium.* We see that ammonium hydroxide is a base; it neutralizes an acid to form a salt and water only. Note that it is an exception to the rule given on p. 102 that a base is nearly always a metallic oxide or a metallic hydroxide. We now see why its formula is written  $\text{NH}_4\text{OH}$ . This brings out its resemblance to the *metallic* hydroxides. We must remember that a molecule of the gas ammonia is written  $\text{NH}_3$ , while ammonium is a group of atoms acting like a metal and written  $\text{NH}_4$ . This group cannot exist by itself.

*Experiment.* Grind a little ammonium chloride or sal ammoniac in a mortar with a little solid sodium hydroxide or potassium hydroxide. In each case there is a strong smell of ammonia.

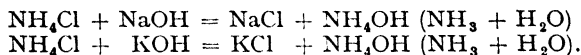

*Experiment.* Prepare the salt ammonium nitrate by neutralizing

nitric acid with ammonium hydroxide. Evaporate down and mix the residue with sodium hydroxide.

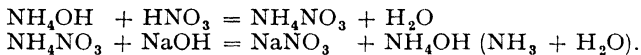

*Experiment.* Make ammonium sulphate or sulphate of ammonia, then mix with sodium hydroxide.

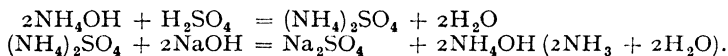

We see that ammonium salts are readily decomposed by strong bases like quicklime, sodium hydroxide, and potassium hydroxide. Ammonium hydroxide is only a weak base, but its salts are extremely useful.

#### *Demonstration Experiments.*

The most convenient way of obtaining a large quantity of the gas for demonstration is to warm a little of the Liquor Ammoniae Fortis S.G. 0.880 in a flask (Fig. 96). A flask can be filled with the gas and the solubility and alkaline nature of the gas demonstrated by means of the fountain experiment (p. 81), this time dipping the tube into *red* litmus solution.

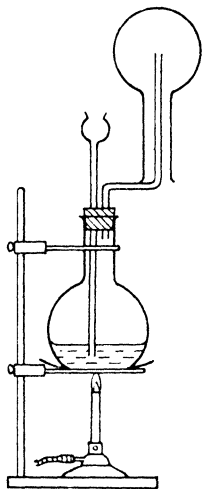

FIG. 96.

The gas can be prepared *dry* by passing it up a quicklime tower and collecting over mercury (Fig. 97). If a piece of wood charcoal is heated to redness, then immediately plunged under the mercury and made to pass up the tube, the charcoal absorbs the gas and the mercury rises.

The modern scientist uses another term to describe this sort of absorption. When a sponge absorbs water, it only takes in roughly its own volume, but charcoal takes in many times its own volume of ammonia. The molecules of ammonia, instead of being widely separated as they were before, now form a film on every bit of surface of the carbon. If it were merely a case of the pores becoming filled with gas, the charcoal would just take in its own volume as the sponge did. You may picture the molecules as if they were

packed on the surface 'shoulder to shoulder.' This kind of absorption of molecules by a surface is called *adsorption*.

Since catalysis always depends on the large surface presented by the catalyst in a finely divided condition, most cases of catalysis are now thought to be examples of adsorption. Thus in the forma-

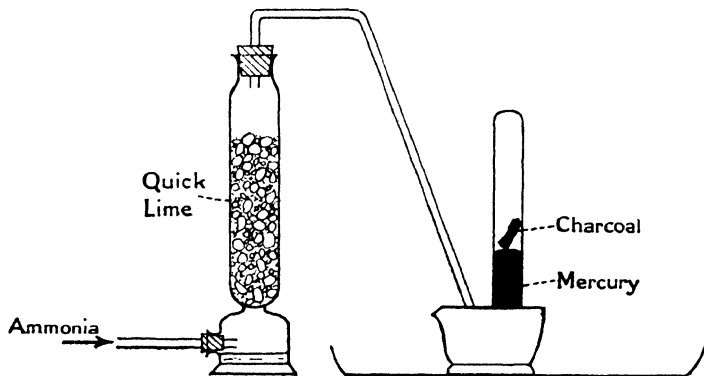
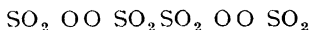
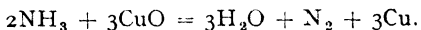

FIG. 97.

tion of sulphur trioxide by platinized asbestos (p. 78) the  $\text{SO}_2$  and  $\text{O}_2$  molecules come together to form a film on the large platinum surface. Here they are much closer together than they were before, so they unite much more frequently and then pass off as  $\text{SO}_3$  molecules.



The fact that ammonia contains nitrogen and hydrogen can be proved by passing the dried gas over heated copper oxide. Water and nitrogen are formed and copper is left.



#### *Uses of Ammonia and its Compounds.*

Ammonia gas can easily be liquefied. Its critical temperature (see p. 44) is  $130^\circ \text{C}$ . When it gasifies, it can be made to take its latent heat of vaporization from its surroundings. This fact is used in refrigerators (see *General Science Physics*, pp. 112, 113).

Ammonium carbonate,  $(\text{NH}_4)_2\text{CO}_3$ , is used with perfumes in smelling-salts bottles.

## 142 SOME IMPORTANT NITROGEN COMPOUNDS

Ammonium hydroxide dissolves grease, and mixed with ammonium carbonate is often used for cleaning clothes.

Sal volatile is a mixture of alcohol, water, Liq. Ammon. Fort., ammonium carbonate, oil of lemon, and oil of nutmeg.

Sulphate of ammonia has already been mentioned as an artificial manure.

When sal ammoniac is touched with a soldering bit, it splits up into ammonia and hydrochloric acid. The latter cleans the copper bit. More important is the use of this substance in Leclanché and dry cells.

Ammonium nitrate when heated gives off nitrous oxide, the gas used by dentists.

Last, but certainly not least from the small boy's point of view, we must mention ammonium sulphide, which gives forth a smell beyond all his dreams. A solution of ammonium sulphide is used in analysis.

### The Nitrogen Cycle.

The living matter of a plant or animal is called *protoplasm*. Protoplasm is a mixture of compounds—water, protein, fats, carbohydrates, and mineral salts. *Protein*, the second in order of abundance, is an extremely complex *nitrogen* compound.

Nitrogen then is an essential constituent of plants and animals. Where does it come from? There is of course an abundance in the air, but no animal and very few plants can make use of it. It may be said at once that the animal gets protein ready-made by eating a plant or another animal. The plant can *make* protein, but to do this it must be supplied with nitrogen in the form of nitrate (or nitrite).

The nitrates actually present in the soil would be quickly used up, but the soil contains minute chemical manufacturers called **bacteria**. Now bacteria have a thoroughly bad reputation. In the popular mind they are associated with typhoid, anthrax, consumption, and various other troubles. But many of them are extremely useful. Are these bacteria little animals or little plants? It is safer to put them in a class by themselves and be content to call them *micro-organisms*.

One kind of bacteria<sup>1</sup> living in the soil turns atmospheric nitrogen into ammonium compounds. Plant and animal remains are also gradually converted into ammonium compounds by

<sup>1</sup> Azotobacter.

another type of bacteria, and these act similarly on animal excretions which happen to find their way into the soil. Another crowd, the so-called *nitrifying bacteria*,<sup>1</sup> are ready to turn all these ammonium compounds into nitrates, and these nitrates

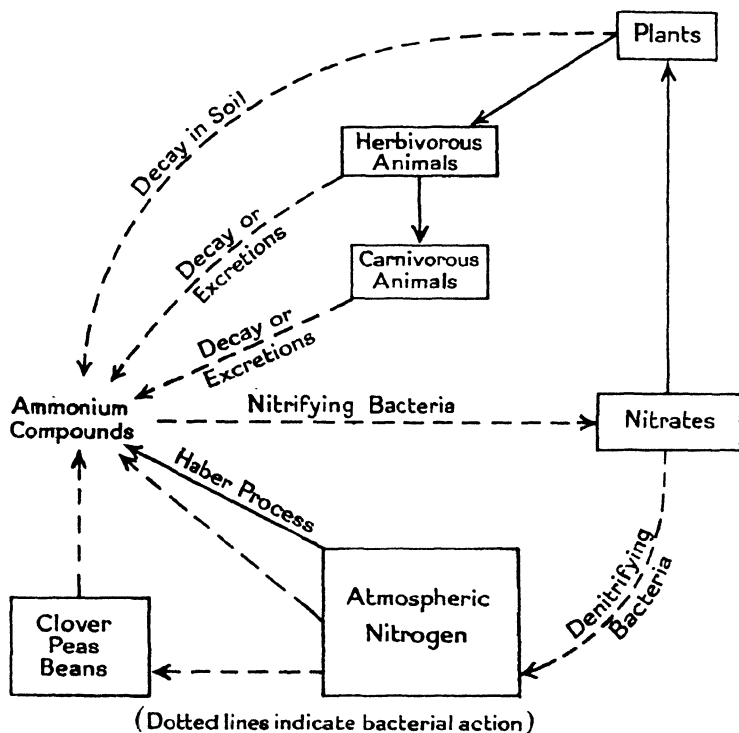

FIG. 98.

are just what the plant is waiting for. The reason for manuring soil will now be evident.

There is one peculiar type of bacteria<sup>2</sup> which forms colonies in nodules on the roots of peas, beans, clover, and other plants belonging to the same family.<sup>3</sup> This type also makes nitrogen

<sup>1</sup> Nitrosomonas and Nitrobacter.

<sup>2</sup> Bacillus radicola.

<sup>3</sup> Leguminosae.

compounds for the plant on which it lives, using nitrogen which has come into the soil from the air.

Now since two kinds of bacteria are busy using up atmospheric nitrogen, it might be thought that the air would gradually get richer and richer in oxygen. But there is a balancing influence at work, for still another peculiar crowd, the so-called *denitrifying* bacteria, are busy *breaking up* nitrates and sending nitrogen back into the air. We thus have a number of *nitrogen cycles* (Fig. 98).

Wheat is found to be specially fond of nitrates, and the soil after one wheat crop would certainly not grow a very good second wheat crop. The farmer gets over this difficulty by adopting what is known as *rotation of crops*.

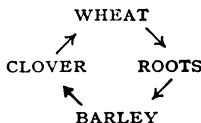

Bacteria will make nitrate for the clover. The farmer may then crop the clover or even plough it in to rot for the next wheat crop.

Another device is to add nitrate to the soil. For this purpose Chile nitre,  $\text{NaNO}_3$ , may be used. But this substance is also used in manufacturing nitric acid as a starting point in the making of explosives. Many wars have helped to deplete the nitre beds, and in 1898 Sir William Crookes expressed the opinion that the white races would soon go short of wheat unless they found some means of making nitrate by using the nitrogen of the air.

**Fixation of Nitrogen.** The problem of using atmospheric nitrogen to make nitrate is called *fixation of nitrogen*. Since 1898 many methods of doing this have been discovered.

If a mixture of nitrogen and oxygen is sparked, a little nitric oxide,  $\text{NO}$ , is formed. This with more oxygen and water form nitric acid.

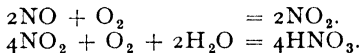

This is the basis of the Birkeland-Eyde process used in countries which have abundant electric power from waterfalls.

The method of fixing nitrogen used in England is called the Haber (pronounced *hah'-bare*) process, after its German inventor. He found that 1 volume of nitrogen would unite with 3 volumes of hydrogen to form 2 volumes of ammonia gas if the mixed gas was passed over a heated catalyst.

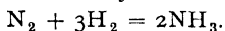

Since there is a reduction from 4 volumes to 2 volumes, pressure will help the process. Accordingly a pressure of about 200 atmospheres is used. The catalyst is generally a mixture of finely divided iron and molybdenum.

We are thus able to make *synthetic ammonia*. If this is dissolved in sulphuric acid we have ammonium sulphate, which soil bacteria can readily convert into nitrates.

But the ammonia can also be converted into nitric acid in the factory. A mixture of air and ammonia is passed over another heated catalyst, generally platinum.

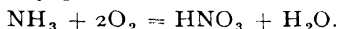

This can be very roughly imitated in the laboratory.

A slow current of oxygen from a gasometer is passed through concentrated ammonia solution in a conical flask (Fig. 99). The gasometer in the figure consists of a bell jar, a Winchester quart, and the necessary tubes and clips. A platinum spiral is sealed into a bent glass tube. The spiral is heated in the Bunsen, then plunged into the gaseous mixture in the flask. The spiral glows vigorously and fumes of ammonium nitrate are formed. Occasionally the ammonium nitrate disappears with a loud explosion, but this never seems to do any harm.

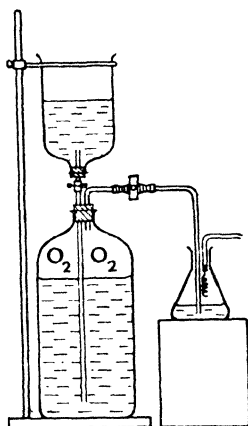

FIG. 99.

### Ammonia in Drinking Water.

From our nitrogen cycle, it will be evident that natural water may often contain dissolved ammonium salts derived from decaying animal or vegetable matter. Such water is always treated with suspicion, for besides containing some of the friendly

bacteria, it is also liable to contain some of the vindictive type. Ammonia is therefore one of the first things looked for in testing drinking water.

The reagent used is called Nessler's Solution. It is closely related to an experiment we have already done, namely, the formation of mercuric iodide by double decomposition (p. 111). A rough Nessler's solution can be made by adding potassium iodide solution to mercuric chloride solution until the precipitate first formed just re-dissolves, then making alkaline with potassium hydroxide.

Two jars of tap water are now placed on a sheet of white paper and a little of the solution added to one. There should be no yellow colour. The test is then repeated on a jar of water to which a drop of ammonia solution has been added.

#### Nitrous Oxide, 'Laughing Gas' or Dentists' Gas ( $N_2O$ ).

*Experiment.* Fill an ordinary test-tube with ammonium nitrate crystals. Fit a cork and delivery tube as in Fig. 100. Gently warm the whole length of the tube until the crystals melt. Then keep

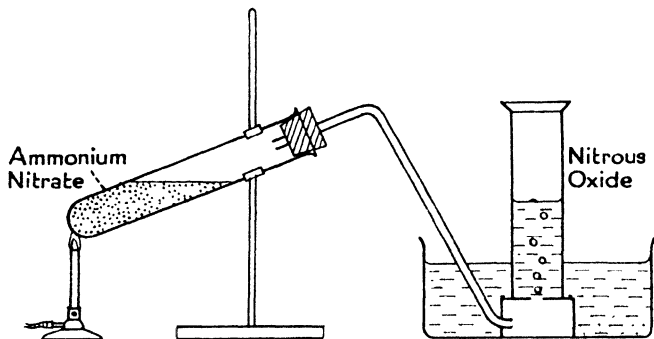
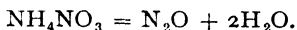

FIG. 100.

the flame low and close to the end of the tube, so that only the liquid is heated and not the gas above the liquid. In this way an explosion can be avoided. Collect the gas over water. Hot water is generally recommended, but this is not absolutely necessary since the gas is only about as soluble as carbon dioxide. Both these gases can readily be collected over cold water.



*Tests.*

(a) Collect a test-tube half full of the gas. Close with the thumb, shake vigorously and open under water. The gas is noticeably soluble in cold water.

(b) The gas relights a glowing splint.

(c) Phosphorus and sulphur burn readily in the gas forming the oxides of these elements.

(d) It has a faint sweetish smell and when inhaled it sometimes produces hysterical laughter, but its powers in this direction and as an anaesthetic are not generally studied in schools.

To stop the experiment the apparatus is lifted out of connection with the trough.

**Nitric Oxide, NO.**

*Experiment.* Add nitric acid of half-strength to copper turnings

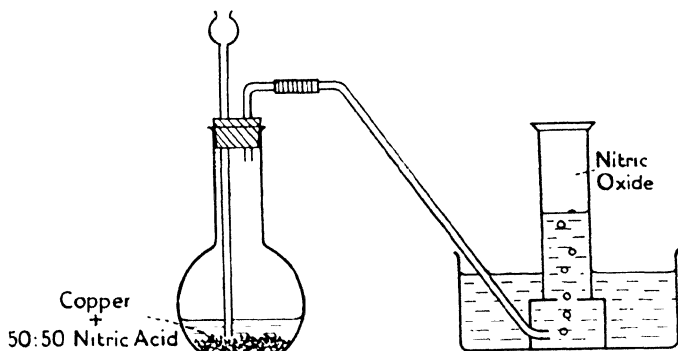
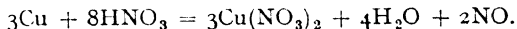

FIG. 101.

in a flask fitted up as shown in Fig. 101. The gas is collected over water.



*Tests.* [Caution: Nitric oxide is very poisonous.]

(a) The gas forms brown fumes in the generating flask but in the jar it is clear. Open the jar against a sheet of white paper. Brown fumes of **nitrogen peroxide** are seen.

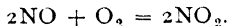

(b) Collect a test-tube half full of the gas. Close with the

## 148 SOME IMPORTANT NITROGEN COMPOUNDS

thumb, shake vigorously and open under water. The gas is not very soluble in water.

(c) Collect a jar one-third full of nitric oxide. Pass in **oxygen** until it is two-thirds full. Brown fumes are formed. Shake with water and replace the jar. The fumes readily dissolve in water, forming nitric acid and nitrous acid.

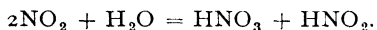

(d) Pass **nitrous oxide** into the nitric oxide. There are no **brown fumes**.

NOTE: **Nitrous Oxide** + Nitric oxide  $\rightarrow$  no action.

**Oxygen** + Nitric oxide  $\rightarrow$  brown fumes.

(e) Nitric oxide extinguishes a lighted splint. Vigorously burning phosphorus continues to burn, but sulphur does not.

(f) Pass nitric oxide into a test-tube or jar containing ferrous sulphate solution. A **dark brown liquid** is formed. Keep the liquid in the generating-flask.

*Test for Nitric Acid and Nitrates.* The last test is closely connected with the so-called **ring test** for nitric acid and nitrates: Add ferrous sulphate solution to the suspected solution. Slant the tube, then pour strong sulphuric acid in. Wait a few seconds, then hold the tube vertically. A brown ring forms at the junction of the acid and the mixture.

To show how delicate this test is, add a few drops of nitric acid to a beaker of water and test for nitric acid. Pour half the weak acid away, fill up with water and test again. Repeat until no brown ring can be seen against a sheet of white paper.

### To make Basic Oxides.

*Experiment.* Pour off the liquid from the nitric oxide flask into a dish. Evaporate in the fume chamber. The green residue is *copper nitrate*. This on further heating gives off nitrogen peroxide and leaves black *copper oxide*. If dilute sulphuric acid is added, we get copper sulphate. Adding zinc displaces copper and we can start again. We have a sort of "copper cycle."

Nitric acid is a very useful **oxidizing agent** for making those basic oxides which take a long time by direct oxidation in the air. In this way we can make lead monoxide or litharge and mercuric oxide. Sometimes the equivalent of copper is found by this method.

The method can be varied. We may make the nitrate, then

add sodium hydroxide or sodium carbonate solution, filter, and heat the precipitated hydroxide or carbonate thus:

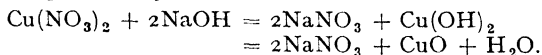

**Nitrogen Peroxide,  $\text{NO}_2$ .** (Caution: Poisonous!)

We have met incidentally two methods of making the brown gas nitrogen peroxide. (a) The action of oxygen on nitric oxide. (b) The heating of a nitrate. Can you name three nitrates which would *not* give the brown gas on heating?

*Experiment.* Gently heat and stir some powdered lead nitrate in a dish. Allow to cool in a desiccator. Half fill a hard glass tube

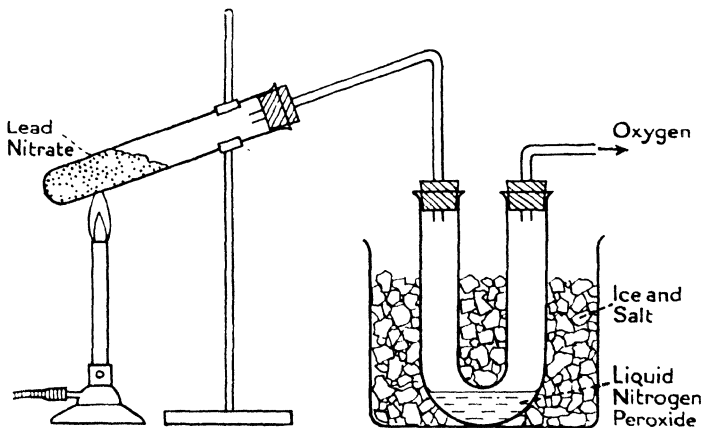

FIG. 102.

with the dry powder. Heat gently and pass the gases evolved through a U-tube immersed in ice and salt (Fig. 102). Test the gas evolved at the end of the apparatus with a glowing splint. After about ten minutes, lift the U-tube out of the freezing mixture. A liquid has collected which is probably green but becomes straw-coloured on standing. The green liquid is a mixture of a blue liquid, nitrogen trioxide,  $\text{N}_2\text{O}_3$ , and a yellow liquid, nitrogen peroxide,  $\text{N}_2\text{O}_4$ . The blue liquid soon decomposes and passes off. A sample of it can be seen by pouring a little of the final yellow liquid on ice in a test-tube. An inky blue liquid forms and quickly disappears.

## 150 SOME IMPORTANT NITROGEN COMPOUNDS

Liquid nitrogen peroxide is regarded as  $N_2O_4$ . As the temperature rises these molecules dissociate until at about  $140^\circ C$ . the formula is  $NO_2$ . Nitrogen peroxide has a powerful smell, and this is what we actually smell when nitric oxide is being prepared. It is impossible to tell whether nitric oxide has a smell of its own or not. (Why?)

Nitrogen peroxide is an *acidic oxide*. It dissolves in water to form two acids, nitric and nitrous.

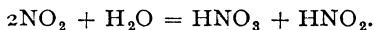

If the gas is dissolved in an alkali, say sodium hydroxide, sodium nitrate,  $NaNO_3$ , and sodium nitrite,  $NaNO_2$ , are formed.

Sodium nitrite can be mixed with ammonium chloride and heated to produce a sample of **nitrogen gas**. The apparatus is the same as for nitrous oxide (p. 146).

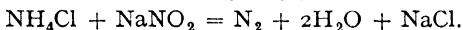

Nitrogen gas does not burn or support combustion or turn limewater milky. These tests are sufficient to identify it.

### Formulae of Acids, Bases, and Salts.

It will be convenient here to clear up a difficulty which may have been bothering you. Why  $NaCl$  but  $CaCl_2$ ? Why  $Na_2SO_4$  but  $CaSO_4$ ?

Consider again the second definition of valency given on p. 127 and repeated here. The *valency of an element is the number of hydrogen atoms which one atom of the element will combine with or displace*. Since the formula for water is  $H_2O$ , the valency of oxygen is 2 or oxygen is bivalent. Since the formula for hydrochloric acid is  $HCl$ , the valency of chlorine is 1 or chlorine is univalent. Again, the formula for common salt is  $NaCl$ , so sodium must be univalent.

We often represent valency by straight lines called 'valency bonds.' On this scheme we should put  $H-$ ,  $-O-$ ,  $Cl-$ . To make a stable compound, the bonds of one element must link up with the bonds of another element thus:  $H- -O- -H$  or  $H-O-H$ . Again, common salt is  $Na- -Cl$  or  $Na-Cl$ .

But the metal calcium is bivalent,  $-Ca-$  or  $Ca=$ , so we picture a molecule of quicklime to form thus:  $Ca= =O$  or  $Ca=O$ . Similarly calcium chloride would be  $Ca \begin{matrix} \diagup Cl \\ \diagdown Cl \end{matrix}$ . Aluminium and sometimes iron are trivalent  $Al\equiv$ ,  $Fe\equiv$ .

FORMULAE OF ACIDS, BASES, AND SALTS 151

We also speak of the valency of an acid radical. Thus, since nitric acid is  $\text{HNO}_3$ , we say the valency of the nitrate radical,  $\text{NO}_3$ , is 1. So calcium nitrate would be  $\text{Ca} \begin{smallmatrix} \text{NO}_3 \\ \text{NO}_3 \end{smallmatrix}$  or  $\text{Ca}(\text{NO}_3)_2$ . Again, the valency of the  $\text{SO}_4$  group is 2, so we must have  $\text{Na} \begin{smallmatrix} \text{SO}_4 \\ \text{SO}_4 \end{smallmatrix}$  but  $\text{Ca}=\text{SO}_4$ .

Now we can look upon water as a hydroxide,  $\text{H}(\text{OH})$ , and we see that the valency of the hydroxyl group  $\text{OH}$  must be 1, hence  $\text{Na}-(\text{OH})$  but  $\text{Ca} \begin{smallmatrix} \text{OH} \\ \text{OH} \end{smallmatrix}$ .

The valency of an element or radical may be indicated thus:  $\text{O}''$ ,  $\text{Na}'$ ,  $\text{SO}_4''$ .

Formulae in which valency bonds are shown are called *structural formulae* because they indicate the structure of the molecule. You will find them extremely important if you ever do organic chemistry. A structural formula tells the trained scientist most of the properties of the compound.

The appended table will now be easily understood. It is a good exercise to copy the tops and sides and try to complete the table (Fig. 103).

H'	H <sub>2</sub> ' O''	H' OH'	H' Cl'	H' NO <sub>3</sub> '	H <sub>2</sub> ' SO <sub>4</sub> ''	H <sub>2</sub> ' CO <sub>3</sub> ''
Na'	Na <sub>2</sub> O	NaOH	NaCl	NaNO <sub>3</sub>	Na <sub>2</sub> SO <sub>4</sub>	Na <sub>2</sub> CO <sub>3</sub>
K'	K <sub>2</sub> O	KOH	KCl	KNO <sub>3</sub>	K <sub>2</sub> SO <sub>4</sub>	K <sub>2</sub> CO <sub>3</sub>
Ag'	Ag <sub>2</sub> O	AgOH	AgCl	AgNO <sub>3</sub>	Ag <sub>2</sub> SO <sub>4</sub>	Ag <sub>2</sub> CO <sub>3</sub>
NH <sub>4</sub> '		NH <sub>4</sub> OH	NH <sub>4</sub> Cl	NH <sub>4</sub> NO <sub>3</sub>	(NH <sub>4</sub> ) <sub>2</sub> SO <sub>4</sub>	(NH <sub>4</sub> ) <sub>2</sub> CO <sub>3</sub>
Cu''	CuO	Cu(OH) <sub>2</sub>	CuCl <sub>2</sub>	Cu(NO <sub>3</sub> ) <sub>2</sub>	CuSO <sub>4</sub>	CuCO <sub>3</sub>
Hg''	HgO	Hg(OH) <sub>2</sub>	HgCl <sub>2</sub>	Hg(NO <sub>3</sub> ) <sub>2</sub>	HgSO <sub>4</sub>	HgCO <sub>3</sub>
Ca''	CaO	Ca(OH) <sub>2</sub>	CaCl <sub>2</sub>	Ca(NO <sub>3</sub> ) <sub>2</sub>	CaSO <sub>4</sub>	CaCO <sub>3</sub>
Ba''	BaO	Ba(OH) <sub>2</sub>	BaCl <sub>2</sub>	Ba(NO <sub>3</sub> ) <sub>2</sub>	BaSO <sub>4</sub>	BaCO <sub>3</sub>
Zn''	ZnO	Zn(OH) <sub>2</sub>	ZnCl <sub>2</sub>	Zn(NO <sub>3</sub> ) <sub>2</sub>	ZnSO <sub>4</sub>	ZnCO <sub>3</sub>
Mg''	MgO	Mg(OH) <sub>2</sub>	MgCl <sub>2</sub>	Mg(NO <sub>3</sub> ) <sub>2</sub>	MgSO <sub>4</sub>	MgCO <sub>3</sub>
Pb''	PbO	Pb(OH) <sub>2</sub>	PbCl <sub>2</sub>	Pb(NO <sub>3</sub> ) <sub>2</sub>	PbSO <sub>4</sub>	PbCO <sub>3</sub>
Fe''	FeO	Fe(OH) <sub>2</sub>	FeCl <sub>2</sub>	Fe(NO <sub>3</sub> ) <sub>2</sub>	FeSO <sub>4</sub>	FeCO <sub>3</sub>
Fe'''	Fe <sub>2</sub> O <sub>3</sub>	Fe(OH) <sub>3</sub>	FeCl <sub>3</sub>	Fe(NO <sub>3</sub> ) <sub>3</sub>	Fe <sub>2</sub> (SO <sub>4</sub> ) <sub>3</sub>	Fe <sub>2</sub> (CO <sub>3</sub> ) <sub>3</sub>
Al'''	Al <sub>2</sub> O <sub>3</sub>	Al(OH) <sub>3</sub>	AlCl <sub>3</sub>	Al(NO <sub>3</sub> ) <sub>3</sub>	Al <sub>2</sub> (SO <sub>4</sub> ) <sub>3</sub>	Al <sub>2</sub> (CO <sub>3</sub> ) <sub>3</sub>

FIG 103.

## 152 SOME IMPORTANT NITROGEN COMPOUNDS

If you know a few formulae with certainty, it is possible to build up all the rest. Thus NaCl is the clue to the sodium compounds, CaCO<sub>3</sub> to the calcium compounds, and so on.

When you have become thoroughly at home with the above table, it is worth remembering that copper and mercury, as we saw on pp. 133 and 135, can be univalent and bivalent. The table may also be extended so as to include sulphides, sulphites, bicarbonates, etc.

## CHAPTER XII

### CHLORINE AND ITS RELATIONS. THE HALOGEN FAMILY

WHEN we made hydrochloric acid (p. 81) we tested it by warming with manganese dioxide. A green suffocating gas came off which bleached red and blue litmus papers. In the present chapter we shall study this gas, chlorine, in greater detail.

*Experiment (demonstration).* Place lumps of manganese dioxide and some strong hydrochloric acid in a flask fitted up as shown in

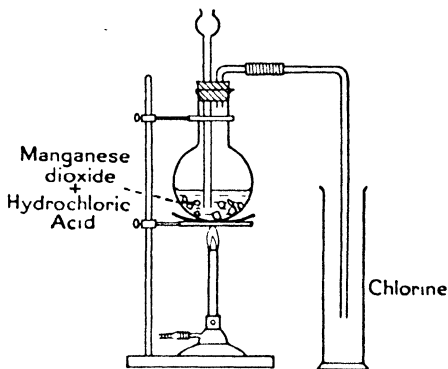
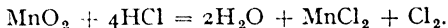

FIG. 104.

Fig. 104. Heat gently in a fume chamber and place a piece of white paper behind the receiving jar. The oxygen in the manganese dioxide *oxidizes* the hydrogen in the hydrochloric acid.



*Tests.* [Caution: Poisonous!]

(a) The gas is green in colour, heavier than air, and has a strong, irritating smell.

(b) The gas puts out a lighted match and does not burn itself.

(c) Press damp red and blue litmus papers against the inside of a jar of chlorine. Put in some green grass and some damp paper bearing print and ordinary writing. Everything is bleached but the print. But if the gas is first dried by passing through strong sulphuric acid, and the materials are all dry, there is no bleaching.

(d) Place a small piece of phosphorus on a burning-spoon and plunge into the gas. The phosphorus ignites spontaneously, giving fumes of phosphorus trichloride,  $\text{PCl}_3$ , and phosphorus pentachloride,  $\text{PCl}_5$ .

(e) Heat a small piece of sodium on a burning-spoon until it lights, then plunge into a jar of chlorine. Sodium chloride is formed.

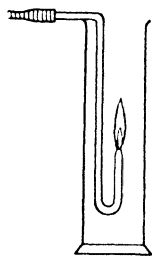
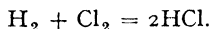

FIG. 105.

(f) A lighted hydrogen jet when plunged into the gas burns with a ghostly flame (Fig. 105). Hydrochloric acid gas is formed and can be identified with the ammonia stopper.



(g) A lighted candle mounted on a spoon burns with evolution of much smoke (carbon) and hydrochloric acid gas. The latter is identified as before.

(h) A piece of cotton-wool or filter-paper is thoroughly moistened with turpentine, opened out, dropped into the gas and *the plate left off*. There is no need to warm the turpentine if the jar is really full of chlorine. A vortex ring of smoke and hydrochloric acid gas is formed.



(i) A jar of 'H<sub>2</sub>S' and a jar of chlorine are mixed.

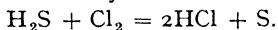

(j) A large quantity of chlorine is passed into a small quantity of water by means of a thistle funnel attached to the delivery tube. A yellowish-green solution called 'chlorine water' is obtained. This will remove ink stains from an old piece of rag.

(k) Pass the gas through a strong solution of potassium bromide in a test-tube. Bromine is liberated.

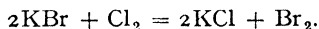

(l) Pass the gas through a strong solution of potassium iodide

until solid iodine appears. Filter and dry the iodine, which will be used later.



### Chlorine as a Bleaching Agent and Disinfectant.

We saw that dry chlorine will not bleach a dry material; water must be present, and the following is thought to be the real explanation of bleaching:

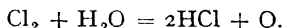

If there is anything on which the 'lonely' oxygen atom can act, then bleaching takes place. If there is nothing to bleach, then the single oxygen atoms join to form comparatively inactive oxygen molecules. The above equation must be regarded as a very temporary state of affairs. Oxygen just liberated in the atomic form is often spoken of as 'nascent' oxygen (Lat. *nascens*, being born).

When chlorine is passed through cold sodium hydroxide solution, a substance called sodium hypochlorite,  $\text{NaOCl}$ , is formed in the solution, as well as sodium chloride.

When chlorine acts on dry slaked lime, 'bleaching powder' is formed. This is rather a loose or unstable compound, but it is generally given a formula— $\text{CaOCl}_2$ . Sodium hypochlorite and bleaching powder are both good disinfectants and bleaching agents. Both give off chlorine when acted upon by a dilute acid. Chlorine can be used for bleaching cotton and linen fabrics and wood pulp.

Chlorine kills all kinds of bacteria, including the typhoid bacillus. It is often used in swimming baths and even in drinking water, either in the elementary form or combined as bleaching powder and sodium hypochlorite. Chlorine also comes on the market in liquid form. It is one of the easily liquefied gases—critical temperature  $146^\circ \text{C}$ .

### Other Methods of making Chlorine.

In our preparation of chlorine it must be borne in mind that the manganese dioxide is here not a catalyst but one of the main reacting substances; it oxidized the strong hydrochloric acid. Other substances can be used for the same purpose.

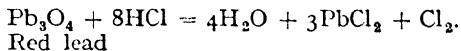

Red lead

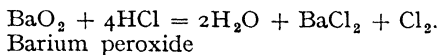
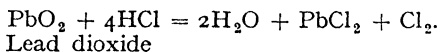

Note that these four oxides are called *metallic peroxides*. They may be defined as *metallic oxides which contain more oxygen than the corresponding basic oxides*.

There is still another laboratory method of making chlorine and it has the advantage that it will work in the cold.

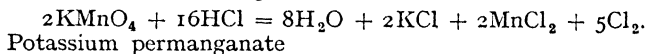

Vast quantities of chlorine are made on the large scale by the **electrolysis of brine**.

#### Volumetric Synthesis of Hydrogen Chloride.

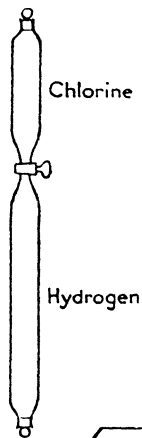

This is a very important experiment from the point of view of the establishment of formulae. The apparatus consists of two tubes joined by a tap and closed at each end by good-fitting glass stoppers (Fig. 106).

The upper tube is filled with chlorine by downward displacement and the lower one with hydrogen by upward displacement. The stoppers are inserted and the tap opened so that the gases mix. The apparatus is put into diffused daylight for a day, then in sunlight. The green colour of the chlorine will now have disappeared. The long end is immersed in mercury and the stopper removed. *No mercury enters. Therefore the volume of gas is unchanged.* The end is now raised into water standing on top of the mercury. The water enters to dissolve the hydrochloric acid gas. It will be found that some hydrogen is left and the volume which disappeared is the

FIG. 106.

same as the volume of the chlorine.

∴ 1 vol. hydrogen + 1 vol. chlorine = 2 vols. hydrogen chloride, a result which we shall use later.

### Chlorine's Relations.

The first member of the family is a pale yellow gas called fluorine, F (at. wt. 19). It reacts with nearly all other elements, and for this reason was very difficult to isolate, a feat first accomplished by Henri Moissan in 1886. Its most important compound is hydrofluoric acid, already dealt with on p. 116.

Chlorine is the second member of this family. The third member is a dangerous dark red liquid called bromine, Br (at. wt. 80). It is used in making complex compounds in the dye industry, and in the preparation of 'ethyl' petrol. Some of its simpler compounds, e.g. potassium bromide, KBr, are used in photography, and in medicine to produce sleep.

The fourth member, iodine, I, you already know in the form of black crystalline plates. It is obtained from sodium iodate,  $\text{NaIO}_3$ , which occurs mixed with Chile nitre and also from the ash of seaweed.

Iodine is an essential constituent of human diet. A compound of it occurs in the thyroid glands of the neck. A deficiency of iodine or defective thyroid glands cause loss of energy in the adult and stunted growth and development in the young. Iodine, potassium iodide, and alcohol, form **tincture of iodine**, used as an antiseptic for cuts.

When iodine is heated in a test-tube, it quickly passes through the liquid state to form violet vapours which again condense to form the black shiny crystals. Iodine dissolves only slightly in water, but dissolves readily if a crystal of potassium iodide is added.

*Experiment.* Shake a little starch in a test-tube with water. Add this to a beaker of boiling water and continue the boiling for a few minutes. Allow to cool. Pour a little of this 'starch solution' into a test-tube containing (a) potassium iodide solution, (b) potassium iodide and iodine solution.

Nothing happens in (a), but a blue colour appears in (b). *Free iodine gives a blue colour with starch.* The fact is useful as a test for iodine or starch. The blue colour disappears on heating but returns on cooling.

*Experiment (Demonstration).* Grind a little iodine with strong ammonia in a mortar. A black paste is formed. Filter. Break up the filter paper into several pieces, each bearing a little of the paste. Allow these to dry on a radiator *some distance away from spectators.* Loud explosions will soon occur.

The black paste contains nitrogen tri-iodide,  $\text{NI}_3$  (full formula  $\text{NI}_3 \cdot \text{NH}_3$ ). Nitrogen tri-iodide is tame compared with its dangerous relative nitrogen trichloride,  $\text{NCl}_3$ , which cost its discoverer, Dulong, an eye and a badly damaged hand.

The name 'halogen' means *salt-producer*, and is given to the family because all the members form stable salts—fluorides, chlorides, bromides, and iodides.

## CHAPTER XIII

### SULPHUR AND SULPHUR DIOXIDE

#### Occurrence.

SULPHUR occurs (a) in the native state; (b) as sulphides, e.g. iron pyrites,  $\text{FeS}_2$ , galena,  $\text{PbS}$ , cinnabar,  $\text{HgS}$ , etc.; (c) as sulphates, e.g. gypsum,  $\text{CaSO}_4$ ; (d) in organic compounds in eggs, mustard, garlic, onions.

Iron pyrites is sometimes roasted to get sulphur dioxide as a starting point in the manufacture of sulphuric acid,

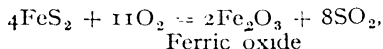

but the sulphur which comes on the market as an element is obtained from rich deposits in Texas, Sicily, and Japan.

The deposits in Texas are about 100 feet thick and situated at depths varying from 400 to 800 feet. Ordinary mining here is impossible because of an overlying bed of quicksand. When this method was tried, the men were either drowned or poisoned by water charged with 'H<sub>2</sub>S' and sulphur dioxide, or else the mine-shaft was squeezed in by the enormous pressure of the quicksand.

The winning of sulphur in Texas

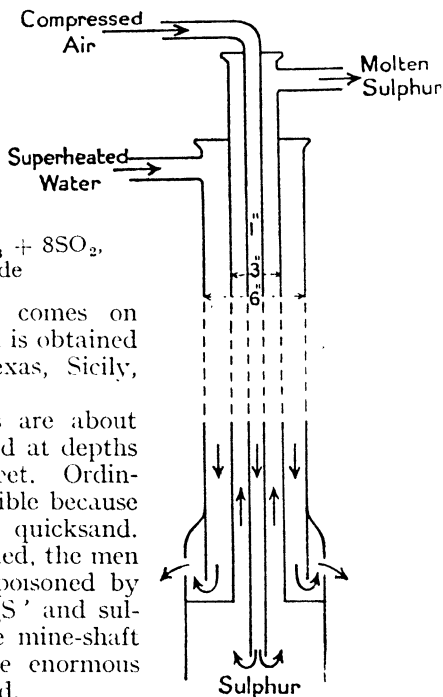
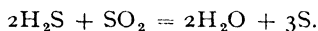

FIG. 107.

dates from 1903, when Hermann Frasch, an American engineer, first made a commercial success of his sulphur pump (Fig. 107).

Sulphur melts at 115° C. Water superheated to 180° C. is sent down a 6-inch pipe. This high temperature is necessary because of the cooling due to the quicksand. Compressed air is sent down a 1-inch pipe. This drives the molten sulphur up the 3-inch pipe. The sulphur flows into an enormous cooling bin or vat 50 feet high and about half the size of a football pitch. When the vat is full and the sulphur solid, the sides of the vat are pulled down and the sulphur is loaded into trucks. This American sulphur needs no purifying.

Sulphur deposits may have originated in two or three ways. When the volcanic gases, hydrogen sulphide and sulphur dioxide, meet, sulphur is deposited.



Another possible explanation is this. Deposits of gypsum have been reduced by carbon to form calcium sulphide.

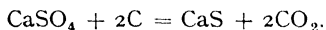

The calcium sulphide is then attacked by water and carbon dioxide.



Now certain *sulphur bacteria* feed on 'H<sub>2</sub>S,' retaining the sulphur in their bodies. When they die the sulphur is deposited.

### Uses of Sulphur.

The chief use of sulphur is to make sulphur dioxide. This gas can be used for bleaching, disinfecting rooms, and as a starting point in the manufacture of sulphuric acid.

Raw rubber is heated with sulphur to destroy its natural stickiness and to make it withstand temperature changes without losing its elasticity. This process is *vulcanization*. A little sulphur makes ordinary soft rubber, higher proportions produce vulcanite and ebonite.

Sulphur also plays a part in the making of gun-powder and matches.

Finely ground sulphur is used as a fungicide in vineyards and hop gardens. Mixed with lard it is used as an ointment for

the ringworm fungus and other skin affections. Internally it is used as a laxative, for skin diseases, and for rheumatism.

### Properties of Sulphur.

When sulphur is boiled in an iron retort and the vapour passed into a brick chamber, **flowers of sulphur** form on the walls. If the chamber is allowed to get hot, the sulphur melts and may be run into cylindrical moulds forming **roll sulphur**.

*Experiment.* Gently heat sulphur in a test-tube. It melts to form an amber-coloured liquid which on further heating goes brown and eventually boils at  $445^{\circ}\text{C}$ . Allow the tube to cool. Shake it and tilt it over a sink. The liquid is fairly *thin* and limpid, but soon it goes *thick* and will not run out. On further cooling it goes *thin* again and finally solidifies.

*Experiment.* Bring some sulphur almost to boiling point, then pour into cold water. **Plastic sulphur** is formed. It is quite safe to chew a little, though it is not particularly pleasurable. Press a little on a coin.

*Experiment.* Shake a little roll sulphur in a test-tube with carbon disulphide (Caution! inflammable). Some of the sulphur dissolves. Pour a little into a watch glass and allow the liquid to evaporate off. The crystals are  $\alpha$ -sulphur, **rhombic sulphur**, or **octahedral sulphur** (Fig. 108).

*Experiment.* Heat some sulphur in a Battersea crucible while stirring with a stick. When all the sulphur has melted, allow to cool. A crust forms from the sides towards the centre. Just before the centre closes, pour out the molten sulphur. Crystals will be left behind. These are  $\beta$ -sulphur, **monoclinic**, or **prismatic sulphur**.

*Experiment.* Add some dilute hydrochloric acid to 'hypo' in a test-tube. Sulphur dioxide comes off and sulphur is precipitated. This is one of several forms of **amorphous** (without form) sulphur.

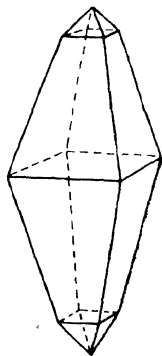
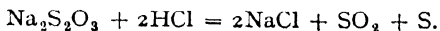

FIG. 108.

### Allotropy.

These four varieties of sulphur, rhombic, prismatic, plastic, and amorphous, are different in appearance, density, and melting point. Also the crystalline forms dissolve in carbon disulphide.

but the non-crystalline forms do not. The rhombic variety is the most stable at ordinary temperatures, and the other three forms, if left, gradually change into tiny rhombic crystals. All four of them are certainly sulphur and sulphur only, for when the same weight of each is burnt, the same weight of sulphur dioxide is formed and nothing else.

When an element is capable of appearing in different disguises in this way, it is said to possess the property of *allotropy* (Gk. *allos*, another, and *tropos*, form). The different forms are called *allotropes* or *allotropic modifications*.

*Allotropy* may be defined as *that property by reason of which*

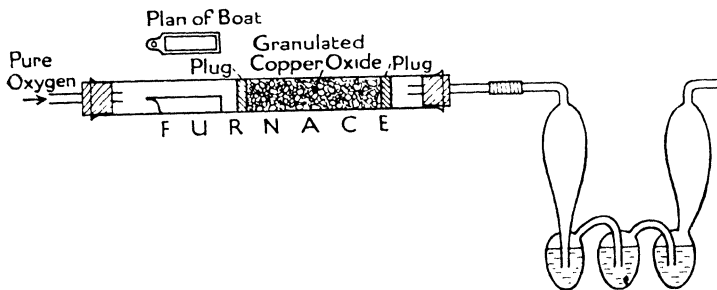

FIG. 109.

*an element may exist in two or more forms which are different physically and often chemically. The different forms are mutually convertible, and when a given weight of each is burnt, they give the same product and the same weight of it and nothing else.*

Roll sulphur and flowers of sulphur are not allotropes. The former consists almost entirely of rhombic sulphur, while the latter is partly rhombic and partly amorphous.

Another element exhibiting allotropy is **carbon**. Thus diamond, graphite, and charcoal differ in appearance, hardness, and density. All three have been shown to be mutually convertible. Diamond has been converted to graphite by heating to a high temperature in absence of air. Henri Moissan dissolved charcoal in molten iron, cooled the mass suddenly, then dissolved the iron with acid. Tiny diamonds were left.

All three have been burnt and the same weight of carbon

jar cover with thread and plasticine. Leave the straw hanging in a jar of the gas for some time, then compare with untreated straw. The bleaching is thought to be due to nascent hydrogen, the sulphurous acid acting as a reducing agent

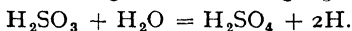

Sulphur dioxide is used in bleaching straw, wool, and silk, which would be damaged by chlorine. The action is quite temporary in the case of straw, the oxygen of the air soon restoring the original yellow colour.

(e) Pass the gas into chlorine water or bromine water. The liquids are decolorized and the solution now contains sulphuric acid and the corresponding halogen acid.

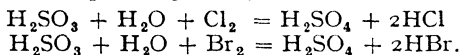

Sulphur dioxide is here a reducing agent.

(f) Pass the gas into solutions of potassium permanganate and potassium dichromate, each acidified with a little dilute sulphuric acid. The former goes colourless and the latter green. Both changes are examples of the reducing action of sulphur dioxide.

(g) Pass the gas into nitric acid. Brown fumes are seen.

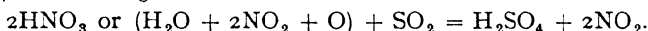

Sulphur dioxide is a reducing agent and nitric acid an oxidizing agent.

(h) Invert a jar of sulphur dioxide over a jar of 'H<sub>2</sub>S' and allow to stand for a short time. Both jars are soon covered with sulphur

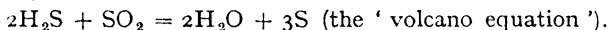

(i) Pile up a deflagrating spoon with lead dioxide, PbO<sub>2</sub>. Immerse in the gas without previous heating. The mass glows and finally leaves a white mass of lead sulphate—a striking example of chemical change:

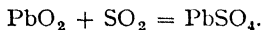

(j) Collect a test-tube of the gas. Add a few drops of sodium hydroxide, close with the thumb and shake. There is a vacuum because the gas, like carbon dioxide, is very soluble in sodium hydroxide and potassium hydroxide.



Just as carbon dioxide forms carbonates and bicarbonates, e.g.

$\text{Na}_2\text{CO}_3$  and  $\text{NaHCO}_3$ , so sulphur dioxide forms sulphites and bisulphites, e.g.  $\text{Na}_2\text{SO}_3$  and  $\text{NaHSO}_3$  (see pp. 104 and 116). When sulphites are treated with dilute acids, sulphur dioxide is liberated.

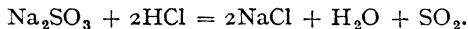

Compare

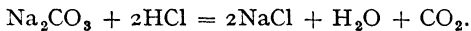

Sulphur dioxide is easily liquefied and often comes on the market in syphons (see p. 77, Fig. 66).

The black mass left in the generating-flask of our last experiment may surprise you. It is not blue, because the excess of concentrated sulphuric acid makes the copper sulphate anhydrous. It is not white, because there is a small quantity of a black substance, cuprous sulphide,  $\text{Cu}_2\text{S}$ , formed. If the contents of the flask are added to water and warmed, a blue liquid is obtained on filtering.

## CHAPTER XIV

### CARBON COMPOUNDS

WE have already made a close acquaintance with the most important compound of carbon, namely, carbon dioxide. We have also met carbohydrates such as cane sugar,  $C_{12}H_{22}O_{11}$ , and starch  $(C_6H_{10}O_5)_n$ .

*A carbohydrate is a substance containing carbon, hydrogen and oxygen, the hydrogen and oxygen being in the same proportions as in water.*

Turpentine, petrol, and candle-wax are *hydrocarbons*, that is, *compounds of hydrogen and carbon only*. Thus turpentine is  $C_{10}H_{16}$ . Petrol and candle-wax are mixtures of several hydrocarbons. We may write them  $C_xH_y$ .

**Methane.** The simplest hydrocarbon of all is one which you may collect for yourself from any stagnant stream. It is only necessary to invert a bottle of water in the stream and stir the decaying vegetation at the bottom (Fig. III). When the bottle is full, the gas may be ignited; it burns with a flame slightly more luminous than that of hydrogen.

The gas is methane or marsh-gas,  $CH_4$ , or written as a structural formula

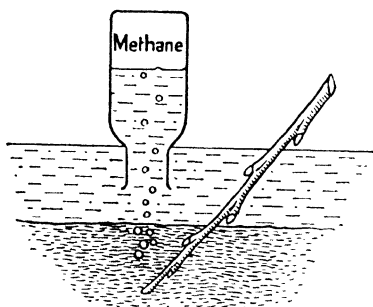
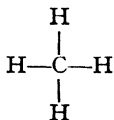
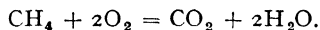

FIG. III.

the carbon atom being quadrivalent. The combustion of the gas is represented thus:



Coal gas contains about a third of its volume of methane.

Since this gas results from the decay of vegetable matter, it often occurs in coal seams as 'fire-damp.' Mixed with air it forms an explosive mixture. When a colliery explosion takes place many of the miners are killed by the resulting 'after-damp,' a mixture of nitrogen, carbon dioxide, and carbon *monoxide*. The last-named gas has already been mentioned on page 37. Its formula is CO, and it results because there is not enough oxygen to burn the methane completely. Carbon monoxide is not merely suffocating like carbon dioxide; it is actually a deadly poison, forming a compound with part of the blood so that this cannot carry on its ordinary work.

Colliery explosions are sometimes caused by fine coal dust, this forming with the air a very explosive mixture. To guard against this, inert stone dust is often thrown down. This is called 'stone-dusting.'

### Carbon Monoxide.

The gas may be prepared by passing carbon dioxide over heated charcoal in an iron tube (Fig. 112). The unused carbon

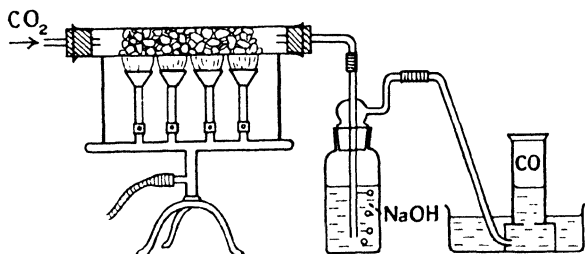

FIG. 112.

dioxide is absorbed by sodium hydroxide in a Drechsel bottle and the carbon monoxide collected over water.



Carbon monoxide does not turn limewater milky, but when the gas is ignited a blue flame passes down the jar, and the resulting gas is carbon dioxide. This carbon monoxide flame is often seen at the top of a coal fire which is burning well. Here also it is a case of carbon dioxide passing through heated charcoal.

Carbon monoxide is prepared in a similar way on a large scale for use in the extraction of **nickel** from its ores.

When air is passed through incandescent coke, we have **producer gas**, which is a mixture of nitrogen and carbon monoxide. It is much used in industry, because a gaseous fuel is so easily controlled.

At the gas-works the chief aim is to turn out a combustible gas, so the coke left in the retorts is partly converted into combustible gas by passing steam through the coke heated to incandescence.



The mixture of carbon monoxide and hydrogen is called **water gas** and is passed into the gasometers with the ordinary gas. It is chiefly the carbon monoxide which makes the present-day gas supply poisonous. Motor-car exhaust fumes also contain carbon monoxide.

Water gas is also manufactured in order to obtain hydrogen on a large scale. One method of separating the two gases is to cool and compress the mixture sufficiently to liquefy the carbon monoxide but not the hydrogen.

Other laboratory methods of making carbon monoxide are to warm formic acid or oxalic acid with strong sulphuric acid. This can be done in a test-tube or on a larger scale with the usual flask fitted with thistle-funnel and delivery-tube.

Formic acid was formerly prepared by squashing ants and distilling the product (Lat. *formica*, an ant). The structural formula of formic acid is

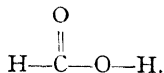

Note that the carbon atom is again quadrivalent. The formula may be written in one line thus,  $\text{H.COOH}$ .

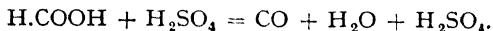

The sulphuric acid takes the elements of water to dilute itself.

The structural formula of oxalic acid is

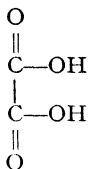

Note that the carbon atom is again quadrivalent. To economize space the formula may be written  $\begin{array}{c} \text{COOH} \\ | \\ \text{COOH} \end{array}$  or  $(\text{COOH})_2$  or  $\text{HOOC.COOH}$ .



When preparing carbon monoxide by this method, the resulting gas is passed through sodium hydroxide solution to remove the carbon dioxide.

In organic chemistry you will meet many compounds having this *COOH* group as part of their molecules. They are always acids.

The carbon atom in carbon monoxide is not exerting its full valency, and the gas is a powerful reducing agent. When passed over metallic oxides, these are reduced to metals and carbon dioxide is formed.

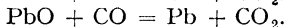

It is used for this purpose in iron smelting.

### Carbonization of Coal.

The destructive distillation of coal described on p. 49 results in gas, ammoniacal liquor, tar, and coke. This process is often called 'carbonization.' This title is quite appropriate when the process is carried out in the smelting industry, for here the object is to make carbon or coke to reduce ores to metals; the gas is a by-product and is used on the spot as a fuel. But 'carbonization' is not a good term for the job of the gas manufacturer, for the production of carbon is not his main object.

The crude gas, as we have seen, contains 'H<sub>2</sub>S.' This is poisonous, and when burnt would give sulphur dioxide which would also be a nuisance. It is got rid of by passing the gas

through ferric oxide,  $\text{Fe}_2\text{O}_3$ . Ferric sulphide,  $\text{Fe}_2\text{S}_3$ , is formed, and this, on exposure to air, gives sulphur and ferric oxide again.

The gas supplied to the consumer contains about 50% hydrogen, 33% methane, and 14% carbon monoxide. The rest is mainly hydrocarbons like acetylene, ethylene, and benzene vapour. Hydrogen and methane are both lighter than air.

Coal gas is not meant to give a very luminous flame because to-day it is nearly always used to make a gas mantle white-hot.

The ammoniacal liquor is converted into ammonium sulphate or other ammonium compounds.

The tar is distilled to get benzol or benzene, naphthalene, carbolic acid, anthracene, etc. Some of these are used in making dyes, antiseptics, motor spirit, and even strange substances like saccharin.

Some time ago a German scientist, Dr. Bergius, worked out a scheme for treating tar and some types of coal with hydrogen at a high pressure with a view to producing motor spirit. This process is called 'hydrogenation.' It is quite successful but cannot yet compete with natural petrol as regards cost.

### Flame.

We have seen in an earlier chapter that combustion may be slow or rapid. Rapid combustion results in flame.

A flame is never quite uniform in appearance; there are well-marked zones generally having the shape of cones. When we used a blowpipe flame on p. 59 we were careful to bring the oxide into the inner or reducing flame. The outer or oxidizing flame would merely burn the charcoal block.

A candle flame is well worth study. There are four zones. At the bottom there is a small *blue* zone, further up a *dark* zone containing unburnt gas. Above this is a *yellow* zone, luminous because of the glowing particles of carbon in it. The presence of this carbon or soot can be shown with a porcelain dish. To see the fourth zone, get a little damp salt on the end of a matchstick and approach the edge of the yellow flame with it. In this *practically invisible* zone, oxidation is complete.

When we close the air-holes of a Bunsen, we get a luminous flame, again caused by glowing carbon particles. When more air is admitted, these burn completely, and we get the ordinary non-luminous hot flame.

It is only on the outside of a flame that oxidation is going on.

Here we have an **area** where gases meet to form new compounds giving out heat during the process. The hollow nature of a flame can easily be shown. We can, in fact, *turn the flame inside out*, like the finger of a glove.

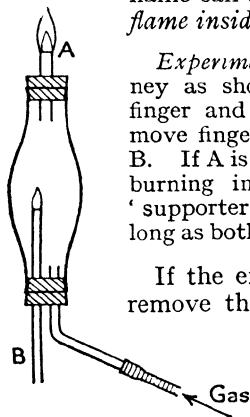

FIG. 113.

*Experiment* (Demonstration). Fit up a lamp chimney as shown in Fig. 113. Close tube A with the finger and drive gas in. Light the gas at B and remove finger from A. The flame passes to the top of B. If A is lighted, we have gas burning in air, and air burning in gas, simultaneously. 'Combustible' and 'supporter of combustion' are only relative terms. As long as both are present 'business' goes on.

If the experiment fails, fit a wider tube at A or remove the top cork, but in the latter case the chimney will soon crack.

*Experiment.* (a) Rapidly depress a piece of paper on to a Bunsen flame. The paper is scorched along a *ring*.

(b) Stick a pin through a match near the head. Place the pin across the Bunsen flame so that the match hangs down the chimney (Fig. 114). Light the burner. Even when the burner is set for a non-luminous flame, the match head will not light for some time.

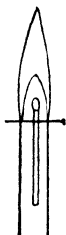

FIG. 114.

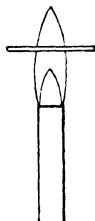

FIG. 115.

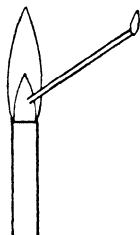

FIG. 116.

(c) Hold a match across the Bunsen flame (Fig. 115). The match burns at two places where it touches the flame surface.

(d) Hold a glass tube slantwise in a candle flame or a Bunsen flame so that the lower end is in the inner zone of the flame (Fig. 116). Inflammable vapours may be ignited at the top of the tube.

All the above experiments show the hollow nature of the flame and that oxidation is only taking place on a *surface*.

Why does the Bunsen flame stay at the top of the tube instead of running down to the jet? Because the gas mixture is traveling up the tube faster or at least as fast as the flame could travel down. If we open the air holes of a Bunsen and diminish the speed of the gas mixture by gradually turning off the gas, the flame then strikes back and burns at the jet. This striking back can be well illustrated with a cocoa 'tin' or any other 'tin' carrying a lid.

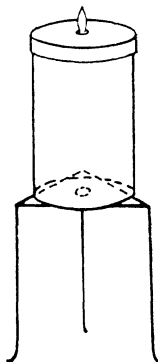

FIG. 117.

*Experiment* (Demonstration). Punch a hole in the bottom of the tin big enough for the rubber gas tube and a rather smaller hole in the lid. Support the tin on a tripod (Fig. 117). Pass gas in at the bottom for about 10 seconds then turn out the gas, remove tube and set a light to the lid hole. Stand back a yard or two and wait. The flame gradually diminishes and air enters at the bottom. An explosive mixture forms and soon the lid is shot into the air. The experiment also illustrates the explosion in an internal combustion engine.

## CHAPTER XV

### GAY-LUSSAC AND AVOGADRO

WE have seen that when gases are compressed at constant temperature, they all obey the same rule called Boyle's Law.

Again, when gases are heated at constant pressure, they all expand at the same rate (Charles's Law).

This uniform behaviour of gases is so very different from the varied behaviour of liquids and solids, that chemists came to the conclusion that there must be some uniform arrangement of the molecules in all gases.

About 1808 Gay-Lussac pointed out that **when gases react together, they do so in volumes which bear a simple ratio to one another, and also to the volume of the product if this is a gas.** This statement is called *Gay-Lussac's Law of Combining Volumes*. Here again there is the suggestion that there must be something simple and uniform about gases.

As illustrations of the Law we may note that

(a) 1 vol. of hydrogen combines with 1 vol. of chlorine to form 2 vols. of hydrogen chloride.

(b) 2 vols. of hydrogen combine with 1 vol. of oxygen to form 2 vols. of steam.

(c) 1 vol. of nitrogen combines with 3 vols. of hydrogen to form 2 vols. of ammonia.

In 1811 an Italian physicist, **Avogadro**, put forward the hypothesis that **equal volumes of all gases at the same temperature and pressure contain the same number of molecules.**

Let us apply this idea to (a).

1 vol. of hydrogen + 1 vol. of chlorine = 2 vols. of hydrogen chloride  
 $n$  mols. of hydrogen +  $n$  mols. of chlorine =  $2n$  mols. of hydrogen chloride

1 mol. of hydrogen + 1 mol. of chlorine = 2 mols. of hydrogen  
chloride

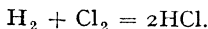

Thus if we regard the molecules of hydrogen and chlorine as containing two atoms each, Gay-Lussac's result fits in quite nicely with the Atomic Theory.

Applying the idea to (b), we have the final result,

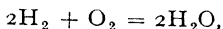

the oxygen molecule being regarded as containing two atoms.

Applying the idea to (c), we shall arrive at

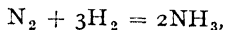

the nitrogen molecule being also regarded as containing two atoms.

For various reasons the importance of Avogadro's Hypothesis was not really appreciated until after his death. In 1858 an Italian chemist, Cannizzaro, showed that Avogadro's Hypothesis could be used in fixing molecular weights and atomic weights.

About this time, too, James Clerk Maxwell (1831-79) and other physicists were working out the Kinetic Theory of Gases. They showed that Boyle's Law, Charles's Law, and Avogadro's Hypothesis all fitted in very well with this theory.

To-day scientists have gone a step further and they are able to tell roughly how many molecules there are in a litre of any gas measured at N.T.P. The number is  $275 \times 10^{20}$  ! We may now therefore drop the word 'hypothesis' and refer in future to Avogadro's **Law**.

### Vapour Density.

The relative density of a solid or liquid is always found by comparing the weight of a known volume with the weight of the same volume of *water*. In dealing with a gas or any substance which has been converted into a vapour, we compare the weight of a known volume with the weight of the same volume of *hydrogen*. But here we must be careful that both volumes are at the same temperature and pressure. This does not, of

course, matter with solids and liquids. Bearing this in mind, we have

$$\begin{aligned} \text{Vapour Density of a substance} &= \frac{\text{weight of a known volume of the vapour}}{\text{weight of the same volume of hydrogen}} \\ &= \frac{\text{weight of } n \text{ molecules of the vapour}}{\text{weight of } n \text{ molecules of hydrogen}} \quad (\text{Avogadro's Law}) \\ &= \frac{\text{weight of 1 molecule of the vapour}}{\text{weight of 1 molecule of hydrogen}} \\ &= \frac{\text{molecular weight of the vapour}}{2} \end{aligned}$$

Thus the Vapour Density is half the molecular weight. If we know the molecular weights we can find the vapour densities, thus—

Gas . . . . .	H <sub>2</sub>	O <sub>2</sub>	CO <sub>2</sub>	H <sub>2</sub> S	NH <sub>3</sub>
Mol. Wt. . . . .	2	32	44	34	17
V.D. . . . .	1	16	22	17	8.5

Now scientists have found by very careful experiment that

**2 gm. of hydrogen occupy 22.4 litres at N.T.P.**

A little thought will convince you that the following statements are true :

22.4 litres of H <sub>2</sub>	measured at N.T.P.	weigh	2 gm
22.4 " "	O <sub>2</sub> " "	" "	32 gm.
22.4 " "	CO <sub>2</sub> " "	" "	44 gm.
22.4 " "	H <sub>2</sub> S " "	" "	34 gm
22.4 " "	NH <sub>3</sub> " "	" "	17 gm.

The numbers on the right are the molecular weights in grams, or the Gram-Molecular-Weight. The number on the left is called the Gram-Molecular-Volume. **The molecular weight in grams of any gas occupies 22.4 litres at N.T.P.**

In other words, the G.M.W. occupies the G.M.V.

## Molecular Weight of Carbon Dioxide.

We may also find the vapour density by experiment, and then use it to determine the molecular weight. Let us consider one simple example. Using the well-known apparatus shown in Fig. 118, we may find the *volume* of carbon dioxide by dis-

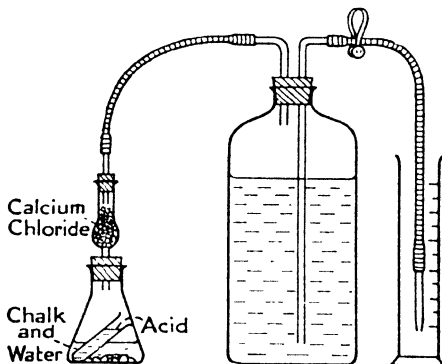

FIG. 118.

placement and the *weight* of the carbon dioxide by finding the loss of weight of the generating apparatus. The calculation is as follows :

Wt. of carbon dioxide	0.63 gm.
Vol. of carbon dioxide at N.T.P.	320 c.c.
0.32 litre of carbon dioxide weighs	0.63 gm.

$$\therefore 22.4 \text{ " " " " " " } \frac{0.63 \times 22.4}{0.32} \text{ gm.}$$

$$\therefore \text{V.D.} = \frac{\text{wt. of 22.4 litres of carbon dioxide}}{\text{wt. of 22.4 litres of hydrogen}} = \frac{0.63 \times 22.4}{0.32} \div 2$$

$$= 22.$$

$$\therefore \text{molecular wt. of carbon dioxide} = 44.$$

Using a hard glass tube containing potassium chlorate, we can find the molecular weight of oxygen in a similar way.

G.S.C.

N

**Formula of Carbon Dioxide.**

Carbon is burnt in oxygen in the apparatus shown in Fig. 119.

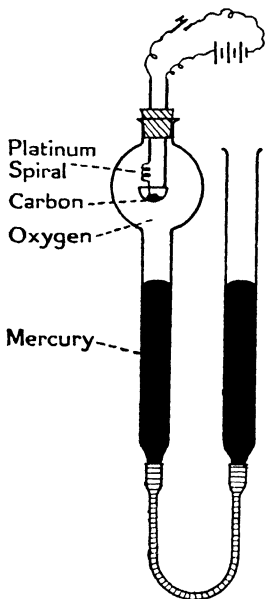

FIG. 119.

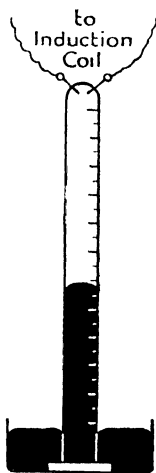

FIG. 120.

On allowing the apparatus to cool, it is found that the carbon dioxide formed has the same volume as the oxygen used.

$\therefore$  Carbon + 1 vol. oxygen = 1 vol. carbon dioxide

$\therefore$  Carbon + 1 mol. oxygen = 1 mol. carbon dioxide

(Avogadro's Law)

$\therefore C_x + O_2 = C_xO_2$

but

$C_xO_2 = 44$  from above

and

$O_2 = 32$

$\therefore C_x = 12$

but C is 12, therefore formula is  $CO_2$ .

The formula of sulphur dioxide can be found with the same apparatus.

*Problem : What volume of oxygen at N.T.P. could be obtained from 10.8 gm. of mercuric oxide ?*

Method :  $2\text{HgO} = 2\text{Hg} + \text{O}_2$   
 $2(200 + 16)$  gm. give 32 gm. or 22.4 litres at N.T.P.  
 432 gm. „ 32 gm. or 22.4 litres at N.T.P.  
 $\therefore$  10.8 gm. „ 0.56 litres or 560 c.c.

*Problem : What volume of hydrogen at 15° C. and 745 mm. can be obtained by dissolving 10 gm. of zinc in dilute hydrochloric acid ?*

Method :  $\text{Zn} + 2\text{HCl} = \text{ZnCl}_2 + \text{H}_2$   
 65 gm. give 22.4 litres at N.T.P.  
 10 gm. „  $\frac{22.4 \times 10}{65}$  litres at N.T.P.

Vol. of hydrogen =  $\frac{22.4 \times 10}{65} \times \frac{288}{273} \times \frac{760}{745} = 3.71$  litres at 15° C. and 745 mm.

*Problem : What weight of marble chips must be dissolved in hydrochloric acid to give 5 litres of carbon dioxide measured at 18° C. and 780 mm. ?*

Method :  $\text{CaCO}_3 + 2\text{HCl} = \text{CaCl}_2 + \text{H}_2\text{O} + \text{CO}_2$   
 $40 + 12 + 48$  give 22.4 litres of gas at N.T.P.  
 100 gm. give 22.4 litres of gas at N.T.P.

Vol. of gas at 18° C. and 780

$$= \frac{22.4}{1} \times \frac{291}{273} \times \frac{760}{780} = 23.3 \text{ litres.}$$

Then 23.3 litres of gas are given by 100 gm. marble

$$\therefore 5 \text{ „ „ „ „ } \frac{100 \times 5}{23.3} \text{ gm. marble} \\ = 21.5 \text{ gm.}$$

*Problem : What volume of oxygen at N.T.P. could be obtained from 49 grams of potassium chlorate ?*

Method :  $2\text{KClO}_3 = 2\text{KCl} + 3\text{O}_2$   
 $2(122.5)$  gm. give  $22.4 \times 3$  litres at N.T.P.

$$\therefore 49 \text{ gm. give } \frac{67.2 \times 49}{245} = 13.4 \text{ litres at N.T.P.}$$

*Problem : 10 c.c. of carbon monoxide are mixed with 30 c.c. of air in a eudiometer (Fig. 120). The tube is held down on a rubber pad in the trough while a spark is passed. What will be the final volume ?*

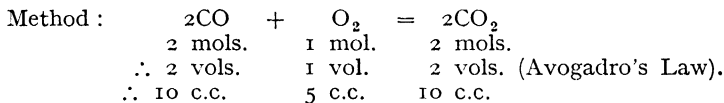

One-fifth of the air is oxygen, i.e. 6 c.c. The gas left will be 24 c.c. nitrogen + 1 c.c. oxygen + 10 c.c. carbon dioxide. Total 35 c.c.

*Problem :* Find the volume of oxygen required to burn 30 c.c. of hydrogen. What would be the volume of the product if all measurements were made at (a) 20° C., (b) 200° C.?

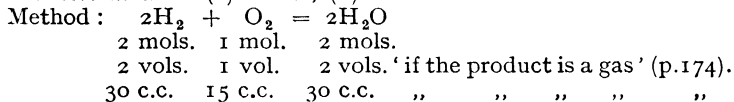

*Ans.* 15 c.c. oxygen, (a) negligible, (b) 30 c.c.

## CHAPTER XVI

### UNCLASSIFIED TOPICS

#### WINNING OF METALS.

**Iron.** The ores used in smelting are the oxides haematite,  $\text{Fe}_2\text{O}_3$ , magnetite,  $\text{Fe}_3\text{O}_4$ , and the carbonate,  $\text{FeCO}_3$ , mixed with clay and other impurities.

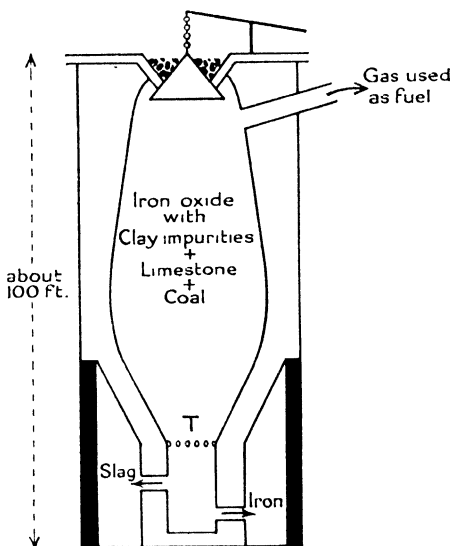

FIG. 121.

The ores are roasted to get rid of moisture and carbon monoxide, then mixed with limestone and coal, and fed into the top of a blast furnace (Fig. 121). A hot-air blast is driven in through

the holes T, and this forms carbon monoxide with some of the coal. The limestone splits into quicklime and carbon dioxide. The latter acts on some of the coal to produce more carbon monoxide. The coal and carbon monoxide reduce the iron oxide to iron, which melts and drops to the bottom. The quicklime unites with the clay to form a molten slag, which forms a layer on top of the molten iron. The gases escaping at the top still contain carbon monoxide, and the gaseous mixture is used to heat the air blast. Periodically the slag and molten iron are drawn off. The slag is sometimes used in mending roads and sometimes in making cement or bricks.

The molten iron runs into sand moulds and is called **pig iron** or **cast iron**. This is the impurest form of iron; it contains up to 4.5% of carbon besides other impurities, but it has the valuable property that it expands on cooling to make well-defined castings. It is therefore re-melted in the foundry and run into sand moulds to make gates, railings, stoves and any article where shape is important but brittleness does not matter.

To make **wrought iron** or **soft iron**, the pig iron is heated with ferric oxide,  $\text{Fe}_2\text{O}_3$ . The oxygen in this changes the carbon and other impurities to oxides, some of which go off as gases, while others form compounds with the iron oxide. These are squeezed out with steam-hammers. Wrought iron is the purest form of iron. It has the property of softening before it melts. In this condition it can still be held with tongs and beaten into various shapes, or two pieces can be welded by hammering them together on an anvil.

**Steel** can be made from wrought iron or from cast iron. The idea is to remove the ordinary impurities and add *definite* quantities of the same or other impurities to produce a steel having special properties. It is a substitution of controlled impurities in place of accidental impurities. Thus *stainless steel* contains about 13% of chromium, while the addition of manganese produces a hard steel.

When steel is made from cast iron, a huge pear-shaped steel vessel lined with lime,  $\text{CaO}$ , and magnesia,  $\text{MgO}$ , is often used. This is called the *Bessemer converter* (Fig. 122). While the vessel is in the horizontal position, about 10 tons of molten cast iron are poured in. An air blast is sent in through the holes, the converter is swung into the vertical position, and the air blast continued. The carbon in the iron is thus oxidized to

carbon monoxide, which burns at the mouth. Other impurities oxidize, then dissolve in the lining to form basic slag, a valuable phosphatic fertilizer. The converter is now swung into the horizontal position, and the necessary substances, carbon (up to 1.5%), manganese, chromium, etc., added. The converter is once more swung into the vertical to ensure proper mixing. It is then tilted again so that the molten steel can run into moulds.

The properties of steel depend very much on **tempering**, which consists of *hardening* and *annealing*. The sample of steel is heated to redness and plunged into cold water. This produces

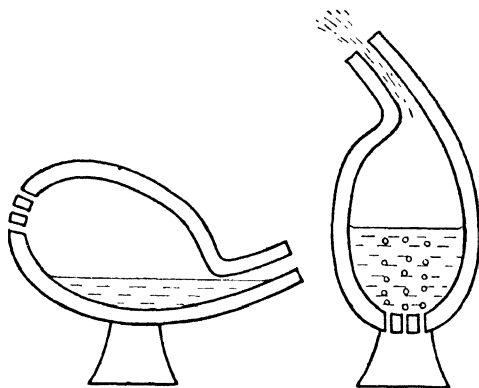

FIG. 122.

steel *hard* enough to scratch glass. The steel is now heated to any definite temperature and allowed to cool gradually. This removes the hardness to an extent depending on the temperature to which it was heated. Thus steel for razor blades is not heated to such a high temperature as steel for chisels. The second heating and cooling is known as *annealing*.

One great disadvantage of iron is the ease with which it rusts. This is prevented in various ways: (a) painting; (b) dipping into molten zinc, which gives 'galvanized iron'; (c) dipping into molten tin—this gives 'tins' and tinsplate; (d) steel fittings on motor-cars are chromium-plated, that is, they are electroplated with copper, then nickel, then chromium.

**Other Metals.**

The winning of tin, zinc, copper, silver, gold, was dealt with on pp. 59, 60, 74, 110.

The winning of lead from galena is a little involved. When the ore is roasted, it is partly converted to lead monoxide, PbO, and partly to sulphate, PbSO<sub>4</sub>.

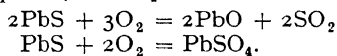

These two then react with unchanged galena to give the metal.

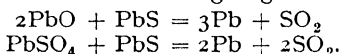
**ALLOYS.**

When metals are melted together, they frequently dissolve one another, forming mixtures called alloys. The different varieties of iron and steel may be regarded as alloys as long as we remember that the element which causes most variation in the properties of the iron is not a metal at all; that element is carbon.

Any classification of alloys is bound to be difficult, but a rough grouping will be given here for reference purposes.

*Light Alloys.*

- (a) Elektron: About 90% Mg, the rest Al, Zn, Mn, Si.  
Specific Gravity 1.82—the lightest alloy known.
- (b) Magnalium: 90% Al, 10% Mg. Specific Gravity 2.5.
- (c) Duralumin: 95.5% Al, 3% Cu, 1% Mn, 0.5% Mg.  
Specific Gravity 2.8.

These alloys are specially useful for airships and aeroplanes.

*Coinage Alloys.*

Gold: Gold and copper in proportions varying according to time and country of issue.

Silver: Silver and copper in varying proportions.

Bronze: Copper, tin, and zinc in varying proportions.

Nickel: Copper and nickel in varying proportions.

*Note: The fact that tin hardens copper was known in the Bronze Age.*

*Low Melting-Point Alloys.*

Rose's Metal: 50% Bi, 27% Pb, 23% Sn. M.P. 94° C.

Wood's Metal: 50% Bi, 27% Pb, 13% Sn, 10% Cd. M.P. 60-70° C.

These alloys are often used as safety devices in case of fire ; the high temperature melts the alloy and releases a supply of water which is sprinkled over the goods.

**Soft Solders :** The melting-point of lead is  $327^{\circ}$  C., the M.P. of tin is  $232^{\circ}$  C. By mixing the two in certain proportions a melting-point as low as  $180^{\circ}$  C. may be obtained. This fact is used in making soft solders. Thus plumber's solder is made by melting together 2 parts of lead and 1 part of tin. The plumber is able to 'wipe joints' with this mixture, for it remains pasty from about  $220^{\circ}$  C. to  $180^{\circ}$  C., whereas either metal by itself would be either definitely liquid or definitely solid, and therefore useless for the purpose. Plumber's solder can be made and studied in the laboratory.

*Experiment.* Melt 40 grams of lead and 20 grams of tin in a Battersea crucible, then remove the burner. Dip a test-tube containing a little mercury into the alloy. If the mercury boils, wait until it does not, then dip a long-range thermometer into the mercury (Fig. 123). Take temperature readings every half-minute. Draw a graph with temperature on the vertical and time on the horizontal. The pasty period will be noticed and on the graph it will be indicated by a portion where the slope becomes more gradual, about  $40^{\circ}$  above the melting-point.

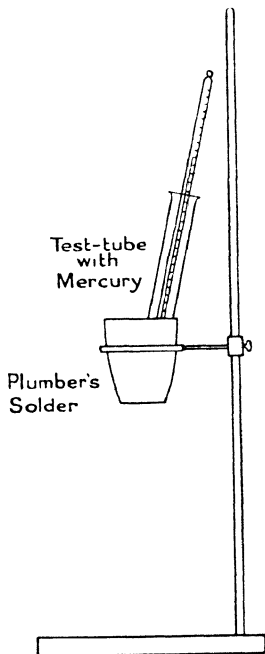

FIG. 123.

#### *Other Alloys.*

**Brasses :** Copper and zinc in various proportions. Brasses are harder than copper, have a fine appearance, and are easily worked.

**Nickel-Iron Alloys :** 36 : 64 is 'Invar,' which has a negligible coefficient of expansion. The 45 : 55 alloy can be sealed into glass like platinum, and is of course much cheaper. *Nichrome,*

used in electric fires, contains nickel, iron, and chromium; it has a high resistance and a high melting-point. *German silver* or *nickel silver* contains copper, zinc, and nickel.

### Rocks.

A rock is a *natural* mass of substance forming part of the earth's crust. Coal, peat, and clay are rocks because they have been formed naturally. The expression 'as hard as a rock' has no meaning in science.

About 5,000 million years ago<sup>1</sup> the Earth was a molten mass split off from the Sun. Gradually the surface cooled to form a crust. Then moisture condensed to form rivers, lakes, and seas. In time the surface rocks were broken up by the action of carbon dioxide and water, expansion, contraction, freezing, thawing, wind, and glacial action. Layer upon layer of sediment was deposited under water to form new rocks—the **sedimentary, aqueous, or stratified rocks** like sandstone, limestone, and a kind of clay called shale. Frequently these layers would be pushed up by internal disturbance and would become dry land. In other places there would be sinking and the deposit of further layers. Occasionally molten rock from within would push its way to the surface, cooling to form the so-called **igneous or fire-formed rocks** like lava, basalt, and granite. These are crystalline in structure, while the sedimentary rocks are formed of amorphous particles.

Some of the rocks originally sedimentary have been much altered by heat and pressure until they have lost their original form and become more or less crystalline. Thus limestone has become marble, while slate is shale hardened and laminated by heat and pressure. Such rocks are called *metamorphic* (Gk. *meta*, change; *morphe*, form).

Chalk, coral, and coal are sedimentary rocks of organic origin. Chalk is a deposit of the skeletons of minute sea animals called foraminifera. Coral is also a deposit of external skeletons of tiny sea animals. Both these rocks are calcium carbonate. Coal is the remains of ancient forests. On a small scale we can

<sup>1</sup> This estimate is based on the fact that the metal uranium gradually changes into helium and lead at a known rate. By finding the proportion of lead in uranium ores we get an approximate figure for the age of the Earth.

see a similar thing going on to-day in a boggy area. When sphagnum moss dies, new moss grows on the top until a thick layer of peat is formed. The lower layers are hard and compact, and may be used as a fuel.

The sedimentary rocks contain fossils. The term 'fossil' is applied to any dug-up trace of a living organism of long ago. It may be the hard parts of the actual organism like shells, skeletons, teeth, or plant-cell walls. It may be that an animal died in the mud, and the body became impregnated with mineral salts, which preserved the form of the body after the actual body had decayed. Frequently the fossil is just an impression left in the mud, which afterwards hardened.

Valuable information can be obtained from fossils. Fossil sea-urchins are sometimes found high up in the hills. This shows that this particular area was at one time under the sea, and was later pushed up to its present altitude by some internal disturbance. By studying the fossils found in different layers at the same place, we often find that the climate must have changed several times in the course of ages.

Biologists say that life on the Earth started with some single-celled organism able to live on air, water, and mineral salts, absorbing energy from the sun by means of chlorophyll. In course of time this gave rise to two types of organism, one having chlorophyll, the other not. These were the first plants and animals respectively. As time went on, these plants and animals changed in various ways to give us the numerous species of plant and animal which we have to-day. Fossil study confirms some of these ideas, especially the idea that birds and mammals were preceded by reptiles, these by amphibians, and these by fishes. Fossil remains of horses have been found in rocks of different ages, and we are able in this way to learn how the modern horse has gradually evolved from ancestors much different in many ways.

## SOIL.

What is the chief industry of any country? Agriculture! We are all dependent upon the soil, since we all eat plants or animals which fed on plants.

The first plants only took root on land when some kind of soil had been formed from the rocks by weathering (action of carbon dioxide, water, temperature, and wind). Even to-day

we can see some lowly plants which do not require very much soil. A lichen will grow on a bare rock. The carbon dioxide formed in its breathing dissolves in water and helps to break up the rock still further. Then mosses get a foothold, and the process goes on till more complex plants find it possible to colonize the spot.

All soils are formed by the breaking up of rocks. We can see the result of this process in railway cuttings, quarries, and other excavations. At the top is the soil, then comes the subsoil with the original rock underneath. The farmer must be careful in ploughing not to bring the subsoil to the top or the field may be spoiled for some years. The soil gradually gets deeper owing to the action of roots and worms. The latter by their burrowing make passages for air and water to get down to the subsoil, which is thus gradually broken up. Worms also eat leaves and other vegetable matter buried in the soil. This vegetable matter is thus reduced to fine particles and expelled in worm casts, and the soil is thereby improved.

A good soil consists of sand, clay, limestone and humus (decayed vegetable and animal matter). There should be enough sand to make the soil porous so that air can get in, enough clay to retain the necessary moisture, enough limestone to neutralize excess acid, and enough humus to supply nitrogen compounds to the plant. Humus also helps to hold water and keeps the soil porous.

Sometimes one constituent predominates, and we have a sandy soil, a clay soil, a limestone soil, or a peat soil. When clay and sand predominate over limestone we have a **loam**. If limestone and clay predominate we have a **marl**. When sand and limestone predominate we have a **calcareous soil**.

The water-holding properties of various soils can be compared by drying, say, 10 grams in a dish in a steam oven, and weighing again. If this is then heated to redness, the humus chars and burns away. In this way the proportion of humus in a soil can be found. If a sample of soil is soaked with rain water or distilled water and the water then poured through a filter and evaporated, there is a residue left of soluble mineral salts. These serve as part of the plant food.

Plants may contain many elements, but only ten are essential—carbon, hydrogen, oxygen, nitrogen, sulphur, potassium, phosphorus, calcium, magnesium, and iron. This can be proved

by water-culture experiments. A solution may be made up as follows :

Calcium nitrate $\text{Ca}(\text{NO}_3)_2$	. . . . .	2.0 gm.
Magnesium sulphate $\text{MgSO}_4, 7\text{H}_2\text{O}$	. . . . .	1.0 gm.
Potassium nitrate $\text{KNO}_3$	. . . . .	0.5 gm.
Potassium hydrogen phosphate $\text{KH}_2\text{PO}_4$	. . . . .	0.5 gm.
Ferric chloride solution	. . . . .	2 drops.
Water . . . . .	. . . . .	4 litres.

A plant is grown in a bottle of this solution, and other samples of the same plant in bottles containing solutions with various things missing. When iron and magnesium are missing, the plant cannot make chlorophyll. The latter is a constituent of chlorophyll.

The last seven of the essential ten elements must be present in the soil associated with the sand, clay, limestone, and humus. Most of these seven elements are returned to the soil as dead plant, dead animal, or waste animal matter. This is why farmyard manure is so important. A serious fault in our method of turning sewage into the sea is that we are in this way constantly robbing the soil of important elements. This is specially serious in the case of one element ; there is not much phosphorus available in the whole world.

### OZONE.

You will probably have noticed a peculiar smell near a Wims-hurst machine and in a bottle containing phosphorus. The smell is caused by the formation of *ozone*, an allotropic modification of oxygen :

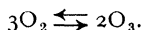

It is not possible to convert a sample of oxygen entirely into ozone, but a sample of ozonized air or ozonized oxygen can be prepared in the laboratory by Brodie's apparatus (Fig. 124). A silent electric discharge is passed through oxygen. The oxygen coming out contains a small percentage of ozone.

Since the ozone molecule is unstable, it is a powerful oxidizing agent. A filter paper soaked in starch and potassium iodide is turned blue by ozone.

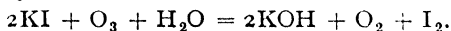

If ozone is passed into mercury, the latter becomes slightly

oxidized even in the cold and the mercury does not run so freely; it is said to 'tail.' When ozone is heated, it changes to ordinary oxygen.

Air is ozonized on a large scale for use in sterilizing the water supply and for purifying the atmosphere in the London Tube

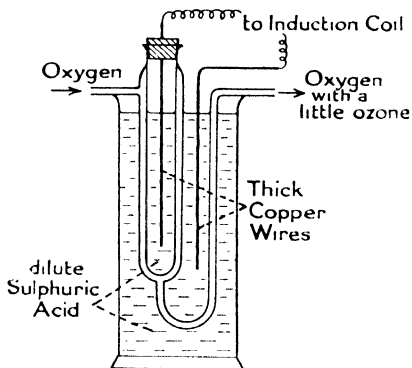
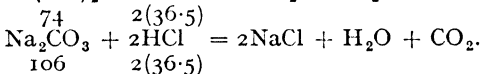
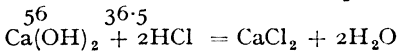
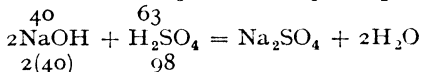
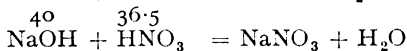

FIG. 124.

Railways. The old idea that sea air contains perceptible quantities of ozone is now treated as a joke; but there is much ozone in the higher layers of the atmosphere.

#### VOLUMETRIC ANALYSIS.

Consider the following well-known equations:



The following definitions will now be readily understood. *The equivalent of an acid is that weight which contains one weight unit*

of *replaceable hydrogen*. Thus the equivalent of hydrochloric acid is 36.5, the equivalent of nitric acid is 63, *but* the equivalent of sulphuric acid is 49. *The equivalent of any substance which reacts with an acid is that weight which reacts with the equivalent of the acid.* Thus the equivalent of sodium hydroxide is 40, the equivalent of potassium hydroxide is 56, *but* the equivalent of calcium hydroxide is 37.

We may state the above results thus, it being understood that the pure substances are used in all cases :

36.5 gm. HCl gas  $\equiv$  63 gm.  $\text{HNO}_3 \equiv$  49 gm.  $\text{H}_2\text{SO}_4 \equiv$  40 gm.  
 NaOH  $\equiv$  56 gm. KOH  $\equiv$  37 gm.  $\text{Ca}(\text{OH})_2 \equiv$  53 gm.  $\text{Na}_2\text{CO}_3$ .

If any of the above gram-equivalents are dissolved in water and made up to 1 litre, the solution is called a **Normal Solution**. Thus 40 grams of sodium hydroxide in 1 litre of solution is called a normal solution of sodium hydroxide and written N. NaOH. If 80 grams were dissolved in 1 litre of solution, we should call it 2N. NaOH. If 4 grams were dissolved in 1 litre of solution, we should have N/10. NaOH or decinormal sodium hydroxide, and so on.

If we have a standard solution of one substance, we can find the strength of any other solution which reacts with it, and the method is called **Volumetric Analysis**. Thus we may prepare pure sodium carbonate by heating sodium bicarbonate.



Then 53 grams of this pure sodium carbonate dissolved in distilled water and made up to 1 litre gives N.  $\text{Na}_2\text{CO}_3$ , and with it we can standardize any acid and indirectly any alkaline solution.

**Note :** Equal volumes of normal solutions are equivalent to one another.

*Problem :* To make a semi-normal solution of sulphuric acid.

Method : Put bench sulphuric acid in a burette and titrate 25 c.c. of the N.  $\text{Na}_2\text{CO}_3$  as on p. 105.

Suppose 8 c.c. of bench acid were needed.

Then 25 c.c. N.  $\text{Na}_2\text{CO}_3 \equiv$  8 c.c. bench acid.

$\therefore$  1,000 c.c. N.  $\text{Na}_2\text{CO}_3 \equiv$  320 c.c. bench acid.

but 1,000 c.c. N.  $\text{Na}_2\text{CO}_3 \equiv$  1,000 c.c. N.  $\text{H}_2\text{SO}_4$

$\therefore$  320 c.c. bench acid  $\equiv$  1,000 c.c. N.  $\text{H}_2\text{SO}_4$ .

Hence to make semi-normal acid we make up 160 c.c. of bench acid to 1 litre with distilled water.

*Question:* Express the strength of the bench acid in terms of normality and in grams of pure acid per litre.

8 c.c. of X.  $\text{H}_2\text{SO}_4 \equiv 25$  c.c. N.  $\text{Na}_2\text{CO}_3 \equiv 25$  c.c. N.  $\text{H}_2\text{SO}_4$

$$\therefore X = \frac{25}{8}N$$

Therefore the acid contains  $\frac{25}{8} \times 49$  gm. pure acid per litre.

Normality 3.13N, gm. per litre 153.

### OXIDES (Revision and Extension).

Oxides are sometimes classified as follows :

<i>Acidic.</i>	<i>Basic.</i>		<i>Metallic Peroxides.</i>	<i>Neutral Oxides.</i>
$\text{P}_2\text{O}_5$			$\text{MnO}_2$	$\text{H}_2\text{O}$
$\text{SO}_2$	<i>Soluble in Water.</i>	<i>Insol. in Water.</i>	$\text{Pb}_3\text{O}_4$	$\text{H}_2\text{O}_2$
$\text{SO}_3$	$\text{Na}_2\text{O}$	$\text{ZnO}$	$\text{PbO}_2$	$\text{CO}$
$\text{CO}_2$	$\text{K}_2\text{O}$	$\text{PbO}$	$\text{BaO}_2$	$\text{NO}$
$\text{SiO}_2$	$\text{CaO}$	$\text{CuO}$		$\text{N}_2\text{O}$
	$\text{MgO}$	$\text{Fe}_2\text{O}_3$		

*Acidic oxides* generally dissolve in water to form acids, and are therefore called 'acid anhydrides.' They *always* dissolve in sodium hydroxide to form sodium salts.

*Metallic Peroxides.* When heated alone or with strong sulphuric acid give oxygen. When heated with strong hydrochloric acid they give chlorine.

*Hydrogen Peroxide.* When barium peroxide is treated with cold dilute sulphuric acid and filtered, a solution of hydrogen peroxide,  $\text{H}_2\text{O}_2$ , is obtained.

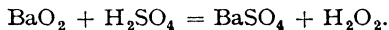

Pure hydrogen peroxide is a syrupy liquid but is difficult to obtain owing to the readiness with which it decomposes.

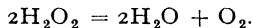

The dilute solution comes on the market labelled '10 vol.' or '20 vol.', which means that the solution will give off 10 times or 20 times its own volume of oxygen when decomposed. The solution is a germicide, therefore makes a good mouth-wash and gargle. It is also used for bleaching delicate fabrics and sometimes human hair.

### Tests for Hydrogen Peroxide.

(a) The solution turns potassium dichromate solution acidified

with sulphuric acid from orange to deep blue. The colour soon disappears but is permanent if ether is added.

(b) The solution decolorizes potassium permanganate solution acidified with sulphuric acid, and oxygen comes off.

(c) A piece of filter paper blackened with lead acetate solution and 'H<sub>2</sub>S' is made white again

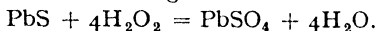

*Lead Dioxide* is easily made by stirring up red lead, Pb<sub>3</sub>O<sub>4</sub>, with dilute nitric acid and filtering. The red lead behaves as if it were a mixture of litharge and brown oxide

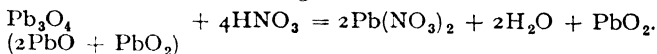

The lead dioxide is left on the filter paper and may be dried.

*Ferric Oxide*, Fe<sub>2</sub>O<sub>3</sub>, can be made by roasting iron pyrites (p. 159) or by heating ferrous sulphate (green vitriol).

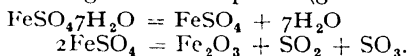

This reaction has historic importance, for it was the first method of making sulphuric acid or 'oil of vitriol.' The sulphur oxides were dissolved in water and the mixture allowed to stand in the air. (Why?)

Ferric oxide is a red powder used as a pigment and in polishing silver, hence the name *jeweller's rouge*. It is the chief constituent of iron rust.

Ferric oxide is not a convenient starting-point in making ferric salts because it only dissolves slowly in acids. Ferrous salts are made by dissolving iron in the appropriate acid, and the ferric salts can then be made by oxidation with a mixture of the same acid plus nitric acid. Thus

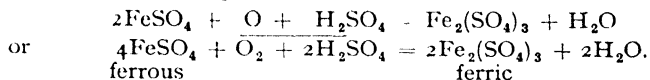

Magnetic oxide of iron, Fe<sub>3</sub>O<sub>4</sub>, is the oxide formed when iron burns in oxygen and when steam is passed over heated iron.

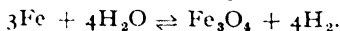

It may be regarded as a compound of the unstable ferrous oxide, FeO, and ferric oxide, Fe<sub>2</sub>O<sub>3</sub>, hence the name ferroso-ferric oxide. When dissolved in acids, it gives a mixture of ferrous and ferric salts.

## QUESTIONS

Draw a labelled drawing when it will save a long description. It is not necessary to label well-known articles like 'Bunsen burner,' 'flask,' 'retort'; these things should speak for themselves. The chief things to label are the contents of vessels and gases going in or coming out. Atomic weights may be found on pp. 90, 91.

1. Describe any experiments you know to prove that air is necessary for ordinary combustion.
2. How would you prove that air has weight?
3. What do you consider the best way of finding out the percentage of oxygen in the air? Describe the method in full.
4. What are the necessary conditions before iron will rust? Describe experiments which prove your statements.
5. How would you prove as conclusively as possible that the air contains oxygen? (O. and C.)
6. How is oxygen usually prepared (a) on a large scale, (b) in the laboratory?
7. The word *oxygen* means 'acid producer.' Support or criticize this name.
8. Describe **two** methods by which hydrogen can be prepared. Give an account of its properties. (O. and C.)
9. Mention all the ways you know for getting hydrogen from water. Describe one method in full.
10. What are the *constituents* of water? Mention the most important *properties* of water.
11. Mention any dangerous chemicals you have met. Say why they are dangerous and give precautions for using them.
12. Explain exactly why an airship or balloon rises. Mention the advantages and disadvantages of hydrogen and helium when used in this way.
13. The word *hydrogen* means 'water producer.' Support or criticize this name as fully as you can.
14. How can it be established that chalk and marble are the same chemical substance? (L.)
15. Give an account of the preparation and properties of carbon dioxide.

How would you prove that the gas obtained by burning carbon is the same as the gas obtained by heating chalk? (O. and C.)

16. Describe the more important properties of the carbonates. How may a carbonate be converted into a bicarbonate, and a bicarbonate into a carbonate? (O. and C.)

17. How does the air exhaled by a man differ from the air inhaled?

18. Describe any one experiment to determine the composition of water by weight. Point out any precautions necessary to ensure an accurate result. (C.W.B.)

19. Describe in detail experiments you may have done, or seen, which illustrate, (a) the reduction of a metallic oxide to the metal, (b) the oxidation of a metal to its oxide.

You may choose any metal and any oxide, but you must state your choice clearly. (J.M.B.)

20. Describe experiments, which you either have seen or have carried out, to ascertain the condition under which iron rusts. How would you change the iron rust back into iron? Sketch the apparatus which you would use. (C.W.B.)

21. Describe a synthetic method of showing that water is composed of hydrogen and oxygen.

Give two methods by which you could show that the substance was water.

22. Describe the principal properties of oxygen gas.

How could you prepare oxygen from some chemical compound? How could you show it was identical with atmospheric oxygen? (O. and C.)

23. By what chemical and physical properties can a liquid be identified as *pure* water?

State the percentage composition of water, (a) by volume, (b) by weight. (L.)

24. Describe carefully how you would determine the volume percentage of oxygen contained in the air of the laboratory. If air is shaken up with distilled water and the dissolved air then expelled by heating, would you expect the expelled air to be richer or poorer in oxygen than it was before? Give your reason. (J.M.B.)

25. Explain fully what is meant by the term 'solution.' Give examples of the use of different solvents of importance in everyday life. (O. and C.)

26. Draw solubility curves from the given data.

Temperature	5° C.	10°	15°	30°	40°	50°	60°	potassium
Solubility .	15 gm.	21	26	43	64	84	110	nitrate

Temperature Solubility .	0° C. 35.6 gm.	10° 35.8	15° 35.9	20° 36.1	30° 36.4	40° 36.6	60° 37.1	80° 38	sodium chloride
--------------------------	-------------------	-------------	-------------	-------------	-------------	-------------	-------------	-----------	-----------------

Temperature Solubility .	0° C. 3 gm.	10° 4	20° 7	30° 9.5	40° 13.5	50° 18	60° 24	80° 40	potassium chlorate
--------------------------	----------------	----------	----------	------------	-------------	-----------	-----------	-----------	--------------------

27. Draw labelled diagrams illustrating the preparation of the three mineral acids (sulphuric, hydrochloric, and nitric).

28. Give all the tests you know which would enable you to distinguish between the mineral acids.

29. Explain the use of chemical equations and state the precautions which must be taken when using them. Illustrate your answer with examples.

30. 'Air is a mixture but water is a chemical compound.' State fully your reasons for accepting the truth of this statement.

How can you prove the presence of dissolved air in tap-water and in what respect does such air differ from atmospheric air ?

(L.)

31. Calculate the percentage composition of water from its formula.

32. The formula of ferric oxide is  $\text{Fe}_2\text{O}_3$ . Calculate its percentage composition.

33. Calculate the percentage of magnesium and of water in Epsom Salt,  $\text{MgSO}_4 \cdot 7\text{H}_2\text{O}$ .

34. What is the percentage of water of crystallization in Glauber's Salt,  $\text{Na}_2\text{SO}_4 \cdot 10\text{H}_2\text{O}$  ?

35. What weight of mercury can be obtained from 70 gm. of red scales ? (Eqn.  $2\text{HgO} = 2\text{Hg} + \text{O}_2$ ).

36. What weight of anhydrous zinc sulphate is formed when 13 gm. of zinc are dissolved in dilute sulphuric acid ?

37. 200 gm. of potassium chlorate are heated. What weight of potassium chloride will be left and what weight of oxygen will be given off ? (Eqn.  $2\text{KClO}_3 = 2\text{KCl} + 3\text{O}_2$ ).

38. 137 gm. of red lead are heated. What weights of litharge and oxygen will be obtained ? (Eqn.  $2\text{Pb}_3\text{O}_4 = 6\text{PbO} + \text{O}_2$ ).

39. An oxide of iron contains 70% of iron. What is its formula ?

40. A compound has the following percentage composition : Fe 36.84%, S 21.05, O 42.11%. Calculate the simplest formula.

41. What is the simplest formula of the compound which contains 26.17% N, 7.48% H, 66.35% Cl ?

42. Write the names and formulae of any twenty compounds you know. Work out their molecular weights.

43. Two grams of an impure limestone gave 1.02 grams of quicklime. What was the percentage purity of the limestone ?

(J M.B., part question.)

44. Explain what is meant by 'water of crystallization.' A hydrated salt was found to contain 20.72% of sodium, 14.41 of sulphur and 64.86 of water. Deduce its formula. (O. and C.)

45. A green crystalline solid is tested and found to be a chloride and to contain copper. 9 grams of it are heated gently and water of crystallization is driven off till a constant weight of 7.10 grams is reached.

If the formula for the substance is  $\text{CuCl}_2 \cdot x\text{H}_2\text{O}$ , calculate the value of  $x$ . (J.M.B.)

46. What is the maximum weight of hydrogen which can be obtained by passing steam over 42 grams of heated iron? (Eqn.  $3\text{Fe} + 4\text{H}_2\text{O} \rightleftharpoons \text{Fe}_3\text{O}_4 + 4\text{H}_2$ ).

47. What weight of iron can be obtained by passing hydrogen over 29 grams of heated magnetic oxide,  $\text{Fe}_3\text{O}_4$ ?

48. What experiments would you make in order to show the changes in chemical composition and weight which take place when chalk is heated? What would be the change in weight on heating 5 grams of chalk? (L.)

49. Explain how you would obtain:

(a) common salt from muddy brine;

(b) hydrogen from cold water;

(c) lead from litharge.

(J.M.B.)

50. Write down, in tabular form, the names and formulae of some common acids and bases. Give three examples in each case. Describe the preparation of a salt, using substances which you have named. (L.)

51. Describe the preparation and properties of calcium oxide. By what experiments may this compound be distinguished from (a) chalk, (b) slaked lime? (O. and C.)

52. Give *two* examples of the formation of a salt by a precipitation process. (J.M.B.)

53. Give an account of some naturally-occurring phenomena in which carbon dioxide is involved. (O. and C.)

54. Explain the terms: efflorescence, double decomposition, sublimation. In each case give one illustrative example. Explain clearly the difference between 'dissolving' and 'melting.'

(J.M.B.)

55. Describe the preparation and properties of nitric acid. What weight of nitric acid could be prepared from one ton of potassium nitrate? (O. and C.)

56. How would you prepare a pure crystalline specimen of ferrous sulphate ( $\text{FeSO}_4 \cdot 7\text{H}_2\text{O}$ ) from iron?

How much ferrous sulphate could be obtained from 42 grams of iron?

57. 13.38 grams of litharge are dissolved in nitric acid. What weight of lead nitrate is formed?

58. What weight of pure nitric acid can be obtained by heating 90.9 grams of saltpetre with strong sulphuric acid?

59. 11.7 grams of common salt are gently heated with strong sulphuric acid. What weight of sodium bisulphate could be obtained?

60. How may hard water be softened on a large scale? To what impurities is this hardness due, and why is it undesirable?  
(O. and C.)

61. Describe the preparation of sulphuretted hydrogen. State its more important properties. What is its chief use in the laboratory?  
(L.)

62. A litre of air is measured under a barometric pressure of 740 mm. What volume will it occupy at a pressure of 760 mm. if the temperature remains constant?

63. 100 c.c. of oxygen are measured at  $100^{\circ}\text{C}$ . What volume will the gas occupy at  $-100^{\circ}\text{C}$ . if the pressure is constant?

64. Convert the following gaseous volumes to volumes at N.T.P.

(a) 450 c.c. at  $8^{\circ}\text{C}$ . and 730 mm.

(b) 146 c.c. at  $10^{\circ}\text{C}$ . and 770 mm.

(c) 700 c.c. at  $19^{\circ}\text{C}$ . and 750 mm.

65. A litre of hydrogen is measured at  $0^{\circ}\text{C}$ . and 760 mm. Find its volume at  $15.5^{\circ}\text{C}$ . and 740 mm.

66. 0.375 gram of zinc on solution in hydrochloric acid gave 135.3 c.c. of hydrogen at  $15^{\circ}\text{C}$ . and 780 mm. pressure. What is the equivalent of zinc?

[1,000 c.c. of hydrogen weigh 0.09 gram at N.T.P.] (O. and C.)

67. 1 gram of metallic wire when dissolved in dilute sulphuric acid yielded 422 c.c. of hydrogen measured dry at  $17^{\circ}\text{C}$ . and 760 mm. pressure. Calculate the gram equivalent of the metal.  
(C.W.B.)

68. When 0.18 gram of a metal was dissolved in hydrochloric acid 250 c.c. of hydrogen measured at  $15^{\circ}\text{C}$ . and 720 mm. were evolved. Calculate the equivalent weight of the metal. What would be the percentage weight of chlorine in the chloride formed in this experiment?  
(J.M.B.)

69. Calculate the equivalent of a metal whose weight is increased by 25% when it is heated to constant weight in oxygen.  
(O. and C.)

70. Explain the terms atomic weight, equivalent weight, and point out the relations between them.

A metallic chloride contains 60% of metal. Calculate the equivalent weight of the metal. (Cl = 35.5) (O. and C.)

71. Use the table on p. 129 to test Dulong and Petit's Law.

72. When 1.68 grams of a metallic powder were heated to constant weight in a current of oxygen, 2.40 grams of oxide were obtained. What was the equivalent weight of the metal?

The specific heat of the metal was 0.11; what was the atomic weight? (O. and C.)

73. Draw a labelled sketch of the Dumas experiment. The tube containing copper oxide weighed 105.6 grams before the experiment and 101.6 grams after. The water-collecting apparatus weighed 80.3 grams before and 84.8 grams after. Calculate the equivalent of oxygen.

74. Two grams of zinc when completely dissolved in hydrochloric acid, liberated 0.062 gram of hydrogen. The same weight of zinc when added to excess of copper sulphate solution, precipitated 1.89 grams of copper. Calculate the equivalent of copper.

(O. and C.)

75. The chloride of a metal contains 73.8% of the metal. Calculate the equivalent of the metal.

76. Water and copper sulphate solution were electrolysed in series. 50 c.c. of hydrogen at 16° C. and 780 mm. were evolved and 0.138 gram of copper was deposited. Calculate the equivalent of copper.

77. What volume of hydrogen at N.T.P. would be obtained by dissolving in hydrochloric acid 2 grams of a metal whose equivalent is 9?

What weight of oxide would be obtainable from 2 grams of the same metal?

78. 1.62 grams of silver were dissolved in nitric acid, to which hydrochloric acid was added until the silver was converted into silver chloride. The latter when washed and dried was found to weigh 2.151 grams. Calculate the equivalent of silver. (Cl = 35.5.)

(O. and C.)

79. What laws govern the weights of substances which combine chemically?

0.15 gram of magnesium, when dissolved in hydrochloric acid, displaces 0.0123 gram of hydrogen. This weight of hydrogen, on burning, yields 0.1104 gram of water and 0.50 gram of magnesium yields 0.828 gram of oxide. Show that these figures are in accordance with one of the laws stated.

(L.)

80. Two oxides of a certain element contain 42.8% and 27.3% of the element respectively and their molecular weights are 28 and 44 respectively. Calculate the probable value of the atomic weight of the element.

(L.)

81.  $a$  grams of cupric oxide give  $b$  grams of copper.

$c$  grams of cuprous oxide give  $d$  grams of copper.

If the Law of Multiple Proportions holds good, what relation must there be between  $a$ ,  $b$ ,  $c$ ,  $d$ ?

82. If two elements A and B can combine in the ratio  $x/y$  to form compound C, or in the ratio  $x/z$  to form compound D, what can be predicted of the ratio  $y/z$ ? Illustrate your answer by reference to any pair of elements. How does this affect your ideas on the nature of matter? (O. and C.)

83. An element forms three compounds with oxygen, the percentages by weight of oxygen being 72.72, 57.14, and 40.00 respectively. Show that these figures agree with the Law of Multiple Proportions. (L.)

84. Two oxides of nitrogen possess the following percentage compositions:

	(1)	(2)
Nitrogen . . . . .	63.64	46.67
Oxygen . . . . .	36.36	53.33

Are these figures in agreement with the Law of Multiple Proportions? (O. and C.)

85. Three oxides of a metal contain respectively 7.20, 9.39 and 13.44% of oxygen. Show by calculation that these figures are in accordance with the Law of Multiple Proportions. (J.M.B.)

86. What is the equivalent weight of copper in (a) cupric oxide, CuO, and (b) cuprous chloride  $\text{Cu}_2\text{Cl}_2$ ? (J.M.B.)

87. An element, of atomic weight 56, is found to have two distinct equivalent weights, viz. 28 and 18.66, both referred to the equivalent weight of oxygen as 8. Deduce the formulae of the oxides, chlorides and sulphates of the element. (C.W.B.)

88. Give as many tests as you can to distinguish between the three mineral acids (a) when concentrated, (b) when dilute.

89. Given copper and strong nitric acid, how would you find the equivalent of copper?

90. Starting with common salt, how could you prepare a quantity of chlorine gas? What is the action of chlorine on (a) water, (b) 'H<sub>2</sub>S,' (c) a cold solution of sodium hydroxide, (d) potassium iodide solution, (e) a hydrocarbon?

91. What is meant by the term allotropy? Describe the preparation of two allotropic forms of sulphur.

Starting from sulphur, how would you obtain fairly pure samples of (a) sulphur dioxide, (b) sulphur trioxide? (C.W.B.)

92. Write down the names and formulae of two gases which possess bleaching properties.

Describe the preparation of one of these gases and account for its bleaching properties. (L.)

93. Write down the names and formulae of two oxides of carbon.

State *briefly* how they are prepared and how they can be distinguished from one another. (L.)

*Note : In the next six questions use the fact that 2 grams of hydrogen occupy 22.4 litres at N.T.P.*

94. 144 grams of steam are passed over heated iron. What volume of hydrogen at N.T.P. will be formed ?

95. What volume of nitric oxide at N.T.P. can be obtained by dissolving 9.54 grams of copper in nitric acid ?

96. What volume of carbon dioxide at 6° C. and 744 mm. will be obtained by dissolving 10 grams of marble in hydrochloric acid ? (Eqn.  $\text{CaCO}_3 + 2\text{HCl} = \text{CaCl}_2 + \text{H}_2\text{O} + \text{CO}_2$ ).

97. How much water must be electrolysed to give a litre of gas at 15° C. and 740 mm. ?

98. What weight of ammonium nitrate is required to give 4 litres of nitrous oxide at 10° C. and 780 mm. ?

99. What volume is occupied by 6.8 grams of ammonia gas at N.T.P. ?

100. What volume of oxygen will be required to burn completely a mixture of 30 c.c. of hydrogen and 20 c.c. of carbon monoxide ? What will be the volume of the product if all measurements are taken (a) at 15° C., (b) at 150° C. ?

101. 100 c.c. of oxygen are exploded with an equal volume of hydrogen. What contraction in volume will there be if all the gases are measured at 20° C. ?

102. Say what you know of the occurrence and winning of the non-ferrous metals.

103. How has soil been formed ?

Of what four main constituents does a good soil consist ? What particular work has each of these to do ? (C.W.B.)

104. 'Equal volumes of normal solutions are equivalent to one another.' Explain and extend this statement, giving examples.

105. How many cubic centimetres of normal hydrochloric acid are necessary to neutralize 32 c.c. of N/5 sodium hydroxide solution ? (J.M.B.)

What is the normality of a solution of sulphuric acid which contains 9.8 grams of the pure acid ( $\text{H}_2\text{SO}_4$ ) in 500 c.c. ? (J.M.B.)

106. Name three methods which are available for the preparation of metallic oxides. Give an example of the use of each method.

What is a *per-oxide*, and by what chemical tests can such an oxide be recognized ? (L.)

107. 1 gram of sodium hydroxide was dissolved in 50 c.c. of normal hydrochloric acid solution. How many c.c. of normal sodium hydroxide solution will be needed to make the solution neutral ? (J.M.B.)

**108.** Give (a) the chief method of preparation with labelled diagram and equation, (b) chief properties with equations, (c) other methods of preparation if possible of any *one* of the following: hydrogen, oxygen, nitrogen, chlorine, hydrochloric acid, nitric acid, sulphuric acid, sulphur dioxide, sulphur trioxide, carbon dioxide, carbon monoxide, ammonia, nitric oxide, nitrous oxide, nitrogen peroxide.

**109.** Write out and translate the equations relating to the preparation and properties of any *one* substance in Question 108.

**110.** A given compound, whose molecular weight is known to be 287, was found to contain 43.9% of water of crystallization. Calculate the number of molecules of water of crystallization in the compound. (L.)

**111.** A tube containing copper turnings weighed 32.4 grams. The tube was heated and hydrogen sulphide passed over the copper. The tube and its contents finally weighed 36.8 grams, and 3.10 litres of hydrogen were collected at N.T.P. Calculate the equivalent of sulphur in hydrogen sulphide. (1 gram of hydrogen occupies 11.2 litres at N.T.P.) (O. and C.)

**112.** A crystalline substance contains 12 molecules of water of crystallization, and the percentage of anhydrous material is 48.32. Find the full molecular weight of the crystalline substance. (L., part question)

**113.** Calculate the percentage purity of a sample of sulphuric acid from the following data: 40 grams of the impure acid were dissolved in water and the solution, after cooling, made up to 1 litre. Of this solution 50 c.c. required for exact neutralization 35.2 c.c. of a solution of caustic soda containing 30 grams per litre. (J.M.B.)

**114.** 1 gram of anhydrous sodium carbonate neutralized 50 c.c. of a solution of sulphuric acid. What was the strength of the acid in grams per litre? (O. and C.)

**115.** Write equations and translate them for the action of heat on the nitrates of lead, copper, potassium, sodium and ammonium.

**116.** A solution of caustic potash contains 9 grams of KOH per litre. What volume of dilute sulphuric acid containing 8 grams of the acid per litre would be required to neutralize 25 c.c. of the caustic potash solution? (L., part question.)

**117.** 100 grams of calcium carbonate is heated until constant weight is obtained. What will be the weight of the residue? What volume of gas at N.T.P. will be evolved? (O. and C.)

**118.** Describe the laboratory preparation of hydrochloric acid. What is the action of hydrochloric acid on ammonia, zinc, manganese dioxide and calcium carbonate? (L.)

**119.** 1,000 c.c. of ozonized oxygen were heated. When the temperature had regained its original value the volume was found

to be 1,025 c.c. Calculate the volume of ozone in the original mixture. (O. and C., part question.)

120. How is pure ammonia made and what is the principal source of commercial ammonia?

Give *three* examples of the uses of ammonium compounds.

(J.M.B.)

# LOGARITHMS

	0	1	2	3	4	5	6	7	8	9	1	2	3	4	5	6	7	8	9
10	0000	0043	0086	0128	0170	0212	0253	0294	0334	0374	4	9	13	17	21	26	30	34	38
11	0414	0453	0492	0531	0569	0607	0645	0682	0719	0755	4	8	12	15	19	23	27	31	35
12	0792	0828	0864	0899	0934	0969	1004	1038	1072	1106	3	7	11	14	18	21	25	28	32
13	1139	1173	1206	1239	1271	1303	1335	1367	1399	1430	3	7	10	13	16	20	23	26	30
14	1461	1492	1523	1553	1584	1614	1644	1673	1703	1732	3	6	9	12	15	18	21	24	28
15	1761	1790	1818	1847	1875	1903	1931	1959	1987	2014	3	6	9	11	14	17	20	23	26
16	2041	2068	2095	2122	2148	2175	2201	2227	2253	2279	3	5	8	11	14	16	19	22	25
17	2304	2330	2355	2380	2405	2430	2455	2480	2504	2529	3	5	8	10	13	15	18	20	23
18	2553	2577	2601	2625	2648	2672	2695	2718	2742	2765	2	5	7	9	12	14	16	18	21
19	2788	2810	2833	2856	2878	2900	2923	2945	2967	2989	2	4	7	9	11	13	16	18	20
20	3010	3032	3054	3075	3096	3118	3139	3160	3181	3201	2	4	6	8	11	13	15	17	19
21	3222	3243	3263	3284	3304	3324	3345	3365	3385	3404	2	4	6	8	10	12	14	16	18
22	3424	3444	3464	3483	3502	3522	3541	3560	3579	3598	2	4	6	8	10	12	14	15	17
23	3617	3636	3655	3674	3692	3711	3729	3747	3766	3784	2	4	6	7	9	11	13	15	17
24	3802	3820	3838	3856	3874	3892	3909	3927	3945	3962	2	4	5	7	9	11	12	14	16
25	3979	3997	4014	4031	4048	4065	4082	4099	4116	4133	2	3	5	7	9	10	12	14	15
26	4150	4166	4183	4200	4216	4232	4249	4265	4281	4298	2	3	5	7	8	10	11	13	15
27	4314	4330	4346	4362	4378	4393	4409	4425	4440	4456	2	3	5	6	8	9	11	13	14
28	4472	4487	4502	4518	4533	4548	4564	4579	4594	4609	2	3	5	6	8	9	11	12	14
29	4624	4639	4654	4669	4683	4698	4713	4728	4742	4757	1	3	4	6	7	9	10	12	13
30	4771	4786	4800	4814	4829	4843	4857	4871	4886	4900	1	3	4	6	7	9	10	11	13
31	4914	4928	4942	4955	4969	4983	4997	5011	5024	5038	1	3	4	6	7	8	10	11	12
32	5051	5065	5079	5092	5105	5119	5132	5145	5159	5172	1	3	4	5	7	8	9	11	12
33	5185	5198	5211	5224	5237	5250	5263	5276	5289	5302	1	3	4	5	6	8	9	10	12
34	5315	5328	5340	5353	5366	5378	5391	5403	5416	5428	1	3	4	5	6	8	9	10	11
35	5441	5453	5465	5478	5490	5502	5514	5527	5539	5551	1	2	4	5	6	7	9	10	11
36	5563	5575	5587	5599	5611	5623	5635	5647	5658	5670	1	2	4	5	6	7	8	10	11
37	5682	5694	5705	5717	5729	5740	5752	5763	5775	5786	1	2	3	5	6	7	8	9	10
38	5798	5809	5821	5832	5843	5855	5866	5877	5888	5899	1	2	3	5	6	7	8	9	10
39	5911	5922	5933	5944	5955	5966	5977	5988	5999	6010	1	2	3	4	5	7	8	9	10
40	6021	6031	6042	6053	6064	6075	6085	6096	6107	6117	1	2	3	4	5	6	8	9	10
41	6128	6138	6149	6160	6170	6180	6191	6201	6212	6222	1	2	3	4	5	6	7	8	9
42	6232	6243	6253	6263	6274	6284	6294	6304	6314	6325	1	2	3	4	5	6	7	8	9
43	6335	6345	6355	6365	6375	6385	6395	6405	6415	6425	1	2	3	4	5	6	7	8	9
44	6435	6444	6454	6464	6474	6484	6493	6503	6513	6522	1	2	3	4	5	6	7	8	9
45	6532	6542	6551	6561	6571	6580	6590	6599	6609	6618	1	2	3	4	5	6	7	8	9
46	6628	6637	6646	6656	6665	6675	6684	6693	6702	6712	1	2	3	4	5	6	7	7	8
47	6721	6730	6739	6749	6758	6767	6776	6785	6794	6803	1	2	3	4	5	5	6	7	8
48	6812	6821	6830	6839	6848	6857	6866	6875	6884	6893	1	2	3	4	4	5	6	7	8
49	6902	6911	6920	6928	6937	6946	6955	6964	6972	6981	1	2	3	4	4	5	6	7	8
50	6990	6998	7007	7016	7024	7033	7042	7050	7059	7067	1	2	3	3	4	5	6	7	8

LOGARITHMS—continued

	0	1	2	3	4	5	6	7	8	9	1	2	3	4	5	6	7	8	9		
51	7076	7084	7093	7101	7110	7118	7126	7135	7143	7152	I	2	3	3	4	4	5	6	7	8	9
52	7100	7108	7117	7125	7133	7141	7149	7157	7165	7173	I	2	2	3	4	4	5	6	7	7	8
53	7243	7251	7259	7267	7275	7284	7292	7300	7308	7316	I	2	2	3	4	4	5	6	6	7	7
54	7324	7332	7340	7348	7356	7364	7372	7380	7388	7396	I	2	2	3	4	4	5	6	6	7	7
55	7404	7412	7419	7427	7435	7443	7451	7459	7466	7474	I	2	2	3	4	4	5	5	6	6	7
56	7482	7490	7497	7505	7513	7520	7528	7536	7543	7551	I	2	2	3	4	4	5	5	6	7	7
57	7559	7566	7574	7582	7589	7597	7604	7612	7619	7627	I	2	2	3	4	4	5	5	6	7	7
58	7634	7642	7649	7657	7664	7672	7679	7686	7694	7701	I	1	2	3	4	4	4	5	6	7	7
59	7709	7716	7723	7731	7738	7745	7752	7760	7767	7774	I	1	2	3	4	4	4	5	6	7	7
60	7782	7789	7796	7803	7810	7818	7825	7832	7839	7846	I	1	2	3	4	4	4	5	6	6	6
61	7853	7860	7868	7875	7882	7889	7896	7903	7910	7917	I	1	2	3	4	4	4	5	6	6	6
62	7924	7931	7938	7945	7952	7959	7966	7973	7980	7987	I	1	2	3	3	3	3	4	5	6	6
63	7993	8000	8007	8014	8021	8028	8035	8041	8048	8055	I	1	2	3	3	3	4	4	5	6	6
64	8062	8069	8075	8082	8089	8096	8102	8109	8116	8122	I	1	2	3	3	3	4	4	5	6	6
65	8129	8136	8142	8149	8156	8162	8169	8176	8182	8189	I	1	2	3	3	3	4	4	5	6	6
66	8195	8202	8209	8215	8222	8228	8235	8241	8248	8254	I	1	2	3	3	3	4	4	5	6	6
67	8261	8267	8274	8280	8287	8293	8299	8306	8312	8319	I	1	2	3	3	3	4	4	5	6	6
68	8325	8331	8338	8344	8351	8357	8363	8370	8376	8382	I	1	2	3	3	3	4	4	5	6	6
69	8388	8395	8401	8407	8414	8420	8426	8432	8439	8445	I	1	2	2	3	3	4	4	5	6	6
70	8451	8457	8463	8470	8476	8482	8488	8494	8500	8506	I	1	2	2	3	3	4	4	5	6	6
71	8513	8519	8525	8531	8537	8543	8549	8555	8561	8567	I	1	2	2	3	3	4	4	5	5	5
72	8573	8579	8585	8591	8597	8603	8609	8615	8621	8627	I	1	2	2	3	3	4	4	5	5	5
73	8633	8639	8645	8651	8657	8663	8669	8675	8681	8686	I	1	2	2	3	3	4	4	5	5	5
74	8692	8698	8704	8710	8716	8722	8727	8733	8739	8745	I	1	2	2	3	3	4	4	5	5	5

75	8751	8756	8762	8768	8774	8779	8785	8791	8797	8802	I	1	2	2	3	3	4	4	5	5	5
76	8808	8814	8820	8825	8831	8837	8842	8848	8854	8859	I	1	2	2	3	3	4	4	5	5	5
77	8865	8871	8876	8882	8887	8893	8899	8904	8910	8915	I	1	2	2	3	3	4	4	5	5	5
78	8921	8927	8932	8938	8943	8949	8954	8960	8965	8971	I	1	2	2	3	3	4	4	5	5	5
79	8976	8982	8987	8993	8998	9004	9009	9015	9020	9025	I	1	2	2	3	3	4	4	5	5	5
80	9031	9036	9042	9047	9053	9058	9063	9069	9074	9079	I	1	2	2	3	3	4	4	5	5	5
81	9085	9090	9096	9101	9106	9112	9117	9122	9128	9133	I	1	2	2	3	3	4	4	5	5	5
82	9138	9143	9149	9154	9159	9165	9170	9175	9180	9186	I	1	2	2	3	3	4	4	5	5	5
83	9191	9196	9201	9206	9212	9217	9222	9227	9232	9238	I	1	2	2	3	3	4	4	5	5	5
84	9243	9248	9253	9258	9263	9269	9274	9279	9284	9289	I	1	2	2	3	3	4	4	5	5	5
85	9294	9299	9304	9309	9315	9320	9325	9330	9335	9340	I	1	2	2	3	3	4	4	5	5	5
86	9345	9350	9355	9360	9365	9370	9375	9380	9385	9390	I	1	2	2	3	3	4	4	5	5	5
87	9395	9400	9405	9410	9415	9420	9425	9430	9435	9440	0	1	2	2	2	2	3	3	4	4	4
88	9445	9450	9455	9460	9465	9469	9474	9479	9484	9489	0	1	2	2	2	2	3	3	4	4	4
89	9494	9499	9504	9509	9513	9518	9523	9528	9533	9538	0	1	2	2	2	2	3	3	4	4	4
90	9542	9547	9552	9557	9562	9566	9571	9576	9581	9586	0	1	2	2	2	2	3	3	4	4	4
91	9590	9595	9600	9605	9609	9614	9619	9624	9628	9633	0	1	2	2	2	2	3	3	4	4	4
92	9638	9643	9647	9652	9657	9661	9666	9671	9675	9680	0	1	2	2	2	2	3	3	4	4	4
93	9685	9689	9694	9699	9703	9708	9713	9717	9722	9727	0	1	2	2	2	2	3	3	4	4	4
94	9731	9736	9741	9745	9750	9754	9759	9763	9768	9773	0	1	2	2	2	2	3	3	4	4	4
95	9777	9782	9786	9791	9795	9800	9805	9809	9814	9818	0	1	2	2	2	2	3	3	4	4	4
96	9823	9827	9832	9836	9841	9845	9850	9854	9859	9863	0	1	2	2	2	2	3	3	4	4	4
97	9868	9872	9877	9881	9886	9890	9894	9899	9903	9908	0	1	2	2	2	2	3	3	4	4	4
98	9912	9917	9921	9926	9930	9934	9939	9943	9948	9952	0	1	2	2	2	2	3	3	4	4	4
99	9956	9961	9965	9969	9974	9978	9983	9987	9991	9996	0	1	2	2	2	2	3	3	4	4	4



## ANSWERS TO NUMERICAL EXAMPLES

- (31) 88.9 % O, 11.1 % H  
 (32) Fe 70 %, O 30 %  
 (33) 9.76 % Mg, 51.22 % H<sub>2</sub>O  
 (34) 55.9 % H<sub>2</sub>O  
 (35) 65 gm.  
 (36) 32 gm.  
 (37) 121.6 gm. KCl, 78.4 gm. O  
 (38) 133.8 gm. PbO, 3.2 gm. O  
 (39) Fe<sub>2</sub>O<sub>3</sub>  
 (40) FeSO<sub>4</sub>  
 (41) NH<sub>4</sub>Cl  
 (43) 91.1 %  
 (44) Na<sub>2</sub>S. 8H<sub>2</sub>O  
 (45) 2  
 (46) 2 gm.  
 (47) 21 gm.  
 (48) 2.2 gm. loss  
 (55) .62 ton  
 (56) 208.5 gm.  
 (57) 19.86 gm.  
 (58) 56.7 gm.  
 (59) 24 gm.  
 (62) 974 c.c.  
 (63) 46.4 c.c.  
 (64) 420 c.c., 143 c.c., 646 c.c.  
 (65) 1.085 litre  
 (66) 31.6  
 (67) 28  
 (68) 9, 80 %  
 (69) 32  
 (70) 53.25
- (72) 18.7, 56  
 (73) 8  
 (74) 30.5  
 (75) 100  
 (76) 31.6  
 (77) 2.47 l., 3.78 gm.  
 (78) 108  
 (80) 12  
 (81)  $\frac{a-b}{b} \cdot \frac{c-d}{d}$  is a simple ratio  
 (86) 31.8, 63.6  
 (87) XO, XCl<sub>2</sub>, XSO<sub>4</sub>, X<sub>2</sub>O<sub>3</sub>,  
           XCl<sub>3</sub>, X<sub>2</sub>(SO<sub>4</sub>)<sub>3</sub>  
 (94) 179.2 l.  
 (95) 2.24 l.  
 (96) 2338 c.c.  
 (97) .49 gm.  
 (98) 14.2 gm.  
 (99) 8.96 l.  
 (100) 25 c.c., 20 c.c., 50 c.c.  
 (101) 150 c.c.  
 (105) 6.4 c.c., .4N  
 (107) 25 c.c.  
 (110) 7  
 (111) 15.0  
 (112) 418  
 (113) 64.7 %  
 (114) 18.5 gm.  
 (116) 24.6 c.c.  
 (117) 56 gm , 22.4 l.  
 (119) 50 c.c.



## INDEX

- Absolute temperature, 96, 123  
Accumulator acid, 79  
Acidic oxide, 17, 113, 192  
Acid radical, 193, 151  
Acid salts, 116 ff.  
Adsorption, 140, 141  
After-damp, 37, 168  
Air, a mixture, 87  
Alkali, 16  
Allotropy, 161 ff.  
Alloys, 185 ff.  
Alums, 120  
Amalgams, 20, 74  
Amethysts, 113  
Ammonia, 80, 138 ff.  
Ammonium, 139 ff.  
Analysis, 17  
Anhydrous, 40, 49  
Anode, 18, 112, 132, 136  
Aqua fortis, 82  
— regia, 83  
Atomic theory, 87, 134  
— weight tables, 90, 91  
*Avogadro*, 91, 174, 175  
Azote, 65
- Bacteria, 142 ff., 155, 160  
Baking powder, 41  
Balance, 3  
Balloons, 27 ff.  
Base, 102  
— Exchange Process, 119  
Basic oxide, 102, 148  
— salts, 121  
— slag, 183  
*Becher and Stahl*, 64  
*Berzelius*, 91  
Bicarbonates, 41  
'Bi' Salts, 41, 116 ff.
- Bleaching, 155, 160, 165  
— powder, 155  
Bluestone, 48  
Boiler scale, 120  
Boyle's Law, 112  
British Oxygen Co., 12  
Bromine, 154, 157  
By-products, 138
- Caesium, 41  
Calcium, 16, 19  
Calx, 8, 62 ff.  
Candle, 2, 4, 154, 167  
Carbohydrates, 52, 167  
Carbon, 16, 162  
— assimilation, 57  
— cycle, 56  
— dioxide (formula), 178  
— monoxide, 37, 168 ff.  
Carbonates, 38  
Carbonization, 170  
Cast iron, 182  
Catalyst, 78  
Caustic soda, manufacture, 112  
*Cavendish, Henry*, 25, 63  
Charles's Law, 123  
Chemical affinity, 58  
— change, 39  
'Chemistry Sets,' 117  
China clay, 56  
Chloride test, 112  
Chlorine, 81, 153 ff.  
— manufacture of, 112, 156  
Chlorophyll, 57, 187  
Chromium plating, 183  
Cinnabar, 159  
Clark's process, 118  
*Claude, Georges*, 12  
Coal, 1, 49, 180

- Coal gas, 49, 171  
 Cod-liver oil, 75  
 Colliery explosions, 37, 168  
 Combining weight, 126  
 Compound, 17, 25, 85  
 Contact process, 78  
 Copper, 4  
   — 'cycle,' 148  
   — equivalent of, 132 ff.  
 Critical temperature, 44, 141, 155  
 Crops, rotation of, 144  
 Crystals, 69, 72  
  
*Dalton, John*, 91, 122, 134  
 Daniell cell, 130  
 Deliquescent, 101  
 Dentists' gas, 142, 146  
 Desiccator, 101  
 Destructive distillation, 50  
 Disinfectants, 155, 160  
 Displacement of metals, 130  
 Dissolved air, 55  
 Double decomposition, 110, 112,  
   118 ff.  
   — salts, 120  
 Drinking water, 145  
*Dulong*, 158  
 Dulong and Petit's Law, 128  
*Dumas*, 91  
 Dumas experiment, 61  
  
 Earth, age of, 186  
 Efflorescent, 40  
 Electro-chemical series, 130  
 Electrode, 18  
 Electrolysis, 18, 132, 136, 156  
 Electrolytic gas, 19  
 Element, 17  
 Emulsions, 74  
 Energy, 53  
 Epsom salt, 72, 101  
 Equivalent, 126, 190  
 Etching, 115  
 Ether (physical), 63  
   — (chemical), 73  
 Eudiometer, 24, 178  
  
*Faraday*, 131  
 Felspar, 56  
 Fermentation, 47  
 Ferrous and ferric, 151, 193  
  
 Fertilizer, 138, 183  
 Filter pump, 3  
 Fire-damp, 168  
 Fire extinguisher, 46  
 Fixation of nitrogen, 144 ff.  
 Flame, 171 ff.  
 Flints, 113  
 Fluorine, 157  
 Flux, 22  
 Formaldehyde, 129  
 Formic acid, 169  
 Fossils, 187  
 Fountain experiment, 81, 140  
 Fungicide, 160  
 Fur of a kettle, 120  
  
 Galena, 159, 184  
 Gas pressure, 96  
 Gaseous diffusion, 96  
*Gay-Lussac*, 91, 174  
 Glass, 114 ff.  
 Glucose, 129  
 Gold, 59, 74, 83  
 Gram-molecular-volume, 176  
 Gram-molecular-weight, 176  
 Granite, 56, 186  
 Grape sugar, 129  
 Gunpowder, 100  
 Gypsum, 159  
  
 Haber process, 145  
 Halogen, 158  
 Hard water, 118 ff.  
   ' Harpic,' 117  
 Helium, 28, 186 n.  
*Hermann Frasch*, 160  
   ' Howlers,' 95, 104  
   ' H<sub>2</sub>S,' 49, 86, 107, 121, 170  
 Humus, 188  
 Hydrocarbons, 167  
 Hydrofluoric acid, 116, 157  
 Hydrogen bubbles, 27  
   — chloride synthesis, 156  
   — peroxide, 192  
 Hydrogenation, 171  
 Hydroxides, 39  
 Hygroscopic, 101  
 Hypo, 71, 76, 104  
  
 Indestructibility of matter, 52  
 Indicators, 106

- Iodides, 104, 146  
 Iodine crystals, 76, 157  
 Iodine (tincture), 73, 157  
 Ions, 136  
 Iron, 4, 6, 21  
 — pyrites, 159  
 — smelting, 181 ff.  
  
 Jeweller's rouge, 193  
  
 Kathode, 18, 112, 132  
 Kinetic theory, 96, 175  
*Kipp*, 32, 108  
  
 Laughing gas, 146  
*Lavoisier*, 64 ff.  
 Law of Avogadro, 174  
 — — Boyle, 112  
 — — Combining Weights or Reciprocal Proportions, 126  
 — — Constant or Definite Proportions, 84  
 — — Dalton, Charles and Gay-Lussac, 123  
 — — Dulong and Petit, 128  
 — — Electrolysis (Faraday), 131  
 — — Gay-Lussac, 174  
 — — Indestructibility of matter, 52  
 — — Multiple Proportions, 134  
 Lead acetate, 49, 107  
 — dioxide, 156, 165, 193  
 Lichens, 15, 188  
 Liebig condenser, 52, 68  
 Light energy, 57  
 Limewater, 16  
 Liquid Air, 11, 87  
 Liquor Ammoniae Fortis, 130  
 Lithium, 41  
 Litmus, 15  
 Loam, 188  
*Lothar Meyer*, 128  
  
 Mackintosh, 74  
 Magnesium, 2, 3, 16, 20, 127  
 Magnetic oxide of iron, 193  
 Manganese dioxide, 15, 153  
 Marl, 188  
 Matches, 163  
*Maxwell, J. C.*, 175  
*Mendelejeff*, 128  
  
 Mercury, 59  
 — calx, 8, 65  
 — equivalent of, 135  
 Metallic peroxides, 156  
 Metals and non-metals, 17, 102  
 Methane, 167  
 Methylated spirit, 73  
 Methyl orange, 105, 106  
 Mica, 56  
 Milk, 74  
 Mixture, 25, 85  
*Moissan*, 157, 162  
 Molecular weight, 92, 176 ff.  
 Molecule, 88  
*Morley, E. W.*, 61  
 Mortar, 104  
*Moseley, H. G. J.*, 128  
 'Moth balls,' 76  
 Multiple Proportions, 134  
 Muriatic acid, 81  
  
 Nascent hydrogen, 165  
 — oxygen, 155  
 Native state, 59  
 Nessler's solution, 146  
*Newlands*, 128  
 Nickel, 29, 169  
 Nickel-iron accumulator, 131  
 Nitrate test, 148  
 Nitric acid, 27, 82  
 — oxide, 146  
 Nitrogen, 8, 150  
 — cycle, 142 ff.  
 — peroxide, 147, 149  
 — tri-iodide, 158  
 — trioxide, 149  
 Nitrous oxide, 146  
 Normal solution, 191  
 'Novox,' 47  
 N.T.P., 123  
  
 Opals, 113  
 Organic chemistry, 129, 170  
 Osmosis, 97  
 Oxalic acid, 169  
 Oxidation, 8, 135, 136, 152, 155  
 Oxide, 17, 192  
 Oxidizing agent, 146  
 'Oxygen mixture,' 15  
 Ozone, 189

- Paint and varnish, 72  
 Periodic classification, 128  
 Permanent hardness, 118  
 Permanganate of potash, 156, 165  
 Permutite, 119  
 Petrol, 69, 167  
 Phenolphthalein, 106  
 Philosopher's wool, 38, 63  
 Phlogiston, 62  
 Phosphorus, 2 ff., 15, 163, 183, 188  
 Photography, 157  
 Photosynthesis, 53  
 Physical change, 39  
 Plant colonization, 188  
 — life, 53, 56, 188  
 Platinized asbestos, 77  
 Platinum, 83  
 Potash, 42  
 — bulbs, 163  
 Potassium, 41  
 — bromide, 157  
 — chlorate, 15  
*Priestley*, 62  
 Producer gas, 169  
 Protein, 142  
 'Proto' apparatus, 37  
 Protoplasm, 142  
 Puncture solution, 74  
 Pyrogallol, 9, 37  
 Pyrolusite, 15  
  
 Qualitative work, 85  
 Quantitative work, 85  
 Quartz, 56, 113  
 Quicklime, 30 ff.  
  
 Radical, 103, 151  
 Red lead, 58, 155, 196  
 Reduction, 58 ff., 135, 136, 165  
 Refrigeration, 141  
 Respiration, 54  
 Reversible reaction, 119  
 Ring test, 148  
 Rocks, 186  
 Rouge, 193  
 Rubidium, 41  
 Rusting of iron, 4 ff.  
  
*Sabatier*, 29  
 Sal ammoniac, 75, 81, 138 ff.  
 Salicornia, 42  
 Saltpetre, 100  
  
 Sal volatile, 142  
 Sand, 113  
*Scheele*, 62, 100  
 Silica garden, 112  
 Silicon, 113 ff.  
 Silver, 59  
 Soap, 75, 119  
 Soda lime, 4  
 — water, 43  
 Sodium, 16  
 — amalgam, 19  
 — hypochlorite, 155  
 — permutite, 119  
 Soil, 187  
 Soldering, 22, 185  
 Solubility, 69  
 Solute and solvent, 67  
 Solvents, 73  
 Sparklet, 46  
 Sphagnum moss, 187  
 Spirit, 50, 82  
 — of salt, 22  
 Stainless steel, 182  
 Stalactite, 118  
 Stalagmite, 118  
 Starch, 51, 52, 129, 167  
 — 'solution,' 157  
 Stomata, 55  
 'Stone-dusting,' 168  
 S.T.P., 123  
 Structural formulae, 151  
 Sublimation, 75  
 Sugar, 51, 52, 56, 167  
 Sulphate test, 111  
 Sulphides, 109  
 Sulphites, 104  
 Sulphur, 16, 159 ff.  
 — compounds, 49, 159 ff.  
 — dioxide (formula), 178  
 Sulphuric acid, 25, 77 ff.  
 Supersaturated solution, 71  
 Synthesis, 17, 156  
 Synthetic ammonia, 145  
 Syphon (soda), 43  
 — (SO<sub>2</sub>), 77  
  
 Tar, 49, 50, 171  
 Temporary hardness, 118  
 Thilorier's mixture, 45  
 Thyroid glands, 157  
 Tin, 59

- Titration, 105  
Turpentine, 72, 154, 167  
Typhoid, 155
- Ultra-violet radiation, 114, 115  
Uranium, 186 n.
- Valency, 127, 150 ff.  
— table, 151  
Vapour density, 175  
Verdigris, 38, 121  
Vita glass, 115  
Vitriol, 49, 193  
Voltmeter, 18, 131, 132  
Volumetric analysis, 190  
Vulcanization, 160
- Washing soda, 40  
Water, composition by volume, 18,  
24
- Water, composition by weight, 62  
— formula of, 88 ff.  
— gas, 169  
— glass, 112  
— of crystallization, 40, 48  
— supply disinfecting, 155, 190  
— tests for, 24  
— vapour in air, 10  
Weathering of rocks, 56  
White lead, 121  
Winning of metals, 59, 74, 110, 131,  
169, 181 ff.  
Wood, 1, 49  
— spirit, 50  
Woulfe's bottle, 133
- Yeast, 47
- Zinc, 22, 26, 63













