

UNIVERSAL
LIBRARY

OU_158339

UNIVERSAL
LIBRARY

THE
ENERGY CHART

*PRACTICAL APPLICATIONS TO
RECIPROCATING STEAM-ENGINES*

BY

CAPTAIN H. RIALL SANKEY, R.E. (*ret.*)

Member of the Institution of Civil Engineers,
Member of the Institution of Mechanical Engineers,
etc.

RUGBY:

ALBERT FROST AND SONS,
WARWICK STREET.

1905

**ALBERT FROST AND SONS,
PRINTERS,
RUGBY.**

PREFACE.

THE preparation of this book was begun about nine years ago, but it is only recently that the Author has had time to complete it for the press. As the title implies, the scope of the book is confined to the application of the energy chart to reciprocating steam engines, and special attention has been paid to the explanation of practical methods. It is true that in Chapter II. the thermodynamics of a perfect gas are explained in an elementary manner by means of the chart, but this is done as an introduction to its application to the steam engine.

The energy chart for a steam engine is drawn for 1 lb. of H_2O , the chemical symbol being used to express the fact that in a steam engine a mixture of steam and water is in reality the working fluid; the word steam is thus used in the sense of dry saturated or else superheated steam; strictly therefore its use should be limited to reversible cycles in which the weight of the substance is constant, but by the use of the "quality line," a conception described for the first time in this book, the chart can be used for any weight of H_2O desired. Little progress can be made with the practical application of the chart without this conception, combined with the convention that, except during expansion, the chart shall only represent the pressure, temperature, and volume, but not the heat (*i.e.*, the entropy), for the reason that in an actual engine the weight of H_2O is constantly varying, except during expansion and compression, and then only if there are no leaks.

In Chapters X. and XI. a method of designing the cylinders and obtaining the economy of an engine by means of the energy chart is developed, and this the Author believes will be found superior to the ordinary or $p v$ method. Attention is also called

to the method of obtaining the cylinder ratios, as illustrated by the case of a quadruple expansion marine engine.

It is hoped that the short chapter on the SO_2 engine will prove of interest. This chapter, together with Appendix I., was contributed by Mr. G. P. Mair, to whom the Author owes thanks for revising the proofs, and for making many of the drawings and calculations. He also wishes to express his indebtedness to Mr. C. Hole, who drew most of the figures, to Mr. A. E. Reynolds for revising the calculations, and to Mr. C. H. Wingfield for many valuable hints. The energy chart, Plate I., was drawn in 1893 by Mr. Guy E. Lloyd, under the Author's direction, and was published for the first time in its complete form in Professor Ripper's book on the Steam Engine.

Great pains have been taken to obviate clerical errors, but undoubtedly some must exist, and the Author will be much obliged if any reader who finds such errors, will communicate with him.

The Author has ventured to re-name the chart, and call it the *energy chart*. The name *temperature-entropy chart* strictly applies only when the temperature and entropy alone of the substance at all state points are given. When, however, volume lines are added, work as well as heat is represented by areas on the chart, and it then becomes in reality an energy chart.

H. RIALI SANKEY.

7 DEAN'S YARD,
WESTMINSTER,
September, 1905.

CONTENTS.

CHAPTER I.

	PAGE.
INTRODUCTORY	I
Various Methods of Graphic representation of Thermodynamics — <i>p. v.</i> Method, or Pressure-Volume Method— $\theta \phi$ Method, or Entropy-Temperature Method—Entropy (Thermodynamic Function)—Elementary Principles—Constant Volume Line for a Gas—Constant Pressure Line for a Gas—State-Point.	

CHAPTER II.

THERMODYNAMICS OF A PERFECT GAS EXPRESSED ON AN ENERGY CHART	7
Representation of Internal Energy—Representation of External Work Done—Transformations at Constant Temperature, Heat, Volume and Pressure—Complete Cycle (Illustrated by Stirling Hot Air Engine)—Carnot Cycle—Constant Volume Cycle.	

CHAPTER III.

ENERGY CHART FOR H ₂ O (MIXTURE OF STEAM AND WATER) ..	20
Water Line and Saturation Line—Constant Volume Lines— Constant Pressure Lines—Dryness Fraction Lines—Chart for Superheated Steam—Determination of the Internal Energy at any Point—Representation on the Energy Chart—Scale of Internal Energy—Lines of Equal Internal Energy—Lines of Equal Total Heat.	

CHAPTER IV.

ELEMENTARY THERMODYNAMICS OF H ₂ O EXPRESSED ON THE ENERGY CHART	28
Comparison of $\theta \phi$ and <i>p. v.</i> Diagrams—Representation of External Work, and Heat Changes—Transformations in an Ideal Steam Cylinder—Transformation at Constant Pressure—Adiabatic Expansion—Transformation at Constant Volume—Transfor- mation along any Line—Measurement of External Work Done —Measurement of Heat Supply.	

CHAPTER V.

	PAGE.
APPLICATION TO A RECIPROCATING STEAM ENGINE. PRINCIPLES	41
Comparison of Ideal and Actual Steam Engine Cylinders—Effect of Feed-Water Temperature—Effect of Initial Condensation—Effect of Clearance—Quality Line—Proportional Water Line—Compression Pressure less than Boiler Pressure—Expansion Line with Initial Condensation—Equivalent Weight of Water and Theoretical Re-evaporation Line—Expansion Line with Leaky Admission Valve—Expansion Line with Leaky Exhaust Valve—Expansion Line with Leaky Admission and Exhaust Valves—Expansion Line with Jacket and Leaky Admission Valve—Exhaust Line : Incomplete Expansion—Summary—To Draw the Quality Line Corresponding to any Given Transformation Line—To Draw the Transformation Line for Less than 1lb. of Steam, given the Quality Line—To find the Temperature and Pressure at the end of a given Number of Expansions under Adiabatic Conditions—Determination of Point of Cut-off—Economy of the Rankine Engine—Economy of an Actual Engine—Steam Consumption of an Engine—Mean Pressure of Rankine Engine—Mean Pressure of Actual Engine—Equivalent Feed.	

CHAPTER VI.

$\theta \phi$ DIAGRAMS OF STEAM ENGINES DERIVED FROM THEIR INDICATOR DIAGRAMS	69
Location of Initial Point—Corresponding $\theta \phi$ Engine and Volume Factor—Plotting of the $\theta \phi$ Diagram (Numerical Example)—Energy Retained in Cylinder (" Play " Energy)—Heat Energy per $\theta \phi$ Diagram— $\theta \phi$ Cylinder Feed—Comparison with Rankine Cycle—Location of Losses—Loss due to Throttling—Loss due to Initial Condensation, Leakage and Radiation—Loss due to Incomplete Expansion—Loss due to Throttling through Exhaust Ports—Loss due to Compression and Clearance—Leakage of Admission Valve past Cylinder, direct into the Exhaust—Losses in a Locomotive Cylinder due to Throttling at Admission and at Exhaust—Combining the Forward and Back-end Indicator Diagrams of a Cylinder.	

CHAPTER VII.

$\theta \phi$ DIAGRAM OF A SIMPLE JACKETED ENGINE	84
Plotting the $\theta \phi$ Diagram (Numerical Example)—Heat per $\theta \phi$ Diagram—Comparison with Non-Jacketted Engine and with Rankine Cycle.	

CHAPTER VIII.

$\theta \phi$ DIAGRAMS OF COMPOUND ENGINES	87
Rankine Cycle for Compound Engine (Numerical Example)—Effect of Leak from H.P. Cylinder—Effect of Clearance—Initial Condensation in L.P. Cylinder—Expansion in L.P. Cylinder—Exhaust Line of L.P. Cylinder—Other Assumptions.	

CHAPTER IX.

	PAGE.
COMPOUND ENGINES. TRANSFER OF INDICATOR DIAGRAMS TO THE ENERGY CHART	97
Volume Factor for Each Cylinder.	
Example I.—Compound Condensing Engine (Non-Jacketted).	
Example II.—Compound Condensing Engine.	
Example III.—Jacketted Compound Condensing Engine with Reheater between the Cylinders.	
Example IV.—Compound Condensing Engine, Large Cylinder Ratio, with Reheater.	
Example V.—Triple-Condensing Engine.	
Example VI.—Triple-Condensing Jacketted Engine, with and without Reheater and Jackets.	

CHAPTER X.

USE OF THE ENERGY CHART IN DESIGNING STEAM ENGINES ..	111
Pre-Determination of $\theta \phi$ Diagram—Example, Simple Engine—Sketching in $\theta \phi$ Diagram—Adjustment of Mean Pressure—Effect of Clearance—Results Obtained—Comparisons with Standard—Effect of changing the assumptions made—Change in Admission Line—Effect of Adding a Jacket—Increase in Clearance—Leakage past Admission Valve direct into Exhaust.	

CHAPTER XI.

DESIGN OF COMPOUND STEAM ENGINES	121
Standard of Comparison (Numerical Example)—Sketching $\theta \phi$ Diagrams of proposed Engine—Adjustment of Work Done in the Cylinders—Determination of Ratio of Cylinders—Alteration of Cut-Off in H.P. (to reduce Mean Pressures)—Equalization of Work in the Cylinders—Alteration of Cut-Off to Increase Mean Pressure—Cylinder ratios for a quadruple expansion Marine Engine.	

CHAPTER XII.

SUPERHEATED STEAM	133
Constant Pressure and Constant Volume Lines, with old and new valves of Specific Heat—Internal Energy—Superheating at Constant Pressure—Rankine Cycle for Superheated Steam—Comparison with Saturated Steam Engine Using same range of Pressures— $\theta \phi$ Diagrams of Actual Engines working with Superheated Steam—Example I.: Compound Condensing Engine with Reheater (moderate economy)—Example II.: Compound Condensing Engine with Reheater (very good economy).	

CHAPTER XIII.

	PAGE.
EXPANSION OF STEAM WITHOUT DOING EXTERNAL WORK..	.. 144
Two Numerical Examples—Expansion after formation at Constant Pressure; Superheating by Throttling—Velocity of issuing Steam—Recovery of Motion Energy.	

CHAPTER XIV.

APPLICATION OF THE ENERGY CHART TO OTHER SUBSTANCES	.. 150
Chart for Sulphur Dioxide (SO_2)—Principles of Binary Engines—Example of a Combined Steam and SO_2 Engine.	

APPENDIX I.

PLOTTING $\theta \phi$ DIAGRAMS BY MEANS OF THE SLIDE-RULE.	.. 156
---	--------

APPENDIX II.

USEFUL FORMULAE IN CONNECTION WITH THE ENERGY CHART FOR H_2O , ILLUSTRATED BY MEANS OF NUMERICAL EXAMPLES	157
---	-----

BIBLIOGRAPHY. 165
---------------	-------------

SPECIAL TERMS.

REFERENCES TO THOSE USED IN THIS BOOK 166
---------------------------------------	-------------

THE ENERGY CHART

PRACTICAL APPLICATION TO RECIPROCATING STEAM ENGINES.

CHAPTER I.

INTRODUCTORY.

OF late years it has become more and more the custom to use a graphic method in making thermodynamic investigations in connection with heat engines, and this method has many advantages over the purely algebraical.

In dealing with the thermodynamic relations of a substance it is necessary, in order to define the state of the substance, to consider the temperature and pressure as well as the volume occupied for a given weight; and in the case of a transformation of the substance from one state to another the quantity of heat to be added or subtracted, and also the work that has to be done either by or on the substance, have to be determined.

The graphic representation should therefore exhibit in a convenient manner all the above particulars.

Several methods were described by Willard Gibbs in 1872, but for practical use there are two of these methods which offer special advantages. The first is that in conformity with which the indicator diagrams of an engine are drawn, and in which the pressures are taken as ordinates and the volumes as abscissae; the temperature of the substance could be exhibited by a series of curves, and heat and work by areas; this is the pressure-volume or " $p v$ " method. In the second method the temperature of the substance is taken as the ordinate, and for the abscissa a certain function of the heat supply known as "entropy" is plotted.

It was Clausius who gave the name of "entropy" to this function, and it is usually denoted by ϕ . Rankine, however, called it the "thermodynamic function." Maxwell denoted absolute temperature by θ , and J. McFarlane Gray, who was the first* to introduce the method into this country gave the name of $\theta \phi$ chart to a diagram prepared on these principles. This method is therefore known as the temperature-entropy or $\theta \phi$ method. Pressures and volumes can be exhibited by curves, heat and work by areas, as will presently be shown. A chart so drawn is an *energy chart*, as explained at page 15.

There has been a great deal of discussion as to the precise meaning of the term "entropy," and there appears to be a considerable amount of misconception. Strictly, "change of entropy" is the conception to be considered, and it can only be applied in relation to the state of the substance in one condition to its state in another condition, *when* the change of state is so produced that it could be reversed step by step—or, as it is generally expressed—when the change is reversible. In practical heat engines (either gas or steam) the majority of changes produced in the working substance during the stroke are *not* reversible, and the term "entropy" is therefore not strictly applicable to practical cases. Hence in the practical use of the method, the abscissae of the diagram only represent the changes of entropy of the working substance for certain portions of the stroke, as will be seen in the sequel. It is only by limiting the entropy scale on the $\theta \phi$ chart to certain portions of the cycle of operations, that practical use can be made of the $\theta \phi$ method.

The Author has now for several years past studied the $\theta \phi$ method with a view of applying it practically in the drawing office, not only for designing engines, but also as a means of analysing the indicator diagrams of engines in order to discover the thermodynamical defects that may exist. He is satisfied that the method offers advantages in these directions far exceeding those of the $p v$ method when used alone, and the object of this book is to develop these practical applications.

Elementary Principles.—To commence with a simple case, as is well-known 1 lb. of water at 60° F. requires the addition of one British

* "On the Rationalization of Regnault's Steam Experiments" by J. McFarlane Gray. Paris Meeting of the Institution Mechanical Engineers. 1880.

Thermal Unit to raise its temperature 1° F., in other words the specific heat of water at 60° F. is one B.Th.U. or 778 foot-lbs. (778 is now very generally accepted as Joule's equivalent instead of 772). To represent this fact graphically, let an ordinate of temperature pP (Fig. 1) be measured from absolute zero to represent $461 +$

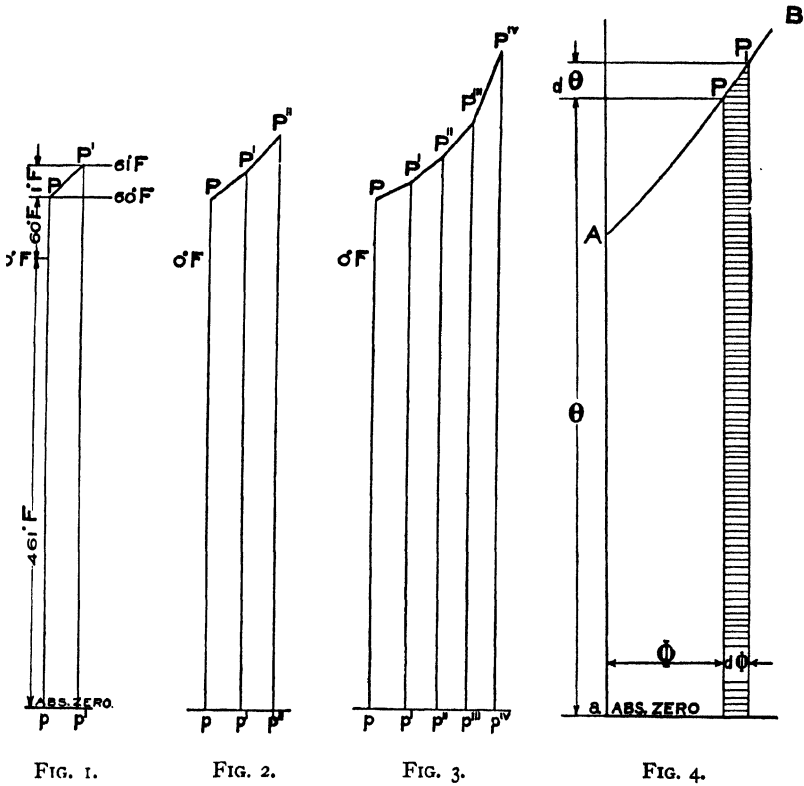

60° F., and let the vertical strip $P'p$ represent one B.Th.U. by its area, then, since the difference in the ordinates at p and p' is one degree,

$$p p' \left(461 + \frac{60 + 61}{2} \right) = 1 \text{ B.Th.U.}$$

$$= 778 \text{ foot-lbs.}$$

If now one more heat unit is added to the lb. of water, the graphic representation would be the strip $p' P''$ (Fig. 2), and since the mean height of this strip is greater than that of the former, obviously

$$p p' > p' p''$$

from which it follows that the inclination of PP' to the axis of x is less than the inclination of $P'P''$. Continuing this process it is clear that the successive additions of one B.Th.U. to the lb. of water can be represented graphically as in Fig. 3.

If instead of the temperature rising one degree at a time the increments were infinitely small, the polygon $P P' P'' \dots P^{iv}$ would become a curve, and it is this curve which has to be found. The assumption will be made that the specific heat of water is constant, which it is not quite, but for practical purposes it can be considered as such.*

Let AB (Fig. 4) be this curve, let θ , the absolute temperature at the point P be taken as the ordinate, and let the "entropy" ϕ be the abscissa of this point measured from some arbitrarily chosen origin. The increment of heat to be added to raise the temperature of the 1 lb. of water $d\theta^\circ$ is $d\theta$ because the specific heat of water is taken as unity, and this increment of heat is represented graphically by the area of the strip below PP^1 , shaded horizontally. This area is equal to $\theta d\phi$.

Hence
$$d\theta = \theta d\phi$$

or
$$d\phi = \frac{d\theta}{\theta} \quad \text{whence } \phi = \log_{\epsilon} \theta + \text{const.}$$

In the case of the so-called perfect gases, the specific heat when the volume is unchanged is practically a constant, at any rate at moderate temperatures, and so likewise is the specific heat for change of condition under a constant pressure. The question of the specific heat of gases at high temperatures is at the present moment *sub judice*. The experiments of Mallard and Le Chatelier seem to prove that the specific heat increases considerably with temperature; but Dugald Clerk asserts that these experiments have been wrongly interpreted. At present the specific heat of atmospheric air at constant volume is taken as 0.168; water being unity.

* See "Variable and absolute specific heats of water," by J. M. McFarlane Gray. Proceedings Institution Civil Engineers. Vol. CXLVII., page 347.

Constant Volume Line for a Gas.—By the reasoning adopted in the case of water, the graphic representation on an energy chart for a gas receiving heat at constant volume is $C_v d\theta = \theta d\phi$, where C_v is the specific heat at constant volume. Hence $\phi = C_v \log_{\epsilon} \theta + \text{const.}$ is the equation to a constant volume line for a gas. To determine the integration constant it is to be noted that the origin has been chosen arbitrarily. It can therefore be assumed that ϕ is zero when the temperature of the substance is θ_1 . In other words θ_1 is the intercept on the axis of Y of the particular constant volume line under consideration; that is the length Aa in Fig. 4.

Hence
$$\phi = C_v \log_{\epsilon} \frac{\theta}{\theta_1}$$

As an example the constant volume line for 7 cubic feet of atmospheric air has been drawn, as shown in Fig. 5, arranging the origin in such a position that:

$$\theta_1 = 215 + 461.$$

To draw this curve, points in the curve

$$\phi = 0.168 \log_{\epsilon} \frac{\theta}{215 + 461}$$

have to be computed and plotted. A constant volume line for any other volume can be similarly drawn, and a chart can be prepared giving a number of such volume lines, as in Fig. 6.

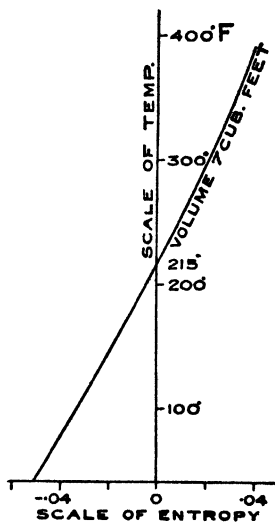

FIG. 5.

Constant Pressure Line for a Gas.—

If the change in the condition of a gas is effected by the addition or subtraction of heat at constant pressure, the change can be followed on an energy chart by means of lines at constant pressure. Such a line will have the same general form as a constant volume line. Thus for atmospheric air the specific heat at constant pressure is 0.238, so that the equation to the constant pressure line for one atmosphere is

$$\phi = 0.238 \log_{\epsilon} \frac{\theta}{\theta_1}$$

THE ENERGY CHART.

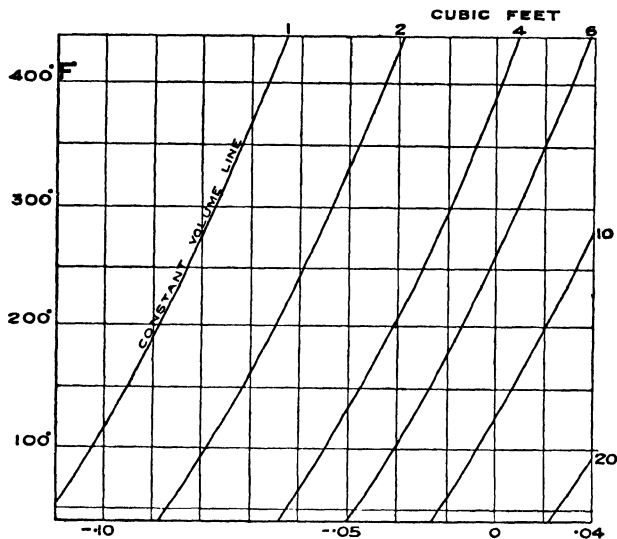

FIG. 6.

A series of constant pressure lines can be drawn, as has been done for atmospheric air in Fig. 7.

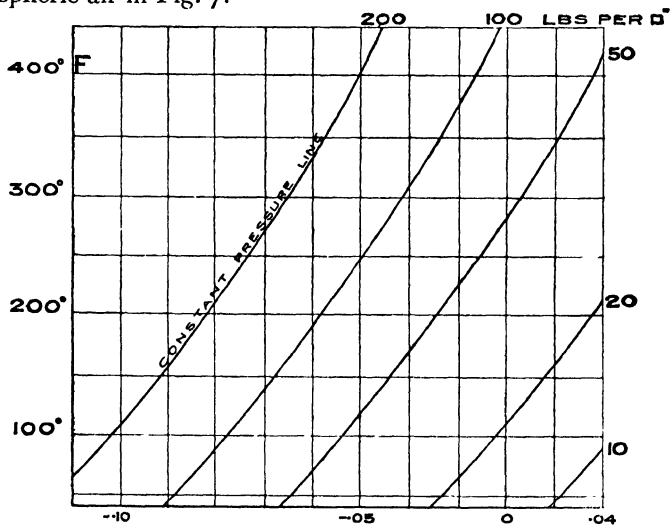

FIG. 7.

Obviously the constant volume and constant pressure lines can be combined together on one chart. Any point on such a chart expresses a definite state of the substance and is called a *state-point*. A continuous succession of state-points is a *transformation line*.

CHAPTER II.

THERMODYNAMICS OF A PERFECT GAS EXHIBITED ON AN ENERGY CHART.

Representation of Internal Energy.—If the change of state in a gas due to the addition of heat is effected at constant volume, no external work is done by the gas. In other words, the whole of the heat added is expended in increasing the internal energy of the gas. In Fig. 8 a constant volume line has been drawn through the state point P , and a transformation at constant volume is effected until the state point Q is reached. The heat it is necessary to supply is represented by the area shaded by vertical lines, and this area also represents the amount by which the internal energy at Q is greater than it is at P . During this transformation the gas is supposed to be contained in a closed vessel of unchangeable volume.

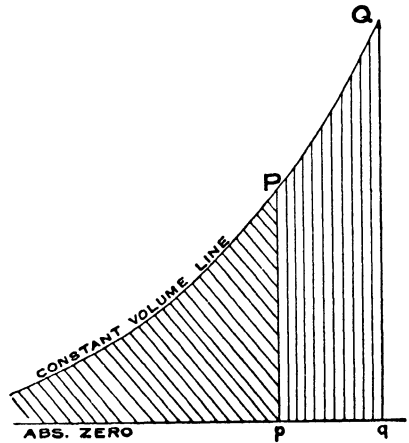

FIG. 8.

Returning to the state-point P , it will be supposed that heat is abstracted from the closed vessel until finally the absolute zero of temperature is reached. During this process the state-point will travel along the constant volume line, and obviously therefore, the area included between the constant volume line through P , the vertical through P , and the horizontal line representing the absolute zero of temperature, an area which is shaded with diagonal lines in Fig. 8, represents the total internal energy of the gas under consideration when in the condition represented by the state-point P . To repeat; the diagonally-shaded area represents the total internal

at Q , and further that the heat supply and the work done are equal. If, however, the gas is not perfect, the specific heat will vary, and the internal energy at P will not be equal to what it is at Q .

Representation of External Work Done.—On referring to Fig. 6, it will be seen that the volume at Q is greater than it is at P , and the external work done by the gas in expanding from P to Q is represented by the vertically-shaded area included between the transformation line at constant temperature, and the two constant volume lines V and V_1 continued to infinity to meet the horizontal line representing absolute zero.

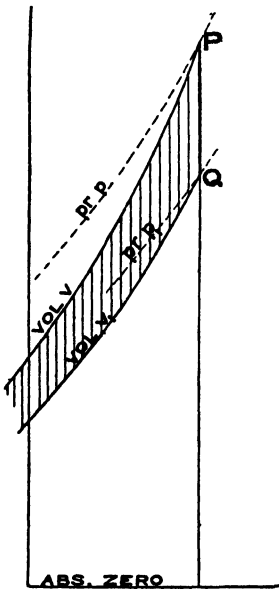

FIG. 11.

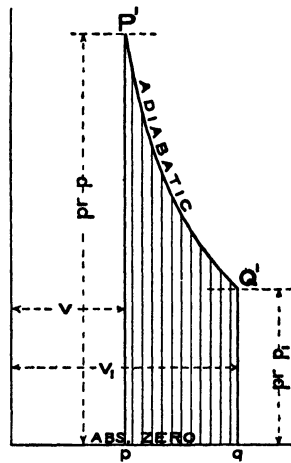

FIG. 12.

Fig. 10 is the $p v$ diagram corresponding to Fig. 9. $P Q$ is here represented by a curve $P Q$ marked "isothermal." The verticals $P p$ and $Q q$ are represented by the adiabatic curves through P and Q , and the constant volume lines V and V_1 , by the verticals $P p$ and $Q q$. The correspondingly shaded areas in the two figures are equal, if the scale of foot-lbs. per square inch employed are the same in both. It is interesting to note that in the $\theta \phi$ diagram

the heat area is bounded by finite lines and the work area by infinite lines. The reverse is the case in the $p v$ diagram.

If the transformation had taken place from Q to P , Fig. 9, it would be necessary to abstract heat represented by the rectangle $P Q p q$, and at the same time to do work in compressing the gas; this work is represented by the area included between the constant volume lines, V and V_1 , and $P Q$.

Figs. 11 and 12 show the case of adiabatic expansion, that is to say, no heat is either added or abstracted. The external work done by

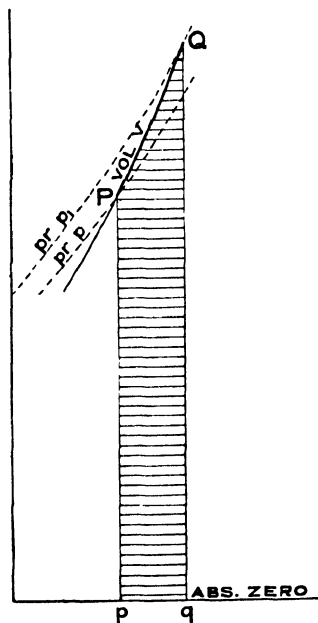

FIG. 13.

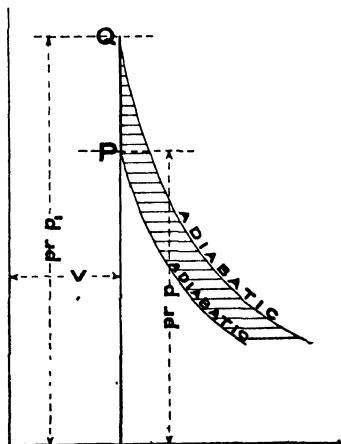

FIG. 14.

the gas is given by the area included between the constant volume lines and is shaded by vertical lines both in Fig. 11 and in Fig. 12, and obviously the internal energy at Q is less than it is at P by the amount of the work done in expanding.

Figs. 13 and 14 show a transformation at constant volume, that is to say, the point Q is situated on the same volume line as P . No external work is done, although the pressure of the gas increases (see Fig. 7) from p to p_1 , but internal work is done equal to the heat added, and is given by the horizontally-shaded area.

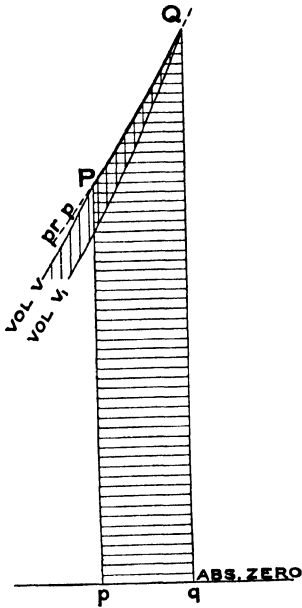

FIG. 15.

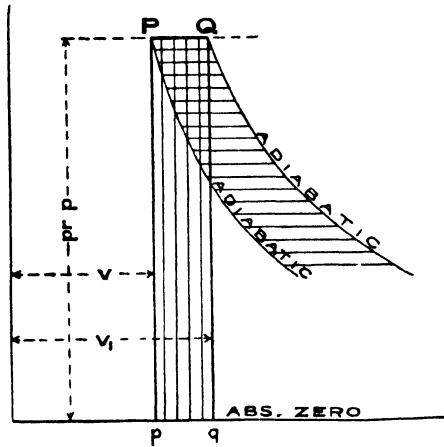

FIG. 16.

Figs. 15 and 16 show a transformation at constant pressure from P to Q . It will be seen that the gas is expanded and therefore does work, and that heat has to be added.

The following transformations have up to the present been shown :—

- (1) At constant temperature, Figs. 9 and 10.
- (2) At constant heat, Figs. 11 and 12.
- (3) At constant volume, Figs. 13 and 14.
- (4) At constant pressure, Figs. 15 and 16.

If through any state-point P (Fig. 17) the constant volume line and the adiabatic be drawn, the heat chart will be divided into four unequal portions or zones, which are marked I., II., III., and IV. If the transformation line lies wholly in I., then, as shown in Fig. 18, work has to be done on the gas to compress it, and at the same

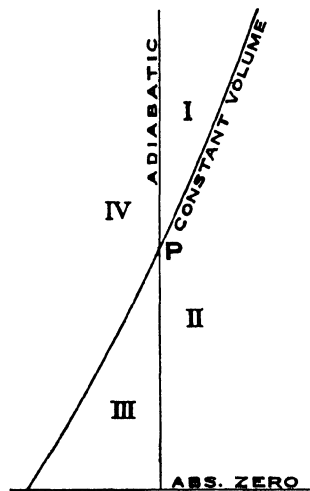

FIG. 17.

time heat has to be supplied, and the addition of this work and heat to the internal energy of the gas at P gives the internal energy of the gas at Q . The amount of heat supplied is shown by the horizontally-shaded area, and the external work done on or by the gas by the vertically-shaded area. This shading of areas has been adopted throughout the book, and applies whether the heat is added or abstracted, or whether the work is done *on* or *by* the gas. Fig. 19 is the $p v$ diagram corresponding to Fig. 18.

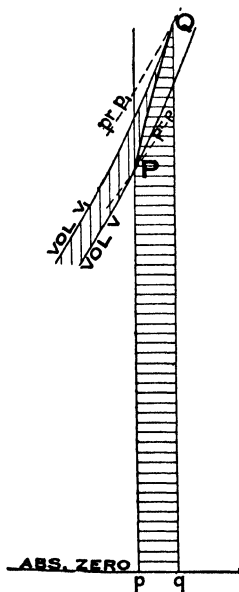

FIG. 18.

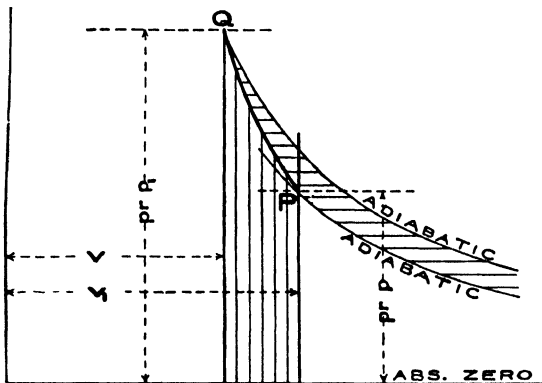

FIG. 19.

If PQ lies in II. (Figs. 20 and 21), heat has to be supplied and work is done *by* the gas. A portion of the heat supplied is, so to speak, *directly converted into work*, as shown by the double shading, and the internal energy at Q is equal to the internal energy at P , less the remainder of the work done by the gas, plus the remainder of the heat.

When PQ lies in III. (Figs. 22 and 23), work is done by the gas and heat has to be removed. The internal energy of the gas at Q is equal to that at P , less the work done and less the heat removed.

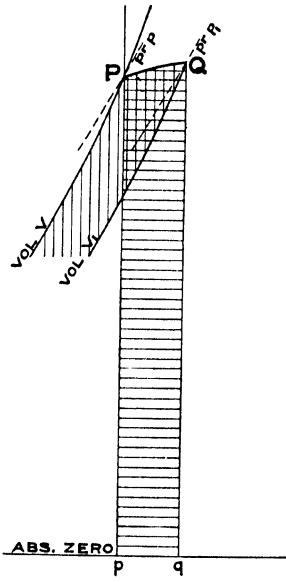

FIG. 20.

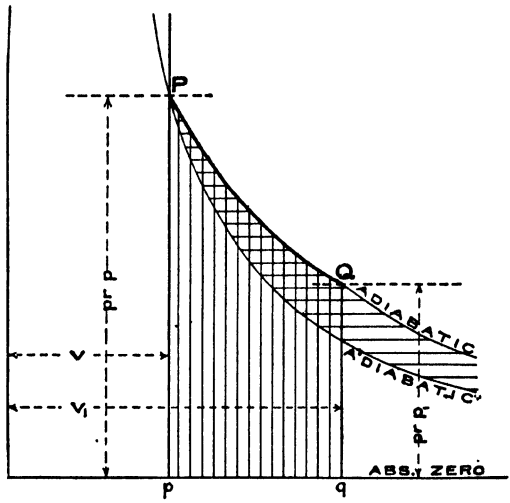

FIG. 21.

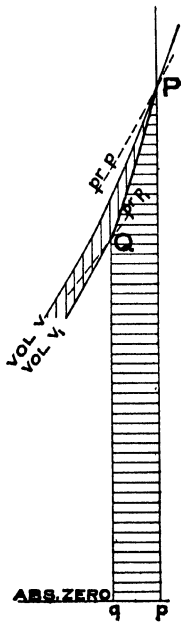

FIG. 22.

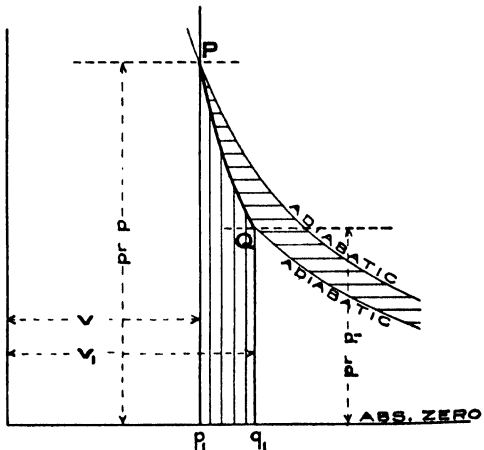

FIG. 23.

Should Q lie in IV. (Figs. 24 and 25), work has to be done on the gas and heat has to be abstracted. In this case a certain portion of the heat abstracted is, so to speak, directly converted into the work of compressing the gas (compare Fig. 20), and the internal energy at Q is equal to that at P plus the remainder of the work done on the gas, less the remainder of the heat abstracted.

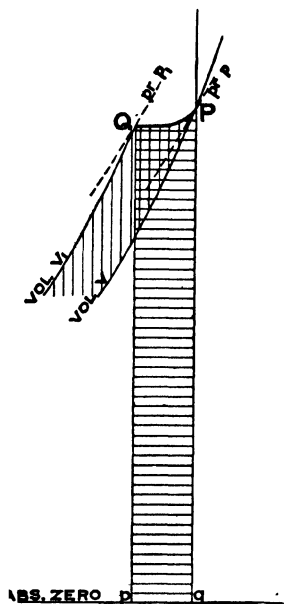

FIG. 24.

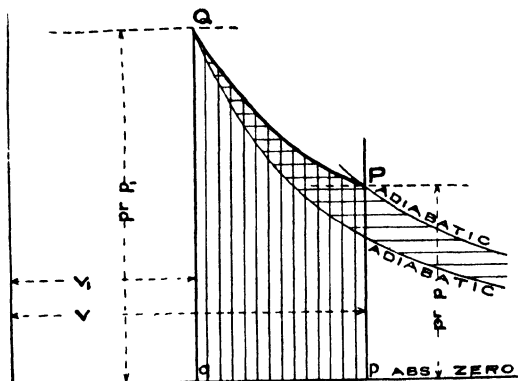

FIG. 25.

It is obvious from the above that, whatever change takes place in a gas, the amount of work done on or by the gas, and the amount of heat required to be supplied or abstracted in order to produce the change, can be exhibited graphically on the chart. The condition of the gas after the application of a given amount of work or heat is, however, indeterminate, because it depends on the path followed by the transformation, as the following will explain:— If two states of the gas are given at P and Q , the state Q can be reached from P by various paths. The state of the gas and its internal energy at Q are however independent of the paths, in accordance with the second law of thermodynamics, but the path

followed depends upon the amount of the heat and of the external work, and on the manner of their application. Thus in Fig. 26, if the path $P n Q$ is followed, the heat to be supplied is greater than for the path $P m Q$, but the external work is less, by the exact amount that the heat is greater.

It will be seen from the above that *the heat added or abstracted is always represented by the area included by the transformation line and the adiabatics drawn through the initial and final state points; and the work done by or on the gas is represented by the area included*

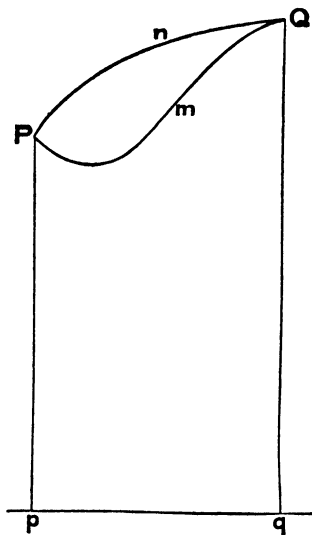

FIG. 26.

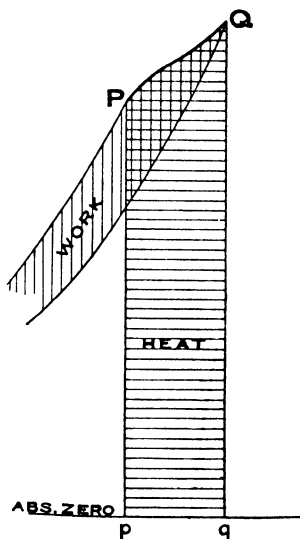

FIG. 27.

between the transformation line and the constant volume lines drawn through the initial and final state points. This rule is shown in Fig. 27 by the areas shaded by horizontal lines for the heat supply and by vertical lines for the work done.

This conclusion is in reality true for any substance, therefore a $\theta \phi$ chart provided with constant volume lines not only exhibits graphically the heat changes that are necessary to effect the transformation of a substance from one state to another, but also the work that has to be done by the substance or on the substance. Such a $\theta \phi$ chart is therefore an *energy chart*—not merely a heat chart.

Complete Cycle.—If the gas is subject to a series of transformations and finally returns to the initial state, it is said to have completed a closed cycle and the process can be exhibited graphically by combining the four figures 18, 20, 22, 24, as follows:—

$A B C D$ (Fig. 29), is the indicator diagram of a hot-air engine with a closed cycle. Fig. 28 shows the corresponding $\theta \phi$ diagram. During the transformation $D A$, the air receives heat at constant volume, and there is a further addition of heat, at a slightly diminishing temperature, during $A B_1 B$. At the point B begins the abstraction of heat at constant volume along the transformation line $B C$, and during $C D_1 D$ heat is further abstracted at a slightly

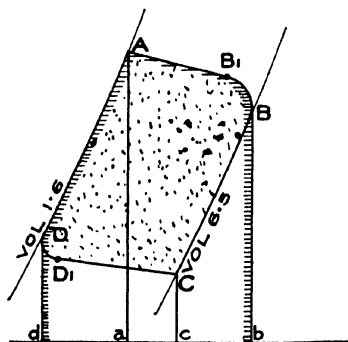

FIG. 28.

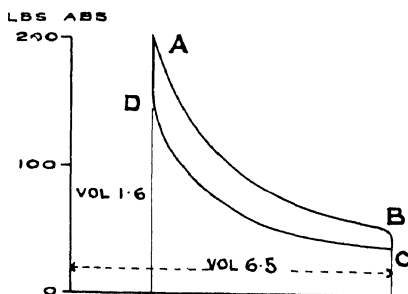

FIG. 29.

rising temperature. It will be seen that:—

$A B_1 B$	is an example of	Fig. 20
$B C$	„ „ „	22
$C D_1 D$	„ „ „	24
$D A$	„ „ „	18

The algebraical sum of the work done by and on the gas is the area $A B_1 B C D_1 D$, and the difference between the heat added and the heat abstracted during the cycle is equal to the same area. The thermal efficiency is the ratio of the heat utilised as work to the total heat supply, which is obviously equal to

$$\frac{\text{Area } A B_1 B C D_1 D}{\text{Heat supply.}}$$

The apparent heat supply is shown in Fig. 28 by the area edged with horizontal lines, but these diagrams are those of a Stirling

hot-air engine, an engine in which the regenerative principle is applied—that is to say, the heat abstracted during the transformation BC is stored in the regenerator and is part of the heat added at the next stroke during the transformation DA . By the use of the regenerator, therefore, the actual heat supply is reduced to the heat represented by the area $dDA B_1 BCc$, and the actual heat rejected to the heat abstracted during the transformation CD_1D . The thermal efficiency, when a regenerator is used, is therefore much increased, and is:—

$$\frac{\text{Area } ABCD}{\text{Area } dDA B_1 BCc}$$

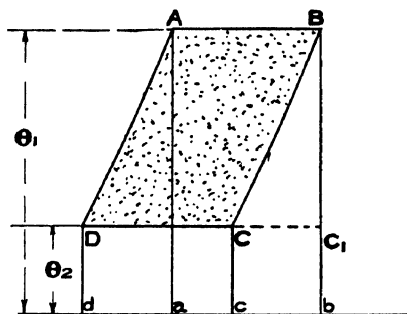

FIG. 30.

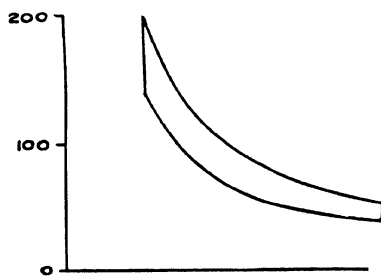

FIG. 31.

Ideally the transformations AB and CD should be carried out at constant temperature, as shown in Figs. 30 and 31. It will be seen that the area $ABCD$ is equal to the rectangle AC_1 , therefore the thermal efficiency of the ideal Stirling cycle with regenerator is:

$$\frac{\text{Rectangle } AC_1}{\text{Rectangle } Ab}$$

which is obviously equal to $\frac{\theta_1 - \theta_2}{\theta_1}$ or the same as that of the Carnot cycle (*see below*).

As a general rule the cycles that have practically to be considered consist of a transformation during which heat is supplied (admission period), followed by a transformation at increasing volume and diminishing pressure (expansion period), after which heat is abstracted or rejected (exhaust period), and finally the initial state is reached by a transformation at diminishing volume and increasing pressure (compression period).

Carnot Cycle.—A cycle consisting of two isothermal and two adiabatic transformations is known as the Carnot cycle, and it can be shown to be the most efficient cycle that can be arranged for a given highest temperature and a given lowest temperature. The general proof is more readily effected analytically, but any special case can be proved with great simplicity by means of the chart. Thus, for instance, $A B C D$ (Fig. 32) is a Carnot cycle, inasmuch as $A B$ and $C D$ are transformations at constant temperature (isothermal), and $B C$ and $D A$ are transformations at constant heat (adiabatic). The cycle $A B^1 C^1 D$ differs only in that the trans-

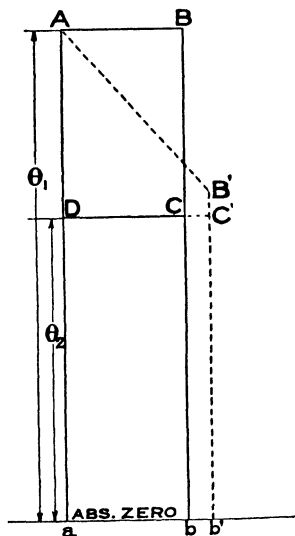

FIG. 32.

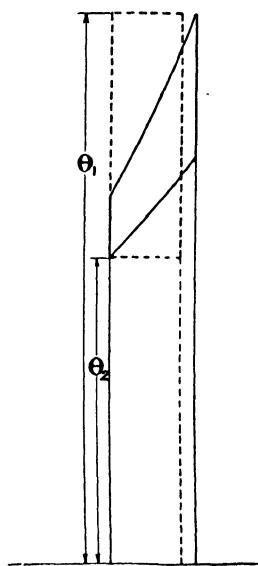

FIG. 33.

formation $A B^1$ is not at constant temperature, and matters have been so arranged that the heat supply is equal to that of the Carnot cycle, *i.e.*, the area $A B^1 b^1 a$ is equal to the area $A B b a$. In the Carnot cycle the heat rejected is the rectangle $D b$, and in the other cycle the heat rejected is the rectangle $D b^1$, which is greater by the rectangle $C b^1$. Since the heat supplied is the same in both cases, it is obvious that the second cycle is not so efficient as the Carnot. It will be observed that the highest and lowest temperatures are the same in both cycles, namely θ_1 and θ_2 . As before stated, the thermal

efficiency of a cycle is obtained by dividing the amount of heat utilised as work by the heat supplied. In the case of the Carnot cycle, the heat utilised is represented by the rectangle $A C$, and the heat supplied by the rectangle $A b$. The areas of these rectangles are proportional to $\theta_1 - \theta_2$ and θ_1 respectively. Hence the thermal efficiency of the Carnot cycle = $\frac{\theta_1 - \theta_2}{\theta_1}$

Constant Volume Cycle.—A cycle may be limited by other considerations than that of temperature. For instance, the transformation during the supply of heat may be at constant volume, as is the case for instance in an ideal gas engine, because the piston theoretically does not move until the explosion is complete. Or the supply of heat may be partially at constant volume and partially at constant pressure, as in an actual gas engine, because the piston begins to move before the explosion is completed. The rejection of heat may also be at constant volume. Fig. 33 shows a cycle in which the heat supply is at constant volume and the heat rejection is also at constant volume, and such a cycle is obviously far less efficient than the Carnot cycle for the same total range of temperature as is shown by the dotted lines. The development of the application of the $\theta \phi$ method to these constant volume and constant pressure cycles belongs to the domain of the internal combustion engine, and cannot therefore be proceeded with in this book.

CHAPTER III.

ENERGY CHART FOR H_2O .

(MIXTURE OF STEAM AND WATER)

Water Line and Saturation Line.—Returning to page 4, it was seen that the $\theta \phi$ line for water is a logarithmic curve. Take any point *A* (Fig. 34) on this curve at temperature θ , and let the pressure remain constant whilst heat is still being added to the water. As is well known, steam will be formed, and when sufficient heat has been added (namely, the latent heat) the whole of the water will have been converted into steam. Further, so long as any water is present, both the pressure and the temperature remain constant. This physical fact is expressed on the chart by making the point representing the state of the substance (H_2O) move along the horizontal *straight line* drawn through the point *A*. The heat added from the moment steam commences to be formed to the moment all the water has been converted into steam is represented by a rectangle whose height is θ , and whose width is such that the area, $AB \times \theta$, is equal to the latent heat of steam at the temperature θ . It will be noted that the point *B* represents on the chart the condition of 1 lb. of dry saturated steam at a temperature θ . Evidently for each point *A* on the water line a point can be found corresponding to *B*. All these points lie on the "Saturation line."

Constant Volume Lines.—The next step is to draw the constant volume lines. When half the latent heat has been applied, one half of the lb. of water will have been converted into steam, and the state point will have obviously travelled half way from *A* to *B*, to the point *M* (Fig. 34). The volume of the steam is, of course, one half what it is at *B*, therefore the volume of the mixture ($\frac{1}{2}$ lb. of water and $\frac{1}{2}$ lb. of steam) at *M* (neglecting the water volume) is very approximately one half the volume at *B*. Similarly the volume at

the point *N*, where *AN* equals $\frac{1}{n}$ *AB* is approximately $\frac{1}{n}$ th of the volume at *B*.

As stated, the water volume has been neglected, and a slight correction is required in this respect ; to make this clear, let Fig. 35 represent a cylinder containing 1 lb. of water at temperature θ and provided with a tight-fitting piston, weighted to correspond with the saturated steam pressure at the temperature θ . The volume

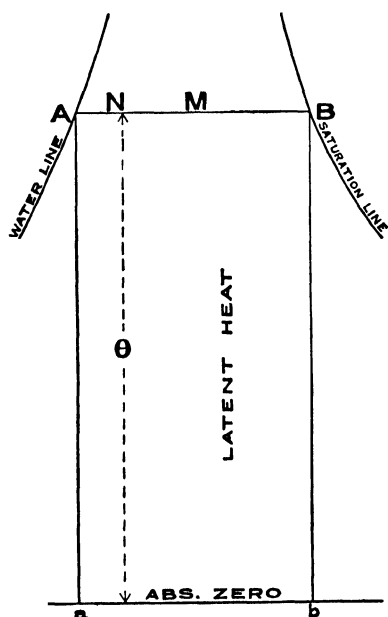

FIG. 34.

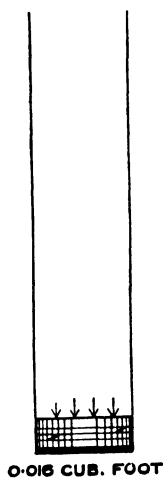

FIG. 35.



FIG. 36.

below the piston is 0.016 cubic foot very approximately at any temperature that need practically be considered. Now let half the latent heat be added, the volume of the steam will be half the steam volume at *B*, and to this must be added the volume of $\frac{1}{2}$ lb. of water, as represented in Fig. 36. The water present is represented by the thick black line in Figs. 35 and 36. Similarly at the point *N* (Fig. 34) the volume of the mixture is equal to $\frac{1}{n}$ th volume of steam at *B* plus $\left(n - \frac{1}{n}\right)$ volume of 1 lb. of water.

As a practical matter, the easiest way to find the constant volume lines is to first find the points on the saturation curve where the volume is 1, 2, 3, 4, etc., cubic feet, which can readily be done by means of a steam table such, for instance, as that published in Professor Ewing's book on the Steam Engine.*

The next step is to divide the horizontal intercepts, AB (Fig. 34), drawn through these volume points, into a number of equal spaces, so as to find the positions of volumes 1, 2, 3, 4, etc., on each of them. The correction for water volume can then be applied if desired, but

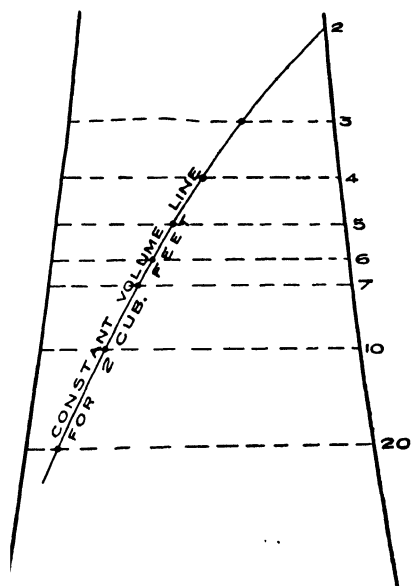

FIG. 37

except at high temperatures it is practically negligible. Points of equal volume can then be joined together by a fair curve. This process is illustrated in Fig. 37, where the volume line for two cubic feet is shown.

Constant Pressure Lines.—

As regards the constant pressure lines, they are evidently horizontal during the period of steam formation, and can be plotted by means of a table giving pressures and temperatures. Thus finally the chart for 1 lb. of H_2O , as given in Plate 1, is obtained.

Dryness Fraction Lines.—

This energy chart also gives lines of constant "dryness fraction." They are similar curves to the saturation line, and the method of plotting them is obvious.

In order to obtain diagrams of suitable size for this book, two other energy charts for H_2O have been used. One of them (Fig. 38), is used in those cases where the absolute zero is shown, the temperature scale is $300^\circ F.$ per inch, and the heat scale is 300 B.Th.U. per square inch. (For example see Fig. 91). In the second chart (Fig. 39)

* The Steam Engine and other Heat Engines, by J. A. Ewing, M.A., B.Sc., F.R.S., M.Inst.C.E.

(see, for instance, Fig. 85), the temperature scale is 75° F. per inch, and the heat scale is 60 B.Th.U. per square inch.

Chart for Superheated Steam.—

The energy chart for superheated steam is also given in Plate I. The constant pressure and volume lines are logarithmic curves, similar to those given in Figs. 6 and 7

for air. They were originally drawn several years ago, when there was not sufficient evidence to depart from the then accepted value of the specific heat of superheated steam, namely, 0.37 at constant volume, and 0.48 at constant pressure. These lines were therefore drawn according to the equations :

$$\phi = 0.48 \log_{\epsilon} \frac{\theta}{\theta_1} \text{ and}$$

$$\phi = 0.37 \log_{\epsilon} \frac{\theta}{\theta_1}$$

It will be noticed that only a few constant volume lines are given, but that a pressure and a volume scale are marked. By means of these scales the pressure or volume at any point of the superheated field can be read off the chart.

These scales are based on a property of these logarithmic curves, that

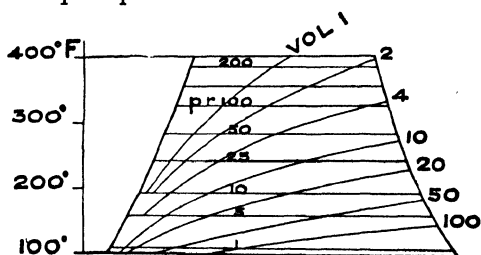

FIG. 38.

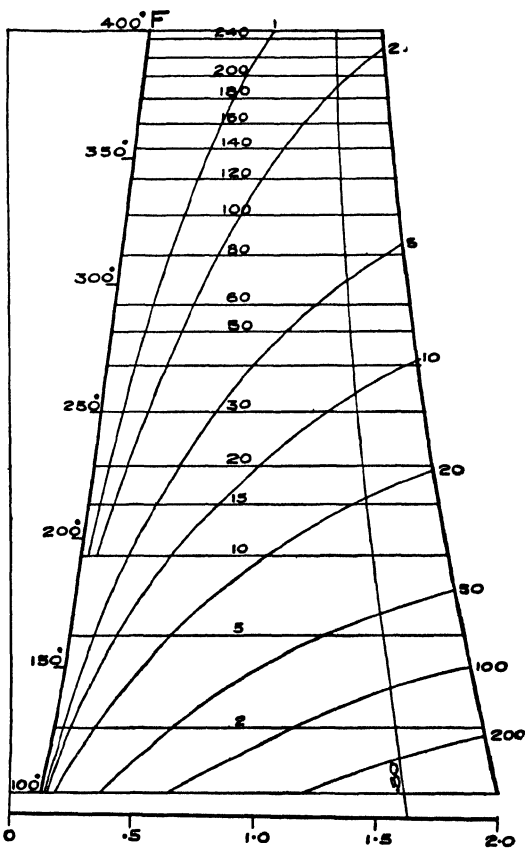

FIG. 39.

the horizontal intercept between any pair of them (either two constant pressure or two constant volume lines), is constant. The scales themselves are logarithmically divided.

A new chart for the superheated field, based on the latest determinations, has, however, now been drawn, and is given in Fig. 135.

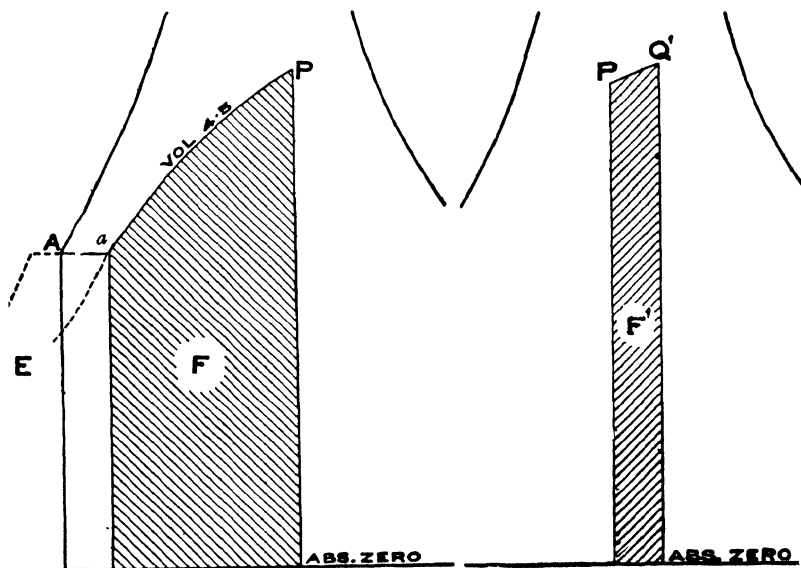

FIG. 40.

FIG. 41.

Determination of the Internal Energy at any Point.—In Fig. 40, let P be any point on the chart. Through this point draw the constant volume line. If this constant volume line could be continued down to absolute zero, then the area bounded by this line, by the vertical through the point P , and the horizontal line representing absolute zero would represent the internal energy of 1 lb. of H_2O in the condition defined by the point P . As, however, this curve cannot be drawn, another manner of procedure must be adopted.

Representation on the Energy Chart.—Let E be the unknown internal energy in 1 lb. of water at $32^\circ F.$, this will be the internal energy at the point A . Let steam be made at the pressure corresponding to $32^\circ F.$, namely at 0.089 lbs. per square inch. When the volume of

the point P has been reached at a the heat supplied will be represented by the rectangular area below $A a$. The heat added will have been expended both in doing work against the pressure at A , and in adding to the internal energy of the substance. The work done is equal to the volume at P multiplied by the pressure per square foot at A , and the heat units added are equal to $A a$ multiplied by the absolute temperature at A , namely 493° F. But $A a$ is equal to:—

$$\frac{\text{Volume at } P.}{\text{Volume of saturated steam at } 32^{\circ} \text{ F.}} \times \frac{\text{the entropy of saturated steam at } 32^{\circ} \text{ F.}}$$

and the volume of saturated steam at 32° F. can be taken as 3400 cubic feet per lb., and the entropy of saturated steam at 32° F., as 2.2. Hence the heat units added are:—

$$493 \times \frac{\text{volume at } P}{3400 \text{ cubic ft.}} \times 2.2 = 0.318 \times \text{volume at } P.$$

The pressure per square foot at A is 12.8 lbs., so that the work done expressed in B.Th.U. is:—

$$\frac{12.8}{778} \times \text{volume at } P = 0.016 \times \text{volume at } P.$$

Hence the addition made to the internal energy by shifting the state point from A to a is:—

$$(0.318 - 0.016) \text{ volume at } P = 0.302 \times \text{volume at } P.$$

The internal energy at the point P is F B.Th.U. greater than the internal energy at A , where F is the number of heat units represented by the shaded area in Fig. 40. Thus finally the internal energy at P is:—

$$E + 0.302 \times \text{vol. at } P + F.$$

where E is the internal energy of water at A , *i.e.*, at 32° F.

To take a numerical example, let P be taken in the position shown in Fig. 40. Reading from the chart, it will be seen that the volume at P is 4.5 cubic feet, and by measuring the shaded area, F is found to be equal to 622 B.Th.U. Thus the internal energy at this point is:—

$$E + 0.302 \times 4.5 + 622 = E + 636.4 \text{ B.Th.U.}$$

Generally the internal energy is stated as from 32° F., therefore the term E is omitted.

Scale of Internal Energy.—Practically it is inconvenient to measure the area F when it extends so far down as 32° F. But if

dryness fraction is 0.743, and is made up of the internal energy of 0.743 lbs. of steam at 250.5° F., and of 0.257 lbs. of water at the same temperature.

Another Method.—This indicates another way of determining the internal energy at any point. On the chart (Plate 1), the internal energy for 1 lb. of water at varying temperature, and likewise the internal energy for 1 lb. of saturated steam is given by means of the internal energy scales. From these scales it will be seen that the internal energy of 1 lb. of water at the temperature of the point *P* (250.5°) is 220 B.Th.U., and of 1 lb. of steam at the same temperature, 963.5 B.Th.U. Hence the internal energy at *P* is:

$$963.5 \times 0.743 + 220 \times 0.257 = 771.5 \text{ B.Th.U. as before.}$$

Lines of Equal Internal Energy.—

From the preceding there is obviously no difficulty in obtaining a series of points on the chart

at which the internal energy will have the same value, and if such points be joined, curves of equal internal energy will be obtained. A few of these lines are shown on Fig. 43.

Lines of equal total heat of formation at constant pressure can obviously be drawn in a similar way. Such lines are desirable when using the chart to calculate the blading of steam turbines, but are not helpful for reciprocating steam engines, and are therefore not given here.

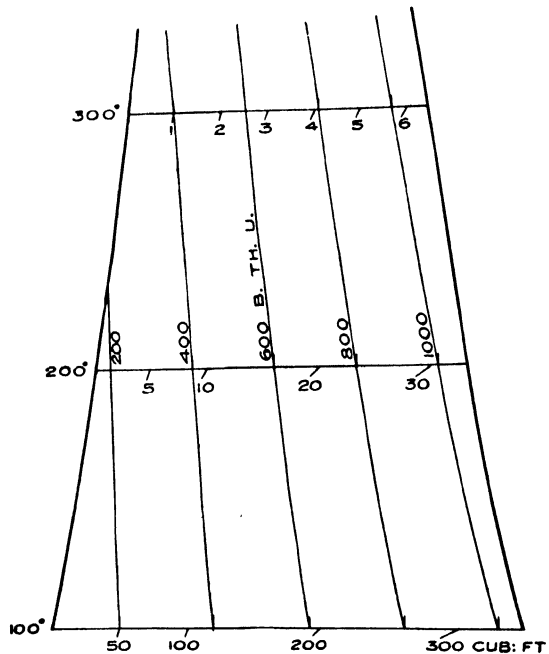

FIG. 43.

CHAPTER IV.

ELEMENTARY THERMODYNAMICS OF H₂O EXPRESSED ON THE ENERGY CHART.

THE energy chart for H₂O can be used precisely in the same way as the chart for a gas, and the heat added or abstracted, and the work done by the H₂O, or done on it can be represented graphically in the same manner. One example will suffice. Suppose the original state point is *P* (Fig. 44), and that the path *PQ* is followed to reach the state point *Q*, then the area shaded vertically contained between the constant volume lines drawn through *P* and *Q* respectively, is the external work done by the expanding H₂O, and the area shaded horizontally is the heat required to be supplied. The condition of the H₂O at any point during the transformation can be read off the chart, thus at *X* (Fig. 44), there is :—

Pressure28.0 lbs. per square inch (abs.)
Temperature.....246.3 °F.
Volume10.0 cubic feet.
Dryness fraction0.69

At *P* the volume is 4 cubic feet, and at *Q* it is 15 cubic feet, so that the steam has been expanded as it obviously must have been since it has done external work.*

Comparison of $\theta\phi$ and $p v$ Diagrams.—The expansion line of the corresponding $p v$ diagram can readily be plotted by reading off the volume and pressure at a number of points from the chart and the expansion line *PQ* (Fig. 45) is thus obtained. The converse is, however, not possible without further knowledge; that is to say, if *PQ* is given on the $p v$ diagram it cannot be located on the chart, because the dryness is not known. *PQ* might, for instance, be the expansion line of the indicator diagram of a simple non-

* It is recommended that Fig. 44 be plotted on Plate I. and the above values read off.

condensing steam engine as shown in Fig. 46. The volumes marked are obtained by measurement of the engine cylinder. At the point x , for instance, the volume is 10 cubic feet, and this is the volume of *steam* present in the cylinder at the point under consideration. The indicator diagram does not tell, however, how much water is present in the cylinder at the same point, and thus the dryness cannot be determined, and consequently the point X cannot be located on the chart. All that is known is that it must be

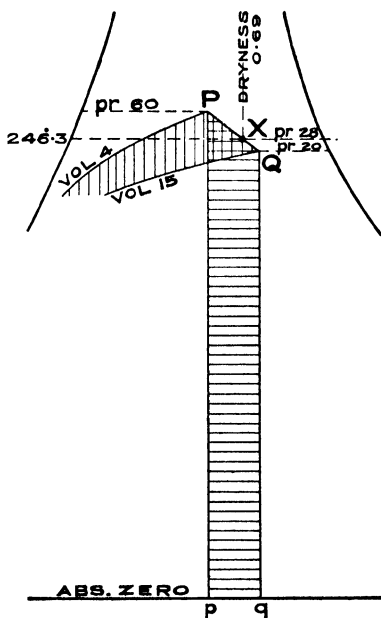

FIG. 44.

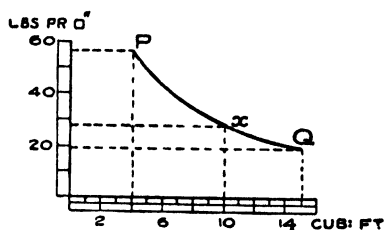

FIG. 45.

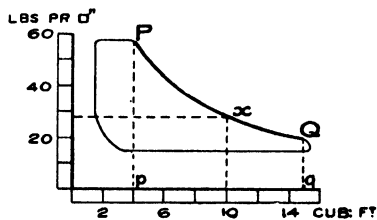

FIG. 46.

somewhere on the constant pressure line equal to the pressure at x , viz., 28 lbs. per square inch absolute. It will, however, be shown in the sequel (page 70) how the point X can be fixed on the chart, when the weight of feed per stroke is known.

It is important to note that the work done by the steam in expanding from the state P to the state Q (Fig. 46), is equal to the area $PQq\phi$, and that this area is independent of the quantity of water present. It follows that the work area on the chart included between the constant volume line through P , the transformation line PQ , and the constant volume line through Q , is

constant, no matter what the dryness fraction may be, so long as the pressures are the same and the number of expansions are the same. This is shown in Fig. 47 by a comparison of two expansion lines PQ and P_1Q_1 . On the other hand, the heat required to be added does depend on the dryness fraction, and the greater the dryness fraction (or, in other words, the greater the proportion of steam), the greater is the quantity of heat to be added. Fig. 48 will make this clear; the various expansion lines have the same number of expansions, as

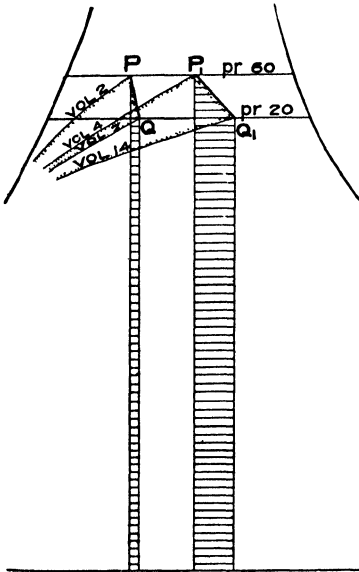

FIG. 47.

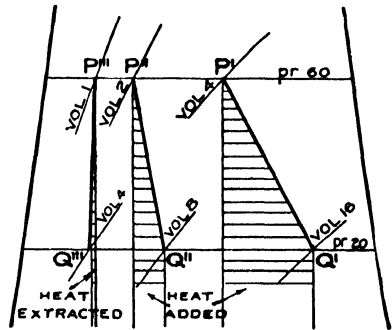

FIG. 48.

can be ascertained by replotting on Plate I, and since the slope of these lines becomes greater and greater as the dryness increases, it follows that the vertical strip representing the heat supply also increases, or, in other words, the heat to be added is greater the greater the dryness. In fact, when there is very little steam present, as in the case of the expansion line $P'''Q'''$, heat has to be abstracted. The $p-v$ diagram gives no information on the heat supply, so that the $\theta-\phi$ diagram is more complete in this respect. It will be seen, in fact, that the $\theta-\phi$ diagram gives all the information obtainable from the $p-v$ diagram, and in addition shows the quantities of heat to be added or abstracted to obtain a given transformation. At the same time, it

would be a great mistake to abandon the $p v$ diagram in favour of the $\theta \phi$ diagram; on the contrary, they should be employed conjointly, and it must not be forgotten that practically the start must be made from the $p v$ diagram, inasmuch as this is the diagram given by the steam engine indicator.

Transformations in an Ideal Steam Cylinder.—Let it be supposed that there is a cylinder fitted with a steam-tight piston, which can be weighted so as to produce any desired pressure per square inch in the cylinder. Let it also be supposed that there are means to enable heat to be introduced into the cylinder or abstracted from it in any desired manner. Let the cylinder contain 1 lb. of H₂O, and let it further be assumed that when operations are commenced the pressure is 100 lbs. absolute per square inch and that the volume is 2 cubic feet. These data locate the state point on the chart at the intersection of the constant pressure line 100 and the constant volume line 2, and it will be seen by reference to Plate 1 that

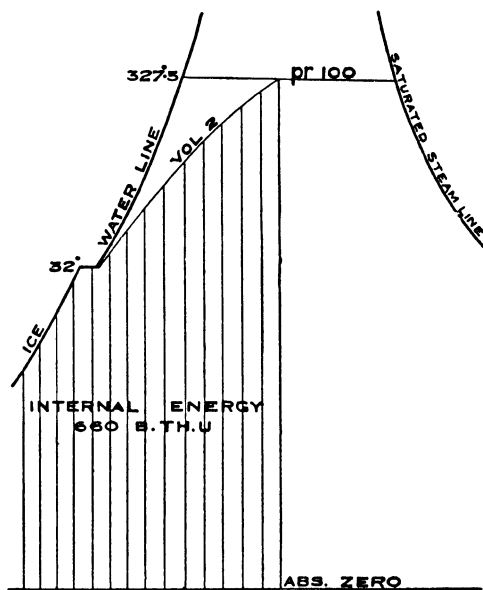

FIG. 49.

the dryness fraction is 0.45, that is, the cylinder contains 0.45 lb. of steam and 0.55 lb. of water, amounting, of course, to 1 lb. of H₂O. The internal energy of the lb. of H₂O is represented by the vertically-shaded area in Fig. 49. The method of measuring this area and finding the corresponding heat units has been given in Chapter III. In this case the internal energy is 660 B.Th.U. A graphic representation of all the data concerning the 1 lb. of H₂O contained in the cylinder is thus obtained, namely, the pressure (100 lbs., per square inch), the volume (2 cubic feet), the temperature (327.5° F.),

the proportion of steam to water (0.45), and the internal energy (660 B.Th.U.)

Transformation at Constant Pressure.—Now let a transformation be effected in the cylinder by adding 210 B.Th.U. and maintaining a constant pressure on the piston. In these circumstances the state point will move along the horizontal constant pressure line until the point *Q* (Fig. 50) is reached, the position of *Q* is determined by making—

$$P Q \times (327.5 + 461) = 210 \text{ B.Th.U.}$$

$$\text{or} \quad P Q = \frac{210}{788.5} = 0.266$$

The distance 0.266 is to be measured on the entropy scale.

The state of the H_2O in the vessel after the transformation has taken place is given by the position of the point *Q* on the chart, and is read off as follows :—

Pressure	100 lbs. per square inch abs.
Temperature	327.5° Fahr.
Volume	3.05 cubic feet.
Dryness fraction ..	0.69.

Although the volume of the *steam* has been increased from 2 cubic feet to 3.05 cubic feet by the transformation, it has not been “expanded” because the increase in volume is due to evaporation of some of the water. External work has been done in pushing back the piston, and this work is represented on the chart by the vertically-shaded area which is equal to the pressure per square *foot*, multiplied by the increase of volume, divided by Joule’s equivalent :—

$$\frac{100 \times 144 \times 1.05}{778} = 19.4 \text{ B.Th.U.}$$

On comparing Fig. 50 with Fig. 9, which is the corresponding case for a gas, it will be noticed that the external work done is much less than the heat supplied, and *not* equal as it is in Fig. 9. The reason is that in the present case a large proportion of the heat is required to evaporate the water in the cylinder, *i.e.*, to do internal work.

Adiabatic Expansion.—Returning to the initial state, let a transformation take place by allowing the steam to expand by reducing the pressure on the piston, but without adding or deducting any heat. The state point will in this case obviously follow a vertical line

(adiabatic expansion), as shown in Fig. 51. If, for instance, the steam is allowed to expand four times, *i.e.*, until the volume = $2 \times 4 = 8$ cubic feet before the transformation ceases, the position of *Q* on the chart will be determined by the intersection of the vertical through *P* and the constant volume line 8. The state of the H₂O at point *Q* as read off the chart (Plate I), will be found to be ;

- Pressure 23.4 lbs. per square inch abs.
- Temperature.....236.5° F.
- Volume 8 cubic feet.
- Dryness fraction .. 0.47

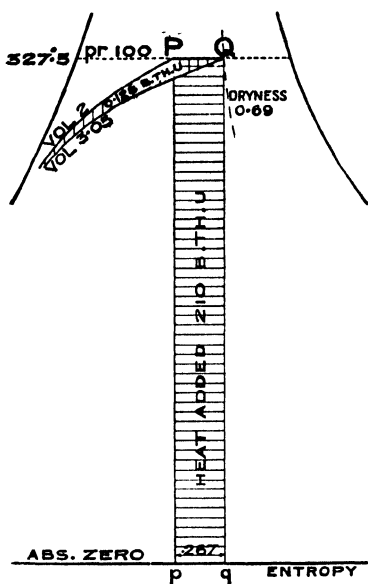

FIG. 50.

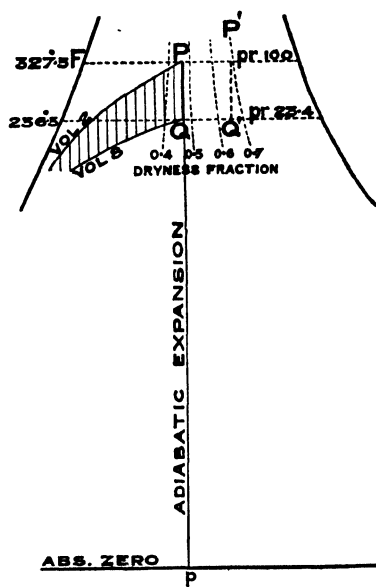

FIG. 51.

The dryness fraction is thus slightly greater than at the point *P*, where it was 0.45: the steam is therefore drier after expansion than before, although no heat has been added. If, however, the point *P* had been situated more to the right, as at *P*¹, for instance, where the dryness fraction is 0.7, then at *Q*¹, the dryness fraction would be 0.66, so that the steam would be wetter at the end of the adiabatic expansion than at the beginning. The general rule is that the steam will be wetter, at the end of the adiabatic expansion than at the

will have been abstracted*, and the state of the 1 lb. of H₂O can be read off the chart (Plate I) as follows :—

Pressure 50 lbs. per square inch abs.
 Temperature 281° F.
 Volume 2 cubic feet
 Dryness fraction .. 0.24

The internal energy is less at *Q* than at *P* by an amount represented by the horizontally-shaded area = 212 B.Th.U., which is obviously correct since no external work has been done.

Transformation at constant volume produced by adding heat is clearly the reverse of the above.

Transformation along any Line.—

Now let the point *Q* representing the end of the transformation be situated as in Fig. 53, and let the transformation take place along the line *PQ*. The external work done by the expanding steam is given by the vertically-shaded area, and the heat which has to be added is shown by the horizontally-shaded area. The internal energy at *Q* is, by the law of conservation of energy, equal to the internal energy at *P*, less the work done, plus the heat added, and a moment's consideration will show that the graphic representation on the chart agrees with this.

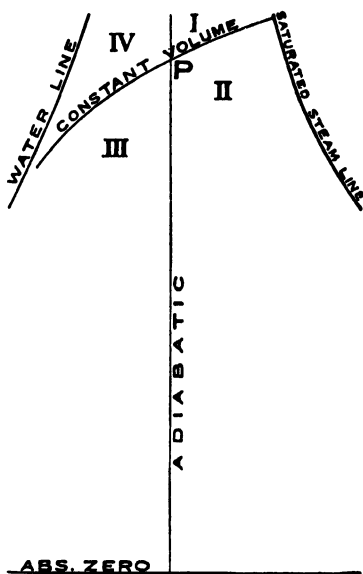

FIG. 54.

In a manner similar to that shown in Fig. 17, the chart for H₂O can be divided into four zones, as shown in Fig. 54, around the point *P*, as marked I., II., III., and IV. If the point *Q* representing the end of the transformation lies in Zone I., the following differences in the state at *Q* and *P* occur :—

* The B.Th.U. represented by the shaded area are easily calculated as follows :—The average temperature between *P* and *Q* is 304.2°F, and the difference of the entropy between *P* and *Q* is 0.277. Hence the B.Th.U. required = (304.2 + 461) × 0.277 = 212. This calculation assumes that *PQ* is a straight line :— the curvature of this line will add about 0.1 B.Th.U.

The volume is less.

The pressure is greater,

External work has to be done on the H_2O , and heat added to it,
and the internal energy is greater by the sum of these two.

The dryness fraction may be greater or less according to the
relative positions of P and Q .

This is shown in Fig. 55, and Fig. 56 is the corresponding $p v$ diagram.

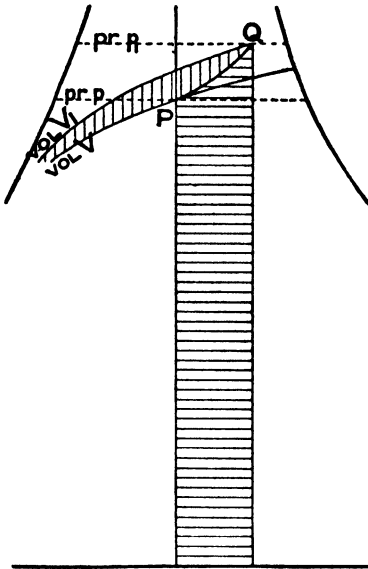

FIG. 55.

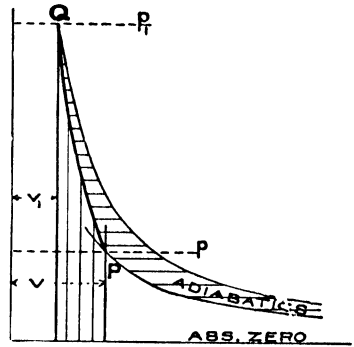

FIG. 56.

If Q lies in the Zone II.:—

The volume is greater.

The pressure may be greater or less according to the relative
positions of P and Q .

External work is done by the expanding H_2O , and heat
has to be added.

The internal energy and the dryness fraction may be greater
or less according to the relative position of P and Q .

This transformation is illustrated in Fig. 57, and Fig. 58 is the
corresponding $p v$ diagram.

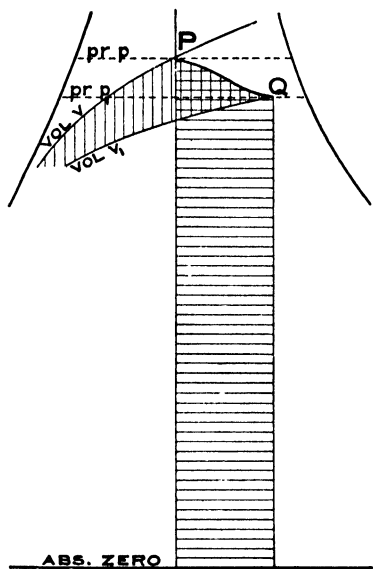

FIG. 57.

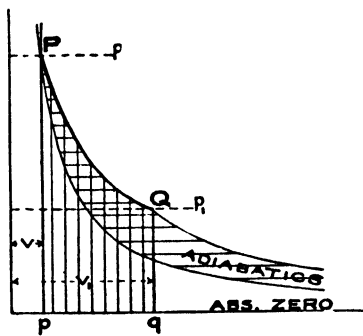

FIG. 58.

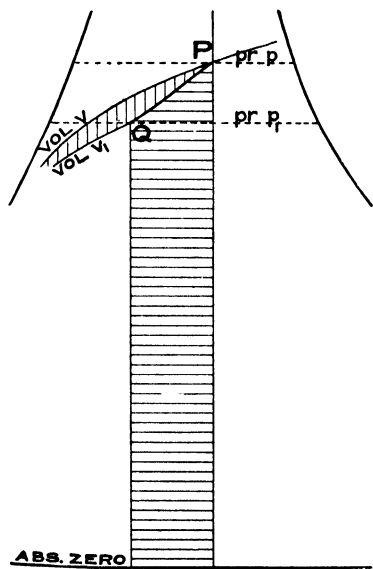

FIG. 59.

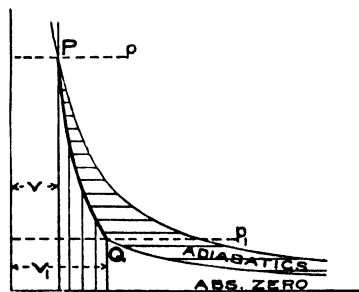

FIG. 60.

If Q lies in Zone III.:—

The volume is greater.

The pressure is less.

External work is done by the expanding H_2O , and heat has to be abstracted.

The internal energy at Q is less than that at P by the sum of the external work done and the heat abstracted.

The dryness fraction may be greater or less according to the relative positions of P and Q .

This transformation is illustrated in Fig. 59, and Fig. 60 is the corresponding $p v$ diagram.

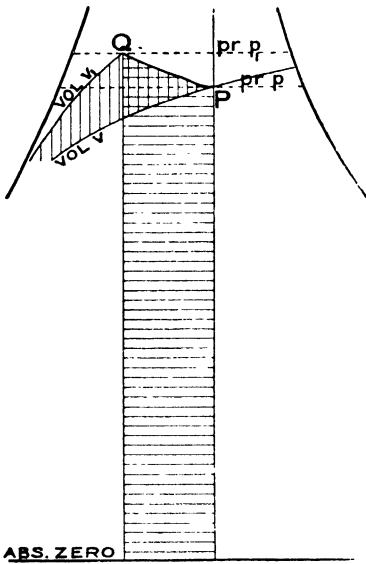

FIG. 61.

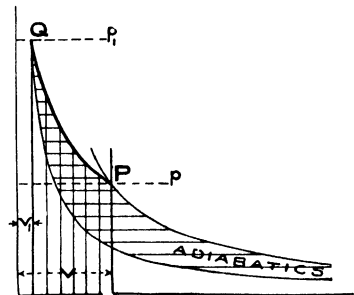

FIG. 62.

If Q lies in Zone IV.:—

The volume is less.

The pressure may be greater or less according to the relative positions of P and Q .

The internal energy may be greater or less according to the relative positions of P and Q .

External work is done in compressing the H_2O , and heat has to be abstracted.

This transformation is illustrated in Fig. 61, and Fig. 62 gives the corresponding $p v$ diagram.

Measurement of External Work Done.—It will be seen from the preceding that any transformation that can be effected in the condition of the 1 lb. of H_2O contained in the cylinder can be represented graphically on the chart, and further that the amount of work done by or on the H_2O and the amount of heat supplied or abstracted, can be obtained by the simple measurement of areas. As an illustration, let the transformation given in Fig. 63 be considered to show how these areas can be readily ascertained. The first step is to draw a horizontal straight line $Q b a$. The area representing the work done is thus divided into two portions. The area between the constant volume lines and $a Q$ can be obtained by calculation, as it is the work done at the constant pressure at Q (28 lbs. per square inch in this case) by the change of volume from that at P to that at Q , that is, in this case from 2 cubic feet to 10 cubic feet. This portion of the work is thus equal to:

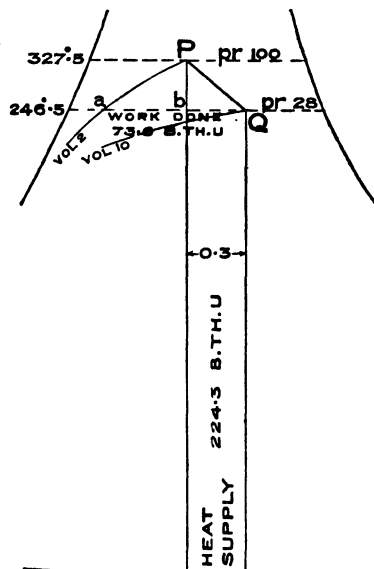

FIG. 63.

$$28 \times 144 (10 - 2) \text{ foot-lbs.} = \frac{32256}{778} = 41.5 \text{ B.Th.U.}$$

The remainder of the work done is found by measuring the area $a P Q$, which is 3.21 square inches on Plate 1. The heat scale is such that 1 square inch represents 10 B.Th.U. Therefore this area represents 32.1 B.Th.U. On the whole, therefore, the work done by the expanding H_2O is $41.5 + 32.1 = 73.6$ B.Th.U.

Measurement of Heat Supply.—As regards the heat added it is equal to the area $b P Q$, plus the rectangle below $b Q$. The former area measures 1.21 square inches, so that it represents 12.1 B.Th.U., and the latter is found by measuring $b Q$ on the entropy scale, namely 0.3, and multiplying this figure by the absolute temperature at Q or $246.5 + 461 = 707.5^\circ$. This rectangle, therefore, contains 212.2 B.Th.U., and altogether the heat added is 224.3 B.Th.U.

All other cases can be similarly treated, noticing, however, that the horizontal line ba should always be drawn through whichever of the two points P or Q is the lower.

CHAPTER V.

APPLICATION TO A RECIPROCATING STEAM ENGINE : PRINCIPLES.

It is most important to observe, and it is the essence of the whole reasoning of the preceding chapter, that the cylinder at all times contains 1 lb. of H_2O . In an actual steam engine cylinder, however, it is only during the expansion period and the compression period that no change takes place in the weight of H_2O contained in the cylinder, and this is only true if no leakage in or out of the cylinder takes place during the expansion or the compression, and moreover during the latter period the weight is far less than during the former. During the admission period the weight is continually being increased, and during the exhaust diminished. By making certain reservations, it is, however, possible to apply the results obtained in Chapter IV. to the case of an actual steam engine cylinder, as will now be shown.

Comparison of Ideal and Actual Steam Engine Cylinder.—Fig. 65 shows two cylinders, one of them represents the ideal cylinder, which contains at all times 1 lb. of H_2O , and which in this chapter will be called the vessel, the other is an engine cylinder connected to a boiler in which a constant pressure is maintained of say 150 lbs. per square inch absolute, the temperature of which is 358.2° F. The weight of H_2O in this cylinder varies from zero at the beginning of admission (supposing there is no clearance) to 1 lb. at cut-off, remains constant during expansion (supposing there are no leaks), after which it diminishes to zero again at the moment the revolution is completed.

The admission of steam from the boiler to the cylinder corresponds to the supply of heat to the H_2O in the closed vessel, and when the admission is complete the piston in the cylinder will have moved through a volume equal to the volume of 1 lb. of saturated

steam at 358.2° F., viz., 2.97 cubic feet, and the external work done will, therefore, be $2.97 \times 150 \times 144$ foot-lbs. But, 1 lb. of water has been taken out of the boiler, and in order to maintain the pressure in it, 1 lb. of water must be pumped in against a pressure of 150 lbs. per square inch. The volume of this 1 lb. of water is 0.016 cubic foot, and the work expended is therefore $0.016 \times 150 \times 144$ foot-lbs.

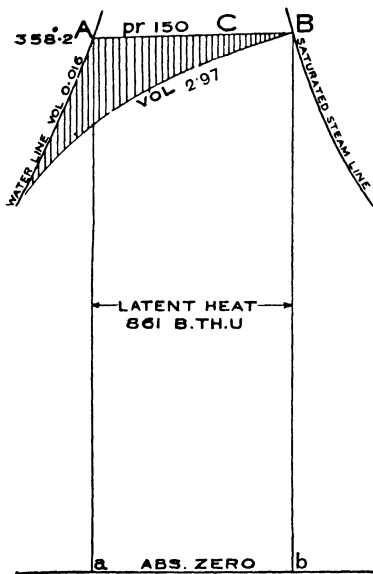

FIG. 64.

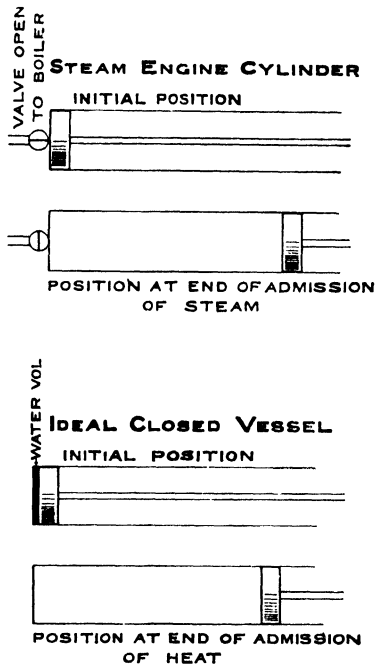

FIG. 65.

The net work done is therefore

$$(2.97 - 0.016) \times 150 \times 144 \text{ foot-lbs.}$$

In the vessel the space occupied behind the piston is also 2.97 cubic feet so soon as all the water is evaporated, but the piston did not start from the end of the vessel, there was the volume of 1 lb. of water behind it, namely 0.016 cubic foot, so that the work done in this case is also $(2.97 - 0.016) \times 150 \times 144$ foot-lbs.

It will be seen, therefore, that in both cases the work done is the same. Referring to the chart, the "waterline" represents the

volume 0.016, as has already been mentioned, and thus the vertically-shaded area in Fig. 64 represents the work done in either case.

If it is assumed that the temperature of the water in the vessel at the beginning of the admission period is the same as that of steam at 150 lbs. pressure, namely 358.2° F., the amount of heat to be introduced into the vessel to evaporate the water is the latent heat of 1 lb. of steam at 358.2° F., namely 861 B.Th.U. In the case of the steam engine cylinder it is clear that this is also the amount of heat that has to be added to maintain the pressure in the boiler, if it is supposed that the boiler feed is at 358.2° F. This amount of heat is represented on the chart (Fig. 64) by the rectangle $ABba$. Under these conditions, therefore, the chart gives both the work done and the heat required for the whole transformation AB , whether the 1 lb. of water be contained in a closed vessel, or introduced into a steam cylinder from a boiler.

An important difference, however, exists between the vessel and the steam cylinder, so long as the transformation is incomplete. When for instance, the state point has arrived at C (Fig. 64) the proportion of water and steam in the closed vessel can be read off the chart; but, in the case of the steam cylinder, the information is that at the point C there is $\frac{AC}{AB}$ lbs. of steam in the steam cylinder, but the amount of water, if any, is not known. In the ideal steam engine, for instance, there would be no water.

Effect of Feed-water Temperature.—It will now be supposed that the feed-water enters the boiler at a lower temperature, say at 100° F., and that the water in the vessel is also at this temperature at the beginning of admission. This obviously makes no difference in the work done, neglecting the quite secondary consideration of the very small difference in the water volume. A greater amount of heat, must, however, be added to the vessel to raise the temperature of the water from 100 to 358.2° F., namely* :—

$$330.8 - 68.4 = 262.4 \text{ B.Th.U. additional.}$$

The total heat required is shown on the chart (Fig. 66), by the horizontally-shaded area. In the engine cylinder the 1 lb. of feed enters at 100° F., and to maintain the pressure and to raise the temperature of the feed to 358.2° F., 262.4 B.Th.U. have to be

* See Scale of Water Heat, Plate I.

added. The heat required is, therefore, the same both in the vessel and in the cylinder, namely :—

$$262.4 + 861 = 1123.4 \text{ B.Th.U}$$

Effect of Initial Condensation.—Let it next be supposed that as the steam enters the steam cylinder a certain proportion of it is condensed, say 10%. When the valve closes, therefore, the steam cylinder contains 1 lb. of H_2O , composed of $\frac{1}{10}$ th lb. of water and $\frac{9}{10}$ th lb. of steam. To make the comparison, the supply of

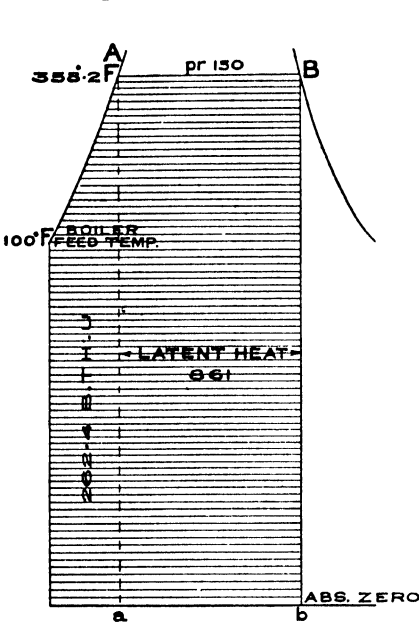

FIG. 66.

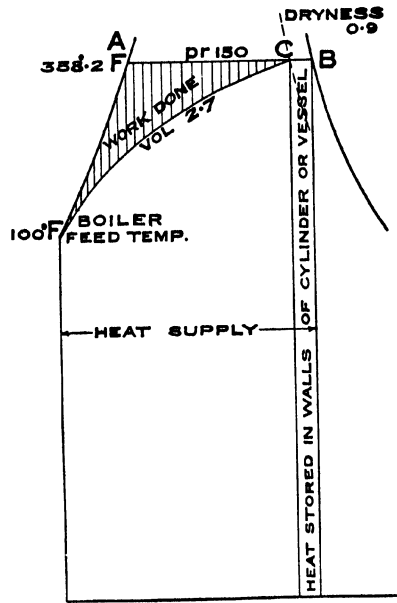

FIG. 67.

heat to the closed vessel must be stopped when $\frac{9}{10}$ ths of a lb. of steam have been evaporated, that is, when the state point C (Fig. 67) is reached. In the case of the steam engine cylinder, the amount of heat introduced, so to speak, with the steam into the cylinder, is equal to the larger area shaded horizontally in Fig. 66, but the difference has been abstracted by the cylinder walls, etc., thus causing the initial condensation. Therefore the total amount of heat introduced is the same in both cases. The two cases would, however, be more strictly comparable if it were supposed that the walls of the closed vessel were capable of storing up heat: in the case under consideration

the storage would be $\frac{1}{10}$ th of the latent heat, and is represented by the rectangle under CB (Fig. 67).

As regards the work done in the vessel, it is

$$\frac{9}{10} \times 144 (2.97 - 0.016) \text{ 150 foot-lbs.}$$

In the steam engine cylinder, the volume swept through as regards the steam is $\frac{9}{10} \times 2.97 = 2.67$ cubic feet,* together with $\frac{1}{10} \times 0.016$ cubic foot in respect of the water produced by condensation; but 1 lb. of feed water has to be introduced, so that the net work done is

$$\frac{9}{10} \times 144 (2.97 - 0.016) \text{ 150 foot-lbs.}$$

or the same as in the vessel. Fig. 67 therefore represents the state of things both in the vessel and in the cylinder, as regards work done and heat supply, and, at the state point C the condition of the steam, both in the cylinder and in the vessel as regards, pressure, volume, and dryness fraction, can be read off the chart.

Effect of Clearance.—So far it has been assumed that there is no clearance in the vessel or in the cylinder. It will now be shown how clearance can be exhibited on the chart, supposing, in the first instance, that the steam in the clearance is compressed in such a manner that it reaches boiler pressure at the moment the admission valve opens. Under these circumstances no steam will be required to fill up the clearance in the cylinder to boiler pressure. Dealing with a numerical example in which the admission temperature is 358.2° F. and the exhaust temperature 257.5° F. , let it be supposed that the clearance in the cylinder and in the vessel is 0.2 cubic foot and that at the moment of closing of the exhaust there is 2.0 cubic feet in the cylinder. The condition of the 1 lb. of H_2O in the vessel corresponding to these two points will therefore be given by the state points G and F on Fig. 68, and the transformation may take place along any line joining these two points, such as the line shown in the figure. In order to effect this transformation in the vessel, heat has to be abstracted from the lb. of H_2O , as shown by the horizontally-shaded area included between the adiabatics through G and F , and the transformation line FG . Work has to be done in compressing the steam in the clearance, as given by the

* This is also the steam volume at the point C , see the chart, Plate I.

vertically-shaded area between the constant volume lines. The $p v$ diagram of $F G$ is given in Fig. 69, and in this figure the work done is represented by the vertically-shaded area, and this figure will obviously also represent the compression portion of the $p v$ diagram of the engine cylinder. Therefore the work done in compressing the steam that remains in the cylinder at the moment of closing the exhaust is given by the vertically-shaded area on the chart (Fig. 68). It is, however, otherwise with the heat required to be abstracted from the steam in the engine cylinder; it is not equal to

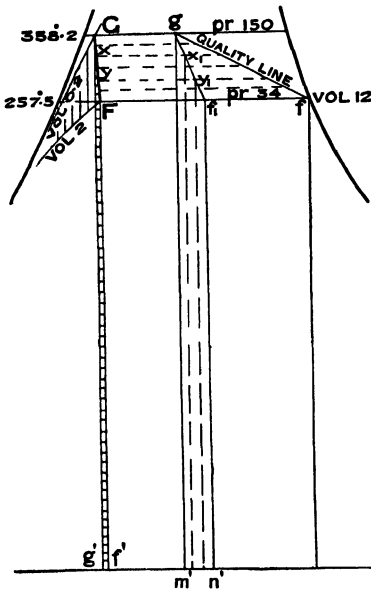

FIG. 68.

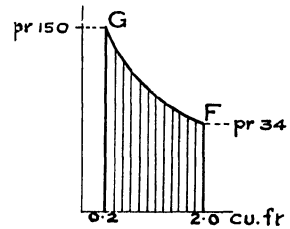

FIG. 69.

the horizontally-shaded area in Fig. 68, because in the cylinder there must be considerably less than 1 lb. of H_2O . It is to be observed that the weight of *steam* is the same both in the vessel and in the cylinder at all times, and in the numerical example under consideration at the moment corresponding to the closing of the exhaust valve, the vessel contains 2 cubic feet of steam at the exhaust temperature $257.5^\circ F.$; on referring to the chart (Plate I), it will be seen that at this temperature saturated steam has a volume of 12 cubic feet, hence the weight of the 2 cubic feet of steam will be $\frac{1}{6}$ th lb. In the vessel there is, therefore, $\frac{5}{6}$ lb. of *water* at the moment the

exhaust closes, but there is no means of telling how much water there is in the cylinder. It will, therefore, be assumed that all the water was swept out by the exhaust or else evaporated, so that at the moment the exhaust valve closes the cylinder contains dry steam, the weight of which, as shown above, is $\frac{1}{6}$ th lb.

Quality Line.—The amount of heat abstracted from the cylinder during the compression period can be readily determined by means of the chart. Let it be imagined that there is another cylinder just so much bigger than the engine cylinder that it contains 1 lb. of dry steam at the moment of closing of its exhaust valve, and let it further be assumed that the quality of the steam in the large cylinder is the same as in the original cylinder at corresponding points. The transformation line in the large cylinder will start from f on the saturation line (Fig. 68) in accordance with the assumption that the steam is dry at the corresponding point F , and the remainder of the transformation line $f g$, can be easily plotted, since at corresponding points the volumes must be in the proportion of 1 to 6 (in the numerical example under consideration). It will be seen that the transformation line $f g$ gives the *quality* of the steam in the original engine cylinder at all points during the compression, and it will therefore be called the “quality line.” Thus at the point G (Fig. 68) the quality of the steam, as represented by the “quality point” g , has a dryness fraction of 0.4 nearly. The heat it is necessary to abstract from the large cylinder to make the 1 lb. of H_2O in it follow the transformation line $f g$, is given in Fig. 68 by the area below $g f$ down to absolute zero, and the heat required to be abstracted from the original engine cylinder will evidently be this area divided in proportion to the volumes of the two cylinders, that is, in the present numerical example in the proportion of 1 to 6. If $g f_1$ is a curve drawn proportionately to $g f$ in the above ratio, it is clear that the area $g f_1 n_1 m_1$ is the heat required to be abstracted from the engine cylinder during the transformation $F G$. Further, the heat change during any portion $y x$ of the transformation $F G$ is equal to the area bounded by the portion $y_1 x_1$ of the curve $g f_1$ and the dotted verticals drawn down to absolute zero through the points x_1 and y_1 . To make this point clear, a portion of Fig. 68 has been re-drawn in Fig. 70, in which the temperature scale is larger, and the area giving

THE ENERGY CHART.

the heat required to be abstracted from the engine cylinder during the portion Fx of the compression is shown shaded horizontally.

Fig. 71 gives a case of a quality line in which the compression line FG is vertical, so that as far as the closed vessel is concerned it is an adiabatic, that is to say, no heat change takes place in the vessel. In the case of the engine cylinder, however, heat represented in amount by the horizontally-shaded area (carried down to absolute zero) has to be abstracted. On measurement it is found that this amount of heat is 92.5 B.Th.U.

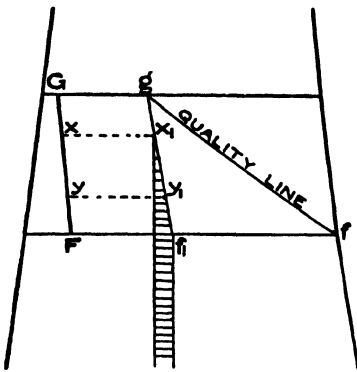

FIG. 70.

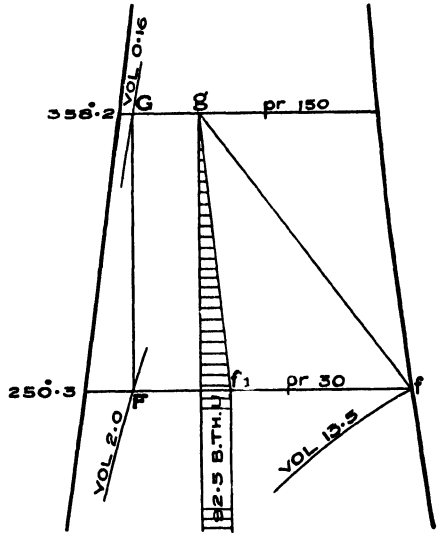

FIG. 71.

It has been assumed so far that the compression starts at F with dry saturated steam. There may, however, be a certain proportion of water remaining in the engine cylinder, at the point F , say, for instance, 0.03 lb.; so that dealing with the previous numerical example the engine cylinder at the moment the exhaust valve closes, will contain $\frac{1}{8}$ lb. of steam and 0.03 of water. The dryness fraction at the point F is therefore

$$\frac{\frac{1}{8}}{\frac{1}{8} + 0.03} = 0.848$$

and the state point of the steam on the "quality" line is, therefore, given by the point f in Fig. 72. The curve fg can be

determined from the curve $F G$, as was done in the case given in Fig. 68, and further the curve $g f_1$ can be obtained in a like manner.

From the above it will be seen that even in the case of a cylinder containing less than 1 lb. of H_2O , the work done and the heat changes due to any transformation can be graphically shown on the chart.

Proportional Water Line.—In the preceding, only the heat change required to effect the transformation of the fraction of the 1 lb. of H_2O in the cylinder itself has been considered, but obviously during this transformation the balance of the 1 lb. (in the form of water)

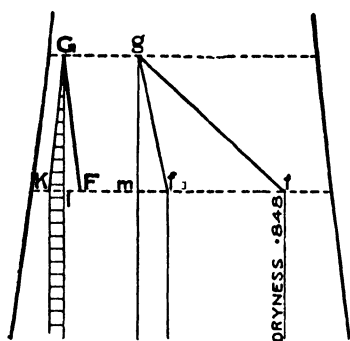

FIG. 72.

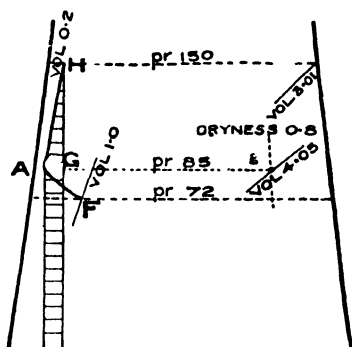

FIG. 73.

must be raised, in the boiler, from the exhaust temperature at F to the admission temperature at G . In the numerical example given in Fig. 72 there was $\frac{1}{8} + 0.03 = 0.197$ lb. of H_2O in the steam cylinder at the point F , in fact, during the whole of the transformation $F G$; therefore, in this case, 0.803 lb. of feed water had to be raised in temperature in the boiler. A curve $G K$ can be drawn, as shown in Fig. 72, based on the water line of the chart, which may be called the "proportional water line," and the area contained by this curve and the verticals through K and G down to absolute zero, and shaded horizontally in Fig. 72, gives the heat necessary to raise the temperature of the 0.803 lb. of feed water in the boiler, from the temperature at F to the temperature at G . Fig. 72 therefore shows graphically, by means of two separate areas, the heat change in the cylinder itself, and also the heat supply required to raise the temperature of the feed water. In the closed vessel the

heat required to be abstracted during the transformation $F G$ is shown on the chart by the horizontally-shaded area below $F G$ (Fig. 68), and the two areas referred to above when added together, having regard to their sign, total up to this area, as appears from the following. In Fig. 72 it is found by measurement that the area below $g f_1$ is $0.123 + \theta \times m f_1$, where θ is absolute temperature at f_1 , and the area below $G K$ is $0.059 + \theta \times K l$; the former area is to be taken with a negative sign, because the heat is abstracted. Hence added together the two areas makeup $0.064 + (m f_1 - K l) \theta$. It is also found by measurement, that the area below $F G$ (Fig. 68) is $0.064 + \theta \times g' f'$, and that: $g' f' = m f_1 - K l$. A general proof of this proposition is complicated, and it is suggested that it be verified by working out several numerical examples.

Compression Pressure less than Boiler Pressure.—It will now be supposed that the cylinder has not only clearance, but, further, that the compression does not reach the boiler pressure. In the vessel this state of things would be represented by the transformation line following a constant volume line $G H$, as shown in Fig. 73, as soon as the compression ceased. It is not necessary to consider the portion $F G$ as that has already been done in the previous investigation. No external work is done during the transformation $G H$, because the volume does not change and this is shown on the chart, but an amount of heat represented by the horizontally-shaded area below $G H$ has to be supplied. In the steam cylinder matters are, however, somewhat different. Let g represent the quality of the steam in the steam cylinder at the point G just before the admission from the boiler opens; immediately afterwards the communication is established and steam rushes in to fill up the clearance to boiler pressure. The question arises how much steam has thus to be admitted. To simplify matters let it be supposed that the cylinder walls are non-conducting. If the boiler is large enough not to appreciably drop in pressure when admission takes place, the steam that fills the clearance will have been evaporated at constant pressure. (In the vessel, it will be observed, the steam is formed at constant volume during the transformation $G H$). The energy due to the velocity of the in-rushing steam is derived from the steam itself: this velocity will at first cause eddies which in time will disappear, the energy

again appearing as steam energy. Let it be supposed that sufficient time elapses for this process to be completed before the condition of the steam at H is considered, and that it is then dry saturated steam. The question how much steam has been admitted from the boiler to produce this result, under the limitation assumed, can most readily be answered by calculation. At G the quality of the steam is that represented by g , and, using the method described on page 27, the internal energy of 1 lb. of H_2O whose state is represented by g is equal to 936.4 B.Th.U. But from Fig. 73 there is only

$$\frac{A G}{A g} \text{ lb.} = \frac{0.2}{4.05} \text{ lb. of } H_2O$$

in the steam cylinder, so that the internal energy at G is

$$936.4 \times \frac{0.2}{4.05} = 46.2 \text{ B.Th.U.}$$

At H there is 0.2 cubic foot of dry steam at 150 lbs. pressure and since 1 lb of steam at this pressure has a volume of 2.97 cubic feet and the internal energy is 1109 B.Th.U. per lb. (see Plate 1), it follows that the internal energy in the steam cylinder at H is 74.7 B.Th.U. Clearly, therefore, the boiler has had to provide

$$74.7 - 46.2 = 28.5 \text{ B.Th.U.}$$

Now the total heat at 150 lbs. pressure is 1191 B.Th.U. Hence $\frac{28.5}{1191}$ lb. of steam has to be introduced from the boiler to carry out the transformation GH , bearing in mind the limitations that have been assumed, namely that the walls are non-conducting, that the cylinder at the point G contains steam, whose dryness fraction is 0.8, and that all the eddies induced by the in-rush of the steam on entering have disappeared.

If the steam at G is wetter than assumed, more heat will obviously be required, and the amount could be ascertained as shown above if the quality of the steam were known. More steam from the boiler will be required if the walls are conducting in order to make up for initial condensation. It is to be observed that the condensation here considered is that occurring during the period of making up the pressure in the cylinder to that in the boiler (during "pre-admission" in fact). The condensation which takes place during admission, is not included.

Expansion Line, with Initial Condensation.—A transformation line, such as that shown in Fig. 74, due to the expansion in a steam engine cylinder will now be considered. It will first be assumed that both the admission valve and the exhaust valve are absolutely tight. It is obvious that in the case given in Fig. 74 heat has to be supplied to the 1 lb. of H_2O contained in the cylinder, during expansion, and the total amount so supplied from C to D is represented by the area below CD bounded by the adiabatics through C and D and shaded horizontally.

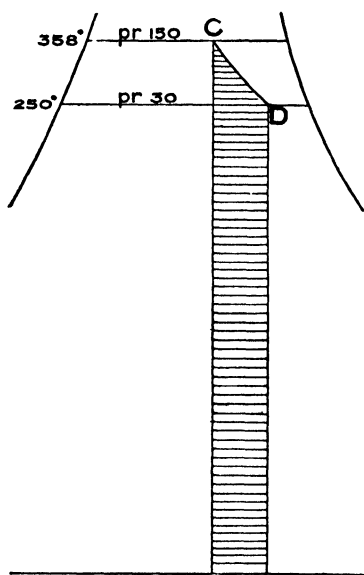

FIG. 74.

On the assumption that the valves are tight, this heat can only be supplied, in an actual engine, from heat due to initial condensation and stored in the cylinder walls or in the water produced up to the point of cut-off, or by heat transmitted through the cylinder walls from jackets.

The case in which the heat derived from initial condensation is stored in the cylinder walls, etc., will be considered more closely. On the supposition that the cylinder has no clearance, the cylinder receives 1 lb. of steam per stroke, and the heat supply per stroke is thus represented by the area below $A_1 A B$ (Fig. 75), a portion of this heat is transferred to the cylinder walls by condensation, and

the state of the steam at cut-off is represented by the point C . The work done up to this point is represented by the area bounded by $A_1 A C$, and the constant volume line through C ; the remainder of the heat supplied per stroke is contained in the steam in the cylinder, in the cylinder walls, in eddies, and in the water produced by condensation. The heat stored in the cylinder walls and contained in eddies is evidently equal to the *latent* heat of the steam which has been condensed, and this amount of heat is shown on the chart by the rectangular area below $C B$. But the heat contained

The work areas are also shown on the $p v$ diagram (Fig. 76). The heat stored in the cylinder walls is equal to 0.326 of the latent heat per lb., at 150 lbs. pressure which is 861 B.Th.U. Thus 281 B.Th.U. are stored in the cylinder walls and in eddies.*

The heat in the water produced by condensation is 0.326 of the water heat of 1 lb. of water at 150 lbs. pressure, and is therefore 0.326 (330 + E), and can be shown on the chart (see Fig. 75) by drawing a "proportional water line" for 0.326 lb. of water. Hence

$$\text{Work done} = 55.6 \text{ B.Th.U.}$$

$$\text{Heat in walls and in eddies} = 281 \text{ B.Th.U.}$$

$$\text{Heat in the water in the cylinder} = 0.326 (330 + E) \text{ B.Th.U.}$$

$$\text{Total} = 443 + 0.326 E \text{ B.Th.U.}$$

The internal energy in the steam in the cylinder at the point C (Fig. 75) must therefore be: $1191 - 443 + 0.674 E = 748 + 0.674 E$. But the internal energy of 0.674 of 1 lb. of steam at 150 lbs. pressure is $0.674 (1109 + E) = 748 + 0.674 E$, which agrees with the above result.

Equivalent Weight of Water and Theoretical Re-evaporation Line.—An "equivalent" weight of water† can be calculated such that the heat in the cylinder walls and in eddies is just sufficient to raise its temperature from that at the point A_1 to that at the point A (Fig. 75). This water would then act as a store for the heat represented by the rectangle below CB . In the numerical example under consideration this heat is 281 B.Th.U. and the difference of temperature is 108° F. , hence the weight of the "equivalent" water in this case is

$$\frac{281}{108} = 2.59 \text{ lbs.,}$$

which, added to the 0.326 of a lb. of water produced by condensation gives 2.92 lbs. of water at a temperature 358.2° F. If this water cools with the steam as the expansion proceeds, giving up heat to the steam, it is clear that when the temperature of 250.2° F. is reached $2.92 \times 108 = 315.3 \text{ B.Th.U.}$ will have been transferred from the "equivalent" water to the steam in the

* From the chart the area below CB is equal to $CB \times 819.2$, but by measurement $CB = 0.343$, hence heat = $0.343 \times 819 = 281 \text{ B.Th.U.}$, or the same number.

† The idea of this "equivalent" weight of water is due to P. W. Willans—
See Min. Proc., C.E., Vol. CXIV., page 35.

cylinder. The expansion line will therefore be placed to the right of the adiabatic through *C* as shown by *CR* (Fig. 77); the point *R* must be so situated that the area below *CR* is 315.3 B.Th.U. The expansion line *CR* (Fig. 77) shows the greatest amount of heat that can be restored, from the heat in the equivalent water, to the steam in the cylinder of an engine, when the admission and exhaust valves are quite tight and there are no jackets, and this expansion line *CR* can be called the "theoretical re-evaporation line." In an actual engine the expansion always falls considerably short of *CR*., unless the admission valve is leaking

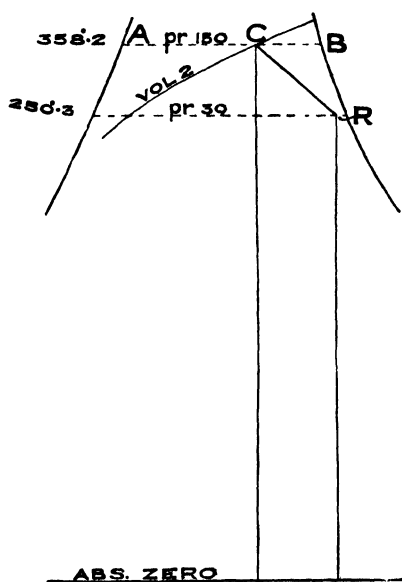

FIG. 77.

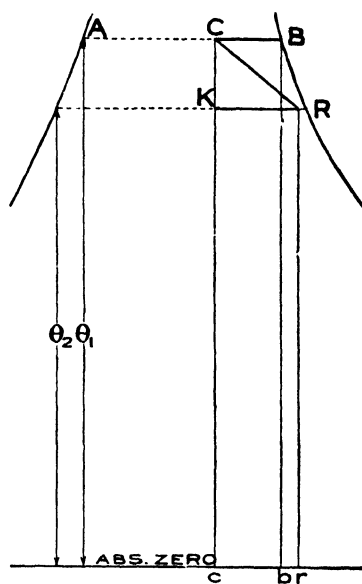

FIG. 78.

This theoretical re-evaporation line is important, and it will, therefore, be shown how to obtain it generally, not merely by a numerical example. In Fig. 78, the heat stored in the "equivalent" weight of water is equal to the area of the rectangle below *CB*, which is = $CB \times \theta_1$, and since the temperature through which the "equivalent" weight of water is raised is $\theta_1 - \theta_2$, its weight is

$$\frac{CB \times \theta_1}{\theta_1 - \theta_2}$$

To this must be added the weight of water produced by condensation equal to $\frac{C B}{A B}$ lb., and which at the beginning of expansion is at the temperature θ_1 . The supposition is that as the expansion proceeds, and the temperature of the steam drops, the temperature of these two weights of water will keep exact pace, and that the resulting heat is transmitted to the steam. The amount of heat thus transmitted when the expansion is complete at the point R is :

$$\frac{C B}{A B} (\theta_1 - \theta_2) + C B \times \theta_1 \text{ B.Th.U.},$$

and this heat is represented on the chart by the area below $C R$.

But this area is equal to $K R \left(\frac{\theta_1 + \theta_2}{2} \right)$

$$\text{Hence} \quad K R = \frac{2 C B}{\theta_1 + \theta_2} \left(\frac{\theta_1 - \theta_2}{A B} + \theta_1 \right)$$

It is to be observed that $K R$, $C B$, and $A B$, can be measured on the chart on the entropy scale, thus in the case of the numerical example previously considered the values are :

$$C B = 0.343 \text{ and } A B = 1.05,$$

and since $\theta_1 = 358.2 + 461$ and $\theta_2 = 250.2 + 461$

$$\begin{aligned} \text{therefore } K R &= \frac{0.686}{711.2 + 819.2} \left(\frac{108}{1.05} + 358.2 + 461 \right) \\ &= \frac{0.686}{1530} (102.7 + 819.2) = 0.413 \text{ entropy units.} \end{aligned}$$

The two areas which total up to make up the area below $C R$ (Fig. 77) are shown graphically on the chart as follows (see Fig. 75):—The heat stored in the walls of the cylinder and in eddies is the area below $C B$ shaded horizontally. The heat in the water produced by condensation is equal to $\frac{C B}{A B} \times$ the water heat at A , and is equal to the area shaded by dots obtained by drawing a curve $A a$, deduced from the water curve by proportioning the horizontal distances to the vertical through A in the ratio $\frac{C B}{A B}$. This area is in fact the heat required to raise $\frac{C B}{A B}$ lb. of water from temperature θ_1 to temperature θ_2 . Further the loss of $p v$ due to condensation is shown by the area between the constant volume lines through C and B , and is shaded vertically.

Expansion Line with Leaky Admission Valve.—Let it now be supposed that the inclination of the expansion line is not due to heat recovered from the walls or from the condensed steam* or to the effect of a jacket, but is solely caused by *leakage* from the admission valve, and that the exhaust valve is absolutely tight. This being the case it must be considered that at the point *D* (Fig. 79) the cylinder contains 1 lb. of H₂O, and consequently the state of the steam in the cylinder at that point can be read off the chart. There will, however, be less than 1 lb. of H₂O at *C*, and at all other points between *C* and *D*. The question is, what amount of steam has leaked into the

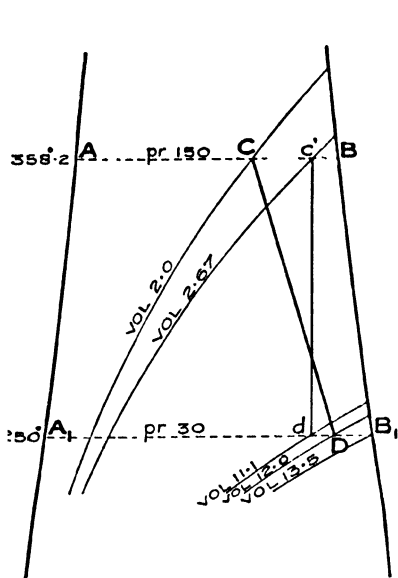

FIG. 79.

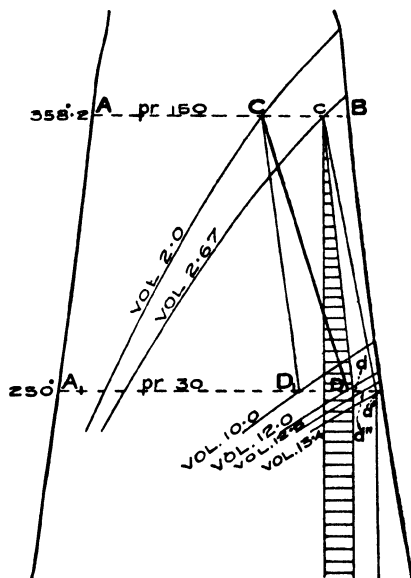

FIG. 80.

cylinder between the points *C* and *D*. This question cannot be answered definitely because the weight of *water* present in the cylinder at the point *C* is not known, although the weight of *steam* present is known, being equal to $\frac{C A}{A B}$ lb. Some idea can, however, be formed if an assumption is made as to the weight of water present at *C*. Suppose, for instance, that the dryness fraction is 0.9. The

* This is a purely imaginary case, as there must always be some heat returned to the steam by the walls during expansion.

state of the H₂O is, therefore, represented by the point *c*. If steam of this quality were expanded adiabatically it would follow the line *cd*, and reading from the chart (Plate 1), the volume of steam at *d* would be 11.1 cubic feet. At *c* the volume is 2.67, thus the steam would have expanded $\frac{11.1}{2.67}$ or 4.16 times. Hence, if in the actual cylinder there were no leakage, and consequently under the assumed conditions the expansion were adiabatic, the volume of the steam at *C*, equal to 2.0 cubic feet, would have increased to $4.16 \times 2 = 8.32$ cubic feet at the end of the expansion. In the case under consideration, however, there are 12 cubic feet of steam in the cylinder at the point *D*, so that evidently $12 - 8.32 = 3.68$ cubic feet, at

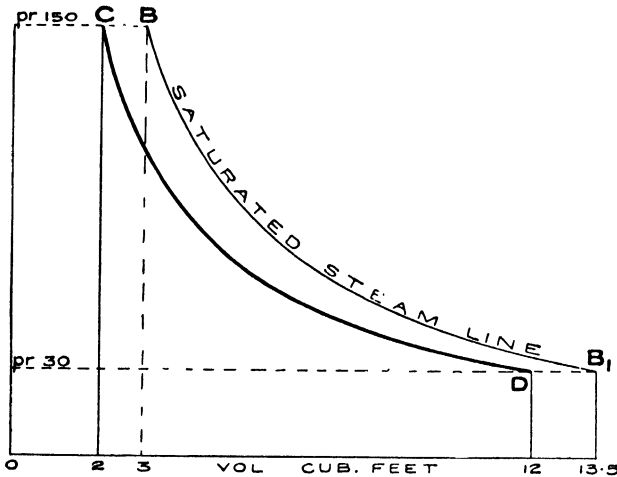

FIG. 81.

the pressure 30 lbs. per square inch, have leaked past the admission valve into the cylinder during the expansion; but the volume of *saturated* steam at the pressure of the point *D* is 13.5 cubic feet, so that $\frac{3.68}{13.5} = 0.27$ lb. of steam has leaked into the cylinder. Strictly, a correction is needed to the above, because the argument used implies that the steam leaking into the cylinder was formed at the pressure at which it leaked in, that is at varying pressures dropping from the pressure at *C* to the pressure at *D*. In practice, however, the steam would be produced at the boiler pressure, which is certainly somewhat higher than the pressure at *C*. Eddies will therefore be formed by the steam leaking in, and in so far as they are re-converted into heat before the point *D* is

reached, a corresponding weight of water will be evaporated. The calculation, therefore, shows a slightly too great an amount of leakage. The expansion line CD has been plotted on the $p v$ diagram (Fig. 81), together with the corresponding saturated steam line.

Expansion Line with Leaky Exhaust Valve.—If the admission valve is tight, the expansion line will, due to the leakage of the exhaust valve, fall far short of the theoretical expansion line, even to the extent of sloping to the left of the adiabatic at the beginning of the expansion, where, owing to the greater difference of pressure, the leakage through the exhaust valve is greatest.

Expansion Line with Leaky Admission and Exhaust Valves.—It is obviously difficult to disentangle the effects of both these leakages with any accuracy, but from the above it will be evident that the expansion line will be nearly adiabatic at the beginning, or even slope to the left, and at the end of the expansion will slope considerably to the right. Fig. 112 is an example.

Expansion Line with Jacket and Leaky Admission Valve.—Lastly, let the expansion line CD be due, partly to heat added during the expansion by means of a jacket and partly to leakage past the admission valve, the exhaust valve being supposed to be absolutely tight. Since by supposition the admission valve leaks the cylinder will contain the maximum weight of H_2O at the point D , and this weight will be weight of the feed less the weight of steam passing through the jacket per stroke; the latter can be determined experimentally and for a numerical example let it be supposed to be $\frac{1}{17}$ th of the feed. The cylinder thus contains $\frac{16}{17}$ ths of the feed at the point D , but, since the chart (Plate 1) is drawn for 1 lb. of H_2O , it must be considered that the cylinder contains 1 lb. of H_2O at the point D , hence the feed per stroke is $\frac{17}{16}$ of a lb., and the jacket steam is $\frac{1}{16}$ th of a lb. per stroke.

Since the cylinder is jacketed the condensation ought to be small, and therefore let it be assumed that the dryness fraction of the steam in the cylinder at C is 0.9, and it is to be remarked that there is less than 1 lb. of H_2O at C . The *quality* of the steam at C is therefore represented by the point c on the chart (Fig. 80). Let another and larger cylinder containing 1 lb. of H_2O in the state

represented by c be considered whose admission valve is, however, absolutely tight, and let it be supposed that this cylinder is provided with a jacket supplying more heat than the previous one in the proportion of the volume at c to the volume at C , namely in the proportion of 2.67 to 2. The heat given up by the second jacket per

stroke is that due to the condensation of $\frac{2.67}{2}$ of $\frac{1}{8}$ th of a lb. of steam and by the resulting water falling in temperature from 358.2 °F. to 250.3° F., and this amount of heat can be found by proportion from the corresponding amount for 1 lb. of steam, as represented on the chart by the area below $A' A B$. Thus the line $c d$ has been so

drawn that the horizontally-shaded area is equal to $\frac{2.67}{2} \times \frac{1}{8}$ th of the area below $A' A B$. It follows that $c d$ would be the expansion line in the larger cylinder if the whole of the heat in the jacket were transmitted to that cylinder. Further, if the whole of the heat due to condensation were recovered the expansion line in the larger cylinder would be shifted to $c d'$, the point d' being found as previously explained. In practice the whole of the heat stored in the walls due to condensation cannot be recovered, nor can all the heat expended in the jackets be transferred to the steam in the cylinder. Hence $c d'$ is the limiting expansion line due to all the heat from the jacket, and from the walls of the cylinder, when there is no leak past the admission valve. From the chart it is seen that the volume at d' is 13.4 cubic feet, obviously, therefore, the corresponding volume

in the smaller cylinder would be $\frac{2}{2.67} \times 13.4 = 10$ cubic feet,

which gives the point D_1 ; that is to say if there were no leak, and all the heat in the jacket were transferred, and all the heat stored in the cylinder walls, etc., were recovered, the expansion line in the smaller cylinder would be $C D_1$, instead of $C D$. The volume at D is, however, 12 cubic feet, so that if all the jacket heat and all the heat in the walls is recovered, the leakage is $12 - 10 = 2$ cubic feet, and since 1 lb. of saturated steam at 250.3° F., has a volume of 13.5 cubic feet, it follows that the leakage per stroke is

$$\frac{2}{13.5} = 0.148 \text{ lb.}$$

This is the minimum leakage, because it has been obtained

on the supposition that the whole of the jacket heat is transferred and all heat stored in the walls of the cylinder is recovered. If, however, $\frac{2}{3}$ rds of the jacket heat is transferred and a similar proportion recovered from the cylinder walls, then the point d' will be shifted to d'' by making the area below $c d''$ $\frac{2}{3}$ rds the area below $c d'$. The volume at d'' is found to be 12.6 cubic feet, so that the corresponding volume in the smaller cylinder is

$$12.6 \times \frac{2}{2.68} = 9.42 \text{ cubic feet,}$$

and the leakage is $12 - 9.42 = 2.68$ cubic feet, the weight of which is

$$\frac{2.68}{13.5} = 0.198 \text{ lbs.}$$

On comparing Figs. 79 and 80, it will be seen that the lines $C D$ are the same; in the former case it was supposed that the whole effect was due to leakage, and it was found that this leakage was 0.27 lb. of steam per stroke. In the second case the effect was due partly to leakage and partly to a jacket and to heat recovery from the walls, and it has been shown that then the *minimum* leakage is 0.148 lb. per stroke. The result has thus been established that the minimum leakage is 0.148 lb., and the maximum leakage 0.27 lb. Limits to the leakage are thus fixed.

Exhaust Line : Incomplete Expansion.—An exhaust line at constant volume will next be considered as represented by $D E$ in Fig. 82. In the closed vessel which contains 1 lb. of H_2O it will be seen that at D the state of the steam is

Pressure	30 lbs. per square inch
Volume	10 cubic feet
Temperature.....	250.3° Fahr.
Dryness fraction	0.74

The transformation line $D E$ is obtained by abstracting heat as shown by the area below $D E$ shaded horizontally and there is no internal work done.

At E the state of the 1 lb. of H_2O is:—

Pressure	15 lbs. per square inch
Volume	10 cubic feet
Temperature.....	213.2° Fahr.
Dryness fraction	0.385
Internal energy	626 B.Th.U.

In the steam engine cylinder, however, matters are somewhat different. At the point *D* the state of the H_2O is by assumption the same, both in the closed vessel and in the cylinder, but at *E* the cylinder contains only steam, except a little water that may cling to the walls and the piston body. There is no means of knowing what this amount of water is, and it depends much on the design of the engine as regards drainage. From the chart it will be seen that at the point *E* the cylinder contains 0.385 lb. of steam, at a

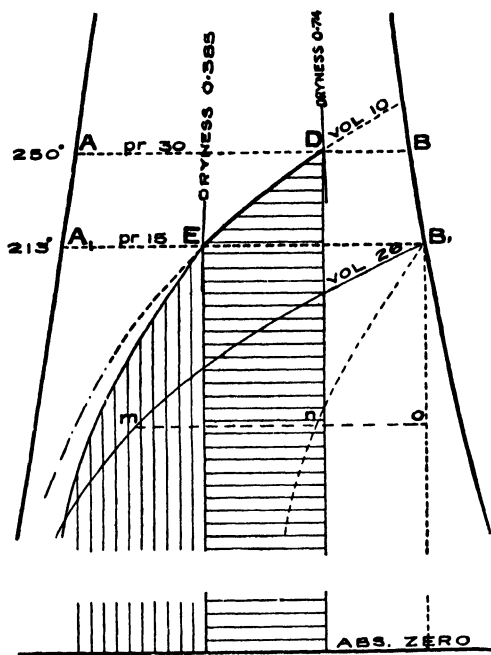

FIG. 82.

pressure of 15 lbs., and at a temperature of $213.2^{\circ}F$. The internal energy of this steam is 0.385 times that of 1 lb. of saturated steam at 15 lb. pressure, which is 1075 B.Th.U., as read on the scale of internal energy on the chart (Plate 1). This energy is therefore 414 B.Th.U., and is shown by the vertically-shaded area. It will be observed that this energy is less than the internal energy of the 1 lb. of H_2O at the corresponding point in the closed vessel, which is represented by the area below the dotted constant volume line. The internal energy

of 1 lb. of saturated steam at the pressure of 15 lbs. per square inch is also shown in Fig. 82 by the area below the constant volume line for 26 cubic feet drawn through the point B_1 , and the dotted line drawn through the same point is such that the horizontal intercepts to the adiabats through B_1 are in the ratio 0.385 to 1, for instance $no/mo = 0.385/1$. The area below this dotted line represents therefore the internal energy of the steam present at *E*, and is equal to the vertically-shaded area.

Summary.—Reviewing the various cases of transformation lines that have been considered in detail, it will be seen that in every case the external work done by or on the steam in the cylinder is correctly shown on the chart, but that the heat added or abstracted is not, in many cases, shown directly on the chart, but that it can always be obtained in these cases by various geometrical constructions, or by simple calculations.

A variety of useful problems will now be considered.

To draw the Quality Line corresponding to any given Transformation Line.—Let $P H$ (Fig. 83) be a transformation line for less than 1 lb. of steam, the quality of the steam at the point P is given, as represented by the point p . It is desired to draw the quality line. The first step is to find the weight of H_2O present during the transformation $P H$. The weight of *steam* present at P will evidently be less than 1 lb. in the proportion of the volume of saturated steam at the pressure of P to the volume at P , and the weight of *water* at P will be in proportion to the dryness fraction at p . Thus the weight of H_2O at P can be readily found, and, from the conditions of the problem, this is the weight of H_2O throughout the transformation $P H$. The next step is to find the “quality” point for any other point Q , situated on $P H$. The weight of *steam* at Q is less than 1 lb. in the proportion of the volume of saturated steam at the pressure of Q , to the volume at Q . This weight, deducted from the weight of H_2O previously found, gives the weight of *water* at Q . The dryness fraction at Q is therefore known, and the position of the point q can be fixed. The quality line $p h$ can therefore be drawn. The following numerical example (given in Fig. 83) will further illustrate the matter:—

The weight of steam at P is

$$1 \times \frac{2}{13.5} \text{ lb.} = 0.148 \text{ lb.},$$

and since the dryness at p is 0.9, the weight of water at P is

$$(1 - 0.9) \frac{2}{13.5} \text{ lb.} = 0.0148 \text{ lb.}$$

The weight of H_2O is therefore 0.163 lb., and this is the weight during the transformation $P H$.

At Q the weight of steam is $1 \times \frac{1.1}{7} = 0.157 \text{ lb.}$ Hence the

one, and in Fig. 84 a numerical example is given showing how to draw an adiabat through the point H for $\frac{0.5}{4} = 0.125$ lb. of steam ; the steam at H being saturated. At g the dryness is seen from the chart to be 0.9, hence the weight of steam at G is $0.125 \times 0.9 = 0.1125$ lb. The volume of saturated steam at the pressure of G is 13.5 cubic feet, hence the volume of steam at G is $13.5 \times 0.1125 = 1.5$ cubic foot. G is therefore located, and any other point can be located in the same way.

To find the Temperature and Pressure at the end of a given number of Expansions under Adiabatic Conditions.— Let C (Fig. 85) be the state point of the beginning of the expansion. The volume at this point can be read off the chart. Multiply this volume by the number of expansions and find the intersection D of the adiabat through C , with the volumeline for the expanded steam. The temperature and pressure can be read off the chart.

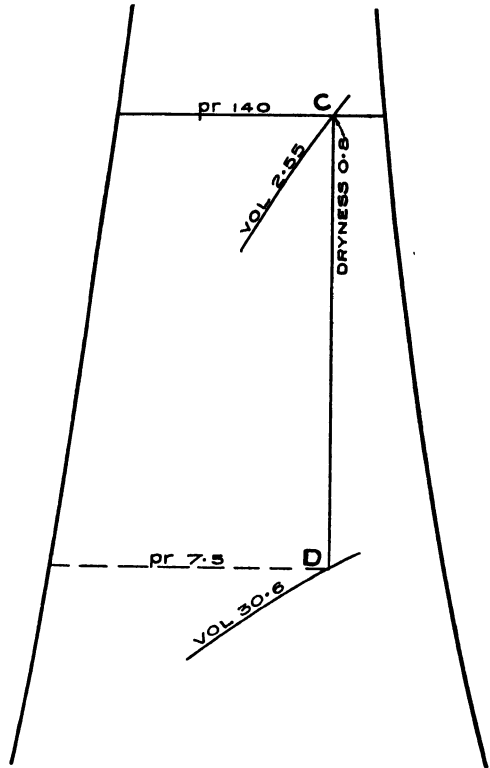

FIG. 85.

In Fig. 85 the number of expansions has been taken as 12. Hence the volume at D is $2.55 \times 12 = 30.6$ cubic feet, and as read off the chart :—

Pressure at $D = 7.5$ lbs. per square inch abs.

Temperature „ = 180 °F.

It is interesting to note that Rankine, in his “Steam Engine and Prime Movers,” says at page 392 that the above problem can only be worked out (by means of thermodynamic formulæ) by “ a tedious

process of trial and error" (see also Appendix II., Steam engine trials, by P. W. Willans, M.Inst.C.E. Vol. CXIV., Min. Proc. Inst. C.E.).*

The problem could be equally easily solved by means of the chart if the expansion $C D$ were *not* adiabatic.

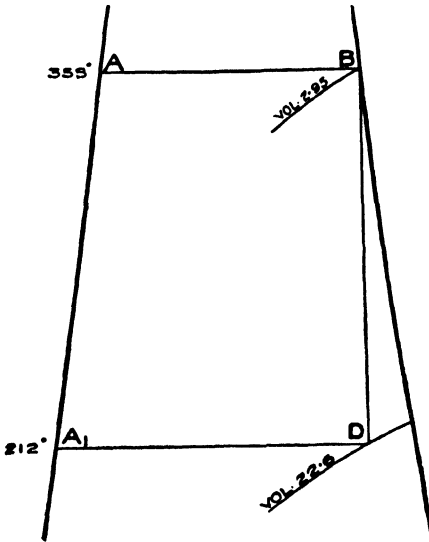

FIG. 86.

Determination of point of Cut Off.—Referring to Fig. 86, $A B D A_1$ is the $\theta \phi$ diagram for a perfect steam engine (Rankine cycle), working between the temperatures of 359° F. and 212° F. , and it will be seen that the volume of the steam at release in the cylinder is 22.6 cubic feet, and that at cut-off it is 2.95 cubic feet. The cut-off, therefore, obviously takes place at $\frac{2.95}{22.6} = 0.13$ of the stroke, and the steam is expanded $\frac{22.6}{2.95} = 7.66$ times.

In the case of an actual engine, account must be taken of the clearance volume, and a moment's consideration will show that the point of cut-off can be obtained from the formula :

$$\text{Point of cut-off} = \frac{\text{volume at cut-off} - \text{volume in clearance.}}{\text{volume at release} - \text{volume in clearance.}}$$

Economy of the Rankine Engine.—The area of the $\theta \phi$ diagram of the perfect engine (Fig. 86) is found on measurement to be equal to 17.2 square inches when drawn on Plate 1, and, since the heat scale is 10 B.Th.U. per square inch, it represents 172 B.Th.U. This perfect steam engine therefore produces 172×778 foot-lbs. of work for every lb. of feed water. Further, the number of

* Willans' construction applies only to the case when the steam initially, at the point C, is dry saturated.

B.Th.U.* required by the engine per lb. of feed water is total the heat at 359° F., less the water heat at 212° F. = 1010 B.Th.U. Therefore an expenditure of 1010 B.Th.U. is required in order to obtain 172 B.Th.U. of work per stroke. But 1 horse-power per minute is equal to

$$\frac{33000}{778} = 42.4 \text{ B.Th.U.},$$

so that this perfect steam engine can do

$$\frac{172}{42.4} = 4.06 \text{ horse-power per lb. of feed, per minute,}$$

that is for an expenditure of 1010 B.Th.U. Hence, the economy of this engine, as defined by the Thermal Efficiency Committee of the Inst. Civil Engineers, is 252 B.Th.U. per I.H.P. per min. The various operations just performed are included in the formula :—

$$\begin{aligned} \text{Economy of engine} &= 42.4 \frac{\text{Heat supply per stroke.}}{\text{Heat represented by } \theta \phi \text{ diagram.}} \\ &\text{(expressed as B.Th.U.)} \\ &\text{(per I.H.P. per min.)} \\ &= \frac{42.4}{\text{Thermal efficiency.}} \end{aligned}$$

Economy of an Actual Engine.—This formula applies also in the case of an actual engine; thus, for example, referring to Fig. 91, it will be seen that the vertically-shaded area of the $\theta \phi$ diagram (representing the work done) is 65.5 B.Th.U., and the heat supply per stroke is represented by the area whose contour is dotted and is equal to 821 B.Th.U. (as found on page 75). Using the above formula :

$$\text{Economy of actual engine} = 42.4 \times \frac{821}{65.5} = 533 \text{ B.Th.U. per I.H.P. per min.}$$

Steam Consumption of an Engine.—One H.P. is equal to

$$42.4 \times 60 = 2545 \text{ B.Th.U. per hour.}$$

Hence the feed water can be obtained by dividing 2545 by the number of B.Th.U. utilized as work per lb. of $\theta \phi$ cylinder feed,†

* The † B.Th. U. 'utilised by the Rankine engine can be found with sufficient accuracy thus :—The mean temperature is

$$\frac{359 + 212}{2} = 285^{\circ} \text{ F.},$$

and at this temperature the horizontal distance between the water line and the adiabatic B D, measured on the entropy scale (Plate 1), is 1.17 and the difference of temperature is 359 — 212 = 147° F. Hence, very approximately, the area, A₁ A B D represents = 1.17 × 147 = 172 B.Th.U.

† For definition see page 73.

as given by the area of the $\theta \phi$ diagram or diagrams. The formula is therefore

$$\left. \begin{array}{l} \text{Lbs. of feed water per} \\ \text{I.H.P. per hour} \end{array} \right\} = 2545 / \begin{array}{l} \text{B.Th.U. represented by } \theta \phi \text{ dia-} \\ \text{grams per lb. of } \theta \phi \text{ cylinder feed.} \end{array}$$

Mean Pressure of Rankine Engine.—Referring again to the perfect steam engine of Fig. 86, it is obvious that the work represented by the $\theta \phi$ diagram, namely 172 B.Th.U., must be equal to the mean pressure in the cylinder \times the volume swept by the piston. From the figure it will be seen that this volume is 22.6 cubic feet. Hence the mean pressure is

$$\frac{172 \times 778}{22.6} = 5920 \text{ lbs. per square foot} = 41.1 \text{ lbs. per square inch.}$$

Mean Pressure of Actual Engine.—In the actual engine of Fig. 91, the work done is 65.5 B.Th.U., and the volume in the cylinder at release is 12.3 cubic feet, but the volume in the clearance is 0.8 cubic foot, so that the volume swept by the piston, being the difference between these two volumes, is 11.5 cubic feet. Hence the mean pressure is

$$\frac{65.5 \times 778}{11.5 \times 144} = 30.7 \text{ lbs. per square inch,}$$

which is the same as the mean pressure obtained from the $p v$ diagram (Fig. 87), see page 73. The general formula is :

$$\text{M. E. P.} = 5.4 \frac{\text{B.Th.U. represented by } \theta \phi \text{ diagram}}{\theta \phi \text{ Volume at release} - \theta \phi \text{ Volume of clearance.}}$$

“*Equivalent*” *feed*. As explained under Line 131, Report of the Committee of the Institution of Civil Engineers, on Steam Engine and Boiler trials, the equivalent feed is obtained by the formula :

$$\text{Equivalent feed} = \frac{\text{Lbs. of feed water per}}{\text{I.H.P. per hour}} \times \frac{\text{Heat supply per lb.}}{1100}$$

The next step is to apply these various cases and constructions to the complete indicator diagram of a steam engine.

CHAPTER VI.

$\theta \phi$ DIAGRAMS OF STEAM ENGINES DERIVED FROM THEIR INDICATOR DIAGRAMS.

THE indicator diagram given in Fig. 87 will be taken as a first example. Further data relating to this diagram are as follows:—

Boiler pressure : 115 lbs. per sq. in. absolute (100 lbs. gauge)

Pressure at engine stop-valve : 110 lbs. per sq. in. absolute

Exhaust pressure : 14.7 lbs. per sq. in. absolute

Area of piston : 155 square inches.

Stroke : 6 inches. Therefore the volume swept by the piston is 0.538 cubic foot.

Weight of feed per stroke, *i.e.*, per diagram, corrected* for leakage past the cylinder into the exhaust is : 0.0382 lb.

Location of Initial Point.

—Selecting *M* on the expansion line at a point before the exhaust valve opens, it will be seen from Fig. 87 that at this point the

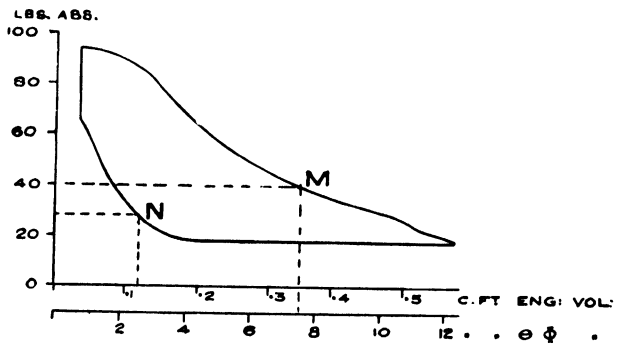

FIG. 87.

volume of steam in the cylinder is 0.35 cubic foot, and that the pressure is 40 lb. per square inch absolute. Referring now to the chart, it will be seen that the volume of saturated steam at this pressure is 10.3 cubic feet per lb. Thus obviously the cylinder contains $\frac{0.35}{10.3} = 0.0340$ lb. of saturated steam. A portion of this

* The engine was fitted with a slide valve, 5% was therefore deducted from the actual feed. See also page 120.

steam, however, is due to that retained in the clearance each stroke. Let it be assumed that at the point *N*, about half-way up the compression line, the cylinder contains only saturated steam; at this point the volume in the engine cylinder is 0.125 cubic foot and the pressure 27 lbs. per square inch absolute as read off the *p v* diagram.

At this pressure saturated steam has a volume of 14.9 cubic feet per lb. Hence the weight of steam in the cylinder at the point *N* is $\frac{0.125}{14.9} = 0.0084$ lb., and this is the weight of steam retained in the

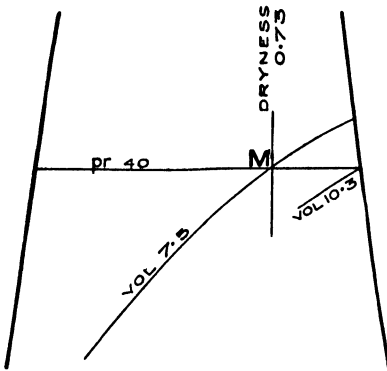

FIG. 88.

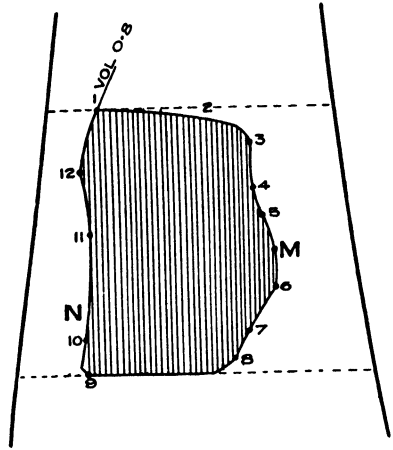

FIG. 89.

clearance on the assumption made. Deducting this weight from the weight of steam at the point *M*, namely 0.034, it is found that the diagram accounts for 0.0256 lb. of steam passing through the cylinder per stroke. According to the data, however, the weight of feed per stroke is 0.0382 lb., and the difference, namely

$$0.0382 - 0.0256 = 0.0126 \text{ lb.},$$

must obviously be in the cylinder at the point *M* in the form of water, since the correction for leakage direct into the exhaust has been made. Thus at this point there is 0.034 lb. of steam and

0.0126 lb. of water. Hence the dryness fraction is :—

$$\frac{0.034}{0.034 + 0.126} = 0.73.$$

The point *M* can therefore be located on the chart (see Fig. 88), as the point on the 40 lbs. per square inch constant pressure line at which the dryness fraction is 0.73.

Corresponding $\theta \phi$ Engine and Volume Factor.—In the actual engine there was present at the point *M*, 0.0466 lb. of H_2O , consisting of 0.034 lb. of steam and of 0.0126 lb. of water, occupying a volume of 0.35 cubic foot. At the point *M* on the chart there is, however, 1 lb. of H_2O , consisting of 0.73 lb. of steam and of 0.27 lb. of water, occupying a volume of 7.5 cubic feet. The engine con-

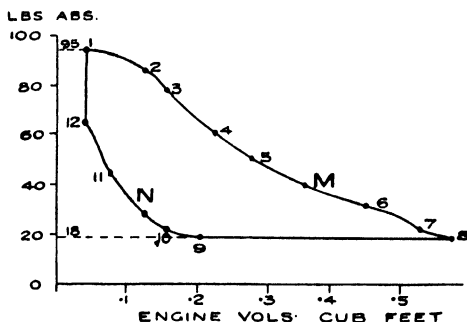

FIG. 90.

templated by the chart is, therefore $\frac{7.5}{0.35} = 21.4$ times larger than the actual engine, all volumes relating to the actual engine must therefore be multiplied by this factor to obtain the transfer of the $p v$ diagram to the chart. The engine whose diagram is drawn on the chart can conveniently be called the “corresponding $\theta \phi$ engine,” and the factor the “volume factor.”* An equivalent way of looking at the matter is to apply a new volume scale to the $p v$ diagram of the actual engine as shown in Fig. 87.

Plotting of the $\theta \phi$ Diagram.—The next step is to take a number of points on the contour of the $p v$ diagram marked 1, 2, 3, in Fig. 90, and read off the pressure and volume for each point. The volumes are then to be multiplied by the volume factor. The following table is thus established :—

* This term “volume factor” was first used by the Author in 1894—see Proceedings of the Institution of Mechanical Engineers, 1st and 2nd Feb., 1894. The volume factor there mentioned is, however, the inverse of that of the text.

TABLE.

1	2	3	4
Reference Number of Point.	Volumes.		Abs. Pressure per square inch.
	$p v$	$\theta \phi$	
1	.037	0.80	95
2	.125	2.67	87
3	.155	3.32	77
4	.225	4.81	59
5	.275	5.88	50
<i>M</i>	.350	7.49	40
6	.450	9.63	32
7	.525	11.22	23
8	.575	12.30	18
9	.200	4.28	18
10	.150	3.21	21
<i>N</i>	.125	2.68	27
11	.075	1.61	44
12	.037	0.80	66

The point on the chart corresponding to point 1 on the $p\bar{v}$ diagram is obviously the intersection of the constant pressure line for 95 lbs. per square inch (Col. 4) with the constant volume line for 0.80 cubic foot (Col. 3), and similarly for all the other points. The $\theta \phi$ diagram given in Fig. 89 is thus obtained. No pressure and volume lines are shown in this figure, and it is suggested that columns 3 and 4 in the table be plotted on tracing paper placed over the chart (Plate I). A more rapid method is given in Appendix I.

The shaded area in Fig. 89 is the work done by the "corresponding $\theta \phi$ engine" expressed in B.Th.U., and is therefore equal to the work done by the actual engine multiplied by the volume factor, viz., 21.4. The area* of the $\theta \phi$ diagram when plotted on Plate I,

* Fig. 73 is drawn to too small a scale to be able to measure this area with any accuracy. The figure given in the text was obtained by plotting on Plate I. This remark applies to all subsequent diagrams of the same kind.

will be found on measurement to be 6.55 square inches, and since the heat scale of this chart is 10 B.Th.U. per square inch, the work done by the "corresponding $\theta \phi$ engine" is $6.55 \times 10 = 65.5$ B.Th.U.

The mean pressure of the actual engine obtained in the usual way from the $p v$ diagram (Fig. 87) is 30.6 lbs. per square inch, so that the work done per stroke by the actual engine is: Mean pressure per square foot \times volume swept by piston $= 30.6 \times 144 \times 0.54$ foot-lbs.; or equal to $\frac{2380}{778} = 3.06$ B.Th.U. Multiplying by the volume factor 21.4, gives 65.2 B.Th.U. as the work done by the $\theta \phi$ engine. The agreement of this figure with that obtained from the $\theta \phi$ chart is a check on the accuracy of the plotting.

Energy retained in Cylinder ("play" energy).—From Fig. 89 it will be seen that the admission valve opens at the point 12 and at this point the $\theta \phi$ engine has a cylinder volume of 0.8 cubic foot. What is the internal energy of the H_2O contained at this point in the cylinder, just before the admission valve opens? By drawing the *quality line* as explained at page 63, the dryness fraction is found to be 0.695, and the pressure is 66 lbs. per square inch, and at this point it is found that the internal energy is 835 B.Th.U. per lb. (see Fig. 43). At 12 there is, as already seen 0.0084 lb. of H_2O . Hence the internal energy in the cylinder at 12 is 7.0 B.Th.U. This amount of energy is retained in the engine clearance each stroke and might be called the "play" energy, corresponding to the "play" steam.

Heat Energy per $\theta \phi$ diagram.—The next investigation will be to show graphically on the chart the amount of heat energy introduced per diagram into the $\theta \phi$ cylinder. The first step is to find the feed water per diagram, or the " *$\theta \phi$ cylinder feed.*" From the given data the feed water per stroke of the actual engine is 0.0382 lb., and since the $\theta \phi$ engine is 21.4 times larger, the feed water per diagram for it is 0.818 lb. Another way of obtaining this figure is as follows:—At the point *M* (Fig. 89) the $\theta \phi$ engine contains 1 lb. of H_2O , but as previously shown the weight of steam remaining in the clearance is

$$0.0084 \times 21.4 = 0.180 \text{ lb.}$$

It follows that the feed of the $\theta \phi$ engine is $1 - 0.180 = 0.820$ lb. per diagram or practically the same figure as before. The area whose con-

tour is dotted in Fig. 91, which is Fig. 89 reproduced on a smaller scale, is, therefore, the representation of the heat supply per stroke, and it can thus be seen at a glance what a small proportion of the heat supply has been utilised as work. This proportion is the "thermal efficiency of the actual engine."*

Comparison with Rankine Cycle.—The question arises what proportion would a perfect steam engine (Rankine cycle) have been able to utilise under the circumstances. In the first place it is to be observed that the pressure at the engine stop-valve is less than in the boiler owing to losses in the steam pipes, so that the pressure at the engine stop-valve is 110 lbs. per square inch, as given in the data.

This must be considered as the pressure the perfect steam engine has to work with, corresponding to a higher temperature limit of 334.5° F., and the loss due to the drop of pressure must be laid to the account of the steam pipes. Further, the exhaust pressure is 14.7 lbs. per square inch which corresponds to a temperature of 212° F., and this is the lower limit of temperature for the perfect steam engine of comparison. It will be observed that the feed temperature is lower, but this is due to defective feed arrangements, and the consequent loss must be placed to their account, since theoretically the feed can be raised to the exhaust temperature.

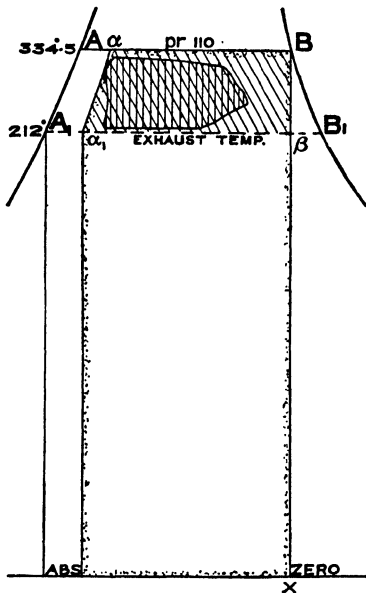

FIG. 91.

It follows from the above that the heat supplied per stroke is the latent heat of 0.818 lbs. of steam evaporated at a pressure of 110 lbs. per square inch absolute, added to the water heat of the same weight of water raised from 212° F. to 334.5° F. If the engine has no clearance, then the diagram of the Rankine cycle is shown by the area $A_1 A B \beta$, and

* Subject to the feed having been corrected for leakage past the cylinder direct into the exhaust.

this is for an engine using 1 lb. of feed. The $\theta \phi$ engine under discussion, however, uses 0.818 lbs. of H_2O per stroke, so that for comparison the Rankine cycle should be drawn for 0.818 lb. of H_2O , or in other words, should contain 0.818 of the heat units in the area $A_1 A B \beta$. In order to show this graphically, the point α_1 is found

such that $\frac{\alpha_1 \beta}{A_1 \beta} = 0.818$, and similarly other points are found

along the curve $\alpha \alpha_1$. Then the area $\alpha_1 a B \beta$ represents the work done by the Rankine engine using 0.818 lb. of dry steam. The heat supplied per diagram, and the manner of supplying it, is, therefore, shown in Fig. 91, by the area whose contour is shaded by dots. This is the amount of heat supplied per diagram both to the $\theta \phi$ engine corresponding to the actual and to the perfect steam engine, and on measurement is found to be equal to 821 B.Th.U. Hence, the

thermal efficiency of the actual engine is $\frac{65.5}{821} = 0.08$. As regards

the Rankine engine, it rejects the heat represented by the rectangle $\alpha_1 X$, and therefore converts into work the remainder of the area, as shown by oblique shading. It must be borne in mind that the perfect engine has no clearance, although Fig. 91 might make it appear that it had, but the weight of steam supply to the perfect engine is 0.818 lb. per diagram, and it will be seen therefore that $\alpha_1 a$ is really the water line of the chart drawn for 0.818 lb. of water; it follows also that neither the steam line nor the volume lines nor the dryness fraction lines of the chart apply to the perfect steam engine of the dimensions now being considered. The obliquely shaded area therefore represents *only the heat* utilised by the perfect steam engine, and it is found by measurement that it is equal to 118.4 B.Th.U.*

Location of Losses.—It can be judged from Fig. 91 to what extent the actual engine fails, and also where the failure takes place. It has

* This figure can be obtained by calculation, with ample accuracy, thus: The range of temperature of the Rankine cycle is from 334.5° to 212° F. The mean of these temperatures is 273° , and the horizontal distance between the water line and the adiabatic drawn through the point B (Fig. 91) is 1.18 measured on the entropy scale. The range of temperature is $334.5^\circ - 212^\circ = 122.5^\circ$. Hence the B.Th.U. converted into work by the Rankine cycle for 1 lb. of steam $= 1.18 \times 122.5^\circ = 144.6$. Therefore for a $\theta \phi$ cylinder feed of 0.818 lb. the heat utilized is: $144.6 \times 0.818 = 118.3$ B.Th.U.

admission and exhaust pressures are shown. It would appear at first sight that the loss due to throttling is represented by the area $A_1 A B C$. It is not, however, quite so great as this, because the energy represented by this area is still present in the steam in the form of velocity of the whole mass, a velocity which is, at any rate in part, arrested when the steam enters the cylinder, so that it re-appears as heat, and is thus able to do work in the engine cylinder. The theoretical amount of this possible work must, therefore, be deducted from the work represented by the area $A_1 A B C$, in order to find the theoretical loss due to throttling. The matter may be regarded in this way: One lb. of steam, in the condition of the state-point C , receives an amount of heat represented by the area $A_1 A B C$, and thus attains to the state point S in the superheated field. $B_1 S$ is a constant pressure line, and the area below $C B_1 S$ is equal to the area $A_1 A B C$.—The triangular area below $B_1 S$ is so small that it may be neglected, and therefore the value of $D K$, which determines the position of S can be found, with all needful accuracy, from the following equation:—

$$D K \times \theta_c = \frac{A B + A_1 C}{2} \times (\theta_A - \theta_{A_1})$$

The lengths $A B$ and $A_1 C$ can be measured from the chart (Plate 1), and the temperatures can be read off it. It is clear that of the heat thus added to the steam the portion represented by $C B_1 S K D$ can theoretically be converted into work, and this portion should be deducted from the area $A_1 A B C$ to obtain the true theoretical loss due to wire-drawing from the pressure at A to the pressure at A_1 . If, therefore, a line $L M$ be drawn such that the area $L A B M$ is equal to the area $C B_1 S K D$, then the area

$A_1 L M C$ shaded thus  represents the loss due to wire-drawing. It is obvious that :

$$A L / A A_1 = C D / C c$$

The point L can therefore easily be found, since $A A_1$, $C D$ and $C c$ can be read off the chart (Plate I).

Fig. 92 is not drawn to scale in order to better exhibit the

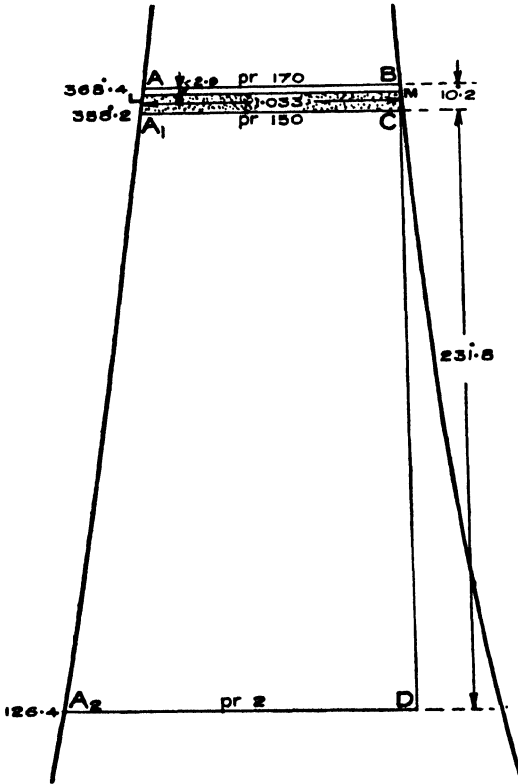

FIG. 93.

areas under discussion. Fig. 93 is, however, drawn to scale, and represents the case in which the steam is wire-drawn from 170 to 150 lbs. per square inch, and the exhaust is 2 lbs. per square inch. The calculation is as follows:—

From Plate I it is found that

$$A A_1 = 10.2^\circ \text{ F.}$$

$$C D = 231.8^\circ \text{ F.}$$

$$C c = 358.2 + 463 = 819.2^\circ \text{ F.}$$

Hence

$$A L = \frac{231.8 \times 10.2}{819.2} = 2.9^\circ \text{ F.}$$

The mean width of the area $A_1 L M C$ as measured on the entropy scale is 1.033. Hence the loss due to wire-drawing in this case is $(10.2 - 2.9) 1.033 = 7.5$ B.Th.U. per lb. of feed.

Loss due to initial Condensation, Leakage and Radiation.—In Fig. 94 the line $C D$ represents the expansion line. If the engine had been

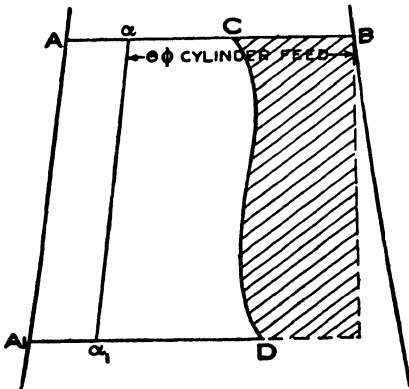
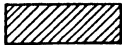

FIG. 94.

perfect the exhaust line would have been the adiabetic through *B*. The loss is therefore represented by the area included between the adiabetic through *B* and the line *C D*. As explained on page 74, to take account of the effect of clearance, the Rankine cycle diagram must be drawn so that the expansion line falls on the adiabetic through *B*, and the water line falls on $\alpha \alpha_1$; this is the Rankine cycle for an engine using the " $\theta \phi$ cylinder feed" per stroke. The losses under consideration, per diagram,

are therefore represented by the area shaded thus, 

and the B.Th.U.'s measured off the chart must be increased in the proportion of

$$\frac{\text{I}}{\text{"} \theta \phi \text{ cylinder feed"}}$$

to obtain the losses per 1 lb. of steam passed through the cylinder. But, on the other hand, the ratio of the actual areas show the percentage losses.

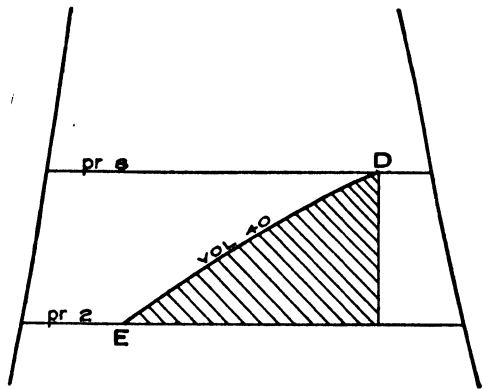

FIG. 95.

Loss due to Incomplete Expansion.—In Fig. 95, *D E* represents the release at constant volume, and if an adiabetic be drawn through *D*, the approximately triangular area

shaded thus 

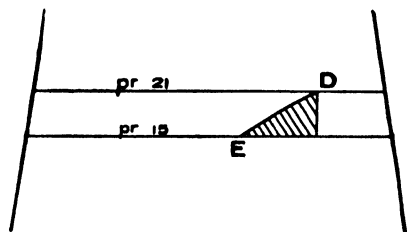

FIG. 96.

represents the loss due to incomplete expansion. It will be seen that this loss is considerable in the case shown in Fig. 95, which is that of a condensing engine. For a non-condensing engine the loss is much less, as will be seen by examining Fig. 96, in which the drop of pressure is the same as in Fig. 95, namely 6 lbs. per square inch.

Loss due to Throttling through Exhaust Ports.—In Fig. 97, *E F*

represents the pressure in the cylinder during exhaust, and A_1 is at the pressure in the exhaust. The difference between these two pressures is the pressure required to drive the steam through the exhaust ports and the area

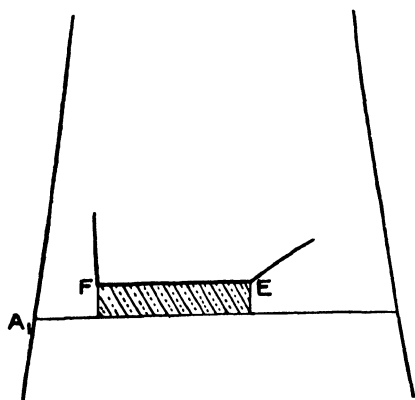

FIG. 97.

a clearance represented by the volume at G , is αa_1 (Fig. 98), and if FG is the compression line and GH the constant volume line of the clearance. it will be seen that the area included between the two lines αa_1 and FGH , shaded

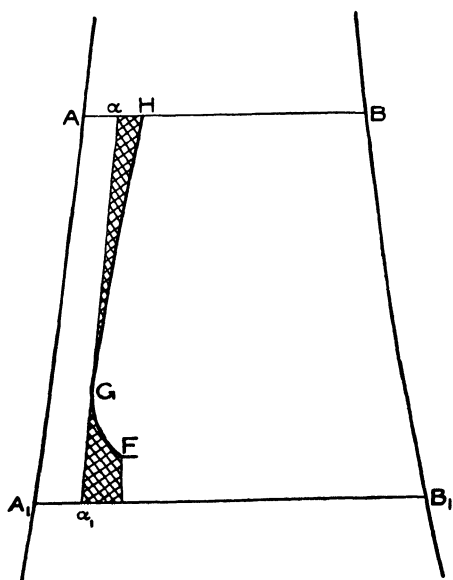

FIG. 98.

thus represents the loss due to compression and clearance per " $\theta \phi$ cylinder feed" which must be increased as before to obtain the loss for 1 lb. of steam passed through the engine.

The principal losses occurring in a reciprocating steam engine have now been located on the chart, and the results obtained have been collected together in Fig. 99. The area $\alpha_1 a B \delta$ represents the work that a Rankine

engine, whose temperature limits are 350° and 130° F. would do, the feed per stroke being taken as 0.818 lb., and this area divided into the area H C D E F G representing the work done by the actual engine is the "Efficiency ratio."

Leakage of Admission Valve past Cylinder Direct into the Exhaust.

—In the example worked out in this chapter it was stated that the feed had been corrected for the direct leakage into the exhaust. There does not appear to be any particular advantage in showing this loss graphically on the chart, although this could be done by an area added on the right hand side of the saturation line. Account should, however, be taken of this leakage in calculating the thermal efficiency and the efficiency ratio. Thus, if the direct leakage into

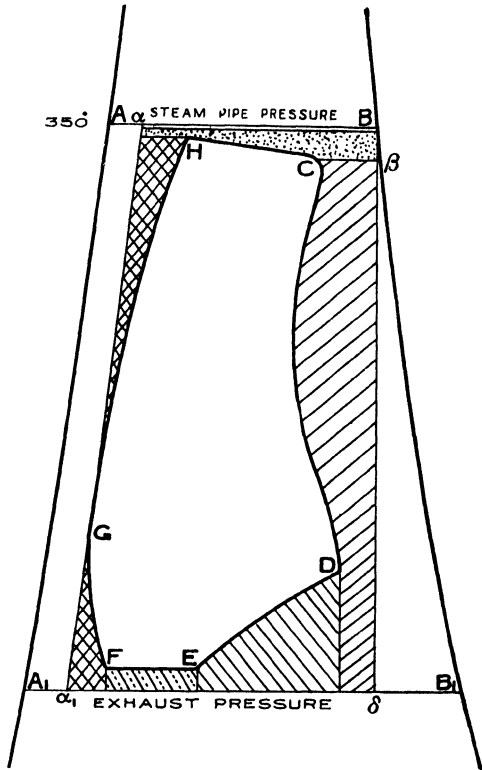

FIG. 99.

the exhaust is 0.004 lb. per stroke, the real feed, in the example, will be $0.0382 + 0.004 = 0.0422$ lb. per stroke and the thermal efficiency becomes $0.08 \times \frac{0.0382}{0.0422} = 0.072$, and the efficiency ratio is $0.55 \times \frac{0.0382}{0.0422} = 0.50$.

Some of the losses tabulated at page 76 are inherent to the conditions under which the engine is working, and the material used in its construction. Others have to be incurred in order to save greater losses in other directions. such, for instance, is in-

complete expansion, wire-drawing at admission, and the loss due to clearance. None of these losses can be absolutely expunged although, with suitable arrangements, they can be reduced very materially from what they are in the case under consideration. What these arrange-

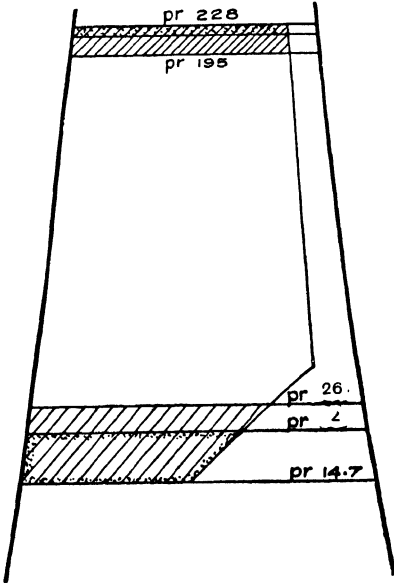

FIG. 100.

ments are is not in the province of this book to consider, but their thermodynamic advantage can easily be tested by means of the chart, as is illustrated by the following example :—

Losses in a Locomotive Cylinder due to Throttling at Admission and at Exhaust.—

As an example, the results of a trial on engine No. 3001 of the Paris-Orléans Railway can be taken. The indicator cards are given on page 382, Proceedings, Institution Mechanical Engineers, February, 1904. From these cards it is seen that at a speed of 36.6 miles per hour :—

Boiler pressure	=	228 lbs per sq. in. abs.
Admission „	=	216 „ „
Exhaust „	=	22 „ „

and at a speed of 68.0 miles per hour :

Boiler pressure	=	228 lbs. per sq. in. abs.
Admission „	=	195 „ „
Exhaust „	=	26 „ „

The data available is insufficient to enable the $\theta \phi$ diagrams to be plotted, but the effect of the throttling of the steam can readily be seen by the following approximate method. On the chart (Plate I.) the pressures are set off, and an approximate expansion curve is sketched in as in Fig. 100. Then the losses are shown, when the engine is running at the slower speed, by the areas of which the con-

tours are dotted, and when running at the higher speed, by the shaded areas.

Strictly speaking, the admission loss is not as great as here shown, but should be corrected by the method described on page 77. Nevertheless this approximation shows the exhaust loss to be very much larger than the admission loss both at the slower and higher speeds, and it is therefore evident that a valve gear that will produce a free exhaust, so long as there is sufficient pressure for the blast, is of greater economical value than fancy gears for improving the admission.

Indicator diagrams of the L.N.W.R. locomotive "Precursor" are given in the Proceedings of the Mechanical Engineers referred to above (page 82), and it will be found on plotting them, as just described, that the same inference can be drawn.

Combining the Forward and Back End Indicator Diagrams of a Cylinder.—In a double-acting engine, the feed is distributed between the two ends of the cylinder, probably not exactly equally. If it is assumed that the efficiency ratio of each end of the cylinder is the same (which is probably very nearly true for a horizontal engine, but only approximately true for a vertical engine owing to the difference in drainage of the two ends), an approximation, sufficiently close for practical purposes, will be obtained by combining the two diagrams and taking the arithmetic mean of the pressures at the same volume.

CHAPTER VII.

$\theta \phi$ DIAGRAM OF A SIMPLE JACKETED ENGINE.

THE $\theta \phi$ diagrams of a simple jacketted engine will next be considered. In this case the steam going through the cylinder and that going through the jackets must be separated, and having done so the plotting of the $\theta \phi$ diagram is effected exactly in the same manner as described for the non-jacketted engine. The comparison with the corresponding Rankine engine is, however, somewhat different. The

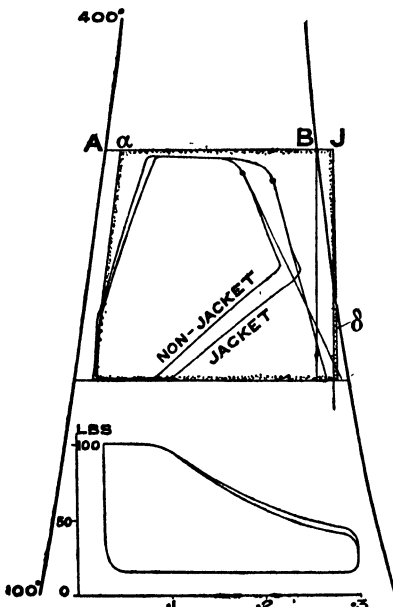

FIG. 101.

matter will be illustrated by considering the following numerical example. The $p v$ diagram is shown in Fig. 101, which gives the absolute pressures and volumes in the actual engine. From experiment it was found that 0.0321 lbs. of feed were required per diagram, of which 0.0023 lbs. passed through the jacket, leaving 0.0298 lbs. as the cylinder feed per diagram. The temperature of the water drained from the jacket was 240° F.

Plotting the $\theta \phi$ Diagram.—

Carrying out the method described on pages 69 to 72, it is found that the dryness fraction of the

H_2O in the cylinder at release is 0.87, and that the volume factor is 32.15. The $\theta \phi$ diagram can now be plotted, as in Fig. 101, as well as the diagram for the Rankine steam engine having the same weight

passing through the cylinder. On the same figure is shown the $p v$ diagram and $\theta \phi$ diagram for the engine when working between the same temperature limits, but without the jackets in use. A direct comparison can be made between the conditions of the steam during expansion by drawing the theoretical re-evaporation lines by the method given on page 54. It will be noticed that in the case of the non-jacketted engine the theoretical re-evaporation line falls outside the diagram, while in the jacketted engine it falls inside. This improvement is effected by the jacket by reducing the condensation.

Heat per $\theta \phi$ Diagram.—In order to ascertain the actual value of the jacket, it is desirable to show graphically the amount of heat supplied by that portion of the boiler feed which is used for the purpose of warming the jackets. In the actual engine 0.0023 lbs. passed through the jacket per diagram, and since the volume factor is 32.15 the weight passing through the jacket of the $\theta \phi$ engine is 0.074 lb. Prolong $A B$ to J (Fig. 101) so that

$$\frac{B J}{a B} = \frac{\text{jacket feed}}{\text{cylinder feed}}$$

then the rectangle below $B J$ will represent the latent heat in the steam passing into the jacket per diagram. Then draw through J a curve $J \delta$, proportionate to the water line, down to a temperature of 240° F. which is the temperature at which the water leaves the jacket. The area below $B J \delta$ is the heat per stroke in the jacket, so that altogether the area whose contour is dotted represents the heat converted into work per diagram for the perfect jacketted $\theta \phi$ engine. This area is found by measurement to represent 143 B.Th.U., and likewise the heat represented by the $\theta \phi$ diagram of the jacketted engine is 85.1 B.Th.U.; hence its "Efficiency Ratio" is

$$\frac{85.1}{143} = 0.598.$$

The $\theta \phi$ diagram for the engine without jackets measures 74.1 B.Th.U., but in this case the heat supply is smaller, namely 133 B.Th.U. Hence the "Efficiency Ratio" is

$$\frac{74.1}{133} = 0.556;$$

which is less, so that in this case there is a gain by using jackets. The theoretical diagram thus found does not show the losses in the cylinder due to incomplete expansion, etc., but these are given by comparing the actual expansion curve with the adiabatic of the Rankine engine drawn through the point *B*.

CHAPTER VIII.

$\theta \phi$ DIAGRAMS OF COMPOUND ENGINES.

THE diagram of the H.P. cylinder can obviously be treated exactly as if it were the diagram of a simple engine. The L.P. diagram, however, requires some special consideration because it receives its steam not from a boiler, but either from the H.P. cylinder direct or through the intermediary of a receiver, and in some cases the steam in the receiver is "re-heated." Further, owing to leaks, the L.P. cylinder may receive either more or less steam than the H.P. cylinder. If, therefore, the feed is measured *into* the engine there is no certain knowledge as to the amount of feed per diagram in the L.P. cylinder. If, on the other hand, the consumption of the engine is measured by the condenser method, then the feed passing through the L.P. per diagram is known, apart from the direct leakage past this cylinder into the exhaust, but there is doubt about the feed of the H.P. cylinder, a doubt which cannot be removed without further data.

Rankine Cycle for Compound Engine.—Before considering the case of an actual engine, that of the perfect compound steam engine (Rankine cycle) will be dealt with. In Fig. 102 let θ_a be the admission temperature, θ_b the exhaust temperature of the H.P. cylinder and also the admission temperature of the L.P. cylinder, and θ_c the exhaust temperature of the L.P. cylinder. Consider two separate closed vessels each fitted with a piston and each containing 1 lb. of H_2O , and let it be supposed that heat can be introduced into or abstracted from these vessels in any desired manner. Let these vessels be called I. and II., and to commence the cycle, let vessel I. contain 1 lb. of water at a temperature of θ_b . The state point is A_1 in Fig. 102. Heat is applied to vessel I. to raise the temperature of the water to θ_a , so as to reach the state point A , and then further heat is applied to evaporate at constant pressure from A to B .

The steam is then allowed to expand adiabatically to the point C . At this stage let vessel II. be considered and suppose that it contains 1 lb. of water at the temperature θ_b — state point A_1 , and let matters be so adjusted that the heat abstracted from vessel I., in order to follow the transformation line $C A_1$, can be introduced into vessel II., in such a way that the 1 lb. of water it contains shall follow the

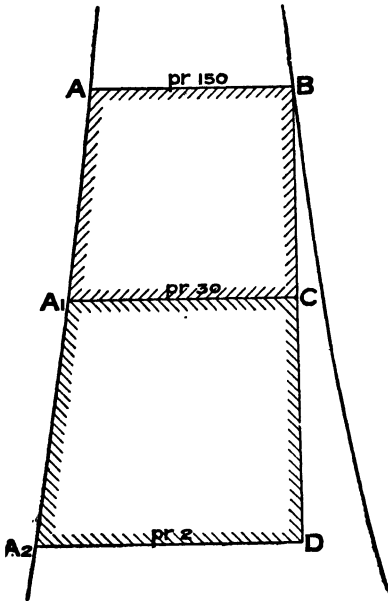

FIG 102.

transformation line A_1C . It is clear from an inspection of Fig. 102 that the heat rejected by vessel I. during the transformation $C A_1$ is exactly equal to heat required by vessel II. to follow the transformation A_1C , hence at the moment the 1 lb. of H_2O in vessel I. becomes water at A_1 (thus completing the cycle in this vessel), the 1 lb. of H_2O in vessel II. will have reached the state point C , and the heat transfer from vessel I. to vessel II. is complete. It will be noticed that the H_2O in vessel II. is not fully evaporated, but it is now allowed to expand adiabatically until the state point D is

reached, after which heat is abstracted and work done by the piston on the H_2O in such a manner as to obtain the transformation line $D A_2$. At A_2 , vessel II. contains 1 lb. of water at temperature θ_c , and to complete the cycle in this vessel heat has to be introduced into it to raise the temperature of the water to θ_b . The cycles in both vessels have thus been completed and the initial conditions again obtained. It will be observed that the heat utilised per lb. of feed is the same as that of the perfect steam engine (Rankine cycle) working between the extreme limits of temperature, namely θ_a and θ_c . The two vessels I. and II. represent therefore the perfect compound steam engine. The matter has been considered as if it were a transfer

of heat from vessel I. to vessel II. during the transformation $C A_1$, but obviously as regards vessel II. the result would be the same if the actual 1 lb. of H_2O contained in vessel I. at the point C were transferred in its then condition to vessel II. Vessel I. can, therefore, be regarded as representing the H.P. cylinder and vessel II. as representing the L.P. cylinder of a perfect compound engine. The arguments and results obtained at page 41 *et seq.*, by comparing a closed vessel with a steam engine cylinder, apply equally to each of the above vessels and their corresponding steam engine cylinders. A triple, or quadruple, expansion engine can obviously be treated in the same way.

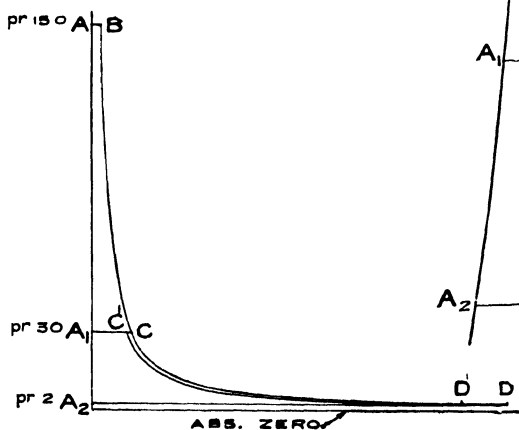

FIG. 103.

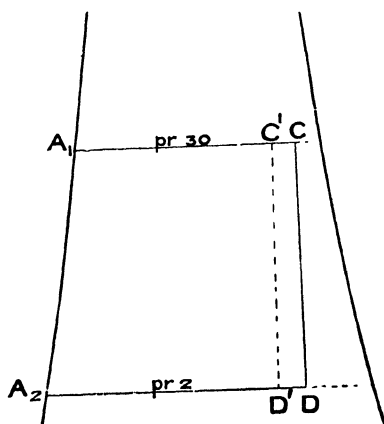

FIG. 104.

Effect of Leak from H.P. Cylinder.—Let it now be supposed that there is a leak, so that only $\frac{9}{10}$ ths of the steam present at C is transferred from the H.P. cylinder to the L.P. cylinder, the remaining $\frac{1}{10}$ th being lost so far as the engine is concerned. The volume of steam in the L.P. cylinder at the point corresponding to C will in this case be $\frac{9}{10}$ ths of the volume at C ; this determines the point C' (Fig. 104). The *quality* of the steam will still, however, be represented by the point C if the leakage past the L.P. cylinder consists of water and steam in such proportion that the quality of the steam introduced into the L.P. cylinder is the same as in that

of the Rankine engine and if the expansion is adiabatic the quality of the steam during expansion is given by the straight line CD , from which the line C^1D^1 is deduced in the manner explained on page 64.

Fig. 103 gives the $p v$ diagram of this compound engine with a leak past the L.P. cylinder, deduced from its $\theta \phi$ diagram (Fig. 104);

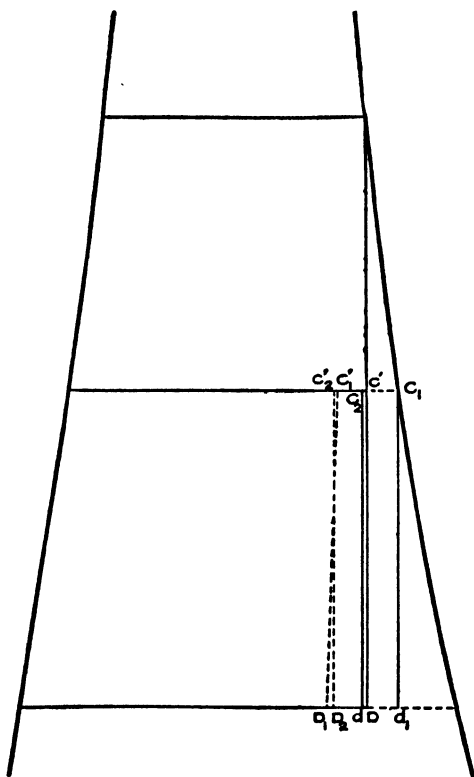

FIG. 105.

the line CD shows what the L.P. $p v$ diagram would have been had there been no leak. As regards the quality of the steam in the L.P. cylinder, two extreme cases may occur. In the first case the whole of the water present in the H.P. cylinder may leak away together with $\frac{1}{10}$ th of the steam present at the point C ; the steam in the L.P. cylinder would then be dry saturated steam at the point C_1 , and the quality line would be C_1d_1 (Fig. 105), assumed adiabatic, from which the expansion line $C'D_1$ is deduced. The other extreme

case is when none of the water present at C in the H.P. cylinder leaks away, *i.e.*, it is all transferred to the L.P. cylinder together with $\frac{9}{10}$ ths of the steam. The weight of the water at C (Fig. 102 or 104) is found from the chart to be 0.097 lb. for the numerical data given in Fig. 102, and this weight of water mixed with $\frac{9}{10}$ ths of the steam at C , namely,

$$(1 - 0.097) \frac{9}{10} = 0.813 \text{ lb. of steam,}$$

gives 0.910 lb. of H_2O , and the dryness fraction works out to

time. On this assumption there are : $12.2 (1 - 0.1) = 11.16$ cubic feet of steam at 30 lbs. pressure, whose weight is $\frac{11.16}{13.48} = 0.828$ lb., to put into the L.P. cylinder, which at that moment contains steam in the condition, as regards pressure and volume, represented by the point F_1 (the point F_1 can be located because the back pressure is 2 lbs. abs., and the clearance volume is 3 cubic feet). If it is assumed that there is no water present at F_1 , the quality in the L.P. cylinder at this point is represented by f_1 on the saturation line.

Initial Condensation in L.P. Cylinder.—A portion of the steam from the H.P. cylinder on entering the L.P. will be condensed, and its latent heat will disappear into the cylinder walls, etc. Let it be assumed that 10% is condensed then $\frac{1}{10} \times 0.828$ lb. of water will be produced. On the assumption already made that there is no water in the L.P. cylinder at the point F_1 , the weight of steam present at that point will be in the ratio of the volumes at F_1 and f_1 , or :

$$= 1 \times \frac{3}{172} = 0.017 \text{ lb.}$$

Altogether, therefore there will be $\frac{9}{10} \times 0.828 + 0.017 = 0.762$ lb. of steam, and 0.083 lb. of water present in the two cylinders immediately after communication has been established, which gives a dryness fraction of 0.9. The combined volume is $12.2 + 3.0 = 15.2$ cubic feet, so that the volume per lb. is

$$\frac{15.2}{0.762} = 20.0 \text{ cubic feet,}$$

and on reference to Plate I., it will be seen that the intersection of this volume line with the 0.9 dryness fraction line occurs at a pressure of 17.7 lbs. per square inch—therefore, this must be the pressure established in the L.P. cylinder when the communication is opened between it and the H.P. cylinder. The intersection of this pressure line with the volume line for 3 cubic feet gives the point H_1 of the L.P. cylinder (Fig. 106), and the intersection with the 12.2 cubic foot volume line the point E of the H.P. cylinder. The quality of the H_2O is = 0.9, and the "quality point" e is thus located. A property of the quality line is that the ratio of the volume at any point on this line to the volume of the steam it represents is a constant. In the case under consideration the steam is contained in two com-

municating cylinders. Hence the ratio of the volume on the quality line to the sum of the volumes of the two cylinders will be a constant for any pressure line, and in the example this ratio is: the sum of the volumes at H_1 and E ($= 15.2$) to the volume at e ($= 20.0$).

The ratio is therefore $\frac{15.2}{20.0}$.

Expansion in L.P. Cylinder.—This engine has no receiver, and therefore the same valve acts as the exhaust valve of the H.P. cylinder and as the cut-off valve of the L.P. cylinder. Until the valve closes the two cylinders are in communication, and the steam expands in them as if they were one vessel. Let it be supposed that this expansion is adiabatic, and that none of the heat stored in the cylinder walls is returned to the steam. The quality of the mixture at the beginning of the expansion is given by e , so that the quality line of the mixture is the adiabatic $e d_1$. At the moment the valve closes the volume in the H.P. cylinder is, by the assumption made as to clearance, 0.5 cubic foot, and the time required for describing EF is obviously that required for one stroke. During this time the L.P. piston will also have moved one stroke, that is to say, the L.P. exhaust valve will be on the point of opening. At this stage it is necessary to know the volume swept by the L.P. piston; and inasmuch as the clearance was not specified as a percentage of the volume swept, any reasonable volume can be assumed for the *purpose of this example*, say 33 cubic feet. Therefore at the moment the valve closes there are $33.0 + 3.0 + 0.5$ cubic feet in the two cylinders, and the steam has therefore expanded from 15.2 to 36.5 cubic feet or 2.4 times. The volume at e for 1 lb. of steam is seen from the chart to be 20 cubic feet, so that with 2.4 expansions the volume at the point in the quality line corresponding to the point F will be $20 \times 2.4 = 48$ cubic feet, and it will be seen from the chart that this point on the quality line is at the pressure 6.5 lbs. per square inch. The point F in the H.P. cylinder is therefore found by the intersection of the 6.5 pressure line with the 0.5 cubic foot volume line, and the point D_1 , in the L.P. cylinder is at the intersection of the same pressure line with the $33.0 + 3.0 = 36.0$ cubic foot volume line.

In the above, the quality line $e d_1$ was assumed to be adiabatic,

and it will be interesting to find the effect of a different assumption on the position of the points F and D_1 . Fig. 107 is a reproduction of a portion of Fig. 106. First, let it be assumed that the quality line is $e d'_1$. As previously, the point d'_1 (corresponding to D_1) will lie on the 48 cubic foot volume line, and is therefore determined as shown in Fig. 107 whence D'_1 and F' are found by drawing the pressure line through d'_1 . The same construction holds if the "quality" line is $e d''_1$, and the points D''_1 , and F'' are thus found.

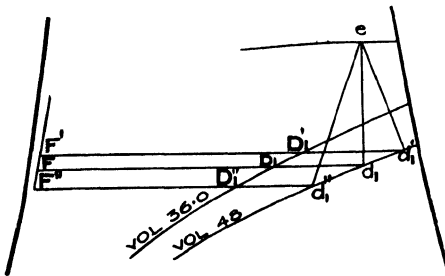

FIG. 107.

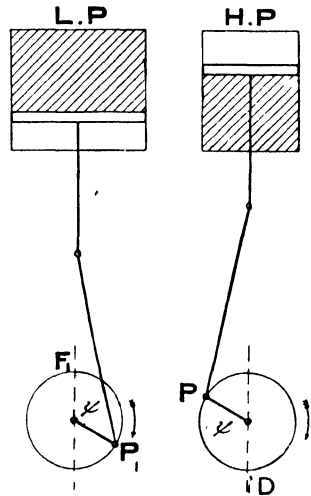

FIG. 108.

To fix other points in the lines $H_1 D_1$ and $F E$ it is first necessary to find the relation that exists between the volumes in the two cylinders at different points of the stroke. As the case under investigation is purely ideal, it will be assumed that the ratio of the connecting rod to the crank is infinity. The point D in Fig. 106 corresponds to point D in Fig. 108, and the cranks being assumed opposite, the simultaneous point for the H.P. cylinder is F_1 , both in Fig. 106 and Fig. 108. This latter figure shows the condition of things after an angle ψ has been described by the crank pins. The volume

swept by the L.P. piston up to the point P is*

$$\left(r - r \cos (2 \pi - \psi) \right) L$$

where L is area of L.P. piston. But $2 r L$ plus the clearance is obviously equal to the volume in the cylinder at the point D_1 (Fig. 106), which is seen to be 36 cubic feet. Hence the volume in this cylinder when the crank has described an angle of ψ is

$$\frac{36 - 3}{2} \left(1 - \cos (2 \pi - \psi) \right) + 3 \text{ cubic feet.}$$

Similarly the volume in the H.P. cylinder at the same moment is

$$\frac{12.2 - 0.5}{2} \left(1 - \cos (2 \pi - \psi) \right) + 0.5 \text{ cubic feet.}$$

The sum of these volumes at the point P under consideration is therefore.

$$22.35 \left(1 - \cos (2 \pi - \psi) \right) + 3.5 \text{ cubic feet.}$$

Referring to Fig. 106, suppose it is desired to find for each cylinder the point on the respective $\theta \phi$ diagram when the pressure is 11 lbs. absolute. The volume on the quality line at this pressure is seen to be 30.5 cubic feet, and since the volume on the quality line at e is 20.4 cubic feet, and the sum of the volumes in the two cylinders at H_1 and E , is 15.2 cubic feet, therefore the sum of the cylinder volumes at P and P_1 is

$$\frac{15.2}{20.4} \times 30.5 = 23.2.$$

Equating this volume to the expression found above, the following equation is obtained:—

$$23.2 = 22.35 \left(1 - \cos (2 \pi - \psi) \right) + 3.5$$

whence $1 - \cos (2 \pi - \psi) = 0.882$

and finally

$$\text{Volume in H.P.} = 5.85 \times 0.882 + 0.5 = 5.66 \text{ cubic feet.}$$

$$,, \quad ,, \quad \text{L.P.} = 16.5 \times 0.882 + 3.0 = 17.55 \text{ cubic feet.}$$

The points on the 11-lb. pressure line can thus be located at P and P_1 . Other points can similarly be obtained, and thus the complete exhaust line in the H.P. cylinder, and the admission line in the L.P. cylinder can be drawn.

* On the assumption just made, that the connecting rod is infinite, although not so shown in Fig. 108.

Exhaust Line of L.P. Cylinder.—At D_1 the exhaust of the L.P. opens, and the diagram of this cylinder follows the constant volume line drawn through D_1 until the back pressure line at 2 lbs. is reached at E_1 , then it follows the pressure line up to the point F_1 .

Other Assumptions.—To obtain these $\theta \phi$ diagrams a great number of assumptions have had to be made. Any other assumptions could, however, have been dealt with in a similar manner, such, for instance, as initial condensation in the H.P. cylinder, leakage past the piston rings, drop of pressure through the exhaust valve of the H.P. cylinder, etc., and the corresponding $\theta \phi$ diagrams could have been drawn.

The above example is not intended to represent the case of an actual compound steam engine, but to exhibit various thermodynamic transformations on the chart, and to show the comparative ease with which such problems can be solved by this graphic method. It will be probably admitted that such problems are practically insoluble by a purely algebraical method.

CHAPTER IX.

COMPOUND ENGINES.

TRANSFER OF INDICATOR DIAGRAMS TO THE ENERGY CHART.

IN this chapter several examples of compound and triple-expansion engines have been placed on the chart, but before describing them it is necessary to settle whether the volume factors should be taken the same for each cylinder or not.

Volume Factor.—On referring to page 71 it will be seen that the volume factor depends on the total volume in the steam cylinder which is the sum of the clearance volume and the volume swept by the piston. Therefore, if in a compound or triple-expansion engine each cylinder is treated separately, the volume factor will not be the same for each cylinder, unless the weight of play steam in each cylinder is the same. This method of treating each cylinder separately was originally adopted by the Author, as will be seen by referring to the remarks he made at a meeting of the Institution of Mechanical Engineers (February, 1894), and has the advantage of showing the quality of the steam *during the expansion* in each cylinder, provided, however, there are no leaks out of or into the engine; that is to say, the flow of H_2O in each cylinder is the same. There is, however, the disadvantage that the areas of the $\theta \phi$ diagrams are not proportional to the work done in each cylinder, as they would be if each cylinder had the same volume factor. On the whole, however, it is better to use different volume factors, as by this method the various calculations are considerably simplified, and the graphic representation is more easily grasped, and therefore it has been adopted in the following examples :—*

EXAMPLE I.

Compound Condensing Engine (non-jacketted).—The indicator diagrams for this engine are given in Fig. 109, and the following particulars of the engine are needed to draw the $\theta \phi$ diagrams :—

* Although the references are not given, the data for these examples are taken from actual tests.

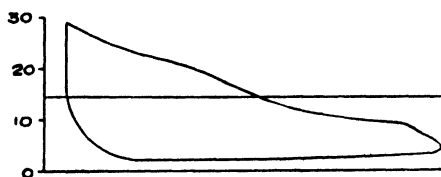
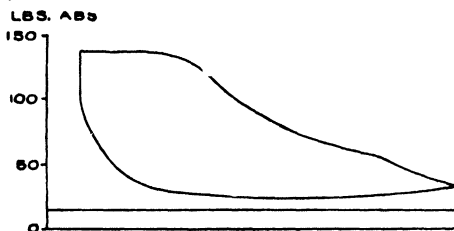

FIG. 109.

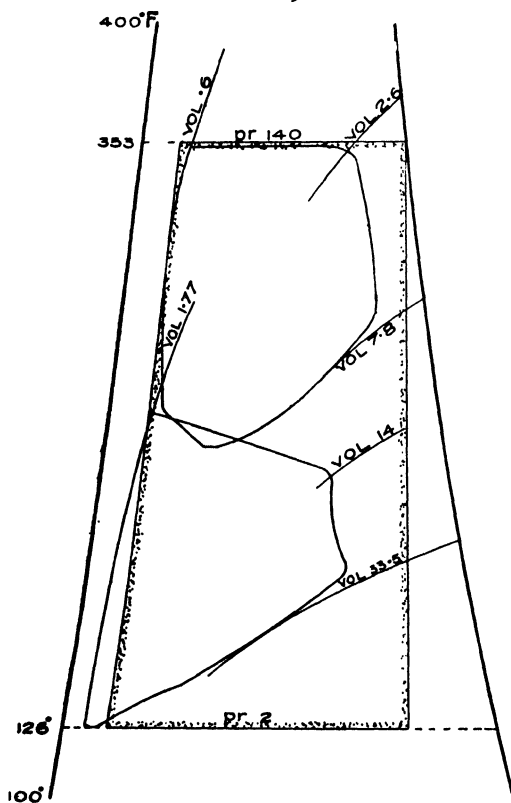

FIG. 110.

Diameters :

H.P. cylinder = $15\frac{5}{8}$ ins.

L.P. cylinder = $31\frac{5}{8}$ ins.

Stroke = 48 ins.

Revs per min. = 75

Clearances :

H.P. cylinder = 8.3 %

L.P. cylinder = 5.6 %

Cylinder feed per

stroke = 0.612 lbs.

The same process is used as for the example given on page 69, a different volume factor being obtained for each cylinder, which works out as follows :—

H.P. cylinder = 1.35

L.P. cylinder = 1.44

The $\theta \phi$ diagrams have been plotted from the indicator cards, using the method given in Appendix I., and are given in Fig. 110; it will now be shown how the economy, thermal efficiency, efficiency ratio, etc., can be arrived at from these diagrams.

The areas of the $\theta \phi$ diagrams are found to represent in the H.P. cylinder 79.7 B.Th.U., and in the L.P. cylinder 74.5 B.Th.U.

The $\theta \phi$ cylinder feed of the H.P. cylinder is found by multiplying the H.P. cylinder feed by the corresponding volume factor, and is therefore equal to 0.85 lb.

The Rankine cycle corresponding to this $\theta \phi$ feed has been drawn and is shown by the area whose contour is dotted. Since, however, the L.P. volume factor is larger than that of the H.P. cylinder, its $\theta \phi$ feed will also be larger in proportion of the volume factors.* Hence the 74.5 B.Th.U. shown by the L.P. diagram must be reduced to agree with the smaller H.P. $\theta \phi$ cylinder feed so that the corrected value is :

$$74.5 \times \frac{1.35}{1.44} = 69.9 \text{ B.Th.U.}$$

Efficiency Ratio.—The area of the Rankine engine cycle represents 234 B.Th.U., and the sum of the H.P. and L.P. diagrams of the actual engine = 79.7 + 69.9 = 149.6 B.Th.U. Therefore the

$$\text{Efficiency ratio} = \frac{149.6}{234} = 0.64.$$

Economy of the Engine.—As was proved in Chapter VIII.

$$\text{Economy of engine} = 42.4 \times \frac{\text{Heat supply per stroke}}{\text{Heat represented by } \theta \phi \text{ diagram}}$$

(expressed as B.Th.U.)
per I.H.P. per min.)

The heat supply per stroke is found in the following manner :—

$$\text{Total heat of steam at } 353^{\circ} = 1189.6 \text{ B.Th.U.}$$

$$\text{Less water heat at } 126^{\circ} = \underline{94.2 \text{ ,,}}$$

$$\text{Nett heat supply} = 1095.4 \text{ ,,}$$

These values are read off the chart (Plate 1), and are for 1 lb. of steam, but the actual engine works with 0.85 lbs. of $\theta \phi$ cylinder feed. Therefore the nett heat supply per stroke for this engine is equal to $1095.4 \times 0.85 = 931$ B.Th.U. Thus :

$$\text{Economy of engine} = 42.4 \times \frac{931}{149.6} = 264 \text{ B.Th.U. per I.H.P. per min.}$$

Thermal Efficiency.—The heat converted into work has just been found to be 149.6 B.Th.U. Hence :—

$$\text{Thermal efficiency} = \frac{149.6}{931} = 0.161$$

* This accounts for the compression line of the L.P. cylinder lying to the left of the Rankine cycle water line.

Steam Consumption of Engine.—This is obtained by the formula given at page 67, and in this case the consumption is :

$$\frac{2545}{149.6} \times 0.85 = 14.46 \text{ lbs. per I.H.P. per hour.}$$

The "equivalent feed" will be smaller than this in the proportion of the nett heat supply per stroke (viz., 1095.4) to 1100 B.Th.U.* or :

$$\text{Equivalent feed} = 14.46 \times \frac{1095.4}{1100} = 14.40 \text{ lbs. per hour.}$$

Mean Pressure.—The formula as given in Chapter VIII. is :

$$\text{M.E.P.} = 5.4 \times \frac{\text{Heat represented by } \theta \phi \text{ diagram.}}{\theta \phi \text{ Vol. at release} - \theta \phi \text{ Vol. of clearance.}}$$

In the case of the H.P. cylinder this works out as follows :—

$$\text{M.E.P.} = 5.4 \times \frac{79.7}{7.8 - 0.6} = 59.8 \text{ lbs. per square inch.}$$

The M.E.P. referred to the L.P. cylinder is calculated in a similar manner, but here it is necessary to alter the volume in the clearance and at the release by the ratio of volume factors.

$$\begin{aligned} \text{Thus M.E.P.} &= 5.4 \times \frac{79.7 + 69.9}{33.5 \times \frac{1.35}{1.44} - 0.6} \\ &= 26.3 \text{ lbs. per square inch.} \end{aligned}$$

Cut-Off in Cylinders.—The cut off is given by the formula :

$$\text{Point of cut off} = \frac{\text{Volume at cut off} - \text{clearance volume}}{\text{Volume swept by the piston.}}$$

Hence for the H.P. cylinder

$$\text{Point of cut off} = \frac{2.6 - 0.6}{7.8 - 0.6} = 28\% \text{ of the stroke.}$$

and for the L.P. cylinder

$$\text{Point of cut off} = \frac{14.0 - 1.77}{33.5 - 1.77} = 38.6\% \text{ of the stroke.}$$

Number of Expansions.—This is given by the formula :

$$\begin{aligned} \text{Number of expansions} &= \frac{\text{Total volume in L.P. cylinder.}}{\text{Volume at C.O. in H.P. cylinder.}} \\ &= \frac{33.5 \times \frac{1.35}{1.44}}{2.6} = 12.1 \end{aligned}$$

It is clear that the total volume has to be adjusted proportionately to the volume factors.

Cylinder Ratio.—The clearance and release volumes for both cylinders are read off the chart, and those of the L.P. cylinder must be adjusted by multiplying by the ratio of the volume factors thus :—

H.P. $\theta \phi$ Clearance volume			= 0.6 cubic feet
H.P. , Release	,,		= 7.8 ,,
L.P. ,, Clearance	,,	= 1.77 \times 0.937	= 1.6 ,,
L.P. ,, Release	,,	= 33.5 \times 0.937	= 31.4 ,,
Then $\theta \phi$ volume swept by H.P. piston			= 7.2 ,,
,, ,, ,, L.P. ,,			= 29.8 ,,

$$\text{Hence the cylinder ratio} = \frac{7.2}{29.8} = 1 \text{ to } 4.14$$

Proportion of Work Done in Each Cylinder.—The work done in each cylinder is in the proportion of the areas of the diagrams adjusted for the volume factors, thus :

$$\frac{\text{Work done in H.P. cylinder}}{\text{,, ,, ,, L.P. ,,}} = \frac{79.7}{69.9} = \frac{1}{0.88}$$

EXAMPLE II.

Compound Condensing Engine.—The $p v$ diagrams for this engine are given in Fig. 111, and it requires 25.5 lbs. of steam per I.H.P. per hour. The $\theta \phi$ diagrams are given in Fig. 112.

A comparison of the $p v$ diagrams of this engine with those of the last example gives no indication that the engine is far less economical, although working under the same conditions, but a comparison of the $\theta \phi$ diagrams brings out this fact in a clear manner. The theoretical expansion line has been drawn through the point of cut-off in the H.P. cylinder, and the actual expansion line falling so far inside this line indicates that a serious leak takes place in this cylinder, namely past the piston and through the exhaust ports and into the L.P. cylinder. The effect of the additional weight of steam flowing through the L.P. cylinder is well exhibited by the increased size of its $\theta \phi$ diagram.

LBS. ABS.

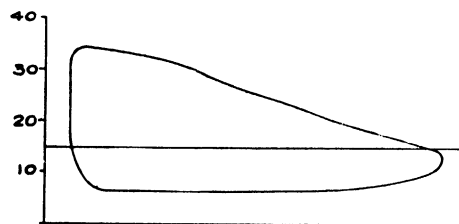
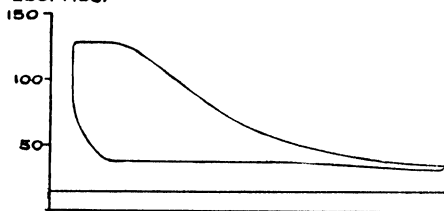

FIG. 111.

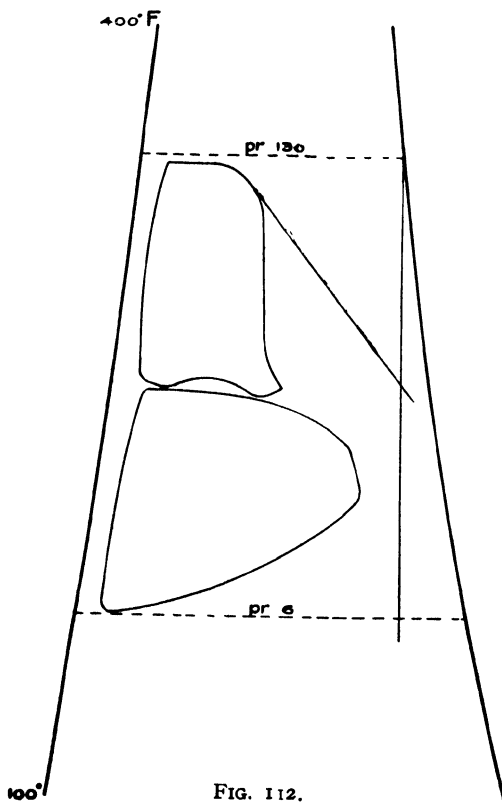

FIG. 112.

The following particulars relating to this engine have been calculated in the same manner as given in Example I.

Volume factors :

$$\text{H.P. cylinder} = 1.29$$

$$\text{L.P. cylinder} = 1.37$$

$$\begin{aligned} \text{Heat supplied per} \\ \text{min. per I.H.P.} \\ = 438 \text{ B.Th.U.} \end{aligned}$$

$$\begin{aligned} \text{Equivalent feed} \\ = 24.3 \end{aligned}$$

$$\begin{aligned} \text{Efficiency ratio} \\ = 0.48 \end{aligned}$$

$$\begin{aligned} \text{Thermal efficiency} \\ = 0.097 \end{aligned}$$

EXAMPLE III.

Jacketted Compound Condensing Engine, and with Reheater between the Cylinders.

Pressure at stop valve
= 171 lbs. per square
inch, abs.

Superheat at stop valve
= 81.5° F.

The $p v$ diagrams for this engine are given (re-heater in action), in Fig. 113, and the $\theta \phi$ diagrams in Fig. 114.

Lbs. of steam used per
I.H.P. per hour =
11.24

The $\theta\phi$ diagrams have
been drawn with the fol-
lowing volume factor ratio:
H.P. cylinder = 1
L.P. cylinder = 1.05

It will be noticed that
the steam in the L.P. cyl-
inder is nearly dry when
the re-heater is in use,
but is somewhat wet,
as shown by the dotted
expansion line, when the
re-heater is out of action.
It will also be noticed that
the steam at cut off in the
H.P. diagram is very dry
owing to the use of super-
heated steam, but the ini-
tial superheat is not suffi-
cient to keep the steam
superheated up to the
point of cut off. The
following are the econo-
mic results deduced for
this engine :—

Heat supplied per min.
per I.H.P. = 214
B.Th.U.
Equivalent feed
= 11.7
Efficiency ratio
= 0.715
Thermal efficiency
= 0.198

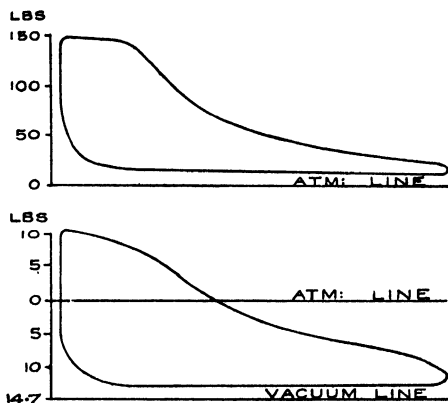

FIG. 113.

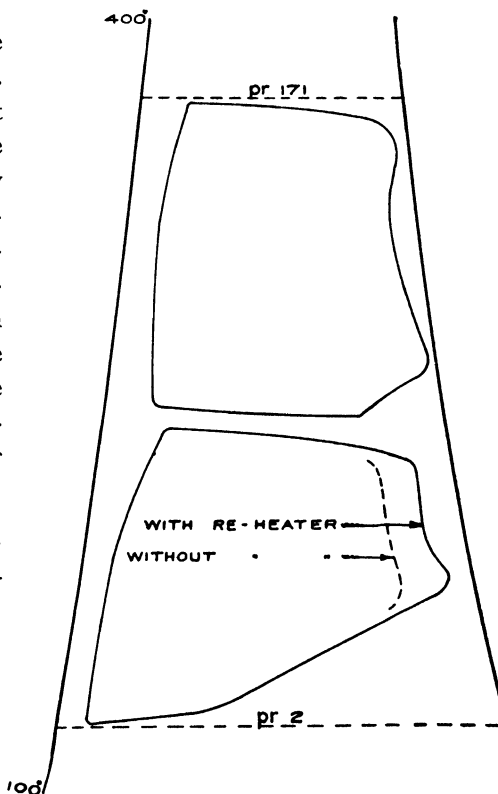

FIG. 114.

A close comparison of the indicator diagrams given in Figs. 110, 111, 113, and their respective $\theta \phi$ diagrams is recommended, and attention is called to the manner in which the latter exhibit the great difference in economy that exists between these three engines, a difference which is not shown by the indicator cards.

EXAMPLE IV.

Horizontal Four-valve Fleming Compound Engine, with Reheater between the Cylinders.—The indicator diagrams for a test made at about the full rated load (500 I.H.P.) are given in Fig. 115, and the further particulars needed to transfer the diagrams to the energy chart are as follows:—

High pressure cylinder diameter	15	inches.
Low " " "	40.5	"
Stroke " " "	27	"
Diameter, piston rod, H.P.	$2\frac{1}{8}$	"
" " " L.P.	} Crank end .. Head end ..	$4\frac{3}{4}$	"
		$2\frac{1}{8}$	"
Clearance, H.P. cylinder	3.95	%
" L.P. "	4.67	%
Feed water per I.H.P. per hour passing through the cylinders..	12.8	lbs.
Reheater steam (5% of cylinder steam)	..	0.7	lb.
Leakage past admission valve into the exhaust (3% of cylinder steam)	..	0.4	lb.

The $\theta \phi$ diagrams should be drawn for a feed of 12.4 lbs., and are given in Fig 116. The stop-valve pressure, 167 lbs. per square inch absolute, and the condenser pressure 1.9 lb. per square inch absolute, have been marked. On measuring the diagrams it is found that the H.P. diagram represents 91.5 B.Th.U., and the L.P. diagram 91.1 B.Th.U., and since the percentage clearance is nearly the same in both cylinders, the difference in the volume factors can be neglected.

The following calculations are given to show the degree of accuracy that may be expected from $\theta \phi$ diagrams.

The point α on the 167 lb. pressure line is found* to be situated

at the volume 0.22 cubic foot, and since the volume of saturated steam at this pressure is 2.68, the

$$\theta \phi \text{ cylinder feed is } \frac{2.68 - 0.22}{2.68} = 0.92 \text{ lb.}$$

But the steam going through the re-heater is 5%, and 3% has to be added for the direct leakage. Hence the total feed of the corresponding $\theta \phi$ engine per stroke is

$$0.92 (1 + 0.05 + 0.03) = 0.994 \text{ lb.}$$

from which the feed per I.H.P. of the actual engine works out to

$$\frac{2545}{91.5 + 91.1} \times 0.994 = 13.8 \text{ lbs.}$$

instead of: 13.9 as given by the data.

The mean pressure of the H.P. cylinder is

$$5.4 \times \frac{91.5}{7.2 - 0.28} = 70.8 \text{ lbs. per square inch,}$$

and the figure given in the Paper† is 69.9. The mean pressure of the L.P. cylinder is

$$5.4 \times \frac{91.1}{52 - 2.4} = 9.9 \text{ lbs. per square inch,}$$

whereas the figure given in the Paper is 9.7.

The ratio of the cylinders is

$$\frac{7.2 - 0.28}{52 - 2.4} = \frac{1}{7.2}$$

whereas in the Paper the ratio is given as 1 : 7.33.

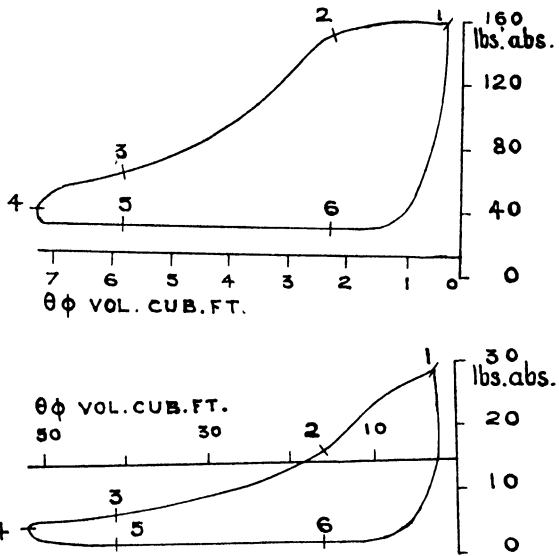

FIG. 115.

† The data for this example are taken from a Paper read before the American Society of Mechanical Engineers (Vol. XXV.)

The total heat per lb. of steam for the admission temperature of 367° F., and the exhaust* temperature of 130° F. will be found to be, on reference to Plate I., $1193.8 - 98.3 = 1095.5$ B.Th.U. Hence the thermal efficiency as regards the steam passing through the cylinders of the engine is

$$\frac{91.5 + 91.1}{1095.5 \times 0.92} = 0.181$$

But this figure must be reduced to take account of the direct leakage and of the re-heater steam, in the proportion of 0.994 to 0.92 (see above). Thus the thermal efficiency of the engine is

$$0.181 \times \frac{0.92}{0.994} = 0.169$$

The heat converted into work by the corresponding Rankine engine is $1.19 \times 243 = 289$ B.Th.U.

Hence the thermal efficiency of the Rankine engine is

$$\frac{289}{1095.5} = 0.264$$

and the efficiency ratio is $\frac{0.169}{0.264} = 0.64$. Lastly, the economy of

the engine is $\frac{42.4}{0.169} = 251$ B.Th.U. per I.H.P. per minute.

It will be observed that the cylinder ratio is very high for a compound engine, but the cut-off in the L.P. cylinder has been arranged so as to equalize the work done in each cylinder, namely, 91.5 and 91.1 B.Th.U. A very considerable toe is thus produced in the H.P. diagram, as is seen both on the $\theta \phi$ and on the indicator diagram; it is, however, more conspicuous on the former. Mr. Rockwood, who is the author of compound engines with large cylinder ratios, maintains that this drop tends to dry the cylinder walls, and thus reduces the initial condensation. It may be added that Mr. Willans was of the same opinion, and the quality of the steam during the expansion, as shown by the $\theta \phi$ diagram of the H.P. cylinder confirms this view. The shape of the L.P. expansion line points to a leak (see page 59) in the admission valve of that

The temperature at the exhaust of the engine is not given in the data, but it may reasonably assumed to be 130° F., and this is the temperature to take as the lower limit for the Standard of Comparison of the Institution of Civil Engineers. The Superheat has also been neglected.

cylinder, and if this leak had not existed, the expansion line would have followed approximately the chain dotted line, and the drying effect of the re-heater would have become more obvious (compare Fig. 110). Points have been marked along the perimeter of the indicator diagrams at equal intervals of time, namely $\frac{1}{8}$ th of a revolution, and since the cylinders are placed tandem fashion, the instant 1 will be at the beginning of the stroke in both cylinders. These points have also been marked on the $\theta \phi$ diagrams.

EXAMPLE V.

Triple-Condensing Engine.—In Fig. 117 are given the $p v$ diagrams for this engine and in Fig. 118 are shown the corresponding $\theta \phi$ diagrams. There is nothing specially noticeable about this engine, and it can be classed as of an average type, but the economy is very good.

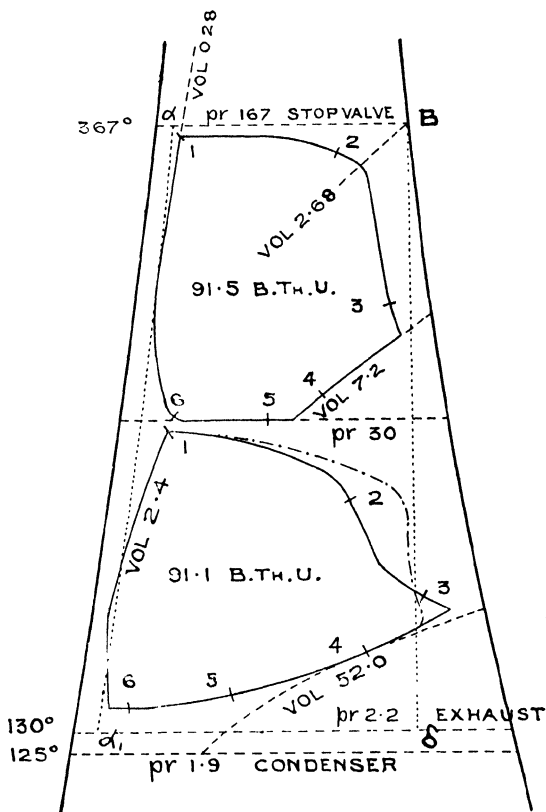

FIG. 116.

The following are the economic results for this engine:—

Heat supplied per min. per I.H.P.	=	217
Lbs. of steam used per hour per I.H.P.	=	11.8
Equivalent feed	=	11.7

Efficiency ratio
Thermal efficiency

= 0.764
= 0.197

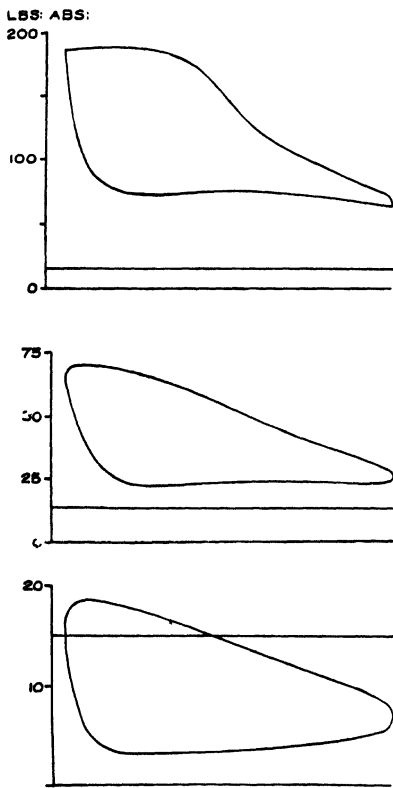

FIG. 117.

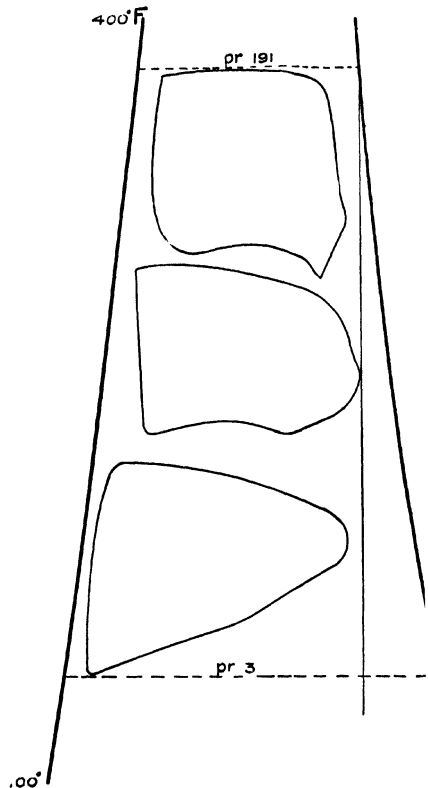

FIG. 118.

EXAMPLE VI.

Triple-Condensing Jacketed Engine With and Without Reheater and Jackets.—Fig. 119 shows the $p v$ diagrams for this engine with the reheater in use, and Fig. 120 with the reheater out of action. Fig. 121 shows the $\theta \phi$ diagrams for the two cases; the full lines being those for the engine when using the reheater and jackets, and the dotted lines without the reheater and jackets. The two diagrams plotted on the chart show in a very clear manner how much drier the steam is throughout the expansion when the engine is using the reheater and jackets.

LBS. ABS.

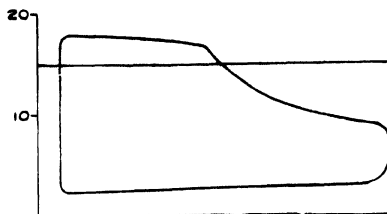
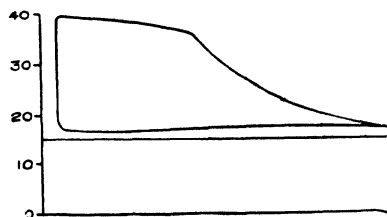
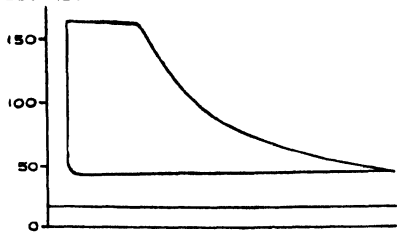

FIG. 119.

LBS. ABS.

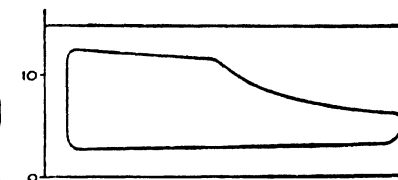
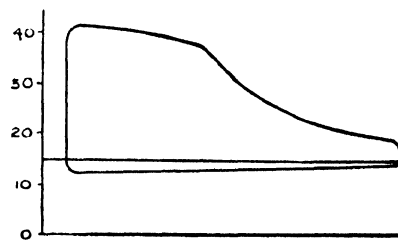
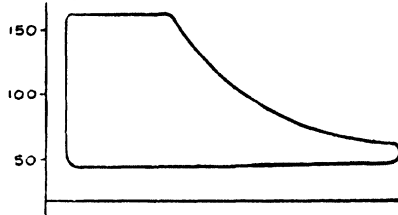

FIG. 120.

The following are the economic results for this engine :—

	With Re-heater	Without Re-heater
Heat supplied per min. per I.H.P. ..	249.7	264.4
Lbs. of steam used per hour per I.H.P.	13.5*	13.9
Equivalent feed	13.7	14.1
Efficiency ratio	0.610*	0.575
Thermal efficiency	0.171*	0.161

* The steam flowing through the cylinders was 11.3 lbs. per I.H.P. per hour; the difference, 2.2 lbs., was used by the re-heater and jackets. The efficiency of the steam in the cylinder is therefore 0.73, and its thermal efficiency is 0.204.

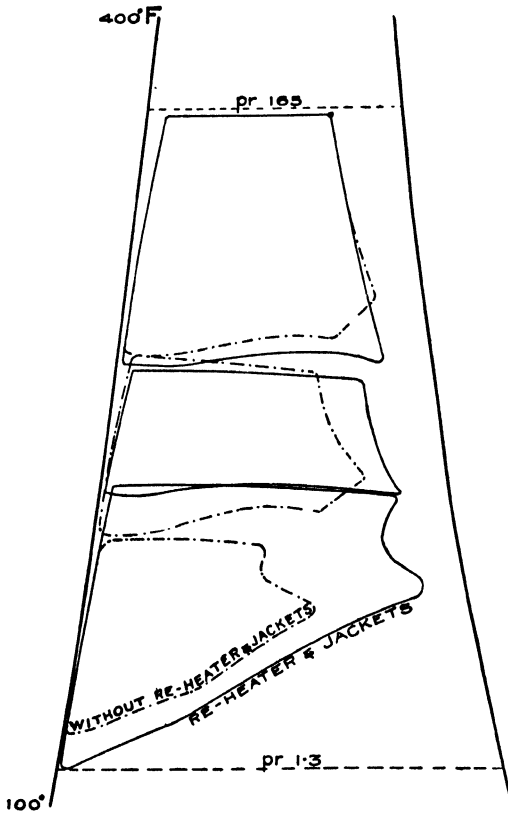

FIG. 121.

On page 81 (Fig. 99) it was shown how the amount of the various losses due to initial condensation and leakage, etc., incomplete expansion, back pressure, etc., could be graphically shown on the chart, and this process can be applied in a precisely similar manner to the preceding examples. This is a matter left to the student.

CHAPTER X.

USE OF THE ENERGY CHART IN DESIGNING STEAM ENGINES.

So far the $\theta \phi$ diagrams have in general been obtained from the indicator diagrams and the dimensions of the engine. It is now proposed to reverse the process, that is to say, it is required to draw the $\theta \phi$ diagrams, and from them determine the proportions of the engine and the indicator diagrams.

Pre-determination of $\theta \phi$ Diagram.—From the various formulæ given at the end of Chapter V. it will be seen that if the $\theta \phi$ diagram of a simple engine is given, the mean pressure, the point of cut-off, and the economy of the engine can be calculated very easily, and obviously the $p v$ diagram can be obtained by simply plotting the pressures and corresponding volumes as read off the chart. The question thus arises can the $\theta \phi$ diagram of a steam engine be pre-determined. The answer is, it can be done with fair accuracy in any case, and if there is some previous knowledge of the type of engine under consideration, its valve motions, etc., etc., the $\theta \phi$ diagrams can be laid down with a considerable degree of accuracy. It is certain that the design of an engine can be worked out, as regards its thermo-dynamics, far more easily by this method than by the usual $p v$ method, and with a greater degree of accuracy. This statement will be illustrated by means of the two following numerical examples.

Example—Simple Engine.—Determine approximately the $\theta \phi$ diagram of a non-condensing, non-jacketted simple engine, when working at the best point of economy, with a stop-valve pressure of 100 lbs. per square inch absolute. Speed about 150 r.p.m.

Since no details are given, any reasonable assumptions are admissible. Some of these assumptions will afterwards be varied to see the effect on the general result.

*Sketching in $\theta \phi$ Diagram.**—The admission line must first be dealt

* It is suggested that the diagram be sketched on tracing paper placed over the chart, Plate I.

with, and it will be assumed that there is 5 lbs. drop in pressure at the beginning of admission, gradually increasing to 10 lbs. at the point of cut-off. Since the engine is non-jacketted and the speed is moderate, it is a matter of general knowledge that there will be considerable initial condensation; let it therefore be assumed that the dryness fraction at cut-off is only 0.65. On these assumptions the admission line HC can be drawn as shown in Fig. 122, neglecting for the moment the clearance in the cylinder. The theoretical re-evaporation line through C is now drawn by the method explained on page 54, as shown by the chain-dotted line, and it is known by experience

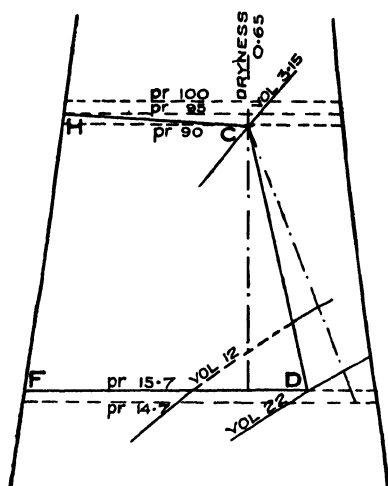

FIG. 122.

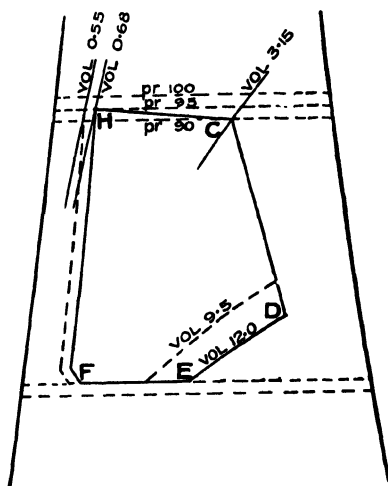

FIG. 123.

that the actual expansion line falls somewhat short of this, it can therefore be drawn in approximately as shown by the full line CD . Turning to the exhaust line, let it be assumed that the opening of the exhaust valve is such that a difference of 1 lb. per square inch in pressure is required to drive the steam out of the cylinder, that is to say, since the back pressure is 14.7, the exhaust pressure must be 15.7 lbs. per square inch absolute. The exhaust line FD of the diagram can therefore be drawn in. The intersection D of this exhaust line with the expansion line CD occurs where the volume is 22 cubic feet, and the area of the diagram included between the

lines $H C D F$ is found on measurement* to be 10.0 square inches, representing 10 × 10 B.Th.U., so that the mean pressure is

$$= \frac{100 \times 778}{22 \times 144} = 24.5 \text{ lbs. per square inch.}$$

Adjustment of Mean Pressure.—From many trials it is known that for a non-condensing engine the best economy is obtained with a mean pressure between 40 and 45 lbs. per square inch; the release volume must therefore be reduced approximately in the proportion of 24.5 to 45, that is to say, it ought to be about 12 cubic feet. The release at constant volume ought, therefore, to take place approximately along the 12.0 cubic foot constant volume line, as shown in Fig. 122. The area of the $\theta \phi$ diagram is thus reduced to 9.42 square inches, and the mean pressure becomes

$$5.4 \times \frac{94.2}{12} = 45.0 \text{ lbs. per square inch.}$$

which is within the limits assigned above.

Effect of Clearance.—Let it now be assumed that the clearance is 6% of the total volume of the cylinder, that is of the volume swept by the piston, then the clearance volume must be

$$\frac{6}{100 + 6} \times 12 = 0.68 \text{ cubic foot,}$$

and thus the compression line $F H$ can be drawn (Fig. 123), on the supposition that the exhaust closes at such a point that the compression pressure will just reach stop-valve pressure at the moment the admission valve opens. Judging from the $\theta \phi$ diagrams given in Figs. 110 to 121, no serious error will be made if $F H$ (Fig. 123) be taken as the compression line of the $\theta \phi$ diagram. The volume swept by the piston is, however, diminished by the clearance volume and becomes $12 - 0.68 = 11.32$ cubic feet. The area of the $\theta \phi$ diagram is thus somewhat reduced, in fact to 7.3 square inches, so that the mean pressure is reduced to 34.6 lbs. per square inch. This is a somewhat low mean pressure for economy under the conditions imposed, the release volume must therefore again be reduced to, say 9.5 cubic feet, which alters the clearance volume to 0.55 cubic foot. The area of the $\theta \phi$ diagram

* When laid down on the larger energy chart, Plate I. This note applies to all the subsequent areas given.

now becomes 6.87 square inches, so that the mean pressure is

$$5.4 \times \left(9.5 - \frac{9.5 \times 6}{100} \right) = 42.0 \text{ lbs. per square inch.}$$

which is within the limits specified above, and thus the final $\theta \phi$ diagram is as shown in Fig. 125.

Results Obtained.—The point of cut-off is obtained from the formula given at page 66, so that inserting the numerical values of the various volumes as read off the chart (see also Fig. 124):—

$$\text{Point of cut-off} = \frac{3.15 - 0.55}{9.5 - 0.55} = 0.29$$

The economy of the engine can be obtained by applying the formulae given at page 67, or else as follows:—From Fig. 125 it will be seen that $\frac{4.36 - 0.55}{4.36^*} = 0.87$ of a lb. of steam is admitted

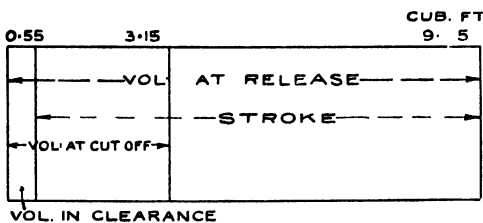

FIG. 124.

to the cylinder per stroke. The temperature of admission is 327.5° F., and the temperature of the exhaust steam is 212° F. Hence the B.Th.U. supplied per lb. of steam is $1182 - 180 = 1002$

B.Th.U. per lb. Hence the heat supplied per stroke is $0.87 \times 1002 = 872$ B.Th.U. The work produced is represented by the area of the $\theta \phi$ diagram (Fig. 125), which has already been found to be equal to 68.7 B.Th.U., therefore the thermal efficiency of the

engine is $\frac{68.7}{872} = 0.079$, and the economy of the engine

$$= \frac{42.4}{0.079} = 534 \text{ B.Th.U. per I.H.P. per minute.}$$

4.36 cubic feet is the volume of 1 lb. of saturated steam at the stop valve pressure, viz.: 100 lbs. per square inch abs., which is the pressure the engine has to account for. 0.55 is sensibly the volume at the point *a* of the "proportional" water line of the Rankine cycle corresponding the $\theta \phi$ cylinder feed.

Comparison with Standard.—The Institution of Civil Engineers standard steam engine of comparison working under the same temperature conditions and supplied with 872 B.Th.U. per stroke, produces the work, represented in Fig. 125 by the area whose contour is shaded by dots, containing 12.02 square inches. Hence the thermal efficiency of the corresponding standard steam engine is

$$\frac{120.2}{872} = 0.138,$$

and the "efficiency ratio" is $\frac{0.079}{0.138} = 0.57$.

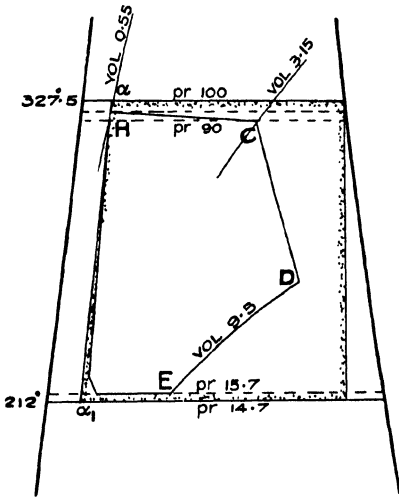

FIG. 125.

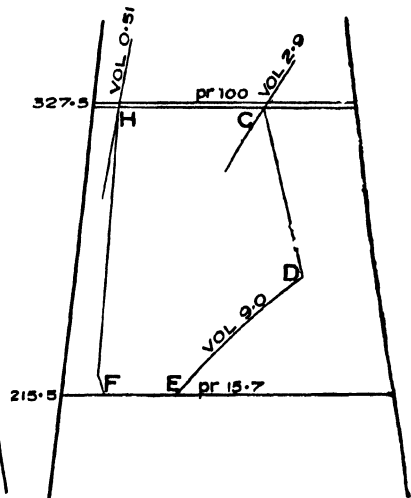

FIG. 126.

On reference to Fig. 3 of the Report of the Thermal Efficiency Committee of the Institution of Civil Engineers, it will be found that the standard engine of comparison working between the temperature limits of 327.5° F. and 212° F., requires 310 B.Th.U. per I.H.P. per minute. Hence the efficiency ratio = $\frac{310}{544} = 0.57$ or the same result as before

The indicator diagram corresponding to the $\theta \phi$ diagram thus obtained should be plotted, as a final check, but this is left to the student.

Effect of Changing the Assumptions made.—The shape of the $\theta \phi$ diagram just obtained depends on the assumptions made, which are tabulated below for reference :—

Admission line : 5 lbs. drop at admission, increasing to 10 lbs. drop at cut-off.

Expansion line : Dryness fraction of steam present at cut-off 0.65. Expansion line sketched in, using theoretical re-evaporation line as a guide.

Release : Adjusted to give between 40 and 45 lbs. mean pressure.

Exhaust line : 1 lb. loss of pressure due to ports.

Compression line : Such as to give admission pressure at the moment of admission.

Clearance in cylinder : 6%.

The effect on the diagram of varying some of these assumptions will now be made.

Change in Admission Line.—The admission line will first be varied by supposing that the engine is fitted with a better admission valve, and that in this way the drop at the beginning of the stroke is reduced to 1 lb., and the drop at cut-off to 2 lbs. The $\theta \phi$ diagram given in Fig. 126 is thus obtained. It will be seen that the volume at cut-off is less than in Fig. 125, and therefore, since the point of cut-off has not been altered, the release volume must be diminished. Referring to the formula given on page 66, it will be found by transposition that :

$$V_r = \frac{V_c - V_h}{c} + V_h$$

where V_r = Volume at release

V_c = „ „ cut-off

V_h = „ „ in clearance

and c = Point of cut-off

If k is the percentage clearance, then

$$V_h = k (V_r - V_h)$$

or
$$V_h = \frac{k}{1 + k} \cdot V_r$$

Hence

$$V_r = \frac{V_c - \frac{k}{1+k} V_r}{c} + \frac{k}{1+k} V_r$$

$$V_r = \frac{V_c}{c \left(1 + \frac{k}{1+k} (c - 1) \right)} = \frac{1+k}{c+k} \cdot V_c$$

and in the numerical example

$$V_r = \frac{1 + 0.06}{0.29 + 0.06}$$

$$= 9.0 \text{ cubic feet approximately,}$$

which is the volume at release as shown in Fig. 126. The area of this $\theta \phi$ diagram is found to be 7.15 square inches. Hence the mean pressure is

$$5.4 \times \frac{71.5}{(9.0 - 0.5)} = 45.4 \text{ lbs. per square inch,}$$

or, as might be expected, higher than before, but still not too high for economy. The heat supplied per stroke is, however, somewhat larger than in the former case, because the clearance volume is smaller. Thus, the weight of feed per stroke is

$$\frac{4.36 - 0.51}{4.36} = 0.883 \text{ lb.,}$$

and since the total heat per lb. is the same as before, namely, 1002 B.Th.U., the heat supply per stroke is 885 B.Th.U. Thus the Thermal efficiency is

$$\frac{71.5}{885} = 0.08,$$

and the Efficiency ratio is

$$\frac{0.08}{0.138} = 0.59.$$

Finally the economy of the engine is

$$\frac{42.4}{0.08} = 530 \text{ B.Th.U. per I.H.P. per minute,}$$

or nearly the same figure as before. The reason that there is no sensible thermo-dynamic improvement is that the cut-off has been kept the same—if it were made slightly earlier a better economy would be obtained as can easily be verified by assuming a release volume of, say 10.0 cubic feet, and re-calculating. As already observed, there is a considerable increase in the M.E.P., so that the economy per B.H.P. would be improved.

Effect of Adding a Jacket.—The next alteration made will be to reduce the initial condensation by adding a jacket, and let it be assumed that 0.8 is the dryness fraction at cut-off, so that the volume at cut-off is 3.65 cubic feet. The expansion line will slope more to the right owing to the heat supplied by the jacket during expansion, as shown in Fig. 127, and if the cut-off remains as before, namely, at 0.29 the release volume will be found to be 11.8 cubic feet as shown in Fig. 127, and the $\theta \phi$ diagram can be completed as shown. The actual clearance volume has been kept the same as in Fig. 126, *i.e.*, 0.51 cubic foot, so that the percentage clearance will be reduced. The mean pressure of this diagram will be found to be 45 lbs. per square inch.

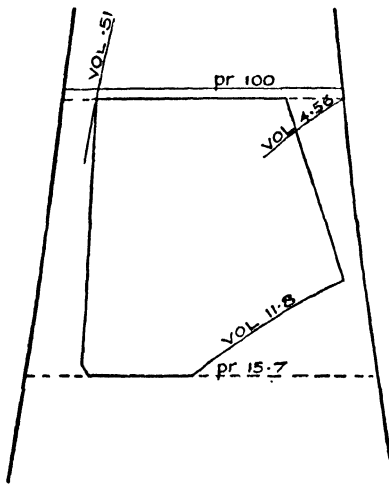

FIG. 127.

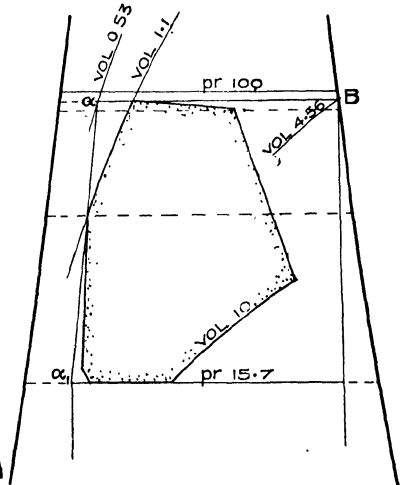

FIG. 128.

The work done per stroke is equal to 94 B.Th.U., and this work is produced by the expenditure of the heat in the cylinder steam and in the jacket steam. The weight of cylinder feed per stroke is

$$\frac{4.36 - 0.51}{4.36^*} = 0.883 \text{ lb.}$$

so that the heat required for the cylinder steam is 885 B.Th.U. per stroke, and if it is assumed that the jacket steam is $\frac{1}{10}$ th of the cylinder steam, a usual proportion, 88 B.Th.U. have to be added, so that altogether the heat required by the engine per stroke

is 973 B.Th.U. The thermal efficiency is therefore

$$\frac{94}{973} = 0.096,$$

and the economy of the engine is

$$\frac{42.4}{0.096} = 441 \text{ B.Th.U. per I.H.P. per minute.}$$

Thus, in this case, the jackets, combined with the reduced clearance, effect an improvement of 16.8 %.

Increase in Clearance.—As a last example the original assumptions tabulated at page 116 will be reverted to, except that the clearance will be increased to 12 % of the volume swept by the piston ; and it will be further assumed that the compression only reaches 50 lbs. per square inch absolute. This reduction in compression will cause additional condensation, so that the dryness fraction of the steam at cut-off will be less than in Fig. 126, say 0.6.

The expansion line can be drawn in as before, but if the same mean pressure is to be maintained the release volume will have to be modified (only a little, however, because the increased clearance reduces the volume swept by the piston), say, as a first trial, to 10.0 cubic feet. The admission line, the expansion line, and the exhaust line can thus be sketched in, as shown in Fig. 128. There is no reason to suppose that the compression will materially differ from the lower portion of that shown in Fig. 125. Therefore the compression line can be drawn in as far as the intersection with the volume line representing the clearance, which is approximately 1.1 cubic foot. The diagram is closed by the intersection of this constant volume line with the admission line. The area of the $\theta \phi$ diagram thus drawn is found to be 6.76 square inches, so that the heat utilised is 67.6 B.Th.U., and the mean pressure is

$$5.4 \times \frac{67.6}{10 - 1.1} = 41 \text{ lbs. per square inch.}$$

which is approximately the same as for Fig. 123.

To find the weight of feed per stroke it must be noticed that steam has to be supplied first to fill the clearance from 50 lbs. to admission pressure, and afterwards to follow up the piston to the point of cut-off. As shown on page 74 and Fig. 91, the heat units required per stroke are shown by the area below $a_1 a B$ (Fig. 128), which is found to be 882 B.Th.U.; or by calculation as follows :

The weight of feed per stroke is

$$\frac{4.36 - 0.53}{4.36} = 0.88 \text{ lb,}$$

and, as before the heat supply per lb. is 1002 B.Th.U., thus the B.Th.U. per stroke are 882. Hence thermal efficiency is

$$\frac{67.6}{882} = 0.0765,$$

and the economy of the engine is

$$\frac{42.4}{0.0765} = 552 \text{ B.Th.U. per minute,}$$

from which it appears that the increased clearance results in a reduction of economy at about 3.4 %.

Leakage past Admission Valve Direct into Exhaust.—In the above calculations no account has been taken of the direct leakage into the exhaust. The amount of this leakage depends in a very large measure on the type of admission valve, and is certainly far greater with slide valves than it is with piston valves fitted with rings and springs.† A correction should, therefore, be made in the efficiency and economy figures obtained. Suppose that the engine is fitted with a slide valve, then since the speed is 150 r.p.m. it would appear from Professor Capper's report to the Steam Engine Research Committee of the Institution of Mechanical Engineers, that the leakage in question is about 5% of the cylinder feed.‡ The figures previously obtained must therefore be corrected in this proportion. Thus, in the last case of the unjacketed engine (Fig. 125), the economy of the engine would be altered to $534 \times 1.05 = 560$ B.Th.U. per minute per I.H.P., and the Efficiency ratio would be reduced to $\frac{0.59}{1.05} = 0.56$.

In the case of engines having piston valves fitted with rings and springs, the leakage in question is very small and no practical correction is needed; but if not fitted with rings and springs this leakage will be serious, anything from 5 to 20% of the cylinder feed.§ At present there is little or no experimental data for Corliss and drop valves, an allowance of from 1 to 3% may be made however.

* 0.53 is the volume at the point corresponding to the point *a* in Fig. 91.

† Probably from five to ten times greater.

‡ See leakage for trial CC₃, Proceedings Institution Mechanical Engineers, March, 1905.

§ See the Author's remarks on Prof. Capper's paper on "Steam Research." Proceedings Institution Mechanical Engineers, March, 1905.

CHAPTER XI.

DESIGN OF COMPOUND STEAM ENGINES.

THE following numerical example illustrating the use of the energy chart in designing a compound steam engine will be considered.

Find the approximate $\theta \phi$ diagrams of a condensing steam engine working at 28 lbs. mean pressure referred to the L.P. cylinder, the stop valve pressure being 140 lb. absolute, and the condenser pressure 2 lbs. absolute.

Standard of Comparison.—The $\theta \phi$ diagrams of the perfect compound steam engine (Rankine cycle), working under these conditions are given in Fig. 129, assuming equal division between the cylinders of the total temperature range (353° to 126.5°). For the sake of comparison with the engine being designed, the following figures in connection with this “perfect” compound steam engine are tabulated below :—

The heat supplied per stroke is,

$$1189.5 - 94.5 = 1095 \text{ B.Th.U. per lb.}$$

H.P. Cylinder.

Work done 127.5 B.Th.U.

Economy..... 327 B.Th.U. per I.H.P. per min.

Mean pressure 48.1 lbs. per square inch.

Point of cut-off 0.222 of stroke.

Dryness fraction at exhaust 0.895

L.P. Cylinder.

Work done 145 B.Th.U.

Economy..... 312 B.Th.U. per I.H.P. per min.

Mean pressure 5.76 lbs. per square inch.

Point of cut-off 0.105.

Dryness fraction at exhaust.. 0.800

Ratio of L.P. cylinder to H.P.

cylinder 1 to 9.5.

Both Cylinders combined.

Thermal efficiency..... 0.248

Economy..... 172 B.Th.U. per I.H.P. per min.

Equivalent feed..... 9.4 lbs. per I.H.P. per hour

Mean pressure referred to L.P. cylinder.. 6.85 lbs. per sq. inch

In reckoning the economy of the L.P. cylinder, it has been considered that it is supplied with steam of the quality represented by the point *D* (Fig. 129).

Sketching $\theta \phi$ Diagrams of proposed Engine.

—For the actual engine it will be assumed that the quality of the steam at cut-off in the H.P. cylinder is 0.80, and further, the following assumptions have been made :—

- H.P. cylinder clearance..... 5.25 %
- L.P. cylinder clearance..... 4.7 %
- Drop of pressure between H.P. and L.P. cylinder .. 2 lbs. per square inch.

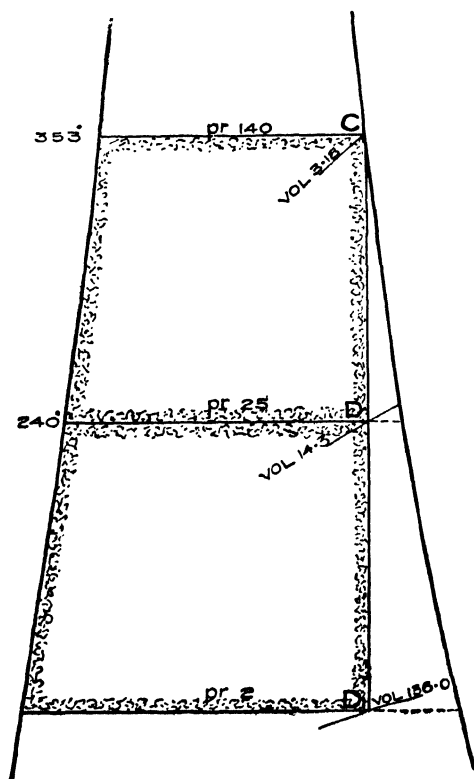

FIG. 129.

Back pressure in L.P. cylinder .. 1 lb. per square inch.

As in the case of the simple engine, the $\theta \phi$ diagrams shown in Fig. 130 can be sketched in a preliminary manner. —The area of both these diagrams together is found to represent 172.4 B.Th.U., and with the release volume shown (40 cubic feet) a mean pressure of 23.6 lbs.

It is suggested that the diagrams be sketched on tracing paper over the Energy chart, Plate I.

per square inch is obtained. To increase this to 28 lbs. (as required by the example), the release volume must be diminished to about 33 cubic feet, as shown by the dotted release line.

Adjustment of Work Done in the Cylinders.—It will be seen that the work done in the H.P., as represented by its $\theta \phi$ diagram, is greater than that done in the L.P. cylinder. If it is desired that, when the mean pressure is 28 lbs. the work done in each cylinder should be equal, the exhaust of the H.P. must be raised somewhat.

The areas, when the diagrams are laid down on Plate I. are found to be 9.12 and 8.12 square inches respectively, and half the difference should be deducted from the H.P. diagram, and since the length of the exhaust line (FE) of the H.P. diagram is 1.7 inches, the amount to raise the exhaust of the H.P. and the admission of the L.P. is $\frac{1}{2} (9.12 - 8.12)$

$$\frac{1}{1.7} = 0.294 \text{ inch.}$$

On thus altering the diagrams, it is found that the L.P. diagram is a little larger than the H.P. A further correction can be made if deemed

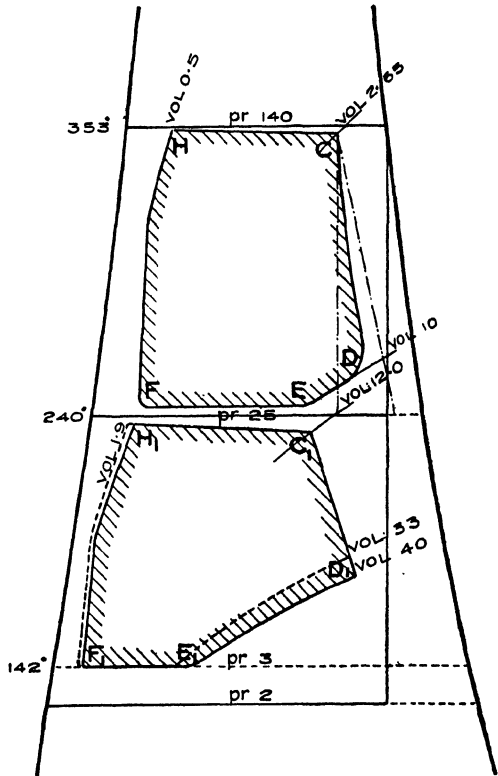

FIG. 130.

necessary, and finally the $\theta \phi$ diagrams given in Fig. 131 are obtained, from which the following results are deduced:—

Results:— $\theta \phi$ feed for each cylinder: 0.905 lb.

H.P. Cylinder.

Work done 82.7 B.Th.U.

Economy 502 B.Th.U. per I.H.P. per minute.

Mean pressure 47.0 lbs. per square inch.
 Point of cut-off 0.226 of stroke.

L.P. Cylinder.

Work done 84.0 B.Th.U.
 Economy..... 489 B.Th.U. per I.H.P. per minute.
 Mean pressure 14.6 lbs. per square inch.
 Point of cut-off..... 0.285 of stroke

Ratio of L.P. to H.P. cylinder 1 to 3.2.

Both Cylinders combined.

Thermal efficiency 0.168
 Economy 254.5 B.Th.U. per I.H.P. per min.
 Equivalent feed 13.9 lbs. per I.H.P. per hour.
 Efficiency ratio..... 0.660
 Mean pressure referred
 to L.P. 27.6 lbs. per square inch.

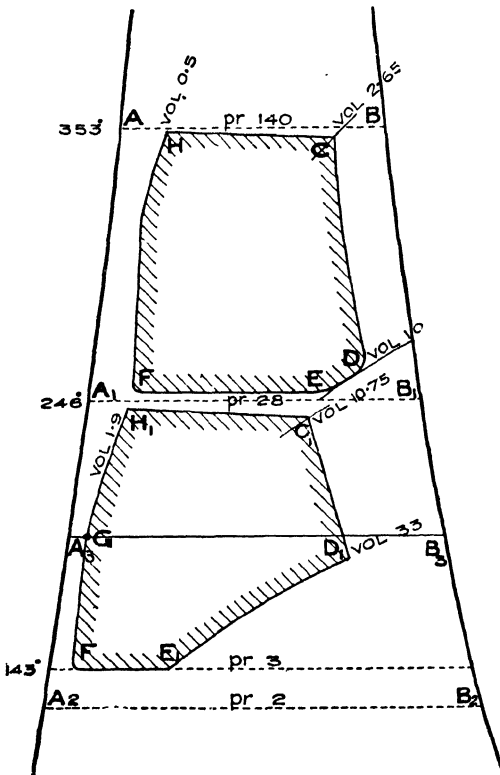

Determination of Ratio of Cylinders.—The method of determining the ratio of the L.P. to the H.P. cylinder requires some explanation. The volume of the steam at release in the H.P. cylinder is seen (Fig. 131) to be 10 cubic feet, but the volume in the clearance is 0.50 cubic foot, so that the volume swept by the piston is 9.5 cubic feet. In the same way the volume swept by the L.P. piston is 33.0 — 1.9 = 31.1 cubic feet. Hence the ratio between the volumes of the two cylinders is 1 : 3.2.

FIG 131.

The manner of deter-

mining the points of cut-off was explained on page 66.

The diagrams have been drawn on the supposition that the $\theta \phi$ feed is the same in both cylinders, and this assumption is only true, as was explained at page 97, if the weight of play steam is the same in both cylinders.

Assuming that the steam in the clearance of the L.P. cylinder is saturated at the point G the weight of H_2O in the clearance will be

$$1 \times \frac{\text{Vol. at } G,}{\text{Vol. at } B_3,}$$

where B_3 is the point on the saturation curve at the same temperature as G . In the case under consideration this is

$$1 \times \frac{1.9}{34.4} = 0.055 \text{ lb.}$$

Hence the total steam = $0.905 + 0.055 = 0.960$ lb. Therefore, in order that the expansion line of the L.P. diagram shall represent the quality of the steam on the chart, which is drawn for 1 lb. of H_2O , the volumes of the L.P. $\theta \phi$ diagram must be increased in the ratio of 0.96 to 1, and the volume factor must be increased in the same proportion, and becomes 1.04.

The corrected volumes in the L.P. cylinder are thus :—

Clearance	1.9	$\times 1.04 = 1.97$	cubic feet
Cut-off	10.75	$\times 1.04 = 11.2$	„
Release	33.0	$\times 1.04 = 34.3$	„

and the L.P. diagram can be re-drawn for these values.

It is thus seen that no serious error is introduced in assuming the L.P. diagram to remain as drawn, and in general it will be found that the volume factors are practically equal to one another except in the case of a large difference between the percentage clearances of the two cylinders.

Alteration of Cut-off in H.P.—The effect of altering the cut-off in the H.P. cylinder, without altering either the cut-off in the L.P. or the ratio of the cylinders will now be considered. As an example, let the cut-off be changed to 0.1. If this change in the cut-off did not affect the initial condensation, the volume at cut-off would still be 2.65 cubic feet (see Fig. 131), but the volume at release would be increased to 21.4, as shown by the dotted line in Fig. 132. The

range of temperature in the H.P. cylinder would thus be increased from 103° F. to 133° F., and although the real increase is not so great as this (as will be seen from Fig. 132), the initial condensation will be greater, or the quality of the steam at cut-off will be reduced to say 0.68, and on referring to the chart (Plate 1), it will be seen that the volume at cut-off is thus 2.15 cubic feet. The volume in

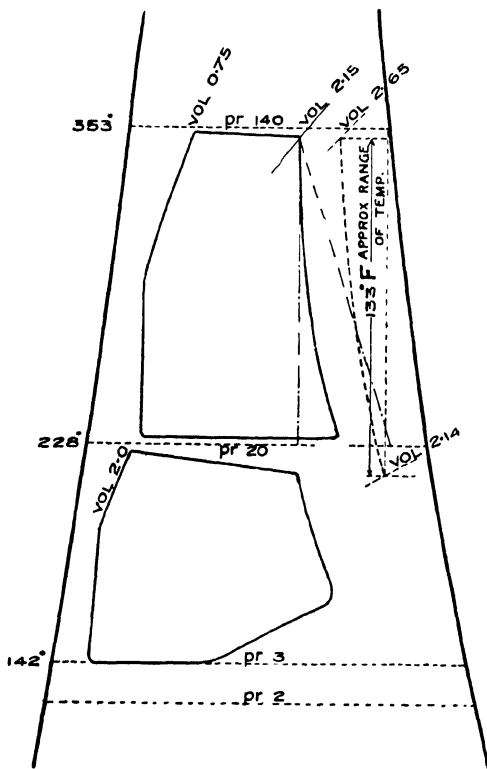

FIG. 132.

the clearance in the H.P. cylinder can best be determined by trial and error. Assume that it is 0.8 cubic foot, then the volume at release =

$$\frac{(2.15 - 0.8)}{0.1} = 13.5$$

cubic feet, and this would make the volume in the clearance

$$13.5 \times \frac{5}{100} = 0.675.$$

Take 0.7 cubic foot as a second approximation, the release volume then becomes 14.5 cubic feet, and the clearance volume is 0.725. A third trial will show that 0.75 is near enough for practical purposes, and this gives a release volume of 14.0 cubic feet, and the

$\theta \phi$ diagram of the H.P. cylinder can be drawn in as shown in Fig. 132. Since the ratio of the L.P. to the H.P. cylinder is 1 to 3.2, it follows that the release volume in the L.P. will be $14.0 \times 3.2 = 45$ cubic feet, and since the cut-off in this cylinder by supposition remains unchanged at 0.285, the volume at cut-off will be

$$45 \times 0.285 + 2 = 14.8 \text{ cubic feet.}$$

The $\theta \phi$ diagram of the L.P. cylinder can thus be sketched in as

shown in Fig. 132, and the following results are obtained in the manner previously described :—

Results.—Heat supplied per stroke : $1095 \times 85 = 930$ B.Th.U.

H.P. Cylinder.

Work done 84.5 B.Th.U.

Economy..... 470 B.Th.U. per I.H.P. per minute.

Mean pressure 34.3 lbs. per square inch.

L.P. Cylinder.

Work done 66.0 B.Th.U.

Economy..... 601 B.Th.U. per I.H.P. per minute.

Mean pressure 8.5 lbs. per square inch.

Both Cylinders combined.

Economy..... 266 B.Th.U. per I.H.P. per minute.

Efficiency ratio 0.632

Mean pressure referred to L.P. .. 18.7 lbs. per square inch.

Equalization of Work in the Cylinders.—It will be seen that the work done in the H.P. cylinder is now considerably greater than in the L.P. Can the work be equalised by altering the cut-off in the L.P.? Suppose, for instance, the L.P. cut-off is made 0.2 instead of 0.285, then, since the release volume of the L.P. remains the same, the admission volume will be reduced to 10.4 cubic feet. This approximately determines the exhaust pressure of the H.P. cylinder, and since

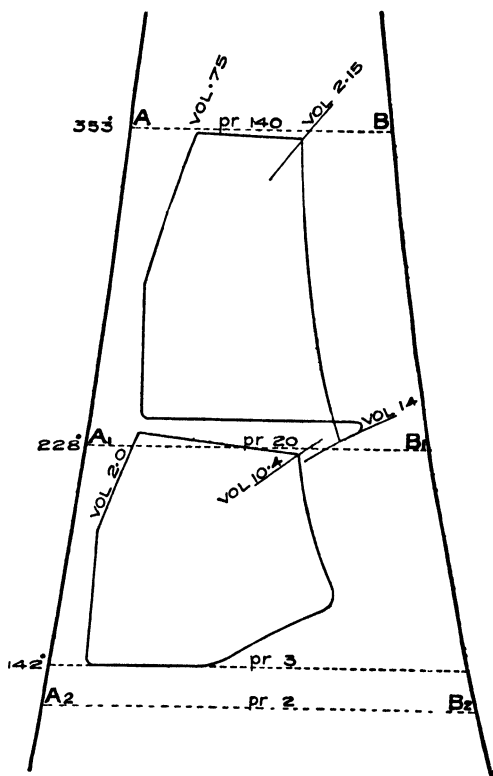

FIG. 133.

the number of expansions in this cylinder are not altered there must be a loop at the end of the expansion as shown in Fig. 133. The change made in the point of cut-off of the L.P. has had the effect of approximately equalising the work in the two cylinders.

The I.H.P. developed by the engine, if the revolutions remain constant, will be proportional to the mean pressure referred to the L.P. cylinder. Hence the change of cut-off in the H.P. cylinder from 0.226 to 0.10 reduces the I.H.P. in the ratio of 27.6 to 18.7.

Alteration of Cut-off to increase Mean Pressure.—If it were desired to find the cut-off in the H.P. cylinder that would give a greater mean pressure referred to the L.P. of say 40 lbs. per square inch, the release volume in the L.P. would have to be diminished, and from Fig. 131, and the results obtained above, it will be seen that the release volume will have to be somewhat less than $\frac{27.6}{40} \times 33 = 23$ cubic feet. The release volume of the H.P. will then become $\frac{23}{3.2} = 7$ cubic feet. The volume at cut-off in the H.P. will, however, be greater than in Fig. 131 because the initial condensation will be reduced. The drawing in of the $\theta \phi$ diagrams from these particulars is left to the student.

Assuming that the volume at cut-off is 2.9 cubic feet, corresponding to 0.9 dryness fraction, the cut-off will be $\frac{2.9}{7} = 0.41$.

Cylinder Ratios for a Quadruple Expansion Marine Engine.—The following example is intended to show how easily the ratio of cylinders can be determined by means of the chart. This ratio depends not only on the admission and exhaust pressures, but also on the conditions under which the engine is working. The engine is supposed to be a four-crank marine engine, quadruple expansion, the cylinders being placed side by side, and giving equal turning efforts at the economical load. The engine is intended for a cargo vessel, and therefore the steam economy is of importance. Let 13.5 lbs. per I.H.P. be aimed at. Let the *admission* pressure be 160 lbs. per square inch absolute, and the *exhaust* pressure in the L.P. cylinder be 3 lbs. per square inch absolute. Under these circumstances, experience teaches that a mean pressure of

30 lbs. per square inch is suitable. It will be found that the Rankine engine for the pressures given, converts 255 B.Th.U. into work, and that its release volume is 95 cubic feet, as shown in Fig. 134, at the point δ . The mean pressure is therefore

$$5.4 \times \frac{255}{95} = 14.5 \text{ lbs. per square inch,}$$

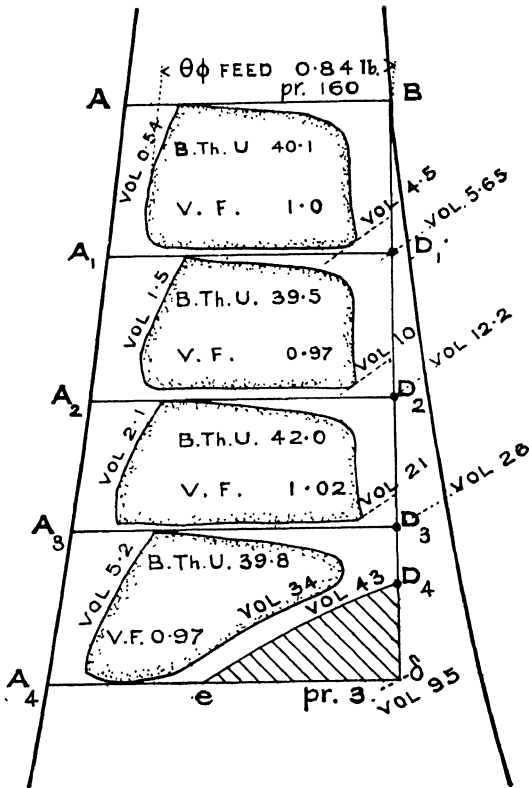

FIG. 134.

so that for 30 lbs. mean pressure the release volume must be reduced to something less than 45 cubic feet. By plotting on the chart, it will be found that the shaded area $e D_4 \delta$, when the release volume is 43 cubic feet, is 14 B.Th.U., so that the mean pressure becomes

$$5.4 \times \frac{255 - 14}{43} = 30.3 \text{ lbs. per square inch,}$$

which is near enough. The area $A_4 A B D_4 e$ represents the $\theta \phi$ diagram of an ideal engine without clearance, or any losses except that due to cutting off the toe. Let this area be divided into four equal parts each containing 60 B.Th.U., so as to conform to the condition that each cylinder is to give an equal turning effort. This division is made by the lines $A_1 D_1$, $A_2 D_2$, and $A_3 D_3$, and the volumes at the points $D_1 D_2 D_3$ and D_4 are the release volumes of the respective cylinders. As read off the chart they are:—

H.P.	1st I.P.	2nd I.P.	L.P.
5.65	12.2	26.0	43.0 cubic feet.

So that the ratios are:—

$$1 : 2.15 : 4.6 : 7.6$$

Since these are the ratios for an engine without losses, they might be regarded as those to be aimed at, but it is desirable to find what these ratios would be in an actual engine with the usual clearances, which for a marine may be taken as:—

H.P.	1st I.P.	2nd I.P.	L.P.
12%	15%	10%	15%

and on this basis, and by the method previously described in this Chapter, the $\theta \phi$ diagrams for the actual engine have been sketched in as shown in Fig. 134. Taking the volume factor of the H.P. cylinder as unity, the volume factors of the other cylinders are found to be as given in the figure. Further, the $\theta \phi$ feed of the H.P. cylinders is 0.84 lb. Hence the work done in the various cylinders per lb. of steam is as follows:—

H.P.	1st. I.P.	2nd. I.P.	L.P.
$\frac{40.1}{0.84}$	$\frac{39.5}{0.84 \times 0.97}$	$\frac{42.0}{0.84 \times 1.02}$	$\frac{39.8}{0.84 \times 0.97}$

equal to:—

48.0	48.2	49.0	48.5 B.Th.U.
------	------	------	--------------

Altogether, therefore, the work done by the engine per lb. of steam is 193.7 B.Th.U., so that the economy is $2545/193.7 = 13.1$ lbs. of steam, or somewhat better than aimed at. From Fig. 134 it will be seen that the volume swept by the L.P. piston is $34.0 - 5.2 = 28.8$ for the $\theta \phi$ feed of the L.P. cylinder, which corresponds to

$$\frac{28.8}{0.84 \times 0.97} = 35.4 \text{ cubic feet per lb. of feed.}$$

Hence the mean pressure is

$$5.4 \times \frac{193.7}{35.4} = 29.6 \text{ lbs. per square inch.}$$

which practically agrees with the conditions laid down. The volumes swept by the pistons in the various cylinders, adjusted for the volume factors are as follows:

H.P.	1st I.P.	2nd I.P.	L.P.
4.5 — 0.54	$\frac{10 — 1.5}{0.97}$	$\frac{21.0 — 2.1}{1.02}$	$\frac{34.0 — 5.2}{0.97}$
= 3.96	8.78	18.5	29.7

The cylinder ratios are therefore:—

$$1 : 2.2 : 4.7 : 7.5$$

which, it will be seen, are practically the same as those for the ideal engine. Thus it is only necessary to lay down the ideal engine, $A_4 A B D_4 e$, if the object is to obtain the ratio of the cylinders

It is worth noting that in the *Quadruple Expansion Rankine* engine, that is, when the expansion is carried down to the point δ (Fig. 134), it is only the L.P. cylinder which will be very much larger than that of the actual engine, because the lines $A_1 D_1$, $A_2 D_2$ and $A_3 D_3$ will only be slightly lowered, to make each cylinder of the Rankine engine account for $\frac{1}{4}$ th of the area $e D_4 \delta$ which was found to be equal to 14 B.Th.U. Hence $A_1 D_1$ will be lowered 3.4° F. ; $A_2 D_2$ 6.2° F. , and $A_3 D_3$ 8.8° F. On working this out it will be found that the cylinder ratios for the quadruple Rankine engine are:

$$1 : 2.32 : 5.8 : 16.2$$

In the $\theta \phi$ diagrams, as sketched, the expansion has been carried down to the exhaust pressure in the first three cylinders. Judging from Example No. IV. (page 104), and from general experience, it is probable that a better economy would be obtained by releasing the steam somewhat earlier in each of these cylinders, so as to get the drying effect of the "toe." Suppose, for instance, that a 4 lb. drop is allowed for in each cylinder, then a small (approximately) triangular area corresponding to this drop will have to be deducted at the points $D_1 D_2$ and D_3 . These deductions will slightly affect the positions of the lines $A_1 B_1$ $A_2 B_2$

and A_3B_3 (but to no practical extent) if it is desired to have equal work in the four cylinders, the release volumes will, however, be reduced as will be seen by plotting on the chart, Plate I., thus :

H.P.	1st I.P.	2nd I.P.	L.P.
5.40	10.8	22.5	43.0

so that the cylinder ratios are :

$$1 : 2.0 : 4.2 : 8.0$$

As before, these are the ratios for the ideal engine ; it is suggested, as an exercise, to sketch in the $\theta \phi$ diagrams of the proposed actual engine to see to what extent the ratios will vary from those just obtained.

CHAPTER XII.

SUPERHEATED STEAM.

Constant Pressure and Constant Volume Lines.—In the case of superheated steam the constant volume and pressure lines will conform to those of a gas, as shown in Plate I. This energy chart was drawn many years ago, and for want of authentic information the specific heat at constant pressure was taken as a constant and equal to 0.48, and the specific heat at constant volume as 0.37. Referring to page 23, it will be seen that the constant pressure curves are therefore drawn according to the equation

$$\phi = 0.37 \log_{\epsilon} \frac{\theta}{\theta_1}$$

and the constant volume lines according to the equation

$$\phi = 0.48 \log_{\epsilon} \frac{\theta}{\theta_1}$$

Recently, however, many determinations of the specific heat of superheated steam have been made which show that it is not constant, and that the value is higher than given above. These determinations still need confirmation, but for practical purposes it would appear that, for the range within which superheated steam is used, C_p can be taken as 0.6, and C_v as 0.46.

These new values have been taken for working out the examples, and a chart has been drawn for them in Fig. 135, the old values being shown by dotted lines.

The entropy at any point in the superheated field is given by the general equation

$$\phi_s = \phi_1 + C_p (\log_{\epsilon} \theta_s - \log_{\epsilon} \theta_1),$$

where ϕ_1 = entropy of saturated steam at the absolute temperature θ_1 , and θ_s = absolute temperature of superheat.

Thus the *increase* of entropy of steam in the superheated field above the entropy at the same pressure on the saturation line varies in

direct proportion to the value taken for C_p , and the existing chart in Plate I can be used, making the correction for the particular value

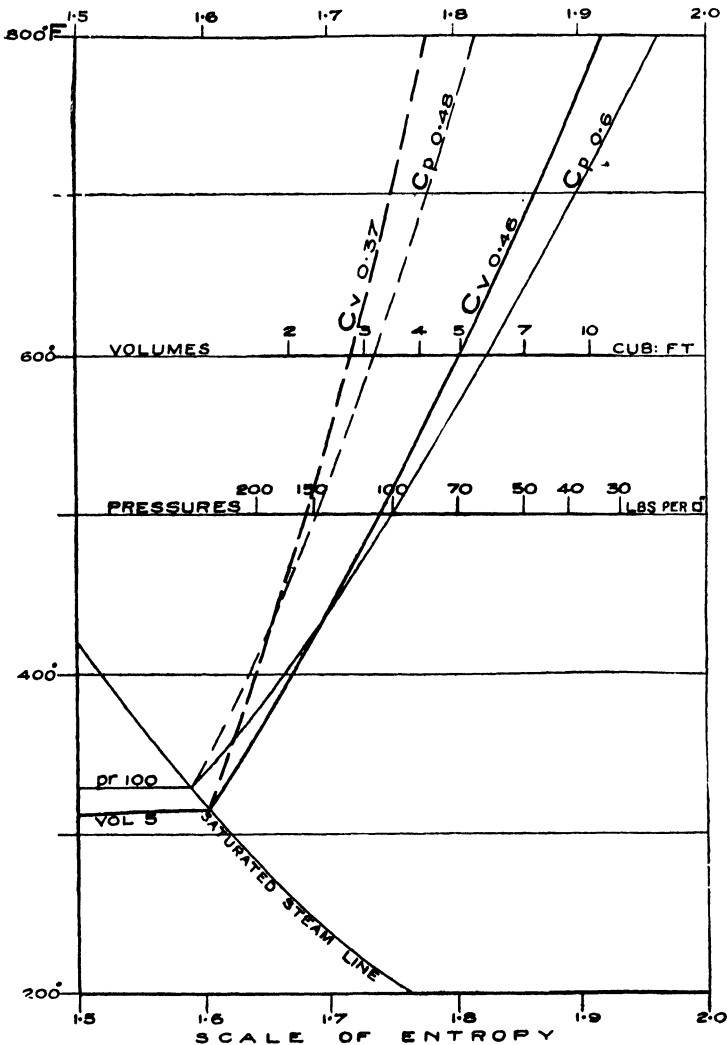

FIG. 135.

of C_p , that may be accepted when definite data are available. The same correction can be made with respect to the constant volume lines.

The following numerical examples were originally worked out on the chart for superheated steam (Plate 1), and the results then obtained are given as well as those derived from the new data, in this way it is easy to note the difference made.

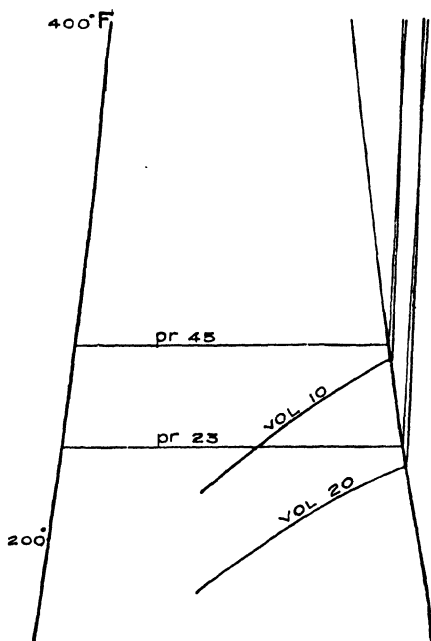

FIG. 136.

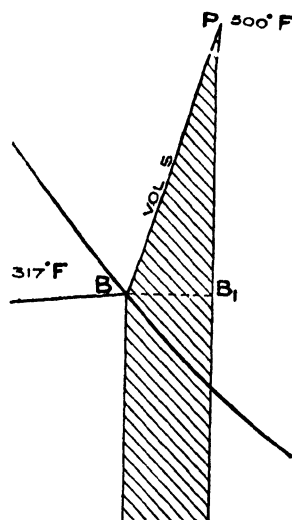

FIG. 137.

Two constant pressure and constant volume lines are shown in Fig. 136, and it will be noticed how very nearly vertical they are owing to the temperature and entropy scales chosen for this figure. In Fig. 137 the temperature scale has been reduced, and the entropy scale has been increased. In this way the curves become much flatter, and the intersections of the volume and pressure lines are somewhat less acute.

Internal Energy.—To find the internal energy at any point of the superheated field, it is only necessary to add the heat required to superheat at constant volume to the internal energy of *saturated* steam at the same volume. Thus in the case of point *P* (Fig. 137), at which the volume is 5.0 cubic feet it will be seen from the chart (Plate 1) that 1 lb. of saturated steam of this volume has an

internal energy of 1099 B.Th.U., and the heat required to superheat at constant volume from B to P is represented by the shaded area in Fig. 137. This area is more readily obtained by calculation than by measurement if the specific heat at constant volume is assumed constant. The temperature at B is 317° F., and at P it is 500° F., and

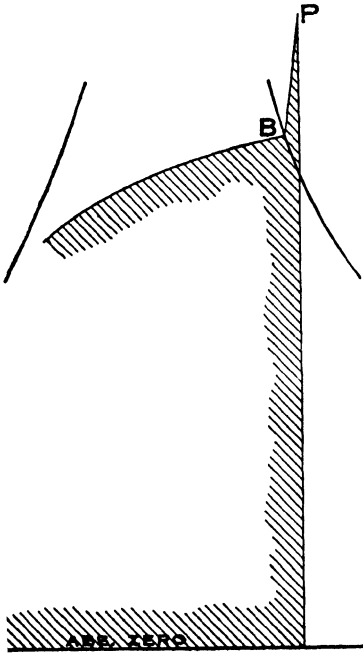

FIG. 138.

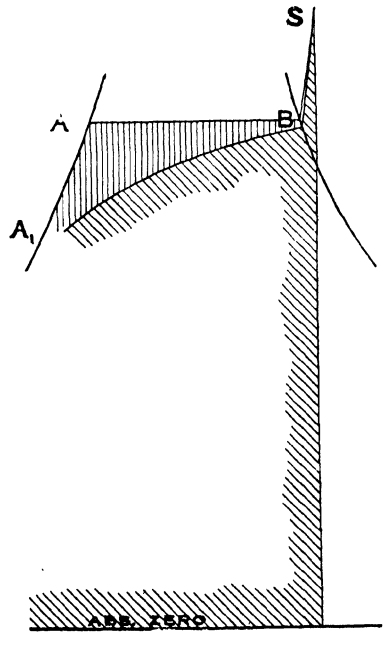

FIG. 139.

taking the specific heat as 0.37 the heat required to superheat from 317° F. to 500° F., at constant volume is

$$(500 - 317) \times 0.37 = 67.6 \text{ B.Th.U.}$$

The internal energy at P is therefore

$$1099 + 67.6 = 1166.6 \text{ B.Th.U.},$$

and is represented by the shaded area in Fig. 138.

If, in accordance with the latter determinations, the specific heat at constant volume is taken at 0.46, the heat required to superheat from 317° to 500° at constant volume is

$$(500 - 317) \times 0.46 = 84 \text{ B.Th.U.}$$

With the new value, therefore, the shaded area in Fig. 137 represents 84.0 B.Th.U., and thus the internal energy at P is found to be

$$1099 + 84 = 1183 \text{ B.Th.U.},$$

or 16.4 B.Th.U. more than with the old value.

Superheating at Constant Pressure.—When a superheater is used the steam is superheated at constant pressure, that is, it flows from the boiler through the superheater at the boiler pressure, at any rate, theoretically it is supposed to do so. Practically, however, there is a drop of pressure due to the resistance of the pipes.

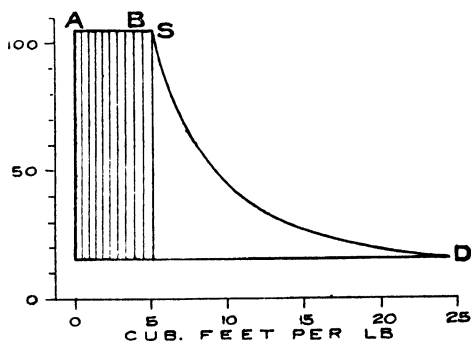

FIG. 140.

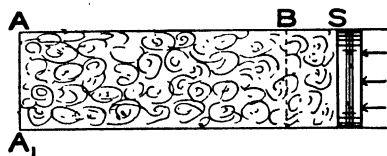

FIG. 141.

Rankine Cycle for Superheated Steam.—Let the case of an ideally perfect steam engine be considered, supplied with superheated steam produced at constant pressure. Starting with the feed water at the exhaust temperature, saturated steam is first formed according to the transformation line $A_1 A B$ (Fig. 139), and the corresponding points are shown on the $p v$ diagram (Fig. 140) and on the ideal closed vessel (Fig. 141). The steam is then superheated at constant pressure along the line $B S$, and there will now be 1 lb. of superheated steam behind the piston. The heat supplied is the area below the transformation line $A_1 A B S$, and the area shaded by vertical lines is the work done on the piston, reckoned to the back pressure, in moving it from A to S (Fig. 141), and is also represented on the $p v$ diagram by the area shaded by vertical lines. The internal energy of the steam at the point S , is represented by the area in Fig. 139, shaded by lines sloping from left to right.

At *S* the heat supply is stopped and the steam is expanded adiabatically until the exhaust temperature is reached, after which the heat remaining in the cylinder is rejected at constant pressure, thus completing the cycle as shown in Fig. 142. The figure whose area is shaded with dots is the $\theta \phi$ diagram of the ideal superheated steam engine giving the maximum utilisation as work, and the $p v$ diagram

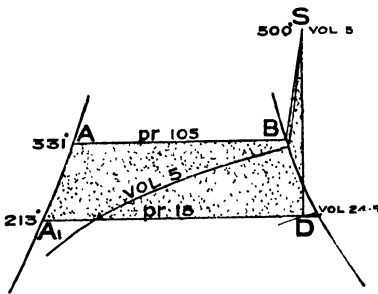

FIG. 142.

of this engine is easily derived, and is given in Fig. 140. From the chart it will be seen that in the case of the numerical example chosen, the volume of the steam at *S* is 5.0 cubic feet, and at *D* it is 24.5 cubic feet. Hence the number of expansions is 4.9.

The following results are readily obtained by using the methods described in chapter V. :—

Rankine Cycle for Superheated Steam.	Specific Heat $C_p = 0.48$.	New value of Specific Heat = 0.6.	
Heat supplied	1082	1102	B.Th.U. per lb.
Work done	157.0	159.6	B.Th.U.
Thermal efficiency	0.1450	0.1448	
Economy	294.5	295.0	B.Th.U. per I.H.P. per min.
Mean pressure	34.6	35.1	Lbs. per square inch.

Comparison with Saturated Steam Engine using same Range of Pressures.—It will be interesting to compare this ideal superheated steam engine, with an ideal saturated steam engine, working between the same pressures. The $\theta \phi$ diagram of the ideal saturated steam engines is given in Fig. 143. The only conditions are that the pressure of supply shall be the same as in the case of the superheated steam engine and that the exhaust pressure shall also be the same. The results obtained are as follows :—

Heat supplied	1001 B.Th.U. per lb.
Work done	139 B.Th.U.
Thermal efficiency	0.139
Economy.....	307 B.Th.U. per I.H.P. per min.
Mean pressure	32.6 Lbs. per square inch.
Ratio of expansion.....	5.54

$\theta \phi$ Diagrams of Actual Engines Working with Superheated Steam.—The transfer of the $p v$ diagrams to the chart is effected in precisely the same manner as for engines using saturated steam, it is only necessary therefore to give a numerical example as follows:—

EXAMPLE I.

Compound Condensing Engine with Reheater.—In Fig. 145 are shown $p v$ diagrams of an engine using superheated steam, the H.P. and L.P. diagrams being combined in the usual way in the proportion of the cylinder

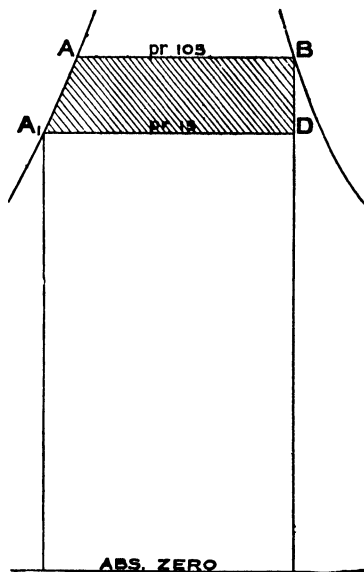

FIG. 143.

volumes, and the saturation curve has been added. The actual feed was 10.36 lbs. per I.H.P. per hour, and the following temperatures were observed:—

Temperature in superheater	750° F.
„ at stop valve	635° F.
„ in reheater	320° F.

Fig. 144 shows the corresponding $\theta \phi$ diagrams. It is to be noticed that the steam is superheated at the point of cut-off, the temperature being 490° F., and further that the superheat is maintained throughout the expansion in the H.P. cylinder. In the L.P. cylinder the steam is practically saturated at cut-off

owing both to the steam at the H.P. release being slightly super-

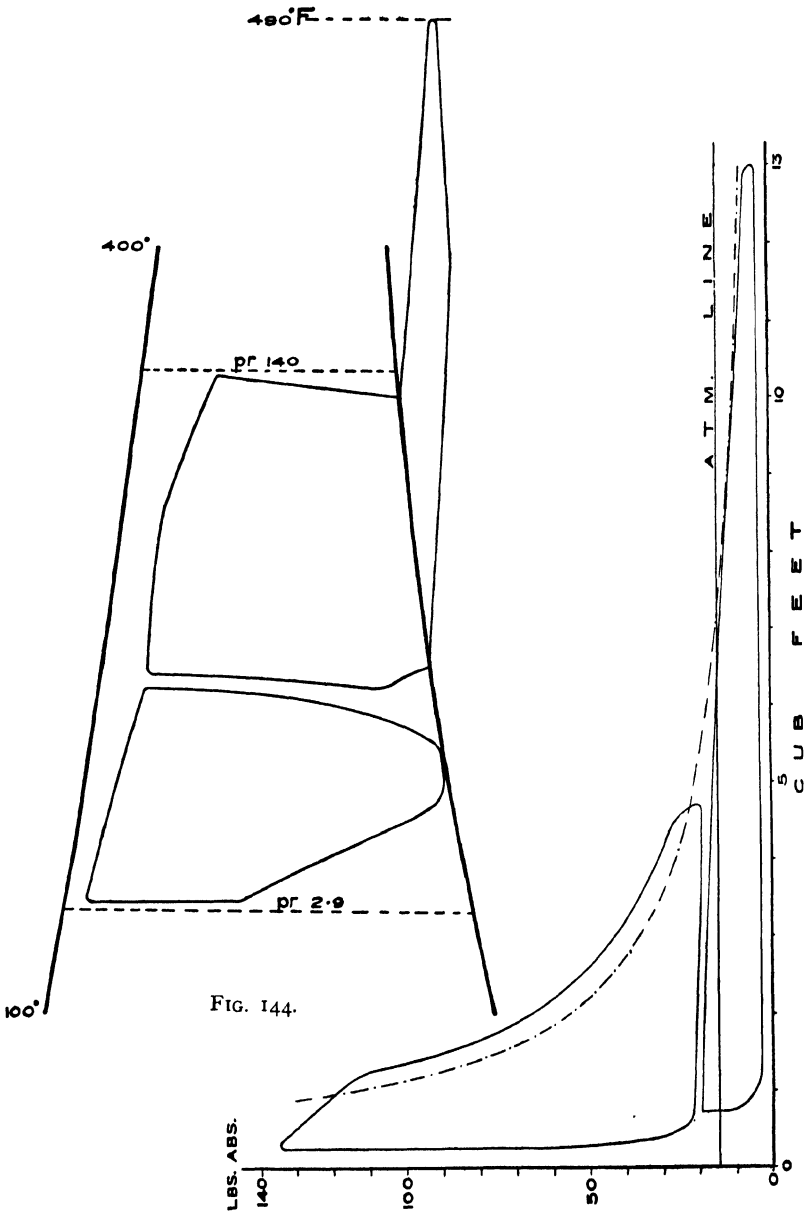

FIG. 144.

FIG. 145.

heated, and also to the effects of the reheater. The economic results obtained are as follows:—*

Economy: 206 (200) B.Th.U.'s per I.H.P. per minute.

Or 11.8 (11.5) lbs. "equivalent feed."

Thermal efficiency ... 0.198 (0.204)

Efficiency ratio 0.790 (0.812)

EXAMPLE II.

Compound Engine using Superheated Steam compared with the same Engine using Saturated Steam.—The data for this example are taken from a paper by Professor D. S. Jacobus, read before the American Society of Mechanical Engineers, in December, 1903 (Vol. XXV.)

The indicator diagrams for Test No. 2 with superheated steam, are given in Fig. 146, and for Test No. 4 with saturated steam, in the same figure (dotted lines). The particulars of these tests are as follows:—

			Test No. 2.		Test. No. 4.
Horse Power (indicated)		420.4	406.7
Feed Water, per I.H.P.		9.56 lbs.	13.84
Equivalent Feed		11.4	13.7
Steam Pressure at Engine		157.1 abs.	159.8 abs.
Superheat at Throttle		374.5° F	—
Vacuum at Engine		25.8 ins.	24.47
Cylinders	H.P.	16.37 inches.		
	„ L.P.	28.03 „		
Stroke	42 „		
Piston Rods,	H.P.	3.0 „		
	„ L.P.	3.5 „		
Clearances	H.P.	4.1%		
	„ L.P.	5.8%		

By means of the above data the $\theta \phi$ diagrams given in Fig 147 have been plotted, those for the superheated steam engine being

* Taking $C_p = 0.6$; the figures in the brackets are based on $C_p = 0.48$.

shown in full lines, and those for the saturated steam engine in

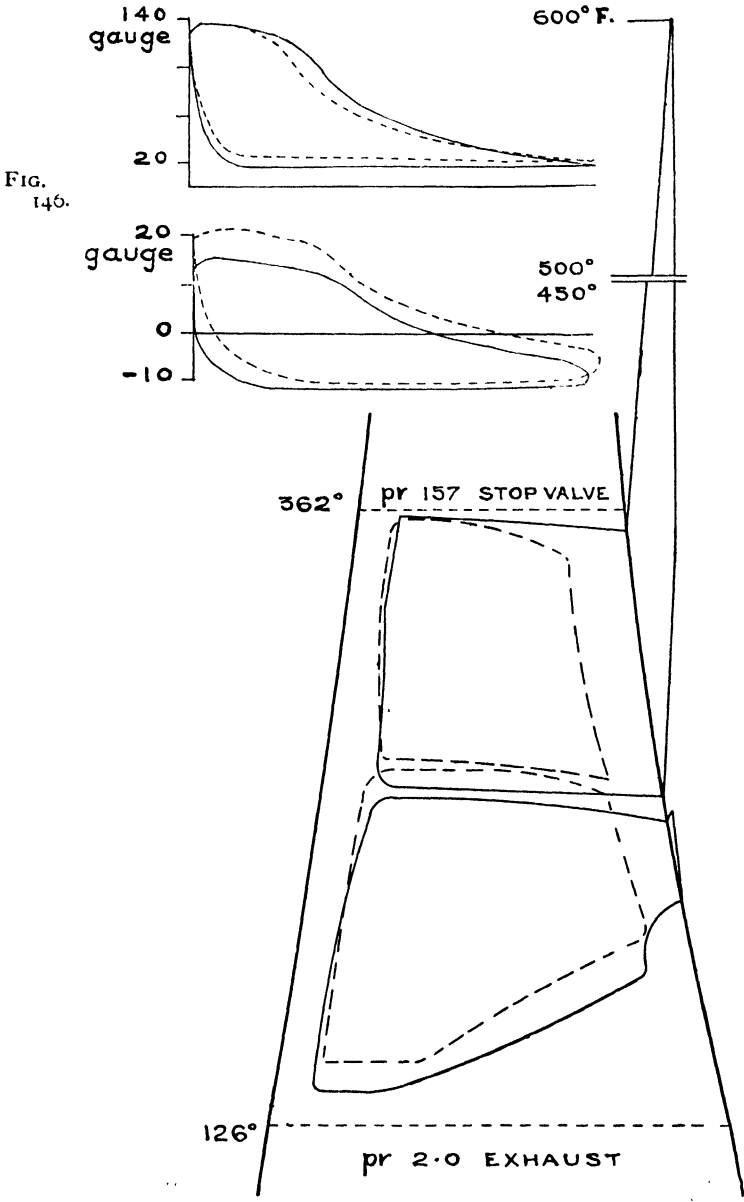

FIG. 146.

FIG. 147

dotted lines. The great increase in the area of the former will be noticed, corresponding to the actual feed per I.H.P.; but the true economy is *not* in proportion to these areas because the heat supply per lb. of feed is considerably greater with the superheated steam, as shown in Fig. 139. In the paper Professor Jacobus gives the economy of the two tests as 205.0 and 248.2 B.Th.U. per I.H.P. per minute, figures which are proportional to the "equivalent" feeds.

CHAPTER XIII.

EXPANSION OF STEAM WITHOUT DOING EXTERNAL WORK.

LET it be supposed that there is an adiabatic vessel containing V cubic feet, divided by a diaphragm DD into two parts, whose volumes are

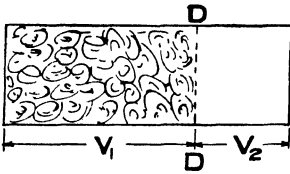

FIG. 148.

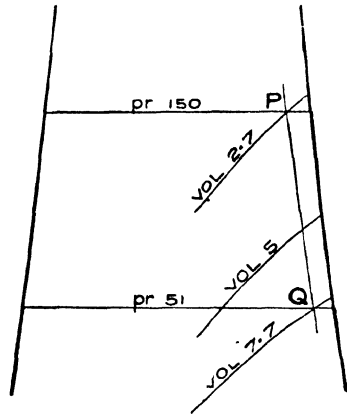

FIG. 149.

V_1 and V_2 respectively (Fig. 148), and let the portion whose volume is V_1 contain 1 lb. of H_2O in the state represented by the point P on the chart (Fig. 149), and let the portion whose volume is V_2 be at absolute zero of pressure. Now let the diaphragm be removed; in what condition will the lb. of H_2O be, so soon as any eddies, that may have been formed, have disappeared?

It is clear that the internal energy in the new condition will be the same as in the old, as by supposition there has been neither gain nor loss of energy, the state point must therefore lie at the intersection of the volume line V and the curve of equal internal energy drawn through P . The point Q in Fig. 149 is thus obtained.

Example No. 1.—To illustrate this two numerical examples will be taken and it will be assumed in the first that P is at 150 lbs. per square inch, $V_1 = 2.7$ cubic feet and $V_2 = 5.0$ cubic feet, so that $V = 7.7$ cubic feet.

On referring to the chart giving lines of internal energy (Fig. 43), it will be seen that the internal energy at the point P is 1040 B.Th.U., and from Fig. 149, that the intersection of the 1040 B.Th.U. line of internal energy and the 7.7 cubic foot volume line is at Q on the 51 lbs. per square inch pressure line. The two points P and Q can be plotted on the chart (Plate I.), and it

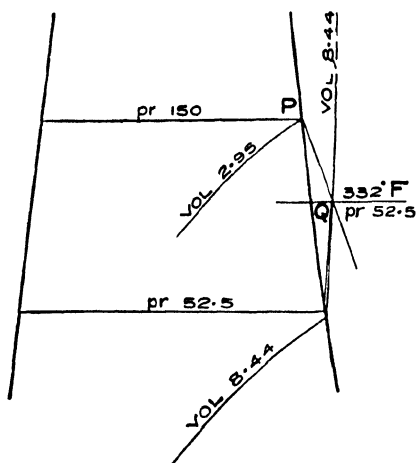

FIG. 150.

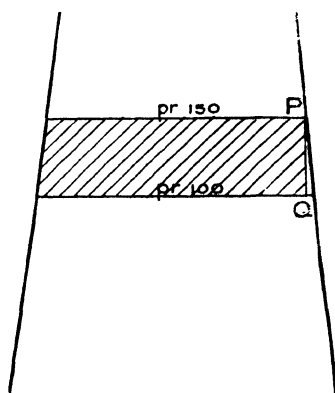

FIG. 151.

will then be seen that the dryness fraction at P is 0.91 and at Q 0.935. Hence the following result has been obtained: If steam at 150 lbs. per square inch absolute pressure and of dryness 0.91 expands $7.7/2.7 = 2.85$ times without doing external work, its condition will be defined by 51 lbs. per square inch absolute pressure and 0.935 dryness.

Example No. 2.—In the second example the pressure will be taken as before at 150 lbs. per square inch, but the volume V_1 will be increased to 2.95 cubic feet, so that P lies on the saturation line; V_2 will be taken at 5.48 so that $V = 8.44$, and the number of expansions will be the same as before. On referring to Fig. 43,

it will be found that the internal energy at P is 1109 B.Th.U., and that the intersection of this internal energy line with the 8.44 volume line lies in the superheated field at the point Q (Fig. 150), whose temperature is 332° F. and pressure 52.5 lbs. per square inch. On referring to Plate 1, it will be seen that the temperature of saturated steam at 52.5 lbs. pressure is 284° F. Hence the steam has been superheated 48° F. by expanding without doing work.

Expansion after Formation at Constant Pressure.—Superheating by Throttling.—It will be noticed that in the above the 1 lb. of H_2O was assumed to be in the state represented by P , without any reference as to the manner in which the steam was formed. A case in which steam is formed at constant pressure, and then expanded by

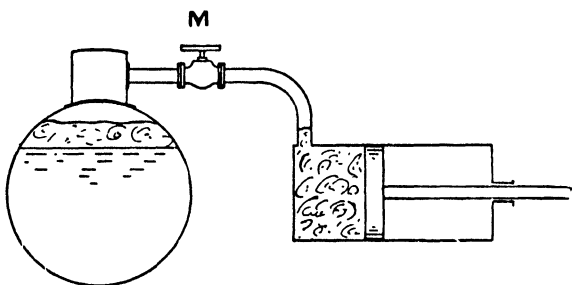

FIG. 152.

throttling to a lower pressure, will now be considered. In Fig. 152 is shown a diagrammatic representation of a boiler connected to a cylinder by a pipe fitted with a valve M , by means of which valve the steam pressure can be throttled before it reaches the piston. The piston is shown at the point of cut-off, and it is supposed that the cylinder at this moment contains 1 lb. of steam at the reduced or throttled pressure. This steam will obviously be superheated, and the problem is to find the quality of the steam at this state point on the chart. The first step is to find the velocity of the steam.

Velocity of Issuing Steam.—When the steam rushes into the cylinder under the effect of the difference of pressure existing between the boiler and the cylinder, a portion of its energy will be expended in giving velocity to the steam, in other words in producing motion energy, and the equivalent of heat energy disappears. In the cylinder this motion energy will take the form of "eddies" in the steam, and these eddies will gradually die away, and as they do so, the energy in question will re-appear as heat. The steam as

it leaves the boiler is represented, as regards its condition, by the point P (Fig. 151), and assuming no gain or loss of energy from or to external objects the expansion through the valve M will be adiabatic, and hence the condition of the 1 lb. of H_2O (which after passing the valve is moving with a high velocity V), is represented by the point Q ; a moment's consideration will show that the heat energy converted into motion energy is represented by the shaded area of the Rankine cycle (Fig. 151). If R is taken to denote the number of B.Th.U. in this area, then obviously

$$\frac{V^2}{2 \times g} = 778 \times \sqrt{R}$$

or
$$V = 223 \sqrt{R} \text{ feet per second.}$$

Example.—As a numerical example if P is at 150 lbs., and Q at 100 lbs. per square inch, it will be found by measurement that $R = 32$ B.Th.U. Hence $V = 223 \sqrt{32} = 1280$ feet per second.

Recovery of Motion Energy.—The matter will be further discussed by means of the same numerical example (Fig. 151); the boiler pressure being 150 lbs. absolute, and the pressure in the cylinder 100 lbs. absolute. The internal energy of the steam in the cylinder at the moment the lb. of H_2O has been introduced will be equal to the energy required to produce 1 lb. of saturated steam in the condition represented by the point P , less the work done on the piston up to this point, and less whatever portion of the motion energy still remains in the form of eddies. There is no means of telling what this portion is, but limits can be fixed. Thus the conversion of the motion energy in the form of eddies back into heat may be exceedingly rapid so that no eddies (and therefore no motion energy), remain at the point of cut-off. The other limit would occur if the transformation of motion energy into heat energy is a slow process, in comparison with the piston speed, so that the whole of the motion energy is rejected from the engine in the exhaust.

Each limit will be considered separately.

In the first case, when all the motion energy is re-converted into heat, the condition of the steam at the moment of closing the admission valve will evidently be found by determining the intersection of the constant pressure line through P with the constant internal energy line for the total heat of steam at pressure P , less the

work done at the pressure of P . In the numerical example the total heat is 1191 B.Th.U., but the volume V is not known, and thus the value of $p v$ cannot be found, and a process of approximation must be resorted to.

Assuming, as a first approximation, 5 cubic feet as a value for V (which it will be observed, is rather more than the volume of saturated steam at the cylinder pressure, viz., 100 lbs. per square inch) the work done up to the point of cut-off is

$$\frac{100 \times 144 \times 5}{778} = 93 \text{ B.Th.U.}$$

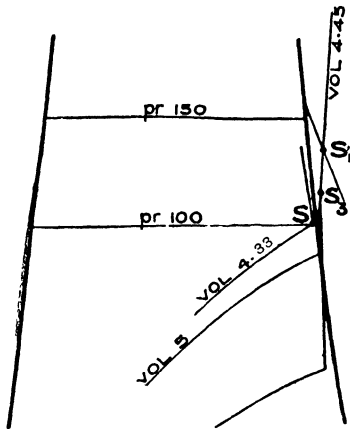

FIG. 153.

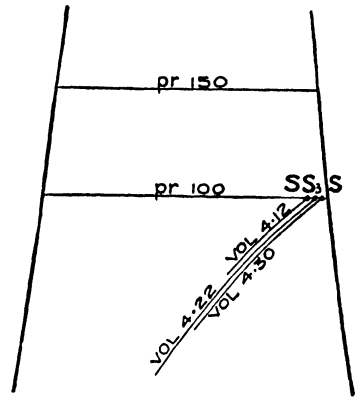

FIG. 154.

The internal energy remaining will therefore be $1191 - 93 = 1098$ B.Th.U. On reference to Fig. 43 it will be seen that the intersection of the internal energy line for 1098 B.Th.U., and the pressure line for 100 lbs. per square inch, occurs in the saturated field, and the volume at the point of intersection S (Fig. 153) is 4.33 cubic feet. Taking this volume for a second approximation the point S_1 (Fig. 153), which occurs in the superheated field, is determined, and at this point the volume is 4.45 cubic feet.

Repeating the above operation twice more, the volume at the point of cut-off is found to be 4.38 cubic feet, and S_3 is the point representing the condition of the steam in the cylinder. The cycle is continued by adiabatic expansion and release at constant pressure as shown in Fig. 153.

The second limiting case assumes that the whole energy of motion imparted to the steam in entering the cylinder remains as such up to the point of cut-off. The internal energy of the steam at the point of cut-off is therefore less than in the first case by the amount of the motion energy, which latter can be found by using the formula given on page 147, and is 32 B.Th.U. The internal energy of the steam at cut-off is therefore (1191 — 32) less the work done. As before, the volume V at cut-off is not known, but by repeating a similar process, a series of approximations marked $S, S_1, S_2,$ and $S_3,$ in Fig. 154 are obtained, and the point S_3 represents the state of the steam at cut-off with sufficient accuracy, and is found to be at a volume 4.22 cubic feet. The limits are, therefore, 4.22 and 4.38 cubic feet, and as a practical matter the volume after the expansion by throttling can be taken as 4.3 cubic feet.

CHAPTER XIV.

APPLICATION OF THE ENERGY CHART TO OTHER SUBSTANCES.

So far the chart has been drawn, and its use shown for the substance H_2O , and in Chapter II. some particulars were given as to its adaptation to air and other gases. The energy chart can, however, be drawn for any other substance, if the necessary physical properties are known, in exactly the same manner as that for H_2O ; for instance, for such substances as ammonia (NH_3), carbon dioxide (CO_2), and sulphur dioxide (SO_2), all of which are used in refrigerating machines, and the indicator cards from such engines can be transferred to their respective charts.

The energy chart for sulphur dioxide is given in Fig. 155, and, as an example of its use, the case of a binary engine will be considered. The use of the secondary or binary engine operated in conjunction with a primary steam engine has long been known and has from time to time been advocated, but the first difficulty was to find a suitable substance, that is to say, a substance such, that with the ranges of temperature available, will give a reasonable mean pressure, say from 40 to 50 lbs. per square inch, and whose vapour pressure at the exhaust temperature of the primary steam engine is not too great for constructional reasons, say 300 lb. per square inch. Sulphur dioxide meets these requirements with a *condensing* steam engine. The second difficulty, which has only been recently overcome, is to arrange the stuffing boxes, valves and joints so that there will be *no* leaks, so as to guard against the harmful effects of such leakage, and to obviate the loss of a costly substance. These difficulties have been solved by Prof. Josse, of Berlin, and there are many SO_2 engines running in Germany, the largest of which indicates 400 H.P., but the question is still undecided whether the undoubted large thermodynamic gain is sufficiently great to show a commercia

profit, after the increased depreciation, interest on capital, etc., has been allowed for.

The actual SO₂ engine from which the data for the following example has been obtained is working in a spinning mill in Germany, and during the trial was developing 327 H.P.

The indicator diagram taken from the engine does not materially differ in appearance from that of a steam engine with the exception that the cylinder clearance of the SO₂ engine is very much larger owing to larger valves being used on account of the great viscosity of the vapour. In this particular engine the clearance is as much as 29.5%.

Fig. 156 shows the $\theta\phi$ diagram of the engine, and it will be noted how

the large clearance affects the position of the diagram on the chart.

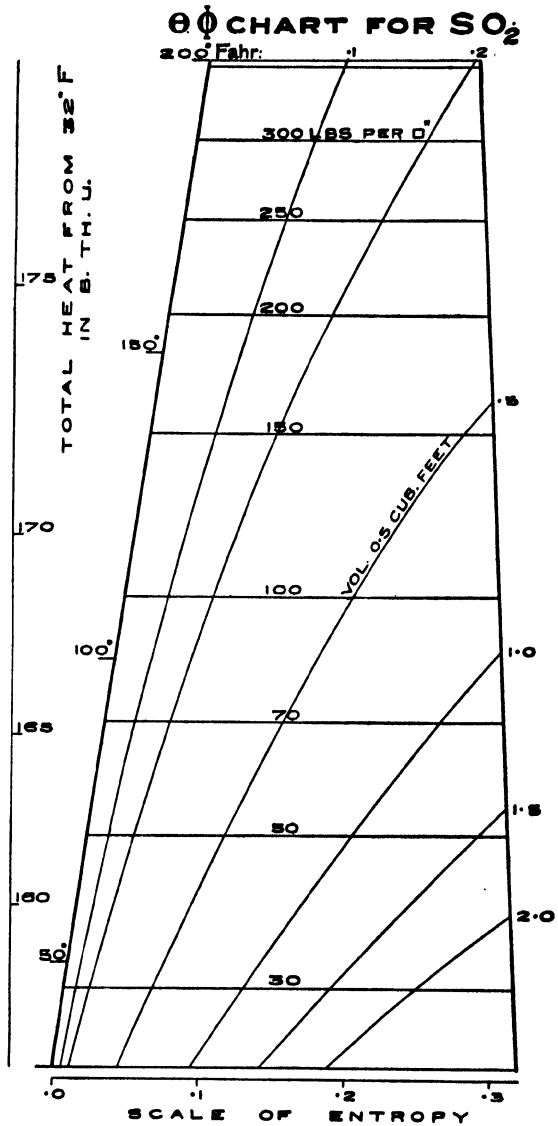

FIG. 155.

On the same figure is given the exhaust temperature of the L.P. cylinder of the steam engine, viz., 161.4° F., and the lower part of its diagram is represented by the area whose contour is shaded with dots.

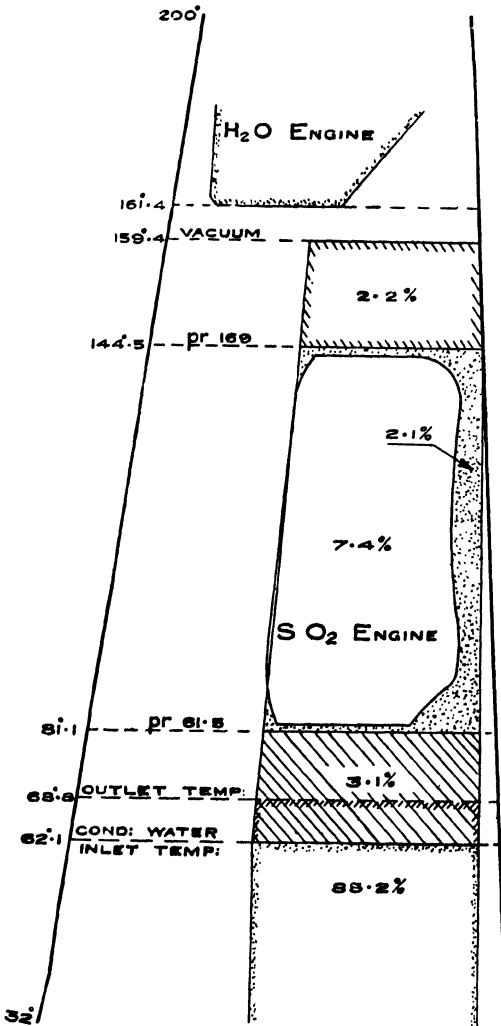

FIG. 156.

steam engine. The SO_2 is evaporated and reaches the engine stop valve at a temperature of 144.5° F., corresponding to a pressure of 169 lbs. per square inch absolute. It passes through the SO_2 engine,

Before the SO_2 engine was fitted the steam engine exhausted at this temperature, and the exhaust steam was condensed by coming into contact (in a jet condenser) with condensing water at 62.1° F. This range of temperature $161.4 - 62.1 = 99.3^{\circ}$ F. was entirely lost for the expansion of the steam, and it is the function of the binary engine to utilise this range.

With this object in view, the exhaust steam of the steam engine is condensed by means of liquid SO_2 (instead of as usual by water) in a surface condenser which is both the condenser of the steam engine and the boiler of the SO_2 engine. In this way a vacuum corresponding to 159.4° is maintained in the exhaust pipe of the

expanding and doing work, and is then exhausted into a surface condenser at a pressure of 61.5 lbs. per square inch, where it is condensed by cooling water whose temperature is 62.1° F. The Rankine cycle for an engine using the same $\theta \phi$ feed, namely, 0.545 lb. of SO₂, is shown in Fig. 156, and the various losses are easily localised, and are given as percentages of the heat supply due to the exhaust steam.

The shaded area between the temperature 159.4° and 144.5°, representing 2.2%, is the loss in the boiler of the SO₂ engine due to radiation, loss by transmission of heat, etc.

The SO₂ engine works between the temperature limits 144.5° and 81.1°, converting 7.4% of the heat supply into work, while the area shaded by dots represents the engine's losses, namely 2.1%. These losses include the loss due to condensation, incomplete expansion, throttling through the admission and exhaust ports, and to clearance, etc.

The area shaded between the temperature 81.1° and 62.1°, namely 3.1%, represents the loss due to the inefficiency of the condenser, and this can be subdivided into a portion due to the transmission of heat through the tubes, namely, between the temperatures 81.1° and 68.8°, and a second portion due to the rise in temperature of the condensing water, namely between the temperature 68.8° and 62.1°. The remainder of the heat supply is rejected to the exhaust and this amounts to 85.2%.

The economic results of this SO₂ engine obtained from the chart are as follows:—

Heat supplied per I.H.P. per minute	=	577 B.Th.U.
Flow of SO ₂ per I.H.P. per hour	=	208.5 lbs.
Thermal efficiency	=	0.074
Efficiency ratio	=	0.778
M.E.P.	=	46.1 lbs. per sq. in.
Number of expansions	=	2.22
Cut off	=	48% of stroke

1 lb. of exhaust steam from the H₂O engine evaporates 5.6 lbs. of SO₂ in the boiler, so that the H₂O used per I.H.P. per hour for the secondary engine

$$= \frac{208.5}{5.6} = 37.3 \text{ lbs.}$$

It must be borne in mind, however, that the heat in this "feed" water is recovered from the waste heat of the primary steam engine, or to put it in another way, 327 I.H.P. are developed by the aid of the SO₂ engine without burning any additional coal. It is desirable to know the thermal efficiency and the economy of the H₂O and SO₂ engines *combined*, and this can be done as follows, the data being obtained from the trial referred to above. There were two steam engine supplying exhaust steam to the SO₂ boiler, one of which was economical and the other not.

	I.H.P	Feed-Water lbs. per hour.	B.Th.U. per I.H.P. per minute.
No. 1 steam engine	505	15.1	276
No. 2 ,, ,,	209.6	21.9	409
Both steam engines combined..	714.6	17.1	315
SO ₂ engine alone	327.	—	577

The total I.H.P. is therefore 1041.6, and the total feed water is $714.6 \times 17.1 = 12,220$ lbs. per hour. Hence the feed water per I.H.P. is 11.7 lbs. per hour. By a similar calculation it will be found that the B.Th.U. per I.H.P. per minute are 216, so that the gain in comparison with the two steam engines combined is

$$100 \times \frac{315 - 216}{216} = 45.8\%.$$

It is to be observed that this considerable gain is in part due to the steam engines not being economical. Had they been economical the percentage gain would have been less. Thus if the primary steam engine required 12 lbs. of "equivalent" feed per I.H.P. hour the thermodynamic gain due to the addition of an SO₂ engine would be about 28 %, so that the "equivalent" feed water for the combined H₂O and SO₂ engines would be reduced to 9.3 lbs.

Or

$$\begin{aligned} \text{B.Th.U. per I.H.P. per min. for steam engine} &= 220 \\ \text{,, ,, ,, combined H}_2\text{O and} & \\ \text{SO}_2 \text{ engine ..} &= 170 \end{aligned}$$

As a comparison, it may be stated that a steam engine using superheated steam, and requiring the very small actual feed of 9.3 lbs., would need about 10.4 lbs. of "equivalent" feed, corresponding to 190 B.Th.U. per I.H.P. per minute.

APPENDIX I.

PLOTING $\theta \phi$ DIAGRAMS BY MEANS OF THE SLIDE RULE.

The method of transferring an Indicator Diagram to the Energy Chart is given in extenso in Chapter VI., but in actual practice the process can be much shortened by the help of the Slide Rule as follows:—

At any point M , Fig. 157 (which is a partial reproduction of Fig. 87) the dryness fraction is ascertained by the method given at page 70. Then, knowing the pressure and dryness fraction, the point M can be located on the chart, and in the example given it will be found that this point falls on volume line 7.49.

If K is any other point on the Indicator Diagram then :

$$\theta \phi \text{ volume at } K = \frac{\theta \phi \text{ volume at } M}{A M} \times B K$$

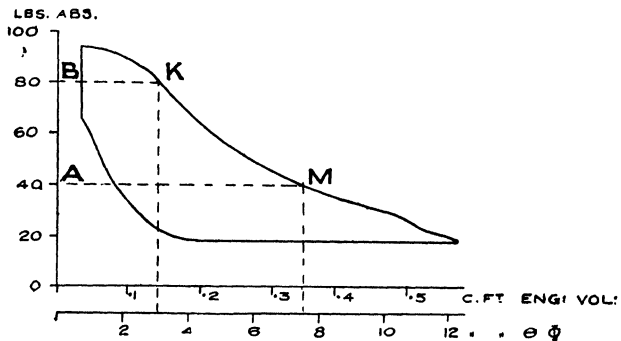

FIG. 157.

The term: $\frac{\theta \phi \text{ volume at } M}{A M}$ can be set as a constant on the slide rule, and when multiplied by the length of $B K$ for different positions of K , measured on the same scale of equal divisions as $A M$, will give the $\theta \phi$ volume at the various points. Obviously the positions of K would be chosen at pressures suitable for easy plotting on the chart, such for instance as 20, 40, 60, 80, and 90 in the example given.

APPENDIX II.

USEFUL FORMULAE IN CONNECTION WITH THE ENERGY CHART FOR H₂O.

ILLUSTRATED BY MEANS OF NUMERICAL EXAMPLES.

For ease of reference the various formulae used in this book have been collected together.

Notation.—The following Notation has been used:—

- H* Total heat expressed in B.Th.U., reckoned from 32° F.
h Water heat expressed in B.Th.U., reckoned from 32° F.
R B.Th.U. utilized by Rankine cycle.
c Point of cut-off.
k Percentage clearance calculated on piston displacement.
V_c Volume in cylinder at point of cut-off.
V_r Volume in cylinder at point of release.
V_k Volume in clearance.
θ Absolute temperature.
t₁ Initial temperature of steam
t₂ Exhaust temperature of steam } in °F.
t_s Temperature of superheated steam.
-

Point of Cut-off.—The point of cut-off can be found from the following equation:

$$c = \frac{V_c - V_k}{V_r - V_k}$$

Example No. 1 (see Fig. 125).

$$V_c = 3.15, \quad V_k = 0.55, \quad V_r = 9.5 \text{ cubic feet.}$$

$$c = \frac{3.15 - 0.55}{9.5 - 0.55} = 0.29$$

Release Volume.—The release volume can be found from either of the following equations :

$$V_r = \frac{V_c - V_k}{c} + V_k$$

$$V_r = \frac{1 + k}{c + k} \cdot V$$

Example No. 2 (see Fig. 125).

$$V_k = 0.55, \quad V_c = 3.15 \text{ cubic feet.}$$

$$c = 0.29, \quad k = 0.06$$

$$V_r = \frac{3.15 - 0.55}{0.29} + 0.55 = 9.5 \text{ cubic feet.}$$

or :

$$V_r = \frac{1 + 0.06}{0.06 + 0.29} \times 3.15 = 9.5 \text{ cubic feet.}$$

Number of Expansions.—The number of expansions in *any* cylinder are equal to $\frac{V_r}{V_c}$

Example No. 3 (see Fig. 125).

$$V_r = 9.5, \quad V_c = 3.15 \text{ cubic feet.}$$

$$\text{Number of expansions} = \frac{9.5}{3.15} = 3.01$$

In a compound or triple-expansion engine the total number of expansions is

$$\frac{V'_r \times \text{volume factor of H. P. cylinder.}}{V_c \times \text{volume factor of L. P. cylinder.}}$$

where V'_r is the release volume of the low pressure cylinder and V_c is the volume at cut-off in the H. P. cylinder.

Example No. 4 (see Fig. 110).

$$V_c = 2.6, \quad V'_r = 33.5 \text{ cubic feet.}$$

Volume factors .. H.P. cylinder, 1.35; L.P. do., 1.44.

$$\text{Number of expansions} = \frac{33.5 \times 1.35}{2.6 \times 1.44} = 12.1.$$

Volume swept by Piston.—The volume swept by the piston of the $\theta \phi$ engine is $V_r - V_k$. To obtain the volume swept by the piston of the actual engine, divide by the volume factor.

Example No. 5 (see Figs. 87 and 89).

$$V_k = 0.8, \quad V_r = 12.30, \quad \text{Volume factor} = 21.4.$$

Volume swept by piston of actual engine

$$= \frac{12.30 - 0.8}{21.4} = 0.538 \text{ cubic foot.}$$

Cylinder Ratio.—The cylinder ratio is equal to the volume swept by the H. P. piston divided by the volume swept by the L. P. piston or

$$\text{Cylinder ratio} = \frac{V_r - V_k}{(V'_r - V'_k)} \times \frac{\text{Volume factor of L.P. cylinder.}}{\text{Volume factor of H.P. cylinder.}}$$

Example No. 6 (see Fig. 110).

Volume factors: H.P. cylinder, 1.35; L.P. cylinder, 1.44.

$$V_k = 0.6, \quad V'_k = 1.77, \quad V_r = 7.8, \quad V'_r = 33.5.$$

$$\text{Cylinder ratio} = \frac{7.8 - 0.6}{33.5 - 1.77} \times \frac{1.44}{1.35} = \frac{1}{4.14}$$

Heat Supply.—As defined by the Thermal Efficiency Committee of the Institution of Civil Engineers, the heat supply is equal to the total heat of the steam, at the pressure and temperature of formation, less the water heat at the temperature of the exhaust. The total heat and the water heat can be obtained from the energy chart, Plate I.

Example No. 7 (see Figs. 87 and 89).—*Saturated Steam.*

Pressure, 115 lbs. per square inch abs.

Exhaust temperature, 212° F.

$$H = 1183.6 \text{ B.Th.U.}, \quad h = 180 \text{ B.Th.U.}$$

$$\text{Heat supply per lb.} = 1003.6 \text{ B.Th.U.}$$

Example No. 8 (see Figs. 144 and 145).—*Superheated Steam.*—

Pressure, 140 lbs. per square inch.

Temperature of superheat, 635° F.

Exhaust Temperature, 140° F.

$$H = 1189.5 + (635 - 353) 0.6 = 1358.7. \quad h = 108.0.$$

$$\text{Heat supplied per lb.} = 1250.7 \text{ B.Th.U.}$$

Heat Utilization of the Rankine Cycle.—The heat utilization of the Rankine Cycle can be found by means of the $\theta \phi$ chart, by the following very approximate formula:

$$R = (t_1 - t_2) \times \text{width of Rankine cycle diagram at the mean temperature } \frac{t_1 + t_2}{2}$$

measured on the entropy scale.

Example No. 9 (see Fig. 91).

$$t_1 = 334.5^\circ \text{ F.} \quad t_2 = 212^\circ \text{ F.}$$

Width of diagram at the mean temperature 273° is 1.18

Heat utilized by Rankine cycle :

$$R = (334.5 - 212) 1.18 = 144.6 \text{ B.Th.U.}$$

For *superheated steam* add to the above: $\frac{t_s - t_1}{2} \times$ additional width of diagram due to superheating, measured on the entropy scale.

Example No. 10 (see example No. 1, page 139).

Temperature of superheat $t_s = 635^\circ \text{ F.}$; other temperatures as in example 9.

Additional width of diagram 0.16 entropy units.

Additional heat units utilized

$$= \frac{635 - 359}{2} \times 0.16 = 22 \text{ B.Th.U.}$$

Total heat units utilized by Rankine cycle (superheated steam)

$$R = 144.6 + 22 = 166.6 \text{ B.Th.U.}$$

$\theta \phi$ Cylinder Feed.—The $\theta \phi$ cylinder feed is equal to the actual feed multiplied by the volume factor. The volume factor can be obtained as shown on page 71.

Example No. 11 (see Fig. 91).

Actual feed, 0.0382 lb. per minute.

Volume factor, 21.4.

$$\theta \phi \text{ cylinder feed} = 0.0382 \times 21.4 = 0.818 \text{ lb.}$$

The $\theta \phi$ cylinder feed is also equal to $\frac{V_c - V_a}{V_c}$, where V_a is the volume at admission of the proportional water line of the Rankine cycle for the $\theta \phi$ cylinder feed (for example volume at the point a Fig. 91). If the compression in the engine reaches admission pressure, as in Fig. 123, V_a is equal to the clearance volume V_h . If the compression is less than the admission pressure, V_a can be found by drawing a line parallel to the water line through the state point representing the end of compression (see Fig. 128).

Example No. 12 (see Fig. 125).

$$V_a = 0.55, \quad V_c = 9.5 \text{ cubic feet.}$$

$$\theta \phi \text{ cylinder feed} = (9.5 - 0.55) = 0.895 \text{ lb.}$$

Heat Utilization of an Actual Engine.—The heat utilized by the actual engine corresponding to the $\theta \phi$ engine can in the case of a simple engine be obtained by measuring the area of the $\theta \phi$ diagram in square inches and multiplying by the heat scale.

Example No. 13 (see Fig. 89).

Area of $\theta \phi$ diagram .. 6.55 square inches.

Heat scale 10 B.Th.U. per square inch.

Hence :

$$\text{Heat utilized} = 6.55 \times 10 = 65.5 \text{ B.Th.U.}$$

In a compound or triple-expansion engine the area of the $\theta \phi$ diagrams must be adjusted for the different values of the volume factors. If the feed is measured into the boiler, then the volume factor of the H.P. cylinder should be taken as the basis, and the areas of the $\theta \phi$ diagram of the other cylinders should be multiplied by their volume factor, divided by the volume factor of the H.P. cylinder. If, however, the steam supply to the engine is measured by the condenser method, then the volume factor of the L.P. cylinder should be taken as the basis.

Example No. 14 (see Fig. 110).

Area of H.P. cylinder $\theta \phi$ diagram .. 7.97 square ins.

„ L.P. „ „ .. 7.45 „ „

Volume factor H.P. cylinder 1.35

„ „ L.P. „ 1.44

Heat scale = 10 B.Th.U. per square inch.

Feed measured into the boiler—

$$\begin{aligned} \text{Heat utilized by the engine} &= 7.97 \times 10 + 7.45 \frac{1.35}{1.44} \times 10. \\ &= 149.6 \text{ B.Th.U.} \end{aligned}$$

Heat Supply per Stroke.—The heat supply per diagram or per stroke is equal to: $\theta \phi$ cylinder feed \times heat supply per lb.

Example No. 14 (see Fig. 91).

$\theta \phi$ cylinder feed : 0.818 (the same as in example No. 11).

Heat supply per lb. : 1003.6 („ „ „ No. 7).

Heat supply per stroke = 1003.6 \times 0.818 = 821 B.Th.U.

Thermal Efficiency of Rankine Cycle.—The thermal efficiency of the Rankine cycle is equal to $\frac{R}{H - h}$

Example No. 16 (see Fig. 91).

$$\begin{aligned} R &= 144.6 \text{ (From example No. 9).} \\ H &= 1183.6 \\ h &= 180. \end{aligned} \left. \vphantom{\begin{aligned} R \\ H \\ h \end{aligned}} \right\} \text{(From example No. 7).}$$

$$\text{Thermal efficiency of Rankine engine} = \frac{144.6}{1003.6} = 0.14.$$

Thermal Efficiency of an Actual Engine.—The thermal efficiency of an actual engine is

$$= \frac{\text{Area of } \theta \phi \text{ diagram} \times \text{heat scale.}}{(H - h) \times \theta \phi \text{ cylinder feed.}}$$

Example No. 17 (see Fig. 91).

$$\begin{aligned} \text{Area of } \theta \phi \text{ diagram} &.. 6.55 \text{ square inches.} \\ \text{Heat scale} &.. 10 \text{ B.Th.U. per square inch.} \\ H &.. .. 1183.6 \text{ B.Th.U.} \\ h &.. .. 180 \text{ B.Th.U.} \\ \theta \phi \text{ cylinder feed} &.. 0.818 \text{ lb. per hour.} \end{aligned}$$

$$\text{Thermal Efficiency} = \frac{655 \times 10}{1003.6 \times 0.818} = 0.08.$$

Efficiency Ratio.—The efficiency ratio is:

$$\frac{\text{Thermal Efficiency of actual Engine.}}{\text{Thermal Efficiency of Rankine cycle.}}$$

and can also be found from:

$$\frac{\text{area of } \theta \phi \text{ diagram.}}{\text{area of Rankine cycle} \times \theta \phi \text{ cylinder feed.}}$$

Example No. 18 (see Fig. 91).

Taking the same data as for examples 16 and 17:

$$\text{Efficiency ratio} = \frac{0.08}{0.14} = 0.56.$$

or with the data of examples 9, 11, and 13:

$$= \frac{65.5}{144.6 \times 0.818} = 0.56.$$

Economy.—The economy of the engine when expressed in B.Th.U., as recommended by the Thermal Efficiency Committee of the Institution of Civil Engineers, is

$\frac{42.4}{\text{Thermal Efficiency of Actual Engine}}$ B.Th.U. per I.H.P. per min.

Example No. 19 (see Fig. 91).

Thermal Efficiency = 0.08 (as in example No. 17).

Economy = $\frac{42.4}{0.08} = 530$ B.Th.U. per I.H.P. per minute.

If the economy is to be expressed in terms of the *actual* feed water it can be found by the following formula :

lbs. of feed water per I.H.P. per hour = $2545 \frac{\text{B.Th.U. represented by } \theta \phi \text{ diagrams}}{\text{per lb. of cylinder feed}}$

Example No. 20 (see Fig. 91).

B.Th.U. represented by $\theta \phi$ diagram .. 65.5.

$\theta \phi$ cylinder feed 0.818 lb.

Feed water = $\frac{2545 \times 0.818}{65.5} = 31.6$ lbs. per I.H.P. per hour.

Example No. 21 (see Fig. 144).

B.Th.U. represented by $\theta \phi$ diagrams.. 206.

$\theta \phi$ cylinder feed 0.85 lb.

Feed water = $\frac{2545 \times 0.85}{210} = 10.36$ lbs. per I.H.P. per hour.

Equivalent Feed.—The “equivalent” feed is equal to the actual feed divided by 1100 and multiplied by the heat supply per lb. (see page 89, Report of the Committee on Steam Engine and Boiler Trials, Institution Civil Engineers).

Example No. 22 (see Fig. 91).

In example No. 7 the heat supply is 1003.6 B.Th.U., and from example No. 20 the actual feed is 31.6 lbs. Hence the equivalent feed is :

$$= \frac{31.6 \times 1003.6}{1100} = 28 \text{ lbs. per I.H.P. per hour.}$$

Example No. 23 (see Fig. 144).

In example No. 8 the heat supply is 1250.7 B.Th.U., and if the actual feed is 10.36 (example No. 21), the equivalent feed is

$$= 10.36 \times \frac{1250.7}{1100} = 11.8 \text{ lbs. per I.H.P. per hour.}$$

BIBLIOGRAPHY.

The following is a list of the principal books dealing with the subject of the entropy-temperature or energy chart :—

- Transactions of the Connecticut Academy of Science. Vol. ii., page 309. 1873.
- Zeitschrift des Vereines Deut., Ing. M. Schroeter. 1883.
- Rationalization of Regnault's Experiments. Proc. Inst. Mech., Engineers, 1889. J. Macfarlane Gray.
- Steam Engine Trials. Proceedings of Inst. C.E. Vol. xciii., 1889, and vol. cxiv., 1893. P. W. Willans.
- Superheated Steam Engine Trials. Proc. Inst. C.E. Vol. cxxviii. 1897. Wm. Ripper.
- The Theta-Phi Diagram. Henry A. Golding. 1898. Technical Publishing Co., Manchester.
- Revue de Mecanique. Professor Boulvin. June, 1897.
- A new graphical method of constructing the Entropy Temperature Diagram of a Gas or Oil Engine from its Indicator Card. H. T. Eddy. Vol. xxi. Trans. of American Soc. of Mech. Engineers. 1900.
- Cours. de Mécanique appliquée aux machines. 3^{me} fascicule theories des machine thermiques. J. Boulvin, Paris. 1893.
- The Steam Engine and other Heat Engines, by J. A. Ewing, M.A., B.Sc., F.R.S., M. Inst. C.E. 1894.
- The Entropy Temperature Analysis of Steam Engine Efficiencies. Sydney A. Reeve. 1897.
- The Entropy Diagram and its Uses. H. B. Brydon. Power. June and July, 1904.
- Entropy in Steam Engine Practice (serial). The Mechanical Engineer, August 27th, 1904.

- Steam Engine Theory and Practice. W. Ripper. 1899.
 Entropy, or Thermo-dynamics from an Engineer's standpoint, and the Reversibility of Thermo-dynamics. Jas. Swinburne. 1904.
 The Theory of Heat Engines. An address delivered to the Students of the Institution of Civil Engineers, 17th January, 1902. By Capt. H. Riall Sankey, R.E. (*ret.*) M. Inst. C.E.
 The Temperature-Entropy diagram. G. James Wells. Proc. Manchester Society of Engineers.

REFERENCES TO SPECIAL TERMS USED IN THIS BOOK.

	PAGE.		PAGE.
Constant pressure line ..	5, 22	Proportional water line ...	49
Constant volume line ...	5, 20	Quality line	47
Corresponding $\theta \phi$ engine	71	Saturation line	20
Dryness fraction line ...	22	State point	6
Energy chart	2, 15	Theoretical re-evaporation line	54
Entropy	2	$\theta \phi$ cylinder feed	73
Equivalent feed	68	$\theta \phi$ diagram	28
Heat energy per $\theta \phi$ diagram	73	Transformation line	6
Heat scale	I, 22	Volume factor	71
Initial point	69	Water line.....	20
Lines of equal internal energy	27		

INDEX.

	PAGE.		PAGE.
Adiabatic expansion	32	Constant volume cycles	19
" " Temperature and pres- sure at the end of	65	" " line 11, for a gas 5, for H ₂ O	20
Admission line, simple engine	116	" " Transformation at	34
Admission valve, Leakage of	57 59 76	Corresponding $\theta \phi$ engine	71
" " " direct into exhaust	81 120	" " " Work done by	73
" " Wetness of steam at	76	Clausius	2
" " Wire drawing at	76	Clearance, Compression in	76 80 113
Air engine, Stirling's	16	" " Effect of	45 91
Binary engine	150	" " Weight of steam remaining in	73
B. Th. U. utilised as work	67 159	" " Work done in compressing the steam in	45
Capper, Professor (on leakage)	120	Cut off, Determination of point of	66
Carnot cycle	17 18	" " in cylinders	100
" " Thermal efficiency of	19	" " " Alterations of, in H. P. cylinder	125
Chart for superheated steam	23 134	Cycle of operations in Carnot's engine	18
Combine forward and back end indicator diagram	83	" " " steam engines	41
Comparison of ideal and actual steam engine cylinder	41	Cylinder feed, $\theta \phi$	79 160
" " with Rankine cycle, I. C. E. standard	74 115	Cylinders, Cut off in	66 100 125 128
Comparison of $\theta \phi$ and $p. v.$ diagrams	28	" " Equalisation of work in	127
Complete cycle	16	" " ratio	101 121 124 159
Compound engines, Examples of 97 101 102 104 121 139 141		" " walls, Heat stored in	52
" " expansion in L.P. cylinder	93	Design of compound steam engine	121
" " with large cylinder ratio	104	" " simple engine	111
" " medium " " " "	97	Designing steam engines by means of energy chart	111 121
" " leak from H. P. cylinder	89 101	Determination of point of cut off	66 100
" " Rankine cycle of	87	Division of energy chart into four zones	11 35
" " $\theta \phi$ diagrams of	87 97-108 123-128 139	Dryness fraction	71
" " Sketching $\theta \phi$ diagrams of	122	" " lines	22
" " Standard of comparison	121	Dugald Clark (specific heat of gases)	4
" " Exhaust line of	96	Economy of actual steam engine	67 99 162
" " transfer of indicator dia- grams to the energy chart	97 139	" " Rankine engine	66 121
Compound engines volume factor	97 103	Eddies due to leaks	58
Compression in clearance	76 80 113	" " Effect of	51
Compression pressure	50	Efficiency ratio	99 162
Condensation initial	52 76 78	" " of compound engine	115
" " during pre-admission	51	" " of jacketed engine	85
" " Effect of initial	44	Elementary Thermodynamics of H ₂ O	28
" " Water produced by	53	Energy chart	2 13 20
" " compound engine superheated with reheater	139 142	" " applied to other substances	150
Constant pressure cycles	19	" " Division of, into four zones	35
" " " for a gas 5, for H ₂ O	22	" " for H ₂ O	20
" " Superheating at	137	" " for SO ₂	150
" " Transformation at	11 32	" " Representation of internal energy on	24
		Energy chart, Superheated steam, new values of specific heat	134
		Energy, Internal	7 24 27 53 62

	PAGE.		PAGE.
Energy retained in cylinder ...	73	Feed, θ ϕ cylinder ...	79
Engine, Actual economy of ...	67	Factor, Volume ...	71
" " mean pressure of ...	68 124	Gas engine ...	19
" " steam consumption of ...	67	" " cycle ...	19
" Stirling's... ...	16	" perfect ...	4
" Binary ...	150	" Specific heat of ...	4
" Compound, examples of 101 102 104 139		Graphic representation of energy chart ...	3
" " volume factor ...	97	Gray, J. McFarlane ...	2 4
" " Example of jacketed ...	102	H ₂ O, Elementary thermodynamics of ...	28
" " " non-jacketed ...	97-102	Heat energy per θ ϕ diagram ...	73 161
" " " with reheater ...	104	" per θ ϕ diagram jacketed engine ...	85
" " " with large cylinder ratio ...	104	" scale... ...	22
" " Sketching ϕ θ diagrams of ...	122	" stored in the cylinder walls ...	52
" " Theoretical, " " 	87	" supply, Measurement of ...	39 159
" Condensing, superheated compound		" utilized by actual engine ...	73 161
" with reheater ...	139 142	" " " Rankine engine ...	74 159
" Corresponding θ ϕ ...	71	H.P. cylinder effect of alteration of cut off ...	125 128
" Designing, by means of energy		" " Leak from ...	89 101
" chart ...	111 121	Incomplete expansion ...	61 76 79
" Economy of ...	67 99 162	Increase in clearance, Effect of, in simple engines ...	119
" Jacketed, compound condensing		Indicator diagram, combined forward and backward end ...	83
" with reheater ...	102	Indicator diagram, compound engines, transfer of, to energy chart ...	97
" Jacketed, efficiency ratio of ...	85	Indicator diagram, simple engines, transfer of, to energy chart ...	69
" Loss of heat in engine ...	76 et seq.	Indicator diagram, transfer to energy chart with superheated steam ...	139
" Rankine, economy of ...	66 121 159	Initial condensation ...	52
" " Mean pressure of ...	68 121	" " Effect of ...	44
" " for superheated steam ...	137	" " in L.P. cylinder ...	92
" simple admission line ...	116	Initial point, Location of ...	69
" " effect of increased clearance ...	119	Internal energy ...	7 24 53 62
" " point of cut off ...	114	" " Lines of equal ...	27
" Steam consumption of ...	100	" " representation on energy chart ...	24
" Thermal efficiency of ...	74 162	" " of steam ...	34
" triple condensing, Examples of 108-110		" " superheated steam ...	135
" " " jacketed with re-heater and jackets ...	108	Isothermal expansion ...	8
" Waste heat, numerical example of... ..	151	Isothermal lines for steam ...	20
Entropy ...	1 2	Jacket, Effect of adding ...	118
Equivalent feed ...	68 163	Jacketed engine, compound, condensing, with reheater ...	102
" Definition of (Inst. Civil Engineers) ...	68	Jacketed engine, Efficiency ratio of ...	85
Equalisation of work in the cylinders ...	127	" " heat per θ ϕ diagram ...	85
Equivalent weight of water ...	54	Jacket and leaky admission valve ...	59
Examples. See table of contents, Chapters VII., VIII., IX. and XII.		Joule's equivalent of heat ...	3
Exhaust line ...	61 79	Leakage, Maximum ...	58
" of L.P. cylinder ...	96	" Minimum ...	60
" loss ...	79	" Admission valve ...	57 59 76 78 120
" locomotive cylinder ...	82	" " " direct into exhaust ...	81 120
" ports, Throttling through... ..	79	" of exhaust valve ...	59 76
" valve, Leaky ...	59	" past cylinder into the exhaust ...	69
" wire drawing ...	76 79	" past piston rings ...	76
Expansion, Adiabatic ...	32	Leaks, Eddies due to ...	58
" Incomplete ...	61 76 79	Lines of equal internal energy ...	27
" Isothermal ...	8	" total heat ...	27
" line ...	52 57 59 79	Location of losses ...	75 76
" in L.P. cylinder ...	93	" of initial point ...	69
Expansions of steam without doing external work ...	144	Locomotive cylinder, exhaust loss ...	82
Expansions, Number of ...	100 158	" " losses due to throttling at admission and at exhaust ...	82
External work, Measurement of ...	39	Losses due to throttling ...	76 82
" " Representation of ...	9		
Feed, Equivalent ...	68 163		
" temperature, Effect of ...	43		

	PAGE.		PAGE.
Losses, List of	76	Saturated steam engine compared with superheated steam engine	138
" Location of, on energy chart	75 76	Saturation line	20
L.P. cylinder, Initial condensation in	92	Saturated steam	21
McFarlane Gray	2 4	Scale of internal energy	25
Maximum leakage... ..	58	Simple jacketed engine	84
Mean pressure	68 100 164	Specific heat of gases	4
" Adjustment of	113 123	" of superheated steam	23 134
" Increase of, by altering cut off	128	Standard of comparison for compound engine	121
" of an actual engine determined from $\theta \phi$ diagram	68 100	State point	6 7
" of Rankine engine	68 121	Steam, Chart for superheated	23 134
Measurement of external work done	39	" consumption of an engine	67 100
" of heat supply	39	" cylinder, Transformation in an ideal	31
Mechanical equivalent of heat	3	" in clearance, Work done in compressing in	45
Minimum leakage	60	" engines, see under engine	
Motion energy, Recovery of	147	" formator under constant pressure	20
Non-condensing engine	69	" Internal energy of	24
Number of expansions, Calculation of	100	" Superheated	133
Perfect gas	4	" Transformation line for less than one lb. of	64
" Thermodynamics of	7	" velocity of issuing	146
" heat engine (Carnot cycle)	18	" Work done by expanding	29
Piston rings, Leakage past... ..	76	Stirling hot air engine	17
Piston, Volume swept by	158	Superheated steam	23 133
Play energy	73	" Chart for	23 134
" steam	73	" engine, Compound condensing, with reheater	139 142
Point of cut off, simple engine	100 114	Superheated steam constant pressure line	133
" compound engine	100 125	" volume line	133
Pre-admission, Condensation during	51	" energy chart, new values of specific heat	134
Pre-determination of $\theta \phi$ diagram	111 <i>et seq.</i>	Superheated steam engines compared with saturated steam engine	138
Pressure, compression	50	Superheated steam engine compared with combined steam and waste heat engine	155
" constant, Transformation at	11 32	Superheated steam, internal energy	135
" lines, Constant... ..	5 6 11 22	" Rankine cycle for	137
" Superheated steam	133	" transfer of indicator diagrams to energy chart	139
" Mean effective	68 100 164	Superheating at constant pressure... ..	137
<i>p. v.</i> diagrams, comparison with $\theta \phi$ diagrams	28 69 104	" steam by expansion without doing work (by throttling)	146
<i>p. v.</i> method	1	SO ₂ , Energy chart for	150
Prof. Josse	150	" engine	150
Proportional water line	49	" combined with steam engine, numerical example	151
Proportion of work done in each cylinder	101 123	Temperature entropy method	2
Plotting the $\theta \phi$ diagram	71 84 97	Temperature and pressure at end of adiabatic expansion	65
Quality line	47 73 93	Theoretical re-evaporation line	54
" corresponding to any given transformation line	63	Thermal efficiency	17 99
Quality point	63 92	" of an actual engine	74 162
Rankine	2	" of Carnot cycle	19
" engine, Comparison with	74 115 122	" of Rankine engine	121 161
" for compound engines	87 122	Thermodynamics of a perfect gas	7
" Economy of	66 121 159	" H ₂ O	28
" Mean pressure of	68 121	Total heat, Lines of equal	27
" for superheated steam	137	Transformation along any line	35
" Thermal efficiency of	74 161	" at constant pressure	11 32
Ratio, Cylinder	101 124 159	" at constant temperature	18 33
" Efficiency	99 162	" at constant volume	10 34
Re-evaporation line, Theoretical	54	" line for less than one pound of steam	64
Reheater compound condensing engine (superheated steam)	139		
Reheater compound condensing engine jacketed	102		
Release volume	79 158		
Reversibility of heat engines	2		
Representation of external work	9 29		

