

UNIVERSAL  
LIBRARY

**OU\_150190**

UNIVERSAL  
LIBRARY



**OSMANIA UNIVERSITY LIBRARY**

Call No. 531.32/L42C Accession No. 46982

Author Lefschetz, S., ed.

Title Contributions to the theory of  
nonlinear oscillations vol 1 1963

This book should be returned on or before the date last marked below.

## ANNALS OF MATHEMATICS STUDIES

*Edited by Robert C. Gunning, John C. Moore, and Marston Morse*

1. Algebraic Theory of Numbers, *by* HERMANN WEYL
3. Consistency of the Continuum Hypothesis, *by* KURT GÖDEL
11. Introduction to Nonlinear Mechanics, *by* N. KRYLOFF *and* N. BOGOLIUBOFF
16. Transcendental Numbers, *by* CARL LUDWIG SIEGEL
19. Fourier Transforms, *by* S. BOCHNER *and* K. CHANDRASEKHARAN
20. Contributions to the Theory of Nonlinear Oscillations, Vol. I, *edited by* S. LEFSCHETZ
21. Functional Operators, Vol. I, *by* JOHN VON NEUMANN
24. Contributions to the Theory of Games, Vol. I, *edited by* H. W. KUHN *and* A. W. TUCKER
25. Contributions to Fourier Analysis, *edited by* A. ZYGMUND, W. TRANSUE, M. MORSE, A. P. CALDERON, *and* S. BOCHNER
28. Contributions to the Theory of Games, Vol. II, *edited by* H. W. KUHN *and* A. W. TUCKER
29. Contributions to the Theory of Nonlinear Oscillations, Vol. II, *edited by* S. LEFSCHETZ
30. Contributions to the Theory of Riemann Surfaces, *edited by* L. AHLFORS *et al.*
33. Contributions to the Theory of Partial Differential Equations, *edited by* L. BERS, S. BOCHNER, *and* F. JOHN
34. Automata Studies, *edited by* C. E. SHANNON *and* J. MCCARTHY
36. Contributions to the Theory of Nonlinear Oscillations, Vol. III, *edited by* S. LEFSCHETZ
38. Linear Inequalities and Related Systems, *edited by* H. W. KUHN *and* A. W. TUCKER
39. Contributions to the Theory of Games, Vol. III, *edited by* M. DRESHER, A. W. TUCKER *and* P. WOLFE
40. Contributions to the Theory of Games, Vol. IV, *edited by* R. DUNCAN LUCE *and* A. W. TUCKER
41. Contributions to the Theory of Nonlinear Oscillations, Vol. IV, *edited by* S. LEFSCHETZ
42. Lectures on Fourier Integrals, *by* S. BOCHNER. In preparation
43. Ramification Theoretic Methods in Algebraic Geometry, *by* S. ABHYANKAR
44. Stationary Processes and Prediction Theory, *by* H. FURSTENBERG
45. Contributions to the Theory of Nonlinear Oscillations, Vol. V, CESARI, LASALLE, *and* LEFSCHETZ
46. Seminar on Transformation Groups, *by* A. BOREL *et al.*
47. Theory of Formal Systems, *by* R. SMULLYAN
48. Lectures on Modular Forms, *by* R. C. GUNNING
49. Composition Methods in Homotopy Groups of Spheres, *by* H. TODA
50. Cohomology Operations, *lectures by* N. E. STEENROD, *written and revised by* D. B. A. EPSTEIN
51. Lectures on Morse Theory, *by* J. W. MILNOR
52. Advances in Game Theory, *edited by* M. DRESHER, L. SHAPLEY, *and* A. W. TUCKER

CONTRIBUTIONS TO THE  
THEORY OF  
NONLINEAR OSCILLATIONS

---

S. P. DILIBERTO	J. G. WENDEL
L. L. RAUCH	C. E. LANGENHOP
F. H. BROWNELL	A. B. FARNELL
M. L. CARTWRIGHT	W. WASOW

EDITED BY S. LEFSCHETZ

---

*VOLUME I*

PRINCETON  
PRINCETON UNIVERSITY PRESS

1950

**COPYRIGHT, 1950, PRINCETON UNIVERSITY PRESS**  
**LONDON: GEOFFREY CUMBERLEGE, OXFORD UNIVERSITY PRESS**

Second Printing 1956  
Third Printing 1960  
Fourth Printing 1963

The papers in this volume by Diliberto, Rauch, Cartwright, Langenhop, Farnell, and Wasow were prepared under contract with the Office of Naval Research, and reproduction in whole or in part for any purpose of the United States Government will be permitted.

**PRINTED IN THE UNITED STATES OF AMERICA**

## PREFACE

The common theme of the monographs in the present collection is the study of nonlinear periodic motions in dissipative systems. In the relatively simple case of one degree of freedom the basic equation for free oscillations is of the form

$$(1) \quad \ddot{x} + p(x, \dot{x})\dot{x} + q(x) = 0$$

where dots indicate time derivatives. The dissipative middle term may arise from friction in a mechanical system or from resistance in an electrical circuit. Such systems may well assume spontaneously oscillations very different from those occurring in the usual (linear) harmonic oscillators. A well-known instance is given by the equation of van der Pol

$$(2) \quad \ddot{x} + \mu(x^2 - 1)\dot{x} + x = 0.$$

Nonlinear conservative oscillators have been investigated mainly in connection with celestial mechanics, and the information available for them is therefore rather extensive. It is known, for example, that the trajectories are extremals of a variational problem, so that one may bring to bear upon the problem Morse's technique for the discovery of closed geodesics on manifolds. Nothing of the sort is at hand for the dissipative type, making progress rather slow. A renewal of interest in this field has taken place in the last thirty years due mainly to van der Pol and the

followers of Liapounoff in the USSR who have known how to make extensive application of the classical discoveries of Poincaré, Liapounoff, and G. D. Birkhoff. In this connection see notably N. Minorsky, Introduction to Nonlinear Mechanics (David Taylor Model Basin Report, also issued by Edwards Bros., 1947), and A. A. Andronow and C. E. Chaikin, Theory of Oscillations (Princeton University Press, 1949).

Three of the monographs that follow, those by Diliberto, Rauch, and Brownell, deal with nonlinear non-conservative oscillators. Diliberto takes up a number of general questions connected with Poincaré's early work on differential equations. Rauch discusses a problem of the third order arising out of an electrical circuit with vacuum tubes, establishes the existence of a definite oscillation and studies a number of its properties. His work has close connections with an earlier paper by Friedrichs on a similar question. Brownell investigates the oscillatory solutions of a large class of difference-differential equations arising for instance in control problems. Equations of this nature are obtained in physical systems with retarded responses to a disturbance. The effect is generally parasitical and makes its study all the more desirable.

If a physical system governed by an equation (1) is subjected to a variable effect depending upon the time one must replace (1) by an equation of the type

$$(3) \quad \ddot{x} + p(x, \dot{x})\dot{x} + q(x) = e(t) ,$$

where  $e(t)$  is referred to as the forcing term. The interesting case, from the standpoint of oscillations

is when  $e(t)$  is periodic, say of period  $T$ . One will look for oscillations of the same period  $T$  (harmonic resonance) or of period  $kT$  ( $k > 1$ ; subharmonic resonance). Noteworthy work has been done on these questions of late by Cartwright and Littlewood and by Norman Levinson. Miss Cartwright's contribution is based upon a set of lectures on forced oscillations given at Princeton in the spring of 1949, and deals with the general equation (3). The same topic is dealt with in the paper by Wendel, but his mode of attack is generally distinct from that of Miss Cartwright. In their paper Langenhop and Farnell consider a special forced oscillation problem and by new methods, applicable to other problems as well; they succeed in "localizing" periodic solutions in certain regions of the phase plane. Finally Wasow, in his paper, discusses the periodic solutions in a system degenerating when a certain small parameter  $\epsilon$  tends to zero, and this has connections with the problem dealt with by Miss Cartwright and by Wendel.

S. Lefschetz

Princeton University

May 1949



## CONTENTS

	Page
I. On Systems of Ordinary Differential Equations . . . . .	1
By S. P. Diliberto	
II. Oscillation of a Third Order Nonlinear Autonomous System . . . . .	39
By L. L. Rauch	
III. Nonlinear Difference-Differential Equations. . . . .	89
By F. H. Brownell	
IV. Forced Oscillations in Nonlinear Systems . . . . .	149
By M. L. Cartwright	
V. Singular Perturbations of a Van der Pol Equation. . . . .	243
By J. G. Wendel	
VI. The Existence of Forced Periodic Solutions of Second Order Differential Equations near Certain Equilibrium Points of the Unforced Equation. . . . .	291
By C. E. Langenhop and A. B. Farnell	
VII. The Construction of Periodic Solutions of Singular Perturbation Problems. . . . .	313
By Wolfgang Wasow	



# I. ON SYSTEMS OF ORDINARY DIFFERENTIAL EQUATIONS

By Stephen P. Diliberto<sup>1</sup>

## §1. Introduction.

New results concerning the following three problems are established: I. The reduction, by linear transformations, of systems of first order linear differential equations with variable coefficients to diagonal or triangular form (theorems 1, 2, 3). II. Geometric criteria for stability of periodic solutions (closed trajectories) of systems of first order nonlinear differential equations (theorems 4, 5, 6). III. Bounds on the number of periodic solutions of a system of first order differential equations with polynomial functions (theorems 7).

Theorems 1 and 2 are used as tools for developing a direct treatment of the main results on the (generalized) characteristic exponent (Liapounoff) [M.L.], [O.P.2].

The connecting link between the results presented is corollary 1.1 which shows that two dimensional variational equations are integrable by quadratures.

---

1. Princeton University and the University of California. The author's thesis, "Reduction Theorems for Systems of Ordinary Differential Equations", Princeton University 1947, done under partial sponsorship of O.N.R., NR 043-942, constitutes about half of the results of this paper.

References to the bibliography are indicated by [ ].

We acknowledge our indebtedness to Professor Lefschetz for the generous amounts of time he has spent discussing these problems with us, his mathematical criticisms, and his constant encouragement.

### §2. Notations.

We shall use both caps and small letters to denote vectors, but otherwise standard notation for matrices, vector differential equations, vector norms and inner products.

We recall some old notations and associated formal properties: let  $B = (b_{ij})$  then  $B^j$  and  $B_i$  stand respectively for the  $j$ -th column and  $i$ -th row of  $B$ . (Thus they are vectors). Let  $B = AC$  and let  $I$  be the identity matrix; we then have the following properties

$$(P_1) \quad B^j = AC^j; \quad B_i = A_i C$$

$$(P_2) \quad b_{ij} = (A_i \cdot C^j)$$

$$(P_3) \quad I^j = A^{-1} A^j = A(A^{-1})^j; \quad I_i = A_i A^{-1} = A_i^{-1} A$$

$$\delta_{ij} = (A_i^{-1} \cdot A^j) = (A_i^{-1} (A^{-1})^j)$$

### §3. Reduction to Triangular Form.

Our first result parallels a well-known theorem on constant matrices.

Theorem 1. Let

$$(1) \quad \frac{dy}{dt} = A(t) y$$

where the matrix  $A = (a_{ij})$  and the  $a_{ij}$  are real and continuous for all  $t$ . There exists an orthogonal matrix  $B = (b_{ij})$ , defined for all  $t$ , with  $b_{ij}$  continuously differentiable, such that if  $x = B^{-1}y$  then  $x$  will satisfy the differential equation

$$(2) \quad \frac{dx}{dt} = C(t)x ; \quad C = B^{-1}AB - B^{-1} \frac{dB}{dt}$$

where  $C$  is triangular (i.e.  $c_{ij}(t) = 0$  if  $i < j$ ).  
 Furthermore if the  $a_{ij}$  are bounded so are the  $c_{ij}$ .

This sharpens a result of Perron's [O.P.1], which stated that a reduction to a triangular array of coefficients could be accomplished by means of a matrix  $B$  for which  $B$  and  $B^{-1}$  are bounded. For applications, Perron had an important side condition to the effect that for any  $\epsilon > 0$  there is a  $B$  (producing the desired reduction) such that

$$\left| \int_0^{\infty} \text{Trace} \left( B^{-1} \frac{dB}{dt} \right) dt \right| < \epsilon .$$

For theorem 1, one clearly has  $|B| = |B^{-1}| = 1$  and  $\text{trace } B^{-1} \frac{dB}{dt} = 0$  (this last follows by differentiating  $BB^{-1} = I$  and observing that  $B^{-1} = B^1$ ).<sup>(2)</sup>

Proof of theorem 1: Using the Gram-Schmidt orthogonalization process we shall construct  $B^j$  i.e., the columns of  $B$ . Let  $y^1, \dots, y^n$  be any base of solutions for (1). We shall define, by induction, vectors  $b^1, B^1, \dots, b^n, B^n$  : let  $b^1 = y^1$  and put  $B^1 = b^1 / \|b^1\|$ . Assume  $b^1, B^1, \dots, b^{k-1}, B^{k-1}$  already defined and set

$$b^k = y^k - \sum_{j=1}^{k-1} (y^k \cdot B^j) B^j, \quad B^k = b^k / \|b^k\|$$

(2) Perron used his result in order to study stability questions [O.P.2]. Theorem 1 affords noticeable simplification of Perron's work and some sharpening of his results.

Our construction of  $B$  is now completed and it is clear that  $B$  is orthogonal; furthermore observe that the first  $s$  of the  $y^i$  are linearly dependent on the first  $s$  of the  $B^i$ , and conversely, the coefficients being (obviously) continuously differentiable. Thus

$$y^i = \sum_{j=1}^i g_{ij} B^j, \quad B^i = \sum_{j=1}^i f_{ij} y^j$$

Using this fact and that  $y^k$  is a solution of (1) yields

$$\begin{aligned} C^j &= B^{-1} (AB^j - \frac{dB^j}{dt}) \\ &= B^{-1} \left( \sum_{r=1}^i f_{jr} \left[ Ay^r - \frac{dy^r}{dt} \right] - \sum_{r=1}^i \frac{df_{jr}}{dt} y^r \right) \\ &= - \sum_{r=1}^i \frac{df_{jr}}{dt} (B^{-1} y^r) = - \sum_{r=1}^i \sum_{s=1}^r \frac{df_{jr}}{dt} g_{rs} (B^{-1} \cdot B) \end{aligned}$$

Since  $B$  is orthogonal  $(B_1^{-1})' = B^1$  and so

$$\begin{aligned} c_{ij} &= - \sum_{r=1}^i \sum_{s=1}^r \frac{df_{jr}}{dt} g_{rs} (B_1^{-1} \cdot B^s) \\ &= - \sum_{r=1}^i \sum_{s=1}^r \frac{df_{jr}}{dt} g_{rs} (B^{-1} \cdot B^s) \end{aligned}$$

Thus  $c_{ij} = 0$  if  $i > j$  because then  $i > s$  and  $(B^{-1} \cdot B^s) = 0$  by construction.

To prove that if  $|a_{ij}| < M$  the  $c_{ij}$  are bounded it is sufficient to show that  $\frac{db_{ij}}{dt}$  are bounded. Consider for example  $b_{j1}$ . Since  $b_{j1} = y_j^1 / \|y^1\|$  we have

$$\begin{aligned} \frac{db_{j1}}{dt} &= \frac{\frac{dy_j^1}{dt}}{\|y^1\|} + \frac{y_j^1 \sum_{s=1}^n y_s^1 \frac{dy_s^1}{dt}}{\|y^1\|^3} = \sum_{s=1}^n a_{js} \frac{y_s^1}{\|y^1\|} \\ &+ \sum_{r=1}^n \sum_{s=1}^n a_{rs} \frac{y_j^1 y_r^1 y_s^1}{\|y^1\|^3} \end{aligned}$$

Thus,

$$\left| \frac{db_{ji}}{dt} \right| < M(n + n^2) .$$

While the proof of theorem 1 is strictly algebraic, the ideas leading to our proof of it are based on the geometry involved in the following result.

Corollary 1.1. Let  $x_1 = u_1(t)$  be a solution of

$$(2) \quad \frac{dx_1}{dt} = X_1(x_1, x_2) \quad , \quad (i = 1, 2) .$$

Then the variational equations of this system,

$$(3) \quad \frac{d\zeta_i}{dt} = \sum_{j=1}^2 \frac{\partial X_1}{\partial x_j} \Big|_{x_k = u_k(t)} \zeta_j \quad , \quad (i=1, 2)$$

are integrable by quadratures.

Using  $X$  to denote the vector  $(X_1, X_2)$ ,  $|X|$  its length, and  $\rho(t)$  the radius of curvature of the given solution, two linearly independent solutions are (set  $x_k = u_k(t)$  everywhere).

$$(4)_a \quad \zeta_1 = X_1 \quad ; \quad \zeta_2 = X_2$$

and

$$(4)_b \quad \left\{ \begin{aligned} \zeta_1 &= X_1 \int_0^t \frac{1}{|X|^2} \left\{ \frac{|X|}{\rho} - \text{curl } X \right\} e^{\int_0^r \text{div } X dt} d\tau \\ &\quad - \frac{X_2}{|X|^2} e^{\int_0^t \text{div } X d\tau} \\ \zeta_2 &= X_2 \int_0^t \frac{1}{|X|^2} \left\{ \frac{|X|}{\rho} - \text{curl } X \right\} e^{\int_0^r \text{div } X dt} d\tau \\ &\quad + \frac{X_1}{|X|^2} e^{\int_0^t \text{div } X d\tau} \end{aligned} \right.$$

Since the variational equations (3) are the first approximation of the equations (2) relative to a rectangular coordinate system  $(\xi_1, \xi_2)$  whose origin moves along the trajectory with velocity  $X$  (the  $\xi_1$  axis remaining parallel to the  $x_1$  axis) it is more natural to use instead of the  $\xi$  coordinates an  $\eta$  coordinate system with one axis moving so as to remain tangent to the given trajectory and the other axis perpendicular to the trajectory. This change of coordinates is expressible directly in terms of the  $X_1$  and the  $u_1(t)$  (i.e. may be given explicitly), and when the transformation has been effected the new system of differential equations has a triangular array of coefficients. Such systems are integrable, and provides a general solution of the original equations (i.e. equations (4) )

Excluding, temporarily, the method of arriving at it, our result may (in the general case of  $n$  equations) be given the following geometric formulation: "If a set of trajectories near a given trajectory have, at a given time, their representative points in a hyperplane perpendicular to that trajectory then at any later time the corresponding representative points will, in the first approximation, lie in a hyperplane perpendicular to the given trajectory."

This principle has certainly been known for at least one hundred years. We have found several writers in differential geometry and also Birkhoff [G.B.], pp.55-58 and M. Morse [M.], p.108 who know and use it. The extent to which they have may be outlined as follows: (1) The principle is easily verified when the given trajectory is a straight line along which the velocity is unity. (2) Topologically the sets of

trajectories neighboring any two given trajectories is the same and thus a mapping exists which carries any trajectory and its neighboring trajectories into the straight line, constant-velocity trajectory -- the mapping being defined only for a finite time interval. Our reduction by-passes the heavy machinery for such a procedure since it deals with the equations only after they are already linear and as a result the reduction is given explicitly and defined for all time.

Proof of corollary 1.1. Let  $x_i = u_i(t)$ ,  $i=1,2$  be a solution of

$$\frac{dx_i}{dt} = X_i(x_1, x_2), \quad i=1,2$$

Using the subscript "u", i.e.  $( )_u$ , to denote that the arguments are "evaluated at  $u_i(t)$ " we may write the variational equations

$$\frac{d}{dt} \begin{pmatrix} \zeta_1 \\ \zeta_2 \end{pmatrix} = \begin{pmatrix} \frac{\partial X_1}{\partial x_1} & \frac{\partial X_1}{\partial x_2} \\ \frac{\partial X_2}{\partial x_1} & \frac{\partial X_2}{\partial x_2} \end{pmatrix}_u \begin{pmatrix} \zeta_1 \\ \zeta_2 \end{pmatrix}$$

Using  $\|X\|$  as the norm of  $X = (X_1, X_2)$ , and defining an auxiliary variable  $\eta$  by

$$\eta = T\zeta^{-1}, \quad T = \frac{1}{\|X_u\|} \begin{pmatrix} X_1 & -X_2 \\ X_2 & X_1 \end{pmatrix}_u$$

a simple computation shows that  $\eta$  satisfies the differential equation

$$\frac{d}{dt} \begin{pmatrix} \eta_1 \\ \eta_2 \end{pmatrix} = \begin{pmatrix} ||X||^{-1} \frac{d}{dt} ||X||, & 2 ||X||^{-2} (X_1 \frac{dX_2}{dt} - X_2 \frac{dX_1}{dt}) + \frac{\partial X_1}{\partial x_2} - \frac{\partial X_2}{\partial x_1} \\ 0, & -||X||^{-1} \frac{d}{dt} ||X|| + \frac{\partial X_1}{\partial x_1} + \frac{\partial X_2}{\partial x_2} \end{pmatrix} \begin{pmatrix} \eta_1 \\ \eta_2 \end{pmatrix}$$

These equations may be integrated directly, and recalling that the curvature  $H = \frac{1}{\rho}$  of the given solution, curl  $X$ , and div  $X$  have the expressions

$$\frac{1}{\rho} = ||X||^{-3} X_1 \frac{dX_2}{dt} - X_2 \frac{dX_1}{dt}$$

$$\text{curl } X = \frac{\partial X_2}{\partial x_1} - \frac{\partial X_1}{\partial x_2}, \quad \text{div } X = \frac{\partial X_1}{\partial x_1} + \frac{\partial X_2}{\partial x_2}$$

we may write a pair of independent solutions as

$$\eta_1 = \eta_1(0) \frac{||X||_u}{||X||_{u(0)}}$$

$$\eta_2 = 0$$

$$\tilde{\eta}_1 = \frac{||X||_u}{||X||_{u(0)}} \left[ \tilde{\eta}_1(0) + \right.$$

$$\left. + \tilde{\eta}_2(0) ||X||_{u(0)}^2 \int_0^t ||X||^{-2} \left[ \frac{||X||}{\rho} - \text{curl } X \right] e^{\int_0^t \text{div } X_u dt} \right]$$

$$\tilde{\eta}_2 = \tilde{\eta}_2(0) \frac{||X||_{u(0)}}{||X||_u} e^{\int_0^t (\text{div } X)_u dt}$$

Choosing  $\eta_1(0) = 1$ ,  $\tilde{\eta}_1(0) = 0$ ,  $\tilde{\eta}_2(0) = 1$ , and applying

T will give the solutions of the variational equations in (4).

Corollary 1.2. The variational equations of a Hamiltonian system with two degrees of freedom are integrable by quadratures.

Proof of corollary 1.2: Consider the system

$$\frac{dq_r}{dt} = \frac{\partial H}{\partial p_r}, \quad \frac{dp_r}{dt} = - \frac{\partial H}{\partial q_r} \quad (r=1,2)$$

Then it is known [W.]p.314 that by means of the energy integral  $H(p_1, p_2, q_1, q_2) = \text{const.}$ , and if  $\frac{\partial H}{\partial p_1} \neq 0$ , this system can be reduced to a system of one less degree of freedom:

$$\frac{dq_2}{dq_1} = \frac{\partial K}{\partial p_2}, \quad \frac{dp_2}{dq_1} = - \frac{\partial K}{\partial q_2}$$

Consequently corollary 1.1, applies to the variational equations of this latter system. Since the initial reduction was based on  $\partial H / \partial p_1 \neq 0$ , the conclusion will, in general, be valid only locally.

Corollary 1.3. Let  $x = x(t, c_1, \dots, c_k)$  be for each  $c = (c_1, \dots, c_k)$  in some domain and all  $t$  a solution, analytic in the  $c_i$ , of the equation

$$(5) \quad \frac{dx_i}{dt} = X_i(x_1, \dots, x_n), \quad (i = 1, 2, \dots, n)$$

where the  $X_i$  are holomorphic in their arguments, and the

solution is such that the rank of the Jacobian matrix (c fixed)

$$\left\| \frac{\partial (X_1, \dots, X_n)}{\partial (t, c_1, \dots, c_n)} \right\|$$

is k+1. Then there exists an orthogonal transformation  $U = (u_{ij})$  with  $u_{ij}$  continuously differentiable,  $U$  given explicitly in terms of  $x(t, c_1, \dots, c_k)$ , such that the variational equations

$$(6) \quad \frac{d\xi}{dt} = V\xi ; \quad V = (v_{ij}), \quad v_{ij} = \frac{\partial X_i}{\partial x_j} \Big|_{x=x(t, c_1, \dots, c_k)}$$

of the original system transform under  $\xi = U\eta$  to

$$(7) \quad \frac{d}{dt} \eta = W\eta ; \quad W = \begin{pmatrix} A & B \\ C & D \end{pmatrix}, \quad C = (0)$$

and  $A$   $k+1$  square and triangular.

Proof of corollary 1.3: Construct the first  $k+1$  columns  $U^1$  of  $U$  by using the Gram-Schmidt process on the vectors  $\frac{\partial x}{\partial t}$ ,  $\frac{\partial x}{\partial c_i}$  ( $i=1, 2, \dots, k$ ). Let  $U^1$  ( $i=k+2, \dots, n$ ) be any  $n-k-1$  differentiable normal orthogonal vectors in the orthogonal complement of the space of the first  $k+1$   $U^1$ 's (such are easily constructed from the  $\frac{\partial x}{\partial t}$ ,  $\frac{\partial x}{\partial c_1}$ , and the generalized normals to the curve  $u(t)$ ). Using the fact that  $\frac{\partial x}{\partial t}$ ,  $\frac{\partial x}{\partial c_1}$  are solutions of the variational equations [S.L.], p.52, the proof now parallels that of theorem 1.

One result implicitly contained in the corollaries 1.1 and 1.3 and their proofs is: "The solution of a system of  $n$  linear first order differential equations for which  $k$  solutions are known can be reduced to a system of  $n-k$  equations plus a quadrature. If desired the reduction can be accomplished by an orthogonal transformation.

§4. First Diagonalization Theorem.

The method of proving theorem 1 yields devices which establish

Theorem 2: Let

$$(8) \quad \frac{dy}{dt} = A(t) y$$

where the  $a_{ij}$  are real and continuous for all  $t$ . There exists a non-singular  $B=(b_{ij})$  with  $b_{ij}$  continuously differentiable and uniformly bounded, such that if  $x=B^{-1}y$  then

$$(9). \quad \frac{dx}{dt} = Cx$$

where  $C$  is diagonal ( $c_{ij}=0, i \neq j$ ). Furthermore the  $c_{ij}$  are bounded if the  $a_{ij}$  are bounded.

This improves the reduction of theorem 1 at the expense of admitting the possibility that the elements of  $B^{-1}$  become unbounded, and raises the question as to when  $B^{-1}$  of theorem 2 will have bounded elements (e.g.  $|B| > \delta > 0$ ). If one dropped the requirement that  $B$ , itself, be bounded the existence of the reductions would be trivial. Namely, since  $C=B^{-1}(AB-\frac{dB}{dt})$  we would merely have to choose  $B$  such that  $\frac{dB}{dt}=AB$  and  $C$  would be diagonal -- in fact, identically zero.

Proof of theorem 2: Let  $y^1, \dots, y^n$  be any base of solutions of (8) and define  $B^j = y^j / ||y^j||$ . Proceeding as before

$$\begin{aligned} C^j &= B^{-1} (AB^j - \frac{dB^j}{dt}) \\ &= B^{-1} \frac{1}{||y^j||} [Ay^j - \frac{dy^j}{dt}] + \frac{y^j}{||y^j||} \frac{d}{dt} \log ||y^j|| \\ &= B^{-1} B^j \frac{d}{dt} \log ||y^j|| \end{aligned}$$

Thus,

$$c_{ij} = \left( \frac{d}{dt} \log \|y^i\| \right) (B_i^{-1} \cdot B^j) = \delta_{ij} \frac{d}{dt} \log \|y^j\| \\ = 0 \text{ for } i \neq j .$$

Paralleling corollary 1.2 of theorem 1 we have using theorem 2:

Corollary 2.1: If in corollary 1.3 of theorem 1 we remove the requirement that  $U^{-1}$  be bounded then  $A$  can be made diagonal.

Proof of corollary 2.1: Construct the first  $k+1$  columns of  $U$  from  $\frac{\partial x}{\partial t}$ ,  $\frac{\partial x}{\partial c}$  as in theorem 2 and the last  $n-k-1$  as in corollary 1.3. The verification that this transformation is of the desired kind is immediate.

### §5. Natural Base.

We define the natural base  $\{y^i\}$  ( $i=1,2,\dots,n$ ) of solutions of a system of linear differential equations to be a base such that  $y^i(0)=I^i$ , i.e., the  $i$ -th unit vector.

We shall make repeated use of the following obvious lemmas.

Lemma 1. Let  $\{x^i\}$  and  $\{u^i\}$  be the respective natural bases for the adjoint systems

$$\frac{dx}{dt} = Cx ; \quad \frac{du}{dt} = -uC ; \quad C = (c_{ij}) ; \quad c_{ij} = 0 \quad i > j .$$

Then,

$$x_i^j = 0 \quad i > j ; \quad u_i^j = 0 \quad i < j$$

Lemma 2. Let  $\{y^i\}$  be any base of  $\frac{dy}{dt} = Ay$  and  $\{x^i\}$  the natural base of the reduced system (via theorem 1)  $\frac{dx}{dt} = Cx$  where  $c_{ij} = 0$  if  $i > j$ . Then there exist constants  $d_{ir}$  and  $d_{ir}^*$  such that

$$Bx^1 = \sum_{r=1}^1 d_{1r} y^r \quad ; \quad B^{-1}y^1 = \sum_{r=1}^1 d_{1r}^* x^r .$$

### §6. Liapounoff's Characteristic Exponents.

These exponents are associated with equations

$$(10) \quad \frac{dy}{dt} = A(t)y$$

where it is assumed that the  $a_{1j}(t)$  are continuous and uniformly bounded. We shall recall all definitions and two elementary propositions. We shall, however, use Perron's definition of characteristic exponent [O.P.2] since proposition II (below) is not true for characteristic exponents as first defined by Liapounoff -- as Liapounoff himself shows by an example [M.L.], p.236.

The characteristic exponent  $\lambda$  (or  $\lambda(y)$  of  $y$ , a solution of (10), is defined by

$$\lambda = \overline{\lim}_{t \rightarrow \infty} \frac{1}{t} \log ||y(t)|| .$$

Let  $\lambda_1 < \lambda_2 < \dots < \lambda_k$  be all the different values that  $\lambda$  may assume for different  $y$  (all solutions of (1), of course). Let  $e_1$  be the number of  $s_1$  linearly independent  $y$  for which  $\lambda(y) = \lambda_1$ ; let  $\sum_{i=1}^k e_i$  be the number of linearly independent solution  $y$  for which  $\lambda(y) = e_s$ . Then  $e_1$  is called the multiplicity of  $\lambda_1$ . Two important results are [O.P.2] :

Proposition I: If  $|a_{1j}(t)| \leq C$ , then for any solution of (10)  $|\lambda(y)| \leq nC$

Proposition II:  $\sum_{i=1}^k e_i = n$

Recalling that if  $\lambda(y^k) < \lambda(y^j)$ , then for  $b \neq 0$   $\lambda(ay^k + by^j) = \lambda(y^j)$ . (This and similar statements which are exercises in  $\overline{\text{lim}}$  will not be proved here)

we see that there is always a bases  $y^1, \dots, y^n$  for which all the  $\lambda(y)$  are equal. For the opposite situation we define a maximal base  $y^1, \dots, y^n$  to be one such that, if  $\lambda_1, \dots, \lambda_k$  are the characteristic exponents of (1), then this base shall have exactly  $e_j$  solutions for which  $\lambda(y) = \lambda_j$ .

The principal results on characteristic exponents are contained in the following three theorems for which we give new proofs:

Theorem A: Let  $\{y^i\}$  be any base of solutions of (10) with  $a_{ij}(t)$  continuous and uniformly bounded; then

$$\sum_{i=1}^n \lambda(y^i) \geq \overline{\lim}_{t \rightarrow +\infty} \frac{1}{t} \int_0^t \sum_{i=1}^n a_{ii}(\tau) d\tau$$

We shall first prove two lemmas.

Lemma 3. If  $u = By$  where  $B$  and  $B^{-1}$  are bounded, then

$$\lambda(u) = \lambda(y)$$

Proof:

$$\begin{aligned} \lambda(u) &= \lambda(By) \leq \max_{-1} \lambda\left(\sum_{j=1}^n b_{ij}y_j\right) \leq \max_{ij} a_{ij} \times \lambda(b_{ij}y_j) \\ &\leq \lambda(y_j) \leq \lambda(y) \end{aligned}$$

Similarly  $y = B^{-1}u$  will imply  $\lambda(y) \leq \lambda(u)$ , proving the lemma.

Lemma 4. If  $B$  is orthogonal and  $b_{ij}(t)$  continuously differentiable, then

$$\text{Trace } A = \text{Trace } (B^{-1}AB - B^{-1} \frac{dB}{dt})$$

Proof: For constant matrices the trace is invariant under similarities; hence for  $t$  fixed  $\text{Trace } A = \text{Trace } B^{-1}AB$ , and by differentiating  $B^{-1}B = I$

we will find  $\text{Trace} (B^{-1} \frac{dB}{dt}) = 0$ .

Proof of theorem A: Use the given base  $\{y^i\}$  to effect the reduction of theorem 1 and let  $\{x^i\}$  be the base of the reduced system.

By Lemma 2, of section 5, and Lemma 3 above

$$\lambda(y^i) = \lambda \left( \sum_{k=1}^1 d_{ik} x^k \right)$$

Now among all the  $x^k (k=1, \dots, 1)$   $x^i$  is the only one with an  $i$ -th component, which is

$$x_j^i = e^{\int_0^t c_{ii}(\tau) d\tau}$$

Thus  $\lambda(y^i) \geq \lambda(x_j^i) = \overline{\lim} \frac{1}{t} \int_0^t c_{ii}(\tau) d\tau$ , and so using Lemma 4

$$\begin{aligned} \sum_{i=1}^n \lambda(y^i) &\geq \sum_{i=1}^n \overline{\lim} \frac{1}{t} \int_0^t c_{ii}(\tau) d\tau \geq \overline{\lim} \frac{1}{t} \int_0^t \sum_{i=1}^n c_{ii}(\tau) d\tau \\ &= \overline{\lim} \frac{1}{t} \int_0^t \sum_{i=1}^n a_{ii}(\tau) d\tau \end{aligned}$$

Theorem B: Let  $\{y^i\}$  and  $\{z^i\}$  be respective bases  
of

$$(11) \quad \frac{dy}{dt} = Ay, \quad (11)_A \quad \frac{dz}{dt} = -zA$$

where  $\lambda(y^1) \leq \dots \leq \lambda(y^n)$  and  $\lambda(z^1) \geq \dots \geq \lambda(z^n)$

Then

$$\lambda(y^i) + \lambda(z^i) \geq 0, \quad (i = 1, 2, \dots, n)$$

Proof of Theorem B: First of all it is sufficient to prove it when  $\{y^i\}$  and  $\{z^i\}$  are both maximal bases (with  $\lambda(y^1) \leq \dots \leq \lambda(y^n)$  and  $\lambda(z^1) \geq \dots \geq \lambda(z^n)$ ). For let  $\{\bar{y}^i\}$  and  $\{\bar{z}^i\}$  be any other bases ordered as to  $\lambda$ ; then

by definition of maximal bases  $\lambda(\bar{y}^1) \geq \lambda(y^1)$  and  $\lambda(\bar{z}^1) \geq \lambda(z^1)$  for all 1. Hence  $\lambda(y^1) + \lambda(z^1) \geq 0$  implies  $\lambda(\bar{y}^1) + \lambda(\bar{z}^1) \geq 0$ .

We shall now prove the theorem for a maximal base of (11) and some base of (11)<sub>A</sub>. Let  $\{y^1\}$  be a maximal base of (11) and  $\lambda(y^1) \leq \dots \leq \lambda(y^n)$ . Construct B as in Theorem 1, i.e., put  $y = Bx$ . In addition put  $z = uB^{-1}$ . Then

$$(12) \quad \frac{dx}{dt} = Cx, \quad (12)_A \quad \frac{du}{dt} = -uC$$

By Lemma 3 it is sufficient to prove our statements for (12) and (12)<sub>A</sub>. By construction the natural base of (12) is also a maximal base. Letting  $\{x^1\}$  and  $\{u^1\}$  be the natural bases of (12) and (12)<sub>A</sub> respectively, we assert that

$$(13) \quad \lambda(x^1) + \lambda(u^1) \geq 0.$$

To prove inequality (13) observe that

$$a) \quad \lambda(x^1) \geq \lambda(x_1^1) \quad \text{and} \quad \lambda(u^1) \geq \lambda(u_1^1),$$

$$b) \quad x_1^1 = e^{\int_0^t c_{11}}; \quad u_1^1 = e^{-\int_0^t c_{11}}$$

Hence,

$$\begin{aligned} \lambda(x^1) + \lambda(u^1) &\geq \overline{\lim} \frac{1}{t} \int_0^t c_{11} + \overline{\lim} -\frac{1}{t} \int_0^t c_{11} \\ &\geq \overline{\lim} \frac{1}{t} \int_0^t c_{11} - \underline{\lim} \frac{1}{t} \int_0^t c_{11} \geq 0 \end{aligned}$$

We are not done yet since for the natural base  $\{u^1\}$  we do not necessarily have  $\lambda(u^1) \geq \dots \geq \lambda(u^n)$  or even that it is maximal.

However, let  $\{\bar{u}^1\}$  be a maximal base of (12)<sub>A</sub> where  $\lambda(\bar{u}^1) \geq \dots \geq \lambda(\bar{u}^n)$ . Then

$$\bar{u}^k = \sum_{j=1}^n f_{kj} u^j, \quad f_{kj} \text{ const.}$$

Construct a new maximal base  $\{\hat{u}^1\}$  as follows: let  $l(\hat{u}^n)$  be the lowest index  $l$  of the  $u^1$  which make up  $\hat{u}^n$ . Subtract off the appropriate multiple of  $\hat{u}^n$  from every  $\hat{u}^i$  of lower index so that no  $\hat{u}^i$  contains  $u^1$ . Let  $l(\hat{u}^{n-1})$  be the lowest index  $l$  of the  $u^1$  occurring in the just modified  $\hat{u}^i$  for all  $i \leq n-1$ , etc. The new base is still maximal.

We assert that for the  $\{\hat{u}^1\}$  it is true that

$$(14) \quad \lambda(x^1) + \lambda(\hat{u}^1) \geq 0.$$

Since the  $\hat{u}^1$  are linear combinations of the  $u^j$ , each has a lowest indexed  $u^j$  occurring in it. Thus, since  $u_i^j = 0$ , if  $i > j$

$$(15) \quad \lambda(\hat{u}^1) \geq \lambda(u^j)$$

Suppose that  $i \geq j$ ; then

$$\lambda(\hat{u}^1) + \lambda(x^1) \geq \lambda(u^j) + \lambda(x^1) \geq \lambda(u^j) + \lambda(x^j) \geq 0.$$

For  $i=n$  it is always true that  $i \geq j$ ; hence (14) is proved for  $n$ . Suppose that it holds for  $n, n-1, \dots, n-(k-1)$ . We shall show that it holds also for  $n-k$ . If in the desired inequality

$$\lambda(\hat{u}^{n-k}) \geq \lambda(u^j)$$

we have  $n-k \geq j$  we are done (use the same argument as for  $i=n$ ). If, on the other hand,  $n-k < j$ , since each of the  $k$  previous steps has used up a different  $j$  in (15), it follows that at least one of them, say  $l$ , satisfies  $l \leq n-k$ . Let  $u^{l'}$  be the corresponding  $\hat{u}$ . (Thus  $l' > n-k$ ).

$$\text{Thus } \lambda(\hat{u}^{n-k}) \geq \lambda(u^{l'}) \geq \lambda(u^l) \text{ and } l \leq n-k \text{ and}$$

$$\lambda(\hat{u}^{n-k}) + \lambda(x^{n-k}) \geq \lambda(u^l) + \lambda(x^l) \geq 0.$$

Theorem C: In theorem B  $\lambda(y^1) + \lambda(z^1) = 0$  if and  
only if  $\lim_{t \rightarrow \infty} \frac{1}{t} \int_0^t \sum_{i=1}^n a_{ii}(t) dt$  exists and equals  $\sum_{i=1}^n \lambda(y^i)$

and  $-\sum_{i=1}^n \lambda(z^i)$  .

Proof of theorem C: This will follow readily from the proofs of theorems A and B. We assert that the additional hypothesis implies that

$$\lambda(x^i) = \lambda(x_1^i) = -\lambda(u^i) = -\lambda(u_1^i).$$

Observe that these assertions prove the theorem.

Going back to the proof of theorem A, it is clear that we now have (by the hypothesis and the last four lines of that proof) that

$$\lambda(y^i) = \lambda(y_1^i) = \overline{\lim}_{t \rightarrow \infty} \frac{1}{t} \int_0^t c_{i1}(\tau) d\tau = \lim_{t \rightarrow \infty} \frac{1}{t} \int_0^t c_{i1}(\tau) d\tau$$

or else

$$\sum_{i=1}^n \lambda(y^i) > \lim_{t \rightarrow \infty} \frac{1}{t} \int_0^t \sum_{i=1}^n a_{i1}(\tau) d\tau .$$

Hence by similar arguments

$$\lambda(u^i) = \lambda(u_1^i) = -\lim_{t \rightarrow \infty} \frac{1}{t} \int_0^t c_{i1}(\tau) d\tau$$

and  $\lambda(y^1) \leq \dots \leq \lambda(y^n)$  imply  $\lambda(u^1) \geq \dots \geq \lambda(u^n)$ . That

the  $\{u^i\}$  are a maximal base follows from this last inequality and that  $y_1^i = 0$  if  $i \leq j$ .

The "only if" part of theorem C follows from an example [O.P.2], p.754.

### §7. A Theorem of Poincaré

As a further application of theorems 1 and 2 (and using our results on characteristic exponents) we have a slight extension of an old theorem of Poincaré [S.L.], p.113.

Corollary 2.2: The variational equations of

$$(16) \quad \frac{dx_i}{dt} = X_i(x_1, \dots, x_n), \quad (i = 1, 2, \dots, n)$$

$X_i$  of class  $C^1$ , based on a solution  $x_i = u_i(t)$  which is

bounded and approaches no singular point, have at least one solution whose characteristic exponent is zero.

Poincaré's theorem asserted the existence of a zero exponent for the case of  $u_1(t)$  periodic.

Proof of corollary 2.2: By lemma 3, last section, two linear systems which are related by a bounded transformation with bounded inverse will have the same set of characteristic exponents. Hence it will be sufficient to prove this corollary for the reduced form of the variational equations as given by corollary 1.3. These equations have the form

$$\frac{d\eta}{dt} = W \eta \quad , \quad W = \begin{pmatrix} w_{11} & w_{12} & \cdots & w_{1n} \\ 0 & w_{22} & \cdots & \\ \vdots & & & \\ 0 & w_{n2} & \cdots & w_{nn} \end{pmatrix} ,$$

where  $w_{11} = \frac{d}{dt} \log ||u(t)||$ , ( $u(t)$  being the solution on which the variational equations were based). Consequently one solution of this equation is  $\eta_1 = ||u(t)||$ ,  $\eta_2 = \dots = \eta_n = 0$ . The norm  $||\eta||$ , of this solution is simply  $||u(t)||$ . The hypothesis implies that there exist positive constants  $c_1$  and  $c_2$  such that

$$0 < c_1 \leq ||u(t)|| \leq c_2 .$$

And so  $\lambda(\eta)$  the characteristic exponent of this solution is zero; namely

$$\lambda(\eta) = \overline{\lim} \frac{1}{t} \log ||u(t)|| \leq \frac{1}{t} \lim_{\infty} \log c_2 = 0$$

and

$$\lambda(\eta) \geq \frac{1}{t} \lim_{\infty} \log c_1 = 0$$

### §8. Second Diagonalization Theorem

We shall now answer a question raised by theorem

2: when can a reduction to diagonal form be effected by a transformation  $B$ , for which both  $B$  and  $B^{-1}$  are bounded?

If  $A$ , the matrix of coefficients, is constant a sufficient condition for such a reduction is that all the characteristic roots of  $A$  be distinct. In that case (A constant, distinct characteristic roots) the equation has  $n$  linearly independent solutions  $y^i$  ( $i=1, \dots, n$ ) such that

$$(17) \quad \lim_{t \rightarrow \infty} \frac{1}{t} \log \|y^i\| = \lim_{t \rightarrow \infty} \frac{1}{t} \int_0^t \frac{\frac{d}{dt} \|y^i\|}{\|y^i\|} dt = \lambda_i$$

where  $\lambda_i$  ( $i=1, 2, \dots, n$ ) are the distinct characteristic roots of  $A$ . Not only do the mean values (17) exist -- they even exist uniformly, that is for each  $i$

$$(18) \quad \int_0^t \left( \frac{\frac{d}{dt} \|y^i\|}{\|y^i\|} - \lambda_i \right) dt = o(1)$$

(i.e. is bounded). When the elements of  $A$  are periodic with common period, the  $\lambda_i$  of (17) always exist; and if there are  $n$  solutions for which they are different then a reduction by means of theorem 2 can be effected so that  $B^{-1}$  is bounded. In the case of periodic coefficients, also, condition (18) is automatically satisfied.

Theorem 3 asserts that conditions (17) and (18) are sufficient for the desired reduction. They are in a reasonable sense necessary, as shall be pointed out at the end of this section.

Theorem 3. Let

$$(19) \quad \frac{dy}{dt} = Ay$$

where the  $a_{ij}$  are real, continuous, and bounded for all  $t$ .

Assume:

(H<sub>1</sub>) The system has n different characteristic exponents  $\lambda_1, \dots, \lambda_n$ .

(H<sub>2</sub>) For a maximal base  $\{y^i\}$

$$(20) \quad \lim_{t \rightarrow \infty} \frac{1}{t} \int_0^t \frac{\frac{d}{dt} \|y^i\|}{\|y^i\|} dt \quad \text{exists.}$$

(H<sub>3</sub>) For each  $y^i$  of the maximal base and its characteristic exponent  $\lambda_i$

$$(21) \quad \int_0^t \left( \frac{\frac{d}{dt} \|y^i\|}{\|y^i\|} - \lambda_i \right) dt = o(1).$$

Then there exists a (non-singular) matrix B defined for all t, B and B<sup>-1</sup>, having bounded elements, such that if  $x = B^{-1}y$  then

$$(22) \quad \frac{dx}{dt} = (\lambda)x$$

where  $(\lambda)$  is the diagonal matrix of the elements  $\lambda_i$ .

Proof of theorem 3. the assumption that the  $a_{ij}(t)$  are bounded implies (see proposition 1, section 6) that for any solution y of

$$(19) \quad \frac{dy}{dt} = Ay \quad ; \quad A = (a_{ij}(t)).$$

$\lambda(y)$  is bounded. Let  $\{y^i\}$  be a base of solutions for which  $\lambda(y^1) < \lambda(y^2) \dots < \lambda(y^n)$  (guaranteed to exist by the hypothesis). Clearly any such basis is maximal. Note that (21) implies  $\|y^i\| = \psi^i(t) e^{\lambda_i t}$  where  $0 < a_1 \leq \psi^1 \leq b^1$  for some constants  $a_1$  and  $b_1$ , for  $i=1, 2, \dots, n$ .

Use the given base  $\{y^i\}$  to effect the reduction of the given system (19) -- by means of theorem 1 -- to

triangular form

$$(23) \quad \frac{dx}{dt} = Cx; \quad C = (c_{ij}(t)); \quad c_{ij}(t) \equiv 0 \quad i > j.$$

By lemma 2, section 5, we have that if  $\{x^i\}$  is the natural base of (23) then  $\|y^i\| = \|x^i\|$ . Consequently the problem has been reduced to verifying the theorem for a system with a triangular array of coefficients and for which the natural base is also maximal.

We now use theorem 2 and the natural base to effect a further reduction to a system

$$\frac{dy}{dt} = Dy; \quad D = (d_{ij}); \quad d_{ij} = \delta_{ij} \frac{d}{dt} \log \|x^i\|.$$

Observe that if it is true that  $B^{-1}$  the inverse of this last transformation, is bounded we are done, for we will have reduced the problem to a system whose matrix of coefficients is diagonal and for which the hypothesis applies. This case is trivial.

We claim that  $B^{-1}$  is bounded. Since  $b_{ij}$  are bounded we need merely show that  $|B|$ , the determinant of  $B$ , is bounded above zero; and since  $B$  is triangular it is sufficient to show that for any  $i$   $b_{ii} > 0$ . (Recall that if  $x^i$  is the natural base then  $b_{ii} = x_i^i / \|x^i\|$ ).

It will be general enough to do this for  $n = 2$ :

$$\frac{dx_1}{dt} = ax_1 + bx_2$$

$$\frac{dx_2}{dt} = 0 + cx_2$$

where  $a, b, c$ , are bounded. The natural base is

$$x^1 = (e^{\int_0^t a dt}, 0)$$

$$x^2 = (e^{\int_0^t a dt} \int_0^t b e^{-\int_0^r a dt} e^{\int_0^r c dt} dr, e^{\int_0^t a dt})$$

Now  $H_3$  implies  $\|x^1\| = \psi^1(t)e^{\lambda_1 t}$ ;  $0 < a_1 \leq \psi^1 \leq b_1$ . Clearly  $b_1^{-1} = x_1^1 / \|x^1\| = 1$ . Also  $\|x^2\| = \psi^2(t)e^{\lambda_2 t}$  implies  $e^{\int_0^t c dt} = \tilde{\psi}(t)e^{\lambda_2 t}$  where  $\tilde{\psi} < b_2$ ; and we must show that

$$\tilde{\psi} \geq \delta > 0.$$

We shall do this by contradiction. For simplification define

$$K = \text{l.u.b.}_{t, r} \left| \frac{b(r)\psi^1(t)}{\psi^1(r)} \right|, \quad \text{finite by hypothesis;}$$

$$\lambda = \lambda_2 - \lambda_1, \quad \text{positive by hypothesis;}$$

$$\text{l.u.b.}|f(t)| = \text{l.u.b.}|c(t) - \lambda_2| \leq M, \quad \text{finite by hypothesis}$$

$$e^{\int_0^t f(t)} \leq b_2.$$

We may then write

$$(24) \quad a_2 e^{\lambda_2 t} \leq \|x^2\| \leq e^{\lambda_2 t} \left\{ 2 \int_0^t f + k^2 \left( e^{-\lambda t} \int_0^t e^{\lambda t} e^{\int_0^r f} \right)^2 \right\}^{1/2}$$

If  $\liminf \tilde{\psi} = \liminf e^{\int_0^t f} = 0$  then for any  $\frac{\epsilon}{B_0}$  there is a  $t_1$  such that  $e^{\int_0^{t_1} f} \leq \frac{\epsilon}{B_0}$ . Choose

$$\epsilon \leq \min \left( b_2, \frac{\frac{1}{2} a_2}{\sqrt{4k^2/\lambda^2 + 1}} \right)$$

$$B_0 \geq \max \left( 1, \left( \frac{b_2}{\epsilon} \right)^{M/\lambda} \right)$$

and determine  $t_1$  so that  $e^{\int_0^{t_1} f(t) dt} \leq \frac{\epsilon}{B_0}$ . Choose

$$t_2 = t_1 + \log \left( \frac{b_2}{\epsilon} \right)^{1/\lambda}.$$

$$e^{\int_0^{t_1} f(t) dt} \leq \frac{\epsilon}{B_0} \quad \text{at } t = t_1 \quad \text{and we first find an upper}$$

bound for its size at  $t = t_2$ . Clearly

$$\begin{aligned} e^{\int_0^{t_2} f} &= e^{\int_0^{t_1} f} e^{\int_{t_1}^{t_2} f} \leq \frac{\epsilon}{B_0} e^{(t_2 - t_1)M} \\ &\leq \frac{\epsilon}{B_0} e^{\log \left( \frac{b_2}{\epsilon} \right)^{M/\lambda}} \leq \frac{\epsilon}{B_0} e^{\log B_0} = \epsilon. \end{aligned}$$

hence, we may estimate the round bracket term in (24) as

$$\begin{aligned} e^{-\lambda t_2} \int_0^{t_2} e^{\lambda t} e^{\int_0^t f} dt &\leq e^{-\lambda t_2} \left[ b_2 \int_0^{t_1} e^{\lambda t} dt + \epsilon \int_{t_1}^{t_2} e^{\lambda t} dt \right] \\ &\leq \frac{b_2}{\lambda} \left[ e^{-\lambda(t_2 - t_1)} - e^{-\lambda t_2} \right] + \frac{\epsilon}{\lambda} \left[ 1 - e^{-\lambda(t_2 - t_1)} \right] \\ &< \frac{b_2}{\lambda} e^{-\lambda(t_2 - t_1)} + \frac{\epsilon}{\lambda} = \frac{b_2}{\lambda} e^{-\lambda \log \left( \frac{b_2}{\epsilon} \right)^{1/\lambda}} + \frac{\epsilon}{\lambda} \\ &< \frac{\epsilon}{\lambda} + \frac{\epsilon}{\lambda} = 2 \frac{\epsilon}{\lambda} \end{aligned}$$

Thus we have, for (24):

$$\begin{aligned} a_2 e^{\lambda_2 t_2} \leq \|x^2\| &\leq e^{\lambda_2 t_2} \left\{ \epsilon^2 + k^2 \left( \frac{4\epsilon^2}{\lambda^2} \right) \right\}^{\frac{1}{2}} \\ &= e^{\lambda_2 t_2} \epsilon \sqrt{1 + 4k^2/\lambda^2} \\ a_2 e^{\lambda_2 t_2} \leq \|x^2\| &\leq \frac{a_2}{2} e^{\lambda_2 t_2} \end{aligned}$$

which is a contradiction. This completes the proof. Our original argument for the last part of the above proof was quite involved and the above details follow a suggestion of E. W. Barankin.

This theorem is a first result on a problem raised indirectly by Liapounoff [M.L.], pp.241-242. The stimulus for results in this direction is due to the fact that they give immediately strong stability theorems -- which theorems for the case of variable coefficients now hinge on the assumption that the integral of the trace is bounded (automatically excluding the constant coefficient stable case!). This raises the question as to when  $H_2$  and  $H_3$  of the preceding theorem are true, and we conjecture that this will be the case if the  $a_{1j}(t)$  satisfy analagous conditions, i.e. if there exist constants  $\mu_{1j}$  such that

$$\lim_{t \rightarrow \infty} \frac{1}{t} \int_0^t a_{1j}(\tau) d\tau = \mu_{1j}, \text{ and}$$

$$\int_0^t (a_{1j}(t) - \mu_{1j}) dt = o(1).$$

Second, this corollary is directed towards a generalization of the classical representations for solutions of systems of linear differential equations with either constant or periodic coefficients which may be stated: the  $s$ -th component,  $x_s$ , of any solution  $x$  of the equation

$$\frac{dx}{dt} = Ax; \quad A = (a_{1j}) \quad ; \quad a_{1j} \text{ constant(periodic)}$$

may be written when all the characteristic roots are distinct

$$x_s = \sum_{i=1}^n \varphi_{is} e \quad ; \quad \varphi_{is} \text{ constant(periodic)}$$

This theorem is not true for almost periodic coefficients, as this example due to Cameron shows:

$$\begin{aligned} \frac{dy}{dt} &= \varphi(t)y \quad ; \quad \varphi(t) = \sum \frac{1}{n^2} \cos \frac{1}{n^3} \\ y &= y(t) = y(0) e^{\int_0^t \varphi(\tau) d\tau} \\ \lambda &= \lambda(y) = \lim_{t \rightarrow \infty} \frac{1}{t} \int_0^t \varphi(\tau) d\tau = 0. \end{aligned}$$

Hence, if the desired representation were to hold  $e^{\int_0^t \varphi(\tau) d\tau}$  would have to be almost periodic; in particular, bounded. But this is not the case since  $\int_0^t \varphi(\tau) d\tau$  takes on arbitrarily large positive values. In theorem 3 this type of behavior is eliminated by  $H_3$ .

It is clear that, although one would like to exchange hypotheses  $H_2$  and  $H_3$  for conditions on  $a_{1j}$ , theorem 4 is best possible insofar as having weaker conditions on  $\|y^i\|$  is concerned. This follows from Cameron's example.

The role of the "uniform condition"  $H_3$  in theorem 3 was to show, at a critical point, that the matrix of solutions of a special linear system of differential equations had a determinant bounded away from zero. By virtue of lemma 4, section 6, and the relation

$$|X| = ce^{\int_0^t \text{trace} A} \quad \text{if } \frac{dx}{dt} = Ax \text{ ([S.L.], p.53) it is clear}$$

that  $H_3$  can be given a modified statement in terms of the trace of coefficients. We consider such a "mixed" hypothesis objectionable.

Given

$$\frac{dx}{dt} = -x + \varphi(t)$$

than as  $t \rightarrow \infty$  clearly

$$\underline{\lim} \varphi < \underline{\lim} x < \overline{\lim} x < \overline{\lim} \varphi .$$

The crux of the argument in the proof of theorem 3 is the following: to show that if

$$\varphi = e^{\int_0^t f dt} ; |f| \leq \text{const.},$$

then  $\underline{\lim} \varphi = 0$  implies  $\underline{\lim} x = 0$  (this elementary exercise is apparently a new stability result).

### §9. Two Stability Theorems.

The following results are suggested by corollary 1.1, in particular by equations 4:

Theorem 4. A periodic solution of

$$(25) \quad \frac{dx_i}{dt} = X_i(x_1, x_2), \quad (i=1,2)$$

is stable if at each point it is in a region where the curvature, H, of the orthogonal trajectories is negative; or equivalently if at each point (on the given trajectory) the derivative of the first approximation of the normal distance from near by solutions (to the given trajectory) is negative.

From these results it is clear that a stable periodic solution, satisfying the given conditions, plays among its neighboring trajectories a role analogous to that of a "regular" maximum point of a function of a single variable. The test in the latter case given by a non-zero second derivative, is replaced in the former by the curvature of the orthogonal trajectories.

Proof of theorem 4. Our object is to construct simple closed curves inside and outside the given trajectory which are very close to it and such that in the annular region so constructed the boundary vectors (of the flow) are, as a consequence of the hypothesis, directed inward. This would prove the theorem.

At a point  $p$  of the given periodic solution  $C$ , let  $L$  be a segment perpendicular to  $C$  and parametrized (linearly) by a variable  $u$  which is zero on  $C$  and increases in the direction obtained by rotating the tangent to  $C$  (at  $p$ )  $90^\circ$  counterclockwise. Let  $\theta(u) = \theta$  be the angle, measured counterclockwise, from a vector of the flow (on  $L$ ) to the direction of increasing  $u$ . We wish to calculate  $\left. \frac{d\theta}{du} \right|_{u=0}$ . It will be convenient to use the abbreviations:

$$\begin{aligned} \dot{x}_1(u) &= x_1 + (-1)^1 X_{1+1}(x_1, x_2)u; & x_1(0) &= x_1 \\ X_1(u) &= X_1(x_1(u), x_2(u)) & ; & X_1(0) = X_1 = X_1(x_1, x_2) \\ X(u) &= (X_1(u), X_2(u)) & ; & X(0) = X = (X_1, X_2) \\ X_\perp &= (-X_2, X_1) \end{aligned}$$

Now

$$\theta = \theta(u) = \cos^{-1} \left[ \frac{(X_\perp \cdot X(u))}{\|X_\perp\| \cdot \|X(u)\|} \right]; \quad \theta(0) = 90^\circ$$

$$\left( \frac{d\theta}{du} \right)_{u=0} = \left( \frac{1}{\sin\theta} \frac{d}{du} \left[ \frac{(X_\perp \cdot X(u))}{\|X_\perp\| \cdot \|X(u)\|} \right] \right)_{u=0} = \left( \frac{d}{du} [\dots] \right)_{u=0}$$

$$\left( \frac{d}{du} [\dots] \right)_{u=0} = \left( \frac{\|X(u)\| \frac{d}{du} (X_\perp \cdot X(u)) - (X_\perp \cdot X(u)) \frac{d}{du} \|X(u)\|}{\|X_\perp\| \cdot \|X(u)\|^2} \right)_{u=0}$$

$$= \|X\|^{-2} \left( X_\perp \cdot \left[ \frac{d}{du} X(u) \right] \right)_{u=0}$$

$$\left[ \frac{d}{du} X(u) \right]_{u=0} = \left( \frac{\partial X_1}{\partial x_1} X_2 + \frac{\partial X_1}{\partial x_2} X_1, -\frac{\partial X_2}{\partial x_1} X_2 + \frac{\partial X_2}{\partial x_2} X_1 \right)$$

and finally

$$\begin{aligned} \left( \frac{d\theta}{du} \right)_{u=0} = & ||X||^{-2} \left( \frac{\partial X_2}{\partial x_2} X_1^2 - X_1 X_2 \left( \frac{\partial X_1}{\partial x_2} + \frac{\partial X_2}{\partial x_1} \right) \right. \\ & \left. + \frac{\partial X_1}{\partial x_1} X_2^2 \right) \end{aligned}$$

We wish to compare this with the curvature  $H(p)$  of the trajectory through that point. If  $s$  is arc length

$$H(p) = \pm ||\frac{d^2x}{ds^2}|| \quad ||\frac{dx}{dt}|| = ||X||$$

$$\begin{aligned} \frac{d^2x}{ds^2} = & ||\frac{dx}{dt}||^{-4} \left\{ -\frac{1}{2} \left( \frac{d}{dt} ||\frac{dx}{dt}||^2 \right) \frac{d}{dt} \right. \\ & \left. + ||\frac{dx}{dt}||^2 \frac{d^2}{dt^2} \right\} x \end{aligned}$$

Evaluating this shows

$$\left( \frac{d^2x}{ds^2} \right)_1 = ||X||^{-4} \left( X_1 \frac{dX_2}{dt} - X_2 \frac{dX_1}{dt} \right) \left( (-1)^1 X_{1+1} \right)$$

Choosing the proper sign shows that

$$\begin{aligned} H(p) = & ||X||^{-3} \left( X_1 \frac{dX_2}{dt} - X_2 \frac{dX_1}{dt} \right) \\ = & ||X||^{-3} \left( X_1^2 \frac{\partial X_2}{\partial x_1} - X_2 X_1 \left[ \frac{\partial X_1}{\partial x_1} - \frac{\partial X_2}{\partial x_2} \right] - X_2^2 \frac{\partial X_1}{\partial x_2} \right) \end{aligned}$$

hence for the orthogonal trajectories (replace  $X_1$  by  $(-1)^1 X_{1+1}$ ) the curvature  $H_0(p)$  is

$$H_0(p) = ||X||^{-3} \left( X_1^2 \frac{\partial X_2}{\partial X_2} - X_1 X_2 \left[ \frac{\partial X_2}{\partial X_1} + \frac{\partial X_1}{\partial X_2} \right] \right. \\ \left. + X_2^2 \frac{\partial X_1}{\partial X_1} \right)$$

We now wish to evaluate the first approximation to the rate of "normal approach". This is clearly

$\frac{d\eta_2}{dt}$  as defined in §3.

$$\begin{aligned} \frac{d\eta_2}{dt} &= \left[ -||X||^{-1} \frac{d}{dt} ||X|| + \left( \frac{\partial X_1}{\partial X_1} + \frac{\partial X_2}{\partial X_2} \right) \right] \eta_2 \\ &= \left[ -\frac{1}{2} \frac{d}{dt} ||X||^2 + ||X||^2 \left( \frac{\partial X_1}{\partial X_1} + \frac{\partial X_2}{\partial X_2} \right) \right] ||X||^{-2} \eta_2 \\ &= \left[ X_1^2 \frac{X_2}{X_2} - X_1 X_2 \left( \frac{\partial X_1}{\partial X_2} + \frac{\partial X_2}{\partial X_1} \right) + X_2^2 \frac{\partial X_1}{\partial X_1} \right] ||X||^{-2} \eta_2 \end{aligned}$$

Thus summing up we have the relationships

$$\frac{d\eta_2}{dt} = \left( \eta_2 \frac{d\theta}{du} \right)_{u=0}, \quad H_0 = ||X||^{-1} \left( \frac{d\theta}{du} \right)_{u=0}$$

From these we have that if one of the quantities

$\frac{d\eta_2}{dt}$ ,  $H_0$ ,  $\left( \frac{d\theta}{du} \right)_{u=0}$  is negative on a periodic solution

(closed trajectory) then so are the remaining two. To

prove theorem 4 we then need only show that  $\left( \frac{d\theta}{du} \right)_{u=0} < 0$

at each point of the closed trajectory implies stability.

The geometry of the condition  $\frac{d\theta}{du} < 0$  is clear and to complete the argument we define, for a closed, simple, twice differentiable (Jordan) curve, a  $\delta$ -parallel to be the locus of end points of all normals of length  $\delta$  on one side of the curve. For  $\delta$ -parallels we need the easily proved lemma: if C is a simple closed C<sup>2</sup> (Jordan

curve and  $C_\delta$ ; the corresponding  $\delta$ -parallel then there exists a  $\delta_0$  such that if  $\delta < \delta_0$  then  $C_\delta$  is also simple. Further if, using the natural correspondence between the curves,  $C_\delta(t)$  is the point corresponding to  $C(t)$  then at these points the two curves have parallel tangents.

Proof of the lemma: let  $C: x_i = x_i(s)$   $i=1,2$  be a simple analytic closed curve with  $s$  the arc length  $((x'_1)^2 + (x'_2)^2) = 1, 0 \leq s \leq 1$ . Then one  $\delta$  parallel  $C_\delta$  is given by

$$\begin{aligned} x_1^*(s) &= x_1(s) - \delta x_2'(s) \\ x_2^*(s) &= x_2(s) + \delta x_1'(s) \end{aligned}$$

The corresponding tangents are

$$C : \begin{cases} x_1'(s) \\ x_2'(s) \end{cases} \quad C_\delta : \begin{cases} x_1^{*'}(s) = x_1'(s) - \delta x_2''(s) \\ x_2^{*'}(s) = x_2'(s) + \delta x_1''(s) \end{cases} \quad (3)$$

Since these tangents are of non-zero length, a vanishing cross product will mean they are parallel:

$$x_1' x_2^{*'} - x_2' x_1^{*'} = \delta (x_1' x_1'' + x_2' x_2'') = \frac{\delta}{2} \frac{d}{ds} [(x_1')^2 + (x_2')^2] = 0$$

Thus  $C$  and  $C_\delta$  are parallel for any sufficiently small  $\delta$ .

Suppose  $C_\delta$  is not simple for all sufficiently small  $\delta$ . Then there exists a sequence  $\delta_1$  and a double sequence  $\{a_1, b_1\}$  where  $a_1$  and  $b_1$  are on  $C$  and such that the normals at  $a_1$  and  $b_1$  of length  $\delta_1$  have a common end point, and where  $\lim |\delta_1| = 0$ . Since  $C$  is compact there exists a subsequence  $\{\tilde{a}_1\}$  of  $\{a_1\}$  which converges to a

3.  $C_\delta$  will have no cusps if  $\delta$  is small enough since  $(x_1^{*'})^2 + (x_2^{*'})^2 = 1 + \delta(2x_2'' x_1' - 2x_1'' x_2') + \delta^2 (x_1'')^2 + (x_2'')^2 \neq 0$  for small  $\delta$  since  $x_1', x_1''$  ( $i=1,2$ ) are finite.

single limit point, say,  $a$ . Let  $\{\tilde{b}_1\}$  be the sequence of the  $\{b_1\}$  corresponding to the  $\tilde{a}_1$ . Then  $\lim \tilde{b}_1$  is also  $a$ , for  $\text{dist}(\tilde{a}_1, \tilde{b}_1) \leq 2\delta_1$  which becomes arbitrarily small.

Let  $s_1, \tilde{s}_1$  be the parameter values giving  $\tilde{a}_1$  and  $\tilde{b}_1$  respectively. The common end point condition gives the relations

$$\begin{cases} x_1(s_1) - \delta_1 x_2'(s_1) = x_1(s_1) - \delta_1 x_2'(\tilde{s}_1) \\ x_2(s_1) + \delta_1 x_1'(s_1) = x_2(s_1) + \delta_1 x_1'(\tilde{s}_1) \end{cases}$$

These may be arranged

$$\begin{cases} x_1(s_1) - x_1(\tilde{s}_1) = \delta_1 [x_2'(s_1) - x_2'(\tilde{s}_1)] \\ x_2(s_1) - x_2(\tilde{s}_1) = \delta_1 [x_1'(s_1) - x_1'(\tilde{s}_1)] \end{cases}$$

Squaring both sides, adding, dividing by  $(s_1 - \tilde{s}_1)^2$

( $\neq 0$ ) and taking the limit gives

$$1 = \lim_{\delta_1 \rightarrow 0} \delta_1^2 \{ (x_2'')^2 + (x_1'')^2 \}$$

And so finite curvature implies  $\lim \delta_1 \neq 0$  -- a contradiction completing proof of the lemma.

Consider a point  $C(t)$  on  $C$  where  $\left. \frac{d\theta}{du} \right|_{u=0} < 0$ . Then the two vectors at the end of the two normals (one on each side of  $C$ ) have projections -- parallel to the tangent of  $C$  -- which lie on this segment if the segment is small enough, say less than  $\delta(t)$ . The same property is true for any  $\delta < \delta(t)$ . It is obvious that this is a continuous point function on  $C(t)$  and since  $\delta(t) \neq 0$  it has a minimum, say  $\delta_0 > 0$  on  $C(t)$ . It follows that if  $C$  is any  $\delta$ -parallel to  $C$  with  $\delta < \delta_0$  then the flow vectors at points of  $C$  are directed into the annulus bounded by  $C_\delta$  and  $C_{-\delta}$ . Hence once a trajectory gets within  $\delta_0$  of the orbit  $C$  its distance from the orbit decreases

monotonically. Q.E.D.

Theorem 4 does not generalize directly. For one thing orthogonal surfaces will not in general exist. Secondly, when they do there is an indeterminacy in the case  $K > 0$ , as to whether the surface normal (given by differential equation) and the surface are on the same side of the tangent plane; hence stability or instability will be determined only by some additional hypothesis --

Theorem 5: A given periodic solution, i.e. closed trajectory, of

$$(26) \quad \frac{dx_i}{dt} = X_i = \frac{\partial F}{\partial x_i} \quad , \quad (i=1,2,3)$$

along which  $K > 0$  will be stable (unstable) if either (a)  $\sum X_i = \sum \frac{\partial F}{\partial x_i} < 0$  ( $> 0$ ) along the trajectory or else (b) there exists a trajectory which for  $t \rightarrow +\infty$  ( $-\infty$ ) is asymptotic to the given one.

If  $\eta$  represents the first approximation to the normal distance of near by trajectories to the given closed trajectory the condition  $K > 0$  and stability (instability) is equivalent to

$$\frac{d\eta}{dt} < 0 \quad \left( \frac{d\eta}{dt} > 0 \right)$$

The proof of theorem 5 is omitted in as much as no ideas, not already in the proof of theorem 4, enter.

In three dimensions a different type of circumstance can arise. This is covered by

Theorem 6: Let P be a periodic solution of

$$\frac{dx_i}{dt} = X_i = \frac{\partial F}{\partial x_i} \quad , \quad i = 1,2,3$$

along which  $K < 0$ . Then there exist two linear manifolds

$M_1$  and  $M_2$ , of solutions, through  $P$  such that in  $M_1$  trajectories are stable (asymptotic to  $P$  as  $t \rightarrow +\infty$ ) while in  $M_2$  trajectories are unstable (asymptotic to  $P$  as  $t \rightarrow -\infty$ ).

The idea of the proof will be very close to that used in discussing the saddle point in "singular point theory" in the two dimensional case. Theorems 4, 5, 6 extend to  $n$ -dimensions and the results there complete an analogue to critical point theory "in the small". Results connecting the number of different types of periodic solutions can be obtained to give an analogue of critical point theory in the large.<sup>(4)</sup>

#### §10. A Problem of Hilbert.

The quadrature occurring in (4) suggests that the class of the periodic solutions on which the sign of  $\text{div } X$  is fixed may well have interesting properties. This is so and in fact defining strongly stable (unstable) periodic solutions (closed trajectories) as ones on which  $\text{div } X < 0$  ( $\text{div } X > 0$ ), we are able to give the first results on the second half of Hilbert's sixteenth problem.<sup>(5)</sup>

Theorem 7: Let

$$(27) \quad \frac{dx_i}{dt} = X_i(x_1, x_2), \quad (i=1, 2)$$

where  $X_i$  are polynomials of degree at most  $n$ . If all the periodic solutions of (27) are either strongly stable or strongly unstable the total number of periodic solutions is less than  $\frac{1}{2} (n-2)(n-3) + 1$ .

4. The only known results in this direction are those of N. Levinson [N.L.]p.731, where a related result is given for  $n=3$ . The proof of Theorem 7 and the  $n$ -dimensional results will be published elsewhere.

5. Probleme der Topologie algebraischer Kurven und Flaechen [H.]pp.223-224.

If in addition they are nested and surround just one singular point this estimate can be sharpened to  
 $\lfloor \frac{n-1}{2} \rfloor$  ( $\lfloor \cdot \rfloor$  is the integer part of) -- and this is best possible. This last statement is valid if all the periodic solutions form at most two nests.

It appears very difficult to obtain estimates on general periodic solutions. Preliminary study indicates that the estimate  $\lfloor \frac{n-1}{2} \rfloor$  will be valid for certain special equations (i.e. restrictions are placed on the form of the differential equation rather than the type of periodic solution) in particular for equations of van der Pol type (see the remarks of [S.L.]p.193).

Proof of theorem 7. The idea of the proof will be to establish that there are at least as many closed finite branches of

$$\operatorname{div} X = \frac{\partial X_1}{\partial x_1} + \frac{\partial X_2}{\partial x_2} = 0$$

as there are periodic solutions of the specified types. Let  $\{C_1\}$  be the set of such solutions; then if  $R_1$  is the region bounded by  $C_1$

$$0 \equiv \oint_{C_1} (X_2 X_1 - X_1 X_2) dt = - \oint_{C_1} X_2 dx_1 - X_1 dx_2 = \iint_{R_1} \operatorname{div} X dx_1 dx_2.$$

Since  $\operatorname{div} X \neq 0$  on  $C_1$  and  $\iint_{R_1} \operatorname{div} X = 0$  there must exist a

region  $\gamma_1$  on which  $\operatorname{div} X$  has a sign opposite to its sign on the boundary.  $\gamma_1$  is separated from  $C$  by a closed finite branch of  $\operatorname{div} X = 0$ . ( $\gamma_1$  need not "a priori" be connected so  $\operatorname{div} X$  may have many closed finite branches inside  $C_1$ ; we merely note that there is at least one.) This closed branch is a closed curve, but not necessarily a simple one.

Calling such a branch  $B_1$  we claim there are as many  $B_1$  as  $C_1$ . Namely, let  $C_1$  be some periodic solution and  $C_{1_1}, \dots, C_{1_k}$  be those periodic solutions inside  $C_1$ , but with no  $C_{1_j}$  contained in a  $C_m$  where  $C_m$  is in  $C_1$ . Clearly

$$\iint_{R_1} \operatorname{div} X = 0$$

$$R_1 - \sum_{j=1}^k R_{1_j}$$

By the previous reasoning we may find a  $B_1$  in  $R_1 - \sum_{j=1}^k R_{1_j}$  which is associated with no other  $C_1$ . Thus we must now determine the maximum number of closed finite disjoint branches which  $\operatorname{div} X=0$  may have. This is  $\frac{1}{2}(n-2)(n-3)+1$  [C.]p.56. This estimate is clearly a poor one since we have avoided any mention of the relative positions of the  $C_1$ . Thus for example if no  $C$ 's are nested there must be at least one branch (not necessarily finite) separating all the stable solutions from the unstable ones.

When all the periodic solutions are nested ( $C_1 \supset C_2 \dots \supset C_k$ ) we may improve the estimate. First it follows from classical results [S.L.]p.181 that if  $C_1$  is stable then  $C_2$  is unstable,  $C_3$  stable, etc. Consequently it must be true that  $C_1 \supset B_1 \supset C_2 \supset B_2 \dots$ , for every point on  $C_1$  must be separated from every point of  $C_{i+1}$  and  $C_{i-1}$ . Thus we have  $B_1 \supset B_2 \supset \dots$ . When an algebraic equation of degree  $k$  has all its branches nested the maximum number of these is  $\lfloor \frac{1}{2}k \rfloor$ . This estimate is even true if there are exactly two nests -- i.e. if it is true that  $B_1 \supset B_3 \dots$  and  $B_2 \supset B_4 \dots$ .

For the case of nested ovals the estimate is easily seen to be the best possible from the example

$$\frac{dx}{dt} = y - x \prod_{i=1}^n (x^2 + y^2 - i^2)$$

$$\frac{dy}{dt} = -x - y \prod_{i=1}^n (x^2 + y^2 - i^2)$$

which has as strong periodic solutions the circles  $x^2 + y^2 = i^2$  -- and no others.

Hurewicz has pointed out that theorems 4, 5 and 6 will undoubtedly follow from classical results on (generalized) characteristic exponents, i.e. are weaker results; but, in distinction to the characteristic exponents, they give a direct stability criterion.

#### REFERENCES

- [G.B.] George D. Birkhoff, Dynamical Systems. New York, Amer. Math. Soc., 1927.
- [C.] J. L. Coolidge, A Treatise on Algebraic Plane Curves. Oxford, Clarendon Press, 1931.
- [H.] D. Hilbert, Mathematische Probleme. Archiv der Math. u. Phys. (3) 1 (1901), pp.44-63, 213-237.
- [N.L.] N. Levinson, Transformation Theory of Non-linear Differential Equations of the Second Order. Ann. of Math. (2) 45 (1944), pp.723-737.
- [S.L.] S. Lefschetz, Lectures on Differential Equations. Princeton Univ. Press, 1946.
- [M.L.] M. A. Liapounoff, Problème Général de la Stabilité du Mouvement. Ann. Fac. Sci. Univ. Toulouse (2) 9 (1907), pp.203-469. (Reprinted as Ann. of Math. Studies No. 17, Princeton Univ. Press, 1947.)

## REFERENCES (cont'd)

- [M.] M. Morse, The Calculus of Variations in the Large.  
New York, Amer. Math. Soc., 1934.
- [O.P.1] O. Perron, Uber ein matrixtransformation. Math. Zeit. 32 (1930), pp.465-473.
- [O.P.2] - -----, Die ordnungszahlen linearer differentialgleichungs-systeme. Math. Zeit. 31 (1930), pp.748-766.
- [W.] E. T Whittaker, A Treatise on the Analytical Dynamics of Particles and Rigid Bodies, 4th ed. Cambridge Univ. Press, 1937.

## II. OSCILLATION OF A THIRD ORDER NONLINEAR AUTONOMOUS SYSTEM

By Lawrence Lee Rauch \*

### Preface

Much of the modern engineering interest in the theory of nonlinear oscillations stems from a desire to avoid unwanted oscillations in physical systems. The classical interest in the mathematical theory of oscillating systems as such which began with the work of Van der Pol never carried far down into the ranks of practicing engineers. This probably resulted from the fact that most useful oscillating systems are small and apparently the cheapest and easiest way to investigate the solution for any given system is by an analog method, namely, by building the system itself and operating it.

In recent years a new situation has confronted the practicing engineer in the form of very expensive and complex devices<sup>1</sup> whose actions as a function of time must be controlled without the aid of constant and detailed human supervision. This has resulted in numerous applications of particular nonlinear operators on

---

\* Princeton University and the University of Michigan.  
1. Aircraft, guided missiles, and automatic chemical process plants are examples of important classes.

functions of time<sup>2</sup> without an appreciation of the more general aspects of nonlinear operator theory.

In practical cases it is not always clear whether or not a proposed nonlinear operator is unstable in the sense that the function of time resulting from the operator may not always be sufficiently controlled by the impressed function of time. Inability to settle this stability question by theory has resulted in very expensive experimentation sometimes accompanied by loss of life. Without an understanding of the theory, even extensive experimentation cannot infallibly eliminate the possibility that the output function of a nonlinear operator may become uncontrolled as a result of certain impressed functions.

One important example involving the above considerations occurs in what are called "closed-loop control systems" where it is desired to make the output of a device behave in a specified manner.

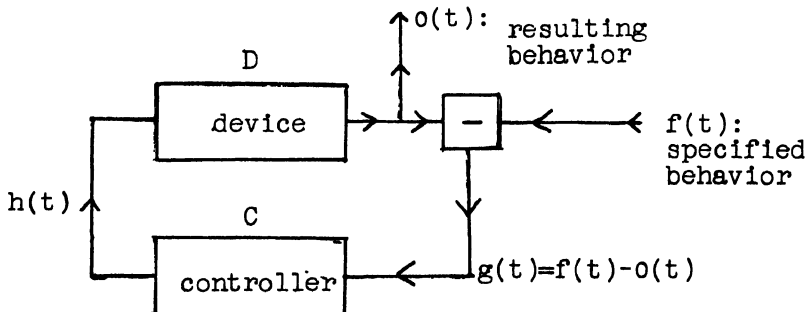

2. Transmission of intelligence by radio cannot be accomplished without the use of such nonlinear operators as amplitude modulation, frequency modulation, pulse-position modulation, etc.

In the diagram, the output  $O(t)$  from the device depends on the input  $h(t)$  to the device in a manner prescribed by the nonlinear operator  $D$

$$O(t) = D[h(t)] .$$

It is desired to make  $O(t)$  as nearly equal to  $f(t)$  as possible. To this end the difference  $g(t)$  is operated on by  $C$  in the controller and applied to the input of the device

$$h(t) = C[g(t)] ..$$

The total result is

$$O(t) = D[C[f(t) - O(t)]] ,$$

If  $D$  has an inverse and  $C$  is linear

$$(D^{-1} + C)[O(t)] = C[f(t)]$$

If  $D^{-1} + C$  has an inverse

$$O(t) = (D^{-1} + C)^{-1}[C[f(t)]]$$

In many practical systems  $D^{-1}$  exists and  $C$  is linear, but trouble occurs in attempting to take the inverse of  $D^{-1} + C$ . It can occur that even if  $f(t) = 0$  the closed-loop control system will generate an  $O(t)$  which does not approach zero or for that matter which does not even remain less in absolute value than a small constant for  $t$  sufficiently large.

In the language of differential equations this amounts in many cases to an  $n$ -th order nonlinear ordinary system with a single forcing function  $f(t)$  and solution  $O(t)$ . When  $f(t) = 0$  we have an autonomous system whose only stable solution must be an unique stable singular point near the origin if the closed-loop control system is to be successful. Thus a better understanding of the qualitative nature of solutions of nonlinear autonomous systems is important

in understanding the stability of control systems. In-the-large properties of solutions of second order nonlinear systems<sup>3</sup> are rather well understood, but much less is known about higher order nonlinear systems.

Techniques are well developed to handle strictly linear systems<sup>4</sup> where limit cycles and similar phenomena cannot exist and stability is determined entirely by the singular points.

I wish to express my sincere appreciation to Professor S. Lefschetz for his interest and encouragement since first introducing me to the field of nonlinear differential equations. Also I wish to thank Drs. A. B. Farnell, C. E. Langenhop, and LeRoy A. MacColl who were kind enough to read the first draft and point out instances of obscurity in the presentation and a number of typographical errors.

#### INTRODUCTION, SUMMARY

This paper deals with the in-the-large properties of the solution of a third order system of nonlinear ordinary differential equations. As in Van der Pol's work the system arises from a vacuum-tube circuit. The system is a generalization of the well-known Van der Pol and Liénard systems to the third order in contrast to the generalization of Levinson and Smith which remains within the framework of the second order where questions of stability are more easily handled.

---

3. See Andronow and Chaikin, Theory of Oscillations, Princeton University Press, 1949.

4. See Bode, Network Analysis and Feedback Amplifier Design, D. van Nostrand Company, 1945.

In the circuit the vacuum tube is assumed to introduce a general nonlinear characteristic determining the anode current as a function of the grid voltage only (exemplified by the pentode type of vacuum tube). This is shown to be essentially different from the circuit considered by Friedrichs where the vacuum tube is assumed to determine the anode current as a function of the weighted sum of the grid and anode voltages (exemplified by the triode type of vacuum tube). In both cases it is assumed that there is no grid current.

The differential system considered in this paper, when represented as a single third-order equation, takes the form

$$k_1 \ddot{x} + (k_2 + k_3 g(x)) \dot{x} + k_3 g'(x) \dot{x}^2 + g(x) \dot{x} + x = 0$$

where  $g(x)$  depends on the nonlinear characteristic of the vacuum tube and the constant circuit parameters and  $k_1$ ,  $k_2$ , and  $k_3$  depend on the constant circuit parameters.

When  $k_1 = k_3 = 0$  and  $k_2 = 1$  the equation becomes

$$\ddot{x} + g(x) \dot{x} + x = 0$$

which is the equation investigated by A. Liénard [1].

It includes as a special case Van der Pol's equation [2]

$$\ddot{x} + \mu(x^2 - 1) \dot{x} + x = 0 .$$

However it does not include the general equation for relaxation oscillations

$$\ddot{x} + g(x, \dot{x}) \dot{x} + h(x) = 0$$

investigated by Levinson and Smith [3].

We prove the following

Theorem: The differential equation

$$k_1 \ddot{x} + (k_2 + k_3 g(x)) \dot{x} + k_3 g'(x) \dot{x}^2 + g(x) \dot{x} + x = 0$$

will have a periodic solution if

$$1.) \quad g(0) < -\frac{k_2}{2k_3} + \sqrt{\frac{k_2^2}{4k_3^2}} + \frac{k_1}{k_3}$$

$$2.) \quad f^2(x) < C < \infty$$

$$3.) \quad 1 > 4.6 \frac{k_1 - k_2 k_3}{k_1} \sup_{-\infty < x < \infty} \frac{f(x)}{x} \\ + 9.7 \frac{k_1 - k_2 k_3}{k_1} + \frac{5.0}{m_1} \frac{k_3^3}{k_1 - k_2 k_3} \\ + 2.4 \frac{k_3^3}{k_1 - k_2 k_3}$$

where we define

$$f(x) = m_1 \left[ \frac{(k_1 - k_2 k_3)^2}{k_1 k_3^2} + m_1 + 1 \right] x - m_1 \frac{k_1 - k_2 k_3}{k_1 k_3} \int_0^x g(x) dx$$

and  $m_1 > 0$  may be chosen arbitrarily.

In the latter part of the paper we consider the case when certain of the parameters are functions of the variables. A special case leads to the more general second order equation

$$\ddot{x} + g(x) \dot{x} + h(x) = 0$$

The paper is arranged as follows: In Part I the vacuum tube circuit is presented and its mathematical description formulated. The difference between this circuit and the circuit of Friedrichs [4] is pointed out in the Appendix.

In Part II three physically significant variables are chosen and a system of three first order equations is obtained in terms of these variables, thereby defining a phase space. The difference between this differential system and that of Friedrichs is also pointed out in the Appendix. New physically dimensionless variables are introduced for convenience and a single third order equation is obtained in terms of one of these variables.

In Part III the uniqueness and type of the singular point in terms of the physical parameters is established.

In Part IV a closed three dimensional region which is topologically equivalent to a solid torus is defined in the phase space. The vector field is shown to point inward at all points of the boundary of the region with suitable restrictions upon the physical parameters. An additional step proves that the paths of the vector field circulate around inside the torus. The singular point lies outside the torus. A surface of section of the torus is a simply connected two dimensional closed region. A continuous mapping of any point back into the region is defined by following the corresponding path around the torus until it intersects the surface of section again. An application of Brouwer's fixed point theorem [5] establishes the existence of a fixed point of the mapping. Therefore one of the paths is closed after one revolution around the torus. This corresponds to a periodic solution.

In Part V it is shown that with two singular exceptions any path outside the torus eventually enters it; that is, all oscillatory solutions must lie inside the torus. It is pointed out that the periodic solution of Part IV is not necessarily stable under the proved topology. An example is given showing an unstable periodic solution, a stable periodic solution whose period requires

any desired number of revolutions around the torus, and a stable non-periodic solution.

In Part VI a method is established for placing upper bounds upon the instantaneous values of the variables when the system is oscillating.

In Part VII it is pointed out that the existence proof still holds when certain of the physical parameters are permitted to be suitable restricted functions of the variables.

## PART I. THE VACUUM TUBE CIRCUIT

The circuit under consideration is the well-known RC multivibrator with two additional reactive elements. A capacitance  $C_2$  is placed between the anode and cathode of the tube and an inductance  $L$  is placed in series with the plate load resistance  $R$  as shown in Figure 1. In practice it is well known that this circuit will oscillate when the parameters are properly adjusted. We shall follow the convention that the current in the circuit is in the direction of electron flow.

The electron currents in the four branches of the circuit are  $i_a$ ,  $i_c$ ,  $i_L$ , and  $i$  with directions as indicated by the arrows. The voltage on the anode of the tube with respect to the cathode is  $e$  and the voltage on the grid is  $e_g$ . The box directly below the tube  $T$  indicates that the sign of the voltage across  $r$  is changed before it is applied to the grid as  $e_g$ . This must be done in order to create an unstable condition which will lead to oscillation. In practice this phase reversal may be provided by a second vacuum tube arranged to operate only over the linear part of its range when the circuit is oscillating.

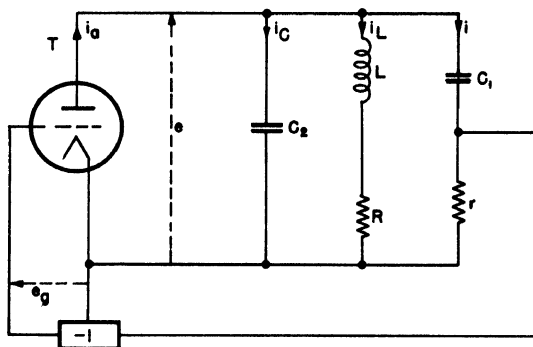

FIG. 1

The only nonlinear element in the circuit is the vacuum tube which determines the anode current  $i_a$  as a continuous single-valued function of the grid voltage  $e_g$

$$(1-1) \quad i_a = \varphi(e_g) .$$

For an actual tube the nonlinear function may appear as in Figure 2. The operating point transconductance  $g_m$  is defined by

$$(1-2) \quad g_m = \varphi'(0) > 0 .$$

We assume

$$(1-3) \quad \varphi(0) = 0 \text{ and } e_g \varphi(e_g) \geq 0 .$$

It will be observed that according to Figure 2 the anode current  $i_a$  may be either positive or negative in accordance with the grid voltage  $e_g$ . In actual practice vacuum tubes can have only positive anode current. The justification for the assumption of positive and negative anode current is that it simplifies the presentation. An actual tube may be made to have a characteristic as in Figure 2 by connecting a

constant voltage source in series with the grid, a constant current source between the anode and cathode, and a constant voltage source in series with the anode and then calling this whole affair the "vacuum

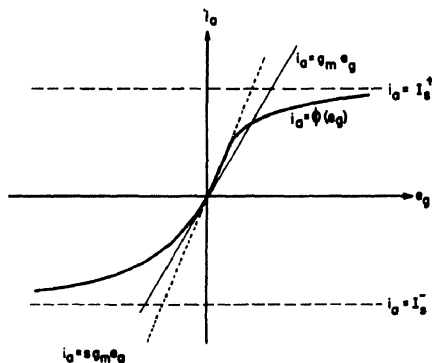

FIG. 2

tube" considered in this paper. The operation of the circuit is in no way affected by this procedure.

We define

$$(1-4a) \quad I_s^+ = -\infty \sup_{-\infty < e_g < \infty} \varphi(e_g) < \infty$$

$$(1-4b) \quad I_s^- = -\infty \inf_{-\infty < e_g < \infty} \varphi(e_g) > -\infty$$

$$(1-4c) \quad I_s = I_s^+ - I_s^-$$

For the proof of the existence of a periodic solution it will only be necessary to assume the existence of  $\varphi'(0)$ . However at other times we shall assume that  $\varphi'(e_g)$  exists everywhere.

The following relations between the variables are obtained by considering the various junctions and

branches of the circuit.

$$(1-5) \quad i_a = \varphi(e_g)$$

$$(1-6) \quad e_g = ir$$

$$(1-7) \quad i_a = i_c + i_L + i$$

$$(1-8) \quad e = -\int^t \frac{i_c}{C_2} dt$$

$$(1-9) \quad e = -L \dot{i}_L - Ri_L$$

$$(1-10) \quad e = -\int^t \frac{1}{C_1} dt - ri .$$

## PART II. THE DIFFERENTIAL SYSTEM

The system of equations (1-5) to (1-10) may be reduced to a system of three first-order differential equations in three of the physical variables. The important question is which three variables shall be chosen. (Of course the natural physical variables are not the only choice.) Some choices will result in phase spaces in which the geometry of the vector field makes it very difficult to construct the stable region necessary to prove the existence of a periodic solution. By a combination of physical reasoning and geometrical experimentation the variables  $i$ ,  $e$ , and  $i_L$  were chosen. Thus we want to eliminate  $i_a$ ,  $e_g$ , and  $i_c$ .

Substituting (1-6) and (1-7) in (1-5) gives

$$(2-1) \quad \varphi(ri) = i_c + i_L + i .$$

Differentiating (1-8) and substituting for  $i_c$  from (2-1) we have

$$(2-2) \quad \dot{e} = -\frac{1}{C_2} [\varphi(ri) - i - i_L] .$$

Differentiating (1-10) and substituting for  $\dot{e}$  from (2-2) gives

$$(2-3) \quad \dot{i} = \frac{1}{rC_2} \left[ \varphi(r1) - \left( 1 + \frac{C_2}{C_1} \right) i - i_L \right].$$

Solving (1-9) for  $i_L$ ,

$$(2-4) \quad i_L = -\frac{1}{L} (e + Ri_L) .$$

Equations (2-2), (2-3), and (2-4) together form our system of three first order differential equations defining the phase space in  $i$ ,  $e$ , and  $i_L$

$$(2-5a) \quad \dot{i} = \frac{1}{rC_2} \left[ \varphi(r1) - \left( 1 + \frac{C_2}{C_1} \right) i - i_L \right]$$

$$(2-5b) \quad \dot{e} = -\frac{1}{C_2} [\varphi(r1) - i - i_L]$$

$$(2-5c) \quad \dot{i}_L = -\frac{1}{L} (e + Ri_L) .$$

These three variables have the physical dimensions of current, voltage, and current respectively. To avoid awkward expressions in the calculations to follow we introduce physically dimensionless variables  $x$ ,  $y$ , and  $z$  defined by

$$(2-6a) \quad i = I_s x$$

$$(2-6b) \quad e = RI_s y$$

$$(2-6c) \quad i_L = I_s z.$$

We also define

$$(2-7) \quad \varphi(r1) = I_s f(x) .$$

Note that

$$(2-8) \quad -1 \leq f(x) \leq 1, \quad f(0) = 0, \quad \text{and} \quad xf(x) \geq 0$$

and

$$(2-9) \quad f'(0) = rg_m$$

Substituting (2-6) and (2-7) in (2-5) results in the physically dimensionless system

$$(2-10a) \quad \dot{x} = \frac{1}{rC_2} \left[ f(x) - \left( 1 + \frac{C_2}{C_1} \right) x - z \right]$$

$$(2-10b) \quad \dot{y} = -\frac{1}{RC_2} [f(x) - x - z]$$

$$(2-10c) \quad \dot{z} = -\frac{R}{L} [y + z] .$$

To express (2-10) as a single third-order differential equation we eliminate  $y$ ,  $\dot{y}$ ,  $z$ , and  $\dot{z}$  in the usual way. The final result is

$$(2-11) \quad LC_2 r \ddot{x} + \left[ RrC_2 + L \left( 1 + \frac{C_2}{C_1} \right) - Lf'(x) \right] \ddot{x} - Lf''(x) \dot{x}^2 + \left[ r + R \left( 1 + \frac{C_2}{C_1} \right) - Rf'(x) \right] \dot{x} + \frac{1}{C_1} x = 0 .$$

From (1-6) and (2-6a)

$$(2-12) \quad e_g = rI_s x .$$

In order to better understand the operation of the circuit of Figure 1 consider the following special cases of (2-11): 1.)  $L = 0$ , 2.)  $C_2 = 0$ , 3.)  $L = C_2 = 0$ , 4.)  $R = 0$ , and 5.)  $R = C_2 = 0$ . The first case is a second order equation of the type studied by Liénard. The second case is a second order equation with the coefficient of the highest derivative vanishing for certain values of the dependent variable. The solution of the equation must terminate at the time the co-

efficient vanishes. The differential equation does not in itself contain sufficient information to determine the discontinuity. Recourse must be made to the physical problem by application of the Mandelstam jump conditions [6] to find a new starting point for the solution of the differential equation after the discontinuity. The third case is similar to the second except that the equation is of the first order. The fourth case is similar to the full equation (2-11) except that the coefficient of the first derivative is constant. The last case is similar to the second case except that the coefficient of the first derivative is constant.

### PART III. THE SINGULAR POINT

From (2-10) any singular points must be solutions of the system

$$(3-1a) \quad f(x) - \left(1 + \frac{C_2}{C_1}\right)x - z = 0$$

$$(3-1b) \quad f(x) - x - z = 0$$

$$(3-1c) \quad y + z = 0$$

Subtracting (3-1a) from (3-1b) provides the result  $x = 0$ . Substituting this in (3-1b) and recalling that  $f(0) = 0$  gives  $z = 0$ . Then from (3-1c) it follows that  $y = 0$ . Therefore the system (2-10) has just one singular point and it is located at the origin of the phase space coordinates  $x, y, z$ .

In order to study this singular point we "linearize" the system (2-10) at the origin by the substitution

$$(3-2) \quad f(x) = f'(0)x = g_m r x .$$

The second equality is due to (2-9). The "linearized" system is then

$$(3-3a) \quad \dot{x} = \frac{1}{rC_2} \left[ \left( g_m r - 1 - \frac{C_2}{C_1} \right) x - z \right]$$

$$(3-3b) \quad \dot{y} = -\frac{1}{RC_2} [(g_m r - 1)x - z]$$

$$(3-3c) \quad \dot{z} = -\frac{R}{L} [y + z] .$$

The "linearized" version of (2-11) is

$$(3-4) \quad LC_2 r x + \left[ RrC_2 + L \left( 1 + \frac{C_2}{C_1} \right) - Lg_m r \right] \ddot{x} + \left[ r + R \left( 1 + \frac{C_2}{C_1} \right) - Rg_m r \right] \dot{x} + \frac{1}{C_1} x = 0 .$$

The cubic equation satisfied by the characteristic roots  $\lambda_1$ ,  $\lambda_2$ , and  $\lambda_3$  of the matrix of the right member of (3-3) is

$$(3-5) \quad \lambda^3 - \left[ \frac{g_m}{C_2} - \frac{1 + \frac{C_2}{C_1}}{rC_2} - \frac{R}{L} \right] \lambda^2 + \left[ \frac{1}{LC_2} + \frac{R \left( 1 + \frac{C_2}{C_1} \right)}{LrC_2} - \frac{Rg_m}{LC_2} \right] \lambda - \left[ -\frac{1}{LrC_1C_2} \right] = 0 .$$

The brackets before  $\lambda^2$ ,  $\lambda$ , and 1 are respectively

$$(3-6a) \quad A_2 = \lambda_1 + \lambda_2 + \lambda_3 = \frac{g_m}{C_2} - \frac{1 + \frac{C_2}{C_1}}{rC_2} - \frac{R}{L}$$

$$(3-6b) \quad A_1 = \lambda_1(\lambda_2 + \lambda_3) + \lambda_2\lambda_3 = \frac{1}{LC_2} + \frac{R\left(1 + \frac{C_2}{C_1}\right)}{LrC_2} - \frac{Rg_m}{LC_2}$$

$$(3-6c) \quad A_0 = \lambda_1\lambda_2\lambda_3 = -\frac{1}{LrC_1C_2},$$

the first being the trace of the matrix of (3-3) and the last being the determinant of the matrix of (3-3).

The solution of (3-4) is of course

$$(3-7) \quad x = \psi_1 e^{\lambda_1 t} + \psi_2 e^{\lambda_2 t} + \psi_3 e^{\lambda_3 t}$$

if  $\lambda_1 \neq \lambda_2 \neq \lambda_3 \neq \lambda_1$ .

It is known from the physical problem of Figure 1 that the circuit breaks into oscillation for  $g_m > G > c$  and does not do so for  $g_m < G$ . That is, the singular point is stable for  $g_m < G$  and unstable for  $g_m > G$ . We shall now prove this and also obtain the value of  $G$  in terms of the circuit parameters.

By (3-6c)  $\lambda_1\lambda_2\lambda_3$  is real and negative. Hence there is always at least one real and negative root. Let it be  $\lambda_1$ . Therefore the singular point must be one of just four structurally stable [7] types:

$$(3-8a) \quad \begin{array}{c} \text{stable} \\ \lambda_1 < 0, \lambda_2 < 0, \lambda_3 < 0 \end{array}$$

$$(3-8b) \quad \lambda_1 < 0, \lambda_2 = u + iv, \lambda_3 = u - iv, u < 0, v > 0$$

$$(3-8c) \quad \begin{array}{c} \text{unstable} \\ \lambda_1 < 0, \lambda_2 = u + iv, \lambda_3 = u - iv, u > 0, v > 0 \end{array}$$

$$(3-8d) \quad \lambda_1 < 0, \lambda_2 > 0, \lambda_3 > 0.$$

The stable conditions may be called respectively a

stable node and a stable node-focus. The unstable conditions may be called respectively a focal saddle point and a nodal saddle point.

It is clear that the transition from stability to instability must take place in the presence of the focal condition by passing from condition (3-8b) to (3-8c). Otherwise  $\lambda_2$  and  $\lambda_3$  would have to vanish at the transition point in passing from condition (3-8a) to (3-8d). This is impossible since  $\lambda_1 \lambda_2 \lambda_3 < 0$  in view of (3-6c). The transition case  $u = 0$ , although important as distinguishing between the stable and unstable focal cases, is not physically interesting because it is a stable node-center and this does not have structural stability.

We now show that the transition condition  $u = 0$  can only occur when

$$(3-9) \quad A_2 A_1 = A_0 .$$

Substituting from (3-6),

$$(3-10) \quad 2 \lambda_1 \lambda_2 \lambda_3 + \lambda_1 \lambda_2^2 + \lambda_1 \lambda_3^2 + \lambda_1^2 \lambda_2 + \lambda_1^2 \lambda_3 + \lambda_2^2 \lambda_3 + \lambda_2 \lambda_3^2 = 0 .$$

After factoring this becomes

$$(3-11) \quad (\lambda_2 + \lambda_1)(\lambda_3 + \lambda_1)(\lambda_2 + \lambda_3) = 0 .$$

The solutions are of course

$$(3-12a) \quad \lambda_2 = -\lambda_1$$

$$(3-12b) \quad \lambda_3 = -\lambda_1$$

$$(3-12c) \quad \lambda_2 = -\lambda_3 .$$

That is, (3-9) implies at least one of (3-12) and any one of (3-12) implies (3-9). We recall that  $\lambda_1$  is real and negative while  $\lambda_2$  and  $\lambda_3$  are either both real and of the same sign or else complex conjugates. The

condition (3-12c) is equivalent to  $u = 0$  in (3-8), the transition between stability and instability. Conditions (3-12a) and (3-12b) fall under condition (3-8) where the negative damping is greater than critical. Now the negative damping increases with  $g_m$  so that (3-12c) corresponds to a smaller value of  $g_m$  than (3-12a) or (3-12b).

Expressing (3-9) in terms of the circuit parameters by means of (3-6) we have

$$(3-13) \left[ \frac{g_m}{C_2} - \frac{1 + \frac{C_2}{C_1}}{rC_2} - \frac{R}{L} \right] \left[ 1 + \frac{R}{r} \left( 1 + \frac{C_2}{C_1} \right) - Rg_m \right] + \frac{1}{rC_1} = 0 .$$

Rewriting this as a quadratic in  $g_m$ ,

$$(3-14) \quad g_m^2 - \left[ \frac{1}{R} + \frac{2}{r} \left( 1 + \frac{C_2}{C_1} \right) + \frac{RC_2}{L} \right] g_m + \frac{1}{Rr} + \frac{C_2}{L} + \frac{RC_2}{Lr} \left( 1 + \frac{C_2}{C_1} \right) + \frac{1}{r^2} \left( 1 + \frac{C_2}{C_1} \right)^2 = 0$$

The roots are

$$(3-15) \quad g_m = \frac{1}{2R} + \frac{RC_2}{2L} + \frac{1}{r} \left( 1 + \frac{C_2}{C_1} \right) \pm \sqrt{\left( \frac{1}{2R} - \frac{RC_2}{2L} \right)^2 + \frac{C_2}{RrC_1}}$$

Clearly one root is real and positive and the other must be also since the constant term of (3-14) is positive.

The smaller root must be the transition condition  $u = 0$  of (3-12c) and the larger root must be (3-12a) or (3-12b). This can be seen by noting that (3-12c) must occur for some value of  $g_m$ . For when  $g_m = 0$  (no

energy input) the real parts of  $\lambda_2$  and  $\lambda_3$  are non-positive and by (3-6a) when  $g_m$  is sufficiently large positive the real parts of  $\lambda_2$  and  $\lambda_3$  are positive. Note that  $\lambda_2$  and  $\lambda_3$  are continuous functions of  $g_m$

Thus the condition that the singular point be unstable is

$$(3-16) \quad g_m > G = \frac{1}{2R} + \frac{RC_2}{2L} + \frac{1}{r} \left( 1 + \frac{C_2}{C_1} \right) \\ \sqrt{\left( \frac{1}{2R} - \frac{RC_2}{2L} \right)^2 + \frac{C_2}{RrC_1}} ,$$

and the condition that it be stable is

$$(3-17) \quad g_m < G .$$

In the limiting case when  $\frac{R}{L} \rightarrow \infty$  we have

$$(3-18) \quad G = \frac{1}{R} + \frac{1}{r} \left( 1 + \frac{C_2}{C_1} \right) .$$

For  $g_m = 0$  (vacuum tube not acting) the singular point will be a stable node or a stable node-focus depending upon whether the circuit is more or less than critically damped. As  $g_m$  becomes positive the damping decreases until it reaches zero at the transition node-center. Further increase in  $g_m$  leads to a focal saddle point and then finally to a nodal saddle point.

Critical damping occurs when the discriminant of the cubic (3-5) vanishes.

In the remainder of our work we assume that (3-16) holds.

For later use it is important to obtain information about the principal direction of the negative real

root  $\lambda_1$ . The particular solution of (3-4)

$$(3-19) \quad x = e^{\lambda_1 t}$$

is a straight line through the origin of the phase space and in the principal direction of  $\lambda_1$ . Substituting this solution in (3-3a) and (3-3c) gives

$$(3-20) \quad z = \left[ g_m r - \left( 1 + \frac{C_2}{C_1} \right) - r C_2 \lambda_1 \right] x$$

$$(3-21) \quad y = - \left( 1 + \frac{L}{R} \lambda_1 \right) z$$

which reduces the matter of the principal direction of  $\lambda_1$  to the problem of determining  $\lambda_1$ .

If we write (3-20) and (3-21)

$$(3-22) \quad z = \alpha x$$

$$(3-23) \quad y = -\beta z$$

where

$$(3-24) \quad \alpha = g_m r - \left( 1 + \frac{C_2}{C_1} \right) - r C_2 \lambda_1$$

$$(3-25) \quad \beta = 1 + \frac{L \lambda_1}{R}$$

then the direction cosines of the principal direction of  $\lambda_1$  are

$$(3-26) \quad X = \frac{1}{\sqrt{1 + \alpha^2 (1 + \beta^2)}},$$

$$Y = \frac{-\alpha\beta}{\sqrt{1 + \alpha^2 (1 + \beta^2)}},$$

$$Z = \frac{\alpha}{\sqrt{1 + \alpha^2 (1 + \beta^2)}}.$$

PART IV. EXISTENCE OF A PERIODIC SOLUTION

In this chapter we shall prove the  
 Theorem: The system

$$(2-10a) \quad \dot{x} = \frac{1}{rC_2} \left[ f(x) - \left( 1 + \frac{C_2}{C_1} \right) x - z \right]$$

$$(2-10b) \quad \dot{y} = - \frac{1}{RC_2} [f(x) - x - z]$$

$$(2-10c) \quad \dot{z} = - \frac{R}{L} [y + z]$$

representing the circuit of Figure 1 has a periodic solution if

$$1.) \quad g_m > \frac{1}{2R} + \frac{RC_2}{2L} + \frac{1}{r} \left( 1 + \frac{C_2}{C_1} \right) \sqrt{\left( \frac{1}{2R} - \frac{RC_2}{2L} \right)^2 + \frac{C_2}{RC_1 r}}$$

where  $g_m r = f'(0)$

$$2.) \quad \varphi^2(e_g) \leq C < \infty$$

where  $\varphi(r_1) = I_g f(x)$

$$3.) \quad \frac{R}{L} > \frac{4.6}{RC_2} \sup_{-\infty < x < \infty} \frac{f(x)}{x} + \frac{9.7}{RC_2} + \frac{5.0}{rC_2} + \frac{2.4}{rC_1}$$

where we assume  $f'(0) > 0$  exists,  $xf(x) \geq 0$ , and  $f(x)$  continuous and single valued. Although nothing can be said about the in-the-small stability of the periodic solution it will be seen that there is a sort of in-the-large stability.

The first step in proving the existence of a periodic solution is to define a closed region in the phase space topologically equivalent to a solid torus

in such a manner that the path passing through any point on the boundary surface enters the interior. That is, the vector with components  $(x, y, z)$  defined by (2-10) points into the interior at every point of the boundary surface. Thus any path beginning inside the torus would remain within it. The construction of the torus takes place in three steps. First, we define two cones with vertices at the origin which form the lateral boundaries. Second, we define a closed surface around the origin which forms the outer radial boundary. Third, we define a cylinder which forms the inner radial boundary, eliminating the singular point at the origin.

### 1. Lateral Boundaries

Consider two right circular cones with the line  $y = z, x = 0$  as a common axis and with the origin as a common vertex as in Figure 3 (the  $x$ -axis points vertically upward from the plane of the paper). The convex sides face each other across the plane  $y + z = 0$ , the

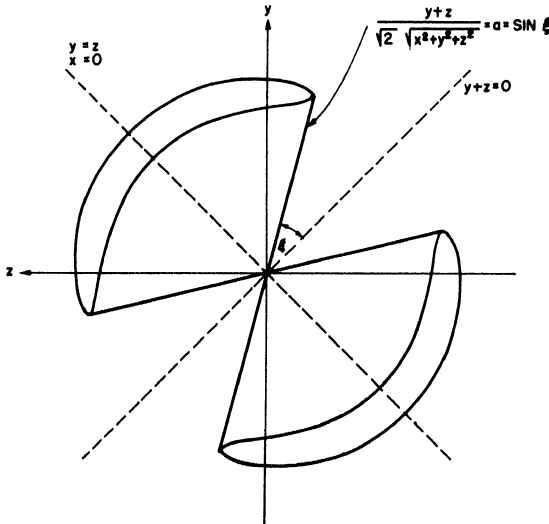

FIG. 3

generators making an angle  $\xi$  with this plane, The closed region lying between the two cones will be used in forming the torus. We were led to consider this region because (2-10c) represents a sort of attraction on any path acting toward the plane  $y + z = 0$ .

The distance of any point  $(x, y, z)$  from the plane  $y + z = 0$  is

$$(4-1) \quad \rho = \frac{y + z}{\sqrt{2}}$$

The distance of any point from the origin is

$$(4-2) \quad \rho = \sqrt{x^2 + y^2 + z^2} .$$

Therefore the equation of the cones is

$$(4-3) \quad \frac{y + z}{\sqrt{2}} = \frac{\rho}{\rho} = \sin \xi = a$$

where  $\frac{\pi}{4} > \xi > 0$  gives the upper left cone and  $-\frac{\pi}{4} < \xi < 0$  gives the lower right cone. For the present we limit ourselves to the upper left cone. The component of the vector field

$$(2-10a) \quad \dot{x} = \frac{1}{rC_2} \left[ f(x) - \left( 1 + \frac{C_2}{C_1} \right) x - z \right]$$

$$(2-10b) \quad \dot{y} = - \frac{1}{RC_2} [f(x) - x - z]$$

$$(2-10c) \quad \dot{z} = - \frac{R}{L} [y + z]$$

which is normal to the conical surface (4-3) and pointing toward the plane  $y + z = 0$  is

$$N_c = -\rho \dot{\xi}$$

Now by (4-3)

$$(4-4) \quad \xi = \arcsin \frac{y + z}{\sqrt{2}}$$

so

$$(4-5) \quad N_c = \frac{1}{\sqrt{2 - 2a^2}} \left[ \frac{\sqrt{2a}}{\rho} (\dot{x}x + \dot{y}y + \dot{z}z) - \dot{y} - \dot{z} \right].$$

We need to establish conditions under which  $N_c > 0$ .

Substituting for the derivatives in (4-5) by use of (2-10) we have

$$(4-6) \quad \begin{aligned} & \sqrt{2 - 2a^2} N_c \\ &= \frac{\sqrt{2a}}{\rho r C_2} x f(x) - \frac{\sqrt{2a}}{\rho r C_2} \left( 1 + \frac{C_2}{C_1} \right) x^2 - \frac{\sqrt{2a}}{\rho r C_2} xz \\ & \quad - \frac{\sqrt{2a}}{\rho r C_2} y f(x) + \frac{\sqrt{2a}}{\rho r C_2} xy + \frac{\sqrt{2a}}{\rho} \left( \frac{1}{r C_2} - \frac{R}{L} \right) yz \\ & \quad + \frac{1}{r C_2} f(x) - \frac{1}{r C_2} x - \frac{1}{r C_2} z - \frac{\sqrt{2a} R}{\rho L} z^2 \\ & \quad + \frac{R}{L} (y + z). \end{aligned}$$

From (4-2) and (4-3) it follows that

$$(4-7) \quad z = \frac{a\rho \pm \rho \sqrt{1 - a^2 - \frac{x^2}{\rho^2}}}{\sqrt{2}}$$

$$(4-8) \quad y = \frac{a\rho \mp \rho \sqrt{1 - a^2 - \frac{x^2}{\rho^2}}}{\sqrt{2}}$$

where the signs before the radicals must be opposite when the relations are used simultaneously. Using these to substitute for  $y$  and  $z$  in (4-6) and making one

substitution  $x = \rho w$ , we have

$$\begin{aligned}
 \sqrt{2 - 2a^2} N_c &= \frac{1-a^2}{RC_2} f(\rho w) + \frac{\sqrt{2}a}{rC_2} wf(\rho w) \\
 &\pm \frac{a}{RC_2} f(\rho w) \sqrt{1-a^2-w^2} \\
 &+ \rho\sqrt{2} a(1-a^2) \left( \frac{R}{L} - \frac{1}{RC_2} \right) \\
 (4-9) \quad &- \rho \left( \frac{a^2}{rC_2} + \frac{1-a^2}{RC_2} \right) w \mp \rho \left( \frac{a}{rC_2} + \frac{a}{RC_2} \right) w \sqrt{1-a^2-w^2} \\
 &\mp \rho \left( \frac{\sqrt{2}a^2 R}{L} + \frac{1}{\sqrt{2} RC_2} \right) \sqrt{1-a^2-w^2} \\
 &+ \rho \left( \frac{a}{\sqrt{2}RC_2} - \frac{\sqrt{2}a}{rC_2} - \frac{\sqrt{2}a}{rC_1} \right) w^2
 \end{aligned}$$

where  $w^2 \leq 1-a^2$ . The only term which is independent of  $w$  and does not vanish for some value of  $w$  is the third line of the right member. If we want  $N_c > 0$  so that the vectors point into the region it is easily seen that this constant term must be positive. That is we must have

$$(4-10) \quad \frac{R}{L} > \frac{1}{RC_2} .$$

On the other hand  $\frac{R}{L}$  can be made sufficiently large so that  $N_c > 0$  for any particular  $a$  in

$$(4-11) \quad 0 < a^2 < \frac{1}{2} .$$

So it remains to determine a lower bound for  $\frac{R}{L}$  to insure  $N_c > 0$ .

If  $\rho$  is sufficiently large the terms in the first line will play no role in determining the lower bound

$\frac{R}{L}$ . When  $\rho$  is small these terms will serve to raise the lower bound and so we shall obtain an estimate for the lower bound with  $\rho$  small. For any set of values of the parameters  $R, r, C_1, C_2$  there is a best value of  $a$  which will permit a greatest range for  $L$  while  $N_c > 0$ . In order to be able to write down explicit conditions we shall arbitrarily choose  $a = \frac{1}{2}$  at this point. Then to obtain an estimate we choose the value of  $w$  in each case which makes the term least positive or most negative, having previously selected the negative signs where possible. The result is

$$\begin{aligned}
 \frac{\sqrt{3}}{\sqrt{2} \rho} N_c &\geq \left( \frac{3\sqrt{2}}{8} - \frac{\sqrt{6}}{8} \right) \frac{R}{L} \\
 &- \frac{1}{RC_2} \left( \frac{3}{4} + \frac{\sqrt{3}}{4} \right) \frac{\sqrt{3}}{2} \sup_{-\infty < \eta < \infty} \frac{f(\eta)}{\eta} \\
 (4-12) \quad &- \left( \frac{3\sqrt{2}}{8} + \frac{3\sqrt{3}}{8} + \frac{3}{8} + \frac{\sqrt{3}}{2\sqrt{2}} \right) \frac{1}{RC_2} \\
 &- \left( \frac{\sqrt{3}}{8} + \frac{3}{8} + \frac{3\sqrt{2}}{8} \right) \frac{1}{rC_2} \\
 &- \frac{3\sqrt{2}}{8} \frac{1}{rC_1}
 \end{aligned}$$

where  $\eta$  is defined by  $\eta = \rho w$ . We recall that by (2-7)

$$(4-13) \quad \frac{f(\eta)}{\eta} = \frac{(I_S r \eta)}{I_S \eta}$$

Therefore by (2-9)

$$(4-14) \quad \sup_{-\infty < \eta < \infty} \frac{f(\eta)}{\eta} \geq g_m r$$

where equality holds only if the incremental transconductance is never greater than the working-point transconductance. Let us assume, as represented by the dotted line in Figure 2, that the supremum of all incremental transconductances is  $s$  times the working-point transconductance. Then

$$(4-15) \quad \sup_{-\infty < \eta < \infty} \frac{f(\eta)}{\eta} = s \epsilon_m r \quad \text{where } s \geq 1 .$$

Then for  $N_c > 0$ , so that the vectors point into the region, a sufficient condition is

$$(4-16) \quad \frac{R}{L} > \frac{4.6}{RC_2} s \epsilon_m r + \frac{9.7}{RC_2} + \frac{5.0}{rC_2} + \frac{2.4}{rC_1} .$$

When  $a = -\frac{1}{2}$  we want  $N_c < 0$ . By obvious modifications in the argument the same condition (4-16) is obtained.

## 2. Outer Radial Boundary

Consider the family of closed surfaces about the origin

$$(4-17) \quad p = C_2 R^2 y^2 + C_1 (Ry + rx)^2 + Lz^2$$

where the value of  $p$  determines a particular surface of the family. For any  $p$  this surface serves to limit the region between the two lateral boundary cones. We shall show that if  $p$  is sufficiently large then the part of the surface used, the part lying between the two lateral boundary cones, has the property that the vector field of (2-10) at every point points toward the interior. We were led to the surface (4-17) by energy considerations in the circuit of Figure 1. The parameter  $p$  is proportional to the energy stored in the circuit at any time  $t$ .

A n.a.s.c. that the vector at any point of the

surface (4-17) points toward the interior is

$$(4-18) \quad \dot{p} < 0 .$$

$$(4-19) \quad \frac{\dot{p}}{2} = C_2 R^2 \dot{y} \dot{y} + C_1 (R \dot{y} + r \dot{x}) (R \dot{y} + r \dot{z}) + L \dot{z} \dot{z} .$$

Substituting for the derivatives from (2-10), we have

$$(4-20) \quad \frac{\dot{p}}{2} = - R y f(x) - r x^2 - R z^2 .$$

Therefore the condition (4-18) that the vectors point toward the interior amounts to

$$(4-21) \quad r x^2 + R z^2 > - R y f(x) .$$

A stronger condition insuring this is, since  $f^2(x) < 1$ ,

$$(4-22) \quad r x^2 + R z^2 > R |y| .$$

This inequality is satisfied by all points lying outside the two paraboloids

$$(4-23) \quad r x^2 + R z^2 = R |y|$$

with vertices at the origin and axes along the  $y$ -axis.

The region outside the paraboloids where  $\dot{p} < 0$  leaves the  $y$ -axis like  $\sqrt{y}$  while the region between the two lateral boundary cones leaves the  $y$ -axis like  $y$ . Therefore it is only necessary to choose  $p$  large enough so that the portion of the outer radial boundary lying between the two lateral boundary cones is outside of the paraboloids (4-23) so that  $\dot{p} < 0$  and the vectors point toward the interior at all points.

We have now established a stable bounded closed region in the phase space. Its thickness becomes zero at the origin, but it does contain the singular point at the origin and it is necessary to remove a neighborhood of the origin before we can complete the existence proof for a periodic solution.

### 3. Inner Radial Boundary

Before we can use the Brouwer fixed point theorem to establish the existence of a periodic solution in the stable region we must remove the known fixed point at the origin. Otherwise, as will be seen, the results of our labor will be merely to establish the existence of the fixed point at the origin.

There is no possibility of establishing the inner radial boundary by defining a closed surface about the origin at all points of which the vector field points outward. For since  $\lambda_1 < 0$  in (3-8) there are always two paths approaching the origin. At the origin they are tangent to the straight line in the principal direction of  $\lambda_1$ . However it appears that we should be able to construct a cylinder around the straight line through the origin in the principal direction of  $\lambda_1$  such that sufficiently near the origin the vector field at each point of the cylinder points away from the interior. Then if the principal direction lies outside of the solid angle between the lateral boundary cones, the cylinder will serve to put a hole through the stable region in such a manner that a neighborhood of the origin is removed and the remaining region is still stable and now topologically equivalent to a torus.

We first prove that the principal direction of  $\lambda_1$  lies outside the solid angle between the lateral boundary cones. Since by the assumption  $a = \pm \frac{1}{2}$  the generator of the cones makes an angle of  $\frac{\pi}{3}$  with the line  $y = z, x = 0$  it is only necessary to show that the angle between the principal direction of  $\lambda_1$  and the line  $y = z, x = 0$  is less than  $\frac{\pi}{3}$ . Now the

direction cosines of the line  $y = z$ ,  $x = 0$  are

$$(4-24) \quad X = 0, \quad Y = \frac{1}{\sqrt{2}}, \quad Z = \frac{1}{\sqrt{2}}.$$

We recall from (3-26) that the direction cosines of the principal direction of  $\lambda_1$  are

$$(3-26) \quad X = \frac{1}{\sqrt{1 + \alpha^2(1 + \beta^2)}},$$

$$Y = \frac{-\alpha\beta}{\sqrt{1 + \alpha^2(1 + \beta^2)}};$$

$$Z = \frac{\alpha}{\sqrt{1 + \alpha^2(1 + \beta^2)}}.$$

Therefore the cosine  $b$  of the angle between them is

$$(4-25) \quad b = \frac{1}{\sqrt{2}} \frac{\alpha(1 - \beta)}{\sqrt{1 + \alpha^2(1 + \beta^2)}}$$

where from (3-24) and (3-25)

$$(3-24) \quad \alpha = g_m r - \left(1 + \frac{C_2}{C_1}\right) - rC_2\lambda_1$$

$$(3-25) \quad \beta = 1 + \frac{L}{R} \lambda_1.$$

Thus to prove  $b > \frac{1}{2}$  we must establish an estimate for  $\lambda_1$ . To this end let us write the cubic (3-5) in the form

$$(4-26) \quad S(\lambda) = [LC_2 r] \lambda^3 + \left[ RC_2 r + L \left(1 + \frac{C_2}{C_1}\right) - Lg_m r \right] \lambda^2$$

$$+ \left[ r + R \left(1 + \frac{C_2}{C_1}\right) - Rg_m r \right] \lambda + \frac{1}{C_1}$$

where  $\lambda_1, \lambda_2,$  and  $\lambda_3$  are solutions of  $S(\lambda) = 0$ .

Now

$$(4-27) \quad S\left(-\frac{R}{L}\right) = -\frac{Rr}{L} + \frac{1}{C_1}$$

By (4-16)  $\frac{R}{L} > \frac{1}{rC_1}$  so that

$$(4-28) \quad S\left(-\frac{R}{L}\right) < 0$$

independently of  $g_m$ . Now by (3-16) when  $g_m = G, \lambda_1$  is the only real root. In this case  $S(\lambda) < 0$  means  $\lambda < \lambda_1$ . Since  $\lambda_1$  is a continuous function of the coefficients of the cubic we conclude from (4-28) that

$$(4-29) \quad -\frac{R}{L} < \lambda_1$$

Let  $0 < k < 1$ .

$$S\left(-\frac{kR}{L}\right) = k^2(1-k)\frac{R^3C_2r}{L^2} + k(1-k)\frac{R^2}{L}\left[g_m r - \left(1 + \frac{C_2}{C_1}\right)\right]$$

(4-30)

$$-k\frac{Rr}{L} + \frac{1}{C_1}$$

Now

$$(4-31) \quad g_m r - \left(1 + \frac{C_2}{C_1}\right) > 0$$

for by (3-16)

$$(4-32) \quad g_m r - \left(1 + \frac{C_2}{C_1}\right) > \frac{r}{2R} + \frac{RrC_2}{2L} - \sqrt{\left(\frac{r}{2R} - \frac{RrC_2}{2L}\right)^2 + \frac{rC_2}{RC_1}}$$

and the right member is positive if  $\frac{R}{L} > \frac{1}{rC_1}$  which is assured by (4-16).

Therefore by (4-30) it is sufficient for

$$(4-33) \quad S\left(-\frac{kR}{L}\right) > 0$$

that

$$(4-34) \quad k^2(1-k) \frac{R^3 C_2 r}{L^2} > k \frac{Rr}{L}$$

Multiplying by  $\frac{L}{kR^2 r C_2}$  gives the condition

$$(4-35) \quad k(1-k) \frac{R}{L} > \frac{1}{RC_2} .$$

Now by (4-16)

$$(4-36) \quad \frac{R}{L} > \frac{9.7}{RC_2}$$

so the largest value of  $k$  is determined by

$$(4-37) \quad k(1-k) = \frac{1}{9.7} .$$

This gives  $k = 0.876$  so

$$(4-38) \quad S\left(-\frac{0.876R}{L}\right) > 0$$

from which it follows that

$$(4-39) \quad \lambda_1 < -0.876 \frac{R}{L} .$$

This together with (4-29) gives

$$-\frac{R}{L} < \lambda_1 < -0.876 \frac{R}{L}$$

Applying this to (3-24) and (3-25), using (4-16), gives

$$(4-40) \quad \alpha > 4.38$$

$$(4-41) \quad \beta < 0.124 .$$

Substituting these conditions in (4-25) gives finally

$$(4-42) \quad b > 0.60 .$$

Thus we have proved that the principal direction of  $\lambda_1$  lies outside the solid angle between the two lateral boundary cones.

It remains to construct the cylinder and prove that at all points of the surface sufficiently close to the origin the vector field points outward. By a linear transformation of  $x, y,$  and  $z$  into  $q_1, q_2,$  and  $q_3$  the "linearized" system (3-3) can be brought into the normal form

$$(4-43a) \quad \dot{q}_1 - \lambda_1 q_1 = 0$$

$$(4-43b) \quad \dot{q}_2 - u_1 q_2 - v q_3 = 0$$

$$(4-43c) \quad \dot{q}_3 + v q_2 - u_2 q_3 = 0$$

Here the  $q_1$ -axis is along the principal direction of  $\lambda_1$  and the  $q_2$ - and  $q_3$ -axes are determined by  $\lambda_2$  and  $\lambda_3$ . When  $\lambda_2$  and  $\lambda_3$  are real then  $v = 0, u_1 = \lambda_2$  and  $u_2 = \lambda_3$ . When  $\lambda_2$  and  $\lambda_3$  are complex conjugates then  $u_1 = u_2 = u$  as in (3-8). The condition (3-16) gives

$$(4-44) \quad u_1 > 0, u_2 > 0$$

Of course the linear transformation depends on the parameters in (3-3).

The nonlinear system (2-10) can be written

$$(4-45a) \quad \dot{x} = \frac{1}{rC_2} \left[ \left( rg_m^{-1} - \frac{C_2}{C_1} \right) x - z \right] + \frac{1}{rC_2} (f(x) - rg_m x)$$

$$(4-45b) \quad \dot{y} = -\frac{1}{RC_2} [(rg_m^{-1} - 1)x - z] - \frac{1}{RC_2} (f(x) - rg_m x)$$

$$(4-45c) \quad \dot{z} = -\frac{R}{L} [y + z]$$

If we now apply the same linear transformation to the nonlinear system (4-45) then we have

$$(4-46a) \quad \dot{q}_1 - \lambda_1 q_1 = c_1 S(x)$$

$$(4-46b) \quad \dot{q}_2 - u_1 q_2 - v q_3 = c_2 S(x)$$

$$(4-46c) \quad \dot{q}_3 + v q_2 - u_2 q_3 = c_3 S(x)$$

where

$$(4-47) \quad S(x) = f(x) - rg_{\mathbb{S}^m} x .$$

By (2-8) and (2-9) we have

$$(4-48) \quad S(0) = S'(0) = 0 .$$

This means that  $\frac{S(x)}{x}$  approaches zero with  $x$ .

Let the equation of the cylinder be

$$(4-49) \quad 0 < K = q_2^2 + q_3^2 .$$

The normal component of the vector field of (2-10), that is of (4-46), will be in the outward direction if and only if  $\dot{K} > 0$ .

$$(4-50) \quad \frac{\dot{K}}{2} = q_2 \dot{q}_2 + q_3 \dot{q}_3 .$$

Substituting for the derivatives from (4-46) gives

$$(4-51) \quad \frac{\dot{K}}{2} = u_1 q_2^2 + u_2 q_3^2 + (c_2 q_2 + c_3 q_3) S(x) .$$

Since  $\frac{S(x)}{x} \rightarrow 0$  with  $x$ , near the origin  $\dot{K} > 0$  and we can always take  $K$  small enough so that the part of the cylinder inside the lateral boundary cones is sufficiently near the origin.

Thus the inner radial boundary is established.

#### 4. The Mapping

We have now established a stable closed region containing no singular points and topologically equivalent to a solid torus. The cross section for  $x = 0$  appears in Figure 4. The section  $S_1$  is a closed simply connected two dimensional region. We shall show

that the paths form a continuous mapping of  $S_1$  into itself. That is, all of the paths inside the torus circulate around it without "getting lost". We have already established in the preceding sections of this Part that no path can leave the torus.

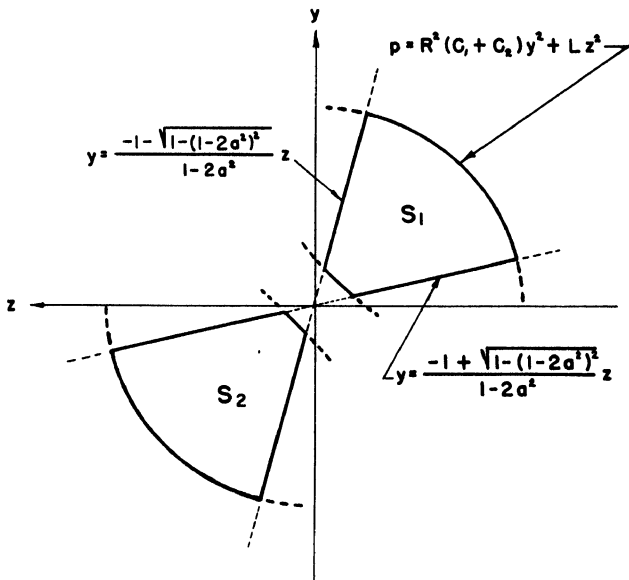

FIG. 4

Consider that path through any point of  $S_1$ . By

$$(2-10a) \quad \dot{x} = \frac{1}{rC_2} \left[ f(x) - \left( 1 + \frac{C_2}{C_1} \right) x - z \right]$$

that path will travel in the positive  $x$ -direction for a finite distance since  $z$  is negative and has a negative upper bound in  $S_1$ . For the same reason the path cannot return to  $S_1$  from the positive  $x$ -direction. However the path does in fact cross  $x = 0$  or at least approaches arbitrarily close to  $x = 0$ . In order to see this, multiply (2-10a) by  $r$  and (2-10b) by  $R$  and add to obtain

$$(4-52) \quad r\dot{x} + R\dot{y} = -\frac{1}{C_1} x .$$

Integration from a point  $(0, y_0, z_0)$  in  $S_1$  at time  $t_0$  to a point  $(x, y, z)$  at time  $t$  gives

$$(4-53) \quad rx + R(y - y_0) = -\frac{1}{C_1} \int_{t_0}^t x \, dt .$$

Since  $x$  and  $y$  are bounded the integral in the right member is bounded so that if  $x$  does not become negative it must become (although not necessarily remain) arbitrarily small after a sufficiently long time. Now since the path cannot return arbitrarily close to  $S_1$  for  $x > 0$  it must approach arbitrarily close to  $S_2$ . However this means it actually reaches  $S_2$  in a finite length of time since by (2-10a)  $\dot{x}$  is negative for at least a small distance from  $S_2$ .

By a similar argument the path can be shown to proceed from  $S_2$  to  $S_1$  with  $x \leq 0$ . We remark that (4-53) does not prevent  $x$  from momentarily becoming large from time to time. This would not interfere with the mapping. The mapping of  $S_1$  into  $S_1$  thus established is continuous since the right member of (2-10) is continuous and without singular points in the stable closed region through which the paths must travel. The famous fixed point theorem of Brouwer states that a continuous mapping of a closed simply connected region into itself has at least one fixed point. Therefore the mapping of  $S_1$  into itself has at least one fixed point. This means there is at least one path which is closed on itself after circulating around the torus once. That is, our system (2-10) possesses at least one periodic solution.

A review of the above proof of the existence of

a periodic solution shows that we require only of  $f(x)$  that  $f'(0)$  exist and be within proper bounds and that  $f(x)$  be continuous and bounded above and below. Thus the right member of (2-10) may not satisfy the Lipschitz condition for certain values of  $x$ . In this case the continuous mapping of  $S_1$  into itself may not be one-one, but this does not affect the Brouwer fixed point theorem and the existence of a periodic solution.

5. Parameters of the Third Order Equation

It can be seen that the equation

$$(4-54) \quad LC_2 r \ddot{x} + \left[ RC_2 r + L \left( 1 + \frac{C_2}{C_1} \right) - Lf'(x) \right] \dot{x} - Lf''(x) \dot{x}^2 + \left[ r + R \left( 1 + \frac{C_2}{C_1} \right) - Rf'(x) \right] \dot{x} + \frac{1}{C_1} x = 0$$

has only three independent parameters by writing it in the form

$$(4-55) \quad k_1 \ddot{x} + [k_2 + k_3 g(x)] \dot{x} + k_3 g'(x) \dot{x}^2 + g(x) \dot{x} + x = 0,$$

as in the Introduction , Summary, where

$$(4-56a) \quad g(x) = rC_1 + R(C_1 + C_2) - RC_1 f'(x)$$

$$(4-56b) \quad k_3 = \frac{L}{R}$$

$$(4-56c) \quad k_2 = RC_1 C_2 r - \frac{LC_1 r}{R}$$

$$(4-56d) \quad k_1 = LC_1 C_2 r .$$

These serve to determine only three combinations of the physical parameters such as

$$(4-57) \quad \frac{L}{R} = k_3$$

$$(4-58) \quad \frac{1}{RC_2} = \frac{k_1 - k_2 k_3}{k_1 k_3}$$

$$(4-59) \quad \frac{1}{rC_1} = \frac{k_3^2}{k_1 - k_2 k_3}$$

while two other combinations may be defined arbitrarily as

$$(4-60) \quad \frac{C_2}{C_1} = m_1$$

$$(4-61) \quad R = m_2 .$$

The condition (3-16) for spontaneous oscillations (unstable singular point) becomes

$$(4-62) \quad g(0) < -\frac{k_2}{2k_3} + \sqrt{\frac{k_2^2}{4k_3^2} + \frac{k_1}{k_3}} .$$

We note that

$$(4-63) \quad \frac{1}{RC_1} = m_1 \frac{k_1 - k_2 k_3}{k_1 k_3}$$

$$(4-64) \quad \frac{r}{R} = m_1 \frac{(k_1 - k_2 k_3)^2}{k_1 k_3^3}$$

$$(4-65) \quad \frac{1}{rC_2} = \frac{1}{m_1} \cdot \frac{k_3^2}{k_1 - k_2 k_3} .$$

Therefore

$$(4-66) \quad f(x) = \left[ m_1 \frac{(k_1 - k_2 k_3)^2}{k_1 k_3^3} + m_1 + 1 \right] x \\ - m_1 \frac{k_1 - k_2 k_3}{k_1 k_3} \int_0^x g(x) dx$$

where  $f(x)$  must satisfy the condition that it be

bounded above and below.

Now since  $f'(0) = g_m$  the condition (4-16) insuring the existence of the lateral boundary surfaces (and therefore of the stable region) becomes

$$(4-67) \quad 1 > 4.6 \frac{k_1 - k_2 k_3}{k_1} \sup_{-\infty < x < \infty} \frac{f(x)}{x} + 9.7 \frac{k_1 - k_2 k_3}{k_1} \\ + \frac{5.0}{m_1} \frac{k_3^3}{k_1 - k_2 k_3} + 2.4 \frac{k_3^3}{k_1 - k_2 k_3} .$$

The relations (4-62), (4-66), and (4-67) give rise to the theorem stated in the Introduction ,  
Summary.

#### PART V. OTHER IN-THE-LARGE PROPERTIES OF SOLUTIONS

It is difficult to say anything about the stability in-the-small of the periodic solutions or whether there is a unique periodic solution. However we can prove that after a long enough time any solution cannot be too far from the periodic solutions whose existence we have proved in Part IV. That is, every path eventually enters the stable region of the solid torus or else approaches the origin. If (3-16) is satisfied, that is we have condition (3-8c) or (3-8d) there can be only two paths which approach the origin (if a Lipschitz condition is satisfied). These are the two paths which in the "linearized" case approach the singular point at the origin from opposite directions along the principal axis corresponding to the real negative characteristic root  $\lambda_1$ .

As a matter of fact we prove considerably more.

With the exception of the singular paths approaching the origin the path through any point must cross to the other side of the plane  $y + z = 0$ . Of course this means that the paths must oscillate back and forth from one side of the plane to the other indefinitely or until they approach the origin. Thus the paths certainly enter the region between the lateral boundary cones.

Let us pick a point to the left of the plane  $y + z = 0$  in Figure 3 and assume that the path through it does not cross the plane. Thus by (2-10c)  $\dot{z} \leq 0$ . Now either there exists  $P < 1$  such that

$$(5-1) \quad \frac{\dot{y}}{-\dot{z}} < P$$

at all times after some particular time or else

$$(5-2) \quad \frac{\dot{y}}{-\dot{z}} \geq \frac{1}{2}$$

at least some of the time after any time. Let us assume (5-1) is true. Then the point must lie to the right of the plane determined by the initial point and the slope

$$(5-3) \quad \frac{\dot{y}}{-\dot{z}} = P$$

and to the left of the plane  $y + z = 0$ . These two planes intersect in a line parallel to the  $x$ -axis with a finite value of  $y$ , say  $y_1$ . Now the point must move to the right ( $\dot{z} < 0$ ) as long as it is to the left of the plane  $y + z = 0$ . The path must approach some line parallel to the  $x$ -axis and in the plane  $y + z = 0$ . For if it does not do this for some smaller  $y$  it must certainly do so for  $y = y_1$ . Thus

$$(5-4) \quad \dot{z} \rightarrow 0$$

and  $z$  approaches some constant, say  $z_1$ . In the limit we have, by (2-10a),

$$(5-5) \quad \dot{x} = \frac{1}{RC_2} \left[ f(x) - \left( 1 + \frac{C_2}{C_1} \right) x - z_1 \right].$$

Since  $f^2(x) \leq 1$  it is clear that  $x < 0$  for  $x$  large and positive and  $x > 0$  for  $x$  large and negative. So the path cannot go to infinity in the  $x$ -direction. Moreover it cannot oscillate in the  $x$ -direction since (5-5) defines  $\dot{x}$  as a single-valued function of  $x$ . Therefore  $x$  must approach a limit and by (5-5)  $\dot{x}$  approaches a limit which must be zero

$$(5-6) \quad \dot{x} \rightarrow 0.$$

In the limit we have, by (2-10b),

$$(5-7) \quad \dot{y} = -\frac{1}{RC_2} [f(x) - x - z_1].$$

Therefore  $\dot{y}$  approaches a limit which must be

$$(5-8) \quad \dot{y} \rightarrow 0$$

since we have already noted that  $y$  approaches a limit. As a result of (5-4), (5-6), and (5-8) the phase velocity approaches zero. Therefore the path must be approaching the unique singular point at the origin.

Still assuming that the path does not cross to the right of the plane  $y + z = 0$  let us consider the only remaining alternative, namely, that (5-2) holds at least some of the time after any time. It is only necessary to consider  $z < 0$  for if the path does not move into the region where  $z < 0$  then the previous argument can be applied to show that the path approaches

the origin. Moreover it follows that  $z$  becomes negative without limit and  $y$  becomes positive without limit.

Substituting in (5-2) from (2-10b) and (2-10c) provides the result

$$(5-9) \quad -\frac{L}{R^2 C_2} \frac{f(x) - x - z}{y + z} \geq \frac{1}{2},$$

and since  $y + z \geq 0$  we must have

$$(5-10) \quad f(x) - x - z \leq 0.$$

Since  $z$  becomes arbitrarily large negative and  $f^2(x) < 1$  this means that

$$(5-11) \quad \frac{x}{-z} \geq 1 - \epsilon_1$$

where  $\epsilon_1$  is arbitrarily small positive. We recall that by our assumption (5-11) is true at least some of the time after any time.

Now during at least some of the time that (5-11) is true

$$(5-12) \quad \frac{x}{-z} \geq 1 - \epsilon_1 - \epsilon_2$$

where  $\epsilon_2$  is arbitrarily small positive. This can be seen by realizing that (5-11) requires that the path is not on a certain side of the plane  $x + (1 - \epsilon_1)z = 0$  at least some time after any time. In case (5-11) holds all of the time it is clear that (5-12) must hold some of the time. In case (5-11) does not hold at some time there will be a later time when it just becomes true as the path crosses the plane  $x + (1 - \epsilon_1)z = 0$ . Just at this time (5-12) must be true.

Substituting for the derivatives in (5-12) by means of (2-10a) and (2-10c) gives

$$(5-13) \quad \frac{L}{RC_2 r} \frac{f(x) - \left(1 + \frac{C_2}{C_1}\right) x - z}{y + z}$$

$$\geq 1 - \epsilon_1 - \epsilon_2 > 0 .$$

The denominator is non-negative. However since  $\frac{C_2}{C_1} > 0$  then after a long enough time  $z$  will become so large and negative that as a result of (5-11) the numerator will be negative. Thus a contradiction is established. This means that if the path does not cross the plane  $y + z = 0$  it must approach the origin. A similar argument gives the same result if we start from the right side of the plane  $y + z = 0$ .

Once the path is between the two lateral boundary cones it will come in until it is inside the outer radial boundary.

It is easy to see that the stable solid torus is not enough topology to say anything about uniqueness of periodic solutions or in-the-small stability. Choose a toroidal coordinate system with variables  $r, \theta, \varphi$  where  $r$  is the distance from the circular center line,  $\theta$  is the angle along the center line, and  $\varphi$  is the angle around the center line. Let  $\dot{\theta} = \Omega$  and  $\dot{\varphi} = \omega$  where  $\Omega \geq \omega$ . If  $\dot{r} = -r$  we have a stable periodic solution along the center line. If  $\frac{\dot{r}}{r} = 1 - r$  and  $\Omega = n\omega$  we have an unstable periodic solution on the center line and a stable periodic solution on the torus  $r = 1$  which requires  $n$  revolutions before completing one period. If  $\frac{\Omega}{\omega}$  is irrational the stable solution on the torus is not periodic.

## PART VI. UPPER LIMIT ON MAGNITUDE OF OSCILLATIONS

In this Part we shall point out how the value of the parameter  $p$  in the equation (4-17) of the outer radial boundary can be determined. Then in any particular case bounds can be established upon the variables  $x$ ,  $y$ , and  $z$  and therefore on the physical variables  $i$ ,  $e$ , and  $i_L$ .

The paraboloids of (4-22) will intersect the lateral boundary cones in closed curves passing through the origin. The outer radial boundary of (4-17) will intersect the lateral boundary cones in closed curves around the origin. It is necessary to determine  $p$  in (4-17) just large enough so that on each lateral boundary cone the closed curve from the intersection of (4-17) just contains the closed curve from the intersection of (4-22).

Consider for the moment the upper left cone. Construct a coordinate system on the cone by

$$(6-1) \quad x = \rho \sqrt{1 - a^2} \sin \theta$$

$$(6-2) \quad y = \rho \sqrt{\frac{1 - a^2}{2}} \cos \theta + \frac{a}{\sqrt{2}}$$

$$(6-3) \quad z = -\rho \sqrt{\frac{1 - a^2}{2}} \cos \theta + \frac{a}{\sqrt{2}}$$

where  $\rho$  is the distance from the vertex of the cone at the origin and  $\theta$  is the angle between the plane  $x = 0$  and the plane determined by the point in question and the line  $y = z$ ,  $x = 0$ . The equation of the intersection of the paraboloid is

$$(6-4) \rho_p = \left| \frac{R\sqrt{1-a^2} \cos \theta + \frac{Ra}{\sqrt{2}}}{r(1-a^2)\sin^2\theta + \frac{R}{2}(1-a^2)\cos^2\theta - Ra\sqrt{1-a^2}\cos \theta + \frac{Ra^2}{2}} \right|.$$

The equation of the intersection of the outer radial boundary is

$$(6-5) \begin{aligned} \frac{D}{\rho_o^2} = & (C_1R^2 + C_2R^2 + L)\frac{1-a^2}{2} \cos^2\theta + (C_1R^2 + C_2R^2 - L)a\sqrt{1-a^2}\cos \theta \\ & + C_1r^2(1-a^2)\sin^2\theta + 2C_1Rra\sqrt{\frac{1-a^2}{2}} \sin \theta \\ & + 2C_1Rr \frac{1-a^2}{\sqrt{2}} \sin \theta \cos \theta + (C_1R^2 + C_2R^2) \frac{a^2}{2} + \frac{La^2}{2}. \end{aligned}$$

It is necessary to determine  $\rho$  just large enough so that

$$(6-6) \rho_o > \rho_p$$

for all  $\theta$ . Then the stable region will be explicitly determined and the upper bounds on the absolute value of the variables can be determined.

### PART VII. NONLINEAR CIRCUIT PARAMETERS

When deriving the system (2-10) from the circuit of Figure 1 it was not necessary to differentiate directly any term containing the parameters  $C_1$ ,  $C_2$ ,  $R$ , or  $L$ . This means that the system (2-10) holds without change in form when the parameters are functions of the respective variables, namely,  $C_1(x)$ ,  $C_2(y)$ ,  $R(z)$ , and  $L(z)$ . We then write

$$(7-1a) \quad \dot{x} = \frac{1}{rC_2(y)} \left[ f(x) - \left( 1 + \frac{C_2(y)}{C_1(x)} \right) x - z \right]$$

$$(7-1b) \quad \dot{y} = - \frac{1}{R(z)C_2(y)} [f(x) - x - z]$$

$$(7-1c) \quad \dot{z} = - \frac{R(z)}{L(z)} [y + z] .$$

The proof of the existence of a periodic solution given in Part IV will still go through provided  $C_1(x)$ ,  $C_2(y)$ ,  $R(z)$ , and  $L(z)$  are bounded above and below by positive constants in such a manner that the inequalities (3-16) and (4-16) are satisfied.

In the case of the outer radial boundary it is necessary to replace (4-17) by a more complicated expression which is proportional to the energy stored in the circuit at any time  $t$  in terms of the variable circuit parameters. The expression (4-20) will remain unchanged in form. It is clear that the new expression for (4-17) will still define a closed surface about the origin for otherwise at least one of the physical variables could be infinite and still have only a finite energy storage in the circuit.

One case of special interest is when only the parameter  $C_1 = C_1(x)$  is a nonlinear function of the variable. In this case we obtain the third-order equation

$$(7-2) \quad LC_2 r \ddot{x} + [RrC_2 + L - Lq'(x)]\dot{x} - Lq''(x)x^2 \\ + [r + R - Rq'(x)]\dot{x} + \frac{x}{C_1(x)} = 0.$$

If we define

$$(7-3) \quad g(x) = r + R - Rq'(x)$$

$$(7-4) \quad h(x) = \frac{x}{C_1(x)}$$

then (7-2) becomes

$$(7-5) \quad K_1 \ddot{\ddot{x}} + (K_2 + K_3 g(x)) \ddot{x} + K_3 g'(x) \dot{x}^2 + g(x) \dot{x} + h(x) = 0.$$

As pointed out in the Introduction, Summary the special case for  $k_1 = k_3 = 0$  and  $k_2 = 1$  ( $L = 0$  and  $RrC_2 = 1$  in (7-2))

$$(7-6) \quad \ddot{x} + g(x)\dot{x} + h(x) = 0$$

is the well-known generalization of Liénard's equation to the case of a nonlinear spring constant.

#### APPENDIX: DIFFERENTIAL SYSTEM OF FRIEDRICHS

Friedrichs [4] has considered the oscillations of the circuit shown in Figure 5. Unlike the circuit considered in this dissertation it is assumed that the anode current  $i_a$  of the vacuum tube is a function of a weighted average of the grid and anode voltages

$$(1) \quad i_a = \varphi\left(e_g + \frac{e_a}{\mu}\right)$$

where the amplification factor  $\mu$  is finite and positive. In addition to this we have the following relations from the circuit

$$(2) \quad e_a = -L_a \dot{i}_a - M \dot{i}_L$$

$$(3) \quad e_g = M \dot{i}_a + L_g \dot{i}_L$$

$$(4) \quad e_g = r i_r$$

$$(5) \quad e_g = \int^t \frac{i_C}{C} dt$$

$$(6) \quad i_C + i_r + i_L = 0 .$$

This is a third order system and we wish to obtain a single third order equation in some variable which is physically equivalent to the variable  $x$  (which is

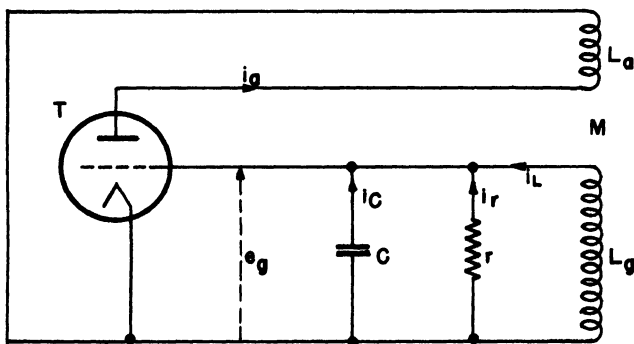

FIG. 5

proportional to the grid voltage  $e_g$ ) of equation (2-11) in Part II. The physically equivalent variable in this case would have to be the argument  $e_g + \frac{e_a}{\mu}$  of the nonlinear function. This is called the effective grid voltage. We define

$$(7) \quad v = e_g + \frac{e_a}{\mu}$$

and eliminate  $e_a$  from the equations (1) through (6). This gives, in place of (1) and (2),

$$(8) \quad i_a = \phi(v)$$

$$(9) \quad \mu (v - e_g) = -L_a \dot{i}_a - M \dot{i}_L .$$

We eliminate all variables except  $v$  and obtain

$$\begin{aligned}
 (10) \quad & \left[ \frac{C}{\mu} (L_a L_g - M^2) \varphi'(v) \right] \ddot{v} + \left[ \frac{1}{\mu r} (L_a L_g - M^2) \varphi'(v) + L_g C \right] \dot{v} \\
 & + \left[ \frac{3C}{\mu} (L_a L_g - M^2) \varphi''(v) \right] \dot{v} \dot{v} + \left[ \frac{1}{\mu r} (L_a L_g - M^2) \varphi''(v) \right] \dot{v}^2 \\
 & + \left[ \frac{C}{\mu} (L_a L_g - M^2) \varphi(v) \right] \dot{v}^3 \\
 & + \left[ \frac{1}{\mu L_g} (L_a L_g - M^2) \varphi'(v) + \frac{L_g}{r} - \left( M - \frac{M^2}{\mu L_g} \right) \varphi'(v) \right] \dot{v} + v = 0.
 \end{aligned}$$

This single third-order equation is quite different from equation (2-11) of Part II.

Note that if the anode current  $i_a$  is made a function of  $e_g$  only, as in this dissertation, by letting  $\mu \rightarrow \infty$  the equation (10) of Friedrichs becomes

$$[L_g C] \ddot{v} + \left[ \frac{L_g}{r} - M \varphi'(v) \right] \dot{v} + v = 0$$

which is no longer of the third order. That is, if the tube in Friedrichs' circuit is assumed to be of the pentode type, as in this dissertation, then the system reduces to one of the second order.

#### REFERENCES

- [1] A. Liénard, Étude des Oscillations entretenues, Revue Générale de l'électricité, vol. 23, pp. 901-946; 1928.
- [2] B. Van der Pol, On Relaxation Oscillations, Philosophical Magazine, 7th series, vol. 2; Nov. 1926.
- [3] N. Levinson and O. K. Smith, A General Equation for Relaxation Oscillations, Duke Mathematical Journal, vol. 9, pp. 382-403; 1942.
- [4] K. O. Friedrichs, On Nonlinear Vibrations of Third Order, Studies in Nonlinear Vibration Theory, Institute for Mathematics and Mechanics; New York University, 1946.

- [5] S. Lefschetz, Introduction to Topology, pp. 117-119; Princeton University Press, 1949.
- [6] A. Andronow and S. Chaikin, Theory of Oscillations, pp. 37-41; Princeton University Press, 1949.
- [7] Ibid., pp. 337-340.

### III. NON-LINEAR DELAY DIFFERENTIAL EQUATIONS

By F. H. Brownell 3rd

#### Introduction

This paper concerns the oscillatory behavior of the autonomous delay differential equation

$$1.1) \sum_{k=0}^n \sum_{p=0}^r a_{k,p} x^{(k)}(t-b_p) + Q(x^{(n-1)}(t), \dots, x^{(n-1)}(t-b_1), \dots, x(t-b_r)) = 0$$

where  $Q(y_1, \dots)$  is usually a power series in the  $y_1$  with zero and first degree coefficients absent.

First we give a review of the essentially linear theory of the equation 1.1). Here the behavior at infinity of solutions of the linear part of 1.1) is characterized by the zeros of the auxiliary exponential polynomial, and the solutions are represented by a Laplace transform. Using the same representation for the inhomogeneous equation, we can apply an iteration process, in the case where these zeros have negative real parts, to show that the solution of 1.1) itself decays exponentially as  $t \rightarrow \infty$  for sufficiently small initial conditions.

---

\* This paper constituted the author's dissertation for the Ph.D. at Princeton University, 1949, and was prepared while he held an Atomic Energy Commission predoctoral fellowship for 1948-1949.

Next we consider 1.1) as the zeros of the auxiliary polynomial cross to the right of the imaginary axis under parametric variation of the  $a_{k,p}$ . Here we give up in characterizing the general solution of 1.1) for the initial condition problem, and instead look for special periodic solutions, which thus imposes boundary conditions and allows 1.1) to be transformed into an integral equation. Using the linear theory criterion for the existence of periodic solutions of the linear part of 1.1), we now use the methods of Schmidt [17]\* to prove the existence of periodic solutions of 1.1) and give asymptotic formulae for the frequency and amplitude. The results are collected in a summary at the end.

The writer here wishes to acknowledge his indebtedness to Prof. S. Lefschetz, who suggested the topic, and to Prof. D. G. Bourgin for several suggestions widening the scope of the results.

## CHAPTER I

For integer  $n \geq 1$  we consider the equation

$$1.2) \sum_{k=0}^n \sum_{p=0}^r a_{k,p} x^{(k)}(t-b_p) = g(t) \quad \text{over real } t > 0,$$

where we are given some real  $\alpha_0$  such that  $e^{-\alpha_0 t} g(t) \in L_2[0, \infty)$ . A generalization of 1.2) studied by Pitt [29], [30] is

$$1.3) \sum_{k=0}^n \int_{0 \leq h}^{\infty} x^{(k)}(t-h) d F_k(h) = g(t)$$

where  $F_k(h) = 0$  for  $h \leq 0$ ,  $F_k(h)$  is a complex function of

---

\* See the bibliography at the end.

bounded variation on every finite interval such that

$$\int_{0 < h < \infty} e^{\beta h} |d F_k(h)| < +\infty \text{ for some } \beta > 0, \text{ and where}$$

Lebesgue-Stieltjes integrals are meant in 1.3).

We always require some  $b > 0$  such that

$$1.4) F_k(h) = a_{k,0} \text{ for } 0 < h < b, 0 \leq k \leq n, \text{ and } a_{n,0} = 1.$$

$$1.5) F_n(h) = a_{n,0} = 1 \text{ for } h > 0,$$

$$\text{so } \int_{0 \leq h} x^{(n)}(t-h) dF_n(h) = x^{(n)}(t),$$

is a second condition which is sometimes imposed.

We now wish to define a solution of 1.3) for certain admissible initial conditions.

Definition 1:1)

Let  $L$  be the greatest lower bound of all real  $y$  such that  $F_k(h) = F_k(y)$  for all  $h \geq y$ ,  $k = 0, 1, \dots, n$ ,  $L = +\infty$  being allowed. If  $L > 0$ , then a complex valued function  $\phi(t)$  is said to be an admissible initial condition for 1.3) if  $\phi(t) = 0$  for  $t > 0$  or  $t < -L$ , if  $\phi^{(k)}(t)$  exists absolutely continuous over every finite subinterval of  $[-L, 0]$  for  $k = 0, 1, \dots, n-1$ , and if for any real  $\alpha > -\beta$  we have

$$1.6) \phi(t)e^{\alpha|t|} \in L_2(-L, 0) \text{ and } \phi^{(k)}(t) \in L_2(-L, 0)$$

for  $k = 1, 2, \dots, n-1$ , and including  $k = n$  if 1.5) fails.

If  $L=0$ , then an admissible initial condition is any collection of  $n$  complex constants, denoted by  $\{\phi^{(k)}(0^-)\}$ ,  $k=0, 1, \dots, n-1$ .

It should be remarked that if  $L < +\infty$  and 1.5) holds, then 1.6) is automatically satisfied by the preceding condition on  $\phi(t)$ .

## Definition 1.2)

A complex valued function  $x(t)$  on  $(-\infty, \infty)$  is said to be a solution of 1.3) for an admissible initial condition  $\phi(t)$ , or  $\{\phi^{(k)}(0^-)\}$  if  $L = 0$ , if

- a)  $x(t) = \phi(t)$  for  $t < 0$ , or  $x^{(k)}(0^+) = \phi^{(k)}(0^-)$  for  $0 \leq k \leq n-1$  if  $L = 0$ ;
- b)  $x^{(k)}(t)$  exists absolutely continuous over every finite subinterval of  $(-L, +\infty)$  for  $k = 0, 1, \dots, n-1$ .
- c)  $x^{(n)}(t)$  exists satisfying 1.3) almost everywhere in  $t > 0$ .

## Theorem 1.3)

If condition 1.4) is satisfied, then for any admissible initial condition  $\phi(t)$  there exists a unique solution  $x(t)$  of equation 1.3)

Moreover if condition 1.5) is satisfied, and if  $g(t)$  is continuous, then  $x^{(n)}(t)$  exists continuous and satisfies equation 1.3) in all  $t > 0$ .

## Proof

In equation 1.3) transpose all terms in the integrals such that  $h \geq b$  to the right side, yielding by condition 1.4) with  $b > 0$

$$1.7) \quad x^{(n)}(t) + \sum_{k=0}^{n-1} a_{k,0} x^{(k)}(t) = g_m(t)$$

over the interval  $(m-1)b < t \leq mb$ ,  $m=1, 2, \dots$ , etc., where  $g_m(t)$  is determined by induction on  $m$  from preceding intervals and the initial condition  $\phi(t)$ . Also we have  $g_m(t) \in L_1((m-1)b, mb)$  by induction; for the four monotone components of  $F_k(h)$  generate bounded Borel measures on  $(0, \infty)$ ,  $x^{(k)}(t')$  is Borel measurable and Lebesgue integrable over  $-L < t' \leq (m-1)b$  by condition 1.6) and induction from preceding intervals, and we can apply the Fubini theorem.

Thus we have our desired induction result, since equation 1.7) obviously satisfies a uniform Lipschitz condition, by modifying the classical Picard uniqueness theorem to allow  $g_m(t)$  to be merely integrable instead of continuous.

Also if 1.5) holds and  $g(t)$  is continuous, then so is  $g_m(t)$ ; hence  $x^{(n)}(t)$  exists continuous in  $t > 0$  by 1.7).

Q.E.D.

We remark that a rather wide variety of continuity conditions other than those chosen could have been imposed in the definition of an admissible initial condition, and corresponding continuity results obtained for a solution  $x(t)$ .

Lemma 1:4)

If condition 1.4) holds and  $x(t)$  is a solution of equation 1.3) for an admissible initial condition, then for  $k=0, 1, \dots, n-1$  and as  $t$  and  $T \rightarrow \infty$ ,

$$1.8) \quad |x^{(k)}(t)| = O(e^{c_1 t}) \text{ and } \int_0^T |x^{(n)}(t)| dt = O(e^{c_1 T}).$$

Proof:

We are given  $g(t)e^{-\alpha_0 t} \in L_2(0, \infty)$  in equation 1.3), so by Schwarz

$$\int_0^T |g(t)| dt \leq M \left[ \int_0^T e^{2\alpha_0 t} dt \right]^{1/2} \leq \frac{M}{\sqrt{2(|\alpha_0| + 1)}} e^{(|\alpha_0| + 1)T}$$

Thus by the argument of E. M. Wright [7], theorem 3), p.182, which can easily be generalized from equation 1.2) to equation 1.3) by using condition 1.4) with  $b > 0$ , we get the desired result 1.8).

Q. E. D.

With  $\alpha > \alpha_0$  and  $\alpha > -\beta$  for the  $\beta$  of equation 1.3), we now let  $s = \alpha + i\omega$  and

$$D(s) = \sum_{k=0}^n s^k \int_0^{\infty} e^{-sh} dF_k(h), \quad G(s) = \int_0^{\infty} g(t) e^{-st} dt,$$

$$1.9) \quad f(s) = \begin{cases} \frac{G(s)}{D(s)} + \sum_{j=0}^{n-1} \frac{\phi^{(j)}(0^-)}{s^{j+1} D(s)} \left( \sum_{k=j+1}^n s^k \int_0^{\infty} e^{-sh} dF_k(h) \right) \\ + \int_{-\infty}^0 \phi(t) e^{-st} dt \\ - \frac{1}{D(s)} \sum_{k=0}^n \int_0^{\infty} \int_{-h}^0 \phi^{(k)}(t) e^{-s(t+h)} dt \end{cases} dF_k(h)$$

Now if we take the Laplace transform of equation 1.3) at  $\alpha > \max(\alpha_0, -\beta, c_1)$ , then by integrating by parts and using 1.8) we get  $\int_{-L}^{\infty} x(t) e^{-st} dt = f(s)$ . Also  $f(s)$  is analytic in  $\alpha > \max(\alpha_0, -\beta)$  except for poles at the zeros of  $D(s)$ , since  $s^{k-1-j}$  has  $k-1-j > 0$ , and by condition 1.4) it follows easily that  $\alpha_1 = (\inf \text{ of } \alpha \text{ such that } \alpha > -\beta \text{ and } |D(s)| \geq \frac{1}{2}|s|^n \text{ over } \mathcal{R}(s) \geq \alpha) < +\infty$ . Thus by contour shifting we have the following theorem, where  $\int$  denotes  $\lim_{A \rightarrow \infty} \int_{-A}^A$ .

Theorem 1:5)

If condition 1.4) is satisfied and if  $\phi(t)$  is an admissible initial condition, then the unique solution  $x(t)$  of equation 1.3) has for all  $\alpha > \max(\alpha_0, -\beta, \alpha_1)$  that for all real  $t$

$$1.10) \quad x(t) = \frac{e^{\alpha t}}{2\pi} \int_{-\infty}^{\infty} f(\alpha + i\omega) e^{i\omega t} d\omega.$$

It should be remarked that at least for  $L < +\infty$  an alternate proof of 1.5) can be given by defining  $x(t)$  by 1.9) and 1.10) and showing conditions a), b) and c) of definition 1:2) are satisfied, (see Bellman

[10] for a special case). Similar results have also been obtained by still different methods, [6], [4]. Much early work, [1] through [5] in general, has also been done on this subject under initial order assumptions on  $x(t)$  like 1.8); Schmidt [3] gives a particularly good bibliography.

In the following theorem  $m_j$  is the multiplicity of a zero  $s_j$  of  $D(s)$ ,  $N_\alpha$  is the cardinal of the set of zeros  $\{s_j\}$  of  $D(s)$  such that  $s_j = \alpha_j + i\omega_j$  has  $\alpha_j > \alpha$  for the given  $\alpha > -\beta$ , and  $\lambda = n-1$  if condition 1.5) holds,  $\lambda = n$  otherwise. Also the  $b_{j,q}$  appearing are complex constants depending on  $\phi(t)$  but not on  $\alpha$ ,  $M_1(\alpha)$  is a positive real number independent of  $\phi(t)$ , and

$$f_0(s) = f(s) - \int_{-L}^0 \phi(t)e^{-st}dt,$$

$$f_k(s) = f_0(s) - \sum_{j=0}^{k-1} \frac{1}{s^{j+1}} \phi^{(j)}(0^-).$$

Theorem 1:6)

If condition 1.4) holds, if  $\phi(t)$  is admissible, if  $0 > \alpha > \max(\alpha_0, -\beta)$  with  $D(s) \neq 0$  for  $s = \alpha + i\omega$ , and if  $N_\alpha$  is finite and  $|\frac{1}{D(s)}| = O(\frac{1}{|s|^n})$  for large  $|s|$  with  $R(s) \geq \alpha$ , then for  $t \geq 0$  and  $k = 0, 1, \dots, n-1$

$$1.11) \quad x(t) = [ \sum_{j=1}^{N_\alpha} ( \sum_{q=0}^{m_j-1} b_{j,q} t^q ) e^{s_j t} ] + R_\alpha(t),$$

$$R_\alpha^{(k)}(t) = \frac{e^{\alpha t}}{2\pi} \int (\alpha + i\omega)^k f_k(\alpha + i\omega) e^{i\omega t} d\omega, \text{ and}$$

$$1.12) \quad |R_\alpha^{(k)}(t) - \frac{e^{\alpha t}}{2\pi} \int \frac{s^k G(s)}{D(s)} e^{i\omega t} d\omega| \leq$$

$$\leq M_1(\alpha) \left\{ \sum_{j=0}^{n-1} |\phi^{(j)}(0^-)| + \sum_{j=0}^{\lambda} [ \int_{-L}^0 |\phi^{(j)}(t)|^2 dt ]^{\frac{1}{2}} \right\}$$

In case condition 1.5) holds as well as 1.4), then for any  $\alpha > -\beta$ ,  $N_\alpha$  is necessarily finite and  $|\frac{1}{D(s)}| = O(\frac{1}{|s|^n})$  for large  $|s|$  with  $R(s) \geq \alpha$ .

Proof

First 1.11) with  $k=0$  follows at once from 1.10) by using  $|\frac{1}{D(s)}| = o(\frac{1}{|s|^n})$  to shift contours, since  $x(t) = x(t) - \phi(t)$  over  $t > 0$  and since  $f(s)$  is analytic in the right places as was used in theorem 1:5).

To verify this analyticity it is merely necessary to show  $\int_0^L \int_{-h}^0 \phi^{(k)}(t) e^{-s(t+h)} dt d F_k(h)$  analytic in

$$R(s) = \alpha > -\beta. \text{ Here } \int_{-h}^0 |\phi^{(k)}(t) e^{-s(t+h)}| dt \leq \leq e^{-\alpha h} \|\phi^{(k)}\|_{L_2} \left( \frac{\exp(2\alpha h) - 1}{2\alpha} \right)^{1/2}. \text{ Also } 0 \leq \frac{e^{2\alpha h} - 1}{2\alpha} = \sum_{v=0}^{\infty} h \frac{(2\alpha h)^v}{v+1} \leq h e^{2|\alpha|h}, \text{ so if } \alpha > -\frac{1}{3}\beta \text{ we have}$$

$$\int_0^L \frac{1}{\sqrt{h}} e^{(|\alpha| - \alpha')h} |d F_k(h)| \leq \int_0^L \frac{1}{\sqrt{h}} e^{\frac{2}{3}\beta h} |d F_k(h)| = M_k + \infty.$$

On the contrary if  $-\beta < \alpha' \leq \alpha \leq -\frac{1}{3}\beta$ ,  $\frac{e^{2\alpha h} - 1}{2\alpha} < \frac{3}{2\beta}$  and  $\int_0^L e^{-\alpha h (\frac{3}{2\beta})} |d F_k(h)| \leq (\frac{3}{2\beta}) \int_0^L e^{-\alpha' h} |d F_k(h)| =$

$M(\alpha') < +\infty$ . Thus for  $\alpha = R(s) \geq \alpha' > -\beta$ , we have  $M_0(\alpha') < +\infty$  and

$$1.13) \int_0^L \left( \int_{-h}^0 |\phi^{(k)}(t) e^{-s(t+h)}| dt \right) |d F_k(h)| \leq \leq \left| \int_{-L}^0 |\phi^{(k)}(t)|^2 dt \right|^{1/2} M_0(\alpha').$$

By the Cauchy integral and the Fubini theorem we thus get the desired analyticity.

Now  $\int_{-\infty}^0 e^{-(\alpha+i\omega)t} dt = -\frac{1}{\alpha+i\omega}$  if  $\alpha < 0$ , so thus  $\frac{e^{\alpha t}}{2\pi} \int_{-\alpha+i\omega}^{\infty+i\omega} \frac{e^{i\omega t}}{\omega} d\omega = \begin{cases} 0 & \text{if } t > 0 \\ -1 & \text{if } t < 0 \end{cases}$  and  $\frac{e^{\alpha t}}{2\pi} \int_0^{\infty} f_0(s) e^{i\omega t} d\omega = \frac{e^{\alpha t}}{2\pi} \int_{-}^{\infty} f_1(s) e^{i\omega t} d\omega$  over  $t > 0$ . Also  $(\alpha+i\omega)^k f_k(\alpha+i\omega) \in L_2(-\infty, \infty)$  over  $\omega$  for  $k \leq n-1$  and  $0 > \alpha > \max(\alpha_0, -\beta)$ ,

since 1.13) holds  $\frac{s^k}{D(s)} \in L_2(-\infty, \infty)$ ,  $G(s)$  is bounded, since

$$\left| \frac{\phi^{(j)}(0^-)}{s^{j+1}D(s)} \left( \sum_{k'=j+1}^n s^{k'} \int_0^L e^{-sh} dF_{k'}(h) \right) - \frac{\phi^{(j)}(0^-)}{s^{j+1}} \right| (s)^k =$$

$$= \frac{-s^k \phi^{(j)}(0^-)}{D(s)} \sum_{k'=0}^j s^{k'-j-1} \int_0^L e^{-sh} dF_k(h) \in L_2(-\infty, \infty) \cap L_1(-\infty, \infty),$$

and since  $k < j+1$  if the  $\phi^{(j)}(0^-)$  term in  $f_k(s)$  has not yet been subtracted out. Thus by the standard theorem on derivatives and Fourier transforms [5], we see that 1.11) holds for  $k = 1$ , and similarly for  $k = 2, 3, \dots, n-1$ .

Now to get 1.12), putting  $\varphi_k(s) = f_k(s) - \frac{G(s)}{D(s)} =$

$$f(s) - \int_{-L}^0 \phi(t) e^{-st} dt - \frac{G(s)}{D(s)} - \sum_{j=0}^{k-1} \frac{1}{s^{j+1}} \phi^{(j)}(0^-),$$

for  $k = 0, 1, \dots, n-1$  we see that all the coefficient functions of  $\phi^{(j)}(0^-)$  in the expression for  $s^k \varphi_k(s)$  are actually in  $L_1(-\infty, \infty)$  over  $\omega$  except for the term

$$\frac{s^k}{s^{k+1}} \phi^{(k)}(0^-) = \frac{1}{s} \phi^{(k)}(0^-), \text{ which can be dropped}$$

for 1.12) since  $\frac{e^{\alpha t}}{2\pi} \int \frac{e^{i\omega t}}{\alpha + i\omega} d\omega = 0$  for  $\alpha > 0$  over

$t > 0$ . For the rest of  $s^k \varphi_k(s)$  we have with  $K(t, h) =$

$$= \begin{cases} 0 & \text{if } t > h \\ 1 & \text{if } t \leq h \end{cases} \text{ that}$$

$$\int_0^L \int_{-h}^0 \phi^{(k)}(t) e^{-s(t+h)} dt dF_k(h) =$$

$$= \int_0^L \left\{ \int_0^L K(t, h) \phi^{(k)}(t-h) dF_k(h) \right\} e^{-\alpha t - i\omega t} dt$$

by 1.13) and the Fubini theorem, and is actually in  $L_2(-\infty, \infty)$  over  $\omega$ . For since  $e^{-\alpha t} \leq e^{\beta h}$  over  $0 \leq t \leq h$  by  $\alpha > -\beta$ ,

$$\begin{aligned}
 & \int_0^L \left| \int_0^L \mathbf{K}(t, h) \phi^{(k)}(t-h) dF_k(h) e^{-\alpha t} \right|^2 dt \leq \\
 1.14) & \leq \int_0^L \int_0^L \int_0^L \mathbf{K}(t, h) \mathbf{K}(t, h') |\phi^{(k)}(t-h)| |\phi^{(k)}(t-h')| e^{-2\alpha t} dt |dF_k(h)| |dF_k(h')| \\
 & \leq \left[ \int_{-L}^0 |\phi^{(k)}(t)|^2 dt \right] \left( \int_0^L e^{\beta h} |dF_k(h)| \right) \left( \int_0^L e^{\beta h'} |dF_k(h')| \right)
 \end{aligned}$$

by Schwarz and the Fubini theorem. Thus the Plancherel theorem and  $\frac{s^k}{D(s)} \in L_2(-\infty, \infty)$  for  $k \leq n-1$  yields 1.12) from 1.14) and the former  $L_1$  bound on the  $\phi^{(j)}(0^-)$  coefficients.

Q. E. D.

Now  $\int_b^\infty e^{-\alpha h} |dF_n(h)|$  is monotone in  $\alpha \geq -\beta$  and bounded by  $\int_b^\infty e^{\beta h} |dF_n(h)|$  so there always exists a

unique  $\alpha_2 < +\infty$  and  $\geq -\beta$  such that  $1 = \int_b^\infty e^{-\alpha_2 h} |dF_n(h)|$

or  $\alpha_2 = -\beta$ ; it is clear that  $\alpha_2 = -\beta$  if condition 1.5) holds. It should now be remarked that any real  $\alpha > \alpha_2$  has  $N_\alpha$  finite and  $|\frac{1}{D(s)}| = O(\frac{1}{|s|^n})$  as  $|s| \rightarrow \infty$  over  $\mathcal{R}(s) \geq \alpha$ , so that theorem 1:6) may be applied if  $\alpha_2 < 0$ .

Theorem 1:6) shows that if  $g(t) \equiv 0$ , so that we can take  $\alpha_0 = -\beta$ , and if conditions 1.4) and 1.5) hold, then the behavior of a solution  $x(t)$  of equation 1.3) as  $t \rightarrow \infty$  is completely determined by the location of the zeros of  $D(s)$ . This has been considered by Langer and others, [11] through [16], when the  $F_k(h)$  are step functions with a finite number of jumps.

We will need the following corollary for our later results.

Corollary 1:7)

If conditions 1.4) and 1.5) hold and if  $g(t) \equiv 0$ , then in order that there exist a non-constant  $x(t)$  with a continuous  $n^{\text{th}}$  derivative satisfying equation 1.3) for all real  $t$ , and such that  $x(t + \frac{2\pi}{\omega_0}) \equiv x(t)$  for some  $\omega_0 > 0$ ,

$D(im \omega_0) = 0$  for some integer  $m \neq 0$  is necessary and sufficient.

Also  $D(i(2m+1) \omega_0) = 0$  for integer  $m$  is likewise for  $x(t + \frac{\pi}{\omega_0}) \equiv -x(t)$ .

Proof

$x(t) = e^{i(m\omega_0)t}$ , or  $x(t) = e^{i(2m+1)\omega_0 t}$ , obviously yields the sufficiency. Conversely if  $x_0(t)$  is the given non-constant, periodic solution then  $x_0(t)$  is an admissible  $\phi(t)$  if  $L < +\infty$  so that 1.6) is satisfied, and hence  $x_0(t)$  is the unique solution of theorem 1:3) for  $\phi(t) = x_0(t)$  on  $(-L, 0]$ . Thus 1.11) with  $\alpha = -\frac{1}{2}\beta < 0$ , so  $R_\alpha(t) \rightarrow 0$  as  $t \rightarrow -\infty$  by 1.12), yields  $D(im \omega_0) = 0$  from  $x_0(t + \frac{2\pi}{\omega_0}) = x_0(t)$  obviously, and similarly  $D(i(2m+1)\omega_0) = 0$  from  $x_0(t + \frac{\pi}{\omega_0}) \equiv -x_0(t)$

However if  $L = +\infty$ , then 1.6) fails and  $x_0(t)$  is not admissible. However, defining for integer  $N > 0$

$$F_{k,N}(h) = \sum_{j=1}^N \left\{ F_k \left( h + (j-1) \frac{2\pi}{\omega_0} N \right) - F_k \left( (j-1) \frac{2\pi}{\omega_0} N^- \right) \right\}$$

for  $0 < h \leq \frac{2\pi}{\omega_0} N$ ,  $F_{k,N}(h) = 0$  for  $h < 0$ , and

$$F_{k,N}(h) = F_k(+\infty) \quad \text{for } h > \frac{2\pi}{\omega_0} N,$$

we see by  $F_k(0^-) = 0$  that  $\int_0^{\frac{2\pi}{\omega_0} N} |dF_{k,N}(h)| \leq \int_0^{\infty} |dF_k(h)| < +\infty$  and  $F_{k,N}(h)$  has its four component measures on  $[0, \frac{2\pi}{\omega_0} N)$  to be absolutely convergent sums of the  $F_k(h + (j-1)\frac{2\pi}{\omega_0} N)$  measures, and uniformly convergent over all Borel subsets. Thus since  $x_0(t + \frac{2\pi}{\omega_0}) = x_0(t)$ , we see that  $x_0(t)$  satisfies equation 1.3) with  $F_{k,N}(h)$  replacing  $F_k(h)$  and  $L = \frac{2\pi}{\omega_0} N < +\infty$  and hence  $D_N(im_N \omega_0) = 0$  as before.

$$\begin{aligned} \text{Now } \sum_{j=2}^{\infty} \int_0^{\frac{2\pi}{\omega_0} N} e^{\beta h} |dF_k(h + (j-1)\frac{2\pi}{\omega_0} N)| &\leq \\ \leq e^{\beta \frac{2\pi}{\omega_0} N} \int_{-\frac{2\pi}{\omega_0} N}^{\infty} |dF_k(h)| &\leq \int_{\frac{2\pi}{\omega_0} N}^{\infty} e^{\beta h} |dF_k(h)| \rightarrow 0 \text{ as } N \rightarrow \infty \end{aligned}$$

so that it is clear that  $\frac{1}{|s|^n} D_N(s) \rightarrow D(s) \frac{1}{|s|^n}$  uniformly over  $R(s) \geq -\beta$  and  $|s| \geq 1$ . But by condition 1.5),  $\frac{1}{|s|^n} D(s)$  is bounded away from 0 for  $R(s) \geq -\beta$  and  $|s|$  large, so  $D_N(im_N \omega_0) = 0$  implies that  $m_N$  is bounded as  $N \rightarrow \infty$ . Thus there must exist an integer  $m' \neq 0$  such that  $m_N = m'$  for infinitely many  $N$ , and hence  $D_N(s) \rightarrow D(s)$  yields  $D(im' \omega_0) = 0$  as desired.

Similarly  $D(i(2m'+1)\omega_0) = 0$  follows from  $x_0(t + \frac{\pi}{\omega_0}) = -x_0(t)$

Q. E. D.

We now want to use theorem 1:5) to study a slight generalization of equation 1.1), the equation

$$1.15) \left\{ \sum_{k=0}^n \int_{0 \leq h} x^{(k)}(t-h) \delta F_k(h) \right\} + [P(x)](t) = 0,$$

where the nonlinear part  $[P(x)](t)$  is of the following type.

Type I)

1.16)

$$[P(x)](t) = Q \left( x^{(n-1)}(t), \dots, x(t), x^{(n-1)}(t-b_1), \dots, x(t-b_r) \right)$$

where the  $b$ 's are real constants with  $0 < b_1 < b_2 < \dots < b_r$  and  $Q(y_1, \dots)$  is a power series in  $(r+1)n$  complex variables which lacks zero and first degree terms and which converges absolutely and uniformly over  $|y_1| \leq \rho$  for some  $\rho > 0$ .

Type II)

$$1.17) [P(x)](t) = \sum_{p_1 + \dots + p_n \geq 2} \int_0^\infty \dots \int_0^\infty \left\{ \prod_{k=1}^n (x^{(k-1)}(t-h_k))^{p_k} \right\} d\phi_{p_1, \dots, p_n}(h_1, \dots, h_n)$$

such that

$$\sum_{p_1 + \dots + p_n \geq 2} (e)^{p_1 + \dots + p_n} \int_0^\infty \dots \int_0^\infty e^{\phi(h_1 p_1 + \dots + h_n p_n)} |d\phi_{p_1, \dots, p_n}(h_1, \dots, h_n)| < +\infty$$

for some  $\rho > 0$ , where  $p_k \geq 0$  and the  $\phi$ 's are complex valued, completely additive, bounded set functions over Borel subsets of the  $n$  fold product space of  $0 \leq h_k < \infty$ , which also have zero variation on the product  $0 \leq h_k < b$  by  $[0, \infty)$  for the remaining  $n-1$  variables for  $k=1, 2, \dots, n$ .

Type III)

$[P(x)](t)$  is given by 1.16) again, but where now  $Q(y_1, \dots)$  is a real valued function of  $(r+1)n$  real variables with continuous second order partials over  $|y_1| \leq \rho$  for some  $\rho > 0$ , and such that  $Q(0, \dots, 0)$  vanishes as well as all first order partials at the origin.

It is clear that type II) and type III) are both generalizations of type I, but in different directions so that it is difficult to unite them.

A  $\phi(t)$  is said to be an admissible initial condition for equation 1.15) if  $|\phi^{(k)}(t)| < \rho$  on  $-L' < t < 0$ ,  $k = 0, 1, \dots, n-1$  and  $\phi(t)$  otherwise satisfies definition 1:1) with  $L'$  replacing  $L$ , and if  $\phi(t)$  is real valued for type III). Here  $L'$  is defined to give zero variation to the  $\bar{\phi}$ 's if any  $h_k > L'$  and to the  $F$ 's if  $h > L'$ , just as  $L$  was for the  $F$ 's alone.

A solution  $x(t)$  for 1.15) on  $0 < t \leq t_1$  is defined by 1:2) with equation 1.15) replacing 1.3) in c), and with the additional restriction  $|x^{(k)}(t)| < \rho$  and  $x(t)$  real for type III), so that  $[p(x)](t)$  can be defined.

It is clear by the obvious local Lipschitz condition for types I), II), and III), using  $b > 0$  for type II), that the argument of theorem 1:3) can be extended to equation 1.15). Hence any solution for an admissible  $\phi(t)$  must be unique, and also must exist locally over  $t > 0$ . This allows extension to all  $t > 0$  if the  $x^{(k)}(t)$  remain bounded by  $\rho$ .

Now for any  $\alpha \geq 0$  put

$$\|x\|_\alpha = \operatorname{ess\,sup}_{\substack{-\infty < t < +\infty \\ k=0,1,\dots,n-1}} |x^{(k)}(t) e^{\frac{\alpha}{2}(t+|t|)}|$$

if  $x^{(k)}(t)$  exists for almost all real  $t$  for such  $k$ .

It is clear by rearranging absolutely convergent sums

or using the mean value theorem that for  $t \geq 0$  and  $0 \leq \alpha \leq \beta$

1.18)

$$|[P(x_1)](t) - [P(x_2)](t)| \leq M_0 \|x_1 - x_2\| ( \|x_1\|_\alpha + \|x_2\|_\alpha ) e^{-2\alpha t}$$

if  $\|x_1\|_\alpha$  and  $\|x_2\|_\alpha \leq \frac{1}{3} \rho$  for either type I), II), or III).

For use in the following theorem for a given admissible  $\phi(t)$  define  $x_m(t)$  inductively by 1.9) and 1.10) from  $g_m(t)$ , where  $g_0(t) = 0$  and  $g_{m+1}(t) = -[P(x_m)](t)$  for  $m \geq 0$ .

We also need the condition

1.19)  $D(s) \neq 0$  for  $\mathcal{R}(s) \geq 0$ .

Theorem 1:8)

If conditions 1.4), 1.5), and 1.19) hold for equation 1.15), then there exists some  $\rho_1, 0 < \rho_1 \leq \rho$ , such that for any admissible  $\phi(t)$  with  $\|\phi\|_0 < \rho_1$ , we have  $x_m(t)$  existent as defined above for  $m \geq 0$  and  $x(t) = \lim_{m \rightarrow \infty} x_m(t)$  exists for real  $t$  as the unique solution of

1.15) over  $t > 0$ .

Moreover,  $\alpha_1 = [D(s)]_{D(s)=0}^{\sup} \mathcal{R}(s) < 0$  and  $\lambda = | \frac{\alpha_1}{2} |$  has

1.20)  $\lim_{m \rightarrow \infty} \|x - x_m\|_\lambda = 0$  and  $|x^{(k)}(t)| \leq \|x\|_\lambda e^{-\lambda t}$  over  $t \geq 0, k = 0, 1, \dots, n-1$ , with  $\|x\|_\lambda < +\infty$ .

This theorem follows from 1.12) and 1.18) with  $\alpha = -\lambda$  and  $\lambda$  respectively, since  $R_{-\lambda}(t) = x_0(t)$  for  $g(t) = 0$  from  $N_{-\lambda} = 0$  by 1.19). The method is the usual technique of successive approximations (lemma 2:7). For this yields equation 1.10) for  $x(t)$  with  $g(t) = \lim_{m \rightarrow \infty} g_m(t) = -[P(x)](t)$  so that  $x(t)$  is a solution

of equation 1.3) by theorem 1:5) for this  $g(t)$ , and hence of 1.15).

This theorem is due to Bellman [10], who proves a special case with  $n = 1$ . By a result of Wright [8] taken together with 1.20) it follows that the solution  $x(t)$  of equation 1.15) under our conditions can be represented by an asymptotic series like 1.11), except that sums of the  $s_j$  occur as exponents as well as the original zeros of  $D(s)$ . It seems that theorem 1:8) is of some importance in applied mathematics, justifying the use of condition 1.19) to prevent undesired oscillations in the design of control circuits.

## CHAPTER II

We would now like to determine the behavior at  $\infty$  of solutions of 1.1) or 1.15) for the initial condition problem in case condition 1.19) fails. Here in the linear case by 1.11) we see that  $x(t)$  is a sum of oscillations growing in amplitude exponentially in general. Clearly the situation will be radically altered in the non-linear case, since the non-linear terms will predominate as the amplitude increases; if the non-linear terms are properly chosen, we may hope that the amplitude of oscillation will stabilize at a constant value. Thus it is reasonable to look for periodic solutions to 1.15), which thus imposes boundary conditions and allows conversion to an integral equation. These integral equations allow one to study the growth of non-zero periodic solutions of 1.15) as the zeros of  $D_\eta(s)$  cross the imaginary axis as  $\eta$  varies, the  $F$ 's and  $\phi$ 's now depending on the parameter  $\eta$ .

The method of attack is first to extend the theory of non-linear integral equations developed by Schmidt [17], and others [18], [19], [20] to cover general matrix valued kernels. Then in the next chapter we return to apply these results to equation 1.15). This extension is almost trivial, but it seems desirable to write out the details for the sake of completeness.

We start with a few well known lemmas on bounded linear operators. First if  $T$  is a linear operator on a Banach space  $X$ , we define  $\|T\| = \sup_{\|x\| \leq 1} \|T(x)\|$  as the operator norm of  $T$ , and say that  $T$  is bounded if  $\|T\| < +\infty$ , [28].

Lemma 2:1)

If  $B$  and  $A$  are two bounded linear operators on a Banach space  $X$ , if  $A$  is one-to-one from  $X$  onto  $X$ , and if  $\|A-B\| < \frac{1}{\|A^{-1}\|}$  then  $A^{-1}$  and  $B^{-1}$  are bounded

linear operators on  $X$  and

$$2.1) \quad B^{-1} = A^{-1} \left( I + \sum_{n=1}^{\infty} [(A-B)A^{-1}]^n \right)$$

Proof

By Banach [28], p.41,  $A$  being one-to-one and bounded makes  $A^{-1}$  bounded. Also  $\|(A-B)A^{-1}\| \leq \|A-B\| \|A^{-1}\| < 1$  is given, so with operator norm convergence  $V = \sum_{n=1}^{\infty} [(A-B)A^{-1}]^n$  exists as a bounded

linear operator on  $X$ , and thus  $C = A^{-1}(I+V)$  can be defined.

$$2.2) \quad \mathbf{BC} = [\mathbf{A} - (\mathbf{A} - \mathbf{B})] \mathbf{C} = (\mathbf{I} + \mathbf{V}) - (\mathbf{A} - \mathbf{B}) \mathbf{A}^{-1} (\mathbf{I} + \mathbf{V}) = \\ \mathbf{I} + \mathbf{V} - \mathbf{V} = \mathbf{I},$$

$$2.3) \quad \mathbf{CB} = \mathbf{A}^{-1} (\mathbf{I} + \mathbf{V}) [\mathbf{A} - (\mathbf{A} - \mathbf{B})] = \mathbf{I} + \mathbf{A}^{-1} \mathbf{VA} - \mathbf{A}^{-1} (\mathbf{I} + \mathbf{V}) (\mathbf{A} - \mathbf{B}) \\ = \mathbf{I} + \mathbf{A}^{-1} \mathbf{VA} - \mathbf{A}^{-1} \mathbf{VA} = \mathbf{I}$$

now follow from  $\mathbf{V} = (\mathbf{A} - \mathbf{B}) \mathbf{A}^{-1} (\mathbf{I} + \mathbf{V}) = (\mathbf{I} + \mathbf{V}) (\mathbf{A} - \mathbf{B}) \mathbf{A}^{-1}$  and thus  $\mathbf{B}^{-1} = \mathbf{C}$  exists as a bounded linear operator.

Q. E. D.

$$2.4) \quad (\lambda \mathbf{I} - \mathbf{T})^{-1} = \frac{1}{\lambda} \mathbf{I} + \sum_{n=1}^{\infty} \frac{1}{\lambda^{n+1}} \mathbf{T}^n \quad \text{for } |\lambda| > \|\mathbf{T}\| \quad \text{and}$$

$$2.5) \quad \lambda (\lambda \mathbf{I} - \mathbf{T})^{-1} = \\ \lambda_0 (\lambda_0 \mathbf{I} - \mathbf{T})^{-1} \left\{ \mathbf{I} + \sum_{n=1}^{\infty} \left( \frac{\lambda_0}{\lambda} - 1 \right)^n \mathbf{T}^n [(\lambda_0 \mathbf{I} - \mathbf{T})^{-1}]^n \right\}$$

for  $|\frac{\lambda_0}{\lambda} - 1| < [ \|\mathbf{T}\| \|(\lambda_0 \mathbf{I} - \mathbf{T})^{-1}\| ]^{-1}$  are obvious special cases of 2.1), with  $\mathbf{A} = \frac{1}{\lambda_0} (\lambda_0 \mathbf{I} - \mathbf{T})$  in the latter.

If  $X$  is a separable Hilbert space,  $\{\phi_p\}$  a complete orthonormal base for  $X$ , we define  $N(\mathbf{T}) = [ \sum_{q,p=1}^{\infty} |(\mathbf{T}(\phi_q), \phi_p)|^2 ]^{1/2}$  as the base norm of  $\mathbf{T}$  as in

(25). We note that always  $\|\mathbf{T}\| \leq N(\mathbf{T})$ .

Lemma 2:2)

If  $N(\mathbf{T}) < +\infty$ , then  $\mathbf{T}$  is compact.

Proof

$X$  being separable is isomorphic to  $L_2[0,1]$ , the isomorphism taking  $\mathbf{T}$  into an integral operator with its kernel in  $L_2([0,1] \times [0,1])$  for which the result is well known, [24].

Q. E. D.

To introduce integral operators we consider a non-negative measure  $\mu$  over a measure space  $S$  which is a countable union of finite  $\mu$  measure sets, and a  $\mu$  measurable subset  $R$  of  $S$ . Let  $L_2^\mu(C_n, R)$  denote the set of functions  $x(t)$  from  $R$  to  $C_n$ ,  $n$  dimensional unitary space, such that each complex component function  $x_1(t)$  is in  $L_2^\mu(R)$ . Clearly the definition

$$(x, y) = \sum_{j=1}^n \int_R x_j(t) \overline{y_j(t)} d\mu(t) \text{ makes } L_2^\mu(C_n, R) \text{ a}$$

Hilbert space.

Now if  $K(t, \tau)$  is an  $n$  by  $n$  complex matrix valued function over  $S \times S$ , each component  $K_{ij}(t, \tau)$  being a  $\mu \times \mu$  measurable complex function on  $S \times S$ , we can define the operators  $\mathbf{K}$  and  $\mathbf{K}^*$  by

$$2.6) \quad [\mathbf{K}(x)](t) = \int_R K(t, \tau) x(\tau) d\mu(\tau) \quad \text{and} \\ [\mathbf{K}^*(x)](t) = \int_R K^*(\tau, t) x(\tau) d\mu(\tau) \quad \text{for } t \in S,$$

where  $K^*(u, v)$  denotes the adjoint matrix of  $K(u, v)$ , provided the vector integrands in 2.6) have their components in  $L_1^\mu(R)$  over  $\tau$  for almost all  $t \in S$ .

In our application  $S = (-\infty, \infty)$ ,  $R = [0, \pi]$  or  $[0, 2\pi]$ , and  $\mu$  will be ordinary Lebesgue measure.

Lemma 2:3)

If  $K_{ij}(t, \tau) \in L_2^{\mu \times \mu}(S \times S)$ , and if  $L_2^\mu(S)$  is separable, then  $\mathbf{K}$  and  $\mathbf{K}^*$  are bounded linear operators on  $L_2^\mu(C_n, R)$  into itself, and actually into  $L_2^\mu(C_n, S)$  as well, with finite base norm

$$2.7) \quad N(\mathbf{K}) = N(\mathbf{K}^*) = \left[ \sum_{i,j=1}^n \int_R \int_R |K_{ij}(t, \tau)|^2 d\mu(\tau) d\mu(t) \right]^{\frac{1}{2}}.$$

## Proof

The first statements are obvious by the Schwarz inequality. Since  $L_2^\mu(R)$  may be considered a subspace of  $L_2^\mu(S)$ , it as well as  $L_2^\mu(C_n, R)$  is separable. Thus letting  $\{\bar{\phi}\}$  be a complete orthonormal set, by the Bessel equality we have

$$\begin{aligned} & \sum_{i,j=1}^n \int_R \int_R |K_{ij}(t, \tau)|^2 d\mu(\tau) d\mu(t) = \\ & = \sum_{i=1}^n \int_R \left\{ \sum_{q=1}^{\infty} \left| \sum_{j=1}^n \int_R K_{ij}(t, \tau) \phi_q(\tau) d\mu(\tau) \right|^2 \right\} d\mu(t) \\ & = \sum_{q=1}^{\infty} \| \mathbf{K}(\phi_q) \|^2 = \sum_{p,q=1}^{\infty} |(\mathbf{K}(\phi_q), \phi_p)|^2 = [N(\mathbf{K})]^2 . \end{aligned}$$

Q. E. D.

We always assume hereafter that  $L_2^\mu(S)$  is separable.

Lemma 2.4)

If  ${}_1K_{ij}(t, \tau)$  and  ${}_2K_{ij}(t, \tau)$  are  $\mu\mu$  measurable and essentially bounded in absolute value by  $M_1 < +\infty$  on  $S \times S$ , if  $\mu(R) < +\infty$ , and if  $\mathbf{T}$  is a bounded linear operator on  $L_2^\mu(C_n, R)$  into itself then

$${}_3K_{ij}(t, \tau) = [{}_1\mathbf{K}(y_{j,\tau})]_i(t), \quad y_{j,\tau} = \mathbf{T}(g_{j,\tau}), \text{ and}$$

$$2.8) \quad [g_{j,\tau}(i)]_p = {}_2K_{p,j}(t, \tau)$$

define  ${}_3\mathbf{K}(t, \tau)$  as a  $\mu\mu$  measurable matrix function satisfying on  $S \times S$

$$2.9) \quad |{}_3K_{ij}(t, \tau)| \leq n \mu(R) \| \mathbf{T} \| (M_1)^2 \quad \text{almost everywhere.}$$

Also as an operator on  $L_2^\mu(C_n, R)$  into itself we have

$$2.10) \quad {}_3\mathbf{K} = {}_1\mathbf{K} \mathbf{T} {}_2\mathbf{K}$$

Proof

By the Fubini theorem, we know that except for  $\tau \in S'$  of  $\mu(S') = 0$  we have  $g_{j,\tau} \in L_2^\mu(C_n, R)$  with  $\|g_{j,\tau}\| \leq M\sqrt{n\mu(R)}$ , and hence  $y_{j,\tau} \in L_2^\mu(C_n, R)$  with  $\|y_{j,\tau}\| \leq \|\mathbf{T}\| \|g_{j,\tau}\|$ . Thus 2.8) defines  ${}_3K_{1j}(t, \tau)$  as a  $\mu$  measurable function of  $t \in S$  for almost all  $\tau \in S$ , and 2.9) is satisfied. By using the assumption that  $L_2^\mu(S)$  is separable, we get an orthogonal expansion for  $g_{j,\tau}$  of the form  $g_{j,\tau} = \sum_{p=1}^{\infty} f_{j,p}(\tau) \phi_p$ , from which it is easy to see that  ${}_3K_{1j}(t, \tau) = \sum_{p=1}^{\infty} f_{j,p}(\tau) h_{1,p}(t)$  convergent almost everywhere on  $S \times S$  is actually  $\mu^\mu$  measurable there.

Clearly from 2.8) and 2.9),  ${}_3\mathbf{K}$  is a bounded linear operator from  $L_2^\mu(C_n, R)$  into itself according to 2.6). Thus using the fact that any bounded linear operator on Hilbert space possesses a unique adjoint, which coincides with  $\mathbf{K}^*$  of 2.6) for kernel operators, we have by 2.8), 2.9), and the Fubini theorem that

$$\begin{aligned}
 ({}_3\mathbf{K}(x), y) &= \\
 2.11) \quad &= \int_R \sum_{j=1}^n \left\{ \int_R \sum_{p=1}^n \int_R \overline{y_1(t)} {}_1K_{1p}(t, \tau) [y_{j,\tau}(\tau)]_p d\mu(\tau) d\mu(t) \right\} x_j(\tau) d\mu(\tau) \\
 &= \sum_{j=1}^n \int_R \left\{ (\mathbf{T}(g_{j,\tau}), {}_1\mathbf{K}^*(y)) \right\} x_j(\tau) d\mu(\tau) \\
 &= \sum_{j=1}^n \int_R (g_{j,\tau}, \mathbf{T}^*({}_1\mathbf{K}^*(y)) x_j(\tau) d\mu(\tau)
 \end{aligned}$$

$$\begin{aligned}
&= \sum_{j=1}^n \int_R \int_R \overline{[T^*(\cdot, K^*(y))]_1(\zeta)} \cdot {}_2K_{1j}(\zeta, \tau) x_j(\tau) d\mu(\tau) \\
&= \left( {}_2K(x), T^*(\cdot, K^*(y)) \right) = \left( T({}_2K(x)), {}_1K^*(y) \right) \\
&= \left( {}_1K T {}_2K(x), y \right)
\end{aligned}$$

for all  $x$  and  $y \in L_2^\mu(C_n, R)$ . Thus  ${}_3K = {}_1K T {}_2K$  for 2.10).

Q. E. D.

In the following theorem  $\gamma$  denotes a vector parameter,  $\gamma = (\gamma_1, \dots, \gamma_k)$  with  $\gamma_p$  real or complex and  $||\gamma|| = \sqrt{|\gamma_1|^2 + \dots + |\gamma_k|^2}$ .

Theorem 2:5)

If  $K(t, \tau, \gamma)$  is a matrix kernel satisfying the conditions of lemma 2:4 for  $||\gamma|| \leq b$  with  $\mu(R) < +\infty$ , if  $K_\gamma$  on  $L_2^\mu(C_n, R)$  is operator norm continuous with respect to  $\gamma$  over  $||\gamma|| \leq b$  and if  $\lambda = 1$  is not in the point spectrum of  $K_0$ , then there exists a  $\mu$  measurable matrix kernel  $V(t, \tau, \lambda, \gamma)$  with, for some finite  $M_2$  and  $\rho > 0$ ,

$$2.12) \quad |V_{1j}(t, \tau, \lambda, \gamma)| \leq M_2 \quad \text{almost everywhere on } S \times S$$

for  $|\lambda - 1| \leq \rho$  and  $||\gamma|| \leq \rho$ ; also if  $X$  denotes the Banach space  $L_\infty^\mu(C_n, S)$  of essentially bounded vector functions over  $S$ , then as operators both on  $X$  as well as  $L_2^\mu(C_n, R)$  we have

$$2.13) \quad V_{\lambda, \gamma} = \lambda (\lambda I - K_\gamma)^{-1} - I.$$

Proof

$$\text{Since } [N(\mathbf{K}_\gamma)]^2 = \int_R \int_R \sum_{j=1}^n |K_{1j}(t, \tau, \gamma)|^2 d\mu(\tau) d\mu(t)$$

$\leq [n M_1 \mu(R)]^2$  we have  $\mathbf{K}_\gamma$  to be compact by lemmas 2:2) and 2:3). Thus by the Riesz theory [21], [28], the spectrum  $\sigma(\mathbf{K}_0)$  of  $\mathbf{K}_0$  is a pure point spectrum except possibly for  $\lambda = 0$ , and for any  $\delta > 0$  contains only a finite number of points  $\lambda$  in the plane such that  $|\lambda| \geq \delta$ . Also  $\|\mathbf{K}_0\| \leq N(\mathbf{K}_0) \leq n M_1 \mu(R)$ , so  $(\lambda_0 \mathbf{I} - \mathbf{K}_0)^{-1}$  is given by 2.4) as an operator on  $L_2^\mu(C_n, R)$  for  $\lambda_0 = n M_1 \mu(R) + 1$ .

Since we are given  $\lambda_1 = 1 \notin \sigma(\mathbf{K}_0)$  we thus can construct a polygonal arc  $L_0$  from  $\lambda_0$  to  $\lambda_1$ , consisting of at most two line segments, such that  $|\lambda| \geq 1$  and  $\lambda \notin \sigma(\mathbf{K}_0)$  for all  $\lambda \in L_0$ . Now by 2.5),  $(\lambda \mathbf{I} - \mathbf{K}_0)^{-1}$  is operator norm continuous in  $\lambda \in (E_2 - \sigma(\mathbf{K}_0))$ , which includes  $L_0$ , and hence  $\|(\lambda \mathbf{I} - \mathbf{K}_0)^{-1}\|$  is bounded over the compact set  $L_0$ , say by  $M_3 < +\infty$ . Then we can choose a finite set  $\lambda_2, \lambda_3, \dots, \lambda_N$  with  $\lambda_N = \lambda_0$ , such that  $|\lambda_p - \lambda_{p+1}| \leq \frac{1}{2} (\|\mathbf{K}_0\| M_3 + 1)^{-1}$  and  $\lambda_p \in L_0$  for  $p = 1, 2, \dots, N-1$ .

Now by 2.8) and 2.9) we can define the pointwise bounded kernel  $V(t, \tau, \lambda_0, 0)$  on  $S \times S$  so that by 2.10) 2.14) 
$$\mathbf{V}_{\lambda, 0} = \frac{1}{\lambda} \mathbf{K}_0 + \frac{1}{\lambda} \mathbf{K}_0 \left( \mathbf{I} + \sum_{n=1}^{\infty} \left( \frac{1}{\lambda} \mathbf{K}_0 \right)^n \right) \frac{1}{\lambda} \mathbf{K}_0 = \sum_{n=1}^{\infty} \left( \frac{1}{\lambda} \mathbf{K}_0 \right)^n$$

at  $\lambda = \lambda_0$  as operators on  $L_2^\mu(C_n, R)$ ; we see from 2.14) that 2.13) holds by use of 2.4). Now by using this same lemma 2:4), we extend  $V(t, \tau, \lambda, 0)$ , successively from  $\lambda_{p+1}$  to  $\lambda_p$ , to all  $\lambda$  such that  $|\lambda| \geq \frac{1}{2}$  and  $|\lambda - \beta| \leq \frac{1}{2} (\|\mathbf{K}_0\| M_3 + 1)^{-1}$  for  $\beta$  equal to some  $\lambda_p$ , and such that the form 2.10) takes is

$$\begin{aligned}
 \mathbf{V}_{\lambda,0} &= \mathbf{V}_{\beta,0} + \left(\frac{1}{\lambda} - \frac{1}{\beta}\right)(\mathbf{K}_0 \mathbf{V}_{\beta,0}^2 + 2 \mathbf{K}_0 \mathbf{V}_{\beta,0} + \mathbf{K}_0) \\
 2.15) \quad &+ \mathbf{K}_0 \left\{ (\mathbf{V}_{\beta,0} + \mathbf{I}) \sum_{n=1}^{\infty} \left(\frac{\beta}{\lambda} - 1\right)^n \mathbf{K}_0^{n-2} [(\beta \mathbf{I} - \mathbf{K}_0)^{-1}]^n \right\} \mathbf{K}_0 \\
 &= \mathbf{V}_{\beta,0} + (\mathbf{V}_{\beta,0} + \mathbf{I}) \sum_{n=1}^{\infty} \left(\frac{\beta}{\lambda} - 1\right)^n \mathbf{K}_0^n [(\beta \mathbf{I} - \mathbf{K}_0)^{-1}]^n.
 \end{aligned}$$

Again from this last form and 2.5), it is clear by induction that  $\mathbf{V}_{\lambda,0} = \lambda(\lambda \mathbf{I} - \mathbf{K}_0)^{-1} - \mathbf{I}$  and 2.13) holds for the stated  $\lambda$  and for  $\gamma = 0$ , the convergence requirement for 2.5) being satisfied by

$$\begin{aligned}
 \left| \frac{\beta}{\lambda} - 1 \right| &\leq \frac{1}{2|\lambda|} ( \|\mathbf{K}_0\| M_3 + 1 )^{-1} \leq ( \|\mathbf{K}_0\| M_3 + 1 )^{-1} \\
 &< \frac{1}{\|\mathbf{K}_0\| \| [(\beta \mathbf{I} - \mathbf{K}_0)^{-1}] \|} .
 \end{aligned}$$

For the final extension of  $V(t, \tau, \lambda, \gamma)$  to the  $\lambda$  and  $\gamma$  stated in the theorem, since  $\|(\lambda \mathbf{I} - \mathbf{K}_0)^{-1}\|$  is bounded in some complex neighborhood of  $\lambda = 1$ , we can choose  $\rho > 0$  such that for some  $r$ ,  $\|\mathbf{K}_\gamma - \mathbf{K}_0\| \|(\mathbf{I} - \mathbf{K}_0)^{-1}\| \leq r < 1$  for  $|\lambda - 1| \leq \rho$  and  $\|\gamma\| \leq \rho$  where all the operators denoted here are on  $L_2^\mu(C_n, R)$ . Then we finally define  $V(t, \tau, \lambda, \gamma)$  in the obvious way so that 2.10) takes the form

$$\begin{aligned}
 2.16) \quad \mathbf{V}_{\lambda,\gamma} &= \left\{ \begin{aligned} &\mathbf{V}_{\lambda,0} + \frac{1}{\lambda} \left[ (\mathbf{K}_\gamma - \mathbf{K}_0) + (\mathbf{K}_\gamma - \mathbf{K}_0) \mathbf{V}_{\lambda,0} + \mathbf{V}_{\lambda,0} (\mathbf{K}_\gamma - \mathbf{K}_0) \right] \\ &\quad + \mathbf{V}_{\lambda,0} (\mathbf{K}_\gamma - \mathbf{K}_0) \mathbf{V}_{\lambda,0} \\ &+ \frac{1}{\lambda} \left[ \begin{array}{l} \mathbf{V}_{\lambda,0} (\mathbf{K}_\gamma - \mathbf{K}_0) \\ + (\mathbf{K}_\gamma - \mathbf{K}_0) \end{array} \right] \left\{ (\lambda \mathbf{I} - \mathbf{K}_0)^{-1} \sum_{n=0}^{\infty} \left[ (\mathbf{K}_\gamma - \mathbf{K}_0) (\lambda \mathbf{I} - \mathbf{K}_0)^{-1} \right]^n \right\} \\ &\quad \cdot \left[ (\mathbf{K}_\gamma - \mathbf{K}_0) \mathbf{V}_{\lambda,0} + (\mathbf{K}_\gamma - \mathbf{K}_0) \right] \end{aligned} \right\} \\
 &= \mathbf{V}_{\lambda,0} + \lambda (\lambda \mathbf{I} - \mathbf{K}_0)^{-1} \sum_{n=1}^{\infty} \left[ (\mathbf{K}_\gamma - \mathbf{K}_0) (\lambda \mathbf{I} - \mathbf{K}_0)^{-1} \right]^n .
 \end{aligned}$$

By comparing this last form with 2.1) after taking  $\mathbf{A} = \lambda \mathbf{I} - \mathbf{K}_0$  and  $\mathbf{B} = \lambda \mathbf{I} - \mathbf{K}_\gamma$ , we see that  $\mathbf{V}_{\lambda,\gamma} = \lambda (\lambda \mathbf{I} - \mathbf{K})^{-1} - \mathbf{I}$  for the stated  $\lambda$  and  $\gamma$ , since the convergence inequality is satisfied. Thus 2.13) has been shown over  $L_2^\mu(C_n, R)$ , and 2.12) follows from 2.9) at each induction stage 2.14), 2.15), and 2.16).

It remains to verify 2.13) with the operators being interpreted as on  $X$  into  $X$ . First 2.13) is by definition always equivalent to

$$2.17) \quad \frac{1}{\lambda} (\lambda \mathbf{I} - \mathbf{K}_\gamma) (\mathbf{I} + \mathbf{V}_{\lambda,\gamma}) = \mathbf{I} = \frac{1}{\lambda} (\mathbf{I} + \mathbf{V}_{\lambda,\gamma}) (\lambda \mathbf{I} - \mathbf{K}_\gamma),$$

or,  $\mathbf{V}_{\lambda,\gamma} - \mathbf{K}_\gamma = \mathbf{V}_{\lambda,\gamma} \mathbf{K}_\gamma = \mathbf{K}_\gamma \mathbf{V}_{\lambda,\gamma}$ .

But the operator formulae 2.17) correspond in the obvious way to kernel formulae on  $S \times S$ , the indicated integrations being over  $R \subset S$  as usual. These kernel formulae obviously hold for the  $V(t, \tau, \lambda_0, 0)$  definition preceding 2.14), and can easily be verified for those in the induction stages 2.15) and 2.16) by formally mimicking the manipulation in 2.2) and 2.3). The kernel formulae being proved, 2.17) follow as operator formulae on  $X$  as well as  $L_2^\mu(C_n, R)$ , and thus so does the equivalent 2.13).

Q. E. D.

If in theorem 2:5) we now allow  $\lambda = 1$  to be in the point spectrum of  $\mathbf{K}_0$  on  $L_2^\mu(C_n, R)$ , denote by  $\varphi$  and  $\psi$  the eigenvectors of  $\mathbf{K}_0$  and  $\mathbf{K}_0^*$  at  $\lambda = 1$ , so that actually  $\varphi(t)$  and  $\psi(t)$  are defined throughout  $S$  by  $\varphi = \mathbf{K}_0(\varphi)$  and  $\psi = \mathbf{K}_0^*(\psi)$  from 2.6); hence  $\varphi$  and  $\psi$  are both in  $X$ . Also define  $\psi(t) \overline{\varphi(\tau)}$  to be the matrix kernel whose

1j component is  $\psi_1(t) \overline{\varphi_j(\tau)}$ . It should be noted that, by the uniqueness of the inverse,  $V_{1j}(t, \tau, 1, \gamma)$  is real valued on  $S \times R$  if  $K_{1j}(t, \tau, \gamma)$  is so, and that we can and will take  $\varphi_j(t)$  and  $\psi_1(t)$  to be real valued on  $S$  if  $K_{1j}(t, \tau, 0)$  is so on  $S \times S$ .

Theorem 2:6)

If  $K(t, \tau, \gamma)$  satisfies all the conditions of theorem 2:5), except that now we allow  $\lambda = 1$  to be in the point spectrum of  $K_0$  over  $L_2^\mu(C_n, R)$ , then  $K_0$  and  $K_0^*$  have an equal, finite number  $m$  of orthonormal eigenvectors,  $\{\varphi_r\}$  and  $\{\psi_r\}$  at  $\lambda = 1$ . Moreover, if  $E(t, \tau, \gamma)$  is defined by

$$2.18) \quad E(t, \tau, \gamma) = K(t, \tau, \gamma) + \sum_{p=1}^m p \psi(t) \overline{p \varphi(\tau)}$$

over  $S \times S$  and  $\|\gamma\| \leq b$ , then almost everywhere here we have

$$|\psi_1(t)| \leq M_1 [n \mu(R)]^{\frac{1}{2}}, \quad |\varphi_j(\tau)| \leq M_1 [n \mu(R)]^{\frac{1}{2}}$$

2.19)

$$|E_{1j}(t, \tau, \gamma)| \leq M_1 + m(M_1)^2 n \mu(R).$$

Also  $\lambda = 1$  is not in the point spectrum of  $E_0$  over  $L_2^\mu(C_n, R)$

Proof

Since  $N(K_0) = N(K_0^*) < +\infty$  by 2.7), we have that  $K_0$  and  $K_0^*$  are compact, and thus by the Riesz theory, [21], the subspaces of  $L_2^\mu(C_n, R)$  spanned by the eigenvectors of  $K_0$  and  $K_0^*$  respectively at  $\lambda = 1$  are finite dimensional. By Banach, [28], page 154 and the reflexivity of Hilbert space, these dimension numbers are equal. Thus  $\{p \varphi\}$

and  $\{\psi_p\}$ ,  $1 \leq p \leq m$ , can be chosen as orthonormal bases.

Now 2.19) is obvious from  $\psi = K_0^*(\psi)$  and  $\varphi = K_0(\varphi)$  with  $||\varphi|| = 1 = ||\psi||$ , from the Schwarz inequality, and from the definition 2.18).

To prove the final statement, suppose on the contrary we have some  $u \in L_2^\mu(C_n, R)$ ,  $||u|| = 1$ , such that  $E_0(u) = u$ . Then by definition, with  $c_p = (u, \psi_p)$ ,

$$2.20) \quad K_0(u) = E_0(u) - \sum_{p=1}^m c_p \psi_p = u - \sum_{p=1}^m c_p \psi_p.$$

Now if each  $c_p = 0$ , then this equation shows  $K_0(u) = u$  so that  $u$  is an eigenvector of  $K_0$  at  $\lambda = 1$ , and hence  $u = \sum_{p=1}^m c_p \psi_p$  by the definition of  $\{\psi_p\}$ . However, this yields the contradiction  $1 = ||u||^2 = \sum_{p=1}^m |c_p|^2 = 0$ .

On the other hand if  $c_j \neq 0$  for some  $p = j$ , then from 2.20) we have  $\sum_{p=1}^m c_p \psi_p = u - K_0(u)$  and thus the contradiction  $0 \neq c_j = (\sum_{p=1}^m c_p \psi_p, \psi_j) = (u, \psi_j) - (u, K_0^*(\psi_j)) = 0$

from  $K_0^*(\psi_j) = \psi_j$ . Hence such  $u$  cannot exist, and so  $\lambda = 1$  is not in the point spectrum of  $E_0$ .

Q. E. D.

The Fredholm theory results afforded by theorems 2:5) and 2:6) now permit us to carry through the Schmidt theory for matrix valued kernels, and thus to attack equation 1.15). The all important pointwise bound 2.12) presumably should be derivable from the argument of Carleman [22] in reaching his equation 13), page 201, suitably modified to take care of matrix valued kernels [23]. However, the proof via 2.1) and lemma 2:4) seems simpler.

To start the Schmidt theory we give a general implicit function lemma, due to Hildebrandt and Graves [20].

Lemma 2:7)

If L is a set and Y a Banach space, and if  $T_{\zeta}(y)$  is a function over  $\zeta \in L$  and  $y \in Y$  into Y such that for all  $\zeta \in L$  there exists some real  $\rho_{\zeta}$ ,  $0 \leq \rho_{\zeta} < 1$  such that

$$2.21) \quad ||T_{\zeta}(y) - T_{\zeta}(y')|| \leq \rho_{\zeta} ||y - y'||$$

whenever  $||y||$  and  $||y'||| < \delta$ , and if for this same positive  $\delta$  we have.  $\theta$  being the zero of Y,

$$2.22) \quad \delta > \frac{1}{1-\rho_{\zeta}} ||T_{\zeta}(\theta)|| \quad \text{over } \zeta \in L$$

then there exists a unique function  $f(\zeta)$  over L into Y such that  $||f(\zeta)|| < \delta$  and

$$2.23) \quad f(\zeta) = T_{\zeta}(f(\zeta)).$$

Moreover,  $f(\zeta) = \lim_{n \rightarrow \infty} T_{\zeta}^n(\theta)$  convergent in Y norm.

Proof

Let  $g_0(\zeta) = \theta$  and  $g_n(\zeta) = T_{\zeta}(g_{n-1}(\zeta))$ , so that  $g_n(\zeta) = T_{\zeta}^n(\theta)$  We note from 2.22) that

$$2.24) \quad ||g_1(\zeta)|| = ||T_{\zeta}(\theta)|| < (1 - \rho_{\zeta})\delta \leq \delta$$

As an induction hypothesis assume  $||g_p(\zeta)|| \leq ||g_1(\zeta)|| \frac{1 - (\rho_{\zeta})^p}{1 - \rho_{\zeta}}$  for  $1 \leq p \leq n$ , which is obvious if  $n = 1$ . By 2.21)

$$2.25) \quad ||g_{n+1}(\zeta) - g_n(\zeta)|| = ||T_{\zeta}(g_n(\zeta)) - T_{\zeta}(g_{n-1}(\zeta))|| \leq \\ \leq \rho_{\zeta} ||g_n(\zeta) - g_{n-1}(\zeta)|| \leq (\rho_{\zeta})^n ||g_1(\zeta)||,$$

since 2.24) and the induction hypothesis insure that

2.21) yields. Thus  $\|g_{n+1}(\xi)\| \leq$   
 $\leq \|\varepsilon_n(\xi)\| + \|g_{n+1}(\xi) - g_n(\xi)\|$  yields

$$2.26) \quad \|g_{n+1}(\xi)\| \leq \|g_1(\xi)\| \left( \frac{1-\rho_\xi^n}{1-\rho_\xi} + \rho_\xi^n \right) =$$

$$= \|g_1(\xi)\| \frac{1-(\rho_\xi)^{n+1}}{1-\rho_\xi}$$

verifying the induction hypothesis.

Now from 2.25) we see that by 2.24)

$$2.27) \quad \|g_{m+n}(\xi) - g_n(\xi)\| \leq \rho_\xi^n (1 + \rho_\xi + \dots + \rho_\xi^{m-1}) \|g_1(\xi)\|$$

$$< \rho_\xi^n (1 - \rho_\xi^m) \delta$$

and  $\{g_n(\xi)\}$  is a Cauchy sequence.  $Y$  being complete, there exists  $f(\xi) \in Y$  so that  $\lim_{n \rightarrow \infty} \|f(\xi) - g_n(\xi)\| = 0$

at each  $\xi \in L$ . Thus by 2.26)

$$\|f(\xi)\| \leq \lim_{n \rightarrow \infty} \sup_p \|g_1(\xi)\| \frac{1-\rho_\xi^n}{1-\rho_\xi} =$$

$$= \|g_1(\xi)\| (1-\rho_\xi)^{-1} < \delta, \text{ and hence}$$

$$2.28) \quad \|T_\xi(f(\xi)) - g_{n+1}(\xi)\| \leq \rho_\xi \|f(\xi) - g_n(\xi)\|.$$

Thus  $T_\xi(f(\xi)) = \lim_{n \rightarrow \infty} g_{n+1}(\xi) = f(\xi)$  as desired.

Also for uniqueness if  $\|h(\xi)\| < \delta$  and

$T_\xi(h(\xi)) = h(\xi)$ , then by 2.21)  $\|f(\xi) - h(\xi)\| \leq \rho_\xi \|f(\xi) - h(\xi)\|$   
 so that  $f(\xi) = h(\xi)$  since  $\rho_\xi < 1$ .

Q. E. D.

For the rest of this chapter we will assume for simplicity that  $S$  is the real line  $(-\infty, +\infty)$  and that arbitrary translates of  $\mu$  measurable sets are  $\mu$  measurable. Letting  $X = I_\infty^\mu(C_n, S)$  as usual, we define  $X_\rho$  as the set of  $u \in X$  such that the norm  $\|u\| = \max_{1 \leq n} (\text{ess sup}_{t \in S} |u_1(t)|) \leq \rho$ . We assume that each

$[P_j(u, \gamma)](t)$  is defined according to type I, II, or III as in 1.15), with convergence uniformly over

$\|\gamma\| \leq \rho_1$  for  $\|u\| \leq \rho$  and with the second partials continuous in  $y_1$  and  $\gamma$  for type III, except that the  $n$  component functions  $u_1(t), \dots, u_n(t)$  replace  $x(t), x^{(1)}(t), \dots, x^{(n-1)}(t)$  there. Then if  $C(t, \tau, \gamma)$  satisfies the conditions for theorem 2:6), for  $\|\gamma\| \leq \rho_1$  we define the non-linear operator  $B_\gamma$  on  $X_\rho$  into  $X$  by

$$2.29) [B_\gamma(u)]_1(t) = \sum_{j=1}^n \int_R C_{1j}(t, \tau, \gamma) [P_j(u, \gamma)](\tau) d\mu(\tau).$$

From 1.18) for all real  $t$  with  $\alpha = 0$  we have

$$2.30) \|B_\gamma(u') - B_\gamma(u)\| \leq M_3 \|u' - u\| (\|u'\| + \|u\|)$$

for  $\|\gamma\| \leq \rho_1$  and  $\|u'\| \leq \frac{1}{3} \rho, \|u\| \leq \frac{1}{3} \rho$ . In the theorems following we assume  $K_{1j}(t, \tau, \gamma)$  real valued on  $S \times S$  and  $y_1(t)$  so on  $S$  if the  $P$ 's are of type III.

Theorem 2:8)

If  $K_\gamma$  satisfies the conditions of theorem 2:5) over  $\|\gamma\| \leq \rho_1$ , then for some positive  $\delta, \rho_2$ , and  $\rho_3$  any  $y \in X$  with  $\|y\| < \rho_3$  and  $\|\gamma\| < \rho_2$  implies the existence of a unique  $u \in X$  with  $\|u\| < \delta < \frac{1}{3} \rho$  satisfying in  $X$

$$2.31) \quad y = u - K_\gamma(u) - B_\gamma(u).$$

Proof

By theorem 2:5) we can find a positive  $\rho_2 < \rho_1$  such that  $V_{1,\gamma}$  exists satisfying 2.21) and 2.13) for  $\|\gamma\| \leq \rho_2$  so that 2.31) is equivalent in  $X$  to

$$2.32) \quad u = y + V_{1,\gamma}(y) + G_\gamma(u),$$

where  $G_\gamma = B_\gamma + V_{1,\gamma} B_\gamma$ .

Now as an  $X$  operator norm,  $\|V_{1,\gamma}\| \leq n \mu(R) M_2$

by 2.12), so from 2.30) we have for  $|||u|||$  and

$$|||u' ||| \leq \frac{1}{3} \rho$$

$$2.33) \quad |||G_\gamma(u') - G_\gamma(u)||| \leq$$

$$\leq (1 + n\mu(R)M_2)M_3 (|||u' ||| + |||u|||) |||u' - u|||.$$

Now we can choose  $\delta > 0$  so that  $\delta < \frac{1}{3} \rho$  and

$$(1+n\mu(R)M_2)M_3(2\delta) \leq \frac{1}{2} \text{ and then } \rho_3 > 0 \text{ so that}$$

$$\delta \geq 2(1 + n\mu(R)M_2)\rho_3 \text{ which implies for } |||y||| < \rho_3$$

$$2.34) \quad \delta > \frac{1}{1-1/2} |||y + V_{1,\gamma}(y)|||.$$

But  $T_y(u) = y + V_{1,\gamma}(y) + G_\gamma(u)$  thus satisfies the conditions of lemma 2:7), so 2.32) and hence 2.31) has the desired solution.

Q. E. D.

Theorem 2:9)

If  $K_\gamma$  only satisfies the conditions of theorem 2:6) over  $|||\gamma||| \leq \rho_1$ , then for some positive  $\delta, \rho_2$ , and  $\rho_3$  with  $\delta < \frac{1}{3} \rho$  there exists a function  $f(y, z_1, \dots, z_m, \gamma)$  into  $X$  over complex  $z_p$  (real for P's of type III) and  $y \in X$  with  $|||y||| < \rho_3, |z_p| < \rho_3$  and  $|||\gamma||| < \rho_2$  such that:

:1) If for such  $y, z_p$ , and  $\gamma$  the  $m$  equations 2.35) below are satisfied, then  $u = f(y, z_1, \dots, z_m, \gamma)$  satisfies 2.31) in  $X$  and  $z_p = (u, p^\psi)$  for  $p = 1, 2, \dots, m$ .

:2) If for such  $y$  and  $\gamma$  we have  $u \in X_\delta$  satisfying 2.31) in  $X$ , and if  $z_p = (u, p^\psi)$  have  $|z_p| < \rho_3$ , then  $u = f(y, z_1, \dots, z_m, \gamma)$  and  $y, z_1, \dots, z_m, \gamma$  satisfy equations 2.35).

$$2.35) \quad \left( y + W_{1,\gamma}(y), r^\psi \right) - \sum_{p=1}^m z_p \left( p^\psi + W_{1,\gamma}(p^\psi), r^\psi \right) + \left( H_\gamma(f(y, z_1, \dots, z_m, \gamma)), r^\psi \right) = z_r$$

for  $r=1,2,\dots,m$ , where  $\mathbf{E}_\gamma$  is defined by 2.18),  $\mathbf{W}_{\lambda,\gamma}$  is the resulting  $\mathbf{V}_{\lambda,\gamma}$  of theorem 2:5) if  $\mathbf{E}_\gamma$  replaces  $\mathbf{K}_\gamma$ , and  $\mathbf{H}_\gamma = \mathbf{B}_\gamma + \mathbf{W}_{1,\gamma} \mathbf{B}_\gamma$ .

Proof

First from 2.18) we see 2.31) is equivalent to

$$2.36) \quad y - \sum_{p=1}^m z_p p^\psi = u - \mathbf{E}_\gamma(u) - \mathbf{B}_\gamma(u)$$

with  $z_p = (u, p^\varphi)$ , which in turn is equivalent to

$$2.37) \quad y + \mathbf{W}_{1,\gamma}(y) - \sum_{p=1}^m z_p \{ p^\psi + \mathbf{W}_{1,\gamma}(p^\psi) \} + \mathbf{H}_\gamma(u) = u$$

for sufficiently small  $\|\gamma\|$  by theorem 2:5), since 2.19 shows  $\mathbf{E}_\gamma$  satisfies the needed conditions.

Now  $\mathbf{H}_\gamma$  satisfies exactly similar conditions to  $\mathbf{G}_\gamma$  of 2.32), so for given arbitrary  $z_p$  equation 2.37) can be solved exactly like 2.32),  $f(y, z_1, \dots, z_m, \gamma)$  being the solution. But taking the inner product in  $L_2^\mu(C_n, \mathbb{R})$  of 2.37) with  $r^\varphi$  yields 2.35), so the theorem is proved.

Q. E. D.

We note by uniqueness that  $f(0, 0, \dots, 0, \gamma) = 0$ , and hence that  $y = 0$  and  $z_1 = z_2 = \dots = z_m = 0$  is a trivial solution of 2.35).

The following lemma considerably simplifies the computation necessary to solve the  $m$  equations 2.35).

Lemma 2:10)

Under the conditions of theorem 2:9)

$$2.38) \quad p^\psi + \mathbf{W}_{1,0}(p^\psi) = -p^\varphi, \quad r^\varphi + \mathbf{W}_{1,0}^*(r^\varphi) = -r^\psi \text{ at} \\ \text{least over } t \in \mathbb{R},$$

$$\left( p^\psi + \mathbf{W}_{1,0}(p^\psi), r^\varphi \right) = -\delta_{p,r},$$

$$\left( \mathbf{H}_0(u), r^\varphi \right) = -\left( \mathbf{B}_0(u), r^\psi \right)$$

Proof

$(\mathbf{I} - \mathbf{E}_0)_p \varphi = {}_p \varphi - \mathbf{K}_0({}_p \varphi) - {}_p \psi = - {}_p \psi$  by 2.18),  
 so by 2.13)  ${}_p \psi + \mathbf{W}_{1,0}({}_p \psi) = (\mathbf{I} - \mathbf{E}_0)^{-1}({}_p \psi) = -{}_p \varphi$ .

For the second equation to be proved we put

$v = (\mathbf{I} - \mathbf{E}_0)^{-1}(u)$  for any  $u \in L_2^\mu(C_{n,m}, \mathbb{R})$ ,

$$\begin{aligned}
 v - \mathbf{K}_0(v) &= v - \mathbf{E}_0(v) + \sum_{p=1}^m (v, {}_p \varphi) {}_p \psi = \\
 &= u + \sum_{p=1}^m (v, {}_p \varphi) {}_p \psi. \\
 (u, {}_p \psi) &= - (v, {}_p \varphi) + (v - \mathbf{K}_0(v), {}_p \psi) = \\
 &= - (v, {}_p \varphi) + (v, {}_p \psi - \mathbf{K}_0^*({}_p \psi)) \\
 &= - (v, {}_p \varphi) = - (u, {}_p \varphi + \mathbf{W}_{1,0}^*({}_p \varphi))
 \end{aligned}$$

2.39)

thus results from  $\{{}_p \psi\}$  orthonormality,  $\psi = \mathbf{K}_0^*(\psi)$  and 2.13). Thus  ${}_p \psi = {}_p \varphi + \mathbf{W}_{1,0}^*({}_p \varphi)$  as elements of the Hilbert space  $L_2^\mu(C_n, \mathbb{R})$ , which gives the result.

Q. E. D.

We see that theorem 2:9) reduces the original integral equation 2.31) to the  $m$  complex scalar equations 2.35), which then can be solved by standard implicit function theorems. These scalar equations are called the branch equations, following Schmidt and Iglisch [17], [18], [19]. In case the  $\mathbf{B}_\gamma$  are defined by  $P$ 's of type I or II, then it is obviously possible to speak about the terms of  $\mathbf{B}_\gamma(u)$  having a specified formal degree in  $u$ . Thus we may then define

$${}_1^w(y, z_1, \dots, z_m, \gamma) = y + W_{1,\gamma}(y) - \sum_{p=1}^m z_p \{ \psi_p + W_{1,\gamma}(\psi_p) \}$$

$$q^w(y, z_1, \dots, z_m, \gamma) = q \text{ degree terms of } y, z_1, \dots, z_m$$

$$\text{in } H_\gamma \left( \sum_{\nu=1}^{q-1} \nu^w \right),$$

$$2.40) \quad h^\nu(y, \gamma) = \text{coefficient of } (z_1)^{h_1} (z_2)^{h_2} \dots (z_m)^{h_m}$$

$$\text{in } |h|^w,$$

$${}_p L_k(\gamma) = (h^\nu(0, \gamma), {}_p \varphi) \text{ for } h_0 = 0.$$

Here  $h_\nu \geq 0$ ,  $h = (h_0, h_1, \dots, h_m)$  is a multiple index with  $|h| = h_0 + h_1 + \dots + h_m$ , so that  $h_0$  is the formal degree of  $y$  in  $h^\nu$ , and  $k = (h_1, \dots, h_m)$ .

With these definitions it can be proved, by using the technique of the majorant analogously to Schmidt [17], that actually for P's of type I or II

$$2.41) \quad f(y, z_1, \dots, z_m, \gamma) =$$

$$= \sum_{\nu=1}^{\infty} \left\{ \sum_{|h|=\nu} (z_1)^{h_1} \dots (z_m)^{h_m} h^\nu(y, \gamma) \right\}$$

convergent in X norm for sufficiently small  $\|y\|$ ,  $\|\gamma\|$  and  $|z_p|$ . Also the branch equations 2.35) now become, for  $y = 0$ ,

$$2.42) \quad z_p = \sum_{\nu=1}^{\infty} \left\{ \sum_{|h|=\nu} (z_1)^{h_1} \dots (z_m)^{h_m} {}_p L_h(\gamma) \right\},$$

$$p = 1, \dots, m.$$

The L's here are known as the Schmidt L numbers. We note that  ${}_1^w(y, z_1, \dots, z_m, \gamma)$  can always be defined by 2.40) regardless of  $B_\gamma$ , and that in general for P's of type III by using the Taylor expansion form of the mean value theorem we can define  ${}_1^w$  and thus  ${}_1 L$  for  $\nu < q$  if the P's have  $q$  th order continuous partials

in a neighborhood about the origin. Actually if for type III P's we only required first order differentiability, then in place of 1.18) we would have

$$2.43) \quad | [P(x_1)](t) - [P(x_2)](t) | \leq \\ \leq \|x_1 - x_2\|_{\alpha} e^{-\alpha t} \delta (\|x_1\|_{\alpha}, \|x_2\|_{\alpha})$$

where  $\delta(\rho, \rho') \rightarrow 0$  as  $\rho$  and  $\rho' \rightarrow 0+$  with a similar alteration of 2.39). This condition would still be enough to get theorem 2:9), since lemma 2:7) is still applicable, but not enough for theorem 1:8) due to replacing  $e^{-2\alpha t}$  in 1.18) by  $e^{-\alpha t}$ .

This terminates the generalization of the results of Schmidt which we needed here to attack our problem.

CHAPTER III

We now wish to construct the connection between the results of chapter II, chiefly theorem 2:9), and our original non-linear delay differential equation 1.15), and then to solve the branch equations 2.35) under the resulting special conditions.

First we note that for arbitrary positive  $\omega$  by making the transformation  $u_j(t) = \omega^{j-1} \frac{d^{j-1}}{dt^{j-1}} x(\frac{t}{\omega}) = x^{(j-1)}(\frac{t}{\omega})$  we can write 1.15) in the vector form

$$\frac{du_j(t)}{dt} = \frac{1}{\omega} u_{j+1}(t) \quad , \quad j < n, \\ 3.1) \quad \frac{du_n(t)}{dt} = - \frac{1}{\omega} \left\{ \sum_{k=0}^{n-1} \int_{0 \leq h}^{\infty} u_{k+1}(t-\omega h) dF_k(h) \right\} - \\ - \frac{1}{\omega} [P_n(u, \omega)](t)$$

conditions 1.4) and 1.5) being assumed satisfied from now on. Here  $[P_n(u, \omega)](t)$  is defined from the  $[P(x)](t)$  of 1.15) by replacing  $x^{(j-1)}(t-b_p)$  by  $u_j(t-\omega b_p)$  in 1.16), and  $x^{(j-1)}(t-h_j)$  by  $u_j(t-\omega h_j)$  in 1.17).

Since we are looking for periodic solutions we have  $x(t + \frac{2\pi}{\omega}) = x(t)$ , or thus the boundary conditions

$$3.2) \quad u(t + 2\pi) = u(t).$$

We also sometimes impose the stronger condition

$$3.3) \quad u(t + \pi) = -u(t).$$

Following Courant and Hilbert, [31], p.304, we see that  $G_\sigma(t - \tau)$  for  $\sigma > 0$  is the Green function for the operator  $\frac{dy}{dt} + \sigma y$  and the boundary condition 3.2), where

$$G_\sigma(t) = \frac{\exp(-\sigma t)}{1 - \exp(-2\sigma\pi)} \quad \text{for } 0 \leq t < 2\pi$$

3.4)  $G_\sigma(t + 2\pi) = G_\sigma(t)$  is the extension elsewhere. Similarly for  $\frac{dy}{dt}$  and the boundary condition 3.3) we have  $H(t - \tau)$  the Green function, where

$$3.5) \quad H(t) = \frac{1}{2} \quad \text{for } 0 \leq t < \pi, \quad H(t + \pi) = -H(t) \quad \text{elsewhere.}$$

Thus we easily see that 3.2) and the vector equation 3.1) are equivalent to  $u \in L_\infty(C_n, (-\infty, \infty))$  and over  $-\infty < t < +\infty$

$$u_j(t) = \int_0^{2\pi} G_1(t - \tau) \{u_j(\tau) + \frac{1}{\omega} u_{j+1}(\tau)\} d\tau,$$

$$j < n,$$

3.6)

$$u_n(t) = \int_0^{2\pi} \left\{ -\frac{1}{\omega} \left\{ \sum_{k=0}^{n-1} u_{k+1}(\tau) \int_{0 \leq h}^{\infty} G_1(t - \omega h - \tau) dF_k(h) \right\} \right. \\ \left. G_1(t - \tau) u_n(\tau) - \frac{1}{\omega} G_1(t - \tau) [P_n(u, \omega)](\tau) \right\} d\tau,$$

by using the Fubini theorem and 3.2) in order to shift the lag  $-\omega h$  from the unknown vector function  $u$  into the  $G_1$  kernel. Here both 3.1) and 3.6) need

$\| \| u \| \| \leq \rho$  for  $[P_n(u, \omega)](t)$  to be defined.

Similarly if  $P_n(u)$  is odd,  $P_n(-u, \omega) = -P_n(u, \omega)$ , 3.1) and the boundary condition 3.3) are equivalent to  $u \in L_\infty(C_n, (-\infty, \infty))$  and on  $(-\infty, +\infty)$

$$u_j(t) = \frac{1}{\omega} \int_0^{\cdot \Pi} H(t-\tau) u_{j+1}(\tau) d\tau, \quad j < n,$$

$$3.7) \quad u_n(t) = - \frac{1}{\omega} \left\{ \begin{array}{l} \int_0^{\cdot \Pi} H(t-\tau) [P_n(u, \omega)](\tau) + \\ \sum_{k=0}^{n-1} u_{k+1}(\tau) \int_{0 \leq h}^{\infty} H(t+\omega h-\tau) d F_k(h) \end{array} \right\} d\tau$$

Now in 3.6 or 3.7) we assume that  $F_k(h) = F_k(h, \eta)$  is a real valued function of a real parameter  $\eta$  such that over  $|\eta| \leq b$  and  $0 \leq h$

$$3.8) \quad | d F_k(h, \eta') - d F_k(h, \eta) | \leq |\eta' - \eta| d \bar{\phi}(h)$$

where  $\bar{\phi}(h)$  is monotone increasing over  $0 \leq h$ ,  $\bar{\phi}(0) = 0$ ,  $\bar{\phi}(+\infty) < +\infty$ . By taking  $\eta' = 0$ , 3.8) shows the measure  $|dF_k(h, \eta)|$  to be dominated over  $[0, \infty)$  by the measure  $b d\bar{\phi}(h) + |dF_k(h, 0)|$  for all  $\eta$  such that  $|\eta| \leq b$ .

Now put the two dimensional parameter  $(\omega - \omega_1, \eta) = \gamma$  for some  $\omega_1 > b > 0$ , and let  $K_\gamma$  be the operator defined as the linear part of the integral operator in 3.6) or 3.7). From 3.8) and dominated convergence in 2.7), we see that with  $R = [0, \pi]$  or  $[0, 2\pi]$

$$\lim_{\|\gamma' - \gamma\| \rightarrow 0} N(K_\gamma - K_{\gamma'}) = 0. \quad \text{Hence } \| \| K_\gamma - K_{\gamma'} \| \| \leq N(K_\gamma - K_{\gamma'})$$

shows that  $K_\gamma$  satisfies the conditions of theorems 2:8) or 2:9) over  $\|\gamma\| \leq b$ . Thus if we also assume that

$[P_n(u, \omega)](t) = [P_n(u, \omega, \eta)](t)$  is a function of  $\eta$  such that for type III the second partials of  $Q$  are continuous in  $y_1$  and  $\eta$  and for I or II the power series convergence holds uniformly over  $|\eta| \leq b$ , then 2.30) follows and theorems 2:8) or 2:9) apply to equations 3.6) and 3.7). Since  $y = 0$ , if 2:8) applies we have the unique solution  $u = 0$ ; if 2:9) applies we merely have to solve the  $m$  complex scalar equations 2.35) to get the solution.

It should be noted that the Schmidt procedure used here appears to be the only way of attacking 1.15) for periodic solutions. At first one might think Poincare's method of small parameters would apply, [26], pages 35, 114, 194. However, there the solution is analytic in the initial conditions at a time  $t_0$ , whereas we have seen the general solution of 1.15) to depend upon a  $\phi(t)$  over the whole interval  $t_0 - L' < t < t_0$ . Also we actually need the general Fredholm theory developed in theorem 2:5). For since the  $K_\gamma$  in 3.6) and 3.7) turn out not to be normal, the spectral resolution is not available. Also since the kernel matrices do not commute, the original Fredholm formulae for the resolvent kernel do not apply, and we seem forced to rely on the general Riesz theory, [21].

Turning to the solution of equation 2.35), we define  $D_\eta(s) = \sum_{k=0}^{n-1} s^k \int_{0 \leq h}^{\infty} e^{-sh} dF_k(h, \eta)$  as in 1.9) and assume for simplicity hereafter that

3.9)  $D_0(i\omega_1) = 0$ ,  $D_0(i\nu\omega_1) \neq 0$  for integer  $\nu \neq \pm 1$  in case of 3.6) or condition 3.2), and that

3.10)  $D_0(1 \omega_1) = 0$ ,  $D_0(1(2\nu + 1)\omega_1) \neq 0$  for  
 integer  $\nu \neq 0, -1$

in case of 3.7) or condition 3.3).

We here can allow  $D_0(1 \omega) = 0$  for any other real  $\omega$  if 3.9) or 3.10) still hold, and indeed this can happen, usually with  $\frac{\omega}{\omega_1}$  irrational, for any number of real  $\omega$  by proper choice of  $F_k(h,0)$  as has been experimentally investigated by Blumberg and Minorsky, [32].

Under these conditions we now have the following lemma.

Lemma 3:1)

$\lambda = 1$  is in the point spectrum of  $K_0$  with  $m = 2$ , and  $1\varphi, 2\varphi, 1\psi, 2\psi$  can be taken as follows:

$$\tilde{\varphi}_j = (1 \omega_1)^{j-1}, \tilde{\psi}_j = - \sum_{k=0}^{j-1} (-1 \omega_1)^{k-j} \int_{0 \leq h}^{\infty} e^{i\omega_1 h} dF_k(h,0),$$

$$3.11) \quad 1\psi_j(t) = \mathcal{R}[e^{it} c_1 \tilde{\psi}_j], \quad 2\psi_j(t) = \mathcal{L}[e^{it} c_1 \tilde{\psi}_j],$$

$$1\varphi_j(t) = \mathcal{R}[e^{it} c_2 \tilde{\varphi}_j], \quad 2\varphi_j(t) = \mathcal{L}[e^{it} c_2 \tilde{\varphi}_j],$$

where  $c_1 = (\pi \sum_{j=1}^n |\tilde{\psi}_j|^2)^{-1/2}$ ,  $c_2 = (\pi \sum_{j=1}^n |\tilde{\varphi}_j|^2)^{-1/2}$  for 3.6),

and  $c_1 = (\frac{\pi}{2} \sum_{j=1}^n |\tilde{\psi}_j|^2)^{-1/2}$ ,  $c_2 = (\frac{\pi}{2} \sum_{j=1}^n |\tilde{\varphi}_j|^2)^{-1/2}$

for 3.7).

Proof

The first conclusion comes from the equivalence of the linear part of 3.6) or 3.7 with the linear part of 1.15) and 3.2) or 3.3), and by using conditions 3.9) or 3.10) with corollary 1:7).

Equations 3.11) then follow by an obvious computation of the known sinusoidal solutions of the equivalent linear differential equations, the adjoint one for both 3.6) and 3.7) being

$$3.12) \quad \psi_1'(t) = -\frac{1}{\omega_1} \psi_{1-1}(t) + \frac{1}{\omega_1} \int_0^{\infty} \psi_n'(t + \omega_1 h) dF_{1-1}(h, 0),$$

with  $\psi_0(t) = 0$  as definition.

Q. E. D.

From lemma 3:1) we see that for our problem 2.35) becomes simply two equations in  $z_1, z_2, \omega$ , and  $\eta$  with  $y = 0$ . Actually there is a further simplification since 1.15) or 3.1) is autonomous. For then if  $u(t)$  is a vector solution of 3.1) and the appropriate boundary condition, so is  ${}_{\theta}u(t)$  for any real  $\theta$  where  ${}_{\theta}u(t) = u(t - \theta)$ . Now it is easily verified from 3.11), since  $({}_{\theta}u, \varphi) = (u, {}_{-\theta}\varphi)$  by using the boundary conditions 3.2) or 3.3), that

$$3.13) \quad ({}_{\theta}u, {}_2\varphi) = (u, {}_2\varphi) \cos \theta + (u, {}_1\varphi) \sin \theta$$

Thus if we restrict ourselves to real valued solutions, as we will do from now on,  $\frac{(u, {}_2\varphi)}{(u, {}_1\varphi)}$  is real so that  $\theta = \arctan \left( -\frac{(u, {}_2\varphi)}{(u, {}_1\varphi)} \right)$  yields  $z_2 = ({}_{\theta}u, {}_2\varphi) = 0$ .

Thus with  $z = z_1$  and after dividing by  $z$  to remove the trivial  $z = 0$  solution noted before, 2.35) reduces to

$$3.14) \quad \begin{aligned} 1 &= {}_1L_{1,0}(\omega, \eta) + \frac{1}{z} (\mathbf{H}_{\gamma}(f(0, z, 0, \gamma)), {}_1\varphi) \\ 0 &= {}_2L_{1,0}(\omega, \eta) + \frac{1}{z} (\mathbf{H}_{\gamma}(f(0, z, 0, \gamma)), {}_2\varphi) \end{aligned}$$

where now  $z, \omega$ , and  $\eta$  are to be real,  $\gamma = (\omega - \omega_1, \eta)$ .

In order to get a theorem on the solution of 3.14), we greatly strengthen 3.8) by assuming for simplicity  $dF_k(h, \eta) = g_k(h, \eta)d\tilde{F}_k(h)$ ,  $\tilde{F}_k(h)$  to be of bounded variation on  $[0, \infty)$ , and  $g_k(h, \eta)$ ,  $\frac{\partial}{\partial \eta} g_k(h, \eta)$ , and  $\frac{\partial^2}{\partial \eta^2} g_k(h, \eta)$  to exist continuous in  $\eta$  at all  $h$  and to be Borel measurable over  $h$  and bounded absolutely by  $f(h)$  for  $|\eta| \leq b$  such that  $\int_0^\infty f(h)|d\tilde{F}_k(h)| < +\infty$ .

Also for  $P_n(u, \omega, \eta)$  we require if it is of type III that the third or less order partials of  $Q(y_1, \eta)$  in  $y_1$  must possess first partials in  $\eta$  which are simultaneously continuous in  $y_1$  and  $\eta$  over  $|y_1| \leq \rho, |\eta| \leq b$ . If  $P_n(u, \omega, \eta)$  is of type I or II, we require in 1.17) that

$$\sum_{|p| \geq 2} \rho^{|p|-2} \int_0^\infty \dots \int_0^\infty \left| \begin{array}{c} d\bar{\phi}_{p_1, \dots, p_n}(h_1, \dots, h_n, \eta') \\ -d\bar{\phi}_{p_1, \dots, p_n}(h_1, \dots, h_n, \eta) \end{array} \right| < \\ < | \eta' - \eta | M'$$

for  $|\eta|$  and  $|\eta'| \leq b$ . Thus in either case we always have

$$3.15) \quad |||P_n(u, \omega, \eta') - P_n(u, \omega, \eta)||| \leq |\eta' - \eta| |||u|||^2 M_1.$$

Under these assumptions, and with  $L'$  defined as the sup over  $|\eta| \leq b$  of that in the definition of admissible  $\phi(t)$  for equation 1.15), we now have the following theorem.

Theorem 3:2)

If  $L'$  is finite and if the Jacobian  $J \neq 0$ , where

$$3.16) \quad J = {}_1L_{2,0}(\omega_1, 0) {}_2L'_{1,0}(\omega_1, 0) \\ - {}_2L_{2,0}(\omega_1, 0) {}_1L'_{1,0}(\omega_1, 0),$$

then there exist some positive  $\rho_4$  and  $\rho_5$  such that for any real  $\eta$ ,  $|\eta| < \rho_4$  there exist  $z(\eta)$  and  $\omega(\eta)$  unique real valued solutions of 3.14) in  $|z| < \rho_5$  and  $|\omega - \omega_1| < \rho_5$ .

Furthermore, defining  $\tilde{z}(\eta)$  and  $\tilde{\omega}(\eta)$  by

3.17)

$$\tilde{z}(\eta) = J^{-1} A \eta,$$

$$A = {}_2L_{1,0}(\omega_1, 0) {}_1L_{1,0}(\omega_1, 0) {}_1L_{1,0}(\omega_1, 0)^{-1} {}_1L_{1,0}(\omega_1, 0) {}_2L_{1,0}(\omega_1, 0)$$

$$\tilde{\omega}(\eta) = \omega_1 + J^{-1} B \eta,$$

$$B = {}_2L_{2,0}(\omega_1, 0) {}_1L_{1,0}(\omega_1, 0) {}_1L_{2,0}(\omega_1, 0) {}_2L_{1,0}(\omega_1, 0)$$

we have as  $\eta \rightarrow 0$  that

$$\omega(\eta) - \tilde{\omega}(\eta) = o(\eta^2) \text{ and } z(\eta) - \tilde{z}(\eta) = o(\eta^2).$$

Proof

I) First we need to show that the first order Schmidt L numbers possess continuous first partial derivatives in  $\omega$  and  $\eta$  about  $(\omega_1, 0)$ , so that 3.16) and 3.17) have meaning. First from 2.40),  ${}_1L(\omega, \eta) = ({}_1v(\omega, \eta), {}_1\psi)$

and  ${}_1v(\omega, \eta) = -(\mathbf{I} - \mathbf{E}_{\omega, \eta})^{-1}({}_1\psi)$ , or thus

$${}_1v(\omega, \eta) - \mathbf{K}_{\omega, \eta}({}_1v(\omega, \eta)) = ({}_1L_{1,0}(\omega, \eta) - 1) {}_1\psi +$$

$+ {}_2L_{1,0}(\omega, \eta) {}_2\psi$ . But the equivalent differential equations are known to be

$${}_1v'_j(t) - \frac{1}{\omega} {}_1v_{j+1}(t) = ({}_1\sigma - 1) {}_1\psi'_j(t) + {}_2\sigma {}_2\psi'_j(t),$$

$$j < n,$$

3.18)

$${}_1v'_n(t) + \frac{1}{\omega} \sum_{k=0}^{n-1} \int_{0 \leq h}^{\infty} {}_1v_{k+1}(t-\omega h) dF_k(h, \eta) =$$

$$= ({}_1\sigma - 1) {}_1\psi'_n(t) + {}_2\sigma {}_2\psi'_n(t)$$

with the appropriate boundary condition 3.2) or 3.3), where we also require

$$3.19) \quad {}_1\sigma = ({}_1v, {}_1\varphi) \quad \text{and} \quad {}_2\sigma = ({}_1v, {}_2\varphi).$$

Now we know  ${}_1v(\omega, \eta, t) = -{}_1\psi(t) - [W_{\omega, \eta}({}_1\psi)](t)$  to be the unique solution of 3.18) and 3.19), so  ${}_1v_j(t)$  and hence  ${}_1v'_j(t)$  by 3.18) are continuous, and thus  ${}_1v'(t) \in L_2(C_{\eta}, [0, 2\pi])$ . Hence term by term differentiation of the Fourier series for  ${}_1v_j(t)$  is valid, and hence by taking Fourier coefficients of 3.18) and using 3.11) the uniqueness of the solution shows

$$3.20) \quad {}_1v_j(t) = \alpha_j \sin t + \beta_j \cos t.$$

But substituting 3.20) in 3.18) now shows that

$$\alpha_j \text{ and } \beta_j \text{ are rational functions of } \omega, \int_{0 \leq h}^{\infty} \cos(\omega h) dF_k(h, \eta), \text{ and } \int_{0 \leq h}^{\infty} \sin(\omega h) dF_k(h, \eta) \text{ and}$$

linear in  $\sigma_1$  and  $\sigma_2$  with an added constant. Thus finally substituting in 3.19) determines  ${}_1\sigma = {}_1L_{1,0}(\omega, \eta)$

and  ${}_2\sigma = {}_2L_{1,0}(\omega, \eta)$  as rational functions of  $\omega$ ,

$$\int_{0 \leq h}^{L'} \cos(\omega h) dF_k(h, \eta), \text{ and } \int_{0 \leq h}^{L'} \sin(\omega h) dF_k(h, \eta).$$

Since  ${}_1L_k(\gamma)$  and  ${}_2L_k(\gamma)$  are always continuous in  $\gamma$  from theorem 2:6) and 2:5) proofs, so that there are no zeros in the denominators of these rational functions, this gives our result from the assumed differentiability and  $L' < +\infty$ .

II) In order to solve 3:14) we first need some Lipschitz conditions in order to apply lemma 2:7). First consider the integral  $\int_0^{2\pi} |G_1(t-\tau-\omega'h) - G_1(t-\tau-\omega h)| d\tau$

for  $|\omega' - \omega| \leq b$ ,  $|\omega - \omega_1| \leq b$ , and  $0 \leq h \leq L'$ . This is bounded by  $2\pi \leq |\omega' - \omega| L'$  if  $|\omega' - \omega| L' \geq 2\pi$ , and if not by  $|\omega' - \omega| h (1 + 2\pi \frac{1}{1 - e^{-2\pi}}) \leq |\omega' - \omega| L' (1 + \frac{2\pi}{1 - e^{-2\pi}})$ , since  $|\omega' - \omega| h$  is the length of the  $\tau$  interval over which  $t - \tau - \omega'h$  and  $t - \tau - \omega h$  are separated by a multiple of  $2\pi$  and  $\frac{1}{1 - e^{-2\pi}}$  is a bound for  $G_1'(y)$  when no separation occurs. A similar estimate holds for  $H(t - \tau - \omega h)$ , so that for either 3.6) or 3.7) we have by  $L' < +\infty$  and 3.8)

$$3.21) \quad |||E_{\gamma'}(u) - E_{\gamma}(u)||| = |||K_{\gamma'}(u) - K_{\gamma}(u)||| \leq \\ \leq |||u||| (|\omega' - \omega| + |\eta' - \eta|) M_1$$

for all  $|||\gamma'|$  and  $|||\gamma||| \leq b$ . Thus by 2.13) as  $X$  operators, 2.1) shows that for  $|||\gamma'| \leq b_1$  and  $|||\gamma||| \leq b_1$  we have

$$3.22) \quad |||W_{1,\gamma'} - W_{1,\gamma}||| \leq (|\omega' - \omega| + |\eta' - \eta|) M_2.$$

Now for  $u \in X$  define  ${}_h u(t) = u(t + h)$  for real  $h$ , and  $|||u|||_d = \sup_{h \neq 0} \left( \frac{1}{|h|} |||{}_h u - u||| \right)$ . We see as in 2.30)

$$|||B_{\omega',\eta}(u) - B_{\omega,\eta}(u)||| \leq \\ \leq 2 M_3 |||u||| \left( \sup_{0 \leq h \leq L'} |||u - (\omega' - \omega)h u||| \right) \leq \\ \leq M_3' |||u||| |||u|||_d |\omega' - \omega| L',$$

so that by  $L' < +\infty$  and 3.15)

$$3.23) \quad ||| \mathbf{B}_{\gamma_1}(u) - \mathbf{B}_{\gamma}(u) ||| \leq \\ \leq M_4 |||u||| (|\omega' - \omega| ||u||_d + |\eta' - \eta| ||u||),$$

and hence by 3.22) a similar result holds for

$$\mathbf{H}_{\gamma} = \mathbf{B}_{\gamma} + \mathbf{W}_{1,\gamma} \mathbf{B}_{\gamma}.$$

Now in the proof of theorem 2:9), we see that  $f(0, z, 0, \gamma)$  is always defined as the solution of 2.37) or 2.36) even if 2.35) fails, so

$$\dot{f} = \mathbf{E}_{\gamma}(f) - z \dot{\psi} + \mathbf{B}_{\gamma}(f)$$

Now  $|| \mathbf{E}_{\gamma}(u) ||_d \leq M |||u|||$  and  $|| \mathbf{B}_{\gamma}(f) ||_d \leq M |||P_n(f, \gamma)|||$  similarly to the 3.21) argument. Thus by 1.18) we have

$$3.24) \quad |||f(0, z, 0, \gamma)||_d \leq |z| ||\dot{\psi}|| + M |||f||| \leq M_5 |z|,$$

since by 2.26) in lemma 2:7), with  $g_1(\xi) = z$  and  $\rho_{\xi} = \frac{1}{2}$  in theorems 2:8) and 2:9), we have

$$3.25) \quad |||f(0, z, 0, \gamma)||| \leq 2 |||\dot{\psi}||| |z| = M_6 |z|.$$

Now again from 2.37) for  $f$ , we see

$$f(0, z, 0, \gamma) + z \{ \dot{\psi} + \mathbf{W}_{1,\gamma}(\dot{\psi}) \} = \mathbf{H}_{\gamma}(f(0, z, 0, \gamma))$$

for  $|z|$  and  $||\gamma||$  small, and thus by 3.22), 3.23),

3.24), 2.30), and 3.25) we have the bootstrap inequality

$$3.26) \quad \begin{aligned} & \left\| \left\| \begin{aligned} & f(0, z', 0, \gamma) + z' \{ \dot{\psi} + \mathbf{W}_{1,\gamma}(\dot{\psi}) \} \\ & - f(0, z, 0, \gamma) - z \{ \dot{\psi} + \mathbf{W}_{1,\gamma}(\dot{\psi}) \} \end{aligned} \right\| \right\| = \\ & = \left\| \left\| \mathbf{H}_{\gamma'}(f(0, z', 0, \gamma')) - \mathbf{H}_{\gamma}(f(0, z, 0, \gamma)) \right\| \right\| \leq \\ & \leq \left\| \left\| \mathbf{B}_{\gamma'}(f') - \mathbf{B}_{\gamma}(f') \right\| \right\| + \left\| \left\| \mathbf{B}_{\gamma}(f') - \mathbf{B}_{\gamma}(f) \right\| \right\| + \\ & + \left\| \left\| \mathbf{W}_{1,\gamma'} \mathbf{B}_{\gamma'}(f') - \mathbf{W}_{1,\gamma} \mathbf{B}_{\gamma}(f') \right\| \right\| + \end{aligned}$$

$$\begin{aligned}
& + \left\| \left\| W_{1,\gamma'} B_{\gamma'}(f') - W_{1,\gamma} B_{\gamma}(f') \right\| \right\| \\
& + \left\| \left\| W_{1,\gamma} B_{\gamma}(f') - W_{1,\gamma} B_{\gamma}(f) \right\| \right\| \\
& \leq M_7^1 (|z'| + |z|)^2 (|\omega' - \omega| + |\eta' - \eta|) \\
& + M_7^1 (|z'| + |z|) \left\| \left\| f' - f \right\| \right\|
\end{aligned}$$

for  $|z'|$ ,  $|z|$ ,  $|\gamma'|$  and  $|\gamma|$  sufficiently small. Thus

$$\begin{aligned}
& \text{since } \left\| \left\| z' \{ \psi + W_{1,\gamma'}(\psi) \} - z \{ \psi + W_{1,\gamma}(\psi) \} \right\| \right\| \leq \\
& \leq M_8^1 [ |z' - z| + (|z'| + |z|)(|\omega' - \omega| + |\eta' - \eta|) ],
\end{aligned}$$

by choosing  $|z'| + |z| \leq \frac{1}{2} M_7^1$  and substituting back into 3.26) with the triangle inequality we get

$$\begin{aligned}
& \left\| \left\| f(0, z', 0, \gamma') - f(0, z, 0, \gamma) \right\| \right\| \leq \\
3.27) \quad & \leq [ |z' - z| + (|z'| + |z|)(|\omega' - \omega| + |\eta' - \eta|) ] M_8.
\end{aligned}$$

Putting this back into 3.26) we have

$$\begin{aligned}
3.28) \quad & \left\| \left\| \begin{aligned} & f(0, z', 0, \gamma') + z' \{ \psi + W_{1,\gamma'}(\psi) \} \\ & - f(0, z, 0, \gamma) - z \{ \psi + W_{1,\gamma}(\psi) \} \end{aligned} \right\| \right\| \leq \\
& \leq (|z'| + |z|) \left[ |z' - z| + (|z'| + |z|)(|\omega' - \omega| + |\eta' - \eta|) \right] M_7
\end{aligned}$$

for  $|z'|$ ,  $|z|$ ,  $|\gamma'|$ , and  $|\gamma|$  sufficiently small.

Q. E. D. (II)

III) As additional notation define  $\hat{B}_\gamma = 2$ nd order operator terms only in  $B_\gamma$ . Thus  $B'_\gamma = B_\gamma - \hat{B}_\gamma$  has like 2.30) and 3.23) by the three times differentiability assumption,

$$\| \| B'_\gamma(u') - B'_\gamma(u) \| \| \leq \left( \| \| u' \| \| + \| \| u \| \| \right)^2 \| \| u' - u \| \| M_9;$$

3.29) 
$$\| \| B'_{\gamma'}(u) - B'_\gamma(u) \| \| \leq \| \| u \| \| \left( \| \| u \| \| |\omega' - \omega| + \| \| u \| \| |\eta' - \eta| \right)$$

for  $\| \gamma \|$ ,  $\| \| u' \| \|$ , and  $\| \| u \| \|$  sufficiently small. We also define  $\check{H}_\gamma = \check{B}_\gamma + W_{1,\gamma} \check{B}_\gamma$ ,  $H'_\gamma = H_\gamma - \check{H}_\gamma$  and note that  $P_{2,0}(\omega, \eta) = (\check{H}_\gamma, (1^v(\gamma)), p)$  for  $1^v(\gamma) = 1^v - W_{1,\gamma}(1^v)$  by 2.40).

Also we see that  $[\check{P}_n(u, \omega, \eta)](t)$  in  $\check{B}_\gamma$  is now always given by 1.17) with  $p_1 + \dots + p_n = 2$  regardless of the original type of  $P_n(u, \omega, \eta)$  in  $B_\gamma$ , and hence

$$\check{P}_n(u + v, \omega, \eta) = \check{P}_n(u, \omega, \eta) + \check{P}_n(v, \omega, \eta) + C(u, v, \omega, \eta)$$

with

$$3.30) \quad [C(u, v, \omega, \eta)](t) = \sum_{1 \leq k < k' \leq n} \prod_{i=0}^{\infty} \left\{ \begin{matrix} u_k(t - \omega h_k) v_{k'}(t - \omega h_{k'}) + \\ + v_{k'}(t - \omega h_{k'}) u_k(t - \omega h_k) \end{matrix} \right\} d\check{\alpha}_{p_1, \dots, p_n}^{(h_1, \dots, h_n, \eta)}$$

where  $p_1 = 0$  except for  $i = k$  and  $k'$ ,  $p_k = 1$ ,  $p_{k'} = 1$ .

Thus we see that with  $F_\gamma(u, v)$  defined from  $[C(u, v, \omega, \eta)](t)$  exactly as was  $\check{H}_\gamma$  from  $[\check{P}_n(u, \omega, \eta)](t)$ , we have

$$\check{H}_\gamma(u+v) = \check{H}_\gamma(u) + \check{H}_\gamma(v) + F_\gamma(u, v),$$

3.31) 
$$F_\gamma(u, v) = F_\gamma(v, u),$$

$$\| \| F_\gamma(u', v) - F_\gamma(u, v) \| \| \leq \| \| u' - u \| \| \| \| v \| \| M_{10},$$

$$\| \| F_{\gamma'}(u, v) - F_\gamma(u, v) \| \| \leq$$

$$\left\{ \begin{matrix} |\omega' - \omega| \left( \| \| u \| \| \| \| v \| \|_d + \| \| v \| \| \| \| u \| \|_d \right) + \\ + |\eta' - \eta| \| \| u \| \| \| \| v \| \| \end{matrix} \right\} M_{11}$$

exactly like 2.30) and 3.23).

IV) Now to return to the original equations 3.14) which we wanted to solve, we see that by using

${}_1L_{1,0}(\omega_1, 0) = 1$  and  ${}_2L_{1,0}(\omega_1, 0) = 0$  from 2.38) we have the equivalent pair of equations,  $p = 1$  or  $2$ ,

$$\begin{aligned}
 -\eta {}_pL'_{1,0}(\omega_1, 0) &= (\omega - \omega_1) {}_pL'_{1,0}(\omega_1, 0) + z {}_pL_{2,0}(\omega_1, 0) + \\
 &+ {}_pR_1(\omega, \eta) + {}_pR_2(\omega, \eta, z) + \\
 3.32) \quad &+ {}_pR_3(\omega, \eta, z) + z {}_pR_4(\omega, \eta)
 \end{aligned}$$

where

$$\begin{aligned}
 {}_pR_1(\omega, \eta) &= {}_pL_{1,0}(\omega, \eta) - {}_pL_{1,0}(\omega_1, 0) - \eta {}_pL'_{1,0}(\omega_1, 0) - \\
 &-(\omega - \omega_1) {}_pL'_{1,0}(\omega_1, 0),
 \end{aligned}$$

$${}_pR_2(\omega, \eta, z) = \frac{1}{z} \left( \mathbf{H}'_{\gamma}(f(0, z, 0, \gamma)), {}_p\varphi \right)$$

$${}_pR_3(\omega, \eta, z) = \frac{1}{z} \left( \check{\mathbf{H}}_{\gamma}(f(0, z, 0, \gamma)) - \check{\mathbf{H}}_{\gamma}(z, v(\gamma)), {}_p\varphi \right), \text{ and}$$

$$\begin{aligned}
 {}_pR_4(\omega, \eta) &= {}_pL_{2,0}(\omega, \eta) - {}_pL_{2,0}(\omega_1, 0) = \\
 &= \left( \check{\mathbf{H}}_{\gamma}(v(\gamma)) - \check{\mathbf{H}}_0(v(0)), {}_p\varphi \right).
 \end{aligned}$$

Now  $f(0, z, 0, \gamma) = z v(\gamma) + \mathbf{H}_{\gamma}(f(0, z, 0, \gamma))$  from 2.37), so

$$3.33) \quad {}_pR_3(\omega, \eta, z) = \left( \mathbf{F}_{\gamma}(v, \mathbf{H}_{\gamma}(f)) + \frac{1}{z} \check{\mathbf{H}}_{\gamma}(\mathbf{H}_{\gamma}(f)), {}_p\varphi \right)$$

from 3.31). Also since  $\|\mathbf{H}_{\gamma}(u)\|_d \leq M \|u\|^2$  as for 3.24) and since  $\|\check{\mathbf{H}}_{\gamma}(u)\| \leq M \|u\|^2$  from 2.30) we get from 3.33)

$$3.34) \quad |{}_pR_3(\omega', \eta, z) - {}_pR_3(\omega, \eta, z)| \leq |\omega' - \omega| |z|^2 M_{12}$$

by using 3.31), 3.27), 3.22) for  $v(\gamma) = -\psi - W_{1, \gamma}(\psi)$ , 3.24), 3.25), and the equivalent of 3.23) for  $\mathbf{H}_{\gamma}$  and  $\check{\mathbf{H}}_{\gamma}$ . Similarly from 3.33)

$$3.35) \quad |{}_pR_3(\omega, \eta, z') - {}_pR_3(\omega, \eta, z)| \leq |z' - z| (|z'| + |z|) M_{13}$$

by taking care of the  $\frac{1}{z}$  factor first for the obvious case  $\frac{1}{2} |z| \leq |z'| \leq 2|z|$ , and if this fails then

$|z| \leq 2|z'-z|$  and  $|z'| \leq 2|z'-z|$  which again makes the result obvious. Likewise from 3.27) and 3.29) we have

$$3.36) \quad |{}_pR_2(\omega', \eta, z') - {}_pR_2(\omega, \eta, z)| \leq \\ \leq \left\{ (|z'| + |z|)|z'-z| + \right. \\ \left. + (|z'| + |z|)^2 |\omega' - \omega| \right\} M_{14}$$

Also by the mean value theorem with known differentiability

$$3.37) \quad {}_pR_1(\omega', \eta) - {}_pR_1(\omega, \eta) = \\ = (\omega' - \omega) [{}_pL_{1,0}^1(\omega'', \eta) - {}_pL_{1,0}^1(\omega, \eta)]$$

with  $|\omega'' - \omega| < |\omega' - \omega|$ . Again by 3.22) and 3.23)

$$3.38) \quad |z' {}_pR_4(\omega', \eta) - z {}_pR_4(\omega, \eta)| \leq \\ \leq |z'| |\omega' - \eta| M + |z' - z| |{}_pR_4(\omega, \eta)| \leq \\ \leq \left\{ (|z'| + |z|)|\omega' - \omega| + (|\omega - \omega_1| + |\eta|)|z' - z| \right\} M_{15}$$

Now putting  ${}_pR(\omega, \eta, z) = {}_pR_1 + {}_pR_2 + {}_pR_3 + z {}_pR_4$  we have 3.32) to be equivalent to

$$\omega - \omega_1 = \eta B J^{-1} + {}_2L_{2,0}(\omega_1, 0) J^{-1} {}_1R(\omega, \eta, z) - \\ - {}_1L_{2,0}(\omega_1, 0) J^{-1} {}_2R(\omega, \eta, z)$$

$$3.39) \quad z = \eta A J^{-1} - {}_2L_{1,0}^1(\omega_1, 0) J^{-1} {}_1R(\omega, \eta, z) + \\ + {}_1L_{1,0}^1(\omega_1, 0) J^{-1} {}_2R(\omega, \eta, z)$$

since we are given  $J \neq 0$ . Thus  $y = (\omega - \omega_1, z)$ ,  $Y$  being euclidean two space and  $T_\eta(y) =$  right hand side of 3.39) gives the proper form for lemma 2:7). Also  ${}_pL_{1,0}^1(\omega, \eta)$  was shown to have continuous first partials in part I), so by 3.37) and 3.34) through 3.38) as well,  $T_\eta(y)$  satisfies condition 2.21) with  $\rho_\eta = \frac{1}{2}$  for  $|\eta|, |\omega - \omega_1|$  and  $|z| < \delta$  for some  $\delta > 0$ . Also at  $z = 0$ ,

$pR_2 = pR_3 = z_pR_4 = 0$  so that

$$3.40) \quad pR(\omega_1, \eta, 0) = pR_1(\omega_1, \eta) = pL_{1,0}(\omega_1, \eta) - \\ - pL_{1,0}(\omega_1, 0) - \eta pL'_{1,0,\eta}(\omega_1, 0).$$

But with  $\delta > 0$  fixed, by 3.40) and the known differentiability of  $pL_{1,0}(\omega, \eta)$  we can find  $\rho_4 > 0$ ,  $\rho_4 \leq \delta$  such that  $\|T_\eta(0)\| < \frac{1}{2} \delta$  for  $|\eta| < \rho_4$  and hence condition 2.22) is satisfied.

Thus with  $\rho_5 = \delta$  we have our desired unique solution  $\omega(\eta)$  and  $z(\eta)$  to 3.14), and  $|\omega(\eta) - \omega_1| + |z(\eta)| \leq |\eta| M$  from 2.26) as usual. But by the assumed twice differentiability in  $\eta$  of  $F_k(h, \eta)$ , the part I) proof shows  $pL_{1,0}(\omega, \eta)$  to have continuous second partials in  $\omega$  and  $\eta$ , so that we have  $|pR_1(\omega, \eta)| \leq (|\omega - \omega_1| + |\eta|)^2 M$ . Thus by 3.35), 3.36), and 3.38)

$$3.41) \quad |pR(\omega, \eta, z)| \leq (|z| + |\omega - \omega_1| + |\eta|)^2 M_{16}$$

for sufficiently small  $|\omega - \omega_1|$ ,  $|\eta|$  and  $|z|$ . But this combined with  $|\omega(\eta) - \omega_1| + |z(\eta)| \leq |\eta| M$ , 3.39), and 3.17) thus yields  $\omega(\eta) - \tilde{\omega}(\eta) = o(\eta^2)$  and  $z(\eta) - \tilde{z}(\eta) = o(\eta^2)$  as desired.

Q. E. D.

Actually if our original equation was 3.7) rather than 3.6), then  $P_n(u, \omega, \eta)$  is odd and hence  $pL_{2,0}(\omega, \eta) \equiv 0$ . Thus  $J = 0$  and theorem 3:2) is of no use. In order to take care of this situation we have the following corollary.

We make all the assumptions preceding theorem 3:2) and in addition assume the second order derivatives

in  $Q(y_1, \eta)$  or second order terms in 1.17) vanish identically for  $|\eta| \leq b$ ; also we assume  $Q(y_1, \eta)$  is four in place of three times differentiable in  $y_1$  if  $P_n(u, \omega, \eta)$  is of type III.

Then in 3.16) and 3.17) replace  $p^{L_{3,0}}(\omega_1, 0)$  by  $p^{L_{3,0}}(\omega_1, 0)$  to define  $J^\dagger$  and  $B^\dagger$  and let  $\tilde{\omega}^\dagger(\eta) = \omega_1 + B^\dagger(J^\dagger)^{-1}\eta$  and  $\tilde{z}^\dagger(\eta) = \sqrt{A(J^\dagger)^{-1}\eta}$ . Under our assumptions we then have the following.

Corollary 3:3)

If  $L' < +\infty$  and if  $J^\dagger \neq 0$ , then there exist some positive  $\rho_4$  and  $\rho_5$  such that for any real  $\eta$  satisfying  $|\eta| < \rho_4$  and  $A(J^\dagger)^{-1}\eta \geq 0$  there exists a unique real valued solution  $z(\eta)$  and  $\omega(\eta)$  of 3.14) in  $0 \leq z < \rho_5$  (or in  $-\rho_5 < z < 0$ ) and  $|\omega - \omega_1| < \rho_5$ .  
Furthermore, as  $\eta \rightarrow 0$ ,  $\omega(\eta) - \tilde{\omega}^\dagger(\eta) = o(\eta^{3/2})$  and  $[z(\eta)]^2 - [\tilde{z}^\dagger(\eta)]^2 = o(\eta^{3/2})$ .

Proof

Here we merely need to mimic theorem 3:2), first noting that in place of 3.15) we now have 3.15)<sup>†</sup> by replacing  $|||u|||^2$  by  $|||u|||^3$  and similarly for 2.30) 3.23), 3.26) and 3.28) by adding one to the exponent of the obvious factor.

Letting  $\tilde{B}_\gamma^\dagger =$  the third order terms in  $B_\gamma$ , and  $B_\gamma^\dagger = B_\gamma - \tilde{B}_\gamma^\dagger$ , we get 3.29)<sup>†</sup> from 3.29) by replacing the exponent 2 by 3 similarly.

Also letting  $C^\dagger(u, v, \omega, \eta)$  be the sum of the cross terms in  $P_n^\dagger(u + v, \omega, \eta)$  and defining  $F_\gamma^\dagger(u, v)$  from  $C^\dagger(u, v, \omega, \eta)$ , we now get in place of 3.31)

$$\begin{aligned}
 & \tilde{H}_\gamma^\dagger(u+v) - \tilde{H}_\gamma^\dagger(u) - \tilde{H}_\gamma^\dagger(v) = F_\gamma^\dagger(u,v) = F_\gamma^\dagger(v,u), \\
 3.31) \quad & \| \| F_\gamma^\dagger(u,v) - F_\gamma^\dagger(u,v) \| \| \leq \\
 & \leq \| \| u' - u \| \| \left( \| \| v \| \| + \| \| u' \| \| + \| \| u \| \| \right) \| \| v \| \| M, \\
 & \| \| F_\gamma^\dagger(u,v) - F_\gamma^\dagger(u,v) \| \| \leq \\
 & \leq \left\{ |\omega' - \omega| \left( \| \| u \| \| \| \| v \| \|_d + \| \| v \| \| \| \| u \| \|_d \right) + |\eta' - \eta| \| \| u \| \| \| \| v \| \| \right. \\
 & \quad \left. \cdot \left( \| \| u \| \| + \| \| v \| \| \right) M \right\}.
 \end{aligned}$$

Also 3.14) is now equivalent to the pair,  $p = 1$

or 2,

$$\begin{aligned}
 3.32) \quad & -\eta {}_pL_{1,0}^\dagger(\omega, \eta) = (\omega - \omega_1) {}_pL_{1,0}^\dagger(\omega, \eta) + z^2 {}_pL_{3,0}^\dagger(\omega, \eta) \\
 & + {}_pR_1(\omega, \eta) + {}_pR_2^\dagger(\omega, \eta, z) + \\
 & + {}_pR_3^\dagger(\omega, \eta, z) + z^2 {}_pR_4^\dagger(\omega, \eta),
 \end{aligned}$$

with  ${}_pR_2^\dagger = \frac{1}{z} (\tilde{H}_\gamma^\dagger(f(0, z, 0, \gamma)), {}_p\varphi)$ ,

${}_pR_3^\dagger = \frac{1}{z} (\tilde{H}_\gamma^\dagger(f) - \tilde{H}_\gamma^\dagger(z, \gamma), {}_p\varphi)$ , and

$$\begin{aligned}
 & {}_pR_4^\dagger = {}_pL_{3,0}^\dagger(\omega, \eta) - {}_pL_{3,0}^\dagger(\omega_1, 0) = \\
 & = \left( \tilde{H}_{\gamma_1}^\dagger(v(\gamma)) - \tilde{H}_0^\dagger(v(0)), {}_p\varphi \right). \text{ Thus putting} \\
 & z = \sqrt{\alpha} \geq 0 \text{ for } \alpha \geq 0, \quad {}_pR^\dagger = {}_pR_1 + {}_pR_2^\dagger + {}_pR_3^\dagger + \alpha {}_pR_4^\dagger,
 \end{aligned}$$

we see from  $J^\dagger \neq 0$  that 3.32)† is equivalent to

$$\begin{aligned}
 3.39) \quad & \omega - \omega_1 = \eta B^\dagger (J^\dagger)^{-1} + {}_2L_{3,0}^\dagger(\omega_1, 0) (J^\dagger)^{-1} {}_1R^\dagger(\omega, \eta, \sqrt{\alpha}) - \\
 & - {}_1L_{3,0}^\dagger(\omega_1, 0) (J^\dagger)^{-1} {}_2R^\dagger(\omega, \eta, \sqrt{\alpha}) \\
 & \alpha = \eta A (J^\dagger)^{-1} - {}_2L_{1,0}^\dagger(\omega_1, 0) (J^\dagger)^{-1} {}_1R^\dagger(\omega, \eta, \sqrt{\alpha}) + \\
 & + {}_1L_{1,0}^\dagger(\omega_1, 0) (J^\dagger)^{-1} {}_2R^\dagger(\omega, \eta, \sqrt{\alpha}).
 \end{aligned}$$

Now from the preceding inequalities as before we have strong enough Lipschitz conditions on the residual terms in 3.39)<sup>†</sup> so that for  $0 < \alpha < \delta$ ,  $|\omega - \omega_1| < \delta$  and  $|\eta| < \delta$  condition 2.21) holds with  $\rho_\eta = \frac{1}{2}$ ; hence any solution of 3.39)<sup>†</sup> is necessarily unique in this neighborhood. Also 2.22) obviously holds for small  $|\eta|$ . but since we require  $\alpha \geq 0$  we must review lemma 2:7). In constructing the solution there we note from 2.26) that we only need consider  $\omega$  and  $\alpha$  such that

$$\sqrt{|\omega - \omega_1|^2 + \alpha^2} \leq 2 \|T_\eta(\theta)\| \leq |\eta| M \text{ like 3.40).}$$

But since  $\eta A(J^\dagger)^{-1} \geq 0$  is given and since the residual terms in 3.39)<sup>†</sup> are  $O(\alpha^{3/2})$ , it is clear that this means for sufficiently small  $\eta$  the component of  $T_\eta(\omega - \omega_1, \alpha)$  for  $\alpha$  in 3.39)<sup>†</sup> is always non-negative for such  $\omega$  and  $\alpha$ . Thus the construction in lemma 2:7) gives the desired unique solution.

Q. E. D.

We note in 3.32)<sup>†</sup> that if we had replaced  $z$  by  $-\sqrt{\alpha} \leq 0$ , we would similarly get a unique solution in  $-\rho_5 < z \leq 0$ . Also all the residual terms in 3.32)<sup>†</sup> are actually  $O(z^4)$  except for  ${}_p R_2^\dagger$ , and it would be also if  $P_n(u, \omega, \eta)$  had fifth instead of fourth order differentiability and the fourth order terms vanish. The latter holds necessarily for 3.7) where  $P_n(u, \omega, \eta)$  must be odd. If the residual terms are  $O(z^4)$ , then we see that  $\omega(\eta) - \omega^\dagger(\eta) = O(\eta^2)$  and  $[\tau(\eta)^2] - [\xi^\dagger(\eta)]^2 = O(\eta^2)$ .

Also we remark that if  $P(x, \eta)$  in the original

differential equation 1.15) is odd, then both 3.6) and 3.7) apply. Thus by theorem 2:9) and corollary 3:3), if 3.9) is satisfied, a sufficiently small solution of 1.15) and the boundary condition 3.2) also satisfies 3.3).

It should be noted that if  $P_n(u, \omega, \eta)$  is of type I or II, then the form 2.42) of equations 2.35) has each  $p_{L_n}(\omega, \eta)$  analytic in both  $\omega$  and  $\eta$  by an argument similar to part I) of the theorem 3:2) proof. In place of 3.20) here we would get  $[v_{m,0}(\gamma)]_j(t)$  to be a finite Fourier sum with angular frequencies 1, 2, ..., m. Also it is easy to obtain bounds for the absolute value sums of the right sides of 2.42) over all complex  $\eta$  and  $z$  and all real  $\omega$  near 0,  $0, \omega_1$ . Thus if we had been able to extend these bounds to complex  $\omega$ , by an application of the Montel theorem and the standard implicit function theorem of complex variables we could have eliminated the lengthy proof of theorem 3:2).

The non vanishing of the Jacobian is an important restriction to the solution of our problem, since it requires that not both the second order  $L$  numbers, or the third order in 3:3), vanish at the origin. For this reason the Schmidt technique is not applicable to equations which become linear at  $\eta = 0$ , as for example Van der Pol's equation.

We now have the following result for the form of the solution  $f(0, z, 0, \gamma)$  with  $z = z(\eta)$ ,  $\gamma = (\omega(\eta) - \omega_1, \eta)$ , and where  $x_\eta(t)$  denotes the corresponding solution of 1.15) and  $\tilde{x}_\eta(t)$  its first Fourier component for the period  $\frac{2\pi}{\omega(\eta)}$ .

Corollary 3:4)

In theorem 3:2) and corollary 3:3) we have for all real t and  $|\eta| < \rho_4$

$$3.42) \quad |x_\eta(t) - \tilde{x}_\eta(t)| \leq \eta^2 M \text{ for 3:2),}$$

$$|x_\eta(t) - \tilde{x}_\eta(t)| \leq \eta^{\frac{3}{2}} M \text{ for 3:3).}$$

Also with  $a_0 = \frac{1}{\sqrt{\pi}}$  for 3:6) and  $a_0 = \sqrt{\frac{2}{\pi}}$  for 3:7),

$$3.43) \quad \tilde{x}_\eta(t) = z(\eta) \left( \frac{\sqrt{1 + \omega_1^2 + \dots + \omega_1^{2(n-1)}}}{1 + \omega_1 \omega(\eta) + \dots + (\omega_1 \omega(\eta))^{n-1}} \right) a_n \cos(t\omega(\eta)).$$

Proof

First from the integral equation 3.6) or 3.7), the n th derivative of  $x_\eta(t)$  is continuous in real t, and thus the Fourier series for  $x_\eta(t)$  can be differentiated term by term. Thus 3.43) follows from

$$u_j(\eta, t) = x_\eta^{(j-1)} \left( \frac{t}{\omega(\eta)} \right), \quad 3.11), \text{ and from}$$

computing  $z = (u(\eta), \varphi_1)$  and  $0 = (u(\eta), \varphi_2)$ , these inner products being over  $[0, 2\pi]$  or  $[0, \pi]$  for 3.6) or 3.7)

Now for 3.42) we first note from 3.20) that with  ${}_1\tilde{v}_j(\omega(\eta), \eta, t)$  and  $\tilde{u}_j(\eta, t)$  the first Fourier components of  ${}_1v_j(\omega(\eta), \eta, t)$  and  $u_j(\eta, t)$  we have  ${}_1\tilde{v}_j(\omega(\eta), \eta, t) = {}_1v_j(\omega(\eta), \eta, t)$ . Thus by the integral definition of Fourier coefficients for  $[0, 2\pi]$  we have

$$3.44) \quad \begin{aligned} |||\tilde{u}(\eta) - z(\eta) {}_1v(\omega(\eta), \eta)||| &= \\ &= |||\tilde{u}(\eta) - z(\eta) {}_1\tilde{v}(\omega(\eta), \eta)||| \leq \\ &\leq 2 |||u(\eta) - z(\eta) {}_1v(\omega(\eta), \eta)||| \end{aligned}$$

But 3.28) shows  $|||u(\eta) - z(\eta) {}_1v(\omega(\eta), \eta)||| \leq M |z(\eta)|^2$  for 3:2), and 3.28)† makes it  $\leq M |z(\eta)|^3$  for 3.33), and from 3:2) results  $|z(\eta)| = o(|\eta|)$  while

$|z(\eta)| = o(|\eta|^{-\frac{1}{2}})$  from 3:3). Thus we get 3.42) obviously from 3.44).

Q. E. D.

Let us denote by  $\overset{\circ}{x}_\eta(t)$  the result if in 3.43) we replace  $z(\eta)$  and  $\omega(\eta)$  by  $\overset{\circ}{z}(\eta)$  and  $\overset{\circ}{\omega}(\eta)$  if 3:2) was used, or by  $\overset{\circ}{z}^\dagger(\eta)$  and  $\overset{\circ}{\omega}^\dagger(\eta)$  if 3:3) was used. We see by 3:4) that  $\overset{\circ}{x}_\eta(t)$  may be considered the first order approximation to  $x_\eta(t)$  over  $0 \leq t \leq \frac{2\pi}{\omega_1}$  as  $\eta \rightarrow 0$ .

If we actually carry out the computation outlined in part I) of the theorem 3:2) proof, we can easily verify the following formulae.

$$h_j(\omega) = \sum_{k=1}^{j=1} (i\omega)^{j-k} c_1 \psi_k, \quad V(\omega) = \frac{c_2}{a_0^2} \sum_{j=1}^n h_j(\omega) (-i\omega_1)^{j-1},$$

$$g(\omega, \eta) = h_{n+1}(\omega) + \sum_{k=0}^{n-1} h_{k+1}(\omega) \int_0^\infty e^{-i\omega h} dF_k(h, \eta),$$

$$3.45) \quad R(\omega) = [1 + \omega\omega_1 + \dots + (\omega\omega_1)^{n-1}] [1 + \omega_1^2 + \dots + \omega_1^{2(n-1)}]^{-1};$$

$$H(\omega, \eta) = 1 + V(\omega) - R(\omega) \frac{g(\omega, \eta)}{c_2 D_\eta(i\omega)},$$

$${}_1L_{1,0}(\omega, \eta) = \mathcal{R} \left[ 1 - \frac{1}{H(\omega, \eta)} \right], \quad {}_2L_{1,0}(\omega, \eta) = \mathcal{I} \left[ 1 - \frac{1}{H(\omega, \eta)} \right],$$

where "a<sub>0</sub>" is defined as in 3.43) and the rest as in 3.11).

$${}_1L'_{1,0,\eta}(\omega_1, 0) = \mathcal{R} \left[ \frac{c_2}{g(\omega_1, 0)} \left[ \frac{\partial}{\partial \eta} D_\eta(i\omega_1) \right]_{\eta=0} \right],$$

$${}_2L'_{1,0,\eta}(\omega_1, 0) = \mathcal{I} \left[ \frac{c_2}{g(\omega_1, 0)} \left[ \frac{\partial}{\partial \eta} D_\eta(i\omega_1) \right]_{\eta=0} \right],$$

$$3.46) \quad {}_1L'_{1,0,\omega}(\omega_1, 0) = \mathcal{R} \left[ \frac{c_2}{g(\omega_1, 0)} \left[ \frac{\partial}{\partial \omega} D_0(i\omega) \right]_{\omega=\omega_1} \right],$$

$${}_2L'_{1,0,\omega}(\omega_1, 0) = \mathcal{I} \left[ \frac{c_2}{g(\omega_1, 0)} \left[ \frac{\partial}{\partial \omega} D_0(i\omega) \right]_{\omega=\omega_1} \right].$$

By means of 2.38) and 3.46) we can now compute J, A, and B and hence  $\ddot{x}_\eta(t)$ . This is carried out for a few simple examples.

example I)

$$0 = x''(t) + a_{1,0}x'(t) + (1+r\eta)a_{0,0}x(t) + (1+\eta)\{a_{0,1}x(t-b) + f(x(t-b))\}$$

with  $f(y)$  odd, four times differentiable, and  $f'(0) = 0$ . We use 3.7) here and get for  $\omega_1$  satisfying 3.10)

$$J^\dagger = \frac{3\pi f''''(0)(c_2)^4}{8\sqrt{2}(\omega_1)^2(1+\omega_1^2 + (a_{1,0})^2)} \left\{ \begin{array}{l} (2\eta + a_{0,1}b \sin(\omega_1 b)) \sin(\omega_1 b) \\ - (a_{1,0} - a_{0,1}b \cos(\omega_1 b)) \cos(\omega_1 b) \end{array} \right\},$$

$$A = \left(\frac{c_2}{c_1}\right)^2 \frac{1}{(\omega_1)^2(1+(\omega_1)^2 + (a_{1,0})^2)^2} \left\{ \begin{array}{l} (r a_{0,0} + a_{0,1} \cos(\omega_1 b))(a_{1,0} - a_{0,1}b \cos(\omega_1 b)) \\ - a_{0,1} \sin(\omega_1 b)(2\eta + a_{0,1}b \sin(\omega_1 b)) \end{array} \right\}$$

$$B^\dagger = \frac{3\pi f''''(0)(a_2)^4}{8\sqrt{2}(\omega_1)^2(1+\omega_1^2 + (a_{1,0})^2)} \left\{ r a_{0,0} \sin(\omega_1 b) \right\}$$

We can verify that  $f''''(0) \neq 0$ , and  $a_{0,0}a_{0,1} > -\frac{1}{2}(a_{0,1})^2(1-\frac{c_2}{\pi})b$ , and  $a_{0,1} \neq 0$  are sufficient to make

$J^\dagger \neq 0$ . If we had taken  $r = 0$ , these equations simplify so that  $\ddot{\omega}^\dagger(\eta) = \omega_1$ ,

$$\ddot{x}_\eta(t) = \sqrt{\eta \left( -8 \frac{a_{0,1}}{f''''(0)} \right)} \cos(\omega_1 t).$$

example II)

$$0 = x''(t) + a_{1,0}x'(t) + (1+\eta) f(x'(t-b)) + a_{0,0}x(t)$$

with  $f(y)$  satisfying the same conditions as in example I).

Again using 3.7) we get for  $\omega_1$  satisfying 3.10)

$$J^{\dagger} = \frac{3\pi f'''(0)(c_2)^4 \omega_1^2}{8\sqrt{a_{1,1}}(1 + (\frac{a_{0,0}}{\omega_1})^2)} \quad \omega_1 b a_{1,1}^2 - a_{1,1}(2\omega_1 \cos(\omega_1 b) + a_{1,0} \sin(\omega_1 b)) ,$$

$$A(J^{\dagger})^{-1} = - \frac{8\sqrt{a_{1,1}}}{(c_1 c_2)^2 3\pi f'''(0)(\omega_1^2 + a_{0,0}^2)} = - 8 \frac{a_{1,1}}{f'''(0)} \frac{1}{\omega_1^2 c_2^2} ,$$

$B = 0$  so that  $\ddot{x}(t) = \omega_1$  ,

$$\ddot{x}_{\eta}(t) = \sqrt{\eta \left( - 8 \frac{a_{1,1}}{(\omega_1)^2 f'''(0)} \right)} \cos(\omega_1 t) .$$

It should be noted in these examples that the same final expression for  $\ddot{x}_{\eta}(t)$  could also be obtained by following the method of Duffing and Hamel [27] in a formal way. However, due to the presence of the time delay terms it seems difficult to extend their method of justification, as the existing solution of a variational problem, to our case.

### Summary of Results

Our main result here that appears to be new deals with the equation

$$1.15) \quad 0 = x^{(n)}(t) + \sum_{k=0}^{n-1} x^{(k)}(t-h) dF_k(h, \eta) + \\ + [P(x, \eta)](t)$$

Defining  $D_\eta(s)$  as the auxiliary exponential polynomial for the linear part of this, we assume  $D_0(i\omega_1) = 0$  and the rest of 3.9) or 3.10) is satisfied for some  $\omega_1 > 0$ . The Schmidt technique of non-linear integral equations extended in theorem 2:9) can then be applied to 1.15) with periodic boundary conditions. Our results are then given in theorem 3:2) and corollary 3:3) and 3:4), which show the existence of and give asymptotic formulae as  $\eta \rightarrow 0$  for a non zero periodic solution  $x_\eta(t)$  of 1.15), which is unique up to an arbitrary phase constant,  $x_\eta(t + \theta)$  being the general form.

## Bibliography

- 1) Hurwitz; Acta Math., 20, (1897), p.285
- 2) Pincherle; Rend. Circ. Mat. Palermo, 18, (1904), p. 273
- 3) Schmidt, E.; Math. Ann., 70, (1911), p.499
- 4) Hilb, E.; Math. Ann., 78, (1918), p.137
- 5) Bochner, S.; "Vorlesung über Fouriersche Integrale", 1932, Leipzig
- 6) Titchmarsh; Journal Lond. Math. Soc., 14, (1939), p. 118
- 7) Wright, E. M.; Proc. Camb. Phil. Soc., 44, (1947), p.179
- 8) Wright, E.M.; Quarterly Journal Math., 17, (1946), p. 245
- 9) Wright, E. M.; Proc. Royal Soc. Edin., to appear
- 10) Bellman; Annals Math., 50, (1949), to appear
- 11) Hartree; Proc. Royal Soc. London, A-161, (1937), p. 460

- 12) Minorsky; Journal Applied Math., 64, A-65, (1942)
- 13) Langer, R. E.; Trans. A. M. S., 31, (1929) p.837
- 14) Langer, R. E.; Bull. A. M. S., 37, (1931), p.213
- 15) Sherman; Quarterly Applied Math., 2, (1947), p. 92
- 16) Ansof; Quarterly Applied Math., 6, (1948), p. 337
- 17) Schmidt, E.; Math. Ann., 65, (1908), p.370
- 18) Iglisch, R.; Math. Ann., 101, (1929), p.98
- 19) Iglisch, R.; Monatsheft Math. u. Phys., 37, (1930)  
p.325
- 20) Hildebrandt and Graves; Trans. A.M.S., 29, (1927),  
p.127
- 21) Riesz, F.; Acta Math. 41, (1918), p.71
- 22) Carleman; Math. Zeitschrift, 2, (1921), p.196
- 23) Hille and Tamarkin; Acta Math., 57, (1931), p. 1
- 24) Hille; Annals Math., 35, (1934), p.445
- 25) Stone; "Transformations in Hilbert Space", 1932,  
New York
- 26) Lefschetz, S.; "Lectures on Differential Equations",  
1946, Princeton
- 27) Hamel; Math. Ann., 86, (1922), p.2
- 28) Banach; "Théorie des Opérations Linéaires", 1932,  
Warsaw
- 29) Pitt, H. R., ; Proc. Camb. Phil. Soc., 40, (1944),  
p. 199
- 30) Pitt, H. R.,; Proc. Camb. Phil. Soc., 43, (1947)  
p. 153
- 31) Courant and Hilbert, "Mathematische Physik", vol.  
I, 1931, Berlin
- 32) Blumberg and Minorsky, N6-ONR-251 Task Order II  
report, Feb. 15, 1949

## IV. FORCED OSCILLATIONS IN NONLINEAR SYSTEMS

By M. L. Certwright

### FORWARD

The following pages contain the substance of a short course of informal lectures to Professor Lefschetz's seminar on differential equations and were originally written with a view to private circulation in mimeographed form. Time did not allow me to revise as carefully as I should have liked and the informal character of the course is reflected in many places where the treatment is over condensed and unsolved problems are discussed in a somewhat casual manner.

#### Part 1. General Topological Background

§1.1 Introduction. The following lectures are based on work (some of it unpublished) which I have done in collaboration with Prof. J. E. Littlewood on ordinary nonlinear differential equations of the second order. A typical equation is van der Pol's equation with forcing term,

$$(1) \quad \ddot{x} - k(1-x^2)\dot{x} + x = bk \lambda \cos(\lambda t + \alpha),$$

---

Written under the auspices of the Office of Naval Research, Contract No. N6or1-105, NRO43-942.

another is

$$(2) \quad \ddot{x} + k\dot{x} + x + cx^3 = bk \lambda \cos(\lambda t + \alpha),$$

where dots denote differentiation with respect to  $t$  which I shall call the time. Both these equations belong to the general form, said by Levinson to be 'dissipative for large displacements,' viz

$$(3) \quad \ddot{x} + f(x)\dot{x} + g(x) = p(t),$$

where the forcing term  $p(t)$  has period  $\frac{2\pi}{\lambda}$ , the damping  $f(x) \geq 1$  for  $|x| \geq a$ , and the restoring force  $g(x)$  satisfies  $\frac{g(x)}{x} \geq 1$  for  $|x| \geq a$ . These equations can be normalized in different ways by putting  $x' = \alpha_1 x + \beta_1$ ,  $t' = \gamma_1 t + \delta_1$ . Different forms are convenient for different purposes.

Our interest in such equations was aroused by a memorandum issued by the Radio Section of the Department of Scientific and Industrial Research in 1938 appealing to pure mathematicians for assistance in determining the possible steady states (or stable oscillations) in certain types of circuit, and their frequencies, and also how the latter varied with the parameters of the system. There was considerable emphasis on the frequency in some of the references given and in subsequent correspondence, and comparatively little on the amplitude, and this has, I think, influenced our outlook, making us prefer to deal with the  $x, t$  plane in which the time is explicit, rather than the phase plane  $(x, y)$  where  $y = \dot{x}$ . The problem of determining periodic solutions is not easy to solve satisfactorily by numerical methods, nor do numerical results show how solutions vary with parameters unless a very large number are obtained.

We have spent most of our time on equation (1) which<sup>1</sup> may seem extremely special. The reason is that van der Pol<sup>2</sup> suggested that, if  $k$  is large, (1) corresponds to a physical system which he investigated experimentally with van der Mark<sup>3</sup>. The experimental results showed stable oscillations of periods  $(2n-1)\frac{2\pi}{\lambda}$  and  $\frac{4n\pi}{\lambda}$  for certain values of the parameters. Actually equation (1) does not correspond to this particular physical system because the latter needs a very unsymmetrical nonlinear function for its representation, as van der Pol explained in a letter. With the symmetrical function  $1 - x^2$  in equation (1), it may be observed that if we put  $t' = t + (2n+1)\frac{\pi}{\lambda}$  and  $x' = -x$ , the equation is unchanged, so that, if a solution is periodic, odd multiples of  $\frac{2\pi}{\lambda}$  with  $n + \frac{1}{2}$  waves above  $x = 0$  and  $n + \frac{1}{2}$  similar waves below  $x = 0$  seem more probable than even multiples. The stable oscillations with period  $(2n+1)\frac{2\pi}{\lambda}$  are in fact like this, but not all the unstable oscillations. It seemed that equation (1) was the simplest type of equation likely to have two stable periodic oscillations with periods prime to one another, and so we attacked it on the grounds that it is best to tackle a really difficult problem first in its simplest form. Once done much of the work carries over to more general equations with very little alteration. These lectures are mainly concerned with the general background and nearly linear oscillations, except in Part 9.

---

1. M. L. Cartwright and J. E. Littlewood, Journal of London Math. Soc. 20 (1945) 180-189.

2. B. van der Pol, Proc. Inst. Radio Eng. 22 (1934) 1051-1086.

3. B. van der Pol and J. van der Mark, Nature. (1927) 363-364.

§1.2. Existence and Uniqueness. It is known from the general theory that if  $p(t)$ , and  $f(x)$  are continuous and  $g(x)$  satisfies a Lipschitz condition for the values of  $x$  and  $t$  considered, there is a solution  $x(t, x_0, y_0)$  of (3) for which  $x(0, x_0, y_0) = x_0$  and  $\dot{x}(0, x_0, y_0) = y_0$ . The usual uniqueness result requires  $f(x)$  to satisfy a Lipschitz condition, but this is not necessary and  $x(t, x_0, y_0)$  is uniquely determined by the above conditions. For if not, let  $X(t, x_0, y_0)$  be another solution for which  $X(0, x_0, y_0) = x_0$ ,  $\dot{X}(0, x_0, y_0) = y_0$ . Write  $\dot{x} = y$ ,  $\dot{X} = Y$ , and let

$$(4) \quad \mu = \max (Y - y), \quad 0 \leq t \leq \alpha.$$

Then there exists a  $K$  such that for any  $\alpha \leq 1$

$$(5) \quad |f(x)| < K, \quad |g(X) - g(x)| < K|X - x|, \quad 0 \leq t \leq \alpha.$$

Hence

$$(6) \quad |X - x| = \left| \int_0^t (Y - y) dt \right| \leq \mu t \leq \mu \alpha,$$

and from (3)

$$Y - y = - \int_{x_0}^X f(X) dX + \int_{x_0}^x f(x) dx - \int_0^t (g(X) - g(x)) dt,$$

so that by (5)

$$\begin{aligned} |Y - y| &\leq \left| \int_x^X f(x) dx \right| + \int_0^t |g(X) - g(x)| dt \\ &\leq K(X - x) + t K(X - x) \end{aligned}$$

By (6)

$$|Y - y| \leq K(1 + \alpha)\mu \alpha \leq 2K\mu \alpha < \frac{1}{2}\mu$$

for  $0 \leq t \leq \alpha = \min(1, \frac{1}{4K})$  which contradicts (4) for a sufficiently small  $\alpha$ . By repeating the process, we can cover any interval  $0 \leq t \leq \alpha_1$  in which the conditions (4) and (5) hold.

A slight modification shows that the solutions vary continuously with  $(x_0, y_0)$ .

§1.3. The Topological Transformation. Let us consider the solutions of (3) in three dimensions  $x, y, t$ ; since  $p(t)$  has period  $\frac{2\pi}{\lambda}$ , the equation itself is the same at  $t = 0$  and  $t = \frac{2\pi}{\lambda}$ , and so we obtain from the solutions of (3) a transformation  $T$  of the point  $P_0(x_0, y_0)$  in the plane  $t = 0$  into the point  $P_1(x_1, y_1)$  in the plane  $t = \frac{2\pi}{\lambda}$ . We may also consider it as a transformation of the  $x, y$  plane into itself and write  $P_1 = T(P_0)$ ,  $P_2 = T(P_1)$  and so on. It follows from the remarks of §1.2 that  $T$  is  $(1, 1)$  and continuous, and it is also orientation preserving, that is to say if  $P_0$  describes a certain continuous closed curve  $C$  counter clockwise, then  $P_1$  will describe the corresponding curve  $C_1 = T(C)$  counter clockwise. For the transformation is the result of a continuous deformation with  $t$  from one plane to another.

If  $p(t) \equiv 0$ , the equation (3) is the same for all  $t$ , and so we may choose the period  $2\pi/\lambda$  as we please. If there is a periodic solution  $x = x(t), y = y(t)$  it can be represented in the  $x, y$  plane by a simple closed curve  $\Gamma$  (or in some cases a single point). If we take the period of  $\Gamma$  as the period determining the transformation, every point of  $\Gamma$  is fixed. In three dimensions all the solutions with initial values

$x_0, y_0$  on  $\Gamma$  wind up a cylinder on  $\Gamma$  as base. If  $p(t)$  is not identically 0, a solution of (3) when represented in the  $x, y$  plane may cross itself, and also since  $p(t)$  varies with  $t$ , a set of solutions corresponding to a closed curve  $l'$  in the  $x, y$  plane will wind up a surface which is not cylindrical. For even if its sections by  $t = 0$  and  $t = \frac{2\pi}{\lambda}$  are the same, the sections between will vary with  $t$ .

#### §1.4. Fixed Points and Periodic Solutions.

A solution of (3) with period  $\frac{2\pi}{\lambda}$  obviously corresponds to a fixed point  $P$  such that  $P = T(P)$ . A solution with least period  $\frac{2m\pi}{\lambda}$ ,  $m > 1$ , corresponds to a point with period  $m$  such that  $P = T^m(P)$  and  $P \neq T^{m'}(P)$  for  $m' = 1, 2, \dots, m-1$ . There are always  $m$  points  $P, T(P) \dots T^{m-1}(P)$  corresponding to each solution with least period  $m$  at times  $t = 0, \frac{2\pi}{\lambda}, \dots, (m-1)\frac{2\pi}{\lambda}$ .

There are certain standard types of fixed point, most of them correspond closely to standard types of singular point for equations of order 1.

Let  $P_0$  with coordinates  $(x_0, y_0)$  be a fixed point, and suppose that the point  $(x, y)$  near  $(x_0, y_0)$  goes into the point  $(x', y')$ . If the functions  $f, g, p$ , in (3) satisfy certain additional conditions, it is possible to express  $x', y'$  in the form

$$x' - x_0 = a(x - x_0) + b(y - y_0) + o(r)$$

$$y' - y_0 = c(x - x_0) + d(y - y_0) + o(r),$$

where  $r^2 = (x - x_0)^2 + (y - y_0)^2$ , and  $ad - bc \neq 0$ . The types of fixed point can then be determined to some extent by means of the roots  $\rho_1, \rho_2$  of the

characteristic equation<sup>4</sup>

$$\begin{vmatrix} a - \rho & , & b \\ c & , & d - \rho \end{vmatrix} = 0.$$

However I shall confine myself here to the main topological features connected with the simplest classes of isolated fixed point, and leave the discussion of analytic details and all finer points.

(1) Stable points. These are points  $P_0$  such that  $P_0 = T(P_0)$  and if  $P$  is sufficiently near  $P_0$ , then  $T^n(P) \rightarrow P_0$  as  $n \rightarrow \infty$ . In the most usual cases if  $C$  is a sufficiently small circle with centre  $P_0$ ,  $T(C) \subset C$ , and so the vector  $P, T(P)$  points into the interior of  $C$ , and as  $P$  describes  $C$  counter clockwise it rotates through an angle  $2\pi$  counterclockwise. We therefore say that it has index +1. This is true whether  $P$  moves towards  $P_0$  more or less radially as in the case of nodes, or winding spiral fashion as in the cases of foci, in the theory of singular points, but it should be remembered that  $P$  moves by jumps  $T(P), T^2(P)$ , and so on, not continuously along a curve.

I shall show later that in the general case through each point  $P$  sufficiently near  $P_0$  there is a simple closed curve  $C$  such that  $T(C) \subset C$ . Any stable oscillation with period  $2m\frac{\pi}{\lambda}$  corresponds to a stable fixed point under  $T^m$ .

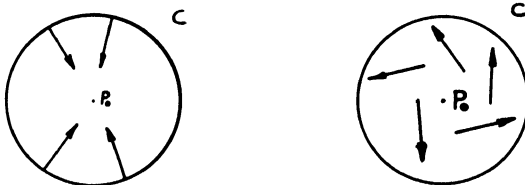
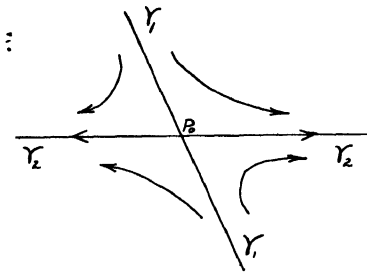

Figure 1.

<sup>4</sup>. See N. Levinson, Annals of Math., 45 (1944) 723-737.

(2) Direct cols or saddle points. These are fixed points  $P_0$  which have two pairs of special invariant directions or continua  $\gamma_1$  and  $\gamma_2$ . The pair  $\gamma_1$  separate points  $P$  near  $P_0$  which move away from  $P_0$  in opposite directions under  $T$  and the pair  $\gamma_2$  separate points  $P$  near  $P_0$  which move away from  $P_0$  in opposite directions under  $T^{-1}$  the inverse of  $T$ . Points on the continua  $\gamma_1$  move towards  $P_0$  under  $T$ , but all others eventually move away under  $T^n$  for  $n$  sufficiently large. Similarly points on  $\gamma_2$  move towards  $P_0$  under  $T^{-1}$ , but



all others move away under  $T^{-1}$ . This type of point has index number  $-1$ , for the vector  $P, T(P)$  rotates clockwise as it describes a small circle counter clockwise.

Figure 2.

(3) Completely unstable points. We need only say that these are stable under the inverse of  $T$ . They have index number  $+1$ , as the vector  $PT(P)$  turns counter

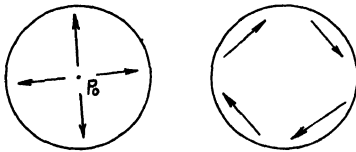

clockwise as  $P$  describes a small circle counter clockwise.

Figure 3.

(4) Inverse cols or saddle points. Behaviour near these is similar to that described for saddle points except that the figure is rotated through an angle  $\pi$ , each branch of  $\gamma_1$  goes into the opposite one and similarly each branch of  $\gamma_2$  goes into the

opposite one. The upper right hand set between  $\gamma_2$  and  $\gamma_1$  goes into the bottom left and vice-versa. Since vectors all cross over  $P_0$  approximately, the directions of the vectors are roughly similar to those in Fig. 1, and so the index number is  $+1$ . Under  $T^2$  an inverse col becomes a direct col with index number  $-1$ .

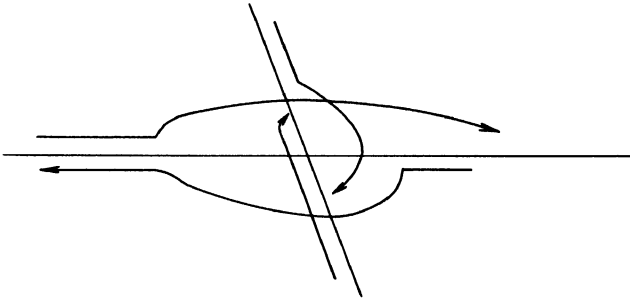

Figure 4.

(5) Centres. These are transitional between the spiral forms of (1) and (3) as in the theory of singular points. They are rather special points; it is difficult to distinguish centres from stable or completely unstable points in analytical work, and difficult to describe the behaviour near a centre correctly and precisely. All that concerns us now is that a centre has index  $+1$  and may therefore be included with stable or with completely unstable points in counting index numbers.

(6) Multiple points. These may be formed by points of types (1) and (2) or types (2) and (3) coalescing, in which case the index number is 0, and other multiple points of index  $\pm p$ , where  $p$  is an integer greater than 1 also exist. There may also be fixed points which are limit points of fixed points, and other points whose index numbers cannot be so easily determined even if it can be defined.

§1.5. The Existence of One Fixed Point. There are various results known showing that there exists a constant  $K$  such that for every point  $P$ ,  $T^n(P)$  lies in the circle  $x^2 + y^2 < K^2$  for  $n > n_0(x_0, y_0)$ . We shall prove a result of this type in the next part and from this it follows as we shall see later that there is a simply connected domain  $D$  bounded by a continuous curve  $C$  containing  $(x_0, y_0)$  such that  $T(\bar{D}) \subset \bar{D}$ . It then follows from the Brouwer fixed point theorem that  $\bar{D}$  contains at least one fixed point.<sup>5</sup>

§1.6. The Maximum Invariant Set  $S$ . Since  $T(\bar{D}) \subset \bar{D}$  and  $T$  is  $(1, 1)$   $T^2(\bar{D}) \subset T(\bar{D})$  and so on. Hence  $T^n(D) \rightarrow S$  a closed connected set such that  $T(S) = S$ . Its complement is a domain and it will be shown that if the point at infinity is added to the plane,  $C(S)$  is simply connected.  $S$  contains all fixed points, periodic points, and also all other recurrent points. A point  $P$  is recurrent if for every  $\delta > 0$ ,  $T^n(P)$  lies in a circle of centre  $P$  and radius  $\delta$  for an infinity of  $n$ . Certain types of recurrent point correspond to uniformly almost periodic solutions<sup>6</sup> which may in a certain sense be stable.

§1.7. A Finite Number of Fixed Points. If there are only a finite number of fixed points or periodic points in  $S$ , we can say something about the relation between the numbers of the different types. For we can draw a circle round each point fixed under  $T^m$ ,  $m \geq 1$ , so small that no two intersect, and then join each circle to another by parallel segments of straight lines in such a way as to form a simple closed contour  $C'$  containing all the points fixed under  $T^m$ . Now  $C$  the frontier of  $D$  is deformed into  $C'$ , the vector  $P, T(P)$

5. See R. Courant and H. Robbins, What is Mathematics? (Oxford 1943).

6. See §8.4.

varies continuously and does not vanish. Hence the index number of  $C'$  is the same as the index number of  $C$ . But it is also the sum of the index numbers of the small circles. For the angle through which the vector turns on a line joining any two circles is equal and opposite to the angle turned through as  $P$  describes the parallel line in the reverse direction. Hence writing  $S_m$ ,  $D_m$ ,  $U_m$ ,  $I_m$  for the numbers of stable points, direct cols, completely unstable points and inverse cols respectively, we have

$$S_m + U_m + I_m - D_m = \text{index number of } C.$$

If fixed points of any other types occur, they must of course be included in  $S_m$ ,  $U_m$  or  $I_m$  if their index numbers are  $+1$ , and in  $D_m$  if their index numbers are  $-1$ , and counted  $p$  times if the index is  $\pm p$ .

In the most usual case  $T(C)$  lies in the interior of  $D$ , in which case the index number of  $C$  is  $+1$ , for the vector behaves in a manner similar to the case of a stable point. Hence in the most usual standard cases we have

$$S_m + U_m + I_m - D_m = 1,$$

although many other exceptional cases actually occur in the case of differential equations of type (3).

## Part 2. Forced Oscillations in Nonlinear Systems

### A general analytical theorem on boundedness

#### §2.1. The formulation of the theorem. In

Part 1 we discussed certain topological results associated with the equation

$$(1) \quad \ddot{x} + f(x)\dot{x} + g(x) = p(t), \quad p(t) \text{ of period } \frac{2\pi}{\lambda},$$

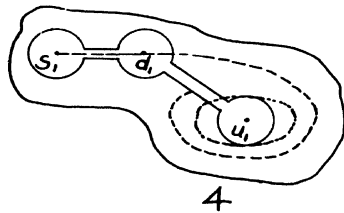
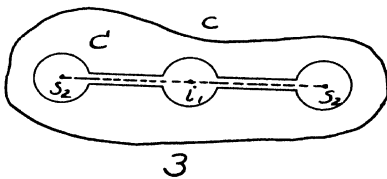
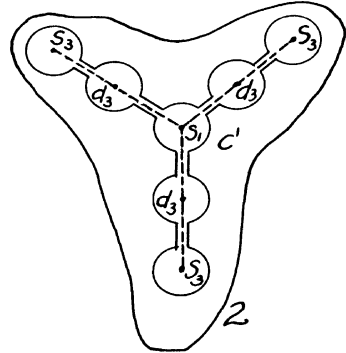
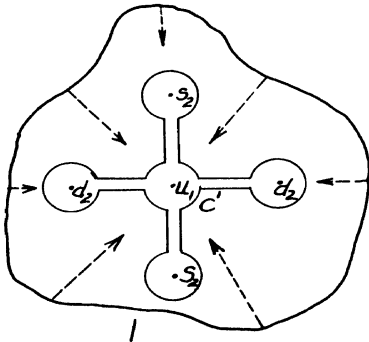
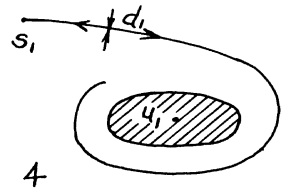
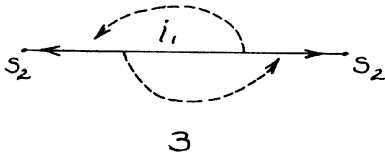
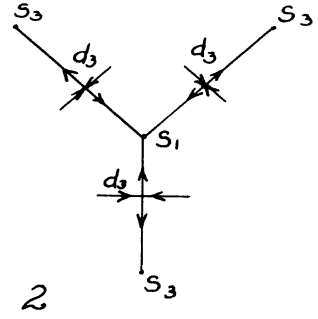
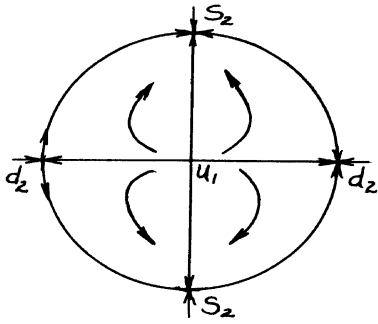

Figure 5.

where  $f$ ,  $g$ ,  $p$  satisfy certain other conditions, and mentioned the equation

$$(2) \quad \ddot{x} - k(1 - x^2)\dot{x} + x = bk\lambda \cos(\lambda t + \alpha),$$

which is especially interesting both for  $k$  large and for  $k$  small. Writing  $y = \dot{x}$ , we stated that there is a constant  $K$  such that for every  $x_0, y_0$  the solution of (1) for which  $x = x_0, y = y_0$  at  $t = 0$  satisfies  $x^2 + y^2 < K$  for  $t > t_0(x_0, y_0)$ , provided of course that  $f, g, p$  satisfy suitable conditions. Further we stated that from this certain topological results which imply the existence of a periodic solution can be deduced. Some general bounding theorem seems essential for further progress, and for the study of equation (2) a quantitative result involving  $k$  is needed. We therefore consider equation (1) in the modified form

$$(3) \quad \ddot{x} + k f(x, k) \dot{x} + g(x, k) = k p(t, k),$$

where  $p(t, k)$  is now not necessarily periodic. For this is an unnecessary restriction in the main theorem which follows. As before it will be assumed that  $f(x, k), p(t, k)$  are continuous functions of  $x$  and  $t$  respectively, and that  $g(x, k)$  satisfies a Lipschitz condition in  $x$  for all values considered, so that (3) has a unique solution  $x(t, x_0, y_0)$  for which  $x = x_0, y = y_0$  at  $t = 0$  and this solution varies continuously with  $x_0, y_0$ . We denote by  $B$  a positive constant independent of  $x_0, y_0, t$  and  $k$ , not necessarily the same in each place unless a suffix is attached, but  $B_1, B_2, \dots$  remain the same throughout. Although  $f, g, p$  may depend on  $k$ , they will satisfy bounding conditions independent of  $k$ , and therefore we usually write  $f(x), g(x), p(t)$ .

Theorem 1. Hypotheses

- (i)  $f(x) \geq b_1 > 0$  for  $|x| \geq 1$  and  $f \geq -b_2$   
always,
- (ii)  $g(x) \operatorname{sgn} x \geq b_3 > 0$  for  $|x| \geq 1$ , and  
 $|g(x)| \leq \gamma(\xi)$  where  $\gamma$  is independent of  $k$   
 for  $|x| \leq \xi$ .
- (iii)  $|p(t, k)| \leq B$ ,  $\left| \int_0^t p(t, k) dt \right| t < B$ .

Conclusion For every  $x_0, y_0$  the solution of (3) for  
which  $x = x_0, \dot{x} = y = y_0$  at  $t = 0$  satisfies

$$|x| < B, \quad |\dot{x}| < B(k+1),$$

where  $B$  is independent of  $x_0, y_0$  for  $t > t_0(x_0, y_0)$ .

The result can be improved so that if

$x_0^2 + y_0^2 \leq R^2$ ,  $t_0$  depends only on  $R$ , but I shall not attempt to include this.

It should be observed that (1)  $f(x)$  does not depend on  $\dot{x}$  or  $t$ , for if it does, some additional condition such as a Lipschitz condition is necessary for uniqueness, (2)  $p(t)$  is not necessarily periodic, but  $\int p dt$  is bounded, so that positive and negative values of  $p(t)$  average about the same, (3) various normalizations are possible by putting  $x' = \alpha_1 x + \beta_1$ ,  $t' = \alpha_2 t + \beta_2$ , and we have chosen  $|x| \leq 1$  as the critical strip, (4) some parts of the proof have to be separated for  $k$  large and  $k$  small. In the conclusion  $|\dot{x}| < B$  is the significant part for  $\dot{x}$  when  $k$  is small, and  $|\dot{x}| < Bk$  when  $k$  is large.

§2.2. The use of the integrated equation. Our main tool in the four following lemmas is the integrated equation

$$\begin{aligned}
 (4) \quad \dot{x} - Y + k \int_X^x f(x)dx + \int_T^t g(x) dt \\
 = k \int_T^t p(t)dt.
 \end{aligned}$$

Here and in what follows  $x = x(t, x_0, y_0)$  is the solution of (3) such that  $x(0, x_0, y_0) = x_0$  and  $\dot{x}(0, x_0, y_0) = y_0$  and  $X = x(T, x_0, y_0)$ ,  $Y = \dot{x}(T, x_0, y_0)$ .

Writing

$$F(x) = \int_X^x f(x)dx, \quad p_1(t) = \int_T^t p(t)dt,$$

(4) becomes

$$(4') \quad \dot{x} - Y + k F(x) + \int_T^t g(x)dt = k p_1(t).$$

Lemma 1.  $|x|$  is not greater than 1 for all large  $t$ .

Suppose  $x \geq 1$  for  $t > T$ , then by hypothesis (1)  $F(x) \geq 0$  and by (ii)  $g \geq b_3 > 0$ , and so using (4') and (iii) we have

$$\begin{aligned}
 b_3(t-T) &\leq \int_T^t g(x)dt = k p_1(t) - \dot{x} + Y - k F(x) \\
 &\leq B k - \dot{x} + Y.
 \end{aligned}$$

As  $t \rightarrow \infty$ , the left hand side tends to infinity, and so  $\dot{x}$  must tend to  $-\infty$ ; but then  $x \rightarrow -\infty$  which gives a contradiction. Hence  $x$  is not greater than 1 for  $t > T$ , and similarly  $x$  is not less than -1.

§2.3. The strip  $|x| < 1$ . Lemma 2. If  $|x| < 1$  on an arc PQ,

$$(5) \quad |\dot{x}_Q| < |\dot{x}_P| + B_1(k+1),$$

and more generally if  $|x| \leq b_0$  on an arc PQ,

$$(6) \quad |\dot{x}_Q| < |\dot{x}_P| + B_1(b_0)(k+1).$$

If  $|x| \leq 1$  and  $\dot{x} > k + 1$  on an arc PQ, the time taken to describe PQ is less than or equal to  $\frac{2}{k+1}$ . For if not, since  $x_Q - x_P = \int_T^t \dot{x} dt$ ,

$$x_Q - x_P \geq (k+1) \cdot (t-T) \geq 2,$$

and since  $-1 \leq x_P \leq x_Q \leq 1$  this gives a contradiction. Similarly  $\dot{x}$  is not less than  $-(k+1)$  on any arc lasting a time longer than  $\frac{2}{k+1} \leq 2$ .

Let  $P_1$  be the last point before Q at which  $|\dot{x}| \leq k + 1$  or P itself whichever is the latest. Then the time from  $P_1$  to Q is at most 2, and  $\dot{x}$  has the same sign as  $\dot{x}_Q$  on PQ. Suppose that  $\dot{x}_Q > 0$  so that  $x$  is increasing, and use (4') with T and t corresponding to  $P_1$  and Q respectively. This gives

$$(7) \quad \dot{x}_Q - \dot{x}_{P_1} < -k F(x) + \int_T^t |g| dt + k |p_1(t)|.$$

Since by hypothesis (i)  $f(x) > -b_3$  and  $x > X$ ,  $F(x) > -b_3(x-X) \geq -2b_3$ . By (ii)  $|g| < \gamma(1)$ , and by (iii)

$$|p_1(t)| = \left| \int_0^t - \int_0^T p dt \right| \leq B.$$

Further  $t-T \leq 2$ , and so combining these with (7), we have

$$\dot{x}_Q < \dot{x}_{P_1} + Bk + (t-T)\gamma(1) < \dot{x}_{P_1} + B(k+1).$$

Since  $\dot{x}_Q > 0$ ,  $\dot{x}_{P_1} > 0$ , this is the required result if  $P_1 = P$ , and if  $P_1$  is not  $P$ ,  $\dot{x}_{P_1} \leq k+1$ , and so  $\dot{x}_Q \leq B(k+1)$  which includes (5).

If  $\dot{x}_Q < 0$ ,  $\dot{x} < 0$  on  $PQ$ , and since  $x$  is decreasing, we obtain the corresponding result for  $-\dot{x}_Q$  when we replace (7) by

$$(7') \quad -\dot{x}_Q + \dot{x}_{P_1} < k F(x) + \int_T^t |g| dt + k|p_1(t)|$$

because

$$F(x) = - \int_x^X f(x)dx \leq b_3(X-x) \leq 2b_3.$$

The result for  $|x| \leq b_0$  follows by precisely similar methods.

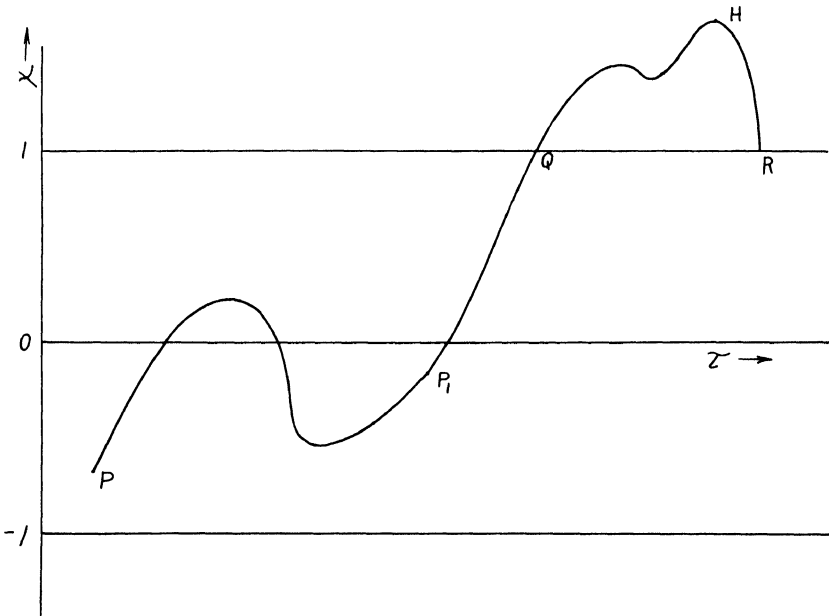

Figure 6.

§2.4. Above  $x = 1$ . Lemma 3. If the arc QR lies above  $x = 1$  and begins and ends on  $x = 1$ , the greatest height  $h$  satisfies

$$(8) \quad h < \frac{\dot{x}_Q}{k b_1} + B_2.$$

We integrate from Q to H, the point at which  $x = h$ ,  $\dot{x} = 0$ , and using (4) we have

$$\begin{aligned} \dot{x}_H = 0 &= \dot{x}_Q - k \int_1^h f(x) dx - \int_T^t g(x) dt + k \int_T^t p dt \\ &\leq \dot{x}_Q - k b_1 (h-1) + Bk, \end{aligned}$$

in virtue of hypotheses (i), (ii), (iii). Hence

$$h-1 \leq \frac{\dot{x}_Q}{k b_1} + B$$

which is equivalent to (8).

Lemma 4. If QR is an arc above  $x = 1$  beginning and ending on  $x = 1$ , then the time  $\tau$  taken to describe QR is less than  $B_3(\dot{x}_Q + k)$ .

Integrating from Q to any point in QR

$$(9) \quad \dot{x} = \dot{x}_Q - k \int_X^x f(x) dx - \int_T^t g dt + k \int_T^t p dt$$

$$< \dot{x}_Q - b_3(t-T) + Bk.$$

Also  $0 = x_R - x_Q = \int_0^{\tau} \dot{x} dt < B(\dot{x}_Q + k)\tau - b_3 \frac{\tau^2}{2}$ . Hence  $\tau < B_3(\dot{x}_Q + k)$  which is the required result.

§2.5. The use of the energy equation. The next lemma, which is in many respects the kernel of the proof,

depends on the energy equation

$$(10) \quad \dot{x}^2 - Y^2 + 2k \int_T^t f(x) \dot{x}^2 dt + \int_X^x g(x) dx \\ = 2k \int_T^t p(t) \dot{x} dt.$$

This is obtained from (3) by multiplying by  $2\dot{x}$  and integrating.

In lemmas 1, 3 and 4 we used the fact  $f(x) \geq 0$  for  $x \geq 1$ , but we only used  $f(x) \geq b_1 > 0$  in lemma 3 to obtain the special quantitative result (8). In the next lemma  $f(x) \geq b_1 > 0$  is vital in order to obtain a decrease of energy on an arc above  $x = 1$  with sufficiently large energy, that is to say for sufficiently large  $\dot{x}_Q$  when  $x_Q = 1$ .

Lemma 5. If QR is an arc above  $x = 1$  beginning and ending on  $x = 1$ , then for given  $B_1 \geq 1$  there exists  $B_4 \geq B_1$  such that if  $\dot{x}_Q > B_4(k+1)$

$$\dot{x}_R^2 < \dot{x}_Q^2 - 8B_1 k \dot{x}_Q.$$

Suppose that  $|\dot{x}_Q| \geq k$ . The energy equation for QR is

$$(11) \quad \dot{x}_R^2 - \dot{x}_Q^2 = -2k \int_T^t f(x) \dot{x}^2 dt + 2k \int_T^t p(t) \dot{x} dt.$$

Let  $J = k \int_T^t f(x) \dot{x}^2 dt \geq k b_1 \int_T^t \dot{x}^2 dt$ , and let  $t - T = \tau$ , then using Cauchy's inequality and lemma 4, we obtain from (11)

$$\begin{aligned}
 (12) \quad \dot{x}_R^2 - \dot{x}_Q^2 &< -2J + Bk \int \dot{x} dt \\
 &\leq -2J + Bk \tau^{1/2} \left( \int |\dot{x}|^2 dt \right)^{1/2} \\
 &\leq -2J + B_5 k^{1/2} \dot{x}_Q^{1/2} J^{1/2} \\
 &= -2J \left( 1 - \frac{1}{2} B_5 \left( \frac{k \dot{x}_Q}{J} \right)^{1/2} \right),
 \end{aligned}$$

where  $B_5$  depends on  $B_3$ . We may suppose that  $B_5^2 > 8B_1$ .

Then the right hand side of (12) is less than

$-J \leq -B_5^2 k \dot{x}_Q$  whenever  $J \geq B_5^2 k \dot{x}_Q$ , and if this is true the required result follows.

On the other hand if  $J < B_5^2 k \dot{x}_Q$ , integrating from  $Q$  until  $\dot{x} = (1/2)\dot{x}_Q$  or  $x = B_6$  whichever comes first, we have  $x$  increasing, and so

$$\int_T^t p(t)\dot{x} dt = \left| \int_1^{B_6} p(t)dx \right| \leq B \cdot (B_6 - 1)$$

Hence by (11)

$$\begin{aligned}
 \dot{x}^2 - \dot{x}_Q^2 &= -2k \int_T^t f(x)\dot{x}^2 dt + k \int_T^t p(t)\dot{x} dt \\
 &\quad - \int_1^{B_6} g(x)dx \geq -2J - k B \cdot B_6 - B \\
 &\geq -2B_5^2 k \dot{x}_Q - kB \cdot B_6 - B \geq -1/2 \dot{x}_Q^2,
 \end{aligned}$$

provided that  $\dot{x}_Q > B_4(k+1)$ , where  $B_4$  depends on  $B_5$  and  $B_6$ . It follows that  $\dot{x}^2 > 1/2 \dot{x}_Q^2$ , and that means  $\dot{x} > 1/2 \dot{x}_Q$ , so that  $x$  reaches  $B_6$  first. But then

$$J \geq k b_1 \int_1^{B_6} \dot{x} dx \geq k b_1 (B_6 - 1) \frac{\dot{x}}{2} \geq k B_5^2 \dot{x}_Q,$$

which is a contradiction, if  $B_6$  is chosen sufficiently large. Hence  $J \geq k B_5^2 \dot{x}_Q$  and the result holds.

§2.6. Proof of the theorem for  $k \geq 1$ . By

lemma 1 we know that every solution enters the strip  $|x| \leq 1$  at some time  $t > 0$ ; if it remains in the strip, we have  $|x| \leq k + 1$  at some point within time less than or equal to 2 and so the result follows from lemma 2 with the  $|x| \leq 1$ . If the solution emerges from the strip at Q returns to it at R, and next emerges again at S, (see Fig. 2) then  $|\dot{x}_S| < |\dot{x}_Q| - 2B_1k$ , provided that  $|\dot{x}_Q| > B_4(k+1)$ . For by lemma 2 with  $R = P$  and  $S = Q$ ,  $|\dot{x}_S| \leq |\dot{x}_R| + B_1(k+1) \leq |\dot{x}_R| + 2B_1k$ , and so

$$\begin{aligned} |\dot{x}_S|^2 &< (|\dot{x}_R| + 2B_1k)^2 \\ &= |\dot{x}_R|^2 + 4B_1k|\dot{x}_R| + 4B_1^2k^2. \end{aligned}$$

By lemma 5  $|\dot{x}_R|^2 \leq |\dot{x}_Q|^2 - 8B_1k|\dot{x}_Q| \leq |\dot{x}_Q|^2$ , and so

$$\begin{aligned} |\dot{x}_S|^2 &\leq |\dot{x}_Q|^2 - 8B_1k|\dot{x}_Q| + 4B_1k|\dot{x}_Q| + 4B_1^2k^2 \\ &\leq |\dot{x}_Q|^2 - 4B_1k|\dot{x}_Q| + 4B_1^2k^2 < (|\dot{x}_Q| - 2B_1k)^2 \end{aligned}$$

for  $|\dot{x}_Q| > B_4(k+1) > 2B_1k$ .

Hence the value of  $|\dot{x}|$  decreases by  $2B_1k$  each time it emerges until  $|\dot{x}_Q| \leq B_4(k+1)$ , and so any solution emerging from the strip at Q does so with  $|\dot{x}_Q| \leq B_4(k+1)$ , provided that  $t > t_0(x_0, y_0)$ . But if  $|\dot{x}_Q| \leq B_4(k+1)$ , then the maximum height or depth reached on the succeeding arc outside the strip is less than  $B_7$  by lemma 3 (8). Hence  $|x| < B_7$  for  $t > t_0$ . Returning to lemma 2 and putting  $b_0 = B_7$ , we have  $|\dot{x}| < B_4(k+1) + B_1k = Bk$  which completes the proof.

§2.7. The case  $k < 1$ . If  $k \leq 1$ , the result of lemma 2 is inadequate because the reduction in energy

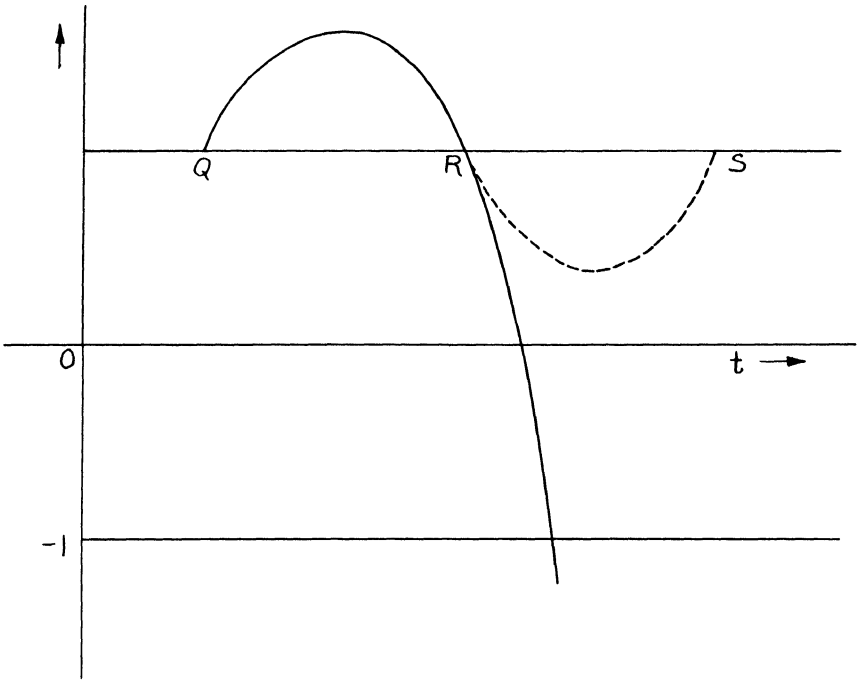

Figure 7.

obtained by lemma 5 on the arc QR above  $x = 1$  is now comparatively small. At the same time we shall see that the energy added on any arc PQ inside the strip is not very large, but in order to have the change of the energy in a usable form we may have to shift the strip a little. Let

$$G = \int_{-1}^1 g(x)dx.$$

It follows from (ii) that

$$|G| \leq \int_{-1}^1 \gamma(1)dx = 2\gamma(1).$$

If  $G > 0$ , since  $g \leq -b_3$  for  $x < -1$ ,  $\int_{-b_4}^{-1} g \, dx \leq -b_3(b_4 - 1)$ , and so there is a  $b_4$  such that

$$\int_{-b_4}^{-1} g \, dx = -G,$$

and similarly if  $G < 0$ ,  $\int_1^{b_5} g \, dx = -G$  for some  $b_5$ , and

$$(13) \quad \max(b_4, b_5) < B_8.$$

In both cases by putting  $x = \alpha_1 x' + \beta_1$  and choosing  $\alpha_1$  and  $\beta_1$  so as to include the extra interval in  $(-1, 1)$  we can make

$$(14) \quad \int_{-1}^1 g(\alpha_1 x' + \beta_1) \, dx = 0.$$

It follows from (13) that this normalization will only add a constant  $B$  to the existing  $B$ 's.

Lemma 6. If the arc PQ lies in  $|x| < 1$  and begins and ends on  $x = 1$ , and if

$$(15) \quad \int_{-1}^1 g(x) \, dx = 0,$$

then

$$\dot{x}_Q^2 < \dot{x}_P^2 + 4B_1 k |\dot{x}_P| + 4B_1 k.$$

for  $B_1$  sufficiently large and  $|\dot{x}_P| > B_9$ .

Suppose first that  $|\dot{x}| < \frac{1}{2} |\dot{x}_P|$  at some point  $P_1$  in  $PQ$ . Then by lemma 2 with  $P = P_1$ , we have

$$|\dot{x}_Q| < \frac{1}{2} |\dot{x}_P| + 2B_1, \text{ and so}$$

$$\dot{x}_Q^2 < \frac{1}{4} \dot{x}_P^2 + 2 B_1 |\dot{x}_P| + 4 B_1^2 < \dot{x}_P^2$$

provided that  $\dot{x}_P > B_1$ .

If  $|\dot{x}| \geq \frac{1}{2} |\dot{x}_P|$  on PQ, we may suppose without real loss of generality that  $\dot{x} > 0$ , so that  $x$  is increasing and then the energy equation gives

$$\begin{aligned} \dot{x}_Q^2 - \dot{x}_P^2 &= -2k \int_T^t f(x) \dot{x}^2 dt - 2 \int_v^{x_Q} f dx + k \int_T^t p \dot{x} dt \\ &\leq 2k b_2 \int \dot{x} dx + k \int p dx \\ &\leq 2k b_2 (\dot{x}_P + 2B_1 + B) \\ &\leq 4k B_1 (|\dot{x}_P| + 1) \end{aligned}$$

for  $B_1$  sufficiently large which is the result required.

§2.8. The height. Although (8) is valid for  $k$  small, it is inadequate, and we need

Lemma 7. If the arc QR lies above  $x = 1$  and begins and ends on  $x = 1$ , the greatest height  $h$  satisfies

$$h < 1 + B_3 (\dot{x}_Q + k)^2.$$

By (9)  $\dot{x} < \dot{x}_Q + Bk$  on QH, and by lemma 4 the time taken is less than  $B_3 (\dot{x}_Q + k)$ . Hence

$$h - 1 = \int_T^t \dot{x} dt \leq \int_T^t (\dot{x}_Q + Bk) dt \leq B_3 (\dot{x}_Q + k)^2.$$

§2.9 Proof of the theorem for  $k \leq 1$ . Normalize so that (15) holds. In virtue of (13) this only changes  $\gamma(1)$ ,  $b_2$  and therefore only the precise  $B$

obtained in the conclusion. As before we reduce the proof to the consideration of a solution which emerges from the strip  $|x| \leq 1$  at Q with  $\dot{x}_Q$  large and after returning to it at R emerges again at S. By lemma 6 with  $R = P$ ,  $S = Q$ , we have

$$\dot{x}_S^2 < \dot{x}_R^2 + 4B_1 k |\dot{x}_R| + 4B_1 k,$$

for  $|\dot{x}_R| > B_9$ . If  $|\dot{x}_R| \leq B_9$  by lemma 2,  $|\dot{x}_S| \leq B_9 + 2B_1$ , and so we have a solution emerging at R with  $|\dot{x}| < B$ .

If  $|\dot{x}_R| > B_9$ , by lemma 5

$$\begin{aligned} |\dot{x}_S|^2 &< \dot{x}_Q^2 - 8B_1 k |\dot{x}_Q| + 4 B_1 k |\dot{x}_Q| + 4 B_1 k \\ &= \dot{x}_Q^2 - 4B_1 k |\dot{x}_Q| + 4 B_1 k < (\dot{x}_Q - 2 B_1 k)^2 \end{aligned}$$

and so  $|\dot{x}_S| < |\dot{x}_Q| - 2 B_1 k$ , provided that  $|\dot{x}_Q| > B_4(k+1)$ . Hence  $|\dot{x}_Q|$  decreases at each subsequent point where the solution emerges from the strip until  $|\dot{x}_Q| < B_{10} = \max(B_9, B_4(k+1))$ . But now the maximum height is less than  $B_{11}$  by lemma 7, and the result follows from lemma 2.

Part 3. Topological Consequences of Theorem 1

§3.1. We now return to the case of 1 (3) in which  $p(t)$  has period  $2\pi/\lambda$ , and consider the topological consequences of theorem 1. As we said the solution of 1 (3) (and therefore the solution of 2 (3) with  $k = 1$  and  $p(t)$  having period  $2\pi/\lambda$ ) gives rise to a (1,1) continuous orientation-preserving transformation  $T$ . Theorem 1 asserts that for every  $x_0, y_0$   $|x(t, x_0, y_0)|$  and  $|\dot{x}(t, x_0, y_0)|$  are less than  $B$  where  $B$  is independent of  $x_0, y_0$  for  $t > t_0(x_0, y_0)$ . In particular

$$|x_n| = |x(2n/\lambda, x_0, y_0)| < B$$

$$|y_n| = |y(2n/\lambda, x_0, y_0)| < B$$

for  $n > n_0(x_0, y_0)$ , and this means in the notation of 1.3 that there is a  $B$  such that  $T^n(P_0)$  lies in  $x^2 + y^2 < B$  for all  $x_0, y_0$  and all  $n > n_0(x_0, y_0)$ . We shall now prove a fundamental result based on a more general hypothesis suitable for later applications, and then deduce from the fundamental result properties of an invariant set and the existence of a fixed point in it.

Theorem 2. Let  $T$  be a (1,1) continuous transformation of the plane into itself, and let  $D_0$  be a fixed domain and  $D$  a domain containing  $D_0$  bounded by a closed Jordan curve  $J$ . Suppose that if  $P$  is a point of  $\bar{D}$ , every  $T^n(P)$  lies in  $D_0$  for all  $n > n_0(P)$ .

Then there is a domain  $\Delta$  depending on  $D$  having the following properties:

- (i)  $\Delta$  is bounded by a closed Jordan curve
- (ii)  $\Delta$  contains  $D$ ,
- (iii)  $T(\bar{\Delta})$  is contained in  $\bar{\Delta}$ .

§3.2. We need a compactness result

Lemma 8. Suppose that the hypotheses of theorem 2 hold, and let  $n(P)$  be the first  $n \geq 1$  for which  $T^n(P)$  lies in  $D_0$ . Then there is an  $N$  such that  $n(P) \leq N$  for all  $P$  in  $\bar{D}$ .

Corresponding to each  $P$  in  $\bar{D}$  there is an  $n(P)$  such that  $T^{n(P)}(P)$  lies in  $D_0$ , and since  $D_0$  is an open set there is an open circle  $\gamma(P)$  with centre  $P$  a point of  $\bar{D}$  such that  $T^{n(P)}(\gamma(P))$  lies in  $D_0$ . The set of circles  $\gamma(P)$  form an open covering of the closed set  $\bar{D}$ , and so by the Heine-Borel-Lebesgue theorem we can extract a finite covering  $\gamma(P_1) + \gamma(P_2) + \dots + \gamma(P_m)$ . Then  $N$ , the maximum of  $n(P_\mu)$  for  $\mu = 1, 2 \dots m$  satisfies the

result. For every  $P$  of  $\bar{D}$  lies in some  $\gamma(P_\mu)$ , and so  $T^n(P)$  lies in  $D_0$  for some  $n \leq (P_\mu) \leq N$ .

§3.3. We also need a lemma on connectivity based on the use of the Jordan curve theorem and other allied results.

Lemma 9. If  $D_1$  and  $D_2$  are the interior domains of two closed Jordan curves  $J_1$  and  $J_2$ , and if  $D_1 \cdot D_2$  is not null, then the frontier  $\Gamma$  of the unbounded component  $U$  of the complement of  $J_1 + J_2$  is a closed Jordan curve  $\Gamma$  whose interior domain  $\Delta$  contains  $D_1$  and  $D_2$ , and  $\Gamma$  is contained in  $J_1 + J_2$ .

There are three possibilities, either (1)  $D_1 \subset D_2$ , or (2)  $D_1 \supset D_2$ , or (3) neither (1) nor (2) is true. In case (1)  $\Gamma = J_2$ ,  $D = D_2$  and the result is obvious; similarly in case (2)  $\Gamma = J_1$ ,  $D = D_1$ . In the remaining case there are points of  $D_2$  in  $D_1$  by hypothesis and also points outside, but  $D_2$  does not contain  $D_1$ . Hence there are points of  $J_2$  both inside  $J_1$  and outside it. For if there were no points of  $J_2$  outside  $D_1$ , the points of  $D_2$  outside  $D_1$  could be joined to infinity without meeting  $J_2$ , and if there were no points of  $J_2$  in  $D_1$ ,  $D_1$  would be included in  $D_2$ . It is easy to see that  $\Gamma$  is contained in  $J_1 + J_2$ , and if it is a closed Jordan curve, the interior domain  $\Delta$  of  $\Gamma$  must contain  $D_1 + D_2$ . It therefore remains to prove

Lemma 10. Let  $J_1$  and  $J_2$  be two simple closed curves such that  $J_2$  contains points in the interior and in the exterior domain of  $J_1$ . Then the frontier  $\Gamma$  of the unbounded component  $U$  of the complement of  $J_1 + J_2$  is a closed Jordan curve.

The following proof is due to Mr. Floyd. For this lemma only we use small letters to denote points, or mappings.

We define a map  $f$  of  $\Gamma$  into  $J_1$ , and prove that

it is a homeomorphism of  $\Gamma$  onto  $J_1$ . Suppose that  $x \in \Gamma$  and  $x \in J_1$ . Then define  $f(x) = x$ . Suppose next that  $x \in \Gamma$ , but  $x$  does not belong to  $J_1$  so that  $x$  belongs to  $J_2$ . Then there is a unique sub-arc  $A_x$  of  $J_2$ , containing  $x$  as an interior point, whose interior points are points of  $\Gamma$  but not of  $J_1$ , and whose end points  $a, b$  are points of  $J_1$ . Then  $J_1 + A_x$  is a theta curve (a curve consisting of three arcs intersecting only in their end points). Hence  $J_1 + A_x$  divides the plane into three domains, the two bounded domains being disjoint from  $U$ . Let  $R_x$  denote the complementary domain of  $\Gamma - A_x$  which is bounded and has  $A_x$  on its frontier, so that  $R_x \cdot U = 0$ . Let  $B_x$  be the arc of  $J_1$  which is on the frontier of  $R_x$ . Then we can define  $f$  on  $A_x$  as a homeomorphism of  $A_x$  on to  $B_x$  which keeps the end points of  $A_x$  fixed, and the definition is complete.

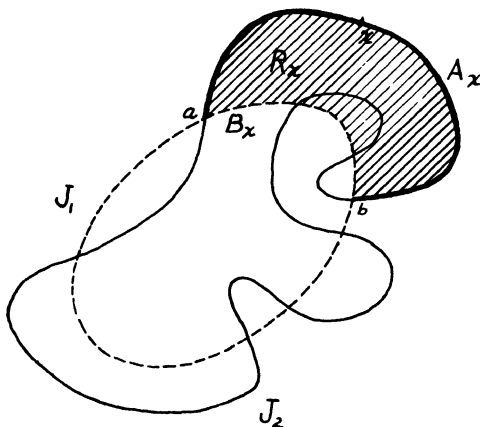

Figure 8.

We next show that to every  $x$  of  $J_1$  corresponds a point  $f^{-1}(x)$  of  $\Gamma$ . If  $x \in J_1$  and  $x \in \Gamma$  this is obvious. If  $x \in J_1$ , but  $x$  does not belong to  $\Gamma$  we can construct an arc  $C_x$  from  $x$  to infinity which meets  $J_1$  only at  $x$ .

Let  $y$  be the first point of the arc which intersects  $\Gamma$ . Then the domain  $R_y$  defined as before contains the part of  $C_x$  from  $x$  to  $y$ , and hence  $x$  is the image of some point of  $A_y$  under  $f$ .

In order to see that  $f$  is  $(1,1)$ , we suppose that if  $x_1, x_2 \in \Gamma$  and  $f(x_1) = f(x_2)$ . If  $x \in \Gamma$  and  $x$  does not belong to  $J_1$ , then  $f(x)$  does not belong to  $\Gamma$ . Hence if  $f(x_1) \in \Gamma$ ,  $x_1 = x_2$ . Suppose then that  $f(x_1)$  does not belong to  $\Gamma$ , then  $A_{x_1}$  and  $A_{x_2}$  are disjoint, except possibly for their end points. We have  $f(x_1)$  a frontier point of both  $R_{x_1}$  and  $R_{x_2}$ , and not an end point of  $A_{x_1}$  or  $A_{x_2}$ , so that  $R_{x_1}$  and  $R_{x_2}$  have common points. But this is impossible. For if points of  $R_{x_1}$  belong to  $R_{x_2}$  they can be joined to the point at infinity by an arc only meeting  $J_2$  in  $A_{x_2}$ , and so not meeting either  $A_{x_1}$  or  $B_{x_1}$ .

Finally we observe that  $f$  is continuous. For the arcs  $A_x$  are countable in number, and only a finite number of the sets  $R_x$  can exceed a given positive number  $\epsilon$  in diameter.

§3.4. From lemma 9 we deduce at once

Lemma 11. Let  $T$  be a  $(1,1)$  continuous transformation of the plane on to itself, and  $D$  a domain bounded by a closed Jordan curve  $J$ . If  $D \cdot T(D) \neq 0$ , then the frontier  $\Gamma_N$  of the unbounded component  $U_N$  of the complement of  $J + T(J) + \dots + T^N(J)$  is a closed Jordan curve whose interior domain  $\Delta_N$  contains  $D + T(D) + \dots + T^N(D)$ .

If  $N = 1$ , putting  $D_1 = D$ ,  $D_2 = T(D)$  we obtain the result from lemma 9. Suppose that the result holds for  $N - 1$ , and put  $D_1 = \Delta_{N-1}$ ,  $D_2 = T^N(D)$ . Then  $J_1 = \Gamma_{N-1}$ , and  $J_2 = T^N(J)$  are closed Jordan curves, and since  $\Delta_{N-1}$  contains  $D + T(D) + \dots + T^{N-1}(D)$ , the unbounded component of the complement of  $\Gamma_{N-1} + T^N(J)$  will be the unbounded component  $U_N$  of the complement of

$J + T(J) + \dots + T^N(J)$ . Since  $D \cdot T(D) \neq 0$ , we have  $T^{N-1}(D) \cdot T^N(D) \neq 0$ , and since  $\Delta_{N-1}$  contains  $T^{N-1}(D)$ , this implies  $\Delta_{N-1} \cdot T^N(D) \neq 0$ . Hence the conditions of lemma 9 are satisfied, and the frontier  $\Gamma_N$  of  $U_N$  is a simple closed curve whose interior domain contains  $\Delta_{N-1}$  and  $T^N(D)$ , and therefore  $D + T(D) + \dots + T^N(D)$ .

§3.5. Proof of Theorem 2. First of all  $D_0$  and  $T(D_0)$  have points in common. If not, whenever  $T^n(P) \in D_0$ ,  $T^{n+1}(P)$  does not, which gives a contradiction for any fixed  $P$  and  $n > n_0(P)$ . Since  $D$  and  $T(D)$  have the set  $D_0 \cdot T(D_0)$  in common we can apply lemma 11. Let  $N$  be the number defined in lemma 8. Then for all  $P \in \bar{D}$ ,  $T^n(P) \in D_0$  for some  $n \leq N$  and  $D_0$  is contained in  $D$ , and so in  $\Delta_{N-1}$ . For  $T^N(P) = T^{N-n}(T^n(P))$ , where  $T^n(P) \in D_0$ , and  $n(P) \geq 1$  so that  $T^{N-n(P)}(D_0)$  is contained in  $\Delta_{N-1}$ . Hence  $T^N(\bar{D})$ , and so,

$$T(D + T(D) + \dots + T^{N-2}(D)) + T^N(D)$$

are contained in  $\Delta_{N-1}$ . Also since  $T^N(\bar{D})$  lies in  $\Delta_{N-1}$ ,  $T^N(J)$  lies in  $\Delta_{N-1}$ , and so  $T(\Gamma_{N-1})$  lies in  $\bar{\Delta}_{N-1}$ , and therefore  $\Delta_N \equiv \Delta_{N-1}$ . It is now easy to verify that  $\Delta = \Delta_{N-1}$  satisfies all the conclusions of theorem 2.

§3.6. The maximum invariant set. Various consequences follow from theorem 2.

Theorem 3. If the hypotheses of theorem 2 hold, then

$$\bigcap_{n=1}^{\infty} T^n(\bar{\Delta}) = S$$

is a closed connected set such that  $T(S) = S$ . Further the complement of  $S$  is a simply connected domain if the point at infinity is included in it.

Since  $\Delta$  contains  $T(\bar{\Delta})$  which contains  $T^2(\Delta)$  and so on, and all these sets are closed and connected,  $S$  is

a closed connected set, and obviously  $T(S) = S$ . Further if  $C$  is any closed Jordan curve in the complement of  $S$ , then  $C$  lies in the exterior domain  $D_e^{(n)}$  of  $T^n(\Gamma)$  for some  $n$ , and since the exterior domain of a closed Jordan curve is simply connected if the point at infinity is included,  $C$  can be deformed into a point in  $D_e^{(n)}$  which is obviously contained in the complement of  $S$ . Hence the complement of  $S$  is a simply connected domain

A Fixed Point Theorem. The following result now follows easily

Theorem 4. If the hypotheses of theorem 2 hold, there is a fixed point in  $S$  and  $\Gamma$  has index number  $+1$ .

By theorem 2(11) the Brouwer fixed point theorem can now be applied to the 2-cell  $\bar{\Delta}$ , and so  $\bar{\Delta}$  contains a fixed point, but by the definition of  $S$  if there is a fixed point in  $\bar{\Delta}$  it must lie in  $S$ . Further since for each point  $P$  of  $\bar{\Delta}$   $T^n(P)$  lies in  $D_0$  (which is in  $\Delta$ ) for  $n > n_0(P)$ , no point of  $\Gamma$  is fixed. Hence for every point  $P$  on  $\Gamma$  the vector  $P, T(P)$  has positive length, and so as  $P$  describes  $\Gamma$  the vector turns continuously. By mapping  $\Delta(1,1)$  and continuously on the unit circle it can be shown that the vector turns through a total angle  $+1$ .

§3.7. Properties of solutions. From these theorems we now deduce the following with the help of the remarks made in 3.1

Theorem 5. If the hypotheses of theorem 1 hold, and also  $p(t)$  has period  $2\pi/\lambda$ , then there is at least one solution of 2.1 (3) (or 1.1(3)) with period  $2\pi/\lambda$ . Further if the number of solutions with period  $2m\pi/\lambda$  is finite, the corresponding points satisfy 1.7 (1):

This follows immediately from theorems 1, 3 and 4.

§3.8. Since by theorems 2 and 3  $T^n(\Delta)$  tends to  $S$  and  $T(\Delta)$  is contained in  $\Delta$ . for every  $\delta > 0$  every

solution of 1.1 (3) for which  $(x_0, y_0)$  lie in  $D$  has  $(x_n, y_n)$  within a distance  $\delta$  of  $S$  for  $n \geq N_0$ , where  $N_0$  depends only on  $D$ . By the well known existence theorem methods if  $|x_n| < B_1$ ,  $|y_n| < B_1$ ,  $|x(t, x_n, y_n)| < B_2$ ,  $|\dot{x}(t, x_n, y_n)| < B_2$ , where  $B_2$  is independent of  $t, x_n, y_n$ , for  $0 \leq t \leq 2\pi/\lambda$ , and so all solutions tend uniformly to  $S$ . A similar quantitative result for 2.1(3) in terms of  $k$  requires some sort of uniformity in Theorem 1.

It should be observed that solutions do not converge uniformly to  $D_0$ . For solutions starting in  $D_0$  may emerge after an arbitrarily long time.

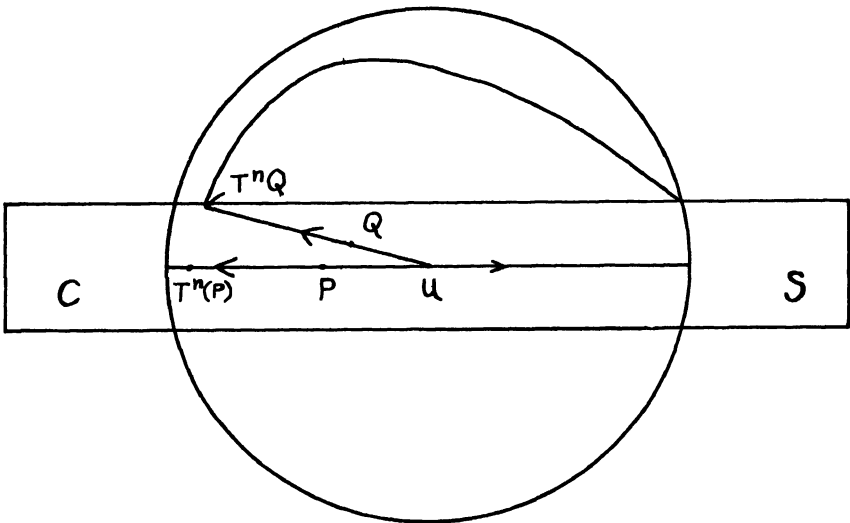

Figure 9.

This may be seen by considering an invariant set  $S$  consisting of a circle with a stable point, and a col at opposite ends of a diameter, and an unstable point at its centre. Then  $D_0$  can be taken to be a thin rectangle containing this diameter in its interior. For all  $P$  except the col and unstable point which are fixed in  $D_0$  tend to the stable point which is fixed in  $D_0$ . But a point  $P$  near the unstable point on the radius to the col

ends to the col, and so  $T^n(P)$  is on the radius near the col for all large  $n$ . Hence for a point  $Q$  sufficiently near  $P$   $T^n(Q)$  is near  $T^n(P)$ , and if  $T^n(Q)$  is near the col, it will obviously emerge from  $D_0$  before reentering and tending to the stable point.

As we observed in §2.1 the methods of theorem 1 can be improved so as to give uniformity with respect to  $(x_0, y_0)$ .

§3.9. Damping and Area. Suppose now that

$$x_1 = x(2\pi/\lambda, x_0, y_0), y_1 = y(2\pi/\lambda, x_0, y_0)$$

have continuous derivatives with respect to  $x_0, y_0$ . This will be the case if  $f, g$  in 1.1(3) have continuous derivatives of the second order, and  $p$  has a continuous derivative of the first order.

Theorem 6. If in the equation 1.1(3)  $f$  and  $g$  have continuous derivatives of the first two orders, and  $p(t)$  has a continuous derivative of the first order under the transformation  $T$  defined by the equation, then any sufficiently small area  $\delta x_0 \delta y_0$  goes into an area

$$\left( e^{-\int_0^{2\pi/\lambda} f dt} + \epsilon \right) \delta x_0 \delta y_0,$$

where  $\epsilon \rightarrow 0$  as  $\delta x_0, \delta y_0 \rightarrow 0$ .

Corollary. If  $f > b_1 > 0$  for all  $x$ , then under  $T$  each sufficiently small area  $\delta x_0 \delta y_0$  goes into an area less than  $e^{-2b_1\pi/\lambda} \delta x_0 \delta y_0$ , and so all finite areas tend to 0 under  $T^n$  as  $n \rightarrow \infty$ . In particular  $S$  has zero area, and cannot contain a simple closed curve.

After time  $t$  the area  $\delta x_0 \delta y_0$  occupies an area  $J(t) \delta x_0 \delta y_0$  approximately, where

$$J(t) = \begin{vmatrix} \frac{\partial x}{\partial x_0} & \frac{\partial x}{\partial y_0} \\ \frac{\partial y}{\partial x_0} & \frac{\partial y}{\partial y_0} \end{vmatrix}$$

Now since the derivatives are continuous we can change the order of differentiation, and so

$$\frac{dJ}{dt} = \begin{vmatrix} \frac{\partial \dot{x}}{\partial x_0} & \frac{\partial \dot{x}}{\partial y_0} \\ \frac{\partial \dot{y}}{\partial x_0} & \frac{\partial \dot{y}}{\partial y_0} \end{vmatrix} + \begin{vmatrix} \frac{\partial x}{\partial x_0} & \frac{\partial x}{\partial y_0} \\ \frac{\partial \dot{y}}{\partial x_0} & \frac{\partial \dot{y}}{\partial y_0} \end{vmatrix}$$

But  $\dot{x} = y$ , and  $\dot{y} = \ddot{x} = -f(x)y - g(x) - p(t)$ , and  $p(t)$  is independent of  $x_0, y_0$ . Hence

$$\frac{\partial \dot{y}}{\partial x_0} = -f(x) \frac{\partial y}{\partial x_0} - (f'(x)y + g'(x)) \frac{\partial x}{\partial x_0}$$

and similarly for  $y_0$ . All determinants with two rows the same vanish, and so

$$\frac{dJ}{dt} = -f(x)J.$$

Integrating from 0 to  $2\pi/\lambda$ , we have

$$J(2\pi/\lambda) = \exp \left( - \int_0^{2\pi/\lambda} f(x) dt \right).$$

which is the required result.

The corollary is an obvious consequence of theorem 5.

§3.10. Recurrent Points. The points of  $S$  may be divided into two classes (a) wandering points (b) recurrent points. If there is a neighborhood  $U(P)$  of a point  $P$  such that  $T^n(P)$  does not lie in  $U(P)$  for  $n > n_0$ , then  $P$  is a wandering point. Otherwise  $P$  is recurrent. A fixed point, and a periodic point are recurrent points.

Let  $P$  be a recurrent point. Consider the set  $E = \sum T^n(P)$ , where  $n$  runs through all integers from  $-\infty$  to  $+\infty$ . Then every point of  $E$  is recurrent. In most cases  $E'$  also consists of recurrent points. A minimal recurrent set  $M$  is a closed set of recurrent points which has no proper closed subset of recurrent points. If  $P$  is fixed or periodic,  $M$  is finite. In all other cases  $M$  is infinite. It may, or may not, be locally connected. It is known that sets which are not locally connected exist, and also, I think, that locally connected sets correspond to uniformly almost periodic solutions, and cannot occur when  $S$  has zero area. It is an interesting unsolved problem whether any recurrent set other than fixed or periodic points can occur for transformations corresponding to equations 1.1 (3) satisfying the conditions of theorem 6 Corollary. Levinson has given an example of an  $S$  of zero area containing a recurrent set which is not periodic, but his transformation does not necessarily make all small areas reduce by a factor less than  $J_0 < 1$  as in the corollary of theorem 6.

#### Part 4. Positive Damping

§4.1. We now return to the discussion of the equation (3) of §2.1 from an analytical point of view.

It is known<sup>7</sup> that the solutions of §2.1 (3) for

---

7. See M. L. Cartwright and J. E. Littlewood, Journal of the London Math. Soc. 20 (1945) 180-189, also N. Levinson, Annals of Math. 50 (1949), 126-153.

$f$  and  $g$  may include stable and unstable solutions of different periods, combined with an irregular type of recurrent solution; and it is easy to construct functions  $f$  and  $g$  for which the equations have both periodic and almost periodic solutions. In fact if  $f = 0$ ,  $|x| \leq \frac{1}{2}$ ,  $f = 2(|x| - \frac{1}{2})$ ,  $|x| \geq \frac{1}{2}$ ,  $g = x$ ,  $p(t) = \frac{1}{4} \cos t$ , the equation will satisfy our conditions and have almost periodic solutions for irrational  $\lambda$ . The richest variety of solutions is usually associated with equations for which  $f < 0$  for some  $x$ , and so, although we cannot hope to prove any very precise result without further hypotheses, we may expect some sharper results if  $f \geq b_1 > 0$  for all  $x$ . Theorem 8, below, although it says little about the solutions, strengthens this conjecture<sup>8</sup>. Sharper results are in fact obtainable for  $f \geq b_1 > 0$ , although in order to obtain a single stable periodic solution to which all others converge we have to make additional assumptions about  $g$  as well.

§4.2. In the next theorem  $p$  need not be periodic, and the result is merely a quantitative improvement of theorem 1.

Theorem 7. If the hypotheses of theorem 1 hold, and if  $f \geq b_1 > 0$  for all  $x$  and  $k \geq 1$ , then

$$|\dot{x}| < B, F(x) - p_1 = C - \frac{1}{k} \int_0^t g dt + o\left(\frac{1}{k}\right),$$

where the constant implied in the  $o$  is a  $B$ .

Cor. If  $f'$  and  $p'$  exist and  $|f'| < B$ ,  $|p'| < B$ , then  $|x| < B$  and  $fx = p + o\left(\frac{1}{k}\right)$ .

Proof of Theorem 7. Let  $r(t) = \int_0^t f(x)dt$ , then  $r \geq b_1 t$

---

8. The theorems of this section and their proofs are taken from M. L. Cartwright and J. E. Littlewood, Annals of Maths. 48 (1947) 472-494.

for  $t \geq 0$ . By theorem 1  $|x| < B$  and so  $|g(x)| < \gamma(B) = B$ . Further there exists a  $P$  for  $t > t_0$  such that  $|\dot{x}_P| \leq 1$ . For if not,  $|x|$  cannot remain less than  $B$ . Changing the origin so that  $t = 0$  at  $P$ , and multiplying by  $e^{k\tau}$ , we obtain the equation in the form

$$\frac{d}{dt} (\dot{x} e^{k\tau}) = e^{k\tau} (kp - g).$$

Integrating we have

$$|\dot{x} e^{k\tau}| \leq |\dot{x}_P| + Bk \int_0^t e^{k\tau(t)} dt.$$

But  $\tau' = f$ , and  $e^{k\tau} > 0$  for  $t > 0$ , so

$$\begin{aligned} \int_0^t e^{k\tau} dt &= \int_0^t e^{k\tau} f \frac{dt}{f} \\ &\leq \frac{1}{b_1} \int_0^t e^{k\tau f} dt \leq \frac{e^{k\tau}}{kb_1}. \end{aligned}$$

Hence  $|\dot{x}| \leq 1 + B/b_1 = B$ . The rest of the theorem follows from the integrated equation 2.2(4').

Proof of the Corollary. Put  $u = f\dot{x} - p/k$  so that  $\ddot{x} = -ku - g$ , and  $\dot{u} = -kfu + h$ , where  $h = -fg + f'\dot{x}^2 - \dot{p}/k = o(1)$ . For  $\dot{u} = f'\ddot{x} + f'\dot{x}^2 - \dot{p}/k$ . Now

$$\frac{d}{dt} (u e^{k\tau}) = h e^{k\tau},$$

and so

$$u = u_0 e^{-k\tau} + e^{-k\tau} \int_0^t h e^{k\tau} dt,$$

where  $u = u_0$  at  $t = 0$ . Hence

$$\begin{aligned} |u| &\leq |u_0| e^{-k\tau} + B e^{-k\tau} \int_0^t e^{k\tau} dt \\ &= o(e^{-k\tau}) + o(1/k) = o(1/k). \end{aligned}$$

Hence  $\ddot{x} = 0(1)$  and the result follows.

§4.3. We next add hypotheses on  $g$  and introduce the idea of convergence. Any two solutions  $X_1(t)$ ,  $X_2(t)$  are said to converge if  $X_1(t) - X_2(t) \rightarrow 0$  and  $\dot{X}_1(t) - \dot{X}_2(t) \rightarrow 0$  as  $t \rightarrow \infty$ .

Theorem 8. Suppose that the hypotheses of theorem 7 hold, and that  $p(t)$  has period  $2\pi/\lambda$ . Suppose further that  $g(0) = 0$ ,  $g' \geq b_4 > 0$  for all  $x$  and  $|g''(x)| \leq G(\xi)$  for  $|x| \leq \xi$ , where  $G$  is independent of  $k$ . Then all solutions for which

$$(1) \quad |x| \leq \xi_0, \quad |\dot{x}| \leq \eta_0 \quad \text{for } t \geq t_0$$

converge, provided that

$$(2) \quad 2\eta_0 G(\xi_0) < k b_1 b_4.$$

Cor. 1. All solutions converge for  $k > k_0$ .

Cor. 2. If  $p(t)$  is periodic, there exists a periodic solution  $X^*$  to which all solutions satisfying (1) and (2) converge.

Proof of theorem 8. Consider any two solutions  $x_1(t)$ ,  $x_2(t)$  of §2.1 (3), and let  $z = x_2 - x_1$ ,  $\Delta g = g(x_2) - g(x_1)$ ,  $\Delta F = F(x_2) - F(x_1)$ , where  $F(x) = \int_0^x f(x)dx$  as usual. Then substituting in the equation and subtracting, we have

$$(3) \quad \ddot{z} + k \frac{d}{dt} \left\{ \frac{\Delta F}{z} \cdot z \right\} + \frac{\Delta g}{z} \cdot z = 0.$$

Multiply by  $z$  and integrate. This gives

$$\begin{aligned}
 (4) \quad 0 &= \frac{1}{2}(\dot{z}^2 - \dot{z}_0^2) + k \left| \frac{\Delta F}{z} \cdot z \cdot \dot{z} \right|_0^t \\
 &- k \int_0^t \frac{\Delta F}{z} \cdot z \cdot \ddot{z} \, dt + \left[ \frac{\Delta G}{z} \cdot \frac{1}{2} z^2 \right]_0^t \\
 &- \int_0^t \frac{1}{2} z^2 \frac{d}{dt} \left( \frac{\Delta G}{z} \right) \, dt .
 \end{aligned}$$

The integrated terms are  $O(1)$  as  $t \rightarrow \infty$ , (the constant implied is  $Bk^2$  but this is irrelevant). Substituting for  $\dot{z}$  from (3), we have

$$\begin{aligned}
 -k \int \frac{\Delta F}{z} \cdot z \cdot \ddot{z} \, dt &= k \int \left\{ k \frac{d}{dt} \left( \frac{\Delta F}{z} \cdot z \right) \right. \\
 &+ \left. \frac{\Delta G}{z} \cdot z \right\} \frac{\Delta F}{z} \cdot z \, dt = \frac{1}{2} k^2 \left| \left( \frac{\Delta F}{z} \cdot z \right)^2 \right|_0^t \\
 &+ k \int_0^t \frac{\Delta F}{z} \cdot \frac{\Delta G}{z} \cdot z^2 \, dt .
 \end{aligned}$$

Hence, as  $t \rightarrow \infty$ ,

$$(5) \quad \int \left\{ k \frac{\Delta F}{z} \cdot \frac{\Delta G}{z} - \frac{d}{dt} \left( \frac{\Delta G}{z} \right) \right\} z^2 \, dt = O(1).$$

Let  $x = x_1$ ,  $x + z = x_2$ . By Taylor's theorem

$$\begin{aligned}
 \frac{d}{dt} \left( \frac{\Delta F}{z} \right) &= \frac{\dot{x}}{z} (g'(x + z) - g'(x)) \\
 - \frac{\dot{z}}{z^2} \left\{ g(x + z) - g(x) - z g'(x + z) \right\} &= \dot{x} g''(x + \vartheta z) \\
 &- \frac{\dot{z}}{x^2} \frac{1}{2} (-z)^2 g''(x + z - \vartheta' z),
 \end{aligned}$$

where  $0 < \vartheta < 1$ ,  $0 < \vartheta' < 1$ . Since  $|g''| \leq G(\xi_0)$  for  $|x| \leq \xi_0$ , and  $|x| \leq \xi_0$ ,  $|\dot{x}| \leq \eta_0$ ,  $|\dot{z}| \leq 2\eta_0$ ,

we have

$$\frac{d}{dt} \left( \frac{\Delta g}{z} \right) \leq 2 \eta_0 G(\xi_0).$$

Since  $\Delta F/z = f(x + \vartheta''z) \geq b_1$ ,  $0 < \vartheta'' < 1$ , and  $\Delta g/z \geq b_4$  (because  $g' \geq b_4$ ), the part of the integrand bracketed in (5) is greater than or equal to  $k b_1 b_4 - 2 \eta_0 G(\xi_0) > 0$  if (2) holds. Hence (5) gives

$\int_0^t z^2 dt = o(1)$  as  $t \rightarrow \infty$ . Since  $\dot{z} = o(1)$ , it follows that  $z \rightarrow 0$ , and since  $\dot{z} = o(1)$ , this gives  $\dot{z} \rightarrow 0$ . Hence the solutions satisfying (1) and (2) converge in the sense defined. It may happen that no solutions or only one satisfy (1) and (2).

Proof of the corollaries. Corollary 1 follows immediately from theorem 1 and theorem 2 by taking  $\xi_0, \eta_0$  sufficiently large, and then  $k_0 = 2\eta_0 G(\xi_0)/(b_1 b_4)$ .

For corollary 2 we suppose that  $p(t)$  has period  $2\pi/\lambda$ , and write  $x_n, \dot{x}_n$  for the values of  $x(t, x_0, y_0)$  at  $t = 2n\pi/\lambda$ .  $x(t, x_0, y_0)$  and  $x(t + 2p, x_0, y_0)$  converge and that means

$$x_n - x_{n+p} \rightarrow 0 \quad \dot{x}_n - \dot{x}_{n+p} \rightarrow 0$$

for all  $p$  as  $n \rightarrow \infty$ . Let  $(X, Y)$  be a limit point of  $x_n, \dot{x}_n$ . Then  $x = x(t, X, Y)$  has period  $\frac{2\pi}{\lambda}$ , and all solutions converge to it.

§4.4. Some of the best known cases of positive damping are associated with hysteresis phenomena which may perhaps be represented by an equation of the form

$$(1) \quad \ddot{x} + f(x, \dot{x})\dot{x} + g(x, \dot{x}) = p(t),$$

although it is not clear precisely how the functions  $f$  and  $g$  should be defined. In this form the proof of

lemma 2 in theorem 1 requires a slight modification, but the result of that theorem remains true provided that  $f(x, \dot{x})$  and  $g(x, \dot{x})$  satisfies hypotheses (i) and (ii), and the same is true of theorem 7. Theorem 8 however depends on properties of  $F(x) = \int_0^x f(x)dt$  which does not exist and the result is not true<sup>1</sup> for equation (1) in general. Hysteresis occurs in problems of ferroresonance<sup>2</sup> and subharmonics have also been observed in such problems when the damping depends only on  $x$ , but  $g''$  is very large. The equation<sup>3</sup>

$$\ddot{x} + k \dot{x} + x(1 - \epsilon + \frac{4}{3} \epsilon x^2) = \frac{1}{3} \epsilon \cos 3t,$$

also has three subharmonic solutions for  $\epsilon < \epsilon_0$  and  $k < k_0(\epsilon)$ , and many other equations of a similar type have subharmonic solutions. The modified form of lemma 2 of theorem 1 to cover equation (1) is as follows: Let  $|\dot{x}_Q| = |\dot{x}_P| + u$ ,  $u \geq 1$ . We have to prove  $u < B$ . We may suppose  $Q$  the first point after  $P$  at which  $|\dot{x}_Q| = |\dot{x}_P| + u$ . Let  $Q_1$  be the last point before  $Q$  at which  $|\dot{x}| = |\dot{x}_P| + \frac{1}{2} u$ . Then in  $Q_1Q$   $|\dot{x}|$  lies between  $|\dot{x}_P| + \frac{1}{2} u$  and  $|\dot{x}_P| + u$ , and so it is of constant sign, say, positive. Then  $\ddot{x}$  at a point of  $Q_1Q$  is algebraically at most

$$-f \dot{x} + |g| + |p| \leq B (|\dot{x}_P| + u) + B = \alpha, \text{ say.}$$

---

1. See M. L. Cartwright and J. E. Littlewood, Annals of Math., 48 (1947) 490-494.

2. See W. H. Surber, Jr., A study of ferroresonant and subharmonic oscillations, Thesis for the degree of electrical engineer (Princeton 1948).

3. See M. L. Cartwright and J. E. Littlewood, Annals of Math., 48 (1947) 490 et. seq. The term

$a_3 a_{-1}^2$  has been omitted from some of the calculations of the order of  $k$ .

The time from  $Q_1$  to  $Q$  is at least  $\frac{1}{2} u/\alpha$ , and

$$x_Q - x_{Q_1} = \int_{Q_1}^Q \dot{x} dt \geq (|\dot{x}_P| + \frac{1}{2} u) \frac{1}{\alpha} u.$$

Since  $-1 \leq x_{Q_1} < x_Q < 1$ , we have

$$(|\dot{x}_P| + \frac{1}{2} u)u < B(|\dot{x}_P| + u) + B,$$

and whatever the value of  $\dot{x}_P$ , this implies  $u < B$ .

### Part 5. Nearly Linear Oscillations

§5.1. In this part I propose to review the methods for nearly linear oscillations. That is to say cases in which certain periodic or almost periodic solutions of 1.1(3) and 2.1(3) are nearly equal to solutions of a linear equation over a fairly long time. The equation 2.1(3) itself is nearly linear for  $|x| < K$ ,  $|y| < K$  if it can be written in the form

$$(1) \quad \ddot{x} + k\dot{x} + \omega^2 x = p(t) + \epsilon \varphi(x, \dot{x}, \epsilon),$$

where  $k \geq 0$ ,  $\epsilon$  is small and positive and

$$(2) \quad |\varphi| < B$$

for all  $t$  over the range of  $x$ ,  $y$  and  $\epsilon$  considered. The constant  $B$  is independent of  $\epsilon$  here and also in what follows. We shall suppose, as is usually the case, that  $p(t)$  is of the form

$$(3) \quad p(t) = \sum_{n=1}^{\infty} p_n \cos(\lambda_n t + \alpha_n),$$

where  $\lambda_n > 0$  because we assumed that  $\left| \int_0^t p(t) dt \right| < B$  in theorem 1. Further we may obviously suppose that  $k$

and  $\omega^2$  are either 0 or not  $0(\epsilon)$ . For if one of them is  $0(\epsilon)$ , the corresponding term can be absorbed into  $\varphi$ . This still leaves the possibility that  $k$  and  $\omega^2$  may depend on  $\epsilon$ .

§5.2. The case  $\omega \neq 0$ . Suppose first that  $\omega \neq 0(\epsilon)$ , in this case it is best to normalize by putting  $\omega t = t'$  so that  $\omega = 1$ . Suppose that when this has been done we obtain the equation

$$(4) \quad \ddot{x} + k\dot{x} + x = p(t) + \epsilon \varphi(x, \dot{x}, \epsilon),$$

where

$$(5) \quad |\varphi| < B \text{ for } |x| < B, |\dot{y}| < B.$$

The corresponding linear equation is

$$(6) \quad \ddot{x} + k\dot{x} + x = p(t),$$

which has a solution of the form

$$(7) \quad x = a_1 e^{-kt} \cos \mu t + a_2 e^{-kt} \sin \mu t + \sum_{n=1}^{\infty} p_n \frac{(1 - \lambda_n^2) \cos(\lambda_n t + \alpha_n) + k \sin(\lambda_n t + \alpha_n)}{(1 - \lambda_n^2)^2 + k^2}$$

provided that  $k$  and  $\lambda_n - 1$  are not both 0.

If  $k > 0$  (and so by our hypotheses not  $0(\epsilon)$ ), and if the partial derivatives of  $\varphi$  are bounded by  $B$ 's, the conditions of theorem 8 hold. For in the notation of theorem 8, we have

$$f \geq k - \epsilon B \geq \frac{1}{2} k, \quad g' \geq 1 - \epsilon B, \quad |g''| < B \epsilon,$$

so that  $b_1 \geq \frac{1}{2}k$ ,  $b_4 \geq \frac{1}{2}$  and  $G \leq \epsilon B$  so that 4.3(2) holds. Hence all solutions converge to a solution which is given approximately by (7) with  $a_1 = a_2 = 0$ .

If  $k = 0$ , it may be observed that by adding  $0(\epsilon)$  to  $\omega^2$  before standardization we can avoid the case in which  $\lambda_n = 1$  exactly, but if  $\lambda_n - 1$  is small the solution given by (7) may go outside the range in (5) unless  $p_n$  is also small. In this case the solution is not nearly linear, and so we shall not consider it. In other cases where  $k = 0$  by putting

$$x = \sum p_n \frac{\cos(\lambda_n t + \alpha_n)}{1 - \lambda_n^2} + x_1,$$

and dropping the suffix we obtain an equation of the form

$$(8) \quad \ddot{x}_1 + x_1 = \epsilon \Phi(x_1, \dot{x}_1, t, \epsilon),$$

where

(9)

$$\Phi(x, \dot{x}, t, \epsilon) = \varphi_0(x, \dot{x}, \epsilon) + \sum_{n=1}^{\infty} \frac{\varphi_n}{n} (x, \dot{x}, \epsilon) \cos(\lambda_n t + \alpha_n),$$

and

$$(10) \quad |\Phi(x, y, t, \epsilon)| < B \quad \text{for } |x| < B, \quad |y| < B.$$

§5.3. The case  $\omega^2 = 0$ . Before proceeding further, it is worthwhile considering the case  $\omega = 0$  which we passed over. The solution of the corresponding linear equation for  $\omega = 0$  viz.

$$(1) \quad \ddot{x} + k\dot{x} = p(t)$$

is of the form

$$(2) \quad x = a + b e^{-kt} + \sum_{n=1}^{\infty} p'_n \cos(\lambda_n t + \alpha'_n) = X(t, a, b)$$

where  $\underline{a}$  and  $\underline{b}$  are arbitrary constants. Putting

$$x = X(t, a, b) + \epsilon x_1$$

in 5.1(1) which is now of the form

$$(3) \quad \ddot{x} + k\dot{x} = p(t) + \epsilon \varphi(x, \dot{x}, \epsilon),$$

we have

$$(4) \quad \ddot{x}_1 + k\dot{x}_1 = \varphi(X, \dot{X}, \epsilon) + \epsilon \varphi_1(x_1, \dot{x}_1, X, \dot{X})$$

The first approximation of (4) is

$$(5) \quad X_1 = A + B e^{-kt} + \varphi(a, 0)t + \varphi_2$$

where  $A$  and  $B$  are arbitrary constants, and  $\varphi_2$  contains  $t$  only in the form  $e^{-kt}$ ,  $\cos(\lambda_n t + \alpha_n)$  so that  $\varphi_2$  is bounded as  $t \rightarrow \infty$  but  $x_1$  is not unless  $\varphi(a, 0) = 0$ , which cannot occur in equations derived from 2.1(3) unless  $\underline{a}$  takes a special value or  $f(x)$  is linear over some range. If  $\varphi(a, 0) \neq 0$  for  $\underline{a}$  near  $a_0$ , it is clear from (5) that the solution tends to move away from the solution obtained by putting  $a = a_0$ ,  $b = B = 0$ , and so even if there is a periodic solution of 2.1(3) it cannot be stable unless perhaps the period tends to infinity as  $\epsilon \rightarrow 0$ . For this reason we exclude this case, also the one with  $\omega = 0$  and  $k = 0$  from consideration. If  $k > 0$  and  $\varphi(a, 0) = 0$ , the result is similar to that in §5.2.

§5.4. In virtue of the preceding remarks, the

main problems connected with the equation 2.1(3) in its nearly linear forms can be reduced to the consideration of the equation 5.2(8) namely

$$(1) \quad \ddot{x} + x = \epsilon \Phi(x, \dot{x}, t, \epsilon),$$

where  $\Phi(x, \dot{x}, t, \epsilon)$  and its first and second derivatives are bounded by numbers independent of  $\epsilon$ , and

$$\Phi(x, \dot{x}, t, \epsilon) = \sum_{n=0}^{\infty} \phi_n(x, \dot{x}, \epsilon) \cos(\lambda_n t + \beta_n).$$

In most special cases the series for  $\Phi$  only contains a finite number of terms.

The main problem in the modern physical theory of oscillations is to determine what types of oscillation are likely to occur in a system, either by varying the parameters of the system, or by the application of some jerk or shock. This is equivalent to determining solutions, usually periodic or almost periodic solutions, which have some kind of stability for small displacements. The unstable periodic or almost periodic solutions are of interest to the pure mathematician, partly as a means of determining the existence of stable solutions. These qualitative results are usually determined by the first and second terms in the approximation, or rather by determining how the first approximation varies. The higher approximations are of minor interest, but are sometimes required in order to obtain the frequency of periodic solutions accurately. In all cases we require an approximation valid over a very long time, and so the Poincaré method is of little value unless combined with other devices.

In estimating the values of the various methods available it may be useful to consider, (1) whether a method is convenient practically, (2) to what extent it

is accurate, and how easy it is to justify it, (3) whether it is adequate for dealing with all the cases which arise. Under (3) we may consider methods in relation to the following important cases of the equation 5.2(8): (a)  $\phi$  independent of  $t$ , (no forced oscillation); (b)  $\lambda_1$  near a certain integer or rational fraction,  $\lambda_n = n\lambda_1$ , and conditions such that there is a periodic solution, (this may be described as the resonant case with synchronization); (c) the non-resonant case in which no  $\lambda_n$  is near any significant rational fraction and the solution is not periodic, but is a perturbation about a solution of the form  $b \cos(t + \alpha)$ ; (d) transition phenomena between (b) and (c). The cases may be illustrated by van der Pol's equation in the form

$$\ddot{x} + x = \epsilon (1 - x^2)\dot{x} + p \epsilon \lambda \cos(\lambda t + \alpha)$$

Case (a) occurs if  $p = 0$ , case (b) occurs if  $\lambda - 1 = 0(\epsilon)$ , provided that  $p$  is sufficiently large, and also when  $\lambda - 3 = 0(\epsilon)$  and  $p\epsilon$  is not small. The latter case is called the case of subharmonic resonance, and the integer 3 has a special significance because the only non-linear term is of the third degree. Case (c) occurs with  $\lambda$  not near 1 or 3 and then the solution is a perturbation about the solution with  $p = 0$ , and case (d) occurs on the borders of (b) and (c). In cases (a) and (b) we have the advantage of a clear aim viz. exact periodicity, in case (c) of a slight deviation from the better known case. (a).

§5.5 Problems of Approximation. There are two problems of approximation which may be worth mentioning. The first is that if the original equation 1.1(3) or 2.1(3) contains several small terms it is usual to

normalize so that there is only one small parameter to consider. This process nearly always cuts out at least one special case which needs separate consideration. For instance Mandelstam and Papalex<sup>9</sup> in their work on subharmonic resonance standardize in a way which is roughly equivalent to making

$$f(x)\dot{x} = \epsilon (\alpha + x + \gamma x^2)x$$

which excludes any even function  $f(x)$  such as  $\epsilon (1 - x^2)$  which occurs in van der Pol's equation, and also all other functions with very small odd terms in  $f(x)$ .

The other problem is that of the treatment of  $\varphi$  when it is not regular. The non linear function may have discontinuous derivatives of some order. It will be clear from what follows that it is the Fourier coefficients of  $\varphi(X, \dot{X}, t, \epsilon)$  where  $X, \dot{X}$  are the first approximations which are most important. In physical problems harmonics higher than the third are often negligible and even the third is small, and so it is sometimes assumed that it will be sufficient to use a cubic polynomial as an approximation for  $\varphi$ . But this is not necessarily the case except for fixed values of the parameters. For  $\varphi$  may be strictly linear from  $x = -1$  to  $x = 1$ , say, and need substantial second and third degree terms for its representation outside this range. For instance  $f(x)$  in 1.1(3) may be of the form shown, where BC is a straight line.

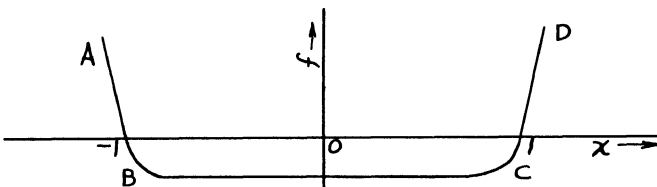

9. L. Mandelstam and N. Papalex, Zeitschrift fur Physik, 73 (1932) 223-248.

§5.6. Fourier Series. The most obvious method in cases (a) and (b) is to try substitution of a Fourier series. If there is a periodic solution, it certainly can be represented as a Fourier series, and if the series contains one or two dominating terms it is fairly easy to estimate their amplitudes. There is something to be said for using a complex Fourier series

$$x = \sum_{n=-\infty}^{\infty} a_n e^{ni\mu t}$$

which makes combination of terms arising from multiplication fairly easy, but even so it is easy to overlook certain combinations.

The method gives necessary conditions for certain types of periodic solution and is valuable in the preliminary stages. Other methods are needed for the discussion of stability, and the method fails to give any information if the Fourier series converges so slowly that many terms are of comparable magnitude; for then very many product terms have to be considered. Even with two terms of comparable magnitude in the Fourier series the estimation of the higher approximations rapidly becomes laborious by this, and, I think, by any other method.

§5.7. The method of Lindstedt was used by Appleton and Greaves<sup>10</sup>. It can be used to obtain a periodic solution in case (a), but needs modification in case (b) and for non-periodic solutions. The method consists in arranging the approximation so that each term of order  $\epsilon^n$ ,  $n = 1, 2 \dots$ , consists of a periodic

---

10. E. V. Appleton and W. M. H. Greaves, Phil. Mag. 45 (1923) 401-414. For justification and discussion of stability see W. M. H. Greaves, Proc. Roy. Soc. A, 103 (1923) 516-524, and Proc. Cambridge Phil. Soc. 22 (1923), 16-23.

function of  $t$  independent of  $\epsilon$ . In case (a) the period is of the form  $2\pi/\Omega$ , where  $\Omega^2 = 1 + \epsilon\omega_1^2 + \epsilon^2\omega_2^2 + \dots$ , and so by changing the variable  $t$ , we can obtain the equation 5.4(1) in the form

$$\begin{aligned} \ddot{x} + x(1 + \epsilon\omega_1^2 + \epsilon^2\omega_2^2 + \dots) \\ = \epsilon\varphi_1(x, \dot{x}) + \epsilon^2\varphi_2(x, \dot{x}) + \dots \end{aligned}$$

with a solution of period  $2\pi$  exactly. Equating coefficients of  $\epsilon^n$  we have a first approximation  $\ddot{x} + x = 0$  with solution  $x = a \sin(t + \alpha)$ . By a change of origin, we make  $\alpha = 0$ , substitute  $x = a \sin t + \epsilon x_1$ , and equate coefficients so that

$$\ddot{x}_1 + x_1 = -\omega_1^2 a \sin t + \varphi_1(a \sin t, a \cos t).$$

Here the values of  $a$  and  $\omega_1$  are chosen so that no term in  $\sin t$  or  $\cos t$  occurs on the right hand side thus eliminating secular terms.

The method can easily be justified in this case by the use of classical theorems, and seems quite well suited to obtaining higher approximations of periodic solutions. It does not touch the question of stability or general qualitative results.

In case (b) the period, if it exists, must be a multiple of the period  $2\pi/\lambda$  of  $\varphi(x, y, t, \epsilon)$  in  $t$ . The method has been applied to this case, but it is less easy to justify it here. The method of Poincaré gives a solution in the form of series in power of  $\epsilon$  provided that the initial values of  $x$  and  $\dot{x}$  are fixed, and of course that  $\varphi$  is analytic in all the variables. But the initial values of  $x$  and  $\dot{x}$  which give rise to a periodic solution vary with  $\epsilon$ , and so the series obtained by Lindstedt's method may be only an asymptotic series.

§5.8. The remaining methods are applicable more generally and are suitable for qualitative results, but in some cases they do not go beyond determining roughly how the first approximation varies over a fairly long time. They are based on the fact, which is evident, that over any limited time a solution of 5.4(1) which is bounded is of the form

$$(1) \quad x = b_1 \sin t + b_2 \cos t,$$

where  $b_1, b_2$  vary slowly, which is equivalent to

$$(2) \quad x = b \sin (t + \alpha),$$

or

$$(3) \quad x = b \sin \theta,$$

where  $b, \alpha$  vary slowly and  $\theta$  is nearly  $t$ .

Appleton<sup>11</sup> and van der Pol<sup>12</sup> used (1) and assumed on physical grounds that  $\dot{b}_1, \dot{b}_2$  are small and that  $\dot{b}_1, \dot{b}_2$  are negligible compared with certain terms in  $b_1, b_2$ . They give no purely mathematical justification. But Mandelstam and Papalexi<sup>13</sup> used  $b_1, b_2$  as parameters, adding the condition

$$(4) \quad 0 = b_1 \sin t + b_2 \cos t.$$

By this means exact equations for  $b_1$  and  $b_2$  are obtained, and if 5.4(1) is of the form 5.1(1) so that  $\phi$  has period  $2\pi/\lambda$ , we have

---

11. E. V. Appleton, Phil. Mag. 47 (1924) 609-619.

12. B. van der Pol, Phil. Mag. 3 (1927) 65-80.

13. See, A. A. Andronov and C. E. Chaikin, Theory of Oscillations, edited and translated by S. Lefschetz, (Princeton 1949), also L. Mandelstam, and N. Papalexi, A. Andronov, S. Chaikin and A. Witt, Tech. Phys. of U.S.S.R. 2 (1935)(in French) 81-134.

$$(5) \quad \begin{aligned} \dot{b}_1 &= \epsilon \left\{ \psi_0(b_1, b_2) + \psi_1(b_1, b_2, t) \right. \\ \dot{b}_2 &= \epsilon \left\{ x_0(b_1, b_2) + x_1(b_1, b_2, t) \right. \end{aligned}$$

where  $\psi_1, x_1$  are represented by Fourier series having terms of the form  $\cos(n \pm m\lambda)t, \sin(n \pm m\lambda)t$ , but no constant term. In case (a)  $\lambda$  does not occur, and putting  $\epsilon t = t'$  in (5) we obtain equations with a short period  $2\pi\epsilon$  of the type considered by Fatou<sup>14</sup>.

$$(6) \quad \begin{cases} \frac{db_1}{dt'} = \psi_0(b_1, b_2) + \psi_1(b_1, b_2, \frac{t'}{\epsilon}) \\ \frac{db_2}{dt'} = x_0(b_1, b_2) + x_1(b_1, b_2, \frac{t'}{\epsilon}) . \end{cases}$$

Fatou showed that for every  $T$ , the solution of (6) differs from the solution of

$$(7) \quad \begin{aligned} \frac{db_1}{dt'} &= \psi_0(b_1, b_2) \\ \frac{db_2}{dt'} &= x_0(b_1, b_2) \end{aligned}$$

for  $t_0 \leq t \leq t_0 + T$  by less than  $B\epsilon$ , and so (5) is fairly accurately represented over a time of length  $T/\epsilon$  if we put  $\psi_1 = x_1 = 0$ . This time is long enough to establish most of the properties required with some trouble; but it is worth while to consider the reason for Fatou's result. Over a time  $2\pi\epsilon$  any term in  $\cos nt$  or  $\sin nt$

---

<sup>14</sup>. P. Fatou, Bull. de la Soc. Math. de France 56 (1928) 98-139.

passes through the same negative range as it does positive, and since  $b_1$  and  $b_2$  have not had time to vary much the effect cancels out over any complete period, and the average effect over any fairly long time is negligible. The method is also applicable in cases (b), (c), (d), although Fatou's result is only applicable in case (b) and sometimes by special arrangement in (c). It is easy to see that in the interior of any one period  $2\pi\epsilon$  the effect of  $\psi_1$  and  $x_1$  in (6) is not negligible compared with  $\psi_0$ ,  $x_0$  and so the expressions obtained for  $x$  only represent the average behaviour with accuracy of order  $O(\epsilon)$  and not the variation throughout the period. The method only gives limited information in (b) and (d) as to the form of the solution.

There is much to be said for putting  $x=b \sin (t+\alpha)$  instead of (1) because this only involves the substitution of one term, and gives a result in terms of amplitude and phase which are physically important, but it is perhaps a little more tiresome to obtain the equation for  $b$  and  $\alpha$ .

§5.9. Kryloff and Bogoliuboff<sup>15</sup> lean heavily on the methods of Poincare and Liapounov. They use the form 5.2(3) and obtain equations for  $a$  and  $\theta$  corresponding to 5.8(5); by a further transformation

$$b = b_1 + \epsilon u(b_1, \theta_1, t), \theta = \theta_1 - \frac{\epsilon}{b_1} v(b_1, \theta_1, t),$$

they remove the terms  $\epsilon u$  and  $\epsilon v/\omega a$  corresponding to  $\psi_1$  and  $x_1$ , so that they obtain equations 5.8(7) for  $b_1, \theta_1$  in place of  $b$  and  $\theta$ . In this form 5.8(7) give

---

15. N. Kryloff and N. Bogoliuboff, Introduction to Nonlinear Mechanics, trans. by S. Lefschetz, Annals of Maths. Studies, No. 11, (Princeton 1943).

give the true approximation of order  $\epsilon$  throughout any one period. Most of the theoretical work of Kryloff and Bogoliuboff proceeds, by means of assuming that one or more characteristic roots of certain equations is not zero, to show that stable or unstable, periodic or almost periodic, solutions exist. Their theory appears to be very complete, since it only fails in exceptional cases where the characteristic roots of certain equations are zero, but in fact it is not always simple to verify for a given equation that the exceptional case is confined to isolated values of a parameter under consideration. So far as we know the exceptional case may occur for every value of a parameter in an interval. Further some of the general theorems quoted are hard to recognize or trace in the literature, and consequently it is hard to form any precise estimate of the error terms.

§5.10. The method of Cartwright and Littlewood depends on difference equations, and uses less of the general theory. It will be applied to a special case in the next part. It is very generally applicable, and easy to justify, and consequently it is easy to see what error is involved at each stage, but the formal calculations may seem longer, and less mechanical than some of the methods of 5.8 and 5.9.

#### Part 6. Nearly Linear Resonance.

§6.1. In this part I propose to discuss one particular type of nearly linear differential equation in detail by the method of Cartwright and Littlewood<sup>16</sup>. I choose van der Pol's equation with forcing term in the form

---

<sup>16</sup>. See M. L. Cartwright, Proc. Cambridge Phil. Soc. 45 (1949) 495-501.

$$(1) \quad \ddot{x} - k(1 - x^2)\dot{x} + x = pk \lambda \cos(\lambda t + \alpha),$$

where  $k$  is small, and  $\lambda$  near 1 because this is a case which shows a considerable variety of phenomena without too heavy formal calculations. There are other interesting cases of resonance, for instance subharmonic resonance in (1) with  $\lambda = 3$ , and resonance with nonlinear restoring force as in an equation of the form

$$(2) \quad \ddot{x} + k\dot{x} + x + kcx^3 = pk \lambda \cos(\lambda t + \alpha),$$

where  $k$  is small and  $\lambda$  near 1. Subharmonic resonance in (1) in its most interesting form appears with  $pk = p'$  not small, and the formal calculations become lengthy because two trigonometrical terms of nearly equal magnitude have to be cubed and then reduced to linear functions. In (2) there is no stable oscillation for  $p = 0$ , and so less varied phenomena may be expected<sup>17</sup>.

§6.2. A fundamental lemma. The justification of all the approximations which we shall use is effected by means of the following lemma which in its turn depends directly on the method of successive approximations.

Lemma. Let  $F(x, y, t, k)$  be a continuous function of  $t$  with continuous partial derivatives with respect to  $x$  and  $y$ , and suppose that

$$(1) \quad F(x, y, t, k) \leq M + |x| + |y|$$

for  $|x| \leq a$ ,  $|y| \leq a$ ,  $|t| \leq 3\pi$ ,  $k < k_0$ ,  $M$  being independent of  $x, y, t, k$ . Then the solution of the equation

---

<sup>17</sup>. See K. O. Friedrichs and J. J. Stoker, Quarterly Journal of Applied Mathematics, 1 (1943) 97-115.

$$(2) \quad \ddot{x} + x = F(x, \dot{x}, t, k)$$

for which  $x = 0$ ,  $\dot{x} = 0$  at  $t = 0$  satisfies

$$(3) \quad \begin{cases} |x| \leq \frac{1}{2} M(e^{2t} - 1) \\ |\dot{x}| \leq \frac{1}{2} M(e^{2t} - 1), \end{cases}$$

provided that  $k < k_0$ ,  $M(e^{6\pi} - 1) < 2a$ ,  $0 \leq t \leq 3\pi$ .

Proof. Since  $F$  is continuous in  $t$ , and has partial derivatives with respect to  $x$  and  $y$ , a unique solution exists near  $x = 0$ ,  $\dot{x} = 0$ , and continues to exist as long as  $|x|$  and  $|\dot{x}|$  remain less than or equal to  $a$ . Writing  $\dot{x} = y$ ,  $\dot{y} = -x + F$ , we have

$$(4) \quad |\dot{x}| + |\dot{y}| \leq M + 2(|x| + |y|)$$

so long as  $|x| \leq a$ ,  $|y| \leq a$ ,  $|t| \leq 3\pi$ .

Since  $x(0) = \dot{x}(0) = 0$ , it is easy to show by applying the method of successive approximation<sup>18</sup> to the equation  $\dot{u} = F_1(u, t, k)$ , where  $|F_1| \leq M + 2|u|$ , that

$$|x| + |y| \leq \frac{1}{2} M(e^{2t} - 1).$$

So if  $M(e^{6\pi} - 1) < 2a$ , we have (3).

§6.3. The Approximations. We have shown in theorem 1 that all solutions of 6.1(1) are bounded by a constant  $B$  independent of  $k$  for  $k \leq 1$  as  $t \rightarrow \infty$ , and it is easy to show by the method of lemma 1 of part 2 that they cross the axis  $x = 0$  an infinity of times. Hence for the purpose of discussing any kind of periodic or almost periodic solution or steady state solution,

18. See Kamke, Differentialgleichungen reeller Funktionen, (Leipzig 1930) 93.

and behaviour of solutions starting near such solutions, it will be sufficient to consider a solution of (1) for which  $x = 0, \dot{x} = b \geq 0$  when  $t = 0$ ,  $b$  being independent of  $k$  for  $k \leq 1$ . Let

$$(1) \quad x = b \sin t + k \xi_1,$$

then  $\xi_1 = \dot{\xi}_1 = 0$  at  $t = 0$  and

$$(2) \quad \ddot{\xi}_1 + \xi_1 = p \lambda \cos(\lambda t + \alpha) + b \cos t(1 - b^2 \sin^2 t) \\ + k \varphi(\xi_1, \dot{\xi}_1, t, k, b) = \psi_1(t, p, b, \alpha, \lambda) \\ + k \varphi_1(\xi_1, \dot{\xi}_1, t, k, b),$$

where  $\varphi_1$  is a polynomial in  $\xi_1, \dot{\xi}_1$  having no constant term. It is easy to see that for every  $\underline{a}$  and  $\underline{b}$  there exist constants  $M_1 = M_1(p, b), N_1 = N_1(a, b)$  such that for all  $t$  and  $k \leq 1$ ,

$$(3) \quad |\psi_1(t, p, b, \alpha)| \leq M_1 \\ |\varphi_1(\xi, \eta, t, k, b)| \leq N_1(|\xi| + |\eta|), \\ |\xi| \leq a, |\eta| \leq a.$$

It follows immediately from the lemma that

$$(4) \quad |\xi_1| \leq \frac{1}{2} M_1(e^{6\pi} - 1), |\dot{\xi}_1| \leq \frac{1}{2} M_1(e^{6\pi} - 1),$$

provided that  $k < k_0(p, b)$ . For, choosing  $a = M_1(p, b)(e^{6\pi} - 1)$ ,  $N_1(a, b)$  is fixed and then for  $k < k_0(p, b)$ ,  $kN_1 < 1$  so that 6.2(1) holds. Combining (1) and (4) we have a first approximation

$$(5) \quad x = b \sin t + o(k), \quad \dot{x} = b \cos t + o(k)$$

Let  $X = X(t, b, \alpha)$  be the solution of

$$\begin{aligned} \ddot{x} + x &= \psi_1(t, p, b, \alpha) \\ &= p \lambda \cos \alpha \cos \lambda t - p \lambda \sin \alpha \sin \lambda t \\ &+ b(1 - \frac{1}{4}b^2) \cos t + \frac{1}{4} b^3 \cos 3t \end{aligned}$$

for which  $X(0) = \dot{X}(0) = 0$ , so that

$$(6) \quad \begin{aligned} X(t) &= \frac{p \lambda}{\lambda^2 - 1} \cos \alpha (\cos t - \cos \lambda t) \\ &+ \frac{p \lambda}{\lambda^2 - 1} \sin \alpha (\sin \lambda t - \lambda \sin t) \\ &+ \frac{b}{2} (1 - \frac{1}{4} b^2) t \sin t + \frac{1}{2} b^3 (\cos t - \cos 3t). \end{aligned}$$

Let  $\xi_1 = X(t) + k\xi_2(t)$  so that

$$(7) \quad x = b \sin t + k X(t) + k^2 \xi_2(t)$$

is a solution of 6.1(1). By (2)  $\xi_2$  satisfies an equation of the form

$$\ddot{\xi}_2 + \xi_2 = \psi_2(t) + k \varphi_2(\xi_2, \dot{\xi}_2, t, k),$$

where  $\varphi_2$  is a polynomial in  $\xi_2, \dot{\xi}_2$  with no constant term.

Since  $X$  as well as  $\xi_1$  satisfies (4), we have

$$\begin{aligned} |\xi_2| &\leq M_2(p, b) \\ |\varphi_2| &\leq N_2(a, b, p) (|\xi_2| + |\dot{\xi}_2|) \end{aligned}$$

for  $|\xi_2| \leq a$ ,  $|\dot{\xi}_2| \leq a$ ,  $|t| \leq 3\pi$ , and  $k < k_0(p, b)$ .

Hence by the lemma of 6.2

$$(8) \quad |\xi_2| \leq \frac{1}{2} M_2(p,b)(e^{6\pi} - 1), \quad |\dot{\xi}_2| \leq \frac{1}{2} M_2(p,b)(e^{6\pi}-1),$$

provided that  $k < k_0$ , where  $k_0 N_2 \leq 1$ . Combining this with (7), we may write

$$(9) \quad \begin{aligned} x &= b \sin t + k X(t) + o(k^2), \\ \dot{x} &= b \cos t + k X(t) + o(k^2), \end{aligned}$$

provided that  $b = o(1)$  for  $0 \leq t \leq 3\pi$ , the constants in the  $o$ 's being independent of  $k$ . This holds for all  $\lambda$ , provided that  $k < k_0(\lambda, p, b)$ .

§6.4. The Difference Equations. From 6.3(5) it follows that the solution crosses  $x = 0$  again with  $\dot{x} = b' > 0$  at  $t = 2\pi + k\tau$ , where  $|\tau| \leq M$  independent of  $k$ . Hence we have a solution of 6.1(1) with

$$(1) \quad \alpha' = \alpha + 2\pi(\lambda - 1) + k\lambda\tau$$

instead of  $\alpha$ , such that  $x = 0$ ,  $\dot{x} = b' > 0$  at  $t = 0$ , and we can repeat the process. The solutions therefore set up a (1,1) transformation of the point  $(b, \alpha)$  on to the point  $(b', \alpha')$ . This transformation is only of interest to us for  $b > 0$ ,  $b' > 0$ ,  $0 \leq \alpha \leq 2\pi$ ; for the cases in which  $b$  or  $b'$  is negative can be obtained from these by a change of approximately  $\pi$  in  $\alpha$  or  $\alpha'$ , and since the functions involved have period  $2\pi$  in  $\alpha$  and  $\alpha'$ , the transformations repeat themselves outside the strip  $0 \leq \alpha \leq 2\pi$ . In fact we could regard  $(b, \alpha)$  as polar coordinates, but the curves which we use later seem a little simpler with  $\alpha$  and  $b$  as rectangular coordinates.

Since  $x = 0$  at  $t = 2\pi + k\tau$ , 6.3(5)(6) and (7) give

$$\begin{aligned} 0 &= b \sin(2\pi + k\tau) + k X(2\pi + k\tau) + o(k^2) \\ &= bk\tau + \frac{k\rho\lambda \cos \alpha}{\lambda^2 - 1} \{\cos k\tau - \cos(2\pi(\lambda - 1) + k\tau)\} \\ &+ \frac{k\rho\lambda \sin \alpha}{\lambda^2 - 1} \{\sin(2\pi(\lambda - 1) + k\lambda\tau) - \lambda \sin k\tau\} + o(k^2), \end{aligned}$$

so that

$$\begin{aligned} b\tau &= -p\lambda \cos \alpha \frac{1 - \cos 2\pi(\lambda - 1)}{\lambda^2 - 1} \\ &- p\lambda \sin \alpha \frac{\sin 2\pi(\lambda - 1)}{\lambda^2 - 1} + o(k). \end{aligned}$$

By (1) we have

$$\begin{aligned} (2) \quad \frac{\alpha' - \alpha}{\pi\lambda k} &= \frac{2(\lambda - 1)}{k} - \frac{p\lambda \cos \alpha(1 - \cos 2\pi(\lambda - 1))}{\pi b(\lambda^2 - 1)} \\ &- \frac{p\lambda \sin \alpha}{\pi b(\lambda^2 - 1)} \sin 2\pi(\lambda - 1) + o(k). \end{aligned}$$

So far we have not used the fact that  $\lambda$  is near 1, and the result holds for all  $\lambda$ , provided that  $k > k_0(\lambda)$ .

Now if  $\lambda$  is near 1, (2) reduces to

$$\begin{aligned} (3) \quad \frac{\alpha' - \alpha}{\pi k} &= 2\rho - \frac{p \sin \alpha}{b} + o(k) + o(\lambda - 1), \rho = \frac{\lambda - 1}{k}, \\ &= \Lambda(b, \alpha) + o(k) + o(\lambda - 1) \end{aligned}$$

Similarly by using 6.3 (5) with  $x = b'$  at  $t = 0$ , we have

$$\begin{aligned}
 b' &= b + k \dot{X}(2\pi + k, \tau) + o(k^2) \\
 &= b + \frac{p \lambda k \cos \alpha}{\lambda^2 - 1} \sin 2\pi(\lambda - 1) + \pi b \left(1 - \frac{1}{4} b^2\right) \\
 &\quad + o(k^2),
 \end{aligned}$$

so that

$$\frac{b' - b}{\pi \lambda k} = \frac{p \cos \alpha}{\pi (\lambda^2 - 1)} \sin 2\pi(\lambda - 1) + \frac{b}{\lambda} \left(1 - \frac{1}{4} b^2\right) + o(k),$$

and for  $\lambda$  near 1

$$\begin{aligned}
 (4) \quad \frac{b' - b}{\pi k} &= p \cos \alpha + b \left(1 - \frac{1}{4} b^2\right) + o(k) + o(\lambda - 1) \\
 &= B(b, \alpha) + o(k) + o(\lambda - 1).
 \end{aligned}$$

#### §6.5. Stable Non-periodic Solutions. From

6.4(3) and (4) we can make various deductions, almost immediately. For instance if  $p$  is small, and  $b$  is near 2,  $b$  does not change much, and if  $b - 2$  is large compared with  $p$ ,  $b$  tends to return to 2, while  $\alpha' - \alpha$  is approximately  $2(\lambda - 1)$ . Hence there is a stable oscillation which of the form

$$x = 2 \sin t + o(p) + o(k) + o(\lambda - 1)$$

over the interval  $0 \leq x \leq 3\pi$ . It is not periodic and has an increasing phase.

Again if  $\lambda - 1$  is small, but large compared with  $k$ , the difference  $\alpha' - \alpha$  varies much more rapidly than  $b$  and so if  $b$  starts near 2,  $\alpha$  varies through the range  $0 \leq \alpha \leq 2\pi$  in  $o(1/(\lambda - 1))$  steps approximately, but during this time  $b$  only varies by  $o(k/(\lambda - 1))$  which is

small. Further, of these steps, those for which  $\cos \alpha < 0$  approximately balance those for which  $\cos \alpha > 0$  (so far as the term  $p \cos \alpha$ ) is concerned, and so we again have a tendency to return to  $b = 2$ .

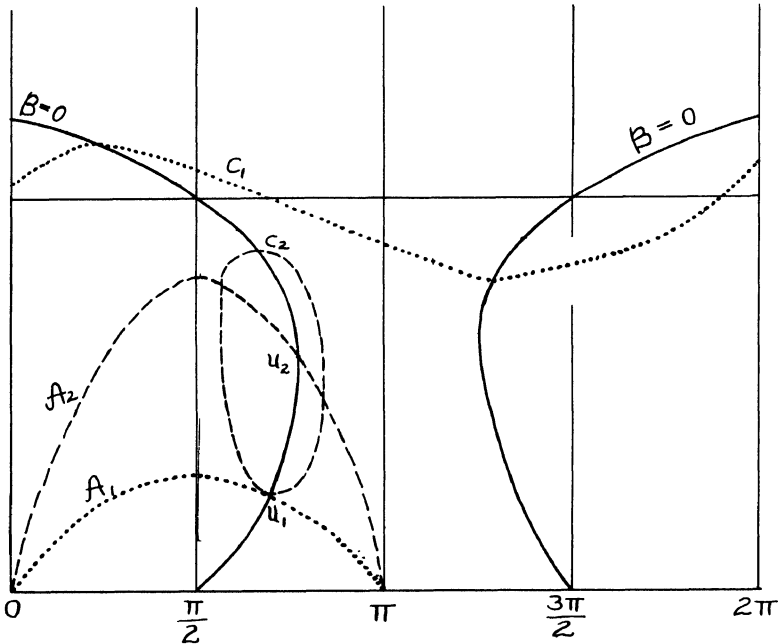

Fig. 10. The curve  $B = 0$  with two curves  $A_1 = 0$ ,  $A_2 = 0$  for a fairly large value of  $p$ . The limit cycles  $C_1$  and  $C_2$  correspond to  $A_1$  and  $A_2$  respectively, and similarly the singular points  $u_1$  and  $u_2$  are at the intersections of  $B = 0$  with  $A_1 = 0$  and  $A_2 = 0$  respectively.

§6.6. Periodic Solutions. The solutions of 6.1(1) of period  $2\pi/\lambda$  are given approximately by the intersections of the curves<sup>19</sup>

$$A(b, \alpha) = 0,$$

$$B(b, \alpha) = 0.$$

19. For a discussion of the general form of the solutions, see M. L. Cartwright, Journal of Inst. of Elec. Eng. 95 III (1948) 88-96.

and that is

$$b = p \frac{\sin \alpha}{2 \rho}$$

$$b(\frac{1}{4} b^2 - 1) = p \cos \alpha.$$

Squaring and adding, we have

$$b^2 (4 \rho^2 + (\frac{1}{4} b^2 - 1)^2) = p^2$$

which determines the amplitudes of all periodic solutions for given  $p, \lambda, k$ . For  $p^2 \geq \frac{16}{27}$  there is only one  $b$ , for  $p^2 < \frac{16}{27}$  there may be three roots. This may be seen by putting  $b^2 = z$  and drawing the curves

$$(1) \quad z(4\rho^2 + (\frac{1}{4} z - 1)^2) = p^2$$

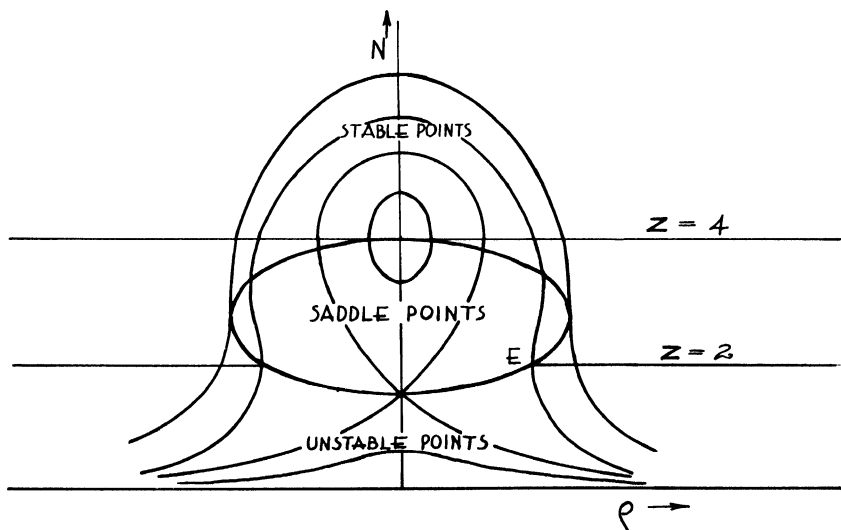

Fig. 11. It should be observed that the horizontal scale is very much larger than the vertical. The line  $z = 2$  meets the stability ellipse at the point  $E$  where  $\rho = \frac{1}{4}$ .

in the  $z, \rho$  plane. The points where the tangents are vertical are given by

$$4\rho^2 + \frac{3}{16}z^2 - z + 1 = 0,$$

and there

$$\frac{z^2}{2} \left(1 - \frac{z}{4}\right) = \rho^2$$

which has only one root  $z = \frac{8}{3}$  for  $\rho^2 = \frac{32}{27}$  corresponding to  $\rho^2 = \frac{1}{12}$ . The curves have a double point at  $\rho = c$

if  $\frac{3}{16}z^2 - z + 1 = 0$  which has two positive roots  $z = 4$  and  $\frac{4}{3}$ . The root  $\frac{4}{3}$  corresponds to a real value of  $b$  such that  $\rho^2 = \frac{16}{27}$ . For  $\rho^2 < \frac{16}{27}$  the curve breaks up into an oval and a curve going to infinity in both directions.

§6.7. Stability. In order to discuss the stability of solutions of period  $2\pi/\lambda$ , we put  $b = b_0 + c$ ,  $b' = b_0 + c'$ ,  $\alpha = \alpha_0 + \beta$ ,  $\alpha' = \alpha_0 + \beta'$ , where

$$(1) \quad A(b_0, \alpha_0) = B(b_0, \alpha_0) = 0$$

and suppose that  $c$  and  $\beta$  are small. At first we suppose that terms of the form  $o(k)$  and  $o(\lambda-1)$  are small compared with  $c$  and  $\beta$ . Then it follows from 6.4(3) and (4) that

$$(2) \quad \begin{aligned} c' &= Ac + B\beta + o(k^2) + o(k(\lambda-1)) + o\left(k(|c| + |\beta|)^2\right), \\ \beta' &= Cc + D\beta + o(k^2) + o(k(\lambda-1)) + o\left(k(|c| + |\beta|)^2\right), \end{aligned}$$

where  $A = 1 + \pi k \left(1 - \frac{3}{4}b_0^2\right)$ ,  $B = -\pi k p \sin \alpha_0 = -2\rho b_0 \pi k$ ,

$$C = 2\rho\pi k/b_0, \quad D = 1 - \pi k(p/b_0) \quad \cos \alpha_0 = 1 + \pi k(1 - \frac{1}{4} b_0^2).$$

It follows that approximate stability depends on the roots  $1 + k\mu_1, 1 + k\mu_2$  of the equation

$$(3) \quad \begin{vmatrix} A - x, & B \\ C & , D - x \end{vmatrix} = 0.$$

An elementary calculation gives

$$(4) \quad \left. \begin{matrix} \mu_1 \\ \mu_2 \end{matrix} \right\} = \pi \left\{ 1 - \frac{1}{2} b_0^2 \pm \frac{1}{4} (b_0^4 - 64\rho^2)^{\frac{1}{2}} \right\}.$$

The vectors of the transformation  $(c, \beta) \rightarrow (c', \beta')$  point approximately along the curves which are solutions of

$$(5) \quad \frac{db}{dt} = B(b, \alpha), \quad \frac{d\alpha}{dt} = A(b, \alpha),$$

and so by the classical theory<sup>20</sup> the periodic solutions cannot be stable unless the real parts of both  $\mu_1$  and  $\mu_2$  are negative. This means that for stability

$$(6) \quad b_0^2 > 2 \text{ and } \frac{3}{16} b_0^4 - b_0^2 + 1 + 4\rho^2 > 0.$$

Further it is possible to establish the existence of exactly periodic solutions of 6.1(1) by the use of index numbers and fixed point theory, except in certain critical cases where the index number of the approximation is 0. More delicate topological arguments establish that

---

20. See S. Lefschetz, Lectures on Differential Equations (Annals of Math. Studies, No. 14 (1946) 125-132.

there is only one periodic solution with the appropriate stability properties corresponding to each root of (1). The existence of periodic solution can also be established by putting  $b' = b$ ,  $\alpha' = \alpha$  in 6.4(3) and (4) and using the implicit function theorem.

Part 7. Some Problems of Nearly Linear Resonance

§7.1. In the preceding part I obtained very precise difference equations determining the behaviour of solutions of

$$(1) \quad \ddot{x} - k(1 - x^2)\dot{x} + x = pk \lambda \cos(t + \alpha).$$

In this part I propose to discuss various problems in connection with nearly linear resonance which are not completely solved. The first problem is whether the results would be changed in any marked respect if the nonlinear function  $x^2 - 1$  were replaced by a more general function  $f(x)$  changing sign from positive to negative and back again as  $x$  runs from  $-\infty$  to  $+\infty$ , in particular if the function  $f(x)$  is nearly constant from  $-1 + \delta$  to  $1 - \delta$  where  $\delta$  is small and positive. For this is the type of function which is likely to occur in radio problems, but so far as I know the problem has not been tackled.

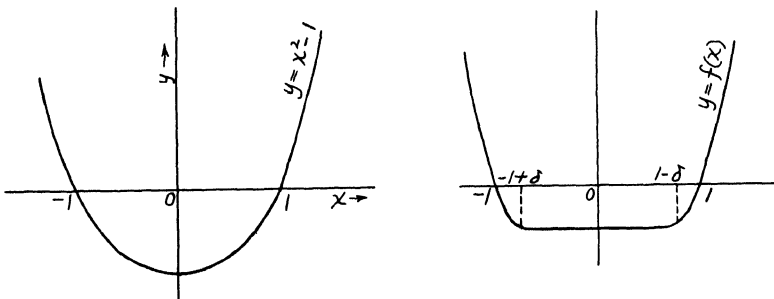

Figure 12.

The remaining problems fall into three main classes:

(a) The problem of determining the behaviour of the solutions of the corresponding differential equations

$$(2) \quad \frac{db}{dt} = B(b, \alpha), \quad \frac{d\alpha}{dt} = A(b, \alpha).$$

For the transformations given by 6.4(3) and (4) consist of small steps of length  $O(k)$  along the solutions of (2), the end point of the step being within  $O(k^2) + O(k(\lambda-1))$  of the solution through the initial point of the step.

(b) The problem of determining how far the transformations given by the difference equations follows the differential equations (2) when repeated indefinitely.

(c) The problem of determining precisely the behaviour of the solutions of (1) corresponding to points on a closed limit cycle of (2).

(d) The problem of presenting the rather complicated results in a reasonably intelligible form.

These problems are of course interrelated.

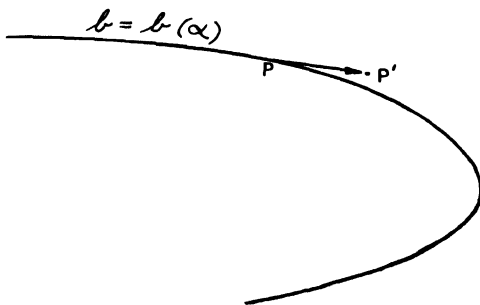

Fig. 13. The curve  $b = b(\alpha)$  is a solution of (2). P is the point  $(b, \alpha)$ , and P' the point  $(b', \alpha')$ .

§7.2. Problem (a). As we have already seen the singularities of (2) and their forms are fairly easy to

determine, and the results can be displayed by means of the curves 6.6(1) and the inequalities 6.7(6) written in the form

$$(1) \quad z > 2, \quad \frac{3}{16} (z - \frac{8}{3})^2 + 4\rho^2 > \frac{1}{3}.$$

It will be observed that there are no stable periodic solutions for  $\rho > \rho_0(p)$ , and it is not difficult to see that in such cases if  $b$  and  $\alpha$  are used as polar coordinates there must be a closed limit cycle with an unstable point inside it. By the classical theory this limit cycle cannot disappear by a change of parameter unless it passes through a singularity of 7.1(2). It is fairly easy<sup>21</sup> to see that for large fixed values of  $p$  the limit cycle shrinks as  $\lambda - 1$  decreases to the singular point on  $b^2 = 2$ . For  $p$  very small, it passes through the singular point corresponding to a point on the upper part of the ellipse

$$(2) \quad \frac{3}{16} (z - \frac{8}{3})^2 + 4\rho^2 = \frac{1}{3}.$$

Between these two cases for reasons of continuity there must be cases where it passes through singular points of the saddle point type inside the ellipse (2). The curve through the point where  $z = 2$  meets the ellipse determines the largest value of  $p$  for which this phenomenon occurs, but it is not known what the smallest value is. The cycle certainly passes through a singular point corresponding to a point on the upper part of the ellipse for some  $p^2 > \frac{16}{27}$ , but the phenomenon of limit cycles shrinking to a point occurs for all  $p^2 > 1$ , as may be seen by investigating the neighborhood of the unstable points for which  $b^2$  is just less than 2. There is no

<sup>21</sup>. See M. L. Cartwright, Journal of Inst. Elec. Eng. 95 III (1948), where references to earlier work will be found.

obvious method of determining when a limit cycle disappears by passing through a saddle point, but this is the only possible transition from one to the other of the better known types.

§7.3. Critical Limit Cycles. If the closed limit cycle with  $(b, \alpha)$  as polar coordinates encloses the origin, it appears, when  $b$  and  $\alpha$  are used as rectangular coordinates, as a curve from  $\alpha = -\infty$  to  $\alpha = +\infty$ , and the phase  $\alpha$  increases with  $t$ ; other limit cycles on which  $\alpha$  oscillates appear as closed curves. (See Fig. 10  $C_1$  and  $C_2$ ). There is no obvious method of determining the values of  $p$  and  $\rho$  for which the transition occurs, but we may obtain some information by writing 7.1(2) in the form  $(2\rho b - p \sin \alpha) \frac{db}{d\alpha} = p \cos \alpha + b(1 - \frac{1}{4} b^2)$ . It follows that

$$(1) \quad [\rho b^2 - bp \sin \alpha]_C = \int_C b^2 (1 - \frac{1}{4} b^2) d\alpha.$$

If  $C$  is a closed limit cycle, the left hand side of (1) returns to its initial value, and so

$$(2) \quad \int_C b^2 (1 - \frac{1}{4} b^2) d\alpha = 0.$$

Hence if  $\alpha$  is still increasing,  $b$  takes values above and below 2. In the case of the critical limit cycle through  $b = \alpha = 0$  the right hand side of (1) first increases from 0 to a positive value for which  $b = 2$  and then while  $b > 2$  decreases until  $b = 2$  where it is negative; it then increases to 0 as it descends to  $b = 0$  with  $\alpha = \pi$ . (For it may be seen by inspection of the curves  $B(b, \alpha) = 0, A(b, \alpha) = 0$  that it has only one maximum in each period). Hence the left hand side is 0 for some  $b > 2$ , while the curve

$$\Lambda(b, \alpha) = 0 \quad (\text{which is } b = \frac{p}{2\rho} \sin \alpha)$$

must still meet  $B(b, \alpha) = 0$  in a single unstable point which is therefore below  $b = 2$ . Hence for a critical cycle  $2\rho < p < 4\rho$ .

§7.4. Stability of Limit Cycles. Since 7.3(2) necessarily holds for a limit cycle there is at most one limit cycle enclosing the origin. For considering  $b$  and  $\alpha$  as rectangular coordinates, there is one and only one solution through any given point  $(b, \alpha)$ . But if one limit cycle is above the other for some  $\alpha = \alpha_1$ , say, the positions must be reversed for some other  $\alpha = \alpha_2$ , say, in order to preserve 7.3(2). Hence the limit cycles cross which contradicts the uniqueness property.

For limit cycles not enclosing the origin this argument fails because  $b$  takes two different values  $b_1 > b_2$  say for the same  $\alpha$ , and (2) may be written in the form

$$\int_{\alpha_1}^{\alpha_2} (b_1^2 - b_2^2) \left(1 - \frac{1}{4} (b_1^2 + b_2^2)\right) d\alpha = 0$$

whence  $b_1^2 + b_2^2$  takes values both greater and less than 4 so that  $b_2 < 2^{\frac{1}{2}}$  for some  $\alpha$  and  $b_1 > 2^{\frac{1}{2}}$  for some  $\alpha$ . But so far as we know such a ring may split into several and reassemble as  $k, \lambda$  or  $p$  varies. If so, the outer ring is approached spiral-fashion by solutions outside it, and the inner ring is approached by solutions inside it. We can only settle problem (b) (See §7.5) with regard to limit cycles which are strongly stable, and this we only know when  $p$  is small or  $\lambda - 1$  large.

§7.5 Problem (b). So far as the singular points of 7.1(2) and periodic solutions of 7.1(1) are concerned, we have a fairly complete solution. For at the critical points of index 0 a slight change in parameters may cause the singular point to appear or disappear, and we must therefore allow a latitude corresponding to the error terms in which the corresponding periodic solution may appear or disappear.

In 6.5 we sketched an argument showing that, if  $p$  is small or  $(\lambda - 1)/k$  large, the solutions clearly move towards  $b = 2$  and stay near it with  $\alpha$  increasing to  $\infty$ , and in this case we may describe the limit cycle  $C$  as strongly stable. In order to deal with limit cycles in general we have to define strong stability more precisely by means of what may be described as quasi-Liapounov coordinates. The general theorems of Liapounov show that near  $C$  the equations 7.1(2) can be written in the form<sup>22</sup>

$$\dot{\xi} = 1, \dot{\eta} = -a\eta, \underline{a} \text{ being a real constant.}$$

This depends on the fact that  $B$  and  $A$  are analytic. The following method can be applied whenever  $B$  and  $A$  have continuous partial derivatives of the first three orders. First we may transform to coordinates  $\xi$  and  $\eta$ , where  $\xi$  is the arc of  $C$  measured from some fixed point, and  $\eta$  is the length along the normal. The transformation is obviously  $(1,1)$  for all points sufficiently near  $C$ , and we obtain

---

22. See N. Kryloff and N. Bogoliuboff, *Methodes de la mecanique non-lineaires appliquees a l'etude des oscillations stationnaires*. Monograph in Russian with summary in French (Kiev 1934) Ukrainska akad. nauk., Inst. mech., Report 8.

$$(1) \quad \dot{\xi} = P_1(\xi) + \eta Q_1(\xi, \eta), \quad \dot{\eta} = \eta \left( (P_2(\xi) + \eta Q_2(\xi, \eta)) \right),$$

where  $P_1, Q_1, P_2, Q_2$  have continuous derivatives of the first two orders, and period  $L$  in  $\xi$ ,  $L$  being the time taken to describe  $C$ . By a change of scale of  $t$ , we may obviously suppose that  $L = 2\pi$ . Further since  $B$  and  $A$  are not both 0 on  $C$ ,  $P_1(\xi) \neq 0$  and  $t$  is uniquely defined as a continuous function of  $\xi$ , and putting  $\xi' = t$ , we obtain the equation in the form

$$\dot{\xi}' = 1, \quad \dot{\eta}' = \eta (P_2'(\xi') + \eta Q_2'(\xi', \eta))$$

Let  $\frac{1}{2\pi} \int_0^{2\pi} P_2'(\xi') d\xi' = -a$ , then  $C$  is said to be strongly stable if  $a > 0$ , and strongly unstable if  $a < 0$ . The second case may be handled in the same way as the first by changing the sign of  $t$ . If  $a > 0$ , we put

$$\eta' = \eta e^{-\int_0^{\xi'} (P_2' + a) d\xi'}$$

which makes

$$\frac{\dot{\eta}'}{\eta'} = \frac{\dot{\eta}}{\eta} - (P_2' + a),$$

and, dropping the primes, we obtain from (1)

$$(2) \quad \dot{\xi} = 1, \quad \dot{\eta} = -a\eta + \eta^2 Q_2(\xi, \eta),$$

where  $Q_2$  has period  $2\pi$  in  $\xi$ . The transformation is valid in a certain neighborhood  $D$  of  $C$ , and that is for  $|\eta| < \delta$ , where  $\delta$  is sufficiently small. In  $D$  the difference equations 6.4(3) and 6.4(4) may, by the same transformation as that used to obtain (2), be written

$$(3) \quad \begin{aligned} \xi_1 &= \xi + \pi k + k^2 F_1(\xi, \eta) + k(\lambda - 1)F_2(\xi, \eta) \\ \eta_1 &= \eta(1 - \pi k a) + \pi k \eta^2 Q_2(\xi, \eta) + k^2 G_1(\xi, \eta) \\ &\quad + k(\lambda - 1) G_2(\xi, \eta), \end{aligned}$$

where  $F_1, F_2, G_1, G_2$  have period  $2\pi$  in  $\xi$ , and they and their derivatives are bounded for  $k \leq 1, |\lambda - 1| \leq 1$ . For simplicity we shall concentrate on the case in which  $\lambda - 1 = o(k)$ , and then we can drop  $F_2, G_2$ , and by a change of factor  $\pi$  in  $k$  use the transformation (3) in the form

$$(4) \quad \xi_1 = \xi + k + k^2 F_1(\xi, \eta)$$

$$(5) \quad \eta_1 = \eta(1 - k a) + k \eta^2 Q_2(\xi, \eta) + k^2 G_1(\xi, \eta),$$

where  $F_1, Q_2, G_1$ , and their derivatives are bounded for  $|\eta| < \delta, 0 < k < 1, |\lambda - 1| < 1$  and have period  $2\pi$ .

§7.6. The following theorem, although stated in terms of the special difference equations obtained from 7.1(2), holds generally for all difference equations which can be reduced to the form 7.5(4) and (5) by means of a small parameter and their corresponding differential equations.

Theorem. Suppose that C is a strongly stable closed limit cycle for the equations 7.1(2), and let T be the transformation 7.5(4),(5). Then there is a neighborhood D of C depending only on 7.1(2) such that if  $\Gamma_0$  is a closed curve deformable into C in D,  $T^n(\Gamma_0)$  tends to a unique simple closed curve  $\Gamma$  as  $n \rightarrow \infty$ , provided that  $k < k_0$ . Further each point of  $\Gamma$  lies within  $B_k$  of C and

$\frac{d\eta}{d\xi}$ ,  $\frac{d^2\eta}{d\xi^2}$  are bounded by B's on  $\Gamma$ .

Proof. We shall consider  $\xi, \eta$  as Cartesian coordinates, so that C is the axis  $\eta = 0$ , and the transformation has period  $2\pi$  in  $\xi$ . Suppose first that  $\Gamma_0$  is the line  $\eta = \eta_0(\xi) = \delta$  and that it lies in the domain where 7.5(4) and (5) hold. Then  $\Gamma_1 = T(\Gamma_0)$  is a curve  $\eta = \eta_1(\xi)$  with period  $2\pi$  on which

$$(1) \quad \eta_1 < \eta_0 (1 - ka) + B(k\eta_0^2 + k^2) < \eta_0 = \delta,$$

provided that  $\delta < \delta_0(B)$ ,  $k < k_0(\delta, B, a)$ . In these circumstances  $\Gamma_1$  lies completely below  $\Gamma_0$ , and therefore, since T is (1,1),  $\Gamma_2$  lies below  $\Gamma_1$  and so on. Similarly if  $\Gamma'_0$  is  $\eta = -\delta$ ,  $\Gamma'_1$  lies above  $\Gamma'_0$  and below  $\Gamma_n$ . Hence  $\Gamma_n$  tends to an invariant closed set  $\Gamma$  with period  $2\pi$ , and  $\Gamma'_n = T^n(\Gamma'_0)$  tends to an invariant closed set  $\Gamma'$  with period  $2\pi$  lying below  $\Gamma$ . It is easy to see from 7.5(5) that  $|\eta|$  will be reduced by the transformation so long as it is not  $O(k)$ . Hence both  $\Gamma$  and  $\Gamma'$  lie within  $Bk$  of C. It remains to show that  $\Gamma$  and  $\Gamma'$  are curves with bounded derivatives, and then that they coincide

§7.7. The derivatives of  $\Gamma$ . Let  $\eta_n(\xi)$  denote generally the value of  $\eta$  corresponding to  $\xi$  on the curve  $\Gamma_n$  and  $\xi_n$  the value of  $\xi$  obtained from an arbitrary value  $\xi_0$  by  $T_n$ . Then

$$(1) \quad \frac{d\eta_{n+1}}{d\xi_{n+1}} = \frac{d\eta_{n+1}}{d\xi_n} \quad / \quad \frac{d\xi_{n+1}}{d\xi_n},$$

and by 7.5(4) and (5)

$$\begin{aligned}
 (2) \quad \frac{d\xi_{n+1}}{d\xi_n} &= 1 + k^2 \left( \frac{\partial F_1}{\partial \xi_n} + \frac{\partial F_1}{\partial \eta_n} \cdot \frac{d\eta_n}{d\xi_n} \right) \\
 &= 1 + o(k^2) + o(k^2) \frac{d\eta_n}{d\xi_n},
 \end{aligned}$$

$$\begin{aligned}
 (3) \quad \frac{d\eta_{n+1}}{d\xi_n} &= (1 - ka) \frac{d\eta_n}{d\xi_n} + k \left( \frac{\partial(\eta^2 Q_1)}{\partial \xi_n} + \frac{\partial(\eta^2 Q_1)}{\partial \eta_n} \frac{d\eta_n}{d\xi_n} \right) \\
 &\quad + k^2 \left( \frac{\partial G_1}{\partial \xi_n} + \frac{\partial G_1}{\partial \eta_n} \cdot \frac{d\eta_n}{d\xi_n} \right) \\
 &= (1 - ka) \frac{d\eta_n}{d\xi_n} + o(k\eta) + o(k^2) + \frac{d\eta_n}{d\xi_n} \left( o(k\eta) + o(k^2) \right).
 \end{aligned}$$

Combining (1), (2), and (3), and supposing that  $\frac{d\eta_n}{d\xi_n} = o(k\delta)$ , we have

$$\frac{d\eta_{n+1}}{d\xi_{n+1}} \left( 1 + o(k^2) + o(k\delta) \right) = (1 - ka) \frac{d\eta_n}{d\xi_n} + o(k\delta) + o(k^2)$$

so that

$$(4) \quad \frac{d\eta_{n+1}}{d\xi_{n+1}} = o(k\delta).$$

Since  $\frac{d\eta_0}{d\xi} = 0$ , (4) holds for all  $n$ , and so  $\Gamma_n$  tends to a curve  $\Gamma$  with a derivative  $\frac{d\eta}{d\xi} = 0(k\delta)$  for small  $k$  and  $\delta$ .

The higher derivatives can be treated in the same way. For 7.5(4) is practically a translation while 7.5(5) is practically a slight reduction in  $|\eta|$ , so that the vector from  $(\xi, \eta)$  to  $(\xi_1, \eta_1)$  points along the axis  $\eta = 0$  making an angle whose tangent is nearly  $-(1-ka)\eta$  with it. Similar results obviously hold for the derivatives of  $\Gamma'$ .

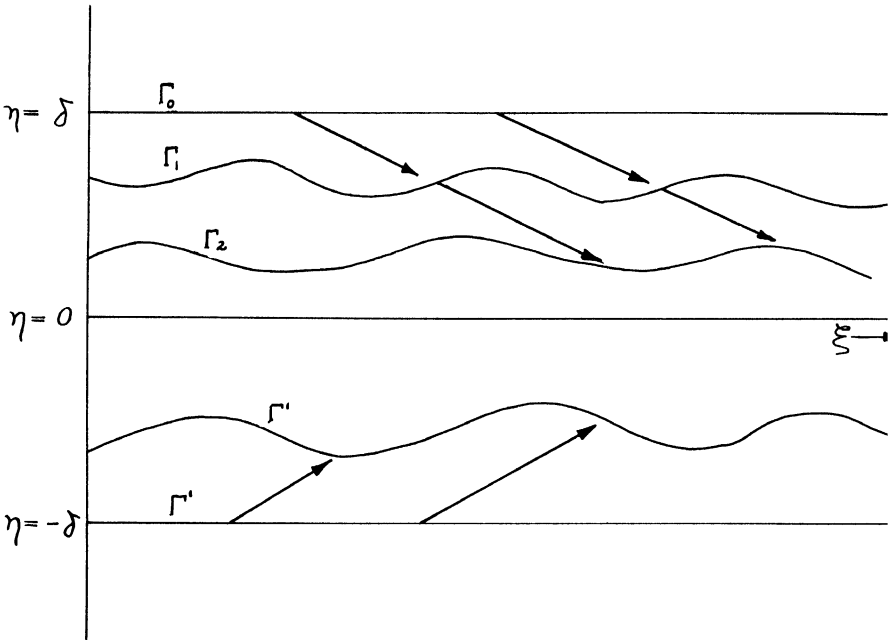

Figure 14.

§7.8 Uniqueness. Suppose that  $\eta, \eta'$  are distinct values of  $\eta$  corresponding to the same value  $\xi = \xi_R$  on  $\Gamma$  and  $\Gamma'$  respectively. Let  $\xi_P, \xi_{P'}$  be the values of  $\xi$  corresponding to  $\xi_R$  on  $\Gamma$  and  $\Gamma'$  respectively under the inverse of  $T$ , and let  $\eta_P, \eta_{P'}$  be the values of  $\eta$  corresponding to  $\xi_P$  on  $\Gamma$  and  $\Gamma'$  and  $\eta_{P'}$ , the value of  $\eta$  corresponding to  $\xi_{P'}$  on  $\Gamma'$ .

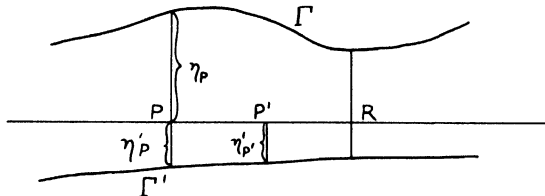

Figure 15.

Since there is only one value  $\xi_R$  corresponding to both  $\xi_P$  and  $\xi_{P'}$ , by 7.5(4), we have

$$\begin{aligned}
 (1) \quad 0 &= \xi_P - \xi_{P'} + k^2 \left( F_1(\xi_P, \eta_P) - F_1(\xi_P, \eta_{P'}^I) \right. \\
 &\quad \left. + F_1(\xi_P, \eta_{P'}^I) - F_1(\xi_{P'}^I, \eta_{P'}^I) \right) \\
 &= \xi_P - \xi_{P'} + k^2 \left( (\eta_P - \eta_{P'}^I) \frac{\partial F_1}{\partial \eta}(\xi_P, \eta_{P'}^I) \right. \\
 &\quad \left. + (\xi_P - \xi_{P'}^I) \frac{\partial F_1}{\partial \xi}(\xi_{P'}^I, \eta_{P'}^I) \right),
 \end{aligned}$$

where  $\eta_{P'}^I < \eta_{P'}^{\prime\prime} < \eta_P$ ,  $\xi_{P'}^I < \xi_{P'} < \xi_{P'}^{\prime\prime} < \xi_{P'}$ , so that

$$(2) \quad (\xi_P - \xi_{P'}) (1 + o(k^2)) = o(k^2 (\eta_P - \eta_{P'}^I)).$$

By 7.5(5) we have

$$\begin{aligned}
 (3) \quad \Delta_R &= \eta_R - \eta_R^I = (\eta_P - \eta_{P'}^I) (1 - k\alpha) \\
 &\quad + k \left( \eta_P^2 Q_2(\xi_P, \eta_P) - \eta_{P'}^I{}^2 Q_2(\xi_{P'}^I, \eta_{P'}^I) \right) \\
 &\quad + k^2 \left( G_1(\xi_P, \eta_P) - G_1(\xi_{P'}^I, \eta_{P'}^I) \right)
 \end{aligned}$$

We can treat the differences of  $\eta^2 Q_2(\xi, \eta)$  and  $G_1$  as we treated the difference for  $F_1$  in (1) and (2). Also since  $\Gamma'$  has a derivative of order  $o(k\delta)$  we have

$$\begin{aligned}
 (4) \quad \eta_P - \eta_{P'}^I &= \eta_P - \eta_{P'}^I + \eta_{P'}^I - \eta_{P'}^I \\
 &= \eta_P - \eta_{P'}^I + (\xi_P - \xi_{P'}^I) \frac{d\eta^I}{d\xi}(\xi^I), \quad \xi_{P'}^I < \xi^I < \xi_{P'} \\
 &= \Delta_P + o(k\delta)(\xi_P - \xi_{P'}^I).
 \end{aligned}$$

Hence (2), (3) and (4) give

$$\Delta_R = \Delta_P \left( 1 - ka + o(k\delta) + o(k^2) \right)$$

for  $\delta < \delta_0(a, \epsilon)$ ,  $k < k_0(\delta, a)$ . Hence the maximum distance between  $\Gamma$  and  $\Gamma'$  is reduced by the transformation which is incompatible with the fact that they are invariant, and so  $\Gamma = \Gamma'$ .

§7.9 Problem (c). The theorem of 7.6 reduces the problem of solutions associated with a strongly stable limit cycle of 7.1(2) to the discussion of solutions with initial values on a simple closed curve  $\Gamma$ , or transformations of  $\Gamma$  into itself, and therefore of the unit circle into itself. This type of transformation has been much discussed, and since it involves the theory of rotation numbers we postpone it until part 8.

§7.10. Problem (d). We next consider the problem of representing the complicated phenomena displayed by the solutions of 7.1(2). The curves in 6.6 Fig. 11 show the periodic solutions adequately, and for limit cycles we may plot

$$(1) \quad z = \lim_{T \rightarrow \infty} \frac{1}{T} \int_0^T b^2 dt$$

against  $\rho$  on the same figure. If the limit cycle shrinks to a point,  $z$  obviously tends to the value of  $b^2$  at the point. If the limit cycle does not shrink to a point, but vanishes because it passes through a singular point, it is easy to see that just before this happens  $B$  and  $A$  are both small together. This means that both  $b$  and  $\alpha$  are small, and so the point lingers near that part of the limit cycle. It seems certain

that the limit in (1) tends in this case also to the value of  $b^2$  at the singular point, but no formal proof of this has been given. Further it would seem likely that as  $\rho$  tends to 0 the average of  $b^2$  decreases monotonically until the limit cycle disappears, but this has not been proved. Again there are various reasons for supposing that the time taken to describe the limit cycle increases monotonically as  $\rho$  decreases, and that except when the limit cycle shrinks to a point, the time increases to  $+\infty$  monotonically as  $\rho$  decreases to the values at which synchronization takes place, but this has not been proved.

#### Part 8. Rotation Numbers

§8.1. There are a number of problems connected with the application of rotation numbers to the transformations connected with the theory of forced oscillations both in the case of the simple closed curves which we discussed in the preceding part, and also for the general theory of the frontier of the invariant set  $S$  of Part 3. The idea of a rotation number is due to Poincaré<sup>23</sup>, but the following proof is due to Denjoy.<sup>24</sup>

§8.2. Let  $\theta$  be the angular coordinate of a point on the unit circle, and  $\theta \rightarrow \theta_1(\theta)$  a continuous (1,1) order preserving transformation  $T$  such that  $0 \leq \theta_1(0) < 2\pi$ . Then since order is preserved  $\psi_n(\theta) = \theta_n(\theta) - \theta$  has period  $2\pi$ , and since it is continuous and periodic it is bounded. Hence it attains its lower and upper bounds  $m_n, M_n'$  such that

$$m_n \leq \theta_n(\theta) - \theta \leq M_n', \quad \text{where } 0 \leq M_n' - m_n < 2\pi.$$

---

23. H. Poincaré, Oeuvres, 1 (1928), 145.

24. A. Denjoy, Journal de Math. (9) 11 (1932), 333-375.

For fixed  $n$  and large  $N = rm + s$ ,  $0 \leq s \leq n - 1$ , we have

$$m_n \leq \theta_{\mu n}(\theta_0) - \theta_{(\mu-1)n}(\theta_0) = \theta_n \left( \theta_{(\mu-1)n}(\theta_0) \right)$$

$$- \theta_{(\mu-1)n}(\theta_0) \leq M_n, \quad (\mu = 1, 2, \dots, r),$$

$$m_1 \leq \theta_k(\theta_0) - \theta_{k-1}(\theta_0) \leq M_1 \quad (k = 1, 2, \dots, s),$$

and so

$$rm_n + sm_1 \leq \theta_N - \theta_0 \leq rM_n + sM_1.$$

Hence

$$\frac{rm_n + sm_1}{N} \leq \frac{m_N}{N} \leq \frac{M_N}{N} \leq \frac{rM_n + sM_1}{N},$$

and making  $N \rightarrow \infty$

$$\frac{m_n}{n} \leq \liminf \frac{m_N}{N} \leq \overline{\lim} \frac{M_N}{N} \leq \frac{M_n}{n}.$$

The extremes differ by less than  $2\pi/n$ , and so making  $n \rightarrow \infty$  we have<sup>25</sup>

$$(1) \quad \lim \frac{m_N}{N} = \lim \frac{M_N}{N} = 2\pi\rho.$$

$$\text{Also } \frac{m_n}{n} \leq 2\pi\rho \leq \frac{M_n}{n} \text{ for every } n > 0,$$

and so we may write

$$m_n = 2\pi n\rho - \beta_n, \quad M_n = 2\pi n\rho + \gamma_n,$$

---

25. We adhere to the traditional notation in spite of using  $\rho$  quite differently in parts 6 and 7. Throughout this part  $\rho$  is the rotation number.

where  $\beta_n \geq 0$ ,  $\gamma_n \geq 0$ ,  $\beta_n + \gamma_n < 2\pi$ .

Since  $0 \leq \theta_1(0) < 2\pi$ ,  $0 \leq \theta_n(0) < 2\pi n$ , and so  $0 \leq \rho < 1$ . If  $\rho = 0$ , we have  $-\beta_1 \leq 0 \leq \gamma_1$ , and since  $\theta_1(0)$  is continuous,  $\theta_1(\theta) - \theta = 0$  for some  $\theta$  and so the transformation  $T$  has a fixed point. If  $\rho > 0$ , it is easy to see from (1) that there is no fixed point.

If  $\rho = p/q$ , an irreducible fraction,

$$m_q = 2\pi p - \beta_q \leq 2\pi p \leq M_q = 2\pi p + \gamma_q,$$

and so  $\theta_q(\theta) - \theta = 2\pi p$  for some  $\theta = \theta_0$ , say, which means that  $\theta_0$  is fixed under  $T^q$ . Further if  $q'$  is a positive integer less than  $q$ , no point is fixed under  $T^{q'}$ , for its rotation number is the fractional part of  $pq'/q$  which is positive.

§8.3. It is well known that if  $T$  has one point fixed, then every point is fixed or tends to a fixed point under  $T^n$  as  $n \rightarrow \infty$ . This is easily seen by taking the fixed point as origin and drawing the curves  $y = \theta_1(\theta)$  and  $y = \theta$  on the same figure. The values  $\theta_1(\theta)$ ,  $\theta_2(\theta)$ ,  $\theta_3(\theta)$  on the  $\theta$  axis can be constructed by steps from the points  $P_1, P_2, P_3$  on the curve  $\theta_1(\theta)$  corresponding to the points  $\theta, \theta_1(\theta), \theta_2(\theta) \dots$  respectively.

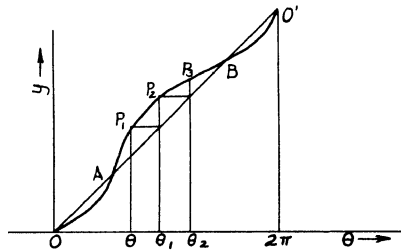

Figure 16.  $0, A$  and  $B$  are fixed points, and  $O'$  represents the same point as  $0$ .

Similarly if one point is fixed under  $T^q$ , then every point is fixed under  $T^q$ , or tends to a fixed point under  $T^{nq}$  as  $n \rightarrow \infty$ .

§8.4. If  $\rho$  is irrational, there are no fixed points under  $T^q$  for any  $q$ , and there are two distinct types of transformation. Either for every  $\theta_0$ ,  $\theta_n(\theta_0)$ ,  $n = 1, 2, \dots$  takes values near every value to modulus  $2\pi$ , or this is not so. In the first case there is a continuous increasing function  $\varphi(\theta)$  such that  $\varphi(0) = 0$ ,  $\varphi(2\pi) = 0$ , and if  $\varphi_1(\theta) = \varphi(\theta_1)$   $\varphi_1(\theta) = \varphi(\theta) + 2\pi\rho$  for all  $\theta$ , so that the transformation is reduced to a pure translation

$$\varphi_1 = \varphi + 2\pi\rho.$$

We put  $\varphi$  equal to the fractional part of  $n\rho$  when  $\theta = \theta_n(0)$ . This defines  $\varphi(\theta)$  for all points  $\theta = \theta_n(0)$ , and since  $\theta_n(0)$  takes values near every value, and order is preserved,  $\varphi$  is defined at the remaining points by continuity.

In the second case  $\theta_n(0)$  does not take values in certain intervals, and no such function  $\varphi$  exists. Denjoy<sup>26</sup> showed that if  $\frac{d\theta_1}{d\theta}$  is of bounded variation, the second case cannot occur.

§8.5. Returning to the case of Part 7 where we had a closed limit cycle  $C$  for the differential equations 7.1(2) in  $b$  and  $\alpha$ , we suppose that it is strongly stable. Then by transforming to the coordinates  $(\xi, \eta)$  we showed that there was a unique curve  $\Gamma$  with continuous derivatives of the first two orders which remained

---

26. See Denjoy, loc. cit.

invariant under the transformation. The difference equations on  $\Gamma$  was reduced to the form

$$\xi' = \xi + k' + k'^2 F_1(\xi, 0),$$

where  $F_1$  has period 1 in  $\xi$ , and is bounded as  $k'$  tends to 0,  $k$  being a multiple of the original  $k$ . Hence the transformation has a rotation number

$$\rho = k' + O(k'^2)$$

considered as a transformation of  $\theta = 2\pi\xi$  on the unit circle. Obviously if  $\rho$  is a rational fraction  $\frac{q_1}{q_2}$ , since  $q_1 \geq 1$ , the denominator  $q_2$  is greater than

$$\frac{1}{k'} + O(1).$$

In this case there is a value of  $\xi$  for which the transformation (and therefore the corresponding  $b$  and  $\alpha$ ) has least period  $P > Nk^{-1}$ , where  $N$  is a positive number independent of  $k$ , and all solutions of the difference equations corresponding to points on  $\Gamma$  have period  $P$ , or tend to solutions having this period.

Kryloff and Bogoliuboff<sup>27</sup> claim to have proved in similar cases that  $\rho$  is continuous and satisfies a Lipschitz condition, and therefore passes through both rational and irrational values. I am unable to see that they have proved more than that  $\rho$  satisfies a Lipschitz condition as  $k \rightarrow 0$ . They further seem to assume that

---

27. N. Kryloff and N. Bogoliuboff, Méthodes de la mécanique non-linéaires appliquées à l'étude des oscillations stationnaires, Monograph in Russian with summary in French (Kiev, 1934) Ukrainska Akad. nauk. Inst. mech. Report 8.

for rational values the fixed points are of one of the standard types and therefore, if any parameter is changed by a sufficiently small amount, the fixed point still exists so that  $\rho$  is constant in certain intervals. It seems difficult to reconcile this with the continuity of  $\rho$ . On the other hand if  $\rho$  varies continuously and is not constant in any interval, we might, in virtue of §8.3, expect a line of fixed points. But then the two equations in  $b$  and  $\alpha$  must define an analytic function and  $\Gamma$  is an analytic curve, so that another question arises, is  $\Gamma$  analytic?

If  $\rho$  is irrational, since the transformations in  $b, \alpha$  are analytic, and  $\Gamma$  has continuous derivatives, we may reduce the  $\xi$  transformation on  $\Gamma$  to one satisfying Denjoy's criterion, and hence to the form  $\xi' = 2\pi\rho + \xi$ , such that  $b = b(\xi)$ ,  $\alpha = \alpha(\xi)$  have period  $2\pi$  in  $\xi$ . Hence the solution of the original equation can be expressed in the form<sup>28</sup>

$$(1) \quad x = x(\lambda\Gamma, \frac{\lambda t}{\rho}),$$

where  $x(u, v)$  has period  $2\pi$  in  $u$  and  $v$  and is continuous. It is evident that (1) is uniformly almost periodic. There is an extensive theory of almost periodic functions and transformations,<sup>29</sup> and the type in (1) is a very special type of almost periodicity. Birkhoff<sup>30</sup> has shown that the necessary and sufficient condition for  $x$  to be recurrent under a transformation such as those considered here is that it is almost periodic in a more general sense.

---

28. See Kryloff and Bogoliuboff, loc. cit.

29. See G. A. Hedlund, Amer. Journal of Math. 66 (1941) 605-620.

30. G. D. Birkhoff, Dynamical Systems (New York 1927) 199-200.

§8.6. The remaining cases in which the limit cycle  $C$  is not strongly stable present a more general problem. We do not know that the curve  $\Gamma$  exists, but in some cases it is possible to show that an invariant set exists which is the frontier of a domain, in this case the problem is similar to that of the invariant set  $S$  of Theorem 3 in 3.6.

Map the exterior domain of  $S$  on  $|z| > 1$  by a transformation  $Z$ . This is possible because  $C(S)$  is simply connected, and we can make the point at infinity correspond to itself. Then  $F(S)$  corresponds to  $|z| = 1$  in such a way that to each accessible point corresponds one and only one point on  $|z| = 1$ . Further the prime ends<sup>31</sup> of  $C(S)$  correspond  $(1,1)$  in cyclic order to points on  $|z| = 1$ , each prime end goes into a prime end under  $T$  in such a way that  $\tau = Z T Z^{-1}$  is  $(1,1)$  and continuous for  $|z| \geq 1$  (but not for  $|z| < 1$ ). We can now define the rotation number of  $\tau$ , and if it is 0 or a rational fraction  $p/q$ , we get points on  $|z| = 1$  fixed under  $T$  or  $T^q$ , and this means prime ends fixed under  $T$  or  $T^q$ . Prof. Littlewood and I are in process of investigating in what circumstances a fixed prime end implies a fixed point, and how far a fixed point on  $F(S)$  is compatible with a positive rotation number; but the general theory of irrational rotation numbers for this case has hardly been investigated. There is much general theory for various types of spaces, some require an area preserving transformation, some a semi-locally connected set. Most investigations do not seem to use that  $T$  is  $(1,1)$  and continuous outside the invariant set which is always the case with transformations derived from this type of differential equation. Is it possible to have the most general type of frontier with an irrational  $\rho$ ? Can the

---

31. C. Caratheodory, Math. Annalen 73 (1913).

most peculiar types of non-wandering point occur for the type of transformation associated with these differential equations. The examples of Levinson, Cartwright and Littlewood suggest that this is so, but the rotation numbers are not known for these examples.

Part 9. The Singular Case.

§9.1. We return now to the case in which the nonlinear terms are not small, and in particular to the equation

$$(1) \quad \ddot{x} + kf(x)\dot{x} + g(x) = kp(t)$$

with  $k$  large. This is sometimes called the singular case<sup>32</sup> because dividing by  $k$  and making  $k \rightarrow \infty$ , we obtain the degenerate equation

$$(2) \quad f(X)X = p(t).$$

This has a solution of the form

$$(3) \quad F(X) - F(X_0) = \int_{X_0}^X f(x)dx = \int_0^t p(t)dt = P(t)$$

such that  $x = x_0$  at  $t = 0$ , but it is not possible to assign an arbitrary value of  $\dot{x}$  at  $t = 0$ . On the other hand there may be more than one value of  $X$  for which (3) holds,  $t$  and  $X_0$  being given.

§9.2. Suppose for simplicity that, in addition

---

32. Compare N. Levinson, *Annals of Math.* where further references are given. The following very brief sketch makes use of material by J. G. Wendel (in this volume), particularly in connection with the condition for a stable solution with period  $2\pi/\lambda$  when  $f(x)$  and  $p(t)$  change sign more than twice.

to the hypotheses of theorem 1,  $f(x)$  and  $p(t)$  only vanish for a finite number of values of  $x$  and  $t$  respectively at which they change sign, and that  $g(x)/x \geq b_3$  for all  $x$ . Then the curve

$$y = \int_0^X f(x)dx = F(X)$$

has only a finite number of maxima and minima,

$y = \beta_1, \beta_2, \dots, \beta_{2m}$ , say, at  $x = \alpha_1, \alpha_2, \dots, \alpha_{2m}$ .

Between these values of  $x$  the function  $F(x)$  is monotonic, and  $F(x)$  tends to  $+\infty$  or  $-\infty$ , as  $x$  tends to  $+\infty$  or  $-\infty$  respectively. Consider 9.1(3) in the form

$$(1) \quad F(X) = P(t) + C.$$

Since  $P(t)$  is bounded, and  $p(t)$  periodic, so is  $P(t)$ .

For fixed  $t$  (1) has at least one root  $X_s(t, C)$ , and not more than  $2m+1$ . Then we may write

$$X_1(t, C) \leq \alpha_1 \leq X_2(t, C) \leq \alpha_2 \leq \dots \leq \alpha_{2m} \leq X_{2m+1}(t, C),$$

where  $X_s(t, C)$  may be non-existent for an even number of adjacent pairs of values of  $s$ .  $P(t) + C$  varies from  $P_1$  to  $P_2$  as  $t$  varies from 0 to  $2\pi/\lambda$ , and so  $X_s(t, C)$  takes values on the thick parts of the  $y = F(X)$  in Fig. 17 for the appropriate values of  $t$ . As  $t$  varies  $P(t)$  increases or decreases, returning to its initial values after time  $2\pi/\lambda$ ; but during this process two adjacent roots such as  $X_1$  and  $X_2$  or  $X_3$  and  $X_4$  in the figure may coalesce and disappear, so that the corresponding solution of the degenerate equation 9.1(2) does not exist over the whole period, while  $X_6$  and  $X_7$  suddenly appear.

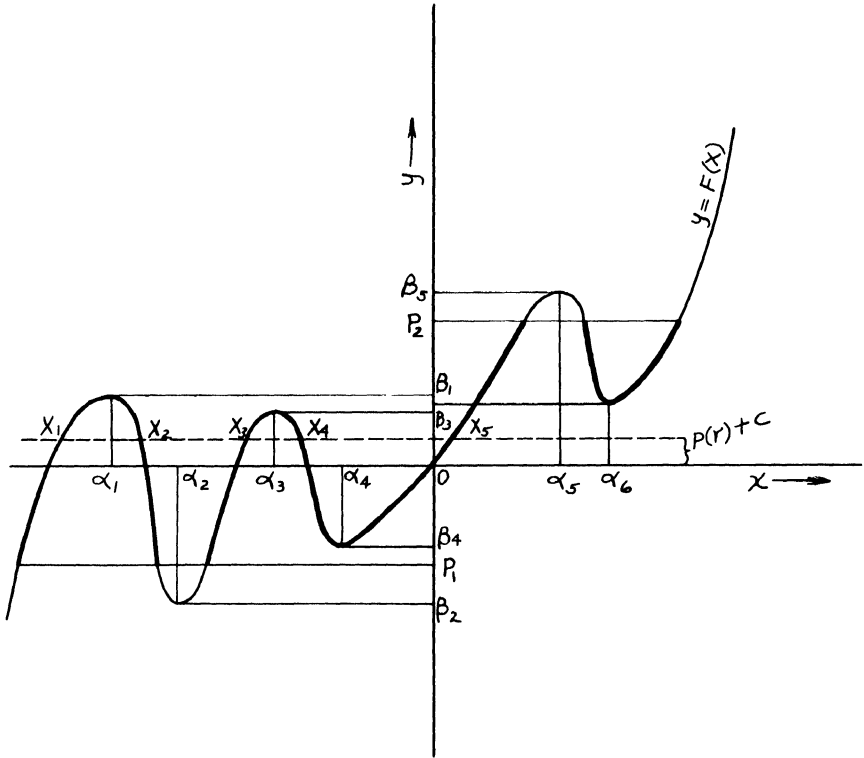

Figure 17.

It should be observed that if  $P(t)$  increases with  $t$  the solutions  $X_1, X_3, X_5, \dots$ , which lie in the intervals where  $F$  increases, also increase with  $t$ , but the solutions  $X_2(t;C), X_4(t;C), \dots$ , which lie in the intervals where  $F$  decreases, decrease with  $t$ , and of course vice versa when  $P(t)$  decreases.

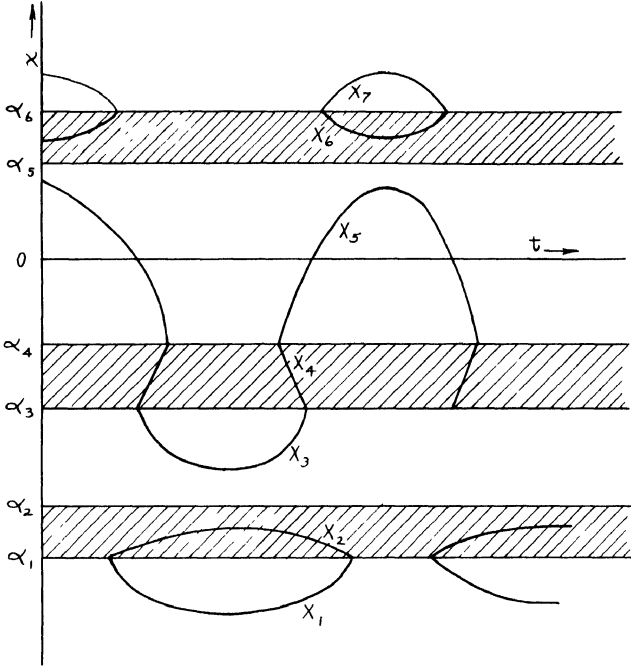

Figure 18. The curves  $x = X_s(t, C)$  correspond to the thick segments in Figure 17. They have period  $2\pi/\lambda$  in  $t$ .  $F(x)$  decreases in the shaded regions.

§9.3. The integrated equation of 9.1(1) is

$$(1) \quad \frac{\dot{x} - \dot{x}_0}{k} + F(x) - F(x_0) + \frac{1}{k} \int_0^t g(x) dt = P(t).$$

By theorem 1,  $|x| < B$ ,  $|\dot{x}| < Bk$ , and further it follows from this that  $|\dot{x}| < B$  at some point in each interval of length  $B$ . Choose as origin a point at which  $|\dot{x}| < B$  so that  $|\dot{x}_0| < B$  in (1). Then (1) can be written

$$(2) \quad \frac{\dot{x}}{k} + F(x) - P(t) - C = 0 \left( \frac{1}{k} \right)$$

for  $0 \leq t \leq B$ , and in particular for  $0 \leq t \leq 3\pi/\lambda$ .

There are four important cases to be considered

(i)  $|\dot{x}| < B$ , and  $|f(x)| > B_2$  in a subinterval,

(ii)  $|\dot{x}| > B_2 k$  in a subinterval.

(iii)  $|x - \alpha_s| < \delta$ , where  $\alpha_s$  corresponds to a maximum or minimum of  $F(x)$ , and  $\delta$  is a small positive number.

(iv) Subintervals not covered by (i) (ii) or (iii).

§9.4. In case (i) put

$$(1) \quad x = X_s(t, C) + x_1,$$

then

$$F(X_s + x_1) - F(X_s) = x_1 f(X_s + \theta x_1), \quad 0 < \theta < 1,$$

and so putting  $x_0 = X_s(0, C)$  in 9.3(1) we have

$$x_1 f(X_s + \theta x_1) = o\left(\frac{1}{k}\right).$$

Since  $|f| \geq B_2$ , we have

$$(2) \quad x_1 = o\left(\frac{1}{k}\right)$$

in a subinterval of type (i).

Further, dividing the original equation by  $k$ , we have

$$\frac{\ddot{x}}{k} + f(X_s + x_1)\dot{x} + \frac{gx}{k} = p(t),$$

and so, if  $x$  is sufficiently large, the term  $f(X_s + x_1)x$  outweighs  $gx/k$  and  $p(t)$ , and so  $x$  and  $\dot{x}$  have the same or the opposite signs according as  $f(X_s + x_1)$  is negative or positive. Hence the solution given by (1) and

(2) is very stable if  $f \geq B_2$  and very unstable if  $f \leq -B_2$ . In fact if  $X_s$  belongs to an interval in which  $f \geq B_2 > 0$ ,  $x = X_s(t, C) + o(1/k)$  from the point where  $|\dot{x}| < B$  until  $X_s(t, C)$  meets a maximum or minimum and ceases to exist. The term  $\frac{1}{k} \int_0^t g(x) dt$  in 9.3(1) makes the constant  $C$  gradually decrease if  $\int g(X_s) dt$  over a period is positive, and increase if the integral is negative.

§9.5. As regards case (ii) the interval can only last a time  $B/k$ . For if not,  $x$  goes out of the strip  $|x| < B$ .

If  $|x - \alpha_s| < \delta$  where  $\alpha_s$  is a maximum or minimum  $f(x) < B_2 = \epsilon$  where  $\epsilon$  may be as small as we please by making  $\delta$  sufficiently small, and so by 9.1(1)

$$\ddot{x} = kp(t) + o(\epsilon k) + o(1).$$

Since  $p(t)$  has only a finite number of maxima and minima, this gives  $\ddot{x} > kB_4$  if the interval lasts a sufficiently long time, greater than  $B_5$ , say, and so  $|\dot{x}| > kB$ , and  $x$  moves outside  $|x - \alpha_s| < \delta$  within a time  $B$  for  $\delta$  sufficiently small.

§9.6. We have already shown that solutions tend to move towards  $X_1, X_3, X_5$  and away from  $X_2, X_4, \dots$ . To find the time of transition from an interval of type (i) to an interval of type (ii) or vice versa, we suppose that  $f(x) \geq B_2$  and that  $\delta$  and  $D$  are positive constants and that  $\dot{x}$  decreases from  $\delta k$  to  $D$  as  $t$  increases from 0 to  $t_1$ . Then, if  $D$  is sufficiently large, since  $x > D$ ,

$$\ddot{x} = -k f(x)\dot{x} - g(x) - k p(t)$$

$$\leq -k B_2 \dot{x} + kB \leq -\frac{1}{2}k B_2 \dot{x},$$

and so integrating we have

$$\left[ \log \dot{x} \right]_0^{t_1} \leq -\frac{1}{2}k B_2 t_1.$$

Hence

$$\log D - \log \delta k \leq -\frac{1}{2}k B_2 t_1$$

and

$$t_1 \leq 2 \frac{\log k}{k B_2} \quad \text{for } k > k_0.$$

The intervals in which  $\dot{x}$  is negative of  $f(x) \leq -B_2$  may be treated in a similar manner.

§9.7. We now assemble these results. So far as any stable solution is concerned we may ignore  $X_2, X_4, \dots$ , and define a degenerate solution of 9.1(1) to be a solution of 9.1(2) for which  $X$  lies in an interval where  $f(x) > 0$ , and if  $\dot{X}_{2s-1}(t_0, C) = 0$ , we take the value  $X = X_{2s-3}$  or  $X = X_{2s+1}$  for  $t - t_0$  according as  $P(t)$  is increasing or decreasing.<sup>32</sup> The solution then moves round a circuit consisting approximately of parts of the curves  $x = X_{2s+1}$  joined by arcs on which  $|\dot{x}| > Bk$ , in such a way that

$$\int_0^t g(x) dt$$

---

<sup>32</sup>. The case in which  $P(t)$  has a maximum or minimum needs further discussion.

tends to 0 as  $t \rightarrow \infty$ . For a solution of period  $2\pi/\lambda$ , it follows from the original equation that

$$\int_0^{2\pi/\lambda} g(x) dt = 0,$$

and therefore for the approximate solution

$$\int_0^{2\pi/\lambda} g(X) dt = 0.$$



# V. SINGULAR PERTURBATIONS OF A VAN DER POL EQUATION <sup>1</sup>

By James G. Wendel

## Preface

The classical perturbation theory dating back to the work of Liapounoff [9] and Poincare [12] deals with systems of differential equations of the (vector) form  $\dot{x} = f(x,t;\epsilon)$ , where  $\epsilon$  is a small parameter and  $f(x,t;\epsilon)$  is continuous at  $\epsilon = 0$ . More recently, interest has focussed on the problems arising from the assumption that one or more of the components of  $f$  is unbounded as  $\epsilon$  tends to zero. The principal difficulty encountered in this new class of problems is that formally, the system  $x = f(x,t; 0)$  may be degenerate, which is to say that one or more of the initial conditions imposed on the perturbed equation must be relinquished.

For example, in the work of Friedrichs and Wasow [4], the system under consideration is

$$(1) \quad \begin{aligned} x_1 &= f_1(x_1, \dots, x_n), \quad i = 1, 2, \dots, n-1 \\ \epsilon x_n &= f_n(x_1, \dots, x_n), \end{aligned}$$

which becomes, when  $\epsilon = 0$ ,

$$(2) \quad \begin{aligned} x_1 &= f_1(x_1, \dots, x_n) \\ 0 &= f_n(x_1, \dots, x_n) \end{aligned}$$

---

1. A dissertation, submitted to the California Institute of Technology in partial fulfillment of the requirements for the degree of Doctor of Philosophy, June 1948. A preliminary report has appeared in Bull. Amer. Math. Soc., Vol. 54(1948), p.836. I wish to thank Professor F. Bohnenblust for invaluable encouragement and guidance throughout the course of the work.

In the study of the relationship between solutions of (1) and of (2) cognizance must be taken of the fact that in (1) the initial values  $x_1^0, x_2^0, \dots, x_n^0$  are independent, whereas the last equation of (2) imposes the restriction  $f(x_1^0, \dots, x_n^0) = 0$ .

The results of Friedrichs and Wasow pertain to the approximation to solutions of (1) by solutions of (2) in those cases where the solutions of (2) are continuous. Volk [13] discusses a similar problem in which the right members depend explicitly on  $t$ . The so-called relaxation oscillation problems in which the  $\epsilon = 0$  system has discontinuous solutions have been treated by Flanders and Stoker [3], who discuss the van der Pol equation  $\epsilon \ddot{x} + (x^2 - 1)\dot{x} + \epsilon x = 0$  for  $\epsilon$  small, and more recently by LaSalle [14] who studies the general case  $\epsilon \ddot{x} + f(x)\dot{x} + \epsilon x = 0$ .

Systems in which the right members depend explicitly on the independent variable and in which the degenerate system has discontinuous solutions have been discussed by Minorsky [11], Cartwright and Littlewood [1], and Levinson [5], [6]. Cartwright and Littlewood announce results pertaining to the equation  $\epsilon \ddot{x} + (x^2 - 1)\dot{x} + \epsilon x = b \lambda \cos(\lambda t + \alpha)$  where  $b, \alpha, \lambda$  are positive constants independent of  $\epsilon$ ;  $\epsilon$  is taken to be small and positive, the latter being only an apparent restriction as is seen by replacing  $t$  by  $-t$  in the equation. They find that the value  $b_0 = \frac{2}{3}$  is a critical value for the parameter  $b$ : if  $b > b_0$  then, if  $\epsilon$  is small enough, there is a single periodic solution, which has period  $2\pi/\lambda$ , and which is stable in the sense that as  $t \rightarrow \infty$  any other solution tends to the periodic one. If  $b < b_0$ , then the behaviour is very complicated even for  $\epsilon$  small: both stable and unstable

periodic solutions of least period  $\frac{2\pi}{\lambda} n$  appear, and in addition to these "subharmonics", solutions of the type called "discontinuous recurrent" are found. And there is, finally, a single periodic solution of period  $2\pi/\lambda$  which is unstable. Levinson [6] makes a study of similar phenomena in the case of the equation

$\epsilon \ddot{x} + \dot{x} \operatorname{sgn}(|x| - 1) + \epsilon x = b \sin t$ ,  $0 < b < b_0 = 1$ .  
The case of  $b > b_0$  is not discussed.

These equations are each of the Van der Pol type  $\epsilon \ddot{x} + f(x)\dot{x} + \epsilon g(x) = e(t)$ , and in each case the difficulties which arise are due to the fact that the "damping factor"  $f(x)$  can change sign. The solutions of the degenerate equation  $f(y)\dot{y} = e(t)$  have discontinuities, in general, and the situation as regards uniqueness and stability of periodic solutions is far more complex than in the case when  $f(x)$  is of fixed sign, as has been shown by Cartwright-Littlewood[2] and Levinson [8].

We propose then to study the equation  $\epsilon \ddot{x} + f(x)\dot{x} + \epsilon g(x) = e(t)$  and its degenerate form  $f(y)\dot{y} = e(t)$ , where  $f(x)$  is not required to be of fixed sign. In part I (§§1 and 2) solutions of the degenerate equation having certain desirable properties are defined and shown to exist uniquely; important features of these solutions are discussed. In part II (§§3-7) we discuss the perturbed equation; §3 sets forth elementary boundedness properties of its solutions and establishes the existence of a periodic solution under appropriate conditions on the functions  $e, f, g$ . In §4 we prove lemmas needed to establish the convergence theorem of §5; this theorem states conditions under which a solution of  $\epsilon \ddot{x} + f(x)\dot{x} + \epsilon g(x) = e(t)$  tends, as  $\epsilon \rightarrow 0$ , to a solution of  $f(y)\dot{y} = e(t)$ ; the theorem is presumably a consequence of a result announced by Levinson [5] but is included here for completeness. In §6 we

state and prove the Global Stability Theorem, on the behavior of solutions of the perturbed equation as  $t \rightarrow \infty$ . It will be shown that the condition  $b > b_0$  is necessary and sufficient that for the equations of Cartwright-Littlewood and Levinson the hypotheses of the Global Stability Theorem be satisfied. At the present we are unable to prove (or disprove) that a periodic solution of our equation must be stable or even unique; the theorem in §6 is our best approximation to the results announced in [1] for the special equation  $\epsilon \ddot{x} + (x^2 - 1)\dot{x} + \epsilon x = b\lambda \cos(\lambda t + \alpha)$ ,  $b > b_0 \equiv \frac{2}{3}$ . However, in §7 we prove by means of a method due to Levinson [7], a result in the same direction, that our equation possesses a maximum invariant finite domain of zero area.

## I. The Degenerate Equation

### §1. Introduction.

As indicated in the preface we wish to obtain information about the solutions of

(1)  $\epsilon \ddot{x} + f(x)\dot{x} + \epsilon g(x) = e(t)$ ,  $\epsilon > 0$ ,  $\epsilon$  small,  
from a study of the equation

(2)  $f(y)\dot{y} = e(t)$ .

The chief case of interest is that in which  $f(x)$  can change sign.

We suppose that  $e$ ,  $f$ , and  $g$  are continuous, and that  $f$  and  $g$  satisfy a Lipschitz condition; then for any initial values  $x_0$ ,  $\dot{x}_0$ ,  $t_0$  (1) has a unique solution  $x(t)$  such that  $x(t_0) = x_0$ ,  $\dot{x}(t_0) = \dot{x}_0$ . Under relatively mild additional assumptions we can guarantee that no solution goes to infinity in a finite time; hence every solution is continuable for all  $t$ ,  $t \geq t_0$ . The most important extra condition is that  $\int_{x_0}^x f(u)du$  shall be unbounded above and below as  $x$  varies from  $-\infty$  to  $+\infty$

We write this condition in the normalized form  
 $\lim_{|x| \rightarrow \infty} F(x) \operatorname{sgn} x = +\infty$ , where  $F(x) \equiv \int_0^x f(u) du$ .

On the other hand, if  $f(x)$  has zeroes the equation (2) may possess no solutions for some initial values, and certain of its solutions may remain bounded, yet continuable only for values of  $t$  in a restricted interval about  $t_0$ . Nevertheless equation (2) in its integrated form

(3)  $F(y) = F(x_0) + E(t) - E(t_0)$   
 where  $E(t) \equiv \int_0^t e(u) du$  has solutions  $y = y(t)$  such that  $y(t_0) = x_0$  for all values  $x_0, t_0$ ; these solutions are continuable (although perhaps not uniquely) for all  $t \geq t_0$  because of the behaviour of  $F(x)$  at infinity.

In the simplest case, when  $f$  has isolated zeroes, we can select from among the solutions of (3) a special class of functions  $y(t)$  which approximate the solutions of (1) for small positive  $\epsilon$ . We outline in the paragraphs to follow the heuristic considerations which motivate the definition of these "degenerate solutions".

Let (1) be transformed into an equivalent pair of first-order equation by the substitution  $w = \epsilon \dot{x} + F(x)$ . Then

$$(4a) \quad \epsilon \dot{x} = w - F(x)$$

$$(4b) \quad \dot{w} = e(t) - \epsilon g(x).$$

The solutions of (1) may now be thought of as trajectories  $(x(t), w(t))$  in the  $x, w$  plane. The curve  $\Gamma : w = F(x)$  plays an important role in the study of the trajectories; for by (4a), if  $(x(t), w(t))$  lies above  $\Gamma$  then  $\dot{x}(t) > 0$ , while if  $(x(t), w(t))$  lies below  $\Gamma$  then  $\dot{x}(t) < 0$ . Indeed, for small  $\epsilon$ , if  $w(t) - F(x(t))$  is not "very" small then  $\dot{x}(t)$  is large. Equation (4b) shows that  $w$  is probably bounded, as  $\epsilon \rightarrow 0$ .

Since  $f(x)$  has isolated zeroes,  $F(x)$  is piecewise strictly monotone. Let  $F_+$  denote the set of values of  $x$  at which  $F(x)$  is increasing,  $F_0$  the isolated points at which  $F(x)$  has extrema,  $F_-$  the remaining points. In Figure 1,  $x_1, x_2$  and  $x_3$  are in  $F_0$ ; the open interval  $(x_1, x_2)$  is in  $F_+$ ; the open interval  $(x_2, x_3)$  belongs to  $F_-$ . Horizontal inflectional tangents, such as at  $x_4$ , are not excluded.

It seems plausible that the set of points  $(x, w)$  near to  $\Gamma$  with  $x$ -coordinates in  $F_+$  should be a strongly stable region for solutions of (1). For suppose that at a certain time a trajectory point is at  $P$  (Figure 1).

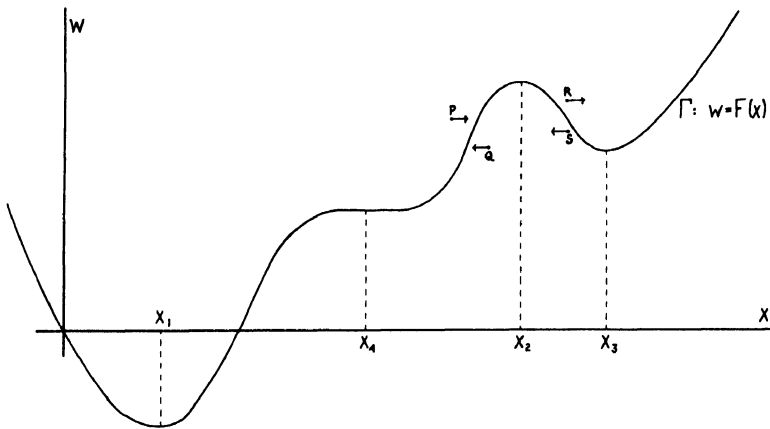

FIG. 1

Then, since it lies above  $\Gamma$ , it has a large positive horizontal velocity, and hence tends to move rapidly towards  $\Gamma$ ; its velocity decreases as it approaches  $\Gamma$ . Similarly a trajectory point at  $Q$  will have a large negative horizontal velocity and therefore should move towards  $\Gamma$ , decreasing the magnitude of  $x$ . Of course, either trajectory may cross  $\Gamma$ ; but once near to it

should be nearly impossible for a trajectory to leave, so long as  $x(t)$  remains in  $F_+$ .

By a similar argument it appears that the region near  $\Gamma$  with  $x$  in  $F_-$  will be highly unstable. Any slight initial tendency to leave  $\Gamma$  is quickly reinforced; trajectory points such as those at R and S are expected to "jump" horizontally to the first accessible increasing branch of  $\Gamma$ .

Assuming that the term  $\epsilon g(x)$  may be neglected we integrate (4b) and obtain

$$(5) \quad w - w_0 = E(t) - E(t_0).$$

Then if  $\epsilon \dot{x}$  is small we combine (4a) and (5) to obtain the equation

$$(6) \quad F(x) = F(x_0) + E(t) - E(t_0) = w$$

where we have also assumed that  $\epsilon \dot{x}_0$  is small.

The second equation of (6) should be a good approximation to the actual motion defined by (4a,b), since only the term  $\epsilon g(x)$  has been neglected. The first equation of (6) will be a reasonable approximation if  $\epsilon \dot{x}$  is small, which, by the stability argument above, should be the case as long as  $x(t)$  stays in  $F_+$ . Thus, wherever (6) is applicable, the true solution  $x(t)$  should lie near to an appropriate solution of (3).

Let us follow the approximate motion of a trajectory beginning at  $P_{00}(x_{00}, w_0)$  in Figure 2.<sup>2</sup> Since  $P_{00}$  is well above  $\Gamma$  the initial velocity is positive and large. Hence there is an almost instantaneous horizontal jump to  $P_0(x_0, w_0)$ , which we may think of as

---

2. No significance attaches to the fact that  $\Gamma$  has been drawn for different  $F(x)$  in Figures 1 and 2, nor to the fact that all of the action takes place in the first quadrant.

a preliminary adjustment of initial conditions.

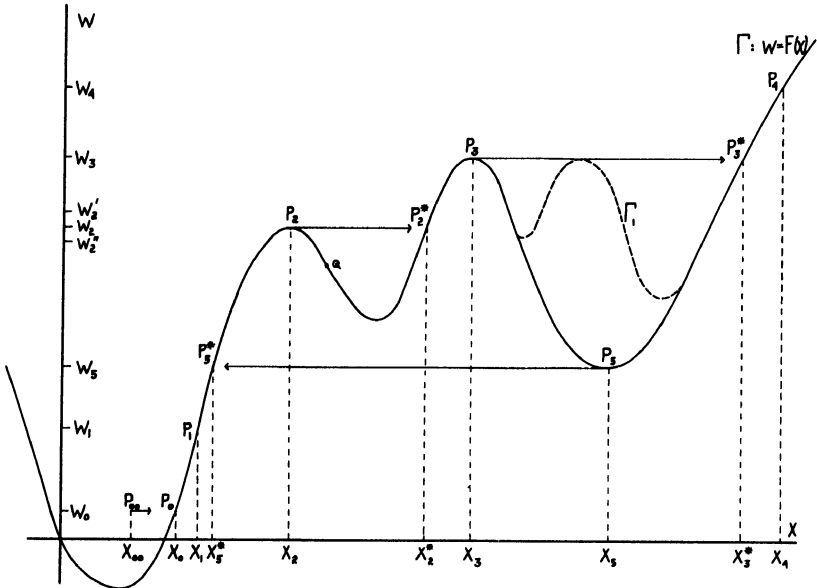

FIG. 2

Suppose first that  $e(t)$  is such that the function  $w = F(x_0) + E(t) - E(t_0)$  varies between the levels  $w_0$  and  $w_1$ . Then the solution trajectory moves along  $\Gamma$  between  $P_0$  and  $P_1$ ; we expect that  $x(t)$  is closely approximated by that solution  $y(t)$  of the equation  $F(y) = F(x_0) + E(t) - E(t_0)$ , which lies between  $x_0$  and  $x_1$ .

Suppose instead that  $w$  increases steadily from  $w_0$  to  $w_4$ . Then until  $w$  is near to  $w_2$ ,  $x(t)$  is near to the solution  $y(t)$  of  $F(y) = F(x_0) + E(t) - E(t_0)$  lying between  $x_0$  and  $x_2$ . Then as  $w$  continues to rise the trajectory is carried to a level considerably above  $\Gamma$  and thus  $x(t)$  acquires a very large positive velocity.

Suppose instead that  $w$  increases steadily from  $w_0$  to  $w_4$ . Then until  $w$  is near to  $w_2$ ,  $x(t)$  is near to the solution  $y(t)$  of  $F(y) = F(x_0) + E(t) - E(t_0)$  lying between  $x_0$  and  $x_2$ . Then as  $w$  continues to rise the trajectory is carried to a level considerably above  $\Gamma$  and thus  $x(t)$  acquires a very large positive velocity.

The trajectory point then jumps to the next increasing branch of  $\Gamma$  say to the vicinity of  $P_2^*$ : now as  $w$  rises to the level  $w_3$ ,  $x(t)$  is approximated by the solution  $y(t)$  of  $F(y) = F(x_0) + E(t) - E(t_0)$  which moves from  $x_2^*$  to  $x_3$ .

At  $P_3$ ,  $w$  is still rising; there is another jump to the right to the position  $P_3^*$ . The rest of the motion is now smooth, from  $x_3^*$  to  $x_4$ . The situation would not be different if  $\Gamma$  had the form of the dotted curve  $\Gamma_1$  with a maximum point  $P_3'$  at the same height as  $P_3$ .

If now  $w$  falls steadily from  $w_4$  to  $w_0$  then the trajectory moves smoothly from  $P_4$  to  $P_5$  along  $\Gamma$ , jumps to  $P_5^*$  and returns smoothly to  $P_0$ . The corresponding solution  $y(t)$  of (3) moves from  $x_4$  to  $x_5$ , jumps to  $x_5^*$ , then moves to  $x_0$ . Of course, if  $\Gamma$  is changed to  $\Gamma_1$ , the number and location of jumps on the downward cycle is altered.

The case where extrema of  $F(x)$  and  $E(t)$  coincide presents special difficulties and will have to be excluded - cf. the definition of "regular solutions" in the next section. For suppose that  $w$  rises from  $w_0$  to  $w_2$ , then falls to  $w_0$ . Then  $x(t)$  might simply move to  $x_2$ , and return to  $x_0$ . But we cannot exclude the possibility that the trajectory moves into  $F_-$ , following  $\Gamma$  smoothly to a point such as  $Q$ , and then suddenly jumping to right or left. Such motions should actually exist, on grounds of continuity. For by slight changes of initial value  $x_0$  we can raise or lower  $w_2$  to positions such as  $w_2'$  or  $w_2''$ , obtaining qualitatively different approximate solutions.

The foregoing discussion suggests that the true solutions  $x(t)$  of (1) are approximated by "degenerate

solutions"  $y(t)$  whose essential features are (i)  $y(t)$  satisfies  $F(y) = F(x_0) + E(t) - E(t_0)$ ; (ii)  $y(t)$  lies in  $\bar{F}_+$ ; (iii)  $y(t)$  is continuous when  $y(t) \in F_+$ ,  $y(t)$  jumps to the right or left from  $F_0$  according as  $F(y(t))$  is a maximum or a minimum. We proceed now to the precise definition of degenerate solutions and the derivation of their salient properties.

## §2. Degenerate Solutions.

Let  $f(x)$  be continuous for all  $x$ , with isolated zeroes, if any. Let  $F(x) \equiv \int_0^x f(u)du$ ,  $\lim_{|x| \rightarrow \infty} F(x) \operatorname{sgn} x = +\infty$ . Designate by  $F_+$  the set of  $x$  at which  $F$  is increasing and by  $F_0$  the isolated points at which  $F$  has extrema. Let  $e(t)$  be continuous,  $E(t) \equiv \int_0^t e(u)du$ .

For each  $x$  in  $\bar{F}_+$  we define a number  $x^*$  by the following rules:

if  $x$  is in  $F_+$ ,  $x^* = x$  ;

if  $F$  has a maximum at  $x$ , then  $x^*$  is the least number  $y$  of  $F_+$  such that  $y > x$  and  $F(y) = F(x)$ :

if  $F$  has a minimum at  $x$ , then  $x^*$  is the greatest number  $y$  of  $F_+$  such that  $y < x$  and  $F(y) = F(x)$ . The pairs  $x_2, x_2^*$  and  $x_5, x_5^*$  in Figure 2 illustrate the definition. It is easy to see by referring to the figure that if  $x \leq \xi \leq x^*$  then  $F(\xi) \leq F(x)$ , and if  $x \geq \xi \geq x^*$  then  $F(\xi) \geq F(x)$ . Furthermore, if  $\xi$  is in  $\bar{F}_+$  so that  $\xi^*$  is defined, then  $x < \xi^* < x^*$  implies  $F(\xi) < F(x)$ , while  $x > \xi^* > x^*$  implies  $F(\xi) > F(x)$ .

Let  $t_0$  be arbitrary and  $y(t)$  a function defined for all  $t \geq t_0$  such that

(i)  $F(y(t)) = F(y(t_0)) + E(t) - E(t_0)$ ;

(ii)  $y(t)$  is in  $\bar{F}_+$  ;

(iii)  $y(t - 0)$  exists and  $y(t - 0) = y(t)$  for all  $t > t_0$ ;

(iv)  $y(t+0)$  exists and  $y(t+0) = y(t)^*$  for all  $t \geq t_0$  .

Such a function  $y(t)$  will be called a degenerate solution. To emphasize its dependence on initial values  $t_0$  and  $y(t_0) \equiv x_0$  we shall sometimes write  $y(t; x_0)$  or  $y(t; x_0, t_0)$ .

From the definition of the  $*$  - operation it is clear that  $x = x^*$  if and only if  $x$  is in  $F_+$ . Therefore, using (iii) and (iv),  $y(t)$  is continuous when and only when  $y(t)$  is in  $F_+$ . We note further that the values of  $t$  for which  $y(t)$  is in  $F_0$  are isolated. These remarks combined with the implicit function theorem immediately yield the existence-uniqueness theorem for degenerate solutions.

We merely state the result:

Theorem 2.1. Let  $x_0$  lie in  $\bar{F}_+$  and  $t_0$  be arbitrary. Then there exists one and only one degenerate solution  $y(t)$  such that  $y(t_0) = x_0$ .

Hence if  $y(t)$  and  $Y(t)$  are two degenerate solutions with initial times  $t_0$  and  $T_0$  and if  $y(t_1) = Y(t_1)$  for some value  $t_1 \geq \max(t_0, T_0)$  then  $y(t) = Y(t)$  for all  $t \geq t_1$ . Even more is true, and easily proved:

Lemma 2.2. If  $y(t)$  and  $Y(t)$  are two degenerate solutions such that  $F(y(t)) = F(Y(t))$  and if  $Y(t_1)$  lies in the closed interval between  $y(t_1)$  and  $y(t_1+0)$  then  $y(t) = Y(t)$  for all  $t > t_1$ .

We now prove a theorem concerning the monotonicity of  $y(t)$  as a function of  $y(t_0)$ .

Theorem 2.3. If  $y(t_0) \geq Y(t_0)$  and  $F(y(t_0)) \geq F(Y(t_0))$  then  $t \geq t_0$  implies  $y(t) \geq Y(t)$ .

Proof: If the theorem is false then by theorems 2.1 and 2.2 there is a  $t_1 > t_0$  such that  $y(t_1) > Y(t_1)$ ,  $y(t_1+0) < Y(t_1+0)$ , and  $Y(t_1) \neq y(t_1+0)$ .

Therefore either  $Y(t_1) < y(t_1+0) < Y(t_1+0)$  or  $y(t_1+0) < Y(t_1) < y(t_1)$ .

Because of the equation  $F(y(t)) - F(Y(t)) = F(y(t_0)) - F(Y(t_0)) \geq 0$  these are both impossible. For if  $Y(t_1) < y(t_1+0) < Y(t_1+0)$  then, since  $y(t_1+0) \in F_+$  we have  $y(t_1+0) = y(t_1+0)^*$ . Therefore  $Y(t_1) < y(t_1+0)^* < Y(t_1)^*$ . Hence  $F(y(t_1)) = F(y(t_1+0)^*) < F(Y(t_1))$ , a contradiction. On the other hand, if  $y(t_1+0) < Y(t_1) < y(t_1)$  then  $y(t_1)^* < Y(t_1) < y(t_1)$  and also  $y(t_1)^* < Y(t_1)^*$ . Hence  $F(y(t_1)) < F(Y(t_1))$ , a contradiction.

Combining this result with Lemma 2.2 we have

Lemma 2.4. If  $y(t_0+0) \geq Y(t_0)$  and  $F(y(t_0)) = F(Y(t_0))$  then  $t > t_0$  implies  $y(t) \geq Y(t)$ .

Suppose now that  $E(t)$  is periodic with least period  $p$ . It is clear that there may exist degenerate solutions which are not periodic. Suppose for example that in Figure 2  $w$  oscillates between the levels  $w_2$  and  $w_0$ ; then a solution starting at  $R$  will never return to  $R$ . However this solution is periodic from the moment it reaches the branch  $P_0P_2$ , and this occurs within a period. We show that this phenomenon is general:

Theorem 2.5. If  $E(t+p) = E(t)$  then  $t \geq t_0 + p$  implies  $y(t+p) = y(t)$ , for all degenerate solutions  $y(t)$ .

Proof: For all  $t$  we have  $E(a) \geq E(t) \geq E(b)$ , where either  $t_0 \leq a < b < t_0 + p$  or  $t_0 \leq b < a < t_0 + p$ . We give the proof only for the first case, the second being analogous.

Clearly,  $t > a$  implies  $y(t) \leq y(a+0)$ . For otherwise  $t_1 > a$  exists such that  $y(t_1+0) > y(a+0)$

$\geq y(t_1)$ : since  $y(a+0) \in F_+$  then  $y(t_1)^* > y(a+0)^*$   
 $\geq y(t_1)$  whence  $F(y(t_1)) > F(y(a))$ , contradicting  
 $E(t_1) \leq E(a)$ .

Similarly  $t > b$  implies  $y(t) \geq y(b+0)$ .

Let  $y(t+p) \equiv Y(t)$ . Then  $F(y(t)) = F(Y(t))$  and  
 $Y(a) = y(a+p) \leq y(a+0)$ . Then by Lemma 2.4,  $t > a$   
implies  $y(t) > Y(t)$ . Then in particular  $y(b) \geq Y(b)$ .  
But  $y(b+p) \geq y(b+0)$ . Therefore,  $y(b) \geq Y(b) \geq y(b+0)$ .  
Then by Lemma 2.2,  $t > b$  implies  $y(t) = Y(t)$ , which is  
to say:  $y(t) = y(t+p)$ .

The monotonicity theorem may be stated in a  
stronger form when the degenerate solutions are  
periodic.

Theorem 2.6. If  $y(t)$  and  $Y(t)$  are periodic with  
period  $p$  and  $y(t_0) > Y(t_0)$  then  $y(t) > Y(t)$  for all  $t$   
 $\geq t_0$ .

Proof: If  $F(y(t_0)) \geq F(Y(t_0))$  then by Theorem  
2.3,  $y(t) \geq Y(t)$  for all  $t \geq t_0$ ; the periodicity and  
theorem of uniqueness preclude equality.

If  $F(y(t_0)) < F(Y(t_0))$  and the theorem is false  
then  $t_1 > t_0$  exists such that  $y(t_1) < Y(t_1)$ . But  $F(y(t_1))$   
 $- F(Y(t_1)) = F(y(t_0)) - F(Y(t_0)) < 0$  Hence by Theorem  
2.3 applied with initial time  $t_1$ , we have  $y(t) \leq Y(t)$   
for all  $t \geq t_1$ . But  $y(t_0 + np) > Y(t_0 + np)$  for all  
 $n$ , a contradiction.

### Regular Degenerate Solutions

We noted in §1 that if a degenerate solution  $y(t)$   
appears in  $F_0$  at a time when  $E(t)$  has an extremal value  
then that degenerate solution could not be expected to  
mirror the behavior of solutions of the perturbed  
equation. It is therefore necessary to exclude degenerate

solutions of this type.

To make the description as simple as possible we add the requirement that  $e(t)$  have isolated zeroes, so that  $E(t)$  is piecewise strictly monotone. (For the present we are not assuming that  $E(t)$  is periodic.)

A degenerate solution  $y(t)$  will be called regular on the interval  $(t_0, t_0 + T)$  provided that all of the numbers  $y(t_0)$ ,  $y(t_0 + T)$  and  $y(\theta)$  are in  $F_+$ , where  $\theta$  is any value of  $t$  in  $(t_0, t_0 + T)$  at which  $E(t)$  has an extremal value; of course there are at most a finite number of points  $\theta$  in the interval.

The initial value  $x_0 \equiv y(t_0)$  will be called a regular initial condition. With  $t_0$  and  $T$  fixed the equation  $F(y(\theta)) = F(x_0) + E(\theta) - E(t_0)$  shows that the set of regular initial conditions  $x_0$  is a non-empty open set. We denote by  $I$  a closed interval all of whose points are regular initial conditions.

In proving the convergence theorem of §5 we shall need two results concerning regular degenerate solutions. These are

Theorem 2.7. Let  $x_0$  be in  $I$  and  $y(\tau_0; x_0)$  in  $F_0$ . Then there exists a unique function  $\tau(x)$ , defined and continuous on  $I$ , with  $\tau(x_0) = \tau_0$  and  $y(\tau(x); x) = y(\tau_0; x_0)$ . Furthermore  $\tau(x)$  is monotone on  $I$ .

Lemma 2.8. Let  $u < t < v$  be an interval such that every degenerate solution  $y(t; x)$ ,  $x$  in  $I$ , is in  $F_0$  for exactly one value of  $t$  interior to  $[u, v]$ . Let  $E(t)$  be increasing for  $u < t < v$ . Then nine numbers  $-\infty < x_1 < x_2 < \dots < x_9 < +\infty$  exist such that  $x_1$  and  $x_9$  are in  $F_0$  if they are finite; the open intervals  $(x_1, x_5)$  and  $(x_6, x_9)$  lie in  $F_+$ ;  $x_5$  and  $x_6$  are in  $F_0$ ;  $F(x_4) > F(x_6)$ ; and for  $x$  in  $I$ ,  $x_2 < y(u; x) < x_3$  and  $x_7 < y(v; x) < x_8$ .

Theorem 2.7 is important because it enables us to isolate the values of  $t$  at which  $y(t; x_0)$  is in  $F_0$ , uniformly with respect to  $x_0$ , if the interval  $I$  over which  $x_0$  varies is chosen sufficiently small. This can be seen as follows.

Suppose that  $y(t; x_0)$  is regular for  $t_0 \leq t \leq t_0 + T$ , and is in  $F_0$  at successive times  $\tau_1, \tau_2, \dots, \tau_n$ . Then by Theorem 2.7 there exist continuous functions  $\tau_j(x)$  defined on  $I$  with  $\tau_j(x) = \tau_j$ , and  $y(\tau_j(x); x) = y(\tau_j; x_0)$  in  $F_0$ . By applying the Theorem again we see conversely that if  $y(\tau; x)$  is in  $F_0$  then  $\tau = \tau_j(x)$  for some  $j$ .

Since the functions  $\tau_j(x)$  are continuous we can select numbers  $u_j$  and  $v_j$  so that if  $I$  is small enough then  $u_j < \tau_j(x) < v_j$ , the total length of the intervals  $(u, v)$  is as small as we wish, and  $E(t)$  is monotone for  $u_j \leq t \leq v_j$ . For  $t$  in the interval  $[u_j, v_j]$  each  $y(t; x)$  has one and only one value in  $F_0$ , and the point of  $F_0$  is independent of  $x$ . For  $t$  in the closed interval  $[v_{j-1}, u_j]$  no solution  $y(t; x)$  is in  $F_0$ .

In order to establish these results we introduce an auxiliary function  $G(w; y)$ , defined for all real  $w$  and for all  $y$  in  $F_+$ , in terms of which we can write a more explicit formula for the regular degenerate solutions.  $G$  is a sort of inverse function to  $F$ , and is defined by

$$G(F(y); y) = y \quad ;$$

$$\text{If } w > F(y), \quad G(w; y) = \min\{x | x > y, w = F(x)\} \quad ;$$

$$\text{If } w < F(y), \quad G(w; y) = \max\{x | x < y, w = F(x)\} \quad .$$

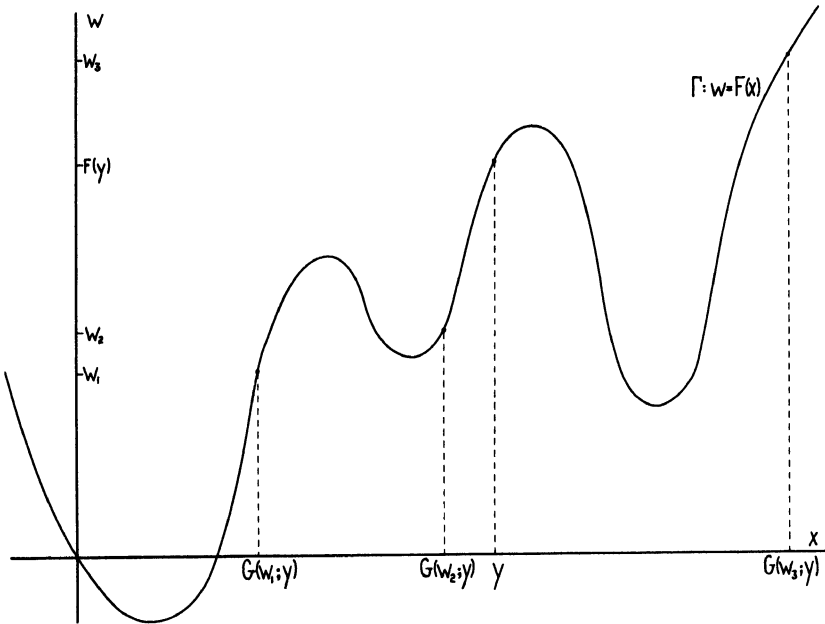

FIG. 3

Figure 3 illustrates the definition of  $G$ . We observe that  $F(G(w; y)) = w$  for all  $y$ , and that  $G(w; y)$  is a strictly increasing function of  $w$  for each  $y$ . Furthermore, if  $y_1$  and  $y_2$  are two numbers lying in the same component of  $F_+$  then for all  $w$  we have  $G(w; y_1) = G(w; y_2)$ . Finally, if  $w \geq F(y)$  then  $G(w - 0; y) = G(w; y)$ ,  $G(w + 0; y) = G(w; y)^*$ ; if  $w \leq F(y)$  then  $G(w - 0; y) = G(w; y)^*$ ;  $G(w + 0; y) = G(w; y)$ .

If we write  $w(t)$  for  $F(x_0) + E(t) - E(t_0)$  we see at once that the following lemma holds:

Lemma 2.9. If  $y(t_1)$  is in  $F_+$  and  $E(t)$  has no extreme values in the interval  $t_1 < t < t_2$  then  $y(t) = G(w(t); y(t_1))$  for all  $t$ ,  $t_1 \leq t \leq t_2$ .

Lemma 2.9 yields an algorithm for the computation of regular degenerate solutions. For if  $E(t)$  has successive extrema at times  $\theta_1, \theta_2, \dots, \theta_n$  then all of the numbers  $y(\theta_j)$  are in  $F_+$ . Hence  $y(t) = G(w(t); y(t_0))$  when  $t_0 \leq t \leq \theta_1$ ;  $y(t) = G(w(t); y(\theta_1))$  when  $\theta_1 \leq t \leq \theta_2$ ; and so on. In particular, if  $I$  is a closed interval all of whose points  $x_0$  are regular initial conditions then as  $x_0$  varies over  $I$  each of the numbers  $y(\theta_j; x_0)$  varies over a closed interval lying in  $F_+$ .

Proof of Theorem 2.7. Since  $y(\tau_0; x_0) \in F_0$  and  $y(t; x_0)$  is regular we know that  $E(t)$  does not have a maximum or minimum at time  $\tau_0$ . Hence for some  $j$ ,  $\theta_j < \tau_0 < \theta_{j+1}$ , letting  $\theta_0 = t_0$ . Then by the formula above we have

$$y(\tau; t) = G(F(x) + E(\tau) - E(t_0); y(\theta_j; x)) \text{ if}$$

$\theta_j < \tau < \theta_{j+1}$ . But  $y(\theta_j; x)$  and  $y(\theta_j; x_0)$  lie in the same component of  $F_+$ . Hence we may replace the last  $x$  in the preceding equation by  $x_0$  and obtain

$$y(\tau; x) = G(F(x) + E(\tau) - E(t_0); y(\theta_j; x_0)).$$

Since

$$y(\tau_0; x_0) = G(F(x_0) + E(\tau_0) - E(t_0); y(\theta_j; x_0))$$

it will be sufficient to show that the equation

$$F(x) + E(\tau) = F(x_0) + E(\tau_0)$$

has a continuous monotone solution  $\tau = \tau(x)$  with  $\tau(x_0) = \tau_0$  and  $\theta_j < \tau(x) < \theta_{j+1}$ . This is certainly true in a neighborhood  $V$  of  $x_0$ , since  $E(\tau_0)$  is not an extreme value and  $F(x)$  is monotone and continuous on  $I$ . If  $x_2$  is the upper bound of  $V$  and lies interior to  $I$  then  $\tau(x_2 - 0)$  exists and  $F(x_2) + E(\tau(x_2 - 0)) = F(x_0) + E(\tau_0)$ .

Then  $y(\tau(x_2-0); x_2)$  is in  $F_0$ , so that  $E(t)$  is not extremal at  $t = \tau(x_2-0)$ , and  $\theta_j < \tau(x_2-0) < \theta_{j+1}$ . Defining  $\tau(x_2) \equiv \tau(x_2-0)$  we may continue the solution beyond  $x_2$ , and hence to the upper bound of  $I$ . Similarly at the lower bound.

Before proving Lemma 2.8 we need to discuss the continuity of  $y(t; x)$  as a function of  $x$ . We have:

Lemma 2.10. If  $y(t; x_0)$  is a regular degenerate solution and  $y(t_1; x_0)$  is in  $F_+$  then  $y(t_1; x)$  is a continuous function of  $x$  at  $x = x_0$ .

Proof: Let  $\theta_j \leq t_1 < \theta_{j+1}$ . Then

$$y(t_1; x) = G(F(x) + E(t_1) - E(t_0); y(\theta_j; x))$$

by Lemma 2.9. As in the previous proof we may replace the last  $x$  by  $x_0$ . Then

$$\begin{aligned} y(t_1; x_0 \pm 0) &= G(F(x_0 \pm 0) + E(t_1) - E(t_0); y(\theta_j; x_0)) \\ &= G(F(x_0) + E(t_1) - E(t_0) \pm 0; y(\theta_j; x_0)) \\ &= G(F(x_0) + E(t_1) - E(t_0); y(\theta_j; x_0)) \\ &= y(t_1; x_0) \end{aligned}$$

since  $y(t_1; x_0)$  is in  $F_+$  whence  $y(t_1; x_0)^* = y(t_1; x_0)$ .

Proof of Lemma 2.8. (See Figure 4).

Let  $I$  be the closed interval of  $x' \leq x \leq x''$ . Let  $x_2 = y(u; x')$ ,  $x_3 = y(u; x'')$ ,  $x_7 = y(v; x')$ ,  $x_8 = y(v; x''$ . Then by Theorem 2.3

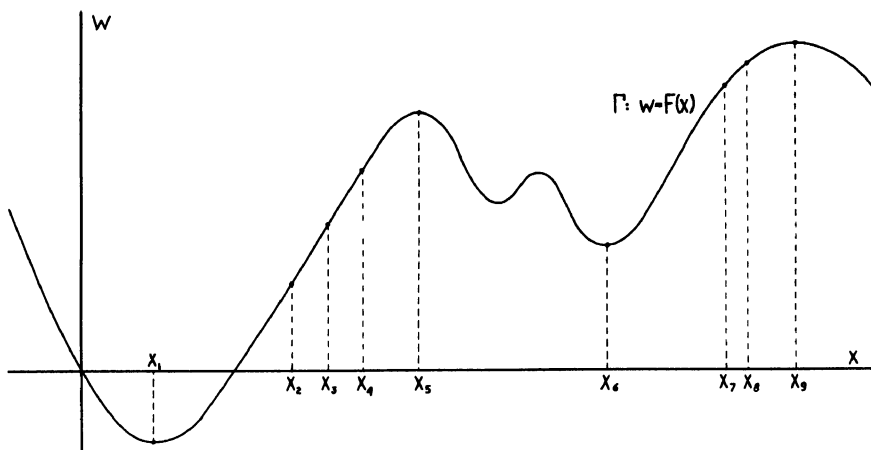

FIG. 4.

$x_2 \leq y(u; x) \leq x_3$  and  $x_7 \leq y(v; x) \leq x_8$  for  $x$  in  $I$ .  
 By hypothesis for each  $x$  there is a unique  $\tau(x)$  with  $u < \tau(x) < v$  and  $y(\tau(x); x)$  in  $F_0$ . Theorem 2.7 guarantees that the point in  $F_0$  is independent of  $x$ ; denote it by  $x_5$ . Then by lemma 2.9

$$x_3 = G(F(x'')) + E(u) - E(t_0) ; y(u; x'')$$

$$x_5 = G(F(x'')) + E(\tau(x'')) - E(t_0); y(u; x'').$$

But  $G(w; y)$  is an increasing function of  $w$  and  $E(\tau(x'')) > E(u)$  since  $E$  was assumed increasing on  $[u, v]$ . Therefore  $x_3 < x_5$ ; similarly  $x_5 < x_7$ , and indeed  $x_5^* < x_7$ . Let  $x_6$  be the greatest number of  $F_0$  less than  $x_5^*$ .  $F(x_6) < F(x_5)$ , and therefore we may choose  $x_4$  between  $x_3$  and  $x_5$  so that  $F(x_4) > F(x_6)$ . Finally take  $x_1$  equal to the greatest number in  $F_0$  less than  $x_2$ , or  $-\infty$  if there is none, and take  $x_9$  equal to the least number in  $F_0$  greater than  $x_8$ , or  $+\infty$ . The open intervals  $(x_1, x_2)$  and  $(x_3, x_5)$

clearly lie in  $F_+$ ; the closed interval  $[x_2, x_3]$  lies in  $F_+$  by the continuity of  $y(u; x)$ , lemma 2.10. Hence  $(x_1, x_5)$  is in  $F_+$ ; similarly  $(x_6, x_9)$  lies in  $F_+$ . Thus all the conditions in the conclusion of the lemma are fulfilled.

## II. The Perturbed Equation

### §3. Elementary Properties of Solutions.

We consider the equation

(1)  $\epsilon \ddot{x} + f(x)\dot{x} + \epsilon g(x) = e(t)$ ,  $0 < \epsilon < 1$ , under the assumptions

(a)  $f(x)$ ,  $g(x)$ ,  $e(t)$  are continuous and  $f(x)$ ,  $g(x)$  satisfy a Lipschitz condition in any bounded interval; hence (1) has a unique solution for given initial values  $x_0$ ,  $\dot{x}_0$ .

$$(b) |e(t)| \leq e_0$$

(c)  $E(t) \equiv \int_0^t e(u)du$  has finite oscillation,  $E_0$ .

$$(d) F(x) \equiv \int_0^x f(u)du; \quad \lim_{|x| \rightarrow \infty} F(x) \cdot \text{sgn } x = +\infty.$$

(e) There exist positive constants  $a_1$ ,  $a_2$ ,  $a_3$  such that the inequalities  $f(x) \geq a_2 |g(x)|$ ,  $F(x) \text{sgn } x > 0$ ,  $g(x) \text{sgn } x \geq a_3$  hold when  $|x| \geq a_1$ .

It will frequently be convenient to replace (1) by the equivalent pair of first order differential equations

$$(2) \quad \epsilon \dot{x}(t) = w(t) - F(x(t))$$

$$\dot{w}(t) = e(t) - \epsilon g(x(t)).$$

The first four theorems of this section present boundedness properties of solutions of (1). The methods employed and results obtained are very similar to those of Cartwright and Littlewood [2]. Our hypothesis (e)

is somewhat less restrictive on the function  $g(x)$ ; in [2] it is required that  $g(x) \geq 0(x)$  for large  $x$ .

Theorem 3.1. There exists a constant  $A$  such that for any solution  $x(t)$  the inequality  $|\epsilon \dot{x}(t)| \leq |\epsilon \dot{x}_0| + A$  holds for all  $t \geq t_0$ .

Proof: If  $|\epsilon \dot{x}(t)| \leq |\epsilon \dot{x}_0| + 2a_2^{-1}$  for all  $t \geq t_0$  we are through. If not,  $t_1$  and  $t_2$  exist such that  $|\epsilon \dot{x}(t_1)| = |\epsilon \dot{x}_0| + 2a_2^{-1}$  and  $t_1 \leq t \leq t_2$  implies  $|\epsilon \dot{x}(t)| \geq |\epsilon \dot{x}_0| + 2a_2^{-1}$ . Assuming for definiteness  $\dot{x}(t_1) > 0$  these relations become

$$(3) \quad \epsilon \dot{x}(t_1) = |\epsilon \dot{x}_0| + 2a_2^{-1}$$

$$t_1 \leq t \leq t_2 \text{ implies } \epsilon \dot{x}(t) \geq |\epsilon \dot{x}_0| + 2a_2^{-1}$$

so that

$$(4) \quad \dot{x}(t)^{-1} \leq \frac{1}{2} \epsilon a_2.$$

Integrating (1) from  $t_1$  to  $t_2$  yields

$$\begin{aligned} \epsilon \dot{x}_2 - \epsilon \dot{x}_1 + F(x_2) - F(x_1) &= E(t_2) - E(t_1) \\ &- \epsilon \int_{t_1}^{t_2} g(x(t)) dt, \end{aligned}$$

where  $x_1 \equiv x(t_1)$ ,  $\dot{x}_1 \equiv \dot{x}(t_1)$ .

Then using (c), (3) and (4) and  $\epsilon \leq 1$ , we obtain

$$0 \leq \epsilon \dot{x}_2 \leq |\epsilon \dot{x}_0| + 2a_2^{-1} - F(x_2) + F(x_1) + E_0$$

$$+ \frac{1}{2} a_2 \int_{x_1}^{x_2} |g(x)| dx, \text{ since } x_2 > x_1.$$

Hence

$$0 < \epsilon \dot{x}_2 \leq |\epsilon \dot{x}_0| + 2a_2^{-1} + E_0 + \frac{1}{2} a_2 \int_{x_1}^{x_2} [ |g(x)| - 2a_2^{-1} f(x) ] dx$$

If  $|x| \geq a_1$ , then  $0 \geq |g(x)| - a_2^{-1} f(x) > |g(x)| - 2a_2^{-1} f(x)$ .

Therefore, no matter what the values of  $x_1$  and  $x_2$ ,

$$0 < \epsilon \dot{x}_2 \leq |\epsilon \dot{x}_0| + 2a_2^{-1} + E_0 + \frac{1}{2}a_2 \int_{-a_1}^{a_1} |g(x)| \\ -2a_2^{-1} f(x) \Big| dx \equiv |\epsilon \dot{x}_0| + A.$$

The proof is similar if  $\dot{x}(t_1) < 0$ .

Theorem 3.2. For each solution  $x(t)$  and each  $t_1$ , there is a  $t_2 \geq t_1$  such that  $|x(t_2)| < a_1$ .

Proof: If  $x(t_2) \geq a_1$  for every  $t_2 \geq t_1$  then by integrating (1) we obtain

$$F(x_2) - F(x_1) + \epsilon \int_{t_1}^{t_2} g(x) dt = E(t_2) - E(t_1) \\ -\epsilon(\dot{x}_2 - \dot{x}_1).$$

Hence

$$\left| F(x_2) + \epsilon \int_{t_1}^{t_2} g(x) dt \right| \leq A', \text{ a constant depending}$$

on the initial conditions, by Theorem 3.1. But if  $x \geq a_1$ , then  $F(x)$  and  $g(x)$  have the same sign, by (e). Hence

$$\left| \int_{t_1}^{t_2} g(x) dt \right| \leq \text{a constant.}$$

Therefore  $|(t_2 - t_1) a_3| \leq \text{a constant}$ , for every

$t_2 > t_1$ . As this is ruled out the theorem is proved.

Similarly if  $t_2 \geq t_1$  implies  $x(t_2) < -a_1$ .

Theorem 3.3. For each pair of constants B and C there exists a constant D independent of  $\epsilon$  such that, if  $|x(t_0)| \leq B$  and  $|\epsilon \dot{x}(t_0)| \leq C$  then  $t \geq t_0$  implies

$$|x(t)| \leq D.$$

Proof: First consider the case  $B \leq a_1$ . If  $|x(t)| \leq a_1$  for all  $t \geq t_0$  we may take  $D = a_1$ . If  $x(t)$

has values greater than  $a_1$ ,  $x(t)$  must take on the value  $a_1$  at, say,  $t = t_1$  and again, by Theorem 3.2, at  $t = t_3$ . At an intermediate value  $t_2$   $x(t)$  has a maximum value  $x_2$  and  $\dot{x}(t_2) = 0$ . Integrating (1) from  $t_1$  to  $t_2$  we obtain

$$F(x_2) - F(a_1) = E(t_2) - E(t_1) + \epsilon \dot{x}_1 - \epsilon \int_{t_1}^{t_2} g(x) dt.$$

Therefore  $F(x_2) \leq F(a_1) + E_0 + |\epsilon \dot{x}_0| + A \leq F(a_1) + E_0 + C + A$ , since  $g(x) \geq a_3 > 0$  when  $x \geq a_1$ . Therefore  $F(x_2)$  and consequently  $x_2$  is bounded above by a constant depending only on  $B$  and  $C$ . Similarly, if  $x(t)$  takes values less than  $-a_1$   $x(t)$  is bounded below.

Now take  $B > a_1$  and let  $t_0 \leq t \leq t_1$  imply  $x(t) \geq a_1$ , let  $x(t_1) = x_1$ . Then

$$F(x_1) = F(x_0) + E(t_1) - E(t_0) + \epsilon \dot{x}_1 - \epsilon \dot{x}_0 - \epsilon \int_{t_0}^{t_1} g(x) dt$$

$$\leq \max \{ |F(x)| \mid |x| \leq B \} + E_0 + 2C + A$$

and again  $x_1$  is bounded by a constant independent of the initial conditions. The case  $x(t) = -a_1$  is analogous.

The theorem which follows gives ultimate bounds (as  $t \rightarrow \infty$ ) for an arbitrary solution  $x(t)$  and its derivative.

Theorem 3.4. There exist constants  $B_0$  and  $C_0$  such that every solution  $x(t)$  satisfies  $|x(t)| \leq B_0$ ,  $|\epsilon \dot{x}(t)| \leq C_0$  for all large  $t$ .

Proof:  $|\dot{x}(t)|$  must take on arbitrarily small values since  $x(t)$  is bounded. Let  $t_1$  be such that  $|\dot{x}(t_1)| \leq 1$ ; then, applying Theorem 3.1,  $t \geq t_1$  implies  $|\epsilon \dot{x}(t)| \leq 1 + A = C_0$ . By Theorem 3.2.,  $t_2 \geq t_1$  exists such that  $|x(t_2)| \leq a_1$ . Now apply Theorem 3.3., with

$B = a_1$ ,  $C = C_0$ , writing  $B_0$  for the associated constant  $D$ . We have  $|x(t_2)| \leq a_1$ ,  $|\epsilon \dot{x}(t_2)| \leq C_0$ ; hence  $t \geq t_2$  implies  $|x(t)| \leq B_0$ ,  $|\epsilon \dot{x}(t)| \leq C_0$ .

The boundedness properties proved in the above theorems show that if  $e(t)$  is periodic of period  $p$  then (1) has a periodic solution of period  $p$ . This follows from a remarkable theorem due to Messera [10].

Theorem 3.5. (Messera). Let  $f(x,y,t)$  be continuous, periodic in  $t$  of period  $p$ , and satisfying a Lipschitz condition in  $x,y$ . If no solution of the system

$$(5) \quad \begin{aligned} \dot{x} &= f(x,y,t) \\ \dot{y} &= g(x,y,t) \end{aligned}$$

tends to infinity in a finite time and if (5) has a solution  $(x(t), y(t))$  which is bounded for  $t \geq t_0$ , then (5) has a periodic solution of period  $p$ .

Theorem 3.6. If  $e(t)$  is periodic of period  $p$ , then (1) has a periodic solution of period  $p$ .

Proof: We apply Theorem 3.5 to the system (2). By theorems 3.1 and 3.3 every solution is bounded for  $t \geq t_0$  and hence no solution goes to infinity in a finite time. Hence (2) and therefore (1) has a solution of period  $p$ .

#### §4. Behavior as $\epsilon \rightarrow 0$ .

In this section we collect some lemmas which we shall need for the proof of the principal theorems. In addition to assumptions (a) - (e) we require that  $e$  and  $f$  have isolated zeroes; we use the notation of §2. The function  $w(t)$  was defined by (2) of §3.

To save writing we state here a hypothesis which is common to all of the lemmas to follow:  $B, C$  are arbitrary positive constants;  $0 < \epsilon < 1$ ;  $t_0$  is

arbitrary and  $x(t)$  is an arbitrary solution of (1) for which  $|x(t_0)| \leq B$ ,  $|\epsilon \dot{x}(t_0)| \leq C$ . Any other constant whose existence is asserted is understood to be dependent on  $B$  and  $C$ , but not on the particular solution  $x(t)$ , nor on any other quantity unless explicitly stated.

Lemma 4.1. There exists a constant  $G$  such that  
 $\text{Osc}(w(t) - E(t)) \leq \epsilon GT$  for  $t_0 \leq t \leq t_0 + T$ .

Proof: Let  $D$  be the number in the conclusion of Theorem 3.3, and put  $G = \max\{|g(x)| \mid |x| \leq D\}$ . Integrating the second equation of (2) between any two limits in  $[t_0, t_0 + T]$  yields the result.

Lemma 4.2. There exists a constant  $H$  such that if  
 $t_0 \leq t_1 \leq t_2$  and  $|\dot{x}(t)| \geq \epsilon^{-1/2}$  for all  $t$ ,  $t_1 \leq t \leq t_2$ , then  
 $|w(t_2) - w(t_1)| \leq H \epsilon^2$ .

Proof: Let  $H = 2D(e_0 + G)$ . By Theorem 3.3,  $|x(t)| \leq D$ . Then  $2D \geq |x(t_2) - x(t_1)| \geq (t_2 - t_1) \epsilon^{-1/2}$ , so that  $(t_2 - t_1) \leq 2D \epsilon^{1/2}$ : Then

$$w(t_2) - w(t_1) = \int_{t_1}^{t_2} e(t) dt - \epsilon \int_{t_1}^{t_2} g(x(t)) dt$$

whence

$$|w(t_2) - w(t_1)| \leq 2D \epsilon^{1/2} (e_0 + \epsilon G) \leq H \epsilon^{1/2}.$$

The next lemma makes rigorous the argument given in §1 on stability of the region  $F_+$ . We obtain only a weak bound on  $\dot{x}(t)$ , namely,  $|\dot{x}(t)| \leq O(\epsilon^{-1/2})$ . But this is enough to guarantee that  $(x(t), w(t))$  is close to  $\Gamma$ :  $w(t) - F(x(t)) = \epsilon \dot{x}(t) \leq O(\epsilon^{1/2})$ . This result will be strengthened in §5.

Lemma 4.3. If there exist  $t_1 < t_2$  such that  $x(t)$   
 $\in \bar{F}_+$  for all  $t$ ,  $t_1 \leq t \leq t_2$ , and  $|\dot{x}(t_1)| \leq J \epsilon^{-1/2}$

where  $J \geq 1$ , then for all  $t$ ,  $t_1 \leq t \leq t_2$ , we have  $|\dot{x}(t)| \leq (H + J)\epsilon^{-1/2}$ .

Proof: It is sufficient to prove that

$$|\dot{x}(t_2)| \leq (H + J)\epsilon^{-1/2}.$$

Let  $|\dot{x}(t_2)| = (H' + J)\epsilon^{-1/2}$  with  $H' > 0$ . Let  $t' \geq t_1$  be a number such that  $|\dot{x}(t')| = J\epsilon^{-1/2}$ ,  $t' \leq t \leq t_2$  implies  $|\dot{x}(t)| > J\epsilon^{-1/2}$ .

If  $\dot{x}(t_2) > 0$  then  $\dot{x}(t') > 0$  and we have by Lemma 4.2 and the definition of  $F_+$ ,  $H\epsilon^{1/2} \geq w(t_2) - w(t')$   
 $= \epsilon\dot{x}(t_2) - \epsilon\dot{x}(t') + F(x(t_2)) - F(x(t')) \geq \epsilon\dot{x}(t_2)$   
 $- \epsilon\dot{x}(t') = (H' + J - J)\epsilon^{1/2} = H'\epsilon^{1/2}$ . Hence  $H \geq H'$ .  
 Similarly if  $\dot{x}(t_2) < 0$ .

Lemma 4.4. If  $x(t_0) \in F_+$ , if  $\epsilon \leq T^{-2}G^{-2}$  and if  $|\dot{x}(t_0)| \leq (1 + H)\epsilon^{-1/2}$  then  $|w(t) - F(y(t))| \leq (2+H)\epsilon^{1/2}$  for all  $t$ ,  $t_0 \leq t \leq t_0 + T$ .

Proof: By Lemma 4.1.  $|x(t) - E(t) - w(t_0) + E(t_0)| \leq \epsilon GT$ . But  $w(t_0) = \epsilon\dot{x}(t_0) + F(x_0)$  and  $F(y(t)) = E(t) + F(x_0) - E(t_0)$ . Therefore,  $|w(t) - F(y(t))| < \epsilon GT + |\epsilon\dot{x}(t_0)| < (2+H)\epsilon^{1/2}$ .

The convergence theorem of §5 rests essentially on lemmas 4.3 and 4.4. For combining the results of these lemmas we have  $|F(x(t)) - F(y(t))| \leq O(\epsilon^{1/2})$ , so that  $x(t)$  and  $y(t)$  are close together.

The next four lemmas will be used to establish the global stability theorem of §6. The common hypothesis of the first three lemmas, that  $t_1 > t_0$  exists such that  $|\dot{x}(t_1)| \leq 1$ , is introduced to ensure that we are not dealing with a solution which has just come from infinity.

Lemma 4.5. Suppose that numbers  $w_1$  and  $w_2$  exist such that the equation  $F(x) = w$  has exactly one solution if  $w_1 \leq w \leq w_2$ . There exists  $\epsilon_0$  such that, if  $\epsilon \leq \epsilon_0$ ,

if  $t_0 \leq t_1 \leq t_4$  are such that  $|\dot{x}(t_1)| \leq 1$  and  $w_1 \leq w(t_4)$   $\leq w_2$  then  $|\dot{x}(t_4)| \leq (1 + H)\epsilon^{-1/2}$  and  $x(t_4)$  is in  $F_+$ .

Proof: Choose  $\epsilon_0$  less than 1 and small enough so that if  $\epsilon \leq \epsilon_0$  and  $w_1 - (1+H)\epsilon^{1/2} \leq w \leq w_2 + (1+H)\epsilon^{1/2}$ , then  $F(x) = w$  has exactly one solution  $x = \varphi(w)$ . The solution  $\varphi(w)$  is a continuous function of  $w$  and is in  $F_+$  since  $F(x) \text{ sgn } x \rightarrow \infty$  as  $|x| \rightarrow \infty$ .

If  $|\dot{x}(t_4)| \leq (1+H)\epsilon^{-1/2}$  then  $|F(x(t_4)) - w(t_4)| \leq (1+H)\epsilon^{1/2}$  and  $w_1 - (1+H)\epsilon^{1/2} \leq F(x(t_4)) \leq w_2 + (1+H)\epsilon^{1/2}$ . Then  $x(t_4)$  is a solution, perforce the unique one, of  $F(x) = F(x(t_4))$ . Hence  $x(t_4) \in F_+$ .

We now show that  $|\dot{x}(t_4)| > (1+H)\epsilon^{-1/2}$  is impossible. Suppose for definiteness that  $\dot{x}(t_4) > (1+H)\epsilon^{-1/2}$ . Then  $t_2$  exists such that  $t_1 < t_2 < t_4$  and  $\dot{x}(t_2) = \epsilon^{-1/2}$ , while  $t_2 \leq t \leq t_4$  implies that  $\dot{x}(t) \geq \epsilon^{-1/2}$ . Then by Lemma 4.2,  $|w(t_2) - w(t_4)| \leq H\epsilon^{1/2}$ . Hence  $w_1 - H\epsilon^{1/2} \leq w(t_2) \leq w_2 + H\epsilon^{1/2}$ . Then  $w_1 - (1+H)\epsilon^{1/2} \leq F(x(t_2)) \leq w_2 + (1+H)\epsilon^{1/2}$ . Therefore,  $x(t_2) \in F_+$ . By Lemma 4.3., if  $t_2 \leq t \leq t_4$  implies  $x(t) \in F_+$  then  $|\dot{x}(t_4)| \leq (1+H)\epsilon^{-1/2}$ . Hence,  $x(t)$  must leave  $F_+$  at, say,  $t = t_3$ ,  $t_2 < t_3 < t_4$ , with  $x(t_3) \in F_0$ ,  $\epsilon^{-1/2} \leq \dot{x}(t_3) \leq (1+H)\epsilon^{-1/2}$ , applying Lemma 4.3 once again. But  $|w(t_3) - w(t_4)| \leq H\epsilon^{1/2}$  by Lemma 4.2. Therefore by the argument used above for  $x(t_2)$  we conclude that  $x(t_3) \in F_+$ , a contradiction. This completes the proof.

Lemma 4.6. Suppose that numbers  $V_1$  and  $x_1$  exist such that  $F(x) > V_1$  whenever  $x \geq x_1$ . If  $t_1 > t_0$  exists such that  $|\dot{x}(t_1)| \leq 1$ , and if  $t_3 \geq t_1$  is such that  $w(t_3) \leq V_1$ , then  $x(t_3) < x_1$  -- provided  $\epsilon \leq \epsilon_0$ , a constant.

Proof: Choose  $\epsilon_0$  so small that  $\epsilon \leq \epsilon_0$  implies  $V_1 < F(x_1) - \epsilon^{1/2}$  and so that, if  $\epsilon \leq \epsilon_0$  then  $x_1 \leq x$  implies  $V_1 + (1+H)\epsilon^{1/2} < F(x)$ .

Then if  $x(t_3) \geq x_1$  we have  $F(x(t_3)) > V_1 + (1+H)\epsilon^{1/2} \geq w(t_3) + (1+H)\epsilon^{1/2} > w(t_3) + \epsilon^{1/2}$ . Therefore,  $\dot{x}(t_3) < -\epsilon^{1/2}$  by the definition of the function  $w(t)$ .

Since  $|\dot{x}(t_1)| = 1$  and  $\epsilon \leq 1$ , there exists  $t_2$  between  $t_1$  and  $t_3$  such that  $\dot{x}(t_2) = -\epsilon^{-1/2}$  while  $\dot{x}(t) \leq -\epsilon$  for all  $t_2 \leq t \leq t_3$ .

Then by Lemma 4.2,  $w(t_2) < w(t_3) + H\epsilon^{1/2} \leq w_1 + H\epsilon^{1/2}$ . Hence  $F(x(t_2)) = w(t_2) + \epsilon^{1/2} < V_1 + (1+H)\epsilon^{1/2}$ . Therefore  $x(t_2) < x_1$ . But  $t_2 \leq t \leq t_3$  implies  $\dot{x}(t) < 0$ , and so  $x(t_3) < x(t_2) < x_1$ , completing the proof.

In the same way we can prove

Lemma 4.7. If  $V_2$  and  $x_2$  are such that  $F(x) < V_2$  whenever  $x \leq x_2$ , then, if  $|\dot{x}(t_1)| \leq 1$  and  $t_3 \geq t_1$  exists such that  $w(t_3) \geq V_2$ , we have  $x(t_3) > x_2$  for all small  $\epsilon$ .

Lemma 4.8. If  $x(t)$  and  $x^*(t)$  are two solutions of (1) and if  $t_0 \leq t < t_1$  implies  $x(t) < x^*(t)$  while  $x(t_1) = x^*(t_1)$  then  $w^*(t_0) < w(t_0) + 2\epsilon G(t_1 - t_0)$ .

Proof:  $\dot{x}^*(t_1) < \dot{x}(t_1)$  by the uniqueness of solutions of (1). Therefore  $w^*(t_1) < w(t_1)$ ,

since  $F(x^*(t_1)) = F(x(t_1))$  and  $w(t) = F(x(t)) + \epsilon \dot{x}(t)$ .

But

$$w(t_1) - w(t_0) = E(t_1) - E(t_0) - \epsilon \int_{t_0}^{t_1} g(x(t)) dt$$

and

$$w^*(t_1) - w^*(t_0) = E(t_1) - E(t_0) - \epsilon \int_{t_0}^{t_1} g(x^*(t)) dt.$$

Then

$$\begin{aligned} w(t_0) - w^*(t_0) &= w(t_1) - w^*(t_1) + \epsilon \int_{t_0}^{t_1} (g(x(t)) \\ &\quad - g(x^*(t))) dt > \epsilon \int_{t_0}^{t_1} (g(x(t)) \\ &\quad - g(x^*(t))) dt \geq -2\epsilon G(t_1 - t_0). \end{aligned}$$

### §5. The Convergence Theorem.

The principal results of this section are essentially special cases of a theorem announced by Levinson [5]; we are able to state a little more, in that the convergence here is uniform in a specified range of initial conditions.

Throughout the section  $t_0$  and  $T$  are fixed,  $t_0 \leq t \leq t_0 + T$ ;  $I$  is a closed interval in  $F_+$  such that  $x_0$  in  $I$  yields regular degenerate solutions: cf. definition in §2. We are assuming  $|x_0| \leq B$ .

The solution of (1) with parameter  $\epsilon$  and initial values  $x_0$  and  $\dot{x}_0$  at time  $t_0$  is written  $x(t; x_0, \dot{x}_0; \epsilon)$ ; the corresponding degenerate solution is  $y(t; x_0)$ . The convergence theorem is concerned with the truth of the equation

$$\lim_{\epsilon \rightarrow 0} x(t; x_0, \dot{x}_0; \epsilon) = y(t; x_0).$$

In the sequel we suppress the symbol " $\epsilon \rightarrow 0$ ", writing simply "lim".

The proof of the convergence theorem rests on the next three lemmas. Lemma 5.1 amounts to the convergence theorem in the special case where  $y(t; x_0)$  has no jumps; lemma 5.2 discusses the convergence in the case where  $y(t; x_0)$  has a single jump and yields convergence at a time slightly after the jump as a consequence of convergence at a time slightly before the jump. The full theorem then follows by induction, using alternately lemmas 5.1 and 5.2, with lemma 5.3 to connect them.

Lemma 2.7 and the remarks which follow it show that the discontinuities of  $y(t; x)$  can actually be isolated as specified in the hypotheses of lemma 5.2 and Theorem 5.4.

Lemma 5.1. Let  $t_1$  and  $t_2$  be fixed numbers such that  $y(t; x_0)$  is in  $F_+$  for all  $x_0$  in  $I$ ,  $t_1 \leq t \leq t_2$ . Suppose that  $\lim x(t_1; x_0, \dot{x}_0; \epsilon) = y(t_1; x_0)$  uniformly for  $x_0$  in  $I$ ,  $|\dot{x}_0| \leq (1+H)\epsilon^{-1/2}$ , and that, if  $|\dot{x}_0| \leq (1+H)\epsilon^{-1/2}$  then  $|\dot{x}(t_1; x_0, \dot{x}_0; \epsilon)| \leq (1+H)\epsilon^{-1/2}$

Then  $\lim x(t; x_0, \dot{x}_0; \epsilon) = y(t; x_0)$  uniformly for  $x_0$  in  $I$ ,  $|\dot{x}_0| \leq (1+H)\epsilon^{-1/2}$ ,  $t_1 \leq t \leq t_2$ , and  $|\dot{x}(t_2; x_0, \dot{x}_0; \epsilon)| \leq (1+H)\epsilon^{-1/2}$  uniformly for all small  $\epsilon$ .

Proof: Let  $y_1 = \min \{y(t; x_0) \mid t_1 \leq t \leq t_2, x_0 \in I\}$ ,  
 $y_2 = \max \{y(t; x_0) \mid t_1 \leq t \leq t_2, x_0 \in I\}$ .

By hypothesis  $y_1$  and  $y_2$  lie in the same component of  $F_+$ . Let  $y'$  ( $y''$ ) be the left (right) hand boundary point of the component, or  $-\infty$  ( $+\infty$ ) if the component is unbounded below (above).

Let  $\epsilon_0 < 1$ ,  $\epsilon_0 < T^{-2}G^{-2}$ , be chosen so that  $\epsilon < \epsilon_0$  implies

- (1)  $F(y'') > F(y_2) + (2+H)\epsilon^{1/2}$
- (2)  $F(y') < F(y_1) - (2+H)\epsilon^{1/2}$
- (3)  $y' < x(t_1; x_0, \dot{x}_0; \epsilon) < y''$ .

(These are vacuously satisfied if  $y'$  and  $y''$  are infinite.) Then  $t_1 \leq t \leq t_2$  implies  $x(t; x_0, \dot{x}_0; \epsilon) \in F_+$ . For by Lemma 4.3 with  $J = 1 + H$ ,  $|\dot{x}(t)| \leq (1+2H)\epsilon^{-1/2}$  as long as  $x(t)$  remains in  $F_+$ . If  $x(t)$  leaves  $F_+$  at  $t = t'$  then  $x(t') = y'$  or  $y''$ . If  $x(t') = y'$  then  $0 \geq \dot{x}(t') \geq -(1+2H)\epsilon^{-1/2}$ . Then  $w(t') \geq F(y(t'; x_0)) - (2+H)\epsilon^{1/2}$  by Lemma 4.4; therefore  $w(t') \geq F(y_1) - (2+H)\epsilon^{1/2} > F(y') = F(x(t'))$  and so  $\dot{x}(t') > 0$ , which is a contradiction. Similarly if  $x(t') = y''$ .

Therefore  $t_1 \leq t \leq t_2$  implies  $x(t) \in F_+$  which in turn implies  $|\dot{x}(t)| \leq (1+2H)\epsilon^{-1/2}$ . Then  $|w(t) - F(x(t))| \leq (1+2H)\epsilon^{1/2}$ . Hence, by Lemma 4.4,  $|F(y(t; x_0)) - F(x(t))| \leq 3(1+H)\epsilon^{1/2}$ . Therefore as  $\epsilon \rightarrow 0$   $F(x(t; x_0, \dot{x}_0; \epsilon))$

tends to  $F(y(t; x_0))$  uniformly in  $t$  and  $x_0$ .

Since  $F(x)$  has a unique continuous inverse in the range  $y' \leq x \leq y''$ , which is a fortiori uniformly continuous, we conclude that  $x(t; x_0, \dot{x}_0; \epsilon)$  tends uniformly to  $y(t; x_0)$ .

The last part of the lemma follows from the fact that if  $t' \leq t \leq t''$  implies  $|\dot{x}(t)| \geq \epsilon^{-1/2}$  then  $t'' - t' \leq 2D \epsilon^{1/2}$ , together with Lemma 4.3.

Lemma 5.2. Let  $t_1, t_3$  be such that the closed interval  $[t_1, t_3]$  contains no extremal points of  $E(t)$  and such that for each  $x_0$  in  $I$  there is a unique  $t_2 = t_2(x_0)$  in  $(t_1, t_3)$  such that  $y(t_2(x_0); x_0)$  is in  $F_0$ . If  $|\dot{x}(t_1)| \leq (1+H)\epsilon^{-1/2}$ , if  $|\dot{x}_0| \leq (1+H)\epsilon^{-1/2}$ , and if  $\lim x(t_1; x_0, \dot{x}_0; \epsilon) = y(t_1; x_0)$  uniformly for  $x_0$  in  $I$  and  $|\dot{x}_0| \leq (1+H)\epsilon^{-1/2}$ , then  $\lim x(t_3; x_0, \dot{x}_0; \epsilon) = y(t_3; x_0)$  uniformly for all  $x_0$  in  $I$  and  $|\dot{x}_0| \leq (1+H)\epsilon^{-1/2}$  and  $|\dot{x}(t_3)| \leq (1+H)\epsilon^{-1/2}$ .

Proof: Assume for definiteness that  $E(t)$  is increasing in  $t_1 \leq t \leq t_3$ . Then  $y(t_2(x_0); x_0)$  is a fixed maximum of  $F(x)$ , for all  $x_0 \in I$ , by Theorem 2.7.

Let numbers  $-\infty \leq x_1 < x_2 < x_3 < x_4 < x_5 < x_6 < x_7 < x_8 < x_9 \leq +\infty$  be determined as in Lemma 2.8:  $x_1 \in F_0$  if finite,  $x_1 < x < x_5 \subset F_+$ ;  $x_5, x_6 \in F_0$ ;  $x_9 \in F_0$  if finite;  $x_6 < x < x_9 \subset F_+$ ;  $x_2 \leq y(t_1; x_0) \leq x_3$ ;  $F(x_4) > F(x_6)$ ;  $x_7 \leq y(t_3; x_0) \leq x_8$ .

Let  $\epsilon_0$  be chosen so that, if  $\epsilon < \epsilon_0$  then

- (1)  $F(x_2) - (2 + H)\epsilon^{1/2} > F(x_1)$
- (2)  $x_1 < x(t_1; x_0, \dot{x}_0; \epsilon) < x_5$
- (3)  $F(x_5) - (4 + 2H)\epsilon^{1/2} > F(x_4) > F(x_6)$
- (4)  $F(x_7) - (2 + H)\epsilon^{1/2} > F(x_5) + (1 + 4H)\epsilon^{1/2}$
- (5)  $F(x_8) + (2 + H)\epsilon^{1/2} < F(x_9)$ .

The proof proceeds in the following eleven steps.

(a)  $t_1 \leq t \leq t_3$  implies  $x(t; x_0, \dot{x}_0; \epsilon) > x_1$ .  
 For otherwise  $t_2 > t_1$  must exist such that  $x(t_2) = x_1$ ,  
 $\dot{x}(t_2) \leq 0$ . Then  $w(t_2) \leq F(x(t_2)) = F(x_1)$  while  $w(t_2)$   
 $\geq F(y(t_2; x_0)) - (2 + H)\epsilon^{1/2} > F(x_2) - (2 + H)\epsilon^{1/2}$   
 $> F(x_1)$  by Lemma 4.4;  $F(x_1) \geq w(t_2) > F(x_1)$  is impossible

(b)  $w(t_3) \geq F(y(t_3; x_0)) - (2 + H)\epsilon^{1/2} \geq F(x_7) -$   
 $(2 + H)\epsilon^{1/2} > F(x_5) + (1 + 4H)\epsilon^{1/2}$ .

(c) Therefore  $x(t)$ , in  $F_+$  at  $t = t_1$ , must leave  
 before  $t = t_3$ . For by assumption,  $|\dot{x}(t_1)| \leq (1 + H)\epsilon^{-1/2}$ .  
 Hence if  $t_1 \leq t \leq t_3$  implies  $x(t) \in F_+$  then  $|\dot{x}(t_3)| \leq$   
 $(1 + 2H)\epsilon^{1/2}$ , by lemma 4.3 with  $J = 1 + H$ . But then  
 $w(t_3) \leq F(x(t_3)) + (1 + 2H)\epsilon^{1/2} \leq F(x_5) + (1 + 2H)\epsilon^{1/2}$   
 contradicting (b).

(d) Let  $x(t)$  leave  $F_+$  at  $t = u_1$ . Then by (a),  
 $x(u_1) = x_5$ ,  $0 \leq \dot{x}(u_1) \leq (1 + 2H)\epsilon^{-1/2}$ . Then  $F(x(u_1))$   
 $= F(x_5) \leq w(u_1) \leq F(x_5) + (1 + 2H)\epsilon^{1/2} < F(x_5) +$   
 $(1 + 4H)\epsilon^{1/2} < F(x_7) - (2 + H)\epsilon^{1/2} \leq w(t_3)$  by (b).  
 Also  $F(y(u_1; x_0)) \geq w(u_1) - (2 + H)\epsilon^{1/2} \geq F(x_5) -$   
 $(2 + H)\epsilon^{1/2}$ . Since  $t_3 \geq t > u_1$  implies  $F(y(t))$   
 $> F(y(u_1))$  we have  $t_3 \geq t > u_1$  implies  $w(t) \geq F(y(t))$   
 $- (2 + H)\epsilon^{1/2} > F(y(u_1)) - (2 + H)\epsilon^{1/2} > F(x_5) -$   
 $(4 + 2H)\epsilon^{1/2} > F(x_4)$ .

(e) Hence  $u_1 \leq t \leq t_3$  implies  $x(t) \geq x_3$ . For  
 otherwise  $u_2 > u_1$  exists such that  $x(u_2) = x_3$ ,  $\dot{x}(u_2) \leq 0$ .  
 Then  $w(u_2) \leq F(x(u_2)) = F(x_3) \leq F(x_4)$  contradicting (d).

(f) There exists  $u_3, u_5$  with  $u_1 \leq u_3 < u_5 < t_3$ ,  
 such that

$$w(u_3) = F(x_5) + (1 + 2H)\epsilon^{1/2}$$

$$w(u_5) = F(x_5) + (1 + 4H)\epsilon^{1/2}$$

$u_3 \leq t \leq u_5$  implies  $w(u_3) \leq w(t) \leq w(u_5)$ . This follows from (d) and the continuity of  $w(t)$ .

(g) Therefore there exists  $u_4$ ,  $u_3 \leq u_4 \leq u_5$ , such that  $|\dot{x}(u_4)| \leq \epsilon^{-1/2}$ . For  $w(u_5) - w(u_3) = 2H\epsilon^{1/2}$  and the statement follows from Lemma 4.2.

(h)  $t_1 \leq t \leq t_3$  implies  $x(t) < x_9$ . The proof of this is a repetition of the argument in (a), using inequality (5) in place of (1).

(i) Hence  $x_6 < x(u_4) < x_9$ . For by (e),  $x(u_4) \geq x_3$ . By (g),  $|F(x(u_4)) - w(u_4)| \leq \epsilon^{1/2}$ , which implies  $F(x(u_4)) \geq w(u_4) - \epsilon^{1/2} \geq w(u_3) - \epsilon^{1/2} = F(x_5) + 2H\epsilon^{1/2}$ . But  $x_3 \leq x \leq x_6$  implies  $F(x) \leq F(x_5)$ .

(j)  $u_4 \leq t \leq t_3$  implies  $x_6 < x(t) < x_9$  and therefore  $x(t) \in F_+$ . For by (h),  $x(t) < x_9$ . If  $u_6$  exists such that  $x(u_6) = x_6$ ,  $\dot{x}(u_6) \leq 0$ ,  $u_4 < u_6 \leq t_3$ , then  $w(u_6) \leq F(x(u_6)) = F(x_6)$ . But  $u_4 > u_1$  and so by (d),  $w(u_6) > F(x_4) > F(x_6)$  which gives a contradiction.

(k) Therefore  $u_4 \leq t \leq t_3$  implies  $|\dot{x}(t)| \leq (1+H)\epsilon^{-1/2}$  by Lemma 4.3 with  $J = 1$ . Hence  $|w(t_3) - F(x(t_3))| \leq (1+H)\epsilon^{1/2}$ , implying  $|F(y(t_3)) - F(x(t_3))| \leq (3+2H)\epsilon^{1/2}$  by Lemma 4.4. Therefore  $x(t_3) \rightarrow y(t_3)$  as  $\epsilon \rightarrow 0$ , uniformly for  $x_0 \in I$ .

The proof is similar if  $E(t)$  is decreasing in the closed interval  $[t_1, t_3]$ .

Lemma 5.3. Conditions as in Lemma 5.2. Let  $t_4$  be such that  $y(t; x_0)$  is in  $F_+$  for  $t_3 \leq t \leq t_4$ ,  $x_0$  in  $I$ . Then  $\epsilon_0$  exists such that if  $\epsilon \leq \epsilon_0$  then  $|\dot{x}(t_4)| \leq (1 + H)\epsilon^{-1/2}$

Proof: This is a corollary to Lemma 5.2. For with  $u_4$  of (g) above we have  $|\dot{x}(u_4)| \leq \epsilon^{-1/2}$ ,  $u_4 \leq t \leq t_3$  implies  $x(t) \in F_+$ . By arguments similar to those in (a) above we can guarantee that  $t_3 \leq t \leq t_4$  implies  $x(t) \in F_+$  if  $\epsilon$  is small enough. Then Lemma 4.3 with  $J = 1$  yields the result.

Theorem 5.4. (The Convergence Theorem). Let  $I$ ;  $t_0 < t_1 < t_2 < \dots < t_n \leq t_0 + T$  be such that if  $x_0$  is in  $I$  then  $t_{2r} \leq t \leq t_{2r+1}$  implies  $y(t; x_0) \in F_+$ , the closed interval  $[t_{2r+1}, t_{2r+2}]$  contains no extrema of  $E(t)$ , and such that for each  $r$  there exists a unique  $t'_r = t'_r(x_0)$  such that  $y(t'_r(x_0); x_0)$  is in  $F_0$  with  $t_{2r+1} < t'_r < t_{2r+2}$ ,  $r = 0, 1, 2, \dots, n$ . If  $|\dot{x}_0| \leq (1 + H)\epsilon^{-1/2}$  then  $\lim x(t; x_0, \dot{x}_0; \epsilon) = y(t; x_0)$  uniformly for  $x_0 \in I$ ,  $t_{2r} \leq t \leq t_{2r+1}$ ; and  $|\dot{x}(t_{2r+1})| \leq (1 + H)\epsilon^{-1/2}$ .

Proof: The theorem is evidently true for  $r = 0$  by Lemma 5.1. We assume that it holds for  $r$  and show that it must then hold for  $r + 1$ .

We are assuming that  $|\dot{x}(t_{2r+1})| \leq (1 + H)\epsilon^{-1/2}$  and  $\lim x(t_{2r+1}) = y(t_{2r+1}; x_0)$  uniformly in  $x_0$ . Then by Lemma 5.2,  $|\dot{x}(t_{2r+2})| \leq (1 + H)\epsilon^{-1/2}$  and  $x(t_{2r+2})$  tends uniformly to  $y(t_{2r+2})$ . Then by Lemma 5.1 again,  $t_{2r+2} \leq t \leq t_{2r+3}$  implies  $x(t) \rightarrow y(t)$  uniformly in  $t$  and  $x_0$ . By Lemma 5.3,  $|\dot{x}(t_{2r+3})| \leq (1 + H)\epsilon^{-1/2}$ . This completes the proof.

Theorem 5.5. Let  $x_0$  be in  $F_+$  and  $y(t; x_0)$  be regular. Let  $|\dot{x}_0| \leq (1 + H)\epsilon^{-1/2}$ . If  $q(x)$  is continuous then

$$\lim_{\epsilon \rightarrow 0} \int_{t_0}^{t_0 + T} q(x(t; x_0, x_0; \epsilon)) dt = \int_{t_0}^{t_0 + T} q(y(t; x_0)) dt.$$

Proof:  $x(t; \epsilon) \rightarrow y(t)$  except at the values of  $t$  for which  $y(t) \in F_0$ , by Theorem 5.4 applied to the case  $I = x_0$ . By Theorem 3.3  $x(t; \epsilon)$  is uniformly bounded. Hence the result.

M. Cartwright has suggested a method by which we can also get convergence of the velocity  $\dot{x}$  to the degenerate velocity  $\dot{y}$ . We must add to the hypotheses on  $e, f, g$  the condition that they have first derivatives which are bounded on closed intervals.

Theorem 5.6. Let  $x_0$  be a regular initial condition and  $[t_1, t_2]$  a closed interval in which  $f(y(t; x_0)) \geq \delta > 0$ , with  $t_1 > t_0$ . Then  $\lim \dot{x}(t; x_0, \dot{x}_0; \epsilon) = \dot{y}(t; x_0)$  uniformly on  $[t_1, t_2]$  for  $|\dot{x}_0| \leq (1 + H)\epsilon^{-1/2}$ .

Proof: Since  $y(t; x_0)$  is continuous when in  $F_+$  and  $f$  is continuous we can choose  $\tau$  so small that  $t_1 - 2\tau > t_0$  and such that  $f(y(t; x_0)) \geq 2/3\delta$  for  $t_1 - 2\tau \leq t \leq t_2 + 2\tau$ . By the convergence theorem we may choose  $\epsilon_0$  so small that if  $\epsilon < \epsilon_0$  and  $t_1 - 2\tau \leq t \leq t_2 + 2\tau$  then  $f(x(t; x_0, x_0; \epsilon)) \geq 1/3\delta$ .

Since by Theorem 3.3  $|x(t)| \leq D$ , in any interval of time of length  $\geq \tau$  the inequality  $|\dot{x}(t)| \leq \frac{2D}{\tau}$  must be satisfied for some  $t$ .

Applying this remark to the intervals  $[t_1 - 2\tau, t_1 - \tau]$  and  $[t_2 + \tau, t_2 + 2\tau]$  we conclude that either  $|\dot{x}(t)| < 2D/\tau$  throughout  $[t_1 - \tau, t_2 + \tau]$

or  $|\dot{x}(t')|$  a maximum and  $\dot{x}(t') = 0$  must occur for some  $t'$  interior to that interval. If  $\dot{x}(t') = 0$  the differential equation yields  $f(x(t')) \dot{x}(t') + \epsilon g(x(t')) = e(t')$ , and hence  $|\dot{x}(t')| \leq 3/\delta (e_0 + G)$ . Thus in either case we find that on the interval  $[t_1 - \tau, t_2 + \tau]$   $\dot{x}(t)$  is bounded by a constant independent of  $\epsilon$ ; for simplicity we write this result  $|\dot{x}(t)| \leq M$ .

By a similar argument,  $|\ddot{x}(t)| \leq \frac{2M}{\tau}$  for some  $t$  in the closed intervals  $[t_1 - \tau, t_1]$ ,  $[t_2, t_2 + \tau]$ . Then on  $[t_1, t_2]$  we have either  $|\ddot{x}(t)| \leq \frac{2M^2}{\tau}$  always, or  $\ddot{x}(t) = 0$  for some  $t$ . Differentiation yields

$$\epsilon \ddot{x} + f(x)\dot{x} + f'(x)\dot{x}^2 + \epsilon g'(x)\dot{x} = \dot{e}(t),$$

so that, when  $\ddot{x} = 0$ ,

$$\ddot{x} = \left\{ \dot{e}(t) - f'(x)\dot{x}^2 - \epsilon g'(x)\dot{x} \right\} / f(x)$$

which is uniformly bounded by a constant independent of

$\epsilon$

Therefore for  $t_1 \leq t \leq t_2$  we have

$$f(x(t)) \dot{x}(t) - e(t) = -\epsilon \ddot{x}(t) - \epsilon g(x(t)) = O(\epsilon).$$

But  $e(t) = f(y(t)) \dot{y}(t)$  and  $f(x(t)) \geq 1/3\delta$ . Therefore  $\dot{x}(t)$  tends to  $\dot{y}(t)$  uniformly as  $\epsilon \rightarrow 0$ , and the proof is complete.

### §6. The Global Stability Theorem.

If, in addition to the basic hypotheses,  $e(t)$  is periodic of period  $p$  then by theorem 3.5 the differential equation

$$(1) \quad \epsilon \ddot{x} + f(x) \dot{x} + \epsilon g(x) = e(t)$$

has at least one periodic solution  $x(t)$  of period  $p$ . If also  $e(t)$  has mean value zero then integrating (1) over a period shows that the mean value of  $g(x(t))$  is zero. Since  $E(t)$  is also periodic there are periodic degenerate solution, by theorem 2.5. If also  $g(x)$  is

a strictly increasing function of  $x$  then by Theorem 2.6 there is at most one periodic degenerate solution,  $y(t)$  such that  $g(y(t))$  has mean value zero. We might hope to use such a degenerate solution to predict the location of the periodic solutions of (1).

$$\text{Let } \bar{g}(x_0) = \int_{t_0}^{t_0+p} g(y(t; x_0, t_0)) dt, \text{ where}$$

$y(t; x_0, t_0)$  is periodic. By studying the relation between  $g(x_0)$  and the curve  $\Gamma: w = F(x)$  we can make some plausible guesses about stability of periodic solutions of (1).

To see this we integrate the equation

$$\dot{w}(t) = e(t) - \epsilon g(x(t))$$

over a period and use  $\bar{g}(x_0)$  as an approximation to the mean value of  $g(x(t))$ . We obtain

$$w(t_0+p) - w(t_0) = -\epsilon \bar{g}(x_0).$$

If  $\bar{g}(x_0)$  is not zero then  $w(t)$  is not periodic. Indeed, the change in  $w$  has opposite sign to  $\bar{g}(x_0)$ .

As argued in §1 the trajectory  $(x(t), w(t))$  tends to remain near to  $\Gamma$ . Therefore we expect that  $x(t_0+p)$  is different from  $x_0$ , although, to be sure, the difference is very small. Since we are on an increasing branch of  $\Gamma$  the sign of the difference will be the same as the sign of  $w(t_0+p) - w(t_0)$ .

For example if  $\bar{g}(x_0) > 0$  we expect  $w(t_0+p) < w(t_0)$  and  $x(t_0+p) < x(t_0) = x_0$ . Using  $x(t_0+p)$  as a new initial condition  $x_1$  we expect that  $\bar{g}(x_1)$  is still positive although slightly smaller than  $\bar{g}(x_0)$ . We may now repeat the argument, and find that over the next period,  $t_0+p$  to  $t_0+2p$ , we should again expect a decrease in  $w$  and in  $x$ .

Let us repeat this process  $n$  times, writing  $w_n$  and  $x_n$  for the values of  $w$  and  $x$  at  $t_0 + np$ . As  $n$  becomes very large one of two things can happen: either  $w_n$  drifts into such a position that  $\bar{g}(x_n)$  is almost zero, or there is a sudden jump in the values of  $\bar{g}(x_n)$  from large and positive to large and negative. In the first case we would expect that a stable position had been attained; since the sign of  $w_{n+1} - w_n$  is opposite to that of  $\bar{g}(x_n)$ . In the second case there are again two possibilities: a drift to equilibrium ( $\bar{g}(x_n)$  very small) or a jump to a region where  $\bar{g}(x_n)$  is again positive.

Which of these alternatives occur will evidently depend on the geometry of  $\Gamma$ .

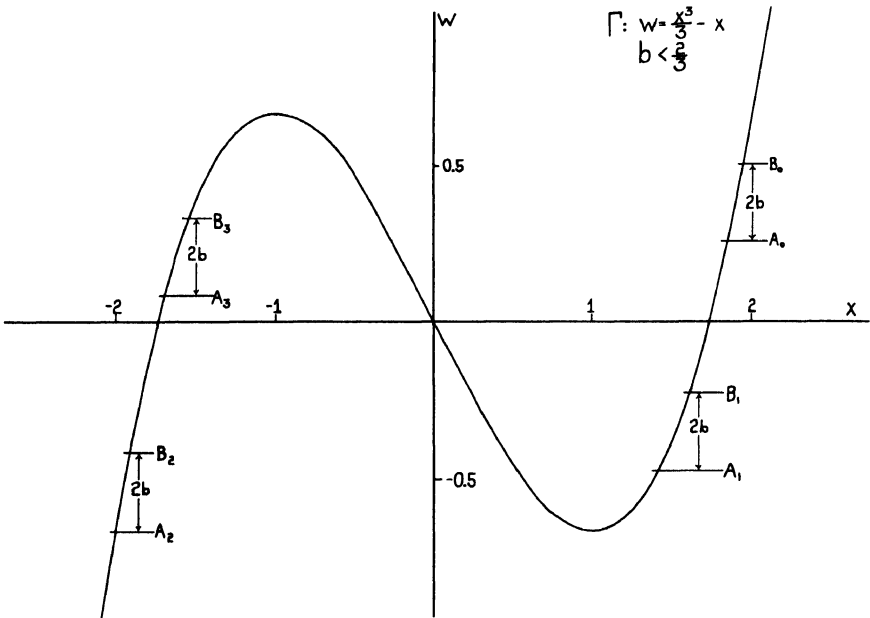

FIG. 5.

In Figure 5 we have drawn  $\Gamma$  for the function  $f(x) = x^2 - 1$ ,  $F(x) = \frac{x^3}{3} - x$ . The extrema of  $F(x)$  occur at  $x = \pm 1$ , and  $F(1) = -F(-1) = 2/3$ . Let  $g(x) = x$  and  $e(t) = b \cos t$ . If  $b > 2/3$  then clearly there is a degenerate solution  $y(t)$  symmetrical to the origin and for that solution  $g(y(t)) = y(t)$  has mean value zero. Solutions starting above or below that one will simply drift down or up into the equilibrium position, and we expect that (1) will have a periodic solution which is at least approximately stable.

On the other hand, if  $b < 2/3$  there is no degenerate solution of mean value zero. A solution oscillating initially near to  $\Gamma$  between the levels  $A_0$  and  $B_0$  will have  $\bar{g}(x)$  positive and will consequently drift downward. After a great many periods it finds itself oscillating between  $A_1$  and  $B_1$ , with  $\bar{g}(x)$  still positive. The downward trend continues; the trajectory must soon have a point considerably below  $\Gamma$ , causing a large negative horizontal velocity. Within a very few periods then the solution jumps to the left, and reestablishes oscillation between the levels  $A_2$  and  $B_2$ . But now  $\bar{g}(x)$  is negative, and hence  $w$  rises. After many periods we are in the position  $A_3B_3$ , there is a sudden jump across the gap, and  $\bar{g}(x)$  is again positive! The trajectory drifts downwards once again to  $A_1B_1$ , jumps to  $A_2B_2$ , rises to  $A_3B_3$ , jumps once more, and so on. The subharmonic solutions found by Cartwright and Littlewood exhibit this type of behavior.

In Figure 6 we have a case intermediate to these extremes; of course here we do not suppose that  $f$  and  $g$  have symmetry properties. The equilibrium position is marked  $A_5B_5$ . A solution starting in  $A_0B_0$  drifts slowly downward to  $A_1B_1$ , jumps to  $A_2B_2$ , drifts upward to

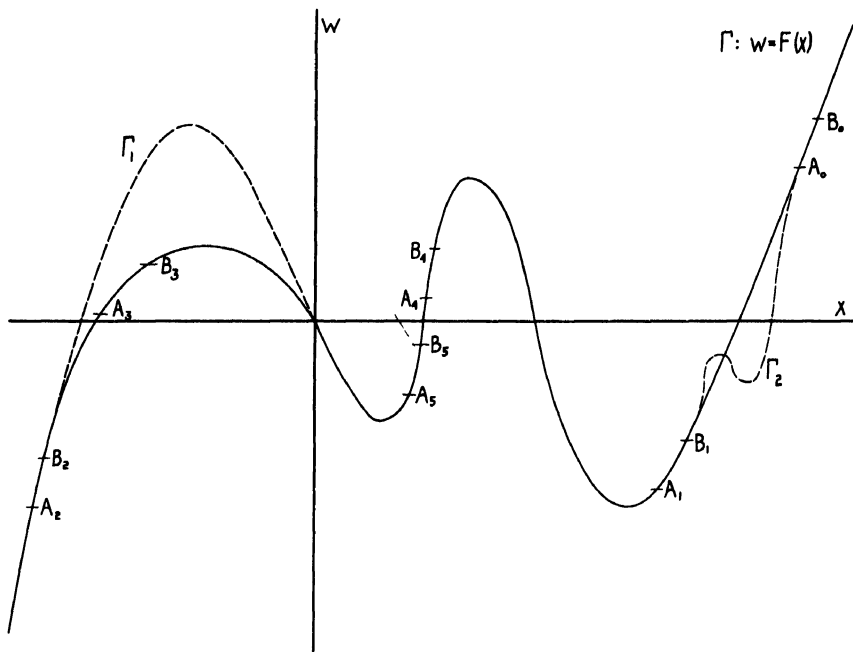

FIG. 6.

$A_3B_3$ , jumps to  $A_4B_4$ , and finally drifts downward into the region of equilibrium. If however, the form of  $\Gamma$  is slightly changed, say to the dotted curve  $\Gamma_1$ , then a solution starting at  $A_0B_0$  can never reach equilibrium, but must cycle around forever. The solution in  $A_4B_4$  can however drift down to the equilibrium position  $A_5B_5$ .

It should be remarked that the appearance of small "bumps" on  $\Gamma$  does not alter these considerations -- for example the dotted  $\Gamma_2$ .

We are, however, not able to follow this process of drift -- and -- jump directly with rigor. We must therefore resort to an indirect approach, which is

successful only in the simplest case, when the equilibrium position is accessible from above and from below without intermediate jumps in the sign of  $\bar{g}(x)$ . We retain the hypotheses of §§ 3, 4 on the differential equation (1) and add

- (2)  $E(t)$  is periodic with period  $p$ ;
- (3)  $g(x)$  is strictly monotone increasing;
- (4) There exist numbers  $\bar{x}$ ,  $\bar{t}$  such that
  - (a)  $(\bar{x}, \bar{t})$  are regular initial conditions;
  - (b)  $F(x) = F(\bar{x})$  implies  $x = \bar{x}$ ;
  - (c)  $\int_{\bar{t}}^{\bar{t}+p} g(y(t; \bar{x}, \bar{t})) dt = 0$ .

A sufficient condition for these hypotheses to be satisfied is that  $f(x)$  is an even function,  $g(x)$  an odd function,  $e(t)$  is even and of mean value zero, and  $\max E(t)$  is larger than the greatest maximum of  $|F(x)|$ . We may then take  $\bar{x}$  to be the solution  $x$  of the equation  $F(x) = \max E(t)$  and  $\bar{t}$  the time at which  $E$  attains its maximum. These conditions are fulfilled in the Cartwright-Littlewood equation if and only if  $b > 2/3$ .

Hypothesis (4b) guarantees that  $y(t; \bar{x}, \bar{t})$  is periodic with period  $p$ . For by (1) of §2,  $F(y(\bar{t})) = F(y(\bar{t} + p)) = F(\bar{x})$  and therefore  $y(\bar{t}) = y(\bar{t} + p)$ .

Hypotheses (3) and (4c), together with Theorem 2.6, imply that for a given  $\bar{t}$ , at most one such  $\bar{x}$  exists.

There evidently exists a number  $\Delta$  such that if  $|x_0 - \bar{x}| < \Delta$  then  $F(x) = F(x_0)$  implies  $x = x_0$ , and  $(x_0, \bar{t})$  is regular.

Theorem 6.1. (Global Stability Theorem) Let  $\delta$  be given  $\delta \leq \Delta$ . There exists  $\epsilon_0$  such that, for any fixed  $\epsilon \leq \epsilon_0$ , and for any solution  $x(t)$  with any given initial conditions whatsoever, there exists an integer  $m$  such that  $n \geq m$  implies

$$|x(\bar{t} + np) - \bar{x}| < \delta$$

$$|\dot{x}(\bar{t} + np)| \leq (1 + H)\epsilon^{-1/2}$$

Proof: Define  $x_1 = \bar{x} - 1/4\delta$ ,  $x_2 = \bar{x} + 1/4\delta$ ;  
 $w_1 = F(\bar{x} - 3/4\delta)$ ,  $w_2 = F(\bar{x} + 3/4\delta)$ ;  $V_1 = F(\bar{x} - 1/2\delta)$ ,  
 $V_2 = F(\bar{x} + 1/2\delta)$ .

Then  $w_1 \leq w \leq w_2$  implies  $F(x) = w$  has but one solution. If  $x_1 \leq x$  then  $V_1 < F(x)$ ; if  $x_2 \geq x$  then  $V_2 > F(x)$ .

Let  $g_1 = \int_{\bar{t}}^{\bar{t}+p} g(y(t; x_1, \bar{t}))dt$ ,  $i = 1, 2$ . Then

$g_1 < 0 < g_2$  by Theorem 2.6, and (3), (4c) above. Let  $g$  denote the smaller of  $-1/2 g_1$  and  $1/2 g_2$ .

Let  $x_i(t)$  be the solutions of the differential equation such that  $x_i(\bar{t}) = x_i$ ,  $\dot{x}_i(\bar{t}) = 0$ . Let  $\epsilon_0$  be chosen so small that, if  $\epsilon \leq \epsilon_0$ , then

$$(5) \quad \int_{\bar{t}}^{\bar{t}+p} g(x_1(t))dt \leq -g$$

$$\int_{\bar{t}}^{\bar{t}+p} g(x_2(t))dt \geq g;$$

$$(6) \quad \begin{aligned} F(x_1) - V_1 &> 2\epsilon pG \\ V_2 - F(x_2) &> 2\epsilon pG \\ V_1 - w_1 &> \epsilon pG \\ w_2 - V_2 &> \epsilon pG \end{aligned}$$

$$(7) \quad w_2 \geq F(x) - (1 + H)\epsilon^{1/2} \quad \text{implies } x < \bar{x} + \delta$$

$$w_1 \leq F(x) + (1 + H)\epsilon^{1/2} \quad \text{implies } x > \bar{x} - \delta.$$

(5) is possible by Theorem 5.5 applied to  $q(x) \equiv g(x)$ . A consequence of (6) is that  $V_2 - V_1 > 4\epsilon pG$ .

Let  $\epsilon \leq \epsilon_0$  be fixed,  $x(t)$  a solution of the differential equation. By Theorem 3.4 we may assume  $|x(t)| \leq B_0$ ,  $|\epsilon \dot{x}(t)| \leq C_0$ , all  $t \geq t_0$ ; thus  $t_1 > t_0$  exists such that  $|\dot{x}(t_1)| \leq 1$ .

It is sufficient to prove that an integer  $m$  exists such that for all  $n \geq m$  the inequality

$$(8) \quad w_1 \leq w(\bar{t} + np) \leq w_2$$

holds. For then applying Lemma 4.5 we conclude that

$$|\dot{x}(t + np)| \leq (1 + H)\epsilon^{-1/2}, \text{ whence}$$

$$F(x(\bar{t} + np)) - (1 + H)\epsilon^{1/2} \leq w(\bar{t} + np) \leq w_2$$

$$F(x(\bar{t} + np)) + (1 + H)\epsilon^{1/2} \geq w(\bar{t} + np) \geq w_1$$

and so by (7),  $\bar{x} - \delta < x(\bar{t} + np) < \bar{x} + \delta$ .

To prove (8) we observe first that for any  $n$ , if  $w(\bar{t} + np) \leq V_1$  then by Lemma 4.6,  $x(\bar{t} + np) < x_1$ . Let  $x^*(t) = x_1(t - np)$ ;  $x^*(t)$  is a solution with  $t_0 = \bar{t} + np$ ,  $x^*(t_0) = x_1$ ,  $\dot{x}^*(t_0) = 0$ , by the periodicity of  $e(t)$  and the uniqueness of solutions.

Then  $w^*(t_0) = \epsilon \dot{x}^*(t_0) + F(x^*(t_0)) = F(x_1) > V_1 + 2\epsilon pG \geq w(t + np) + 2\epsilon pG$ . Since  $x^*(\bar{t} + np) = x_1 > x(\bar{t} + np)$  we conclude by using Lemma 4.8 that  $\bar{t} + np \leq t \leq \bar{t} + (n + 1)p$  implies  $x(t) < x^*(t)$ . Hence  $g(x(t)) < g(x^*(t))$ . Therefore

$$\int_{\bar{t}}^{\bar{t}+p} g(x(t + np))dt < \int_{\bar{t}}^{\bar{t}+p} g(x^*(t + np))dt \leq -g.$$

$$\text{But } w(\bar{t} + (n+1)p) - w(\bar{t} + np) = -\epsilon \int_{\bar{t}}^{\bar{t}+p} g(x(t+np)) dt,$$

so that  $w(\bar{t} + (n+1)p) - w(\bar{t} + np) \geq \epsilon$ , and  $w(\bar{t} + (n+1)p) - w(\bar{t} + np) \leq \epsilon p G < V_2 - V_1$ . Therefore  $w(\bar{t} + (n+1)p) \leq V_2 + w(\bar{t} + np)$ ,  $-V_1 \leq V_2$ . Thus we have proved

$$(9) \quad w(\bar{t} + np) \leq V_1 \text{ implies } \epsilon g + w(\bar{t} + np) \leq w(\bar{t} + (n+1)p) \leq V_2.$$

In analogous fashion we can prove

$$(10) \quad w(\bar{t} + np) \geq V_2 \text{ implies } -\epsilon g + w(\bar{t} + np) \geq w(\bar{t} + (n+1)p) \geq V_1.$$

Finally, since  $|w(\bar{t} + (n+1)p) - w(\bar{t} + np)| \leq \epsilon p G$  and  $\epsilon p G < \min(w_2 - V_2, V_1 - w_1)$  we have

$$(11) \quad V_1 \leq w(\bar{t} + np) \leq V_2 \text{ implies } w_1 \leq w(\bar{t} + (n+1)p) \leq w_2.$$

Since  $w_1 < V_1 < V_2 < w_2$  an easy induction completes the proof of (8).

Applying Theorem 6.1 to the periodic solutions whose existence was demonstrated in Theorem 3.6 we have

Theorem 6.2. If  $\epsilon$  is small enough the periodic solutions all satisfy  $|x(\bar{t}) - \bar{x}| < \delta$ .

If  $e$ ,  $f$ , and  $g$  are differentiable and  $f(\bar{x}) > 0$  we may apply Theorem 5.6 to conclude that the periodic solutions also satisfy

$$|\dot{x}(\bar{t}) - \dot{y}(\bar{t})| < \eta$$

for  $\epsilon \leq \epsilon(\eta)$  and that an arbitrary solution  $x(t)$  satisfies

$$|\dot{x}(\bar{t} + np) - \dot{y}(\bar{t})| < \eta$$

for all large  $n$ .

§7. The Maximum Invariant Finite Domain.

We define a transformation  $T$  of the  $x - \dot{x}$  plane into itself by  $T(x_0, \dot{x}_0) = (x_1, \dot{x}_1)$  where

$$\begin{aligned}x_1 &= x(t_0 + p; x_0, \dot{x}_0; t_0; \epsilon) \\ \dot{x}_1 &= \dot{x}(t_0 + p; x_0, \dot{x}_0; t_0; \epsilon),\end{aligned}$$

$x(t)$  being a solution of the differential equation with parameter  $\epsilon$  and initial conditions as indicated.

Since the equation has a periodic solution there are points in the plane left invariant by  $T$ . It is the purpose of this section to show that under the conditions of Theorem 6.1, if  $\epsilon$  is small enough, then  $T$  possesses a maximum invariant finite domain  $D$  of zero area, and that under iterations of  $T$  all points tend to  $D$ .

Following Levinson [7] we consider the affect of  $T$  on an element of area  $dx_0 d\dot{x}_0$ . We have  $T(dx_0 d\dot{x}_0) = dx_1 d\dot{x}_1 = J(x_0, \dot{x}_0) dx_0 d\dot{x}_0$ , the Jacobian  $J$  being given by

$$J(x_0, \dot{x}_0) = \begin{vmatrix} \frac{\partial x_1}{\partial x_0} & \frac{\partial x_1}{\partial \dot{x}_0} \\ \frac{\partial \dot{x}_1}{\partial x_0} & \frac{\partial \dot{x}_1}{\partial \dot{x}_0} \end{vmatrix}$$

We easily find by the usual method:

$$J(x_0, \dot{x}_0) = \exp\left(-\epsilon^{-1} \int_{t_0}^{t_0+p} f(x(t; x_0, \dot{x}_0, t_0; \epsilon)) dt\right)$$

Theorem 7.1. Let the conditions of Theorem 6.1 be satisfied. There exists an  $\epsilon_0$  such that if  $\epsilon < \epsilon_0$ , then  $T$  has a maximum invariant domain of zero area, toward which all points tend under iterations of  $T$ .

**Proof:** Take  $t_0 = \bar{t}$ ,  $\bar{t} \leq t \leq \bar{t} + p$ . Let  $I_\delta$  be the interval  $|x_0 - \bar{x}| \leq \delta$ , where  $\delta$  is small enough so that the  $y(t; x)$  are regular and so that their discontinuities can be uniformly isolated, as in Theorem 2.7; write  $m_\delta$  for the total length of the intervals  $[u_j, v_j]$  (cf. remarks following Theorem 2.7).

Let  $T_\delta$  be a set of points  $t$  lying in closed intervals (of the form  $t_{2r} \leq t \leq t_{2r+1}$  of Theorem 5.4) insulated away from the discontinuities of  $y(t; x)$ , such that the measure of the excluded points is  $\leq 2m_\delta$ , and such that  $T_{\delta_1} \supset T_{\delta_2}$  if  $\delta_1 < \delta_2$ .

Let  $\varphi_\delta(x_0) = \int_{T_\delta} f(y(t; x_0, t)) dt$  and put  $\varphi_\Delta$

$= \min \varphi_\Delta(x_0)$  for  $x_0 \in I_\Delta$ . Then  $\varphi_\delta(x_0) \geq \varphi_\Delta(x_0) \geq \varphi_\Delta > 0$ . Let  $f = -\min f(x)$  for all  $x$ .

Choose  $\delta$  small enough so that  $m_\delta \leq \frac{\varphi_\Delta}{8f}$ ; choose  $\epsilon_1$  so small that Theorem 6.1 holds for  $\epsilon \leq \epsilon_1$ , and the chosen value of  $\delta$ . Choose  $\epsilon_0 < \epsilon_1$  so that if  $\epsilon < \epsilon_0$  then throughout  $T_\delta$   $x(t; x_0, \dot{x}_0, t; \epsilon)$  will lie close to  $y(t; x_0, t)$  -- in particular, so that if  $|\dot{x}_0| \leq (1 + H)\epsilon^{-1/2}$  then

$$\int_{T_\delta} f(x(t; x_0, \dot{x}_0; t; \epsilon)) dt \geq 1/2 \int_{T_\delta} f(y(t; x_0, \bar{t})) dt \geq 1/2 \varphi_\Delta.$$

Then  $\int_{\bar{t}}^{\bar{t}+p} f(x(t)) dt \geq 1/2 \varphi_\Delta \cdot 2fm_\delta \geq 1/4 \varphi_\Delta > 0$ ,

uniformly in  $|x_0 - \bar{x}| \leq \delta$ ,  $|\dot{x}_0| \leq (1+H)\epsilon^{-1/2}$ . Denoting this region in the  $(x_0, \dot{x}_0)$  plane by  $R$  we have, for any solution in  $R$  at  $t = \bar{t}$ ,  $J \leq \exp(-1/4k^{-1}\varphi_\Delta)$ , and  $D \subset R$  by Theorem 6.1. Hence

$$\text{area of } D \leq \iint_D J \leq (\exp(-1/4k^{-1}\varphi_\Delta)) \cdot (\text{area of } D),$$

and hence the area of  $D$  is zero.

Since all solutions ultimately appear in  $R$  and since all limit points of  $T^n(x, \dot{x})$  are in  $D$  the proof is complete.

## REFERENCES

1. Cartwright, M., and Littlewood, J. On Nonlinear Differential Equations of the Second Order I. J. London Math. Soc. (1945) 20, p.180.
2. Cartwright, M., and Littlewood, J. On Nonlinear Differential Equations of the Second Order II. Ann. of Math. (2) 48, 472-494 (1947).
3. Flanders, D., and Stoker, J. The Limit Case of Relaxation Oscillations Studies in Vibration Theory. New York University, (1946).
4. Friedrichs, K., and Wasow, W. Singular Perturbations of Nonlinear Oscillations. Duke Math. Journal (1946), 13, p. 367.
5. Levinson, N. Perturbations of Discontinuous Solutions of Nonlinear Systems of Differential Equations. Proc. National Academy, (1947) 33, p. 214.
6. Levinson, N. A Simple Second Order Differential Equation with Singular Motions. Proc. National Academy, (1948), 34, p. 13.
7. Levinson, N. Transformation Theory of Nonlinear Differential Equations of the Second Order. Annals of Mathematics, (1944), 45, p.723.
8. Levinson, N. On a Nonlinear Differential Equation of the Second Order. J. Math. Phys., (1943) 22, p. 181.

9. Liapounoff, A. Problème Général de la Stabilité du Mouvement. Annals of Mathematics Studies, No. 17.
10. Massera, J. On the Existence of Periodic Solutions of Differential Equations. Bull. Amer. Math. Soc. (1948) 54, p. 636. Abstract No. 250.
11. Minorsky, N. Nonlinear Mechanics. Edwards, (1946).
12. Poincaré, H. Les Methodes Nouvelles de la Mecanique Celeste, Vol. I, Paris, 1892.
13. Volk, I. A Generalization of the Method of Small Parameter in the Theory of Nonlinear Oscillations of Non-Autonomous Systems. C. R. (Doklady) Acad. Sci. U.S.S.R., (1946) 51, p. 437.
14. LaSalle, J. Relaxation Oscillations. Quart. J. App. Math. (1949) 7, p. 1.

VI. THE EXISTENCE OF FORCED PERIODIC SOLUTIONS OF  
SECOND ORDER DIFFERENTIAL EQUATIONS NEAR CERTAIN  
EQUILIBRIUM POINTS OF THE UNFORCED EQUATION

By C. E. Langenhop and A. B. Farnell\*

1. Introduction

In this paper we discuss first the equation  
(1)  $\ddot{x} + a\dot{x} + x + \frac{1}{2}x^2 = \frac{1}{2}k \cos \omega t$ ,  $a > 0$ ,  $k > 0$ ,  
in some detail to make our method clear. Similar  
results can then be easily established for a more  
general equation

(2)  $\ddot{x} + f(x)\dot{x} + g(x) = ke(t)$ ,

with suitably restricted  $e$ ,  $f$  and  $g$ . We shall through-  
out consider  $x$  as a real variable and  $t$  as time.

Equation (1) (with a slightly different standardiza-  
tion of form) has been the subject of some investigation  
by D. R. Hartree, M. L. Cartwright and others, and  
according to Miss Cartwright was originally proposed in  
connection with a loud-speaker in which subharmonics  
were observed. In an article on the differential  
analyzer Hartree<sup>1</sup> uses the equation (1) as an illus-  
tration of setting up the analyzer for calculating  
solutions of differential equations, but no results  
are given there except for a figure or two showing the  
type of curves obtained.

---

\* Iowa State College and the University of Colorado,  
respectively. This paper was prepared under a Navy  
contract at Princeton University.

1. D. R. Hartree, Math. Gazette, vol. 22(1938), pp.342-  
364.

In the numerical work it was necessary to consider negative values of  $x$  beyond the range in which the differential equation corresponds to the physical problem in order to obtain subharmonic solutions.

Aside from this practical objection, there are certain interesting results derivable from this equation, and in view of the fact that the method we apply to it can be used to some extent in more general cases, it seems to be of sufficient interest.

The general equation (2) with  $f(x)$  a constant includes Duffing's equation and arises in connection with pendulum problems, electrical circuits containing iron core inductances and the hunting of synchronous electrical machinery<sup>2</sup>.

## 2. Preliminaries

The existence of a periodic solution of (1) (or(2)) is proved in the following classical way: with equation (1) (or (2)) and the period  $p$  of the right-hand side there is associated a topological mapping  $T$  of the  $(x,y)$  plane ( $y = x$ ) into itself obtained by replacing  $t$  by  $t + p$  in any solution of the equation. Under the transformation  $T$  there is a closed two-cell (convex region), referred to in the sequel as  $\Delta$ , which is mapped into itself, and by Brouwer's fixed point theorem  $T$  has a fixed point in  $\Delta$  and hence (1) (or (2)) has a periodic solution of period  $p$ .

For a more detailed exposition of this part of the argument the reader is referred in particular to a paper by Levinson<sup>3</sup> or a popular presentation by Cartwright<sup>4</sup>.

2. Friedrichs and Stoker, Quart. Applied Math., vol.1 (1943), pp.97-115.

3. Levinson, Annals of Math., vol. 45 (1944), pp.723-737.

4. Cartwright, Research, vol. 1 (1948), pp.601-606.

The theorem concerning (2) which we prove is local in character, the  $\Delta$  regions being in general smaller than in previous application of Brouwer's theorem, and it applies to many new cases not previously covered by other authors. The particular case (1) discussed here in detail is evidence of this fact.

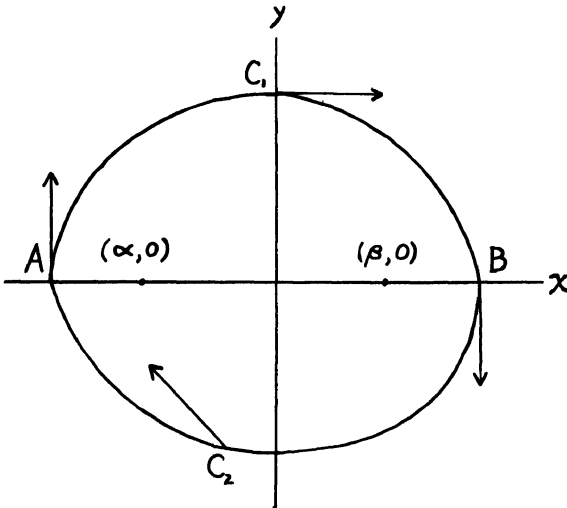

FIG. 1

The closed convex region which we obtain is bounded by a simple closed curve  $\Lambda$  formed by two analytical arcs between points A and B as in Fig. 1 (the curve may or may not have a continuous tangent at points A and B). If the vector  $[\dot{x}, \dot{y}]$  at all points of the boundary is directed at all times toward the interior of such a region, then it is clear the region would be mapped into itself under  $T$ . For the regions that we obtain the vector field may be tangent to the boundary and in this connection we prove the

following Lemma and Theorem.

Lemma: If

$$(3) \quad \begin{aligned} \dot{x} &= f(x, y, t) \\ \dot{y} &= g(x, y, t), \end{aligned}$$

where f and g are analytic and satisfy the conditions

$$\begin{aligned} f(0,0,t_0) &= \sigma > 0 \\ g(0,0,t_0) &= 0, \end{aligned}$$

and

$$(4) \quad g(x,0,t) < 0, \quad 0 < x < \bar{x}, \quad t \geq t_0,$$

then there exists a  $t_1 > t_0$ , such that  $y(t) < 0$  for  $t_0 < t < t_1$ , where  $[x(t), y(t)]$  is the solution of (3) which passes through  $(0,0)$  at  $t = t_0$ .

The condition that f and g be analytic is sufficient to insure the uniqueness of solutions of (3). The function  $f(x,y,t)$  being analytic is certainly continuous and since  $f(0,0,t_0) = \sigma > 0$  there is a circular region in the  $(x,y)$  plane with  $(0,0)$  as center and radius  $\rho$ ,  $0 < \rho \leq \bar{x}$ , such that for points in this region (Fig.2)

$$(5) \quad \dot{x} = f(x,y,t) > 0, \quad t_0 \leq t \leq t'; \quad t_0 < t'.$$

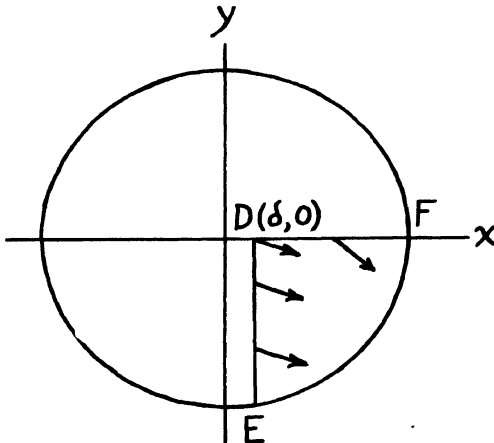

Let  $[x(x_0, y_0, t), y(x_0, y_0, t)]$  be the solution of (3) which passes through  $(x_0, y_0)$  at  $t = t_0$ . Pick now  $t, t_0 \leq t \leq t'$ , such that the trajectory  $[x(0, 0, t), y(0, 0, t)]$  remains in the circular region during the interval  $t_0 \leq t \leq t'$ . Since  $x(x_0, y_0, t), y(x_0, y_0, t)$  are continuous functions of  $x_0$  and  $y_0$  there is a neighborhood of the origin such that if  $(x_0, y_0)$  is in this neighborhood, then  $[x(x_0, y_0, t), y(x_0, y_0, t)]$  likewise remains in the circular region for  $t_0 \leq t \leq t'$ . In particular this is true for points  $(\delta, 0)$  when  $\delta > 0$  is sufficiently small.

Now if there is no  $t_1 > t_0$  such that  $y(0, 0, t) \leq 0$  for  $t_0 \leq t \leq t_1$ , there is a  $t_2, t_0 < t_2 \leq t'$  such that  $y(0, 0, t_2) = \epsilon > 0$ . But  $y(\delta, 0, t_2) < 0$  ( $\delta > 0$ ) since by (4) and (5) the vector field of (3) along DF and DE in Fig. 2 points toward the interior of the half-segment DEF and for  $\delta$  sufficiently small the trajectory  $[x(\delta, 0, t), y(\delta, 0, t)]$  must remain inside the circle for  $t_0 \leq t \leq t'$ . Thus

$$|y(0, 0, t_2) - y(\delta, 0, t_2)| > \epsilon > 0.$$

We have then a contradiction since for  $\delta$  sufficiently small we must be able to make  $|y(0, 0, t_2) - y(\delta, 0, t_2)|$  as small as we please. There is then a  $t_1 > t_0$  such that  $y(0, 0, t) \leq 0$  for  $t_0 \leq t \leq t_1$ , and the Lemma is proved.

Theorem I: Let  $\Lambda$ , consisting of two analytical arcs,  $AC_1B$  and  $AC_2B$  as shown in Fig. 1, be the boundary of a convex region. Suppose that the velocity vector  $(\dot{x}, \dot{y}) = [P(x, y, t), Q(x, y, t)]$ , where  $P$  and  $Q$  are analytic and of period  $p$  in  $t$ , satisfies the following conditions at points of  $\Lambda$ :

- (a) at A it is zero at discrete times and otherwise tangent to the arc  $AC_1B$  as shown;  
 (b) at B it is tangent at all times to the arc  $AC_2B$  as shown;  
 (c) at  $C_1$  it is tangent to the arc  $AC_1B$  at discrete times and otherwise points inward;  
 (d) at all other points it is directed inward at all times.

Then the closed region bounded by  $\Lambda$  is mapped into itself under  $T$ .

Let  $\Psi$  be the open region bounded by  $\Lambda$ . We show first that any solution of

$$(6) \quad \begin{aligned} \dot{x} &= P(x,y,t) \\ \dot{y} &= Q(x,y,t) \end{aligned}$$

starting at any point on  $\Lambda$  at  $t = t_0$  remains in  $\bar{\Psi}$  for a short time interval after  $t = t_0$ , say  $t_0 \leq t \leq t_1$ . Clearly we need only examine the behavior of the solutions passing through the points A, B, and  $C_1$  where the field of (6) is tangent to  $\Lambda$ , and then only at the instants the tangency occurs.

Let L be any of the points A, B, or  $C_1$  and suppose that the vector  $(P,Q)$  at  $t=t_0$  is tangent to  $\Lambda$  at L but not zero.

Then since the arc to which the vector is tangent is analytical, a neighborhood of the arc can be mapped conformally on the  $(x_1, y_1)$  plane so that L goes into the origin, the arc into the  $x_1$ -axis and the interior of  $\Psi$  in the neighborhood in question goes below the  $x_1$ -axis. The system (6) is then transformed into

$$(7) \quad \begin{aligned} \dot{x}_1 &= f(x_1, y_1, t) \\ \dot{y}_1 &= g(x_1, y_1, t) \end{aligned}$$

where the system (7) satisfies the conditions of the Lemma. The conclusion of the Lemma then clearly implies that the solution of (6) which passes through L at  $t = t_0$  remains in  $\bar{\Psi}$  for an interval  $t_0 \leq t \leq t_1$ .

We have still to consider the point A at times when the field (6) is zero there. Suppose this to be the case when  $t = t_0$ . It is not zero then for  $t_0 < t < t'$  for some  $t' > t_0$  since by hypothesis the vector is zero only at discrete times. Now pick any  $t'' \leq t'$  so that trajectories starting at  $t = t_0$  very near A cannot pass through  $C_1$  or B during the interval  $t_0 < t < t''$ . Now if the trajectory passing through A at  $t = t_0$  is outside of  $\bar{\Psi}$  at  $t = t''$ , then because of continuity, trajectories starting at points of  $\Lambda$  very near A at  $t = t_0$  must also be outside  $\bar{\Psi}$  by  $t = t''$ . This cannot happen, since by condition (d) and the choice of  $t''$ , in order for any nearby trajectory to get outside  $\bar{\Psi}$  by  $t = t''$  it must pass through A. By the time this trajectory reaches A the vector (P,Q) will be tangent to  $\Lambda$  and different from zero and will remain different from zero for the rest of the interval  $t_0 < t \leq t''$ . Thus by the previous case this nearby trajectory must remain in  $\bar{\Psi}$  for this interval. This contradiction then completes the proof that a trajectory passing through any point of  $\Lambda$  at  $t = t_0$  is in  $\bar{\Psi}$  for a short time interval  $t_0 \leq t \leq t_1$ .

It is clear then that under the transformation T the region  $\bar{\Psi}$  is mapped into itself, for if  $P_0 \in \bar{\Psi}$ , then  $TP_0 = P_1 \in \bar{\Psi}$  since trajectories starting in  $\bar{\Psi}$  or on  $\Lambda$  at  $t = t_0$  cannot escape from  $\bar{\Psi}$ . That  $\bar{\Psi}$  is homeomorphic to a two-cell is clear since it is convex. Thus Brouwer's theorem applies and T has a fixed point in  $\bar{\Psi}$  corresponding to a periodic solution of (6).

In the sequel we make considerable use of systems of the type

$$(8) \quad \dot{x} = y, \quad \dot{y} = -ay - x + \gamma$$

with  $a > 0$ . The one singular point at  $x = \gamma$ ,  $y = 0$  is

a stable node or focus depending on whether  $a \geq 2$  or  $a < 2$  (i.e. the damping in the differential equation  $\ddot{x} + a\dot{x} + x = \gamma$  is greater than critical or less than critical). The nature of the solutions in these two cases is shown in Figures 3 and 4.

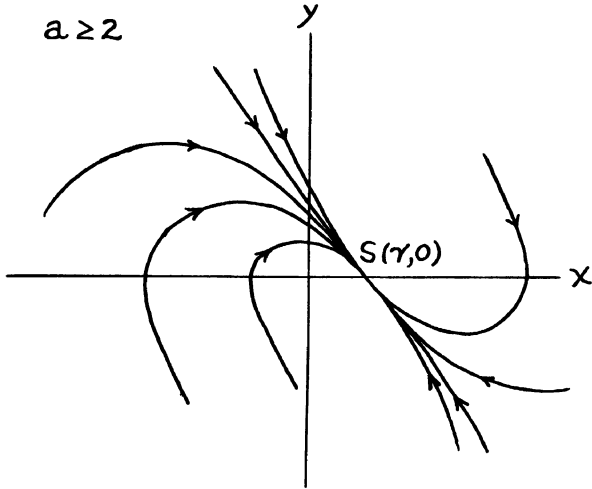

FIG. 3

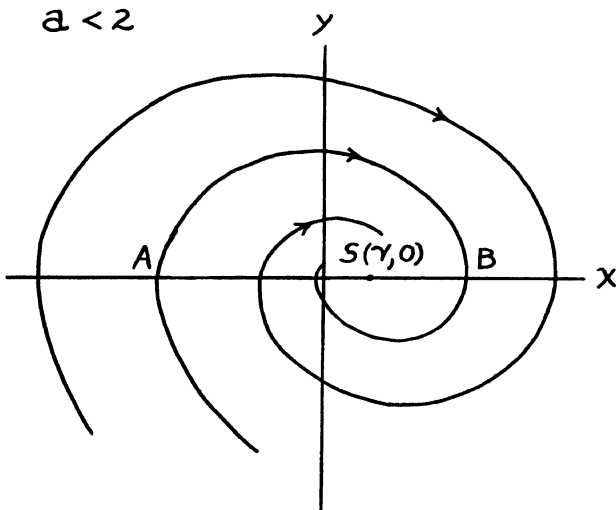

FIG. 4

In the case  $a < 2$  a path satisfying (8) crosses the x-axis an infinite number of times. The distance from S to successive crossings decreases geometrically so that in Figure 4

$$(9) \quad SB = \lambda AS.$$

In fact  $\lambda = \exp [ -\pi(4-a^2)^{-1/2} a ]$ , so that  $0 < \lambda < 1$  for  $a > 0$ .

In the case  $a > 2$  a path which crosses the x-axis proceeds directly to S. The point analogous to B above is then coincident with S so in this case also we have (9) holding with  $\lambda = 0$ . The case  $\lambda = 1$  (i.e.  $a = 0$ ) will be treated separately.

We note here two other properties of the paths in Figures 3 and 4 which we use in the sequel: (1) On those parts of the paths which lie entirely above the x-axis or on those parts which lie entirely below the x-axis there are no points of inflection ( $d^2y/dx^2 = 0$  is possible only at  $(\gamma, 0)$ ). (2) For all points of an arc lying below the x-axis or above as AB in Fig. 4 we have

$$(10) \quad x_A \leq x \leq x_B.$$

This is true since  $\dot{x} = y$  so that in each of the half-planes,  $y > 0$  and  $y < 0$ ,  $x$  is a monotonic function of  $t$  along a path. Again the node of Fig. 3 is no exception in this respect only here  $x_B = x_S = \gamma$ .

The regions  $\Delta$  which we obtain later are formed by piecing together such arcs as those in Figures 3 and 4, i.e. the analytical arcs  $AC_1B$  and  $AC_2B$  in Figure 1 are solutions of linear systems such as (8). The properties (1) and (2) discussed above are sufficient to make the region bounded by these arcs convex as required in Theorem I.

3. The existence of a region  $\Delta$  for (1).

We replace the equation (1) by the system

$$(11) \quad \dot{x} = y, \quad \dot{y} = -ay - x - \frac{1}{2}x^2 + \frac{1}{2}k \cos \omega t.$$

To obtain a picture of the vector field in the  $(x,y)$  phase plane we introduce the two parabolas

$$p_1(x,y) \equiv -ay - x - \frac{1}{2}x^2 + \frac{1}{2}k = 0$$

$$p_2(x,y) \equiv -ay - x - \frac{1}{2}x^2 - \frac{1}{2}k = 0.$$

It will soon become evident that, for our method to apply, we must assume  $k \leq 1$ . (This insures that  $p_2(x,y) = 0$  crosses the  $x$ -axis.) This together with  $a > 0, k > 0$  will be assumed throughout unless otherwise specified.

Consideration of (11) leads to the schematic picture of the vector field shown in Fig. 5 where the double vectors at representative points indicate the extreme possibilities for the field. Note that at any point the  $x$ -component of the vector is independent of  $t$  so that intermediate positions of the field vectors ( $y \neq 0$ ) are in the angle less than  $180^\circ$  formed by the double vectors of Fig. 5.

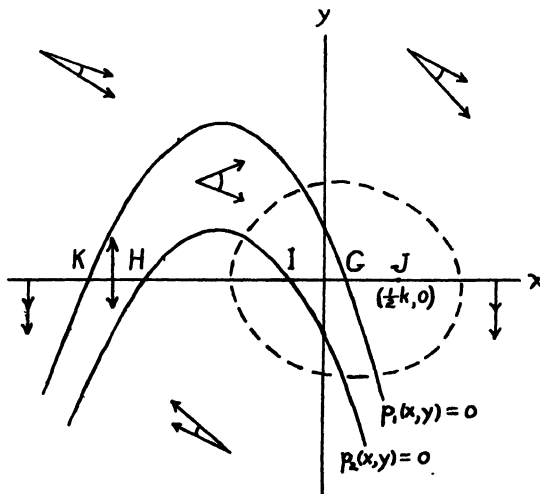

Figure 5 gives an indication of some sort of circulation about the segment IG and in fact the region  $\Delta$  which we obtain contains this segment. To find the region  $\Delta$  we replace (11) by a system having a vector field which diverges more from the origin (at least in the vicinity of the origin) than (11) does at any time. This is accomplished by increasing  $\dot{y}$  for  $y > 0$  and decreasing  $\dot{y}$  for  $y < 0$ . Thus consider the system

$$(12) \quad \dot{x} = y \quad \begin{cases} \dot{y} = -ay - x + \frac{1}{2}k, & y > 0, \\ \dot{y} = -ay - x - \frac{1}{2}h^2 - \frac{1}{2}k, & y < 0. \end{cases}$$

Note that we have the following relations between the  $\dot{y}$ 's of system (11) and system (12):

$$(13) \quad \dot{y}_{11} = -ay - x - \frac{1}{2}x^2 + \frac{1}{2}k \cos \omega t \leq -ay - x + \frac{1}{2}k, \quad y > 0,$$

with equality only at  $x = 0$  and  $t = 2n\pi/\omega$ ,

$$(14) \quad \dot{y}_{11} \geq -ay - x - \frac{1}{2}h^2 - \frac{1}{2}k, \quad |x| \leq h, \quad y < 0,$$

with equality only at  $x = \pm h$  and  $t = (2n+1)\pi/\omega$ , so that the solutions of (11) intersect the paths of (12) as indicated by the arrows in Figure 6.

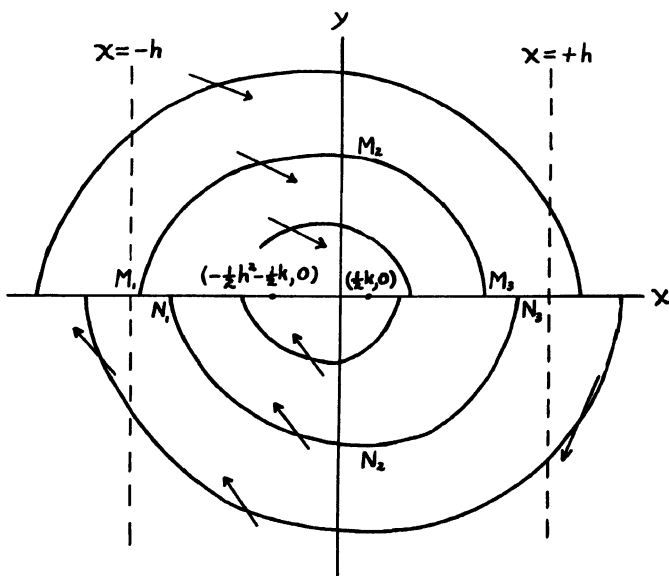

From (13) we see that above the x-axis the arrows all point toward the concave side of the arcs they cross, while below, because of (14) they do this only in the strip  $|x| < h$ , possibly at times pointing toward the convex side at points where  $|x| > h$ . Figure 6 depicts the case  $a < 2$ , but the case  $a \geq 2$  is similar.

The paths of Fig. 6 can be obtained from Fig. 4 by shifting the two half-planes  $y > 0$  and  $y < 0$  so that S is placed at  $(\frac{1}{2}k, 0)$  for  $y > 0$  and at  $(-\frac{1}{2}h^2 - \frac{1}{2}k, 0)$  for  $y < 0$ . If we can show there are solutions of (12) situated such as  $M_1M_2M_3$  and  $N_1N_2N_3$  the region  $\Delta$  will be established, being indeed bounded by these arcs and the segments  $M_1N_1$  and  $M_3N_3$  provided that at all times the vectors of (11) point up along  $M_1N_1$  and down along  $M_3N_3$ .

We can in fact show that there are solutions of (12), one above and one below, which join as in Fig. 1 and these in general bound a smaller region than  $M_1M_2M_3N_3N_2N_1M_1$ . In any case the solution for  $y < 0$  which we use must lie in the strip  $|x| < h$  so that at all points of this arc the vector field of (11) points toward the concave side (or is tangent as it must be at points of the x-axis). This then requires (for Fig. 1)

$$(15) \quad -h < x_A < x_B < +h.$$

If this can be satisfied, then by (13), (14) and the property of the paths discussed in connection with (10), the vectors will point as desired.

We have from (9)

$$(16) \quad \begin{aligned} x_B - \beta &= \lambda(\beta - x_A) \\ \alpha - x_A &= \lambda(x_B - \alpha) \end{aligned}$$

the solution of which is (recall that  $\lambda < 1$  so that a solution exists)

$$(17) \quad \begin{aligned} x_A &= \frac{\alpha - \beta\lambda}{1 - \lambda} \\ x_B &= \frac{\beta - \alpha\lambda}{1 - \lambda} . \end{aligned}$$

Using (15) and putting  $\beta = \frac{1}{2}k$ ,  $\alpha = -\frac{1}{2}h^2 - \frac{1}{2}k$  we get the following two inequalities to determine  $h$ :

$$\begin{aligned} z_1(h) &\equiv h^2 - 2(1-\lambda)h + (1+\lambda)k \leq 0 \\ z_2(h) &\equiv \lambda h^2 - 2(1-\lambda)h + (1+\lambda)k \leq 0. \end{aligned}$$

Now  $z_1(0) = z_2(0)$  and  $z_1(h) - z_2(h) = (1-\lambda)h^2 > 0$  since  $\lambda < 1$ . Thus the two roots of  $z_1(h) = 0$  lie between the two roots of  $z_2(h) = 0$  if they are real, and consequently the two inequalities are satisfied for values of  $h$  lying between the two roots of  $z_1(h) = 0$ . That is to say, (15) will be satisfied if

$$(18) \quad 1 - \lambda - \frac{[(1-\lambda)^2 - (1+\lambda)k]^{\frac{1}{2}}}{+ [(1-\lambda)^2 - (1+\lambda)k]^{\frac{1}{2}}} \leq h \leq 1 - \lambda$$

which is a real interval if

$$(19) \quad k \leq \frac{(1-\lambda)^2}{(1+\lambda)} \leq 1.$$

With  $k$  satisfying (19) and with a choice of  $h$  satisfying (18) the solutions of (12) passing through A and B with coordinates given by (17) are two analytical arcs with the desired properties. They form a simple closed curve (indicated by the dotted curve of Fig. 5) on which, by (13) and (14), the velocity vector  $(\dot{x}, \dot{y})$  of (11) satisfies all the conditions of Theorem I. Hence there is a periodic solution of (1) of period  $2\pi/\omega$  in the region bounded by these arcs.

In the case  $a = 0$ , we have  $\lambda = 1$ . Equations (14)

are then inconsistent unless  $\alpha = \beta = 0$ . This however implies  $h = 0$  and the construction of a  $\Delta$  region by this method fails in this case.

4. Region of divergence.

An examination of Fig. 5 also reveals that some solutions of (1) diverge from the origin of the phase plane rather than remain in a neighborhood of the origin as do those in  $\Delta$ . It is possible to find quite a large region which serves to bound solutions of (1) away from the origin and this larger region gives rise to further interesting results for (1).

We first find a line with negative slope passing through  $K$  with respect to which the vectors of system (11) will be as indicated in Fig. 7.

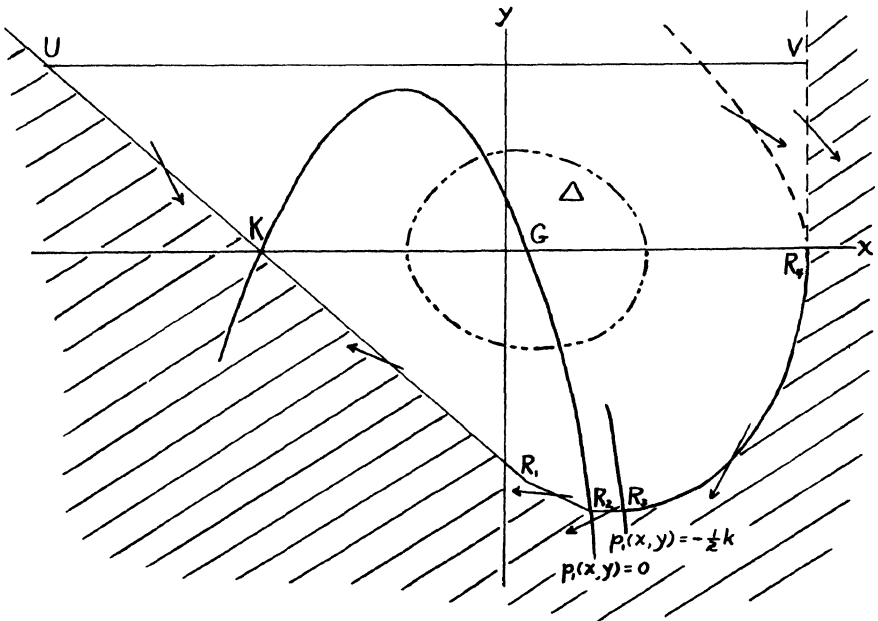

FIG. 7.

We have

$$\dot{y}_{11} \leq -ay - x - \frac{1}{2}x^2 + \frac{1}{2}k$$

so that

$$\dot{y}_{11}/\dot{x} \leq -a - \frac{1}{2}(x-x_K)(x-x_G)/y, \quad y \leq 0.$$

Along the line  $y = m(x-x_K)$  we must have then

$$\dot{y}_{11}/\dot{x} \leq -a - (x-x_G)/2m \leq m, \quad x \leq x_K.$$

To obtain an  $m$  for the interval  $x_K \leq x \leq x_G$ , or the interval  $x < x_K$ , we set  $x = x_K$  as the extreme requirement. This leads, in both cases to

$$m_1 = -\frac{1}{2} \{ a + [a^2 + 4(1+k)^{\frac{1}{2}}]^{\frac{1}{2}} \}$$

as the best choice of  $m$ , i.e. the smallest possible value of  $m$  for  $x \leq x_K$  and the largest possible value of  $m$  for  $x_K \leq x \leq x_G$ . The line  $y = m_1(x-x_K)$  for  $x \leq x_G$  will then form part of the boundary of the region of divergence.

To the right of  $x = x_G, (-\frac{1}{2}x^2 - x + \frac{1}{2}k)/y > 0$  ( $y < 0$ ), so that in this region

$$\dot{y}_{11}/\dot{x} \geq -a.$$

From  $R_1$  in Fig. 7 then we continue with a line of slope  $-a$  to  $R_2$  on the parabola  $p_1(x,y) = 0$ ,

Since  $-ay - x - \frac{1}{2}x^2 + \frac{1}{2}k < 0$  to the right of the parabola  $p_1(x,y) = 0$ , in this region

$$\dot{y}_{11}/\dot{x} \geq 0.$$

Hence we may proceed from  $R_2$  to  $R_3$  on the parabola

$p_1(x,y) = -\frac{1}{2}k$  with a horizontal line. Above

$p_1(x,y) = -\frac{1}{2}k$  we have  $\dot{y}_{11} \leq -\frac{1}{2}k$  and here we take as part of the boundary joining  $R_3$  to  $R_4$  on the  $x$ -axis

the solution of the system

$$\dot{x} = y, \quad \dot{y} = -\frac{1}{2}k$$

which passes through  $R_3$ .

Various possibilities beyond the point  $R_4$  are indicated by the dotted curves in Fig. 7. For our purposes it is sufficient to take simply  $x = x_{R_4}$  for  $y \geq 0$ .

This then establishes the larger region such that solutions of (11) once having crossed its boundary necessarily remain in the region. Clearly the Lemma can be used at points of the boundary at which the vector field of (11) is tangent or zero in the same manner as it was used in the proof of Theorem I. This region we denote by  $\Omega$  and its boundary by  $\Gamma$ .

#### 5. Existence and location of other periodic solutions.

In Section 3 we have shown that there exists a periodic solution of (1) in  $\Delta$ . Remarkably enough (as pointed out to us by Miss Cartwright) it is possible to prove the existence of another periodic solution.

Indeed let  $\Phi$  be the convex region  $UKR_1R_2R_3R_4VU$  in Fig. 7 where  $UV$  is any horizontal line above the parabola  $p_1(x, y) = 0$ . We prove

Theorem II. There is a periodic solution of (1) of period  $2\pi/\omega$  in the annular region  $\Phi - \Delta$ .

(a) The index of  $\mu$ , the boundary of  $\Phi$ , relative to the vector field  $\vec{P}_0P_1$ ,  $P_1 = TP_0$ , is zero. (see Fig. 8).

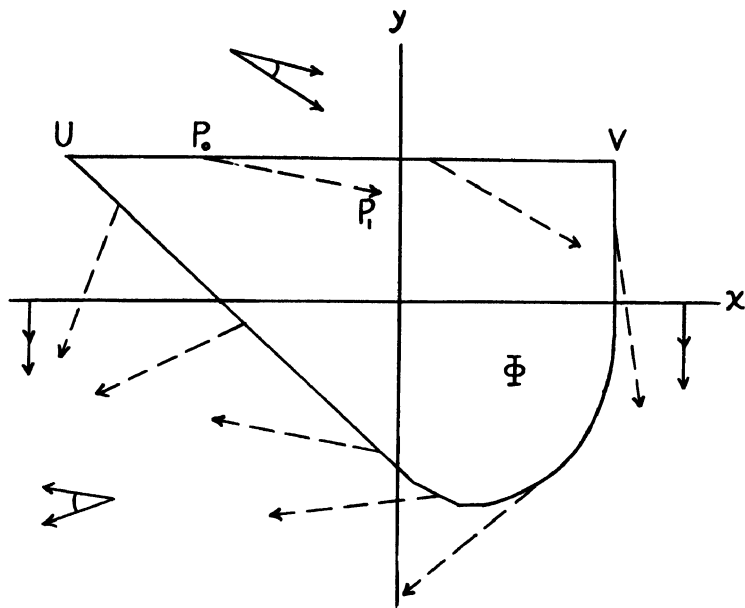

FIG. 8

In fact the vector  $\overrightarrow{P_0P_1}$ , where  $P_0$  is any point on the curve  $\mu$  never takes a direction in the first quadrant and hence as  $P_0$  describes  $\mu$ ,  $\overrightarrow{P_0P_1}$  must return to its original position without having made a full turn. For if  $P_0$  is any point on  $UV$ ,  $P_1$  will lie below  $P_0$  since at all points of the line  $UV$   $\dot{y} < 0$  ( $UV$  lies above  $p_1(x,y) = 0$ ). Furthermore if  $P_0$  is any point on that part of  $\Gamma$  below  $UV$ ,  $P_1$  cannot lie in the bounded region  $\Phi$  so  $P_1$  must lie below or to the left of  $P_0$ . This proves our assertion.

(b) The transformation T has fixed points in  $\Phi - \Delta$ .

Since  $\Delta$  is mapped into itself under T its boundary has index + 1 relative to the vector field  $\overrightarrow{P_0P_1}$ . Property (b) follows then from (a) since  $\Delta$

lies wholly in  $\Phi$  .

(c) To a fixed point  $W$  of  $T$  in  $\Phi - \Delta$  there corresponds a periodic solution  $\eta$  of (1), which lies wholly in  $\Phi - \Delta$  .

That  $W$  corresponds to a periodic solution is obvious. Clearly  $\eta$  cannot penetrate  $\Delta$  for if it did it could not again leave  $\Delta$ , and as shown in Section 4 if it leaves  $\Phi$  , which can occur only along  $\Gamma$  , then it must remain outside of  $\Phi$  . Since  $\eta$  is periodic it must therefore lie entirely in  $\Phi - \Delta$  .

Property (c) completes the proof of the theorem.

Remarks. I. If  $T$  has a finite number of fixed points in  $\Phi$  , then one of the periodic solutions is unstable. For since the index of  $\Phi$  is zero and that of  $\Delta$  is + 1, one of the fixed points in  $\Phi - \Delta$  must have negative index.

II. All periodic solutions of (1) must lie in  $\Phi$  . As pointed out earlier no periodic solution can lie partly in  $\Phi$  and partly out. Also no periodic solution can encircle  $\Phi$  since the vector field of (11) always points downward on the x-axis outside  $\Phi$  , and for the same reason there can be no periodic solution outside  $\Phi$  which lies partly above the x-axis and partly below. Finally there can be no periodic solution outside  $\Phi$  which lies entirely above the x-axis or entirely below, since in the former region  $\dot{y} < 0$  and in the latter region  $\dot{x} = y < 0$  .

## 6. The general theorem.

The foregoing treatment of Equation (1) is an interesting special case of the following

Theorem III: The differential equation

$$(2) \quad \ddot{x} + f(x)\dot{x} + g(x) = ke(t),$$

where  $f(x)$  and  $g(x)$  are analytic, and  $e(t)$  is analytic, periodic, and  $|e(t)| < 1$ , possesses, for  $k$  sufficiently small, a periodic solution in the neighborhood of points  $x = x_0$ ,  $\dot{x} = 0$  for which  $g(x_0) = 0$ ,  $g'(x_0) > 0$ ,  $f(x_0) \neq 0$ . The period of this solution is the same as that of  $e(t)$ .

We establish the theorem for the case  $f(x_0) > 0$ . The case  $f(x_0) < 0$  follows on replacing  $t$  by  $-t$  in (2).

First we make the change of variable  $x = x_0 + \xi$ , and replace (2) by the system

$$(20) \quad \dot{\xi} = y, \quad \dot{y} = -f(x_0 + \xi)y - g(x_0 + \xi) + ke(t).$$

Since  $f(x_0 + \xi)$  is continuous, there is an interval, say  $|\xi| < \bar{C}$ , in which  $f(x_0 + \xi) \geq a > 0$ . If  $f(x_0)^2 > 4g'(x_0)$  we may take  $a$  such that  $a^2 \geq 4g'(x_0)$ . In the linear systems introduced below, this leads to systems which have nodal singular points. If  $f(x_0)^2 \leq 4g'(x_0)$ , it may be necessary to choose  $a$  smaller in which case the systems will have focal singular points. Consider then the system

$$(21) \quad \dot{\xi} = y, \quad \dot{y} = -ay - g'(x_0)\xi + R(\xi) + ke(t),$$

where  $R(\xi) = g'(x_0)\xi - g(x_0 + \xi)$ ,  $a > 0$ . It is easily seen that when  $|\xi| \leq \bar{C}$ ,  $\dot{y}_{20} \ll \dot{y}_{21}$  for  $y \ll 0$  [ $\dot{y}_m$  denotes as before  $\dot{y}$  of system (m)]. Moreover, since  $g(x)$  is analytic, we have for  $|\xi| < \bar{C}$ ,

$$|R(\xi)| < b\xi^2.$$

As in our previous work, we replace  $R(\xi) + e(t)$  by certain extreme values and we are lead to linear systems of the type

$$\dot{\xi} = y, \quad \dot{y} = -ay - g'(x_0)\xi + \gamma$$

which have a singular point at  $\xi = \gamma/g'(x_0)$ ,  $y = 0$ . In particular we consider the following extreme system

obtained from (21):

$$(22) \quad \begin{aligned} \dot{y} &= -ay - g'(x_0)\xi + \max_{|\xi| \leq h} R(\xi) + k, \quad y > 0, \\ \dot{\xi} &= y, \\ \dot{y} &= -ay - g'(x_0)\xi + \min_{|\xi| \leq h} R(\xi) - k, \quad y < 0, \end{aligned}$$

where  $h \leq \bar{C}$ .

The discussion again follows the general lines developed for the special case. We take a solution of (22) for  $y > 0$  which starts at point A on the  $\xi$ -axis and proceeds to point B on the  $\xi$ -axis (see Fig. 1). Then we take the solution of (22) for  $y < 0$  which goes from B to A. These two arcs make up the closed curve  $\Lambda$ . As before

$$x_A = \frac{\alpha - \lambda\beta}{1 - \lambda}, \quad x_B = \frac{\beta - \lambda\alpha}{1 - \lambda},$$

where now

$$\lambda = \exp \left\{ -\pi a (4g'(x_0) - a^2)^{-\frac{1}{2}} \right\}, \quad \begin{aligned} 0 < a^2 < 4g'(x_0), \\ = 0, & \quad a^2 \geq 4g'(x_0), \end{aligned}$$

and

$$\begin{aligned} \beta &= (\max_{|\xi| \leq h} R(\xi) + k) / g'(x_0), \\ \alpha &= (\min_{|\xi| \leq h} R(\xi) - k) / g'(x_0). \end{aligned}$$

Imposing the requirement that  $x_B \leq h$  leads to the inequality

$$(23) \quad \max_{|\xi| \leq h} R(\xi) - \lambda \min_{|\xi| \leq h} R(\xi) \leq h(1-\lambda)g'(x_0) - k(1+\lambda).$$

Since  $\max_{|\xi| \leq h} R(\xi) \leq bh^2$ ,  $-\min_{|\xi| \leq h} R(\xi) \leq bh^2$ , this inequality

certainly holds if

$$bh^2(1+\lambda) \leq h(1-\lambda)g'(x_0) - k(1+\lambda).$$

For  $k < (1-\lambda)^2 g'(x_0)^2 / 4b(1+\lambda)^2$ , this inequality is satisfied for an interval to the right of

$$h = \frac{(1-\lambda)g'(x_0) - [(1-\lambda)^2 g'(x_0)^2 - 4kb(1+\lambda)^2]^{\frac{1}{2}}}{2b(1+\lambda)} > 0$$

This gives the smallest value of  $h$  for which the above described construction is possible. (Requiring that  $x_A \geq -h$  leads to the same inequality.)

With  $a$ ,  $h$ , and  $k$  properly chosen there are then two solutions of (22) which form the curve  $\Lambda$  satisfying the conditions of Theorem I - more specifically the points where the velocity vector  $(\dot{x}, \dot{y})$  of (20) is tangent to  $\Lambda$  are isolated and of the types described in that theorem. The region bounded by  $\Lambda$  is therefore mapped into itself under the transformation  $T$  and there is then a fixed point in this region corresponding to a periodic solution of (2).

At points where  $f(x_0) < 0$  there is a fixed point under  $T^{-1}$  by this reasoning, but such a point would likewise be fixed under  $T$ , since  $T$  is one-one. If this is the only fixed point in the region then clearly the periodic solution to which it corresponds is unstable.

Reasoning similar to that used in Sections 4 and 5 on the region of divergence for the equation (1) can be used to advantage in particular cases of the general equation (2).

The theorem of this section might seem to restrict  $k$  always to be very small, but of course the size of  $k$  is determined by the form of the functions  $f(x)$  and  $g(x)$ . For instance the linear equation

$$\ddot{x} + a\dot{x} + x = k \cos \omega t, \quad a > 0,$$

possesses a periodic solution (period  $2\pi/\omega$ ) no matter how large  $k$  might be. Our theorem confirms

rather than denies this. It should be noted that (see (23) ) the restriction on  $\underline{k}$  in this case becomes

$$0 \leq h(1-\lambda) - k(1+\lambda),$$

since here  $R(\xi) = 0$ . This can be satisfied no matter how large  $\underline{k}$  be taken since  $\underline{h}$  may be taken as large as we please (  $f(0+\xi) = a > 0$  for all  $\xi$  ).

## VII. ON THE CONSTRUCTION OF PERIODIC SOLUTIONS OF SINGULAR PERTURBATION PROBLEMS

By Wolfgang Wasow<sup>1</sup>

### Introduction

The classical perturbation theory is concerned with differential equations which, when solved for the highest derivative, depend continuously on a small parameter  $\epsilon$ .<sup>2</sup> More recently, perturbation problems for differential equations in which the highest derivative is multiplied by a positive power of the parameter have been studied by several authors. Following the terminology introduced in [1] such perturbation problems will be called singular.

I. M. Volk has developed in [5], [6], [7] a convenient formal scheme by means of which the existence and construction of singular perturbations satisfying prescribed conditions can be studied in many cases. The method is particularly well adapted to the construction of periodic singular perturbations. This is the problem discussed by Volk. But Volk's proof of the validity of his method contains a serious error, which will be pointed out in the appendix. In view of this error, Volk's results can be considered proved only in the case that the variational equations have

1. Department of Mathematics, Swarthmore College.

2. The results presented in this paper were obtained in the course of research conducted under the sponsorship of the Office of Naval Research, contract no. N6ori-105, Task order 5, identification number NR043-942.

constant coefficients.

The aim of the present paper is to investigate, with the help of Volk's scheme, problems whose variational equations do not necessarily have constant coefficients. This will be done by combining ideas of Volk with methods similar to those used in [4]. That paper is essentially based on the general asymptotic theory of linear differential equations involving a large parameter (see, e.g., Turrittin, [3]). This theory has not yet been developed in sufficient generality for systems of differential equations. For this reason the present paper deals with a single equation of the  $n$ -th order rather than with a system of first order equations as in the papers by Volk and in [1]. This is, of course, more a difference in form than in substance.

Our problem also differs in several respects from the one discussed in [1]. It is more general in that the drop in the order of the differential equation when  $\epsilon$  is replaced by zero may here be greater than one, and also, because our present method yields a practical scheme for the construction of the perturbation. As in [4] the result will be seen to depend essentially on the size of the drop in the order of the differential equation. On the other hand, we have to assume here that the differential equation depends analytically on the unknown function and its derivatives, whereas in [1] only the existence of two continuous derivatives was required.

### Part 1. Non-autonomous oscillations

§1. Statement of the problem. The differential equation in whose periodic solutions we are interested is of the form

$$(1.1) \quad \epsilon^k \frac{d^n X}{dt^n} = F(X, \frac{dX}{dt}, \dots, \frac{d^m X}{dt^m}; t; \epsilon)$$

In this differential equation  $t$  is a real variable,  $\epsilon$  is a small real parameter,  $k$  a positive integer, and  $n > m$ . The right member is regular analytic in all its arguments and real for real arguments. More precisely: The function  $F(z_0, z_1, \dots, z_m; t; \epsilon)$  is regular in all arguments in an open domain  $D$  of the  $(z_0, z_1, \dots, z_m; t; \epsilon)$ -space containing the whole  $t$ -axis, an interval  $|\epsilon| \leq \epsilon_0$ , where  $\epsilon_0 > 0$ , and intervals of the  $z_\nu$  ( $\nu = 0, 1, \dots, m$ ) to be specified later. We assume that the function  $F$  is periodic in  $t$  with a period  $T$  which is independent of  $\epsilon$  and of the  $z_\nu$ .

In this part we study the non-autonomous case, i.e.,  $F$  must actually depend on  $t$ . The more difficult autonomous case in which  $F$  is assumed to be independent of  $t$  is the subject of part II.

If  $\epsilon$  is replaced by zero in the "full differential equation" (1.1), the "reduced differential equation"

$$(1.2) \quad 0 = F(x, \frac{dx}{dt}, \dots, \frac{d^m x}{dt^m}; t, 0)$$

is obtained, whose order is at most  $m$ .

Wherever possible we shall use capital letters to designate functions depending on  $\epsilon$ , and lower case letters for quantities independent of  $\epsilon$ . Accordingly, we have denoted the solutions of (1.2) by  $x$  and those of (1.1) by  $X$ .

Without loss of generality we exclude the possibility that the right hand side of (1.2) is identically zero; for in that case cancellation of a power of  $\epsilon$  on both sides of (1.1) would reduce the problem to a similar one with a smaller value of  $k$  and a right

member which does not vanish identically for  $\epsilon = 0$ , or to a problem in which the  $n$ -th derivative of  $X$  does no longer disappear when  $\epsilon$  is replaced by zero.

Our perturbation method is based on the assumption that we know a periodic solution  $x = u(t)$  with period  $T$  of the reduced equation (1.2). This function  $u(t)$  will be referred to as the "base solution". It is assumed to possess continuous derivatives of all orders. We mention this because perturbation problems with discontinuous base solutions have also been studied recently (cf. e.g., N. Levinson, [2]). We have to require, of course, that all points

$$z_\nu = u^{(\nu)}(t), \quad \epsilon = 0, \quad (\nu=0,1,\dots,m)$$

of the  $(z_0, z_1, \dots, z_m; t; \epsilon)$ -space lie in  $D$ .

Our aim is to find periodic solutions  $U(t, \epsilon)$  of (1.1) such that

$$\lim_{\epsilon \rightarrow 0} U(t, \epsilon) = u(t)$$

We shall show that such solutions exist, if the variational equation belonging to  $u(t)$  satisfies certain conditions.

Let the periodic function  $p_i(t)$ ,  $(i=0,1,\dots,m)$  be defined by

$$p_{i\downarrow}(t) = \frac{\partial}{\partial u^{(i)}} F(u, u', \dots, u^{(m)}; t; 0), \quad (i=0,1,\dots,m)$$

Assumption A: The function  $p_m(t)$  is different from zero for all  $t$ .

This assumption is similar to inequality (4) of [1], but it is less restrictive, since the latter inequality corresponds to the special case  $m = n - 1$ .

Assumption A implies, in particular, that the order of the reduced equation is not less than  $m$ .

We shall have to distinguish between the "full variational equation"

$$(1.3) \quad \epsilon^k \frac{d^n V}{dt^n} = \sum_{i=0}^m p_i(t) \frac{d^i V}{dt^i}$$

and the "reduced variational equation"

$$(1.4) \quad 0 = \sum_{i=0}^m p_i(t) \frac{d^i V}{dt^i}$$

By virtue of Assumption A equation (1.4), when solved for  $\frac{d^m V}{dt^m}$ , has analytic periodic coefficients.

Definition: In the non-autonomous case the base solution  $u(t)$  is called degenerate, if one of the characteristic exponents of the corresponding reduced variational equation is zero.

Assumption B: The base solution is not degenerate.

It is clear that this condition is equivalent to the requirement that the reduced variational equation have no non-trivial solution of period  $T$ .

The differential equation (1.1) is, of course, not the most general differential equation for which singular perturbation problems can be formulated. In particular, it could be generalized by permitting the presence of terms involving orders of differentiation between  $m$  and  $n$ . It seems doubtful, whether the results of the present paper remain valid when these additional terms are nonlinear. If they are linear, the differential equation can be written in the form

$$(1.1a) \quad \epsilon^k \frac{d^n X}{dt^n} + \sum_{\nu=1}^{n-m-1} \epsilon^{k_\nu} a_\nu(t, \epsilon) \frac{d^{(n-\nu)} X}{dt^{n-\nu}} \\ = F\left(X, \frac{dX}{dt}, \dots, \frac{d^m X}{dt^m}; t, \epsilon\right),$$

where the  $k_\nu$  are positive integers, and the functions  $a_\nu(t, \epsilon)$  are regular analytic at  $\epsilon=0$  without vanishing there identically in  $t$ . The methods of the present paper can be extended to differential equations of the form (1.1a). In the interest of a more readable presentation we shall limit our investigations to the equation (1.1) except for the remark that our conclusions remain literally unchanged, if the exponents  $k_\nu$  in (1.1a) satisfy the inequalities

$$\frac{k_\nu}{k_\nu} \leq \frac{n-m}{n-m-\nu}, \quad (\nu = 1, 2, \dots, n-m-1)$$

If these inequalities are not satisfied, the analog of lemma 3.1 below will be subject to modifications which affect the result of the argument.

§2. The Formal Procedure      If we define  $Y(t)$  by

$$(2.1) \quad X(t) = u(t) + Y(t)$$

equation (1.1) becomes

$$(2.2) \quad \epsilon^{k_Y(n)} = F(u+Y, u'+Y', \dots, u^{(m)}+Y^{(m)}; t; \epsilon) - \epsilon^{k_u(n)}$$

We expand the right side in powers of  $Y, Y', \dots, Y^{(m)}, \epsilon$  combined, and obtain

$$(2.3) \quad \epsilon^{k_Y(n)} = \sum_{i=0}^m p_i(t) Y^{(i)} + \epsilon a(t) + H(Y, Y', \dots, Y^{(m)}; t; \epsilon)$$

where

$$a(t) = \begin{cases} \left( \frac{\partial}{\partial \epsilon} F(u, u', \dots, u^{(m)}; t; \epsilon) \right)_{\epsilon=0} - u^{(n)}(t), & \text{if } k=1 \\ \left( \frac{\partial}{\partial \epsilon} F(u, u', \dots, u^{(m)}; t; \epsilon) \right)_{\epsilon=0}, & \text{if } k>1 \end{cases}$$

and  $H$  is a convergent power series in  $Y, Y', \dots, Y^{(m)}, \epsilon$  combined, which contains no terms of lower than second degree. The coefficients of this power series are known functions of  $t$  with period  $T$ .

In order to find a periodic solution of (2.3) we write, tentatively,

$$(2.4) \quad Y = \sum_{r=1}^{\nu} \epsilon^r Y_r$$

and insert this series in (2.3), differentiating termwise without regard to convergence. Then we rearrange the resulting power series formally with respect to  $\epsilon$ . But in contrast to the usual procedure we preserve the factor  $\epsilon^k$  in the left member, so that we obtain, upon formal identification of the coefficients of like powers of  $\epsilon$  on both sides of the equality, the infinite sequence of differential equations

$$(2.5) \quad \epsilon^k Y_r^{(n)} = \sum_{i=0}^m p_i(t) Y_r^{(i)} + H_r, \quad (r=1, 2, \dots)$$

here  $H_r$  is a polynomial in the quantities  $Y_{\alpha}^{(\nu)}$ , ( $\nu=0, 1, \dots, m$ ) with no value of  $\alpha$  greater than  $r-1$  occurring, in consequence of the fact that the power series  $H$  contains no terms of lower than the second degree. In particular,  $H_1 = a(t)$ .

This property of  $H_r$  permits us to determine all  $Y_r$  by solving the linear differential equations (2.5) for successive values of  $r$ . At each stage  $H_r$  is a known function of  $t$  and  $\epsilon$ .

This formal scheme is analogous to the one used by Volk in [5].

It should be emphasized that (2.4) is not a power series, since the solutions of (2.5) depend on  $\epsilon$ .

Each equation (2.5), being a linear non-homogeneous

differential equation with coefficients of period  $T$  possesses a periodic solution for all those values of  $\epsilon$  for which zero is not a characteristic exponent of the full variational equation. This periodic solution is unique for given value of  $\epsilon$ . Since, by assumption B, the reduced variational equation does not have zero as characteristic exponent, it seems plausible to expect that - under appropriate conditions - each equation (2.5) has a periodic solution tending, as  $\epsilon \rightarrow 0$ , to a periodic solution of the corresponding reduced equation obtained by setting  $\epsilon = 0$  in (2.5).

In the next section it will be shown that this is actually the case. In §4 the series (2.4) will then be shown to converge and to represent a solution of (1.1) with period  $T$ .

### §3. Lemmas On Linear Differential Equations

We shall need some facts concerning the asymptotic character of the solutions of the full variational equation. These facts are an immediate application of the classical asymptotic theory of differential equations involving a parameter (see [3] and [4]). In order to state them in convenient form we introduce the following abbreviations.

#### Definition 3.1

a) Whenever the special nature of a function is irrelevant, the letter  $E$  will be used as a generic symbol for functions of  $t$  and  $\epsilon$  which are bounded, together with their  $n-1$  first derivatives with respect to  $t$ , for  $\alpha \leq t \leq \beta$ , and for  $\epsilon$  in some closed interval  $I$  that includes  $\epsilon = 0$  as interior or endpoint. Whenever necessary,  $\alpha$ ,  $\beta$  and  $I$  will be specified in subsequent applications of this symbol. Occasionally, the letter  $E$  will designate a function of  $\epsilon$  alone, independent of  $t$ .

b) The symbol  $[f(t)]$  will be used to denote a function of the form

$$(3.1) \quad [f(t)] = f(t) + \epsilon^\delta E, \quad \delta > 0$$

Whenever necessary, the value of  $\delta$  will be specified.

Lemma 3.1. The full variational equation possesses a fundamental system  $V_\nu = V_\nu(t, \epsilon)$ ,  $(\nu=1, 2, \dots, n)$ , with the asymptotic representation

$$(3.2a) \quad V_\nu = \begin{cases} e^{\sigma \Phi_\nu(t)} [\eta] & \nu = 1, 2, \dots, n-m \\ [v_{\nu-n+m}] & \nu = n-m+1, \dots, n \end{cases},$$

In these expressions

1)  $v_1, \dots, v_m$  is an arbitrary fundamental system of the reduced variational equation,

$$2) \sigma = |\epsilon^{-k/(n-m)}|$$

3) The number  $\delta$  of (3.1) is equal to  $k/(n-m)$  in (3.2a) and equal to  $k$  in (3.2b).

The interval  $I$  of definition 3.1 may here be any interval containing  $\epsilon = 0$  as endpoint, but it should be noted that a fundamental system represented asymptotically by (3.2) for positive  $\epsilon$  is not necessarily so represented for negative  $\epsilon$ . The interval  $\alpha \leq t \leq \beta$  is arbitrary.

5)  $\Phi_\nu(t) = \int_\alpha^t \varphi_\nu(\tau) d\tau$ , where  $\varphi_\nu(t)$  are the  $n-m$  determinations of

$${}^{n-m} \sqrt{\operatorname{sgn}(\epsilon^k) p_m(t)}$$

6)  $\eta = \eta(t)$  is a function whose precise form is

irrelevant for our purpose, except for the fact that it is indefinitely differentiable and different from zero for all  $t$ .

A proof of a theorem containing this lemma as a special case may, e.g., be found in [3].

In order to avoid the complications that would be introduced by the occurrence of pure imaginary exponents in (3.2a) we introduce a third - and last - restrictive condition.

Assumption C. At least for one of the two possible signs of  $\epsilon$  all  $n-m$  determinations of  $\epsilon^{n-m} \sqrt{\operatorname{sgn}(\epsilon^k) p_m(t)}$  have non-vanishing real parts.

In the sequel the letter  $I$  will be reserved for closed intervals of the  $\epsilon$ -axis containing the point  $\epsilon=0$  and such that no value of  $\epsilon^{n-m} \sqrt{\operatorname{sgn}(\epsilon^k) p_m(t)}$  has non-vanishing part for  $\epsilon$  in  $I$ .

Lemma 3.2. In the differential equation

$$(3.3) \quad \epsilon^k Z^{(n)} = \sum_{i=0}^m p_i(t) Z^{(i)} + G(t, \epsilon)$$

let assumption C be satisfied, and let  $G(t, \epsilon)$  be continuous for  $\alpha \leq t \leq \beta$  and for  $\epsilon$  in an interval  $I$  containing  $\epsilon=0$  as an endpoint, then there exists a particular solution  $Z=W$  of (3.3) for which in  $\alpha \leq t \leq \beta$

$$(3.4) \quad |W^{(j)}| \leq \begin{cases} c \max |G(t, \epsilon)|, & (j=0, 1, \dots, m) \end{cases}$$

$$(3.5) \quad \begin{cases} \sigma^{(j-m)} c \max |G(t, \epsilon)|, & (j=m+1, \dots, n-1) \end{cases}$$

where  $c$  is independent of  $G(t, \epsilon)$  and of  $\epsilon$ , and  $\max |G(t, \epsilon)|$  is the maximum of  $|G(t, \epsilon)|$  in  $\alpha \leq t \leq \beta$ , for  $\epsilon$  in  $I$ .

Proof: Let the functions  $V_j$  be arranged in such a way

that, for  $\epsilon$  in  $I$ ,

$$(3.6) \quad \operatorname{Re}(\Phi_1) \geq \operatorname{Re}(\Phi_2) \geq \dots \geq \operatorname{Re}(\Phi_{n-m})$$

and let  $p$  be the largest integer such that  $\operatorname{Re}(\Phi_p) > 0$ . By assumption C all  $\Phi$  with  $\nu > p$  have negative real parts. If we denote by  $\tilde{V}_\nu$  the solutions of the linear algebraic system

$$(3.7) \quad \sum_{\nu=1}^n V_\nu^{(j-1)} \tilde{V}_\nu = \delta_{nj}, \quad (j=1, 2, \dots, n)$$

then it follows from well-known theorems that

$$(3.8) \quad W = \int_{\beta}^t \sum_{i=1}^p V_i(t) \tilde{V}_i(\tau) \epsilon^{-k} G(\tau, \epsilon) d\tau \\ + \int_{\alpha}^t \sum_{i=p+1}^n V_i(t) \tilde{V}_i(\tau) \epsilon^{-k} G(\tau, \epsilon) d\tau$$

is a solution of (3.3). A straightforward calculation shows that

$$(3.9) \quad \tilde{V}_\nu = \begin{cases} \sigma^{-(n-1)} e^{-\sigma \Phi_\nu} E, & \nu = 1, 2, \dots, n-m \\ \sigma^{-(n-m)} E, & \nu = n-m+1, \dots, n \end{cases}$$

If the expressions (3.9) as well as the asymptotic formulas (3.2) are inserted in (3.8), we find

$$(3.10) \quad W = \sigma^{-(m-1)} \int_{\beta}^t \sum_{i=1}^p e^{\sigma(\Phi_1(t) - \Phi(\tau))} E(t, \epsilon) E(\tau, \epsilon) G(\tau, \epsilon) d\tau \\ + \sigma^{-(m-1)} \int_{\alpha}^t \sum_{i=p+1}^{n-m} e^{\sigma(\Phi_1(t) - \Phi(\tau))} E(t, \epsilon) E(\tau, \epsilon) G(\tau, \epsilon) d\tau \\ + \int_{\alpha}^t \sum_{i=n-m+1}^n E(t, \epsilon) E(\tau, \epsilon) G(\tau, \epsilon) d\tau$$

In order to estimate these integrals and their derivatives, let  $E(t, \tau, \epsilon)$  be a function uniformly bounded for  $t$  and  $\tau$  in the closed interval bounded by  $\alpha$  and  $\beta$ , and for  $\epsilon$  in  $I$ . We then note that for any integral of the form

$$\int_{\beta}^t e^{\sigma(\Phi_1(t) - \Phi_1(\tau))} E(t, \tau, \epsilon) G(\tau, \epsilon) d\tau$$

with  $1 \leq p$  we have the estimate

$$\begin{aligned} & \left| \int_{\beta}^t e^{\sigma(\Phi_1(t) - \Phi_1(\tau))} E(t, \tau, \epsilon) G(\tau, \epsilon) d\tau \right| \\ & \leq \sigma^{-1} c_1 \max |G(t, \epsilon)| \int_{\beta}^t e^{\sigma \operatorname{Re}(\Phi_1(t) - \Phi_1(\tau))} \sigma \operatorname{Re} \varphi_1(\tau) d\tau \\ & = \sigma^{-1} c_1 \max |G(t, \epsilon)| \left[ e^{\sigma \operatorname{Re}(\Phi_1(t) - \Phi_1(\tau))} \right]_{\beta}^t \\ & \leq \sigma^{-1} 2c_1 \max |G(t, \epsilon)| \end{aligned}$$

where  $c_1$  is the maximum of  $\left| \frac{E(t, \tau, \epsilon)}{\operatorname{Re} \varphi_1(\tau)} \right|$  for  $t$  and  $\tau$  in  $(\alpha, \beta)$  and  $\epsilon$  in  $I$ . Analogous estimates hold for such integrals extended from  $\alpha$  to  $t$ , when  $p < i \leq n - m$ . Using these estimates the inequalities (3.4) and (3.5) are an immediate consequence of formula (3.10) and the equalities obtained by differentiating it repeatedly.

Lemma 3.3. If the assumptions A, B and C are satisfied and if the function  $G(t, \epsilon)$  of lemma 3.2 has the period  $T$  in  $t$ , then there exists a number  $\epsilon_1 > 0$ , independent of  $G(t, \epsilon)$  such that for  $|\epsilon| \leq \epsilon_1$  and in  $I$  the differential equation (3.3) has a unique periodic solution  $Z(t, \epsilon)$  of period  $T$ . This solution satisfies the relation

$$(3.11) \quad \lim_{\epsilon \rightarrow 0} Z^{(j)}(t, \epsilon) = z^{(j)}(t), \quad (j=0, 1, \dots, m), \quad \epsilon \text{ in } I$$

where  $z(t)$  is the unique solution of period  $T$  of the reduced differential equation

$$(3.12) \quad 0 = \sum_{i=0}^m p_i(t) z^{(i)} + G(t, 0)$$

The convergence is uniform for all  $t$ . If a fundamental system of the full variational equation is known,  $Z(t, \epsilon)$  can be found by quadratures and rational operations.

Proof: In the argument that follows let  $I$  be chosen so that  $\epsilon = 0$  is an endpoint of  $I$ . If intervals  $I$  containing  $\epsilon = 0$  as interior point are possible (we recall the remark following assumption C), then the reasoning can be applied to each of the two subintervals of  $I$  bounded by  $\epsilon = 0$  separately. Let

$$(3.13) \quad W = Z - z$$

The function  $W$  satisfies the differential equation

$$(3.14) \quad \epsilon^k W^{(n)} = \sum_{i=0}^m p_i W^{(i)} + Q(t, \epsilon)$$

where

$$(3.15) \quad Q(t, \epsilon) = G(t, \epsilon) - G(t, 0) - \epsilon^k z^{(n)}(t)$$

$Q(t, \epsilon)$  has the period  $T$ . Observe that

$$(3.16) \quad \lim_{\epsilon \rightarrow 0} Q(t, \epsilon) = 0, \quad \text{for } \epsilon \text{ in } I$$

uniformly for all  $t$ . Let  $W_p$  be a particular solution of (3.14), then the general solution  $W$  will be given by

$$(3.17) \quad W = \sum_{\nu=1}^n C_\nu V_\nu + W_p$$

where  $C_\nu$  are arbitrary constants depending on  $\epsilon$ . This solution  $W$  will have the period  $T$ , if and only if the  $C_\nu$  are determined in such a way that the equations

$$(3.18) \quad \sum_{\nu=1}^n C_\nu (V_\nu^{(\mu)}(\alpha+T) - V_\nu^{(\mu)}(\alpha)) = W_p^{(\mu)}(\alpha) - W_p^{(\mu)}(\alpha+T)$$

$$(\mu=0, 1, \dots, n-1)$$

hold for some particular  $\alpha$  - and hence for all  $\alpha$ .

Let us take as  $W_p(t, \epsilon)$  a solution of (3.14) to which lemma 3.2 can be applied. In applying this lemma we take  $\beta = \alpha + T$ . Let  $\Delta$  be the determinant of the left members in the linear algebraic system (3.18) and  $\Delta_\nu$  the determinant obtained by replacing the  $\nu$ -th column by the right members. In these determinants we insert now the asymptotic expressions (3.2) and apply the inequalities (3.4) and (3.5) to  $W_p$ .

If the determinant  $\Delta$  is expanded with respect to the minors of the first  $n-m$  columns, it is seen that the term originating from the last  $n-m$  rows has formally higher order of magnitude than all the others. A short calculation shows that this term is of the form



(3.20)

$$C_\nu = \begin{cases} \sigma^{-m} \epsilon^{-\sigma} \Phi_\nu(\alpha+T) E \max |Q(t, \epsilon)| & , \nu=1, 2, \dots, p \\ \sigma^{-m} E \max |Q(t, \epsilon)| & , \nu=p+1, \dots, n-m \\ E \max |Q(t, \epsilon)| & , \nu=n-m+1, \dots, n \end{cases}$$

If these results, as well as (3.2) are inserted in (3.17) the periodic solution  $W$  is seen to be of the form

$$(3.21) \quad W = \sigma^{-m} \sum_{\nu=1}^p e^{\sigma(\Phi_\nu(t) - \Phi_\nu(\alpha+T))} E + \sigma^{-m} \sum_{\nu=p+1}^{n-m} e^{\sigma\Phi_\nu(t)} E \\ + \max |Q(t, \epsilon)| E + W_p$$

$W_p$  satisfies the inequalities (3.4) and (3.5) with  $G(t, \epsilon)$  replaced by  $Q(t, \epsilon)$ . It follows that  $W$  and its first  $m$  derivatives tend to zero, as  $\epsilon \rightarrow 0$  in  $I$ , uniformly in every closed subinterval of  $\alpha < t < \alpha + T$ . For the  $m$ -th derivative the points  $\alpha$  and  $\alpha+T$  might possibly be exceptional. But since  $\alpha$  is arbitrary and  $W$  has the period  $T$ , this implies that  $W^{(j)}$  tends to zero uniformly for all  $t$ , for  $j=0, 1, \dots, m$ . This completes the proof of lemma 3.3.

The periodic solution  $z$  of (3.12) satisfies an inequality of the form

$$|z^{(i)}| \leq c_2 \max |G(t, 0)| \quad , \quad (i=0, 1, \dots, m)$$

where  $c_2$  is a constant independent of  $G(t, 0)$ . The expressions  $E$  occurring in (3.21) are independent of  $G(t, \epsilon)$ . This shows readily that the following corollary is true.

Corollary: Under the assumptions and with the notations of lemma 3.3 there exists a constant  $c$ , independent of  $t, \epsilon, \nu$  and  $G(t, \epsilon)$  such that

$$|Z^{(\nu)}(t, \epsilon)| \leq c \max |G(t, \epsilon)|, \quad (\nu=0, 1, \dots, m)$$

for all  $t$ , and for all  $\epsilon$  in  $I$  for which  $|\epsilon| \leq \epsilon_1$ .

#### §4. The Convergence Proof

Lemma 3.3 applied successively to the differential equations (2.5) for  $r=1, 2, \dots$  shows that, if there is an interval  $I$  of  $\epsilon$  in which condition C is satisfied, then there exists for every  $\epsilon$  in  $I$  with  $|\epsilon| \leq \epsilon_1$  a periodic solution  $Y_r$  tending to a finite limit together with its first  $m$  derivatives, as  $\epsilon \rightarrow 0$ . All these solutions satisfy the inequalities

$$(4.1) \quad \left| Y_r^{(\nu)} \right| \leq c \max \left| H_r \right|, \quad (\nu=0, 1, \dots, m)$$

for  $\epsilon$  in  $I$  and  $|\epsilon| \leq \epsilon_1$  (cf. the preceding corollary).

To complete our arguments we have to investigate the convergence of the series (2.4) when the  $Y_r$  are these periodic functions.

We begin by constructing a power series dominating the power series  $H(Y, Y', \dots, Y^{(m)}; t; \epsilon)$  occurring in (2.3). Let  $\eta_\nu, (\nu=0, 1, \dots, m), \epsilon_2$  be numbers such that the series  $H$  converges for

$$(4.2) \quad \left| Y^{(\nu)} \right| \leq \eta_\nu, \quad |\epsilon| \leq \epsilon_2$$

and let  $A_{k_0, \dots, k_m, k}$  be the coefficient of the term in that series which contains  $Y^{(\nu)}$  to the power  $k$ . If  $h$  is some constant such that

$$|H| \leq h$$

in the domain defined by (4.2) and for all  $t$ , then it is well known that

$$(4.3) \quad |A_{k_0, \dots, k_m, k}| \leq \frac{h}{\epsilon_2^k \prod_{\nu=0}^m \eta_\nu^{k_\nu}}$$

If we replace each coefficient of the series for  $H$  by the corresponding right member of (4.3), we obtain a new power series, which dominates  $H$ ; it is independent of  $t$  and converges in the domain defined by (4.2). Also, it contains no term of lower than second degree. Let  $\hat{H}(Y, Y', \dots, Y^{(m)}; \epsilon)$  be the function defined by this series.

Now we introduce a formal series

$$(4.4) \quad \sum_{r=1}^{\infty} a_r \epsilon^r$$

with the  $a_r$  as yet undetermined, and replace every  $Y^{(\nu)}$ , ( $\nu=0, 1, \dots, m$ ) in the series for  $H$  by this series. After reordering with respect to powers of  $\epsilon$ , there results a formal power series in  $\epsilon$  in which the coefficient  $\theta_r$  of  $\epsilon^r$  is a polynomial in the  $a_r$ . These formal operations are analogous to those by means of which the functions  $H_r$  in (2.5) were obtained from  $H$  in (2.3). From the properties of  $H$  it follows, in particular, that  $\theta_r$  contains no  $a_\nu$  with a subscript greater than  $r-1$ .

It is also seen that if the  $a_r$  are chosen so as to satisfy for any  $s > 1$  the inequalities

$$(4.5) \quad \left| Y_r^{(j)} \right| \leq a_r, \quad \text{for} \quad \begin{cases} j=0, 1, \dots, m \\ r=1, 2, \dots, s-1 \\ \text{all } t, \epsilon \in I, |\epsilon| \leq \epsilon_1 \end{cases}$$

then the inequality

$$(4.6) \quad |H_s| \leq \theta_s$$

follows.

In order to find values of  $a_r$  satisfying (4.5) for all  $s$  and suitable for our purpose we chose  $a_1$  arbitrarily, but so that (4.5) is satisfied for  $s=2$  and determine  $a_r$ ,  $r > 1$ , successively from the equations

$$(4.7) \quad a_r = c\theta_r(a_1, a_2, \dots, a_{r-1}), \quad (r=2, 3, \dots)$$

where  $c$  is the constant occurring in (4.1). Let us assume for the purpose of mathematical induction that the inequalities (4.5) are true for a given  $s$ . Then (4.6) is true and, using (4.1), we have

$$\left| Y_s^{(r)} \right| \leq c \max |H_s| \leq c\theta_s = a_s$$

Hence, (4.5) is true for all  $r$ .

In order to establish the uniform convergence of the series (2.4) and its formal derivatives up to order  $m$  it suffices, in view of (4.5), to prove the convergence of series (4.4) with the  $a_r$  defined by (4.7).

To do this we note that, in consequence of the definition of  $\theta_r$ , this series (4.4) could be constructed - once  $a_1$  is chosen - by inserting (4.4) for  $\xi$  in the equation

$$(4.8) \quad c \hat{H}(\xi, \xi, \dots, \xi; \epsilon) + \epsilon a_1 - \xi = 0$$

and setting the coefficients of all powers of  $\epsilon$  equal to zero. On the other hand, (4.8) is satisfied by  $\epsilon = \xi = 0$ , and the partial derivative of the left member of (4.8) with respect to  $\xi$  does not vanish at  $\epsilon = \xi = 0$ ; In fact, it is equal to -1 there. From the implicit function theorem for analytic functions it follows then that (4.8) defines  $\xi$  as a regular analytic function of  $\epsilon$  in the neighborhood of  $\epsilon=0$ . The series (4.4), constructed above, must therefore represent this function, and, thus, it converges for  $|\epsilon| \leq \epsilon_3$ , with  $\epsilon_3 > 0$ .

The foregoing convergence proof is a variation of the reasoning in Volk [5].

Next, we must prove that the series (2.4) satisfies the differential equation (2.3). To that end we multiply the  $r$ -th equation (2.5) by  $\epsilon^r$  and sum over  $r$ . In view of the uniform convergence with respect to  $t$  of the termwise derivatives of (2.4) up to order  $m$ , proved above, the right hand side of the resulting equation is for fixed  $\epsilon$  a uniformly convergent series, and the same must therefore be true of the left hand side, i.e. of  $\epsilon^k \sum_{r=1}^{\infty} \epsilon^r Y_r^{(n)}$ . Because of the way the functions  $Y_r$  were defined, the series on the right hand side represents the function on the right hand side of (2.3). So it remains only to be shown that  $\sum_{r=1}^{\infty} \epsilon^r Y_r^{(n)} = Y^{(n)}$ . This follows from the uniform convergence of  $\sum_{r=1}^{\infty} \epsilon^r Y_r^{(m)}$ , by means of a fairly obvious modification of the standard proof justifying termwise differentiation of a convergent series, if the resulting series converges uniformly.

Before we proceed to summarize our results in the form of a theorem we reformulate assumption C in a more immediately verifiable manner. It is readily seen that

1) Condition C is satisfied for positive as well as for negative  $\epsilon$ , if  $n-m$  is odd, and also if  $n-m$  is even and at the same time  $k$  is even and  $(-1)^{(n-m)/2} p_m(t)$  is negative. In that case our results concerning the convergence of  $Y(t, \epsilon)$  are true for approach to  $\epsilon = 0$  from either side. We then call the differential equation (1.1) parametrically regular.

2) If  $n-m$  is even and  $k$  is odd, condition C is satisfied for positive  $\epsilon$  only, if  $(-1)^{(n-m)/2} p_m(t)$  is positive. In this case the differential equation (1.1) will be called parametrically halfregular from the right. Similarly, if  $n-m$  is even,  $k$  is odd and  $(-1)^{(n-m)/2} p_m(t)$  is negative, condition C is satisfied

for negative  $\epsilon$  only. We then call the differential equation (1.1) parametrically halfregular from the left.

3) If  $n-m$  is even,  $k$  is even and  $(-1)^{(n-m)/2} p_m(t)$  is positive, condition C is never satisfied. This is the parametrically irregular case.

Theorem 1.

(a) If conditions A and B are satisfied and the differential equation (1.1) is not parametrically irregular, there exists a closed interval I containing the point  $\epsilon=0$ , such that for every  $\epsilon$  in I this differential equation possesses a periodic solution  $U(t, \epsilon)$  of period T, for which

$$\lim_{\epsilon \rightarrow 0} U^{(j)}(t, \epsilon) = u^{(j)}(t), \quad (j=0, 1, \dots, m)$$

uniformly in t.

If the differential equation is parametrically regular,  $\epsilon=0$  is an interior point of I; if it is half regular from the right or left,  $\epsilon=0$  is the left or right endpoint of I, respectively.

(b) If a fundamental system of the full variational equation is known, a convergent series representation for  $U(t, \epsilon)$  can be found by quadratures. This series is of the form

$$U(t, \epsilon) = u(t) + \sum_{r=1}^{\infty} Y_r(t, \epsilon) \epsilon^r$$

where the functions  $Y_r(t, \epsilon)$  are continuous for  $\epsilon$  in I and have the period T in t.

Remark 1: Applying lemma 3.3 to the differential equation (2.5) for  $r=1$  we see that to within terms of order higher than one in  $\epsilon$ ,  $U(t, \epsilon)$  equals the function

$$u(t) + \epsilon y_1(t)$$

where  $y_1(t)$  is the periodic solution of

$$0 = \sum_{i=0}^m p_i y_1^{(i)} + a(t)$$

Remark 2: Nothing has been proved here concerning the parametric irregular case. Simple examples (see Volk [5], p. 573) show that the statements of our theorem do not always extend to that case.

Remark 3: Our theorem does not imply that the derivatives of  $U(t, \epsilon)$  of order higher than  $m$  converge to the corresponding derivatives of  $u(t)$ , as  $\epsilon \rightarrow 0$  in  $I$ .

## Part II. Autonomous Oscillations

### §5. The Problem. The Non-Degeneracy Condition

In this part the results of Part I will be extended to the differential equation

$$(5.1) \quad \epsilon^k \frac{d^n X}{dt^n} = f\left(X, \frac{dX}{dt}, \dots, \frac{d^m X}{dt^m}; \epsilon\right)$$

which differs from (1.1) only in that  $t$  does not occur explicitly in the right member.

In the present problem every solution  $X(t, \epsilon)$  of (5.1) gives rise to infinitely many solutions of the form  $X(t+t_1, \epsilon)$  where  $t_1$  is an arbitrary constant. If one of these solutions has the period  $T$ , all of them do. The same is true for the solutions of the reduced equation

$$(5.2) \quad 0 = F\left(x, \frac{dx}{dt}, \dots, \frac{d^m x}{dt^m}; 0\right)$$

It follows that if there is one periodic solution  $U(t, \epsilon)$  of (5.1) tending uniformly to a given periodic solution  $u(t)$  of (5.2) there are infinitely many others with this property, e.g., all functions  $U(t + \epsilon t_1, \epsilon)$ . It is therefore possible and desirable to impose an additional condition on the periodic solution to be found. We find it convenient to require that

$$(5.3) \quad U(0, \epsilon) = u(0)$$

In the present problem the base period  $T$  is defined by the period of the given base solution  $u(t)$  and not by the differential equation itself. It is therefore plausible that the special case  $u(t) = \text{constant}$  will give rise to a perturbation problem of a somewhat exceptional character, since the period  $T$  is undefined. If the derivative  $\partial F(z_1, \dots, z_n; \epsilon) / \partial z_1$  does not vanish for  $z_1 = u$ ,  $z_2 = z_3 = \dots = z_n = 0$ ,  $\epsilon = 0$ , the implicit function theorem guarantees then the existence of a constant real solution of (5.1) tending to  $u(t)$  as  $\epsilon \rightarrow 0$ . Except for this one remark we leave this case aside and stipulate that  $u(t)$  is not a constant.

Finally, since  $u(t + t_1)$  is, for all  $t_1$ , a periodic solution of (5.2), and since  $u(t)$  is not a constant, no loss of generality is involved, if we assume that

$$(5.4) \quad u'(0) \neq 0$$

In addition to the conditions mentioned the base solution will have to satisfy assumptions A and B of Part I. However, condition B differs from the analogous condition in Part I, because the concept of degeneracy must here be defined differently.

In fact, the reduced variational equation

possesses in  $v=u'(t)$  a non-trivial periodic solution. This implies that one of its characteristic exponents is zero.

Definition: In the autonomous case the base solution  $u(t)$  is called degenerate, if the corresponding reduced variational solution has zero as a multiple root.

Lemma 5.1. Let  $v_j(t)$ , ( $j=1,2,\dots,m$ ), be a fundamental system of solutions of the reduced variational equation corresponding to the base solution  $u(t)$ . Then  $u(t)$  is degenerate, if and only if the rank of the matrix

(5.5)

$$\begin{pmatrix} u'(0) & v_1(T)-v_1(0) & v_2(T)-v_2(0) & \dots & v_m(T)-v_m(0) \\ u''(0) & v_1'(T)-v_1'(0) & v_2'(T)-v_2'(0) & \dots & v_m'(T)-v_m'(0) \\ \dots & \dots & \dots & \dots & \dots \\ \binom{m}{u(0)} & \binom{m-1}{v_1(T)-v_1(0)} & \binom{m-1}{v_2(T)-v_2(0)} & \dots & \binom{m-1}{v_m(T)-v_m(0)} \end{pmatrix}$$

is less than  $m$ .

Proof: It is clear that the rank of the matrix (5.5) does not depend on the choice of the fundamental system  $v_j(t)$ . Without loss of generality we may therefore assume that

$$(5.6) \quad v_j^{(i-1)}(0) = \delta_{ji} \quad , \quad (i,j=1,2,\dots,m)$$

where  $(\delta_{ji}) = I$  is the identity matrix. To abbreviate the notation we write  $A$  for the matrix with the element  $v_j^{(i-1)}(T)$  at the intersection of the  $j$ -th column and the  $i$ -th row. Since  $u'(t)$  is a solution of the reduced variational equation, we can write

$$u'(t) = \sum_{j=0}^m u^{(j)}(0)v_j(t)$$

and the periodicity of  $u'(t)$  expresses itself by the relation

$$(5.7) \quad (A-I)\vec{d} = 0$$

where  $\vec{d}$  is the column vector with components  $u'(0)$ ,  $u''(0), \dots, u^{(m)}(0)$ . If and only if the rank of the matrix (5.5) is less than  $m$ , there exists a vector  $\vec{e}$ , linearly independent of  $\vec{d}$ , such that

$$(5.8) \quad (A-I)\vec{e} = \lambda \vec{d}$$

where  $\lambda$  is a scalar constant. The relations (5.7) and (5.8) taken together are equivalent to the statement that the matrix  $A$  has one as a multiple root (see, e.g., H. Weyl, Math. Analyse des Raumproblems, p.92). The characteristic roots of  $A$  are the characteristic roots of the reduced variational equation. If one is a multiple characteristic root of that differential equation, then zero is a multiple characteristic exponent and vice versa.

Corollary: The values 0 and  $T$  may be replaced in (5.5) by  $\alpha$  and  $\alpha+T$ , where  $\alpha$  is arbitrary.

Remark: As in [1] it could be shown that  $u(t)$  is non-degenerate, if and only if all solutions  $x(t)$  differ from periodicity by terms of the first order, provided the point  $t=0$  is adjusted so that  $x(0)=u(t)$ .

§6. The Formal Procedure. The periodic solutions of (5.1), if they exist, will have a period that depends on  $\epsilon$ . In order to operate with a constant period we

introduce a new independent variable  $s$  by the transformation

$$(6.1) \quad t = s(1+\Omega)$$

where  $\Omega$  is a function of  $\epsilon$  to be determined later. This transformation changes the differential equation (5.1) into

$$(6.2) \quad \epsilon^k X^{(n)} = (1+\Omega)^n F(X, X' (1+\Omega)^{-1}, \dots, X^{(m)} (1+\Omega)^{-m};$$

Here the dash indicates differentiation with respect to  $s$ .  
If we define  $Y(s)$  by

$$(6.3) \quad X(s) = u(s) + Y(s)$$

and expand the right member of (6.2) in powers of  $Y, Y', \dots, Y^{(m)}, \Omega, \epsilon$ , combined, we obtain, in analogy to (2.5)

$$(6.4) \quad \epsilon^k Y^{(n)} = \sum_{i=0}^m p_i(s) Y^{(i)} + a(s)\epsilon + b(s)\Omega + H(Y, Y', \dots, Y^{(m)}; s; \Omega);$$

where

$$(6.5) \quad b(s) = - \sum_{j=1}^m j p_j(s) u^{(j)}(s)$$

and the power series  $H$  contains no terms of less than second degree. We try again to find for  $Y$  a series of the form (2.4) and, similarly, for  $\Omega$  a series of the form

$$(6.6) \quad \Omega = \sum_{r=1}^{\infty} \epsilon^r \Omega_r$$

Substitution into (6.4) and comparison of coefficients leads again to an infinite sequence of differential equations, which here will have the form

$$(6.7) \quad \epsilon^k Y_r = \sum_{i=0}^m p_1(s) Y_r^{(i)} + b(s) \Omega_r + H_r$$

$H_r$  being a polynomial in  $Y_\alpha^{(\nu)}$ ,  $\Omega_\alpha$ , ( $\nu=0,1,\dots,m$ ,  $\alpha=1,2,\dots,r-1$ ).

Since in the autonomous case the reduced variational equation has zero as a characteristic exponent, the non-homogeneous equations belonging to the reduced variational equation will, in general, not have a periodic solution. The periodic solutions - if any - of (6.7) must therefore in general be expected to diverge, as  $\epsilon \rightarrow 0$ . But we shall show in the next section, that the periodic solutions of (6.7) do converge, as  $\epsilon \rightarrow 0$ , provided  $\Omega_r$  is chosen in an appropriate manner as a function of  $\epsilon$ .

### §7. More Lemmas On Linear Differential Equations

Consider a differential equation of the form

$$(7.1) \quad \epsilon^k Z^{(n)} = \sum_{i=0}^m p_1(s) Z^{(i)} + b(s) \Gamma + G(s, \epsilon)$$

where  $\epsilon$ ,  $k$ ,  $p_1(s)$  and  $b(s)$  have the same meaning as before in this part, and  $G(s, \epsilon)$  has the same properties as in §3. The letter  $\Gamma$  denotes a function of  $\epsilon$  which will be determined later. Together with (7.1) we consider the reduced equation

$$(7.2) \quad 0 = \sum_{i=0}^m p_1(s) z^{(i)} + b(s) \gamma + G(s, 0)$$

in which  $\gamma$  is a parameter independent of  $\epsilon$ .

Lemma 7.1: If assumptions A and B are satisfied in the autonomous case, there exists a unique value of  $\gamma$  for which the differential equation (7.2) possesses periodic solutions of period T. There is exactly one such solution  $z(s)$ , for which

$$(7.3) \quad z(0) = 0$$

If a fundamental system of the reduced variational equation is known, the periodic solution  $z(s)$  can be found by quadratures and rational operations.

Proof: Let  $v_j(s)$ , ( $j=1,2,\dots,m$ ) be a fundamental system of the reduced variational equation with  $t$  replaced by the letter  $s$ . But instead of characterizing the fundamental system by the initial conditions (5.6) we now assume that

$$(7.4) \quad v_1(s) = u'(s)$$

without committing ourselves as to the choice of the remaining  $m-1$  solutions  $v_j(s)$ .

Denote by  $z_1(s)$  some particular solution of the differential equation

$$(7.5) \quad 0 = \sum_{i=0}^m p_i z_1^{(i)} + b(s)$$

and by  $z_2$  some particular solution of

$$(7.6) \quad 0 = \sum_{i=0}^m p_i z_2^{(i)} + G(s,0)$$

Then any solution of (7.2) is of the form

$$(7.7) \quad z = \sum_{j=1}^m c_j v_j(s) + \gamma z_1(s) + z_2(s)$$

where the  $c_j$  are arbitrary constants. A solution  $z(s)$  will have the period  $T$ , if and only if the equations

$$z^{(i)}(T) - z^{(i)}(0) = 0, \quad (i=0,1,\dots,m-1)$$

are satisfied, i.e., if

$$\begin{aligned} (7.8) \quad & \sum_{j=2}^m c_j (v_j^{(i)}(T) - v_j^{(i)}(0)) + \gamma (z_1^{(i)}(T) - z_1^{(i)}(0)) \\ & = z_2^{(i)}(0) - z_2^{(i)}(T), \quad (i=0,1,\dots,m-1) \end{aligned}$$

For arbitrary  $\gamma$  it will, in general, not be possible to determine the  $m-1$  constants  $c_2, \dots, c_m$  so as to satisfy the  $m$  linear conditions (7.8). But if we consider the equations (7.8) as a linear algebraic system for the  $m$  variables  $c_2, \dots, c_m, \gamma$ , a solution will be shown to exist. To prove this, we note first that the rank of the coefficient matrix of the left members in (7.8) does not depend on the choice of the particular solution  $z_1(s)$  of (7.5). Let us therefore take  $z_1(s) = su'(s)$ . This is, in fact, a solution of (7.5), as can be readily verified with the help of formula (6.5). The matrix of the left members of (7.8) becomes then

$$(7.9) \quad \begin{pmatrix} v_2(T) - v_2(0) & \dots & v_m(T) - v_m(0) & Tu'(0) \\ \dots & \dots & \dots & \dots \\ v_2^{(m-1)}(T) - v_2^{(m-1)}(0) & \dots & v_m^{(m-1)}(T) - v_m^{(m-1)}(0) & Tu^{(m)}(0) \end{pmatrix}$$

In view of our choice of  $v_1(s)$  in (7.4) this matrix differs from (5.5) only by the absence of a column of zeros, by the factor  $T$  in the last column, and by the

position of this column. It follows, that the vanishing of the determinant of the matrix (7.9) would imply that the matrix (5.5) has rank  $m-1$  at most, in contradiction to lemma 5.1 and assumption B. Hence, the system (7.8) has a unique solution. The most general solution with period  $T$  of the differential equation (7.2) is then obtained by choosing  $c_1$  arbitrarily. Because of (5.4) there is a unique value of  $c_1$ , such that the resulting periodic solution satisfies (7.3).

Lemma 7.2: Let  $z(s)$  be a prescribed solution of (7.2) with period  $T$ , and assume that conditions A, B and C are satisfied, then there exists a number  $\epsilon_1 > 0$  and a unique function  $\Gamma$  of  $\epsilon$  alone, such that for  $|\epsilon| \leq \epsilon_1$  and  $\epsilon$  in  $I$  the differential equation (7.1) has a unique periodic solution  $Z(s, \epsilon)$  of period  $T$ , satisfying the initial condition

$$(7.10) \quad Z(0, \epsilon) = z(0)$$

For this solution

$$(7.11) \quad \lim_{\epsilon \rightarrow 0} Z^{(j)}(s, \epsilon) = z^{(j)}(s), \text{ for } j=0, 1, \dots, m,$$

and  $\epsilon$  in  $I$ ,

uniformly for all  $s$ . For the corresponding quantity  $\Gamma$

$$(7.12) \quad \lim_{\epsilon \rightarrow 0} \Gamma = \gamma \quad \text{for } \epsilon \text{ in } I$$

If a fundamental system of the full variational equation is known,  $Z$  and  $\Gamma$  can be found by quadratures and rational operations.

Corollary: The statement of the corollary to lemma 3.3

remains true in the autonomous case, and, in addition, the inequality

$$|\Gamma| \leq c \max |G(s, \epsilon)|$$

holds.

Proof: It will be sufficient to emphasize those features of this proof which are different from the proof of the analogous lemma 3.3. The difference

$$(3.13) \quad W = Z - z$$

of two solutions of (7.1) and (7.2), respectively, satisfies

$$(7.13) \quad \epsilon^k W^{(n)} = \sum_{i=0}^m p_i(s) W^{(i)} + b(s)\Lambda + Q(s, \epsilon)$$

where

$$(7.14) \quad \Lambda = \Gamma - \gamma.$$

The general solution of (7.13) has the form

$$(7.15) \quad W = \sum_{\nu=1}^n C_{\nu} V_{\nu} + \Lambda W_1 + W_2$$

where  $W_1$  is a particular solution of

$$(7.16) \quad \epsilon^k W_1^{(n)} = \sum_{i=0}^m p_i(s) W_1^{(i)} + b(s)$$

and  $W_2$  one of (3.14).

We observe that  $W_1$  can be chosen so that

$$(7.17) \quad W_1 = [z_1]$$

where  $z_1$  satisfies (7.5). To see this we need only

apply lemma 3.2 to the differential equation

$$\epsilon^k \frac{d^n}{ds^n} (W_1 - z_1) = \sum_{i=0}^m p_i \frac{d^i}{ds^i} (W_1 - z_1) - \epsilon^k z_1^{(n)}$$

obtained by subtracting (7.5) from (7.16).

W will be periodic with period T, if and only if  $C_\nu$  and  $\Lambda$  can be determined so that

$$(7.18) \quad \sum_{\nu=1}^n C_\nu (V_\nu^{(\mu)}(\alpha+T) - V_\nu^{(\mu)}(\alpha)) + \Lambda (W_1^{(\mu)}(\alpha+T) - W_1^{(\mu)}(\alpha)) \\ = W_2^{(\mu)}(\alpha) - W_2^{(\mu)}(\alpha+T), \quad (\mu=0, 1, \dots, n-1).$$

To these equations we add condition (7.10), i.e.,

$$(7.19) \quad \sum_{\nu=1}^n C_\nu V_\nu(0) + \Lambda W_1(0) = -W_2(0).$$

The asymptotic values of the  $C_\nu$  and  $\Lambda$  can now be found by the same method as in the proof of lemma 3.3. The only non-trivial difference is that the second of the two determinants in (3.19) has to be replaced by

$$\begin{vmatrix} 0 & v_2(\alpha+T) - v_2(\alpha) & \dots & v_m(\alpha+T) - v_m(\alpha) & z_1(\alpha+T) - z_1(\alpha) \\ 0 & v_2^1(\alpha+T) - v_2^1(\alpha) & \dots & v_m^1(\alpha+T) - v_m^1(\alpha) & z_1^1(\alpha+T) - z_1^1(\alpha) \\ \dots & \dots & \dots & \dots & \dots \\ 0 & v_2^{(m-1)}(\alpha+T) - v_2^{(m-1)}(\alpha) & \dots & v_m^{(m-1)}(\alpha+T) - v_m^{(m-1)}(\alpha) & z_1^{(m-1)}(\alpha+T) - z_1^{(m-1)}(\alpha) \\ v_1(0) & v_2(0) & \dots & v_m(0) & z_1(0) \end{vmatrix}$$

This determinant is not zero. For,  $v_1(0) \neq 0$ , in consequence of (7.4) and (5.4), and the cofactor of  $v_1(0)$  does not vanish, because of assumption B, the corollary to lemma 5.1 and our remarks following formula (7.9).

The resulting formulas for  $Q_\nu$  are again (3.20). The proof of (7.11) is then strictly analogous to that of (3.11) in Part I. In addition, we find

$$\Lambda = E \max |Q(s, \epsilon)|$$

which implies (7.12). The corollary follows as in the proof of lemma 3.3. This completes the proof of lemma 7.2.

### §8. The Main Theorem of Part II

Lemma 7.2 shows that the  $Y_r$  and  $\Omega_r$  of the formal scheme explained in §6 can be successively calculated so as to obtain for the  $Y_r$  bounded periodic functions in I. The convergence proof is literally the same as in the non-autonomous case.  $\Omega_r$  is simply treated like the  $Y_r^{(j)}$  in applying the method of dominating series. There is no point in repeating the arguments. It will suffice to state the result.

Theorem 2:

(a) If conditions A and B are satisfied, and the differential equation (5.1) is not parametrically irregular, there exists a closed interval I containing the point  $\epsilon = 0$ , such that for every  $\epsilon$  in I this differential equation possesses a periodic solution  $U(t, \epsilon)$  of period  $T_\epsilon = T(1 + \Omega)$ , for which

$$\lim_{\epsilon \rightarrow 0} U^{(j)}(t, \epsilon) = u^{(j)}(t) \quad , \quad (j=0, 1, \dots, m)$$

uniformly in t,

$$\lim_{\epsilon \rightarrow 0} T_\epsilon = T \quad ,$$

and

$$U(0, \epsilon) = u(0) \quad .$$

The position of the interval I with respect to the point  $\epsilon=0$  follows the same rules as in theorem 1.

(b) If a fundamental system of the full variational equation is known, a convergent series representation for  $U(t, \epsilon)$  can be found by quadratures. This series is of the form

$$U(t, \epsilon) = u(s) + \sum_{r=1}^{\infty} Y_r(s, \epsilon) \epsilon^r \quad .$$

Here

$$s = t(1 + \Omega) \quad ,$$

where

$$\Omega = \sum_{r=1}^{\infty} \Omega_r(\epsilon) \epsilon^r \quad .$$

is a series which can be found by rational operations. The  $Y_r(s, \epsilon)$  have  $m$  bounded derivatives with respect to  $s$ , for  $\epsilon$  in  $I$ . They have the period  $T$  in  $s$ .

Remark: By collecting terms of order one with respect to  $\epsilon$  in the foregoing result, we find, with the help of lemma 7.2, that, to within terms of order higher than one in  $\epsilon$ ,

$$(8.1) \quad U(t, \epsilon) = u(t) + \epsilon(t\omega_1 u'(t) + y_1(t))$$

$$T_\epsilon = T + \omega_1 T$$

for  $\epsilon$  in I. Here  $\omega_1$  is the number for which the differential equation

$$0 = \sum_{i=0}^m p_i(t) y^{(i)} + \omega_1 b(t) + a(t)$$

has a solution of period T with  $y(0) = 0$ , and  $y_1(t)$  is that solution. In order to obtain a good approximation from (8.1) in - say - the interval  $-T \leq t \leq T$ , the parameter  $\epsilon$  must be very small by comparison with  $2T$ .

§9. Appendix: A Remark Concerning Volk's Article [5]

Since Volk deals with systems of first order equations, he is led to investigate a variational system of the form

$$(9.1) \quad \frac{dZ_\nu}{dt} = \mu^k \sum_{r=1}^n p_{\nu r}(t) Z_r, \quad (\nu=1, 2, \dots, n)$$

In this section we adopt Volk's notation.  $\mu$  is the small parameter called  $\epsilon$  previously, the  $p_{\nu r}(t)$  are functions of period T, and the  $k_\nu$  are integers, some of which we assume to be negative. In analogy to our discussion in §3, it has to be shown, that a non-homogeneous system corresponding to (9.1) possesses a periodic solution which - under appropriate conditions - remains bounded, as  $\mu \rightarrow 0$ .

In order to do this, Volk proceeds as follows. Let  $k$  be the algebraically smallest of the integers  $k_\nu$ , ( $k$  is negative), and change the variable  $t$  into  $\vartheta$ , where  $\vartheta$  is defined by

$$\vartheta = \mu^k t.$$

The variational system is then changed into

$$(9.2) \quad \frac{dZ_\nu}{d\vartheta} = \sum_{r=1}^n q_{\nu r}(\vartheta, \mu) Z_r, \quad (\nu=1, 2, \dots, n)$$

where

$$(9.3) \quad q_{\nu r} = \mu^{k_\nu - k} p_{\nu r}(\vartheta \mu^{-k})$$

The  $q_{\nu r}$  are continuous at  $\mu=0$ . The period of the  $q_{\nu r}$  with respect to  $\vartheta$  is  $\theta = \mu^k T$ . Following Volk [5], §2, let

$$(9.4) \quad Z_\nu = \sum_{r=1}^{\infty} \alpha_{\nu r} \eta_r \quad (\nu=1, 2, \dots, n)$$

be the linear transformation which reduces the system (9.2) to the canonical form

$$(9.5) \quad \frac{d\eta_\nu}{d\vartheta} = l_\nu \eta_\nu + \sigma_{\nu-1} \eta_{\nu-1}, \quad (\nu=1, 2, \dots, n)$$

Here the  $l_\nu$  are the characteristic exponents of the system (9.2). The  $\sigma_{\nu-1}$  are zero or one. In particular,  $\sigma_0=0$ , always, so that  $\eta_0$  does not occur in (9.5), and need not be defined. The  $l_\nu$  are functions of  $\mu$ , but independent of  $\vartheta$ . The  $\alpha_{\nu r}$  are functions of  $\mu$  and  $\vartheta$ , with period  $\theta$  in  $\vartheta$ .

It can be proved that, if the coefficients of a system of linear differential equations with periodic coefficients depend continuously on a parameter  $\mu$ , then the characteristic exponents as well as the matrix of the transformation to canonical form are continuous functions of  $\mu$ . From this theorem Volk concludes that the quantities  $\alpha_{\nu r}$  as well as the elements  $\beta_{\nu r}$  of the inverse matrix are bounded at  $\mu=0$ . But this conclusion is not valid, since that theorem presupposes that the period of the coefficients does not depend on  $\mu$ . In the present case that period,  $\theta$ , tends, however, to

infinity, as  $\mu \rightarrow 0$ .

It is easy to show by the simplest examples, that the  $\alpha_{\nu, r}$  are not always bounded at  $\mu=0$ , even if  $\mu$  is limited to one sign. Take, e.g., the case  $n=1$ . Then (9.1) reduces to

$$(9.6) \quad \frac{dZ}{dt} = \mu^k p(t)Z, \quad (k < 0)$$

and (9.2) becomes

$$(9.7) \quad \frac{dZ}{d\vartheta} = p(\vartheta \mu^{-k})Z.$$

The most general transformation of the form (9.4) is, in this case

$$(9.8) \quad Z = \alpha \eta$$

where

$$(9.9) \quad \alpha = C(\mu) e^{\int_0^{\vartheta} p(\vartheta \mu^{-k}) d\vartheta - \frac{\vartheta}{\Theta} \int_0^{\Theta} p(\vartheta \mu^{-k}) d\vartheta}$$

$C(\mu)$  is an arbitrary function of  $\mu$  alone. When written in canonical form (9.6) and (9.7) become then, respectively,

$$\frac{d\eta}{d\vartheta} = \frac{1}{\Theta} \int_0^{\Theta} p(\vartheta \mu^{-k}) d\vartheta \cdot \eta$$

and

$$\frac{d\eta}{dt} = \frac{\mu^k}{T} \int_0^T p(t) dt \cdot \eta$$

Assuming that  $C(\mu)$  is bounded, (9.9) would indeed be a bounded function of  $\mu$  at  $\mu=0$ , if  $\Theta$  were a

constant with respect to  $\mu$ . But this is not the case. In fact, returning to the variable  $t$  we find

$$(9.10) \quad \alpha = C(\mu) e^{\mu^k \left( \int_0^t p(t) dt - \frac{t}{T} \int_0^T p(t) dt \right)}$$

when  $p(t)$  is not a constant,  $\alpha$  or  $\beta = \frac{1}{\alpha}$ , or both, are unbounded at  $\mu=0$ . The boundedness of  $\alpha_{\nu R}$  and  $\beta_{\nu R}$  is used by Volk in an essential way to prove his equivalent of our inequality (4.1), for he proves a similar inequality for the simpler system (9.5) and then returns to  $Z_{\nu}$  by the inverse of the transformation (9.4). It is clear that our inequality (4.1), or some equivalent, is needed to establish the convergence of the method.

### References

1. K. O. Friedrichs and W. R. Wasow, Singular Perturbations of nonlinear oscillations. Duke Math. J., Vol. 13 (1946), pp. 367-381.
2. N. Levinson, Perturbations of discontinuous solutions of nonlinear systems of differential equations. Proc. Nat. Acad. Sci. U.S.A., Vol. 33 (1947), pp. 214-218.
3. H. L. Turrittin, Asymptotic solution of certain ordinary differential equations associated with multiple roots of the characteristic equation. Amer. J. Math., Vol. 58 (1936), pp. 364-376.
4. W. Wasow, On the asymptotic solution of boundary value problems for ordinary differential equations containing a parameter. J. of Math. and Phys., Vol. 23 (1944), pp 173-183.
5. I. M. Volk, On the periodic solutions of non-autonomous systems depending on a small parameter. (Russian). Akad. Nauk. SSSR. Prikl. Mat. Meh., Vol. 10 (1946), pp 559-574
6. I. M. Volk, Generalization of the method of a small parameter in the theory of periodic motions of non-autonomous systems. (Russian.) Akad. Nauk. SSSR. Prikl. Mat. Meh., Vol. 11 (1947), pp. 431-444.
7. I. M. Volk, On periodic solutions of autonomous systems. (Russian.) Akad. Nauk. SSSR. Prikl. Mat. Meh., Vol. 12 (1948), pp 29-38.



