

UNIVERSAL
LIBRARY

OU_174113

UNIVERSAL
LIBRARY

ROORKEE TREATISE

ON

CIVIL ENGINEERING.

SANITARY ENGINEERING

PART I—WATER-SUPPLY.

BY

C. E. V. GOUMENT, C.S.I., M.I.C.E..

*Late Chief Engineer and Secretary to Government
in the Public Works Department, United Provinces, India.
(Reprint)*

ROORKEE :

PRINTED AT THE PHOTO.-MECH. AND LITH. DEPARTMENT, THOMASON COLLEGE.

1925.

On Sale in the Book Depot, Thomason College, Roorkee.

ROORKEE TREATISE

ON

CIVIL ENGINEERING.

SANITARY ENGINEERING.

PART I—WATER-SUPPLY.

BY

C. E. V. GOUMENT, C.S.I., M.I.C.E.,

*Late Chief Engineer and Secretary to Government
in the Public Works Department, United Provinces India.
(Reprint)*

ROORKEE :

PRINTED AT THE PHOTO.-MECHL. AND LITHO. DEPARTMENT, THOMASON COLLEGE.

1925.

On Sale in the Book Depot, Thomason College, Roorkee.

PREFACE.

As Waterworks Engineering has advanced considerably since the original edition was issued, I have recast this Manual entirely and written what is practically a new book. In writing the Manual, I have endeavoured, as far as possible, to keep in view the fact that this subject is only one of many the Civil Engineer student has to take up in his three years' course at the College and that it is therefore necessary to confine the matter in it to the first principles of the subject, leaving the student to acquire later, if required, fuller information on any particular points he wishes to investigate by consulting professional papers and more advanced books copious references to which have been given in the text.

There are two important classes of work connected with water-supply schemes which I have only been able to touch on lightly for the reasons explained in the Manual, viz. : the construction of dams and the design and erection of pumping plant. It has not been considered desirable to swell the size of this Manual by a lengthy description of these, as they are taken up in full detail by students in other parts of their college course. References have been given to good standard works, and the Manual merely explains the conditions under which the different types are suitable for water-supply schemes and their leading features.

I have availed myself freely of information contained in the best and most recent publications on the subject and my acknowledgements are chiefly due to the sources of information noted below :—

1. Proceedings of the Institution of Civil Engineers.
2. "Distributions d'Eau : Assainissement."
3. "Sanitary Engineering with respect to Water-Supply and Sewage Disposal," by Vernon Harcourt. Published by Messrs. Longmans, Green & Co., London.
4. "Lectures on Water-Supply," by A. R. Binnie. 2nd edition. Chatham, 1887.
5. Original edition of the Manual, by D. Aikman.

C. E. V. G.

CONTENTS.

CHAPTER I.

INTRODUCTION	<i>Paragraphs.</i> 1 to 5
--------------	-----	-----	-----	-----	------------------------------

CHAPTER II.

RAINFALL AND SOURCES OF WATER-SUPPLY...	6 to 20
Variations of rainfall	7, 8
Average annual rainfall	9
Losses by absorption and evaporation	10
Available rainfall	11
Sources of supply	12 to 18
Gauging quantity available	19
Testing the quality of water	20

CHAPTER III.

GRAVITATION SUPPLY FROM LAKES OR RESERVOIRS	21 to 44
Drainage area	22
Size of reservoir	23 to 25
Best site for a dam	26
Types of dams	27
Subsidiary works	29
Outlets and valve towers	30 to 32
Aqueducts	33 to 40
Pipe crossings	41
Hydraulic gradient	42
Break pressure or balancing reservoirs...	43

CHAPTER IV.

PUMPING ARRANGEMENTS AND RISING MAINS	45 to 58
Intakes and unfiltered water-pumping stations	47 to 49
Pumping machinery suitable for different conditions	50
Filtered water stations	51
Size and quality of pumping engines	52

	<i>Paragraphs.</i>
Specification	53
Tests	54
Comparative economic values of pumping installations	55
Rising mains	56 to 58

CHAPTER V.

WATER-SUPPLY FROM WELLS	59 to 78
Types of wells	60
Shallow wells	61 to 66
Deep wells	67, 68
Driven tube wells in soft soil	69, 70
Different varieties of tube wells	71 to 78

CHAPTER VI.

PURIFICATION OF WATER-SUPPLIES	79 to 107
Mineral impurities	80 to 84
Organic impurities	85
Analysis of water	86, 87
Impurities in water from different sources	88
Settling tanks	89 to 91
Filters	92 to 105
Clear water reservoirs	106
Methods of sterilization	107

CHAPTER VII.

DISTRIBUTION OF WATER	108 to 136
Intermittent and constant systems	108 to 111
Service reservoirs	112 to 114
Distribution pipes	115 to 117
Pipe fittings—bends, valves, hydrants, etc.	118 to 124
House-connections	124 to 128
Discharge of pipes and delivery required	129, 130
Relation between height of service reservoir and size of distribution pipes	131
Alignment of mains and sub-mains	132
Example showing method of calculating sizes of distribution pipes	136

CHAPTER VIII.

MEASUREMENT OF WATER AND PREVENTION OF WASTE				137 to 143
Positive meters	138
Inferential meters	139
Venture meter	141
Prevention of waste	142
Deacon's waste meter system		143

APPENDIX A.—Bradford water-works outlet and valve tower.

APPENDIX B.—Note on the Amritsar water-works.

APPENDIX C.—Specification for pumping machinery.

APPENDIX D.—Sample specification for cast-iron pipe and fittings.

Sanitary Engineering has for its object the supply in sufficient quantity of pure water for large communities and the rapid removal from towns of sewage and surface drainage before these reach the condition when they become injurious to health. Both water-works and drainage works are absolutely necessary for the healthiness of any large number of persons collected together within a limited area and are so inseparably connected that they must both be classed as Sanitary Engineering Works. They are dealt with in two separate parts in this Manual : (1) water-supply ; (2) sewerage and drainage works.

PART I—WATER-SUPPLY.

CHAPTER I. INTRODUCTION.

Good and ample supply of water indispensable.—Of the three essential requirements of human life, **air, water, and food**—, water plays the most important part of maintaining the tissues of the body in healthy action. Without an ample supply of wholesome water, all the animal functions suffer as the body degenerates; air cannot clarify the blood sufficiently and food is imperfectly assimilated. Water is also indispensable for cleanliness and for manufacturing purposes. If the supply is impure, it endangers the lives of those who consume it, and if insufficient, it detracts largely from the amenities of modern civilised life. In ancient times, towns and villages were invariably situated on or near the banks of streams and rivers from which they conveniently drew their supply of water, but when population increased and extended into districts which had no natural supplies, artificial methods of securing the requisite supply became necessary, which have developed gradually into the modern elaborate systems of water-works briefly described in this Manual.

2. **Ancient water-works.**—In India, the water-supply of towns in very early times was derived from large tanks excavated on minor drainage lines which collected and stored the rainfall in the wet season to provide a supply during the dry periods. In Egypt, Babylonia, and Assyria—flat countries traversed by rivers subject to floods—water was supplied by means of open canals with large storage basins. Wells were also used in many countries, in ancient times to utilise the underground waters which were raised from them by simple mechanical contrivances, still to be seen in Egypt and India. Wells are also known to have been used at remote periods in ancient Greece and Italy and artesian wells were sunk in China in very early times.

The numerous conduits which supplied ancient Jerusalem are very old; no date can be assigned to their construction but they probably go back to the times of the Kings of Judah, 600 to 900 B. C. The two most important of these conduits were carried at different levels to the City from a large reservoir consisting of the three Pools of Solomon built in three terraces, the highest 60 feet above the lowest. The conduits were rock-cut canals, partly built in masonry. Valleys were crossed by syphons formed of large pierced stones embedded in rubble masonry.

The Greeks were very skilful in their methods of bringing water to their towns in conduits along the contour lines of their hills, or through tunnels, but they did not resort to the practice of constructing large masonry aqueducts for crossing valleys such as those the Romans built, the remains of which are to be seen at the present day.

Ancient Rome had an abundant supply of water from distant sources and the prominent feature of the water-works of this town was the magnificent conduits which conveyed the water across deep valleys on arched masonry or brick aqueducts of imposing dimensions which still stand as remarkable engineering records of those early times. The first Roman aqueduct was built in 312 B.C. by the Censor Appius Claudius from whom it derived its name, Aqua Appia. It was 11 miles long, of which all but 300 feet were below ground. It brought water to the City from the base of the Alban hills.

Another large aqueduct, the Anis Vetus, was built about 270 B. C. It conveyed water from the river Anis near Tivoli. From its source to Rome it was 41 miles long of which only about 1,100 feet were above ground. There were seven other aqueducts of this kind, of which the two latest and most important were the Aqua Claudia and the Aqua Novus begun A.D. 38 and completed A.D. 52. They were 45 miles and 62 miles in length respectively. Ten miles of the former and $9\frac{1}{2}$ of the latter were above ground. Their size varied considerably. The Aqua Novus, the largest of them all, measured three to four feet wide and nine feet high to the top of the pointed roof. They were lined with very hard cement containing fragments of broken brick.*

Figs. 1† and 2 at the end of the chapter show two good examples of these ancient aqueducts.

* Encyclopedia Britannica, XI edition, Vol. II.

† "Sanitary Engineering," Vernon Harcourt,

All the old Roman aqueducts terminated near the City in huge reservoirs in which the water was clarified by settlement. From these settling basins the water was led into smaller service tanks in the City for distribution. Many of these tanks were covered in with a vaulted roof and some of them were very large. The tank still preserved at Fermo is built in two storeys, each having three oblong basins communicating with each other. The wells and pillars of these tanks were usually coated with a very hard stucco.

3. The ancient Greeks and Romans were apparently familiar with the use of pipes for conveyance of water. They used earthenware, wood, and lead pipes and they seem to have known the value of inverted syphons for crossing valleys and dips on the alignment of their aqueducts. Old leaden syphons have recently been discovered in the remains of ancient cities. The Romans were evidently aware of the liability of lead pipes to contaminate water and also of their inferior strength to resist heavy pressures, and they therefore preferred, as a rule, aqueducts for crossing deep valleys.

4. **Modern water-works compared with ancient.**—The manufacture of cast and wrought-iron pipes at a reasonable cost and their general adoption in modern times has enabled supplies of water to be conveyed economically under high pressures in inverted syphons and removed the necessity, except in very special cases, of building lofty arched aqueducts of masonry for crossing deep valleys. The use of iron pipes for conveyance of water on a large scale has, moreover, made it possible to distribute the water in all important streets of a town and to convey it inside houses, when required, to permit of its convenient use for domestic purposes.

5. As stated in paragraph 2, the water-works of ancient Rome consisted of aqueducts conveying water to the City from distant sources, settling tanks outside the town, and service reservoirs within. The distribution system in the City was very imperfect and there were no connections to individual houses as there are now. The quality of the supply, as regards purity, depended on the nature of its source, as filters were unknown and nothing could be done to purify the water beyond the removal of the heavier suspended matter by settlement. The quantity provided was generally ample for the population, but the size of the conduits and aqueducts seems to have been fixed in a haphazard manner without considering the volume they would discharge with the fall available. The sectional area was apparently determined solely by the

necessity to keep them large enough to be readily accessible for cleaning and repairs.

اسپولیتو آکویڈکٹ

SPOLETO AQUEDUCT.

Fig. 1.

SPOLETO AQUEDUCT.

Fig. 1.

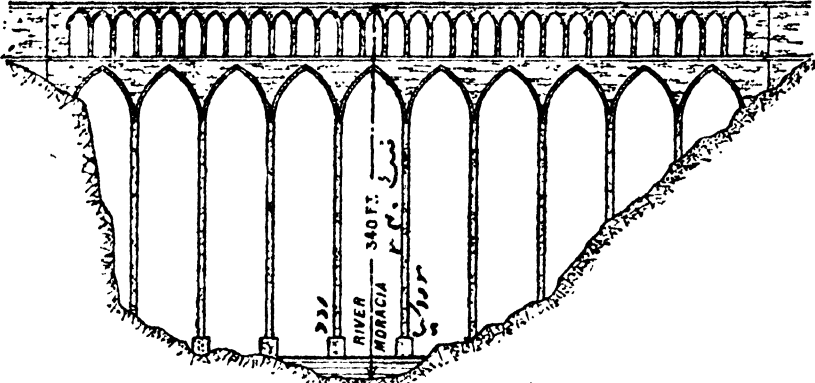

پونٹ دو گارد آکویڈکٹ

PONT DU GARD AQUEDUCT.

Fig. 2.

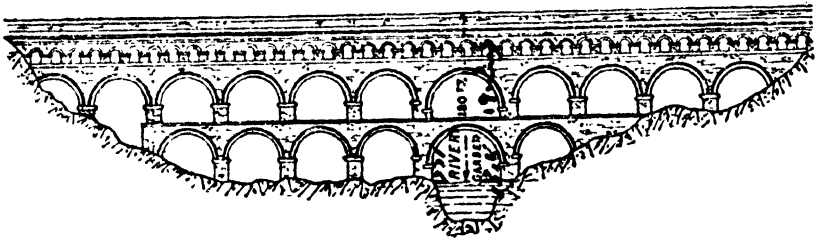

CHAPTER II.

RAINFALL AND SOURCE OF SUPPLY.

6. The original source of all supplies of fresh water is rain and this again is derived from the sea and, to some extent, from the land, by the natural processes of evaporation and condensation with which all students are no doubt familiar. The rain-water which escapes evaporation from the surface of the land and absorption by vegetables and the soil either runs directly from the surface of the ground into streams and rivers or it sinks into the ground and, flowing through the crevices of permeable strata, escapes at their outcrop in **springs**, or it collects in porous strata from which it is drawn by means of **wells**. The amount of rain which falls on the land varies to a great extent at different places, in different seasons, and in different years.

7. **Variations of rainfall in different localities and in different seasons.**—Rain is chiefly derived from the sea and places near the sea therefore get the most rain, especially if they are situated in the course of the prevalent winds and these winds have passed over a wide stretch of water. Rainfall is greater in mountainous districts and particularly so on **mountain-ranges** near the sea coast which intercept wind currents from the ocean, heavily charged with moisture, and, by condensation under the influence of the low temperature at higher elevations, cause them to precipitate their vapours in the form of rain on the upper slopes. This accounts for the heavy rainfall in India on the west coast bordered by the "Ghats," the slopes of the Himalayas nearest the Bay of Bengal, and portions of the Malay Archipelago. Countries in the interior of large continents are generally rainless, as they are cut off from the ocean by high mountain-ranges which intercept the moisture of the wind currents during their passage over them from the sea. As instances of such countries may be mentioned the deserts of North Africa, Central Asia, Arabia, and Persia.

Generally speaking, rainfall decreases from the sea coast towards the interior for the reasons above explained and from the tropics towards the poles owing to diminished evaporation in a lower temperature, while it increases with the elevation within limits depending upon the latitude and locality.

In tropical countries there is usually more rain in summer, when the sun is nearly vertical overhead and in countries subject to periodical wind the direction of the wind has a great influence on the rainfall. In India, where the monsoons blow regularly in two different directions during definite seasons of the year, the rainy season occurs on the western side during the prevalence of the south-west monsoon from May to October and on the eastern coast during the earlier part of the north-east monsoon from October to February.

As the rainfall in any locality depends upon its position in relation to the sea, the prevalent winds and the physical characteristics of the surrounding country, it shows considerable variations in different parts of the world and even in different parts of the same country. The rainfall, for instance, on the extensive inland deserts of Asia is practically zero, while that of Chera Punji in the Kasi Hills of Assam is the highest in the world, viz. an annual average of 445 inches a year. In the interior of India, again, the average annual rainfall is very much smaller than it is on the seaward and windward slopes of the hills Malcolmpeth and Satara and the Western Ghats near Poona have an average annual fall of about 281. inches; Lalakbal and Sylhet in Assam 266 inches; Matheran, at an elevation of 2,200 feet on the Ghats near Bombay, 209 inches; while the average annual fall at Delhi is only 28 inches, at Lahore 18 inches, at Peshawar near the Khyber Pass 12 inches, at Quetta 18 inches, at Bellary in the centre of Southern India 18½ inches.

Fig. 3* shows the rainfall in different parts of India.

8. **Fluctuation from year to year.**—Not only does the rainfall vary with the locality and with the seasons of the year as explained above, but its total yearly amount exhibits large fluctuations from year to year in the same locality. In India and Burma, the highest annual rainfall at the stations where records are kept is generally less than double the minimum, but in a few places it is four times the minimum and even more. The maxima and minima, for instance, at Bombay are 93 and 37, at Calcutta 78 and 48, at Poona 57 and 12, at Delhi 43 and 8, at Lahore 38 and 5, at Peshawar 28 and 5, at Quetta 22 and 4. Fortunately for water-supply schemes, wet years alternate to some extent with dry ones, and it is unusual for the rainfall to be below the average during three consecutive dry years.

9. **Average annual rainfall.**—In order to ascertain the average annual rainfall of a place for forming an estimate of the quantity available

* { "Sanitary Engineering with respect to Water-supply and Sewage Disposal," by Vernon Harcourt.
 * { "Rainfall of India," Meteorological Department, Calcutta, 1890—1900.

for storage, it is necessary to observe the rainfall at that place by means of rain-gauges for a series of years. Where observations have only been recorded for a short time, it is often possible to get a more accurate average by ascertaining for the shorter period, the average rainfall of a place with a long record, under similar meteorological conditions and generally resembling the one under consideration as regards its physical features, comparing it with the average of the whole record of the place and then modifying the average of the place with the short record in the same proportion. An investigation of a large number of long records of rainfall by Mr. (now Sir) Alexander Binnie showed that a record of 35 years gave an average within 2 per cent. of the exact mean and a record of 20 years gave an average within $3\frac{1}{4}$ per cent. of the real mean.

10. **Losses by absorption and evaporation.**—All the rain that falls on a drainage area is by no means available for a water-supply. Some of it is lost by evaporation from the ground surface some is absorbed by vegetation, while some percolates through the sub-soil to feed springs or underground reservoirs. The actual run-off from any drainage area is affected by many varying causes—geological structure and permeability of the soil, saturation of the soil from previous rain, steepness of the hillslopes, humidity of the climate, and nature of the vegetation. The behaviour of each catchment in this respect requires individual study, but much may be learned from records of similarly circumstanced catchments if data regarding the area under consideration are scanty or non-existent.

In the upper provinces of India there are two well-marked divisions of the year as regards the rainfall. The rainy or monsoon season from the 15th June to the end of September and the dry season which embraces the remaining months of the year when only a few scattered showers fall. The ground at the end of the hot season in May is exceedingly dry and for the most part free from vegetation. As the monsoon progresses, the soil becomes more and more saturated and vegetation springs up rapidly everywhere. This season therefore affords an excellent opportunity of studying the laws which govern the discharge from the gathering ground of the rain which falls upon it in different states of saturation.

The following extract from lectures delivered at Chatham by Mr. A. R. (now Sir) Alexander Binnie in 1877 gives results of his observations at Nagpur which are most instructive and interesting :—

On the diagram (plate I) I have plotted the result of the observations which I made at Nagpur, during the years 1869 and 1872, of the actual flow of water from a drainage area of 4,224 acres. This drainage area is a barren, almost treeless, uninhabited tract of

undulating and rocky ground, situated about four miles west of the city. Looking at the two figures in the diagram, you will see that the horizontal scale represents inches of rain which fell, and the vertical scale corresponds to the percentage of it which flowed from the ground and was impounded in the reservoir.

Taking the lower and more perfect of the two figures of the diagram, that for 1872, you will notice that during the month of June 6.77 inches of rain fell, and as 4,885,500 cubic feet of water flowed from the ground, we know that about 95 per cent. must have been absorbed or evaporated; we, consequently at the point 6.77 on the horizontal scale plot up the exact discharge as 4.7 per cent.; during the following month of July the rainfall was 12.70 inches, and we find the quantity of water flowing from the ground was 44,396,700 cubic feet, which represents 22.7 per cent.; up to the end of July, the quantity which had fallen since the commencement of the rains was 19.47 inches and as of this 49,282,200 cubic feet, or 16 per cent. had been discharged, we plot 16 on our vertical scale at the point on the horizontal corresponding to 19.47 inches, and join it with the 4.7 at the end of June and zero by a roughly curved line.

Proceeding onwards, we find that during August 11.82 inches of rain fell, and that of this amount 101,136,100 cubic feet or 55.8 per cent. was discharged; up to the end of August the total rainfall had been 31.29 inches and the total amount discharged being 150,482,300 cubic feet, or 31 per cent., we plot that amount on our vertical which corresponds to 31.29 inches on the horizontal scale, and join the point so found with that previously marked at the end of July.

Proceeding now to the month of September, we find that the rainfall of that month 7.99 inches, of which 19,196,200 cubic feet, or 74.4 per cent. flowed from the ground; this makes a total fall of 39.28 inches up to the end of September, and as 241,614,500 cubic feet had been discharged, we plot its equivalent quantity, 40 per cent., on our vertical scale and join it with that for August.

The rains were now nearly over, but after a short interval of fine weather, a fall of 4.37 inches was recorded during October, of which 26,430,800 cubic feet, or 39.4 per cent., flowed from the ground. Up to the 6th of October, when the rains ceased, 43.65 inches was the total fall, of which 260,045,300 cubic feet having been discharged, we plot its corresponding amount, 40 per cent., at the end of the diagram. The diagram for 1869 has been formed upon the same principle as that for 1872, and if you were to place one upon the other you would find that the curves of discharge would nearly coincide; in other words, for the same number of inches measured on the horizontal scale the vertical height of the curve will give nearly the same percentage in both cases. Now, what we learn from these diagrams is that as the ground becomes more saturated the flow from it increases in a regular ratio up to a discharge of 40 per cent for the total quantity; and in the particular case under notice, as the drainage area is always in the same state of extreme dryness at the beginning of the rains, we can tell roughly what would be the total quantity discharged in any particular year by measuring the rainfall of that year on our horizontal scale, and finding what percentage is due to that amount. Besides the gradual increase in the total discharge, as shown by the curved lines, you see how rapidly it is augmented during the different months commencing with 4.7 per cent., for June, running up through 22.7, 55.8 during July and August to nearly 75 per cent. for the month of September, and it no doubt would have increased still more had not the 4.37 inches which fell during October been preceded by the few days of fine weather of which I have spoken.

The general law then which we have to bear in mind is that first the proportion of the rainfall which flows from the ground is a variable quantity; and, second, that the

amount of the variation in the proportion flowing from the ground depends (all other circumstances being equal) upon the comparative dryness of the climate and the total amount of rain which falls.

Thus, in the dry climate of Nagpur in 1868, when the total rainfall was only 19½ inches, 15½ per cent. flowed from the ground; whereas in 1872 when it was 43½ inches, the yield was 40 per cent. In the humid climate of Bombay, the yield varies from 50 to 80 per cent. of the rainfall, being different in amount according to the total annual fall.

11. Allowances to be made in estimating the available rainfall from a given drainage area.—It will be seen from the foregoing that the average rainfall, when determined, has to be modified by several varying factors in estimating the *available* rainfall from a given drainage area. In the first place an allowance has to be made in the case of large storage schemes for periods of consecutive dry years which are known to occur at intervals, the average rainfall of which is only about three-fourths of the mean average. The mean of a long series of years should therefore be reduced by 25 per cent. to allow for this deficiency. The next point to be settled is how much is absorbed and evaporated and the determination of this point is a matter of great difficulty. The run-off should be ascertained as nearly as possible in the manner explained in paragraphs 9 and 10.

There will be further losses in the reservoir itself by evaporation and percolation. These will be dealt with in a subsequent chapter where the capacity of storage reservoirs is discussed, see paragraph 24.

For small schemes providing storage sufficient only to balance the varying supply and demand at different seasons of the year up to the amount available in that year, the minimum fall of the extreme dry year should be taken into consideration instead of the average of three dry consecutive years.

12. Sources of supply.—Water-supplies are usually obtained from sources over or below the ground where rain-water has been collected by natural causes in large quantities. They may be obtained by storage of rainfall from roofs or drainage areas, from mountain streams, from lakes which form natural reservoirs on some river valleys or from rivers in the lower part of their course where they have a more uniform flow throughout the year. Water may also be collected from springs which are the natural outlet of underground flow or it may be pumped up from wells sunk into water-bearing strata.

13. Storage of rain-water.—This method is usually adopted in tropical countries where there is a wet and dry season to obtain, during the rains, a sufficient supply to last through the dry months. The collection is usually effected by damming valleys or by digging tanks in

the ground and lining them with an impervious layer of clay when the strata are permeable. A large portion of the rain falling on the impervious roofs of houses and sheds covered with slates or tiles might also be readily stored by leading it through gutters and down pipes into covered cisterns of iron or masonry.

Certain precautions are necessary to maintain the purity of a rain-water supply. Rain is very pure as it falls from the clouds, but in towns it is subject to contamination in its descent, by smoke, dust, and impure air and, consequently, in crowded centres of population it should, if possible, be only used for washing, for which purpose it is often preferable to water obtained from other sources on account of its softness. The use of rain-water collected from roofs for drinking and culinary purposes should be confined to country districts and isolated dwellings in cool climates, where other sources of supply are not available or are too costly and, when it forms the sole supply for domestic purposes, it should be boiled before use to secure it from danger as drinking-water. The first flow of rain off a roof, after dry weather, collects various impurities and is usually diverted from the cistern by an automatic tipper which runs the water to waste until turned. After passing through a strainer which arrests leaves and other debris, it is led into a settling-tank from which it overflows and passes through a filter into the collecting cistern.

Water collected in storage reservoirs from drainage areas in the open country is treated before use as described later in the chapters on gravitation supplies and purification.

14. **Mountain streams.**—Very good supplies of water may be derived from mountain streams draining uncultivated and uninhabited rocky country. The gathering ground of these streams is, however, too limited as a rule to provide a large perennial flow and the impermeability of the strata in hilly regions combined with steep slopes render their discharge very irregular, forming a rushing torrent in wet weather and falling very low in the summer months. On this account, the waters of such streams, though excellent in quality, can only, as a rule, be made available for the supply of towns by storing the flood discharges in reservoirs formed by damming the valleys. Purification of water derived from this source, by settling and filtration, is necessary before it is utilised for domestic use.

15. **Lakes.**—These are usually formed by a depression in a mountain valley with a ridge of rock or impervious material at its lower end over which the water has to rise before the stream flowing in at the upper end can continue its course down the valley below. The lake acts as a regulator to balance the unequal flow of the stream in the different seasons

of the year and also as a settling basin in which all the silt brought down by it is deposited where the current is checked on entering the lake. Lakes situated in mountainous districts provide excellent reservoirs of the purest water secured by their extent and depth from being silted up within any measurable period, and they are generally situated at such an elevation above the towns to be supplied as to admit of the water being delivered by the action of gravity. The value of lakes for town supplies depends upon (1) the discharge of the streams flowing into them, together with the flow off their own gathering ground and (2) the freedom of the drainage area and the shores from sources of pollution.

Besides providing enormous space for sedimentation, lakes furnish comparatively a very large storage by a moderate raising of their water level by a low dam across the outlet.

16. **Rivers.**—In temperate regions rivers generally furnish an ample volume of water for the requirement of towns situated on their banks and they are more frequently used for this purpose than any other source of supply. They generally have a large and fairly regular flow in the lower parts of their course, as compared with streams in the upper parts of valleys, owing to their draining extensive areas, the meteorological conditions of which are not everywhere the same.

Where rivers are utilised for a water-supply, very efficient methods of purification have to be adopted to render the water unobjectionable for domestic use. When in flood, they are generally turbid and polluted with organic matters washed down from the land. The methods adopted for purifying river-water and making it fit for use are described at length in chapter VI.

In spite of its exposure to pollution, river-water is often the only source of supply available for a large town; and this being the case it is satisfactory to note that in the United States, as estimated by the typhoid death-rate, filtered river-water has been placed second on the list for purity, mountain springs being first, and underground waters, impounded waters and lake waters below it in this respect.*

17. **Springs.**—Rain percolating through a porous stratum descends till it is stopped by an underlying impermeable stratum over which it flows to the lowest point of the outcrop where it emerges at the surface as a spring. The yield of a spring depends upon the area and volume of sub-soil drained by it and the amount of rainfall percolating into the ground. Springs from small gathering grounds usually vary considerably

* "Water and Public Health," by J. H. Fuertes.

in discharge at different times of the year and in different years according to the rainfall. When the outcrop of the permeable stratum which feeds the spring is considerable in extent and also at some distance from the spring, the discharge is steadier and follows less closely on the rainfall as it is impeded by friction in passing along the stratum. In selecting a spring for a water-supply, its minimum flow should be ascertained by measuring its discharge after a period of drought and allowing for any excess of rainfall producing this discharge measured over the minimum recorded rainfall of the district. Owing to the irregularity of flow from springs, it is necessary, as a rule, to provide storage reservoirs to supplement their yield in the dry periods.

The wholesomeness of spring-water, except when exposed at a small depth to surface contamination, is due to its thorough filtration in passing through a considerable thickness of porous soil before issuing as a spring. Though usually very free from organic matter it is, however, often charged with salts and gases in solution collected from the permeable strata it has passed through. It is sometimes so highly impregnated with iron, saline or sulphurous compounds as to be only fit for medical purposes. Chemical analysis is absolutely necessary to prove the fitness of spring-water for domestic use.

18. **Wells.**—Underground waters are tapped by sinking wells into water-bearing strata and raising the water from them to the surface by pumping. A well-supply has the advantage of a short lead from the site of the wells to the places to be supplied, and it delivers the water by means of pumps at any required pressure of elevation above the town. They are often sunk to considerable depths to reach underground waters which could not otherwise be utilised. On the other hand, the cost of sinking wells is usually more than that of works required for the collection of water from springs, the pumping involves a constant outlay and the yield is more uncertain than the flow of a spring.

Water from wells is very similar in its origin and composition to water from springs, but it is more liable to pollution by the surface water near the well being drawn into it when pumping is in progress. Such contamination is guarded against by a watertight steining where the well passes through permeable strata and by conserving a certain area all round the site of the well.

19. **Gauging quantity available.**—The source of supply for a town having been selected tentatively, it is necessary to gauge the quantity of water available from it. If the supply is from a stream or springs, the

flow at different times of the year, and specially at the driest time just before the break of the rains should be ascertained by measuring the discharge, if small, in a vessel of known capacity or, if large, by passing it over a notch gauge in a dam. If the supply is from wells, the yield should be investigated by pumping from an experimental well as explained further on.

Where only small discharges from streams or springs have to be dealt with, the simplest method of measurement is to observe the time taken to fill a vessel of known capacity. For very small springs, a kerosene oil tin, holding four gallons, will be found as useful and handy as anything else; for larger springs, specially made rectangular cans of two to five cubic feet capacity should be used. In making these observations, it is necessary to see that there is as little leakage or overflow as possible from the channel in which the stream runs and also that the water is delivered with a free fall into the measuring vessel.

For streams and springs the flow of which is too large to be measured by the above method, a notch gauge must be resorted to. This consists of a thin metal plate with a rectangular notch in it of a size sufficient to take the discharge to be measured.

The gauge plate is attached to the upstream side of a frame of wood or metal set in a watertight weir of masonry or concrete thrown across the stream. The weir is sometimes formed of thick boards placed horizontally across the stream as shown in Figs. 4 and 5* below. In such weirs the notch is made in the boards with knife-edged sides. The length of the sill should be such that the depth of water flowing over it will not be less than four inches. The level of the water on the downstream side should be well below the sill to allow access of atmospheric air under the discharging stream—not less than half the maximum depth of water flowing over it. On the upstream side of the weir, to prevent the water approaching the notch with sensible velocity, the channel should be much wider and deeper than the notch to form a quiet pool. If the sectional area of the water as it passes through the notch be more than one-fifth of the area of the channel of approach, it will be necessary to take account of the velocity of approach in calculating the discharge. The height of the water above the bottom of the opening is measured for convenience from the water level in the pool on a gauge fixed above the place where it begins to drop, Fig. 5.* The discharge through the notch in cubic feet per second is given by the formula $3.33\sqrt{H^3} (B - \frac{1}{2} H)$ where B represents the breadth of the notch and H the height above zero (sill level) registered on the gauge.

* "Sanitary Engineering" by Vernon Harcourt.

Fig 4.—Sketch of Stream and Notch.

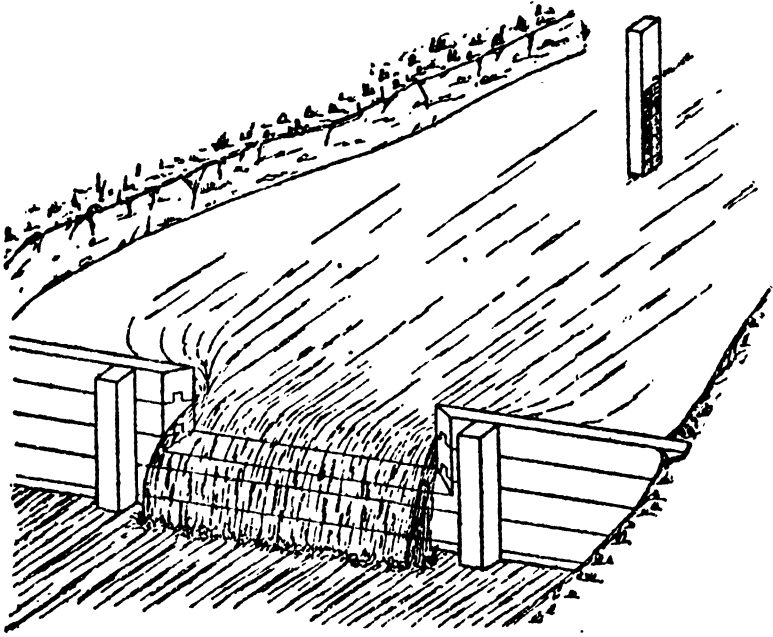
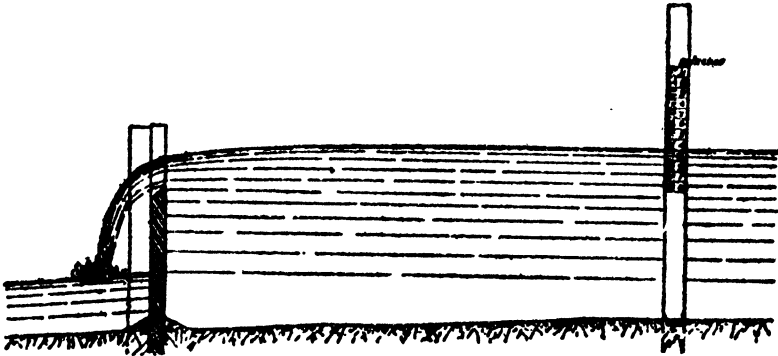

Fig. 5.—Section of Flow through Notch.



The discharge of larger streams is obtained by finding the width and depth of the stream at regular intervals across it at a point where it flows in a straight uniform channel and thence calculating its sectional area, and then measuring the velocity of the stream by means of floats or a current meter at several points along the section to obtain the mean velocity. This mean velocity multiplied by the area of the cross-section gives the discharge of the stream.

The safe yield of a well is ascertained by pumping from an experimental well at different levels below that at which the water normally stands and noting the rates at which the water is drawn from it at these levels. The lowering of water by pumping should be small at first, say four feet, and it should be increased a little weekly till it is found that the inrush of water to the well is so great as to bring in sand with it. This can be detected by examining the water brought up each day in a clear glass vessel and by taking daily soundings of the depth to the sand bottom from a bench-mark on the rim of the well. The permanent safe yield will be the quantity of water that can be abstracted continuously without disturbing after the first few days' pumping the soil or sand in which the well is sunk. This will be obtained at a depth varying in the alluvial soil of Upper India from six to eight feet below the normal water table according to the coarseness of the sand. Besides measuring the quantity of water which can safely be taken from wells, it is also necessary to observe the effect that this continuous abstraction of water has on bore-holes or trial shafts within a radius of 300 feet in order to determine the cone of exhaustion surrounding a well when it is being pumped and the economical distance at which they should be pitched if the supply is to be drawn from a series of them.

26. Testing the quality of the water.—The actual examination of a water as to its quality and suitability for potable purposes should always be carried out by an expert medical officer or analyst, but Engineers may be called upon to take samples for the expert to analyse and instructions as to how these samples should be taken will not therefore be out of place in this Manual. The following extract from "Theory and Practice of Hygiene," by Notter and Firth, explains clearly how this should be done and what information should be furnished with the samples :—

Great care must be taken that a fair sample of water is collected in perfectly clean glass vessels (not in earthenware jars). Winchester quarts, which hold about half a gallon and can be obtained of most chemists are most convenient; they should be repeatedly washed out with some of the water to be examined. In taking water from a stream or lake, the bottle ought to be plunged below the surface before it is filled. In drawing from a pipe, a portion ought to be allowed to run away first, to get rid of any impurity in the pipe. In judging of a town supply, samples should be obtained direct from the mains, as well as from the houses. The bottle should be stoppered; a cork should be avoided, except in great emergency, but if used it should be quite new, well tied down and sealed. No luting of any kind (such as linseed meal and the like) should be used.

For a complete sanitary investigation, half a gallon is necessary, but with a litre or a couple of pints pretty good examination can be made if more cannot be obtained. If a detailed mineral analysis is required (which will only be seldom), a gallon ought to be provided. It is always advisable to have a good supply in case of breakage or accident; two

Winchester quarts of each sample will generally be found sufficient. The examination ought to be undertaken immediately after collection, if possible. If this cannot be done, then as short a time as may be allowed to elapse, for changes in the most important constituents take place with great rapidity. Pending examination, it should be kept in a dark cool place.

The fullest information ought always to be furnished with the sample, the following being the most important particulars :—

- (a) Source of the water, viz. from tanks, or cisterns, main or house pipe, spring, river, stream, lake or well.
- (b) Position of source, strata so far as they are known.
- (c) If a well, depth, diameter, strata through which sunk, whether imperviously stoned in the upper part, and how far down. Total depth of well and depth of water to be both given. If the well be open, furnished with cover, or with a pump attached.
- (d) Possibility of impurities reaching the water ; distance of well from cesspools, drains, middens, manure heaps, stables, etc. ; if drains or sewers discharge into streams or lakes ; proximity of cultivated land.
- (e) If a surface water or rain-water, nature of collecting surface and conditions of storage.
- (f) Meteorological conditions with reference to recent drought or excessive rainfall.
- (g) A statement of the existence of any disease supposed to be connected with the water-supply, or any other special reasons for requiring analysis.

Any further information that can be obtained will always be useful. Each bottle should be distinctly labelled, so as to correspond with the official letter or invoice.

When it is possible, it is most desirable that the medical officer or analyst should visit the locality itself whence the water is obtained : in this way he may obtain information which might otherwise escape him. If the analysis can be made immediately on the spot, it will be all more valuable.

From the above it will be seen that it is most essential to describe as fully as possible the sources of supply of the samples sent for examination as also their surroundings, because water that is collected from a polluted area or one that is liable to contamination may be condemned as dangerous even though analyses, both chemical and biological, show that the sample analysed is of good potable water. Many cases have occurred in which severe epidemics of cholera and typhoid have been traced to a water-supply, samples of which had previously been analysed and found to be good.

CHAPTER III.

GRAVITATION SUPPLY FROM LAKES OR STORAGE RESERVOIRS.

21. Points to be determined in designing a gravitation scheme.—

In designing a gravitation scheme, the Engineer has first to determine the supply of water required for the town, the storage necessary to meet the supply, the quantity available from the drainage area selected. He has then to design a reservoir or reservoirs to store the supply. And, finally, he has to find the most suitable line of aqueduct to convey the water to the town where it is required. If the supply available from the drainage area selected falls short of the total supply required, an auxiliary system of supply from some other source by gravitation or pumping must be considered and the Engineer will have to investigate the best method of combining this auxiliary system with the main gravitation scheme.

22. **Selection of the drainage area.**—The rainfall available for storage from a drainage area is estimated by the methods already described in chapter II. The selection of a suitable drainage area will depend to a great extent on the geographical and geological nature of the country in which the works are situated. It should, if possible, be at such an elevation as to command the whole area to be supplied without pumping, and it should be impervious, steep, and as free from cultivated or manured land as possible. Granite, clayslate, schist, and similar crystalline or metamorphic rocks, as also those of the basalt and trap series, are the most impervious and yield water of the purest and softest quality. Limestone districts usually contain numerous fissures and should be avoided unless the site is covered by drift or boulder clay which is often found at the bottom of valleys rendering them impervious and keeping the water soft by preventing contact with the limestone rocks below. The dip and strike of the rocks should also be examined to see if any permeable beds occur which incline away from the drainage area and are likely to lead the water away from it.

23. **Determination of size of the reservoir.**—The supply of water required and the yield of the drainage area having been ascertained as explained in chapter II and in paragraph 130, chapter VII, the next question to be decided is what the size of the reservoir should be to ensure the daily demand being continuously delivered.

This will depend chiefly upon the climatic conditions of the locality and is principally affected by the duration of the longest period of dry weather.

In dry climates where the droughts are long and rain infrequent, or, where the rainy seasons are separated by long periods of dry weather greater storage capacity will be required than in moist climates where rainy days are frequent and the soil is always more or less damp. Each place must be considered with regard to its own peculiar conditions. In the north of England, for instance, on the western side among the hills where rainfall is comparatively heavy, reservoirs containing 120 days' supply have been found sufficient; further eastward and a little to the south, 180 days, and further south 250 to 300 days' supply may be required. In India, in such a climate as that of the Upper Provinces, two years' supply should for safety be provided, for if the rains fail any one year, as they often do, the reservoir may be called upon to give a supply during two dry seasons without much recouplement from the rains of the bad year. In deciding the size of reservoir required for a certain net storage capacity, the losses due to evaporation and percolation from the reservoir itself during the long dry intervals must not be overlooked. The loss from evaporation in Upper India between two rainy seasons, i.e. from October to June, has been observed to be about four feet vertical and it is usual to allow another two feet for percolation, or six feet altogether from both causes. This loss in vertical depth takes place gradually in nine months' time between the high water and low water levels of the reservoir and the total volume lost should therefore be calculated approximately from the mean spread of water between these two levels and not from the superficial area at high water level only.

24. Reduction of capacity by accumulation of deposits.—If the stream impounded by a reservoir brings down large quantities of silt and detritus, there may be considerable accumulation of deposit and a reduction in the capacity of the reservoir. Examples of reservoirs which have been filled up with sediment to such an extent as to become useless are not unknown. To avoid deposit in the reservoir, it is sometimes practicable to form a channel at the side leading into the stream below, into which the water may be diverted when the stream is in flood. When this would be too costly, a settling pond may be formed above the upper end of the reservoir into which the stream might be diverted during floods and, depositing the greater portion of its sediment therein, overflow in a comparatively clear condition into the main reservoir. The deposit thus intercepted is readily removed periodically from this small, shallow settling basin.

Separating weirs are sometimes used to intercept automatically the clear flow of a stream before it enters the reservoir while the turbid flow

of heavy floods runs to waste through bye-channels into the stream below the dam. Two designs of such weirs are shown in Figs. 6 and 7 below,

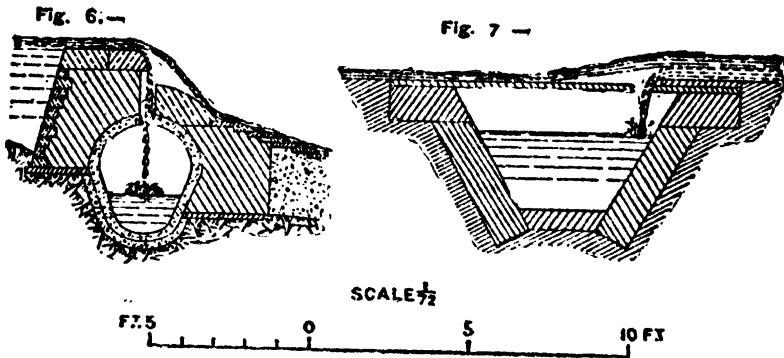

25. **Methods of increasing the capacity of reservoirs.**—There are two ways in which the capacity of reservoirs in valleys may be increased if the flow off the drainage area is sufficient to admit of the increase: (1) by making a series of reservoirs in steps up the valley, or (2) by building a higher dam lower down the valley. A high dam has, for perfect security, to be constructed of masonry on a foundation of sound rock which is not always available, and it is therefore not always practicable to provide a very capacious reservoir by the latter method even when the conformation of the valley is suitable for it.

26. **Best site for a dam.**—If the supply is to be drawn from a lake or natural reservoir, ample storage will be easily provided by constructing a low dam on the crest of the ridge which already exists and impounds the water of the lake, but, if an artificial storage reservoir has to be constructed, a careful investigation will be necessary to determine the best site for the dam, as the future success of the work will depend on its careful selection. A narrow gorge with a *wide flat* valley above it should be chosen if obtainable for the site of a dam. Some point immediately below the junction of two or more streams often affords a good site. Generally speaking, the best sites are those where the largest amount of water can be stored by the shallowest and shortest dams or embankments. The submerged area above the dam should be impervious and free from cracks or faults which may let the water through below the base of the dam or round its ends.

27. **Types of dams commonly used.**—Two types of dams are commonly used for forming reservoirs, namely, earthen embankments,

with an inner core wall of masonry, concrete or puddle clay, and masonry dams. The first type is generally adopted for dams of moderate height where a solid rock foundation is not available and the second for dams on solid rock, especially when the height is considerable.

In places where the ordinary methods of construction would be very expensive or impracticable, the power of a large jet or stream of water under pressure has been occasionally adopted in America for the economical construction of earthen dams. This jet is used to disintegrate strata composed of fairly loose materials, such as clay, sand, gravel, and small boulders and the loosened material is transported in channels, wooden troughs or pipes to a lower position in the valley to form a dam.

Steel dams, consisting of braced triangular frames placed about eight feet apart on concrete foundations and covered with steel plates on the water face, have recently been constructed in America, to impound water to depths of 50 to 60 feet. The design of these steel dams is that of a triangle with the upstream face so flatly inclined that the water-pressure gives increased stability by its weight. The vertical component of the static pressure secures such dams more firmly to their foundations, while in the usual type of gravity masonry or concrete dams, where the upstream pressure is chiefly horizontal, it tends to overturn the dam which has to be made sufficiently massive to resist this thrust by weight alone. Many reinforced concrete dams, designed on the same principle as steel dams, have also been constructed in America within the last twelve years, varying in height from ten to eighty feet and in lengths from sixty to twelve hundred feet. These types of dams will be found fully described in Schuyler's book, referred to in paragraph 28, and in "Engineering News" of the 12th May, 1898, and the 15th August, 1901.

28. Books of reference on the subject of construction of dams.—
The construction of dams is one of the most important works a water engineer is called upon to undertake. It would have been described in this Manual in detail if it had not been so fully dealt with in the Irrigation Manual. Students are referred to that Manual for further information on the subject. The following are useful reference books and papers:—

- (1) "Reservoirs for Irrigation, Water Power-, and Domestic Water-Supply," by J. D. Schuyler.
- (2) "Indian Storage Reservoirs," by Strange.
- (3) "Proceedings of the Institution of Civil Engineers," volumes CXV, CXXVI, and CLVIII.
- (4) "The Water-Supply of the City of New York," by E. Wegmann.
- (5) "The Design and Construction of Dams," by E. Wegmann.

Three good examples of water-works dams may be seen in India at Tansa near Bombay and at Jabalpur and Nagpur in the Central Provinces; the two first are masonry dams and the third is an earthen embankment. A description of the Tansa dam will be found in volume CXV of the Proceedings Inst. C. E.

29. **Works required in connection with dams.**—Besides the construction of the dam itself, the following works have to be executed in connection with it:—

- (1) A waste weir or bye-wash channel to provide for the harmless escape of floods after the reservoir has been filled.
- (2) Tunnel culvert or syphon which forms the outlet from the reservoir.
- (3) Valve tower from which the admission of water into the outlet is controlled.
- (4) The aqueduct from the reservoir to the town to be supplied.

The first is fully described, with dams, in the Irrigation Manual. The other three will be described in the following paragraphs, as their design for water-works dams is not quite the same as that of corresponding works for irrigation schemes.

30. **Outlets and valve towers of earthen dams.**—Some years back it used to be the custom to provide reservoir outlets in the forms of pipes or culverts laid through, or under, the made earthwork of an embankment at its deepest part. This led to several serious failures in England and America by the fracture of the outlet culverts or pipes at the point where they cross the core trenches owing to the unequal settlement of the embankment and the very different pressures produced by the varying height of the bank from its centre to the toe of the slopes.

The present practice is to disconnect as far as possible the outlets from the embankments and make them independent of one another. All earthwork settles for some time after it has been thrown up and the firmest material, except perhaps hard rock, compresses to some extent under heavy weight. The outlet should therefore be so designed that the embankment can settle and compress the ground on which it stands without injuring the outlet or any work connected with it and it should be so controlled at the inner end that any leakage from it cannot injure the embankment and can be readily attended to. To satisfy these conditions, tunnel outlets have been adopted in the latest reservoirs constructed in England. These outlets are placed in a regularly mined tunnel lined with masonry, concrete or iron on an alignment running round and clear of the embankment, or, if passing under any portion of it, situated at a considerable depth in the

solid rock below the embankment and its core. A very good example of such an arrangement is the outlet from the Bradford water-works reservoir described by Sir Alexander Binnie in his Chatham lectures an extract from which is given in appendix A.

The flow in these tunnel outlets is generally regulated by a valve tower in the reservoir at the inner end of the tunnel in which is placed a vertical pipe with branches at two or more levels, each controlled by a sluice valve. These branches enable the water to be drawn off from or near the water surface at different depths according to the condition and level of the water in the reservoir. The pipes leading from the tower usually pass through a massive brick stopping preventing the entry of any water into the tunnel which is consequently always empty for inspection.

A tunnel outlet has the great advantage of being useful during construction of the dam for the diversion of the stream and it thus does away in some cases with the necessity for constructing a bye-channel if this is not required permanently for the diversion of turbid flood-waters.

In the case of a low embankment, if the outlet culvert *must* cross the embankment and cannot be laid outside on one of the flanks and the expense of a tunnel cannot be faced, a culvert may be laid just below bed level in cutting if the soil is firm, but if such an expedient is adopted it is very necessary to see that the culvert is at least placed some depth below ground surface, that it rests on a good firm foundation, and that its cross-section is strong enough to withstand all pressures to which it will be subjected.

31. **Syphon outlets of earthen dams.**—In shallow reservoirs not exceeding 25 to 27 feet in depth, a syphon outlet might be adopted instead of a tunnel by means of which the water can be carried over the top of the embankment or round one of its ends. The syphon may be carried over the embankment some few feet below its top or it may be laid as an ordinary pipe in the solid ground on a line running up the toe of the inner slope and round the end of the whole work. Both its inner and outer ends should be fitted with sluice valves and the one at the end of the outer arm should be some feet lower than the lowest level to which the water is to be drawn. Suitable valves should be fixed at the summit for extracting the air and charging the syphon with water. Outlets of this description have been used successfully for the Nagpur reservoirs in the Central Provinces and for the Bolton water-works reservoir in England.

32. **Outlets and valve towers of masonry dams.**—With masonry dams, on a foundation of rock, the conditions are somewhat different and it is permissible in their case to place the valve tower near or at the dam.

But even for masonry dams many engineers consider it preferable to place the intake and discharge culvert away from the dam to one side to avoid all risk of weakening it. Where a discharge outlet is carried through a masonry dam the valve tower from which the outflow is controlled is made as a rule in a short breast or projection from the dam on the inner face. See Fig. 8, which shows the section of the Tytam* concrete dam taken through the intake placed at different levels and the valve well. The water is conveyed in this case through the dam by an 18" pipe laid in a culvert near the base of the dam.

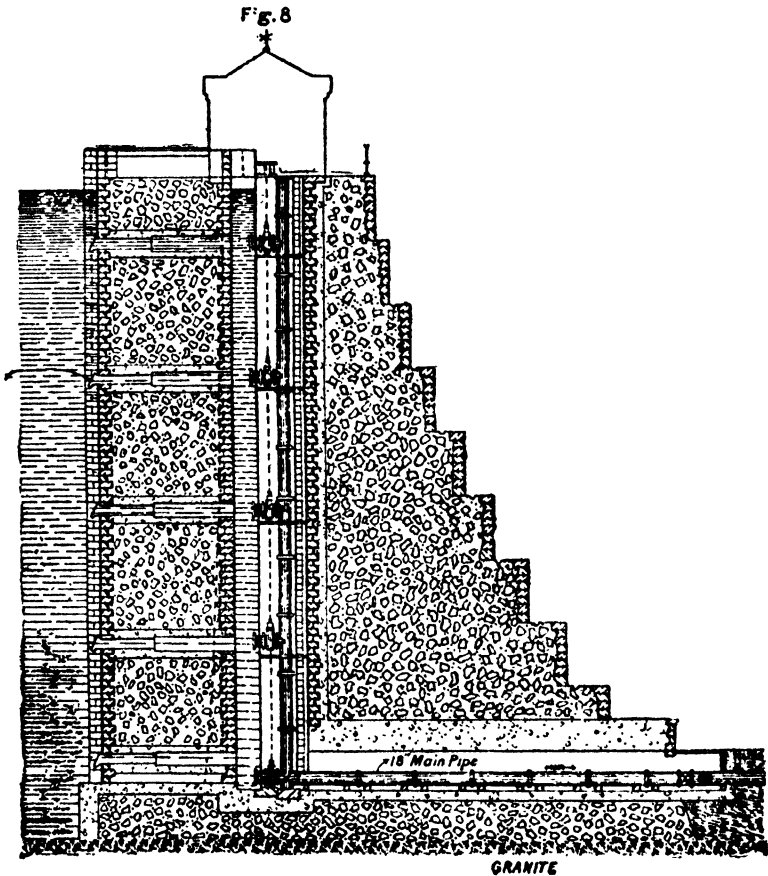

33. **Aqueducts of open or covered conduits or pressure pipes.**— Water may be conveyed from the reservoirs to the town by an open or covered conduit with a free gravity flow, or it may be carried by pipes under pressure, or it may be taken partly by one method and partly by the other.

The selection of one or other of these means of conducting the water will be governed by the nature of the country to be traversed, but there is one general principle which should be kept in view in making the selection, and that is a gravity duct or canal requires less fall per mile than a line of pipes under pressure—a matter of considerable importance in aqueducts of great length where the head is limited, or, in other words, where the water has to be delivered at the highest possible level below the source of supply. Generally speaking, the line of aqueduct follows the contour of the hills through which it passes, but it is necessary for economical reasons to bridge or pipe across valleys in some places or to tunnel through spurs of hills in preference to going round them.

If the aqueduct is to take the form of a canal, it is a matter for careful consideration whether it should be covered over or left open. A covered conduit keeps the water cool and protects it from frost and dust; but, on the other hand, its inspection and repairs are difficult and its cost much higher. The water in an open conduit is exposed to light and air, which by some is considered an advantage, but, against this, must be considered its liability to contamination and, if the velocity be slow, the growth of vegetation which may obstruct the flow of the channel. If the conduit is to collect surface water along its course in wet seasons it may be necessary to keep it open, but even in this case it might be covered, if, for other reasons, this is considered advisable, and have surface catch water drains leading into it at intervals.

34. Slopes of conduits and pipe lines.—The slope should be so adjusted as to give a velocity, when the channel is running full, which will not injure the material of which it is made, and, should the fall of the ground be very rapid, the bed slope of the channel should be laid out in steps or a line of pipes introduced where the ground is steepest.

If the slope is too steep throughout for a canal or duct, a line of pipes must be adopted, and if the fall be excessive even for ordinary pipes the head should be broken by constructing balancing reservoirs at intervals in suitable positions on the line (see paragraphs 42 and 43).

35. Size of aqueduct.—In determining the size of the aqueducts, the maximum daily consumption should first be fixed as described in chapter VII and, after allowing a reasonable addition to this quantity for future increase of population, it should be assumed that the daily flow will be delivered in one continuous stream running the whole 24 hours. The arrangements necessary for balancing the unequal demand at different hours of the day, stoppage for repairs, and the like are generally provided for by a service reservoir in or near the town and by the increased size of

the mains which connect this service reservoir with the distribution system. Without such a service reservoir at the lower end of the aqueduct, it would be necessary to make the whole length of the aqueduct large enough to meet the maximum rate of consumption in the 24 hours which is about three times the mean—obviously a very costly arrangement.

The calculation of the discharge of conduits and pipes of different shapes and sizes under varying conditions is not dealt with in this Manual, as it forms part of the subject of Hydraulics which students take up in their mathematical course.

36. **Materials of construction.**—The material to be used for the construction of the aqueduct will of course depend largely upon the resources of the district through which it runs. It may be made of stone masonry or brickwork or concrete lined internally with cement plaster, or of iron pipes, cast or wrought. If pipes are used, the question as to whether they should be of cast-iron or mild steel should be decided by the consideration set forth in paragraph 57, chapter IV.

37. **Section of conduits.**—The form of canals and ducts is generally the same in tunnel, in the open or in cut-and-cover. By cut-and-cover is meant construction in cutting filled up after the cover is built over. See Figs. 9 to 13* which illustrate the usual sections adopted for conduits in cut-and-cover and in tunnels.

AQUEDUCTS.

<i>Fig. 9.</i>	<i>Fig. 10.</i>	<i>Fig. 11.</i>	<i>Fig. 12.</i>
Thirlmere	Elan	Lock Katrine	New Croton Aqueduct. Tunnel in
Aqueduct.	Aqueduct.	New Aqueduct.	loose and compact rock, under
			high ground.

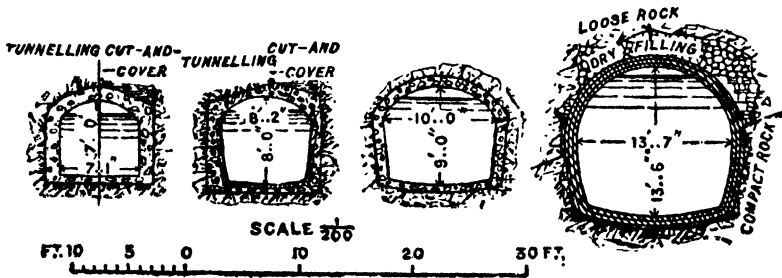
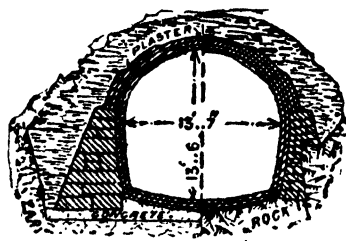
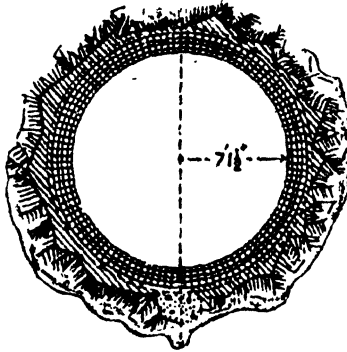

Fig. 13.
Cut-and-Cover Croton Aqueduct.



Covered lengths under low ground or at crossings of roads or drains in which the water is under slight pressure should be given a circular section as shown in Fig. 14, * this section being the most suitable for resisting internal bursting pressure.

FIG 14



38. Drainage and road crossings on lines of conduits.—Drainage and road crossings on the line of a duct are of the usual type employed for such purposes on canal works. The conduit is usually carried at such crossings in masonry or iron channels. Wrought-iron tubes resting on masonry piers are sometimes used, the tubes being so fixed as always to run full. As these crossings are similar to those required for canals and distributaries which are described in the *Irrigation Manual*, it is not necessary to refer to them here at greater length.

39. Exclusion of turbid flood-water of streams crossed by conduits.—It is often necessary to take in the pure water of streams crossed on the line of the aqueduct to increase the supply and at the same time to exclude all the turbid water brought down by these streams. This is effected by separating or leaping weirs which have been described above in paragraph 25.

40. Catchpits to intercept heavy solid matter.—Catchpits or settling cisterns are provided at intervals along the line of a duct, especially where it runs into a line of pipes. The floors of such cisterns are sunk some feet below the bottom of the duct to intercept any sand or other heavy solid matter which may be carried by the water.

41. Pipe crossings.—When it is necessary to take the water for facility of construction from a duct on one side of a deep valley to a duct on the other, iron pipes are laid across the valley in the form of an inverted syphon, the lowest point of which is situated at the stream or

river over which a bridge of iron or masonry or wrought-iron tube is built to carry the water across. If the bed of the river is rock or firm material not likely to be eroded by the action of floods, the pipes are often buried in a deep trench cut into the bed and filled up with concrete. The former method, though more expensive, is to be preferred, wherever it is feasible at a reasonable cost, as pipes laid above channels are readily accessible for inspection and repairs. Manholes and scouring valves should always be provided for emptying, cleaning, and inspecting the pipe and at each end of the crossing there should be an inlet or outlet basin, the former being provided with proper gratings to prevent the entry into the pipes of large solid matter. There should also be some provision in these basins for stopping the flow of water and running it to waste to admit of repairs or clearance of the lower length of the aqueduct. The outlet end of the pipes in such a syphon is placed at such a level relatively to the inlet as will afford the head required to overcome friction.

Stop valves are introduced at places along the syphon to stop the flow and isolate any section between two of them when desired. (See paragraph 119.) Some of these valves are closed by hand, whilst others close automatically on the occurrence of a fracture, owing to the increased pressure of the water on a disc, which always faces the flow produced by the augmented velocity of the escaping water. The disc is kept in position against the ordinary current by a counterbalance weight; but a considerable increase in the velocity of flow pushes forward the disc, which by means of a lever arm, releases a trigger in moving, thereby setting free a weight which closes the valve. To provide for the flushing out and emptying of the syphons, sluicing pipes furnished with stop valves, lead from the bottom of all the downward bends of the pipe into the nearest watercourses.

42. Hydraulic gradient.—The average hydraulic gradient of the whole length of an aqueduct from the storage reservoir to the service reservoir in the town is the slope of the line joining the water levels in these two reservoirs. Every endeavour should be made to make the slopes of the aqueduct in its different lengths, where it is not under pressure, coincide with this gradient as far as possible. In the case of pipe syphons under pressure the two ends of the syphons should be on this slope, the size of the pipes forming the syphon being so calculated as to give the required discharge at the gradient so obtained. If for the sake of economy or convenience in construction at awkward places or special positions, it is desirable to make the hydraulic gradient steeper or flatter for certain lengths, the necessary modifications can be readily effected by

varying the size of the aqueduct to suit the altered gradients for the requisite flow and by adjusting the hydraulic gradients at convenient adjoining places for the requisite lengths to return to the average gradient for the whole line. Fig. 15* is a longitudinal section of the Thirlmere aqueduct of the Manchester waterworks. It is 96 miles long, of which about 37 miles of covered concrete channels and 14 miles of tunnels, or 51 miles altogether, have been constructed to the hydraulic gradient of 20 inches in a mile; and the remaining 45 miles consist of inverted syphons crossing the valleys of the river Lune, the river Ribble, and several other smaller rivers. For a length of 83 miles from Thirlmere, the syphons as well as the tunnels and covered channels are aligned on a uniform gradient of 20 inches in a mile. The last 13-mile length near Manchester is a syphon on a gradient of 35 inches in a mile, the steeper gradient enabling the cast-iron pipes of this very long syphon to be made 36 inches in diameter in place of 40 inches, the diameter of the other syphons.

43. **Break pressure or balancing reservoirs.**—In very long continuous syphons the static pressure on the pipes towards the lower end tends to become excessive if it is not broken at intervals. It becomes possible to break pressure without affecting the discharge where the syphon pipe line approaches the average hydraulic gradient by building open break pressure or balancing reservoirs at these points.

44. For further details of construction of aqueducts, the student should refer to the following publications:—

- (1) "The Thirlmere Works for the Water-supply of Manchester," by G. H. Hill, Proc. Inst. C. E., vol. CXXVI.
- (2) "The Vyrnwy Works for the Water-supply of Liverpool," by C. E. Deacon, Proc. Inst. C. E., vol. CXXVI.
- (3) "The Water-supply of the City of New York," by E. Wegmann.
- (4) "The Construction of the Elan Aqueduct," by H. Lapworth, Proc. Inst. C. E., vol. CXL.

* Volume CXXVI, Proc. Inst. C. E.

CHAPTER IV.

PUMPING ARRANGEMENTS AND RISING MAINS.

45. **Various conditions under which pumping machinery is employed for raising water.**—Pumping engines may be employed to force water into the distribution system of a town from a river, well, natural lake or a storage reservoir either directly into the network of distribution pipes or into one or more service reservoirs in the town connected with the distribution system. In a supply from wells, the engines draw directly from the wells through a tapering suction pipe as described in the note on the Amritsar water-works in appendix B. The headworks at the pumping station are very similar in all the other cases. They usually consist of an intake, settling basins, filters, and clear water reservoir. When the supply is drawn from a river which is turbid in the flood season and has a very variable water level it is usual to do the pumping in two lifts: (1) from the river intake to the purification works situated at some convenient point near the town, and (2) from the clear water reservoir of the latter to the town. (See plate II.)

46. **Supplies pumped from lakes, reservoirs, and rivers.**—The pumping arrangements for supplies from lakes and reservoirs being very similar to those for river-supplies and simpler as a rule, will not be described in detail in this Manual. The following paragraphs deal with pumping schemes which draw their supply from a large river as those of Delhi, Agra, Lucknow, Cawnpore, Allahabad, and other large towns in Upper India. The purification works at the filtered water-pumping station, consisting usually of settling basins, filter beds, and a clear water reservoir are described in chapter VI on The Purification of Water-Supplies. The rest of the pumping arrangements will be taken up in this chapter. The diagram on plate II shows the usual relative positions of these works.

47. **Site of intake and pumping station.**—The selection of a site for the intake and river pumping station is governed by the following considerations :—

- (1) It should be on the upstream side of the town and, as far as possible, above all sources of contamination in the vicinity of the town.
- (2) It should be above the highest flood level and large enough to hold conveniently the pumping station and all its subsidiary buildings.

- (3) It should be at a point on the river where the hot weather current has a distinct set against the bank on which the pumping station is to be placed and is not likely to move off to the opposite bank. It should, at the same time, be on a high permanent bank which is not likely to be carried away by the river when in flood.

The first two points can only be satisfactorily investigated by a careful and intelligent inspection of the locality and all known flood marks. The third point will require for decision a detailed survey of the river for some miles above the town, but, without enormous expenditure on training works it will not be possible for the water-works engineer to ensure the low water channel always remaining under the bank at the point he has selected. Large sandy rivers in Upper India have a tendency to change their low water channels sometimes and in the years when these move away from the intake it becomes necessary to cut an artificial channel to the stream and endeavour by temporary spurs to train the river to where it is wanted. If the training works are not successful the artificial channel has to be kept open till the river rises again. The site should be protected by pitching, spurs, embankments, or otherwise from the eroding action of the river during floods.

48. **Intake.**—Plate III shows a typical design for an intake. It should be pushed well back into the bank to avoid obstruction of the flow of the river and consequent scour as far as possible and, in sandy soil, the walls should be founded on wells to be safe against any possible scour that may occur. The intake consists of two chambers: one for each suction pipe of the pumps. In front of each chamber there are grooves in the masonry side walls into which wooden beams, four inches thick, are lowered horizontally to admit comparatively clear water from the surface and exclude silt and floating débris. When the river is in high flood and the water very turbid, it is usual to drop beams into the groove till the top one is a little above the river level, the supply for the suction well entering it through the small open spaces between the beams. If this does not give a sufficient supply for the pumps, the top plank is raised slightly above the lower one.

49. **Unfiltered water-pumping station.**—From the intake, the water is led by duplicate suction pipes in an underground tunnel or culvert to a pump well in the pumping station immediately under the engines. These pipes, usually of cast-iron, have strainers at their river ends to keep sticks and other large objects from entering the pump chambers and damaging the valves. If the pipes are of considerable length, vacuum

vessels are fixed near the pump barrels to prevent shock as far as possible and ensure a uniform flow of water into the suction chambers of the pumps. The pumping station building generally consists of two rooms and a chimney, if steam engines are used. In one room are the pumping engines, steam gauges, vacuum gauges, hydraulic gauges, delivery pipe connections, condensers, etc., and in the other are the boilers with their adjuncts such as donkey feed pumps, and automatic stokers. The economiser is fixed in a separate chamber between the boilers and the chimney and a small workshop is generally attached for convenient execution of petty repairs to the machinery. (See plate IV.) As the design, testings, and working of engines will be taken up by students in full detail in their Mechanical Engineering course, these points will not be treated at length in this Manual. It will be sufficient to note here those points only which come within the province of the Civil Engineer responsible for the construction of waterworks. For fuller information on the subject of pumping machinery, the student should refer to the following book recently published: "Modern Pumping and Hydraulic Machinery," by E. Butler, M.I.M.E.

50. **Types of pumping machinery suitable for different working conditions.**—The unfiltered water pumping station at the river bank is very similar in its internal arrangements to the filtered water station, but the quality of the water pumped at these stations being different, the type of engine to be selected in each case has to be specially considered. The turbid water dealt with by the unfiltered water engines wears away the plungers and valves of ordinary reciprocating pumps rapidly, and causes considerable slip and consequent loss of efficiency. For the river station it is therefore advisable to provide either rotary pumps without valves and pistons, if the water is very silty, or, externally packed plunger pumps of the reciprocating type if the water is not particularly gritty. The latter are so made that the plungers can easily be taken out and packed externally without much trouble when they begin to show signs of wear. If rotary pumps are adopted, the use of Diesel oil engines to drive them should be carefully considered, as these engines are now coming rapidly to the front; they are more economical* and more suitable than compound or triple expansion steam engines for working such pumps. If electric current is available, it might be utilised for driving rotary pumps by electric motors, as is now done at Rurki for the College water-supply from the Ganges Canal. As a possible alternative, suction gas engines might also be

* Oil engines consume from $\frac{1}{2}$ pint to one pint of oil per pump horse-power hour. Diesel engines are slightly more economical than other varieties.

mentioned though these have not been used yet to any extent for pumps and are still under trial in India. Humphrey gas pumps, recently invented, provide a very powerful means of raising economically a large quantity of water, filtered or unfiltered, when the lift is not more than 35 to 40 feet. Quite recently, the London Metropolitan Water Board have installed a large Humphrey pumping plant for raising 180 million gallons a day from the river Lea to their large reservoirs at Chingford, the lift being 25 to 30 feet. The tests show that the fuel consumption is about 1 lb. of anthracite per pump horse-power, the cost of which is only about half that of coal required for a triple expansion steam plant doing the same duty. The cost of the plant, inclusive of gas-producers, buildings, and foundations was £ 19,000 less than that of the lowest tender received for a triple expansion steam engine and centrifugal pumping plant. The novel feature of the Humphrey gas pump is the explosion of a combustible mixture of gas and air in a cylinder to produce direct pressure on the surface of water to be raised. For further information regarding the details of this plant, the student is referred to the following papers:—

- (1) "Proceedings of the Institution of Mechanical Engineers,"
November 1909.
- (2) The "Engineering" of February 14, 1913.
- (3) Ditto of December 19, 1913.

The large plants of this description hitherto erected have been suitable for low lifts only and no suction, but Mr. Humphrey has recently patented pumps for deep suction and high lifts; also a very ingenious two-cycle pump, having but one combustion chamber. He is also adapting two pumps to work with liquid fuel. The gas used for this plant is generated from anthracite in Dowson producers. This pump has not yet had a long trial and is still in the experimental stage.

51. **Filtered water-pumping station.**—The filtered water-pumping engines, having to force clear water against a considerable head, are generally steam engines of the direct-acting type, compound condensing or triple expansion. The smaller sizes, of 60 to 100 horse-power, use 4 to 5 lbs. of the best Indian coal per pump horse-power hour, but large engines of this class with high duty attachments are much more economical and can be run with 2½ to 3 lbs. of coal of the same quality. The latter are, however, more expensive, and it is a matter for comparative calculation in each case whether their higher first cost, as compared with that of an ordinary triple expansion plant, is justified by the saving in fuel expenses.

The boilers for such engines are usually of the water tube type, of which the Babcock-Wilcox is a good example.

The description of plant to be used for raising filtered water should be carefully considered in each case, as it is possible that conditions may sometimes exist for which an oil-engine pump, a suction gas pump, an electrically-driven pump, or a water-power turbine pump would be more suitable than a direct-acting steam pump, especially when the water is delivered for distribution at a uniform rate into a service reservoir in the town against a more or less fixed head of pressure. Tenders should be called for from makers of the types likely to be suitable in each particular case and the decision as to which type is the best in that case should be based on a careful consideration of the claims put forward by each tenderer.

The design of the filtered water-pumping station building is very similar as a rule to that of the unfiltered water station described in paragraph 49. (See plate IV.)

52. Size and quality of engines.—When the horse-power required exceeds 150 it is usual to provide it in two working units, a third unit of the same power being provided as a reserve against accidents; with smaller engines, the practice is to put in an engine of the full power to do the work required and to provide a duplicate as a stand-by. A small engine is not so economical as a big one in fuel-consumption and its first cost is proportionately greater.

It is most essential that the pumping machinery should be the best procurable for reliability and economy and that a sufficient supply of spare parts should be provided to preclude the possibility of an engine being thrown out of work for a considerable time whenever there is a breakage of one of its minor parts.

53. Specification.—In specifying for pumping machinery, a Civil Engineer should be careful to confine himself to a general description of the plant he requires. He should not attempt to specify the minor mechanical details, as the makers prefer to have a free hand as regards these in framing their tenders. The specification should, as a rule, be limited to a careful statement of the following points:—

- (1) The quality of water to be pumped.
- (2) The maximum quantity to be delivered (a) per diem, (b) per hour.
- (3) Length and size of delivery main.
- (4) Length of suction main. (Its diameter is always slightly larger than that of the delivery main.)
- (5) The levels at which the different parts of the machinery should be fixed with reference to the source of supply and the point

or points, of delivery. (The suction lift should not, if possible, exceed 20 feet.)

- (6) Whether the engines are to be of the condensing or non-condensing type.
- (7) Whether such fuel-saving appliances as economisers and super-heaters are to be provided.
- (8) The class of boiler to be supplied.
- (9) The lowest efficiency that will be accepted (with the remark that any increase over the specified minimum will be given due weight in deciding which tender should be accepted).

An example of a specification for pumping engines and boilers to accompany a call for tenders is given in appendix. C.

54. **Test of pumping plant.**—When the plant has been erected, its efficiency should be tested as regards delivery of water and fuel-consumption before final payment is made to contractors. A record of the tests made by the writer in the case of the Amritsar water works plant will be found in appendix B.

55. **Comparative values of pumping installations for a certain duty.**—In comparing the real value of pumping engines, it is necessary to consider their annual charges as well as their first cost, as it might well happen that an expensive engine consuming a certain amount of fuel for a given duty may prove more economical in the long run than a cheaper one using a much larger quantity of fuel for the same work. The example given below shows how such comparisons should be made. The pumping engines in this example are steam engines but similar calculations could readily be made for producer gas or oil engines by substituting, where necessary, coke, charcoal or oil fuel for coal in the calculations.

Data—

- (1) Three engines to be provided, each of 150 pump horse-power; two to be at work at one time and one to stand-by.
- (2) Number of working hours a day, ordinarily, to be 16 but the average number of working hours in the year may be taken to be $12 \times 365 = 4,380$.
- (3) Evaporative power of the coal used in ordinary working is 5 lbs. of water or steam per pound of coal.
- (4) Cost of coal, 15 rupees per ton.
- (5) Rate of interest at which money can be borrowed, 4 per cent.
- (6) Loan to be repaid in 22 years, making the total annual payment for interest and repayment of loan, say 6 per cent.
- (7) Two tenders are received for the installations from A and B,

A's installation is to cost, completely erected, 4,00,000 rupees and the guaranteed consumption of steam* is 12 lbs. per pump horse-power per hour with a boiler-pressure of 160 lbs. per square inch.

B's installation is to cost 3,00,000 rupees and the guaranteed consumption of steam is 20 lbs., the boiler-pressure being the same.

Comparative calculations—

A's tender—

	Rs.
The interest and sinking fund on A's tender of Rs. 4,00,000 at Rs. 6 per cent. per annum	24,000
The annual coal bill will be	21,118
$\frac{12 \times 300 \times 4,380 \times 15}{\text{lbs.} \quad \text{lbs.}}$ $2,240 \times 5.$	
Total annual cost of A's installation for interest and sinking fund and coal	45,118

B's tender—

The interest and sinking fund on B's tender of Rs. 3,00,000 at Rs. 6 per cent	18,000
The annual coal bill will be	35,190
$\frac{20 \times 300 \times 4,380 \times 15}{\text{lbs.} \quad \text{lbs.}}$ $2,240 \times 5$	
Total annual cost of B's installation	53,190

There would be other annual charges for lubricating oil, small stores, repairs and establishment, but as these would practically be the same for both installations they have been disregarded.

The comparative calculations show that though A's tender is Rs. 1,00,000 more than B's in first cost, it is decidedly the more favourable of the two as it will result in a net annual saving of about 8,000 rupees.

56. Rising mains.—The mains through which water is pumped from the unfiltered water station to the purification works, and from the filtered water station to the town, are usually made of cast-iron or mild steel, generally the former. When the working pressure to which the pipes will be subjected does not exceed that due to a static head of 400 feet

* The guaranteed consumption is stated in terms of steam used instead of coal as the latter varies in efficiency in different places, while the former furnishes a fixed standard which is universally applicable.

of water, cast-iron pipes will, as a rule, be found preferable. Beyond that pressure, the lead joints of cast-iron pipes begin to be troublesome and mild steel pipes, with flange joints, will be found to be more serviceable.

The working pressure in a pipe consists of (1) the static head and (2) the friction head due to the velocity with which the water is delivered through the pipe at times of maximum demand. The actual pressure in the pipes is sometimes greatly in excess of this working pressure, owing to the "water ram" caused by a sudden check to the velocity of flow by the rapid closing of sluice valves. In a long line of pipes, this "ram" may increase the bursting pressure momentarily to a considerable extent. Pipes required for a certain working pressure should, therefore, be tested to a head of at least 200 feet in excess of that pressure.

57. **Mild steel and cast-iron pipes compared.**—Mild steel pipes having greater tensile strength and a higher bursting resistance are very much lighter than cast-iron pipes for the same service, and although, weight for weight, cast-iron costs less than wrought-iron, the former often works out cheaper even for lower pressures than 400 feet head, owing to the saving in transport. In comparing the cost of the two classes of pipes, it must not, however, be overlooked that the life of the thick cast-iron pipes is, as a rule, greater than that of the mild steel tubes. No exact figures can be given for the life of the two classes, as it varies to a great extent with the nature of the soil in which the pipes are buried, the quantity and nature of acids present in the water and the efficiency of the coating. Wrought-iron or steel corrodes more quickly underground than cast-iron, especially in soils charged with salts, and there being less material in the steel tubes, their life must obviously be shorter. Cast-iron pipes have been known to be serviceable after being 50 years in the ground, or even longer. Steel tubes have not been in use nearly so long, and their maximum life is, therefore, unknown.

58. **Size of rising mains.**—The size of pumping mains is governed by the following considerations. The greater the velocity of flow, the smaller and cheaper will the mains be, but the greater will be the friction head against the pumps; the engines will, therefore, be larger and more expensive, and the coal-consumption will be greater. To arrive at the most economical size of main, it is necessary to make two or three comparative calculations assuming velocities between $9\frac{1}{2}$ and $3\frac{1}{2}$ feet a second. The former is accepted in practice as the minimum velocity which will keep the mains free from deposits, and the latter is seldom exceeded for economical reasons. Having assumed a certain velocity, the cost of the main for that velocity should be calculated, as also the cost of

the engines with all their adjuncts. The annual charges should then be derived from these by allowing 6 per cent. for interest, depreciation, and maintenance on the main, if of cast-iron, and 10 per cent. on the engines, adding to these the cost of coal consumed in each case. If the main is of mild steel or wrought-iron, the interest, depreciation, and maintenance charge on it might be assumed to be 7 per cent. The size of main which gives the lowest result, being the most economical, should be adopted.

CHAPTER V.

WATER-SUPPLY FROM WELLS.

59. **Advantage of well-supplies.**—Water-supplies from wells are comparatively very economical because the water is so pure, if the wells are in unpolluted sites, that it can be pumped directly into the supply mains without first being lifted into settling tanks, then purified by passing through filters and finally, pumped a second time into the distribution system. The cost of the settling tanks, filter beds, and clear water reservoir is thereby avoided and with only one set of pumping engines at work, the maintenance charges are materially reduced.

60. **Different types of wells.**—Three types of wells are used for water supplies; (1) shallow masonry wells sunk into alluvial sand or other permeable strata a short distance below ground surface; (2) deep wells carried down by borings to considerable depths through impervious strata into underlying water-bearing strata; (3) tube wells in soft soil.

61. **Shallow wells.**—Shallow wells are generally of brickwork or masonry, 8 to 12 feet internal diameter, and 50 feet to 60 feet deep. The method of constructing and sinking such wells in Upper India is fully described in the Manual on Bridges in the chapter on Foundations and will not be referred to further in this Manual. Though shallow wells—especially when less than 50 feet deep—are generally regarded as objectionable sources of water-supply owing to the difficulty of protecting them from pollution, they often prove very serviceable as a means of easily procuring water at a small cost; and they are still very extensively made use of in the United States and in India, not only in rural districts but also for towns where a supply of water is readily obtainable at a small depth below the surface. The safety of such supplies for domestic use depends upon the position of the wells in relation to dwellings and other sources of contamination and upon the amount of natural filtration the water undergoes in passing through the permeable water-bearing stratum before reaching the well. Suitable sites for wells for town-supplies are unmanured sandy tracts at a distance from villages or towns. Low-lying tracts heavily manured and

cultivated in the vicinity of inhabited areas or impure tanks should be carefully avoided. Such wells should have a thoroughly watertight steining of sound brickwork or masonry from top to bottom. A good site for wells may often be found in Upper India near main canals or their distributaries. The source is unfailing and may be freer from contamination than cultivated and possibly manured sandy surface areas fed by rainfall. In this connection it should be noted that the sub-soil water level always falls from a canal on a watershed to the normal water table on both sides while it rises, as a rule, between two rivers or lines of drainage. The following diagrams will illustrate this remark :—

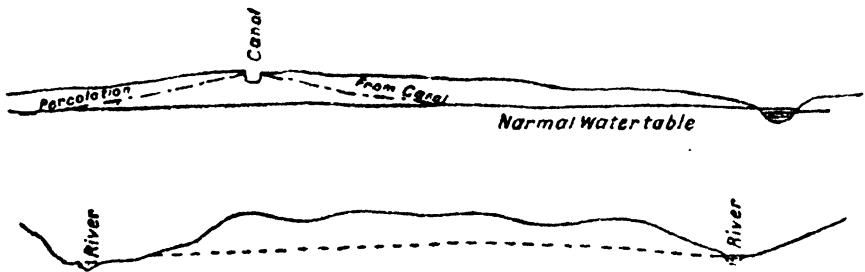

62. **Depth to which shallow wells should be sunk.**—Before sinking wells for a town-supply, borings should be made on the selected site to show the nature of the sub-soil for a considerable depth below ground surface. The wells should go down at least 50 feet below ground into a layer of good water-bearing coarse sand or rest on a thick bed of clay or “*mota*” as it is called in Upper India, if this is available. If the wells are on “*mota*” a hole four to six inches in diameter is bored through it to the sand below from which the well derives its supply. When a “*mota*” well is first worked, sand will pass up through the hole in the “*mota*” from the conical cavity formed below and will continue to come up until the area of the surface of the cavity is large enough to supply the water pumped from the well at a safe velocity. (See Fig. 18.) A “*mota*” well usually gives a much better yield than an ordinary well resting in sand, but the safe head under which it is to be worked permanently should be determined with great caution. If the water drawn is excessive, the cavity may increase to such an extent that the “*mota*” is no longer capable of withstanding the weight of the well on it and collapse will probably result. If after a short period of pumping it is found that the water drawn from a well under a certain head is charged with sand, even in small quantities,

it should be taken as an indication that the head is excessive and should be reduced.

"Mota" wells should be firmly embedded for a couple of feet in the "mota" clay. If this is not done, the water will rush in under the edge of the well curb bringing sand with it and this endangers the stability of the well as shown on the diagram below. Fig. 19.

Fig. 18,

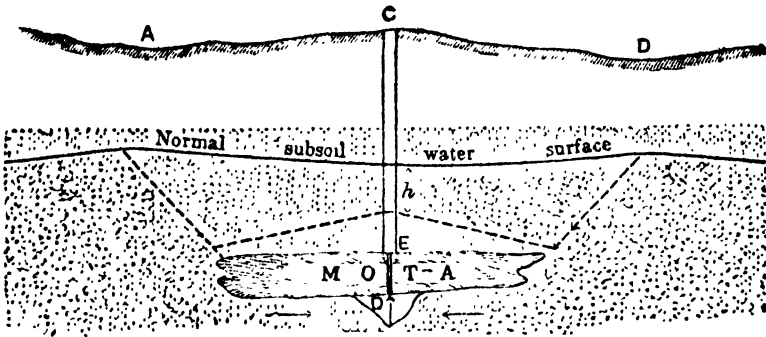
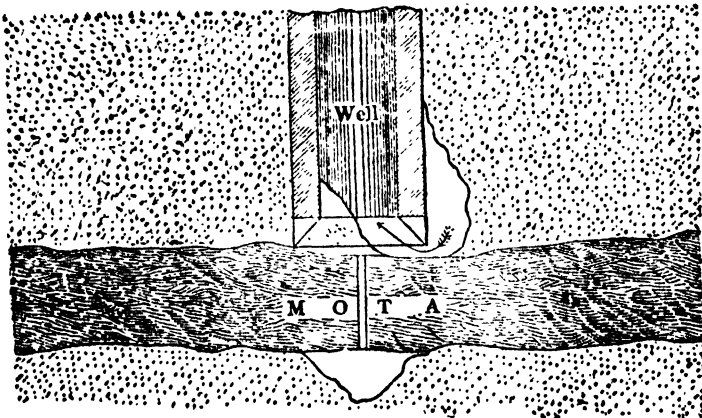

Fig 19.



In some cases, where the "mota" is at considerable depths below ground surface to which brick cylinders could not be sunk without incurring excessive expenditure, a bore tube about six inches diameter taken down from the bottom of a shallow well through the "mota" to the sand stratum below has often improved the yield of the well very considerably.

63. **Yield of shallow wells.**—The safe yield of a shallow well in ordinary coarse sand, such as is found in the alluvial plains of Upper India, is 1,500 to 3,000 gallons an hour for a well 10 feet to 12 feet diameter. This discharge is obtained by lowering the normal water level six to eight feet. A good “*mota*” well of the same size will often give twice this discharge with safety under the same head.

64. **Groups of wells for large water-supplies.**—For the collection of water for large towns, a group or line of wells is generally used with a suction pipe connecting them all and leading at the centre of the group or line to the pumping engines. A good example of this system of supply is the Amritsar water-works, of which a description is given in appendix B.

65. **Lowering of water-table by continuous pumping.**—The water-table at a site which is heavily drawn on by a series of wells for a large town-supply usually falls a few feet permanently shortly after the pumping is regularly established. This permanent drop of normal subsoil water-level in the vicinity of wells in regular use must be taken into account in fixing the levels of the pumping engines and suction pipes to which the well system will be connected. It varies from two to six feet.

66. **References.**—The following Government publications contain interesting information on the subject of shallow wells:—

- (1) “Papers relating to the Construction of Wells in the North-Western Provinces, Roorkee, 1883,” by Captain Clibborn.
- (2) “Note on above,” by H. B. Medlicott, Esq., Part 4, volume XVI, Records of the Geological Survey, 1883-84.
- (3) “Reply to Mr. Medlicott’s Note No. L 11,” Professional Papers on Indian Engineering, 1883-84.
- (4) “Note by Colonel Brownlow, R.E., on *Mota* Wells,” dated the 23rd October, 1884.
- (5) “Reply to above,” by Captain Clibborn, dated the 11th April, 1885.
- (6) “Experiments on the Passage of Water through Sand, 1895.”

67. **Deep wells.**—Deep wells generally consist of an upper portion of large diameter constructed in the same way as the shallow wells above described and of a boring taken down from the bottom of this large well to the water-bearing stratum below from which the supply is to be drawn. The large upper portion enables the pump to be placed in it at a lower

level than would be possible if the bore-hole came up to the surface, and it also provides some storage for the water issuing from the bore-hole, thereby equalizing the efflux from the well. Such wells are always lined in the upper part to provide against surface pollution and where they traverse soft soil or strata which are liable to yield water unfit for use.

The geological features of a locality have to be carefully considered in selecting a site for a deep well, such as the depth below the surface of the stratum from which it is intended to take water, the probable thickness of this stratum, its dip, its general character, the possible extent of its outcrop and freedom from pollution, and the prospects of the existence of faults. Faults often mislead the engineer in his search for water by producing an impenetrable barrier across a water-bearing stratum, which renders the conditions on the two sides of the fault absolutely different. See the diagram * below :—

WELLS AFFECTED BY FAULT.

Fig. 20.

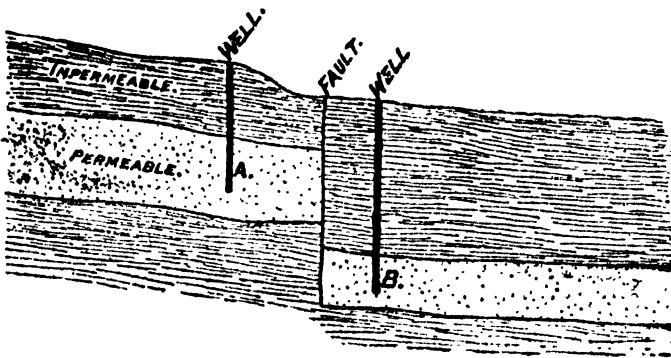

In the above case an underlying permeable stratum dips uniformly, though dislocated by a fault, so that its dip is towards the fault on the upper side and away from the fault on the lower side. The permeable stratum at A will therefore be fully charged with water, while the permeable stratum on the other side of the fault will be practically devoid of it. Under these conditions a well sunk into the permeable stratum at A above the fault will receive an abundant supply, whereas a well sunk into the original continuation of the stratum at B will get little or nothing.

* "Sanitary Engineering," by Vernon Harcourt.

"Artesian" wells are deep shafts sunk or bored through impermeable strata to a water-bearing stratum below from which the water is forced up to the ground surface or ejected above it by the hydrostatic pressure due to the higher level in hills or mountain ranges at which it entered the porous stratum. If the water under pressure rises as

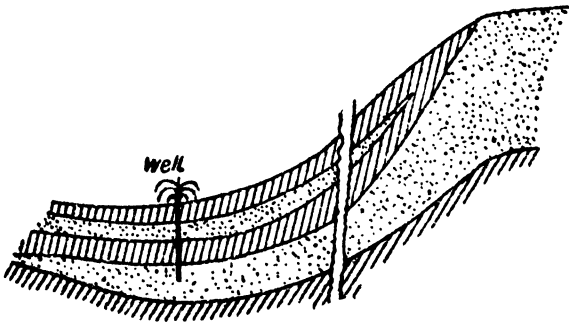

a jet above ground level the well is called "Artesian," but if it only rises a part of the way up to ground surface from the water table it is called "Sub-Artesian." An artesian supply is most useful if it can be secured at a reasonable cost as it can be utilised by flow at ground surface and saves the cost of pumping. The author is not aware of any successful artesian wells in India. Some deep borings have been made to find an artesian source of supply, but in no case that he knows of has any success been attained.

68. **Methods of boring for deep wells.**—There are two methods of making deep well borings. By one method, the strata pierced are broken up into small fragments and dust by the boring tool and the loose material thus produced is removed from the hole as dust or mud. This is the ordinary method. By the second method a rotating diamond drill scoops out a circular ring with an external diameter, the same as that of the bore-hole, and leaving a central solid core which is taken out afterwards and indicates the exact nature of the strata passed through much better than the pulverised and frequently pulpy material produced by the first method. The first system is usually adopted where a small bore-hole has to be formed through hard loose soil, such as gravel and stone, of moderate hardness, as it is affected by the fall of a simple tool, though it is somewhat wasteful of labour in pulverising the strata it passes through. It has recently been extended to borings of large diameter by means of special appliances. The second system is more advantageous when the boring is to be very deep and large and in hard rock, but it is costly and involves the use of complicated machinery.

The following extract from "Sanitary Engineering," by Vernon Harcourt, explains clearly how ordinary borings are made and what tools are used in forming the bore-holes :—

The earliest method of boring employed in Europe, borrowed from the Chinese, consisted of a chisel suspended from a rope, guided in a tube, and raised and dropped by means of a lever. The twisting of the rope causes the chisel to vary the position of its blow ; and the shattered rock is removed at intervals by a cylindrical shell with a valve opening upwards at the bottom, through which the débris enters and is retained on lowering the shell into it, thereby clearing the whole on raising the shell (Fig. 21). In stiff strata, such as clays, the hole is formed by an auger, which is pressed into the soil and turned so as to force the material into it ; and the auger is then raised and its load discharged (Fig. 22).

By substituting rods screwed together for the rope, greater control was obtained over the boring tool, the rods being turned by projecting arms from the top ; and the chisel, weighted with the boring rods, delivered a hard blow when dropped on the bottom of the bore-hole. This modification enables holes of small diameter to be bored to a great depth in search of water.

Various forms of chisels, made of the best wrought iron or mild steel, are employed for pounding up the rock in forming a bore-hole. Flat chisels with straight or pointed ends (Fig. 23) require to have their position constantly shifted to made a round hole ; but when

SHELL WITH VALVE FOR CLEARING BORE-HOLE

Fig 21



AUGER FOR BORING IN CLAY.

Fig. 22



BORING CHISELS.

Fig. 25
Cylindrical Chisel.



Fig. 23
Flat Chisel.

Fig. 24
Chisel with T-piece.



BORING TOOLS.

Fig. 26
Spring Rimer.



Fig. 27
Expanding Cutters.

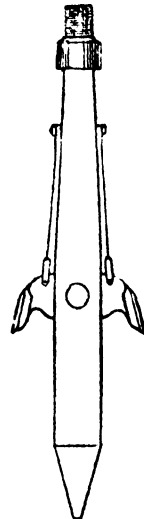

the flat chisels are provided with a projecting segmental piece at the side, corresponding to the circumference of the hole (Fig. 24), the circular form is more readily obtained with fewer shifts of the tool. A duplex chisel, in the form of a cross, is another shape employed; while a cylindrical chisel (Fig. 25) enables a bore-hole to be trimmed to a perfectly circular and vertical form. A kind of worm screw is used for loosening soft soil; and a corkscrew form of a screw serves for recovering broken off tools, for which purpose various other kinds of apparatus are also resorted to.

In passing through soft soil, or through unsatisfactory permeable strata, the bore-hole has to be lined with tubes, to prevent the falling in of the sides in the former case, and the influx of unsuitable water in the latter. The first tube, or pipe, should be furnished with a steel shoe, having a cutting edge at the bottom, so as to shear off any roughness or projections at the side of the bore-hole, and thus facilitate the descent of the pipes. In traversing soft soil, when the tubing has been forced down with the aid of a turning movement, or driven down, if necessary, to the bottom of the hole, the boring is recommenced; and the hole is enlarged below the pipes by means of a spring rimer when the tubing does not descend readily, which is turned round in the hole on expanding after leaving the lining (Fig. 26). Another tool with expanding cutters is also used for riming the bore-hole below the tubing (Fig. 27). The tubes may, with advantage, be made of steel with socket joints, and a special flange screwed on at the top of the tubing when driving has to be resorted to.

Trestles, shear-legs or staging are erected over the bore-holes and provided with a windlass and tackle for lowering and raising the boring rods and tools and for handling the tubes; whilst occasionally, for an important work, steam power is employed.

Boring with diamond drills.—All the systems of boring described above depend upon the rock in the bore-hole being sufficiently broken up to be removed in some form of cylindrical shell or shell pump; whereas the rotary, circular diamond drill merely grinds out a circular ring leaving a central, solid core of rock, which, when taken out, reveals the exact condition of the rock traversed as it exists *in situ*. Diamond drills, however, are not suited for boring in loose or soft strata, or in strata of variable character; but they are very valuable for boring in hard rock, especially where the depth to be traversed is considerable; and their economy varies in proportion to the size of the bore-hole and the hardness of the rock.

The diamonds used for this drilling are an amorphous black variety of the gem, of great hardness, found in the province of Bahia in Brazil, and some inferior qualities of Kimberley diamonds incapable of being cut into jewels. These stones, though of no value for ornamental purposes, have greatly increased in price of recent years owing to the difficulty of obtaining them. The diamonds are set at intervals in steel crowns fastened to hollow rods, which are revolved very rapidly; and when set for rimering out a hole, they have to be placed close enough together to attack the whole annular surface of the rock to be removed. The central core is removed at intervals by being gripped, broken off and lifted by an annular steel spring attached to the crown, when the crown is raised by the boring rods. The ground-up rock is removed by forcing a stream of water down the hole, which also keeps the drill cool.

For more detailed information on this subject, students are referred to "Well-boring for Water and Oil," by C. Isler.

Fig. 28.

Fig. 28
Driving tube well
with clamps

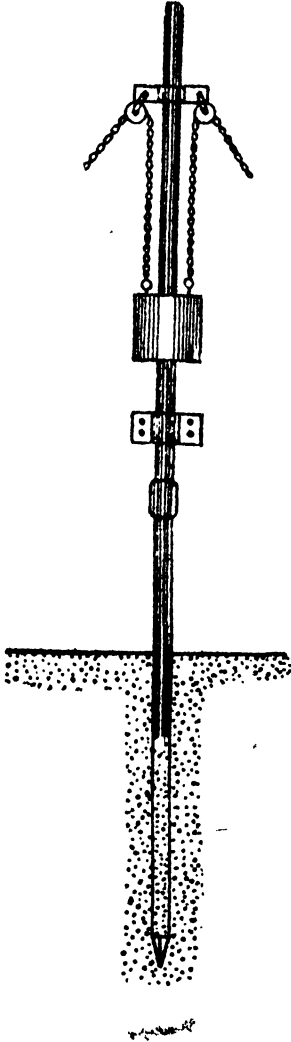

69. Driven tube wells in soft soils.— Driven tube wells of the kind shown in Fig. 28* are very useful for obtaining small supplies in soft soils. They are perforated wrought iron tubes $1\frac{1}{2}$ " to 3" diameter with a pointed end driven down to water-bearing strata at a moderate depth below the surface. The bottom length is perforated for the first two or three feet above the point. The pipe is let down into a vertical hole in the ground made by a crowbar. A cap is fitted to the top and the pipe, if small, is driven down by the blows of a hammer. When the top of the tube is driven down to within a few inches of the ground the cap is removed and another length is screwed on. This is driven down in the same manner and the process is repeated until the water-bearing stratum is reached. Larger tubes have to be driven by a falling weight or ram as in pile driving. The upper part of the tube is generally utilised to serve as a guide for the falling weight as shown in Fig. 28. The weight encircles the tube and falls on a clamp fastened round the lower part of the tube. It is raised by ropes running round pulleys supported by an upper clamp.

It has sometimes been found that the clamps cut badly into the tubes in this arrangement. To get over this difficulty a vertical solid rod is attached on top of a driving cap to act as a guide for the ram instead of an additional length of tube. This contrivance enables the ram

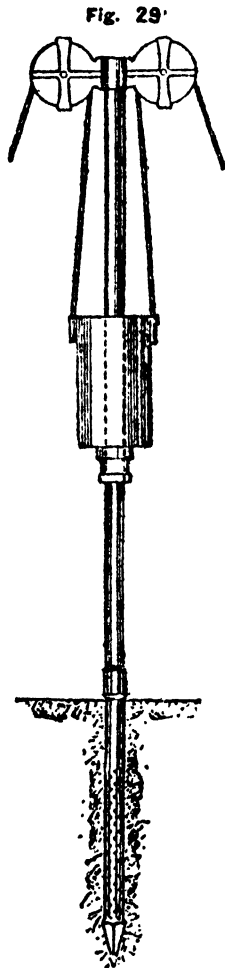

to deliver its blows more effectively on the head of the tube through the cap. (See Fig. 29.)*

In the process of driving the tube is liable to get blocked by the entry of fine sand through the perforations. This has to be removed periodically from the tube. It is usually cleared by lowering a small pipe down the tube to a short distance above the top of the deposit and pouring water down it to mix with the sand which is then drawn up by a pump fixed at the top of the small pipe. When the tube is in fine sand the perforations of the tube well are covered by a fine copper or brass gauze strainer having holes proportioned to the size of the sand to be dealt with, the gauze being protected by a thicker sheet of brass with larger perforations.

When the tube well has penetrated the water-bearing stratum a few feet, a pump is attached to the top and worked vigorously for some time till the fine particles in the surrounding soil are withdrawn

and the water runs clear. If the underground water level is beyond the limit of suction, i.e., more than 28 feet below surface, the barrel of the pump has to be placed low enough in the tube to be within this limit. (See Fig. 30.)*

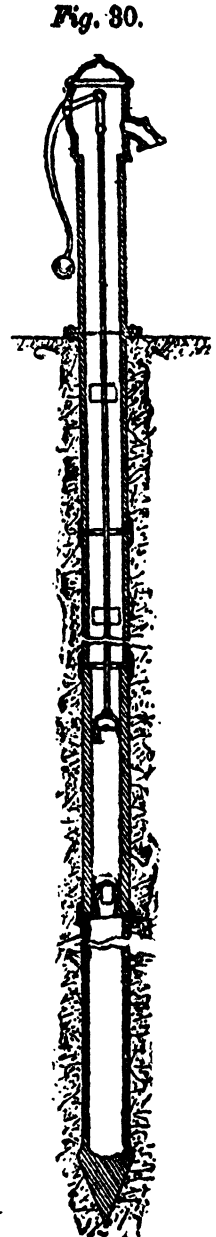

* "Sanitary Engineering," by Vernon Harcourt.

70. **When driven tube wells are useful.**—These tube wells are generally used for raising water from moderate depths, but they are often carried down to a depth of over 60 feet and occasionally they have been taken down to a depth of 100 feet.

Their main advantage lies in their enabling small supplies of water (about 600 gallons an hour per tube) to be obtained rapidly in an economical manner. They are quickly put down, quickly removed, and are easily carried from one place to another. They are, therefore, specially valuable for camps and for armies on the march in arid country, and they have been used for this purpose in India and Abyssinia, and in the United States. They are also useful for finding the position, extent and yield of water-bearing strata at moderate depths before the execution of more permanent works.

Driven tube wells are not well adapted for water supplies of a permanent nature. The gauze strainer being in close contact with the perforated tube reduces the waterway very considerably, and owing to the fineness of the wires required for a small mesh gauze the strainer is not durable and needs frequent renewal. These difficulties have been met to some extent by designs recently adopted in America, India, and the Continent.

71. **Cook's tube well.**—The American patent tube well, known as "Cook's tube," is said to have proved very satisfactory for discharges of five to eight thousand gallons an hour. It consists of an

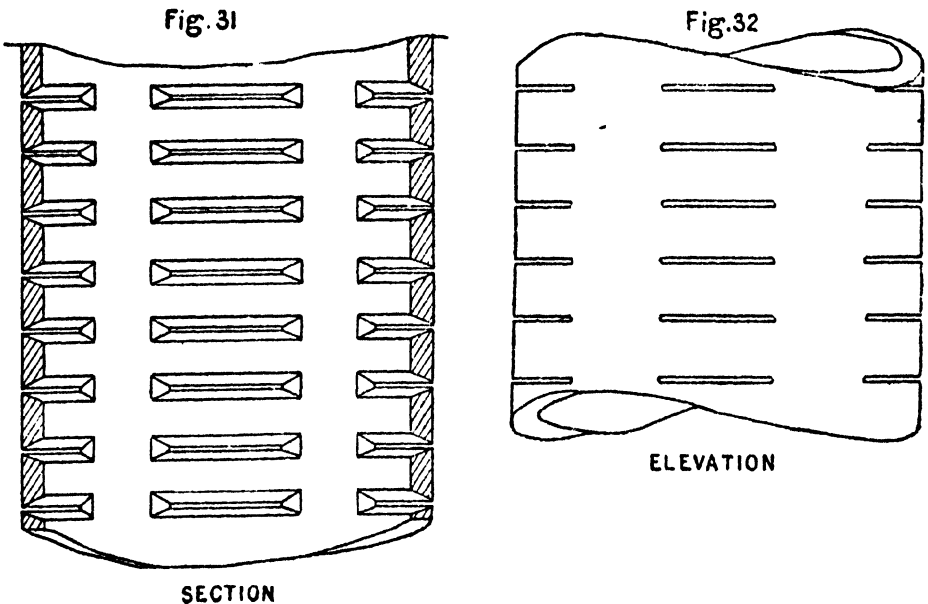

ordinary brass tube with circumferential slots about one inch long and one-hundredth inch wide at intervals of about one-fifth inch. The metal at the edges of the slots is bevelled off on the inside of the tube to allow very small grains of sand to pass easily into the tube during the preliminary clearing operations instead of packing up against the outside and choking the slot. Figs. 31 and 32 show the arrangement and shape of the slots. The tubes are sunk to a depth of 100 feet or more according to the supply required.

72. Experimental wells sunk at Lahore.—In 1906 an experimental tube well 8 inches diameter and 100 feet deep was sunk at the head works of the Lahore water supply. The lower 50 feet of this tube was perforated and the water was raised by an air lift. The work was done in accordance with the specifications of an air lift patentee in England who was supplied with samples of the sand at different depths on the site selected for the experiment. The discharge obtained was about 8,000 gallons an hour. The tube worked satisfactorily at first and gave the specified yield, but a good deal of sand was drawn in each day with the water pumped and after about two months it gave way by subsidence of the surrounding soil. Another trial of a tube well was made at the Lahore Jail in 1909. In this case a 6-inch tube was driven 96 feet into the ground and a strainer 42½ feet long was let down to the bottom. The outer tube was then drawn up till its bottom edge was 2½ feet below the top of the strainer leaving 40 feet of the strainer exposed. The space between the outer tube and top of strainer was then made water-tight by a lead bush joint. The strainer consisted of 4½ inches perforated wrought iron pipes screwed together with a plug at the bottom. A brass wire was wrapped round the perforated tube at 18 inches intervals, and over these wires was secured fine brass wire netting of 40 meshes to the inch. The object of the intermediate wire hoops was obviously to keep the fine strainer away from the perforations and so make the latter more effective for admitting water into the tube. The total area of holes in the perforated tube was 14 square feet. The discharge from the tube was 5,500 gallons under a head of 12 feet, 3,200 gallons an hour under a head of 7 feet and 2,300 gallons under a head of 5 feet. These experiments were made for a few hours at a time for about 20 days. No conclusive results were obtained, but a good deal of sand was apparently drawn in daily, and it is probable that the tube would have failed if the experiments had been continued longer.

73. Millar Brownlie's tube well.—Quite recently another form of tube well called the "Convolute tube well" has been patented by

Mr T. A. Millar Brownlie in India. The diagrams on plate V show the general design of this tube. The convoluted tube itself is made of thick sheet steel. The strainer consists of heavy copper wires laid parallel across the convolutions, the fine space between them being maintained by the wires being woven at short intervals with pairs of fine copper ribbons which prevent slipping or other alteration of the position of the wires in handling or sinking the tubes. The advantages claimed by the patentee for his design are (1) The strainer not being in direct contact with the perforated tube all over, the area of perforations is not obstructed by the wires of which the strainer is composed to any appreciable extent. (2) The strainer is placed at such a distance from the perforations in the tube that the waterway in both is about the same and there is therefore no change of velocity between the strainer and the tube. (3) The superficial area of metal in the perforated tube is more than twice the area of perforations and there are therefore no eddies or back flow at the perforations. (4) The strainer presents a large free waterway per foot length of the tube and is at the same time composed of heavy wire which will stand without damage fairly rough handling in transport and lowering and will be lasting. The critical velocity, i.e., the velocity up to which water can be drawn clear through the strainer in fine sand, is said to be half an inch per second through the perforations, and the effective discharging velocity through the tube three to five feet per second. In a descriptive pamphlet issued by the patentee he states as follows :—

Convoluted tube wells are made in several sizes for discharges varying from one quarter to two cusecs, or in other words, from 5,625 to 45,000 gallons per hour. These sizes have been standardised and are all made from the plain sheet on one machine thus resulting in remarkably cheap tube wells.

The deliveries expected by the manufacturers of these tube wells are stated to be 1 cusec from a 7-inch tube sunk 74 feet, and 2 cusecs from a 9-inch tube sunk 95 feet.

These tube wells are still in the experimental stage in the Punjab, and, until they have been in regular use for some considerable time, it is not possible to say whether they will be successful in extracting, *permanently*, for water supply schemes, such large quantities as those expected by the patentee from the sub-soil of the Upper Provinces, which consists usually of alternate layers of fine and coarse sand, the size of the grains varying from $\frac{1''}{30}$ to $\frac{1''}{200}$ diameter, the bulk of them being between $\frac{1''}{40}$ and $\frac{1''}{120}$. Until further experience has been obtained, it is also not possible to estimate the probable life of such tubes to compare their ultimate capitalised cost with that of ordinary brick wells.

74. Method of sinking deep tube wells in soft soil.—In sinking deep tube wells in soft soils, the strainer tube is usually inserted in a bore tube of larger diameter which is sunk previously and withdrawn when the inner strainer tube is in position. The bore tube is generally sunk by using a water jet provided by a steam or oil pump, the delivery pipe of which terminates in a nozzle kept a few inches above the bottom of the bore tube while sinking. To allow for the varying depth of the bore tube as it sinks, a length of flexible tube connects the vertical delivery pipe inside the tube with the pump. To make it sink readily the boring tube is loaded by clamping to it two pairs of wooden beams with semi-circular notches cut in them to engage the boring tube and by placing bags filled with sand on the beams. When the required depth of boring has been completed, the pump and delivery pipe are removed and the perforated tube with strainer lowered in position. The bore tubes are finally withdrawn by using screws or hydraulic jacks under the wooden beams used for carrying the sand bags.

75. German practice.—The German practice in sinking tube wells is to pack graded filtering material, consisting of coarse sand and small gravel, between an outer perforated bore tube and the inner perforated tube from which the water is drawn. When this is done, the outer bore tube has to be of a much larger diameter to take the filtering material, and an intermediate removable tube is sometimes let down temporarily between the outer and inner tubes to keep the coarse sand and gravel apart when they are being packed in. In some cases a removable strainer basket is introduced inside the perforated tube which can be occasionally drawn up and cleaned and a small scour pipe is frequently inserted in the tube through which water under pressure is forced down to clean the strainer (Fig. 34).

In Fig. 33 it will be seen that the outer bore tube is provided with a convex bottom which closes that tube. This is placed in position after the tube has been dredged down to its full depth below the water bearing stratum. When the filtering material is dirty, it is taken up with the inner tube and cleaned and the latter is set up again for a fresh charge. It is reported, however, that this operation has never been necessary. The sub-soil water is so pure that when the safe velocity of ingress has been determined by experiment and the movement of the fine sand has been checked, the filter discharges its function indefinitely and does not require cleaning. This experience shows that it would be possible to dispense with the outer cylinder altogether which may be safely withdrawn after the filter has been packed and the filtering material left in contact with the suction tube inside and the sand outside. In several

instances, the tube does not extend up to ground level but stops at the bottom of a masonry well which is founded just above the natural spring level or water table. The pump is placed in this well and the motor, steam, oil or electric outside at ground level.

Fig. 34.

Tube well movable
filter basket, mesh
 $\frac{1''}{12}$ to $\frac{1''}{120}$ according
to fineness of
sand.

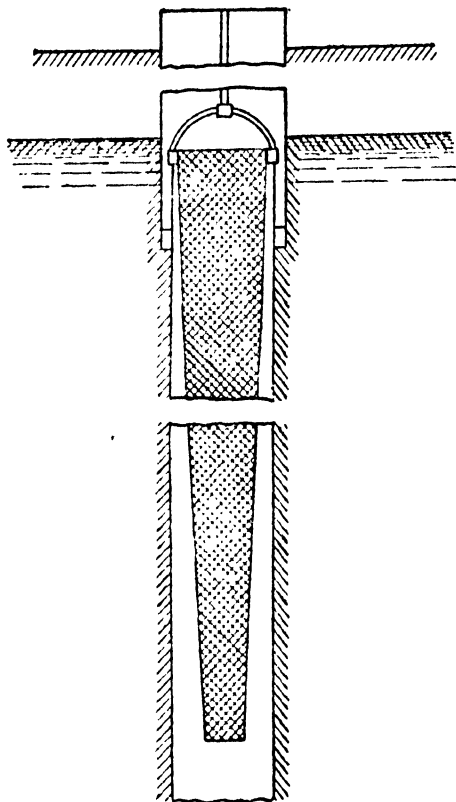
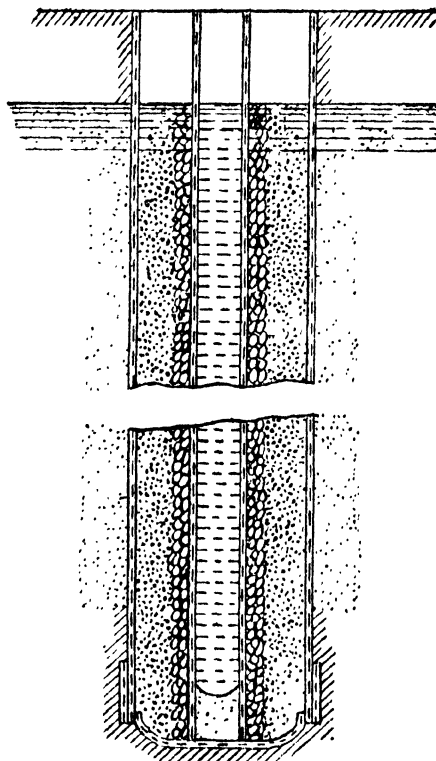

Fig. 33.

Tube well with
graded filtering
material.



76. **Dutch practice.**—In Holland Mr. Van Hasselt has adopted for a long time the following method of sinking tube wells in fine sand. An iron cylinder twelve inches diameter mounted on a wooden base B is filled with the filtering material required and in the middle is placed the suction tube about 3 inches diameter. The cylinder is closed by an upper wooden cover of a diameter slightly larger than that of the base; an iron rod is screwed into the bottom cover and is secured to the upper by a bolt. Perforated tubes M are fixed outside the cylinder as shown in Fig. 35, which

illustrate the application of this method. These tubes are used for the sinking of the cylinder by ejecting water under pressure through their perforations and churning up the surrounding fine sand which permits of the progressive descent of the entire apparatus. When the cylinder has reached the depth desired the rod is unscrewed from the lower base and raised to the surface with the upper cover and the cylinder with its perforated tubes, leaving the inner tube in position with the filter surrounding it.

Fig. 35.

Dutch tube well.

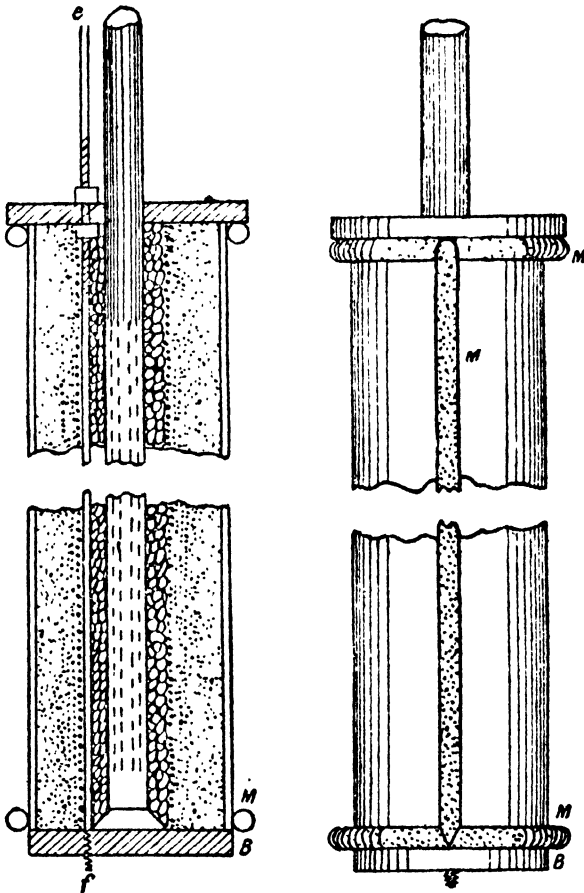

77. **Nuremburg and Tilburg tube wells.**—Many installations of the designs described above have been established in Germany and Holland during the last 30 years for the water supply of towns. The wells are usually in groups or lines connected by a common suction pipe leading to the pumps. They vary in depth from 30 feet to 150 feet, and in diameter

from 6 inches to 30 inches. Most of them are in coarse sand or gravel, but there are several instances of such wells in what is described as very fine sand, notably those of Nuremburg and Tilburg.*

The Nuremburg wells are 6 inches diameter with a surrounding filter 30 inches diameter. They are only about 25 feet deep, the valley in which they are sunk being an uninhabited desert. There are 83 wells, 40 feet apart, in two lines 65 feet apart. The total yield is 1,600 gallons a minute or about 20 gallons a minute per well, which is about $\frac{1}{18}$ cusec.

The Tilburg wells are 50 feet to 65 feet deep with an inner tube 12 inches diameter and an outer 20 inches. The filtering material between the two tubes varies in size from $\frac{1}{12}$ inch to $\frac{1}{50}$ inch. There are 70 wells yielding about 140,000 gallons an hour between them, or 30 gallons a minute each, which is about $\frac{1}{12}$ cusec.

78. Author's opinion on the use of tube wells for water supplies.—

The writer is of opinion that the method of putting down two concentric tubes and surrounding the inner with graded filtering material is likely to be the most successful where the sand to be dealt with is not very coarse, as it draws on a much larger circumferential area of sand with a reduced velocity and the intervening graded filter checks the movement of sand towards the inner tube. With pure water, the filtering material should not require attention for years, provided the rate at which the water is drawn from the well does not exceed the limit at which it begins to bring sand with it when pumping is in progress. The deeper the well the better is the yield likely to be for obvious reasons, if the sub-soil is suitable. The most economical proportion of depth to diameter and the yield which may be expected permanently are points which can only be determined by experiment in each particular case.

* Distribution d'eau.

CHAPTER VI.

PURIFICATION OF WATER SUPPLIES.

79. **Impurities of water.**—Perfectly pure water is seldom met with in natural state. Its purest form is rain, but even in this condition it collects impurities from the gases of putrefying organic matters, smoke and dust, which rise into the surface of the earth and contaminate it in its descent. Pure water can be obtained artificially by distillation, but this is a process much too costly to be resorted to ordinarily for water supplies.

The impurities of water are found in suspension and in solution. The former, consisting chiefly of sand and clay, can be readily removed by settlement and filtration.

The dissolved impurities are more difficult to deal with. They may be divided into two general classes, the one derived more directly from minerals, the other derived directly or indirectly from living organisms. The first are termed *mineral* impurities and the other *organic* impurities.

80. **Mineral impurities.**—The mineral impurities are usually found to be derived from one or more of the most generally distributed metallic elements, as calcium, magnesium, sodium, potassium, etc., chiefly in the form of carbonates, sulphates and chlorides.

Deep well and spring waters, except those from alluvial sand or old sandstone strata, are especially liable to impregnation with mineral salts. These impurities, when present in quantities that are harmful to the animal constitution, are almost invariably perceptible to the taste and are rejected instinctively.

81. **Hardness.**—The solutions of salts of lime and magnesia are among the chief causes of the quality called *hardness* in water. Their bicarbonates are broken up by boiling, which dissipates some of the carbonic acid when the insoluble carbonates are deposited. Their effect is termed *temporary hardness*. The sulphates, chlorides and nitrates of lime and magnesia are not dissipated by ordinary boiling; their effect is, therefore, called *permanent hardness*. Within moderate limits, that is up to about 16° or 17°, this hardness of water does not appear to be prejudicial to

health, but hard water cannot be used for manufacturing purposes, it does not readily form a lather with soap and the deposits produced by evaporation in steam boilers are very injurious.

82. **Removal of temporary hardness.**—Temporary hardness can be reduced by boiling as stated above, the reaction being

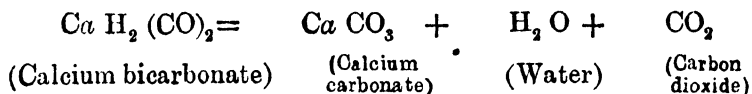

but this process is much too costly to be adopted on a large scale for water supplies. The Clark process is usually resorted to. This consists in adding the calculated quantity of lime water to convert the soluble calcium bicarbonate into calcium carbonate which is insoluble.

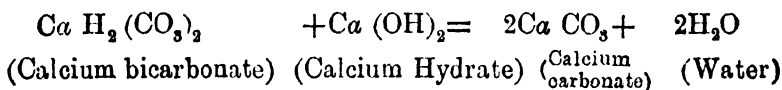

83. **Removal of permanent hardness.**—Permanent hardness is not affected by the above softening process. To remove magnesium and calcium sulphates from the water, a calculated quantity of sodium hydrate has to be added which effects the transposition of the sodium and the calcium or magnesium with the formation of their hydrates and sodium sulphate which do not increase the hardness of the water. The calcium hydrate thus formed enters at once into combination with the calcium bicarbonate in solution and forms calcium carbonate, which being insoluble is precipitated, the two reactions taking place in rapid succession.

Reaction 1.

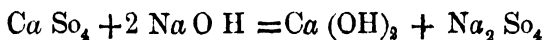

Reaction 2.

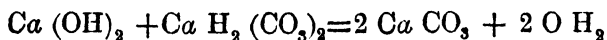

Both the above processes are troublesome and expensive and it is therefore advisable to avoid hard waters for public water supplies as far as possible.

84. **References.**—For further information on this subject the student is referred to the following papers :—

“Water-softening and purification,” by L. Archbutt, Proc. Inst. Mech. E. 1898, p. 414.

“Water-softening and filtering apparatus at Penarth,” by W. E. Pullen, Proc. Inst. C. E., volume XCVII, pages 362 and 363.

85. **Organic impurities.**—Organic impurities are derived from the decomposition of organic bodies by heat in the presence of oxygen, and by fermentation and putrefaction. There are a few elements that, united, form *organic* matter, as carbon, oxygen, hydrogen, nitrogen, sulphur, phosphorus, potassium, calcium, sodium, magnesium, chlorine and iron. Certain of these enter into all organised bodies from the lowest order of plants to the most perfect quadrupeds and the human species, but their mode of union, by which organic matter is vitalised, still remains a sealed mystery. Organic impurities in water indicate contamination likely to be much more harmful to the human constitution than mineral impurities, especially if they are products of animal decomposition. In the natural decomposition of animal matters, especially in the stage of putrefaction, their elements are often in a condition of molecular activity that will not admit of their being safely introduced into the human system, where they are liable to introduce similar conditions. The excreta of living animals also pass through a similar decomposing transformation, in which stage they are most harmful to human beings when received in water, however finely they may be dissolved. Potable waters, when exposed to such organic matters in process of rapid decay, receive their most dangerous sources of contamination and these *are not readily detected by the eye and tongue.*

86. **Chemical analysis.**—Chemical analysis determines the relative quantities of the mineral salts in solution and thus shows the suitability or otherwise of a water for domestic or manufacturing purposes. It is also useful in indicating by inference the presence of organic impurities. A higher percentage of chlorine than can be accounted for by the calcium and magnesium chlorides present points to sewage contamination and also the presence of combined nitrogen in the form of ammonia nitrates and nitrites. A large amount of free ammonia renders a water suspicious as it is produced by bacteria from urea, while albuminoid, or the ammonia remaining after the removal of the free ammonia, furnishes a measure of the unoxidised organic matter in the water.

87. **Bacteriological analysis.**—This is necessary to show whether the organisms present in the water are of a harmful or harmless variety and their numbers. Chemical analysis can only indicate the presence of organisms by the chemical changes they produce and by the discovery of nitrogenous compounds necessary for their food, but it gives no clue to the *character* of the organisms and the *number* of each variety. These points are ascertained by the careful examination under the microscope of

cultures made under different conditions. All the bacteria found in water are not of the harmful or pathogenic variety. Some are benign or non-pathogenic and actually necessary for the healthy performance of animal functions, but there are others, such as the coli communis which always indicate with certainty sewage contamination. No water is entirely free from bacteria, but the presence of bacteria in large numbers affords good grounds for suspecting organic contamination.

For detailed information as to the minimum limit of mineral and organic impurities, which are permissible in a good potable water, the student is referred to Notter and Firth's "Hygiene," in which this subject is fully treated.

88. **Impurities in water obtained from different sources.**—Spring and deep well waters are generally very free from suspended mineral matter and organic impurities which have been removed from them in their subterranean course by the process of natural filtration, but they are often charged with excessive quantities of objectionable mineral salts in solution which they have picked up from the rocks or soil through which they have passed. Rivers and streams fed by springs are liable to contain the same impurities as springs. Rivers draining large tracts of country are exposed to various sorts of contamination, both organic and mineral, from the inhabited and agricultural districts traversed by them, especially during floods which bring large volumes of surface drainage into them. The purification works required for supplies from rivers are described in the following paragraphs. They consist chiefly of settling tanks, filter bed and clear water reservoirs.

89. **Settling tanks.**—To rid the water of most of its solid impurities in suspension, it is necessary to bring it to rest in large tanks for a period long enough to allow the greater portion of the silt with which it is charged to separate itself from the water and fall to the bottom as a deposit, which can then be readily removed from time to time. Large settling tanks are also useful in intercepting a certain proportion of bacteria, but their chief function is the separation and retention of the coarser silt.

Where the water supply is taken from a stream by means of a storage reservoir, that reservoir forms an efficient settling tank, but where it is derived direct from rivers or streams, it is necessary to provide special settling tanks to catch the solid impurities before filtration, the number and size of these tanks depending on the quantity and fineness of the silt in the water when the river is in flood.

There are two types of settling tanks :—(1) The intermittent settling tank, in which the water to be settled is brought to complete rest for a period, and (2) the continuous flow settling tank, in which the water, though never at complete rest, flows so slowly that it deposits most of its solid impurities. The velocity of flow in the latter is fixed according to the fineness of the silt to be got rid of, and seldom exceeds a few feet per hour. Continuous flow tanks are usually adopted when the suspended matter is fairly coarse and will settle quickly, and where the levels of the site are such that the water must be drawn off from the tanks at as high a level as possible, to avoid loss of available head. Where these conditions do not obtain, there is little to choose between the two types as regards efficiency, and the cheaper of the two in any particular case should be adopted.

90, **Intermittent settling tanks.**—Plate VI shows a set of three intermittent tanks. These tanks are usually made cheaply by excavation of the ground, but they should be fairly water-tight, especially when they are filled by water pumped up at great expense from a distant river. If the soil, though not impervious, is sound and firm, nine inches of concrete well rammed in two layers will be sufficient to make the bottom fairly water-tight. To facilitate silt clearance, this concrete should be laid with a good fall from the sides to the centre at the intake end, and this fall towards the centre line should increase gradually till it reaches its maximum at the sludge outlet end. The side slopes of the tanks are usually puddled, the top of the puddle being finished off with a layer of concrete slabs to protect it from damage by the wash of waves.

Plate VII shows the details of a typical inlet and outlet to a settling tank of the intermittent variety. The water to be settled is discharged from the inlet pipe into a central chamber in a long trough. The water passes out from this chamber into the trough through holes in the bottom, and thus loses all its original velocity. It then trickles gently over the inner edge of the trough and falls over a series of steep steps, which aerate it on its passage to the tank. There are many devices for drawing off the water ; one of the most common is that shown in the plate. It consists of a floating arm made of an iron tube, jointed at the bottom in such a way as to permit it to rotate upwards or downwards as the water in the tank rises or falls. A float is attached to the upper end to keep the mouth of the tube just a little below the surface where the water is always clearest.

There are generally three tanks in a set, each holding a day's supply between low water level and full supply level. One tank is drawn on for the supply while another is being filled and the third is being cleared of silt.

91. **Continuous flow settling tanks.**—Plate VIII shows typical continuous flow settling tanks. The unfiltered water is discharged from the inlet pipe into a large trough or catchpit. The velocity being checked here, a considerable proportion of the larger and heavier matter sinks to the bottom at once. This deposit in the catchpit is removed daily by opening for a few minutes a sluice valve on the scour pipe leading out from the pit. From the catchpit the water relieved of its coarse material flows gently over a stone-capped weir into the settling tanks. At the bottom of the tanks small water cushions are formed under the weir to break the fall of the water when the tanks are being charged after cleaning. The size and number of the tanks are so adjusted that the velocity of flow through them will allow of the proper settlement of the suspended matter in the water under treatment. At Meerut and Delhi the effective velocity was found to be $\frac{1}{18}$ inch per second. Each tank is divided into three compartments, as shown in the plate, to prevent any tendency to direct flow from inlet to outlet. With this arrangement, the water travels from the inlet down the first compartment, up the centre one, and down the third compartment before it reaches the outlet to the filters. When the water in the river is very turbid in the flood season, and it is found that the settling basins are not capable of removing sufficient silt to render the water fit for the filters, a chemical precipitant is generally mixed with the water just before it enters the settling tanks to precipitate silt rapidly and so help the settling action of the sedimentation tanks.* The coagulant used for this purpose is aluminoferric which is very effective, but unfortunately somewhat expensive. To reduce the costs, it has been tried recently at Calcutta in combination with lime, but the result of this trial is not yet known. Generally, the quantity used is about two grains per gallon, but it varies according to the condition of the water under treatment.

92. **Filters.**—After the water has deposited its coarse impurities in the settling tanks, it is filtered to remove the finer particles of matter remaining in suspension, and to free it from organic matters with which river and other surface waters are likely to be contaminated, especially

* Also used for intermittent tanks under similar conditions.

the dangerous kinds of bacteria already alluded to. Filtration is occasionally dispensed with in the case of waters which have been stored for some time in large reservoirs, but a possibility of accidental contamination is always present, and it is, therefore, advisable to filter even reservoir water before it is delivered into service reservoirs for distribution in a town. This has been done in the Croton water supply for New York, and in the supplies from the Rivington and Vyrnwy reservoirs for Liverpool. It has, moreover, been found necessary in some cases, as, for instance, at Vyrnwy, to filter the water as near the storage reservoir as possible, to prevent the formation of a ferruginous gelatinous slime in the pipes which is sufficient to impede the flow of water materially. This slime only appears in pipes conveying unfiltered water, and is due to the presence of iron and manganese in the water, combined with acids.

Two systems of filtration are adopted, (1) slow filtration through fine sand, and (2) rapid filtration through coarse sand, in which a chemical coagulant is added to the water to free it from the fine particles in suspension and make the filtration more efficient.

In slow filtration, the sand filter beds are placed in shallow masonry or concrete tanks, which are generally left open to the air at the top. Plate IX shows the plan and sections of a typical filter. The floor of this filter is laid with a slope from the end walls to the cross drain. The floor of the main drain from the centre of the cross drain to the valve well chamber is laid with a reverse slope. The flooring usually consists of 9 inches of concrete covered with brick on edge in lime mortar. The drains are covered with 2 inches stone slabs. The walls may be of brickwork or masonry, cement plastered on the inner surface to make them thoroughly watertight. The filtering media are as follows:—The first layer of bricks is laid flat with dry joints in longitudinal lines from the end walls to the cross drain, a space the width of a brick being left between each line. On this a second dry layer (i.e., without mortar) is laid across the first one as closely as the bricks can be packed. The spaces of the first layer are thus converted into covered drains, which discharge, through openings, into the cross drain. Over the second layer of bricks broken stone or gravel is placed, six inches thick; then comes a 6-inch layer of coarse sand, above all a layer of fine sand, averaging 2½ feet thick.

The fine sand should be selected with great care. It should be sharp and clean and as free from other mineral matter as possible. It should be fine, but the grains should not be too small. The rate of filtration will

be very slow if the sand is too fine and the filter will clog rapidly. Very fine sand is, moreover, seldom found clean. It is difficult to wash, and large quantities are lost in washing. The coarse sand and gravel are mainly used as a means of preventing the fine sand being washed through the filter.

93. Rate of filtration.—The rate of filtration per square foot in 24 hours varies from 30 to 50 gallons, according to the quality of the water to be filtered. It should be decided in each case by the results of the bacterial and chemical analysis of the filtered water. The discharge from a filter is due to the difference in level between the water in the filter above the sand and the water in the effluent chamber which is shown at the end of the filter in section A B in plate IX. The water from the filter passes through the sand and gravel, then along the numerous spaces in the layers of brick into the main drain, which conveys it into the effluent chamber, where it rises to the same level as the water above the sand when the filter is not at work. To bring the filter into action, the outlet sluice valve in the effluent chamber is opened when the level in this chamber drops below that in the filter, and the difference in the two levels depends on the quantity drawn from the filter. When a filter is first started, the difference of level or "head" is small, but, if the discharge is kept constant by regulation of the outlet sluice valve, it gradually increases owing to the increased resistance offered by the film of zooglea which forms at the surface after a time. The head increases gradually and slowly up to a certain limit, after which it increases rapidly. When this occurs the filter is clogged and should be thrown out of action at once. Just before this point is reached, the filter gives its best result. It should be the duty of the attendant to learn by experience how far he can safely push a filter and when he should shut it off for cleaning. The maximum safe filtering head is as a rule 12 inches, but it should be determined in each case by the result of analysis.

94. Measurement of discharge from filters.—To measure the quantity of water discharged by each filter, it is useful to have a low pressure meter on its delivery pipe. There are several low pressure meters now on the market which measure with a fair degree of accuracy without losing more than a few inches of head. The head on the filter should be measured by two float gauges near one another, one in the effluent chamber and the other in the filter, the latter being placed in a small masonry chamber, communicating at the bottom with the filter to protect it as far as possible from the disturbing effect of waves.

The flow of water through a filter under varying heads due to the constantly changing condition of the filter is controlled automatically in some large installations in Europe by a regulating apparatus fixed at the inlet or outlet end of a filter. There are many varieties of such regulators, but the type commonly used consists of a vertical telescopic pipe attached to a float and sliding over the end of another vertical pipe leading into the clear water tank. The telescopic pipes and float are in an intermediate chamber in communication with the filter between the clear water tank and the filter. There are two rectangular openings near the top of the floating telescopic pipe which are always at a constant depth below the water level in the chamber and admit a constant flow of filtered water into the pipe leading to the clear water tank irrespective of the filtering head between the filter and the effluent chamber which varies with the condition of the filter. The rate of filtration can be adjusted by regulating the size of the opening in the telescopic pipe by means of a small annular valve.

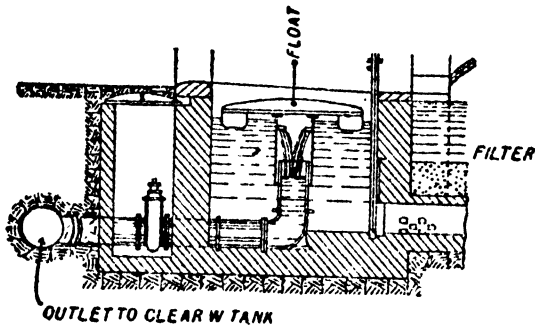

95. **Action of filters.**—It was formerly supposed that the action of filters was purely mechanical, the sand acting as a sieve to hold back the impurities, but recent investigation has shown that their straining action is only a part of the work done by them. It is certainly useful in clarifying the water to a certain extent, but the actual purification and removal of organic impurities is due to certain micro-organisms which exist in the gelatinous slime that forms on the surface of the sand when a filter is in use. This slime forms an ideal habitat for microbes, and their food is the organic impurities in the water, which passes through the slime to the media below. The longer a filter is worked, the thicker this film of slime becomes, and the greater is the head of water required to

overcome the resistance it offers, till, eventually, the pressure due to the head becomes excessive and the filter gets clogged.

96. **Cleaning filters.**—When a filter is thrown out of action, and the water has been turned off through the scour valve, the layer of slime is carefully scraped off the top of the sand and removed. The fresh surface of the sand should be exposed to the sun's rays for a day or two before the filter is recharged, and the effluent should be run to waste for the first 12 to 24 hours, till a film has begun to form, if thoroughly good results are desired.

97. **Air shafts.**—To prevent the breaking up of the filtering media by the irregular escape of air as the water rises from the bottom during the charging of a filter, the longitudinal channels in the lower layer of dry bricks are connected by transverse channels along the end walls, and the air passes out from these channels through air pipes built into the end walls (see section C D, plate IX).

98. **Filter fittings.**—Besides the outlet pipe in the effluent chamber, already referred to, a filter is fitted with a bell-mouthed inlet and an overflow and scour pipe. These are shown in plate IX, the first on the left side of section A B, and the other two at the effluent chamber on the right side. The inlet and scour pipes are controlled by sluice valves. The sand surrounding the former is covered for a few feet all round by 2 inches stone slabs to prevent the sand being disturbed by the first rush of water.

99. **Sand washing.**—All the sand used in a filter should be first washed with pure water, and the scrapings from a filter, when it is being cleaned, should be carefully washed clean and reused. There are many kinds of sand washers. The best known is Walker's patent. It consists of a hollow inverted cone of galvanized iron sheets hung on trunnions. The sand to be washed is put into this cone, and filtered water is admitted from the apex of the cone below under considerable pressure. It flows through the sand, and escapes, by overflow, from a lip at the top. When the overflow runs clear, the sand is clean. The water is then shut off and the cone is emptied by tipping.

100. **Spare beds.**—After several scrapings of a filter, it becomes necessary to add fresh sand to replace the loss. While the sand is being scraped, or renewed, one or more filter beds are not working, and provision has to be made for spare beds. The number of spare beds required depend on the quality of the fine sand used and the purity of the water filtered. When the sand is of suitable size and the water of good quality, it will be sufficient to have one spare bed for every five in use, but with

very fine sand, and water containing a large quantity of silt, it may be necessary to provide one spare bed in four.

101. **Peuch Chabal system of Multiple Filters.**—A new method of filtration by the “Peuch Chabal system of Multiple Filters” has recently been adopted for a few towns in Europe. This is now under trial at Cawnpore. As it is still in the experimental stage in India, a detailed reference to it will not be attempted in this Manual. It has been found to be fairly successful with waters of continental rivers, but it has yet to be proved (1) whether it is capable permanently of dealing with the very turbid silty water of the rivers of Upper India in the flood season, and (2) whether the extra cost of this system is justified by the better results obtained from it as compared with the installations of settling basins and slow sand filters hitherto in use. It consists chiefly of three separate sets of beds; the upper ones containing graded gravel, called “degrossisseurs” or strainers, merely hold back the very coarse material in the water and have but little effect in removing bacteria. They are cleaned periodically by blowing compressed air through them from perforated pipes laid in the basins. The intermediate beds are composed of a layer of coarse sand about 20 inches in thickness resting on a layer of gravel. These intermediate beds, called prefilters, are cleaned by scraping them occasionally in the usual manner. The prefilters clarify the water still further and it is found that they also dispose of some of the bacteria. Finally, the water is passed through ordinary fine sand filters, but owing to the preliminary treatment received in the strainers and prefilters, it is claimed that the rate of filtration in the last set of beds can be increased to an extent not possible in the system of settling basins and filters which has hitherto been adopted. No coagulants are used in this system as a rule, the “degrossisseurs” and prefilters taking the place of precipitants and settling basins.

102. **Mechanical filters.**—Rapid filtration is effected in mechanical filters, of which there are many varieties. This method of filtration consists chiefly in the addition of a coagulant to the water previous to filtration for aggregating and precipitating the particles in suspension, followed by the rapid passage of the water through a layer of coarse sand or crushed quartz, from two to four feet thick, contained in a tank of wood or iron and resting on a system of strainers, which allow the filtered water to pass through without washing out the sand. Revolving mechanical contrivances are fitted to them for raking and agitating the sand in the process of cleaning, which has to be done frequently owing to the heavy

deposit of the flocculent precipitate formed by the coagulant. See Figs. 36 and 37.*

Fig. 36.

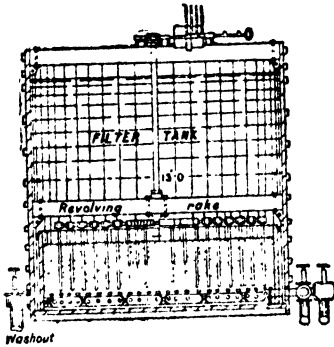
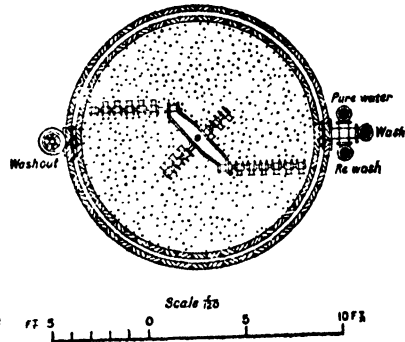

Fig. 37.



In open mechanical filters, called gravity filters, the requisite head is obtained by the depth of water over the bed of sand. In closed filters, called pressure filters, the rapid filtration is effected by water under pressure. Heads of 10 to 12 feet are often employed to avoid very frequent washing, which is usually carried out once in 24 hours under ordinary conditions and occupies from 15 to 20 minutes. It is effected by forcing water up through the sand from below, while it is being agitated by the revolving rakes or by compressed air.

103. **Coagulant used in mechanical filters.**—The coagulant generally employed is aluminium sulphate, but ordinary alum is sometimes used for cheapness. Half a grain to two grains of alum per gallon, or a little less of aluminium sulphate, are generally used for ordinary water, but for turbid and coloured waters five to six grains may be necessary, together with the addition of some lime. The exact amount required in any particular case should be fixed by an expert chemist after carefully considering the water under treatment. Too small a quantity reduces the efficiency of clarification, while too large an amount charges the filtered water with alum, which is liable to be detrimental to health, acts injuriously on iron pipes, and renders the water unfit for washing and certain industrial purposes. The action of the coagulant is as follows :—

The aluminium sulphate reacts with the bicarbonates of calcium and magnesium forming sulphates of these alkaline earths together with aluminium hydrate. The fine particles of suspended silt become entangled

in the flocculent gelatinous precipitate of aluminium hydrate and are deposited with the precipitant when the water is allowed to settle.

104. **Rate of filtration in mechanical filters.**—The rate of discharge through these filters is generally from 2,000 to 2,500 gallons per square foot in 24 hours.

105. **Slow sand and rapid mechanical filters compared.**—When worked under careful supervision, mechanical filters have been found to effect a considerable reduction in the number of bacteria, ranging in some instances from 86 to 99 per cent. Though their efficiency has sometimes approximated to that of slow sand filtration, the system has not yet been subjected to the same long test of over half a century, and it requires much more careful watching and manipulation to give the same satisfactory result. There may be special cases, in which for the want of space or time or for financial reasons, they have an advantage over the others, but under ordinary conditions, for large supplies in India, the slow sand filters are still in favour with most water-works engineers.

106. **Clear water reservoirs.**—When the supply is by gravity and the filters are so placed that their effluent runs directly into the service reservoirs connected with the distribution system in the town, clear water reservoirs are not required to receive the outflow from the filters, but when the filtered supply is pumped, it is necessary to store the effluent from the filters during the hours when the pumps are not in action. Filters as a rule work continuously, but pumps are usually in action for 16 hours a day. In addition to this storage, it is necessary to have a small reserve of filtered water sufficient to recharge a filter occasionally from below after it has been emptied and scraped. A clear water reservoir should hold about one-half the maximum quantity to be pumped in a day. This will be generally sufficient to meet all requirements and will allow a small margin for future expansion.

Clear water reservoirs should always be roofed, as they hold filtered water which must be carefully protected from contamination of any kind. In Upper India the roof is generally made of jack arches covered with concrete. Lines of masonry pillars, connected by arches, support these arches. The roof is ventilated to admit air and allow of its escape when the reservoir is emptying or filling. The ventilators are covered with fine wire gauze to keep out impurities as far as possible. The reservoirs are provided with the usual inlet, outlet, overflow and scour fittings. Plate X shows plans and sections of a typical clear water reservoir.

107. **Methods of sterilization still under experiment.**—Several methods of sterilization of water in connection with purification works

have recently been tried in England and on the Continent. These are in the experimental stage at present, but deserve mention :—

(a) *Hypochlorite method*.—Hypochlorite of lime (bleaching powder) is a strong sterilizing reagent. It is a “mixed salt” consisting of equal parts of calcium chloride and calcium hypochlorite. The former remains inert, but the latter breaks up under the action of the free carbonic acid present in natural waters forming calcium carbonate and hypochlorous acid. When used for sterilising water on a large scale, it is first formed into a thick cream and then mixed with a large volume of water to form a weak solution of standard strength. When this solution is applied to the water to be sterilized, hypochlorous acid is liberated, and this is a most powerful oxidizing agent. In the presence of organic matter it gives up its oxygen in a nascent state with an amount of energy which makes it equal to ozone in its intensity as a sterilizing agent. It is generally used in combination with a coagulant (Sulphate of Alumina) for preliminary treatment of turbid river waters in systems of rapid filtration. Full particulars of this method may be obtained by application to the Paterson Engineering Company, 12, Norfolk Street, Strand, London, W.C.

(b) *Excess lime method*.—Dr. Houston, Director of Water Examinations, London Metropolitan Water Board, in his Eighth Research Report of February, 1912, refers to the method of sterilizing water by the excess lime treatment. By this method, lime is used not only to obtain the softening and mechanical precipitating effects hitherto secured by its use, but also the sterilization of the greater part of the total volume being dealt with. Dr. Houston found that when one part of quicklime (about 75 per cent. Ca O) was added to 5,000 parts of raw Thames water, about .007 per cent. free Ca O was left in the mixture and the excess was sufficient to kill B. Coli in from 5 to 24 hours. To neutralize the excess Ca O, 25 per cent. of stored water had subsequently to be added. The greater the temporary hardness of a water the larger obviously is the proportion of the whole which can be sterilized by this method. A part of the water is purposely overdosed with lime to produce a known bactericidal effect, and then, after a suitable interval, this is mixed with enough “untreated water” to combine with the excess of lime.

(c) *Ozone method*.—The mixing of water with ozonized air at suitable concentration has the effect of destroying the germs in the water. The procedure adopted is generally as follows :—

Dry air is drawn into a chamber of laminar compartments with insulated walls maintained at a high difference of potential. Alternate partitions

are connected to one pole of a step-up transformer raising the voltage to about 40,000, while the other partitions are joined to the other pole or the earth. In the compartments there passes a silent discharge of electricity which converts a part of the oxygen of the air passing through into ozone. The application of the ozone to the water is effected by scrubbing towers of various designs in which the ozone is brought into intimate film or spray contact with the water.

Sterilization by ozone is a finishing operation and does not obviate the necessity for filtration which must be carried out for turbid waters before the ozone is applied.

(d) *Ultra violet ray method.*—As with ozone sterilization, the raw water for this process must be previously filtered, otherwise the suspended matter screens the bacteria from the influence of the rays. In applying the ultra violet rays, the water is made to flow slowly past a mercury vapour lamp enclosed in a special chamber constructed of quartz. By a suitable arrangement of baffle plates, the water is made to approach and recede from the lamp several times, to preclude the possibility of any bacteria escaping from the deadly influence of the ultra violet rays.

CHAPTER VII. DISTRIBUTION OF WATER.

108. **Systems of distribution.**—The distribution of water in a town may be intermittent or constant. In the intermittent system, water is available from the pipes and taps only at certain hours of the day—generally from 6 to 10 a.m. and from 4 to 8 p.m. In a system of constant supply water is always available.

109. **Intermittent system.**—In the earlier days of water-works the intermittent system was commonly adopted, because it was thought that less water would be used by the public if they could only draw it at certain hours of the day, and that the waste from imperfect leaky fittings would be considerably reduced.

In supplies that were pumped it was, moreover, considered an economical and convenient arrangement, both as regards fuel and establishment charges, to keep the engines under steam for a limited time, instead of working them all through the hours of demand, from 5 a.m. to 9 p.m.

110. **Intermittent and constant systems compared.**—It is now generally recognised that for many reasons the intermittent system is unsatisfactory, and that a constant system is decidedly to be preferred. These reasons are briefly as follows. The demand for water during the day is not appreciably affected by the system of distribution, as the supply required for domestic and municipal purposes is practically a fixed quantity which has to be provided in any case. If it can only be drawn at certain hours, there is a greater rush for it during those hours, and some consumers, who do not require it at the time it is available, store it in tanks and cisterns, from which it can be drawn for use at any time. The only result of limiting the supply to certain periods is that the excessive draught during these periods necessitates larger distribution mains to keep up the required pressure in the system. As to waste from leaky fittings, this can be prevented to a great extent by an installation of waste water meters, and a systematic inspection of streets and house fittings, as explained further on. Under the intermittent system, taps are often left open, and as soon as the pumping engines stop working, there is a partial vacuum in many places in the pipe system, which is relieved by an inrush of air into the empty mains through the open valves and taps, the air

coming perhaps from an adjacent filthy house drain, or some other polluted spot in the streets. This is distinctly objectionable, especially during an epidemic of cholera or other waterborne disease.

An intermittent system is hardly ever adopted when the supply is obtained by gravitation. The few advantages it possesses are appreciable only when pumping engines are employed for charging the mains under direct pressure without a service reservoir. The mechanical arrangements of direct acting pumps which admit of this method of supply are simple, and several leading engine makers in England and America have adapted their plan to its special requirements, but the method of direct pumping still remains inferior in point of reliability to gravity flow or supply through service reservoirs. When direct pumping is resorted to, the engines and pumps have to be designed sufficiently powerful to meet the greatest rate of demand during the day. This maximum rate is twice to three times the mean and for short periods may be considerably greater as there are sometimes violent fluctuations of short duration in a distribution system. Such fluctuations cause severe strains on the engines and pumps, even if they are large enough to meet the maximum demand and they do not work economically. If, on the other hand, engines pump steadily into a service reservoir, they can be designed much smaller, the wear and tear on them is considerably reduced, the cost of their upkeep is lower and they have a longer life.

111. **Constant system.**—The system now generally accepted is that of constant distribution from one or more service reservoirs in or near the town, which are kept filled by the supply main from the head works of a gravitation supply, or from the pumping engines of a pumped supply. The supply main in the former case delivers the water into the service reservoirs by continuous flow, and in the latter, during the hours the pumps are at work, usually 16, which admit of two working shifts of eight hours each.

112. **Service reservoirs.**—As regards the functions, situation and capacity of service reservoirs, the writer cannot do better than quote verbatim the following extract from Spon's Dictionary of Engineering, which explains the matter fully and clearly :—

“It is hardly possible for a distribution of water to be carried on without a reservoir ; for the consumption is variable whilst the supply is constant. The water brought by natural courses, or raised by hydraulic machinery, is constant during the 24 hours ; whilst the consumption in general goes on only during the 12 hours ; and during these 12 hours the consumption is not regular ; so that, even with steam pumping machinery, we are obliged to have a reservoir in order to prevent waste of water, the supply of which, at certain

moments exceeds the consumption. Beside this, a reservoir allows of the machinery being stopped for repairs, without interfering with the service. It is then almost indispensable ; and the only question to be decided is its situation and capacity.

If the reservoir were placed at the head of the aqueduct towards H. Fig. 88, the dimensions of the aqueduct should be such that it will discharge, not the product a second of the engine or spring but the maximum consumption a second. But this consideration would often greatly increase the cost of the aqueduct, and more than this any accident or repairs among the network of service pipe would interrupt the service. If the reservoir were placed towards M. its position would be better. The aqueduct reduced to minimum section, and consequently to a minimum cost, may be, according to the capacity of the reservoir, closed for a greater or shorter time, without interrupting the service ; but as the pipe M. X. d D. R. from the reservoir must be of sufficient diameter to discharge the maximum consumption, any repairs at X would stop the service.

If, on the contrary, the reservoir were placed at R. the end of the principal conduit, whatever accident may happen, it would only cause a suspension of the service between the nearest neighbouring stop-cocks. Besides this, as the pipe M. X. d D. R. is fed from both sides during the time of the greatest consumption, its diameter may generally be much smaller than in the preceding example. The extreme end of the principal pipe, which traverses the boundary is then the position which best satisfies the conditions of good distribution ; but several circumstances will often interfere to cause us to prefer another situation. The cost of the reservoir, which, as we have already seen, varies considerably according to the nature of the surface of the district, is one of the most important. If, for example, the level at R, sensibly below M. only allows for the construction of a reservoir to carry on the distribution during the time that the direct service is interrupted, we should, in that case, only erect a reservoir to take the surplus water during the time that the consumption is at its lowest. It should be borne in mind, when making comparison between the various systems of distribution which may be adopted in any particular case, that the principal reservoir should be placed at a sufficient height to command all the orifices of discharge ; and that it is advantageous to place it at the end of the main, which starts from the origin of the supply and traverses the boundary of the district.

Concerning the capacity of the reservoir, it cannot be too large ; for the larger it is the longer the time during which repairs may be carried on without interrupting the service ; its capacity will be determined by the facilities which we have for its construction, and the chances of interruption to which the supply is liable ; and we have to determine upon a minimum. The same may also be said of the height and depth ; the overflow cannot be too high, nor the bottom too low. The height will be limited, either by the level of the source or the power of the engine and the depth must be such that it will still be able to supply the highest orifices when the water has descended nearly to the bottom.

Instead of one reservoir we might have several, thus, one might be placed at M., another at N. and another at C. ; in these two latter positions they would have the advantage of increasing the power of the conduits at the ends of which they were placed. It is well in all cases to reserve to ourselves the power of adding fresh reservoirs to the system according as necessity shall call for them.

The considerations which we have just been explaining apply with equal force to the case where the water is brought from the source O. by means of a force-pipe O. F. D. But then we shall have to consider if it will not be better to divide this conduit into two pipes of equal diameter so that in case of repairs the service may not be interrupted. Bearing in

mind that one of the effects of this arrangement will be an increase of .45 in the cost of the rising main we shall have to determine whether the advantages of the system will bear sufficient compensation for this increase."

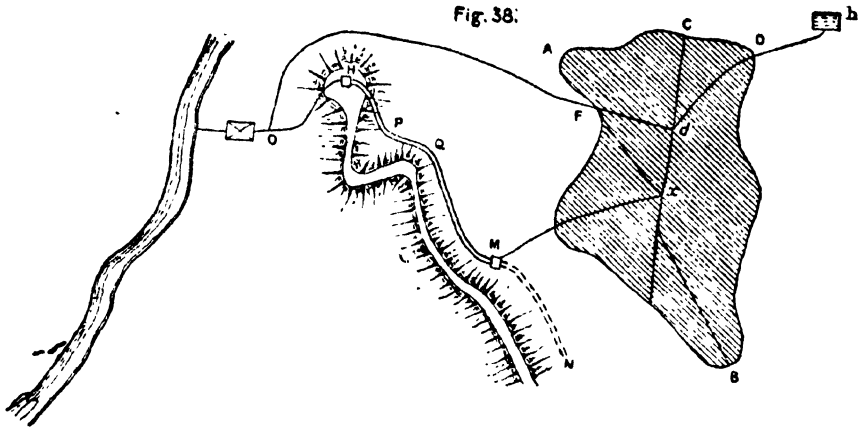

113. **Size of service reservoir.**—The minimum size of reservoir required is that which will feed the distribution pipes in the area controlled by it under a reasonable head of pressure, with a quantity of water which is the difference, during the hours of maximum demand, between the quantity of water drawn from the mains and that supplied by the pumps working at a uniform rate for 16 hours to meet the total daily demand. The hours of maximum demand in Upper India are 6 to 10 a.m. and 4 to 8 p.m. Pumping engines usually work in two shifts, from 5 a.m. to 9 p.m. The rate of maximum draw from the pipes is usually taken to be half the whole daily supply in four hours, or one-eighth per hour. The maximum capacity of reserve required for effectively balancing the varying demand of the day would, therefore, be the difference of one-eighth and one-sixteenth of the daily supply multiplied by four, the number of hours for which the high rate of demand continues, that is, one-fourth of the daily supply. This supply has to be provided above the *lowest* level from which an effective pressure can be maintained in the pipes of the area controlled by the service reservoir.

The above is the *minimum* storage required for working, and for an extensive inhabited area it is usually found more economical to provide it at two or [more points instead of one. This minimum does not, however, allow for irregularities in supply or demand, or for fire extinction, and it is therefore the practice to provide, for balancing purposes, reservoirs holding half a day's supply, if the municipality can afford it.

114. **Design of service reservoirs.**—It is not always possible, especially in the flat plains of Upper India, to get natural sites for reservoirs

at such an elevation as will give sufficient head to force the water at a reasonable pressure through the distribution pipes. When such sites are available the design of service reservoirs is very similar to those of the clear water reservoir described in chapter VI. When they cannot be constructed at, or below, ground level these reservoirs are usually designed in the form of iron tanks resting at the required height on masonry or iron supports built up from the ground. Fig. nos. 39,* 40* and 41† show some types of reservoirs designed for this purpose. Indian examples of such reservoirs will be found in Allahabad and Meerut cantonments and in Calcutta. The new raised reservoir of reinforced brickwork at Roorkee College also furnishes an interesting example on a small scale.

Yet another design is that of the tank pipes recently erected at Meerut, Ludhiana, Amritsar and other places in the Punjab and the United Provinces. These consist of cylindrical shells of mild steel plate, supported on a masonry or concrete platform, rising 5 to 10 feet above ground level. A tank, 25 feet diameter and 34 feet high, holding 100,000 gallons, costs about Rs. 16,000. This design has the merit of cheapness and simplicity, but it is not beautiful. If such tanks have to be erected for municipalities of slender resources, they should not be placed in prominent positions, and they should be screened, if possible, by a belt of high trees. Plate XI shows the details of construction of a tank of this description.

Reinforced concrete is now commonly adopted in Europe and America or elevated reservoirs and for those built on or below ground level. For tanks partly or wholly buried in the ground, the bottom usually consists of a flat slab of concrete, but the bottoms of elevated tanks are spherical and convex upward. Roofs are generally flat slabs of reinforced concrete if they carry no load, or spherical if they are loaded. The reinforcement of spherical roofs and bottoms of tanks consists as a rule of concentric rings of rod iron and of radial members fastened together by wire ties. The shape of such reservoirs should preferably be cylindrical. The side wall reinforcement of cylindrical tanks consists of (1) a series of horizontal rings of rod iron placed close together vertically at the bottom and increasing gradually in distance apart towards the top, and (2) a series of vertical rods spaced uniformly round the tank and connected by wire ties to the horizontal rings. At the junction of the side wall and the bottom the rods are bent well into the bottom round the angle to prevent cracks. Instead of horizontal and vertical rods in the side

* "Sanitary Engineering," by Vernon Harcourt.

† Proceedings Inst. C., E., volume C., plate 7, Fig. 1.

Fig. 39.

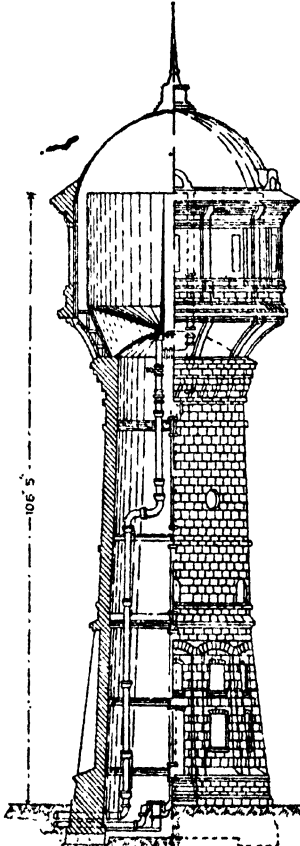

Fig. 40.

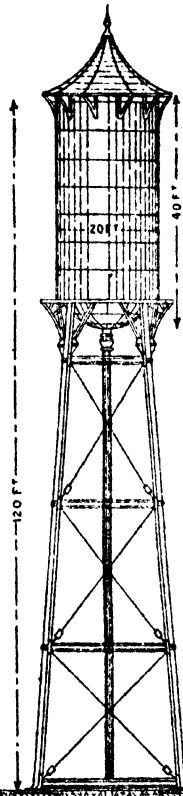
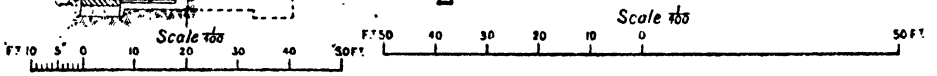
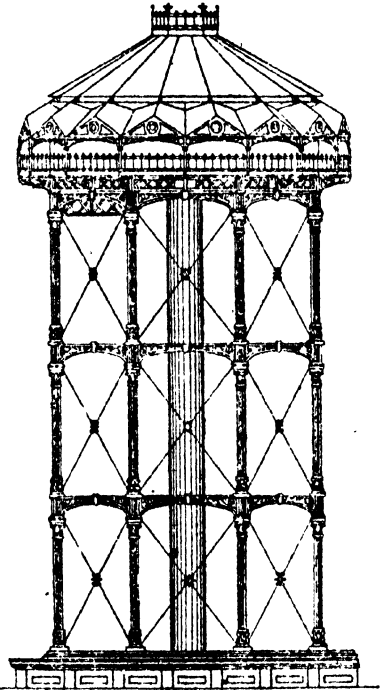

Fig. 41.



walls, a mesh reinforcement of expanded metal or wire netting is sometimes used. In this case a double layer near the bottom and a single layer above are used for deep tanks, but for shallow tanks the same strength of reinforcement may be used throughout.

The mixture in which the reinforcement is embedded consists usually of a mortar composed of one part of Portland cement to four of sand. When concrete is used it is made of Portland cement, sand and gravel or small broken stone in the proportion of 1—2—4. The inner or water face is lined with asphalt or a 1—1 mixture of cement and sand.

Reinforced concrete work in reservoirs will, as a rule, be found more expensive in India, owing to the high cost of cement, than a plain iron, masonry or concrete construction. The work, moreover, has to be done under difficulties in a cramped space filled with a network of steel rods or bars and it must be exceptionally good to be successful.

Students who wish to obtain further information regarding reinforced concrete reservoirs should consult "Reinforced Concrete Construction," by Buel and Hill and Paper no 3846 in volume 180 of the Proc. Inst. C. E. The latter is particularly instructive as it gives a description of a large reinforced reservoir which failed and explains the causes of failure.

In designing service reservoirs the question of foundations needs special consideration and the maximum pressures per square foot on the soil under the reservoir and on the footings should be well within the limit the materials are capable of taking.

A bye-pass pipe is usually provided which runs round the reservoir outside and connects the inlet and outlet pipes to enable the supply to the town to be run through when the reservoir is being cleared or repaired. A meter on the outlet is also useful to measure the supply at different times of the day and year. The inlet, outlet, overflow and scouring arrangements are similar to those of filters and clear water reservoirs referred to in paragraphs 98 and 106.

115. Distribution pipes.—The pipes used for distribution are chiefly of cast iron. English manufacturers usually make cast iron pipes from 3 to 14 inches diameter, 9 feet long, and above 14 inches diameter, 12 feet long. They are protected from rust, both externally and internally, by a coating of coal pitch and mineral oil applied hot, according to Dr. Angus Smith's patent.

Internal corrosion generally starts at soft exposed spots where the coating has worn off. Waters containing considerable amounts of free carbonic acid are the most corrosive. The iron is attacked by the carbonic acid in the water forming ferrous carbonate which is then

oxidised to ferric hydrate by the oxygen in the water and adheres to the pipe in the form of tubercles. Some hard waters deposit crystals of lime and form a crust in the pipe which obstructs the flow of water considerably. External corrosion is chiefly due to salts in the soils in which the pipes are buried.

Pipes are kept clean internally by frequent scouring through valves fixed in all depressions from which water can be readily drained away, but, in spite of this, they become incrustated after a time. When the incrustation gets so thick as to obstruct the discharge seriously, it has to be removed by a scraper (see sketch below). This is propelled in the pipe by water pressure acting against a disc or piston behind which the water is admitted. Hatch pipes with removable covers are placed at intervals along the lines to be scraped to allow of examination and removal of dirt. This liability to incrustation shows that some allowance must always be made in the diameter of pipes over and above what theory demands. Plate XII illustrates the different kinds of cast iron pipes in common use and their various fittings. A full specification is given in Appendix D.

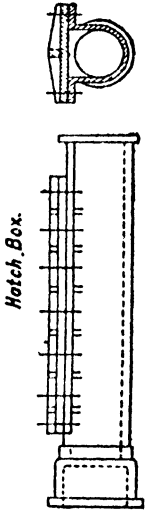

All street pipes should have at least 3 feet 6 inches of earth cover to protect them from frost in winter and the heat of the sun in summer.

Pipe Scraper.

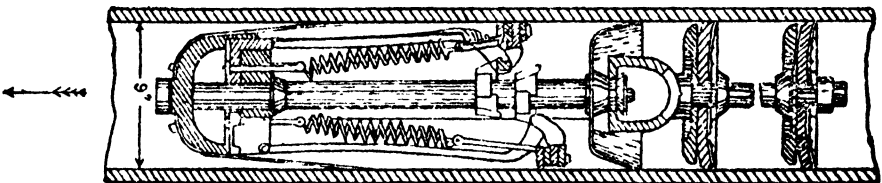

116. **Thickness of pipes.**—The theoretical thickness of cast iron pipes to resist the actual bursting pressure and water-ram, even with a large factor of safety, would be so small in ordinary cases that they would not in practice be cast of this thickness, and even if they could, they would be so

fragile that they would be liable to fracture in transport and handling, or from any slight settlement of the ground. Many empirical formulæ have been given by different authors for calculating the thickness of cast iron pipes. These will be found, by those who wish to use them, in Molesworth's Pocket Book of Engineering, in Fanning's Hydraulics and Water Supply Engineering and other text-books on the subject. The results obtained from them will differ in almost every case, and, in some cases, very considerably. The practical method of ascertaining the thickness and weight is to consult maker's catalogues, which give the stock sizes and weights of pipes available in the market for different pressures. Very light pipes should not be ordered even for low pressures, if they are to be transported long distances by sea or carts as the loss by breakage in transit will probably outweigh the small saving effected by cutting down the weights too fine.

117. **Pipe joints.**—There are three kinds of joints for cast iron pipes, (1) the ordinary spigot and socket lead joint, (2) the turned spigot and bored socket joint, and (3) the bolted flange joint.

These are shown in figures 42 to 46 below :—

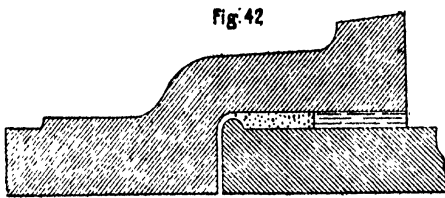

Fig. 42
Lead joint

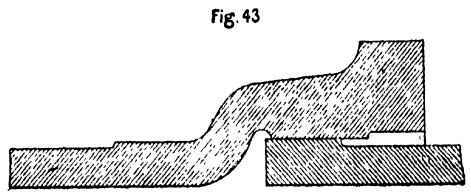

Fig. 43
Turned and bored joint.



Fig. 44

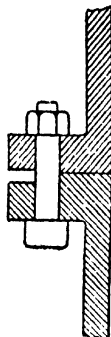

Fig. 45

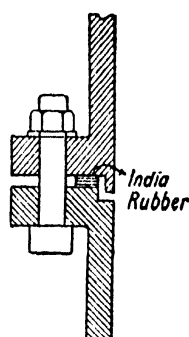

Fig. 46

Flange joints.

In making the lead joint, the spigot end of one pipe is placed into the socket of the other, into which it fits loosely; then several strands of

yarn rope, of a thickness which fits tightly into the space between them, are driven well home against the shoulder of the socket. This prevents the lead entering the pipes and maintains a uniform width of space all round between the spigot and the socket. A band of plastic wet clay is then formed round the spigot outside the socket and against it, so as to close in the space between the two without filling it. At the top the clay band is formed into a cuplike cavity, with an opening in the bottom, communicating with the empty space between the spigot and the socket. Molten lead is then poured into the cup till it fills the joint and runs over. The clay is finally removed, and the lead is trimmed off and caulked tightly into the joint. Owing to the yielding nature of the lead, a joint of this description allows of expansion and contraction in the pipes due to variations of temperature, without leaking. Wide lead joints are also useful in rough hilly ground, where the lines cannot be laid dead straight for long distances, as a slight difference of thickness in the lead of the joint, where the pipes joined are not in a true straight line, does not affect water-tightness. For joining pipes of large diameters, a gasket of plaited yarn or a special iron clip is used instead of clay which would not stand the weight of lead in large bore joints.

A new method of making lead joints has recently been introduced by the Lead Wool Company, Kent. By this method lead wool is used consisting of very fine threads of pure lead which weld together when hammered in tight, in a cold state, by a heavy caulking tool. Joints so made are said to stand heavy pressure without leakage. They have been used in the college water supply pipes.

In turned and bored joints a short length of the socket inside is bored accurately on a lathe, with an inward faced taper of 1 in 32. The spigot is turned and faced with a corresponding taper. The spigot end of the pipe to be laid is inserted into the socket of the last pipe laid, after being carefully cleaned with water to remove all grit; a block of wood is then placed against its socket and it is driven home by swinging the next pipe to be laid and using it as a ram against the wooden buffer. These joints are absolutely rigid and do not admit of any deviation from the straight line. For a long line, it is usual to make every tenth joint a wide lead one, to allow of expansion and contraction due to changes of temperature.

Flanged joints are more expensive than the other two, and are only used in special cases where the others would be unsuitable, as, for instance, in the suction pipes of pumps, in valve connections, and in the vertical inlet, outlet, or overflow pipes of deep reservoirs. The pipes have a flange

cast on each end, which is planed true on a lathe on the outer face. The flanges of the two pipes to be joined are smeared with a mixture of red and white lead, with a couple or three turns of string embedded in it; they are then brought together truly and firmly bolted up. For heavy pressures, a rubber ring is used between the flanges instead of string and red lead.

118. **Special fittings.**—For turning round corners in pipe lines "bends" are provided; these are called "quarter," "eighth," or "sixteenth" bends, according to the fraction of a complete circle covered by them. They have leaded joints, and in pipes of large diameters, when pressures are heavy, they are set in concrete and anchored down to prevent the thrust of the water in motion drawing the bend out of its joint. For branches taking off at right angles to the pipe line, the pipes of the shape of the letter T are used, and, for branches at other angles, breeches pipes or angle branch pipes. These are shown in plate XII, which also illustrates other special fittings in common use.

119. **Sluice valves.**—The flow of water in pipes is controlled by sluice valves, Figs. 47 and 48.

These valves consist of a circular disc or sluice, which, sliding in a groove, can either be raised by a screw into a chamber or bonnet, or it can be screwed down to stop the flow. To facilitate its movement, the disc is slightly wedge-shaped, and, to prevent corrosion, both the disc and the groove in which it works are faced with gun metal.

Under ordinary conditions these valves are worked by hand, but when they are large, and the pressure is great, special arrangements are necessary to overcome the friction. One of these is the provision of a by-pass, Figs. 49 and 50.* This is a small pipe, with a valve, which is connected to the main pipe on each side of the sluice valve. The small valve on the by-pass, when opened, admits water from the pressure side of the main valve to the other side, and so equalises the pressure on each face of the latter, which is then readily opened.

For very large mains of 30 inches diameter and over sluice valves are not only provided with a by-pass, but they are contracted in diameter to about two-thirds that of the main to further reduce the pressure to be overcome in working the sluices. Contracting the main at the valve in this manner does not seriously affect the discharge as might be supposed. The water rushes through the valve at a greater velocity and the head lost is very small. See Fig. 51 and paragraph 141.

* "Lectures on Water Supply," by A. R. Binnie.

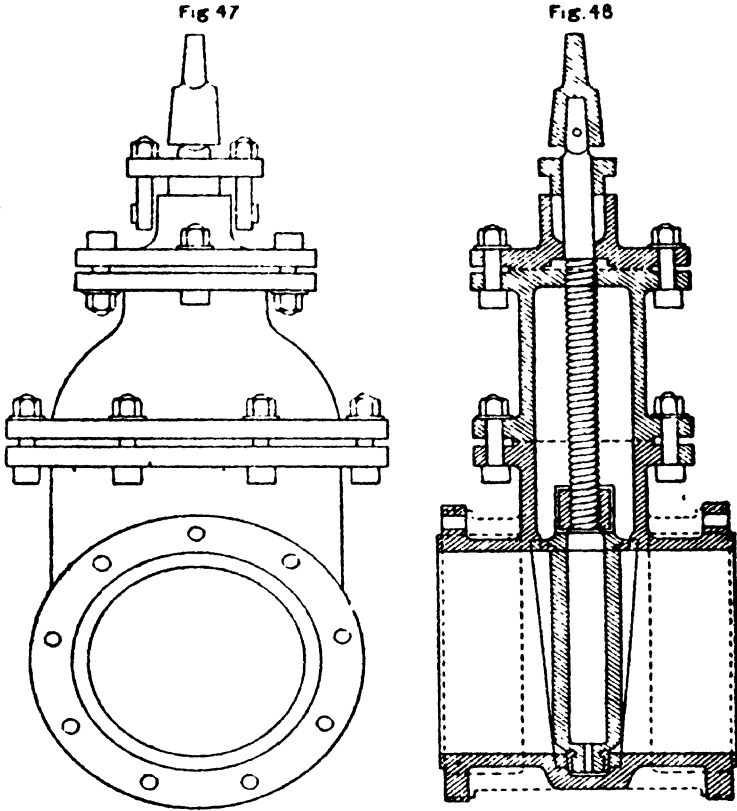

Fig. 9.
Bye-pass valve.

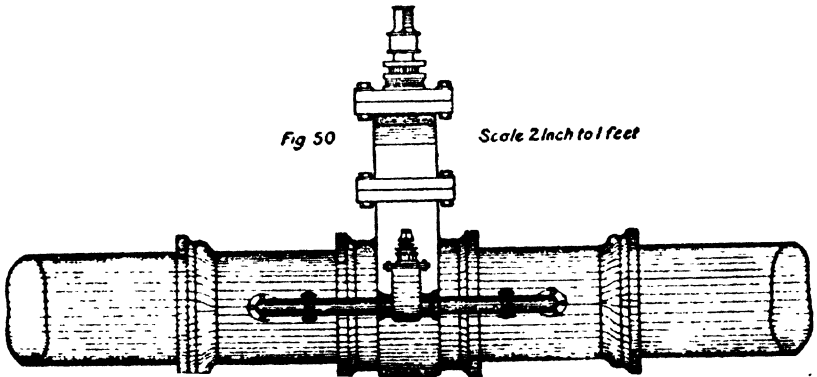
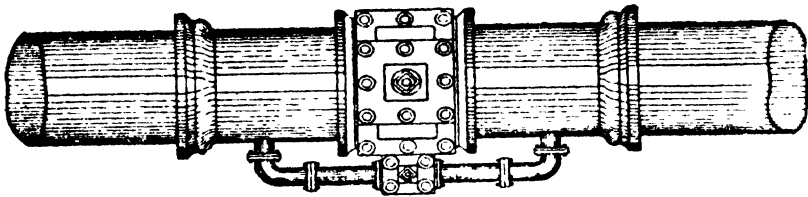
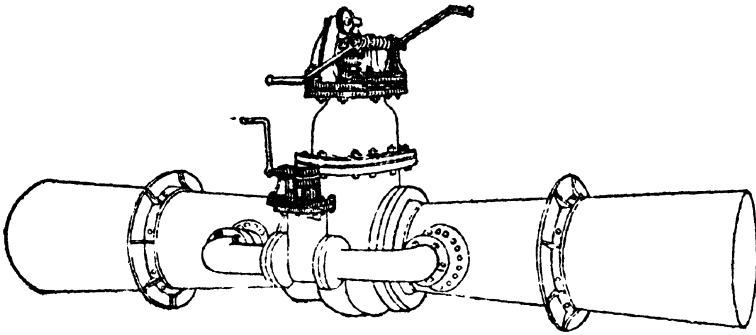

Fig 50

Scale 2 Inch to 1 foot

Fig. 51



Treble Slide Valve Fig 52.

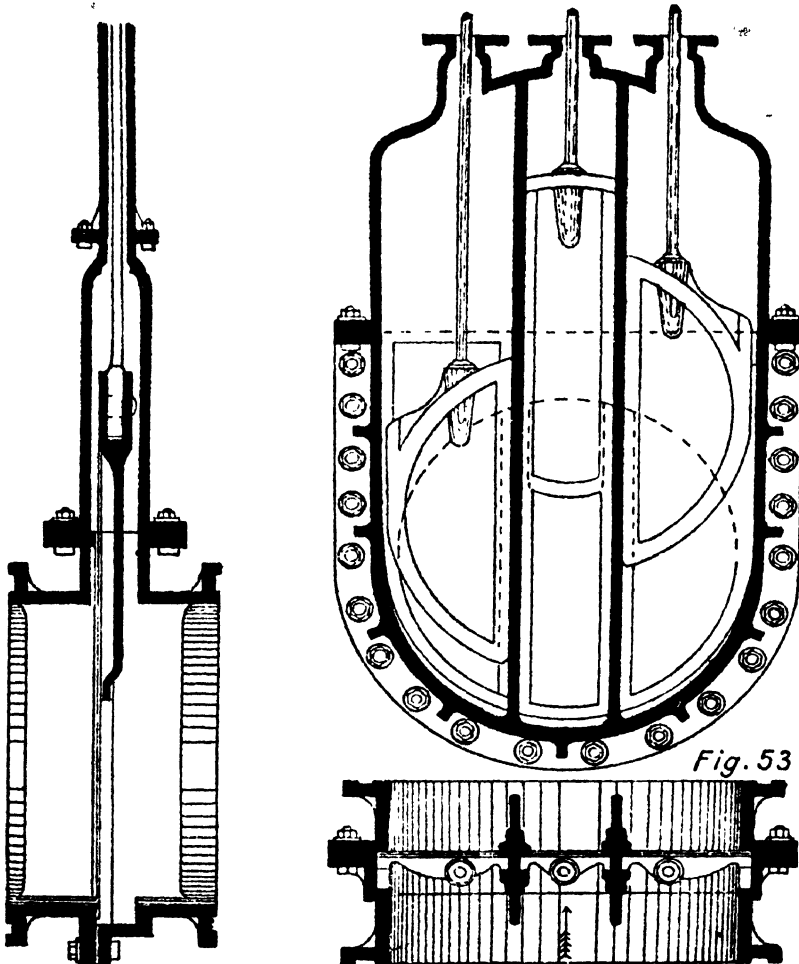
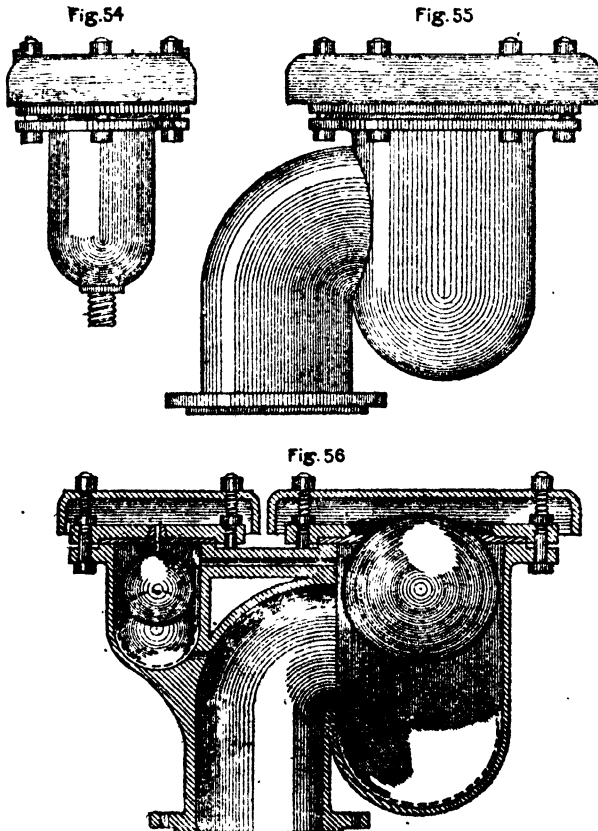

Fig. 53

Another arrangement is to form the sluice or disc in three or more slides of various sizes, each moved by its own screw and gearing, Figs. 52 and 53.*

In addition to the sluice valves, on all important lines of pipes, for control of flow, valves should be provided at all dips and depressions to enable the pipes to be scoured occasionally for removal of any deposits that may form in them in course of time. These should be so arranged as to allow of the waste water being discharged into some neighbouring stream or drain.

120. **Air valves.**—At all summits in the pipe lines some arrangement is necessary to admit of the escape of air when the pipes are being charged, and also of any which may accumulate at these points when water is flowing through them. The release of air from such positions is effected by what are called air valves. These may be simple cocks screwed into the top of the pipe, by opening which the air would escape, but automatic valves are usually provided which are independent of hand control, Figs. 54 to 56.*



They consist of cast iron chambers, with a circular hole at the top and a floating ball of cork or guttapercha. When the pipe is empty, this ball rests on the seat provided for it in the chamber, leaving the hole at the top open for the escape of air when the pipe is charged, the water rises in the chamber and carries the ball with it, till the latter closes the hole and prevents the escape of water; see chamber on left of Fig. 56. A larger size is used to release large volumes of air when empty pipes are being charged, and a smaller to act under pressure and admit of the escape of the small quantities of air which are liberated from flowing water and rise to all summits. The two sizes are often combined in one valve, as shown in Fig. 56.

121. **Relief or momentum valves.**—On very long lines of pipes, relief or momentum valves are fixed, to relieve the shock produced by a long column of flowing water suddenly stopped by the closing of sluice valves, Figs. 57 and 58.*

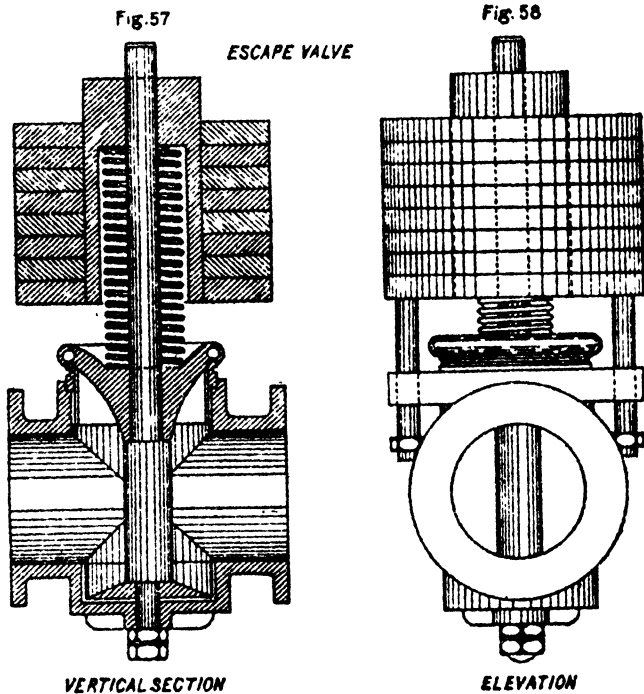

These are heavily weighted valves, which open under pressures exceeding those for which they are set, and act in the same way as the ordinary steam safety valve.

* "Lectures on Water Supply," by A. R. Binnie.

122. **Reflux valves.**—On very long pipe lines of large bore, self-acting reflux valves are sometimes fixed at the foot of all steep inclines, to prevent the pipes emptying themselves backwards at a high velocity by a reflux of water in the event of a burst. These valves are shown in Figs. 59 and 60.*

They consist of a frame in an enlargement of the pipe carrying a series of leather or rubber flap valves. As long as the water flows in its normal direction these flaps keep open, but if the current is reversed by a burst on the downstream side of the valve, it closes all the flaps in the frame and prevents the flow of water in this direction from the upstream side.

Fig. 59.

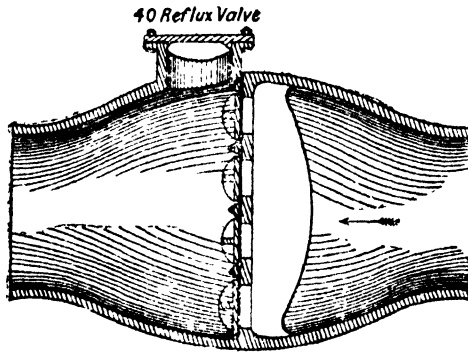

*Vertical Section.
Fig 60*

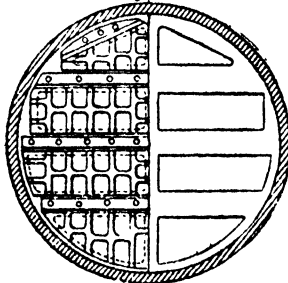

123. **Standposts.**—It is necessary to provide standposts in streets for drawing water from the mains for the public water supply, and hydrants for street watering and fire extinction.

The best pattern of standpost now in the market is the Glenfield, illustrations of which will be found by the student in most catalogues of firms dealing in water-works fittings. This standpost is worked by turning a knob handle, and keeping it turned till sufficient water is

* "Lectures on Water Supply," by A. R. Binnie.

drawn : when the handle is released, a counterweight inside the standpost drops and causes the tap spindle to revolve, which cuts off the supply of water. Another pattern is the push cock, which is opened by pressing against a strong spring ; when released, the spring throws back the spindle to the closed position. This is not very durable, as the spring becomes weak after a time and the tap leaks ; it is also unsatisfactory because sticks or stones can be wedged in between the push and the casing to let the tap run continuously to waste.

124. **Hydrants.**—Hydrants are fixed at convenient places to provide water for filling watering carts, for scouring drains, or for fire extinction. The supply is delivered through a flexible hose, which is attached temporarily by a screw coupling to the outlet of the hydrant. A special upright pipe is generally used for making a connection with the hydrant below the street.

The hose is screwed on to the outlet of the upright pipe, and the latter is fixed on top of the hydrant when it is to be put into action. The water is turned on by operating a screw in the upright pipe, by means of a head at the top, which, by pushing down a cap attached to its lower end, forces down the ball of the hydrant. See Fig. 61. *

FIRE-HYDRANT WITH BALL-VALVE:

Fig. 61

FIRE-HYDRANT WITH SLUICE-VALVE
AT SIDE.

Fig. 62



* "Sanitary Engineering," by Vernon Harcourt.

In some types, the hydrant is opened and closed by an ordinary valve in a pipe at the side leading to the hydrant at the base of the upright pipe, Fig. 62.

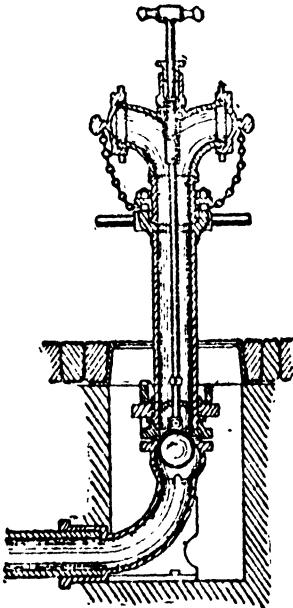
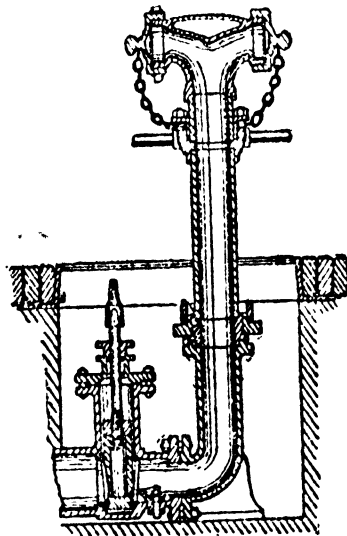
In other cases, the hose is attached directly to the outlet of a special pipe casting controlled by a valve, Fig. 63.

Fig 63.

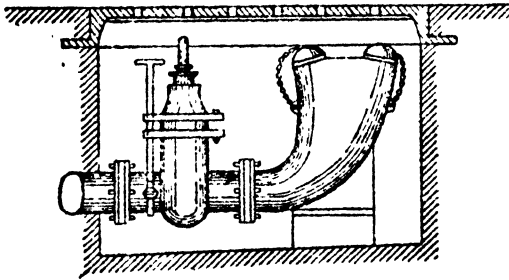

125. **House connections.**—In addition to the public supply from standposts in the street, water is delivered inside the more important houses through a system of small bore piping, from $\frac{3}{4}$ to $1\frac{1}{2}$ inch diameter, technically called "house connections." These pipes used to be of lead, but they are now of wrought iron as a rule either galvanised or coated with a special preparation of asphaltum.

The branch to a house is taken off the street main by boring a hole in the latter and screwing a small brass tube called a ferrule into it. The wrought iron service branch is screwed on to the other end of the ferrule (see plate XIII). In fixing the diameter of the connection pipe, the quantity of water to be delivered to the householder for the water rate he pays, or for the number of taps on the connection, should be first ascertained; the pressure available at the take off should then be determined by a pressure gauge, or by calculation, and the size of the pipe calculated therefrom. The ferrule should be $\frac{1}{2}$ inch to $\frac{1}{4}$ inch less in diameter than the pipe. In important house connections, it is customary to carry the connection pipe straight from the street main to the house cistern near the roof, from which the distribution is taken off to the various taps in different parts of the building. The house cistern is of the "ball cock" variety, in which the supply is cut off automatically by a ball float, which introduces a plug into the mouth of the inlet pipe when the water in the tank has risen to a certain level, Fig. 64. For important residential buildings, especially in the hills, a hot water system is often provided in connection with the cold water distribution system. This consists chiefly of a boiler or water heater in the basement and a hot water cylinder at a

higher level with an open expansion pipe above it carried a little higher than the main house cistern, Fig. 65. A cold water pipe from the main cistern enters the hot water cylinder near its bottom immediately opposite the mouth of the return pipe and feeds the boiler when water is drawn from the system. The cold water pipe might enter the boiler direct near its bottom but many Sanitary Engineers consider it bad practice to allow dead cold water to enter a very hot boiler and prefer to pass it through the hot cylinder near its bottom. The house branches are taken off the expansion pipe rising above the hot cylinder or from the top of the hot cylinder itself. For fuller information on this subject the student is referred to an excellent book just published called "Hot Water Supply," by Dye, or, to "Domestic Sanitation and Plumbing," by Herring Shaw.

Fig 64.

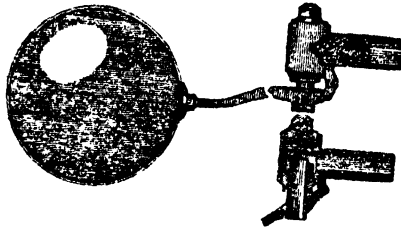
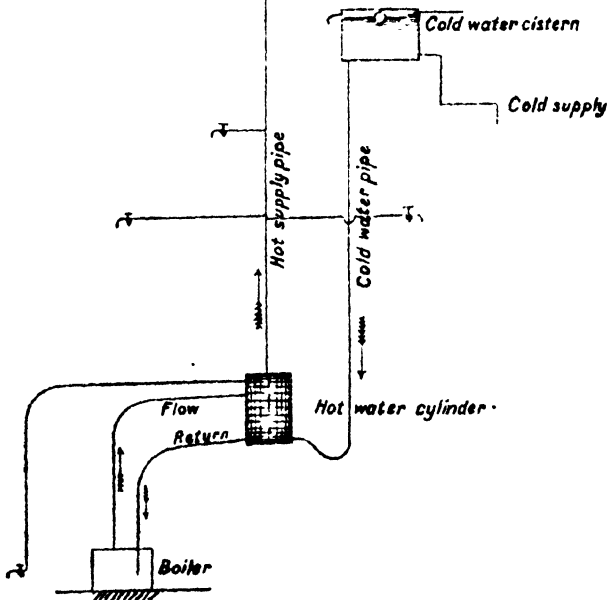

Fig. 65



126. **Sizes of house distribution piping.**—The sizes of house distribution pipes and their branches should be so fixed as to feed the taps on them at the following rates except in special cases : —

One tap	8 gallons a minute.
Two taps	12 „
Three to five taps	18 „
Six to ten taps	24 „

It is not necessary as a rule to make the pipes large enough to feed all the taps at once, when these exceed three, as all the taps are never likely to be opened simultaneously in a service which has numerous taps on it.

127. **Street stop cock.**—A stop cock in a surface box is always placed on the service pipe before it enters the house to control the whole system, see Fig. 66, and it is desirable to fix a meter, as far as possible, on all important connections to check the consumption and prevent waste, even when water is not charged for according to the volume actually supplied,

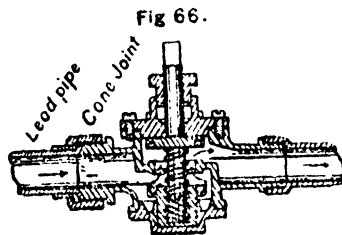

128. **Wrought iron pipes and fittings.**—Plate XIII contains illustrations of wrought iron pipes and their special fittings, such as bends, elbows, tees, sockets, etc.

Wrought iron pipes of large diameter are protected against corrosion by a coating similar to Dr. Angus Smith's composition commonly used for cast iron pipes. Pipes of small diameter are galvanised for this purpose.

All the taps should be screw-down taps so that they cannot be closed rapidly and cause severe water-ram in the pipes. They should be strong and of the best make procurable to minimise leakage as far as possible.

Figs. 67 and 68 show an ordinary screw-down tap. Plug cocks of a cheap variety should be avoided in all important services.

Fig. 67.

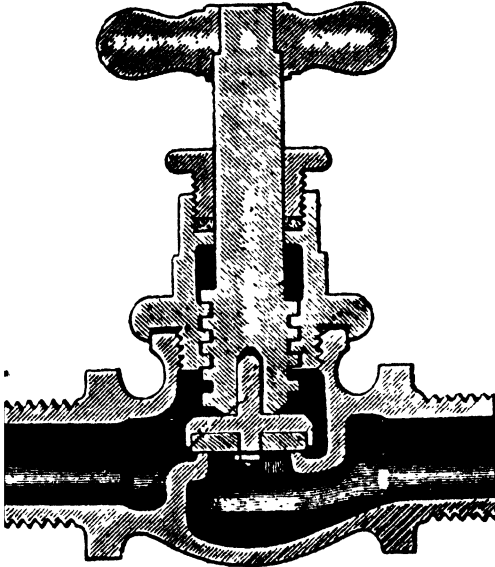
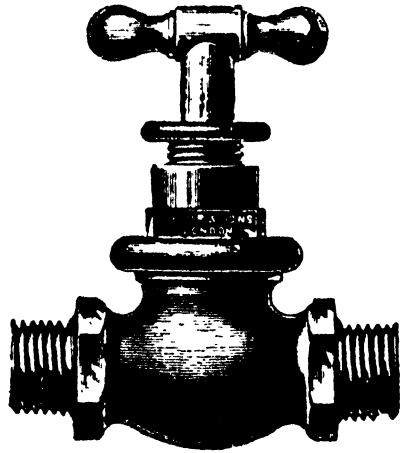

Fig. 68.



129. **Calculation of discharge of pipes.**—The calculation of the discharge of pipes under varying conditions of length, pressure, etc., may be obtained by numerous formulæ which are in use for the purpose. The most reliable of these are, perhaps, Darcy's for clean and incrustated pipes, as their co-efficient of discharge varies with the diameter and the roughness of the internal surface of the pipe. These formulæ can be found in any text-book on Hydraulics or pocket book of Engineering, and are not given in this Manual as they are of no practical use to a water works engineer when he is designing a distribution system. He generally takes his discharge from a diagram, or table, or a slide rule. The writer has always used the tables in Box's Hydraulics and found them most reliable for pipes under ordinary working conditions, i.e. neither perfectly clean nor very badly encrusted. If the water is very hard, and there is likely to be serious incrustation in consequence, a further allowance should be made for this in fixing the sizes of the pipes, by adding an inch to the diameters given in Box's tables.

130. **Delivery required.**—In estimating the delivery required, the first point to be determined is the mean daily supply to be given per head of population.

This must be fixed in each particular case with regard to local conditions. It varies from 10 gallons a head in small towns to 30 gallons a head in large towns like Calcutta and Bombay with an underground sewerage system and numerous factories. Up-country towns, such as Lahore, Delhi, Agra, Allahabad, began with 10 gallons a head and are now using 12 to 15. The distribution pipes must be designed to deliver the maximum demand per hour or minute at any time of any day in the year. The maximum daily demand during the hot dry weather in India is generally assumed to be one-third more than the mean daily supply of the year and the maximum supply per hour one-eighth of the maximum daily supply. If, for instance, the mean daily supply of the year is assumed to be 15 gallons a head, the maximum daily demand will be $15 \times \frac{15}{8} = 20$ gallons a head, and the maximum rate of demand will be $\frac{20}{8} = 2.5$ gallons per hour per head, or $\frac{20}{8 \times 60} = 0.04$ gallons per minute, see (paragraph 113). No separate allowance is made for fire supply as very few Indian towns can afford the extra cost of increasing the diameter of their distribution piping sufficiently to give an independent supply for fire extinction *in addition* to the supply for ordinary purposes. Fire engines are employed for extinguishing fire in most Indian towns as the pressures are low, and if a fire happens to occur during the period of maximum demand, the supply is concentrated on the fire, as far as possible, by closing rapidly, for a time, the valves on all branches and sub-mains which do not help to feed the main pipe line directly between the fire and the service reservoir or pumping station.

131. Relation between height of service reservoir and size of distribution pipe.—Before proceeding to consider the arrangement of pipe lines in a distribution network, it is necessary to fix approximately the maximum height to which raised reservoirs should be built in order to give a good working head for the distribution with pipes of reasonable size, and also the approximate hydraulic mean gradient which should be aimed at for pipes of different diameters. These two facts depend largely on local conditions, the chief of which are the rate of supply, and the height to which water is to be raised for house services and for extinction of fire by direct hose connection with street mains. In the large towns of Europe and America and in the Presidency towns of this country, the rate of supply and the pressures are very much greater than those needed for towns in Upper India. The higher the service reservoir, the less will be the cost of the distribution system, and the better the pressures, but if the water is pumped into the town the pumping expenses will be heavier, and if the reservoir is a raised one its cost

will be greater. The usual practice for small Indian towns is to make the base of the reservoir, or the low water level in it, 35 to 40 feet above ground level, and to aim at a hydraulic gradient of 2 or 4 per thousand in pipes below 6 inches in diameter, and 4 to 5 per thousand in larger pipes. The terminal head at the end of the distribution should be at least 20 feet.

The usual velocity of flow in distribution pipes up to 12 inch bore is 1·8 to 2·5 feet per second, but in larger bores, if sufficient head is available 3 to 4 feet a second is often allowed to keep down the cost of the heavier pipe.

132. Alignment of main and sub-main.—As to the alignment of the mains, sub-mains and branches, much will depend on the plan of the roads, and side streets, but in large towns which are fairly compact it is a good arrangement, as a rule, to make the main pipe branch out as it enters the town, and pass round it within the extreme edge, or boundary, with a trunk line laid diametrically across through the centre of the town where the markets and most important commercial buildings are generally located. The sub-mains take off from the ring main at convenient points, and crossing the town along the streets, cut it up into different districts of supply. This system may not always be feasible, owing, for instance, to the relative positions of the service reservoir and supply main, or the situation of industrial centres, markets, and main roads, but it is a good plan to be kept in view for adoption if local conditions will permit of it.

133. Gridiron arrangement of distribution pipe.—The mains, sub-mains and branches are generally arranged so as to be connected in a sort of network, or gridiron, so that dead ends are avoided. With this arrangement, if an accident happens to a pipe or a valve in any central position, there are at least two lines of sub-mains round that point, and the supply will be maintained with certainty at points beyond. The pressures, moreover, are improved as the water is drawn at every point from two directions, instead of one. Dead ends are objectionable, as they cause stagnation of water and impede free circulation throughout the system which is most desirable.

134. Stop valves on branches.—It is necessary to provide a sufficient number of stop valves, so that it is possible, by closing one or more of them, to cut off any pipe or branch pipe from the supply, without interfering with the rest of the system. To do this completely, each branch should have two valves, one at each end, as shown in Fig. 69, but as this would be a very expensive plan, the valves are reduced in number by being so arranged that three or four valves have to be closed, instead of two, to

cut off some of the branches. Fig. 70 shows a plan by which the valves are reduced in number from 20 to 11, but it necessitates the closing of four valves in some cases to isolate a branch.

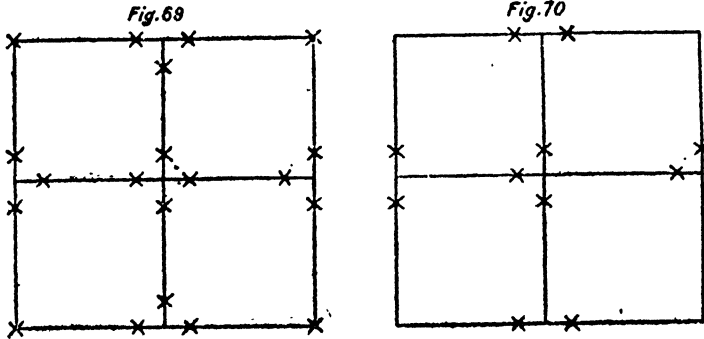

135. **Minimum size of cast iron pipes.**—It is not advisable to have cast iron pipes of smaller diameter than three inches in the street distribution system on account of the incrustation which usually takes place on the inner surface reducing the available capacity of small bores to such an extent as to render them useless in a few years.

136. **Example illustrating method of calculating the diameter of pipes in a distribution system.**—The following example illustrates the method of calculating the diameter of pipes in a distribution system. Plate XIV shows a sketch of a small town, or a sub-division of a town, with 20,000 inhabitants covering 100 acres. The firm lines represent streets, which divide the town into several blocks, the population of which is assumed to be of a uniform density, for purposes of calculation. Unless census records are available, from which the population of each block can be derived, some approximation of this kind is necessary to furnish data for the calculations. If census figures can be obtained, they should, of course, be adopted in preference. Some allowance should also be made in fixing the population of outlying blocks for future extensions of the town and for increase of population, if it is possible to foresee exactly what these are likely to be.

Serial number.	Line.	Area served.	Population at 200 per acre.	Supply in gallons per minute at 0.4 gallons a minute per head for each length.	Serial numbers of lines contributing to total supply of line.	Total supply of line in gallons per minute.	Length in yards.	Diameter in inches.	Loss of head in feet per yard by friction. (From Box's hydraulic tables).	Total loss of head. Column 8 X column 10.	Red. level of hydraulic gradient.		Ground level at lower end.	Head available for service above ground level. Column 13 - column 14.
1	2	3	4	5	6	7	8	9	10	11	12	13	14	15
1	R. A.	100	20,000	800	2 to 16	800	200	11"	.015	3.0	500.0	497.0	466.0	31.0
2	A. B.	6.5	1,300	52	2 to 4 and 9 to 16.	576	300	10"	.014	4.2	497.0	492.8	464.5	28.8
3	B. C.	4.5	900	36	3 to 4 and 13 to 16.	316	250	8"	.013	3.2	492.8	489.6	464.0	25.6
4	C. D.	4.5	900	36	5 to 6	36	200	4"	.006	1.2	489.6	488.4	464.5	28.9
5	A. E.	6.5	1,300	52	5 to 6	120	150	6"	.008	1.2	497.0	495.8	464.0	29.8
6	E. F.	8.5	1,700	68	7 to 8	68	320	5"	.006	1.9	495.8	493.9	465.0	28.8
7	A. K.	5.0	1,000	40	7 to 8	104	120	6"	.006	0.7	497.0	496.3	466.0	30.8
8	K. J.	8.0	1,600	64	9 to 10	64	280	5"	.006	1.7	496.3	494.6	464.0	30.6
9	B. F.	6.0	1,200	48	9 to 10	112	200	6"	.006	1.2	492.8	491.6	465.0	26.6
10	F. G.	8.0	1,600	64	11 to 12	64	200	5"	.006	1.3	491.6	490.4	466.0	24.4
11	B. J.	3.5	700	28	11 to 12	96	150	6"	.006	0.9	492.8	491.9	464.0	27.9
12	J. H.	8.5	1,700	68	13 to 14	120	250	5"	.006	1.5	491.9	490.4	466.0	24.4
13	C. G.	4.5	900	36	13 to 14	120	180	6"	.008	1.4	489.6	488.2	466.0	23.2
14	C. D.	10.5	2,100	84	15 to 16	84	250	5"	.008	2.0	488.2	486.2	464.5	21.7
15	C. H.	4.0	800	32	15 to 16	134	200	6"	.008	1.6	488.6	488.0	466.0	22.0
16	H. D.	11.5	2,300	92	..	92	250	5"	.010	2.5	488.0	485.5	464.5	21.0

The population of the town being 20,000 and the area 100 acres the density per acre is 200. The population of each block is calculated at this rate from its area. The rate of supply per head of population is assumed to be 0·04 gallons per minute, as calculated in paragraph 130.

Only sub-mains in the important streets are shown in the sketch. The smaller side streets and lanes in the blocks are served by 3 inch branches, connected at each end with the sub-mains.

The dotted lines in the various blocks bisect the angles approximately and are intended to mark roughly the boundaries of the areas served by each length of pipe on each side.

It is convenient to tabulate the data and calculations in the form of a statement, of which a type is given in the statement attached. The headings explain themselves. Columns 1 to 8 and column 14 should first be filled up from the plan. Column 9 should then be filled up tentatively from column 7 and Box's Hydraulic tables, bearing in mind what the slope of the Hydraulic gradient should be (4 to 5 per thousand* for large pipes and 2 to 4 for the smaller bores). Column 11 should then be calculated from columns 8 and 10, and columns 12, 13 and 15 will follow from the figures in this column.

The terminal heads (in column 15 of the statement) should be a little above 20 at the tail end of distribution for a good efficient service. If on the first trial it is found that some of the lines will stand a greater reduction of head, without loss of efficiency, their diameter should be reduced and the calculations revised accordingly. If, on the other hand, there has been too much loss of head in certain lines, as compared with others, their diameters should be increased and a fresh calculation made. If, on completing the first trial, it is found that the terminal head falls lower than is desirable, it will probably be necessary to raise the service reservoir or increase the pumping head of the engines.

The pressures will actually be better everywhere than those shown on the statement as the supply will reach every point from two directions instead of one owing to the network connection.

* Four per thousand = ·004 per foot or ·012 per yard ; 8 per thousand = ·008 per foot or ·024 per yard ; and so on.

CHAPTER VIII.

MEASUREMENT OF WATER AND PREVENTION OF WASTE.

137. **Measurement of water.**—When water is paid for according to the quantity actually used, it is necessary to measure the flow, by meter, to every house or factory at the point where it enters. It is also sometimes necessary to measure the water given to large houses and institutions to check consumption and prevent waste, even when water is charged for by a water rate. There are numerous types of water meters on the market but they all come under two heads, the positive and the inferential. The former measure the actual quantity passing through them by filling and emptying chambers of known capacity, by means of a piston actuated by the flow of water. The strokes of the piston are recorded by a registering mechanism on an index and dial attached on the meter. Inferential meters on the other hand consist chiefly of a turbine worked by the flow of water and serving as a measure of the velocity of water passing through. An index on a dial is moved by gearing to indicate the volume of water passing through as inferred from the number of revolutions recorded by the meter.

138. **Positive meters.**—Positive meters record both large and small flows of water accurately. The best known meters of this type are Kennedy's Frost's and Schonheyder's. Figs. 71-A and B show the

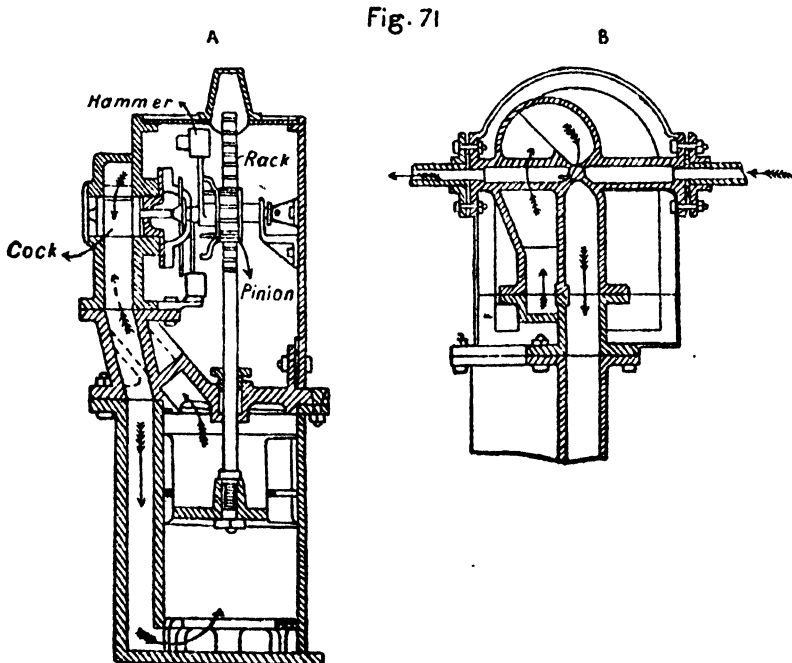

different parts of a Kennedy meter. The complete section A shows the piston working in the cylinder, and the inlet and outlet passages; the part section B shows the cock or valve near the top, which reverses the flow, when it is turned over by the sudden fall of a hammer, shown near the top at A directly the piston reaches the top of its stroke. For a fuller description of this meter see Glenfield and Kennedy's illustrated catalogue which is available in most Public Works department offices in India.

139. **Inferential meters.**—Good inferential meters record large flows of water fairly accurately, when in proper order, but they do not always revolve with small flows, especially if the water is turned on very gradually. Some types, moreover, cause a considerable reduction in the pressure owing to the small passages in the turbine, and their accuracy is liable to be affected by a reduction of the size of the orifices by accretion from sediment in the water. These meters are cheaper than positive meters, and are sometimes used instead of the others for economy when the system of supplying water entirely through meters is adopted and large numbers have to be used, as in Berlin.

Fig. 72

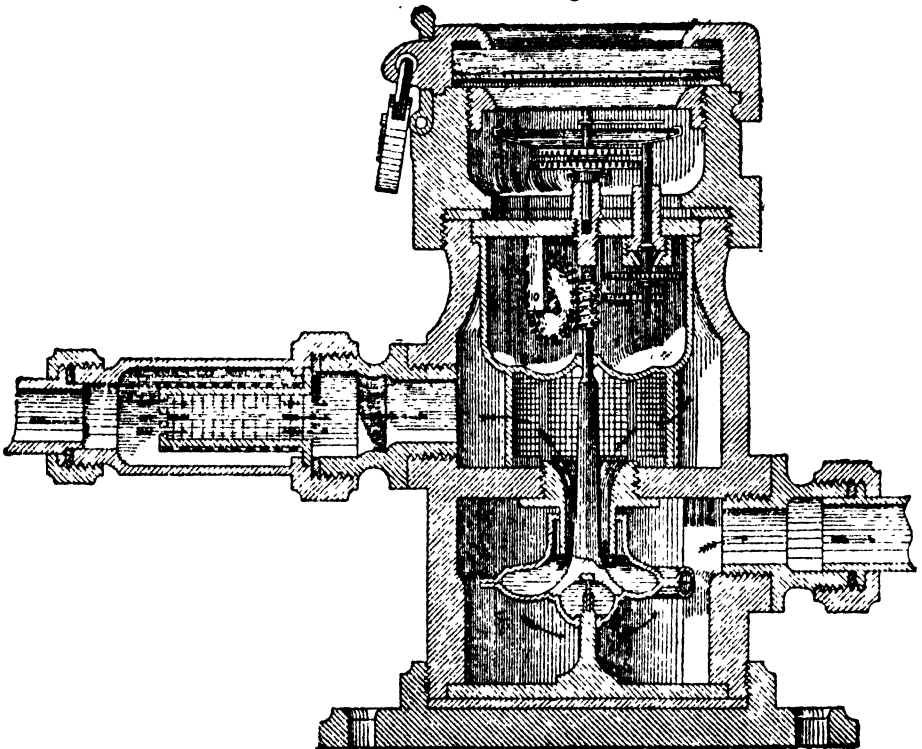

Though distinctly less accurate than positive meters, inferential meters satisfy ordinary requirements, and when employed extensively for large towns, it is usual to make an allowance in fixing the price of water for their short reckonings, in the case of very small flows. The best meters of this kind in the market are Siemens' turbine water meters, Siemens' and Halske vane water meters, and Tylor's vane water meters.

Fig. 72 shows a Siemens' meter, as manufactured by Messrs. Guest and Chrimes of Rotherham. The body of the meter is a casting in two chambers, an upper and lower. The water enters the upper chamber, and passes, by a spout, through the wheel in the lower chamber. The wheel is made of stout brass, stamped to proper curves, and rivetted together to form suitable curved channels to convey the water from the centre to the circumference. The simple revolution of the wheel could not, of itself, correctly measure the water going through, as its velocity would not be constant. To compensate for this variation, vanes are attached to it, so formed as to offer a resistance which varies as the square of the velocity and a balance of power is obtained in this way. The number of revolutions are, therefore, constant for similar quantities of water passing through, even though the pressure vary.

140. **Points of a good meter.**—A good meter for the sale of water by measure for domestic purposes should satisfy the following conditions. It should be cheap, of moderate size, easily fixed and removed, capable of running for a long time without needing repairs, causing only a slight loss in the pressure of water passing through, and recording the flow at different pressures with an error not exceeding about 2·5 per cent.

141. **Venturi meter.**—For measuring cheaply the flow of water in large pipes, with only a very slight loss of head, the Venturi meter is most valuable. It is based on the principle that water flowing through a

The Venturi Meter.

Fig. 73.

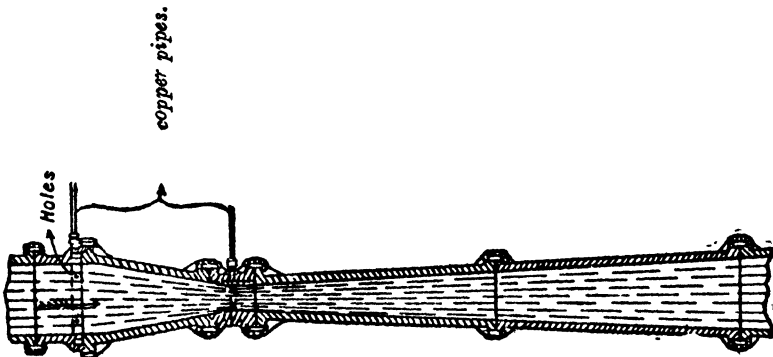

diminishing taper pipe acquires a higher velocity but loses pressure, (see Fig. 73). The difference in pressure at the inlet and at the contracted throat, called the venturi head, is proportional to the square of the velocity at the throat. If, therefore, the venturi head is known, the velocity can be easily deduced therefrom. This head is measured on a tube containing mercury by connecting it with the water at the inlet and throat by means of the copper pipes shown on Fig. 73. These pipes take off from hollow pressure chambers at the inlet and throat which communicate with the interior of the pipes by a few holes. The mercury in the tube actuates a float which registers the velocity on a diagram throughout a given period, the time during this period being registered on the diagram by means of a drum revolved by clock work in the usual manner. The meter has been named after the Italian philosopher who first established the principle on which it is based.

142. **Prevention of waste.**—The sale of water by measure is obviously such a satisfactory method of reducing waste, as it enlists the sympathy of consumers, that it seems unaccountable why any other method has been adopted. Two objections have been urged against this method, which deserve consideration. One is that it would tend to make the poorer classes stint themselves in the use of water to an extent that would be detrimental to health; and the other is that the cost of meters and their supervision would be out of all proportion to the receipts from the poor tenements. These objections, however, could be easily met (1) by making a fixed charge or levying a water rate on the house for a quantity per head ordinarily sufficient for domestic use, and by only charging by measure for any consumptions beyond this allowable quantity, and (2) by dispensing with the meter system for the poorest class of houses, where the water consumed is too small to bear the cost of the meter and its supervision in every house.

143. **Deacon's waste meter system.**—Another method of checking waste by leakage, or otherwise, is that known as Deacon's waste meter system. The town is divided into a suitable number of districts served by a main, or sub-main with its branches, and valves are so fixed on the pipes at the boundary of each district that it can be readily isolated from the rest for purposes of test. A waste water meter, as described below, is fixed at the head of the district on the sub-main near its junction with the principal main. The flow through the meter between 1 a.m. and 4 a.m. (when there should be no flow ordinarily) indicates the waste that is taking place in each district. Diagrams are taken periodically on the meter of each district, and the districts showing the greatest waste are dealt with first.

DEACON'S WASTE WATER METER.

Fig. 74

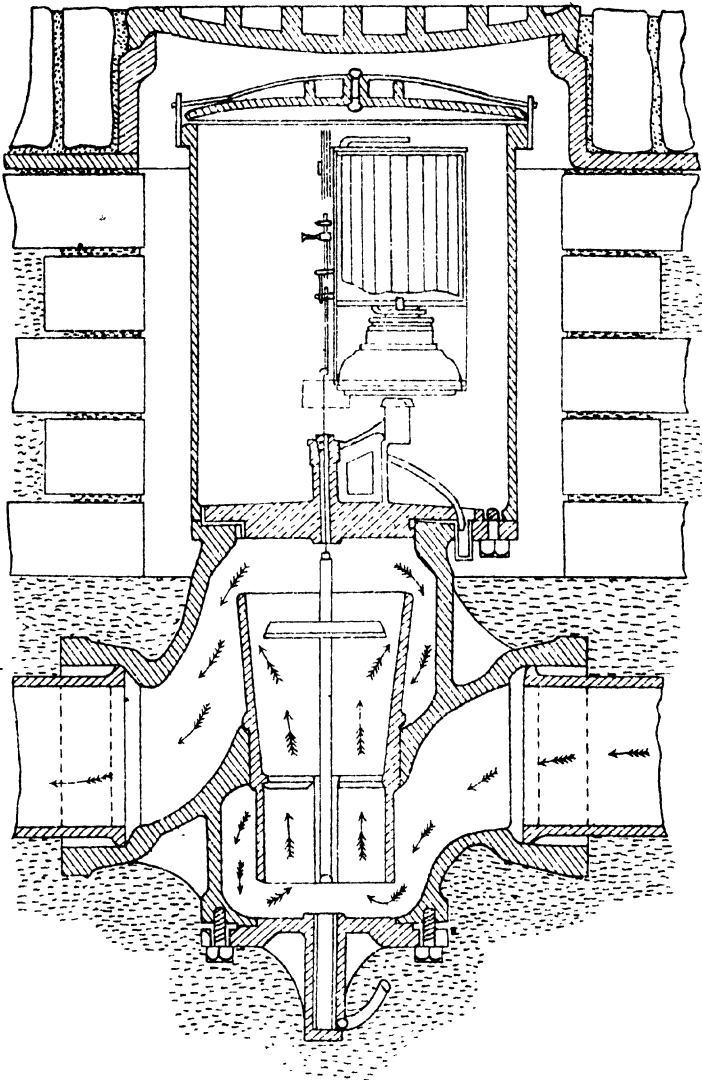
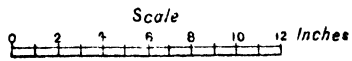

WASTE-WATER METER.

Fig. 74.

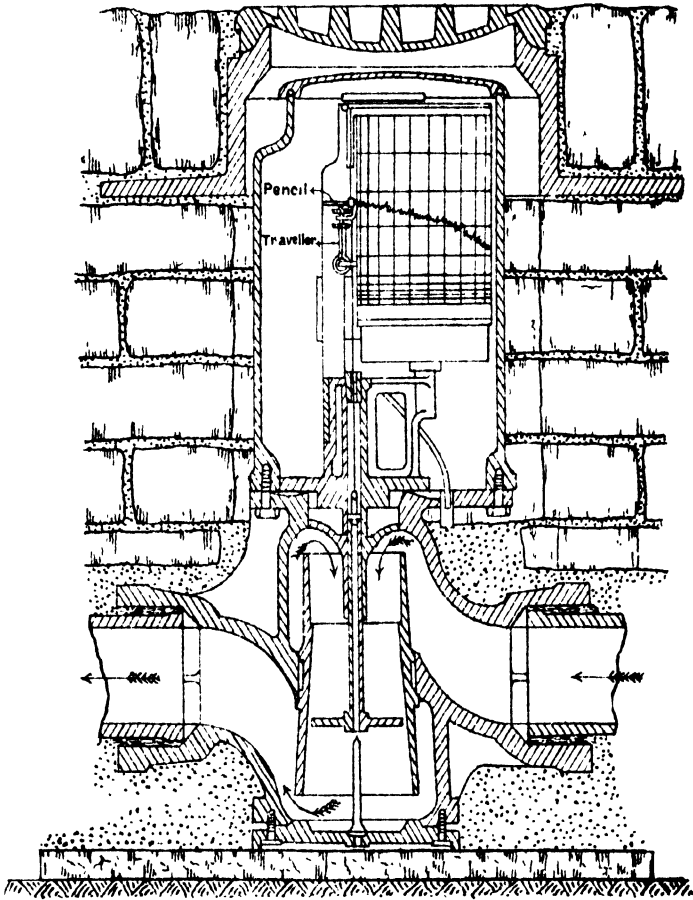

The district to be examined is cut off from the rest at about 12 midnight and the examination commences at 1 a.m. street by street. The stopcocks in the street on the service pipes taking off to each house, or factory, and all hydrants accessible from the street, are sounded with a turning key, or steel bar, serving as a stethoscope. If any noise of running water is heard, the stopcock is closed, and its number and the exact time of closing noted in a pocket book. If the noise continues after the stopcock is closed, it points to leakage from the length of service pipe between the main and the stopcock, or from the main, which is further located latter on by other soundings close by. But if the noise ceases when the stop valve is closed it points to leakage in the house system, and subsequent inspection of the diagram on the meter will show a drop at the exact time the stop valve was closed, which will indicate the amount of leakage that was taking place. The premises where waste has been detected are examined in detail next day, and repairs and renewals ordered. The effect of the repairs is indicated on a subsequent diagram.

The waste water meter is shown in Fig. 74. It consists of a horizontal circular gunmetal disc, carried by a hollow brass spindle which slides in a vertical brass tube extending upwards from the conical chamber, in which the disc works up and down and over a pointed rod at the bottom. A fine wire connects the disc spindle with a small travelling carriage, running vertically between guides, which is suspended by a wire cord passing over a pulley and counterweighted. The traveller carries a pencil which traces a diagram on a sheet of section paper wrapped round a drum revolving once in 24 hours by clockwork. The horizontal lines traced on the paper by the pencil indicate the time in hours, and the vertical lines the flow proceeding from zero by increments of 500 gallons per hour. The diagram, therefore, records the movements of the disc. When no flow is taking place, the discs drawn up to its highest position by the counterweight, and the pencil registers zero on the diagram. When flow occurs, the disc is forced down the cone in proportion to the volume passing through, and the pencil moving records the amount of flow at the time it is taking place. As the drum revolves once in 24 hours, the diagram sketched by the pencil indicates at a glance the variations in flow along the main throughout the 24 hours. When, owing to a fire or other exceptional cause, the demand is greatly in excess of the ordinary discharge, the disc is forced down to the bottom, clear of the cone, and there is no interference with the flow. The meter is generally placed under the roadway, on a bye-pass, with a valve on each side and a valve on the main, as shown in the sketch below, Fig. 75. It can thus be entirely cut

off, if necessary, and all the water passed down the main. When the meter is in action, the valve on the main is closed and the bye-pass valves opened.

Fig. 75.

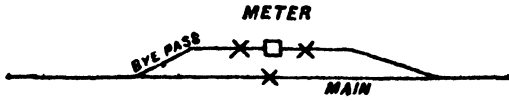

APPENDIX A.

BRADFORD WATER WORKS OUTLET AND VALVE TOWER.

(Extract from "Lectures on Water-Supply," by A. R. Binnie.)

The tunnel is driven through rock and shale, round and clear of the end of the embankment so that its inner and outer ends meet near the end of the embankment at an angle of about 84° , at which point is situated an air shaft, its inner end being closed by a valve tower approached by a foot bridge from the side of the reservoir, see Figs. 1 and 2.

The excavation for the tunnel is oval, about 8 feet 5 inches high by 6 feet 11 inches wide and is lined with cast iron plates, backed with one foot in thickness of Portland cement concrete; these lining plates are one inch in thickness, and each ring, 2 feet 6 inch in length, is divided into four segments, bolted to each other by means of internal flanges, truly planed. It has a clear height and width of 5 feet 9 inch by 4 feet 3 inch; each ring of plates has an external blank flange to make a tie between it and the concrete, Figs. 3 and 4.

On the line of the tunnel at several points, at the bottom of the shaft at the intersection of the two straight lines, and at the inner end at the valve tower foundation, strong brick in cement stopping pieces are built around the cast iron projecting some feet below and at the side into the natural rock, so as to prevent any creep of water between the concrete and the natural strata, see Fig. 7.

At the inner end, where the tunnel terminates by an expansion joint sliding into a projection from the foot of the valve tower, a watertight bulkhead, through which the outlet pipe passes, is secured; this is made of boiler plate one inch in thickness, one-half of it being formed so that it can be removed, see Fig. 5.

At the intersection of the two straight lines the shaft used during the driving of the tunnel is lined with cast iron pipes, so as to afford access and ventilation.

This tunnel at the reservoir end terminates at the bottom of a shallow pit or shaft, about 16 to 20 feet deep, in which is founded the base of the valve tower which is also formed of cast iron; it is circular in plan, the outside diameter being 7 feet 10 inch and it varies from $1\frac{1}{4}$ to 2 inches in thickness, see Figs. 5 and 6.

I have built one of these towers in segmental plates, 5 forming one ring 4 feet deep but have now adopted the plan of having each ring cast

whole, 4 feet deep, connected together by a compound socket and flange joint.

In this tower stands a vertical pipe open at the top, which, at its lower end, communicates with the outlet pipe.

Radiating at different angles from this vertical pipe are branches at different levels, to which are attached, by stuffing box connections, 3 valves, which are also fitted to special castings on the sides of the tower; there are also vertical ladders and platforms at each valve for examination, repair, or removal; externally each valve is commanded by an outside flap valve, worked by a chain and screw gearing from the top of the tower; from between the outer flap valve and inner side valve, a vertical pipe is brought up inside the tower to allow of the escape of air and to equalise the pressure of water when opening the flap valve, a pipe of small diameter, governed by a valve, being passed through the side of the tower to admit the water when required.

By this arrangement the whole length of the outlet pipe and inside of the tunnel are always open to inspection as well as the valves and gearing in the valve tower which are also so constructed that by lowering the simple outside flap valves they can be removed and replaced without emptying the reservoir, and should any accident happen to the valve tower, the watertight bulk head at the inner end of the tunnel will prevent emptying itself.

Fig. 1.
BRADFORD CORPORATION WATERWORKS.

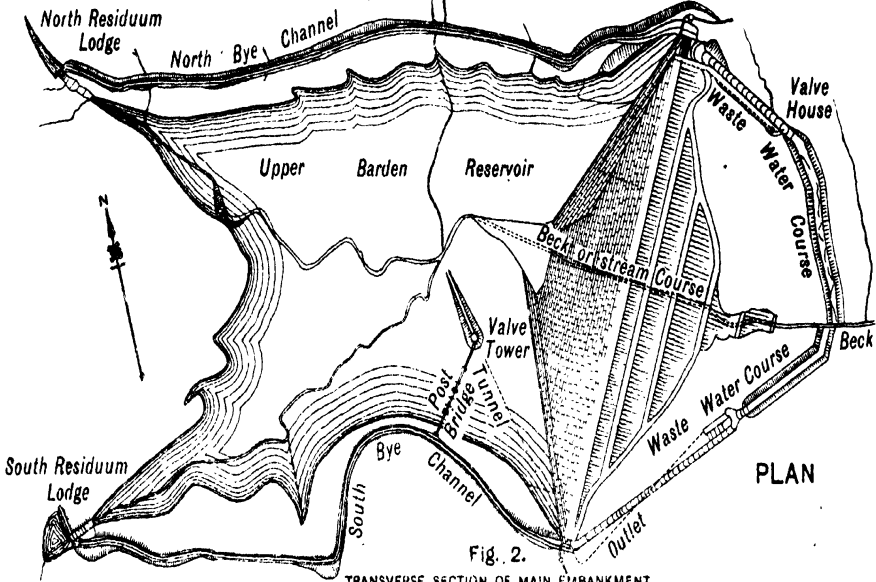

PLAN

Fig. 2.
TRANSVERSE SECTION OF MAIN EMBANKMENT
ON LINE OF BECK.

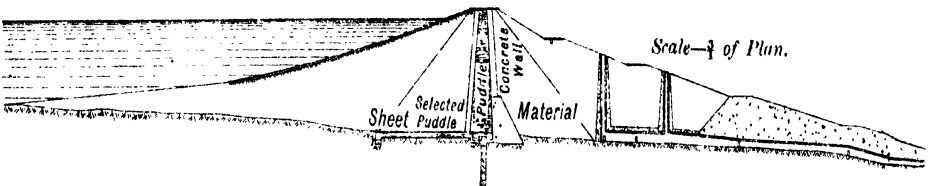
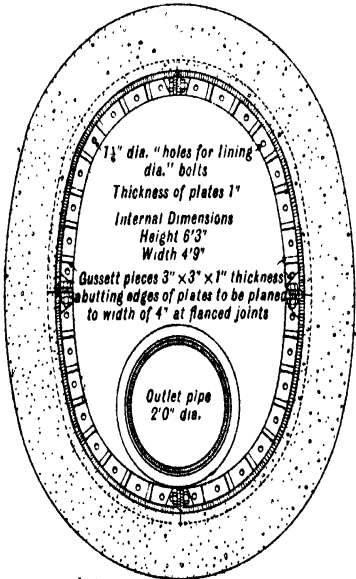
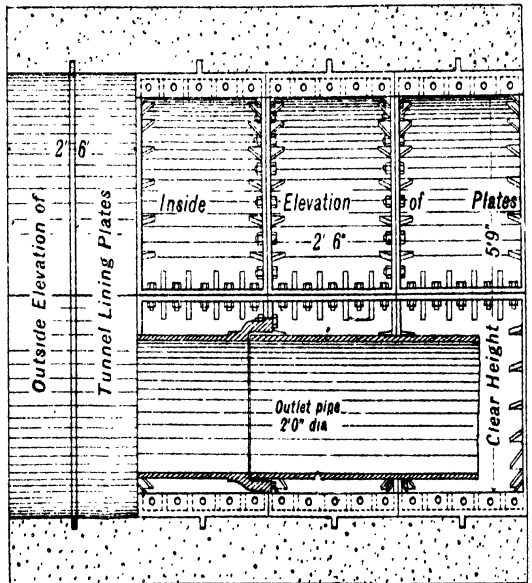

Fig. 3
TRANSVERSE SECTION.



TUNNEL OUTLET
 $\frac{3}{16}$ Full size.

Fig. 4.
LONGITUDINAL SECTION
CAST IRON PLATES 2'6" LONG 1" METAL.



LONG. SEC. OF TUNNEL OUTLET SHEWING STOPPING PIECE.

Fig. 7.

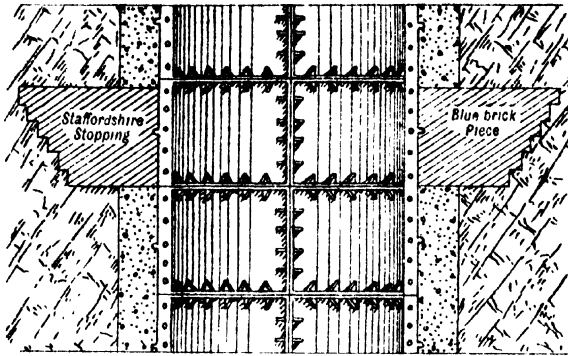

PLAN ELEVATION AND SECTION OF CAST IRON VALVE TOWER.

Scale—14 Feet = 1 Inch.

Fig. 6.
ELEVATION.

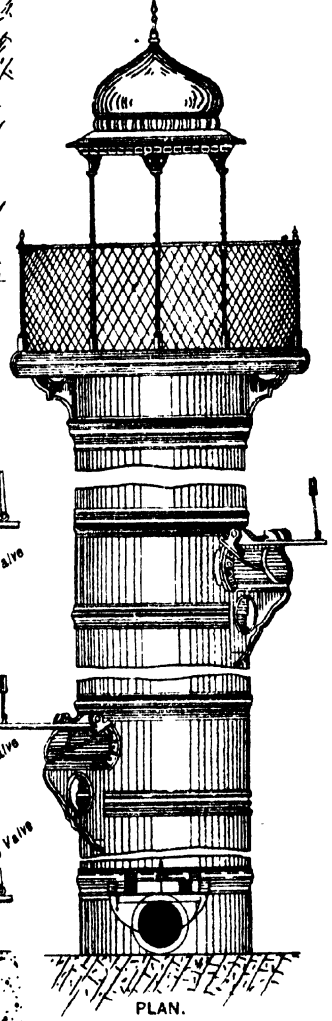
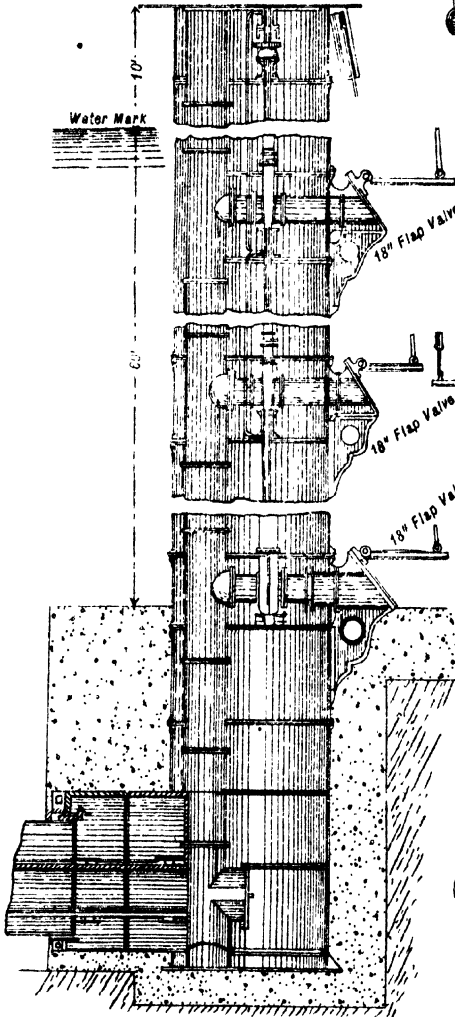

Fig. 5.
SECTION.



APPENDIX B.

Note on the Amritsar Water Works, dated February 1903.

* * * *

3. The well scheme was finally accepted, but with certain modifications which reduced the estimate to 12½ lakhs for a supply of 1¼ million gallons a day or 13½ lakhs for the full ultimate supply of 1¾ million gallons. This estimate provided for 80 wells sunk to a depth of 45 feet below ground and was approved by the Government of India. Medical opinion being still against the site selected, the question of the exact location of the wells was again reopened and another site was selected in 1902 on high ground in the angle between the North-Western and Amritsar-Pathankot lines. This site is well drained, has never been heavily manured and is some distance from the Tung Dhab. It was finally approved by the Sanitary Commissioner, the Municipal Committee and the Public Works department in January 1902, and the revised estimate, on which the work has been carried out, was sanctioned by Government in April 1903.

4. The present supply is 1¼ million gallons a day which allows about 8 gallons a head for an existing population in the city, civil lines and cantonments of 160,000. The future supply, which the works can be easily extended to meet, is to be 1¾ million gallons or 10 gallons a head for a prospective population of 175,000. A trial well was sunk on the accepted site in 1902 and the experiments made on the yield of this well showed that by lowering the water in the wells 4 feet and pumping 16 hours a day, 1¼ million gallons might be expected from a line of 40 wells. This number has accordingly been sunk and the experience gained up to date shows that the forecast of supply was fully justified. As to the quality of the sub-soil water, it has been tested chemically and bacteriologically from deep wells in the neighbourhood and found to be good. The bacteriological tests carried out in 1896 by Mr. Hankin, Chemical Examiner and Bacteriologist to the Government of the United Provinces and Oudh, proved conclusively that water, practically free from germs, can be obtained from the sub-soil at a depth of 20 feet.

5. The wells have been sunk to a depth of 65 to 70 feet below ground surface or 60 feet below spring level which, at the site of the wells is only about 5 feet below ground. The object of sinking the wells to such a great depth below the water table is twofold. Owing to the coarseness of the sand at this depth, the yield of the wells is much better than it would have been if the wells had been shallower, and by taking

the supply from a great depth below the surface, the chances of drawing in harmful microbes from the surrounding soil are entirely obviated as these exist mostly at or near ground surface. The wells are 12 feet diameter and 124 feet apart. Their steining is of brickwork in lime mortar and is two feet thick from top to bottom. They are lime plastered outside and covered by a concrete dome to protect them from contamination. For the present there are 28 on the north-east line parallel to the Pathankote Railway and 12 on the east side parallel to the main line. When an increased supply of water is required, these lines will be extended up to 30 wells in each line or 60 in all. Each line of wells is connected by a tapering suction main (21 inches diameter at the engine end) which runs along the entire length of the two lines of wells about 12 feet away from the steining, each well having a 6-inch connection. Valves are fixed at suitable points to allow of each well or section of main being cut off at any time for examination or repairs without stopping the entire supply. To prevent serious damage to the suction main and its connections by further settlement of the wells, a length of thin pipe, 4 feet long, is inserted between each well and its valve, resting on the edge of a short length of Tee iron. If the well settles, it is expected that the thin pipe will snap across and prevent damage to the suction mains.

6. The average yield per well, when they are working together is 1,765 gallons per hour under a head of 5.2 feet. The suction main is of unusual length, 3,600 feet, and the possibility of creating a satisfactory vacuum to keep it fully charged with water was at one time considered doubtful, but no difficulty has been experienced so far in producing a satisfactory vacuum and the pumping engines work smoothly after the suction barrels of the pump have been filled with water and all the air in the suction main has been exhausted by means of the steam ejector attached to the pumps. The ejector is capable of charging the mains in 8 to 10 minutes when they are quite empty. The mains are now so air-tight that it is only necessary to use the ejector once a day before starting work for 3 minutes and again for about the same time on stopping work to expel any air that may have collected in the interval and to leave the mains full up to the top of the gauge glass on the suction vessel. To help the ejector and save steam, a 6-inch link connects the rising main with the suction main by means of which the latter can be charged from the former, and, if necessary for testing purposes, it can be put under pressure from the head available at the tanks in the city. The suction main consists of flanged pipes with rubber ring joints and one lead socket joint between each well to allow for expansion and contraction,

7. The distribution pipes are so arranged by districts that every part of the system is controlled by a waste-water meter, which, if read systematically, will indicate by a diagram what leakage there is, if any, in each pipe line of the district it serves, and the valves on the pipes are so arranged that short lengths of pipes may be cut off for repairs without causing a stoppage of the supply to other parts of the town. 250 stand-posts have been fixed in the city and civil lines and a large number of fire hydrants have been put down at suitable places in the city.

8. The pumping plant consists of three compound horizontal surface condensing flywheel pumping engines by Messrs. James Simpson and Co. of London, each capable of pumping 875,000 gallons per day of 16 hours through one 15" rising main. The valves and connections of the plant are so arranged that one, two, or all of the pumping engines can pump into either or both rising mains from either or both branches of the suction main. There are three boilers of the Babcock and Wilcox type connected with one another and the engines in such a way as to be capable each of supplying steam to any of the engines. Each boiler is fitted with a superheater and there is an economiser between the chimney and the boilers. The pumps are driven from direct prolongations of the piston rods and the surface condensers are placed on the delivery side of the pumps. The engines, boilers and pumps were tested after erection on the 29th December, 1904, and 1st January, 1905. The results of the tests are given in the following statements :—

	4 hours' test.		2 hours' test.	
	29th December, 1904.		1st January, 1905.	
	Gladys.	Edith.	Gladys.	Edith.
Number of revolutions of counter ..	14,330	14,140	7,140	7,050
Ditto ditto per minute ..	59.7	58.9	59.5	58.8
Delivery of water per hour by displacement	114,233 gallons.		113,994 gallons.	
Ditto ditto measurement	111,745		109,318	
in city reservoir	2.2 per cent.		4.1 per cent.	
Slip of pumps	88		88.8	
Total head, including friction in suction and delivery pipes	49.6		49.0	
Pump, H. P.	31.6		32.1	
I. H. P.	33.8		33.0	
Efficiency	76 per cent.		75 per cent.	
Steam consumption per I. H. P. hour ..	17.4		17.2	
Ditto P. H. P.	22.7		22.8	

	4 hours' test.		2 hours' test.	
	29th December, 1904.		1st January, 1905.	
	Gladys.	Edith.	Gladys.	Edith.
Coal used, lb.	978		502	
Ashes and clinker, lb.	207		99	
Barrakar coal consumption per I. H. P. hour	3.7		3.8	
Barrakar coal consumption per P. H. P. hour	4.9		5.05	
Steam evaporated per lb. of coal	5.5		5.4	
Boiler pressure	118 lb. per sq. in.		117.8 lb. per sq. inch.	
Steam in engine-room	116 lb. per sq. in.		117.2 lb. per sq. inch.	
Temperature of feed water	74.5°		74°	
Ditto economiser outlet water	196°		187°	
Ditto steam in superheater	432°		436°	
Ditto steam in engine-room	386°		380°	
Ditto condenser discharge	92°		92°	

DIMENSIONS.

Pump plungers $9\frac{1}{2}$ " diameter; effective area of plunger, allowing for rods, 69.37 square inch.

Delivery of each pump per revolution 16 gallons.

GLADYS.	H. P.	L. P.	H. P.	L. P.
	Mean pressure	52.9	16.85	52.8
Piston effective area	60.93	198.41	60.93	198.41
Length of stroke		16"		
Number of revolutions	59.7		59.5	
I. H. P.	16.1	15.5	15.5	16.6
	31.6		32.1	
EDITH.				
Mean pressure	51.45	19.45	51.5	19.20
Piston effective area	60.93	198.41	60.93	198.41
Length of stroke		16"		
Number of revolutions	58.9		58.8	
I. H. P.	14.9	18.4	14.9	18.1
	33.3		33.0	

9. The rising mains are two lines of cast iron spigot and socket pipes 15" diameter. They are laid about 4 feet below ground surface with a gentle downward slope up to the Ghi Mandi gate of the city, where 15" valves are fitted for scouring purposes, and from this point they rise to an open plot of ground in the middle of the city called the

Kaiseri Bagh where the balancing tanks are situated. Venturi meters are fixed on the mains at the headworks to register the quantity of water pumped through.

10. The balancing tanks consist of a group of four mild steel cylinders, 25 feet diameter and 40 feet high, each capable of holding 100,000 gallons of water. These tanks are mounted on brickwork and concrete platforms 52 feet square at base and built $13\frac{1}{2}$ feet above ground level. The foundations are splayed to such an extent as to reduce the pressure on the ground to 0.75 ton per square foot. It was considered advisable to reduce the pressure to this low limit as the site on which the tanks are erected is made ground. The site was formerly a swamp and was filled up to its present level about 30 years ago. The details of the tanks and all their pipe connections are clearly shown on plate 3.

11. The city distribution system is shown on plate 3. It consists of a main line taking off from the rising mains and encircling the city about half way between the centre and the outer walls. From this ring main, smaller branches take off at intervals and serve the more important streets of the town, being arranged on the "Gridiron" principle without any dead ends. Every branch is controlled by a valve at each end and the whole system is so arranged that every line can be tested for leakage from one or other of the Deacon's waste water meters which are fixed in different parts of the town. The civil station, where the European officials reside, is outside the city and is served by two independent lines which take off (1) from the rising main at the Grand Trunk Road crossing and (2) from the Hall Gate 12" main (see plan). A 3" line takes off from the latter near the Hall Gate of the city and runs to the boundary of Gobindgarh Fort. At the far end of the civil station a raised balancing tank of 18,000 gallons capacity has been provided to regulate the supply and demand at different hours of the day. The military cantonments lie beyond the civil station and are served by a pipe line which takes off from this balancing tank and runs up to the boundary of the cantonment area where the military authorities take off their supply through a meter. Of the total supply to the city, the civil station takes 60,000 gallons a day and the cantonment 17,000 gallons.

14. The cost of the work was as follows :—

<i>Wells.</i>		<i>Rs.</i>
(1) Well-sinking 2619.7 l.ft. at Rs. 20-13-9 per vertical ft.	..	54,654
(2) Wire fencing	1,061
(3) Machinery for well-sinking	12,044

	Rs.
(4) Experimental wells (Parkes)	2,141
(5) Cost of old experiments'	2,082
(6) Woodwork of curbs, 4,693 c.ft., at Rs. 1-14-0	8,804
(7) Concrete in domes, 38,127 c.ft., at Rs. 31-4-0	11,910
(8) Brickwork in wells, 237,508 c.ft., at Rs. 31-6-0	74,527
(9) Wrought iron work in wells curb, tie bars, and well covers, 69.5 tons, at Rs. 341	24,390
(10) Cast iron work, 6.44 tons, at Rs. 161	1,031
(11) Cast iron piping in suction pipes, 408.7 tons, at Rs. 143	60,486
(12) Cast iron piping, specials, 42.67 tons, at Rs. 210	8,957
(13) Valves, 6", 41 at Rs. 45 each	1,845
(14) Strainers. Foot valves, 40, at Rs. 147 each	5,869
(15) Valves, 21", 4 at Rs. 347-8-0 each	1,390
(16) Valves, 20", 2 at Rs. 334 each	668
(17) Valves, 18", 2 at Rs. 296 each	592
(18) Lime plaster 103,345 s. ft., at Rs. 3-4-9	8,398
(19) Petty items	653
(20) Contingencies and petty establishment	15,978
(21) Land	12,624
Total	3,16,456

Pumping installation.

(22) Drivers' house	6,377
(23) Servants' quarters and cook-house	1,369
(24) Godown (Kaiseri Bagh)	1,282
(25) Petty establishment quarters	3,158
(26) Engine house and chimney	16,044
(27) Pumping installation	1,07,895
(28) Contingencies and petty establishment	4,771
Total	1,40,991

Rising Main.

(29) Cast iron pipes, 727.44 tons, at Rs. 132-1-6	96,077
(30) Ordinary bends, 28.79 tons, at Rs. 198-1-5	5,708
(31) Valves, 15", 11 at Rs. 175 each	1,925
(32) Culverts under railway	2,415
(33) Culverts, 5 at Rs. 208 each	1,039
(34) Approach road	3,860
(35) Venturi meters, 15", 2 at Rs. 3,639 each	7,279
(36) Petty items	1,001
(37) Contingencies and petty establishment	6,404
Total	1,25,723

Kaiseri Bagh tanks.

	Rs.
(38) Concrete, 85,908, at Rs. 15	5,390
(39) Brickwork, 76,842 c.ft., at Rs. 28	21,498
(40) Steel Tanks, 2,246 cwt., at Rs 19-3-0	43,117
(41) Petty items	1,555
(42) Contingencies and petty establishment	2,309
Total ..	<u>73,849</u>

City distribution.

(43) Cast iron pipes, 1,361 tons, at Rs. 150-9-0	2,04,925
(44) Cast iron ordinary bends, 92.44 tons, at Rs. 214-12-6	19,860
(45) Foundation hydrants, 66 at Rs. 124	8,182
(46) Fountains 145 at Rs. 72-3-1 each	11,043
(47) Hydrants, 91 at Rs. 34-7-8 each	3,138
(48) Valves, 15", 3 at Rs. 175 each	525
(49) Valves, 12", 4 at Rs 110 each	440
(50) Valves, 4", 23 at Rs. 29 each	668
(51) Valves, 3", 64 at Rs. 23-4-6 each	1,490
Total ..	<u>2,50,276</u>

Deacon's Waste Water-meters.

(52) Deacon's 7", 1 at Rs. 1,269	1,269
(53) Deacon's, 6", 2 at Rs. 1,051 each	2,102
(54) Deacon's 5", 3 at Rs. 949-5-0 each	2,848
(55) Deacon's 4", 4 at Rs. 658-8-0 each	2,634
(56) Surface boxes, 336, at Rs. 4-14-0 each	1,638
(57) Petty items	925
(58) Contingencies and petty establishment	6,940
Total ..	<u>18,356</u>

Civil Lines tank.

(59) Steel tank, including wooden cover 144.1 cwt. at Rs. 29-11-6	4,285
(60) Petty items	1,336
(61) Contingencies and petty establishment	523
Total ..	<u>6,144</u>

Combined Civil and Military Distribution.

(62) Cast iron pipes 233.6 at Rs. 135	31,510
(63) Ordinary bonds, 3.35 at Rs. 165	355
(64) Petty items	364
Total ..	<u>32,427</u>

Civil Lines Distribution.

				Rs.
(65) Cast iron pipes 37·96 at Rs. 142	5,386
(66) Fountains, 2 at Rs. 57 each	114
(67) Hydrants, 5 at Rs. 11-6-0	57
(68) Fountain hydrants, 19 at Rs. 118-8-0 each	2,251
(69) Petty items	382
(70) Contingencies and petty establishment	1,652
				<hr/>
		Total	..	9,842
				<hr/>
(71) Pipes handed over to the municipality for repairs and apparatus for laying and testing the same	17,715
		Total	..	9,91,779
				<hr/>

C. E. V. GOUMENT,
Sanitary Engineer to Government, Punjab.

APPENDIX C.

Specification for engines, pumping machinery and boilers required for the Allahabad unfiltered water supply.

The unfiltered water will be taken from the Jumna at Karela Bagh through an inlet well and culvert, and pumped by a special engine through one 20" rising main, 10,000 feet long, into the settling tanks at the distributing station.

The levels between which the pumping will be done are as follows:—

The ground level	288·00
The highest flood level	291·00
Lowest level of Jumna	235·87
Level of inlet sill of settling tanks		323·50

There is thus a difference between low and high water of 55·13 and the greatest static lift is 87·63 feet. The average static lift is, however, about 77 feet. The net quantity of water required is 3,200 gallons a minute or 192,000 gallons an hour. The pumping plant must be able to lift this quantity of water after allowing for slip in the pumps against a static head of 89 feet ($87\frac{1}{2} \times 1\frac{1}{2}$ to allow for raising the level of the inlet weir) and to overcome the friction of this discharge delivered through a rising main 10,000 feet long and 20" in diameter, which in incrustated pipes is equivalent to a head of 34 feet. The total lift is therefore for incrustated pipes $89 + 34 = 123$ feet. The capacity of the engine will therefore be $\frac{3200 \times 10 \times 123}{33,000}$

$$= 119\cdot2 \text{ say } 120 \text{ P. H. P.}$$

The average lift for the year will be, including friction, about 110 feet.

2. The ground level of the site on the river bank has been formed to 296·00.

The well containing the pump may be of a size to be fixed by the engine makers and will be placed about 140 feet inland from the well containing the vertical portion of the suction pipe.

The suction pipes will be carried from the pump well to the suction well in a nearly horizontal culvert, the floor of which will be about 10 feet above the lowest Jumna level.

3. Full discretion is given to the engine makers tendering for the works to propose any type of engine, which appears to them best suited to conditions of the case; but the contractor whose tender is accepted will have to guarantee that the pumps will deliver the full quantity of water specified at a stated speed of working and with a given boiler pressure. In considering the tenders great stress will be laid on the efficiency and

economy of the pumping plant. In order to enable engine makers to estimate accurately the amount that may be economically spent in increasing the efficiency of the pumping plant it has been calculated from the evaporative power of the quality of coal likely to be used, from its price at site, from the average number of hours the engine is likely to work per day, and from the average lift, that the capitalized value of each 1 lb. of water used as steam per pump horse power per hour that can be saved is equal to £ 500. That is to say, for example, if an engine maker by expending, say, an additional £ 800 on his engine can increase its efficiency so that it would use 2 lb. less of water as steam per pump horse power per hour it would be advantageous to do so, but if the saving effected were only to be 1 lb. or $1\frac{1}{2}$ lb. it would not be worth the money expended on this increased efficiency.

4. The tender must state the guaranteed consumption of water as steam in pounds per pump horse power per hour. This consumption to be measured from the air pump discharge and the combined discharge from the jackets. This guarantee will form the basis of the contract, and the test will be made within sixty days of starting the engines to regular pumping. The test to last over a period of not less than twelve hours from a running start. Should this test show that the consumption of water as steam per pump horse power per hour exceeded the guarantee by more than half a pound, then for each additional one-tenth of a lb. over this half pound margin a penalty of £ 50 will be deducted from the amount tendered. For example, if the guaranteed consumption of water as steam be 12 lb. per pump horse power per hour and the trial showed it to be 14 lb. then the penalty enforced would be $(14 - 12 - \frac{1}{2}) 10 \times £50 = £ 750$.

BOILER.

5. The dimensions of the boiler, its heating surface and grate area must be given. The tender for the boiler will include a donkey feed-pump in addition to the main engine feed-pump, all valves, water and pressure gauges, safety valves, blow-off-cocks, and other fittings for a complete outfit of boilers.

6. The boiler is to be fitted with a superheater and a feed water heater, both of the most approved type.

7. The grate area designed for the boiler should be for coal of a heating power equal to 80 per cent. of English coal.

8. The steam pipes from the boiler to the steam cylinders are to be arranged with proper copper expansion joints or bends where necessary; and the steam pipes and mountings are to be in accordance with the practice of the best boiler insurance companies.

All steam pipes are to be coated with Leroy's or other approved non-conducting composition neatly finished off.

Steam pipes in the engine room are to be lagged with teak, bound with brass.

9. The water from the condenser and cylinder jackets is to be led by suitable pipes to the boiler-feed tanks.

ENGINE.

10. The engine is to be of the very highest class and finish. It must be self-contained and independent of wall supports; the moving parts must be perfectly balanced, and it must do its work smoothly and noiselessly, and run steadily and evenly, without vibration on the framing.

11. Whatever type of engine is adopted the piston speed is to be stated when the engine is doing full work, and the least speed at which it is possible to run the engine dead slow against the full head of pressure must also be stated.

12. The tender is to include all pipes, cocks, valves, counters, gauges, and fittings, from the end of the suction pipe up to the first joint of the delivery main beyond the engine house building (a detailed and fully dimensioned drawing of this joint must be submitted).

13. The tender must specify the arrangements proposed for cutting off steam by hand while the engine is in motion and securing at least ten grades of expansion and the conditions of the cut-off and expansions when performing the contract work.

14. The diameter and stroke of all steam cylinders and pistons must be stated in the specification in clear detail. Full details of the foundations must be given in a foundation drawing, but a general sketch of the pumping engine is all that is necessary in the shape of further drawings.

PUMP.

15. Owing to the large quantity of sand and silt in the river water at certain times of the year the plungers must be externally packed and the pump valves designed in such a way and of such material that the wear and tear will be reduced to a minimum.

The working of the pumps will have to be noiseless and free from shocks and banging of valves, and the required discharge must be delivered evenly and uniformly.

16. A sectional drawing of the pump to a scale of $1\frac{1}{2}$ " to one foot must accompany the tender; and a description of all valves, the diameter of the suction and delivery pipes, the area of the waterway of all valves and their lift must be stated in the specification accompanying the tender.

The tender is to include suitable air-vessels, their position with reference to the pumps must be stated, and an air-pump is to be provided for charging them with air, if necessary.

Foot valve and strainer are to be supplied at the end of the suction pipe.

GENERAL CONDITIONS.

17. All pump-rods, valve rods, and other gear and all cranks are to be of wrought iron or wrought steel, and to be got up bright and polished. All cylinder covers to be bright and polished. All nuts about the engine work and about the pumps above floor level to be bright. All indicator pipes and jacket drain pipes are to be of copper, All hand-railings are to be of polished brass. The specification must state the kind of lagging to be used on the steam cylinder, which must be neat and well finished in a workman-like manner.

18. Fly-wheels, when specified, are to be turned bright on the rims and sides. All holes in the engine and pump work are to be drilled, and the engine is to be got up in every way as a bright engine.

19. Sight feed lubricators and all other lubricators to be provided where necessary and to be of the latest and most approved pattern; copper oil-catchers under all bearings are to be provided, also an efficient oil filter.

20. In designing the pumps an allowance of $7\frac{1}{2}$ per cent. is to be made for slip.

21. All brasses to be of phosphor or manganese bronze and to have ample bearing area.

22. All materials used in the work are to be of the best description, and no part of the machinery is to be strained to more than one-tenth of its breaking weight.

23. The tender is to include the following details:—

- (1) A set of spare working parts of the engine and pumps: details of the spare parts it is proposed to supply must accompany the tender:
- (2) A suitable overhead travelling crane, or other arrangement for lifting the heavy parts of the engine and pump.

24. The tender is to specify separate sums for the engine, boiler, spare working parts and the overhead travelling crane, and must further state the rate per maund at which the railway freight from Howrah to Allahabad has been calculated and, should a subsequent concession

reduction on that freight be obtained, the actual saving so caused will be deducted from the amount paid to the contractor.

MAINTENANCE AND ERECTION.

25. Coal, oil and waste will be supplied to the contractor by the Board. The charges for erection and maintenance are to include watching and guarding the plant before erection, all sheds for its protection before erection, repairs, losses, and accidents during erection and during the period of maintenance of the machinery (which will not exceed twelve months and is not likely to exceed three months), the cost of necessary alterations and all stores other than coal, oil and cotton waste, including the supply of tools and plant of every description, required for erection and maintenance such as chains, ropes, pulleys and windlasses, etc. The engine room establishment must be maintained and when necessary supplied by the contractor during the period of maintenance. It is expected the average hours of pumping will be about 16 hours.

26. The engine is to get three coats of paint on all surfaces not bright during the period of maintenance, of a colour and pattern to be approved of by the Sanitary Engineer.

27. The total amount of the tender must be held to include the complete cost of the installation of the fittings herein described to the Board, delivered over in complete working order with the spare parts specified, after a period of continuous work during maintenance, including charges of every description, with the exception of the supply of oil, cotton waste and coal, from the day the engine and boilers are despatched from the works to the date on which they are finally accepted by the Sanitary Engineer as up to specification, up to which date the responsibility of the contractors for the carriage, custody, workmanship, design and material of the engine is to be absolute and complete.

28. The tender must be submitted to the Chairman, Municipal Board, Allahabad, in the annexed form in sealed cover and marked on the outside "Tender for engine and boiler" not later than

29. The board does not bind itself to accept the lowest or any tender and will give no reason for refusing or accepting any tender.

TERMS OF PAYMENT.

30. When the engines and boilers are half ready for shipment, 30 per cent. of the price agreed upon will be paid. On delivery at Allahabad another 45 per cent. will be paid. On completion of erection and setting to work, a further 15 per cent. and the remaining 10 per cent. will be

paid after the period of maintenance has expired, on the certificate of the Sanitary Engineer that the machinery has been working satisfactorily, is in perfect order, and up to specification.

PENALTY FOR BREACH OF CONDITIONS.

31. The penalty for the breach of any of the conditions of this specification must be laid down in the Contract Agreement.

ALLAHABAD :

March, 1912.

W. GUNNELL WOOD,
Sanitary Engineer to Government,
United Provinces.

APPENDIX D.

Sample specification for cast-iron pipes and fittings.

The lines of pipes to be laid down and their sections are shown in the drawings and schedule hereto attached. The contractor will be required to check the lengths of all pipes given in the schedule, and satisfy himself as to any discrepancies in the length before entering into the contract. The weights of the pipes in the schedules are supposed to include the entire weights of all bends, tees and special castings, and no extra charge in rate or weight will be allowed in carrying out the contract for the complete system of pipes herein specified. The contractor must carefully consider this condition in framing his tender, which is a lump sum contract for the complete work

Joints.—The pipes are generally to have turned and bored joints, with a taper of 1 in 32, but about $7\frac{1}{2}$ per cent. of them will be taken with ordinary wide sockets, which are to have half an inch for the thickness of the joint, for all sizes over 4 inches diameter and $\frac{1}{2}$ inch for 4 inches diameter and less. The weight of lead in each joint must not be less than shown in the following table:—

Bore of pipe.	Least weight of lead.	Bore of pipe.	Least weight of lead.
2"	2 lb.	6"	9.0 lb.
3"	2.4 „	7"	10.0 „
4"	3.6 „	9"	12.0 „
5"	8.0 „	12"	15.0 „

Lettering.—Every pipe to be marked outside the socket F. W. W., Roman capital letters, $1\frac{1}{2}$ inches in length and $\frac{1}{8}$ th of an inch in projection: the year in which the pipe is cast is also to be marked upon the socket. The thickness of the pipe is to be distinctly cast in figures on the socket under the above letters and date.

Manufacture of pipes.—The pipes must be cast vertically in dry sand-mould, with the sockets downwards. They are to be of uniform thickness of metal throughout, without any belts, and to be cast without the aid of core nails, chaplets, or thickness-pieces, or any substitutes therefor. The sand shall be sufficiently fine and fresh to produce a smooth and perfect surface, and all the moulds and cores shall be properly blackwashed and carefully dried.

The metal shall be made from mine-pig, without admixture of cinder-iron or other inferior metal, and shall be stout, tough and close-grained. It shall be re-melted in the cupola and of such strength that a bar, one inch square and 38 inches long, will, when supported at points 36 inches apart, and loaded in the middle, sustain a weight of not less than 700 lb.

The pipes shall be free from scoriæ, sandholes, air bubbles, cold-shuts, laps, washes, and other imperfections of casting; shall be easily chipped or drilled; and shall be truly cylindrical in-bore, straight in the lines, smooth within and without, and internally of the full specified diameter, and they shall have their inner and outer surfaces perfectly concentric. They shall be perfectly fitted and cleaned, so that no pumps or rough places shall be left in the barrels or sockets, and all runners are to be fully cleaned off.

All the pipes, as soon as possible after they have left the mould—if possible before they are cold—are to be dressed and cleaned of all sand, dust, etc., and then to be coated internally and externally by being immersed in a hot mass of coal pitch and oil, according to Dr. Angus Smith's process. The coating to be applied at a proper heat before rust sets in, and the application is to be continued until the composition enters the pores of the metal, so that, when the coating is dry, it shall have a smooth glazed surface which will not rub off. The material for coating the pipes to be renewed at least once a month, the tanks being previously cleaned of all stuff remaining therein, which must not be used again.

Each pipe to be tested by Hydrostatic pressure, equal to a column of water 400 feet in height. Whilst in the press the pipes must be smartly rapped with a 4-lb. hammer from end to end, in order to discover any sandy, porous, or blown places, or other imperfections that are not otherwise discoverable. The contractor will make his own arrangement with the pipe founder to have these tests carried out, and will be required to furnish a certificate, duly signed by some responsible person, that each pipe has satisfactorily stood this test, but such certificate will in no way relieve him from any responsibility as to the soundness of the pipes when laid.

The Engineer will, if he thinks fit, have this test repeated on the works. In this case one anna per cwt. will be deducted from the prices tendered by the contractor to cover the cost of so re-testing them, if the pipes do not satisfy the specified conditions.

All bends to be segments of a circle in plan. Flanges of flange-pipes in all cases to be machine-faced all over.

All bends and junctions must be cleaned off, and left perfectly true and smooth inside.

Pipes shall be rejected for the following defects:—

- (1) Thickness below standard specified.
- (2) Sand-holes, air-holes, or other defects.
- (3) Thickness not uniform.
- (4) Coating insufficiently carried out.
- (5) Pipes not admitting of a circular disc, $\frac{1}{8}$ th of an inch less than the specified diameter, passing freely through the pipes.
- (6) Weights more than 3 per cent. below the weights specified.

Pipe laying.—The pipes will be laid in straight lines as far as possible, free from all sharp bends and vertical undulations. The trenches are to be excavated to depths to secure a covering over the pipes of not less than $3\frac{1}{2}$ feet and the trench must be kept dry during the progress of the work. The trenches must be got out accurately to the depths and gradients, and so that each pipe shall have a solid bearing over its whole length; where there are lead joints, the joint-holes being got out no larger than is strictly necessary for the purpose of caulking.

Each pipe before it is laid shall be examined and tested with a hammer to prove its soundness and shall then be brushed through and washed to remove all dirt, soil or stone. The spigot and socket of the turned and bored pipes to be perfectly bright and clean. The pipes shall be placed in the trench by means of proper shear legs and chains or other tackle, and then driven home, care being taken to wet the turned and bored surfaces before bringing the pipes together.

The wide socket-pipes will be jointed in the following manner.

First, as many laps of white hempen spun yarn as will fit into the socket leaving the space required for the lead, shall be driven to the bottom of the socket, without being forced through the joint into the pipe.

Then, as much lead (being not less than the quantity stated in the above table) as may be necessary to fill up the remainder of the socket and leave a projection for caulking, shall be run in.

The lead used must be pig-lead of the best quality, and shall be run with a jointed clasp ring or clay fillet with one or two ladles, but so as to be practically ~~at~~ one pouring, and then set up with properly proportioned caulking irons and hammers, so as to make a thoroughly sound and water-tight joint. After being well and evenly set up, the lead fringe must be pared off and the joint left flush, neat, and even with the socket.

Pipe jointers must have strict injunctions to satisfy themselves that sockets are not split in caulking, and to report immediately to their Foreman if they are doubtful of the soundness of any pipe or joint before the trench is filled in.

The interior of the Pipes to be kept clean.—The interior of the pipes must be carefully freed from all dirt as the work proceeds, for which purpose a disc-plate or mould brush sufficiently long to pass two or more joints from the end of the pipe last laid, shall be continuously worked forward as the line of pipes is completed.

The open ends of the pipes to be protected.—The ends of the pipes must be securely protected during the progress of the work. The pipes laid are not to be made receptacles of tools, or any other matter or thing during the progress of the works.

Pipe-trenches.—The pipe-trenches will be marked out by the contractor. No excavation must be commenced of any trench until the pipes intended to be laid therein shall have been ranged along its side, with all the necessary appliances for laying and jointing them. In the execution of the work of pipe-laying, no greater length of trench than can be laid in 48 hours must be opened; and should the pipe-laying be delayed or stopped from any cause, the excavation of the trench must be stopped until the pipe-laying is resumed.

Filling trenches.—After the pipes have been properly laid the trenches are to be filled with earth well packed under the pipes and carefully rammed, in 6-inch layers, and well watered, so as to speedily consolidate. The metalling of metalled roads will be restored and the surface neatly dressed to a proper level and maintained in that state until thoroughly consolidated. All extra earth or rubbish left on the completion of the filling in of the trench is to be removed by the contractor to places selected by the Engineer in the immediate vicinity.

The work of pipe-laying must be carried out in conformity with the orders of the Chairman to the Commissioners with reference to the public convenience.

Watching and fencing.—The contractor will supply all requisite shoring, fencing and lighting for guarding open pipe-trenches, and be held responsible for all damages caused by his neglect in this respect, as well as for accidents caused by holes and settlement in the trenches.

Tender to include all special castings.—The price tendered is to include laying and fixing; the provision of all bends, tees, caps, reducing pieces, the lead in joints laid with wide sockets and special casting; all trenching, lighting and expenses connected with laying and maintaining the system for a period of six months after the opening of the works.

Maintenance.—Should any pipe burst during the period of maintenance it must be renewed at the expense of the contractor. The contractor will be held responsible for the stoppage of all leaks and for the damage

caused thereby during the time of maintenance. And should any obstruction be found in the pipes, the contractor shall remove the same and pay all costs incurred in so doing.

Sluice-valves.—The sluice-valves to be enumerated in the tender. They are to be double-faced with gun-metal ; to be of the best approved manufacture and in accordance with patterns approved by the engineer. They are to be supplied with suitable surface-boxes and cast-iron covers, and brick work required for setting them and keys for working them are to be included in the prices tendered. The sluice-valves are to be tested by the makers by hydrostatic pressure equal to a column of water 400 feet in height. Should any leakage occur after the valves are fixed, the contractor will have to rectify the defects, or supply new sluice-valves before handing over the work.

Bends to be backed with brickwork.—All sharp bends where subject to considerable pressure must be backed with concrete and brickwork to the satisfaction of the Engineer. The cost of this is to be included in the price tendered for the pipes.

Surplus pipes, Collars, etc.—In addition to the pipes enumerated in the schedule attached, the municipality will take over a certain number of pipes and pieces of pipes with the requisite number of collars for repairing the pipes of various diameter should any burst occur after the period of maintenance and will pay for them at the rates tendered for.

Stand-posts.—The number of stand-posts to be supplied is stated in the annexed schedule. They will be of the ordinary pillar pattern fitted with patent "Waste-not valves" to discharge 3 gallons at a time, of a pattern approved by the Engineer. Samples will be submitted by the contractor for the selection of the board.

The stand-posts will be fixed on the road-side in the positions pointed out by the Resident Engineer. They will be placed on a brick or stone platform of design to suit the position chosen. The brick or stone work to be carried out as specified for first class work. They must be thoroughly drained by a connecting pipe or drain to the nearest side-drain, as decided by the Resident Engineer.

The price tendered for the stand-posts will not include the cost of the platforms but will include the erecting of the stand-posts on them, the connections with the mains and ferrules regulating the discharge of each tap to a rate of 10 gallons per minute, maintaining them for six months after the water works are opened, and delivering them in perfect working order at the expiration of the period of maintenance.

THE NAGPUR WATER WORKS. MONSOON OF 1889.

June, July, August & September
99.79 ins. 123,511,800 c. ft.—
0.268.

June, July & August
58.31 ins. 11,338,700
c. ft.—0.220.

June, July, August & September
101.11 ins. 100,000,000
c. ft.—0.250.

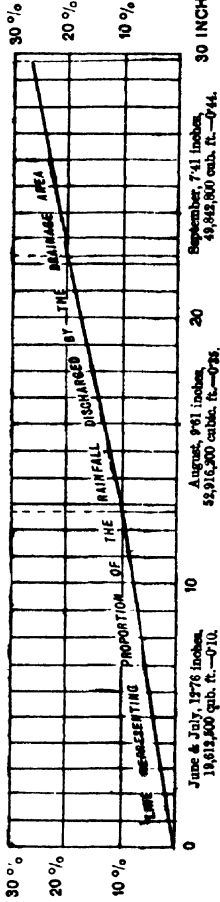

NOTE.
The Horizontal Figures below the Diagrams refer to the Rainfall and Discharge of each month separately.
The Figures at the Top of the Diagrams refer to the Rainfall and Discharge for the Month of the month.

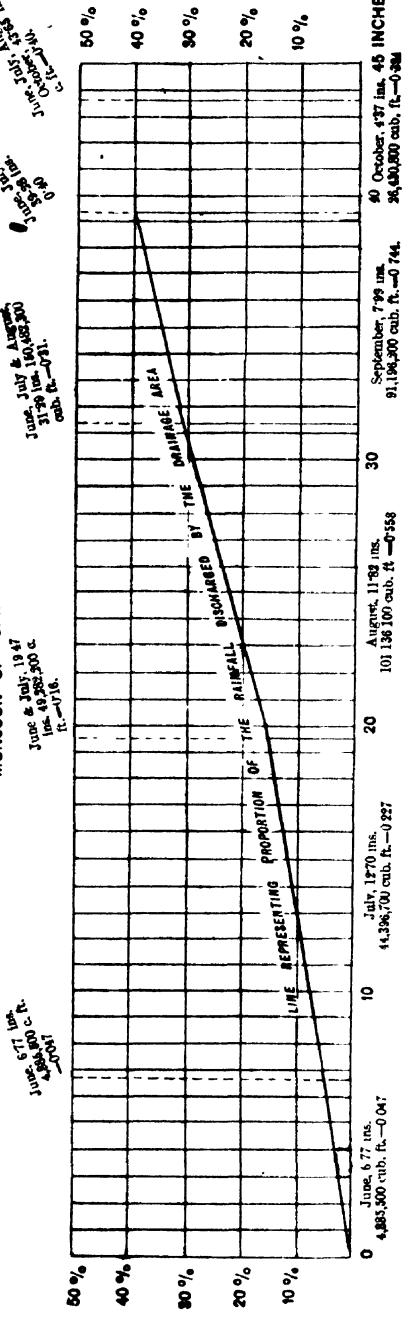

June, 6.77 ins. 4,883,500 cub. ft.—0.047
July, 12.70 ins. 14,396,700 cub. ft.—0.227
August, 119.8 ins. 101,136,100 cub. ft.—0.258
September, 79.9 ins. 91,150,500 cub. ft.—0.744
October, 49.7 ins. 45 INCHES 36,480,500 cub. ft.—0.351

DIAGRAMS OF THE DISCHARGE OF RAINFALL FROM THE DRAINAGE AREA OF 4224 ACRES.

PLATE II.
(Para. 46)

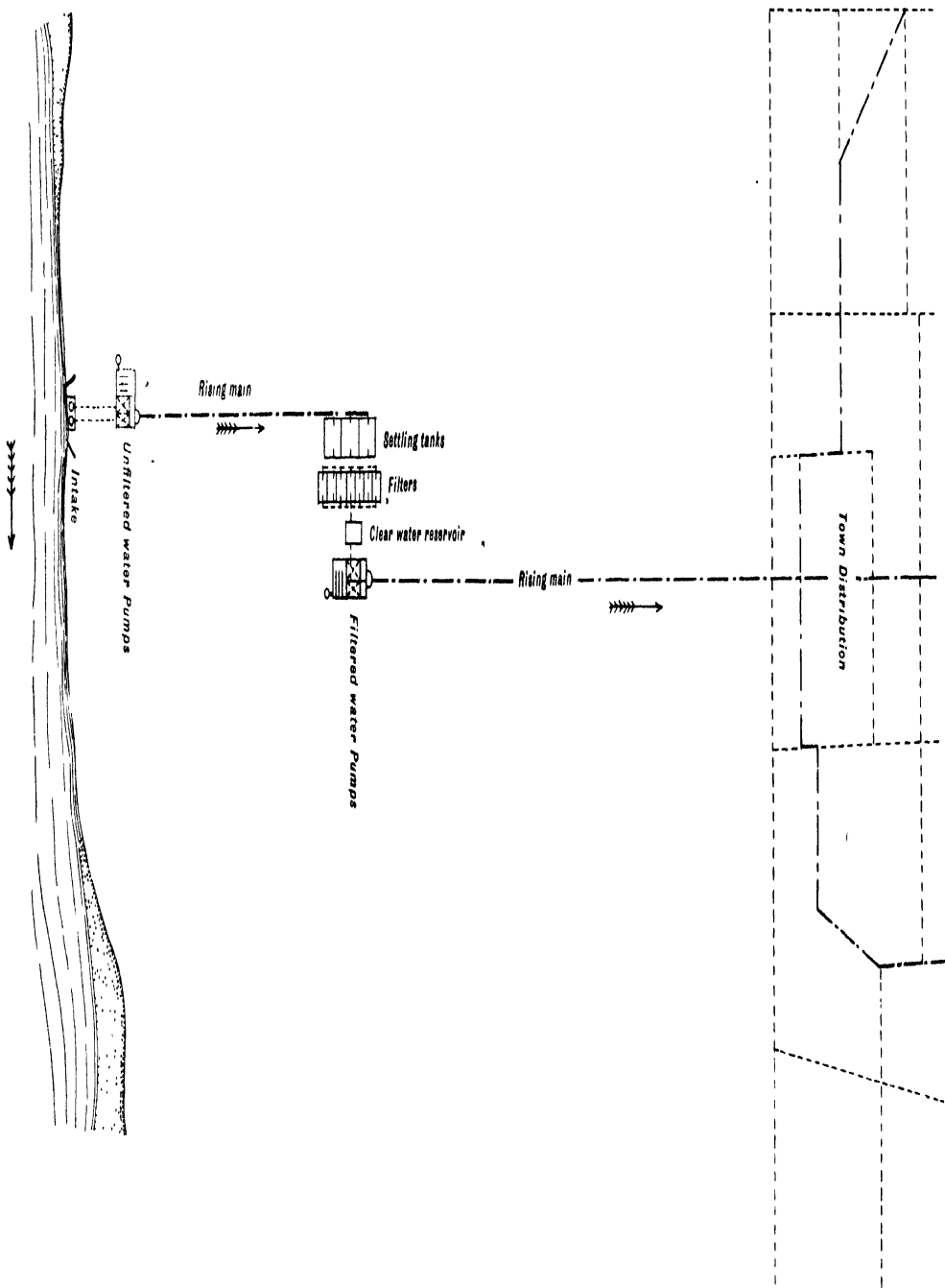
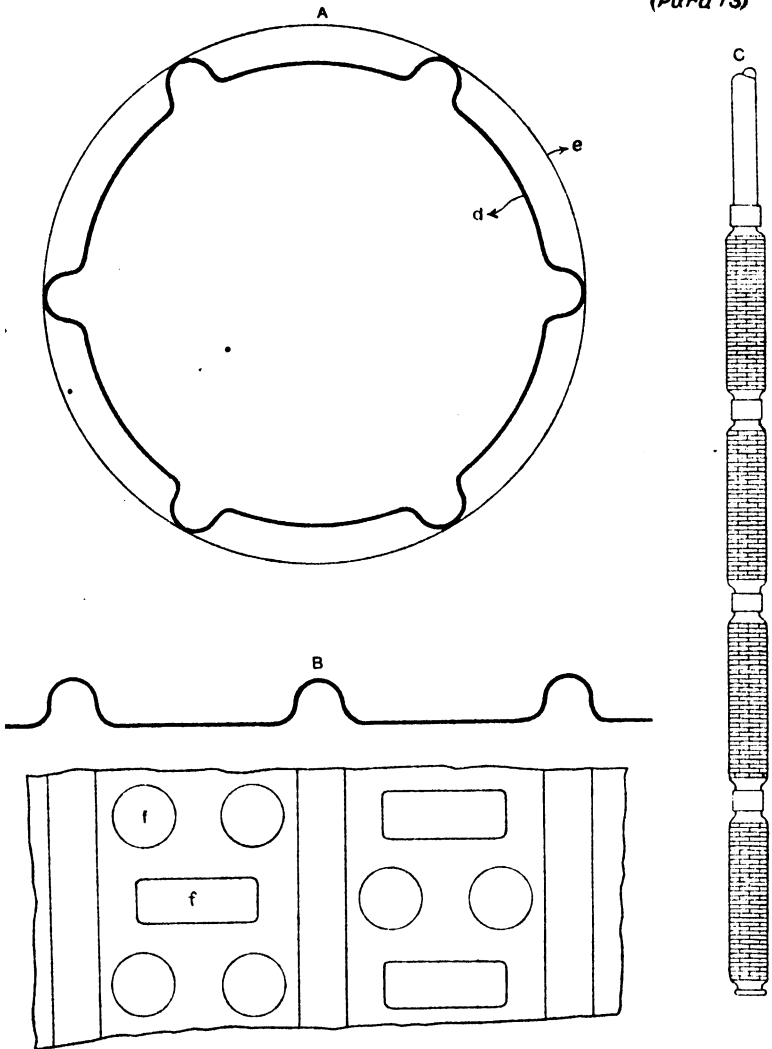

PLATE V.
(Para 73)



- A.—Cross section of convoluted tube well ; (d), body of tube ; (e), straining material.
B.—Piece of convoluted sheet before forming into tube ; (f), perforations in sheet.
C.—Elevation of convoluted tube well.

PLAN OF CONTINUOUS FLOW SETTLING TANKS

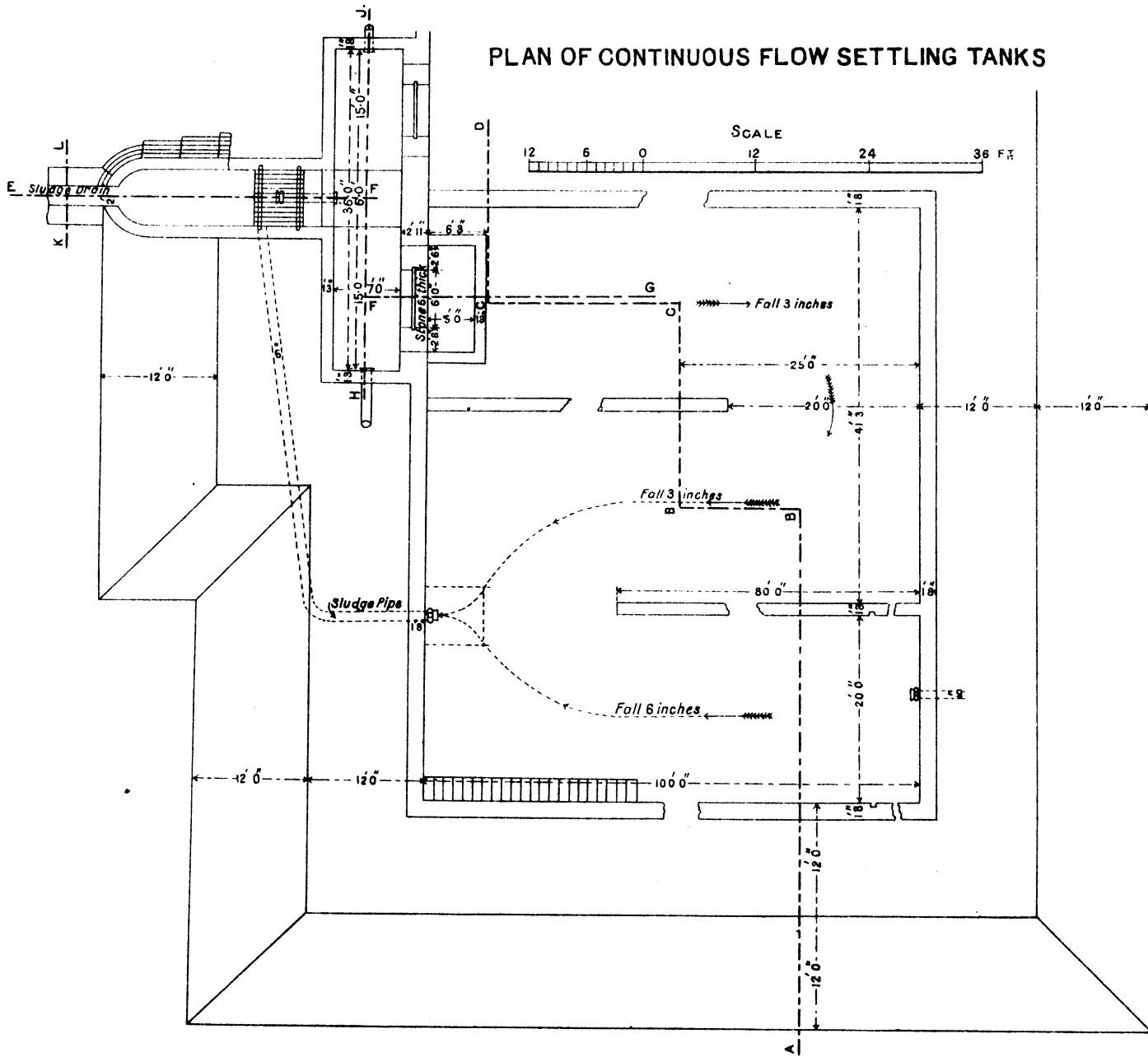
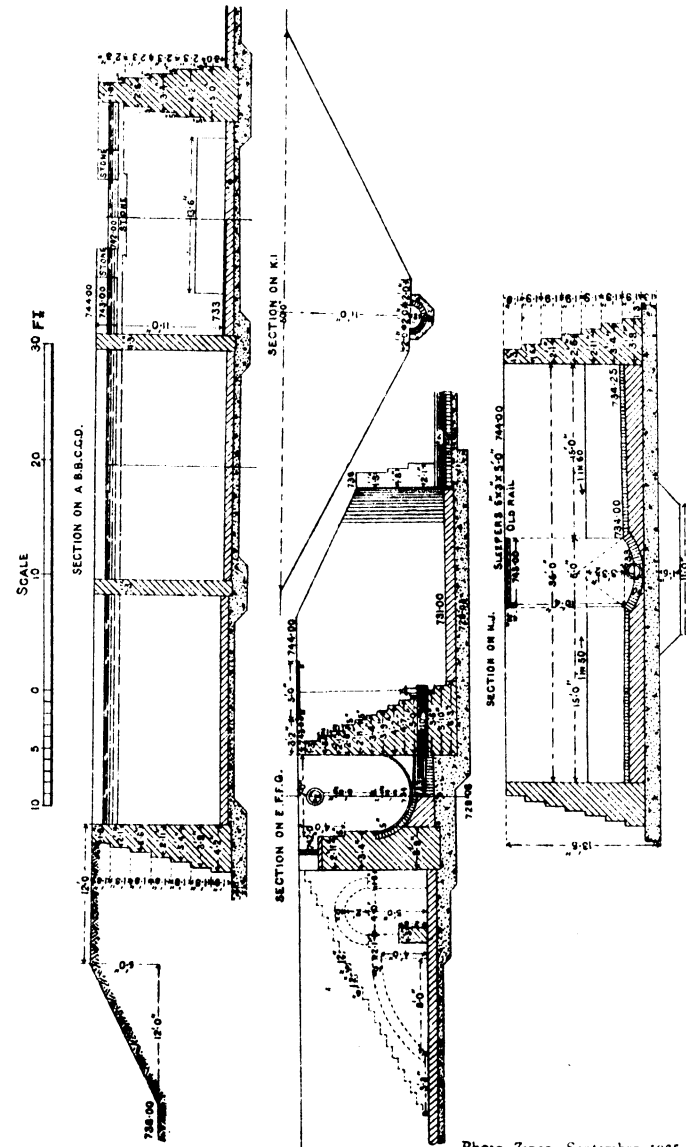
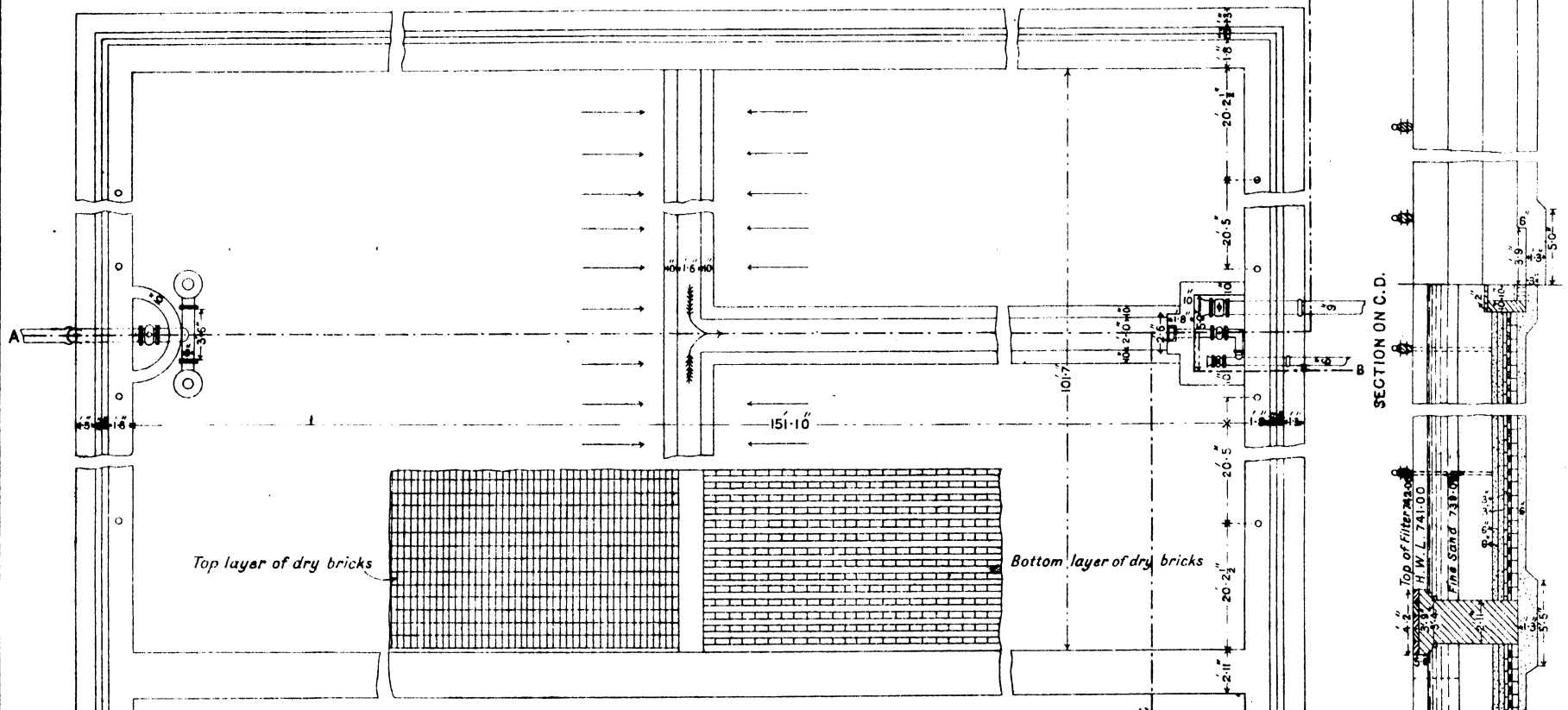
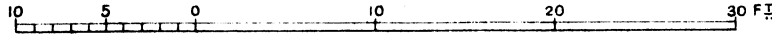

PLATE VIII. (Para 91)



PLAN OF FILTER.

SCALE



Top layer of dry bricks

Bottom layer of dry bricks

SECTION ON A. B.

Top of filter 742.00
H. W. L. 741.00

Fine Sand 739.00

Floor sloping 4" towards cross drain

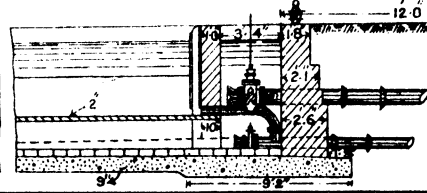
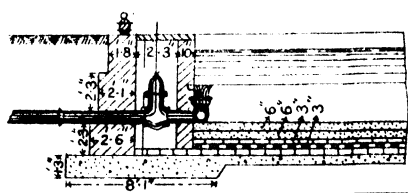

SECTION ON C. D.

Top of Filter 742.00
H. W. L. 741.00
FINE SAND 739.00

(Para 93)

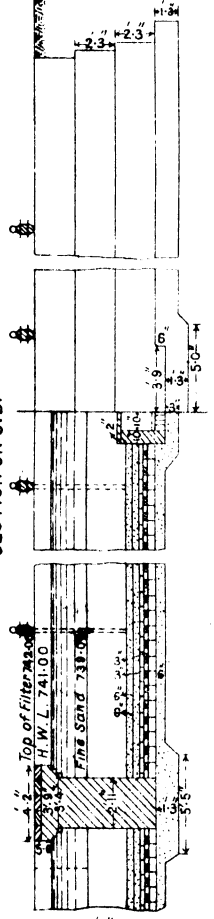

RAISED TOWER.

SCALE

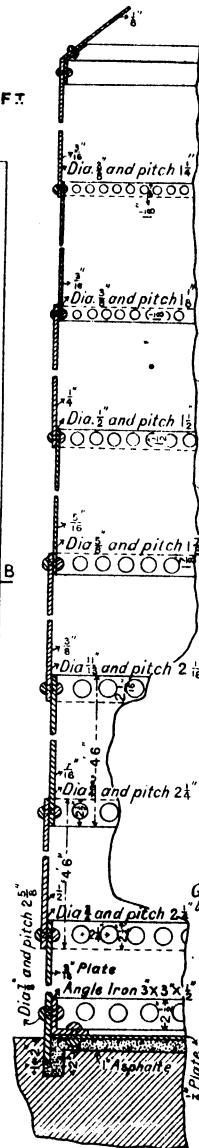
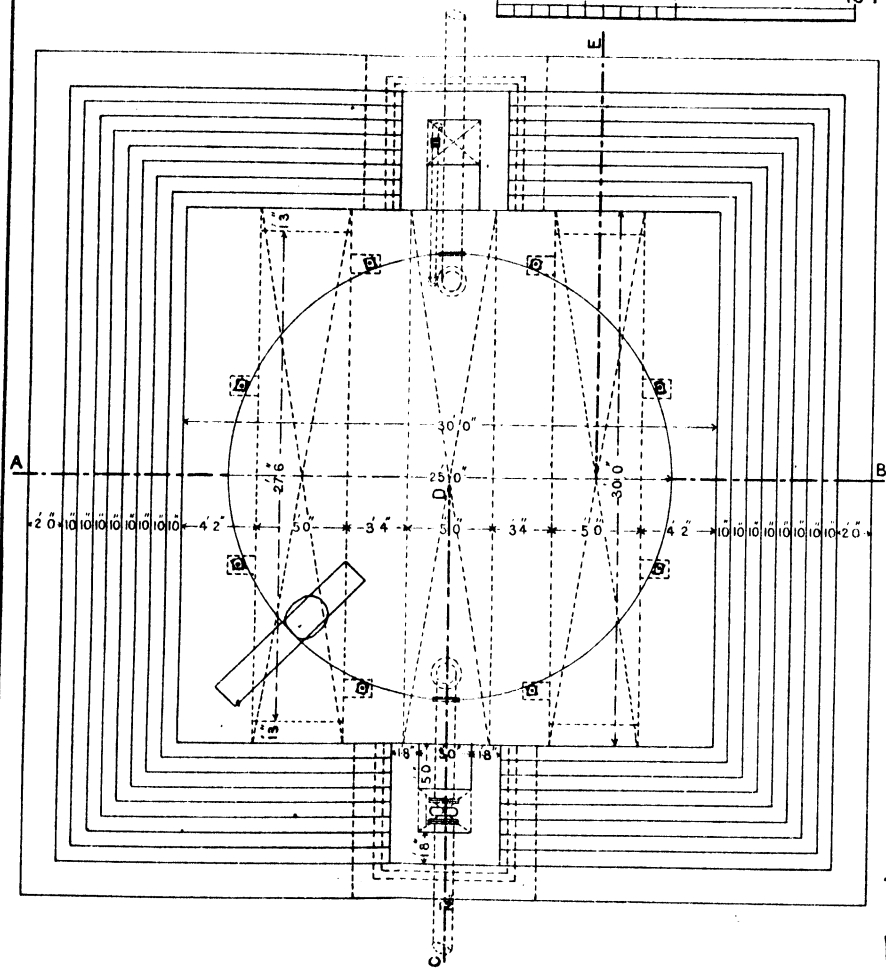
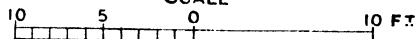

SECTION ON C.D. D.E.

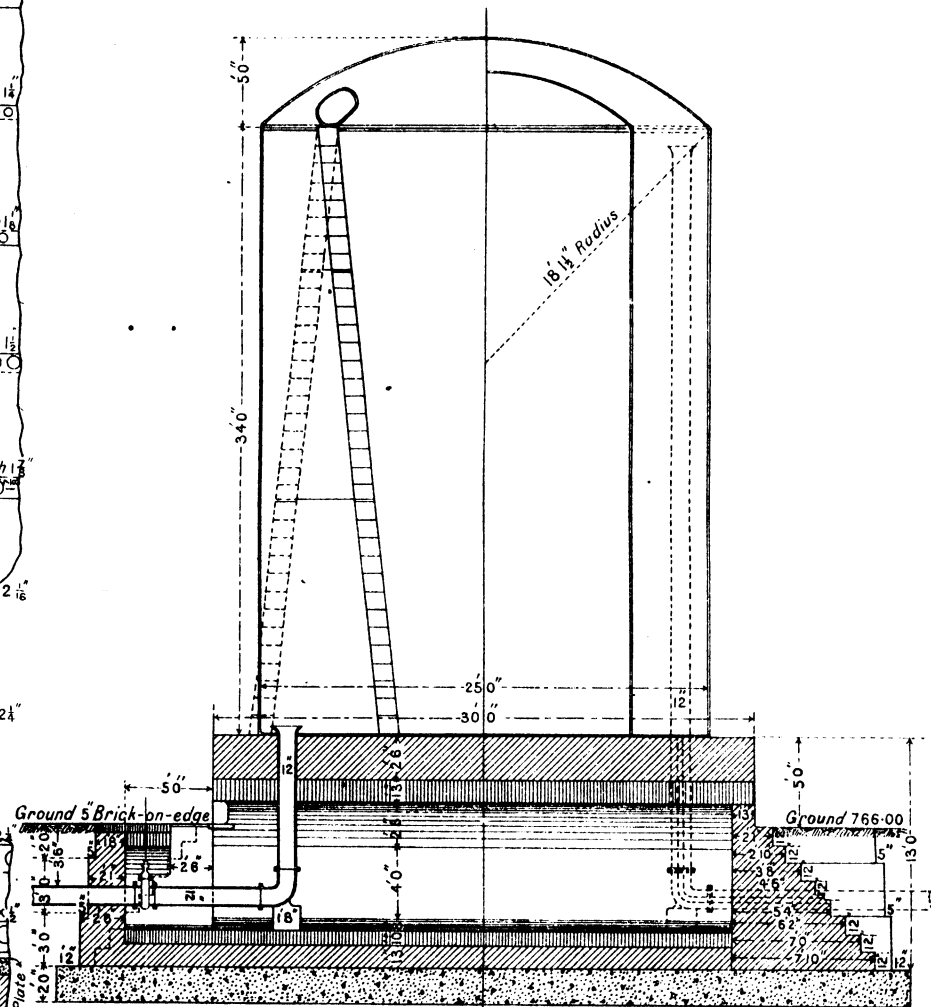

CAST IRON PIPES, ORDINARY AND SPECIAL.

Socket and Spigot Pipes.

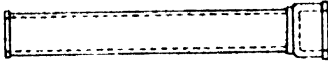

Turned and Bored Pipes

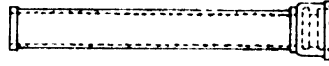

Double Flange Pipes

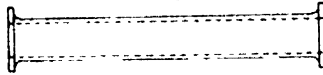

Quarter Bend

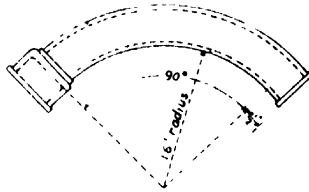

Double Collar



lead jointed
for joining two plain ends

Tee pipe

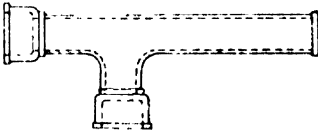

Reducing Pipe

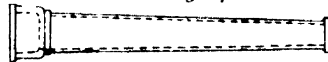

Angle Branch Pipes

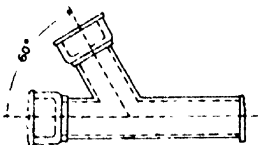

Breeches, or Y Pipe.

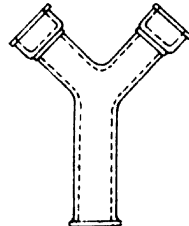

WROUGHT IRON TUBES AND FITTING

PLATE XIII
(Para 128)

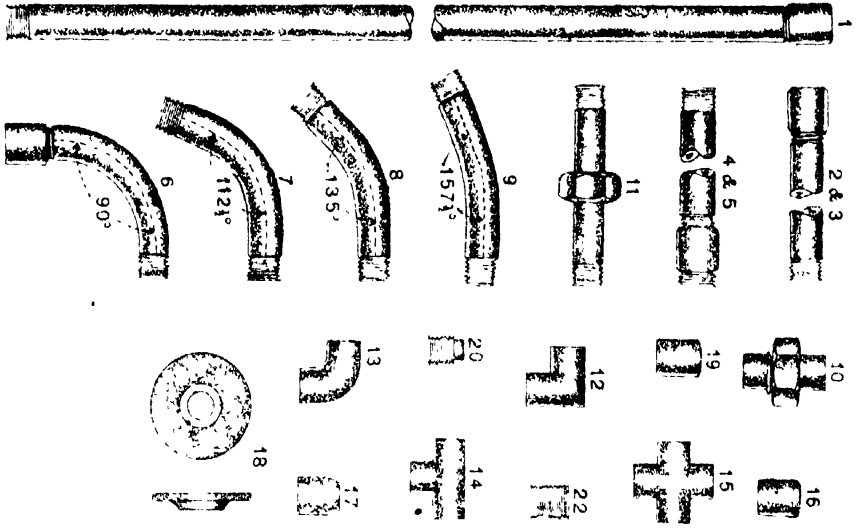

1 Tubes. 2 & 3 Make-up pieces 4 & 5 Long screws. 6 to 9 Bends. 10 & 11 Unions. 12 & 13 Elbows 14 Tees. 15 Crosses. 16 Sockets. 17 Tapers 18 Flanges 19 Caps 20 Plugs.

FERRULES

