

# **ROORKEE TREATISE on CIVIL ENGINEERING.**

---

**VOLUME II.**

**SECTION IX.**

# **RAILWAYS.**

*SIXTH EDITION.*

**W. B. ELLIOTT, Assistant Secretary, Railway Board.**

UNIVERSAL  
LIBRARY

OU\_168807

UNIVERSAL  
LIBRARY





# **ROORKEE TREATISE on CIVIL ENGINEERING.**

---

**VOLUME II.**

**SECTION IX.**

# **RAILWAYS.**

*SIXTH EDITION.*

REVISED BY

**W. R. HORN, Assistant Secretary, Railway Board.**

A L L A H A B A D:

PRINTED BY THE SUPERINTENDENT, GOVERNMENT PRESS, UNITED PROVINCES

1 9 1 9 .

---

*(All rights reserved by the Secretary of State for India in Council.)*



# TABLE OF CONTENTS.

## PART I.—DESCRIPTIVE.

		PAGE.
CHAPTER	I.—Introduction. Substructure of Railways ...	1
CHAPTER	II.—Permanent Way and Ballast ... ..	18
CHAPTER	III.—Points and Crossings ... ..	37
CHAPTER	IV.—Station Works and Requirements ...	49
CHAPTER	V.—Station Machinery ... ..	57
CHAPTER	VI.—Carriage and Wagon Stock and Brakes ...	68
CHAPTER	VII.—Locomotives ... ..	80

## PART II.—THEORY, PRACTICE AND DESIGN.

CHAPTER	VIII.—Plate-laying ... ..	90
CHAPTER	IX.—Superelevation and the Transition Curve. The Vertical curve ... ..	100
CHAPTER	X.—The Mechanical Theory of Railway Traction	129
CHAPTER	XI.—The Theory of Points and Crossings ...	145
CHAPTER	XII.—Station Yard Design—Wayside Stations ...	168
CHAPTER	XIII.—Station Yard Design—Sectional Yards and Junctions ... ..	178
CHAPTER	XIV.—Signals and their Uses ... ..	190
CHAPTER	XV.—Interlocking Principles ... ..	201
CHAPTER	XVI.—Interlocking Mechanism ... ..	212

## PART III.—GENERAL.

CHAPTER	XVII.—Maintenance of Railways ... ..	224
CHAPTER	XVIII.—Mountain Railways ... ..	236
CHAPTER	XIX.—The Gauge Question ... ..	251
CHAPTER	XX.—Light Railways, Mono-Railways and Tram- ways ... ..	261
CHAPTER	XXI.—Selection of Alignment and Surveys. ...	268



# ROORKEE TREATISE.

## Section IX--RAILWAYS.

### PART I.—DESCRIPTIVE.

#### CHAPTER I.

##### INTRODUCTION. SUBSTRUCTURE OF RAILWAYS.

1. The term "Railway" originally denoted merely a road, on which slabs of stone or wood, or iron plates (so-called "rails") supported on cross-sleepers, were laid in parallel continuous lengths to form hard even surfaces for the wheels of the ordinary traffic of the road. Later on, to confine the wheels to the track, the rails took the form of continuous iron plates with their outer or inner edges turned up. Finally, the idea was conceived of raising the rails above the surface of the road and of furnishing the wheels of vehicles with flanges to prevent their leaving the rails; and thus was evolved the modern railway with its specialised track and rolling-stock.

2. On the early English railways, which were mainly colliery lines, vehicles were hauled by animal power. But after the invention of the steam engine in the latter half of the 18th century, the idea of a steam locomotive began to take shape. The first locomotive of which we have record, was built by Cugnot in France in 1769; but its further development in that country was prevented by the outbreak of the Revolution. In 1784, Watt, who had so large a share in the perfecting of the steam engine, built a locomotive to run on an ordinary road. In 1802, Trevethick built locomotives to work the colliery lines at Merthyr Tydvil in Wales. These engines had smooth wheels running on smooth rails, but beyond this bore little resemblance to the modern locomotive; in consequence of their lightness, there was insufficient adhesion between the rails and the wheels to allow of loads being hauled, heavy enough to be commercially profitable; and to remedy this Blenkinsop in 1811 fitted a rack to the outer face of one rail, the locomotive being driven by means of a cog-wheel engaging with this rack, and the top of the rail being left smooth for the tread of the wheel. But the experiments of William Hedley showed that by concentrating sufficient weight on the driving-wheels, it was perfectly feasible to design a locomotive with smooth wheels working on smooth

rails and capable of developing a sufficient tractive effort to draw a train of loaded wagons; and Hedley in 1813 placed such a locomotive on the Wylam colliery line near Newcastle. This engine, which worked continuously for 50 years over a length of five miles of line, may be regarded as the first example of a commercially successful locomotive working by the adhesion of smooth wheels to smooth rails. Two years later, in 1815, George Stephenson built an engine of the same type for the Killingworth colliery, in which for the first time the driving-wheels were driven direct by cranks without the interposition of toothed gearing. In the following years, Stephenson introduced many minor improvements and in 1825 when the Stockton and Darlington line was opened one of Stephenson's locomotives known as "No. 1," built for the colliery traffic of that line, was successfully used for the haulage of passenger traffic also.

3. The first line regularly constructed for the express purpose of carrying passengers and goods by steam-power was the Liverpool and Manchester Railway which was opened for public traffic in 1825. In 1829, the Directors of that line had offered a prize of £500 for the best engine. This was won by the "Rocket" (Fig. 1) built by George Stephenson, who then for the first time introduced the tubular boiler and separate fire-box, which have led largely to the present form of the locomotive.

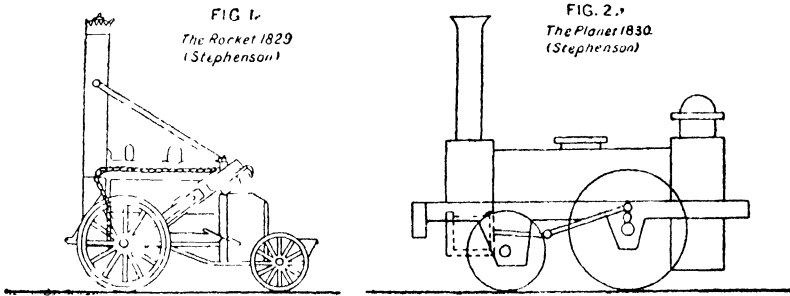

The last distinctive feature of the early locomotives, namely the vertical or inclined cylinders, disappeared in 1830, when the "Planet" (Fig. 2) was built with horizontal cylinders; and since that date the main features of the locomotive have not altered to any great extent.

With the opening of railways for public traffic, animal traction rapidly disappeared; and since then the locomotive has been identified with railway expansion all over the world, so that at the present day the term "Railway" is applied almost exclusively to lines using steam traction. The term is further restricted to lines having a certain standard of

equipment in the matter of stations, signals, etc., and subject to more or less stringent regulations for working. Lines not conforming with those standards are commonly called "Tramways," whether mechanical or animal traction be employed. Of late years steam has, to a certain extent, given place to electric traction. All the subterranean "tube" railways of London are electric, while the old District and Metropolitan lines have been "electrified" at great expense. In India schemes are under consideration for converting to electric working some of the lines in the neighbourhood of Bombay and Calcutta. But while this form of traction has been applied with commercial success to certain railways within confined areas and under special local conditions, there is no present prospect of its being applied to railways in general; and for many years to come the term "Railways" will continue to mean for most people, in India at all events, lines worked by steam traction. Only such railways will be dealt with in this Manual.

4. **Railways in India.**—The first recorded proposal for a railway in India was put forward by an English Company headed by Sir **Madonald Stephen** in 1844, at the commencement of a period of great activity in railway construction in all the civilised countries of the world. The proposal, which was for an experimental line extending from Calcutta for 140 miles in the direction of Allahabad, was on the basis of a Government guarantee of 3 per cent. interest on capital outlay. This led to a prolonged correspondence, extending over several years, between the Secretary of State for India, the Indian Government and the Court of Directors of the East India Company, as to the terms under which the general policy of railway construction in India was to be initiated. The Government of India in the first instance objected to the principle of a guarantee, but it was finally recognized that if British capital were to be attracted, a guarantee of a minimum rate of interest on capital outlay was, in the then undeveloped state of the country, necessary; at the same time it was held to be essential in the interests of the country that the Government should exercise a certain measure of control over the operations of all companies undertaking the construction of railways. Under these general terms agreements were signed between the Secretary of State and the East Indian and Great Indian Peninsula Railway Companies in 1849, and the actual construction of these railways was commenced in 1850 under Lord Dalhousie's administration. The main provisions of the agreements were, that land should be provided by Government on a lease of 99 years; that all works undertaken should be subject to approval by the Government; that interest at 5 per cent. on

capital outlay should be guaranteed to the Company for the term of the agreement; and that the option lay with the Government of purchasing the lines after the first completed period of 25 or 50 years. When the profits of the undertaking fell below 5 per cent., it was stipulated that the deficit should be made good by the Government, and when the profits exceeded the guaranteed percentage, that one-half of the excess should be credited to the Company and the other half applied towards refunding sums paid by the Government under the preceding clause; when these sums had been repaid in full, all profits were to go to the Company.

5. It will thus be seen that under the original "guarantee" system, as it was called, the Government had no share in the profits of any railway and that in the case of those lines which failed to earn an amount equal to the guaranteed percentage, the system resulted in direct financial loss to the State. On the other hand, the main object of the Government—the opening up and development of the country—was secured; and the system had the advantage, as compared with any scheme of construction by State agency, that capital could always be raised without difficulty by the Company on the strength of the Government guarantee; whereas, had the funds been provided by Government loan, it would probably have been necessary, in times of financial stress, to divert money allotted to railways to other and more urgent ends.

6. The first sections of the Great Indian Peninsula and East Indian Railways were opened in 1853 and 1854, respectively, and between these dates and 1859 Companies were formed for the construction under the guarantee system of most of the other great trunk lines of India—the Madras, the Bombay-Baroda, the Sindh Punjab and Delhi, the Eastern Bengal and the Great Southern of India (now the South Indian) Railways. Later on in 1863 an attempt was made without success by the Indian Branch Railway Company to raise capital without a guarantee for the construction of railways in Oudh and Rohilkhand; and eventually the construction of the Oudh and Rohilkhand Railway had to be undertaken under a contract slightly modified from the original guarantee system.

7. By 1870, the trunk lines laid under this system were virtually completed and aggregated about 5,000 miles. In the meantime, the working of the early guaranteed lines, mainly owing to their high cost and the high rate of guaranteed interest and to the fact that their traffic had not developed as rapidly as had been expected, had resulted in a steadily increasing drain on the Indian finances. Moreover, new lines, which did not promise to be remunerative in themselves, were urgently

required for the development of the country, and, as has been seen, efforts to raise money through the agency of a company without a guarantee had proved unsuccessful; it was therefore decided in 1871 to enter on a programme of construction, by direct State agency, of a number of lines of a cheaper character than those already constructed—a policy which was steadily pursued for the next 10 years. Thus came into being the Indus Valley, the Lahore-Rawalpindi, the Rajputana-Malwa and the Punjab Northern State Railways. Of these the first section of the Rajputana-Malwa Railway was opened in 1873 and the last from Ajmere to Ahmedabad, in 1879.

8. A series of disastrous famines occurred during the period 1874—79, which showed the inadequacy of the existing railway systems for the rapid transport of food-stuffs for the relief of scarcity; and to remedy this a Commission appointed in 1880 recommended the early construction of 5,000 miles of new railways. But as the finances of India did not admit of these lines being carried out entirely by State agency, it became essential again to enlist the assistance of private enterprise, either with or without a guarantee. In this way, in 1882, the Southern Mahratta Railway was started by an “assisted” company, that is to say, the Railway was to be considered as being the property of the State, but was to be worked and the funds were to be supplied, by the company on a guarantee of 4 per cent. for 7 years and  $3\frac{1}{2}$  per cent. thereafter. The Bengal and North-Western Railway, which followed, was constructed by a company without a guarantee. But in the case of the Bengal-Nagpur, started in 1885, and the Indian Midland, in 1887, a 4 per cent. guarantee was agreed to. After this it was decided that the State could no longer afford to aid private enterprise, beyond granting land free. On these terms the Delhi-Umlalla-Kalka Railway was constructed in 1889. At the same time the State continued to construct lines, which were considered politically or strategically necessary, but which did not promise to be sufficiently remunerative to attract private capital. Of this description were the Sindh-Peshin and Chaman Railways on the North-West frontier. Thus between 1880 and 1890, the policy of construction by State agency, initiated in 1871, was continued side by side with a partial reversion to the earlier guarantee system in a modified form, together with a few instances of private enterprise in which no guarantee or other assistance, beyond the free grant of land, was given.

9. In the meantime in the case of the majority of the early guaranteed lines, the State had, on the expiry of the first period of 25 years specified in their contracts, exercised its right of purchase of these lines. The

exceptions were the Great Indian Peninsula, the Bombay-Baroda and the Madras Railways, in the case of which new contracts were executed in 1869 which provided that the tenure of the Companies should be extended for a second period of 25 years, but that for the remainder of the lease surplus profits over 5 per cent. should be divided equally between the Government and the Companies. The East Indian Railway was, in 1879 on the expiry of the first term of 25 years, acquired by the State and practically handed back to the original company re-constituted as a working agency; and in the case of the Eastern Bengal Railway the State in 1884 assumed working control. Again, the Sindh Punjab and Delhi Railway was taken over by the State in 1886 and amalgamated with the Indus Valley, the Lahore-Rawalpindi and the Punjab Northern State Railways; the combined system, under the name of the North-Western Railway, being placed under State management. The Oudh and Rohilkhand Railway, taken over in 1889, also became a State-worked line. On the other hand, the working of the Rajputana-Malwa, one of the original State railways, was in 1884 handed over to the Bombay, Baroda and Central India Railway Company on a working agreement.

10. Thus, by 1889, the railway systems of India had become very complex; and as the rate of exchange was falling rapidly, the Government of India could neither afford to encourage private enterprise by the grant of any sort of guarantee, nor enter upon extensive schemes of construction by State agency. It was difficult even to provide for the demands of existing lines. During the first part of the following decade, therefore, there was very little construction work, except in Upper Burma, which was in urgent need of opening out and where construction was undertaken by the State. But the closing of the mints in 1893 inaugurated a new era of railway activity. For the consequent stability of the currency lightened the problem of railway finance and amongst the first results of the improved conditions, was the construction by the State of the Mushkaf-Bolan and Mari-Attock Railways.

11. For the next few years, the open mileage of Indian railways continued to increase steadily at an average annual rate of 700 miles; and between 1899 and 1905, under Lord Curzon's administration, new construction was pushed on with great vigour, attaining 1,000 miles a year for that period. But the traffic of open lines had meanwhile been increasing at such a rate that, when the Railway Board assumed office in 1905, they were confronted with two serious problems—a general shortage of rolling stock on existing railways, and a financial system inadequate to cope with the growing demands of the country either in the matter of construction

of new lines or of the improvement of existing lines. A committee was appointed in 1908 by the Secretary of State to investigate these matters and to suggest remedial measures; and on their recommendation, it was decided that the annual allotment of funds for Railway purposes should be substantially increased, but that the equipment and improvement of existing lines should for the present take precedence of the construction of new lines. While therefore, in accordance with this policy the carrying capacity of existing railways has, in the last few years, been greatly increased, the annual rate of new construction has fallen considerably below the figures for the years 1900—1905.

12. In 1899 for the first time in their history the working of Indian Railways resulted in a net profit to the State. This state of prosperity continued until 1908—a year of abnormal trade depression, accentuated by famine—when a loss had again to be recorded. A recovery was however made in 1909, and since that year the annual gain to the State has increased at a rate, which has shown the wisdom of the decision referred to in the last paragraph.]

13. As regards the ownership and working of railways, the policy of late years has been for the State to acquire guaranteed and “assisted” railways as soon as their contracts have expired, and to hand them back to the companies on working contracts. The Great Indian Peninsula (1900) and the Bombay, Baroda and Central India (1905) Railways may be quoted as recent examples. The South Indian Railway became the property of the State in 1890 and the contract then entered into was renewed in 1910. The Madras Railway, the last of the old guaranteed lines was, on its being acquired by the State in 1907, dismembered, the section north of Jalarpet being amalgamated with the Southern Mahratta Railway, and the remainder being handed over to the South Indian Railway.

14. **Branch lines.**—In 1893 an important departure was made by the Government of India from the policy previously pursued in the offer of special terms to private companies or local bodies for the construction of branch lines, intended to serve as feeders to existing railways and to be worked by the parent line administrations. Financial assistance was offered in the shape either of a guarantee of interest on capital outlay or a rebate from the earnings brought to the main line by traffic interchanged with the branch. The first railway constructed by a private company under these terms was the Southern Punjab, which was completed and opened to traffic in 1897, and amongst others may be mentioned the Sutlej Valley, the Tapti Valley, the Ahmedabad-Parantij and the Amritsar-Patti Railways. The “Branch Line” terms, as they are called, were revised in 1896 and

again, with a view to making them considerably more liberal, in 1910 and 1913. The result of these revisions has been apparent in the large number of companies of Indian domicile, which have recently been floated for the construction of branch railways in all parts of India; and up to the present time (1917) in spite of the continuance of the war in Europe, there appears to have been no reduction in the activity of Branch Line companies, which have sought concessions under the very favourable terms now offered by the Government of India.

15. A noteworthy feature of railway policy in Southern India, is the encouragement given to District and Local Boards in the Madras Presidency to embark on the construction of "feeder" lines, intended to develop their own districts. In 1900, the Tanjore District Board, with great enterprise, raised funds for the construction of what is now called the Tanjore District Board Railway, 103 miles in length, the first section of which was opened in 1900, and which is worked by the South Indian Railway. Their example was followed by the Kistna District Board, whose railway—the Bezwada-Masulipatam Branch—was opened to traffic in 1908. These two lines have not only served to develop trade in the districts traversed by them but have proved to be decidedly successful as commercial undertakings. They were, until recently, the only railways owned by District Boards, open to traffic in India; a number of Boards have, however, for some years been steadily accumulating funds, raised by the levy of a special railway tax or cess, for the purpose of railway construction; and the Podanur-Pollachi, Tenali-Repalle and Nidamangalam-Mannargudi Railways, constructed under the Branch Line terms at the cost of the Coimbatore, Guntur and Tanjore District Boards respectively, have recently been opened to traffic, while several other District Board Railways are under construction, and a large number are in view.

16. **Lines in Native States.**—An account of the history and development of Indian railways, however brief, would be incomplete without some mention of the lines constructed by, or at the instance of, the Governments of several of the Native States of India. The earliest line to be so constructed was on the 2 feet 6 inches gauge from Myagam to Dabhoi, a length of 20 miles in Baroda State, which was opened to traffic in 1873. This example was followed by the Governments of other States, including Mysore, Hyderabad, Jodhpur, Bikanir and a number of others, and at the present day upwards of 4,500 miles of such lines have been opened to traffic, while several hundred miles of railway are at present under construction.

Of the lines owned by Native States, the majority are worked by companies, the agreements being modelled in most instances on those under which lines are worked by companies in British India. Notable examples of lines worked under a guarantee are the Nizam's Guaranteed State Railway, 330 miles long, built on the 5 feet 6 inches gauge, and the Hyderabad-Godavari Valley Railway, 391 miles long on the metre gauge. Not a few of the Native State lines are, however, worked by the Darbars themselves, and the most important of such lines is the Jodhpur-Bikanir Railway, 1,200 miles long, owned and worked jointly by Jodhpur and Bikanir States.

17. The Railway Traffic Conference, which has become an annual institution, first met in 1880. The Locomotive, Carriage and Wagon Superintendents' Conference, a similar institution, was started in 1889. The present Indian Railways Act dates from 1890, and the General Rules for working open lines, at present in force, were issued by the Government of India in 1906 and were adopted with effect from July 1st, 1907. Revised rules for working lines under construction were issued in 1913, and revised Schedules of Dimensions, for the 5' 6" metre and 2' 6" gauges, to be observed on all railways in British territory, were published in the same year.

18. **The gauge problem.**—A troublesome question which has grown with the expansion of railways, but which has not been alluded to in the above historical sketch, is that of the *gauge*. The gauge of a railway is the clear distance between the inner or running faces of the two rails which form the track. This fixes the distance apart of the wheels, and thus governs the design of the rolling-stock. In the early English railways a gauge of 4' 8½" was adopted, for the reason that that happened to be about the width of the colliery tramway on which locomotive power was first tried. Wider gauges were subsequently tried, including a 7-foot gauge introduced on the Great Western Railway by Brunel, whose argument was that on this gauge trains could be worked more economically and at higher speeds than on narrower gauges. But it was soon realised that, in a small and thickly-populated country like England, with busy centres of trade at short distances apart, uniformity of gauge was a more important consideration than the intrinsic merit of any particular gauge. And as the majority of railways in England had by that time adopted the 4' 8½" gauge, those which had been laid to other gauges were subsequently converted to that gauge, with the exception of the Great Western Railway, which for many years retained the 7-foot gauge. To prevent further confusion, Parliament clinched matters about 1845 by deciding that, except

in special cases, there should in future be only two gauges in England : the 7' 0" or broad gauge, and the 4' 8½" or narrow gauge. [It is interesting to note that the 7' 0" gauge on the Great Western survived until 1892, when, under the pressing need for uniformity with other railways, it was finally converted to the normal 4' 8½". For many years a great part of the line had been laid with three rails to carry trains of either gauge, and the broad gauge had been eliminated from the northern parts of the line several years previously.]

19. Such was the state of affairs in England when railway construction was commenced in India in 1850. The gauge originally proposed by the Court of Directors of the East India Company for adoption on the railways then about to be commenced, was the normal English one of 4' 8½". This proposal was however contested by Lord Dalhousie, who recommended a 6-foot gauge and by Mr. W. Simms, Consulting Engineer to the Government of India, who was in favour of a 5' 6" gauge. The Court of Directors finally decided to adopt the latter gauge, and, this decision being accepted by the Government of India, the 5' 6" gauge was used on all the early guaranteed lines.

20. In 1871, when about 5,000 miles had been laid to this gauge, the decision (referred to in paragraph 7) to construct cheap railways by State agency led to the introduction of the metre gauge (3' 3⅜"). This step gave rise to much discussion both in England and in India, mainly with regard to the construction of the Indus Valley and Punjab Northern Railways, which were amongst the first metre gauge lines sanctioned. Two sections of the Indus Valley Railway amounting to 324 miles in length had, however, already been constructed to the standard gauge of 5' 6"; and in consideration of this and of the importance of the two lines from a military point of view, it was finally decided, when their construction as metre gauge lines was well advanced, to alter them to standard gauge. This decision did not, however, affect the other metre gauge lines projected and their construction was proceeded with; but as fresh controversies on the question of gauge continued to arise for every new railway proposed, the Government of India in 1883 considered it advisable to determine on a fixed policy with regard to the distribution of the standard and metre gauges.

21. After a careful consideration of the subject, in the course of which the relative merits of the two gauges were fully discussed, the Government of India in 1884 laid the matter before the Secretary of State. A Select Committee of the House of Commons, to whom it was in the same year referred, recommended as a broad principle that the leading trunk

lines with their more important feeders should be on the standard gauge; and that the metre gauge should as far as possible be confined to districts where it was already in successful operation, and to local lines where traffic was unlikely to be heavy. This decision by no means settled the question however, and in 1889, on a proposal being made for the conversion of an important line from the metre to the standard gauge, the subject was raised afresh.

22. By this time, Indian Railways comprised about 8,000 miles of standard gauge and 5,000 miles of metre gauge; while a total of 800 miles of original metre gauge line had been converted to standard gauge and nearly 200 miles of the latter to metre gauge. It was anticipated that the necessity might arise for further conversions on a large scale and it was therefore considered that the time had arrived for the declaration of a definite policy for the future. In submitting a despatch to the Secretary of State on the subject, the Government of India therefore proposed that, while certain defined areas in which the metre gauge was already established should be as a rule reserved for that gauge, all new main lines constructed outside those areas should, without exception, be on the standard gauge; and further that no material expansion of the metre gauge system should be permitted. These views were not, however, accepted by the Secretary of State, who, in a reply issued in August, 1890, stated his opinion that it was unnecessary to lay down any absolute rule, and that the question of the gauge for any particular line should be decided on its merits, the principles laid down by the House of Commons Committee of 1884 being observed as a general guide.

23. Although the question has been raised several times since the date of this reply (notably in 1906 when it was discussed by the Institution of Civil Engineers and in 1914 during a lecture on the subject by Sir Guilford Molesworth at the Caxton Hall, London) the policy then enunciated by the Secretary of State has been adhered to. As a result the metre gauge mileage has grown almost as rapidly as that of the standard gauge and at the present time (1917) the respective mileages are 18,190 miles of standard gauge and 14,756 miles of metre gauge, while over 3,200 miles of minor gauges (chiefly 2' 6") are open to traffic.

24. The above is a brief sketch of the history of the gauge question. A further consideration of the subject in the abstract will be found in Chapter XIX.

25. **The substructure of a Railway.**—Reserving for later chapters the consideration of the alignment, gradients and curves of a proposed line of railway, and assuming that the alignment has been marked out, we

may conclude this chapter with a few remarks on the substructure and other matters, which have certain features in common with road construction, or which are fully dealt with in other Manuals, and thus clear the way for the more technical details of railway design and construction, which will be commenced in the next chapter.

26. **Land.**—In railway construction, as in road-making, the first stage is the preparation of a “formation.” The breadth of formation depends upon the gauge, the number of tracks, the clear space between them, and the margin considered necessary outside the rails. These details being fixed, the permanent land-widths are calculated by adding the horizontal components of the slopes of banks and cuttings, side drains, and marginal strips for contingencies. Outside the permanent land-widths, land is also temporarily acquired for the borrow pits for banks, or the spoil from cuttings. The general cross sections given in Figs. 3 and 4 show the minimum dimensions prescribed by the Government of India for the standard (5' 6") gauge. The extra width shown on one side of the centre-line is intended to provide for the possibility of the line being doubled at some future date; incidentally also this extra width provides space for a cart-road for use during construction. For the metre gauge the minimum widths prescribed are 6 feet less land and 2 feet 6 inches less for mation width.

For station-yards a sufficient area of land must be acquired to allow of the construction of the platform, sidings, station buildings and staff quarters, and to provide a reasonable margin for future extensions of the yard. For an ordinary wayside station on an important standard gauge railway, a strip of land 2,500 feet long, with side-widths of 150 and 250 feet on either side of the centre line, would usually be a sufficient area. For the metre gauge a length of 2,000 feet would be suitable, with side widths of 100 and 200 feet. On railways of less importance, in the case of which cheapness of construction is desirable, or on which the steepness of the grades limits the length of trains, the land areas acquired for station-yards may be considerably reduced. The rules of the Government of India require that sufficient land should be acquired to enable at least one crossing siding to be lengthened, if necessary, to the following dimensions:—

On sections where the steepest gradient is—	5' 6" gauge.	Metre gauge.
1 in 500 or flatter ...	2,500 feet	} 2,000 feet.
Between 1 in 500 and 1 in 300	2,000 ,,	
,, 1 in 300 and 1 in 100	1,800 ,,	1,800 ,,
,, 1 in 100 and 1 in 50	1,600 ,,	1,600 ,,
.. Steeper than 1 in 50 ...	1,200 ,,	1,200 ,,

# MINIMUM SIDE-WIDTHS.

5 ft. 6 in. gauge.

FIG. 3.

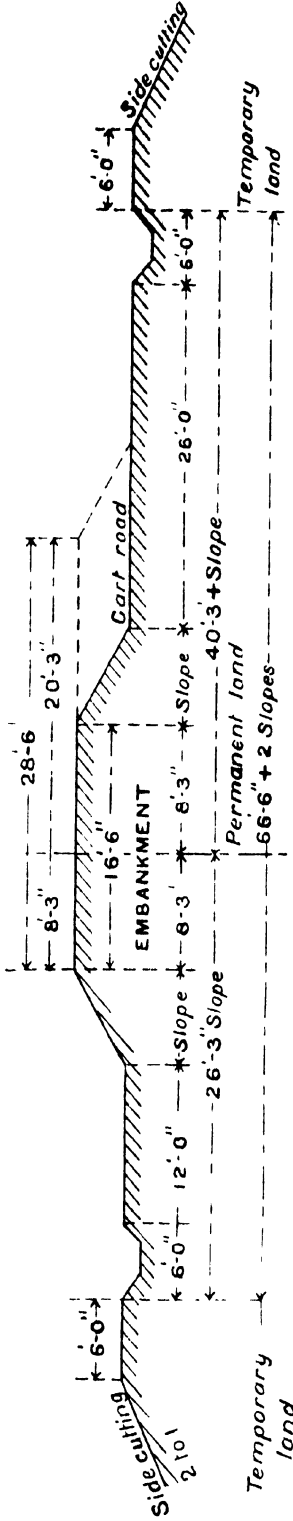
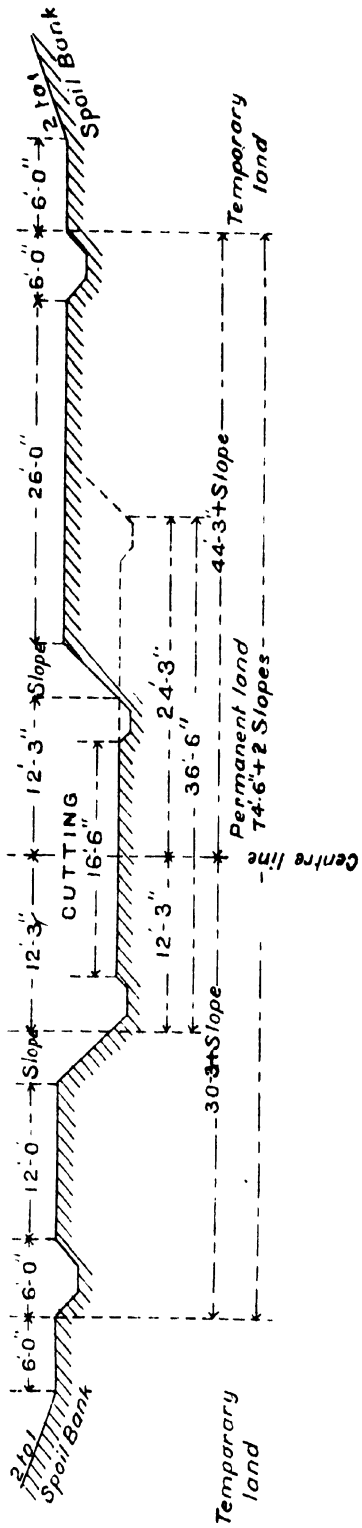

FIG. 4.



NOTE.—Extra widths of formation to be allowed on curves.



Extra land is also necessary for the ramps of level crossings, road and river diversions, and other isolated works of a similar kind.

Finally, it is usual to demarcate the boundaries of all land acquired for railways by means of stone or masonry pillars placed at all points of variation in the land-widths, and elsewhere at intervals of 660 feet.

27. **Earthwork.**—Though the principles which govern the selection of railway gradients are somewhat different from those applying in the case of roads, the execution of earthwork up to (or down to) a predetermined formation is the same in both cases. Hence the student is referred to the Manuals on "*Earthwork*" and "*Roads*" for a description of the methods followed in the laying out, calculation, and actual construction to formation level, of cuttings and embankments. As regards embankments, the common plan in this country is to put up profiles consisting of bamboo uprights and string, and make the bank by coolie labour from side excavations or "borrow-pits," care being taken that the earth is deposited in layers, and all clods broken up during the operation.

An allowance for sinkage, which may amount to as much as  $2\frac{1}{2}$  inches per foot of height in the case of bad soil, must be provided for in setting up the profiles.

Before work is commenced on the construction of the banks, masonry pillars should be built at the tangent points of all curves and at suitable intervals (preferably 2,000 feet) along the intermediate lengths of straight. These pillars, which are built up to exact formation level, and at a distance equal to half the formation-width from the centre line of the railway, mark the chainage and at the same time serve as permanent marks from which to set out centre stakes for the use of the plate-laying gangs; and if they are finished off with stone or masonry caps built up to the exact level of the rails, they are of the greatest use in the subsequent maintenance of the line. A line exactly parallel with the centre-line should be marked on the pillars before the centre-line pillars, constructed during the survey, have been embedded in the earthwork.

The side-slopes of railway embankments are usually 2 (horizontal) to 1 (vertical) and of cuttings in ordinary earth  $1\frac{1}{2}$  (horizontal) to 1 (vertical), but this rate of slope varies according to the nature of the material through which the cutting is made, and in cuttings through hard rock, the walls may be vertical.

On the completion of an embankment the top surface should be finished off with a succession of low longitudinal and transverse bunds, to imprison rain-water and thus ensure that as much consolidation of the earthwork as possible shall have taken place before the rails are laid.

28. **Tunnels.**—In consequence of the easy gradients required for railways, as compared with roads, the depth of cutting in uneven or mountainous country is often very great, and when that depth increases beyond a certain figure—usually about 60 feet—it is generally more economical to resort to a tunnel. For a description of the methods employed in the construction of tunnels the student is referred to the “*Roads*” Manual. The minimum dimensions of tunnels, as laid down by the Government of India, are shown in Figs. 5 and 6.

29. **Bridges** are described in the Manual on “*Bridges*,” so need not be discussed here.

30. **Road Crossings** and diversions of other lines of communication. When the course of a railway crosses that of a previously existing road, the railway may be carried either over or under it by means of a bridge, or across it on the same level. When a canal or a river is to be crossed, the railway must be carried over or, in rare cases, under it. In order to provide such crossings without undue expense, it may be necessary to alter the level or divert the course of existing lines of communication; and in some cases a diversion may be required independently of any crossing, as for instance when a road, or stream or canal, would otherwise encroach too closely upon the railway alignment. Those parts of a road whose levels are altered for the purpose of carrying a railway across it, are called the *approaches* to the crossing, and when the road and the railway are built to the same level, the crossing is said to be a *Level Crossing*.

A bridge carrying a road over a line of railway is called an *Over-bridge*, while when the road passes under the railway, the bridge is called an *Under-bridge*.

When the railway alignment crosses a road, stream or canal, at a sharp angle, it will generally be advisable to divert them to a direction as nearly as possible at right angles to the line.

31. **Level Crossings** (see Plate I) however well they may be guarded or protected, are always a possible source of danger to road traffic and should for that reason, more especially in populous districts, be avoided whenever possible. In a level country, however, the expense of providing over or under-bridges at all road crossings would be prohibitive and on Indian Railways level-crossings are numerous. At important roads they should have gates closing across the road on both sides of the line in one position and across the railway in the other, so as to prevent animals from straying on the line. A common method of protecting the less important road-crossings in India is to provide a chain suspended across the road between two posts on each side of the railway. A gate-man

# MINIMUM DIMENSIONS

OF

# TUNNEL SECTIONS FOR STANDARD AND METRE GAUGES.

Scale— $\frac{1}{8}$  Inch = 1 Foot.

NOTE.—The hatched section shows the outline which should not be infringed, Below the line A A the sides may be vertical or built with a straight batter. In bad soil an invert will be required.

FIG. 5.

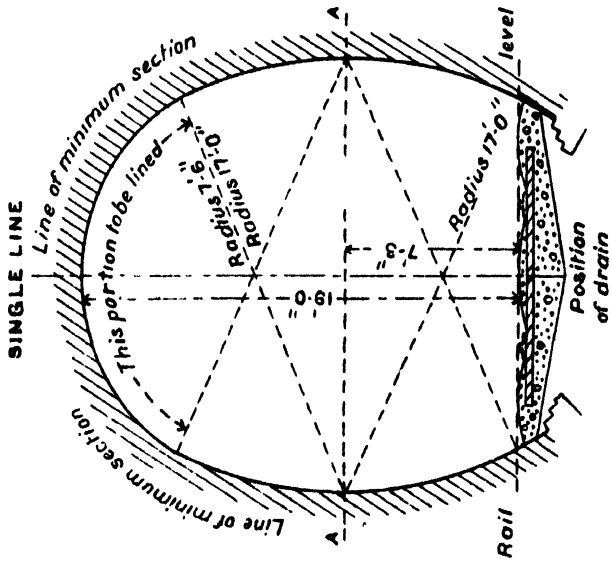
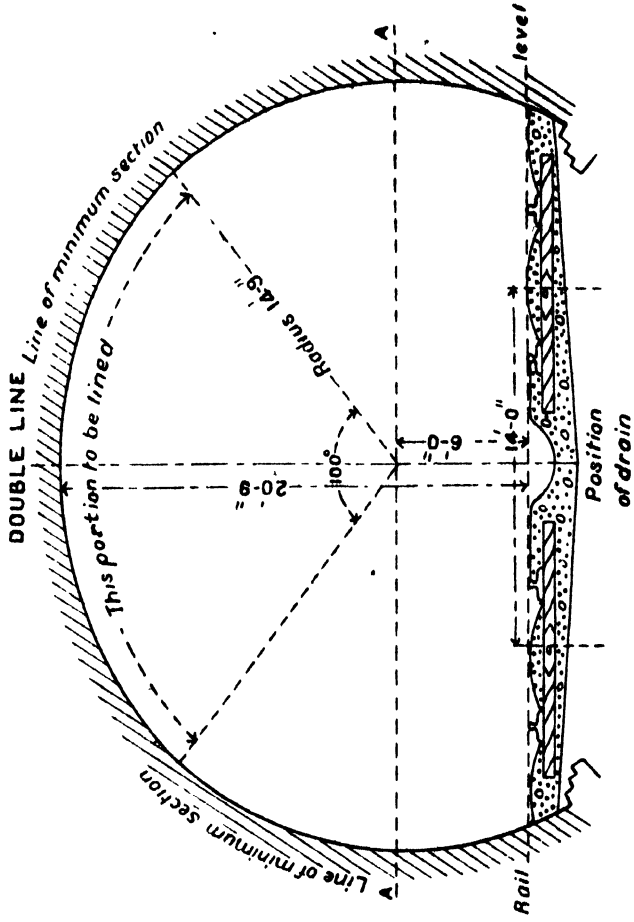

FIG. 6.



NOTE.—Extra widths to be allowed on curves.



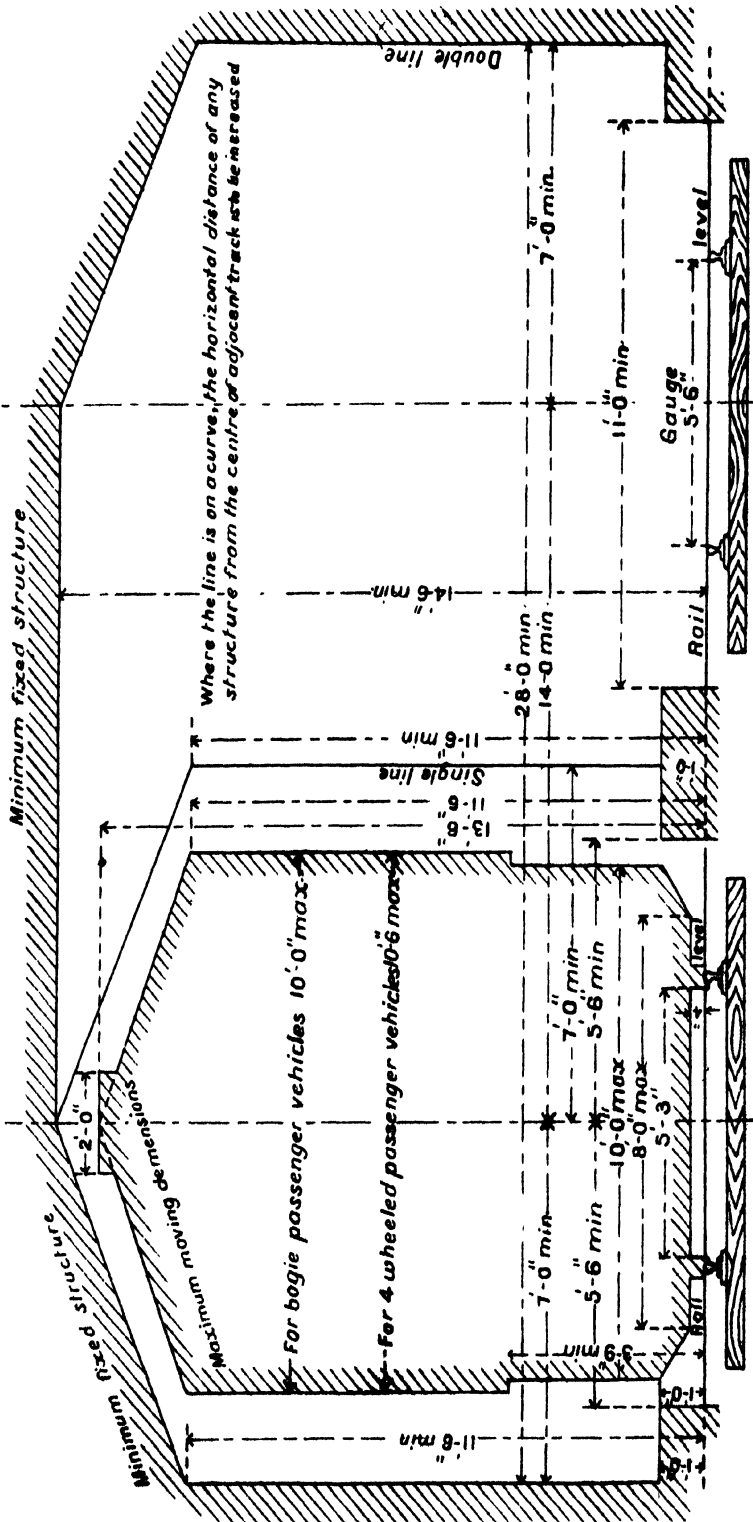

FIG. 7.

5' 6" GAUGE  
MAXIMUM AND MINIMUM  
DIMENSIONS

DIMENSIONS OUT OF STATIONS.

Scale  $\frac{1}{4}$  inch to 1 foot



is then required to remove and re-fix the chains, and gate-keepers must be provided in all other cases in which a gate may be so placed as to obstruct the line.

32. To save the expense of maintaining gate-men, self-closing gates are occasionally used, but are not to be recommended as, unless carefully maintained, they seldom work satisfactorily, and when villagers have learnt the secret of securing them in the open position, they become worse than useless, and may be a positive danger. When the expense of keeping a gate-man is not justified, it is far better to have no gates at all and to provide cattle-guards, as they are called, to prevent cattle straying on the line. A cheap and effective type of cattle-guard consists of a grating composed of a number of thin planks or metal bars arranged parallel to each other and tilted on their edges, like the leaves of a partially open Venetian blind, the whole being secured in a strong framework. The spaces between the planks are sufficiently wide to allow the hoof of a cow or a horse to pass between them; but owing to the tilted arrangement of the planks, it is impossible for cattle to pass over them. These gratings which should be made about 6 or 8 feet wide are firmly fixed between, and outside, the rails on each side of the level crossing, the planks being parallel to the road-way.

33. At crossings over important roads, the approaches should be on an easy gradient, as possible. The inclination should not, as a rule, exceed 1 in 40 for main roads such as the Trunk roads of India or roads in the neighbourhood of large towns; while for less important roads and ordinary field-crossings an inclination of 1 in 30 would be suitable. If it has been necessary to divert the road in order to obtain a square crossing an important point to be observed is, that sharp curves and in particular reverse curves should be avoided on the approaches; and care should be taken to ensure that a clear view of the crossing both from the road-way and from an approaching train is not obstructed. When the approach banks are high, it may be necessary to provide fences or low walls of mud or masonry at the edges of the slopes for the protection of the road traffic; high walls should never be built as they obstruct the view.

34. **Overbridges** should have a minimum clear head-way above rail-level of 14 feet 6 inches for standard gauge lines and 12 feet 6 inches for the metre gauge; while the abutments or piers should not be less than 7 feet and 6 feet 3 inches, for the respective gauges, from the centre of the nearest track; if they consist of masonry arches they should not infringe the dimensions shown on Figs. 7 and 8; beyond this, they will follow the

ordinary rules for road bridges. In dangerous soil, however, special precautions should be taken to prevent the vibration of the trains disturbing the foundations; in such cases an invert should connect the two abutments, so that the whole bridge may shake together.

35. Under bridges should have a clear head-way of 15 feet, to enable a loaded camel or wagon to pass; the width between abutments will depend on the importance of the road, but should never be less than 16 feet for a public road. As they have to carry the railway and to withstand the vibration of trains passing over them, they should, if arched, be made of the very best masonry; and the depth of the arch should be somewhat greater than for a road bridge, and a cushion of earth, at least 2 feet thick, provided between the bottom of the ballast and the top of the arch on all bridges of 15 feet span or over: on smaller spans the thickness of the cushion may be reduced. Steel girders are however now generally employed.

When a railway line passes over a navigable stream or canal, care should be taken to allow sufficient head-way for the masts or cargo of a vessel to pass well clear of the underside of the girders.

36. **Fencing.**—The object of the provision of fencing is to prevent trespass by persons and animals. Almost all of the earlier Indian railways were fenced on both sides and in England the provision of fencing is compulsory. Experience has shown, however, that in India it is almost impossible to prevent human trespass, an ordinary fence acting as no deterrent; while with the fitting of efficient cow-catchers to engines the need for fencing as a preventive of accident from cattle trespass has grown less pronounced. On many of the later railways therefore, which were not intended for high speeds, fencing, which always forms a considerable item of cost in a railway estimate, has been omitted, except around station yards and at level crossings; and it is now usually only on high-grade lines intended for fast mail and passenger train services that fencing is provided throughout.

37. Amongst the more common descriptions of fence in use are the ditch and bank, walls of mud or dry stone, hedges of various kinds, the post and rail, and wire fencing, and of these the most satisfactory is wire fencing; the others, owing to the difficulty and cost of maintaining them, easily fall into disrepair and are then useless for the prevention of cattle trespass. A good type of wire fence should be not less than 4 feet high and should have the wires sufficiently close to prevent cattle forcing their way through them—usually 5 wires are provided—and the posts should not be more than 12 feet apart. In districts where good stone is obtainable,

**METRE GAUGE  
MAXIMUM AND MINIMUM  
DIMENSIONS**

**FIG. 8.  
DIMENSIONS OUT OF STATIONS.**

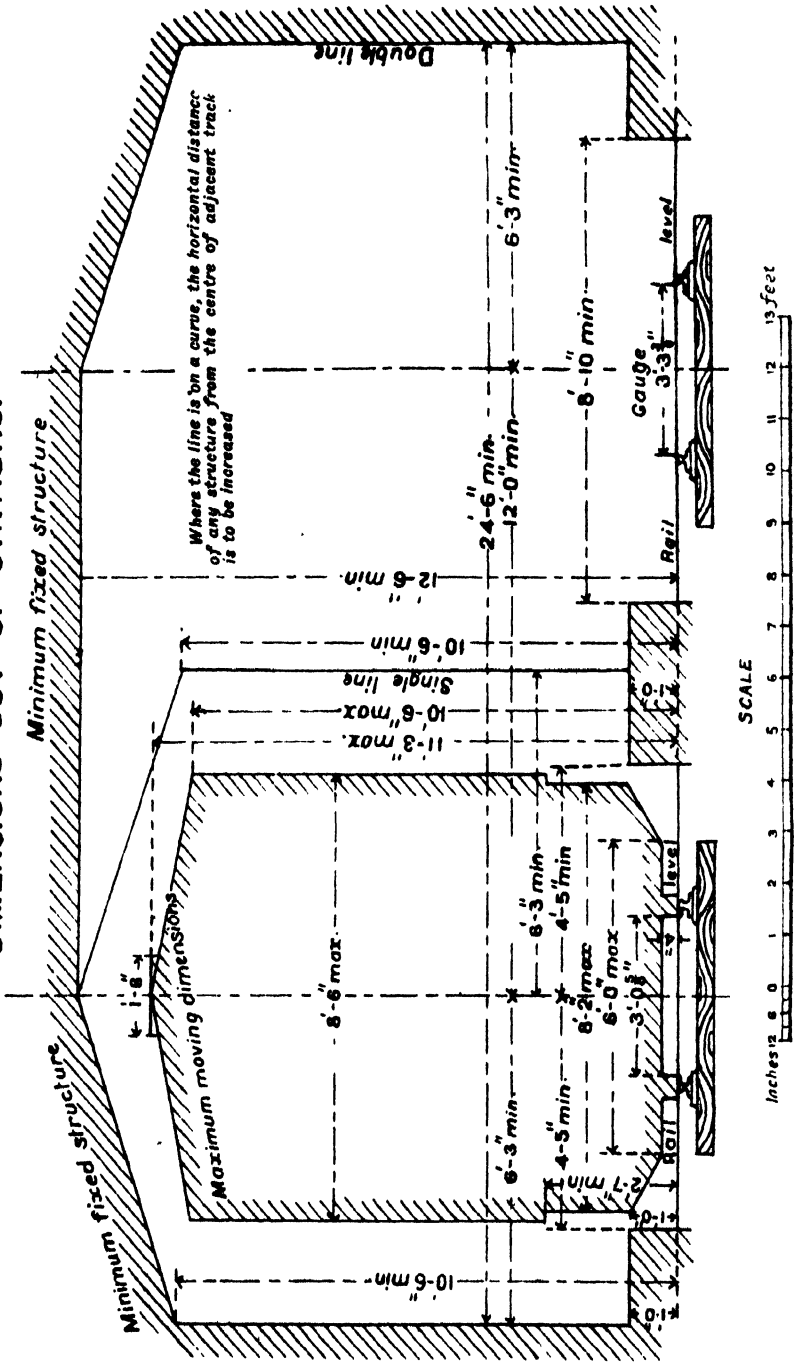



fencing posts may be of this material, stone fencing posts are not however to be recommended, as they are easily broken by cattle. Many types of iron posts are in use, and one of the best consists of an upright of light channel section set in a heavy cast-iron base, provided with vertical fins which ensure that it is firmly held in the ground. Straining-posts should be provided at frequent intervals; and they should be fitted with some arrangement which permits of the tightening and adjustment of the wires, or the wires themselves may be fitted with adjusting screws. At all right-angle bends in the alignment of the fencing, strong struts should be provided to prevent the corner-posts being pulled over out of plumb; and end-posts should be similarly strutted.

When fencing is provided, it is usual to erect it at the boundaries of the permanently acquired land (see Figs. 3 and 4). At level crossings the fencing should be carried up to the gate-posts (see Plate I) and similarly, where bridges occur, up to the masonry of the return or wing-walls.

## CHAPTER II.

### PERMANENT WAY AND BALLAST.

1. On completion of the works—embankments, cuttings, bridges, culverts etc.—which go to make up the substructure of a railway and to which reference has been made in the preceding chapter, the next operation in the construction of a railway is the laying of the track on the levelled formation.

2. A railway track consists of two parallel rails (made formerly of iron but now exclusively of steel) so designed that the flanged wheels of vehicles may run smoothly upon the upper surfaces or tables of the rails. The rails are supported firmly and held at a constant distance apart, by transverse ties or, as they are usually called, "sleepers," which may be either of wood, iron or steel. The sleepers again are bedded on the "ballast" which must be of such material that, while affording a firm support to the sleepers, it permits of the exact adjustment of the level of the rails to any desired height above the surface of the formation. In the present chapter the various types of rails and sleepers now in general use, with their connections and fastenings, will be described; and a brief account given of the materials which experience has shown are best suited for use as ballast.

3. **Permanent way.**—On English and European railways, built through countries where borrow-pits would be highly objectionable it was, and still is, the practice, except under unusual circumstances, to construct the banks from soil excavated from the cuttings; and for this purpose it was the custom to lay temporary lines of railway for the conveyance of the wagon-loads of earth used in constructing the embankments. As opposed to these temporary lines the permanent line was, in the early days of railway construction, called the *Permanent Way*, and this name has been adopted even in countries where no temporary lines whatever have been used for the construction of the banks.

4. At the present day, two distinct types of rail—the bull headed and the flat-footed type, each of which has certain modifications—are in general use. The former was evolved gradually: the earlier rails were of cast-iron in short lengths, supported in suitable *chairs* on stone blocks at their ends. Rails of wrought-iron were next introduced, in longer lengths, the chair being retained at the ends, and intermediate chairs being provided. It was then found that the ends of the rails required *fishing*, as when only supported in the chairs they sagged under the load

of every passing wheel, so that a severe shock took place in passing over the joint. It was also found that the head wore out by crushing, generally long before the rest of the rail was appreciably damaged; so it was considered advisable to make the top and bottom alike, with the purpose that, when the upper table was sufficiently worn, the rail might be reversed in the chairs and the unworn lower table brought into use. Thus was evolved the double-headed rail, which it was hoped would have practically double the life of a rail having only one table designed to carry the wheels of the rolling-stock. Experience soon showed, however, that the surface of the lower table was so indented by long contact with the chairs, that smooth running on it was no longer possible, and the double-headed rail gradually gave place to the "bull-headed" type, shown in Fig. 9, in which the head has a considerably

FIG. 9.  
SECTION OF 50 lbs  
BULL-HEADED RAIL

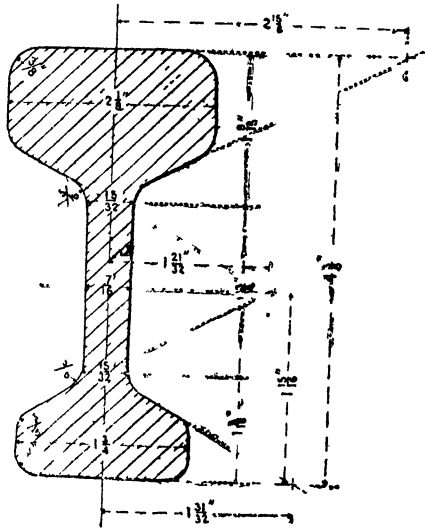

larger section than the foot, the latter being now only designed to add strength to the rail and to form a bearing for its support in the chair.

5. As the design of the rail was thus gradually improved, it was found at an early stage that something more satisfactory than the stone blocks, on which the chairs were originally supported was required; and these were soon superseded by wooden transverse sleepers, to which the chairs were secured by spikes. The rail was held between the jaws of the chair by a *key*, generally of wood, which on some railways was

placed outside and on others between the rails. This arrangement which is shown on Plate II Type A and to a larger scale in Figs. 10 and 11, is probably that best suited to conditions in England. It was inaugurated at a time when rails of wrought-iron cost four or five times as much per ton as the chairs of cast-iron; it has the advantage that, if the chairs are broken, or the development of traffic requires a heavier chair to carry a heavier rail, they can be melted down and re-cast at a comparatively small outlay; while for firmly holding the rail and distributing the loads to which it is subjected over a large area of the sleeper, the chair is in advance of anything that has yet been applied to the flat-footed rail. Further advantages are that a damaged or broken rail can be removed without disturbing the sleeper fastenings; and as the section of a bull-headed rail lends itself to easy rolling in the mills, there is much greater probability of obtaining uniformity in the metal than in the case of a rail rolled to any other section.

6. In the *Vignoles* (so called after its inventor) or flat-footed type, the foot of the rail itself is rolled out to form a base, usually rather narrower than the height of the rail, on which it rests on the sleeper, being attached to it directly by dog-spikes or other fastenings. Types B and C, Plate II, give the general arrangement of this type of permanent way, and details are shown in Figs. 12 and 13.

7. The earlier Indian Railways followed the English practice of double-headed rails in cast-iron chairs; but recently flat-footed rails have been largely used. The latter have a decided advantage where the cost of carriage of materials forms a considerable proportion of the total cost and tends to equalise the value of cast and wrought iron or steel; they have a further advantage in a country where the cost of recasting broken or obsolete chairs is considerable, and the introduction of steel in place of iron for rails has given them a still greater advantage.

8. The flat-footed rail is therefore cheaper in first cost. When made of steel it will last as long as a bull-headed rail of the same weight. Since chairs are not required, it can be made considerably heavier and stronger than the bull-headed rail, as a less total cost for the permanent way; it has greater lateral rigidity, which is a considerable advantage; and it requires fewer parts for its attachment to the sleepers and can be more rapidly laid in consequence. On the other hand, when laid directly on wooden sleepers, the small area of its bearing on the sleepers results in their being crushed at the rail-seat and in a consequent lessening of the life of the sleepers; while the holding power of the dog-spike, which until recently was the usual fastening, was insufficient

**FIG. 10.**  
**85-LB. BULL-HEADED**  
**RAIL WITH CHAIR**  
*Scale  $\frac{1}{8}$*

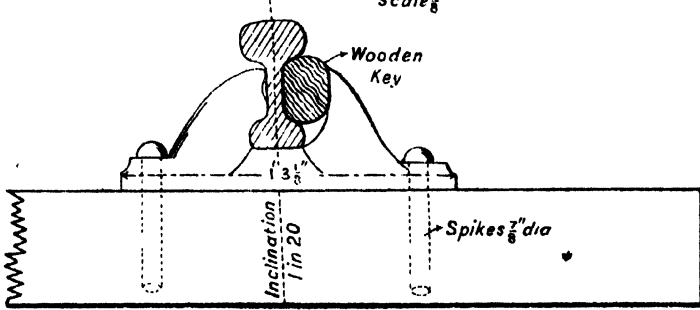

**FIG. 11**  
*Plan of Chair*  
*(Rail and Fastenings removed)*

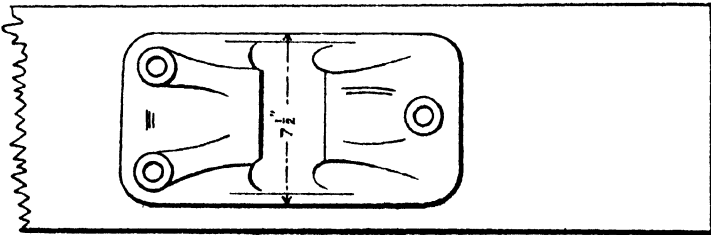

**FIG. 12**  
**75-LB. FLAT-FOOTED**  
**RAIL WITHOUT BEARING-PLATES.**  
*Scale  $\frac{1}{8}$*

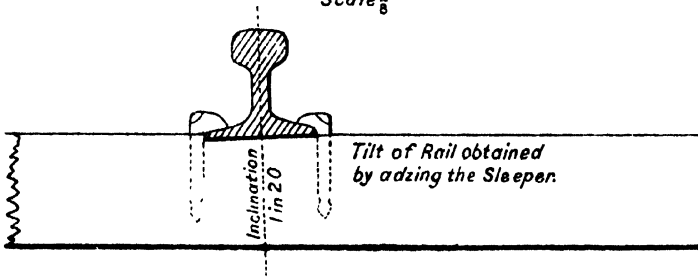

**FIG. 13.**  
*Plan Showing relative*  
*position of Dog-spikes*

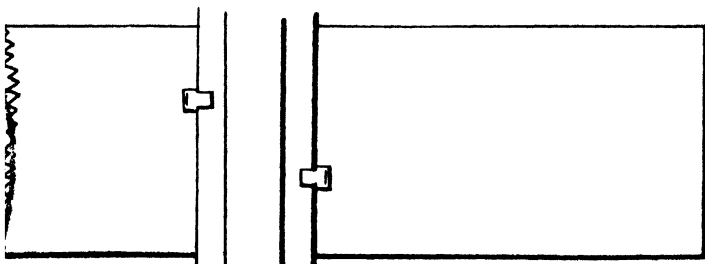



## PERMANENT WAY AND BALLAST.

in many cases to prevent its gradual withdrawal under the continued rise and fall of the rail, caused by passing trains. These disadvantages have, however, been to a large extent overcome by the use of bearing-plates and screw-spikes (vide para. 21); but as no form of bearing plate can afford the same lateral support as the cast-iron chair of the bull-headed rail, the latter has a decided advantage in that there is no possibility of the outward tilting of the rail on sharp curves, which is liable to occur when the fastenings of a flat-footed rail have been badly worn or have worked loose.

9. The principal requirements of any system of permanent way are—1st, that it should be fixed so firmly that the gauge (i.e. the distance between the inner faces of the rails) shall always be preserved; 2nd, that it should preserve a horizontal position transversely to the line [except in the case of curves, where provision is made for superelevating the outer rail above the inner (vide Chapter IX)] or the resulting oscillation would injure the rolling stock; 3rd, that it should preserve an even gradient otherwise the carriages would proceed in a succession of lurches which would cause a loss of power from increase of friction, and be highly injurious to springs and axles; 4th, that there should be a certain elasticity in the roadway, whereby the harshness of the impact between rails and wheels will be reduced, such harsh impact being dangerous to the axles and causing much wear and tear; 5th, that the friction between the wheels and rails should be a minimum beyond the amount necessary to ensure the wheels "biting;" 6th, that the rails should be strong enough between the points of support to bear without appreciably changing form the greatest weight liable to come upon them; 7th, that it should be so constructed as to enable any portion requiring repair to be removed and replaced with ease; 8th, that it should be capable of distributing the weight of the train, which is concentrated at the points of contact of the wheels with the rails, in such a manner as to prevent any permanent settlement or crushing of the different parts.

10. **Rails.**—Sir Benjamin Baker's formula for the weight of rails is as given below, assuming the usual spacing of sleepers, i. e. about a yard centre to centre.

Let L = the maximum load on one axle in tons;

V = " " speed of trains in miles per hour;

W = weight of rail in pounds per yard.

$$\text{Then } W = 17\sqrt{\frac{L}{3}} + 000025LV^2$$

This works out as follows :—

Speed in lbs per hour.	Axle-loads.			
	5-Tons.	10-Tons	15-Tons.	20-Tons.
20	Rail 32 lbs.	Rail 51 lbs.	Rail 67 lbs.	Rail 81 lbs.
40	34½	55	72	87
60	38	61	80	97

In the rules of the Government of India it is prescribed that for rails of 60 lbs. weight per yard and under, the axle-load in tons should not exceed  $\frac{1}{4}$ th of the weight of the rail in lbs per yard. For rails weighing more than 60 lbs. per yard, the following formula expresses very approximately, the relation between maximum permissible axle-load and weight of rail :—

$$L = \frac{W}{20} \left( 1 + \frac{W}{25} \right) + 1.8,$$

where L and W have the same meanings as above.

To simplify the manufacture of and placing of orders for rails, the British Standards Committee have drawn up a series of types of rail sections, in sizes which are multiples of 5 lbs. per yard, with the recommendation that railways should quote from these types when indenting for rails. This recommendation has been adopted by the Government of India.

11. When the rail had attained its first stage of development it consisted, as has been said in paragraph 4 above, of two similar tables with rounded sides connected together by a web, the whole made of iron and rolled in lengths of 20 to 24 feet. The proportions, curves, and inclinations of the shoulders were decided rather by convenience for rolling than by the efficiency of the section when finished; it was not possible with the earlier appliances to roll them successfully, unless the angle  $bac$  (see Fig. 17) was comparatively large, the radius  $or$  of the tables comparatively small, and the web or central portion comparatively thick, and all the fillets and angles rounded off with a comparatively large radius. Nearly all these conditions are the reverse of what are required: a small radius for the head rapidly wears the tyres of the wheels hollow; the large angle  $bac$  is unfavourable for fishing; a web thicker than is absolutely necessary is so much metal wasted; and a large radius for the fillets and angles prevents the fish-plates fitting properly.



RAIL SECTIONS, HALF SIZE.

FIG. 14.

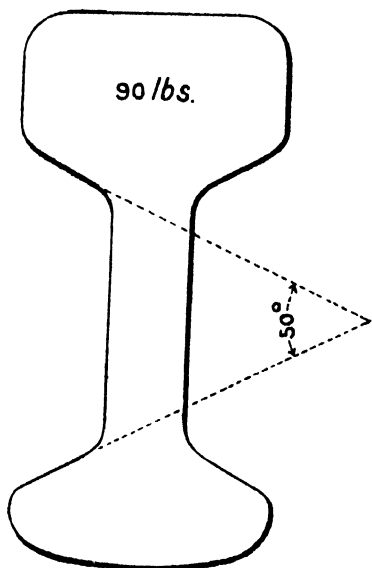

FIG. 15.

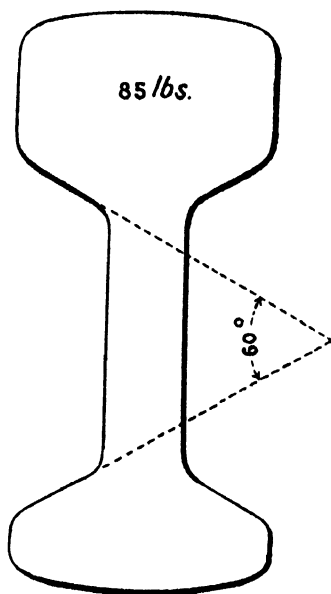

FIG. 16.

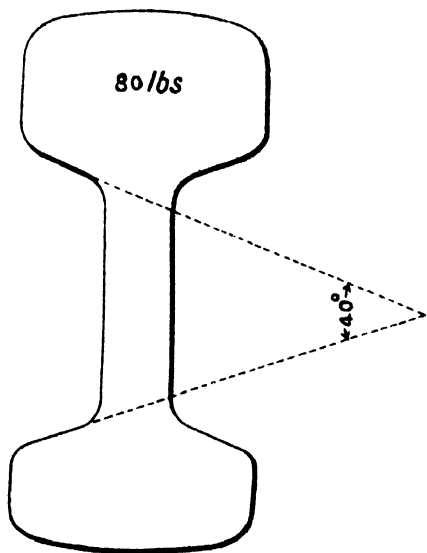
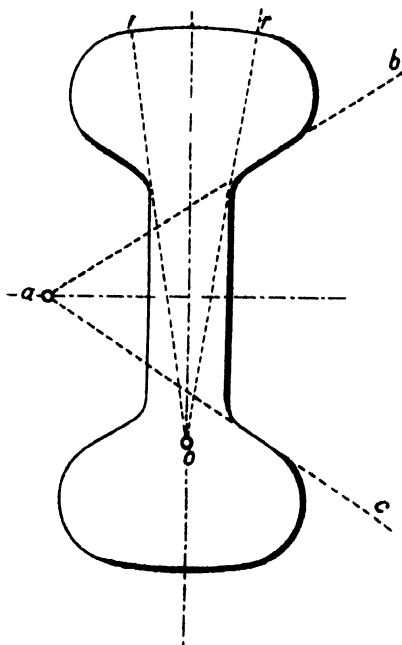

FIG. 17.



12. **Bull-headed rails.**—With the introduction of steel in place of iron, and improved methods of rolling, the section of the rail has also been improved; rails to be used in chairs are now almost invariably made bull-headed; the radius of the top and bottom tables varies from 8 to 16 inches, of the shoulders from  $\frac{5}{16}$  to  $\frac{1}{2}$  inch, of the fillet between the web and head and foot from  $\frac{1}{4}$  to  $\frac{3}{8}$ , and of the angles between the sides and sloping parts of the head and foot from  $\frac{3}{8}$  to  $\frac{1}{2}$ . The web in England, where rails rust more rapidly than in India, is from  $\frac{5}{8}$  to  $\frac{1}{2}$  inch thick, and the weight of the rails from 80 to 110 lbs. per yard, generally in lengths of 30 feet, but occasionally they are made in special lengths, particularly for use on bridges, as long as 60 feet or more.

13. The following table gives the weight and loading dimensions of the rails in use on some of the principal English railways; the weight of rails is always given in pounds per yard; with iron rails this was ten times their sectional area in inches, so that a rail of 8 inches section was spoken of as 80 lbs. per yard; with steel the weight is about  $2\frac{1}{2}$  to 3 per cent. greater, so that 8 inches section would correspond to a weight of about 82 lbs :—

Railway.	Weight of rail.	Depth.	Width of head.	Thickness of web.	Angle between fishing planes
	Lb.	In.	In	Sixteenths.	Degrees.
London and North-Western .. ..	90	$5\frac{9}{16}$	$2\frac{1}{2}$	13	60
North-Eastern .. ..	90	$5\frac{1}{2}$	$2\frac{1}{16}$	11	58
London and South-Western .. ..	87	$5\frac{9}{16}$	$2\frac{1}{2}$	11	50
Great Western .. ..	86	$5\frac{1}{8}$	$2\frac{1}{2}$	11	45
Lancashire and Yorkshire .. ..	86	$5\frac{9}{16}$	$2\frac{3}{8}$	12	45
Manchester, Sheffield and Lincoln ..	86	$5\frac{1}{2}$	$2\frac{1}{2}$	13	50
Metropolitan .. ..	86	$5\frac{9}{16}$	$2\frac{1}{2}$	11	48
Midland .. ..	85	$5\frac{1}{8}$	$2\frac{3}{8}$	12	60
Great Eastern .. ..	85	$5\frac{1}{2}$	$2\frac{1}{8}$	11	65
London, Brighton and South Coast ..	84	$5\frac{1}{2}$	$2\frac{1}{16}$	12	52
North British .. ..	84	$5\frac{1}{2}$	$2\frac{1}{8}$	11	60
London, Chatham and Dover .. ..	83	$5\frac{1}{16}$	$2\frac{1}{16}$	11	50
Hull and Burnley .. ..	80	$5\frac{1}{2}$	$2\frac{1}{2}$	12	70
Highland .. ..	80	$5\frac{1}{2}$	$2\frac{1}{2}$	11	40

Figs. 14, 15, and 16 show the sections of the London and North-Western 90 lbs., the Midland 85 lbs., and the Highland 80 lbs. rails to half size. These are good examples of British rails.

14. **Flat-footed rails.**—Plate III shows the British Standards Committee's 90 lbs. flat-footed or Vignoles rail adopted for use on Indian State Railways. For the 75 lbs. type the dimensions are proportionately reduced, the height being  $4\frac{1}{8}$  inches, the head  $2\frac{7}{8}$  inches wide and the foot  $4\frac{1}{8}$ , the same as the height. The old Indian State Railway type of 75 lbs. rail

is seen in Plate VI. In its case there were special reasons for making the head  $2\frac{3}{4}$  inches wide and the foot 4 inches wide, as these were the widths in the rails previously in use. A great length of railway was laid with steel sleepers, and serious difficulties would have arisen had these widths

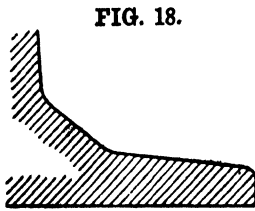

FIG. 18.

been departed from. But for these considerations the rail would have been better designed if the head had been made  $2\frac{1}{2}$  inches and the foot  $4\frac{1}{2}$  inches wide. In flat-footed rails it is very desirable to make the upper surface of the foot practically plane (as in Plate III): in many of the older rails the foot is made of the section shown in Fig. 18; this is particularly

liable to flaws, as the metal, unless very soft, will not enter the rolls easily.

15. Rails are now made of Bessemer steel, which is run into ingots in a molten state, and then gradually rolled out to the required section. The steel should contain not less than 0·3, nor more than 0·45 per cent. of carbon, nor more than 0·06 per cent. of silicon, 0·06 per cent. of arsenic and phosphorus together, nor more than 0·06 per cent. of sulphur. The most objectionable ingredient is phosphorus, which makes the rails brittle; if this could be entirely removed, a greater proportion of carbon could be used, and the rails would wear better. They are rolled in lengths of 30 to 40 feet,\* but it is usual to specify for a proportion of about 6 per cent in lengths 3 and 6 feet shorter to give the manufacturers an opportunity of utilizing in shorter lengths any of which the ends may be slightly defective. The ends are cut off square while hot with a circular saw, and the holes for the bolts are drilled.

16. **Fish-plates and Joints.**—The joints between the ends of rails are now invariably made by fish-plates, which consist generally of a pair of plates rolled to a section to fit between the head and foot of the rail and held together by bolts passing through holes in the web of the rail.

17. The requirements of a good joint are (1), that it shall hold the two rail ends as nearly as possible not only at the same level, but in the same straight line; (2), that its flexibility and strength shall be as nearly as possible the same as that of the solid rail; (3), that it shall provide for the expansion by heat, or contraction by cold, of the rails; (4), that it shall be so arranged that any rail can be easily disconnected for renewal and replaced; (5), that it shall be capable of adjustment as the surfaces of contact between the rail and fish-plate wear. The first two conditions can only be partially attained. Under a passing wheel, the natural

\* The British standard length is now 36 feet.

tendency is for the end of one rail to sink below the other, so that there is a jump from one rail to the other; and however strong the fish-plates be made, the tables of the two rails will not be in the same plane, as the stiffness of the rail and fish-plates together must be greater than that of the fish-plates alone, so there will be an angle slightly less than two right angles between the surfaces of two adjacent rails. It seems impossible to avoid having a rail of a certain uniform flexibility, than near the ends a sudden increase in rigidity, and at the joint itself a sudden decrease. To provide for condition (3), it is necessary that the plates shall not grip the rail too tightly, and this also prevents the first condition being completely attained. The variation in temperature may amount to 180 degrees Fahrenheit between the hottest period of the day in the hot weather, and the coldest at night in the winter though such an extreme range is unusual; but a range of 130 degrees is common, and this will cause a difference in length of about  $\frac{1}{4}$  to  $\frac{5}{8}$  of an inch in a 30 feet rail, and there must be at least this space between the ends of the rails when they are fully contracted. To allow for this expansion and contraction the holes in the ends of the rails, through which the fish-bolts pass are made of larger diameter than the fish-bolts; they are sometimes made oval in shape the longer axis being horizontal, vide Plate V. If expansion or contraction were entirely arrested it would produce a stress of about 10 tons per square inch of section of the rail, or 75 tons for a 75 lb. rail, sufficient to carry away any ordinary fastening, or to cause the rails to buckle and spring out of line, either laterally or vertically. There must therefore be a certain amount of slackness between the plates and the rails. Conditions (4) and (5) are attained by adopting a suitable angle of inclination between the fishing planes, that is to say, between the planes of contact between the rail and the plate; and by leaving a suitable space between the web of the rail and the fish-plates, the fish-bolts being tightened up as the fishing-surfaces wear. It has been found in practice that it is advisable that the angle of inclination between the fishing planes and the horizontal should not be less than 1 in  $4\frac{1}{2}$ ; the standard now adopted in America is 1 in  $4\frac{1}{2}$ , and on Indian State Railways 1 in 4. There are no advantages, and several disadvantages, in using very long plates, or a large number of bolts; with a very long plate it is questionable whether the same amount of metal could not be more efficiently disposed in a different way to get a better joint; if more than four bolts be used, the stress on each bolt will not be decreased, but the grip of the plates on the rail tending to stop free expansion and contraction will be increased, as well as the cost of the plates.

It is very desirable to have a fastening for fish-plates which will not work loose under the vibration of a passing train; various forms of spring washers and lock-nuts have been introduced for this purpose; the former do not appear to have been very successful, the latter are expensive; and unless kept entirely free from rust, become worse than useless; and it is held by most engineers that an ordinary bolt of large diameter with a nut of a length of  $1\frac{1}{4}$  to  $1\frac{1}{2}$  times the diameter of the bolt is as good as, and much cheaper than, any lock nut.

18. As the depth between the fishing planes of the fish-plates is fixed by the design of the rail their strength and stiffness can only be increased, without making them needlessly heavy and clumsy, by bending them out first to clear the foot of the rail, and then continuing them down to or below the level of the foot of the rail, vide Plate V. With bull-headed rails this is now generally done, but, as it is very important that the first sleeper on each side of the joint should be brought up as close to the joint as possible in order to support it firmly, the extension of the section of the fish-plate below the rail is frequently, more especially when the sleepers are of the cast-iron pot type shown on Plate IV, only carried to a short distance on each side of the joint; the fish-plate is then described as "*fish-bellied.*" With flat-footed rails the plate is seldom carried below the level of the bottom of the rail: the plates are then called angle fish-plates, see Plate III. A well designed pair of angle plates will give a stiffness equal to  $\frac{2}{3}$ rds that of the rail itself. The fish-plates shown in Plate VI are not carried down; they are so arranged that they do not interfere with the keys of the steel sleepers. They are fastened by four one-inch bolts, an unusually large size for such a rail; the bolts have square heads, which are held by a groove in the plate, a washer being laid in this groove under the nut which is hexagonal: the holes for the bolts,  $1\frac{1}{8}$ th inch in diameter, are punched while the plates are hot. To allow for the expansion of the rails the holes in the rail ends are made  $\frac{5}{8}$ th to  $\frac{1}{2}$ th inch larger than the bolts.

19. **Chairs and other supports.**—A double-headed or bull-headed rail, if the sleepers are of wood, requires for its support chairs which are made of cast-iron. These were first made of about 20lbs. weight each, but the advantage of a heavy chair, which distributes the pressure over a large area of the sleeper, and adds to the general stability of the permanent way, is now so well recognised that 45 to 50 lbs. each is now the usual weight on main lines in England, and the Board of Trade require that they shall be not less than 40 lbs. on lines with heavy traffic worked at high speeds. Their bases are flat, giving an even bearing on the timber sleepers 1 foot



FIG. 19.

WOODEN KEY

SIDE ELEVATION ON C.D.

SIDE ELEVATION ON A.B.

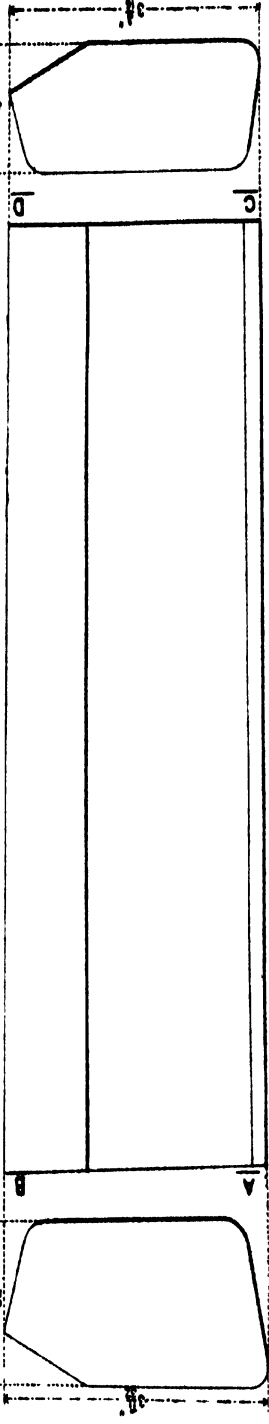

FIG. 20.

STEEL COILED KEY

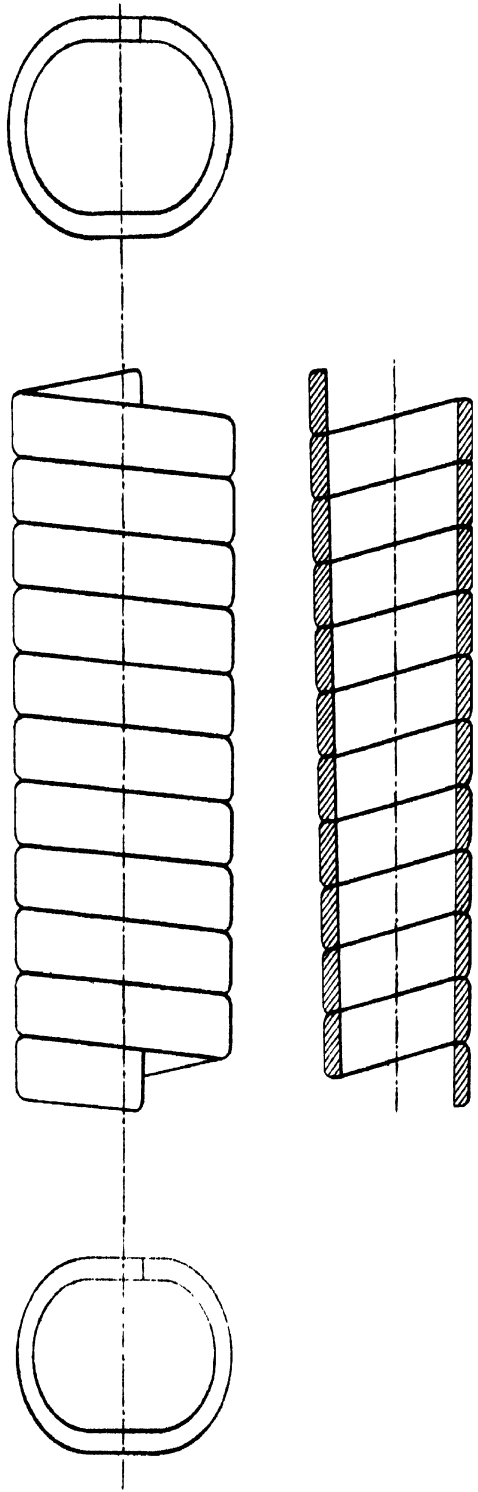
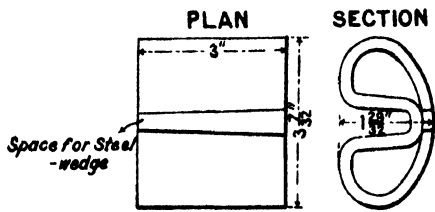
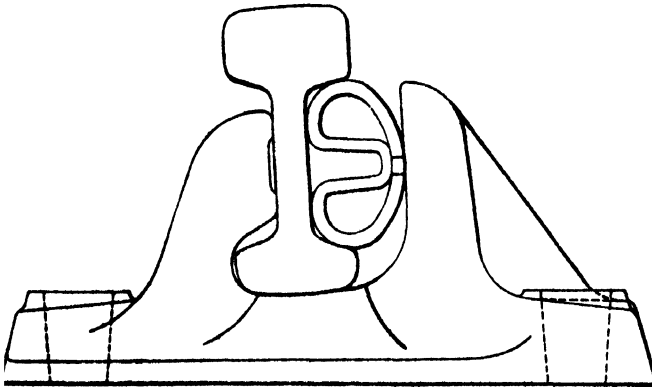
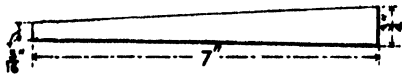



FIG. 21.  
STUARTS  
PATENT KEY



WEDGE



Scale  $\frac{1}{4}$  Full Size

2 inches to 1 foot 4 inches long at right angles to the rail, and  $6\frac{1}{2}$  to  $7\frac{3}{4}$  inches wide, measured parallel to it, the bearing area on the sleeper being 100 to 120 square inches. The rail is dropped in between the jaws, the inner jaw bears against the web and holds down the foot of the rail, the space between the inner and outer jaws being wide enough to let the rail drop into place; and it is then held firmly in position by a key, generally of hard wood but frequently of metal, driven between the outer jaw and the web of the rail. The keys are now almost invariably placed on the outer side of the rail, but in some of the older patterns they were on the inner side: practice has shown that the outside key reduces vibration, especially on sharp curves. The bearing of the foot of the rail on the chair should be 6 to  $7\frac{1}{2}$  inches long, and should fit the rail accurately for a width of at least 2 inches, and the jaws, as well as the bearing part, should be so shaped as to give the head of the rail an inward inclination equal to that of the coning of the wheels, usually about 1 in 20 (see Figs. 10 and 21.) Figs. 19, 20 and 21 show different patterns of keys, Fig. 19 showing a wooden key, while Figs. 20 and 21 show steel keys. Stuart's key (Fig. 21) is probably the best steel key, that has hitherto been designed, being strong and durable, and as it exercises a powerful grip on the rail, it has been exceptionally successful in resisting creep (vide Chapter XVII). It is now being extensively used on several railways in England and India.

20. **Fastenings.**—The chairs are fastened to the sleepers generally by two round iron spikes (see Fig. 22) about  $\frac{3}{4}$  or  $\frac{7}{8}$  inch diameter, and one or two wooden trenails, about  $1\frac{1}{2}$  inch diameter. The latter are used in England to prevent rattling, as it is not possible to cast the holes in the chairs with sufficient accuracy (except at prohibitive cost) to make them fit the spikes. Various plans for overcoming this difficulty have been tried, but not with very great success: the best appears to be to make the holes in the chairs large and put in a wooden thimble, through which the spike passes. Neither trenails nor wooden thimbles are likely to succeed in India, except perhaps in places close

FIG. 22.

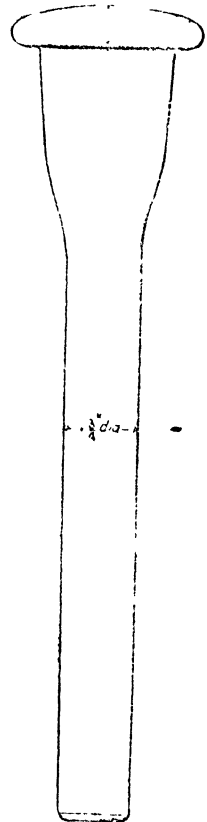

to the sea, where the climate does not vary greatly. It was once thought that a better fastening than a spike would be a bolt (see Fig. 23) with a broad nut or "fang" on the underside of the sleeper. But the fang was found to be so inconvenient when renewals of rails or sleepers had to be carried out, that the fang-bolt has now fallen into disuse in India, and is not much used elsewhere. Coach screws have been used with success in England but it is now considered that smooth spikes inserted in hollow wooden trenails or plugs are just as effective and less costly.

FIG. 23

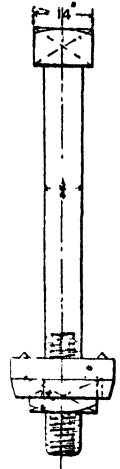

21. Flat-footed rails were, and still are in many cases, spiked direct to the sleepers with *dog spikes* (see Plate III) about  $\frac{5}{8}$  inch square, and 5 inches long under the head, the sleeper being adzed to the necessary inclination, usually about 1 in 20, to form the rail seat (see Fig. 12). This is a weak fastening: only the outer spike holds the rail in position when subjected to lateral shocks from a passing train and prevents its sliding outwards; the bearing of the rail on the sleeper is limited by the width of the rail foot, multiplied not by the whole width of the sleepers, but by only a part of it, as the edges of the wood soon lose their elasticity and give no support. The adzing of the sleeper to give the inclination to the rail also affects its vitality; and leaves a raw place at which decay and cracks start.\* *Bearing plates* (see Plate III) are now generally used on all sleepers next the rail joints, and under the outside rail on sharp curves. These are plates about  $7\frac{1}{2}$  to 10 inches wide measured at right angles to the rail, and  $6\frac{1}{2}$  to 9 inches measured along the rail, rolled to such a section as to give the necessary inclination to the head of the rail, and with holes punched in them for the spikes (see Plate III). These increase the bearing area on the sleeper and hold all the spikes up tight against the foot of the rail, so that all exercise the proper holding power whichever way the rail tends to shift; they also do away with the necessity for adzing the sleeper. It seems probable that the use of such plates with pine sleepers in all cases, and with wood of a medium hardness, such as deodar, will add sufficiently to the life of the sleepers to pay for their cost, but with hard wood, such as teak, their advantages are not so marked. Their use will however in all cases undoubtedly give a better road, and to some extent increase the life of the sleepers.

\* For this reason the experiment of laying flat-footed rails in an upright position, i. e. without the usual tilt of 1 in 20, has been tried in India in cases where bearing plates are not used. In America, flat-footed rails are laid without tilt.

The chisel edge of a dog spike should be driven across the grain of the sleeper (vide note on Plate III). In France screw-spiques (see Plate III) have been used with considerable success, and on a large scale, for attaching flat-footed rails to timber sleepers, the sleepers being generally of oak or beech; while in India they are also now being extensively used.

**22. Sleepers.**—On the earlier railways these were stone blocks bedded firmly in the ground. It was soon found that under the vibration and pressure of the load sleepers sank unevenly, and when a wheel passed over one which happened to have sunk less than the others the effect was very similar to a blow from a hammer. Another of the early ideas was to fasten down heavy longitudinal timbers on to the tops of piles driven into the ground, and lay the rails on these; this, with the exception of the piles, survived for many years on the Great Western Railway of England, but was gradually abandoned on account of its high cost, both in timber and maintenance, which was only partly compensated for by the use of a lighter rail. The qualifications required of sleepers are (1), to hold the rails firmly to gauge, and at an inclination parallel to the coning of the wheels; (2), to interpose an elastic medium between the rail and the ballast, capable of absorbing the blows and vibrations of trains; (3), to distribute the weight on the rails over a sufficiently large area of ballast; (4), to enable the rails to be supported evenly by lifting and packing ballast under the sleepers when they sink; (5), to assist generally in the stability of the permanent way as a whole.

For these purposes nothing has yet been found to compare with cross sleepers of good, sound, well seasoned timber. These are generally for the 5 feet 6-inch gauge, 9 to 10 feet long, 10 inches wide, and 5 inches deep, of various sorts of timber. Teak is perhaps the best, but its cost is in most cases prohibitive and it is now generally used only for sleepers on girder bridges; sal is largely used, also deodar. The latter is a wood well suited for sleepers, being fairly hard, and standing extremes of damp and dryness well; it is, however, liable to split, and breaks across under a heavy blow somewhat easily. Pine, generally imported and creosoted, is also used a good deal in India, but will not last any length of time in a dry climate; also, being soft, it is quickly crushed under the load unless bearing plates or chairs, having a large bearing area, are used. In England pine sleepers are used almost exclusively and are generally creosoted, to preserve them from decay, the bases of the chairs having a very large bearing area. Australian timber sleepers are now being extensively used in India.

**23.** Sleepers are packed by beating ballast underneath them till they support the rails evenly; the area required to be packed for the 5 feet

6-inch gauge being about 400 square inches under each rail, or a length with ordinary sleepers of about 1 foot 9 inches on each side of the rail. The central part of the sleepers should never be packed, for if the packing under the rails sinks the sleepers would otherwise rock on their centres. Fig. 24 shows a packing tool; the tapered end of the tool being used for

FIG. 24.

PLATELAYERS'  
BEATER

loosening ballast, and the other end for beating the ballast firmly under the sleeper. In packing pot-sleepers, it is difficult to ensure that the interior of the pot is properly filled with firmly-packed ballast, if the sleepers are packed from beneath. Sleepers of this type are therefore usually packed from above by means of crowbars, holes being provided in the castings specially for the purpose; these holes are clearly shown on Plate IV.

24. Sleepers are generally spaced at an average distance of about 3 feet centres, those nearest the rail joints being closer together and those near the centre of the rail further apart. On lines with heavy traffic it is now generally recognized as desirable to make the maximum distance between the centres of the sleepers 3 feet, and make those near the joints less, while the sleepers immediately on either side of the joint should be brought up as close to the joint as the fish-plates will allow, in order to afford a firm support to the joint. In Plate III, the joint sleepers are 1' 7" apart, and in Plate V, 2' 8½". A good method of spacing is to put the sleepers next to the joints at 2 feet 2 inches centres, the next 2 feet 3 inches to 2 feet 4 inches, the next 2 feet 8 inches to 2 feet 9 inches, the next 2 feet 11 inches, and the remainder 3 feet: there will thus be one more sleeper per rail length than there are yards in the length of the rail. The best distance apart for the sleepers will depend to some extent on the strength of the rails in proportion to the load they have to carry: a light rail will require more, and a heavy rail fewer sleepers. But a practical limit is set by the fact that if there is less than 2 feet clear space between sleepers it is difficult to pack them properly.

25. Figs. 25 and 26 illustrate two methods frequently adopted in the sleepers of girder bridges. In Fig. 25, is shown an ordinary girder bridge deck-type, with cross-sleepers of wood, which are prevented from moving

**FIG. 25.**  
**CROSS SECTION**

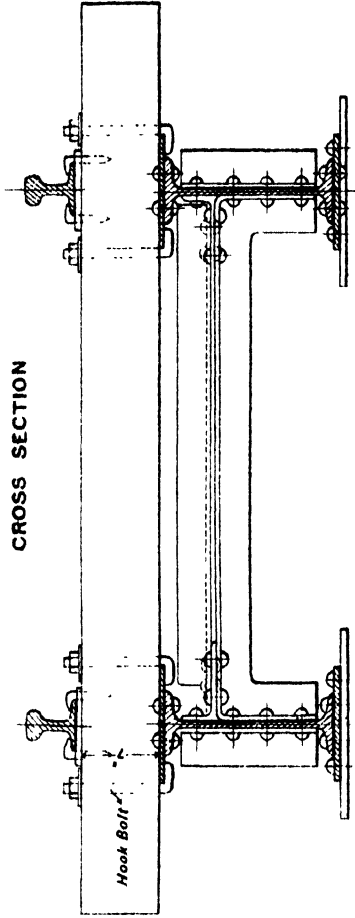

**FIG. 26.**  
**CROSS SECTION**

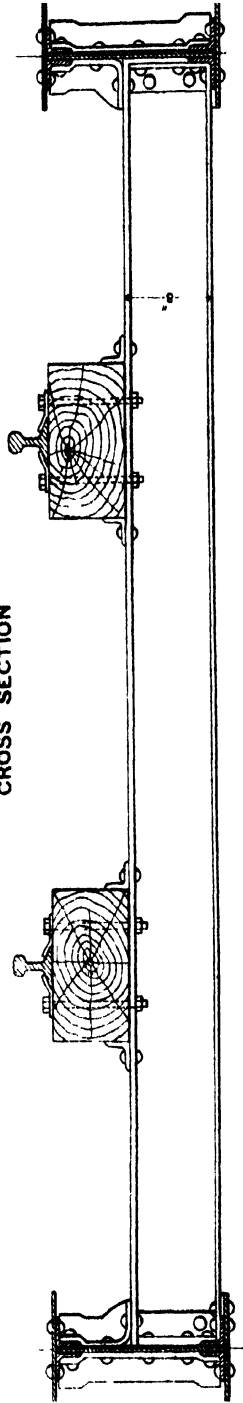



laterally, by so-called hook-bolts, which pass through the sleeper, and are bent so as to project under the upper flange of the girder. In the Figure, four of these bolts are shown; two would however be sufficient, either both outside or both inside the girder flanges. Fig. 26 shows a girder of the *through* type, with longitudinal timbers resting on cross-girders. The timbers are bolted to the flanges of the cross-girders, and are further safe-guarded against lateral movement by means of angle-iron cleats riveted to the flanges of the cross-girders.

26. On bridges, where the sleepers rest directly on the girders, cross sleepers are preferable in all cases where they can be used. They are generally made rather thicker than ordinary sleepers, partly because they exercise a cushioning effect between the train-load and the material of the bridge structure but chiefly to avoid the risk of breakage in case a wagon gets off the rails; for the latter reason they are also put closer together, usually at 2 feet to 2 feet 6 inches centres. Longitudinal timbers on bridges, except when laid in trough girders, should be avoided as far as possible; they do not hold the spiko so well;\* it is more difficult with them to keep the rails to gauge; and if a vehicle gets off the rails there is nothing to support it.

27. **Metal sleepers.**—Though timber sleepers undoubtedly make the best road, the supply of timber is limited. That available in India is certainly not sufficient to maintain all the existing lines, even without any provision for new ones. Various forms of metal sleepers have therefore from time to time been introduced, and have been very largely used in India. No exact data are available, but probably two-thirds of the broad gauge railways in India are laid with metal sleepers: on the metre gauge, as the sleepers are smaller, about 6 feet by 8 inches by  $4\frac{1}{2}$  inches, timber is more largely used.

28. **Pot sleepers.**—When double-headed or bull-headed rails in chairs were used, the first step was to enlarge the base of the chair to the form of an inverted saucer, and connect the pair together by a wrought-iron tie-bar to hold them to gauge. This form, called the "Pot Sleeper," has considerable hold on the ballast, and in the older roads laid with it the tie-bars were only used in about three or four sleepers in each rail length. Experience has shown that this is not wise, as the sleepers are disturbed in packing, and tie-bars are now generally used on every sleeper. The next development with this form of sleeper was to make it oval, supporting the rail on two bearings about a foot apart, the idea being that fewer sleepers would thus be required, the distance between the supports of the

---

\*Special spikes should be used, *vide* note on Plate III.

rail on two adjoining sleepers remaining the same ; but as the support was at some distance from the centre of the bearing of the sleepers on the ballast this was not satisfactory.

29. One of the latest developments of this class of sleeper, which is a good illustration of the class, is shown in Plate IV. This is the sleeper used on the Great Indian Peninsula Railway. It is designed for a flat-footed rail, which it holds by the foot by means of a fixed lug on the outer side, and a movable clip and key on the inner side, the table on which the rail rests being given an inclination of 1 in 20. The gauge and proper inclination are preserved by a wrought-iron tie-bar, passing through the two pots and held by a gib on one side of the pot and a cotter on the other. The cotter is  $\frac{1}{4}$  inch wider at the centre than the gib, so that by reversing the position of the gib and cotter on one pot the gauge can be increased by  $\frac{1}{4}$  inch, and by reversing it on both pots, it can be increased  $\frac{1}{2}$  inch. The tie-bar passes through a sleeve cast in the pot, to prevent the points of contact between the bar and pot getting filled with fine grit and mud, which would soon make the bar rust in.

The earlier forms of pot sleepers, of which there are a very large number on Indian railways, were similar to this in general arrangement, except that they had two jaws, like a chair, between which a double or bull-headed rail was keyed.

30. **Plate sleepers.**—Another pattern of cast-iron sleeper is the Plate Sleeper. In this the cast-iron part takes the form of a plate, generally oblong, with its greatest length at right angles to the rail ; but it may be circular or oval. It is strengthened by ribs on the top which are shaped to form jaws or clips for holding the rail, and through which the tie-bar passes between the foot of the rail and the top of the plate. There is a small cross rib underneath to give a lateral hold in the ballast. This form of sleeper has less hold in the ballast than the pot-form.

31. An example of this pattern is give in Plate V, which shows the Denham-Olphert Plate Sleeper used on the East Indian Railway. Its chief peculiarity is that the rail, instead of resting on its base, is held up by its shoulders which rest on the jaws of the sleeper. This was invented in the days of double-headed iron rails which were reversible (*see* para. 4), the advantage being that when the rails were reversed their bases, which then became their heads, were free from chair-marks. With steel rails the advantages of this method of support are very questionable. Instead of having the whole depth of the rail between the wheel and the sleeper, there is only the head of the rail to transmit the shocks and blows caused by the train load, and the head is, in consequence, more liable to damage.

The outer jaw forms part of the plate ; the inner jaw is separate, and is held in place by a key passing through ribs on the plate, and through the tie-bar. This key, being horizontal, has very little vertical stiffness to hold the tie-bar and loose jaw down to the plate, and it is in practice easy by lifting the outer edge of the plate with a lever to tilt the whole plate and rail bodily inwards. This danger might be reduced by increasing the length of the tie-bar, and the distance from the rail of the point at which it rests on the top of the plate ; but this would not altogether remove the danger, as if the outer edge of the plate were firmly packed, and the inner edge loose, either the key would be bent or the moveable jaw or ribs on the plate broken when a load passed over it. The sleeper as a whole is defective in stiffness transversely to the rails. All Plate sleepers have the same general form, with differently shaped ribs and jaws or clips for holding the rails and tie-bars.

32. Plate V also shows the rail and fish-plate. The rail is of the old pattern—the fish-plate is peculiar, as it has six holes. This, as explained in para. 17, has no advantages and several disadvantages. With a plate 18 inches long with only four bolts it was found that the joints were not properly supported, but this was due rather to the bad fishing-angle than to the shortness of the plate. The plate was therefore lengthened by 4 inches at each end, making it 26 inches long, and two more bolts were added. It has been found that the six bolts increase the grip of the plates on the rail to such an extent as to be a source of danger by stopping the expansion of the rail while they do not add materially to the support of the joint ; and four bolts are now used with these plates, the two next to the joint and the two next to the ends of the plate only being inserted. The plate being 2 feet 2 inches long, the sleepers next to the joint cannot be less than 2 feet 8 inches centres, and if the joints are at all out of square, which always occurs on curves, this distance is increased.

33. One of the most recent cast-iron sleepers, introduced into India, is the Fowler box sleeper with which a considerable mileage has been laid on the Oudh and Rohilkhand Railway. The sleeper, as designed for a standard gauge track laid with flat-footed rails, consists of two hollow cast-iron boxes about 3 feet long, connected by a tie-bar and held in place on the tie-bar by tapered cotters, by means of which the gauge can be adjusted to a nicety. The section of the boxes is about equal to that of an ordinary wooden sleeper and the length of the box is transverse to the rail which is held between lugs cast on the upper surface of each box, a steel key similar to that shown on Plate VI being driven between the inner lug and the foot of the rail. The box, being hollow, may be filled with sand

of fine gravel, which adds considerably to its weight and consequently to the stability of the track as a whole.

84. **Wrought-iron and steel sleepers.**—Several patterns of longitudinal wrought-iron or steel sleepers have been tried, but not with any great success. Pots or bowls have also been stamped in wrought-iron or steel, somewhat similar in shape and design to the cast-iron pot sleepers; but the only class of sleeper in these materials which has attained any degree of success is the cross sleeper, generally of inverted channel or trough-shape. The principal difficulty has been to secure an efficient fastening between the rail and sleeper: any form of fastening secured by a bolt is liable to become loose, and the points of contact between the rail and sleeper are then rapidly worn by one part rubbing and rattling on the other, the process being aided by the presence of moisture and grit. This difficulty has been overcome in the Stamped Steel Sleeper, shown in Plate VI which is formed out of one piece of steel, rolled to the section required, and cut off into lengths of 9 feet; it is then, while hot, put into a press, and pressed into shape, and the lugs or clips for holding the rail cut and bent into the proper shape—all at one stamping. All sleepers must be stamped at about the same heat or, when they cool down to the ordinary temperature, their gauge will vary considerably. In the earlier forms of this sleeper a single key was used to each rail; the distance between the lugs on the sleeper was then less than the width of the rail foot, and it was difficult to get the rail into place; also, the width of metal left undisturbed under the foot of the rail was small, so that a crack was very liable to form across it. Recently these sleepers have been made with a key and distance-piece to each rail. The distance between the lugs exceeds the width of the foot of the rail so that the rail can be more easily laid or removed, and the amount of metal undisturbed under the rail foot is greater. When the key is driven home both it and the distance piece wedge the foot of the rail firmly down on its seat, so that there is no clatter. The distance piece is made somewhat wider than the key, so that by reversing their positions the gauge may be varied.

85. Sleepers of this class have certain defects, which are however more than compensated for by their advantages:—The sleeper is weakest at the rail seat, where the greatest strength is required; the sloping ends of the sleepers have a tendency to make the road shift sideways, when, as is frequently the case, the ballast sinks more under one rail than the other; there is no medium to absorb the shock between the rail and the ballast, there being only the thickness of the sleeper, about  $\frac{1}{4}$ th inch, between them. The plate being of uniform section there is a large

amount of metal in the centre part which is more or less wasted, and the thin metal is liable to corrosion in saline soils, which are common in India. On the other hand the sleeper is all in one piece; the rail fastenings are few and simple in design; and both they and the sleeper are easily and quickly manufactured, while the sleeper is comparatively light and easily handled, a point of great importance in laying new lines, although its lightness is a disadvantage as far as stability of the road is concerned. The rule about not packing the centre part of the sleeper applies with increased force in the case of this class of sleeper; it is best to leave a hollow *well below the bottom* of the sleeper in the centre between the two rails, the natural tendency of the sloping ends being to force the ballast inwards towards the centre as the sleeper sinks.

**36. Cement-concrete sleepers.**—In several countries, in which timber is not available for use as sleepers, and in which the cost of metal sleepers is prohibitive, cross-sleepers of cement concrete reinforced with iron or steel bars have been largely used. The advantage of a sleeper of this material is that it is practically imperishable, but the difficulty is to design an efficient fastening for the rail; in one type the rail rests on a bearing-plate fastened by bolts passing through the sleeper; in another the bearing plate is fastened by spikes driven into metal tubes embedded in the concrete. Experiments have been made in India with cement concrete sleepers but so far their use has been confined to experiment.

**37. Ballast.**—The ballast of a railway is the material, usually broken stone or brick, shingle or kankar, gravel or sand, which is laid on the formation to form a bed for the permanent way. In the case of high banks only recently constructed, it is best to omit the ballast at first, and to pack the sleepers with earth only for a few months' traffic, so as to allow the banks to settle, their surfaces to harden, and avoid the loss of ballast by sinkage into the soft soil. When the bank is of a soft or muddy nature, a layer of moorum, sand, or other dry material may with advantage be laid below the ballast proper to assist in the consolidation of the formation. This is particularly to be recommended, when the soil of the banks is what is known as "black cotton soil" which is peculiarly treacherous after heavy rain. [In England the formation is pitched with stone slabs, called "bottom ballast" on which the ballast proper is laid, but this practice is not suitable for India, as it presupposes a consolidated formation prior to the laying of the track, which is never the case in India. Needless to say stone pitching on an unstable formation would be worse than useless.]

**38.** The functions of the ballast are (1), to provide a good, hard, level foundation for the sleepers to rest on; (2) to provide a bed in which

they may be held without risk [of displacement during the passage of trains; (3) to admit of efficient drainage to keep the sleepers, if of wood dry; (4) to protect the surface of the formation generally; (5) to transfer the applied load over a large surface; and (6) to give elasticity to the road bed.

39. As regards the best materials for ballast, they will differ according as the sleepers are of wood, cast-iron or steel. For wooden sleepers or cast-iron sleepers of the plate or box variety broken stone when it can be obtained of suitable quality, in pieces not larger than will pass through a  $1\frac{1}{2}$  inch or 2-inch ring is excellent; coarse gravel is all the better for an admixture of finer gravel or other light material to assist it as packing under the sleepers. The more soft and easily broken stones, and those which are of a friable character, or apt to be affected by weather, or to go into dust or mud, are not suitable; but the harder materials form the best of ballast, as well as slag and refuse from iron furnaces and coarse gravel. In India, hard kankar where procurable, is excellent, but soft kankar is liable to cake; broken overburned brick or "dice ballast"—*i.e.*, clay cut into diamond form and burned expressly for ballast—is often used from want of better material.

When the sleepers are of the cast-iron pot type, no better ballast can be found than clean, coarse river-sand; but when the ballast is of this material, it is essential that it should be entirely covered by a layer of some binding material, such as broken stone or kankar, in order to keep down dust when a train is passing. For steel trough sleepers, stone with an admixture of gravel makes excellent ballasting material.

40. The minimum depth of ballast below sleepers adopted by the various railways in India is 8 inches for standard gauge and 6 inches for metre gauge (vide Plate II). The ballast is usually nearly level with the top of the rails on the outside of the rails, and to a width at the top, of about 6 inches beyond the ends of the sleepers, with suitable slopes; between the rails it is generally level with the tops of the sleepers, but sometimes the sleepers are entirely covered. It is however always an advantage for purposes of inspection that the rail-fastenings should be kept entirely clear of ballast.

The cubic content is about 16 and 10 feet per foot run for important lines on the standard and metre gauges, respectively.

41. The portion of the ballast which is rammed or packed under the sleepers is called the *packing*, and the upper ballast, which is loosely filled in, the *boxing*. The method of packing has been described in paragraph 23 above.



FIG. 27.

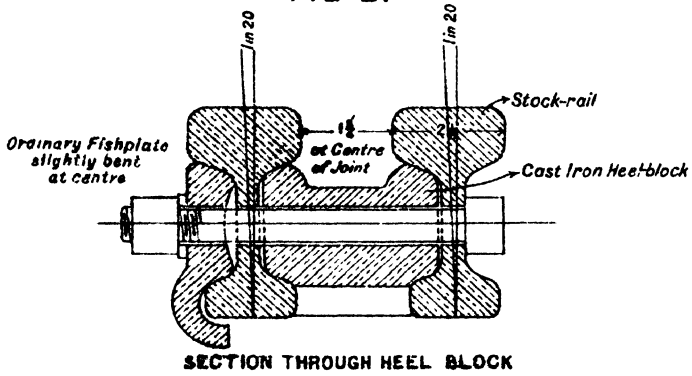

FIG. 28.

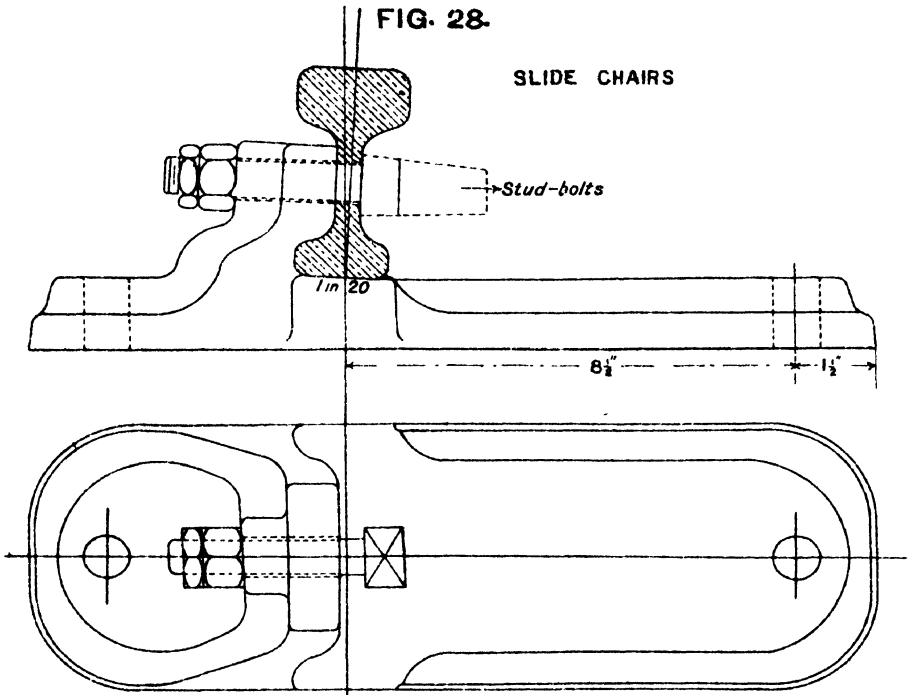
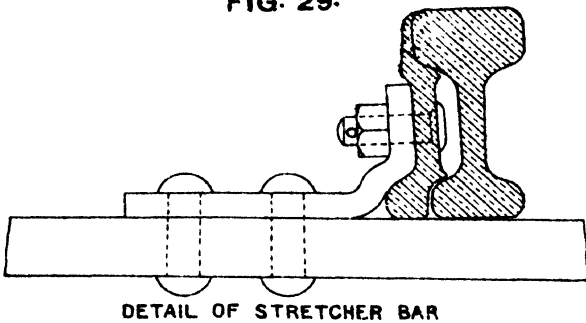

FIG. 29.



## CHAPTER III.

### POINTS AND CROSSINGS.

1. A set of points or switches is shown on Plate VII. It consists of (1) a pair of "stock rails" which are firmly fixed in chairs; (2) a pair of "switch" or "tongue" rails which lie between the stock-rails, and are tapered over a considerable part of their length to a point or tongue (the pointed end of a switch is called the "toe" and the other or untapered end the "heel"); (3) a pair of "heel blocks," or "heel-chairs," by which the heels of the switches are held at the proper distance from the stock-rails (vide Fig. 27 which shows a heel-block for bull-headed rails); (4) a number of "slide-chairs," (see Fig. 28) so called because they are specially constructed to allow the switches to slide laterally, and to support them throughout their movement; the slide-chairs usually have a single jaw on the outer side of the stock-rail, and are so shaped as to hold the stock-rail firmly, generally by means of pins passing through the jaws of the chairs and the web of the rail; (5) one or more "stretcher-bars," fastened to both tongue-rails at their tapered ends (see Fig. 29) for the purpose of holding them at an invariable distance apart; and lastly (6) a gauge-tie (see Plate VII) which may consist of an adjustable rod passing through the webs of the stock-rails immediately in front of the switches, or of a plate or bar passing under the stock-rails and bent upwards at the ends, which are securely fastened to the outer sides of the stock-rails, the object being to prevent the gauge from "spreading," or widening, in front of the switches.

2. Since the switch is actually only held at the heel, it is essential that it should receive as much support as possible, at other points of its length, from the stock-rail; for this reason the tapered part of the switch is machined to the shape of those parts of the stock-rail with which it is in contact, and at the toe its web is housed partly under the head of the stock-rail. This is shown clearly in Fig. 29, which shows the switch and stock-rail in contact. For the rest of its length, it is supported laterally by special thimbles or "stud-bolts," as they are called (vide Fig. 28), formed on the heads of the pins that hold the stock-rails; these thimbles being graduated in size so as to keep the running face of the switch at an even inclination to the stock-rail. At the heel, sufficient space must be left between the switch and the stock-rail (vide Fig. 27) to allow the flanges of wheels to pass freely between them with a small clearance. The clear distance should be, as a minimum,  $1\frac{1}{4}$ " for the standard gauge

and  $1\frac{1}{8}$ " for the metre gauge, and should not be less than this at any point when the switch is open; adding this clear distance to the width of the rail-head, we obtain what is called the "clearance" at the heel of the switch, which may therefore be defined as the offset between the gauge faces of the switch and stock-rail, measured perpendicularly to the latter, at the heel of the switch. Thus if, on the standard gauge with a rail  $2\frac{1}{8}$ " wide at the head, a clear flange-way of  $1\frac{1}{8}$ " between the switch and stock-rail be allowed, the clearance will be  $4\frac{1}{2}$ ". These considerations also fix the "throw" of the tongues, that is, the space through which the toe of the switch may move—usually about  $4\frac{1}{2}$  inches,—and which is regulated by the length of the stretcher-bars. These latter are adjusted so that when one switch is housed close against its stock-rail, the toe of the other is at a distance equal to the "throw" from the gauge face of its stock-rail. If now, referring to Plate VII, we suppose a vehicle to be passing over the points in the direction of the arrow, it is clear that the flanges of the wheels on one side of the vehicle will enter the space between the open switch and its stock rail, the wheels themselves running on the stock-rail, while on the other side, since the closed switch forms with its stock-rail a continuous running edge, the wheel flanges will be thrust aside by the toe of the switch, and the wheels will then run on the table of the switch. The gauge will therefore be the distance between the inner face of the switch and that of the opposite stock-rail; and at the heels, the distance between the inner faces of the stock-rails will be the gauge *plus* the clearance, as defined above.

3. Points may be worked either by levers concentrated in a frame and connected by means of rodding and cranks with the front stretcher-bars of the points.\* (This arrangement is adopted in important station yards, which are completely interlocked, vide Chapter XV); or the levers may be situated close to the points themselves, being for convenience generally bolted down to the first pair of sleepers at the toe, specially long sleepers being provided for the purpose. Such a lever of the "throw-over" type is illustrated on Plate VII; in this arrangement which is usually seen in the case of unimportant sidings or goods lines, the points are said to be "locally-worked."

4. It will be observed from Fig. 27 that a fish-plate is provided on the inner or gauge side of the switch, to hold the heel of the latter to the

---

\* *Note.*—In this case when the length of the rodding exceeds 80 feet, it is necessary to place in the line of rodding a temperature "compensator," shown on Plate VII, as described in Chapter XVI.

heel-block, but since the joint must be such that it allows of the movement of the switch from the closed to the open position, it is obvious that, if the fish-bolts are all tightly screwed up when the switch is in the open position, they cannot be so when the switch is closed; and it is precisely in this position that the switch requires to be most firmly supported; the joint is therefore not a very satisfactory one. This objection may be partly overcome by slightly bending the fish-plate at its centre (see note against Fig. 27), so that it fits the heel of the switch and the end of the rail adjoining it, when the switch is open; the fish-bolts may then all be tightly screwed up and when the switch is closed, the inner fish-bolt will still hold it more or less firmly, while the fish-plate itself will be rigidly held by the remaining bolts.

5. The "spring" switch, which is the most modern development of the switch, is free from the objection noted in the preceding paragraph. Referring to Fig. 32 where the arrangement is shown in diagrammatic form, the switch T A B will be seen to consist of a long rail in a single piece usually from 30 to 36 feet long—tapered at one end like an ordinary switch but held firmly to the stock-rail between the points A and B at its other end in double chairs, which also accommodate the stock-rail. The length T A is sufficient to allow of the toe of the switch being sprung open against the resilience of the metal, and thus in the open position (shown in dotted lines) the switch is actually a spring. Switches of this kind have recently been tried on some of the railways in India and have been found to be very satisfactory, being practically as easy to work as ordinary switches and affording very easy running over turn-outs.

6. **Crossings** are the appliances used at the junction between two lines of rail which cross each other. It is obvious that at such a crossing neither of the rails can be continuous over the point of intersection, since a gap must be left in each rail to allow the flange of a wheel, travelling on the other, to pass. Two kinds of crossings are in use; (1), when the right-hand rail of one track crosses the left hand rail of the second and (2) when the rails which cross are right hand for both tracks, or left-hand for both tracks. The first type of crossing, which is shown in detail on Plate VII, is called an ordinary or "V" crossing, and the second type, shown diagrammatically in Fig. 31, a "diamond" crossing. Strictly speaking, the term "Diamond" crossing should be applied to the arrangement shown in Fig. 50, which represents one track completely crossing the other; and the complete diamond crossing will therefore include two "V" crossings and two diamond crossings, with their guard and wing rails, the necessity for which is explained in the following paragraphs.

7. A "V" crossing at the junction of two tracks is shown in Fig. 30. The crossing itself will be seen to consist of the V portion (sometimes called the "frog"), which is usually constructed out of a pair of rails strongly spliced at the nose; and a pair of wing rails, marked  $a b$  on the figure; the whole being supported on chairs as shown on Plate VII, and strongly bolted together with suitable distance-blocks between the several parts. The clearance between the wing rails and running faces of the V portion must be sufficient to allow the flange of a wheel to pass freely between them. If now  $a$  be the angle of the crossing, that is to say, the angle formed by the gauge faces of the V portion, and  $d$  be the clearance between the wing-rail and the V portion, it will be seen that the length of the gap on each gauge face, between the nose and the throat of the crossing, will be  $d \operatorname{cosec} a$ ; and if we imagine a vehicle to be travelling from A to B, it will be clear that the wheels on the right-hand side must be carried over this gap on the length  $ce$  of the wing-rail, the treads of the tyres being wide enough to permit of this. The dimension  $d$  will usually be  $1\frac{1}{8}$ " for standard gauge, and  $1\frac{1}{4}$ " for metre gauge. Crossings and the maximum value of  $\cot a$  permitted by the Government of India, is 12. Thus the maximum length of the gap, between the throat and the point of intersection of the gauge lines, will be for standard gauge  $1' 10\frac{1}{2}"$  and for metre gauge  $1' 9"$ . Actually, however, this gap is from  $4"$  to  $7\frac{1}{2}"$  longer than these dimensions, as the nose of the crossing must be sufficiently strong to bear the impact of wheels passing over it, and cannot in consequence be brought to an absolute point; the nose is therefore cut off at some distance short of the actual point of intersection of the gauge faces. The necessity for the guard-rail  $fg$  will now be apparent; its purpose is to ensure that the flange of a wheel, passing over the crossing, shall be accurately guided into the space between the nose of the crossing and the wing-rail, and that it shall not strike the nose. The clearance between the guard and running rail is therefore reduced slightly at a point directly opposite to the nose of the crossing, from its width at the ends of the guard rail, the variation being made by graduating the thicknesses of the distance blocks between the two rails. The maximum clearance between guard and running rail, opposite the nose of a crossing, has been fixed by the Government of India at  $1\frac{7}{8}"$  for standard gauge, and  $1\frac{1}{2}"$  for metre-gauge crossings, and the respective minimum clearances at  $1\frac{1}{8}"$  and  $1\frac{1}{8}"$ .

8 The usual arrangement of wing-rails for a diamond crossing is shown in Fig. 31. If a vehicle be travelling from A to B, it will be seen that there is considerable danger of the wheel flanges striking the noses

FIG. 30.

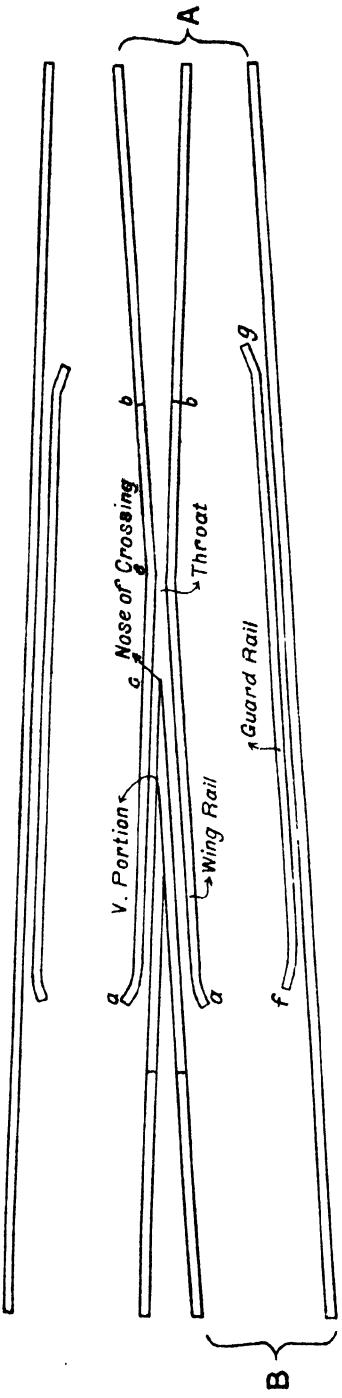

FIG. 31.

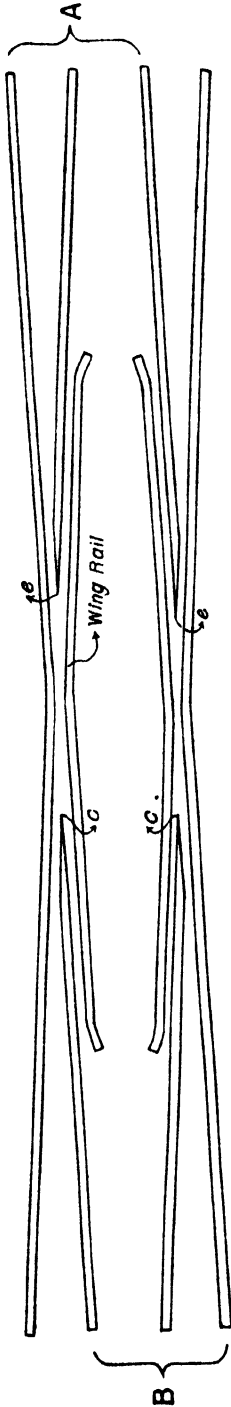

FIG. 32.

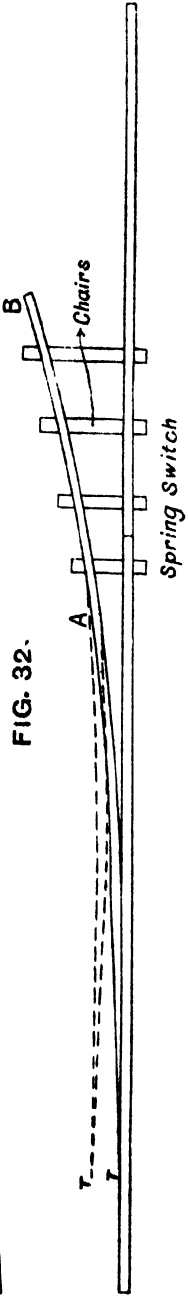





FIG. 33.

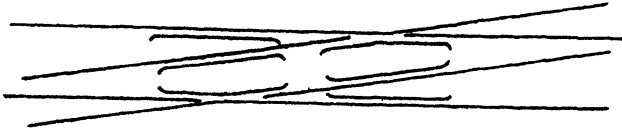

FIG 34.

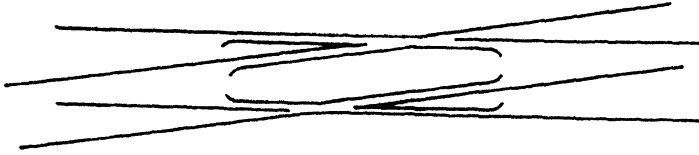

FIG. 35.

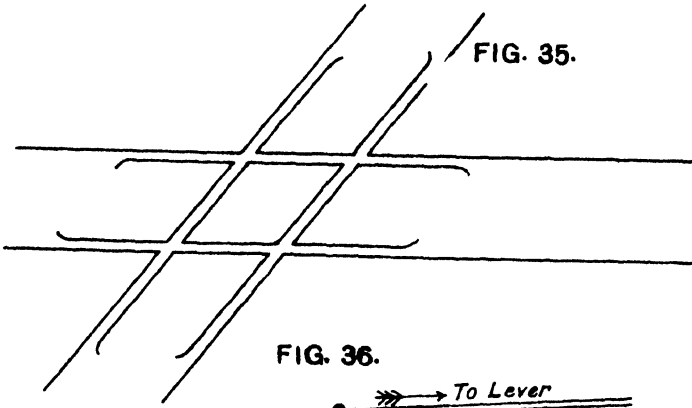

FIG. 36.

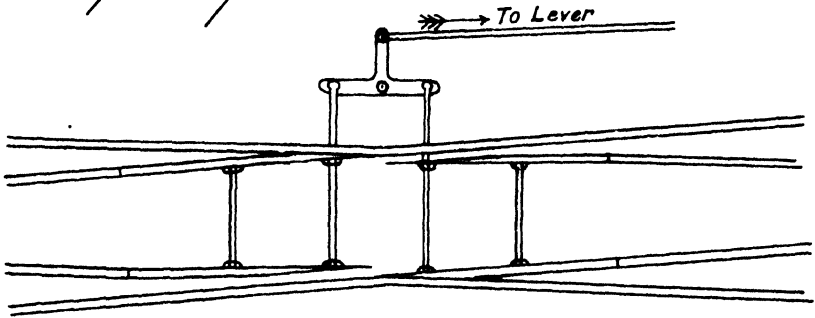
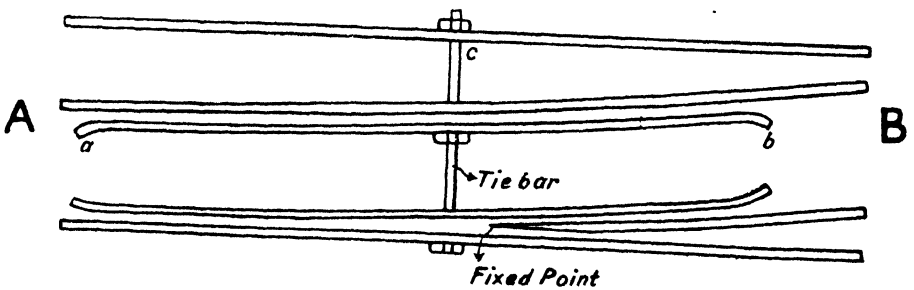

FIG. 37.



*cc* of the running rails or of entering the wrong gaps. If *d* be the clearance between the wing and running rails, and  $\alpha$  the angle formed by the gauge faces of the running rails, the total length of the gap *cc* on each gauge face will be  $d(\operatorname{cosec} \alpha + \cot \alpha)$  and it will be clear that if the two crossings are very nearly directly opposite each other as is the case when two lines of the same gauge cross at an acute angle, it is impossible to arrange the wing-rails (which really act the part of guard-rails) so as efficiently to protect the noses *cc*, there being a possibility of sideways movement of a wheel passing over the gap *cc*. The risk of a derailment will be increased if the vehicles are of short wheel base, and there is any slackness of gauge, and will be greater with wheels of small diameter than with those of large diameter. If the two tracks be of gauges differing considerably in width, say, standard and metre, the risk of derailment with an acute crossing disappears, since (see Fig. 33) the diamond crossings are not then directly opposite each other, and guard-rails may be so placed as to afford complete protection to the noses of the crossings. If the two gauges differ but slightly in width (as, for instance, metre and 2' 6" gauges) the arrangement of wing-rails shown in Fig. 34 may be adopted.

9. Fig. 35 shows the usual arrangement when the angle of inclination of the crossing is less acute.

10. For the reasons explained in paragraph 8, diamond crossings of an angle, the cotangent of which is greater than 10, are not permitted on the standard gauge; while on the metre gauge,  $8\frac{1}{2}$  is the maximum permissible. When it is desired to carry one line across another at an angle flatter than these, the arrangement shown in Fig. 36, known as a "switch diamond" crossing or as a diamond crossing with "movable frogs," should be adopted. Indeed, this form of crossing is to be preferred for all ordinary angles, but when used in lines carrying passenger traffic, the movable frogs require to be completely interlocked (vide Chapter XV) in the same manner as ordinary switches. The diagram shows the arrangement clearly—it consists of two pairs of short switches, set facing each other, and worked in opposing directions from a T crank by a single lever, so that, when one pair of diagonally opposite switches are closed, the others are in the open position. Continuous running edges on both rails of either track are thus obtained.

11. Both diamond and V crossings are usually of the "built up" type, that is to say, they are constructed out of rail-pieces, bent or machined as the case may be, to the desired shape and bolted together. Formerly, however, crossings of cast steel were much used, the complete

crossing being cast in one solid piece with grooves for the wheel flanges ; more recently, solid cast crossings have been made of manganese-steel, which is very tough and durable, and well suited to resist the shocks and blows, to which a crossing is subjected on a busy line. Manganese-steel crossings are now being used on several of the railways in India with satisfactory results, and they are very largely used for street tramways.

12. Points and crossings are used in combination to enable a train to pass from one line to a neighbouring line. The manner in which this is accomplished will be apparent from Figs. 38 and 39, the upper one of which shows the points set for the passage of a train from A to B or B to A, and the lower one for a passage from A to C or C to A. It will be seen that the heel of each switch is connected by a line of rail to a wing of the crossing, the outer rail of each track containing the stock rail. The curved track is known as a "turn-out;" which may be defined as the short length of line, leading, by means of a set of points and a crossing, from one track to another.

13. Referring to Figs. 38 and 39, if a train be proceeding from A to B or C, it will, as is evident, pass over the points in a direction from toe to heel, in which case the points are said to be *facing*. If the train be proceeding in the reverse direction, that is from either B or C towards A, it will pass over the points from heel to toe, and they are then called *trailing* points. On a line on which trains may run in either direction therefore, points may be either facing or trailing.

14. If now, in Fig. 38, the switch *b* be slightly open, it is clear that the flanges of the wheels of a vehicle, approaching from A, would enter the spaces between both switches and their stock-rails, and the wheels would then travel on the diverging outer rails of the two tracks, and a derailment would take place. It is therefore essential that, when a train passes over a pair of facing points, they should be clamped and locked, to prevent any possibility of their being reversed or moved out of position before the whole train has passed. This is usually effected, in the case of locally-worked (vide paragraph 3) points, by means of a pin passing through the switch and stock-rail and secured by a cotter, which is then padlocked. If however a pair of trailing points are not correctly set for the passage of a train, there is not the same danger of a derailment. Thus, for instance, if the points be set as in Fig. 38 for a train proceeding from C to A, the flanges of the wheels will force the switch *b* away from its stock-rail and the train will, under ordinary circumstances, pass over the points in safety ; the switches or their connections would, however

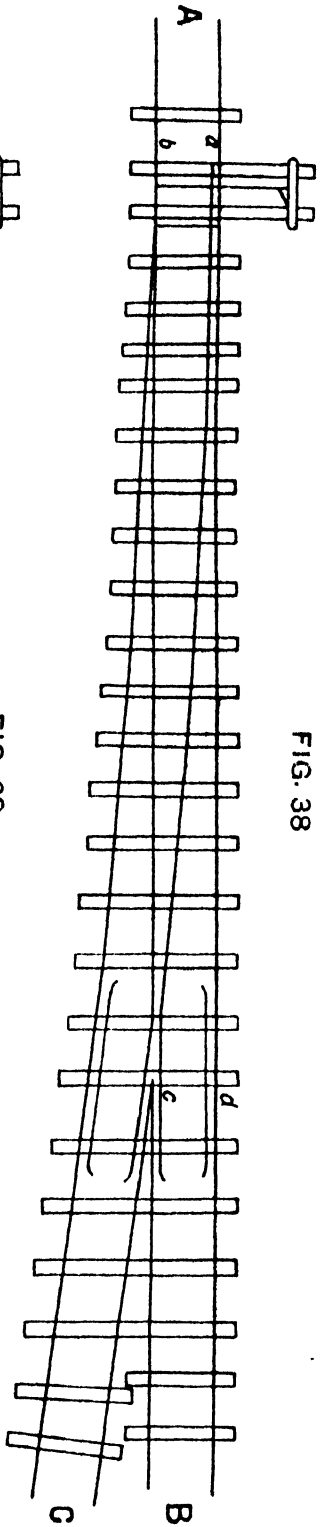

FIG. 38

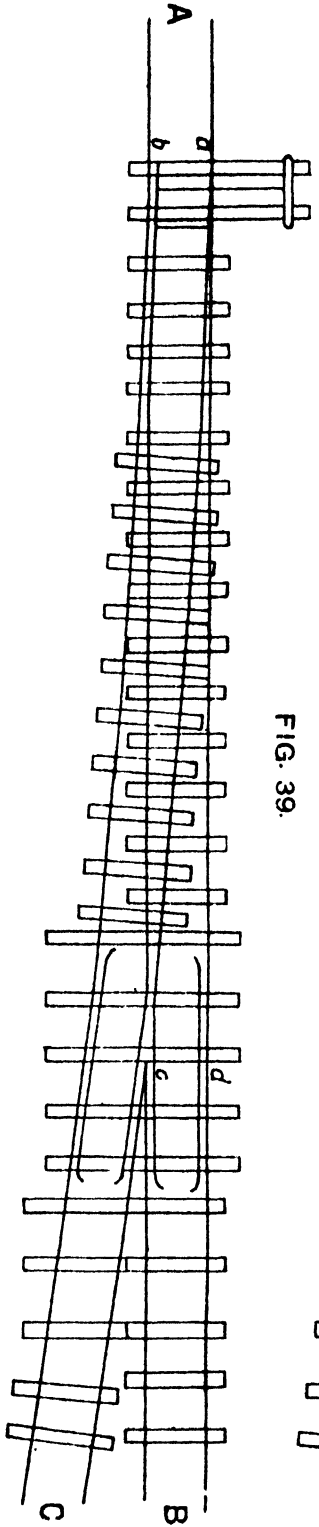

FIG. 39.

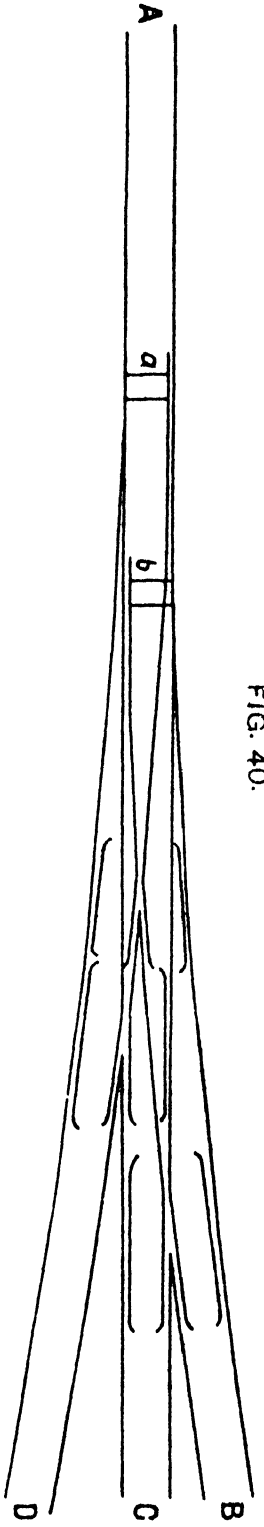

FIG. 40.



if the points were locked, usually be bent or otherwise damaged.\* When a pair of trailing points have been run through in this manner, they are said to have been "trailed."

15. It has been said in paragraph 2 that the gauge face of a switch is at an even inclination to that of its stock-rail, and it will therefore be evident that, when a train enters or leaves a turn-out from a straight main line, a sudden change in the direction of motion takes place at the toe of the switch, each wheel in turn being subjected to a lateral blow when passing over the toe. If the speed be great, the shock of this blow may be sufficient to break or damage some part of the running gear, or to cause a derailment, and in any case the resulting lurch would be felt uncomfortably by passengers. The same thing occurs if the turn-out takes off from a curve. In this case, both switch and stock-rail will usually be curved, but there will be a sudden change or break in the continuity of the curvature, the effect being precisely the same as in the case of a turn-out from the straight. For these reasons the speed of all trains passing over the curved line of a turn-out—whether the points be facing or trailing—is limited in India to 10 miles an hour.

16. The change in the direction of motion will evidently depend on the length of the switch employed and on the clearance at the heel. As the clearance, vide paragraph 2, is practically fixed for any given type of rail, it would seem at first sight that the shock, caused by the change of direction, could be reduced to any desired extent by increasing the length of the switch. A practical limit to the length of switch that can be employed is, however, set by the necessity for making the tapered part of the requisite strength. In India, the *minimum* lengths of switch, permitted on the standard and metre gauges, are 12 and 9 feet respectively, and for turn-outs of very easy curvature the usual lengths are 15 feet and 12 feet for the respective gauges. Some railway engineers prefer rather longer switches, and in England and elsewhere, switches up to 21 feet in length are sometimes employed. The stock-rails are usually made about 6 feet longer than the switches, and project about equal distances beyond both ends of the switches.

17. When a turn-out takes off *from a straight main line*, the points—regarded as a complete set—are described as "right-hand" or "left-hand" according as the turn-out, looked at from the facing direction

---

\* Occasionally special "trailable" switches are employed. They are fitted with a spiral spring in the stretcher-bar, with which the lever is connected. When the points are trailed, the spring forces them back into their correct position, after each pair of wheels passes. Trailable switches are also to be seen on all street tramways.

takes off to the right or to the left of the main line. Thus in Figs. 38 and 39 the points are right-hand and in Fig. 40 the first set of points marked *a* is right-hand and that marked *b* left-hand.

Similar terms are used to distinguish between the two switches of a set of points; although in this case, their use is not perhaps very appropriate, since the right-hand switch is to the left of a person looking at the points from the facing direction, and the left-hand switch to his right. The explanation is that the right-hand switch is that which would turn a vehicle on to the track which lies to the right of a man, looking at the points as described; and the left-hand switch is that which would turn the vehicle on to the track lying to his left. Referring to Fig. 38 or Fig. 39, the switch marked *a* is therefore the right-hand switch, and that marked *b* the left-hand switch.

18. The *number* of a crossing is usually defined to be the cotangent of the angle formed by its gauge faces, and if *n* be this number, the crossing would be described as a *1 in n* crossing. Referring to Fig. 41, if *AB* and *A'B'* represent the gauge faces of the crossing and if *B'D* and *A'D'* be drawn perpendicular to *AB*, the cotangent of the angle of the crossing will be  $\frac{CD}{B'D}$  or  $\frac{OD'}{A'D'}$  or  $\frac{D D'}{B'D + A'D'}$ . The last expression suggests the easiest method of practically measuring the inclination of the crossing. Find two points on the same gauge line—one behind the nose, the other in front of it—at which the sum of the perpendicular offsets to the other gauge line is 1 foot, and measure the distance between these two points; this distance expressed in feet will give the number of the crossing.

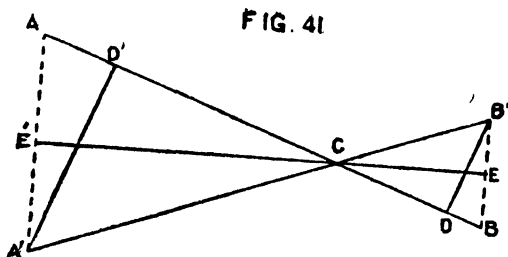

In the older text-books on points and crossings, the number of a crossing is defined as half the cotangent of half the angle. If in Fig. 41 *EE'* be drawn bisecting the angle between the gauge lines, this number

would be expressed by the ratio  $\frac{CE}{BB'}$  or  $\frac{E'E}{B'B+AA'}$ . This definition, which is still in use in America, has the advantage that the formulæ employed in calculating the radii of turn-outs can be more simply expressed in terms of the crossing number than with the definition given above.\*

19. It has been said in paragraph 7, that the actual nose of the crossing is at some distance short of the intersection point of the gauge lines and in laying the crossing it will be necessary to be able to find this point of intersection. It can be readily found by stretching two fine strings along the gauge faces; the point at which the strings cross will be the intersection point of the gauge lines and will mark the position of the "theoretical nose" of the crossing.

20. Since one or both of the lines of rail, in which crossings are laid, may be curved, their gauge faces should, strictly speaking, be curved to the radii of the lines of which they form part. This is, however, clearly impracticable, since the crossings must be made beforehand to suit lines of any curvature within ordinary limits, and the gauge faces are therefore made straight. (In this connection see Chapter XI, paragraph 4.)

21. Figs. 38 and 39 show two methods, commonly employed, of sleep-  
 ering an ordinary turn-out. In the first, all four rails of the turn-out are laid on the same sleepers, which are gradually increased in length to a point at a short distance beyond the crossing. Turn-outs sleep-  
 ered in this manner present a neat appearance, but the alignment of the rails must be carefully marked on the sleepers before the rails or chairs are spiked down, since the sleepers would be seriously damaged if a re-alignment were found necessary, and fresh spikeholes had to be bored.

In the second method, through sleepers are only used under the points and for a short distance on either side of the crossing, the intervening

\* Referring to Chapter XI, paragraph 24, the formula expressing the relation between the radius of a turn-out and that of the main line is  $\frac{1-\cos \alpha}{g} = \frac{1}{R} = \frac{1}{r_1} + \frac{1}{r_2}$ , the symbols having the meanings assigned to them in the chapter. If  $n = \cot \alpha$ , we get for the value of  $\frac{1-\cos \alpha}{g}$  the clumsy expression  $\frac{\sqrt{1+n^2}-n}{g\sqrt{1+n^2}}$ . If however  $n$  be defined as  $\frac{1}{2} \cot \frac{\alpha}{2}$ , we get the simple result  $\frac{1-\cos \alpha}{g} = \frac{2}{g(1+4n^2)}$ . The most convenient definition of the number of a crossing would however be  $n = \frac{1}{2} \operatorname{cosec} \frac{\alpha}{2}$ . We should then get  $\frac{1-\cos \alpha}{g} =$

$\frac{1}{2gn^2}$ . The practical measurement of the number of a crossing would also be extremely simple with this definition. Referring to Fig. 41, the number would be represented by  $\frac{AB}{AA'+BB'}$ , the lengths involved being all more easily measured than in the case of the two definitions given in the text.

lengths of the two tracks being separately sleepere*d*. The advantages of this method are that the same care as in the first method is not necessary in aligning the rails, since the two lengths of track, which are separately sleepere*d*, may be slewe*d* to correct alignment after the rails have been spiked down; and it has the further advantage, in a line laid with pots or steel sleepers, that these sleepers may be used between the switch-heels and the crossing—obviously the sleepers under the points and the crossing must *always* be of wood. Again in a wooden-sleepere*d* line, sleepers of only two different lengths are required and this is a convenience, but a greater quantity of timber will be used than with the first method, which will consequently be the cheaper. The appearance of a turn-out, sleepere*d* according to this method, is also never so neat as in the first method, and the sleepers are as a rule too close together to be properly packe*d*. It should be noted that since a line, joining the rail joints immediately in front of the switches, will be normal to the main line, it follows that the line joining the heels of the switches will also be normal to the main line.

22. On the curved line of a turn-out from a straight main line, most engineers prefer not to super-elevate (see Chapter IX) the outer rail above the inner. It will be obvious that this super-elevation could only be provided by notching down the sleepers under the inner rail of the turn-out. If the main line itself be on a curve, super-elevation must be provided on the main line, if trains are to run over it at speed; but the tables of the rails of the turn-out will be in the same plane as those of the main line rails. If the turn-out takes off on the inner side of the main line curve, the outer rail of the turn-out curve will then have the same super-elevation as that of the main line. If however the turn-out takes off on the outer side of the main line curve, then provided the two curves are of contrary flexure, the inner rail of the turn-out will be super-elevated above the outer, which is of course incorrect, vide Chapter IX, paragraphs 8 and 9. The slow speeds enforced over turn-outs, however, obviate the danger that this involves, but this is an additional reason for strictly enforcing a slow speed. Under the rules of the Government of India, super-elevation on the main line must be uniform, that is to say, there must be no change in the super-elevation, between points at a distance of 60 feet on either side of a turn-out.

23. Figs. 42—45 show the more usual combinations of points and crossings, met with in station yards.

24. Fig. 42 shows a *cross-over* road, forming a connection between two neighbouring tracks. The "fouling-marks," shown on the figure, are placed at points at which the distance between the centre-lines of the

cross-over road and of the main line is exactly 14 feet.\* They are intended to mark the positions beyond which vehicles should not be allowed to stand when a train is passing over the cross-over. When two cross-over roads cross each other by means of a diamond crossing between the two tracks, we get the arrangement shown in Fig. 43, known as a *scissors cross-over*, which is frequently adopted at junction stations between a main line and a branch, to enable trains from both lines to be admitted to either of two platforms. It is also occasionally used directly in front of a station platform, when it is desired to draw up two trains, proceeding in opposite directions, at the platform at the same time; each train as it enters the station is brought on to the platform line, either along the straight or over one of the cross-overs, and halted in advance of the scissors cross-over, and may then proceed on its journey without the necessity of shunting.

25. In Fig. 40 is shown an arrangement known as "following points" sometimes adopted when two turn-outs are required to take off from a main line, one to the right and the other to the left, and it is necessary to save space. Usually, however, the second turn-out would take off beyond the crossing of the first. It will be seen from the figure, that three crossings are involved, one on each rail of the main line and the third at the intersection of the outer rails of the two turn-outs. Formerly "three-throw" points, a somewhat similar arrangement, in which, however, the two turn-outs took off from the main line at the same point, were frequently used; but owing to the overlapping of the two sets of switches, the arrangement was unsatisfactory and is now obsolete.

26. Fig. 44 shows an ordinary double line junction, the directions in which trains proceed being shown by arrows. It will be seen that there is a set of facing points in the Down Main Line. On double lines it is usually possible to avoid facing points in the main lines, since trains run in one direction only on each line; but in the case of a double line junction, this is clearly impossible.

27. In Figs. 51 and 52 are shown a single and a double slip respectively. By comparing them with the diamond crossing shown above them in Fig. 50, it will be seen that they consist of a complete diamond crossing and, in addition, connections allowing access from one or both of the intersecting lines on one side of the diamond crossing to the track which in each case crosses them. Thus, in the case of the single slip, a train may proceed from *b* to either *c* or *d*, and vice versa; but a train from *a* can only proceed to *d*. Similarly, a train from *d* may proceed to either *a* or *b*, but a train from *c* can only proceed to *b*. In the double slip, however, a train from either *a* or *b* may proceed to either *c* or *d* and similarly a train may proceed from

---

\* For the broad gauge.

either *c* or *d* to either *a* or *b*. Fig. 45 shows an arrangement frequently seen in double line stations, which allows access from the Up Main Line to the Down Main Line and to a siding. There is a single slip in the Down Main Line, but it will be observed that facing points in the main lines are avoided.

28. When two lines of different gauges cross a river, to save the expense of building two bridges, they are frequently carried over the same bridge; and the usual practice then is to lay three lines of rail only, one rail being common to each gauge; at points where the lines diverge the arrangement shown in Fig. 37, and known as a *fixed point*, is usually adopted. Its use will be clear from the figure; if we suppose a broad gauge train to be proceeding from A to B, the wheel flanges on the right hand side will be forced into the space between the fixed point and the running rail, by the pressure of the rail *c* on the flanges of the wheels on the other side; the gauge at the fixed point being made tight, to ensure that the wheel flanges shall not strike the nose of the fixed point. Similarly, the guard-rail *a b* ensures that the wheel flanges of a narrow gauge train, proceeding from A to B, shall be accurately guided into the space between the fixed point and its wing-rail. The tie-bar shown on the figure preserves the gauge of both lines in front of the fixed point. Fixed points are in use at the junction of the Oudh and Rohilkhand and Rohilkhand and Kumaun Railways at the Ramganga Bridge near Moradabad, and at the junction of the Madras and Southern Mahratta Railway's standard and metre gauge lines at the Kistna Bridge near Bezvada.

29. In station yard plans various conventions are adopted by different railways to show the normal setting of points. Two of these are shown in Figs. 46 and 47. In the first figure, the switch which is away from the stock-rail, is drawn in an exaggerated position. In the second the line for which the points are normally set is shaded. Thus in both figures, the points are set for the straight.

A track in a station yard can, however, very conveniently be represented by a single straight line, and the setting of points is then indicated by making the line, for which the points are set, continuous. Thus the cross-over road shown in Fig. 42 may be represented by single lines, as shown in Figs. 48 and 49; in Fig. 48 the points being set for both straight lines, and in Fig. 49, for the cross-over road.

FIG 42.

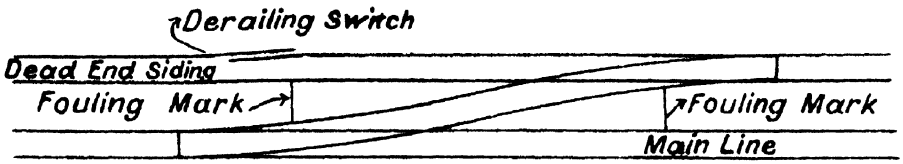

FIG. 43.

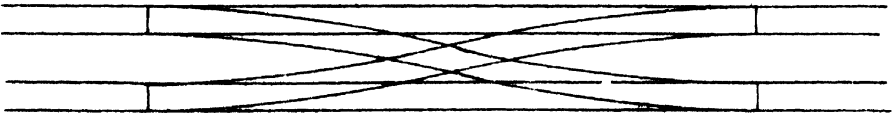

FIG. 44.

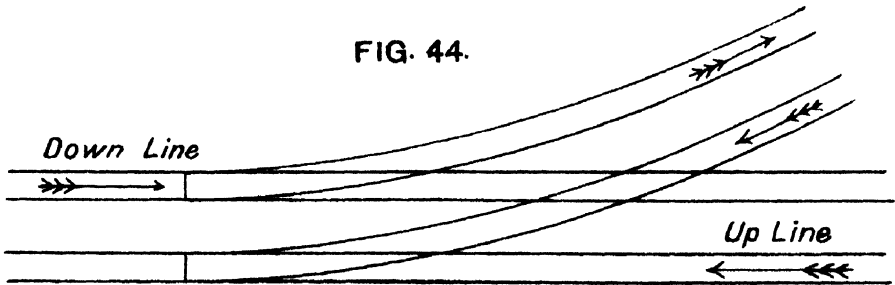

FIG. 45.

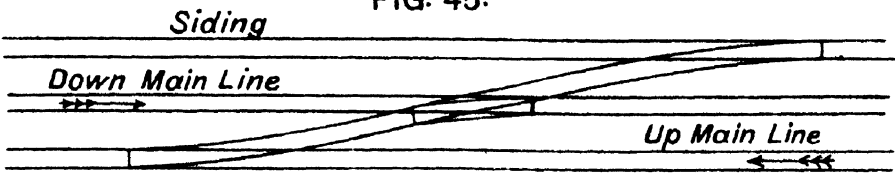

FIG. 46

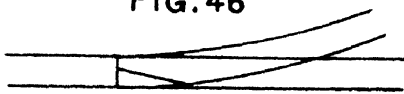

FIG. 47.

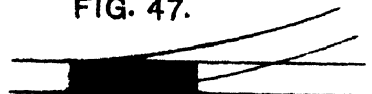

FIG. 48.

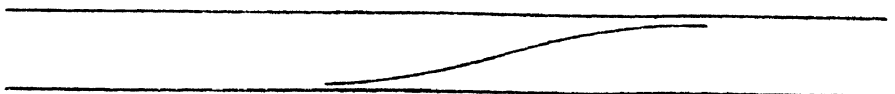

FIG. 49.

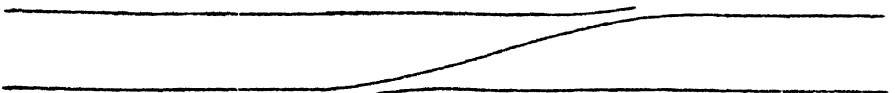



FIG. 50.

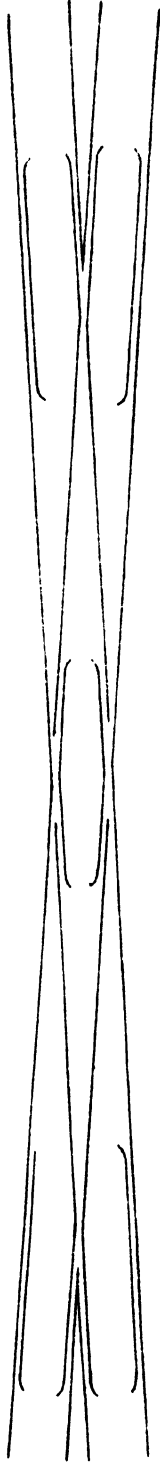

FIG. 51.

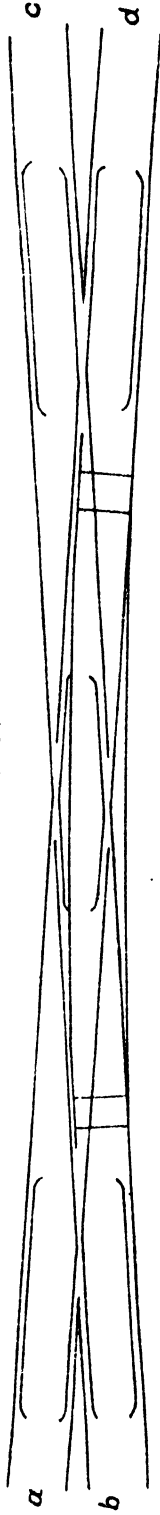
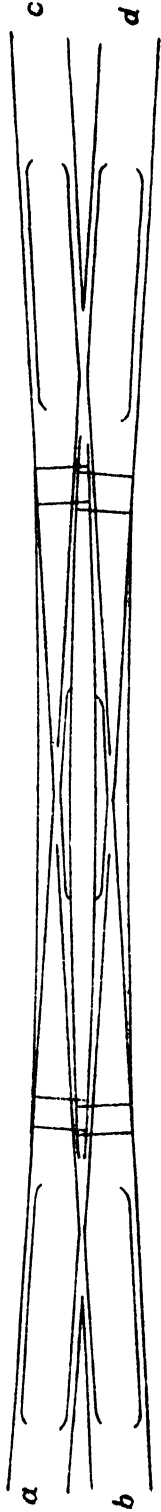

FIG. 52.





## CHAPTER IV.

### STATION WORKS AND REQUIREMENTS.

1. A station is defined, in the Rules for Working Railways, as any place on a line of railway at which (1) traffic is booked and dealt with or at which (2) an authority to proceed is given under the system of working in use. The latter phase of the definition includes what are generally called "block stations," which are sometimes situated at places where traffic is not booked; the former phase of the definition includes "flag stations," which are places where a train stops between two ordinary stations to take up or set down passengers, but at which there are no apparatus or staff for controlling the movements of the trains. The classification of stations will be dealt with more fully in the Chapters on Station Design. The present Chapter will deal only with the general requirements of stations from the public point of view.

2. It will fall to the Engineer, during survey or construction, to select suitable sites for all stations. As stations are intended to suit the convenience of the public, their sites should invariably be settled after consultation with the Civil authorities, to whose opinions due weight should be given; if there happen to be Cantonments or military works in the neighbourhood, the military authorities should also be consulted. In India it frequently happens that there is a large native town and, at a distance of between two and five miles from it, a civil station or a military Cantonment. In such cases, the convenience of the town, which furnishes the greater part of the traffic, is the more important, the station being placed as near to it as possible, and a second station being generally provided for the civil station or Cantonment. Whenever possible a fairly level, well-drained site should be chosen, where there is a good water-supply, plenty of room for extending the station, and convenient roads already existing to give access to it. Under the conditions usually prevailing in the plains of India, the more nearly the rail-level approximates to ground-level, the more economical and convenient will the site be: the most economical site is one in which the formation is either at ground-level, provided facilities for proper drainage exist, or one or two feet above it. It must be remembered that such things as ash-pits, etc., are necessary in stations, and provision must be made for draining them at all seasons. The station ground should also be as nearly as possible on the level; if it be in cutting this will make it difficult to drain, hence a station, if in cutting, may to facilitate drainage be made on a slight

gradient, which should however never be steeper than 1 in 1,000, unless great expense is involved in the adoption of so flat a gradient; if the station is in bank, it is best made absolutely level. Under the present orders of the Government of India no station may, without special sanction, be made on a grade steeper than 1 in 400, nor must a grade steeper than this commence within 150 feet of the outermost facing points.

3. If it can be avoided, a station should not be on or near a curve in the line. If it is located on a curve, the station-master cannot obtain a proper view of the yard, while if the approaches are curved, the view of signals is obscured both from the station and from a train entering it. Near important stations the digging of borrow-pits to make up either the embankment, the platforms or approach roads, should be strictly forbidden. Borrow-pits in a large station, even if they have not to be filled up afterwards to provide for extensions as the traffic develops, are always a source of inconvenience and make the site unhealthy.

4. The essential features of all stations are—(1). For the public, (a), an office at which tickets can be obtained, and parcels and goods be booked; (b), one or more platforms more or less raised above the level of the rails for convenience in entering and leaving the trains; (c), suitable protection from the weather for passengers waiting at the station; (d), a supply of good drinking-water; (e), suitable retiring and sanitary arrangements; and (f), where trains run at night, proper lighting arrangements. These are generally considered as necessities. Refreshment-rooms, waiting-rooms, bath-rooms, etc., are only required in special cases. (2). For the Traffic Department, (g), arrangements for booking passengers and goods and weighing the latter, with proper apparatus for holding, issuing and dating tickets, luggage labels and goods invoices: for collecting these at the end of the journey, and for keeping the cash; (h), arrangements for controlling and recording the movements of trains, generally by means of the electric telegraph, supplemented either by written orders given to the driver, or by signals visible to the driver; (k), suitable signals for protecting trains while standing in the station, or controlling the movements of trains independently of, or in connection with, the arrangements mentioned under (h); (l), on single line, a siding long enough to hold the longest train, and allow another train, if going in the opposite direction, to cross it; if going in the same direction to pass it; (m), sufficient siding accommodation to hold vehicles required for the traffic of the station, such sidings being so placed as to be conveniently accessible from the station building and being additional to any sidings required for holding trains waiting to cross or pass one another; (n), suitable platforms and sidings

for loading and unloading goods, and storing the same either from the time of receipt till their despatch, or from the time of arrival till made over to the owners; (o), accommodation for the staff of station masters, and assistants, signallers, goods clerks, ticket collectors, pointsmen, porters, guards, etc., according to the numbers of staff required, and a suitable place for keeping and trimming lamps when traffic is conducted at night. (3). For the Locomotive Department, (p), arrangements for supplying the engines with fuel and water at suitable intervals, and for cleaning out the ash-pans and examining the working parts of the locomotives; (q), arrangements for inspecting the vehicles at suitable intervals; (r), accommodation for fueling and inspecting staff and, at engine-changing stations, for the running staff, i.e., drivers, and firemen. (4). For the public and all departments, (s), convenience of access and compactness; (t), clocks to show the correct time.

**5. Passenger station buildings.**—At minor stations all that is required is a room about 200 square feet area, with a ticket window about 18 inches square. This should have a counter projecting about 9 inches or a foot, *both on the inside and outside* of the window, perfectly smooth and flush from edge to edge, on which the cash, tickets and change are laid when passengers book. By this window is placed a table on which are the ticket holders, dating-press, etc.: the table generally has drawers for holding small cash. On the opposite side of the room is a table or bench on which the telegraph instruments are placed. A small cash safe should be built either into one of the walls or into the floor, and a clock should be hung on the wall. A door should open out on the side next the platform, generally into a small open verandah. It is best not to have a door at the back. The ticket window should be in the wall at right angles to the platform, and passengers taking tickets should always be under shelter. Where there is a large number of passengers it is usual to provide a waiting shed. The lamp-room in this arrangement is best placed at the back; we thus get the plan shown in Type A, Plate VIII. Such a station will have a staff of one station master and one assistant station master, who will take duty alternately, and attend to both the booking and signalling; three or four pointsmen who will attend to the points; one of these or, in some cases, one at each end of the station, will generally also have charge of the level-crossing gates; one bhisti; one sweeper; and one lamp-man. There will also generally be two or more of the railway police. If many trains are run on the line, involving constant attendance, there will be in addition one or more signallers, as, under these circumstances, the station master or his assistant cannot continuously attend to both the booking and

signalling; in such cases a separate room may be given for the telegraph instruments, etc., communicating with the booking office by a door. When only one or two trains are run each way daily, one station master and one signaller, or even, in some cases, one station master only, can do all the work. More important stations differ only in the number of staff and the amount of accommodation required.

6. At important stations the station master's or assistant station master's duties are confined to supervision only. The booking is done by booking clerks, and the signalling by the signallers. At such stations there will generally be a considerable amount of first and second class passenger traffic, booking of parcels, luggage, etc., and for each branch there will be separate clerks. A convenient arrangement at a station of medium importance is shown in Type B, Plate VIII. On one side of the booking-office is the third class waiting-shed, the office having a ticket-window at which tickets are issued to passengers in the shed. On the other side is a passage, and on this first and second class passengers book and their luggage is weighed. A barrier or railing should be erected in front of the ticket-windows, to keep intending passengers from crowding round them, and make them approach in file. On the other side of this passage is the telegraph office, with windows at which the public are attended to. Next to this office is the station master's office, with a window or door opening into the telegraph office. Beyond this come waiting-rooms, refreshment-rooms, lavatories, urinals, etc. The lamp-room is generally placed beyond the third class shed; and where there are refreshment-rooms a cook-house has to be provided conveniently situated: the best place for this is generally over the refreshment-room. The cloak-room, at which luggage may be left may be behind the booking office. At such stations, all booking and loading of goods would be carried out at a separate platform.

7. At very important stations the arrangement just described would be too cramped. In such cases there will generally be a large central hall for first and second class passengers in which all booking, including that of passengers' luggage and parcels, is conducted at separate counters; a separate booking-place and entrance-hall for third class passengers; and a general waiting-room, out of which the other waiting-rooms open. Rooms will also be required for platform inspectors, ticket-collectors etc., etc. In all cases where the ordering of train running is under charge of the station master his office should be near the train signalling office, which at important stations is sometimes separate from the public telegraph office.

8. At all stations it is desirable to separate, as far as possible, passengers coming in from those going out. The former should have access direct to the booking offices, after which they can pass on to the waiting-rooms or the platform. Third class passengers are, in India, generally kept in the waiting-shed, till after the train has arrived, and all passengers intending to do so have alighted. They should take their tickets either in the shed itself, or before entering it, and there should be facilities for obtaining water, and a latrine to which they may have access while waiting, without coming on to the platform.

In all cases third class passengers, and at important stations first and second class also, should leave the station by an exit quite separate from the entrance. At junction stations passengers for the branch should be separated from those for the main line. At junctions there is usually a separate platform for the branch trains to depart from, but it is convenient in most cases for the train from the branch to arrive at the main line platform whenever this can be arranged, as it reduces the difficulty of transferring the luggage and passengers.

9. **Passenger platforms.**—These should usually, on important railways, be of the full length of a passenger train, however unimportant the station itself may be. The minimum length recommended by the Government of India for use on important lines is 600 ft. for both standard and metre-gauges. At unimportant stations the earth is simply made up to rail-level and covered with ballast, cinders or sand. At other minor stations on the 5 feet 6 inch gauge, platforms may be of a maximum height of 1 foot 2 inches above rail-level, and at more important stations 2 feet 9 inches (maximum) and 2 feet 6 inches (minimum); on the metre gauge the maximum height for any passenger platform has been fixed at 1 foot 4 inches, while the height recommended by the Government of India for use on important lines is 1 foot. Platform walls (see Fig. 53)

FIG. 53.

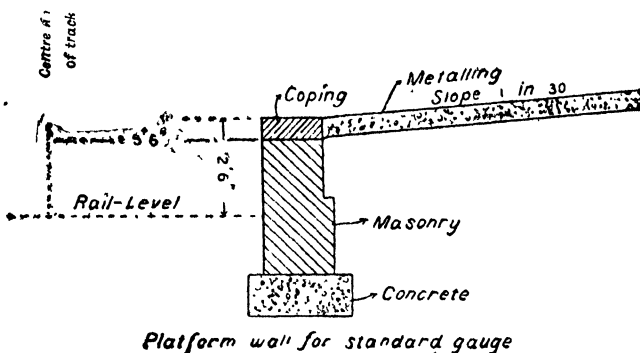

should be built not less than 5 feet 6 inches for the standard gauge, and 4 feet 5 inches, for the metre gauge, clear from the centre line of the nearest track. These are generally 18 inches wide at top; this width may be continued down for a depth of 2 feet from the top, below which extra thickness is advisable. If the platform be on a sharp curve the distance of the platform wall from the centre-line of the nearest track must be increased: points and crossings should never be laid in the line adjoining a platform if it can be avoided. A platform should have a good coping, which should preferably not have any chamfer or rounding on its outer shoulder. On the standard gauge, the face of the coping should be exactly 5 feet 6 inches and on the metre gauge, 4 feet 5 inches from the centre-line of the nearest track. In England, it is required by the Board of Trade that the edge or coping of the platform shall overhang not less than 12 inches beyond the face of the wall: if any one should fall between the vehicles and platform he will fall into this space, and not be cut to pieces between the wall and the lower steps of the vehicle. No pillar, lamp post, or other obstruction of any sort should be allowed within 6 feet of the edge of the platform. The platform should have ample width, say, 30 feet: the Government of India require that no part of any building be allowed within 18 feet of the edge of the platform without special sanction: though a width of 30 feet is seldom required, it is not desirable to cramp the space by buildings.

Platforms should be metal led, or paved for a width of at least 12 feet—more at important stations; the ends of all platforms should be ramped with a slope of about 1 in 6; they should be fenced off, so that passengers cannot depart without giving up their tickets. A ticket gate is provided at minor stations in the fence, but at large stations the exit is sometimes through the building. On all platforms, latrines should be provided for native passengers, so arranged that they may be cleaned without the sweeper coming on to the platform. At suitable intervals along the line drinking-fountains should be provided on station platforms, and in all cases where trains run at night, the platforms should be properly lighted with lamps: and the latrines should also be lighted. At important stations the platforms are generally roofed over for at least part of their length.

10. **Goods platforms.**—These may be made of a maximum height of 3 feet 6 inches above rail-level on the standard gauge, and 2 feet 3 inches on the metre gauge. Their length will depend on the amount of traffic; where the traffic is large, a separate platform, or different parts of the same platform, are generally set apart for outwards and inwards goods.

Goods sheds are also required in many cases. For bulky traffic low open sheds, with their eaves overhanging the edge of the platform, are well suited; but a closed shed, with doors that can be locked, will always be required for valuable goods. This is frequently made at one end of the open shed. A goods office is also required, and this is more convenient if separate from the shed. Weighing machines will be required at all stations where goods are booked, whether there be a separate goods platform or not. The proper drainage of goods platforms is of even greater importance than that of passenger platforms; they should always have a good slope: access to all parts of them is also necessary. A low platform wall about 18 inches or 2 feet high on the side near to the road, at which carts can be loaded and unloaded is a good arrangement and economises space: where this plan is adopted, a width of 20 to 30 feet of platform is generally ample. The sidings leading to the platforms must be so arranged that wagons can be easily moved from the *inwards* to the *outwards* part, and taken from either part to the running or standing lines with the minimum amount of shunting.

**11. Sidings.**—These are divided broadly into two classes—“Working sidings,” such as the passing loops on single line or the sidings at goods platforms; and “Lay-bye sidings,” on which spare stock stands. In all sidings a certain amount of length is lost between the points and crossings and the “fouling-marks” (see Chapter III, paragraph 24). The distance between the fouling-marks at each end of a siding is called the clear-length of the siding, and is equal to the length of the longest train that may be accommodated on it. A given number of sidings is laid out to the greatest advantage, from the point of view of economy of space, when the proportion of length not available as standing room is a minimum. In all stations, however unimportant, the sidings should be so laid as to admit of expansion, and lay-bye sidings should be so arranged that when this expansion becomes necessary all sub-grade works, e.g., earthwork and culverts, constructed for the lay-bye sidings, may be used for the working sidings in the new yard: the means of access from one part of the station yard to another should be as short and direct as possible, and no siding should be longer than is necessary for dealing with the traffic of the yard. No definite rules can be laid down on any of these points. The Government of India require that at all ordinary non-watering stations, where it is intended to cross trains, at least one siding shall be provided of a clear length equal to that of the longest train permitted to run on the section *plus* 7 per cent; at watering stations, the clear length should be such that when a train-engine is standing to take

water at a water column, the rear of the longest train permitted to run on the section shall be at least 50 feet clear of the fouling-mark. The minimum distance between centres of adjoining tracks on the standard gauge has been fixed at 14 feet, the distance recommended for important railways being 15 feet 6 inches. On the metre gauge the minimum distance between centres of tracks not used for passenger trains is 12 feet 6 inches, and between the centres of a passenger line and the one next adjoining it, 14 feet 6 inches. Sidings should be so arranged that trains entering or leaving the station may have as few facing points as possible to pass over.

12. **Signals.**—Will be described in the Chapter on Station Machinery and their functions in a subsequent Chapter, as the subject is a very important one.

13. **Staff-quarters.**—A great deal of care is necessary in selecting suitable sites for staff-quarters. They should be so placed as not to interfere with the expansion of the station. At small stations some economy can be effected by making the station master's and assistant station master's quarters in one block with the station building. In such cases there should be no direct access from the platform to the quarters, the entrance being at the back or side. There is nearly always a level crossing at one or both ends of a station yard, necessitating the construction of at least one gate-keeper's hut, the gate-keeper acting also as a pointsman, and it will be generally economical to put a double-unit hut here. Plate IX shows a double-unit suitable for the accommodation of a station master and his assistant; similar accommodation (omitting the verandah and cook-houses) would be suitable for the station menials. Where pointsmen are on duty continuously at a distance from their quarters they require some sort of shelter: a small shelter constructed of wood, and sufficiently large for the pointman to sit in, will usually be sufficient.

At large stations the quarters will necessarily be at some distance from the lines. The commonest mistake in building quarters is to put them too near the line—even in the case of pointsmen's and gate-keepers' huts, sufficient room should be left for at least one additional line to be put in (*see* Plate I) that is, they should be at least 25 feet clear from the centre line; more if it can be conveniently arranged. The sites for quarters should never be arbitrarily fixed off a plan: a variation of 100 yards in their position may make all the difference between a healthy site and an unhealthy one.

## CHAPTER V.

### STATION MACHINERY.

1. Station machinery includes all machinery and arrangements in use at stations for watering, fueling, and turning of engines; repairing, cleaning, and examination of running locomotives and carriage and wagon stock; loading, unloading, and weighing of goods; shunting or transfer of rolling stock from one line to another (except points and crossings, which are classed under the head of permanent way) and starting, stopping and crossing of trains. Under this head, therefore, are classed such items as engine sheds, wells, reservoirs, tanks, tank-houses, pumps, piping, water-cranes, ash-pits, turn-tables, fuel-stages, carriage-sheds, carriage-examining pits, traversers, hydraulic machinery, capstans, platform cranes, weigh-bridges, buffer-stops, scotch-blocks, signals, etc.

2. **Engine-sheds.**—These are covered sheds, having lines of rail laid through them in which are pits over which the engines stand, so that any part of them can be easily got at for examination or repairs. Alongside the pits are hydrants, to which hoses can be attached for washing out the engines, the water being supplied under a head of about 30 feet for this purpose. Either in or adjoining the shed is a small workshop in which petty repairs can be carried out, and a store-room. Outside the shed one or more ash-pits are provided, at which the ashes are raked out before the engine goes into the shed. Plate X shows the general arrangement usually adopted; the shed shown on the Plate is capable of housing two engines, and would be suitable for the terminal station of a short branch line. A water-tank has been shown erected on the roof of one of the offices to supply water to the shed. In large sheds the arrangements are of course much more elaborate than those shown on the Plate. In India, where free ventilation is generally desirable, the ends of the shed are open, and openings for ventilation are provided both in the roof and sides; and the shed is generally made accessible at both ends, with a loop line round it outside.

3. **Turn-tables.**—Engine turn-tables as now designed consist of (1) a central pivot, of cast steel firmly bedded on masonry and concrete; (2) a casting in the shape of the letter X in plan, but hollow in the middle, the pivot passing up the centre: on the top of the casting is bolted a cap which rests on the top of the pivot, and on to the arms are bolted—(3) a pair of girders which carry the rails on which the engine and tender

stand. Cross frames are placed between the girders near the ends, and outside these are bolted brackets, carrying wheels which run on a circular path, the whole being in a circular pit. Under the ends of the girders are locking bolts, worked by levers; when the turn-table is in line with the rails on either side, these bolts are shot into castings, resting on the masonry, so that no weight then comes on the wheels. The locking bolts also prevent any movement of the turn-table, while an engine is coming on to or leaving it.

The central cap can be so adjusted by screws that when the turn-table is properly balanced (with the centre of gravity of the engine and tender over its centre) there is no weight on the wheels which run on the circular track, though these just touch the rails: when the balance is not quite correct, these wheels carry a small part of the load, and the turn-table can easily be turned by two men. When an engine enters or leaves the table the weight comes on the locking bolts, not on the wheels. The space between the rails, and for about four feet outside them, is generally decked over, the rest of the pit being open. *See* Plate XI. Figs. 1 to 3, which show a metre gauge turn-table of old pattern; those now used, both on 5 feet 6-inch and metre gauge are very similar in design, the former are 50 to 60 feet and the latter 36 to 50 feet in diameter.

4. Turn-tables are placed in the locomotive yard, generally in such a position that engines entering the yard may have direct access to them so as to be able to turn before going into shed. They should also be so arranged that, in case the turn-table is damaged, access to the shed will not be blocked. At stations where a very large number of engines are stabled there are often two or more turn-tables in the yard.

Occasionally a turn-table is placed in the centre of a circular engine-shed, as shown diagrammatically in Fig. 54. A number of short lengths of track, each having an ash-pit, radiate from the pit of the turn-table, and each ash-pit may accommodate an engine. Such an arrangement is exceedingly compact, but it has the disadvantage that if the turn-table fails, all engines that may happen to be in the shed must lie idle, until the necessary repairs can be carried out to the turn-table.

5. **Triangles.**—If it be desired to reverse the direction of an engine or train, and to avoid the expense of providing a turn-table or to serve the purpose of one temporarily, either of the arrangements shown in Figs. 55 and 56 may be adopted. It will be clear from the figures that, if an engine or train pass completely round the triangle, as shown by the arrows, its direction will be reversed. If triable switches (vide footnote to Chapter III, paragraph 14) are used, and the points be normally set as

FIG. 54.

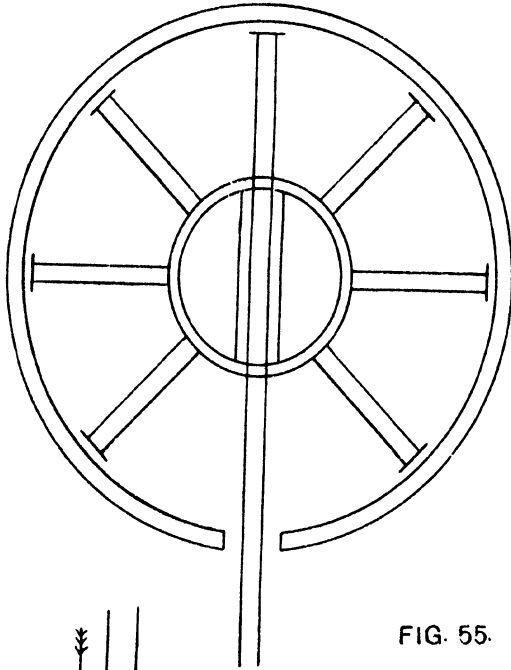

FIG. 55.

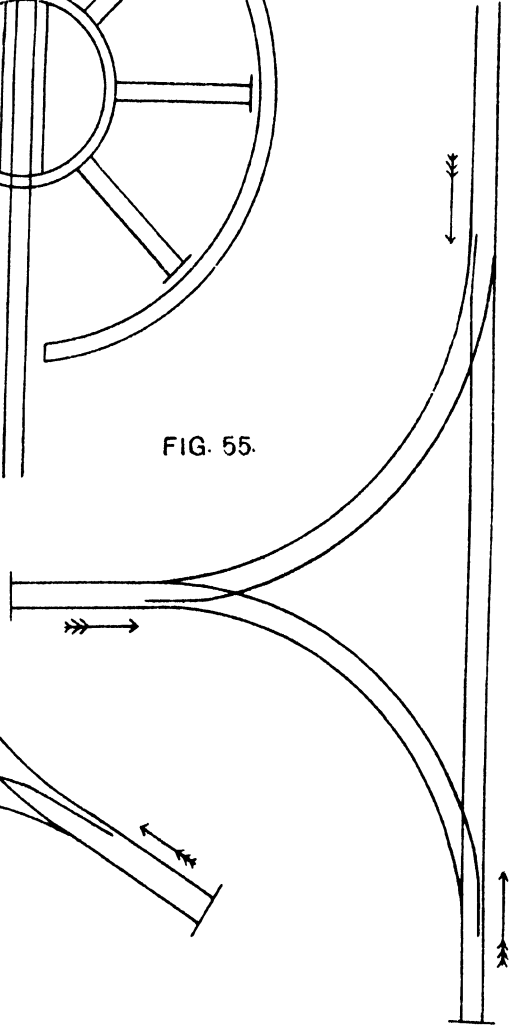
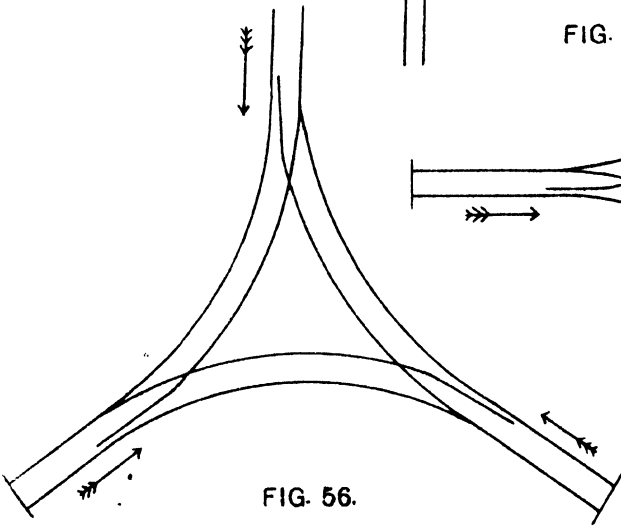

FIG. 56.





shown in the figures, it will be unnecessary to have the points manned; each set of points, as it is trailed through (*see* Chapter III, paragraph 14) in turn, will spring back to its correct setting. A triangle may be used with advantage at the temporary terminus of a line, which it is proposed to extend in the future. They do not, properly speaking, come under the head station machinery, but would be merely classed as sidings; the permanent way in them would generally be removed and used elsewhere, when the line was extended.

6. **Water-columns, ash-pits, and fuel-stages.**—Water-columns and ash-pits have to be provided at stations at intervals of not more than 30 miles on the main line. The water-column, a common type of which is

FIG. 57.

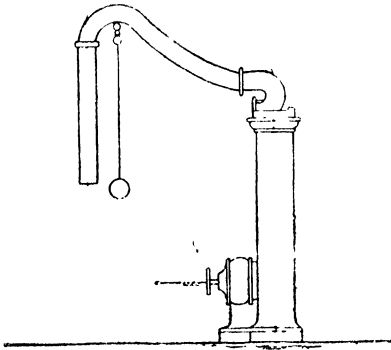

shown on Fig. 57, consists of a vertical pillar, with a swiveling pipe, in the form of a swan neck, fitting into a stuffing box on the head of the pillar, so that it can revolve horizontally and stand either parallel to or at right angles to the line; the radius of swing is from 7 to 8 feet, and the ring and chain shown on the figure suspended from the swan neck, are for the purpose of revolving the swan neck. A valve is

shown at the foot of the pillar, which is connected by a line of piping with an overhead water tank; when the valve is opened the water passes by gravity up through the pillar and the swan neck, and through a canvas or leather hose (shown in the figure), or a sheet-iron funnel, into the tank of the tender or engine. The water-column is best placed between the platform line and the next adjacent line, so that an engine can water on either (*see* Plate XII), and it should be at a sufficient distance from the end of the platform to allow the engine of a train to take water when the brakevan at the rear of the train is at least 50 feet away from the fouling-mark (*see* Chapter III, paragraph 24) of the facing points at the further end of the station yard. Care should also be taken that, when the train is drawn up for the engine to take water, passenger vehicles should not be away from the passenger platform. There should usually be a water-column, at each end of the yard, and if the main water-tank is situated close to one column, there should be a subsidiary tank, connected

by piping with the main tank, close to the other, the subsidiary tank being supplied by gravitation from the main tank. This is to ensure that engines watering at either column may be able to fill their tanks as rapidly as possible. A common type of main-tank with masonry supporting structure, is shown on Plate XIII, and a subsidiary tank, in Fig. 58; the drawings show the piping arrangements clearly. The Government of India prescribe that the minimum height of the bottom of a tank above rail level, for watering engines, should be 25 feet for the standard gauge and 20 feet for the metre. The water is raised into the main tank from a well, reservoir or river either by hand or bullock-power, or when a large quantity is required, by a steam pump. At stations, where water is not required for locomotive purposes, a small well is generally constructed for supplying drinking-water to the staff and passengers.

7. Ash-pits consist of two parallel walls, on which are bolted longitudinal timbers carrying the rails. Plate XIV shows the usual arrangement, as well as details of the method of securing the timbers. Between the walls is a pit, of depth 2 feet 6 inches to 3 feet 6 inches below rail level; the bottom should be paved, being slightly convex transversely and with a fall towards the centre, so that water may drain down each side towards the centre; drains to carry off the water must be provided. The pit is required to enable a man to get under the engine to clean out the ash-pan and examine the moving parts. It should be placed so that the engine stands over it while taking water, as shown on Plate XII, and should be long enough to allow a man to get under the engine from either the front end or the back of the tender. The clear length at the bottom is now required by the Government of India to be 65 feet for standard and 50 for metre gauge, and the average depth below rail 2 feet 6 inches for standard and 3 feet 6 inches for metre gauge. Ash-pits as a rule are required only at watering stations.

8. Fuel-stages and fuel stacking-grounds are, when wood fuel is used, required at some of the intermediate stations and they are generally provided at the watering stations. The stage should be opposite the tender when the engine is taking water. The best type of stage is probably one nearly level with the top of the tender, but the Government of India's schedule of dimensions requires that they shall, if of this height, be 9 feet clear of the centre of the track, which leaves a gap of 4 feet 6 inches between the stage and the tender: this can be bridged by a plank or the fuel may be thrown over. Ample stacking-ground is required adjoining the stage, and it is desirable that the stage itself should be covered, so that the fuel during the rains may be comparatively dry when

FIG. 58.

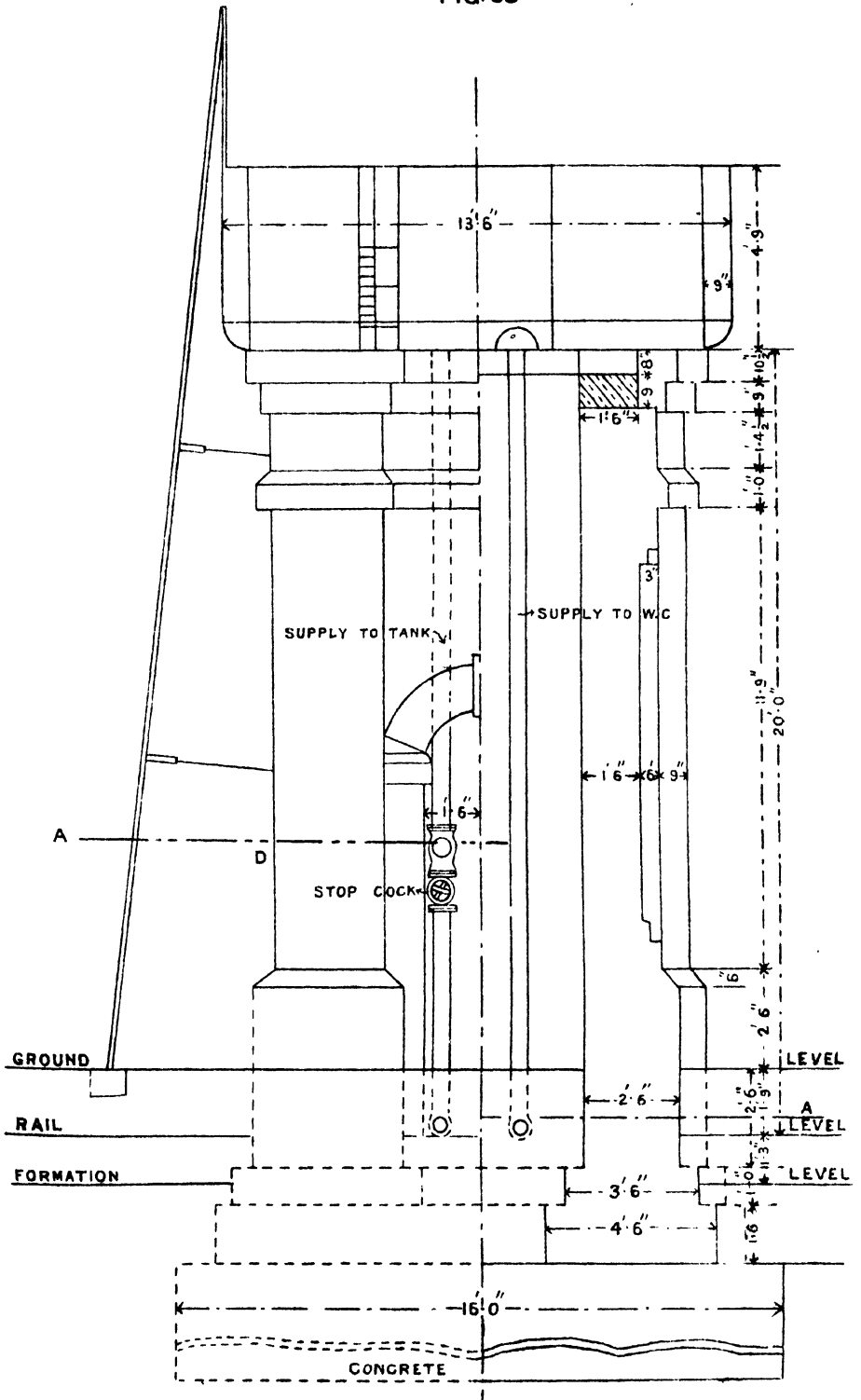



delivered to the tender. When coal only is used all the fueling is done in the locomotive yard at the engine-changing station.

9. **Carriage-examining pits.**—These are similar to ash-pits, but are generally rather deeper and are required to be of the whole length of a train. They are necessary for the proper examination of the automatic brake gear, and also of the bogie attachments where this class of stock is used: for the examination of ordinary four-wheeled stock they are not necessary. The wheels, axle-boxes, springs, brake gear, and bogie gear require frequent examination on running trains; the wheels are tapped with a hammer to detect cracked or loose tyres, and the axle-boxes should be examined, to detect any sign of their running hot, the springs also being noticed to see that no fractures have occurred. These are generally easily accessible from outside, but the automatic brake and bogie gear cannot be inspected except by going under the carriage. The best place for the examining pits seems to be in the line next the platform, but a continuous pit about 600 feet long is a serious source of inconvenience and danger in any station, wherever it be placed.

10. Water-columns, ash-pits, fuel-stages, etc., are all required in locomotive yards. In large yards it is usual to have pumps for raising water in duplicate, also duplicate wells or reservoirs for supplying it, and either separate tanks or one large tank divided into two separate compartments so that either can be used when the other is out of use. Wells, reservoirs and tanks require periodical cleaning out, and pumps also require to be repaired; and if any of these operations necessitated stopping the water-supply, serious inconvenience would result.

11. Station yards are generally arranged as a number of lines more or less parallel to one another. To transfer a vehicle from any one of these to any other, three different methods may be adopted—(a), the lines may be connected by “points and crossings” and the vehicle taken over them from one line to the other either by an engine or by horse or hand-power; (b), the vehicle may be run on to a “traverser,” and then traversed at right angles to the lines from one to another, or (c), it may be run on to a “turn-table”, turned partly round, and then run on a track, at an angle with the lines, till it reaches the line required when it is again turned on another table and run on to this line. Methods (b) or (c) are generally provided as a supplementary means of carrying out the transfer in addition to method (a).

12. A traverser consists of a platform, mounted on small wheels or rollers, which run on rails at right angles to the track. There are generally four of these rails; the middle pair carry wheels or rollers fixed

on their axles and having flanges, and the outer pair simply support the rollers at the ends of the platform; the middle pair are laid at a rather higher level than the rails of the main line and siding tracks, to allow the flanges of the rollers to pass over the latter; the outer rails are laid flush with the rails of the tracks. The platform carries shallow rails which, when it is in position, come immediately over the rails of the tracks, and at the ends are tapered pieces, working on horizontal pivots, and balanced by a counter-weight. When a vehicle is pushed towards the traverser its wheels deflect this tapered piece, and mount on to the platform; the traverser and vehicle are then pushed sideways on to the other line, and the vehicle pushed off it on to the track. Plate XI, Figs. 4 to 7, show the details of a traverser for the metre gauge: those for the 5 feet 6-inch gauge are similar in design, but larger

13. Turn-tables for carriages and wagons are similar in principle to those used for engines, and described in paragraph 3, but being of much smaller diameter and having to carry much less weight, this weight, instead of being balanced on the centre, is carried by a number of wheels running on the circular path. They are generally made 15 feet in diameter, and have two sets of rails on them at right angles, so that when the table has been turned through  $90^{\circ}$  the second set comes into the line originally occupied by the first set. Now that the length of vehicles is greater than in the early days of railways, carriage and wagon turn-tables are rapidly going out of use, as they cannot conveniently be used for long vehicles. Traversers are also seldom used: with a suitably arranged station, the sorting of trains can be more efficiently carried out by shunting over the points, and the general introduction of long bogie vehicles for passenger traffic will probably result in traversers not being used at all for making up trains, though in workshops they will continue to be used, on account of the economy of space which their use admits of.

14. In England horses are generally used for moving one or two vehicles at a time in making up trains: in India this is generally done by men. In large dépôts in England hydraulic power is frequently employed. A number of small vertical capstans are erected between the tracks, each capstan being worked by a small hydraulic engine. A rope is attached to the vehicle to be moved, and given one or two turns around the capstan, which is then started. Hydraulic lifts are also used to lift wagons in goods warehouses, or on piers, and tipping apparatus, for tipping up a wagon bodily to shoot its contents into a barge or ship. Such appliances are special, and a detailed description of them is not necessary. Cranes are frequently used for lifting heavy articles into or out of trucks: they

may be either fixed or movable, mounted on a carriage running on rails on the platform: this class is frequently used for loading timber.

15. Weigh-bridges consist merely of very large platform weighing-machines, large enough to weigh a whole wagon and its contents. They are laid in a pit built in the line of the track, and carry rails, resting on girders which, when the weighing apparatus is put in gear, are supported by knife-edges on the levers; these communicate by suitable multiplying gear with the beam, which is generally in a small hut adjoining. When the apparatus is out of gear, the girders rest on supports on the masonry. No engine should be allowed to pass over a weigh-bridge, and it is in consequence generally placed on a siding which is in communication with the goods lines, but does not block the entrance to them. Weigh-bridges are required where goods, such as coal, timber, etc., are loaded in bulk direct into the trucks.

16. **Signals.**—The primary object of signals is to prevent a running train from coming in contact with another train or any other form of obstruction. Trains in motion are controlled by signals, which may be “fixed,” “hand” or “detonating.” It is unnecessary in this Manual to discuss the last two. It is sufficient to state that all the regular movements of trains are controlled by fixed signals of the *semaphore* type. The semaphore is an arm extending from a vertical post. The arm is usually about 4 to 5½ feet long, 10 to 14 inches deep at the outer end, 1 to 2 inches less at the inner end, and pivoted at the latter end on a horizontal pin near the top of the post. The front, or significant view of the semaphore is shown in Figs. 59 and 60 with the arm extending to the left of the post. [This is also the English custom, but in America the practice is reversed.] As seen from the back, the arm would of course appear to the right. Further to distinguish the back from the front, the front is painted red, with a white band near the outer end, and the back white with a black band. But as both sides are liable to be blackened by smoke in some stations, and as the colours may not always be distinguishable, as for instance when the sun is behind the signal, drivers, when approaching signals, instinctively look out for those whose arms extend to the left, as being the only ones which face their way. It is also customary to place the signal post on the *left side of the track*, as seen by an approaching driver, unless by reason of curves or other local conditions it would be more clearly seen on the right.

17. Signals are of two classes, (a) *stop* signals, (b) *warning* signals, or warners. We shall deal first with the former,

18. In *stop* signals the arm is *square-ended*, and is arranged to give two indications, viz., "stop" and "proceed," either by the position of the arm or by the showing of a light. Thus (i) the horizontal position of the arm (Fig. 59), or, at night, the showing of a red light constitutes the "on" or "danger" position, and signifies "stop" (i.e., a driver may not pass the signal in this position), (ii) the inclined position of the arm (Fig. 60) lowered to an angle of from  $45^\circ$  to  $60^\circ$  below the horizontal, or at night the showing of a green light, constitutes the "off" position, and signifies "proceed" (i.e., a driver may pass the signal in this position). It should here be noted that the first position conveys a definite order, namely, a prohibition; the second position merely withdraws that prohibition, and does not of itself convey an order. In the first or "danger" position the signal

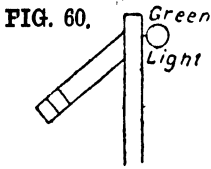
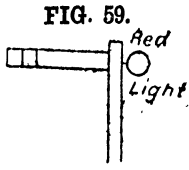

is said to be "against" an approaching train, in the second or "proceed" position, it is said to be "for" or "in favour of" the train.

19. *Warning* signals and their uses will be explained later on, but it may here be remarked that their mechanism is much the same as that of stop signals.

20. The *light*, which is required at night to indicate the position of the signal, is given by means of a lamp attached to the post and fitted with a lens to focus the light along the line. In front of this works a frame called a "spectacle," containing a red and a green glass connected to the arm in such a way that it shows a red light when the arm is up, and green when it is down. To enable the station master or signalman\* to see from the station whether the lamp is burning properly and what indication it gives, a small lens, called a "back light" is provided at the back of the lamp, fitted with a small back spectacle showing a white light when the front light shows red, and no light when the signal is lowered. Back lights are now sometimes made without any glasses, and with only a small hole in a plate; when the front light shows red, a white light is seen through this hole; when the front light shows green the back light cannot be seen when the arm is lowered. An essential principle in signalling is that the absence of a signal in the place where one is usually exhibited must be considered as a danger signal, or if a signal gives a defective indication, it must equally be considered a danger signal. This precludes lowering

---

\* Signalman is the man who attends to and works the signals: he must not be confused with the signaller, who works the Telergaph apparatus.

the arm into or in line with the post, as a driver then cannot see it, and could not distinguish whether it were in that position or had been broken off by a storm; it also precludes the use of a white light for a signal, as a white light would be shown if the red spectacle were broken.

21. **Signal mechanism.**—The most important requirement of signals is that, whatever may go wrong with the apparatus, it shall not be possible for a signal to show "Proceed" when it should show "Stop." Only a slight delay will be caused by a signal showing "Stop" when it should show "Proceed," but a serious accident may result if the case is reversed. It is also necessary that there be no possible mistake as to which indication the signal gives. Plate XV shows an Indian State Railway pattern of signal. This consists of the following essential parts: (1), the semaphore, or arm, which is counterbalanced by a weight at the small end, to ensure its remaining at danger, in case a breakage should occur in the connections; this arm is always on the left of the post as seen from an approaching train; (2) a crank or other device keyed on to a horizontal pin, on which the arm is also keyed so that they move together; (3), a rod to actuate this crank; (4), a weighted lever revolving about a pin—to the short end of the lever, is attached the wire or rod by which the signalman works the signal; to the long end near the pivot, is attached the rod which actuates the crank of the semaphore, and at the end is a weight which has sufficient leverage to pull back the wire when the signalman releases it; (5), a lamp with a suitable lens for throwing a ray of light along the line, and a small lens at the back called a back light; (6), a spectacle containing a red and a green glass, which is usually rigidly attached to the semaphore, in such a way as to show a red light when the arm is "on" and green when "off," and (7), a small back spectacle, fixed on the same pivot as the front spectacle and indicating its position to the signalman. Formerly there used to be a windlass for lowering and raising the lamp, which slid in vertical guides by means of a pulley and chain. But there was always the risk of the lamp not being pulled to the end of its run, and of stopping opposite the green spectacle when the arm was at danger. For this reason the lamp is now fixed on a bracket bolted on to the signal post and access to it obtained by a ladder.\* There is also a universal pulley at the foot of the post, over which a chain passes to connect the lever with the wire, and the lever is frequently bent to a right angle so that the pull of the wire is obtained direct. If any part of this mechanism breaks, the signal should show "Stop" or "Danger." A

---

\* The ladder also enables the spectacle to be got at for cleaning—a very important matter,

defect in the old type of post was that it was slotted so that the arm when lowered could fall into it, and become invisible ; a stop is now placed to prevent this. The lever is actuated by wire, supported on pulleys at intervals, and worked either by a lever or windlass at the station. As the wire expands and contracts by heat, as well as stretching from use, provision must be made to counteract this. The arrangement most commonly adopted in India in the case of signals which are not worked from a cabin is Blood's patent lever, *see* Plate XV, Fig. 2. In this a weight is attached to the end of the wire by a chain which passes over a grooved pulley ; a jointed lever pivots on the same centre as this pulley, and when the lever is raised a projection on it engages with one of the links of the chain, and pulls over the chain and pulley together, thus drawing in the wire and lowering the signal. Additional weight has to be put on the signal to balance the weight on the end of the wire, which slightly increases the work to be done ; the wire is always tight, however much it may expand and contract. Windlasses are sometimes used in old installations, but they allow the wire to run out, till it is slack and hangs on the ground, when it is liable to get caught and bent ; they have the further defect that, unless carefully used, the wire may be broken by the excessive strain which may be thrown on it, and their use has now been practically abandoned. Whatever arrangement is used it is essential that the signalman sees that the signal actually does go to " danger " when the wire is released ; when the signal cannot be seen by the signalman, electric repeaters should be used. An electric repeater is a small instrument placed in the signal-cabin, having a dial face, and a miniature semaphore, the motion of which is controlled electrically by the semaphore of the signal, in such a way that it shows the exact position of the latter at any given moment.

22. **Point indicators** are appliances fitted to and working with points, to indicate by day or by night the position in which the points are set. They are not signals, and must not be treated as such. They are generally in the form of a revolving disc carrying a lamp and working with the points ; but moving lamps are always objectionable, and several forms are now used in which the lamp remains fixed. As a rule they are arranged to show *green* when the points are set for the turnout or cross-over, and *white* when set for the straight track.

23. **Buffer-stops.**—These are used at the dead ends of sidings to prevent vehicles going over the end. They consist generally (*see* Plate XVI) of a horizontal beam fixed at the level of the buffers of the vehicles supported at the back by struts, and at the front by ties which connect it to the rails ; the struts, ties and verticals being generally made of old rails

bent to the proper shape and bolted together. Care must be taken that the stops are so arranged as not to damage the footboards or brake gear of vehicles, and in the case of vehicles having combined buffers and couplings, as on the metre gauge, the stop must be so arranged as not to damage the coupling. Where space permits, buffer stops may be backed by a heap of earth or ballast enclosed with a row of old sleepers. There are sometimes cases where it would cause less damage to allow a train or vehicle to run over the end of a siding on to the ground, rather than forcibly bring it to a stand by a buffer-stop: such cases are exceptional.

24. **Scotch-blocks.**—These are movable obstructions which can be placed on or across a rail in a siding, to prevent vehicles escaping from it. A convenient form is one which, when in position, stands vertically upon the rail, its ends being shaped approximately to the curve of the wheels; it turns round a horizontal hinge, so that, when not in use, it lies below the level of the rails. It should be of such a height as not to damage the gear of automatic brakes, the brake blocks of which frequently come rather low down on the wheels, and it should be capable of being locked, either on the rail, or out of position below it. Scotch-blocks are objectionable even when well designed and properly looked after: a better arrangement is a *trap* or *derailing-switch*; this may either be a complete set of switches and a crossing, leading either into a dead siding or out on to the ground so as to catch any runaway vehicle, or a single switch, laid in the rail further from the main line, and facing towards the siding, so that any vehicle which tries to leave the siding, when this is open, will run off the rails, on the side further from the main line. If a vehicle enters the siding when the switch is open the wheels close it and no harm is done. A derailing-switch is shown on Fig. 42.

## CHAPTER VI.

### CARRIAGE AND WAGON STOCK AND BRAKES.

1. The term "carriage and wagon" stock comprises all the rolling stock of a railway with the exception of locomotives and their tenders. For traffic purposes it is divided into two classes—coaching-stock and goods-stock. In England these two classes differ considerably in their general construction and arrangement; but in India, where "mixed" trains are run on most railways, and it is desirable that all stock should be of such a character as to be suitable for the transport of troops, camp-followers, horses, guns, equipment, and baggage in one and the same train, the difference between the two classes is not so marked.

2. Coaching stock includes all kinds of vehicles which are usually run on fast passenger trains, such as first, second, and third class passenger carriages, mail-vans, luggage vans, horse-boxes, carriage-trucks, brake-vans, and vans specially constructed for carrying comparatively light articles, for which rapidity of transit is of importance, such as parcels, fruit, fish, meat, etc. Goods-stock includes vehicles constructed for carrying heavy and bulky articles, for which rapidity of transit is not of such great importance. In England the difference between the two classes is marked: all coaching stock has long flexible springs between the frame and wheels, spring buffers, screw couplings with springs, and is fitted with the necessary apparatus for working one or more forms of continuous brakes: each vehicle has at least six wheels, which are generally of special design with wooden bodies, the tyres being held on by a continuous fastening, so that in case of breakage, they cannot leave the body of the wheel; and the load on any single axle seldom exceeds five tons, and hardly ever reaches six tons. Goods stock, on the other hand, generally has strong, short springs, buffers solid with the frame, ordinary chain couplings, a hand-brake worked independently by a lever on each vehicle, generally only four wheels to each vehicle, the wheels being heavier in design, and the load on each axle frequently as high as 10 or 11 tons, though eight or nine tons is a more common limit. In India all vehicles have screw couplings and spring buffers, and the other differences are less marked; goods vehicles on the 5 feet 6 inch gauge are now made to carry 12 tons on one axle, including the weight of wheels and axle.

3. All vehicles may be also divided into two distinct types: bogie vehicles and non-bogie vehicles. The latter may be further sub-divided into those with a rigid wheel-base, and those with a flexible wheel-base.



## CHAPTER VI.

### CARRIAGE AND WAGON STOCK AND BRAKES.

1. The term "carriage and wagon" stock comprises all the rolling stock of a railway with the exception of locomotives and their tenders. For traffic purposes it is divided into two classes—coaching-stock and goods-stock. In England these two classes differ considerably in their general construction and arrangement; but in India, where "mixed" trains are run on most railways, and it is desirable that all stock should be of such a character as to be suitable for the transport of troops, camp-followers, horses, guns, equipment, and baggage in one and the same train, the difference between the two classes is not so marked.

2. Coaching stock includes all kinds of vehicles which are usually run on fast passenger trains, such as first, second, and third class passenger carriages, mail-vans, luggage vans, horse-boxes, carriage-trucks, brake-vans, and vans specially constructed for carrying comparatively light articles, for which rapidity of transit is of importance, such as parcels, fruit, fish, meat, etc. Goods-stock includes vehicles constructed for carrying heavy and bulky articles, for which rapidity of transit is not of such great importance. In England the difference between the two classes is marked: all coaching stock has long flexible springs between the frame and wheels, spring buffers, screw couplings with springs, and is fitted with the necessary apparatus for working one or more forms of continuous brakes: each vehicle has at least six wheels, which are generally of special design with wooden bodies, the tyres being held on by a continuous fastening, so that in case of breakage, they cannot leave the body of the wheel; and the load on any single axle seldom exceeds five tons, and hardly ever reaches six tons. Goods stock, on the other hand, generally has strong, short springs, buffers solid with the frame, ordinary chain couplings, a hand-brake worked independently by a lever on each vehicle, generally only four wheels to each vehicle, the wheels being heavier in design, and the load on each axle frequently as high as 10 or 11 tons, though eight or nine tons is a more common limit. In India all vehicles have screw couplings and spring buffers, and the other differences are less marked; goods vehicles on the 5 feet 6 inch gauge are now made to carry 12 tons on one axle, including the weight of wheels and axle.

3. All vehicles may be also divided into two distinct types: bogie vehicles and non-bogie vehicles. The latter may be further sub-divided into those with a rigid wheel-base, and those with a flexible wheel-base.

Those with a rigid wheel-base may have either four or six wheels; but in most cases they have only four. A four-wheeled vehicle consists of the following essential parts:—

4. An “under-frame,” (see Plate XVII) which in India is now nearly always made of steel; this consists of two “sole bars” generally of channel steel, which form the two sides, and are laid over, or nearly over, the centres of the journals of the axles, which are outside the wheels; two “head-stocks” of similar section to the sole bars, which form the ends, are attached to the sole bars by brackets and gusset plates, riveted to the flanges of both, on the top and underneath; two or more “cross-bars” laid between the sole bars, generally of **H** or double **T** section, and two or more “longitudinals,” laid between the cross-bars and head-stocks parallel to the sole bars; but in the two end panels they frequently splay out from the cross-bar to the head-stock. The head stock generally projects beyond the sole bars on each side, and outside the sole bars, opposite the cross bars, are fastened brackets. The cross bars, longitudinal, and brackets serve only to stiffen the frame, and transfer the weight on the floor, and the pull on the draw bar, to the sole bars. In metal frames, unless they are of considerable length, more than three to four times their width, there is generally no diagonal bracing, the gusset plates affording sufficient stiffness, but in timber frames diagonals are employed.

5. To the sole bars are bolted “axle-guards,” generally, but not necessarily, on the inside of the sole bars; these consist each of two vertical bars, usually formed of one bar bent into inverted **U**-shape, between which the axle-boxes slide vertically; to the lower end of these verticals are welded two diagonals, to prevent the longitudinal displacement of the verticals, and the upper ends of these diagonals are also bolted to the sole bars, the whole being like the letter **W** but the centre part instead of being an inverted **V** is an inverted **U**. A short piece of bar is bolted on to the bottom of the verticals, to connect them together; this is removed when the axle-box is put in or taken out. Between these bars slides the axle-box, which is not part of the frame, and on the top of the axle-box is a spring generally composed of a number of flat steel plates, the ends of which are attached by links and pins to brackets fixed generally under the sole bar; the ends sometimes rest direct in shoes fixed to the sole bars, but this practice is seldom followed, as it does not afford the same elasticity as in the case of links or hangers. Several variations from the above arrangement are frequently adopted: the

guards may be outside the sole bars, and the springs either inside or outside instead of underneath them.

6. The head-stock carries the "buffers" (see Plate XVII); on the 5 feet 6-inch gauge in India and on English railways, there are two at each end of the vehicle near the corners, but on the metre-gauge in India there is only one at the centre (see Fig 61). A buffer consists essentially of a plate attached to the end of a shank, which moves in a guide; it is provided with a spring, which when the buffer receives a blow, absorbs the shock and

brings the face of the buffer-plate back to its original position. The shank may be either in the form of a bar, or of a comparatively large hollow cylinder; the front or outer guide, called the buffer casing, may be either a prolongation of the sole bar with a guide fastened to it, or a hollow cylinder or bent bar bolted to the head stock; the springs may be either laminated plate, coiled, or helical springs, or India rubber blocks. The buffer must be so arranged that its stroke cannot exceed a certain length. A section through a cylindrical buffer is shown in

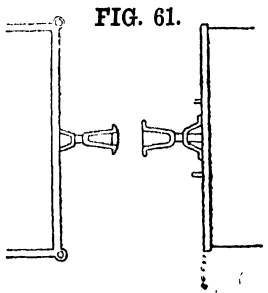
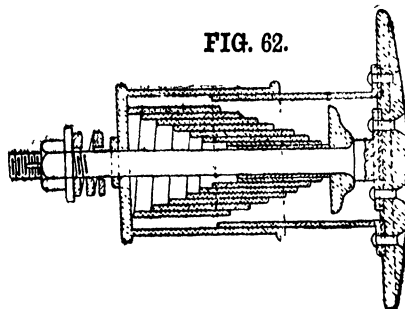

Fig. 62. On goods stock in England the buffers are simply prolongations of the side soles, with a block of wood attached inside them so as to double their thickness: this is the origin of the use of the corner or side-buffers, which on lines with sharp curves are a source of considerable trouble.

7. The head stock also carries the "draw-bar" (see Plate XVII). This is a strong iron or steel bar, with a hook forged on the end; the shank passes through the head stock, and is generally continued to pass through the first cross bar; on the end is a nut secured by a pin or cotter, and between this and the cross bar is placed a spring. The pull is thus transmitted through the bar and spring to the cross bar; and so through



the frame as a whole to the other end of the vehicle. Draw-bars are sometimes made continuous or semi-continuous, by linking together the inner ends of the two draw-bars of each vehicle; in this case only the pull, due to the vehicle, itself is transmitted from the draw-bar to the frame of the vehicle; in the other case the pull of all the following vehicles in addition is so transmitted.

8. To the shank of the hook is attached, by a pin and shackle, the "screw coupling" (see Plate XVII and Fig. 63). This consists of two U-shaped links. Between the two arms of the U is a boss tapped in one with a right-hand, and in the other with a left-hand, screw; these are connected together by a right and left-hand screw, with a jointed lever at its centre, by means of which it is turned. Turning the screw one way increases the distance between the links, so as to enable the coupling to be passed over the hook of the next vehicle, and turning it the other way decreases it, so that the two vehicles can be brought up close together with their buffers slightly compressed; when not in use the loose end of the coupling is hung on a small hook under the head stock to prevent it dragging along the ground. On the metre-gauge in India, the buffer and coupling are both central: the buffer is placed in the middle of the head stock, and in the centre of the buffer is a hook (see Fig. 64); the shank of the buffer has a slot in the centre for a short distance, in which the shank of the hook rests, being held by a pin, about which it revolves vertically: the hook passes over a pin in the shank of the buffer of the next vehicle, and falls into its place automatically when two vehicles are brought together: it is prevented from jumping out by a small chain passed over it. The couplings of coaching stock on the metre-gauge are now provided with an apparatus somewhat similar to a screw coupling for drawing the pin tight up into the bight of the hook (see Fig. 64). The arrangement is therefore different at the two ends of the vehicles. At one is a hook, at the other the pin and tightening apparatus: on the 5 feet 6 inch gauge the arrangement is the same at both ends.

9. On each side of the central coupling are what are called "safety chains" or side chains (see Plate XVII), the idea being that, if the coupling breaks, the side chains will hold the vehicles together. But in practice this result is usually not attained. The side chains necessarily have a certain amount of slack to enable them to be fastened together, and when the main coupling fails the jerk which follows frequently breaks the side chains or tears out their fastenings.

10. In order that all vehicles on the same gauge may be coupled up together, it is necessary ( $\alpha$ ), that the height of buffers above rail level

shall not vary beyond a certain limit: some variation is necessary to allow for the play of the springs when vehicles are empty or loaded; (b), that when side buffers are used their distance from the centre shall always be the same; (c), that the distance from the face of the buffers to the bight of the coupling, whether this be a loop or a hook, and to the face of the hook over which the shackle passes on the 5 feet 6 inch gauge, or of the pin over which the hook passes on the metre-gauge, shall not vary beyond a small limit. When couplings and draw-hooks are all made of one pattern this practically fixes the distance between head stocks, which is 4 feet 2 inches on the 5 feet 6 inch gauge, and rather less on the metre-gauge when the buffers are just touching. This distance having once been fixed to suit the particular coupling and buffers in use at the time, cannot be altered without causing serious inconvenience, and side buffers, having been once adopted, cannot be changed for central ones.

11. **Wheels and axles.**—The wheel consists of a boss or nave, a body, a rim and a tyre. The boss, body, and rim together are called the wheel-centre, and may be all in one piece, or built up of different pieces. The body may take the form of spokes or of a disc. The tyre is rolled into a ring out of one solid piece of steel. The “tread” or part which rests on the rails, is coned or tapered about 1 in 20, and on the inside of the rails a flange projects, the face next the rail being tapered about 1 in  $2\frac{1}{2}$  from the vertical, and joining up with the tread by a fillet of about  $\frac{3}{4}$  inch radius. The inside of the tyre is turned up perfectly true to a diameter slightly smaller than that of the rim, and it is then heated and shrunk on to the wheel centre. The boss of the wheel is bored to a diameter slightly smaller than that of the body of the axle, and the two wheels are pressed into their place by an hydraulic pressure of 40 to 60 tons. The wheels and journals are then turned up perfectly true. Tyres even when made of the best material are liable gradually to develop cracks in working, and for all coaching stock they should be attached to the wheel bodies by a continuous fastening, to prevent pieces of the tyre flying off in case it should break. Tyres should also be frequently examined by tapping with a hammer to detect flaws or cracks. There are numerous forms of continuous fastenings. In most of them there is a projecting lip on the side of the wheel rim, which fits into a corresponding circular recess, cut in a piece which projects on the inside of the tyre. The tyre is heated and placed over the wheel body; it is then turned over, and a circular ring placed in a groove cut inside the tyre at the back edge of the rim: the ring is thicker at the bottom of this groove than at the

FIG. 64.

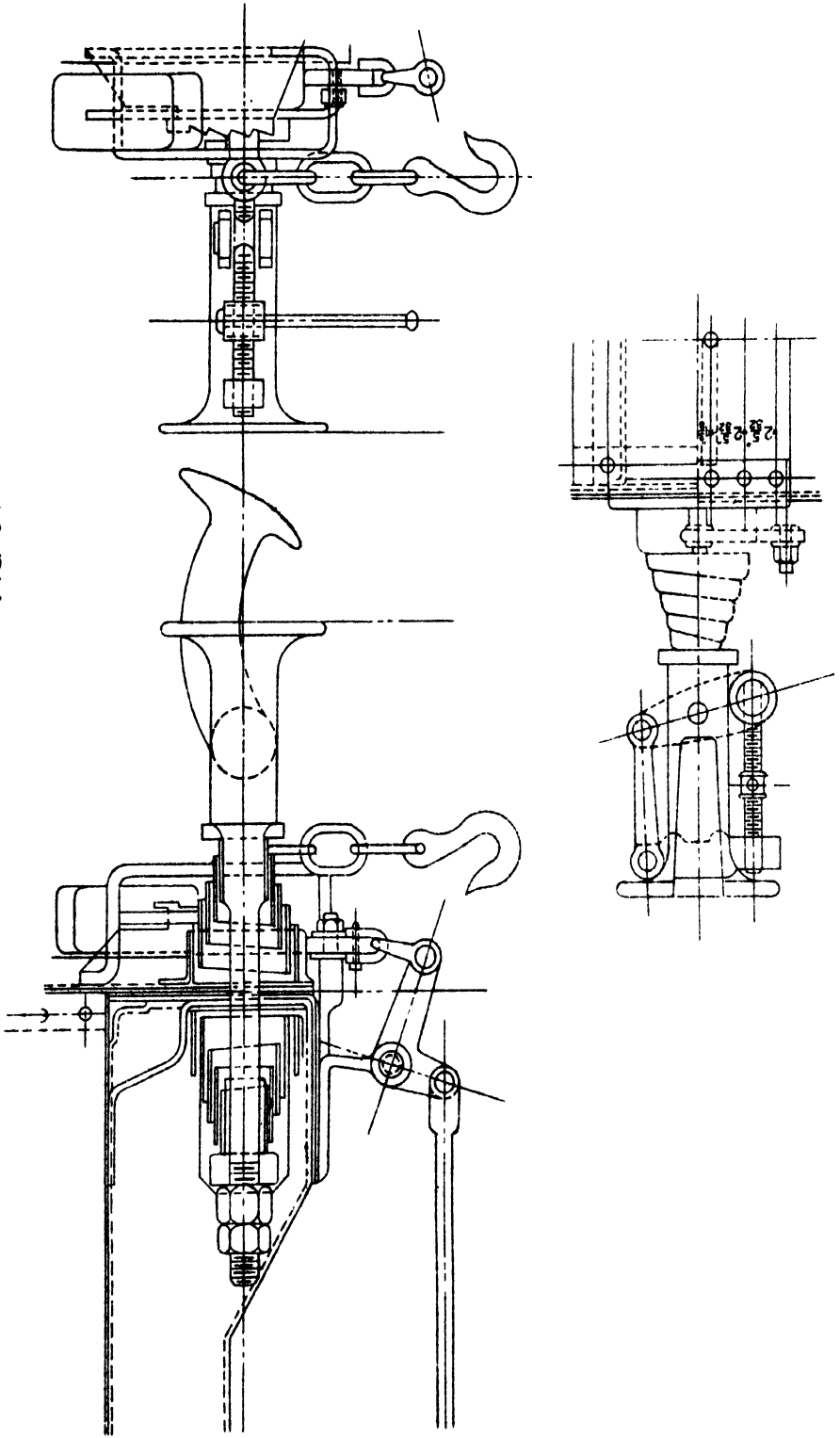
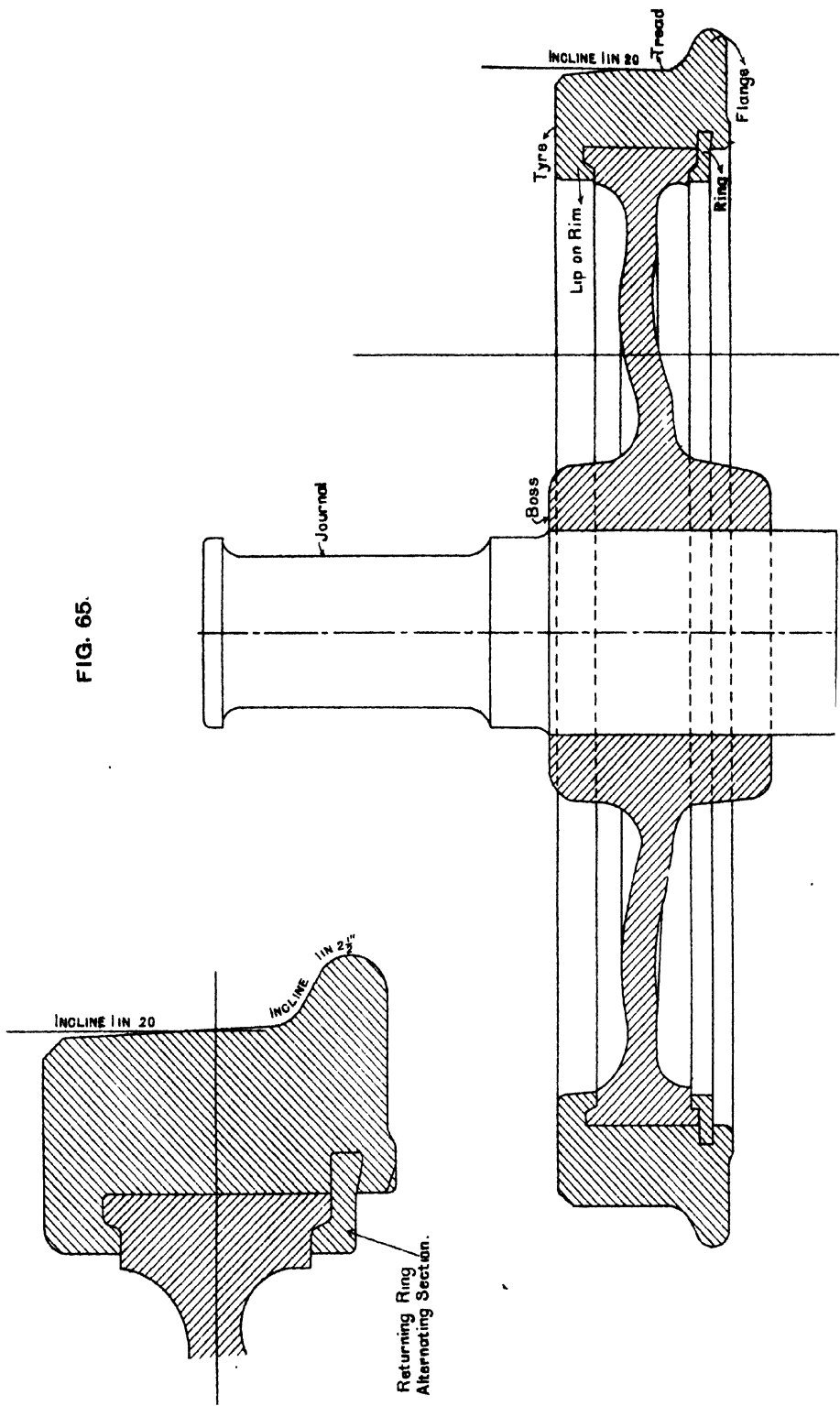





FIG. 65.



top, and the metal of the tyre is hammered down tight on to it so that it cannot come out. Sometimes two rings are used, one outside, and one inside; in this case the rings have a projection which fits into grooves in the tyre, and the two rings are bolted together through the body of the wheel.

The wheels of all rolling-stock are coned (Fig. 65), the tread forming part of a cone tapering about 1 in 20. The original intention of this was to facilitate passing round curves, on which the outer leading wheel runs on a diameter correspondingly larger than that of the inner wheel. A wheel 3 feet 6 inches diameter, tapered 1 in 20, forms part of a cone 35 feet high. Its circumference at the base is approximately 11 feet. At a point 1 inch above the base it is  $\frac{11}{35}$ ths of an inch less. Therefore the outer wheel will go 11 feet and  $\frac{11}{35}$ ths of an inch, while the inner wheel goes 11 feet, if the wheels are  $\frac{1}{2}$  inch outside the central position on the rails. On the 5 feet 6 inch gauge this would make them run evenly on a curve of about half-a-mile radius, but on sharp curves the effect would be small and, as the trailing wheel tends towards the inner rails, the effect of coning on it acts in the wrong direction. (Compare Chapter X.)

12. **Axles.**—These are made either of the best class of iron or of steel, rolled approximately to shape. The part on which the boss of the wheels fits should be of larger diameter than the centre, and should be turned perfectly cylindrical, without any shoulder for the wheel to fit against, as this might cause cracks to develop. On the ends of the axle are the journals (see Fig. 65), which are turned down to the smallest diameter consistent with proper strength, a small allowance being made for wear, so as to reduce the friction to a minimum; the length of the journal is usually about twice the diameter, or slightly more, and the two shoulders should have a large radius, which reduces the risk of cracks developing; the part between the journal and the wheel is turned down to a diameter intermediate between that of the journal and the part in the boss of the wheel so as to fit the dust shield in the axle box.

13. **Axle-boxes.**—These consist (see Plate XVIII) of a box either of cast-iron or steel, or of wrought steel pressed to shape and welded up. On the sides are vertical guides, or grooves, which hold the box in position between the axle guards, and allow it to slide vertically up and down. In the top of the box is the brass on which the journal runs, which is slightly shorter than the journal of the axle, to allow a little play to the shoulders of the journal. The width of the body of the brass is generally about half to three-quarters the diameter of the journal: if made much

more than this the friction is increased ; if too narrow the pressure between journal and brass will be excessive. The bottom of the box holds the oil, which is kept in contact with the journal either by brush, or by filling the box with waste : as the axle revolves the oil is smeared on the bottom of the journal, and thus is carried between the journal and brass. The hole in the back of the box must be considerably larger than the part of the axle between the journal and the wheel to allow for wear of the brass and it is covered by a dust shield, which slides in grooves in the box, and has a hole in it exactly fitting the axle to exclude dust from the bearing ; and on the top of the box is the seating for the spring. The front of the box can be removed for the purpose of renewing the brasses, cleaning, or renewing the brush or waste, and is generally fastened either by studs, or by a hinge. It has a hole closed by a plug or small cover through which oil is introduced. This hole is best made at the level of the bottom of the hole in the back through which the axle passes. Oil is poured in up to this level : if more were put in it would run out at the back and be wasted.

14. There is in practice a certain limit of distance beyond which it is not advisable to increase the rigid wheel-base, or distance between the outside fixed wheels of a vehicle, or the resistance and wear, and the danger of leaving the rails in passing round curves will become excessive. It is usual to limit the rigid wheel-base to between three and four times the gauge. A third pair of wheels may be placed in the centre, these being given lateral play either in the axle-boxes, or in the flanges of the wheels, but unless special precautions are adopted, such a vehicle, particularly if one end only is loaded, or the rails are uneven, is more likely to leave the rails than one having only four wheels. This disadvantage can be met by making the springs of the central wheels more flexible than those of the end ones, or by putting in equalizing levers between the springs of the outer and central wheels.

15. **Flexible Wheel-base.**—If vehicles of greater length than this are required they must be either on bogies or have a flexible wheel-base. In the latter case the outer wheels move in radial axle-guards, or some equivalent device, so arranged that when the vehicle comes on a curve the axles move into a position radial to the curve. The central wheels, of which there may be either one or two pairs, are carried in axle-guards in the usual way. The end wheels are generally arranged with their axle-guards and springs in a separate rectangular frame, moving laterally in guides fixed on the main frame.

These guides are struck radially from a centre in such a way that the axle may arrange itself radially to any curve: in Fig. 66 if the vehicle be moving on a left-hand curve in the direction of the arrow, the wheel will be deflected to the left, the axle-box A will move inwards and forward, and B outwards and backward, so that the axle will be radial or at right angles to the curve. Special precautions are necessary to ensure

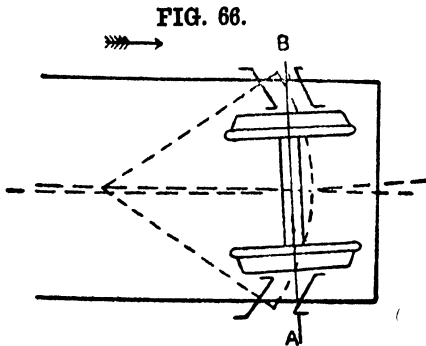

an even distribution of the weight on the end wheels or they may leave the rails, as explained in the previous paragraph. In vehicles with flexible wheel-base the weight is distributed evenly on different parts of the frame, consequently heavy frames are not necessary.

16. **Bogies.**—Bogie vehicles consist essentially of two bogie trucks or frames (see Plate XIX) with axle-guards, boxes, and springs carried either on four or six wheels each, and which themselves carry the main frame on central pivots, round which each truck is capable of turning so as to accommodate itself to the rails on sharp curves. Besides this advantage, they are useful on lines of narrow gauge, where vehicles of a suitable carrying capacity cannot otherwise be constructed: on lines of broader gauge they offer special advantages for coaching stock intended to run at high speeds, for which it is desirable that each individual vehicle should have considerable length, so as to minimise the pitching. As the weight is brought on to each bogie truck at its centre, the load is always equally distributed between the two axles of the truck, which makes it less liable to leave the rails if the road is uneven; and on lines with very sharp curves they give less wear and resistance than ordinary vehicles; on the other hand bogies have certain disadvantages, which do not however outweigh their advantages; they cannot be used on ordinary carriage or wagon turn-tables, traversers, and weigh-bridges, nor in the special tipping apparatus frequently used at docks for tipping materials direct out of trucks into the hold of a ship, nor in the ordinary hydraulic lifts largely employed in goods dépôts in large cities; they make the safety apparatus required for locking points, which consists of a bar longer than the greatest distance between any two wheels, heavy and difficult to work; they are in many cases an inconveniently large unit, and if any

damage is caused to any part of it, the whole of this unit is thrown out of use. When long vehicles only are used, whether they be bogies or vehicles with flexible wheel-base, the couplings and buffers, though they will stand at a considerable angle with one another on adjacent vehicles when running over a sharp curve, are not a serious source of danger, but when long vehicles are mixed up with others of moderate length, this becomes a serious danger, and the long vehicles have in many cases pushed the shorter ones off the rails, or have even themselves been pushed off. For this reason, bogie vehicles should invariably be marshalled together on a train.

17. The bodies of vehicles are of various patterns. Passenger vehicles may have either side doors or end doors with end platforms, but vehicles for carrying luggage, parcels or goods generally have side doors, for convenience of access from the platforms. Certain classes of vehicles have end doors for convenience of loading such things as carriages, carts, etc. : in this case there is an end flap, which when let down projects nearly as far as the buffers, and the loading is done from a "dock," a wall built up nearly to the level of the floor of the vehicle, and at right angles to the rails ; when the vehicle is placed against the dock it forms a prolongation of the road leading to the dock.

18. Plate XX shows four types of goods wagons in common use on railways in India. Manual labour being cheap, loading and unloading are mostly done by coolies and the greater part of the goods traffic is carried in covered goods wagons ; these are generally built of iron, as in the dry climate of Upper India wood soon becomes brittle ; but in the south of India and districts near the sea, wood is largely used. The doors of covered goods wagons are usually made in three pieces ; a bottom flap, usually about four feet wide and two feet high, which turns on a horizontal hinge at floor level, and when let down, forms a ramp from the platform to the floor of the vehicle, and two top flaps each about two feet wide, which turn on vertical hinges and close the upper part. It is essential that the door should close tight so as to exclude sparks, and the space between the sides and roof of the vehicle should be spark-proof. Sliding doors are sometimes used, but it is difficult to make them spark-proof. This class of vehicle when built with a wooden floor, and fitted with panels about two feet square on each side between the door and the ends of the vehicle which can be opened as ventilators, is well suited for the carriage of horses, ponies, or cattle, two rows being carried face to face, tethered to cross bars fastened across the vehicle on each side of the doors. To carry two rows of horses, with space between them for their equipment and

attendants, requires a length of 18 feet, and this length is also well suited for *ordinary* goods traffic on lines of 5 feet 6 inch gauge; but on the metre gauge a length of 14 to 15 feet is more generally used for goods traffic, and vehicles for carrying horses have to be made of a special length, and consequently are heavier. For carrying horses, these vehicles require cross bars, mangers, wainscoting boards, and drainage holes in the floor, but these can be provided when required.

19. A particular class of open vehicle (see Plate XX) is also useful for the carriage of guns, etc.: this is 19 feet 3 inches long: it has end flaps which let down over the buffers, the sides are 2 feet 6 inches to 3 feet high, and there is a door 7' 10 $\frac{1}{4}$ " wide in the centre of each side, which lets down for convenience of loading from a platform. These are suitable for carrying many varieties of ordinary goods traffic, such as grain in bags, small timber, bricks, ballast, etc., as well as guns, carts or carriages. Ordinary open wagons are also made without end flaps, and with either high or low sides, and occasionally without doors: the framework of the sides can be made a good deal lighter than when doors have to be provided. Platform wagons are also used: these generally have no ends, and either no sides at all or very low sides, and often have movable stanchions at the sides. When they are longer than the longest articles which they are usually required to carry, as in the case of long bogie vehicles, they are often provided with ends: they also frequently take the form of bolster wagons, which are generally shorter than ordinary wagons, and are provided with a timber bolster laid across the centre. Such wagons are used in pairs for carrying long timbers; when the length of the timbers or other articles is more than that of two vehicles, an ordinary platform vehicle *without bolsters* is placed in the middle, as long articles should never rest on more than two points when carried by more than one vehicle. Platform wagons when comparatively long frequently have two fixed bolsters, one over each axle or bogie truck.

20. All wagon stock should be fitted with hand lever brakes; a horizontal lever on each side of the wagon is attached to a brake block, and pressing down this lever applies the brake to one or more pairs of wheels; when not in use the lever is hooked up, and when it is applied it should be capable of being pinned down, so as to keep the brake on. The arrangement will be understood from Plate XXI, which shows the fittings and connections for a vehicle which may be braked either by hand or through the vacuum brake. The levers are frequently placed on one side only of the vehicle, but it is better to have them on both. In addition to this, on every train there should be at least one brake-van, in which the brake can

be applied to all four wheels while the train is in motion. On lines with heavy grades, where a pushing-engine is not used at the tail of the train, the total weight of all the brake-vans should, as explained in Chapter X, be a certain fraction of the total weight of the train, excluding engine and tender: this fraction should be such that if the coupling next to the engine broke during the ascent of a steep gradient, the brakes would have sufficient power to prevent the whole train running back.

**21. Continuous brakes.**—In England the Board of Trade requires that all trains carrying passengers shall be fitted with a brake, capable of instantaneous application by either driver or guard to every vehicle in the train, which must be self-applying in case of any failure of continuity, such as would be caused by a broken coupling. A brake complying with the above conditions is called an "automatic continuous brake." Many of the earlier forms of continuous brake were non-automatic; of these the simplest was the Vacuum brake (now called the Simple Vacuum to distinguish it from the automatic); a continuous tube was run along all the vehicles, and by creating a partial vacuum in this by an ejector on the engine, the brakes were applied by means of a collapsible cylinder on each vehicle. In another form of continuous brake, which approached the character of automatic, the brakes were applied by a weighted lever, held up by tightening a cord or chain, which was loosened to put the brakes on.

**22. Automatic continuous brakes.**—There are several varieties of these, but in all, the general principle is the same: a reserve of energy is stored in each vehicle, and this energy is utilized to apply the brake at the wish either of the guard or the engine driver, or automatically in case of an accident to any of the connections. The two commonest forms are the Westinghouse, in which compressed air is used, and the Vacuum, in which a partial vacuum is used; in both, there is a reservoir to each vehicle, a cylinder with a piston, one side of which is connected to this reservoir, and the other side to the train pipe (see Plate XXI). The same pipe is used for supplying the energy to the reservoir (either compressed air or partial vacuum), and for setting this energy to work in the cylinders by means of a 3-way valve; as long as the pressure in the pipe and the reservoir remains approximately the same, no work is done in the cylinders but directly the pressure differs, by letting air out of the pipe in the case of the Westinghouse, or into the pipe in that of the Vacuum, the power stored up in the reservoir moves the valve; the pressure on one side of the piston is that of the reservoir, and on the other that of the train pipe, and this applies the brake, the intensity of application depending upon the difference in pressure in the reservoir and train pipe; the brake may

be worked at any part of the pipe, whether opened intentionally or by accident; as the joints cannot be made absolutely air-tight, there is always a little leakage, and this, if not looked after, may in course of time apply the brake; but the valves are so arranged that they will not act until the difference of pressure is considerable. The term "instantaneous," used by the Board of Trade, is comparative only; there is no such thing as absolutely instantaneous action, even when the brake is applied by electricity, and in the vacuum brake, where the difference in pressure cannot exceed about 14 and seldom exceeds 12 pounds per square inch, it takes an appreciable time to apply the brake from one end to another of a long train: in the Westinghouse, where the difference of pressure may be over 60 lbs. per square inch, the action is much more rapid, and a quick action valve is used, which passes the motion on to the next vehicle immediately. The cylinders, pipes, etc., in the Vacuum have to be very much larger than in the Westinghouse, but, in both, the areas of the pistons are so proportioned that the pressure on the brakes is the same, not quite sufficient to skid the wheels. In both, it is necessary to maintain the vacuum or pressure in the reservoirs whether the brake is being applied or not: where the brakes are applied continuously, as in descending a long steep grade, it is claimed that this can be done more effectually in the Vacuum than in the Westinghouse; both are liable to fail if this precaution be neglected. Gauges are provided both in the guard's van and on the engine showing the pressure both in the reservoir and in the train pipe, and it is the duty of the driver to see that the energy stored in the reservoir is replenished before it is entirely exhausted.

23. The automatic vacuum brake is now the standard brake for India, and is being gradually adopted on all lines on which trains run at high speed. On each vehicle the pipe and fittings are fixtures, but the pipe couplings between the vehicles are of flexible hose, and all have to conform to a particular standard, so that vehicles may be coupled up together. As a large number of vehicles in India have end doors, this standard connection is below the floor level, and the arrangement differs from that adopted in England, though the actual coupling itself is the same. Plate XXI shows a plan and elevation (in diagram form) of a vehicle fitted with the vacuum brake apparatus, the brakes being also capable of being applied by hand. When the vacuum brake is in use, it is actuated by the piston-rod (shown projecting from the cylinder in the elevation) which raises an arm (shown dotted in both plan and elevation) projecting from the main shaft of the mechanism.

## CHAPTER VII.

### LOCOMOTIVES.

1. In Chapter I we gave a brief history of the development of the locomotive. In the present chapter, we shall describe some of its structural details.

2. The essential parts of a locomotive are ; (1) a boiler capable of producing a large quantity of steam, the heating surface being concentrated into the smallest possible space ; (2) two or more cylinders in which the power of the steam is converted into work and employed to drive one or more of the axles ; (3) a strong frame carrying the boiler and cylinders and supported by springs on two or more pairs of wheels ; (4) arrangements for supplying fuel and water, and carrying a reserve either in a separate tender, or on the same frame as the engine.

3. Plates XXII and XXIII show longitudinal and cross-sections of a modern boiler. It consists of (1) the fire-box, a double casing called the inner and outer fire-box, the inner box containing the grate ; (2) the barrel of the boiler, which is a cylinder containing a large number of tubes and is built to withstand a working steam-pressure of 140 to 180 lbs. per square inch ; and (3) the smoke-box, which is not part of the boiler proper (and is not shown on the Plates), but a chamber into which the tubes open, and allow the gases to pass up the chimney. The smoke-box contains generally both the pipes, which lead the steam from the boiler to the cylinders, and those by which the exhaust steam is led from the cylinders to the funnel. The latter unite into one nozzle to form a steam jet or blast, by which the draught through the fire-box and boiler tubes is maintained. The boiler has on it a steam dome from which the steam for the cylinders is taken by a pipe, as high as possible above the surface of the water, the mouth of the pipe being closed by a valve controlled by the regulator. Also a safety valve for allowing the steam to escape if the pressure rises too high ; a pressure gauge for showing the driver what that pressure is ; a water gauge, to show the driver the height of the water in the boiler ; arrangements for supplying water and fuel, emptying, filling, and cleaning out the boiler, and for regulating the supply of air to the fire. There is also a pipe and valve, called the blower, by which a steam jet may be turned up the funnel to make a draught when the engine is standing still ; and generally one or more steam whistles, for calling attention—and most modern engines have either a steam brake, or an appliance either for creating a vacuum or

compressing air, for working some form of automatic brake; and a steam jet for blowing sand under the wheels when they slip on the rails, the sand being stored in a box or boxes either on the side frames or on the top of the engine.

4. The inner fire-box or fire-box proper, is nearly always rectangular and is made of three plates; the front and back plates are flanged over on three sides, the top and sides being of one plate bent to shape and rivetted to the front and back plates. In the back plate is the fire door hole; in the front plate are the holes for the tubes; this part of the plate is generally made thicker than the rest for holding the tubes firmly. The bottom is open and contains the grate. The inner fire-box is nearly always made of copper, this being less liable to deteriorate from the use of bad fuel or water than iron or steel, its extra cost being covered by the value of the old copper when the box is worn out. Copper of a rather hard quality is preferred, as being less liable to abrasion by heavy lumps of fuel. The outer fire-box, or fire-box shell, also consists of three plates, but of steel or iron; the front plate is generally flanged over to join into the top and sides, and has a round hole cut in it, the edges of which are flared out to join on to the barrel, but it is sometimes connected to the barrel by an angle-iron ring. The inside radius of the top plate is frequently made the same as the outside radius of the barrel, and is rivetted direct on to it; the front plate is then attached to the barrel only on the lower half of its circumference. The inner and outer box have a space between them of about three inches at the bottom, increasing towards the top; they are connected at the bottom either by a foundation ring, a solid rectangular ring through which they are riveted together, or by bending out the sheets till they meet, and then riveting. They are connected in the same way at the fire door. All the flat surfaces of the outer box, and those of the inner box which are opposite one another, are stayed together by stays, generally of copper, about  $\frac{1}{2}$  inch diameter and four inches pitch screwed into both boxes, and the ends riveted over: the diameter at bottom of screw thread should be the same as in the body of the stay, and a small hole is often drilled down the centre of the stay, so as to exhibit a leak if the stay breaks across. The part of the back plate above the inner box is stayed either by long stays to the front plate of the boiler, called the front tube plate, or by diagonal stays to the top and sides; and the top of the inner box is stayed to a series of bridge girders which stretch across it: in some patterns, it is stayed to the top of the outer shell in the same way as the sides. It is most important that the top of the fire-box should never be uncovered by water, or a

failure is certain to result: to guard against this, fusible plugs are screwed into it. These are gunmetal plugs, with a hole through them filled with lead: if the water falls too low, the lead melts and the steam puts the fire out. The front plate of the inner box is supported by the tubes described hereafter. The grate is placed a little above the bottom, as sediment is deposited here, which might make the plates overheat and burn. It consists of bars about three-fourths to one inch wide at the top, but narrower at the bottom, laid with spaces of three-fourths to one inch between them. The bars are usually three to four feet long. If a longer box is required two rows are used, their ends resting on a cross-bar in the middle. Below the grate is an ash-pan of sheet-iron, with a damper both in front and at the back, which can be opened or closed as required.

5. The barrel of the boiler is generally made of three plates, each bent to a circle, and riveted together telescopically, the plate next the fire-box being outside the middle one and the middle one outside the front one. The longitudinal joints are double-riveted butt joints and are arranged not to come near the bottom of the boiler, where they would be liable to be abraded by the action of the sediment. The smoke-box tube plate, which forms the front of the boiler proper, is a flat plate riveted to the barrel by a circular angle-iron. In the top of this is the hole through which the steam pipe passes from the dome into the smoke-box, and the lower part holds the tubes which pass through it. The part above the tubes is stayed in the same way as the back plate.

6. The tubes are generally of brass, about  $1\frac{1}{2}$  to 2 inches outside diameter, and  $\frac{1}{8}$ th to  $\frac{1}{16}$ th of an inch thick. They are passed through the tube plates in the fire-box and smoke-box, and expanded so as to fill the holes completely. At the fire-box end the holes are generally larger than at the other end; the tubes are enlarged to fit them; the ends riveted over, and a taper steel ferrule driven in tightly. This cannot be done at the smoke-box end; as the ferrule would obstruct the free passage of small cinders and the tube would be choked. The object of the tubes is to get as large a heating surface as possible; the efficiency of this surface decreases rapidly as the distance from the fire-box increases, and little is gained by making the tubes longer than about 12 feet, which fixes the length of the barrel of the boiler.

7. On the top of the boiler, generally in the centre of the middle plate, is placed the dome: this has a flange at the bottom curved to fit the barrel to which it is riveted, and a movable top, bolted down to a flange. Inside the dome is the steam pipe, its end being covered by a valve, worked from the foot-plate by the regulator, the spindle of

which passes inside the boiler through a stuffing-box. A small man-hole is generally made in the bottom of the boiler, and washing-out plugs are screwed into the lower part of the fire-box shell, through which the deposit is cleared out when the boiler is washed. Water is generally supplied to the boiler by an injector. A jet of steam is passed through an annular nozzle to which water is supplied from the tender; the steam, being condensed by the water, imparts to it a good deal of its velocity, and so blows it through a second nozzle into a pipe leading into the boiler.

8. The smoke-box is simply a chamber in front of the boiler into which the tubes pass. In front is an air-tight door, through which access to the tubes for cleaning, etc., is obtained. On the top is the funnel, which projects down a few inches into the smoke-box. Under this is the blast pipe by which the exhaust steam is discharged up the funnel. On escaping from the blast the steam expands and draws with it the heated gases from the smoke-box, tubes, and fire-box. The more steam goes up the funnel, the more air is drawn through the fire, so that the rate of combustion, to a great extent, automatically adjusts itself to the rate at which the steam is used.

9. The boiler is fixed to the engine frames at the smoke-box end, and at the other end it slides between them, being supported by angle-irons, fixed to the fire-box shell, which slide on the frames. This arrangement is necessary to provide for the expansion and contraction of the boiler.

10. The cylinders are nearly always placed at the extreme front of the engine. They are sometimes placed between the engine side-frames and sometimes outside, and all engines are divided into two classes—the “inside cylinder” and “outside cylinder”—accordingly.

11. In outside cylinder engines the connecting rod acts direct on a crank pin, fixed either in the driving wheel itself or in a crank fixed on a prolongation of the axle, the axle itself being straight; in inside cylinder engines the axle itself is cranked, and it has in consequence to be very heavy and strong, and even then is more liable to failure than a straight axle. Fig. 67 shows in diagrammatic form the relation between the

FIG. 67.

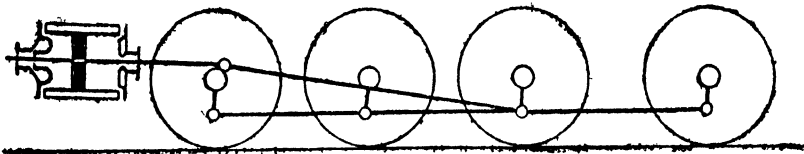

cylinder of an outside cylinder engine and the driving wheels. The connecting-rod necessarily acts directly on one driving-wheel only, the remaining driving-wheels being driven by means of "coupling-rods" from the crank of the wheel on which the connecting-rod acts.

12. The side-frames which carry the boiler and working parts on the wheels, and also have to transmit the pressure of the driving axles, are generally placed inside the wheels; but in narrow-gauge locomotives they are frequently placed outside, and some engines with inside cylinders have double frames, one inside and one outside the wheels, the inside frame taking horizontal stresses, and the outside one the vertical stresses due to the weight. They are generally cut to the required shape out of solid plate, 1 inch to 1½ inch thick, extending the whole length of the engine from the buffer beam in front to the foot-plate at the back. The frames are connected together by the "spectacle plate." In inside cylinder engines, this carries the ends of the slide bars, which guide the piston rods, and also the guides of the valve spindles; this spectacle plate is usually about half-way between the cylinders and driving wheels. The frames are also connected in front of the fire-box by a stay-plate, and behind the fire-box by the foot-plate, the latter generally a heavy casting designed to balance the engine, in which the weight of all the working parts is near the front end. In inside cylinder engines the cylinders are bolted between the front ends of the frames, and connect them together; in outside cylinder engines the cylinders are bolted on outside and the front tube plate of the boiler extends down between the frames.

13. The openings for the axle-boxes are fitted with cast-iron or steel horn blocks of considerable width, to transmit the horizontal pressure to the frames, and provided with wedges for taking up the slack as the parts in contact wear. The axle-boxes are carried by springs in much the same way as in coaching and goods stock; the springs are in most cases placed below instead of above the axle-boxes, the attachments are made adjustable, so as to distribute the weight properly on the different wheels, and compensating beams are frequently used. These are beams connected by a pin at their centre to the frame and, at both ends, to the ends of the two adjoining springs; if more weight than usual comes on one spring, this end of the beam rises and the other end falls, so transferring part of the weight from one axle to the other. An angle-iron is fastened along the top of each frame on the outside, and on the top of this are fixed the side plates, which form a gangway and strengthen the frame: holes are cut in these where the tops of the wheels come through, and are covered over by splashers, made to clear the upper parts of the wheels.

## LOCOMOTIVES.

14. All locomotives must be reversible, or capable of running either backwards or forwards. The valve of each cylinder is usually worked by two eccentrics fixed on the driving axle, one for forward gear, the other for backward gear. An eccentric is in effect a crank, of which the crank pin is made of a radius greater than the length of the crank *plus* the radius of the axle. Each eccentric is set to an angle of  $90^\circ + \delta$  in advance of the driving crank, where  $\delta$  is the so called angle of advance (for a full description of the effect of lap and lead, the student must refer to a work on the steam engine). In the earlier engines one or other of these was thrown out of gear, and the other connected by a hook on the end of the eccentric rod to a stud on the valve spindle. Stephenson connected the ends of the two eccentric rods by a curved link with a slot in it (see Plate XXIV), in which slid a block connected with the end of the valve spindle. The link connecting the two eccentric rods is under the control of the driver by means of the "lever," so that it can be raised or lowered. When the block is in the centre of the link, as on the Plate, and the lever at the centre of its stroke the valve is moved at each revolution through a distance of  $2r \sin \delta$ , where  $r$  is the distance from centre of axle to centre of eccentric, and the valve is made longer than the distance from outside to outside of the steam ports by this amount, so that the port is never uncovered, and no steam enters the cylinder. If the block is at either end of the link and the lever at either end of its stroke, the valve is in full gear, controlled by one eccentric only, and has the maximum amount of movement, admitting steam to the cylinder throughout the greater part of the stroke; if the block and lever are at any intermediate position the valve is controlled partly by one and partly by the other eccentric, and according as it is near the end or the centre, steam is admitted to the cylinder for a greater or less proportion of each stroke of the piston. The use of the link therefore gives a convenient method, not only of reversing the engine, but also of controlling the amount of steam admitted to the cylinder at each stroke.

In Stephenson's link the eccentric rods and link are raised or lowered, the movement of the block being only in a straight line backwards and forwards, the radius of the link being struck from the centre of the driving axle.

In Gooch's link the link is suspended at a uniform height and the valve spindle is jointed, the block fixed to its end being raised or lowered and the radius of the link struck from the joint of the valve spindle.

In Allan's link the two motions are combined, the link being lowered and the block on the jointed end of the valve spindle raised simultaneously, and *vice versa*, and the link is made straight.

Many forms of valve gear have been used in which the movement of the valve is controlled partly by the eccentric and partly by the connecting rod, and in Joy's valve gear it is controlled entirely by the movement of the connecting rod. Walschaert's valve gear has been recommended by the Locomotive Standards Committee for general adoption in metre-gauge locomotives as, being outside the frames and wheels, it is easily examined and oiled, and it permits the use of the balanced slide valve. It is now in use in India on many standard gauge engines also. The gear is shown on Plate XXIV, which also gives a diagrammatic sketch of the rod-connections. It will be seen from the drawing that the valve-stem is actuated partly by the motion of the piston cross-head, and partly by the motion of the link, which is itself actuated by a connecting-rod worked from the crank of the driving-wheel.

15. Cylinders vary in size from 16 inches diameter and 22 inches stroke to 20 inches diameter and 28 inches stroke for the standard gauge, the ordinary size being 18 inches by 24 to 26 inches stroke. For the metre gauge the usual size is 14 inches diameter and 20 inches stroke, but engines with smaller cylinders are frequently used for special purposes.

16. It is necessary that all revolving parts be accurately balanced ; in

the case of cranks, this is easily done by attaching weights to each wheel (see Fig 68) till the balance is attained ; the big end of the connecting rod which is attached to the crank also moves in a circle, and can be balanced by a weight attached to the wheels, but the other end and the piston rod move in a straight line only, and the intermediate parts of the connecting rod move in curves intermediate between a straight line and a circle. At one part of the stroke their movement is very rapid, at

FIG. 68.  
Balance weight

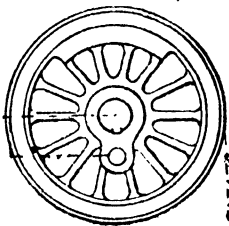

another they are momentarily stationary, and then they move in the opposite direction. Their movement cannot be accurately balanced by any revolving weight. The best result is perhaps obtained by taking half the weight of the connecting-rod, considering it as revolving weight, and applying balances accordingly. For a description of the theory of balancing, the student must refer to a work on the steam-engine.

17. Engines are divided into classes according to the kind of work they have to perform—(1) Express or mail engines, suitable for high

speeds but not for hauling very heavy loads. The typical express engine used to have only one pair of driving wheels, seven to eight feet in diameter, with a considerable load on them, 16 or 17 tons in many cases, in order to obtain the necessary adhesion; but with the increased loads of modern express trains the adhesion of a single pair of driving wheels is hardly sufficient, and the most recent types of express engines have four-coupled driving wheels. To these are added either a four-wheeled bogie, or a pair of wheels about four to five feet in diameter in front, and a similar pair behind (no locomotives used in regular train service ever have fewer than six wheels), cylinders about 18 inches by 24 or 26 inches, and a tender capable of carrying a large supply of fuel and water. (2). Passenger or mixed engines, in which two or three pairs of wheels are coupled together, i. e., four or six-coupled, their diameters varying from five to seven feet according as power or speed may be of greater importance. The size of the cylinders also varies according to the power required, but 18 by 26 is now the most usual size for engines of full power on the standard-gauge. They usually have either a bogie or a pair of radial wheels in addition to the coupled wheels. This class of engine is now generally used for all passenger trains, whether mail or ordinary. (3). Goods engines in which three or four pairs of wheels are coupled together, i. e., six or eight-coupled. The wheels are generally from  $3\frac{1}{2}$  to 5 feet in diameter and they develop great power, but are not suited for high speeds. (4). Tank engines, in which the fuel and water, instead of being carried in a separate tender, are carried on the engine itself. Engines in class (2) for local traffic are frequently built as tank engines as a matter of convenience, a tank engine being suitable for running backwards, a great convenience and saving of time in trains which run a short distance and back again, while an engine with a tender attached is very liable to push the tender off the rails if run backwards at even a moderate speed. Where the run is a short one, enough water and fuel can easily be carried on the engine without unduly increasing its weight, and the tender can be dispensed with. Engines in class (3) are frequently built as tank engines with the express object of increasing the weight on the driving-wheels and so obtaining greater tractive power, see Chapter X; the weight on the driving-wheels, and consequently their tractive power, will however decrease as the tanks and fuel-bunkers become empty.

18. A convenient method of classifying engines has now been generally adopted. Three figures are used, the first denoting the number of leading wheels (i. e., those in front of the driving wheels), the second the number of driving wheels (including coupled wheels), the third the number of

trailing wheels (i.e., those behind the driving wheels). When there are no leading or trailing wheels their absence is denoted by a zero. Thus, the "Rocket" would be described as 0-2-2, the "Planet" 2-2-0, the engine in Fig. 69 would be 2-4-2; that in Fig. 70, 4-4-0, in Fig. 71. 0-6-0, and so on.

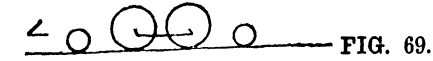

FIG. 69.



FIG. 70.

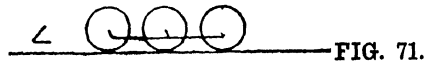

FIG. 71.

19. Compound engines have of late years come largely into use. The advantage of the compound engine depends on the fact that steam, when expanded to any great degree in one cylinder, lowers the average temperature of the cylinder to such an extent that, when the high pressure steam is admitted from the boiler for the next stroke, part of it is condensed by the cool cylinder and wasted. In the compound engine the steam is first admitted into a comparatively small high pressure cylinder, in which it is expanded to a small degree only; and this partially expanded steam is then passed on into a low-pressure cylinder of greater diameter, where it is further expanded before being finally discharged up the funnel. As the ratio of expansion in each cylinder is much reduced, there is much less loss through the difference in temperature between the steam and the cylinders. The objection to compound engines is that they require a rather more complicated valve gear, and special arrangements for starting and stopping: also, where the high-pressure cylinder is on one side and the low pressure on the other, the work done on the two sides is only the same when the degree of expansion is exactly that for which the engine is designed. When working hard, as in starting or pulling up an incline, or working easy, as in going down an incline, more work will be done in one cylinder than the other. Some compound engines have four cylinders, a high pressure and low pressure on each side, and in Mr. Webb's arrangement, used on the London and North-Western Railway, there are two high-pressure cylinders, one on each side working direct on to one pair of driving wheels, and one low-pressure cylinder in the centre working direct on to the axle of another pair of driving wheels, so that the engine has all the advantages and none of the disadvantages of a four-coupled engine.

20. Amongst recent improvements in the modern locomotive is the introduction of "superheaters," which superheat the steam before it is admitted into the cylinders. By their use not only is a great economy in fuel effected, particularly in fast traffic, but also in steam, so that a superheater engine can make a considerably longer run than an ordinary engine with the same fuel and water capacity.

Oil-burning locomotives, or locomotives burning partly oil and partly solid fuel, have also recently been tried in India with good results.

21. **Locomotive brake-gear.**—Locomotives are provided with brakes applied either by steam, as stated in paragraph 3, or by hand; the latter, which are used generally on the tender, being of the screw type as used in ordinary brake-vans. They are also, as mentioned in the same paragraph, fitted with the gear necessary for applying to trains the automatic continuous brakes described in the last chapter.

22. Plate XXV illustrates a 4-6-0 type of passenger engine for standard (5' 6") gauge, Plate XXVI a 2-8-0 goods engine for 5' 6" gauge, Plate XXVII a 4-6-0 mixed traffic or goods engine for metre (3' 3½") gauge, and Plate XXVIII, a tank engine, 0-8-4 type for 2' 6" gauge.

## PART II.--THEORY, PRACTICE, AND DESIGN.

### CHAPTER VIII.

#### PLATE-LAYING.

1. The operation of laying-out, on the prepared formation of a railway, and connecting up, the rails and sleepers, composing the permanent way, is termed plate-laying. This word was coined in the early days of railways when the rails consisted of iron plates. And though the subsequent history of permanent-way has been a history of constant change, the word "plate-laying" has survived all changes.

2. When all the material for a new track can be laid out beforehand, by train service from a neighbouring track, as for instance, when a line is being "doubled," the labour can be spread out and the operations of plate-laying carried on simultaneously in many places. Such a method is obviously suitable only when *doubling*, or *renewing*, an existing track is in hand.

3. When a new line of railway is under construction the materials have to be collected at the base of operations and led out, as required, day by day, the newly-laid track being utilized for the purpose. The point up to which the track has been laid at any time is called *rail-head*, and the daily progress is recorded by the mileage of rail-head from the base at the end of each day's work. The following notes deal with the method described in this paragraph.

4. During the first few days, when the lead does not exceed a mile or so, the materials may be led out on trollies propelled by hand. After a mile has been reached, if there is no immediate fear of an interruption (due either to formation not being ready, or to materials running short at the base, or to scarcity of labour) a train should be employed. In this connection it may be observed that it is uneconomical to commence plate-laying, unless there is a fair prospect of uninterrupted progress for some weeks at least. For after a train service has been established, and labour gangs and supervising staff engaged, the daily expenses and hire charges of the one and the daily pay of the other mount up continuously whether any work is done or not; hence every hitch means a waste of money.

5. The details of the distribution of labour at rail-head will necessarily vary with the type of the permanent way and the weight of the materials to be handled, but in any case there must be (1) *material gangs*, who unload material and lead it to site, (2) *linking-in gangs* who

fix the rails to the sleepers and link the rails together with fish-plates, (3) *packing gangs* who pack and straighten the track in rear.

6. The *material gangs* may be divided into sleeper, rail, and small material gangs. If carts are available at rail-head the sleepers can be loaded on to them and led out; otherwise they may be trollied out as far as the rails will admit, but must then be spread by the gangmen. The *sleepers* (if wooden) usually arrive already sized or otherwise prepared, with a saw-mark in the centre of each. Assuming that the centre line has been carefully pegged out on the formation beforehand, a string is stretched from peg to peg and the sleepers laid transversely under it, spaced approximately correctly (i. e., so many per rail-length) and carefully centred by means of the string. The *small materials*—fish-plates, spikes, bolts, and bearing-plates or chairs (if used)—are then led out and laid as nearly as can be guessed in their proper positions alongside the sleepers.

7. Then follow the *rail-carriers*. The number per rail depends on the length and weight of the rail and the physique of the men. It requires at least 16 sturdy men to carry a rail weighing half a ton for a lead of about a furlong, making about 70 trips in an ordinary day's work. This gives a working load of 70 lbs. per man. The men are arranged in pairs, each pair being provided with a sling, the bar or yoke of which rests on their shoulders, the rail, gripped by the jaws of the sling, being suspended between them. An untrained gang will sometimes try to carry a rail on their shoulders; but this is dangerous and should be strictly prohibited, for if one man stumbles, it jerks the rail from some of the other men's shoulders, with the result that the remainder are weighed down by the extra load thus suddenly imposed on them.

8. A rail having been brought to site is deposited on the ground and the *linking-in gang* then proceed to fix it to the sleepers. The method of doing this depends on the type of rail, e.g., if bull-headed rails are used, the chairs must be partially fixed beforehand, and the same remark applies to flat-footed rails when bearing plates are used; otherwise the rail is fixed direct to the sleepers. The method of attachment, again, depends on the type of sleeper, so that the actual details of "linking-in" would vary with every type. But certain general principles are observed—(1) each rail should be chalk-marked at measured intervals to indicate the spacing of the sleepers, a rod, equal in length to half that of the rail, and with the sleeper-spacing marked on it, being used for the purpose; (2) the sleepers are then spaced under the rail to correspond with the chalk marks [in doing this care must be taken not to shift them out of centre

(vide paragraph 6)]; (3) as soon as a sleeper is fixed to a rail, the fixing of the opposite rail may be proceeded with; an accurate *gauge* (see Fig. 72)

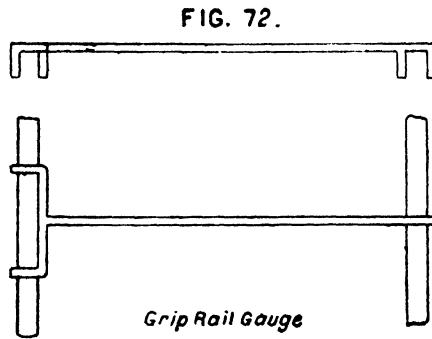

which grips the head of each rail, should be used for the purpose of ensuring that the rails are laid to the proper gauge; (4) it is not necessary to wait for a rail-length to be fully fixed to the sleepers before it is connected up with the previously laid length; it is better to perform this operation as soon as possible after the new rail has been placed on the sleepers, for, as soon as the fish-plates are fixed and the rails attached to the end sleepers (and perhaps to one or two intermediate ones), trollies can be passed over.

9. The operation of *fish-planting* is the same for all types of permanent way. A piece of metal (or preferably of wood) called a *liner*, the thickness depending on the amount of space to be allowed at the joint for expansion (see paragraph 17, chapter II) is placed against the end of the last laid rail, and the new rail butted on to it. A pair of men then fix the fish-plates in position, put two bolts through (one for each rail-end), and roughly tighten them. These men (there would usually be a pair for each line of rails) have to keep pace with the arrival of each rail-length, so they have not much time to spare for tightening up the bolts. They are followed by other pairs at some distance in rear, who tighten up the first two bolts fully and insert and tighten the remaining bolts, after which the expansion liners, if of metal, are removed and returned to the issuing authority. The advantage of using wooden liners is that, being of no value, they may be left in the rail-joints, thus ensuring that the spacing of the rails is not disturbed by the operations of the packing-gangs. If the rails expand the wood is merely crushed, so that there is no danger of the rails buckling.

10. Steel expands or contracts  $\cdot 000065$  of its length for every degree Fahrenheit through which the temperature rises or falls. If therefore

the maximum range of temperature throughout the year in a given locality be 130 degrees Fahrenheit, a steel rail will expand about  $\cdot 01$  of an inch per foot of its length. In deciding what should be the space left at the joint for expansion during actual plate-laying, the temperature may be taken two or three times a day (say, during the morning, at midday, and during the afternoon) and the range of temperature to be provided for will be the difference between the actual temperature at the time and the maximum possible temperature during the hottest period of the year. For example, if the actual temperature is found to be  $70^{\circ}$  Fahrenheit, and the highest possible temperature during the year is assumed to be  $160^{\circ}$ , then the spacing at the joints of rails 30 feet in length should be  $12 \times 30 \times (160 - 70) \times \cdot 0000065$  inches, that is  $\cdot 21$  of an inch, which might be increased, for safety's sake, to  $\frac{1}{4}$  inch. If the liners be of wood, a fairly large stock of them should be kept, of thicknesses varying by sixteenths of an inch from  $\frac{1}{8}$  to  $\frac{3}{8}$  inches: greater refinement than this is not necessary.

11. The *packing-gangs* have first to straighten the newly-laid track and to bring it to an even gradient by packing earth under the sleepers where they are unsupported, and (occasionally) to remove lumps where the formation is too high. (A packing-tool or *beater*, as it is called, is illustrated in Fig. 24; for packing earth the beater should preferably be made of wood.) It would be obviously impossible for this gang to do much in front of the train, but a few men should follow on the heels of the linking-in gangs, to straighten the line roughly between the train and the last-laid rail-length. The remainder of the gang would work in rear of the train.

12. As regards the employment of trains and trollies, one arrangement is that, on arrival of the train at rail-head with the day's supply, all the materials are at once unloaded and the train returns to the base, the materials being carried forward by trollies, of which perhaps a dozen or so are kept for this purpose at rail-head. But a more convenient arrangement is for the train to remain at rail-head all day, only sufficient material being unloaded at a time for, say, one furlong of permanent-way, which can be dealt with by six trollies only. This material is unloaded as close to rail-head as possible, and the train is then shunted back to allow the trollies to be brought up alongside the material. After a furlong has been fully linked-up immediately in front of the train, the latter moves forward by that amount, depositing material for another furlong, and so on. Thus, the position of the train will be normally about a quarter of a mile in rear of rail-head, of which distance the forward furlong will be only partially linked, fit for the passage of trollies, while the rear furlong is approaching a state of completion. This arrangement necessitates the use of two

trains, or rather two sets of trucks, so that while one is at rail-head the other can be loaded up at the base ready for the next day's work.

13. In loading rails on to trollies the latter are used in pairs, with a space between, so as to distribute the load. A pair of trollies will thus carry rails sufficient for a furlong of track at a time.

14. The marshalling of a permanent-way material train requires consideration. If there are no trollies available the most convenient arrangement is to have all the rail-trucks in front, then the small materials, then the engine, then the sleeper-trucks. The latter are placed in rear, because they would block the view of the driver on the outward journey if placed in front. When trollies are available the small materials may be placed in front, then the rail-trucks, then the engine and, lastly, the sleeper-trucks as before.

15. The length of track laid in a day will depend on the numerical strength of the gangs, the extent of their experience, the type and weight of the material, and the adequacy of the arrangements generally. As a rule, of the total labour available at rail-head three-quarters should be allotted for the material and linking-in gangs, and the remaining quarter reserved for packing and straightening.

16. To estimate the number of men required at rail-head to lay *one mile of permanent way in a day of 8 hours*, a good rule is to allow *one man for every ton of permanent way per mile* (including rails, sleepers, and fastenings). This will cover all operations except leading-out sleepers, for which operation add  $12\frac{1}{2}$  per cent. (one-eighth) if carts are used, or 25 per cent. (one-fourth) if carts are not used. The above rule assumes that the sleepers are adzed and bored or otherwise prepared in dépôt before despatch to rail-head, and that all spiking, or other method of fixing rails to sleepers, is done at rail head. If a proportion of chairs are spiked to sleepers in dépôt, the spiking party at rail head (normally about 20 per cent. of the total strength) will be proportionately reduced. Again, if boring is done at rail-head (which is not recommended, but is sometimes necessitated by force of circumstances) a further 30 per cent. would have to be added.

17. The following examples, selected at random, will serve to show how the above rule is borne out by actual experience:—

- (a) Agra-Delhi Chord, standard (5' 6") gauge, rails bull-headed, 85lbs per yard and 40 feet long, chairs cast-iron 45lbs. each, alternately right and left-handed, with keys of babul wood to correspond, sleepers deodar 10' × 10" × 5", 14 per rail-length, spikes three per chair, fish-plates 4-holed. Total weight of

permanent-way material about 346 tons per mile. The train remained all day at rail-head, six trollies were used (four for rails and two for small material), and 50 bullock-carts were employed in leading out sleepers for about a mile in advance of the train. Four sleepers in every rail-length were spiked at the dépôt before being sent to rail-head. Fifty-three miles of this material were laid by military labour. It was found that 412 sepoy, assisted by 50 cartmen at rail-head, could lay  $1\frac{1}{4}$  mile in 8 hours, to which must be added 25 men in dépôt, spiking  $\frac{4}{14}$ ths of the sleepers before despatch. The distribution was as under:—

Laying $1\frac{1}{4}$ mile in 8 hours.				Equivalent number for 1 mile in 8 hours.
		Sepoys	Civil labour.	
Spreading sleepers	.. .. .	16	50 (cartmen).	53
Handling rails (exclusive of trollies) including two artificers for repairs	.. .. .	154		122
Trolleying rails	.. .. .	80		64
Distributing small material	.. .. .	52		42
Fish-plating	.. .. .	36		29
Spiking, keying, etc., including two artificers	.. .. .	74	25 (in dépôt)	80
	Total	412	+75 = 487	390

According to the rule, men required for 1 mile (346 tons) = 346  
 Add  $12\frac{1}{2}$  per cent. for sleepers led by carts = 44  
 Total ... 390

(b) Suakim-Berber Railway, 4'  $8\frac{1}{2}$ " gauge, rails flat-footed 56lb per yard, 24 feet long, sleepers wooden 9'  $\times$  10"  $\times$  5" (no bearing-plates), fish-plates spikes, etc., ordinary type. Weight per mile 196 tons. No carts were used. The train did not remain at rail-head. At least 10 trollies were used. From data indirectly obtained the following was the minimum strength found necessary to lay 1 mile in  $9\frac{1}{2}$  hours:—

Laying 1 mile in $9\frac{1}{2}$ hours.				Equivalent number for 1 mile in 8 hours.
Spreading sleepers	.. .. .	74		88
Handling rails	.. .. .	48		57
Trolleying rails	.. .. .	20		24
Distributing small material	.. .. .	10		12
Fish-plating	.. .. .	20		24
Spiking, keying, etc	.. .. .	36		43
	Total	208		248

Applying the rule, men required for 1 mile (196 tons) =	196
Add 25 per cent. for sleepers led by hand =	49
Total	245

(c) Rajputana-Malwa Railway, metre (3'3 $\frac{3}{8}$ " gauge, rails flat-footed 41 $\frac{1}{2}$  lb. per yard, 30 feet long, sleepers deodar 6' x 8" x 4 $\frac{1}{2}$ ", fish-plates 4-holed, bearing-plates at joints only, spikes ordinary. Weight per mile about 150 tons. No carts used. To lay 1 $\frac{1}{2}$  miles in 8 hours. The following strength was found necessary :-

Laying 1 $\frac{1}{2}$ mile in 8 hours.	Equivalent number for 1 mile in 8 hours.
Spreading sleepers .. .. . 65	43
Handling rails .. .. . 50	33
Trolleying rails .. .. . 53	35
Distributing small materials .. .. . 19	13
Fish-plating .. .. . 14	9
Spiking, keying, etc. .. .. . 78	52
Total .. 279	185

By the rule, men required for 1 mile (150 tons) ..	= 150
Add 25 per cent, for sleepers led by hand ..	= 38
Total	.. 188

18. Thus it will be seen that the actual numbers of men employed in the cases given correspond very closely with the numbers calculated by the rule. Of course the length laid in the recorded time in each case represents progress made under the most favourable conditions; i.e., when the men had gained experience and when there were no hitches. In Europe or America, with skilled labour, probably two-thirds, or even one-half of the above strength would be found sufficient. But the rule, as given, may be considered as applicable to ordinary Indian conditions.

19. In malarious districts the estimated strength at rail-head may have to be increased by from 33 to 50 per cent. to allow for casualties and for the poor physique of the men. The following is an example of plate-laying in a very feverish part of Upper Burma in 1894:—

(d) The Mu Valley-Mogoung Railway, metre (3'3 $\frac{3}{8}$ " gauge, rails flat-footed 41 $\frac{1}{2}$  lb. per yard, 30 feet long, sleepers pinkado or teak 6' x 8" x 4 $\frac{1}{2}$ ", fish-plates 4-holed, spikes, etc., ordinary,

weight per mile 150 tons. No carts used. Boring done at rail-head. The following strength was found necessary (allowing one-third of total for casualties) to lay  $\frac{1}{4}$  mile in 8 hours:—

Laying $\frac{1}{4}$ mile in 8 hours.	Equivalent number for 1 mile in 8 hours, including casualties.	Working strength, omitting casualties.
Spreading sleepers .. .. . 30	90	60
Handling rails .. .. . 24	72	48
Trolleying rails .. .. . 12	36	24
Distributing small materials .. .. . 5	15	10
Fish-plating .. .. . 5	15	10
Spiking .. .. . 16	48	32
	<hr/>	<hr/>
	92	184
Add auger-men for boring .. .. . 30	90	60
	<hr/>	<hr/>
Total .. 122	366	244
<hr/>		
Applying the rule, men required for 1 mile (150 tons) .. .. .	=	150
Add 25 per cent. for leading out sleepers by hand .. .. .	=	38
		<hr/>
		188
Add 30 per cent. for boring sleepers .. .. .		57
		<hr/>
		245
Add 50 per cent. for casualties .. .. .		123
		<hr/>
		368
		<hr/>

20. Although the actual distribution differs in each of the above cases, it will be noted that the totals agree closely with the numbers computed by the rule. It may also be noted that the actual linking-in operators, i.e., the fish-plating and spiking-gangs, aggregate in each case about one-quarter of the total.

21. **Packing-gangs.**—For rough-packing, the strength should be about a third of that of the rail-head gangs. This was about the proportion on the Agra-Delhi Chord Railway. In the Rajputana-Malwa example the proportion was 20 per cent., but it was followed shortly afterwards by a full-packing gang of 40 per cent., strength, and lastly by a ballasting gang of 40 per cent so that the combined strength of these three gangs was equal to that of the rail-head gangs. It is seldom the case that the formation is sufficiently consolidated to admit of a line being fully packed and ballasted immediately after it is laid. It will usually be advisable to

wait until the banks have had the benefit of two, or preferably three, seasons of heavy rain, before complete ballasting is attempted.

22. **Curves.**—On straight roads the joints should be kept exactly square. On curves the inner rail will gradually obtain a lead over the outer. If  $a$  be the central angle of a curve in circular measure and  $r_1$  and  $r_2$  the radii of the outer and inner rails, then the length of the outer rail will be  $r_1 a$ , while that of the inner rail will be  $r_2 a$ . The difference in length between outer and inner rails will therefore be  $(r_1 - r_2) a$ , that is  $ga$ , where  $g$  is the gauge between the rails. If  $a$  be expressed in degrees, then this difference is equal to  $\frac{ga}{57.295}$ . When the lead amounts to about 4 inches or a distance equal to the pitch of the bolt-holes at the end of the rail, the usual practice is to cut off a length from the end of the inner rail equal to *twice* this distance, fresh holes being bored for the fish-bolts. The joint on the inner rail is then in rear of that of the outer, and when it again attains sufficient lead over the outer rail, the operation is repeated.

23. Some engineers, however, prefer that on curves the joints of the outer and inner rails should be "staggered," that is to say, that the joints of the inner rail should be opposite to the centres of the outer rails, and those of the outer rail opposite to the centres of the inner rails. This is the practice in America; it interferes however with the spacing of the sleepers, and it is doubtful whether it has any advantages over the method described in the preceding paragraph.

24 On very sharp curves it may be necessary to bend the rails. For this purpose a "jim-crow," as it is called, (see Fig. 73) is used. The tool

FIG. 73.

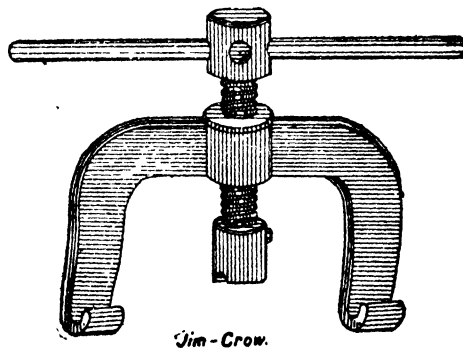

consists of a powerful screw-press, the rail being held by two jaws at a distance of about two feet apart, and being bent to the requisite curve, by turning the screw, which is midway between the jaws. The jim-crow is

also exceedingly useful for cutting rails when a proper rail-saw is not available. A chisel drift is cut around the rail at the section at which it is desired to cut it; the rail is then placed in the jim-crow, with the weakened section caused by the chisel-drift immediately below the screw. When the latter is turned, the rail breaks cleanly at the weakened section.

25. On curves the gauge should also be widened in order that a vehicle with a rigid wheel-base may run freely around it. In Fig. 74,

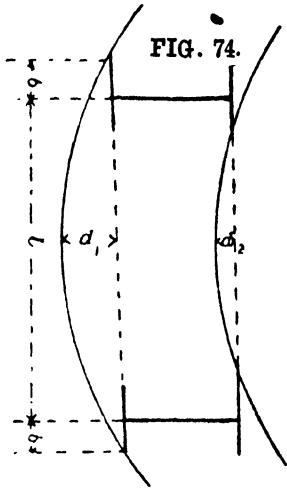

which represents to an exaggerated scale a four-wheeled vehicle passing around a curve, let  $l$  be the maximum rigid wheel-base, that is, the maximum distance between centres of parallel axles; then it is clear that  $b$ , which represents the horizontal distance between the centre of an axle and the point on the flange of the wheel which is in contact with the rail, will be equal to  $\sqrt{2rt}$ , where  $r$  is the radius of the flange of the wheel and  $t$  is the depth of the flange below the tread of the wheel. The length of the chord

between the points of contact of the wheels with the outer rail is therefore  $l + 2b$ , while the length of the corresponding chord for the inner rail is  $l - 2b$ . Now the extra width of gauge which it is necessary to allow is clearly  $d_1 - d_2$ , that is  $\frac{(l + 2b)^2}{8R} - \frac{(l - 2b)^2}{8R} = \frac{lb}{R}$ ,  $R$  being the radius of the curved track.\*

For the standard-gauge, the maximum rigid wheel-base permissible is 20 feet for passenger vehicles and 16 feet for goods vehicles; and for the metre gauge 20 feet for passenger vehicles and 12 feet for goods vehicles.

26. In the next chapter the subject of railway curves will be more fully dealt with and an investigation of the important subject of super-elevation will be there given.

---

\* We shall see from Chapter X, that a vehicle with a rigid wheel-base running on a curve would not actually take up the position shown in Fig. 74, but that the flange of the outer leading-wheel only would hug the rail, the trailing outer wheel moving inwards. There is however always sufficient play between the flanges and the gauge-faces of the rails to allow of the rear axle taking up the position, which as explained in Chapter X, it actually does assume.

## CHAPTER IX.

### SUPERELEVATION AND THE TRANSITION CURVE.

#### THE VERTICAL CURVE.

1. A **circular curve** may be defined either by its radius or its *degree of curvature*. The degree of curvature of a circular curve is defined in the rules issued on the subject by the Government of India as *the angle subtended at the centre by an arc of the curve 100 feet in length*. Since the circular measure of an angle of  $1^\circ$  is  $\cdot 0174533$ , the radius of a  $1^\circ$  curve is  $\frac{100}{\cdot 0174533} = 5729\cdot 578$  feet. The radius of a curve of  $n^\circ$  will therefore be  $\frac{100}{n \times \cdot 0174533} = \frac{5729\cdot 578}{n}$  feet. Thus, the radius of a  $2^\circ$  curve is 2864 $\cdot$ 789 feet and that of a  $3^\circ$  curve 1909 $\cdot$ 859 feet.

2. Again, if we calculate any function of a curve of  $1^\circ$ , the same function for a curve of  $n^\circ$ , of the same total central angle, is obtained by dividing the result for a  $1^\circ$  curve by  $n$ . Thus if the total central angle of a curve of  $1^\circ$  be  $\alpha^\circ$ , the length of its tangent\* is  $5729\cdot 578 \tan \frac{\alpha^\circ}{2}$ ; and the length of the tangent to a curve of  $n^\circ$  whose central angle is  $\alpha^\circ$  will be  $\frac{5729\cdot 578 \tan \frac{\alpha^\circ}{2}}{n}$ . Similarly the length of the arc of a  $1^\circ$  curve whose central angle is  $\alpha^\circ$  is  $100\alpha$ , and that of a curve of degree  $n$ , and central angle  $\alpha^\circ$ , is  $\frac{100\alpha}{n}$ .

[In several American and a few English text-books, the degree of curvature of a circular curve is defined as the angle subtended at the centre by a *chord* 100 feet long. This definition has, however, the disadvantage that the simple relation established in the preceding paragraphs between any function of a  $1^\circ$  curve and the same function of a curve of other degree, does not hold. For example, according to this definition, the radius of a  $1^\circ$  curve is  $\frac{100}{2 \sin 30^\circ}$ , while the radius of a curve of degree  $n$  is  $\frac{100}{2 \sin \frac{n^\circ}{2}}$ . It is true that in setting out a circular curve with a theodolite and chain, the chain is actually stretched along the chord and not along the arc, but the error involved will be inappreciable if we adopt chords of short length for curves of high degree. We may in practice, without appreciable error, set out curves of from 1 to 5 degrees with 100 feet chords; curves of from 5 to 10 degrees with 50 feet chords and from 10 to 20 degrees with 25 feet chords.]

3. These considerations give us a simple method for determining practically the degree of curvature of a curve laid out on the ground,

---

\* Tables for setting out circular curves usually give the lengths of tangents to a  $1^\circ$  curve for different central angles.

when the curvature is not known. Let ACB (Fig. 75) be a curve whose degree of curvature we wish to determine. If AB be any chord whose central ordinate is CD, then if R be the radius of the curve, we have by geometry

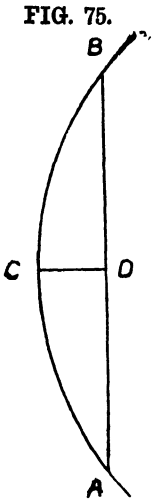

$$\frac{A B^2}{4} = 2R \times C D.$$

Let  $AB = l$  and  $CD = d$ .

$$\text{Then } d = \frac{l^2}{8 R}.$$

Now if  $n$  be the degree of the curve, we have from paragraph 1 above,

$$R = \frac{5729 \cdot 578}{n}.$$

We therefore have  $d = \frac{l^2 n}{8 \times 5729 \cdot 578}$ ; and it follows that if  $l$  be constant,  $d$  varies as  $n$ .

Now let  $l$  be so chosen that the length of  $CD$  expressed in inches is equal to the degree of the curve.

We then obtain  $\frac{n}{12} = \frac{l^2 n}{8 \times 5729 \cdot 578}$  from which we obtain the required value of  $l$ .

We have  $l = 61 \cdot 8$  feet. *If therefore we stretch a string of length 61.8 feet on the inner side of any curve whatever, the middle ordinate to the curve expressed in inches will give the degree of curvature.*

4. On railways in India, it is prescribed that the degree of curvature for unlimited speeds on the standard gauge should not exceed  $3^\circ$ ; for moderate speeds  $5^\circ$ ; and it should not under any circumstances, for example in difficult country exceed  $10^\circ$ . The corresponding figures for the metre gauge are  $4^\circ$ ,  $8^\circ$ , and  $17^\circ$  respectively.

The methods employed in setting out circular curves are fully described in the Manual on Surveying, to which the student is referred for further information on the subject.

5. **Superelevation.**—When a body moves with constant velocity on a curve we know from the science of Mechanics that the resultant acceleration of the body is directed at each instant towards the centre of curvature. If  $v$  be the velocity in feet per second and  $\rho$  the radius of curvature in feet at any point, the resultant acceleration in feet per second per second is known to be equal to  $\frac{v^2}{\rho}$ ; and if  $W$  be the weight of the body in pounds, the force in pounds weight required to produce that acceleration—or, as it is called, the effective force—is  $32 \cdot \frac{W v^2}{18 \rho}$ . Now in the



From equation (i) we see that the horizontal pressure of the outer rail on the flanges is equal in magnitude to the total effective force. As this latter force varies as the square of the velocity, it will be understood that the pressure between the outer rail and the flanges of the wheels becomes very great at high speeds.

Taking moments about A we get

$$\frac{Wc}{2} = Tc + Fh^*$$

therefore  $T = \frac{W}{2} - \frac{Fh}{c}$  ... .. (iii)

Hence  $S = W - T = \frac{W}{2} + \frac{Fh}{c}$  ... .. (iv)

Thus not only do we get a considerable lateral pressure between the outer rail and the wheel flanges, which increases rapidly as the speed increases, but the vertical pressure on that rail is considerably greater than on the inner rail. There will therefore be more wear on the outer rail than on the inner, and consequently on the wheels which run on the outer rail of the curve. But there is a much more serious effect than this wear and tear. We see from equation (iii) that when  $\frac{W}{2} = \frac{Fh}{c}$ , that is when

$$\frac{W}{2} = \frac{Wv^2h}{32 \cdot 18 R c}, \text{ or when } v^2 = \frac{16 \cdot 09 R c}{h},$$

the vertical pressure on the inner wheels becomes zero, while that on the outer wheels becomes equal to W. The resultant of the forces S and P will then pass through G, and if the velocity be increased, this resultant will pass below G and *the vehicle will overturn.*

8. The evils enumerated in the preceding paragraph may be entirely eliminated by raising the outer rail by an amount which we shall determine.

FIG. 77.

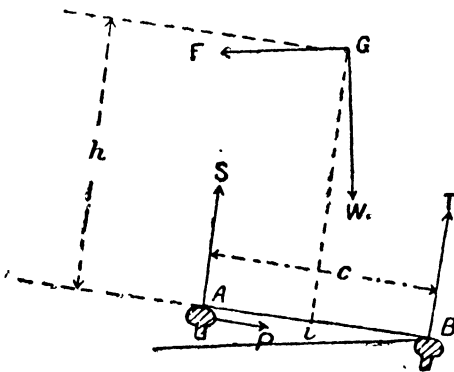

If we cant the track through an angle *i*, the forces S, T, and P will still be normal or parallel, as the case may be, to the treads of the wheels, that is to the line A B, but the weight W will remain vertical and the reversed effective force horizontal. The forces will then be as shown in Fig. 77. We therefore have, resolving parallel

and at right angles to A B

\* We neglect the small difference between *h* and the vertical distance of G above the line of action of P.

$$P = F \cos i - W \sin i \quad \dots \quad \dots \quad \text{(v)}$$

$$S + T = W \cos i + F \sin i \quad \dots \quad \dots \quad \text{(vi)}$$

and taking moments about A

$$Tc = W\left(\frac{c}{2} \cos i + h \sin i\right) - F\left(h \cos i - \frac{c}{2} \sin i\right)$$

that is 
$$T = \frac{W}{2} \cos i + \frac{F}{2} \sin i + \frac{Wh}{c} \sin i - \frac{Fh}{c} \cos i \quad \dots \quad \dots \quad \text{(vii)}$$

Therefore

$$S = \frac{W}{2} \cos i + \frac{F}{2} \sin i - \frac{Wh}{c} \sin i + \frac{Fh}{c} \cos i \quad \text{(viii)}$$

Now if we choose  $i$  so that

$\tan i = \frac{F}{W}$ , we see that  $P$  becomes zero and  $S$  and  $T$  each become equal to  $\frac{W}{2} \cos i + \frac{F}{2} \sin i$ , that is, to  $\frac{W}{2} \cos i + \frac{W}{2} \tan i \sin i$  or  $\frac{W}{2} \sec i$ .

We thus see that the lateral pressure of the outer rail on the wheel flanges entirely disappears and the pressures on the treads from the outer and inner rails are equal. The vehicle will therefore be as stable as though it were moving on a straight level track, and since the forces have no resultant moment about the centre of gravity, there will be no tendency to overturn.

9. The meaning of the term "superelevation" will now be clear. It represents the height to which the table of the outer rail A has been raised above that of the inner rail. The term "cant" is frequently loosely used as synonymous with "superelevation" but, properly speaking, "cant" should be used to denote the angle of transverse slope at which the track lies. The superelevation is equal to  $c \sin i$ , that is to  $c \cos i \cdot \tan i$ , or  $c \cos i \times \frac{F}{W}$ , and substituting for  $F$  its value  $\frac{Wv^2}{32 \cdot 18R}$  we get superelevation in feet  $= c \cos i \frac{v^2}{32 \cdot 18R}$ . In practice  $c \cos i$  is usually taken as equal to the gauge  $g$  and if we express  $v$  in miles per hour and the superelevation in inches, we obtain the formula

*Superelevation in inches*  $= \frac{gV^2}{1 \cdot 25 R}$  where  $V$  is the speed in miles per hour and  $R$  the radius of the curve in feet,  $g$  being the gauge in feet.

**Example (1).**—What amount of superelevation should be provided on a curve of  $3^\circ$  on the standard gauge, the speed being 50 miles per hour?

We have required superelevation  $= \frac{5 \times 50^2}{1 \cdot 25 \times 1909 \cdot 859} = 5\frac{1}{2}$  inches.

**Example (2).**—*What is the superelevation required for a curve of 5° on the metre gauge, the speed being 25 miles an hour?*

$$\text{The superelevation} = \frac{3 \cdot 28 \times 25^2}{1 \cdot 25 \times 1145 \cdot 916} = 1 \frac{7}{16} \text{ inches.}$$

10. We have obtained the above expression for superelevation by supposing the wheels to be frictionless, the treads cylindrical, and the springs of the vehicle incompressible. Actually, the friction of the wheels, the conicity of the wheel-treads, the parallelism of the axles, and the compressibility of the springs, which causes displacement of the centre of gravity of the vehicle, introduce disturbing factors and a number of formulae have been proposed and are in use, which are claimed to be better in practice than the formula we have arrived at. These formulae however must necessarily be purely empirical, and experience has shown that the theoretical formula is, to say the least, as safe as any of them; and this formula is in general use in India.

11. Since the superelevation depends on the speed, it is obvious that a given superelevation can only be correct for trains traveling at the speed for which that superelevation has been calculated. It is of course, impossible on any railway to secure the condition that all trains should travel at the speed for which the superelevation has been calculated, for the speeds suitable for passenger and mail trains are higher than is necessary for goods trains; and the safest plan is to arrange the superelevation to suit the maximum permissible speed of the fastest regular trains on the line subject to a limit of, say  $\frac{1}{10}$ th of the gauge (a speed restriction being imposed if necessary), so that vehicles standing or moving slowly on the curve may not have too much weight thrown on their inner springs by reason of the tilt, or too little on their outer wheels. In the latter case the outer leading wheel, if too lightly loaded, may have a tendency to mount the rail, against which its flange presses forcibly (see Chapter X, paragraph 17) when the curve is very sharp.

**Example.**—*Find the maximum speed in miles per hour permissible on a curve of radius R, on the assumption that the superelevation shall not exceed  $\frac{1}{10}$ th of the gauge.*—[We shall see that on this assumption, the expression for the maximum permissible speed for a curve of given radius is independent of the gauge, that is to say, it is the same for all gauges. The speed on narrow gauges is however also limited by mechanical considerations.]

We have—

$$\text{Superelevation in inches} = \frac{gV^2}{1 \cdot 25 R}$$

Therefore superelevation in feet =  $\frac{gV^2}{12 \times 1.25R}$

If then the superelevation is equal to  $\frac{1}{10}$ th of the gauge, we have—

$$\frac{g}{10} = \frac{gV^2}{15R}$$

Therefore the maximum permissible speed in miles per hour is—

$$V = \sqrt{\frac{3}{8}R} = 1.22\sqrt{R} = \frac{92.76}{\sqrt{n}}$$

where  $n$  is the degree of curvature of the curve.

12. It is sometimes necessary in practice to test the superelevation of an actual curve the radius of which may not be known. Referring to Fig. 75, if  $l$  be the length in feet of a chord, whose middle ordinate to a curve of radius  $R$  is  $E$  inches, we have as in para. 3,  $2R \times \frac{E}{12} = \frac{l^2}{4}$ , that is

$$E = \frac{3l^2}{2R}$$

If therefore the chord be of such a length that its middle ordinate to the curve is equal to the superelevation, we have—

$$\frac{3}{2} \frac{l^2}{R} = \frac{gV^2}{1.25R}, \text{ from which we obtain—}$$

$$l = \frac{11}{15} V \sqrt{g}, \text{ where } V \text{ is the speed in miles per hour and } g \text{ the}$$

gauge in feet. We thus see that  $l$  is a constant for all curves for a given gauge and a given speed limit. Having calculated  $l$  for a given gauge, if a string of the calculated length be stretched from one point to another on the inside of any curve whatever on that gauge, its offset to the rail at its middle point will be equal to the required superelevation. On the standard gauge  $l = 1.72V$ , and on the metre gauge  $l = 1.33V$ .

13. **Transition curves.**—When a vehicle or train enters a curve, the superelevation at the point of commencement of the curve should be the full amount corresponding to the speed of the train and the radius of the curve. It follows therefore that if the curve takes off from a straight tangent, this superelevation must for practical reasons be gradually attained on the straight, where it is not required. The provision of superelevation on the straight does not however lessen the shock consequent on the entry of the vehicle on to the curve; for the central acceleration is communicated to the vehicle on the instant it enters the curve and there can of course be no such acceleration on the straight. For these reasons circular curves are now almost always connected with their tangents by transition curves, which as the name implies are intended to render the passage of a train from a straight tangent to a circular curve as easy and free from shock as possible. Since the central acceleration on the circular curve is  $\frac{v^2}{R}$ , the transition curve must be such that the quantity  $\frac{v^2}{\rho}$  ( $\rho$  being the radius of

curvature at any point) increases gradually from zero at the commencement of the curve to  $\frac{v^2}{R}$ , its value for the circular curve. Any curve therefore of continuous curvature whose radius of curvature varies from infinity to a minimum would serve as a transition curve; and many such curves, including parabolas of various orders, lemniscates, and other curves, have been proposed. In the *ideal* transition curve however, the rate of increase of the central acceleration will be uniform throughout.

14. Expressing this mathematically, we have the differential equation

$\frac{d\left(\frac{v^2}{\rho}\right)}{dt}$  = a constant, where  $t$  represents the time which has elapsed since the vehicle entered the curve. Since  $v$  is constant for any given curve the space passed over will vary as  $t$ ; hence we may write—

$\frac{d\left(\frac{1}{\rho}\right)}{ds}$  = a constant, where  $s$  is the distance measured along the curve from its point of commencement. Integrating we get

$$\frac{1}{\rho} = s \times \text{a constant, that is}$$

$$\rho s = \text{a constant, say } \frac{k^2}{2} \quad \dots \quad \dots \quad \text{(ix)}$$

*The radius of curvature therefore varies inversely as the length measured along the curve.*

Now  $\rho = \frac{ds}{d\psi}$ ,  $\psi$  being the tangential deflection at any point measured from the tangent at the origin.

Hence  $s ds = \frac{k^2}{2} d\psi$ ; and integrating again, we obtain

$$s^2 = k^2 \psi, \text{ which is the intrinsic equation of the true transition curve.}$$

If  $R$  be the radius of curvature at the end of the transition curve, and  $\psi$  and  $s$  be now taken to represent the terminal values of those variables we have—

$$s^2 = k^2 \psi \quad \dots \quad \dots \quad \text{(x)}$$

and eliminating  $k$  between (ix) and (x)

$$s^2 = 2Rs\psi, \text{ whence } s = 2R\psi \quad \dots \quad \dots \quad \text{(xi)}$$

The latter equation shows that the *length of the transition curve is exactly twice that of an arc of its circle of curvature, having the same tangential deflection.*

15. Referring to Fig. 78, which shows the transition curve A E and FIG. 78.

AE = S    ∠EFG =  $\psi$   
 AC = x    GE = y  
 AF = T    FE = t  
 AB = D    BC = d

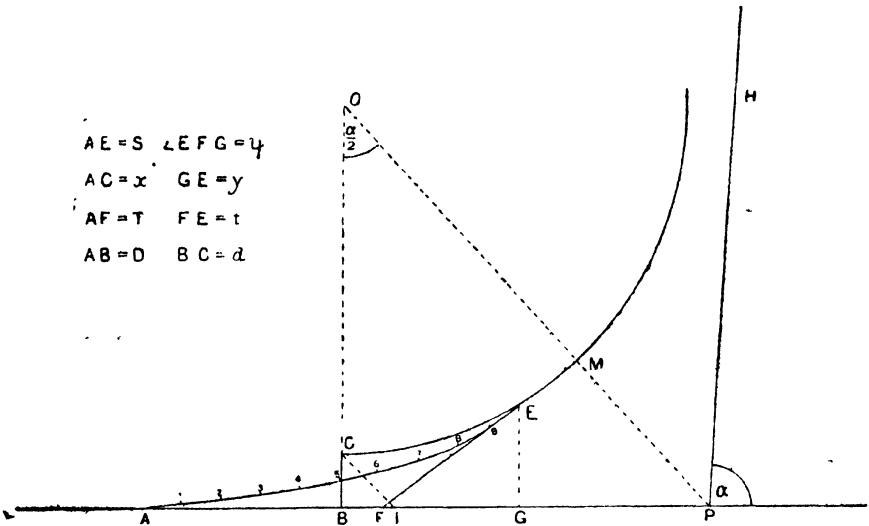

its circle of curvature C E M, it is obvious that the transition curve may be used to connect a straight tangent A P with a circular curve E M coinciding with the circle of curvature at E.

16. We proceed to deduce certain expressions for several quantities, the values of which it is necessary to determine in order to set out the transition curve on the ground.\* From the intrinsic equation  $s^2 = k^2 \psi$  we can readily obtain in the usual manner the Cartesian co-ordinates of any point on the curve.

*Cartesian co-ordinates.*—We have  $s = k \sqrt{\psi}$ , therefore  $ds = \frac{k}{2} \frac{d\psi}{\psi^{1/2}}$

Now  $dx = ds \cos \psi$  and  $dy = ds \sin \psi$

Hence expanding  $\cos \psi$  and  $\sin \psi$  in terms of  $\psi$ , we get

$$dx = \frac{k}{2} \frac{d\psi}{\psi^{1/2}} \left\{ 1 - \frac{\psi^2}{\Gamma 2} + \frac{\psi^4}{\Gamma 4} - \dots \right\}$$

$$dy = \frac{k}{2} \frac{d\psi}{\psi^{1/2}} \left\{ \psi - \frac{\psi^3}{\Gamma 3} + \frac{\psi^5}{\Gamma 5} - \dots \right\}$$

Integrating we have

$$x = k \left\{ \psi^{1/2} - \frac{\psi^{5/2}}{\Gamma 2 \cdot 5} + \frac{\psi^{9/2}}{\Gamma 4 \cdot 9} - \dots \right\}$$

$$y = k \left\{ \frac{2}{3} \psi^{3/2} - \frac{\psi^{7/2}}{\Gamma 3 \cdot 7} + \frac{\psi^{11/2}}{\Gamma 5 \cdot 11} - \dots \right\}$$

\* The student need not attempt to learn the values of the expressions deduced in this paragraph. They are merely introduced for the purposes of the argument in paras. 17 to 19 which it is most important that the student should thoroughly understand.

Hence  $\frac{x}{s} = 1 - \frac{\psi^2}{\underline{L}2.5} + \frac{\psi^4}{\underline{L}4.9} - \dots$

and  $\frac{y}{s} = \frac{\psi}{3} - \frac{\psi^3}{\underline{L}3.7} + \frac{\psi^5}{\underline{L}5.11} - \dots$

Value of  $\theta$ . By actual division we obtain

$$\tan \theta = \frac{y}{x} = \frac{1}{3}\psi + \frac{1}{105}\psi^3 + \frac{26\psi^5}{155925} + \text{etc.}$$

By Gregorie's series

$$\theta = \tan^{-1} \frac{y}{x} = \frac{y}{x} - \frac{y^3}{3x^3} + \frac{y^5}{5x^5} - \text{etc.}$$

$$\therefore \theta = \frac{1}{3}\psi + \frac{1}{105}\psi^3 + \frac{26\psi^5}{155925} + \text{etc.}$$

$$-\frac{1}{3}\left(\frac{\psi^3}{27} + \frac{\psi^5}{315} + \text{etc.}\right)$$

$$+\frac{1}{5}\left(\frac{\psi^5}{243} + \text{etc.}\right)$$

$$\therefore \theta = \frac{\psi}{3} - \frac{8\psi^3}{2835} - \frac{32\psi^5}{467775}$$

Lengths of tangents.—Let the tangent AF, see Fig. 78, be represented by T, and FE by  $t$ . We then have

$$T = x - y \cot \psi, \text{ therefore}$$

$$\frac{T}{s} = \frac{x}{s} - \frac{y}{s} \cot \psi. \text{ Substituting for } \frac{x}{s} \text{ and } \frac{y}{s} \text{ and developing}$$

$\cot \psi$  in terms of  $\psi$ , we obtain—

$$\frac{T}{s} = \frac{2}{3} + \frac{11\psi^2}{315} + \frac{139\psi^4}{41580} + \text{etc.}$$

Again  $t = y \operatorname{cosec} \psi$

$$\therefore \frac{t}{s} = \frac{y}{s} \operatorname{cosec} \psi = \left(\frac{\psi}{3} - \frac{\psi^3}{\underline{L}3.7} + \frac{\psi^5}{\underline{L}5.11} - \dots\right) \left(\frac{1}{\psi} + \frac{\psi}{6} + \frac{7\psi^3}{360} + \dots\right)$$

$$\therefore \frac{t}{s} = \frac{1}{3} + \frac{2\psi^2}{63} + \frac{34\psi^4}{10395} + \text{etc.}$$

Values of AB and BC (Fig. 78).—If the circle of curvature be continued to the point C at which its tangent is parallel to AB, the offset BC is sometimes called the "shift." The meaning of this term will be explained later

Let AB be represented by D and BC by  $d$ . Then we have—

$$D = x - R \sin \psi.$$

$$\therefore \frac{D}{s} = \frac{x}{s} - \frac{R}{s} \sin \psi = \frac{1}{3} - \frac{\psi^2}{\underline{L}2.5.6} + \frac{\psi^4}{\underline{L}4.9.10} - \text{etc.}$$

$$\text{Also } d = y - R.(1 - \cos \psi)$$

$$\therefore \frac{d}{s} = \frac{y}{s} - \frac{R}{s}(1 - \cos \psi) = \frac{\psi}{12} - \frac{\psi^3}{\underline{L}3.7.8} + \frac{\psi^5}{\underline{L}5.11.12} - \text{etc.}$$

17. We have now obtained expressions for the values of all quantities required for setting out a transition curve. It has been seen that the

angle  $\theta$ , and the ratios  $\frac{x}{s}, \frac{y}{s}, \frac{T}{s}, \frac{t}{s}, \frac{D}{s}$ , and  $\frac{d}{s}$  are solely dependent on  $\psi$ ; if therefore these ratios be calculated for any given value of  $\psi$ , their values will be the same for all transition curves for the same value of  $\psi$ . Since  $\psi$  is in circular measure the series which express the values of the different quantities, will be rapidly convergent for all values of  $\psi$  likely to occur in practice.

18. If now the curve be divided at the points 1, 2, 3 . . . . 9, into 10 arcs of equal length, we shall have from equation (X).

$\psi_1 = (.1)^2 \psi$ ;  $\psi_2 = (.2)^2 \psi$ ;  $\psi_3 = (.3)^2 \psi$ ; . . . and  $\psi_9 = (.9)^2 \psi$ ;  $\psi$  being the terminal value of the angle of deflection, and its value at the points 1, 2, 3, . . . . 9, being denoted by suffixes. It follows at once that the ratios—

$$\frac{x_1}{s}; \frac{x_2}{s}; \frac{x_3}{s}; \dots \dots \frac{x_9}{s}.$$

$$\frac{y_1}{s}; \frac{y_2}{s}; \frac{y_3}{s}; \dots \dots \frac{y_9}{s}.$$

and the angles  $\theta_1; \theta_2; \theta_3; \dots \dots \theta_9$ ; are all solely dependent on the value of  $\psi$ . Further since by formula (xi)  $s = 2 R \psi$ , we get the result that each of the following quantities :—

$$\frac{x_1}{R}; \frac{x_2}{R}; \frac{x_3}{R}; \dots \dots \frac{x}{R}.$$

$$\frac{y_1}{R}; \frac{y_2}{R}; \frac{y_3}{R}; \dots \dots \frac{y}{R}.$$

$$\theta_1; \theta_2; \theta_3; \dots \dots \theta.$$

$$\frac{T}{R}; \frac{t}{R}; \frac{D}{R}; \frac{d}{R}; \text{ also } \frac{s}{R}.$$

is constant for the same value of  $\psi$  in all transition curves. The methods about to be described for setting out a transition curve depend on this result.

19. The student will now have no difficulty in seeing that, if the values of  $x_1; x_2; x_3; \dots \dots x$ ,

$$y_1; y_2; y_3; \dots \dots y,$$

$$T; t; D; d \text{ and } s.$$

be calculated for a given value of  $\psi$ , for a transition curve connecting a straight tangent with a circular curve of  $1^\circ$ , we derive the values of these quantities for a transition curve leading to a circular curve of degree  $n$ , by simply dividing the calculated results for the former case by  $n$ . For example, let  $x$  be the abscissa to a point on a transition curve leading up to a curve of  $1^\circ$ , and  $x_n$  the abscissa, corresponding to the same value of  $\psi$ , of a point on a transition curve leading up to a curve of degree  $n$ . If  $R$  be

the radius of the curve of degree  $n$ , we have proved in the preceding paragraph that  $\frac{x}{5729.578} = \frac{x_n}{R}$ . But  $R = \frac{5729.578}{n}$ . Hence we have  $x_n = \frac{x}{n}$ , which proves the statement; and precisely the same reasoning applies in regard to any other function of the two curves. In the tables at the end of the chapter, the values of the quantities mentioned at the beginning of the paragraph are calculated for values of  $\psi$  between  $1^\circ$  and  $20^\circ$ ; and these tables will be found to be sufficiently extended to cover all cases likely to be met with in practice.

20. Before however we can apply the results arrived at, it remains to find a working rule for determining the value of  $\psi$  suitable for any given case. We have said, in paragraph 13, that the rate of increase of the central acceleration on a transition curve is uniform, and experience shows that an increase of one foot per second, is, as nearly as may be, the maximum that can be allowed without causing discomfort to passengers. Assuming this rate, since the central acceleration at the end of the curve is  $\frac{v^2}{R}$ ,  $R$  being the radius of the circular curve, it is clear that the time occupied in attaining this acceleration will be  $\frac{v^2}{R}$  seconds; and as this also denotes the time occupied in passing over the curve, the *minimum* length of curve is  $\frac{v^3}{R}$ . It follows from formula (xi) that the corresponding value of  $\psi$  is  $\frac{v^3}{2R^2}$ , in which  $\psi$  is in circular measure, and  $v$  is the velocity in feet per second.

21. It will be convenient to express  $\psi$  in degrees and the speed in miles per hour, and to define the curvature of the circular curve by its degree of curvature. We then obtain

$$\psi \text{ in degrees} = \frac{57.29578}{2} \times \left(\frac{5280}{3600}\right)^3 \times \frac{V^3 n^2}{(5729.578)^2} = .00275 \left(\frac{V}{10}\right)^3 n^2$$

where  $V$  is the speed in miles per hour, and  $n$  is the degree of curvature of the circular curve. The greater the value of  $\psi$  assumed in any given case, the easier will be the motion around the curve, and we may if we please in practice make  $\psi$  anything up to a maximum of, say, twice the value given above. The formula for  $\psi$  will thus be —

$\psi$  in degrees =  $.00275 \left(\frac{V}{10}\right)^3 n^2$  (minimum) to  $.0055 \left(\frac{V}{10}\right)^3 n^2$  (maximum). Minimum values of  $\psi$ , calculated from this formula for different speeds and degrees of curvature, are given in Table I at the end of the chapter.

22. We now proceed to explain how to set out the transition curve on the ground. Referring to Fig. 78, which represents two tangents,  $AP$  and  $PH$ , connected by a circular curve  $ME$  with a transition curve at

either end, we see that if the tangents were connected directly by a circular curve of radius  $R$ , the springing point of this curve would be at the point  $I$ , where  $IP = R \tan \frac{\alpha}{2}$ . This curve if moved in a direction parallel to  $OP$ , will come into the position  $CEM$  which it actually occupies when connected with the transition curves. The term "shift" mentioned in paragraph 16, represents the distance through which the tangent to the circular curve is moved parallel to itself.

The distance  $IB$  is clearly equal to  $BC \tan \frac{\alpha}{2}$ , that is, to  $d \tan \frac{\alpha}{2}$ ; therefore  $AP$ , the distance of the springing point of the transition curve from  $P$ , =  $AB + BI + IP$ .

$$= D + (d + R) \tan \frac{\alpha}{2}.$$

To facilitate the calculation of this length, values of  $(d + R)$ , and of its logarithm for a transition curve leading up to a circular curve of  $1^\circ$  are given in Table II.

23. Two methods of setting out the curve will now be considered: (I) by offsets from the tangent  $AG$ ; and (II) by deflection angles from the tangent.

24. **First method. By offsets.**—The first step is to arrive at a suitable value of  $\psi$ . The minimum value of this angle may either be calculated from the formula  $\psi = .00275 \left(\frac{V}{10}\right)^3 n^2$  or it may be taken directly from Table I. As we have said in paragraph 21 above, we may in practice assume any value up to a limit of twice that given in the table. We then calculate the length of  $AP = D + (d + R) \tan \frac{\alpha}{2}$  for a transition curve leading up to a circular curve of degree  $1^\circ$ , the values of  $D$  and  $(d + R)$  corresponding to the assumed value of  $\psi$ , being taken from Table II. If  $n$  be the degree of the main circular curve, we obtain the corresponding length of  $AP$ , by dividing the result obtained for the circular curve of 1 degree, by  $n$ ; and the point  $A$  is determined by measuring off from  $P$  the length  $PA$  so calculated.

Now take from Table II the values of  $T$  and  $t$  corresponding to the assumed value of  $\psi$  and divide them each by  $n$ ; the result gives the values of  $T$  and  $t$  for the case we are considering. Measure off  $AF = T$  and set off the angle  $EFG = \psi$ ; then measure off  $FE = t$ . This fixes the point  $E$ , and also the tangent  $EF$  from which the circular curve  $EM$  can be subsequently set out. We could of course fix the point  $E$  by taking from Tables III and IV the values of  $x$  and  $y$ , corresponding to the value of  $\psi$  we have assumed; these values divided by  $n$  give the co-ordinates of the point  $E$ .

Similarly to find the co-ordinates of the points 1, 2, 3, . . . 9, we take from Tables III and IV the values of the co-ordinates corresponding to the assumed value of  $\psi$  and divide each by  $n$ .

25. The following examples will make the method clear:—

**Example I.**—*The deflection angle between two tangents is  $67^\circ 20'$ . It is required to connect the two tangents by a  $4^\circ$  circular curve with transition curves at each end suitable for a speed of 45 miles an hour.*

From Table I we find the minimum value of  $\psi$ , for a speed of 45 miles an hour and a main circular curve of  $4^\circ$ , to be  $4^\circ$ ; and for easy running we may assume  $\psi = 8^\circ$ . For this value of  $\psi$  we find from Table II.  $D = 799 \cdot 480$  feet and  $(d + R) = 5748 \cdot 182$  feet.

We therefore have for a transition curve leading up to a  $1^\circ$  circular curve,  $AP = D + (d + R) \tan 33^\circ 40'$ .

$$= 799 \cdot 480 + 5748 \cdot 182 \tan 33^\circ 40'.$$

$$= 4,628 \cdot 213 \text{ feet.}$$

The value of AP for a transition curve leading up to a  $4^\circ$  circular curve is therefore 1157·053 feet  $\left[ = \frac{4628 \cdot 213 \text{ feet}}{4} \right]$ .

We thus obtain the point A by measuring 1157·053 feet from P.

From Table II we find the values of T and  $t$  corresponding to  $\psi = 8^\circ$  to be 1067·757 and 534·326 feet respectively, for a curve leading up to a circular curve of  $1^\circ$ ; dividing each of these figures by 4, we obtain the length of T and  $t$  266·939 and 133·581 feet respectively for the case under consideration. We then measure  $AF = 266 \cdot 939$  feet; set off the angle  $EFG = 8^\circ$ , and measure  $FE = 133 \cdot 581$  feet, which fixes the point E.

In exactly the same way we obtain the co ordinates of the points 1, 2, 3, . . . 9, by dividing by 4 the values of  $x_1, x_2, x_3 \dots x_9$  and  $y_1, y_2, y_3, \dots, y_9$ , corresponding to  $\psi = 8^\circ$ , given in Tables III and IV. Thus we have—

$x_1 = 40 \cdot 00$	feet	...	$y_1 = 0 \cdot 018$	foot.
$x_2 = 80 \cdot 00$	„	...	$y_2 = 0 \cdot 149$	„
$x_3 = 119 \cdot 998$	„	...	$y_3 = 0 \cdot 503$	„
$x_4 = 159 \cdot 992$	„	...	$y_4 = 1 \cdot 191$	„
$x_5 = 199 \cdot 976$	„	...	$y_5 = 2 \cdot 327$	feet.
$x_6 = 239 \cdot 939$	„	...	$y_6 = 4 \cdot 021$	„

$$\begin{array}{lll}
 x_7=279.869 \text{ feet} & \dots & y_7= 6.383 \text{ feet.} \\
 x_8=319.744 \text{ ,,} & \dots & y_8= 9.526 \text{ ,,} \\
 x_9=359.540 \text{ ,,} & \dots & y_9=13.559 \text{ ,,}
 \end{array}$$

Finally from Table II we find the length of the curve corresponding to  $\psi = 8^\circ$ , to be  $s = \frac{1600}{4}$  feet = 400 feet.

**Example II.**—*It is required to set out a transition curve to connect with a circular curve of  $16^\circ$ , the maximum speed being 20 miles an hour.*

We find from Table I, the minimum value of  $\psi$  suitable for a speed of 20 miles an hour and a main circular curve of  $16^\circ$  to be  $6^\circ$ . We may therefore assume  $\psi = 12^\circ$ .

The calculations will be exactly the same as in the preceding example. We obtain the values of the quantities  $D$ ,  $d$ ,  $T$ , etc., and the co-ordinates of the points 1, 2, 3 . . . 9 by dividing by 16 the values of these quantities given in the tables corresponding to  $\psi = 12^\circ$ . Thus  $s = 150$  feet;  $D = 74.891$  feet;  $T = 99.606$  feet;  $x_3 = 44.999$  feet;  $y_7 = 3.589$  feet.

26. **Second method. By deflection angles.**—We first proceed to find a suitable value of  $\psi$ , and to determine the points A and E as in the first method; the length of the curve is also obtained as in that method. The theodolite is then set up at A, the horizontal plate clamped at zero, and the telescope directed on P. The values of  $\theta_1, \theta_2, \theta_3, \dots, \theta_9$ , corresponding to the assumed value of  $\psi$ , are then taken from Table V and set off successively on the instrument; the points, 1, 2, 3 . . . 9 being set out with a chord equal to  $\frac{1}{10}$ th of the length of the curve in precisely the same manner as that in which a circular curve is set out.

27. **Example III.**—*Set out by the second method the curve given in Example I.*—In Example I we have assumed  $\psi = 8^\circ$ , and the length of the curve corresponding to this value of  $\psi$  was found to be 400 feet. The length of chord, therefore, to be used in setting out the curve is 40 feet. The values of  $\theta_1, \theta_2, \theta_3, \dots, \theta_9$ , corresponding to  $\psi = 8^\circ$  are then taken directly from Table V and set off in succession as described.

Thus the angle of deflection to the point 4 is  $25' 36''$  and to the point 9,  $2^\circ 9' 35''$ .

28. Hitherto we have only considered the transition curve as connecting a straight tangent with a circular curve; but it is clear that it may also be used to connect two circular curves coinciding with its circles of curvature at any two points, and a simple modification of the methods we have already described will be found to be applicable to this case also.

29. Let N O Q (Fig. 79) be three points on the curve at distances  $s-s_1$ ,  $s$ , and  $s + s_1$  measured along the curve from the origin A, so that the

FIG. 79.

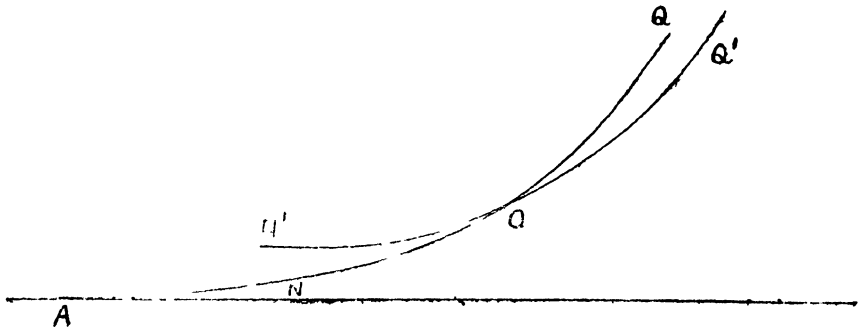
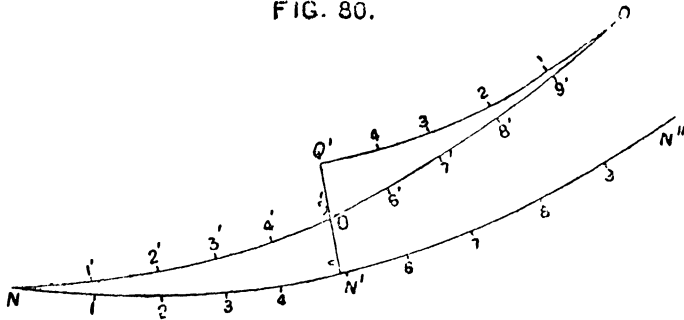

FIG. 80.



points N and Q are equi-distant from O.

Let  $\psi_1$ ,  $\psi_0$  and  $\psi_2$  be the angles of deflection of the tangents at the points N O Q from the tangent at the origin A.

We then have from formula (X) paragraph 14.

$$\psi_2 - \psi_0 = \frac{(s + s_1)^2 - s^2}{k^2} = \frac{2ss_1}{k^2} + \frac{s_1^2}{k^2}$$

But if R be the radius of curvature at O, we have  $2 R s = k^2$ ; hence we may write—

$$\psi_2 - \psi_0 = \frac{s_1}{R} + \frac{s_1^2}{k^2}$$

Similarly we may prove

$$\psi_0 - \psi_1 = \frac{s_1}{R} - \frac{s_1^2}{k^2}$$

Now  $\frac{s_1}{R}$  is the angle of tangential deflection between two points at a distance  $s_1$  apart on the circumference of a circle of radius R; also  $\frac{s_1^2}{k^2}$  is the angle of tangential deflection of a point, at a distance  $s_1$  from the origin

A of the transition curve, from the tangent at the origin. We therefore obtain the result that the transition curve deflects from its circle of curvature at O at the same rate on both sides of O; and further that this rate is equal to that at which it deflects from the tangent at the origin. Since O may be any point whatever on the curve the rate of deflection of the transition curve from the circle of curvature is the same for all points on the curve.

30. If therefore we draw the arc  $N'OQ'$  of the circle of curvature at O,  $N'O$  and  $OQ'$  being each equal to  $s_1$ , we see that the angle between the tangent at  $Q'$  to the circle of curvature and the tangent at Q to the transition curve is exactly equal to the angle between the tangent at  $N'$  to the circle of curvature and the tangent at N to the transition curve; and further that these angles are each equal to the angle between the tangent at the origin of the transition curve and the tangent at a point distant  $s_1$  along the curve from the origin. It follows\* at once that when the offsets  $NN'$  and  $QQ'$  are small in comparison with the length  $s_1$  (as they always are in practice), the offsets  $NN'$  and  $QQ'$  are each very approximately equal to the offset from the tangent at the origin of the transition curve to a point on the curve distant  $s_1$  from the origin; and it further follows that the angles  $NON'$  and  $QOQ'$  are each equal to the angle contained between the tangent at the origin and the line joining the origin to the point at a distance  $s_1$  measured along the curve.

31. We now see that if the arc  $ON'$  or  $OQ'$  of the circle of curvature be divided into 10 equal lengths at the points 1, 2, 3, . . . , 9 the offsets between these points and corresponding points 1', 2', 3', . . . 9' on the transition curve, are very approximately equal to the ordinates from the tangent at the origin to points dividing an arc of length  $s_1$ , measured from the origin, into the same number of equal parts; also the angles subtended at O by the offsets 11', 22', 33' . . . . 99', are equal to the values of  $\theta_1, \theta_2, \theta_3, \dots, \theta_9$ , the angles of deflection from the tangent at the origin to points dividing an arc of length  $s_1$  measured from the origin, into 10 equal parts. We are thus enabled to make use of the tables derived from the consideration of the case of a transition curve connecting a straight tangent with a circular curve.

---

\* The proofs which follow in this paragraph and in paragraph 31, are not, of course, rigorous. Rigorous proofs of the propositions proved in these paragraphs may be obtained by treating the formula  $\psi_2 - \psi_0 = \frac{2 s s_1}{k^2} + \frac{s_1^2}{k^2}$  as the intrinsic equation of the curve, assuming the origin at the point O in Fig. 79.

32. Referring now to Fig. 80, which shows a transition curve NOQ and its circles of curvature NN' and QQ' at the points N and Q respectively; if O be the middle point of NQ, and the circular arcs NN' and QQ' be each equal in length to NO or OQ, then it is clear from paragraph 30 that the tangents at N' and Q' to the circular arcs must be parallel, seeing that the angle between the tangent at N' and the tangent at O is equal to the angle between the tangent at Q' and the tangent at O; further we see that the offset ON' is equal to the offset OQ'. It therefore follows that O the middle point of the curve NQ bisects N'Q', the shortest distance between the circular arcs NN' and QQ'. The distance N'Q' is, on the analogy of the case considered in paragraphs 14 to 16, sometimes called the "shift."

33. To find the length of the curve NQ in terms of the tangential deflection between N and Q, and the radii of curvature  $r_1$  and  $r_2$  at N and Q, we have, by adding the values of  $(\psi_2 - \psi_0)$  and  $(\psi_0 - \psi_1)$  given in paragraph 29.

$$\psi_2 - \psi_1 = \frac{2s_1}{R}$$

$$\therefore 2s_1 \text{ (the length of the curve NQ)} = R (\psi_2 - \psi_1)$$

$$\text{Now since by paragraph 14, } r_1 (s - s_1) = Rs = r_2 (s + s_1) = \frac{k^2}{2}$$

$$\text{We obtain } s - s_1 = \frac{k^2}{2r_1}; s = \frac{k^2}{2R}; s + s_1 = \frac{k^2}{2r_2}$$

$$\text{whence we have } \frac{1}{r_1} + \frac{1}{r_2} = \frac{2}{R}, \text{ that is } R = \frac{2r_1 r_2}{r_1 + r_2}$$

Therefore  $2s_1 = \text{length of curve NQ} = \frac{2r_1 r_2}{r_1 + r_2} (\psi_2 - \psi_1)$ , where, of course,  $\psi_2$  and  $\psi_1$  are in circular measure. It will be convenient to express  $\psi_2$  and  $\psi_1$  in degrees, and  $r_1$  and  $r_2$  in terms of  $n_1$  and  $n_2$ , the degrees of curvature at N and Q.

$$\text{We then have, length of curve NQ} = \frac{2 \times 5729.578}{n_1 + n_2} (\psi_2 - \psi_1)$$

where  $\psi_2$  and  $\psi_1$  are now expressed in degrees

$$\text{It follows that NQ} = \frac{200}{n_1 + n_2} (\psi_2 - \psi_1)$$

34. We may find a suitable value for  $(\psi_2 - \psi_1)$  for any given case from the result given in paragraph 21. The minimum value of  $\psi_2$  in degrees there given is  $.00275 \left(\frac{\sqrt{V}}{10}\right)^3 n_2^2$ , where  $n_2$  is the degree of the curve at Q; similarly the minimum value of  $\psi_1$  is  $.00275 \left(\frac{\sqrt{V}}{10}\right)^3 n_1^2$

Hence the minimum value of  $\psi_2 - \psi_1$  is  $.00275 \left(\frac{\sqrt{V}}{10}\right)^3 (n_2^2 - n_1^2)$ . Substituting this value of  $\psi_2 - \psi_1$  in the equation expressing the length of the curve NQ, we obtain

$$\text{minimum length of curve} = \cdot 55 \left(\frac{V}{10}\right)^3 (n_2 - n_1)$$

Now it follows from paragraph 2 that the tangential deflection between the point N'' and N on the circle of curvature at N will be  $\frac{\text{length of curve} \times n_1}{100}$ ; and substituting in this the value obtained above for the length of the curve, we obtain:—

$$\begin{aligned} &\text{Tangential deflection between the points N and N''} \\ &= \cdot 0055 \left(\frac{V}{10}\right)^3 n_1 (n_2 - n_1) \end{aligned}$$

We therefore have the angle, which we shall call  $\psi$ , (expressed in degrees) between the tangents at Q and N''

$$\begin{aligned} &= \psi_2 - \psi_1 = \cdot 0055 \left(\frac{V}{10}\right)^3 n_1 (n_2 - n_1) \\ &= \cdot 00275 \left(\frac{V}{10}\right)^3 (n_2^2 - n_1^2 - 2n_1 n_2 + 2n_1^2) \\ &= \cdot 00275 \left(\frac{V}{10}\right)^3 (n^2 - n_1)^2, \text{ and this is the value we must assume as} \end{aligned}$$

corresponding to the minimum value of  $\psi$ , in making use of the tables at the end of the chapter. We may, as before, in practice assume this angle to have any value up to a maximum of twice the value obtained above. The student will see that this formula is exactly analogous to that expressing the value of  $\psi$  in paragraph 21,  $n_2 - n_1$  being substituted for  $n$  in that paragraph.

35. We are now in a position to describe how to make use of the Tables at the end of the chapter, in any given case. As before, there will be two methods.

**Method I.** *By offsets from the circle of curvature at one end of the curve.*

Referring to Fig. 80 the first step is to find a suitable value for the angle between the tangents at Q and N'' (=  $\psi$  say) either from the formula:—minimum value of angle =  $\cdot 00275 \left(\frac{V}{10}\right)^3 (n_2 - n_1)^2$ —or from Table I, remembering that in applying this table,  $n$  is to be taken as equal to  $n_2 - n_1$ .

From Table II we find the length of the transition curve by dividing by  $n_2 - n_1$  the value of  $s$  there given, corresponding to the value of  $\psi$  obtained above. The next step is to set out the circular arc NN'', of length equal to the length of the transition curve. The circular arc should be divided into 10 equal arcs at points numbered 1, 2, 3, . . . . 9.

Then from Table IV we obtain the offsets from the pegs 1, 2, 3, . . . . 10, to corresponding points 1', 2', 3', . . . . 10', on the

transition curve by dividing by  $n_2 - n_1$  the values of  $y_1, y_2, y_3, \dots$   $y$  given in the table corresponding to the assumed value of  $\psi$ .

**Example.** *It is required to connect a  $4^\circ$  circular curve with an  $8^\circ$  curve by means of a transition curve suitable for a speed of 30 miles an hour.*—We have here  $n_2 - n_1 = 8^\circ - 4^\circ = 4^\circ$ , which is the value we must assume for  $n$  in applying the tables. We obtain the minimum value of  $\psi$  from Table I, suitable for a speed of 30 miles an hour and a  $4^\circ$  curve to be  $1^\circ$ . We may therefore assume  $\psi$  to be  $2^\circ$ . From Table II we find the value of  $s$  corresponding to  $\psi = 2^\circ$  to be 400 feet; the length of the curve in the example will therefore be  $\frac{400}{4}$  ft = 100 feet.

We therefore set out the circular curve NN" 100 feet in length, and obtain 10 points on it, dividing it into 10 equal arcs at the points 1, 2, 3 ... 9. We obtain the offsets from these points and N" to corresponding points 1', 2', 3', . . . . 9', Q, on the transition curve by dividing by  $n_2 - n_1 (=4)$  the values of  $y_1, y_2, y_3, \dots y$  in Table IV corresponding to the value of  $\psi = 2^\circ$ .

These offsets are therefore—

- 11' = .005.
- 22' = .037.
- 33' = .126.
- 44' = .298.
- . . . . .
- 99' = 3.392.
- N"Q = 4.653.

The transition curve may also be set out from the circle of curvature at Q by using the same offsets in the reverse order.

**36. Second Method.** *By deflection angles from the tangent at N.* This method may be best understood by solving the example given in the preceding paragraph.

The value of  $\psi$  and the length of curve are first found as in that paragraph. Now it is clear from the results obtained in paragraph 30, that the angles subtended by the offsets 11', 22', 33', . . . . 99' and N"Q are the values of  $\theta_1, \theta_2, \theta_3, \dots \theta$  given in Table V, corresponding to  $\psi = 2^\circ$ .

To obtain the angles of deflection from the tangent at N to the points 1', 2', 3', . . . Q, we therefore add to the values of  $\theta_1, \theta_2, \theta_3, \dots \theta$  the deflection angles from the tangent at N to the points 1, 2, 3, . . . N". The latter deflection angles are obviously, since the curve NN" is of  $4^\circ$  curvature, 12', 24', 36' 48', ..... 2°.

The angles of deflection from the tangent at  $N$  to the points  $1', 2', 3', \dots, Q$  will therefore be  $12' + \theta_1, 24' + \theta_2, 36' + \theta_3, 48' + \theta_4; \dots, 2^\circ + \theta$ ; that is to say,  $12' 24'', 25' 36'', 39' 36'', 54' 24'', \dots, 2^\circ 40''$

By setting off these angles in succession from the tangent at  $N$ , the transition curve may be set out with a chord of  $\frac{1}{16}$ th of its length, i. e. 10 feet in the case under consideration, in precisely the same manner as that employed for setting out a circular curve. If a theodolite is used, the first two or three points will probably be too close to the instrument for correct focussing; if so, these points can be fixed from the point  $Q$ , as described in the following paragraph.

37. The transition curve may as before be set out from the tangent at  $Q$ , but it will then be clear that the angle of deflection between the tangent at  $Q$  and any point on the transition curve will be equal to the *difference* between the value of  $\theta$  and the angle contained between the tangent at  $Q$  and the line joining  $Q$  to the corresponding point on the circular curve  $QQ'$ . For example, in the case under consideration, the angle of deflection from the tangent at  $Q$  to the point  $1$  on the circular curve  $QQ'$  will be  $24'$ , since the curve  $QQ'$  is of  $8^\circ$ . The angle of deflection between the tangent at  $Q$  and the point  $9'$  on the transition curve will therefore be  $24' - \theta_1 = 23' 36''$ . Similarly the angle of deflection between the tangent at  $Q$  and the point  $8'$  on the transition curve will be  $48' - 1' 36'' = 46' 24''$ .

38. The student will have seen that, in the case we have been considering of two circular arcs of similar flexure connected by a transition curve, the circular curve of smaller radius must necessarily lie entirely within that of larger radius.

39. It occasionally happens (for example in hilly country) that it is necessary to set out the circular curves to suit the contour of the country and subsequently to determine the transition curve of the proper length to connect them. In such a case we must adopt a somewhat different procedure for finding the appropriate length of transition curve and the appropriate value of  $\psi$ .

Let Fig. 80 represent two circular curves  $NN'$  and  $QQ'$  which it has been obligatory to set out on the ground, before the transition curve  $NQ$  is set out. We have proved in paragraph 32 that the tangents at  $N'$  and  $Q'$  are parallel and that the length  $N'Q'$  is the shortest distance between the two circular curves. Now it is obvious that the distance  $N'Q'$  (or the "shift," vide paragraph 32) corresponds to the distance  $d$  in the case of a transition curve connecting a straight tangent with a circular curve. From the formula in paragraph 16 we can easily obtain an approximate value of  $d$  in terms of  $s$ , the length of the curve,

We have  $\frac{d}{s} = \frac{\psi}{12}$  — higher powers of  $\psi$ , and on the analogy of this result we may write  $\frac{N'Q'}{NQ} = \frac{\psi}{12}$  approximately,  $\psi$  being in circular measure.

Expressing  $\psi$  in degrees, we obtain  $\frac{N'Q'}{NQ} = \frac{\psi}{12 \times 57.29578}$ ,

Now we see from a comparison of the values obtained in paragraph 34 for  $\psi$  and the length of the curve, that length of curve  $NQ = \frac{200\psi}{n_2 - n_1}$ , that is  $\psi = \frac{NQ(n_2 - n_1)}{200}$ . Substituting this value of  $\psi$  in the equation above,

$$\text{we get } N'Q' = \frac{NQ^2(n_2 - n_1)}{2400 \times 57.29578} =$$

$$\text{Hence we obtain } NQ = \frac{\sqrt{24 \times 57.29578 N'Q'}}{\sqrt{n_2 - n_1}}$$

$$= 370.82 \frac{\sqrt{N'Q'}}{\sqrt{n_2 - n_1}}$$

When therefore the two circular curves are first set out on the ground, we measure the shortest distance  $U'Q'$  between them, and obtain the appropriate length of the transition curve from the equation last obtained.

We derive the corresponding value of  $\psi$  from the equation

$$\psi \text{ (in degrees)} = \frac{NQ(n_2 - n_1)}{200}$$

The transition curve may then be set out as previously described.

40. If the two circular curves are of *contrary* flexure, the circles of which they form parts must lie entirely outside each other, and the results obtained in paragraphs 29 to 39 will apply to this case if the sign of  $n_1$  be changed in all the formulae.

Thus the minimum value of  $\psi$  will be

$\cdot 00275 \left(\frac{V}{10}\right)^3 (n_2 + n_1)^2$  and the minimum length of the transition curve  $\cdot 55 \left(\frac{V}{10}\right)^3 (n_2 + n_1)$ . Similarly the length of the transition curve expressed in terms of the shortest distance between the two circular curves will be —

$$NQ = \text{minimum length of curve} = 370.82 \frac{\sqrt{N'Q'}}{\sqrt{n_2 + n_1}}$$

and the value of  $\psi$  in terms of the length of the transition curve will be

$$\psi \text{ in degrees} = \frac{NQ(n_2 + n_1)}{200}.$$

41. **The cubic parabola as transition curve.**—From the equations for  $x$  and  $y$  given in paragraph 16 we see that the cubic parabola  $y = \frac{x^3}{3k^2}$  is a first approximation to the true transition curve. The cubic parabola is the most common of approximate curves, ordinarily in use. It has no advantages over the true form of the curve while it has several disadvantages; it will not be dealt with further here. The student desiring to obtain further information about its use as a transition curve may

refer to "Notes on Plate-laying and Points and Crossings," 6th edition, by W. H. Cole. All the results there obtained may be arrived at as approximations to the results obtained in paragraph 16 of this chapter.

42. It remains to describe how superelevation is adjusted on the transition curve, and the following cases have to be considered :--

1. When the transition curve connects a straight tangent with a circular curve.

2. When the transition curve connects—

(a) two curves of similar flexure.

(b) two curves of contrary flexure.

*Case 1.* Since (vide paragraph 9) the superelevation varies inversely as the radius of curvature, and (vide paragraph 14) the length of the transition curve measured from the origin also varies inversely as the radius of curvature, it follows that the superelevation at any point of the transition curve is directly proportional to the distance of the point measured along the curve from the origin. If  $i$  be the superelevation for the main circular curve and  $s$  be the whole length of the transition curve, then the superelevation at a point distant  $s_1$  from the origin will be  $\frac{s_1}{s} i$ .

*Case 2 (a).* It is obvious from what has been said on the previous case, that the superelevation will vary at a uniform rate between the two circular curves.

If  $i$  be the superelevation for the circular curve of larger radius, and  $i'$  that for the circular curve of smaller radius,  $s$  being the length of the transition curve between the two circular curves, then the superelevation at a point distant  $s_1$  measured along the transition curve from its point of contact with the circular curve of larger radius, will be  $i + \frac{s_1}{s}(i' - i)$ .

*Case 2 (b).* In this case if  $i$  and  $i'$  be the superelevations for the two main circular curves, and  $s$  be the whole length of the transition curve, the superelevation at a point distant  $s_1$  along the transition curve from its point of contact with the curve whose superelevation is  $i$  will obviously be  $i - \frac{s_1}{s}(i + i')$

43. **Vertical curves.**—We shall conclude the chapter by describing briefly what are usually called "vertical curves," that is, the curves employed for easing the junctions of gradients. A gradient is usually defined by the horizontal distance in feet, in which the vertical rise or fall is 1 foot. Thus a 1 in 500 gradient falls 1 foot vertical in 500 feet horizontal; the tangent of the angle of slope is therefore  $\frac{1}{500}$ . Occasionally gradients are defined by the rise or fall per 100 feet. Thus a gradient of 1 in 500 would be described as a gradient of .2 per cent.

44. The vertical curve is usually so designed that the rate of change of gradient in passing from one gradient to another is constant. In *Cartesian* co-ordinates this may be expressed by the differential equation  $\frac{d}{dx}(\frac{dy}{dx})=k$ , where  $k$  is a constant.

Two successive integrations give the result  $y=k\frac{x^2}{2} + k_1x + k_2$ , where  $k_1$  and  $k_2$  are constants of integration.

The curve is therefore an ordinary parabola with its axis vertical.

Let AB and BC (Fig. 81) represent two gradients in profile. If ADC

FIG. 81.

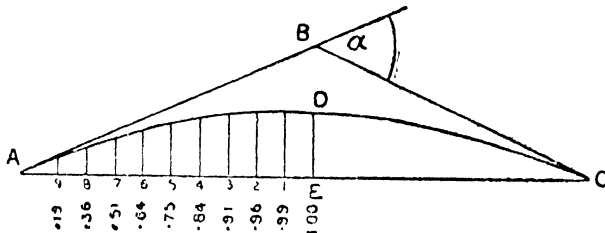

be a parabola tangent to AB and BC, we have from the geometry of the parabola,  $BD=DE$ . The vertical curve therefore bisects the vertical line contained between B, the junction point of the gradients and AC, the line connecting the tangent points of the curve. If we divide AE into 10 equal parts at the points 1, 2, 3, . . . 9, the ordinates to the curve, measured from AE parallel to ED, will have the values shown in Fig. 81, the distance ED being assumed equal to 1.

If  $\alpha$  be the exterior angle at the junction of the gradients and  $V$  be the speed in miles per hour, the length of the tangent AB or BC may in practice be taken as equal to  $200V\alpha$ . As  $\alpha$  will in practice be small, it may be taken as equal to its tangent and if  $t$  be this tangent, we have  $AB=BC=200 V t$ . If the grades be 1 in  $n_1$  and 1 in  $n_2$  falling in *opposite* directions,  $t$  will be very approximately  $\frac{1}{n_1} + \frac{1}{n_2}$ ; if the grades fall in the *same* direction,  $t$  will be very nearly  $\frac{1}{n_1} - \frac{1}{n_2}$ . Thus if the junction be formed by two grades of 1 in 100 and 1 in 200 falling in opposite directions, the speed being 50 miles per hour, we have

$$AB=200 \times 50 \times \left(\frac{1}{100} + \frac{1}{200}\right) = 150 \text{ feet.}$$

Transition curves.

TABLE I.

Minimum Values of  $\psi$  for different speeds.

Degree of main circular curve.	Minimum values of $\psi$ for speed, of.											10 miles per hour.															
	60.	55.	50.	45.	40.	35.	30.	25.	20.	15.	12.																
0	0	0	0	0	0	0	0	0	0	0	0	0															
1	1	1	1	1	1	1	1	1	1	1	1	0															
1½	2	1	1	1	1	1	1	1	1	1	1	0															
2	3	2	2	2	2	2	2	2	2	2	2	0															
2½	4	3	3	3	3	3	3	3	3	3	3	0															
3	5	4	4	4	4	4	4	4	4	4	4	0															
3½		5	5	5	5	5	5	5	5	5	5	0															
4			6	6	6	6	6	6	6	6	6	0															
4½				7	7	7	7	7	7	7	7	0															
5					8	8	8	8	8	8	8	0															
5½						9	9	9	9	9	9	0															
6							10	10	10	10	10	0															
6½								11	11	11	11	0															
7									12	12	12	0															
8										13	13	0															
8½											14	0															
9												15															
9½													16														
10														17													
10½															18												
11																19											
11½																	20										
12																		21									
12½																			22								
13																				23							
13½																					24						
14																						25					
14½																							26				
15																								27			
15½																									28		
16																											29

Note. The speed on a curve of degree  $n$  in the above table by the formula.  
 Maximum permissible speed in miles per hour =  $\frac{92.76}{\sqrt{n}}$  (vide para. 11)

**Transition curves.**

**TABLE II.**

Showing values of S, D, d, T, t, etc. for a transition curve leading up to a main circular curve of 1 degree, for different values of  $\psi$ .

$\psi$ in degrees.	S	D.	d.	T.	t.	R+d.	Log (R+d.)
1	200	99.939	.291	133.336	66.669	5729.809	3.7581447
2	400	199.992	1.114	266.683	133.349	5730.742	3.7582109
3	600	299.973	2.018	400.058	200.052	5732.196	3.7583211
4	800	399.955	3.053	533.409	266.791	5734.231	3.7584752
5	1000	499.975	4.270	666.935	333.575	5736.848	3.7586733
6	1200	599.781	10.408	800.400	400.418	5740.046	3.7589154
7	1400	699.652	14.245	934.065	467.831	5743.824	3.7592011
8	1600	799.480	18.004	1067.757	534.326	5748.182	3.7595306
9	1800	899.261	22.541	1201.555	601.413	5753.119	3.7599084
10	2000	998.985	29.057	1335.467	668.607	5758.635	3.7603196
11	2200	1098.650	35.152	1469.509	735.917	5764.730	3.7607790
12	2400	1198.218	41.822	1593.692	803.357	5771.400	3.7612812
13	2600	1297.773	49.070	1738.031	870.938	5778.648	3.7618262
14	2800	1397.218	56.893	1872.538	938.673	5786.471	3.7624139
15	3000	1496.579	65.290	2007.227	1006.574	5794.868	3.7630435
16	3200	1595.849	74.261	2142.110	1074.654	5803.839	3.7637154
17	3400	1695.024	83.803	2277.208	1142.922	5813.381	3.7644288
18	3600	1794.094	93.916	2412.526	1211.395	5823.494	3.7651837
19	3800	1893.056	104.599	2548.081	1280.084	5834.177	3.7659796
20	4000	1991.906	115.850	2683.889	1349.003	5845.428	3.7668163

*Explanation.*—To find the values of S, D, d, etc., corresponding to a given value of  $\psi$ , for a transition curve leading up to a main circular curve of 1 degree n, divide by n the figures shown in the table opposite the given value of  $\psi$ .

Transition Curves.

TABLE III.

Values of  $x_1, x_2, x_3, \dots, x$  for a transition curve leading up to a circular curve of 1 degree, for different values of  $\psi$ .

$\psi$ in degrees.	$x_1$	$x_2$	$x_3$	$x_4$	$x_5$	$x_6$	$x_7$	$x_8$	$x_9$	$x$
1	20.000	40.000	60.000	80.070	100.000	120.000	139.999	159.998	179.996	199.994
2	40.000	80.000	120.000	160.000	199.999	239.996	279.992	319.984	359.971	399.951
3	60.000	120.000	180.000	239.998	299.995	359.987	419.972	479.946	539.903	599.836
4	80.000	160.000	239.999	319.996	399.988	479.970	559.934	639.872	719.770	799.610
5	100.000	200.000	299.998	399.992	499.976	599.940	699.872	799.751	899.550	999.241
6	120.000	240.000	359.997	479.987	599.959	719.898	839.779	959.568	1079.228	1198.685
7	140.000	279.999	419.995	559.979	699.935	839.838	979.649	1119.315	1258.707	1397.912
8	160.000	319.999	479.992	639.968	799.903	959.758	1119.476	1278.978	1438.159	1580.883
9	180.000	359.999	539.989	719.955	899.811	1079.655	1259.254	1438.545	1617.379	1795.564
10	200.000	399.998	599.985	799.938	999.810	1199.526	1398.976	1598.005	1796.406	1993.916
11	220.000	439.997	659.980	879.917	1099.747	1319.369	1538.638	1757.345	1975.216	2191.905
12	240.000	479.997	719.974	959.892	1199.671	1439.181	1678.232	1916.553	2153.792	2389.494
13	260.000	519.996	779.967	1039.863	1299.582	1558.960	1817.752	2075.617	2332.109	2589.647
14	280.000	559.995	839.959	1119.829	1399.477	1678.700	1957.192	2234.528	2510.147	2789.328
15	300.000	599.993	899.950	1199.789	1499.358	1798.400	2036.547	2393.271	2637.685	2979.503
16	320.000	639.992	959.939	1279.745	1599.250	1918.061	2235.509	2551.685	2865.299	3175.135
17	340.000	679.990	1019.927	1359.693	1699.065	2037.674	2374.974	2710.209	3042.873	3370.190
18	360.000	719.989	1079.914	1439.636	1798.890	2157.289	2514.034	2868.880	3219.081	3564.631
19	380.000	759.987	1139.898	1519.572	1898.694	2276.752	2652.985	3026.336	3395.407	3758.424
20	400.000	799.984	1199.882	1599.508	1998.477	2396.213	2791.813	3184.067	3571.326	3951.537

Explanation. Similar to that given on Table II.

Transition Curves.

TABLE IV.

Values of  $y_1, y_2, y_3, y_4, y_5, y_6, y_7, y_8, y_9, y_{10}$  for a transition curve leading up to a circular curve of  $1^\circ$ , for different values of  $\psi$ .

$\psi$ in degrees	$y_1$	$y_2$	$y_3$	$y_4$	$y_5$	$y_6$	$y_7$	$y_8$	$y_9$	$y_{10}$
1	0.001	0.009	0.031	0.074	0.145	0.251	0.399	0.596	0.848	1.163
2	0.005	0.037	0.126	0.268	0.582	1.005	1.596	2.383	3.393	4.634
3	0.010	0.084	0.283	0.670	1.309	2.212	3.192	5.861	7.633	10.470
4	0.019	0.149	0.503	1.191	2.327	4.071	6.385	9.550	13.519	18.610
5	0.029	0.233	0.786	1.862	3.436	6.283	9.976	14.880	21.198	29.073
6	0.042	0.335	1.131	2.681	5.236	9.047	14.365	21.440	30.521	41.855
7	0.057	0.456	1.539	3.749	7.126	12.313	19.551	29.178	41.534	56.953
8	0.074	0.596	2.011	4.766	9.308	16.082	25.534	38.106	54.237	74.364
9	0.094	0.754	2.645	6.032	11.780	20.353	32.313	43.250	68.627	94.082
10	0.116	0.931	3.442	7.446	14.543	25.126	39.889	59.521	84.702	115.102
11	0.141	1.126	4.501	9.010	17.586	30.400	45.560	72.007	102.459	140.420
12	0.168	1.340	5.824	10.722	20.940	36.176	57.427	85.676	121.894	167.027
13	0.197	1.573	7.509	12.584	24.574	42.454	67.388	100.528	143.005	195.918
14	0.229	1.824	9.517	14.594	28.499	49.233	78.143	116.561	165.788	237.086
15	0.262	2.094	11.808	16.754	32.715	56.513	89.692	138.773	190.240	260.521
16	0.298	2.383	14.442	19.061	37.221	64.293	102.033	152.162	216.355	296.215
17	0.336	2.690	17.479	21.518	42.017	72.574	115.165	171.726	244.129	334.158
18	0.377	3.016	20.978	24.123	47.103	81.356	129.089	192.463	273.558	374.341
19	0.420	3.360	24.940	26.877	52.480	90.637	143.803	214.371	304.635	416.755
20	0.455	3.723	29.465	29.780	58.146	100.418	159.306	237.447	337.359	461.386

Explanation. Similar to that given on Table II.

Transition Curves.

TABLE V.

Values of  $\theta_1, \theta_2, \theta_3, \theta_4, \theta_5, \theta_6, \theta_7, \theta_8, \theta_9, \theta_{10}$  for different values of  $\psi$ .

$\psi$ , in degrees.	$\theta_1$	$\theta_2$	$\theta_3$	$\theta_4$	$\theta_5$	$\theta_6$	$\theta_7$	$\theta_8$	$\theta_9$	$\theta_{10}$
1	12'	48"	1'	3'	5'	7'	9'	12'	16'	20'
2	24'	30"	3'	6'	10'	14'	19'	25'	32'	40'
3	36'	24"	5'	9'	15'	21'	29'	38'	48'	1° 0'
4	48'	12"	7'	12'	20'	28'	39'	51'	1° 4'	1° 20'
5	1° 0'	0"	9'	16'	25'	36'	49'	1° 4'	1° 21'	1° 40'
6	1° 12'	48"	10'	18'	30'	43'	58'	1° 16'	1° 37'	1° 59'
7	1° 24'	36"	12'	21'	35'	50'	1° 8'	1° 24'	1° 53'	2° 9'
8	1° 36'	24"	14'	25'	40'	57'	1° 18'	1° 42'	2° 8'	2° 39'
9	1° 48'	12"	16'	28'	45'	1° 4'	1° 28'	1° 55'	2° 25'	2° 59'
10	2° 0'	0"	18'	32'	50'	1° 12'	1° 38'	2° 7'	2° 41'	3° 15'
11	2° 12'	48"	19'	35'	55'	1° 19'	1° 47'	2° 20'	2° 58'	3° 39'
12	2° 24'	36"	21'	38'	1° 0'	1° 26'	1° 57'	2° 33'	3° 14'	3° 59'
13	2° 36'	24"	23'	41'	1° 5'	1° 38'	2° 7'	2° 46'	3° 30'	4° 18'
14	2° 48'	12"	25'	44'	1° 10'	1° 40'	2° 17'	2° 59'	3° 40'	4° 33'
15	3° 0'	0"	27'	48'	1° 15'	1° 47'	2° 26'	3° 11'	4° 2'	4° 59'
16	3° 12'	48"	28'	51'	1° 20'	1° 55'	2° 30'	3° 24'	4° 19'	5° 19'
17	3° 24'	36"	30'	54'	1° 25'	2° 2'	2° 46'	3° 27'	4° 35'	5° 39'
18	3° 36'	24"	32'	57'	1° 30'	2° 9'	2° 56'	3° 50'	4° 51'	5° 58'
19	3° 48'	12"	34'	1° 0'	1° 35'	2° 16'	3° 6'	4° 8'	5° 7'	6° 18'
20	4° 0'	0"	36'	1° 4'	1° 40'	2° 23'	3° 15'	4° 15'	5° 23'	6° 39'

## CHAPTER X.

### THE MECHANICAL PRINCIPLES OF RAILWAY TRACTION.

1. In Chapter VII, we described some of the structural details of the locomotive. In the present chapter we shall discuss the mechanics of the locomotive considered as a machine for converting power into motion, and the various retarding forces or resistances which the locomotive has to overcome.

2. When a train is in motion, we know, by d'Alembert's principle in Mechanics, that the resultant of the external forces acting on the locomotive is in equilibrium with the reversed effective force, corresponding to the actual motion of the locomotive. If the locomotive be moving with constant velocity, this effective force is nil (we neglect the effective forces due to the inertia of moving parts); consequently under this condition the external forces acting on it must be in static equilibrium. Now the only external forces acting on the locomotive will then be (1) its weight acting vertically downwards; (2) the vertical reactions of the rails on the wheels acting upwards; (3) the resistance due to motion through the air; (4) the frictional forces, acting on the periphery of the wheels either in the direction of motion or the opposite direction; and (5) the pull on the drawbar. In so far as the forward motion of the locomotive is concerned, we need not consider forces (1) and (2), as they obviously balance each other and have no component in the direction of motion. We are thus led to the result that, when the speed of the train is constant the resultant frictional forces between the rails and the wheels of the locomotive acting in the direction of motion are in equilibrium with (a) the resultant of the frictional forces acting in the contrary direction (b) the air-resistance and (c) the pull on the drawbar. Now the only frictional forces acting in the direction of motion, are those called into play at the periphery of the driving wheels by the thrust or pull of the connecting and coupling rods (see Fig. 67) and it is these frictional forces which cause the motion. The student may perhaps find it difficult at first to grasp this fact, but a little consideration will make it clear. For example, if the engine were placed on perfectly frictionless rails it is easy to see that the wheels would merely slip on the rails and the locomotive remain stationary.

The resultant of these frictional forces on the driving-wheels is thus equivalent to the hauling effort of the engine. For convenience we shall call this resultant the *tractive effort* of the engine.

3. We proceed now to determine the amount of these frictional forces.

FIG. 82.

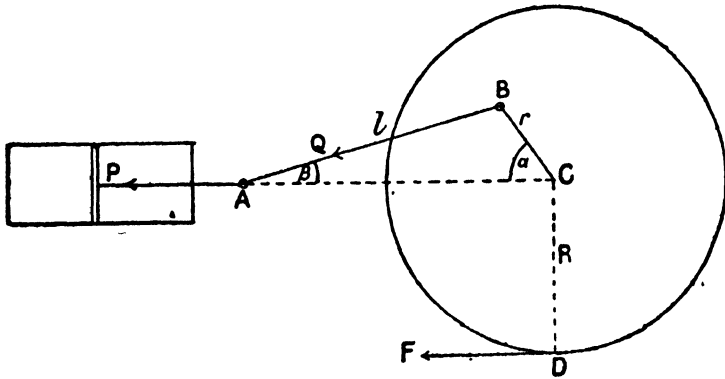

Let Fig. 82 represent the connecting rod and driving-wheel of a locomotive (for simplicity's sake we shall assume a single driving-wheel only on each rail); let  $P$  be the total pressure of the steam in the cylinder on the piston,  $Q$  the pull of the connecting rod, and  $F$  the tractive effort of the engine.

Now considering the forces acting on the wheel we shall have in addition to the forces  $Q$  and  $F$  (neglecting for the present friction of the working parts) certain reactions from the frame of the engine on the axle, also the weight on the axle acting vertically downwards and the vertical reaction of the rail on the wheel; all of which additional forces will act through the centre of the axle.

4. By d'Alembert's principle, if the wheel be revolving with constant angular velocity, the forces acting on it will be in static equilibrium. We have therefore, taking moments about the centre of the wheel, the moment of  $Q$  about the centre is equal and opposite to the moment of  $F$  about the centre. The reactions on the axle of the frame of the engine, also the weight on the axle and the vertical reaction of the rail on the wheel have obviously no moment about the centre.

5. Let  $R$  be the radius of the wheel,  $r$  the crank-radius,  $\alpha$  the angle  $BCA$  (see Fig. 82) and  $\beta$  the angle  $BAC$ . Then we have

$$FR = Qr \sin(\alpha + \beta)$$

Now considering the forces acting on  $A$ , the cross-head of the engine and resolving these forces horizontally we clearly have

$$Q \cos \beta = P.$$

Hence we have

$$FR = Pr \frac{\sin(\alpha + \beta)}{\cos \beta}$$

$$\text{or } F = \frac{Pr}{R} (\sin \alpha + \cos \alpha \tan \beta).$$

Now if  $l$  be the length of the connecting-rod we have  $\frac{l}{r} = \frac{\sin \alpha}{\sin \beta}$  and therefore

$$\tan \beta = \frac{r \sin \alpha}{\sqrt{l^2 - r^2 \sin^2 \alpha}}$$

Hence we have

$$F = \frac{Pr \sin \alpha}{R} \left( 1 + \frac{r \cos \alpha}{\sqrt{l^2 - r^2 \sin^2 \alpha}} \right)$$

$$= \frac{Pr \sin \alpha}{R} \left( 1 + \frac{n \cos \alpha}{\sqrt{1 - n^2 \sin^2 \alpha}} \right)$$

where  $n$  is equal to the ratio  $\frac{r}{l}$ .

6. The tractive effort thus varies with the angle  $\alpha$ . It is *nil* when  $\alpha = 0^\circ$  or  $180^\circ$ , that is it say, when the crank-pin is in line with the cross-head and the centre of the wheel. These two positions of the crank-pin are known as the "dead-points." When  $\alpha$  is  $90^\circ$  or  $270^\circ$ ,  $F = \frac{Pr}{R}$ ; and  $F$  will attain its maximum value at a point at which  $\alpha$  is somewhat less than  $90^\circ$  or greater than  $270^\circ$ , its value depending on the ratio  $\frac{r}{l}$ .

We see also, that the tractive effort becomes greater as  $R$  is decreased. The driving-wheels of engines which are required to exert great power, such as goods engines, are therefore made of small radius.

7. It will be clear that if the angle  $\alpha$  for the cranks on both sides of the engine were made the same, or if the two angles differed by  $180^\circ$ , the cranks would both be at a dead-point at the same time. The joint tractive effort due to both cylinders would then be *nil* and the engine would be unable to start if the cranks were in this position. To obviate this, one crank is set at a lead of  $90^\circ$  in advance of the other and the tractive effort due to the second cylinder is then seen to be

$$\frac{Pr}{R} \sin(\alpha + 90^\circ) \left\{ 1 + \frac{n \cos(\alpha + 90^\circ)}{\sqrt{1 - n^2 \sin^2(\alpha + 90^\circ)}} \right\}$$

The joint tractive effort for *any* position of the cranks is obtained by taking the sum of the expressions for the tractive effort due to each cylinder, for that position. In applying this result, it should be remembered that as each crank passes through a dead-point, the direction of

the steam-pressure on the corresponding piston is reversed, and the force  $P$  therefore changes in sign.

8. In the above investigation, we have assumed a single driving-wheel on each side of the engine; if however there are more driving-wheels than one, it will be obvious that the value of the tractive effort, as obtained above will not be changed.

9. We obtain the mean value of the tractive effort by equating the value of the work done by the expansion of the steam in the two cylinders, during a complete revolution of the driving-wheel, to the product of the tractive effort into the circumference of the wheel.

If  $p$  be the mean effective pressure in lbs. per square inch of the steam in the cylinder,  $d$  the diameter of the piston in inches,  $s$  the stroke of the piston in feet,  $D$  the diameter of the driving-wheels in feet, then the work in foot-pounds done in the two cylinders will clearly be  $2p \times \frac{\pi d^2}{4} \times 2s$ , seeing that each piston moves through a distance equal to twice the stroke during a complete revolution of the driving-wheel. We thus have

$$p \pi d^2 s = F \times \pi D$$

or  $F = \frac{p d^2 s}{D}$ , where  $F$  is now the mean joint tractive effort due to both cylinders\*. In an actual case,  $p$  would of course be found from indicator diagrams of the work done in the cylinders.

10. Now it will be clear that  $F$ , being equal to the resultant of the frictional forces between the rails and the wheel, can never in actual working be in excess of the limiting adhesional friction due to the weight on the driving-wheels (if it were in excess, the wheels would slip on the rails) or in other words it can never be in excess of the product of this weight into the co-efficient of friction between the wheels and the rails. This limiting friction may therefore be called the *tractive power* of the engine, since it represents the maximum tractive effort that the engine can develop. The engine must however for obvious reasons be so designed, that the boiler and cylinder power is always somewhat in excess of the full tractive power. The co-efficient of friction in ordinary weather conditions will be about  $\frac{1}{6}$ , and in misty weather  $\frac{1}{3}$ ; if sand be used on the rails (see Chapter VII, paragraph 3), or if the rails be either very wet or very dry, its value may be taken at  $\frac{1}{4}$ ; if the rails be greasy, it may be as low as  $\frac{1}{12}$ .

---

\* We might have obtained this result by evaluating the integral  $2 \int F ds$  for a complete revolution of the wheel and dividing the result by  $s$ , where  $s$  is the circumference of the wheel and  $F$  is the value given in paragraph 5 for the tractive effort due to one cylinder. The integral  $\int F ds$  represents the work done on the crank during a complete revolution, and if it be divided by  $s$  we get the mean tractive effort.

11 Having thus dealt with the force of traction developed by the engine, we shall now consider the retarding forces which the locomotive has to overcome.

12 **Resistance due to rolling friction.**—This resistance is caused by the distortion of the surfaces of contact between the rail and the wheel caused by the weight on the axle. Let Fig. 83 represent the profile of a

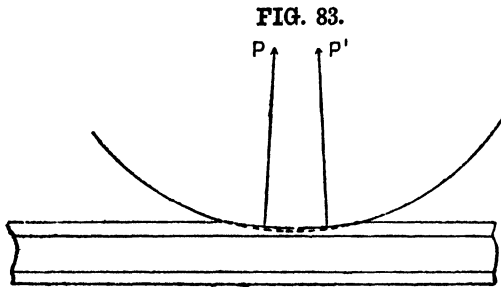

wheel in motion on a rail; then at the surface of contact, the table of the rail will be slightly crushed and the perimeter of the wheel will be distorted to a larger radius, as shown to an exaggerated scale in the figure. Now as the wheel progresses, the material of the rail in advance of a vertical line drawn through the centre of the wheel, will be compressed, while the portion of the rail in rear of this line will be recovering its normal shape. The compression will give rise to a resultant pressure  $P$  on the wheel, whose line of action will be a little in advance of the centre of the wheel; the elasticity of the portion of the rail which is tending to recover its normal shape will similarly give rise to a pressure  $P'$ , whose line of action will be a little in rear of the centre of the wheel. As the elasticity of the material of the rail can never be mathematically perfect,  $P$  will always be greater than  $P'$ ; also if the wheel be in rapid motion, the hysteresis of the metal of the rail will tend further to reduce  $P'$ ; hence there will always be a moment about the centre of the wheel, opposing its motion. If  $T$  be the force at the periphery of the wheel required to overcome this moment, then  $T$  is called, inappropriately enough, the *rolling-friction* of the wheel.

In addition to the effect described above, the rail will deflect slightly as a girder between its points of support on the sleepers, and this will cause a further resistance to the forward motion of the wheel.

13. **Resistance due to journal friction.**—The friction on the journals of wheels will also give rise to a moment, which will oppose the motion of

the vehicle. As in the case of rolling-friction, the force at the periphery of the wheel necessary to overcome this moment represents the resistance due to journal friction.

14. In the majority of text-books, the resistances due to rolling-friction proper and to journal-friction, are classed together under the heading *rolling-resistance* or *train-resistance*; to fall into line with these text-books, we shall adopt the same expressions. The rolling-resistance on a straight level track, of ordinary passenger or goods vehicles at slow speeds depends on the lubrication and other uncertain factors, but may be taken at an average of about  $\frac{1}{25}$ th, or 0.20 per cent. of their weight, or say 4½ lbs. per ton; and is fairly constant for a given train on a straight track. The resistance at starting is usually higher, and more uncertain, but it may be assumed to be about double the normal rolling resistance, that is, about  $\frac{1}{10}$ th of the weight, or 9 lbs per ton. Thus we see that the minimum tractive force required to start a train on the level should be reckoned at not less than 9 lbs. for every ton to be hauled; but that when motion is established, 4½ lbs. per ton would be enough to maintain it.

The rolling-resistance of locomotives is greater than that of ordinary vehicles partly owing to the greater weight on the wheels, which increases the rolling friction, and partly because the journals are larger in proportion to the size of the wheels. It is here necessary to warn the student that the friction of the working parts of the mechanism of the engine, while it reduces the tractive effort as defined in paragraph 3, does not reduce the tractive power, nor does the journal friction of the driving-axles of the engine. This statement should be carefully noted. The tractive effort as we have seen depends on cylinder power, and is therefore reduced by the loss in power due to the friction of the working parts and of the journals of the driving wheels; the tractive power, however, depends solely on the weight on the rails transmitted by the driving-wheels, and the only tax on it consists in the rolling-friction of the driving-wheels, and the rolling-resistance (i. e. rolling friction *plus* journal friction) of the other wheels, including of course those of the tender. The total resistance of locomotives ranges from  $\frac{1}{20}$ th to  $\frac{1}{10}$ th i. e. from 0.25 to 0.50 per cent. of the weight, or from about 5½ lbs. to 11 lbs. per ton; the average for a locomotive and tender together being between 6 and 7 lbs. per ton.

15. **Grade resistance.**—On an ascending gradient the component of the weight of the train, parallel to the gradient, opposes the motion of the train; though not properly-speaking a resistance in the same sense as

those considered above, this component is usually known under the name of grade resistance.

As explained in Chapter IX, paragraph 43, a gradient is defined either by the horizontal distance in feet, in which a rise or fall of one foot takes place, or by the rise or fall which takes place in a horizontal distance of 100 feet. Thus a gradient of 0·43 per cent. rises or falls 0·43 feet per 100 feet horizontal. Let Fig. 84 represent a vehicle on a gradient whose

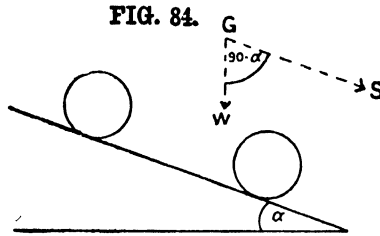

angle of inclination is  $\alpha$ ,  $G$  being the centre of gravity of the vehicle. If  $W$  be the weight of the vehicle and  $S$  the component of  $W$  in a direction parallel to the gradient, then

$$S = W \sin \alpha$$

As  $\alpha$  is in practice small  $\sin \alpha$  may be taken as equal to  $\tan \alpha$  and therefore  $S = W \times \text{rate of inclination of gradient}$ . Thus the grade resistance on a grade of 2 per cent. or 1 in 50 is equal to  $\frac{W}{50}$

16. **Curve resistance.**—On curves another sort of resistance is met with, which depends on the radius of the curve and the gauge, and is due mainly to (a) sliding of the wheel treads on the tables of the rails and (b) grinding of the flange of the outer leading wheel against the rail.

It would be out of place in this Manual to enter on a complete mathematical investigation of the causes which give rise to curve resistance. Such a mathematical investigation would in any case be of little use for practical purposes; there are so many factors, which affect the question and which differ for every vehicle and even for every wheel and every rail, that the subject is one almost solely for experimental enquiry; and any mathematical investigation can only be of use as enabling us to interpret intelligently the results of experiment. It is, however, essential that the student should have some understanding of the causes which give rise to this form of resistance, and in the following paragraphs we shall attempt to explain these causes as simply as possible.

17. When a pair of wheels rigidly attached to an axle moves on a curve, it is clear that if the axle is to remain radial to the curve, the outer wheel must move over a greater distance than the inner.

(For simplicity's sake we shall assume the treads of the wheels to be cylindrical). Let Fig. 85 represent such a pair of wheels travelling on a

FIG. 85.

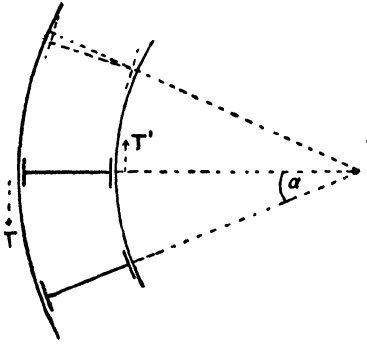

curve; and let us suppose that the axle is compelled to maintain a position radial to the curve. Let  $R$  be the radius of the centre line of the curve, and  $g$  be the gauge,  $a$  being the circular measure of the angle through which the axle is displaced. Then the distance through which the outer wheel moves is  $(R + \frac{g}{2})a$ , and the distance through which the inner wheel moves is  $(R - \frac{g}{2})a$ . Now

as the wheels are rigidly attached to the axle, either the outer or the inner wheel, or partly one and partly the other, must slip through a total distance equal to  $(R + \frac{g}{2})a - (R - \frac{g}{2})a = ga$ . If the slip takes place entirely on the outer rail, the frictional force on the outer wheel will be in the direction of the force  $T$  on the figure. Again if the slip takes place entirely on the inner rail, the frictional force on the inner wheel will be in the direction of  $T'$  in the figure. If the

FIG. 86.

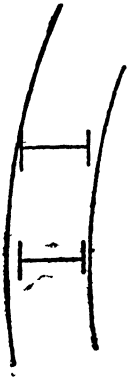

slip be partly on one rail and partly on the other, we shall have a combination of these frictional forces on both rails. Now in every one of these cases, the frictional forces tend to move the wheels and axle into some such position as that shown by the dotted lines in the figure, that is to say, into a position inclined to the radial position. When two axles are connected together by a rigid frame, the same forces are brought into play in the case of each axle, with the result that the vehicle takes up some such position on the rails as that shown in Fig. 86, in which the flange of the leading outer wheel hugs the outer rail while the flange of the trailing outer wheel maintains a position clear of

the outer rail.

18. A number of writers have asserted that the trailing-axle invariably takes up a position radial to the curve; this may be true in the case of vehicles of certain dimensions, but it clearly cannot hold as a general law. All that we can say is what is stated above, namely, that the flange

of the leading outer wheel is pressed against the outer rail, while the flange of the trailing outer wheel moves away from the outer rail. The pressure of the flange of the leading outer wheel on the outer rail will give rise to a frictional force, tangential to the inner face of that rail which will constitute part of the resistance due to the curve.

19. The sliding of the wheels described in paragraph 17 will also contribute to the curve resistance. If  $F$  denote the limiting value of the sliding friction between a wheel and a rail, then the work done during the sliding will be  $Fga$ , however the sliding may be distributed between the two rails. Now this work is distributed over the whole length traversed by the vehicle, which length is equal to  $Ra$ . Hence the mean value of the resistance\* due to the sliding is  $\frac{Fga}{Ra} = \frac{Fg}{R}$ ; that is to say, it is proportional to the gauge and to the degree of curvature.

20. Now with the axles in the position described in paragraph 18 above, it will be clear that, in addition to the longitudinal slip on the rails, there will be a continuous transverse slipping of the treads of the wheels on the rails. This is due to the fact that the position of each axle is inclined to the radial position; and therefore the wheels tend to move in a direction which is inclined to the tangent to the curve. The transverse slip will not, however, directly affect the curve resistance, except in so far as it increases the lateral pressure between the flange of the leading outer wheel and the outer rail, and consequently increases the friction between that wheel and rail in the direction of motion. This statement should be clearly understood; a number of writers have made entirely misleading statements with regard to the transverse slip, which is assumed directly to affect the curve resistance. A little consideration will convince the student of the incorrectness of this assumption. For it will be clear that no force however great, acting on a body at right angles to its direction of motion, can of itself affect the magnitude of the forces acting in the direction of motion. As we have said, however, the increase, due to the transverse slip, in pressure between the flange of the leading outer wheel and the rail will result in an increase of the friction between the flange and the rail, and will therefore add to the curve resistance.

---

\* It may appear at first sight difficult to understand why, if the slipping takes place on the inner rail, this should give rise to a resistance to motion, seeing that in this case the friction on the wheel acts in the direction of motion of the vehicle. The reason is that if the slipping takes place on this rail, it can only be through the wheel revolving on the rail without moving forward. The friction then opposes the revolution of the wheel and is therefore a resistance to motion.

21. **Influence of coning of wheels, superelevation, etc., on curve resistance.**—In the case of the leading axle the coning of the wheels not only reduces the amount of the longitudinal slip of the wheels on the rails, but also their transverse slip; for the wheels will of themselves tend naturally to move on a curve of similar curvature to the rails. In so far as this axle is concerned, therefore, coning reduces the curve resistance. In the case of the rear axle, however, since the inner rail is closer to the wheel flange than the outer, coning has the opposite effect, seeing that the radius of the portion of the tread, on which the inner wheel runs, is greater than the radius of the corresponding portion of the tread of the outer wheel. The wheels and axle therefore tend naturally to move on a curve of opposite curvature to the rails. The slipping of the wheels is thus increased, and with it the curve resistance due to this axle. It is more than doubtful therefore whether coned wheels, which were originally introduced with the idea that they would facilitate motion around curves, have any advantage in this respect over wheels whose treads are cylindrical. The only advantage, in fact, that can be claimed for coning is that it allows a margin for wear of the tyre.

The superelevation on the curve also affects the curve resistance, unless the train is moving at the exact speed for which the superelevation has been calculated. Without going into details, we may say that if the superelevation is in excess of the true amount which corresponds to the speed of the train, the pressure of the flange of the outer leading wheel against the rail is reduced, and consequently the curve resistance will also be reduced. If the superelevation be less than that corresponding to the actual speed, the curve resistance will be increased.

Finally the curve resistance of a vehicle is reduced somewhat by the pull of the coupling of the vehicle in advance, which tends to draw the leading outer wheel away from the outer rail, and thus lessens the lateral pressure between them.

22. In the rules of the Government of India it is assumed that, for a given gauge, the curve resistance varies directly as the degree of curvature. This, although not strictly correct, is sufficiently in accord with the results of experiment for practical purposes.

For the standard gauge, the co-efficient of curve resistance is taken at  $\cdot 0004$  per degree of curvature (that is to say, the curve resistance of a vehicle of weight  $W$  is  $\cdot 0004 W$  per degree of curvature), for the metre gauge  $\cdot 0003$ , and for the  $2'6''$  gauge  $\cdot 0002$ .

23. Allowance is made for curve resistance in determining the profile of a railway, by reducing any gradient, on which a curve occurs, of which the grade resistance, combined with the curve resistance, would be in excess of the resistance attributable to the maximum gradient permissible on the straight on the railway.

For example, if the maximum gradient permissible (usually called the ruling gradient) is  $1\frac{1}{2}$  per cent. the gradient would be reduced by  $\cdot 04$  per cent. per degree of curvature for the standard gauge,  $\cdot 03$  per cent. for the metre gauge and  $\cdot 02$  per cent. for the 2'6" gauge.

When allowance is thus made for curvature on a gradient, the latter is said to be "compensated for curvature."

**Example.**—*On the 5'6" gauge determine a gradient such that the grade resistance, together with the curve resistance due to a curve of  $5^\circ$ , shall be equal to the resistance due to a ruling gradient of 1 in 200.*

A gradient of 1 in 200 is equivalent to one of  $0\cdot 5$  per cent. The amount of compensation for a  $5^\circ$  curve is  $0\cdot 2$  per cent. The gradient sought is therefore  $0\cdot 5 - 0\cdot 2$  or  $0\cdot 3$  per cent. that is, 1 in 333.

24. In the examples given towards the end of the chapter, we shall assume that all gradients are compensated for curvature; it will then be unnecessary to consider further the effect of curve resistance.

25. **Resistance due to velocity of train.**—Under this heading comes the resistance due to the air, and certain others due to inequalities in the level and alignment of the track and to oscillation of the engine and vehicles. These resistances, though inappreciable at slow speeds, increase approximately as the square of the speed. The air resistance is due to two causes, (1) direct pressure on the surface exposed transversely to the direction of motion, and (2) side friction on the surfaces parallel to the direction of motion. The former is the principal factor; the latter comparatively small. It will be noted that the air resistance depends on the form and size of the surfaces exposed, and has nothing to do with the weight of the train. However, as trains do not differ much in general shape and as the size of a train may be assumed under average working conditions to be roughly proportional to its weight, it is possible to obtain formulæ for air resistance in terms of the weight approximate enough for practical purposes.

The combined resistances due to velocity will vary between  $\cdot 006V^2$  and  $\cdot 012V^2$  lbs. per ton weight of the train; and as a mean value we may take  $\cdot 009 V^2$  lbs. per ton.

26. **Summary of results.**—It will be convenient to summarise the results we have obtained, before proceeding to apply them to actual examples. They are :—

*Mean tractive effort of engine in lbs.* =  $\frac{p d^2 s}{D}$ , where  $p$  is the mean effective steam pressure in lbs. per square inch in the cylinders,  $d$  is the diameter of the piston in inches,  $s$  ,, stroke ,, ,, feet, and  $D$  ,, diameter of the driving-wheels in feet.

*Tractive power of engine in lbs.* =  $C \times W_D \times 2240$ , where  $W_D$  is the total weight on the driving-wheels in tons, and  $C$  is a coefficient, which is equal to  $\frac{1}{8}$  in ordinary weather conditions;  $\frac{1}{4}$  if sand be used on the rails, or if the rails be either very wet or very dry, and  $\frac{1}{12}$  if the rails be greasy.

*Rolling resistance of locomotive and tender combined*, average value = about  $6\frac{1}{2}$  lbs. per ton weight, or at starting 11 lbs.

*Rolling resistance of ordinary vehicles* =  $4\frac{1}{2}$  lbs. per ton weight, or at starting 9 lbs.

*Grade resistance in lbs.* assuming that gradient is compensated for curvature =  $\frac{2240}{n} (W + G)$ , where the gradient is 1 in  $n$ , and  $W$  and  $G$  represent the weights in tons of the engine with its tender, and of the vehicles respectively.

*Velocity resistance in lbs.* average value =  $\cdot 009 V^2$  per ton weight of train.

We thus see that the *total resistance in lbs.* of a train, composed of an engine, which with its tender weighs  $W$  tons, and of a train of vehicles of weight  $G$  tons, moving at a speed of  $V$  miles per hour on a gradient of 1 in  $n$  compensated for curvature, may be expressed by the following formula :—

$$\text{Total resistance in lbs.} = 6\cdot 5 \times W + 4\cdot 5 \times G + \frac{2240}{n} (W + G) + \cdot 009 V^2 (W + G).$$

27. **Example I.**—*Find the tractive effort developed by the Planet (see Chapter I, Fig. 2) having given the following data: Mean effective steam pressure 40 lbs. per square inch, diameter of cylinder 11 inches, stroke 16 inches (=  $1\frac{1}{2}$  feet), diameter of driving-wheels 5 feet.*

We have—

Tractive effort of engine in lbs. =  $\frac{40 \times 11^2 \times \frac{1}{2}}{5} = 1291$  lbs. The weight on the driving-wheels of the Planet was about 6 tons or 13440 lbs.

The adhesional friction between the driving-wheels and the rails would therefore be  $\frac{1}{8} \times 13440$  lbs. = 2240 lbs. in ordinary weather conditions; so that we see the Planet did not comply with the rule mentioned in para. 10, that the engine should always be capable of developing a tractive effort slightly in excess of the adhesional friction between the rails and the driving-wheels.

28. **Example II.**—*Find what weight of train the Barsi Light Railway engine shown on Plate XXVIII can haul on a level straight track at 15 miles an hour.*

We see from the Plate, that the total weight on the driving-wheels is 19.75 tons, the total weight of the engine being 29.4 tons. The tractive power will therefore be in ordinary weather conditions,  $\frac{1}{8} \times 19.75 \times 2240$  lbs. or 7373 lbs. If therefore G be the weight in tons of the heaviest train the engine can haul on the straight, we have the following equation to find G :—

$$7373 = (6.5 \times 29.4) + (4.5 \times G) + .009 \times 225 (29.4 + G)$$

Therefore G = 1091 tons.

29. **Example III.**—*Find what load the Barsi Light Railway engine referred to in the preceding example can haul up a grade of 1 in 50, compensated for curvature, at a speed of 15 miles an hour.*

The equation for finding G is—

$$7373 = (6.5 \times 29.4) + (4.5 \times G) + \frac{1}{80} (29.4 + G) \times 2240 + .009 \times 225 (29.4 + G)$$

We obtain G = 113 tons.

30. If the train be gaining speed, the effective force corresponding to the acceleration of the train must be deducted from the tractive power available for overcoming the resistances described above. Though, like grade resistance, this effective force is not a resistance to motion in the strict sense of the word, it is called in some text-books the acceleration resistance. If the acceleration of the train be  $a$  feet per second, the weight of the engine and train being respectively W and G tons, then the effective force in lbs. is equal to  $\frac{(W + G) \times 2240 a}{32.18}$ , and as stated above this quantity must be deducted from the tractive power in order to obtain the net power available for overcoming the rolling, grade and velocity resistances.

31. **Brake power.**—The mechanism of the brake has been described in Chapter VI, and is illustrated on Plate XXI. The brake acts by the pressure of a cast-iron block against the treads of the revolving wheels, thus setting up a retarding force by the friction of the rubbing surfaces,

This pressure must not be so powerful as to "grip" the wheels and prevent them from revolving while the train is in motion; for in that case the wheels would "skid," a contingency which would be not only detrimental to the wheels and rails, but also less effective as a retarding force than if the rolling were maintained to the end.

32. A *sprag* is a bar applied by hand and jammed between a spoke and the frame of a vehicle to prevent the wheel from rolling. In fact, a sprag is simply a primitive device for making a wheel "skid," the very contingency which brakes are designed to avoid. Sprags are therefore, at the best, only makeshifts as retarding agents, but are useful and sometimes necessary in shunting operations, when it is desired to stop a wagon not provided with a proper brake. Sprags have a more legitimate use, when fixed to loose wagons at rest, in preventing such wagons from moving.

33. Effective brake power is therefore limited to that pressure which, if exceeded ever so little, would cause the wheels to "skid." Experience shows that at slow speeds the retarding force may be reckoned at about  $\frac{1}{3}$ th of the weight on the brake wheels, but that it may fall as low as  $\frac{1}{15}$ th if the rails are damp and greasy, or may rise as high as  $\frac{1}{4}$ th with dry rails. In computing the brake power required for a given contingency, it may be assumed that the requisite pressure between the brake-block and the wheel, short of "skidling," can always be obtained by the mechanism of the brake gear.

34. Now if  $W$  and  $G$  be, as before, the weights in tons of an engine and its train of vehicles, the kinetic energy of translation in foot-lbs. of the whole train is:  $\frac{(W+G)v^2}{2g} \times 2240$  where  $v$  is the speed in feet per second, and  $g=32.18$ , the value of the acceleration due to gravity. We may assume that the kinetic energy of rotation of the wheels of the engine and train will amount to about 6 per cent. of this quantity. The total kinetic energy of the train will therefore be  $\frac{W+G}{64.36} \times 2240 \left(1 + \frac{6}{100}\right) v^2 = \frac{W+G}{64.36} \times 2307v^2$ . Now if  $R$  be the total retarding force in lbs. required to bring the train to a stand-still in a distance of  $s$  feet, the work done by this retarding force will be  $Rs$  foot-lbs. We therefore have the equation  $Rs = \frac{W+G}{64.36} \times 2307 v^2$ .

35. **Example.**—*In what distance can the engine referred to in Example III, paragraph 29 above, bring a train of 113 tons moving at a speed of 15 miles an hour to a stand, (a) on the level, (b) on a down grade of 1 in 100, (c) on an up grade of 1 in 100, assuming that the driving wheels of the engine alone are braked.*

(a) If we neglect the resistances due to the velocity of the train, the retarding force will be made up of the rolling resistance

of the train and the retarding force due to the brakes. The rolling resistance in lbs. will be  $6.5 \times 29.4 + 4.5 \times 113$  lbs. = 699.6 lbs.

The retarding force of the brakes will be  $\frac{1}{8} \times 19.75 \times 2240$  lbs. = 5530 lbs. The total retarding force thus is 6229.6 lbs.

The kinetic energy of the train is  $\frac{142.4}{64.36} \times 2307 \times 484 = 2,470,511$  foot-lbs.

We therefore have  $6229.6 \times s = 2,470,511$  from which we obtain  $s = 396$  feet.

(b) On a down grade of 1 in 100, the retarding forces obtained above will be *reduced* by the down grade component of the weight of the train. This down grade component is equal to  $\frac{142.4 \times 2240}{100}$  lbs. = 3190 lbs.

The net value of the retarding force will therefore be  $6229.6 - 3190$  lbs. = 3039.6 lbs. Therefore the distance in which the train will be brought to a stand =  $\frac{2,470,511}{3039.6}$  feet = 812 feet.

(c) In this case (on an up grade of 1 in 100) the retarding force will be *increased* by the down grade component of the weight of the train. The total retarding force will thus be  $6229.6 + 3190$  lbs. = 9419.6 lbs. and the distance in which the train will be brought to a stand will be  $\frac{2,470,511}{9419.6}$  feet = 262 feet.

36. In the preceding examples we have seen that the brake power of the engine alone is more than sufficient to keep the train under control. It is, however, necessary on all trains to have one or more brake-vans, the brake power of which is sufficient to control the train on the steepest gradient if the coupling next to the engine should happen to break. Thus if the steepest grade be 1 in  $n$ , and  $G$  be the weight in tons of the train (excluding engine and tender), then the force tending to cause the train to move down the grade is equal to  $\frac{G}{n} \times 2240 - 4.5G$ , the latter term representing the rolling resistance, and the former the down grade component of the weight of the train. Now if  $w$  be the total weight in tons of all the brake-vans on the train, the retarding force due to the brakes will be  $\frac{w}{8} \times 2240$  lbs.; and this retarding force must obviously be greater than the force tending to cause motion down the grade. We therefore have  $\frac{w}{8} \times 2240 > \frac{G}{n} \times 2240 - 4.5G$ . For example if the gradient be 1 in 100, we obtain the result  $\frac{w}{G} > \frac{6.4}{100}$ ; that is to say, the total weight of the brake-vans must be at least somewhat in excess of 6.4 per cent. of the total weight of the train, including that of the brake-vans.

If the rails be damp or greasy, the retarding force due to the brakes might, as explained in paragraph 33, be as low as  $\frac{w}{12}$ ; if the rails be dry it may rise as high as  $\frac{w}{4}$ ; if the train attains considerable velocity before the brakes are applied it will take some time to stop it, even if the power be sufficient.

37. For calculating the speed imparted to a train, by an unbalanced force in a given space, we have the formula  $Rs = \frac{W+G}{64 \cdot 36} (v^2 - v_0^2) \times 2307$  where R is the down grade component of the accelerating force,  $v_0$  is the speed in feet per second when the force commences to act, and  $v$  is the speed in feet per second when the train has passed over the space of  $s$  feet. W and G are as before in tons and R is in lbs.



FIG. 87.

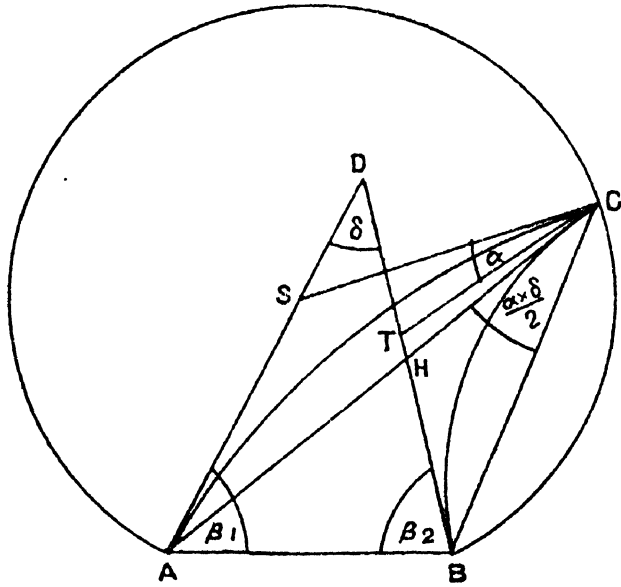
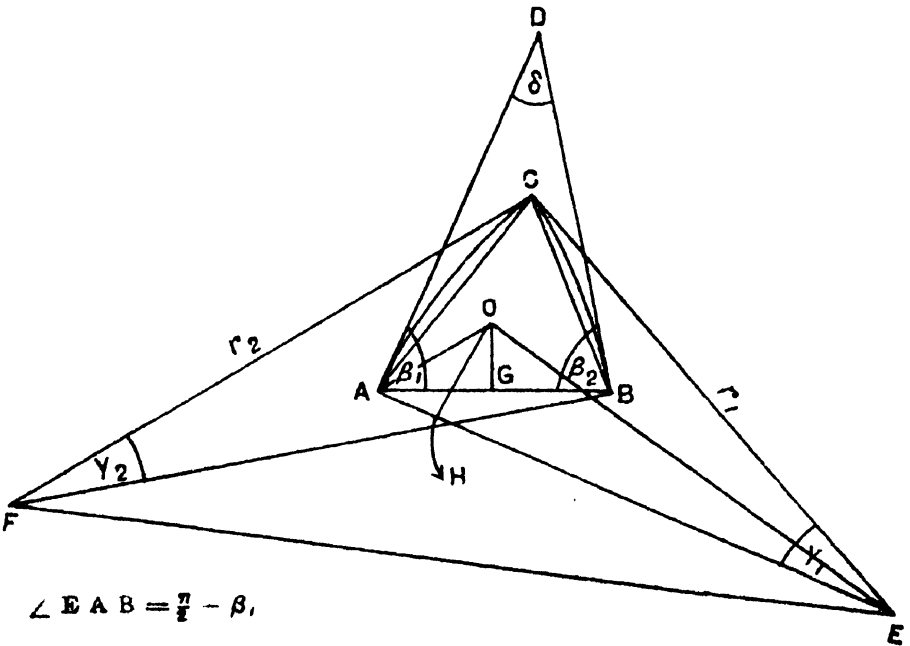

FIG. 88.



$$\angle EAB = \frac{\pi}{2} - \beta_1$$

$$\angle FBA = \frac{\pi}{2} - \beta_2$$

$$\angle ECF = \pi - \alpha$$

$$\angle DAC = \frac{\gamma}{2}$$

$$\angle DBC = \frac{\gamma_2}{2}$$

$$\angle CAB = \beta_1 - \frac{\gamma_1}{2} = \frac{\pi}{2} - \frac{\alpha + \beta_2 - \beta_1 - \gamma_2}{2}$$

$$\angle ABC = \beta_2 - \frac{\gamma_2}{2} = \frac{\pi}{2} - \frac{\alpha + \beta_1 - \beta_2 - \gamma_1}{2}$$

## CHAPTER XI.

### THEORY OF POINTS AND CROSSINGS.

1. The curves employed in connection with points and crossings are circular and the problem of laying out the various arrangements of points and crossings, met with in a station yard, is therefore purely a geometrical one.

2. This problem in its most general form may be stated thus:—

*Given two intersecting circular curves, to find the relation that exists between their radii and their angle of intersection.* For the setting out in practice of any given arrangement or grouping of points and crossings, we shall require to have certain information in addition to the relation referred to, but we shall see that this can be readily deduced when once we have established that relation.

Referring to Fig. 87, let A and B be any two points on the curves AC and BC which intersect in C; then these curves will be completely determined if we know (1) the length of AB, (2) the radii of the curves, (3) the angles between AB and the tangents at A and B to the two curves, and (4) the side of the tangent on which each curve lies. In the figure let AD and CS be drawn tangent to the arc AC, and BD and CT tangent to the arc BC; the angle of intersection between the curves will then be the angle SCT formed by the tangents at C to the two curves; and the problem resolves itself into finding the value of the angle SCT, or one of its functions, in terms of AB, the angles DAB and DBA, and the radii of the two curves.

3. Before proceeding further it will be necessary to refer to a geometrical theorem, which is of considerable importance in the theory of points and crossings and in the theory of railway curves generally. In Fig. 87 let the angle ADB be represented by  $\delta$ , and the angle of intersection SCT of the curves by  $\alpha$ , then it may be proved that the angle ACB is equal to  $\frac{\alpha + \delta}{2}$ . It therefore follows that\* *the locus of*

\* This theorem was published by the present writer in *Engineering News* of October 23rd, 1913. It may be proved as follows:—

$$\begin{aligned} \angle ACB &= DHC - HBC = (ADB + SAC) - TCB \\ &= (\delta + SCA) - (ACB + TCH) \\ &= \delta - ACB + SCA - TCH \\ &= \delta - ACB + \alpha \\ ACB &= \frac{1}{2}(\delta + \alpha) \text{ which proves the theorem.} \end{aligned}$$

Since  $\alpha$  may have any value whatever, the theorem will hold when  $\alpha = 0$  or  $\pi$ , that is to say, when the curves AC and BC touch each other. The theorem and the results given in paragraphs 5—10 will therefore apply to all cases of compound or reverse circular curves. A few applications of the theorem to such cases will be found in *Engineering News* of October 23rd, 1913.

*the point of intersection of all curves touching AD and BD at A and B, and intersecting at a constant angle  $\alpha$ , is a circle passing through A and B whose radius is*

$$\frac{AB}{2 \sin \frac{\alpha + \delta}{2}}$$

We see then that if one of the curves as AC be given, the point at which a curve drawn touching BD at B will cut the curve AC at an angle  $\alpha$  will be at the point of intersection of the curve AC with the circumference of a circle of radius  $\frac{AB}{2 \sin \frac{\alpha + \delta}{2}}$  described to pass through A and B.

4. We are now in a position to solve completely the problem enunciated in paragraph 2. To fix our ideas we shall regard the two curves AC and BC as lines of rail, crossing each other by means of a crossing of angle  $\alpha$ , the point C representing the theoretical nose of the crossing (It is here necessary to remark that although as we have seen in Chapter III, paragraph 20, the running faces of a crossing are necessarily made straight, the lengths of these faces are so small in comparison with the radii of the curves employed, that they may be regarded without appreciable error as forming arcs of the curves.) Assuming that we know or have found the radii of the curves AC and BC, several methods will suggest themselves for accurately fixing the position of C and for correctly aligning the curves. For example we may calculate the lengths of the arcs AC and BC and align the curves by offsets from the tangents AD and BD, measuring the calculated lengths along the arcs; or we may calculate the length of one of the chords AC and BC, and set out the angle which this chord makes with AB, the curves being then aligned, by one of the methods described in the Manual on Surveying, by offsets either from the tangents or from the chords; or again if the chords are short, we may find the point C by stretching strings of the calculated lengths AC and BC from A and B, and thus obtaining their point of intersection. Finally, if the curves are long, they should preferably be set out by theodolite and chain. In applying any of the above methods it is necessary to know the lengths of the two arcs, in order to ensure that the rails forming these arcs may be cut to the exact lengths required.

5. **To find the relation between the radii of the curves and the angle of the crossing.**—Referring to Fig. 88 let  $r_1$  and  $r_2$  be the radii of the curves AC and BC respectively; and let  $\beta_1$  and  $\beta_2$  represent the angles DAB and DBA. Draw the radii EA, EC and FB, FC at the ends of the curves, E and F being the centres; and let  $\gamma_1$  and  $\gamma_2$  be the angles



FIG. 89.

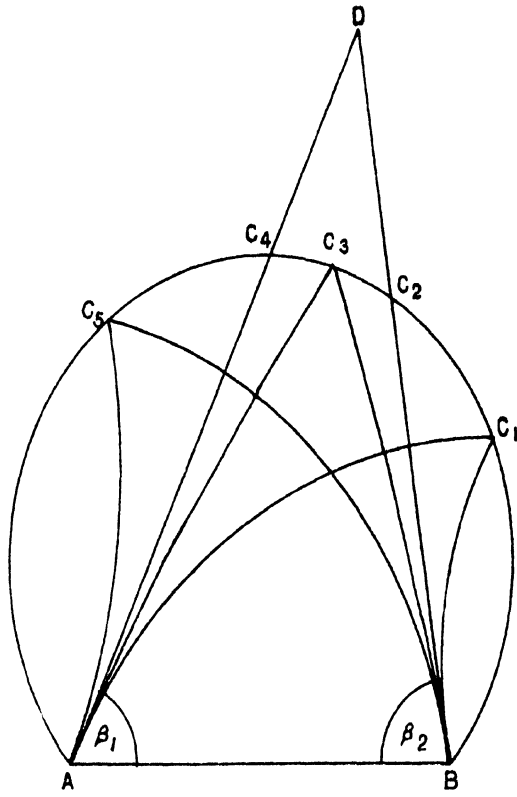
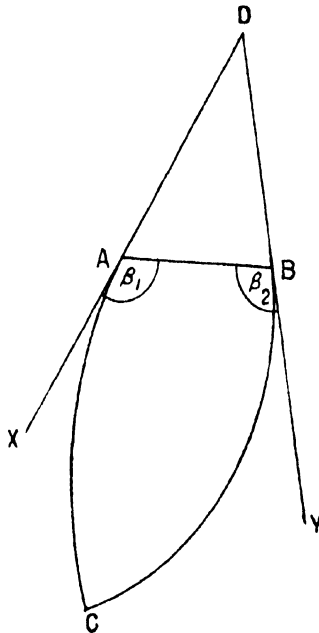

FIG. 90.



subtended by the two arcs at their centres. The student will then have no difficulty in arriving at the values of the various angles shown below the figure. Let  $AB$  be represented by  $c$ .

Then considering the triangle  $ECF$ , we have—

$$EF^2 = EC^2 + FC^2 - 2 EC.FC. \cos ECF.$$

$$= r_1^2 + r_2^2 + 2r_1 r_2 \cos \alpha.$$

Again considering the quadrilateral  $ABEF$ , we have—

$$EF^2 = EA^2 + AB^2 + BF^2 - 2 AB(EA \cos EAB + BF \cos ABF)$$

$$+ 2 EA.BF \cos (EAB + ABF)^*$$

$$\text{Therefore } EF^2 = r_1^2 + r_2^2 + c^2 - 2c (r_1 \sin \beta_1 + r_2 \sin \beta_2)$$

$$- 2 r_1 r_2 \cos (\beta_1 + \beta_2)$$

Hence equating the two values obtained for  $EF^2$ , we have—

$$2 r_1 r_2 \left\{ \cos \alpha + \cos (\beta_1 + \beta_2) \right\} = c^2 - 2c (r_1 \sin \beta_1 + r_2 \sin \beta_2)$$

which is the relation we desired to find.

We may write it in the more symmetrical form :—

$$\cos \alpha + \cos (\beta_1 - \beta_2) = 2 \left( \sin \beta_1 - \frac{c}{2r_1} \right) \left( \sin \beta_2 - \frac{c}{2r_2} \right) \dots (i)$$

and this is the form which is best adapted for arithmetical computation. We see that this formula is symmetrical with regard to  $r_1$  and  $r_2$ , and  $\beta_1$  and  $\beta_2$ , that is to say, if we interchange  $r_1$  and  $r_2$ , and  $\beta_1$  and  $\beta_2$ , we obtain precisely the same result. This property enables us to make use of the formula for any possible case that may arise. For this purpose it will be necessary to adopt a simple convention which we now proceed to explain.

6. In Fig. 89 let  $AC_5C_3C_1B$  represent the circular locus of the point  $C$ , for all curves which are tangential to  $AD$  and  $BD$ . Then we see that as the point  $C$  moves from  $C_3$  to  $C_2$  the radius of the curve  $BC$  continually increases, until when  $C$  is at  $C_2$  this radius is infinitely large. Further, as  $C$  passes through  $C_2$  towards  $C_1$ , the curvature of the arc  $BC$  is *reversed* and the radius decreases from its infinite value. We must therefore regard the radius of the curve  $BC_1$  as being opposite in sign to that of the curve  $BC_3$ , and similarly the radius of the curve  $AC_5$  will be opposite in sign to that of the arc  $AC_3$ . Hence if we consider the radii

\* *Proof.*—Let  $a, b, c$  and  $d$  be the sides of the quadrilateral shown in the accompanying figure, and let  $\beta, \gamma, \delta$  be the angles between  $b, c$  and  $d$ , respectively, and  $a$ . Then taking projections parallel and at right angles to  $a$ , we obtain—

$$c \cos \gamma = a - b \cos \beta - d \cos \delta$$

$$c \sin \gamma = d \sin \delta - b \sin \beta.$$

Squaring and adding we get—

$$c^2 = a^2 + b^2 + d^2 - 2 a (b \cos \beta + d \cos \delta) + 2 b d \cos (\beta + \delta)$$

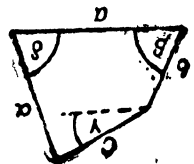

of the curves  $AC_3$  and  $BC_3$  as positive, as has been done in the above investigation, we must consider the radii of  $BC_1$  and  $AC_5$  to be negative. This convention is expressed in the following easily remembered rule:— *The radius of a curve which is concave to a point on  $AB$  is positive and that of a curve which is convex to a point on  $AB$  is negative.* A necessary consequence of this convention is that *the angle subtended by an arc at its centre, must be of the same algebraic sign as the radius of the arc*, for it will be seen that the arc itself, whose length is equal to the product of the radius into the central angle, is drawn in an invariable direction while  $C$  moves round the circumference  $AC_4 C_2 B$ , and must therefore be considered to be positive throughout.

Again, with regard to the angles  $\beta_1$  and  $\beta_2$ ; *these must be measured from  $AB$  to the tangents to the curves, drawn towards the same direction as the arcs themselves.* Thus in Fig. 90 if the curves  $AC$  and  $BC$  are drawn towards the side of  $AB$  which is remote from  $D$ , the angles  $\beta_1$  and  $\beta_2$  must also be measured towards that side of  $AB$ . The angles  $\beta_1$  and  $\beta_2$  will thus be in this case  $XAB$  and  $YBA$ . This case will not be of very frequent occurrence in practice.

7. Returning now to formula (i), if we know all except one of the quantities  $r_1$ ;  $r_2$ ;  $\beta_1$ ;  $\beta_2$ ;  $a$  and  $c$ , it is clear that we can at once find the value of the remaining one. For instance, to find the value of  $a$  in terms of the remaining quantities we have—

$$\cos a = 2 \left( \sin \beta_1 - \frac{c}{2r_1} \right) \left( \sin \beta_2 - \frac{c}{2r_2} \right) - \cos (\beta_1 - \beta_2) \dots \dots \dots (ii)$$

and again, to find  $r_2$ , we have—

$$r_2 = \frac{c \left( \frac{c}{2r_1} - \sin \beta_1 \right)}{\cos a + \cos (\beta_1 + \beta_2) + \frac{c}{r_1} \sin \beta_2} \dots \dots \dots (iii)$$

We may obtain the value of  $r_1$  in terms of the other quantities from equation No. (iii) by interchanging  $r_1$  and  $r_2$ , and at the same time  $\beta_1$  and  $\beta_2$ . Thus—

$$r_1 = \frac{c \left( \frac{c}{2r_2} - \sin \beta_2 \right)}{\cos a + \cos (\beta_1 + \beta_2) + \frac{c}{r_2} \sin \beta_1}$$

If on working out the right hand side of (iii) in an actual case, we obtain a negative value for  $r_2$ , this will signify, in accordance with the convention mentioned in the preceding paragraph, that the curve  $BC$  is convex to a point on  $AB$ ; while if we get a positive value for  $r_2$ , it will mean that the curve  $BC$  is concave to a point on  $AB$ .

8. To find the lengths of the arcs AC and BC.—Referring again to Fig. 88, let O be the centre of the circular locus of C. Then OA is the radius of this circular locus, and if we assume  $OA = \rho$  we have—

$$\rho = \frac{c}{2 \sin \frac{a + \delta}{2}} = \frac{c}{2 \sin \frac{a + \pi - (\beta_1 + \beta_2)}{2}} = \frac{c}{2 \cos \frac{\beta_1 + \beta_2 - a}{2}}$$

Now if OG and OH be drawn perpendicular to AB and AE, we see that the angle AOG = the angle ACB =  $\frac{\pi}{2} - \frac{\beta_1 + \beta_2 - a}{2}$ .

Hence the angle OAG =  $\frac{\beta_1 + \beta_2 - a}{2}$ , and it follows that the angle OAH = OAG + EAB =  $\frac{\beta_1 + \beta_2 - a}{2} + \frac{\pi}{2} - \beta_1 = \frac{\pi}{2} - \frac{a + \beta_1 - \beta_2}{2}$ .

Also the bisector of the angle CEA clearly passes through O, hence we have—

$$\tan \frac{\gamma_1}{2} = \frac{OH}{HE} = \frac{OA \sin OAH}{AE - OA \cos OAH} = \frac{\rho \cos \frac{a + \beta_1 - \beta_2}{2}}{r_1 - \rho \sin \frac{a + \beta_1 - \beta_2}{2}}$$

or as we may write it—

$$\gamma_1 = 2 \tan^{-1} \frac{\cos \frac{a + \beta_1 - \beta_2}{2}}{\frac{r_1}{\rho} - \sin \frac{a + \beta_1 - \beta_2}{2}} \dots \dots \dots (iv)$$

$$\text{Hence the arc AC} = r_1 \gamma_1 = 2 r_1 \tan^{-1} \frac{\cos \frac{a + \beta_1 - \beta_2}{2}}{\frac{r_1}{\rho} - \sin \frac{a + \beta_1 - \beta_2}{2}} \dots \dots \dots (v)$$

$$\text{where } \rho = \frac{c}{2 \cos \frac{\beta_1 + \beta_2 - a}{2}}$$

We might obtain by symmetry—

$$\gamma_2 = 2 \tan^{-1} \frac{\cos \frac{a + \beta_2 - \beta_1}{2}}{\frac{r_2}{\rho} - \sin \frac{a + \beta_2 - \beta_1}{2}} \dots \dots \dots (vi)$$

$$\text{And the arc BC} = r_2 \gamma_2 = 2 r_2 \tan^{-1} \frac{\cos \frac{a + \beta_2 - \beta_1}{2}}{\frac{r_2}{\rho} - \sin \frac{a + \beta_2 - \beta_1}{2}} \dots \dots \dots (vii)$$

There is, however, a simple relation between  $\gamma_1$  and  $\gamma_2$ , from which if we know one angle we can at once find the other. Referring to Fig. 88 we see that the angle CAB is equal to  $\beta_1 - \frac{\gamma_1}{2}$ , but it is also equal to  $\pi - \text{ACB} - \text{ABC}$ , that is, to  $\frac{\pi}{2} - \frac{a + \beta_2 - \beta_1 - \gamma_2}{2}$ .

Hence we have  $\beta_1 - \frac{\gamma_1}{2} = \frac{\pi}{2} - \frac{a + \beta_2 - \beta_1 - \gamma_2}{2}$  and therefore

$$\gamma_1 + \gamma_2 = a + \beta_1 + \beta_2 - \pi \quad \dots\dots\dots \text{(viii)}$$

In formulae (v) and (vii), the values of  $\gamma_1$  and  $\gamma_2$  must of course be in circular measure.

**9. To find the values of angles ABC and CAB.**—From the preceding paragraph we have angle  $CAB = \beta_1 - \frac{\gamma_1}{2} = \frac{\pi}{2} - \frac{a + \beta_2 - \beta_1 - \gamma_2}{2}$  and by symmetry—

$$\text{angle } ABC = \beta_2 - \frac{\gamma_2}{2} = \frac{\pi}{2} - \frac{a + \beta_1 - \beta_2 - \gamma_1}{2}$$

**10. To find the lengths of the chords AC and BC.**—The chord AC is common to the arc AC and to the circular locus of C. Hence we have—

$$\begin{aligned} \text{chord } AC &= 2 r_1 \sin \frac{\gamma_1}{2} = 2 \rho \sin ABC \\ &= 2 \rho \cos \frac{a + \beta_1 - \beta_2 - \gamma_1}{2} = 2 \rho \sin \left( \beta_2 - \frac{\gamma_2}{2} \right) \dots\dots\dots \text{(ix)} \end{aligned}$$

By symmetry we have—

$$\text{chord } BC = 2 r_2 \sin \frac{\gamma_2}{2} = 2 \rho \cos \frac{a + \beta_2 - \beta_1 - \gamma_2}{2} = 2 \rho \sin \left( \beta_1 - \frac{\gamma_1}{2} \right) \dots\dots \text{(x)}$$

11. We have thus obtained expressions for all the quantities which, as we have seen in paragraph 4, are necessary for accurately fixing the point C, and for aligning the two curves. It will be necessary to see how the formulae are modified, when either  $r_1$  or  $r_2$  has an infinite value, that is to say, when one of the curves is a straight line.

12. Case in which  $r_1$  or  $r_2$  is infinite.

If we suppose  $r_1$  infinite, we easily see, referring to formula (i), that the quantity  $\frac{c}{2r_1}$  becomes zero, hence this formula reduces to—

$$\cos a + \cos (\beta_1 - \beta_2) = 2 \sin \beta_1 \left( \sin \beta_2 - \frac{c}{2r_2} \right) \dots\dots\dots \text{(i) (a)}$$

We therefore obtain—

$$\begin{aligned} \cos a &= 2 \sin \beta_1 \left( \sin \beta_2 - \frac{c}{2r_2} \right) - \cos (\beta_1 - \beta_2) \\ &= -\frac{c \sin \beta_1}{r_2} - \cos (\beta_1 + \beta_2) \dots\dots\dots \text{(ii) (a)} \end{aligned}$$

$$r_2 = -\frac{c \sin \beta_1}{\cos a + \cos (\beta_1 + \beta_2)} \dots\dots\dots \text{(iii) (a)}$$

When  $r_1$  is infinite, the point C will fall on A D and the arc A C will coincide with its chord; hence  $\gamma_1 = 0$ . Formula (v) therefore gives an indeterminate result; but we have from formula (ix), since  $\gamma_1$  is zero,

$$\text{arc } AC = \text{chord } AC = 2 \rho \cos \frac{a + \beta_1 - \beta_2}{2} \dots\dots\dots \text{(ix) (a)}$$

$\rho$  having the same value as before.

---

\* We see therefore that  $\gamma_2 = a - \delta$ .

We also have from formula(viii).....

$$\gamma_2 = \alpha + \beta_1 + \beta_2 - \pi \dots\dots\dots(vi) (a)$$

therefore the arc  $BC = r_2 (\alpha + \beta_1 + \beta_2 - \pi) \dots\dots\dots(vii) (a)$

and the chord  $BC = 2 r_2 \sin \frac{\alpha + \beta_1 + \beta_2 - \pi}{2} = 2 \rho \sin \beta_1 \dots\dots\dots(x) (a)$

If  $r_2$  be infinite, we may as before obtain the formulae relating to this case, by interchanging  $\beta_1$  and  $\beta_2$  and writing  $r_1$  for  $r_2$  in the above formulae.

13. Although in the preceding investigation we have made no mention of points or switches, it will be obvious that the results obtained will not be affected in any way if we consider a pair of switches placed in continuation of the curves CA and CB, the points A and B representing the heels of the switches. The distance  $c$  and the angles  $\beta_1$  and  $\beta_2$  will then have special values, depending on the gauge and on certain considerations, which we proceed to set forth. It has been explained in paragraph 15 of Chapter III that, when a train enters a turn-out either from a straight or a curve main line, it is impossible from the nature of the construction of the switch to avoid a certain kink at the toe of the switch. If the switch is not tangential to the curve of the turn-out, there will be a second kink at the heel of the switch. In the first of the methods about to be described, therefore, the curve of the turn-out is so adjusted as to be tangential to the face of the switch when the latter is housed close against its stock-rail. In the second and more usual method, however, no attempt is made to ensure that the switch and the curve of the turn-out shall be tangential; the latter curve is merely made tangential to the main line curve, and the heel of the switch placed at a point at which the offset between the two curves is equal to the "clearance" (vide Chapter III, paragraph 2) at the heel, the resulting kink at this point being regarded as of no importance.

14. **First method for turnouts. Curves tangential to the switches.**— In Fig. 91, which for clearness is drawn to an exaggerated scale, let

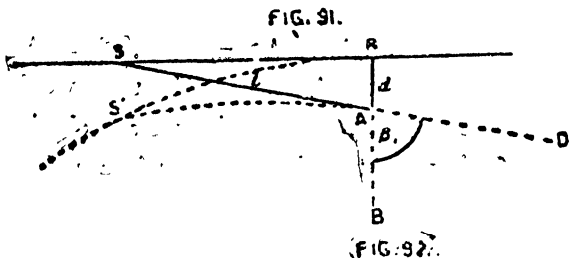

AS be a straight switch, and RS its stock-rail, SA and SR being the running or gauge faces. Then, if AR be drawn perpendicular to RS, AR ( $= d$ ) is the clearance at the heel, and if  $l$  be the length of the switch, we have  $\cos \text{SAR} = \frac{d}{l}$ . If we produce SA and RA to D and B, respectively, we clearly obtain  $\cos \beta_1 = \frac{d}{l}$ .

Now if the stock-rail be bent to any curve as shown by the dotted line S'R, the switch will also be bent to a curve, but owing to the construction of the heel-block which holds the heel of the switch to the stock-rail, the gauge lines S'R and S'A will remain tangential to their former directions. Hence, to whatever curve the stock-rail may be bent,  $\cos \beta_1$  remains constantly equal to  $\frac{d}{l}$ , and for the purposes of our calculations in any given case, we may regard the stock-rail and switch as being straight.

15. Now let Fig. 92 represent an ordinary turn-out from a curved main line with a crossing of angle  $a$  at C, formed by the intersection of the rail BCM of the main line with the rail ACT of the turn-out. Let A and B be the heels of the switches and let the switches be so placed that AB is normal to the gauge face of the main line rail BM.

FIG. 92.

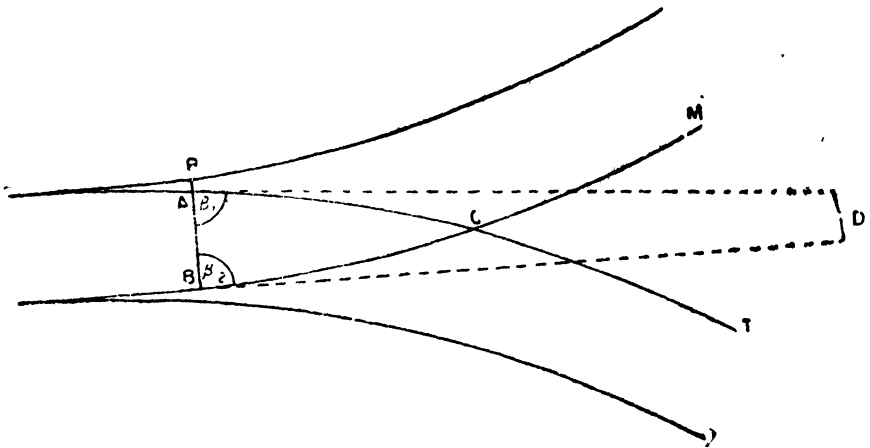

Then if  $g$  be the gauge we have  $AB = g - d$ . Let AD and BD be drawn tangentially to the curves AC and BC; then we have as in the preceding paragraph  $\cos \beta_1 = \frac{d}{l}$ , from which we can obtain the value of  $\beta_1$ ; and clearly  $\beta_2$  is a right angle. If therefore  $r_1$  be the radius of the rail ACT and  $r_2$  that of the rail BCM, we can at once apply the general formulae (i) to (x) to the figure ABC, by substituting in them

these values of  $\beta_1$  and  $\beta_2$ , and replacing  $c$  by its value  $g - d$ . For example, formula (i) becomes -

$$\cos \alpha + \cos \left( \beta_1 - \frac{\pi}{2} \right) = 2 \left( \sin \beta_1 - \frac{g-d}{2r_1} \right); \left( \sin \frac{\pi}{2} - \frac{g-d}{2r_2} \right);$$

that is -

$$\cos \alpha + \sin \beta_1 = 2 \left( \sin \beta_1 - \frac{g-d}{2r_1} \right) \left( 1 - \frac{g-d}{2r_2} \right)$$

in which  $\sin \beta_1$  would have the value  $\frac{\sqrt{l^2 - d^2}}{l}$

The student will have no difficulty in making the substitutions in the general formulae for finding the lengths of the arcs AC and BC, and their chords.

**16. Second method for turn-outs. Curve of turn-out tangential to the curve of the main line.**—Although the method just described is, for the reason given in paragraph 13, the more accurate of the two, the second method is, as we have said, more usually employed, the reason being that the formulae, more especially when the main-line is straight, are considerably simplified.

17. Since the curves of the main line and the turn-out are tangential, we may, for the purpose of applying general formulae (i) to (iii), leave the switches out of consideration, the points A and B of Fig. 88 being chosen at the common tangent points of the main line and turn-out curves.

Let Fig. 93 represent the case of a turn-out laid as described, the crossing C being at the intersection of the rail BCM of the main line and the rail ACT of the turn-out. Then, if we apply the formulae to the figure ABC, since A and B are the common tangent points of the curves, the angles  $\beta_1$  and  $\beta_2$  will evidently both be right angles; and if  $g$  be the gauge, we have  $AB = g$ .

FIG 93

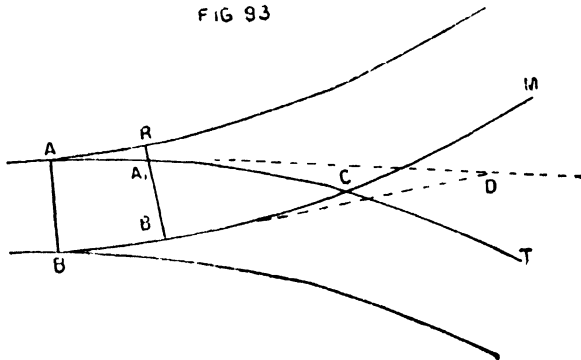

Hence, substituting in formula (i), we obtain—

$$\cos \alpha + \cos \left( \frac{\pi}{2} - \frac{\pi}{2} \right) = 2 \left( \sin \frac{\pi}{2} - \frac{g}{2r_1} \right) \left( \sin \frac{\pi}{2} - \frac{g}{2r_2} \right)$$

which reduces to—

$$1 + \cos \alpha = 2 \left( 1 - \frac{g}{2r_1} \right) \left( 1 - \frac{g}{2r_2} \right) \dots \dots \dots (i) (b)$$

Formulae (ii) and (iii) therefore become—

$$\cos \alpha = 2 \left( 1 - \frac{g}{2r_1} \right) \left( 1 - \frac{g}{2r_2} \right) - 1 \dots \dots \dots (ii) (b)$$

$$r_2 = \frac{g \left( 1 - \frac{g}{2r_1} \right)}{1 - \cos \alpha - \frac{g}{r_1}} \dots \dots \dots (iii) (b)$$

18. If now we applied to the figure ABC the remaining general formulae (iv) to (x), we should obtain the lengths of the arcs AC and BC and their chords. It is of much greater importance, however, to obtain the lengths of the arcs between the heels of the switches and the nose of the crossing; and the chords of those arcs; and for this purpose we require to know how to fix the position of the heel of the switch leading to the turn-out, which, as we have said in paragraph 13, is placed at a point at which the offset between the curves of the main line and of the turn-out is equal to the clearance at the heel of the switch.

19. Let therefore A<sub>1</sub> and B<sub>1</sub> be the switch heels, the line A<sub>1</sub> B<sub>1</sub> being normal to the gauge face of the main line curve BCM. Then, if we draw A<sub>1</sub> D and B<sub>1</sub> D touching the curves at A<sub>1</sub> and B<sub>1</sub>, we see that the angle A<sub>1</sub> B<sub>1</sub> D is a right angle; and we may obtain the value of the angle B<sub>1</sub> A<sub>1</sub> D by applying general formula (1) to the figure A<sub>1</sub> B<sub>1</sub> C. Thus we have, since A<sub>1</sub> B<sub>1</sub> = g - d

$$\cos \alpha + \cos \left( \beta_1 - \frac{\pi}{2} \right) = 2 \left( \sin \beta_1 - \frac{g-d}{2r_1} \right) \left( \sin \frac{\pi}{2} - \frac{g-d}{2r_2} \right)$$

that is—

$$\cos \alpha + \sin \beta_1 = 2 \left( \sin \beta_1 - \frac{g-d}{2r_1} \right) \left( 1 - \frac{g-d}{2r_2} \right)$$

from which we obtain—

$$\sin \beta_1 = \frac{r_2 \left\{ \cos \alpha + \frac{g-d}{r_1} - \frac{(g-d)^2}{2r_1 r_2} \right\}}{r_2 - g + d}$$

If we substitute the value of cos α obtained from equation (ii) (b), we finally obtain—

$$\sin \beta_1 = 1 - \frac{d}{r_1} - \frac{d \left( 1 - \frac{d}{2r_1} \right)}{r_2 - g + d} \dots \dots \dots (xi)$$

Having found the value of β<sub>1</sub> from this equation, we can now apply general formulae (iv) to (x) to the figure A<sub>1</sub> B<sub>1</sub> C and thus find the lengths of the arcs A<sub>1</sub> C and B<sub>1</sub> C and their chords.

20. The reader must be careful to remember that we have obtained formula (xi) by supposing  $A_1 B_1$  normal to the curve  $B_1 C$ . If we had taken  $A_1 B_1$  as normal to the curve  $A_1 C$  we should have obtained for formula (xi)—

$$\sin \beta_2 = 1 - \frac{d}{r_1} - \frac{d(1 - \frac{d}{2r_1})}{r_1 - g + d}$$

As we have stated in Chapter III, paragraph 21, it is usual to place the switches so that the line  $A_1 B_1$  is normal to the main line; and the correct formula to be used in any given case will of course depend on which of the two curves  $A_1 C$  and  $B_1 C$  is taken as the main line. This matter will, however, present no difficulty if a figure be drawn for each case and the lettering adopted in Fig. 88 be invariably followed.\*

21. It remains to consider how formulæ (i) (b), (ii) (b), (iii) (b) and (xi) are modified when  $r_2$  becomes infinite. We see that in this case the quantity  $\frac{g}{2r_2}$  in formula (i) (b) vanishes and the formula becomes —

$$1 + \cos a = 2 - \frac{g}{r_1}; \text{ that is —}$$

$$\cos a = 1 - \frac{g}{r_1} \dots \dots \dots \text{(ii) (c)}$$

$$\text{Hence we get } r_1 = \frac{g}{1 - \cos a} \dots \dots \dots \text{(iii) (c)}$$

Formula (xi) becomes—

$$\sin \beta_1 = 1 - \frac{d}{r_1} \dots \dots \dots \text{(xi) (c)}$$

22. The following examples are worked out to illustrate the use in practice of the formulæ for the second method for turn-outs.

**Example (1).**—*To set out a 1 in 12 turn-out from a straight main line. Gauge 5' 6". Clearance 4½".*

FIG. 94.

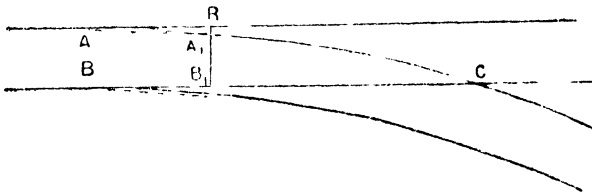

\* Until he becomes thoroughly acquainted with the special formulæ for the second method the student is advised to use the general formulæ in paragraphs 5—10 in all cases, and to substitute in these formulæ any special values, which the angles  $\beta_1$  and  $\beta_2$ , and the lengths  $g$ ,  $r_1$  and  $r_2$  may have.

Since in the figure we have taken BC as the main line, and as  $r_2$  is therefore infinite, the formulæ to be applied are (iii) (c) and (xi) (c). Referring to the table at the end of this chapter, we see that for a 1 in 12 crossing  $\frac{1}{1 - \cos \alpha} = 289.4991$ .

Hence we have—

$$r_1 = \frac{g}{1 - \cos \alpha} = 5.5 \times 289.4991 = 1592.25 \text{ feet.}$$

Thus the radius of the rail AC = 1592.25 feet.

To find the angle between  $A_1B_1$  and the tangent at  $A_1$  to the curve  $A_1C$ , we have from formula (xi) (c)—

$$\sin \beta_1 = 1 - \frac{d}{r_1} = 1 - \frac{.375}{1592.25} = .9997645.$$

Hence  $\beta_1 = 88^\circ 45' 24''$ .

To find the length of the arc  $A_1C$  and its chord and of  $B_1C$  we thus have the following data :—

$\alpha = 4^\circ 45' 49''$  (see table at end of chapter)

$\beta_1 = 88^\circ 45' 24''$

$\beta_2 = 90^\circ$  and  $\gamma_2 = \text{zero}$ , since  $r_2$  is infinite.

Hence from formula (viii) we have  $\gamma_1 = \alpha + \beta_1 + \beta_2 - \pi = 3^\circ 31' 13''$  or in circular measure  $\gamma_1 = .0614404$ .

Therefore the length of the arc  $A_1C = r_1 \gamma_1 = 1592.25 \times .0614404 = 97.83$  feet.

The chord  $A_1C = 2r_1 \sin \frac{\gamma_1}{2} = 2 \times 1592.25 \times \sin 1^\circ 45' 37'' = 97.82$  feet.

Finally to find  $B_1C$ , we have the radius of the circle circumscribing  $A_1B_1C$

$$A_1B_1C = \frac{g - d}{2 \cos \frac{\beta_1 + \beta_2 - \alpha}{2}} = \frac{5.125}{2 \cos 86^\circ 59' 48''} = 48.908 \text{ feet.}$$

Hence  $B_1C = 2 \rho \cos \frac{\alpha + \beta_2 - \beta_1}{2} = 97.816 \times \cos 3^\circ 0' 13'' = 97.68$  feet.

We might also have found the chord  $A_1C$  from formula (ix); thus,  $A_1C = 2\rho \sin \left( \beta_2 - \frac{\gamma_2}{2} \right) = 2\rho \sin \frac{\pi}{2} = 2\rho = 97.82$  feet as before.

To set out the turn-out on the ground, we should first place the crossing C in position, then measure  $CB_1 = 97.68$  feet, and place the heel of the left hand switch at  $B_1$ ; the heel  $A_1$  of the other switch would then be placed directly opposite to  $B_1$  and the curved line  $A_1C$  set out by offsets, either from the main line rail which is tangential to it, or from the chord  $A_1C$ .

**Example (2).**—To set out a 1 in 12 turn-out from a curve of  $2^\circ$  (radius of centre line 2,865 feet), the crossing being on the inner rail of the main line. Gauge 5' 6". Clearance  $4\frac{1}{2}$ ".

FIG 95.

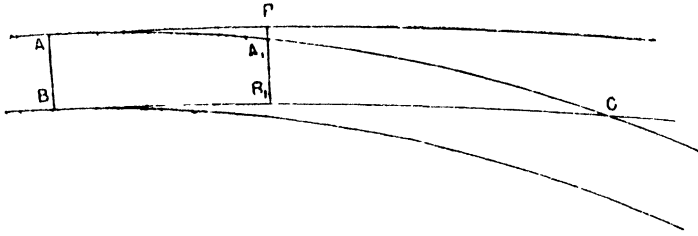

Let Fig. 95 represent the turn-out. Then since the radius of the centre line of the main line is 2865 feet, that of the inner rail BC is  $2865 - 2 \cdot 75 = 2862 \cdot 25$  feet.

As we have drawn the figure, the radius of the main line rail on which the crossing lies is  $r_2$ , hence we require to find the value of  $r_1$ . The formula corresponding to (iii) (b) is by symmetry—

$$r_1 = \frac{g \left( 1 - \frac{g}{2r_2} \right)}{1 - \cos a - \frac{g}{r_2}}$$

Now the curve of the rail BC is *convex* to a point on AB. Hence in accordance with the convention stated in paragraph 6, we must consider its radius to be of negative sign. That is to say, in applying the above formula,  $r_2$  must be taken as  $-2862 \cdot 25$  feet.

The value of  $\cos a$  for a 1 in 12 crossing is (see the table at the end of the chapter)  $\cdot 9965458$ . Hence we obtain—

$$r_1 = \frac{5 \cdot 5 \left( 1 + \frac{5 \cdot 5}{2 \times 2862 \cdot 25} \right)}{1 - \cdot 9965458 + \frac{5 \cdot 5}{2862 \cdot 25}} = 1024 \cdot 09 \text{ feet} *$$

which is the radius of curvature of the rail AC.

Since  $r_1$  is a positive quantity, the curve of the rail will be *concave* to a point on AB.

---

\* NOTE.—We see that the curvature of the turn-out is considerably sharper than that of the main line. For this reason, turn-outs taking off on the inner side of a curve should be avoided, whenever possible.

Now if  $A_1$  and  $B_1$  be the switch-heels, and  $A_1 B_1$  be normal to the rail  $B_1 C$  of the main line, then to find the angle  $\beta_1$  for the figure  $A_1 B_1 C$ , we have from formula (xi)—

$$\sin \beta_1 = 1 - \frac{d}{r_1} - \frac{d \left(1 - \frac{d}{2r_1}\right)}{r_2 - g + d}.$$

Substituting  $r_1 = 1024 \cdot 09$  and  $r_2 = -2862 \cdot 25$ , we obtain—

$$\begin{aligned} \sin \beta_1 &= 1 - \frac{.375}{1024 \cdot 09} - \frac{.375 \left(1 - \frac{.375}{2 \times 1024 \cdot 09}\right)}{-2862 \cdot 25 - 5 \cdot 5 + .375} \\ &= .9997646 \end{aligned}$$

Hence  $\beta_1 = 88^\circ 45' 24''$

Again we have the radius of the circle circumscribing the figure  $A_1 B_1 C$

$$= \frac{g-d}{2 \cos \frac{\beta_1 + \beta_2 - \alpha}{2}} = \frac{5 \cdot 125}{2 \cos 86^\circ 59' 45''} = 48 \cdot 908 \text{ feet}$$

Hence we have—

$$\begin{aligned} \gamma_1 &= 2 \tan^{-1} \frac{\cos \frac{\alpha + \beta_1 - \beta_2}{2}}{r_1 - \sin \frac{\alpha + \beta_1 - \beta_2}{2}} = 2 \tan^{-1} \frac{.9955281}{20 \cdot 9088822} \\ &= 5^\circ 28' 26'' = .0955375 \text{ radians.} \end{aligned}$$

Therefore the arc  $A_1 C = r_1 \gamma_1 = 1024 \cdot 09 \times .0955375 = 97 \cdot 84$  feet.

From formula (viii) we obtain—

$$\gamma_2 = \alpha + \beta_1 + \beta_2 - \pi - \gamma_1 = -1^\circ 57' 13'' = -.0340969 \text{ radians.}$$

We obtain a negative value of  $\gamma_2$  for the reason explained in paragraph 6.

Hence the arc  $B_1 C = -2862 \cdot 25 \times -.0340969 = 97 \cdot 59$  feet.

Finally we have chord  $AC = 2r_1 \sin \frac{\gamma_1}{2} = 97 \cdot 81$  feet; and chord  $BC$

$$= 2r_2 \sin \frac{\gamma_2}{2} = 97 \cdot 58 \text{ feet.}$$

**Example (3).**—To set out a 1 in  $8\frac{1}{2}$  turn-out from a curve of  $3^\circ$  (radius 1910 feet), the crossing to be on the outer rail of the curve. Gauge  $5'6''$ . Clearance  $4\frac{1}{2}''$ .

FIG. 98.

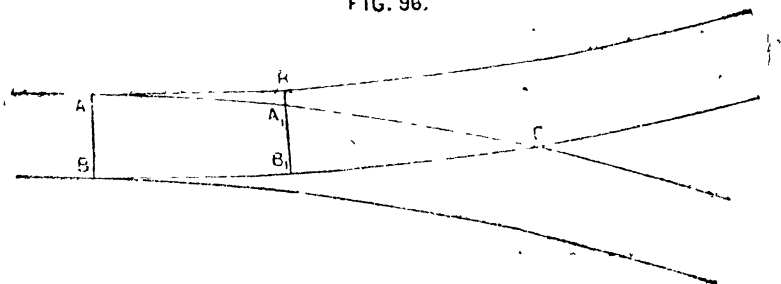

Let Fig. 96 represent the turn-out. Then since the radius of the centre line of the main line is 1910 feet, that of the outer rail  $BB_1C$  will be 1912.75 feet. Also for a 1 in  $8\frac{1}{2}$  crossing  $\cos \alpha = .9931507$ .

Hence by formula (iii) (b) we have—

$$r_1 = \frac{g \left(1 - \frac{g}{2r_2}\right)}{1 - \cos \alpha - \frac{g}{r_2}} = \frac{5.5 \left(1 - \frac{5.5}{2 \times 1912.75}\right)}{1 - .9931507 - \frac{5.5}{1912.75}} = 1382.04 \text{ feet.}$$

To find the angle  $\beta_1$  for the figure  $A_1B_1C$ , we have from formula (xi)—

$$\sin \beta_1 = 1 - \frac{d}{r_1} - \frac{d \left(1 - \frac{d}{2r_1}\right)}{r_2 - g + d} = .9995321$$

Therefore  $\beta_1 = 88^\circ 14' 49''$ .

Also  $\alpha = 6^\circ 42' 35''$ .

Therefore the radius of the circle circumscribing the figure  $A_1B_1C$

$$= \frac{g-d}{2 \cos \frac{\beta_1 + \beta_2 - \alpha}{2}} = \frac{5.125}{2 \cos 85^\circ 46' 7''} = 34.73 \text{ feet.}$$

Hence we have—

$$\gamma_1 = 2 \tan^{-1} \frac{\cos \frac{\alpha + \beta_1 - \beta_2}{2}}{\frac{r_1}{\rho} - \sin \frac{\alpha + \beta_1 - \beta_2}{2}} = 2 \tan^{-1} \frac{\cos 2^\circ 28' 42''}{\frac{1382.04}{34.73} - \sin 2^\circ 28' 42''} = 2^\circ 52' 46'' = .0502558 \text{ radians.}$$

The arc  $A_1C = r_1 \gamma_1 = 1382.04 \times .0502558 = 69.46$  feet.

From formula (viii) we have—

$$\gamma_2 = \alpha + \beta_1 + \beta_2 - \pi - \gamma_1 = 2^\circ 4' 38'' = .0362544 \text{ radians.}$$

Hence the arc  $B_1C = r_2 \gamma_2 = 1912.75 \times .0362544 = 69.35$  feet.

The chord  $A_1C = 2 r_1 \sin \frac{\gamma_1}{2} = 69.45$  feet; and the chord  $B_1C = 2 r_2 \sin \frac{\gamma_2}{2} = 69.34$  feet.

**Example (4)**—Find the angle of the crossing suitable for a turn-out from a main line of 1910 feet radius, the crossing being on the outer rail of the main line and the radius of the centre line of the turn-out being 1379.29 feet. Gauge 5' 6".

Since the radius of the turn-out is less than that of the main line, we see that the crossing must also be on the outer rail of the turn-out. The radii of the two rails which cross will therefore be 1382.04 and 1912.75 feet respectively. Also, since both curves are concave to a point on  $AB$ , see Fig. 96, the radii will be positive,

We have therefore from formula (ii) (b)—

$$\begin{aligned} \cos \alpha &= 2 \left( 1 - \frac{5.5}{2 \times 1382.04} \right) \left( 1 - \frac{5.5}{2 \times 1912.75} \right) - 1 \\ &= .9931505. \end{aligned}$$

The angle of the crossing is therefore 6° 42' 35", that is the crossing is 1 in 8½ (see table at end of chapter).

23. The formulae deduced in the preceding paragraphs of this chapter are exact; it is, however, possible to obtain somewhat simpler formulae, which will give results sufficiently accurate for all ordinary cases of simple turn-outs.

24. **Second method for turn-outs—Approximate formulae.**—If the factors on the right hand side of formula (i) (b) be multiplied out, we get—

$$\begin{aligned} 1 + \cos \alpha &= 2 - g \left( \frac{1}{r_1} + \frac{1}{r_2} \right) + \frac{g^2}{2r_1 r_2}, \text{ which reduces to—} \\ \frac{1 - \cos \alpha}{g} &= \frac{1}{r_1} + \frac{1}{r_2} - \frac{g}{2r_1 r_2}. \end{aligned}$$

Now for all crossings in ordinary use in simple turn-outs, the gauge  $g$  will be small in comparison with the radii of the curves employed, hence in the above formula we may neglect the quantity  $\frac{g}{r_{12}}$  in comparison with  $\frac{1}{r_1} + \frac{1}{r_2}$ , and the formula will then become—

$$\frac{1 - \cos \alpha}{g} = \frac{1}{r_1} + \frac{1}{r_2}$$

But we have seen from formula (iii) (c) that, if  $R$  be the radius of a turn-out from a straight main line—

$$\frac{1 - \cos \alpha}{g} = \frac{1}{R}$$

We therefore get the simple result\*—

$$\frac{1 - \cos \alpha}{g} = \frac{1}{R} = \frac{1}{r_1} + \frac{1}{r_2} \dots \dots \dots \text{(ii) (d)}$$

Similarly in formula (xi), if we neglect the quantity  $\frac{d}{2r_1}$  in the numerator of the last term on the right hand side, as being very small in comparison with unity, and if at the same time we neglect  $g - d$  in the denominator the formula reduces to—

$$\sin \beta_1 = 1 - d \left( \frac{1}{r_1} + \frac{1}{r_2} \right) = 1 - \frac{d}{R} \dots \dots \dots \text{(xi) (d)}$$

We may therefore in calculating the value of  $\sin \beta_1$  for any turn-out whatever, simply assume its value for a turn-out from the straight. A

---

\* NOTE.—If  $r_1$  and  $r_2$  be equal, then each will be equal to  $2R$ . When two diverging lines of equal curvature take off thus, the arrangement is called a *split turn-out*. For a crossing of given angle, we see that a split turn-out gives the easiest possible curvature for both lines.

comparison of the values of  $\sin \beta_1$  obtained in Examples 1 and 2 will show that the formula gives a very close approximation to the true value.

Values of R for different crossings will be found in the table at the end of the chapter.

25. Examples (5) and (6) which follow are intended to illustrate cases for which the general formulae (i) to (x) should be used. They should be noted carefully as similar cases are constantly met with in all the larger station yards.

**Example (5).**—*To lay a cross-over road between two curved tracks. Gauge 5' 6".*

Let Fig. 97 represent two curved tracks XX and YY, which may or may not be concentric. Let the curvature of the centre line of the upper track be  $2^\circ$  (radius 2,865 feet) and that of the centre line of the lower track  $3^\circ$  (radius 1,910 feet), and let it be desired that the crossing on the inner rail of the upper track shall be 1 in 12, and that on the outer rail of the lower track 1 in  $8\frac{1}{2}$ .

FIG. 97.

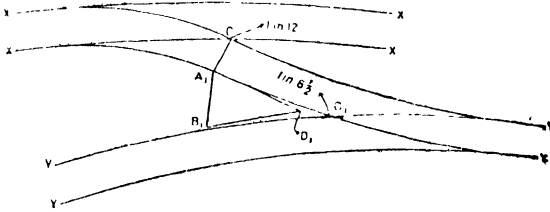

Let C be the position of the 1 in 12 crossing, which should be laid as indicated in Example (2) ; and let  $A_1$  be the point on the inner rail of the turn-out directly opposite to C. To fix the position of the 1 in  $8\frac{1}{2}$  crossing we take  $B_1$  any point on the rail YY, and measure the distance  $A_1B_1$  which we shall suppose is 20 feet. Let  $A_1D_1$  and  $B_1D_1$  be tangents to the rails  $XA_1$  and  $YB_1$  at  $A_1$  and  $B_1$  respectively. Measure the angles  $D_1A_1B_1$  and  $D_1B_1A_1$ , which we shall suppose are  $86^\circ 30'$  and  $80^\circ 20'$  respectively. If now  $C_1$  be the 1 in  $8\frac{1}{2}$  crossing, we may apply the general formulae to the figure  $A_1B_1C_1$ .

We have the following data:—

Radius of rail  $B_1C_1 = r_2 = -1912.75$  (the sign being negative because the curve  $B_1C_1$  is convex to a point on  $A_1B_1$ )

$$\beta_1 = 86^\circ 30'$$

$$\beta_2 = 80^\circ 20'$$

$$A_1B_1 = 20 \text{ feet.}$$

and  $\cos a = .9931507$  (see table at end of chapter).

We therefore have by formula (iii)—

$$\begin{aligned} \text{radius of curve } A_1C_1 = r_1 &= \frac{c\left(\frac{c}{2r_2} - \sin \beta_2\right)}{\cos a + \cos(\beta_1 + \beta_2) + \frac{c}{r_2} \sin \beta_1} \\ &= \frac{20\left(-\frac{20}{2 \times 1912.75} - \sin 80^\circ 20'\right)}{.9931507 + \cos 166^\circ 50' - \frac{20}{1912.75} \sin 86^\circ 30'} \\ &= -2201.68 \text{ feet.} \end{aligned}$$

The negative sign indicates that the curve  $A_1C_1$  is also convex to a point on  $A_1B_1$ .

We have from formula (v), the radius of the circle circumscribing the

$$\begin{aligned} \text{figure } A_1B_1C_1 &= \frac{A_1B_1}{2 \cos \frac{\beta_1 + \beta_2 - a}{2}} \\ &= \frac{20}{2 \cos 80^\circ 3' 43''} = 57.943 \text{ feet.} \end{aligned}$$

Therefore by formula (vi)—

$$\begin{aligned} \gamma_2 &= 2 \tan^{-1} \frac{\cos \frac{a + \beta_2 - \beta_1}{2}}{\frac{r_2 - \sin \frac{a + \beta_2 - \beta_1}{2}}{r_1}} \\ &= 2 \tan^{-1} \frac{\cos 0^\circ 16' 18''}{-\frac{1912.75}{57.943} - \sin 0^\circ 16' 18''} = 2 \tan^{-1} \frac{.9999888}{-.330061373} \\ &= -3^\circ 28' 14'' = -.0605727 \text{ radians.} \end{aligned}$$

Therefore  $B_1C_1 = -1912.75 \times -.0605727 = 115.86$  feet.

We thus obtain the position of the crossing  $C_1$  by measuring 115.86 feet from  $B_1$  along the curve  $B_1C_1$ . The student will have no difficulty in finding the length of the curve  $A_1C_1$ . The 1 in  $8\frac{1}{2}$  turn-out may then be laid as explained in Example (3).

The most common cases in practice of the problem dealt with in the above example will be the laying of a cross-over road between two parallel curved or straight tracks.

**Example 6.**—*The gathering line at the end of a station yard has a number of parallel tracks, spaced at 15 feet 6 inches centres, taking off from it, the crossings in the main line and the first loop being 1 in 12, and those in the remaining loops 1 in  $8\frac{1}{2}$ . To make the calculations necessary for laying out the gathering line. This problem is of constant occurrence in station yards, which have two lines for passenger traffic and*



The length of the arc BC = 4565.403 ( $a + \beta_1 + \beta_2 - \pi$ )

= 155.07 feet; and as we have found the radius to be 4565.403 feet, the curve BC can also be set out.

To obtain the position of the crossing  $C_1$  we must first find the radius of the curve  $LC_1B_1$  which will cut the curve  $BC_1C$  at an angle of  $4^\circ 45' 49''$  and will at the same time touch the line  $CB_1$ .

We have by formula (iii) (b), the radius of the curve  $LC_1B_1$  is—

$$\frac{5.5 \left( 1 - \frac{5.5}{2 \times 4565.403} \right)}{1 - .9965458 - \frac{5.5}{4565.403}} = 2443.52 \text{ feet.}$$

Now from the condition that the curve  $LC_1B_1$  must touch the line  $CB_1$ , we obtain, by applying formula (i) to the figure  $CC_1B_1$ , a quadratic equation for finding the length of  $CB_1$ . Replace the letter C by  $A_1$  for convenience in applying the formula. Then we have—

$$\begin{aligned} \beta_1 &= 180^\circ - 6^\circ 42' 35'' = 173^\circ 17' 25'' & \beta_2 &= \text{zero.} \\ a &= 4^\circ 45' 49'' \\ r_1 &= -4565.403 & r_2 &= -2443.52. \end{aligned}$$

the negative signs being used because the curves  $A_1C_1$  and  $B_1C_1$  are both convex to a point on  $A_1B_1$ .

We therefore obtain from formula (i)—

$$\begin{aligned} \cos 4^\circ 45' 49'' + \cos 173^\circ 17' 25'' &= \\ \left( \sin 173^\circ 17' 25'' + \frac{c}{2 \times 4565.403} \right) \frac{c}{2443.52} \end{aligned}$$

The solution of this quadratic equation is—

$$c = -533.44 \pm 600.33 = 66.89 \text{ feet or } -1133.77 \text{ feet.}$$

The latter solution is inadmissible (it gives the distance of  $B_1$  from the point at which the curve  $CC_1B$  if continued would again cut the line  $B_1CA$ ), hence we have  $A_1B_1 = 66.89$  feet, which fixes the position of the point  $B_1$ .

The radius of the circle circumscribing the figure  $A_1B_1C_1$  is therefore

$$\frac{66.89}{2 \cos \frac{\beta_1 + \beta_2 - a}{2}} = \frac{66.89}{2 \cos 84^\circ 15' 48''} = 334.596 \text{ feet.}$$

Hence—

$$\begin{aligned} \gamma_1 &= 2 \tan^{-1} \frac{\cos \frac{a + \beta_1 - \beta_2}{2}}{\frac{r_1}{\rho} - \sin \frac{a + \beta_1 - \beta_2}{2}} = 2 \tan^{-1} \frac{\cos 89^\circ 1' 37''}{\frac{-4565.403}{334.596} - \sin 89^\circ 1' 37''} \\ &= 2 \tan^{-1} (-.0011596) = -.0023192 \text{ radians.} \end{aligned}$$

Therefore the arc  $A_1C_1 = -4565.403 \times -.0023192 = 10.59$  feet.

To fix the position of the crossing  $C_1$  we therefore measure 10.59 feet from  $A_1$  along the arc  $A_1B$ ; and the curve  $LC_1B_1$  may now be laid,

If the crossing  $C_4$  had been 1 in  $8\frac{1}{2}$ , its position would evidently be at  $C$ ; and similarly the crossing  $C_2$  will be at the intersection of the rail  $BCC_2$  with a line drawn parallel to, and at a distance of 15'6" from  $B_1M$ .

26. We shall conclude this chapter by indicating briefly how a diamond crossing and the more usual combinations of points and crossings which include diamond crossings are laid. Let Fig. 99 represent a

FIG. 99.

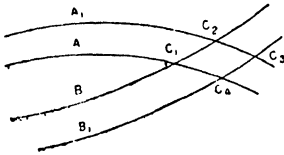

a diamond crossing formed by two curved tracks, and let  $C_1, C_2, C_3$  and  $C_4$  be the points of intersection of the gauge lines. Then if we take any four points  $A_1, A, B$  and  $B_1$ , on the two pairs of rails, the general formulæ (i) to (x) may be applied to each of the figures

$AB C_1, A_1 B C_2, A_1 B_1 C_3$  and  $AB_1 C_4$  in turn. It should be noted that the angles of the four crossings will in general be different.

27. If the lines which cross are straight as in Fig. 100 it is clear that, if they are of the same gauge—

FIG. 100.

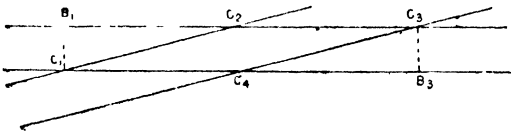

the quadrilateral  $C_1C_2C_3C_4$  will be a rhombus; that is, its four sides will be equal, and the lines  $C_2C_4$  and  $C_1C_3$  joining the pairs of opposite crossings will be at right angles to each other.

If  $a$  be the angle of the crossing, we see that—

$$B_1C_2 = g \cot a = C_4B_3$$

$$C_2C_3 = C_1C_2 = g \operatorname{cosec} a = C_1C_4.$$

And if  $n$  be the number of the crossing we have—

$$B_1C_2 = C_4B_3 = ng$$

$$C_2C_3 = C_1C_4 = g \sqrt{n^2 + 1}$$

If the lines be not of the same gauge, let  $g$  be the gauge of the track  $C_2C_3, C_1C_4$ ; and  $g_1$  that of the other.

Then the figure  $C_1C_2C_3C_4$  will be a parallelogram of area  $C_2C_3 \times g$  or  $C_1C_2 \times g_1$ . But  $C_1C_2 = g \operatorname{cosec} a$

$$\therefore C_2C_3 \times g = g \operatorname{cosec} a \times g_1, \text{ therefore } C_2C_3 = g_1 \operatorname{cosec} a$$

Hence we have  $B_1C_2 = g \cot a = ng = C_4B_3$  and

$$C_2C_3 = g_1 \operatorname{cosec} a = g_1 \sqrt{n^2 + 1} = C_1C_4.$$

28. In laying a single or a double slip, see Figs. 51 and 52, the first step is to fix the positions of the four crossings as for a simple diamond crossing. The stock-rails with their switches attached should then be placed in position (usually slips are so designed that the stock-rails in the four sides of the diamond crossing are fished directly to the wings of the "V" crossings) and the curved lines are laid so as to lie tangential to the faces of the switches when the latter are housed against the stock-rails.

29. A scissors cross-over, see Fig. 43, consists of a diamond crossing and four ordinary turn-outs; and here again the first step should be to place the four crossings composing the diamond crossing correctly in position. It is clear that if  $\alpha$  be the angle of the crossings in the two main tracks, then  $2\alpha$  will be the angle of the crossings composing the diamond crossing. Referring to Fig. 101 it will be evident that the figure is symmetrical about the two lines  $C_2C_4$  and  $C_1C_3$ , connecting the pairs of opposite crossings of the diamond crossing. If these two lines cut at  $O$ , then  $O$  is midway between the two main tracks; and  $OC_3 = C_2C_3 \cos \alpha$  and  $OC_2 = C_2C_3 \sin \alpha$ .

FIG. 101.

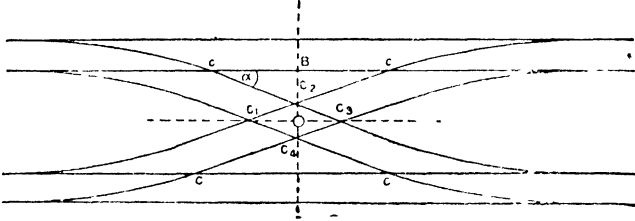

But we have from paragraph 27,  $C_2C_3 = g \operatorname{cosec} 2\alpha = \frac{g}{2 \sin \alpha \cos \alpha}$ ; therefore  $OC_3 = \frac{g}{2} \operatorname{cosec} \alpha$  and  $OC_2 = \frac{g}{2} \sec \alpha$ . Having calculated these dimensions we can at once place the four crossings,  $C_1C_2C_3$  and  $C_4$  in position. To fix the positions of the four crossings  $C$ , we have if  $d$  be the distance between the centres of the main tracks  $OB = \frac{d-g}{2}$

$$\text{Therefore } C_2B = OB - OC_2 = \frac{d-g}{2} - \frac{g}{2} \sec \alpha$$

$$\text{Hence } BC = \left( \frac{d-g}{2} - \frac{g}{2} \sec \alpha \right) \cot \alpha$$

30. For the purpose of applying the formulae in the preceding paragraph as well as some of those in the earlier paragraphs of the chapter, the student should be able to express the different functions of the angle

of a crossing in terms of the crossing-number. If  $n$  be the number of a crossing of angle  $a$ , we have—

$$\begin{aligned} \cot a &= n & \sin a &= \frac{1}{\sqrt{1+n^2}} & \cos a &= \frac{n}{\sqrt{1+n^2}} \\ \tan a &= \frac{1}{n} & \operatorname{cosec} a &= \sqrt{1+n^2} & \sec a &= \frac{\sqrt{1+n^2}}{n} \end{aligned}$$

$$\frac{1}{1-\cos a} = \frac{1}{1-\frac{n}{\sqrt{1+n^2}}} = \frac{\sqrt{1+n^2}}{\sqrt{1+n^2}-n} = \sqrt{1+n^2}(\sqrt{1+n^2}+n)$$

$$= 1+n^2+n\sqrt{1+n^2}$$

31. In the following table, giving for crossings of different angles, values of quantities which occur in the formulae deduced in paragraphs 21 and 24 of this chapter,  $R$  represents the radius of a turn-out from a straight main line, calculated by the second method for turn-outs.

Number of crossing $n = \cot a$ .	Angle of crossing $a$ .	Cos $a$ .	$\frac{1}{1-\cos a}$ .	R in feet.		
				5' G <sup>s</sup> g. uge.	Metre gauge	2' G <sup>s</sup> g. uge.
6	9° 27' 44"	·9863939	73·4966	464·231	241·135	183·741
7	8° 7' 48"	·9899496	99·4975	547·236	326·441	248·744
8	7° 7' 30"	·9922779	129·4981	712·239	424·870	323·745
8½	6° 42' 35"	·9931507	145·9983	802·991	479·006	364·996
9	6° 20' 25"	·9938884	163·4985	899·242	536·424	408·746
10	5° 42' 38"	·9950372	201·4988	1108·243	661·097	503·747
11	5° 11' 40"	·9958933	243·4990	1339·244	798·896	608·747
12	4° 45' 49"	·9965458	289·4991	1592·245	949·818	723·748

## CHAPTER XII.

### STATION YARD DESIGN. WAYSIDE STATIONS.

1. For the purposes of this chapter, the term "station" applies to any place at which a running train may be required to halt for traffic purposes. The stopping place may be marked simply by a level patch of ground or "platform" alongside the track, for the convenience of passengers entering, or alighting from, the train. This is the simplest type, and if, as is usually the case, such a station is not in telegraphic communication with the stations on either side, it falls within the definition of a "flag station" (vide Chapter IV), that is to say, it has no control over the movements of trains.

2. The next simplest type is a wayside station on double line (Fig. 102)

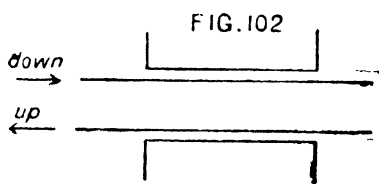

where each line has its own platform, and there are no connections between the two tracks. It may here be remarked that in double-line working, one line is used for all trains going in one direction, and the other for all in the opposite direction. The directions are distinguished as "up" and "down" respectively.

It is immaterial which is called the up line and which the down, provided that the terms are used consistently throughout any given railway system. On some railways the "up" direction is towards the headquarters of the railway system, e.g., on the Great Indian Peninsula Railway, the "up" direction is towards Bombay; on others, e.g., the Madras and Southern Mahratta Railway, the "up" direction is away from headquarters. It should be noted, however, that in double-line working a train invariably uses the left-hand track, looking in the direction in which it is proceeding; thus in Fig. 102 the arrows denote the directions in which trains run on each track. This is the practice in England as well as in India. (In America it is reversed.) The platforms are also distinguished as "up" or "down" according to the track served.

3. If in the above station we insert a cross-over AB (Fig. 103) this

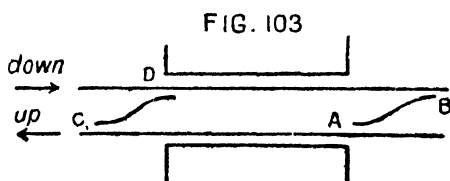

would enable a train to pass from one line to the other in an emergency. A second cross-over at CD would make this station suitable to be the terminus of a local train service. For, say a down train has

arrived at DB; the engine (at B) could uncouple, pass round by the cross-overs BA, CD to the rear of the train, couple up there, and haul the train on to the up line for the return journey, the engine running tender foremost. It will be noted that the cross-overs are set in a trailing direction. Facing points should always be avoided, when possible, for reasons given in Chapter III.

4. It is occasionally necessary for a slow train to make way for a fast one in the same direction. This could, of course, be done by means of one of the cross-overs in the preceding figure. But the objection to this is that it would temporarily obstruct the other line.

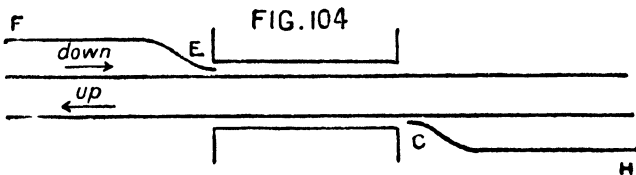

It is better that the slow train should go into a siding specially apart for that purpose. Such a siding is called a lay-bye or refuge siding. Each line might have its own lay-bye; thus in Fig. 104, EF would be the down and GH the up lay-bye. Observe here again, the points are laid trailing, so that a train using a siding would have to back into it.

5. It is, however, sometimes extravagant to provide two lay-byes at the same station, for unless traffic is very heavy, they would hardly ever both be used at the same time. Hence, though the above arrangement is simple, it is not always economical. A more economical arrangement is a single siding serving both lines, as in Fig. 105, where EF takes the

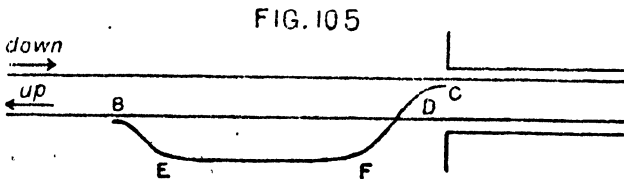

place of the lay-bye, joining the up line at B and the down line at C (both trailing) the down connection CF crossing the up line by a diamond crossing at D.

6. By using single-slip points at D (Fig. 106) CD' may be used as a cross-over. CDF then represents the arrangement shown in Fig. 45, Chapter III.

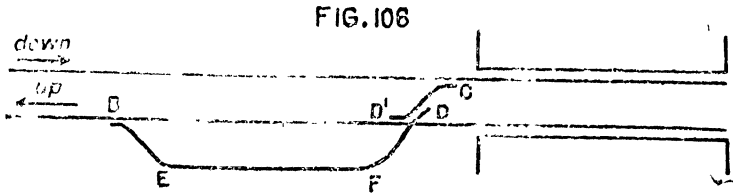

7. Another case is when it is desirable to have two lay-bye sidings and to locate them on the same side of the station. The arrangement

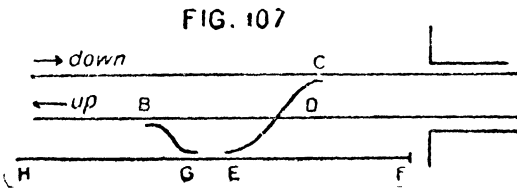

would then be as in Fig. 107, EF being the up lay-bye and GH the down, the points E and G being close together. It will be seen that the alignment BEF is practically the same as in the last figure,

but that the down connection CDF of that figure is shifted to the position ODG in the present case, and an extra length of siding GH added.

8. The question of dealing with goods traffic at wayside stations will be dealt with later on. We now proceed to the consideration of single-line stations.

9. A single-line station is somewhat more difficult to design than one on double line, because provision has to be made not only for an occasional slow train being overtaken by a fast one, but more especially for trains running in opposite directions on the same line at the same time. As most of the railways of India are on single line, the problem is a very important one.

10. To enable an up and a down train to pass or "cross" one another

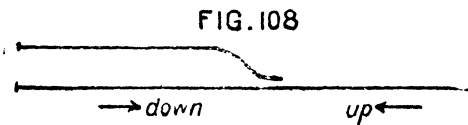

the most primitive arrangement would be a single dead siding or lay-bye, taking off the main line, as in Fig. 108. The first train would occupy this siding

till the other had passed. The objection to this arrangement is that the train using it would either have to back in, or back out, according to its direction. It is true that back shunting is also involved in the types described above for double-line stations; but this cannot be avoided

no facing-points are to be used. On a single line facing points are unavoidable ; and on a moderately busy line, the delay which back-shunting involves (delays in working obviously affect a single line more than a double one even if the latter has a considerably heavier traffic) justifies the use of a crossing-loop, with facing-points at each end, on which trains may be received direct without the necessity of shunting.

11. Three types of loops, A, B and C (Figs. 109, 110 and 111) are in use. The first type A (Fig 109) is known as the "split-turnout,"

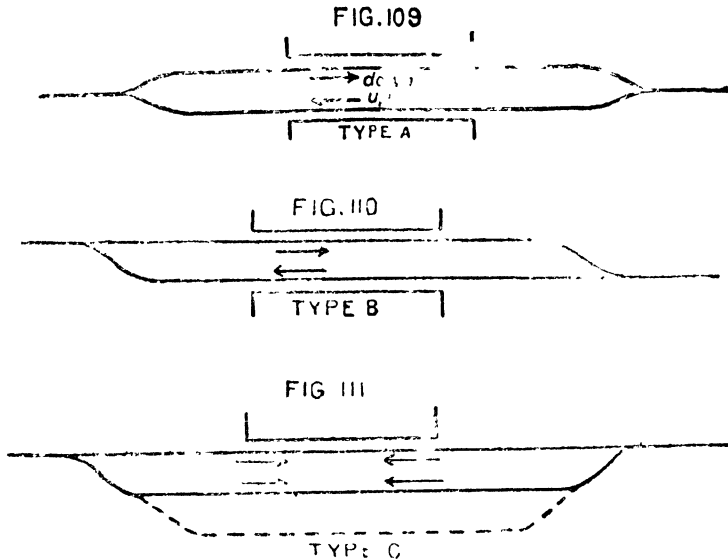

the second B (Fig. 110) as the "facing-straight and trailing-turnout." In both these types the double-line principle is maintained, one line being reserved for up trains, the other for down, each with its own platform. The objection to the first type is that it is unsuited for fast through trains which are not required to stop at the station. Such trains, unless the speed were considerably reduced, would be subjected to a succession of severe lurches when passing over the curves at the ends of the station. The second type is only a degree less objectionable, for although fast through trains would enter it on the straight, they would leave it over a reverse curve. It is true, there are examples of both these types in England and Scotland, but it must be remembered that in English railways double lines are the rule, single lines the exception, so that it is natural to extend the double-line principle to the comparatively few single-line stations which have to be dealt with there. In India, on the contrary, the bulk of the fast through traffic has to be dealt with on single lines; hence the design of single-line wayside or "crossing" stations has been the subject of

special study in this country. As the outcome of much discussion it is now agreed that a straight run-through line for trains in both directions is essential, but that it is unnecessary, under Indian conditions, to retain the two platforms provided on English railways. This has resulted in the "straight and loop" type C, Fig. 111, which is now recognized as the standard type. There has also been considerable discussion as to whether the platform should be on the straight or on the loop. The disadvantage of the "platform-on-loop" type is that, if an additional loop siding is found to be necessary, it must take off from the main line, which involves the use of four sets of points in that line (vide Fig. 112). It is

FIG. 112

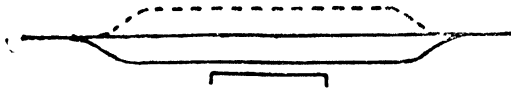

clear also that, if the turn-outs leading to the new loop take off within those leading to the platform loop (as in Fig. 112), the length of train which the main line can accommodate, while a second train is entering the new loop, is very considerably reduced. For under these conditions, the length of train which the main line can hold is equal to the distance between the fouling-marks of the new loop (see Chapter III, paragraph 24), and this is obviously less than the distance between the fouling-marks of the old loop. On the other hand, if the platform be placed on the straight, as in type C, Fig. 111, an additional loop may be provided as shown by the dotted line on the figure without interfering with the main line. (It is true that the length of train which the old loop will accommodate will then be reduced, but this is not so objectionable as a reduction of the capacity of the main line.) For these reasons the balance of opinion amongst railway officers is in favour of the "platform-on-straight" type of station, although it has the disadvantage that if a train is waiting on the loop, to be crossed by a fast run-through train, there is a risk that careless passengers from the waiting train, who may happen to be between it and the platform, may be run over.

12. Additional siding accommodation may be provided, in the case of a station of the "platform-on-loop" type in the manner shown in Fig. 113 where a dead-end siding, taking off from the loop, is

FIG. 113

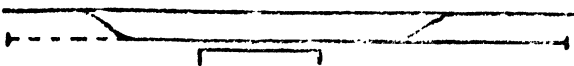

provided sufficiently long to accommodate a train. Such a station could deal with three trains simultaneously. This arrangement, however, clearly makes the station yard of an unnecessarily great length, and has the further disadvantage that a train standing in the dead end would be at an inconvenient distance from the station building and so from the station master's direct authority. A short dead-end siding might be provided at the other end of the loop for the stabling of a small number of vehicles.

13. We are now in a position to consider the question of dealing with goods traffic at a wayside station. Now, whether the main line be double or single, there will usually be only one goods shed or platform to deal with both inwards and outwards traffic. The arrangements about to be described will therefore in all cases be suitable both for double and for single line.

14. When the amount of traffic is small, say 4 or 5 wagons of inwards goods per day and the same number of outwards wagons, a simple dead-end siding 300 or 400 feet long with a cheaply constructed loading-ramp or platform, and with or without (according as the goods are perishable or not) a small shed, will be sufficient. In such a case the shed should preferably be constructed of corrugated-iron sheeting with angle-iron uprights, so that, if it be found necessary to extend the goods yard at some future date, the shed may be dismantled and re-erected at small cost either at the same station or elsewhere.

15. It is here necessary to remark that, both in England and in India, it is required that all sidings on which vehicles—considered as distinct from complete trains consisting of an engine, a number of vehicles and one or more brake-vans—may be stabled, or on which shunting habitually takes place, must be isolated from “running” lines, that is to say, from lines on which trains may be received or from which they may depart. The object is to ensure the safety of trains standing or moving on the running lines. The isolation is effected by means of a trap-siding or trap switch (see Fig. 42 and Chapter V, paragraph 24) in a manner which will be clear from the next paragraph.

16. Returning to the case considered in paragraph 14, let EF in Fig. 114 represent a running line, either of a double or of a single-line station; GI is a short dead-end siding, with a loading-ramp or platform H alongside it, and EG is a turn-out connecting GI with EF. The dead-end GI may be isolated from the running line (1) either by means of the trap-siding shown by the dotted line or (2) by means of a trap-switch

inserted at G as shown by the full lines. It will be clear that in either case

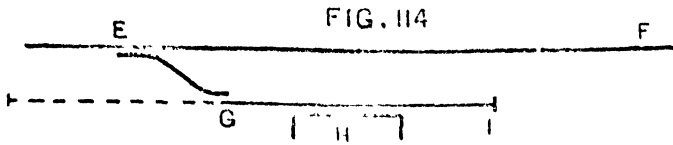

with the points set as shown in the figure if a wagon be moving on the dead-end siding in the direction from I to G it cannot possibly escape so as to foul the running line; in the first case it will run on towards the buffer-stop at the end of the trap-siding; in the second, it will be derailed at the trap-switch G. In a non-interlocked station-yard, a scotch-block (see Chapter V, paragraph 24) might take the place of the trap-switch.

17. If we apply the arrangement just described to the double-line station shown in Fig. 105 we get the result appearing in Fig. 115. The

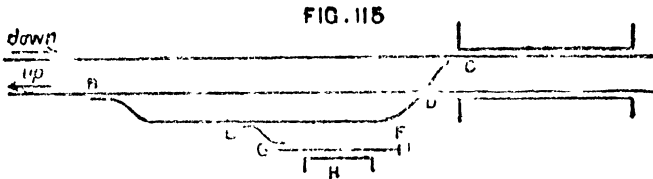

outlet GE from the goods siding would be arranged to face in the up or down direction according as the greater part of the goods traffic of the station is up or down. Goods wagons to be attached to a down train would be hand-shunted from GI on to EF, from which they would be drawn by the train engine; wagons to be attached to an up train would be drawn from GI direct by the train engine. Similarly wagons to be detached from a down train would be placed by the train-engine on EF, from which they would be hand-shunted to GI, wagons from an up train being placed directly on GI by the train engine.

18. Figs. 116 and 117 show the arrangement as applied to the single-line stations shown in Figs. 111 and 113. In the case of Fig. 116

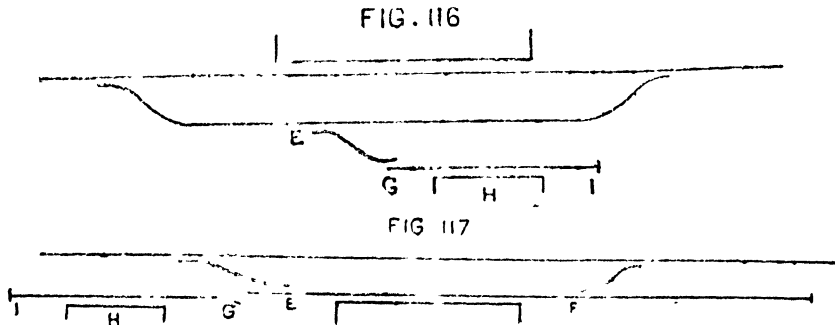

the shunting operations would be exactly the same as for the double-line station just described. In the case of Fig. 117 the shunting for a down train would be done entirely by the train engine, while for an up train the shunting would have to be done partly by the train engine and partly by hand. In both cases the arrangement is essentially the same, the only difference being that in the latter case EG and GI are in the same straight line. Comparing the cases further, the station shown in Fig. 116 will have a certain advantage as regards convenience of working over that shown in Fig. 117, inasmuch as in the former case the goods platform is directly opposite the station platform, while in the second case it is some distance away. The entire work on the goods platform can therefore in the former case practically be supervised and directed by the station master from the station platform; or if he finds it necessary to visit the goods platform, he has only a few yards to walk.

19. For larger stations, separate sidings would be necessary for inwards and outwards wagons, and separate ends of the goods yard would be set apart for up and down traffic. (In the following paragraphs we shall assume that the down direction in any figure is from left to right of the page and the up direction from right to left.) Fig. 118 illustrates a type of goods yard suitable for dealing with 15 or more inwards wagons per day, and the same number of outwards wagons. In the figure AB is a running line and the sidings EF and IJ are for outwards and inwards down traffic, the corresponding sidings DC and HG at the opposite end of the yard being for up traffic. The engine of a down

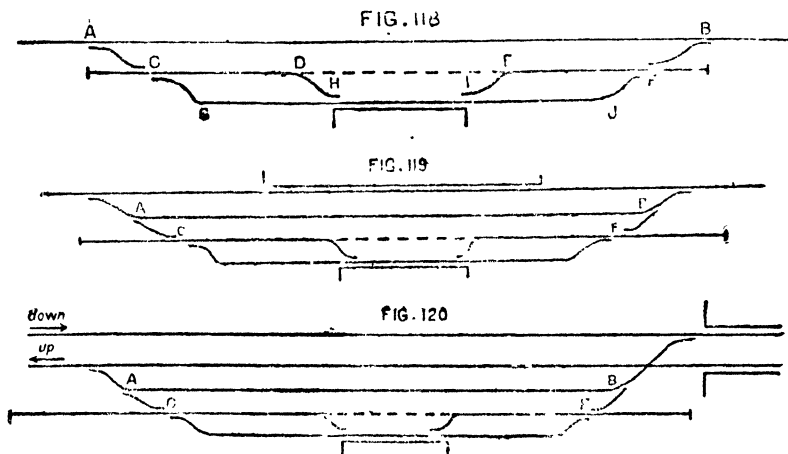

train with wagons to detach at the station would pass over BFJ and leave the wagons on JI; it would then shunt forward, reverse and couple on to the outwards wagons standing on EF, and return to

its train. The shunting movements for an up train would be precisely similar. It will be observed that the goods sidings are isolated from the running lines, by means of the trap-sidings in continuation of EF and DC. If these trap sidings be made of sufficient length, shunting may be performed on them without interfering with train movements on the running lines. A dead-end siding used for the purpose of such shunting operations is called a *shunting-neck*. Additional standing room for vehicles may be provided by connecting up E and D as shown by the dotted line on the figure; and the capacity of the goods yard may be increased to any desired extent by extending the sidings EF, IJ, etc.

20. In Figs. 119 and 120 the goods yard just described is shown combined with the stations shown on Figs. 111 and 105. To avoid obstructing the main lines while shunting is in progress, a goods train having wagons to attach or detach would be drawn up on AB before the engine uncoupled to perform its shunting.

21. Another type of goods yard, which has been adopted on the North-Western Railway, is that shown on Fig. 121, where ABC is a running line, and ED, Fd, E'D' and F'd' are goods sidings. The shunting

FIG. 121.

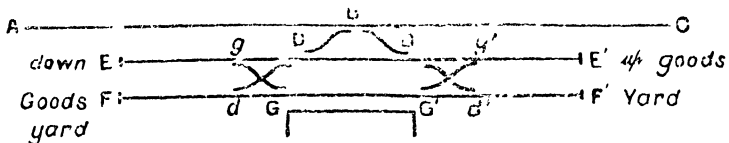

movements will be readily understood from the description given of the movements in the case of the yard described in paragraph 19. The engine of a down train having wagons to detach at the station would pass over the turn-out BD, giving access to the sidings DE and dE, one of which would be reserved for inwards traffic and the other for outwards traffic. The cross-overs G g and and G' g' are provided for the sake of convenience in hand-shunting between the sidings.

22. Combining this goods yard with the double-line station shown in Fig. 105 we get the result shown in Fig. 122. In this case it will be

FIG. 122

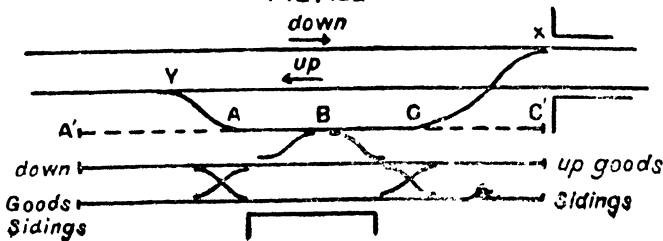

clear that unless the sidings AB and BC are each long enough to accommodate a full train, shunting cannot be performed, unless the goods train is left standing either on the up or the down main line, obstructing that line until shunting is completed. This disadvantage may be

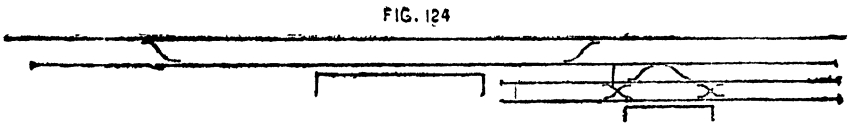
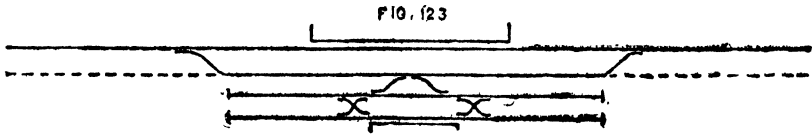

got over by providing the dead-end sidings shown in dotted lines on the figure. A down train might then be placed on the siding BA' or an up train on BC' before shunting was commenced.

23. In addition to the disadvantage pointed out in the preceding paragraph, it will be observed, comparing the station yards shown on Figs. 122 and 120, that the amount of shunting to be done in the case of the former is considerably greater than in that of the latter. In Fig. 120 the down goods sidings are conveniently situated at the end of the yard in which the engine of a down goods train will draw up, on the arrival of the train in the siding AB; whereas in Fig. 122 the down goods sidings are at the opposite end of the yard.

24. Figs. 123 and 124 show the second type of goods yard combined with the single-line stations shown on Figs. 111 and 113. The objections pointed out in paragraphs 22 and 23 apply in large measure to these cases also.

25. **Watering stations.**—The special arrangements necessary for watering stations have been described in Chapter V, paragraphs 6—8, and are illustrated on Plate XII.

## CHAPTER XIII.

### STATION YARD DESIGN. SECTIONAL YARDS AND JUNCTIONS.

1. In wayside goods yards, as described in the last chapter, we had only to consider the movements of a single train, dealing with the station-to-station traffic on a section between two big *dépôts* or junctions. The latter *dépôts*, which form the termini or distributing centres of a traffic section, are called "sectional" yards, and may be either actual termini or junctions. The functions of a sectional yard are to sort the wagons arriving by trains from various directions and to make them up into fresh trains according to their destinations. Thus, as a general rule, all trains arriving at a sectional yard are immediately broken up to form parts of various new trains, which are in turn despatched from the yard as soon as ready. When wagons bound for destinations beyond the *next* sectional yard in any direction are sufficient to make up a full train-load, they would be run direct as a *through* train to that yard, without stopping to pick up the wayside traffic of the intervening section. The latter would be dealt with by local or "pick-up" trains. A sectional yard frequently has a local goods traffic of its own, in which case a local goods shed with its own sidings would be provided. It may also occasionally happen (as at certain seasons of the year, when the bulk of the traffic converges on a particular route bound for a seaport) that a goods train arriving at a sectional yard is composed almost entirely of wagons bound for the same destination. In this case, it would not usually be broken up, but would, after detaching such wagons as were not going on in the same direction, and attaching perhaps some that were ready to be taken on, proceed on its way almost intact as a through train. It is usually also found convenient to have engine-changing arrangements at a sectional station.

2. Thus the design of a sectional yard would depend on many local considerations, but the following features would in a greater or less degree be common to all; (i) *reception sidings*, where trains on arrival would either await their turn to be broken up or (occasionally) pass on intact, or with a slight re-adjustment of load, as the case may be, after changing engines; (ii) *sorting sidings*, each allotted to wagons bound for a particular destination, into which the wagons of trains would be sorted as soon as possible after arrival, to make up new trains; (iii) *marshalling sidings*, in which a rake of wagons taken from one or more of the sorting sidings to make up a new train, would be arranged in "station order," i.e., the wagons for the nearest station would be placed in front, and so on

When there is local goods traffic, there would also be (iv) a *goods shed* with its own sidings.

3. **Systems of shunting.**—The operation of re-arranging wagons in a yard, for sorting or marshalling purposes, may be done either (a) by *gravitation* or (b) by *engine power*. The most complete example of the gravitation system is that at Edgehill, on the London and North-Western Railway (see Plate XXIX), described in the note at the end of the chapter. For a very busy yard there is probably no more efficient and economical system than the gravitation system. But it entails a larger outlay on permanent-way than would be necessary with engine-shunting. Hence, when the traffic is of a fluctuating character, or when a large portion flows along a particular route, so as to entail very little breaking up in a sectional yard *en route*, it is a question whether the outlay on a gravitation yard would be justified by the use made of it in the course of the year. The gravitation system undoubtedly pays at Edgehill, where between 500 and 600 trains have to be broken up and re-arranged every day. A partial use of gravitation in the form of a “hump” between the reception and sorting sidings also pays in many yards in Europe and America where the traffic conditions are favourable. The “hump” system of shunting has also been introduced into India, but under the fluctuating conditions of traffic prevalent on Indian railways the outlay on a gravitation system would not always be justified. Shunting by engine-power may therefore be regarded as the normal system for sectional yards in India, and the following notes on sectional yards are based on that understanding.

4. **Sorting sidings.**—On arrival at the reception sidings (which will be described later), wagons intended to form parts of trains to various destinations would be put into sorting sidings allotted to those destinations. From the fan-like appearance of the sidings radiating from the rear end of their shunting neck, this set is called a “*fan*” (Fig. 125). There would be one such set of sidings for up destinations, another for down, each set with its own shunting-neck. And if the traffic dealt with does not originate at the station, but is merely received from other stations for further conveyance, there is no object in having these fans near the shed, nor is it necessary that they should be near one another. On a double line, for instance, it might be more convenient to have the “up” fan on one side and the “down” fan on the other side of the main lines. On the other hand, if the station is an important originating or terminal *dépôt*, it might be advisable to have both fans within convenient distance of the shed or sheds. One or two sidings should be set apart in the fan for spare wagons and disabled stock. When used for the latter purpose they are

technically known as "sick" sidings. It is a good plan for a sick siding to form a loop with a spare siding, so that individual wagons can be more easily got at when desired. Examining pits would be provided on sick sidings (see Fig. 125).

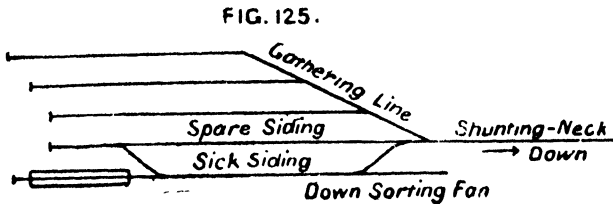

5. **Marshalling sidings.**—The wagons taken out of the sorting sidings to make up a train must be marshalled in a particular order; those which have to be detached first on the journey being placed near the engine, and so on. This remark applies chiefly to the trains which have to deal with wayside traffic, but the wagons of through trains also have occasionally to be marshalled in a particular order, if there are no facilities for doing so further on. Consequently, when a train-load is taken from the fan it usually cannot be despatched as it stands; arrangements must be provided to enable the wagons which compose it to be marshalled in the order required for the journey. This may be done by means of a "grid" (Fig. 126) or a "spike" (Fig. 127). The grid, or

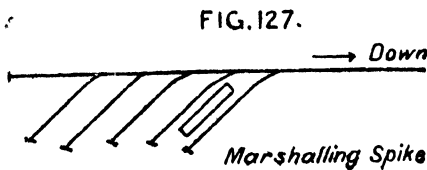
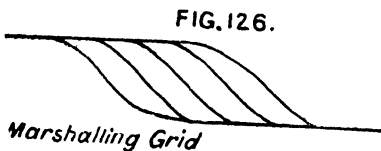

grid-iron so called from its shape, can be used for marshalling trains from either direction, i.e., either up or down trains; the spike only for trains in one direction. Thus, if the spike is used there must be an up spike for up trains and a down spike for down trains. (The spike in the figure is for down trains.) As in a well-designed yard the up and

down goods traffic should be separated as much as possible; it would rarely be convenient to make a single grid available for marshalling trains in both directions; two grids would usually be required, and in that case spikes would be more economical and just as efficient. The grid is a special feature of the gravitation system, vide the note at the end of the chapter.

6. Goods have occasionally to be *transhipped* from one wagon to another. A tranship platform is used for the purpose, and a convenient position for it would be between two arms of a spike (see Fig 127).

7. The *shed sidings* would be arranged in accordance with principles already described for a wayside station, namely, up and down shunting necks, each serving its outwards and inwards sidings. As a rule, there would be only one goods shed or platform for both up and down traffic. Hence the details of a wayside goods yard would be more or less applicable to the shed sidings of a sectional yard. For large yards, however, where the amount of shunting to be done is considerable and where consequently shunting-engines are employed specially for the purpose, the arrangement of sidings shown on Fig. 123 would not be suitable. In that case the use of dead sidings for the outwards and inwards traffic is only rendered practicable from the fact that a great part of the shunting between the shed and the sidings is performed by hand. Where shunting is performed—as in all busy station yards—entirely by engine power, goods loops of the form IEFJ of Fig. 118 which we shall call a *service loop* with a shunting neck as shown on the figure would be essential. A loop of this description may be regarded as the arrangement most suitable for the exchange of wagons generally in any part of a large yard. For instance, suppose most of the wagons of a train arriving in a sectional yard are destined for the next sectional station and beyond, this train would not break up, but would merely detach the wagons booked to this yard, pick up any that might be ready to be taken on, and proceed at once as a through train. A shunting engine would have previously collected the outwards wagons and placed them on the outwards siding. The train engine would then merely have to detach its inwards wagons on the inward siding, pick up the outwards wagons on the other siding, and proceed on its way exactly as described in paragraph 19 of Chapter XII, leaving the shunting engine to deal with the inwards consignment.

8. **Reception sidings** would take off from the main line. The simplest arrangement would be as in Fig 128, where five such sidings,

FIG. 128.

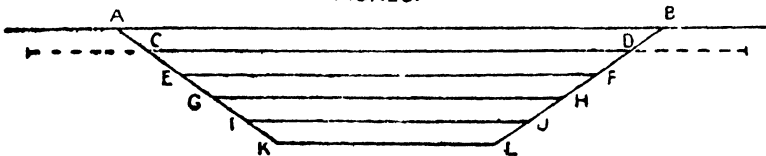

CD, EF, GH, IJ and KL, take off from the main line AB. In this case

the siding KL should be sufficiently long to accommodate the longest goods train run on the section. The sidings CD, EF, GH and IJ would, however, then be unnecessarily long and a more economical arrangement would be of the grid form as in Fig. 130. To enable a passing train to pick up or detach wagons *en route*, a service loop as described in paragraph

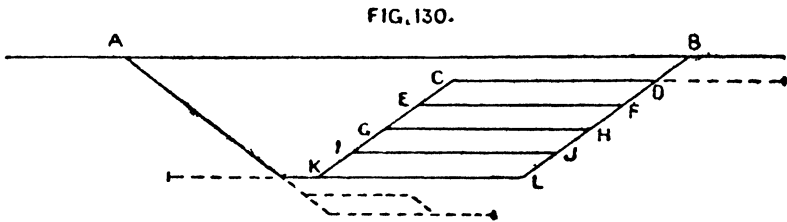

7 above should be provided conveniently near the head of the grid (as shown in dotted lines in the figure) both for the up and the down reception lines, whether on double or on single line. Shunting-necks would also be provided (as shown dotted in Fig. 130) to avoid obstructing the main line.

9. Applying the foregoing principles to the design of a moderately large sectional yard, we get some such arrangement as that shown in Fig. 129.

Of course, when first laying out a yard, many sidings might be omitted, but space should always be reserved for their subsequent insertion. For instance, in Fig. 129 one set of through-goods sidings, say, the up through-goods, might be omitted, and the down through-goods sidings utilized for both up and down traffic for the time being. Again, many of the sidings in the sorting fans might be omitted in the first instance. But the point to be borne in mind is that in first laying out a yard space should be reserved for all probable future extensions. It will be seen in particular that if the goods platform be placed too close to the main lines in the first instance, the yard will be permanently cramped.

10. The student should endeavour to trace out hypothetical movements of trains on this plan. For instance, say a down through-goods train has to detach 10 wagons at this station and to pick up 8. Having arrived *via* X on one of the down reception sidings, the engine takes the 10 wagons (leaving the rest of the train on the siding) *via* H on to the shunting neck L, and then backs them, *via* K, on to the inwards line of the down service loop, where they are cut off. It then picks up the 8 outwards wagons, previously assembled on the outwards line of this loop, attaches them to its train, and thence proceeds on its journey *via* the down departure line HZ. In the meantime the 10 wagons left on the

FIG. 129.

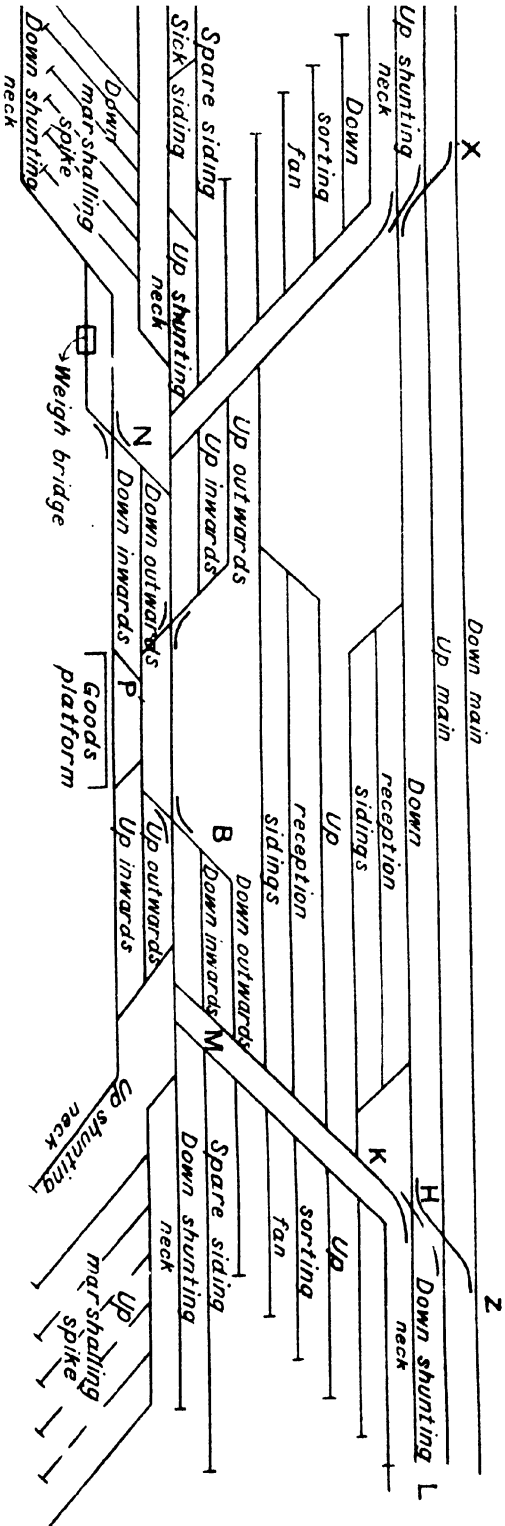



inwards line are dealt with by a shunting engine. Perhaps 5 of them are booked to the shed, 3 to a foreign railway junction somewhere in the up direction, while 2 are for a wayside station a few miles further down, where through-goods trains do not stop. The first 5 will be taken to the shed (to be unloaded or loaded as the case may be), the next 3 put into a siding allotted to the abovementioned foreign railway junction in the up sorting fan (whence they will be conveyed by the next train destined for that junction), while the last 2 will be taken to the local siding in the down fan, to be attached to the next down local train which stops at every station in the adjacent section.

11. It will be observed that there are four service-loops in Fig. 129. Those adjacent to the goods platform might be called the "shed" service loops and the others the "general" service loops, to distinguish their functions. Thus BM would be the down general service loop, and NP the down shed service loop.

12. The design shown in Fig. 129 is based on the assumption that local goods traffic is an important feature of the station; hence both up and down sorting fans are placed on the same side of the main lines as the goods shed. It may happen that local goods traffic is insignificant, or only in one direction, and that the station is mainly a forwarding or distributing centre for rail-borne goods. In this case, it would probably be more convenient to have all the up sidings on one side of the line, and the down sidings on the other, as in Fig. 131. The precise position of

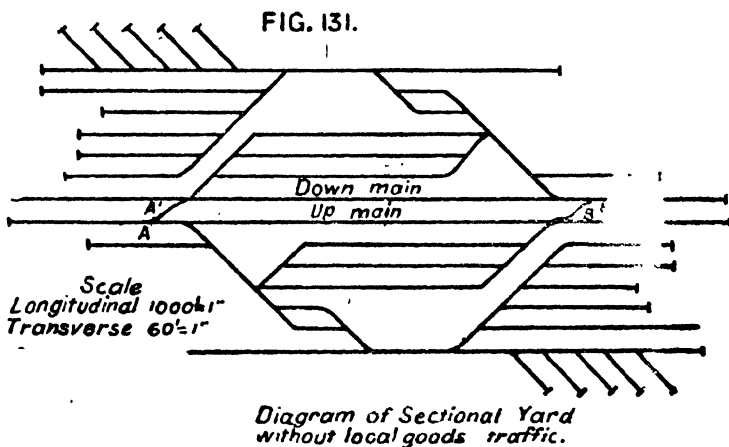

the local goods shed, if there is one, would then be immaterial, provided access is obtainable from one side of the yard to the other, in the case of double line, by means of suitable cross-overs AA' and BB' between the up

and down main lines. Plate XXX shows a plan of an actual section yard, which exemplifies the above principles.

13. **Junctions.**—The simplest kind of junction is at a wayside station on single line, when the traffic of the branch line as well as that of the junction station itself is very light. In this case assuming that all trains can be dealt with on a single platform, and taking Fig. 116 as representing the type of wayside station under consideration, the branch line can meet the main line outside the facing points, as at A in Fig. 132

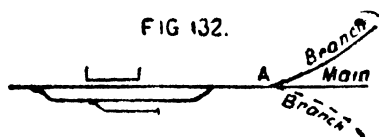

With anything but the lightest traffic however, the objection to a single platform is that it handicaps the time-table. For it is manifestly impossible to arrange satisfactory train connections if a branch train and a main line train cannot be admitted into a yard simultaneously. Thus if the traffic is likely to be considerable, a second or a double platform should be provided, and a separate approach given to the branch line, as in Figs. 133 and 134. The loop provided for the branch line is

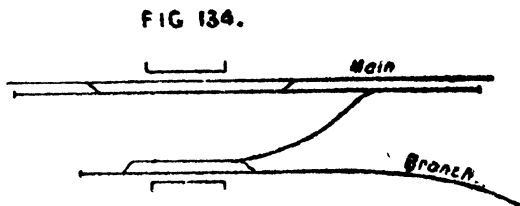
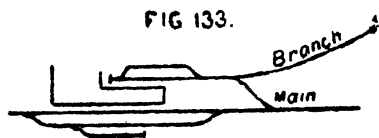

for the purpose of enabling the engine to run round its train and couple up at the other end for the return journey. At such a station, the engine of the branch train would usually water at the main line water-columns, hence easy means of access from the branch platform lines to the main line or its loop should be provided as shown in the figures.

Figs. 135, 136, 137 and 138 show suitable arrangements for a junction

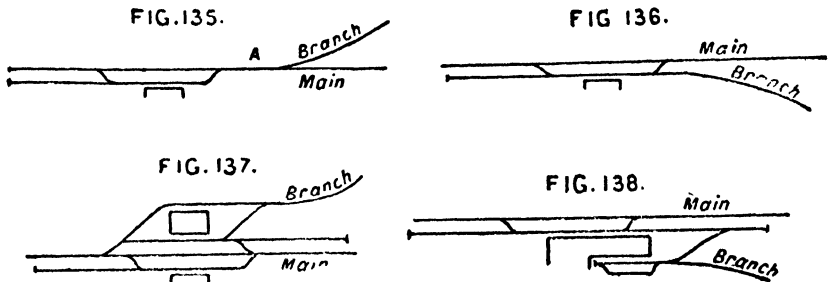

with a main station of the type shown in Fig. 117.

14. In the case of a single-line branch connecting with a double line station, the arrangement might be as in Fig. 139. Or, if branch train

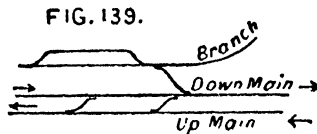

services do not terminate at the junction, a more convenient arrangement would be as in Fig. 140.

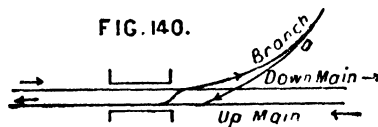

15. When both the main and branch lines are double, the arrangement is comparatively simple as in Fig. 141.

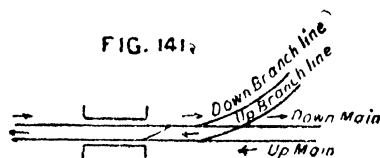

16. Hence at important junctions where several branches meet, the double-line principle of working should be observed, and the branches themselves should be double line as far as the nearest station or block cabin on each from the junction, even though they may be single line beyond, as shown in Fig. 140. As a rule there would be not only an up and a down main platform for through trains, but also a separate platform or dock for each local passenger service. The principle is that the various

branches should join the main line under the control of a junction cabin at some distance from the station proper in either direction, and should then splay out towards their respective docks at the station. Thus, in Fig. 142

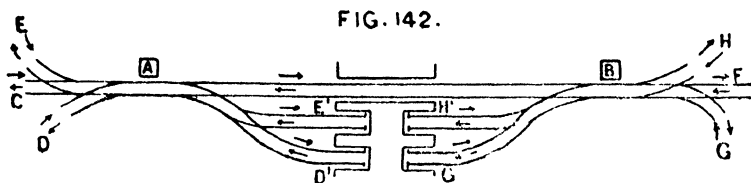

CABF is the main line (double), EA and DA double-line branches joining the main line near the junction cabin A at one end of the station, and HB and GB similar branches joining the main line near cabin B at the other end. Between the cabins and the station, the branches splay out to their respective local train docks, branch D to D', E to E', and so on. The goods yard, if there is one, should be quite separate from the passenger station. It might take off from, and rejoin, the main lines somewhere near A and B, respectively.

17. **Termini.**—The design of terminal yards will follow generally the principles set forth in this and the preceding chapter. Thus, almost any of the stations we have described would serve the purpose of a terminal station if we imagine access cut off at one end or the other. In addition, there must be some means of turning an engine, either by a turntable or a triangle, as described in Chapter V.

18. At junctions, as well as at termini, lay-by sidings have to be provided as required for stabling rakes of carriages at the end of a journey, till such time as they may be required again. Such sidings would be provided with examining-pits and carriage-cleaning arrangements.

19. **Locomotive yards.**—In ordinary country a run of 80 to 120 miles is reckoned a fair day's trip for an engine. Hence, engine-changing stations are required on an average about 100 miles apart. A fast express engine, which makes very few halts and does not haul a heavy load, may do a double run in a day. But as a rule an engine on arriving at an engine-changing station may be assumed to have finished its day's work. It will then proceed to the locomotive yard, where its fire will either be drawn completely, or cleared of ashes and banked up for the return journey next day, according to circumstances. Before dropping steam it would be required to go on to the turntable to be turned for the return trip, then to the fuel platform for fuel, and lastly to the siding allotted to it in the running shed (or in the yard, if the shed is full), when it would halt over an ashpit, with a water-column alongside, to enable its

interior economy to be attended to, until ready to start on the return journey.

20. About once a week, a day, known as *shed-day*, is set apart for an engine to be thoroughly overhauled in the shed, and its boiler washed out with water under considerable pressure from a tank at least 30 feet, and preferably 40 or 50 feet, above rail level.\* This treatment of the boiler is called a *washout*. Ordinary repairs can be done while it is in the shed, but if considerable repairs are required it should be removed to a "sick" siding. There may be several such sidings, according to the size and requirements of the yard.

21. The above are the main requirements of a locomotive yard. When designing one, the following points should be observed:—(i) there should be a clear run (outside the shed) from the traffic yard to the turntable,† (ii) the latter should be at the end of a dead siding, so as not to form an obstruction, (iii) there should be a clear run from the traffic yard to the fuel platform to give access to fuel trains, (iv) this fuel siding should include a loop opposite the fuel platform long enough to accommodate the longest fuel train, (v) the shed sidings should offer sufficient accommodation for the largest number of engines likely to be in the yard at one time, but the actual shed need only be large enough for the largest number requiring a "washout" at one time, (vi) the sick sidings should be easily accessible, (vii) there should be a second or emergency entrance to the locomotive yard from the traffic yard, in case of the regular one being blocked by accident, (viii) the actual position of the tank (which will partly depend on the position of the well, or source of supply) is immaterial, as pipes would be laid from it to the washout hydrants in the shed and to the water-columns outside; but of course the

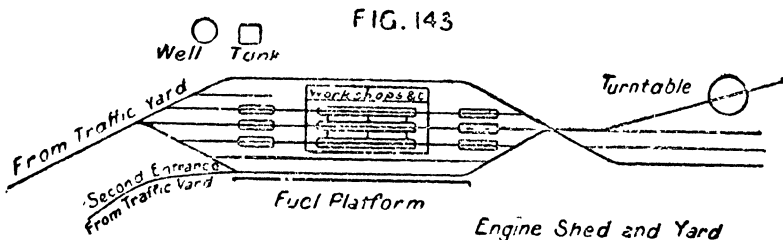

nearer it is to the shed the less loss of head there would be through the pipes. The well, with its pump-house, should also be as near at hand as possible to facilitate supervision. Fig. 143 may be taken as an

\* The minimum height prescribed by the Government of India is 30 feet for the metre gauge and 40 feet for the standard gauge.

† Vide Chapter V, paragraph 4.

example of a locomotive yard complying more or less with the above principles, though of course it is open to many modifications, depending on local conditions.

22. It is impossible within the limits of this Manual to go more fully into the principles which should be observed in the design of station yards, on the efficiency of which the great problem of railway transportation so largely depends. In the foregoing paragraphs only the fringe of the subject has been touched. It is only in recent years that the design of station yards has been accorded the attention which it deserves. Many of the old yards which are to be found on every line have grown indiscriminately from small beginnings, and without any definite plan being followed, with the result that under present-day conditions of traffic they are ill-adapted for their requirements and very large sums are now being expended on re-arranging or entirely re-constructing them.

#### NOTE ON SHUNTING BY GRAVITATION.

At the top of the incline (see Plate XXIX) are the arrival or reception sidings. The wagons of trains arriving here have to be made up into trains for various destinations. Say a train has just arrived, to be broken up, the wagons are one by one shunted by gravitation into one or another of the lines of the sorting group. Each of these lines is reserved for a train to a particular destination. Thus the train just arrived may contribute wagons to half a dozen different future trains.

In this way, the wagons of trains arriving at the reception sidings are gradually "sorted" into sidings where they become the component parts of future trains. Directly one of the sorting sidings is sufficiently full to make up a train load, its wagons are marshalled by being passed through two "grids" (still by gravitation), Fig. 144. In the first grid the wagons

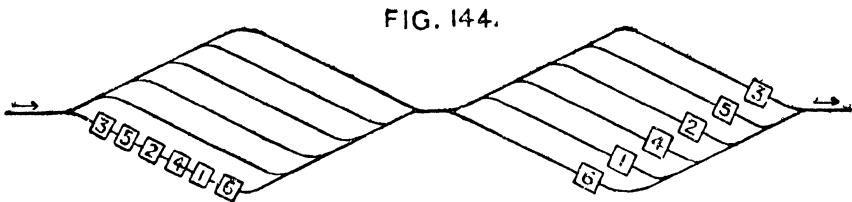

are sorted according to stations; thus siding A will be for wagons for station A, siding B for station B, and so on. In the second the wagons of the nearest station (which will be placed next to the engine) are put parallel to one another, one wagon at the departure end of each siding. The

wagons of the next station will be similarly ranged behind them, and so on. Lastly, the wagons are admitted one by one, in final order required for the train, into one of the departure sidings, where, when the operation is complete, the train will be ready for despatch as soon as an engine is attached. The second grid is sometimes omitted.

The following details may be noted. Shunters are ready to put the side brakes on wagons as soon as they arrive in position in their respective sidings. In case they should not be alert enough, special *chain drags* are placed at the lower end of each group of sidings to catch runaway wagons. These drags act automatically, a protruding hook catching the axle when the signal which presides over the drag is at "danger." Lastly, a catch siding is provided at the lower end of the departure sidings, to protect the main line. The points are worked from cabins.

A partial use of the gravitation system is often found in England, the sorting being done by gravitation and the marshalling by shunting-engines.

## CHAPTER XIV.

### SIGNALS AND THEIR USES.

1. In Chapter V a "stop" signal was defined and described in detail, and its use and significance explained. We have now to consider where stop signals should be placed in order to fulfil their primary purpose of protecting trains from the danger of collision with obstructions.

2. The physical basis of the whole question is the distance in which a train in motion can be brought to a halt. This distance depends on four principal factors—(i) the weight of the train, (ii) the speed, (iii) the brake power, (iv) the grade. It will have been seen from Chapter X, paragraphs 34 and 35, that it may be stated broadly that, with a given weight and a given brake power on the level, the stopping space will vary as the square of the speed, and will be greater downhill than uphill.

3. In practice, when the grades are easy, the full brake power of a train is not used for every halt, nor is it applied for any specified length of time. It is usually within the control of the driver who uses his discretion in applying it. Hence it may be said that on ordinary easy gradients there is sufficient play in the third factor to nullify the effects of slight variations in the fourth, so that the stopping-space may be said to depend ordinarily on the first three factors only. Even these three variables in combination do not yield as wide a range of results as might be expected. For, in practice, the heaviest trains are not usually the fastest, and imperfectly braked trains are not allowed to run at high speeds. The net result is that most standard-gauge trains, running at their highest permissible speeds, on easy grades, can be brought to a halt within a *quarter of a mile* from the place where the brakes are first applied (steam having previously been shut off). The corresponding space for metre-gauge trains may be taken at about one-third of that distance. In somewhat hilly country this stopping-space would be increased in the direction of a falling gradient and reduced in the case of a rising gradient. Again, in ghaut working, where the grades are very steep, special brake power is provided, speed restrictions are enforced, and brakes are applied continuously downhill to prevent the train exceeding the speed limit. Under these conditions the train is kept well under control, and brought to a halt in practically as short a space as on the level. To provide for the remote contingency of brakes failing and trains getting out of control, special catch sidings are provided. But these need not be considered here as they

do not affect the question of the stopping-space under normal working conditions.

4. To sum up, it may be assumed that in level country, as well as on steep down grades worked under special brake rules, the stopping-space to be provided for *stan dard-gauge* trains should not be less than a *quarter of a mile*, and for *metre-gauge* trains not less than 400 feet. Also that on moderate down grades not subject to special rules these distances should be increased, but that on up grades some reduction might in certain circumstances be permissible.

5. To apply the above principles, let XY be a line of standard-gauge  
 X  $\longrightarrow$   $a$   $A$   $B$   $b$   $\underline{\hspace{1.5cm}}$  Y railway and AB a section on which there is  
 an obstruction. Let the arrow represent a (down) train from X travelling at its customary speed in the direction XY. To avoid a collision at A it is evident that the driver must begin to retard his speed at some point  $a$  at least a quarter of a mile short of A. It is equally evident that this interval of a quarter of a mile would allow no margin of safety, for a slight error of judgment on the part of the driver or slight defect in the brake action might result in his overshooting the point A, and so colliding with the obstruction. It is therefore necessary that he should begin to pull up before reaching the point  $a$ , and the simplest way to ensure his doing so is to put a "stop" signal at  $a$  and to keep it at "danger." If he then accidentally overshoots the signal  $a$ , passengers at least will be protected from disaster owing to the intervening margin of safety. It must be borne in mind, however, that this margin is for the protection of passengers and not for the convenience of the driver. As far as the latter is concerned, the overshooting of a signal by careless driving is a criminal offence and must be treated as such.

6. It may be thought that this quarter-mile is an unnecessarily large margin of safety. And so it would be if a driver could be depended on to see the signal for at least a quarter of a mile before arriving at it. But it must be remembered that trains have to travel by night as well as by day, in fogs and dust-storms as well as in clear atmosphere, round curves and in cuttings that obstruct the view, as well as on the straight and open track ; also that signal  $a$  is the first stop signal the driver would meet after a run of, perhaps, several miles in the dark, and that from various causes he may not see it until he is close to it; in which case the quarter-mile margin between him and the obstruction would be none too great.

7. Now, after the driver has brought the train to a halt at signal  $a$ , there would be no harm in taking that signal "off" to allow him to

proceed as far as A, provided there is another stop signal against him at A. For the element of danger, represented by the kinetic energy of the running train when approaching *a*, is destroyed by the halt at that spot, *after* which the train may be considered sufficiently "in hand" to be beckoned on at slow speed to within a few feet of the obstruction.

8. Now, let AB represent a station section, i.e. the space liable to be obstructed by a halted or shunting train at a station, and let us consider only trains moving in one direction, say, the down direction, i.e. from X to Y. The first stop signal at *a* is called the "*outer*," and the second stop signal, which in this case marks the rear of the station section (although in single-line working, as we shall see later on, its position does not always coincide with the section limit), is called the "*home*" signal. The space between the *outer* signal and the rear limit A of the station section may be called the *sub-section*.

9. In accordance with the foregoing principles, when the station section is obstructed, as, for instance, by a train standing or shunting therein, both the home and outer signals must be kept "on," i.e. against a running train from X, until such train comes to a halt, when the outer if necessary may be taken "off" to admit it as far as the home.

10. Now let us go a step further, and suppose that the obstruction in AB has been removed, so that the line is clear as far as B, but obstructed immediately beyond in the direction of Y. Then provided the distance AB is not less than a quarter of a mile, the outer may be taken off for a running train from X, till the train is brought to a halt at the home, after which the latter signal may be lowered to admit the train to the station section.\*

11. Lastly, if the line is known to be clear for at least a quarter of a mile beyond B in the direction of Y, both the outer and the home may be safely lowered for a running train from X, to admit the train direct to the station section.

12. It will now perhaps occur to the student that there ought to be a stop signal at B also, to mark the forward limit of the station section. It is true that the forward limit must be clearly demarcated, but it does

---

\* In the majority of interlocking installations in India, the home is so interlocked with the outer that the latter cannot be lowered until the home has first been lowered. In such a case the train would have to come to a halt at the outer, and to stand there until the obstruction was removed, and both home and outer could be lowered; or it might be beckoned by hand-signal up to the home, and after coming to a halt there, be admitted to the station section, by the lowering of the home.

not follow that a stop signal of the semaphore type is necessary, for the following reasons. When a train is within a station section its movements are under the orders of the station master, consequently no train may leave the station until the driver has received authority from the station master to do so. Now, on a single line, the "authority to proceed" is in the form of a special ticket or token which is issued by the station master and handed to the driver as his passport to the next station. In the absence of such a passport the driver may not go beyond the station section limits, but with this passport he is at liberty to take his train on. Thus it will be seen that, under single-line working conditions, a semaphore stop signal at B would be superfluous, for even if lowered it would not justify the driver in passing it without his passport; while on the other hand, if the signal is there, the formality of lowering it would have to be performed every time a passport is issued, and before such passport could be acted upon. Nevertheless, such signals are occasionally used in single line stations over a certain size, and when so used they are called *starting signals* or *starters*. When starting signals are not used, the station section limit is most conveniently demarcated by a board marked "shunting limit" or some such device.

13. On double-line, for reasons which we need not stop to consider, it is not considered necessary to issue a special passport to the driver to leave a station: his movements are sufficiently controlled by signals only. In this case, therefore, a starting signal is invariably placed at the station section limit B, the lowering of which is his "authority to proceed" to the next station.

14. It will, of course, be noted that both in single-line and double-line stations, the limit B should be placed sufficiently far forward to allow of all ordinary shunting operations being carried out without passing it. About 200 yards in advance of the furthest set of trailing points (on the main line) is usually considered sufficient, and it is not considered desirable to exceed this distance. On the rare occasions when a train of greater length has to shunt clear of the points, the station master can give special authority to pass the limit for the purpose.

15. It will be gathered from the foregoing remarks that the really essential stop signal at any station is the *outer*, which must be at least a quarter of a mile from the station section limit on the approach side. Also that in double-line stations the station section limits are marked by stop signals for convenience of working, the one on the approach side being called the *home*, and the one at the departure end the *starter*. Thus,

an ordinary double-line station of the type shown in Fig. 103 would be signalled as shown in Fig. 145.

FIG. 145.

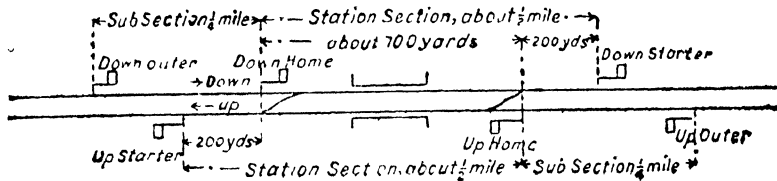

Note that the homes are placed so as to protect the cross-overs.

16. The type shown in Fig. 122, with a small goods yard attached, would be signalled as in Fig. 146.

FIG. 146.

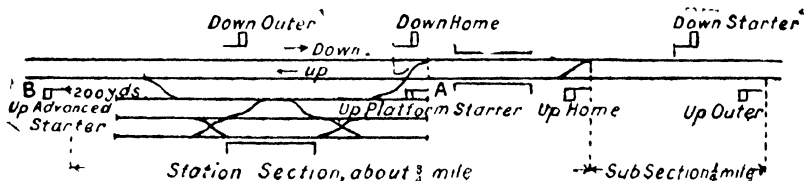

In this case an extra stop signal is advisable, to protect the diamond crossing on the up track. This would be placed at the forward end of the up platform, as shown at A. A signal in this position is also called a starter, but as it does not mark the station section limit, it should not be confused with the real starter, which is placed at B, 200 yards beyond the trailing points of the goods yard. To distinguish between these two signals, the inner one which protects the diamond crossing is called the platform starter, or simply the starter, and the other which marks the forward limit of the station section, the advanced starter.

17. We have now to consider whether a *home* signal is necessary in a single-line station, and, if so, where it should be located. Taking the standard type of single-line crossing station shown in Fig. 111, which consists of a straight line and a loop, the first thing to decide is where to fix the station section limits. If the main line points at each end mark the limits, all shunting beyond those points on the main line would obstruct the sub-section, and would have to be stopped before a train from a neighbouring station could be permitted to approach. It would, therefore, be more convenient to fix the limits beyond those points, say,

200 yards beyond, for shunting purposes. Hence, if A, Fig. 147, marks the

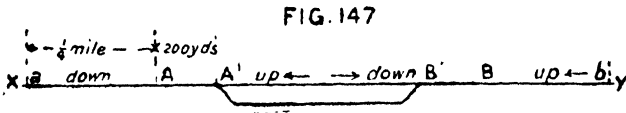

shunting limit 200 yards from the point A' in the direction of X, and the outer is placed at *a*, a quarter mile from A (assuming a standard-gauge line), a down train from X may be permitted to approach as far as the outer *a* (which must of course be kept "on") while an up train is shunting as far as A. As soon as the shunting train has backed within the loop, the points at the A' end may be set for the down train, and the outer lowered to admit it. Thus, a home signal is not required to mark the station section limit A, as that is done by the shunting board. Nor is a home signal essential at the facing points A', as far as the driver is concerned, for by hypothesis the outer is not lowered until the station section is ready to receive him. Nevertheless, facing point signals have their uses in the form of "routing" signals, which we now proceed to describe.

18. A *routing* signal is a bracketed stop signal, of the form shown in Fig. 148, placed at facing points to indicate for which track the points are set. The arm relating

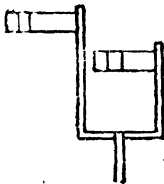

to the straight or main track is usually placed higher than that for the loop. Thus, the signal as shown in the figure is applicable to the facing points A', the straight being on the left-hand side. These signals are usually interlocked with the points, in such a way that it is mechanically impossible to

lower one arm when the points are set for the route to which the other applies. Thus, routing signals are useful from the station master's point of view as ensuring that the arm which is lowered correctly indicates the setting of the points, while the information they convey to the driver enables him to decide how to enter the points, i.e. if set for the loop he should slacken speed to mitigate the inevitable lurch, but if for the straight he can go ahead with confidence. On the other hand, if neither track is ready for his reception, both arms would remain "on." But the existence of this second stop signal, which constitutes the *home* in this case, would enable the train to be drawn close up to the points if desired, *after* being brought to a halt at the outer, as already explained. The signalling of a station of the type shown in Fig. 116 would be as in Fig. 149. On metre-gauge lines the

same arrangement would apply, except that the sub-section might be reduced from a quarter of a mile to about 400 feet when conditions are favourable, although a wider margin, say, 600 feet, would be safer.

FIG. 149

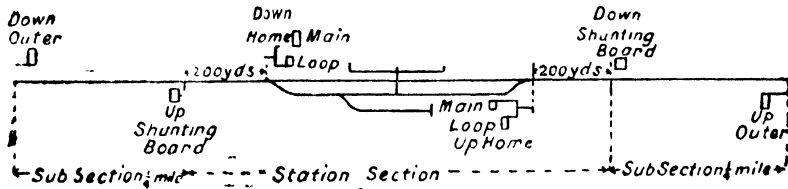

19. Routing signals can be made with any number of arms to indicate a corresponding number of diverging tracks. For instance, the left end of the junction station in Fig. 137 might have a routing signal as shown in Fig. 150.

FIG 150.

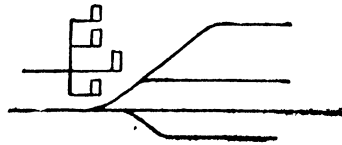

20. In single-line stations the minimum length of loop laid down by the Government of India for both standard and metre-gauge stations is 7 per cent. greater than the length of the longest train running on the section. Thus, a home signal placed at the facing points would always protect the rear of a train halted at the station. In double-line stations, where there are no facing points to mark the position of a home signal, care should be taken to place the latter at a sufficient distance in rear of the next stop signal (platform starter, or whatever it may be) to protect the rear of the longest train, subject to a *minimum* of a quarter mile.

21. **The Absolute Block System.**—The object of this system is to regulate the movements of trains. As we have seen in Chapter IV there are certain stations, technically called flag stations, which are not equipped with apparatus or staff for controlling the movements of trains, and which are, in fact, not regular stations. These are not recognized in the block system, being merely halting places *en route* between two regular stations. The latter, which are called *block stations*, may be defined as the stations at which authority to proceed is given under the

system of working in force on the railway. This definition includes block cabins, which though controlling the movements of trains are sometimes situated at places where traffic is not booked, and which are consequently unknown to the general public as "stations."

22. Block stations being telegraphically connected with one another, the fundamental rule is that no train may leave one station for the next until the latter has telegraphed permission to approach. This permission applies to the section of line between the departure end of the first station section [i.e. the shunting board or (advanced) starter, as the case may be] and the first stop signal of the next station (i.e. the outer), together with the sub-section extending from the outer to the station section of the second station. This section of line (including the sub-section) is called the *block section* and the permission to approach accorded or refused by one station to another is based on accurate knowledge as to whether the block section is clear or not. This knowledge is obtained by the mutual telegraphic record kept by each station, of the departure and arrival of every train at either end of the block section. Again, in giving permission to approach, it is not sufficient that the block section up to the outer should be clear: the sub-section of the receiving station must also be clear. Even then, as we have seen, the outer must be kept "on" unless the station section is also clear, or otherwise until the approaching train has been brought to a halt. While a train is on a block section, the section is said to be blocked.

23. It may sometimes happen that a train does not require to stop at a block station. In this case permission to approach is obtained beforehand, not only for that station but also for the next station ahead, so that when the train arrives at the run-through station it may, without stopping, be given "authority" to proceed. On double line this is managed by simply lowering the starter as well as the home and outer. The train then runs through. But on single line where, as we have explained, the "authority to proceed" takes the form of a ticket or token, which the driver must have in his possession, and which applies only to one block section at a time, the rule is for the station master of the run-through station to get the ticket or token for the next section ready beforehand, and to hand it to the driver as he reaches the facing points of the run-through station.

24. A number of token instruments have been devised and are in use, for the purpose of ensuring that when a token has been issued to the driver of a train proceeding on a given block section, it shall be mechanically impossible for the station master at either of the stations at the ends

of the section to obtain a second token for the same section, until the train has passed out of it, and the token in use has been delivered up and placed in the instrument at the end of the section. Further, neither station master can issue a token without the knowledge and co-operation of the other. Thus, if the instruments are in order, it is impossible for two trains to be on a section simultaneously, and the risk of collision between two stations is entirely eliminated. The instruments, which are worked and controlled electrically, are of many types. That most commonly in use in England is known as Tyler's Tablet Instrument, of which a number of different models have been designed from time to time by the inventor. In this instrument the token is in the form of a metal disc; in others, it may be a key or a ball. Theobald's Key Instrument and Neale's Ball Voucher Instrument are types of Block Instruments well known in India.

25. On lines not provided with block instruments, the authority to proceed is, as stated above, usually a ticket, which is written up by the station master issuing it, after he has obtained the necessary authority to do so from the station master at the other end of the section.

26. If the section ahead is blocked when the train arrives, the train of course has to be stopped. It is therefore desirable that the driver of a run-through train should know, before he actually arrives at a station, whether the section beyond is clear or not.

This information is conveyed to him by *warning signals*, or *warners*, which we now proceed to describe. A *warner* is a semaphore signal with a fish-tailed arm (Fig. 151) to distinguish it from a stop signal. It is usually placed on the same post as, and 6' or 7' lower than, a stop signal (usually the outer), see Fig. 152. Warner arms are pro-

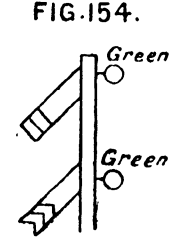
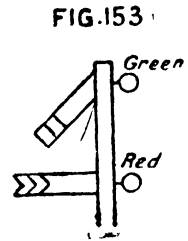
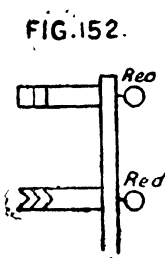
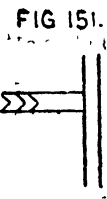

vided with lights, as in the case of stop signals, to indicate their position by night. When the warner is "on" it implies that the block section ahead is blocked, and when "off" that it is clear. Although it

has separate operative mechanism, it is partially controlled by, or "slotted to" (as it is technically called), the outer: that is to say, it cannot be taken "off" when the outer is "on." Not being a stop signal, a driver may pass it when "on," if the stop signal above it (i.e. the outer) is "off"—vide Fig. 153—but must proceed cautiously and must be prepared to stop at the station, or even at the next stop signal (the home), if that is against him. When both the outer and the warner are "off" (Fig. 154) the driver may proceed with confidence, knowing that the block section ahead is clear. (He would still however on single line have to pick up a line clear ticket or token when passing the facing points, as already explained.) At night the warner can be distinguished by the relative positions of the two lights. Thus, red over red (Fig. 152) means "stop," green over red (Fig. 153) "proceed with caution," and green over green (Fig. 154) "proceed with confidence."

27. On double line it may sometimes happen that the stations are so close to one another that the (advanced) starter of one coincides with the outer of the next (i.e. the block section in this case consists of a subsection only), or may at all events be very close to it, in which case the warner would naturally be placed on the (advanced) starter, so that the driver of a run-through train would know before leaving the first station whether he would be "blocked" at the next station or not.

28. In order to prevent warners from giving false information, their use is confined, in practice, to interlocked stations only, so that it is mechanically impossible to lower a warner unless the outer, home and starter (if used) have all previously been lowered, and the points for the departure, as well as the arrival end, correctly set for the run-through train.

29. **Signal repeaters** are sometimes used when the driver's view of the signals to which they refer is obstructed by curves or other causes. (N.B.—These are not to be confused with the electrical repeaters described in Chapter V, paragraph 21.) The outer repeater is an indicator fixed at an adequate distance outside the outer signal for the purpose of advising the driver whether the outer is "off" or "on." It may take the form of a white disc showing a black horizontal bar (signifying caution), when the outer signal is on, and a black diagonal bar (signifying "proceed") when the outer is "off." If used at night the repeater must be so illuminated as to make its indications clearly visible.

30. **Co-acting signals** are duplicate signals fixed at least 15 feet vertically below ordinary signals, and are provided where, in consequence of the great height of a signal post, or of there being an overbridge or

other obstacle, the main arm or light is not in view of the driver during the whole time that he is approaching it.

31. **Dwarf or Miniature signals** are sometimes used for shunting and other purposes in a large yard. But they need not be described in detail here. Fancy signals may be multiplied to any extent, but unless they are clearly distinguishable, more especially at night, from the main signals, their extensive use is not desirable, as they only tend to confuse a driver. For it must be remembered that the safety of the travelling public depends, after all, entirely on the driver's interpretation of, and attention to, the signals he sees. Those signals must therefore be as simple and as unambiguous as possible, and as few in number as may be consistent with safe working.

32. The above principles of signalling form the basis of the system approved by the Government of India for adoption as the standard system for railways in British India. Some relics of older systems are still to be seen on certain railways, but as renewals fall due or alterations are carried out, they are gradually being eliminated.

## CHAPTER XV.

### PRINCIPLES OF INTERLOCKING.

1. On railways where traffic is light and trains have to stop at every station, pointsmen can usually be trusted to set points and to lower signals correctly, under the general orders of the station master. If they do occasionally make mistakes, say, by admitting a train on to a siding already occupied by another train, or by lowering a signal too soon, the comparatively slow speed of the trains prevents really bad accidents from happening if the driver is fairly alert.

2. But when fast trains have to run through a station without stopping, the case is very different; for the driver has to trust entirely to signals, and if these are wrongly lowered, or if points are wrongly set, disaster is inevitable. The first essential of safe working, then, is (i) that it shall be impossible to lower a signal for an approaching train unless the line to which it relates is correctly set and locked; and that, conversely, while the signal is lowered it shall be impossible to unlock or reverse the points. The second essential is (ii) that it shall be impossible for loose wagons from any part of the yard to obstruct the line prepared for an expected train, after the signals relating to that line have been lowered for the train. Lastly, (iii), it shall be impossible to lower signals for the admission of trains from opposite or converging directions to the same line at the same time (i.e. contradictory signals). These essentials are secured by mechanical interlocking between the levers which work the signals and actuate the points.

3. Dealing with the first essential, let us consider the down signals of a typical crossing station, Fig. 155 (which is Fig. 149 with warners

FIG. 155.

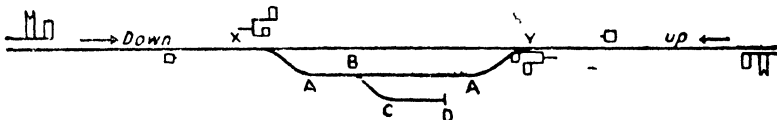

added). The routing signals X will be so interlocked with the facing points that the loop signal cannot be lowered when the points are set for the main line, and vice versa. Again, the down outer will be so interlocked with the routing signals that it cannot be lowered until one of them is first lowered. Lastly, assuming that the facing points are set for the main line, and the main home and outer both lowered, the warner

(for a run-through train) cannot be lowered unless the trailing points **Y** are also set and locked for the main line.

4. Next, with regard to the second essential, let us suppose that the dead-end siding **BCD** (Fig. 155) is used for the purposes of goods traffic or for stabling spare vehicles, then as explained in Chapter XII, paragraph 16, so long as the trap points **C** are set against the dead-end as at **G** in Fig. 116, it is impossible for loose wagons from the dead-end to obtain access to the loop or the main line. We must therefore ensure that the trap points are set against the dead-end, when signals are lowered for the reception of a train either on the main or the loop line. The points of the crossover leading to the dead-end would be set normally as shown in Fig. 116, and the interlocking would be so arranged that it would be mechanically impossible to work the trap points, when the loop or the main line routing signal at either end of the yard was lowered. The subject of "trapping" is most important, and the student should remember that not only dead-end sidings used as described at the beginning of the paragraph, but also all goods and locomotive yards should be trapped from all running lines.

5. Coming now to the third essential of interlocking, namely that contradictory signals should not be capable of being lowered simultaneously, this can be effected by a direct interlock between the principal up and down signal levers. In a station yard similar to that under discussion, it should not be possible for more than one train to be admitted to the station at the same time. It might appear at first sight that it would be permissible to admit a down train to the main line and an up train to the loop simultaneously. This is not the case, however, as, if either train overshot the point at which it was intended to halt, a collision might take place either at the up or the down end of the yard. When therefore either the main line or the loop routing signal at either end of the yard is lowered, it should be impossible to lower any one of the others.

6. Direct locking between signal levers is however seldom required, as the locking can usually be provided indirectly through the points levers and locks. For instance, if **A** is the junction of two branches **AB**, **AC** and **B**, **C**, their respective home signals, the signals **B** and **C** would not be interlocked with one another,

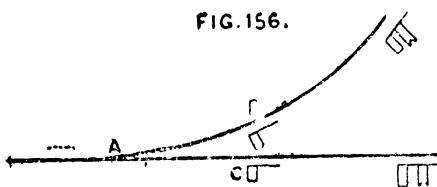

but with the points at A, so that it would be impossible to lower signal B if the points were set for A C, and vice versa.

7. The actual mechanism of interlocking will be considered in the next chapter.

8. It will now be shown how the wayside station shown in Fig. 155 may be interlocked in accordance with the foregoing principles. First let

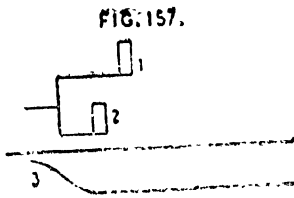

us take the routing signals at the turnout X of that figure, and let us assume that each of the signals and the points will be operated by a lever in a lever frame conveniently situated. Thus, No. 1 lever will work, say, the main signal, No. 2 the loop signal, and No. 3 the points, corresponding to the numbering shown on the diagram,

Fig. 157. Let us also assume that the normal setting of the points is for the main line, and the normal position of the signals at danger as shown. Now, if we wish to ensure that No. 1 cannot be lowered when No. 3 is set for the loop, we must interlock 1 and 3 in such a way that the pulling of one lever prevents the other from being pulled. This is briefly expressed, in the language of interlocking, by saying that 1 *locks* 3, and 3 *locks* 1, the full meaning of which is that 1 when pulled locks 3 in the normal position and similarly that 3 when pulled locks 1 in the normal position.

9. Similarly, to ensure that 2 cannot be lowered when 3 is set for the main line, we must interlock 2 and 3 in such a manner that 2 cannot be pulled until 3 has first been pulled, and conversely that 3 cannot be restored to its normal position until 2 has first been restored. This is expressed by saying that 3 *releases* 2 and 2 *back-locks* 3, the full meaning being that 3 when pulled releases 2, and that 2 when pulled prevents 3 from being restored to normal. The interlocking table would read as under :—

Lever No.	Releases.	Locks	Back-locks.
1		3	
2			3
3	2	1	

10. Now, the above interlocking arrangements, although theoretically complete, are deficient in one particular. In the case of facing points, it is not sufficient that the points should be correctly set by the points lever; for the presence of a small pebble or other obstruction between the

tongue and the stock rail, with which it is supposed to be in close contact, may be sufficient to cause a slight gap even when the lever is pressed home. Or, even if in close contact before the arrival of a train, slight lateral movements caused by the weight of a passing train may be sufficient to create a slight gap between the tongue and the switch ; in which case some of the wheels of a vehicle passing over the points in the facing direction would be liable to mount the switch and take the wrong track, an accident known as "split points." This risk may be accepted in ordinary shunting operations, but is highly dangerous in the case of fast trains. Hence, it is a stanling rule (as pointed out in paragraph 14, Chapter III) that facing points must always be locked for running trains in such a way that the toague is pressed tight against the stock rail during the movement. In un-interlocked stations this is usually done by means of an ordinary bolt and cotter with a padlock. But in interlocked stations, some form of plunger lock (Fig. 158), acting on the stretcher bar, or on a special sliding bar parallel to the stretcher bar, so as to lock the points firmly in either setting, is used.

11. In the diagram, Fig. 157, let us suppose such a lock provided, and let us call the locking lever No. 4, its normal position representing the lock open that is to say, with the points unlocked and free for shunting. (The facing points lock, as it is called, will be marked in the diagram by a short disconnected stroke near the facing points to which it relates--vide Fig. 159.) Then the interlocking must be so arranged that no signal for a train passing over the points in a facing direction can be lowered until the points have been locked (in either setting) by pulling over the locking lever No. 4.

FIG. 159.

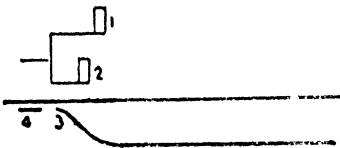

the lock open that is to say, with the points unlocked and free for shunting. (The facing points lock, as it is called, will be marked in the diagram by a short disconnected stroke near the facing points to which it relates--vide Fig. 159.)

12. The foregoing tables would then require certain additions so as to include No. 4, and they would then read as follows :—

Lever.	Releases	Locks.	Back-locks.
1		3	4
2			3 4
3	2	1	
4	1·2	<u>3</u>	3

Observe that 3 is shown as being both locked and lack-locked by 4. When a lever number thus appears in two columns in the same line, it is usual to underline it as shown.

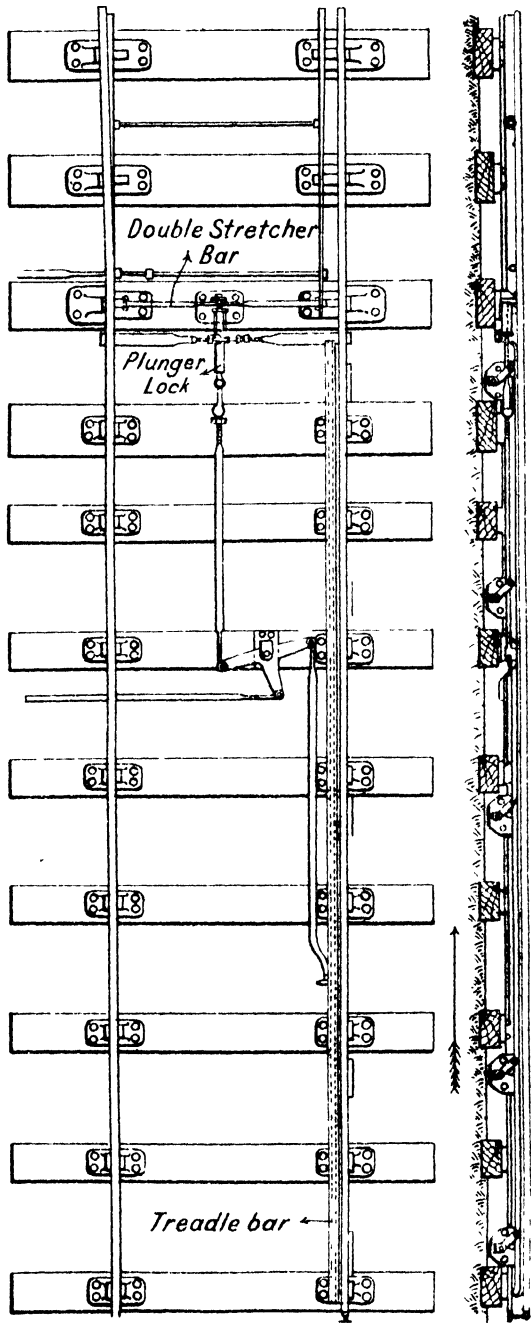

FIG. 158.

FACING POINT LOCK AND TREADLE BAR.



13. Now, let us add an outer signal, Fig. 160, the lever of which we may call 5. Then all that we require is that 5 should be released by either 1 or 2 and conversely, either 1 or 2 should be back-locked by 5. The table with this

addition will then read as under:—

Lever.	Releases.	Locks.	Back-locks.
1	(5)	3	4
2	(5)		3·4
3	2	1	
4	1·2	3	3
5		—	1 or 2

As 5 back-locks 1 or 2, we draw a circle round 5 in the release column against 1 and 2, respectively, to call attention to this relationship.

14. Lastly, let us add a warner, No. 6 (Fig. 161). Now it should

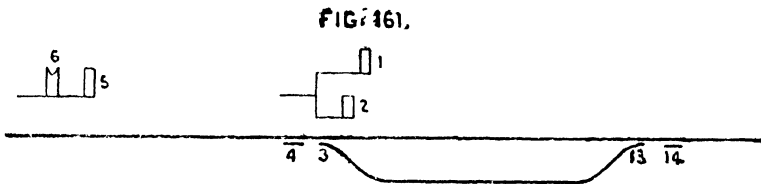

not be possible to lower this unless (i) Nos. 1 and 5 are both lowered, and (ii) the trailing points No. 13 are set for the main line. It is unnecessary that 13 should be locked by 14, as the points are trailing; it is however essential that the signalman should be unable to work No. 14 lever, when once No. 6 has been pulled. Thus, 6 is released by pulling 1 and 5; and, conversely, 6 when pulled, back-locks 1 and 5. Also, 6 when pulled locks 13 and 14; and conversely 13 or 14 when pulled locks 6.

15. Before adding these entries to our table, we may as well complete the diagram for the station (Fig. 162) by adding the signals at

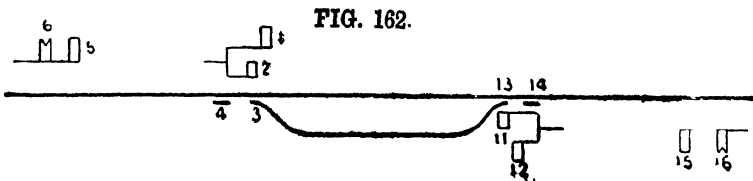

the other end and numbering them. In the figure, we have omitted Nos. 7, 8, 9 and 10. In practice it is usual to have a few spare levers in the frame for future connections if required. In the present case we may assume these four levers to be spare, so that the numbers of the points and signals at the other end may be exactly 10 in advance of the corresponding ones at the end we have been dealing with. This will make it easy for the student to identify them in the table. Thus, the main home signal at one end being 1, at the other end it is 11; the point lock at one end being 4, at the other end it is 14, and so on. Lastly, to prevent *contradictory signals* from being lowered simultaneously, we must make 1 lock 11 and 12, and 2 lock 11 and 12. The complete table in which we have shown the designation of the signals, points and point-locks worked by the various levers, would then be as below :—

Lever No.	Designation.	Releases.	Locks.	Back-locks.	
1	Signal down (home or) routing main	..	⑤·6	3·11·12	4
2	"    "    "    "    loop	..	⑤	11·12	3·4
3	Points facing down main to loop	..	2	1 16	..
4	Points-lock to No 3 points	..	1·2	3·16	3
5	Signal down outer	..	6	..	1 or 2
6	"    warner	..	..	13·14	1·5
7 to 10	Spare	..	..	..	..
11	Signal up (home or) routing main	..	⑤·16	1·2·13	14
12	"    "    "    "    loop	..	⑤	1·2	13·14
13	Points facing up main to loop	..	12	6·11	..
14	Points-lock to No. 13 points	..	11·12	6·13	13
15	Signal up outer	..	16	..	11 or 12
16	"    warner	..	..	3·4	11·15

16. The student will easily see from the above table that for a down train, intended to draw up on the main line at the station, the levers would have to be pulled in the following order :—4.1.5. For a down train intended to run through the station without stopping, the order would be 4.1.5.6. Finally for a down train intended to draw up on the loop, the order would be 3.4.2.5.

17. We have seen from paragraphs 8 and 9 above that if one lever locks another, it is necessary that the second lever should lock the first. Also, that if one lever releases another the second must necessarily back-lock the first. (The manner in which this is accomplished will be explained in the next chapter.) In the preceding table we may therefore entirely omit either the "releases" column or the "back-locks" column. Similarly, when one lever locks another, it is unnecessary to

show this against both levers in the "locks" column. Thus, the complete table of interlocking might be as shown in the following table:—

Lever No.	Releases.	Locks.
1	⑤·6	3·11·12
2	⑤	11 12
3	2	16
4	1·2	(3) 16
5	6	..
6	..	13·14
7—10	..	..
11	⑤·16	13· ..
12	⑤	..
13	12	..
14	11·12	(13)
15	16	..
16	..	..

In the "locks" column the numbers 3 and 13 are enclosed in brackets to indicate that levers Nos. 3 and 13 are both locked and back-locked by levers Nos. 4 and 14, respectively. The student should carefully compare the tables given above in order to impress on his mind the significance of the statements made at the commencement of the paragraph.

18. We may now consider the interlocking of the dead-end siding BCD shown on Fig. 155 in order to fulfil the second essential mentioned in paragraph 2. The normal setting of the points will be as in Fig. 163, in which it will be seen that we have numbered the points at both ends

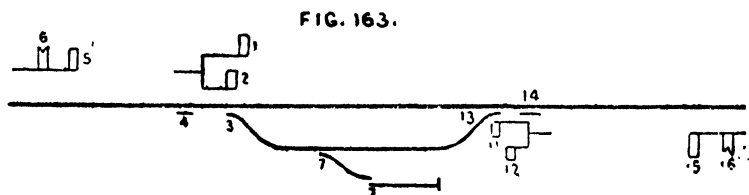

of the crossover leading to the dead-end with the same number 7, indicating that they are both worked simultaneously by lever No. 7. The reason for this is obvious for it will be seen that for a vehicle passing over the crossover from or to the dead-end, both sets of points must be reversed, and it is convenient therefore that they should both be worked by a single lever, the two sets of points being connected together by suitable rodding. This arrangement is called "grouping" of points.

19. Now all that is necessary to ensure that the second essential of interlocking is fulfilled is to make No. 7 lever lock 1, 2, 11 and 12. It will then be impossible to lower a signal for a train to enter the station in either direction, and either on the main or the loop line, while the

crossover leading to the dead-end is in use ; and, conversely, when signals are lowered for any train to enter the station, the crossover cannot be brought into use. We should therefore have to add to the table in paragraph 15 the following locks :—

- 1 locks 7.
- 2 „ 7.
- 11 „ 7.
- 12 „ 7.
- 7 „ 1, 2, 11, 12.

or to the table in paragraph 17 :—

- 7 locks 1, 2, 11, 12.

20. For the station shown in Fig. 164 if we assign numbers 7 and 10 to the coupled points and traps leading to the dead-ends, as shown in the figure, we should have to add to the table shown in paragraph 17 the following locks :—

FIG. 164.

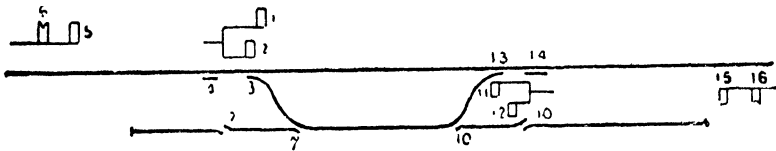

- 7 locks 1, 2, 11, 12.
- 10 „ 1, 2, 11, 12.

21. As explained in paragraph 15, we have made use of the numbering of levers adopted in the preceding paragraphs merely for convenience in identifying the signals, points and point-locks, to which the numbers relate. In an actual lever-frame however the numbering of the levers would be such that the group of levers which the signalman had to pull for the admission of a train to the station would as far as possible be in convenient sequence in the frame. Thus, for the station discussed in paragraphs 8 to 17, the numbering actually adopted in the lever-frame would be as shown in Fig. 165.

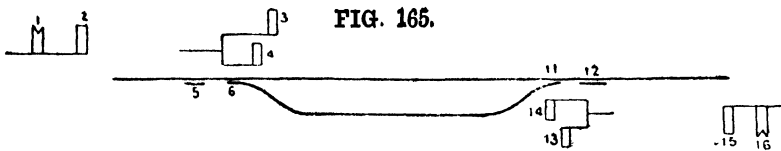

The order in which the levers would be pulled for a down train running through the station would then be 5, 3, 2, 1 ; and similarly for trains halting at the station, the levers would be in convenient sequence.

22. In enunciating the principles stated in paragraph 2 we have considered only the safety of trains entering or passing through a station yard. It is, however, also necessary to observe certain principles for the protection of the points connections during shunting operations. We have already considered one case of this in paragraph 18, in which we have seen that the points at either end of the crossover, leading to the dead-end siding in Fig. 163, are worked simultaneously by the same lever. If the points were worked by separate levers it would be necessary to make the lever working the points in the loop-line release the lever working the dead-end points. This is in order to avoid damage to the points in the loop line in case a vehicle left the dead-end before the loop-line points were properly set. An accident of this kind to the points in the dead-end would obviously be less serious than the damaging of the loop-line points.

23. Similarly in Fig. 166, which represents one end of a station yard

FIG. 166.

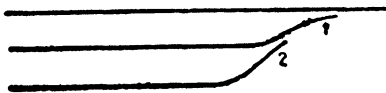

with two loops on the same side of the main line, it would be necessary to make points lever No. 1 release points lever No. 2, for it is obvious that it

should be impossible to allow a vehicle coming from the second loop to pass over points No. 2 until lever No. 1 has first been pulled.

24. In other cases, the setting of certain points should prevent other points from being worked. For example, in Fig. 167, which represents

FIG. 167.

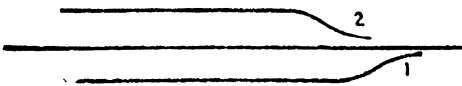

one end of a station yard, with a loop on each side of the main line, it should be impossible to reverse points Nos. 1 and 2 at the same time, since a vehicle passing over points

No. 2 from the upper loop would then trail through and damage points No. 1. We therefore make lever No. 1 lock lever No. 2.

25. Another common example of the grouping of points is illustrated

FIG. 168.

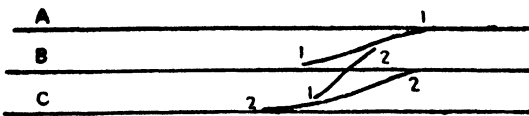

in Fig. 168, which shows the manner in which the different sets of points in a gathering line containing a double slip are connected.

If lever No. 1 only is pulled, access will be possible from line A to line B and vice versa. Similarly,

if lever No. 2 only is pulled, access may be obtained from line B to line C and vice versa. If however levers Nos. 1 and 2 are both pulled, access will be obtained from line C to line A and vice versa.

**26. Interlocking of level-crossing gates.**—In England it is required that all level-crossing gates shall be fully signalled as for a station yard, and that the gates must be locked against the road before signals can be lowered for a train. The gates may either be worked mechanically by means of rodding and cranks from a winch in the signalman's cabin, in which case a lever would be provided in the cabin to lock the winch; or they may be worked by a gateman specially appointed to attend the gates, which are coupled together by underground rodding, and move simultaneously when one is moved. In the latter case, the signalman's locking lever would lock a bar attached to the gate mechanism. In both cases the locking lever also actuates a number of stops, which normally lie below the road surface and which, when raised, prevent the gates from straining their connections through wind or other causes.

In India provided the gates are so arranged that they cannot foul a running train, they are usually not signalled. When however it is possible so to place a gate that it may foul a running train, the gate must be provided with at least one stop signal for each direction, which must be locked at danger when the gates are open for road traffic.

**27.** The student who has carefully followed the examples, given in the preceding paragraphs, of the application of the principles enunciated at the beginning of the chapter, will readily understand the table of interlocking for the station yard shown on Plate XXXI. Special points of interest in connection with this table are, that points locking-levers release all signals for trains passing over the points in a facing direction, and lock all signals for the opposite direction. This obviates the necessity for a direct interlock between signals for opposing directions. It should also be noted that points lock No. 14 only locks points No. 13 in their normal position and not, as is customary, both when normal and reversed. The reason is that, since only three lines are signalled, trains can only be received on these three lines, and it is therefore not necessary that points No. 13 should be locked, when they are set so as to give access to the goods loop. Again, points No. 10 release points lock No. 11 for the reason that it is only necessary to use the points lock after the points have been reversed, and never while the points are normal. Number 11 also locks Nos. 13 and 14, which ensures that these levers cannot be moved when the starting signal No. 4 is lowered. Further, it will be seen that the

outer signal and the warner are worked by a single lever, No. 24. When this lever is pulled, however, only the outer falls, the warner remaining at danger until released by the signalman at the other end of the yard; who cannot do so, until the road at that end of the yard is correctly set for a run-through train, and both the main line starter and the advanced starter at that end of the yard have been lowered. In the interlocking table No. 1 lever is the release lever for the up warner signal at the other end of the yard.

A level-crossing occurs near the main line facing points and the locking lever of the gates is No. 17 of the table. When No. 17 is pulled the gates are locked for road traffic; and no signal for a train, intended to pass over the level crossing, can be lowered until No. 17 lever has been pulled.

## CHAPTER XVI.

### INTERLOCKING MECHANISM.

1. The simplest and least expensive kind of interlocking is *key interlocking*, of which the Annett's lock is the best known example. To illustrate its use, let us suppose that a dead siding takes off a running line from a point A (Fig. 169) under the protection of a running line stop signal B;

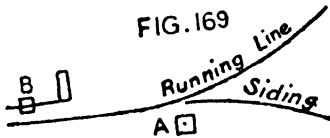

and suppose we wish to ensure that when the points are set for the siding the signal cannot be lowered. Accordingly, an Annett's lock is fixed to the mechanism of the signal arm B, and another to that of the points A. These locks are worked

by one key in such a way that the withdrawal of the key locks the signal B at danger and the points A at the setting for the running line. To lower the signal the key is inserted and turned in lock B. This releases the signal, which when lowered prevents the key from being withdrawn. Hence, when the signal is lowered we may be sure that the points A are correctly set for the running line. Similarly, if we wish to use the siding we withdraw the key from lock B (thereby locking the signal at danger), and insert and turn it in lock A. This releases the points, which may then be set for the siding. The key then cannot be withdrawn until the points are set again for the running line. Thus, while the siding is in use, the signal cannot be lowered for a running train. The signal lock B need not be on the signal post itself, but may be anywhere on the signal mechanism, as for instance in the signal lever frame on the platform, or elsewhere.

2. It will be seen from the above description that Annett's locks are used in pairs, with one key between them.

3. In the above example no allusion is made to the trapping of the siding. This would be done as explained in Chapter XII, paragraph 16,

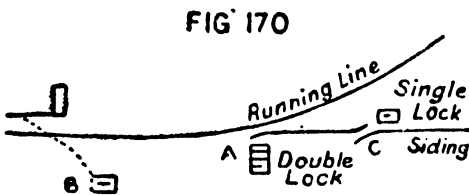

by means of a derailing switch or short trap siding at C (Fig. 170). To ensure that the trap points are open, i.e., against the siding, when the points A are set for the running line, one method would be to couple the

points A and C by rodding and work them as an ordinary coupled-cross over by one lever (compare Chapter XV, paragraph 18). In order however to save the expense of rodding between A and C, an extension of the Annett's lock principle, known as a double-lock, is frequently

used. This double-lock is placed on the main line points A and in addition single locks are placed on the points C and on the signal lever B, respectively. In the normal position the points A and C are set and locked as shown in the figure. To set the points for the siding the B key (which we may call the master-key, or the siding key) is taken out of the B lock (thus locking the signal at danger) and inserted and turned in one compartment of the double-lock at the points A. This releases the main line points, which must then be reversed and set for the siding. The action of reversing these points releases another key, called the trap points key, from the other compartment of the double-lock. The extraction of the trap points key prevents the main line points from being again reversed, and so locks up the master or siding key for the time being. The trap points key is then inserted and turned in lock C, thus unlocking the trap points, which can then be reversed and set for the siding. This reversal locks up the trap points key, so that, when the siding is in use, neither that key nor the siding key can be extracted, and consequently the signal cannot be lowered.

4 This form of interlocking which is technically known as succession locking can be applied very conveniently in controlling the working of the dead-end siding shown in Fig. 163. A double-lock would be placed at the points in the loop line and one of the single locks at the trap points. The other single lock would be placed on the lever frame in the signal cabin (as shown on Fig. 171). The withdrawal of the master-key from

FIG. 171

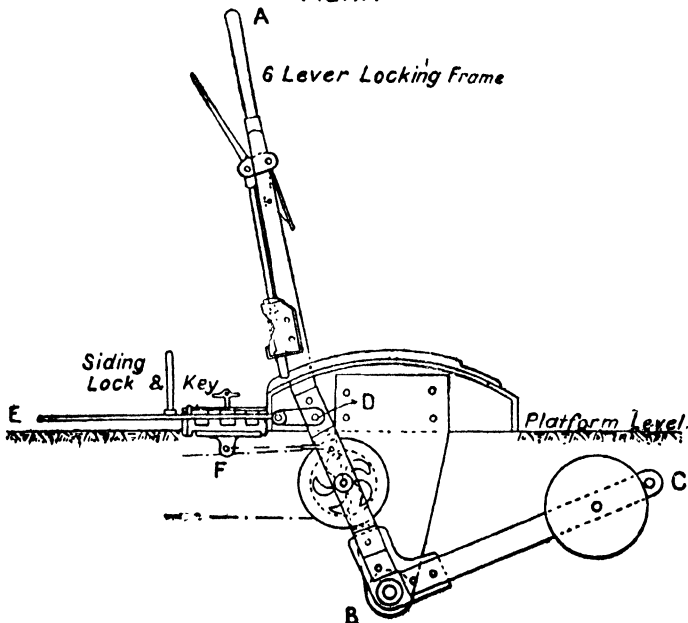

the last mentioned lock would move a slide in the lever frame, the motion of which would lock the four home signal levers Nos. 1, 2, 11 and 12 (Fig. 163) in their normal position, i e., with the signals at danger. The master-key would then be used, as explained in the preceding paragraph, to work the crossover leading to the dead-end; and no signal could then be lowered for the admission of a train to the station. The signal levers would remain locked, until the master-key was replaced and turned in the lock on the lever frame. Similarly, when one of the home signal levers has been pulled, the key cannot be withdrawn from the frame. Thus, so long as the master-key is out of the lock on the lever frame, no train can be admitted to the station; and conversely, when the key is in the lock on the lever frame, the station master knows that the crossover points leading to the dead-end siding must be locked in their normal position, and that it will be safe to admit a train.

5. The device is sometimes also used effectively in connection with level-crossing gates, the locks being so arranged that the signals on either side of the gates (see Chapter XV, paragraph 26) cannot be lowered when the gates are open to the road.

6. Key-interlocking has also been successfully employed for the working of running line points and signals in general at wayside stations. In the *List-and-Morse* type of signalling, as used at wayside stations on the North-Western Railway, the key-locking principle has been developed into a *key control* system, the special feature being that the signal keys, as well as the siding keys above described, are kept in a box in the station master's office, and interlocked with one another in such a manner that the keys relating to conflicting signals cannot be withdrawn at the same time.

7. Applying the *List-and-Morse* system to the station shown in Fig. 164 the routing (main and loop) signal keys 1, 2, 11 and 12, and two siding keys, 7 and 10, are kept, as already stated, in an interlocked box in the station master's office. As regards the operation of the points and signals, dealing first with the group at the left end of the figure, the points interlocking arrangements and the signal lever of No. 5 are near the points, and only the signal levers for 1 and 2 are on the platform. Now, supposing it is desired to lower the main signal No. 1, the pointsman sets the points for the main line (if not already so set), inserts No. 1 main signal key (which he has brought from the station master's office) into its proper lock at the points, and turns it. This locks the points and releases in one direction a sliding bar connected with a certain lever which we may call the locking

lever No. 4.\* If the pointsman now moves this lever in the free direction (which we will suppose is northward), he releases the gear of No. 1 signal lever. The station master on the platform is then able to lower that signal. This movement liberates the lever of No. 5, which the pointsman is then able to lower. The signals can then be put back in reverse order by restoring levers 5 and 1 in succession. The lowering of No. 5 does not, as a matter of fact, backlock No. 1, but an equivalent result is obtained by a device by which, if the station master puts No. 1 back to danger before No. 5 has been put back, the latter will simultaneously fly back to danger, so that No. 5 is never "off" when No. 1 is "on." When the signal levers are restored to their normal position the locking lever can be similarly restored, thereby moving the sliding bar back to its original position, when No. 1 key can be withdrawn and returned to the station master.

8. Again, if it is desired to lower signal No. 2, the points are set for the loop, and a key, which we may call No. 2 loop, inserted and turned in its lock. This locks the points for the loop and releases the sliding bar connected with the locking lever in a contrary direction to that referred to in the first operation. The locking lever being now moved in this direction (which we will call southwards) releases the loop signal gear, when signals 2 and 5 can be lowered in succession.

9. Thus, in this system all the essentials of the locking list are complied with, but it will be observed that the act of locking the points (which results in the release of the signals) is not completed till the locking lever (No. 4) is moved one way or the other. In short, the key-locking in this instance is only the initial act which enables the gear interlocking to come into operation. It may be added (as a detail of the List-and-Morse mechanism) that Nos. 1 and 2 signals are operated from the platform, not by two separate levers, but by a single lever, which is pushed *forward* or pulled *back*, as the case may be, from its normal central position, the forward movement actuating one signal, and the rear movement the other.

10. The actual interlocking mechanism between the points and the signals depends, as we have seen, on a sliding bar moved by a lever. The sliding bar in some form or other is common to nearly all systems of interlocking, the precise method in which it is utilised being the particular feature which distinguishes one system from another. For instance, in the

---

\* This is called, on the North-Western Railway, the "setting" lever, but as it has nothing to do with the setting of points, it will be referred to in this Manual as the locking lever, to avoid confusion.

system used on the Rajputana-Malwa Railway, the special feature is the points lock No. 4, which is a plunger lock known as the Sydney-Jones lock, actuated by a lever which moves in a horizontal arc between the rails, and is operated in that position by a pointsman. This movement also operates a transverse sliding bar which acts on the signal mechanism at the foot of the signal post. All the signal levers, including the outers and warners, are on the platform, so that the locking of the points merely liberates one of the routing signals, which can then be operated from the platform. The rest of the interlocking mechanism is in the signal lever frame on the platform. The position of the locking lever between the rails prevents the lock from being moved while a train is passing over the points. (In this connection, see paragraph 25.)

11. Now let us suppose No. 1 signal has been lowered, by pulling No. 1 lever. This releases No. 5 lever, which when pulled lowers the outer. The warner lever is then released, so far as No. 5 is concerned, but it cannot be lowered unless the trailing points No. 13 are set and locked for the main line. This is arranged by means of an Annett's lock applied to the warner lever and also to a sliding bar connected with No. 13 points. The key, removed from No. 13 and applied to No. 6, locks the former and releases the latter. The lowering of conflicting signals is prevented by direct interlocking between the signal levers on the platform.

12. In both the List-and-Morse and the Sydney-Jones system, as applied to wayside stations, the points levers, as we have seen, are close to the points and are operated by pointsmen, while all—or at least the principal (in the case of the List-and-Morse)—signal levers are worked from the platform by wire connections. It would be convenient if the points could also be worked from the platform; but points cannot be worked by wire connections, and the only other method of connection would be by rodding, which would usually be too expensive for ordinary wayside stations.

13. The disadvantage of all systems of key interlocking is that a considerable amount of time is lost in carrying the keys backwards and forwards, between the station platform and the points. In large yards, therefore, and sometimes even in small yards where traffic is very heavy, it is necessary to group points levers and signal-levers together for facility of working. We then have what are called *signal cabins*. The signals are still worked by wire connections, but the points are connected with their respective levers in the cabin by rodding. But there is a limit even to the distance at which points can be worked. In India it is found that 900 feet is about the limiting distance at which

points either facing or trailing can be efficiently worked from a cabin, though signals can be worked up to 3,000 feet. Hence in a station of the type shown in Fig. 163 or 164, where the points 3 and 13 are usually more than 2,000 feet apart, it would be impossible to work the entire yard from one cabin.

14. If the traffic justified the expense, the yard could be divided into two areas, and a cabin located centrally in each as in the case of the station-yard shown on Plate XXXI. Each cabin would then preside over a complete interlocking scheme of its own, but in order to avoid the operations of one cabin clashing with those of the other, certain signals of one would have to be "controlled" by the other cabin. In technical language, the signals thus controlled are said to be "slotted" to the cabin which controls them. For instance on Plate XXXI if we call the left and right end cabins A and B, respectively, No. 24 warner clearly belongs to A cabin, while the trailing points at the other end of the yard, which affect it, belong to B cabin. In B cabin, therefore, there must be a lever "slotted" to No. 24 signal, so that before the warner will go "off," A and B must *both* perform the necessary preliminary operations. At first sight this seems like divided responsibility; but it is only so in a negative sense, inasmuch as it requires the combined action of two men to lower the signal, failing which, the signal remains at danger. Moreover, the slotting mechanism is so arranged that if lever No. 24 is put back in either cabin (irrespective of the other) the signal will at once go back to danger. In the interlocking table on the Plate, No. 1 lever is slotted to the warner at the opposite end of the yard.

15. In very large yards there may be two or more cabins at each end to control the approaches. Each cabin would then have a complete signalling installation of its own, subject to such mutual control as may be required. For instance, the last stop signal of cabin X may also serve as the first stop signal of cabin Y, or in other words the starter of X is the outer of Y, in which case X's starter would be "slotted" to Y's outer, and so on.

16. Now, as regards the interlocking mechanism in the lever frame, it is impossible in this Manual to go into minute details. But it may be stated that the *tappet* system is now universally adopted in lever frames. To describe this system, let ABC (Fig. 171) represent a lever, A being the handle and B the fulcrum about which the lever turns. At a point D in AB, a flat bar E is attached by means of a link; the bar slides backwards and forwards in the locking-box as the lever is worked. This

sliding-bar is called the *spear* and it is manifest that when the lever is fully reversed, the spear will move horizontally through a fixed distance.

17. Now let us imagine two such levers placed side by side in a frame, one of which works points No. 3 of Fig. 162, and the other the main home signal No. 1; and let it be required to interlock these two levers in such a way that the home signal cannot be lowered, when the points have been set for the loop; and conversely that the points cannot be set for the loop when the main home signal has been lowered. A plan of the spears as seen side by side in the locking-box is given in Fig. 172, the vertical ribs of the locking-box being shown cross-hatched. When lever No. 1 is pulled, the point  $A'$  moves into the position occupied by  $A$  in the figure; similarly when lever No. 3 is pulled, the point  $B'$  comes into the position occupied by  $B$ . Notches are cut in both spears as shown in the figure, and a sliding-piece or *tappet* (from which the name of the system of interlocking is derived),  $F$  the ends of which are cut to the same shape as the notches in the spears, can slide between the vertical ribs of the locking-box. Now it is evident that when lever No. 1 is pulled, since the full width  $A'$  of the spear will come opposite the end of the tappet  $F$ , the spear of lever No. 3 will be held fast by the tappet and the latter lever will be firmly locked until lever No. 1 is returned to normal. If now lever No. 3 be pulled the tappet  $F$  will slide laterally and its end will enter the notch in the spear of No. 1 lever, which will be locked until No. 3 is returned to normal. The lock is thus a reciprocal one, that is to say, No. 1 locks No. 3 and No. 3 locks No. 1, as is required by the principles of interlocking.

18. Fig. 173 shows the interlock between levers Nos. 2 and 3 of Fig. 162. We require to make lever No. 3 release lever No. 2, and the latter to back-lock No. 3. It will be clear from Fig. 173 that lever No. 2 remains locked until No. 3 is pulled, when the notch  $B'$  comes opposite to the end of the tappet  $F$ ; which is then free to slide into the notch, when No. 2 is pulled. When No. 2 has been pulled over,  $A'$  comes into the position  $A$  in the figure, holding the tappet  $F$  in the notch  $B'$ , thus back locking lever No. 3.

19. The two locks above described are those which occur most commonly in interlocking installations. In the interlocking table in Chapter XV, paragraph 15, however, we have a case of what is known as *special locking*, namely the interlock between levers Nos. 1, 2 and 5, by which either 1 or 2 releases 5. The lock is illustrated in Fig. 174. On the spear of lever No. 2 is a movable piece  $BB'$ , held by a stud working in a slot at either end, and free to move laterally through a small distance.

FIG. 172.

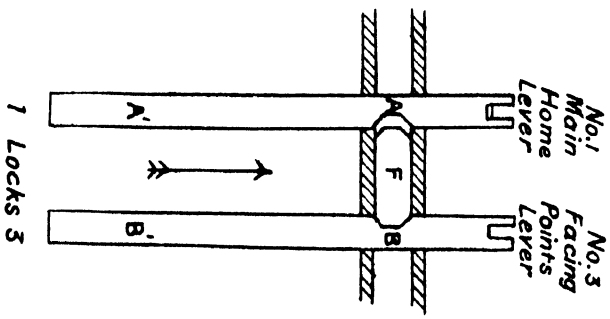

FIG. 173.

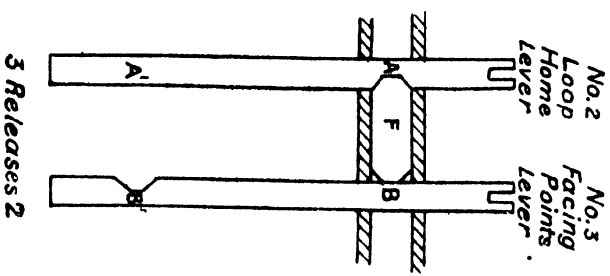
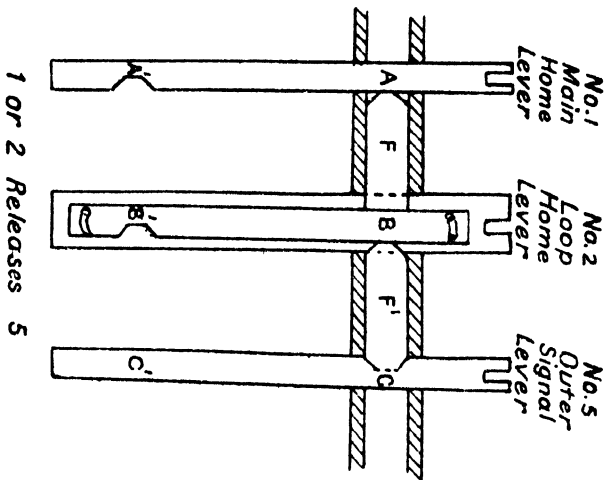

FIG. 174.





The tappet F is square at one end, which abuts on the edge of the movable piece BB'. If lever No. 1 be pulled, the notch A' comes opposite the end of tappet F; lever No. 5 may then be pulled, the tappet F' and the movable piece BB' both being forced sideways, and the tappet F entering the notch A'. Again if lever No. 2 be pulled, the notch B' comes opposite the end of the tappet F', and lever No. 5 is again freed.

20. There are several other kinds of special locking, designed to meet certain conditions; e.g. a lever may be required to lock a second lever, when a third is pulled, but not when the third is normal. Frequently, also, a lever when pulled and returned to normal is required to lock itself in the normal position, until a second lever has been pulled and returned. For a description of these, as well as of other special locks, however, the student must refer to a work on interlocking.

21. The actual design of the locks, to accord with an interlocking table, is sometimes very complicated. In order that the locking boxes may be as compact as possible, as many as four tappets may be placed in the same compartment of the box. (They are usually not made so large as is indicated in Figs. 172—174.) The locking-box will also usually consist of several compartments as in Fig. 171 and in special cases there may be two or more spears attached to each lever, each spear working in a separate locking-box. It is however impossible in this Manual to go into greater detail on the subject.

22. The lever illustrated in Fig. 171 is intended for working a signal. The signal-wire passes around a pulley attached to the lever, and the end is fixed to a stud at the bottom of the locking-box. The object of this arrangement is to obtain a pull of sufficient length on the wire, the length of pull of the wire being twice the movement of the centre of the pulley. For working a set of points an arm would be attached to the foot of the lever on the side opposite to and in continuation of CB, and the rodding actuating the points would be connected to a point on this arm.

23. **Detectors.**—Another very important feature in interlocking, to which we have not yet referred, is the means employed for preventing signals from being lowered when any part of the interlocking apparatus concerned is out of order. For instance, points 3 (Fig. 162), when set for the main line and unlocked, may be burst trailing by a train running through them from the loop. This would damage the switches and the stretcher-bar, but it is quite possible that the fact might not be noticed by any one on the train or in the yard. It certainly would not alter the appearance of the levers in the cabin. Suppose it is desired subsequently to admit an approaching train over these points facing. The points lever is normal,

so to the cabin-man the points appear to be correctly set. He then tries to pull the locking lever No. 4. But it refuses to move for the simple reason that, as the stretcher-bar has been bent, the points lock will no longer fit the slot; hence lever No. 4 meets with an obstruction, and the cabin-man immediately becomes aware that something is wrong. And as lever No. 4 is interlocked with Nos. 1 and 5, the signals cannot be lowered. In this case the condition of the points is *detected* by the points-lock. Since it may happen that the attachment of one switch to the stretcher-bar may be damaged, while that of the other switch remains intact, the stretcher-bar should be made *double*, one bar being attached to one switch and the second bar to the other. The points-lock will then detect any injury to the attachments of either of the switches.

24. But in the case supposed in the preceding paragraph, it might have happened that the points were locked at the time when they were burst trailing. In this case No. 4 lever having already been pulled over, there would be nothing to prevent signals 1 and 5 from being lowered. To provide against such a contingency some additional device for detecting

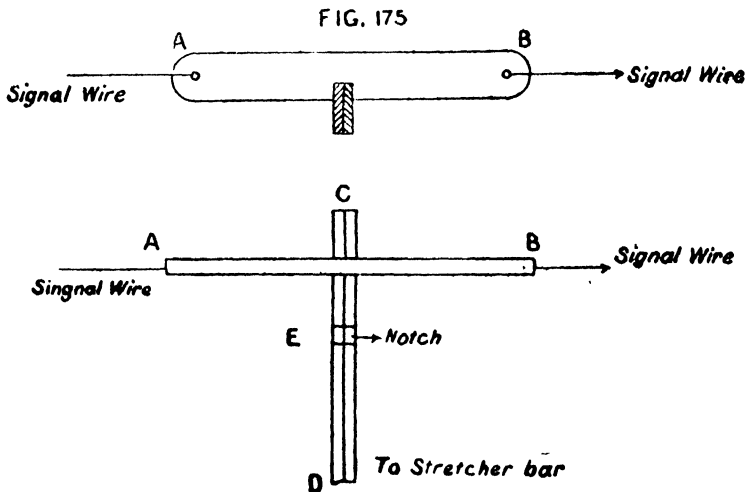

the condition of the points is necessary. Such additional devices are called *detectors*. To detect burst points, a double-bar, called a detector-bar, connects the stretcher-bar with a box through which a slide connected at each end with the signal wire passes, in such a way that if the detector-bar is not in a particular position (owing to the stretcher-bar being damaged) the signal wire cannot be pulled. For instance, let AB (Fig. 175) be the slide, to be pulled in the direction of the arrow, and let CD be the movable detector-bar, one leaf of which is connected with each switch. The

detector-bar has a slot E, through which the slide can be drawn freely, when the bar is in the correct position. If however either of the switches be damaged, the slide will obviously be unable to pass through the notch E, and the signalman will be unable to lower the signal. Of course care should be taken that the slot E is only just wide enough transversely for the slide AB, otherwise the latter might be forced through when the points were not quite accurately set, in which case the object of the detector would be defeated.

25. **Treadle-bars.**—A device for preventing facing points from being moved while a train is passing over them is a treadle-bar (see Fig. 158) or locking bar, as it is sometimes called. This is placed close to the rail on the approach to the points, and is supported on cranks and attached to the locking gear in such a way (i. e., the crank that works the facing point lock is attached to the treadle-bar) that every reversal of the points lock causes the bar to rise above rail-level during the movement. When the points are set in either position, with the switch close to the stock rail, and the points lock either completely locked or unlocked, the treadle-bar is sufficiently below rail-level to be just clear of the wheel flanges of passing vehicles; but the clearance is so little that if the slightest effort is made to move the lock, the bar comes in contact with the wheel flanges and so prevents any further movement. The bar is made sufficiently long to ensure that before one wheel has quitted it at one end another has arrived at the other end. To provide for the longest bogie vehicles now in use, the bar should be at least 40 feet long. For reasons given in paragraph 10, a treadle-bar is not necessary when the Sydney-Jones lock is used.

26. **Compensators.**—In order to allow for contraction and expansion in signal and points connections, due to variation of temperature, various devices are used. Signal wires can usually be adjusted from time to time without difficulty by means of small winches or adjusting-screws in the cabin. But in the case of points rodding, special *compensators* are required, to be fixed about midway between the cabin and the points, and in the case of a crossover, a second compensator is required between the facing and trailing points. A common form of compensator is shown in Plate VII. The method of calculating the positions of the compensators is explained in the following illustration:—Let AB (Fig. 176) be a crossover and C,D,

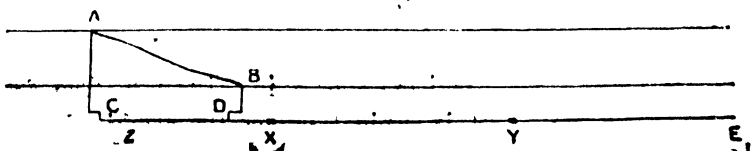

the cranks connecting the rodding with the cabin E. Now, it will be seen that the crank D is such as to convert a pull at E into a push at B, but that the crank C transmits to A the pull or push at E without alteration. Taking first the crank D, the pull-and-push action partly counteracts the effects of contraction and expansion. That is to say, if in DE a length DX equal to DB is taken, BDX is self-compensated (by the pull-and-push action) and it only remains to deal with the length XE by placing a compensator at Y midway between X and E. As regards the portion ACD, the force applied at D is transmitted in the same sense throughout, hence the proper place for the second compensator is at Z, midway between A and D on the line of rodding ACD. Rodding should be compensated in all cases in which the length of lead from the lever to the points exceeds 80 feet.

27. **Slotting arrangements.**—The ordinary form of slotting arrangement is of the “drop-off” type. Two levers are fixed, side by side on the signal post, as in Fig. 179.

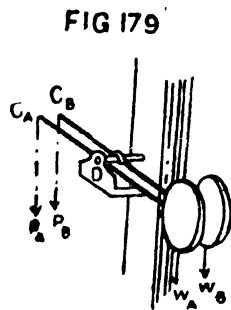
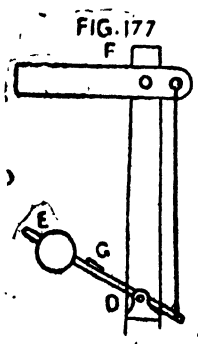

The fulcrum being D, the weights  $W_A$  and  $W_B$  can be raised independently by the wires  $P_A$  and  $P_B$  being pulled by the signalmen of cabins A and B respectively. Now, if we attach these arms to the signal post DF (Fig. 177), so as to make the arms  $C_A D$ ,  $C_B D$  support the

FIG. 178

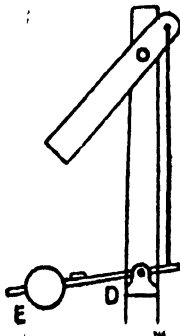

crossbar G of a counterweighted arm DE (Fig. 177) of slightly less weight than either  $W_A$  or  $W_B$  (the arms being assumed to be of equal length) the arm DE will be kept in the raised position shown in the figure, by either  $W_A$  or  $W_B$  separately in their normal position (as in Fig. 179) even if we pull one wire. But when both wires  $P_A$  and  $P_B$  are pulled (thus raising both the weights  $W_A$  and  $W_B$ ) the counterweight E, being no longer supported, will fall into the position shown in Fig. 178. The falling of this weight under the combined action of

the two signalmen is utilised to lower the signal, as shown. The general appearance of the combination, which is known as the "drop-off" slot, is shown in Fig. 180. The same principle may be applied to the

FIG. 180

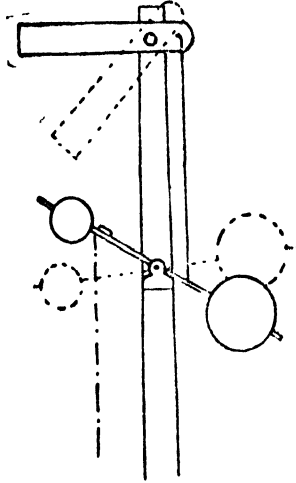

slotting of a warning to an outer signal on the same post, see paragraph 26, Chapter XIV.

28. It is impossible to go further into the subject of interlocking in this Manual, but if the broad principles herein laid down are thoroughly grasped, the student will be in a position to pursue the subject on his own account by carefully inspecting existing signal cabins and interlocked yards generally, preferably under the guidance of a signal engineer at first and later on by personal observation.

29. Plate XXXII shows typical signalling diagrams for wayside stations, single and double-line. The details for the single-line type relate specially to the List-and-Morse system described in paragraphs 6 to 9 of this chapter (though the actual numbering of the levers is not the same as that given in Fig. 164), while the diagram for the double-line station might apply to any system.

## PART III.—GENERAL.

### CHAPTER XVII.

#### MAINTENANCE OF RAILWAYS.

1. The present chapter deals with the maintenance of the permanent way, works and buildings, rolling stock, machinery and appliances which go to make up a railway. Of these, the engineer is chiefly concerned with the maintenance of the permanent way, works and buildings.

2. **Permanent way maintenance.**—As soon as the track has been laid, arrangements have to be made for keeping it in good running order; for several months after laying, it will require considerable attention, which cannot be relaxed until the formation has become fairly consolidated, the line has been fully ballasted, and the track has “settled down” to its bedding on the ballast. As has been seen in Chapter II, it will be advisable to delay full ballasting until the banks have become well consolidated, which will not be the case until they have been through two or three seasons of heavy rain. During the first two or three years about six men per mile will be required for permanent way maintenance. After that the number may be reduced to two and a half or three per mile. These men might be arranged in gangs of ten or nine men each, with a mate or ganger in charge, and a keyman, every four or three miles apart. No gang-beat should be more than four and a half miles long, and this length should be reduced if any portion of a station-yard comes within the beat. Gang huts should, as far as possible, be situated in the middle of their respective beats.

3. On the metre gauge, and on unimportant branches of the standard-gauge, the normal strength for maintenance may often be kept down to two men a mile. But it should be borne in mind that the question of the strength of the gangs should be determined not by the gauge, but by the volume of traffic, the nature of the soil and the strength of the permanent way. Local conditions also have to be taken into consideration, such as the rainfall and its effect on the embankments. Lines laid through sandy deserts are exposed to sand-storms. Cuttings in such localities are specially liable to be blocked with sand-drifts which have to be constantly cleared for the passage of trains. Hence two men per mile must be regarded as the minimum under the most favourable conditions. With huts three miles apart this would give gangs of six men each, together with a mate and keyman. With huts four miles apart the gangs would consist of eight men each, besides mate and keyman. The latter is a more convenient size for a gang.

4. The mate of a gang is responsible for the upkeep of the track in his beat, and must keep it in good running condition at all times. To attain this, his gang should carefully uncover, re-level and re-pack a definite section, say 100 yards, or the distance between two telegraph posts, every day. This is called *through-packing*. But in doing this the gang must not neglect the general condition of their beat as a whole. So the mate must be ever watchful for weak spots by personal inspection of the whole of his beat, and summon his gang, or a part of it, for necessary daily repairs. If the gang work methodically they should through-pack at least a mile a month, besides keeping the whole of their beat in good running order from day to day. In this way, the whole beat will be through-packed, or thoroughly overhauled, once in three or four months, or at least three times a year. If renewals of rails or sleepers have to be done on a large scale, extra gangs would be employed. It is essential that the rails in a transverse section of the permanent way should be on the same level on the straight, and at such different levels as may be required by the super-elevation on curves. To ensure accuracy in these particulars, each gang is provided, with, among other things, a spirit level, a straight-edge consisting of an ordinary plank, and a so-called "height-board", stepped as shown in Fig 181, which shows all three implements used to test the superelevation on a curve.

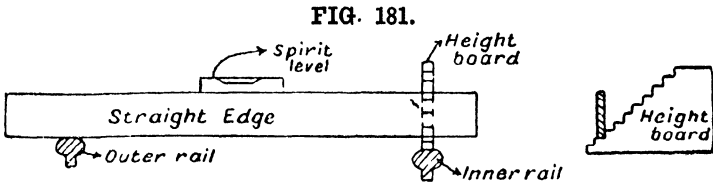

5. The duty of the keyman is to inspect all the fastenings (fishbolts, keys, spikes, etc.), throughout his beat every day. He carries a hammer for driving home loose spikes and keys, and a wrench for tightening or easing fish-bolts, and he should go along one rail on the outward journey, returning along the other. Fig. 182 shows the keyman's tools; one end

*Keyman's tools.*

**FIG. 182.**

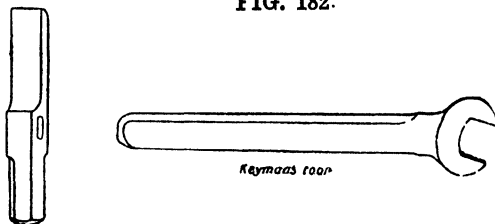

of the hammer is used for driving wooden keys, and the other for driving spikes. The keyman also acts as a patrol, and must note everything amiss in connection with the permanent way, ballast, formation or bridging, especially after or during heavy rain, as he goes along, taking such action as he considers necessary for the safety of trains. Special patrols may be necessary in the rains.

6. Once a year the gang should open out all the rail-joints on their length, oil the fish-bolts and nuts, and clean and reverse the fish-plates, that is to say, the outer fish-plate at each joint should be reversed end for end and placed on the inner side of the joint, the inner plate being placed on the outer side. This is necessary in order to prevent rusting of the plates and bolts; in particular, rust occurring between the fishing surfaces of the rail and the plate tends to stop the free expansion and contraction of the former, and may result in the line "buckling" or springing out of alignment.

7. It is unnecessary, for the purposes of this Manual, to go into greater detail on the subject of maintenance staff and their duties. It will suffice to state that for administrative purposes all the gangs in a length of between 50 and 70 miles act under the orders of a Permanent Way Inspector, who is responsible to the Sub-divisional Officer for the running condition of the track in his charge. He is sometimes assisted by a Sub-Inspector. All important renewals of rails or sleepers should be done under the direct supervision of the Inspector or his assistant.

8. **The creep of rails.**—The creep or travel of rails is one of the most troublesome and, if not attended to, one of the most dangerous matters a railway engineer has to deal with. Rails tend to travel with the load. The causes of this have never been quite satisfactorily explained. It is most probably partly due to the same causes as give rise to the "rolling friction" of the wheels; as we have seen in Chapter X, paragraph 12, each wheel runs in a slight depression on the table of the rail and therefore tends continually to push the rail forward. The blow at the end of a rail, when a wheel passes over a joint, is probably also a contributory cause. If the speed of the train be either rapidly decreasing or increasing (as at stopping or starting) the frictional forces between the wheels and the rails will have a large resultant in the direction of motion or in the opposite direction; and it is probable that these frictional forces then play a very considerable part in causing the rails to travel. At the approaches to stations therefore and on down grades, where brakes are applied to check the speed, frictional forces will have a considerable effect

on creep. On a double line the movement of the rails is in the direction of the traffic on each line. On a single line it is generally in the direction of the heaviest traffic. There are numerous cases on record in which rails have travelled in one direction while the heaviest traffic has been in that direction, and have then travelled in the opposite direction when the direction of the traffic changed. Where rails are held by keys all tapered and driven in one direction, that is, all right-hand led or all left-hand led, if the rails move in the *same* direction as that in which the keys are driven, the latter are tightened and this checks the movement, but if the rails move in the *opposite* direction the keys are loosened, and the tendency to travel is increased. Under these circumstances the travel of one rail is always greater than that of the other, and the two rails will sometimes travel different ways.

9. The expansion and contraction of the rails play a very important part in their travel. A comparatively small force will stop creep, but as we have shown in Chapter II, paragraph 17, the force exerted by the rail while it is expanding or contracting is enormous. We start with a line properly laid, with proper spaces between the ends of the rails: one rail is secured rather more firmly than the rest, the rails on one side of this, which are not so securely held, travel till several of the joints are closed, and on the other side till several of the joints are fully open; then if the temperature increases, the extension of the several rails with the joints closed is sufficient to start this one fixed rail. If it decreases, the contraction of the rails on the other side with the joints fully open has the same effect, and the whole track again starts creeping till there is a long length of rails with all the joints tight. If the creep goes on when the rails are cold, so as to close the joints as the rails contract, a point will be reached at which the force of expansion, when the rails get warm again and expand, will be insufficient to move the long length of rail over which all joints are tight: the result will be that the rails will spring out sideways forming a kink. If the joints be all open the contraction when the rails cool may produce force enough to break the fish-plates and bolts. The effect of creep is always most dangerous in the early morning or late evening and at the beginning of the hot and the cold weather, as the range of temperature during a few hours is then greatest; it is also greatest on bridges, as the temperature of the rails varies more rapidly than on the solid ground, and there is more vibration under traffic.

10. Creep can only be prevented by completely checking it from the very beginning. The difficulty is to find anything to which to fasten the rails, as the sleepers themselves are liable to shift; and if

once sufficient creep takes place to jam or fully open two or three consecutive joints, sufficient force may be generated to carry away any ordinary fastening. Nevertheless, except in unusual cases, if movement of the rail in the sleeper fastenings can be prevented, the development of creep can to a large extent be arrested. One of the most successful plans, which is almost universally adopted in America, is to use angle fish-plates and notch the bases of these to hold the spikes, which then anchor each pair of plates to two sleepers—as in Plate III—; boring holes through the foot of the rails, and putting a pin through has also been used with success, but this obviously destroys a considerable proportion of the strength of the rail.\* The edge of the foot of a steel rail should never be notched, or the notch is certain to develop into a crack which will extend till the rail breaks. As stated in Chapter II, paragraph 19, Stuart's key has proved to be exceptionally successful in arresting creep; if three or four sleepers per rail length be provided with these keys, creep will in ordinary cases be entirely checked; in worse cases, a larger proportion of sleepers may be fitted with the keys. The method of keying flat-footed rails in pressed steel sleepers also gives a very firm grip; with rails in chairs in England it has been found advantageous to use chairs, the keyway of which has no taper, only the edges rounded, the key also having no taper and being driven from either direction. Wooden keys without taper are not likely to succeed in India, as they swell and contract considerably with variations of moisture. The use of bearing-plates tends to decrease the creep, as it increases the grip of the spikes on the foot of the rail.

11. Creep is especially troublesome, if it is allowed to occur near points and crossings, particularly if the points be interlocked: it will usually result in disturbing the gauge, and will throw the connections of the points and the interlocking gear out of adjustment. If a "buckle" occurs (see paragraph 6) a train travelling at speed runs a very serious risk of derailment. Constant attention to creep is therefore very necessary, and where it is excessive, the rails must either be pulled back and properly re-spaced, or they must be cut at one end of the length on which it occurs and longer rails put in at the other, the intermediate joints being eased as much as possible. Creep generally occurs less with heavy than with light rails, and may be diminished by increasing the number of sleepers per rail length. Any attempt to check it is not likely

---

\* The North-Western Railway, India, uses special creep-chairs in certain localities, on steep grades and at the approaches to stations.

to be successful unless the device adopted for the purpose is applied to every rail.

12. **The wear of rails.**—The wear of rails depends principally not on the total load that passes over them, but on the *maximum* load which comes on them under any one wheel: for example, a four-wheeled truck weighing 4 tons might pass over a set of rails 1,000,000 times without producing any perceptible wear, while a six-wheeled engine weighing, with its tender, 80 tons, might by passing over the same rails 50,000 times completely wear them out. The total tonnage passing over would be the same in both cases. Under ordinary conditions the total tonnage passing over railways having similar traffic will produce the same amount of wear on rails of similar section and materials, maintained to the same standard, but with engines of equal weight the number of engines would generally be a better criterion than the total tonnage. Defects in any one part of the permanent way, or in the maintenance, will react on all the other parts, and decrease their life; thus weak fish-plates will increase the jolt at the joint and consequently the wear of both rails and sleepers. On a straight and level piece of line the wear of the rails, provided they be properly designed and proportioned for the work they have to do, is due almost entirely to the rusting of the exposed surfaces: the top of the rail, which is polished by the passage of every wheel, rusts more rapidly than the rest and, consequently, wears faster. This rusting away occurs more slowly in India, where the climate is either continuously dry or continuously damp and the air pure, than in England, where damp and dryness alternate rapidly, and the air is, near towns at least, laden with smoke. The top of the rail is also hardened by the rolling of the wheels on it, and if their weight be excessive, or not distributed over a sufficiently large area on the table of the rail it will be gradually crushed and the metal will lose its cohesion, thin strips, resembling very fine shavings, coming off it. If the metal is soft it will be crushed out of shape, and the head will become uneven.

13. As explained in Chapter X, paragraph 12, the surfaces of contact between the head of a rail and a wheel resting on it, are distorted from their true shape, the curvature of the wheel being reduced at its surface of contact and the table of the rail being slightly depressed. The depth of this depression is a direct measure of the fatigue of the rail; it will vary directly as the load on it and inversely as the area of the surface of contact. In addition to this effect, the rail will deflect as a girder, causing, after long use, fatigue in the fibres of the metal, and lessening its power of resistance to the stresses to which it is subjected.

14. The tyre of a wheel (see Fig. 65, paragraph 11, Chapter VI) consists of a slightly conical part, called the tread, a flange projecting below the rail on the inner side, and a fillet or curved portion, joining the two, the radius of which is about three-fourths of an inch. It would seem at first sight that the greatest bearing area between rail and wheel would be obtained by making the rail-head of exactly the same section. This is not the case for several reasons—*firstly*, the gauge must be greater than the distance between the outer faces of the wheel flanges; absolute equality between the two is impossible, and, even if it were obtained, could not be maintained as both rails and flanges wear; *secondly*, if the flanges actually touched the rails, the wear of both and the resistance to motion would be greatly increased; *thirdly*, if the inner shoulder of the rail were made of large radius, then for a given width of rail-head, its section would be considerably reduced, and as the rails must be made symmetrical, a similar reduction of section would take place at the outer shoulder, with the result that, *fourthly*, directly the flange ceased to press against the rail, a width equal to the sum of the whole radius of the inner shoulder and a part of the radius of the outer shoulder would have to be deducted from the bearing area. The best result will be obtained by making the upper surface of the rail-head of large radius, and the shoulders of small radius. If however the latter radius be too small, the shoulder will, when the fillet of the flange runs on it, be crushed and will also wear the flange hollow; on sharp curves, where the flange bears against the rail with considerable force, a small shoulder radius will increase the resistance to motion and the shoulder will itself be rapidly worn away, as well as rapidly cutting the flanges. There is therefore a happy mean for this shoulder radius, somewhere between  $\frac{1}{4}$  and  $\frac{3}{8}$  of an inch.

15. As the student will have understood from Chapter X, special wear of rails occurs on curves and steep gradients and the approaches to stations, where brakes are constantly applied. On a curve the slipping of the tread of the wheel on the table of the rail will wear the surface of the table; and the grinding action of the flange of the leading wheel against the outer rail will rapidly cut away the inner shoulder and face of that rail. The point of contact between the flange and side of the rail is in advance of that between the tread of the wheel and the rail top. Any particular point on the flange describes on the side of the rail a path which forms part of the loop of a curtate cycloid; the point will generally be in contact with the rail only while descending, and will then have a very powerful cutting action on the side and top shoulder of the rail. If

the top shoulder has a small radius it will be rapidly ground down till it is about  $\frac{1}{8}$  inch radius, or slightly less than the radius of the fillet in the wheel. After this the grinding will go on more slowly.

16. On very sharp curves, it is usual to provide a check-rail on the inner rail of the curve (see Fig. 183); so as to distribute the side-grind-

FIG. 183.

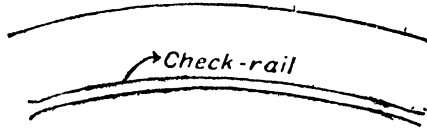

ing between this check-rail and the outer rail, or to relieve the latter entirely of the grinding. The wear of the rail-top, due to the sliding of the tread of the wheel over it, is of course not affected by the provision of check-rails. On steep grades or on the approaches to stations the tables of the rails are worn by the partial or complete sliding of the wheels, caused by the application of brakes: but now that continuous brakes (see Chapter VI, paragraph 21) so adjusted as not to skid the wheels are coming into general use, this wear is less than it used to be under old conditions.

17. Summing up our conclusions, we see therefore that on an ordinary straight length of road, the rails, if of good material, well designed, fitted with proper fish-plates, maintained in proper order and not subjected to too great a load on any one wheel, hardly wear at all, but their surfaces are gradually crushed, until the metal loses its cohesion. This will take place most rapidly at the ends of the rails, which even if the fish-plates are as perfect as possible, become "hogged", that is to say, permanently deflected at the ends. The life of hogged rails may sometimes be increased by cutting off short lengths at the ends, and using the rails thus shortened again. On curves there is considerable wear both of the tables and the sides of the rail, and in places where brakes are frequently applied there is also considerable wear, but less than on curves. The outer skin of a rail as it comes from the rolls is harder than the inside: it will take longer to wear off the first sixteenth-of-an-inch than to wear away a quarter-of-an-inch when the outer skin is once gone. The surface of a rail as it comes from the rolls is never perfectly even, but covered with minute excrescences and depressions; these are soon rolled down to what is practically a smooth surface by the action of the wheels.

18. **Renewals of rails and sleepers.**—On a well maintained main line the average life of rails under traffic will be from 30 to 35 years; or under favourable conditions, it may be as much as 40 years. When therefore the rails on any section are approaching the end of this period of use, it becomes necessary to make provision for their renewal. Theoretically it would seem correct to wait until the full period assumed as their life in the main line had run out, and then to relay the whole section in a single year. This would however entail heavy expenditure in that year and as the cost of renewals of material is borne by the revenues of the line, would greatly diminish the dividend for the year. Practically, therefore, it is better to spread the renewals over several years, commencing a few years before the assumed life of the rails has been reached and completing the renewals a few years later. After removal from the main line their period of usefulness is not at an end; they will still usually be in sufficiently good condition for use in loop sidings or in branch lines, in which a first class standard of permanent way is not required. The life of a second hand rail on a branch line on which traffic is not heavy, may be as much as 20 years, after which it may still be used for several years in an unimportant siding.

19. On ghat railways, where the curves are of sharp curvature, the gradients heavy and brakes constantly in use, the life of a rail will be very considerably reduced, and on sharp curves, the life of the outer rail in particular may be as low as four years. On some railways it is the practice, when the outer rail becomes badly worn, to change the comparatively unworn rails from the inner side to the outer, the outer rails being laid on the inner side. This practice is not however to be recommended; with the reduced section of rail-head, it considerably increases the wear of wheel tyres, and really results in the end in practically no saving in the renewals of permanent way. It is far better to renew the outer rail outright, when it becomes so badly worn as to require it. This may be either when the rail-head loses a certain percentage of its section or when it becomes so worn that the flanges of wheels strike the fish-plates at the joints.

20. Sleepers of cast iron, provided they are not broken through excessive loads or bad maintenance, will have a life in the track of from 50 to 60 years; on their renewal they may be melted down and re-cast at comparatively small cost. Their renewal will however usually be necessitated before the end of this period, either on account of the introduction of increased axle-loads, or a heavier type of permanent way. The life of steel sleepers in the main line will be considerably less, and may be taken at between 25 and 30 years; after renewal they may be transferred to

branch lines or used in sidings. Wooden sleepers, in localities in which white-ants are not prevalent, will last between 10 and 12 years, the harder woods such as sal lasting generally longer than the softer kinds; they will then however in most cases be practically useless except as firewood.

**21. Maintenance of buildings and works.**—The structures requiring the greatest attention on the part of the engineer are the bridges, whether arched or girders. On railways in India, a detailed inspection of every bridge and culvert is carried out at least once a year, at which all defects are carefully noted for subsequent attention and remedy. At important bridges over large rivers, it may be necessary during heavy floods to take soundings periodically at the piers or abutments, to ascertain whether dangerous scour is taking place; when such scour is observed, the usual remedy is to fill or partially fill the scour-holes with pitching-stone, and large reserves of stone are therefore necessary at all important bridges. After floods the training-bunds, flooring and all parts of the sub-structure which are accessible require careful inspection, and if they have been attacked, prompt repair.

**22. In the maintenance of girder bridges, the heaviest item of expense is the protection of the steel-work against corrosion.** Under ordinary circumstances a girder will require to be painted at least once every five years; where, however, girders are exposed to the action of sea-air or are over standing water, the paint will deteriorate very rapidly and it will be necessary to paint them at considerably shorter intervals. On some railways it is the practice to re-paint girders only when actual inspection shows it to be necessary; many railways however find it a justifiable expenditure to have a regular painting programme, under which every girder is painted once in a fixed period, whether the actual condition of the paint shows it to be necessary or not. The latter practice is undoubtedly the sounder, as it ensures that the steel-work is maintained in good condition and that corrosion, which may easily escape notice in any but the most careful examination, is not allowed to take place. Usually a quadrennial or quinquennial programme is sufficient, that is to say the girders may be painted once every four or five years; near the sea-coast they may require painting every second or third year, or under very unfavourable conditions, annually. The best paint for steel-work, exposed to the open air, is undoubtedly red lead; but its high cost, as compared with that of the numerous bituminous paints which have been placed on the market, causes many engineers to prefer the latter on the score of expense.

23. The riveting of all triangulated girders should also be periodically tested; rivets are liable to work loose under the jarring of traffic, and if they are not replaced may in time lead to the failure of the bridge structure. All joints in the main trusses, and the connections between them and the cross-girders, and between the latter and the rail bearers should be specially attended to. It will usually be sufficient to carry out a rivet test (rivets are tested for looseness by tapping them on the head with a light hammer, when any looseness can easily be detected by the sound emitted under the blow, or by placing the finger against the rivet-head when the latter is struck) once every six or eight years.

24. Another important point in connection with the maintenance of girder bridges is the necessity for maintaining the friction or roller bearings of the girders free from dirt and rust; otherwise their free expansion may be interfered with and very considerable stresses set up in the various members. The masonry around bed-stones of girders will require periodical attention; it is liable to become shaken under traffic. For this reason a rail-joint should never be allowed to fall directly over a masonry pier or abutment, or the succession of blows when the wheels of a train pass over it, will very soon damage the masonry.

25. The maintenance of other works, e.g., formation, buildings, etc., requires no remark. Formation should as far as possible be maintained to its full section; in particular, the level of the shoulders of the formation should be kept at the correct distance below rail-level.

26. **Maintenance of rolling-stock.**—Rolling-stock, being in fact, machines, will require the attention and repair incidental to machinery in general. Working parts must be kept well lubricated; worn or broken parts be replaced; the boilers of locomotives must be cleaned periodically as stated in Chapter XIII, paragraph 20; and the bodies of vehicles kept in good condition as regards painting, varnishing and furnishing.

27. Amongst the heavier repairs are those to worn wheel tyres. When the treads become sufficiently worn, the tyres must be trued up in a lathe; or if they are badly worn, they must be replaced. Tyres should be replaced whenever the projection of the flange below rail-level exceeds  $1\frac{3}{8}$  inches on the standard gauge, and  $1\frac{1}{4}$  inches on the metre; also, on the standard gauge, when the thickness of the flange is worn to less than  $\frac{3}{8}$  inch.

28. Axles are usually guaranteed by the makers to run a minimum mileage of 200,000 miles; frequently in practice they run more than double this mileage. They should however be carefully examined for

signs of failure when they have run their guaranteed mileage and periodically thereafter.

29. The boiler of an engine will under ordinary conditions of maintenance and use, require renewal after about 15 years, though the tubes may have to be renewed several times during that period. The engine itself will have a life of about double this period of main line running; it will, however, still be capable of use for many years on branch lines or for shunting purposes. The life of a passenger or goods vehicle may be taken as about 30 years; if it is not then actually worn out, it will certainly be obsolete in type and unsuitable for further use on a main line.

CHAPTER XVIII.  
MOUNTAIN RAILWAYS.

1. **Mountain Railways.**—The question of Mountain Railways is one of considerable importance to India, in connection with the numerous English settlements, military stations, tea plantations, timber forests etc., on the Himalayan Ranges, which form for many hundreds of miles the northern boundary of the country; with the military defence of the passes leading to and from the North-Western and North-Eastern frontiers; and with other hill tracts, such as the Nilgiris, in different parts of the country.

The different modes of ascending mountains by railways may be classed as follows:—

- (1) Railways worked up steep inclines in the usual way by the adhesion of smooth wheels to smooth rails.
- (2) Steep inclines worked by stationary engines and ropes.
- (3) Centre-rail or rack railways with locomotives for working on very steep inclines.

2. **Railways worked up steep inclines by the adhesion of smooth wheels to smooth rails.**—These are worked on grades very seldom exceeding 1 in 25. On such grades the speed must be low, the engines have to be of special design, very powerful and heavy, and the rails must also be weighty. The wear on the permanent way and consequently the cost of upkeep are great; and there is no special security against derailment. Railways of this description have been laid in various parts of the world, but till recently the steepest grades have been almost entirely confined to the United States.

So long ago as 1851 a line worked by locomotives was laid over the Alleghany Mountains. It had an inclination of 1 in  $45\frac{1}{2}$  for 11 continuous miles, and after winding amongst the summits of the mountains for 20 miles, it descended on the western side with an inclination of 1 in  $45\frac{1}{2}$  for 9 continuous miles. Passenger trains travelled at a speed of 15 or 20 miles per hour.

The Mexican Railway has grades of 1 in 25 continuously for 11 miles with curves of 350 feet radius. Other lines, with gradients of 1 in  $17\frac{1}{2}$ , and with curves of 300 feet radius, have been laid, but their engineers advocate them only for temporary use, while the construction of tunnels or more permanent works are in progress.

Great risks are sometimes run with locomotives worked on steep inclines, and it has not seldom happened, when the rails have been greasy, that the engine and train have slid backwards with wheels locked by the brakes from the top to the bottom of the incline.

To show how the inconveniences of continuous steep gradients are felt, it may be mentioned that on a long incline of 1 in 26, near Liège, a perfect system of stationary engines had been in use for many years. The Belgian Government, feeling the inconvenience of that system, had abandoned it, and substituted the locomotive, but such was the uncertainty of the power in meeting the difficulties of the incline, that stationary engines were reverted to.

And these steep inclines are attended with an exceedingly heavy cost for working expenses, exceeding in some cases the total receipts from the traffic. Rail renewals especially are costly, the rails in some cases being completely worn out after a few years of use. On the Bhoze Ghat for example, on the Great Indian Peninsula Railway, the life of the rails is only four years.

Since the introduction of heavy steel rails, more powerful locomotives and continuous automatic brakes, the use of steep gradients has however become more common, and the more serious objections to them have been greatly reduced.

3. **Bhoze Ghat Incline** (vide Plate XXXIII).—Four years were spent in preliminary surveys of this incline, and in laying out and preparing cross sections, to the number of about two thousand, and perhaps the most difficult that have ever been taken.

It is 15 miles 68 chains in length, and the total rise is 1,831 feet. Its average gradient is 1 in 48. The steepest gradients are 1 in 37, extending in one length for 1 mile 10 chains, and 1 in 40 for 5 miles 6 chains. Short lengths of level and of 1 in 330 are introduced into this incline, to facilitate its ascent by the engine. The radii of the curves range from 15 to 80 chains, and a length of 5 miles 33 chains is on the straight. It comprises twenty-five tunnels of a total length of 3,585 yards. The longest is 437 yards: and the longest without a shaft, which is carried through a mountain of basalt, is 346 yards. There are eight viaducts of a total length of 987 yards. The two largest are 168 yards long, and 163 and 160 feet respectively above the foundations. The viaducts are built, up to the surface of the ground, of solid block-in-course masonry, and above, of block-in-course, facework strongly tied through by header bonds of block-in-course to the internal work of sound rubble, and with coursed rubble arches. The total quantity of cutting, chiefly

rock, amounts, by calculation, to 1,263,102 cubic yards, the maximum depth of cutting being 70 feet. The embankments amount to 1,849,934 cubic yards, the maximum height being 74 feet. The slopes average about  $1\frac{1}{2}$  to 1. There are twenty-three bridges of various spans, from 7 feet to 30 feet, and sixty culverts from 2 feet to 6 feet wide. The rails weigh 85 lb. per yard, and are laid with fish-joints, with small cast iron saddles under the joints resting upon longitudinal planks, the ends of which bear upon, and are secured by fang-bolts to, transverse wooden sleepers. The cost of this incline was £750,000. The upper two miles from Khandalla to Lanowlee, with gradients of 1 in 40 and 1 in 50, were opened on the 14th of June, 1858, and have since been worked with safety and regularity.

4. The Chaman Extension Railway rises 1,200 feet in about 10 miles to the Khojak tunnel at the summit, and then falls about 2,000 feet to Chaman station in about  $16\frac{1}{2}$  miles, the gradients being chiefly 1 in 40 which, except for a few lengths of 1 in 45 and a short piece of 1 in 100, is continuous for 14 miles. The Mushkaf Bolan Railway has a short length of double-line, viz., from Abigum to Kolpur, on a ruling gradient of 1 in 25, worked by ordinary adhesion locomotives of a powerful type.

5. **Steep inclines worked by stationary engines.**—Examples are not wanting of inclines worked in the usual manner, with large drums, brakes, wire ropes and stationary engines. There is a long one, with curves, at a gradient of 1 in 12, on the San Paulo Railway in Brazil, and another very steep one opposite Pesth in Hungary. On the railway over the Andes across South America, intended to connect Buenos Ayres on the Atlantic with Valparaiso on the Pacific Ocean, there is one such incline perfectly straight, with an inclination of 1 in 8, for a length of half-a-mile, worked with a single stationary engine. This method is best suited for short lengths and straight lines. Here it works economically. But it is considered utterly unsuited for general use, its radical defect being that the disarrangement of any single length of it by any accident stops the travel on the whole line. It possesses also the danger (more likely perhaps to occur in India, owing to climatic action on the rope) of the hauling wire-rope breaking. (Rankine states the wear of wire-ropes to be from 67 to 100 per cent. *per annum*.) Moreover, locomotives can do the work as well, and are more convenient. For these reasons, the system of working inclines by stationary engines and rope-traction has been abandoned on passenger lines in England, and is confined almost entirely to the haulage of goods, minerals and coals. A rope incline for the haulage of passenger trains is however in use outside the Central

Station in Glasgow while there are many examples on the Continent and elsewhere. The late Mr. Berkely—formerly Chief Engineer of the Great Indian Peninsula Railway—first laid out on the Bhoze Ghat an incline to be worked by a stationary engine, but on the matter being referred to the late Mr. Robert Stephenson, he advised that this plan should, if possible, be avoided, even though its omission were attended with a considerable augmentation of the cost of the work.

**6. Centre-rail Railways with locomotives for working on very steep inclines.**—Of these there are two well-known systems, the leading feature of both being the provision of a central rail in addition to the two ordinary carrying rails.

1. The Fell Centre-rail Railway.

2. Various systems of Rack-rail Railway.

7. The Fell system which was first introduced on the Mt. Ceniz Summit Railway during the construction of the Mt. Ceniz tunnel differs from that of the ordinary railway in the addition to the engine of horizontal pairs of wheels which grip a central rail. These wheels bite the central rail at a level of about 14 inches above the ordinary side rails, and they are driven by the action of machinery unconnected with that of the vertical driving wheels. By means of these horizontal wheels, the driver can put a pressure equal to 56 tons upon the central rail; and can bring a train to a standstill within 100 yards.

The central rail is only placed at those parts of the line where the grade is steeper than 1 in 30, or where the radius of the curve approaches the minimum. The central-rail is a double T, as in the sketch, Fig. 184,

FIG. 184.

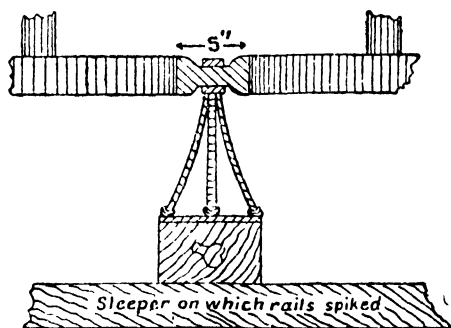

fixed by three iron curved legs at a height of 14 inches above the level of the side rails. As the engine arrives at a spot where the central-rail is

fixed, the horizontal wheels engage it, and are made by the driver to grip it with less or more power, as the occasion requires. At each end of the

FIG. 185.



lengths of centre-rail the ends are tapered off as in Fig. 185 so that the wheels may enter fairly upon it. Each passenger carriage is also furnished with two pairs of horizontal wheels, but they have no apparatus to press them on to the centre-rail, and are simply guides to lessen the risk of the carriages

running off the line at the sharp curves. On the Mont Cenis Railway the maximum grade was 1 in 11, and the minimum radius of curve 40 metres, or 43·745 yards. The express train accomplished its journey of 50 miles in five hours. The width between the ordinary side rails was 42 inches centre to centre. The narrow gauge was necessary in consequence of the sharpness of the curves. The rails were light and spiked on to cross sleepers without chairs being used.

The sharpness of the curves would, it was at first thought, necessitate the use of short four-wheeled carriages, but by the application of "radial axles" on the outer wheels long carriages running on six wheels were successfully used. The carriages were fitted in omnibus fashion, the seats being lengthways instead of transverse. They were coupled close, and platforms between adjoining carriages enabled the guards to pass from one to the other. Each carriage was fitted with a brake, and they were continually being worked throughout the journey.

On the completion of the Mont Cenis tunnel, in 1871, the summit line was taken up, and the experience gained during the five years in which it worked showed that the defects in the system were so serious as greatly to disappoint the hopes which had been held by many persons when it was first started. It consequently proved a financial failure.

The defects of the system as used on the Mont Cenis Railway were complicated machinery, insufficient boiler power, oil droppings from horizontal wheels falling on the centre-rail and thus depriving them of much of their adhesion, and the great amount of friction involved in the mid-rail machinery, producing great wear and tear of working parts, and thus, in the practical daily working of the system, making it costly and unreliable.

In 1873 it was revived under more favourable circumstances on a railway over the Organ Mountains in Brazil, where it is reported to have hauled 15 tons of cargo and 22 passengers up an incline, about 8 miles long, having gradients varying from 1 in 20 to 1 in 12, and curves of 140

feet radius, at a little over 6 miles per hour. The permanent way is the same in construction as that which was laid over Mont Cenis. The gauge is 3 feet  $7\frac{5}{16}$  inches; but the engines have been improved.

The Fell system has also been in successful operation for many years on a railway in New Zealand.

8. **The Righi Ladder-rail-Railway.**—The Righi is an isolated mountain in Switzerland near Lucerne. Its summit is about 4,500 feet above the Lake. A few years ago the average number of tourists visiting it totalled 40,000 annually. It used to be ascended by a zigzag bridle road, and the ascent took 3 or  $3\frac{1}{2}$  hours. A railway to improve this communication was designed by M. Riggenschach. The line is  $3\frac{1}{2}$  miles long, and the maximum gradient, which extends over one-third of the whole length, is 1 in 4, the other gradients varying between that grade and 1 in 6, except in some few places, where the line is purposely made almost level. The curves have a radius of  $8\frac{1}{2}$  chains. The line is formed almost entirely by benching on the sloping side of the rock, with occasional revetment walls on the outside. The permanent way consists of ordinary rails on the 4 feet  $8\frac{1}{2}$  inches gauge and of a very stiff and strong centre wrought-iron rack-rail, formed like a ladder, in addition to the two carrying rails.

Great care was taken in bedding the sleepers firmly, masonry bars being even built at intervals that the whole might not slip down the incline. The engine has strong toothed wheels on its driving wheel axles, the cogs of which work into the ladder-like rack-rail in the centre of the line, and so great power for the ascent of the incline is obtained. The rack-rail is formed of two channel irons with steel cross bars between them like the rungs of a ladder.

9. **The Abt System** has been devised as an improvement on the Riggenschach; the following detailed description of it was communicated to the Roorkee Professional Papers (1891 edition) by Sir Guilford Molesworth, with a summary of general progress in these systems up to date.

“For gradients steeper than 1 in 40, or thereabouts, the ordinary system of traction on railways by adhesion becomes so expensive as to be practically almost prohibitive, because the weight of an engine necessary to secure the proper adhesion is so great that a large proportion of the power of the engine is absorbed in raising its own weight up the incline, leaving but little for the paying load; and in frosty weather, or at times when the rails are greasy, the traction is faulty even with a very heavy co-efficient for adhesion.

“The usual plan of coupling a large number of wheels in ghat engines is by no means satisfactory, for the difficulty of securing equal wear in so many pairs of wheels and the impossibility of getting all the wheels to work together, especially on sharp curves, involves great friction, loss of power, wear and tear of rails, and costly repairs to engine stock.

“The ordinary plan of obtaining adhesion by tank engines is open to grave objection in working long inclines, for, as the fuel and water are expended in a tank engine, the adhesion is diminished, and either the wheel load must be greater than is necessary for adhesion, and thus give unnecessary wear and tear of the rails and engine tyres, or else the engine must take a smaller load than that which is due to its maximum adhesive power.

“Numerous endeavours have been made to devise a satisfactory system for the ascent of sharp inclines, amongst which the most notable of recent times have been—

- (a) The “Fell system” at Mont Cenis, in which the engine had four vertical wheels coupled, giving adhesion in the usual manner, and four horizontal wheels gripping a central rail.
- (b) The “Marsh system” at Mount Washington, in which the “Fell system” has been modified by the addition of a rack to the central rail and the substitution of a single vertical pinion, 2 feet 5 inches diameter, in place of the horizontal wheels.
- (c) The “Riggenbach system” at the Righi, a modification of the “Marsh system,” in which an iron ladder-rack is substituted for the ordinary rack.

“These systems are so well known that it is unnecessary for me to describe them in detail. It is sufficient to remark that, as they have been devised to obviate the observed defects of their predecessors, so the “Abt system” has been devised to meet the observed defects of the “Riggenbach system.”

“These defects may be briefly generalised as follows :—

- 1st.—The difficulty and cost of accurate construction of the ladder-rack.
- 2nd.—The inequality in the pitch of the teeth of the ladder-rack from the expansion and contraction due to variations in the temperature.
- 3rd.—Liability to concussion and wear and tear in the ladder-rack, except at low speeds.

- 4th.—Inequality of strains in the rack and pinion on sharp curves.  
 5th.—Inability of the engine to work at high speed on portions of the line where the gradients may be favourable.  
 6th.—Difficulty of combining the traction of adhesion and that of the pinion on the same axle.

“ During my visit last year to the United States of America Mr. W. W. Evans, the well-known Engineer of New York, directed my attention to the “ Abt system” of ascending steep inclines by rack and pinion ; but as he had not then in his possession full detailed information respecting it, I obtained the sanction of the Secretary of State for India to visit, on my way back to India, a small line of railway which had been constructed on the Hartz Mountains.

“ Leaving England at the end of January, I was met at Cologne by Mr. Rinecker, Mr. Abt’s partner, who courteously placed all possible information at my disposal, accompanying me to the Hartz Mountains, and affording me every facility for examining the “ Abt system” in operation.

“ The Hartz Railway has been constructed principally for the purpose of opening out iron mines, quarries, and iron works in the Hartz Mountains. It is connected with the Halberstad and Blankenburg Railway, joining it at Blankenburg Station, and is of the ordinary English gauge of 4 feet 8½ inches. Shortly after leaving the Blankenburg Station the line begins to ascend the flanks of the Hartz Mountains with a ruling gradient of 1 in 16½, and after crossing several ridges reaches Tanne, a total length of 30½ kilometres, or about 19 miles. The radius of the sharpest curve is 180 metres, or 590 feet, but this radius has not been adopted on the ruling gradient of 1 in 16½, the sharpest radius on that gradient being 280 metres, or 919 feet.

“ After leaving Blankenburg Station the line runs with a ruling gradient of 1 in 100 for a distance of about 2½ miles, it then ascends the mountains with a ruling gradient of 1 in 16½ for 4½ miles to Hüttenrode. Then level for a short distance, after which it descends sharply for 2½ miles to Rubeland with a ruling gradient of 1 in 20.

“ It then ascends again for about 4 miles with a ruling gradient of 1 in 16½, and again descends for 2½ miles to Rothehütte with a ruling gradient of 1 in 16½, after which alternately rising and falling with a ruling gradient of 1 in 48½, but with a general tendency to rise, it reaches Tanne, the present terminus of the railway. The rack is only laid on the steeper gradients.

“ I have appended to this report a section of that portion of line which lies between the 2nd and 9th mile, as representing the greatest difficulties in working. The portion on which the rack is laid is indicated on the section, Plate XXXIV.

“ The form of rack adopted in the “ Abt system ” is shown in Plate XXXV. It is formed of a series of steel bars  $110 \times 20$  mm. ( $4\cdot33$  inches  $\times$   $\cdot79$  inches.) The teeth, which have a pitch of 120 mm. ( $=4\cdot72$  inches), are roughed out and finally accurately finished by machine.

“ Three of these racks are arranged side-by-side in cast-iron chairs, which are firmly fixed to transverse rolled-steel sleepers of the Vautherin type.

“ There is a keeper over each outside joint of the rack-bars. The gauge of the railway is the ordinary 4 feet  $8\frac{1}{2}$  inches of English Railways laid with Vignoles rails.

“ The rack-bars not only break joint with each other, but they are so arranged that the teeth of one rack are a little in advance of those of the adjoining rack, thus securing continuity of contact and smoothness of working. The arrangement is shown in Plate XXXV.

“ Where the ruling gradients are less severe one of the rack-bars may be dispensed with, leaving only two rack-bars instead of three.

“ The locomotives used for working on the “ Abt system ” have two distinct functions :—

1st.—That of traction by adhesion as in ordinary locomotive engines.

2nd.—That of traction by pinions acting upon the rack-bars above described.

“ The function of adhesion is performed in the manner of an ordinary 6-coupled tank locomotive engine with outside cylinders.

The following are the principal dimensions, side-by-side with which I have added similar dimensions of our State Railway locomotive of the L class for the purposes of comparison :—

			Abt Engine.	State Railway Engine, L class.
Number of wheels	..	..	8	10
„ „ coupled	..	..	6	6
Diameter of coupled wheels	..	..	49·2 inches	50
„ „ uncoupled „	..	..	29½ „	33
Wheel loads, coupled „	..	..	44·5 tons.	81
„ „ uncoupled „	..	..	12·4 „	10
Total weight	..	..	56·9	64 including tender.

	Abt Engine.	State Railway Engine, L class.
Wheel base of engine .. ..	17·88 feet	20·83
Rigid wheel base .. ..	10·1 "	10·92
Diameter of cylinders .. ..	17·72 inches	18
Stroke .. ..	23·62 "	26
Pressure per square inch .. ..	150 lbs.	150
Tractive force at 120 lbs. effective pressure ..	18,090 "	20,218
Fire-grate area .. ..	20·13 sq. feet	19·25
Fire-box surface .. ..	89·4 "	107
Total heating surface .. ..	1,636 "	1,226

"It will be seen by this comparison that the Abt locomotives as employed on the Hartz Railway do not differ greatly, so far as traction by adhesion is concerned, from an ordinary State Railway type of Ghat engine, intended for use on gradients of 1 in 45 or 50. The Abt engine has a greater wheel load, inasmuch as it is a tank engine, while our State Railway engine is an ordinary tender engine. The Abt engine has a greater tube surface, but less fire-box surface than the State Railway engine, and it has somewhat smaller tractive power by adhesion.

"But besides its machinery for traction by adhesion it has a separate set of machinery for traction by means of pinions acting upon the rack above described.

"This machinery consists of two inside cylinders working two coupled pinions, each pinion having three rings of teeth spaced in advance of each other so as to correspond with the spacing of the rack-bars; the leading dimensions of the pinion machinery is as follows:—

Diameter of cylinder .. ..	11·81 inches.
Stroke .. ..	23·62 "
Diameter of pinions on pitch line .. ..	22·56 "
Tractive force with 120 lbs. effective pressure ..	17,522 lb.

"It will be seen, therefore, that the function of traction by pinions nearly doubles the tractive power of the engine.

"The connecting rods do not act directly on the crank pins of the pinion axle, but indirectly by means of a rocking lever, so proportioned that though the stroke of the piston is 23·62 inches, the diameter of the circle described by the crank pin of the pinion is only 17·32 inches. The pinions are coupled by side rods of the ordinary character. The framing, on which the pinions work, is hung to the axle-boxes of the leading and trailing coupled wheels, so as to move in concert with them and avoid the vertical action of the springs.

"The rings of teeth forming the pinion are confined between two cheeks bolted together, with an arrangement of alternate steel and

rubber, which imparts a certain amount of elasticity to the teeth, and allows each tooth to take its fair share of the work.

“The brakes are four in number ; two hand brakes acting by friction, and two acting by preventing the free escape of air from the cylinder and thus using the compressed air in retarding the progress of the engine. The two former are used for shunting purposes whilst the latter are used chiefly for descending the steep gradients.

“One of the hand brakes acts on the tyres of the wheels in the ordinary manner ; and the second acts on grooved surfaces on the pinion axles, but can only be used in those places where the rack has been laid down.

“The two compressed air brakes are modifications of the Châtelier “Contrevapeur” brake system. One of these acts by retarding the adhesion wheels ; the compression of the air in the cylinder is regulated by an escape valve under the control of the driver, a little water is injected into the cylinders to act as a lubricant, and to keep down the temperature of the compressed air.

“The other compressed air brake acts in a similar manner, to retard the pinions ; but, as in the case of the pinion brake, it is only available on those portions of the line at which racks are laid down.

“The machinery for each function is provided with separate link and valve motions, separate regulators, and separate steam exhaust pipes. Both sets of machinery are supplied from the same boiler, and as the speed is necessarily lower when the pinion machinery is employed, the consumption of steam in a given time is not greater, when the four cylinders have to be supplied at low speed, than when only two have to be supplied at high speeds ; but as soon as the pinion machinery is put in motion, the number of beats from the blast pipe is increased, exciting the fire as much as if the engine were proceeding at a high speed, and thus supplying the steam necessary.

“The details of the engine have been carefully considered. The glass gauge is at the centre of the boiler barrel, so as to indicate the average level of the water whether on an ascending or descending gradient. When one engine alone is used it is placed at the rear of the train in ascending, and in the front of the train in descending the steep grades, so as to spare the couplings, and obviate the danger of a train breaking away. The arrangement for enabling the engine to enter upon a rack without concussion is by means of a species of tongue-rack. This tongue-rack is supported on volute springs, so as to admit of its vertical

depression if the teeth of the pinion ride upon the teeth of the tongue-rack. The point of the tongue is bent down, and the teeth cut away to nothing as they approach the point. The steam is shut off from the pinion machinery on those lengths where the rack is not laid but when approaching a steep gradient on which the rack is laid the regulator of the pinion machinery is slightly opened, so as to cause the pinions to revolve slowly, and enable them, as they ride on the tongue, to engage the teeth of the tongue-rack without concussion; and as soon as this has been effected the regulator is fully opened, to allow the pinions to take their fair share of the work in the ascent.

“Where it is necessary to cross over portions of the rack-bars the rack is arranged on a sliding base, which is connected with the pointsman’s handles.

“At the time I visited the Hartz Mountains (the 23rd of January) the weather was very severe. There had been so heavy a fall of snow, that I was obliged to go from the railway station to the hotel in a sledge, and in some places there was a considerable amount of snow on the rails and racks, and, even where the rails were clear, they were covered with hoar-frost, so that the conditions for ascending a steep gradient under the ordinary system of adhesion were most unfavourable.

“The train in which I ascended the mountains consisted of one engine, one carriage, six trucks loaded with iron ore, and one brake van, making a total gross load of 120 tons, exclusive of the weight of the engine itself. The train ascended the steep gradients of 1 in  $16\frac{1}{2}$ , shown in the accompanying section, at a rate of between 5 and 6 miles per hour without the slightest difficulty. The engine in every case entered the tongue-rack, and the pinions engaged the rack without the slightest jar perceptible; the speed on the other portions of the line was about 15 miles an hour, but there was nothing to prevent the attainment of a much higher speed had it been desired.

“I carefully examined the rack at different places on the steep inclines, and it appeared to be wearing most satisfactorily; and on my return to Blankenburg I examined the pinions of all the engines in the running shed, and found that the wear was very slight; in case of undue wear, any ring of teeth in the pinion can be very easily removed and replaced by a duplicate.

“The advantages of the “Abt system” may be enumerated as follows:—

- (1) The rack can be easily and cheaply constructed with the utmost precision.

- (2) The rack-bars being in short lengths, the expansion is provided for without difficulty.
- (3) In case of wear or breakage a rack-bar can be taken out and replaced by a duplicate in a few minutes.
- (4) If one tooth should break two others remain to do the work.
- (5) As the rack-bars break joint, there are always two other solid bars opposite every joint, making the whole very firm and strong; there is also a "keeper" opposite every outside joint.
- (6) The spacing of the teeth ensures continuous contact and smooth working.
- (7) The arrangement of the pinions allows of elasticity in the working of the teeth.
- (8) The teeth of the pinions can be replaced with great facility and with very little cost.
- (9) The brake gear is very effective and safe, and completely under control.
- (10) The engines can run at high speeds on flatter grades, and with equal efficiency at slow speeds on heavy grades.
- (11) The cost of the rack may be reduced on the flatter gradients by dispensing with one rack-bar.
- (12) The quadruple exhaust enables the steam to be generated at low speeds equally well as at high speeds.
- (13) The use of two pinions, coupled, halves the stresses on the teeth of the rack, when compared with a single pinion.
- (14) The arrangement of the rack-bars facilitates the construction of the rack on sharp curves.

"The cost of each engine is about £ 3,500.

"The entrance tongue-racks cost about 600 marks, or about £30 each.

"The cost of treble rack-bars, with chairs, is about 26 marks per metre, or, say, £2,100 per mile; the cost of double rack-bars with chairs is about 21 marks, or £1,690 per mile.

"In conclusion, I may say that I was much pleased with the working of the "Abt system" on the Hartz Railway, that I consider it a very great improvement on the "Riggenbach system" of ladder-rack, and that it is in my opinion by far the best plan of ascending steep inclines that has hitherto been invented.

"I think it may with advantage be adopted in several places on our Indian State Railways. For example, on the Upper Bolan Railway, on

the Ootacamund Railway, and in the extensions of the Gulistan Kerez and Killa Abdulla Branches of the Sind-Pishin Railway, should it hereafter be thought desirable to extend those branches up the rivers, as suggested by the Khwaja Amran Railway Committee, of which I was a member."

The system was applied on the Sind-Pishin Railway but has been abandoned in favour of an ordinary adhesion line, as the gradients were not too steep to admit of this being worked. It is now in use on the Nilgiri Railway, between Kullar and Coonoor, but the Coonoor-Ootacamund extension of that railway has been constructed as an ordinary adhesion line.

10. **The Nilgiri Railway** has been constructed on the metre gauge, and ascends nearly 5,000 feet in a length of  $16\frac{3}{4}$  miles on a ruling gradient of 1 in  $12\frac{1}{2}$ . Starting from Mettupalaiyam, the first  $4\frac{3}{4}$  miles have gradients not exceeding 1 in 40 and are worked as an ordinary adhesion railway. The rack commences at Kullar (mile  $4\frac{3}{4}$ ) and continues without interruption, except at intermediate crossing stations, for 12 miles to Coonoor. The minimum radius of curves is 100 metres (328 feet) and the total curved length is 9 miles,  $5\frac{1}{2}$  of which are of the maximum curvature. The earthwork, consisting chiefly of hard rock or of boulders embedded in earth and disintegrated gneiss, aggregated 40 million cubic feet, and the consumption of dynamite for blasting amounted to about 180,000 lbs. The bridging was heavy, and a number of the bridges are on the ruling gradient of 1 in  $12\frac{1}{2}$ .

11. The rack consists of a pair of bars, and the rack-bars measure 3·116 metres in length and 22 millimetres in thickness. The two bars are laid so that they break joint and the teeth break pitch. The rack is carried by cast-iron chairs fitted to specially deep wooden sleepers. An allowance of 2 millimetres for each bar was made for expansion, so that the rack was laid with a gap of 4 millimetres at each joint, except on curves where the gap had to be reduced on the inner rack-bar and increased on the outer.

The adhesion rails are of the flat-footed type, 50 lbs. in weight per yard, with deep six-holed fish-plates.

12. All the carriage and wagon stock is carried on bogies: the passenger coaches are 36 feet long and weigh between 11 and 12 tons. Various types of engines have been employed; the engines as in the case of the Hartz Railway have to be such that they can be used both on the rack and the adhesion section. Plate XXXVI shows the general arrangement of an Abt Combination Adhesion and Rack Locomotive in use on the Nilgiri Railway; the driving pinions, which are shown in broken lines on

the plate are driven by cylinders separate from those which drive the adhesion wheels.

Very powerful brakes are used and it has been found that a train travelling at 12 miles an hour down the ruling gradient can be easily brought to a stand in about 140 yards. In ascending the gradient, the engine pushes its train, and is on the down-grade side during the descent, so that there is no risk of broken couplings or run-away vehicles.

13. A detailed description of the Nilgiri Railway will be found in Vol. CXLV of the Proceedings of the Institution of Civil Engineers, in a paper contributed by Mr. W. G. Weightman, the Engineer in charge of its construction.

## CHAPTER XIX.

### THE GAUGE QUESTION.

1. An outline of the history of the gauge question, as far as concerns England and India, was given in Chapter I. It was there shown that whatever may be the arguments for or against any particular gauge under given conditions, the need for uniformity of gauge generally outweighs all other considerations when there is very extensive interchange of traffic between railways. When goods have to travel over railways of various gauges, it is obvious that they have to be unloaded from one set of wagons and reloaded into another set—*transshipping* this is called—at every station where there is a change or “break” of gauge. When the bulk to be transhipped is considerable this not only entails the provision of costly transshipment yards, but it also causes delay and inconvenience; and the extra cost of handling has been estimated as equivalent to that of an extra haulage of 20 miles for every transshipping station. Another inconvenience is that a break of gauge limits the mobility of rolling stock. That is to say, there may be a great demand for wagons during a rush of traffic in one part of the country, while there may be a number of wagons idle in another part. If there were no such thing as a break of gauge, it would be a simple matter to transfer these wagons from one part to another as required. But wherever a break of gauge intervenes, such borrowing is impossible, consequently each railway has to keep a greater number of wagons than would otherwise be necessary. Thus, the disadvantages of break of gauge are (i) delay in transit, (ii) the incurrence of transshipping charges, (iii) the necessity for the provision of expensive transshipping arrangements and (iv) the inefficient use of rolling stock—all of which disadvantages mean loss of money and would be obviated by uniformity of gauge.

2. The next point to note—and this is a point which has only recently been generally realised—is that the *cost of a railway*, if designed according to traffic requirements and not to any arbitrary standard of strength, &c., is but *slightly affected by the gauge*. This principle was not recognised in 1870 when the metre gauge was first introduced into India. For the assumption then was that a cheaper railway necessarily implied a narrower gauge. It is only by the light of experience since gained that we have begun to see how little the gauge affects the cost. To begin with the cost of the substructure of a railway

depends more on the nature of the country than on the gauge. For instance, if big rivers have to be crossed, the cost of the bridging is practically the same, whether standard or any other gauge is adopted. The same remark applies to high embankments, deep cuttings, and tunnels. That is to say, the difference (if any) due to gauge is such a small fraction of the total cost in such items as to be for practical purposes negligible. In fact, as regards tunnels, the Government of India requires the section for metre gauge to be the same as for the standard gauge in all cases (*vide* Figs. 5 and 6, Chapter I). It is obvious also that the cost of station buildings, staff quarters, gate lodges, signals, and of many other items which help to make up the capital cost of a railway, has nothing to do with the gauge. (At the end of the chapter is a table showing the comparative cost per mile in a typical case of a railway, estimated for the standard and 2'6" gauges, both gauges being equipped to carry the same volume of traffic. This estimate will be seen to bear out the statements made above.) The only other items, other than rolling stock, which we have to consider with reference to the gauge are (i) land, (ii) ordinary banks and cuttings, (iii) bridge masonry, (iv) bridge girders, (v) the track itself.

3. Taking item (1), in the actual case for which the estimate has been prepared, the difference in cost between the land required for the broad gauge line and that for the narrow gauge is Rs. 510 per mile, that is less than 1 per cent. of the total of the standard gauge estimate.

4. As regards item (ii), the cross-sectional area of a bank 5 feet high with side-slopes of 2 to 1, and formation width 12 feet, which is a usual width for 2'6" gauge lines is 110 sq. feet. The area for a standard gauge bank of the same height, and with the same side slopes, but with a formation width of 16 feet 6 inches, (the minimum width permissible, but still suitable for a light standard gauge railway) is 133 sq. ft. The difference in section for the two gauges is therefore only about 17 per cent of the section for the standard gauge. This percentage will decrease as the banks become higher, and for a bank 10 feet high, it amounts to 12 per cent. only. As earthwork is cheap, any difference in cost due to gauge under this head would thus hardly amount to more than 1 or 2 per cent. of the total cost of the railway. In the estimate at the end of the chapter, this difference amounts to 1.5 per cent only of the total of the standard gauge estimate.

5. Considering item (iii), the difference in the cost of minor bridges for the two gauges, taking the same formation widths as above, would be the extra cost of a strip of masonry  $4\frac{1}{2}$  feet wide in piers and abutments

(and in the barrels of arches in the case of arched bridges) together with the same width of concrete in the foundations. The quantities in the wing and return-walls would be the same for both gauges for the same height of bank. As stated above, the cost of bridging large rivers bears little relation to the quantities of masonry or concrete in the bridges, and in the estimate at the end of the chapter there is only a difference of Rs. 110 per mile in favour of the 2'6" gauge under this head. The difference in the cost of major and minor bridges combined is about  $\frac{1}{3}$  per cent. of the total of the standard gauge estimate.

6. As regards item (iv), *girders*, it may be taken as an axiom that in the absence of arbitrary standards their strength would be regulated by the loads and speeds of the vehicles which have to pass over them. In other words the preponderant factor in this case would be the *prospective volume of traffic*, not the gauge.

7. The same consideration would govern the cost of item (v), the *track*. In practice, the rails and sleepers which constitute the track, as well as the girders of bridges, are frequently changed to suit the varying conditions of traffic, heavy traffic demanding a heavy track and heavy girders. So that items (iv) and (v), in the case of a railway not subject to arbitrary standards, would be governed solely by the volume of traffic to be dealt with, and not by the gauge.

8. We have now to consider whether there is any relation between *the volume of traffic* and the gauge. Now the traffic of a line may be described as a succession of loaded trucks travelling at greater or less speeds. Thus the points we have to consider with reference to the gauge are (i) the capacity of the trucks, (ii) the speed.

9. As regards (i) it may at once be stated that within limits a truck of given capacity can be practically designed for any gauge. The accompanying diagram (*Fig. 186*) shows how a 10-ton truck, allowing 100 cubic

FIG. 186.

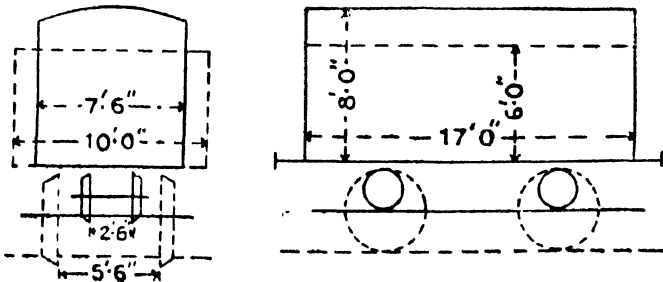

feet per ton, or 1,000 cubic feet capacity in all, may be designed for either 5' 6" or the 2' 6" gauge, the length of the truck being the same in

both cases, namely 17 feet, and the sectional area 60 square feet. In the above diagram the full lines show the general design of the truck for the 2' 6" gauge, and the dotted lines the same adapted to the 5' 6" gauge. In the 2' 6" gauge the width of body is restricted to 7' 6". In the 5' 6" gauge the width may be conveniently increased to 10' 6". Hence a shallower truck is possible with the latter than with the former gauge. It may be mentioned incidentally that 100 cubic feet per ton is a liberal allowance, suitable for light bulky goods, such as would usually be loaded in open trucks. For heavy goods the design would be easier as the height and lateral dimensions would be reduced.

10. The 2' 6" gauge truck in the diagram is shown as a four-wheeler, for simplicity of comparison, but by using bogies the axle-loads would be reduced. There are actual examples of trucks 25 feet long on a 2' 6" gauge railway, weighing 4 or 5 tons and carrying loads of 15 to nearly 16 tons, the gross load being 20 tons, and the axle-loads not exceeding five tons. Trucks of higher capacity than these are rarely required on *any* railway. For, although it has been estimated that with a given load on a given journey a train composed of fully loaded wagons of high tonnage capacity can be hauled more economically than an equivalent train consisting of a larger number of wagons of lower capacity; this statement carries its own limitations. For the high-capacity trucks would be useful only for certain commodities at certain seasons, say for three months of the year; for the remaining nine months they would not be utilised to their full capacity. The same remark applies in a lesser degree to low-capacity wagons. But as the actual *tare* weight of the latter (that is, their weight when empty) would presumably be less than that of high-capacity wagons, it would obviously be more economical to haul a train of half-loaded low-capacity wagons than a similar number of quarter-loaded high-capacity wagons. This sets a practical limit to the economical size of an *average* wagon for commercial purposes on any railway. And as the average is well within the examples we have given, the latter may be taken as sufficiently establishing the truth of our statement in paragraph 9 that a truck of given capacity (neglecting fancy dimensions) can be practically designed for any gauge; also that, as a corollary, the gross load of a truck need never exceed a certain limit per foot run, say one ton per foot over all.

11. We come now to (ii) the speed. A glance at the diagram will at once show how the diameters of the wheels are limited by the gauge. It is found by experience that the diameters of locomotive driving wheels should not much exceed the gauge, and those of carriage and wagon wheels three-fourths of the gauge. This sets a practical limit to the speed.

For in a given number of revolutions the speed is proportional to the diameter of the wheel; also the speed will be limited in practice by the rate at which the journal passes over the surface of the brass. Hence it may be stated that, with similar loads and engine power, *the speed attainable is roughly proportional to the gauge*. In other words, high speeds (as understood on standard gauge railways) are unattainable on narrow gauge lines.

12. Now, reverting to paragraph 8 in which we showed that the volume of traffic was a matter of truck-loads and speeds, let us take the traffic passing over a given spot, say a girder bridge. We have seen that within limits a given load may be placed in a wagon of given length, whatever the gauge may be. We have also seen that the gross load of a truck need never exceed a limit of, say, one ton per foot run. Then (omitting for the present the weights of engines), the strength of the track and the girders need only be sufficient to sustain a moving load of the above limit of one ton per foot run. And this, for a given speed, will be the same for girders of the same span, whatever the gauge may be, and will also be independent of the number of trucks passing over the bridge. For girders of short span, and also for the track itself, the design will depend rather on individual axle-loads than on the weight per foot run of the train. But this will not make a very great difference in the case of girders of large span. For instance, if we put a 20-ton (gross) truck on two axles, the axle-load is ten tons. On the other hand, if we place it on bogies, the axle-load becomes five tons. The former may be taken as representing the 5'6" gauge, the latter the 2'6" gauge. It is clear that this would not affect to any considerable extent the design of girders, the span of which is a large multiple of the bogie wheel base. In such a case, the track would chiefly be affected. That is to say, for the heavier axle-load the rails and sleepers must be of heavier section. The ratio between rail sections for axle-loads of ten and five tons is, under the rules of the Government of India 2 to 1. Hence if the total cost of the permanent way for the ten ton axle-load amounted to one-third or 33 per cent. of the total cost of a standard gauge railway, the saving on permanent way for the narrow gauge would amount to 16½ per cent. of the cost of the standard gauge railway. The average saving in the case of girders might be taken at about 2 per cent. of the total cost of the standard gauge line.

13. Having dealt with the cost of the substructure and fixed portions of a railway in relation to the gauge, we have now to consider the rolling stock. Statistics show that for a given volume of traffic the value of rolling stock is fairly constant, irrespective of the gauge. For

even if we deduct 20 per cent., or  $\frac{1}{5}$ th, for the tare of a carefully designed narrow gauge wagon as compared with a standard gauge wagon of equal capacity, this would affect the total cost of the railway, assuming that the rolling stock accounts for  $\frac{1}{10}$ th of the total cost, by a difference of  $\frac{1}{5}$  of  $\frac{1}{10} = \frac{1}{50}$  or 2 per cent. only—a difference which would probably be nullified by the need for a higher proportion of rolling stock on the narrow gauge than would be necessary in the case of a feeder of uniform gauge with the parent line. Hence, we may say that the cost of rolling stock is independent of the gauge, and is dependent only on the volume of traffic. In many cases, moreover, the main line has a certain amount of surplus stock, or stock no longer fit to run on main line trains, which it could afford to hire to the branch line, if of the same gauge, for a comparatively small charge. In such cases, it would be unnecessary for the branch line to purchase any rolling stock of its own.

14. Summarising our conclusions, we find that the difference in cost between a 5' 6" gauge and a 2' 6" gauge railway in a given tract of average country, and designed for the same volume of traffic at speeds not exceeding, say, 15 or 20 miles an hour may amount to about 22 per cent. of the cost of the standard gauge line. This figure is of course not absolute; it would in fact vary with every railway, but it serves to illustrate the sort of difference that may be expected in average circumstances. In the case of the estimate at the end of the chapter, the difference is slightly over 20 per cent. If we assume that the main line has surplus stock to hire to the branch line, supposed of the same gauge as the main line, the difference may be reduced to less than 10 per cent, as in the case of the estimates at the end of the chapter.

15. If the narrow gauge is a feeder to a standard gauge railway, the inconveniences of break of gauge (paragraph 1) tell more heavily on the feeder than on the parent line. But these disadvantages are proportional to the volume of traffic. In deciding therefore whether a feeder line is to be on a narrow gauge or on the gauge of the parent line, we have to consider whether the capitalised value of the prospective losses due to break of gauge is less or greater than the estimated difference in first cost between the two gauges. If less, an argument is established in favour of the narrow gauge.

16. Against this, however, it must be remembered, that if the traffic increases, as it usually does, a time may come when the capitalised value of the losses due to break of gauge may be greater than the original difference in cost, in which case the dividends of the line would not be as great as if the line had been built originally to the parent gauge.

17. Moreover, the narrow gauge line is permanently handicapped by the speed limit (*vide* paragraph 11) and is therefore exposed to the risk of losing its traffic by the springing up, sooner or later, of competitive routes. For it must be borne in mind that, however deserving an individual line may be, public interests will not admit of a monopoly of traffic being guaranteed to it *in perpetuo*.

18. It may be argued that the estimated small difference in cost between the standard and the narrow gauge lines is based on a speed restriction (paragraph 14), and that if advantage is to be taken of the higher speeds possible on the standard gauge, a heavier type of track and girders would be necessary, in which case the difference in cost would be considerably increased. This is true, but against it we must remember that the higher speed need not be introduced on the feeder line except under stress of competition, or in self-interest. The benefits of uniformity of gauge can be enjoyed even with the existence of speed restrictions.

19. Again, it is argued by some railway officers that a lighter type of track on a feeder line than on the parent line, even though the gauge be the same, is equivalent to a break of gauge, inasmuch as the heavier axle-loads of wagons on the main line would bar them from running on the feeder, and so prevent free interchange of wagons. But this is only partially the case. As we have shown elsewhere, very few wagons on any railway run to full axle-loads all the year round, and it is merely a matter of traffic organization to arrange that wagons intended to run from the main to the branch shall not be loaded above the limit of axle-load for the latter. This could to a great extent be ensured by utilizing wagons which are not designed for high axle-loads. In any case, a partial interchange of wagons would be better than no interchange at all.

20. In paragraph 12 consideration of the weights of engines was specially omitted for the following reason. There is not the same necessity for an interchange of engines as an interchange of wagons between main and branch lines. Engines work in localities. Consequently the engines which work branch lines may be specially designed so as not to exceed the axle loads for which the track is adapted.

21. The result of the foregoing comparison between standard and narrow gauge railways will apply also to the case of the metre and 2' 0" gauges, and in a lesser degree to the standard and metre gauges. It is difficult to test the correctness of the comparison by actual examples, because much of the difference in cost between existing standard and metre gauge lines is due to their having been built for *different loads*, according

to certain minimum standards for strength of bridges, permanent way, etc., laid down by the Government of India for each gauge. This differentiation between the two gauges is the outcome of the original policy which presupposed lighter traffic for the narrower gauge. And although it is necessary now to preserve the dual standard, in view of the extensive and concurrent development of the two gauges in India, it should be clearly recognised that the differentiation is empirical, and bears no relation to the actual traffic with which the various railways have to deal.

22. A relaxation of these standards is however allowed by the Government of India in the case of railways built for avowedly light traffic, otherwise known as "light railways;" but, as we shall see in the next chapter, the relaxation has not hitherto been seriously applied to the design of a light railway on the standard gauge. Traditions die hard, and the public mind cannot readily divest itself of the idea that the cost of a line is proportionate to its gauge. As we have seen, the whole problem, if untrammelled by preconceived standards, can be reduced to a question of intelligent design. But while much ingenuity has hitherto been directed to the design of rolling stock capable of carrying standard gauge train loads (as now conceived) on a narrow (2' 6") gauge track, involving lateral dimensions equal to three times the gauge (*vide* diagram), and obviously incapable of further development, except as regards the multiplication of stock, no corresponding progress has been made in the promotion of light railways on the standard gauge, which would combine cheapness of first cost with unlimited scope for development hereafter. The point that is frequently overlooked in advocating narrow gauge lines is that, even though they may be designed to take the average train-loads of a standard gauge railway, those loads can never be carried at half the speed attainable on the standard gauge. Where speed is no object and traffic is light, the narrow gauge is financially the correct thing. But the question should be considered comprehensively in the light of paragraphs 14 to 16.

23. As far as India is concerned, the recommendations of the Select Committee of 1889, *vide* paragraph 21, Chapter I, may be taken as the best general solution of the gauge problem hitherto formulated. The difficulty is to apply it in individual cases.

24. In mountain railways, for instance, the narrow gauge has an intrinsic value, in that it admits of comparatively sharp curves; whereby the cost is sometimes considerably reduced. But when lines are built for strategic purposes, or as connecting links, the necessity for uniformity

of gauge will usually outweigh all other considerations, even if steep mountain passes have to be negotiated.

25. The gauge problem is not peculiar to India. It arose and was solved in England, as we have seen (paragraph 18, Chapter I), in 1845, when the 4' 8½" gauge became established once for all, though the rival gauge in that case, namely the seven-feet of the Great-Western, survived until 1892. In the United States, a break of gauge between the Northern and Southern States was intentionally introduced originally to check internal commerce, the northern gauge being 4' 8½" (or 4' 9"), while that of the south was fixed at 5' 0". But the effects were so detrimental to the south that in 1886 no less than 13,128 miles of the southern railways were changed from 5' 0" to the northern gauge of 4' 8½". In Canada, again, about 3,000 miles of railway, originally constructed to 5' 6" gauge, had subsequently to be altered to 4' 8½" for the sake of uniformity with the United States Railways. A number of narrow (3' 0") gauge lines were also constructed in North America, but had to be subsequently altered to the normal (4' 8½") gauge. In Australia, since the federation of its constituent states, the question has become acute, and proposals have been put forward to convert the 3' 6" gauge lines of Queensland and the 5' 3" gauge lines of Victoria and South Australia to the normal gauge (4' 8½") of New South Wales. In Egypt there are two gauges, the 4' 8½" north of Luxar station, and 3' 6" southwards. The 3' 6" predominates; the only inconvenience is the break of gauge at Luxar.

26. The following are some of the principal gauges of the world and the countries in which they are found. The 4' 8½" gauge holds the first place and may be called the *normal* gauge of the world. Among European countries it is used in Great Britain, France, North Germany, Holland, Belgium, Austria, Hungary, Turkey, Switzerland, Italy, Norway, Sweden, Denmark. The normal gauge is also used in Canada, the United States, Nova Scotia, New South Wales, Egypt, Brazil, etc., Russia used a 5' 0" gauge for the express purposes of checking international traffic. The Indian standard gauge (5' 6") is found in Spain, Portugal, Brazil, Argentine Republic, and Chili, and is the broadest gauge in use in the world. Next comes the 5' 3" gauge, used in Ireland, Victoria, South Australia, New Zealand and Brazil. The 3' 6" gauge is used in Queensland, Tasmania, Cape Colonies, Norway, Egypt, Brazil and Japan. The metre (3' 3⅓") is found in France, Switzerland, Brazil and Argentine Republic, besides India. A supplementary 3' 0" gauge has been introduced in Ireland. In India there are a number of examples of 2' 6" and 2' 0" gauges, especially the former.

*Comparative estimates of cost of construction of a Branch Railway, on the 5'6" and 2'6" gauges, designed to carry the same traffic on either gauge.*

Head of account.	R t per mile.	
	5'6" Gauge.	2'6" Gauge.
I.—Preliminary expenses—	Rs.	Rs.
(a) Survey expenses .. .. .	8	8
(b) Plant .. .. .	9	9
(c) Establishment .. .. .	158	158
II.—Land .. .. .	1,500	990
III.—Formation.—		
(a) Earthwork .. .. .	4,100	3,250
IV.—Bridgework		
(a) Major bridges .. .. .	2,780	2,670
(b) Minor bridges .. .. .	1,672	1,454
V.—Fencing, etc.—		
(a) Fencing .. .. .	270	270
(b) Road crossings .. .. .	770	790
(c) Mile and gradient posts .. .. .	42	42
VII.—Ballast and permanent way		
(a) Main Line —		
(i) Permanent way .. .. .	20,457	15,288
(ii) Ballast .. .. .	1,330	850
(b) Sidings.—		
(i) Permanent Way .. .. .	3,150	1,428
(ii) Ballast .. .. .	153	105
(c) Points and crossings .. .. .	663	400
VIII.—Stations and buildings.—		
(a) Stations and offices .. .. .	1,540	1,355
(b) Workshops, etc. .. .. .	70	500
(c) Staff quarters .. .. .	2,487	2,600
(d) Station Machinery .. .. .	3,150	2,075
IX.—Plant		
(a) Engineering .. .. .	243	195
(b) Construction .. .. .	260	240
(c) Locomotive .. .. .	80	100
(d) Carriage and Wagon .. .. .	97	70
(e) Station and office furniture .. .. .	247	247
XI.—Rolling-stock .. .. .	7,000	6,000
XII.—General charges.—		
(a) Direction .. .. .	268	250
(b) Engineering .. .. .	3,897	3,897
(c) Stores .. .. .	420	350
(d) Audit and Accounts .. .. .	228	228
(e) Medical and Sanitary .. .. .	455	465
<b>Total Rs.</b>	<b>58,203</b>	<b>46,194</b>

## CHAPTER XX.

### LIGHT RAILWAYS, MONO RAILWAYS AND TRAMWAYS.

1. It was stated in paragraph 3, Chapter I, that the essential difference between a railway and a steam tramway lay in the fact that the former had to conform to certain standards as regards equipment and working regulations to which the latter was not subject. This distinction is based on the tacit assumption that high speeds are unattainable or impracticable on a tramway, as compared with those on a railway. But with the introduction of "light" railways referred to in paragraph 22, Chapter XIX, there is now little to choose between a lightly equipped railway and a highly equipped steam tramway, as far as India is concerned; and the distinction now lies chiefly in the fact that a "tramway" is under the administrative control of a Local Government, whereas a "railway" is under that of the Government of India.

2. Although when the question of light railways was raised in India in 1893 no stipulations were laid down as to the gauge, the light railways which have hitherto been constructed as such have usually been on a narrow gauge, usually 2' 6", so that the term "light railway" has almost become synonymous, in the public mind, with a narrow gauge railway. This confusion of ideas should be carefully guarded against. The example of England is instructive in this connection. The English Light Railways Act of 1896 did not lay down any limitations regarding gauge, but nearly all railways hitherto constructed under that Act have conformed with the normal gauge of the country, *viz.* 4' 8½", for the sake of uniformity.

3. Thus, the "lightness" of a railway has no connection with its gauge, nor even necessarily with its carrying capacity; the term should be restricted to railways having either light axle loads or low speed limits.

4. If a light railway is intended to develop the resources of a tract of country, its gauge should be determined by the considerations set forth in paragraphs 14 to 17 of the last chapter. But if it is intended for temporary purposes only, a narrow gauge should be employed, as being portable, easily laid and easily pulled up again. An example of a light railway used for temporary public traffic was the Delhi Durbar Light Railway laid specially for the Coronation Durbar traffic of 1902-3, and pulled up when done with. This was on the 2' 6" gauge, military type. In this, as in most portable railways, steel trough sleepers were used. Contractors' railways, used in the construction of extensive works, are a more familiar illustration of temporary lines. These are usually of a narrow gauge; the first essential of a contractor's railway being that it

should be portable, as the track has to be shifted from day to day as the work proceeds.

5. The following details of the Barsi Light Railway, 2' 6" gauge, will serve to illustrate the capabilities of a narrow gauge railway. The limiting axle-load on this line is 5 tons, alike for locomotives, carriages and wagons. The locomotives are of the 0-8-4 type (see Plate XXVIII). The driving wheels are of 2' 6" diameter, the cylinders of 13 inches diameter and 18 inches stroke. The weight of the original locomotives in working order is 29 tons 8 cwt. of which 19 tons 15 cwt. are on the coupled wheels. The boiler pressure is 150 lbs. per square inch. The grate area is  $9\frac{3}{4}$  square feet, the heating surface of the firebox 44, and of the tubes 484 square feet, the latter being 110 in number and  $1\frac{1}{4}$  inch outside diameter. The water carried is 800 gallons and the fuel 80 cubic feet. There is a steam brake on all the wheels of the engine, including those of the bogie frames; there is also a hand brake on all wheels of each locomotive. The hauling power on various gradients and curves is as follows:—

On level straight line	..	..	..	..	1,036 tons
On grade 1 in 100, and curves 600' radius	..	..	..	..	276 "
"   1 in 90	..	600'	..	..	245 "
"   1 in 57	..	250'	..	..	151 "
"   1 in 50	..	250'	..	..	136 "

The train-load actually allotted for a gradient of 1 in 100 is 260 tons. The locomotives recently built are somewhat heavier, weighing 36 tons 5 cwt. in all, and can haul 310 tons on a 1 in 100 grade. The coaching stock includes special saloon cars (carrying 8 passengers), upper class cars (carrying 24 passengers), composite brakevans (carrying 6 upper and 32 lower class passengers) and lower class cars (carrying 64 passengers), all of the bogie type and of uniform length of 40' over headstocks and 40' 6" over bodies, by 7' 6" width. The goods stock is all of the bogie type, 25 feet long over headstocks and 28' 3" over buffers, the width being 7 feet. The bogie centres are 16' 8" apart, and their wheel bases 4' 3". Handbrakes are fitted to all. The tare and capacity of the various classes is as follows:—

Description	Tare tons cwt.	Load tons cwt.	Gross load 20 tons in each case.	Cubic capacity.	Remarks.
Low-sided ..	4·2	15·18	} each case.	900 c ft.	Will carry guns. Will carry 6 horses or 8 ponies.
High-sided ..	5·7	14·13		500 "	
Covered (old type) ..	5·18	14·2		1,000 "	
" (new type) ..	6·6	13·14		1,150 "	

The bridge girders are of the Government of India metre gauge type. The permanent way consists of steel rails 35 lbs. per yard, 24 feet long. The fishplates are 4-holed. The sleepers are of the steel trough type, weighing 50lbs. each, 10 to each rail or 2,200 to the mile. On bridges teak sleepers are used. The ballast is broken stone, 7 cubic feet to the foot run.

6. **Steam tramways.**—The description of permanent way used for light railways would apply also to steam tramways, except that when the track is laid on a public road—as often happens in the case of tramways, but very rarely in the case of railways, for the latter are usually fenced off when running alongside a public road—the rail-heads must be flush with the road surface. This entails a special type of permanent way. Self-adjusting or trailable points (see paragraph 14, Chapter III) are also frequently used.

7. Subjoined (Fig. 187) is a cross section of the type of permanent way used for street traffic in Great Britain. The description (as given in

FIG. 187.

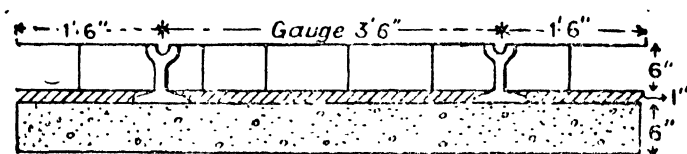

Molesworth's pocket book) is as follows: " Rails of girder type, weighing about 90 to 100lbs per yard on concrete 6 inches deep extending across the track, and 1 feet 6 inches on either side; on this bed the paving material is laid, consisting of wood blocks, granite sets, or other material; the rail

joints are usually stiffened as shown (Fig. 188). Tie bars are used every 7 feet apart; the length of rail is usually 45 feet; the width of groove varies from  $\frac{7}{8}$ " to  $1\frac{1}{8}$ ". For light railways on ordinary roads the same construction is used; if laid on

FIG. 188.

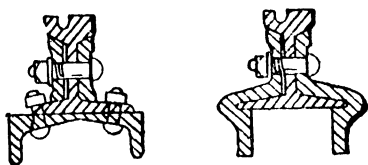

open ground, sleeper construction is generally used, with or without ballast."

8. In the Bombay suburban tramways the same section of rails is adopted, but the rails are laid on wooden sleepers, which rest on a soling of flat pieces of stone, as used in ordinary road construction, the

space up to rail level being then filled up and rammed with ordinary street metal.

9. **Mono-railways.**—There are three principal types of Mono-railways, (i) the *elevated rail* type, in which the cars are slung *pannier* fashion on either side of, and below, the rail, so that stability is secured by the centre of gravity of the cars being *below* rail-level (the wire tramway described at the end of this Chapter contains the same idea in a modified form); (ii) the *Ewing* type, in which the rail is laid on the ground, the car being fitted with grooved wheels to run thereon; in this case (the centre of gravity being *above* rail level) equilibrium is maintained by a *balance wheel* which revolves lightly on the ground about 5 feet from the rail, and parallel thereto, somewhat on the principle of a Singhalese outrigger; the balance wheel is designed to take only from 6 to 10 per cent. of the total load, while its own weight and leverage prevent the vehicle from toppling over on the other side; this type is well-known in India; (iii) the *Brennan* type, in which the centre of gravity of the car is *above* the rail, as in the last type, but each vehicle is capable of maintaining its balance, whether it be standing still or moving, by an ingenious use of *gyroscopes*.

10. **Wire tramways.**—Tramways formed of one rope, or two or more parallel ropes, which are supported by standards, and on which baskets, boxes, or small trucks are conveyed, have been devised and used in different places. For mountainous countries, for short passages for goods across ravines and deep valleys, and generally for quickly opening up communications across a wild country, where the construction of metalled and bridged roads cannot readily be undertaken, this system proves invaluable. A number of ropeways are at present in use for private traffic in various parts of India, and proposals have been put forward for their construction for public traffic, both passenger and goods, to several of the hill stations, in the north of India.

There are two principal systems of wire traction in use—

In the first, two wire ropes are employed, one stationary, called the *carrying rope*, and the other moving, called the *hauling rope*. The second system has a single rope, which combines the functions of *carrying* and *hauling*. In the former the *carrying rope* acts simply as a rail, or support, for the vehicle, which is impelled over it by the *hauling rope*.

The relative advantages of both systems have been much discussed. Generally the double rope arrangement will prove the more efficient,

especially where steep gradients, long spans, and heavy traffic have to be dealt with.

In both systems the ropes are supported at intervals on either built up iron or wooden trestles, resting on solid masonry or concrete foundations (Plate XXXVII, Fig. 1). The carrying rope is rigidly fixed to the support, while the hauling rope passes over suitably arranged pulleys.

In the first system mentioned, the vehicles are provided with small grooved wheels which run on the carrying rope (Plate XXXVII, Fig. 3). A clutch is provided to grip the hauling rope which is automatically released at the end of the journey (Plate XXXVII, Fig. 2). Where one rope only is employed the vehicles grip the rope and pass over large pulleys fixed on the standards or supports. (Plate XXXVIII, Fig. 2\*). The vehicles or carriers are made of various shapes and sizes according to the material they are required to transport (Plate XXXVIII, Fig. 1).

Gradients as steep as 1 in 1 have been successfully worked, transporting loads of one ton in a carrier.

The line should, as far as possible, be laid out in straight lengths, as curves make the introduction of special arrangements necessary, in order to keep the ropes on the guide pulleys of the supports.

The hauling rope is usually driven by steam or other power from a drum at one end of the line, but where an alteration of direction in the line cannot be avoided the driving station is sometimes placed at the deviating point, so that the ropes leave it in two straight lines. In Plate XXXVIII, Fig. 3, a terminal station is shown.

The following is a description † of a line which has been constructed on the double-rope system : —

**Garrucha Line.**—The most important Otto ropeway yet constructed is for the transport of iron ore in southern Spain, from the Serena de Bedar to Garrucha. This line is 9·69 miles long, and divided into four independent sections with lengths of 1·40, 2·11, 3·29 and 2·8 miles respectively. A 30 horse-power engine drives the first two sections, and a 70 horse-power engine the last two.

“After leaving the loading-station at Serena, 905 feet above the sea, the line crosses a number of deep valleys, upwards of half a mile wide and 328 feet deep, and traverses mountain ridges, the highest of which is 1,174 feet above sea-level, to the village of Pinar de Bedar, where, at an elevation of 951 feet, the first power-station is located. From here the

---

\* See Ropeways Syndicate Catalogue.

† Taken from a paper read before the American Institute of Mining Engineers by J. Pohl of Cologne, Germany.

line deflects to the right and again passes over several valleys and ridges, with a gradual descent to an angle-station 370 feet above sea-level. It then bears to the left, extending over a more or less hilly country to the second power-station near Puerto del Coronel at an elevation of 147 feet. From here it again turns to the right, descending at a comparatively easy gradient to the unloading-station on the coast, near the town of Garrucha.

“Viewed from the mountain ridge between Bedar and Serena, whence the line can be traced from end to end, the prospect is imposing—660 buckets travelling back and forth, growing smaller in the distance, until they seem like faint specks; and the ropes brightly reflected in the sunlight, like silver cords. The capabilities of the system are nowhere more strikingly exhibited, and the precision with which the carriers move and deliver their loads heightens the effect.

“The greatest span of the line, near the Villa Reforma is 918 feet. In this span the rope sags 65 feet, and carries six loaded and six empty buckets at a time. Its height above the valley is 164 to 196 feet. The other long spans of the line range from 328 to 750 feet, but the average distance between the supports is only about 130 feet. The steepest gradient, taking into account the sag of the rope, is 1 in  $2\frac{1}{2}$ , and the tallest standard is 118 feet high. The guaranteed capacity of the line is 400 tons per day of 10 hours. With a travelling rate of 300 feet a minute, or about three miles an hour, and with two buckets of 7 cwts. capacity arriving every minute, or 1,200 buckets per day of 10 hours, the actual quantity carried by the line is 420 tons, making its capacity 4,095 ton-miles, which so far as I know, has not yet been equalled by any other line. Owing to the increased demand for Bedar ore, the line has been worked since the commencement of 1890 in two shifts of eight hours, and no less than 900 tons per day have been transported to the coast.

“The carrying ropes for the loaded and unloaded side, respectively are  $1\frac{5}{16}$  and 1 inch in diameter, and the size of the hauling rope is about  $\frac{3}{4}$  inch.

“At the loading-station, bins of 800 tons aggregate capacity are erected, from which the ore is spouted into the buckets. Great care has been bestowed on the design and arrangement of the power-stations and all their gear and engines. The engine and boiler-houses are solidly built and large enough to be used as repair shops.

“The unloading-station on the coast is 150 feet long by 50 feet wide and 32 feet above the ground-level. Its storage capacity is 18,000 to 20,000 tons, so that four to six vessels can be loaded at a time.

“At the various stations sidings are arranged for docking empty carriers of the several sections of the line. Electric signals are used, and the stations are connected by telephones. Despite many difficulties, the line was surveyed, erected and ready for work within 10 months, its total cost amounting to £26,000.

“At the desire of the Mining Company, I undertook to work the line for a number of years at the rate of 28·8\* cents per ton carried, this price covering all costs for labour, maintenance and repairs.”

---

\* 1·6d. per ton mile.

## CHAPTER XXI.

### SELECTION OF ALIGNMENT AND SURVEYS.

1. The principles to be followed in the selection of the alignment for a railway will depend on the objects which the railway is primarily intended to serve. We may consider railways in India to be divided into the following main classes :—

- (i) Lines intended primarily to serve political or strategical purposes, as for example, some of the railways on the northern frontiers of India ;
- (ii) Lines intended to open up new trunk routes either to the ports or between large centres of trade. Recent examples of this class of railway are the Nagda-Muttra and Agra-Delhi Chord Railways.
- (iii) Lines intended to shorten-existing through routes or to relieve overworked sections of existing railways. The Burdwan-Howrah Chord is a case in point.
- (iv) Branch lines forming feeders to existing systems and primarily intended for the opening up of undeveloped tracts.

2. It will be clear that, in the majority of cases of railways falling in the first three classes, the general alignment will depend largely on considerations other than that of the value of the new traffic to be developed by the new railway. In the case of railways of class (i), for example, the factors which decide what places the new railway must serve will be quite special; while, in the case of railways of classes (ii) and (iii), the interests of through traffic must be given preference over those of local traffic; and the object will be, in general, to secure the shortest line between selected terminal points. As regards lines included in class (iv), however, the value of the new traffic to be created will be the governing consideration, and an increase in the length of the line, provided it adds to the value of this traffic and secures the better development of the district through which it passes, will be unobjectionable.

3. It not infrequently happens, however, even in the case of railways of classes (ii) and (iii) that it is desirable to deviate from the general direction, in order either to serve large towns which a direct alignment would leave on one side, or to avoid difficult country. If, for example, two large towns A and B, which it is decided that the line must connect, be situated 100 miles apart in open country, and a third town C be 20 miles to one side of the straight line joining AB, at about equal distances

from both of them, it will add about  $7\frac{1}{2}$  miles or  $7\frac{1}{2}$  per cent. to the total length of the line to take it round by C; so that while all traffic between A and C, as well as between B and C would be added to the line, through traffic between A and B, or from beyond A to beyond B would be burdened by having to be carried this extra distance. If the line be made direct from A to B with a branch from the half-way point, which we will call J, to C, the traffic between A and C or B and C would have to travel 70 miles instead of  $53\frac{1}{3}$ , while the through traffic would travel only 100 instead of  $107\frac{1}{2}$  miles. There would be a total of 120 miles to construct and work instead of  $107\frac{1}{2}$ , and in addition to this, the cost of working comparatively light traffic on the branch would be greater per ton mile than that of working it as an addition to the traffic on the main line, while the cost of constructing and working the junction station at J would also have to be considered.

4. Whether it would be worth while to make such a deviation, will depend to a great extent on the amount of traffic likely to be despatched from or to C, as compared with the amount of through traffic on the main line. If the line were made direct from A to B, it may be accepted as certain that it would not get much of the traffic between C and either A or B, unless the branch were constructed, even if the cost of carting 20 miles to J, then carrying by train to A or B, and finally carting to destination, were less than the cost of carting direct from C to A or B; as, apart from the actual cost of carriage, loading and unloading, and keeping an agent at J, the inconvenience and loss in first transferring from cart to train and then again from train to cart, are considerable, so that goods once loaded into a cart would prefer to go the whole distance by road instead of transshipping.

5. For the same reason it is important, when branch lines are constructed to serve towns lying at some distance from the main line, that each station should be placed as near as possible to the centre of traffic; the railway route from large towns on the main line or other branches will generally be circuitous, and delays at junctions must be allowed for, so that unless the stations are conveniently situated, it is possible that a good deal of the traffic will prefer the more direct carriage by road.

6. The conditions assumed above are seldom or never realized in practice. The crossings of rivers or ranges of hills are generally an important factor in determining the course of a line: an unbridged river on the road between A and C would be a strong inducement for all traffic between those places to go to the railway at J: the actual distances either by railway or road between two places are always greater than

the length of a straight line between them, and it is impossible to make an accurate estimate of the extent to which traffic between any two places will be developed by a railway.

7. In the case of lines of class (iv), the object of which is, as stated above, the opening out of an undeveloped area, there will in general be no places of such outstanding importance as to form obligatory points on the proposed railway. There will usually be a choice between several alignments, and a careful comparison between the merits of these alignments will be necessary before the line is obtained which will best serve the whole area. For this reason, it will always be desirable in the first instance to carry out a careful reconnaissance of the traffic of the area, as described in paragraph 27, on the results of which it will be possible, either to select the best alignment without further investigation, or to decide what alternative alignments should be further examined and compared. In the latter case, an engineering reconnaissance (vide paragraph 29) will be required in order to determine which of the alternatives is the best line, both from the traffic and the engineering point of view, for the area under investigation.

8. When it has been decided what towns a railway shall serve, the duty of the engineer is to lay out and construct the cheapest line which is capable of carrying the traffic safely, and at reasonable speed. The word "cheapest" means that which costs least not only in original outlay, but in interest on first cost, maintenance and renewals, and working expenses combined. These considerations will determine the grades and curves to be used, the class of bridges, etc., to be constructed, the amount of detour to be made in order either to decrease the quantity of work, or to flatten the grades. The time occupied in construction has also to be considered, as the money spent will not be earning any return till the line is opened for traffic.

9. Experience has determined what classes of rolling stock, permanent way, ballast, bridges, etc., are required for any particular standard of railway, and it is not desirable, in the extension of a railway system already existing, to depart materially from these standards. In India, and in most other countries, certain standards have been laid down as compulsory by the Government: on each gauge certain minimum standards for strength of bridges, permanent way, etc., must be complied with irrespective of the amount of traffic likely to be carried,\* and the Engineer has to choose the best alignment, having due regard to serving intermediate towns or districts.

---

\* These rules may, however, be relaxed in the case of "Light" Railways, vide paragraph 22, Chapter XIX.

10. The difference in cost between the cheapest line possible (as defined in paragraph 8) and a line set out and graded more or less at random will not, as a rule, be very great in fairly open country, but in difficult country it may amount to a very large sum, and the whole of it is money absolutely wasted, and not only lost once for all, but the waste goes on yearly in the cost of maintenance and working. It may here be pointed out that the argument sometimes advanced that increasing the length of line does not matter, as all traffic pays by mileage, is a fallacy. The amount which traffic of a particular description can afford to pay to be carried from A to B is the same whether the line be 100 miles or 150 miles long between these two places: if too high a rate be charged the traffic will dwindle; if a low rate be charged the traffic is likely to be developed. The method of charging by the mileage of the railway, is purely arbitrary, and is not always adhered to, especially when there are two alternative routes.

11. After the sites of stations near large towns, the crossings of large rivers are the most important points to consider. A difference of a few miles, or even a few hundred yards, in the place at which a river is crossed may make a considerable difference in the cost of the bridge and if there be no important town near it, which it is necessary to serve, a deviation may be made without adding appreciably to the length of the line. The difference in cost will generally be least in an alluvial river with a sandy bed, and no well defined banks, and greatest in a river flowing partly through rocky and partly through clay or sandy soil. In the former case, an artificial permanent channel is generally made at the site of the bridge, in the latter the channel is defined by the existing banks. The most efficient bridge will be that which allows the maximum amount of water to pass through it in a given time for the least outlay, without producing any dangerous scour either of the foundations, or of the adjoining land or embankments. This condition is most likely to be attained when the velocity of the stream is nearly uniform for the whole length of the bridge, and when the velocity of approach to the bridge is high and uniform; it is therefore desirable to select a straight reach of the river and cross it as nearly as possible at right angles. Beyond this, the cheapest place to cross will generally be one suited for laying economically and rapidly the foundations of the piers and abutments; thus a bottom of sound rock or hard clay at a place where the bed is comparatively wide will often give a cheaper crossing than a narrower channel with a bed of silt, or sand and boulders to some depth. Sometimes an artificially

protected bed can be found, for example, a short distance above a weir thrown over a river for purposes of irrigation.

12. Other important points will be determined by the passage through a range of hills or broken country. It will generally be best to cross a range of hills at the lowest point available, but this is not always the case, as the approaches to some higher pass may be more favourable for the attainment of an easy ruling grade; also where a tunnel is necessary at the summit, the lowest pass will not always give either the shortest tunnel or the easiest approaches to it.

13. Crossing a range of hills nearly always presents the problem of climbing up a certain height and then descending again; the primary object is to reduce the amount climbed to a minimum, and to increase the distance in which the ascent and descent are made to a maximum, without unreasonable increase in the total length of the line. For example, if we have to cross a range of hills 10 miles wide by a pass 500 feet above the level of the surrounding country, it is clear that if we go nearly straight across, the gradient must be at least 1 in 52, and as we are not likely to be able to get a uniform grade, the maximum will probably be 1 in 40. If we wish to get a grade of 1 in 100 we must increase the base from 10 to about 20 miles, that is, the line must be about 10 miles longer than the direct line: a very considerable deviation can be made by adding 10 miles to the length, provided we can start the deviation at some distance from the foot of the hills; if, therefore, by making a deviation adding 10 miles to the direct route we can either reduce the total height to be climbed, or obtain a ruling gradient flatter than 1 in 100, we have gained something.

14. Deviations or alternative alignments are questions of comparative estimates; in many cases it will be apparent at once on going over the ground which line will be preferable, in others it will be desirable to make comparative estimates, based on actual measurements, levels, and other observations. A man of experience will be able to say very nearly how much more or less per mile one line will cost than another, and the distance can be measured off a map. A line through hills may cost from one and-a-half to three times as much to make, and from one and a-half to twice as much to maintain per mile as a line in comparatively open country, and the speed of trains will be from  $\frac{1}{3}$ rd to  $\frac{2}{3}$ rds that of trains on a fairly level line.

15. In the Project for a Railway there will be certain important or obligatory points, such as towns, river crossings, and passages through

hills ; between these there may be similar points of the same nature but of less importance, and all these points will be connected by lines as straight as can conveniently be made, having due regard to obtaining uniform gradients, and accommodating the alignment to the features of the country.

16. On the question of gradients, only general principles can be laid down. If a rise of 100 feet has to be surmounted in 10 miles, the most economical line to work will be one having a uniform gradient of 1 in 528, but to attain this might necessitate very heavy work ; if the rise be made 1 in 300 for part of the distance, and flatter for the rest, the formation can at some intermediate point be raised or lowered as much as 40 feet, and if a falling gradient be adopted for part of the distance, the formation level can be altered still more. If the ruling gradient be made not steeper than about 1 in 300, the carrying power and cost of working the line are not very greatly affected, but for this there is a special reason. The load which a powerful goods engine is capable of hauling at slow speed on very flat grades is so great as to make an inconveniently long train, which would be heavier than the same engine could start if the couplings were all tight ; if the couplings were slack, there would be considerable risk of their being broken. With the powerful engines now generally used, which are capable of hauling about 1,000 tons up a grade of 1 in 300, there is very little advantage in making the ruling gradient flatter than about 1 in 300 to 1 in 400; there will be a slight saving in fuel, but the carrying capacity of the line will not be materially increased. Where light engines of comparatively small power are used, gradients of even 1 in 500 will have an appreciable effect.

17. An engine capable of hauling 1,000 tons up 1 in 300 will, with its tender, weigh about 60 tons, and on other grades, would be capable of hauling the following loads, at slow speeds of about 15 miles an hour :—

1,200	tons	on a gradient of about	1 in 400	or	0·25	per cent.
1,000	„	„	1 in 300	„	0·33	„
800	„	„	1 in 220	„	0·45	„
600	„	„	1 in 155	„	0·65	„
500	„	„	1 in 125	„	0·8	„
400	„	„	1 in 100	„	1·0	„
300	„	„	1 in 75	„	1·33	„
200	„	„	1 in 52	„	1·92	„
100	„	„	1 in 31	„	3·23	„

These loads are not exactly proportional to the gradient because (1) the resistance of the train on the level has to be added to the resistance due to the gradient, and (2) the weight of the engine has to be added to the weight hauled. The same engine would nominally be able to haul about 2,800 tons on the level, but so long a train would be unmanageable, and it is not possible, except at prohibitive cost, to make any long section of railway level. Taking the gradient of 1 in 300 as the standard, it is evident that if the ruling grade be made 1 in 150, the capacity of the line is reduced to slightly below 60 per cent., and if it be made 1 in 100, to 40 per cent.; while if it be as steep as 1 in 50 the capacity is reduced to below 20 per cent.; that is, it will require five trains on 1 in 100 or more than ten trains on 1 in 50 to deal with the same traffic as two trains on 1 in 300. Actually for gradients as steep as 1 in 50, engines of greater power would be used. On the Mushkaf-Bolan Railway, engines weighing 92 tons can haul 200 tons up a gradient of 1 in 25.

18. From the foregoing considerations we may conclude, therefore, that if an engine-run of say 100 miles of line can be made with a gradient not steeper than 1 in 300 except for say a mile of 1 in 200, it would be worth while spending a good deal of money to reduce this piece of 1 in 200 to a flatter gradient; but that, on the other hand, if this 1 in 200 cannot be reduced except at prohibitive cost, the load of a through-train on this 100-mile run is limited by this 1 in 200, in which case there is no object in keeping the rest of the run down to 1 in 300 if the cost of construction can be reduced by a free use of 1 in 200. This grade of 1 in 200 would then be the "Ruling gradient," for that 100-mile run. As railways are divided up into engine runs of about 100 miles each (vide paragraph 19, Chapter XIII), different lengths may have different ruling gradients: in special cases of comparatively short lengths of difficult country necessitating steep gradients special engine stations are used, and the trains either divided up, or worked with two or more engines over these lengths. The extra engines are called "banking" or "pusher" engines.

19. Short gradients, called momentum grades, may be introduced in special cases, with an inclination steeper than the ruling grade, as a train can surmount them by its own momentum. If a train be travelling at 20 miles an hour, or about 30 feet a second, it would, even if steam were shut off, ascend a steep gradient to a height of about 14 feet, and at 30 miles an hour about 30 feet; if the engine be at work while ascending it would surmount a greater height, but in practice the limit of height for

momentum grades is about 20 feet, and they should not be used in positions where a train is likely to be required to stop or slacken speed near their lower end.

20. It will often happen that by far the greater bulk of traffic on any line will be in one direction; thus there is nearly always a greater bulk of traffic towards than from a sea-port. In the case of a railway to a mine or colliery, the traffic will almost entirely be in one direction; in such cases the ruling grade *with* the traffic may often with advantage be made a good deal steeper than the ruling grade *against* it. When the ruling grade on any section has once been fixed, uniformity of grade is of greater importance than the avoidance of a free use of the ruling grade. Frequent and sudden changes of grade should be avoided as far as possible. The effect of a change of grade is measured by the difference in the train resistance; a change from 1 in 200 up to 1 in 200 down gives the same difference in resistance as one from level to 1 in 100 down. Sudden changes at the top of a grade are much less objectionable than at the foot, but both should be avoided as far as possible. The junctions between grades are usually eased by the use of *vertical curves*, as explained in Chapter IX.

21. A cutting or tunnel should never be level for any great length, or it will not be possible to drain it effectively, except at prohibitive cost. Neither should the ruling gradient be used in tunnels, as their prevailing dampness affects the adhesion, and hence the tractive power of the engine. Stations, if in embankment, should be on the level or nearly so; if in cutting it is desirable to introduce an easy grade, say about 1 in 1,000, for the sake of drainage: a grade falling towards a station should be avoided as far as possible; it increases the difficulty of starting trains at a time when the engine is working hardest, and also increases the risk of trains over-running the station. A grade falling away from the station if steeper than 1 in 500 should not commence within about 150 feet of the outside points of the station, or there will be considerable risk of vehicles running away when being shunted. When these conditions are unavoidable, special arrangements, such as catch or slip sidings, have to be provided to catch any vehicles running away.

22. *Curves* appeal at once to the eye, as also does the wear of the rails and wheels caused by them, but gradients, unless very steep, hardly appeal to the human senses at all without the assistance of a levelling instrument; their effect on a train, as already shown, is enormous. For any particular gauge, and description of rolling stock,

curves may be divided broadly into three classes; (i) very easy curves, which do not materially increase either the resistance or the wear and tear: roughly speaking, curves of a radius of over 1,200 times the gauge come under this class; (ii) ordinary curves, in which the resistance and wear and tear are approximately proportional to the degree of curvature or inversely proportional to the radius, and (iii) severe curves. The dividing line between ordinary and severe curves, will depend on the class of locomotives and rolling stock: with the usual proportions of these, ordinary curves may be used with a radius as small as about 120 times the gauge, but if severe curves, which may have a radius as small in some cases as 50 or 60 times the gauge are used, special engines and rolling stock will be required. Vehicles with a rigid wheel base of more than 3 times the gauge will not readily traverse curves with a radius less than about 120 times the gauge, and reduction of speed is necessary on all curves of less than about 240 times the gauge, whether the rigid wheel base be short or not. As pointed out in Chapter X, all curves cause an increase of resistance in the same way as gradients, and a proper allowance must be made for this. Except for this feature, the natural tendency is greatly to over-rate the objections to the use of curves. The objections are so evident, that undue importance is attached to them; in some cases when this fact has been duly appreciated, there has been a tendency to go to the other extreme, and use a larger number of curves, and of smaller radius than the circumstances of the case warrant.

23. The bad effects of curves which are obvious are, limiting the view along the line, increasing the wear and tear and cost of maintenance, and increasing the risk of derailment. As the radius of the curve decreases, these are increased, but with ordinary curves it is by no means certain that the increase is proportional to the decrease of radius, and it is absolutely certain, that for some of the items, the increase is in a smaller ratio; whereas, if it is necessary to turn off through a certain angle, the total length of the curve on which the objectionable conditions prevail is directly proportional to the radius; total risk and wear and tear for a given total deflection are, therefore, rather less on curves of small radius than on those of large, provided the radius does not vary beyond certain limits. In nearly all cases the use of a small radius will permit of a line being laid out with less total deflection on curves, as well as with less total length; on the other hand increasing the radius beyond a certain limit practically eliminates most of the objections to the use of curves.

24. The natural tendency being to avoid the use of curves except where they are absolutely necessary, and to pay comparatively little attention to the gradients, unless they are very steep, when first setting out the line it is always desirable to bear in mind that easy curves may be introduced for the purpose of improving the gradient, in all cases, when this can be done without materially increasing the length of the line; and if the *ruling* gradient can be improved, the use of comparatively sharp curves, and an appreciable increase in the length of the line, will be fully justified. In hilly country it will generally be found that there is a certain minimum radius, depending on the shape of the hills, such that if the curves were made sharper than this, the saving in work would not compensate for the disadvantage of sharper curves, accompanied by increased amount of total deflection; while if the sharpest curves were made easier than this, the increase in work would be out of proportion to the advantage gained. The minimum radius of curve will be fixed by similar considerations to those applying to the ruling grade. In open country there will be no such guide; but in open country there will, as a rule, be no necessity to deflect to any great extent, except perhaps to get a square crossing to a large river, and easy curves of large radius can nearly always be used.

25. The total resistance and other objectionable features of curves are measured rather by the total deflection, usually expressed in degrees, than by the radius or degree of curvature; where curves of small radius or what is the same thing, a high degree of curvature, are used, they are generally accompanied by a considerable amount of total deflection. The accompanying sketch, Fig. 189 shows a full line and a dotted line, which do not very materially differ in position, but the dotted line has both less total deflection and easier curves, and if we consider that the right-handed curves are rounding the nose of a hill and

FIG. 189.



the left-handed ones crossing the head of a valley, it is evident that unless the slope of the ground be very steep, the amount of work on the dotted line will not be much greater than on the full line.

26. **Surveys.**—Surveys may be divided into three classes; (i), a reconnaissance, which would usually consist of an enquiry into the

traffic conditions of a given area, and a rough engineering survey of the route, or alternative routes, which the traffic enquiry indicated as best suited to serve the traffic of the area in question ; (ii), a preliminary survey, designed to ascertain within a moderately close degree of accuracy the length and cost of a railway to be constructed on a previously determined alignment ; and (iii), a detailed survey, in the course of which the alignment on which construction work is actually to be carried out would be located on the ground, and during which sufficient information would be collected for the preparation of an accurate estimate of the cost of a railway constructed on this alignment.

27. **Reconnaissance Survey.**—In the course of the traffic enquiry detailed information should be collected on the following points :—

- (i) The general character of the country, the extent of cultivation, irrigation, local industries, religious festivals, traffic in connection with courts of law ; (ii) the general condition, as regards prosperity etc., of the inhabitants, density of population and its distribution, the larger centres being specially noted ; (iii) existing channels of trade, trade centres, nature and volume of exports and their destination, origin of imports and centres of distribution of imports ; (iv) possibilities of development of industries and of the tract generally, either as a result of the construction of the railway or of that of other public works, such as irrigation schemes, etc.

28. From the information thus collected the engineer will be able to determine the best alignment or alternative alignments, from the traffic point of view, for the area under investigation. In making a selection of alignments, account should not only be taken of traffic directly in sight, but due allowance should be made for anticipated developments of traffic. The enquiry should be completed by a careful study of the rates which it will be possible or desirable to charge for the carriage of traffic by rail ; and it will then be possible to frame an estimate of the gross earnings to be derived from the carriage of this traffic over any of the selected alignments.

29. The object of the engineering reconnaissance, is to determine the approximate cost of a railway constructed on each of the selected alignments. The only instrumental observations will usually be such as can be made with the barometer, prismatic compass, and similar instruments. The passage through a range of hills or specially difficult country should be examined in sufficient detail to determine the ruling gradient and the greatest degree of curvature that it is desirable to adopt. The geological

characteristics of the district should be investigated to enable an opinion to be formed of the probable stability of the line if constructed. The amount of waterway required and the nature of the foundations at all large bridges should also be recorded. Possible alternative alignments should be noted, and information recorded as to suitable station sites, materials for buildings and the labour available. On the information thus collected the engineer will frame his report and a rough estimate of the probable cost of the railway.

30. When the engineering reconnaissance has been completed, it will remain to prepare rough estimates of the cost of working the anticipated traffic over each of the selected alignments. Such estimates of working expenses may either be prepared by considering separately the probable cost of maintenance of way, works and of rolling-stock, and of the handling of traffic; or by comparison with existing railways in which the conditions as regards volume of traffic and character of the country are similar to those obtaining in the area under investigation. The net earnings of the railway will be its gross earnings less its working expenses; and from the net earnings will be calculated the return to be expected on the capital expenditure to be incurred on the railway.

31. **Preliminary survey.**—In certain cases it will be necessary to determine the cost of a railway on an alignment selected as the result of a reconnaissance survey with greater accuracy than is possible with the information collected during the reconnaissance. It will then be desirable to carry out a *preliminary survey* of this alignment.

By a preliminary survey is to be understood, not necessarily a line fully staked out with a theodolite, but a traverse line with levels taken at such intervals as may be necessary, bench marks being left at about half-mile intervals so placed and indicated on the plans that they can be distinguished by subsequent survey parties. A rough plan of the country showing villages and natural features, 500 feet on each side of the line should be made and plotted on the traverse, and all important waterways surveyed for 1 mile up and 1 mile down stream of proposed crossings.

32. **Detailed survey.**—Before any railway can be sanctioned for construction, a detailed survey is necessary. In a detailed survey the line as finally located must be actually laid out on the ground with a theodolite. Substantial pegs should be driven into the ground at every thousand feet, with consecutive numbers branded on them, similar pegs being put in at the beginning and end of each curve and at the intersection

of the tangents: circular masonry pillars should be built round the pegs at the beginning and end of each curve, and square pillars round some of the centre line pegs at intervals of not less than half a mile; those on the highest ground will be the best to select. The exact chainage of all centre line pillars should be recorded both in the field-book and on the plan and section, and their position with reference to any prominent objects, such as buildings, wells, large trees, etc., should also be recorded. Bench-marks should be left at intervals of not more than half a mile, and near the site of all large works, their position and exact level being also recorded.

33. The method of marking the *final location* will now be described, assuming that the best general alignment has already been decided on. In marking out the permanent centre line, care should be taken to make all curves of as large a radius as possible, and where reverse curves are necessary, to have as long a piece of straight between them as possible; in difficult country this piece of straight may be reduced to 120 feet. Curves should be avoided on girder bridges, and even on arched bridges they should be avoided when possible; also in or near the sites of stations, and a curve should be on a bank rather than in a cutting. All large waterways should be crossed as nearly as possible on the square, and at least 100 feet of straight allowed between the abutment and the beginning of any curve. The line is marked out by placing a centre stake at each 100 feet, or in open flat country every 200 feet upon the straight portions, and at each 100 feet upon curves of large radius, but at each 50 feet when the curvature is sharp. At every 1,000 feet, at the tangent points and the intersection of the tangents of curves, and at points of compound curvature, a larger and more permanent stake or post should be placed in the ground, the exact centre being fixed by means of a nail driven into the top. Lest these permanent stakes should be disturbed in the process of construction of the works, their exact distance from several outside points should be carefully measured, and entered in the Engineer's note-book, that they may at any time be replaced. A convenient method is to drive another stake at exactly 20 feet, carefully measured with a pair of 10-foot rods, to one side of the centre line stake, and put a centre mark on this also, and then build a small masonry pillar round it. This side peg will then serve both for a bench-mark and for finding the centre line and the chainage after the earthwork has been commenced. The stakes above referred to show the position of the centre line of the railway, and form the base line from which all operations of construction are carried on,

34. If the preliminary survey has been carefully made, it will generally be evident without further examination of the ground, that certain minor improvements can be introduced, e.g., curves can be eased or perhaps the line can be straightened, rather better crossings can be obtained at certain waterways: a better section can be obtained by shifting the line on to higher ground where the preliminary survey gave a high bank, or on to lower ground where it gave cutting, etc., etc; all such points should be fully considered before the final location is actually marked out.

35. **The Section**—When the centre line has been finally decided on and marked, the next step is to take the levels and prepare the longitudinal section and when this has been plotted, to fix the grades and formation level. The chief points which determine the height of the formation are the headway necessary at the various bridges, and the necessity for avoiding cutting in places where there would be difficulty in keeping them free from water. Level crossings in or near cuttings, particularly if there be a curve in the line, should be avoided; at important roads, if the line be in deep cutting, it is always best to provide an over-bridge, and these considerations also affect the grading. The grading should always be made as flat as possible consistently with reasonable economy in construction, and on sharp curves the ruling gradient should be compensated as explained in Chapter X, paragraph 23. Cross sections should be taken where the side slope of the ground is steep, and at all places where waterways, canals, or roads have to be diverted, the centre line of the diversions should be marked out and levelled. Care should be taken to establish permanent bench-marks at intervals of not more than half a mile, and to keep a record of their exact position. Accurate levels of the bed and flood level of all waterways should be taken and cross sections and levels to ascertain the fall of all large waterways, exceeding about 1,200 square feet sectional area of waterway.

36. The following remarks apply to both preliminary and detailed surveys. The best place for a line of railway, provided it can be located there without excessive deviation or the use of steep grades, is either on a watershed, or as near to it as possible; in very flat country the watershed is, as a rule, not well defined, and the highest ground available should be selected. Even where a line runs nearly at right angles to the general direction of the drainage of the country, it will generally be possible to place it near the watershed separating two tributaries of one of the larger streams. Another point which is fairly

obvious from a consideration of the case, is, that if a line cannot be made parallel or nearly so to the general fall of the country and flow of the rivers, it will be best if at right angles or nearly so to that fall; this is especially the case in comparatively flat country. In undulating country it will frequently be possible to select a good line diagonal to the general fall, by taking advantage of the variation in direction of the minor watersheds; but in all cases, the line where it actually crosses the larger drainage channels will be as nearly at right angles to the direction of flow as can be arranged.

37. Lines are frequently diverted by a curve through a considerable angle to obtain a square crossing of a comparatively unim-

FIG. 190.

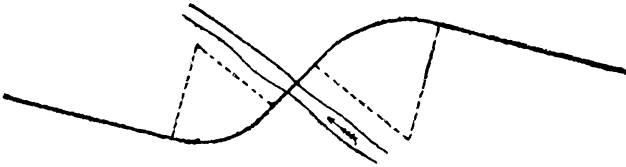

portant waterway, and the length of the line, and wear and tear are thereby materially increased. The objections to the use of a bridge on the skew are comparative only; they are greatest in the case of a large river with a bed of sand or silt, in which a skew crossing not only adds to the length of the bridge, but the line of piers, being diagonal to the stream, also tends to create increased scour, and induce the stream to flow parallel to, instead of through, the bridge, and to attack the abutment which is furthest down-stream. In waterways which have a hard bed, or those which can be crossed by a single span, the objection to a skew bridge is much reduced. On all skew bridges there is the objection that one rail leaves the elastic support of the ballast and subsoil for the comparatively inelastic support of the abutment and girder end before the other, which causes a lateral lurch to the train; but by proper arrangements the evil effect of this can be much reduced. A variation of  $15^\circ$  from a square crossing adds only about  $3\frac{1}{2}$  per cent. to the waterway required, a quantity which in practice may often be neglected; even  $30^\circ$  adds only 15 per cent, while taking off  $30^\circ$  from the angle to be turned through on *each side* of the bridge may very materially decrease the length and cost of the approaches, particularly if the radius of curvature required to be used is large. If the river to be crossed

is a large one, it will never be advisable to depart greatly from a square crossing but the case is very different in comparatively small waterways. In all cases it is desirable to select a reach of the river or stream, as nearly as possible at right angles to the general direction of the line.

38. If fairly accurate maps of the country be available, crossings of the more important rivers can generally be selected on the map; the actual crossing would then be marked out on the ground and its bearing taken, the general direction of the line from the last obligatory point can then be found, and the line would be run as straight as the configuration of the country will permit, to a point on the line of crossing sufficiently far back from the river bank to allow for the necessary curve and a suitable length of straight between it and the bridge; and so on to the next obligatory point.

39. In a preliminary survey the object being to record on the ground, as well as on the plan, the exact position of the line, this is best attained by fixing the position of certain points on the line with reference to surrounding objects, buildings, wells, trees, roads, etc.; measuring all angles in the line accurately, carefully measuring the centre line, keeping a record of the through chainage, for which purpose the difference between the curve and the tangents at all angles should be allowed for, being careful that straight lines really are straight; and finally, selecting for the positions on which to erect the masonry pillars places where these pillars can easily be seen, and are not liable to be damaged, such as on high ground, the edge of the bund of a tank, etc.

When the theodolite is used for measuring angles, it is as well to record (1) the forward angle; (2) the angle of deviation to the right or left from a straight line; and (3) the bearing of the magnetic needle, reading all these direct from the instrument, and comparing them to see that they are correct. In all lines, except those due north and south (by the compass), the magnetic bearing as read will differ slightly from that found by adding and subtracting the angles of deviation, the difference continually increasing, but within the limits of any one survey it will not be very great, and between any two angles in the line will be almost inappreciable. The use of the magnetic needle is, therefore, a convenient check on the accuracy of the records; when the forward angle only is measured there is no check and an error may be introduced either in reading or recording it.

40. An easy and simple method often adopted in setting out, which it is *not* desirable to follow, is to align forwards to some

conspicuous object on high ground, and when this is reached, to turn off slightly to another similar object on high ground further ahead; the result of this method being that all the curves are on high ground, and if the undulations of the ground are considerable, they will all be in cutting, which is highly objectionable. Where the undulations of the ground are sufficient to require cutting through the ridges, care should be taken that no curve is there if it can possibly be avoided.

41. If the country is covered by thick jungle, it will generally be best to run straight lines of as great a length as possible, with as few angles as possible, right through it in the first instance, making a compass survey with levels of the more important waterways crossed, and take flying levels along this line. From the information thus obtained, a line approximating closely to the best alignment can be selected and cleared, after which it can be marked out and levelled for the preliminary survey. It is hopeless to try to locate the line at once in such country: it frequently happens that after setting out 5 or 6 miles it is found that the whole of this has to be abandoned, and a line either higher up or lower down, selected. Had a trial line been run right through at first, it would have shown approximately at what level each part of the final line should be.

42. The art of selecting a good line is one which an Engineer can acquire only by observation. He should always note which way the ground falls, and have a general idea of the rate at which it falls; the direction of flow of every water-course crossed should be recorded at the time; it is not very uncommon to find these shown on the plan flowing the wrong way; every object crossed by the centre line should be marked in the field-book, and drawn at the proper angle, the exact distance to any prominent marks near the centre line being measured and recorded on the plan. Each day's work, both with the level and in marking the centre line, should be plotted roughly as soon as possible, to make sure that no essential feature has been omitted, and that no considerable alteration in the alignment is necessary.

43. For a beginner, the best practice will be to select first a line between two fixed points with a given ruling grade and minimum radius of curvature, and then try to what extent these can be improved by alteration in the alignment without materially increasing the length of the line or the total amount of work to be done; or the amount of work and its cost can be reduced, without using steeper grades or sharper curves. It is of course necessary that the country selected for this purpose be fairly undulating.

44. When projects are submitted to the Government of India for sanction the following are required :—

- (i) A general map of the country traversed by the project, scale 32 miles to 1 inch.
- (ii) An Index map and Section, scale 4 miles to 1 inch horizontal, and 400 feet to 1 inch vertical.
- (iii) Index Plan and Section.
- (iv) Detailed Plans and Sections.
- (v) Plans and Cross Sections of Rivers,
- (vi) Plans of Station Yards.
- (vii) Details or Types of Structures.

45. The Index Plan and Section are to be drawn to a scale of 1 mile to 1 inch horizontal and 100 feet to 1 inch vertical, the plan above the section on the same sheet.

On the *Index Plan* are to be shown all towns, roads, canals, rivers, hills, boundaries of provinces or districts and Native States, and other features of country within a distance of 5 miles on each side of the railway. The centre line of the proposed railway is to be indicated by a full red line one-thirty second of an inch in thickness. The degree and radius of all curves should be figured. The position of each station is to be shown by a block, the name of the station being given. The mileage from fixed point is to be marked and figured at every mile, and the extent of each sheet of the detailed plan shown.\* Care should be taken that the position of every place named in the Report is shown on this plan.

*The Index Section* need only show formation in red. The gradients are to be figured, and height of formation above Mean Sea Level should be entered at each change of gradient. The position of each important bridge with name of river and number and size of bridge spans. All level crossings with their classification as 1st, 2nd or 3rd class. The position of each station with its name and distance from fixed point to the nearest decimal of a mile. The mileage from fixed point is to be marked and figured at every mile.

46. The Detailed Plans and Sections are to be drawn to a scale of 400 feet to 1 inch horizontal, and 40 feet to 1 inch vertical, the plan in

---

\* Where practicable the Index Plan should be traced from the sheets of the Survey of India map published to a scale of 1 mile to 1 inch, the details in the immediate neighbourhood of the railway being filled in, or corrected, if necessary, from the information given by the railway survey. For districts where a map to the scale of 1 mile to 1 inch is not available, the information required should be plotted to that scale from such other maps or data as can be obtained.

each case above the section on the same sheet. Three miles of line should be illustrated on each sheet, and the divisions between the sheets in each case are to be a mile-mark. To admit of the sheets being readily connected it is convenient to have, on each sheet, a skeleton outline for a few hundred feet beyond the mile mark at each end repeated from the adjoining sheets on both the plan and section.

On the *plan* are to be shown in detail all features of the country within a distance of three hundred feet on each side of the centre line of railway with the boundaries of village land, and the apportionment of such lands for different kinds of cultivation, forest, pasture, waste, etc. The centre line of the proposed railway should be indicated by a full red line one-thirty second of an inch in thickness. The position of all masonry centre line pillars and the exact position and description of each benchmark is to be shown.

In difficult or mountainous country it may be necessary to make the plan on a larger scale such as 200 or 100 feet to an inch.

In addition to the foregoing the following details are to be shown, in so far as they lie within a distance of 1,000 feet on either side of the centre line :—

Rivers requiring a waterway of 40 lineal feet or upwards.

Important roads with all bridges, culverts, mile-marks and fractional mile-marks belonging to the same.

Canals and large tanks.

The outlines of all towns and villages, and in the case of large towns, the more important streets and thoroughfares.

The boundaries of Provinces and Local Administrations and Native States.

Hill peaks or other important features of the country.

Great Trigonometrical Survey Stations.

Camping grounds, rifle ranges, etc.

Care should be taken to give sufficient topographical details to exhibit the contour of the ground with accuracy, and to justify the alignment selected.

All new works proposed for the purposes of the railway or for the accommodation of the public are to be marked on the plan, also all alterations, diversions, protection works, etc., proposed in connection with existing railways, roads, rivers, canals or tanks.

On the *section* the formation level is to be shown by a red line, the ground line being black. If practicable, throughout each sheet, the

ground line and formation should be continuous, i.e., without "steps" or changes of datum.

The heights or levels are to be given in feet to one place of decimals, and are to be entered at every 100 feet, vertical ordinates being ruled up to connect the figures with the ground line. These vertical lines to be in blue, except where they occur at a change of gradient where they will be red. Two sets of heights or levels are to be given, viz. :—

- (1) Height of ground above Mean Sea Level.
- (2) Height of formation above Mean Sea Level.

The first set of figures showing ground level are to be the lowest in position, i.e., nearest the bottom of the sheet. The bed level and high flood level of all rivers and nullas should be shown, also the position, description and level of all bench-marks, and position of all masonry pillars.

Gradients are to be entered in a plain and conspicuous manner and defined by the distance corresponding to a rise or fall of one foot, and by their rise or fall in feet per 100 feet. Thus a rising gradient of six inches in a hundred feet is to be described as "rise 1 in 200 or 0.5 per cent." At each change of gradient an ordinate is to be drawn in red up to formation level, and the height of formation noted to two places of decimals. Where a change of gradient occurs at any point other than one of the 100 feet marks, the chainage of the changing point is to be noted. All gradients should be compensated for curvature if the ruling gradient would otherwise be exceeded. (See Chapter X, paragraph 23.)

In addition to the above the following should be shown—the beginning and end of all curves, the mileage and chainage, the general description of the soil, the position of all bridges, level crossings, etc.; where roads or waterways are diverted this should be noted.

Tunnels are to be drawn to scale on the section, and the length in feet to be noted in each case.

A station is to be indicated by a vertical red line at each end drawn upwards from formation level to define the limits of the station yard. The name of the station and the length in feet of the station yard are to be noted.

Where cross sections have been taken, a reference to each is to be given on the main section with a vertical line indicating the position. Cross sections should, as a rule, be plotted to a natural scale, both the vertical and horizontal scales being the same as the vertical scale used

for the main section (i.e., 40 feet to 1 inch), and on each cross section the outline of the cutting or embankment is to be correctly shown.

Long cuttings should be graded with special reference to efficient drainage.

47. For each river requiring a provision of waterway of 1,200 square feet or upwards, the following particulars are to be given:—

- (a) A plan to a scale of 400 feet to 1 inch of such portion of the river and of its affluents as may lie within a distance of not less than one mile from the proposed centre line, of railway, measured from any point on that centre line, or such further distance as the Engineer-in-Charge of the survey may consider necessary. On the plan are to be shown by lines the positions of cross sections taken of the river, with references; the centre line of railway with mile, and 1,000 feet chainage, distances marked and figured; the position of the two abutments of the proposed bridge marked on the railway centre line; the position and extent of any protection or training works proposed with such notes as may appear necessary; the direction of the current to be shown by arrows.
- (b) Three cross sections of the river bed are required plotted to a natural scale of 40 feet to 1 inch. These cross sections are to be taken at typical points selected at intervals of about a mile measured along the centre of the river bed, the first cross section being about one mile above the crossing of the railway, the second at or near the crossing and the third about one mile below the crossing. Each cross section is to be at right angles to the general direction of the river at the place where that cross section is taken, and is to extend from the line of highest known flood on one bank to the corresponding line on the opposite bank. On each cross section, lines are to be drawn to indicate the level of highest known flood, ordinary flood and ordinary low water, with the reduced level figured on each.
- (c) On the cross section taken on the centre line of railway an elevation of the proposed bridge is to be drawn to scale in its proper position. The chainage is also to be figured on this cross section. Where borings or trial pits have been sunk, their position, with note of results, should also be given. The cross sections may be plotted on the same sheet as the plan, or on separate sheets as may be found convenient in each case.

48. With the report on the project, certain abstracts are required ; the most important are those of the curves and gradients as shown below :—

CURVE ABSTRACT.

Angle of Curvature, or Radius.	Number of each.	Total length. Miles.	Total curvature. Degrees.
<i>Form for 5 ft. 6 in. Gauge</i>			
4°—20' (R.=1322 feet) .. .. .	2	0.32	72°·4
4°—0' (R.=1432 feet) .. .. .	1	0.17	36°·0
3°—20' (R =1719 feet) .. .. .	7	1.06	177°·7
3°—0' (R =1910 feet) .. .. .	17	3.10	491°·0
2°—0' (R =2865 feet) up to 20°- 59'	43	8.71	987°·9
1°—0' (R.=5730 feet) up to 1°—59'	58	15.91	943°·0
Flatter than 1°—0' .. .. .	16	2.82	116°·5
Total ..	144	31.99	2849°·5

Ratio of curve to total length of line—21 per cent.

Average amount of curvature per mile—18.7 degrees.

CURVE ABSTRACT.

Angle of Curvature, or Radius.	Number of each.	Total length. Miles.	Total curvature. Degrees.
<i>Form for Metre Gauge.</i>			
6°—40' (R.=859 feet) .. .. .	2	0.34	120°·0
6°—0' (R.=955 feet) .. .. .	1	0.51	48°·0
5°—30' (R =1042 feet) .. .. .	6	0.80	214°·5
5°—0' (R =1146 feet) .. .. .	9	1.20	316°·0
4°—0' (R=1432 feet) up to 4°—59' ..	13	1.73	365°·0
3°—0' (R.=1910 feet) up to 3°- 59' ..	17	3.10	491°·0
Rest of form same as for 5 feet 6 inch gauge.			

NOTE.—For all curves of 3° 0' or sharper on 5 feet 6 inch gauge or of 5° 0' or sharper on metre gauge, the actual angle of curvature, length, etc., are to be shown as in the forms above, Below these limits the curves may be classed as above.

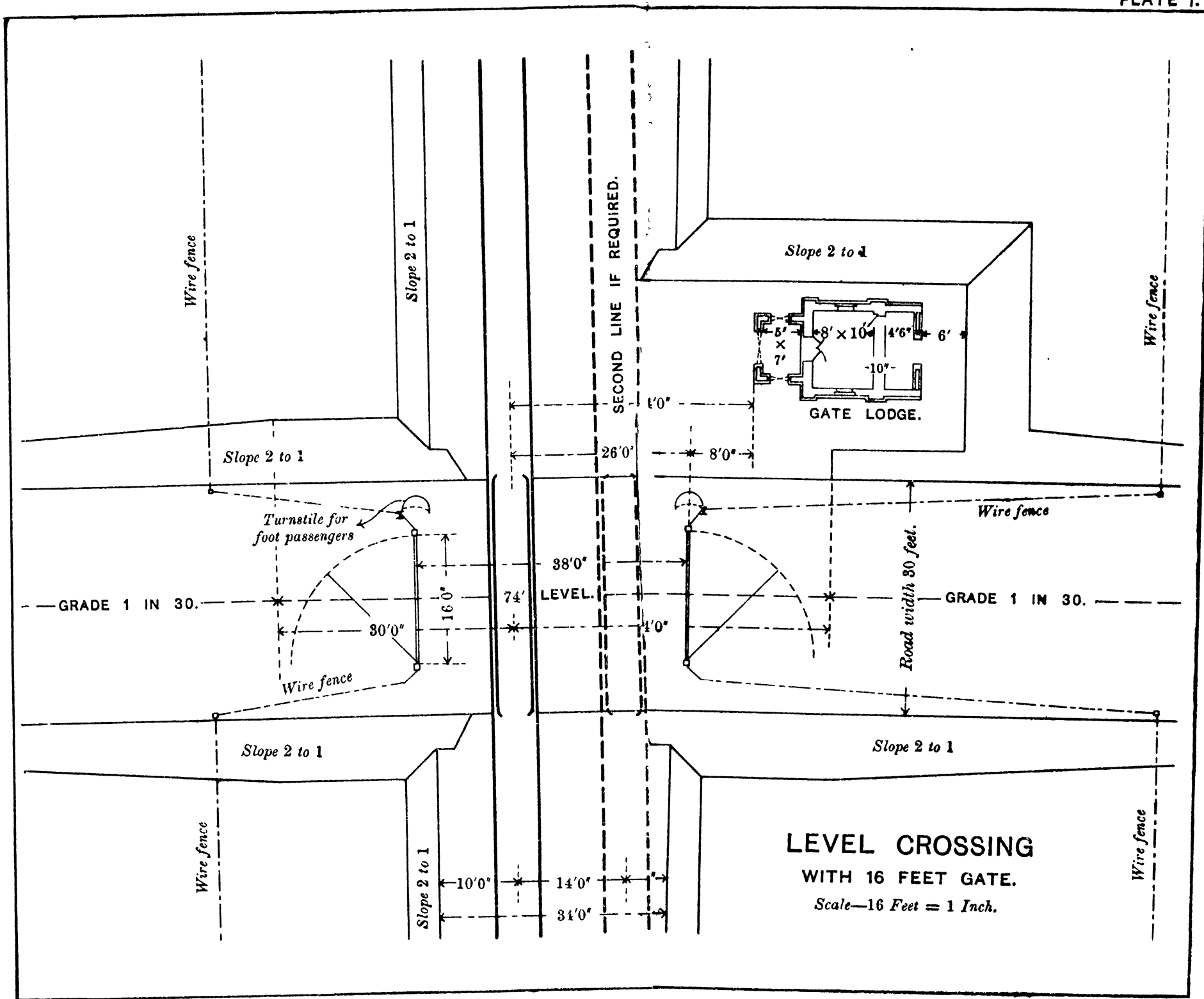

**LEVEL CROSSING**

**WITH 16 FEET GATE.**

Scale—16 Feet = 1 Inch.

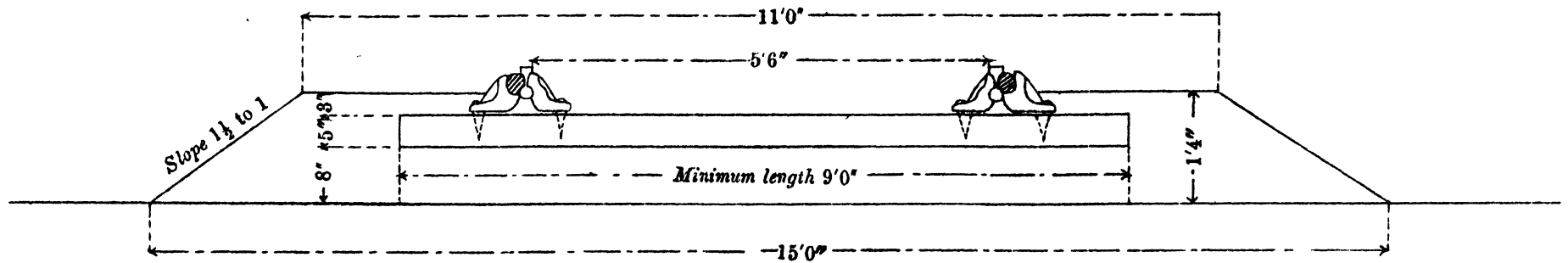

Type A. Standard Gauge—Bull-headed Rails in Chairs, with wooden sleepers.

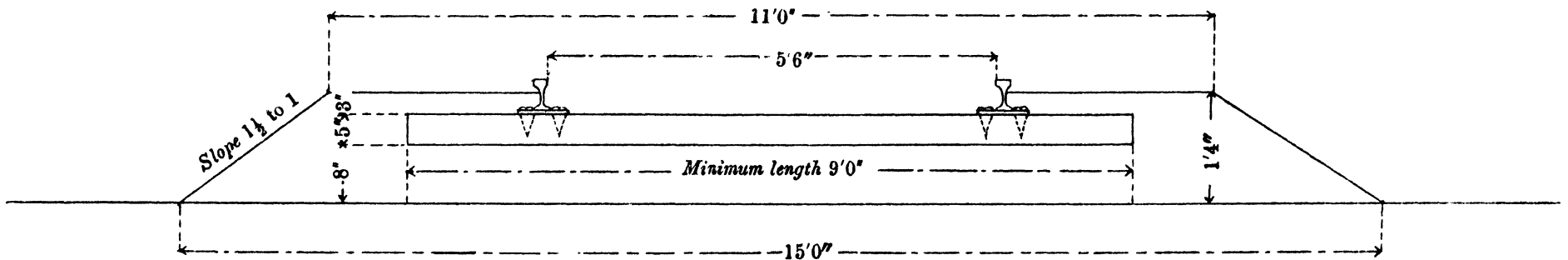

Type B. Standard Gauge—Flat-footed Rails on wooden sleepers, with bearing-plates.

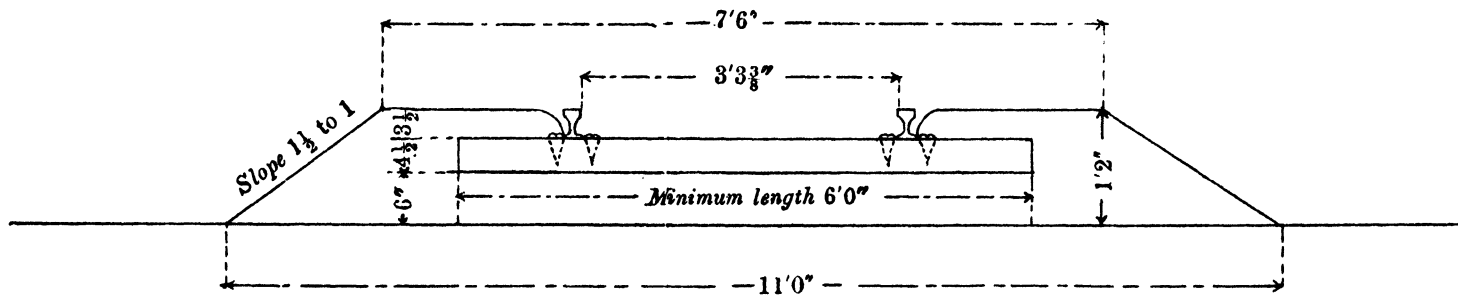

Type C. Metre Gauge—Flat-footed Rails on wooden sleepers, without bearing-plates.

BALLAST AND PERMANENT WAY—TYPICAL CROSS SECTIONS.

# BRITISH STANDARD 90 LBS. RAIL WITH FASTENINGS.

No. 1.  
5 FEET 6 INCHES GAUGE  
PERMANENT WAY I. S. RAILWAYS.  
1907.

**BEARING PLATE.**  
*For Dog spikes*

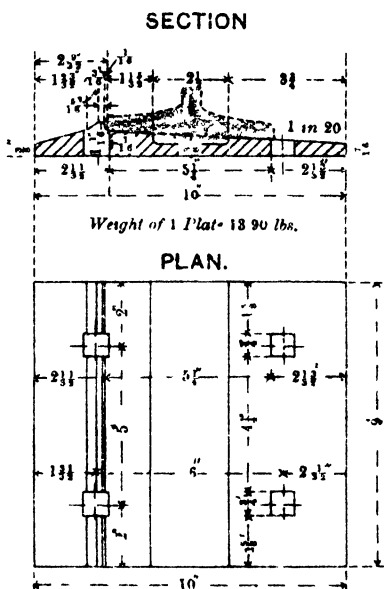

**SECTION OF FISHPLATES**

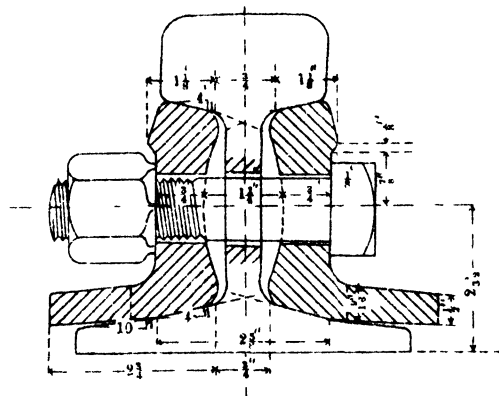

**SECTION OF RAIL**

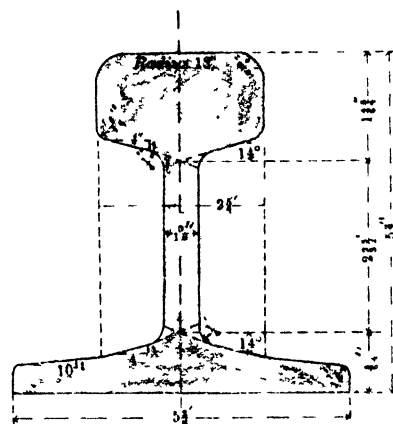

Weight of 1 spike 0.725 lbs  
**DOG SPIKE**

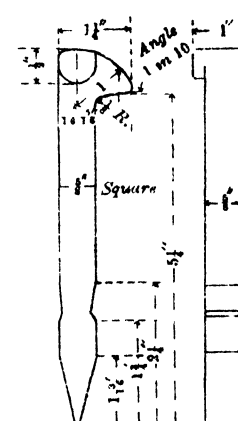

Weight of 1 screw 1.02 lbs  
**COACH SCREW**

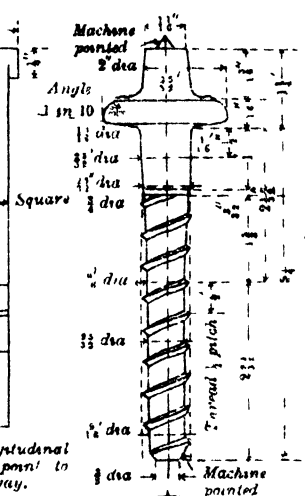

Note - When used with longitudinal sleepers the chisel point is to be turned the other way.

**ELEVATION OF FISHPLATES**  
*Notched for Dog spikes.*

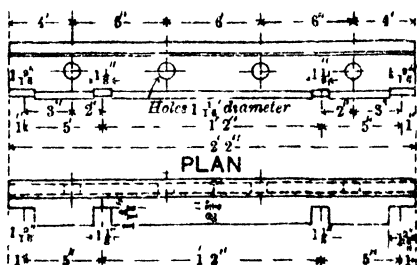

**END OF RAIL**  
*Showing Fishbolt holes.*

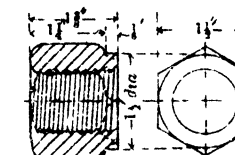

This surface to be faced true in a machine

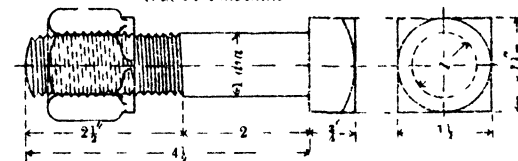

Weight of 1 Bolt and Nut 1.875 lbs

**BEARING PLATE.**  
*For Coach screws.*

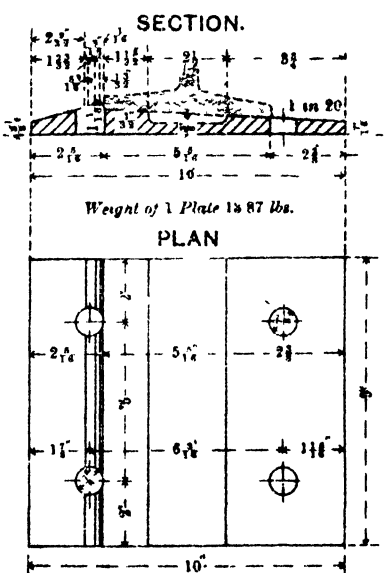

**ELEVATION OF FISHPLATES.**  
*Notched for Coach screws.*

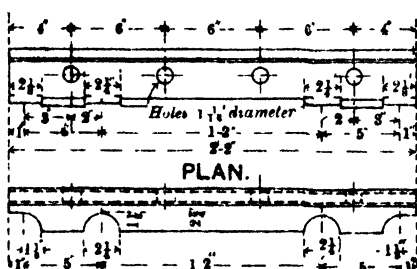

Weight of pair of Fishplates 51.20 lbs

**RAIL JOINT.**

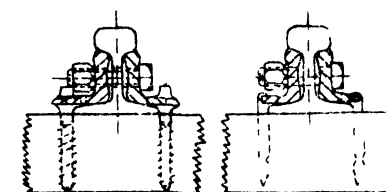
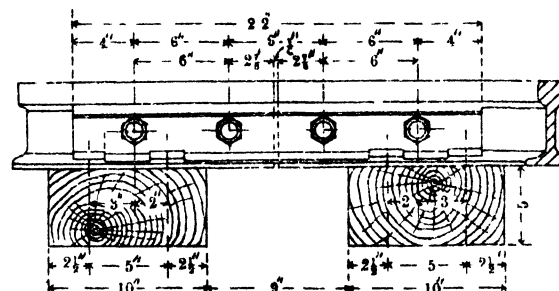

Compiled in Railway Board's Office  
from India Office Dwg No. D. 1786 (By Bd D B No 10260 a.)

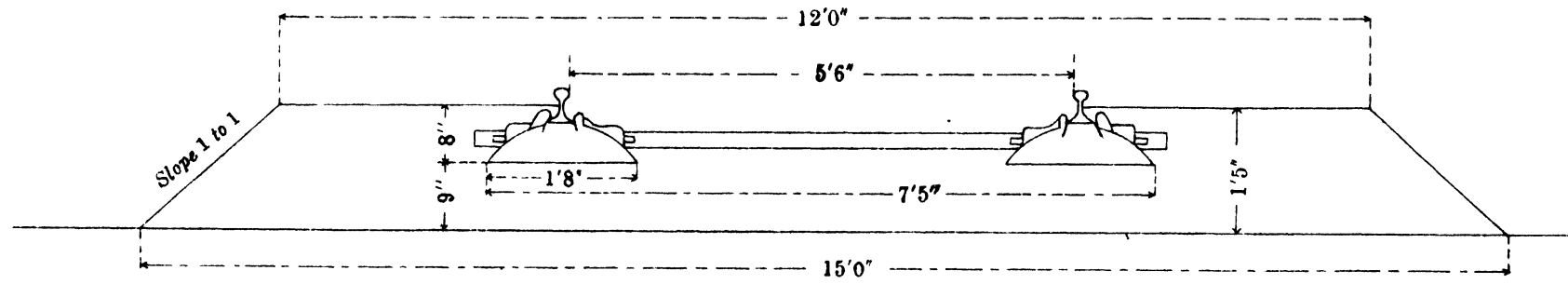

BALLAST SECTION.  
Scale— $\frac{1}{4}$  Inch = 1 Foot.

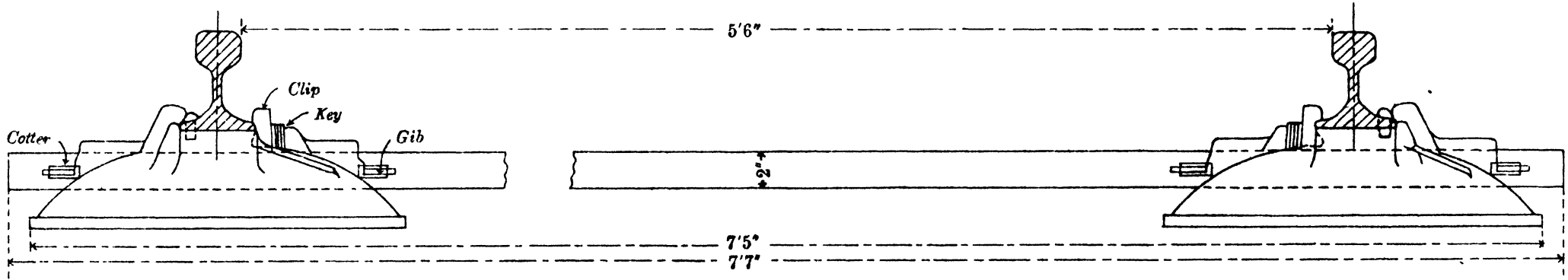
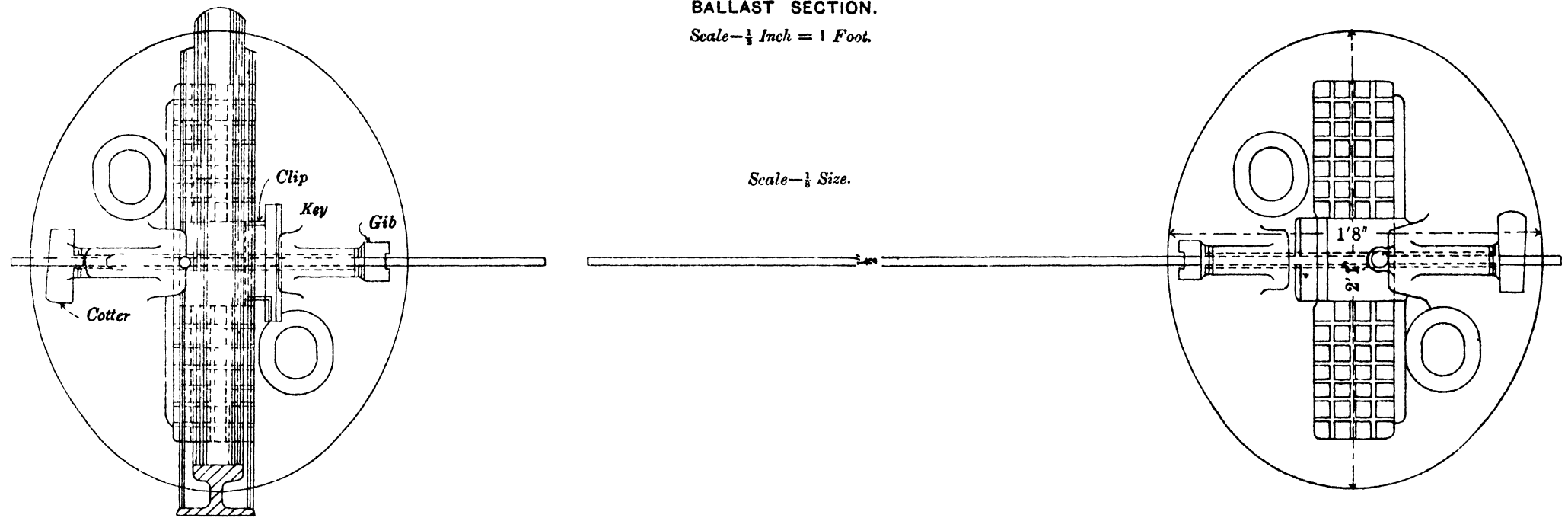

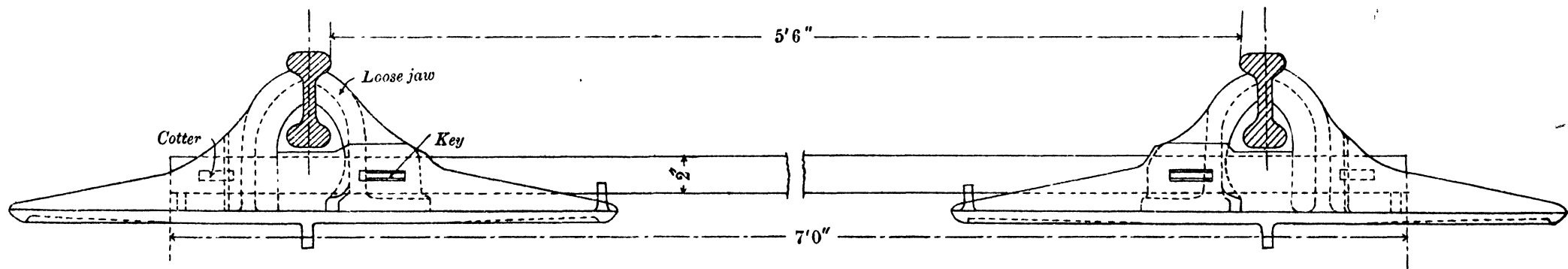
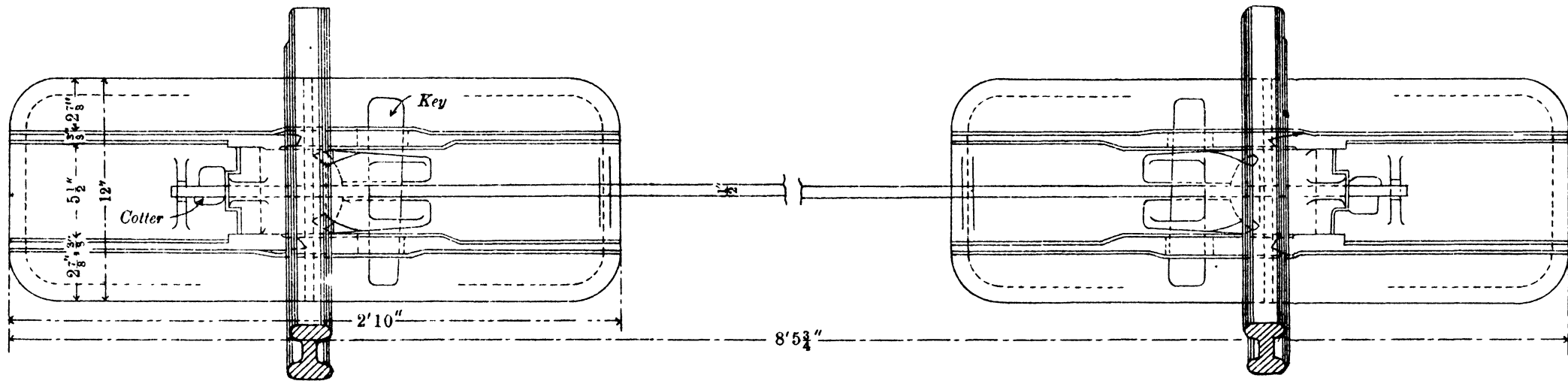
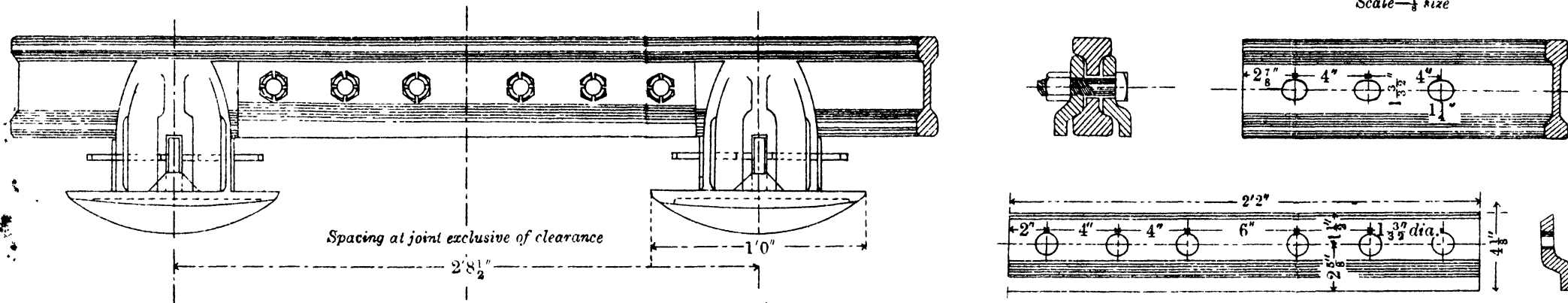

TRANSVERSE STEEL SLEEPER  
FOR 75 LBS. VIGNOLE'S F. F. STEEL RAIL—OLD TYPE.

Scale—2 Inches = 1 Foot.

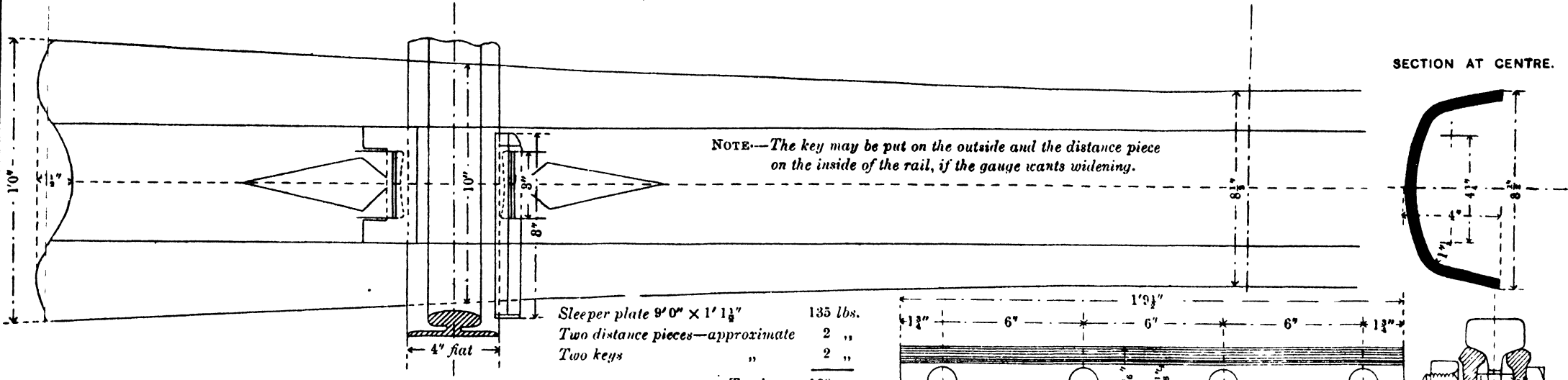
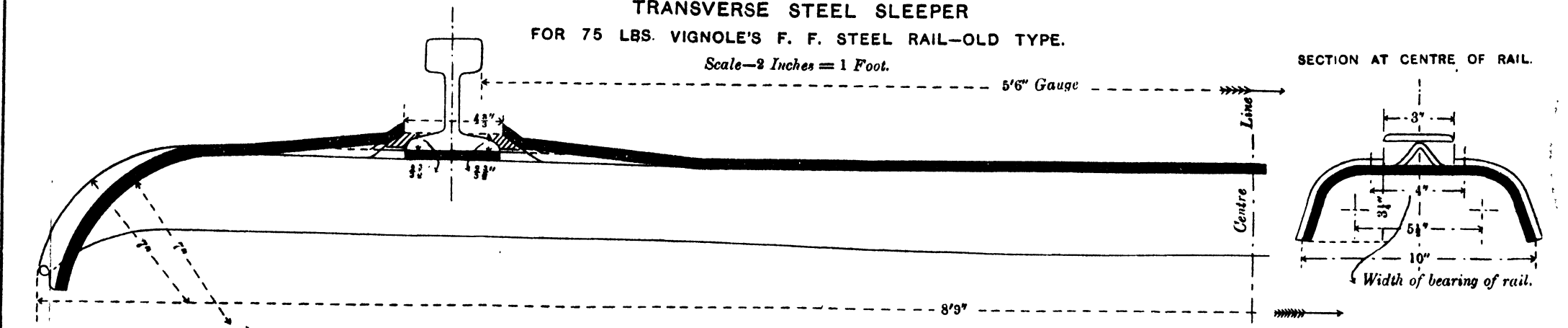

Sleeper plate 9'0" x 1' 1 1/2"	135 lbs.
Two distance pieces—approximate	2 "
Two keys	2 "
<b>Total</b>	<b>139 "</b>

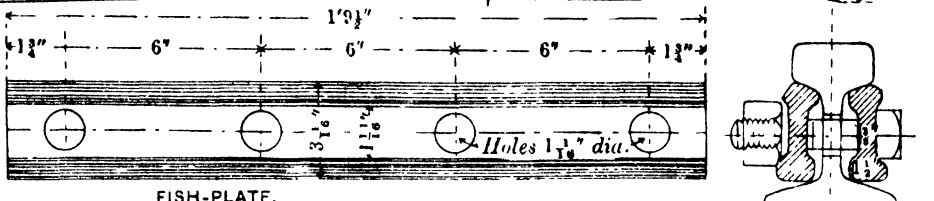

BALLAST SECTION.  
Scale—1/2 Inch = 1 Foot.

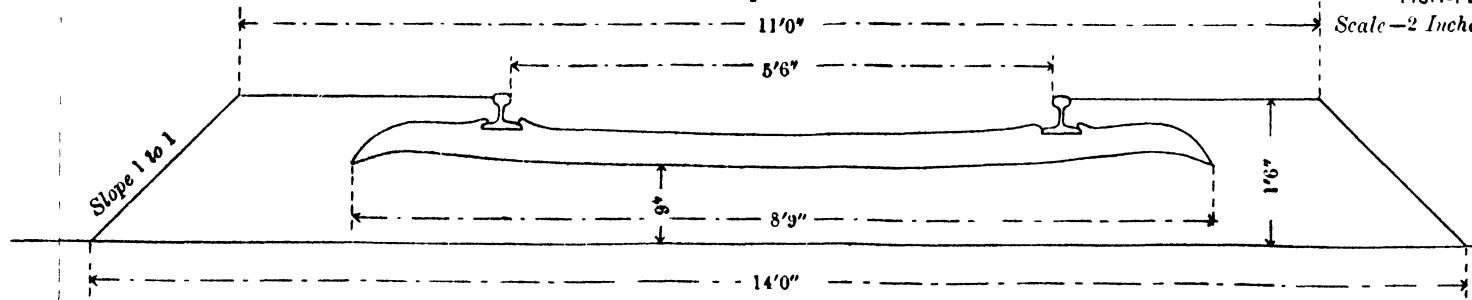

FISH-PLATE.  
Scale—2 Inches = 1 Foot.

SECTION OF RAIL AND RAIL SEAT.

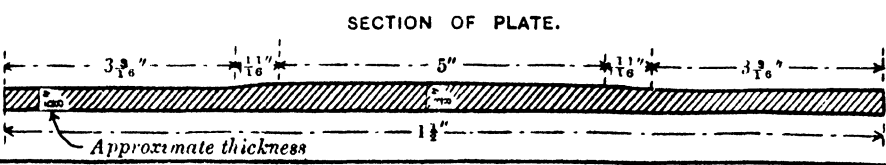
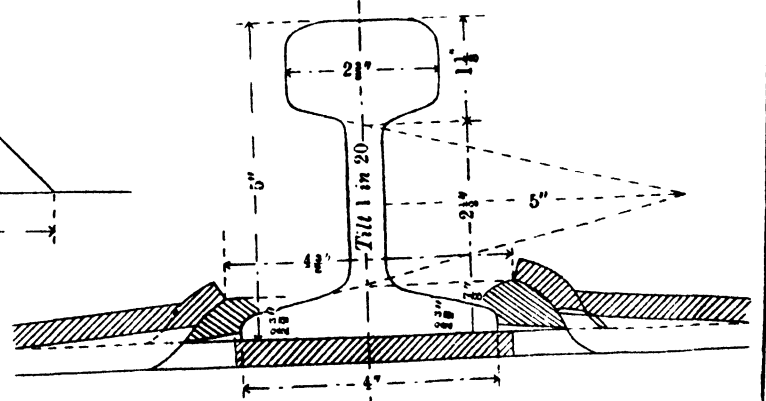

Scale of Details.  
4 Inches = 1 Foot.

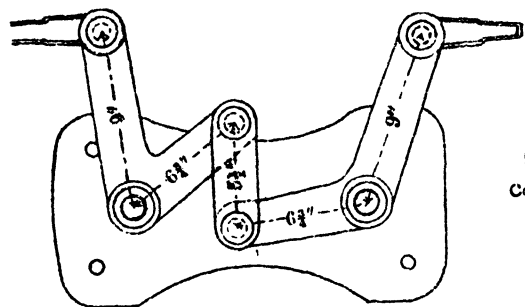

Plan of  
Horizontal  
Point-rod  
Compensator.  
Scale  $\frac{1}{8}$ .

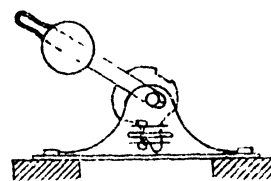

DETAIL PLAN OF POINTS.

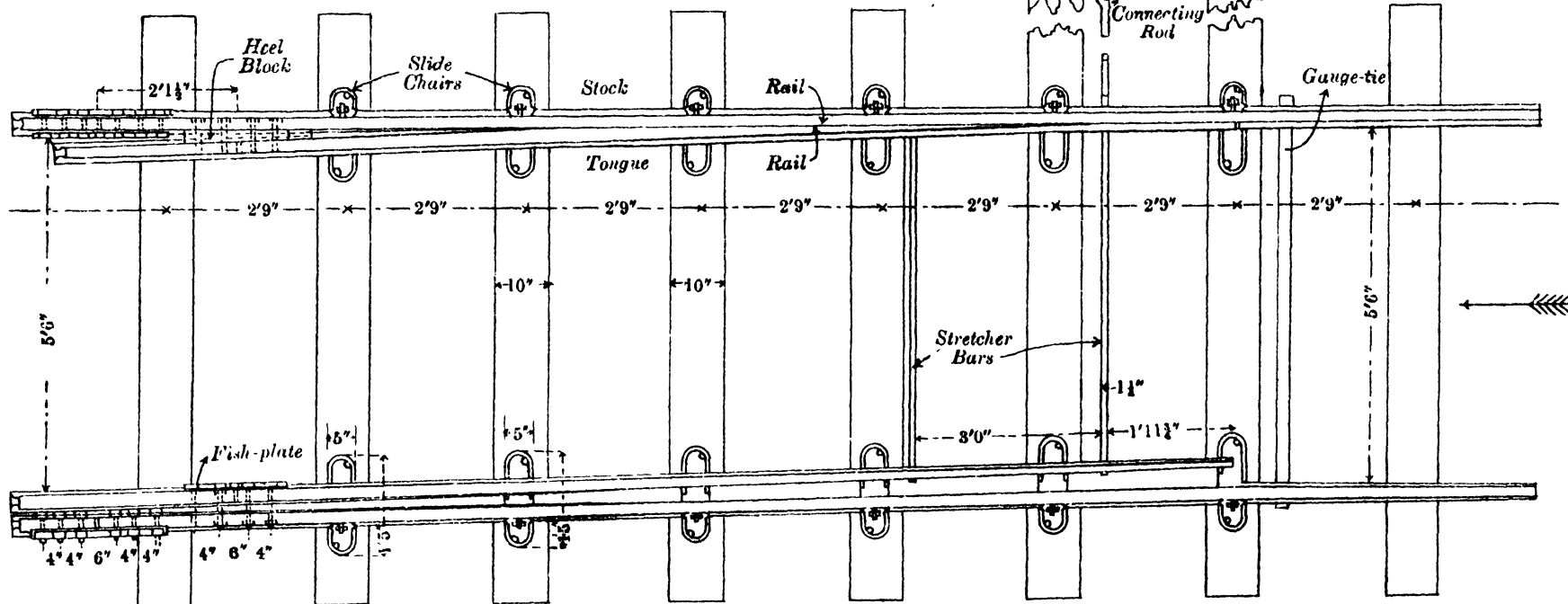

DETAIL PLAN OF CROSSING.

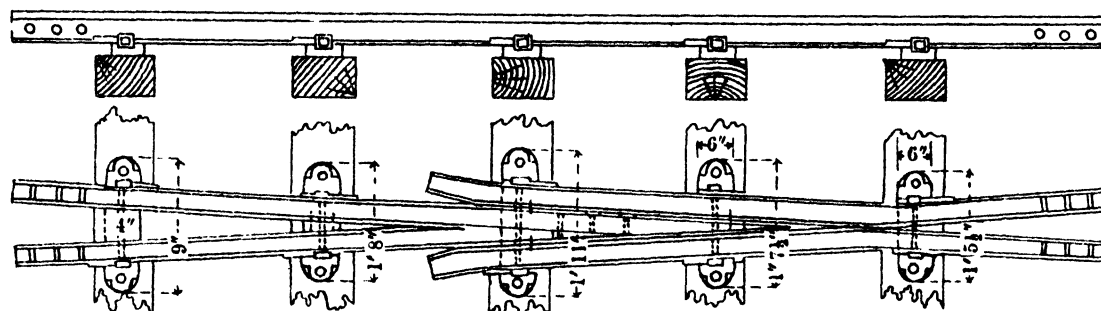

Scale— $\frac{3}{8}$  Inch = 1 Foot.

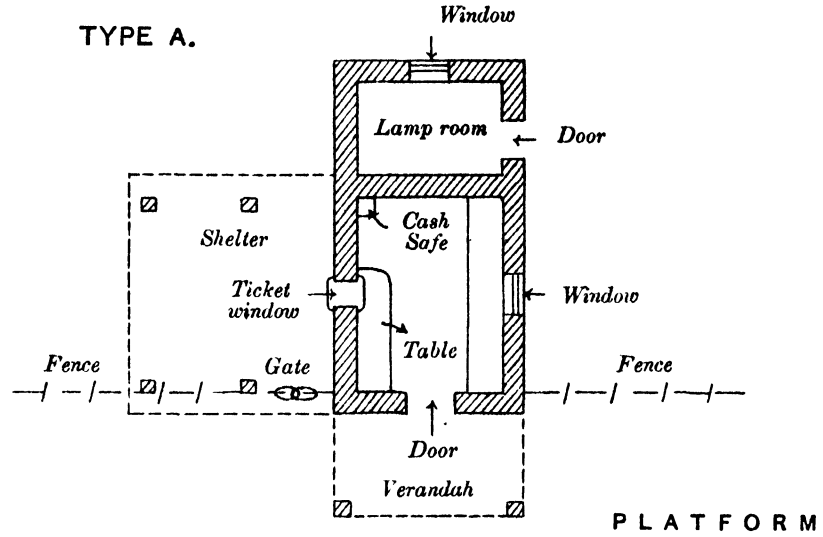

TYPE B.  
APPROACH ROAD

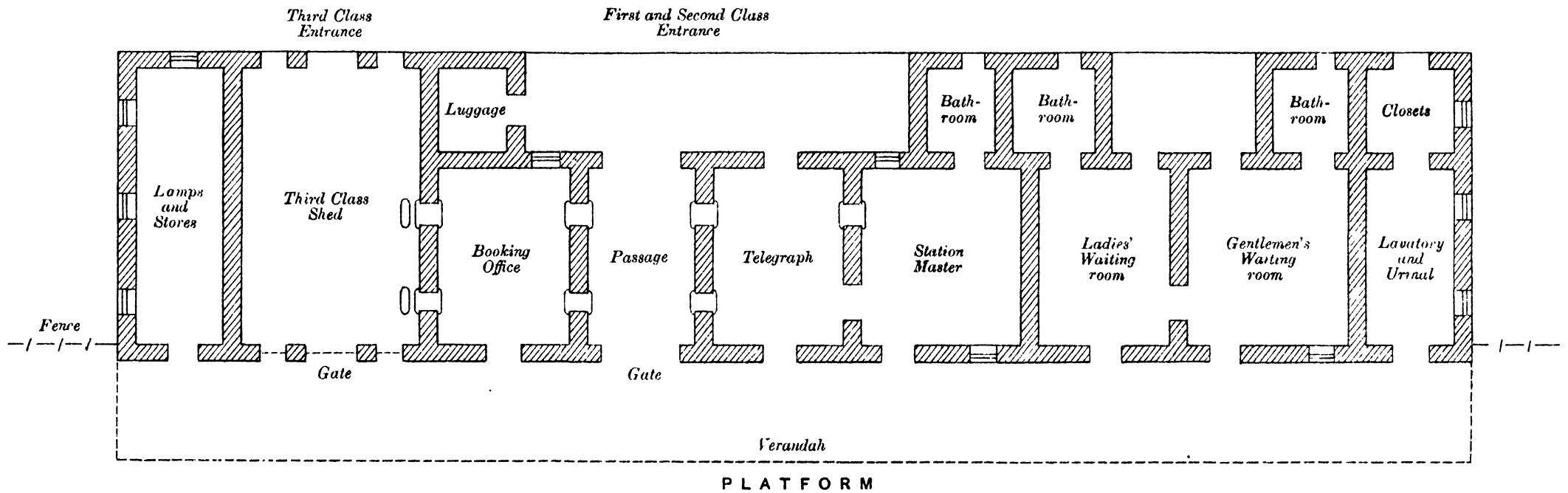

# DOUBLE-UNIT STATION MASTER'S QUARTERS.

NOTE.—To accommodate a Station Master and Telegraph clerk.

SECTION ON A. B.

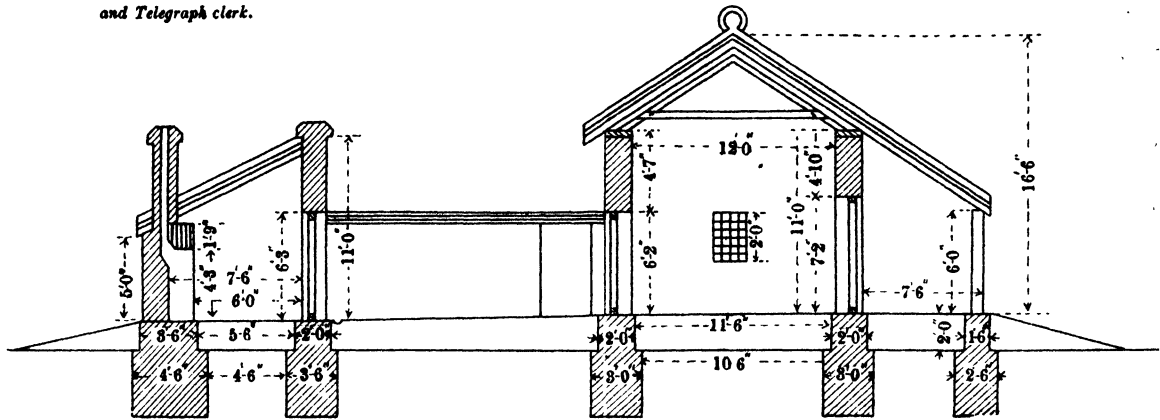

PLAN.

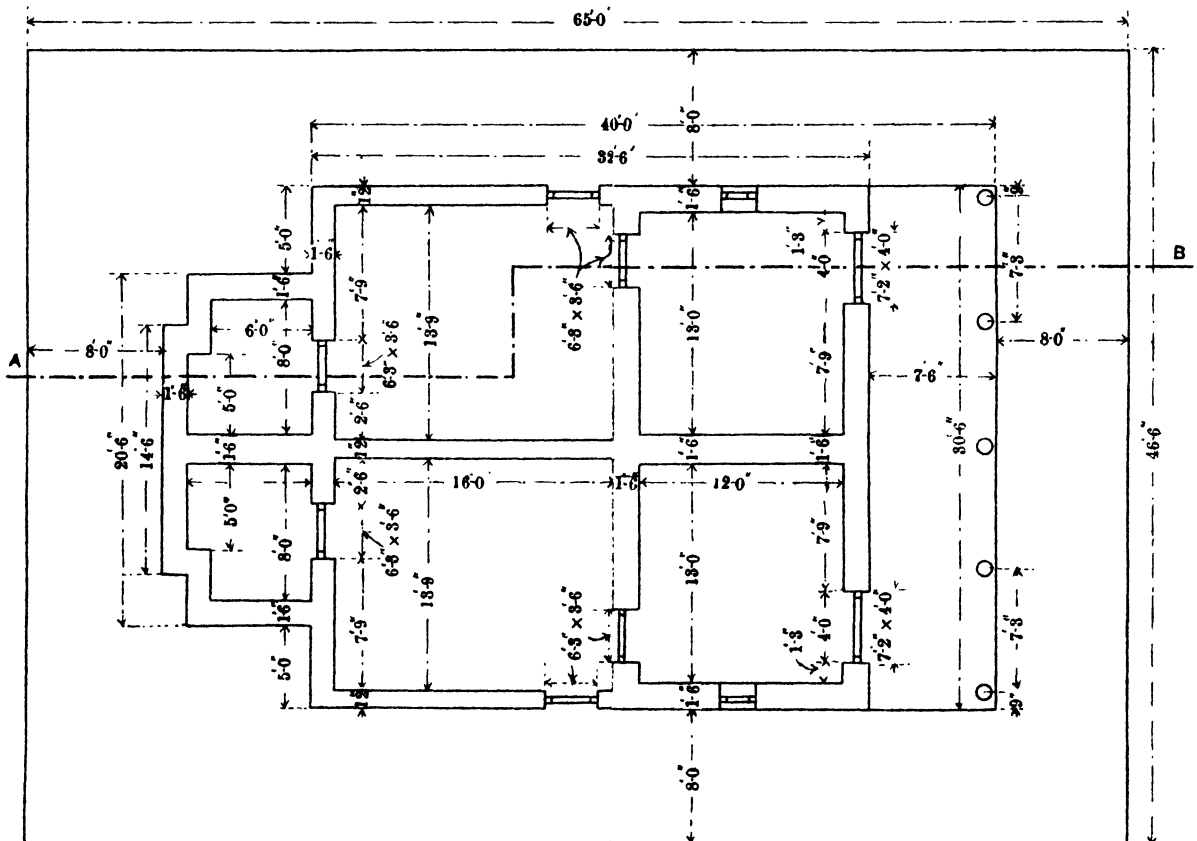

# ENGINE SHED TO ACCOMMODATE TWO ENGINES.

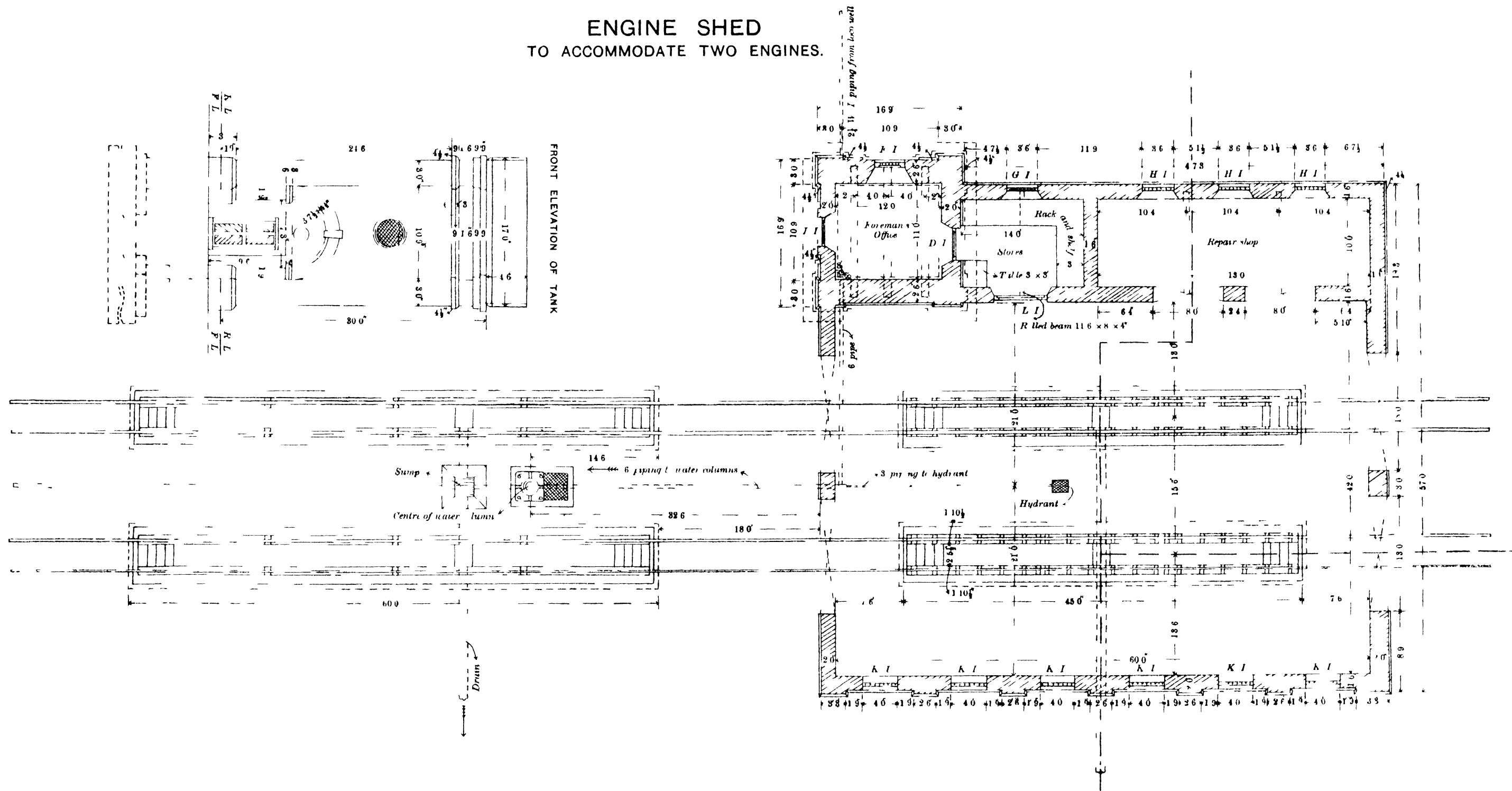

TURNTABLE AND TRAVERSER, INDIAN METRE-GAUGE RAILWAYS.

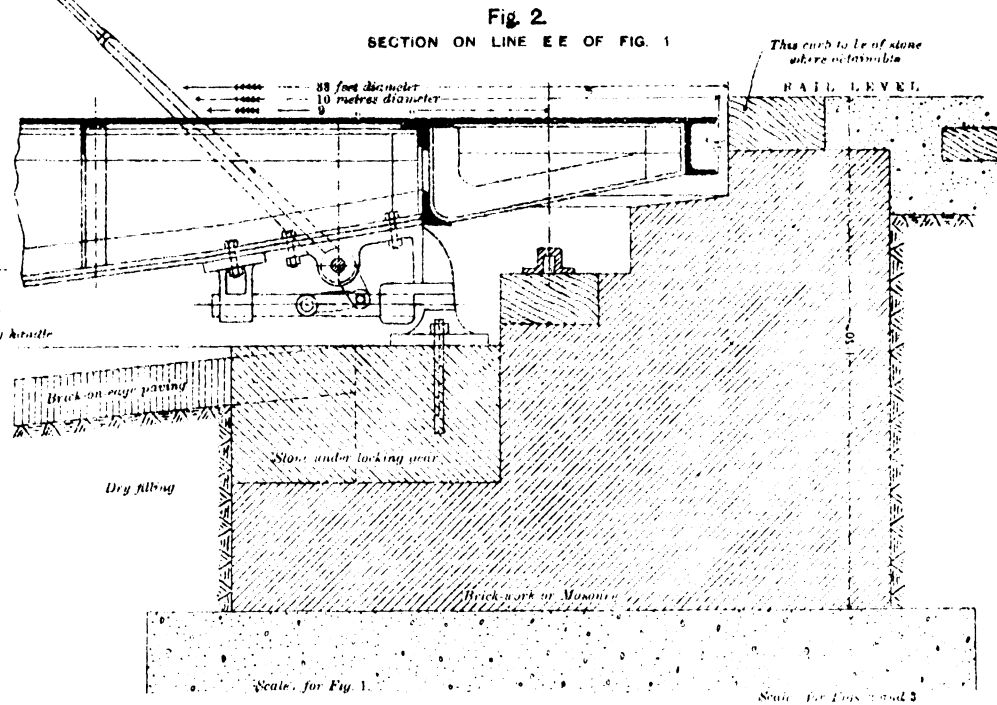
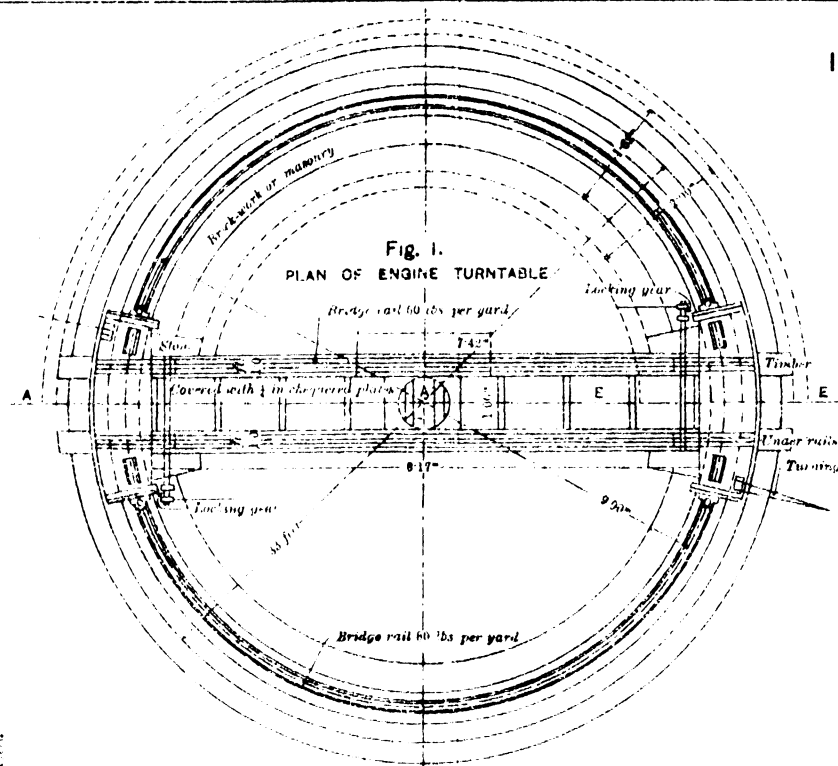

SECTION THROUGH FOUNDATIONS, SHOWING HALF SECTION ON LINE A.A. AND HALF SIDE ELEVATION OF TURNTABLE.

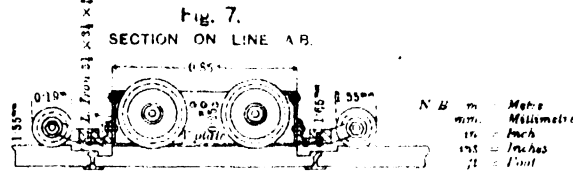
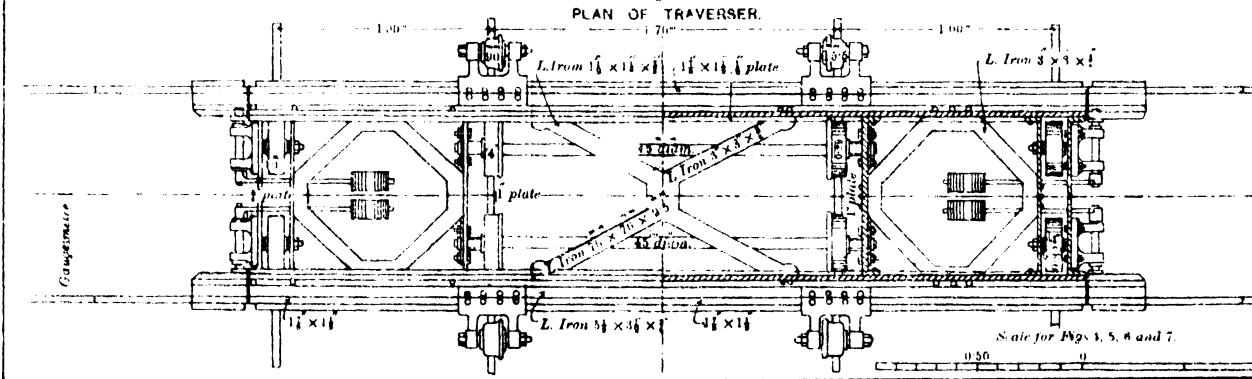
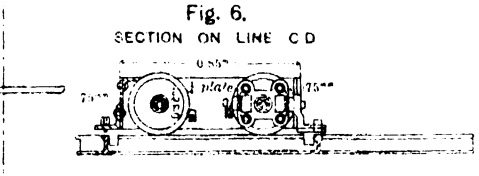
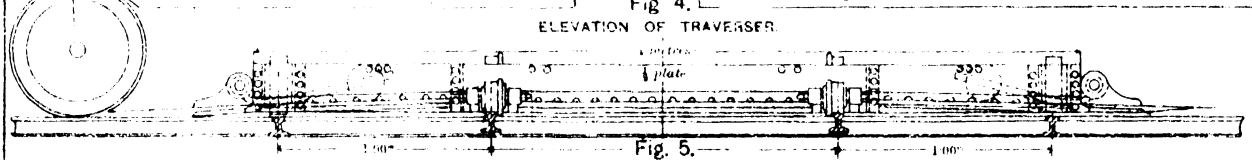
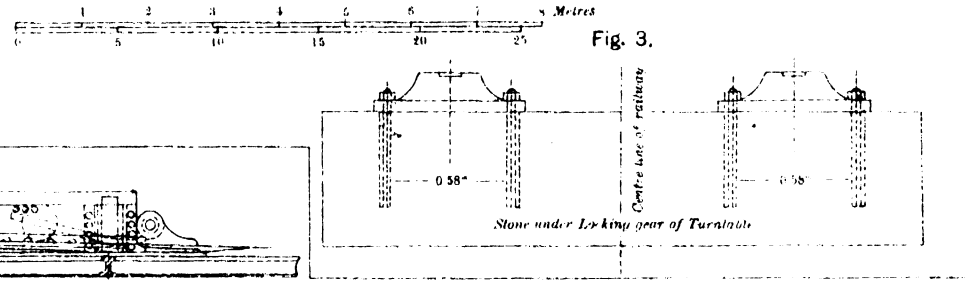
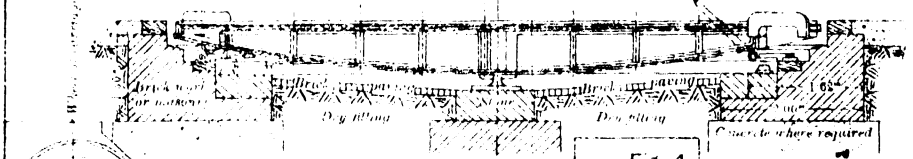
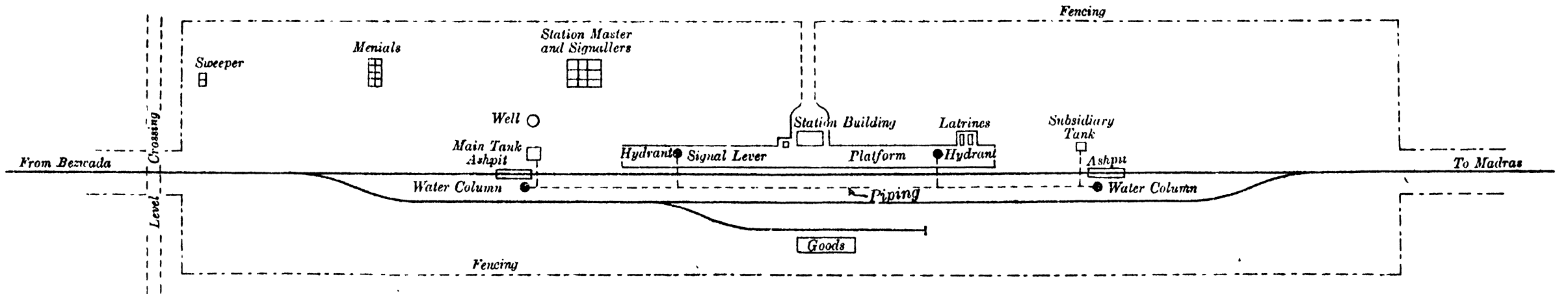
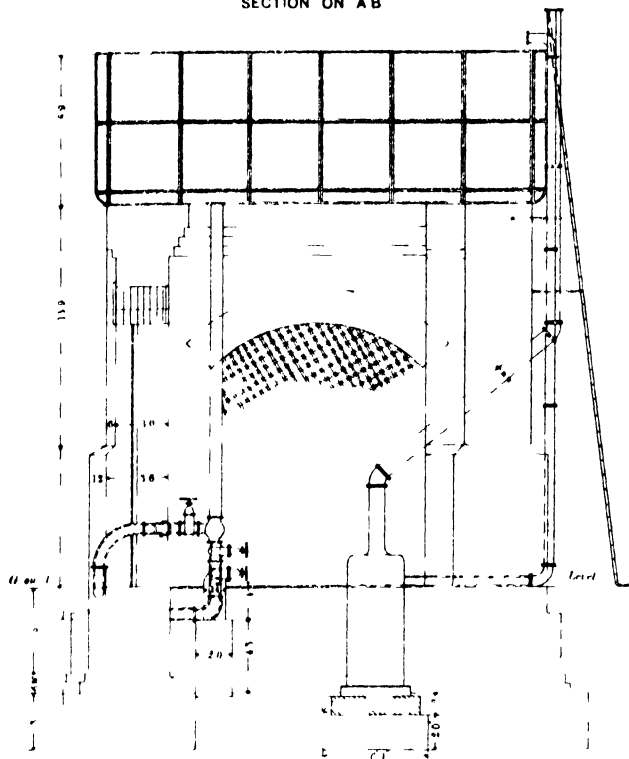

DIAGRAM SHOWING GENERAL ARRANGEMENT OF 3RD CLASS STATION YARD  
WITH WATERING ARRANGEMENTS.



SECTION ON AB



MAIN TANK FOR WATERING STATION

SECTION AT GH

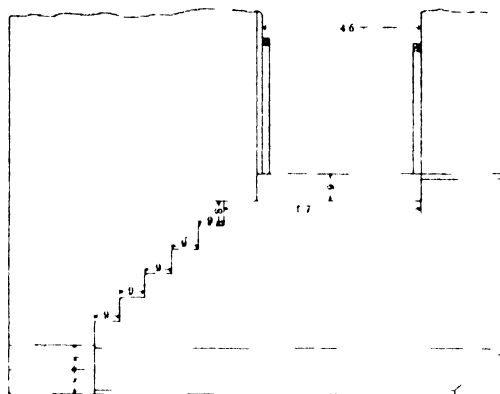

PLAN

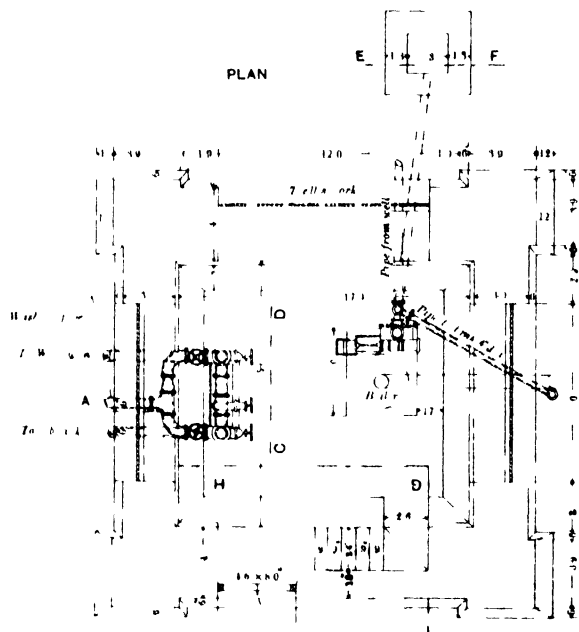

ELEVATION AT CD

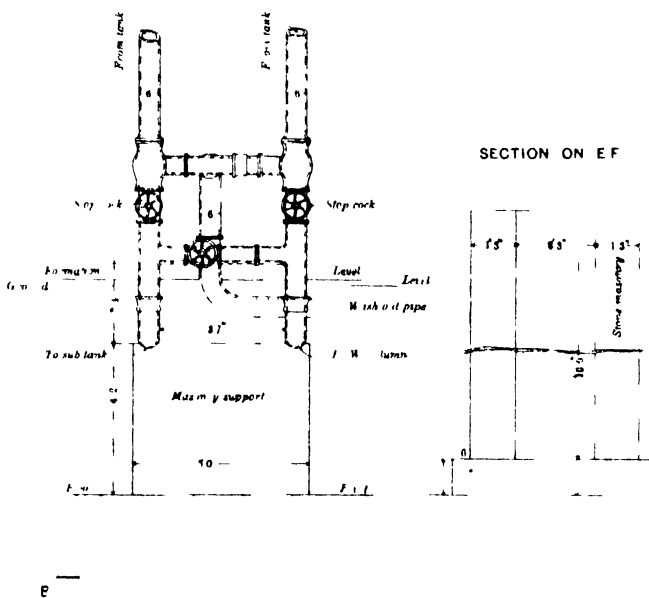

SECTION ON EF



GENERAL ARRANGEMENT OF LEVER AND BOX.

Scale— $\frac{1}{4}$  Inch = 1 Foot.

Fig. 1.

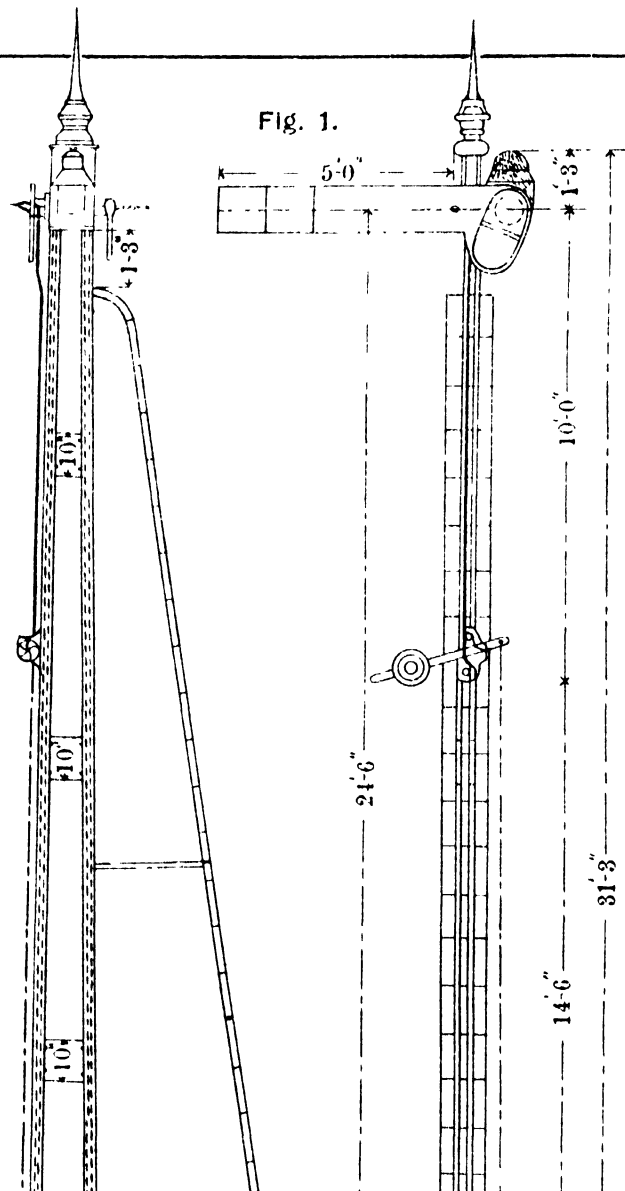
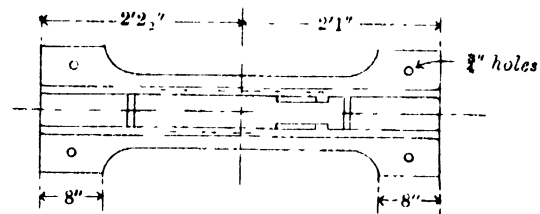
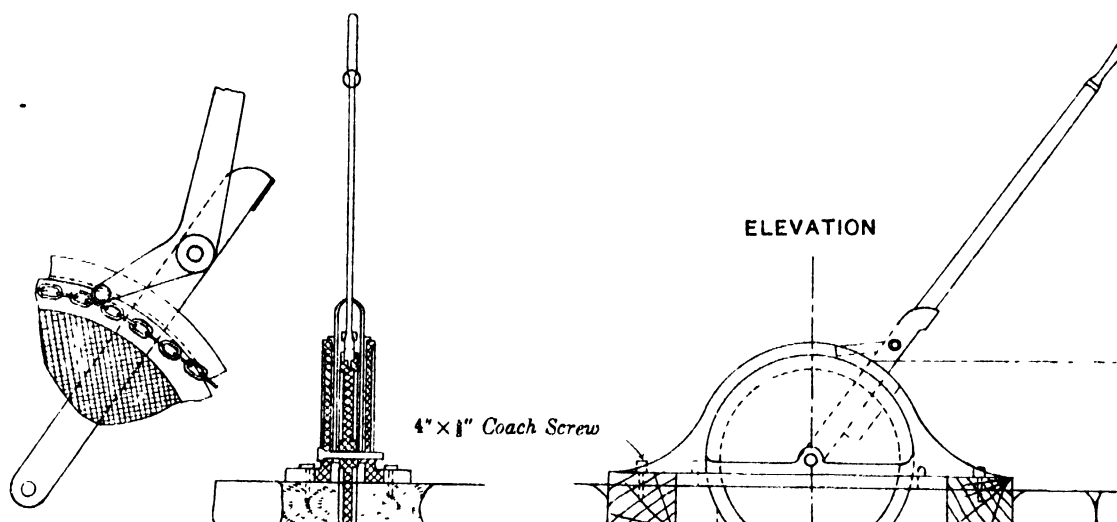

Fig. 2.

PLAN OF BOX.



SECTION.



ELEVATION

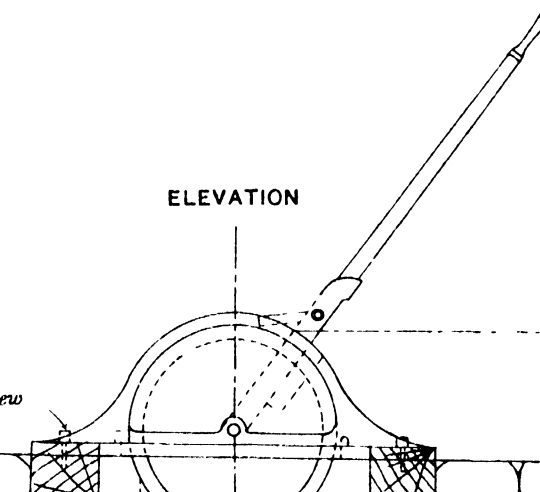

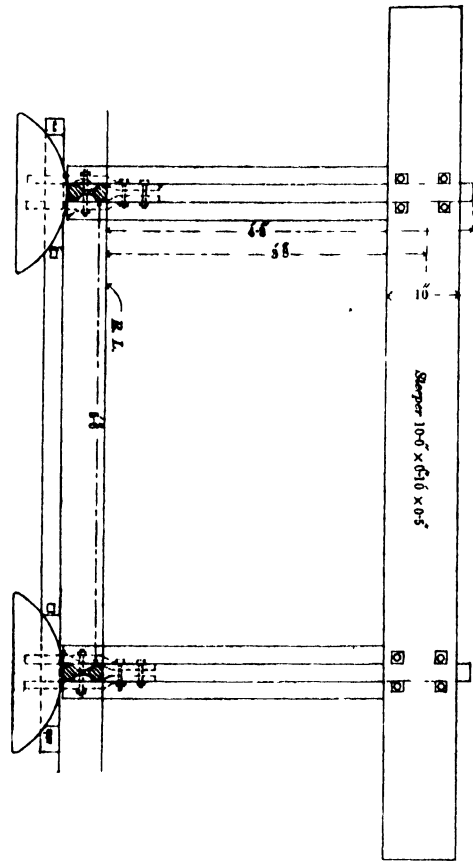

FRONT ELEVATION

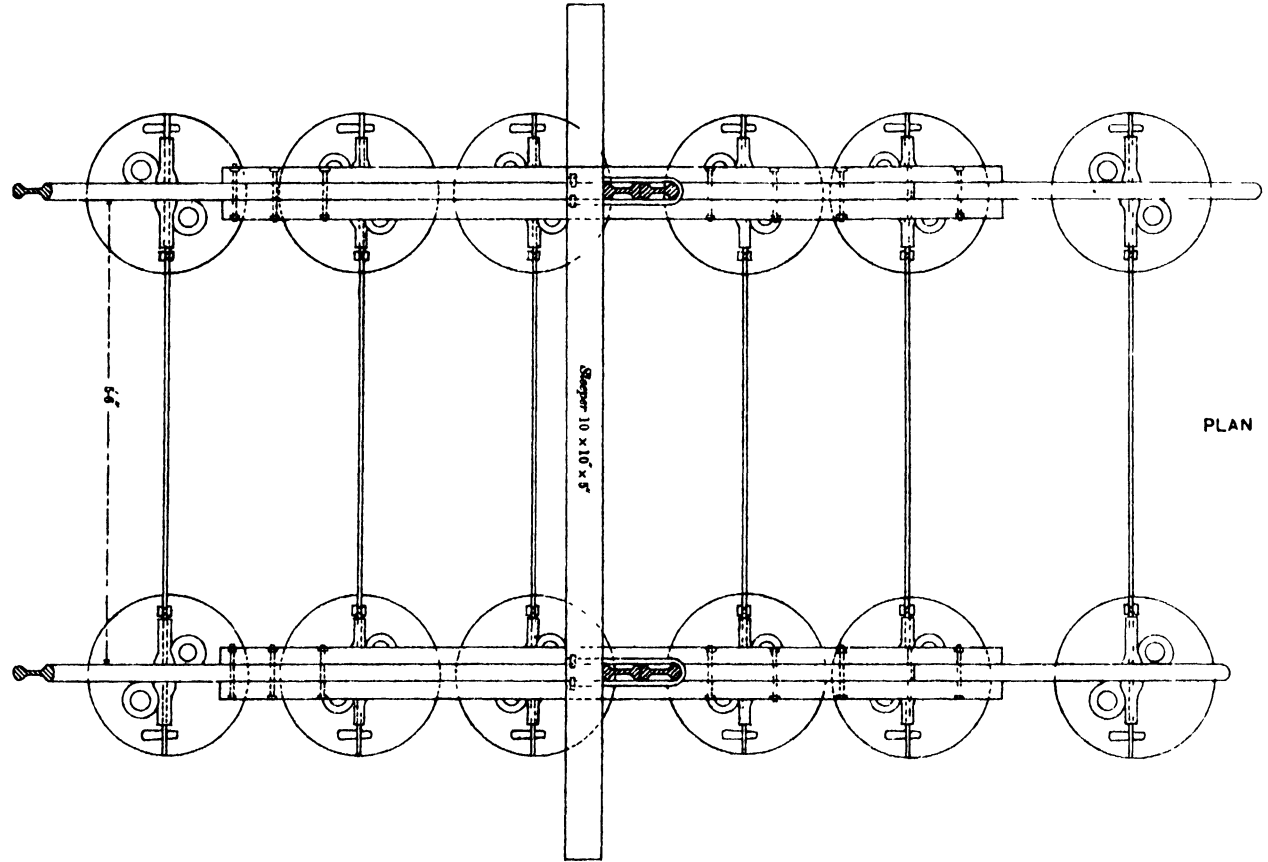

PLAN

SIDE ELEVATION.

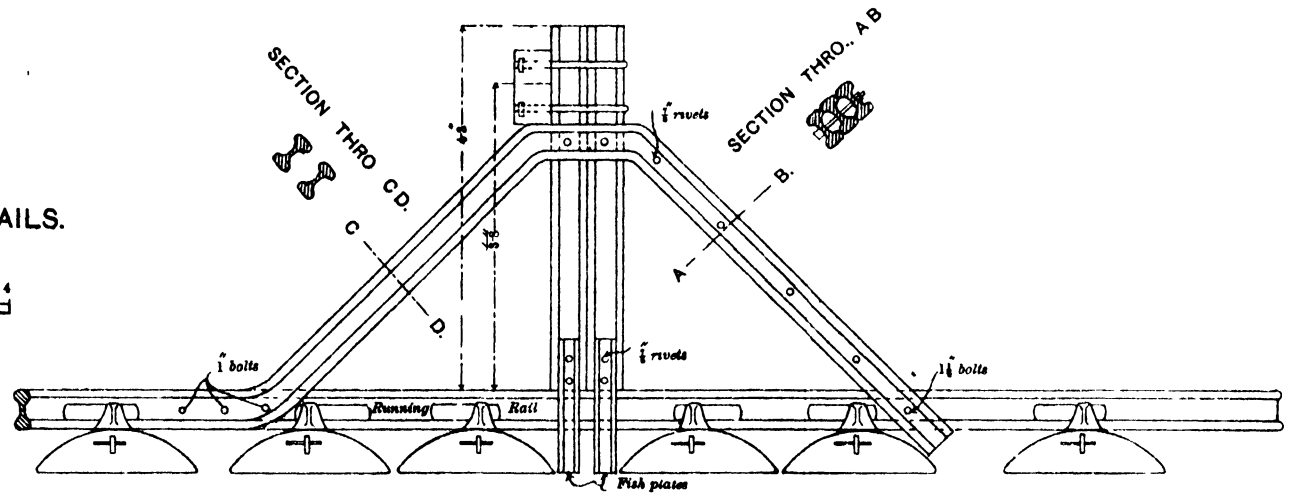

BUFFER STOP MADE OF OLD RAILS.

Scale

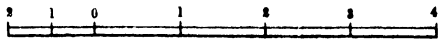

# 18'-0" UNDERFRAME FOR IRON COVERED GOODS WAGON. 5-6" GAUGE.

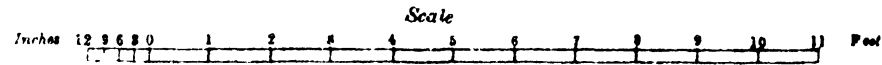

ELEVATION

SECTIONAL ELEVATION

END VIEW

CROSS SECTION ON A B

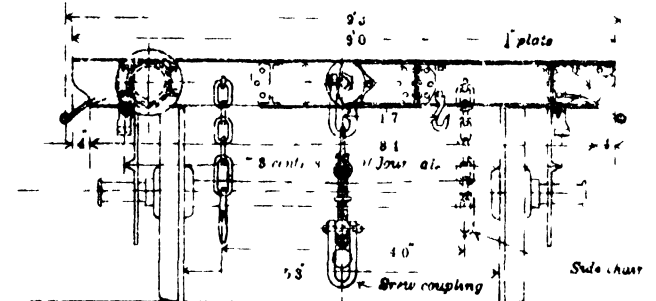
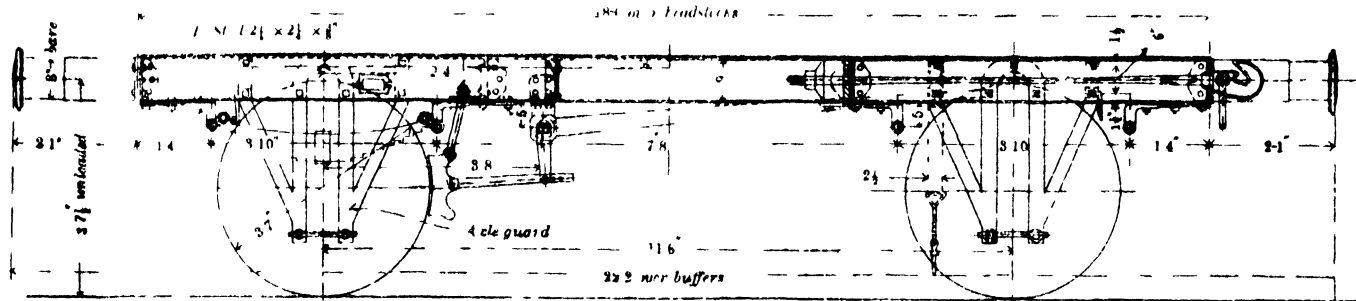

NOTE - Cle guards, scroll irons, link rear buffers and sponder hook to be belted not riveted on

NOTE - For dimensions sole bars, headstocks, cross and longitudinal bars see details



PLAN WITH FLOOR REMOVED

TOP PLAN

Headstocks and sole bars

Cross bars

Longitudinal bars

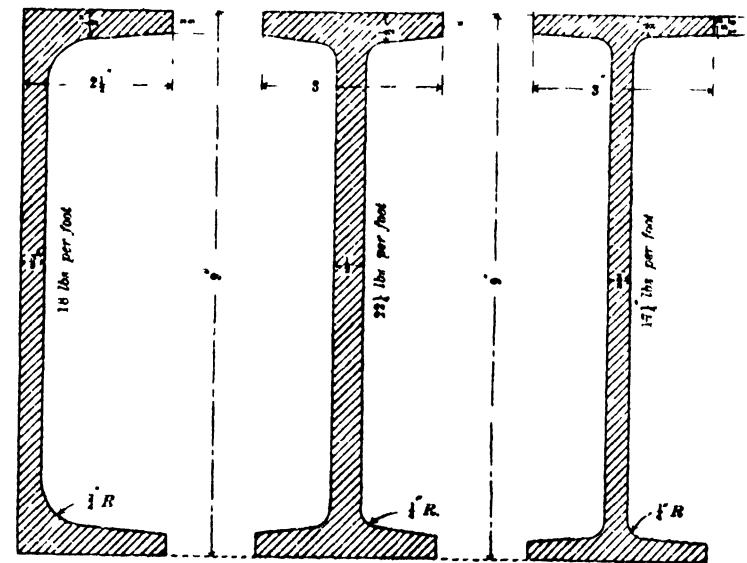
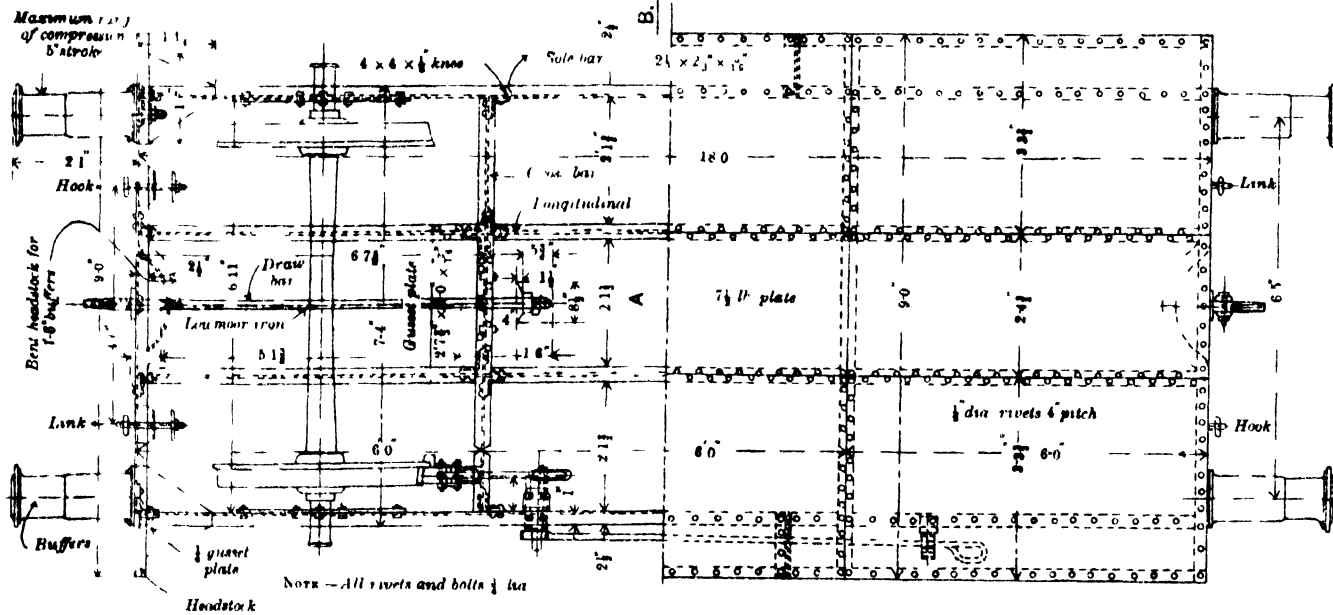

18" centres of journals

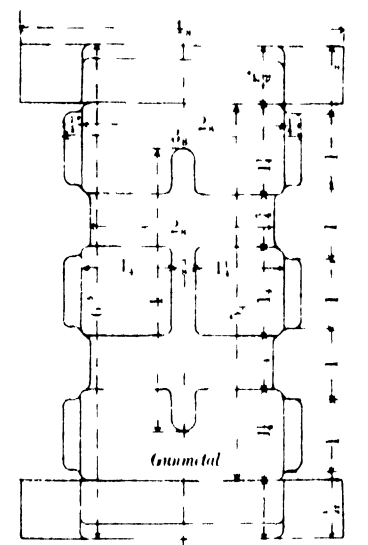
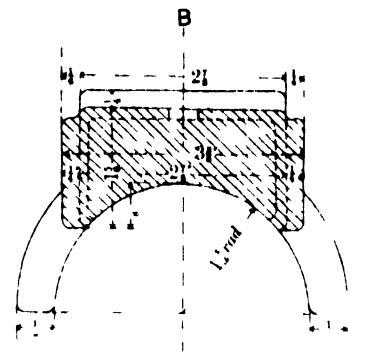
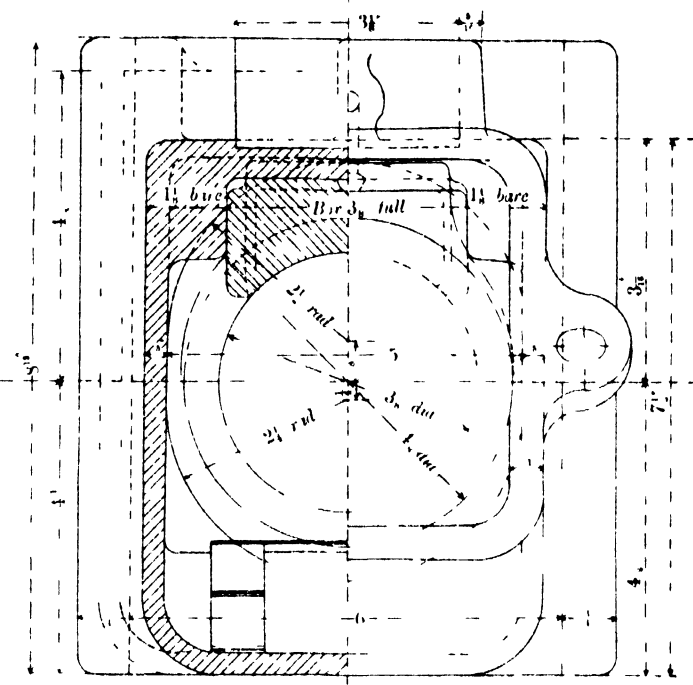
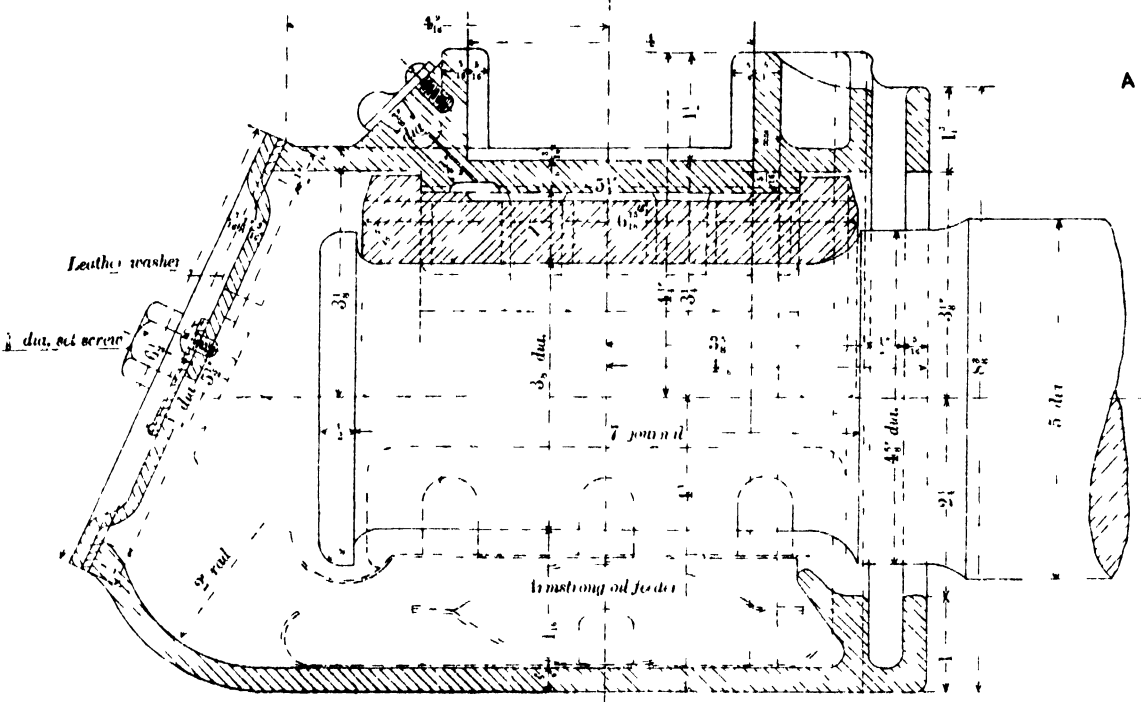

2 1/2" centres of axle journals

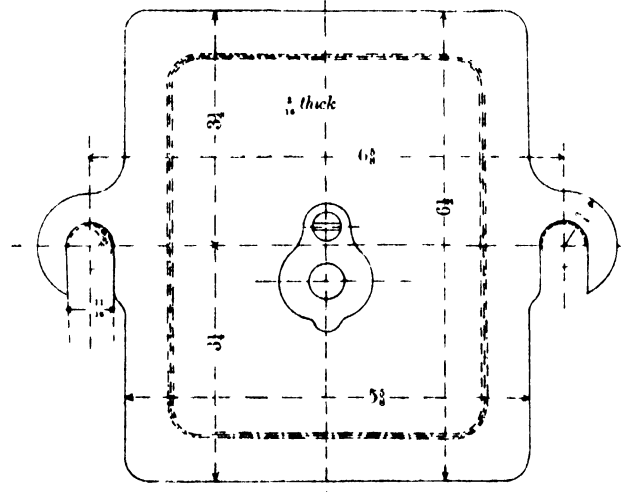
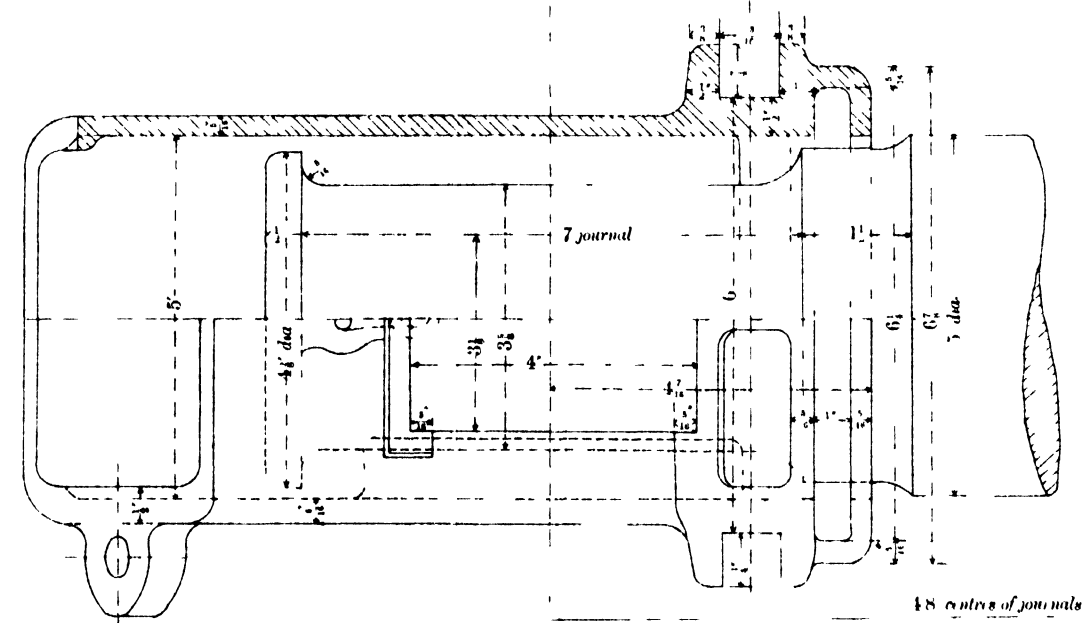

18" centres of journals

**BOGIE TRUCK, GOODS STOCK.**  
**METRE GAUGE.**  
**AXLE-GUARDS INSIDE SOLE BARS**  
**SQUARE FRAMED TRUCK.**

Scale

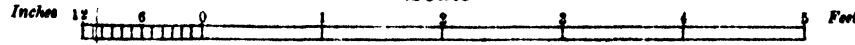

LONGITUDINAL ELEVATION

LONGITUDINAL SECTION.

CROSS SECTION ON A A.

END ELEVATION.

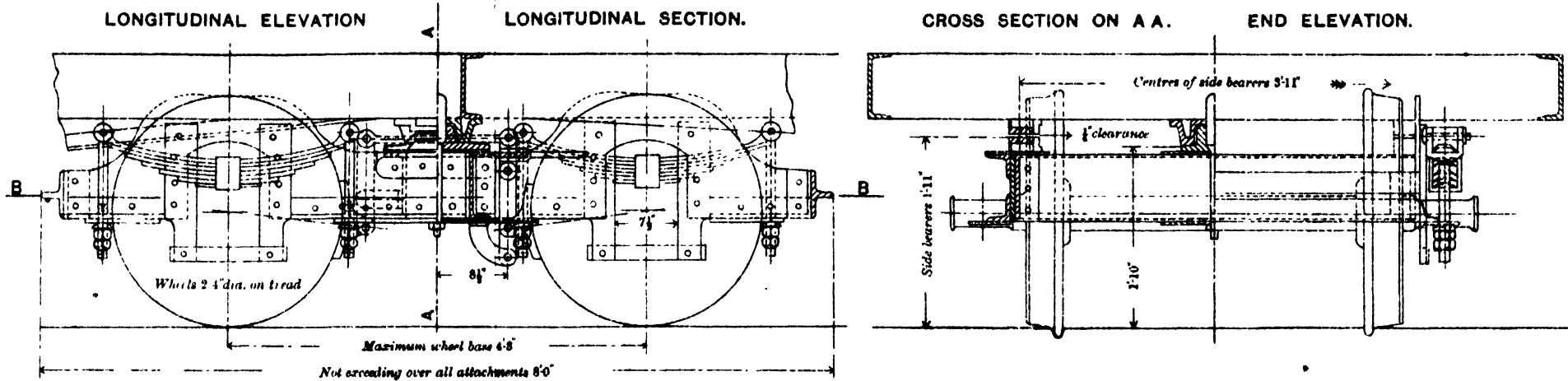

PLAN

Scale



Fig. B.  
CAST METAL PIVOT.

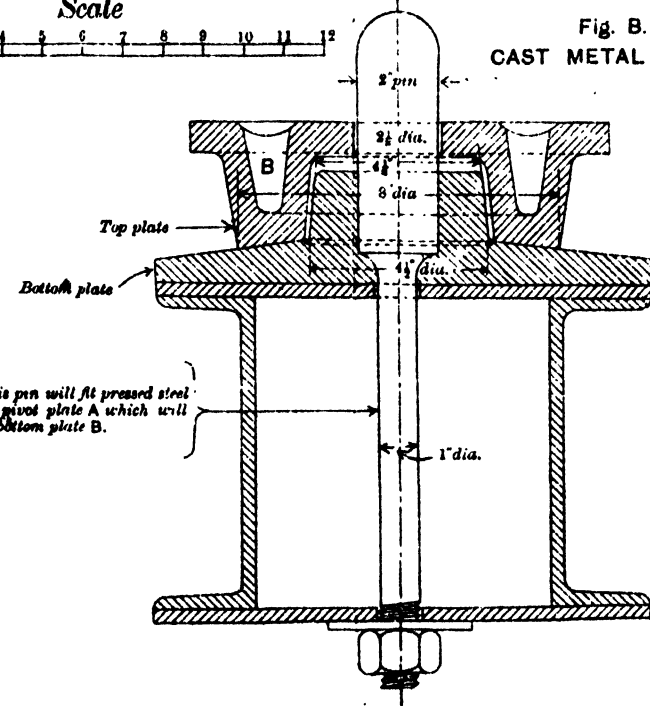
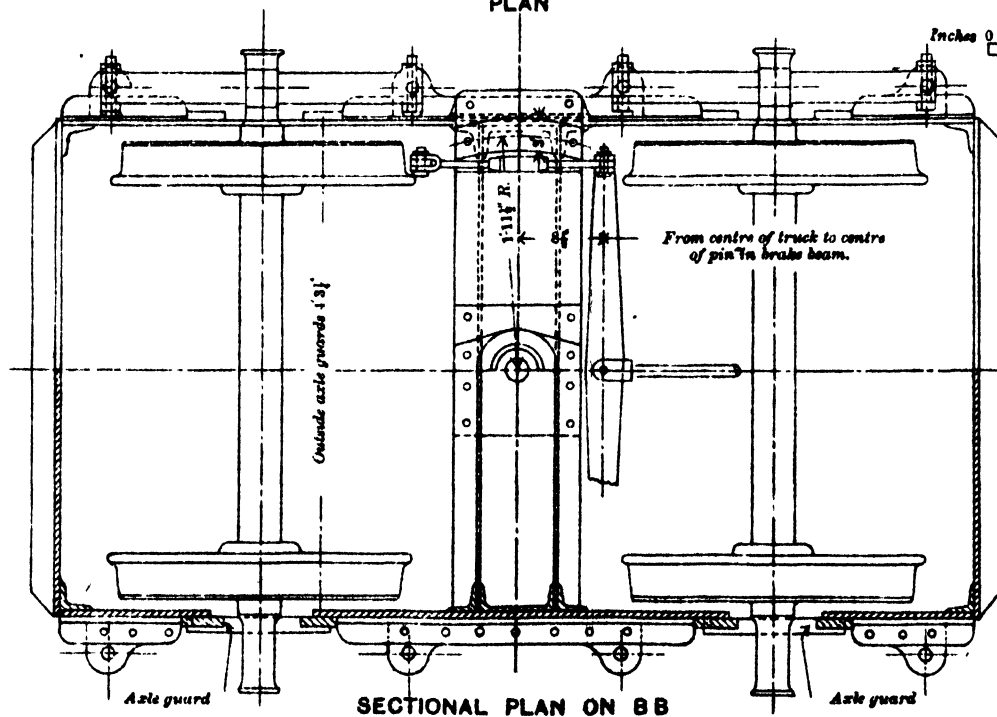

Note — This pin will fit pressed steel top pivot plate A which will fit bottom plate B.

GOODS STOCK  
INDIAN RAILWAYS.

TYPES OF GOODS WAGONS.

COVERED GOODS BOGIE WAGON.

ELEVATION.

SECTION.

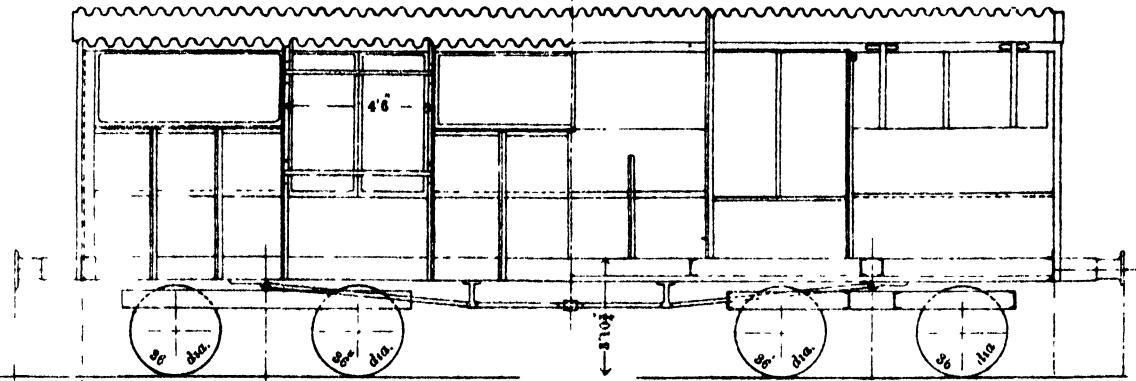

HIGH-SIDED GOODS WAGON

ELEVATION.

SECTION.

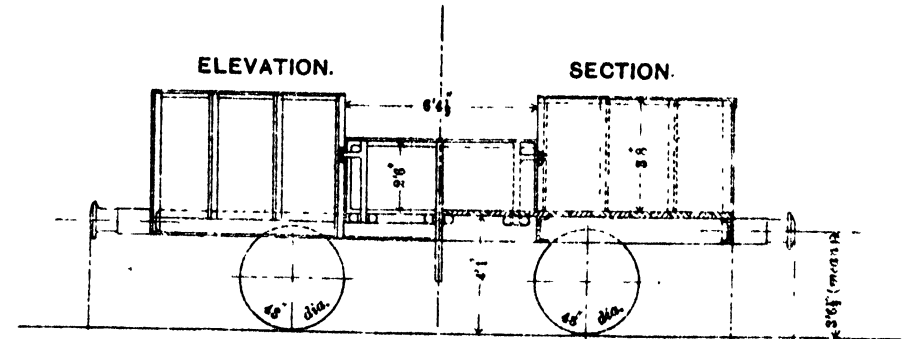

GOODS STOCK  
INDIAN RAILWAYS.

COVERED GOODS FOUR WHEELED WAGON.

ELEVATION.

SECTION.

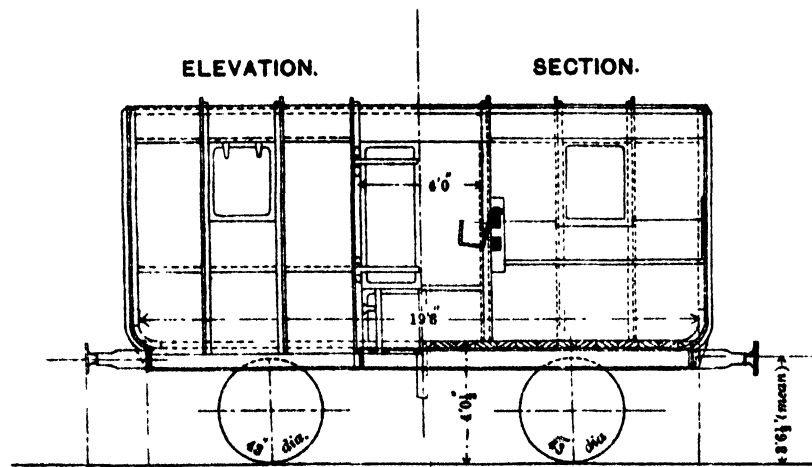

LOW SIDED GOODS WAGON.

ELEVATION.

SECTION.

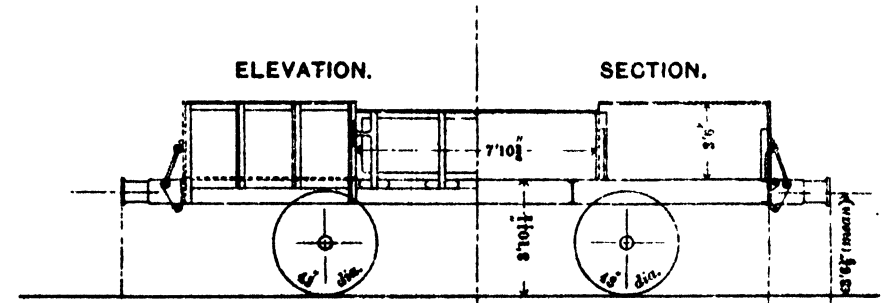





BOILER OF MIXED AND GOODS ENGINE.

FRONT ELEVATION OF BOILER.

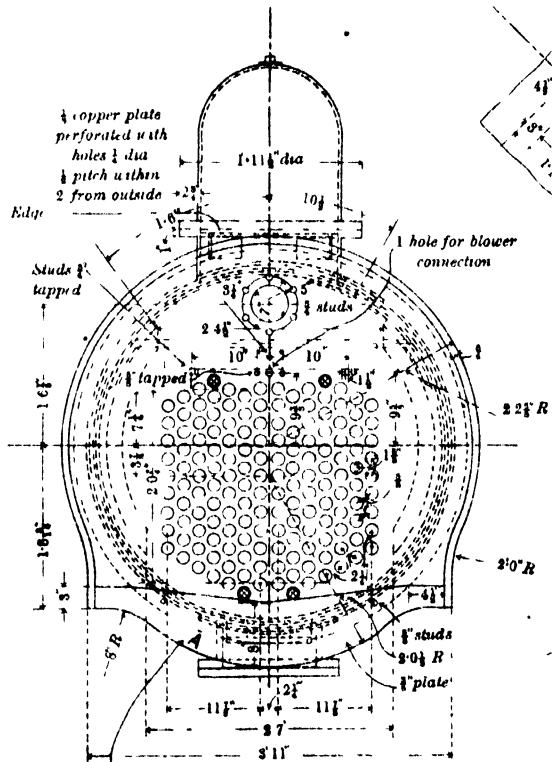
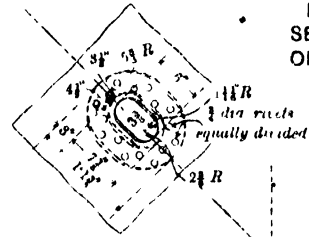

Plate A is bolted on to the smoke box tube plate, the joint being made with red lead to stop the tube plate corroding and can easily be removed at any time for removal. Holes to be marked off tube plate.

**HEATING SURFACE**

Area of fire box	67 sq ft
.. .. tubes	618 ..
<b>Total</b>	<b>685 ..</b>
Area of fire grate	12 ..

HALF SECTION ON D.D.



HALF BACK VIEW OF FIRE BOX.

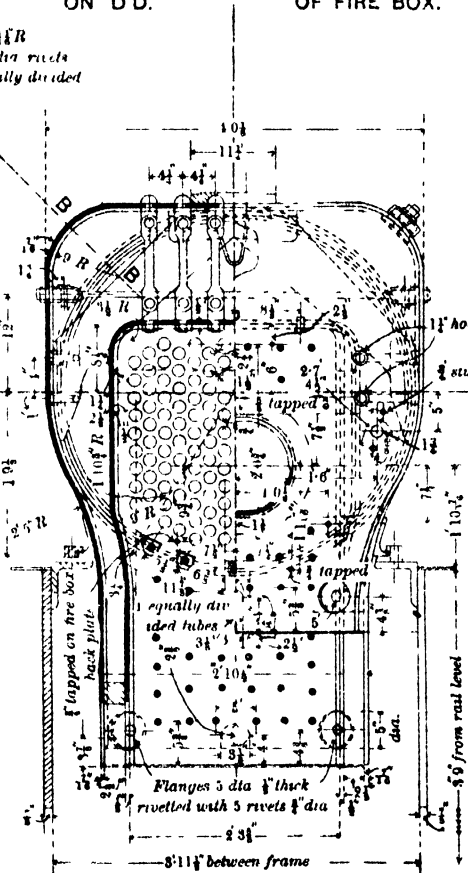

BACK ELEVATION OF FIRE BOX SHOWING POSITION OF MOUNTINGS.

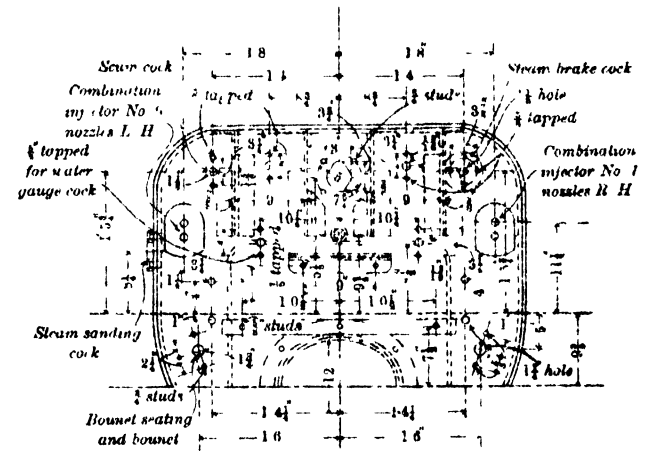

SECTION ON B.B.

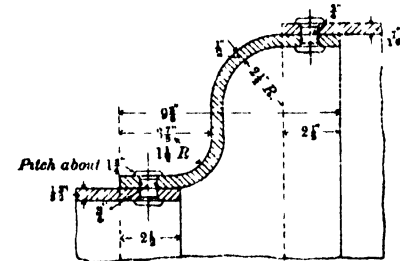

# WALSCHAERT'S AND SHEPHENSON'S VALVE GEARS.

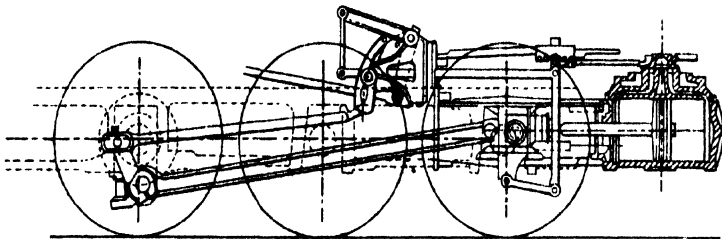

Development of Walschaerts gear completed

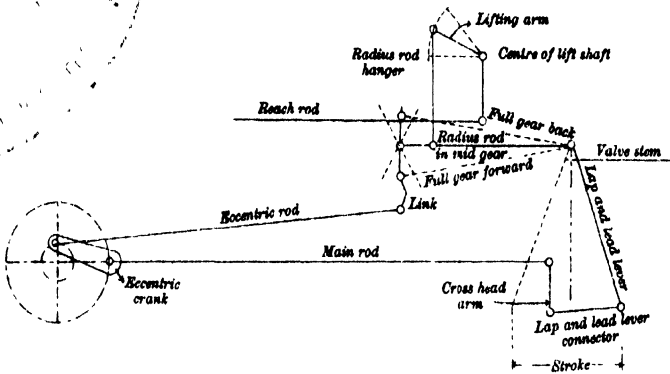
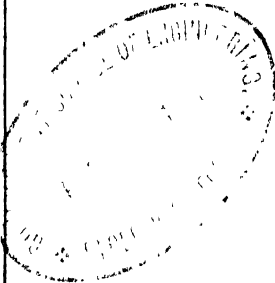
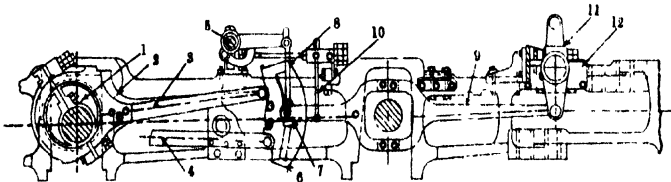

Diagram showing outline and names of parts of Walschaerts gear



## STEPHENSON GEAR.

- |                                  |                               |                              |
|----------------------------------|-------------------------------|------------------------------|
| 1. Eccentric.                    | 4. Back motion eccentric rod. | 9. Transmission bar.         |
| 2. Eccentric strap.              | 5. Lift shaft.                | 10. Transmission bar hanger. |
| 3. Forward motion eccentric rod. | 6. Link.                      | 11. Rocker arm.              |
|                                  | 7. Link block.                | 12. Rocker box.              |
|                                  | 8. Link hanger.               |                              |



### GOODS ENGINE FOR NAGDA-MUTTRA RAILWAY.

5 FEET 6 INCHES GAUGE.

2-8-0 TYPE.

Scale— $\frac{1}{4}$  Inch = 1 Foot.

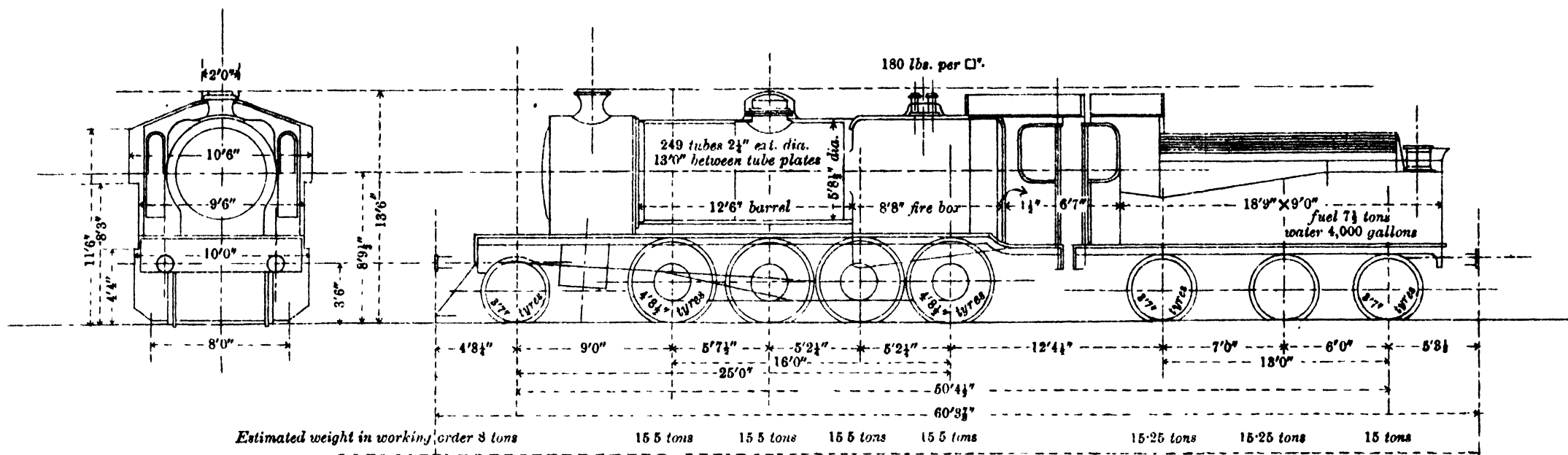

		Tons
Weight in working order	Engine	70
" " "	Tender	45.5
Total weight of Engine and Tender		115.5

Gauge.	Cylinder dis. stroke.	Coupl' of wheels dia	Boiler lbs. per sq. in.	Heating surface square feet	Grate area square feet.	Weight in working order Engine	Tender.	Total	Weight on coupled wheels.	Tractive force	Adhesive weight — tractive force factor of adhesion.
5'6"	21" X 26"	4'9 1/4"	180	Tubes 1908	32	70	45.5	115.5	62 tons	27396 @ 75 o/o Boiler pressure	5.06
				Fire box 173						22976 @ 90 o/o " "	4.22
				Total 2079							

MIXED TRAFFIC OR GOODS ENGINE.

METRE GAUGE.

4-6-0 TYPE.

Scale— $\frac{1}{2}$  Inch = 1 Foot

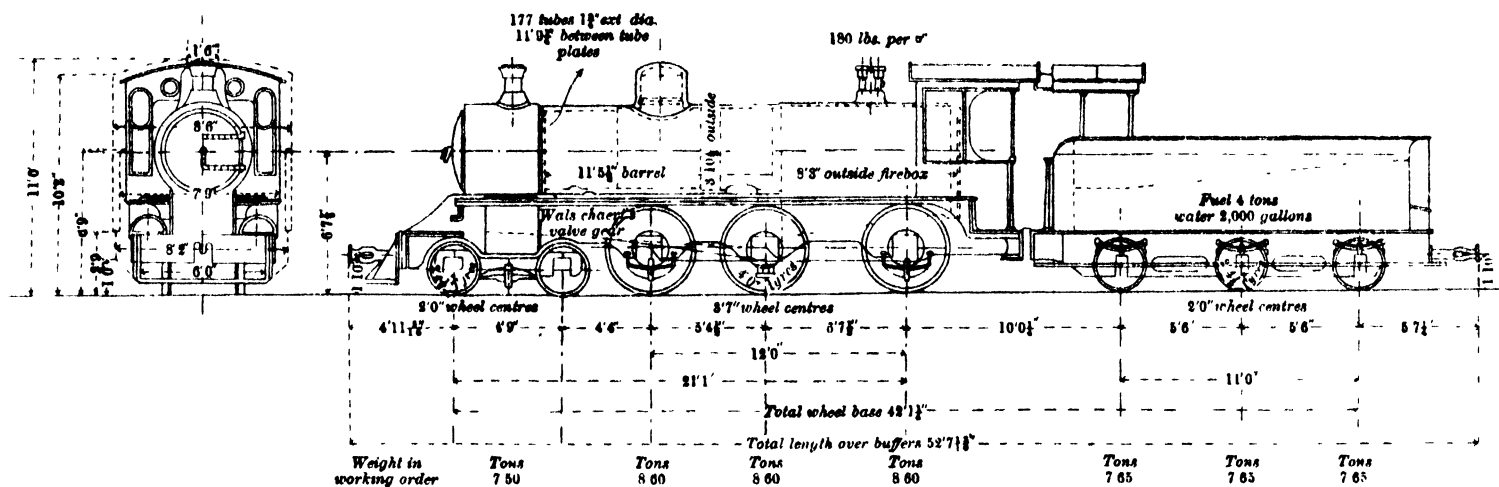

MIXED TRAFFIC OR GOODS STANDARD ENGINE AND TENDER FOR METRE GAUGE.

Weight in working order—engine, 35 30 tons, tender, 22 95 tons, total weight of engine and tender, 56 25 tons. Gauge, metre, cylinder dia 15 by 22 in; couple wheels dia, 4 ft; boiler, 180 lb. per square in, heating surface—tubes, 94 square ft; firebox, 108 square ft., total, 1,062 square ft., grate area 10 square ft., weight on coupled wheels, 25 30 tons, tractive force—13,922 lb. at 75 per cent. boiler pressure; 16,706 lb. at 90 per cent. boiler pressure, adhesive weight divided by tractive force (factor of adhesion) 4.15 and 3.66.

TANK ENGINE, BARSÌ LIGHT RAILWAY.

2'6" Gauge.

0-8-4 Type.

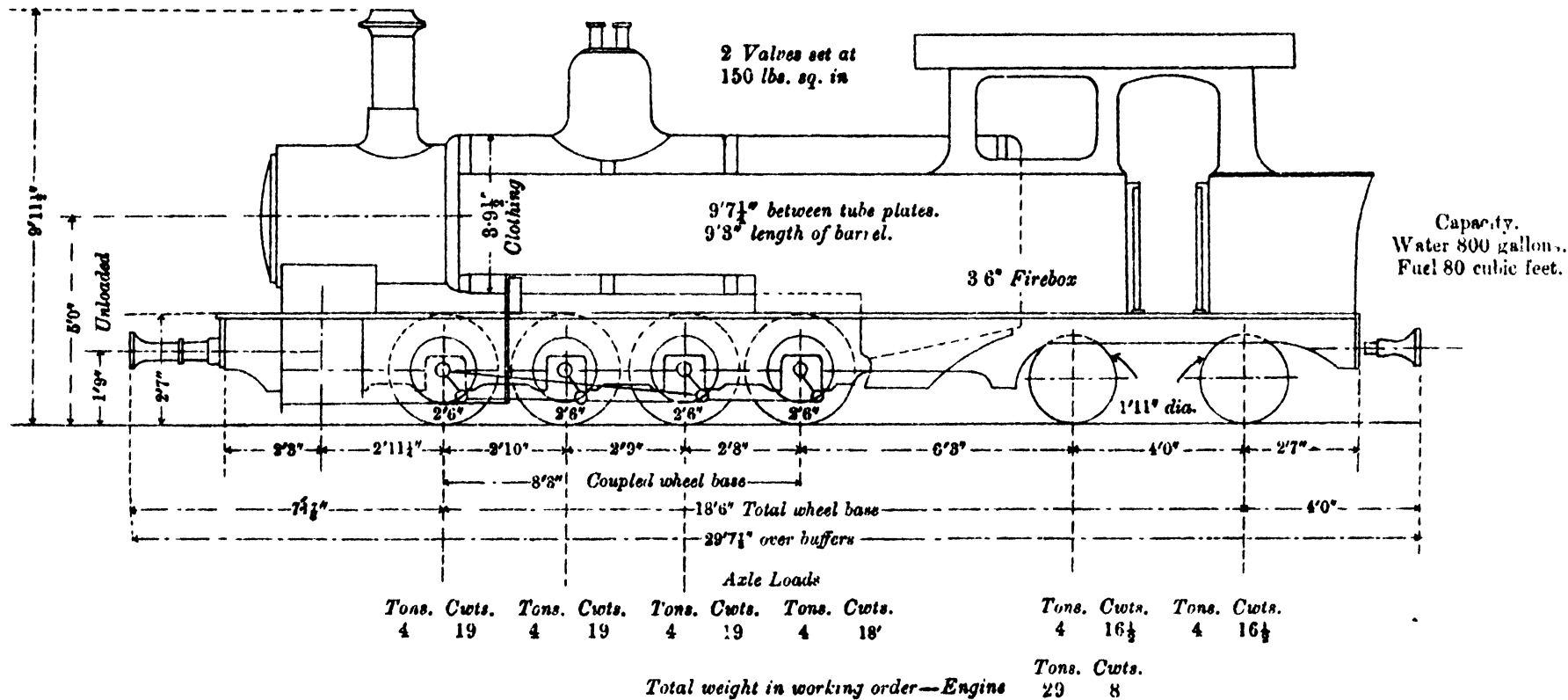

Cylinder diameter,	13 Inches.
"    Stroke	18   "
Heating Surface Tubes.	484 Sq. Ft.
Fire box	44   "
Total,	528   "
Fire grate Area,	9 1/2   "
110 Tubes 1 1/2" dia. outs.	

Scale—1/4 Inch = 1 Foot.

DIAGRAM OF GRIDIRONS,  
EDGE HILL.  
EXAMPLE OF SHUNTING BY GRAVITATION.

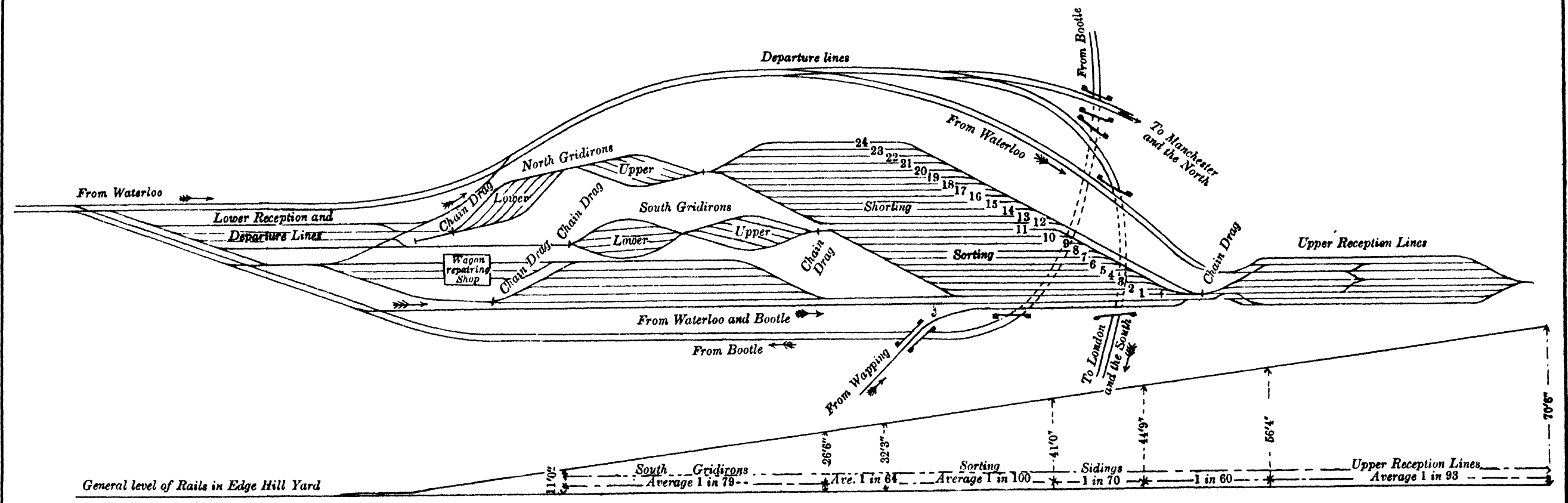
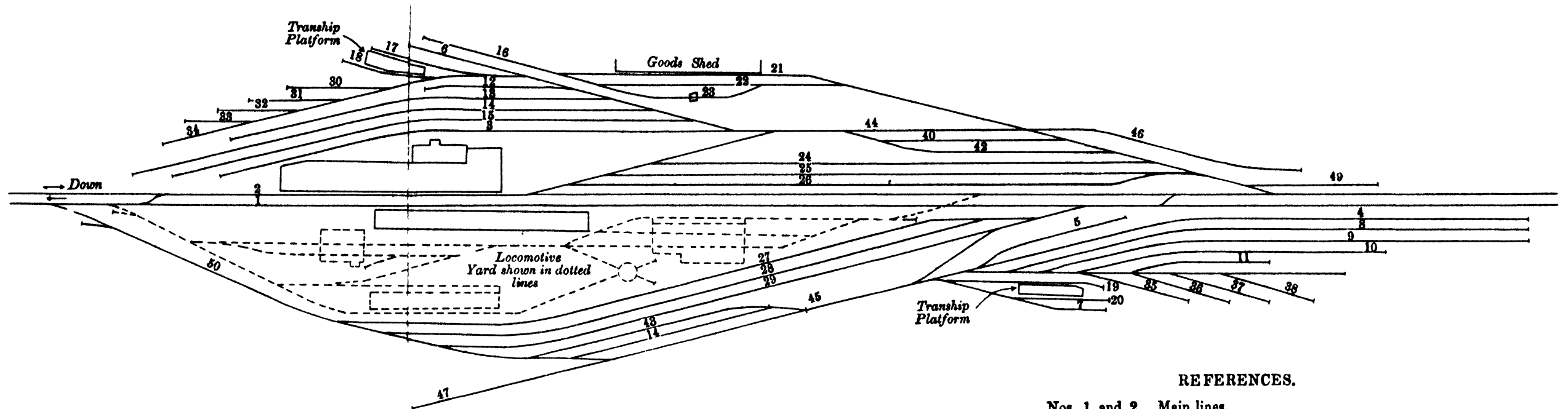

Photo. Zinco, September, 1917.—No. 5111-48.

EXAMPLE OF  
SECTIONAL STATION YARD  
DOUBLE LINE.  
SHUNTING BY ENGINE POWER.



Scales, { Longitudinal—320 Feet = 1 Inch.  
          { Transverse— 160 Feet = 1 Inch.

REFERENCES.

- Nos. 1 and 2. Main lines.
- 3 " 4. Spare for unsorted.
- 5. To local Goods Shed.
- 6 and 7. Sick Wagons.
- 8 to 15. Wagons for A, B, C, D, E, F, G and H.
- 16. Inward to Local Shed.
- 17 to 20. Tranship Wagons.
- 21. Goods Shed line.
- 22 and 23. Local Goods road.
- 24 to 29. Arrival and Departure Loop for Through-goods.
- 30 " 39. Marshalling lines.
- 40 and 41. Loop for Outwards Wagons.
- 42 " 43. " Inwards "
- 44 " 45. Arrival road for Sectional Goods Train.
- 46 " 47. Sorting, Shunting Neck.
- 48. For Outwards Goods Empties.
- 49. Through-Goods Shunting Neck.
- 50. Departure road for Up Trains.

24 LEVERS  
INTERLOCKING TABLE.

Lever No.	Releases.	Locks.	Backlocks.
1			2, 6
2	1	15, 16	17
3		10, 12, 16	15, 17
4		12, 16	11, 17
5	Spare		
6	1		
7	Spare		
8	Spare		
9			18
10	11, 22	8, 21	15
11	4	18, 14	10
12	21, 22	8, 4, (10)	
13	9	11, 14	
14	22	11, 18	
15	8, 10, 21	2, 20	
16	20, 21, 22	2, 8, 4, (15)	
17	2, 3, 4, 20, 21, 22		
18	Spare		
19	Spare		
20	2	15	16, 17
21	3	10	12, 15, 16, 17
22	4	18	10, 12, 14, 16, 17
23	Spare		
24			20 or 21 or 22

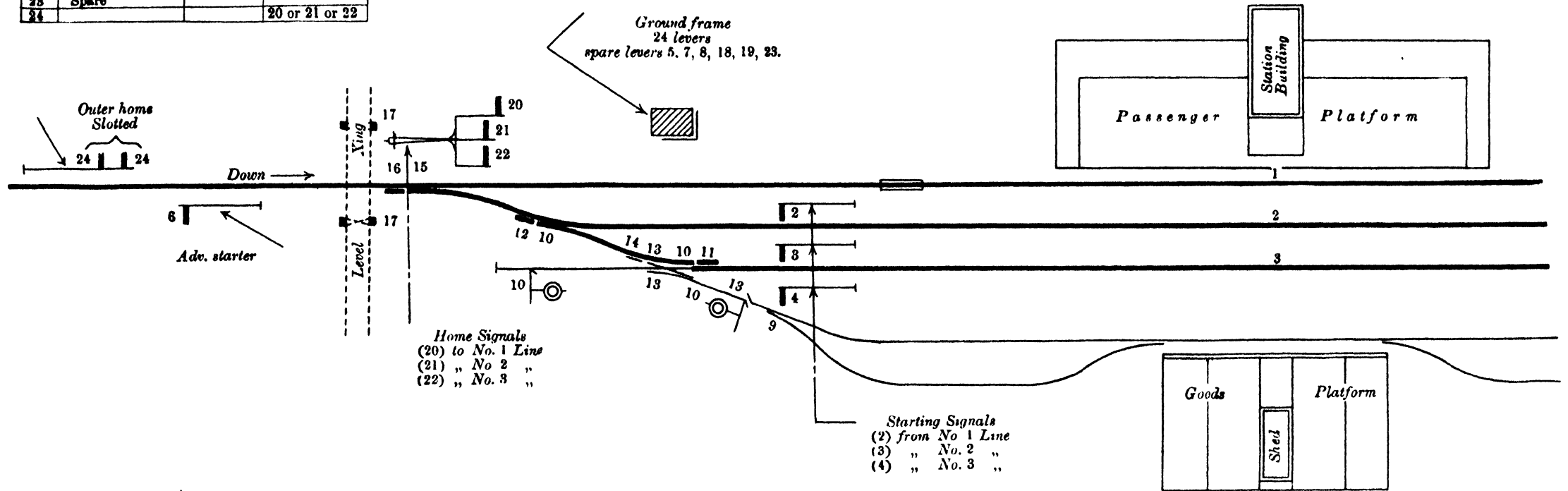

TYPICAL SIGNALLING DIAGRAMS FOR WAYSIDE STATIONS.  
SINGLE AND DOUBLE LINE, NORTH-WESTERN RAILWAY.

Scales, { Longitudinal—600 Feet = 1 Inch.  
          { Transverse — 60 Feet = 1 Inch.

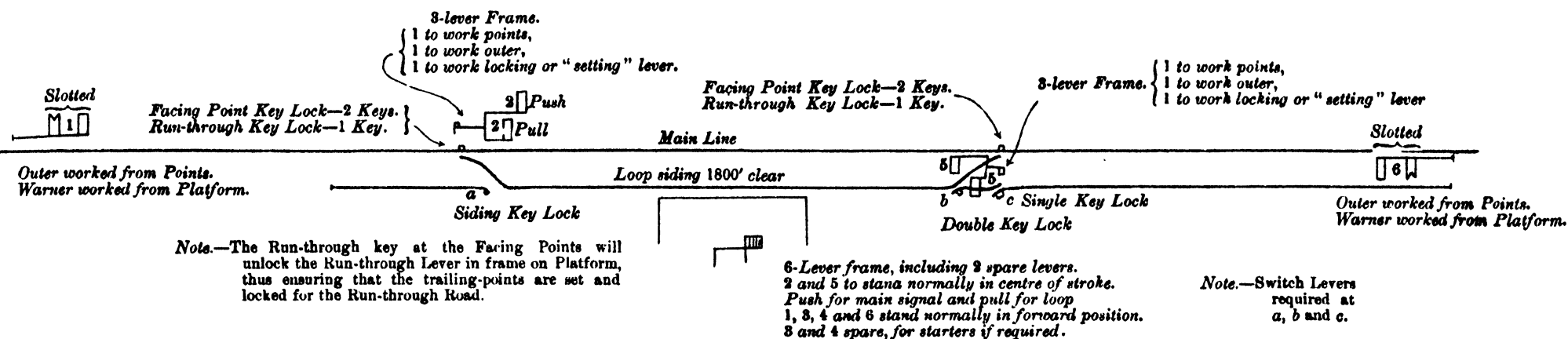

SINGLE LINE.

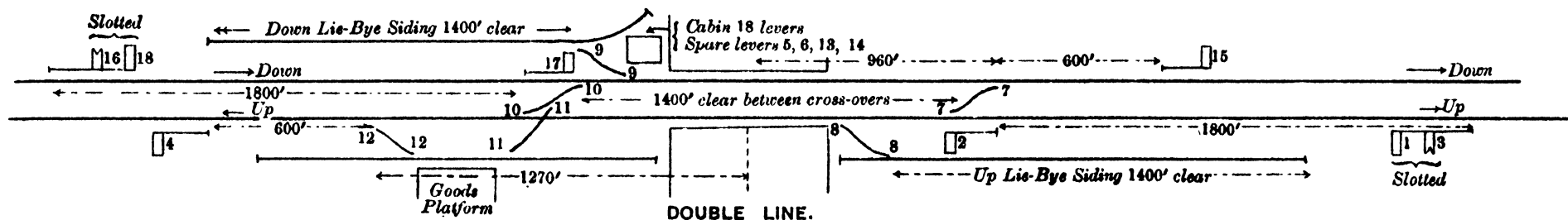

MAP OF BHORE GHAT.

Scale— $\frac{1}{2}$  Inch = 1 Mile.

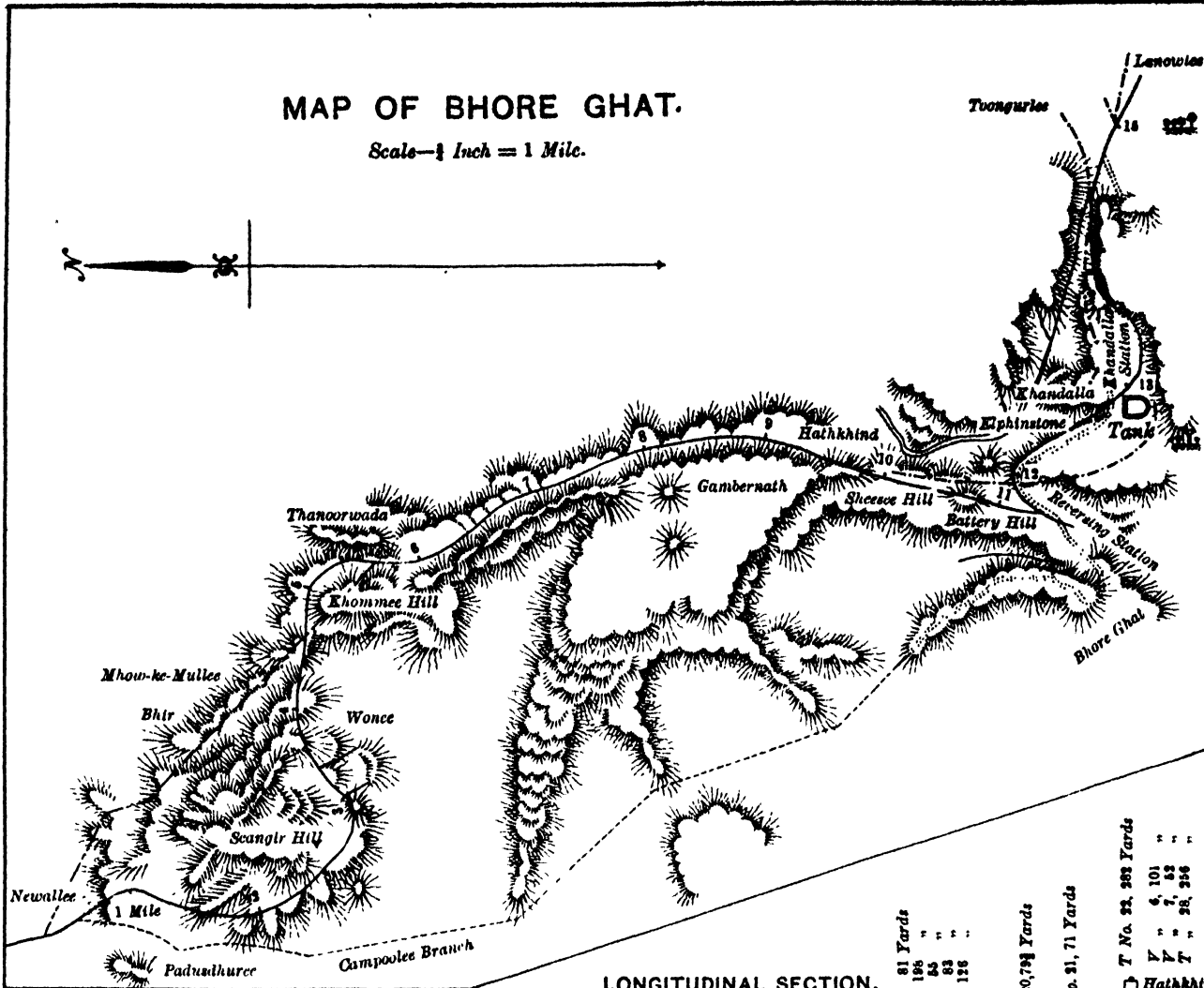

THE BHORE GHAT INCLINE.

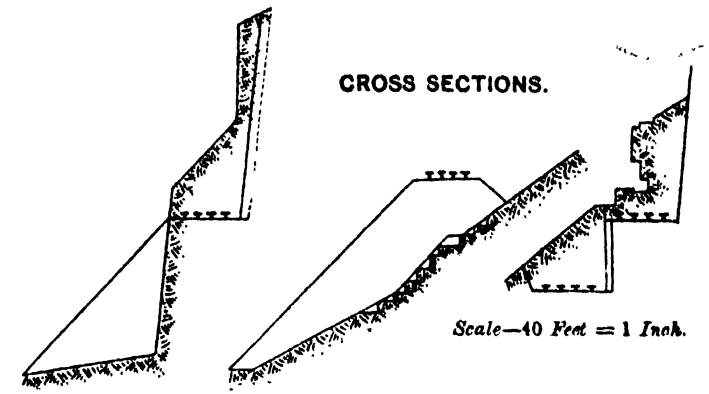

LONGITUDINAL SECTION.

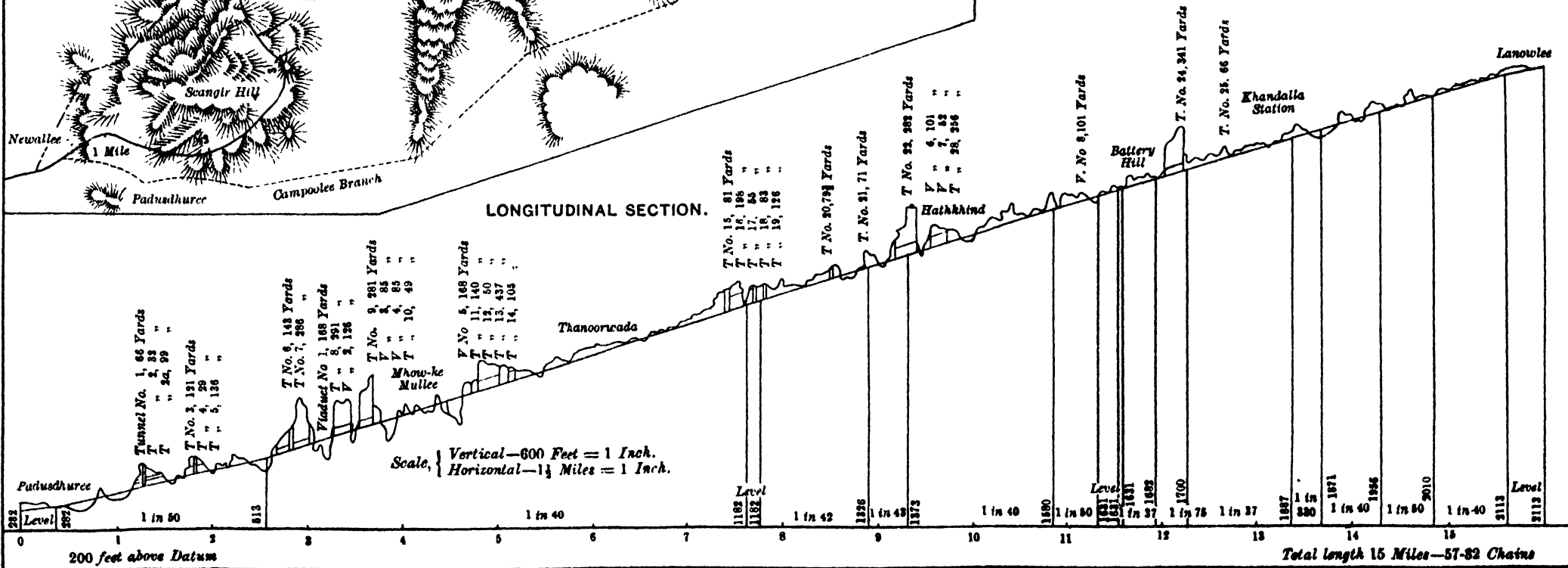

ABT SYSTEM.

Fig. 1.  
SECTION.

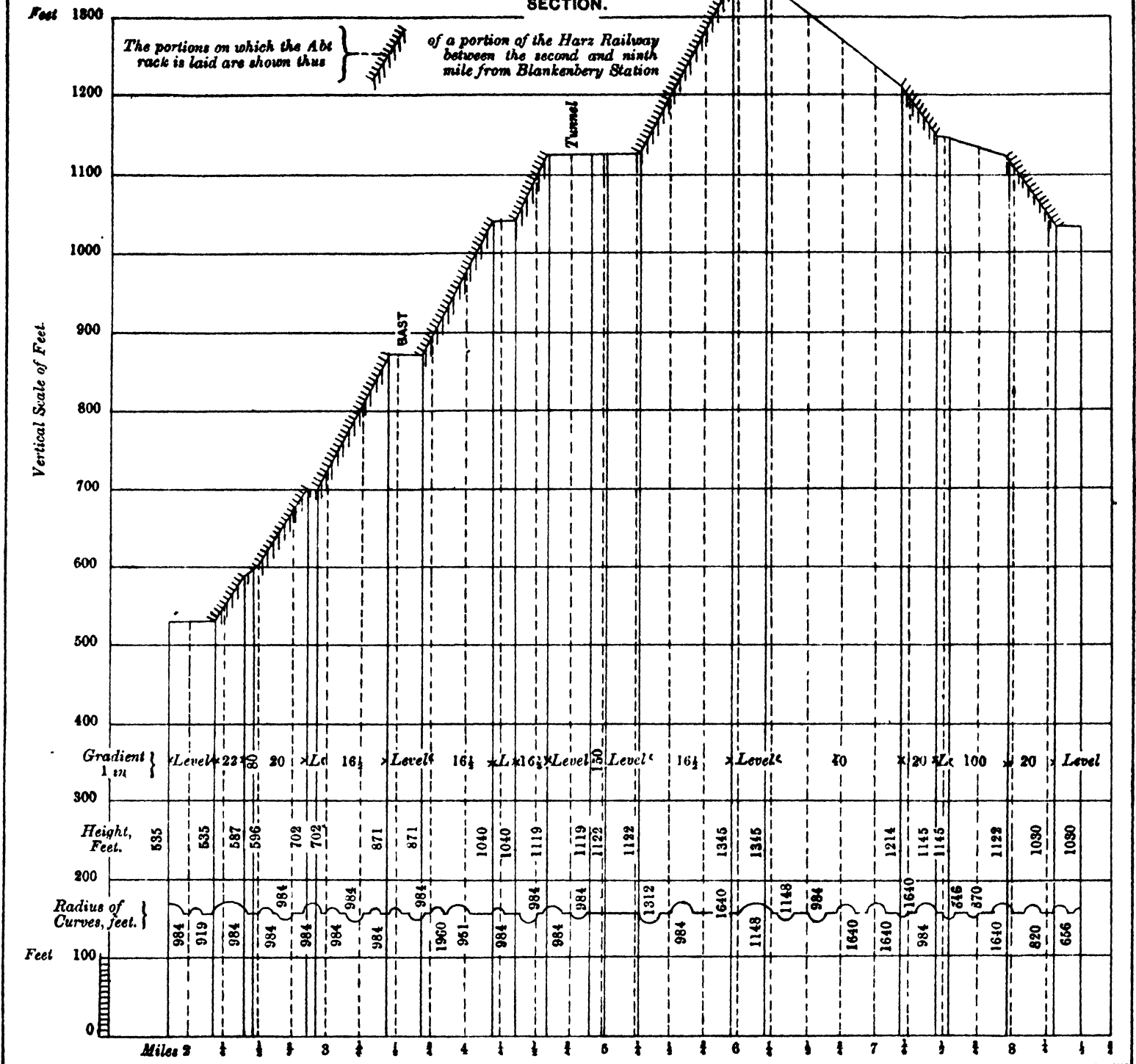
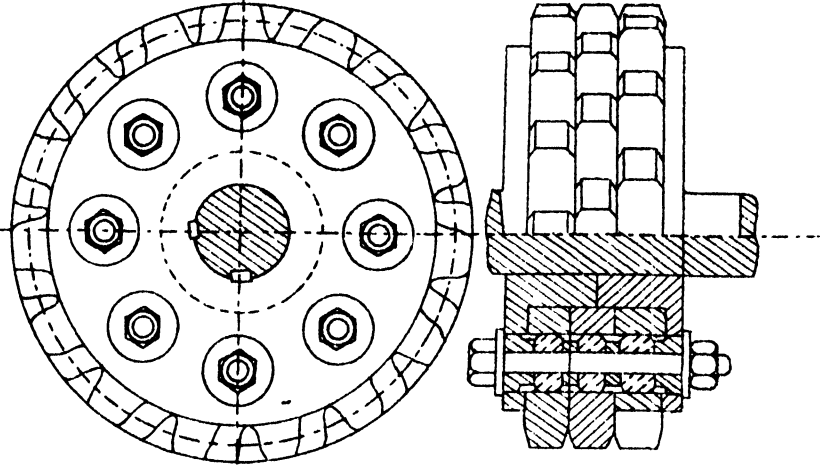
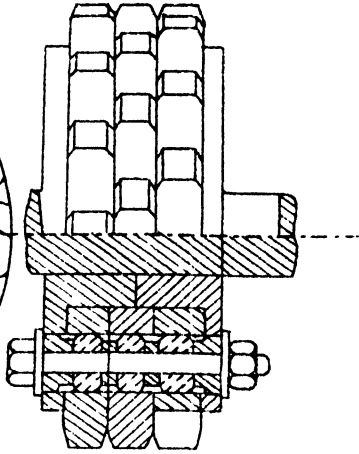

Fig. 5.  
DETAILS OF PINION.



ABT SYSTEM.

DETAILS OF THE RACK.



PRINCIPAL DIMENSIONS OF THE RACK.

	Metres	ft	ins.
Total length of Rack-bar,	2.636	8	7.78
Distance apart of Sleepers centres,	.880	2	10.65
Depth of Rack-bar,	.110		4.33
Pitch of Teeth	.190		4.73
Width of Tooth at top,	.050		1.97
Thickness of Rack-bar,	.020		.79
Clearance of Rack-bars,	.035		1.38

Fig. 3.

PLAN SHOWING THE SPACING OF THE TEETH.

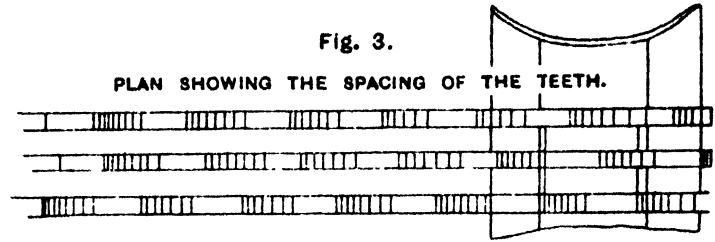

Fig. 2.

ELEVATION OF RACK.

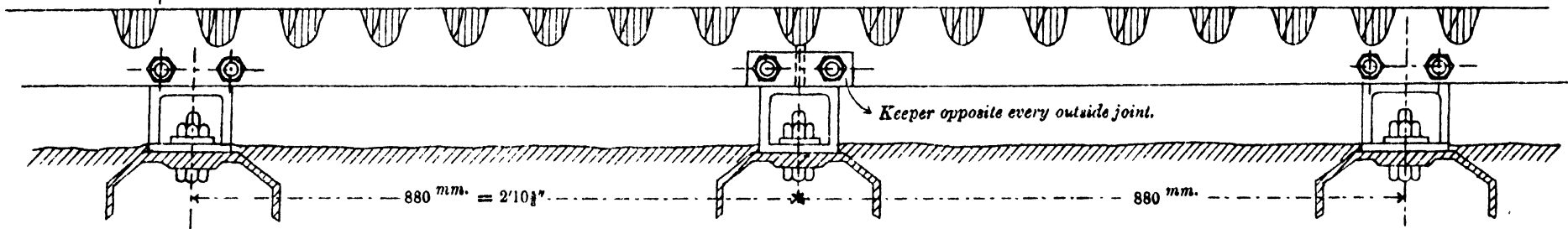
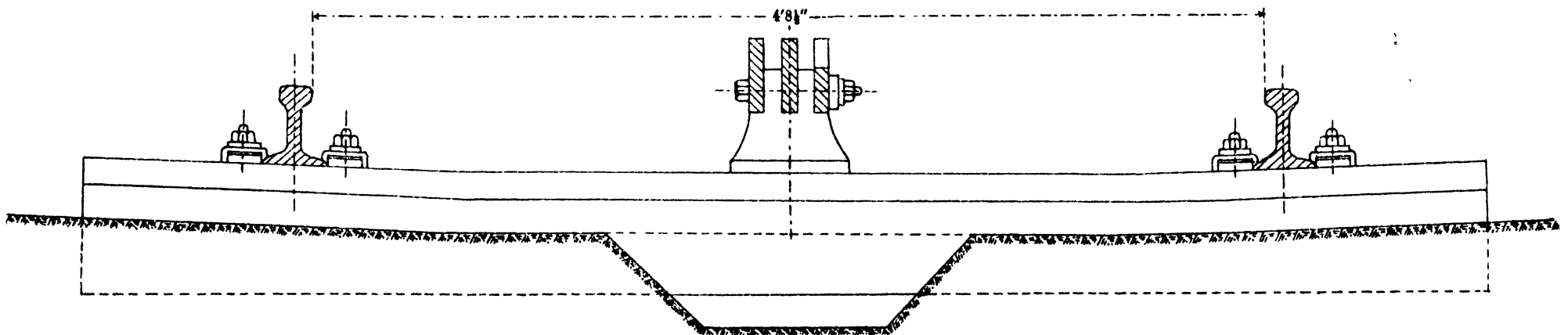
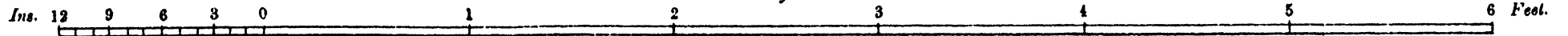

Fig 4.

CROSS SECTION OF RAILS AND RACK



Scale of Feet.



**S. I. R.**  
**NILGIRI MOUNTAIN RAILWAY**  
**ABT COMBINATION ADHESION AND RACK LOCOMOTIVE P. CLASS.**

Scale— $\frac{1}{4}$  Inch to 1 Foot.

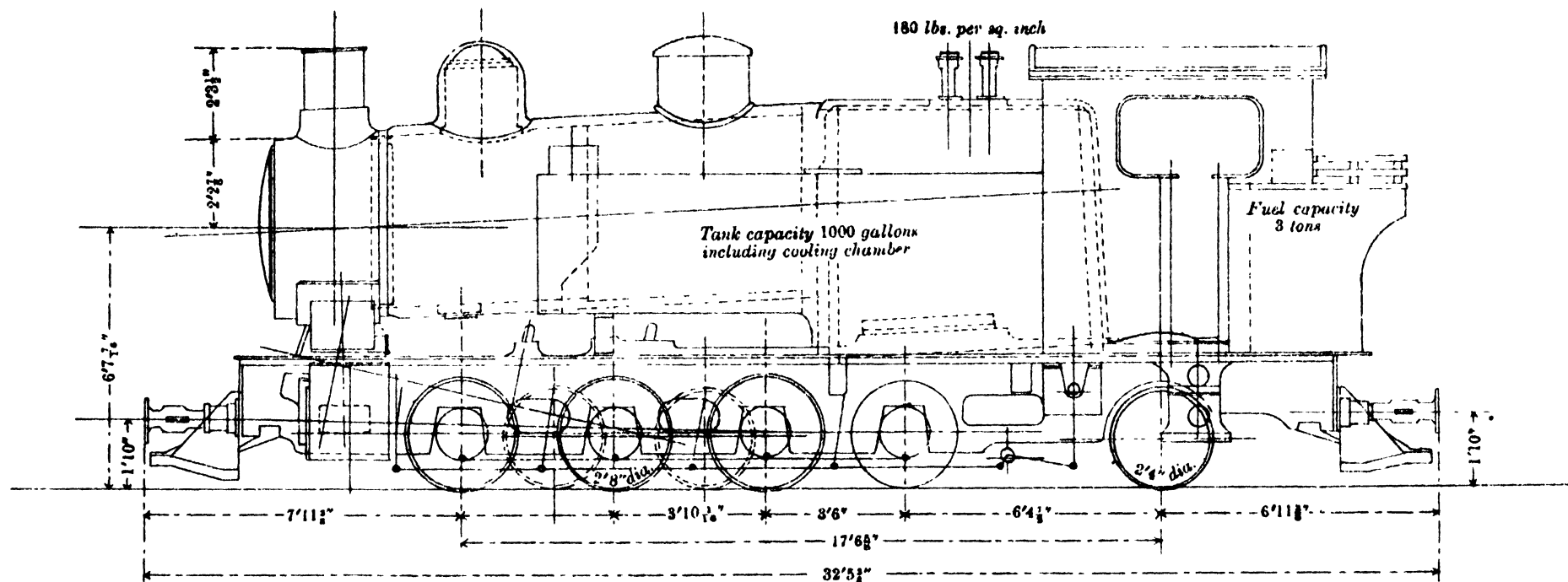

Weights on Rail	T. C. Q.	T. C. Q.	T. C. Q.	T. C. Q.	T. C. Q.
Empty	9 14 2	8 11 0	7 13 2	6 9 2	5 19 2
In full working order	9 19 2	10 1 0	10 2 2	9 9 0	10 0 0
Total weight	Empty	38 8 0	In full working order	49 12 0	

Cylinders Diameter Adhesion	16 1/4 inches.
Stroke	16 "
Diameter Rack	16 1/4 "
Stroke	14 1/4 "
Length between Tube Plates	11 ft. 1 inch.
Heating surface Tubes	sq. ft. 1000
Firebox	" 100
Total	1100 sq. ft.

Number of Tubes	197
Diameter of	1 1/2"
Fire grate	6' 4 1/8" x 3' 4 1/4"
Area	21 1/4 sq. ft.
Tractive force of Engine per lb. of mean effective pressure in Cylinder	136 lbs.

Fig. 1

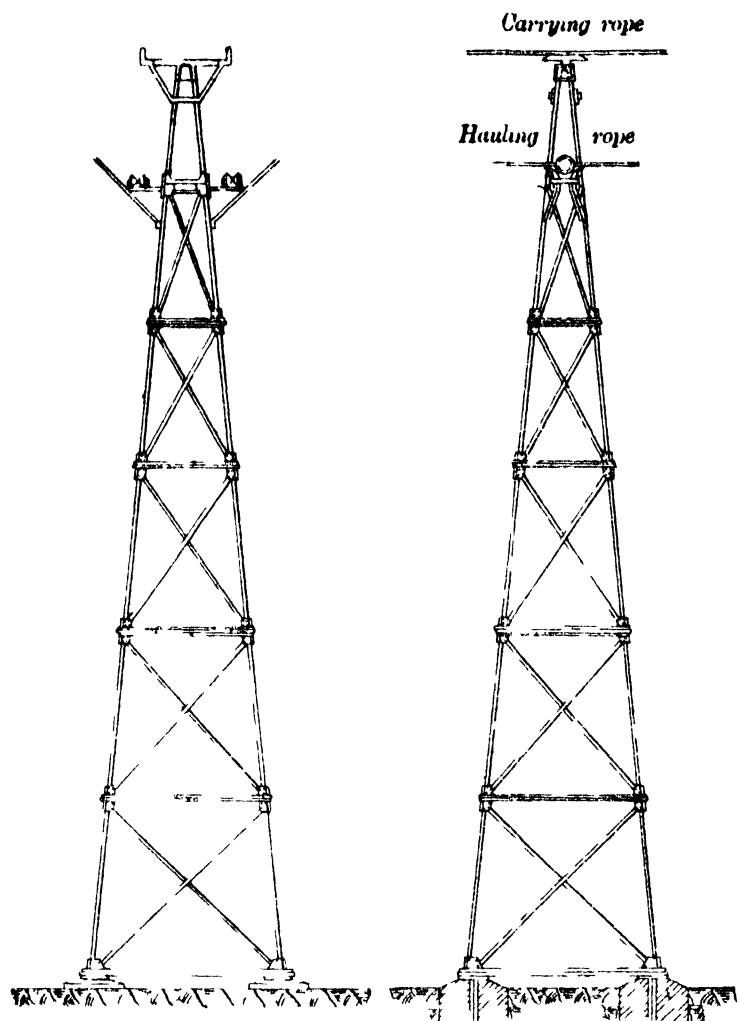

FOUR-LEG IRON STANDARD

Fig. 2.

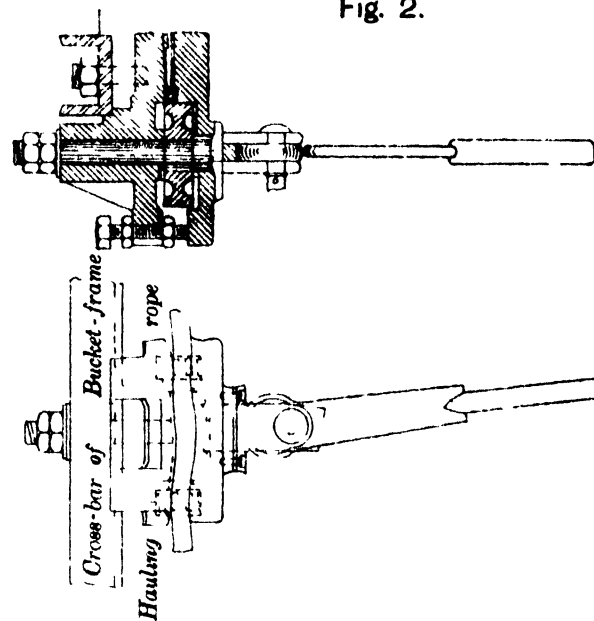

FRICTION GRIP WITH CORRUGATED JAWS

Fig 3

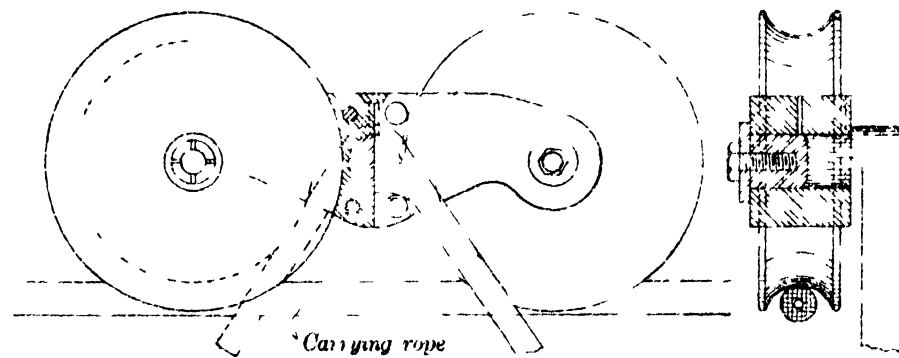

STEEL TRUCK

Fig. 3.

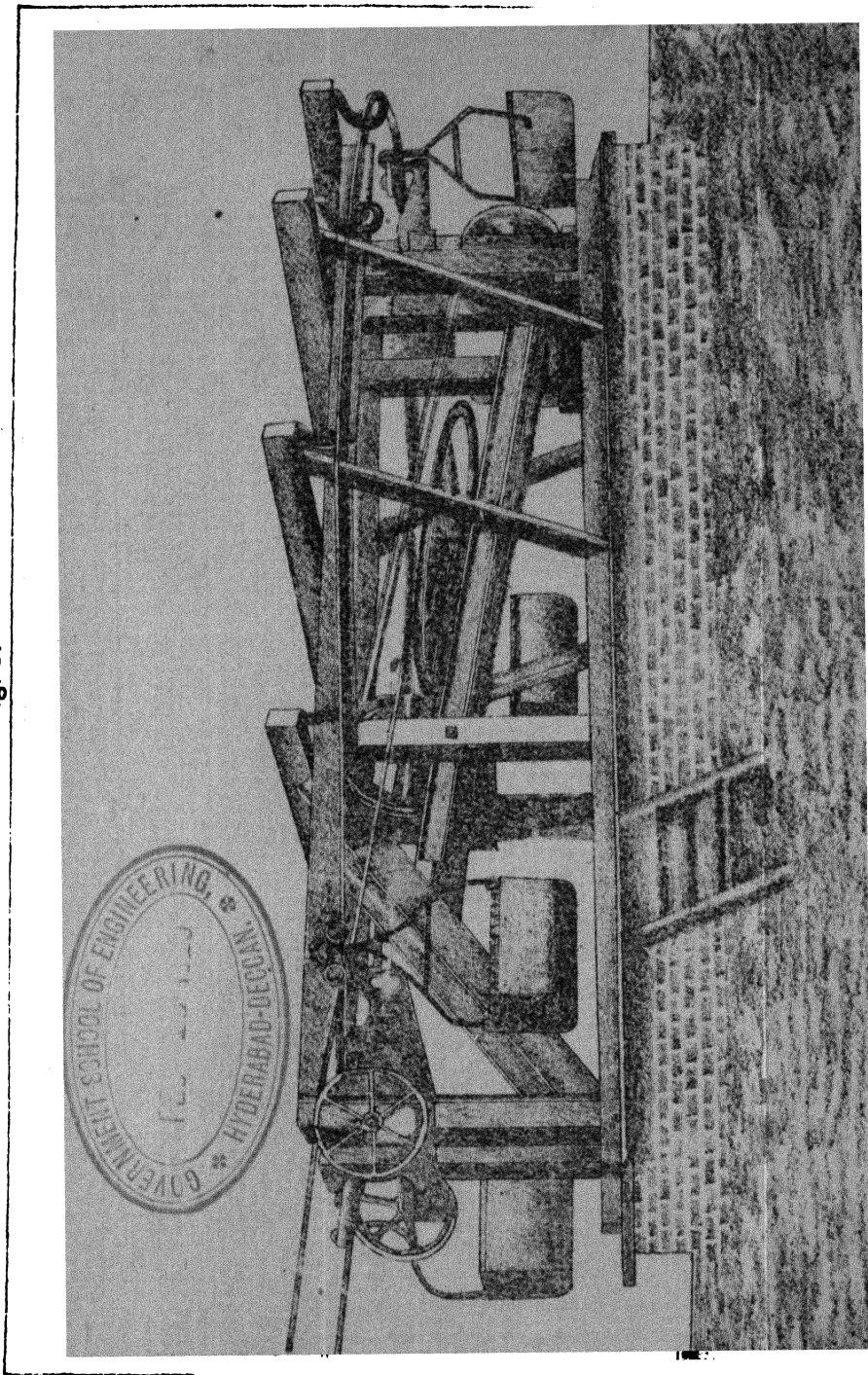

TERMINAL STATION.

Fig. 1.

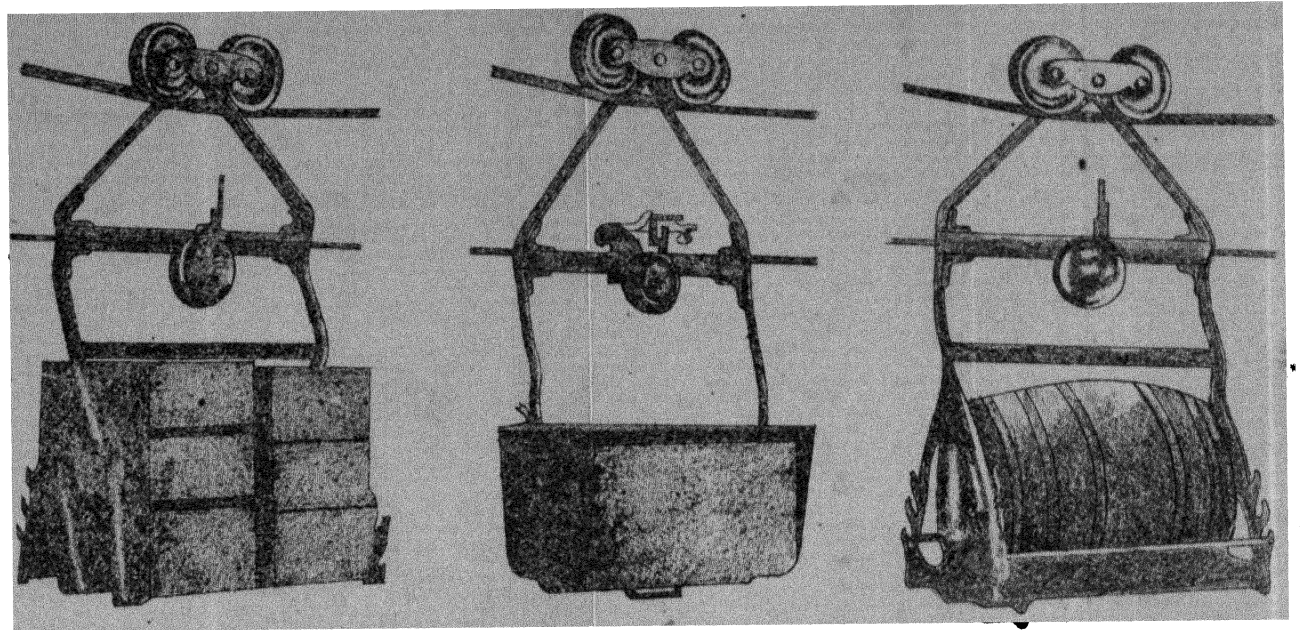

CARRIERS FOR THE "OTTO" AERIAL ROPEWAYS.

Fig. 2.

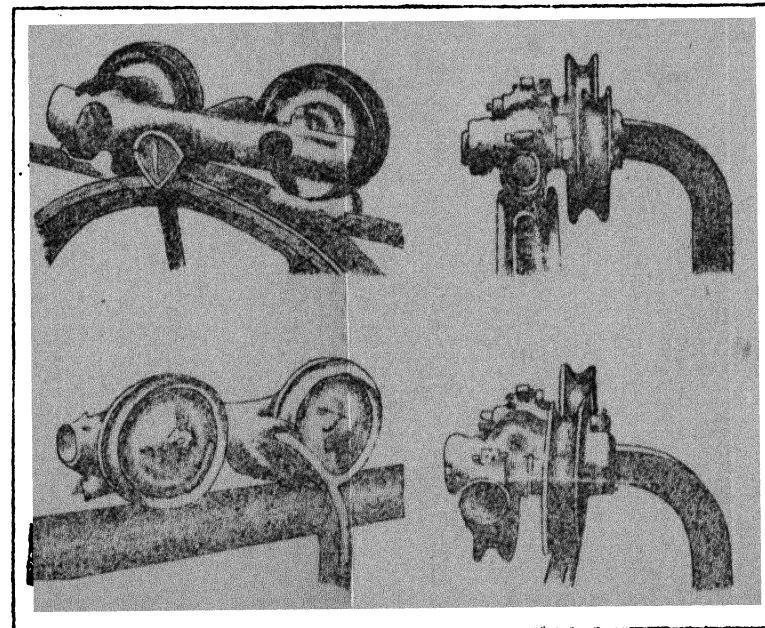

VIEWS OF A ROE CARRIER.















