

DAMAGE BOOK

UNIVERSAL
LIBRARY

OU_164401

UNIVERSAL
LIBRARY

OSMANIA UNIVERSITY LIBRARY

Call No. **537.8**
H53E

Accession No. **3299**

Author **Henderson, J.**

Title **Electronics. 1919.**

This book should be returned on or before the date last marked below.

ELECTROTECHNICS

**PHYSICAL AND ELECTRICAL ENGINEERING
LABORATORY MANUALS.**

PRACTICAL ELECTRICITY AND MAGNETISM. By JOHN HENDERSON, D.Sc., F.R.S.E., A.M.I.E.E., Head of the Physics and Electrical Department, Borough Polytechnic Institute, London, S.E. With 157 Illustrations. Crown 8vo, 7s. 6d.

ELEMENTARY PHYSICS. By JOHN HENDERSON, D.Sc., F.R.S.E., A.M.I.E.E., Head of the Physics and Electrical Department, Borough Polytechnic Institute, London, S.E. Crown 8vo, 2s. 6d.

EXAMPLES IN ELECTRICAL ENGINEERING.
By SAMUEL JOYCE, A.I.E.E. Crown 8vo, 5s.

LONGMANS, GREEN, AND CO.

LONDON, NEW YORK, BOMBAY, AND CALCUTTA

PHYSICAL AND ELECTRICAL ENGINEERING
LABORATORY MANUALS

VOL. III.

ELECTROTECHNICS

BY

JOHN HENDERSON, D.Sc., F.R.S.E., A.M.I.E.E.

HEAD OF THE PHYSICS AND ELECTRICAL DEPARTMENT, BOROUGH
POLYTECHNIC INSTITUTE, LONDON, S.E.



WITH DIAGRAMS

LONGMANS, GREEN, AND CO.

39 PATERNOSTER ROW, LONDON

NEW YORK, BOMBAY, AND CALCUTTA

1901

m

All rights reserved

PREFACE TO THE SERIES

IN bringing before the public these laboratory manuals, it has been the object of the author to provide a course of instruction for carrying out a progressive series of experiments in Physics and Electrical Engineering, arranged so that the usual apparatus at the disposal of a laboratory, though not especially designed for any particular experiment, may nevertheless be used with advantage in a variety of ways.

Able courses of instruction in experimental work have already appeared, and have done a vast amount of good; but as these usually require expensive apparatus made and arranged for each experiment, they have not become so generally useful as otherwise might have been the case, especially in such instances where the scope of the work undertaken precludes all possibility of separate and special apparatus being provided for each independent experiment. In technical work this is more particularly the case, seeing that in actual practice, a set of instruments must be put to very divergent uses, in order that results may be obtained quickly and with sufficient accuracy for commercial work. This use of apparatus for ends not specially intended is in itself a training of considerable importance, to any student who will afterwards, in his daily life, have to so adapt for different purposes such instruments as may be available at the time.

It has not, however, been forgotten that most apparatus thus used is too often placed under circumstances inconsistent with accurate work, and to this end very careful instructions will be found in the more advanced volumes, for guarding against such disturbing influences as time, situation, temperature, and magnetic forces; this being too often neglected in general laboratory and commercial work, it being frequently forgotten that a set of apparatus arranged for a particular test is sometimes not only a centre of disturbance itself, but is liable to disturbance from other apparatus in use in its neighbourhood. The precautions thus indicated are of especial importance in technical work, where the disturbing influences are of such a powerful nature, as may be found in engine-rooms and dynamo houses, where high and varying temperatures and leakage magnetic lines are very prevalent.

Another way in which an alteration has been effected is to, as far as possible, arrange experiments where a student *working alone*, may be able to obtain satisfactory results. In a large proportion of the existing laboratory manuals, groups of students are expected to work together; but a number of years of practical experience with students of all kinds has convinced the author, that habits of individual accuracy and self-reliance can only be acquired by separate and unaided work. Of course, in advanced work it is often necessary that two or more students should work together, in order that simultaneous observations should be taken; but it is most desirable that students so combined should have had considerable individual training and experience.

It is particularly desirable that every experiment should be repeated until a set of consistent results have been obtained. In this way only can experience and accuracy be acquired.

This series is divided into two courses, to which Vol. I. is a general introduction. The future volumes will contain the

advanced work in both Physics and Electrical Engineering, and it is intended that students should be able to take either the one or the other, thus specializing in Physics or Electrical Engineering; but they may combine the two courses with advantage, where time will admit.

J. HENDERSON. ·

PREFACE

IN this, the third volume of the series, the author has reverted to the method adopted in Vol. I., of confining the text entirely to instructions for specific experiments, the reason for this being to keep the book from attaining unwieldy proportions, it being felt that as there are so many excellent text-books already in existence dealing with theory, the student in search of further information can consult these, and thus prevent the book becoming too large to carry to and from his laboratory class. The book has been divided into three parts, corresponding roughly to a three years' course. The first part contains experiments corresponding to the Elementary Stage of the City and Guilds of London Technological Institutes' Syllabus in Electrical Engineering, whilst the second and third parts correspond to the Direct Current and Alternating Current Sections of the Ordinary Grade Course of the same Syllabus.

These Instructions are the result of long experience of them having been distributed to the author's manuscript form for years past. In view, however, of the very limited time that the average evening student has available for his experimental work, it was felt that it would be saved by putting these instructions in a form to be read during the week preceding his labor

could study up the details of the experiment he had to perform.

It will probably be found most satisfactory to arrange for the students to work in pairs, and in most cases they ought to be able to finish one experiment at each class meeting. A schedule should be drawn up showing the number of experiment any given pair of students will work at on any laboratory class meeting for a period of, say, ten weeks. Should a student be absent, or fail to finish his experiment on the night set for it, he will, of course, require to wait till the next schedule is drawn up before another chance will present itself of enabling him to repeat it, otherwise the schedules of all the other members of the class would be interfered with, since it is probable that all the groups will be working on different experiments. This system, although it may have certain drawbacks, will be found to act as an incentive to a good student to get through his work as quickly as is consistent with accuracy.

The tables at the end of the book have been compiled from the latest published results, and have been added to assist the student in obtaining an idea of the magnitude of the quantities he is set to measure in his experimental work.

The author's thanks are due to the various firms who have kindly lent blocks for illustration, also to his assistants, Messrs. Saunders and Nutton, for help in preparing the book for press, the former especially for the trouble he has taken in reading and correcting proofs.

JOHN HENDERSON.

DEPARTMENT,
POLYTECHNIC INSTITUTE,
S.E., June, 1909.

TABLE OF CONTENTS

PART I.

NO.	PAGE
1.—Proof of Ohm's law	1
2.—Proof of Wheatstone bridge law	2
3.—Resistances in series and parallel	4
4.—Laws of resistance (resistance and length)	5
5.— „ „ (resistance and cross-sectional area)	7
6.— „ „ (resistance and temperature)	8
7.—Post-office bridge	9
8.—Measurement of resistivity	11
9.—Variation of carbon and metal filament lamp resistance	13
10.—Testing incandescent lamp currents	14
11.—Secondary battery resistance	15
12.—Insulation testing (direct deflection method)	16
13.—Electrolytic resistance measurement	17
14.—Calibration of an ammeter (fall of potential method)	18
15.— „ „ „ (comparison with Siemens electro- dynamometer)	20
16.—Calibration of a voltmeter (comparison with standard)	22
17.—Comparison of E.M.F.'s by potentiometer	23
18.—Measurement of resistance by potentiometer	25
19.—Measurement of current by potentiometer	26
20.—Calibration of voltmeter by volt-potentiometer	27
21.—Measurement of low resistance	29
22.—Fuse wire testing	31
Measurement of fusing constants of fuse wire metals	32
Potentiometry of incandescent lamps	33
Calibration of a wattmeter	34
Using a supply meter	36

No.	PAGE
27.—Current induction	38
28.—Testing permanent magnets	40
29.—The law of the solenoid	41
30.—Experiments with electro-magnets (1)	43
31.— " " (2)	44
32.—Testing the magnetic flux in an electro-magnetic circuit	45
33.—Magnetization of iron	46
34.—Permeability testing by Ewing's induction balance	48
35.—Experiments with small shunt-wound motor	51

PART II.

36.—Current-carrying capacity of wires	53
37.—Effect of hardening and annealing on electrical resistance	54
38.—Calibration of a voltmeter (potentiometer method)	55
39.—Constant of a Siemens electro-dynamometer	58
40.—Standardization of a Kelvin balance by copper voltameter	60
41.—Measurement of insulation resistance (loss of charge method)	63
42.— " " " (guard ring method)	65
43.—Construction of cadmium standard cells	67
44.—Measurement of the ampère turns required for a moving iron measuring instrument	70
45.—Calibration of a ballistic galvanometer for magnetic induction measurement	71
46.—Measurement of magnetic permeability (Hopkinson's permeameter)	73
47.—Measurement of magnetic permeability (permeability bridge)	74
48.— " " " (bar and yoke method)	76
49.—Measurement of magnetic hysteresis (hysteresis tester)	79
50.—Examination of a dynamo or motor	81
51.—Resistance and insulation tests of a dynamo or motor	82
52.—Magnetic leakage test of a dynamo	83
53.—Distribution of magnetic field round a dynamo armature	85
54.—Distribution of potential round the commutator of a dynamo	86
55.—Fault testing in a dynamo armature	88
56.—Internal characteristic of a shunt dynamo	80
57.—Total characteristic and efficiency of a shunt dynamo	
58.— " " " of a series dynamo	
59.—Testing an automatic magnetic cut out	
60.—Examination of the starting switch of a motor	

Contents

xiii

NO.	PAGE
61.—Brake horse-power and efficiency of a motor	97
62.—Combined efficiency of a motor generator plant	99
63.—Eddy current and hysteresis losses in a dynamo	100
64.—Efficiency of an incandescent lamp	101
65.—Absorption of light by lamp globes	103
66.—Ampère-hour and watt-hour efficiencies of a secondary battery .	104
67.—Examination of and testing an automatic cell charging switch .	106
68.—Test of an energy meter	107

PART III.

69.—Graphical representation of a sine function	110
70.—Properties of a sine curve	112
71.—Graphical representation of A.C. power in a non-inductive circuit	113
72.— „ „ „ in an inductive circuit .	114
73.—Comparison of the heating effects of direct and alternating currents	116
74.—Calibration of an alternating-current ammeter	117
75.— „ „ „ voltmeter	118
76.—Measurement of impedance and inductance	119
77.—Impedances in series	121
78.— „ in parallel	123
79.—Capacity currents	124
80.— „ and inductance in series	126
81.— „ „ in parallel	127
82.—Three-voltmeter method of measuring A.C. power	129
83.—Three-ammeter method of measuring A.C. power	130
84.—Examination of an alternator	132
85.—Tracing the E.M.F. curve of an alternator	132
86.—Characteristic of an alternator	134
87.—Efficiency of a transformer	136

TABLES, ETC.

Logarithm	140, 141
Anti-logarithm	142, 143
Tables	144, 145
of sines	146, 147
of cosines	148, 149
of tangents	150, 151

	PAGE
Conversion tables and constants	152
Tables of specific gravities	152
Wire tables	153
Tables of resistivities	154
Electro-chemical equivalents	156
Fuse wire tables	156
Tables of E.M.F. of cells	157
Arc and incandescent lamp test tables	157
Tables of magnetization constants	158
Power, speed, weight, and efficiency tables of dynamos and motors .	159

ELECTROTECHNICS

PART I

NO. I.—PROOF OF OHM'S LAW

Preliminary.—It was first pointed out by Ohm that, so long as the physical properties of a conductor remain unaltered, when a current of electricity is sent through the conductor there is a constant ratio between the potential difference across its ends and the current flowing through it. This constant ratio he defined as the “electrical resistance” of the conductor. In the following experiment you are required to verify this fact in the case of a coil of wire.

Apparatus.—You are supplied with a coil of wire, a battery, variable resistance, ammeter, voltmeter, and switch.

Method.—(1) Connect up the coil, battery, variable resistance, ammeter and switch in simple series, and connect the voltmeter across the ends of the coil so as to be in parallel with it.

(2) With the largest value of the variable resistance in circuit, switch on the current and adjust the variable resistance until a small current is registered on the ammeter. Read this; also read the voltmeter.

(3) Repeat above with various values for the current, but always taking care to avoid currents which would be large enough to sensibly heat the coil of wire.

(4) Tabulate your results thus:—

P.D. at ends of coil.	Current in coil.	Ratio $\frac{P.D.}{C}$.

Plot a curve from your readings with values of P.D. for ordinates and those of C for abscissæ. Also show what relation exists between the angle of inclination of this straight line to the horizontal and the resistance of the coil of wire.

NO. 2.—PROOF OF WHEATSTONE BRIDGE LAW

Preliminary.—If a circuit carrying a current C is divided into two parts, ABC and ADC , the current C will divide into two parts, c_1 and c_2 , the relative values of which will depend on the relative conductivities of the two branch circuits, but always in such a manner that $c_1 + c_2 = C$. Also, since the potential drop

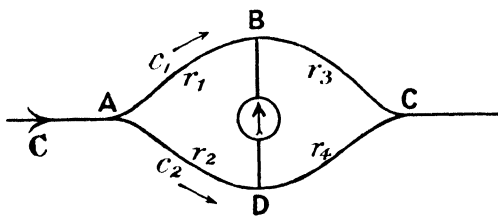

FIG. 1.

down ABC is the same as that down ADC , it follows that for any given point on the circuit ABC there must exist one corresponding point on the circuit ADC which will be at the same potential. Thus if B is such a point, there will be found to be one point, say D , in ADC , such that the potential of $B =$ potential of D , or, in other words, there is no potential difference between B and D when a current is sent through the wires. Hence if a galvanometer is placed across BD no current would pass through it.

Under these circumstances it can be shown that the ratio of the resistances of the portions AB and AD is equal to the ratio of the resistances BC and DC .

Let resistance of $AB = r_1$, resistance of $AD = r_2$, resistance of $BC = r_3$, and that of $CD = r_4$.

Then, since B and D are at the same potential, the P.D.'s

down AB and AD are equal, and those down BC and CD are also equal. But by Ohm's law—

$$\text{P.D. down AB} = c_1 r_1 \qquad \text{P.D. down BC} = c_1 r_3$$

$$\text{P.D. down AD} = c_2 r_2 \qquad \text{P.D. down DC} = c_2 r_4$$

$$\text{Hence } c_1 r_1 = c_2 r_2$$

$$\text{and } c_1 r_3 = c_2 r_4$$

$$\text{and } \frac{c_2}{c_1} = \frac{r_1}{r_2}$$

$$\text{also } \frac{c_2}{c_1} = \frac{r_3}{r_4}$$

$$\text{therefore } \frac{r_1}{r_2} = \frac{r_3}{r_4}$$

In the following experiment you are required to verify this result.

Apparatus.—You are supplied with four boxes of variable known resistances, a galvanometer, battery and keys.

Method.—(1) Connect the four resistance boxes so as to form a Wheatstone Bridge.

(2) Adjust resistances AB and AD to various values, and for each pair of values find the corresponding pair of resistances required in BC and DC to produce equality of potential between B and D. This will be found by adjusting BC and DC until no deflection is obtained on the galvanometer when the battery key is closed.

To facilitate this adjustment some arbitrary value should be chosen for the resistance BC, and then DC altered till the desired result is obtained. If DC is too large, a galvanometer deflection will be obtained to the opposite side of the scale to that produced if it is too small.

(3) Tabulate your results thus :—

Resistance in arm AB (r_1).	Resistance in arm AD (r_2).	Ratio $\frac{r_1}{r_2}$.	Resistance required in arm BC (r_3).	Resistance required in arm DC (r_4).	Ratio $\frac{r_3}{r_4}$.

NO. 3.—RESISTANCES IN SERIES AND PARALLEL.

Preliminary.—If a set of wires whose individual resistances are known are joined in simple series, the total resistance is obtained by adding their individual values together. If however they are joined up in parallel, their joint resistance is represented by the reciprocal of the sum of their several conductivities (conductivity being the reciprocal of resistance). To prove this it is necessary to measure the resistances of a set of coils first individually and afterwards when connected up in various ways, this being done on a stretched wire form of Wheatstone bridge. A wire EF stretched between two copper strips (of negligible resistance) is connected to the two coils

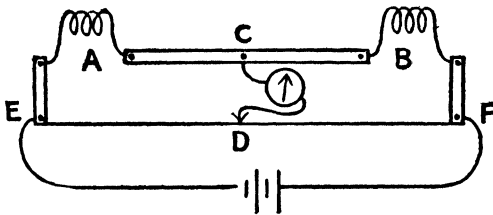

FIG. 2.

whose resistances are to be compared, A and B, through the thick copper strip C. If a battery is connected to the strips at E and F and a galvanometer to C and the wire EF, it will be observed that a Wheatstone bridge is formed of the coils A and B and the lengths of wire ED and DF. Also by altering the position of D which is arranged to slide along the bare wire EF, the ratio of ED to DB can be altered until it is the same as that of A to B, a fact which is indicated by the galvanometer needle remaining at zero, since C and D must then be at the same potential. Now, since the resistance of a bare uniform wire is proportional to its length, it follows that—

$$\frac{\text{resistance of A}}{\text{resistance of B}} = \frac{ED}{DF}$$

then, if the resistance of B is known, that of A can be calculated.

Apparatus.—You are supplied with a set of three coils, A, B, and C, a standard coil of known resistance, S, a wire bridge, battery and galvanometer.

Method.—(1) With coil S in the position B, and coil A in position A, connect up the bridge with the battery and galvanometer as above.

(2) Find the position for D when the galvanometer gives no deflection. Tabulate your results and calculate the resistance of A.

(3) Repeat with B and C in turn.

(4) Connect A, B, and C in series, and measure their joint resistance.

(5) Connect A, B, and C in parallel, and measure their joint resistance.

Tabulate thus :—

Coil or coils in position A.	Coil in position B.	Values of ED.	Values of DF.	Resistance calculated from readings.

Sum of the separate values A, B, and C =

Resistance of A, B, and C when in series =

Reciprocal of the sum of conductivities of A, B, and C =

Resistance of A, B, and C when in parallel =

NO. 4.—LAWS OF RESISTANCE (RESISTANCE AND LENGTH) *Rd l*

Preliminary.—In this experiment you are required to show that the resistance of a wire is proportional to its length. Since resistance is defined for any conductor as the ratio of the P.D. at its ends to the current flowing in it, you can measure the resistance of any length of the straight wire by

finding the P.D. between its ends on a voltmeter and dividing by the current in the wire as indicated on an ammeter.

Apparatus.—A wire of uniform cross section stretched on a graduated scale, a voltmeter, ammeter, and battery.

Method.—(1) Connect up your apparatus thus :—

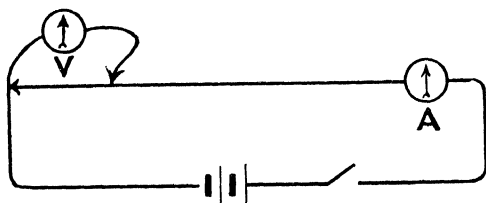

FIG. 3.

(2) With one terminal of the voltmeter connected to one end of the stretched wire, tap the other end on the wire at a point 10 cms. distant. Take the voltmeter and ammeter readings.

(3) Slide the tapping contact of the voltmeter along the wire till it is 20 cms. distant from the other voltmeter wire and read again.

(4) Repeat (3) with 30, 40, 50, etc., cms. between the tapping points.

(5) Tabulate your results thus :—

Distance between tapping points L .	P.D.	C.	$\frac{\text{P.D.}}{C} = R$.

(6) Plot a curve with values of L for ordinates and values of P.D. for abscissæ.

NO. 5.—LAWS OF RESISTANCE (RESISTANCE AND CROSS-SECTIONAL AREA) $R \propto \frac{l}{A}$

Preliminary.—The resistance of wires of the same length and material but of various diameters varies inversely as the cross-sectional area of the wire. In order to measure the resistances of such wires, the P.D. at their ends is measured when known currents are sent through them, the ratio of $\frac{\text{P.D.}}{C}$ being the resistance.

Apparatus.—You are supplied with metre lengths of wires of various gauges, but of the same material, an ammeter, voltmeter, regulating resistance, battery, and micrometer wire gauge.

Method.—(1) Connect one of the lengths of wire in series with the battery, ammeter, and regulating resistance. Place the voltmeter across its ends.

(2) Take simultaneous readings of P.D. and current with various values of current strength, which may be obtained by altering the regulating resistance. Tabulate these readings.

(3) Measure the diameter of the wire by the micrometer gauge.

(4) Repeat (1), (2), and (3) with each of the other pieces of wire.

(5) Tabulate your results thus:—

Length of wire.	S.W.G.	Diam. d cms.	Area $A = \frac{\pi}{4} d^2$.	$\frac{l}{A}$	P.D.	C.	$\frac{\text{P.D.}}{C} = R$.

Plot a curve connecting $\frac{l}{\text{area}}$ with R . What does this curve prove?

NO. 6.—LAWS OF RESISTANCE (RESISTANCE AND TEMPERATURE)

Preliminary.—The majority of conductors alter in resistance when their temperature alters. This change is expressed either as a “temperature coefficient,” which represents the change in resistance of a 1 ohm coil for a change of 1° C. in temperature; or else as a percentage alteration of resistance per 1° C. rise or fall of temperature. The resistance measurement can best be made on a wire bridge.

Apparatus.—You are supplied with the coil of wire to be tested, immersed in a vessel containing water; a thermometer, Bunsen burner, wire bridge with standard resistance, battery, and galvanometer.

Method.—(1) Connect up the coil, standard resistance, battery and galvanometer to the bridge as in Experiment No. 3; place the coil in cold water and note the temperature on the thermometer. Measure its resistance.

(2) Gradually raise the temperature of the water about 10° by means of the Bunsen, taking care to steady the temperature for at least one minute before taking a measurement of resistance and temperature.

(3) Repeat (2) till the water is raised to boiling point.

(4) Repeat, allowing the water to cool slowly till the original temperature has been reached. (To accelerate the rate of cooling at the later stages it may be necessary to add some cold water to the vessel.)

Tabulate your results thus:—

Temperature.	Balance wire bridge.	Standard coil resistance.	Resistance of test coil.

From these readings plot a curve with resistances of the test coil for ordinates against temperatures for abscissæ.

Post-Office Bridge

From this curve calculate :—

- (1) Average change of resistance temperature.
- (2) Average change of resistance per of temperature.
- (3) Percentage change of resistanc temperature.

Also, since $C.^{\circ} = \frac{5}{9} (Fah.^{\circ} - 32^{\circ})$, calculate (2) and (3) in the Fahrenheit scale of temperature.

NO. 7.—POST-OFFICE BRIDGE

Preliminary.—It can be shown, and it has been proved experimentally, that if four resistances R_1, R_2, R_3, R_4 are joined as shown in the diagram, with a galvanometer joining the points A and B, and a battery joining the points C and D, then, if A and B are equipotential points, so that no current flows in the galvanometer, the following relation holds :—

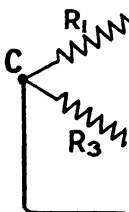

$$\frac{R_1}{R_2} = \frac{R_3}{R_4}$$

Hence, if three of these resistances may be calculated.

The post-office bridge consists of a circuit so arranged as to supply three arms of the bridge, the fourth arm being the unknown resistance required. The diagrams below show this in a post-office bridge and the relation between the arms of the bridge.

The arms R_1 and R_2 are termed the known arms. It is not usual to have more than one coil in an arm at a time. The unknown resistance X is

Electrotechnics

galvanometer and battery are connected to C^1D through the keys A^1 and C^1 .

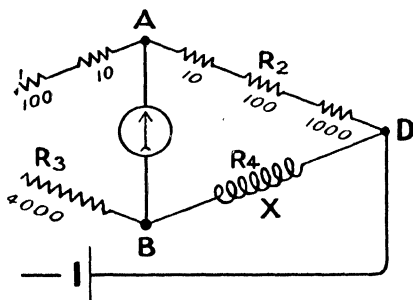

FIG. 5.

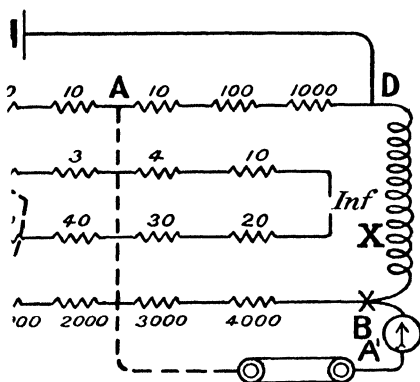

FIG. 6.

be supplied with a P.O. box and set of keys, battery, and galvanometer.

Connect the galvanometer, battery, and one key to the bridge.

Measure the resistance of each of the proportional arms

in the R_3 arm, momentarily close the galvanometer circuits. Note the meter deflection.

Remove the key plug open in the R_3 arm, repeat (3).

The galvanometer deflection should now be to the opposite side of the scale.

(5) By a process of trial and error find the resistance in R_3 which produces an exact balance, *i.e.* no galvanometer deflection. Should no exact balance be obtainable, find two resistances, one of which is too large and the other too small, and observe the galvanometer deflections they produce, from which calculate the exact resistance which would produce a balance. Thus, if 9 ohms gave 7 divisions deflection to the left, and 10 ohms gave 3 divisions deflection to the right, 1 ohm is equivalent to 10 divisions deflection, or 1 division = $\frac{1}{10}$ ohm : hence exact resistance required to balance would be 9.7 ohms.

(6) Repeat with the ratio resistances 100 : 100 and 1000 : 1000.

(7) Repeat for each of the three resistances supplied.

(8) Calculate the sensitiveness of the bridge balance in each case. This you may take as the number of divisions deflection produced by a change of resistance of 1 ohm in the R_3 arm.

(9) Tabulate your results thus :—

Resistance measured.	Resistance R_1 .	Resistance R_2 .	R_3 .	Deflection to right.	Deflection to left with $R_3 + 1$.	True resistance of coil.	Sensitiveness of balance.

What deductions do you make from the values in the last column as to the best arrangement of bridge arms for a given resistance to be measured ?

NO. 8.—MEASUREMENT OF RESISTIVITY

Preliminary.—The resistivity or specific resistance of a conductor is the resistance in ohms of a wire of unit length and

NO. 9.—VARIATION OF CARBON AND METAL FILAMENT LAMP RESISTANCES WITH CURRENT

Preliminary.—As has already been pointed out, the resistance of a conductor varies with its temperature, and since the temperature of a conductor will depend to a certain extent on the heating effect of the current flowing through it, the resistance will therefore vary with the current strength. You are to investigate the extent and nature of this change in the case of (1) a carbon filament lamp; (2) a metal filament (Tantalum) lamp; and (3) a metal filament (Osram) lamp.

Apparatus.—You are supplied with the above-mentioned lamps, a lamp-holder, switch, source of current, ammeter, voltmeter, and variable resistance.

Method.—(1) Connect the lamp-holder, variable resistance, ammeter, and switch, in series with the current supply, and place the voltmeter in parallel across the lamp-holder terminals.

(2) With the carbon lamp in the holder, switch on the current and adjust the variable resistance to give the smallest value of current obtainable. Take simultaneous readings on ammeter and voltmeter.

(3) Repeat with gradually increasing current strengths till the lamp is taking its normal current.

(4) Replace the carbon by the Tantalum lamp and repeat as above.

(5) Replace the Tantalum by the Osram lamp, and again repeat your observations.

Tabulate your results thus :—

Lamp.	Current C.	Voltage V.	$\frac{V}{C} = R.$

Plot three curves, one for each lamp, giving the relation

between R and C. What deductions would you make from these curves?

NO. 10.—TESTING INCANDESCENT LAMP CURRENTS

Preliminary.—In this test you are to measure the currents required to run incandescent lamps of various makes and candle-power, both at their declared voltages, and at voltages 4 per cent. above and below this, 4 per cent. being the maximum variation of pressure allowed by the Board of Trade on lighting circuits.

Apparatus.—You are supplied with a lamp-holder, set of lamps of various makes and candle-powers, an ammeter, voltmeter, variable resistance and source of current.

Method.—(1) Connect the lamp-holder, variable resistance, and ammeter in series with the main terminals of the current supply, and connect the voltmeter in parallel with the lamp-holder.

(2) Place one of the lamps in the holder, and by means of the variable resistance adjust the voltage at its terminals till the voltmeter reads the standard value for the lamp. Take reading of the current on the ammeter.

(3) Alter the voltage at the lamp terminals to 4 per cent. above the declared value: again read current.

(4) Alter the voltage at the lamp terminals to 4 per cent. below the declared value, and read current.

(5) Repeat above with each lamp.

(6) Calculate the power in watts expended in each lamp.

(7) Assuming the lamp to give its declared candle-power at the standard voltage, calculate its inefficiency in watts per candle-power.

Tabulate your results thus:—

Lamp.	Voltage.	Current.	Watts.	Watts per candle.

NO. 11.—MEASUREMENT OF SECONDARY BATTERY RESISTANCE

Preliminary.—The resistance of secondary batteries is so low that the only satisfactory method of measuring it is to take a large current from the battery and find the potential difference used up in forcing this current through the battery. A voltmeter reading across the terminals of the battery when on open circuit gives the E.M.F. of the cells. If a similar reading be taken when the battery is supplying a current of C ampères, it will be found to be less than the reading for the E.M.F. If P.D. is the potential difference at the battery terminals, then E.M.F. - P.D. = volts required to send current C through the battery. This quantity is usually known as the “lost volts” (lv).

$$\begin{aligned} &\text{If } b = \text{battery resistance} \\ &\text{by Ohm's law } lv = Cb \\ &\text{or E.M.F. - P.D.} = Cb \\ &\therefore b = \frac{\text{E.M.F. - P.D.}}{C} \end{aligned}$$

Apparatus.—You are supplied with a battery, ammeter, voltmeter, variable resistance, and switch.

Method.—(1) Connect up the battery, ammeter (A), volt-

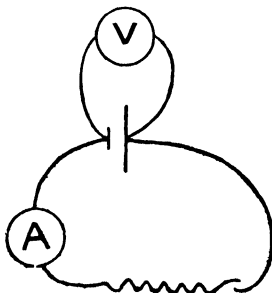

FIG. 7.

meter (V), external resistance (R), and switch as shown in diagram.

(2) Take a number of readings of E.M.F., P.D., and C, with various values of R. Tabulate them thus :—

E.M.F.	P.D.	C.	E.M.F. - P.D.	<i>b.</i>

Plot a curve with values of lost volts against current.

NO. 12.—INSULATION TESTING BY DIRECT DEFLECTION METHOD

Preliminary.—This method of measuring insulation resistance is that employed in the “Silvertown Testing Set,” and is sometimes referred to as the “Silvertown Method.” The test is divided into two parts; the first consists in measuring the deflection on a galvanometer placed in series with the insulation resistance to be measured, when the testing pressure is applied, and the second in calibrating the galvanometer.

Apparatus.—You are supplied with a sensitive galvanometer, shunt-box, standard high resistance, key, and a testing pressure of at least double the working pressure of the circuit whose insulation resistance is to be measured.

Method.—(1) Connect the galvanometer (unshunted) in series with the testing battery, resistance to be measured, and key.

(2) Close the circuit and read the galvanometer deflection (d_1).

(3) Replace the resistance to be measured by the standard high resistance, and shunt the galvanometer.

(4) Adjust the shunt till a deflection d_2 of approximately the same magnitude as d_1 is obtained.

Tabulate thus :—

d_1 .	d_2 .	Multiplying power of shunt = K ¹	Standard high resistance R .	$\frac{d_2 \times K \times R}{d_1}$.

Prove that $\frac{d_2 \times K \times R}{d_1}$ represents the value of the insulation resistance to be tested.

NO. 13.—MEASUREMENT OF THE RESISTANCE OF AN ELECTROLYTE BY THE KOHLRAUSCH BRIDGE

Preliminary.—The measurement of electrolytic resistance presents a difficulty not met with in ordinary metallic conductors, namely the existence of the back electromotive force due to the polarization of the electrodes. This polarization must either be eliminated or allowed for, otherwise it would be reckoned as part of the resistance. In the Kohlrausch method an attempt is made to eliminate it altogether by employing alternating in place of direct currents in the measurement, since with alternating currents no decomposition will occur at the electrodes.

In all other respects the method is similar to the measurement of resistance on a Wheatstone wire bridge. An alternating current, usually taken from the secondary coil of a small induction coil (which has had its condenser removed), replaces the battery of the wire bridge, and as a galvanometer would not give any indication with alternating currents, a telephone is used in its place, the position of the tapping contact on the slide wire being altered until a minimum of sound is heard in

¹ The multiplying power of the shunt K is the multiplier that must be employed to convert the deflections of the shunted galvanometer into the deflections that theoretically would have been obtained if the galvanometer had been unshunted and had had a long proportional scale.

the telephone. The resistance is then calculated in the usual way.

Apparatus.—You are supplied with a wire bridge, induction coil, and battery to work it, telephone and standard resistance, also a cylindrical glass vessel of known diameter provided with adjustable platinum electrodes, a measuring rod, and a set of electrolytic solutions.

Method.—(1) Fill the glass vessel with one of the liquids, and adjust the electrodes about 1 cm. apart. Connect up to the wire bridge and obtain balance. Calculate the resistance.

(2) Separate the electrodes exactly 1 cm., and repeat. The difference between the resistance now obtained and that found in (1) gives the resistance of a column of liquid 1 cm. in length.

(3) From the known diameter of the glass vessel calculate the cross-sectional area of the column of liquid, and hence its specific resistance or resistivity.

(4) Repeat with each of the liquids supplied to you.

Tabulate your results thus :—

Liquid.	First balancing point.	Resistance calculated from this.	Second balancing point.	Resistance calculated from this.	Resistance of column 1 cm. long.	Area.	Resistivity ρ .

NO. 14.—CALIBRATION OF AN AMMETER BY FALL OF POTENTIAL METHOD

Preliminary.—The current flowing through a circuit may be calculated if the fall of potential down a portion of known resistance can be found. You are supplied with a standard resistance of 0.001 ohm which is capable of carrying 500 ampères without altering in resistance, and a standard low-reading voltmeter. If the standard resistance is placed in series with the ammeter to be calibrated, and readings are taken of the

P.D. at the terminals of the standard resistance, the current is calculated by Ohm's law thus :—

$$C = \frac{\text{P.D.}}{R}$$

Apparatus.—You are supplied with a standard resistance, standard low-reading voltmeter, variable resistance, ammeter to be calibrated, and secondary battery.

Method.—(1) Connect up your apparatus thus :—

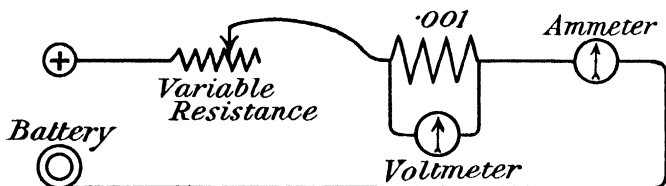

FIG. 8.

The voltmeter reads in thousandths of a volt, and the highest reading is 20 millivolts, *i.e.* 0.02 volt.

(2) Start with a small current and take simultaneous readings on the voltmeter and ammeter.

(3) Gradually increase the current, rising by about 1 ampère each time, till the end of the ammeter scale has been reached.

Tabulate the readings thus :—

Type of ammeter..... Number..... Position in which fixed.....

Ammeter reading.	Millivoltmeter reading.	Current = $\frac{\text{P.D.}}{R}$.

Take a set of readings with the current falling as well as rising.

Plot two curves with ammeter readings against the values

of current obtained from the voltmeter readings for both rising and falling currents.

If the two curves do not coincide, what cause would you ascribe it to?

NO. 15.—CALIBRATION OF AN AMMETER BY COMPARISON WITH A SIEMENS ELECTRO-DYNAMOMETER

Preliminary.—The Siemens electro-dynamometer consists essentially of two coils, one fixed and one movable, with their axes at right angles to each other, and connected in series, so that when a current traverses the coils the movable coil tends to set itself with its axis parallel to that of the fixed coil. The movable coil is attached to one end of a spiral spring, at the other end of which is a torsion head with a pointer moving over a circular scale divided into equal divisions. When no current is passing and the torsion head pointer is at zero on the scale, the movable coil should set exactly at right angles to the fixed coil, this being indicated by a small pointer attached directly to the movable coil. When a current is sent through the instrument the movable coil will deflect, and it must be brought back to its zero position by turning the top torsion head. The number of degrees of twist necessary to do this will be proportional to the magnetic force between the coils, this latter, since the same current traverses the two coils, being proportional to the square of the current. Hence, if θ = number of divisions of twist given to the top torsion head, and C = current in ampères—

$$\begin{aligned} C^2 &\propto \theta \\ \text{or } C &\propto \sqrt{\theta} \\ \text{and } C &= K\sqrt{\theta} \end{aligned}$$

where K is a constant the value of which depends on the size and particulars of the coils and torsion spring, and must be determined experimentally for each instrument.

It is on account of the great permanency of this constant K that the Siemens electro-dynamometer is so largely employed as a “secondary” standard current-measuring instrument.

Apparatus.—You are supplied with an ammeter, electro-dynamometer, regulating resistance, switch, and source of current.

Method.—(1) Connect up the ammeter, regulating resistance, switch, and dynamometer in series with the source of current. (The majority of dynamometers have three terminals, one, the centre one, being a common terminal, and the outer ones belonging respectively to a thick and a thin coil on the dynamometer, thus giving two ranges of current measurements, and, of course, two constants.)

(2) Set the dynamometer so that the axis of the moving coil is parallel to the magnetic meridian, then level it till the moving coil is at right angles to the fixed coil.

(3) Putting the largest value of the variable resistance in circuit, switch on the current. Turn the top torsion head round until the moving coil is brought back to its former position. Take the readings of the torsion-head pointer and of the ammeter.

(4) Repeat with gradually increasing currents until you have reached the maximum for your instrument.

(5) Repeat readings with gradually decreasing currents.

Tabulate your results thus:—

Type of ammeter.. ... Number..... Position in which fixed.....

Ammeter reading.	Torsion head reading θ .	$\sqrt{\theta}$.	Dynamometer constant K.	$K\sqrt{\theta}$.

Plot two curves, for the rising and falling current readings respectively, with $K\sqrt{\theta}$ values for ordinates, and ammeter readings for abscissæ.

NO. 16.—CALIBRATION OF A VOLTMETER BY COMPARISON WITH A STANDARD

Preliminary.—The standard voltmeter used in this experiment is an electrostatic instrument. The two voltmeters, the standard and the one to be calibrated, are connected in parallel, and the wires from them are taken to a potentiometer resistance the P.D. at the ends of which is 100 volts, and this is so arranged that any fraction of the voltage may be applied to the voltmeters. The diagram will show the connections :—

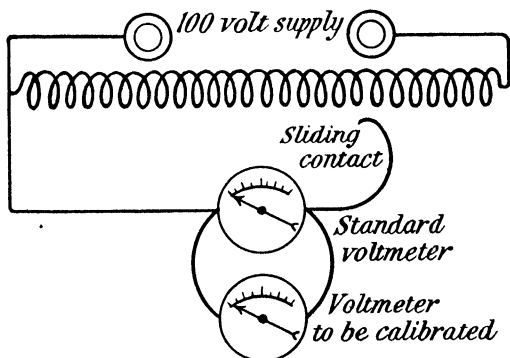

FIG. 9.

Method.—(1) Connect up the voltmeters as in the diagram. Switch on the current and adjust the sliding contact to get a reading of about 40 volts on the electrostatic instrument, and take the reading of the other.

(2) Gradually increase the voltage by 5 volts at a time up to the highest reading.

(3) Without breaking the circuit, gradually diminish the voltage and take another set of readings.

Tabulate your readings thus :—

Type of voltmeter.....	Number.....	Position in which fixed.....
------------------------	-------------	------------------------------

Voltage rising.		Voltage falling.	
Standard.	Voltmeter.	Standard.	Voltmeter.

Plot two curves with the readings obtained, one for rising voltages and one for falling. The object of the two sets of readings is to find if in an electro-magnetic voltmeter there is any hysteresis effect. From the two curves a table of mean corrections can be made out as below :—

Voltmeter reading.	Correction.

The correction is + if it has to be added to the voltmeter reading to get the correct voltage, and - if it has to be subtracted.

NO. 17.—COMPARISON OF E.M.F.'S BY POTENTIOMETER

Preliminary.—The fall of potential along a uniform wire is proportional to its length. In the instrument supplied a uniform wire is stretched over a scale, and is connected in series with 14 exactly similar wires, which are wound on bobbins. A current is sent through the system, and two points are found between which the drop of potential is equal to the E.M.F. of a standard cell. The difference of potential between any other two points can then readily be calculated, since it will be proportional to the length of wire between the points.

The diagram of connection is given below :—

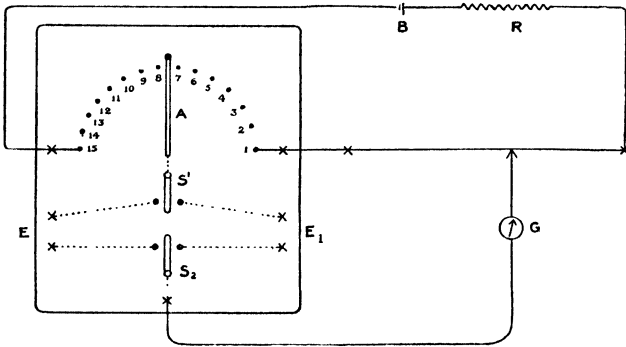

FIG. 10.

Apparatus.—You are supplied with a potentiometer, standard cell, battery, and set of cells whose E.M.F.'s are to be measured.

Method.—(1) Connect one secondary cell to the terminals marked battery and the standard cell to the terminals E, taking care always to connect the positive wires to the terminals marked (+).

(2) Place the rotating arm A at stud 10, and the slider and tapping contact at 19 on the stretched-wire scale. Place the two-way switches, S_1 and S_2 , on the left-hand contacts.

(3) Adjust the resistance R until no deflection is produced on the galvanometer.

(4) Connect one of the cells whose E.M.F.'s are required to terminals E_1 , and change over the two-way switch.

(5) Without altering the resistance R, adjust the arm A and the slider until on making contact no galvanometer deflection is observed. The readings of the rotating arm and sliding contact now give the E.M.F. of the cell. Thus, if the switching arm A was at 13 and the sliding contact at 52, the E.M.F. would be 1.352 volts.

(6) Repeat above with each cell in turn substituted at E_1 .

As the main current may vary slightly during the experiment, it is advisable to verify and if necessary readjust the standard reading as taken previously in (2) and (3).

Tabulate your results thus :—

Name of cell.	Rotating arm reading.	Tapping point.	E.M.F. (volts).

NO. 18.—MEASUREMENT OF RESISTANCE BY POTENTIOMETER

Preliminary.—In the following experiment, as an example of resistance measurement by potentiometer, you are required to measure the resistance of a voltmeter and of an ammeter, as representing a typical high resistance and a typical low resistance. Also calculate the ohms per volt allowed in the voltmeter and drop of potential per ampère in the ammeter.

Apparatus.—You are supplied with a potentiometer, battery, voltmeter, standard high resistance, ammeter, standard low resistance, and rheostat.

Method.—(1) Connect the voltmeter in series with the standard high resistance and battery, and connect the potentiometer battery in circuit. Bring potential wires from the voltmeter and standard resistance to the potentiometer, as shown diagrammatically below :—

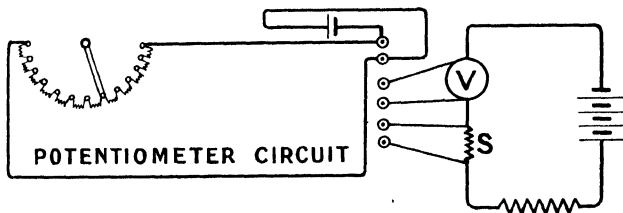

FIG. 11.

(For particulars of the connections of the potentiometer see Experiment No. 17.)

(2) By preliminary experiment find whether the voltmeter or the standard has the higher resistance and adjust the currents in the two circuits till the drop down the whole 15 wires of the potentiometer is nearly equal to the drop down the higher resistance in the other circuit.

(3) Balance the drop down V and down S on the potentiometer for various currents in the voltmeter circuit.

(4) Repeat for the ammeter, placing in series with it the standard low resistance and the rheostat in place of the standard high resistance.

(5) Tabulate thus :—

VOLTMETER.				AMMETER.			
Balancing point for instrument.	Balancing point for standard.	Resistance of instrument.	Ohms per volt.	Balancing point for instrument.	Balancing point for standard.	Resistance of instrument.	P.D. per amp.

NO. 19.—MEASUREMENT OF CURRENT BY POTENTIOMETER

Preliminary.—This experiment is practically the same as No. 14, except that instead of measuring the P.D. at the ends of the standard resistance by means of a voltmeter, you employ a potentiometer as in Experiment No. 17. In this way the current is measured in terms of a standard resistance and P.D., the latter being obtained by direct comparison with the E.M.F. of a standard cell.

Apparatus.—You are supplied with a potentiometer, standard low resistance coil provided with potential terminals, standard cadmium cell (E.M.F. = 1.019 volt), battery, variable resistance, switch and ammeter to be standardized.

Method.—(1) Connect the battery, standard resistance, ammeter, variable resistance and switch in series.

(2) Take a pair of wires from the potential terminals of the standard resistance to the potentiometer.

(3) Adjust the potentiometer so as to read P.D.'s directly in volts, as in Experiment No. 17.

(4) Take a series of rising and then a series of falling current readings on the ammeter.

Tabulate your results thus :—

Type of ammeter..... No. of ammeter..... Position of ammeter.....

Ammeter reading.	Standard resistance R.	Potentiometer balance.	P.D. down standard resistance.	$\frac{\text{P.D.}}{R}$	Error of ammeter.

Plot curves connecting the ammeter readings with the currents for both rising and falling values.

NO. 20.—CALIBRATION OF A VOLTMETER BY THE NALDER VOLT POTENTIOMETER

Preliminary.—By means of this instrument and a standard cell, any voltage from 2 volts to 600 volts can be measured to $\frac{1}{10}$ volt. The principle on which the instrument works is illustrated by the following diagram :—

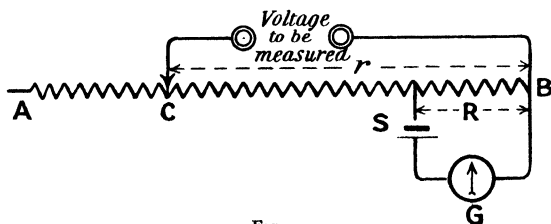

FIG. 12.

The standard cell S in series with the galvanometer G is placed across the ends of a resistance R which is an exact

multiple of the number which represents the E.M.F. of the standard cell. The E.M.F. to be measured is applied to the resistance AB, one terminal being permanently fixed at B, whilst the other, C, is moved between A and B until the drop in pressure in the portion R, due to the current in CB, just balances the E.M.F. of the standard cell. There will then be no deflection on the galvanometer G. If r represents the resistance of CB, we have—

$$\frac{\text{E.M.F. of S}}{R} = \frac{\text{E.M.F. to be measured}}{r}$$

or
$$\text{E.M.F. to be measured} = \frac{\text{E.M.F. of S}}{R} \times r$$

Since a cadmium standard cell, with a negligible temperature coefficient, is employed, $\frac{\text{E.M.F. of S}}{R}$ may be regarded as a constant quantity.

Hence $\text{E.M.F. (to be measured)} = r \times \text{constant}$.

If this constant is known, the resistance AB may be marked off in volts instead of ohms, and the instrument therefore made direct reading. The resistance AB in the actual instrument is made up of separate coils arranged as in a dial resistance box, thus—

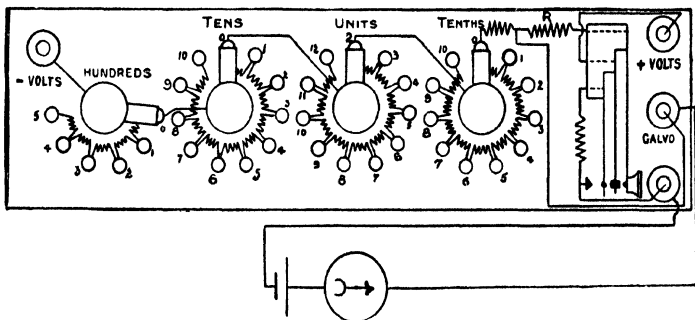

FIG. 13.

The tapping key is so arranged that it first closes the main circuit and then the standard cell circuit, the latter first through a resistance of 0.5 megohm until an approximate balance has

been obtained, this resistance being afterwards short circuited by a further movement of the key.

Apparatus.—You are supplied with a volt potentiometer as above, standard cell, voltmeter to be calibrated, galvanometer, and source of E.M.F., the value of which can be altered.

Method.—(1) Connect the terminals marked + volts and - volts respectively to the positive and negative leads from the source of E.M.F.

(2) Connect the galvanometer and standard cell as shown in the diagram, taking care to connect the positive terminal of the cell to the terminal marked +.

(3) Connect the voltmeter to be calibrated across the terminals marked + volts and - volts; that is, in parallel with the potentiometer.

(4) Switch on the lowest value of E.M.F. that will give a reading on the voltmeter. Adjust the potentiometer dial switches until a balance has been obtained.

(5) Increase E.M.F. about 5 volts, and repeat until you have got to the highest reading on the voltmeter scale.

(6) Take a similar set of readings with falling pressures. Tabulate your results thus:—

Type of Voltmeter..... Number..... Position.....

Voltmeter reading.	Potentiometer readings.

Plot curve of Potentiometer readings against voltmeter readings.

NO. 21.—MEASUREMENT OF LOW RESISTANCE

Preliminary.—When very low resistances have to be measured ordinary bridge methods cannot be used, partly on account of the difficulty of eliminating from the result the

resistance of the connecting wires. The method usually adopted is to compare the drop of potential in the given resistance with that in a standard resistance placed in series with it and therefore carrying the same current.

Apparatus.—You are supplied with a standard resistance of 0·1 ohm stretched round a circular divided scale provided with a sliding contact, which enables contact to be made at any point on its length. This standard is connected in series with the resistance to be measured, battery, and if necessary a regulating resistance. On the same base as the standard resistance is mounted a differential galvanometer, that is, a galvanometer with two separate circuits of the same resistance and producing equal magnetic effects on the needle when carrying equal currents. One of the coils is connected across the ends of the resistance (*x*) to be measured, and the other is connected between one end of the standard resistance and the rotating arm carrying the tapping contact, as illustrated in the following diagram :—

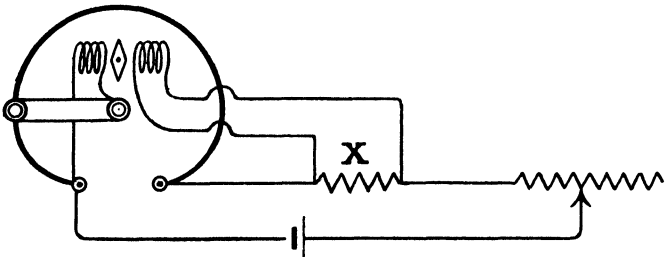

FIG. 14.

Method.—(1) Adjust the galvanometer needle to zero and switch on the current at key K ; again, if necessary, adjust the needle to zero.

(2) Observe the direction of the galvanometer deflection when the tapping circuit is completed and before the wires from X are connected up.

(3) Connect the wires from X so that when the tapping contact is broken the galvanometer deflection due to X alone is to the opposite side to that observed in (2).

(4) Close both tapping circuit and circuit from X, and

adjust the tapping point until the galvanometer needle remains at zero.

(5) Should it be found impossible to get a balance at all, then probably the resistance of X is greater than 0.1 ohm. In this case the galvanometer constant is altered by means of the plugs, attached to it in such a way that the resistances will be in the proportion of 5 to 1 when a balance is obtained.

(6) Measure and tabulate the resistances of the coils supplied, taking each measurement with various values of current in X. This may be effected by altering the variable resistance R.

Tabulate thus :—

Nature of resistance to be measured.	Galv. constant.	Balancing point on wire.	Resistance (ohms).

NO. 22.—FUSE WIRE TESTING

Preliminary.—In this experiment you are required to examine the effect on the current required to fuse a given fuse wire, of (a) the length of the fuse, and (b) of an open or enclosed fuse box.

Apparatus.—You are supplied with a set of fuse boxes for various lengths of fuses, a battery, variable resistance, Siemens electro-dynamometer, some fuse wire, and a switch.

Method.—(1) Connect the battery, switch, variable resistance, and Siemens dynamometer in series with one of the fuse boxes.

(2) Place a fuse in the box and screw on the cover.

(3) With all the variable resistance in circuit, adjust the current and gradually increase it till the fuse has just fused the time the current has been increased.

follow up the increase on the dynamometer. Note the dynamometer reading when the fuse "blows."

- (4) Repeat the above at least three times.
- (5) Repeat the above with the cover of the fuse off.
- (6) Repeat all above with each of the fuse boxes.

Tabulate your results thus :—

Size of fuse.	Material of fuse.	Length of fuse.	Position of cover.	Dyna- mometer reading θ .	Dyna- mometer constant K.	Current $= K\sqrt{\theta}$.

What deductions would you make from these results ?

NO. 23.—MEASUREMENT OF FUSING CONSTANTS OF FUSE WIRE METALS

Preliminary.—It has been shown by Preece that the fusing current for any given wire is proportional to the square root of the cube of the diameter of the wire. So that for any given metal if C = current in ampères required to fuse the wire, and d = diameter of the wire in cms., then—

$$C = K \cdot d^{\frac{3}{2}}$$

where K is a constant depending on the nature of the metal of the fuse wire. You are required to verify the above law and to find the values of K for various substances.

Apparatus.—You are supplied with a fuse wire holder, Siemens electro-dynamometer, variable resistance, source of micrometer wire gauge, and a set of fuse wires.

- (1) Connect the fuse wire holder in series with resistance, dynamometer, and battery.

smallest wire in the fuse holder after having its diameter by the micrometer wire gauge.

great care must be taken not to compress the wire gauge.)

(3) Switch on a small current, which gradually increase till the wire fuses. Note the reading of the dynamometer at fusing.

(4) Repeat at least three times.

(5) Repeat above measurements with each size of fuze wire of the same metal in turn.

(6) Make similar sets of measurements for each metal.

Tabulate your results thus :—

Metal of fuse.	S.W.G. gauge.	Diameter cms.	d^3 .	Fusing current.	K.

Plot a curve with d^3 as abscissæ against C as ordinates.

NO. 24.—PHOTOMETRY OF INCANDESCENT LAMPS

Preliminary.—In this experiment you are required to measure the candlepower of various incandescent lamps when run at their marked pressure. The standard employed is an incandescent lamp of known candlepower.

Apparatus.—You are supplied with a standard lamp (connected to a pressure-regulating resistance, voltmeter and ammeter), stand for test lamp (similarly fitted), photometer bench, Lummer-Brodhun photometer, and set of lamps of 8, 16, 25, 32, and 50 candlepower.

Method.—(1) Place the standard lamp at the extreme end of the scale, the photometer about the middle, and test lamp near the other end. Adjust standard lamp so that filaments are in line with one another and the line joining them at r^2 angles to the bench. Regulate pressure to 100 volts e^v

(2) Place the 8 candlepower lamp in the other its loop broadside on to the photometer, and adjust 100 volts. Read current in this lamp.

(3) Adjust the relative positions of photometer and test lamp until the photometer screen appears uniformly illuminated. Read distance of the photometer from each lamp.

(4) Repeat (3) three times with various distances separating lamps and photometer.

(5) Repeat the above readings with test-lamp filament edge on to the photometer.

(6) Obtain similar sets of readings for the other lamps supplied.

Tabulate your results thus :—

Lamp under test.	Position of filaments.	Voltage at terminals.	Current in amperes.	Distance of test lamp from screen d_1 .	Distance of standard lamp from screen d_2 .	Candle-power of standard lamp.	Candle-power of test lamp.	Watts in test lamp.

When the illumination of the photometer screen is uniform the intensity of illumination due to each lamp at the screen is the same.

$$\text{Intensity of illumination} = \frac{\text{candlepower}}{(\text{distance from screen})^2}$$

$$\therefore \frac{\text{c.p. of test lamp}}{d_1^2} = \frac{\text{c.p. of standard lamp}}{d_2^2}$$

$$\therefore \text{c.p. of test lamp} = \frac{d_1^2}{d_2^2} \times \text{c.p. of standard lamp.}$$

NO. 25.—CALIBRATION OF A WATTMETER

Preliminary.—A wattmeter is an instrument designed to measure the electrical power expended in a circuit. In general form and principle it somewhat resembles a Siemens electro-dynamometer, with the essential difference that the fixed and moving coils represent entirely independent circuits. The moving coil consists of a comparatively few turns of thick wire ; it is a "current" coil, and is placed in series with the

circuit in which the power is to be measured. The movable or "pressure" coil consists of many turns of fine wire, and frequently has a high resistance in series with it. This coil is connected voltmeter-like, in parallel with the circuit in which the power is to be measured. The control and action of the instrument are similar to that of the electro-dynamometer. The magnetic force between the coils is proportional to the product of the currents in them. In one coil this is the main current C , and in the other a small current proportional to the P.D. at the ends of the circuit. Hence the magnetic force is proportional to the P.D. $\times C \propto$ power. Also if $\theta =$ angle of twist of the top torsion head required to restore the movable coil to its normal position, then—

$$\text{P.D.} \times C \propto \theta$$

that is, power (in watts) = $K\theta$

K being a constant depending on the design of the instrument. To determine this constant K , a known P.D. is maintained between the terminals of the movable coil whilst currents of known strength are sent through the fixed coil.

Apparatus.—You are supplied with a wattmeter, standard electrostatic voltmeter, and ammeter, variable resistance, switch, battery, and a source of constant P.D.

Method.—(1) Connect up the battery, variable resistance, ammeter, and switch in series with the current coil of the wattmeter.

(2) Connect the pressure coil to the source of constant P.D., which is adjusted to the lowest value at which the instrument is intended to be used, and place the voltmeter across its terminals thus :—

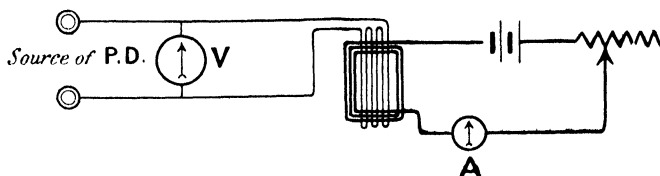

FIG. 15.

(3) Adjust the wattmeter to zero. Then, with for the variable resistance, switch on the cur

movable coil of the wattmeter to zero by turning the torsion head, and note the voltmeter and ammeter readings.

(4) Repeat with gradually increasing current strengths.

(5) Raise the P.D. at the pressure coil to the highest value at which the instrument is to be used, and repeat measurements.

(6) Lower P.D. at pressure coil halfway between the two extreme values and repeat.

Tabulate your results thus :—

Type of instrument..... Number..... Position.....

P.D. at pressure coil.	Current in ammeter.	θ .	P.D. \times C watts.	$K = \frac{\text{watts}}{\theta}$.

Plot curves with K against current for each value of P.D.

NO. 26.—TESTING A SUPPLY METER

Preliminary.—In the following experiment you are required to test the accuracy of the supply meter provided, and also to find the minimum current with which it will start. The meter is a 10 amp. motor meter, and is really an ampère-hour meter graduated in B.O.T. units, it being assumed to run at a constant pressure of 100 volts. As it is an ampère-hour meter it may be calibrated at any voltage, since the number of revolutions of the moving parts is proportional to the quantity of electricity passed through.

Apparatus.—You are supplied with a meter, a low-reading meter, another ammeter reading to 10 amps., resistance, ohm, and source of current.

—(1) Connect the meter in series with the low-reading meter, one secondary cell and the resistance.

Starting with all the resistance in circuit, gradually increase current until the meter commences to move. Note this current.

(2) Increase current to about 1 ampère, and when the meter is running freely gradually decrease current till meter stops. Note the current when this occurs.

(3) Replace the low-reading ammeter by the high-reading instrument, and if necessary increase the number of cells to three. Switch on current and adjust to 10 ampères. Keeping current steady, count the number of revolutions of the meter armature for one complete revolution of the $\frac{1}{100}$ unit dial pointer, and note the exact time in seconds occupied by one complete revolution of this pointer.

(4) Reduce the current to 7.5 amps. and take the time of ten complete revolutions of the armature.

(5) Repeat (4) with currents of 5, 2.5, and 1 ampère.

Tabulate your results thus :—

Current.	Time of 10 armature revs.	Time per revolution.	Coulombs per revolution.	B.O.T. units per rev. at 100 volts.

Type of meter..... Meter No..... Voltage of meter.....
 Current to start meter..... Current at which meter stops.....
 No. of armature revs. for 1 rev. of $\frac{1}{100}$ dial pointer..... (A).
 Time of 1 rev. of $\frac{1}{100}$ dial pointer at 10 ampères..... (B).

From (A) calculate the theoretical B.O.T. units per revolution of armature.

From (B) calculate the actual kilo-ampère hours per revolution of armature; and, assuming constant pressure 100 volts, the actual B.O.T. units per armature rev.

From these two calculate the percentage error γ (10 amps.).

From (A) and (B) calculate the per cent load, $\frac{1}{2}$ load, $\frac{1}{4}$ load, $\frac{1}{10}$ load :—

Tabulate thus :—

Load.	Error.

State whether error is + or —

Note.— $\frac{\text{Coulombs rev.} \times 100}{60 \times 60 \times 1000} = \text{B.O.T. units per rev. at 100 volts.}$

NO. 27.—CURRENT INDUCTION

Preliminary.—When a conductor cuts lines of magnetic force, it has an electromotive force induced in it, of a magnitude depending on the rate of cutting the lines, and of a direction which depends on the direction of cutting the lines. In the following experiment you are required to verify the main facts of current induction. In order to measure the induced E.M.F. the conductor (which consists of a large coil of wire) is connected to a ballistic galvanometer. The induced E.M.F. produces a sudden rush of current through the galvanometer, causing the needle of the latter to swing across the scale. The magnitude of the first swing of the needle may be taken as proportional to the magnitude of the induced E.M.F.

Apparatus.—You are supplied with a large coil of wire, a smaller coil which can be fitted inside the first, a set of iron and steel cores for the smaller coil, a bar magnet, battery and reversing key, and ballistic galvanometer.

Method.—(1) Connect the large coil in series with the ballistic galvanometer.

(2) Introduce a bar magnet slowly to one end of coil and observe the galvanometer deflection.

Repeat (2), moving bar magnet quickly.

Repeat (2) and (3), inserting the opposite end of the

the battery, find in which direction in the

coil (clockwise or counter-clockwise, looked at from the end where the magnet was introduced) the current flows to produce galvanometer deflections to right and left respectively.

(6) Connect up the smaller coil to a battery and simple make-and-break key, and introduce inside the large one.

(7) Start a current in the small coil, and note result.

(8) Break the circuit of the small coil, and again note result.

(9) Connect the small coil to the battery by means of the reversing key.

(10) Reverse the current in the small coil, and observe the effect.

(11) Again reverse current in small coil, but in opposite direction.

(12) Introduce soft iron core into small coil, and repeat (10) and (11).

(13) Introduce steel core into small coil, and repeat (10) and (11).

Tabulate your results thus :—

Diagram showing magnet movement.	Galvanometer swing.		Direction of induced current, clock or counter-clock.
	Right.	Left.	

Direction of current in small coil, clock or counter-clock.	Core in small coil.	Current started, stopped, or reversed.	Galvanometer deflection.		Direction of induced current, clock or counter-clock.
			Right.	Left.	

Give a list of deductions you would make from the above.

NO. 28.—TESTING PERMANENT MAGNETS

Preliminary.—In this experiment tests are applied to a number of bar magnets to show the effects of magnetizing and of ageing. The tests are made by means of a ballistic galvanometer to which is connected a slipping coil which can be quickly threaded on or withdrawn from a bar magnet. The galvanometer having been calibrated for ballistic purposes (see Experiment No. 45), the value of B (lines of force per sq. cm.) in the specimen can be calculated from the throws obtained. The tests are made for each magnet under three conditions as below.

Apparatus.—You are supplied with a ballistic galvanometer and a slipping coil. Also with a large electro-magnet and battery to magnetize the bars with, a set of steel bars, a measuring rod, and a vessel of boiling water.

Method.—(1) Connect the small coil to the galvanometer, and when the needle is perfectly steady quickly insert the N end of a magnet through the coil. Read the resulting ballistic throw.

(2) Withdraw the magnet from the coil when the needle is at rest, and again take the reading.

(3) Repeat the readings for all the magnets.

(4) Remagnetize the magnets strongly on the electro-magnet, and repeat the preceding tests.

(5) After these readings have been taken, place the magnets in boiling water for a quarter of an hour to age them to a certain extent.

(6) Remove the magnets and again apply the tests as above.

(7) Take the dimensions of each magnet and find the sectional area. From this calculate the induction per sq. cm., *i.e.* the value of B .

Tabulate your results thus :—

Number of bar.	Brand of steel.	Condition of bar.	Galvanometer throw.		Mean throw.	Area of bar.	Total flux.	B.	Per cent. change of B on ageing.
			In.	Out.					

The total flux is obtained by multiplying the mean throw of the galvanometer needle by the galvanometer and coil constant.

NO. 29.—THE LAW OF THE SOLENOID

Preliminary.—In the following experiment you are required to investigate the laws affecting the magnetic field set up by a current in a long solenoid. The experiment is divided into two parts:—(1) exploring the field inside the solenoid and noticing its variation with current; (2) exploring the field within the solenoid and investigating its distribution along the axis. The solenoid supplied has a test coil wound round the centre on the outside for part 1, and a test coil of special design is provided for part 2. This latter is so arranged that it may be placed at any point on the axis inside the solenoid and then suddenly rotated through 180° . The throws of the needle on the ballistic galvanometer may be taken as proportional to the magnetic flux through the test coils.

Apparatus.—You are supplied with a long solenoid and test coils, ammeter, reversing key, resistance, ballistic galvanometer and source of current.

Method.—(1) Connect up the apparatus as in the diagram:—

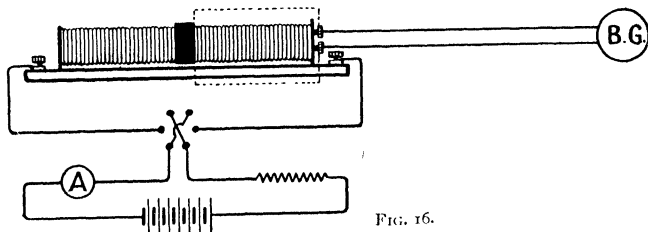

FIG. 16.

(2) Adjust the current in the solenoid to 0.5 amp. and connect the outer test coil terminals direct to the galvanometer. When the galvanometer needle is quite steady, rapidly reverse the current and note the first swing of the needle. Again reverse when needle is steady, and note the first swing to the opposite side of the zero.

(3) Repeat with current increasing 1 amp. each time up to the highest reading.

(4) Disconnect the outer test coil and connect the galvanometer to the terminals of the special test coil. Set this coil in position and insert it into the solenoid until the last mark on the handle is against the end of the solenoid. The coil is then at the centre of the solenoid. Adjust the current in the solenoid to 1 amp., and when the needle is at rest rotate the coil and note the deflection. Repeat the observation at least three times.

(5) Repeat (4), withdrawing the coil 5 cms. each time, as shown by the graduations on the handle, until the end of the solenoid is reached.

Tabulate thus :—

OUTER COIL.			INNER COIL.			
Current in solenoid.	Galvanometer swing.		Mean swing.	Current in solenoid.	Distance of coil from centre of solenoid.	Galvanometer swing.
	To right.	To left.				

Plot two curves : (1) For the outer coil, showing connection between current in solenoid and the magnetic field set up, as indicated by galvanometer swing ; and (2) for the inner coil, showing the variation of magnetic field at different points on the axis of the solenoid.

State what conclusions may be drawn from the experiment.

NO. 30.—EXPERIMENTS WITH ELECTRO-MAGNETS.

(NO. 1)

Preliminary.—In the following experiment you are required to investigate the relation between the magnetic pull exerted on the core of an electromagnet and the ampère turns in the magnetizing coil, first with a coil of few turns taking a large current, and secondly with a coil of many turns taking a small current, the position of the core relatively to the coil being the same in each case.

Apparatus.—You are supplied with two coils of wire of the same length and internal diameter, one containing a small number of turns, the other containing a large number of turns, a source of current, ammeter, variable resistance, and spring balance to measure the pull on the soft iron core which just fits inside the coils.

Method.—(1) Connect up the thick wire coil in series with the battery, ammeter, and variable resistance. Suspend the soft iron core from the spring balance so that it hangs inside the coil. Adjust the distance it projects into the coil by experiment so as to get roughly the position where the force exerted on it is a maximum for any given current.

(2) Switch on a small current in the coil, adjust the position of the coil so that the core projects inside it by the exact amount found in (1). Note the reading of the ammeter and spring balance.

(3) Gradually increase the current strength, noting the current and the corresponding magnetic pull on the core in each case.

The coil must always be adjusted so that for each different current strength the projection of the core into it is the same.

(4) Repeat experiments (1), (2), and (3), using the fine wire coil with the same iron core.

Tabulate your results thus:—

Number of turns on coil.	Current.	Ampère turns.	Spring balance reading.

Plot a curve for each coil with ampère turns as abscissæ against spring balance readings as ordinates.

NO. 31.—EXPERIMENTS WITH ELECTRO-MAGNETS
(NO. 2)

Preliminary.—In this experiment you are required to investigate the relations between the pull exerted on the core of an electro-magnet and the position of the core, for various current strengths, and for different-sized magnets.

Apparatus.—You are supplied with two electro-magnets of equal length and wound with the same number of turns of the same sized wire. One of these coils has, however, half the internal diameter of the other, and its core is half the diameter of the core of the larger coil. You have in addition a battery, variable resistance, ammeter, and spiral spring to measure the pull on the magnet core.

Method.—(1) Connect up the larger coil in series with the battery, variable resistance, and ammeter. Place the core so that it projects $\frac{1}{10}$ of its length inside the coil.

(2) Switch on a small current and adjust the position of the coil so that the core is exactly $\frac{1}{10}$ of its length inside the coil. Note the current and the spring balance reading.

(3) Repeat for various currents up to the largest current you can use.

(4) Repeat (1), (2), and (3) with the core projecting successively 0·2, 0·3, 0·4, 0·5, 0·6, 0·8, and all its length inside the coil, with the same current values as above.

(5) Repeat above, using the smaller coil and core.

Tabulate your results thus :—

Number of turns on coil.	Current in coil.	Ampère turns.	Spring balance reading.	Projection of core in coil.	Particulars of coil.

Plot a set of curves for each coil, having spring balance readings as ordinates against projection of the core into the coil as abscissæ, each curve corresponding to a definite current strength.

NO. 32.—TESTING THE MAGNETIC FLUX IN AN
ELECTRO-MAGNETIC CIRCUIT

Preliminary.—In the following experiment you are required to compare the relative values of the magnetic flux in various parts of the magnetic circuit of an electro-magnet under various conditions. To measure the flux, a test coil is wound round the part of the magnetic circuit under test and connected directly to a ballistic galvanometer, *i.e.* a galvanometer in which the first swing of the needle is proportional to the quantity of electricity discharged through it. In this case the first swing will also be proportional to the magnetic flux.

Apparatus.—You are supplied with a source of current, ammeter, resistance, ballistic galvanometer, reversing key, and an electro-magnet with two magnetizing coils.

Method.—(1) Connect up the battery, ammeter, and one of the magnetizing coils thus :—

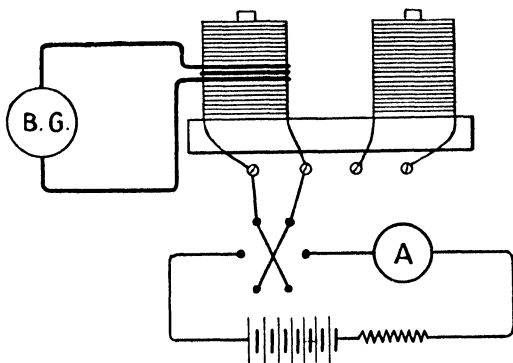

FIG. 17.

Wind the test coil round the middle of the electro-magnet coil, connecting the ends direct to the galvanometer.

(2) Adjust resistance till the ammeter reads 1 amp.

(3) *When the galvanometer needle is perfectly steady* rapidly reverse the current. Note the first swing of the galvanometer needle. Repeat this three times.

(4) Place the test coil successively at each end of the magnetizing coil, and at the centre and each end of the opposite coil. Repeat observations, always keeping the current the same.

(5) Place the large armature across the pole pieces and repeat; also take a reading with the test coil wound the same number of times round the centre of the armature.

(6) Connect the two magnetizing coils in series so that their magnetizing effects are also in series, and repeat all the above, keeping the current always the same.

Tabulate thus:—

Position of test coil.	Galvanometer swing.	Current.	Conditions of magnetic circuit.

(7) Calculate the ratio of the total flux to the flux obtained various parts of the magnetic circuit. This is termed the leakage coefficient. Tabulate thus:—

Part of magnetic circuit.	Leakage coefficient.	Magnetizing coil conditions.

NO. 33.—MAGNETIZATION OF IRON

Preliminary.—You are required to investigate the relations between the magnetizing force applied to an iron bar and

the magnetic flux produced. The magnetizing force is applied by placing the iron bar inside a long solenoid through which a current is passed, the magnetizing force then being proportional to the product of the current in ampères and the number of turns of wire on the solenoid, *i.e.* the ampère turns. The relative values of the magnetic flux produced are obtained by placing the bar so that its axis lies at right angles to the axis of a magnetic needle, and observing the deflections produced on the latter when various currents are sent through the solenoid. The tangent of the angle of deflection of the magnetic needle may be taken as proportional to the magnetic flux.

Apparatus.—You are supplied with a long solenoid containing a known number of turns (N), a battery, variable resistance, ammeter, reversing key, and magnetometer.

Method.—(1) Connect up the solenoid to the reversing key, battery, variable resistance, and ammeter, and place it so that its axis is at right angles to the axis of the magnetometer needle, as in diagram.

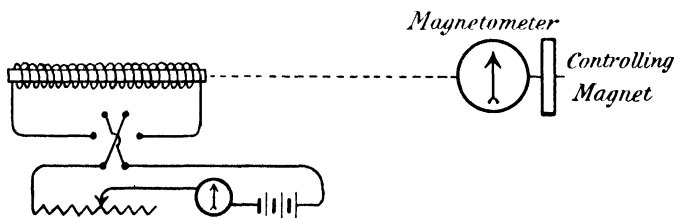

FIG. 18.

(2) Adjust the position of the controlling magnet so that with the largest current to be used a deflection of about 70° is obtained on the magnetometer.

(3) With the maximum current switched on, rapidly reverse the current, and whilst so doing gradually increase the variable resistance till the current is reduced to a minimum, and finally break the circuit. This will de-magnetize the iron bar. Adjust the magnetometer needle to zero by means of the controlling magnet.

(4) Switch on the smallest current, read the current (C) and magnetometer deflection (d).

(5) Slowly increase the current so as to increase the magnetometer deflection by about 5° at a time, taking the corresponding readings of current until the maximum current has been reached.

(6) Without breaking the circuit, gradually reduce the current until the minimum value has been reached.

(7) Reverse the current in the solenoid, and again increase to maximum value, taking readings as in (5).

(8) Gradually reduce current to zero, and repeat readings as in (6).

Note.—All magnetometer deflections to the right are called positive, whilst those to the left are negative; also currents after reversal are called negative.

Tabulate your readings thus :—

Current C.	Number of turns on coil N.	Ampère turns CN.	Magnetometer deflections d .	Tan d .

Plot a curve with values of CN as abscissæ against tan d as ordinates, remembering that all deflections to the left will be plotted below the horizontal axis, and all negative ampère turns to the left of the vertical axis.

Point out where your curves indicate (1) The Remanence, (2) The Coercive force, (3) Hysteresis loss.

NO. 34.—PERMEABILITY TESTING BY EWING'S INDUCTION BALANCE

Preliminary.—This instrument is intended for the rapid magnetic testing of samples of castings or forgings for magnets of dynamos. The sample is turned to the form of a rod 4 inches

long and $\frac{1}{4}$ inch diameter. This rod is laid across the poles of an electro-magnet, and the force required to detach it from one pole is measured: from this measurement the induction in the

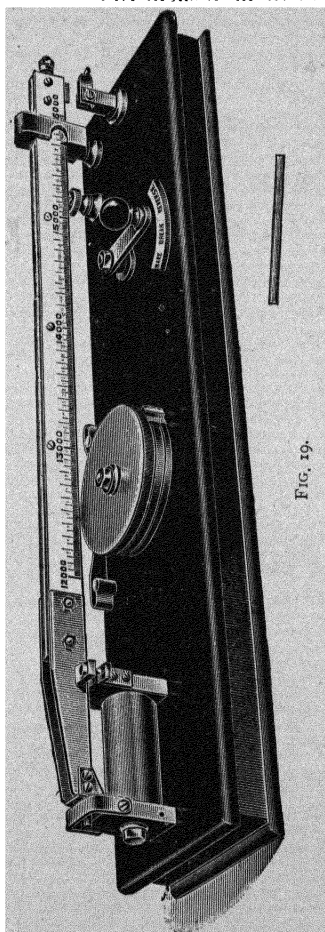

FIG. 19.

rod may be found. The strength of the electro-magnet is such that the bar is subjected to a magnetizing force (H) of 20 C.G.S. units, as this is found to be the best value of H if the magnetic qualities of the samples are to be inferred from

the value of the induction (B) in them. This magnetizing force is obtained by calibrating the apparatus with a standard bar, the value of B for which is known when $H = 20$.

Apparatus.—You are supplied with an induction balance (see Fig. 19) and battery, a standard bar, and set of iron and steel bars of various brands all turned to the standard size.

Method.—(1) To standardize the apparatus, place the standard bar in position, raising the stop at the end of the beam so that the bar is in contact with both poles of the electromagnet. Reverse the current once or twice to remove any previous magnetism from the bar. Then place the sliding weight at the number on the scale representing the value of B in the standard bar, and with the key at “make” adjust the current strength till the beam just drops each time the support is removed. The apparatus is now standardized.

(2) Remove the standard bar and replace by each of the sample bars in turn. Do not alter the current strength, but adjust the sliding weight until the beam just drops every time the support is removed. The scale reading of the sliding weight gives the value of B for $H = 20$. Tabulate your results thus:—

Specimen.	H.	B.	$\mu = \frac{B}{H}$.

In case the current should alter, restandardize the balance before testing each of the specimen bars.

In placing a bar in position see that the beam is first lifted by the stop at the end, and before removing the stop reverse the current once or twice. Before removing a rod, lift the far end of the beam by means of the stop, and put the key at “break.”

On each occasion after using the standard bar, replace it at once in the drawer. Do not let it get mixed with the other bars or fall on a hard surface.

NO. 35.—EXPERIMENTS WITH SMALL SHUNT-WOUND MOTOR

Preliminary.—In this experiment you are to familiarize yourself with the action of a small shunt-wound motor, testing the effect of varying P.D. on speed; direction of current on direction of rotation; shunt resistance on speed, etc.

Apparatus.—You are supplied with a small shunt-wound fan motor, source of current, variable resistance, two ammeters, a voltmeter and speed counter, also a brake for applying a constant load to the machine.

Method.—(1) Connect up the apparatus thus:—

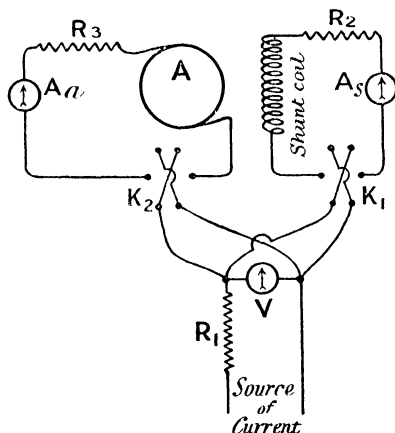

FIG. 20.

The variable resistance R_1 is placed in series with the source of current so as to diminish the available P.D. as measured at V . The resistance R_2 , ammeter A_s , and reversing key K_1 , are placed in the shunt circuit. The resistance R_3 , ammeter A_a , and reversing key K_2 , are placed in series with the armature so as to reduce the P.D. at the brushes and current in armature.

(2) With maximum value for V , $R_2 = 0$ and $R_3 = 0$, switch on current. (Notice this must be done gradually,

starting with all the resistance R_1 in circuit, and cutting out resistance as the speed increases.) Take readings on all the instruments, and also the speed.

(3) Gradually alter R_1 so as to decrease V , and take a series of readings as above.

(4) Start motor, and when V is normal increase R_2 gradually. Note results.

(5) Repeat (4), but alter R_3 instead of R_2 .

(6) Test the effect of reversing the current in the armature only by the reversing key K_2 .

(7) Test the effect of reversing the current in the shunt coil only by the reversing key K_1 .

(8) Test the effect of reversing the current both in the armature and shunt coils.

Tabulate your results thus:—

Number of test.	V.	A_a .	A_s .	Total current.	Speed.

Plot curves of the following relations:—

- (1) Speed and V .
- (2) Speed and A_s , V constant.
- (3) Speed and A_a , V constant.

What deductions would you make from the results of tests (6), (7), and (8), as to the method of reversing the direction of rotation of a shunt motor?

PART II

NO. 36.—CURRENT-CARRYING CAPACITY OF WIRES OF VARIOUS GAUGES AND MATERIALS

Preliminary.—In the following experiment you are required to investigate the relation between the currents that can be sent through bare wire spirals of various metals and alloys, and the rise of temperature produced, with a view to finding the safe current-carrying capacity of the wires. The same length of wire is taken in each case and wound on a mandril into a close spiral, care of course being taken that the windings are not so close as to short circuit. The diameter of the mandril is such that when the spiral is removed from it, it will be possible to put the bulb of a delicate thermometer into the spiral.

Apparatus.—You are supplied with a set of bare wires of various gauges and materials, an ammeter, variable resistance, switch, two thermometers, and a source of current.

Method.—(1) Cut off a length of 1 metre of wire from one of the bobbins, and wind it on the mandril into a close spiral.

(2) Connect the spiral in series with the battery, ammeter, variable resistance, and switch.

(3) Place one of the thermometers so that its bulb is right inside the spiral, and hang the other up to read the temperature of the room.

(4) Switch on a small current, and keep it at a constant value until the thermometer in the spiral has ceased rising. Take readings on both thermometers and on the ammeter.

(5) Repeat with gradually increasing currents, until the limit of the thermometer reading has been reached.

(6) Remove the thermometer, and now increase the current

slowly, until the wire will just char a piece of dry wood. Note this current.

(7) Repeat with each of the wires supplied you.

Tabulate your results thus :—

Material of wire.	Gauge S.W.G.	Diam. cms. (d).	Room temp.	Wire temp.	Excess temp.	Current (ampères).	Remarks.

Plot a curve for each of the wires, connecting current with excess temperature : also a curve connecting excess temperature and diameter, for the same current strength, in different sizes of the same wire.

By plotting the logarithms of the above quantities, see if any exponential law connects them.

NO. 37.—EFFECT OF HARDENING AND ANNEALING ON THE ELECTRICAL RESISTANCE OF A WIRE

Preliminary.—The electrical resistance of a wire is constant for all values of current so long as its physical state remains unaltered, but if by any means its physical state becomes changed, it will be found to produce a change in its resistance. In the following experiment you are required to investigate the effect on the electrical resistance of various wires of the hardening produced by winding them into a coil of small diameter, and subsequently the annealing effect produced by heating the spirals in water.

Apparatus.—You are supplied with a Wheatstone wire bridge set for measuring resistance, a supply of wire of various gauges and materials, a micrometer wire gauge, metre rod, mandril (1 mm. diameter), a vessel of boiling water, and a thermometer.

Calibration of a Voltmeter by Potentiometer Method 55

Method.—(1) Carefully measure off a length of 100 cms. of wire from one of the coils.

(2) Measure the resistance accurately on the bridge. Note the temperature.

(3) Coil this length of wire round the mandril so as to make a tight spiral.

(4) Again measure the resistance of the wire, taking great care that *exactly* the same length of wire is included between the bridge terminals as in (2).

(5) Repeat above for each of the specimens of wire supplied.

(6) Place all the spirals in the vessel of boiling water for half an hour, then remove them and when they have cooled to the original temperature re-measure their resistances.

Tabulate your results thus :—

Material of wire.	Gauge S.W.G.	Diam. cms.	Length cms.	First resistance.	Resistance after coiling.	Per cent. change of resistance.	Resistance after boiling.	*Per cent change of resistance

NO. 38.—CALIBRATION OF A VOLTMETER BY POTENTIOMETER METHOD

Preliminary.—In the following experiment you are required to calibrate a voltmeter reading up to 100 volts by means of a potentiometer, standard cell, and ratio resistance box. As the potentiometer is only designed to measure voltages of the order of two volts, it is necessary to make arrangements to measure on the potentiometer a definite fraction of the P.D. at the voltmeter terminals, from which the actual P.D. can be calculated. This definite fraction is obtained by using the ratio resistance box, which consists of a high resistance in parallel with the voltmeter so arranged that potential terminals are taken off from a known fraction of its total value. A preliminary experiment is necessary to test the accuracy of the ratio box.

The diagram of connections of the ratio box is shown in Fig. 21.

The total resistance between 1 and 0 is about 10,000 ohms, and the numbers give the fractions of this resistance included between 0 and the respective points.

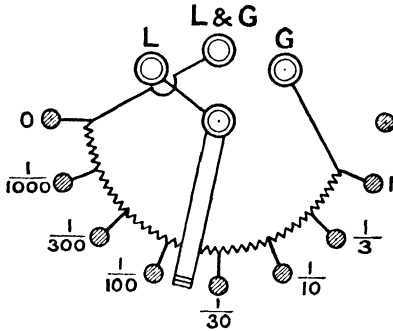

FIG. 21.

Apparatus.—You are supplied with a ratio box, potentiometer, battery, voltmeter, variable resistances, standard cell, and source of E.M.F.

Method.—(A) *To test the accuracy of the ratio box.*

(1) Place a cell across the terminals marked L & G and G. Take potential wires to the potentiometer from the terminals marked L & G and L. Turn the switch to 1 and balance on the potentiometer. Then place the switch at each of the other points $\frac{1}{3}$, $\frac{1}{10}$, etc., in turn, and take readings.

Tabulate thus :—

Number of ratio box... ..

Dial reading.	Potentiometer balance.	Balance at fraction Balance at 1

(B) To calibrate the voltmeter.

(1) Connect up as in Fig. 22. Place the switch of the ratio box at $\frac{1}{100}$. By sliding the contact P across its resistance

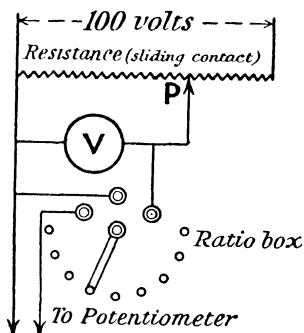

FIG. 22.

any voltage from 0 to 100 may be obtained at the voltmeter terminals, and $\frac{1}{100}$ of it will be measured on the potentiometer. Tabulate thus:—

Type of voltmeter..... Number of voltmeter.....
Position.....

Voltmeter reading.	Potentiometer reading.	Potentiometer reading $\times 100$.

The potentiometer should be adjusted to read directly in volts, and it should be re-standardized frequently by the cadmium standard cell.

Take a set of rising and falling readings on the voltmeter and plot two calibration curves. If the ratio box is inaccurate show how the corrections should be made.

NO. 39.—MEASUREMENT OF THE CONSTANT OF A
SIEMENS ELECTRO-DYNAMOMETER BY MEANS
OF A KELVIN CURRENT BALANCE

Preliminary.—In the Kelvin current balance the magnetic force between coils of wire carrying the same current is measured directly by balancing it against known weights. Hence, since the force of gravity forms the controlling force of the instrument, and as the cores of the coils are non-magnetic, there is very little probability of the constants of the instrument altering once it has been standardized, unless it suffers mechanical damage. For this reason the Kelvin balance is frequently employed as a standard current-measuring instrument, its constant being determined once for all by means of a copper voltameter. In the ordinary type of balance there are six coils, four fixed and two movable, these latter being attached to the ends of a beam hung from its centre by copper filaments, in such a manner that each coil is free to move between two fixed coils. The coils are all in series, the current being conveyed to the movable coils by means of the copper filaments. The direction in which the current traverses the coils is shown in the diagram, and is such as to produce magnetic forces at each of the movable coils tending to rotate the movable beam in a counter-clockwise direction. Several sets of weights are supplied with the balance so as to enable a large range of current to be measured.

Apparatus.—You are supplied with a Kelvin current balance, Siemens electro-dynamometer, variable resistance, switch, and source of current.

Method.—(1) Connect the current balance in series with the fine coil of the Siemens dynamometer, the variable resistance, switch and battery.

(2) Place on the beam of the current balance, the particular weight and corresponding counterpoise which will be required for the magnitude of the current to be measured.

(3) Set the movable weight of the balance at zero on the scale, and if the pointers of the balance beam do not indicate

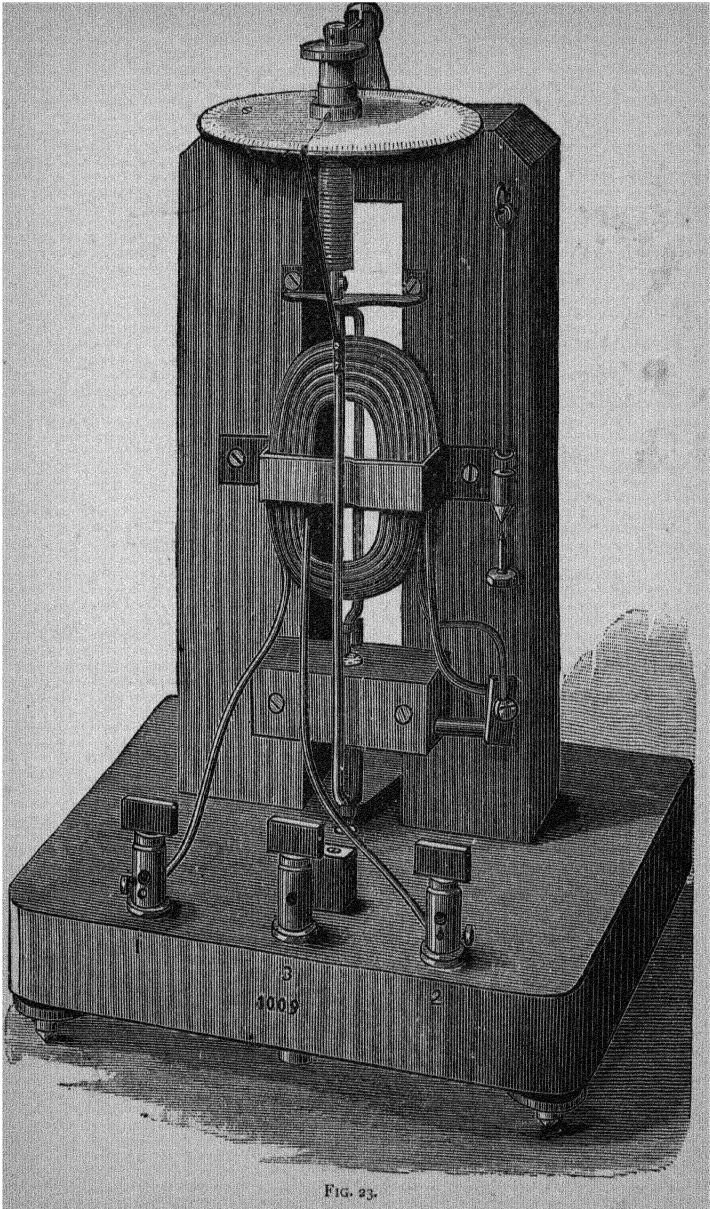

FIG. 23.

exact equilibrium on the end scales, make the exact adjustment by means of the movable brass "flag" attached to the balance beam. Do not alter the position of this "flag" again during the test.

(4) Set the Siemens dynamometer level, with the plane of the moving coil perpendicular to the magnetic meridian, and place the torsion head at zero on the scale.

(5) Switch on a current, and adjust it by means of the variable resistance until the dynamometer torsion head reads 100 scale divisions, when the moving coil pointer is at zero. Slide the movable weight of the Kelvin balance along the scale till the beam of the balance is in exact equilibrium, with its pointers at the zeros on the end scales. Read the position of the pointer attached to the sliding weight on the finely divided scale of the balance.

(6) Repeat for dynamometer readings of 200, 300, and 400.

(7) Repeat, using the thick wire coil of the dynamometer, if necessary altering the sliding weight and counterpoise in the current balance to measure the larger current.

Tabulate thus:—

Dynamometer No. Kelvin balance No.

Dynamometer terminals connected up.	Dynamometer reading (d).	\sqrt{d} .	Kelvin balance weight used.	Kelvin balance reading (r).	$2\sqrt{r}$.	Current per 1 scale div. Kelvin balance.	Current in ampères C.	Dynamometer constant $K = \frac{C}{\sqrt{d}}$

NO. 40.—STANDARDIZATION OF A KELVIN BALANCE BY COPPER VOLTAMETER

Preliminary.—The copper voltameter is chosen as a standard current measurer on account of the invariability of the electro-chemical equivalent of copper under changing local conditions, provided the temperature, strength, and

purity of the copper sulphate solution remain the same. The best strength of solution to employ is one of specific gravity 1.18 to which has been added 1 per cent. by volume of strong sulphuric acid. The quantity of solution used is 3 c.c. per sq. mm. plate area immersed, and the solution should be renewed after being in use for an aggregate time of 10 hours. Each kathode should have an anode on either side of it. The value of the electro-chemical equivalent to be employed will depend on the current density at the kathode. Values of the electro-chemical equivalent (e) at various current densities and temperatures are given below.

Kathode area in sq. cms. per ampère.	Values of electro-chemical equivalent (e).		
	12° C.	23° C.	28° C.
50	0.0003287	0.0003286	0.0003286
100	0.0003284	0.0003283	0.0003281
150	0.0003281	0.0003280	0.0003278
200	0.0003279	0.0003277	0.0003274
250	0.0003278	0.0003275	0.0003268
300	0.0003278	0.0003272	0.0003262

As the Kelvin balance (Fig. 24) is supplied with three sets of weights, corresponding to the various ranges of current strength, it will be necessary to standardize for each weight.

Apparatus.—You are supplied with a Kelvin balance, copper voltameter with several kathodes, variable resistance, balance, stop watch, and battery.

Method.—(1) Calculate from the approximate maximum current corresponding to each of the Kelvin balance weights, the area of kathode surface necessary to correspond to one of the electro-chemical equivalents in the above table. Adjust the voltameter by adding or removing kathodes until the required plate area is obtained. (Note.—Always place an anode on either side of a kathode.)

(2) Adjust the Kelvin balance as in Experiment No. 39, so that its beam-pointers stand at zero. Place the smallest weight in the sliding carriage, and the corresponding counterpoise on the end of the beam. Adjust the sliding weight to

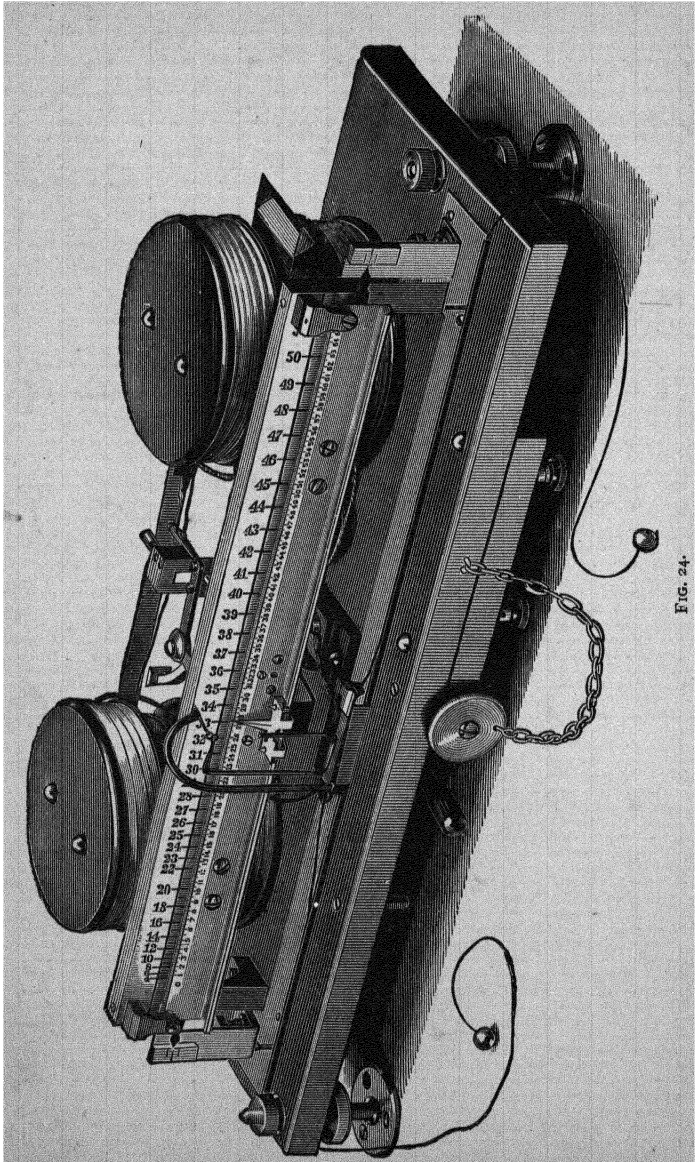

FIG. 24.

the largest reading on the moving scale. Connect the balance in series with the battery, variable resistance and voltameter. Switch on the current, having first verified the fact that the anode is connected to the positive terminal of the battery, and adjust the current until the Kelvin balance beam is in equilibrium.

(3) Switch off the current, remove the kathode (or kathodes if more than one), *immediately* plunge into a tank of water acidulated with sulphuric acid, remove and wash thoroughly in tap water, dry carefully between clean hot sheets of blotting-paper, and when quite cool weigh.

(4) Replace kathode in the voltameter, switch on the current, noting the time exactly on the stop watch. Keep the strength of the current constant, being that corresponding to the maximum scale reading of the Kelvin balance.

(5) After thirty minutes switch off current. Remove kathode, plunge in acidulated water, wash in tap-water, dry in hot blotting-paper, cool and re-weigh.

(6) Repeat above for each of the Kelvin balance weights in turn.

Tabulate thus :—

Kelvin balance weight used.	Kelvin balance scale reading when current flowing d .	$2\sqrt{d}$.	Kathodes.						Total weight of copper deposited W .	Time of deposition seconds t .	Current $\frac{W}{ct}$	Kelvin balance constant $\frac{W}{2\sqrt{det}}$
			Weight before deposition.			Weight after deposition.						
			A.	B.	C.	A.	B.	C.				

NO. 41.—MEASUREMENT OF INSULATION RESISTANCE OF A CABLE BY LOSS OF CHARGE METHOD

Preliminary.—When a cable is charged electrostatically by connecting it to a battery, the first swing of the needle of a ballistic galvanometer in series with it is proportional to the

quantity of electricity given to the cable. If the cable is now insulated for t seconds some of the charge will leak out, and on recharging a smaller swing will be observed on the galvanometer needle, which is proportional to the quantity which has leaked away. If d_1 and d_2 are the respective swings, R the resistance of the dielectric in megohms, and K the capacity of the cable in microfarads, it can be shown that the resistance R in megohms is—

$$R = \frac{t}{K \log_e \frac{\delta_1}{\delta_1 - \delta_2}} = \frac{0.4343t}{K \log_{10} \frac{\delta_1}{\delta_1 - \delta_2}}$$

Apparatus.—You are supplied with a cable in a tank of water, the ends being carefully insulated, a source of E.M.F. of about 100 volts, ballistic galvanometer, and insulating key.

Method.—(1) Test the galvanometer for any leak by connecting EACH galvanometer terminal, IN TURN, to the positive terminal of the supply. If no deflection is obtained the galvanometer insulation is satisfactory: if otherwise, it must be freshly insulated on blocks of clean paraffin wax. When satisfactory connect up the apparatus thus:—

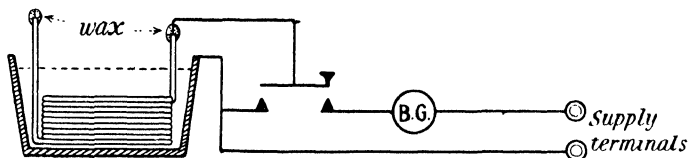

FIG. 25.

(2) Discharge cable by allowing key to rest on back contact.

(3) Charge by pressing key on front contact: observe the first swing of the galvanometer needle.

(4) Insulate the cable by leaving key in middle position, and note the time.

(5) After t seconds recharge cable and note the galvanometer throw.

(6) Repeat, taking various values of t from 10 sec. to 15 mins.

The value of K is determined by a separate experiment.

Tabulate results thus :

Size of cable..... Nature of insulation..... Diam. outside insulation..... Do. inside.....

Length of cable.	δ_1 .	δ_2 .	l .	R.

Calculate specific insulation resistance from formula—

$$\rho = \frac{2\pi Rl}{\log_e \frac{r_2}{r_1}} = \frac{0.8686\pi Rl}{\log_{10} \frac{r_2}{r_1}}$$

where r_1 = radius of core, r_2 = external radius.

To find the capacity of the cable, replace the cable in the above experiment by the standard condenser, and reduce the charging E.M.F. to 1 per cent. of the value employed with the cable. Note the first swing of the galvanometer needle D on charging the condenser. If K = capacity of standard condenser, and k the capacity of the cable, then—

$$k = \frac{Kd_1}{100D_1}$$

since for equal charging pressures the capacities may be taken as proportional to the galvanometer needle-swings.

NO. 42.—MEASUREMENT OF INSULATION RESISTANCE (GUARD RING)

Preliminary.—The method employed in this experiment is simply an application of Ohm's law. A current is sent through the specimen under test, the current being measured on a sensitive galvanometer which has been previously calibrated. The testing E.M.F. is also known, and the resistance can therefore be readily calculated. The material supplied is in the form of thin sheets, which are placed between two

brass plates, connected to the source of E.M.F. through the galvanometer. To prevent any leakage current flowing round the edges of the sheets, the guard-ring arrangement of Price is used. The guard ring is at the same potential as the upper brass plate, thus preventing any surface leakage from it. The galvanometer is connected directly to the upper plate, thus indicating only the current passing through the insulating material. The area of the upper plate, therefore, gives the area of insulating material through which the measured current passes. The E.M.F. is obtained from the voltmeter reading, and the thickness of each sheet by micrometer gauge.

Apparatus.—You are supplied with a guard ring apparatus, sensitive galvanometer whose calibration curve has been obtained, key, voltmeter, set of insulating sheets, micrometer gauge and source of E.M.F.

Method.—(1) Connect up apparatus as in diagram.

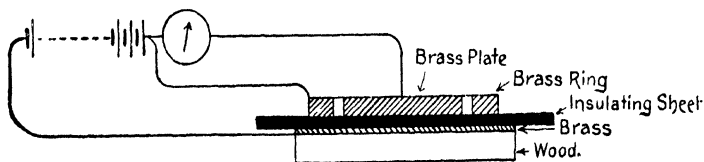

FIG. 26.

TAKE GREAT CARE NEVER TO ALLOW THE UPPER PLATE OR GUARD RING TO COME IN CONTACT WITH THE LOWER PLATE, as this involves the risk of burning out the galvanometer. During the changing of specimens, set the galvanometer shunt-box switch at zero.

(2) Before switching on the current see that the galvanometer spot of light is at zero, and the sheet of material properly placed between the plates, and that there is no direct contact between upper and lower plates.

(3) Complete the circuit at the switch, and after waiting one minute read the deflection.

(4) Repeat for each specimen in turn.

(5) Measure the thickness of each sheet with the micrometer gauge.

Tabulate your results thus :—

Material.	Thickness (cms.) l .	Area (sq. cms.) A .	Deflection.	Current (amps.).	E. M. F. (volts).	Resistance (ohms) R .

Calculate the specific resistance of each material; $\rho = \frac{RA}{l}$.

If in any case the deflection goes off the scale, shunt the galvanometer, and calculate the true deflection by multiplying the observed deflection by the shunt value.

No. 43.—CONSTRUCTION OF CADMIUM STANDARD CELLS

Preliminary.—You are required to construct a crystal type cadmium standard cell.

Materials required.—(1) Containing vessel of glass, $2\frac{1}{2}'' \times 1\frac{3}{4}''$ (internal).

- (2) Quill glass tubing.
- (3) Platinum wire 0.008'' diam. and foil.
- (4) Mercury.
- (5) Cadmium (stick).
- (6) Mercurous sulphate, Hg_2SO_4 .
- (7) Cadmium sulphate, $CdSO_4$.
- (8) Distilled water.
- (9) Fine copper wire (bare), also 3'' No. 24 S.W.G.
- (10) Paraffin wax.
- (11) Marine glue.

Apparatus.—(1) Large glass mortar and pestle.

- (2) Small glass mortar and pestle.
- (3) Balance and weights.
- (4) Three porcelain evaporating basins.
- (5) Two burettes (small).
- (6) Bunsen burner and stand.

- (7) Gas blowpipe.
- (8) Glass flask (small).
- (9) Three glass rods.
- (10) Small hammer.

Method.—(1) Cut a piece of platinum foil $1'' \times \frac{1}{4}''$.

(2) Cut off a piece of platinum wire $3\frac{1}{4}''$ long.

(3) Heat the foil and wire in the blowpipe flame and weld the wire to one end of foil.

(4) Cut a piece of glass tubing $2\frac{1}{2}''$ long.

(5) Thread the glass tube over platinum wire and fuse up the end close to the foil.

(6) Cut off another piece of platinum wire about 2'' long and bend one end into a small loop.

(7) Grind up 150 gms. CdSO_4 crystals in large glass mortar until the powder is free from small hard particles.

(8) Dissolve up 50 gms. of CdSO_4 in about 50 c.c. distilled water until the solution is saturated. (This should be kept standing for two or three days, as the CdSO_4 is nearly equally soluble at all temperatures.)

(9) Weigh out 204 gms. of mercury and 34 gms. cadmium.

(10) Place the cadmium in the mercury and apply gentle heat; stir up from time to time with glass rod till all the cadmium is dissolved: allow to cool, when the liquid should solidify.

(11) Place about 25 c.c. of Hg_2SO_4 in small mortar, a drop or two of mercury, and add drop by drop from the burette some saturated CdSO_4 solution. Mix up thoroughly with glass pestle till the mass has the consistency of very thick cream and the mercury globules are thoroughly mixed up with the paste.

(12) Clean out glass vessel and pour in 80 grammes of mercury.

(13) Heat platinum foil to white heat in a bunsen flame and plunge into a vessel of mercury. This amalgamates the platinum.

(14) Place the foil flat in the bottom of the glass vessel and pour in the Hg_2SO_4 paste, gently tapping the vessel on the table to make the paste settle down.

(15) On the top of the paste pour in powdered CdSO_4 till

you have a layer about $\frac{1}{2}$ " thick. Gently pack the CdSO_4 down with a glass rod, *taking care not to force some of the mercury at the bottom of the vessel through the paste.*

(16) Pour in *drop by drop*, from a burette, some saturated CdSO_4 solution till the whole of the CdSO_4 crystals are *moist*. If necessary introduce more CdSO_4 powder until you have a tightly packed layer of *moist* powder $\frac{1}{2}$ " thick. (In packing in the powdered CdSO_4 be careful to keep the glass rod surrounding the platinum wire well in the centre of the glass vessel.)

(17) Make a few indentations in the surface of the powdered crystals with a glass rod.

(18) Melt the cadmium amalgam over the bunsen flame, and when *quite liquid* pour into the cell.

(19) Plunge the platinum wire you made in (6) into the molten amalgam so that when it solidifies the curved end will be embedded in the amalgam.

(20) Melt some paraffin wax in an evaporating basin and some marine glue in another.

(21) Make a close spiral of fine copper wire about 1" long by winding the wire round a copper wire about No. 24 gauge, and cut into two pieces.

(22) Pour molten paraffin wax into the cell to depth of about $\frac{1}{2}$ ".

(23) When the wax is solid slip the copper spirals over the two platinum wires and fill the cell up to the top with molten marine glue.

When finished the cell should appear as shown :—

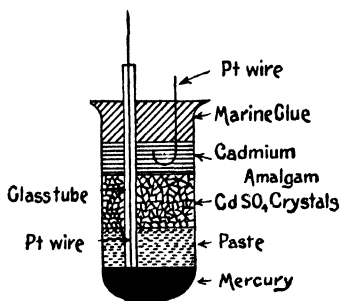

FIG. 27.

NO. 44.—MEASUREMENT OF THE AMPÈRE TURNS
REQUIRED IN A MOVING IRON AMMETER OR
VOLTMETER

Preliminary.—In the following experiment you are required to measure the ampère turns required to produce a full scale deflection in a moving iron type of ammeter or voltmeter, with the object of enabling you to calculate the number of turns of wire and gauge of wire that must be employed if the instrument is to be used for certain ranges of current or P.D. measurement.

Apparatus.—You are supplied with a moving iron instrument complete in every respect except that there is no winding on the bobbin. The space between the first and last scale divisions is divided into a number of equal divisions. You also have an ammeter, variable resistance, battery, supply of insulated copper wire of about No. 20 gauge, and some paper strip.

Method.—(1) Wind one layer of wire on the bobbin, and then fill up the bobbin almost to the top of the cheeks with paper strip; then wind another layer of wire containing the same number of turns on the top of the paper strip, thus representing the top and bottom layers of a fully wound bobbin. Note the total number of turns of wire.

(2) Mount the instrument and set its pointer to zero. Connect it in series with the ammeter, variable resistance, and battery.

(3) Starting with small currents take a set of readings of currents and deflections up to the top scale division.

Tabulate your readings thus :—

Number of turns of wire.	Current ampères.	Ampère turns.	Deflection.

Plot a curve with ampère turns as abscissæ against deflections as ordinates, and from the shape of the curve make any deductions you can as to the nature of the instrument scale when calibrated as an ammeter or voltmeter.

Take the dimensions of the bobbin, and on the assumption that the bobbin is to be completely filled with wire, calculate the gauge of wire that would be required if the instrument was to be used (A) as an ammeter with (1) 10, and (2) 100 ampères as the maximum scale reading; and (B) as a voltmeter allowing a resistance of 50 ohms per volt for ranges of (1) 100 volts, and (2) 500 volts: the wire on the coil to be copper, and the main resistance when used as a voltmeter to be of eureka in series with it. Calculate in each case the eureka resistance required.

Note.—If a = diameter of outside winding, b = diameter of inside winding, c = width of winding, d = diameter of bare wire, D = diameter of covered wire, l = total length of wire on bobbin, ρ = resistivity of wire, R = resistance in ohms of wire required to fill the bobbin—

$$l = \frac{\pi c(a^2 - b^2)}{4D^2}$$

and $R = \rho \frac{c(a^2 - b^2)}{D^2 d^2}$

Show how these formulæ are obtained.

NO. 45.—CALIBRATION OF A BALLISTIC GALVANOMETER FOR MEASUREMENT OF MAGNETIC INDUCTION

Preliminary.—When the magnetic field in a coil of wire has its value altered, a current is momentarily induced in it if its circuit is closed. It can be shown that the quantity of electricity (Q) induced in this way is proportional to $\frac{N}{R}$, where N is the total effective number of lines cut by the coil, and R the total resistance of the circuit. From this it will be seen that if R is kept constant, $N \propto Q$; *i.e.* in the case of a ballistic galvanometer, to the first throw of the galvanometer needle. In

this experiment you are required to obtain the relationship between N and the galvanometer throws for a given value of R .

Apparatus.—You are supplied with a current inductor, battery, reversing key, variable resistance, ammeter, and the galvanometer to be calibrated. The current inductor consists of a long solenoid of 800 turns of wire, mean diameter 10 cms. and length 100 cms. The total induction in it is 790 lines per ampère. Surrounding the centre of this is a test coil of 500 turns of fine wire of resistance 235 ohms. The galvanometer is connected in series with this coil and with a resistance box if necessary.

Method.—(1) Connect up the apparatus as in the diagram.

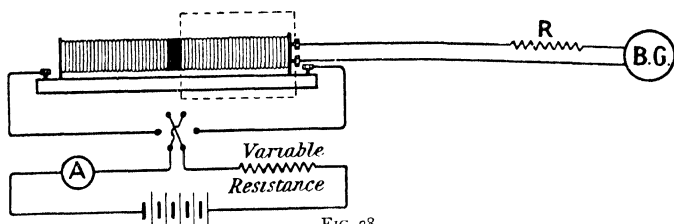

FIG. 28.

(2) Adjust the resistance R so that on reversing a current of not more than 10 ampères in the solenoid, the galvanometer needle just deflects to the end of the scale. This will correspond, of course, to a total cutting of $2 \times 790 \times C \times 500$ lines of force, where C is the current in the solenoid. This gives $N = 790,000 \times C$ lines of force.

(3) Note the galvanometer throw with the reversal of this and various other currents in the solenoid. Tabulate your results thus :—

Type and Number of Galvanometer..... Particulars of Sensibility and Control... ..

Current in solenoid.	Galvanometer throws.		N.	Res. of galv. + test coil.	Resist-ance R.	Total resistance of galvanometer circuit.
	To right.	To left.				

Plot two curves, one for throws to right and one for throws to left, against N .

Show how you would apply the above results if the same galvanometer were used with another test coil of different resistance and different number of turns.

NO. 46.—MEASUREMENT OF PERMEABILITY BY HOPKINSON PERMEAMETER

Preliminary.—In this instrument the specimen rod to be tested is in two parts and is magnetized by two magnetizing coils. The two parts are placed end to end, the contact surfaces of the two bars being carefully faced up. The free ends of the bars pass into a massive soft iron yoke to provide a return path for the lines of force. A small test coil of known number of turns surrounds the bar at the point of contact, and the magnetic induction is determined by separating the bars and quickly removing the test coil, which thus cuts all the lines of force in the bars. The test coil is connected to a ballistic galvanometer which has been calibrated so that the number of lines cut by the coil can be found from the throw of the galvanometer needle.

Apparatus.—You are supplied with a Hopkinson permeameter, ballistic galvanometer of known constant, battery, regulating resistance, ammeter, and reversing switch.

Method.—Connect the apparatus as shown in the diagram.

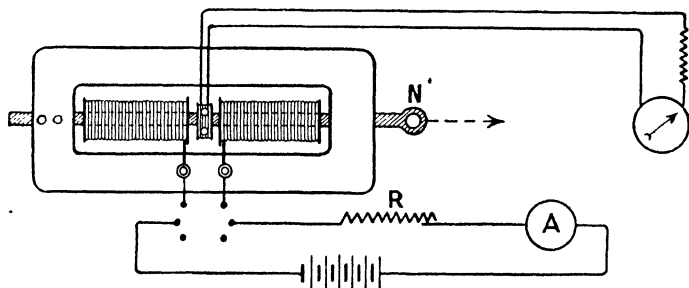

FIG. 29.

(1) Adjust the resistance to get a current of about 0.1

ampère. Open the galvanometer circuit and reverse the current several times, to remove the effect of previous magnetizations.

(2) Close the galvanometer circuit; pull out the bar N, and note the first swing of the spot of light when the test coil springs out.

(3) Replace the test coil and bar, increase current to 0.2 ampère, and repeat.

(4) Continue in this way till a current of 1 ampère is reached.

The value of H may be calculated from the relation $H = \frac{4\pi NC}{10} l$, where N = total number of turns, C = current in ampères, l = length of coil in cms.

The value of B is calculated from the deflection and the known galvanometer constant.

Tabulate your results thus:—

Magnetizing current.	H.	Galvanometer throw d .	Galvanometer const. K.	$B = kd$.

Plot a curve for the values of B against those of H.

NO. 47.—MEASUREMENT OF PERMEABILITY BY PERMEABILITY BRIDGE

Preliminary.—In this apparatus the permeability of the given specimen is found by comparing the magnetizing force necessary to produce the same induction in it as in a standard bar whose magnetic constants are accurately known. The two bars are placed in parallel magnetizing coils, the ends being joined by yokes of soft iron. From the yokes two long soft iron horns project upwards, and nearly meet above. In the

gap between the horns is placed a compass needle. When the induction in both bars is the same there will be no magnetic leakage from horn to horn, and hence on reversing the magnetizing force there will be no permanent deflection of the needle.

Apparatus.—You are supplied with a permeability bridge, battery, ammeter, variable resistance, and set of bars of various brands of iron.

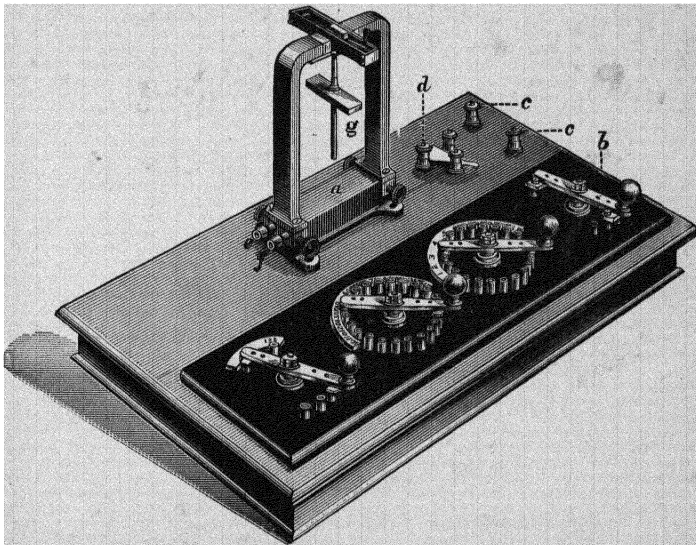

FIG. 30.

Method.—(1) Place one of the bars and the standard bar in position, and connect the bridge in series with a battery, ammeter, key, and variable resistance.

(2) Set the two-way switch to 100; this puts 100 turns on the magnetizing coils of the standard bar.

(3) Adjust the resistance to get a current of about 1 ampère. Reverse the current repeatedly, and adjust the dial switches until on reversing no permanent deflection of the needle results. In judging the effect of each reversal bring the needle each time to its middle position by the

directing magnet. Read the numbers on the dials when a balance is obtained.

(4) The length of the bars is so chosen that H is 10 C.G.S. units per ampère for the standard bar. The magnetizing force on the specimen necessary to produce the same induction as that in the standard bar will be $H \times \frac{\text{dial reading}}{100}$.

B is found from the B - H curve for the standard bar (supplied), and is the value of B which corresponds to the value of the magnetizing force on the standard bar. Take about 10 readings, and do not increase the current beyond 10 ampères.

Tabulate thus:—

Number of turns on standard bar.	Magnetizing current.	H .	Dial reading.	H' , magnetizing force on specimen bar.	B .	Permeability $\mu = \frac{B}{H'}$.

The dial switches alter the number of turns on the magnetizing coils of the specimen bar, but also insert equivalent resistance, so that the current is unaltered. If the largest number of turns given by the dials is not enough to produce a balance, the number of turns on the coils of the standard bar may be reduced to 50 by means of the two-way switch, so that H becomes 5 C.G.S. units per ampère. Repeat for each of the bars supplied you.

Plot the B - H curve from your readings.

NO. 48.—MEASUREMENT OF PERMEABILITY BY BAR AND YOKE METHOD

Preliminary.—One of the most serious drawbacks to the various methods of measuring the magnetic permeability of short iron or steel bars is the difficulty of applying a correction for the demagnetizing effect of the joints in the magnetic

circuit. The following method, which is due to Prof. Ewing, gets over this difficulty by making two sets of measurements of apparent magnetizing force and flux density for two different lengths of magnetic circuit. From these the proportion of total magnetizing force which is taken up in overcoming the demagnetizing effect of the joints, and which is assumed to be the same in the two sets of measurements, is calculated, and hence the real magnetizing force acting on the specimen can be found. The specimen bar is cut into two equal lengths, which are fitted into two adjustable yokes. Two sets of magnetizing and test coils are supplied, containing exactly the same number of turns of wire, one set being half the length of the other. If L_1 and L_2 are the lengths of specimen bar under test in the two cases, M_1 and M_2 the total magnetizing forces, H_1 and H_2 the true magnetizing forces acting on the specimen bars, then we have for experiments on lengths L_1 and L_2 —

$$M_1 = H_1 L_1 + h$$

and

$$M_2 = H_2 L_2 + h$$

where h is the part of the magnetizing force that overcomes the demagnetizing effect of the joints.

Hence

$$H_1 = \frac{M_1}{L_1} - \frac{h}{L_1}$$

and

$$H_2 = \frac{M_2}{L_2} - \frac{h}{L_2}$$

If now we take two values of magnetic force such that the value of B is the same for each, it follows that $H_1 = H_2$.

Therefore

$$\frac{M_1}{L_1} - \frac{M_2}{L_2} = \frac{h}{L_2} - \frac{h}{L_1}$$

and since $L_1 = 2L_2$

$$\frac{M_1}{L_1} - \frac{M_2}{L_2} = \frac{h}{L_1}$$

If we plot the values of $\frac{M_1}{L_1}$ and $\frac{M_2}{L_2}$, which are apparent magnetizing forces, against the values of B , by subtracting the horizontal distance between the two curves from the $B \frac{M_1}{L_1}$ curve, we get the true B-H curve for the iron.

Apparatus.—You are supplied with a pair of specimen

bars, and yokes, also a set of magnetizing and test coils of known number of turns and length, a calibrated ballistic galvanometer, reversing key, ammeter variable resistance and battery.

Method.—(1) Place the long coil on the specimen bars and clamp the yokes close up to the ends of the coils. Connect the magnetizing coils in series so that the magnetizing forces are also in series, and bring the wires from the coils to a reversing key which is connected in series with the variable resistance, ammeter and battery.

(2) Connect the test coils in series with the ballistic galvanometer so that the induced currents in them will also be in series.

(3) Starting with a small current, reverse the current, and note the throw on the ballistic galvanometer.

(4) Repeat with gradually increasing currents up to the maximum current.

(5) Repeat, using the short coils and half the bar lengths in place of the long ones.

(6) Tabulate thus :—

Total length of iron bar under test L_1 or L_2 .	Total turns on the two magnetizing coils = N .	Current amps. C.	Ballistic galv. throw.	Ballistic galv. constant with above test coils.	B.	$M = \frac{4\pi NC}{10}$

Plot two curves, one with $\frac{M \text{ values for long bar}}{L_1}$ against B and one for $\frac{M \text{ values for short bar}}{L_2}$ against B.

From these two curves obtain the third curve giving the true B-H values for the specimen.

NO. 49.—MEASUREMENT OF HYSTERESIS IN SPECIMENS OF TRANSFORMER IRON BY EWING'S HYSTERESIS TESTER

Preliminary.—The specimens to be tested are $\frac{5}{8}$ in. wide and 3 in. long, and are placed in a carrier which is rotated between

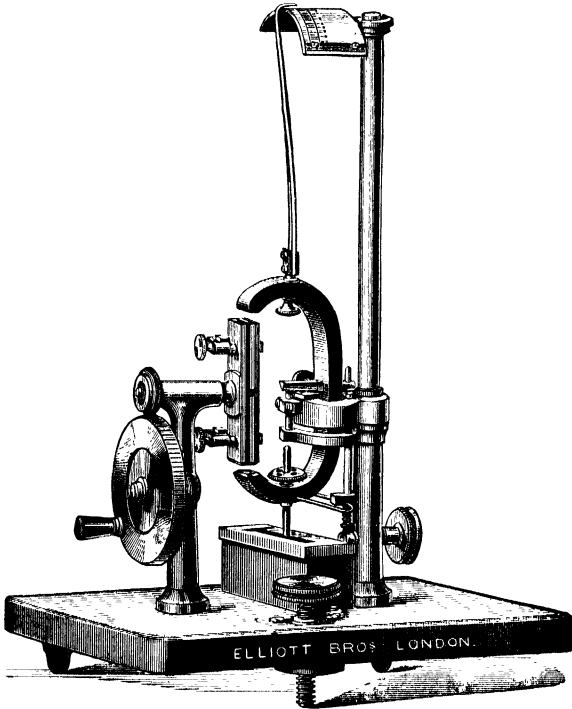

FIG. 31.

the poles of a permanent magnet mounted on a knife-edge. In consequence of the hysteresis effect the magnet tends to rotate with the specimen, and the amount of its deflection is proportional to the hysteresis. The instrument is calibrated by means of standard specimens. The magnetic induction in each case is practically independent of the permeability.

Apparatus.—You are supplied with a Ewing hysteresis tester, two standard specimens and a set of specimens of various brands of iron to be tested.

Method.—(1) Set the apparatus so that it faces north or south.

(2) Raise the magnet off its knife-edge. Insert one of the standard specimens in the carrier with a vulcanite washer on each side of it.

(3) Turn the handle slowly, and *while the specimen is rotating* let the magnet gently down on its bearing. Observe the scale reading.

(4) Reverse the direction of rotation and observe the deflection on the other side.

(5) Repeat the above with the other standard specimen, and likewise with all the samples. Tabulate your results thus:—

Specimen.	Deflection to right.	Deflection to left.	Mean deflection.

Taking the sum of the deflections as the total deflection obviates the necessity for accurate adjustment of the zero at the commencement.

With the results for the standard specimens plot a small curve (two points) with the hysteresis (1) in ergs per c.c., (2) in watts per lb. at 100~ and B 4000, against the total deflection. From these curves and your observations calculate the hysteresis in the samples provided.

Since the relative hysteresis at B = 2500 is 0.47 of that at B = 4000 (the former being the standard value of B and the latter its value in the apparatus), calculate the hysteresis for all the samples at B = 2500.

Steinmetz showed that if W = hysteresis loss at 100 periods per second—

$$W = 100nB^{1.6}$$

where n = Steinmetz coefficient for the specimen. Calculate the coefficient for each sample. This is found by dividing the loss in ergs per c.c. at $B = 4000$ by 580,000, or that in watts per lb. by 381. Tabulate thus :—

Specimen.	Ergs per c.c. $B = 4000.$	Ergs per c.c. $B = 2500.$	Watts per lb. $B = 4000.$	Watts per lb. $B = 2500.$	Steinmetz coefficient.

All the specimens have approximately the same weight.

NO. 50.—EXAMINATION OF A DYNAMO OR MOTOR

Preliminary.—You are required to make a complete examination of a machine, and collect all the data of its construction and design, so as to enable you to make a complete drawing of it and verify all the calculations governing the design of the various parts. The particulars should be tabulated as follows :—

Machine..... Type..... Maker..... Number.....
Date..... Speed..... Output volts..... Output ampères.....

Armature.—Diameter over all..... Length over conductors..... Diameter at bottom of slots..... Internal diameter..... Length over iron..... Effective length..... Depth of slot..... Width of slot..... Number of slots..... Size of armature conductor..... Space factor..... Number of ventilating ducts..... Method of winding..... Resistance of armature (*a*) cold..... (*b*) hot.....

Magnetic Circuit.—Length of pole face..... Length of pole arc..... Pitch of poles..... Number of pairs of poles..... Radial length of poles..... Diameter..... Bore of field..... Depth of air gap..... Outside diameter of yoke..... Size of winding..... Resistance of coils (*a*) cold..... (*b*) hot..... Method of connecting coils..... Ampère turns per pair pole..... Material of coils..... Material of poles..... Current in coils.....

Commutator and Brushes.—Diameter..... Rubbing length..... Number of segments..... Width of segment at top..... Thickness of insulation..... Number of sets of brushes..... Material of brushes..... Number of brushes per set..... Contact area per brush..... Method of connecting brushes..... Current density at brushes.....

Make complete dimensioned sketches of the various parts of the machine.

NO. 51.—RESISTANCE AND INSULATION TESTS OF A DYNAMO OR MOTOR

Preliminary.—In the following experiment you are required to find the resistance of (*a*) the armature, (*b*) field magnets, (*c*) the regulating resistance of a dynamo or motor, and also the insulation resistance of various parts of the machine.

Apparatus.—You are supplied with an Evershed insulation resistance tester, a battery, ammeter, variable resistance, high- and low-reading voltmeters, and a thermometer.

Method.—(1) Disconnect the magnet coils from the brushes and remove the brushes from the brush holders.

(2) By means of the Evershed meggar measure the insulation resistance—

- (1) Between the commutator and the frame of the machine,
- (2) Between the magnet coils and the frame of the machine,
- (3) Between the brush holders and the frame of the machine,
- (4) Between the positive terminal of machine and frame when the brushes are replaced and magnets connected up.

(3) Disconnect the magnet coils from the brushes and connect in series with an ammeter and battery. Place a voltmeter across the terminals of the magnet coils and regulating resistance in series with them. Take a set of readings of P.D. and current for various positions of regulating resistance

Magnetic Leakage Test on a Dynamo Magnetic Circuit 83

switch, commencing with that when all resistance is out. Tabulate thus :—

Position of switch.	P.D.	C.	Total resistance.	Resistance per coil regulating resistance.	Resistance of magnet coil.

(4) Connect the brushes in series with one secondary cell, variable resistance, and ammeter. Place a low-reading voltmeter across the brushes, and take a series of readings for various values of current strength. Tabulate thus :—

Voltmeter reading.	Ammeter reading.	Armature resistance.
Mean value armature resistance		

A reading should be taken on a thermometer placed in close contact with the coils when the resistance is being measured, and this reading tabulated along with the resistance.

NO. 52.—MAGNETIC LEAKAGE TEST ON A DYNAMO MAGNETIC CIRCUIT

Preliminary.—You are required to investigate the magnetic leakage in the magnetic circuit of a dynamo, and to find the value of the leakage coefficient. This latter quantity may be taken as the ratio of the total magnetic flux produced by

the magnet cores to the magnetic flux passing through the armature.

In the machine you are to test there are two poles and four magnet cores, each magnet pole receiving magnetic flux from the cores. The method of measuring the magnetic flux being by means of a test coil and ballistic galvanometer.

Apparatus.—You are supplied with a calibrated ballistic galvanometer, test coil, reversing key, source of current, ammeter, magnetic needle, and dynamo machine.

Method.—(1) Disconnect the brushes of the machine so as to prevent the possibility of a current going through the armature.

(2) Connect one cell of a battery to each of the four magnet coils in turn, and mark which terminal will be positive, so that when a current is sent through the coil the poles of the dynamo will be magnetized in the proper direction.

(3) Connect all four coils in series through a reversing key to a battery of about 10 volts E.M.F.

(4) Take *one* turn of wire as test coil round the middle of one of the magnet coils, and connect to the ballistic galvanometer, adding resistance, if necessary, to this circuit to bring it up to the value for which the galvanometer is standardized.

(5) Reverse the current once or twice in the magnet circuits, and then take three readings of the ballistic galvanometer-swing when the current is reversed in the coils.

(6) Place the test coil round each of the magnet cores in turn, and repeat.

(7) Place the test coil round the armature so that its plane is at right angles to the line joining the pole pieces, and repeat.

Tabulate your results thus :—

Position of test coil.	Galv. throw.	Current in magnet coils.

You may take the total generated magnetic flux as

proportional to the sum of the throws on the four magnet coils $\div 2$, whilst the throw taken when the coil surrounds the armature is proportional to the useful flux.

From the constant of the galvanometer, the actual flux may be calculated from the above and tabulated thus:—

Magnet coil.	Magnetic flux.	Armature flux.	Leakage coefficient.

Should the galvanometer be too sensitive you can reduce its sensibility by adding resistance to the galvanometer circuit, the constant being inversely proportional to the *total resistance of the test coil circuit*.

NO. 53.—DISTRIBUTION OF MAGNETIC FIELD ROUND A DYNAMO ARMATURE

Preliminary.—The E.M.F. induced in any armature conductor depends on the rate at which it cuts the lines of magnetic force; this with an armature rotating at a constant speed will vary with the position of the conductor in the field. The object of this experiment is to determine the distribution of the field by measuring the quantity of electricity induced in a wire moving a definite distance in the field in a similar manner to the armature conductors.

Apparatus.—You are supplied with a dynamo to the shaft of which is attached a lever so that the armature can be rotated by hand through a definite angular distance, this being indicated by a pointer attached to the armature moving across a scale graduated in degrees; a battery to separately excite the field magnets, a ballistic galvanometer, and some wire.

Method.—(1) Make a test coil by winding a single turn of fine copper wire round the armature parallel to the armature

conductors. One half of the coil will lie on the surface of the armature, and the other half must be threaded through the interior of the armature. This wire is connected by long flexible leads to the ballistic galvanometer.

(2) Disconnect the brushes of the dynamo, and send a current from the battery through the magnet coils so as to produce the normal magnetic flux that would be obtained if the dynamo was being run.

(3) By means of the lever attached to the armature shaft sharply jerk the armature through an angle of 10° . Observe the ballistic galvanometer throw.

(4) Repeat (3) moving the armature 10° at a time till one revolution has been completed.

Tabulate your readings thus (note, all galvanometer deflections to the right are taken as positive, and all to the left as negative) :—

Actual degrees test coil moves through.	Galvanometer swing.

Plot a curve with values of galvanometer swing against the mean pointer reading between the beginning and end of the 10° jerk. (Note negative galvanometer swings will be plotted below the horizontal axis.)

On the horizontal scale of the curve mark in the position of the poles of the machine.

NO. 54.—DISTRIBUTION OF POTENTIAL ROUND THE COMMUTATOR OF A DIRECT-CURRENT DYNAMO

Preliminary.—In the following experiment you are required to trace the gradual change of potential round the commutator of a direct-current dynamo. To measure this the machine is fitted with a small exploring brush which can be adjusted to make contact at any point on the circumference of the

commutator. Between this and one of the ordinary brushes, the potential difference is measured by means of a voltmeter. The position of the exploring brush is indicated by means of a pointer attached to it which moves over a scale graduated in degrees. The measurements are made under two conditions, (1) when the machine is running unloaded, and (2) when it is supplying its normal current. The effect, if any, of the armature current on the distribution of potential can thus be determined.

Apparatus.—You are supplied with a shunt dynamo and the means of driving it, a speed indicator, bank of lamps to form a load, an ammeter and voltmeter graduated in volts from 1 to the maximum E.M.F. of the machine.

Method.—(1) With the machine on open circuit, run it up to its normal speed. Connect the voltmeter between one of the brushes and the exploring brush. When the exploring brush is placed at the same part of the commutator as the fixed brush the voltmeter should remain at zero.

(2) Keeping the speed constant, move the exploring brush gradually round the commutator, taking voltmeter readings for every 10° of arc through which it is moved.

(3) Note when the direction of reading of the voltmeter alters and reverse its connections if it is a moving coil instrument. Call all readings with reversed voltage negative.

(4) Switch on the lamp load until the machine gives out its maximum current. The speed must be kept the same, and the position of the dynamo brushes must not be altered.

(5) Repeat the measurements of P.D. between the exploring brush and one of the fixed brushes as in (2).

Tabulate your readings thus :—

Speed of dynamo.	Current.	Angle between fixed brush and exploring brush.	Voltmeter reading (+ or -).

**OSMANI
COLLE**

From your readings plot two curves, one for the machine unloaded and one for the machine loaded, in which ordinates are voltmeter readings and abscissæ are the angles between the fixed brush and exploring brush. On the horizontal axis of this curve mark as far as possible the positions of the poles of the machine.

NO. 55.—FAULT TESTING IN A GRAMME RING ARMATURE

Preliminary.—In the following test you are supposed to be in possession of an armature which is found to spark badly and heat greatly when run. The faults you are to test for are (1) Breakdown of insulation resistance. (2) Short circuiting of an armature coil. (3) Complete break in one coil. (4) Bad contact between one or more commutator segments and the armature coils corresponding to them.

Apparatus.—You are supplied with a source of current, variable resistance, sensitive low-reading voltmeter or galvanometer, and ammeter, and insulation testing set.

Method.—(1) By means of the insulation testing set determine the insulation resistance between the commutator and the driving-shaft, testing each commutator segment in turn.

(2) Connect the battery in series with the ammeter and variable resistance. Place one wire on one of the commutator segments, and with the other wire tap each segment in turn all round the commutator until one or more are found which give no complete circuit. This fixes the position of faults (4).

(3) To test for faults (2) and (3), connect the wires from the battery, ammeter, and variable resistance to two diametrically opposite commutator bars (taking care to avoid the one where the break discovered in (2) occurs). Adjust the current to give a total drop of P.D. at least ten times the minimum reading on the voltmeter.

(4) By means of the voltmeter take the P.D. between

adjacent commutator bars from brush to brush each way round the commutator. Tabulate thus :—

Commutator bars between voltmeter leads.	P.D.
1-2	
2-3	
3-4	
etc.	

Plot a curve with cumulative voltmeter readings against bars of the commutator. Show how faults (2) and (3) are indicated on this curve.

NO. 56.—MAGNETIZATION CURVE OR INTERNAL CHARACTERISTIC OF A SHUNT DYNAMO

Preliminary.—The magnetization curve or internal characteristic of a shunt dynamo is the curve connecting the ampère turns per pole of the dynamo with the E.M.F. at the brushes, when the machine is running at a constant speed. For this purpose the magnet coils are separately excited.

Apparatus.—You are supplied with a shunt dynamo driven from an electric motor so that its speed can be carefully regulated, a battery, variable resistance, ammeter, voltmeter, and speed indicator.

Method.—(1) Disconnect the magnet coils from the brushes and connect them in series with an ammeter, variable resistance and battery, taking care that when a current is sent through them it will magnetize the poles in the same way as when the machine is being used as a dynamo.

(2) Connect the voltmeter across the brushes.

(3) Run the dynamo up to its normal speed and take the voltmeter reading.

(4) Switch on a small current to the magnet coils, and take the voltmeter reading when it is steady.

(5) Repeat with gradually increasing magnet coil currents until you reach a current about 20 per cent. greater than the maximum current the magnet coils normally carry.

Tabulate your results thus:—

Dynamo No..... Make..... Volts..... Ampères.....
Speed.....

Speed of machine.	P.D. at brushes.	Current in magnet coils.	Number of turns per pole.	Ampère turns per pole.

Plot a curve with P.D. at brushes as ordinates and ampère turns per pole as abscissæ. From this curve deduce the critical resistance of the machine: this is the resistance of the shunt circuit, above which the machine will not be adequately magnetized.

NO. 57.—TOTAL CHARACTERISTIC AND ELECTRICAL EFFICIENCY OF A SHUNT DYNAMO

Preliminary.—In this experiment you are required to find the relation between the total current generated in the armature of the dynamo and the total E.M.F. developed at the normal speed of the machine.

Apparatus.—You are supplied with a shunt-wound dynamo, direct driven from a motor of variable speed, ammeter, voltmeter, speed indicator, and resistance consisting of a bank of incandescent lamps, the number of which can be varied.

Method.—(1) Connect the terminals of the machine to the lamp bank through the ammeter and a switch. Connect the voltmeter across the machine terminals.

(2) With no load in the external circuit start the motor and run the dynamo up to its normal speed. If necessary adjust the shunt regulating resistance of the dynamo to give the

proper voltage of the machine. Do not alter this resistance again during the experiment. Tabulate the speed and P.D.

(3) With a gradually increasing external load, take simultaneous ammeter and voltmeter readings until the machine is giving its maximum current, taking care that for each alteration of load the speed is readjusted to the normal value.

(4) Tabulate your results thus :—

Type of machine..... Number of machine..... Make of machine..... Output..... Volts..... Ampères..... Speed..... Armature resistance..... Shunt resistance¹.....

P.D. volts.	Current. ampères.	Speed rev. per min.

Plot a curve with P.D. (volts) as ordinates, and currents (ampères) as abscissæ. This gives what is known as the external characteristic or relation between the terminal P.D. and current in external circuit. To obtain the total characteristic we have to correct for (1) the ampères in the shunt coil, and (2) the volts lost in the armature.

The correction for shunt coil ampères is easily made as follows :—

$$\text{Ampères in shunt coil for any given P.D.} = \frac{\text{P.D.}}{\text{shunt resistance}}$$

We must, therefore, displace the points on the external characteristic curve horizontally by an amount corresponding to $\frac{\text{P.D. of any given point}}{\text{shunt resistance}}$.

From this we get a second curve connecting total current with terminal P.D. We may now correct the points on this curve for armature lost volts by raising each point vertically by

¹ If a regulating resistance has been added to the shunt coil, the value of this must be included in the shunt resistance.

an amount equal to armature resistance \times current, corresponding to that point. This gives us the third curve or total characteristic.

Should any of the readings have been taken at speeds either in excess of or less than the normal speed, they may now be corrected in this third curve by multiplying the values of the E.M.F. by the ratio $\frac{\text{normal speed}}{\text{actual speed}}$, since it is the total E.M.F. that is proportional to the speed.

From the above results calculate the electrical efficiency or economic coefficient of the machine at $\frac{1}{4}$, $\frac{1}{2}$, $\frac{3}{4}$, and full load.

$$\text{Electrical efficiency} = \frac{\text{useful watts}}{\text{total watts}}$$

Tabulate thus :—

Load.	Terminal P.D.	Total E.M.F.	External current.	Total current.	$\frac{\text{P.D.} \times \text{external current}}{\text{E.M.F.} \times \text{total current}}$

NO. 58.—TOTAL CHARACTERISTIC AND ELECTRICAL EFFICIENCY OF A SERIES DYNAMO

Preliminary.—The total characteristic of a series machine is the relation between the current it supplies and the total E.M.F. generated.

Apparatus.—You are supplied with a series dynamo driven from an electric motor, an ammeter, voltmeter, incandescent lamp variable load, switch and speed indicator.

Method.—(1) Connect the ammeter, incandescent lamp bank, and switch in series with the machine, and place the voltmeter across the machine terminals.

(2) With the external circuit open, run the speed of the dynamo up to its normal value, and take voltmeter reading.

(3) Switch on a small load and take simultaneous voltmeter and ammeter readings. Take care to keep the speed constant.

(4) Repeat (3) with gradually increasing loads up to the maximum load of the machine.

Tabulate your results thus :—

Type of machine.....	Number of machine.....	Make of machine.....	Output.....
Speed.....	Armature resistance.....	Series coil resistance.....	Volts..... Ampères.....

P.D. volts.	Current ampères.	Speed revs. per min.

Plot a curve with P.D.'s as ordinates against currents as abscissæ. This gives the external characteristic of the machine or the relation between the terminal P.D. and the total current.

To obtain the total characteristic we must correct for the volts absorbed in the armature and series coils.

This correction is made as follows. For any given current the lost volts will be—

$$v = C(r_a + r_s)$$

where r_a = resistance of the armature, and r_s the resistance of the series coils.

We must, therefore, raise all the points on the external characteristic curve by an amount equal to $(r_a + r_s)$ times the current corresponding to each point. This may easily be done graphically. The new curve so obtained is the total characteristic of the machine.

Should any of the readings have been taken at speeds either in excess of or less than the normal speed, they may be corrected on this second curve by multiplying the E.M.F. values by the ratio $\frac{\text{normal speed}}{\text{actual speed}}$, since the total E.M.F. is proportional to the speed.

The electrical efficiency is $\frac{\text{useful watts}}{\text{total watts}}$, and this may now be calculated for $\frac{1}{4}$, $\frac{1}{2}$, $\frac{3}{4}$, and full load, from the above readings, the results being tabulated thus :—

Load.	P.D. volts.	Total E.M.F.	Current.	Useful watts P.D. \times C.	Lost watts $C(r_s + r_r)$.	Total watts.	Efficiency.

NO. 59. TESTING AND EXAMINING AN AUTOMATIC MAGNETIC CUT OUT

Preliminary.—The automatic magnetic cut out is a switch

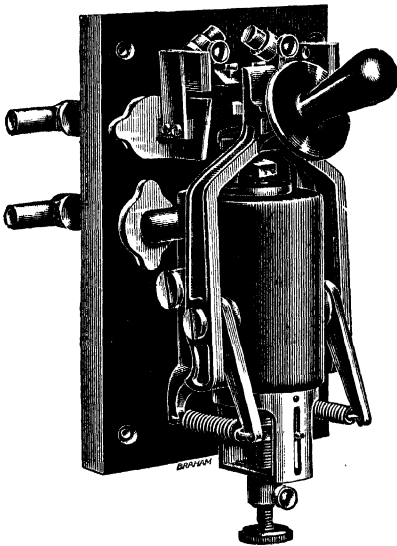

FIG. 32.

combined with an electromagnet in such a way that the switch is automatically “opened” by the current when it reaches a certain value. The magnitude of the current required to operate the cut-out action can be adjusted to various values, these being indicated by a pointer attached to the switch.

Apparatus.—You are supplied with an automatic cut out (see Fig. 32), source of current, regulating resistance and ammeter.

Method.—(1) Set the pointer attached to the switch to the lowest “cut out” current on the scale.

(2) Switch on a current, gradually increase its strength, and take the ammeter reading when the switch cuts out. Repeat this at least three times.

(3) Re-set the pointer to the next value of the current and repeat, until you have got to the maximum current.

(4) Repeat with the currents in the reverse direction.

(5) Tabulate thus :—

Reading of pointer on switch.	Current required to cut out.	Reversed current required to cut out.

Disconnect the switch and take it to pieces. Make careful dimensioned sketches of each part, with a diagram showing how it operates.

NO. 60.—EXAMINATION OF THE STARTING SWITCH OF A MOTOR

Preliminary.—The starting switch of a motor consists of a set of resistance coils in series with the motor to prevent the current reaching too high a value before the motor starts running, when its own back E.M.F. will prevent excessive currents flowing through the armature. The switch is also fitted with (1) an overload release, which breaks the circuit should the load on the motor become excessive; and (2) a no-volt release, which breaks the circuit, and automatically switches in all the starting resistance, should the circuit from any cause become temporarily broken.

Apparatus.—You are supplied with a motor and starting switch (see Fig. 33), a supply of current, ammeter and voltmeter, a brake to absorb the motor power, and a speed indicator.

Method.—(1) Connect the ammeter in series with the motor starting resistance and battery, and place the voltmeter across the motor terminals.

(2) Switch on the current, which is supplied at the proper

voltage for the motor. Bring the starting resistance switch to the first stop, and note the current before the machine starts.

(3) Allow the machine to run until it has attained a steady speed. Note the speed and ammeter reading.

(4) Move the starting switch to the second stop and repeat (3).

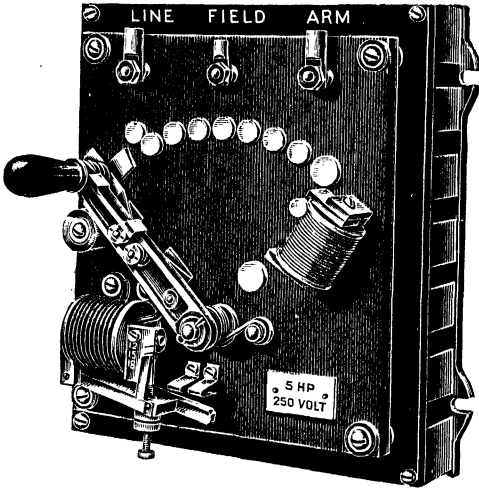

FIG. 33.

(5) Repeat until all the starting resistance has been cut out.

Tabulate thus:—

Type of motor... .. Make of motor..... Number of
 motor..... Max. P.D..... Max. current..... Max. stated
 H.P..... Speed.....

Position of starting switch.	Speed of motor.	Current.

(6) Run the motor up to its normal speed and gradually apply the brake. Note the speed and current when the automatic overload release acts.

Tabulate thus :—

Value of current at which release ought to act.	Current at which release does act.	Speed when cut out acts.

(7) Run the machine up to its normal speed, and then open the main switch. Note the speed of the machine when the no-volt release acts.

(8) Again run the machine up to its normal speed and repeat (7), but just before the no-volt release acts switch on the current again and note the ammeter reading.

Make a careful diagram showing the connections in the starting switch, and how it is wired to the motor.

NO. 61.—BRAKE HORSE-POWER AND EFFICIENCY OF A MOTOR

Preliminary.—The brake horse-power of a motor is measured by absorbing the power of the machine in a friction brake, which may consist of a band or strap placed half round the pulley and pressed on the pulley surface by spring balances, one at either end of the strap, so that the pull in lbs. on each end (P_1 and P_2) can be measured. If the diameter, in feet (d), of the pulley is known, and the speed in revolutions per minute (n) is measured, the horse-power can be calculated thus :—

$$\text{H.P.} = \frac{(P_1 - P_2)\pi dn}{33,000}$$

If at the same time the electrical power supplied to the

vol^t machine is measured, its mechanical efficiency can be calculated thus :—

$$\text{Mechanical efficiency} = \frac{\text{H.P. developed}}{\text{electrical H.P. supplied}}$$

Apparatus.—You are supplied with a motor, brake apparatus, an ammeter, voltmeter, speed indicator, and source of current.

Method.—(1) Place the brake apparatus on the pulley. Connect the ammeter in series with the main terminals of the machine and the battery, and place the voltmeter across the machine terminals.

(2) Start up the motor, adjust the brake band and supply current, until the electrical power supplied is about $\frac{1}{10}$ maximum motor load, the speed being adjusted to the normal value by means of the field resistance. Read the two spring balances, voltmeter, ammeter, and speed simultaneously.

(3) Repeat with approximately $\frac{1}{4}$, $\frac{1}{2}$, $\frac{3}{4}$, and full load currents in motor.

Tabulate your results thus :—

Type of motor..... Number of motor..... Make of motor..... Stated max. power of motor..... Max. volts..... Max. ampères..... Diameter of pulley..... Speed of motor.....

Approximate load at which test is made.	P ₁ .	P ₂ .	N.	P.D.	C.	d.	H.P. developed.	Watts supplied P.D. × C.	E.H.P. supplied.	Efficiency.

Plot a curve with efficiency as ordinates against H.P. developed as abscissæ.

NO. 62.—COMBINED EFFICIENCY TEST OF A MOTOR GENERATOR PLANT

Preliminary.—The motor generator plant you are to test consists of a D.C. motor coupled direct to a dynamo, and you are required to test the combined efficiency of the set at various loads.

Apparatus.—You are supplied with a motor generator set, two ammeters and voltmeters, a speed indicator, a bank of lamps to absorb the power of the dynamo, and a source of current.

Method.—(1) Connect up one ammeter so as to measure the total current supplied to the motor, and place the voltmeter across the main terminals of the machine.

(2) Connect the other ammeter so as to measure the total current supplied to the lamp bank by the dynamo, and place a voltmeter across the main dynamo terminals.

(3) Switch on the motor, and adjust the speed to the standard value by means of the field resistance.

(4) Adjust the dynamo shunt resistance so as to give the proper voltage.

(5) Switch on some lamps to represent roughly $\frac{1}{10}$ total dynamo load. Note the readings on voltmeters and ammeters attached to both machines. The speed must be kept constant throughout the tests.

(6) Repeat (5) with approximately $\frac{1}{4}$, $\frac{1}{2}$, $\frac{3}{4}$, and full load on the dynamo.

Tabulate your results thus:—

Input (motor).		Total watts W_1 .	Output (dynamo).		Total watts W_2 .	Speed revs. per min.	Effi- ciency $\frac{W_2}{W_1}$.	Approx. load.
Voltmeter reading V_1 .	Ammeter reading C_1 .		Voltmeter reading V_2 .	Ammeter reading C_2 .				

Plot a curve with efficiency against load.

NO. 63.—MEASUREMENT OF THE EDDY CURRENT AND HYSTERESIS LOSSES IN A DYNAMO

Preliminary.—This method of separately measuring the eddy current and hysteresis losses in a dynamo is due independently to Kapp and Housman, and depends on the fact that, for a constant magnetic flux, the eddy current losses are proportional to the square of the speed, whilst the hysteresis losses vary directly with the speed.

Apparatus.—You are supplied with a shunt dynamo and the means of driving it, ammeters and voltmeters, a source of current, and a speed counter.

Method.—(1) Separately excite the magnet field with a P.D. across its terminals equal to the normal P.D. of the machine.

(2) Drive the machine at various speeds and measure the E.M.F. at the brushes with the machine on open circuit.

(3) Disconnect the driving power from the armature shaft, and connect the brushes to a source of current so that the machine may be run as a motor, the field strength being kept the same as in (1) and (2). Measure the speed of rotation of the armature at various current strengths up to the normal speed of the machine.

Tabulate your results thus :—

DYNAMO TEST.		
Field P.D.	E.M.F. at brushes.	Speed.

MOTOR TEST.		
Field P.D.	Armature currents.	Speed.

Plot two curves on the same sheet of paper having for vertical ordinates, (a) E.M.F.'s at brushes, (b) armature currents, and for the common abscissæ speeds of rotation. Two curves as in the diagram below will be obtained.

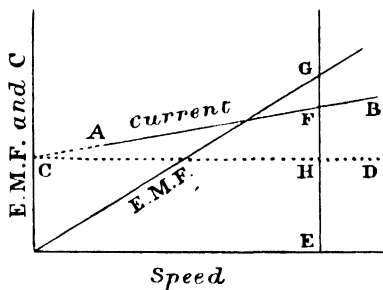

FIG. 34.

Produce AB to cut the ordinate at C ; draw CD parallel to the horizontal axis. Then, at any given speed, say E, the power absorbed in hysteresis and eddy currents = product $EF \times EG$, since EG represents the back E.M.F. produced in the armature when the machine is running at that speed as a motor. Of this $EH \times EG$ represents the hysteresis and friction loss in watts, and $FH \times EG$ represents the eddy current loss in watts.

Tabulate your results thus :—

Speed.	Hysteresis loss.	Eddy current loss.	Total loss.

NO. 64.—MEASUREMENT OF EFFICIENCY OF INCANDESCENT LAMPS

Preliminary.—The efficiency or, as it is sometimes correctly termed, the inefficiency of an incandescent lamp measured by the number of watts absorbed by the lamp

Plot curves for both lamps, connecting watts per candle and voltage.

Also plot curves with log (volts) against log (candle-power), and from this determine the law connecting the candle-power and the voltage.

NO. 65.—MEASUREMENT OF THE ABSORPTION OF
LIGHT BY VARIOUS LAMP GLOBES

Preliminary.—You are required to find the amount of light absorbed by lamp globes of various shapes and tints, by measuring the apparent candle-power of a lamp whose candle-power is known when placed inside them.

Apparatus.—You are supplied with a photometer bench, a standard lamp, and two other lamps, one a carbon lamp and the other a metal filament lamp; this will give you the means of testing the globes with lights of different colours, the metal filament lamp giving a much whiter light than the carbon lamp. You are also supplied with voltmeters for both lamps, a set of globes, and a source of current.

Method.—(1) Connect up the standard lamp with the voltmeter across its terminals, and adjust the pressure to the standard value corresponding to the stated candle-power of the lamp.

(2) Connect up the carbon lamp with a voltmeter across its terminals and a regulating resistance in series with it, and adjust the voltage to the normal value for the lamp. This voltage must be kept constant during the whole experiment.

(3) Place the standard lamp at one end of the photometer bench and the carbon lamp at the other, and adjust the position of the screen until equality of illumination is obtained from the two sources. Note the distance of each lamp from the screen. Calculate the candle-power of the lamp.

(4) Place each of the globes successively over the carbon lamp, and again adjust the screen to obtain balance of illumination. Note the relative positions of the lamps and screen, and calculate the apparent candle-power of the carbon lamp.

(5) Repeat (3) and (4), replacing the carbon lamp by the metal filament lamp.

Tabulate your results thus :—

P.D. at standard lamp terminals.	C.p. of standard lamp.	P.D. at test lamp terminals.	Distance of standard lamp from screen.	Distance of test lamp from screen.	C.p. of test lamp.	Per cent. of light stopped.	Nature of test lamp.	Particulars of globe.

NO. 66.—MEASUREMENT OF AMPÈRE-HOUR AND WATT-HOUR EFFICIENCIES OF A SECONDARY BATTERY

Preliminary.—The ampère-hour efficiency of a secondary battery is the ratio of the ampère-hours of discharge to the ampère-hours of charge necessary to restore the battery to its original condition. The energy efficiency is the ratio of the watt-hours of discharge to the watt-hours of charge necessary to restore the battery to its original condition. The condition of the battery is specified in terms of its E.M.F. on open circuit and its specific gravity, the cell being charged, after a discharge, until the specific gravity and E.M.F. return to their original values.

Apparatus.—You are supplied with a single secondary cell, a voltmeter, ammeter, hydrometer for measuring the specific gravity, suitable variable resistance to regulate the charge and discharge, and a source of E.M.F. to charge the cell.

Method.—(1) Connect the cell in series with the ammeter and variable resistance, and place the voltmeter across the terminals of the cell.

(2) Note the E.M.F. of the cell on open circuit, also the specific gravity of the cell.

(3) Adjust the external resistance to give the maximum current the cell is intended to supply. Note the time of

closing the circuit. Keep this current constant by means of the regulating resistance, and every five minutes take readings of the P.D. at the cell terminals, and of the specific gravity.

(4) After an hour's discharge open the circuit.

Connect the cell up to the charging circuit and charge with the same strength of current as obtained during the discharge, until the hydrometer rises to its original reading. Take the precaution of stirring the acid in the cell from time to time before reading the hydrometer. The E.M.F. on open circuit should now be the same as before discharge. If it is slightly higher it will probably fall to its original value on allowing the cell to stand for a short time.

(6) Readings of the specific gravity and charging P.D. across the cell terminals must be taken every five minutes during the charge.

(7) Tabulate your results thus :—

Original P.D. of cell on open circuit..... Specific gravity of acid before discharge.....

Discharge.				Charge.			
Time.	P.D. at cell terminals.	Current amperes.	Specific gravity.	Time.	P.D. at cell terminals.	Current amperes.	Specific gravity.

Plot curves of P.D. and time for both discharge and charge experiments. Calculate the total ampère-hours of discharge and of charge, and from these values find the quantity efficiency.

From the E.M.F. curves find the mean value of the E.M.F. during discharge and charge, and hence calculate the energy efficiency.

NO. 67.—EXAMINATION AND TESTING OF A CRAWLEY AUTOMATIC CELL CHARGING SWITCH

Preliminary.—The object of this automatic switch is to switch the charging circuit from a dynamo on to a battery of cells whenever the E.M.F. of the machine has risen above the back E.M.F. of the battery, and to break the circuit should the charging E.M.F. fall below that of the cells.

You are required to test the switch, and see if it operates correctly; also to measure the resistances of the various coils

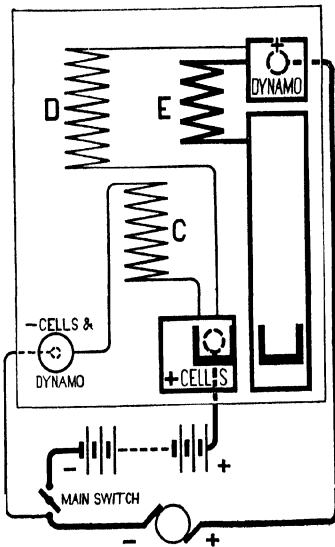

FIG. 35.

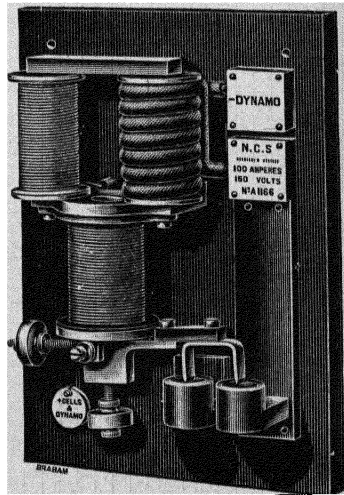

FIG. 35A.

and calculate the watts expended in them when they are carrying their normal currents.

Apparatus.—You are supplied with a dynamo and set of cells to be charged, an ammeter, voltmeter and charging switch. See Fig. 35.

Method.—(1) Thoroughly examine the switch, and draw a diagram showing the arrangement of coils and connections.

(2) Place the voltmeter across the terminals of the battery when it is on open circuit ; this gives the back E.M.F.

(3) Place the voltmeter across the dynamo side of the charging leads running to the automatic switch.

(4) Start the dynamo and gradually raise its E.M.F. by regulating the resistance of its shunt circuit until the switch "cuts in." Note the voltmeter reading when this occurs.

(5) Gradually decrease the E.M.F. of the machine, and note the voltmeter reading when the switch "cuts out" the cells.

(6) Measure the resistance of each of the coils either by sending a known current through them, and measuring the pressure drop between their ends by a voltmeter, or in the case of the high resistance coils by means of a P.O. bridge.

Tabulate your results thus :—

Back E.M.F. of cells.	E.M.F. of dynamo when switch cuts in.	E.M.F. when switch cuts out.	Resistance of series coil.	Resistance of shunt coils.		Watts expended at full load.	
				A.	B.	Series coil.	Shunt coil.

NO. 68.-TEST OF A THOMSON ENERGY METER

Preliminary.--The Thomson energy meter is a motor meter in which the field magnets consist of two coils of wire of low resistance which carry the current to be measured, whilst the armature is wound with fine wire in series with a high resistance and is connected in parallel across the mains. The armature and field coils have non-magnetic cores. The driving torque is therefore proportional to the product of the current and pressure, *i.e.* to the watts. The retarding moment is provided by an eddy current brake consisting of a copper disc attached to the armature spindle, rotating between the poles of a permanent magnet. Since the retarding torque is

proportional to the speed of rotation, it follows that the speed is proportional to the power, and therefore the number of revolutions in a given time is proportional to the energy.

In order to compensate for the friction at the pivots and brushes, a compensating coil is connected in series with the armature circuit which provides a small magnetic field which ought just to fall short of being strong enough to start the armature rotating.

Apparatus.—You are supplied with a meter, standard ammeter, electro-static voltmeter, variable resistance, source of E.M.F. capable of being raised 4 per cent. above or lowered 4 per cent. below the normal working pressure of the meter, small secondary battery, stop-watch, thermometer, and Post Office Wheatstone bridge.

Method.—(1) Measure the resistance of the armature circuit on the Wheatstone bridge, if possible measuring the values for the armature alone and resistance alone.

(2) Connect the small secondary battery in series with the variable resistance, ammeter, and field coils. Measure the P.D. in the field coils at full load, and thence calculate the field-coil resistance.

(3) Connect the armature circuit to the mains in parallel with the electro-static voltmeter. With no current in the field coils raise and lower the main pressure 4 per cent. from the normal value, and observe whether the meter starts rotating (1) when quite free from vibration, (2) when tapped.

(4) Connect the field coils to the small secondary battery in series with the ammeter and variable resistance, and find the current required to start the meter moving (a) with normal E.M.F. across armature circuit, (b) with main pressure 4 per cent. up, (c) with main pressure 4 per cent. down.

(5) Send the maximum current through the meter and observe the number of rotations of the armature corresponding to ten scale divisions of the smallest recording dial. From this calculate the theoretical amount of energy in B.O.T. units per armature revolution.

(6) With the normal voltage across the armature circuit send currents corresponding to $\frac{1}{10}$, $\frac{1}{4}$, $\frac{1}{2}$, $\frac{3}{4}$, full, and $1\frac{1}{4}$ load of

meter through the field coils. Take the time of ten revolutions and thence calculate the time of one revolution. From the known current, voltage and time of a revolution, calculate the fraction of a B.O.T. unit per revolution. The ratio of this number to the theoretical is the multiplying constant of the meter.

(7) Repeat (6) with pressures 4 per cent. in excess of and 4 per cent. below the normal working pressure.

Tabulate your results thus :—

Type of meter..... Number of meter..... Voltage.....
Current..... Stated constant.....

Resistance.—(1) Armature..... (2) Resistance coil.....
Total resistance.....

(2) Field magnet coils..... P.D..... Current.....

Starting test.—Minimum current required to start rotation—

Shunt coils	{	Normal voltage (steady).....
		Normal voltage (tapped).....
		4 per cent. voltage up (steady).....
		4 per cent. voltage up (tapped).....
		4 per cent. voltage down (steady).....
		4 per cent. voltage down (tapped).....

Revolutions of armature per 10 dial divisions.....

Calculated B.O.T. unit per revolution at normal voltage.....

Load.	Current.	Pressure.	Time in secs. per 10 revs.	Actual B.O.T. units per rev.	Calculated B.O.T. units per rev.	Constant.	Temp.

As the constant is liable to vary with changes of temperature, the temperature should be kept constant as far as possible during the test.

PART III

NO. 69.—GRAPHICAL REPRESENTATION OF A SINE FUNCTION

Preliminary.—In working out alternating current problems, we have constantly to deal with functions which follow a simple harmonic or sine law. One may obtain the instantaneous value of such a function at any time by drawing the graph of the function. In the following exercise you are required to draw the graph of a sine function.

Method.—(1) With a centre O and radius OA equal to the maximum value of the sine function describe a circle.

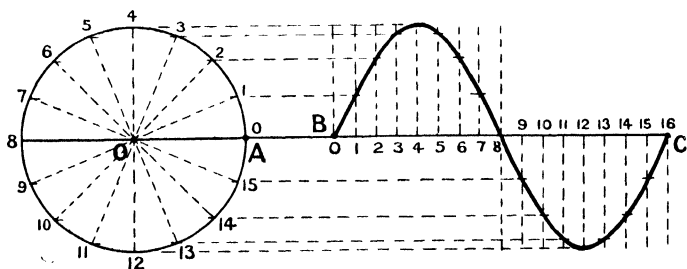

FIG. 36.

(2) Divide the circumference of the circle into a number of equal parts, say sixteen.

Number these, starting from A as zero.

(3) Draw a line BC as a continuation of the OA diameter and of any convenient length; divide it into sixteen equal parts and from these points draw lines perpendicular to BC.

(4) From the points 1, 2, 3, 4, etc., on the circle draw lines

parallel to BC. The points where these lines cut the lines from the corresponding numbered divisions on BC are points on the sine curve. Join these points by a curve. It will be seen that the heights of the ordinates of the curve are proportional to the sines of the angles which the radius of the circle makes with the horizontal diameter at the various points 1, 2, 3, 4, etc., on the circumference of the circle.

(5) The axis BC may be divided into degrees corresponding to the angular position of the radius OA, or it may be taken as a time axis, the radius OA being regarded as rotating with a uniform speed in a counter-clockwise (or positive) direction about the centre O. If so, the time corresponding to one complete rotation of OA is called the periodic time of the function (T). The length of the maximum ordinate OA is termed the amplitude. The instantaneous value of the function will therefore be seen to be the product of a constant (the amplitude) into the sine of the angle which the radius makes with the horizontal axis at any given instant, or as it is generally expressed algebraically $Y = A \sin \theta$.

(6) In dealing with functions like the above it is usual to express the angle θ in radians instead of degrees. If the radius OA is supposed to rotate with uniform velocity (v), the angle swept through in one second is $\frac{v}{OA}$ radians; this is termed the angular velocity (p). Hence the angle swept through in t seconds will be pt radians. Also since in one period (T) the angle described will be 360 degrees or 2π radians, it follows that $pT = 2\pi$, and if the number of periods per second be n , $T = \frac{1}{n}$.

Hence $p = \frac{2\pi}{T} = 2\pi n$. So that the instantaneous value of the sine function may be written $Y = A \sin pt = A \sin 2\pi nt$, t here being the time in seconds that has elapsed from the beginning of the period to the instant in question.

No. 70.—GRAPHICAL PROOF OF THE PROPERTIES OF A SINE CURVE

Preliminary.—Having in the last exercise seen how a sine curve may be drawn, you are now required to investigate some of its properties. In alternating-current work, where the variations of an alternating E.M.F. or current are generally assumed to follow a sine law, there are two relationships frequently required, (1) The relation between the mean value of a sine function and its maximum value, and (2) the relation between the square root of the mean square value, usually termed the root mean square (R.M.S.) or virtual value, and the maximum value. These relations you are required to find.

Method.—(1) By means of the construction in the last exercise draw the graph of a complete period of a sine curve, taking any convenient values for the amplitude and period.

(2) Measure off the lengths of each of the vertical ordinates, giving the instantaneous values at the times 1, 2, 3, 4, etc.

Tabulate thus:—

Point on time axis.	Height of vertical ordinate.	Length of mean ordinate	Ratio $\frac{\text{mean ordinate}}{\text{max. ordinate}}$.

Add all the lengths together and divide by the number of ordinates to get the length of the mean ordinate.

(3) From the above table find the squares of the heights of the vertical ordinates, and hence the R.M.S. value.

(4) Also calculate the ratio of $\frac{\text{R.M.S. value}}{\text{mean value}}$. This is termed the form factor.

Tabulate thus :—

Point on time axis.	Height of vertical ordinate.	Square of vertical ordinate.	Mean square value.	R.M.S. value.	Ratio R.M.S. value max. ordinate	Ratio R.M.S. value mean value

NO. 71.—GRAPHICAL REPRESENTATION OF POWER EXPENDED IN A NON-INDUCTIVE CIRCUIT

Preliminary.—When an alternating current flows in a non-inductive circuit, the current will be in phase with the E.M.F. Then the mean values of the instantaneous products of current and E.M.F. over a complete period, which must represent the true power expended during that period, can be shown to be equal to half the product of their maximum values, that is, to the product of their R.M.S. values. Take the maximum E.M.F. as 100 volts and the maximum current as 10 ampères.

Method.—(1) Round a common centre O draw two circles to any convenient scale, the radius of one to represent 100 volts to some scale, whilst that of the other represents 10 ampères. Draw the graphs of these two sine functions. Since the quantities are in phase with one another, their zero and maximum points will occur at the same instant.

(2) Measure off the lengths of the vertical ordinates at times 1, 2, 3, 4, etc., and tabulate them.

(3) Multiply together the values of E.M.F. and current that occur at the same instant, and thus get a table of instantaneous watts.

(4) Find the mean value of the instantaneous power, and compare it with half the product of the maximum values.

Tabulate thus :—

Time.	Instantaneous E.M.F.	Instantaneous current.	Instantaneous watts.	Mean power.	Max. $\frac{E \times \text{Max. } C}{2}$

NO. 72.—GRAPHICAL REPRESENTATION OF POWER EXPENDED IN AN INDUCTIVE CIRCUIT

Preliminary.—When an alternating current flows in an inductive circuit, it can be shown that the current will no longer be in phase with the E.M.F., but will lag behind it by an amount known as the angle of lag (ϕ). The value of this is defined in terms of its tangent, $\tan \phi = \frac{\rho L}{R}$, where $\rho = 2\pi n$ (n being the frequency), L = inductance, and R = resistance. The relation between current, electromotive force, resistance, and inductance is expressed as follows: $C = \frac{E}{\sqrt{R^2 + \rho^2 L^2}}$, C and E being either maximum or R.M.S. values of current and electromotive force.

$$\text{Impedance} = \sqrt{R^2 + \rho^2 L^2} = \sqrt{\text{resistance}^2 + \text{reactance}^2}$$

In the following exercise you are required to draw the E.M.F. and current curves for a circuit of inductance = 0.01 henry, resistance = 7.358 ohms, supplied with current at 50 periods per second, and a maximum E.M.F. of 80 volts; also to draw in the true power curves, and to compare the true power with (1) the product of the R.M.S. values of current and E.M.F., and (2) with the product of the R.M.S. values of current and E.M.F. $\times \cos \phi$.

Method.—(1) From the relationship $C = \frac{E}{\sqrt{R^2 + \rho^2 L^2}}$ calculate the maximum value of the current; also from the relation $\tan \phi = \frac{\rho L}{R}$, find the value of ϕ .

NO. 73.—COMPARISON OF THE HEATING EFFECTS
OF DIRECT AND ALTERNATING CURRENTS

Preliminary.—In the following experiment you are required to compare the heating effects produced by two equal currents, one continuous and one alternating.

Apparatus.—You are supplied with a calorimeter containing a known volume of water, a thermometer, an incandescent lamp, so arranged that it can be completely immersed in the water contained in the calorimeter, an electro-dynamometer, variable resistance, stop-watch, and sources of direct and alternating currents of approximately the same pressure.

Method.—(1) Connect the incandescent lamp in series with the electro-dynamometer, variable resistance, and source of direct current.

(2) Immerse the lamp completely in the water contained in the calorimeter. Stir the water, and note when the temperature becomes steady.

(3) Switch on the direct current and note the time. Take readings of the temperature every thirty seconds, keeping the water well stirred all the time, until the temperature rises 20° or 30° above the temperature of the room.

(4) Replace the water by an equal quantity of cold water at the same temperature as the original quantity. Connect the lamp to the alternating current supply, and adjust the current to the same value that was obtained in the direct current experiment.

(5) Switch on the alternating current when the lamp has been placed in the calorimeter, and again take readings of the temperature every thirty seconds, keeping the water well stirred all the time, until the rise of temperature is the same as in the first case.

(6) Repeat above with currents of different values.

Tabulate your results thus :—

Direct current.				Alternating current.			
Time.	Temperature.	Current.	Ampères.	Time.	Temperature.	Current.	Ampères.

Plot two curves with temperatures as ordinates and times as abscissæ for each value of current strength, and state what deductions you make from them.

NO. 74.—CALIBRATION OF AN ALTERNATING CURRENT AMMETER

Preliminary.—In the following experiment you are required to calibrate an alternating current ammeter by comparison with a Siemens electro-dynamometer, and to investigate the effect of an alteration of frequency on the readings of the instrument.

Apparatus.—You are supplied with an ammeter, Siemens electro-dynamometer, frequency meter, choking coil, and an alternator capable of being run at various speeds.

Method.—(1) Connect the ammeter, electro-dynamometer, and choking coil in series with the alternator.

(2) Connect the frequency meter across the alternator terminals.

(3) Start up the alternator, and adjust its speed until the frequency meter indicates the normal frequency for which the ammeter is intended.

(4) Switch on the current and take simultaneous readings on the ammeter and dynamometer for various currents up to the maximum reading of the ammeter, adjusting the current by means of the choking coil. Before each reading see that the frequency remains the same; if not, the speed of the alternator must be adjusted until it is.

(5) Repeat with a frequency 5 per cent. in excess of the normal frequency.

(6) Repeat with a frequency 5 per cent. below the normal frequency.

Tabulate your results thus :—

Type of ammeter..... Number of ammeter..... Standard frequency.....

Frequency.	Ammeter reading.	Dynamometer reading.	Dynamometer constant.	Current calculated from dynamometer.

Plot three curves on the same sheet connecting the ammeter readings with the calculated currents for the various frequencies.

NO. 75.—CALIBRATION OF AN ALTERNATING-CURRENT VOLTMETER

Preliminary.—You are required to calibrate an alternating-current voltmeter by comparison with a standard electro-static voltmeter, and to investigate the effect of an alteration of frequency on the readings of the instrument.

Apparatus.—You are supplied with a voltmeter, standard electro-static voltmeter, the readings of which are independent of frequency, frequency meter, potentiometer resistance, and an alternator capable of supplying currents at various frequencies.

Method.—(1) Connect the voltmeter and electro-static standard voltmeter in parallel with each other, and take wires from them to one end and the sliding contact of the potentiometer resistance respectively.

(2) Connect the wires from the alternator across the ends of the potentiometer resistance. Place the frequency meter across ends of the potentiometer resistance.

(3) Adjust the speed of the alternator so as to give the normal frequency.

(4) By means of the sliding contact on the potentiometer vary the P.D. at the voltmeter terminals so as to give various readings on the instruments. Take simultaneous readings on the two voltmeters approximately 10 volts apart throughout the whole range of the voltmeter scale.

(5) Repeat above with a frequency 5 per cent. in excess of the normal value.

(6) Repeat above with a frequency 5 per cent. below the normal value.

Tabulate your results thus :—

Type of voltmeter..... Number of voltmeter..... Standard frequency.....

Frequency.	Voltmeter reading.	Standard electro-static voltmeter reading.

Plot three curves on the same sheet with readings of voltmeter to be calibrated as abscissæ, and electro-static voltmeter readings as ordinates for the various frequencies.

NO. 76.—MEASUREMENT OF IMPEDANCE AND INDUCTANCE

Preliminary.—When an alternating current whose R.M.S. value is represented by C , and whose frequency is n periods per second, flows through a coil of resistance R ohms, and inductance L henries, the P.D. (R.M.S. value) required across the ends of the resistance coil is related to the other quantities in the following way:—

$$C = \frac{\text{P.D.}}{\sqrt{R^2 + 4\pi^2 n^2 L^2}}$$

The quantity $\sqrt{R^2 + 4\pi^2 n^2 L^2}$ is known as the impedance of the coil, whilst the quantity $2\pi nL$ is termed the reactance.

Hence we may write—

$$(\text{impedance})^2 = (\text{resistance})^2 + (\text{reactance})^2.$$

These three quantities may be graphically represented by the three sides of a right-angled triangle. The angle whose tangent is $\frac{\text{reactance}}{\text{resistance}}$ is known as the angle of lag, and represents the angle by which the maximum value of the current lags behind the corresponding maximum value of the E.M.F. or P.D. In the following experiment you are required to measure the impedance and inductance of an adjustable choking coil with various current strengths and with the adjustable core in various positions.

Apparatus.—You are supplied with a choking coil, Siemens electro-dynamometer, electro-static voltmeter, variable resistance and source of alternating current of known frequency ; also a source of continuous current.

Method.—(1) Connect the choking coil in series with the Siemens dynamometer, variable resistance, and alternating current supply. Place the voltmeter in parallel across the terminals of the choking coil.

(2) With the adjustable core in position for maximum inductance, switch on a small alternating current. Read the dynamometer and voltmeter.

(3) Repeat with gradually increasing strengths of alternating currents, adjusting the current strength by means of the variable resistance, until the maximum current has been reached.

(4) Repeat (2) and (3) with the adjustable core in various positions.

(5) Send a continuous current through the choking coil and take simultaneous dynamometer and voltmeter readings. This will enable you to calculate the ohmic resistance. (*Note.*—It may be necessary to use a lower reading voltmeter in this case.)

Tabulate your readings thus :—

Position of core.	Dynamometer A.C. reading.	Voltmeter A.C. reading.	Frequency n .	Impedance $\frac{P.D.}{C}$.	Inductance L.

DC dynamometer reading..... DC voltmeter reading.....
Resistance.....

The value of L can be calculated from the expression
impedance = $\sqrt{R^2 + 4\pi^2 n^2 L^2}$.

Plot a curve with values of L against A.C. currents for the various positions of the adjustable core.

No. 77.—IMPEDANCES IN SERIES

Preliminary.—When two or more coils, each of known impedance, are placed in series in an A.C. circuit, the total

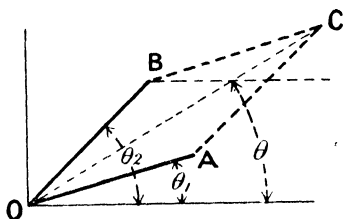

FIG. 37.

impedance is obtained by taking the vectorial sum of the separate impedances. Thus, if I_1 and I_2 represent the impedances of two coils respectively when they each carry a current of C ampères, and if θ_1 and θ_2 represent the angles of lag, calculated for each coil, between the current in the coil and the P.D. across its terminals, then if we set off a line OA to represent I_1 , making an angle θ_1 with the horizontal axis, and another line OB to represent I_2 , making an angle θ_2 with the horizontal, the resultant OC of the parallelogram, made up

with OA and OB as sides, will represent the total impedance I , and the angle θ which it makes with the horizontal axis, represents the angle of lag of the current behind the total P.D. drop down the two coils in series. In the following experiment you are required to verify this.

Apparatus.—You are supplied with two choking coils, three electro-static voltmeters, an A.C. ammeter, adjustable resistance, and source of alternating current of known frequency.

Method.—(1) Connect the coils in series with the ammeter, variable resistance, and source of current.

(2) Connect a voltmeter across the ends of each coil and one across the two coils in series.

(3) Switch on a small current and take simultaneous readings on the ammeter and three voltmeters.

(4) Repeat (3) with currents of various strengths.

Tabulate thus:—

Current C.	Voltmeter reading across coil (1) V_1 .	Voltmeter reading across coil (2) V_2 .	Voltmeter reading across coils (1) and (2) V_3 .	Impedance of coil (1) $\frac{V_1}{C}$.	Impedance of coil (2) $\frac{V_2}{C}$.	Total impedance $\frac{V_3}{C}$.

Resistance of coil (1).	Resistance of coil (2).	Fre- quency.	Reactance of coil (1).	Reactance of coil (2).	Tan θ .	θ .	Total Impedance (calculated).

The reactance is calculated from relation—

$$(\text{impedance})^2 = (\text{resistance})^2 + (\text{reactance})^2$$

and the tangent of the angle of lag ($\tan. \theta$) from—

$$\tan. \theta = \frac{\text{reactance}}{\text{resistance}}$$

From the above find graphically the vectorial sum of the two impedances, and compare your result with the result obtained by experiment.

NO. 78 — IMPEDANCES IN PARALLEL

Preliminary.—When two or more coils possessing resistance and inductance are placed in parallel in an A.C. circuit, the currents in the coils will be proportional to the reciprocals of the impedances. The reciprocal of impedance is termed the admittance.

Thus, if I_1 and I_2 are the impedances of two coils, A_1 and A_2 being their admittances, and θ_1 and θ_2 the angles of lag in

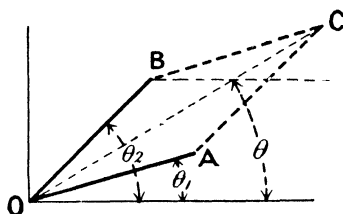

FIG. 38.

the coils respectively, then if we set off a length $OA = A_1$, and making an angle θ_1 with the horizontal, and a length $OB = A_2$ making an angle θ_2 with the horizontal, the resultant OC of the parallelogram made up on OA and OB as sides will represent the joint admittance, and its reciprocal the joint impedance. The angle between OC and the horizontal axis (θ) is the phase angle corresponding to the joint impedance. You are required to verify the above relationship in the following experiment.

Apparatus.—You are supplied with two choking coils, three A.C. ammeters, an electro-static voltmeter, variable resistance, and a source of alternating current of known frequency.

Method.—(1) Connect the two coils in parallel, one ammeter being in series with each coil, and one in series with the two coils in parallel. Connect the above in series with the

variable resistance and source of A.C. current. Connect the voltmeter so as to read the P.D. across the two coils in parallel.

(2) Starting with small currents take simultaneous readings on the three ammeters and voltmeter.

(3) Repeat above for various current strengths.

Tabulate your results thus :—

Total current C.	Current in coil (1) C ₁ .	Current in coil (2) C ₂ .	P.D. across coils V.	Impedance of (1) $I_1 = \frac{V}{C_1}$.	Impedance of (2) $I_2 = \frac{V}{C_2}$.	Total impedance $I = \frac{V}{C}$.

Admittance of coil (1) A ₁ .	Admittance of coil (2) A ₂ .	Resistance of coil (1).	Resistance of coil (2).	Reactance of coil (1).	Reactance of coil (2).	θ_1 .	θ_2 .	Total admittance.	Total impedance (calculated).	Frequency.

The reactance is calculated from—

$$(\text{impedance})^2 = (\text{resistance})^2 + (\text{reactance})^2$$

and θ the angle of lag from—

$$\tan \theta = \frac{\text{reactance}}{\text{resistance}}$$

From the above find graphically the total admittance and the total impedance. Compare your results with the results obtained by experiment.

NO. 79.—CAPACITY CURRENTS

Preliminary.—When an alternating current supply is connected to a circuit which in the ordinary sense of the term is

“open” or not continuously conducting, but possesses a certain electro-static capacity, a current will be found to flow. This current has a value depending on the P.D. applied, the capacity (K) of the circuit, and the frequency (n) of the alternating current, the exact relationship being given by the expression—

$$C = p \cdot KE$$

where C = current in amperes, K = capacity in farads, $p = 2\pi n$, and E = potential difference of alternating current supply. In the following experiment you are required to verify the above relationship.

Apparatus.—You are supplied with a condenser of known and variable capacity, a Siemens electro-dynamometer, electro-static voltmeter, frequency meter, and source of alternating current supply of variable frequency.

Method.—(1) Connect the condenser in series with the Siemens dynamometer and alternating current supply. Place the voltmeter across the condenser terminals, and connect the frequency meter to the terminals of the supply circuit.

(2) With the alternator running at its normal speed, adjust the voltage at the condenser terminals to the lowest value that will give a measurable current by regulating the exciting current of the alternator. The condenser should be adjusted to its maximum capacity. Take simultaneous readings of C , n , and E .

(3) Repeat above, with gradually increasing values of E , obtained by altering the exciting current in the alternator field coils without altering the frequency, until the maximum value of E has been reached.

(4) Adjust E so as to have its maximum value, and, keeping the frequency constant by keeping the speed of the alternator always the same, gradually reduce the value of the condenser capacity. Take a set of readings of C , n , and E for each capacity value.

(5) Adjust K so as to have its maximum value, and then vary the alternator speed so as to vary the frequency. For each frequency adjust the E.M.F. so as to have a constant value by altering the magnetizing current. Take readings of C for each value of n .

Tabulate your results thus :—

Potential difference at condenser terminals E.	Dynamometer reading.	Dynamometer constant.	Current in ampères C.	Capacity (Farads) K.	Frequency μ .	$\phi = 2\pi\mu$.	Values of ϕKE .

Plot three curves with values of—

- (1) C as ordinates against E as abscissæ.
- (2) C as ordinates against K as abscissæ.
- (3) C as ordinates against μ as abscissæ.

NO. 80.—CAPACITY AND INDUCTANCE IN SERIES

Preliminary.—When a condenser of capacity K is connected in series with a coil of resistance R ohms and inductance L henries in an alternating current circuit in which the impressed P.D. is E volts, the current C which flows through the circuit can be shown to be—

$$C = \frac{E}{\sqrt{R^2 + \left(L\phi - \frac{1}{k\phi}\right)^2}}$$

Here ϕ has the usual value $2\pi \times$ frequency.

It will be seen from this formula that when $L\phi = \frac{1}{k\phi}$ the capacity effect entirely annuls the inductance effect, and the current will then be simply $C = \frac{E}{R}$, the same as it would be if direct currents were used. The P.D. across both the condenser terminals and the inductance may considerably exceed the impressed E.M.F. In the following experiment you are required to verify the above relationship.

Apparatus.—You are supplied with a coil of known inductance, a condenser of variable known capacity, an

ammeter, three electro-static voltmeters, and a source of alternating P.D. of known frequency.

Method.—(1) Connect the condenser, inductance coil, and ammeter in series with the source of alternating current supply. Place electro-static voltmeters across the condenser and inductance coil terminals respectively, and one across the two in series.

(2) With the smallest capacity in circuit, switch on the current and take simultaneous readings on the three voltmeters and the ammeter.

(3) Gradually increase the value of the capacity, repeating the above readings for each separate capacity value.

Tabulate your results thus :—

Total impressed P.D. (V).	P.D. across condenser V_1 .	P.D. across inductance V_2 .	Current C (amperes).	Capacity K (farads).	Inductance L (henries).	Resistance R.	Frequency n .	$\phi = 2\pi nt$.	$\frac{V}{\sqrt{R^2 + (L\phi - \frac{1}{\phi C})^2}}$.

Calculate the capacity that would be necessary to annul the inductance completely at the above frequency.

NO. 81.—CAPACITY AND INDUCTANCE IN PARALLEL

Preliminary.—When an inductive resistance is placed in parallel with a condenser, the total current in the inductive circuit may be regarded as made up of (1) the load current which is in phase with the E.M.F., and (2) the idle current which lags 90° behind it. The current in the condenser will be 90° in advance of the E.M.F.; hence there will be a current flowing in the condenser and inductance coil circuit which does not go into the main circuit at all. If the condenser has

a capacity such that its current is equal to the idle current in the inductive resistance, the only current the main circuit will have to supply will be the load current.

A condenser may therefore be employed in parallel with an inductance coil so as to decrease the main circuit current supplied to the latter, and hence increase the power factor of the circuit.

In the following experiment you are required to investigate the effect on the total current supplied to an inductance coil of placing a condenser in parallel with it.

Apparatus.—You are supplied with a coil of known inductance and resistance, a condenser of variable capacity, three ammeters, and a source of alternating current supply of known frequency.

Method.—(1) Connect the condenser and inductance coil each in series with an ammeter, and connect these two circuits in parallel across the mains, placing an ammeter in the mains so as to read the total current.

(2) With the capacity value reduced to zero, switch on the current and take the ammeter readings.

(3) Gradually increase the value of the shunting capacity, taking simultaneous readings on the three ammeters for each value of capacity.

Tabulate your results thus :—

Total current.	Inductance current.	Condenser current.	Frequency.	Capacity.

Plot curves for each of the above sets of current readings, taking current values as ordinates against capacity as abscissæ.

From your curves find the value of capacity that will exactly take all the idle current of the inductance coil, and therefore raise the power factor of the mains to unity.

NO. 82.—THREE-VOLTMETER METHOD OF MEASURING A.C. POWER

Preliminary.—In alternating current circuits possessing inductance the power expended is not expressed simply as the product of the current into the potential difference, since the current is not in phase with the P.D. The product of P.D. and current gives what is termed apparent power, as distinguished from true power, which can be shown to be $P.D. \times C \times \cos \phi$, ϕ being the angle of lag of current behind P.D. As the angle of lag in a circuit is not as a rule known, and as it cannot be measured directly, other methods of measuring power have been developed. In the three-voltmeter method a non-inductive resistance is placed in series with the inductive resistance, and the drop of pressure down each coil and down the two in series is measured. From this it can be shown that the mean power in the inductive circuit is—

$$P = \frac{I}{2r}(V^2 - V_1^2 - V_2^2)$$

where r = resistance in ohms of the non-inductive resistance, V = P.D. down the two coils in series, and V_1 and V_2 the P.D.'s down the inductive and non-inductive coils respectively. To verify this you are to compare the power as calculated above with that measured by a wattmeter capable of reading accurately on low power factor circuits.

Apparatus.—You are supplied with two coils, one inductive and the other of nearly the same ohmic resistance, but wound non-inductively, a wattmeter, three voltmeters and a variable resistance, also a source of A.C. supply.

Method.—(1) Connect the two coils and the variable resistance in series with each other and with the thick coil of the wattmeter, so that the same alternating current will flow through all three. Connect the fine wire coil of the wattmeter as a shunt across the terminals of the inductive coil.

(2) Connect an electro-static voltmeter across the terminals of each of the coils and one across the two in series.

(3) Starting with a small current, take simultaneous readings on each of the voltmeters and on the wattmeter.

(4) Gradually increase the current by adjusting the variable resistance, and take a set of simultaneous readings on the instruments as above.

Tabulate your results thus:—

Wattmeter reading.	Wattmeter constant.	True power.	Total P.D. V.	P. D. down inductive resistance V_1 .	P. D. down non-inductive resistance V_2 .	Value of non inductive resistance r .	V^2 .	V_1^2 .	V_2^2 .	Power $P = \frac{1}{2r}(V^2 - V_1^2 - V_2^2)$.

Plot a curve with power as measured on the wattmeter for ordinates against power as calculated from the voltmeter readings as abscissæ.

NO. 83.—THREE-AMMETER METHOD OF MEASURING A.C. POWER

Preliminary.—This is another method of measuring alternating current power which gets over the objection of having to place a resistance in series with the circuit in which the power is to be measured, as in the three-voltmeter method, and consequently admits of the circuit being subjected to the maximum P.D. for which it was designed without using excessive voltages. In this method a non-inductive resistance of approximately the same ohmic resistance as the inductive coil is placed in parallel with it, and the currents in the two coils, as well as the total current taken from the mains, are measured. The power expended in the inductive coil can then be shown to be—

$$P = \frac{r}{2}(C^2 - C_1^2 - C_2^2)$$

Three-Ammeter Method of Measuring A.C. Power 131

r = ohmic resistance of the non-inductive resistance, C , C_1 , and C_2 being respectively the main circuit, inductive circuit, and non-inductive circuit currents. You are required to verify the above by comparing the power so measured with that measured on a wattmeter which will read accurately on circuits of low power factor.

Apparatus.—You are supplied with two coils, one inductively and the other non-inductively wound, of approximately the same ohmic resistance, three ammeters, a variable resistance, and an alternating current supply.

Method.—(1) Connect each coil in series with an ammeter across the A.C. mains. Place the variable resistance and ammeter in the mains so as to vary and indicate the value of the total current.

(2) Connect the thick coil of the wattmeter in series with the inductive resistance, and the thin coil as a shunt across its ends.

(3) Starting with a small value for the main circuit current, take simultaneous readings on the three ammeters and on the wattmeter.

(4) Repeat above with gradually increasing values for the main circuit current, obtained by adjusting the variable resistance.

Tabulate your results thus :—

Wattmeter reading,	Wattmeter constant.	True power.	Total current C.	Current in inductive resistance C_1 .	Current in non-inductive resistance C_2 .	Resistance of non-inductive coil r .	C^2 .	C_1^2 .	C_2^2 .	Power $P = \frac{r}{2} (C^2 - C_1^2 - C_2^2).$

Plot a curve with power as measured on the wattmeter for ordinates against power as calculated from the voltmeter readings as abscissæ.

NO. 84.—EXAMINATION OF AN ALTERNATOR

Preliminary.—In the following experiment you are required to obtain all the leading dimensions of the alternator supplied, so as to enable you to make a complete drawing of the same. You are also to tabulate particulars of the windings of the armature and field circuits, and measure their ohmic resistances.

Particulars should be tabulated thus :—

Machine.....	Type.....	Maker.....	Number.....
Date.....	Speed.....	Output.....	Volts.....
Frequency.....		Ampères.....	

Armature (Stator).—Bore..... Number of slots.....
 Number of wires per slot..... Number of slots per pole per
 phase..... Size of conductor..... Size of slots..... Resist-
 ance per phase..... Method of winding..... Number of
 conductors per phase..... Arrangement of coils.....

Field (Rotor).—Outside diameter of pole faces..... Air
 space..... Size of wire..... Number of coils..... Number
 of turns per coil..... Total resistance..... Pole arc.....
 Pole pitch..... Field current for maximum output.....

NO. 85.—TRACING THE E.M.F. CURVE OF AN
ALTERNATOR

Preliminary.—In the following experiment you are required to determine the instantaneous values of the E.M.F. induced in the armature coils of an alternator when in various positions relatively to the magnetizing field. In order to do this the machine is supplied with a special contact stud which rotates with the armature, and which once every revolution completes the circuit between two brushes, the position of which relatively to the field magnets can be accurately determined by means of a graduated scale across which they can be moved.

Apparatus.—You are supplied with an alternator fitted with special contact-stud arrangement, speed counter, electrostatic

ltmeter, condenser, ammeter, non-inductive lamp load, also inductive choking coil load.

Method.—(1) Connect one phase on the armature circuit series with the two brushes and an electro-static voltmeter, that when the contact stud is not joining the brushes the circuit to one voltmeter terminal is interrupted.

(2) Connect the condenser in parallel across the voltmeter terminals, and earth the voltmeter terminal that is not connected to the brushes.

(3) Adjust the brushes to the zero on the graduated scale, and note exactly how they are situated relatively to the poles of the magnetizing field.

(4) Start up the alternator and adjust the speed to the normal value. Switch on the normal magnetization current.

(5) Take the electro-static voltmeter readings.

(6) Advance the brushes 10° , and again read the voltmeter.

(7) Repeat this throughout the whole range of movement of the brushes.

(8) Repeat the above with the alternator supplying its maximum current to a non-inductive load.

(9) Repeat with the alternator supplying its maximum current to an inductive load.

Tabulate your results thus :—

Speed.	Magnetizing current.	Armature current.	Voltmeter reading.	Scale reading of brushes.	Nature of external load.

Plot three curves with the voltmeter readings as ordinates against the scale readings of the brushes as abscissæ, and on one abscissæ scale indicate the positions of the poles of the magnetizing field.

NO. 86.—DETERMINATION OF THE CHARACTERISTICS
OF AN ALTERNATOR AND THE EQUIVALENT
ARMATURE INDUCTANCE

Preliminary.—The majority of problems connected with alternators require for their solution a knowledge of (1) the open-circuit characteristic, which is the relation between the the E.M.F. developed in an alternator armature on open circuit and the magnetizing current in the field coils; and (2) the short-circuit characteristic, which is the relation between the armature current when short circuited through a non-inductive resistance and the magnetizing current in the field coils.

Apparatus.—You are supplied with a three-phase alternator and the means of driving it, a battery of secondary cells to supply the magnetizing current, variable resistance, ammeters, electro-static voltmeter, and speed indicator.

Open Circuit Characteristic

Method.—(1) Connect up the secondary battery through an ammeter and variable resistance to the magnetizing field coils of the alternator, and connect the electro-static voltmeter across one pair of mains so as to measure the E.M.F. in one phase. The armature is on open circuit, and it is assumed that the E.M.F.'s in the three phases are equal.

(2) Start up the alternator and adjust the speed until the speed indicator shows that the machine is running at its normal rate. This must be kept constant throughout the experiment.

(3) With all the variable resistance in circuit, switch on the current. Gradually increase the magnetizing current until a reading is obtained on the voltmeter.

(4) Take simultaneous readings on the voltmeter and ammeter for about every ten volts until the maximum E.M.F. of the machine is reached.

(5) Gradually reduce the magnetizing current, and take a similar set of readings with falling currents.

Tabulate your results thus :—

Speed.	Armature E.M.F.	Field current.

Plot two curves connecting E.M.F. and current, one for the rising and one for the falling values of the current. From these draw in a mean curve.

Short Circuit Characteristic

(1) Short circuit two phases on the armature through non-inductive copper straps, and the third phase through a non-inductive ammeter (hot wire for preference).

(2) Run the machine up to its normal speed, and then switch on a very small magnetizing current in the field coils. Take ammeter readings simultaneously in the field and armature circuits.

(3) Gradually increase the field current until the maximum armature current is obtained.

(4) Gradually reduce the magnetizing current and take a similar set of readings with falling currents.

Tabulate your results thus :—

Speed.	Armature current.	Field current.

Plot two curves connecting armature currents with field currents for both rising and falling field current values. From these draw in a mean curve.

Equivalent Armature Inductance

The equivalent armature inductance can be obtained from the open circuit and short circuit characteristics as follows. If the E.M.F. and armature current corresponding to a given current in the magnetizing circuit are represented by E and C, then—

$$\text{Impedance} = \frac{E}{C}$$

also, if R = armature resistance, n = frequency, L = inductance, then—

$$\sqrt{R^2 + 4\pi^2 n^2 L^2} = \frac{E}{C}$$

$$\text{or armature reactance } (2\pi nL) = \frac{\sqrt{E^2 - R^2 C^2}}{C}$$

From the two curves above obtain the values of E and C for various magnetizing currents. Tabulate them thus :—

Magnetizing current.	Open circuit E.M.F. E.	Short circuit armature current C.	Equivalent armature impedance $\frac{E}{C}$.	Frequency.	Armature resistance R.	Armature reactance $\frac{E^2 - R^2 C^2}{C}$.	Armature inductance L.

NO. 87.—EFFICIENCY OF A TRANSFORMER (SUMPNER'S METHOD)

Preliminary.—The efficiency of a transformer is the ratio of the output watts to the input watts. This may be found by actually measuring the watts supplied to the primary and the watts given out at the secondary at all loads, but a more accurate and simpler method, due to Dr. Sumpner, consists in measuring the lost power directly. The lost power in a transformer is made up of (a) the core losses or losses in hysteresis

and eddy currents, and (b) the copper losses or losses due to the ohmic resistances of the coils. The core losses depend on the maximum value of the magnetic flux density in the core, and may be assumed to be constant at all loads, the value being taken as that of the power supplied to the primary coil when the secondary is on open circuit. The copper losses depend on the resistances of the coils and the currents they carry. They may be measured by short circuiting the secondary coil through an ammeter of negligible inductance, and measuring the power supplied to the primary coil when the secondary is carrying its maximum load current. The magnetic flux density in the core is very small in this case, so that the core losses may be assumed negligible. Hence the power supplied to the primary represents the copper loss.

Apparatus.—You are supplied with a transformer, source of alternating current of known frequency, electro-static voltmeter, inductionless ammeter, wattmeter capable of reading accurately on low power factor circuits, and variable resistance.

Method.—(1) Connect the source of alternating current in series with the variable resistance, current coil of the wattmeter, and primary of transformer. Connect the pressure coil of wattmeter and the electro-static voltmeter in parallel with the primary of the transformer.

(2) With the secondary of the transformer on open circuit switch the current on to the primary, and adjust the pressure at its terminals to the normal value, as indicated by the electro-static voltmeter. Note the wattmeter reading.

(3) Switch off the primary current. Place the ammeter across the secondary coil terminals so as to short circuit them; then, with a very high resistance in series with the primary circuit, switch on the current. Adjust the variable resistance till the secondary coil ammeter reads about $\frac{1}{10}$ of the maximum current output of the transformer. Read the wattmeter.

(4) Repeat, adjusting the variable resistance in the primary circuit so as to get successively $\frac{1}{4}$, $\frac{1}{2}$, $\frac{3}{4}$, and full load currents in the secondary circuit.

Tabulate your results thus :—

Primary P.D.	Frequency.	Primary wattmeter reading.	Secondary current.	Total watts lost.

To calculate the efficiency you must add the total watts lost for any given output to the output watts. This will give the total input watts. The ratio of the output watts to the input watts $\times 100$ gives the percentage efficiency.

Tabulate thus :—

Secondary current.	Output watts.	Lost watts.	Total or input watts.	Efficiency.

TABLES

LOGARITHMS.

	0	1	2	3	4	5	6	7	8	9	12	34	5	67	89
10	0000	0043	0086	0128	0170	0212	0253	0294	0334	0374	4 8	12 17	21	25 29	33 37
11	0414	0453	0492	0531	0569	0607	0645	0682	0719	0755	4 8	11 15	19	23 26	30 34
12	0792	0828	0864	0899	0934	0969	1004	1038	1072	1106	3 7	10 14	17	21 24	28 31
13	1139	1173	1206	1239	1271	1303	1335	1367	1399	1430	3 6	10 13	16	19 23	26 29
14	1461	1492	1523	1553	1584	1614	1644	1673	1703	1732	3 6	9 12	15	18 21	24 27
15	1761	1790	1818	1847	1875	1903	1931	1959	1987	2014	3 6	8 11	14	17 20	22 25
16	2041	2068	2095	2122	2148	2175	2201	2227	2253	2279	3 5	8 11	13	16 18	21 24
17	2304	2330	2355	2380	2405	2430	2455	2480	2504	2529	2 5	7 10	12	15 17	20 22
18	2553	2577	2601	2625	2648	2672	2695	2718	2742	2765	2 5	7 9	12	14 16	19 21
19	2788	2810	2833	2856	2878	2900	2923	2945	2967	2989	2 4	7 9	11	13 16	18 20
20	3010	3032	3054	3075	3096	3118	3139	3160	3181	3201	2 4	6 8	11	13 15	17 19
21	3222	3243	3263	3284	3304	3324	3345	3365	3385	3404	2 4	6 8	10	12 14	16 18
22	3424	3444	3464	3483	3502	3522	3541	3560	3579	3598	2 4	6 8	10	12 14	15 17
23	3617	3636	3655	3674	3692	3711	3729	3747	3766	3784	2 4	6 7	9	11 13	15 17
24	3802	3820	3838	3856	3874	3892	3909	3927	3945	3962	2 4	5 7	9	11 12	14 16
25	3979	3997	4014	4031	4048	4065	4082	4099	4116	4133	2 3	5 7	9	10 12	14 15
26	4150	4166	4183	4200	4216	4232	4249	4265	4281	4298	2 3	5 7	8	10 11	13 15
27	4314	4330	4346	4362	4378	4393	4409	4425	4440	4456	2 3	5 6	8	9 11	13 14
28	4472	4487	4502	4518	4533	4548	4564	4579	4594	4609	2 3	5 6	8	9 11	12 14
29	4624	4639	4654	4669	4683	4698	4713	4728	4742	4757	1 3	4 6	7	9 10	12 13
30	4771	4786	4800	4814	4829	4843	4857	4871	4886	4900	1 3	4 6	7	9 10	11 13
31	4914	4928	4942	4955	4969	4983	4997	5011	5024	5038	1 3	4 6	7	8 10	11 12
32	5051	5065	5079	5092	5105	5119	5132	5145	5159	5172	1 3	4 5	7	8 9	11 12
33	5185	5198	5211	5224	5237	5250	5263	5276	5289	5302	1 3	4 5	6	8 9	10 12
34	5315	5328	5340	5353	5366	5378	5391	5403	5416	5428	1 3	4 5	6	8 9	10 11
35	5441	5453	5465	5478	5490	5502	5514	5527	5539	5551	1 2	4 5	6	7 9	10 11
36	5563	5575	5587	5599	5611	5623	5635	5647	5658	5670	1 2	4 5	6	7 8	10 11
37	5682	5694	5705	5717	5729	5740	5752	5763	5775	5786	1 2	3 5	6	7 8	9 10
38	5798	5809	5821	5832	5843	5855	5866	5877	5888	5899	1 2	3 5	6	7 8	9 10
39	5911	5922	5933	5944	5955	5966	5977	5988	5999	6010	1 2	3 4	5	7 8	9 10
40	6021	6031	6042	6053	6064	6075	6085	6096	6107	6117	1 2	3 4	5	6 8	9 10
41	6128	6138	6149	6160	6170	6180	6191	6201	6212	6222	1 2	3 4	5	6 7	8 9
42	6232	6243	6253	6263	6274	6284	6294	6304	6314	6325	1 2	3 4	5	6 7	8 9
43	6335	6345	6355	6365	6375	6385	6395	6405	6415	6425	1 2	3 4	5	6 7	8 9
44	6435	6444	6454	6464	6474	6484	6493	6503	6513	6522	1 2	3 4	5	6 7	8 9
45	6532	6542	6551	6561	6571	6580	6590	6599	6609	6618	1 2	3 4	5	6 7	8 9
46	6628	6637	6646	6656	6665	6675	6684	6693	6702	6712	1 2	3 4	5	6 7	7 8
47	6721	6730	6739	6749	6758	6767	6776	6785	6794	6803	1 2	3 4	5	5 6	7 8
48	6812	6821	6830	6839	6848	6857	6866	6875	6884	6893	1 2	3 4	4	5 6	7 8
49	6902	6911	6920	6928	6937	6946	6955	6964	6972	6981	1 2	3 4	4	5 6	7 8
50	6990	6998	7007	7016	7024	7033	7042	7050	7059	7067	1 2	3 3	4	5 6	7 8
51	7076	7084	7093	7101	7110	7118	7126	7135	7143	7152	1 2	3 3	4	5 6	7 8
52	7160	7168	7177	7185	7193	7202	7210	7218	7226	7235	1 2	2 3	4	5 6	7 7
53	7243	7251	7259	7267	7275	7284	7292	7300	7308	7316	1 2	2 3	4	5 6	6 7
54	7324	7332	7340	7348	7356	7364	7372	7380	7388	7396	1 2	2 3	4	5 6	6 7

ANTILOGARITHMS.

	0	1	2	3	4	5	6	7	8	9	12	34	5	6	7	8	9
'50	3162	3170	3177	3184	3192	3199	3206	3214	3221	3228	1 1	2 3	4	4	5	6	7
'51	3236	3243	3251	3258	3266	3273	3281	3289	3296	3304	1 2	2 3	4	5	5	6	7
'52	3311	3319	3327	3334	3342	3350	3357	3365	3373	3381	1 2	2 3	4	5	5	6	7
'53	3388	3396	3404	3412	3420	3428	3436	3443	3451	3459	1 2	2 3	4	5	6	6	7
'54	3467	3475	3483	3491	3499	3508	3516	3524	3532	3540	1 2	2 3	4	5	6	6	7
'55	3548	3556	3565	3573	3581	3589	3597	3606	3614	3622	1 2	2 3	4	5	6	7	7
'56	3631	3639	3648	3656	3664	3673	3681	3690	3698	3707	1 2	3 3	4	5	6	7	8
'57	3715	3724	3733	3741	3750	3758	3767	3776	3784	3793	1 2	3 3	4	5	6	7	8
'58	3802	3811	3819	3828	3837	3846	3855	3864	3873	3882	1 2	3 4	4	5	6	7	8
'59	3890	3899	3908	3917	3926	3936	3945	3954	3963	3972	1 2	3 4	5	5	6	7	8
'60	3981	3990	3999	4009	4018	4027	4036	4046	4055	4064	1 2	3 4	5	6	6	7	8
'61	4074	4083	4093	4102	4111	4121	4130	4140	4150	4159	1 2	3 4	5	6	7	8	9
'62	4169	4178	4188	4198	4207	4217	4227	4236	4246	4256	1 2	3 4	5	6	7	8	9
'63	4266	4276	4285	4295	4305	4315	4325	4335	4345	4355	1 2	3 4	5	6	7	8	9
'64	4365	4375	4385	4395	4406	4416	4426	4436	4446	4457	1 2	3 4	5	6	7	8	9
'65	4467	4477	4487	4498	4508	4519	4529	4539	4550	4560	1 2	3 4	5	6	7	8	9
'66	4571	4581	4592	4603	4613	4624	4634	4645	4656	4667	1 2	3 4	5	6	7	9	10
'67	4677	4688	4699	4710	4721	4732	4742	4753	4764	4775	1 2	3 4	5	7	8	9	10
'68	4786	4797	4808	4819	4831	4842	4853	4864	4875	4887	1 2	3 4	6	7	8	9	10
'69	4898	4909	4920	4932	4943	4955	4966	4977	4989	5000	1 2	3 5	6	7	8	9	10
'70	5012	5023	5035	5047	5058	5070	5082	5093	5105	5117	1 2	4 5	6	7	8	9	11
'71	5129	5140	5152	5164	5176	5188	5200	5212	5224	5236	1 2	4 5	6	7	8	10	11
'72	5248	5260	5272	5284	5297	5309	5321	5333	5346	5358	1 2	4 5	6	7	9	10	11
'73	5370	5383	5395	5408	5420	5433	5445	5458	5470	5483	1 3	4 5	6	8	9	10	11
'74	5495	5508	5521	5534	5546	5559	5572	5585	5598	5610	1 3	4 5	6	8	9	10	12
'75	5623	5636	5649	5662	5675	5689	5702	5715	5728	5741	1 3	4 5	7	8	9	10	12
'76	5754	5768	5781	5794	5808	5821	5834	5848	5861	5875	1 3	4 5	7	8	9	11	12
'77	5888	5902	5916	5929	5943	5957	5970	5984	5998	6012	1 3	4 5	7	8	10	11	12
'78	6026	6039	6053	6067	6081	6095	6109	6124	6138	6152	1 3	4 6	7	8	10	11	13
'79	6166	6180	6194	6209	6223	6237	6252	6266	6281	6295	1 3	4 6	7	9	10	11	13
'80	6310	6324	6339	6353	6368	6383	6397	6412	6427	6442	1 3	4 6	7	9	10	12	13
'81	6457	6471	6486	6501	6516	6531	6546	6561	6577	6592	2 3	5 6	8	9	11	12	14
'82	6607	6622	6637	6653	6668	6683	6699	6714	6730	6745	2 3	5 6	8	9	11	12	14
'83	6761	6776	6792	6808	6823	6839	6855	6871	6887	6902	2 3	5 6	8	9	11	13	14
'84	6918	6934	6950	6966	6982	6998	7015	7031	7047	7063	2 3	5 6	8	10	11	13	15
'85	7079	7096	7112	7129	7145	7161	7178	7194	7211	7228	2 3	5 7	8	10	12	13	15
'86	7244	7261	7278	7295	7311	7328	7345	7379	7396		2 3	5 7	8	10	12	13	15
'87	7413	7430	7447	7464	7482	7499	7515	7551	7568		2 3	5 7	9	10	12	14	16
'88	7586	7603	7621	7638	7656	7674	7691	7727	7745		2 4	5 7	9	11	12	14	16
'89	7762	7780	7798	7816	7834	7852	7870	7907	7925		2 4	5 7	9	11	12	14	16
'90	7943	7962	7980	7998	8017	8035	8053	8091	8110		2 4	6 7	9	11	13	15	17
'91	8128	8147	8166	8185	8204	8222	8241	8279	8299		2 4	6 8	9	11	13	15	17
'92	8318	8337	8356	8375	8395	8414	8433	8472	8492		2 4	6 8	10	12	14	15	17
'93	8511	8531	8551	8570	8590	8610	8630	8650	8670		2 4	6 8	10	12	14	16	18
'94	8710	8730	8750	8770	8790	8810	8831	8851	8872		2 4	6 8	10	12	14	16	18
'95	8913	8933	8954	8974	8995	9016	9036	9057	9078		2 4	6 8	10	12	15	17	19
'96	9120	9141	9162	9183	9204	9226	9247	9268	9290	9311	2 4	6 8	11	13	15	17	19
'97	9333	9354	9376	9397	9419	9441	9462	9484	9506	9528	2 4	7 9	11	13	15	17	20
'98	9550	9572	9594	9616	9638	9661	9683	9705	9727	9750	2 4	7 9	11	13	15	18	20
'99	9772	9795	9817	9840	9863	9886	9908	9931	9954	9977	2 5	7 9	11	14	16	18	20

SQUARES.

	0	1	2	3	4	5	6	7	8	9	1	2	3	4	5	6	7	8	9
10	1'000	1'020	1'040	1'061	1'082	1'103	1'124	1'145	1'166	1'188	2	4	6	8	10	13	15	17	19
11	1'210	1'232	1'254	1'277	1'300	1'323	1'346	1'369	1'392	1'416	2	5	7	9	11	14	16	18	21
12	1'440	1'464	1'488	1'513	1'538	1'563	1'588	1'613	1'638	1'664	2	5	7	10	12	15	17	20	22
13	1'690	1'716	1'742	1'769	1'796	1'823	1'850	1'877	1'904	1'932	3	5	8	11	13	16	18	22	24
14	1'960	1'988	2'016	2'045	2'074	2'103	2'132	2'161	2'190	2'220	3	6	9	12	14	17	20	23	26
15	2'250	2'280	2'310	2'341	2'372	2'403	2'434	2'465	2'496	2'528	3	6	9	12	15	19	22	25	28
16	2'560	2'592	2'624	2'657	2'690	2'723	2'756	2'789	2'822	2'856	3	7	10	13	16	20	23	26	30
17	2'890	2'924	2'958	2'993	3'028	3'063	3'098	3'133	3'168	3'204	3	7	10	14	17	21	24	28	31
18	3'240	3'276	3'312	3'349	3'386	3'423	3'460	3'497	3'534	3'572	4	7	11	15	18	22	26	30	33
19	3'610	3'648	3'686	3'725	3'764	3'803	3'842	3'881	3'920	3'960	4	8	12	16	19	23	27	31	35
20	4'000	4'040	4'080	4'121	4'162	4'203	4'244	4'285	4'326	4'368	4	8	12	16	20	25	29	33	37
21	4'410	4'452	4'494	4'537	4'580	4'623	4'666	4'709	4'752	4'796	4	9	13	17	21	26	30	34	39
22	4'840	4'884	4'928	4'973	5'018	5'063	5'108	5'153	5'198	5'244	4	9	13	18	22	27	31	36	40
23	5'290	5'336	5'382	5'429	5'476	5'523	5'570	5'617	5'664	5'712	5	9	14	19	23	28	33	38	42
24	5'760	5'808	5'856	5'905	5'954	6'003	6'052	6'101	6'150	6'200	5	10	15	20	24	29	34	39	44
25	6'250	6'300	6'350	6'401	6'452	6'503	6'554	6'605	6'656	6'708	5	10	15	20	25	31	36	41	46
26	6'760	6'812	6'864	6'917	6'970	7'023	7'076	7'129	7'182	7'236	5	11	16	21	26	32	37	42	48
27	7'290	7'344	7'398	7'453	7'508	7'563	7'618	7'673	7'728	7'784	5	11	16	22	27	33	38	44	49
28	7'840	7'896	7'952	8'009	8'066	8'123	8'180	8'237	8'294	8'352	6	11	17	23	28	34	40	46	51
29	8'410	8'468	8'526	8'585	8'644	8'703	8'762	8'821	8'880	8'940	6	12	18	24	29	35	41	47	53
30	9'000	9'060	9'120	9'181	9'242	9'303	9'364	9'425	9'486	9'548	6	12	18	24	30	37	43	49	55
31	9'610	9'672	9'734	9'797	9'860	9'923	9'986				6	13	19	25	31	38	44	50	57
31								10'05	10'11	10'18	1	1	2	3	3	4	5	5	6
32	10'24	10'30	10'37	10'43	10'50	10'56	10'63	10'69	10'76	10'82	1	1	2	3	3	4	5	5	6
33	10'89	10'96	11'02	11'09	11'16	11'22	11'29	11'36	11'42	11'49	1	1	2	3	3	4	5	5	6
34	11'56	11'63	11'70	11'76	11'83	11'90	11'97	12'04	12'11	12'18	1	1	2	3	3	4	5	5	6
35	12'25	12'32	12'39	12'46	12'53	12'60	12'67	12'74	12'82	12'89	1	1	2	3	4	4	5	5	6
36	12'96	13'03	13'10	13'18	13'25	13'32	13'40	13'47	13'54	13'62	1	1	2	3	4	4	5	5	6
37	13'69	13'76	13'84	13'91	13'99	14'06	14'14	14'21	14'29	14'36	1	2	2	3	4	5	5	6	7
38	14'44	14'52	14'59	14'67	14'75	14'82	14'90	14'98	15'05	15'13	1	2	2	3	4	5	5	6	7
39	15'21	15'29	15'37	15'44	15'52	15'60	15'68	15'76	15'84	15'92	1	2	2	3	4	5	5	6	7
40	16'00	16'08	16'16	16'24	16'32	16'40	16'48	16'56	16'65	16'73	1	2	2	3	4	5	5	6	7
41	16'81	16'89	16'97	17'06	17'14	17'22	17	17'47	17'56		1	2	2	3	4	5	5	6	7
42	17'64	17'72	17'81	17'89	17'98	18'06	18	18'32	18'40		1	2	3	3	4	5	5	6	7
43	18'49	18'58	18'66	18'75	18'84	18'92	19'0	19'18	19'27		1	2	3	3	4	5	5	6	7
44	19'36	19'45	19'54	19'62	19'71	19'80	19'89	19'97	20'06		1	2	3	4	5	5	6	7	8
45	20'25	20'34	20'43	20'52	20'61	20'70	20'79	20'88	21'07		1	2	3	4	5	5	6	7	8
46	21'16	21'25	21'34	21'44	21'53	21'62	21'72	21'81	21'90	22'00	1	2	3	4	5	6	7	7	8
47	22'09	22'18	22'28	22'37	22'47	22'56	22'66	22'75	22'85	22'94	1	2	3	4	5	6	7	8	9
48	23'04	23'14	23'23	23'33	23'43	23'52	23'62	23'72	23'81	23'91	1	2	3	4	5	6	7	8	9
49	24'01	24'11	24'21	24'30	24'40	24'50	24'60	24'70	24'80	24'90	1	2	3	4	5	6	7	8	9
50	25'00	25'10	25'20	25'30	25'40	25'50	25'60	25'70	25'81	25'91	1	2	3	4	5	6	7	8	9
51	26'01	26'11	26'21	26'32	26'42	26'52	26'63	26'73	26'83	26'94	1	2	3	4	5	6	7	8	9
52	27'04	27'14	27'25	27'35	27'46	27'56	27'67	27'77	27'88	27'98	1	2	3	4	5	6	7	8	9
53	28'09	28'20	28'30	28'41	28'52	28'62	28'73	28'84	28'94	29'05	1	2	3	4	5	6	7	9	10
54	29'16	29'27	29'38	29'48	29'59	29'70	29'81	29'92	30'03	30'14	1	2	3	4	5	7	8	9	10

SQUARES.

	0	1	2	3	4	5	6	7	8	9	1	2	3	4	5	6	7	8	9
55	30'25	30'36	30'47	30'58	30'69	30'80	30'91	31'02	31'14	31'25	1	2	3	4	6	7	8	9	10
56	31'36	31'47	31'58	31'70	31'81	31'92	32'04	32'15	32'36	32'38	1	2	3	5	6	7	8	9	10
57	32'49	32'60	32'72	32'83	32'95	33'06	33'18	33'29	33'41	33'52	1	2	3	5	6	7	8	9	10
58	33'64	33'76	33'87	33'99	34'11	34'22	34'34	34'46	34'57	34'69	1	2	4	5	6	7	8	9	11
59	34'81	34'93	35'05	35'16	35'28	35'40	35'52	35'64	35'76	35'88	1	2	4	5	6	7	8	10	11
60	36'00	36'12	36'24	36'36	36'48	36'60	36'72	36'84	36'97	37'09	1	2	4	5	6	7	9	10	11
61	37'21	37'33	37'45	37'58	37'70	37'82	37'95	38'07	38'19	38'32	1	2	4	5	6	7	9	10	11
62	38'44	38'56	38'69	38'81	38'94	39'06	39'19	39'31	39'44	39'56	1	3	4	5	6	8	9	10	11
63	39'69	39'82	39'94	40'07	40'20	40'32	40'45	40'58	40'70	40'83	1	3	4	5	6	8	9	10	11
64	40'96	41'09	41'22	41'34	41'47	41'60	41'73	41'86	41'99	42'12	1	3	4	5	6	8	9	10	12
65	42'25	42'38	42'51	42'64	42'77	42'90	43'03	43'16	43'30	43'43	1	3	4	5	7	8	9	10	12
66	43'56	43'69	43'82	43'96	44'09	44'22	44'36	44'49	44'62	44'76	1	3	4	5	7	8	9	11	12
67	44'89	45'02	45'16	45'29	45'43	45'56	45'70	45'83	45'97	46'10	1	3	4	5	7	8	9	11	12
68	46'24	46'38	46'51	46'65	46'79	46'92	47'06	47'20	47'33	47'47	1	3	4	5	7	8	10	11	12
69	47'61	47'75	47'89	48'02	48'16	48'30	48'44	48'58	48'72	48'86	1	3	4	6	7	8	10	11	13
70	49'00	49'14	49'28	49'42	49'56	49'70	49'84	49'98	50'13	50'27	1	3	4	6	7	8	10	11	13
71	50'41	50'55	50'69	50'84	50'98	51'12	51'27	51'41	51'55	51'70	1	3	4	6	7	9	10	11	13
72	51'84	51'98	52'13	52'27	52'42	52'56	52'71	52'85	53'00	53'14	1	3	4	6	7	9	10	12	13
73	53'29	53'44	53'58	53'73	53'88	54'02	54'17	54'32	54'46	54'61	1	3	4	6	7	9	10	12	13
74	54'76	54'91	55'06	55'20	55'35	55'50	55'65	55'80	55'95	56'10	1	3	4	6	7	9	10	12	13
75	56'25	56'40	56'55	57'10	57'25	57'40	57'55	57'70	57'85	57'61	2	3	5	6	8	9	11	12	14
76	57'76	57'91	58'06	58'22	58'37	58'52	58'68	58'83	58'98	59'14	2	3	5	6	8	9	11	12	14
77	59'29	59'44	59'60	59'75	59'91	60'06	60'22	60'37	60'53	60'68	2	3	5	6	8	9	11	12	14
78	60'84	61'00	61'15	61'31	61'47	61'62	61'78	61'94	62'09	62'25	2	3	5	6	8	9	11	13	14
79	62'41	62'57	62'73	62'88	63'04	63'20	63'36	63'52	63'68	63'84	2	3	5	6	8	10	11	13	14
80	64'00	64'16	64'32	64'48	64'64	64'80	64'96	65'12	65'29	65'45	2	3	5	6	8	10	11	13	14
81	65'61	65'77	65'93	66'10	66'26	66'42	66'59	66'75	66'91	67'08	2	3	5	7	8	10	11	13	15
82	67'24	67'40	67'57	67'73	67'90	68'06	68'23	68'39	68'56	68'72	2	3	5	7	8	10	12	13	15
83	68'89	69'06	69'22	69'39	69'56	69'72	69'89	70'06	70'22	70'39	2	3	5	7	8	10	12	13	15
84	70'56	70'73	70'90	71'06	71'23	71'40	71'57	71'74	71'91	72'08	2	3	5	7	8	10	12	14	15
85	72'25	72'42	72'59	72'76	72'93	73'10	73'27	73'44	73'62	73'79	2	3	5	7	9	10	12	14	15
86	73'96	74'13	74'30	74'48	74'65	74'82	75'00	75'17	75'34	76'52	2	3	5	7	9	10	12	14	16
87	75'69	75'86	76'04	76'21	76'39	76'56	76'74	76'91	77'09	77'26	2	4	5	7	9	11	12	14	16
88	77'44	77'62	77'79	77'97	78'15	78'32	78'50	78'68	78'85	79'03	2	4	5	7	9	11	12	14	16
89	79'21	79'39	79'57	79'74	79'92	80'10	80'28	80'46	80'64	80'82	2	4	5	7	9	11	13	14	16
90	81'00	81'18	81'36	81'54	81'72	81'90	82'08	82'26	82'45	82'63	2	4	5	7	9	11	13	14	16
91	82'81	82'99	83'17	83'36	83'54	83'72	83'91	84'09	84'27	84'46	2	4	5	7	9	11	13	15	16
92	84'64	84'82	85'01	85'19	85'38	85'56	85'75	85'93	86'12	86'30	2	4	6	7	9	11	13	15	17
93	86'49	86'68	86'86	87'05	87'24	87'42	87'61	87'80	87'98	88'17	2	4	6	7	9	11	13	15	17
94	88'36	88'55	88'74	88'92	89'11	89'30	89'49	89'68	89'87	90'06	2	4	6	8	9	11	13	15	17
95	90'25	90'44	90'63	90'82	91'01	91'20	91'39	91'58	91'77		2	4	6	8	10	11	13	15	17
96	92'16	92'35	92'54	92'74	92'93	93'12	93'32	93'51	93'70	93'90	2	4	6	8	10	12	14	15	17
97	94'09	94'28	94'48	94'67	94'87	95'06	95'26	95'45	95'65	95'84	2	4	6	8	10	12	14	16	18
98	96'04	96'24	96'43	96'63	96'83	97'02	97'22	97'42	97'61	97'81	2	4	6	8	10	12	14	16	18
99	98'01	98'21	98'41	98'60	98'80	99'00	99'20	99'40	99'60	99'80	2	4	6	8	10	12	14	16	18

RECIPROALS OF NUMBERS FROM 1000 TO 9999.

	0	1	2	3	4	5	6	7	8	9	1	2	3	4	5	6	7	8	9
10	0'00010000	9901	9804	9709	9615	9524	9434	9346	9259	9174	9	18	27	36	45	55	64	73	82
11	0'0009091	9009	8929	8850	8772	8696	8621	8547	8475	8403	8	15	23	30	38	45	53	61	68
12	0'0008333	8264	8197	8130	8065	8000	7937	7874	7813	7752	6	13	19	26	32	38	45	51	58
13	0'0007692	7634	7576	7519	7463	7407	7353	7299	7246	7194	5	11	16	22	27	33	38	44	49
14	0'0007143	7092	7042	6993	6944	6897	6849	6803	6757	6711	5	10	14	19	24	29	33	38	43
15	0'0006667	6623	6579	6536	6494	6452	6410	6369	6329	6289	4	8	13	17	21	25	29	33	38
16	0'0006250	6211	6173	6135	6098	6061	6024	5988	5952	5917	4	7	11	15	18	22	26	29	33
17	0'0005882	5848	5814	5780	5747	5714	5682	5650	5618	5587	3	6	10	13	16	20	23	26	29
18	0'0005556	5525	5495	5464	5435	5405	5376	5348	5319	5291	3	6	9	12	15	17	20	23	26
19	0'0005263	5236	5208	5181	5155	5128	5102	5076	5051	5025	3	5	8	11	13	16	18	21	24
20	0'0005000	4975	4950	4926	4902	4878	4854	4831	4808	4785	2	5	7	10	12	14	17	19	21
21	0'0004762	4739	4717	4695	4673	4651	4630	4608	4587	4566	2	4	7	9	11	13	15	17	20
22	0'0004545	4525	4505	4484	4464	4444	4425	4405	4386	4367	2	4	6	8	10	12	14	16	18
23	0'0004348	4329	4310	4292	4274	4255	4237	4219	4202	4184	2	4	5	7	9	11	13	14	16
24	0'0004167	4149	4132	4115	4098	4082	4065	4049	4032	4016	2	3	5	7	8	10	12	13	15
25	0'0004000	3984	3968	3953	3937	3922	3906	3891	3876	3861	2	3	5	6	8	9	11	12	14
26	0'0003846	3831	3817	3802	3788	3774	3759	3745	3731	3717	1	3	4	6	7	8	10	11	13
27	0'0003704	3699	3676	3663	3650	3636	3623	3610	3597	3584	1	3	4	5	7	8	9	11	12
28	0'0003571	3559	3546	3534	3521	3509	3497	3484	3472	3460	1	2	4	5	6	7	8	10	11
29	0'0003448	3436	3425	3413	3401	3390	3378	3367	3356	3344	1	2	3	5	6	7	8	9	10
30	0'0003333	3322	3311	3300	3289	3279	3268	3257	3247	3236	1	2	3	4	5	6	7	9	10
31	0'0003226	3215	3205	3195	3185	3175	3165	3155	3145	3135	1	2	3	4	5	6	7	8	9
32	0'0003125	3115	3106	3096	3086	3077	3067	3058	3049	3040	1	2	3	4	5	6	7	8	9
33	0'0003030	3021	3012	3003	2994	2985	2976	2967	2959	2950	1	2	3	4	5	6	7	8	8
34	0'0002941	2933	2924	2915	2907	2899	2890	2882	2874	2865	1	2	3	4	5	6	7	8	8
35	0'0002857	2849	2841	2833	2825	2817	2809	2801	2793	2786	1	2	2	3	4	5	6	6	7
36	0'0002778	2770	2762	2755	2747	2740	2732	2725	2717	2710	1	2	2	3	4	5	5	6	7
37	0'0002703	2695	2688	2681	2674	2667	2660	2653	2646	2639	1	2	2	3	4	4	5	6	6
38	0'0002632	2625	2618	2611	2604	2597	2591	2584	2577	2571	1	1	2	3	3	4	5	5	6
39	0'0002564	2558	2551	2545	2538	2532	2525	2519	2513	2506	1	1	2	3	3	4	4	5	6
40	0'0002500	2494	2488	2481	2475	2469	2463	2457	2451	2445	1	1	2	2	3	4	4	5	5
41	0'0002439	2433	2427	2421	2415	2410	2404	2398	2392	2387	1	1	2	2	3	3	4	5	5
42	0'0002381	2375	2370	2364	2358	2353	2347	2342	2336	2331	1	1	2	2	3	3	4	4	5
43	0'0002326	2320	2315	2309	2304	2299	2294	2288	2283	2278	1	1	2	2	3	3	4	4	5
44	0'0002273	2268	2262	2257	2252	2247	2242	2237	2232	2227	1	1	2	2	3	3	4	4	5
45	0'0002222	2217	2212	2208	2203	2198	93	2188	2183	2179	0	1	1	2	2	3	3	4	4
46	0'0002174	2169	2165	2160	2155	2151	2146	2141	2137	2132	0	1	1	2	2	3	3	4	4
47	0'0002128	2123	2119	2114	2110	2105	2101	2096	2092	2088	0	1	1	2	2	3	3	4	4
48	0'0002083	2079	2075	2070	2066	2062	2058	2053	2049	2045	0	1	1	2	2	3	3	4	4
49	0'0002041	2037	2033	2028	2024	2020	2016	2012	2008	2004	0	1	1	2	2	2	3	3	4
50	0'0002000	1996	1992	1988	1984	1980	1976	1972	1969	1965	0	1	1	2	2	2	3	3	4
51	0'0001961	1957	1953	1949	1946	1942	1938	1934	1931	1927	0	1	1	2	2	2	3	3	3
52	0'0001923	1919	1916	1912	1908	1905	1901	1898	1894	1890	0	1	1	1	2	2	3	3	3
53	0'0001887	1883	1880	1876	1873	1869	1866	1862	1859	1855	0	1	1	1	2	2	2	3	3
54	0'0001852	1848	1845	1842	1838	1835	1832	1828	1825	1821	0	1	1	1	2	2	2	3	3

N.B.—Three zeros follow the decimal point in the reciprocal of any four figure whole number except the number 1000.

NOTE.—Numbers in difference columns to be subtracted, not added.

RECIPROCAL OF NUMBERS FROM 1000 TO 9999.

	0	1	2	3	4	5	6	7	8	9	1	2	3	4	5	6	7	8	9
55	0'0001818	1815	1812	1808	1805	1802	1799	1795	1792	1789	0	1	1	1	2	2	2	3	3
56	0'0001786	1783	1779	1776	1773	1770	1767	1764	1761	1757	0	1	1	1	2	2	2	3	3
57	0'0001754	1751	1748	1745	1742	1739	1736	1733	1730	1727	0	1	1	1	2	2	2	3	3
58	0'0001724	1721	1718	1715	1712	1709	1706	1704	1701	1698	0	1	1	1	2	2	2	3	3
59	0'0001695	1692	1689	1686	1684	1681	1678	1675	1672	1669	0	1	1	1	2	2	2	3	3
60	0'0001667	1664	1661	1658	1656	1653	1650	1647	1645	1642	0	1	1	1	2	2	2	3	3
61	0'0001639	1637	1634	1631	1629	1626	1623	1621	1618	1616	0	1	1	1	2	2	2	2	2
62	0'0001613	1610	1608	1605	1603	1600	1597	1595	1592	1590	0	1	1	1	2	2	2	2	2
63	0'0001587	1585	1582	1580	1577	1575	1572	1570	1567	1565	0	1	1	1	2	2	2	2	2
64	0'0001563	1560	1558	1555	1553	1550	1548	1546	1543	1541	0	1	1	1	2	2	2	2	2
65	0'0001538	1536	1534	1531	1529	1527	1524	1522	1520	1517	0	1	1	1	2	2	2	2	2
66	0'0001515	1513	1511	1508	1506	1504	1502	1499	1497	1495	0	1	1	1	2	2	2	2	2
67	0'0001493	1490	1488	1486	1484	1481	1479	1477	1475	1473	0	1	1	1	2	2	2	2	2
68	0'0001471	1468	1466	1464	1462	1460	1458	1456	1453	1451	0	1	1	1	2	2	2	2	2
69	0'0001449	1447	1445	1443	1441	1439	1437	1435	1433	1431	0	1	1	1	2	2	2	2	2
70	0'0001429	1427	1425	1422	1420	1418	1416	1414	1412	1410	0	1	1	1	2	2	2	2	2
71	0'0001408	1406	1404	1403	1401	1399	1397	1395	1393	1391	0	1	1	1	2	2	2	2	2
72	0'0001389	1387	1385	1383	1381	1379	1377	1376	1374	1372	0	1	1	1	2	2	2	2	2
73	0'0001370	1368	1366	1364	1362	1361	1359	1357	1355	1353	0	1	1	1	2	2	2	2	2
74	0'0001351	1350	1348	1346	1344	1342	1340	1339	1337	1335	0	1	1	1	2	2	2	2	2
75	0'0001333	1332	1330	1328	1326	1325	1323	1321	1319	1318	0	1	1	1	2	2	2	2	2
76	0'0001316	1314	1312	1311	1309	1307	1305	1304	1302	1300	0	1	1	1	2	2	2	2	2
77	0'0001299	1297	1295	1294	1292	1290	1289	1287	1285	1284	0	1	1	1	2	2	2	2	2
78	0'0001282	1280	1279	1277	1276	1274	1272	1271	1269	1267	0	1	1	1	2	2	2	2	2
79	0'0001266	1264	1263	1261	1259	1258	1256	1255	1253	1252	0	1	1	1	2	2	2	2	2
80	0'0001250	1248	1247	1245	1244	1242	1241	1239	1238	1236	0	1	1	1	2	2	2	2	2
81	0'0001235	1233	1232	1230	1229	1227	1225	1224	1222	1221	0	1	1	1	2	2	2	2	2
82	0'0001220	1218	1217	1215	1214	1212	1211	1209	1208	1206	0	1	1	1	2	2	2	2	2
83	0'0001205	1203	1202	1200	1199	1198	1196	1195	1193	1192	0	1	1	1	2	2	2	2	2
84	0'0001190	1189	1188	1186	1185	1183	1182	1181	1179	1178	0	1	1	1	2	2	2	2	2
85	0'0001176	1175	1174	1172	1171	1170	1168	1167	1166	1164	0	1	1	1	2	2	2	2	2
86	0'0001163	1161	1160	1159	1157	1156	1155	1153	1152	1151	0	1	1	1	2	2	2	2	2
87	0'0001149	1148	1147	1145	1144	1143	1142	1140	1139	1138	0	1	1	1	2	2	2	2	2
88	0'0001136	1135	1134	1133	1131	1130	1129	1127	1126	1125	0	1	1	1	2	2	2	2	2
89	0'0001124	1122	1121	1120	1119	1117	1116	1115	1114	1112	0	1	1	1	2	2	2	2	2
90	0'0001111	1110	1109	1107	1106	1105	1104	1103	1101	1100	0	1	1	1	2	2	2	2	2
91	0'0001099	1098	1096	1095	1094	1093	1092	1091	1089	1088	0	1	1	1	2	2	2	2	2
92	0'0001087	1086	1085	1083	1082	1081	1080	1079	1078	1076	0	1	1	1	2	2	2	2	2
93	0'0001075	1074	1073	1072	1071	1070	1068	1067	1066	1065	0	1	1	1	2	2	2	2	2
94	0'0001064	1063	1062	1060	1059	1058	1057	1056	1055	1054	0	1	1	1	2	2	2	2	2
95	0'0001053	1052	1050	1049	1048	1047	1046	1045	1044	1043	0	1	1	1	2	2	2	2	2
96	0'0001042	1041	1040	1038	1037	1036	1035	1034	1033	1032	0	1	1	1	2	2	2	2	2
97	0'0001031	1030	1029	1028	1027	1026	1025	1024	1022	1021	0	1	1	1	2	2	2	2	2
98	0'0001020	1019	1018	1017	1016	1015	1014	1013	1012	1011	0	1	1	1	2	2	2	2	2
99	0'0001010	1009	1008	1007	1006	1005	1004	1003	1002	1001	0	1	1	1	2	2	2	2	2

N.B.—Three zeros follow the decimal point in the reciprocal of any four figure whole number except the number 1000.

NOTE.—Numbers in difference columns to be subtracted, not added.

NATURAL TANGENTS.

	·0°	·1°	·2°	·3°	·4°	·5°	·6°	·7°	·8°	·9°
0°	·0000	0017	0035	0052	0070	0087	0105	0122	0140	0157
1	·0175	0192	0209	0227	0244	0262	0 79	0297	0314	0332
2	·0349	0367	0384	0402	0419	0437	0454	0472	0489	0507
3	·0524	0542	0559	0577	0594	0612	0629	0647	0664	0682
4	·0699	0717	0734	0752	0769	0787	0805	0822	0840	0857
5	·0875	0892	0910	0928	0945	0963	0981	0998	1016	1033
6	·1051	1069	1086	1104	1122	1139	1157	1175	1192	1210
7	·1228	1246	1263	1281	1299	1317	1334	1352	1370	1388
8	·1405	1423	1441	1459	1477	1495	1512	1530	1548	1566
9	·1584	1602	1620	1638	1655	1673	1691	1709	1727	1745
10	·1763	1781	1799	1817	1835	1853	1871	1890	1908	1926
11	·1944	1962	1980	1998	2016	2035	2053	2071	2089	2107
12	·2126	2144	2162	2180	2199	2217	2235	2254	2272	2290
13	·2309	2327	2345	2364	2382	2401	2419	2438	2456	2475
14	·2493	2512	2530	2549	2568	2586	2605	2623	2642	2661
15	·2679	2698	2717	2736	2754	2773	2792	2811	2830	2849
16	·2867	2886	2905	2924	2943	2962	2981	3000	3019	3038
17	·3057	3076	3096	3115	3134	3153	3172	3191	3211	3230
18	·3249	3269	3288	3307	3327	3346	3365	3385	3404	3424
19	·3443	3463	3482	3502	3522	3541	3561	3581	3600	3620
20	·3640	3659	3679	3699	3719	3739	3759	3779	3799	3819
21	·3839	3859	3879	3899	3919	3939	3959	3979	4000	4020
22	·4040	4061	4081	4101	4122	4142	4163	4183	4204	4224
23	·4245	4265	4286	4307	4327	4348	4369	4390	4411	4431
24	·4452	4473	4494	4515	4536	4557	4578	4599	4621	4642
25	·4663	4684	4706	4727	4748	4770	4791	4813	4834	4856
26	·4877	4899	4921	4942	4964	4986	5008	5029	5051	5073
27	·5095	5117	5139	5161	5184	5206	5228	5250	5272	5295
28	·5317	5340	5362	5384	5407	5430	5452	5475	5498	5520
29	·5543	5566	5589	5612	5635	5658	5681	5704	5727	5750
30	·5774	5797	5820	5844	5867	5890	5914	5938	5961	5985
31	·6009	6032	6056	6080	6104	6128	6152	6176	6200	6224
32	·6249	6273	6297	6322	6346	6371	6395	6420	6445	6469
33	·6494	6519	6544	6569	6594	6619	6644	6669	6694	6720
34	·6745	6771	6796	6822	6847	6873	6899	6924	6950	6976
35	·7002	7028	7054	7080	7107	7133	7159	7186	7212	7239
36	·7265	7292	7319	7346	7373	7400	7427	7454	7481	7508
37	·7536	7563	7590	7618	7646	7673	7701	7729	7757	7785
38	·7813	7841	7869	7898	7926	7954	7983	8012	8040	8069
39	·8098	8127	8156	8185	8214	8243	8273	8302	8332	8361
40	·8391	8421	8451	8481	8511	8541	8571	8601	8632	8662
41	·8693	8724	8754	8785	8816	8847	8878	8910	8941	8972
42	·9004	9036	9067	9099	9131	9163	9195	9228	9260	9293
43	·9325	9358	9391	9424	9457	9490	9523	9556	9590	9623
44	·9657	9691	9725	9759	9793	9827	9861	9896	9930	9965

NATURAL TANGENTS.

	°0	°1	°2	°3	°4	°5	°6	°7	°8	°9
45°	1'0000	0035	0070	0105	0141	0176	0212	0247	0283	0319
46	1'0355	0392	0428	0464	0501	0538	0575	0612	0649	0686
47	1'0724	0761	0799	0837	0875	0913	0951	0990	1028	1067
48	1'1106	1145	1184	1224	1263	1303	1343	1383	1423	1463
49	1'1504	1544	1585	1626	1667	1708	1750	1792	1833	1875
50	1'1918	1960	2002	2045	2088	2131	2174	2218	2261	2305
51	1'2349	2393	2437	2482	2527	2572	2617	2662	2708	2753
52	1'2799	2846	2892	2938	2985	3032	3079	3127	3175	3222
53	1'3270	3319	3367	3416	3465	3514	3564	3613	3663	3713
54	1'3764	3814	3865	3916	3968	4019	4071	4124	4176	4229
55	1'4281	4335	4388	4442	4496	4550	4605	4659	4715	4770
56	1'4826	4882	4938	4994	5051	5108	5166	5224	5282	5340
57	1'5399	5458	5517	5577	5637	5697	5757	5818	5880	5941
58	1'6003	6066	6128	6191	6255	6319	6383	6447	6512	6577
59	1'6643	6709	6775	6842	6909	6977	7045	7113	7182	7251
60	1'7321	7391	7461	7532	7603	7675	7747	7820	7893	7966
61	1'8040	8115	8190	8265	8341	8418	8495	8572	8650	8728
62	1'8807	8887	8907	9047	9128	9210	9292	9375	9458	9542
63	1'9626	9711	9797	9883	9970	0057	0145	0233	0323	0413
64	2'0503	0594	0686	0778	0872	0965	1060	1155	1251	1348
65	2'1445	1543	1642	1742	1842	1943	2045	2148	2251	2355
66	2'2460	2566	2673	2781	2889	2998	3109	3220	3332	3445
67	2'3559	3673	3789	3906	4023	4142	4262	4383	4504	4627
68	2'4751	4876	5002	5129	5257	5386	5517	5649	5782	5916
69	2'6051	6187	6325	6464	6605	6746	6889	7034	7179	7326
70	2'7475	7625	7776	7929	8083	8239	8397	8556	8716	8878
71	2'9042	9208	9375	9544	9714	9887	0061	0237	0415	0595
72	3'0777	0961	1146	1334	1524	1716	1910	2106	2305	2506
73	3'2709	2914	3122	3332	3544	3759	3977	4197	4420	4646
74	3'4874	5105	5339	5576	5816	6059	6305	6554	6806	7062
75	3'7321	7583	7848	8118	8391	8667	8947	9232	9520	9812
76	4'0108	0408	0713	1022	1335	1653	1976	2303	2635	2972
77	4'3315	3662	4015	4374	4737	5107	5483	5864	6252	6646
78	4'7046	7453	7867	8288	8716	9152	9594	0045	0504	0970
79	5'1446	1929	2422	2924	3435	3955	4486	5026	5578	6140
80	5'6713	7297	7894	8502	9124	9758	0405	1066	1742	2432
81	6'3138	3859	4596	5350	6122	6912	7720	8548	9395	0264
82	7'1154	2066	3002	3962	4947	5958	6996	8062	9158	0285
83	8'1443	2636	3863	5126	6427	7769	9152	0579	2052	3572
84	9'5144	9'677	9'845	10'02	10'20	10'39	10'58	10'78	10'99	11'20
85	11'43	11'66	11'91	12'16	12'43	12'71	13'00	13'30	13'62	13'95
86	14'30	14'67	15'06	15'46	15'89	16'35	16'83	17'34	17'89	18'46
87	19'08	19'74	20'45	21'20	22'00	22'90	23'86	24'90	26'03	27'27
88	28'64	30'14	31'82	33'69	35'80	38'19	40'92	44'07	47'74	52'08
89	57'29	63'66	71'62	81'85	95'49	114'6	143'2	191'0	286'5	573'0

NATURAL SINES.

	•0°	•1°	•2°	•3°	•4°	•5°	•6°	•7°	•8°	•9°
0°	0000	0017	0035	0052	0070	0087	0105	0122	0140	0157
1	0175	0192	0209	0227	0244	0262	0279	0297	0314	0332
2	0349	0366	0384	0401	0419	0436	0454	0471	0488	0506
3	0523	0541	0558	0576	0593	0610	0628	0645	0663	0680
4	0698	0715	0732	0750	0767	0785	0802	0819	0837	0854
5	0872	0889	0906	0924	0941	0958	0976	0993	1011	1028
6	1045	1063	1080	1097	1115	1132	1149	1167	1184	1201
7	1219	1236	1253	1271	1288	1305	1323	1340	1357	1374
8	1392	1409	1426	1444	1461	1478	1495	1513	1530	1547
9	1564	1582	1599	1616	1633	1650	1668	1685	1702	1719
10	1736	1754	1771	1788	1805	1822	1840	1857	1874	1891
11	1908	1925	1942	1959	1977	1994	2011	2028	2045	2062
12	2079	2096	2113	2130	2147	2164	2181	2198	2215	2232
13	2250	2267	2284	2300	2317	2334	2351	2368	2385	2402
14	2419	2436	2453	2470	2487	2504	2521	2538	2554	2571
15	2588	2605	2622	2639	2656	2672	2689	2706	2723	2740
16	2756	2773	2790	2807	2823	2840	2857	2874	2890	2907
17	2924	2940	2957	2974	2990	3007	3024	3040	3057	3074
18	3090	3107	3123	3140	3156	3173	3190	3206	3223	3239
19	3256	3272	3289	3305	3322	3338	3355	3371	3387	3404
20	3420	3437	3453	3469	3486	3502	3518	3535	3551	3567
21	3584	3600	3616	3633	3649	3665	3681	3697	3714	3730
22	3746	3762	3778	3795	3811	3827	3843	3859	3875	3891
23	3907	3923	3939	3955	3971	3987	4003	4019	4035	4051
24	4067	4083	4099	4115	4131	4147	4163	4179	4195	4210
25	4226	4242	4258	4274	4289	4305	4321	4337	4352	4368
26	4384	4399	4415	4431	4446	4462	4478	4493	4509	4524
27	4540	4555	4571	4586	4602	4617	4633	4648	4664	4679
28	4695	4710	4726	4741	4756	4772	4787	4802	4818	4833
29	4848	4863	4879	4894	4909	4924	4939	4955	4970	4985
30	5000	5015	5030	5045	5060	5075	5090	5105	5120	5135
31	5150	5165	5180	5195	5210	5225	5240	5255	5270	5284
32	5299	5314	5329	5344	5358	5373	5388	5402	5417	5432
33	5446	5461	5476	5490	5505	5519	5534	5548	5563	5577
34	5592	5606	5621	5635	5650	5664	5678	5693	5707	5721
35	5736	5750	5764	5779	5793	5807	5821	5835	5850	5864
36	5878	5892	5906	5920	5934	5948	5962	5976	5990	6004
37	6018	6032	6046	6060	6074	6088	6101	6115	6129	6143
38	6157	6170	6184	6198	6211	6225	6239	6252	6266	6280
39	6293	6307	6320	6334	6347	6361	6374	6388	6401	6414
40	6428	6441	6455	6468	6481	6494	6508	6521	6534	6547
41	6561	6574	6587	6600	6613	6626	6639	6652	6665	6678
42	6691	6704	6717	6730	6743	6756	6769	6782	6794	6807
43	6820	6833	6845	6858	6871	6884	6896	6909	6921	6934
44	6947	6959	6972	6984	6997	7009	7022	7034	7046	7059

NATURAL SINES.

	·0°	·1°	·2°	·3°	·4°	·5°	·6°	·7°	·8°	·9°
45	7071	7083	7096	7108	7120	7133	7145	7157	7169	7181
46	7193	7206	7218	7230	7242	7254	7266	7278	7290	7302
47	7314	7325	7337	7349	7361	7373	7385	7396	7408	7420
48	7431	7443	7455	7466	7478	7490	7501	7513	7524	7536
49	7547	7558	7570	7581	7593	7604	7615	7627	7638	7649
50	7660	7672	7683	7694	7705	7716	7727	7738	7749	7760
51	7771	7782	7793	7804	7815	7826	7837	7848	7859	7869
52	7880	7891	7902	7912	7923	7934	7944	7955	7965	7976
53	7986	7997	8007	8018	8028	8039	8049	8059	8070	8080
54	8090	8100	8111	8121	8131	8141	8151	8161	8171	8181
55	8192	8202	8211	8221	8231	8241	8251	8261	8271	8281
56	8290	8300	8310	8320	8329	8339	8348	8358	8368	8377
57	8387	8396	8406	8415	8425	8434	8443	8453	8462	8471
58	8480	8490	8499	8508	8517	8526	8536	8545	8554	8563
59	8572	8581	8590	8607	8616	8625	8634	8643	8652	8661
60	8660	8669	8678	8686	8695	8704	8712	8721	8729	8738
61	8746	8755	8763	8771	8780	8788	8796	8805	8813	8821
62	8829	8838	8846	8854	8862	8870	8878	8886	8894	8902
63	8910	8918	8926	8934	8942	8949	8957	8965	8973	8980
64	8988	8996	9003	9011	9018	9026	9033	9041	9048	9056
65	9063	9070	9078	9085	9092	9100	9107	9114	9121	9128
66	9135	9143	9150	9157	9164	9171	9178	9184	9191	9198
67	9205	9212	9219	9225	9232	9239	9245	9252	9259	9265
68	9272	9278	9285	9291	9298	9304	9311	9317	9323	9330
69	9336	9342	9348	9354	9361	9367	9373	9379	9385	9391
70	9397	9403	9409	9415	9421	9426	9432	9438	9444	9449
71	9455	9461	9466	9472	9478	9483	9489	9494	9500	9505
72	9511	9516	9521	9527	9532	9537	9542	9548	9553	9558
73	9563	9568	9573	9578	9583	9588	9593	9598	9603	9608
74	9613	9617	9622	9627	9632	9636	9641	9646	9650	9655
75	9659	9664	9668	9673	9677	9681	9686	9690	9694	9699
76	9703	9707	9711	9715	9720	9724	9728	9732	9736	9740
77	9744	9748	9751	9755	9759	9763	9767	9770	9774	9778
78	9781	9785	9789	9792	9796	9799	9803	9806	9810	9813
79	9816	9820	9823	9826	9829	9833	9836	9839	9842	9845
80	9848	9851	9854	9857	9860	9863	9866	9869	9871	9874
81	9877	9880	9882	9885	9888	9890	9893	9895	9898	9900
82	9903	9905	9907	9910	9912	9914	9917	9919	9921	9923
83	9925	9928	9930	9932	9934	9936	9938	9940	9942	9943
84	9945	9947	9949	9951	9952	9954	9956	9957	9959	9960
85	9962	9963	9965	9966	9968	9969	9971	9972	9973	9974
86	9976	9977	9978	9979	9980	9981	9982	9983	9984	9985
87	9986	9987	9988	9989	9990	9990	9991	9992	9993	9993
88	9994	9995	9995	9996	9996	9997	9997	9997	9998	9998
89	9998	9999	9999	9999	9999	1'000 nearly.	1'000 nearly.	1'000 nearly.	1'000 nearly.	1'000 nearly.

CONVERSION TABLES, CONSTANTS, ETC.

Inches	×	2.54	=	centimetres
Ounces (avoir.)	×	28.35	=	grammes
Pounds (avoir.)	×	453.59	=	grammes
Gallons	×	4541	=	cubic centimetres
The weight of 1 lb	=	4.45 × 10 ⁵	=	dynes
„	1 gramme	=	981	dynes
1 foot-pound	=	1.356 × 10 ⁷	=	ergs
1 joule	=	10 ⁷	=	„
1 h.p.	{	=	7.46 × 10 ⁹	ergs per sec.
		=	33,000 ft.-lbs.	per min.
		=	746	watts.
1 watt	=	10 ⁷	=	ergs per sec.
1 electrical supply unit	=	1000	=	watt hours
Common logs	×	2.3026	=	Napierian logs
π	=	3.1416		
Area of a circle	=	$\frac{\pi d^2}{4}$	=	0.7854d ²
1 radian	=	57.3	=	degrees
British thermal units	×	0.252	=	calories (kilogramme 1° C.)
British thermal unit	=	778	=	ft.-lbs.
1 gallon (water)	=	10	=	lbs.
1 cubic foot (water)	=	62.35	=	lbs.
1 Hefner unit	×	0.92	=	1 British candle
1 atmosphere	=	14.7	=	lbs. per sq. in.

TABLE OF SPECIFIC GRAVITIES

Substance.	Specific gravity	Substance.	Specific gravity.
Platinum ...	21.5	Sulphur	2.0
Mercury at 0° C. ...	13.596	Ivory	1.9
Lead	11.3	Sand	1.42
Silver	10.5	Hooper's I.R. ...	1.18
Nickel	8.9	Ebony	1.1-1.2
Copper	8.5-8.9	Ebonite	1.15
German silver ...	8.5	Boxwood	0.91-1.03
Brass	8.1-8.6	Oak	0.7-1.0
Steel (cast)	7.8	Guttapercha ...	0.97-0.98
Iron (wrought) ...	7.8	Wax	0.96
„ (wire)	7.7	Indiarubber (pure)	0.93
„ (cast)	7.1-7.6	Cork	0.24
Tin	7.3	H ₂ SO ₄ at 0° C.	1.85
Zinc	7.1	HNO ₃ „	1.56
Glass (flint)	3.0-3.5	HCl „	1.27
„ (crown)	2.5-2.7	CS ₂ „	1.293
Marble	2.5-2.8	Glycerine „	1.27
Aluminium	2.6	Linseed oil „	0.94
Porcelain	2.4	Oil of turpentine „	0.87
Chalk	1.8-2.8	Alcohol „	0.806
Carbon (graphite) ...	2.3	Mineral oil „	0.76-0.83
Gas carbon	1.9	Ether „	0.736
Brick	2.1		

WIRE TABLES

Material.	Size. S.W.G.	Diam. cms.	Diam. inches.	Resistance ohms per metre.	Resistance ohms per yd.	yds. per lb.	Current-carry- ing capacity ampères.
Copper.	8	0'406	0'160	0'00133	0'00122	4'83	31
	10	0'325	0'128	0'00290	0'00191	7'00	21
	12	0'264	0'104	0'00316	0'00289	10'40	15
	14	0'203	0'080	0'00535	0'00489	17'60	9'8
	16	0'163	0'064	0'00834	0'00762	27'45	6'8
	18	0'122	0'048	0'01481	0'01355	48'80	4'2
	20	0'0914	0'036	0'02630	0'02409	86'80	2'6
	22	0'0711	0'028	0'04350	0'03982	143'40	1'7
Manganin.	8	0'406	0'160	0'0326	0'0298	4'33	37
	10	0'325	0'128	0'0511	0'0467	6'81	25
	12	0'264	0'104	0'0783	0'0707	10'2	15
	14	0'203	0'080	0'1306	0'1196	20'9	10
	16	0'163	0'064	0'2040	0'1862	27'5	6
	18	0'122	0'048	0'3630	0'3320	47'1	3'2
	20	0'0914	0'036	0'6450	0'5905	84'8	1'7
	22	0'0711	0'028	1'070	0'9762	140'3	0'9
Eureka.	8	0'406	0'160	0'0366	0'0335	4'27	30'6
	10	0'325	0'128	0'0571	0'0523	6'74	20'37
	12	0'264	0'104	0'0866	0'0793	10'18	12'23
	14	0'203	0'080	0'1441	0'1339	17'25	8'15
	16	0'163	0'064	0'2292	0'2094	26'9	4'89
	18	0'122	0'048	0'4060	0'3718	47'9	2'72
	20	0'0914	0'036	0'7230	0'6613	84'9	1'46
	22	0'0711	0'028	1'1960	1'093	140'0	0'8
Platinoid.	8	0'406	0'160	0'0315	0'0288	4'32	37
	10	0'325	0'128	0'0493	0'0450	6'73	25
	12	0'264	0'104	0'0745	0'0682	10'21	15
	14	0'203	0'080	0'1262	0'1154	17'20	10
	16	0'163	0'064	0'1971	0'1803	27'0	6
	18	0'122	0'048	0'3506	0'3206	47'9	3'3
	20	0'0914	0'036	0'6230	0'5699	85'0	1'8
	22	0'0711	0'028	1'0300	0'9422	140'5	1

I.E.E.
Rule.

To raise temperature
to blood heat.

To raise temperature
to blood heat.

To raise temperature
to blood heat.

A single cotton covering adds 0'006-0'008 inch to the diameter

A double " " 0'012-0'014 " "

A single silk " " 0'002-0'003 " "

A double " " 0'004-0'006 " "

TABLE OF RESISTIVITIES

Material.	Specific Gravity.	Resistivity, microms per c.c.	Resistance, temperature, variation, % per 1° C.	Remarks.
Copper	8.95	1.642	0.388	Hard drawn
„	8.95	1.566	0.418	Electrolytic soft
Platinum	21.5	8.957	0.354	
Silver	10.5	1.488	0.377	
Mercury	13.6	94.070	0.086	
Iron	7.7	9.611	0.513	
Platinum silver	—	31.58	0.024	2 Pt 1 Ag alloy
German silver	9.05	42.88	0.038	Cu Zn Ni alloy
Platinoid	8.83	33.62	0.022	Cu Zn Ni W alloy
Manganin	8.61	39.14	0.0017	Cu Mn Ni
Eureka	8.96	47.40	0.0048	Cu Ni alloy
Nickelin	8.78	39.29	0.018	Ni alloy
Constantan	8.97	48.30	0.0014	Cu Ni alloy
Rheostan	8.61	47.55	0.24	Steel alloy

TABLE OF RESISTIVITIES OF LIQUIDS

Liquid.	Density.	Temperature.	Specific resistance (ohms per c.c.)	Authority.
H ₂ SO ₄	0.9985	22° C.	70.41	Kohlrausch
„	1.0000	„	41.05	„
„	1.0504	„	3.25	„
„	1.0989	„	1.787	„
„	1.1430	„	1.414	„
„	1.2045	„	1.239	„
„	1.3163	„	1.347	„
„	1.3994	„	1.672	„
„	1.4482	„	1.962	„
„	1.5026	„	2.412	„
CuSO ₄	1.0167	10° C.	164.4	Ewing and Macgregor
„	1.0216	„	134.8	„
„	1.0318	„	98.7	„
„	1.0622	„	59.0	„
„	1.1174	„	38.0	„
„ (saturated)	1.2054	„	29.0	„
ZnSO ₄	1.4220	„	33.7	„
HCl	1.109	„	1.31	„
HNO ₃	1.185	„	1.28	„

DIELECTRIC RESISTIVITIES

Material.	Resistivity megohms per c.c.	Dielectric strength, volts per mm.
Bitumen	450×10^6	—
Ebonite	28000×10^6	53000
Glass (ordinary)	90×10^6	285000
Gutta percha	250×10^6	109500
Vulcanized rubber... ..	3800×10^6	538000
Mica	84×10^6	200000
Micanite	2500×10^6	48000
Presspahn	0.25×10^6	16000
Paraffined paper	25400×10^6	40000
Manila paper	0.009×10^6	4800
D.C. wire shellaced	0.06×10^6	12000
Pure rubber	5000×10^6	48000
Thin insulating tape	0.05×10^6	5000
Vulcabeston	0.038×10^6	800
Slate	0.0012×10^6	200

TABLE OF DIELECTRIC RESISTANCE AND CAPACITY OF G.P. COVERED WIRE AFTER ONE MINUTE ELECTRIFICATION

External diameter Internal diameter	Resistance per mile in megohms.	Capacity per mile in microfarads.
2.5	366.1	0.394
2.6	384.8	0.375
2.7	396.9	0.363
2.8	411.4	0.351
2.9	425.4	0.339
3.0	439.0	0.329
3.5	500.6	0.288
4.0	553.9	0.260

TABLE OF VARIATION OF RESISTANCE DUE TO COIL WINDING AND ANNEALING (DRYSDALE)

Material.	% Alteration of resistance due to winding on 1 cm. diam. mandrel.	% Alteration of resistance after heating 10 hrs. at 100° C.
Nickelin	- 0.54%	+ 0.27%
Constantan	+ 1.13%	- 0.06%
Manganin... ..	+ 0.34%	- 0.24%
Rheostan	- 0.42%	+ 0.34%
German silver	- 0.12%	- 0.13%
Eureka	+ 0.6%	- 0.069%
Platinoid	+ 0.237%	+ 0.463%

TABLE OF ELECTRO-CHEMICAL EQUIVALENTS

Element.	Grammes per coulomb.	Element.	Grammes per coulomb.
Silver	0'001118	Lead	0'001071
Copper (cupric)	0'0003279	Tin (stannic) ...	0'000304
" (cuprous)	0'000655	" (stannous)	0'000609
Iron (ferric) ...	0'0001934	Hydrogen ...	0'00001035
" (ferrous) ...	0'0002900	Oxygen ...	0'00008286
Nickel	0'0003042	Water	0'00009321
Zinc	0'0003367	Iodine	0'0013134

Element.	Cub. cm. per coulomb at 0° C. and 760 mm.
Hydrogen	0'1156
Oxygen	0'0578
Water	0'1734

FUSE WIRE TABLES
Nearest size S. W. G.

Fusing current, ampères.	Max. working current, ampères.	Copper.	Tin.	Lead.	Allo. tin.	Platinoid.
1	0'5	47	37	35	35	43
5	2'5	38	25	23	23	32
10	5'0	33	21	19	19	27
20	10'0	27	18	17	17	22
50	25'0	22	13	12	11	18
100	50'0	18	8	7	7	15
200	100'0	15	4	2	2	10

CONSTANTS IN PREECE'S FUSING CURRENT FORMULA

$$C = Kd^{\frac{3}{2}}$$

C = current in ampères. d = diam. in inches.

Metal.	K.
Copper	10,244
Aluminium	7,585
German silver	5,230
Iron	3,148
Tin	1,642
Lead	1,379
Allo. tin-lead (1 : 2) ...	1,318

TABLE OF ELECTROMOTIVE FORCES OF CELLS

Cell.	E.M.F. (volt).
Bunsen	1.9
Daniell	1.07-1.14
Bichromate	2.0
Leclanche	1.5
Dry cells	1.4-1.5
Secondary	1.85-2.1

STANDARD CELL DATA

Clark cell (B.O.T. pattern), E.M.F. at 15° C. = 1.434 volts.
 Temperature coefficient = 0.077% decrease per 1° C. rise of temperature.
 Clark cell (Carhart pattern) E.M.F. at 15° = 1.438 volts.
 Temperature coefficient = 0.0387% decrease per 1° C. rise of temperature.
 Cadmium cell (crystal form) E.M.F. at 15° = 1.019 volts.
 Temperature coefficient = 0.003% decrease per 1° C. rise of temperature.

INCANDESCENT LAMP TESTS

Lamp.	Pressure volts.	Initial candlepower.	Watts per candle.
Ordinary carbon	100	16	3.6
Metallized carbon	100	16	2.8
Nernst	200	25	2.2
Tantalum	110	23	1.9
Osram	100	25	1.4

ARC LAMP TESTS

Lamp.	Pressure volts.	Current ampères.	Watts.	Mean c.p.	Candles per watt.
Ordinary open arc	45.0	10.0	450	830	1.54
Enclosed arc	71.0	6.6	459	360	0.77
Flame arc	46.1	10.0	460	2750	5.80

ABSORPTION OF LIGHT BY LAMP GLOBES

Nature of glass.	% Light absorbed (approx.)
Clear glass	15%
Ground glass	30%
Opalescent glass	50%

MAGNETIZATION OF IRON AND STEEL.

H	B		
	Cast iron.	Wrought iron.	Cast steel.
5	1000	9,000	8,150
10	3000	12,200	12,700
15	3900	13,000	14,000
20	4550	14,450	15,000
25	5100	15,050	15,700
30	5500	15,500	16,200
35	5870	15,800	16,500
40	6180	16,100	16,750
45	6450	16,300	16,900
50	6700	16,500	17,190
60	7150	16,800	17,450
70	7530	17,000	17,750
80	7900	17,220	18,000
90	8250	17,400	18,200
100	8570	17,580	18,400
120	9200	17,930	18,900

AVERAGE VALUES OF B COMPARED WITH THAT AT $H = 20$ (EWING)

H	B				
	12,000	13,000	14,000	15,000	16,000
20	12,000	13,000	14,000	15,000	16,000
25	12,700	13,700	14,600	15,500	16,350
30	13,300	14,200	15,100	15,900	16,000
40	14,200	15,000	15,700	16,400	17,000
50	14,900	15,600	16,300	16,900	17,400

HYSTERESIS LOSS CONSTANTS

Material.	Loss in ergs per c.c. per cycle (E).
Soft iron	10,000
Annealed wrought iron ...	16,000
Mild steel	40,000-60,000
Chrome steel (hard) ...	167,000
Tungsten steel	216,800

$$E \times \frac{n}{10^7 \times 0.0022 \times \Delta} = \text{watts per lb.}$$

n = frequency
 Δ = specific gravity

PERMANENT MAGNET STRENGTH (PREECE)

Magnet steel.	B
Ashforth	1704
Allevard (water tempered)...	1600
Jowitt	1503
Saunderson	1435
Vickers	1174

Bars 10 cms. long, 1 sq. cm. cross-section area.

D.C. MOTORS AND GENERATORS

D.C. MOTOR POWER AND WEIGHT

Brake h.p.	Revs. per min.	Weight.
2	600	8 cwt.
4	560	11 "
10	915	12.5 "
15	870	15 "
30	570	36 "
50	550	46 "

COMPARATIVE EFFICIENCIES OF 4 K.WT. GENERATOR

Load.	Efficiency.
Full	82%
$\frac{3}{4}$	79%
$\frac{1}{2}$	69%
$\frac{1}{4}$	60%

D.C. GENERATOR OUTPUT AND SPEED AND MAX. EFFICIENCY

Output (kilowatts).	Speed.	Efficiency.
50	550	92'6%
100	450	93'0%
200	350	93'4%
400	300	94'0%
500	100	94'4%
750	100	95'0%

INDEX

SUBJECT	EXPT. NO.	PAGE
Absorption of light by lamp globes	65	103
Alternator, examination of	84	132
———, characteristics of	86	134
———, E.M.F. curve of	85	132
Alternating current ammeter calibration	74	117
——— voltmeter calibration	75	118
——— power in non-inductive circuits	71	113
——— in inductive circuits	72	114
——— measurement (three-voltmeter method)	82	129
——— (three-ammeter method)	83	130
Ammeter calibration (fall of potential method)	14	18
——— (comparison with electro-dynamometer)	15	20
Ampère hour efficiency, of secondary battery	66	104
——— turns on moving iron instruments	44	70
Annealing, effect on resistance of wires	37	54
Armature fault testing	55	88
Automatic cell charging switch testing	67	106
——— magnetic cut-out testing	59	94
Ballistic galvanometer calibration	45	71
Bar and yoke method of measuring permeability	48	76
Battery, resistance of secondary	11	15
Brake horse-power and efficiency of motor	61	97
Bridge, post office	7	9
——— Wheatstone	2	2
Cadmium standard cell, construction of	43	67
Calibration of ammeter (fall of potential method)	14	18
——— (comparison with electro- dynamometer)	15	20
——— (alternating current)	74	117
——— of ballistic galvanometer	45	71

SUBJECT	EXPT. No.	PAGE
Calibration of voltmeter (comparison with standard)	16	22
----- (volt potentiometer)	20	27
----- (potentiometer)	38	55
----- (alternating current)	75	118
Calibration of wattmeter	25	34
Capacity currents	79	124
----- and inductance in series	80	126
----- in parallel	81	127
Carbon lamp filament, resistance variation	9	13
Cell charging switch testing	67	106
Characteristics of an alternator	86	134
----- (internal) of shunt dynamo	56	89
----- (total) of shunt dynamo	57	90
----- (total) of series dynamo	58	92
Constant of Siemens electro-dynamometer	39	58
Constants of fuse wire metals	23	32
Copper voltameter	40	60
Current balance standardization	40	60
----- carrying capacity of wires	36	53
----- induction	27	38
----- measurement (potentiometer)	19	26
----- testing in incandescent lamps	10	14
Curve, sine	70	112
Cut-out, testing automatic	59	94
Dynamo armature fault testing	55	88
----- distribution of magnetic field round armature	53	85
----- of potential round commutator	54	86
----- eddy current and hysteresis losses	63	100
----- examination of	50	81
----- magnetic leakage test	52	83
----- resistance and insulation tests	51	82
----- (series), total characteristic and efficiency	58	92
----- (shunt), internal characteristic	56	89
----- , total characteristic and efficiency	57	90
Eddy current losses in dynamos	63	100
Efficiency of incandescent lamps	64	101
----- of motor	61	97
----- of motor generator	62	99
----- of series dynamo	58	92
----- of shunt dynamo	57	90
----- of transformer	87	136
Electro-dynamometer, Siemens	39	58
Electrolytic resistance	13	17
Electro-magnetic circuit testing	32	45

SUBJECT	EXPT. No.	PAGE
Electro-magnets, experiments with	30, 31	43, 44
Electro-motive forces (comparison of, on potentiometer)	17	23
E.M.F. curve of alternator	85	132
Energy meter, testing	68	107
Fault testing in dynamo armatures	55	88
Fuse wire metal constants	23	32
——— testing	22	31
Graphical representation of A.C. power in non-inductive circuits	71	113
————— in inductive cir- cuits	72	114
————— of sine function	69	110
Hardening, effect on the resistance of wires	37	54
Heating effects of D.C. and A.C. currents	73	116
Hopkinson permeameter	46	73
Hysteresis losses in dynamo	63	100
———, magnetic, measurement of	49	79
Impedance and inductance measurement	76	119
Impedances in series	77	121
——— in parallel	78	123
Incandescent lamp current testing	10	14
———, photometry of	24	33
——— efficiency	64	101
Inductance and capacity in series	80	126
——— in parallel	81	127
Instruments, ampère turns in moving iron	44	70
Insulation resistance (loss of charge method)	41	63
——— (guard ring method)	42	65
——— testing	12	16
——— test of dynamo	51	82
Iron, magnetization of	33	46
Kelvin current balance standardization	40	60
Lamp efficiency tests	64	101
——— filament resistance variation	9	13
——— globes, absorption of light	65	103
———, incandescent, current testing	10	14
———, photometry of	24	33
Law of the solenoid	29	41
Leakage, magnetic, test of, in a dynamo	52	83

SUBJECT	EXPT. NO.	PAGE
Magnetic cut-out testing	59	94
——— hysteresis, measurement of	49	79
——— induction, measurement of	45	71
Magnetization of iron	33	46
Magnets, permanent, testing of	28	40
Metal lamp filament, resistance variation	9	13
Meter testing (watt-hour)	68	107
——— (ampère-hour)	26	36
Motor, brake h.p. and efficiency	61	97
———, examination of	50	81
———, experiments with shunt	35	51
——— generator plant, efficiency test	62	99
———, resistance and insulation test	51	82
———, starting switch testing	60	95
Ohm's law, proof of	1	1
Permanent magnet testing	28	40
Permeability, measurement of (bar and yoke method)	48	76
——— (Hopkinson's permeameter)	46	73
——— (magnetic balance)	34	48
——— (permeability bridge)	47	74
Photometry of incandescent lamp	24	33
Post-office bridge	7	9
Potentiometer (comparison of E.M.F.'s)	17	23
——— (measurement of resistance)	18	25
——— (measurement of current)	19	26
——— (calibration of voltmeter)	38	55
Power, measurement of A.C. by three-voltmeter method	82	129
——— by three-ammeter method	83	130
Resistance, measurement of electrolytic	13	17
——— of low	21	29
——— of secondary battery	11	15
——— by potentiometer	18	25
———, effect of hardening and annealing on	37	54
———, variation of carbon and metal filament	9	13
———, insulation measurement (loss of charge method)	41	63
——— (guard ring method)	42	65
———, laws of (resistance and length)	4	5
——— (resistance and area)	5	7
——— (resistance and temperature)	6	8
Resistances in series and parallel	3	4
Resistivity, measurement of	8	11
Secondary battery efficiency	66	104

SUBJECT	EXPT. No.	PAGE
Secondary battery resistance	11	15
Series dynamo characteristic	58	92
Shunt dynamo internal characteristic	56	89
————— total characteristic and efficiency	57	90
Siemens electro-dynamometer	39	58
Sine function graph	69	110
——— curve properties	70	112
Solenoid, law of	29	41
Standard cadmium cell construction	43	67
Starting switch testing	60	95
Supply meter testing	26	36
Switch, automatic cell charging testing	67	106
Temperature resistance variation	6	8
Transformer efficiency test	87	136
Voltmeter calibration (comparison with standard)	16	22
————— (by potentiometer)	38	55
————— (alternating current)	75	118
————— (by volt potentiometer)	20	27
Watt-hour efficiency of secondary battery	66	104
Wattmeter calibration	25	34
Wheatstone bridge	2	2
————— (post office form)	7	9
Wires, current carrying capacity	36	53

THE END

