

UNIVERSAL  
LIBRARY

**OU\_164714**

UNIVERSAL  
LIBRARY





**OSMANIA UNIVERSITY LIBRARY**

Call No. 5781 NISM . Accession No. 23207

Author Naidich, J.

Title Mathematics for the aviation  
trades

This book should be returned on or before the date last marked below



**MATHEMATICS**  
**FOR THE**  
**AVIATION TRADES**



# MATHEMATICS FOR THE AVIATION TRADES

by JAMES NAIDICH

*Chairman, Department of Mathematics,  
Manhattan High School of Aviation Trades*

McGRAW-HILL BOOK COMPANY, INC.  
NEW YORK AND LONDON

MATHEMATICS FOR THE AVIATION TRADES

COPYRIGHT, 1942, BY THE  
MCGRAW-HILL BOOK COMPANY, INC.

---

PRINTED IN THE UNITED STATES OF AMERICA

*All rights reserved. This book, or  
parts thereof, may not be reproduced  
in any form without permission of  
the publishers.*

## PREFACE

This book has been written for students in trade and technical schools who intend to become aviation mechanics. The text has been planned to satisfy the demand on the part of instructors and employers that mechanics engaged in precision work have a thorough knowledge of the fundamentals of arithmetic applied to their trade. No mechanic can work intelligently from blueprints or use measuring tools, such as the steel rule or micrometer, without a knowledge of these fundamentals.

Each new topic is presented as a job, thus stressing the practical aspect of the text. Most jobs can be covered in one lesson. However, the interests and ability of the group will in the last analysis determine the rate of progress.

Part I is entitled "A Review of Fundamentals for the Airplane Mechanic." The author has found through actual experience that mechanics and trade-school students often have an inadequate knowledge of a great many of the points covered in this part of the book. This review will serve to consolidate the student's information, to reteach what he may have forgotten, to review what he knows, and to provide drill in order to establish firmly the basic essentials. Fractions, decimals, perimeter, area, angles, construction, and graphic representation are covered rapidly but systematically.

For the work in this section two tools are needed. First, a steel rule graduated in thirty-seconds and sixty-fourths is indispensable. It is advisable to have, in addition, an ordinary ruler graduated in eighths and sixteenths. Second, measurement of angles makes a protractor necessary.

Parts II, III, and IV deal with specific aspects of the work that an aviation mechanic may encounter. The airplane and its wing, the strength of aircraft materials, and the mathematics associated with the aircraft engine are treated as separate units. All the mathematical background required for this work is covered in the first part of the book.

Part V contains 100 review examples taken from airplane shop blueprints, aircraft-engine instruction booklets, airplane supply catalogues, aircraft directories, and other trade literature. The airplane and its engine are treated as a unit, and various items learned in other parts of the text are coordinated here.

Related trade information is closely interwoven with the mathematics involved. Throughout the text real aircraft data are used. Wherever possible, photographs and tracings of the airplanes mentioned are shown so that the student realizes he is dealing with subject matter valuable not only as drill but worth remembering as trade information in his elected vocation.

This book obviously does not present all the mathematics required by future aeronautical engineers. All mathematical material which could not be adequately handled by elementary arithmetic was omitted. The author believes, however, that the student who masters the material included in this text will have a solid foundation of the type of mathematics needed by the aviation mechanic.

Grateful acknowledgment is made to Elliot V. Noska, principal of the Manhattan High School of Aviation Trades for his encouragement and many constructive suggestions, and to the members of the faculty for their assistance in the preparation of this text. The author is also especially indebted to *Aviation* magazine for permission to use numerous photographs of airplanes and airplane parts throughout the text.

JAMES NAIDICH.

# CONTENTS

	PAGE
PREFACE. . . . .	v
FOREWORD BY ELLIOT V. NOSKA . . . . .	ix
PART I	
A REVIEW OF FUNDAMENTALS FOR THE AIRPLANE MECHANIC	
CHAPTER	
I. THE STEEL RULE . . . . .	3
II. DECIMALS IN AVIATION. . . . .	20
III. MEASURING LENGTH. . . . .	37
IV. THE AREA OF SIMPLE FIGURES . . . . .	47
V. VOLUME AND WEIGHT . . . . .	70
VI. ANGLES AND CONSTRUCTION . . . . .	80
VII. GRAPHIC REPRESENTATION OF AIRPLANE DATA . . . . .	98
PART II	
THE AIRPLANE AND ITS WING	
VIII. THE WEIGHT OF THE AIRPLANE. . . . .	113
IX. AIRFOILS AND WING RIBS. . . . .	130
PART III	
MATHEMATICS OF MATERIALS	
X. STRENGTH OF MATERIAL . . . . .	153
XI. FITTINGS, TUBING, AND RIVETS . . . . .	168
XII. BEND ALLOWANCE. . . . .	181
PART IV	
AIRCRAFT ENGINE MATHEMATICS	
XIII. HORSEPOWER. . . . .	193
XIV. FUEL AND OIL CONSUMPTION . . . . .	212
XV. COMPRESSION RATIO AND VALVE TIMING. . . . .	224
PART V	
REVIEW	
XVI. ONE HUNDRED SELECTED REVIEW EXAMPLES. . . . .	241
APPENDIX: TABLES AND FORMULAS . . . . .	259
INDEX. . . . .	265



## FOREWORD

Aviation is fascinating. Our young men and our young women will never lose their enthusiasm for wanting to know more and more about the world's fastest growing and most rapidly changing industry.

We are an air-conscious nation. Local, state, and federal agencies have joined industry in the vocational training of our youth. This is the best guarantee of America's continued progress in the air.

Yes, aviation is fascinating in its every phase, but it is not all glamour. Behind the glamour stands the training and work of the engineer, the draftsman, the research worker, the inspector, the pilot, and most important of all, the training and hard work of the aviation mechanic.

Public and private schools, army and navy training centers have contributed greatly to the national defense effort by training and graduating thousands of aviation mechanics. These young men have found their place in airplane factories, in approved repair stations, and with the air lines throughout the country.

The material in *Mathematics for the Aviation Trades* has been gathered over a period of years. It has been tried out in the classroom and in the shop. For the instructor, it solves the problem of what to teach and how to teach it. The author has presented to the student mechanic in the aviation trades, the necessary mathematics which will help him while receiving his training in the school shop, while studying at home on his own, and while actually performing his work in industry.

The mechanic who is seeking advancement will find here a broad background of principles of mathematics relating to his trade.

***Foreword***

The text therefore fills a real need. I firmly believe that the use of this book will help solve some of the aviation mechanic's problems. It will help him to do his work more intelligently and will enable him to progress toward the goal he has set for himself.

NEW YORK,  
*December, 1941.*

ELLIOT V. NOSKA,  
*Principal, Manhattan High  
School of Aviation Trades*

## **Part I**

# **A REVIEW OF FUNDAMENTALS FOR THE AIRPLANE MECHANIC**

### **Chapter I: The Steel Rule**

- Job 1: Learning to Use the Rule
- Job 2: Accuracy of Measurement
- Job 3: Reducing Fractions to Lowest Terms
- Job 4: An Important Word: Mixed Number
- Job 5: Addition of Ruler Fractions
- Job 6: Subtraction of Ruler Fractions
- Job 7: Multiplication of Fractions
- Job 8: Division of Fractions
- Job 9: Review Test

### **Chapter II: Decimals in Aviation**

- Job 1: Reading Decimals
- Job 2: Checking Dimensions with Decimals
- Job 3: Multiplication of Decimals
- Job 4: Division of Decimals
- Job 5: Changing Fractions to Decimals
- Job 6: The Decimals Equivalent Chart
- Job 7: Tolerance and Limits
- Job 8: Review Test

### **Chapter III: Measuring Length**

- Job 1: Units of Length
- Job 2: Perimeter
- Job 3: Non-ruler Fractions
- Job 4: The Circumference of a Circle
- Job 5: Review Test

### **Chapter IV: The Area of Simple Figures**

- Job 1: Units of Area
- Job 2: The Rectangle
- Job 3: Mathematical Shorthand: Squaring a Number

- Job 4: Introduction to Square Roots
- Job 5: The Square Root of a Whole Number
- Job 6: The Square Root of Decimals
- Job 7: The Square
- Job 8: The Circle
- Job 9: The Triangle
- Job 10: The Trapezoid
- Job 11: Review Test

**Chapter V: Volume and Weight**

- Job 1: Units of Volume
- Job 2: The Formula for Volume
- Job 3: The Weight of Materials
- Job 4: Board Feet
- Job 5: Review Test

**Chapter VI: Angles and Constructions**

- Job 1: How to Use the Protractor
- Job 2: How to Draw an Angle
- Job 3: Units of Angle Measure
- Job 4: Angles in Aviation
- Job 5: To Bisect an Angle
- Job 6: To Bisect a Line
- Job 7: To Construct a Perpendicular
- Job 8: To Draw an Angle Equal to a Given Angle
- Job 9: To Draw a Line Parallel to a Given Line
- Job 10: To Divide a Line into Any Number of Equal Parts
- Job 11: Review Test

**Chapter VII: Graphic Representation of Airplane Data**

- Job 1: The Bar Graph
- Job 2: Pictographs
- Job 3: The Broken-line Graph
- Job 4: The Curved-line Graph
- Job 5: Review Test

## Chapter I

### THE STEEL RULE

Since the steel rule is one of the most useful of a mechanic's tools, it is very important for him to learn to use it quickly and accurately.

#### Job 1: *Learning to Use the Rule*

Skill in using the rule depends almost entirely on the amount of practice obtained in measuring and in drawing lines of a definite length. The purpose of this job is to give the student some very simple practice work and to stress the idea that accuracy of measurement is essential. There should be no guesswork on any job; there must be no guesswork in aviation.

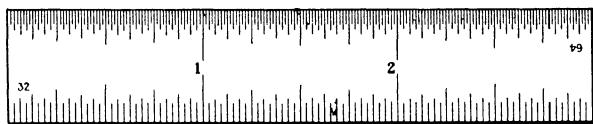

Fig. 1.—Steel rule.

In Fig. 1 is a diagram of a steel rule graduated in 32nds and 64ths. The graduations (divisions of each inch) are extremely close together, but the aircraft mechanic is often expected to work to the nearest 64th or closer.

Examples:

1. How are the rules in Figs. 2a and 2b graduated?



Fig. 2a.



Fig. 2b.

2. Draw an enlarged diagram of the first inch of a steel rule graduated in 8ths. Label each graduation.

3. Draw an enlarged diagram of 1 in. of a rule graduated (a) in 16ths, (b) in 32nds, (c) in 64ths.

4. See how quickly you can name each of the graduations indicated by letters *A, B, C*, etc., in Fig. 3.

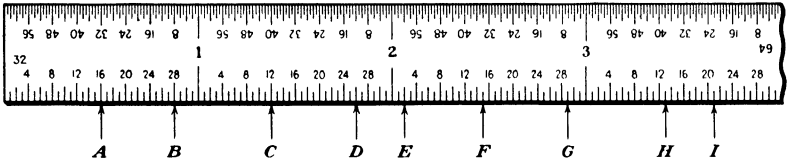

Fig. 3.

5. Measure the length of each of the lines in Fig. 4, using a rule graduated in 32nds.

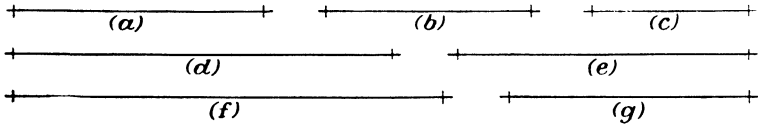

Fig. 4.

6. Carefully draw the following lengths:

(a)  $\frac{7}{8}$  in. (b)  $\frac{3}{16}$  in. (c)  $\frac{5}{32}$  in. (d)  $3\frac{1}{2}$  in. (e)  $1\frac{5}{16}$  in.

7. Measure each of the dimensions in Fig. 5. Read the

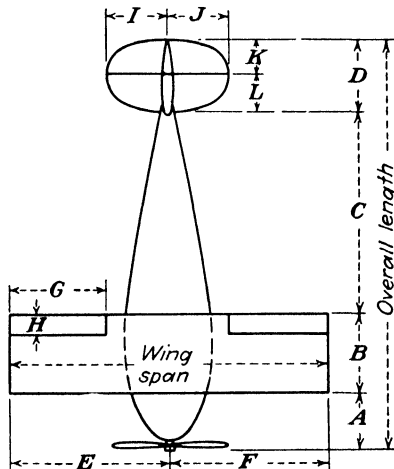

Fig. 5.—Top view of an airplane.

nearest graduation (a) using a rule graduated in 16ths, (b) using a rule graduated in 64ths.

8. Estimate the length of the lines in Fig. 6; then measure them with a rule graduated in 64ths. See how well you can judge the length of a line.

Write the answers in your own notebook. Do NOT write in your textbook.

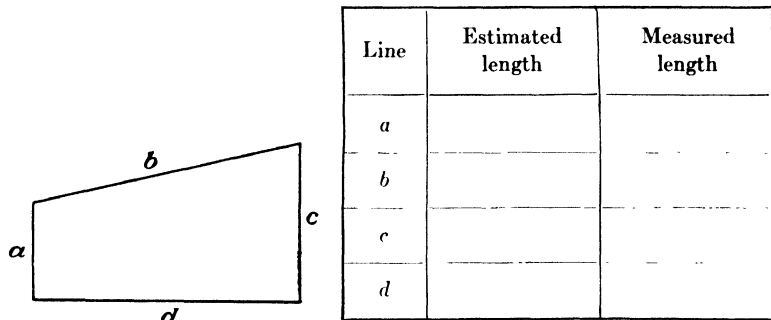

Fig. 6.

### Job 2: Accuracy of Measurement

Many mechanics find it difficult to understand that nothing can ever be measured exactly. For instance, a piece of metal is measured with three different rules, as

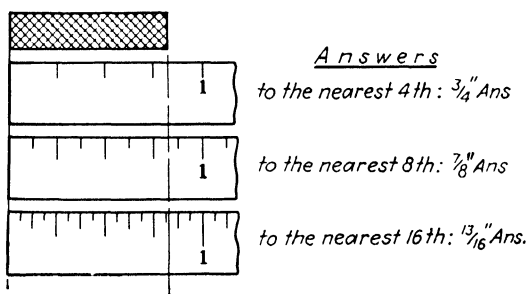

Fig. 7.

shown in Fig. 7. Notice that there is a considerable difference in the answers for the length, when measured to the nearest graduation.

1. The rule graduated in 4ths gives the answer  $\frac{3}{4}$  in.

2. The rule graduated in 8ths gives the answer  $\frac{7}{8}$  in.

3. The rule graduated in 16ths give the answer  $\frac{1\frac{3}{8}}{16}$  in.

Since the first rule is graduated in 4ths, it can be used to measure to the nearest quarter of an inch. Therefore,  $\frac{3}{4}$  in. is the correct answer for the length *to the nearest quarter*.<sup>1</sup> The second rule measures to the nearest 8th (because it is graduated in 8ths) and  $\frac{7}{8}$  in. is the correct answer *to the nearest 8th of an inch*. Similarly, the answer  $\frac{1\frac{3}{8}}{16}$  in. is correct *to the nearest 16th*. If it were required to measure to the nearest 32nd, none of these answers would be correct, because a rule graduated in 32nds would be required.

What rule would be required to measure to the nearest 64th of an inch?

To obtain the *exact* length of the metal shown in the figure, a rule (or other measuring instrument) with an infinite number of graduations per inch would be needed. No such rule can be made. No such rule could be read. The micrometer can be used to measure to the nearest thousandth or ten-thousandth of an inch. Although special devices can be used to measure almost to the nearest millionth of an inch, not even these give more than a very, very, close approximation of the exact measurement.

The mechanic, therefore, should learn the degree of accuracy required for each job in order to know how to make and measure his work. This information is generally given in blueprints. Sometimes it is left to the best judgment of the mechanic. Time, price, purpose of the job, and measuring tools available should be considered.

The mechanic who carefully works to a greater than necessary degree of accuracy is wasting time and money. The mechanic who carelessly works to a degree of accuracy less than that which the job requires, often wastes material, time, and money.

<sup>1</sup> When a line is measured by reading the nearest ruler graduation, the possible error cannot be greater than half the interval between graduations. Thus  $\frac{3}{4}$  in. is the correct length within  $\pm\frac{1}{8}$  in. See Chap. II, Job 7, for further information on accuracy of measurements.

Examples:

1. What kind of rule would you use to measure (a) to the nearest 16th? (b) to the nearest 32nd?

2. Does it make any difference whether a mechanic works to the nearest 16th or to the nearest 64th? Give reasons for your answer.

3. To what degree of accuracy is work generally done in (a) a woodworking shop? (b) a sheet metal shop? (c) a machine shop?

4. Measure the distance between the points in Fig. 8 to the indicated degree of accuracy.

Note: A point is indicated by the intersection of two lines as shown in the figure. What students sometimes call a point is more correctly known as a blot.

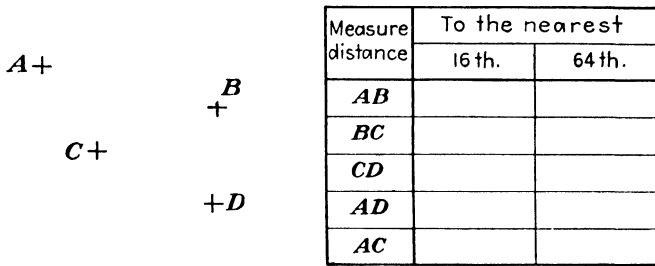

Fig. 8.

5. In aeronautics, the airfoil section is the outline of the wing rib of an airplane. Measure the thickness of the airfoil section at each station in Fig. 9, to the nearest 64th.

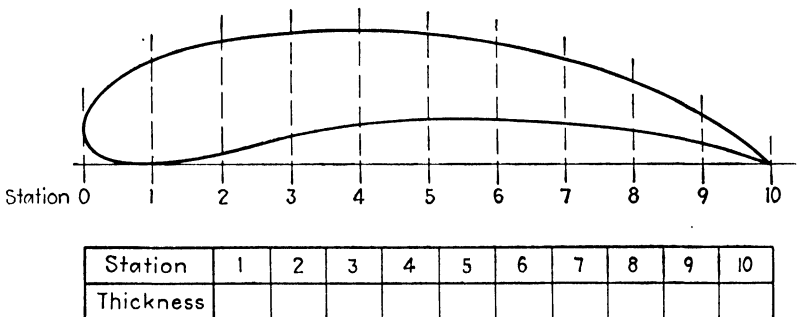

Fig. 9.—Airfoil section.

6. What is the distance between station 5 and station 9 (Fig. 9)?

7. How well can you estimate the length of the lines in Fig. 10? Write down your estimate *in your own notebook*; then measure each line to the nearest 32nd.

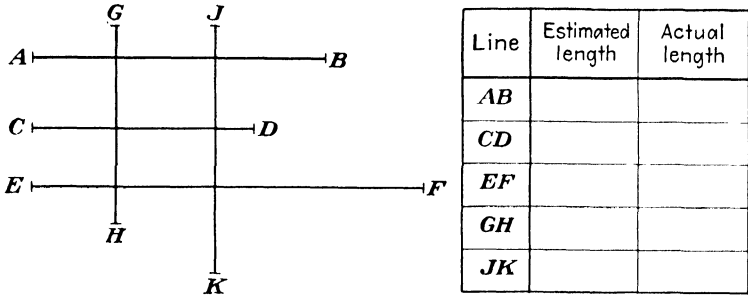

Fig. 10.

8. In your notebook, try to place two points exactly 1 in. apart *without using* your rule. Now measure the distance between the points. How close to an inch did you come?

### Job 3: Reducing Fractions to Lowest Terms

**A. Two Important Words: Numerator, Denominator.** You probably know that your ruler is graduated in fractions or parts of an inch, such as  $\frac{3}{8}$ ,  $\frac{1}{2}$ ,  $\frac{5}{16}$ , etc. Name any other fractions found on it. Name 5 fractions not found on it. These fractions consist of two parts separated by a bar or fraction line. Remember these two words:

*Numerator* is the number *above* the fraction line.

*Denominator* is the number *below* the fraction line.

For example, in the fraction  $\frac{5}{8}$ , 5 is the numerator and 8 is the denominator.

**Examples:**

1. Name the numerator and the denominator in each of these fractions:

$$\frac{3}{4}, \frac{7}{8}, \frac{16}{3}, \frac{5}{9}, \frac{12}{64}, \frac{13}{18}, \frac{1}{2}, \frac{1}{16}$$

2. Name 5 fractions in which the numerator is smaller than the denominator.

3. Name 5 fractions in which the numerator is larger than the denominator.

4. If the numerator of a fraction is equal to the denominator, what is the value of the fraction?

5. What part of the fraction  $\frac{7}{64}$  shows that the measurement was probably made to the nearest 64th?

**B. Fractions Have Many Names.** It may have been noticed that it is possible to call the same graduation on a rule by several different names.

Students sometimes ask, "which of these ways of calling a fraction is *most* correct?" All of them are "equally" correct. However, it is very useful to be able to change a fraction into an equivalent fraction with a different numerator and denominator.

*This graduation can be called  $\frac{3}{4}$  or  $\frac{6}{8}$  or  $\frac{12}{16}$  or  $\frac{24}{32}$ , etc.*

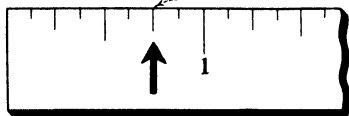

Fig. 11.

Examples:

Answer these questions with the help of Fig. 11:

1.  $\frac{3}{4} = \frac{\text{how many?}}{16}$

2.  $\frac{3}{4} = \frac{\text{how many?}}{32}$

3.  $2\frac{3}{8} = 2\frac{?}{16}$

4.  $2\frac{3}{8} = 2\frac{?}{32}$

*Hint:* Multiplying the numerator and denominator of any fraction by the same number will not change the value of the fraction.

5.  $\frac{1}{2} = \frac{?}{4}$

6.  $\frac{3}{8} = \frac{?}{16}$

7.  $\frac{3}{32} = \frac{?}{64}$

8.  $\frac{1}{8} = \frac{?}{16} = \frac{?}{32}$

9.  $\frac{5}{8} = \frac{?}{16} = \frac{?}{64}$

10.  $2\frac{1}{2} = 2\frac{?}{4}$

11.  $3\frac{3}{4} = 3\frac{?}{32}$

12.  $1\frac{3}{8} = 1\frac{?}{64}$

13.  $\frac{6}{8} = \frac{?}{4}$

14.  $\frac{2}{4} = \frac{?}{2}$

15.  $\frac{10}{16} = \frac{?}{8}$

16.  $\frac{8}{16} = \frac{?}{2} = \frac{?}{4} = \frac{?}{32}$

17.  $\frac{28}{32} = \frac{?}{8} = \frac{?}{64}$

*Hint:* Dividing the numerator and denominator of a fraction by the same number will not change the value of the fraction.

When a fraction is expressed by the smallest numbers with which it can be written, it is said to be in its "lowest terms."

Reduce to lowest terms:

18.  $\frac{6}{16}$

19.  $\frac{8}{16}$

20.  $\frac{12}{32}$

21.  $\frac{30}{32}$

22.  $1\frac{6}{64}$

23.  $2\frac{5}{64}$

24.  $2\frac{50}{64}$

25.  $8\frac{28}{32}$

Which fraction in each of the following groups is the larger?

26.  $\frac{5}{16}$  or  $\frac{1}{4}$

27.  $\frac{3}{32}$  or  $\frac{1}{8}$

28.  $\frac{3}{16}$  or  $\frac{5}{32}$

29.  $\frac{3}{8}$  or  $\frac{23}{64}$

30.  $\frac{9}{16}$  or  $\frac{1}{2}$

31.  $\frac{9}{16}$  or  $\frac{33}{64}$

32.  $\frac{3}{4}$  or  $\frac{45}{64}$

33.  $\frac{7}{8}$  or  $\frac{28}{32}$

#### Job 4: An Important Word: Mixed Number

Numbers such as 5, 12, 3, 1, 24, etc., are called *whole numbers*; numbers such as  $\frac{1}{8}$ ,  $\frac{3}{5}$ ,  $\frac{7}{16}$ , etc. are called *fractions*. Very often the mechanic meets numbers, such as  $5\frac{1}{8}$ ,  $12\frac{3}{16}$ , or  $13\frac{7}{2}$ , each of which is a combination of a whole number and a fraction. Such numbers are called *mixed numbers*.

#### Definition:

A *mixed number* consists of a whole number and a fraction. For example,  $2\frac{5}{8}$ ,  $3\frac{1}{8}$ ,  $1\frac{2}{5}$  are mixed numbers.

Write 5 whole numbers. Write 5 fractions. Write 5 mixed numbers.

Is this statement true: Every graduation on a rule, beyond the 1-in. mark, corresponds to a mixed number?

Find the fraction  $\frac{9}{8}$  on a rule? Notice that it is beyond the 1-in. graduation, and by actual count is equal to  $1\frac{1}{8}$  in.

The fraction  $\frac{9}{8}$  is the same as the mixed number  $1\frac{1}{8}$ .

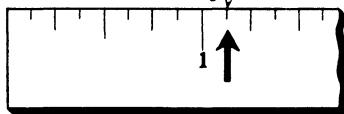

Fig. 12.

**A. Changing Improper Fractions to Mixed Numbers.** Any improper fraction (numerator larger than the denominator) can be changed to a mixed number by dividing the numerator by the denominator.

**ILLUSTRATIVE EXAMPLE**

Change  $\frac{9}{8}$  to a mixed number.

$$\frac{9}{8} = 9 \div 8 = 1\frac{1}{8} \quad \text{Ans.}$$

Examples:

Change these fractions to mixed numbers:

- |                    |                    |                     |                     |                      |
|--------------------|--------------------|---------------------|---------------------|----------------------|
| 1. $\frac{3}{2}$   | 2. $\frac{7}{4}$   | 3. $\frac{6}{4}$    | 4. $\frac{18}{8}$   | 5. $\frac{23}{16}$   |
| 6. $\frac{45}{8}$  | 7. $\frac{48}{16}$ | 8. $\frac{95}{32}$  | 9. $\frac{350}{64}$ | 10. $\frac{164}{64}$ |
| 11. $\frac{23}{3}$ | 12. $\frac{49}{5}$ | 13. $\frac{38}{12}$ | 14. $\frac{29}{17}$ | 15. $\frac{16}{16}$  |

16. Can all fractions be changed to mixed numbers? Explain.

**B. Changing Mixed Numbers to Improper Fractions.** A mixed number may be changed to a fraction.

**ILLUSTRATIVE EXAMPLE**

Change  $2\frac{3}{4}$  to a fraction.

$$2\frac{3}{4} = \frac{(4 \times 2) + 3}{4} = \frac{8 + 3}{4} = \frac{11}{4} \quad \text{Ans.}$$

Check your answer by changing the fraction back to a mixed number.

## Examples:

Change the following mixed numbers to improper fractions. Check your answers.

1.  $3\frac{1}{2}$

2.  $4\frac{1}{8}$

3.  $3\frac{3}{4}$

4.  $6\frac{7}{8}$

5.  $10\frac{4}{5}$

6.  $12\frac{3}{8}$

7.  $19\frac{5}{2}$

8.  $2\frac{3}{6}\frac{5}{4}$

Change the following improper fractions to mixed numbers. Reduce the answers to lowest terms.

9.  $\frac{9}{2}$

10.  $\frac{17}{16}$

11.  $\frac{45}{4}$

12.  $\frac{200}{64}$

13.  $\frac{95}{32}$

14.  $\frac{17}{5}$

15.  $\frac{43}{12}$

16.  $\frac{35}{10}$

**Job 5: Addition of Ruler Fractions**

A mechanic must work with blueprints or shop drawings, which at times look something like the diagram in Fig. 13.

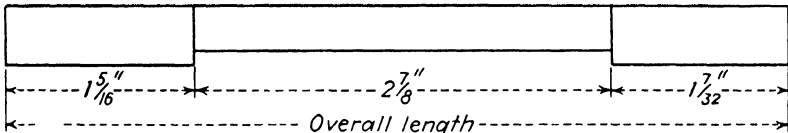

Fig. 13.

**ILLUSTRATIVE EXAMPLE**

Find the over-all length of the job in Fig. 13.

$$\text{Over-all length} = 1\frac{5}{16} + 2\frac{7}{8} + 1\frac{7}{32}$$

$$1\frac{5}{16} = 1\frac{10}{32}$$

$$2\frac{7}{8} = 2\frac{28}{32}$$

$$1\frac{7}{32} = 1\frac{7}{32}$$

$$\text{Sum} = 4\frac{45}{32}$$

$$4\frac{45}{32} = 4 + 1\frac{13}{32} = 5\frac{13}{32} \text{ in. } \textit{Ans.}$$

**Method:**

- Give all fractions the same denominator.
- Add all numerators.
- Add all whole numbers.
- Reduce to lowest terms.

Even if the "over-all length" is given, it is up to the intelligent mechanic to check the numbers before he goes ahead with his work.

Examples:

Add these ruler fractions:

1.  $\frac{1}{4} + \frac{1}{2}$

2.  $\frac{1}{4} + \frac{1}{2} + \frac{3}{4}$

3.  $\frac{1}{8} + \frac{3}{4}$

4.  $\frac{3}{8} + \frac{1}{4} + \frac{5}{8}$

5.  $\frac{3}{4} + \frac{1}{2} + \frac{5}{8}$

6.  $\frac{7}{8} + \frac{5}{8} + \frac{1}{2}$

7.  $\frac{1}{2} + \frac{1}{4} + \frac{1}{8}$

8. Find the over-all length of the diagram in Fig. 14:

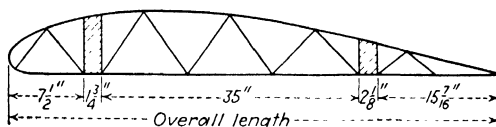

Fig. 14.—Airplane wing rib.

Add the following:

9.  $2\frac{1}{2} + 1\frac{1}{4}$

10.  $3\frac{1}{8} + 2\frac{1}{2}$

11.  $4\frac{1}{8} + 2\frac{1}{16}$

12.  $2\frac{1}{4} + 1\frac{5}{8} + 1\frac{7}{8}$

13.  $3\frac{1}{2} + 5\frac{7}{16} + 9\frac{1}{16}$

14.  $3\frac{3}{8} + 4\frac{7}{8} + 2\frac{3}{16}$

15.  $3\frac{3}{2} + 4\frac{1}{2} + 9\frac{1}{16}$

16. Find the over-all dimensions of the fitting shown in Fig. 15.

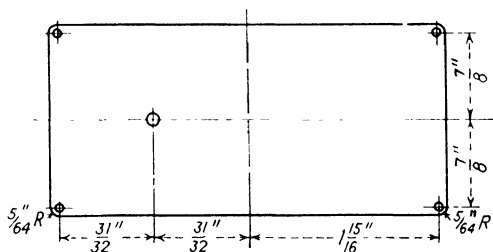

Fig. 15.

### Job 6: Subtraction of Ruler Fractions

The subtraction of ruler fractions is useful in finding missing dimensions on blueprints and working drawings.

#### ILLUSTRATIVE EXAMPLE

In Fig. 16 one of the important dimensions was omitted. Find it and check your answer.

$$\begin{array}{r} 3\frac{3}{4} = 3\frac{6}{8} \\ -2\frac{3}{8} = -2\frac{3}{8} \\ \hline 1\frac{3}{8} \text{ in. } \textit{Ans.} \end{array}$$

Check: Over-all length =  $1\frac{3}{8} + 2\frac{3}{8} = 3\frac{3}{4}$ .

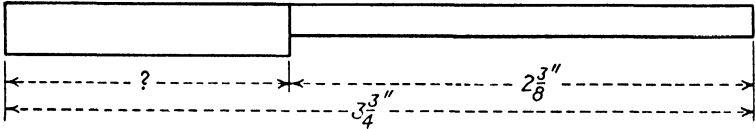

Fig. 16.

**Examples:**

Subtract these fractions:

1.  $\frac{7}{8} - \frac{1}{4}$

2.  $3\frac{1}{64} - \frac{3}{8}$

3.  $1\frac{1}{2} - \frac{3}{4}$

4.  $\frac{3}{4} - \frac{1}{16}$

5.  $3\frac{1}{8} - \frac{5}{16}$

6.  $4\frac{1}{4} - 2\frac{3}{8}$

7.  $3\frac{5}{8} - 2\frac{3}{4}$

8.  $9\frac{1}{64} - \frac{7}{8}$

9.  $1\frac{3}{16} - \frac{1}{64}$

10. What is the length of *B* in Fig. 17? Check your answer.

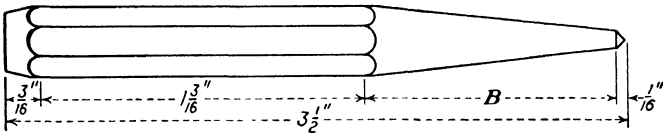

Fig. 17.—Center punch.

Which fraction in each group is the larger, and by how much?

11.  $\frac{7}{8}$  or  $\frac{13}{16}$

12.  $\frac{5}{16}$  or  $\frac{2}{64}$

13.  $\frac{3}{64}$  or  $\frac{3}{8}$

14.  $2\frac{1}{8}$  or  $2\frac{5}{64}$

15.  $5\frac{3}{16}$  or  $5\frac{1}{64}$

16.  $7\frac{1}{32}$  or  $7\frac{3}{64}$

17. Find the missing dimension in Fig. 18.

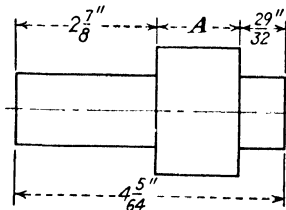

Fig. 18.

**Job 7: Multiplication of Fractions**

The multiplication of fractions has many very important applications and is almost as easy as multiplication of whole numbers.

**ILLUSTRATIVE EXAMPLES**

Multiply  $\frac{3}{8} \times \frac{5}{8}$ .

$$\frac{3}{8} \times \frac{5}{8} = \frac{3 \times 5}{8 \times 8} = \frac{15}{64} \quad \text{Ans.}$$

Take  $\frac{1}{4}$  of  $1\frac{7}{8}$ .

$$\frac{1}{4} \times \frac{15}{8} = \frac{1 \times 15}{4 \times 8} = \frac{15}{32} \quad \text{Ans.}$$

*Method:*

a. Multiply the numerators, then the denominators.

b. Change all mixed numbers to fractions first, if necessary. Cancellation can often be used to make the job of multiplication easier.

**Examples:**

1.  $4 \times 3\frac{1}{2}$

2.  $\frac{6}{7}$  of  $8\frac{1}{3}$

3.  $16 \times 3\frac{5}{8}$

4.  $\frac{7}{9}$  of 18

5.  $\frac{12}{5} \times \frac{3}{5} \times \frac{10}{32}$

6.  $4 \times 2\frac{1}{2} \times \frac{3}{5}$

7.  $33 \times \frac{7}{8} \times \frac{1}{3}$

8. Find the total length of 12 pieces of round stock, each  $7\frac{1}{2}$  in. long.

9. An airplane rib weighs  $1\frac{3}{5}$  lb. What is the total weight of 24 ribs?

10. The fuel tanks of the Bellanca Cruisair hold 22 gal. of gasoline. What would it cost to fill this tank at  $25\frac{1}{4}$ ¢ per gallon?

11. If 3 Cruisairs were placed wing tip to wing tip, how much room would they need? (See Fig. 19.)

12. If they were lined up propeller hub to rudder, how much room would 5 of these planes need (Fig. 19)?

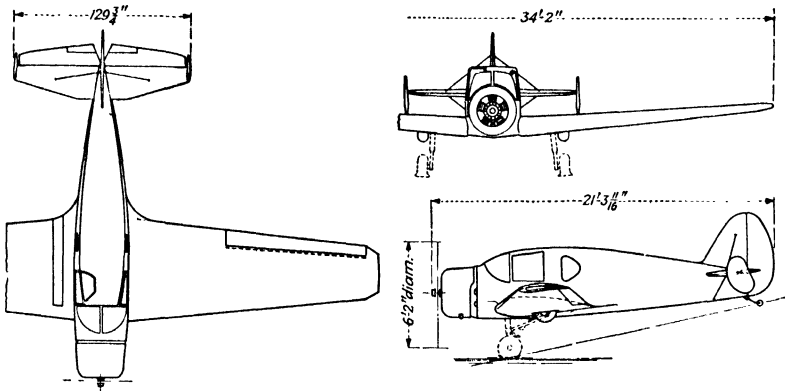

Fig. 19.—Bellanca Crusair low-wing monoplane. (Courtesy of Aviation.)

### Job 8: Division of Fractions

**A. Division by Whole Numbers.** Suppose that, while working on some job, a mechanic had to shear the piece of metal shown in Fig. 20 into 4 equal parts. The easiest way of doing this would be to divide  $9\frac{1}{4}$  by 4, and then mark the points with the help of a rule.

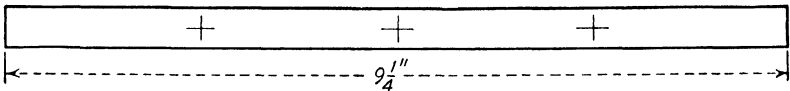

Fig. 20.

#### ILLUSTRATIVE EXAMPLE

Divide  $9\frac{1}{4}$  by 4.

$$9\frac{1}{4} \div 4 = 9\frac{1}{4} \times \frac{1}{4} = \frac{37}{4} \times \frac{1}{4} = \frac{37}{16} = 2\frac{5}{16} \quad \text{Ans.}$$

*Method:*

To divide any fraction by a whole number, multiply by 1 over the whole number.

**Examples:**

How quickly can you get the correct answer?

1.  $4\frac{1}{2} \div 3$

2.  $2\frac{3}{4} \div 4$

3.  $7\frac{3}{8} \div 9$

4.  $6\frac{5}{8} \div 2$

5.  $\frac{5}{8} \div 5$

6.  $\frac{3}{16} \div 6$

7. The metal strip in Fig. 21 is to be divided into 4 equal parts. Find the missing dimensions.

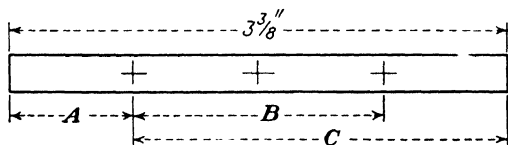

Fig. 21.

8. Find the wall thickness of the tubes in Fig. 22.

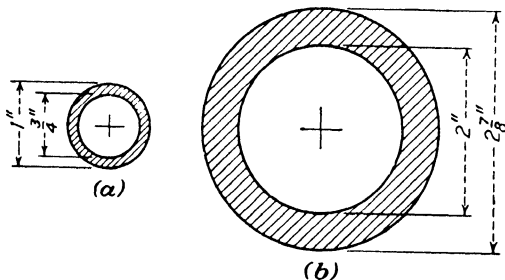

Fig. 22.

### B. Division by Other Fractions.

#### ILLUSTRATIVE EXAMPLE

Divide  $3\frac{5}{8}$  by  $\frac{2}{3}$ .

$$3\frac{5}{8} \div \frac{2}{3} = 3\frac{5}{8} \times \frac{3}{2} = \frac{2\frac{9}{8}}{2} \times \frac{3}{2} =$$

Complete this example.

How can the answer be checked?

#### Method:

To divide any fraction by a fraction, invert the second fraction and multiply.

#### Examples:

1.  $\frac{5}{8} \div \frac{2}{3}$

2.  $1\frac{1}{2} \div \frac{1}{4}$

3.  $6\frac{3}{4} \div \frac{3}{8}$

4.  $12\frac{5}{8} \div \frac{1}{2}$

5.  $14\frac{3}{4} \div 1\frac{5}{8}$

6.  $16\frac{7}{8} \div 7\frac{3}{4}$

7. A pile of aircraft plywood is  $7\frac{1}{2}$  in. high. Each piece is  $\frac{3}{16}$  in. thick. How many pieces are there altogether?

8. A piece of round stock  $12\frac{3}{4}$  in. long is to be cut into 8 equal pieces allowing  $\frac{1}{16}$  in. for each cut. What is the

length of each piece? Can you use a steel rule to measure this distance? Why?

9. How many pieces of streamline tubing each  $4\frac{3}{4}$  in. long can be cut from a 72-in. length? Allow  $\frac{1}{32}$  in. for each cut. What is the length of the last piece?

10. Find the distance between centers of the equally spaced holes in Fig. 23.

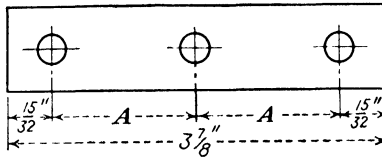

Fig. 23.

### Job 9: Review Test

1. Find the over-all lengths in Fig. 24.

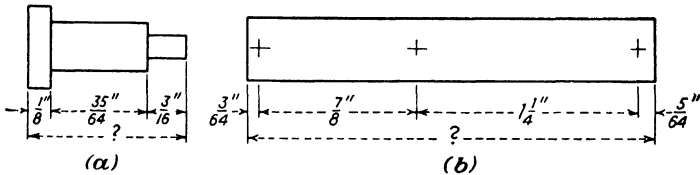

Fig. 24.

2. Find the missing dimensions in Fig. 25.

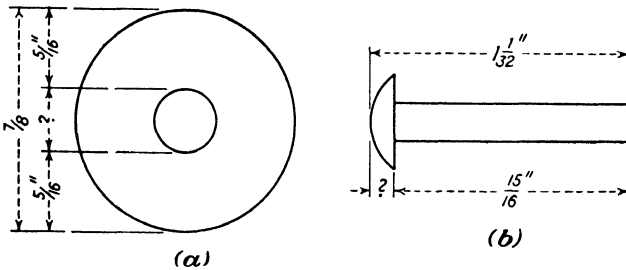

Fig. 25.

3. One of the dimensions of Fig. 26 has been omitted. Can you find it?

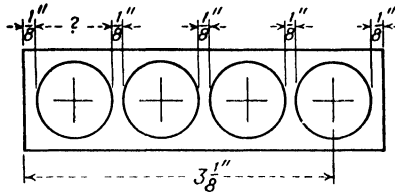

Fig. 26.

4. What is the length of *A* in Fig. 27?

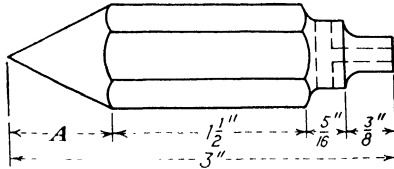

Fig. 27.—Plumb bob.

5. The Curtiss-Wright A-19-R has fuel capacity of 70 gal. and at cruising speed uses  $29\frac{2}{3}$  gal. per hour. How many hours can the plane stay aloft?

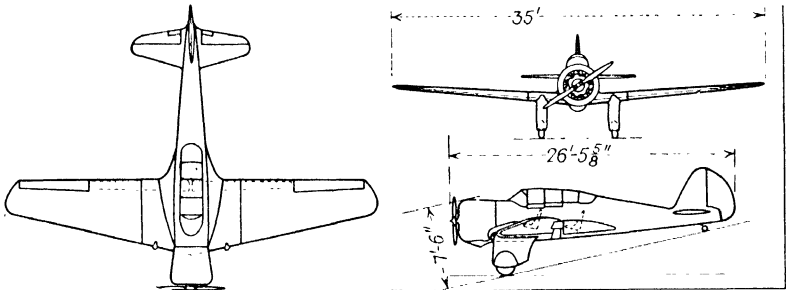

Fig. 28.—Curtiss-Wright A-19-R. (Courtesy of Aviation.)

6. How well can you estimate length? Check your estimates by measuring to the nearest 32nd (see Fig. 29).

*A* +                      + *B*  
  
                                  + *C*  
  
                                  + *D*

Distance	Estimated length	Measured length	Difference
<i>AB</i>			
<i>AC</i>			
<i>BC</i>			
<i>BD</i>			

Fig. 29.

## Chapter II

### DECIMALS IN AVIATION

The ruler is an excellent tool for measuring the length of most things but its accuracy is limited to  $\frac{1}{16}$  in. or less. For jobs requiring a high degree of accuracy the micrometer caliper should be used, because it measures to the nearest thousandth of an inch or closer.

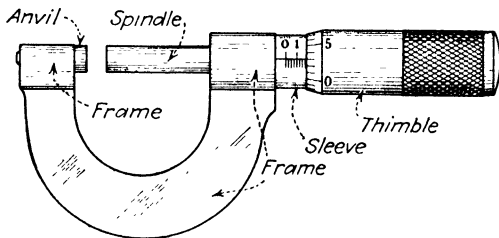

Fig. 30.—Micrometer caliper.

#### Job 1: Reading Decimals

When a rule is used to measure length, the answer is expressed as a ruler fraction, such as  $\frac{5}{8}$ ,  $\frac{3}{32}$ , or  $5\frac{1}{64}$ . When a micrometer is used to measure length, the answer is expressed as a decimal fraction. A decimal fraction is a special kind of fraction whose denominator is either 10, 100, 1,000, etc. For example,  $\frac{7}{10}$  is a decimal fraction; so are  $\frac{35}{100}$  and  $\frac{175}{1,000}$ .

For convenience, these special fractions are written in this way:

$$\frac{7}{10} = 0.7, \text{ read as seven tenths}$$

$$\frac{35}{100} = 0.35, \text{ read as thirty-five hundredths}$$

$$\frac{5}{1,000} = 0.005 \text{ read as five thousandths}$$

$$\frac{45}{10,000} = 0.0045, \text{ read as forty-five ten-thousandths,}$$

or four and one-half thousandths

**Examples:**

1. Read these decimals:

- |           |            |           |            |
|-----------|------------|-----------|------------|
| (a) 0.9   | (b) 0.4    | (c) 0.45  | (d) 0.78   |
| (e) 0.30  | (f) 0.405  | (g) 0.875 | (h) 0.125  |
| (i) 0.003 | (j) 0.0002 | (k) 1.005 | (l) 1.0125 |

2. Write these decimals:

- |                        |                               |
|------------------------|-------------------------------|
| (a) 45 hundredths      | (b) five thousandths          |
| (c) 3 and 6 tenths     | (d) seventy-five thousandths  |
| (e) 35 ten-thousandths | (f) one and three thousandths |

Most mechanics will not find much use for decimals beyond the nearest thousandth. When a decimal is given in 6 places, as in the table of decimal equivalents, not all of these places should or even can be used. The type of work the mechanic is doing will determine the degree of accuracy required.

**ILLUSTRATIVE EXAMPLE**

Express 3.72648:

- |                               |       |      |
|-------------------------------|-------|------|
| (a) to the nearest thousandth | 3.726 | Ans. |
| (b) to the nearest hundredth  | 3.73  | Ans. |
| (c) to the nearest tenth      | 3.7   | Ans. |

**Method:**

- a. Decide how many decimal places your answer should have.
- b. If the number following the last place is 5 or larger, add 1.
- c. Drop all other numbers following the last decimal place.

## Examples:

1. Express these decimals to the nearest thousandth:

(a) 0.6254

(b) 3.1416

(c) 18.6545

(d) 9.0109

(e) 7.4855

(f) 7.5804

2. Express these decimals to the nearest hundredth:

(a) 0.839

(b) 0.7854

(c) 3.0089

(d) 0.721

(e) 3.1416

(f) 0.3206

(g) 8.325

(h) 9.0310

3. Express the decimals in Examples 1 and 2 to the nearest tenth.

**Job 2: Checking Dimensions with Decimals**

A. Addition of Decimals. It is not at all unusual to find decimals appearing on blueprints or shop drawings.

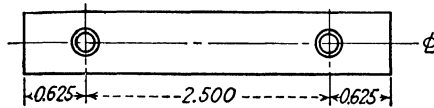

Fig. 31.—All dimensions are in inches.

**ILLUSTRATIVE EXAMPLE**

Find the over-all length of the fitting in Fig. 31.

$$\text{Over-all length} = 0.625 + 2.500 + 0.625$$

$$0.625$$

$$2.500$$

$$0.625$$

$$\hline 3.750$$

$$\text{Over-all length} = 3.750 \text{ in. } \textit{Ans.}$$

**Method:**

To add decimals, arrange the numbers so that all decimal points are on the same line.

**Examples:**

Add

1.  $4.75 + 3.25 + 6.50$

2.  $3.055 + 0.257 + 0.125$

3.  $18.200 + 12.033 + 1.800 + 7.605$
4.  $0.003 + 0.139 + 0.450 + 0.755$
5. Find the over-all length of the fitting in Fig. 32.

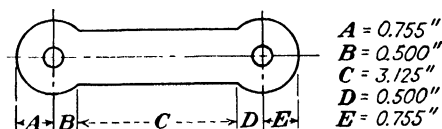

Fig. 32.

6. The thickness gage in Fig. 33 has six tempered-steel leaves of the following thicknesses:

- |                                |                    |
|--------------------------------|--------------------|
| (a) $1\frac{1}{2}$ thousandths | (b) 2 thousandths  |
| (c) 3 thousandths              | (d) 4 thousandths  |
| (e) 6 thousandths              | (f) 15 thousandths |

What is the total thickness of all six leaves?

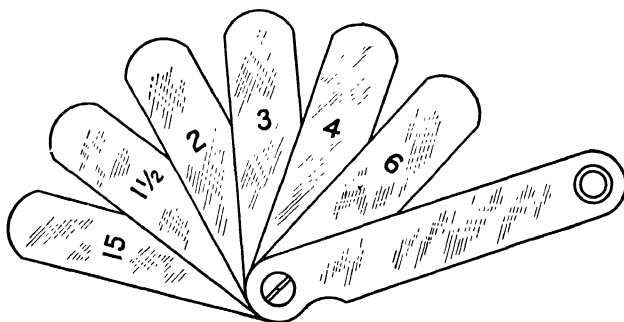

Fig. 33.—Thickness gage.

7. A thickness gage has 8 tempered steel leaves of the following thicknesses: 0.0015, 0.002, 0.003, 0.004, 0.006, 0.008, 0.010, and 0.015.

- a. What is their total thickness?
- b. Which three leaves would add up to  $7\frac{1}{2}$  thousandths?
- c. Which three leaves will give a combined thickness of  $10\frac{1}{2}$  thousandths?

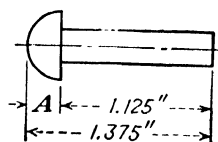

Fig. 34.

**B. Subtraction of Decimals.**

In Fig. 34, one dimension has been omitted.

## ILLUSTRATIVE EXAMPLE

Find the missing dimension in Fig. 34.

$$\begin{array}{r}
 A = 1.375 - 1.125 \\
 1.375 \\
 -1.125 \\
 \hline
 0.250 \text{ in. } \text{Ans.}
 \end{array}$$

*Method:*

In subtracting decimals, make sure that the decimal points are aligned.

**Examples:**

Subtract

- |                      |                    |
|----------------------|--------------------|
| 1. $9.75 - 3.50$     | 2. $2.500 - 0.035$ |
| 3. $16.275 - 14.520$ | 4. $0.625 - 0.005$ |
| 5. $48.50 - 0.32$    | 6. $1.512 - 0.375$ |

7. What are the missing dimensions in Fig. 35?

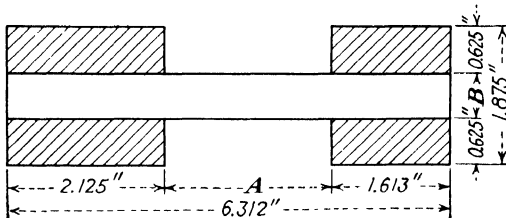

Fig. 35.—Front wing spar.

Do these examples:

8.  $4.325 + 0.165 - 2.050$
9.  $3.875 - 1.125 + 0.515 + 3.500$
10.  $28.50 - 26.58 + 0.48 - 0.75$
11.  $92.875 + 4.312 + 692.500 - 31.145 - 0.807$
12.  $372.5 + 82.60 - 84.0 - 7.0 - 6.5$

### Job 3: Multiplication of Decimals

The multiplication of decimals is just as easy as the multiplication of whole numbers. Study the illustrative example carefully.

ILLUSTRATIVE EXAMPLE

Find the total height of 12 sheets of aircraft sheet aluminum, B. and S. gage No. 20 (0.032 in.).

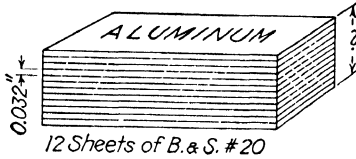

Fig. 36.

Multiply 0.032 by 12.

$$\begin{array}{r}
 0.032 \text{ in.} \\
 \times 12 \\
 \hline
 064 \\
 032 \\
 \hline
 0.384 \text{ in.} \quad \text{Ans.}
 \end{array}$$

Method:

- a. Multiply as usual.
- b. Count the number of decimal places in the numbers being multiplied.
- c. Count off the same number of decimal places in the answer, starting at the extreme right.

Examples:

Express all answers to the nearest hundredth:

- |                         |                               |
|-------------------------|-------------------------------|
| 1. $0.35 \times 2.3$    | 2. $1.35 \times 14.0$         |
| 3. $8.75 \times 1.2$    | 4. $5.875 \times 0.25$        |
| 5. $3.1416 \times 0.25$ | 6. $3.1416 \times 4 \times 4$ |

7. A dural<sup>1</sup> sheet of a certain thickness weighs 0.174 lb. per sq. ft. What is the weight of a sheet whose area is 16.50 sq. ft.?

8. The price per foot of a certain size of seamless steel tubing is \$1.62. What is the cost of 145 ft. of this tubing?

9. The Grumman G-21-A has a wing area of 375.0 sq. ft. If each square foot of the wing can carry an average

<sup>1</sup> The word *dural* is a shortened form of *duralumin* and is commonly used in the aircraft trades.

weight of 21.3 lb., how many pounds can the whole plane carry?

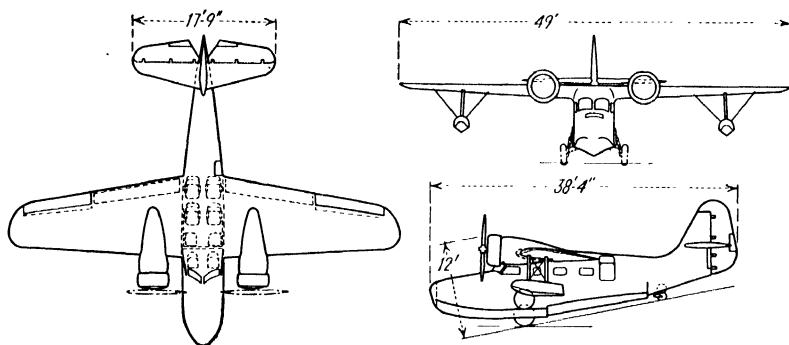

Fig. 37.—Grumman G-21-A, an amphibian monoplane. (Courtesy of Aviation.)

#### Job 4: Division of Decimals

A piece of flat stock exactly 74.325 in. long is to be sheared into 15 equal parts. What is the length of each part to the nearest thousandth of an inch?

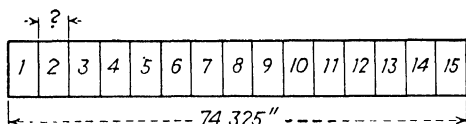

Fig. 38.

#### ILLUSTRATIVE EXAMPLE

Divide 74.325 by 15.

$$\begin{array}{r}
 4.9550 \\
 15 \overline{) 74.325} \\
 \underline{60} \phantom{00} \\
 143 \phantom{00} \\
 \underline{135} \phantom{00} \\
 82 \phantom{00} \\
 \underline{75} \phantom{00} \\
 75 \phantom{00} \\
 \underline{75} \phantom{00} \\
 0
 \end{array}$$

Each piece will be 4.955 in. long. *Ans.*

Examples:

Express all answers to the nearest thousandth:

1.  $9.283 \div 6$                       2.  $7.1462 \div 9$                       3.  $265.5 \div 18$   
 4.  $40.03 \div 22$                       5.  $1.005 \div 7$                       6.  $103.05 \div 37$

Express answers to the nearest hundredth:

7.  $46.2 \div 2.5$                       8.  $7.36 \div 0.8$                       9.  $0.483 \div 4.45$   
 10.  $0.692 \div 0.35$                       11.  $42 \div 0.5$                       12.  $125 \div 3.14$

13. A  $\frac{5}{8}$ -in. rivet weighs 0.375 lb. How many rivets are there in 50 lb.?

14. Find the wall thickness  $t$  of the tubes in Fig. 39.

15. A strip of metal 16 in. long is to be cut into 5 equal parts. What is the length of each part to the nearest thousandth of an inch, allowing nothing for each cut of the shears?

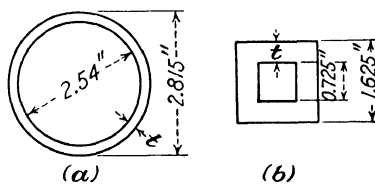

Fig. 39.

**Job 5: Changing Fractions to Decimals**

Any fraction can be changed into a decimal by dividing the numerator by the denominator.

ILLUSTRATIVE EXAMPLES

Change  $\frac{5}{6}$  to a decimal.

$$\frac{5}{6} = \begin{array}{r} 0.8333+ \\ 6 \overline{)5.0000} \end{array} \text{ Ans.}$$

*Hint:* The number of decimal places in the answer depends on the number of zeros added after the decimal point.

Change  $\frac{3}{7}$  to a decimal accurate to the nearest thousandth.

$$\frac{3}{7} = \begin{array}{r} 0.4285+ \\ 7 \overline{)3.0000} \end{array} = 0.429 \text{ Ans.}$$

## Examples:

1. Change these fractions to decimals accurate to the nearest thousandth:

(a) $\frac{3}{8}$	(b) $\frac{5}{8}$	(c) $\frac{5}{16}$	(d) $\frac{7}{8}$
(e) $\frac{5}{32}$	(f) $\frac{9}{16}$	(g) $3\frac{1}{16}$	(h) $7\frac{1}{8}$
(i) $12\frac{1}{32}$	(j) $1\frac{15}{16}$	(k) $3\frac{63}{64}$	

2. Change these fractions to decimals, accurate to the nearest hundredth:

(a) $\frac{5}{9}$	(b) $7\frac{1}{2}$	(c) $\frac{5}{6}$	(d) $1\frac{1}{2}$	(e) $\frac{2}{3}$	(f) $\frac{4}{5}$
-------------------	--------------------	-------------------	--------------------	-------------------	-------------------

3. Convert to decimals accurate to the nearest thousandth:

(a) $\frac{1}{1}$	(b) $\frac{1}{2}$	(c) $\frac{1}{3}$	(d) $\frac{1}{4}$
(e) $\frac{1}{5}$	(f) $\frac{1}{6}$	(g) $\frac{1}{8}$	(h) $\frac{1}{10}$

4. Convert each of the dimensions in Fig. 40 to decimals accurate to the nearest thousandth of an inch.

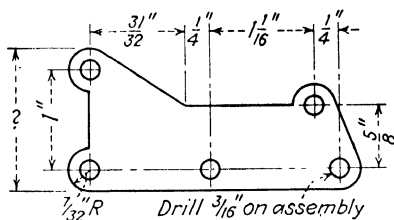

Fig. 40.

5. Find the missing dimension of the fitting in Fig. 40.

6. What is the over-all length of the fitting?

### Job 6: The Decimal Equivalent Chart

Changing ruler fractions to decimals and decimals to ruler fractions is made much easier by the use of a chart similar to the one in Fig. 41.

**A. Changing Fractions to Decimals.** Special instructions on how to change a ruler fraction to a decimal by means of the chart are hardly necessary. Speed and accuracy are

Decimal Equivalents	
$\frac{1}{64}$	.015625
$\frac{2}{64}$	.03125
$\frac{3}{64}$	.046875
$\frac{4}{64}$	.0625
$\frac{5}{64}$	.078125
$\frac{6}{64}$	.09375
$\frac{7}{64}$	.109375
$\frac{8}{64}$	.125
$\frac{9}{64}$	.140625
$\frac{10}{64}$	.15625
$\frac{11}{64}$	.171875
$\frac{12}{64}$	.1875
$\frac{13}{64}$	.203125
$\frac{14}{64}$	.21875
$\frac{15}{64}$	.234375
$\frac{16}{64}$	.25
$\frac{17}{64}$	.265625
$\frac{18}{64}$	.28125
$\frac{19}{64}$	.296875
$\frac{20}{64}$	.3125
$\frac{21}{64}$	.328125
$\frac{22}{64}$	.34375
$\frac{23}{64}$	.359375
$\frac{24}{64}$	.375
$\frac{25}{64}$	.390625
$\frac{26}{64}$	.40625
$\frac{27}{64}$	.421875
$\frac{28}{64}$	.4375
$\frac{29}{64}$	.453125
$\frac{30}{64}$	.46875
$\frac{31}{64}$	.484375
$\frac{32}{64}$	.5
$\frac{33}{32}$	.515625
$\frac{34}{32}$	.53125
$\frac{35}{32}$	.546875
$\frac{36}{32}$	.5625
$\frac{37}{32}$	.578125
$\frac{38}{32}$	.59375
$\frac{39}{32}$	.609375
$\frac{40}{32}$	.625
$\frac{41}{32}$	.640625
$\frac{42}{32}$	.65625
$\frac{43}{32}$	.671875
$\frac{44}{32}$	.6875
$\frac{45}{32}$	.703125
$\frac{46}{32}$	.71875
$\frac{47}{32}$	.734375
$\frac{48}{32}$	.75
$\frac{49}{32}$	.765625
$\frac{50}{32}$	.78125
$\frac{51}{32}$	.796875
$\frac{52}{32}$	.8125
$\frac{53}{32}$	.828125
$\frac{54}{32}$	.84375
$\frac{55}{32}$	.859375
$\frac{56}{32}$	.875
$\frac{57}{32}$	.890625
$\frac{58}{32}$	.90625
$\frac{59}{32}$	.921875
$\frac{60}{32}$	.9375
$\frac{61}{32}$	.953125
$\frac{62}{32}$	.96875
$\frac{63}{32}$	.984375
$\frac{64}{32}$	1.

Fig. 41.

important. See how quickly you can do the following examples.

Examples:

Change these fractions to decimals:

- |                    |                     |                    |                     |
|--------------------|---------------------|--------------------|---------------------|
| 1. $\frac{5}{8}$   | 2. $\frac{3}{4}$    | 3. $\frac{1}{2}$   | 4. $\frac{7}{16}$   |
| 5. $\frac{1}{64}$  | 6. $\frac{19}{32}$  | 7. $\frac{3}{16}$  | 8. $\frac{3}{64}$   |
| 9. $\frac{15}{64}$ | 10. $\frac{41}{64}$ | 11. $\frac{1}{32}$ | 12. $\frac{63}{64}$ |

Change these fractions to decimals accurate to the nearest tenth:

- |                   |                    |                    |                    |
|-------------------|--------------------|--------------------|--------------------|
| 13. $\frac{7}{8}$ | 14. $\frac{1}{16}$ | 15. $\frac{5}{16}$ | 16. $\frac{9}{64}$ |
|-------------------|--------------------|--------------------|--------------------|

Change these fractions to decimals accurate to the nearest hundredth:

- |                    |                     |                     |                     |
|--------------------|---------------------|---------------------|---------------------|
| 17. $\frac{9}{16}$ | 18. $\frac{17}{32}$ | 19. $\frac{27}{64}$ | 20. $\frac{31}{64}$ |
|--------------------|---------------------|---------------------|---------------------|

Change these fractions to decimals accurate to the nearest thousandth:

21.  $\frac{25}{64}$

22.  $\frac{1}{32}$

23.  $\frac{1}{64}$

24.  $\frac{1}{8}$

Change these mixed numbers to decimals accurate to the nearest thousandth:

*Hint:* Change the fraction only, not the whole number.

25.  $3\frac{11}{16}$

26.  $8\frac{1}{32}$

27.  $9\frac{5}{64}$

28.  $3\frac{3}{16}$

Certain fractions are changed to decimals so often that it is worth remembering their decimal equivalents.

Memorize the following fractions and their decimal equivalents to the nearest thousandth:

$\frac{1}{2} = 0.500$

$\frac{1}{4} = 0.250$

$\frac{3}{4} = 0.750$

$\frac{1}{8} = 0.125$

$\frac{3}{8} = 0.375$

$\frac{5}{8} = 0.625$

$\frac{7}{8} = 0.875$

$\frac{1}{16} = 0.063$

$\frac{1}{32} = 0.031$

$\frac{1}{64} = 0.016$

**B. Changing Decimals to Ruler Fractions.** The decimal equivalent chart can also be used to change any decimal to its nearest ruler fraction. This is extremely important in metal work and in the machine shop, as well as in many other jobs.

#### ILLUSTRATIVE EXAMPLE

Change 0.715 to the nearest ruler fraction.

From the decimal equivalent chart we can see that

$$\frac{45}{64} = .703125, \quad \frac{23}{32} = .71875$$

0.715 lies between  $\frac{45}{64}$  and  $\frac{23}{32}$ , but it is nearer to  $\frac{23}{32}$ . *Ans.*

**Examples:**

1. Change these decimals to the nearest ruler fraction:

(a) 0.315    (b) 0.516    (c) 0.218    (d) 0.716    (e) 0.832

2. Change these decimals to the nearest ruler fraction:

(a) 0.842    (b) 0.103    (c) 0.056    (d) 0.9032    (e) 0.621

3. Change these to the nearest 64th:

(a) 0.309    (b) 0.162    (c) 0.768    (d) 0.980    (e) 0.092

4. As a mechanic you are to work from the drawing in Fig. 42, but all you have is a steel rule graduated in 64ths. Convert all dimensions to fractions accurate to the nearest 64th.

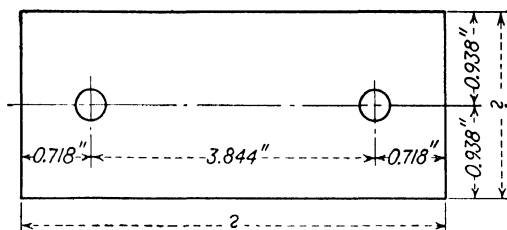

Fig. 42.

5. Find the over-all dimensions in Fig. 42 (a) in decimals; (b) in fractions.

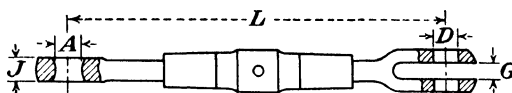

Fig. 43.—Airplane turnbuckle.

6. Here is a table from an airplane supply catalogue giving the dimensions of aircraft turnbuckles. Notice how the letters *L*, *A*, *D*, *J*, and *G* tell exactly what dimension is referred to. Convert all decimals to ruler fractions accurate to the nearest 64th.

AN NUMBER Type 130	STRENGTH POUNDS	L	A	D	J	G
AN130-8S	800	4½"	.188"	.188"	.125"	.109"
AN130-16S	1600	4½"	.219"	.188"	.188"	.150"
AN130-21S	2100	4½"	.219"	.188"	.188"	.150"
AN130-32S	3200	4½"	.281"	.250"	.219"	.203"
AN130-46S	4600	4½"	.313"	.313"	.281"	.203"

7. A line 5 in. long is to be sheared into 3 equal parts. What is the length of each part to the nearest 64th of an inch?

### Job 7: Tolerance and Limits

A group of apprentice mechanics were given the job of cutting a round rod  $2\frac{1}{2}$  in. long. They had all worked from the drawing shown in Fig. 44. The inspector who checked their work found these measurements:

- (a)  $2\frac{31}{64}$       (b)  $2\frac{33}{64}$       (c)  $2\frac{5}{8}$       (d)  $2\frac{17}{32}$       (e)  $2\frac{1}{2}$

Should all pieces except *e* be thrown away?

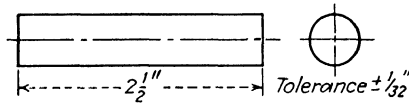

Fig. 44.—Round rod.

Since it is impossible ever to get the exact size that a blueprint calls for, the mechanic should be given a certain permissible leeway. This leeway is called the *tolerance*.

#### Definitions:

*Basic dimension* is the exact size called for in a blueprint or working drawing. For example,  $2\frac{1}{2}$  in. is the basic dimension in Fig. 44.

*Tolerance* is the permissible variation from the basic dimension.

Tolerances are always marked on blueprints. A tolerance of  $\pm \frac{1}{16}$  means that the finished product will be acceptable even if it is as much as  $\frac{1}{16}$  in. greater or  $\frac{1}{16}$  in. less than the basic dimension. A tolerance of  $\pm 0.001$  means that permissible variations of more and less than the basic size are acceptable providing they fall within 0.001 of the basic dimension. A tolerance of  $\begin{matrix} +0.003 \\ -0.001 \end{matrix}$  means that the finished part will be acceptable even if it is as much as 0.003 greater

than the basic dimension; however, it may only be 0.001 less.

Questions:

1. What does a tolerance of  $\pm \frac{1}{8}$  mean?
2. What do these tolerances mean?

- |                 |                 |              |
|-----------------|-----------------|--------------|
| (a) $\pm 0.002$ | (b) $\pm 0.015$ | (c) $+0.005$ |
| (d) $+0.0005$   | (e) $+0.002$    | $-0.001$     |
| $-0.0010$       | $-0.000$        |              |

3. What is meant by a basic dimension of 3.450 in.?

In checking the round rods referred to in Fig. 44, the inspector can determine the dimensions of acceptable pieces of work by adding the plus tolerance to the basic dimension and by subtracting the minus tolerance from the basic dimension. This would give him an upper limit and a lower limit as shown in Fig. 44a. Therefore, pieces measuring less than  $2\frac{1}{2}$  in. are not acceptable; neither are pieces measur-

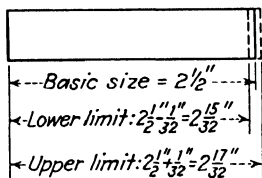

Fig. 44a.

ing more than  $2\frac{1}{2}$  in. As a result pieces *a*, *b*, *d*, and *e* are passed, and *c* is rejected.

There is another way of settling the inspector's problem. All pieces varying from the basic dimension by more than  $\frac{1}{32}$  in. will be rejected. Using this standard we find that pieces *a* and *b* vary by only  $\frac{1}{8}$ ; piece *c* varies by  $\frac{1}{8}$ ; piece *d* varies by  $\frac{1}{32}$ ; piece *e* varies not at all. All pieces except *c* are therefore acceptable. The inspector knew that the tolerance was  $\pm \frac{1}{32}$  in. because it was printed on the drawing.

**Examples:**

1. The basic dimension of a piece of work is 3 in. and the tolerance is  $\pm \frac{1}{16}$  in. Which of these pieces are not acceptable?

- (a)  $3\frac{1}{16}$       (b)  $2\frac{6}{16}$       (c)  $2\frac{7}{8}$       (d)  $3\frac{1}{4}$       (e)  $3\frac{1}{2}$

2. A blueprint gives a basic dimension of  $2\frac{5}{8}$  in. and tolerance of  $\pm \frac{1}{32}$  in. Which of these pieces should be rejected?

- (a)  $2\frac{37}{64}$       (b)  $2\frac{11}{64}$       (c)  $2\frac{9}{32}$       (d) 2.718      (e) 2.645

3. What are the upper and lower limits of a job whose basic dimension is 4 in., if the tolerance is  $\pm 0.003$  in.?

4. What are the limits of a job where the tolerance is  $+0.005$   $-0.001$ , if the basic dimension is 2.375?

5. What are the limits on the length and width of the job in Fig. 44b?

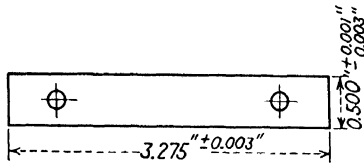

Fig. 44b.

**Job 8: Review Test**

1. Express answers to the nearest hundredth:

- (a)  $3.1416 \times 2.5 \times 2.5$       (b)  $4.75 \div 0.7854$   
 (c)  $4.7625 + 0.325 + 42 - 20.635 - 0.0072$

2. Convert these gages to fractions, accurate to the nearest 64th:

U. S. Standard gage (stainless steel sheets)			Browne and Sharpe gage (aluminum, copper wire, etc.)		
Gage No.	Decimal	Fraction	Gage No.	Decimal	Fraction
1	0.281		1	0.289	
2	0.266		2	0.258	
3	0.250		3	0.229	
4	0.234		4	0.204	
5	0.219		5	0.182	
6	0.203		6	0.162	
7	0.188		7	0.144	
8	0.172		8	0.128	
9	0.156		9	0.114	
10	0.141		10	0.102	

3. Often the relation between the parts of a fastening is given in terms of one item. For example, in the rivet in

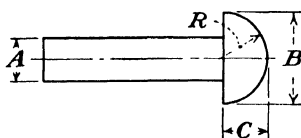

Fig. 45.

Fig. 45, all parts depend on the diameter of the shank, as follows:

$$R = 0.885 \times A$$

$$C = 0.75 \times A$$

$$B = 1.75 \times A$$

Complete the following table:

<i>A</i>	<i>B</i>	<i>C</i>	<i>R</i>
0.125			
0.375			
0.229			
0.016			

4. A 20-ft. length of tubing is to be cut into  $7\frac{1}{2}$ -in. lengths. Allowing  $\frac{1}{8}$  in. for each cut, how many pieces of tubing would result? What would be the length of the last piece?

5. Measure each of the lines in Fig. 45a to the nearest 64th. Divide each line into the number of equal parts indicated. What is the length of each part as a ruler fraction?

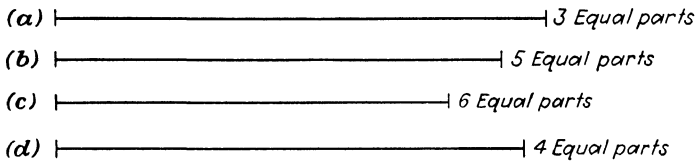

Fig. 45a.

## Chapter III

### MEASURING LENGTH

The work in the preceding chapter dealt with measuring lengths with the steel rule or the micrometer. The answers to the Examples have been given as fractions or as decimal parts of an *inch* or *inches*. However, there are many other units of length.

#### Job 1: Units of Length

Would it be reasonable to measure the distance from New York to Chicago in inches? in feet? in yards? What unit is generally used? If we had only one unit of length, could it be used very conveniently for all kinds of jobs?

In his work, a mechanic will frequently meet measurements in various units of length. Memorize Table 1.

12 inches (in. or ")	=	1 foot (ft. or ')
3 feet	=	1 yard (yd.)
5,280 feet	=	1 mile (mi.)
1 meter	=	39 inches (approx.)

#### Examples:

1. How many inches are there in 5 ft.? in 1 yd.? in  $3\frac{1}{2}$  ft.?
2. How many feet are there in  $3\frac{1}{3}$  yd.? in 48 in.? in  $3\frac{1}{5}$  miles?
3. How many yards are there in 1 mile?
4. How many inches are there in  $\frac{3}{16}$  mile?
5. Round rod of a certain diameter can be purchased at \$.38 per foot of length. What is the cost of 150 in. of this rod?

6. Change 6 in. to feet.

*Hint:* Divide 6 by 12 and express the answer as a fraction in simplest terms.

7. Change 3 in. to feet. Express the answer as a decimal.

8. Change these dimensions to feet. Express the answers as fractions.

- (a) 1 in.      (b) 2 in.      (c) 4 in.      (d) 5 in.

9. Change these dimensions to decimal parts of a foot, accurate to the nearest tenth.

- (a) 6 in.      (b) 7 in.      (c) 8 in.      (d) 9 in.  
 (e) 10 in.    (f) 11 in.    (g) 12 in.    (h) 13 in.

10. Change the dimensions in Fig. 46 to feet, expressing the answers as decimals accurate to the nearest tenth of a foot.

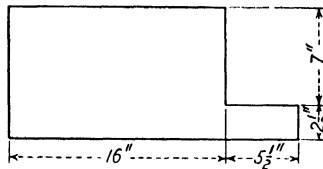

Fig. 46.

11. What are the span and length of the Fairchild F-45 (Fig. 47) in inches?

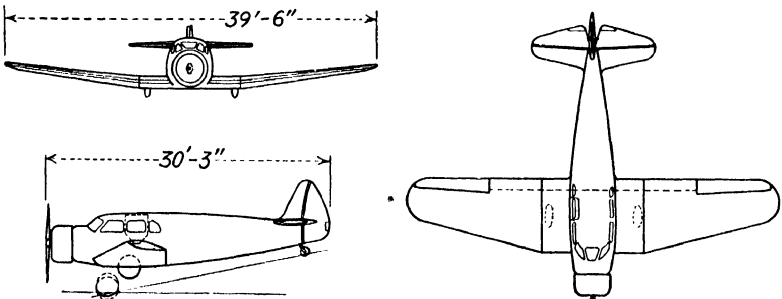

Fig. 47.—Fairchild F-45. (Courtesy of Aviation.)

Job 2: Perimeter

Perimeter simply means the distance around as shown

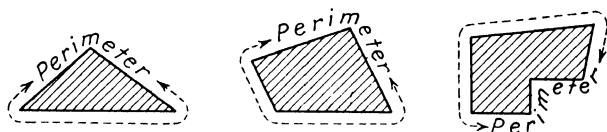

Fig. 48.

in Fig. 48. To find the perimeter of a figure of any number of sides, add the length of all the sides.

ILLUSTRATIVE EXAMPLE

Find the perimeter of the triangle in Fig. 49.

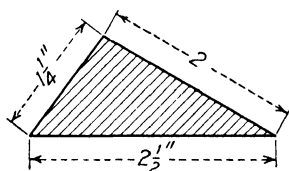

Fig. 49.

$$\text{Perimeter} = 2 + 1\frac{1}{4} + 2\frac{1}{2} \text{ in.}$$

$$\text{Perimeter} = 5\frac{3}{4} \text{ in. } \textit{Ans.}$$

Examples:

1. Find the perimeter of a triangle whose sides are  $3\frac{5}{8}$  in.,  $6\frac{7}{8}$  in.,  $2\frac{3}{4}$  in.

2. Find the perimeter of each of the figures in Fig. 50. All dimensions are in inches.

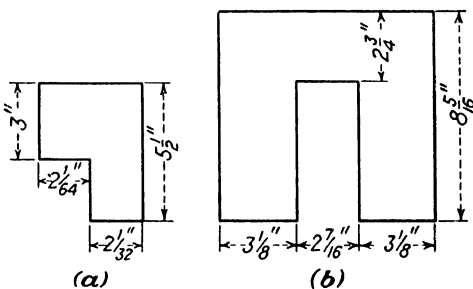

Fig. 50.

3. Find the perimeter of the figure in Fig. 51. Measure accurately to the nearest 32nd.

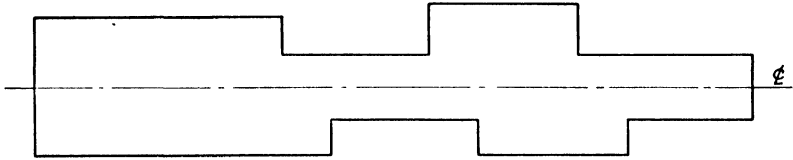

Fig. 51.

4. A regular hexagon (six-sided figure in which all sides are of equal length) measures  $8\frac{1}{4}$  in. on a side. What is its perimeter in inches? in feet?

### Job 3: Nonruler Fractions

It should be noticed that heretofore we have added fractions whose denominators were always 2, 4, 6, 8, 16, 32, or 64. These are the denominators of the mechanic's most useful fractions. Since they are found on the ruler, these fractions have been called *ruler fractions*. There are, however, many occasions where it is useful to be able to add or subtract nonruler fractions, fractions that are not found on the ruler.

#### ILLUSTRATIVE EXAMPLE

Find the perimeter of the triangle in Fig. 52.

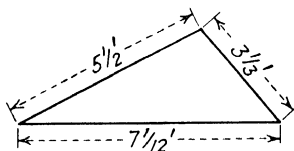

Fig. 52.

$$\text{Perimeter} = 5\frac{1}{2} + 3\frac{1}{3} + 7\frac{1}{2}$$

$$5\frac{1}{2} = 5\frac{6}{12}$$

$$3\frac{1}{3} = 3\frac{4}{12}$$

$$7\frac{1}{2} = 7\frac{6}{12}$$

$$\text{Sum} = 15\frac{16}{12} \text{ ft. } \textit{Ans.}$$

Notice that the method used in the addition or subtraction of these fractions is identical to the method already learned for the addition of ruler fractions. It is sometimes harder, however, to find the denominator of the equivalent fractions. This denominator is called the *least common denominator*.

**Definition:**

The *least common denominator* (L.C.D.) of a group of fractions is the smallest number that can be divided exactly by each of the denominators of *all* the fractions.

For instance, 10 is the L.C.D. of fractions  $\frac{1}{2}$  and  $\frac{1}{5}$  because 10 can be divided exactly both by 2 and by 5. Similarly 15 is the L.C.D. of  $\frac{2}{3}$  and  $\frac{1}{5}$ . Why?

There are various methods of finding the L.C.D. The easiest one is by inspection or trial and error. What is the L.C.D. of  $\frac{1}{2}$  and  $\frac{1}{3}$ ? Since 6 can be divided exactly by both 2 and 3, 6 is the L.C.D.

**Examples:**

1. Find the L.C.D. (a) Of  $\frac{1}{2}$  and  $\frac{1}{3}$   
 (b) Of  $\frac{1}{2}, \frac{1}{3}, \frac{5}{6}$   
 (c) Of  $\frac{1}{4}, \frac{1}{8}, \frac{3}{16}$   
 (d) Of  $\frac{2}{5}, \frac{3}{10}$

2. Add these fractions:

- (a)  $\frac{1}{2}, \frac{1}{3}, \frac{1}{4}$       (b)  $\frac{1}{2}, \frac{1}{5}, \frac{1}{10}$       (c)  $\frac{1}{3}, \frac{1}{4}, \frac{1}{6}$

3. Solve the following:

- (a)  $\frac{2}{3} - \frac{1}{4}$       (b)  $\frac{5}{6} + \frac{2}{3} - \frac{1}{12}$

4. Find the sum of  $4\frac{1}{4}$  ft.,  $5\frac{1}{12}$  ft.,  $1\frac{1}{8}$  ft.

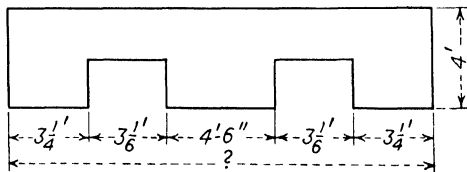

Fig. 53.

5. Find the total length in feet of the form in Fig. 53.
6. Find the total length in feet of 3 boards which are  $5\frac{7}{12}$  ft.,  $8\frac{3}{4}$  ft., and  $12\frac{5}{8}$  ft. long.
7. Find the perimeter of the figure in Fig. 54.

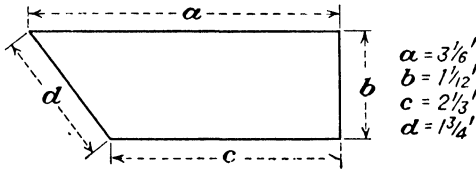

Fig. 54.

8. Find the perimeter of the plate in Fig. 55. Express the answer in feet accurate to the nearest hundredth of a foot.

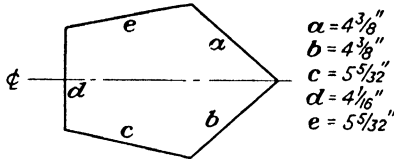

Fig. 55.

9. The perimeter of a triangle is  $12\frac{5}{12}$  ft. If the first side is  $4\frac{1}{3}$  ft. and the second side is  $2\frac{5}{8}$  ft., what is the length of the third side?

10. Find the total length in feet of a fence needed to enclose the plot of ground shown in Fig. 56.

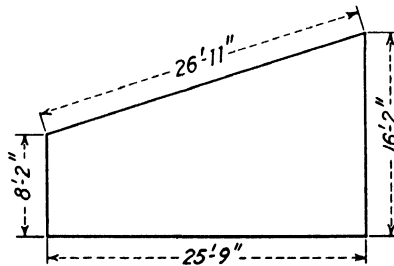

Fig. 56.

### Job 4: The Circumference of a Circle

Circumference is a special word which means the distance around or the perimeter of a circle. There is absolutely no reason why the word perimeter could not be used, but it never is.

#### A Few Facts about the Circle

1. Any line from the center to the circumference is called a *radius*.

2. Any line drawn through the center and meeting the circumference at each end is called a *diameter*.

3. The diameter is twice as long as the radius.

4. All radii of the same circle are equal; all diameters of the same circle are equal.

Finding the circumference of a circle is a little harder than finding the distance around figures with straight sides. The following formula is used:

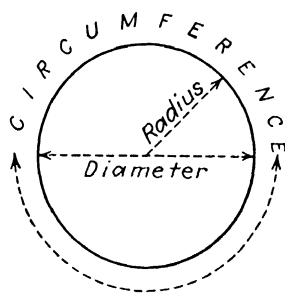

Fig. 57.—Circle.

$$\text{Formula: } C = 3.14 \times D$$

where  $C$  = circumference.

$D$  = diameter.

The "key number" 3.14 is used in finding the circumference of circles. No matter what the diameter of the circle is, to find its circumference, multiply the diameter by the "key number," 3.14. This is only an approximation of the exact number 3.1415926 + which has a special name,  $\pi$  (pronounced *pie*). Instead of writing the long number 3.1415926 +, it is easier to write  $\pi$ . The circumference of a circle can therefore be written

$$C = \pi \times D$$

If a greater degree of accuracy is required, 3.1416 can be used instead of 3.14 in the formula. The mechanic should practically never have any need to go beyond this.

**ILLUSTRATIVE EXAMPLE**

Find the circumference of a circle whose diameter is 3.5 in.

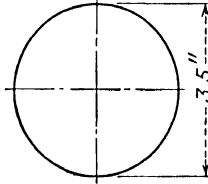

**Fig. 58.**

Given:  $D = 3.5$  in.

Find: Circumference

$$C = 3.14 \times D$$

$$C = 3.14 \times 3.5$$

$$C = 10.99 \text{ in. } \textit{Ans.}$$

**Examples:**

1. Find the circumference of a circle whose diameter is 4 in.
2. What is the distance around a pipe whose outside diameter is 2 in.?
3. A circular tank has a diameter of 5 ft. What is its circumference?
4. Measure the diameter of the circles in Fig. 59 to the nearest 32nd, and find the circumference of each.

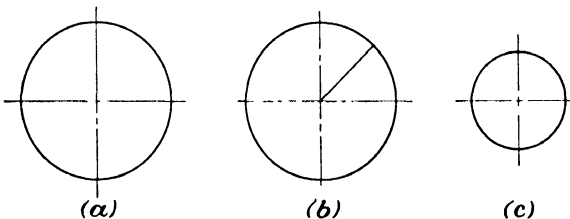

**Fig. 59.**

5. Estimate the circumference of the circle in Fig. 60a. Calculate the exact length after measuring the diameter. How close was your estimate?

6. Find the circumference of a circle whose radius is 3 in. *Hint:* First find the diameter.

7. What is the total length in feet of 3 steel bands which must be butt-welded around the barrel, as shown in Fig. 60b?

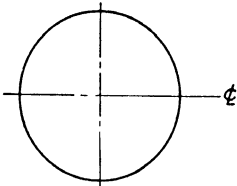

Fig. 60a.

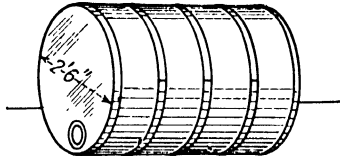

Fig. 60b.

8. What is the circumference in feet of a steel plate whose radius is  $15\frac{1}{2}$  in.?

9. What is the circumference of a round disk whose diameter is 1.5000 in.? Use  $\pi = 3.1416$  and express the answer to the nearest thousandth.

### Job 5: Review Test

1. The Monocoupe shown in Fig. 61 has a length of 246.5 in. What is its length in feet?

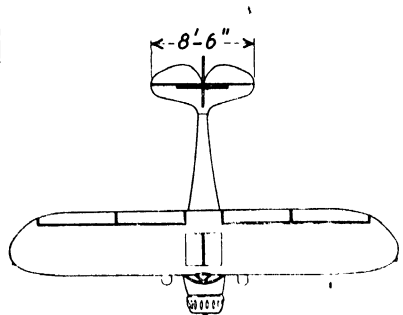
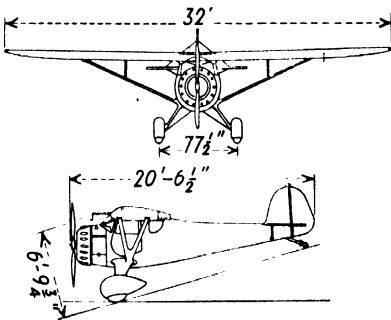

Fig. 61.—Monocoupe high-wing monoplane. (Courtesy of Aviation.)

2. Complete this table:

Airplane	Span	Length	Span	Length
Aeronca	36 ft.	20 ft. 8 in.	in.	in.
Dart	29 ft. $6\frac{7}{8}$ in.	18 ft. 7 in.	in.	in.
Luscombe	ft. in.	ft. in.	372 in.	252 in.
Beech	ft. in.	ft. in.	572 in.	407 in.

3. Find the missing dimensions in Fig. 62.

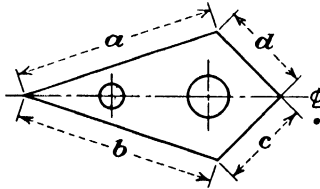

Fig. 62.

$$\text{Perimeter} = 18\frac{3}{16} \text{ in.}$$

$$a = b = 4\frac{1\frac{3}{8}}{2} \text{ in.}$$

$$c = d = ?$$

4. Find the inner and outer circumferences of the circular

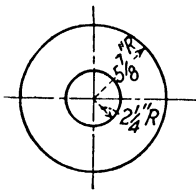

Fig. 63.

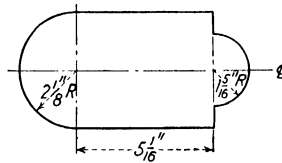

Fig. 64.

disk shown in Fig. 63. Express the answers in decimals accurate to the nearest thousandth.

5. Find the perimeter of the flat plate shown in Fig. 64.

## Chapter IV

### THE AREA OF SIMPLE FIGURES

The length of any object can be measured with a rule. It is impossible, however, to measure area so directly and simply as that. In the following pages, you will meet geometrical shapes like those in Fig. 65.

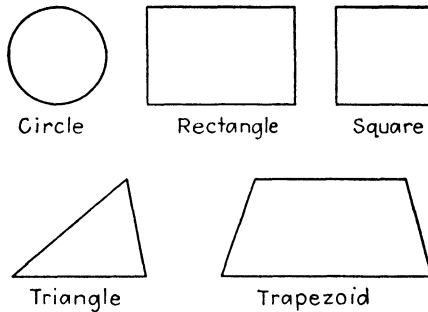

Fig. 65.

Each of these shapes will require a separate formula and some arithmetic before its area can be found. You should know these formulas as well as you know how to use a rule. A mechanic should also know that these are the cross-sectional shapes of most common objects, such as nails, beams, rivets, sheet metal, etc.

#### Job 1: *Units of Area*

Would you measure the area of a small piece of metal in square miles? Would you measure the area of a field in square inches? The unit used in measuring area depends on the kind of work being done. Memorize this table:

TABLE 2.—AREA

144 square inches = 1 square foot (sq. ft.)

9 square feet = 1 square yard (sq. yd.)

640 acres = 1 square mile (sq. mi.)

4,840 square yards = 1 acre

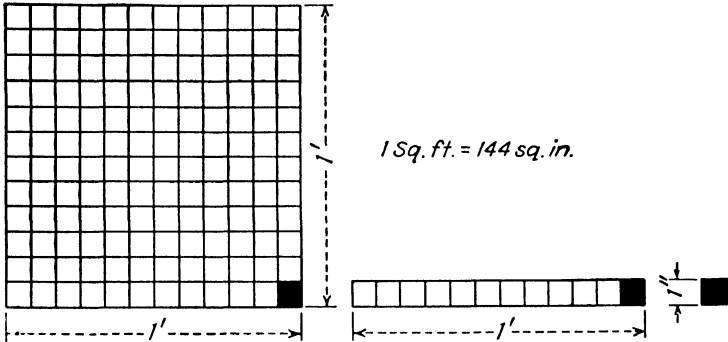

Fig. 66.

**Examples:**

1. How many square inches are there in 3 sq. ft.? 1 sq. yd.?  $\frac{1}{2}$  sq. ft.?  $2\frac{1}{4}$  sq. yd.?

2. How many square feet are there in 4 sq. yd.? 1 sq. mile? 1 acre?

3. How many square yards are there in 5 square miles? 1,000 sq. ft.? 60 acres?

4. If land is bought at \$45.00 an acre, what is the price per square mile?

5. What decimal part of a square foot is 72 sq. in.? 36 sq. in.? 54 sq. in.?

**Job 2: The Rectangle**

**A. Area.** The rectangle is the cross-sectional shape of many beams, fittings, and other common objects.

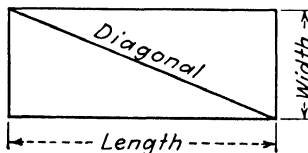

Fig. 66a.—Rectangle.

## A Few Facts about the Rectangle

1. Opposite sides are equal to each other.
2. All four angles are right angles.
3. The sum of the angles is  $360^\circ$ .
4. The line joining opposite corners is called a *diagonal*.

$$\text{Formula: } A = L \times W$$

where  $A$  = area of a rectangle.

$L$  = length.

$W$  = width.

### ILLUSTRATIVE EXAMPLE

Find the area of a rectangle whose length is 14 in. and whose width is 3 in.

Given:  $L = 14$  in.

$W = 3$  in.

Find: Area

$$A = L \times W$$

$$A = 14 \times 3$$

$$A = 42 \text{ sq. in. } \textit{Ans.}$$

### Examples:

Find the area of these rectangles:

1.  $L = 45$  in.,  $W = 16.5$  in.

2.  $L = 25$  in.,  $W = 5\frac{1}{8}$  in.

3.  $W = 3.75$  in.,  $L = 4.25$  in.

4.  $L = 3\frac{3}{4}$  ft.,  $W = 2\frac{1}{2}$  ft.

5.  $L = 15$  in.,  $W = 3\frac{1}{2}$  in.

6.  $L = 4\frac{7}{8}$  ft.,  $W = 3\frac{1}{5}$  ft.

7. By using a rule, find the length and width (to the

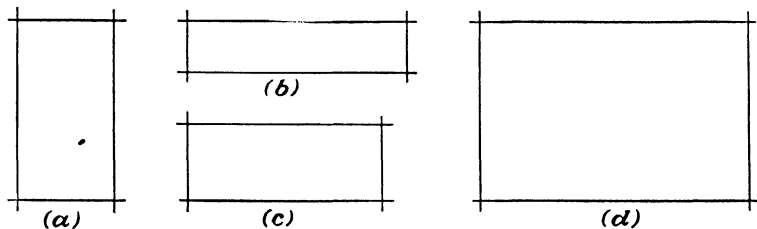

Fig. 67.

nearest 16th) of the rectangles in Fig. 67. Then calculate the area of each.

8. Find the area in square feet of the airplane wing shown in Fig. 68.

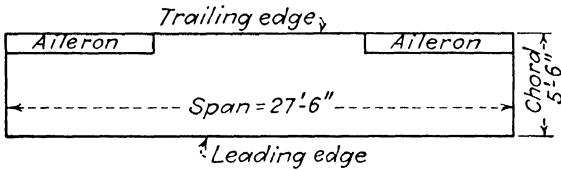

Fig. 68.—Airplane wing, top view.

9. Calculate the area and perimeter of the plate shown in Fig. 69.

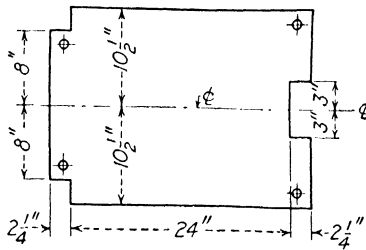

Fig. 69.

**B. Length and Width.** To find the length or the width, use one of the following formulas:

$$\text{Formulas: } L = \frac{A}{W}$$

$$W = \frac{A}{L}$$

where  $L$  = length.

$A$  = area.

$W$  = width.

#### ILLUSTRATIVE EXAMPLE

The area of a rectangular piece of sheet metal is 20 sq. ft.; its width is  $2\frac{1}{2}$  ft. What is its length?

Given:  $A = 20$  sq. ft.

$W = 2\frac{1}{2}$  ft.

Find: Length

$$L = \frac{A}{W}$$

$$L = \frac{20}{2\frac{1}{2}} = 20 \div 2\frac{1}{2}$$

$$L = 20 \times \frac{2}{5} = 8 \text{ ft. } \textit{Ans.}$$

Check:  $A = L \times W = 8 \times 2\frac{1}{2} = 20 \text{ sq. ft.}$

Examples:

1. The area of a rectangular floor is 75 sq. ft. What is the length of the floor if its width is 7 ft. 6 in.?

2-5. Complete this table by finding the missing dimension of these rectangles:

	Area	Length	Width
2	45 sq. in.	in.	$3\frac{3}{8}$ in.
3	$72\frac{5}{8}$ sq. ft.	4 ft. 6 in.	ft.
4	$34\frac{1}{4}$ sq. ft.	36 in.	ft.
5	sq. ft.	15 ft. 9 in.	7 ft. 3 in.

6. What must be the width of a rectangular beam whose cross-sectional area is 16.375 sq. in., and whose length is  $5\frac{3}{16}$  in. as shown in Fig. 70?

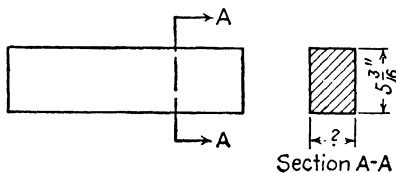

Fig. 70.

7. The length (span) of a rectangular wing is 17 ft. 6 in.; its area, including ailerons, is 50 sq. ft. What is the width (chord) of the wing?

**Job 3: Mathematical Shorthand: Squaring a Number**

A long time ago you learned some mathematical shorthand, for instance, + (read "plus") is shorthand for *add*; - (read "minus") is shorthand for *subtract*. Another important shorthand symbol in mathematics is the small number two (<sup>2</sup>) written near the top of a number: 5<sup>2</sup> (read "5 squared") means  $5 \times 5$ ; 7<sup>2</sup> (read "7 squared") means  $7 \times 7$ .

You will find this shorthand very valuable in working with the areas of circles, squares, and other geometrical figures.

**ILLUSTRATIVE EXAMPLES**

What is 7 squared?

$$7 \text{ squared} = 7^2 = 7 \times 7 = 49 \quad \text{Ans.}$$

What is (a) 9<sup>2</sup>? (b) (3.5)<sup>2</sup>? (c) ( $\frac{3}{2}$ )<sup>2</sup>?

$$(a) 9^2 = 9 \times 9 = 81 \quad \text{Ans.}$$

$$(b) (3.5)^2 = 3.5 \times 3.5 = 12.25 \quad \text{Ans.}$$

$$(c) (\frac{3}{2})^2 = \frac{3}{2} \times \frac{3}{2} = \frac{9}{4} = 2\frac{1}{4} \quad \text{Ans.}$$

**Examples:**

Calculate:

1.  $5^2$

2.  $3^2$

3.  $(2.5)^2$

4.  $1^2$

5.  $(9.5)^2$

6.  $(0.23)^2$

7.  $(2.8)^2$

8.  $(4.09)^2$

Reduce answers to lowest terms whenever necessary:

9.  $(\frac{4}{5})^2$

10.  $(\frac{7}{8})^2$

11.  $(\frac{3}{4})^2$

12.  $(\frac{4}{16})^2$

13.  $(\frac{7}{3})^2$

14.  $(\frac{8}{3})^2$

15.  $(\frac{15}{8})^2$

16.  $(\frac{17}{2})^2$

Calculate:

17.  $(2\frac{1}{2})^2$

18.  $(3\frac{1}{8})^2$

19.  $(4\frac{3}{16})^2$

20.  $(1\frac{1}{64})^2$

21.  $(9\frac{5}{8})^2$

22.  $(12\frac{5}{32})^2$

Complete:

23.  $3 \times (5^2) =$

24.  $4 \times (7^2) =$

25.  $0.78 \times (6^2) =$

26.  $4.2 \times (6^2) =$

27.  $3.1 \times (2^2) =$

28.  $3.14 \times (7^2) =$

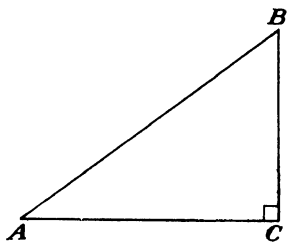

Fig. 71.

29. Measure to the nearest 64th the lines in Fig. 71. Then complete this table:

$AC =$	$\overline{AC}^2 =$
$BC =$	$\overline{BC}^2 =$
$AB =$	$\overline{AB}^2 =$

Is this true:  $\overline{AC}^2 + \overline{BC}^2 = \overline{AB}^2$ ?

30. Measure, to the nearest 64th, the lines in Fig. 72.

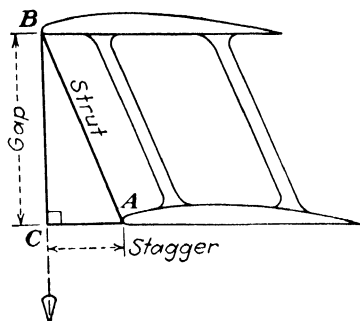

Fig. 72.

Then complete this table:

$AC =$	$\overline{AC}^2 =$
$BC =$	$\overline{BC}^2 =$
$AB =$	$\overline{AB}^2 =$

Is this true:  $\overline{AC}^2 + \overline{BC}^2 = \overline{AB}^2$ ?

Is this true:  $\text{stagger}^2 + \text{gap}^2 = \text{strut}^2$ ?

## Job 4: Introduction to Square Root

The following squares were learned from the last job.

TABLE 3

$1^2 = 1$	$6^2 = 36$
$2^2 = 4$	$7^2 = 49$
$3^2 = 9$	$8^2 = 64$
$4^2 = 16$	$9^2 = 81$
$5^2 = 25$	$10^2 = 100$

Find the answer to this question in Table 3:

What number when multiplied by itself equals 49?

The answer is 7, which is said to be the square root of 49, written  $\sqrt{49}$ . The mathematical shorthand in this case is  $\sqrt{\quad}$  (read "the square root of"). The entire question can be written

What is  $\sqrt{49}$ ? The answer is 7.

Check:  $7 \times 7 = 49$ .

## Examples:

1. What is the number which when multiplied by itself equals 64? This answer is 8. Why?

2. What number multiplied by itself equals 25?

3. What is the square root of 100?

4. What is  $\sqrt{36}$ ?

5. Find

- |                  |                 |                  |                  |
|------------------|-----------------|------------------|------------------|
| (a) $\sqrt{9}$   | (b) $\sqrt{81}$ | (c) $\sqrt{16}$  | (d) $\sqrt{49}$  |
| (e) $\sqrt{400}$ | (f) $\sqrt{1}$  | (g) $\sqrt{144}$ | (h) $\sqrt{121}$ |

6. How can the answers to the above questions be checked?

7. Between what two numbers does  $\sqrt{17}$  lie?

8. Between what two numbers is  $\sqrt{27}$ ?

9. Between what two numbers are

- |                 |                 |                 |                 |
|-----------------|-----------------|-----------------|-----------------|
| (a) $\sqrt{39}$ | (b) $\sqrt{82}$ | (c) $\sqrt{43}$ | (d) $\sqrt{12}$ |
| (e) $\sqrt{34}$ | (f) $\sqrt{75}$ | (g) $\sqrt{92}$ | (h) $\sqrt{21}$ |

10. From Table 1 what is the nearest perfect square less than 75?

**Job 5: The Square Root of a Whole Number**

So far the square roots of a few simple numbers have been found. There is, however, a definite method of finding the square root of any whole number.

**ILLUSTRATIVE EXAMPLE**

What is the square root of 1,156?

$$\begin{array}{r}
 34 \text{ Ans.} \\
 \sqrt{11\ 56} \\
 \underline{9} \\
 64) \ 2\ 56 \\
 \underline{2\ 56} \\
 0
 \end{array}$$

Check:  $34 \times 34 = 1,156$

*Method:*

<p>a. Separate the number into pairs starting from the right:</p>	$\sqrt{11\ 56}$
<p>b. <math>\sqrt{11}</math> lies between 3 and 4. Write the smaller number 3, above the 11:</p>	$\begin{array}{r} 3 \\ \sqrt{11\ 56} \end{array}$
<p>c. Write <math>3^2</math> or 9 below the 11:</p>	$\begin{array}{r} 3 \\ \sqrt{11\ 56} \\ \underline{9} \end{array}$
<p>d. Subtract and bring down the next pair, 56:</p>	$\begin{array}{r} 3 \\ \sqrt{11\ 56} \\ \underline{9} \\ 2\ 56 \end{array}$
<p>e. Double the answer so far obtained (<math>3 \times 2 = 6</math>). Write 6 as shown:</p>	$\begin{array}{r} 3 \\ \sqrt{11\ 56} \\ \underline{9} \\ 6) \ 2\ 56 \end{array}$
<p>f. Using the 6 just obtained as a trial divisor, divide it into the 25. Write the answer, 4, as shown:</p>	$\begin{array}{r} 3 \\ \sqrt{11\ 56} \\ \underline{9} \\ 64) \ 2\ 56 \end{array}$

g. Multiply the 64 by the 4 just obtained and write the product, 256, as shown:

$$\begin{array}{r} 3 \ 4 \ \text{Ans.} \\ \sqrt{11 \ 56} \\ \underline{9} \\ 64) \ 2 \ 56 \\ \underline{2 \ 56} \end{array}$$

h. Since there is no remainder, the square root of 1,156 is exactly 34.

Check:  $34 \times 34 = 1,156$ .

### Examples:

1. Find the exact square root of 2,025.

Find the exact square root of

2. 4,225

3. 1,089

4. 625

5. 5,184

What is the exact answer?

6.  $\sqrt{529}$

7.  $\sqrt{367}$

8.  $\sqrt{8,464}$

9.  $\sqrt{1,849}$

10. Find the approximate square root of 1,240. Check your answer.

*Hint:* Work as explained and ignore the remainder. To check, square your answer and add the remainder.

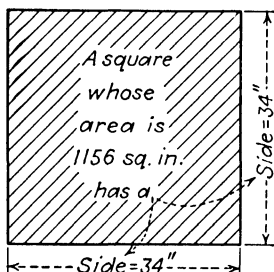

Fig. 73.

Find the approximate square root of

11. 4,372

12. 9,164

13. 3,092

14. 4,708

15. 9,001

16. 1,050

17. 300

18. 8,000

19. Study Fig. 73 carefully. What connection is there between the area of this square and the length of its sides?

### Job 6: The Square Root of Decimals

Finding the square root of a decimal is very much like finding the square root of a whole number. Here are two rules:

**Rule 1.** The grouping of numbers into pairs should always be started from the decimal point. For instance,

- 362.53 is paired as 3 62. 53
- 71.3783 is paired as 71. 37 83
- 893.4 is paired as 8 93. 40
- 15.5 is paired as 15. 50

Notice that a zero is added to complete any incomplete pair on the right-hand side of the decimal point.

**Rule 2.** The decimal point of the answer is directly above the decimal point of the original number.

Two examples are given below. Study them carefully.

ILLUSTRATIVE EXAMPLES

Find  $\sqrt{83.72}$

$$\begin{array}{r}
 9.1 \quad \text{Ans.} \\
 \sqrt{83.72} \\
 \underline{81} \\
 181) \ 2 \ 72 \\
 \underline{1 \ 81} \\
 91
 \end{array}$$

Check:  $9.1 \times 9.1 = 82.81$

$$\begin{array}{r}
 \text{Remainder} = +.91 \\
 \hline
 83.72
 \end{array}$$

Find the square root of 7.453

$$\begin{array}{r}
 2.73 \quad \text{Ans.} \\
 \sqrt{7.4530} \\
 \underline{4} \\
 47) \ 3 \ 45 \\
 \underline{3 \ 29} \\
 543) \ 16 \ 30 \\
 \underline{16 \ 29} \\
 1
 \end{array}$$

Check:  $2.73 \times 2.73 = 7.4529$

$$\begin{array}{r}
 \text{Remainder} = +.0001 \\
 \hline
 7.4530
 \end{array}$$

## Examples:

1. What is the square root of 34.92? Check your answer.

What is the square root of

2. 15.32

3. 80.39

4. 75.03

5. 342.35

What is

6.  $\sqrt{30.35}$

7.  $\sqrt{41.35}$

8.  $\sqrt{7.26}$

9.  $\sqrt{3.452}$

10.  $\sqrt{191.40}$

11.  $\sqrt{137.1}$

12.  $\sqrt{27.00}$

13.  $\sqrt{3.000}$

Find the square root to the nearest tenth:

14. 462.0000

15. 39.7000

16. 4.830

17. 193.2

18. Find the square root of  $\frac{3}{8}$  to the nearest tenth.

*Hint:* Change  $\frac{3}{8}$  to a decimal and find the square root of the decimal.

Find the square root of these fractions to the nearest hundredth:

19.  $\frac{5}{16}$

20.  $\frac{7}{64}$

21.  $\frac{15}{32}$

22.  $\frac{1}{2}$

23.  $\frac{1}{4}$

24. Find the square root of  $\frac{75.00}{.78}$  to the nearest tenth.

### Job 7: The Square

A. **The Area of a Square.** The square is really a special kind of rectangle where all sides are equal in length.

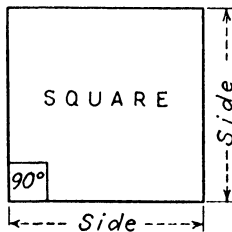

Fig. 74.

A Few Facts about the Square

1. All four sides have the same length.
2. All four angles are right angles.
3. The sum of the angles is  $360^\circ$ .
4. A line joining two opposite corners is called a *diagonal*.

$$\text{Formula: } A = S^2 = S \times S$$

where  $S$  means the side of the square.

ILLUSTRATIVE EXAMPLE

Find the area of a square whose side is  $5\frac{1}{2}$  in.

Given:  $S = 5\frac{1}{2}$  in.

Find: Area

$$A = S^2$$

$$A = (5\frac{1}{2})^2$$

$$A = \frac{11}{2} \times \frac{11}{2}$$

$$A = \frac{121}{4} = 30\frac{1}{4} \text{ sq. in. } \textit{Ans.}$$

Examples:

Find the area of these squares:

1. side =  $2\frac{1}{4}$  in.      2. side =  $5\frac{1}{8}$  ft.      3. side = 3.25 in.

4-6. Measure the length of the sides of the squares shown in Fig. 75 to the nearest 32nd, and find the area of each:

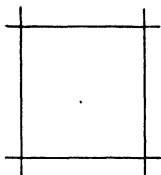

Ex. 4

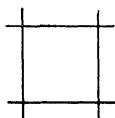

Ex. 5

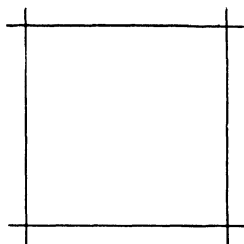

Ex. 6

Fig. 75.

7-8. Find the surface area of the cap-strip gages shown in Fig. 76.

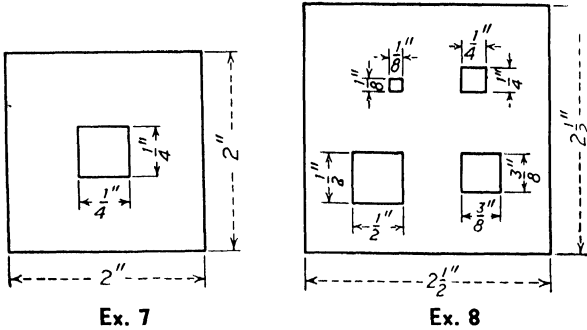

Fig. 76.—Cap-strip gages.

9. A square piece of sheet metal measures 4 ft. 6 in. on a side. Find the surface area in (a) square inches; (b) square feet.

10. A family decides to buy linoleum at \$.55 a square yard. What would it cost to cover a square floor measuring 12 ft. on a side?

**B. The Side of a Square.** To find the side of a square, use the following formula.

$$\text{Formula: } S = \sqrt{A}$$

where  $S$  = side.

$A$  = area of the square.

#### ILLUSTRATIVE EXAMPLE

A mechanic has been told that he needs a square beam whose cross-sectional area is 6.25 sq. in. What are the dimensions of this beam?

Given:  $A = 6.25$  sq. in.

Find: Side

$$S = \sqrt{A}$$

$$S = \sqrt{6.25}$$

$$S = 2.5 \text{ in. } \textit{Ans.}$$

Check:  $A = S^2 = 2.5 \times 2.5 = 6.25$  sq. in.

*Method:*

Find the square root of the area.

**Examples:**

Find to the nearest tenth, the side of a square whose area is

- |                  |                   |
|------------------|-------------------|
| 1. 47.50 sq. in. | 2. 24.80 sq. ft.  |
| 3. 8.750 sq. in. | 4. 34.750 sq. yd. |

**5-8.** Complete the following table by finding the sides in both feet and inches of the squares whose areas are given:

	Area	Side	Side
5	45.0 sq. ft.	ft.	in.
6	20.5 sq. in.	in.	ft.
7	576.0 sq. in.	in.	ft.
8	3 $\frac{1}{2}$ sq. yd.	ft.	in.

### Job 8: The Circle

**A. The Area of a Circle.** The circle is the cross-sectional shape of wires, round rods, bolts, rivets, etc.

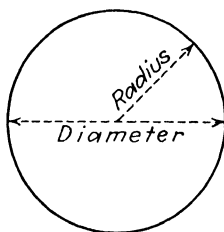

Fig. 77.—Circle.

$$\text{Formula: } A = 0.7854 \times D^2$$

where  $A$  = area of a circle.

$$D^2 = D \times D.$$

$D$  = diameter.

## ILLUSTRATIVE EXAMPLE

Find the area of a circle whose diameter is 3 in.

Given:  $D = 3$  in.

Find:  $A$

$$A = 0.7854 \times D^2$$

$$A = 0.7854 \times 3 \times 3$$

$$A = 0.7854 \times 9$$

$$A = 7.0686 \text{ sq. in. } \textit{Ans.}$$

## Examples:

Find the area of the circle whose diameter is

1. 4 in.

2.  $\frac{1}{2}$  ft.

3. 5 in.

4.  $3\frac{1}{2}$  ft.

5.  $1\frac{1}{2}$  yd.

6.  $2\frac{1}{2}$  mi.

7-11. Measure the diameters of the circles shown in Fig. 78 to the nearest 16th. Calculate the area of each circle.

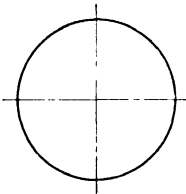

Ex. 7

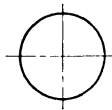

Ex. 8

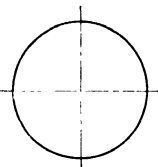

Ex. 9



Ex. 10

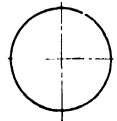

Ex. 11

Fig. 78.

12. What is the area of the top of a piston whose diameter is  $4\frac{7}{8}$  in.?

13. What is the cross-sectional area of a  $\frac{3}{8}$ -in. aluminum rivet?

14. Find the area in square inches of a circle whose radius is 1 ft.

15. A circular plate has a radius of 2 ft. 6 in. Find (a) the area in square feet, (b) the circumference in inches.

**B. Diameter and Radius.** The diameter of a circle can be found if the area is known, by using this formula:

$$\text{Formula: } D = \sqrt{\frac{A}{0.7854}}$$

where  $D$  = diameter.

$A$  = area.

ILLUSTRATIVE EXAMPLE

Find the diameter of a round bar whose cross-sectional area is 3.750 sq. in.

Given:  $A = 3.750$  sq. in.

Find: Diameter

$$D = \sqrt{\frac{A}{0.7854}}$$

$$D = \sqrt{\frac{3.750}{0.7854}}$$

$$D = \sqrt{4.7746}$$

$$D = 2.18 + .1ns.$$

Check:  $A = 0.7854 \times D^2 = 0.7854 \times 2.18 \times 2.18 = 3.73 +$   
sq. in.

Why doesn't the answer check perfectly?

Method:

a. Divide the area by 0.7854.

b. Find the square root of the result.

Examples:

1. Find the diameter of a circle whose area is 78.54 ft.
2. What is the radius of a circle whose area is 45.00 sq. ft.?
3. The area of a piston is 4.625 sq. in. What is its diameter?
4. A copper wire has a cross-sectional area of 0.263 sq. in. (a) What is the diameter of the wire?  
(b) What is its radius?
5. A steel rivet has a cross-sectional area of 1.025 sq. in. What is its diameter (see Fig. 79)?

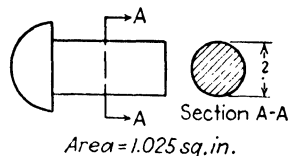

Fig. 79.

6-9. Complete this table:

	Radius	Diameter	Area
6	in.	ft.	100.00 sq. ft.
7	in.	in.	35.055 sq. in.
8	3 ft. 6 in.	ft.	sq. ft.
9	5 ft. 3 in.	in.	sq. in.

10. Find the area of one side of the washers shown in Fig. 80.

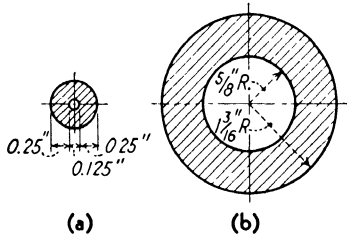

Fig. 80.

### Job 9: The Triangle

So far we have studied the rectangle, the square, and the circle. The triangle is another simple geometric figure often met on the job.

#### A Few Facts about the Triangle

1. A triangle has only three sides.
2. The sum of the angles of a triangle is  $180^\circ$ .

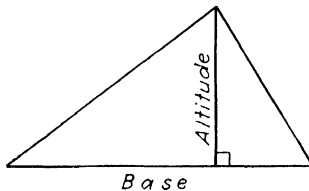

Fig. 81.—Triangle.

3. A triangle having one right angle is called a *right triangle*.

4. A triangle having all sides of the same length is called an *equilateral triangle*.

5. A triangle having two equal sides is called an *isosceles triangle*.

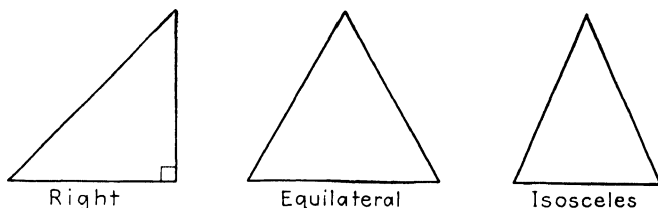

Fig. 81a.—Types of triangles.

The area of any triangle can be found by using this formula:

$$\text{Formula: } A = \frac{1}{2} \times b \times a$$

where  $b$  = the base.

$a$  = the altitude.

#### ILLUSTRATIVE EXAMPLE

Find the area of a triangle whose base is 7 in. long and whose altitude is 3 in.

Given:  $b = 7$

$a = 3$

Find: Area

$$A = \frac{1}{2} \times b \times a$$

$$A = \frac{1}{2} \times 7 \times 3$$

$$A = \frac{21}{2} = 10\frac{1}{2} \text{ sq. in. } \textit{Ans.}$$

Examples:

1. Find the area of a triangle whose base is 8 in. and whose altitude is 5 in.

2. A triangular piece of sheet metal has a base of 16 in. and a height of  $5\frac{1}{2}$  in. What is its area?

3. What is the area of a triangle whose base is  $3\frac{1}{2}$  ft. and whose altitude is 2 ft. 3 in.?

4-6. Find the area of the following triangles:

	Base	Altitude	Area
4	27 in.	$8\frac{1}{2}$ in.	sq. in.
5	$3\frac{1}{3}$ ft.	$1\frac{1}{6}$ ft.	sq. ft.
6	5 ft. 3 in.	2 ft. 6 in.	sq. in.

7-9. Measure the base and the altitude of each triangle in Fig. 82 to the nearest 64th. Calculate the area of each.

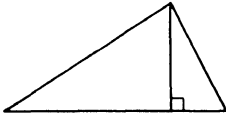

Ex. 7

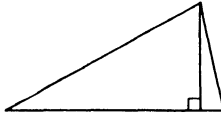

Ex. 8

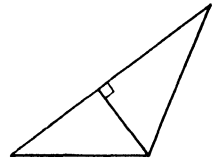

Ex. 9

Fig. 82.

10. Measure to the nearest 64th and calculate the area of the triangle in Fig. 83 in the three different ways shown

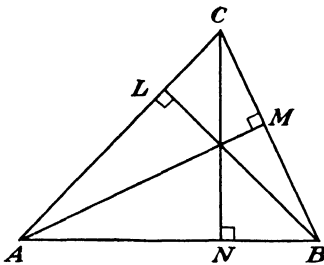

Fig. 83.

Base	Altitude	Area
<i>AB</i>	<i>CN</i>	
<i>BC</i>	<i>AM</i>	
<i>AC</i>	<i>BL</i>	

in the table. Does it make any difference which side is called the base?

### Job 10: The Trapezoid

The trapezoid often appears as the shape of various parts of sheet-metal jobs, as the top view of an airplane wing, as the cross section of spars, and in many other connections.

A Few Facts about the Trapezoid

1. A trapezoid has four sides.
2. Only one pair of opposite sides is parallel. These sides are called the *bases*.

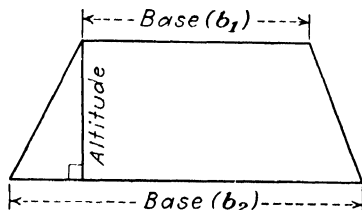

Fig. 84.—Trapezoid.

3. The perpendicular distance between the bases is called the *altitude*.

Notice how closely the formula for the area of a trapezoid resembles one of the other formulas already studied.

$$\text{Formula: } A = \frac{1}{2} \times a \times (b_1 + b_2)$$

where  $a$  = the altitude.

$b_1$  = one base.

$b_2$  = the other base.

ILLUSTRATIVE EXAMPLE

Find the area of a trapezoid whose altitude is 6 in. and whose bases are 9 in. and 7 in.

Given:  $a = 6$  in.

$b_1 = 7$  in.

$b_2 = 9$  in.

Find: Area

$$A = \frac{1}{2} \times a \times (b_1 + b_2)$$

$$A = \frac{1}{2} \times 6 \times (7 + 9)$$

$$A = \frac{1}{2} \times 6 \times 16$$

$$A = 48 \text{ sq. in. } \textit{Ans.}$$

Examples:

1. Find the area of a trapezoid whose altitude is 10 in. and whose bases are 15 in. and 12 in.

2. Find the area of a trapezoid whose parallel sides are 1 ft. 3 in. and 2 ft. 6 in. and whose altitude is 9 in. Express your answer in (a) square feet (b) square inches.

3. Find the area of the figure in Fig. 84a, after making all necessary measurements with a rule graduated in 32nds. Estimate the area first.

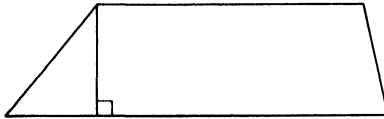

Fig. 84a.

4. Find the area in square feet of the airplane wing, including the ailerons, shown in Fig. 84b.

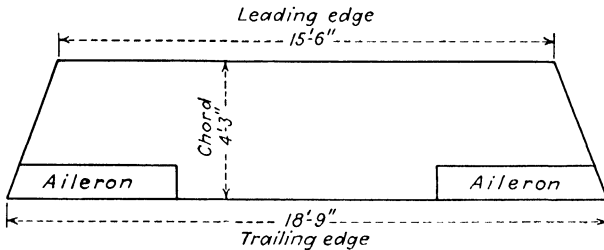

Fig. 84b.

5. Find the area of the figures in Fig. 84c.

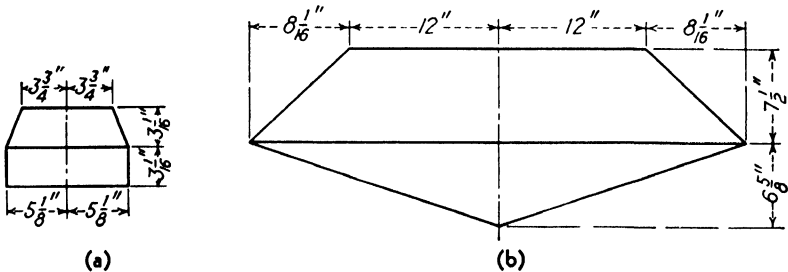

Fig. 84c.

### Job 11: Review Test

1. Measure to the nearest 32nd all dimensions indicated by letters in Fig. 85.

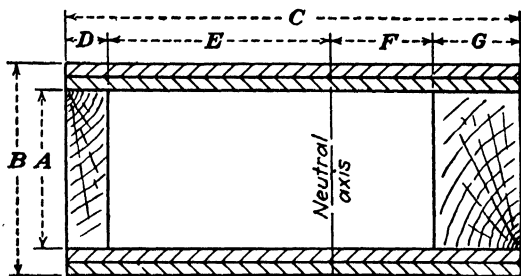
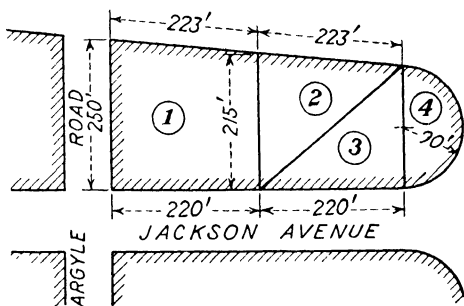

Fig. 85.—Box beam.

2. Calculate the cross-sectional area of the box beam shown in Fig. 85.

3-4. The advertisement shown in Fig. 86 appeared in the real estate section of a large newspaper.



Note: Jackson Ave. crosses at right angles to Argyle Rd.

Fig. 86.

- (a) Find the number of square feet in each of the four lots.  
 (b) What would be the cost of putting a fence completely around lot 4, if the cost of fencing is  $5\frac{3}{4}$ ¢ per foot?

Find to the nearest tenth the square root of

5. 73.62

6. 10,609

7. 0.398

8. What is the diameter of a piston whose area is 23.2753 sq. in.? Express your answer as a decimal accurate to the nearest hundredth of an inch.

9. A rectangular board is 14 ft. long. Find its width if its surface area is 10.5 sq. ft.

10. What is the circumference of a circle whose area is 38.50 sq. in.?

## Chapter V

# VOLUME AND WEIGHT

A solid is the technical term for anything that occupies space. For example, a penny, a hammer, and a steel rule are all solids because they occupy a definite space. Volume is the amount of space occupied by any object.

### Job 1: *Units of Volume*

It is too bad that there is no single unit for measuring all kinds of volume. The volume of liquids such as gasoline is generally measured in gallons; the contents of a box is measured in cubic inches or cubic feet. In most foreign countries, the liter, which is about 1 quart, is used as the unit of volume.

However, all units of volume are interchangeable, and any one of them can be used in place of any other. Memorize the following table:

TABLE 4.--VOLUME

1,728 cubic inches	= 1 cubic foot (cu. ft.)
27 cubic feet	= 1 cubic yard (cu. yd.)
2 pints	= 1 quart (qt.)
4 quarts	= 1 gallon (gal.)
231 cubic inches	= 1 gallon (approx.)
1 cubic foot	= 7½ gallons (approx.)
1 liter	= 1 quart (approx.)

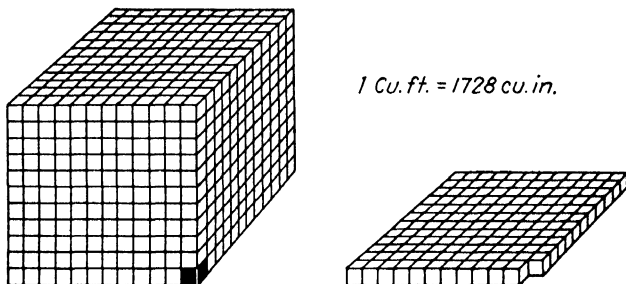

Fig. 87.

Examples:

1. How many cubic inches are there in 5 cu. ft.? in 1 cu. yd.? in  $\frac{1}{2}$  cu. ft.? in  $3\frac{1}{4}$  cu. yd.?
2. How many pints are there in 6 qt.? in 15 gal.?
3. How many cubic inches are there in 2 qt.? in  $\frac{1}{2}$  gal.?
4. How many gallons are there in 15 cu. ft.? in 1 cu. ft.?

Job 2: The Formula for Volume

Figure 88 below shows three of the most common geometrical solids, as well as the shape of the *base* of each.

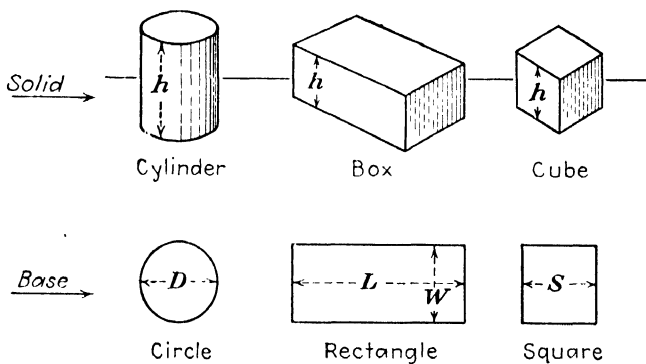

Fig. 88.

The same formula can be used to find the volume of a cylinder, a rectangular box, or a cube.

$$\text{Formula: } V = A \times h$$

where  $V$  = volume.

$A$  = area of the base.

$h$  = height.

Notice that it will be necessary to remember the formulas for the area of plane figures, in order to be able to find the volume of solids.

#### ILLUSTRATIVE EXAMPLE

Find the volume in cubic inches of a rectangular box whose base is 4 by 7 in. and whose height is 9 in.

Given:

Base: rectangle,  $L = 7$  in.

$W = 4$  in.

$h = 9$  in.

Find:

a. Area of base

b. Volume

$$a. \text{ Area} = L \times W$$

$$\text{Area} = 7 \times 4$$

$$\text{Area} = 28 \text{ sq. in.}$$

$$b. \text{ Volume} = A \times h$$

$$\text{Volume} = 28 \times 9$$

$$\text{Volume} = 252 \text{ cu. in. } \textit{Ans.}$$

#### Examples:

1. Find the volume in cubic inches of a box whose height is 15 in. and whose base is 3 by  $4\frac{1}{2}$  in.

2. Find the volume of a cube whose side measures  $3\frac{1}{2}$  in.

3. A cylinder has a base whose diameter is 2 in. Find its volume, if it is 3.25 in. high.

4. What is the volume of a cylindrical oil tank whose base has a diameter of 15 in. and whose height is 2 ft.? Express the answer in gallons.

5. How many cubic feet of air does a room 12 ft. 6 in. by 15 ft. by 10 ft. 3 in. contain?

6. *Approximately* how many cubic feet of baggage can be stored in the plane wing compartment shown in Fig. 89?

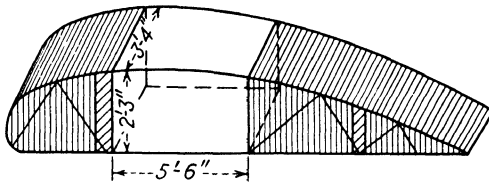

Fig. 89.

7. How many gallons of oil can be contained in a rectangular tank 3 by 3 by 5 ft.?

*Hint:* Change cubic feet to gallons.

8. What is the cost, at \$.19 per gal., of enough gasoline to fill a circular tank the diameter of whose base is 8 in. and whose height is 15 in.?

9. How many quarts of oil can be stored in a circular tank 12 ft. 3 in. long if the diameter of the circular end is 3 ft. 6 in.?

10. An airplane has 2 gasoline tanks, each with the specifications shown in Fig. 90. How many gallons of fuel can this plane hold?

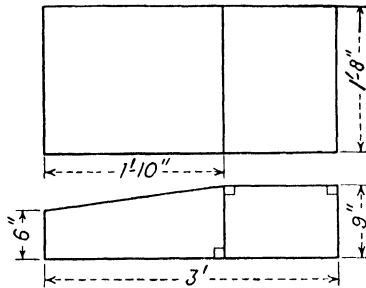

Fig. 90.

### Job 3: The Weight of Materials

In comparing the weights of different materials a standard unit of volume must be used. Why? In the table below, the unit of volume used as a basis for the comparison of the weights of different materials is 1 cu. ft.

TABLE 5.—COMMON WEIGHTS

Metals, lb. per cu. ft.		Woods,* lb. per cu. ft.	
Aluminum.....	162	Ash.....	50
Copper.....	542	Mahogany.....	53
Dural.....	175	Maple.....	49
Iron (cast).....	450	Oak.....	52
Lead.....	711	Pine.....	45
Platinum.....	1342	Spruce.....	27
Steel.....	490		
Air.....			0.081
Water....			62.5

\* The figures for woods are approximate, since variations due to moisture content and other physical properties affect the weight.

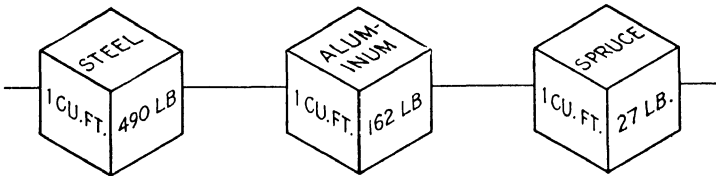

Fig. 91.

The weights in Table 5 are all unit weights based on a volume of 1 cu. ft. To find the actual weight of any object, it will first be necessary to find its volume.

Formula:  $W = V \times \text{unit weight}$

where  $W$  = weight of any object.

$V$  = volume occupied by the object.

Unit weight is the figure obtained from a table of weights per unit volume such as Table 5.

ILLUSTRATIVE EXAMPLE

Find the weight of an oak beam 6 by 12 in. by 9 ft.

Given:  $L = 6 \text{ in.} = \frac{1}{2} \text{ ft.}$

$W = 12 \text{ in.} = 1 \text{ ft.}$

$h = 9 \text{ ft.}$

Find:

a. Volume

b. Weight

a. Volume =  $A \times h$

Volume =  $\frac{1}{2} \times 1 \times 9$

Volume =  $4\frac{1}{2} \text{ cu. ft.}$

$$\begin{aligned}
 b. \text{ Weight} &= V \times \text{unit weight} \\
 \text{Weight} &= 4\frac{1}{2} \times 52 \\
 \text{Weight} &= 234 \text{ lb. } \textit{Ans.}
 \end{aligned}$$

Notice that the volume is calculated in the same units (cubic feet) as the table of unit weights. Why is this essential?

**Examples:**

1. Draw up a table of weights *per cubic inch* for all the materials given in Table 5. Use this table in the following examples.

Find the weight of each of these materials:

2. 1 round aluminum rod 12 ft. long and with a diameter of 6 in.

3. 5 square aluminum rods,  $1\frac{1}{4}$  by  $1\frac{1}{4}$  in., in 12-ft. lengths.

4. 100 square hard-drawn copper rods in 12-ft. lengths each  $\frac{7}{8}$  by  $\frac{7}{8}$  in.

5. 75 steel strips each 4 by  $\frac{3}{8}$  in. in 25-ft. lengths.

Find the weight of

6. A spruce beam  $1\frac{1}{2}$  by 3 in. by 18 ft.

7. 6 oak beams each 3 by  $4\frac{1}{4}$  in. by 15 ft.

8. 500 pieces of  $\frac{1}{4}$ -in. square white pine cap strips each 1 yd. long.

9. A solid mahogany table top which is 6 ft. in diameter and  $\frac{7}{8}$  in. thick.

10. The wood required for a floor 25 ft. by 15 ft. 6 in., if  $\frac{5}{8}$ -in. thick white pine is used.

11. By means of a bar graph compare the weights of the metals in Table 5.

12. Represent by a bar graph the weights of the wood given in Table 5.

13. 50 round aluminum rods each 15 ft. long and  $\frac{3}{4}$  in. in diameter.

14. Find the weight of the spruce I beam, shown in Fig. 92.

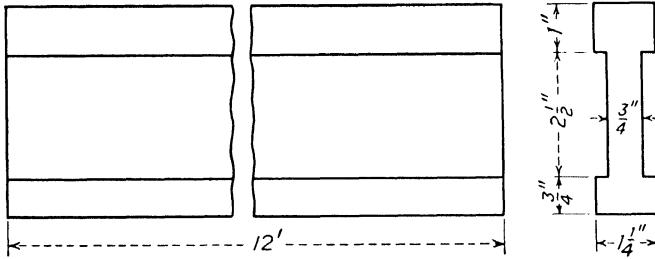

Fig. 92.—I beam.

15. Find the weight of 1,000 of each of the steel items shown in Fig. 93.

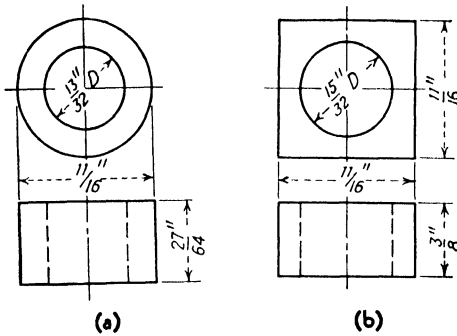

Fig. 93.

**Job 4: Board Feet**

Every mechanic sooner or later finds himself ready to purchase some lumber. In the lumberyard he must know

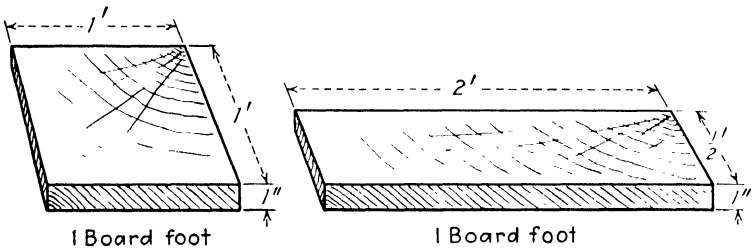

Fig. 94.

the meaning of “board feet,” because that is how most lumber is sold.

**Definition:**

A *board foot* is a unit of measure used in lumber work. A board having a surface area of 1 sq. ft. and a thickness of 1 in. or less is equal to 1 board foot (bd. ft.).

**ILLUSTRATIVE EXAMPLE**

Find the number of board feet in a piece of lumber 5 by 2 ft. by 2 in. thick.

Given:  $L = 5$  ft.

$W = 2$  ft.

$t = 2$  in.

Find: Number of board feet

$$A = L \times W$$

$$A = 5 \times 2$$

$$A = 10 \text{ sq. ft.}$$

$$\text{Board feet} = A \times t$$

$$\text{Board feet} = 10 \times 2 = 20 \text{ bd. ft. } \textit{Ans.}$$

*Method:*

- a. Find the surface area in square feet.
- b. Multiply by the thickness in inches.

**Examples:**

1-3. Find the number of board feet in each of the pieces of rough stock shown in Fig. 95.

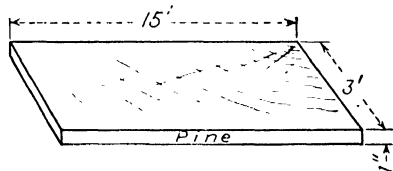

**Example 1**

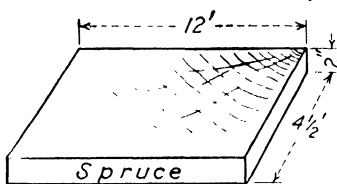

**Example 2**

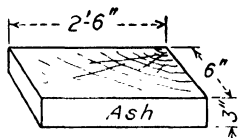

**Example 3**

**Fig. 95.**

4. Find the weight of each of the boards in Examples 1–3.
5. Calculate the cost of 5 pieces of pine 8 ft. long by 9 in. wide by 2 in. thick, at 11¢ per board foot.
6. Calculate the cost of this bill of materials:

Pieces	Dimensions	Price per bd. ft.
15 pine...	10 ft. by 8 in. by $\frac{7}{8}$ in.	\$0.125
9 pine...	12 ft. by 9 in. by 2 in.	0.095
18 oak.....	8 ft. by 12 in. by 1 in.	0.160
12 oak.....	14 ft. by 6 in. by 3 in.	0.180

### Job 5: Review Test

1. Measure all dimensions on the airplane tail in Fig. 96, to the nearest 32nd.

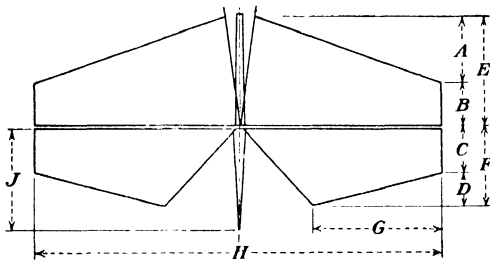

Fig. 96.—Horizontal stabilizers and elevators.

2. Find the over-all length and height of the crankshaft in Fig. 97.

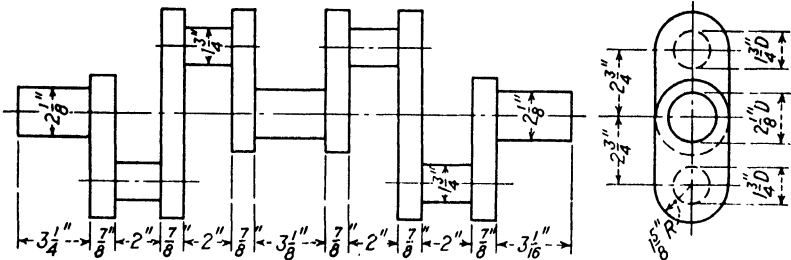
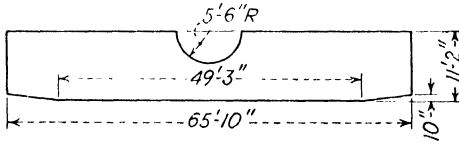

Fig. 97.—Crankshaft.

3. Find the weight of the steel crankshaft in Fig. 97.

4. Find the area of the airplane wing in Fig. 98.



**Fig. 98.**

5. Find the number of board feet and the weight of a spruce board 2 by 9 in. by 14 ft. long.

## Chapter VI

# ANGLES AND CONSTRUCTION

It has been shown that the length of lines can be measured by rulers, and that area and volume can be calculated with the help of definite formulas. Angles are measured with the

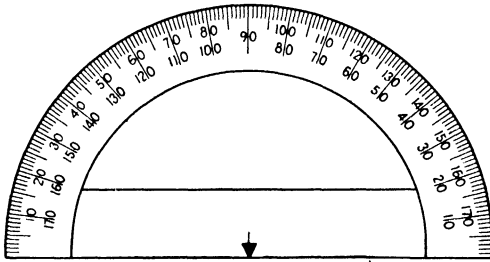

Fig. 99.—Protractor.

help of an instrument called a *protractor* (Fig. 99). It will be necessary to have a protractor in order to be able to do any of the jobs in this chapter.

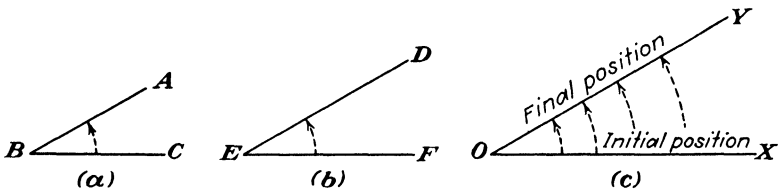

Fig. 100.

In Fig. 100(a),  $AB$  and  $BC$  are *sides* of the angle.  $B$  is called the *vertex*. The angle is known as  $\angle ABC$  or  $\angle CBA$ , since the vertex is always the middle letter. The symbol  $\angle$  is mathematical shorthand for the word *angle*. Name

the sides and vertex in  $\angle DEF$ ; in  $\angle XOY$ . Although the sides of these three angles differ in length, yet

$$\angle ABC = \angle DEF = \angle XOY$$

**Definition:**

An *angle* is the amount of rotation necessary to bring a line from an initial position to a final position. The length of the sides of the angle has nothing to do with the size of the angle.

### Job 1: How to Use the Protractor

#### ILLUSTRATIVE EXAMPLE

How many degrees does  $\angle ABC$  contain?

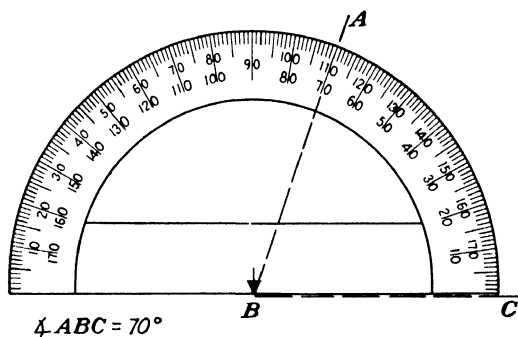

Fig. 101.

*Method:*

- a. Place the protractor so that the straight edge coincides with the line  $BC$  (see Fig. 101).
- b. Place the center mark of the protractor on the vertex.
- c. Read the number of degrees at the point where line  $AB$  cuts across the protractor.
- d. Since  $\angle ABC$  is less than a right angle, we must read the smaller number. The answer is  $70^\circ$ .

Examples:

1. Measure the angles in Fig. 102.

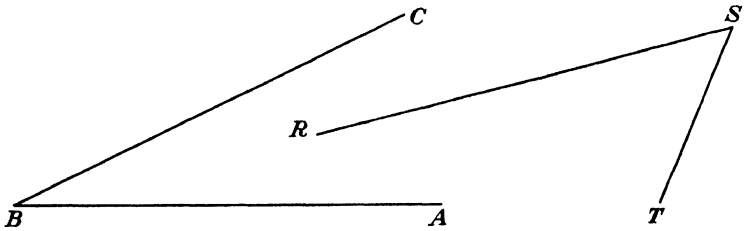

Fig. 102.

2. Measure the angles between the center lines of the parts of the truss member of the airplane rib shown in

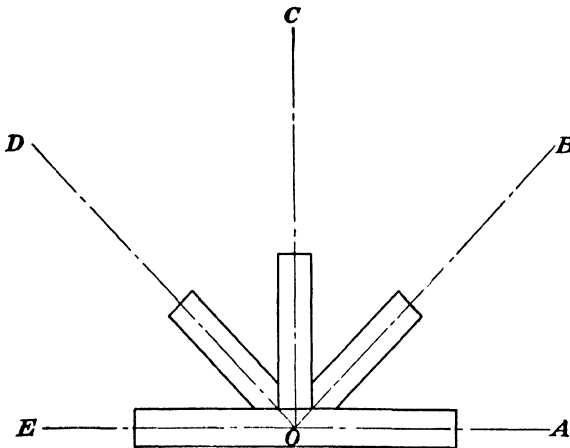

Fig. 103.

Fig. 103. How many degrees are there in

- |                  |                  |                  |
|------------------|------------------|------------------|
| (a) $\angle AOB$ | (b) $\angle BOC$ | (c) $\angle COD$ |
| (d) $\angle COA$ | (e) $\angle EOA$ | (f) $\angle AOD$ |

### **Job 2: How to Draw an Angle**

The protractor can also be used to draw angles of a definite number of degrees, just as a ruler can be used to draw lines of a definite length.

## ILLUSTRATIVE EXAMPLE

Draw an angle of  $30^\circ$  with  $A$  as vertex and with  $AB$  as one side.

*Method:*

a. Place the protractor as if measuring an angle whose vertex is at  $A$  (see Fig. 104).

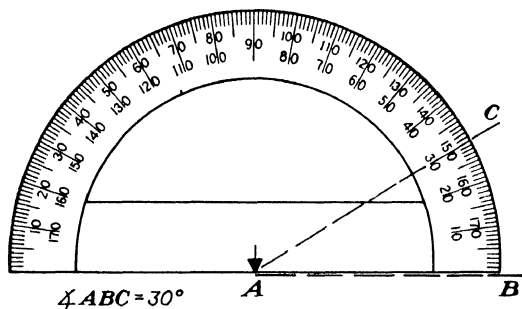

Fig. 104.

b. Mark a point such as  $C$ , at the  $30^\circ$  graduation on the protractor.

c. A line from  $A$  to this point will make  $\angle BAC = 30^\circ$ .

**Examples:**

Draw angles of

- |               |                |                |                |                 |
|---------------|----------------|----------------|----------------|-----------------|
| 1. $40^\circ$ | 2. $60^\circ$  | 3. $45^\circ$  | 4. $37^\circ$  | 5. $10^\circ$   |
| 6. $90^\circ$ | 7. $110^\circ$ | 8. $145^\circ$ | 9. $135^\circ$ | 10. $175^\circ$ |

11. With the help of a protractor bisect (cut in half) each of the angles in Examples 1-5 above.

12. Draw an angle of  $0^\circ$ ; of  $180^\circ$ .

13. Draw angles equal to each of the angles in Fig. 105.

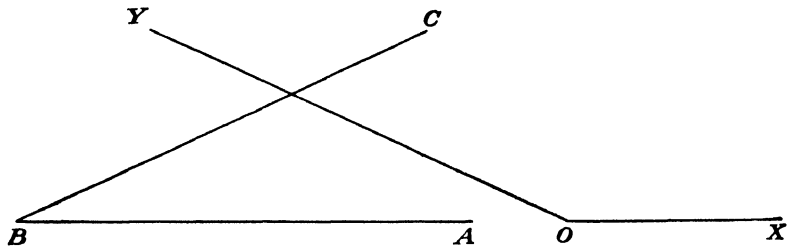

Fig. 105.

14. Draw angles equal to one-half of each of the angles in Fig. 105.

**Job 3: Units of Angle Measure**

So far only degrees have been mentioned in the measurement of angles. There are, however, smaller divisions than the degree, although only very skilled mechanics will have much occasion to work with such small units. Memorize the following table:

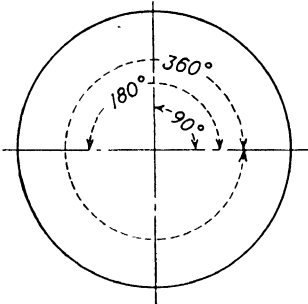

Fig. 106.

TABLE 6.—ANGLE MEASURE

60 seconds (") = 1 minute (')

60 minutes = 1 degree (°)

90 degrees = 1 right angle

180 degrees = 1 straight angle

360 degrees = 1 circle

**Questions:**

1. How many right angles are there
  - (a) in 1 straight angle?
  - (b) in a circle?
2. How many minutes are there
  - (a) in 5°? (b) in 45°? (c) in 90°?
3. How many seconds are there
  - (a) in 1 degree?
  - (b) in 1 right angle?

4. Figure 107 shows the position of rivets on a circular patch. Calculate the number of degrees in

- |                  |                  |
|------------------|------------------|
| (a) $\angle DBC$ | (b) $\angle EBC$ |
| (c) $\angle FBC$ | (d) $\angle ABD$ |
| (e) $\angle ABF$ | (f) $\angle ABC$ |

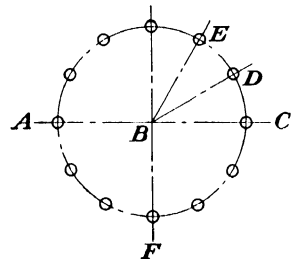

Fig. 107.

**Definition:**

An angle whose vertex is the center of a circle is called a *central angle*. For instance,  $\angle DBC$  in the

circular patch in Fig. 107 is a central angle. Name any other central angles in the same diagram.

Examples:

1. In your notebook draw four triangles as shown in Fig. 108. Measure as accurately as you can each of the angles in

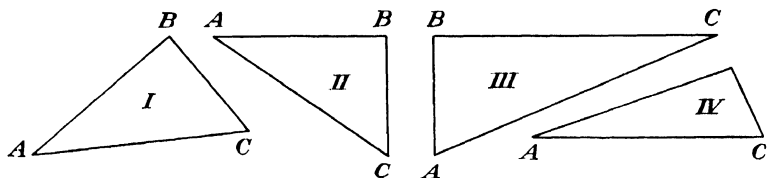

Fig. 108.

each triangle. What conclusion do you draw as to the sum of the angles of any triangle?

Triangle I	Triangle II	Triangle III	Triangle IV
$\angle A =$	$\angle A =$	$\angle A =$	$\angle A =$
$\angle B =$	$\angle B =$	$\angle B =$	$\angle B =$
$\angle C =$	$\angle C =$	$\angle C =$	$\angle C =$
Sum =	Sum =	Sum =	Sum =

2. Measure each angle in the quadrilaterals (4-sided plane figures) in Fig. 109, after drawing similar figures

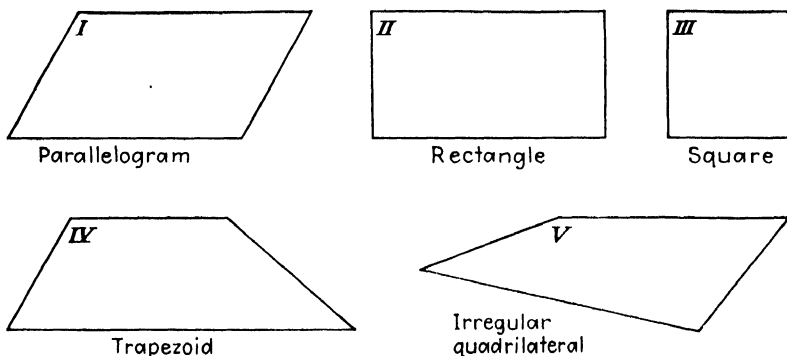

Fig. 109.

in your own notebook. Find the sum of the angles of a quadrilateral.

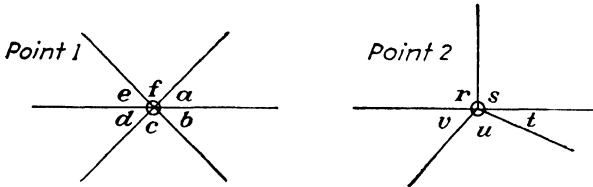

Fig. 110.

3. Measure each angle in Fig. 110. Find the sum of the angles around each point.

Memorize:

1. The sum of the angles of a triangle is  $180^\circ$ .
2. The sum of the angles of a quadrilateral is  $360^\circ$ .
3. The sum of the angles around a point is  $360^\circ$ .

#### Job 4: Angles in Aviation

This job will present just two of the many ways in which angles are used in aviation.

**A. Angle of Attack.** The angle of attack is the angle between the wind stream and the chord line of the airfoil. In Fig. 111,  $\angle AOB$  is the angle of attack.

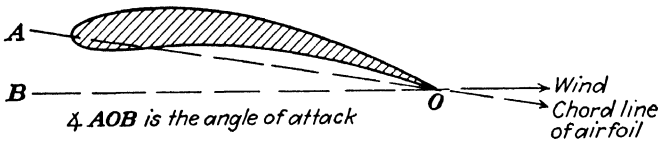

Fig. 111.

The lift of an airplane increases as the angle of attack is increased up to the stalling point, called the *critical angle*.

Examples:

1-4. Estimate the angle of attack of the airfoils in Fig. 112. Consider the chord line to run from the leading edge

to the trailing edge. The direction of the wind is shown by  $W$ .

5. What wind condition might cause a situation like the one shown in Example 4 Fig. 112?

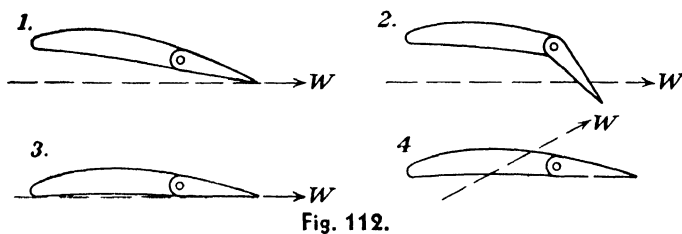

**B. Angle of Sweepback.** Figure 113 shows clearly that the angle of sweepback is the angle between the leading edge and a line drawn perpendicular to the center line of the airplane. In the figure,  $\angle AOB$  is the angle of sweepback.

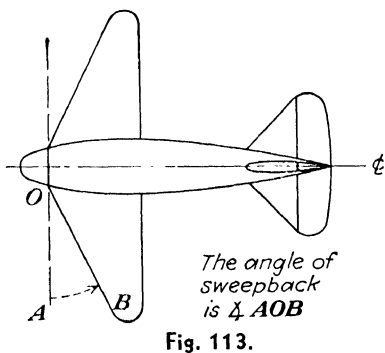

Most planes now being built have a certain amount of sweepback in order to help establish greater stability. Sweepback is even more important in giving the pilot an increased field of vision.

**Examples:**

Estimate the angle of sweepback of the airplanes in Figs. 114 and 115.

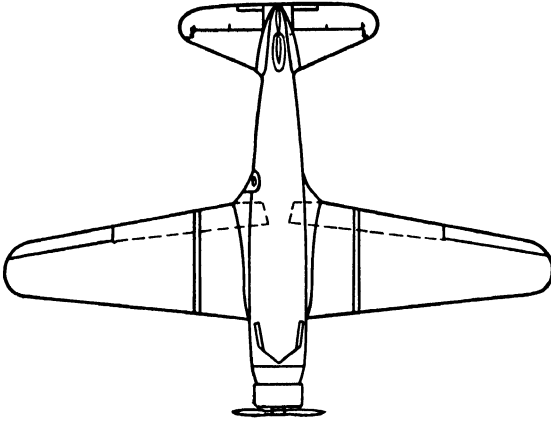

Fig. 114.—Vultee Transport. (Courtesy of Aviation.)

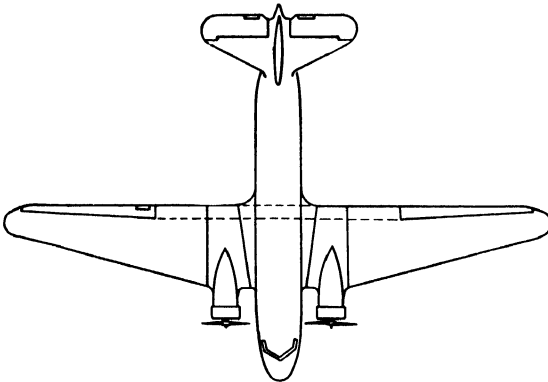

Fig. 115.—Douglas DC-3. (Courtesy of Aviation.)

### **Job 5: To Bisect an Angle**

This example has already been done with the help of a protractor. However, it is possible to bisect an angle with a ruler and a compass more accurately than with the protractor. Why?

Perform the following construction *in your notebook*.

#### **ILLUSTRATIVE CONSTRUCTION**

Given:  $\angle ABC$

Required: To bisect  $\angle ABC$

Method:

- a. Place the point of the compass at  $B$  (see Fig. 116).
- b. Draw an arc intersecting  $BA$  at  $D$ , and  $BC$  at  $E$ .

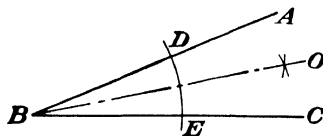

Fig. 116.

- c. Now with  $D$  and  $E$  as centers, draw arcs intersecting at  $O$ . Do not change the radius when moving the compass from  $D$  to  $E$ .
- d. Draw line  $BO$ .

Check the construction by measuring  $\angle ABO$  with the protractor. Is it equal to  $\angle CBO$ ? If it is, the angle has been bisected.

Examples:

In your notebook draw two angles as shown in Fig. 117.

1. Bisect  $\angle AOB$  and  $\angle CDE$ . Check the work with a protractor.
2. Divide  $\angle CDE$  in Fig. 117 into four equal parts. Check the results.

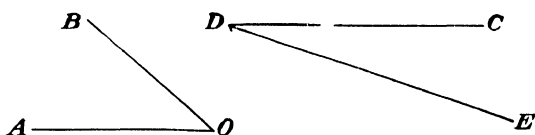

Fig. 117.

3. Is it possible to construct a right angle by bisecting a straight angle? Try it.

### Job 6: To Bisect a Line

This example has already been done with the help of a rule. Accuracy, however, was limited by the limitations of the measuring instruments used. By means of the following method, any line can be bisected accurately without first measuring its length.

## ILLUSTRATIVE CONSTRUCTION

Given: Line  $AB$ Required: To bisect  $AB$ *Method:*

a. Open a compass a distance which you estimate to be greater than one-half of  $AB$  (see Fig. 118).

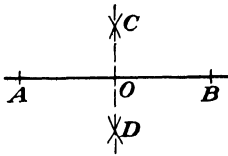

Fig. 118.

b. First with  $A$  as center then with  $B$  as center draw arcs intersecting at  $C$  and  $D$ . Do not change the radius when moving the compass from  $A$  to  $B$ .

c. Draw line  $CD$  cutting line  $AB$  at  $O$ .

Check this construction by measuring  $AO$  with a steel rule. Is  $AO$  equal to  $OB$ ? If it is, line  $AB$  has been bisected.

**Definitions:**

Line  $CD$  is called the *perpendicular bisector* of the line  $AB$ . Measure  $\angle BOC$  with a protractor. Now measure  $\angle COA$ . Two lines are said to be *perpendicular* to each other when they meet at right angles.

**Examples:**

1. Bisect the lines in Fig. 119 after drawing them in your notebook. Check with a rule.

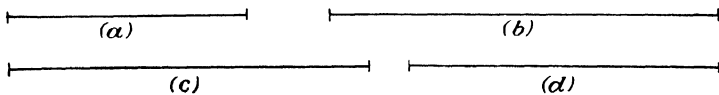

Fig. 119.

2. Draw any line. Divide it into 4 equal parts.

3. Lay off a line  $4\frac{5}{8}$  in. long. Divide it into 4 equal parts.

a. What is the length of each part by direct measurement to the nearest 64th?

b. What should be the exact length of each part by arithmetical calculation?

4. Lay off a line  $9\frac{9}{16}$  in. long. Divide it into 8 equal parts. What is the length of each part?

5. Holes are to be drilled on the fitting shown in Fig. 120 so that all distances marked  $A$  are equal. Draw a line  $5\frac{3}{16}$  in. long, and locate the centers of the holes. Check the results with a rule.

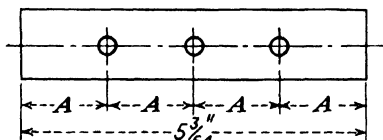

Fig. 120.

6. Draw the perpendicular bisectors of the sides of any triangle. Do they meet in one point?

### Job 7: To Construct a Perpendicular

#### A. To Erect a Perpendicular at Any Point on a Line.

##### ILLUSTRATIVE CONSTRUCTION

Given: Line  $AB$ , and point  $P$  on line  $AB$ .

Required: To construct a line perpendicular to  $AB$  at point  $P$ .

Method:

a. With  $P$  as center, using any convenient radius, draw an arc cutting  $AB$  at  $C$  and  $D$  (see Fig. 121).

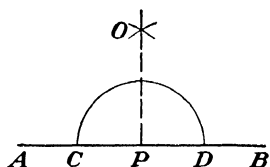

Fig. 121.

b. First with  $C$  as center, then with  $D$  as center and with any convenient radius, draw arcs intersecting at  $O$ .

c. Draw line  $OP$ .

Check:

Measure  $\angle OPB$  with a protractor. Is it a right angle? If it is, then  $OP$  is perpendicular to  $AB$ . What other angle is  $90^\circ$ ?

#### B. To Drop a Perpendicular to a Line from Any Point Not on the Line.

##### ILLUSTRATIVE CONSTRUCTION

Given: Line  $AB$  and point  $P$  not on line  $AB$ .

Required: To construct a line perpendicular to  $AB$  and passing through  $P$ .

*Method:*

With  $P$  as center, draw an arc intersecting line  $AB$  at  $C$  and  $D$ . Complete the construction with the help of Fig. 122.

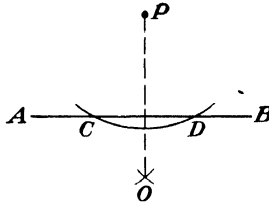

Fig. 122.

**Examples:**

1. In your notebook draw any diagram similar to Fig. 123. Construct a perpendicular to line  $AB$  at point  $P$ .

+C

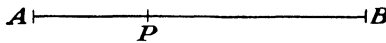

Fig. 123.

2. Drop a perpendicular from point  $C$  (Fig. 123) to line  $AB$ .

Construct an angle of

3.  $90^\circ$

4.  $45^\circ$

5.  $22^\circ 30'$

6.  $67\frac{1}{2}^\circ$

7. Draw line  $AB$  equal to 2 in. At  $A$  and  $B$  erect perpendiculars to  $AB$ .

8. Construct a square whose side is  $1\frac{1}{2}$  in.

9. Construct a right triangle in which the angles are  $90^\circ$ ,  $45^\circ$ , and  $45^\circ$ .

10-11. Make full-scale drawings of the layout of the airplane wing spars, in Figs. 124 and 125.

12. Find the over-all dimensions of each of the spars in Figs. 124 and 125.

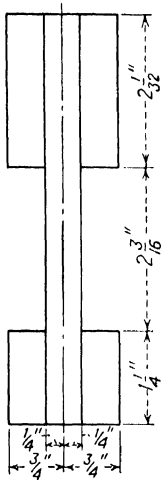

Fig. 124.—Front spar, airplane wing.

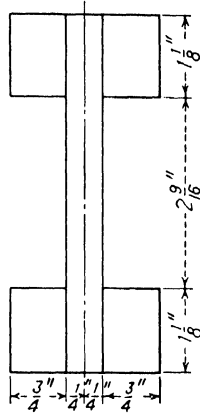

Fig. 125.—Rear spar, airplane wing.

### Job 8: To Draw an Angle Equal to a Given Angle

This is an important job, and serves as a basis for many other constructions. Follow this construction *in your notebook*.

#### ILLUSTRATIVE CONSTRUCTION

Given:  $\angle A$ .

Required: To construct an angle equal to  $\angle A$  with vertex at  $A'$ .

Method:

a. With  $A$  as center and with any convenient radius, draw arc  $BC$  (see Fig. 126a).

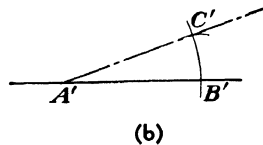
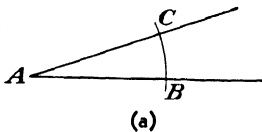

Fig. 126.

b. With the same radius, but with  $A'$  as the center, draw arc  $B'C'$  (see Fig. 126b).

- e. With  $B$  as center, measure the distance  $BC$ .
- d. With  $B'$  as center, and with the radius obtained in (c), intersect arc  $B'C'$  at  $C'$ .
- e. Line  $A'C'$  will make  $\angle C'A'B'$  equal to  $\angle CAB$ .

Check this construction by the use of the protractor.

### Examples:

1. With the help of a protractor draw  $\angle ABD$  and  $\angle EDB$  (Fig. 127) in your notebook. (a) Construct an angle equal to  $\angle ABD$ . (b) Construct an angle equal to  $\angle EDB$ .

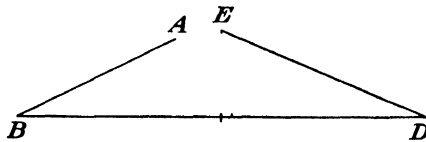

Fig. 127.

2. In your notebook draw any figures similar to Fig. 128. Construct triangle  $A'B'C'$ , each angle of which is equal to a corresponding angle of triangle  $ABC$ .

3. Construct a quadrilateral  $A'B'C'D'$  equal angle for angle to quadrilateral  $ABCD$ .

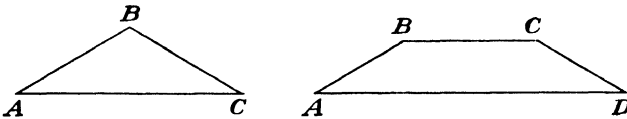

Fig. 128.

### Job 9: To Draw a Line Parallel to a Given Line

Two lines are said to be parallel when they never meet, no matter how far they are extended. Three pairs of parallel lines are shown in Fig. 129.

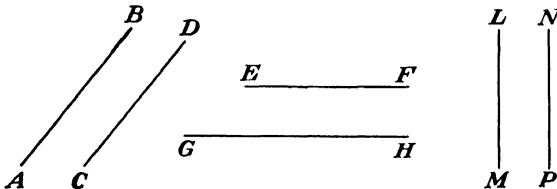

Fig. 129.— $AB$  is parallel to  $CD$ .  $EF$  is parallel to  $GH$ .  $LM$  is parallel to  $NP$ .

## Angles and Construction

### ILLUSTRATIVE CONSTRUCTION

Given: Line  $AB$ .

Required: To construct a line parallel to  $AB$  and passing through point  $P$ .

*Method:*

a. Draw any line  $PD$  through  $P$  cutting line  $AB$  at  $C$  (see Fig. 130).

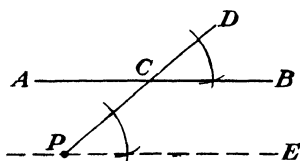

Fig. 130.

b. With  $P$  as vertex, construct an angle equal to  $\angle DCB$ , as shown.

c.  $PE$  is parallel to  $AB$ .

**Examples:**

1. In your notebook draw any diagram similar to Fig. 131. Draw a line through  $C$  parallel to line  $AB$ .

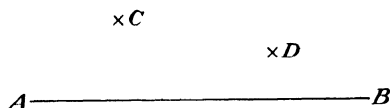

$\times E$   
Fig. 131

2. Draw lines through  $D$  and  $E$ , each parallel to line  $AB$ , in Fig. 131.

3. Draw a perpendicular from  $E$  in Fig. 131 to line  $AB$ .

4. Given  $\angle ABC$  in Fig. 132.

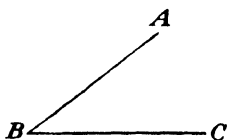

Fig. 132.

a. Construct  $AD$  parallel to  $BC$ .

b. Construct  $CD$  parallel to  $AB$ .

What is the name of the resulting quadrilateral?

5. Make a full-scale drawing of this fitting shown in Fig. 133.

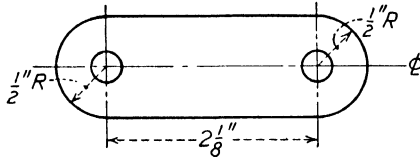

Fig. 133.—Washer plate with 2 holes drilled  $5/16$  in. in diameter.

### Job 10: To Divide a Line into Any Number of Equal Parts

By this method any line can be divided accurately into any number of equal parts without any actual measurements being needed.

#### ILLUSTRATIVE CONSTRUCTION

Given: Line  $AB$ .

Required: To divide  $AB$  into 5 equal parts.

Method:

a. Draw any line, such as  $AH$ . See Fig. 134.

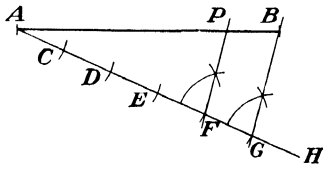

Fig. 134.

b. With any convenient radius, lay off 5 equal parts on  $AH$ . These parts are  $AC$ ,  $CD$ ,  $DE$ ,  $EF$ ,  $FG$ .

c. Draw line  $BG$ .

d. At  $F$  draw a line parallel to  $BG$  cutting line  $AB$  at point  $P$ .

e.  $BP$  is now one-fifth of line  $AB$ .

Find the other points in a similar manner.

Examples:

1. Divide the lines in Fig. 135 into 5 equal parts after drawing them *in your notebook*. Check the results with a steel rule.

2. Draw a line 4 in. long. Divide it into 3 equal parts.

3. Draw a line 7 in. long. Divide it into 6 equal parts. At each point of division erect a perpendicular. Are the perpendicular lines parallel to each other?

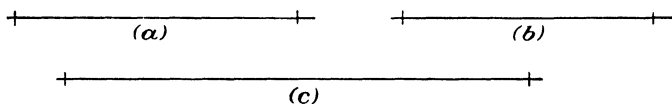

Fig. 135.

**Job 11: Review Test**

1. Construct a square  $3\frac{5}{8}$  in. on a side. What is its area?

2. Construct a rectangle whose length is  $4\frac{7}{16}$  in. and whose width is  $1\frac{1}{8}$  in. Divide this rectangle into 5 equal strips.

3. Make a full-scale drawing of the laminated wing spar, shown in Fig. 136.

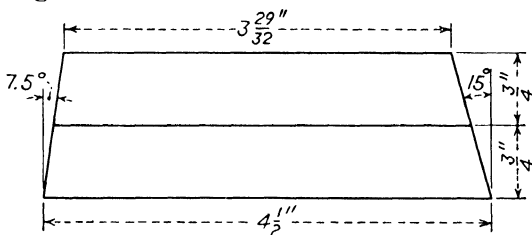

Fig. 136.—Laminated spar, airplane wing.

4. Find the cross sectional area of the spar in Fig. 136. If it were 5 ft. long and made of spruce, how much would it weigh?

5. Draw line  $AB$  equal to 2 in. At points  $A$  and  $B$  construct angles of  $60^\circ$ , by using the protractor, so that a triangle is formed.

- a. How many degrees are there in the third angle?
- b. What is the length of each of the sides?
- c. What is the name of the triangle?

## Chapter VII

# GRAPHIC REPRESENTATION OF AIRPLANE DATA

Graphic representation is constantly growing in importance not only in aviation but in business and government as well. As a mechanic and as a member of society, you ought to learn how to interpret ordinary graphs.

There are many types of graphs: bar graphs, pictographs, broken-line graphs, straight-line graphs, and others. All of them have a common purpose: to show at a glance comparisons that would be more difficult to make from numerical data alone. In this case we might say that one picture is worth a thousand numbers.

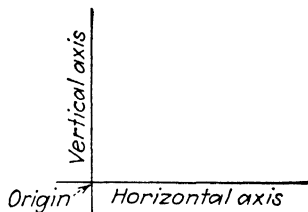

Fig. 137.

The graph is a picture set in a "picture frame." This frame has two sides: the horizontal axis and the vertical axis, as shown in Fig. 137. These axes meet at a point called the *origin*. All distances along the axis are measured from the origin as a zero point.

### Job 1: The Bar Graph

The easiest way of learning how to make a graph is to study the finished product carefully.

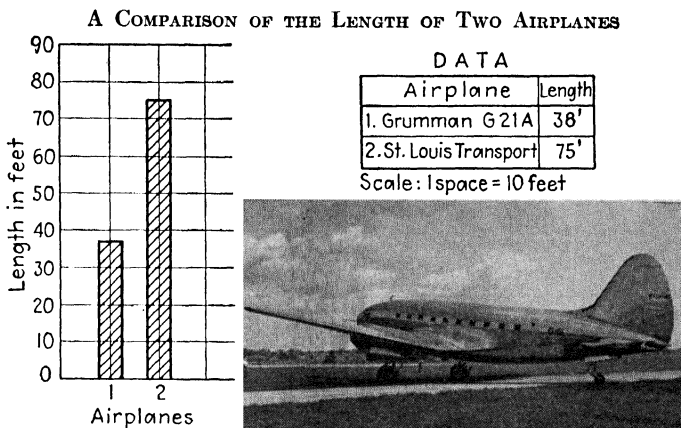

Fig. 138.—(Photo of St. Louis Transport, courtesy of Curtiss Wright Corp.)

The three steps in Fig. 139 show how the graph in Fig. 138 was obtained. Notice that the height of each bar may be approximated after the scale is established.

Make a graph of the same data using a scale in which 1 space equals 20 ft. Note how much easier it is to make a

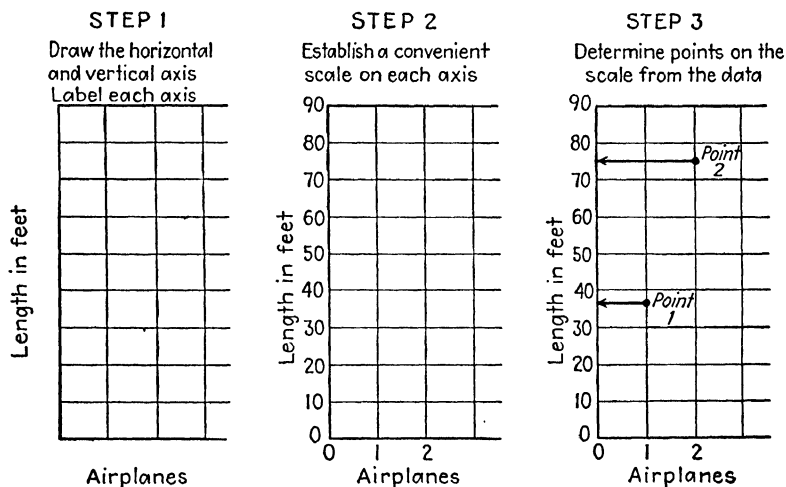

Fig. 139.—Steps in the construction of a bar graph.

graph on "graph paper" than on ordinary notebook paper. It would be very difficult to rule all the cross lines before beginning to draw up the graph.

## Examples:

1. Construct the graph shown in Fig. 140 in your own notebook and complete the table of data.

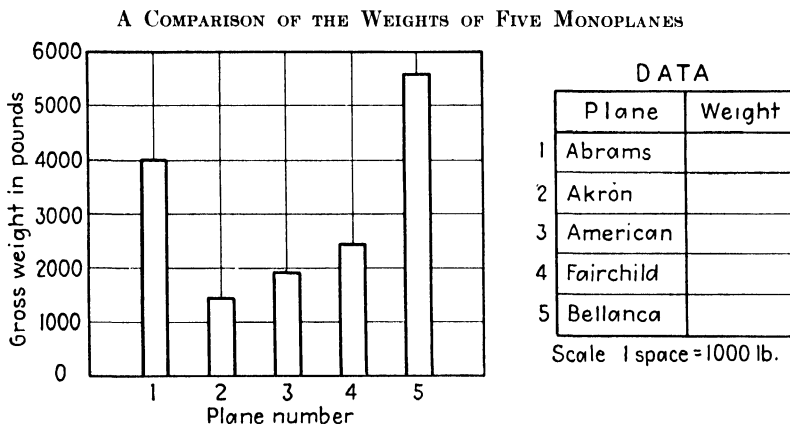

Fig. 140.

2. Construct a bar graph comparing the horsepower of the following aircraft engines:

Engine	Rated hp.	Engine	Rated hp.
Aeronca E 113C.....	40	Continental W-670K.	<b>225</b>
Lycoming R-680. ....	300	Jacobs L5. . . . .	<b>285</b>
Franklin 4AC.....	60	Kinner K5 . . . . .	100

3. Construct a bar graph of the following data on the production of planes, engines, and spares in the United States:

Year	1929	1932	1936	1937	1938
Value (in millions of dollars)...	98	32	77	115	173

4. Construct a bar graph of the following data:

Of the 31,264 pilots licensed on Jan. 1, 1940, the ratings were as follows:

- 1,197 air line
- 7,292 commercial
- 988 limited commercial
- 13,452 private
- 8,335 solo

**Job 2: Pictographs**

Within the last few years, a new kind of bar graph called a *pictograph* has become popular. The pictograph does not need a scale since each picture represents a convenient unit, taking the place of the cross lines of a graph.

**Questions:**

1. How many airplanes does each figure in Fig. 141 represent?

THE VOLUME OF CERTIFIED AIRCRAFT INCREASES STEADILY  
EACH FIGURE REPRESENTS 2,000 CERTIFIED AIRPLANES

Jan. 1

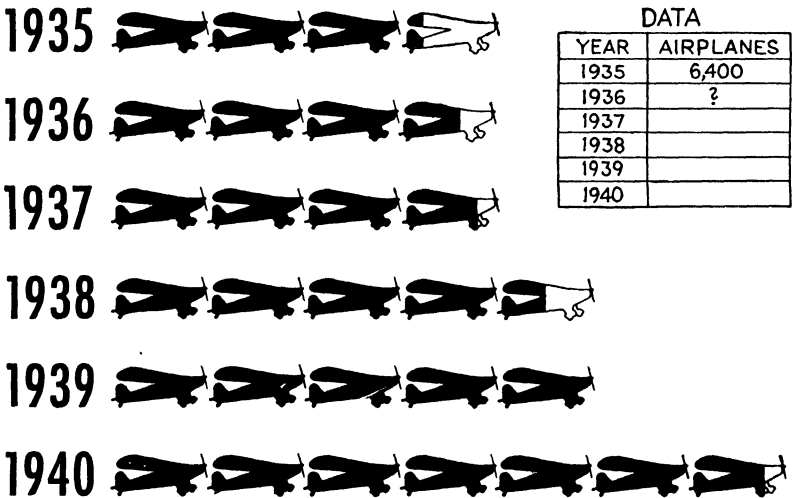

Fig. 141.—(Courtesy of Aviation.)

2. How many airplanes would half a figure represent?
3. How many airplanes would be represented by  $3\frac{1}{2}$  figures?
4. Complete the table of data.

5. Can such data ever be much more than approximate? Why?

Examples:

1. Draw up a table of approximate data from the pictograph, in Fig. 142.

TO OPERATE OUR CIVIL AIRPLANES WE HAVE A GROWING FORCE OF PILOTS  
EACH FIGURE REPRESENTS 2,000 CERTIFIED PILOTS

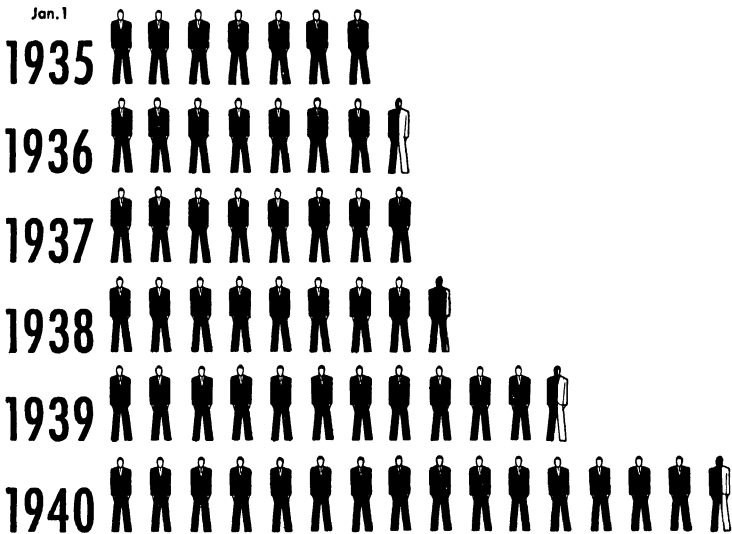

Fig. 142.—(Courtesy of Aviation.)

2. Do you think you could make a pictograph yourself? Try this one. Using a picture of a telegraph pole to represent each 2,000 miles of teletype, make a pictograph from the following data on the growth of teletype weather reporting in the United States:

Year	Miles (approx.)	Year	Miles (approx.)
1934	11,800	1938	21,800
1935	12,700	1939	23,700
1936	13,200	1940	27,000
1937	13,800	1941	29,300(est.)

3. Draw up a table of data showing the number of employees in each type of work represented in Fig. 143.

EMPLOYMENT IN AIRCRAFT MANUFACTURING: 1938  
EACH FIGURE REPRESENTS 1,000 EMPLOYEES

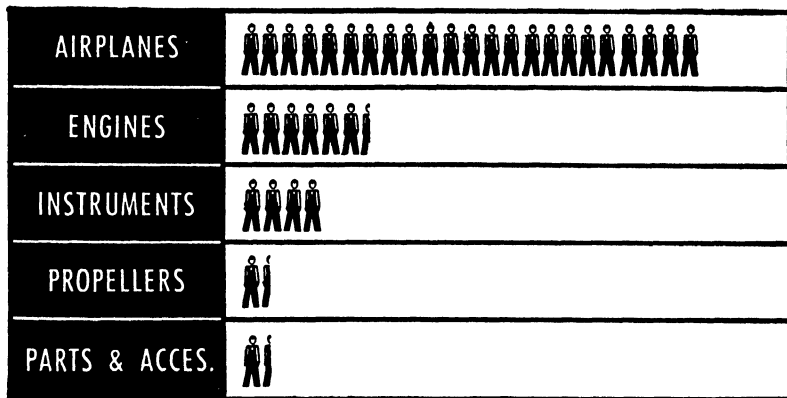

Fig. 143.—(Courtesy of Aviation.)

4. Make a pictograph representing the following data on the average monthly pay in the air transport service:

Flight personnel	Average monthly pay	Ground personnel	Average monthly pay
Pilots....	\$675	Overhaul and maintenance crews....	\$150
Copilots.....	230	Dispatchers.....	240
Hostesses.....	115	Meteorologists...	175
		Radio operators.....	130
		Office employees .....	110
		Field and hangar crews.....	90

Job 3: The Broken-line Graph

An examination of the broken-line graph in Fig. 144 will show that it differs in no essential way from the bar graph. If the top of each bar were joined by a line to the top of the next bar, a broken-line graph would result.

a. Construct a table of data for the graph in Fig. 144.

b. During November, 1939, 6.5 million dollars' worth of aeronautical products were exported. Find this point on the graph.

c. What was the total value of aeronautical products exported for the first 10 months of 1939?

EXPORT OF AMERICAN AERONAUTICAL PRODUCTS: 1939

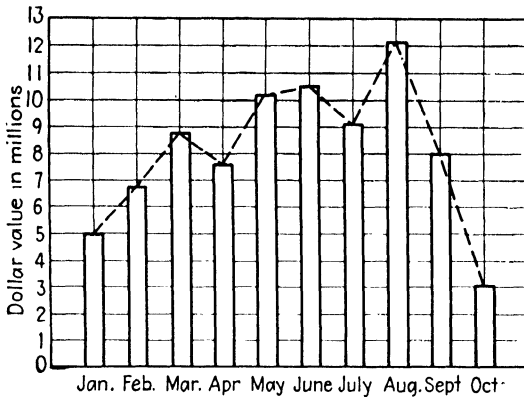

DATA

Month	Value
Jan.	5.0
Feb.	
Mar.	
Apr.	
May	
June	
July	
Aug.	
Sept.	
Oct.	

Scale: 1 space = \$1,000,000

Fig. 144.

Examples:

1. Construct three tables of data from the graph in Fig. 145. This is really 3 graphs on one set of axes. Not only does it show how the number of passengers varied from

PASSENGERS CARRIED BY DOMESTIC AIR LINES

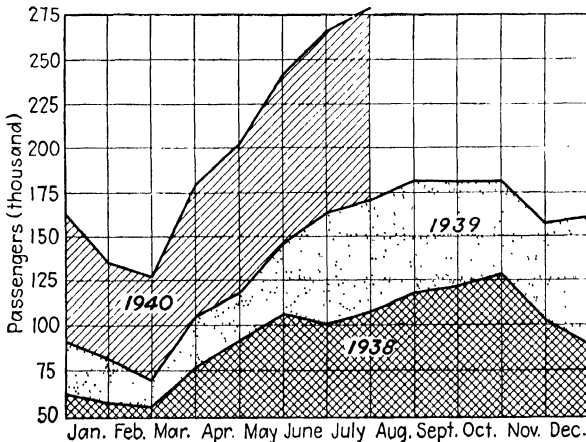

Fig. 145.

month to month, but it also shows how the years 1938, 1939, and 1940 compare in this respect.

2. Make a line graph of the following data showing the miles flown by domestic airlines for the first 6 months of 1940. The data are in millions of miles.

Month	Miles (approx.)	Month	Miles (approx.)
January . . . .	7.25	April . . . . .	8.2
February . . .	6.65	May . . . . .	9.25
March . . . . .	7.95	June . . . . .	9.75

3. Make a graph of the accompanying data on the number of pilots and copilots employed by domestic air carriers. Notice that there will have to be 2 graphs on 1 set of axes.

Year	Pilots	Copilots
1935	528	335
1936	574	468
1937	629	420
1938	671	456
1939	691	694

### Job 4: The Curved-line Graph

The curved-line graph is generally used to show how two quantities vary with relation to each other. For example, the horsepower of an engine varies with r.p.m. The graph in Fig. 146 tells the story for one engine.

The curved-line graph does not differ very much from the broken-line graph. Great care should be taken in the location of each point from the data.

Answer these questions from the graph:

- a. What is the horsepower of the Kinner at 1,200 r.p.m.?
- b. What is the horsepower at 1,900 r.p.m.?
- c. At what r.p.m. would the Kinner develop 290 hp.?

d. What should the tachometer read when the Kinner develops 250 hp.?

CHANGE IN HORSEPOWER WITH R.P.M.  
KINNER RADIAL ENGINE

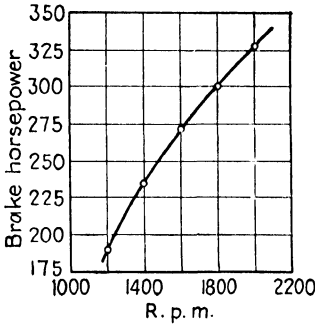

R.p.m.	B. hp.
1200	190
1400	235
1600	272
1800	300
2000	328

Vertical axis:  
1 space = 25 hp.  
Horizontal axis:  
1 space = 200 r.p.m.

Fig. 146.

e. Why isn't the zero point used as the origin for this particular set of data? If it were, how much space would be needed to make the graph?

Examples:

1. Make a table of data from the graph in Fig. 147.

CHANGE IN HORSEPOWER WITH R.P.M.  
RADIAL AIRPLANE ENGINE

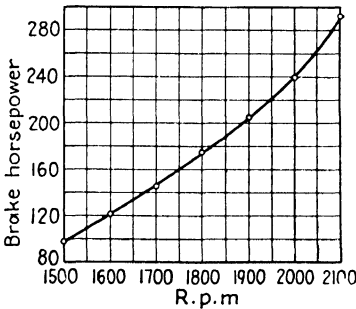

R.p.m.	B. hp.
1500	
1600	
1700	
1800	
1900	
2000	
2100	

Fig. 147.

2. The lift of an airplane wing increases as the angle of attack is increased until the stalling angle is reached. Represent the data graphically.

Angle of attack, deg.	Lift of wing, lb.	Angle of attack, deg.	Lift of wing, lb.
0	500	16	11,900
2	2,000	18	13,200
4	3,500	20	13,900
6	5,000	22	13,700
8	6,500	24	13,000
10	8,000	26	11,900
12	9,500	28	10,800
14	10,500	30	10,000

*Question:* At what angle does the lift fall off? This is called the *stalling angle*.

3. The drag also increases as the angle of attack is increased. Here are the data for the wing used in Example 2. Represent this data graphically.

Angle of attack, deg.	Drag, lb.	Angle of attack, deg.	Drag, lb.
0	100	16	1,000
2	100	18	1,240
4	200	20	1,600
6	250	22	2,100
8	370	24	2,800
10	430	26	3,400
12	600	28	4,000
14	800	30	4,400

*Question:* Could you have represented the data for Examples 2 and 3 on one graph?

4. The lift of an airplane, as well as the drag, depends among other factors upon the area of the wing. The graph in Fig. 148 shows that the larger the area of the wing, the greater will be the lift and the greater the drag. Why are there two vertical axes? Draw up a table of data to show just how the lift and drag change with increased wing area.

LIFT AND DRAG VARY WITH WING AREA

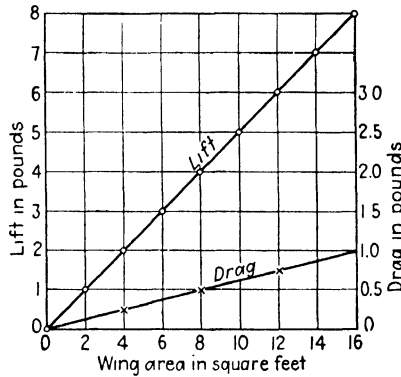

Fig. 148.

**Job 5: Review Test**

1. Make a bar graph representing the cost of creating a new type of aircraft (see Fig. 149).

**COST OF CREATING NEW OR SPECIAL TYPE AIRCRAFT**

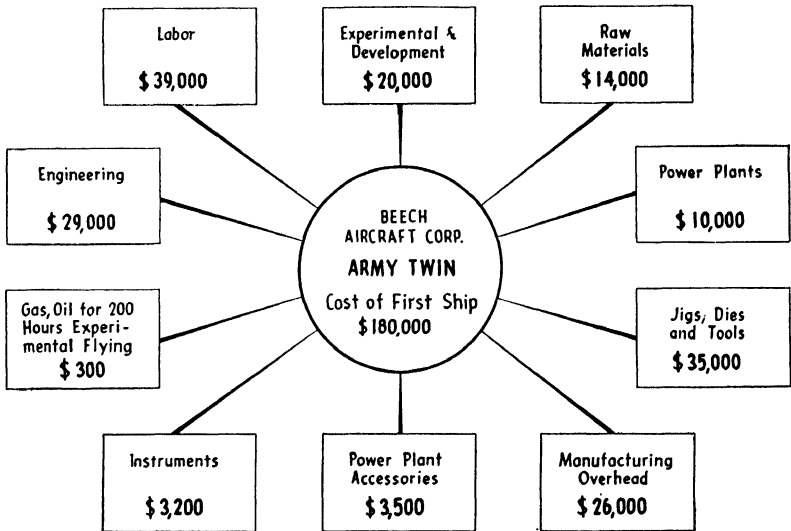

Fig. 149.

2. The air transport companies know that it takes a large number of people on the ground to keep their planes

in the air. Draw up a table of data showing how many employees of each type were working in 1938 (see Fig. 150).

AIR TRANSPORT'S ANNUAL EMPLOYMENT OF NONFLYING PERSONNEL: 1938  
EACH FIGURE REPRESENTS 100 EMPLOYEES

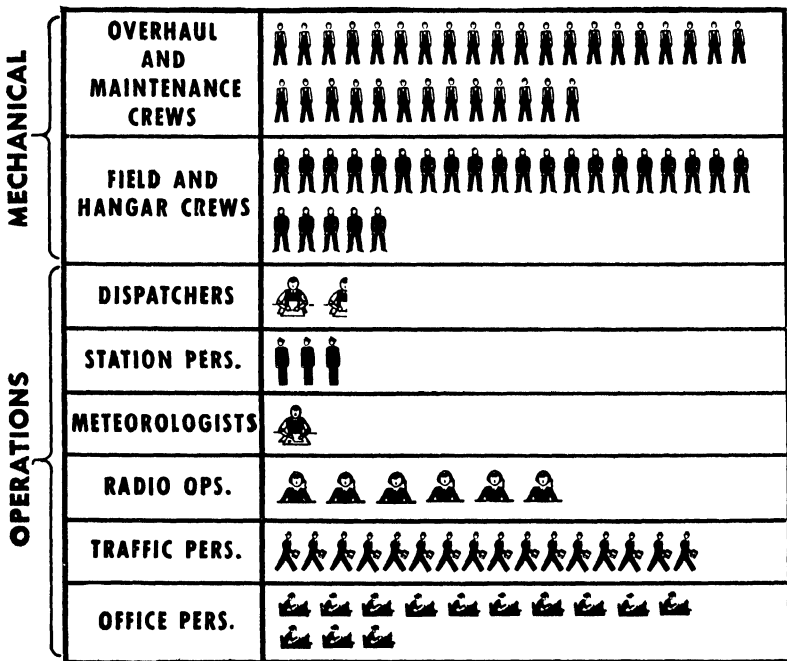

Fig. 150.—(Courtesy of Aviation.)

3. As the angle of attack of a wing is increased, both the lift and drag change as shown below in the accompanying table. Represent these data on one graph.

Angle of attack, deg.	Lift, lb.	Drag, lb.	Angle of attack, deg.	Lift, lb.	Drag, lb.
0	10	1	10	28	18
2	14	5	12	31	16
4	17.5	1	14	32	24
6	21	2	16	31	32
8	24.5	4	18	25	38

4. The following graph (Fig. 151) was published by the Chance Vought Corporation in a commercial advertisement

to describe the properties of the Vought Corsair. Can you read it? Complete two tables of data:

a. *Time to altitude, in minutes:* This table will show how many minutes the plane needs to climb to any altitude.

PERFORMANCE OF THE VOUGHT-CORSAIR LANDPLANE

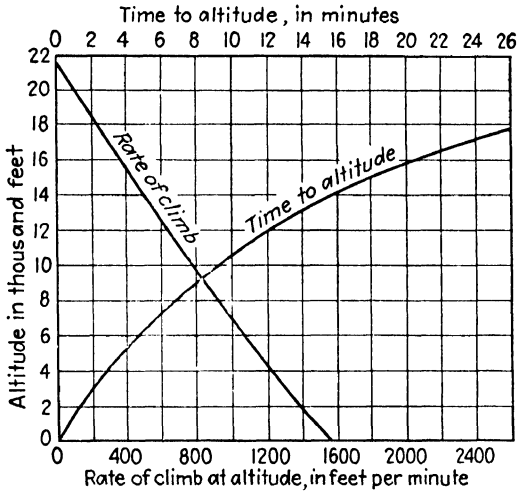

Fig. 151.

b. *Rate of climb at altitude, in feet per minute:* It is important to know just how fast a plane can climb at any altitude. Notice that at zero altitude, that is, at sea level, this plane can climb almost 1,600 ft. per min. How fast can it climb at 20,000 ft.?

## **Part II**

# **THE AIRPLANE AND ITS WING**

### **Chapter VIII: The Weight of the Airplane**

- Job 1: Calculating Wing Area
- Job 2: Mean Chord of a Tapered Wing
- Job 3: Aspect Ratio
- Job 4: The Gross Weight of an Airplane
- Job 5: Pay Load
- Job 6: Wing Loading
- Job 7: Power Loading
- Job 8: Review Test

### **Chapter IX: Airfoils and Wing Ribs**

- Job 1: The Upper Camber
- Job 2: The Lower Camber
- Job 3: When the Data Are Given in Per Cent of Chord
- Job 4: The Nosepiece and Tail Section
- Job 5: The Thickness of Airfoils
- Job 6: Airfoils with Negative Numbers
- Job 7: Review Test



## Chapter VIII

# THE WEIGHT OF THE AIRPLANE

Everyone has observed that a heavy transport plane has a much larger wing than a light plane. The reason is fairly simple. There is a direct relation between the *area* of the wing and the amount of *weight* the plane can lift. Here are some interesting figures:

TABLE 7

Airplane	Gross weight, lb.	Wing area, sq. ft.
Taylor Cub..	1,100	169
Beech D-17-K .....	4,200	296
Bellanca Aircruiser.....	11,400	664
Douglas DC-2 .....	18,560	939
Martin 156C..	63,000	2,300

Draw a broken-line graph of this data, using the gross weight as a vertical axis and the wing area as a horizontal axis. What is the relation between gross weight and wing area?

### Job 1: Calculating Wing Area

The area of a wing is calculated from its plan form. Two typical wing-plan forms are shown in Figs. 152*A* and 152*B*.

The area of these or of any other airplane wing can be found by using the formulas for area that have already been learned. It is particularly easy to find the area of a rectangular wing, as in Fig. 153, if the following technical terms are remembered.

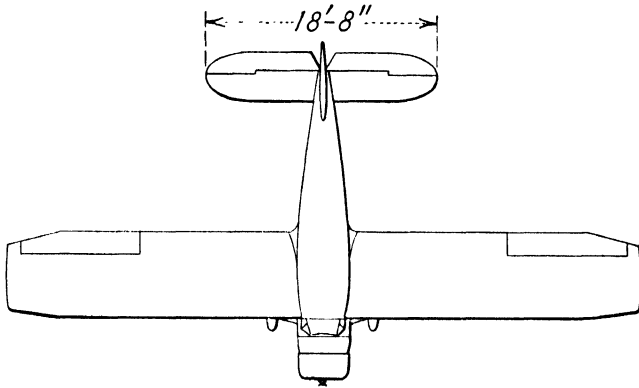

Fig. 152A.—Bellanca Senior Skyrocket with almost rectangular wing form. (Courtesy of Aviation.)

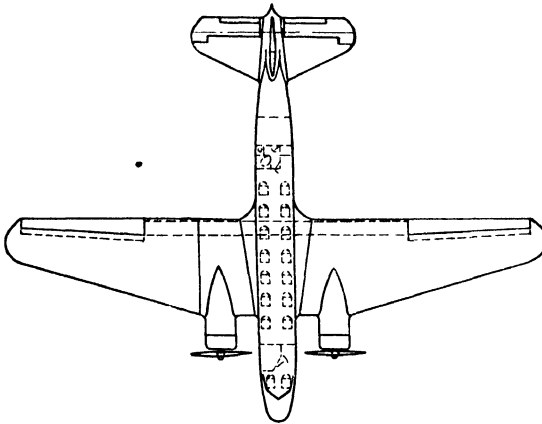

Fig. 152B.—Douglas DC-2 with tapered wing form. (Courtesy of Aviation.)

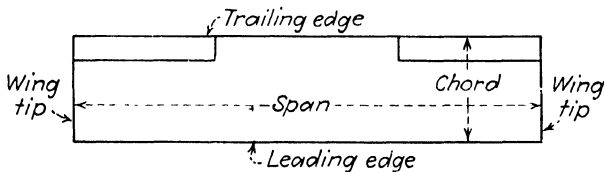

Fig. 153.—Rectangular wing.

**Definitions:**

*Span* is the length of the wing from wing tip to wing tip.

*Chord* is the width of the wing from leading edge to trailing edge.

$$\text{Formula: Area} = \text{span} \times \text{chord}$$

**ILLUSTRATIVE EXAMPLE**

Find the area of a rectangular wing whose span is 25.5 ft. and whose chord is 4.5 ft.

Given: Span = 25.5 ft.

Chord = 4.5 ft.

Find: Wing area

$$\text{Area} = \text{span} \times \text{chord}$$

$$\text{Area} = 25.5 \times 4.5$$

$$\text{Area} = 114.75 \text{ sq. ft. } \textit{Ans.}$$

**Examples:**

1. Find the area of a rectangular wing whose span is 20 ft. and whose chord is  $4\frac{1}{4}$  ft.

2. A rectangular wing has a span of 36 in. and a chord of 6 in. What is its area in square inches and in square feet?

3. Find the area of (a) the rectangular wing in Fig. 154, (b) the rectangular wing with semicircular tips.

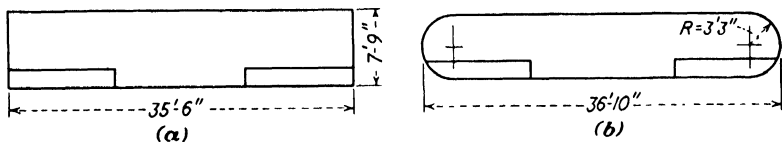

Fig. 154.

4. Calculate the area of the wings in Fig. 155.

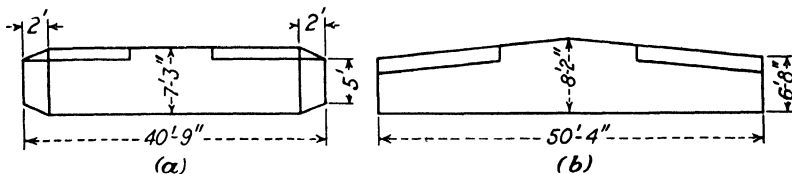

Fig. 155.

5. Find the area of the tapered wing in Fig. 156.

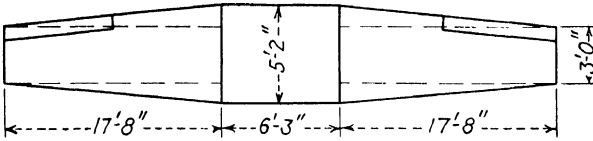

Fig. 156.

### Job 2: Mean Chord of a Tapered Wing

From the viewpoint of construction, the rectangular wing form is probably the easiest to build. Why? It was found, however, that other types have better aerodynamical qualities.

In a rectangular wing, the chord is the same at all points but in a tapered wing there is a different chord at each point (see Fig. 157).

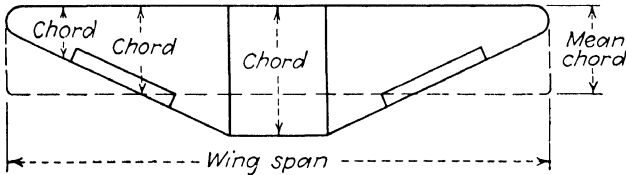

Fig. 157.—A tapered wing has many chords.

#### Definition:

*Mean chord* is the average chord of a tapered wing. It is found by dividing the wing area by the span.

$$\text{Formula: Mean chord} = \frac{\text{area}}{\text{span}}$$

#### ILLUSTRATIVE EXAMPLE

Find the mean chord of the Fairchild 45.

Given: Area = 248 sq. ft.

Span = 39.5 ft.

Find: Mean chord

$$\text{Chord} = \frac{\text{area}}{\text{span}}$$

$$\text{Chord} = \frac{248}{39.5}$$

$$\text{Chord} = 6.3 \text{ ft. Ans.}$$

Examples:

1-3. Supply the missing data:

	Name of plane	Wing area	Span	Mean chord
1	Gwinn I . . . . .	169.4 sq. ft.	24 ft. 0 in.	
2	Welch . . . . .	138.0 sq. ft.	34 ft. 4 in.	
3	Monocoupe . . . . .	94.0 sq. ft.	23 ft. 2.5 in.	

**Job 3: Aspect Ratio**

Figures 158 and 159 show how a wing area of 360 sq. ft. might be arranged:

Airplane 1: Span = 90 ft.  
Chord = 4 ft.

Area = span  $\times$  chord  
Area = 90  $\times$  4  
Area = 360 sq. ft.

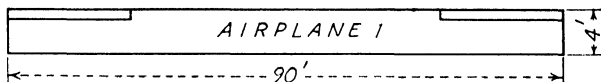

Fig. 158.

Airplane 2: Span = 60 ft.  
Chord = 6 ft.

Area = 60  $\times$  6  
Area = 360 sq. ft.

Airplane 3: Span = 30 ft.  
Chord = 12 ft.

Area = 30  $\times$  12  
Area = 360 sq. ft.

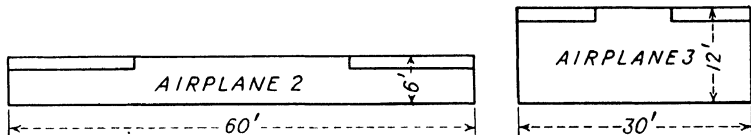

Fig. 159.

*Airplane 1:* It would be very difficult to build this wing strong enough to carry the normal weight of a plane. Why? However, it would have good lateral stability, which means it would not roll as shown in Fig. 160.

*Airplane 2:* These are the proportions of an average plane.

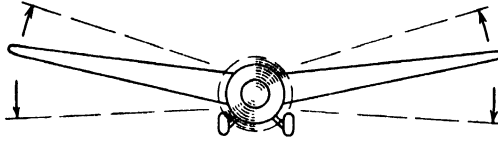

Fig. 160.—An illustration of lateral roll.

*Airplane 3:* This wing might have certain structural advantages but would lack lateral stability and good flying qualities.

*Aspect ratio* is the relationship between the span and the chord. It has an important effect upon the flying characteristics of the airplane.

$$\text{Formula: Aspect ratio} = \frac{\text{span}}{\text{chord}}$$

In a tapered wing, the mean chord can be used to find the aspect ratio.

#### ILLUSTRATIVE EXAMPLE

Find the aspect ratio of airplane 1 in Fig. 158.

Given: Span = 90 ft.

Chord = 4 ft.

Find: Aspect ratio

$$\text{Aspect ratio} = \frac{\text{span}}{\text{chord}}$$

$$\text{Aspect ratio} = \frac{90}{4}$$

$$\text{Aspect ratio} = 22.5 \quad \text{Ans.}$$

#### Examples:

1. Complete the following table from the data supplied in Figs. 158 and 159.

Airplane	Span	Chord	Aspect ratio	Lateral stability
1				Very high
2				Average
3				Very low

2-5. Find the aspect ratio of these planes:

	Airplane	Span	Mean chord	Aspect ratio
2	Bell BG 1.....	36 ft.	9.8 ft	
3	Curtiss.....	31 ft. 6 in.	10.9 ft.	
4	Grumman.....	49 ft.	7.6 ft.	
5	Hall.....	72 ft. 10 in.	16 ft. 1 in.	

6. Make a bar graph comparing the aspect ratios of the four airplanes in Examples 2-5.

7. The NA-44 has a wing area of  $255\frac{3}{4}$  sq. ft. and a span of 43 ft. (Fig. 161). Find the mean chord and the aspect ratio.

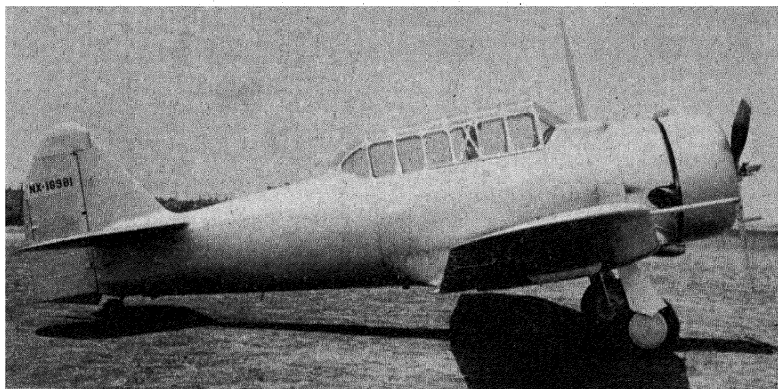

Fig. 161.—North American NA-44. (Courtesy of Aviation.)

8. A Seversky has a span of 41 ft. Find its aspect ratio, if its wing area is 246.0 sq. ft.

#### Job 4: The Gross Weight of an Airplane

The aviation mechanic should never forget that the airplane is a “heavier-than-air” machine. In fact, weight is such an important item that all specifications refer not only to the gross weight of the plane but to such terms as the *empty weight*, *useful load*, *pay load*, etc.

**Definition:**

*Empty weight* is the weight of the finished plane painted, polished, and upholstered, but without gas, oil, pilot, etc.

*Useful load* is the weight of all the things that can be placed in the empty plane without preventing safe flight. This includes pilots, passengers, baggage, oil, gasoline, etc.

*Gross weight* is the maximum weight that the plane can safely carry off the ground and in the air.

**Formula:** Gross weight = empty weight + useful load

The figures for useful load and gross weight are determined by the manufacturer and U.S. Department of

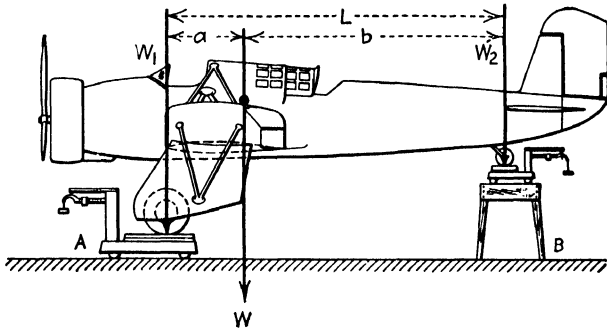

Fig. 162.—The gross weight and center of gravity of an airplane can be found by this method. (Airplane Maintenance, by Younger, Bonnalie, and Ward.)

Commerce inspectors. They should never be exceeded by the pilot or mechanic (see Fig. 162).

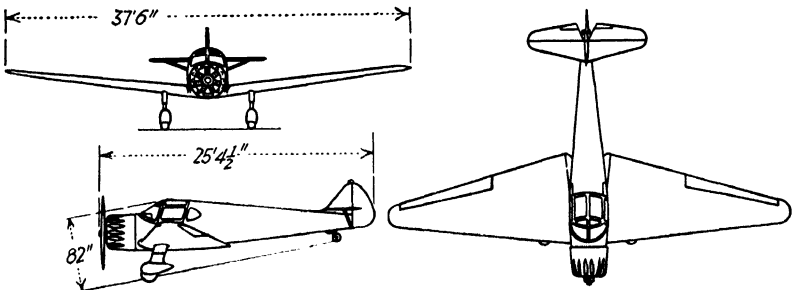

Fig. 163.—The Ryan SC, a low-wing monoplane. (Courtesy of Aviation.)

ILLUSTRATIVE EXAMPLE

Find the gross weight of the Ryan S-C in Fig. 163.

Given: Empty weight = 1,345 lb.

Useful load = 805 lb.

Find: Gross weight

Gross weight = empty weight + useful load

Gross weight = 1,345 lb. + 805 lb.

Gross weight = 2,150 lb. *Ans.*

Examples:

1-3. Calculate the gross weight of the planes in the following table:

	Airplane	Empty weight, lb.	Useful load, lb.	Gross weight, lb.
1	Beechcraft E. . . . .	2,080	1,270	
2	Cessna . . . . .	1,380	970	
3	Boeing 314 . . . . .	48,545	33,955	

4-6. Complete the following table:

	Plane	Empty weight, lb.	Useful load, lb.	Gross weight, lb.
4	Bennett . . . . .	4,000		6,392
5	Consolidated . . . . .		12,840	27,080
6	Grumman . . . . .	5,425		8,000

7. Make a bar graph comparing the empty weights of the Beechcraft, Bennett, Cessna, and Grumman.

Job 5: Pay Load

Pay load is the weight of all the things that can be carried for pay, such as passengers, baggage, mail, and many other items (see Fig. 164). Manufacturers are always



Fig. 164.—Pay load. United Airlines Mainliner being loaded before one of its nightly flights. (Courtesy of Aviation.)

trying to increase the pay load as an inducement to buyers. A good method of comparing the pay loads of different planes is on the basis of the pay load as a per cent of the gross weight (see Fig. 164).

#### ILLUSTRATIVE EXAMPLE

The Aeronca model 50 two-place monoplane has a gross weight of 1,130 lb. and a pay load of 210 lb. What per cent of the gross weight is the pay load?

Given: Pay load = 210 lb.

Gross weight = 1,130 lb.

Find: Per cent pay load

*Method:*

$$\text{Per cent} = \frac{\text{pay load}}{\text{gross weight}} \times 100$$

$$\text{Per cent} = \frac{210}{1,130} \times 100$$

$$\text{Per cent} = 18.5 \text{ Ans.}$$

Examples:

1. The monoplane in Fig. 165 is the two-place Akron Funk B, whose gross weight is 1,350 lb., and whose pay load

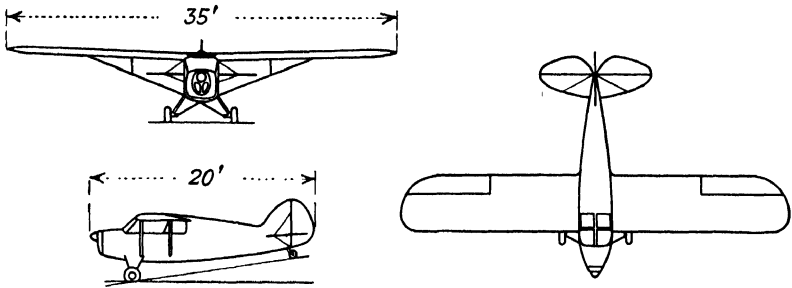

Fig. 165.—The Akron Funk B two-place monoplane. (Courtesy of Aviation.)

is 210 lb. What per cent of the gross weight is the pay load?

2-5. Find what per cent the pay load is of the gross weight in the following examples:

	Plane	Gross weight, lb.	Pay load, lb.	Per cent
2	Allied S-T.....	1,400	170	
3	Bellanca.....	5,600	998	
4	Luscombe.....	1,950	236	
5	Stinson.....	3,875		21.4

6. Explain the diagram in Fig. 166.

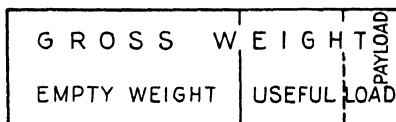

Fig. 166.

**Job 6: Wing Loading**

The gross weight of an airplane, sometimes tens of thousands of pounds, is carried on its wings (and auxiliary supporting surfaces) as surely as if they were columns of steel anchored into the ground. Just as it would be dangerous to overload a building till its columns bent, so it would be dangerous to overload a plane till the wings could not safely hold it aloft.

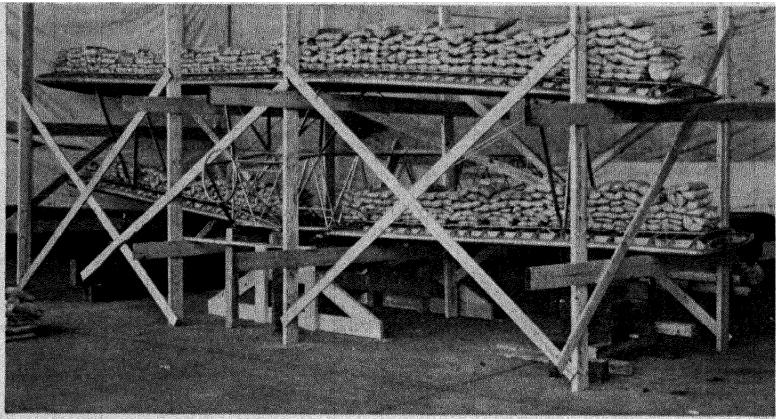

Fig. 167.—Airplane wings under static test. (Courtesy of Aviation.)

Figure 167 shows a section of a wing under static test. Tests of this type show just how great a loading the structure can stand.

**Definition:**

*Wing loading* is the number of pounds of gross weight that each square foot of the wing must support in flight.

$$\text{Formula: Wing loading} = \frac{\text{gross weight}}{\text{wing area}}$$

**ILLUSTRATIVE EXAMPLE**

A Stinson Reliant has a gross weight of 3,875 lb. and a wing area of 258.5 sq. ft. Find the wing loading.

Given: Gross weight = 3,875 lb.

Area = 258.5 sq. ft.

Find: Wing loading

$$\text{Wing loading} = \frac{\text{gross weight}}{\text{wing area}}$$

$$\text{Wing loading} = \frac{3,875}{258.5}$$

$$\text{Wing loading} = 14.9 \text{ lb. per sq. ft. } \textit{Ans.}$$

Examples:

1. The Abrams Explorer has a gross weight of 3,400 lb. and a wing area of 191 sq. ft. What is its wing loading?

2-4. Calculate the wing loading of the Grumman in the following table:

	Airplane	Gross weight, lb.	Wing area, sq. ft.	Wing loading, lb. per sq. ft.
2	Grumman G-37.....	4,553	260.6	
3	Grumman J2F-1.....	6,170	409	
4	Grumman G-21A.....	8,000	375	

5. Represent by means of a bar graph the wing loadings and wing areas of the Grumman planes in the preceding table. One of these planes is shown in Fig. 168.

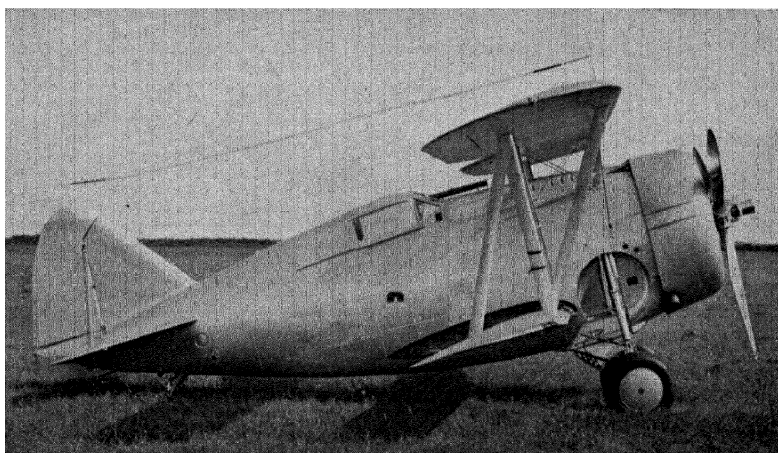

Fig. 168.—Grumman G-37 military biplane. (Courtesy of Aviation.)

6. The Pasped Skylark has a wing span of 35 ft. 10 in. and a mean chord of 5.2 ft. Find the wing loading if the gross weight is 1,900 lb.

### Job 7: Power Loading

The gross weight of the plane must not only be held aloft by the lift of the wings but also be carried forward by the thrust of the propeller. A small engine would not provide enough horsepower for a very heavy plane; a large engine might “run away” with a small plane. The balance or ratio between weight and engine power is expressed by the power loading.

$$\text{Formula: Power loading} = \frac{\text{gross weight}}{\text{horsepower}}$$

#### ILLUSTRATIVE EXAMPLE

A Monocoupe 90A has a gross weight of 1,610 lb. and is powered by a Lambert 90-hp. engine. What is the power loading?

Given: Gross weight = 1,610 lb.

Horsepower = 90

Find: Power loading

$$\text{Power loading} = \frac{\text{gross weight}}{\text{horsepower}}$$

$$\text{Power loading} = \frac{1,610}{90}$$

$$\text{Power loading} = 17.8 \text{ lb. per hp. } \textit{Ans.}$$

#### Examples:

1–3. Complete the following table:

	Airplane	Gross weight, lb.	Engine	Horsepower	Power loading
1	Aeronca.....	1,060	Continental	40	
2	Bellanca.....	5,600	Wright	420	
3	Fleetwings.....	3,800	Jacobs L-5	300	

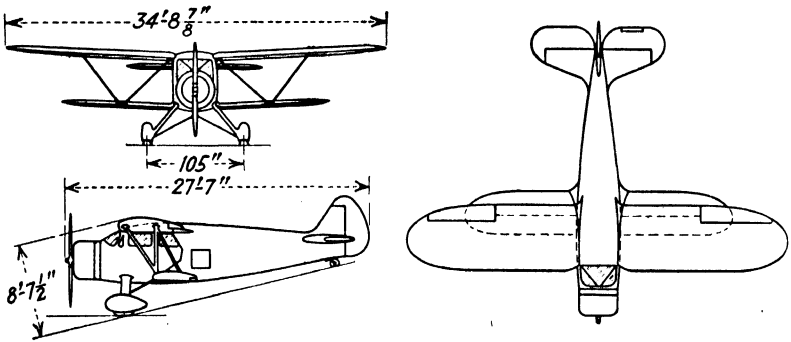

Fig. 169.—The Waco Model C. (Courtesy of Aviation.)  
Empty weight = 2,328 lb. Useful load = 1,472 lb. Engine = 300 hp.

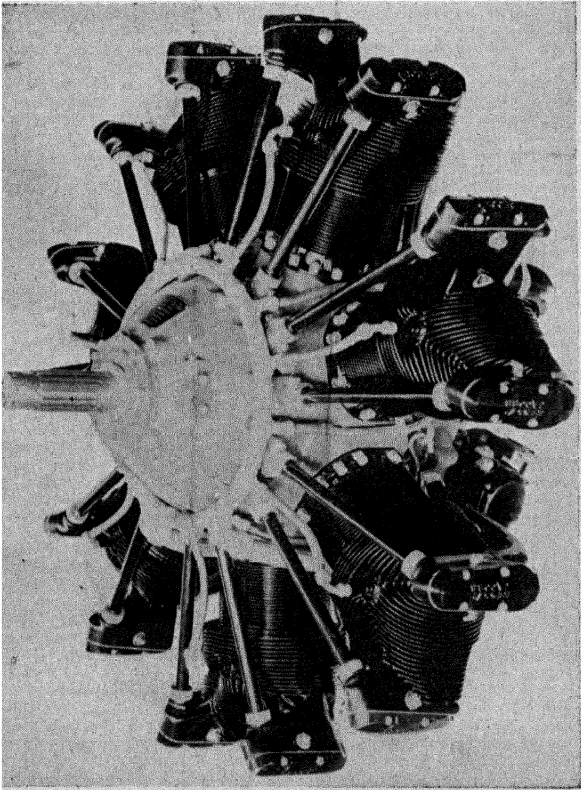

Fig. 170.—The Jacobs L-6 7 cylinder radial engine used to power the Waco C. (Courtesy of Aviation.)

4. Does the power loading increase with increased gross weight? Look at the specifications for light training planes and heavy transport planes. Which has the higher power loading?

*Note:* The student may find this information in his school or public library, or by obtaining a copy of a well-known trade magazine such as *Aviation*, *Aero Digest*, etc.

5. Find the gross weight and the power loading of the Waco model C, powered by a Jacobs L-6 7 cylinder radial engine (see Figs. 169 and 170).

### Job 8: Review Test

The following are the actual specifications of three different types of airplanes:

1. Find the wing and power loading of the airplane in Fig. 171, which has the following specifications:

Gross weight = 4,200 lb.  
 Wing area = 296.4 sq. ft.  
 Engine = Whirlwind, 420 hp.

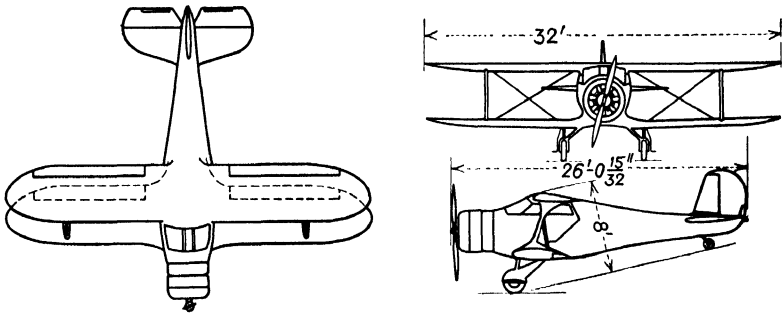

Fig. 171.—Beech Beechcraft D five-place biplane. (Courtesy of Aviation.)

2. Find (a) the wing loading; (b) the power loading; (c) the aspect ratio; (d) the mean chord of the airplane in Fig. 172, which has the following specifications:

Gross weight = 24,400 lb.  
 Wing area = 987 sq. ft.  
 Engines = 2 Cyclones, 900 hp. each  
 Wing span = 95 ft.

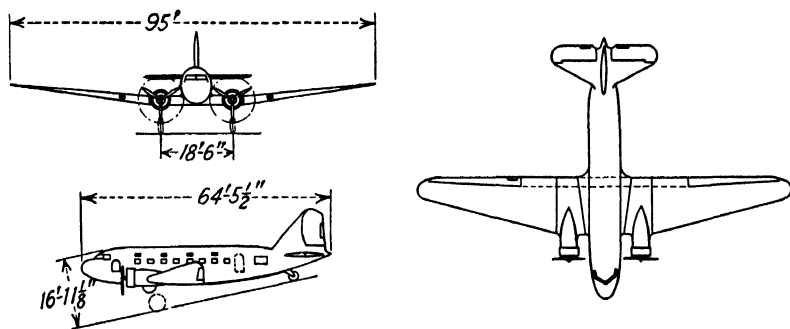

Fig. 172.—Douglas DC-3 24-place monoplane. (Courtesy of Aviation.)

3. Find (a) the gross weight; (b) the per cent pay load; (c) the mean chord; (d) the wing loading; (e) the power

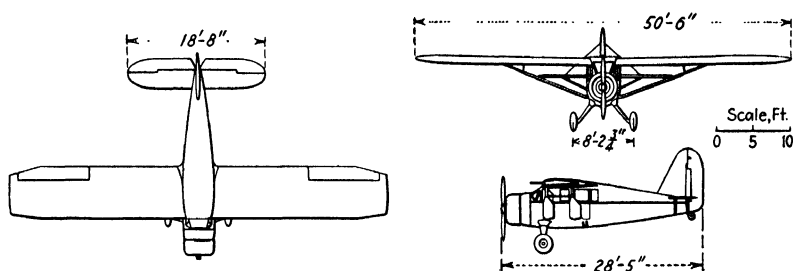

Fig. 173.—Bellanca Senior Skyrocket, six-place monoplane. (Courtesy of Aviation.)

loading; (f) the aspect ratio of the airplane in Fig. 173, which has the following specifications:

Weight empty	= 3,440 lb.
Useful load	= 2,160 lb.
Pay load	= 986 lb.
Wing area	= 359 sq. ft.
Engine	= P. & W. Wasp, 550 hp.
Span	= 50 ft. 6 in.

4. Does the wing loading increase with increased gross weight? Look up the specifications of six airplanes to prove your answer.

## Chapter IX

### AIRFOILS AND WING RIBS

The wind tunnel has shown how greatly the shape of the airfoil can affect the performance of the plane. The airfoil section is therefore very carefully selected by the manufacturer before it is used in the construction of wing ribs.



Fig. 174.—Three types of airfoil section.

No mechanic should change this shape in any way. Figure 174 shows three common airfoil sections.

The process of drawing up the data supplied by the manufacturer or by the government to full rib size is important since any inaccuracy means a change in the plane's performance. The purpose of this chapter is to show how to draw a wing section to any size.

#### Definitions:

*Datum line* is the base line or horizontal axis (see Fig. 175).

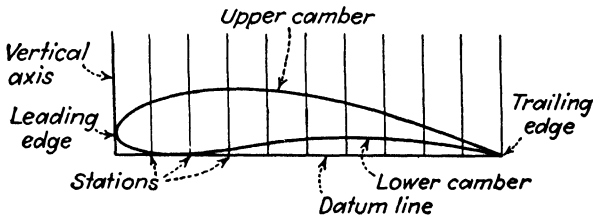

Fig. 175.

*Vertical axis* is a line running through the leading edge of the airfoil section perpendicular to the datum line.

*Stations* are points on the datum line from which measurements are taken up or down to the upper or lower camber.

*Upper camber* is the curved line running from the leading edge to the trailing edge along the upper surface of the airfoil section.

*Lower camber* is the line from leading edge to trailing edge along the lower surface of the airfoil section.

The datum line (horizontal axis) and the vertical axis have already been defined in the chapter on graphic representation. As a matter of fact the layout of an airfoil<sup>1</sup> is identical to the drawing of any curved-line graph from given data. The only point to be kept in mind is that there are really two curved-line graphs needed to complete the airfoil, the upper camber and the lower camber. These will now be considered in that order.

### Job 1: The Upper Camber

The U.S.A. 35B is a commonly used airfoil. The following data can be used to construct a 5-in. rib. Notice that the last station tells us how long the airfoil will be when finished.

AIRFOIL SECTION: U.S.A. 35B  
Data in inches for upper camber only

Station	0	$\frac{1}{2}$	1	$1\frac{1}{2}$	2	$2\frac{1}{2}$	3	$3\frac{1}{2}$	4	$4\frac{1}{2}$	5
Upper camber	$\frac{9}{64}$	$\frac{15}{32}$	$\frac{9}{16}$	$\frac{13}{32}$	$\frac{37}{64}$	$\frac{33}{64}$	$\frac{7}{16}$	$\frac{23}{64}$	$\frac{1}{4}$	$\frac{9}{64}$	$\frac{1}{64}$

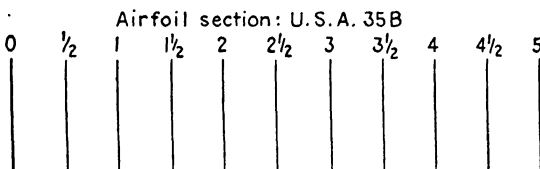

Fig. 176.

<sup>1</sup> The term "airfoil" is often substituted for the more awkward phrase "airfoil section" in this chapter. Technically, however, airfoil refers to the shape of the wing as a whole, while airfoil section refers to the wing profile or rib outline.

*Directions:*

Step 1.—Draw the datum line and the vertical axis (see Fig. 176).

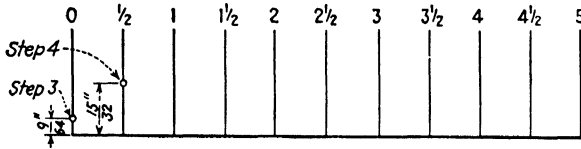

Fig. 177.

Step 2.—Mark all stations as given in the data.

Step 3.—At station 0, the data shows that the upper camber is  $\frac{9}{8}$  in. above the datum line. Mark this point as shown in Fig. 177.

Step 4.—At station  $\frac{1}{2}$  in., the upper camber is  $1\frac{5}{8}$  in. above the datum line. Mark this point.

Step 5.—Mark all points in a similar manner on the upper camber. Connect them with a smooth line. The finished upper camber is shown in Fig. 178.

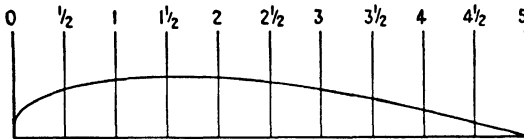

Fig. 178.

**Job 2: The Lower Camber**

The data for the lower camber of an airfoil are always given together with the data for the upper camber, as shown

AIRFOIL SECTION: U.S.A. 35B

Station	0	$\frac{1}{2}$	1	$1\frac{1}{2}$	2	$2\frac{1}{2}$	3	$3\frac{1}{2}$	4	$4\frac{1}{2}$	5
Upper	$\frac{9}{8}$	$1\frac{5}{8}$	$\frac{9}{16}$	$1\frac{1}{2}$	$\frac{3}{4}$	$\frac{3}{8}$	$\frac{7}{16}$	$\frac{3}{4}$	$\frac{1}{4}$	$\frac{9}{64}$	$\frac{1}{64}$
Lower	$\frac{9}{64}$	0	0	0	$\frac{1}{64}$	$\frac{1}{64}$	$\frac{1}{64}$	$\frac{1}{64}$	$\frac{1}{64}$	$\frac{1}{64}$	0

Fig. 179.

in Fig. 179. In drawing the lower camber, the same diagram and stations are used as for the upper camber.

*Directions:*

Step 1.—At station 0, the lower camber is  $\frac{9}{16}$  in. above the datum line. Notice that this is the same point as that of the upper camber (see Fig. 180).

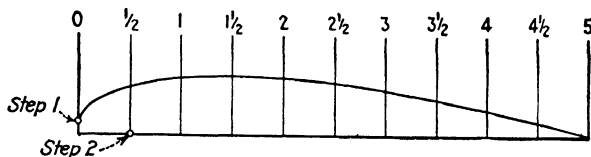

Fig. 180.

Step 2.—At station  $\frac{1}{2}$  in., the lower camber is 0 in. high, that is, flat on the datum line as shown in Fig. 180.

Step 3.—Mark all the other points on the lower camber and connect them with a smooth line.

In Fig. 181 is shown the finished wing rib, together with one of the many planes using this airfoil. Notice that the

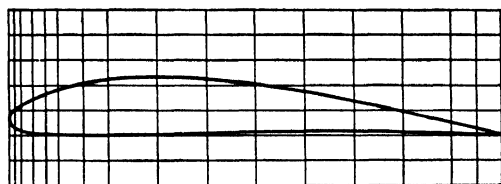
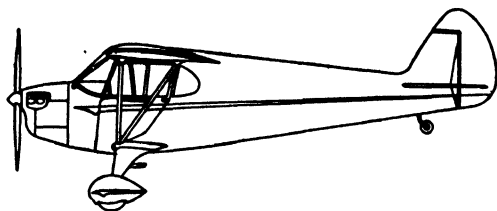

Fig. 181.—The Piper Cub Coupe uses airfoil section U.S.A. 35B.

airfoil has more stations than you have used in your own work. These will be explained in the next few pages.

**Questions:**

1. Why does station 0 have the same point on the upper and lower cambers?

2. What other station must have the upper and lower points close together?

Examples:

1-2. Draw the airfoils shown in Fig. 182 to the size indicated by the *stations*. All measurements are in inches.

Example 1.

AIRFOIL SECTION: N-22

Station	0	1	2	3	4	5	6	7	8	9	10
Upper camber	$\frac{11}{32}$	$1\frac{1}{64}$	$1\frac{3}{32}$	$1\frac{1}{4}$	$1\frac{13}{64}$	$1\frac{7}{64}$	$\frac{61}{64}$	$\frac{49}{64}$	$\frac{9}{16}$	$\frac{5}{16}$	$\frac{3}{64}$
Lower camber	$\frac{11}{32}$	$\frac{1}{64}$	0	0	$\frac{1}{64}$	$\frac{3}{32}$	$\frac{1}{32}$	$\frac{1}{32}$	$\frac{1}{32}$	$\frac{1}{64}$	0

Example 2.

AIRFOIL SECTION: N.A.C.A.-CYH

Station	0	$\frac{1}{2}$	1	$1\frac{1}{2}$	2	$2\frac{1}{2}$	3	$3\frac{1}{2}$	4	$4\frac{1}{2}$	5
Upper camber	$\frac{11}{64}$	$\frac{31}{64}$	$\frac{9}{16}$	$\frac{37}{64}$	$\frac{9}{16}$	$\frac{17}{32}$	$\frac{29}{64}$	$\frac{3}{8}$	$\frac{9}{32}$	$\frac{3}{16}$	$\frac{7}{64}$
Lower camber	$\frac{11}{64}$	$\frac{1}{64}$	0	0	0	0	0	0	$\frac{1}{64}$	$\frac{3}{64}$	$\frac{3}{32}$

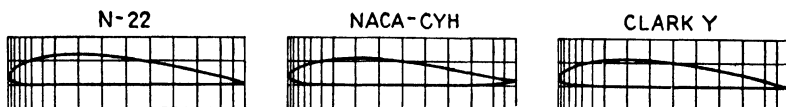

Fig. 182.

The airfoil section N-22 is used for a wing rib on the Swallow; N.A.C.A.-CYH, which resembles the Clark Y very closely, is used on the Grumman G-37.

3. Find the data for the section in Fig. 183 by measuring to the nearest 64th.

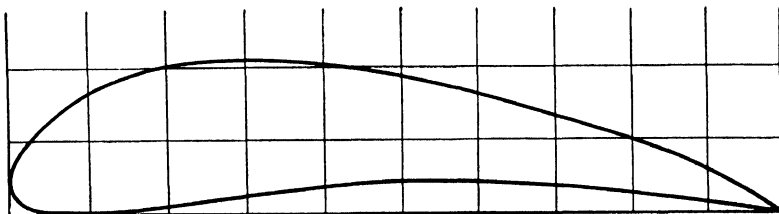

Fig. 183.

4. Draw up the Clark Y airfoil section from the data in Fig. 184.

AIRFOIL SECTION:  
CLARK Y

STA.	UPPER	LOWER
0	$\frac{11}{32}$	$\frac{11}{32}$
1	$\frac{61}{64}$	$\frac{1}{32}$
2	$1\frac{9}{64}$	0
3	$1\frac{11}{64}$	0
4	$1\frac{9}{64}$	0
5	$1\frac{3}{64}$	0
6	$\frac{59}{64}$	0
7	$\frac{47}{64}$	0
8	$\frac{9}{16}$	0
9	$\frac{25}{64}$	0
10	$\frac{1}{64}$	0

The Clark Y airfoil section is used in many planes, such as the Aeronca shown here. Note: All dimensions are in inches.

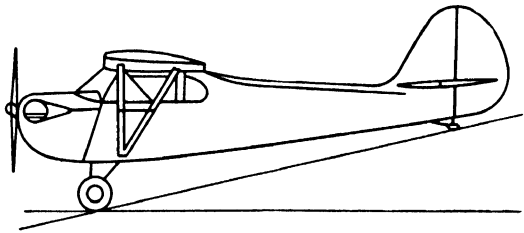

Fig. 184.

5. Make your own airfoil section, and find the data for it by measurement with the steel rule.

### Job 3: When the Data Are Given in Per Cent of Chord

Here all data, including stations and upper and lower cambers, are given as percentages. This allows the mechanic to use the data for *any rib size* he wants; but he must first do some elementary arithmetic.

#### ILLUSTRATIVE EXAMPLE

A mechanic wants to build a Clark Y rib whose chord length is 30 in. Obtain the data for this size rib from the N.A.C.A. data given in Fig. 185. In order to keep the work as neat as possible and avoid any error, copy the arrangement shown in Fig. 185.

It will be necessary to change every per cent in the N.A.C.A. data to inches. This should be done for all the stations and the upper camber and the lower camber.

## AIRFOIL SECTION: CLARK Y, 30-IN. CHORD

N.A.C.A. data (in percentages)			Your data (in decimals)		
Station	Upper	Lower	Station	Upper	Lower
0	3.50	3.50			
10	9.60	0.42			
20	11.36	0.03			
30	11.70	0			
40	11.40	0			
50	10.52	0			
60	9.15	0			
70	7.35	0			
80	5.22	0			
90	2.80	0			
100	0.12	0			

Fig. 185.

*Stations:*

Arrange your work as follows, in order to obtain first the stations for the 30-in. rib.

Rib Size, In.	Stations, Per Cent	Stations, In.
30	$\times 0\% = 30 \times 0.00 =$	0
30	$\times 10\% = 30 \times 0.10 =$	3.0
30	$\times 20\% = 30 \times 0.20 =$	6.0
30	$\times 30\% = 30 \times 0.30 =$	9.0
30	$\times 40\% = 30 \times 0.40 =$	12.0

Calculate the rest of the stations yourself and fill in the proper column in Fig. 185.

*Upper Camber:* Arrange your work in a manner similar to the foregoing.

Rib Size, In.	Upper Camber, Per Cent	Upper Camber, In.
30 ×	$3.50\% = 30 \times .0350 = 1.050$	
30 ×	$9.60\% = 30 \times .0960 = 2.880$	
30 ×	$11.36\% =$	

Calculate the rest of the points on the upper camber. Insert these in the appropriate spaces in Fig. 185. Do the same for the lower camber.

AIRFOIL SECTION: CLARK Y, 30-IN CHORD

Data in decimals, in.			Data in fractions, in.		
Station	Upper	Lower	Station	Upper	Lower
0	1.050	1.050			
3	2.880	0.126			
6	3.408	0.009			
9	3.510	0			
12	3.420	0			
15	3.156	0			
18	2.745	0			
21	2.205	0			
24	1.566	0			
27	0.840	0			
30	0.036	0			

Fig. 186.

The data in decimals may be the final step before layout of the wing rib, providing a rule graduated in decimal parts of an inch is available.

If however, a rule graduated in ruler fractions is the only instrument available, it will be necessary to change the decimals to ruler fractions, generally speaking, accurate to the nearest 64th. It is suggested that the arrangement shown in Fig. 186 be used. Notice that the data in decimals are the answers obtained in Fig. 185.

It is a good idea, at this time, to review the use of the decimal equivalent chart, Fig. 64.

**Examples:**

1. Calculate the data for a 15-in. rib of airfoil N-22, and draw the airfoil section (see Fig. 187).

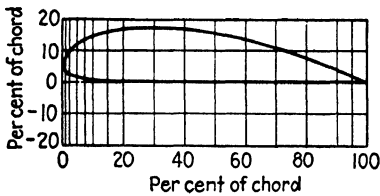

Clark Y-18.

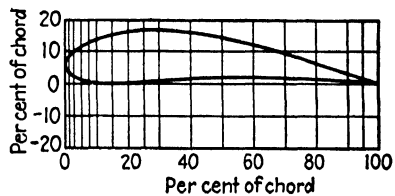

Sikorsky GS-M.

N-22			SIKORSKY GS-M		
Station	Upper	Lower	Station	Upper	Lower
0	3.37	3.37	0	5.58	5.58
10	10.13	0.16	10	13.62	0.18
20	12.01	0.00	20	16.25	0.26
30	12.42	0.05	30	16.72	0.89
40	12.01	0.15	40	16.10	1.48
50	11.04	0.24	50	14.51	1.75
60	9.57	0.30	60	12.18	1.80
70	7.68	0.32	70	9.42	1.64
80	5.51	0.24	80	6.44	1.23
90	3.06	0.12	90	3.37	0.65
100	0.40	0.00	100	0.09	0.09

Fig. 187.

2. Data in per cent of chord are given in Fig. 187 for airfoil Sikorsky GS-M. Convert these data to inches for a 9-in. rib, and draw the airfoil section.

3. Draw a 12-in. diagram of airfoil section Clark Y-18 from the following data:

AIRFOIL SECTION: CLARK Y-18

Station	Upper	Lower	Station	Upper	Lower
0	5.38	5.38	60	14.07	0
10	14.76	0.65	70	11.30	0
20	17.47	0.05	80	8.03	0
30	18.00	0	90	4.31	0
40	17.53	0	100	0.18	0
50	16.19	0			

4. Make a 12-in. solid wood model rib of the Clark Y-18.

#### Job 4: The Nosepiece and Tail Section

It has probably been observed that stations 0 per cent and 10 per cent are *not* sufficient to give all the necessary

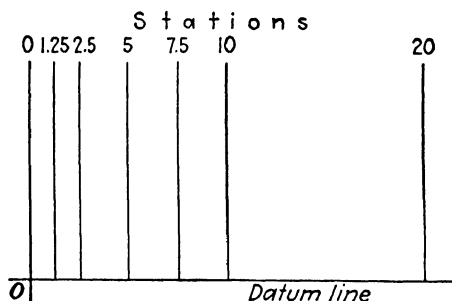

Fig. 188.—Stations between 0 and 10 per cent of the chord.

points for rounding out the nosepiece. As a result there are given, in addition to 0 and 10 per cent, several more intermediate stations (see Fig. 188).

#### ILLUSTRATIVE EXAMPLE

Obtain the data in inches for a nosepiece of a Clark Y airfoil based on a 30-in. chord.

Clark Y (per cent of chord)		
Stations	Upper	Lower
0	3.50	3.50
1.25	5.45	1.93
2.5	6.50	1.47
5.0	7.90	0.93
7.5	8.85	0.63
10	9.60	0.42

Your data (in decimals)		
Stations	Upper	Lower

Here the intermediate stations are calculated exactly as before:

Stations:

Rib Size, In.	Stations, Per Cent	Stations, In.
30	$\times 0\%$	$= 30 \times 0 = 0$
30	$\times 1.25\%$	$= 30 \times 0.0125 = 0.375$
30	$\times 2.5\%$	$= 30 \times 0.025 = 0.750$

In a similar manner, calculate the remainder of the stations and the points on the upper and lower cambers.

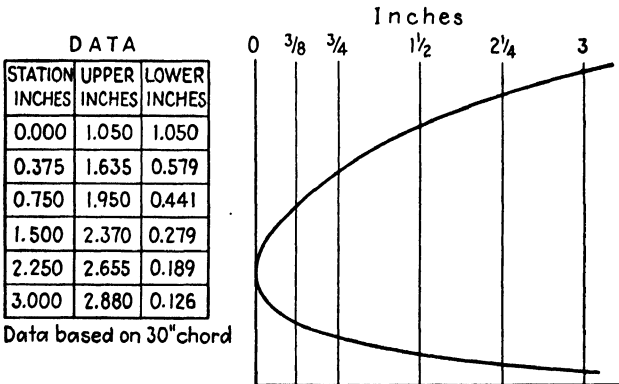

Fig. 189.—Nosepiece: Clark Y airfoil section.



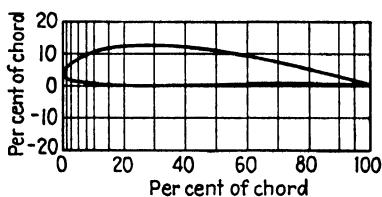

Fig. 191.—Section: N-60.

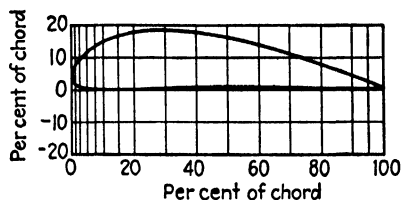

Fig. 192.—Section: U.S.A. 35A.

AIRFOIL: N-60

AIRFOIL: U.S.A. 35A

Station	Upper	Lower	Station	Upper	Lower
0	3.40	3.40	0	4.33	4.33
1.25	5.60	1.91	1 $\frac{1}{4}$	8.09	1.62
2.5	6.76	1.46	2 $\frac{1}{2}$	9.54	1.00
5.0	8.24	0.96	5	11.81	0.46
7.5	9.33	0.62	7 $\frac{1}{2}$	13.58	0.22
10	10.14	0.40	10	14.85	0.10

3-4. Draw the tail sections of the airfoils in the following tables for a 5-ft. chord.

AIRFOIL: N-60

AIRFOIL: U.S.A. 35A

Station	Upper	Lower	Station	Upper	Lower
70	7.66	0.78	70	11.11	0.60
80	5.50	0.64	80	7.88	0.50
90	3.04	0.37	90	4.31	0.32
95	1.72	0.19	95	2.39	0.19
100	0.40	0.00	100	0.43	0.00

### Job 5: The Thickness of Airfoils

It has certainly been observed that there are wide variations in the thickness of the airfoils already drawn.

The cantilever wing, which is braced internally, is more easily constructed if the thickness of the airfoil permits work to be done inside of it. A thick wing section also permits additional space for gas tanks, baggage, etc.

On the other hand, a thin wing section has considerably less drag and is therefore used in light speedy planes.

It is very easy to calculate the thickness of an airfoil from either N.A.C.A. data in per cent of chord, or from the data in inches or feet.

Since the wing rib is not a flat form, there is a different thickness at every station, and a maximum thickness at about one-third of the way back from the leading edge (see Fig. 193).

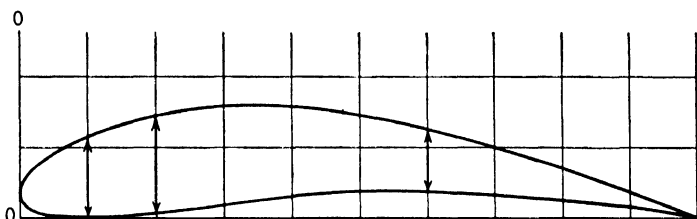

Fig. 193.

## ILLUSTRATIVE EXAMPLE

Find the thickness in inches of the airfoil I.S.A. 695 at all stations given in the data in Fig. 194.

*Method:*

To find the thickness of the airfoil at any station simply subtract the "lower" point from the "upper" point. Complete the table shown in Fig. 194 after copying it *in your notebook*.

**Examples:**

1. Find the thickness at all stations of the airfoil section in the following table, in fractions of an inch accurate to the nearest 64th. Data are given in inches for a 10-in. chord.

AIRFOIL SECTION: U.S.A. 35B

Station	Upper	Lower	Station	Upper	Lower
0	0.276	0.276	5	1.033	0.039
$\frac{1}{2}$	0.752	0.028	6	0.881	0.045
1	0.945	0.007	7	0.708	0.042
2	1.128	0.005	8	0.502	0.035
3	1.176	0.015	9	0.272	0.020
4	1.142	0.028	10	0.025	0.000

2. Figure 193 shows an accurate drawing of an airfoil. Make a table of data accurate to the nearest 64th for this airfoil, so that it could be drawn from the data alone.

3. Find the thickness of the airfoil in Fig. 193 at all stations, by actual measurement. Check the answers thus

AIRFOIL SECTION: I.S.A. 695

Data in inches			Thickness in inches	
Station	Upper	Lower	Station	Thickness
0	0.500	0.500	0	
1	1.232	0.052	1	
2	1.515	0.027	2	
3	1.620	0.142	3	
4	1.575	0.245	4	1.330
5	1.412	0.310	5	
6	1.160	0.337	6	
7	0.845	0.310	7	
8	0.527	0.220	8	
9	0.245	0.095	9	
10	0.043	0.000	10	

Fig. 194.

obtained with the thickness at each station obtained by using the results of Example 2.

### **Job 6: Airfoils with Negative Numbers**

It may have been noticed that thus far all the airfoils shown were entirely above the datum line. There are, however, many airfoils that have parts of their lower camber

below the datum line. This is indicated by the use of negative numbers.

**Definition:**

A *negative number* indicates a change of direction (see Fig. 195).

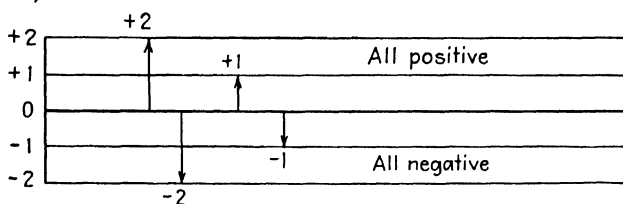

Fig. 195.

**Examples:**

1. Complete the table in Fig. 196 from the information given in the graph.

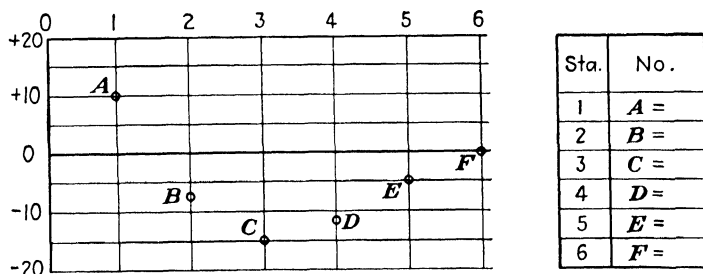

Fig. 196.

2. Give the approximate positions of all points on both the upper and lower camber of the airfoil in Fig. 197.

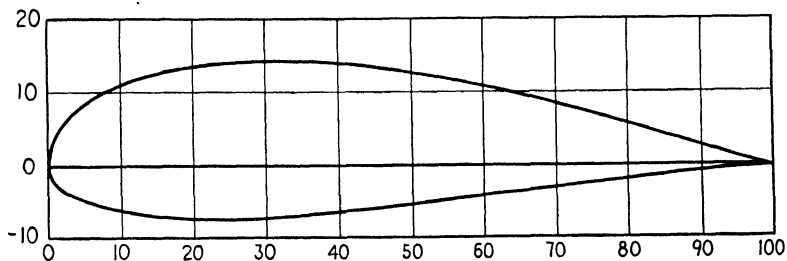

Fig. 197.

**Airfoil Section.** N.A.C.A. 2212 is a good example of an airfoil whose lower camber falls below the datum line. Every point on the lower camber has a minus (−) sign in front of it, except 0 per cent which is neither positive nor negative, since it is right on the datum line (see Fig. 198).

Notice that there was no sign in front of the positive numbers. A number is considered positive (+) unless a minus (−) sign appears in front of it.

In drawing up the airfoil, it has been stated that these per cents must be changed to decimals, depending upon the rib size wanted, and that sometimes it may be necessary to change the decimal fractions to ruler fractions.

The methods outlined for doing this work when all numbers are positive (+), apply just as well when numbers are negative (−). The following illustrative example will show how to locate the points on the lower camber only since all other points can be located as shown in previous jobs.

#### ILLUSTRATIVE EXAMPLE

Find the points on the lower camber for a 15-in. rib whose airfoil section is N.A.C.A. 2212. Data are given in Fig. 198.

AIRFOIL SECTION: N.A.C.A. 2212

Data in per cent of chord

STA.	UP'R.	L'W'R.
0	—	0
1.25	2.44	−1.46
2.5	3.35	−1.96
5.0	4.62	−2.55
7.5	5.55	−2.89
10	6.27	−3.11
15	7.25	−3.44
20	7.74	−3.74
25	7.93	−3.94
30	7.97	−4.03
40	7.68	−3.92
50	7.02	−3.56
60	6.07	−3.05
70	4.90	−2.43
80	3.52	−1.74
90	1.93	−0.97
95	1.05	−0.56
100	—	0

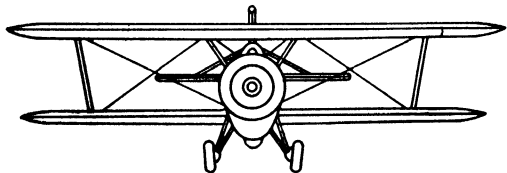
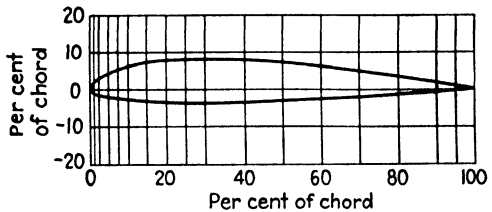

Fig. 198.—The Bell BG-1 uses this section. (Diagram of plane, courtesy of Aviation.)

Rib Size, In.	Lower Camber, Per Cent		Lower Camber, In.		Lower Camber, Fractions
15 ×	0%	= 15 ×	0	= 0	= 0
15 ×	-1.46%	= 15 ×	-0.0146	= -0.2190	= $-\frac{7}{32}$
15 ×	-1.96%	= 15 ×	-0.0196	= -0.2940	= $-\frac{19}{64}$
15 ×	-2.55%	= 15 ×	-0.0255	= -0.3825	= $-\frac{3}{8}$
15 ×	-2.89%	=	=	=	=

The position of the points on the lower camber, as well as the complete airfoil, is shown in Fig. 198.

Examples:

1. Draw a 15-in. rib of the N.A.C.A. 2212 (Fig. 198).
2. Draw the nosepiece (0-10 per cent) of the N.A.C.A. 2212 for a 6-ft. rib.
3. Find the data for a 20-in. rib of airfoil section N.A.C.A. 4418 used in building the wing of the Gwinn Aircar (Fig. 199).

AIRFOIL SECTION: N.A.C.A. 4418  
Data in per cent of chord

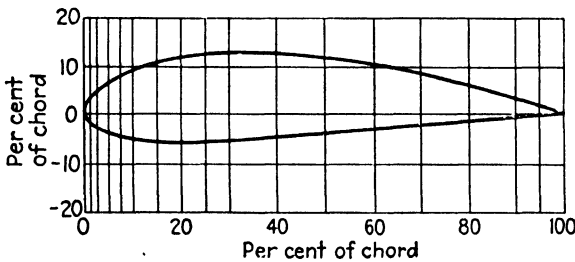

STA.	UP'R.	L'W'R.
0	—	0
1.25	3.76	-2.11
2.5	5.00	-2.99
5.0	6.75	-4.06
7.5	8.06	-4.67
10	9.11	-5.06
15	10.66	-5.49
20	11.72	-5.56
25	12.40	-5.49
30	12.76	-5.26
40	12.70	-4.70
50	11.85	-4.02
60	10.44	-3.24
70	8.55	-2.45
80	6.22	-1.67
90	3.46	-0.93
95	1.89	-0.55
100	—	0

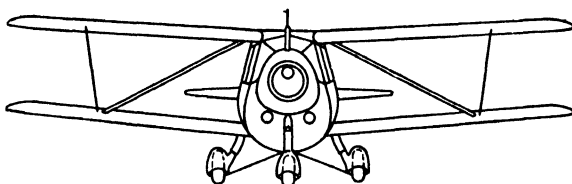

Fig. 199.—The Gwinn Aircar uses this section.

## Job 7: Review Test

1. Calculate the data necessary to lay out a 12-in. rib of the airfoil section shown in Fig. 200. All data are in per cent of chord.

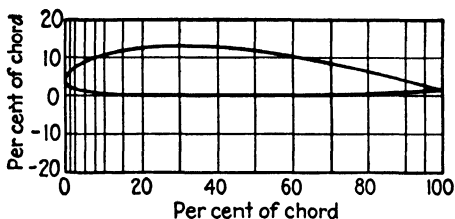

Fig. 200.—Airfoil section: Boeing 103.

AIRFOIL SECTION: BOEING 103

Station	Upper	Lower	Station	Upper	Lower
0	3.56	3.56	40	12.42	0.00
1.25	6.10	2.20	50	11.56	0.02
2.5	7.17	1.73	60	10.21	0.11
5.0	8.56	1.22	70	8.38	0.25
7.5	9.55	0.88	80	6.26	0.46
10	10.35	0.64	90	3.84	0.71
15	11.53	0.32	95	2.50	0.85
20	12.28	0.15	100	1.11	1.00
30	12.70	0.02			

2. Construct a table of data in inches for the nosepiece (0–15 per cent) of the airfoil shown in Fig. 201, based on a 6-ft. chord.

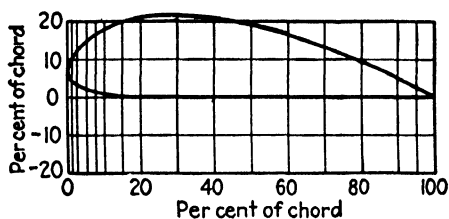

Fig. 201.—Airfoil section: Clark Y-22.

## AIRFOIL SECTION: CLARK Y-22

Station	Upper	Lower	Station	Upper	Lower
0	6.58	6.58	40	21.44	0
1.25	10.25	3.63	50	19.78	0
2.5	12.22	2.77	60	17.20	0
5.0	14.85	1.75	70	13.83	0
7.5	16.63	1.19	80	9.83	0
10	18.05	0.79	90	5.27	0
15	20.10	0.28	95	2.81	0
20	21.37	0.06	100	0.23	0
30	22.00	0			

3. What is the thickness in inches at each station of a Clark Y-22 airfoil (Fig. 201) using a 10-ft. chord?

4. Construct a 12-in. rib of the airfoil section N.A.C.A. 2412, using thin sheet aluminum, or wood, as a material. This airfoil is used in constructing the Luscombe model 90 (Fig. 202).

## AIRFOIL SECTION: N.A.C.A. 2412

Data in per cent of chord

STA.	UP'R.	L'W'R.
0	—	0
1.25	2.15	-1.65
2.5	2.99	-2.27
5.0	4.13	-3.01
7.5	4.96	-3.46
10	5.63	-3.75
15	6.61	-4.10
20	7.26	-4.23
25	7.67	-4.22
30	7.88	-4.12
40	7.80	-3.80
50	7.24	-3.34
60	6.36	-2.76
70	5.18	-2.14
80	3.75	-1.50
90	2.08	-0.82
95	1.14	-0.48
100	0.13	-0.13

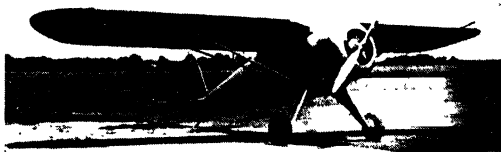
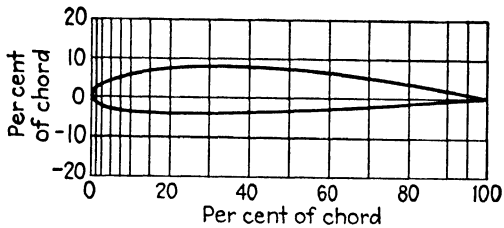
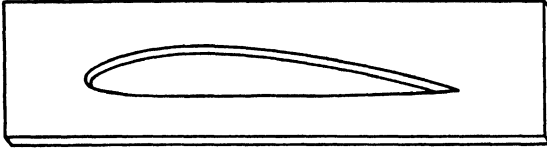

Fig. 202.—The Luscombe 90 uses this section.

5. Construct a completely solid model airplane wing whose span is 15 in. and whose chord is 3 in., and use the airfoil section Boeing 103, data for which are given in Example 1.

*Hint:* Make a metal template of the wing section to use as a guide (see Fig. 203).



**Fig. 203.**—Wing-section template.

## **Part III**

# **MATHEMATICS OF MATERIALS**

### **Chapter X: Strength of Material**

- Job 1: Tension
- Job 2: Compression
- Job 3: Shear
- Job 4: Bearing
- Job 5: Required Cross-sectional Area
- Job 6: Review Test

### **Chapter XI: Fittings, Tubing, and Rivets**

- Job 1: Safe Working Strength
- Job 2: Aircraft Fittings
- Job 3: Aircraft Tubing
- Job 4: Aircraft Rivets
- Job 5: Review Test

### **Chapter XII: Bend Allowance**

- Job 1: The Bend Allowance Formula
- Job 2: The Over-all Length of the Flat Pattern
- Job 3: When Inside Dimensions Are Given
- Job 4: When Outside Dimensions Are Given
- Job 5: Review Test



## Chapter X

# STRENGTH OF MATERIALS

“A study of handbooks of maintenance of all metal transport airplanes, which are compiled by the manufacturers for maintenance stations of the commercial airline operators, shows that large portions of the handbooks are devoted to detailed descriptions of the structures and to instructions for repair and upkeep of the structure. In handbooks for the larger airplanes, many pages of tables are included, setting forth the *material* of every structural part and the *strength characteristic* of each item used. What does this mean to the airplane mechanic?

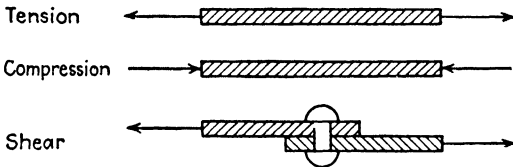

Fig. 204.

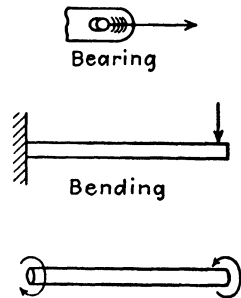

Fig. 205.

It means that in the repair stations of these airlines *the shop personnel is expected to maintain the structural strength of the airplanes.*<sup>1</sup>

When working at a structural job, every mechanic must take into consideration at least three fundamental stresses, tension, compression, and shear (see Fig. 204). In addition there are other stresses which may be analyzed in terms of these three fundamental stresses (see Fig. 205).

<sup>1</sup> FROM YOUNGER, J. H., A. F. BONNALIE, and N. F. WARD, *Airplane Maintenance*, McGraw-Hill Book Company, Inc., Chap. I.

The purpose of this chapter is to explain the elementary, fundamental principles of the strength of materials.

### Job 1: Tension

**A. Demonstration 1.** Take three wires—one aluminum, one copper, and one steel—all  $\frac{1}{8}$  in. in diameter and suspend them as shown in Fig. 207.

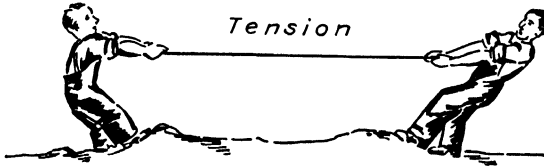

Fig. 206.

Note that the aluminum wire will hold a certain amount of weight, let us say 2 lb., before it breaks; the copper will hold more than 4 lb.; and the steel wire will hold much more than either of the others. We can, therefore, say that the tensile strength of steel is greater than the tensile strength of either copper or aluminum.

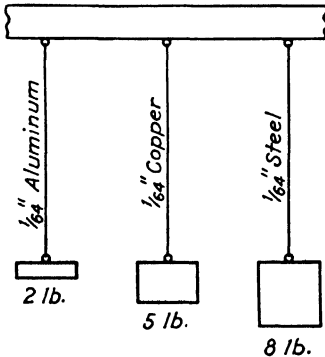

Fig. 207.

#### Definition:

The *tensile strength* of an object is the amount of weight it will support in tension before it fails.

The American Society for Testing Materials has used elaborate machinery to test most structural materials, and published their figures for everybody's benefit. These figures, which are based upon a cross-sectional area of 1 sq. in., are called the *ultimate tensile strengths* (U.T.S.).

#### Definition:

*Ultimate tensile strength* is the amount of weight a bar 1 sq. in. in cross-sectional area will support in tension before it fails.

TABLE 8.—ULTIMATE TENSILE STRENGTHS  
(In lb. per sq. in.)

Aluminum.....	13,000
Cast iron.....	20,000
Copper.....	32,000
Low-carbon steel.....	50,000
Dural-tempered.....	55,000
Brass.....	60,000
Nickel steel.....	125,000
High-carbon steel..	175,000

**Examples:**

1. Name 6 stresses to which materials used in construction may be subjected.

2. What is the meaning of tensile strength?

3. Define ultimate tensile strength.

4. Draw a bar graph comparing the tensile strength of the materials in Table 8.

**B. Demonstration 2.** Take three wires, all aluminum, of these diameters:  $\frac{1}{32}$  in.,  $\frac{1}{16}$  in.,  $\frac{1}{8}$  in., and suspend them as shown in Fig. 208.

Notice that the greater the diameter of the wire, the greater is its tensile strength. Using the data in Fig. 208, complete the following table *in your own notebook*.

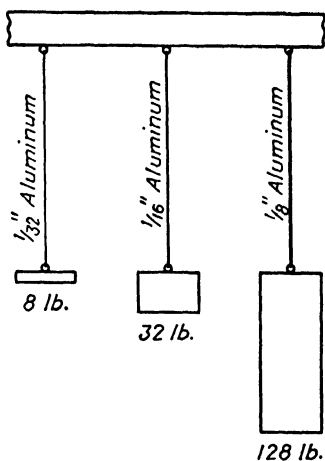

Fig. 208.

Diameter of wire, in.	Cross-sectional area, sq. in.	Tensile strength, lb.
$\frac{1}{32}$		
$\frac{1}{16}$		
$\frac{1}{8}$		

## Questions:

1. How many times is the second wire greater than the first in (a) cross-sectional area? (b) strength?
2. How many times is the third wire greater than the second in (a) area? (b) strength?
3. What connection is there between the cross-sectional area and the tensile strength?
4. Would you say that the strength of a material depended directly on its cross-sectional area? Why?
5. Upon what other factor does the tensile strength of a material depend?

Many students think that the length of a wire affects its tensile strength. Some think that the shape of the cross section is important in tension. Make up experiments to prove or disprove these statements.

Name several parts of an airplane which are in tension.

**C. Formula for Tensile Strength.** The tensile strength of a material depends on only (a) cross-sectional area ( $A$ ); (b) ultimate tensile strength (U.T.S.).

$$\text{Formula: Tensile strength} = A \times \text{U.T.S.}$$

The ultimate tensile strengths for the more common substances can be found in Table 8, but the areas will in most cases require some calculation.

## ILLUSTRATIVE EXAMPLE

Find the tensile strength of a  $\frac{3}{8}$ -in. aluminum wire.

Given: Cross section: circle

$$\text{Diameter} = \frac{3}{8} \text{ in.}$$

$$\text{U.T.S.} = 13,000 \text{ lb. per sq. in.}$$

Find:

- a. Cross-sectional area
- b. Tensile strength

$$a. \text{ Area} = 0.7854 \times D^2$$

$$\text{Area} = 0.7854 \times \frac{3}{8} \times \frac{3}{8}$$

$$\text{Area} = 0.1104 \text{ sq. in. } \textit{Ans.}$$

- b. Tensile strength =  $A \times \text{U.T.S.}$   
 Tensile strength =  $0.1104 \times 13,000$   
 Tensile strength = 1,435.2 lb. *Ans.*

## Examples:

1. Find the tensile strength of a  $\frac{3}{8}$ -in. dural wire.
2. How strong is a  $\frac{1}{2}$  by  $2\frac{1}{2}$ -in. cast-iron bar in tension?
3. Find the strength of a  $\frac{3}{16}$ -in. brass wire.
4. What load will cause failure of a  $\frac{3}{8}$ -in. square dural rod in tension (see Fig. 209)?



Fig. 209.—Tie rod, square cross section.

5. Find the strength in tension of a dural fitting at a point where its cross section is  $\frac{1}{16}$  by  $\frac{1}{2}$  in.
6. Two copper wires are holding a sign. Find the greatest possible weight of the sign if the wires are each  $\frac{1}{8}$  in. in diameter.
7. A load is being supported by four  $\frac{1}{2}$ -in. nickel-steel bolts in tension. What is the strength of this arrangement?
8. A mechanic tried to use 6 aluminum  $\frac{1}{2}$ -in. rivets to support a weight of 200 lb. in tension. Will the rivets hold?
9. Which has the greater tensile strength: (a) 5 H.C. steel  $\frac{3}{4}$ -in. wires, or (b) 26 dural wires each  $\frac{1}{4}$  in. in diameter?
10. What is the greatest weight that a dural strap  $\frac{7}{8}$  by  $3\frac{3}{2}$  in. can support in tension? What would be the effect of drilling a  $\frac{1}{2}$ -in. hole in the center of the strap?

**Job 2: Compression**

There are some ductile materials like lead, silver, copper, aluminum, steel, etc., which do not break, no matter how much pressure is put on them. If the compressive force is great enough, the material will become deformed (see Fig. 211).

On the other hand, if concrete or cast iron or woods of various kinds are put in compression, they will shatter

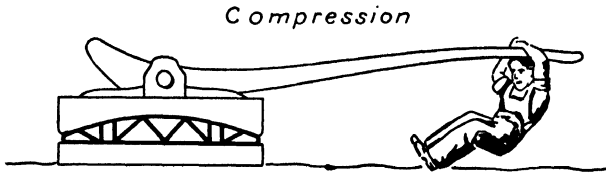

Fig. 210

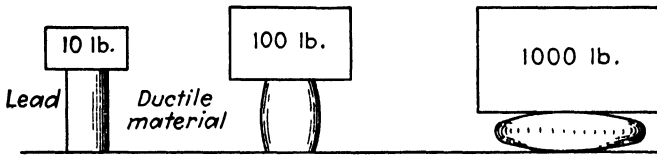

Fig. 211.

into many pieces if too much load is applied. Think of what might happen to a stick of chalk in a case like that shown in Fig. 212.

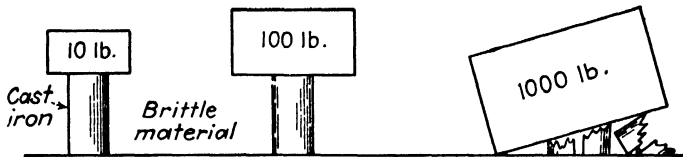

Fig. 212.

### Definitions:

*Ultimate compressive strength* (for brittle materials) is the number of pounds 1 sq. in. of the material will support in compression before it breaks.

*Ultimate compressive strength* (for ductile materials) is the number of pounds 1 sq. in. of the material will support in compression before it becomes deformed.

For ductile materials the compressive strength is equal to the tensile strength.

**TABLE 9.—ULTIMATE COMPRESSIVE STRENGTHS**  
(In lb. per sq. in.)

	Parallel to grain	Across the grain
Maple.....	8,000	1,300
Spruce.....	7,000	700
White pine.....	5,000	700
White oak.....	8,500	2,200
<hr/>		
Concrete.....		2,000
Gray cast iron.....		75,000

The formula for calculating compressive strength is very much like the formula for tensile strength:

**Formula: Compressive strength =  $A \times \text{U.C.S.}$**

where  $A$  = cross section in compression.

U.C.S. = ultimate compressive strength.

### ILLUSTRATIVE EXAMPLE

Find the compressive strength of a  $\frac{1}{2}$  by  $\frac{3}{4}$  in. bar of white pine, used parallel to the grain.

Given: Cross section: rectangle

$$L = \frac{3}{4} \text{ in.}, \quad W = \frac{1}{2} \text{ in.}$$

$$\text{U.C.S.} = 5,000 \text{ lb. per sq. in.}$$

Find: a. Cross-sectional area

b. Compressive strength

a.  $A = L \times W$

$$A = \frac{3}{4} \times \frac{1}{2}$$

$$A = \frac{3}{8} \text{ sq. in.} \quad \text{Ans.}$$

b. Compressive strength =  $A \times \text{U.C.S.}$

$$\text{Compressive strength} = \frac{3}{8} \times 5,000$$

$$\text{Compressive strength} = 1,875 \text{ lb.} \quad \text{Ans.}$$

**Examples:**

1. What is the strength in compression of a 3 by  $5\frac{1}{2}$ -in. gray cast-iron bar?

2. How much will a beam of white pine,  $4\frac{7}{8}$  in. square, support if it is used (a) parallel to the grain? (b) across the grain?

3. Four blocks of concrete, each 2 by 2 ft. in cross section, are used to hold up a structure. Under what load would they fail?

4. What is the strength of a  $\frac{3}{4}$ -ft. round column of concrete?

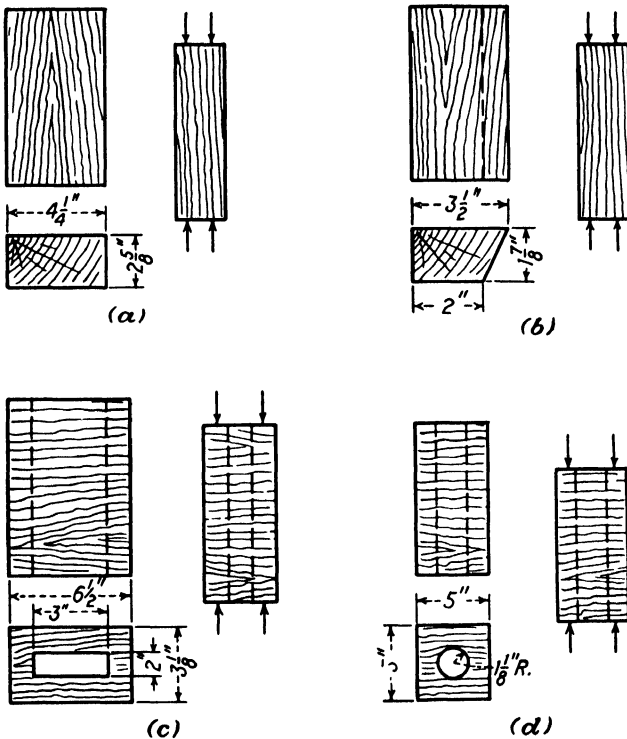

Fig. 213.—All blocks are of spruce.

5. What is the strength of a 2-in. H.C. steel rod in compression?

6. Find the strength in compression of each of the blocks of spruce shown in Fig. 213.

### Job 3: Shear

Two plates, as shown in Fig. 215, have a tendency to cut a rivet just as a pair of scissors cuts a thread.

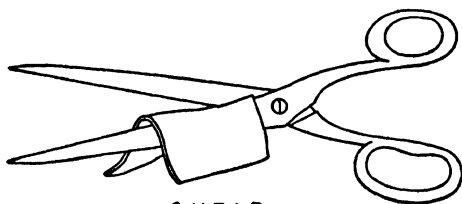

SHEAR  
Fig. 214.

The strength of a rivet, or any other material, in shear, that is, its resistance to being cut, depends upon its cross-sectional area and its ultimate shear strength.

Formula:  $\text{Shear strength} = A \times \text{U.S.S.}$

where  $A$  = cross-sectional area in shear.

U.S.S. = ultimate shear strength.

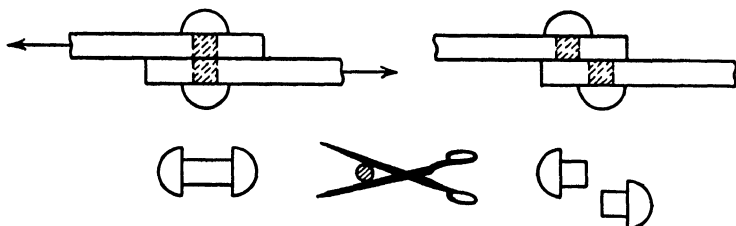

Fig. 215.

TABLE 10.—ULTIMATE SHEAR STRENGTHS  
(In lb. per sq. in.)

S.A.E. 1015.....	25,000	Copper.....	30,000
S.A.E. 1025.....	35,000	Brass.....	36,000
S.A.E. 2330.....	80,000		
S.A.E. X-4130.....	60,000	Spruce.....	750

The strength in shear of aluminum and aluminum alloy rivets is given in Chap. XI.

Do these examples without any assistance from an illustrative example.

Examples:

1. Find the strength in shear of a nickel steel pin (S.A.E. 2330)  $\frac{7}{16}$  in. in diameter.

2. A chrome-molybdenum pin (S.A.E. X-4130) is  $\frac{3}{8}$  in. in diameter. What is its strength in shear?
3. What is the strength in shear of a  $\frac{3}{16}$ -in. brass rivet?
4. A  $2\frac{1}{2}$  by  $1\frac{1}{4}$ -in. spruce beam will withstand what maximum shearing load?
5. What is the strength in shear of three  $\frac{3}{32}$ -in. S.A.E. 1015 rivets?

**Job 4: Bearing**

Bearing stress is a kind of compressing or crushing force which is met most commonly in riveted joints. It usually shows up by stretching the rivet hole and crushing the surrounding plate as shown in Fig. 216.

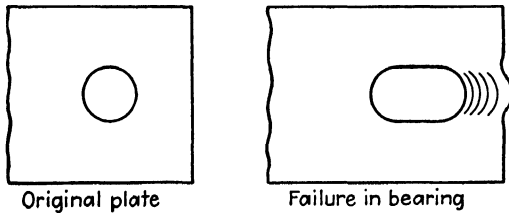

Fig. 216.

The bearing strength of a material depends upon 3 factors: (a) the kind of material; (b) the bearing area; (c) the edge distance of the plate.

The material itself, whether dural or steel or brass, will determine the *ultimate bearing strength* (U.B.S.), which is approximately equal to  $\frac{3}{2}$  times the ultimate tensile strength.

TABLE 11.—ULTIMATE BEARING STRENGTH  
(In lb. per sq. in.)

Material	U.B.S.
Aluminum.....	18,000
Dural-tempered.....	75,000
Cast iron.....	100,000
Low-carbon steel.....	75,000
High-carbon steel.....	220,000
Nickel steel.....	200,000

Bearing area is equal to the thickness of the plate multiplied by the hole diameter (see Fig. 217).

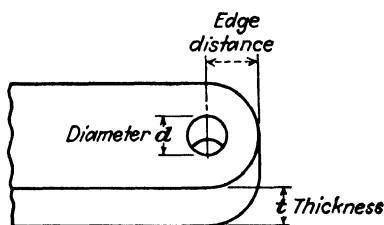

Fig. 217.

$$\begin{aligned} \text{Formulas: Bearing area} &= t \times d \\ \text{Bearing strength} &= A \times \text{U.B.S.} \end{aligned}$$

where  $t$  = thickness of plate.

$d$  = diameter of the hole.

$A$  = bearing area.

U.B.S. = ultimate bearing strength.

All the foregoing work is based on the assumption that the edge distance is at least twice the diameter of the hole, measured from the center of the hole to the edge of the plate. For a smaller distance the bearing strength falls off.

#### ILLUSTRATIVE EXAMPLE

Find the strength in bearing of a dural plate  $\frac{1}{8}$  in. thick with a  $\frac{3}{16}$ -in. rivet hole.

Given:  $t = \frac{1}{8}$

$d = \frac{3}{16}$

Find: a. Bearing area

b. Bearing strength

a. Bearing area =  $t \times d$

Bearing area =  $\frac{1}{8} \times \frac{3}{16}$

Bearing area =  $\frac{3}{128}$  sq. in. *Ans.*

b. Bearing strength =  $A \times \text{U.B.S.}$

Bearing strength =  $\frac{3}{128} \times 75,000$

Bearing strength = 1,758 lb. *Ans.*

Examples:

1. Find the bearing strength of a  $\frac{5}{8}$ -in. cast-iron fitting with a  $\frac{3}{8}$ -in. rivet hole.

2. Find the bearing strength of a nickel-steel lug  $\frac{1}{8}$  in. thick which is drilled to carry a  $\frac{3}{16}$ -in. pin.

3. What is the strength in bearing of a  $\frac{1}{8}$ -in. dural plate with two  $\frac{3}{16}$ -in. rivet holes? Does the bearing strength depend upon the relative position of the rivet holes?

4. (a) What is the strength in bearing of the fitting in Fig. 218?

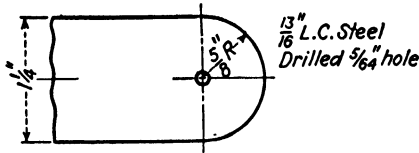

Fig. 218.

(b) How many times is the edge distance greater than the diameter of the hole? Measure edge distance from the center of the hole.

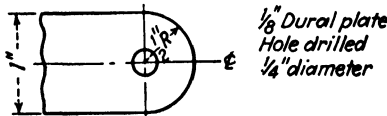

Fig. 219.

5. Find the bearing strength from the dimensions given in Fig. 219.

### **Job 5: Required Cross-sectional Area**

It has probably been noticed that the formulas for tension, compression, shear, and bearing are practically the same.

Strength in tension = area  $\times$  U.T.S.

Strength in compression = area  $\times$  U.C.S.

Strength in shear = area  $\times$  U.S.S.

Strength in bearing = area  $\times$  U.B.S.

Consequently, instead of dealing with four different formulas, it is much simpler to remember the following:

**Formula: Strength = cross-sectional area  $\times$  ultimate strength**

In this general formula, it can be seen that the strength of a material, whether in tension, compression, shear, or bearing, depends upon the cross-sectional area opposing the stress and the ultimate strength of the kind of material.

Heretofore the strength has been found when the dimensions of the material were given. For example, the tensile strength of a wire was found when its diameter was given. Suppose, however, that it is necessary to find the size (diameter) of a wire so that it be of a certain required strength, that is, able to hold a certain amount of weight. How was this formula obtained?

$$\text{Formula: Cross-sectional area} = \frac{\text{strength required}}{\text{ultimate strength}}$$

It will be necessary to decide from reading the example what stress is being considered and to look up the right table before doing any work with the numbers involved.

#### ILLUSTRATIVE EXAMPLE

What cross-sectional area should a dural wire have in order to hold 800 lb. in tension?

Given: Required strength = 800 lb.

Material = dural

U.T.S. = 55,000 lb. per sq. in.

Find: Cross-sectional area

$$\text{Area} = \frac{\text{strength required}}{\text{ultimate strength}}$$

$$\text{Area} = \frac{800}{55,000}$$

$$\text{Area} = 0.01454 \text{ sq. in. } \textit{Ans.}$$

Check: t.s. =  $A \times \text{U.T.S.} = 0.01454 \times 55,000 = 799.70 \text{ lb.}$

#### Questions:

1. Why doesn't the answer check exactly?
2. How would you find the diameter of the dural wire?

It is suggested that at this point the student review the method of finding the diameter of a circle whose area is given.

**Examples:**

1. Find the cross-sectional area of a low-carbon steel wire whose required strength is 3,500 lb. in tension. Check the answer.
2. What is the cross-sectional area of a square oak beam



Fig. 220.—Tie rod, circular cross section.

which must hold 12,650 lb. in compression parallel to the grain?

3. What is the length of the side of the beam in Example 2? Check the answer.
4. A rectangular block of spruce used parallel to the grain must have a required strength in compression of 38,235 lb. If its width is 2 in., what is the cross-sectional length?
5. A copper rivet is required to hold 450 lb. in shear. What is the diameter of the rivet? Check the answer.
6. Four round high-carbon steel tie rods are required to hold a total weight of 25,000 lb. What must be the diameter of each tie rod, if they are all alike? (See Fig. 220.)

**Job 6: Review Test**

1. Find the tensile strength of a square high-carbon steel tie rod measuring  $\frac{3}{64}$  in. on a side.

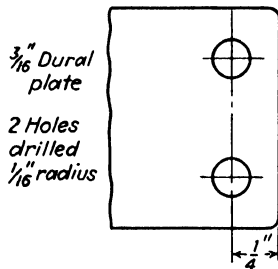
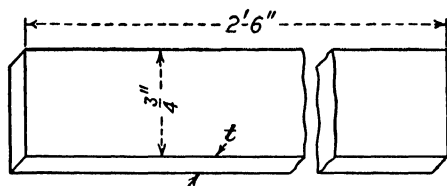

Fig. 221.

2. Find the strength in compression of a 2 by 1-in. oak beam if the load is applied parallel to the grain.

3. What is the strength in shear of a steel rivet (S.A.E. 1025) whose diameter is  $\frac{5}{32}$  in.?

4. What is the bearing strength of the fitting in Fig. 221?



**Fig. 222.**

5. What should be the thickness of a  $\frac{3}{4}$ -in. dural strip in order to hold 5,000 lb. in tension (see Fig. 222)?

6. If the strip in Example 5 were 2 ft. 6 in. long, how much would it weigh?

## Chapter XI

### FITTINGS, TUBING, AND RIVETS

The purpose of this chapter is to apply the information learned about calculating the strength of materials to common aircraft parts such as fittings, tubing, and rivets.

#### Job 1: Safe Working Stress

Is it considered safe to load a material until it is just about ready to break? For example, if a  $\frac{1}{16}$ -in. low-carbon steel wire were used to hold up a load of 140 lb., would it be safe to stand beneath it as shown in Fig. 223?

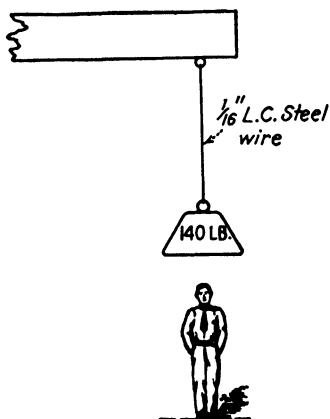

Fig. 223.—Is this safe?

Applying the formula tensile strength =  $A \times \text{U.T.S.}$  will show that this wire will hold nearly 145 lb. Yet it would not be safe to stand under it because

1. This particular wire might not be so strong as it should be.
2. The slightest movement of the weight or of the surrounding structure might break the wire.
3. Our calculations might be wrong, in which case the weight

might snap the wire at once.

For the sake of safety, therefore, it would be wiser to use a table of safe working strengths instead of a table of ultimate strengths in calculating the load a structure can withstand. Using the table of ultimate strengths will tell

approximately how much loading a structure can stand before it breaks. Using Table 12 will tell the maximum loading that can be piled *safely* on a structure.

**TABLE 12.—SAFE WORKING STRENGTHS**  
(In lb. per sq. in.)

Material	Tension	Compression	Shear	Bearing
Dural .....	20,000	20,000	10,000	26,000
L.C. steel.....	35,000	35,000	20,000	50,000
H.C. steel.....	60,000	60,000	36,000	90,000
Nickel steel.....	50,000	50,000	30,000	75,000

**Examples:**

1. What is the safe working strength of a  $\frac{3}{16}$ -in. dural wire in tension?
2. What diameter H.C. steel wire can be safely used to hold a weight of 5,500 lb.?
3. A nickel-steel pin is required to withstand a shearing stress of 3,500 lb. What diameter pin should be selected?
4. What should be the thickness of a L.C. steel fitting necessary to withstand a bearing stress of 10,800 lb., if the hole diameter is 0.125 in.?

**Job 2: Aircraft Fittings**

The failure of any fitting in a plane is very serious, and not an uncommon occurrence. This is sometimes due to a lack of understanding of the stresses in materials and how their strength is affected by drilling holes, bending operations, etc.

Figure 224 shows an internal drag-wire fitting, just before the holes are drilled.

**Questions:**

1. What are the cross-sectional area and tensile strength at line *BB'*, using Table 12?

2. Two  $\frac{1}{4}$ -in. holes are drilled. What are now the cross-sectional shape and area at line  $AA'$ ?
3. What is the tensile strength at  $AA'$ ?

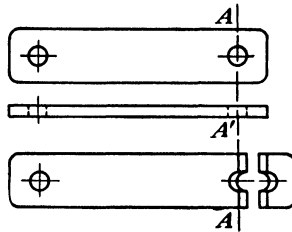
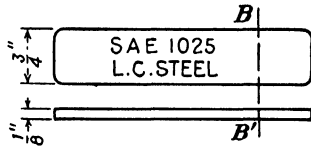

Fig. 224.

Examples:

1. Using Table 12, find the tensile strength of the fitting in Fig. 225, (a) at section  $BB'$ , (b) at section  $AA'$ . The material is  $\frac{1}{16}$ -in. low-carbon steel.
2. Suppose that a  $\frac{1}{2}$ -in. hole were drilled by a careless mechanic in the fitting in Fig. 225. What is the strength of this fitting in Fig. 226 now?

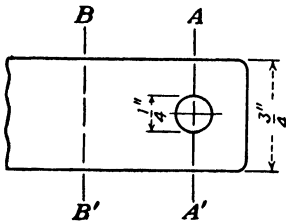

Fig. 225.

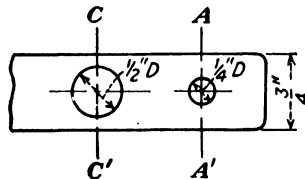

Fig. 226.

Is this statement true: "The strength of a fitting is lowered by drilling holes in it"?

Find the strength of the fittings in Fig. 227, using Table 12.

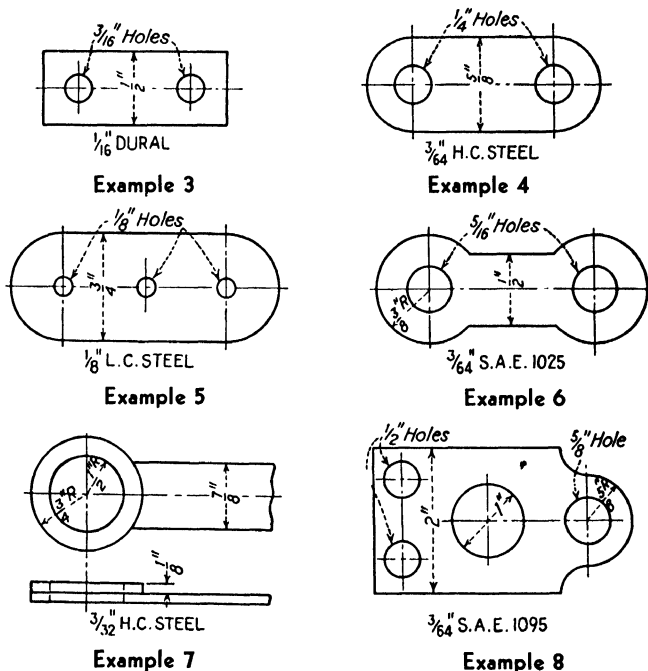

Fig. 227

### Job 3: Aircraft Tubing

The cross-sectional shapes of the 4 types of tubing most commonly used in aircraft work are shown in Fig. 228. Tubing is made either by the welding of flat stock or by cold-drawing. Dural, low-carbon steel, S.A.E. X-4130 or chrome-molybdenum, and stainless steel are among the

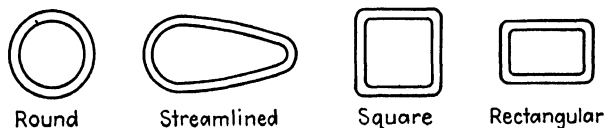

Fig. 228.—Four types of aircraft tubing.

materials used. Almost any size, shape, or thickness can be purchased upon special order, but commercially the outside diameter varies from  $\frac{3}{16}$  to 3 in. and the wall thickness varies from 0.022 to 0.375 in.

**A. Round Tubing.** What is the connection between the outside diameter ( $D$ ), the inside diameter ( $d$ ), and the wall thickness ( $t$ )?

Are the statements in Fig. 229 true?

$$d = D - 2t$$

$$D = d + 2t$$

$$t = \frac{D - d}{2}$$

$$t = R - r$$

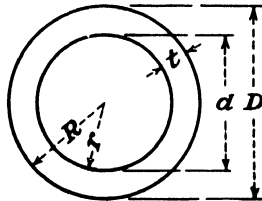

Fig. 229.

Complete the following table:

B.W.S. gauge	Wall thickness, in.	Outside diameter, in.	Inside diameter, in.
22	0.028	$\frac{7}{8}$	
16	0.065	$1\frac{1}{4}$	
14	0.083		$1\frac{7}{16}$
13	0.095		$1\frac{3}{8}$
		$1\frac{1}{2}$	$1\frac{1}{4}$

**B. The Cross-sectional Area of Tubing.** Figure 230 shows that the cross-sectional area of any tube may be obtained by taking the area  $A$  of a solid bar and subtracting the area  $a$  of a removed center portion.

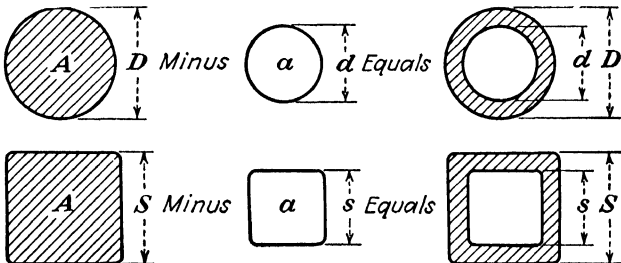

Fig. 230.

**Formula: Cross-sectional area =  $A - a$**

For round tubes:  $A = 0.7854D^2$ ,  $a = 0.7854d^2$ .

For square tubes:  $A = S^2$   $a = s^2$ .

It will therefore be necessary to work out the areas of both  $A$  and  $a$  before the area of the cross section of a tube can be found.

**ILLUSTRATIVE EXAMPLE**

Find the cross-sectional area of a tube whose outside diameter is 2 in. and whose inside diameter is  $1\frac{1}{2}$  in.

Given:  $D = 2$  in.

$d = 1\frac{1}{2}$  in.

Find: (1)  $A$

(2)  $a$

(3) Area of tube

(1)  $A = 0.7854 \times D^2$

$A = 0.7854 \times 2 \times 2$

$A = 3.1416$  sq. in. *Ans.*

(2)  $a$  is found in a similar manner

$a = 1.7667$  sq. in. *Ans.*

(3) Cross-sectional area =  $A - a$

Cross-sectional area =  $3.1416 - 1.7667$

Cross-sectional area =  $1.3749$  sq. in. *Ans.*

Complete this table:

B.W.S. gage	Wall thickness, in.	Outside diameter, in.	Inside diameter, in.	Cross-sectional area, sq. in.
22	0.028	$\frac{5}{8}$		
20	0.035		0.930	
18	0.049	$1\frac{1}{4}$		
16	0.065		0.640	

The struts of a biplane are kept in compression, between the spars of the upper and lower wings, by means of the

tension in the bracing wires and tie rods. A few years ago almost all struts were of solid wooden form, but they are now being replaced by metal tubes.

Answer the following questions because they will help to make clear the change from wood to metal parts in aircraft:

1. What is the compressive strength of a round spruce strut whose diameter is  $2\frac{1}{4}$  in.?

2. What would be the strength of a dural strut of the same size and shape?

3. Why are solid metal struts not used, since they are so much stronger than wooden ones?

a. If the spruce strut were 3 ft. long, what would it weigh?

b. What would the dural strut weigh?

4. Would a  $\frac{1}{4}$ -in. H.C. steel round rod be as strong in compression as the spruce strut whose diameter is  $2\frac{1}{4}$  in.?

5. Why then are steel rods not used for struts?

Rods should never be used in compression because they will bend under a very small load. Tubing has great compressive strength compared to its weight. Its compressive strength can be calculated just like the strength of any other material. It should always be remembered, however, that tubing in compression will fail long before its full compressive strength is developed, because it will either bend or buckle. The length of a tube, compared to its diameter, is extremely important in determining the compressive load that the tube can withstand. The longer the tube the more easily it will fail. This fact should be kept in mind when doing the following examples.

#### Examples:

Use Table 12 in the calculations.

1. Find the strength in compression of a S.A.E. 1015 round tube, whose outside diameter is  $\frac{3}{4}$  in. and whose inside diameter is 0.622 in.

2. Find the strength of a square tube, S.A.E. 1025, whose outside measurement is  $1\frac{1}{2}$  in. and whose wall thickness is 0.083 in.

3. What is the strength in tension of a 16 gage round H.C. steel tube whose inside diameter is 0.0930 in.?

4. A nickel-steel tube, whose wall thickness is 0.028 in. and whose outside diameter is  $1\frac{1}{2}$  in., is placed in compression. What load could it carry before breaking if it did not bend or buckle?

#### Job 4: Aircraft Rivets

A. **Types of Rivets.** No study of aircraft materials would be complete without some attention to rivets and riveted joints. Since it is important that a mechanic be able to recognize each type of rivet, study Fig. 231 carefully, and notice that

1. Most of the dimensions of a rivet, such as width of the head and the radius of the head, depend upon the diameter of the rivet, indicated by  $A$  in Fig. 231.

2. The length of the rivet is measured from under the head (except in countersunk rivets) and is naturally independent of the diameter.

#### Examples:

1. Find all the dimensions for a button head aluminum rivet whose diameter is  $\frac{1}{4}$  in. (see Fig. 231).

2. A countersunk head dural rivet has a diameter of  $\frac{3}{8}$  in. Find the dimensions of the head.

3. Make a drawing, accurate to the nearest 32nd in., of a round head aluminum rivet whose diameter is  $\frac{3}{4}$  in. and whose length is 2 in.

4. Make a drawing of a countersunk rivet whose diameter is  $\frac{1}{2}$  in. and whose length is 3 in.

B. **The Strength of Rivets in Shear.** Many different kinds of aluminum alloys have been classified, and the

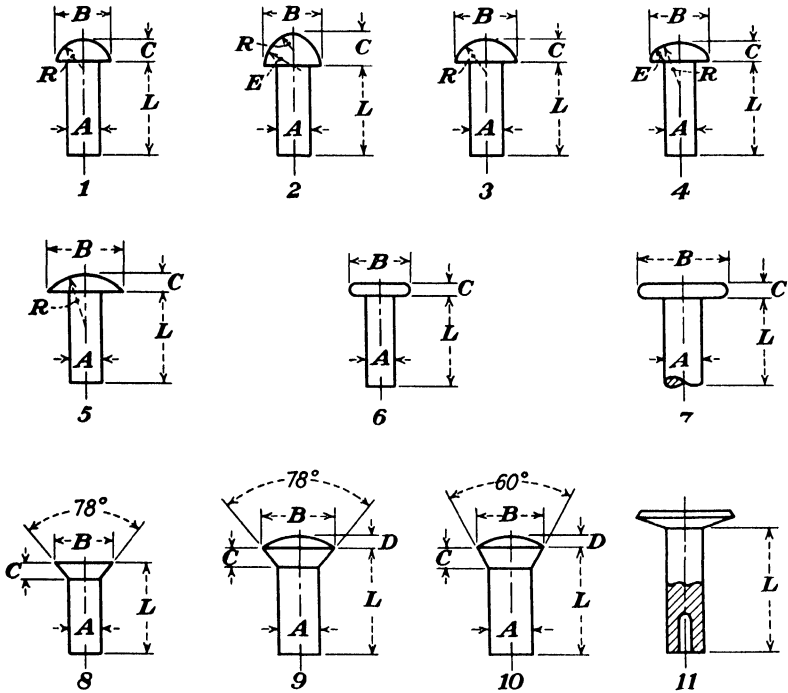

Kind	Width <i>B</i>	Head depth <i>C</i>	Head radius <i>R</i>	Edge radius <i>E</i>	Oval depth <i>D</i>
1 Button head. . .	$1.75A$	$0.75A$	$0.855A$		
2 High button head* American Standard. . . . .	$1.50A + 0.031$	$0.75A + 0.125$	$0.75A - 0.281$	$0.75A + 0.281$	
3 Round head. . .	$2A$	$0.75A$	$1.042A$		
4 Mushroom head. . . . .	$2A$	$0.625A$	$1.634A$	$0.50A$	
5 Brazier head. . . . .	$2.50A$	$0.50A$	$1.8125A$		
6 Flat head. . . . .	$2A$	$0.40A$			
7 Tinner's rivet. . . . .	$2.25A$	$0.30A$			
8 Countersunk head. . . . .	$1.81A$	$0.50A$			
†9 Countersunk oval head. . . . .	$1.81A$	$0.50A$	$1.7656A$		$0.25A$
*10 Countersunk oval head. . . . .	$1.577A$	$0.50A$			$0.187A$
11 Tubular shank. . . . .	This rivet made with several sizes of head.				

\* In sizes 1/2 in. and larger. † For sizes up to and including 7/16 in. diameter.

Fig. 231.—Common types of aluminum-alloy rivets. (From "The Riveting of Aluminum" by The Aluminum Co. of America.)

strength of each determined by direct test. The method of driving rivets also has an important effect upon strength as Table 13 shows.

TABLE 13.—STRESSES FOR DRIVEN RIVETS

Rivet	Driving procedure	U.S.S., lb. per sq. in.
2S	Cold, as received	11,000
3S	Cold, as received	14,000
A17S-T	Cold, as received	30,000
17S-T	Cold, immediately after quenching	34,000
53S-W	Cold, as received	24,000
53S-T	Cold, as received	26,000
24S-T	Cold, immediately after quenching	44,000
17S-T	Hot, 930 to 950°F.	33,000
53S-W	Hot, 960 to 980°F.	18,000
Steel	Hot, 1700 to 1900°F.	45,000

**Examples:**

1. Find the strength in shear of a  $\frac{5}{16}$ -in. button head 17S-T rivet, driven cold, immediately after quenching.

2. What is the strength in shear of a  $\frac{1}{4}$ -in. round head 24S-T rivet driven cold immediately after quenching?

3. Find the strength in shear of a  $\frac{3}{8}$ -in. flat head 2S rivet driven cold.

4. Two 53S-W rivets are driven cold. What is their combined strength in shear, if the diameter of each rivet is  $\frac{1}{16}$  in.?

5. Draw up a table of the shear strength of 2S rivets, driven cold, of these diameters:  $\frac{1}{4}$  in.,  $\frac{3}{8}$  in.,  $\frac{1}{2}$  in.,  $\frac{5}{8}$  in.,  $\frac{3}{4}$  in.,  $\frac{7}{8}$  in.

**C. Riveted Joints.** There are two main classifications of riveted joints: lap and butt joints, as illustrated in Fig. 232.

In a lap joint, the strength of the structure in shear is equal to the combined strength of all the rivets. In a butt joint, on the other hand, the shear strength of the structure is equal to the strength of the rivets on one side of the joint only. Why?

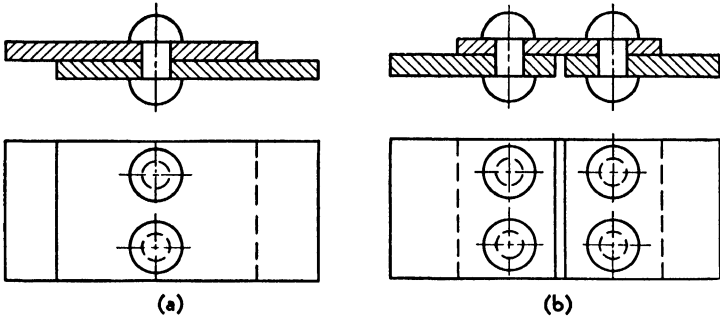

Fig. 232.—Types of riveted joints: (a) lap joint; (b) butt joint.

Examples:

1. Find the strength in shear of the lap joint in Fig. 233, using  $\frac{1}{8}$  in. diameter 17S-T rivets driven hot.

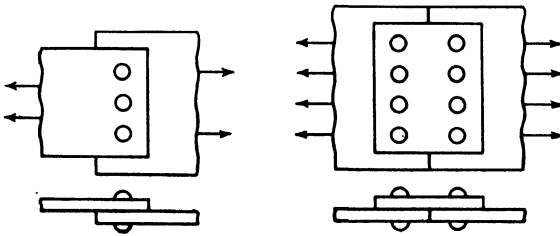

Fig. 233.

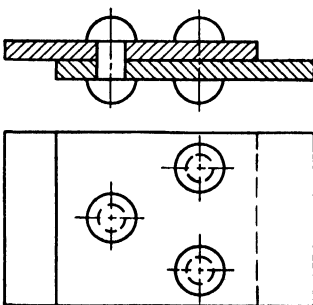

Fig. 234.—Lap joint,  $\frac{5}{64}$  in. diameter, 53S-T rivets, driven cold as received.

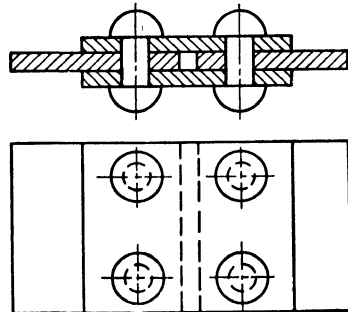

Fig. 235.—Double-plate butt joint,  $\frac{1}{64}$ -in. steel rivets, driven hot.

2. What is the strength of the butt joint in Fig. 233 if all rivets are  $\frac{3}{8}$ -in. 24S-T driven cold immediately after quenching?

3. What would be the strength in shear of a lap joint with one row of ten  $\frac{3}{32}$ -in. 2S rivets driven cold, as received?
4. Find the strength of the lap joint shown in Fig. 234.
5. Find the strength of the butt joint shown in Fig. 235.

**Job 5: Review Test**

1. In a properly designed structure, no one item is disproportionately stronger or weaker than any other. Why?

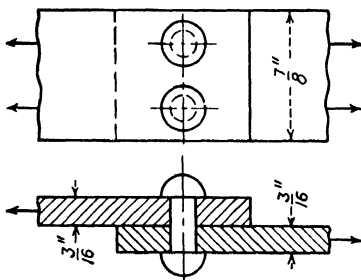
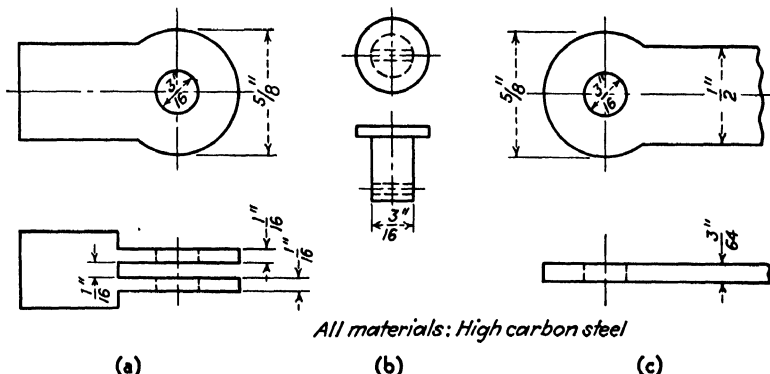

Fig. 236.—Lap joint, dural plates,  $\frac{3}{16}$  in. diameter 17 S-T rivets, driven immediately after quenching.

The riveted joint shown in Fig. 236 is in tension. Find (a) the ultimate strength in tension; (b) the strength of



(a) (b) (c)  
 Fig. 237.—(a) Tie rod terminal, (b) clevis pin, (c) fitting.

the rivets in shear; (c) the strength of the joint in bearing. If this joint were subjected to a breaking load, where would it break first? What changes might be suggested?

2. Examine the structure in Fig. 237 very carefully. Find the strength of (a) the tie rod terminal in tension; (b) the tie rod terminal in bearing; (c) the clevis pin in shear; (d) the fitting in tension; (e) the fitting in bearing. If the tie rod terminal were joined to the fitting by means of the clevis pin and subjected to a breaking load in tension, where would failure occur first? What improvements might be suggested?

NOTE: It will be necessary to find the ultimate strength in each of the parts of the above example.

## Chapter XII

### BEND ALLOWANCE

A large number of aircraft factories are beginning to consider a knowledge of bend allowance as a prerequisite to the hiring of certain types of mechanics. Aircraft manufacturers in some cases have issued special instructions to their employees on this subject.

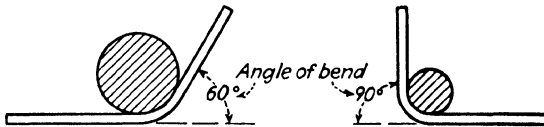

Fig. 238.

Many fittings require that metal be bent from the flat piece, according to instructions given in blueprints or drawings. The amount of bending is measured in degrees and is called the *angle of bend* (see Fig. 238).

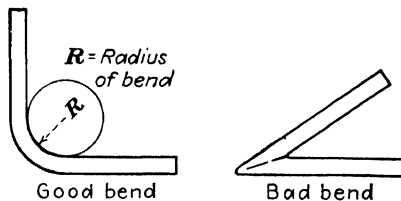

Fig. 239.

When a piece of metal is bent, it is important to round the vertex of the angle of bend or the metal may break. A form is, therefore, used to assist the mechanic in making a good bend. The radius of this form as shown in Fig. 239 is called the *radius of bend*.

A large radius of bend means a gradual curve; a very small radius means a sharp bend. Experience has shown that the radius of bend depends on the thickness of the metal. In the case of steel, for example, for cold bending, the radius of bend should not be smaller than the thickness of the metal.

### Job 1: The Bend Allowance Formula

This job is the basis of all the work in this chapter. Be sure it is understood before the next job is undertaken.

#### Definition:

*Bend allowance* (B.A.) is the length of the curved part of the fitting. It is practically equal to the length of an arc of a circle as shown in Fig. 240.

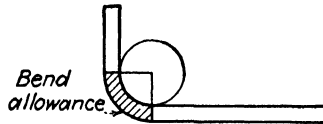

Fig. 240.

The amount of material needed for the bend depends upon the radius of bend ( $R$ ); the thickness of the metal ( $T$ ); the angle of bend in degrees ( $N$ ).

$$\text{Formula: B.A.} = (0.01743 \times R + 0.0078 \times T) \times N^\circ$$

#### ILLUSTRATIVE EXAMPLE

Find the bend allowance for a  $\frac{1}{8}$ -in. steel fitting to be bent  $90^\circ$  over a  $\frac{1}{2}$ -in. radius, as shown in Fig. 241.

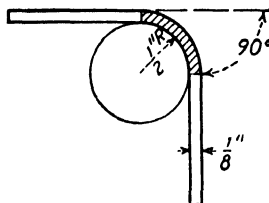

Fig. 241.

Given:  $R = \frac{1}{2}$  in.

$T = \frac{1}{8}$  in.

$N = 90^\circ$

Find: B.A.

$$\text{B.A.} = (0.01743 \times R + 0.0078 \times T) \times N^\circ$$

$$\text{B.A.} = (0.01743 \times \frac{1}{2} + 0.0078 \times \frac{1}{8}) \times 90$$

$$\text{B.A.} = (0.00872 + 0.00098) \times 90$$

$$\text{B.A.} = (0.00970) \times 90$$

$$\text{B.A.} = 0.8730 \text{ in.}$$

To the nearest 64th,  $\frac{7}{8}$  in. *Ans.*

*Method:*

a. Multiply, as indicated by the formula, within the parentheses.

b. Add within the parentheses.

c. Multiply the sum by the number outside the parentheses.

**Examples:**

1. Find the bend allowance for a  $\frac{1}{16}$ -in. steel fitting to be bent  $90^\circ$  over a form whose radius is  $\frac{1}{4}$  in.

2. What is the bend allowance needed for  $\frac{1}{8}$ -in. dural fitting to be bent over a form whose radius is  $\frac{3}{8}$  in. to make a  $45^\circ$  of bend?

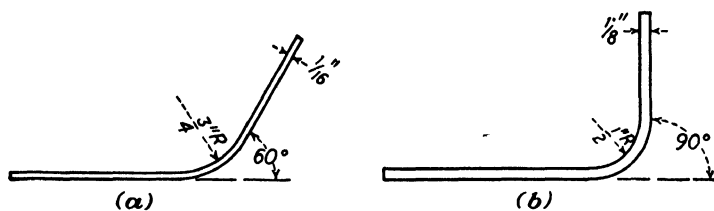

Fig. 242.

3. A  $\frac{3}{16}$ -in. steel fitting is to be bent  $60^\circ$ . The radius of bend is  $\frac{1}{4}$  in. What is the bend allowance?

4. Find the bend allowance for each of the fittings shown in Fig. 242.

5. Complete the following table, keeping in mind that  $T$  is the thickness of the metal,  $R$  is the radius of bend, and that all dimensions are in inches.

BEND ALLOWANCE CHART  
(90° angle of bend)

$R$ $T$	$\frac{1}{8}$	$\frac{1}{4}$	$\frac{1}{2}$
0.120			
0.065			
0.032			

**Job 2: The Over-all Length of the Flat Pattern**

Before the fitting can be laid out on flat stock from a drawing or blueprint such as shown in Fig. 243(a), it is

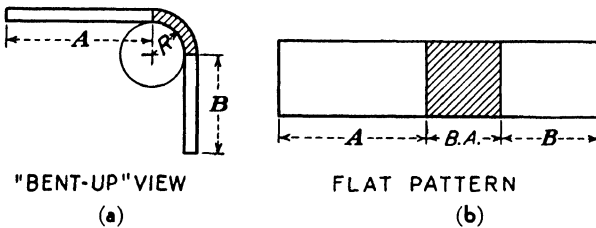

Fig. 243.

important to know the over-all or developed length of the flat pattern, which can be calculated from the bent-up drawing. If the straight portions of the fitting are called  $A$  and  $B$ , the following formula can be used:

Formula: Over-all length =  $A + B + B.A.$

ILLUSTRATIVE EXAMPLE

Find the over-all length of the flat pattern in Fig. 244. Notice that the bend allowance has already been calculated.

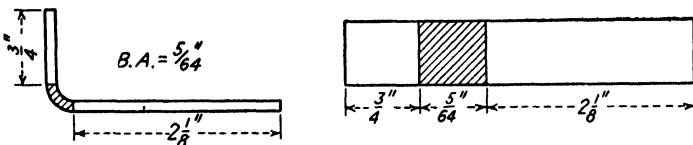

Fig. 244.

Given:  $A = \frac{3}{4}$  in.

$B = 2\frac{1}{8}$  in.

B.A. =  $\frac{5}{84}$  in.

Find: Over-all length

$$\text{Over-all length} = A + B + \text{B.A.}$$

$$\text{Over-all length} = \frac{3}{4} + 2\frac{1}{8} + \frac{5}{84}$$

$$\text{Over-all length} = \frac{48}{84} + 2\frac{8}{84} + \frac{5}{84}$$

$$\text{Over-all length} = 2\frac{13}{84} \text{ in. Ans.}$$

Examples:

1. Find the over-all length of a fitting where the straight parts are  $\frac{1}{8}$  in. and  $\frac{5}{8}$  in., if the bend allowance is  $\frac{7}{16}$  in.

2. Find the over-all length of the fittings shown in Fig. 245.

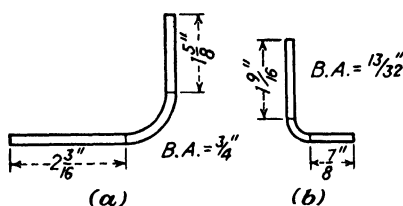

Fig. 245.

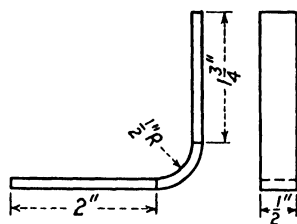

Fig. 246.—1/8-in. cold-rolled steel, 90° bend.

3. Find the bend allowance and the over-all length of the fitting shown in Fig. 246.

4. Draw the flat pattern for the fitting in Fig. 246, accurate to the nearest 64th of an inch.

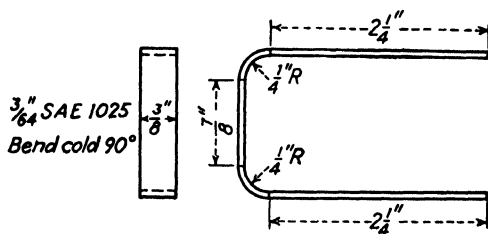

Fig. 247.

5. Draw the flat pattern for the fitting in Fig. 247, after finding the bend allowance and over-all length.

### Job 3: When Inside Dimensions Are Given

It is easy enough to find the over-all length when the exact length of the straight portions of the fitting are given.

However, these straight portions must usually be found from other dimensions given in the drawing or blueprint.

In this case, an examination of Fig. 248 will show that the straight portion *A* is equal to the inner dimension *d*, minus the radius of bend *R*. This can be put in terms of a formula, but it will be easier to solve each problem individually, than to apply a formula mechanically.

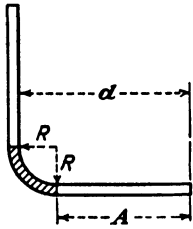

Fig. 248.

$$\text{Formula: } A = d - R$$

where *A* = length of one straight portion.

*d* = inner dimension.

*R* = radius of bend.

*B*, which is the length of the other straight portion of the fitting, can be found in a similar manner.

#### ILLUSTRATIVE EXAMPLE

Find the over-all length of the flat pattern for the fitting shown in Fig. 249.

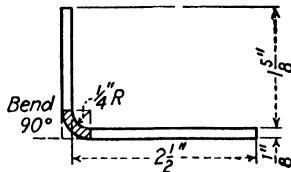

Fig. 249.

Given:  $R = \frac{1}{4}$  in.

$T = \frac{1}{8}$  in.

$N = 90$

B.A. =  $\frac{3}{8}\frac{1}{4}$  in.

Find: Over-all length

$A = 2\frac{1}{2} - \frac{1}{4} = 2\frac{1}{4}$

$B = 1\frac{5}{8} - \frac{1}{4} = 1\frac{3}{8}$

$$\text{Over-all length} = A + B + \text{B.A.}$$

$$\text{Over-all length} = 2\frac{1}{4} + 1\frac{3}{8} + \frac{3}{8}\frac{1}{4}$$

$$\text{Over-all length} = 4\frac{7}{4} \text{ in. } \textit{Ans.}$$

*Method:*

a. First calculate the length of the straight portions,  $A$  and  $B$ , from the drawing.

b Then use the formula: over-all length =  $A + B + \text{A.B.}$

In the foregoing illustrative example, the bend allowance was given. Could it have been calculated, if it had not been given? How?

**Examples:**

1. Find the over-all length of the flat pattern of the fittings shown in Fig. 250. Notice that it will first be necessary to find the bend allowance.

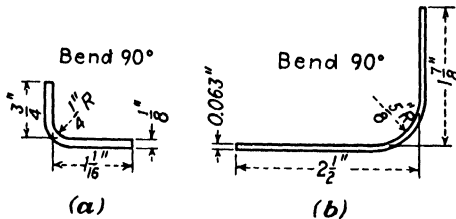

Fig. 250.

2. Find the bend allowance and over-all length of the flat patterns of the fittings in Fig. 251. Observe that in (a) one outside dimension is given.

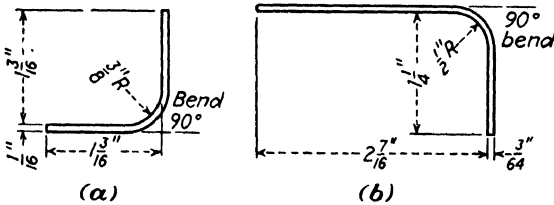

Fig. 251.

3. Find the bend allowance and over-all length of the fitting shown in Fig. 252. Draw a full-scale flat pattern accurate to the nearest 64th.

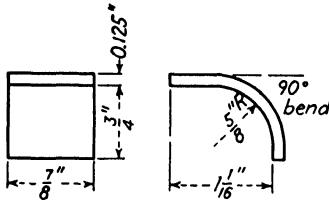

Fig. 252.

#### Job 4: When Outside Dimensions Are Given

In this case, not only the radius but also the thickness of the metal must be subtracted from the outside dimension in order to find the length of the straight portion.

$$\text{Formula: } A = D - R - T$$

where  $A$  = length of one straight portion.

$D$  = outer dimension.

$R$  = radius of bend.

$T$  = thickness of the metal.

$B$  can be found in a similar manner.

Here again no formulas should be memorized. A careful analysis of Fig. 253 will show how the straight portion

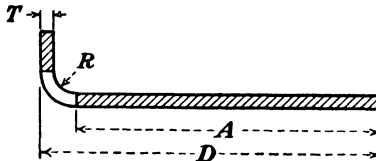

Fig. 253.

of the fitting can be found from the dimensions given on the blueprint.

#### Examples:

1. Find the length of the straight parts of the fitting shown in Fig. 254.
2. Find the bend allowance of the fitting in Fig. 254.
3. Find the over-all length of the flat pattern of the fitting in Fig. 254.

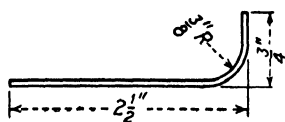

Fig. 254.—3/64-in. L.C. steel bent 90°.

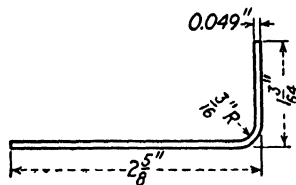

Fig. 255.

4. What is the over-all length of the flat pattern of the fitting shown in Fig. 255? The angle of bend is 90°.

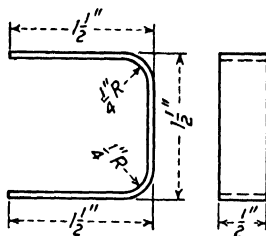

Fig. 256.—0.035 in. thickness, 2 bends of 90° each.

5. Make a full-scale drawing of the flat pattern of the fitting shown in Fig. 256.

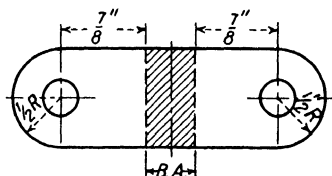

Fig. 257.—1/8-in. H.C. steel bent 90°, 1/4 in. radius of bend.

6. What is the over-all length of the fitting in Fig. 257?

### Job 5: Review Test

Figure 258 shows the diagram of a 0.125-in. low-carbon steel fitting.

1. (a) Find the bend allowance for each of the three bends, if the radius of bend is  $\frac{1}{2}$  in.

(b) Find the over-all dimensions of this fitting.

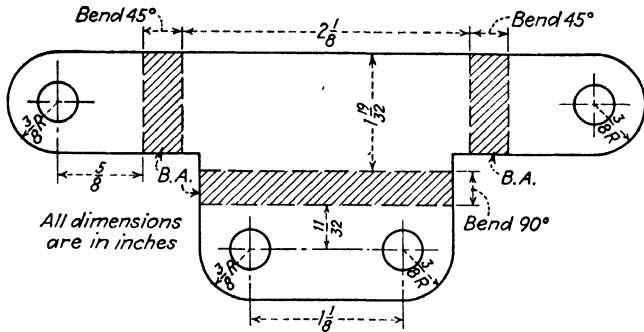

Fig. 258.

2. Find the tensile strength of the fitting in Fig. 258 if the diameter of all holes is  $\frac{1}{4}$  in., (a) each end; (b) at the side having two holes. Use the table of safe working strengths page 169.

3. Make a full-scale diagram of the fitting (Fig. 258), including the bend allowance.

4. Calculate the total bend allowance and over-all length of the flat pattern for the fitting in Fig. 259. All bends are  $90^\circ$

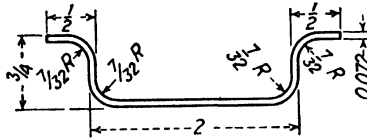

Fig. 259.

## **Part IV**

# **AIRCRAFT ENGINE MATHEMATICS**

### **Chapter XIII: Horsepower**

- Job 1: Piston Area
- Job 2: Displacement of the Piston
- Job 3: Number of Power Strokes
- Job 4: Types of Horsepower
- Job 5: Mean Effective Pressure
- Job 6: How to Calculate Brake Horsepower
- Job 7: The Prony Brake
- Job 8: Review Test

### **Chapter XIV: Fuel and Oil Consumption**

- Job 1: Horsepower-hours
- Job 2: Specific Fuel Consumption
- Job 3: Gallons and Cost
- Job 4: Specific Oil Consumption
- Job 5: How Long Can an Airplane Stay Up?
- Job 6: Review Test

### **Chapter XV: Compression Ratio and Valve Timing**

- Job 1: Cylinder Volume
- Job 2: Compression Ratio
- Job 3: How to Find the Clearance Volume
- Job 4: Valve Timing Diagrams
- Job 5: How Long Does Each Valve Remain Open?
- Job 6: Valve Overlap
- Job 7: Review Test



## Chapter XIII

# HORSEPOWER

*What is the main purpose of the aircraft engine?*

It provides the forward thrust to overcome the resistance of the airplane.

*What part of the engine provides the thrust?*

The rotation of the propeller provides the thrust (see Fig. 260).

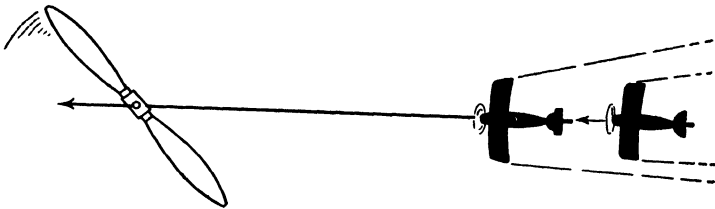

Fig. 260.

*But what makes the propeller rotate?*

The revolution of the crankshaft (Fig. 261) turns the propeller.

*What makes the shaft rotate?*

The force exerted by the connecting rod (Fig. 262) turns the crankshaft.

*What forces the rod to drive the heavy shaft around?*

The piston drives the rod.

Trace the entire process from piston to propeller.

It can easily be seen that a great deal of work is required to keep the propeller rotating. This energy comes from the burning of gasoline, or any other fuel, in the cylinder.

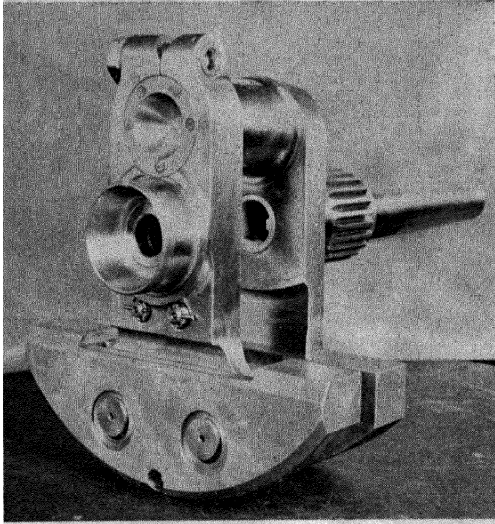

**Fig. 261.** Crankshaft of Wright Cyclone radial engine. (Courtesy of Aviation.)

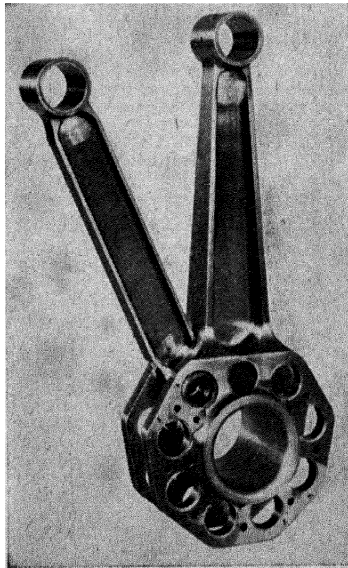

**Fig. 262.**—Connecting rods, Pratt and Whitney radial engine. (Courtesy of Aviation.)

In a very powerful engine, a great deal of fuel will be used and a large amount of work developed. We say such an engine develops a great deal of *horsepower*.

In order to understand horsepower, we must first learn the important subtopics upon which this subject depends.

### Job 1: *Piston Area*

The greater the area of the piston, the more horsepower the engine will be able to deliver. It will be necessary to find the area of the piston before the horsepower of the engine can be calculated.

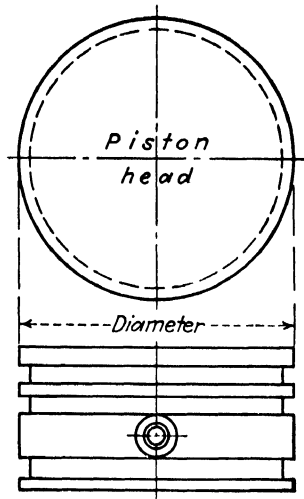

Fig. 263.—Piston.

The top of the piston, called the *head*, is known to be a circle (see Fig. 263). To find its area, the formula for the area of a circle is needed.

$$\text{Formula: } A = 0.7854 \times D^2$$

#### ILLUSTRATIVE EXAMPLE

Find the area of a piston whose diameter is 3 in.

Given: Diameter = 3 in.

Find: Area

$$A = 0.7854 \times D^2$$

$$A = 0.7854 \times 3 \times 3$$

$$A = 7.0686 \text{ sq. in. } \textit{Ans.}$$

Specifications of aircraft engines do not give the diameter of the piston, but do give the diameter of the cylinder, or the bore.

**Definition:**

*Bore* is equal to the diameter of the cylinder, but may correctly be considered the effective diameter of the piston.

**Examples:**

1. Find the area of the pistons whose diameters are 6 in., 7 in., 3.5 in., 1.25 in.

2-9. Complete the following:

	Engine	Bore, in.	Piston area, sq. in.
2	Whirlwind.....	4	
3	Panther.....	5	
4	Lambert.....	4.25	
5	Le Blond.....	$4\frac{1}{8}$	
6	Hornet.....	$6\frac{1}{4}$	
7	Menasco.....	4.75	
8	Lycoming.....	4.625	
9	Jacobs L5.....	5.5	

10. The Jacobs has 7 cylinders. What is its total piston area?

11. The Kinner C-7 has 7 cylinders and a bore of  $5\frac{5}{8}$  in. What is its total piston area?

12. A 6 cylinder Menasco engine has a bore of 4.75 in. Find the total piston area.

The head of the piston may be flat, concave, or domed, as shown in Fig. 264, depending on how it was built by

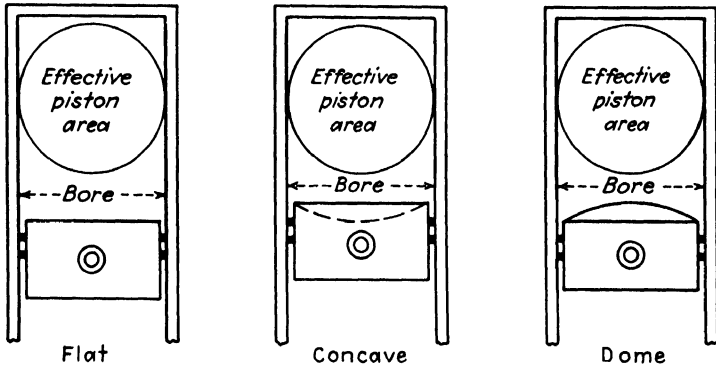

Fig. 264.—Three types of piston heads.

the designer and manufacturer. The effective piston area in all cases, however, can be found by the method used in this job.

### Job 2: Displacement of the Piston

When the engine is running, the piston moves up and down in its cylinder. It never touches the top of the cylinder

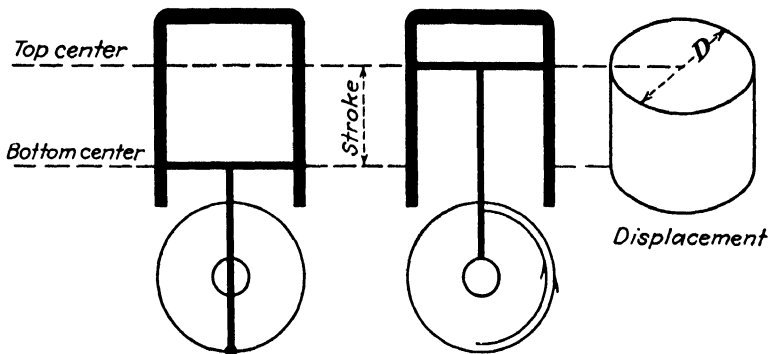

Fig. 265.

on the upstroke, and never comes too near the bottom of the cylinder on the downstroke (see Fig. 265).

**Definitions:**

*Top center* is the highest point the piston reaches on its upstroke.

*Bottom center* is the lowest point the head of the piston reaches on the downstroke.

*Stroke* is the distance between top center and bottom center. It is measured in inches or in feet.

*Displacement* is the *volume* swept through by the piston in moving from bottom center to top center. It is measured in cubic inches. It will depend upon the area of the moving piston and upon the distance it moves, that is, its stroke.

$$\text{Formula: Displacement} = \text{area} \times \text{stroke}$$

**ILLUSTRATIVE EXAMPLE**

Find the displacement of a piston whose diameter is 6 in. and whose stroke is  $5\frac{1}{2}$  in. Express the answer to the nearest tenth.

Given: Diameter = 6 in.

Stroke =  $5\frac{1}{2} = 5.5$  in.

Find: Displacement

$$A = 0.7854 \times D^2$$

$$A = 0.7854 \times 6 \times 6$$

$$A = 28.2744 \text{ sq. in.}$$

$$\text{Disp.} = A \times S$$

$$\text{Disp.} = 28.2744 \times 5.5$$

$$\text{Disp.} = 155.5 \text{ cu. in. } \textit{Ans.}$$

Note that it is first necessary to find the area of the piston.

**Examples:**

1-3. Complete the following table:

	Name of engine	Bore, in.	Stroke, in.	Area, sq. in.	Disp., cu. in.
1	Ranger	4	$5\frac{1}{8}$		
2	Twin Wasp	$5\frac{1}{2}$	$5\frac{1}{2}$		
3	Kinner C-5	$5\frac{5}{8}$	$5\frac{3}{4}$		

4. The Aeronca E-113A has a bore of 4.25 in. and a stroke of 4 in. It has 2 cylinders. What is its total piston displacement?

5. The Aeronca E-107, which has 2 cylinders, has a bore of  $4\frac{1}{8}$  in. and a stroke of 4 in. What is its total cubic displacement?

6. A 9 cylinder radial Wright Cyclone has a bore of 6.12 in. and a stroke of 6.87 in. Find the total displacement.

### Job 3: Number of Power Strokes

In the four-cycle engine the order of strokes is intake, compression, *power*, and exhaust. *Each cylinder* has one power stroke for two revolutions of the shaft. How many power strokes would there be in 4 revolutions? in 10 revolutions? in 2,000 r.p.m.?

Every engine has an attachment on its crankshaft to which a tachometer, such as shown in Fig. 266, can be fas-

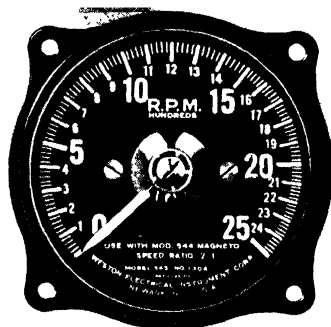

Fig. 266.—Tachometer. (Courtesy of Aviation.)

tened. The tachometer has a dial that registers the number of revolutions the shaft is making in 1 minute.

$$\text{Formula: } N = \frac{\text{r.p.m.}}{2} \times \text{cylinders}$$

where  $N$  = number of power strokes per minute.

R.p.m. = revolutions per minute of the crankshaft.

## ILLUSTRATIVE EXAMPLE

A 5 cylinder engine is making 1,800 r.p.m. How many power strokes does it make in 1 min.? in 1 sec.?

Given: 5 cylinders

1,800 r.p.m.

Find:  $N$

$$N = \frac{\text{r.p.m.}}{2} \times \text{cylinders}$$

$$N = \frac{1,800}{2} \times 5$$

$$N = 4,500 \text{ power strokes per minute } \textit{Ans.}$$

There are 60 sec. in 1 min.

Number of power strokes per second:

$$\frac{N}{60} = \frac{4,500}{60} = 75 \text{ power strokes per second } \textit{Ans.}$$

Examples:

1-7. Complete the following table *in your own notebook*:

	Engine	Cylinders	R.p.m.	Power strokes	
				Per min.	Per sec.
1	Wasp	9	2,000		
2	Conqueror	12	2,400		
3	Cyclone	9	1,950		
4	Aeronca	2	2,540		
5	Franklin	4	1,750		
6	Allison	12	2,300		
7	Kinner	5	1,925		

8. How many r.p.m. does a 5 cylinder engine make when it delivers 5,500 power strokes per minute?

9. A 9 cylinder Cyclone delivers 9,000 power strokes per minute. What is the tachometer reading?

10. A 5 cylinder Lambert is tested at various r.p.m. as listed. Complete the following table and graph the results.

Revolutions		Power strokes	
Per min.	Per sec.	Per min.	Per sec.
1,600			
1,700			
1,800			
1,900			
2,000			
2,100			

### Job 4: Types of Horsepower

The fundamental purpose of the aircraft engine is to turn the propeller. This work done by the engine is expressed in terms of horsepower.

**Definition:**

*One horsepower* of work is equal to 33,000 lb. being raised one foot in one minute. Can you explain Fig. 267?

The horsepower necessary to turn the propeller is developed inside the cylinders by the heat of the combustion of the fuel. But not all of it ever reaches the propeller. Part of it is lost in overcoming the friction of the shaft that turns the propeller; part of it is used to operate the oil pumps, etc.

There are three different types of horsepower (see Fig. 268).

## Definitions:

*Indicated horsepower* (i.hp.) is the total horsepower developed in the cylinders.

*Friction horsepower* (f.hp.) is that part of the indicated horsepower that is used in overcoming friction at the bearings, driving fuel pumps, operating instruments, etc.

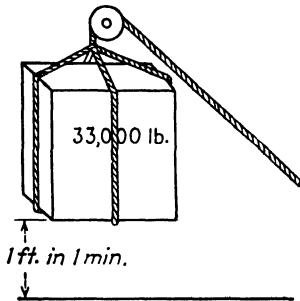

Fig. 267.—1 hp. = 33,000 ft.-lb. per min.

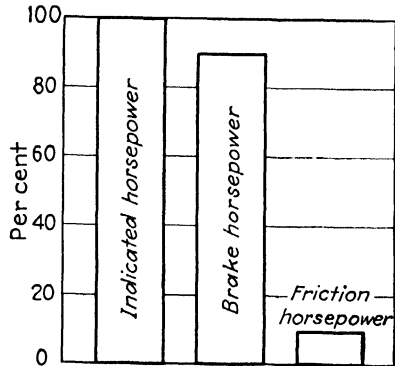

Fig. 268.—Three types of horsepower.

*Brake horsepower* (b.hp.) is the horsepower available to drive the propeller.

Formulas: Indicated horsepower = brake horsepower + friction horsepower

$$i.hp. = b.hp. + f.hp.$$

## ILLUSTRATIVE EXAMPLE

Find the brake horsepower of an engine when the indicated horsepower is 45 and the friction horsepower is 3.

Given: I.hp. = 45

F.hp. = 3

Find: B.hp.

$$I.hp. = b.hp. + f.hp.$$

$$45 = b.hp. + 3$$

$$B.hp. = 42 \text{ Ans.}$$

## Examples:

1. The indicated horsepower of an engine is 750. If 43 hp. is lost as friction horsepower, what is the brake horsepower?

2-7. Complete the following table:

	I.hp.	B.hp.	F.hp.
2		19	3
3		37.5	6.2
4	352		40
5	145.6		37.9
6	49.6	40.2	
7	740.3	672.9	

8. Figure out the percentage of the total horsepower that is used as brake horsepower in Example 7.

This percentage is called the *mechanical efficiency* of the engine.

9. What is the mechanical efficiency of an engine whose indicated horsepower is 95.5 and whose brake horsepower is 65?

10. An engine develops 155 b.hp. What is its mechanical efficiency if 25 hp. is lost in friction?

### Job 5: Mean Effective Pressure

The air pressure all about us is approximately 15 lb. per sq. in. This is also true for the inside of the cylinders before the engine is started; but once the shaft begins to turn, the pressure inside becomes altogether different. Read the following description of the 4 strokes of a 4-cycle engine very carefully and study Fig. 269.

1. *Intake:* The piston, moving downward, acts like a pump and pulls the inflammable mixture from the carburetor, through the manifolds and open intake valve into the cylinder. When the cylinder is full, the intake valve closes.

During the *intake stroke* the piston moves down, making the pressure inside less than 15 lb. per sq. in. This pressure is not constant at any time but rises as the mixture fills the chamber.

2. *Compression:* With both valves closed and with a cylinder full of the mixture, the piston travels upward compressing the gas into the small clearance space above the piston. The pressure is raised by this squeezing of the mixture from about 15 lb. per sq. in. to 100 or 125 lb. per sq. in.

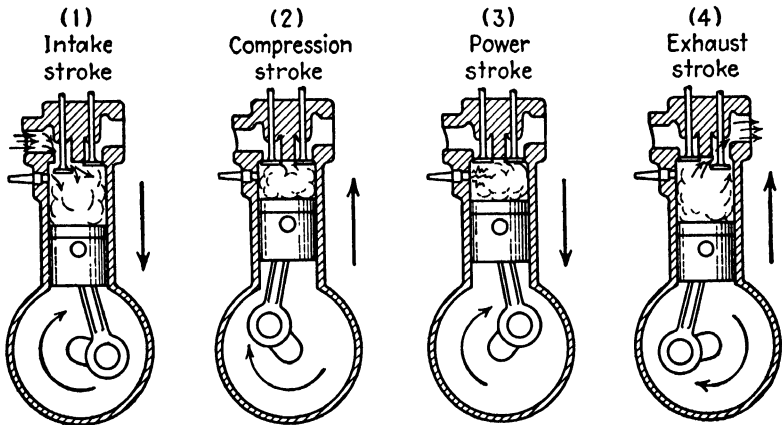

Fig. 269.

3. *Power:* The spark plug supplies the light that starts the mixture burning. Between the compression and power strokes, when the mixture is compressed into the clearance space, ignition occurs. The pressure rises to 400 lb. per sq. in. The hot gases, expanding against the walls of the enclosed chamber, push the only movable part, the piston, downward. This movement is transferred to the crankshaft by the connecting rod.

4. *Exhaust:* The last stroke in the cycle is the exhaust stroke. The gases have now spent their energy in pushing the piston downward and it is necessary to clear the cylinder in order to make room for a new charge. The ex-

haust valve opens and the piston, moving upward, forces the burned gases out through the exhaust port and exhaust manifold.

During the exhaust stroke the exhaust valve remains open. Since the pressure inside the cylinder is greater than atmospheric pressure, the mixture expands into the air. It

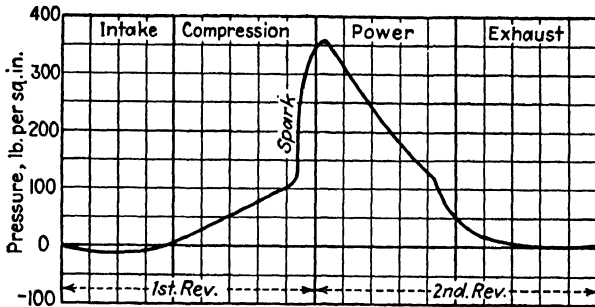

Fig. 270.

is further helped by the stroke of the piston. The pressure inside the cylinder naturally keeps falling off.

The chart in Fig. 270 shows how the pressure changes through the intake, compression, power, and exhaust strokes. The horsepower of the engine depends upon the average of all these changing pressures.

#### Definitions:

*Mean effective pressure* is the average of the changing pressures for all 4 strokes. It will henceforth be abbreviated M.E.P.

*Indicated mean effective pressure* is the actual average obtained by using an indicator card somewhat similar to the diagram. This is abbreviated I.M.E.P.

*Brake mean effective pressure* is that percentage of the indicated mean effective pressure that is *not* lost in friction but goes toward useful work in turning the propeller. This is abbreviated B.M.E.P.

## Job 6: How to Calculate Brake Horsepower

We have already learned that the brake horsepower depends upon 4 factors:

1. The B.M.E.P.
2. The length of the stroke.
3. The area of the piston.
4. The number of power strokes per minute.

Remember these abbreviations:

	Abbreviation	Measured in
Brake horsepower.....	B.hp.	Horsepower
Brake mean effective pressure. . .	B.M.E.P.	Pounds per square inch
Stroke.....	<i>L</i>	Feet
Piston area.....	<i>A</i>	Square inches
Number of power strokes per minute.	<i>N</i>	Strokes per minute

$$\text{Formula: B.hp.} = \frac{\text{B.M.E.P.} \times L \times A \times N}{33,000}$$

## ILLUSTRATIVE EXAMPLE

Given:

- B.M.E.P. = 120 lb. per sq. in.  
 Stroke = 0.5 ft.  
 Area = 50 sq. in.  
*N* = 3,600 per min.

Find: Brake horsepower

$$\text{B.hp.} = \frac{\text{B.M.E.P.} \times L \times A \times N}{33,000}$$

$$\text{B.hp.} = \frac{120 \times 0.5 \times 50 \times 3,600}{33,000}$$

$$\text{B.hp.} = 327 \text{ Ans.}$$

It will be necessary to calculate the area of the piston and the number of power strokes per minute in most of the problems in brake horsepower. Remember that the stroke must be expressed in feet, before it is used in the formula.

## Examples:

1. Find the brake horsepower of an engine whose stroke is 3 ft. and whose piston area is 7 sq. in. The number of power strokes is 4,000 per min. and the B.M.E.P. is 120 lb. per sq. in.

2. The area of a piston is 8 sq. in. and its stroke is 4 in. Find its brake horsepower if the B.M.E.P. is 100 lb. per sq. in. This is a 3 cylinder engine going at 2,000 r.p.m.

*Hint:* Do not forget to change the stroke from inches to feet.

3. The diameter of a piston is 2 in., its stroke is 2 in., and it has 9 cylinders. When it is going at 1,800 r.p.m., the B.M.E.P. is 120 lb. per sq. in. Find the brake horsepower.

4-8. Calculate the brake horsepower of each of these engines:

	Engine	B.M.E.P.	Bore, in.	Stroke, in.	R.p.m.	Cylinders
4	Ranger.....	120	4	5	2,150	6
5	Aeronca.....	106	4½	4	2,400	2
6	Kinner C-7....	126	5.6	6	1,800	7
7	Kinner R-5....	130	4.9	5.2	2,000	5
8	Kinner C-5....	122	5.6	5.7	1,900	5

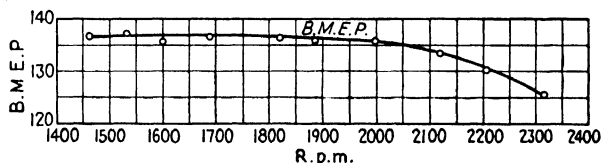

Fig. 271.—Graph of B.M.E.P. for Jacobs aircraft engine.

9. The graph in Fig. 271 shows how the B.M.E.P. keeps changing with the r.p.m. Complete the table of data *in your own notebook* from the graph.

R.p.m.	B.M.E.P.
1,400	
1,600	
1,800	
2,000	
2,200	

10. Find the brake horsepower of the Jacobs L-5 at each r.p.m. in the foregoing table, if the bore is 5.5 in. and the stroke is 5.5 in. This engine has 7 cylinders.

### Job 7: The Prony Brake

In most aircraft engine factories, brake horsepower is calculated by means of the formula just studied. There are, in addition, other methods of obtaining it.

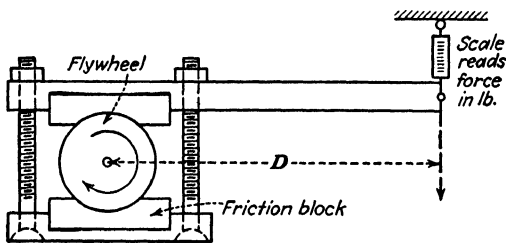

Fig. 272.—Prony brake.

The Prony brake is built in many different ways. The flywheel of the engine whose power is to be determined is clamped by means of the adjustable screws between friction blocks. Since the flywheel tends to pull the brake in the same direction as it would normally move, it naturally pushes the arm downward. The force  $F$  with which it

pushes downward is measured on the scale in pounds.

$$\text{Formula: B.hp.} = \frac{2\pi \times F \times D \times \text{r.p.m.}}{33,000}$$

$F$  is the reading on the scale and is measured in pounds. This does not include the weight of the arm.

$D$  is the distance in feet from the center of the flywheel to the scale.

$\pi$  may be used as 3.14.

#### ILLUSTRATIVE EXAMPLE

The scale of a brake dynamometer reads 25 lb. when the shaft of an engine going 2,000 r.p.m. is 2 ft. from the scale. What is the brake horsepower?

Given:  $F = 25$  lb.

$D = 2$  ft.

2,000 r.p.m.

Find: B.hp.

$$\text{B.hp.} = \frac{2\pi \times F \times D \times \text{r.p.m.}}{33,000}$$

$$\text{B.hp.} = \frac{2 \times 3.14 \times 25 \times 2 \times 2,000}{33,000}$$

$$\text{B.hp.} = 19.0 \text{ hp. } \textit{Ans.}$$

#### Examples:

1. The scale of a Prony brake 2 ft. from the shaft reads 12 lb. when the engine is going at 1,400 r.p.m. What is the brake horsepower of the engine?

2. A Prony brake has its scale 3 ft. 6 in. from the shaft of an engine going at 700 r.p.m. What horsepower is being developed when the scale reads 35 lb.?

3. The scale reads 58 lb. when the shaft is 1 ft. 3 in. away. What is the brake horsepower when the tachometer reads 1,250 r.p.m.?

4. It is important to test engines at various r.p.m. Find the brake horsepower of an engine at the following tachometer readings if the scale is 3 ft. from the shaft:

Tachometer, r.p.m.	Scale, lb.	B.hp.
1,000	18	
1,200	21	
1,400	23.5	
1,600	24.7	
1,800	24.2	
2,000	22.9	

5. Graph the data in Example 4, using r.p.m. as the horizontal axis and brake horsepower as the vertical axis.

### Job 8: Review Test

1. Write the formulas for (a) piston area; (b) displacement; (c) number of power strokes; (d) brake horsepower.

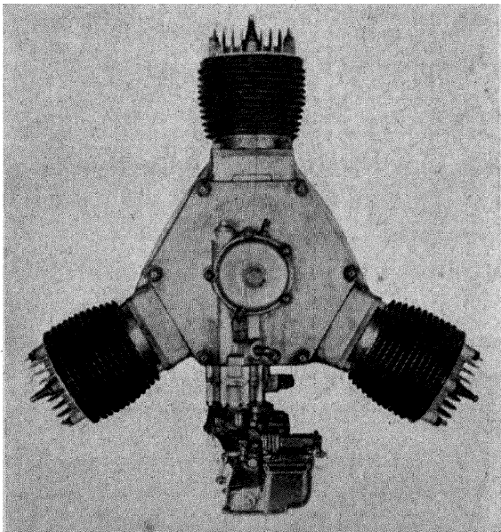

Fig. 273.—Szekely 3-cylinder air-cooled radial aircraft engine. (Courtesy of Aviation.)

2. The following is part of the specifications on the Szekely aircraft engine (see Fig. 273). Complete all missing data.

Name of engine.....	Szekely SR-3 model O
Type.....	3 cylinder, air-cooled, radial, overhead valve
A.T.C.....	No. 70
B.M.E.P.....	107 lb. per sq. in.
Bore.....	4½ in.
Stroke.....	4¼ in.
Total piston area.....	_____ sq. in.
Total displacement.....	_____ cu. in.
Dept. of Commerce rating.....	_____ hp. at 1,750 r.p.m.

3. Complete the missing data in the following specifications of the engine shown in Fig. 274:

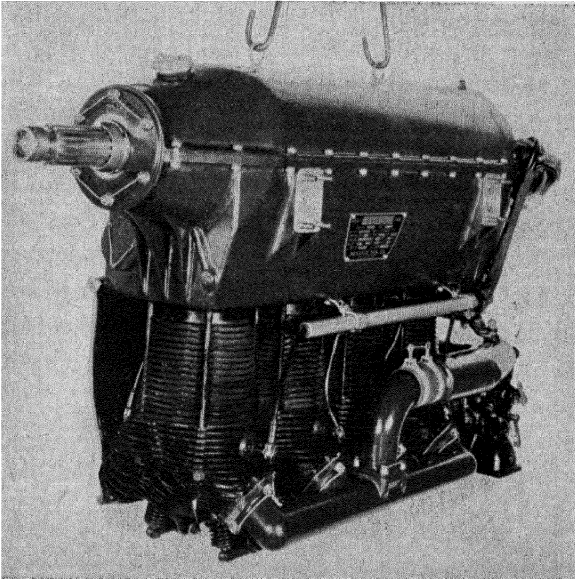

Fig. 274.—Menasco B-4 inverted in-line aircraft engine. (Courtesy of Aviation.)

Name of engine.....	Menasco B-4
Type.....	4 cylinder in-line, inverted, air-cooled
A.T.C.....	No. 65
Dept. of Commerce rating.....	_____ hp. at 2,000 r.p.m.
Manufacturer's rating.....	_____ hp. at 2,250 r.p.m.
B.M.E.P.....	115 lb. per sq. in.
Total displacement.....	_____ cu. in.
Bore.....	4½ in.
Stroke.....	5½ in.

## Chapter XIV

### FUEL AND OIL CONSUMPTION

Mechanics and pilots are extremely interested in how much gasoline and oil their engine will use, because aviation gasoline costs about 30¢ a gallon, and an engine that wastes gasoline soon becomes too expensive to operate. That is why the manufacturers of aircraft list the fuel and oil consumption, in the specifications that accompany each engine.

Fuel consumption is sometimes given in gallons per hour, or in miles per gallon as in an automobile. But both these methods are very inaccurate and seldom used for aircraft engines. The quantity of fuel and oil consumed keeps increasing as the throttle is opened and the horsepower increases. Also, the longer the engine is run, the more fuel and oil are used.

We can, therefore, say that the fuel and oil consumption depends upon the horsepower of the engine and the hours of operation.

#### **Job 1: *Horsepower-hours***

##### **Definition:**

The *horsepower-hours* show both the horsepower and running time of the engine in one number.

$$\text{Formula: Horsepower-hours} = \text{horsepower} \times \text{hours}$$

where horsepower = horsepower of the engine.

hour = length of time of operation in hours.

**ILLUSTRATIVE EXAMPLE**

A 65-hp. engine runs for 2 hr. What is the number of horsepower-hours?

Given: 65 hp.

2 hr.

Find: Hp.-hr.

$$\text{Hp.-hr.} = \text{hp.} \times \text{hr.}$$

$$\text{Hp.-hr.} = 65 \times 2$$

$$\text{Hp.-hr.} = 130 \quad \text{Ans.}$$

**Examples:**

1. A 130-hp. engine is run for 1 hr. What is the number of horsepower-hours? Compare your answer with the answer to the illustrative example above.

2. A 90-hp. Lambert is run for 3 hr. 30 min. What is the number of horsepower-hours?

3-9. Find the horsepower-hours for the following engines:

	Name of engine	Hp.	Running time
3	Whirlwind.....	420	7 hr.
4	Scarab.....	153	2½ hr.
5	Ranger.....	415	4 hr. 30 min.
6	Wasp, Jr.....	385	1 hr. 20 min.
7	Buccancer.....	210	30 min.
8	Pirate.....	156	110 min.
9	Panther.....	158	2 hr. 28 min.

**Job 2: Specific Fuel Consumption**

A typical method of listing fuel consumption is in the number of pounds of fuel consumed per horsepower-hour, that is, the amount consumed by each horsepower for 1 hr. For instance a LeBlond engine uses about ½ lb. of gasoline to produce 1 hp. for 1 hr. We therefore say that the specific fuel consumption of the LeBlond is ½ lb. per hp.-hr. This can be abbreviated in many ways. A few of the different forms used by various manufacturers follow:

$\frac{1}{2}$  lb. per BHP per hour

.50 lb. per HP. hour

$\frac{1}{2}$  lb. /BHP /hour

.50 lb. per HP.-hr.

$\frac{1}{2}$  lb. /BHP-hour

0.50 lb. /hp. hr.

For the sake of simplicity the form lb. per hp.-hr. will be used for the work in this chapter.

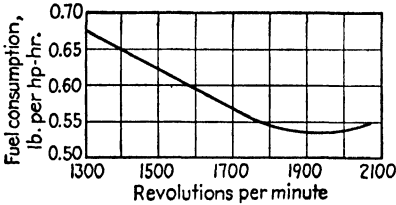

Fig. 275.—Specific fuel consumption of the Menasco B-4.

The specific fuel consumption changes with the r.p.m. The graph in Fig. 275 shows that there is a different specific fuel consumption at each throttle

setting. As the number of revolutions per minute of the crankshaft increases, the specific fuel consumption changes. Complete the following table of data from the graph:

R.p.m.	Specific fuel consumption, lb. per hp.-hr.
1,300	0.675
1,400	
1,500	
1,600	
1,700	
1,800	
1,900	
2,000	
2,100	

Questions:

1. At what r.p.m. is it most economical to operate the engine shown in Fig. 276, as far as gasoline consumption is concerned?

2. The engine is rated 95 hp. at 2,000 r.p.m. What is the specific fuel consumption given in specifications for this horsepower?

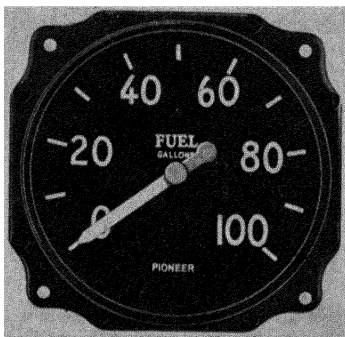

Fig. 276.—Fuel gage. (Courtesy of Pioneer Instrument Division of Bendix Aviation Corp.)

### Job 3: Gallons and Cost

The number of pounds of gasoline an engine will consume can be easily calculated, if we know (a) the specific consumption; (b) the horsepower of the engine; (c) the running time.

Formula: Total consumption = specific consumption  $\times$  horsepower-hours

#### ILLUSTRATIVE EXAMPLE

A Lycoming 240-hp. engine runs for 3 hr. Its specific fuel consumption is 0.55 lb. per hp.-hr. How many pounds of gasoline will it consume?

Given: 240 hp. for 3 hr. at 0.55 lb. per hp.-hr.

Find: Total consumption

$$\text{Total} = \text{specific consumption} \times \text{hp.-hr.}$$

$$\text{Total} = 0.55 \times 720$$

$$\text{Total} = 396 \text{ lb. } \textit{Ans.}$$

*Hint:* First find the horsepower-hours.

Examples:

1-9. Find the total fuel consumption in pounds of each of the following engines:

	Engine	Hp.	Time	Specific consumption, lb. per hp.-hr.
1	Continental.....	165	4 hr.	0.53
2	Jacobs L-4.....	225	5 hr.	0.53
3	Hornet.....	575	8 hr.	0.49
4	Wasp.....	425	4½ hr.	0.48
5	Twin Wasp.....	775	30 min.	0.48
6	Conqueror.....	650	40 min.	0.53
7	Cyclone.....	710	1 hr. 20 min.	0.55
8	Whirlwind.....	700	3 hr. 30 min.	0.55
9	Whirlwind.....	715	1 hr. 15 min.	0.58

10. Find the total consumption in pounds for the Whirlwind in Examples 8 and 9.

If the weights that airplanes must carry in fuel only seem amazing, consider the following:

The Bellanca Transport carries 1,800 lb. of fuel

The Bellanca Monoplane carries 3,600 lb. of fuel

The Douglas DC-2 carries 3,060 lb. of fuel

Look up the fuel capacity of 5 other airplanes and compare the weight of fuel to the total weight of the airplane.

You now know how to find the number of pounds of gasoline the engine will need to operate for a certain number of hours. But gasoline is bought by the gallon. How many gallons will be needed? How much will it cost?

One gallon of aviation gasoline weighs 6 lb. and costs about 30¢.

#### ILLUSTRATIVE EXAMPLE

A mechanic needs 464 lb. of gasoline. How many gallons should he buy at 30¢ a gallon? How much would this cost?

Given: 464 lb.

Find: (a) Gallons

(b) Cost

$$(a) \frac{464}{6} = 77.3 \text{ gal.}$$

$$(b) 77.3 \times .30 = \$23.19 \text{ Ans.}$$

**Method:**

To get the number of gallons, divide the number of pounds by 6.

**Examples:**

1. A mechanic needs 350 lb. of gasoline. How many gallons does he need? If the price is 28¢ per gallon, what is the cost?

2. The price of gasoline is 20¢ per gallon, and a mechanic needs 42 lb. How much should he pay?

3. A pilot stops at three airports and buys gasoline three different times:

La Guardia Airport, 40 lb. at 30¢ per gallon.

Newark Airport, 50 lb. at 28¢ per gallon.

Floyd Bennett Field, 48 lb. at 29¢ per gallon.

Find the total cost for gasoline on this trip.

4. Do this problem without further explanation:

A Bellanca Transport has a Cyclone 650-hp. engine whose specific fuel consumption is 0.55 lb. per hp.-hr. On a trip to Chicago, the engine runs for 7 hr. Find the number of gallons of gasoline needed and the cost of this gasoline at 25¢ per gallon.

*Note:* The assumption here is that the engine operates at a constant fuel consumption for the entire trip. Is this entirely true?

**Shop Problem:**

What is meant by octane rating? Can all engines operate efficiently using fuel of the same octane rating?

**Job 4: Specific Oil Consumption**

The work in specific oil consumption is very much like the work in fuel consumption, the only point of difference being in the fact that much smaller quantities of oil are used.

The average specific fuel consumption is 0.49 lb. per hp.-hr.

One gallon of gasoline weighs 6 lb.

The average specific oil consumption is 0.035 lb. per hp.-hr.

One gallon of oil weighs 7.5 lb.

**Examples:**

Do the following examples by yourself:

1. The Hornet 575-hp. engine has a specific oil consumption of 0.035 lb. per hp.-hr. and runs for 3 hr. How many pounds of oil does it consume?

2. A 425-hp. Wasp runs for  $2\frac{1}{2}$  hr. If its specific oil consumption is 0.035 lb. per hp.-hr., find the number of pounds of oil it uses.

3-7. Find the weight and the number of gallons of oil used by each of the following engines:

	Engine	Hp.	Time	Consumption, lb. per hp.-hr.
3	Wasp.....	425	4 hr.	0.030
4	Conqueror.....	650	30 min.	0.025
5	Cyclone F-2..	735	45 min.	0.035
6	Cyclone F-3..	710	1 hr. 10 min.	0.033
7	Cyclone F-1.....	715	7 hr. 30 min.	0.035

8. A LeBlond 70-hp. engine has a specific oil consumption of 0.015 lb. per hp.-hr. How many quarts of oil would be used in 2 hr. 30 min.?

**Job 5: How Long Can an Airplane Stay Up?**

The calculation of the exact time that an airplane can fly nonstop is not a simple matter. It involves consideration of the decreasing gross weight of the airplane due to the consumption of gasoline during flight, changes in horsepower at various times, and many other factors. However,

the method shown here will give a fair approximation of the answer.

If nothing goes wrong with the engine, the airplane will stay aloft as long as there is gasoline left to operate the engine. That depends upon (a) the number of gallons of gasoline in the fuel tanks, and (b) the amount of gasoline used per hour.

The capacity of the fuel tanks in gallons is always given in aircraft specifications. An instrument such as that appearing in Fig. 276 shows the number of gallons of fuel in the tanks at all times.

$$\text{Formula: Cruising time} = \frac{\text{gallons in fuel tanks}}{\text{gallons per hour consumed}}$$

**ILLUSTRATIVE EXAMPLE**

An airplane is powered with a Kinner K5 which uses 8 gal. per hr. How long can it stay up, if there are 50 gal. of fuel in the tanks?

$$\begin{aligned} \text{Cruising time} &= \frac{\text{gallons in fuel tanks}}{\text{gallons per hour consumed}} \\ \text{Cruising time} &= \frac{50}{8} = 6\frac{1}{4} \text{ hr. } \textit{Ans.} \end{aligned}$$

**Examples:**

1. An Aeronca has an engine which consumes gasoline at the rate of 3 gal. per hr. How long can the Aeronca stay up, if it started with 8 gal. of fuel?

2. At cruising speed an airplane using a LeBlond engine consumes  $4\frac{3}{4}$  gal. per hr. How long can this airplane fly at this speed, if it has  $12\frac{1}{2}$  gal. of fuel in its tanks?

3. The Bellanca Airbus uses a 575-hp. engine whose fuel consumption is 0.48 lb. per hp.-hr. How long can this airplane stay up if its fuel tanks hold 200 gal.?

4. The Cargo Aircruiser uses a 650-hp. engine whose consumption is 0.50 lb. per hp.-hr. The capacity of the tank is 150 gal. How long could it stay up?

5. A Kinner airplane powered with a Kinner engine has 50 gal. of fuel. When the engine operates at 75 hp., the

specific consumption is 0.42 lb. per hp.-hr. How long could it fly?

6. An airplane has a LeBlond 110-hp. engine whose specific consumption is 0.48 lb. per hp.-hr. If only 10 gal. of gas are left, how long can it run?

7. A large transport airplane is lost. It has 2 engines of 715 hp. each, and the fuel tanks have only 5 gal. altogether. If the lowest possible specific fuel consumption is 0.48 lb. per hp.-hr. for each engine, how long can the airplane stay aloft?

### Job 6: Review Test

1. A Vultee is powered by an engine whose specific fuel consumption is 0.60 lb. per hp.-hr. and whose specific oil

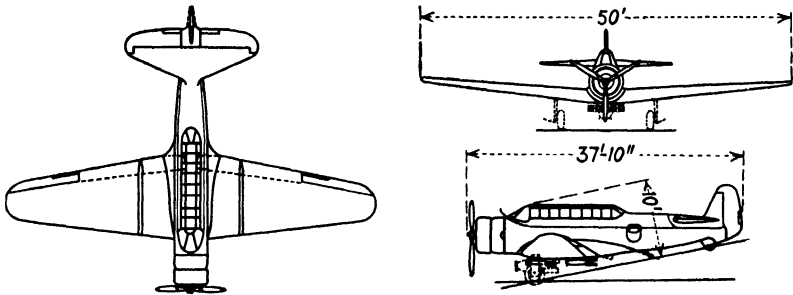

Fig. 277.—Vultee military monoplane. (Courtesy of Aviation.)

consumption is 0.025 lb. per hp.-hr. when operating at 735 hp. (see Fig. 277).

a. How many gallons of gasoline would be used in 2 hr. 15 min.?

b. How many quarts of oil would be consumed in 1 hr. 20 min.?

c. The fuel tanks of the Vultee hold 206 gal. How long can the airplane stay up before all the tanks are empty, if it operates continuously at 735 hp.?

d. The oil tanks of the Vultee have a capacity of 15 gal. How long would the engine operate before the oil tanks were empty?

2. The Wright GR-2600-A5A is a 14 cylinder staggered radial engine whose bore is  $6\frac{1}{8}$  in. and whose stroke is  $6\frac{5}{16}$  in. When operating at 2,300 r.p.m. its B.M.E.P. is 168 lb. per sq. in. At rated horsepower, this engine's

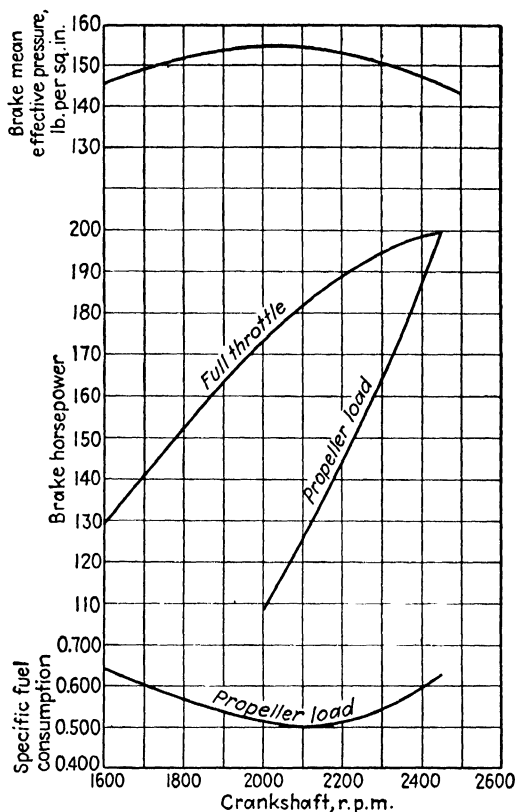

Fig. 278.—Performance curves: Ranger 6 aircraft engine.

specific fuel consumption is 0.80 lb. per hp.-hr. Find how many gallons of gasoline will be consumed in 4 hr.

*Hint:* First find the horsepower of the engine.

3. The performance curve for the Ranger 6 cylinder, in-line engine, shown in Fig. 278, was taken from company specifications. Complete the following table of data from this graph:

A photograph of a Ranger 6 cylinder inverted in-line engine is shown in Fig. 279.

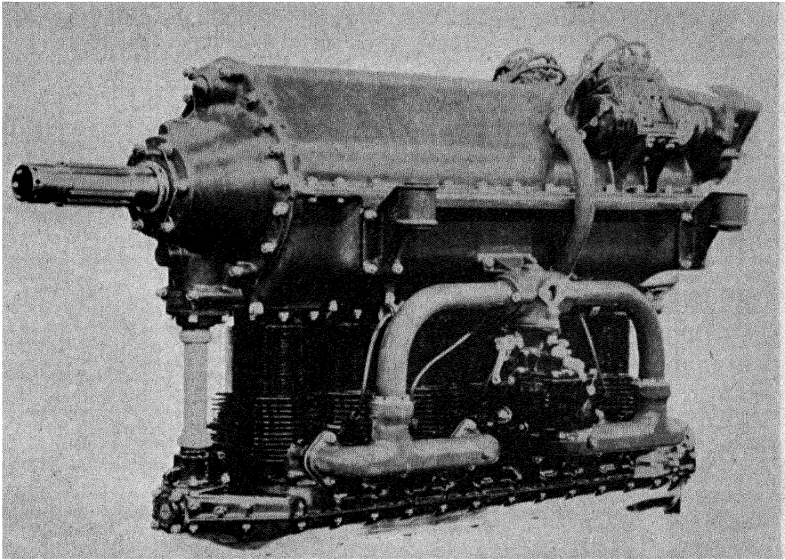

**Fig. 279.**—Ranger 6 cylinder in-line, inverted, air-cooled, aircraft engine. (Courtesy of Aviation.)

R.p.m.	B.M.E.P.	B.hp. full throttle
1,600		
1,800		
2,000		
2,200		
2,400		

4. Complete the following tables and represent the results by a line graph for each set of data.

FUEL CONSUMPTION OF THE RANGER 6

At 2,450 r.p.m.		For 1 hr. of operation	
Running time, hr.	Gallons consumed	B.hp. propeller load	Gallons consumed
1		110	
2		130	
3		150	
4		170	
5		190	
6		200	

Aircraft engine performance curves generally show two types of horsepower:

1. Full throttle horsepower. This is the power that the engine can develop at any r.p.m. Using the formula for b.hp. (Chap. XIII) will generally give this curve.

2. Propeller load horsepower. This will show the horsepower required to turn the propeller at any speed.

A photograph of a Ranger 6 cylinder inverted in-line engine is shown in Fig. 279.

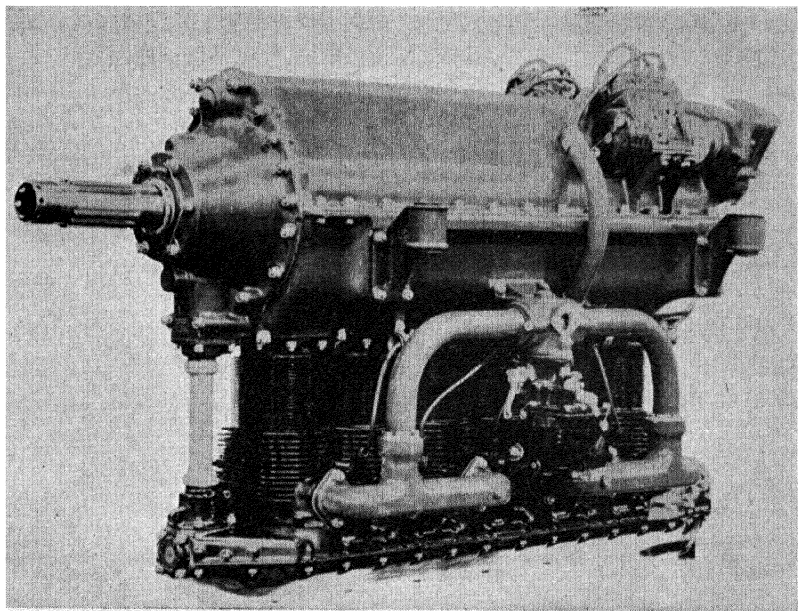

Fig. 279.—Ranger 6 cylinder in-line, inverted, air-cooled, aircraft engine. (Courtesy of Aviation.)

## Chapter XV

### COMPRESSION RATIO AND VALVE TIMING

In an actual engine cylinder, the piston at top center does not touch the top of the cylinder. The space left near the top of the cylinder after the piston has reached top center may have any of a wide variety of shapes depending

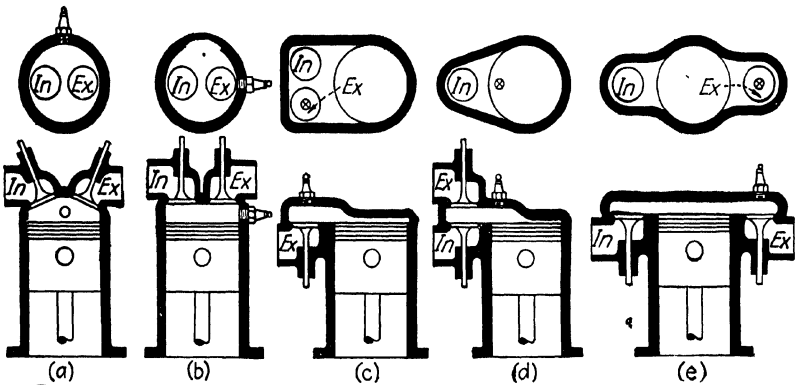

Fig. 280.—Types of combustion chambers from "The Airplane and Its Engine" by Chatfield, Taylor, and Ober.

upon the engine design. Some of the more common shapes are shown in Fig. 280.

#### Job 1: Cylinder Volume

The number of cylinders in aircraft engines ranges from 2 for the Aeronca all the way up to 14 cylinders for certain Wright or Pratt and Whitney engines.

For all practical purposes, all cylinders of a multicylinder engine may be considered identical. It was therefore con-

sidered best to base the definitions and formulas in this job upon a consideration of one cylinder only, as shown in Fig. 281. However, these same definitions and formulas will also hold true for the entire engine.

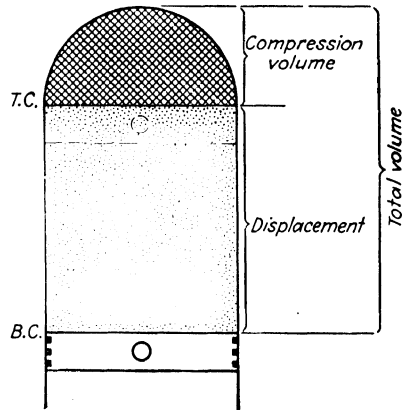
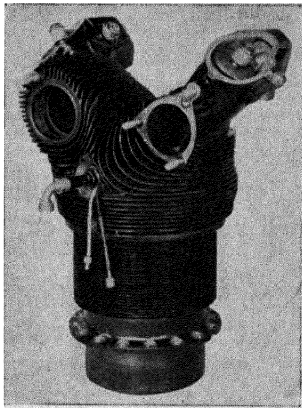

Fig. 281.—Cylinder from Pratt and Whitney Wasp. (Courtesy of Aviation.)

**Definitions:**

1. *Clearance volume* is the volume of the space left above the piston when it is at top center.

*Note:* This is sometimes called the volume of the combustion chamber.

2. *Displacement* is the volume that the piston moves through from bottom center to top center.

3. *Total volume* of 1 cylinder is equal to the displacement plus the clearance volume.

$$\text{Formula: } V_t = \text{Disp.} + V_c$$

where  $V_c$  means clearance volume.

Disp. means displacement for one cylinder.

$V_t$  means total volume of one cylinder.

**ILLUSTRATIVE EXAMPLE**

The displacement of a cylinder is 70 cu. in. and the clearance volume is 10 cu. in. Find the total volume of 1 cylinder.

Given: Disp. = 70 cu. in.

$V_c = 10$  cu. in.

Find:  $V_t$

$$V_t = \text{Disp.} + V_c$$

$$V_t = 70 + 10$$

$$V_t = 80 \text{ cu. in. } \textit{Ans.}$$

### Examples:

1. The displacement of one cylinder of a Kinner is 98 cu. in. The volume above the piston at top center is 24.5 cu. in. What is the total volume of one cylinder?

2. Each cylinder of a Whirlwind engine has a displacement of 108 cu. in. and a clearance volume of 18 cu. in. What is the volume of one cylinder?

3. The Whirlwind engine in Example 2 has 9 cylinders. What is the total displacement? What is the total volume of all cylinders?

4. The total volume of each cylinder of an Axelson aircraft engine is 105 cu. in. Find the clearance volume if the displacement for one cylinder is 85.5 cu. in.

### Job 2: Compression Ratio

The words *compression ratio* are now being used so much in trade literature, instruction manuals, and ordinary auto-

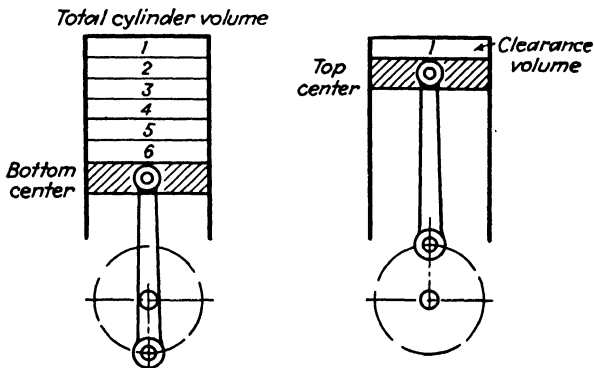

Fig. 282.—The ratio of these two volumes is called the "compression ratio."

mobile advertisements, that every mechanic ought to know what they mean.

It has been pointed out that the piston at top center does not touch the top of the cylinder. There is always a compression space left, the volume of which is called the *clearance volume* (see Fig. 282).

**Definition:**

*Compression ratio* is the ratio between the total volume of one cylinder and its clearance volume.

$$\text{Formula: C.R.} = \frac{V_t}{V_c}$$

where C.R. = compression ratio.

$V_t$  = total volume of one cylinder.

$V_c$  = clearance volume of one cylinder.

Here are some actual compression ratios for various aircraft engines:

TABLE 14

Engine	Compression Ratio
Jacobs L-5.....	6:1*
Aeronca E-113-C.....	5.4:1
Pratt and Whitney Wasp Jr.....	6:1
Ranger 6.....	6.5:1
Guiberson Diesel.....	15:1

\* Pronounced "6 to 1."

Notice that the compression ratio of the diesel engine is much higher than that of the others. Why?

**ILLUSTRATIVE EXAMPLE**

Find the compression ratio of the Aeronca E-113-C in which the total volume of one cylinder is 69.65 cu. in. and the clearance volume is 12.9 cu. in.

Given:  $V_t = 69.65$  cu. in.

$V_c = 12.9$  cu. in.

Find: C.R.

$$\text{C.R.} = \frac{V_t}{V_c}$$

$$\text{C.R.} = \frac{69.65}{12.9}$$

$$\text{C.R.} = 5.4 \text{ Ans.}$$

**Examples:**

1. The total volume of one cylinder of the water-cooled Allison V-1710-C6 is 171.0 cu. in. The volume of the compression chamber of one cylinder is 28.5 cu. in. What is the compression ratio?

2. The Jacobs L-4M radial engine has a clearance volume for one cylinder equal to 24.7 cu. in. Find the compression ratio if the total volume of one cylinder is 132.8 cu. in.

3. Find the compression ratio of the 4 cylinder Menasco Pirate, if the total volume of all 4 cylinders is 443.6 cu. in. and the total volume of all 4 combustion chambers is 80.6 cu. in.

**Job 3: How to Find the Clearance Volume**

The shape of the compression chamber above the piston at top center will depend upon the type of engine, the number of valves, spark plugs, etc. Yet there is a simple method of calculating its volume, if we know the compression ratio and the displacement. Do specifications give these facts?

Notice that the displacement for one cylinder must be calculated, since only total displacement is given in specifications.

$$\text{Formula: } V_c = \frac{\text{displacement}}{\text{C.R.} - 1}$$

where  $V_c$  = clearance volume for one cylinder.

C.R. = compression ratio.

**ILLUSTRATIVE EXAMPLE**

The displacement for one cylinder is 25 cu. in.; its compression ratio is 6:1. Find its clearance volume.

Given: Disp. = 25 cu. in.

C.R. = 6:1

Find:  $V_c$

$$V_c = \frac{\text{Disp.}}{\text{C.R.} - 1}$$

$$V_c = \frac{25}{6 - 1}$$

$$V_c = 5 \text{ cu. in. } \textit{Ans.}$$

Check the answer.

**Examples:**

1. The displacement for one cylinder of a LeBlond engine is 54 cu. in.; its compression ratio is 5.5 to 1. Find the clearance volume of one cylinder.

2. The compression ratio of the Franklin is 5.5:1, and the displacement for one cylinder is 37.5 cu. in. Find the volume of the compression chamber and the total volume of one cylinder. Check the answers.

3. The displacement for all 4 cylinders of a Lycoming is 144.5 cu. in. Find the clearance volume for one cylinder, if the compression ratio is 5.65 to 1.

4. The Allison V water-cooled engine has a bore and stroke of  $5\frac{1}{2}$  by 6 in. Find the total volume of all 12 cylinders if the compression ratio is 6.00:1.

**Job 4: Valve Timing Diagrams**

The exact time at which the intake and exhaust valves open and close has been carefully set by the designer, so as to obtain the best possible operation of the engine. After the engine has been running for some time, however, the valve timing will often be found to need adjustment. Failure to make such corrections will result in a serious loss of power and in eventual damage to the engine.

Valve timing, therefore, is an essential part of the specifications of an engine, whether aircraft, automobile, marine, or any other kind. All valve timing checks and adjustments that the mechanic makes from time to time depend upon this information.

**A. Intake.** Many students are under the impression that the intake valve always opens just as the piston begins to move downward on the intake stroke. Although this may at first glance seem natural, it is very seldom correct for aircraft engines.

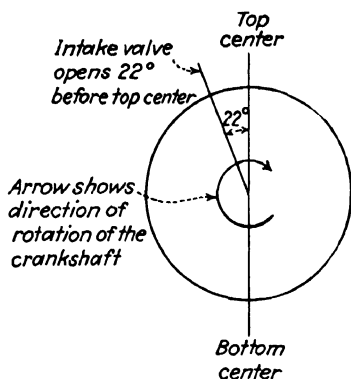

Fig. 283a.

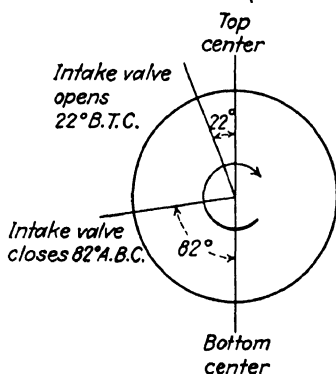

Fig. 283b.

Valve timing data is given in degrees. For instance, the intake valve of the Kinner K-5 opens  $22^\circ$  before top center. This can be diagrammed as shown in Fig. 283(a). Notice that the direction of rotation of the crankshaft is given by the arrow.

In most aircraft engines, the intake valve does *not* close as soon as the piston reaches the bottom of its downward stroke, but remains open for a considerable length of time thereafter.

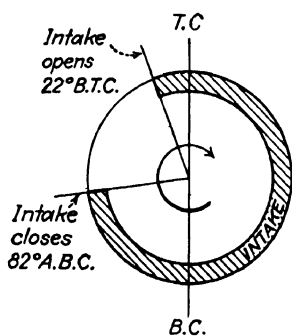

Fig. 284.

The diagram in Fig. 284 shows the valve timing diagram for the intake stroke.

These abbreviations are used:

Top center . . . . . T.C.      After top center . . . . A.T.C.  
 Bottom center . . . . . B.C.      Before bottom center B.B.C.  
 Before top center . . . B.T.C      After bottom center. A.B.C.

**Examples:**

1-3. Draw the valve timing diagram for the following engines. Notice that data for the intake valve only is given here.

Engine	Intake valve	
	Opens B.T.C.	Closes A.B.C.
Continental . . . . .	10°	55°
Axelson . . . . .	5°	55°
Kinner C-5 . . . . .	35°	90°

**B. Exhaust.** Complete valve timing information naturally gives data for both the intake and exhaust valve. For

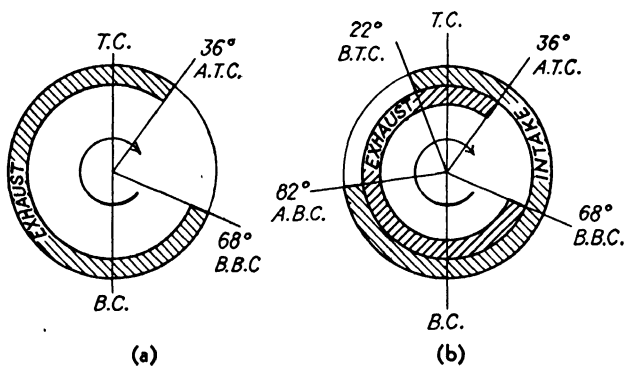

Fig. 285.

example, for the Kinner K-5 engine, the intake valve opens 22° B.T.C. and closes 82° A.B.C.; the exhaust valve opens 68° B.B.C. and closes 36° A.T.C.

Examine the valve timing diagram in Fig. 285(a) for the exhaust stroke alone. The complete valve timing diagram is shown in Fig. 285(b).

## Examples:

1-5. Draw the timing diagram for the following engines:

	Engine	Intake valve		Exhaust valve	
		Opens B.T.C.	Closes A.B.C.	Opens B.B.C.	Closes A.T.C.
1	Kinner C-5...	35°	90°	80°	45°
2	Conqueror...	40°	56°	45°	15°
3	Hornet B...	26°	76°	71°	31°
4	LeBlond...	0°	60°	60°	0°
5	Axelson.....	6°	60°	60°	6°

Figure 286 shows how the *Instruction Book* of the Axelson Engine Company gives the timing diagram for

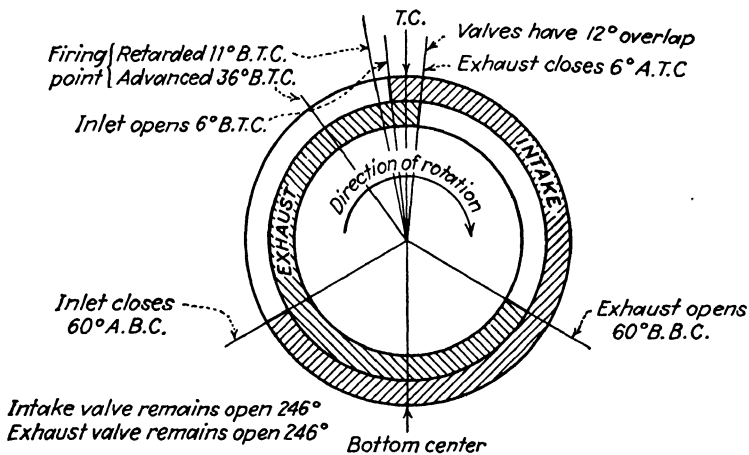

Fig. 286.—Valve-timing diagram: Axelson aircraft engine.

one of their engines. Can you obtain the data used in making this chart? Notice that the number of degrees that the valves remain open is neatly printed on the diagram, as well as the firing points and valve overlap.

### Job 5: How Long Does Each Valve Remain Open?

When the piston is at top center, the throw on the shaft is pointing directly up toward the cylinder, as in Fig. 287.

When the piston is at bottom center, the throw is at its farthest point away from the cylinder. The shaft has turned through an angle of  $180^\circ$  just for the downward movement of the piston from top center to bottom center.

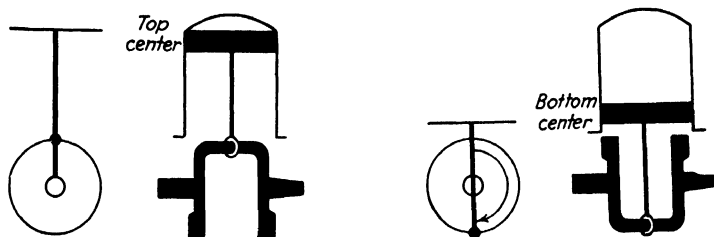

Fig. 287.

The intake valve of the Kinner K-5 opens  $22^\circ$  B.T.C., and closes  $82^\circ$  A.B.C. The intake valve of the Kinner, therefore, remains open  $22^\circ + 180^\circ + 82^\circ$  or a total of  $284^\circ$ . The exhaust valve of the Kinner opens  $68^\circ$  B.B.C., and closes

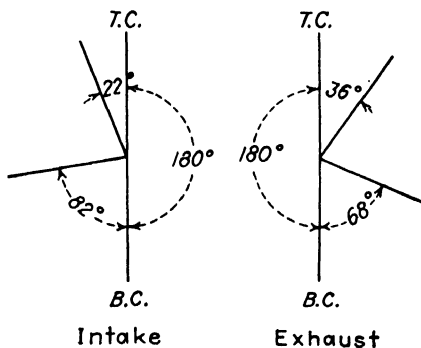

Fig. 288.

$36^\circ$  A.T.C. It is, therefore, open  $68^\circ + 180^\circ + 36^\circ$  or a total of  $284^\circ$  (see Fig. 288).

**Examples:**

1-3. Draw the valve timing diagrams for the following engines and find the number of degrees that each valve remains open:

Engine	Type	Valve timing			
		Intake opens	Intake closes	Exhaust opens	Exhaust closes
1 Tank.....	8 cylinders, air-cooled	12° B.T.C.	45° A.B.C.	50° B.B.C.	6° A.T.C.
2 Szekely SR-3...	3 cylinders, air-cooled, radial	14° B.T.C.	57° A.B.C.	57° B.B.C.	14° A.T.C.
3 Menasco B-4	4 cylinders, in-line, inverted, air-cooled	17° B.T.C.	77° A.B.C.	50° B.B.C.	10° A.T.C.

**Job 6: Valve Overlap**

From the specifications given in previous jobs, it may have been noticed that in most aircraft engines the intake valve opens before the exhaust valve closes. Of course, this means that some fuel will be wasted. However, the rush of gasoline from the intake manifold serves to drive out all

previous exhaust vapor and leave the mixture in the cylinder clean for the next stroke. This is very important in a high-compression engine, since an improper mixture might cause detonation or engine knock.

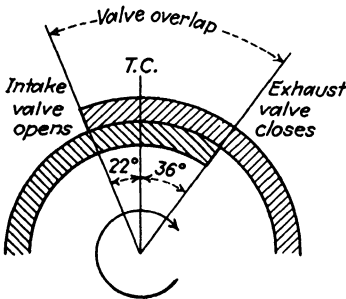

Fig. 289.

**Definition:**

*Valve overlap* is the length of time that both valves remain open at the same time. It is measured in degrees.

In finding the valve overlap, it will only be necessary to consider when the exhaust valve closes and the intake valve opens as shown in Fig. 289.

In finding the valve overlap, it will only be necessary to consider when the exhaust valve closes and the intake valve opens as shown in Fig. 289.

**ILLUSTRATIVE EXAMPLE**

What is the valve overlap for the Kinner K-5?

Given: Exhaust valve closes 36° A.T.C.

Intake valve opens 22° B.T.C.

Find: Valve overlap

$$\text{Valve overlap} = 22^\circ + 36^\circ = 58^\circ \quad \text{Ans.}$$

Examples:

1-3. Find the valve overlap for each of the following engines. First draw the valve timing diagram. Is there any overlap for the Packard engine?

	Engine	Intake valve		Exhaust valve	
		Opens	Closes	Opens	Closes
1	Wright Whirlwind J-5.	8° B.T.C.	60° A.B.C.	60° B.B.C.	8° A.T.C.
2	Curtiss, model D-12 . . .	5° B.T.C.	35° A.B.C.	55° B.B.C.	10° A.T.C.
3	Packard Aircraft. . . . .	10° A.T.C.	45° A.B.C.	48° B.B.C.	8° A.T.C.

## Job 7: Review Test

The specifications and performance curves (Fig. 290) for the Jacobs model L-6, 7 cylinder radial, air-cooled engine

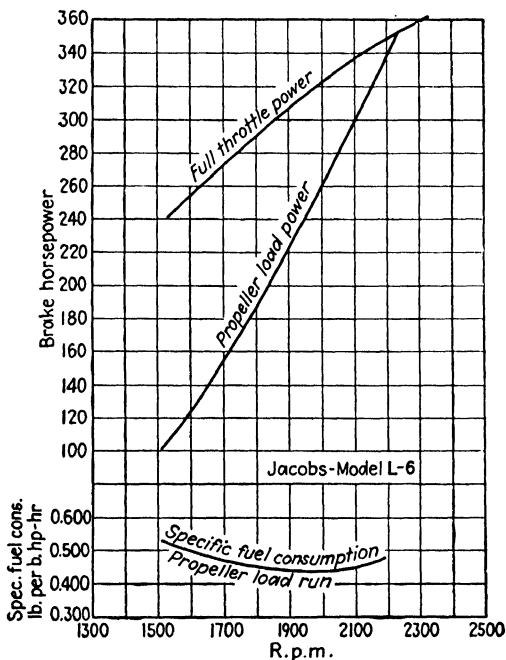

Fig. 290.—Performance curves: Jacobs L-6 aircraft engine.

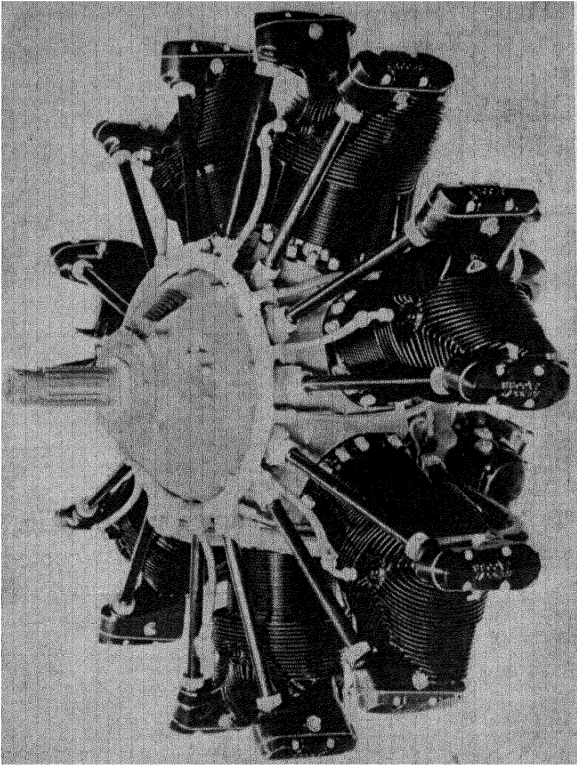

Fig. 291.—Jacobs L-6 radial air-cooled aircraft engine.

(Fig. 291) follow. All the examples in this job will refer to these specifications:

Name and model.....	Jacobs L-6
Type.....	Direct drive, air-cooled, radial
A.T.C. No.....	195
Cylinders.....	7
Bore.....	5½ in.
Stroke.....	5½ in.
B.M.E.P.....	125 lb. per sq. in.
R.p.m. at rated hp.....	2,100
Compression ratio.....	6:1
Specific oil consumption.....	0.025 lb. per hp.-hr.
Specific fuel consumption.....	0.45 lb. per hp.-hr.

Valve timing information:

Intake opens 18° B.T.C.; closes 65° A.B.C.

Exhaust opens 58° B.B.C; closes 16° A.T.C.

Crankshaft rotation, looking from rear of engine, clockwise

**Examples:**

1. Find the area of 1 piston. Find the total piston area.
2. What is the total displacement for all cylinders?
3. Calculate the brake horsepower at 2,100 r.p.m.
4. Complete these tables from the performance curves:

Propeller load horsepower	
R.p.m.	Hp.
1,500	
1,600	
1,700	
1,800	
1,900	
2,000	
2,100	

Fuel consumption	
R.p.m.	Gal. per hr.
1,500	
1,600	
1,700	
1,800	
1,900	
2,000	
2,100	

5. Find the clearance volume for 1 cylinder.
6. Find the total volume of 1 cylinder.
7. Draw the valve timing diagram.
8. How many degrees does each valve remain open?
9. What is the valve overlap in degrees?
10. How many gallons of gasoline would this engine consume operating at 2,100 r.p.m. for 1 hr. 35 min.?



***Part V***

**REVIEW**



## Chapter XVI

# ONE HUNDRED SELECTED REVIEW EXAMPLES

1. Can you read the rule? Measure the distances in Fig. 292:

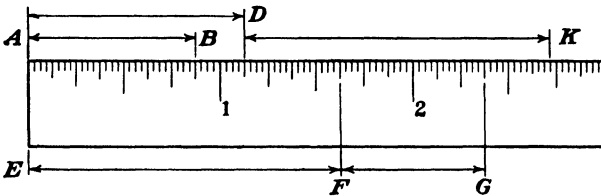

Fig. 292.

- (a)  $AB$  (b)  $AD$  (c)  $EF$  (d)  $GF$  (e)  $GE$  (f)  $DK$

2. Add:

- (a)  $\frac{1}{2} + \frac{1}{4} + \frac{1}{8} + \frac{1}{16}$  (b)  $\frac{1}{2} + \frac{3}{4} + \frac{5}{8}$   
 (c)  $5\frac{3}{4} + 2\frac{1}{16} + 1\frac{1}{8}$  (d)  $\frac{7}{8} + 5\frac{7}{16} + \frac{1}{32}$

3. Which fraction in each group is the larger and how much?

- (a)  $\frac{7}{8}$  or  $\frac{5}{8}\frac{5}{4}$  (b)  $\frac{3}{16}$  or  $\frac{5}{8}\frac{5}{4}$   
 (c)  $\frac{7}{32}$  or  $\frac{1}{4}$  (d)  $\frac{9}{84}$  or  $\frac{1}{8}$

4. Find the over-all dimensions of the piece in Fig. 293.

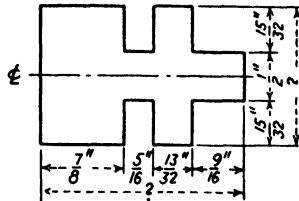

Fig. 293.



10. Find the weight of 35 ft. of round steel rod, if the weight is 1.043 lb. per ft. of length.

11. If 1-in. round stainless steel bar weighs 2.934 lb. per ft. of length, find the weight of 7 bars, each 18 ft. long.

12. Divide:

(a)  $2\frac{1}{2}$  by 4                      (b)  $4\frac{5}{32}$  by  $\frac{3}{4}$                       (c)  $12\frac{5}{8}$  by  $2\frac{1}{16}$

13. Divide. Obtain answers to the nearest hundredth.

(a) 43.625 by 9    (b) 2.03726 by 3.14    (c) 0.625 by 0.032

14. The strip of metal in Fig. 297 is to have the centers of 7 holes equally spaced. Find the distance between centers to the nearest 64th of an inch.

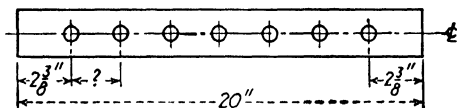

**Fig. 297.**

15. How many round pieces  $\frac{7}{8}$  in. in diameter can be “punched” from a strip of steel 36 in. long, allowing  $\frac{1}{16}$  in. between punchings (see Fig. 298)?

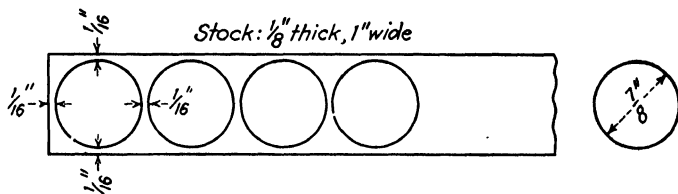

**Fig. 298.**—The steel strip is 36 in. long.

16. a. What is the weight of the unpunched strip in Fig. 298?

b. What is the total weight of all the round punchings?

c. What is the weight of the punched strip?

17. Find the area of each figure in Fig. 299.

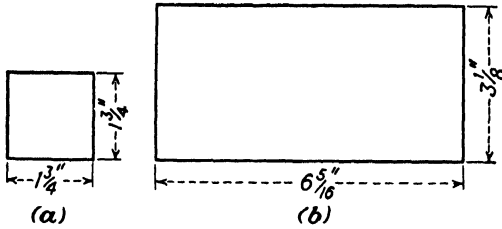

Fig. 299.

18. Find the perimeter of each figure in Fig. 299.

19. Find the area and circumference of a circle whose diameter is  $4\frac{1}{2}$  in.

20. Find the area in square inches of each figure in Fig. 300.

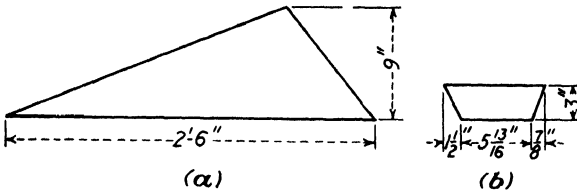

Fig. 300.

21. Find the area of the irregular flat surface shown in Fig. 301.

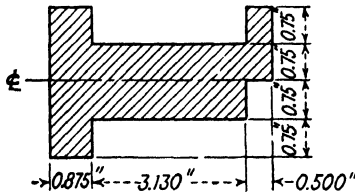

Fig. 301.

22. Calculate the area of the cutout portions of Fig. 302.

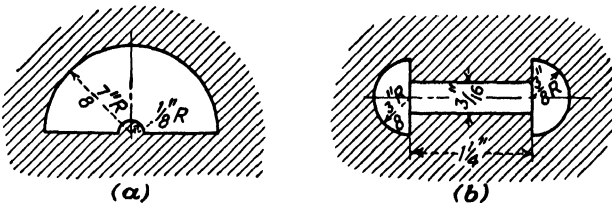

Fig. 302.

**23.** Express answers to the nearest 10th:

- (a)  $\sqrt{7,225}$                       (b)  $\sqrt{18.374}$                       (c)  $\sqrt{0.9378}$

**24.** What is the length of the side of a square whose area is 396.255 sq. in.?

**25.** Find the diameter of a piston whose face area is 30.25 sq. in.

**26.** Find the radius of circle whose area is 3.1416 sq. ft.

**27.** A rectangular field whose area is 576 sq. yd. has a length of 275 ft. What is its width?

**28.** For mass production of aircraft, a modern brick and steel structure was recently suggested comprising the following sections:

Section	Dimension, Ft.
Manufacturing .....	600 by 1,400
Engineering .....	100 by 900
Office .....	50 by 400
Truck garage .....	120 by 150
Boiler house ..	100 by 100
Oil house .....	75 by 150
Flight hangar .....	200 by 200

a. Calculate the amount of space in square feet assigned to each section.

b. Find the total amount of floor space.

**29.** Find the volume in cubic inches, of each solid in Fig. 303.

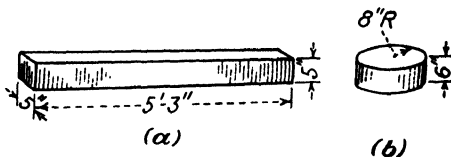

**Fig. 303.**

**30.** How many gallons of oil can be stored in a circular tank, if the diameter of its base is 25 ft. and its height is 12 feet?

31. A circular boiler, 8 ft. long and 4 ft. 6 in. in diameter, is completely filled with gasoline. What is the weight of the gasoline?

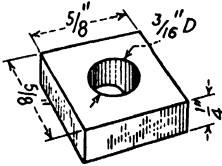

Fig. 304.

32. What is the weight of 50 oak beams each 2 by 4 in. by 12 ft. long?

33. Calculate the weight of 5,000 of the steel items in Fig. 304.

34. Find the weight of one dozen copper plates cut according to the dimensions shown in Fig. 305.

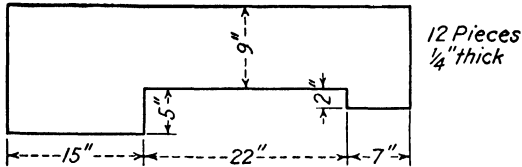

Fig. 305.

35. Calculate the weight of 144 steel pins as shown in Fig. 306.

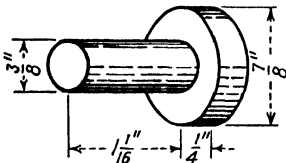

Fig. 306.

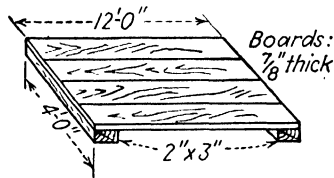

Fig. 307.

36. How many board feet are there in a piece of lumber 2 in. thick, 9 in. wide, and 12 ft. long?

37. How many board feet of lumber would be needed to build the platform shown in Fig. 307?

38. What would be the cost of this bill of material?

No. of pieces	Description	Specifications	Price per bd. ft.
6	White pine	1 in. by 9 in. by 10 ft.	\$.120
15	Oak	2 in. by 4 in. by 8 ft.	\$.155
12	Oak	7/8 in. by 8 in. by 12 ft.	\$.163

39. Find the number of board feet, the cost, and the weight of 15 spruce planks each  $\frac{3}{4}$  by 12 in. by 10 ft., if the price is \$.18 per board foot.

40. Calculate the number of board feet needed to construct the open box shown in Fig. 308, if 1-in. white pine is used throughout.

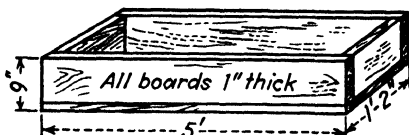

Fig. 308.

41. (a) What is the weight of the box (Fig. 308)? (b) What would be the weight of a similar steel box?

42. What weight of concrete would the box (Fig. 308) contain when filled? Concrete weighs 150 lb. per cu. ft.

43. The graph shown in Fig. 309 appeared in the Nov. 15, 1940, issue of the *Civil Aeronautics Journal*. Notice how much information is given in this small space.

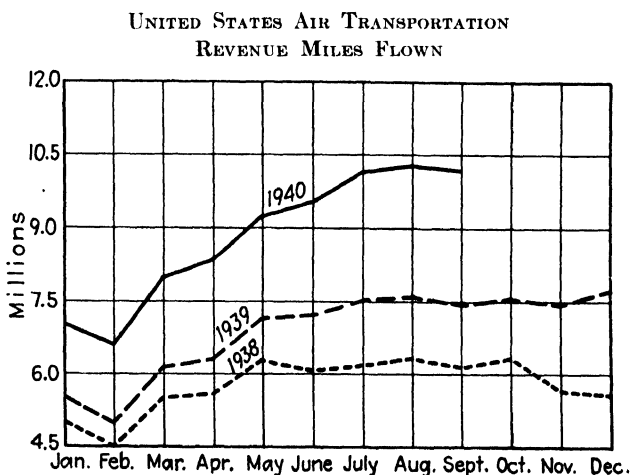

Fig. 309.—(Courtesy of Civil Aeronautics Journal.)

a. What is the worst month of every year shown in the graph as far as “revenue miles flown” is concerned? Why?

b. How many revenue miles were flown in March, 1938? In March, 1939? In March, 1940?

44. Complete a table of data showing the number of revenue miles flown in 1939 (see Fig. 309).

45. The following table shows how four major airlines compare with respect to the number of paid passengers carried during September, 1940.

Operator	Passengers
American Airlines.....	93,376
Eastern Airlines.....	33,873
T.W.A.....	35,701
United Air Lines.....	48,836

Draw a bar graph of this information.

46. Find the over-all length of the fitting shown in Fig. 310.

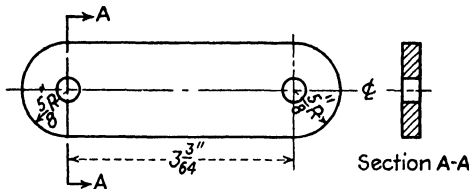

Fig. 310.— $\frac{1}{8}$ -in. cold-rolled, S.A.E. 1025, 2 holes drilled  $\frac{3}{16}$  in. diameter.

47. Make a full-scale drawing of the fitting in Fig. 310.

48. Find the top surface area of the fitting in Fig. 310.

49. What is the volume of one fitting?

50. What is the weight of 1,000 such items?

51. What is the tensile strength at section AA (Fig. 310)?

52. What is the bearing strength at AA (Fig. 310)?

53. Complete a table of data in inches to the nearest 64th for a 30-in. chord of airfoil section N.A.C.A. 22 from the data shown in Fig. 311.

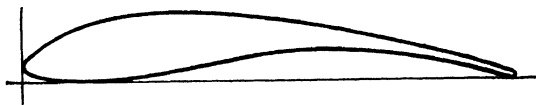

Fig. 311.—Airfoil section: N.A.C.A. 22.

N.A.C.A. 22		
Stations, per cent chord	Upper, per cent chord	Lower, per cent chord
0	2.88	2.88
1 25	5.40	1.09
2 5	6.48	0.65
5	8.02	0.28
7.5	9.11	0.08
10	9.96	0.00
15	11.34	0.12
20	12.29	0.44
30	13.35	1.46
40	13.42	3.08
50	12.60	4.78
60	11.12	5.63
70	9.15	5.79
80	6.68	4.68
90	3.95	2.67
95	2.51	1.32
100	1.13	0.00

54. Draw the nosepiece (0–15 per cent) from the data obtained in Example 53, and construct a solid wood nose-piece from the drawing.

55. What is the thickness in inches at each station of the complete airfoil for a 30-in. chord?

56. Draw the tail section (75–100 per cent) for a 5-ft. chord length of the N.A.C.A. 22.

57. Make a table of data to fit the airfoil shown in Fig. 312, accurate to the nearest 64th.

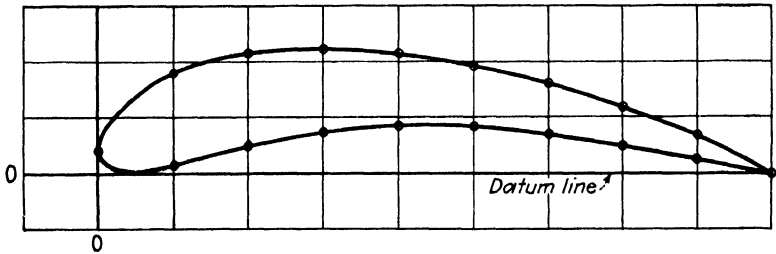

Fig. 312.—Airfoil section.

58. Design an original airfoil section on graph paper and complete a table of data to go with it.

59. What is the difference between the airfoil section in Example 58 and those found in N.A.C.A. references?

60. Complete a table of data, accurate to the nearest tenth of an inch, for a 20-in. chord of airfoil section N.A.C.A. 4412 (see Fig. 313).

## AIRFOIL SECTION: N.A.C.A. 4412

Data in per cent of chord

STA.	UP'R.	L'W'R.
0	—	0
1.25	2.44	-1.43
2.5	3.39	-1.95
5.0	4.73	-2.49
7.5	5.76	-2.74
10	6.59	-2.86
15	7.89	-2.88
20	8.80	-2.74
25	9.41	-2.50
30	9.76	-2.26
40	9.80	-1.80
50	9.19	-1.40
60	8.14	-1.00
70	6.69	-0.65
80	4.89	-0.39
90	2.71	-0.22
95	1.47	-0.16
100	—	0

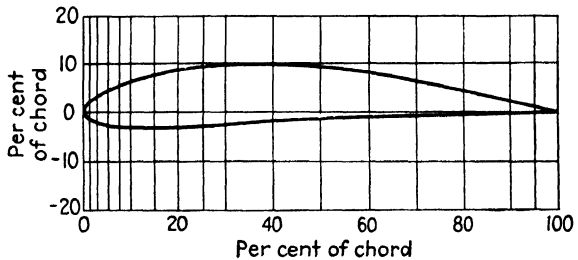

Fig. 313.—Airfoil section: N.A.C.A. 4412 is used on the Luscombe Model 50 two-place monoplane.

61. Draw a nosepiece (0–15 per cent) for a 4-ft. chord of airfoil section N.A.C.A. 4412 (see Fig. 313).

62. What is the thickness at each station of the nose-piece drawn in Example 61? Check the answers by actual measurement or by calculation from the data.

63. Find the useful load of the airplane (Fig. 314).

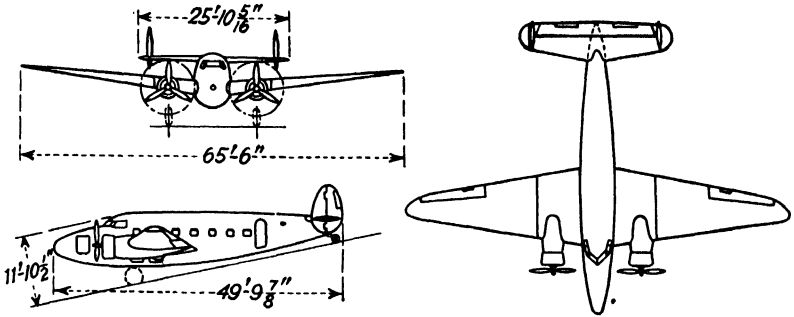

Fig. 314.—Lockheed Lodestar twin-engine transport. (Courtesy of Aviation.)

LOCKHEED LODESTAR

Weight, empty.....	12,045 lb.
Gross weight .....	17,500 lb.
Engines .....	2 Pratt and Whitney, 1200 hp. each
Wing area.....	551 sq. ft.
Wing span .....	65 ft. 6 in.

64. What is the wing loading? What is the power loading?

65. What is the mean chord of the wing?

66. Find the aspect ratio of the wing.

67. Estimate the dihedral angle of the wing from Fig. 314.

68. Estimate the angle of sweepback?

69. What per cent of the gross weight is the useful load?

70. This airplane (Fig. 314) carries 644 gal. of gasoline, and at cruising speed each engine consumes 27.5 gal. per hr. Approximately how long can it stay aloft?

71. What is the formula you would use to find:

- a. Area of a piston?
- b. Displacement?
- c. Number of power strokes per minute?
- d. Brake horsepower of an engine?

*e.* Fuel consumption?

*f.* Compression ratio?

*g.* Clearance volume?

**72.** Complete the following table. Express answers to the nearest hundredth.

FIVE CYLINDER KINNER AIRCRAFT ENGINES

Engine	Bore, in.	Piston area, sq. in.	Stroke, in.	Total displacement, cu. in.
Kinner K-5	4.25		3.75	
Kinner B-5	4.625		5.25	
Kinner R-5	5.0		5.5	

**73.** Represent the results from Example 72 graphically, using any appropriate type of graph. The Kinner K-5 is shown in Fig. 315.

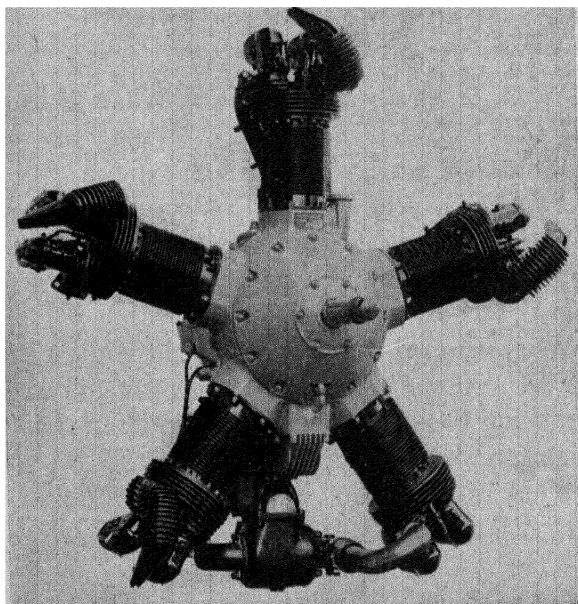

**Fig. 315.**—Kinner K-5, 5 cylinder, air-cooled, radial aircraft engine.

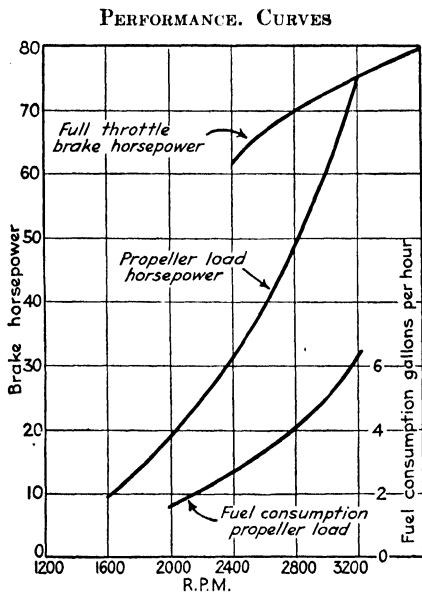

Fig. 316.—Lycoming geared 75-hp. engine.

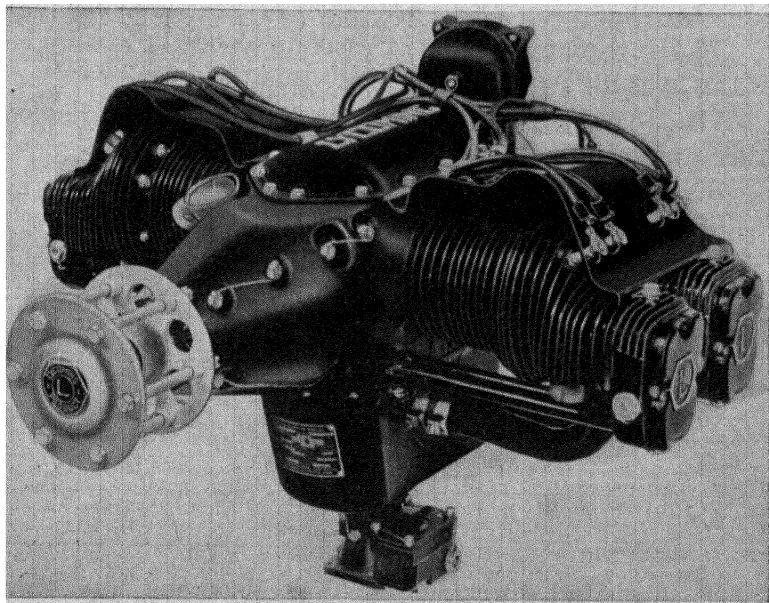

Fig. 317.—Lycoming geared 75-hp., 4 cylinder opposed, air-cooled, aircraft engine. (Courtesy of Aviation.)

The specification and performance curves (Fig. 316) are for the Lycoming geared 75-hp. engine shown in Fig. 317.

Number of cylinders.....	4
Bore.....	3.625 in.
Stroke.....	3.50 in.
Engine r.p.m.....	3,200 at rated horsepower
B.M.E.P.....	128 lb. per sq. in.
Compression ratio.....	6.5:1
Weight, dry.....	181 lb
Specific fuel consumption.....	0.50 lb./b.hp./hr.
Specific oil consumption.....	0.010 lb./b.hp./hr.

*Valve Timing Information*

Intake valve opens 20° B.T.C.; closes 65° A.B.C.  
 Exhaust valve opens 65° B.B.C.; closes 20° A.T.C.

- 74. What is the total piston area?
- 75. What is the total displacement?
- 76. Calculate the rated horsepower of this engine. Is it exactly 75 hp.? Why?
- 77. What is the weight per horsepower of the Lycoming?
- 78. How many gallons of gasoline would be consumed if the Lycoming operated for 2 hr. 15 min. at 75 hp.?
- 79. How many quarts of oil would be consumed during this interval?
- 80. Complete the following table of data from the performance curves:

R.p.m.	B.hp. propeller load	Fuel consumption, gal. per hr.
2,000		
2,400		
2,800		
3,200		

- 81. On what three factors does the bend allowance depend?

82. Calculate the bend allowance for the fitting shown in Fig. 318.

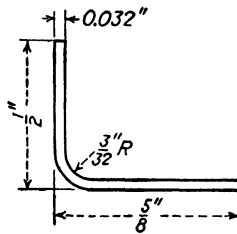

Fig. 318.—Angle of bend 90°.

83. Find the over-all or developed length of the fitting in Fig. 318.

84. Complete the following table:

BEND ALLOWANCE CHART: 90° ANGLE OF BEND  
(All dimensions are in inches)

$R$	$\frac{1}{32}$	$\frac{1}{16}$	$\frac{1}{8}$	$\frac{3}{16}$	$\frac{1}{4}$	$\frac{1}{2}$
$T$						
0.049						
0.035						
0.028						

Use the above table to help solve the examples that follow.

85. Find the developed length of the fitting shown in Fig. 319.

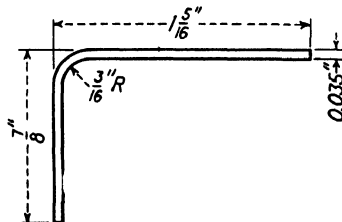

Fig. 319.—Angle of bend 90°.

86. Calculate the developed length of the part shown in Fig. 320.

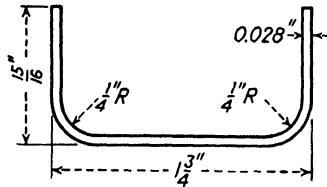

Fig. 320.—Two bends, each 90°.

87. What is the strength in tension of a dural rod whose diameter is 0.125 in.?

88. Find the strength in compression parallel to the grain of an oak beam whose cross section is  $2\frac{1}{8}$  by  $3\frac{3}{4}$  in.

89. What would be the weight of the beam in Example 88 if it were 7 ft. long?

90. Calculate the strength in shear of a  $\frac{3}{16}$ -in. copper rivet.

91. What is the strength in shear of the lap joint shown in Fig. 321?

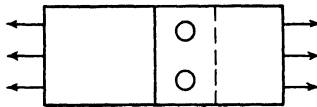

Fig. 321.—Two  $\frac{1}{16}$ -in. S.A.E. X-4130 rivets.

92. What is the strength in bearing of a 0.238-in. dural plate with a  $\frac{1}{4}$ -in. rivet hole?

93. Find the strength in tension and bearing of the cast-iron lug shown in Fig. 322.

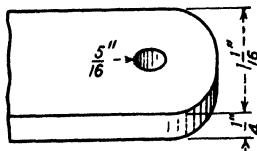

Fig. 322.

94. What is the diameter of a L.C. steel wire that can hold a maximum load of 1,500 lb.?

95. A dural tube has an outside diameter of  $1\frac{1}{4}$  in. and a wall thickness of 0.083 in.

- a. What is the inside diameter?
- b. What is the cross-sectional area?

96. What would 100 ft. of the tubing in Example 95 weigh?

97. If no bending or buckling took place, what would be the maximum compressive strength that a 22 gage (0.028 in.) S.A.E. 1015 tube could develop, if its inside diameter were 0.930 in.?

98. Find the strength in tension of the riveted strap shown in Fig. 323.

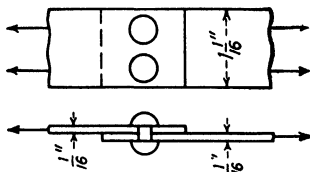

Fig. 323.—Lap joint, dural straps. Two  $\frac{1}{8}$  in., 2S rivets, driven cold.

99. What is the strength in shear of the joint in Fig. 323?

100. What is the strength in shear of the butt joint shown in Fig. 324?

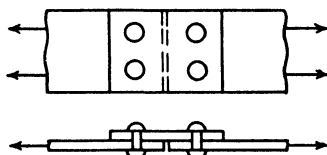

Fig. 324.—All rivets  $\frac{3}{64}$  in. 17 S-T, driven hot.



**APPENDIX**  
**TABLES AND FORMULAS**



## Tables of Measure

TABLE 1.—LENGTH

12 inches (in. or ")	=	1 foot (ft. or')
3 feet	=	1 yard (yd.)
5½ yards	=	1 rod
5,280 feet	=	1 mile (mi.)
1 meter (m.)	=	39 in. (approximately)

TABLE 2.—AREA

144 square inches (sq. in.)	=	1 square foot (sq. ft.)
9 square feet	=	1 square yard (sq. yd.)
4840 square yards	=	1 acre
640 acres	=	1 square mile (sq. mi.)

TABLE 3.—VOLUME

1728 cubic inches (cu. in.)	=	1 cubic foot (cu. ft.)
27 cubic feet	=	1 cubic yard (cu. yd.)
2 pints (pt.)	=	1 quart (qt.)
4 quarts	=	1 gallon (gal.)
231 cubic inches	=	1 gallon (approximately)
1 cubic foot	=	7½ gallons (approximately)
1 liter	=	1 quart (approximately)

TABLE 4.—ANGLE MEASURE

60 seconds (sec. or ")	=	1 minute (min. or')
60 minutes	=	1 degree (°)
90 degrees	=	1 right angle
180 degrees	=	1 straight angle
360 degrees	=	1 complete rotation, or circle

TABLE 5.—COMMON WEIGHT

16 ounces (oz.)	=	1 pound (lb.)
2000 pounds	=	1 ton (T.)
1 kilogram	=	2.2 pounds (lb.) (approximately)

## Formulas

## FROM PART I, A REVIEW OF FUNDAMENTALS

<b>Rectangle:</b>	Area = length $\times$ width Length = $\frac{\text{area}}{\text{width}}$	$A = LW$ $L = \frac{A}{W}$
<b>Square:</b>	Area = side $\times$ side Side = square root of area	$A = s^2$ $s = \sqrt{A}$
<b>Circle:</b>	Area = 0.7854 $\times$ diameter $\times$ diameter or 3.1416 $\times$ radius $\times$ radius Circumference = 3.1416 $\times$ diameter	$A = 0.7854D^2$ or $\pi R^2$ $C = \pi D$ $D = \sqrt{\frac{A}{0.7854}}$
<b>Triangle:</b>	Area = $\frac{1}{2}$ $\times$ base $\times$ altitude	$A = \frac{1}{2}ba$
<b>Trapezoid:</b>	Area = $\frac{1}{2}$ $\times$ altitude $\times$ sum of bases	$A = \frac{a}{2} \times (b_1 + b_2)$
<b>Box, cylinder, cube, prism:</b>	Volume = area of base $\times$ height	$V = A \times h$

## FROM PART II, THE AIRPLANE AND ITS WING

$$\text{Wing area} = \text{span} \times \text{chord}$$

$$\text{Mean chord} = \frac{\text{wing area}}{\text{span}}$$

$$\text{Aspect ratio} = \frac{\text{span}}{\text{chord}}$$

$$\text{Gross weight} = \text{empty weight} + \text{useful load}$$

$$\text{Wing loading} = \frac{\text{gross weight}}{\text{wing area}}$$

$$\text{Power loading} = \frac{\text{gross weight}}{\text{horsepower}}$$

## FROM PART III, MATHEMATICS OF MATERIALS

$$\text{Tensile strength} = \text{area} \times \text{ultimate tensile strength}$$

$$\text{Compressive strength} = \text{area} \times \text{ultimate compressive strength}$$

$$\text{Shear strength} = \text{area} \times \text{ultimate shear strength}$$

$$\text{Cross-sectional area} = \frac{\text{strength required}}{\text{ultimate strength}}$$

Bend allowance =  $(0.01743 \times R + 0.0078 \times T) \times N^\circ$   
 where  $R$  = radius of bend.  
 $T$  = thickness of the metal.  
 $N$  = number of degrees in the angle of bend.

FROM PART IV, AIRCRAFT ENGINE MATHEMATICS

- Displacement = piston area  $\times$  stroke
- Number of power strokes per min. =  $\frac{\text{r.p.m.}}{2} \times$  cylinders
- Indicated hp. = brake hp. + friction hp.
- B.hp. =  $\frac{\text{B.M.E.P.} \times L \times A \times N}{33,000}$
- B.hp. =  $\frac{2\pi \times F \times D \times \text{r.p.m.}}{33,000}$  (using the Prony brake)
- Compression ratio =  $\frac{\text{total cylinder volume}}{\text{clearance volume}}$

Decimal Equivalents																																																																																																																																	
<table style="width: 100%; border-collapse: collapse;"> <tr><td style="text-align: right;">1/32</td><td style="text-align: left;">.015625</td></tr> <tr><td style="text-align: right;">1/16</td><td style="text-align: left;">.03125</td></tr> <tr><td style="text-align: right;">3/32</td><td style="text-align: left;">.046875</td></tr> <tr><td style="text-align: right;">1/8</td><td style="text-align: left;">.0625</td></tr> <tr><td style="text-align: right;">5/32</td><td style="text-align: left;">.078125</td></tr> <tr><td style="text-align: right;">3/16</td><td style="text-align: left;">.09375</td></tr> <tr><td style="text-align: right;">7/32</td><td style="text-align: left;">.109375</td></tr> <tr><td style="text-align: right;">1/2</td><td style="text-align: left;">.125</td></tr> <tr><td style="text-align: right;">9/32</td><td style="text-align: left;">.140625</td></tr> <tr><td style="text-align: right;">5/16</td><td style="text-align: left;">.15625</td></tr> <tr><td style="text-align: right;">11/32</td><td style="text-align: left;">.171875</td></tr> <tr><td style="text-align: right;">3/8</td><td style="text-align: left;">.1875</td></tr> <tr><td style="text-align: right;">13/32</td><td style="text-align: left;">.203125</td></tr> <tr><td style="text-align: right;">7/16</td><td style="text-align: left;">.21875</td></tr> <tr><td style="text-align: right;">15/32</td><td style="text-align: left;">.234375</td></tr> <tr><td style="text-align: right;">1/2</td><td style="text-align: left;">.25</td></tr> <tr><td style="text-align: right;">17/32</td><td style="text-align: left;">.265625</td></tr> <tr><td style="text-align: right;">9/16</td><td style="text-align: left;">.28125</td></tr> <tr><td style="text-align: right;">19/32</td><td style="text-align: left;">.296875</td></tr> <tr><td style="text-align: right;">5/8</td><td style="text-align: left;">.3125</td></tr> <tr><td style="text-align: right;">21/32</td><td style="text-align: left;">.328125</td></tr> <tr><td style="text-align: right;">11/16</td><td style="text-align: left;">.34375</td></tr> <tr><td style="text-align: right;">23/32</td><td style="text-align: left;">.359375</td></tr> <tr><td style="text-align: right;">3/4</td><td style="text-align: left;">.375</td></tr> <tr><td style="text-align: right;">25/32</td><td style="text-align: left;">.390625</td></tr> <tr><td style="text-align: right;">13/16</td><td style="text-align: left;">.40625</td></tr> <tr><td style="text-align: right;">27/32</td><td style="text-align: left;">.421875</td></tr> <tr><td style="text-align: right;">7/8</td><td style="text-align: left;">.4375</td></tr> <tr><td style="text-align: right;">29/32</td><td style="text-align: left;">.453125</td></tr> <tr><td style="text-align: right;">15/16</td><td style="text-align: left;">.46875</td></tr> <tr><td style="text-align: right;">31/32</td><td style="text-align: left;">.484375</td></tr> <tr><td style="text-align: right;">1</td><td style="text-align: left;">.5</td></tr> </table>	1/32	.015625	1/16	.03125	3/32	.046875	1/8	.0625	5/32	.078125	3/16	.09375	7/32	.109375	1/2	.125	9/32	.140625	5/16	.15625	11/32	.171875	3/8	.1875	13/32	.203125	7/16	.21875	15/32	.234375	1/2	.25	17/32	.265625	9/16	.28125	19/32	.296875	5/8	.3125	21/32	.328125	11/16	.34375	23/32	.359375	3/4	.375	25/32	.390625	13/16	.40625	27/32	.421875	7/8	.4375	29/32	.453125	15/16	.46875	31/32	.484375	1	.5	<table style="width: 100%; border-collapse: collapse;"> <tr><td style="text-align: right;">33/32</td><td style="text-align: left;">.515625</td></tr> <tr><td style="text-align: right;">17/16</td><td style="text-align: left;">.53125</td></tr> <tr><td style="text-align: right;">35/32</td><td style="text-align: left;">.546875</td></tr> <tr><td style="text-align: right;">9/8</td><td style="text-align: left;">.5625</td></tr> <tr><td style="text-align: right;">19/16</td><td style="text-align: left;">.578125</td></tr> <tr><td style="text-align: right;">37/32</td><td style="text-align: left;">.59375</td></tr> <tr><td style="text-align: right;">5/4</td><td style="text-align: left;">.609375</td></tr> <tr><td style="text-align: right;">39/32</td><td style="text-align: left;">.625</td></tr> <tr><td style="text-align: right;">5/4</td><td style="text-align: left;">.640625</td></tr> <tr><td style="text-align: right;">21/16</td><td style="text-align: left;">.65625</td></tr> <tr><td style="text-align: right;">43/32</td><td style="text-align: left;">.671875</td></tr> <tr><td style="text-align: right;">11/8</td><td style="text-align: left;">.6875</td></tr> <tr><td style="text-align: right;">45/32</td><td style="text-align: left;">.703125</td></tr> <tr><td style="text-align: right;">23/16</td><td style="text-align: left;">.71875</td></tr> <tr><td style="text-align: right;">47/32</td><td style="text-align: left;">.734375</td></tr> <tr><td style="text-align: right;">3/2</td><td style="text-align: left;">.75</td></tr> <tr><td style="text-align: right;">49/32</td><td style="text-align: left;">.765625</td></tr> <tr><td style="text-align: right;">25/16</td><td style="text-align: left;">.78125</td></tr> <tr><td style="text-align: right;">51/32</td><td style="text-align: left;">.796875</td></tr> <tr><td style="text-align: right;">13/8</td><td style="text-align: left;">.8125</td></tr> <tr><td style="text-align: right;">53/32</td><td style="text-align: left;">.828125</td></tr> <tr><td style="text-align: right;">27/16</td><td style="text-align: left;">.84375</td></tr> <tr><td style="text-align: right;">55/32</td><td style="text-align: left;">.859375</td></tr> <tr><td style="text-align: right;">7/8</td><td style="text-align: left;">.875</td></tr> <tr><td style="text-align: right;">57/32</td><td style="text-align: left;">.890625</td></tr> <tr><td style="text-align: right;">29/16</td><td style="text-align: left;">.90625</td></tr> <tr><td style="text-align: right;">59/32</td><td style="text-align: left;">.921875</td></tr> <tr><td style="text-align: right;">15/8</td><td style="text-align: left;">.9375</td></tr> <tr><td style="text-align: right;">61/32</td><td style="text-align: left;">.953125</td></tr> <tr><td style="text-align: right;">31/16</td><td style="text-align: left;">.96875</td></tr> <tr><td style="text-align: right;">63/32</td><td style="text-align: left;">.984375</td></tr> <tr><td style="text-align: right;">1</td><td style="text-align: left;">1.</td></tr> </table>	33/32	.515625	17/16	.53125	35/32	.546875	9/8	.5625	19/16	.578125	37/32	.59375	5/4	.609375	39/32	.625	5/4	.640625	21/16	.65625	43/32	.671875	11/8	.6875	45/32	.703125	23/16	.71875	47/32	.734375	3/2	.75	49/32	.765625	25/16	.78125	51/32	.796875	13/8	.8125	53/32	.828125	27/16	.84375	55/32	.859375	7/8	.875	57/32	.890625	29/16	.90625	59/32	.921875	15/8	.9375	61/32	.953125	31/16	.96875	63/32	.984375	1	1.
1/32	.015625																																																																																																																																
1/16	.03125																																																																																																																																
3/32	.046875																																																																																																																																
1/8	.0625																																																																																																																																
5/32	.078125																																																																																																																																
3/16	.09375																																																																																																																																
7/32	.109375																																																																																																																																
1/2	.125																																																																																																																																
9/32	.140625																																																																																																																																
5/16	.15625																																																																																																																																
11/32	.171875																																																																																																																																
3/8	.1875																																																																																																																																
13/32	.203125																																																																																																																																
7/16	.21875																																																																																																																																
15/32	.234375																																																																																																																																
1/2	.25																																																																																																																																
17/32	.265625																																																																																																																																
9/16	.28125																																																																																																																																
19/32	.296875																																																																																																																																
5/8	.3125																																																																																																																																
21/32	.328125																																																																																																																																
11/16	.34375																																																																																																																																
23/32	.359375																																																																																																																																
3/4	.375																																																																																																																																
25/32	.390625																																																																																																																																
13/16	.40625																																																																																																																																
27/32	.421875																																																																																																																																
7/8	.4375																																																																																																																																
29/32	.453125																																																																																																																																
15/16	.46875																																																																																																																																
31/32	.484375																																																																																																																																
1	.5																																																																																																																																
33/32	.515625																																																																																																																																
17/16	.53125																																																																																																																																
35/32	.546875																																																																																																																																
9/8	.5625																																																																																																																																
19/16	.578125																																																																																																																																
37/32	.59375																																																																																																																																
5/4	.609375																																																																																																																																
39/32	.625																																																																																																																																
5/4	.640625																																																																																																																																
21/16	.65625																																																																																																																																
43/32	.671875																																																																																																																																
11/8	.6875																																																																																																																																
45/32	.703125																																																																																																																																
23/16	.71875																																																																																																																																
47/32	.734375																																																																																																																																
3/2	.75																																																																																																																																
49/32	.765625																																																																																																																																
25/16	.78125																																																																																																																																
51/32	.796875																																																																																																																																
13/8	.8125																																																																																																																																
53/32	.828125																																																																																																																																
27/16	.84375																																																																																																																																
55/32	.859375																																																																																																																																
7/8	.875																																																																																																																																
57/32	.890625																																																																																																																																
29/16	.90625																																																																																																																																
59/32	.921875																																																																																																																																
15/8	.9375																																																																																																																																
61/32	.953125																																																																																																																																
31/16	.96875																																																																																																																																
63/32	.984375																																																																																																																																
1	1.																																																																																																																																



# INDEX

## A

- Accuracy of measurement, 5-8, 32
- Addition of decimals, 22
  - of nonruler fractions, 40
  - of ruler fractions, 12
- Aircraft engine, 191-237
  - performance curves, 221, 235, 253
- Airfoil section, 130-150
  - with data, in inches, 131
    - per cent of chord, 135
  - with negative numbers, 144
  - nosepiece of, 139
  - tailsection of, 139
  - thickness of, 142
- Airplane wing, 111-150
  - area of, 115
  - aspect ratio of, 117
  - chord, 115
  - loading, 124
  - span of, 115
- Angles, 80-89, 93, 182
  - in aviation, 86
    - how bisected, 88
    - how drawn, 82, 93
    - how measured, 84
    - units of measure of, 84
- Area, 47-69
  - of airplane wing, 113
  - of circle, 61
  - cross-sectional, required, 164
  - formulas for, 261
  - of piston, 195
  - of rectangle, 48
  - of square, 58
  - of trapezoid, 66
  - of triangle, 64

- Area, units of, 47, 261
- Aspect ratio, 117

## B

- Bar graph, 98-101
- Bearing, 162-164
  - strength, table of, 162
- Bend allowance, 181-190
- Board feet, 76-78
- Broken-line graph, 103-105

## C

- Camber, upper and lower, 131-135
- Chord mean, 116
  - per cent of, 135
- Circle, area of, 61
  - circumference of, 43
- Clearance volume, 228, 229
- Compression, 157-160
  - strength, table of, 159
- Compression ratio, 226-228
- Construction, 88-97
  - of angle bisector, 88
  - of equal angle, 93
  - of line bisector, 89
  - of line into equal parts, 96
  - of parallel line, 94
  - of perpendicular, 91
- Curved-line graph, 105, 106
- Cylinder volume, 224-226

## D

- Decimals, 20-36
  - checking dimensions with, 22

Decimals, division of, 26  
 to fractions, 27  
 multiplication of, 24  
 square root of, 56  
 Displacement, 197-199

## E

Equivalents, chart of decimal, 29

## F

Fittings, 169-171  
 Formulas, 260-262  
 Fractions, 8-18, 40-42  
 addition of, 12, 40  
 changing to decimals, 27  
 division of, 16  
 multiplication of, 15  
 reducing to lowest terms, 8  
 subtraction of, 18  
 Fuel and oil consumption, 212-220  
 gallons and cost, 215  
 specific, 213, 217

## G

Graphs, 98-108  
 bar, 98  
 broken-line, 103  
 curved-line, 105  
 pictograph, 101

## H

Horsepower, 193-210  
 formula for, 206  
 types of, 201  
 Horsepower-hours, 212, 213

## I

Improper fractions, 11

## M

Materials, strength of, 153-179  
 weight of, 73-76

Mean effective pressure, 203-205  
 Measuring, accuracy of, 5  
 length, 37-45  
 with protractor, 81  
 with steel rule, 3

Micrometer caliper, 20

Mixed numbers, 10-12

Multiplication, of decimals, 24-26  
 of fractions, 15

## P

Parallel lines, 94  
 Pay load, 121-123  
 Perimeter, 39  
 Perpendicular, 91, 92  
 Pictograph, 101-103  
 Piston area, 195-197  
 Power loading, 126  
 Power strokes, 199, 204  
 Prony brake, 208-210  
 Protractor, 80-82

## R

Rectangle, 48-51  
 Review, selected examples, 241-257  
 Review tests, 18, 34, 45, 68, 78, 97,  
 108, 127, 148, 166, 179, 189, 210,  
 220, 235  
 Riveted joints, 177-179  
 Rivets, 175-179  
 strength of, 175, 177  
 types of, 175, 176

## S

Shear, 160-162  
 strength, table of, 161  
 Span of airplane wing, 115  
 Specific consumption, 213-217  
 of fuel, 213  
 of oil, 217  
 Square, 58-61  
 Square root, 54-56  
 of decimals, 56  
 of whole numbers, 55

Squaring a number, 52-54  
Steel rule, 3-8  
Strength of materials, 153-179  
    bearing, 162  
    compression, 157  
    safe working, 168  
    table of, 169  
    shear, 160  
    tension, 154

**T**

Tables of measure, 259  
Tension, 154-157  
    strength, table of, 155  
Thickness gage, 23  
Tolerance and limits, 32-34  
Trapezoid, 66-68  
Triangle, 64-66  
Tubing, 171-175

**U**

Useful load, 120

**V**

Valve timing, 229-235  
    diagrams, 229  
    overlap, 234  
Volume, of aircraft-engine cylinder, 224  
    of clearance, 228  
    formula for, 71, 72  
    units of, 70  
    and weight, 70-78

**W**

Weight of an airplane, 113-127  
    formula for, 74  
    gross and empty, 119  
    of materials, 73-76  
    table of, 74  
Wing loading, 124-126











