

UNIVERSAL
LIBRARY

OU_150458

UNIVERSAL
LIBRARY

OSMANIA UNIVERSITY LIBRARY

Call No. 612.821^{43E} Accession No. 11958

Author *Sea Shore. Carl. L.*

Title *Elementary experiments in
Psychology (1927)*

This book should be returned on or before the date
last marked below.



This Volume is sold in Gt. Britain by
G. BELL AND SONS, LTD.
PORTUGAL ST. KINGSWAY, LONDON

ELEMENTARY EXPERIMENTS
IN
PSYCHOLOGY

BY

CARL E. SEASHORE

*Head of the Department of Philosophy and Psychology and Dean of the
Graduate College in the State University of Iowa*



NEW YORK
HENRY HOLT AND COMPANY

COPYRIGHT, 1908,
BY
HENRY HOLT AND COMPANY

March, 1925
February, 1926
May, 1926
July, 1927

PRINTED IN THE U S. A BY
QUINN & BODEN COMPANY, INC.
RAHWAY, N. J.

PREFACE

THIS manual is designed to meet the requirements for a series of individual experiments in the first course in psychology. It makes individual experiments, as opposed to class demonstrations, practicable, regardless of laboratory facilities or the size of the class. The student is given means and encouragement for pursuing each problem intensively in order that he may acquire independence of thought and action, realize the actuality of mental processes, and get here and there a vision of the vastness, the orderliness, the practical significance, and the charms of mental life.

No laboratory facilities are required. In this there is a triple gain: it saves the manifolding of equipment, it frees the student from the technicalities incidental to the manipulation of apparatus at a time when his energies need to be conserved for the grasping of the psychological problem, and it saves time for the class period, the experiments being adapted for outside assignments. The apparatus other than that ordinarily at the disposal of students is supplied with the book in the accompanying envelope.*

* The president of a college asked a distinguished psychologist how much money his board ought to appropriate for the equipment of a fair elementary laboratory. The reply came: "Three thousand dollars a year for a good instructor and one dollar for paper and pins." This manual supplies the paper and pins and, in part, the instructor.

The experiments are independent and self-explanatory. Provided the manual is used in connection with the customary elementary text-book or lectures, the experiments require no introduction; the directions are adequate, and the running comment furnishes the setting for each step and enables the student to see the significance of the results. The beginner needs much help in his experiments in psychology, and there is no more practical way of giving it than through a manual.

This is not a laboratory manual. It is a manual of experiments which the student should perform before he is admitted to the laboratory, or in case he does not intend to pursue the subject beyond one course. It is not a text-book by itself, but a supplement to any good text-book. It does not review the field of psychology, but simply furnishes the intensive, individual, experimental part of the instruction. It does not furnish technical instruction on methods of experimenting, but, like the conversational method of teaching language, everywhere encourages right procedure. It does not purport to cover the most important matters; sometimes an almost insignificant topic (for example, the subject of the first chapter) is chosen for the purpose of deepening insight. It by no means supplants the class demonstrations and experiments, except in the few topics selected, and even here the instructor may profitably supplement and show how the same experiments may be performed by the usual laboratory apparatus.

The manual presupposes such knowledge of the nervous system as is imparted by the text-books most used in psychology. It aims to retain the most generally ac-

cepted classifications and terms, to introduce those experiments which have come into most general favor, and to leave untouched those fields in which experiment has been of doubtful value. The discussion on each topic is limited to the bearings of the experiment.

As to the method of using the book, each instructor will naturally adopt that best suited to his situation. If space is available, the students should be encouraged to perform the experiments in the rooms of the department during certain open hours, and under the general supervision of an assistant. There should be sufficient time allowed in the recitation-period for special suggestions and directions to the students, and for reports upon the completed experiment. The students' notes on each topic must be collected and checked rigorously; for, no matter how explicit the directions may be, the quality of the work must be passed upon by the instructor. It is profitable to require the students to take turns in working over the reports to show difficulties, original observations, special demonstrations, etc. Ordinarily each experiment will take two hours. The first experiment should be divided into two assignments, on account of the newness of the work and in order to avoid fatigue.

Titchener's monumental four-volume set of laboratory manuals is a most valuable compendium.* It contains bibliographies, besides technical discussions of nearly every topic in this course. Sanford's,† Wit-

*Titchener, "Experimental Psychology": Qualitative (I) Student's Manual and (II) Instructor's Manual; Quantitative (III) Student's Manual and (IV) Instructor's Manual.

† Sanford, "Experimental Psychology."

mer's,* and Judd's† manuals are helpful references. Baldwin's dictionary of Philosophy and Psychology should also be on the reference-table, together with the most approved elementary texts.

The author has gleaned material from many sources and wishes here to acknowledge his grateful obligations to those who find themselves contributors to this volume. He has had the benefit of helpful advice from many psychologists of experience; several of them have kindly read the manuscript and made valuable suggestions. He is especially indebted to his colleague Dr. Mabel Clare Williams for coöperation.

*Witmer, "Analytical Psychology."

†Judd, "Laboratory Manual of Psychology" and "Laboratory Equipment for Psychological Experiments."

CONTENTS

CHAPTER	PAGE
PREFACE	iii
INTRODUCTION	ix
I. VISUAL AFTER-IMAGES	1
II. VISUAL CONTRAST	13
III. THE VISUAL FIELD	23
IV. VISUAL SPACE	39
V. AUDITORY SPACE	55
VI. TACTUAL SPACE	71
VII. CUTANEOUS SENSATIONS	82
VIII. WEBER'S LAW	91
IX. MENTAL IMAGES	104
X. ASSOCIATION	118
XI. MEMORY	131
XII. APPERCEPTION	144
XIII. ATTENTION	158
XIV. NORMAL ILLUSIONS	172
XV. AFFECTIVE TONE	191
XVI. REACTION-TIME	205

INTRODUCTION

To the Student:

PSYCHOLOGY is a systematic study of mental life. You now turn from the study of physical forces, rocks, flowers, and animal tissues, in nature without, to a study of your own mind. You are to perform experiments upon yourself.

The experimental method enables you to analyze and reduce a mental process to its simplest elements; to control, repeat, and vary the conditions systematically; to record the results; to trace interrelations and explanations of known phenomena; and to discover new facts and problems.

This manual is so arranged as to furnish set exercises in which directions, aids, and explanations are given in the order needed. Only a few of the most general suggestions for your guidance need be given here.

Finish as you go along. The paragraph is the unit; always read a paragraph at a time and perform the experiment, write the report, or master the explanation before you read the next. This is mandatory, because glancing ahead would often vitiate the experiment.

Take systematic notes. The directions for notes are specific in certain minimum requirements. These notes are not primarily for the information of the instructor, or for reviews and examinations, but for the purpose

of clinching the observed facts and gaining practice in the recording of the results, which is an essential step in an experiment. Use loose-leaf note-books; hand in the report for each experiment to the instructor for inspection; and file the notes as they are returned.

Work intensively. Seek the most thorough insight into the problem under consideration; note new observations, test ideas suggested to you, verify and check as much as time permits. Reason, and thus develop confidence in your own judgment and power of observation. But always adhere to the set topic. Do not ramble, or follow up the countless fascinating side lines which come to view. Follow the directions closely, then develop your original ideas.

Apply what you learn. You will learn, for example, many laws of mental economy in this course. When you have discovered and demonstrated such laws, use them. Economize mental energy! Psychologize in your history lesson, your literature, your material science, your athletics,—wherever you are concerned with mental processes. To educate, to heal, to govern, to please, to interpret the efforts and products of the human mind; to understand inclinations, proclivities, and capacities of your own and other minds, involves knowledge of mind, which is psychology.*

*“Only with the aid of psychology can one to the fullest possible extent reap the benefits of the study of other forms of science. Language cannot be understood, literature cannot be appreciated, read, and interpreted, art cannot be profoundly comprehended, and even the natural sciences cannot have their full import revealed, without a knowledge of the mind of man. And, indeed, how could this be otherwise, since all science itself is only the product of the human mind?” (Ladd.)

Be impartial: be not self-centered. You will be called upon to exhibit and measure your mental capacities in various ways, and it requires the integrity and courage of a scientist to observe and report these without bias.

Go only as far in an assignment as you can go thoroughly. One student may be able to proceed two or three times as fast as another. If you find that the lesson is too long for you, do not skim over any part, but proceed as far as you can and record the time limit.

In the experiments that follow, "For one" means that the experiments so headed may be performed by one person alone. "For two" means that two must work together, one acting as experimenter (E) and the other as observer (O). Shift in each experiment so that each one may serve in turn both as experimenter and as observer. Record which one served as observer first. Each should keep the notes which naturally go into his book according to the directions. Record also the date, the hour of the beginning of the experiment, interruptions, and any general conditions which might influence the results. Use terse language.

To experiment is to ask questions of nature. Do not simply repeat the set questions of the book, but let them open deeper and more serviceable inquiries into your mental nature. Your primary aim in this course should be, not to collect facts, but to acquire training. Carry habits of introspection, precision, analysis, and natural explanation into life and you will realize the force of our motto: Not psychology, but to psychologize.

CHAPTER I

VISUAL AFTER-IMAGES

*For One.**

MOST of us have observed that, if we look for a moment at a light as it is being turned out, we see an image of it a while afterward. That image is an after-image, or after-sensation. Such images manifest themselves according to traceable laws and play an important, though seldom recognized, rôle in our experience. We shall now make a study of some of their characteristic modes of behavior.

Success in this experiment depends mainly upon concentration of attention and economy in the use of the eyes. The eyes should not be allowed to wander aimlessly over the figures, and it is well to close them for rest as often as possible. Clear images can be obtained only after steady fixation. It is easier to get the after-image with one eye alone, but in the long run it is more restful to use the two eyes together.

1.●Existence. *a. Brightness.*—Place the black square at the center of the upper half of a white sheet of paper; fixate the center of it (i.e., look intently and

*Take from the envelope the large black and gray squares, and the following small squares: black, gray, white, red, blue, yellow, green, violet, and orange. Make a pinhole at the center of each of these squares.

steadily at the pinhole) for about fifteen seconds;* then look at the center of the lower half of the sheet of white paper and you will see a bright square, which is the after-image. Record your estimate of its relative size and duration.

b. Color.—Try the red square in the same manner. Record the color of the after-image.

An after-image is a sensory image which occurs as the result of the stimulation of a sense-organ but not until after the stimulus has been withdrawn. It is a sort of echo and bears certain relations to the object of which it is a copy as regards space, duration of the primary impression, sense quality, and intensity. Thus, in this experiment, you saw, on the surface of the blank paper, copies of the squares possibly like the original in every respect except brightness† and color. After-images combine certain characteristics of sensations and mental images and might equally well be called after-sensations.

The causes of after-images are present in all our vision and tend to modify practically all that we see. Yet many persons live long and happily without making allowance for their distortions or even discovering the existence of them. Every object that we see leaves an impression which may bob up as an after-image, if sufficiently strong and isolated. We look at a piece of black paper and the next moment we see a copy

* A fixation-time of fifteen seconds is too long for some and too short for other observers; each will soon determine what time is most favorable for his eyes.

† Black, white, and all the intervening grays are called brightnesses. Brightness is also present in color.

of it wherever we cast our eyes; the same is true about a light, a color, an apple, a man, a tree, a book, a house—any object which may impress the eye. The after-images in themselves are not useful, and it is fortunate that we have the instinctive power to disregard them as effectively as we do. But even though we disregard them, they modify our sensory experience and continually tone the colors, lights, and shades of our environment.

After-images occur in all the senses, but the visual are the most conspicuous.

2. **Setting.**—Repeat Exp. 1 *a* and observe that, when the light after-image appears, there is a change in the white surface surrounding it.* Describe the change.

When we look at an object we may secure an after-image not only of that object but also of its surroundings within a limited field of vision. This complexity of the impression is one of the reasons why specific after-images are so difficult to detect and so easy to disregard.

After-images are local effects of the adaptation of the eye to changes in brightness and color. When we enter a dark room, it seems at first intensely dark, but later it assumes gray or color effects. When we pass from a dark into a light room, the light at first is dazzling, but the eye soon adapts itself so that after a while the light does not seem so bright. During adaptation all brightnesses and all colors tend toward

* If the white sheet is placed against a dark background, the outline of the whole sheet may be seen in the after-image.

gray. In the above experiment a square portion of the retina is adapted to dark and the surrounding portion to light.

3. **Color.**—In successive trials, produce after-images of the five colors, blue, green, yellow, violet, and orange. Record the dominating color in each after-image.* Can you formulate a law for this order of color? If so, state it.

The after-image of any color goes through a series of rapid changes, possibly covering the whole spectrum; but there is always one particular color which dominates by being the most distinct and by persisting the longest. This color is complementary to the color of the stimulus.† Of course it is modified, according to certain laws, by the color and the brightness of the background upon which it is projected.

The after-image of the dark stimulus in the first experiment was light; that is, antagonistic. We may therefore combine the observations on brightness and on color and say that the dominant color and brightness of an after-image are antagonistic to the color and brightness of the stimulus. All color after-images also involve brightness-effects. Colors are often seen in the after-images of non-colored objects.

4. **Projection-background.** *a. Brightness-effect on Brightness.*—Repeat Exp. 1 *a* in six successive trials

* Do not try these in too rapid succession; it may be well to intersperse them with following experiments. Beware of looking at the colors out of mere curiosity or aimlessness!

† Every color has a complementary, i.e., an opposite or antagonistic color. Colors are said to be complementary if they neutralize each other and produce gray when mixed.

under uniform conditions, except that you project the image upon different backgrounds; * namely, white, gray, and black, in the double-fatigue order.† Record the relative effectiveness of the three backgrounds.

The clearness of an image depends upon the brightness-difference between it and its projection-background. When projected upon the white ground, in this experiment, the light of the image is intensified and the darkness of the surroundings is reduced by the white; on the black ground, the light of the image is minimized and the darkness of the surroundings is enhanced by the black; while, on the gray, there is a moderate interference with both image and surroundings. Hence brightness of the background makes comparatively little difference in the effectiveness of the after-image, although the brightness of the three images varies greatly. For a dark object the white projection-background is, however, usually more effective, because here the white enhances the image of the object itself, whereas on a black projection-background it is the background of the object that is enhanced.

b. Brightness-effect on Color.—Repeat Exp. 1 *b* in three successive trials, projecting the image upon white, gray, and black backgrounds respectively. Record the effect of the background upon the color of the after-image.

*Use the two large squares for gray and black projection-backgrounds.

† *Double-fatigue order* is the technical term for the giving of a series of trials in one order and repeating them in the reverse order; thus, white, gray, black; black, gray, white. The theory is that such factors as fatigue and practice tend to even up by this order.

There is a distinct effect upon the brightness of the color; the actual color of the image mixes with the brightness of the background.

c. Color-effect on Color.—Project the after-image of the red square, in successive trials, upon the yellow, the blue, and the red square itself. Record the resulting color-effects.

The color of the after-image mixes with the color of the background. Thus, the result on the yellow is a greenish yellow; on the blue, a greenish blue; and on the red a tendency toward gray. This last trial—red upon red—explains why colors change and blur when we look intently at them; the after-image of the red disk is a pale green, and if it were projected upon a pale red of the same strength, the result would be to cancel both colors, according to the law of complementaries.

d. Absence of Background.—Fixate the black square as before, and then put your hands over your eyes and you will see the image projected somewhere into space.* Record your estimate of its size and distance and the relative effectiveness of this and the foregoing modes of projection.

The image may be projected anywhere—upon any color or brightness, upon any form, at any distance within sight. A glance at the setting sun produces shifting color-effects upon the object we look at immediately afterward; the after-image of the green leaf in

* It is usually better to keep the eyes open when covered by the hands; still, it makes but little difference whether they are open or closed, provided the covering is adequate.

a woman's hat may be taken for a rosy blush upon her cheek.

5. **Negative and Positive.**—Look at a lighted lamp * for half a second, and then instantly cover the eyes and observe the radical changes in color of the after-image. Record the two dominant colors in the order of their appearance.†

The positive after-image has the same relations of brightness as the stimulus, as in a photographic positive. The negative after-image has the relations of light and shade reversed, as in the photographic negative. The after-image may be of the same color as the stimulus, or it may be other-colored. There are positive same-colored and positive other-colored, negative same-colored and negative other-colored after-images. Generally, however, positive after-images are same-colored and negative other-colored are complementary.

The positive after-image appears first and is usually very short in duration and difficult to detect. To make it conspicuous, one must employ a strong stimulus, as in this experiment. After some training one may see the positive after-image before the negative in the exposure of ordinary objects of moderate intensity.

* Any kind: daylight does not interfere seriously.

† Positive after-images of brightness without color may be demonstrated as follows: Face some distant object, as the branching limb of a tree outlined against a clear sky; close the eyes and cover with the hands for a minute; then open the hands and eyes for a fraction of a second, and observe, *immediately* after closing the eyes again, an image like the object in brightness. This is the positive after-image.

6. **Size and Distance.**—In three successive trials project an after-image of the black square, as in Exp. 1 *a*, upon backgrounds at different distances from the eye; e.g., 1 ft., 3 ft., and 10 ft. Formulate a law of the relation between size and distance.

This variation of the size with distance shows that the after-image follows the same optical principles of projection as the normal retinal image in perception.

7. **Relief.**—Project an after-image of a hat, a lamp-globe, or any other object that presents relief or volume. Is there any suggestion of relief or volume in the after-image?

The perception of relief depends upon the differences between the images in the two eyes, delicate gradations in brightness, and eye-movements, among other data. The blurred edges, the reversal of brightness, and the confusion of eye-muscle sensations militate against the perceptions of relief in the after-image. Ordinarily the after-image presents only the outline and does not suggest relief, but training and care may enable one to identify marks of relief.

8. **Plasticity.**—Project an after-image of the black square into an upper corner of the room. Record whether the image adapts itself to the ceiling and wall-surfaces, or retains its flat form.

It may do either; which it shall do is a matter of apperception. Usually it adapts itself plastically to the surfaces. This is particularly true if the image is projected upon some familiar surface, as the sleeve or the hand.

9. **Movement.**—Fixate the black square, as in Exp. 1 *a*, and project the image with eyes closed and covered by the hands, and try to keep the after-image directly before you. Does the image seem to move irresistibly? If so, in what direction?

It is clear by this time that the after-image moves with the eyes; with the eyes open, we see it in whatever direction we look. But when the eyes are closed, and we are not aware of their movement, most observers find that the image has a curiously irresistible tendency to move upward.

10. **Latent Period, Duration, and Clearness.**—In each of the following four experiments record (1) the approximate latent time,* (2) duration, and (3) relative clearness.

a. Time.—Project the after-image of the black square first after a fixation of five seconds and then after a fixation of ten seconds,† allowing due time for recovery between the two.

b. Brightness.—Place the black and the gray squares edge to edge upon the white sheet; fixate the adjoining edges and project the double image upon a white background.

c. Color.—Place the red, the green, the yellow, and the blue squares in a cluster upon the white sheet; mark

* The latent time of an after-image is the time which elapses between the withdrawal of the stimulus and the beginning of the appearance of the after-image.

† This time should be adapted to the individual needs, the requirement being that a relatively short exposure-time shall be compared with a longer one.

a point in the center of the cluster; fixate the central point and project the four-colored after-image upon a white background.

d. Area.—Cut a piece of white paper about eight millimeters square and place it and the white square five millimeters apart upon the large black square; fixate a middle point and project the double image upon a white background.*

Long stimulation, large brightness-difference between the object and its background, and a moderately large area are conducive to a short latent time, long duration, and clearness of the after-image.† These laws are, however, subject to numerous qualifications.

These experiments merely show how it is possible to work out laws of the relation between stimuli and after-images.‡ The rule is to study one factor at a time and keep all other conditions constant. The factor which is studied may be varied, as in the above separating of time, brightness, and area under controllable conditions, and the effect of such variations may be measured.

The certainty that the image shall appear depends mainly upon the exposure-time, the area, and the brightness of the stimulus, but also upon such subjective conditions as are mentioned in the following paragraph.

* A millimeter scale is printed on the last page of this book. Fold the margin of that page so as to bring the scale marking to the edge of the page.

† The variations with color are perhaps essentially due to the difference in the brightness of the color. For this reason blue is the most effective color in this group on a white background.

‡ See Franz, "After-images," *The Psychological Review Monograph Supplement*, Vol. III, No. 12.

If any one of these is inadequate the image fails to appear. As a rule, the after-image may be produced if the object is presented under such conditions as to be clearly perceptible. Thus, an electric spark, which endures only for an infinitesimal part of a second, may produce an after-image; in the present experiments the observer may not have noticed the after-image of the white seen through the pinhole, but objects of that size may produce after-images under favorable conditions; and one may not be able to get a distinct image of a white plate upon a white tablecloth because the brightness-difference is too small.

The duration of the after-image varies within wide limits. In extreme cases the impression has been known to persist for days and months, as with Newton, who looked at the sun with his right eye and then saw the sun continually before him for many days. The ordinary duration is, however, limited to a few seconds, and the image passes away gradually. In addition to such objective conditions as exposure-time, area, and brightness which we have noted, there are subjective factors, such as practice, expectation, attention, etc., which condition the duration.

11. **Indirect Vision.**—Fixate a point about seven centimeters away from the center of the back square; it then stimulates the indirect field of the retina. Project the after-image. Compare the effectiveness of this image with the foregoing images from the direct field.

The best after-images are obtained from the center of the retina. Clearness and duration gradually de-

crease toward the periphery, and it is very difficult to get any image from the extreme periphery of the retina. In this respect the after-image behaves like the primary image in perception.

12. **Periodicity.**—Fixate the black square until it begins to blur and then project the after-image in the most favorable way, and observe that it recurs again and again. Record the number of appearances.

Under favorable circumstances the image may appear twenty or thirty times. This periodic recurrence is a fundamental law. Sometimes the usual sequence of positive and negative phases may be observed in each period.

The cause of after-images lies chiefly in the fact that, as soon as a light stimulus ceases to act upon a given portion of the retina, a reaction of the chemically antagonistic sort follows. The play of the after-image in all its transitions through brightness and color follows the course of this reaction in the retinal elements.*

* A good account of the principal physiological theories of color-vision is found in Calkins, "Introduction to Psychology," pp. 464-79.

CHAPTER II

VISUAL CONTRAST

*For One.**

· EVERY sensation is different from what it would have been if it had been experienced together with, or in sequence to, some other sensation. One of the best illustrations of this "law of relativity" is to be found in contrast, which we shall now study in the sense of sight.

These experiments should be performed in good diffused daylight. Unless otherwise directed, the object must invariably be viewed through the tissue-paper. The foregoing exercise has taught the importance of avoiding fatigue for color and brightness. Make prompt judgments and avoid unnecessary exposure of the eyes to the figures.

1. **Brightness-contrast.**—Lay the black and the white squares about three centimeters apart upon the background; place a gray bar upon each of them and cover the whole with the tissue-paper. Compare the

*Take all the small squares from the envelope. Cut two bars from the small gray square and two from the pale green square each 5 millimeters wide. Use the page at the end of the book containing the millimeter scale for a background, and cover the colors laid upon it with the facing sheet of tissue-paper.

brightness of the two gray bars and record which is the brighter.

The two gray bars are exactly alike in brightness; but, by contrast with their backgrounds, one becomes a light gray and the other a dark gray.

There are two kinds of contrast, successive and simultaneous. Successive contrast is in many respects synonymous with after-images, and may be defined as "the apparent alteration of a gray or a colored surface by the previous stimulation of the same retinal area by some other sort of light." (Sanford.) Simultaneous contrast, the theme of the present chapter, is described as "the mutual effects in respect to color and brightness which simultaneously seen but separated visual areas have upon each other." (Baldwin.) The difference between the two kinds of contrast lies in the fact that one is due to successive impressions, whereas the other is due to simultaneous impressions. The effects of the two kinds of contrast are closely related.

Consider for a moment the practical consequences of the phenomenon just demonstrated. Wherever surfaces of different brightness are seen together, each modifies the brightness of the other. To see the world of lights and shades as it really is, to guide ourselves accurately in seeing form, relief, and distance, and to be able to make the proper correction wherever contrast operates, we must carry in our minds an idea of the magnitude and a knowledge of the laws of brightness-contrast. Contrast is both helpful and deceptive; it magnifies differences and therefore often helps in distinguishing surfaces; on the other hand, unless we

are prepared to make the correction, we are constantly deceived as to the strength of lights and shades.*

2. **Color-contrast.**—Lay any two color-squares upon the background; lay one of the gray bars upon each of the colors and cover with the tissue-paper. Observe that the gray of each bar assumes a distinct color-tinge. Record the color of each bar. Repeat the same with other color-squares, pair by pair. If possible reduce these records to a law of color-contrast.†

The two bars are colorless—exactly the same gray, yet each shows a distinct tinge of color. Those who fail to see one or more of the contrast-colors of these figures

* *Supplementary Experiment.*—(Not to be performed unless directed by the instructor.) The following measurement of brightness-contrast is very simple and effective and may be demonstrated if a color-wheel or a color-top is available. Revolve a black and a white disk upon the color-wheel and adjust the proportions of black and white until the resulting gray matches the gray bar on one square. Record the amount of white in the mixture. Then measure the grayness of the other square in the same manner. The difference in the amount of white in the two measurements is a measure of the difference between the two gray bars.

By similar procedure it is easy to determine how much of this contrast-effect is due to the white and the black fields respectively.

† A very pretty demonstration of color-contrast may be made as follows: Put a large white paper or cloth upon a table; place upon it some tall, slender object which will cast a long, narrow shadow; pull down all window-shades except one which is left open about a foot; light a candle or any other artificial light and hold it a little to the side of the window. There will be two shadows of the object, one from the white daylight and the other from the yellow artificial light. The latter shadow is seen distinctly blue. In reality, or physically, it is gray; the blue is the contrast from the surroundings which are made yellow by the artificial light. *The induced blue is a much stronger color than the inducing yellow.*

after a fair trial have a corresponding color-blindness or color-weakness, which can be measured.

Color-contrast is most effective when there is no brightness-contrast between the two fields. The effect would have been very much enhanced in the present figures if each gray bar had been matched in brightness with the color-field upon which it rested. An otherwise strong color-contrast may be almost obliterated by the introduction of a simultaneous brightness-contrast.*

Here again we have a sweeping principle: all colors tinge their surroundings with their complementary color. Things are not what they seem! The colors in nature, art, fabrics—everywhere—are active and modify their environments. Flowers and foliage, grass and sky, all play their harmonies and discords in modulations of color. The artist trusts the subjective colors as surely as he trusts the pigment on his canvas. The milliner and the modiste use contrast effectively and artistically: a dark hat and a green gown give a fair and rosy complexion. There is almost as much in the art of knowing what to avoid as in knowing what to employ.†

3. Brightness-effect on Color.—Lay the black and the white squares upon the background; lay one of the

*The color-contrast may be measured on the same principle as the brightness-contrast.

†Chevreul, "The Laws of Contrast of Color and their Application to the Arts of Painting, Decoration of Buildings, Mosaic Work, Tapestry and Carpet-weaving, Calico-printing, Dress, Paper-staining, Printing, Military Clothing, Illumination, Landscape-gardening, etc.," is an interesting book, though somewhat out of date.

green bars upon each of these and cover with tissue-paper. Record the effect of the black and the white upon the green.

The colorless brightness of the surroundings modifies the color near it. When placed upon similar fields, the two greens are exactly alike; but when placed upon fields which differ in brightness, the greens appear to change in brightness according to the laws of brightness-contrast. A dark field makes an adjacent color brighter, a light field makes it darker.

4. **Color-effect on Color.** *a. Canceling.*—Lay the green and the gray squares upon the white background; lay a pale green bar upon each one and cover with the tissue-paper. Record the effect of the deep green upon the pale green.

b. Enhancing.—Lay one green bar upon the red square and the other upon the gray and cover with the tissue-paper. Record the effect of the red upon the green.

c. Modulating.—Lay the yellow and the blue squares upon the background; lay a green bar upon each one and cover with the tissue-paper. Record the apparent change in the color-tone of the two bars.

These three variations represent the three types of effect of one color upon another. The two pale-green bars are alike, but the one upon the green tends to lose its color, while the one on the red is enhanced in color. The green square throws a contrast red upon its bar and this tends to cancel the green and produce a gray. This illustrates how one color tends to obliterate a neighbor-

ing color. Wherever shades or tints run together with a more saturated form of the same color, the weaker color must be made stronger to compensate for the loss by contrast with its own but stronger color.

The field of the red square induces a contrast green which reinforces the original green of the bar. The effect of the red upon the green illustrates the general law that opposites enhance each other, which is true for both brightness and color.

The green on the yellow field looks bluish green and the one on the blue field looks yellowish green. These are illustrations of the law that colors which are not complementary or identical have a modulating effect upon each other. This is by far the most frequent of the three types of the effect of color upon color.

This condition, that every color changes adjoining colors, reduces itself, then, to a simple order and an easily applicable law. The effect can always be predicted. Knowing the series of complementaries and the principles of color-mixing, we can always predict the result.

All these contrast-phenomena are very much stronger in ordinary experience than under these experimental conditions, because, in the experiment, we are not only in a more critical attitude, but we are also biased by the knowledge of the actual conditions, e.g., that the gray bars are alike and that the green bars are alike. In nature and in art, especially where we are not conscious of the contrast, the illusion has full play.

5. **Effect Immediate.** *a. Direct Observation.*—Repeat Exps. 1 and 2 and observe that the contrast is present as soon as the object is clearly seen.

b. Comparison with After-images.—Determine the shortest exposure-time which will bring out a noticeable after-image of the black square. Record the approximate time.

This experiment proves two things: first, that the purely simultaneous contrast-effect is immediate and is not due to adaptation; and, second, that it is very closely related to the adaptation of successive contrast or after-images in effect, so that the greatest care must be taken to avoid complication of the two kinds of contrast as far as possible. After some training in observation one may obtain an after-image from a mere glance at the figure. We seldom see an object so quickly that adaptation does not play a rôle in the perception.

6. **Effect Marginal and Reciprocal.**—Lay the green, the yellowish-green, the greenish-yellow, and the yellow color-squares side by side in the order named, with edges slightly overlapping. Observe them both with and without the tissue-paper cover. Describe the changes in these colors which are due to the juxtaposition.

Contrast, whether of brightness or color, is always reciprocal. Which of the two or more fields shall show the greatest effect depends upon the means of comparison, the relative area, the relative brightness, the relative saturation, the point of regard, and many other conditions. When seen by itself, each of these squares is of uniform color and brightness; but when seen to-

gether, the green brings out the yellow of the adjoining less green square by counterbalancing the green of the contrast red. The yellow brings out the green of the less yellow square by counterbalancing the yellow with the contrast blue. Each color makes the different element in the contiguous color more conspicuous. The effect is striking even without the elimination of contour by the tissue-paper. When the effect tapers off rapidly from the margin, as in this case, it is spoken of as marginal contrast.

Marginal contrast is one aspect of the general principle that the contrast-effect decreases with increase in the distance between the two contrasting surfaces. Certain conditions tend to make it prominent, as here, but there has been opportunity for observing the fact in every experiment.

7. **Area.**—Place a gray bar and the gray square some distance apart upon the background and cover with the tissue-paper. Record which appears to be the darker.

The two grays are really alike, but the bar looks the darker on account of its relatively small area and the form which is favorable to the exposure from the white inducing field. In all the above experiments the effects have been reciprocal, but we have directed our attention to the smaller areas because they show the greatest relative effect.

8. **Contour.**—Compare the force of the contrast in Exps. 1 and 2 when the squares are covered with the tissue-paper with the force when they are not covered. Record the difference in the effect.

The observer has undoubtedly been annoyed and puzzled by the constant demand for covering with tissue-paper. What can be its purpose? The tissue-paper has been employed for the purpose of eliminating contour, and that only. This has been done on the principle that contrast is very much enhanced by uncertainty in the surface. Surfaces with very sharp delineations counteract the motives for contrast.

There are other ways of eliminating contour. Nature as a rule presents more or less uncertain contour and therefore favors contrast. Distance, for example, serves the same purpose as the tissue-paper. When we admire a flower-bed or a landscape we are far enough away to get the dim outline and the vagueness of contour which are so favorable for contrast.*

9. Contrast in the After-image.—Lay one gray bar upon the black square and the other near by upon the white background; cover with tissue-paper. Fixate a point between them and secure an after-image. Record the relative brightness of the two bars in the after-image.

The contrast is effective in the after-image.

The explanation of visual contrast in color and brightness is probably to be found chiefly in physiological terms—in the indirect stimulation of adjacent areas of the retina.

* The color-wheel serves the same purpose. If we cut three concentric gray circles of different brightness and place them on the wheel, the contrast will hardly be perceptible so long as the wheel is motionless; but revolve the disk and the contrast at once becomes conspicuous, because the spinning takes away the sharp rigidity of outline and surface.

The experiments have all been devoted to color and brightness. The phenomena of visual contrast might have been equally well illustrated in visual perception of space. The general law is that opposites enhance each other although the actual explanation for this may be different in different cases. As black enhances white and red enhances green, so there is a reciprocal enhancement between the long and the short, the large and the small, the narrow and the wide, the irregular and the regular, the dull and the sharp, the smooth and the rough, the straight and the crooked, the ugly and the beautiful, etc. When the tall and the short man walk together, the tall one looks taller and the short one looks shorter than otherwise. A poor penman is mortified to see his signature together with the signature of a good penman. A pocket-knife is dull in comparison with a razor, but sharp in comparison with a hatchet.

Similar illustrations might be found in the time, or duration, of visual acts. Contrast operates in all the attributes of sensation—quality, intensity, duration, and space. And we find it in all the senses. Indeed, one of the laws of contrast is that it is strongest in those senses with which we make the poorest discrimination. Hence the most striking illustrations of contrast are found in the lower senses, as in taste, smell, and temperature.

CHAPTER III

THE VISUAL FIELD

For One.

THE problem is to measure the field of vision for white and colors, and to determine some characteristic color-changes in the indirect field.

Make the following preparation for the experiment: Lay a piece of cardboard back of Fig. 1. Prick through the page with a pin at each number on the arc, at the free end of the heavy line, and at the principal points in the light line. Trim the card by cutting according to the tracing of the light line. Insert the degree-numbers at the appropriate points. Draw the heavy line. Punch a pinhole at the free end of the heavy line, which is the center of the arc. Put a thread through the hole and tie a knot at the back of the card. Tie a knot at the other end of the thread, fifty centimeters away. Take the large black square and the small white, red, green, yellow, and blue squares from the book envelope. Lay the white square upon the large black square as a background; then stick a pin through the knot at the free end of the cord, through the two squares near a corner of the small one, and finally through a cork

which may serve as a handle. The quadrant and object-card thus arranged may be called a perimeter.*

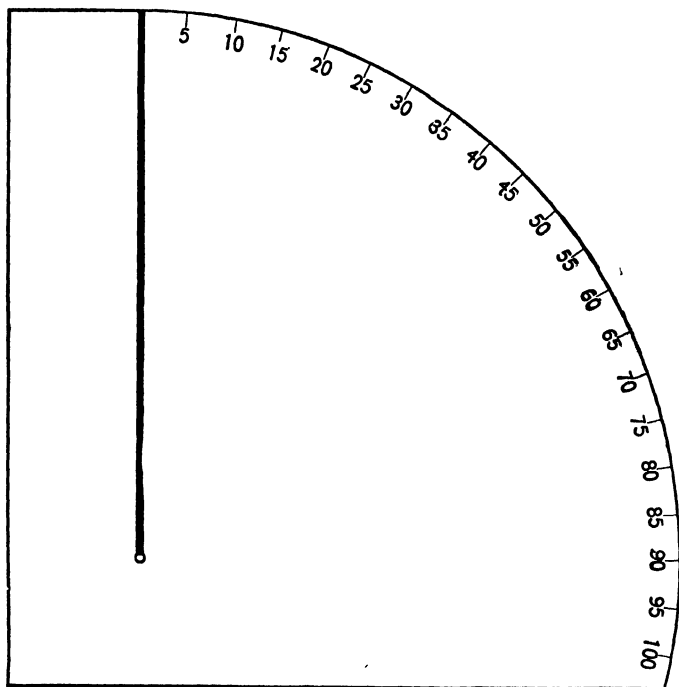

FIG. 1.

The perimeter is a simple means of measuring the direction of an object in the indirect field of vision.

* There have been two general types of instruments employed in perimetry of vision: (1) those in which the measurements are made upon a plane surface, and (2) those in which the measurements are made upon the arc of a circle centered at the eye. The former is called a campimeter, the latter a perimeter. The present outfit works on the perimeter principle. The most effective perimeter is an instrument with colored lights in a dark room.

Seat yourself in good reflected light with the back toward the source of light. Mark a dot on a piece of white paper and fasten it up sixty centimeters directly in front of the eyes. Blindfold one eye; hold the quadrant with one edge close to the other eye so that in looking straight forward at the dot, the eye sights along the heavy straight line on the quadrant. When the eye is fixed upon it, the dot becomes the fixation-point, or point of regard, and is said to lie in the direct field of vision. The visual space around it is spoken of as the indirect field.

1. **The Field for White.**—Hold the quadrant in the horizontal plane in front of the right eye so that the regard-line on the quadrant points exactly toward the fixation-point when you sight along it. Keep the head upright and firm. Fixate the dot which is the point of regard and do not allow the eye to wander away from it during the actual trial. Move the object-card inward from the extreme right until the white disk can first be seen as white.* The thread being held taut will indicate the number of degrees from the line of regard. Record this. Make five trials, and find the average and the mean variation for these.†

Proceed in the same manner and measure along the other three cardinal radii, namely, with the white entering from below, from the left, and from above.

* Move inward at such a rate that the destination is reached in about eight seconds. Take special care that the head does not turn or the eye wander from the point of regard, and that the point of regard is directly in front of the eye.

† The mean variation (m. v.) is a measure of the degree of agreement in a series of records. It represents the average of

To represent these results graphically, draw four radii from a point representing the point of regard—one to the right, one to the left, one down, and one up,—and place a dot on each radius to represent the corresponding measurement on the scale of one millimeter to one degree. Mark each of these dots *w*.*

These results are stated with reference to the field of vision; they might equally well have been stated in terms of regions on the retina. The outer or temporal field of vision corresponds to the inner or nasal region of the retina, and the upper field of vision corresponds to the lower region of the retina. The temporal field of vision is larger than the nasal, and the lower is larger than the upper. This difference is due to the limitations placed by the nose, cheek-bone, and brow.†

the deviations of each individual record from the average of all the records for the group, regardless of sign. Thus

75	-	1
73	-	3
78	-	2
80	-	4
75	-	1
<hr/>		
5)381	5)11	
<hr/>		

Ave. 76 2.2 m. v.

*Thus, if the white square was first seen as white at fifty degrees above the eye, put a dot fifty millimeters from the center on the appropriate radius.

† *Supplementary Exercise*.—There is a totally blind spot in the nasal region of each eye. It is located at the point of entrance of the optic nerve, about fifteen degrees from the fovea, or point of clearest vision. If this exercise is assigned, the student should devise his own methods and means for one or more of three exercises: (1) to locate the blind spot; (2) to survey and determine its shape and area; and (3) to determine how it is filled out in perception.

2. **The Fields for Colors.**—Substitute the red square for the white and determine the limits * for red on the two meridians, right and down, making five trials for each.† Compute the average and mean variation and insert the averages on the two corresponding radii of the chart for Exp. 1 and mark them *r*.

Measure and record in the same manner for yellow, blue, and green.

Assuming that the results for the meridians selected are typical of what we should find in the other meridians in regard to the order of limits, this and the foregoing experiments demonstrate that the color-fields are all smaller than the field for white; and, in the normal eye, the colors supplied have fields which vary in magnitude in the order yellow, blue, red, and green. There is such a large difference that the field for green has less than one-fourth the area of the field for yellow.

How does this affect our ordinary perception of color in the indirect field of vision? If we look steadily at one flower in a flower-bed and attempt, without movement of the eyes, to see the coloration of the whole bed, we observe that, outside of a certain narrow limit, the leaves do not look green; beyond a somewhat larger limit, no flowers are seen red, although the blue and yellow ones look brilliant; and in the outermost parts of the bed all flowers and leaves

* The observer knows what the color is to be, and the task is to discover the limit at which he can identify the disk as being of that particular color. The inward movement should begin just clearly outside the field and be made at such a rate that the limit is reached in from five to ten seconds.

† If desired, these color squares may be cut smaller, but the size must be recorded.

look gray. This is literally true, but not alarming, because we do not usually look at flower-beds in that way. When we want to see the color of a bed of flowers, a painting, or a sky, we regard (that is, pay attention to), or apperceive, only the color of the direct field at and around the point of regard; our eyes sweep back and forth over the object automatically with astonishing swiftness and take a series of snapshots, as it were, on the central portion of the retina, and then we combine these into a whole in memory, although the process is almost instantaneous and seems to be a single act of perception. We have the feeling that the color-impressions from the direct and indirect fields are simultaneous, but the fact is that we have memory-images of impressions from different parts of the object and the simultaneous impressions from the whole object become merely a sort of plat on which we unconsciously distribute these impressions and reconstruct the true color-relations.

If we had used the four truly fundamental colors,* the absolutely complementary pairs, yellow and blue, and red and bluish green, and had reduced them to the same brightness and saturation, we should have found that the limits for blue and yellow coincide and those for red and green coincide. In Fig. 2 the inner curve represents the red-green boundary and the outer the yellow-blue boundary. The shading shows the limit for

* The colors which answer for this purpose are very difficult to obtain. Those furnished are neither fully complementary nor of the right hue as fundamental colors. They also differ much in brightness.

white and should be compared with the record in Exp. 1.

Thus, the retina may be conceived of as being divided into three zones: (1) a central zone over which all colors and brightnesses can be seen; (2) a middle zone over which only blues and yellows and their derivatives can be seen; and (3) an outermost zone over which all objects, colored and uncolored, appear gray. Let us

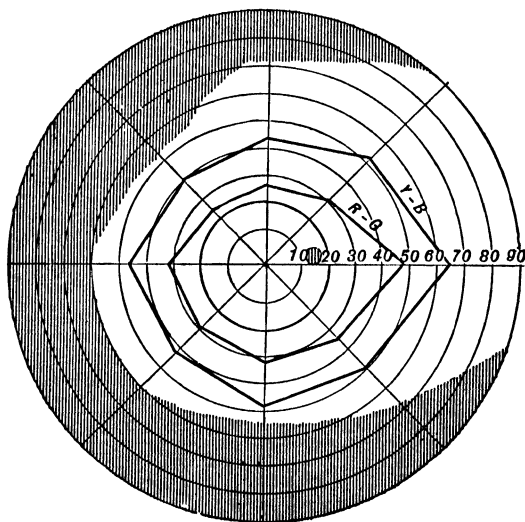

FIG. 2.

note some of the most significant applications of this law of distribution.

Color-vision is made possible by the existence in the retina of the so-called color-elements. There are many theories in regard to the probable number of these. The close coincidence of these two pairs of colors tends to support the conjecture that the retina contains either

two doubly-functioning or two pairs of color-elements, one for red-green and one for yellow-blue. The psychological chart of the fields of color-vision must therefore be used as one of the criteria of a physiological theory of the nature and distribution of the color-elements.

The three zones probably indicate as many epochs in the evolution of color-vision. The primitive eye was sensitive only to brightness; some of these elements in the central portion of the retina differentiated and became sensitive to yellow and blue, and these elements spread gradually, during evolutionary ages, from the fovea to the periphery of the retina and have now reached the expanse outlined by the yellow-blue curve in the chart; very much later, a higher differentiation of the elements at the fovea resulted in the development of sensitiveness to red and green and these elements are now spreading toward the periphery but have not yet reached farther than the limits which correspond to the red-green curve in Fig. 2.*

This arrangement also becomes an explanation for the well-known fact about color-blindness, that by far the most numerous cases of color-blindness are of the red-green type. Why should this be so? There is a well-known biological law to the effect that, in general, the last acquired structure is the first to become defective or to be lost. Now, the red-green elements are the least stable because they have been acquired most recently, and therefore a person is much more likely

* All colors other than the fundamental are mixtures of two or more of the fundamental colors. Hence the four color-elements can produce all the experienced color-effects.

to be red-green blind than yellow-blue blind, if his color-vision is defective.

These zones, as determined in the experiments upon which Fig. 2 is based, are not fixed except for the particular conditions specified. Among the conditions which determine the limits of the zones the following may be noted:

a. Color tone.—The four colors in this experiment go by the same name as the four upon which Fig. 2 is based, but the two sets of colors differ very much in tone and the results vary accordingly.

b. Saturation or Purity.—As a rule, the purer the color the larger the field.

c. Brightness.—The brighter the color or the gray the larger will be its field. One of the chief causes for the difference between the record in this experiment and in the curves in Fig. 2 is that of brightness; in a standard experiment the colors are all reduced to the same brightness, while in the common tones as here used there is a great difference in brightness. As the illumination of the colored stimulus is increased the field is enlarged.

d. Area or Magnitude.—Within certain limits, the larger the colored object the larger is its field.

e. Background.—The background has profound influence upon the color. Numerous laws of the relation of the peripheral color to its background have been worked out. In general for mixed colors (all pigment colors) the field is largest when the contrast between the background and the color is the greatest.

f. Adaptation and Fatigue.—It makes a difference

whether the eye has become adapted to darkness or to some kind of light before a trial. The rested eye is more efficient and gives a larger field than the non-rested eye. Retinal fatigue shows itself more rapidly in a retinal area the farther the area is away from the fovea. We have only to recall what we learned in the two foregoing chapters to realize what a large variable this is. It is necessary to make comparatively rapid movements in order to secure the best results.

g. Practice.—It is probable that the extension of the color-fields as the result of practice is not an increase of sensitivity in the retinal elements, but merely a development in capacity for observation.

h. Age.—Color-fields enlarge with age. The difference between the field of a boy of ten years and one of twenty is large; but we do not know how much of this is due merely to the former's lack of power in application and skill in observation.

i. Disease.—Certain nervous diseases are characterized by peculiar changes in the fields of color. There may be, for example, general contraction of the color-fields, loss of vision in one half of the retina, impairment in the vision of certain colors, or central color-blindness. This last-named defect often results from nicotine-poisoning; it is discovered by the fact that, in order to see colors, the patient must view the object by indirect vision.

j. Color-blindness.—This is a large topic by itself. About one per cent of all women and more than four per cent of all men are distinctly blind to some colors; and indeed the most recent and most efficient tests of

color-blindness make it seem probable that these figures are underestimations. No one can have come successfully to the present stage in this course without discovering whether or not his color-vision is defective.

k. Arbitrary Limits.—A color comes into its field gradually; the magnitude of the field therefore depends upon what degree of resemblance to the color as seen in direct vision the observer has set himself as a standard for the purpose of the measurement. The incoming color is never exactly like the color as known through direct vision.

3. Transition Colors.—Starting to the right, outside the color-field, and going by ten-degree steps toward the point of regard, observe and record the color of the red square as it appears at the first momentary impression in each step. Make three independent series of trials.*

Record three series of observations for yellow in the same manner.†

According to the Hering theory of color-vision, there are four "Urfarben", that is, primary or fundamental colors. All other colors may be built up from these, and to them the color elements in the retina correspond. They are the two pairs of perfect complementaries spoken of in Exp. 2. They undergo no change when passed outward through the indirect field and are therefore called stable colors. All other than the stable

* If the right eye shows fatigue, this and the following experiments may be made with the left eye. The practice gained, however, makes it easier to use the right eye.

† The record must necessarily be a crude description of the changes in color and brightness.

colors undergo more or less radical changes when passed through the indirect field, as in this experiment. The following is a typical record, though much abbreviated:*

<i>Color as seen in the direct field.</i>	<i>Transition colors: the same color when passed inward through the indirect field appeared successively as follows:</i>
Deep red	Yellowish, yellow, orangish yellow, yellow-orange, orange-red, red.
Reddish orange	Yellowish, orangish yellow, reddish orange.
Orange-yellow	Yellowish, yellow, orangish yellow.
Green	Yellowish, yellow, greenish yellow, green.
Blue	Blue. (This happened to be the stable blue.)
Violet	Bluish, blue, violet.
Purple (red end) ...	Yellowish, orange-yellow, yellow-orange, orange-red, red, purplish red, reddish purple, purple.

This record expresses a general law: the colors of the red end of the spectrum first appear as yellowish or yellow in the outer regions of the field of vision, while those of the blue end first appear as bluish or blue. Red, orange, yellow, and green come in with a yellowish tinge, while blue and violet come in with a bluish or blue tinge.

Every color enters the field of vision as a gray. Within the yellow-blue zone all colors appear in some aspect of yellow or blue, if they are seen as colors. Only within the central zone can the reds and greens and their derivatives reveal their true color. A comparison of this statement with the above law makes what is otherwise an apparently chaotic condition of affairs seem natural and intelligible.

*From Baird's "*The Color-sensitivity of the Peripheral Retina*," Publication 29, Carnegie Institution. The present chapter is based mainly upon this monograph.

The pigment colors of papers and fabrics are always mixed colors. The reds, oranges, and greens, for example, contain considerable yellow, and it is this yellow which becomes dominant and represents those colors within the yellow-blue zone. In the same way, it is the blue of the violet end which represents violet outside of the red zone.

All colors also undergo characteristic changes in brightness in passing through the indirect field.

4. **Adaptation Colors.**—Hold the red square at 25° on the right meridian for about ten seconds, being careful to maintain a steady fixation on the point of regard, and observe the changes the color goes through in that time. Record from memory. Make three trials, allowing adequate rest.

Repeat the same for yellow.

Constant stimulation of a given area of the peripheral retina produces definite cycles of change in brightness and color. The following is a typical record of the changes for three seconds by a trained observer:

*Color as seen in
the direct field.*

*Adaptation colors: the succession
of colors this object revealed in a
three-second exposure at 30° right.*

Red	Red, orange, yellow, white, blue.
Orange	Rich orange, yellowish orange, yellow.
Yellow	Orange-yellow, yellow, gray, bluish.
Green	Yellow-green, yellow, gray, bluish. (25° .)
Blue	Blue, gray, yellowish.
Violet	Blue?, blue, bluish.
Purple	Red, orange-red, orangish. (25° .)

From records of this kind we derive a law which expresses a cycle of three stages: the colors of the red

end of the spectrum pass toward yellow, and those of the violet end toward blue; then follows a momentary gray; and then appears the complementary color of the one just before the gray.

In the above fragment of a record, these three stages are represented in the case of red, yellow, green, and blue; the other colors did not complete their cycles within the time limit.

The reasons for this law of adaptation are as follows: * The peripheral retina is not much used and

* Dr. Baird describes this process in a personal letter as follows: "The reasons for the existence of these characteristic phenomena of adaptation or exhaustion are these: The peripheral regions of the retina contain but a relatively scant supply of color-sensing substance; and they, too, are very seldom employed in the vision of every-day life. Consequently the advent of retinal exhaustion must be relatively rapid when these regions are stimulated. Now, the pigment colors which we ordinarily see are not pure, but mixed colors; green leaves and red ribbons contain a considerable admixture of yellow, orange, blue, etc. Hence, when a colored object stimulates the peripheral retina, its stimulation is not confined to a single color-sensing substance, as would be the case if certain pure colors were employed. The impure red of the ribbon may affect both the red-sensing substance and the yellow-sensing substance of the retina. Reasons for believing that the yellow-sensing substance is more stable and persistent in function than the red-sensing substance have already been cited. So long as both these substances continue to function in approximately equal degree, a red (or yellowish red) ribbon will be seen. But in proportion as the red-sensing substance becomes exhausted—by reason of its scantiness or as a result of its lesser tenacity of function—the function of the yellow-sensing substance becomes dominant in the visual process; the ribbon which originally seemed red now appears yellowish or even yellow. This marks the completion of the first phase of the color process of indirect vision, and the beginning of the second phase. If the ribbon still continues to stimulate the same retinal region, the yellow-sensing substance will in turn become exhausted; and the ribbon will appear gray so long as the black-white substance continues to function alone. When this third stage of adaptation is reached the retinal region is completely exhausted. But this peculiar condition of adapta-

therefore fatigues with embarrassing rapidity. The colors we ordinarily see are all mixed, and the yellow or blue element in a mixture is more stable than the red or green, for reasons explained under Exp. 2; hence the latter fatigues more quickly and falls out, leaving the other dominant. This is the goal of the first stage. Then follows the process of adaptation, as in after-images, when the stable color element becomes fatigued, and leaves a blank or gray. Then follows the last stage, which corresponds to the after-image of the strongest element in the first stage.*

The fact of order in these changes is perhaps as astonishing as their rapidity. Our common experience of these changes in daily life has resulted simply in a distrust—both conscious and unconscious—of indirect color-vision. When we think of it, we think of it as chaotic; when we inadvertently follow it, we feel uneasy; in normal perception we automatically neglect it.

These four experiments may suffice to give a glimpse of the complexity and wonderful arrangement of the color-fields and to point the way in which the scientific attitude is rewarded by revelation of system and reason

tion does not last long. A process of regeneration takes place within the organ; and so long as the retinal regeneration continues, one sees color whether the colored object be present or not. This fourth stage of the visual process is analogous to that which you studied in your experiments with after-images. The visual sensation which now appears in indirect vision is complementary to the color which was present in the second stage."

* It is remarkable that after-images are never observed in the periphery of the dark-adapted retina, and very rarely more than 30° from the fovea. They may be observed, however, in the periphery of the light-adapted retina.

in it all. Many of the problems of indirect color-vision have not even been mentioned, and conditions and variables have been stated in the barest way possible. ⁴

In conclusion, let us notice a beautiful biological arrangement. If we compare the direct with the indirect field with reference to sensitiveness, we find that we are most sensitive to color and form in the direct field, and to light and movement in the indirect field. That is, we can see color and form most accurately when the image falls upon the central region of the retina, but we can detect movements and changes in brightness more readily when the outer-lying portions of the retina are stimulated. ⁵

This is a story of adjustment and it suggests to us the real office of the indirect field. The central region of the retina, corresponding as it does to the direct field, is the organ of attention, of concentrated mental activity, which represents the environment in terms of space and color; while the indirect field is merely accessory. Its functions are those of a scout or guardian. The life-preserving value of this arrangement is clear. Consciousness is warned of the presence or approach of an object beneficent or noxious to life, by impressions of luminosity or movement in the indirect field. If then the signal is heeded, the eye quickly turns so as to bring the object of scrutiny into the direct field where its true nature can be seen accurately, by the most efficient and economical expenditure of energy.

CHAPTER IV

VISUAL SPACE

*For One.**

ALTHOUGH we have several space-senses, most of us live predominatingly in a world of visual space. Visual space-perception is therefore one of the largest and most important topics in psychology. We shall limit our experiments in this chapter to a few features of visual space images.

1. Outward Projection of the Visual Image.

a. Floating Flakes.—Look toward the sky with your eyelids almost closed and observe a sort of snowfall effect. Describe it.

These flakes are the shadows, on the retina, of particles floating in the vitreous humor. They are projected as objects in outer space in accordance with the law of outward projection.†

* This chapter presupposes knowledge of the structure and function of the eye, as outlined in the text-books on psychology.

† "We see indistinct motes floating about in the field of view and slowly gravitating downward. Sometimes they are undulating, transparent tubes, with nucleated cells within; sometimes they are like inextricably tangled threads, or like matted masses of spider's web; sometimes they are slightly darker spots, like faint clouds." (Le Conte.)

*b. Shadows of the Retinal Blood-vessels.**—Standing in a dark room with one eye closed, wave a candle-flame or burning match gently in a small circle close to the side and slightly downward and forward from the other eye; look at the opposite wall and you will see a network like Fig. 3. †

Describe size, distance, color if any, stability, etc.



FIG. 3.

The retinal blood-vessels enter at the same point as the optic nerve and spread in a network inside of the retina. As the rods and cones lie back of this layer, the blood-vessels cast shadows which become visible under the prescribed conditions of illumination. There is nothing on the wall to correspond to this system, yet you see it distinctly out there in space, in accordance with the law of outward projection.

We are never directly aware of the retinal impression.

* Perform this experiment in the evening, if necessary.

† Do not fatigue the eye. Nothing is gained by straining it. If you do not get the effect at once, it is because it seems unreasonable to look for such a thing. Look for a network like Fig. 3, very much enlarged, and you will see it. The experiment should not require more than a minute or two.

We always see objects out in space. The retinal impression is automatically referred to its normal source: that is the law of outward projection. The history of the evolution and development of this tendency constitutes one of the most important chapters in psychology as well as in the theory of knowledge.

The conditions of the above experiments were unusual, if not unnatural, but the mind responded in its habitual way, and this misdirected tendency revealed to us something of the nature of the normal process. The image was laid bare, as it were, by the absence of the object.

The retinal light furnishes us another illustration of this class of entoptic phenomena.* But the best and most serviceable illustration of all is the after-image, with which we are already familiar. It represents a physiological condition of the retina but is always seen out in space, never within the eye.†

* To observe the retinal light, go into a dark room and cover your eyes so as to shut out all possibility of objective light. Behold, in a moment you see a gorgeous array of colors in front of the eye. They tend to grow brighter, usually fashion themselves into fantastic designs, and are in a continual kaleidoscopic commotion. These are nothing but the projection of the local irritation of the retina, chiefly through the circulation of the blood. These retinal lights are the stuff from which many visual dreams are "made".

† "Seeing stars" from a blow or fall illustrates the same principle. The story is told of a man who was attacked and knocked senseless by a blow on the temple during a pitch-dark night. He accused a neighbor whom he had to confront in court with the evidence, which was essentially this: "It was pitch-dark, but the moment I felt the blow there was a great flash by the light of which I saw my assailant." This may have been naïve testimony: he had seen a light at the proper time; he suspected his neighbor; his conviction was that he had seen his neighbor.

2. **The Line of Projection.** *a. Projection of the After-image.*—Repeat Exp. 6, Ch. I.

The two spatial factors in the outward projection are distance and direction. We are here concerned with direction. The law of visible direction may be stated thus: When the rays from any radiant strike the retina, the impression is referred back along the ray-line into space. The retina is a small copy of the plane of projection, a plane across the visual field at right angles to the line of regard. This is illustrated in Fig. 4.

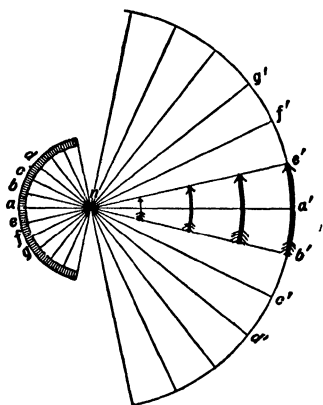

FIG. 4.

Every point in the plane of projection has a corresponding point on the retina. When the retina is stimulated at *c*, let us say, the image is referred back along the ray-line *c-c'* and the object is seen in that direction. If an area, e.g. *b-e*, is stimulated, the object will be seen in the corresponding area *e'-b'* in the plane of projection.

The experiment shows that the size of the after-

image varies with the distance of the plane of projection. This law of size of the retinal image may be derived from the above law of direction. It is illustrated by the four arrows in Fig. 4, which are all projections of the same image but at different distances.*

b. The Size of the Retinal Image.—To determine the length of the retinal image of your pencil held upright at a distance of 50 centimeters in the line of regard, proceed as follows: Let the arrow $e'b'$, Fig. 4, represent the pencil, eb its image upon the retina, and n the nodal point in a simple scheme of the eye. The two triangles $e'b'n$ and ebn are similar. The distance an in the normal eye is about 16 millimeters; the distance $a'n$ is by direction 50 centimeters; you measure the length of the pencil. You then get the proportion $e'n : e'b' :: en : eb$, or x , the length of the retinal image. Assume that the retinal image is on a flat surface in order to simplify the equation.

c. The Inversion of the Retinal Image.—Make a pinhole in a card and hold it toward the light about 10 centimeters from the eye. Looking at the pinhole, hold the head of a pin very close to the eye, and in front of the pupil, and observe that you see the pin inverted back of the card.

Pierce five pinholes close together and proceed as before. Record how many pins you see.

* To illustrate how little attention we pay to the analysis of perceptions, a professor asked a large class in psychology to estimate how large the image of the moon at the horizon would appear if projected upon a plane at arm's length from the eye. The estimates of the diameter were nearly all too large; as, the size of a dollar, a saucer, or a wagon-wheel, but one man said, "The size of a pea," and he was right.

Examination of Fig. 4 showed that normally all rays cross at the nodal point in the eye, and this results in the reversal of the image: what is up in the plane of projection becomes down on the retina; and what is right becomes left. This is true, however, only when the object is at such a distance that the rays from it can pass properly through the lens and form an image on the retina. Now, in this experiment, the pin was held too close to the eye to allow a clear retinal image, and it was so close as to cast a good shadow upon the retina. This shadow is not inverted on the retina, but it is projected according to the normal law of visible direction for inverted images, and the result is that it is seen inverted in the plane of projection.

Our normal projection of the retinal image is a habit based, indeed, upon neural mechanism and inherited tendency, yet subject to modification by training. If we should wear, for a month, prism glasses which completely and consistently reversed the whole visual field, we should in that time acquire new habits of projection and be able to harmonize the reversed retinal images with the touch and movement experiences. Space-perception is always a complex process of association and interpretation, though normally extremely abridged.

d. The Muscular Sensations of Position of the Eye.—Roll a sheet of paper into a tube one inch in diameter. Hold your left hand about 12 centimeters in front of your face; place the tube in front of the right eye, lean it against the hand and point it toward some distant object. Now look with both eyes (in spite of

the fact that the hand is in the way of the left eye) at the distant object and you will see it and a circular section of its surroundings through a round hole in the palm of your hand.

So far, we have considered the retinal image as a basis for the perception of direction. But muscular impressions of position and movement of the eyeball are of no less importance. Normally the two coöperate. Thus, in perceiving the direction of a flock of birds in the distance, the head turns in the approximate direction, then the eyeballs turn for finer adjustment and sweep back and forth from one object to the other, measuring the angular difference in direction, and finally the local sign * of the retinal image indicates the relative direction of the different birds in the flock. The perception of form is, of course, merely the perception of a complex system of directions. †

This experiment illustrates the rigidity of these muscle-sense marks of direction. The hole in the hand is clean-cut and absolute: it is a very striking illusion. The local sign of the retina is so rigid and the position of the eyeball is sensed so accurately that we see the objects upon which the eyeballs were converged in the true direction in spite of the intervening obstacle.

* Local sign is that special character of a sensation whereby we are enabled to refer it to a particular place, "that differential quality of a sensation which varies with the part of the sensitive surface stimulated, but not with the nature of the stimulus." (Stout.)

† Normally we are not conscious of either location of the retinal image or the sensations of muscular adjustment in the eye. The process of vision has become so abbreviated and automatic that we merely have a sort of direct awareness of direction without knowing why or how we become aware of it.

3. **Accommodation.**—*a. Range : the Near-point of Vision.*—Hold the point of a pin close in front of one eye (the other eye covered) and observe that you cannot see it clearly. Move it back and forth and find the nearest point at which you can see it without a blur. That point is called the near-point of vision. Record the distance from the eye.

If we are to have a clear image of the point, the rays of light reflected from that point must come to a focus upon the retina. The near-point marks the limit of nearness for which the lens in the eye can adapt itself. In the normal eye it is about 20 centimeters from the eye. In Fig. 5, p represents the pin-point and r its

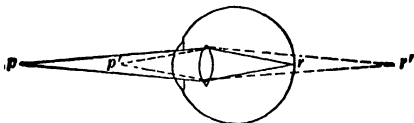

FIG. 5.

image upon the retina. If the pin-point be brought nearer than the near-point of the eye, say to p' , the rays from it, if continued, would come to a focus back of the retina at r' and would form a diffusion circle where the pencil $p'r'$ pierces the retina. This diffusion circle corresponds to the blur which you observed when the pin was too near. We can see objects clearly only when they lie at or beyond the near-point.

Near-sighted persons also have a far-point beyond which objects blur because the lens cannot adapt itself to that distance. But, in the normal eye, this point is at infinite distance; i.e., the eye can accommodate for

parallel rays. The range between the near-point and the far-point is called the range of accommodation.

b. Line of Accommodation.—Pierce two pinholes, about 1 millimeter apart, in a card. Stick two pins through a sheet of paper, 20 centimeters apart. Cover one eye and hold the card close in front of the other eye so that the two holes are in a horizontal position and fall within the circumference of the pupil; hold the paper with the pins pointing upward so that the near pin is 20 centimeters from the eye and the two pin-points

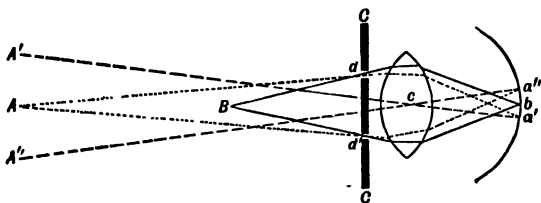

FIG. 6.

are in the same line of regard. Observe that, when you accommodate for the near pin, it is clear, but the distant one is double; and when you accommodate for the distant pin, it is clear and the near one is double. Take out the distant pin and move it toward the near one and find how close you must bring it before you can see both clearly with a single accommodation.* Record this distance, which is called the line of accommodation.

Fig. 6 represents the accommodation for the near pin, and Fig. 7 the distant. Write out a full explana-

* Make sure that both holes are in front of the pupil. Work with precision and a purpose and you will not strain the eye!

tion of each figure, assuming that *A* and *B* represent the two pins.

Strictly the eye can accommodate for only one point in distance at a time. All points in front of and behind that point must appear blurred. This can be verified roughly by looking systematically with one eye along a row of objects in the line of regard. Looking through the two pinholes has the advantage of simplifying the situation by producing two images instead of a blur. If there were more holes, there would be more images.

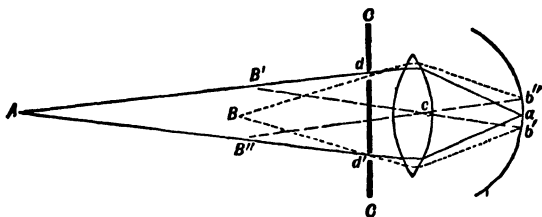

FIG. 7.

Practically, however, the two pins may be separated by a considerable distance and yet both be seen single or clear with the same compromise accommodation because “they seem clear enough.” We must therefore speak of a line of accommodation rather than a point. We can see two or more objects clearly at the same time only if they lie within the line of accommodation.

4. Convergence: Double Images.—*a. Doubling the Distant Object.*—Hold two objects such as a pen and a pencil in the same line of regard, the former about 20 and the latter about 40 centimeters away from the eyes. Fixate the point of the pen and, while the eyes are thus

converged, observe that you see two pencils. Close one eye at a time and determine which of the double images belongs to each eye. Record to which eye each image belongs, the distance between the double images, and the position of the double images with reference to the actual position of the pencil.

Write explanation of Fig. 8, which illustrates this.¹

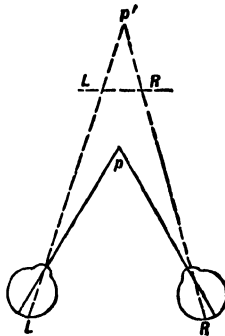

FIG. 8.

Our two eyes constitute an effective mechanism for the perception of distance or relief. One of the limitations which follows from the very efficiency of the mechanism is that we can see only one point in distance clearly at a time; every object nearer or farther away than this point must be seen double if attended to.

* The level of the horizontal line $L-R$ is somewhat arbitrary, expect that it must lie between p and p' . If the observer had not known the actual distance of the pencil he would probably have seen it at about the same distance as the pen; but, knowing the actual distance, there is a tendency to see the double images at approximately the true distance. The level chosen in the diagram represents a compromise.

This experiment has demonstrated that fact as regards an object beyond the fixation-point. The next experiment demonstrates it for objects nearer than the fixation-point, and the experiment following that proves in a most general way that all points within the line of vision, which are nearer or more remote than the fixation-point are seen double.

b. Doubling the Near Object.—With pen and pencil as before, fixate the pencil and, while the eyes are thus converged, observe that you see two pens. Close one eye

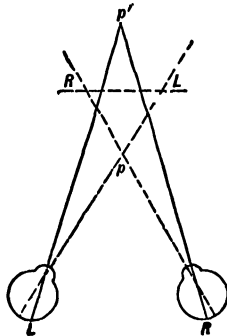

FIG. 9.

at a time to identify the double images and record as in Exp. 4 *a*. Write explanation of Fig. 9, which illustrates this.*

c. Doubling of all Points except the Fixation-point.—Stick a pin into a pencil at the middle, point the pencil

* The double images of objects nearer than the point of fixation are said to be "crossed," while those of objects beyond the point of fixation are "uncrossed." Titchener gives the mnemonic: "Remote regard reverses; Nearer, notice, not."

straight forward and fixate the pin; observe that you see two pencils forming an **X**, with the crossing at the pin. Close one eye at a time and observe that the law of crossed and uncrossed images is verified.

Practically, again, this point of clear vision in convergence is really a line which we might by analogy call the line of convergence. Experiments with fine points show that within a moderately near range it is really a point, for one of two pin-points will double until they come together, but as we recede the possible separation becomes appreciable, although the "line of convergence" is relatively much shorter than the line of accommodation.

d. Double Images in Indirect Vision.—Hold pen and pencil as in Exp. 4 *a*; fixate the pen (near) and observe how far you can move the pencil to the right from the line of vision before one of the double images of the pencil disappears. Record five trials.

It becomes more and more difficult to perceive the double images as we pass the object gradually into the indirect field. One of the double images can be seen far beyond where the two can be seen. In this case it is the right-eye image, as can be demonstrated by closing one eye at a time.

e. Doubling Numerous Objects.—Double a strip of paper and stick a row of five pins through it about 1 centimeter apart. Hold the paper in a horizontal position at arm's length and at right angles to the line of regard; fixate the eyes upon the pen-point, held midway between the eyes and the pins, and count the pins. Record number.

All objects outside of the "line of convergence" double when seen with both eyes.* Why, then, do we see single objects in nature and elsewhere when many objects outside of the line of convergence are seen at the same time? First, we pay attention to only one point at a time; the eyes shift with the greatest rapidity from point to point and make snapshots which we are aware of only as a composite view. Second, the utility of disregarding double images has resulted in a natural capacity for "counting" only the impressions which favor single vision. The fact that the single eye can get a fully satisfactory image only at the fovea favors this discarding of other images. And, third, a complex view is never clear.

But why do we see single objects at all from two images? Like the projection of the single image (indeed it is a part of the process), the identifying of images which fall upon corresponding points of the two retinæ has been learned through race and individual experience in associating sight with touch and movement.

f. Doubling Complex and Large Objects.—Hold one or more postage-stamps or other complex objects at arm's length and observe by near fixation, as in Exp. 4 *b*, or far fixation, as in Exp. 4 *a*, that the whole objects double. Try larger objects, such as a letter or a wall-picture.

* The indirect field, Exp. 4 *d*, is no exception, because when one of the double images disappears we see only with one eye.

Of course, the doubling is always in the line of the eyes, normally the horizontal—the whole paper strip doubled, but lengthwise.

Embody the results of these six experiments on double images in binocular vision in one general law and write it out.

5. Relief.—*a. Similar Images.*—Look at Fig. 3, with one eye at a time, and observe that the two images are similar and there is no relief.

b. Disparate Images.—Hold the closed text-book erect and with the back toward you at arm's length; look at it first with one eye and then with the other and observe that the two images are disparate, i.e., unlike. Look with both eyes and observe that you see the book in relief.

The basis for the perception of relief lies in the disparateness of the two images. Relief is a mental synthesis based upon two independent series of sense data which become harmonized through the relief-interpretation. The mind interprets each image as a different view of the same object. Look again at the book and observe how the two disparate views supplement each other, blend and are satisfied in the appropriate combination. Knowing the character of the difference between two images and the degree of convergence, we can predict the relief. This is well illustrated in stereoscopic vision.

6. Stereoscopic Vision.—Roll a piece of paper into a truncated cone and trim it to a diameter of 8 centimeters at the base and 2 centimeters at the frustum, and make it about 6 centimeters high. Pin it together and set it up about 50 centimeters away, with the frustum

facing you at the level of your eyes. Look at it with the two eyes alternately and observe the disparateness of the two images.

Draw the diameters of the two ends, for each eye separately, as they would be projected on a pane of glass held about 15 centimeters in front of the eyes. When this drawing is seen in a stereoscope it should give the true skeleton of the cone.*

There are two fundamental conditions of stereoscopic vision: first, that the two views shall differ so as to produce the appropriate disparateness in the two retinal images; and, second, that the two views shall be seen with the two eyes converged upon one point. The drawings provide the first; the lenses in the stereoscope, or converging for a point back of the card without the stereoscope, provide for the second.†

* With a little practice stereoscopic views may be seen in relief without the use of the stereoscope by merely converging the eyes upon a point at a suitable distance back of the card. Try it.

† One of the best elementary treatments of this topic, visual space, is found in Witmer, "Analytical Psychology," Ch. IV.

CHAPTER V

AUDITORY SPACE

*For Two.**

THERE are three aspects of the problem of auditory space; namely, direction, distance, and volume. The present chapter is devoted to the problem of hearing the direction of sound.

The experiments in this chapter should be helpful in answering such questions as: Is the ear a space-sense organ? How do we perceive the direction of sound by hearing? What are some of the laws of localization? †

Produce the sound, which is to be localized, by snap-

* These experiments must be performed at some other time than during the class period, unless there is opportunity for the class to scatter into different rooms or out of doors. Two students must work together; the one who manipulates the apparatus is called the experimenter, (E), and the one on whom the experiment is performed is called the observer, (O). Each takes turn as E and O for each experiment. E always keeps the record obtained as experimenter; thus each preserves the record of the other. O should be blindfolded and seated comfortably in such a position that he can hold his head erect and steady in a given position during an experiment.

† There is difference of opinion as to whether or not the ear is a space-sense organ. Those who hold that it is not a space-sense organ base their opinion largely upon two anatomical facts: (1) that the portion of the ear which is the organ of hearing possesses no spread-out surface such that an arrangement of stimulations upon it may represent the spatial relations of the external world; and (2) that the ear is unprovided with a muscular apparatus for focusing itself for different directions. In these respects the ear is contrasted with the visual and tactual arrangements for perception of space.

It is also well to bear in mind the chief theories of localiza-

ping two coins.* Place one coin on each side of the forefinger and press them together with the thumb and the forefinger until they slide together with a snap. Shift the coins deftly from one hand to the other and avoid swaying movements of the body and rustling of the garments. Stand on the side and reach out both arms symmetrically. Blindfold and seat the observer.

1. **Radially in the Median Plane.** †—Let it be understood that the sound may come from any of the seven directions 45° apart: up, up-front, front, down-front, down-back, back, and up-back, all within the median plane. Produce the sound three times in each of these

tion. These may be divided into five classes:

(a) The intensity theory. The difference in the strength of the sound in the two ears is the basis for the hearing of direction.

(b) The tactual theory. Sound vibrations also give rise to sensations of touch, and we confuse these touch sensations with sound sensations.

(c) Semicircular-canal theories. The semicircular canals in the ear are special organs for the sensing of direction.

(d) Original space differences in the sensations of the two ears.

(e) The intensity-quality theory. Both quality and intensity aid in the perception of direction.

At the end of this chapter we shall turn back and ask which of these theories has been supported.

*The following are better sources of sound if available: (1) a telephone receiver in circuit with a battery and a mercury key; (2) a "frog snapper" (electric supply houses, 25 cents); or (3) a paper clip such as is used in hanging placards.

†The apparatus which is used for accurate work in the laboratory is called a sound-perimeter or sound-cage. It is so constructed that the experimenter can manipulate it from one point in the room without moving around. It enables him to vary the direction, the distance, the kind, the strength, the pitch, and the complexity of the sound; to control these conditions; and to make accurate measurements.

†The median plane is that vertical plane which, passing through the body, divides it into right and left symmetrical halves.

directions, at a distance of about 50 centimeters, measuring from the center of the head. Distribute the trials approximately as they might run by chance. Require O to say in which of the seven directions he hears the sound. * Record each answer under the appropriate heading in a prepared tabular form. Figure how many answers out of the 21 are right, and how many are 45° , 90° , 135° , and 180° wrong respectively.

Exp. 1 might well have been entitled the "inability to localize sound." The observer is very much surprised and discouraged when he sees his record.

There are two factors in the record, the number of correct localizations and the magnitude of the incorrect localizations, to be considered. As there are 21 trials distributed equally among 7 points, three of the localizations would be right by pure chance. The trials are not sufficiently numerous to enable us to apply the laws of chance in prediction, but extensive experiments show that a few more localizations than can be accounted for by chance, will be right, probably less than 10 per cent. On that basis, the observer might have four or five correct localizations in this experiment.†

*It is of the greatest importance that O should have no other means of detecting direction than by hearing. E must therefore take every possible precaution to avoid giving any suggestion or clue by word, situation, or movement.

Of course, the experimenter will be shrewd enough to give no intimations to the observer about his errors during the progress of the experiment.

† If the observer gave more than one-fourth of the localizations correctly, it is probable that this was due to failure on the part of the experimenter to snap the coins exactly in the median plane, or to eliminate accessory sounds from his own movements, breathing, etc. Creaking sounds from the coat-sleeve are often taken as a cue.

The other factor, the degree of error in the misplacements, is equally significant. Under strict experimental conditions the observer is almost as liable to make an error of 180° as of 45° misplacement.*

If the same stimulus is used, a person can improve in this localization; but the improvement will be almost entirely lost as soon as the kind of sound and the strength of sound are varied.

It is a striking fact that the observer has undue confidence in his ability. When he said "up-front" he heard the sound distinctly there, although it may have come from any other point. This illusion of certainty is characteristic of all our hearing of direction. We continually either misjudge the direction, or learn the direction through other means than hearing; yet we have a distinct feeling that we have heard the direction.†

2. Horizontally in Front.—Measure the discriminative sensibility for direction of sound in a horizontal plane in front, at the level of the ears. Proceed as follows: Mark a stick about 50 centimeters long into 3-centimeter steps, beginning at the middle, and marking

* This inability to localize sounds in the median plane was discovered by Lord Rayleigh in 1875. The inability is peculiar to this plane, and therefore has great significance as a test of theories.

† Sitting near the central aisle of the Fifth Avenue Cathedral, New York, and looking straight forward, it is practically impossible to tell whether the organ-tones issue from the front or back of the cathedral. If we could see the organ, the matter would be different. One of the reasons that this inability does not disturb us much is that, when there is no correlation in the other senses or in reason, we remain uncorrected in the illusion of having heard the direction rightly.

symmetrically in both directions. Seat O as in Exp. 1. Hold the stick 1 meter from the center of his head, directly in front, in a horizontal position, at right angles to the median plane, and at the level of his ears. Sound, in quick succession, two clicks—the first, or standard, sound directly in front (at the middle or 0° of the stick) and the second, or compared, click on either side of the standard, the order of sides to be practically such as would follow from chance. Require O to say whether the second sound was to his right or left. Start with a distance of 3 centimeters between the standard and compare sounds and repeat the trials until O makes a mistake or has ten successive answers right. If a mistake is made, try with a distance of 6 centimeters in the same way. Continue thus, trying successive larger steps, increasing each time by 3 centimeters, until you have reached one for which O gives ten successive correct answers. Record the number of right answers for each step.

3. Horizontally at the Back.—Make the same measurement as in Exp. 2, for the symmetrical position at the back of O. In this and the following experiments, E should retain the same position, and O should turn around in order to have the resonance in the room constant.

4. Horizontally at the Side.—Make the same measurement as in Exp. 2 for a point in the horizontal plane at the level of the ears and 1 meter directly to the right of the center of O's head. Let O answer "forward" or "backward."

5. **Vertically at the Side.**—From the same position as in Exp. 4, but in the vertical plane, make the same measurement as in Exp. 2. Let O answer “up” or “down.”

6. **Introspections.**—Repeat the largest step in Exp. 4 deliberately a number of times and allow O to study and describe the subjective differences of the sounds by which he judges their direction. Record in full his observations on differences in intensity, quality, distance, tactual sensations, motor tendencies, visual

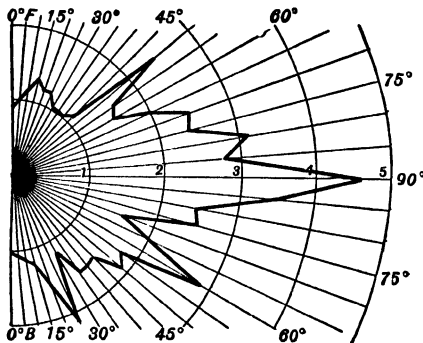

FIG. 10.

imagery,—in short, all features which seem to result from change in the direction of the sound.

The last five experiments may be discussed together most profitably. Fig. 10 is the record of the localizations of a trained observer within the right half of the horizontal plane at the level of the ears. It is based upon 18,000 measurements under the most favorable conditions and therefore has a high degree of validity. The radii show the directions and the arcs represent the

distance between the standard and the compared sound which will yield 75 per cent of right judgments.* As the sounds were produced 1 meter from the center of the head, each degree corresponds to 17.5 millimeters. Thus the curve shows a limit of $.9^\circ$ at 0° F (our Exp. 2), 1° at 0° B (our Exp. 3), and 4.5° at the right (our Exp. 4).

In general, then, the law which should stand as the prediction of our results is that the localization in this horizontal plane is poorest at the side, improves by three large steps in front and three behind in passing toward the median plane; it is about equally fine for front and back, and it is more than four times as delicate for these points as for the side.

Curves of this kind have been worked out for representative planes in the field of space around the head. The results of some of these are shown graphically in Fig. 11, which represents the right hemisphere. Observe that the first vertical at the left stands for the front half of the median plane, and the first vertical at the right represents the back half of the same plane, and that the other vertical lines represent intervening meridians at intervals of 15° on the surface of a hemisphere centered at the observer's head and lying toward

* In laboratory experiments it is customary to use the difference which is calculated to yield 75 per cent of correct judgments as the measure of the discrimination. In the present experiments we have adopted the much higher standard of 100 per cent correct judgments, partly to shorten and simplify the method, and partly to avoid computations. Of course, the records for our experiments will therefore be correspondingly larger. They are also larger on account of the observer's lack of training, but they should express the above general tendency equally well.

his right.* The middle horizontal line represents the one in which our Exps. 4 and 5 are located; above and

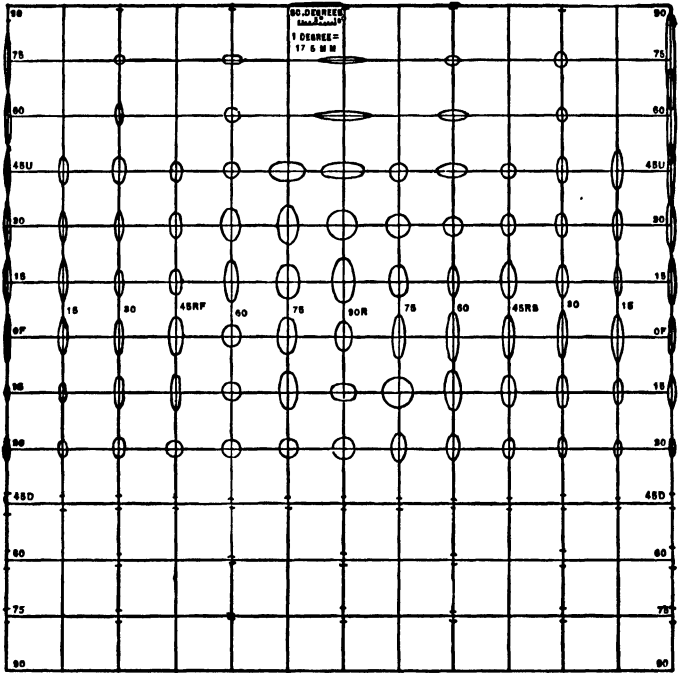

FIG. 11.

below this the parallel horizontal lines represent meridians at the respective latitudes marked.

The little figures may be called sensory ellipses in auditory space discrimination. They are constructed

*In reality these converge to one point at the top and one point at the bottom; the top and bottom lines become single points within the median plane. They are projected in the present manner in order to show the relative dimensions of the ellipses.

in the following manner: At any intersection, vertical and horizontal distances are laid off on the basis of the corresponding measurements. Thus, if the measure of the discriminative ability is 5° , the points are laid off $2\ 1\text{-}2^\circ$ below and $2\ 1\text{-}2^\circ$ above the intersection. Two points are laid off on the horizontal line on the same principle. An ellipse is then constructed with these points as the termini of the two diameters.

The ellipses mean that every diameter represents, on the scale of the chart, the degree of separation of two sounds which would yield 75 per cent correct judgments of direction under the given conditions of the experiments.*

Thus, following the middle horizontal line, 0° F, 0° B, and 90° R represent the points in Fig. 10 which correspond to our measurements in Exps. 2, 3, and 4 respectively. Exp. 5 is represented on the vertical axis at 90° R. This ellipse shows that at this point our discrimination is keener in the horizontal direction than in the vertical.

The psychologist can lay out a plot of the acoustic field, represent measurements of significant distances and directions upon it, trace their laws and distributions and tell why the features represented have taken these particular forms. And furthermore he can give his chart of the acoustic field to the world as a guide in the attempt to hear direction, and as a criterion of the validity of purported hearing of direction.

The introspections in Exp. 6 bring out a number of

* Where there are only two dots and no ellipse, the measurements have not been made for the other diameter.

interesting subjective factors. Some of them may be predicted.

The sound seems to be strongest at the aural axis. This in turn makes the sounds which are at the aural axis seem nearer than those which are away from it; these sounds are also richer and clearer.

There is also a tendency to hear the forward sound as higher and the backward sound as lower in pitch than the standard sound. The most interesting and complicated observations probably refer to misplacements: the observer knows that the sound comes from a given point, but he hears it in some other direction. These misplacements, in a careful observer, follow definite laws, which may be worked out, as many of them already have been.

Most observers have distinct visual imagery for the movements of the sounding body. Frequently one is conscious only of this mental vision, and the sound changes as interpreted in terms of sight. The observer says that the sound is forward because he has a mental picture of the sounding body in that position. Nearly all observers make automatic movements in adaptation to the changes in direction of the sound, and may be conscious of these movements and be guided by them without being aware of their auditory basis. Mental images of movement or tendencies to movement are also prominent. One may detect images of strain and movement which vary with the direction of the sound.

Among the numerous tendencies which affect localization are the following:

There is a tendency to locate every median sound in

the upper front quarter, by the force of habit. Likewise sounds at the level of the ears are usually misplaced upward, and sounds in the vertical plane through the aural axis are usually misplaced forward.

The effect of expectation is exceedingly complicated. Thus, we tend to hear a sound from the direction it is expected; but if the direction is sensibly different, there is a tendency to overestimate this difference. Try it.

There is a tendency to turn the eyes in the direction of attention, and this turning of the eyes influences the perception of direction.

The hearing of direction is a neglected capacity. We ordinarily depend upon sight; but should the exigencies of life demand it, we could improve very much in the hearing of direction.

Two ears are necessary for the normal hearing of direction, but certain localizations are possible with one ear alone. Fig. 12 is the curve of localization, in the same plane as is represented by Fig. 10, for a person who hears only with the right ear. It shows that hearing of direction is keenest opposite the ear which is intact and gradually decreases both in front and behind to a point of poorest hearing in a symmetrical point on the other side. Thus, he detects a difference of 4° opposite the good ear, but there has to be a difference of 21.6° opposite the deaf ear. Note the bearing of this upon a theory. The dotted curve is a copy of Fig. 10.

It is probable that pure tones cannot be localized at all by one ear alone.

Difference in the keenness of the two ears leads to misplacements whenever the decline or restoration of

hearing in one ear is sudden. When the loss or restoration is gradual, we adapt ourselves to it.

There are numerous systems of confusion-points; that is, two points in different quarters which have the same "local sign" so that, although far apart, the sounds from these two sources cannot be distinguished. Thus 45° right-back and 45° right-front are often confused.

Every unnatural position of the body, or part of the body, tends to produce errors in localization. For ex-

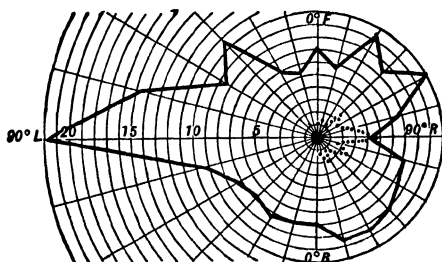

FIG. 12.

ample, if the head is turned to the right, a sound will be slightly misplaced in the direction in which the head is turned.

It is usually supposed that a sound cannot be heard as well from behind as from the front. But experiments show that we can hear just as faint a sound from the back as from the front. Still the common supposition leads to many misplacements.

Our hearing is keenest directly opposite each ear and it decreases gradually toward the median plane both in front and back. Intensity of sound may therefore be

interpreted in terms of direction; it is possible to predict an apparent change in direction from the mere varying of the intensity of the sound.

Other things being equal, the fainter sound is judged to be more distant.

Timbre is the characteristic quality of a sound and depends upon the presence and reinforcement of overtones. The difference between the tones of the various musical instruments is chiefly a difference in timbre. As a rule, the richer the tone the better it can be localized. The human voice in normal speech can be localized better than any other sound. The localization of the sound of a tuning-fork is very much inferior to that of the voice; and some contend that a simple pure tone cannot be localized at all. At any rate, the richer the tone the more "ear-marks" of direction it can have.

The longer a sound lasts within certain limits, the better it is localized.

By introducing a funnel into the ear and turning it in different directions, one can make the same sound seem to come from different places.

The resonance and similar modifications of the sound by the environment are familiar sources of disturbance to localization. If the experiments are made indoors, they should preferably be made near the center of a relatively empty cubical room.

There are exceedingly interesting phenomena of sound fusions. No matter how many sounds are produced simultaneously, no matter from what different directions they may come, provided the sounds are of

the same kind and pitch, they will be heard as one. A very pretty experiment is to connect two telephone receivers to the same tuning-fork so that the same tone is produced in both receivers. The two tones will invariably be heard as one, and this one is located according to definite laws. If the two receivers are pressed against the ears, the fused sound will be heard at the root of the tongue—a very weird experience. The laws for the localization of fused sounds are among the most valuable criteria for testing a theory of sound localization.*

To revert, then, to the questions at the beginning of the chapter, we may sum up the evidence in the form of a reply. The following points may be considered in favor of the intensity theory:

(a) The general variation in the delicacy of localization; that is, the form and distribution of the sensory ellipses.

(b) The existence of confusion-points.

(c) The difficulty of localizing sounds radially in the median plane.

(d) The introspections which reveal our dependence upon intensity.

(e) The inferiority of monaural localization.

From experiments of this kind we may therefore conclude that intensity is the primary factor in the local sign of hearing.

But intensity operates in two distinct ways: (1) through the binaural ratio and (2) through monaural

* This may be made a very effective demonstration exercise to be developed by two or three members of the class.

ratios. With two ears we get simultaneous impressions in which the intensity for one ear stands in a certain ratio to the intensity for the other ear. But, for each ear or with a single ear, a sound in one direction has a certain intensity ratio to the same sound in another direction.*

We have also found distinct evidence of another factor, namely tone quality, or the modification of the character of the sound by the form of the outer ear. Among the evidences for this are:

(a) Complex sounds can be localized more accurately than relatively pure tones.

(b) The possibility of improvement with practice, especially within the median plane.

(c) The inability to localize pure tones by one ear alone.

(d) The curve of monaural localization.

(e) The introspective evidences; i.e., consciousness of quality difference.

Hence we shall conclude in favor of the fifth theory, the intensity-quality theory: sound is localized by means

* An interesting corroboration of this twofold nature of the local sign of direction of sound is found in the "teeth" of the curve in Fig. 10. There are five prominent teeth, namely, 15° RF, 50° RF, 90° R, 60° RB, and 25° RB. The more accurate the measurement the more distinct these teeth become. Now, the explanation is to be found in the fact that there is a change at these points in the means of localization. At 15° RF and 25° RB there is a transition from the simple balancing of the relative intensity of the two ears to the recognition of quality changes for one ear. At 50° RF and 60° RB there is a transition from this double standard to the monaural localization on the basis of the character of the sound. The large peak at 90° R is due to the fact that this represents a sort of zero-point for both modes of localization.

of binaural and monaural ratios of intensity and characteristic differences in quality.*

Is the ear a space-sense organ? It is. As we have in two eyes a means for the perception of distance, we have two ears for the perception of direction. We also have on each side, where the two ears cannot well cooperate, ear-funnels which change the quality and the intensity of the sound with reference to the direction in which the vibrations impinge upon one ear.

Movement, tendencies to movement, images of movement, visual or auditory images, tactual sensations or images, and other factors may have been observed as secondary factors which influence localization.

What are some of the laws of localization? The graphic representation in Fig. 11, for example, embodies a whole system of laws.†

*Quality is here used in the popular sense, as synonymous with timbre. Strictly, the quality of the tone is its pitch.

†A good survey of this topic is found in Pierce, "Studies in Space-perception." The present chapter is based mainly upon Starch, "The Localization of Sound," *The University of Iowa Studies in Psychology*, Nos. 4 and 5.

CHAPTER VI

TACTUAL SPACE

For Two.

1. **Tactual Localization of a Point.**—Mark off an area 50 millimeters wide and 100 millimeters long from the wrist upward, on the volar (inner) surface of the forearm by ink-dots at the corners of the parallelogram. Make a similar plot in the note-book. Working within this area, touch O, who sits with eyes closed, lightly with the point of a pencil and require him to try to locate this spot, eyes opened, by touching with another pencil.* Mark the relative positions of the two spots by dots in the note-book plot, and connect them by a light line to indicate the magnitude of the error. Label the dots S (stimulus) and L (location) respectively. Make 15 trials. Record O's analysis of what constitutes the "local sign"—the terms in which he recognizes the location of a touch.†

There are three factors in the record: the measurement of accuracy of localization in terms of the magnitude of the error; the direction of the error; and the analysis of the local sign.

Accuracy of localization varies for different parts of the skin; in general, the portions of the skin which are

* Keep the results secret from O.

† For definition of local sign see Ch. IV, p. 45.

used most in tactual perception are most sensitive. Hence we find but a crude localization for the large areas for which tactual localization is relatively unimportant, and a fine ability for those portions which are small, movable, and readily accessible. This should be illustrated in the chart just made by large errors in that portion which is toward the middle of the forearm, and small errors at or near the wrist.

The probable direction of an error is predictable according to a general law; the point touched is generally misplaced toward the nearest joint or actively used portion of the skin in the localization. This should show in the chart by a tendency of the L-dots to be nearer the wrist than the S-dots. The largest errors are along the axis of the arm, unless the point touched is on or very close to the wrist. The errors in the radial and ulnar directions are small.

It is difficult to discover by introspection just what constitutes the local sign. The localization of the tactual impression, like the projection of the retinal image, is automatic. The mode of the accompanying consciousness varies for different parts of the skin and with different individuals. The record might mention visual imagery, association with blood-vessels, ridges, wrinkles, curvatures, relative callousness of the skin, tendencies to movement, etc. The following account of the local sign of the skin is apposite.

“Not only is the skin, physiologically regarded, a localizing organ: the organism is endowed with reflex localizing movements. If a spot of the skin is irritated, hand or foot moves to it reflexly, in obedience to purely physiological laws. Out of this unconscious localization the conscious local mark arises, by the following stages: (a) The movement of the hand or foot, though

reflexly set up, occasions organic sensations in the joint, tendon, etc.; so that definite groups of organic sensations become connected with pressures upon particular parts of the body. The local sign may consist, therefore, of remembered organic sensations. (b) The reflex movement toward the irritated spot will usually be seen; so that the local sign may contain a visual sensation, a picture of the part touched, as well as organic sensations. (c) The organic sensations may pass unnoticed, owing to the habitual nature of the movement. The local sign of a pressure will then be a sensation of a quite different order—a sensation of sight. (d) Finally the visual picture itself may disappear, and its place be taken by a word, the name of the part of the body pressed. Often enough, when we say that we remember an occurrence, we remember only the form of the word which describes it. So now, when I am touched upon the arm, there flashes up in my mind the word 'arm,' and this word is the local sign of the pressure."—Titchener, "Outlines of Psychology," p. 157.

Tactual space is inseparably bound up with visual space. In this experiment it is extremely difficult to make a purely tactual localization; there is almost invariably at least a visual image of the arm and particularly the portion stimulated. To test the effect of the visual image upon the accuracy of localization, experiments have been made upon trained observers who had the power of practically inhibiting the visual images, of neglecting them, or of utilizing them in locating the pressure sensations. The results show much greater accuracy with the employment of visual imagery than without it.

Blind persons, however, who cannot rely upon the visual imagery, exhibit no larger errors in localization than seeing persons. This is of course due to the great reliance which they must place upon pressure sensations, and to the practice effects in delicacy of discrimination which follow. This would tend to show that, although vision constitutes for normal persons an im-

portant element in the local sign of pressure, it is not an indispensable element.

The right arm and hand of the observer have been used to carry the pencil in locating the pressure sensations. This has added a whole group of muscle sensations further to complicate matters. It is well known that distances are not properly judged by movements of the arm and hand when flexed, as required in touching a part of the other arm. Much of the constant misplacement distally has been found to be due to this factor. This suggests again the interconnection between tactual and muscular space.*

2. **The Two-point Space Threshold.**—To measure the threshold of space discrimination for two points upon the skin, determine the minimum distance that two spots lying in the longitudinal axis of the volar surface of the forearm, stimulated simultaneously, may be separated and still be perceived as two.

From a calling-card cut a strip 15 millimeters wide and as long as the card; cut this diagonally. Take the two triangular "points," and improvise a pair of compasses by holding these between the thumb and first finger. Set the points at the desired distance by measuring on the millimeter scale. Adopt the following scale of steps in separation: 1, 2, 3, 4, 7, 11, 16, 22,

* Other methods of localizing have been designed to eliminate some of these complicating factors: (a) hold the pencil just over the point stimulated, but do not touch the skin; (b) mark the localization upon a photograph or plaster-of-Paris model of the arm; (c) describe in words as nearly as possible the location. These methods may be combined and other methods derived from them.

29, 37, and 46 millimeters. Press the two points simultaneously, gently and evenly, for about 1 second and require O to report whether he feels one or two.* Start with the smallest step, and if O reports "One" try the next larger step, and continue thus until O reports "Two." With this step give successive trials, interspersing control trials,† until O makes a mistake or has perceived the two points correctly ten times in succession. If a mistake is made, take next higher steps in order until ten successive correct judgments are given on one step. Record the number of correct judgments for each step tried; the last may be considered the threshold required and a measure of O's power of space discrimination under these conditions.

3. Relation to Direction on Limbs.—Measure, in a similar manner, the two-point space discrimination with the compass-points applied in a transverse direction on the same region as in Exp. 2. Compare results with those of Exp. 2.

4. Relation to Part of Body.—Measure the two-point space discrimination, as in Exp. 2, (1) on the tip of the first finger of the left hand and (2) in a vertical line on the back of the neck. Record and compare results.

* Avoid all unnecessary fatigue of the skin area selected for exploitation. Take great care to apply and to withdraw the two points simultaneously. Do not press hard; a clearly defined sensation of contact is all that is necessary.

† Control trials may be made by touching with one point only in about one-third of the trials; if O answers "Two" in a control trial, this is an error indicating that he has not set himself a sufficiently high standard of certainty and he must be tried on a next higher step.

The two-point space threshold, which is measured in Exps. 2, 3, and 4, is an index to spatial sensitiveness.

Exp. 2, the results of which may seem startling to the uninitiated, demonstrates the fact that the two points may be separated some distance and yet be perceived as one. This is to be explained upon the assumption that the local signs for the two points stimulated are indistinguishable and therefore there is no basis for a differentiation of the impressions. The two-point threshold for this direction upon the arm is large.

In Exp. 3, with a transverse direction upon the arm, the threshold is smaller. This is in line with the fact, found in Exp. 1, that the radial and ulnar misplacements in localization are small. The explanation for this is based in part upon the anatomical fact that the pressure-spots lie closer together transversely than in a longitudinal direction.

In Exp. 4 the spatial sensitiveness is found to vary with the different parts of the body; upon the fingers it is very delicate, upon the neck very obtuse. The following table * gives a list of representative threshold values for various parts of the body in longitudinal direction:

Tongue-tip	1.1 m.m.
Palm side of last phalanx of finger	2.2 "
Red part of lips	4.4 "
Tip of nose	6.6 "
Back of second phalanx of finger	11.0 "
Heel	22.0 "
Back of hand	30.8 "
Forearm	39.6 "
Sternum	44.0 "
Back of neck	52.8 "
Middle of back	66.0 "

* James, Psychology, Briefer Course, p. 62.

The space discrimination in any given portion of the skin may be represented by so-called sensory circles, more properly called sensory ellipses, on the same plan as we represented auditory space discrimination in Chapter V, Fig. 11. Thus, the data in this table would furnish the major axes for ellipses.

The difference in distribution of the pressure end-organs and nerves, the unequal amount of practice occasioned by exposure and use of certain parts of the body, and habitual protection of others by the garments, are probably sufficient to account for the wide range of the two-point threshold on different bodily regions.

There is a gradual transition from oneness to twoness. Titchener quotes from Henri the following introspections for a series of increasing distances:

1. One small sharp point.
2. A larger blunter point.
3. A small area of oval form.
4. A line.
5. Two points, near together, connected by a line of light contact.
6. Two separate points; direction of line of junction uncertain.
7. Two separate points; direction known.

The two-point space threshold varies also under other conditions. Practice reduces it; for instance, a threshold of 14 millimeters may after a few periods of practice be reduced to 5 or 6 millimeters. Practice on one area also lowers the threshold for other bodily areas; the left forearm has been stimulated and the threshold for the right forearm thereby reduced from 11 to 7 millimeters in six practice periods. On the other hand, fatigue raises the threshold; that is, it decreases the sensitiveness. And drugs, such as atropine, morphine, strychnine, and alcohol, have a similar effect. With

reference to temperature it may be said that if the points are cold when they are applied to the skin the threshold is in general lower than if the stimulus points are warm: the cold points seem to be more sharply localized. Warming the skin before applying the points also increases the sensitiveness, while cooling the skin has an opposite effect. In the experiments it is best to exclude simultaneous temperature sensations. Rotation of one point reduces the threshold. Disease, especially of the nervous system, affects spatial sensitiveness, sometimes increasing, sometimes decreasing it, depending upon the nature of the disturbance. In some diseases all pressure sensations are lost throughout more or less circumscribed skin areas. Very large individual differences are found among different persons, some being several times more sensitive than others.

5. Simultaneous Compared with Successive Touch.

—Measure the two-point space discrimination in the same region and in the same manner as in Exp. 2, except that instead of touching the two spots simultaneously you touch each with the same point quickly in succession. To regulate the distance, hold a ruler near the skin as a guide.

When two points are applied successively instead of simultaneously, as in Exp. 5, the threshold for the discrimination of two points is very much lowered, probably by about one half.

Two points may be clearly perceptible as two, without knowledge on the part of the observer of the direction of one from the other. Two successive stimuli were

correctly perceived as two upon the forearm when 3 millimeters apart, but their directions were known only when the separation was increased to 7 millimeters. These figures show that the direction threshold is larger than the difference or two-point threshold. The same is true for simultaneous pressures. An analogous tendency is also common in other sensations; for instance, we can tell that an odor is present before we can identify it, or, we may know that two tones are unlike in pitch without being able to tell which is the higher one.

Related to the comparison of simultaneous and successive touch is the discrimination for the motion of a point upon the skin. We can detect motion before we can detect the direction of the motion. The discrimination for motion varies greatly with the rate of motion.

6. Method "with Knowledge" Compared with Method "without Knowledge."—Repeat Exp. 2, but let O, with his eyes open, apply the compasses. Record as before.

In this experiment we have the coöperative effect of the visual, tactual, and muscular space senses; the method is "with knowledge" as compared with the method of Exp. 2, which was "procedure without knowledge." The two-point threshold by this method is lower than when obtained by the method "without knowledge."

The most effective method of securing a knowledge of objects by tactual impressions is not to allow them to press against the unmoved skin, but to pass the sensitive skin surface over the objects and thereby gain a wealth

of information quite impossible by the passive method. This is active pressure. It is keen, quick, and sure. It is the method we most often employ. We do not test the smoothness of a surface by simply laying the hands upon it; we rub the tips of the fingers upon it. The knife-grinder draws the edge of the blade he is sharpening along the finger; he does not merely hold the edge of it against the finger. In active pressure the skin really seems to be more sensitive; certainly the efficiency of the sensitive skin in mediating sensations of the space qualities of objects is very much increased, but this is really due to favorable conditions for perception and does not indicate any real increase in sensitiveness after all.

The blind live in a world of tactual, muscular, and auditory space. Their fine space distinctions are made by touch, in which they acquire most extraordinary skill. A blind person can read with his finger-tips almost as fast as we ordinarily read with our eyes, impossible though it may seem. The print for the blind consists in raised points or ridges made by embossing a stiff paper. We experience difficulty in detecting even the form of a single letter by touch.*

Yet the superiority of the blind in this capacity does not lie so much in superior sensitivity as in the habit of couching impressions in tactual terms. The two-point threshold is only a trifle lower in the blind than in see-

*The style of the raised print has been improved by experiments on the principles here studied; for example, on the relative legibility of a line as compared with a dot alphabet, or simultaneous impressions of dots compared with successive impressions, most favorable spacing, etc.

ing persons after brief practice; and the blind person's sensitivity to pressure does not differ much from that of seeing persons under careful experimental conditions.* But the blind person is a "*tactile*." He thinks in terms of touch as we think in terms of sight. Tactual discriminations therefore have immediate meaning to him. The superiority of the blind in this activity is not in sensation but in perception. This is a fundamental but neglected distinction.

When we read we see one word at a time by direct vision, and the words around this shade off gradually in indirect vision. In the same manner the blind person gets a clear image of one letter or word at a time by the left hand and skirmishes with the right so as to get a general impression of what lies ahead. He may also learn to read by word instead of letter units.

*Put a human hair 3 centimeters long on a sheet of smooth glass. Lay over it a sheet of clear writing-paper and locate the hair by touch. Add sheet after sheet and locate as before until you come to such thickness that you cannot locate the hair by touch. The greatest thickness through which the hair can be located correctly is a measure of the sensitivity to pressure. The average person whose hands are not callous should locate the hair under forty to fifty sheets of "20-pound" bond paper. A blind person cannot do very much better.

CHAPTER VII

CUTANEOUS SENSATIONS

*For One.**

THE problem is to explore, identify, and plot charts of cold spots, warmth spots, pain spots, and pressure spots found in the skin.

Outline four blocks, each 10 by 10 millimeters, into 2-millimeter squares with pen and ink on the back of the left hand. Outline a copy of each of these in the notebook and label them Cold, Warmth, Pain, and Pressure respectively.†

Put six of the nails on crushed ice and the other six into water just below the boiling-point.‡ The sense-organs in the skin fatigue very quickly—almost instantaneously—when touched. Therefore, select points for stimulation systematically; follow parallel lines, apply the stimulus with precision and with a constant vertical pressure, remove it within a second, and always trust to first impressions. Make a few preliminary trials for practice on some other skin area.

* Provide a dozen tenpenny wire nails, a small cork, a horse-hair from the mane, warm water, and ice.

† Freehand ruling is accurate enough for the purpose.

‡ For more accurate work a pointed metal tube is kept at a constant temperature by having warm or cold water at the desired temperature flow through it. Another way is to put the warm water or crushed ice into a tube and change it as often as necessary.

1. **Cold Spots.**—With the point of a cold nail, explore a plotted area of the skin systematically and mark on the note-book copy of this plot the location and approximate area of the spots which give rise to clear and localized sensations of cold.*

When the cold nail touched certain portions of the skin it did not feel cold; but at other places definite and unmistakable sensations of cold were experienced. These spots may perhaps be spoken of more properly as areas.

2. **Warmth Spots.**—Take a warm nail—as warm as it can be made without making it uncomfortable to hold in the hand—and survey another plotted area systematically, and mark on its copy the location and approximate area of the spots which give rise to clear and localized sensations of warmth.

The spots sensitive to warmth are more difficult to find. The warmth spots are less numerous than the cold, they are less sharply localized, and they seem to lie deeper down in the skin than the cold spots. The warmth sensations do not follow so quickly after the application of the stimulus as do the cold sensations; that is, there is a more appreciable latent time. The area of a warmth spot usually seems larger than that of a cold spot.

The kind of stimulus which can best call forth a

* Start at one side and pass by parallel lines until the whole plot has been covered by point stimulations. Never retrace or verify in the same sitting. Lift the nail vertically up and down and touch with the very point. Change the nails as often as it is necessary to keep them cold. If the spots are large and taper off, this may be shown by shading on the chart.

certain sensation is known as an adequate stimulus. Thus, light-waves constitute the adequate stimulus for sight sensations. The adequate stimulus for sensations of cold is the cooling of the skin, or the lowering of its temperature; that for warmth is the warming of the skin, or the raising of its temperature, in other words the application of radiant energy.

Now, since the skin is not the same temperature all over the body, the same object may feel warm to one part and cool to another. The temperature of a given portion of the skin at a given time is known as its physiological zero-point. Whether or not the stimulus shall excite the cold or warmth spots depends in part upon the physiological zero-point; if the stimulus is slightly warmer than the skin, warmth sensations result; if it is slightly cooler, cold sensations result.

The nerve-endings in the skin which correspond to the cold spots are probably separate and distinct from those which correspond to the warmth spots. Each temperature spot has its own nerve-fiber or group of fibers which responds with its own characteristic sensation only; that is, it has its own specific energy. This means that even though a warm stimulus be applied to a cold spot, a sensation of cold and that only, if any, will result. The same principle applies to warmth spots. Ordinarily only warmth spots respond to a warm stimulus and cold spots to a cold stimulus, but they sometimes respond to inadequate stimuli, so that a neutral stimulus, say a pin, may be used to find all four kinds of spots called for in this chapter.

Cold and warmth are the two qualities of temperature

sensations. Introspection has revealed a third temperature experience qualitatively different from cold and warmth, the perception heat. Heat or hotness is something distinct from mere warmth, and it is not due alone to the excessive stimulation of a warmth nerve. Heat is due to a fusion of cold and warmth sensations aroused by the simultaneous stimulation of cold and warmth nerves by rather high temperatures. That is, the same stimulus, by radiation of heat or otherwise, excites both cold and warmth nerves, each of which responds with its specific sensation, but the complex experience is neither that of cold nor of warmth but of heat.

The fact of temperature spots was discovered independently by Blix, Goldscheider, and Donaldson in the years 1884 and 1885. It is thought that the nerve-endings of Ruffini are the organs for warmth, and the endings of Krause are the organs for cold.*

3. Pain Spots.—Slit the small end of the cork and insert a horsehair into the slit, so that a squarely cut end of the hair projects from one side about 5 millimeters. † Hold the cork firmly near the slitted end, and, by pressing the hair down vertically until it begins to bend, survey a third plotted area systematically and mark on the copy of it the location of those spots which give rise to clear and localized sensations of pain.

* See Barker, "The Nervous System."

† The bristle should project from the cork about 3 millimeters if the hand is callous, or 10 millimeters if it is very sensitive. Adjust the length of the hair between these two limits as required. The pressure exerted should be as uniform as possible.

When the whole plot has been surveyed, verify about a dozen pain spots by a single touch at each and mark differences in intensity of painfulness on the scale of 1, 2, 3, where 1 represents the faintest and 3 the strongest sensations, by connecting each spot with a number in the margin, as in correcting printer's proof.

Pain spots are easily located, and the pain sensations are very vivid and very unlike any other cutaneous sensations. The pain sensations usually give rise to distinct reflex movements; indeed the movement is sometimes perceived before the pain. The pain spots are more numerous than even the cold spots; and, while they themselves are very sensitive, intervening skin areas are usually quite anæsthetic as regards pain, sometimes to such a degree that a needle may be inserted deeply into the skin without pain. The cold and warmth spots are analgesic, i.e., insensitive to pain; but it is difficult to stimulate these without at the same time stimulating one of the very numerous pain spots. Pain spots are to be found only upon the skin or structures closely connected with it genetically. The free nerve-endings in the skin are probably the end-organs of pain.

There is no single adequate stimulus for pain. Any of the general classes of stimuli—mechanical, thermal, chemical, electrical—will cause pain. This general nature of pain stimuli is necessary from the biological point of view. Pain is one of the most valuable endowments of living organisms in enabling them to avoid danger. Pain means disaster; when an experience be-

comes painful it means that injury may follow unless there is some protective reaction. The point at which experiences become painful is usually just before injury is likely to result. From the point of view of evolution, pain was probably the first experience to appear, because the most necessary. It is still the best safeguard we ourselves have against bodily injury.

That pain is a special sense is a relatively recent discovery. It was formerly thought that pain resulted from the excessive stimulation of any sensory nerve. Such, however, is not the case. The pain we experience under the influence of a very bright light comes from real pain-nerves in the eye, not from the overstimulation of the optic nerve. The most bitter sensations are not, in the strict sense of the word, painful. When we bear in mind the profuse distribution of the pain end-organs and the general nature of pain stimuli, the above fact readily becomes intelligible.

Our English word "pain" is ambiguous. We use it to refer, on the one hand, to pain sensations, as in this chapter; and, on the other hand, to refer to the feeling of unpleasantness.* Now, pain sensations are nearly always unpleasant, but not all unpleasant experiences are painful by any means. It is exceedingly unpleasant to overturn one's cup of coffee at dinner, but it is not necessarily painful unless one happens to be scalded by the liquid. As we have used the word pain, it has had

* The Germans have two words, "Schmerz" and "Unlust", to cover the ground of our word pain.

reference alone to a special sense of pain, with central, peripheral, and connecting nervous apparatus such as every other special sense possesses.

Pain sensations have only one quality, pain. The various kinds of pain we think we experience, such as throbbing, burning, sharp or dull pains, are due to variation in attributes other than quality and to the accompaniment of sensations other than pain. Thus, a prick, a pinch, a toothache, and a headache differ in local sign, areal distribution, intensity, duration, and combination with other sensations, but, as pains, they all have the same quality.

4. Pressure Spots.—With the same finder as in Exp. 3, and in the same manner, survey the plotted area and mark on the copy of it the spots which give rise to clear and localized sensations of pressure. Record on the same plot the relative position of the nearest hair to each pressure spot.

The fourth specific cutaneous sensation is pressure. Pressure spots are more numerous than cold and warmth spots, but less numerous than pain spots. They are distributed over the surface of the whole body and extend some distance into the natural openings of the body cavities. Each minute hair on the body has its pressure spot, usually situated to the windward, but pressure spots also occur on the hairless regions. The pressure nerves, which of course are distinct from the temperature and pain nerves, have a specialized mode of termination in the skin, each nerve-fiber bearing a little terminal bulb, such as the Pacinian

corpuscle or the spindle of Meissner. The adequate stimulus for pressure is mechanical.

Pressure sensations are of one quality only, usually described as feeling like a tiny seed embedded in the skin and pressed downward. Ordinarily this peculiar quality is not noticed, as a number of pressure spots are stimulated simultaneously, and, for the most part, there are accompanying temperature and pain sensations.

In all the above cutaneous sensations we assume that the "spot" of a specific character is due to the presence of the corresponding specific end-organ. The spot becomes an appreciable area when the taut skin surrounding the end-organ communicates the stimulus indirectly.

A few years ago a schoolboy who did not know how many senses he had would have been considered a dull boy. He learned on his father's knee that he had five, the five gates to Milton's city of Man-soul, namely, eye-gate, ear-gate, nose-gate, tongue-gate, and feel-gate. To-day the professor of psychology does not know with certainty how many senses he has, but he does know that he has more than five—possibly twice as many as he was supposed to have fifty years ago. The newer senses have been discovered and explored by the natural-history method followed in these experiments.

How shall we know when we come across a new sense? Among the chief criteria are the following: (1) the sensation, as a conscious experience, is unlike every other known sense quality; (2) it is objective and localized, and (3) it comes through specific end-organs.

Some psychologists and physiologists hold that hunger and thirst are special senses, but the prevailing opinion is that hunger and thirst fail on the first and the third criteria; they can be reduced to other known sense-complexes.

CHAPTER VIII

WEBER'S LAW

*For Two.**

IF you can just barely perceive a difference of one gram added to twenty grams, what is the smallest difference you can perceive when added to forty grams? Eighty grams? Two hundred grams?

Weber's law gives the answer: "Equal difference between sensations means proportional difference between stimuli." The ratio just posited is 1:20; hence 2 grams added to 40 grams, 4 grams added to 80 grams, and 10 grams added to 200 grams would be equally perceptible.

This law applies in various ways in the different senses. Weber first demonstrated it for the perception of weight, and as this field presents the simplest as well as the most exact conditions for measurement, we shall verify and illustrate the law for lifted weights.

Specifically, this is what we shall try to do: Exp. 1 is a preliminary skirmish to determine within what range of weight it will be most profitable to make the measurement on the observer; Exp. 2 reduces this to an exact measurement; and Exp. 3 makes the same measurement with doubled weight and doubled incre-

* Provide two tumblers, some medium-sized shot or small nails or coins, a wad of cotton, and two small pieces of woolen cloth.

ment. Now, if Weber's law holds, there should be about the same degree of success in the discrimination in Exps. 2 and 3.

Select two ordinary tumblers of the same kind and weight. A fairly heavy jelly-glass is good, but the sides must slope so that the one fits snugly into the other. Put a wad of cotton or soft cloth into the bottom of one. Make a cushion out of three or four folds of cloth on which to set the glass.

Prepare a differential weight as follows: Take a quantity of small pieces of metal that are uniform in weight (e.g., small coins, nails, or shot) and select what you judge to be about one tenth the weight of a glass. Tie these into a small cloth so that this bag can be lifted into the glass and out of it quickly and without sound or other disturbance.

Blindfold O and let him be seated at the table with the padded glass before him in such a position that he can lift it conveniently and accurately by a free-arm movement. Vary the weight of the glass by putting the differential weight into it or taking it out for successive trials. Every precaution must be taken to prevent any other means of information than the actual sense of weight. Use two signals: "Ready" for the first of two liftings in a comparison, and "Now" for the second. Make the time between the two liftings as short as possible. Allow repetition of a trial only when the observer calls for it on the ground of some specific disturbance. Any accidental clue obtained from the experimenter would, of course, be such disturbance.

To determine the order in a comparison, flip a coin

for each trial and put the differential weight into the first lifting if head is up, or into the second if tail is up.

1. The Approximate Threshold of Discrimination for Weight.—Let O lift the glass twice in close succession and say whether it was heavier in the first or the second lifting. If O is right in more than 75 per cent of a few trials, lessen the differential weight; if he is right only in much less than 75 per cent of the trials, increase it. Skirmish in this way until you get such an increment of the weight that O will get about 75 per cent of the judgments right in 20 trials. Between 65 and 85 per cent will do. The increment thus obtained is the one with which to make the more accurate measurement in the next experiment. Record it in terms of the number of objects (coins, nails, or shot).

The weight of an object is judged most accurately when it is lifted in the most convenient position. The same object appears to be heavier if grasped lightly than if grasped tightly. An object appears heavier if lifted in contact with a small area of skin than if in contact with a larger area. An object appears heavier if lifted with a slow movement than if lifted by a quick, but not jerking, movement. A heavy weight grows heavier and a light weight grows lighter when sustained undisturbed in the hand. Of two equal weights lifted in succession, the second appears to be the heavier. An object of moderate weight appears to be heavier or lighter than it really is according as a lighter or a heavier object has been lifted just before. An object held in one hand appears to be lighter than it really is if the other hand

supports another weight or is otherwise engaged, as in a grip or push. Any deviation from the physiological zero of temperature increases the apparent weight of the object. An object appears to be heavier or lighter than it really is according as the material of which it is made suggests lighter or heavier weight than the actual. Of two objects that are of the same weight but different size, the larger appears to be the lighter when lifted.

This formidable array of assertions represents some of the well-established laws of the perception of weight. These laws must be kept clearly in mind in the performance of a weight test in order to avoid introducing errors which would result from the violation of such laws. Thus, two objects which are to be compared in weight by lifting must be lifted in the same position; they must be grasped with the same area of pressure, and with a grip proportional to their weights; they must be lifted at the same rate, to the same height, and be sustained the same length of time; the order must be alternated fairly; contrast-weight, counter-weight, or division of energy must be avoided; temperature must be kept constant; the weights must appear to be made of the same material and must be of the same size. Violation of these principles is certain to result in error and often appears in the most astonishing distortions of weight. We must assume that they are eliminated in the following experiments.*

*The flipping of the coin is another type of precaution. It may seem useless, but it is indeed very essential in order to forestall any tendency in the observer to make some inference, whether true or false, as to what the next order shall be. Suppose that the experimenter should determine the order arbitrarily,

2. **The Least Perceptible Difference.**—With the differential weight which in Exp. 1 gave the nearest to 75 per cent correct judgments, make 100 consecutive trials. Record 1 for right or x for wrong in each trial.

3. **The Least Perceptible Difference in the Double Weight.**—Put the glass used into the other one. Double the differential weight. With this doubled weight and doubled increment make 100 trials in the same manner as in Exp. 2. Compare the per cent of right cases in Exp. 2 and Exp. 3. If Weber's law applies, the per cent of error should be approximately equal in the two cases.

There are mathematical formulæ by which we may calculate from the above results what increment is needed in order to yield any particular degree of certainty. It is customary to use 75 per cent of right judgments as a norm or standard, as it lies half-way between no knowledge and absolute certainty in this method. Thus, if the glass in Exp. 2 weighs 200 grams

that is, as he felt it would run by chance, and suppose that he had given the order "Second heavier" three times in succession, would not the observer require more than an ordinary degree of assurance before he would pronounce a fourth one also of the same order? Yet according to chance, and in the flipping of the coin, the number of times head has been up has not the slightest influence on the next throw. On account of our community of ideas there is always a more or less subconscious tendency present to anticipate the order of a so-called chance series which is determined by one human will for another.

Another important variable is the bodily attitude taken by the observer at the table. The attitude of attention is a bodily attitude of muscular tension. If the observer rests against the back of the chair he will make a much poorer record than if he sits up with body erect and firm, bending his head gently toward the lifting hand.

and the differential weight is 12 grams, and this ratio (6:100) gives 72 per cent of right judgments; then, by referring to a simple table,* we find that the increment must be 14 grams in order to yield a certainty of 75 per cent right judgments. This computation is not needed in the present case because we may here compare the percentages directly.

Working with compact hard-rubber blocks, which are more favorable than the glasses for fine discrimination, the average constant for a good observer is about 1:24. The ratio obtained in this test is probably considerably larger, mainly for two reasons—the bulkiness of the glass,† and the lack of practice of both experimenter and observer.

Similar ratios may be worked out for different conditions in this sense and for different senses. Each individual has his own ratio, which is an expression of his personal equation.

The principle of its application is illustrated in Fig. 13, which is drawn for the constant ratio 1:24. 16, 25, 50, 64, etc., represent selected standards and .6, 1.0, 2.0, 2.6, etc., the respective increments that would be just perceptible.

This illustration and the above experiment have reference to sensation-difference. To be more specific,

* Sanford, "Experimental Psychology," p. 354; or Titchener, "Experimental Psychology," Quantitative, Instructors' Manual, p. 288.

† The more compact the weight is the finer the discrimination will be. The discrimination will be finer if a thick glass is used rather than a thin one, because for the thin glass the bulk is proportionally greater than the weight. Both glasses seem to be lighter than they really are.

the law stated in the first paragraphs might be restated thus: "To increase the sensation-difference in arithmetical ratio, it is necessary to increase the stimulus-difference in geometrical ratio." There is a parallel aspect of Weber's law which has reference in a more direct way to sensation-magnitudes, greater than the least perceptible: "To increase the sensation in arithmetical ratio, it is necessary to increase the stimulus in geometrical ratio." This latter form of the law has great practical significance in our classification of magnitudes by sense-perception.

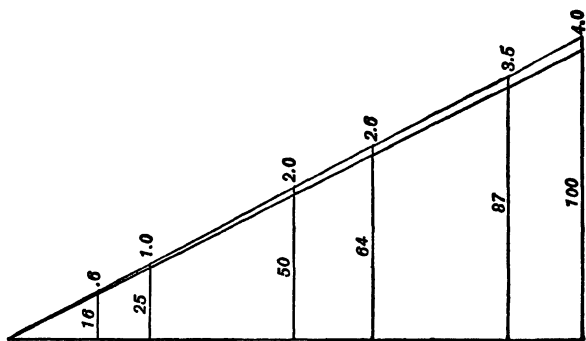

FIG. 13.

Suppose we have a thousand pebbles which range in weight from 1 gram up to 100 grams and we are required to sort them into five piles, according to weight, so divided that we shall be equally sure for each pile that the sorting is right. If we could resort to the use of accurate scales, the piles would range in arithmetical ratio; each pile would cover a range of 20 grams. But not so when we judge the weight by lifting. Weber's law enables us to predict what the grouping should be.

An excellent illustration of this second aspect of the law is found in the astronomer's classification of the stars. Stars are classified into a comparatively small number of groups, usually fifteen, according to their perceived magnitudes. Astronomers assume that this classification follows Weber's law; namely, that the physical magnitudes (the amounts of light emitted) do not stand in a direct arithmetical ratio, but in a geometrical ratio, in the grouping. Each group is supposed to stand in a certain ratio in the following group, say 1:10.

A psychologist attempted to verify this hypothesis. He produced, in the psychological laboratory, artificial stars whose physical magnitudes could be measured, and then he grouped these empirically into five groups on the basis of perceived magnitude and ascertained their average candle-power by physical measurements. The results ran as follows:

<i>Magnitude, or group</i>	I	II	III	IV	V
<i>Average candle-power</i>	269	146	83	45	21

When one considers the crudeness of a measurement of this kind, one feels that these results show a fair approximation to the law.*

Another type of demonstration of Weber's law may

* There is at least a very close analogy to Weber's law in any practical grouping of the stars. Thus from Kapteyn's recent work we learn that within a sphere the radius of which is 560 light-years there will be found:

	1 star giving from	100,000	to 10,000	times the light of our sun
25 stars	"	10,000	"	1,000
1,800	"	1,000	"	100
22,000	"	100	"	10
140,000	"	10	"	1
480,000	"	1	"	0.1
650,000	"	0.1	"	0.01

be made in terms of discrimination-time; that is, the time that it takes to perceive a difference. It rests on the postulate that if differences are equally difficult to perceive, the discrimination-time for all such cases should be the same. Take, for example, an increment of one tenth on different weights. There is an apparatus in the psychological laboratory which consists of a system of weights and balances which may be attached to an instrument that measures time in hundredths of a second. To verify the law, we might measure the discrimination-time for an increment of 1 gram on 10, 5 grams on 50, 9 grams on 90, etc.; and, if the law holds, the discrimination-times should be equal.

We may take a good illustration of the same type from sight—the perception of the difference in the length of lines. Suppose we have three sets of lines, Fig. 14, and we consider the middle one in each group

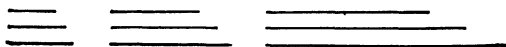

FIG. 14.

the standard for that group. We see in the figure that the longer and the shorter lines differ from the standard by one fifth in all cases. Therefore, the difference should be equally clear in all the cases, according to Weber's law. To measure the discrimination-time, we arrange the apparatus so that a compared line is exhibited immediately after the standard line, and then measure for each group the time it takes the observer to perceive whether the compared line is longer or shorter than the standard. If the law holds, other things being

equal, this discrimination-time should be equal for all the standards within a normal range so long as the ratio is constant.

These three demonstrations of Weber's law—the application to the least perceptible difference, the application to the classification of larger differences in sense-magnitudes, and the application to discrimination-time—might be repeated in various respects for other senses.

We know this world in terms of four aspects of experience, which are the four attributes of sensation, namely, quality, intensity, duration, and extensity. Weber's law is primarily a law of the intensity of sensations, but it applies in some respects to each of the other attributes.

It is generally conceded that the law applies approximately to sensation-intensities in all the senses. We have drawn our experimental illustrations from the kinæsthetic sensations in the perception of weight. The classification of the stars is an illustration from the intensity of light.*

A clear case of the operation of Weber's law is found in the intensity of sound. It is perhaps equally rigid for the intensity of pressure sensations. It has been demonstrated within a narrow range for taste and smell. Although it has not been worked out fully for the intensity of pain and temperature sensations, it probably applies, to some extent, there also.

* Fechner's cloud experiment is the classical illustration in terms of the intensity of light, or brightness. It is to the effect that if we look at a partly clouded sky and select a spot where we can just detect a difference in the shading of the two clouds by the naked eye and then look at this through darkening glasses of different densities, the difference will remain equally clear.

The operation of the law in the other sense-attributes is not so clear. It has been demonstrated for visual qualities (color), for arm-space, eye-movements, the duration of sounds, etc., but even where it applies to sense-attributes other than intensity it has reference to sense-magnitude.

The most general evidence of the law is in terms of the least perceptible difference, as in the above experiments on weight-discrimination. Its application to larger sense-magnitudes is always more doubtful.

The law can apply only within a middle or normal range of sensation-intensities in any sense. It does not hold for very faint sensations, nor for excessively strong sensations.

Much depends upon the method of the test. Thus, the application of the law to lines, Fig. 14, is much more likely to give a positive demonstration by the discrimination-time test than by the classification test; indeed, we should hardly expect any evidence of it by the classification method, because that method introduces factors which may interfere with its operation. We must always bear in mind that every case of discrimination is a complex operation depending upon scores of variables, and the law could at best apply absolutely only to one set of conditions.

The greatest gain in an experiment of this sort should be in the revelation of the complexity and the interrelations of mental laws even in such a simple operation as the lifting of a weight. Such revelations help us to analyze and understand our daily activities and should result in greater efficiency. We follow Weber's law

unconsciously in many of our well-regulated actions in which we are guided by our senses.

Aside from the demonstration of Weber's law, these experiments illustrate a common form of measurement in all the senses; namely, the determination of the least perceptible difference (*l. p. d.*).* The two most elementary forms of measurement in all the senses are (1) the threshold of sensitivity and (2) the *l. p. d.* or threshold of discrimination. In measuring sensitivity we determine the smallest quantity of any stimulus—a color, a pressure, an odor, a sound, etc.—that can be sensed. In measuring discrimination we determine the smallest increase (or decrease) that can be perceived on any given strength of stimulus. The former is chiefly a measure of the delicacy of the organism, while the latter is chiefly a measure of the intellectual capacity for using sense-differences. Thus, if one observer obtained the discrimination ratio 1:12 and the other 1:18 in the above test, we have in these ratios a measure of the relative usefulness of the sense of weight for the two persons.

The *l. p. d.* may be used as a sort of foot-rule in the quantitative study of a great variety of processes. Thus, with it, we may measure features of fatigue, rhythm, attention, memory, mental development, race differences, the effect of a stimulant, the power of emulation, etc., provided always that we bear in mind that in such cases we measure only one feature, the discrimi-

*The term "just noticeable difference" (*j. n. d.*) is often used in place of *l. p. d.*; so also is the term "discrimination limen" (*d. l.*), many authors using the term "limen" for threshold.

nation, and that our conclusions must not go beyond this. To illustrate the reservation, suppose that the experimenter sets himself the task of determining what the mental effect of a cup of coffee is. Among other measurements he may include the discrimination-tests in the various senses and for different attributes in each sense, and after a long series of measurements he should be able to say: My discrimination in such and such activities is heightened to such and such a degree for such and such a period after drinking coffee, and then there is a reaction which shows at such and such a time in such and such a degree for such and such of the activities.

CHAPTER IX

MENTAL IMAGES

For One.

THE problem is to determine the capacity for vividness of mental images. In perception, which we have studied so far, the object is present to sense. We see the color, hear the sound, feel the cold point, etc.; that is, we refer the mental picture to its object. In memory, imagination, and the various stages of thinking, the object is not present, but the mental picture is present as in perception, although usually less integral, less vivid, less enduring, and less distinct. This mental picture which re-presents the object is the mental image.*

To illustrate the fact of imagery, recall your breakfast-table as you sat down to it this morning. What is it that you recall? Is it merely the names for things and qualities, or is it their images? The whiteness of the china and the linen, the brightness of the silver, the form of the sugar-bowl, the taste, the odor, the temperature, and the hardness or softness of the cereal,—how

* "Images, along with sensations, constitute the materials of all intellectual operations; memory, reasoning, imagination, are acts which consist of grouping and coördinating images, in apprehending the relations already formed between them, and in reuniting them into new relations." (Binet.)

do these arise in your memory? Can you image only in certain senses? Or are all these experiences abstractions to you? If they are, in what terms do you remember their names?

If we could compare answers to such questions as these, we should find the most astonishing individual differences in capacity for types of imagery. One person is eye-minded, another is ear-minded. One lives in a world of vivid imagery, another lives in a dull and somber world of vague abstractions and names for things. One has an accurate, serviceable memory, another has a "miserable" memory. One has an aptitude for geometry, another for music. One has a fertile, constructive imagination, another is as devoid of imagination as a desert is devoid of vegetation. One is sensitive and responsive, another is deliberate and unmoved.

If we were blind, or should walk about with our eyes closed, the world would be different to us from what it is now. The congenitally blind person is not only deprived of the ability to see color, form, and motion, but he is also deprived of the power to remember, imagine, and think of colors and visual forms and movements. His world is not a visible world. Similarly, the world to the deaf person is a world without sound. Helen Keller lives in a world in which there is neither light, nor color, nor sound.* Her world is a world of touch, muscle sensations, smell, taste, temperature, and pain.

* Helen Keller retained normal sensibility until she was nineteen months old, and she says: "A person who has ever seen will retain images of light throughout life; sight and sound are, however, of little if any use to me."

Yet she lives a more intelligent and cultured life than the average college graduate.

This shows what great and varied resources the mind has. Our worlds of memory and imagination may be built of vastly varied materials, although to serve the same purpose. Miss Keller judges character by the touch of the hand; so also do many seeing persons. Many persons have normal ears for hearing, but can recall things heard only in terms of the other senses. A comparatively small number of persons can remember coffee in terms of taste and smell.

The differences we notice in the traits of individuals are not due so much to differences in sensory endowment as to differences in the endowment of capacity for representing sensory experiences in realistic, efficient, and economic imagery. Although Aristotle said that one cannot think without a sensible image, it is only a generation ago that the fact of mental imagery attracted much attention. Taine, Sir Francis Galton, Fechner, Charcot, and others found that they had vivid visual imagery, and made investigations which revealed the fact that such imagery is almost universal. These investigations led also to the discovery that some persons have auditory imagery. Later, more general inquiry revealed the fact that it is even possible to have images in terms of each and all the senses.

The main body of this exercise is devoted to a test of the capacity for *vividness* of imagery.

This is a distinct exercise in introspection. It is best to keep the eyes closed as you introspect. If the observer does not have strong imagery he may be lost in

the effort to create an image out of the retinal light. To avoid this, it is best to think of the object as in a distant place; for example, the rose on the bush.

Sometimes the image comes in the most realistic way when it comes without effort as a sort of a reverie image which passes the mental horizon. As a rule, it is best not to direct the attention primarily to the detail of the image, but rather to the effort to recall the fact; when the fact comes into consciousness the character of the image may be observed.

Fix clearly in mind and use as consistently as possible the following scale of degrees of vividness:

0. No image at all.
1. Very faint.
2. Faint.
3. Fairly vivid.
4. Vivid.
5. Very vivid.
6. As vivid as in perception.

Answer the following questions by writing after the number of the question the number which denotes the degree of vividness characteristic of your image.* In-

* To some students this exercise will be entirely too easy; to others, equally bright, it will seem like an impossible task. The reason for this difference lies in the fact that one person may have such vivid imagery that it is as easy for him to answer the first question as to say whether or not he sees a rose which is held before his open eyes, while to another person the task seems unreasonable, for with the best effort, he cannot see the slightest evidence of any concrete image, nor does he know what it is to have such an image. These are extreme types, between which normal types range. The student who finds difficulty should not be discouraged. The aim of this exercise is not to develop imagery, but to test the actual normal capacity.

stead of taking the questions in the order given, follow the order: I 1, II 1, III 1, IV 1, V 1, VI 1, VII 1, VIII 1, I 2, II 2, III 2, IV 2, etc., I 3, II 3, III 3, IV 3, etc. Introspective notes to supplement the numerical answers are very desirable.

- I. VISUAL.—1. Can you image the color of—(a) A red rose? (b) A green leaf? (c) A yellow ribbon? (d) A blue sky?
2. Can you image the brightness of—(a) A white teacup? (b) A black crow? (c) A gray stone? (d) The blade of a knife?
3. Can you image the form of—(a) The rose? (b) The leaf? (c) The teacup? (d) The knife?
4. Can you form a visual image of—(a) A moving express train? (b) Your sharpening of a pencil? (c) An up-and-down movement of your tongue?
5. Can you image simultaneously—(a) A group of colors in a bunch of sweet peas? (b) Colors, forms, brightnesses, and movements in a landscape view?
6. Can you compare in a visual image—(a) The color of cream and the color of milk? (b) The tint of one of your finger-nails with that of the palm of your hand?
7. Can you hold fairly constant for ten seconds—(a) The color of the rose? (b) The form of the rose?
- II. AUDITORY.—1. Can you image the sound of—(a) The report of a gun? (b) The clinking of glasses? (c) The ringing of church-bells? (d) The hum of bees?

2. Can you image the characteristic tone-quality of—
 (a) A violin? (b) A cello? (c) A flute? (d)
 A cornet?
3. Can you repeat in auditory imagery the air of—
 (a) Yankee Doodle? (b) America?
4. Can you form auditory images of the intensity of
 a violin-tone—(a) very strong; (b) strong;
 (c) weak; (d) very weak?
5. Can you form auditory imagery of the rhythm
 of—(a) The snare-drum? (b) The bass-drum?
 (c) “Dixie,” or other air heard played? (d)
 “Tell me not in mournful numbers” spoken by
 yourself?

- III. MOTOR.**—1. Can you image, in motor terms,
 yourself—(a) Rocking in a chair? (b) Walk-
 ing down a stairway? (c) Biting a lump of
 sugar? (d) Clenching your fist?
2. Does motor imagery arise in your mind when you
 recall—(a) A waterfall? (b) A facial ex-
 pression of fear? (c) The bleating of sheep?
 (d) Two boys on a teeter-board?
 3. Aside from the actual inceptive movements, do
 you get motor imagery when recalling—(a) A
 very high tone? (b) A very low tone? (c)
 Words like “Paderewski,” “bubble,” “tête-à-
 tête,” “Hurrah!”?
 4. Can you form motor images of—(a) An inch?
 (b) A yard? (c) A mile?
 5. Can you form a motor image of—(a) The weight
 of a pound of butter? (b) Your speed in run-
 ning a race? (c) The speed of an arrow?

- IV. TACTUAL.—1. Can you form a tactual image of the pressure of—(a) Velvet? (b) Smooth glass? (c) Sandpaper? (d) Mud?
2. Can you form tactual imagery of the following impressions made in the palm of your hand—(a) The size of a certain coin? (b) The form of the same coin? (c) The direction of a line traced by a pencil-point? (d) The intermittent touch of a vibrating body?
3. Can you form tactual imagery of—(a) The flow of water against the finger? (b) The sensation from a pressure spot? (c) The weight of a particular coin in the hand?
- V. OLFACTORY.—1. Can you image the odor of—(a) Coffee? (b) Camphor? (c) An onion? (d) Apple-blossoms?
2. Can you image odors from—(a) A meadow? (b) A confectioner's shop?
- VI. GUSTATORY.—1. Can you image the taste of—(a) Sugar? (b) Salt? (c) Vinegar? (d) Quinine?
2. Can you image the taste of—(a) An apple? (b) A chocolate cake? (c) Beefsteak?
- VII. THERMAL.—1. Can you image the coldness of—(a) Ice cream? (b) A draught of cold air? (c) The sensation from the stimulation of a cold spot?
2. Can you image the warmth of—(a) Hot tea? (b) A warm poker? (c) A warm bath? (d) The sensation from the stimulation of a warmth spot?

VIII. PAIN.—1. Can you secure a sensory image of the pain of—(a) The prick of a pin? (b) Running your finger along the edge of a sharp knife? (c) A toothache or headache? (d) The stimulation of a pain spot?

Compute the averages for all the answers in each of the experiments I to VIII. Lay off a plot in pencil as in Fig. 15, eight blocks long and six high, and number

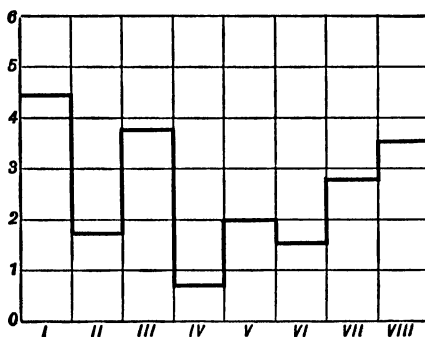

FIG. 15.

as in this figure, where the vertical series represents the scale of vividness from 0 to 6, and the horizontal series represents the senses I to VIII. Plot the averages with ink in a curve as in Fig. 15.*

Thus, we have arrived at a very simple and telling graphic representation of the observer's capacity for vividness of imagery. It is, of course, relative to this

*This model curve is purely arbitrary, and does not purport to represent any particular type of observer. It is inserted merely to show how to make the graphic representation of the results. It shows an average of 4.4 for I, 1.8 for II, 3.8 for III, .8 for IV, etc.

particular set of questions; a different set of questions covering the same ground might change the curve. A set of questions is legitimate only in so far as it covers the principal types of imageable facts in a fair distribution of tests.

You are fully aware of the unreliability of the results. They are unreliable for at least two reasons. First, the power of imagery varies with numerous conditions and attitudes. The method of measuring, crude as it is, is fully fine enough to be commensurate with the constancy of the fact tested. Second, the results are unreliable because you were untrained. This sort of introspection is a severe test upon the power of discriminative attention and is made particularly difficult and uncertain for the beginner on account of the novelty and complexity of the undertaking. Faithful practice in the training of any particular type of imagery is usually rewarded with rapid improvement and increased confidence in judgments. The difficulties and uncertainties are greatest where there is poverty of imagery.

Such factors as vividness, stability, and integrity of the image do not necessarily vary together. An image may be very vivid but flitting; it may be complete but faint. For a full study of the capacity the above questions might be repeated and answered in turn with reference to each of the variables in the image. This same exercise might be used for the determination of such factors as the stability of the image, completeness of the image, effort in producing it, etc. In such cases, words representing stability, completeness, effort, etc.,

would be substituted for the word vivid in the scale; thus: No image, very fluctuating, fluctuating, fairly stable, stable, very stable, as stable as in perception.

It is customary to speak of organic sensations and organic images, but that is rather misleading; for we then refer to sensation-complexes or perceptions. Thus, the organic feeling of movement in pointing a finger may be reduced to sensations of pressure and strain in the joints, muscles, and tendons. Hunger may ordinarily be reduced to a complex of pressure, pain, strain, and temperature. It is of course as much easier, as it is more superficial, to say that one has an image of hunger than to trace the pressure-pain-strain-temperature elements in the composite image.

The sense of equilibrium is not included in the above list, for the reason that it, more than any other sense, acts automatically and therefore plays a very small rôle in consciousness.

Normally the image is in the same sense as the original experience; for instance, the memory of a color comes as a color image, the memory of pressure comes as a pressure image, the memory or imagination of taste comes as a taste image, and even when present, it is often overshadowed by the image in another sense. But this is not always so. One's memory of running blindfolded may be recalled entirely in visual terms; one's memory of the taste of coffee may come in no more significant imagery than sight.

Dream-life is almost purely a life of imagery; and dream images are for many persons as vivid as the perceptions of waking life. They even transcend them,

for we often dream of more brilliant colors, more beautiful harmonies, more graceful movements, than we ever perceive in waking life.

Hallucinations are common occurrences, although but few persons observe or report them. Who has not heard a sound where there was no sound, smelled something where there was nothing to smell, seen something where there was nothing visible? These hallucination images are often vivid; their very vividness makes them deceptive.

This test pertains merely to the capacity for imaging in terms of the respective senses and does not necessarily reveal the dominant type. Indeed, should the capacity be limited to but one or two senses, or should there be no capacity at all, the type would be determined, but such a condition is not a common occurrence. We not infrequently find a record for pain images as high as that for color images, but this does not signify that the world is equally one of pain and of color to the possessor of that curve; for pains do not occur so frequently as colors, and it is customary to translate all imagery into the terms of one sense whenever possible.

There are numerous methods in vogue for determining the type of imagery. One of these is to proceed as follows:

Write, in a column, a list of thirty words that give scope for imagery in the different senses about as in ordinary conversation; for example, dog, field, waves, beefsteak, sunset, war, springtime, accident, apple-blossoms, desert. Cover the list with a card and expose one word at a time. As soon as the word has been seen, look away and note the imagery which comes to represent the word and the object it denotes. Thus, the word dog may be

grasped in terms of visual, auditory, and motor images, and the dog may be imaged as a baying hound close on the scent of a fox, these aspects being experienced in terms of visual, auditory, motor, tactual, and pain images respectively. The record would then read:

<i>Word.</i>	<i>Word Image.</i>	<i>Object Image.</i>
Dog	Visual-auditory-motor	Visual-auditory-motor-tactual-pain.

If a list of such words is made fairly representative, the records will furnish a basis for an estimate of the relative frequency of the images of each sense, both in word memory and object memory. These records may be reduced to percentages.

To show the significance of the sense through which the word is first received, the series should be repeated, by having the words read aloud to the observer. For most persons this will cause a radical change in the imagery.

The type of imagery may also be determined roughly from answers to questions like these:

Into what sense do you normally translate your sensory experiences? In terms of what imagery do you normally remember a person? A place? A date? An abstract quality? Can you secure images in any other sense than sight without also having a visual image? (This question may be adapted to the other senses.) Do you visualize the situations as you read a story? Do you find geometry difficult? Do you recall music readily? Have you a good sense of rhythm? Are you moved by realistic descriptions? Do you dream much and vividly? Is there any sense in which you cannot recall having had a dream image? Is your word imagery conspicuous and helpful?

Among the curious idiosyncrasies which come out in a test like this is that of synæsthesia. Some persons invariably project numbers upon forms or skeletal

shapes which may be maintained constant throughout life. Others have colored hearing; when they hear or remember a tone, it seems to have color. There are numerous other forms of synæsthesia, and these differ very much in force and complexity. Some fairly well-marked form of it may be found in from 5 to 10 per cent of the people in a community. The explanation is to be found in the fact that we have a tendency to give fulness to perceptions and images. Synæsthesia is simply a specialized form of this tendency and should be regarded merely as a habit.*

Reverie also gives opportunity for the flow of realistic imagery. The procession of images moves on without effort as though it were controlled by some external machinery. Reverie and concentrated attention are the antipodal types of normal experience. Our ordinary life is a blending of the two, and even the most reflective student will find upon introspection that reverie plays by far the larger part. The reading of a passage, the solving of a problem, the examination of a situation, or any other such activity as requires concentration of attention is accompanied

* Answers to questions like the following reveal the presence or absence of the principal forms of synæsthesia: "Do you think of particular colors in connection with letters of the alphabet, or numerals, or proper names, or musical sounds, or any other unusual connection? Do you think of numerals or names of months, days, or years, or of any series of words as arranged in any particular shapes, like circles, squares, zigzags, or very long lines? Do single numerals, letters, musical notes, etc., make you think of different shapes? Do you especially like or dislike any numerals, letters, etc.? Do numerals, letters, etc., seem to you to be like people?" (Calkins, *American Journal of Psychology*, VII.)

by broad streams of reverie images. These irrelevant images constitute what we call distraction or mind-wandering; they are often more vivid and coercive than the images obtained from the object of attention.

CHAPTER X

ASSOCIATION

*For Two.**

THE problem is to determine certain characteristics of association; namely, rapidity, kind, reinforcement, error, and persistence.

1. **Rapidity.**—Call out a key-word, for example “star”, and give O exactly 8 seconds, counting from the moment of the giving of the key-word, in which to speak as many disconnected words as he possibly can. Let O write them down in a vertical column, beginning with the key-word, while they are fresh in his memory. Secure five records, using as many key-words. † Find the total number of words in each column excluding the key-word, and divide 8 by that number to get the average duration of each association.

This experiment might be called chain reaction in free association. It has three objects: first, to secure

* Provide coins or disks for Exp. 4, and a paper bag and weights for Exp. 5.

† Speed is the aim. O must not stop to consider the fitness, significance, kind of association, or anything else which may impede the rapidity of speaking. There is a great temptation to hesitate. No series should be considered successful unless O has spoken at least six words in the allotted time. The only limitation on words is that they shall be disconnected; that is, they cannot be a sentence, a familiar list of words, a prepared list, or any series of words which have a fixed connection or sequence.

lists of words under definite conditions for use in the following experiments; second, to measure the rapidity of association; and third, to give a glimpse of the existence and natural flow of associations.

The observer is convinced that the associations came much faster than he could express them. It is equally clear to him that he did not speak as fast as mere words could be uttered; there was a continual groping to extract one out of the many more or less remotely available words.

An average observer should secure a list of about ten words in 8 seconds; the average time for each word would then be .8 of a second.

Each word represents a complex process or act. The average time of such acts varies very much with different conditions and individuals. We speak of one as having a quick reaction-time, and another as having a slow reaction-time. One is mentally alert, another mentally sluggish, and still another is erratic. Such individual differences can be measured in great detail by reaction experiments in association.*

The more completely the observer followed the instructions and abandoned himself in the battle of imagery, the more surprising some of the words were to him. At first thought there may be neither sense nor order in them. Yet every word came according to law. These laws we shall now proceed to trace.

Associations are modes of connection between per-

* In the laboratory, chronoscopes are used which record the time in hundredths or thousandths of a second. One single act at a time is studied, and the conditions are so varied that this act may be separated into its component elements.

cepts, images, and ideas. There is difference of opinion in regard to the number and kinds of association, but this is largely a matter of how fine distinctions we wish to make. For the present purpose it is convenient to posit three kinds of association, namely, contiguity, similarity, and contrast, which include all possible kinds.* These three kinds of association are spoken of as laws. The law of contiguity asserts that things which have occurred together in time or space tend to recur together. The law of similarity asserts that things which are alike tend to recall one another. The similarity may be of any kind,—color, form, sound, odor, motion, use, etc. The law of contrast asserts that opposites tend to recall one another. There may be as many modes of contrast as there are of similarity. The use of this classification may be illustrated best by an actual case. The following record was made by the author when writing this section. The key-word was “fig.”

Fig	“Fig suggested apple (simil.). Tree struggled to appear as a separate word (contig.), but finally fused with apple and formed a compound word denoting three distinct images,—apple, tree, blossoms (contig.). The incongruity of apples and blossoms on the same tree was not noted. The images of flowers were soon accompanied by images of bees (contig.), but as the images came much faster than I could speak the words, the image of honey (contig.) was uppermost in consciousness before I could begin to speak the next word. The image of honey made me irresistibly conscious of the
Apple-tree	
Honey	

* This view is most serviceable for the elementary analysis of a concrete experience, regardless of what ultimate theory of association one may have. Thorndike’s discussion of association in his “Elements of Psychology” would supplement this exercise very well.

question why honey should have followed flower (contig.), and there came to me, as a reply, consciousness of the fact that honey is the juice of a flower (contig. and simil.). This bit of forbidden reasoning, very complex, reminded me that the characteristic quality of flower-juice is sweetness (simil.). (Our imagery is much richer than our vocabulary, and our associations are often couched in words coined at the moment to serve their purpose, for instance 'flower-juice', although they may be of doubtful value for currency in speech.) There followed a bombardment by a mob of images which struggled for recognition as representatives of sweet juices or extracts (simil.). The image of sugar was distinctly in the foreground (simil.), but before I could speak, I thought of malt as an extract which contains sugar (simil.). Then a whole flock of extract-bottles in varied colors and forms flew before my mental eye (simil.). They had so equal recognition of attention that, for the moment, I could not decide to discriminate in favor of one or another in the group by mentioning it, so I compromised by including them all and said extract (simil. by whole and part). But when I heard the word extract I thought 'I'll take vanilla' (simil.), and saw myself seated on a high chair consuming a soda in the front of a drug-store with a fountain to the left, fruit-dishes to the right, and in front of me a white-jacketed waiter (clerk), with a supercilious air and limited brain capacity. (This scene was all one composite image which was suggested by soda-water (contig.). The last-mentioned feature in this impression brought a feeling of compunction which took the form of the question, 'Am I a phrenologist (simil. and contr.), that I profess to judge a man's brain?' There followed a jumble of more or less fragmentary images of long hair, a phrenological chart, the word 'fake', etc., but these overran the time limit."

Juice

Sweetness

Malt

Extract

Vanilla

Clerk

Phrenologist

There are two particularly conspicuous tendencies in this introspection. The first is that, although the observer was free to use any part of speech, nouns were used exclusively. The reason for this lies in the fact that economy of speech has made the object-image the

most available antecedent to a speech-word. The objects, i.e., images of objects, seem to be the things in consciousness. The other peculiarity is that there was only one clear case of association by contrast. Contrast is a principle which should be used only for effect, and in the ordinary flow of images it is not frequent.

If one has a good grasp of images, they may be traced in much greater detail.

2. Kinds of Association: Primary Laws.—Let O trace the chain of associations in one of the lists he has and write out, on the plan of the above specimen, an introspection showing which of the three kinds of association operated in the transition from image to image.* Make the report even more detailed than the model, and point out as many links of association as possible among the images of which the words represent only a few.

An introspection of this kind reveals to the observer something of the richness and connectedness of such a simple and apparently incoherent mental act. There was no trouble in seeing why each word came; there was a reason for every word. The words do not express the full chain of the processes, not even all the clearly conspicuous images, but simply one here and there, for the flow of images is more rapid than thought and incomparably more rapid than speech. There were reasons for every image, though few can be traced. And, furthermore, the images did not stand out isolated and

* Some observers may prefer to make a new list in order to have the chain of associations fresh in the mind.

stripped, but were supported by a background and bridging material of more or less undifferentiated imagery and non-integrated mental activity. There was a reason for each element in this.

Two facts of most profound significance are therefore impressed upon the observer in this experiment: all images flow according to law; the number of primary laws is surprisingly small. Similarity and contrast are usually considered inseparable. Each of these also involves an element of contiguity. This has led some to say that there is only one law of association. But these three phases vary so much in relative prominence that it is helpful to trace the dominating aspect, as in this experiment.

But the question arises, what determined which particular image should come forth by the law of contiguity when there was a vast number of possibilities of the same kind? Why does apple and not a score of equally similar things follow fig? Or, in similarity, why does sweetness suggest sugar and not one of the many other sweet things? Why does darkness suggest black horse and not some of the many other dark things? The answers to these questions are to be found in the secondary laws which are laws of neural action or habit. Four of these are: primacy, frequency, intensity, and recency.* Other things being equal, the first or primary association will dominate; other things being equal, the most frequently repeated association will dominate; other things being equal, the most impressive

* Calkins, "Association", Monograph Supplement to the Psychological Review, No. 2, 1896.

or intense association will dominate; other things being equal, the most recent association will dominate.

These four secondary laws may operate within any of the three primary; that is, contiguity, similarity, and contrast. There is thus established a complex mechanism of forces which coöperate or counteract in various ways and to various degrees.

We may think of the primary laws as kinds of ties or bonds for the image, and the secondary laws as power applied to each tie. Each image ordinarily has a large number of ties. Usually all three kinds are represented, and each is supplied with more or less power. The image brought up by the key-word above had a rich supply of these ties. The next image which came to the front came because it was, as it were, most effectively tied up with the other. This is illustrated in the following introspection which is supplementary to the one quoted above:

"Fig suggested apple because apple is the most common (freq.) specimen of the kind of thing a fig is, a fruit. Apple suggested tree because they have been experienced together frequently (freq.). Tree suggested blossoms because I had been looking for blossoms on the cherry trees this morning (rec.). Blossoms suggested bee because bees are frequently seen with blossoms and their presence has an exciting interest (freq. and int.). Bee suggested honey because bee and honey are thought of as cause and effect (freq.). Honey suggested juice of a flower because the image of honey had followed the image of flowers (rec.). Flower-juice suggested sweetness because sweetness is the principal characteristic of flower-juice or honey (inten. and freq.). Sweetness suggested the mass of images of sweet things because there is a tendency for the mind to think the abstract in terms of the concrete (freq.). Sugar came to the front from these because it is the commonest of sweet things (freq.). Sugar suggested malt because sugar was thought of as an extract and malt is a common form of extract which contains sugar (freq.). Extract was present in the image of malt (rec. and freq.). Vanilla came to the front because it is one of the most familiar extracts

(freq.). Vanilla suggested ice-cream soda on account of my frequent choice of that flavor in soda (freq.). Soda-water suggested myself and the whole setting in the drugstore (prim. and freq.). Clerk was named from the many objects in the setting because the image represented something living and active in relation to myself (inten. and freq.). Phrenologist was drawn out from the situation of my judging brain capacity on account of the strangeness and incongruity of the idea (inten.). The images came very much faster than words could be spoken, and there was a distinct tendency to fit the word to the image which was just coming into consciousness at the moment that I could begin to articulate the next word. For this reason many very strongly associated images were deprived of opportunity for expression."

3. Reinforcement; Secondary Laws.—Let O retrace the chain of associations in the same list as in Exp. 2, and write out an introspection showing, as in the above specimen, where and how the four secondary laws, primacy, frequency, intensity, and recency, operated,—not only for these words, but for all the recognized images which the words represent only in part.

The primary laws are qualitative; they denote kinds of association. The secondary laws are quantitative; they denote force or magnitude of a quality. The two invariably operate together. Had it not been for the sake of clearness, the introspections of Exps. 2 and 3 should have been written out together, stating, for example, that in a given instance the law of contiguity operated in several directions, but a certain one of these became dominant by the law of frequency.

The associations in the list quoted above were in a light, agreeable vein. The observer accounts for this on the ground of "emotional congruity." Emotional congruity is one of a number of so-called laws of association which are neither primary nor secondary. They might properly be described as unanalyzed com-

plexes of association. Thus, according to this law, one thinks of good and pleasant things when one is well and happy, and this in turn makes one better and happier; when one is blue, the disagreeable things come to mind. Now, a state of happiness or a state of misery, if reduced to the constituent elements in so far as they are cognitive, would probably resolve itself into a very intricate complex of the above primary and secondary laws, or laws of a similarly elementary order.

One of the easiest ways of getting material for the study of images and their modes of connection is simply to sit down and relax one's self and allow a passive flow of imagery, as in reverie, for a few seconds, and then go over it and retrace the connections. Another good way is to analyze a specific act of remembering or thinking; for instance, let the observer recall his last boat-ride, or answer the question "What is courage?" Each of these instances can be reduced to a definite network of the operations of these primary and secondary laws of association.*

4. Errors of Association.—Take a dollar, two half-dollars, two quarter-dollars, two nickels, and two dimes † and arrange them edge to edge in a row, with the dollar in the middle and the other coins ranging in opposite directions away from the dollar in the order of diminishing size. Let O take such a position that his eyes are directly over the dollar, the row pointing toward

* Work out these two examples if time permits.

† Circles cut any size but varying in about the same proportion as the coins may be used in place of the coins.

him, and, *without sighting or measuring*, straighten the row of coins so that one side tangent to all the coins will seem to be a straight line. When he is satisfied that the line is as straight as he can make it, without sighting or measuring, lay a straight-edge alongside and measure in millimeters the amount of misplacement of each coin.

The normal observer will arrange the coins so that what seems to be a straight line is really a gracefully curved line. The straight-edge touches only the dollar, and the other coins retreat from it by distances inversely proportional to their size. This is true only for the normal and careful observer; an unfaithful observer may read this paragraph before he performs the experiment and try to correct for the error.

The explanation for this normal error lies in the fact that when we make one judgment we are invariably beset by a number of other, often irrelevant, judgments. In this case the observer was asked to make one side straight; but he could not do that without having more or less dimly in the background of consciousness a line through the center of the coins and a line on the other side of the coins. The presence of these associations influenced his judgment on the straightness of the one line in question.

Fig. 16 illustrates the same principle. The middle sections of the five bars are parallel; they do not look parallel because we cannot entirely dissociate direction of the end lines from the direction of the middle sections.

Normal life, in all its phases and all the degrees of its

complexity, is full of errors; the greatest number of these are errors of association. The association need not be a conscious one; it may have been reduced to the simplest law of neural habit.

Popularly we say "I had something else on my mind." Thus, in reading we read largely by the context; and for this reason there are very few good proof-readers. A good author may read a proof-sheet a half-dozen times without noticing that a senseless word, not to speak of an error in spelling, is flagrantly evident. The good

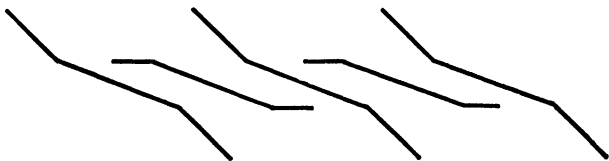

FIG. 16.

proof-reader has mastered, to a considerable extent, the power of suppressing meaning-associations.*

5. Irrepressibility of Association.—Inflate a large paper bag and tie it up. Place this bag on one hand of the observer and put coins, nails, or any other heavy material into the other hand until O judges that the weights in the two hands are equal. Let him change hands and verify his judgments until he is satisfied. Then weigh the bag and the coins separately and record the results.

There is a general tendency toward harmony of

* In reading this last word in the copy, the author read it "meaningless associations."

properties in nature. In the long run, large objects are heavier than small objects. This observed fact has crystallized under the principle of frequency into a neural habit which acts without our attending to it. This association is a very economic principle, for it helps us to adjust our efforts to our tasks. Without thinking of it, we make the proper differences in adjustment of muscles for the lifting of a peck of apples and a bushel of apples. Now, when a large object like the bag is extraordinarily light, the association causes us to put forth too great effort in lifting it and this maladjustment leads to underestimation of the weight of the bag. Similarly, coins are small for their weight, and the same association probably leads us to make too delicate an adjustment for the lifting of these; this maladjustment leads to an overestimation of the weight of small objects. If we now compare the actual weight of the bag with that of the coins, we find that the normal observer has selected coins which weigh only from a half to a tenth as much as the bag. Here is the real answer to the old quibble: which is heavier, a pound of lead or a pound of feathers? That this illusion persists after training and accurate knowledge of the actual weights is an illustration of the fact that habits of association continue irrepressibly in the face of sense and reason.

We have, in this and foregoing chapters, marshalled before our mind's eyes the material in the structure of our knowing processes. The materials are the perceptions, images, and ideas;* the structure is their modes

* All mental life is activity; perceptions, images, and ideas are always *processes*.

of connection—the associations. But just as in a building the material is all there is, so here the perceptions, images, and ideas constitute the mental states, the cognitive life. Association merely denotes the ways in which the materials are joined together in the mental framework.

Education consists in the development of associations. To the uneducated, the grain of sand does not suggest the great number of geological forces that brought it together; it may not even suggest the economical uses to which it might be put.

CHAPTER XI

MEMORY

For Two.

THE problem is to determine certain factors in the capacity for memorizing geometrical figures. Two

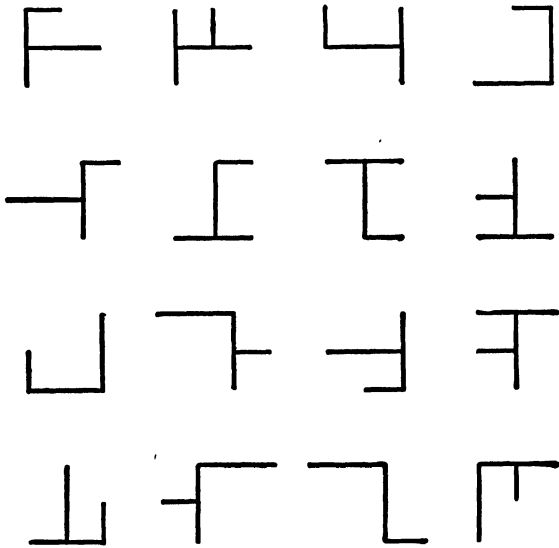

FIG. 17.

styles of figures will be used. One the style shown in Fig. 17, and the other the style shown in Fig. 18. Let

the first experimenter use the former style, and the second the latter. As the illustrations in the book contain the material which is to be memorized, each person must refrain rigorously from examination of the

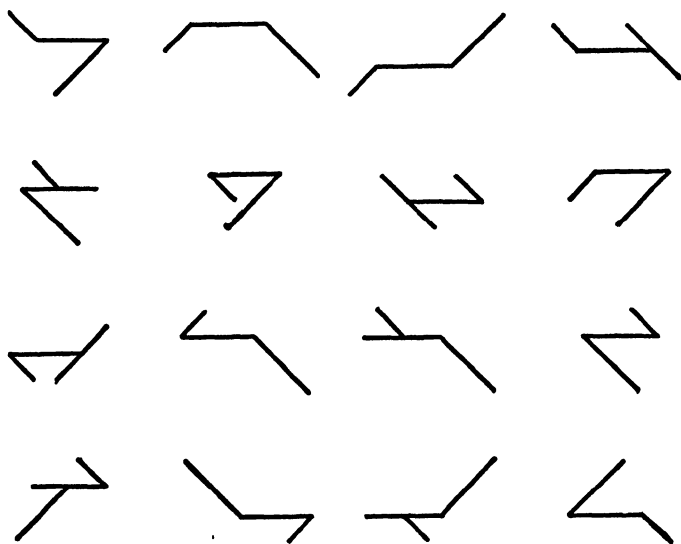

FIG. 18.

material assigned to the other. This is imperative. Both may proceed independently to prepare materials for the experiment, as follows:

Set A: Select nine of the figures of your style and draw them neatly by freehand in a single vertical column in your note-book.

Set B: Arrange the same nine figures, on another page, into a regular parallelogram with three figures in each row horizontally and vertically.

Set C: Rearrange the same nine figures, on another page, into the same kind of a parallelogram but in a radically different order; leave no figures in the same position as in B.

All the figures have certain features in common: * each figure is composed of three lines; the lines are all straight; two lines are equally long, and the third is half as long as these; the two long lines always adjoin each other; the lines join either at the end or in the middle; no line is crossed; no two figures are alike. The angles in one style are right angles, and in the other angles of 45° or the supplement of 45° .

1. **Memorizing the Form of Figures.**—Allow O to see the figures in Set A exactly ten seconds, in a uniform and favorable position, and then let him reproduce as many of these as he can, regardless of the order in the column. Examine the reproduction to see if there is any error or omission † and then cover it with some opaque object. Show him the set again for ten seconds and let him reproduce as before. Repeat this procedure until O has reproduced the form of all the figures correctly, regardless of the order or position in the column.

Check those that are right in each reproduction, and

* In verifying this refer only to the sets of figures you have selected and constructed.

† After examining a reproduction, E can say only "Right" or "Wrong". If any figures are wrong in form, O must discover it for himself.

‡ In case of excessive difficulty the experiment may be left incomplete, say at twelve trials.

write in tabular form the number of correct figures for each trial. Plot a curve of the results, as in Fig. 19, where the numbers at the bottom denote the successive trials, and the numbers at the side denote the number of figures that remain unlearned.

Let O record observations as to method of learning the figures, groupings, disturbing factors, peculiar aids

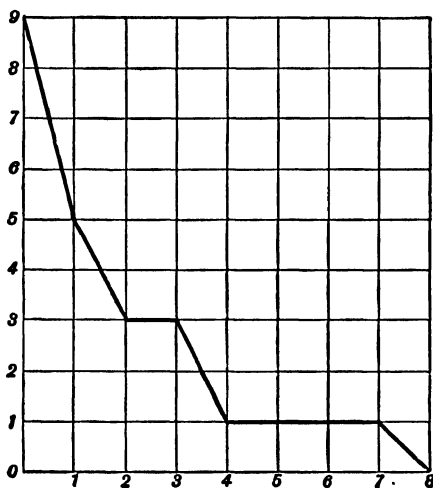

FIG. 19.

such as the use of imagery schemes, etc.—in short, anything which may aid in the interpretation of the curve.

One of the fundamental requirements for an experiment, as we have seen, is that the problem shall be reduced to its elements; only one element at a time may be varied, and all other elements and conditions must

be kept constant. This is an ideal which is never fully attained, yet the value of an experiment may often be measured or tested by this criterion.

This experiment is an illustration of a fair control of conditions in a memory test. The observer started with a full and adequate knowledge of certain specifications as to the number, the length, the straightness, and non-crossing of the lines, the adjacency of the lines, the place of joining, the magnitude of the angle, the number of figures, and the absence of repetition. These are all features in the memorizing of the form of the figures. They could be learned by accurate discrimination in repeated observation, but to have left them unmentioned in the present experiment would have complicated it and made it practically worthless. The experiment begins with the supposition that these are known; hence they are eliminated from the memory task which is before the observer.*

With all these factors under control, the problem was reduced to the specific task of learning the *form* of the figures. Other desirable features, such as the order of the figures, were excluded.

Then followed the control of conditions for learning and recording. The exposure of the figures was made definite,—ten seconds at a time. The time of retention was made definite; the observer reproduced immediately. The means of verifying were limited; the ob-

* Suppose the observer had been required to learn by observation that every figure has three lines, and that no two figures are alike, and to learn by very close discrimination that the lines do not vary in length by small steps, that the angles are uniform, that the place of the joint is limited, etc. He would then have faced a very different problem from the present one.

server had no access to the records of his foregoing trials. The experimenter's approval or disapproval was uniform; the experimenter gave no clue as to which or how many were wrong. The records were all preserved, making it possible to trace certain peculiarities in the learning process objectively.

Yet the introspective notes show that several conditions which might have been controlled were not controlled. For example, the observer might have been instructed as to how to proceed most effectively in mode of impression, grouping, classification, associating, using concrete imagery, etc. He might have been warned of certain avoidable difficulties. In technical experiments such factors must also be isolated and controlled. There are two reasons for not attempting it here: in the natural development of a problem these factors come out in introspection first and are then taken into consideration, one after another, as they are revealed; they are too intricate to control in the time allotted for an elementary experiment. The careful observer has seen the force of many of them and has mentioned them in his introspections.

Closely related to these are many individual and temporary conditions which never can be controlled entirely. Among such are the fluctuations of attention, peculiar associations, temperamental disqualification for the task, imagery types, habits of memorizing, etc.

Thus we see in a general way how far we have succeeded in complying with the requirements for analysis of the problem and control of its elements. The recognition of difficulties is the first step toward progress.

This experiment should serve two purposes: it should give a glimpse of the complexity of the conditions that enter into a memory test, and it should leave the impression that with patience and skill the complex situation may be reduced to more elementary ones which can be isolated and controlled.

2. Memorizing the Position of the Figures.—Allow O to see the figures in Set B in ten-second exposures and proceed as in Exp. 1, except that the task here is to memorize the positions, the forms being known from Exp. 1.

Check, tabulate, plot curve, and write introspections as in Exp. 1.

This experiment builds upon the foregoing. The observer acquired a definite degree of certainty in the memory of the form of the figures in Exp. 1; he was just barely able to reproduce all the forms from memory. These figures, whose form was known, were redistributed and the task was to memorize their present positions.

This task was made difficult by the similarity of the figures and their relative lack of immediate associations or names. The figures were "stripped" in this way to secure relatively simple and homogeneous material which should enable the observer to follow the development of his method and to record his introspections.

Probably the most striking fact the observer learned was that he could not "handle" the figures without enriching them with associations in concrete imagery.

He faced the same kind of difficulty as he would face in trying to remember individually a dozen hailstones, all perceptibly different in shape.

The observers may be divided, on the basis of these two experiments, into two types: those who go about it by some sort of rote method, and those who develop imagery which gives them something tangible. Both of these types have various subtypes, as may be seen in the introspections. In general we may say that those of the first type found the first experiment very difficult and the second even worse; while those of the second type soon mastered the first experiment and profited very much by it in the second. An important exception may be noted later.

It is a well-known fact that memorizing is facilitated by giving meaning to the new material. This is illustrated in the remembering of poetry, a landscape, a face, an invention, a work of art, etc. Such objects are exceedingly rich in meaning; we cannot think of them at all except in terms of certain meanings. Such material is not suitable for experimental study because it is too complex; there are too many possibilities and uncertainties.

Nonsense syllables, as buk, miv, pok, dal, etc., have been used extensively on account of their supposed lack of meaning. But work with such syllables soon reveals the fact that one cannot memorize ten of them without reading into them curious, varied, and efficient associations or meanings. The present figures are undoubtedly much freer from natural associations, yet one cannot regard them without "feeling into them" (German,

hineinfühlen) motor, visual, tactual, or other forms of imagery and perceiving analogies of various sorts.

Let us notice some of the means at the command of the observer of the second, the ingenious, type. He may prepare for the test by fixating clearly an image of the plot of positions and then number these mentally. He may make one of the specifications the basis for a starting-point in the grasping of a figure. Thus, knowing that there is only one short line in each figure, he may classify the figures with reference to the position of the short line, or with reference to the type of figure formed by the other two lines. He may fix in each trial a group of similar figures, the easiest figures, the most difficult figures, the figures in one line, etc., and then proceed systematically by concentrating on as many as he can master in one exposure. He may, if he has a fertile imagination, give fantastic descriptive names to the figures, or make the situation dramatic.* He may classify the figures into the T and F types and then remember them as the one or the other upturned, leaning to the right, leaning forward, top and middle lines interchanged, etc. He will fix the group grasped deliberately in the reproduction so that there shall be no danger of losing any part of it when he gets other groups in mind. He will adhere vigorously to the principle adopted, and not mix methods.

The curve of learning is probably of the same general shape here as in Exp. 1.

*Thus, in the first line of forms in Fig. 18 he may see this episode: The folding chair gives away (1), the man makes a dive (2), he puts the chair into a position for comfort (3), but soon finds it on the floor (4).

3. Memorizing the Position of the Figures after Redistribution.—Allow O to see the figures in Set C in ten-second exposures and proceed as in Exp. 2.

Check, tabulate, plot curve, and write introspections as in Exp. 2.

The object of this experiment is to determine to what extent and in what respect the observer has profited by the foregoing training. The extent of improvement is shown by a comparison of the curves. The character of the cause of improvement is shown in the introspections.

Observers of the first type find this experiment, like the two foregoing ones, difficult, and show but little if any progress; while observers of the second type make improvement and feel the task growing easier.

Those who made improvement have probably recorded that they acquired some power or insight as to means of grasping the figures in the first two experiments. They also probably acknowledge having benefited by one or more of the suggestions in the discussion of Exp. 2. But the greatest gain undoubtedly depends upon the fact that the observer could here place the figures in terms of their position in Set B, which he remembers. Thus, he may have observed at once that the first is now the seventh, the seventh is now the fourth, the second is now the fifth, etc.

In any or all of the experiments a person with natural ability may fail to make good progress for several reasons. He may have undertaken to use some means which are not suited to him. He may change methods and thus lose both by the discarding and by the resulting

confusion. These and many like causes may account for the levels and even rises in the curve at any stage. They are, of course, stated in the introspections, and the idiosyncrasies of the curve are to be explained principally by them.

In foregoing chapters we have learned something about the significance of individual differences in sensibility, discrimination, imagery, and association. There are even greater differences in memory types. One person has good memory for names, another for faces, another for poetry, another for geometrical figures, etc. Here we have tested one narrow type of memory. The observer's other memories may or may not be like it.

This experiment suggests that improvement in memory consists largely in learning how to observe. This fact has great pedagogical and psychological significance. It makes psychological analysis relatively simple, and gives promise that a pedagogy of memory may be based upon a psychology of improvement in memory.

There are three general types of methods employed in experiments on memory: the method of reproduction, the method of identification, and the method of introspection of the memory image. The above experiments have illustrated the first. The second might be illustrated by experiments on the memory for the size of circles. A standard circle is shown; after a given time-interval a compared circle which is either equal to the standard or slightly different in diameter is presented, and the observer is required to say whether it is equal, larger, or smaller. By varying the diameter of the com-

pared circles in small steps and making a large number of trials it is possible to get a measure of the observer's space-memory in terms of the error made. The third method is really not a method of measurement, but a method of controlling introspection. The observer sets himself constant conditions for observation and then observes in repeated trials the character of the imagery and other factors, much in the same way as in the above introspections.*

Memory is not a suitable title for an experimental problem because the term is too comprehensive. It is customary to speak of four elements in memory: impression, retention, recollection, and recognition. These are in turn very broad terms. Thus, we may have impressions through the different senses, imagination, reasoning, and feeling, and all sorts of combinations of these. Within one sense, the impression may have reference to different attributes; namely, quality, intensity, duration, and extensity or space.

The experiment must be limited to one factor at a time, as we have seen. It may be a study, e.g., of the

* Kuhlmann, *American Journal of Psychology*, October, 1907, suggests problems from this third point of view, as follows: "This general aim is threefold. First, the analysis of the memory consciousness into its elements. What different kinds of mental imagery, what organic sensations and affective states occur in the mind from the beginning to the end of the process of the recall of a given thing? Secondly, the determination of the function in the memory consciousness of each of these elements. What is the order in which they appear, of what use is each in attaining the end that is desired, to wit, the reinstatement of the imagery that is wanted and the recognition of this imagery as correct or not? Thirdly, since the end product of a recall process is often a memory illusion, a prominent question in memory analysis is that of the nature and causes of these memory illusions."

materials of impression such as tones, spoken numbers, noises, colors, distances, etc. ; it may be a study of the modes of impression, such as rote, logical analysis, forced association, etc. ; or it may be a study of the effect of repetition, length of retention, mental occupation, etc. The pursuit of any of these problems will do much to enrich one's conception of the orderliness, the beauty, and the worth of the life of re-presentation.

CHAPTER XII

APPERCEPTION

For Two.

APPERCEPTION is the meaning-aspect of experience. It is the grasping of a new experience in terms of previous experience in such a way as to give it meaning and clearness and to make it serviceable. Some authors reduce it to "clearest perception," others identify it with "attention activity," and still others look upon it as a classifying or "pigeonholing" process. It is well to keep these theories in mind. But apperception is not a process in itself, such as perception, memory, or feeling; it rather designates the fusion of the presentative with the representative and the relating processes and all their affective and conative tendencies, in the moment of a new experience.*

1. The Meaning-tendency.—Place a drop of ink on a clean sheet in the note-book, place a sheet of paper over it and press gently so that the ink forms an irregular blot. Make three such blots in each note-book. Let

* Presentation includes sensation and perception; representation includes memory and imagination; and elaboration or the relating processes include conception, judgment, and reasoning. Affection has reference to feeling, and conation to will and action.

each student write for each of these six * "gobolinks" a secret list (not in the note-book) of three different things it might represent, giving them in the order in which they are thought of, but counting only such as are apt.†

When these lists have been completed, without cooperation or consultation, write the two sets of answers from the lists under the respective dots and observe (1) that the objects suggested may be very radically different, (2) that the meaning given is related to the observer's interests, recent experience, habits, etc., and (3) that the actual physical blot seems to change with the change in meaning.

The objects suggested may be widely different; but when one observer sees the other's list he is ordinarily able to see the same interpretations although he had not seen the slightest hint of them before.

If we had hundreds of records of this kind, it would be interesting to compare them and observe how they reflect the observer's interests, recent experiences, habits, temperament, mental capacity, knowledge, etc. It is most significant that the actual physical blot seems to change radically as we pass from one interpretation to another.

The object in using the ink-blots is, of course, clear; there is no intentional design in them and they are free from fixed associations. They should not represent anything, yet they do suggest things in terms of past experience to every alert mind. The person who ap-

* Three in each note-book.

† Do not stare at the figures or search for details.

plies himself to the study of these supposedly meaningless objects in a free and artistic mood gets a glimpse of that tendency in human nature which justifies the poet in saying

“ . . . not the slightest leaf but trembling teems
With golden visions and romantic dreams.”

The analogy between the human eye and the photographic camera is instructive. There is the dark chamber, the sensitive film, the lens with mechanism which adjusts for clearness, distance, and size, the iris diaphragm, and the cap. The camera-maker simply imitates nature. But if this analogy suggests to us that the human eye is nothing but a living camera, it is very misleading. The camera copies the object; the human eye, “the mind’s eye,” interprets the object.

All perception is inceptive interpretation. Among different persons viewing the same point in a landscape under exactly similar outward conditions, the botanist sees the cause for the shape of the overhanging tree, the artist sees effective shadows for the setting of a sketch, the carpenter sees a good location for a cottage, the farmer sees the rich clover going to waste, and the summer girl sees the location for a romance.*

“We see things not as they are but as we are.” (Patrik.)

And let a man recall what he has seen in a familiar landscape as a child, as a ball-player, as a lover, as a

* Speaking of a certain ink-blot, one writer says: “To the hunter it is a beaver or a woodchuck; to the naturalist, a hedgehog or a flounder, according as his mind has been most directed to land animals or fish; to the mason, a trowel; to the keeper of pets, an Angora cat.” (Colgrove.)

real-estate investor, as a naturalist—in happy moods or in gray moods, in company or alone. No matter how constant the outward features, he has always seen in the landscape just what it meant to him in the light of his knowledge, needs, and tendencies of the moment.

All interpretation is partial. It is confined to the limits of the sense-organs, the time, opportunity, and inclination for detailed scrutiny, habits of inference, the purpose in mind, the store of knowledge about it, etc. These facts are so universal that we scarcely take cognizance of them. Before the psychologist was interested in the doctrine of apperception, schoolboys delighted in reciting the happy story of the six blind men of Indostan who went to see the elephant. The essential lines suffice for quotation :

First blind man, falling against the elephant's side:

“God bless me! but this elephant
Is very like a wall.”

Second blind man, feeling the tusk:

“This wonder of an elephant
Is very like a spear.”

Third blind man, grasping the squirming trunk:

“I see”, quoth he, “the elephant
Is very like a snake.”

The fourth blind man, clasping the knee:

“’Tis clear enough, the elephant
Is very like a tree.”

The fifth blind man, catching the ear:

“This marvel of an elephant
Is very like a fan.”

The sixth, seizing the swinging tail:

“I see”, quoth he, “the elephant
Is very like a rope.”

“And so these men of Indostan
Disputed loud and long,
Each in his own opinion
Exceeding stiff and strong,
Though each was partly in the right,
And all were in the wrong.”

The interpretation is personal; it is an act for itself. We can never fully perceive anything without falling into a cluster of associations which are peculiar to ourselves. How does the salad taste? That depends upon the season, how much one has eaten, one's preference for certain dressing, the stage of dyspepsia, and the attitude toward the hostess and the cook. What do you see in this picture? The reflection of something in yourself. It is a happy freak of nature that so many men sincerely marry the “best woman on earth,” and that their children are the most wonderful children in the community.

Our normal interpretation is always purposive. As a rule, we attend to sense impressions only in such a manner as to get the needed meaning out of them. We instinctively do this in the most economic way. As we grow in experience we can get along with less and less of the outward impression, the sensory cue. A good reader will easily see only the significant words on a page; prepositions, articles, and adverbs are often supplied from the context. When we discover that it is John Smith who is approaching, we have attained to certain marks of identification which suffice to give us the desired information. It may be that we have seen

his beard, his profile, the swagger of his walk, his sombrero hat, or merely a vague something in the place which we knew Mr. Smith to be; we may have heard his greeting, or only the sound of his footsteps. When we see a horse we do not ordinarily examine if it has four legs. Many intelligent persons do not know how many legs a fly has, although they have observed flies with decided interest, from the point of view of comfort, a thousand times.

Perception is of "definite and probable things." The sound of the approaching footsteps comes out from the chaos of noises around and becomes something definite.

Furthermore, pictorial representations to the eye are "mere suggestions." An artist can draw a human face, full of expression, with half a dozen lines. The speedy crayon artist can delight his audience with character sketches that remind one of moving pictures. The depth, the distance, the relief, the solidity, and the size in a drawing have hardly any correspondence to real life. Drawing is an exceedingly abbreviated code of signals to the eye. Hence we have formed a habit of approaching all graphic representations with a generous constructive imagination.

2. **Bias.**—Record what Fig. 20 represents to you, and observe the operation of the principles mentioned in Exp. 1.

Which of the two possible views shall present itself first depends largely upon which side of the figure one attempts to read meaning into. The face is of greater significance than the back of the head. One person

sees a rabbit, another sees a duck. Fortunately in this case one can accept the view of the other when it is pointed out.

The thing to be emphasized is that when the object is a rabbit it is a rabbit, and when it is a duck it is a duck. Yet here the object consists in a rigid and clear figure on the paper. Now, when the objective marks are not so rigid, as in vague sensations, indistinct images, partial generalization; and when the interpretation is an expression of feeling or the realization of a longing, what an enormous range in the possibilities of interpretation

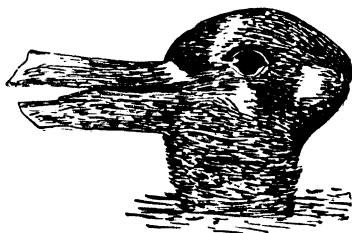

FIG. 20. (After Jastrow.)

is opened! There is abundant opportunity for bias, prejudice, and old-fogyism.

Regarding the kaleidoscopic appearances under the microscope when new features are under discussion, one says rabbit and another says duck. In giving testimony on the incidents of a wreck, one witness maintains rabbit and another maintains duck. Is the world going to the dogs? One says rabbit, another says duck. Considering the beauty of a painting, one says rabbit, another says duck. Considering the future life, one says rabbit, another says duck.

Like the blind men of Indostan, each can remain

sincere, honest, and unshaken in his convictions because he is satisfied with the view he has obtained and does not give the other side an opportunity to develop. One approaches his object with the expectation of rabbit, another with the expectation of duck. This expectation can in turn be traced to environment, temperament, training, desire, etc. Bias is the satisfaction with a partial view. Our experiment contains a simple and rigid illustration. The more complex the situation is, the more danger there is of warp, twist, prepossession,

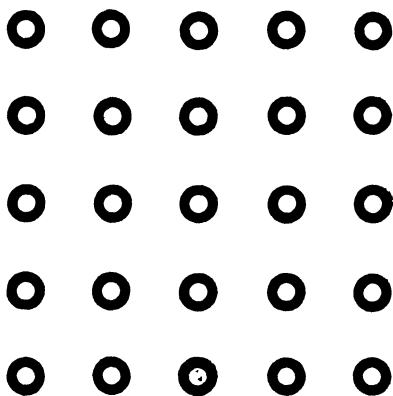

FIG. 21.

bigotry, quirk, crotchet, whim, and other forms of obliquity which may result from falling into a rut.

To become educated is to acquire the ability to put oneself into the place of another.

3. **Subjective Grouping.**—The circles in Fig. 21 are all alike and they are grouped symmetrically. Group them subjectively by voluntary attention in turn as fol-

lows: (1) five horizontal lines, (2) five vertical lines, (3) two diagonal lines, and (4) an outside large square with an inside small square and a circle in the center. Record how these subjective groupings affect the apparent size, clearness, and spacing of the circles.

This experiment further emphasizes the fact that the actual physical object seems to change as we ascribe different meanings to it. This figure in its plainness and rigidity puts the principle to a most critical test. The subjective grouping unquestionably changes the apparent spacing, clearness, and size of the circles.

The same principle is illustrated in Fig. 22. Now it is a star; now it is a polygon with accessory points; now

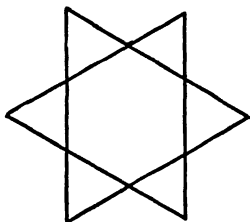

FIG. 22.

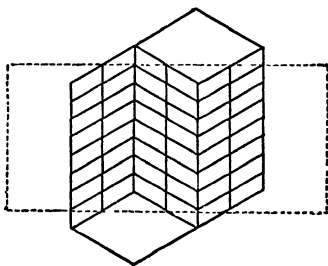

FIG. 23.

it is a figure with two sides parallel and ends feathered. In each case the lines on the page look different.

. 4. **Reversible Perspective.** *a. The Reversal.*—Look for a few moments at Figs. 23, 24, and 25 in turn and observe that these figures are unstable; they are seen clearly and satisfactorily in a given aspect at one moment, but all at once they suddenly lop over and

present a radically different relief.* Record the number of blocks in Fig. 24.

This experiment is introduced in order to illustrate how it is possible to take a given case of apperception and trace it to underlying fundamental motives. There is a reason for every actual apperception of an object or event, no matter how bizarre it may be. It is the

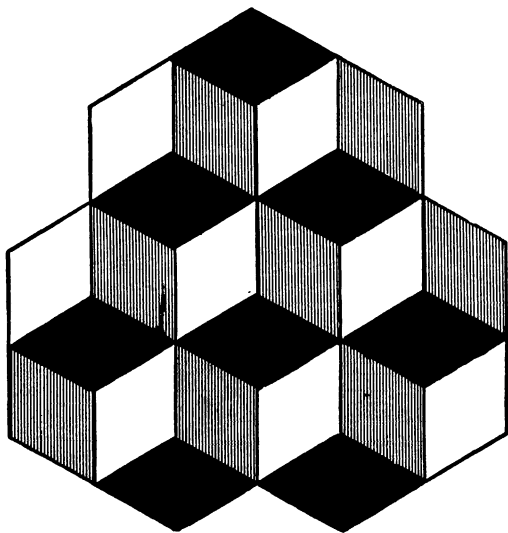

FIG. 24.

business of psychology to trace such motives in order to explain mental life.

These figures are not drawn in true relief; they are made ambiguous so that either of two radically different views may appear. Why should they not be

* Looking at figures with one eye favors the reversal; so does also holding the figure at a distance.

seen as they really are—plane figures on the surface of the page? The answer is to be found in a tendency whose history can be traced. Nearly all objects in which we are interested have volume and relief; relief can be only suggested in a drawing; hence we have formed deep-rooted habits of interpreting objects as having relief, no matter how imperfect the device for representing it in the drawing.

Here again it is significant that when one particular view is obtained it is entirely adequate; there is no

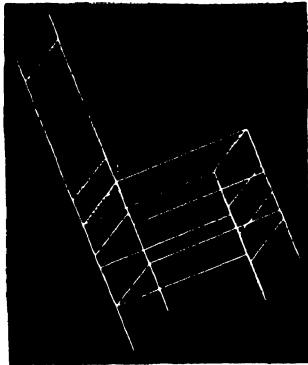

FIG. 25. (After Wallin.)

ambiguity in the experience. Indeed, some observers find difficulty in obtaining any reversal. Yet, presto! there is an instantaneous and complete reorganization of the figure right under the eye, as if by some magic wand. As soon as the reversal has once taken place, the figure continues to oscillate irresistibly. The reason it may not have reversed soon after the first trial is that the observer did not know what to expect to see. Now

that the two views have been seen and are equally clear and convincing, expectant attention favors the change.

b. The Normal Rate of Fluctuation.—Call the first relief that appears “One” and the second “Two.” Let O look continuously at Fig. 23 and call out “One” or “Two” as the respective changes take place. Start when the second-hand of your watch is at 60 and record the position of the hand at each signal for two minutes. Record the approximate duration of each relief in the successive appearances.* Observe Figs. 24 and 25 in the same manner.

The observer has now completely overcome his bias. He has been liberated from the attitude in which he asserted that there were only six blocks and now takes a more generous and enlightened view of the situation. He now realizes that there are greater resources in the figures than he had first credited them with, and perhaps draws a sweeping moral as to the operation of the same principles in his ordinary interpretation of people, events, theories, ideals, etc. After one has once grasped the truth, it will not down, but lights the way for further penetration.

c. The Fastest Rate of Fluctuation.—Proceed with Fig. 23 as in Exp. 4 *b*, but let O force the rate of change as much as possible. Record the number of changes and O’s introspection of the effort to force the rate.

d. The Slowest Rate of Fluctuation.—Proceed as in Exp. 4 *c*, but let O struggle to maintain the figure in a stable view.

* If no reversal takes place in the two minutes, it is because O did not get sufficiently familiar with the two views in Exp. 4 *a*.

The results differ with ingenuity and chance clues of the observer. For some the effect of the effort is to increase the rate of the fluctuation in both experiments; for others there may be some appreciable success both in the increase and the decrease of the rate; still others may discover the secret of the reversal and be able to hold or reverse at pleasure. What this secret is we shall discover in the next experiment.

e. Control of the Reversal.—Observe that Fig. 26 may appear to represent a glass jar one moment as seen

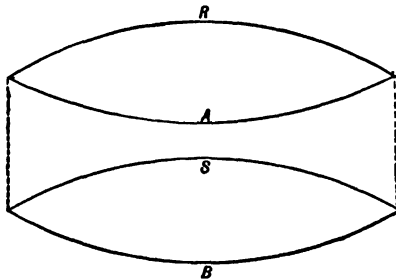

FIG. 26.

from above, and another as seen from below. Fixate the eyes in successive trials, upon the points in the edges marked *A*, *B*, *R*, and *S* respectively, and observe that the figure remains stable so long as you retain a steady fixation of one of these points, and that the relief is always the same for a given point. Record for each point whether the top or the bottom view prevails.

The secret then lies in allowing a certain point in the figure to catch and hold the eye. Fig. 26 is favorable for the demonstration of this because it is large

and simple enough to enable one to control the regard. It is difficult to verify this principle on the smaller figures which have finer patterns over which the eye involuntarily wanders from one point of regard to another.

The general law observed is that the point which first catches the eye or tends to hold its regard is perceived as a near part of the object. This fixes the view.

Why should the part which first catches the eye be judged near? It is a habit. Whenever we look at objects, economy bids us look first at the near side, other things being equal; this has resulted in the tendency of assuming that the first part seen is the near part of the object.

Why should the point upon which we maintain regard be judged near? It is a habit. Whenever we try to see a whole complex object there is a tendency to accommodate for a point near the center of the surface, and this is, as a rule, near us; the uniformity of this experience has resulted in the tendency of assuming that when we regard a fairly central point in a complex figure, this point is a near part of the object.

CHAPTER XIII

ATTENTION

*For Two.**

IN reading this paragraph your attention moves from word to word, following close upon the movement of the point of regard, and you are probably aware of this movement of attention as an expression of personal activity, as an advancing wave in the tide of your feeling of interest, and as a complex of sensory impressions of bodily condition and processes of adjustment. These are the most direct ways in which we become aware of it; but attention is not an activity in itself, it is not essentially a feeling of interest, nor is it essentially awareness of the processes of bodily accommodation. Attention is the focus of consciousness as a whole, the state or form of concentration of the seeing, thinking, remembering, feeling, doing, etc., at a given moment. Attention is to consciousness as the point of regard is to the field of vision, the focal point.

1. **Rhythm of Attention.**—When O is seated with eyes closed, in a quiet room, hold an open watch at such a distance from his ear that he can barely hear it. At a signal let him direct his attention as steadily as

* This experiment must be performed in comparative quiet, which is usually best obtained in the evening.

possible upon the hearing of the sound for one minute and, with a pencil in hand, point upward when he hears the sound and downward when he does not hear it.* Following the second-hand on the watch, tap time quietly in the note-book, making a dotted line, thus,, one dot per second; adopt two levels and trace on the upper when O points upward, and on the lower when he points downward, like this,

Preserve and number the curves as permanent records. Make a table showing the number of periods and the length of each period in seconds (*a*) for "Sound heard" and (*b*) for "Sound not heard." Make five trials.

This experiment demonstrates that attention fluctuates and is periodic. For reasons of biological economy, consciousness cannot remain focused upon a single unchanging object for more than a moment at a time; the focus, i.e., the attention, is intermittent.

A liminal stimulus was chosen because it is easier to observe the changes in that than in strong stimuli, although the principle of fluctuation applies to both, indeed perhaps to all objects of consciousness. And the sense of hearing was chosen because the stimulus can be most satisfactorily controlled for that sense. In

* If the fluctuation does not occur, the watch is either too near or too far away; find such a distance that it will be heard about half of the time.

A common source of failure in a beginner is that he expects to hear the tick at one moment as well as at another and therefore fails to observe that he does not actually hear it but merely imagines that he hears it part of the time. An attentive observer may be able to record the missing of a single tick or two.

If any wave in a curve is due to outside disturbance, discard that record and try it over again.

sight, touch, and smell the test is complicated by the rapid changes of adaptation and fatigue. The most satisfactory stimulus is a constant tone of medium pitch.

The waves of attention are not smooth. If we could get a detailed record of attention to a constant stimulus such as a sustained tone, a gray surface, or a uniform pressure, it would probably take a form something like the white surface in Fig. 27, which might represent the distribution of attention for about ten seconds schemat-

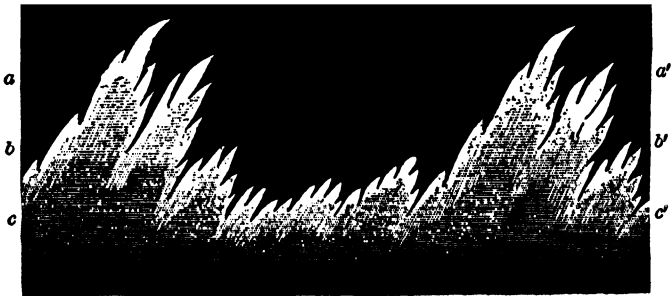

FIG. 27.

ically.* Both crests and troughs are rugged. In the case of a tone, for example, the result of a very faint tone might be represented at the level $a-a'$, where the tone is heard very faintly and only for a relatively short period; the result for a stronger stimulus might be represented at the level $b-b'$, where the tone is clearer and stronger and the periods of duration are relatively longer; while the result for a strong stimulus might be represented at the level $c-c'$, which indicates that the observer has the impression of being aware of the tone

* For attention this is merely a hypothetical diagram; actually it is a photograph of the manometric flame for a vowel.

all the time but that there is a rhythmic fluctuation in its clearness and strength.*

Probably all mental activity—sensation, discrimination, feeling, memory, will, etc.—is rhythmic. The two waves in Fig. 27 are made up of smaller waves, and these in turn of still smaller ones. Measurements on long periods of attention show that there may be waves as long as an hour; smaller waves, reckoned in minutes, may be traced inside of these; and within the “minute-waves” we find the so-called “second-waves.” Our conception of the flow of attention, or the fluctuation in the capacity for a certain conscious activity, is then this: There are infinitely short ripples of attention, hardly perceptible; these form the surface of ripples, which in turn form the surface of wavelets; and these wavelets in turn form the surface of waves, and so on. Thus, all attention is rhythmic, and there is rhythm within rhythm from the infinitesimally short to the very long, even daily and annual periodicities.

The length of the attention-wave (second-wave) varies with numerous conditions, such as kind and strength of stimulus, practice, temperament, psychophysical condition, effort, etc. The shortest fluctuations are probably too rapid to be detected, and ordinarily a single crest of attention cannot be maintained for more than ten or twelve seconds. For conditions

* It is evident that the ratio of the length of the crests to the length of the troughs in the above experiment depended upon the strength of the stimulus adopted. When a stimulus is comparatively weak the troughs are long and the crests short; whereas the order is reversed when the stimulus is comparatively strong.

like those of the present experiment an average of from six to eight seconds for a complete wave is about normal.

The periodicity has come into existence because it is effective, economic, and agreeable.* To illustrate these three features, let us aid our constructive imagination by Fig. 28. The vertical bar represents something that we can be conscious of, e.g., a tone which is not heard because not attended to, and that, as we turn to listen to it, our attention may flow in any one of the forms *a*, *b*, or *c*, which represent surfaces of equal magnitude. Now if it takes the form *a*, the object will be in con-

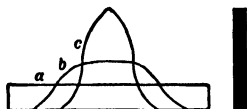

FIG. 28.

sciousness continuously, but only in small part; if it takes the form *c*, the object will be comprehended completely as it passes through consciousness; *b* represents a mean between these two extremes. As nothing would be gained by holding the tone in consciousness longer than *c* does, *c* is the most effective form.

Then, *c* gives consciousness a period of rest proportional in length to the degree of concentration. As *c* accomplishes four times as effective work as *a* with a given quantity of energy and still allows a good period of complete rest before the next wave, it follows that *c* represents the most economic form of expenditure.

* The old philosophers had a sort of poetic dream that all nature is rhythmical; and the more we discover of nature's ways the more we see of periodicity. Electricity furnishes a good example: the alternating current is far more effective and economic than the direct.

When, as in this case, the object of consciousness is constant, when it can be divided into natural groups by attention itself, or when the object is itself periodic, as in music, poetry, or rhythmic movements, the attention-waves adapt themselves to the rhythm so that the essentials of the group are grasped during the crest of the attention-wave and each momentary effort is well timed and is followed by a period of rest. Applying this, then, to the three wave-forms in the figure, we see that as *c* affords the greatest feeling of ease and completeness in the grasp, permits rest, and tends to make the process automatic, it is the most agreeable.*

The psychological explanation for our enjoyment of rhythm in all sorts of mental activity is to be found largely in this basal fact of a natural, biological rhythm of attention.

What are the immediate psychophysical causes and conditions of these wave-forms? Numerous investigators are at work on that problem at the present time, but it is too early to draw any general conclusion, and details would take us too far into technicalities. It is probable that we shall be able to trace the waves into their constituent elements, both central and peripheral.

Language forces us to use terms which might signify the adoption of one or another of the extreme theories of attention. This should not mislead us into thinking that we know what the ultimate nature of consciousness or attention is.

* There is an analogy in the learning of a game. The beginner is conscious of every step in the process and usually fails; whereas the expert times his effort and uses it only at crucial points. The secret of the Japanese wrestling feat jiu-jitsu lies in the instantaneity of the act.

2. **Division of Attention.**—Time O for thirty seconds and let him count aloud as fast as he can from one up and at the same time write numbers in an independent series as fast as he can from one up; thus, 1, 2, 3, etc. Note errors made in the counting. Let O record the number reached in counting and writing respectively, the errors noted in counting and in writing, and any influence of one series upon the other that he can remember or observe. Make five trials.

The observer failed in the effort to divide attention and direct it upon both processes at the same time. He noticed an irresistible tendency to allow the attention to oscillate from one process to the other. In so far as the two processes actually went on simultaneously, one was automatic, i.e., went on without attention. Among the conspicuous errors are probably speaking a number due in writing, writing a number due in speaking, and partial combination of a number in one series with a number in the other.

Strictly we can attend to only one process at a time. When two or more mental processes are supposed to be carried on simultaneously, either the attention oscillates so rapidly from one to the other that they seem simultaneous, or all but one of the processes are automatic. Usually these two principles coöperate.*

* James quotes Paulhan: "I multiply 421,312,212 by 2; the operation takes six seconds; the recitation of four verses also takes six seconds. But the two operations done at once take only six seconds, so that there is no loss of time from combining them." Here the reciting must have been entirely automatic and habitual in connection with the multiplying. We should not think that the reciting required more attention than ordinary, unchecked, happy whistling would.

Still we must remember that attention is a matter of degree of concentration. I may see the whole landscape before me, but see nothing in particular. The process upon which attention is actually directed is in the focus of consciousness, while the other processes must be more or less out of focus, if consciousness is focused at all. All that we do skillfully and nearly all that we do well is done without much attention. Several such processes can go on simultaneously to advantage because they are more or less automatic and demand attention only at crucial points which attention can reach in its oscillations. In the development of habit such points are reduced to a minimum.*

3. The Scope of Attention.—Lay a sheet of paper on the table and tap at a uniform rate with the point of a pencil as rapidly as you can on the sheet. Make from three to twelve taps, and require O to say, without counting them, how many taps he heard. Record O's estimate and the true number as shown by the number of dots on the paper. Make ten trials. Before showing the results to O record his statement of how many taps he feels sure that he can estimate correctly within a single span of attention like this.

The above test, though crude, serves to illustrate the principle that the range, scope, or span of attention is limited. The observer's estimate was probably correct

* In transcribing rough notes into a finished paragraph on the typewriter, reading, thinking, and fingering are three processes which run parallel, thereby favoring oscillation of attention where necessary. Yet the best work is done when the writer is oblivious of notes or fingering and is completely absorbed in the flow of the thought.

up to about five taps, but when a group had more than that number of taps the estimate was more or less of a guess on the "mass."

The experiment is usually performed as a sight test with elaborate apparatus. Letters, numerals, dots, lines, etc., are shown in groups in exposures which are so short as to prevent eye-movement. In a 0.05-second exposure one can normally grasp with certainty from three to six similar and simple objects, such as letters. If the objects are psychologically more complex, fewer are grasped. If the simple objects are united into larger units, e.g., the letters are united into short words, one can grasp almost as many of the larger units, provided they are familiar; one can grasp about three times as many letters when they form words as when they do not form words. It is about as easy to grasp one's full name as to grasp the initials. In short, the span depends upon the coherence of the elements which are grasped together.*

Interest and practice are the main sources of strong grasp of attention. The artist perceives the color

* The capacity for grasping facts by large units increases with mental development. Take the case of writing: the child first begins on the penmanship stage and is conscious of "position" and parts of letters; he then passes to the spelling stage and is conscious of letters as the elements of words; later he enters the grammar stage and is conscious of words in the construction of the sentence; this leads to the rhetoric stage, in which he is conscious of the construction of the paragraph from phrases, clauses, and sentences; and finally, if he really becomes an effective writer, he reaches the logical stage and the writing is grasped in terms of ideas which take the form of paragraphs. As he reaches each higher stage, the units of the lower stage must more or less "take care of themselves". Few adults reach the highest level.

scheme of a painting at a glance; and many a woman sees intricate details in a rival's toilette in but a moment's observation.

4. **Intensifying Effect of Attention.**—Suspend two watches, one to the right and the other to the left of the head, at such distances that each can be just distinctly heard. With eyes closed, direct your attention alternately to one and the other and observe whether the tick seems louder in the one to which you attend.

The sensation to which the attention is directed probably becomes stronger. If we strike a chord on the piano and hold the keys down while the tones ring off, "it is possible, by successive attentions, to construct a melody from the separate tones, while the whole chord sounds on as an accompaniment" (Titchener). Some psychologists think that the same may be illustrated in weak sensations in other senses, e.g., color and touch.* But this intensifying effect is limited to comparatively weak stimuli. Strong tones, colors, and pressures are not intensified by attention. An overtone, but not its fundamental, is intensified by attention.

In a similar manner attention increases the apparent duration of comparatively short mental processes.

A further closely related characteristic of the process attended to is that it seems to precede other processes which occur simultaneously with it but are not attended

* This is the principal element in the explanation of "the feeling of being stared at". Many persons report distinct experiences of feeling that a person somewhere behind is staring at them; they are conscious of prominent tactual sensations in the neck. These sensations are normally always present if attended to; the expectant attention intensifies them.

to. The usual form of the experiment illustrative of this law is to present simultaneously two stimuli while the observer notes that according to the direction of the attention, he can make the one or the other appear to come first. One can make either the bell-stroke or the click of the metronome arise first, although in a good instrument they really sound at the same instant.

This explains a celebrated experiment which proves that we cannot attend to auditory and visual stimuli at the same time. The experiment is an imitation of the recording of the transit of a star by an astronomer. A sound and a visual impression occur together, but the observer invariably records one as having occurred before the other. What the order shall be is determined by the type of imagery the observer represents.*

5. Clearness and Detail.—Look at Fig. 29 and answer the question. Observe the apparent changes in the lines of the figure the moment you solve the puzzle.

Attention makes the image of an object clearer and more meaningful. This is the most striking and fundamental characteristic of attention. Fig. 29 is usually seen first as a disagreeable face and then as

* About a hundred years ago two astronomers who compared notes found that there was a large constant difference in their observations on the transit. Investigation revealed the fact that one of them was a visualizer and the other an audile; one attended first to the visual impression and the other attended first to the auditory impression. The difference between the observations of the two astronomers was always the algebraic sum of their errors. This discovery marks the beginning of the study of the so-called "personal equation".

something entirely different, agreeable, and clear. The details which are clear and dominant when we apperceive one view tend to vanish in the background when we apperceive the other.

It is, however, important to make a distinction between clearness and intensity. Faint stimuli become

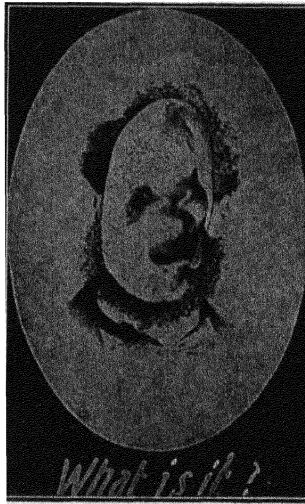

FIG. 29.

both more intense and clear, while medium and strong stimuli, as a rule, gain only clearness through attention.

6. Distraction of Attention: Mind-Wandering.—Select fifteen consecutive lines from a paragraph and count how many *a*'s there are in the selection. Count as fast and accurately as possible and apply yourself to the task as exclusively as possible. Immediately after

the counting, retrace the selection and write out a full, frank, and specific account of the irrelevant impressions, memories, thoughts, feelings, and impulses which came more or less into the focus of attention against your best effort.

Unwavering attention is a fiction. There are great individual differences in the power of application of attention, but no mentally alert student can apply himself so closely even to this simple task but that he will have a long and intricate list of mind-wanderings to report. Indeed, the mind wanders so much for all persons that a scant report in this experiment would be indicative of lack of power of observation rather than a high degree of concentration. Like many other processes, such as after-images, double images, etc., which ordinarily are not desirable, these mind-wanderings are not easy to trace without some practice.

The great scholar who held the egg in his hand while he boiled his watch, and the other one who dropped his watch down the well in place of a stone when he wished roughly to measure its depth, were really thinking about things vastly more important than eggs and watches. There are two kinds of absent-mindedness: the one which comes from extreme absorption in something else (the philosophical), and the one which comes from inability to apply oneself to anything (the scatter-brain).

The conditions of distraction, the effect of various types of training, the relative value of different types of attention, the advantages and disadvantages of distraction, such are some of the numerous problems connected

with this topic which await solution in the experimental psychology of education.

7. Sense Processes in Attention.—Observe by introspection, in repeated trials, and record the sensory and motor tendencies which are characteristic of each of the following attitudes of attention :

- (a) The attitude of listening as in Exp. 4.
- (b) The effort to see clearly the irregularities in the period at the end of this sentence.
- (c) Resting a finger upon the point of a pin or sharp penknife and observing the fluctuation in the sensation of pain from the pricking.
- (d) Thinking the names of the five largest towns in your State, eyes closed.
- (e) Imagining a baseball flying directly toward your face.

All attitudes of attention have certain tendencies in common, and each attitude probably has peculiar tendencies which give characteristic sensory impressions.*

* Pillsbury in his work on "Attention" sums up his chapter on the motor accompaniments of attention as follows: (1) The muscles of the sense-organs contract so as to give the greatest efficiency. (2) The voluntary muscles of the limbs and the trunk tend to make contractions which have been useful in similar situations of previous experience. (3) There is a tendency to contract certain muscles regardless of the nature of the stimulus. (4) The processes of respiration and circulation are profoundly affected. (5) The bodily processes accompany attention; they do not precede it.

It is these motor processes that one has sensory impressions of in the state of attention.

CHAPTER XIV

NORMAL ILLUSIONS

For One.

THE problem is to measure certain normal illusions in visual perception of space. The observer must bear the following principles clearly in mind:

a. These illusions are normal; if they do not appear in the record, that is proof of either incompetence or abnormality in space estimation.*

b. These experiments involve a clear distinction between what *looks* right and what *is* right. We shall here devote attention to the way things look, not what they really are. The observer is asked to make adjustments so that they look right according to his very best ability, but to make any allowance on the basis of a guess or knowledge of the possible direction and magnitude of the illusion is forbidden. The value of these experiments depends upon the power of self-possession in observing this distinction, and its chief training value also lies in this. The assignment of this experiment is an expression of confidence in the ability and integrity of the observer.

c. The observer must perform all the experiments

* Barring rare cases of special training in certain types of illusion.

before checking any or verifying the accuracy of his judgment *by any means whatever*.*

d. The book should lie upon the table in a normal position for reading, except when otherwise specified, and the observer should maintain the same position with reference to it throughout the series of experiments. This will prevent sighting.

1. **The Arc Terminal Illusion.** *a. One Horizontal Distance.*—Place three silver dollars or other coins, † edge to edge, in a straight row on the table. Remove the middle coin and place it to the right, in the same line, in such a position that the distance between the adjacent edges of the moved coin and the coin now in the middle shall be equal to the original distance across the three coins. Measure and record the distance between the middle and right-end coins, but do not measure the standard or verify by it.

b. Two Vertical Distances.—Place the three coins edge to edge as before; push the middle one straight out forward into such a position that the distance from this coin to each of the other coins shall look equal to the original distance across the three coins. Record the two variable distances only.

In the following experiments geometrical figures are made variable by combining some figure in Pl. I on the

* If, by any adventure or slip in self-command, the observer should gain objective knowledge of the validity of his judgment or aid in the estimation, this must be recorded, as it is sure to influence the following experiments.

† In the absence of coins, use three disks cut from paper.

tissue-paper with some figure in Pl. II or Pl. III. Tear the tissue-paper off at the perforation and use it with the printed face down. As printed numbers or letters in the plate would be disturbing elements, we may simply agree upon the following designation of the figures in the plates:

Pl. II: A, the feathered figure at the top; B, the second figure from the top; C, the slanting bar with the three dots; D, the forked figure at the bottom.

Pl. III: A, the large double figure in the upper left-hand corner; B, the slanting, crossed bar with its dot above; C, the cylinder top; D, the parallel lines; and E, the horizontal line.

2. The Angle-line Terminal Illusion: Lengthening and Shortening Effects.—Place the tissue-paper over Pl. II so that the apex of the angle of the figure on the tissue-paper lies over the base-line of Fig. A and points toward the left. Bisect the base-line by placing the apex of the angle so that it looks to be at the middle of the line. Measure and record the left section only.

3. The Angle-line Terminal Illusion: Shifting Effect.—Bisect the base-line of Fig. A, Pl. II, as above, but use one of the dots on the tissue-paper instead of the apex of the angle figure to mark the middle point. Measure and record the left section only.

4. The Secondary-figure Terminal Illusion: Attraction of Regard in Length.—Place the long line of the tissue-paper to the right of Fig. B, Pl. II, by the side of the book; * cover one end with a piece of thick paper

* To measure in the book, mark the distance with some sharp point on the edge of a sheet of paper and then measure that on the millimeter scale.

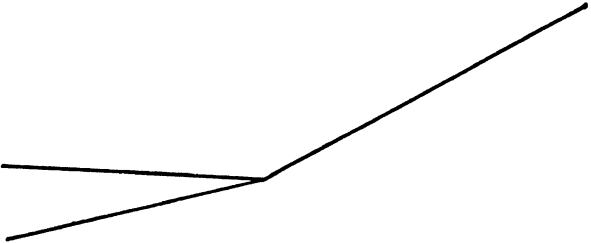

PLATE II.

and adjust this paper until the exposed part of the tissue-paper line looks equal to the middle line of Fig. B. Measure and record the varied line only.

5. **The Attraction of Regard in Direction.**—Place the tissue-paper over Fig. C, Pl. II, so that the short line on the tissue-paper coincides with the line of the three dots, then slide the tissue-paper upward and toward the left, within the same line marked by the dots, until the upper end of the moved line looks to be where the lower line would strike if continued upward in its present direction as a straight line. Measure and record the distance between the right dot and the right end of the moved line only.

6. **The Oppel Illusion: The Bending Effect.** *a. Upper Line.*—Place one of the two dots on the tissue-paper on the joint of Fig. D, Pl. II, and turn the tissue-paper so that the other dot shall indicate what direction the lower left line would take if continued upward to the right as a straight line. Sighting is, of course, forbidden. Measure the distance between the movable dot and the end of the line above it only.

b. Lower Line.—Make the same kind of a measurement for the upper left line.

7. **The Poggendorff Illusion: The Breaking Effect.**—Place one of the dots on the tissue-paper over the right vertical line of Fig. A, Pl. III; indicate with this dot the point at which the short slanting line at the left would strike if continued as a straight line across the

space between the two verticals. Measure and record the distance from the top of the line to the dot only.

8. **The Zöllner Illusion: The Leaning Effect.**—Place one end of the short line on the tissue-paper end to end with the top of the slanting base-line of Fig. B, Pl. III, and adjust the upper end of the movable line until it seems to make a straight and continuous line with the base-line. Beware of sighting! Measure and record the distance between the upper end of this line and the dot lying over toward the left.

9. **The T-Illusion.**—Place the long line on the tissue-paper over Fig. E, Pl. III, so that it crosses it at right angles at the middle; place a sheet of thick white paper over the tissue-paper so that its upper edge is close to and parallel with the lower edge of the line of Fig. E; draw the tissue-paper up or down until the vertical line thus formed above the middle of the horizontal appears to be equal to the horizontal in length. Measure and record the length of the varied line only.

10. **The Illusion of the Vertical.**—Proceed in the same manner and with the same means as in Exp. 9, except that you erect the vertical at one end of the line in Fig. E, instead of at its middle.

11. **The Illusion of Interrupted Space.** *a. Horizontal.*—Place the bar figure on the tissue-paper over Fig. D, Pl. III, so that the bars coincide and adjust up and down until the whole figure looks square. Measure and record the vertical dimension only.

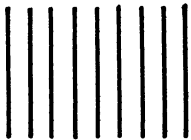
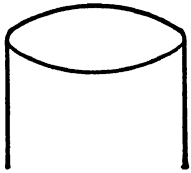
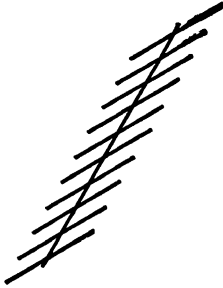

PLATE III.

b. Vertical.—Turn the whole figure through 90° and make sidewise adjustments until the whole figure looks square. Measure the varied dimension only.

12. **The Illusion of Length in the Cylinder.** *a. Vertical.*—Lay the tissue-paper over Fig. C, Pl. III, so that the cylinder base on the tissue-paper telescopes with the cylinder top in the book; adjust up and down until the length of the cylinder appears to be equal to its width. Measure the vertical distance between the top and bottom at the middle.

b. Horizontal.—Repeat the same measurement with the cylinder in the horizontal position.

If the observer has shown fidelity and self-control and has been honest enough in these experiments not to sight or check-measure, he has passed a good test of character and may be recommended for a position of trust. The records also constitute a measure of the power of discrimination in visual perception of space.

The first lesson one learns in the study of sense-perception is that “the senses deceive”. The second lesson is that “there is system in the deception”; being warned of the presence of danger, we may become the masters of our senses and avert the deception. Both these lessons are contained in the above experiments, which are intended to show that there are certain universal motives for illusion and that it is possible to determine their approximate force and thus become able to make due allowance for them.

Now, let the observer turn back to the figures and records and reproduce the setting for each figure (1)

according to the record, (2) according to the standard measurement given below, and (3) according to the average record given below. In stating the magnitude of the normal illusions, it will be given with reference to a *normal adult male who is a reliable observer and is not acquainted with the illusion*. The illusion varies with age, sex, knowledge of the illusion, power of concentration, etc. Thus, one of the laws of illusion is that knowledge of the nature and force of the illusion decreases it, often by as much as one half its force; hence the illusion measurement in the first record should now seem too large.

The standard distance in Exp. 1 is 114 millimeters for dollars or disks. The average normal observer makes the distance about 100 millimeters in 1 *a*, which means an illusion of 12 per cent. The error is much greater in 1 *b*; normally it amounts to more than 20 per cent.

This form of the terminal illusion is very common in ordinary perception. The simplest form of it is where we compare the distance between two more or less round bodies with the diameter of one, as in Fig. 30.* Of course the illusion does not rest upon the comparison. The diameter of the figure is underestimated and the distance between the two figures is overestimated, independently of the comparison, as may be determined by measuring each in terms of a plain line. We need only

* Fig. 30. This is a copy of a small section of wall-paper. The aim of the artist has been to produce the effect of the ratio 1:1, which is the impression obtained by the average observer, but the distance between the figures is actually 10 per cent smaller than the distance across one figure.

look intelligently at our wall-papers, carpets, bed-covers, table-linen, and patterns in dress goods to find evidence of this illusion. The commonest effects sought by artists are approximately the ratios 1:1 and 1:1.6. Find designs which give these effects to the eye when the terminals of the distance are arc-formed, and measure them, and you will find that the artist has made allowance for the illusion, usually 8 to 12 per cent. The designer of patterns makes free-hand sketches by eye

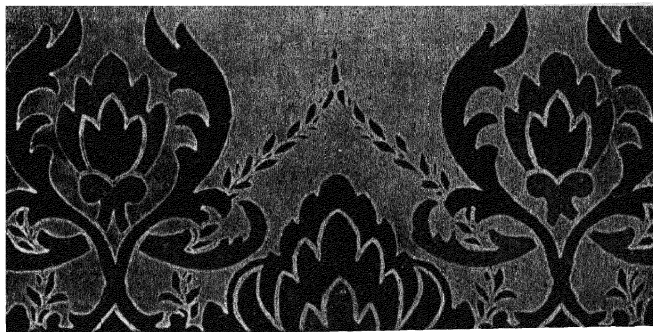

FIG. 30,

estimate and thus naturally makes the proper allowance for the illusion. Where distances of this kind are made equal they do not look equal.

In Exp. 2 the true distance is 34 millimeters. The force of the illusion is approximately the same as in Exp. 1 *a*; that is, the measured section is made about 12 per cent too short. This is a double figure, because one section has the lengthening effect and the other has the shortening effect. It combines two complementary

illusions. Each of these might be measured separately in terms of a plain line. The left end has the lengthening effect and the right end has the shortening effect. The figure is also called "full-fledged" because it has a full set of end lines; a single line would produce the illusion, though not so forcibly.

This illusion is very common in objects around us, as in trees, fences, and lawn-patches, as well as in designs and structural effects, in fact in all sorts of objects in which a linear distance is marked off at one or both ends by one or more end lines.

In Exp. 3 the true distance is again 34 millimeters, but the measured section is usually made from 3 to 6 per cent too short. This means that the center of the base-line is shifted to the left by that amount.

When we bear in mind that it is not necessary that all the end lines should be present, we can realize how commonly the conditions for the shifting effect are present in nature and art. The twigs on a limb seem farther up than they are. The middle point between two branches, one above the other, is not where it seems to be. The cross-line on the letter A seems lower than it really is.

In Exp. 4 the true length is 52 millimeters, but the varied line is probably made from 4 to 8 per cent too long. This again is a very common situation in all that we see. Technically we say the perception of a primary stimulus is influenced by secondary stimuli. The visual length of an object, whatever it may be, varies with the presence of other objects near its ends.

The first four experiments deal with the terminal

illusion of which the angle-line figure, generally known as the Müller-Lyer figure, is the most familiar type. They all illustrate the principle that the appearance of a linear distance is modified by the presence of terminal forms. These forms may be grouped roughly into three classes; namely, the arc, the angle-line, and the detached or secondary figures. The last named are not terminals in the strict sense, as the line is clear-cut in itself, but psychologically they operate as terminals, for we cannot look at the middle line without having our "regard" attracted to the end lines.

The terminal illusion effects may also be grouped into three classes: the lengthening, the shortening, and the shifting. The lengthening effect is illustrated in Exps. 1, 2, and 4, and is the result of outward-pointing arcs, angle-lines, or secondary features. The shortening effect is illustrated in Exps. 1 and 2 (the right half) and is the result of the inward-pointing terminal. The shifting effect is illustrated in Exp. 3 and is due to the fact that the angle-lines point in the same direction.

The strength of the terminal illusion varies with a vast number of conditions in the object, such as the length of the terminals, the angle of the terminals, the number of terminals, the body of the terminals, the relative size of the figures, the vagueness of the terminals, adjacent objects, complexity of the figure, meaning of the figure or object, time of exposure, etc. As a rule the illusion is decidedly stronger in natural objects than in geometrical figures. It varies also with subjective conditions, such as power of visualizing, training, concentration of attention, mode of regarding,

knowledge or suspicion of its existence, etc.* Each and all such variables may be made the object of experiment. Indeed certain laws have been worked out by measurements upon every factor here named.

The same illusion obtains for the sense of touch.

The first four experiments illustrate a certain type of illusion of length; the next four illustrate illusions of direction. The two groups find a natural transition in that Exp. 4, the last in the former group, and Exp. 5, the first in the present group, are both conspicuous illustrations of so-called "attraction of regard". This term is used in both the physical and the mental sense: the physical eye and the "mind's eye" are both attracted. That is a principle which runs through both groups.

In Exp. 5 the true measurement is 11 millimeters. The observer probably made it about 10 millimeters; that is, the adjustable line was not pushed far enough forward. This deflection of the apparent projection of the lower line was caused by the attraction of the upper line. How often do we judge direction of a line without the presence at one side of some other line or object?

In Exp. 6 *a* the dot is placed too high by about 2 millimeters; the true measure is 13 millimeters. In Exp. 6 *b* the dot is placed too low by about 3 millimeters; the true measure is 26 millimeters. If the lower left line were actually drawn straight in extension by a ruler, a close observer would see an apparent bend

* These illustrations are typical of variables in the other eight types of illusion also.

at the joint. Figures 31 and 32 are rather striking illustrations of the Oppel type of small-angle illusion.*

In Exp. 7 the dot is placed from 6 to 10 millimeters too low, often more than this. The true measure is 21 millimeters.

In Exp. 8 the measurement usually shows a deflection of 2 millimeters from the straight line. The Zöllner effect is illustrated in Fig. 33.

The figures in Exps. 6, 7, and 8 may be considered examples of the "small-angle illusion"; not that the

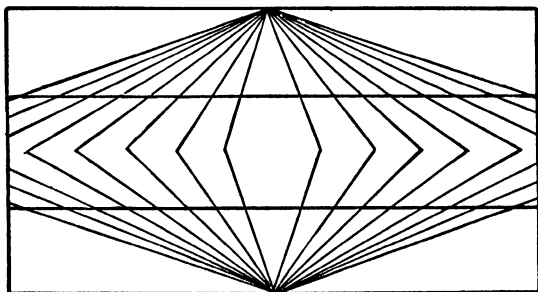

FIG. 31.

small angle is an essential condition for the illusion, nor that it is an explanation, but because it is the principal

* Fig. 31. The two horizontal lines are straight and parallel, but they look bent on account of the cumulative effect of the Oppel illusion.

Fig. 32. The circle and the inscribed square are perfect; but if the square is seen square, the circle looks indented. If the circle is seen as a circle, the sides of the square look curved inward.

Fig. 33. The Zöllner pattern. The columns seem to topple or lean by pairs, although they are parallel. The Poggendorff effect makes the short transversals seem discontinuous or broken. There is also a false perspective; the columns seem to form alternate ridges or troughs.

feature which they have in common. The small angle is overestimated in all these cases. The effects of the

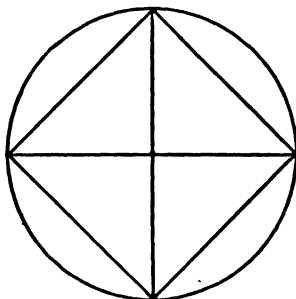

FIG. 32.

three cases may be called, respectively, the bending effect, the breaking effect, and the leaning effect.

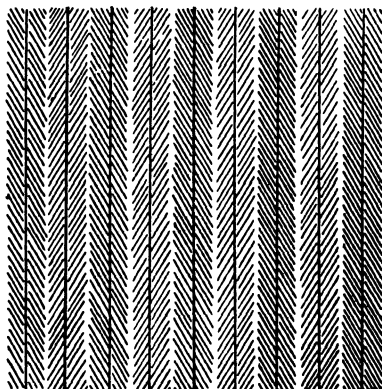

FIG. 33.

These figures represent situations that are not uncommon in nature, industry, and art. When a straight

line crosses concentric circles, the Oppel effect is at its best. Whenever a line strikes another at a small angle, this angle looks larger than it really is and this results in an apparent bend, deflection, or break of the line. Wherever a line or a long object is crossed by other lines or objects at a small angle, it suffers a deflection.

The builders of the Parthenon were well aware of what is now called the Oppel effect, and made corrections for it by making lines that should look straight curve just enough to correct for the illusion.

In Exp. 9 we have an illusion which is exceedingly variable and seems to depend particularly upon the discriminating effort one puts forth. The variable is frequently made from 20 to 30 per cent too short. The standard is 34.5 millimeters. The illusion can reach this alarming force because it is the result of the cooperation of several motives for illusion. Where can one turn without seeing examples of it? Observe a capital T and then measure the proportions. The comparison of the height and the arm-reach of a man standing with arms outstretched is a good illustration.

In Exp. 10 we have the well-known illusion of the vertical. A good observer, who is aware of the illusion, will make the variable line from 5 to 8 per cent too short. The standard is 34.5 millimeters.

In Exp. 11 there is an illustration of the overestimation of filled as compared with empty space. The variable dimension is made about right in the vertical position and from 10 to 15 per cent too short in the horizontal. This result is due, in the latter case, to the cooperation of this illusion with the illusion of the ver-

tical, and in the former case, to the opposition of these two approximately equal motives for illusion.

In Exp. 12 *a* the vertical length is probably made more than 20 per cent too short. This is due to the cooperation of at least four motives for illusion. When the measurement is made in the horizontal position, Exp. 12 *b*, three of these motives are counteracted by the illusion of the vertical and the illusion is probably reduced nearly one half.

The length of a barrel, the depth of a teacup, and the height of a tank are overestimated on these principles. If a person is asked to estimate the height of a silk hat in comparison with the diameter of the crown, he will overestimate the height by more than 20 per cent.

Each experiment represents a very large field for illusion. There are normal illusions in all the senses and within each attribute of each sense. Thus, in sight, we have illusions of color, space, movement, duration, and intensity, and each of these covers numerous types.

CHAPTER XV

AFFECTIVE TONE

For Two.

1. **Color Preferences.**—Each of the eighteen colors supplied in the book envelope is to be compared with every other for the purpose of securing systematic expressions of preference.*

In each note-book cross-rule a page into nineteen spaces in the horizontal direction and nineteen in the vertical. Insert vertical and horizontal headings as in the table below, which gives numerical order to the six colors and their respective tints and shades.

Lay a white paper in such a position on a board or book that it shall be at right angles to O's line of vision, in good light and comfortable position for him. Present two colors at a time, placing them systematically about an inch apart on the white paper, and require O to decide which of the two is more pleasing or less displeasing. The decision should be immediate and intuitive, and free from associations.† The table shows

* This experiment is based on Titchener, "Experimental Psychology, Qualitative," Ch. XXI.

† Avoid theorizing or catering to what ought to be or what would give the best showing as an expression of culture, etc. Let it be a naïve and sincere expression of preference entirely independent of the use of the colors.

the order in which the comparisons should be made; thus, 1 and 2, 1 and 3, 2 and 3, 2 and 4, 3 and 4, 3 and 5, etc. Let O call the order of colors to be presented, following the order shown in the table, and keep the record of his preferences in the prepared blank, simply inserting the

		1	2	3	4	5	6	7	8	9	10	11	12	13	14	15	16	17
		Rt	R	Rs	Os	O	Ot	Yt	Y	Ys	Gs	G	Gt	Bt	B	Bs	Vs	V
2	R	1																
3	Rs	2	3															
4	Os	34	4	5														
5	O	35	36	6	7													
6	Ot	63	37	38	8	9												
7	Yt	64	65	39	40	10	11											
8	Y	88	66	67	41	42	12	13										
9	Ys	89	90	68	69	43	44	14	15									
10	Gs	109	91	92	70	71	45	46	16	17								
11	G	110	111	93	94	72	73	47	48	18	19							
12	Gt	126	112	113	95	96	74	75	49	50	20	21						
13	Bt	127	128	114	115	97	98	76	77	51	52	22	23					
14	B	139	129	130	116	117	99	100	78	79	53	54	24	25				
15	Bs	140	141	131	132	118	119	101	102	80	81	55	56	26	27			
16	Vs	148	142	143	133	134	120	121	103	104	82	83	57	58	28	29		
17	V	149	150	144	145	135	136	122	123	105	106	84	85	59	60	30	31	
18	Vt	153	151	152	146	147	137	138	124	125	107	108	86	87	61	62	32	33

number of the color which he prefers in the square which forms the intersection of the spaces that run to the two numbers he called. Foot up the results in the table so as to show the total number of times that each color was preferred.

To express the results graphically, take a sheet of cross-section paper, or cross-rule one like the above table blank; transfer the headings of the table to the base-line and number the horizontal lines from one to eighteen, counting the base-line zero; make a dot in each vertical column on the horizontal line which denotes the number of times the respective colors were preferred, and connect these dots with one bold line, which will then be the curve of color preference.

It is customary to speak of agreeableness or disagreeableness of experiences as their affective tone. Our affective responsiveness is a matter of taste. It is well known that we have our likes and dislikes for colors, and that our tastes may differ radically.

Here we have worked out a detailed expression of the observer's taste for color under the present conditions. It would vary for the same observer under other conditions, and some of the doubtful cases might be changed in another trial, but that throws no discredit upon the experiment which depicts the observer's typé.

Individual differences are marked. One type prefers the pure colors, another the tints, another the shades; one type prefers the soft, artistic tints and shades as opposed to the bright hues; another type has one or more favorite hues, tints, or shades, etc. The curves give good profiles of each type.

Such measures can, of course, be used effectively for individual psychology. Science, literature, and art are interested in race comparisons and in knowing the culture history of color preferences from the anthropological point of view. The teacher is interested in

knowing the color scheme of the child's temperament. Most of us pass through important changes in color preferences as we pass from childhood into mature age. And, as a mode of teaching the significance of color values, the method could be used effectively.

On the other hand, the psychologist takes only a secondary interest in such directly practical uses. The chief value of experimental methods of studying affective life lies in the insight they favor and the aid they give in the study of the unfoldment and explanation of the laws of its behavior. This particular experiment reveals nothing in regard to the reasons for color preferences, unless it be that the introspection may give some suggestion. But it is by patient and ingenious employment of methods like this under controlled and variable conditions that we shall evolve the real explanation of color preferences.

We know now, in general, that the affective value of color depends upon the specific physiological action of each color, the purpose the color serves, and habits of association. Our experiment, which shows the actual preferences, then naturally suggests three corresponding lines of research in answer to the question, Why is one color preferred to another?

There is a tendency in æsthetics at the present time to look for physiological explanation of modes of agreeableness and disagreeableness. What are the characteristic physiological actions of each color? In attempting to answer that question, the experimenter profitably starts from analogies of known effects upon lower forms of animal life and plant life. Fruits and flowers grown

in experimental greenhouses each covered by a different color of glass show great differences in growth and development. The red light acts like a fertilizer on the soil, while blue and violet light check growth and produce a sort of dormant condition in the plants. Finsen's discovery of the curative value of the ultra-violet rays rests upon the principle that these rays kill certain disease-germs in the human tissue. The same rays, however, favor the development of various larvæ, tadpoles, etc. Color rays strike the most sensitive form of living tissue, the nervous system, through the eye. Ordinarily we become conscious of these affective differences in effect only in attitudes, general awareness of ill-being or well-being. One color is exciting, another is soothing, one is fatiguing, another is restful, etc. Shall the explanation of such a physiological action be given in large part in terms of chemistry?

The second question would search into the significance of the uses of colors. Take red, for example. Red is the symbol of joyous emotion. It is the symbol of sacred rights, of royal power, of victory, of pledged sincerity, and of love. It is the first color to interest primitive man. Words for red are the first color terms to develop in nearly all primitive communities; a tribe may have half a dozen synonyms for red before it has any name for blue or green. Children seem to repeat the tendencies of the race. Red is the primitive color for decoration; men and women smear themselves with red ochre and paint their utensils and implements in brilliant reds. Red is the dominating tone of color in

religious rites, at the wedding, and at the conclave. It is conspicuously absent in mourning. Children, if uninfluenced, tend to use red more than any other color. In abnormal sensitiveness it is red that jars most. The hysteric is conscious, at times, of nothing but red. Likes and dislikes for it are strong. The red flag is the rallying-point for the anarchist. It is the symbol of excitement in epidemics. In brief, red is the color of ripe fruit, it is the color of the flame, and of blood.

Aside from the physiological conditions and the uses of colors there is a third type of problems which pertain more specifically to the explanation of the habits of association. To what extent can color preferences be cultivated? What is the biological explanation for the survival of certain types of color preferences? What is the reason for the order of development of color preference in the race? In the child? The present tendency is toward the so-called artistic colors; is that a permanent characteristic of developed mental life?

Let us notice some instances of the use of the method of this experiment in the study of other affective values.

The matching of color is an important item in dress, in the finishing and furnishing of a room, in art, and in many industries. The psychologist must lay a foundation for canons of color harmony by working out the fundamental laws of affective value of color combinations independently of their use. It has never been done thoroughly. The thing to do is to select a suitable series of colors and grays and treat a match of any two of these as the unit of the experiment; thus, the agreeableness of a red matched with a green may be compared

with a match of red with a dark orange shade. Each color (or gray) must be matched with every other color, and each match must be compared with every other match. From a well-established curve of such results the laws of color harmony might be stated. But when these laws are to be applied in art and industries, the individual variation, accessory influences, etc., must be taken into account, and the problem grows more complicated.

The curve Fig. 34 (from Wundt) expresses the results of some experiments by a cruder method, show-

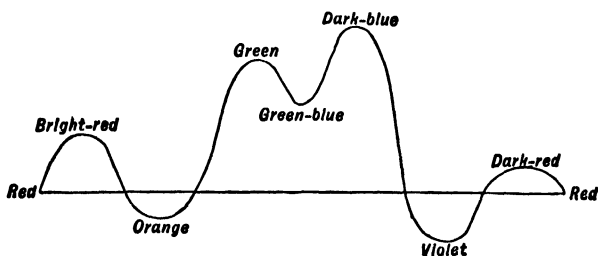

FIG. 34.

ing the affective curves of matches with red. Height above the base-line represents degree of agreeableness of the match of red with a given color, whereas depth below shows degree of disagreeableness of a combination. Thus, red makes pleasing combinations with other colors in the order dark blue, green, bright red, dark red, and displeasing combinations with violet and orange. The greatest agreeableness is approximately at the greatest opposition (complementary color), and there is a general depression into disagreeableness on each side of this crest.

In selecting our stationery, in designing a table-top, in platting our flower-garden—in short, wherever a rectangular surface is designed to be pleasing in proportions, we may look to empirical psychological laws for guidance. The relative agreeableness or disagreeableness of different proportions of a parallelogram is expressed in Fig. 35 (from Wundt, based on Witmer). A series of white cards of equal height but varying length have been compared by a method allied to the one we have used. The length of cards in proportion to their

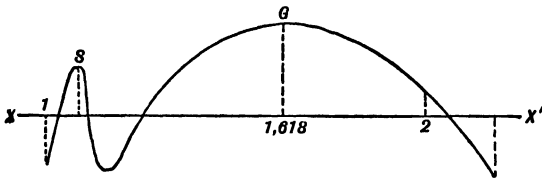

FIG. 35.

height is laid off on the base-line. Elevation above that line indicates relative agreeableness of such proportions, and depression means corresponding disagreeableness. Thus, the most pleasing ratio centers around 1:1.6, which is known as the golden section or golden cut.*

* The golden section for the rectangle is that in which the short side is to the long side as the long side is to the sum of the long and the short sides. This proportion may be applied to various forms such as crosses and complex designs. A study of jewelry, stationery, monuments, etc., reveals a most remarkable adherence to these proportions. The commonest cross is in that proportion; the upper section of the upright is to the lower section as the lower section is to the whole upright. It has been pointed out that many of the forms of nature are shaped in this proportion. Tables, lapboards, and mountings for apparatus made according to the golden section, in the writer's laboratory, give a pleasing effect.

The square is decidedly disagreeable, but the apparent square * is agreeable, although not so agreeable as the golden section. A parallelogram that is a little longer than the apparent square is disagreeable.

The method may be used with equally good effect in hearing. Music depends upon the agreeableness of certain tone-intervals. Different nations have different scales, and there is a process of gradual evolution of musical scales. Some of the intervals are "natural", other intervals are more or less arbitrary. There is an instrument called a tone-variator with which we can produce any desired interval. Suppose that we divide one octave into one hundred equal steps and always use the fundamental as one of the two tones. By comparing each of the hundred intervals in such a series with every interval in the series, we may establish a curve of the relative agreeableness of these intervals. Such a curve will contain a large number of waves of different amplitude, the crests indicating consonant tones and the troughs dissonant. What light would such a curve throw upon our conventional musical scale? It would, of course, reveal the natural intervals and show the order of their preference, and then it would show other desirable intervals in the order that they are agreeable. It would show how arbitrary certain parts of our scale are.

These stimuli are not of any rousing emotional tone. If we should take smell and taste stimuli, we should realize more fully the fact that we are dealing with emotional factors.

* Due to the illusion of the vertical.

At this point we must impress the warning that there is danger of making these measurements seem too simple and too immediately serviceable. Emotional life is more individualized than cognitive life. We cannot set up the curve of one individual as the norm for all others, nor can we take the average of a large number of curves and expect one individual to fit that. The conclusions must also be rigorously limited to the conditions under which they are taken. Thus, the agreeableness of a tone-interval depends upon its sequence, the harmony of the colors depends upon the background, the agreeableness of taste depends upon its relation to other tastes, etc.

But these are matters which may in turn be made the object of study. It is possible to determine statistically the degree of variability among individuals in affective responses. Instead of covering them over, measurement reveals individual differences. Before a curve is used we must know its coefficient of variability.

There are two general types of method that may be employed in studying feeling: the method of impression and the method of expression. The above is a method of impression. That is, the experiment simply favors accurate formation and recording of impressions. Impression methods may, of course, be used in a great variety of ways. In the expression methods some objective bodily expression of feeling is measured. Among these are effects upon the bodily strength, involuntary movements, volume of certain parts of the body, circulation, breathing, secretions, etc. Exp. 2

will illustrate, in a crude way, the characteristic expressions in involuntary movements.

2. Affective Expressions in Involuntary Movements.—The object of the experiment is to determine what direction the involuntary movements of the balanced hand shall take in smelling an agreeable or a disagreeable odor.

Invite some one who knows nothing about this kind of experiments to act as observer, as the response is influenced by a knowledge of the condition of the experiment.*

Select some substances that have decidedly agreeable or disagreeable odor such as perfumes, flowers, ammonia, and vinegar.† Keep these in an adjoining room.

Blindfold the observer and ask him to stand erect and firm and hold his hand about a foot in front of his face. Direct him to say whether an odor is agreeable or disagreeable to him when he smells it.

Now let one of the experimenters hold one of the odoriferous substances under the observer's nostrils three seconds, so that he gets a good whiff of the odor. Let the other experimenter take an advantageous position for observation of the movements of the hand and

* When everything is ready, it should not take more than five minutes to perform the experiment. Proceed with the alertness of a photographer and take the invited observer unawares. Tell him that you wish to test his feelings of agreeableness and disagreeableness for odors, and give no intimation by word or sign about your interest in his movements. You must keep his attention away from his hand.

† One of each kind will do if decided, but it is very advantageous to have a good assortment. Care must be taken that the agreeable odor is not too strong.

trace on paper the approximate direction and magnitude of the movement which is made the moment the observer perceives the odor. Record with this the odor used and the observer's statement about it. Make about five trials with agreeable and five with disagreeable odors.

Agreeable odors have a tendency to cause the hand to reach out away from the body, while disagreeable odors have a tendency to cause a flexion of the arm moving the hand toward the body.

These movements are unconscious rudimentary reactions which do not serve any purpose. They are reflexes which repeat in miniature the general tendencies of action which have as a rule been beneficial. The principle might be stated more freely as follows: When the stimulus is felt as agreeable the hand makes the inceptive movement to get more of it; while, if the stimulus is felt as disagreeable, the hand makes the inceptive fending movement for the purpose of getting it away. This tendency shows itself not only in the hand but in the whole attitude. One is the attitude of attraction; the other is the attitude of aversion or rejection. The direction of the movement may be changed by a slight change in the mode of stimulation.

To make this test accurately, one should use an automograph, which may be made very simply. It consists of a small board suspended from the ceiling as a suitable free support for the hand. A small weighted pencil is placed inside a tube through the board so that it traces the movements of the board upon a sheet of paper laid upon a pane of glass. This is exactly the

same principle as that used in so-called spirit-writing by Planchette or Ouijaboard. These latter instruments convey messages which may be entirely unconscious and involuntary on the part of the writer and still possess coherence and relevancy. The odor experiment above is just as truly spirit-writing as these messages, only it is very much simpler than the mediumistic performances.

The expression of affective tone in strength tests may be demonstrated very simply. The person experimented upon is required to pull against a spring which has a mechanism for graphic tracing of the force of the pull. He is required to pull as hard as he can for fifteen seconds; five seconds after he has started to pull, he is given a whiff of odor (or stimulus through any other sense) and, if the odor is agreeable, the tracing-point will rise, showing an increase in the strength of pull, whereas, if the odor is disagreeable, the tracing-point will fall, indicating a certain amount of falling off in the strength of pull.

We are stronger when we are under the influence of agreeable stimuli than when under disagreeable stimuli. The modern manufacturer takes advantage of this principle. He gives his workmen encouragement and agreeable surroundings, and finds that they are stronger for it.

We can tell by the attitude and expression of the face of a man whether he is happy or sad, proud or humble, courageous or cowardly, etc. These differences may be stated in terms of muscular tension, circulation, breathing, relative changes in the volume of the periphery and

the brain, etc. But very little work of permanent value has been done in this field of investigation.

There are several reasons for the present dearth of experimental studies in feeling. The processes are extremely elusive: when we turn in upon our anger to study it, the anger disappears. The feelings are not correlated directly with traceable objective conditions as sensations are. The feelings are so diffused and complex that it is difficult to obtain and control simple conditions. The term feeling is used in more than a score of sanctioned meanings. Theories of feeling are notoriously numerous.

The order of experiment must always be from the simple to the complex. It would be interesting to experiment on love, hatred, fright, ecstasy, etc., but hardly convenient, or discreet at the present stage. Yet we may answer many of the fundamental questions of complex and strong emotion by systematic study of the simpler forms.

CHAPTER XVI

REACTION-TIME

*For the Whole Class.**

“QUICK as thought” is often taken to mean infinitely short time, or no time at all. Yet thinking is a distressingly slow process with some of us. A century and a half ago a distinguished physiologist estimated that the speed of the nerve-impulse was about 57,600,000,000 feet per second; a century later it was measured and found to be, in round numbers, 100 feet per second. It was for some time thought to have a speed comparable with the speed of the electric current, but the electric current would flash half the distance around the globe at the equator while a nerve-impulse passes from foot to head in man. The conceptions of the time of mental

* If the class is large, it may be divided into sections of about twelve to fifteen. Select a conductor, a timer, and a recorder for each section a week in advance, and let them train themselves so that they are prepared to conduct the experiment efficiently and economically. The conductor shall have general command; the timer shall take the time with a stop-watch; the recorder shall take full notes. The conductor and the recorder cannot be in the chain. If no stop-watch is available, the timer must also be out of the chain so that he can time by counting the ticks of a watch, usually fifths of a second. He can then count by groups of ten-fifths, but may adapt the method of counting to the length of the chain.

The experiment may be performed in one hour if proper preparations have been made and the reading of the explanatory parts is postponed until the experiments have been completed.

processes have undergone equally great revision within the same period. We now measure the duration of mental processes, and these measurements give the mental processes concreteness and a natural setting. They not only furnish the time of the mental act, but also serve to isolate the selected process and make it tangible for the purpose of psychological analysis and synthesis.

The term reaction-time is used to denote these measurements because it is customary to arrange the experiment so that the termination of the act is marked by a reaction.*

To enable the whole class to participate, and to avoid the use of elaborate apparatus, we shall adopt the chain-reaction method. The class forms a chain and a given signal is passed as rapidly as possible from one to the next until it has completed the round. The total time for the chain is divided by the number of participants, which apportions the average individual time required

* "A great variety of actions may be viewed as responses to stimuli. There is a flash of light, and we wink; a burning cinder falls upon the hand, and we draw it away; a bell rings, and the engineer starts his train, or the servant opens the door, or we go down to dinner; the clock strikes, and we stop work, or go to keep an appointment. Again, in such an occupation as copying, every letter or word seen acts as a stimulus, to which the written letter or word is the response; in piano-playing, and the guidance of complicated machinery, we see more elaborate instances of similar processes. The printer distributing "pi", the post-office clerk sorting the mails, are illustrations of quick forms of reaction, in which the different letters of the alphabet or the different addresses of the mail matter act as the stimuli, and the placing them in their appropriate places follows as the response. In many games, such as tennis or cricket, the various ways in which the balls are seen to come to the striker are the stimuli, for each variation of which there is a precise and complex form of response in the mode of returning the ball." (Jastrow, "The Time-relations of Mental Phenomena.")

for the act. It is essential that all should understand clearly what the act is and what attitude to take. Exp. 1 will represent simple reactions; all the following experiments represent complex reactions. It is in the latter that we measure the time of mental processes according to the plan here adopted.

1. Simple Reaction. *a. Visual.*—The signal shall be the quick downward movement of a pencil, and this signal shall be passed as rapidly as possible from one to another. Let the class form a circle and face away from the center. At the conductor's command "Ready!", each one shall raise a pencil into plain view of the person to his right; and, about three seconds after the conductor's warning "Now!", the timer shall simultaneously start the stop-watch and give the signal to the person at his right, who shall in turn give it to the one at his right, and so on, the signal being passed as rapidly as possible until it reaches the timer again; and he, instead of passing it on, shall stop the stop-watch.

In this and each of the following experiments make five successive trials; compute the average of the five trials and divide by the number of participants.

b. Auditory.—The signal shall be the exclamation "Up!". Let all keep their eyes closed. In other respects proceed as in Exp. 1 *a.*

c. Tactual.—The signal shall be a tap on the right shoulder. Let each one turn 90° to the right and, at the conductor's command "Ready!", place the tip of the index-finger of the right hand so that it all but touches

the right shoulder of the person in front of him. Let all keep their eyes closed. In other respects proceed as in Exp. 1 a.

The method of measurement here used is crude. The time-measurement is not fine or exact enough; the signal-response is too indefinite; each participant labors under different conditions; there is little opportunity for introspection; the practice is inadequate and there are many other shortcomings. Yet the experiment serves very well to bring out the experience of time-relations.

In the laboratory the exact experiments are made with chronoscopes or chronographs which measure small intervals of time accurately. A single observer is isolated in an observation-room from which all disturbing stimuli may be excluded. The signal and the response are simplified and made more exact. The observer is trained, numerous trials are made, the variability of the records is computed, the reaction is fractionated* for the purpose of the introspection, and the conditions may be controlled and regulated in great detail.

These "simple reactions" may be reduced to their component parts and, under certain conditions, the time of each of these components may be measured. The complexity of the process becomes apparent when we attempt to trace the physical and the mental steps in the act as in the following outline.

* That is, the observer introspects one aspect of the reaction in one set of experiments and then repeats the experiment and introspects another aspect, etc.

THE PHYSICAL PROCESS

1. The response of the sense-organ* and the transmission of the nerve-impulse to the cortex of the brain.

2. The progress of this impulse through the cortex.

3. The transmission of the nerve-impulse to the muscles, the response of the muscles, and the transmission of sensory impulse from the muscles to the cortex.

THE MENTAL PROCESS

1. The idea of the signal in expectant attention.

2. The perception of the signal, the association of the signal with the response, and the fiat of the will to respond.

3. The idea of the movement followed by sensation of the movement.

The very incompleteness and arbitrariness of this outline serves to bring out the complexity of the act. These three steps are all complex, both on the physical and the mental sides. The real reaction consists in the second step, in which there is a direct correlation between the mental and the neural process. So far as the mental act is concerned, the first step is merely a preparation and the third step is merely a consequence of the reaction. Of the total act, the reaction proper (the second step) occupies but a small portion of the time. There are neural processes in the cortex which correspond to all three steps on the mental side.

Here, then, we have not measured the time of the mental act of reaction, but the time of a unique set of physical and mental processes in which the conscious

*The transmission of the sound-waves through the ear and their conversion into a nerve-impulse; the overcoming of the inertia of the retina; or the overcoming of the inertia of the tactual sense-organ.

reaction is the essential element. The simple reaction becomes simpler and shorter, as well as more uniform and irresistible, with practice; and it tends to be less and less emphatic in consciousness until it becomes practically automatic. All this is implied in and characteristic of the acquisition of skill in any sort of activity. Skill means a quick, uniform, appropriate, and but faintly conscious act.

Life is a series of reactions. Therefore, in selecting some of these for experimentation, we may have great variety in conditions. Among the principal variables in simple reactions are the following: the nature of the impression or signal, the strength of the stimulus, the mode of reaction, the direction of attention, expectation, distraction, degree of concentration, practice, fatigue, individual differences, mental and physical state of health, the influence of stimulants, the influence of mental encouragement or discouragement, etc.

Take one of these, the direction of attention. We find three characteristic types of simple reaction with reference to this: the sensory, in which attention is directed to the stimulus; the motor, in which attention is directed to the response; and the central, in which attention is not focused upon either stimulus or response exclusively, but is allowed to oscillate or take a sort of middle ground. The motor is the quickest and most effective form, and there is a tendency to pass from the other types to this with practice. It may become so simple as to be purely a cerebral reflex.

Or take practice. Practice shortens the reaction-time so rapidly that it becomes a disturbing factor in the

present experiments. The gain by practice in Exp. 1 *c* may so reduce the time in Exp. 2 that the additional factor there involved may not show appreciably in the time. It is customary to distribute the practice evenly among trials which are to be compared. If time had permitted it, that should have been done in the present experiments.

2. **Discrimination.**—The signal shall be a tap, as in Exp. 1 *c*, but it may be given on either shoulder, and the person touched shall respond as soon as he knows which shoulder was touched, but he must determine beforehand which side he shall touch; i.e., the signal shall not determine what the response shall be, but the response shall not be given until the signal has been distinguished as a right-side or a left-side signal. Let each one hold the tip of a finger close to each shoulder of the person in front of him. In other respects proceed as in Exp. 1 *c*.

This act involves the simple reaction to touch plus discrimination; to get the discrimination-time, subtract the time in Exp. 1 *c* from the time in this experiment.

3. **Choice.**—The signal shall be a tap on either shoulder, as in Exp. 2, but the response must be made on the same side as the signal is received, i.e., the person touched must select one of two possible responses according to directions after he has received the signal. In other respects proceed as in Exp. 2.

This act involves the reaction after discrimination, as in Exp. 2, plus the selective choice; to get the time of the choice, subtract the time in Exp. 2 from this.

Discrimination and choice are common acts in life.

The experiments might have been varied as to the number of distinctions or choices, the degree of similarity of the impressions, the specific nature of the impressions, foreknowledge of the conditions, adaptation to the individual, etc.

Discrimination and choice are clearly mental processes. Exps. 2 and 3 illustrate how we may isolate one process after another for the measurement of its duration, for introspection, and for the building up of a complex mental act of which the elements are known and under control.

4. **Cognition.**—The signal shall be a word, and the response shall be another word, predetermined, but spoken only as soon as the signal-word has been “cognized”. Each response becomes the signal for the next person. In other respects proceed as in Exp. 1 *a*.

This act involves reaction after cognition; to get the cognition-time, subtract the simple reaction to sound (1 *b*) from this.

5. **Free Association.**—The signal shall be a word, and the response shall be another word—the first word which comes to mind upon hearing the signal. Be sure to call out the first word which can possibly be drawn from the imagery suggested by the signal-word; do not stop to reason or discriminate.* The response becomes the signal for the next, and so on. In other respects proceed as in Exp. 4.

* As in the experiments on the laws of association, it is all-important that the response shall be immediate and unreflective.

This act involves simple reaction, cognition, and free association; to get the time of the free association, subtract the time in Exp. 4 from this.

6. Restricted Association: Memory.—The signal shall be a word, and the response shall be another word which begins with the final letter of the signal. The response becomes the signal for the next, and so on. In other respects proceed as in Exp. 4.

This act involves simple reaction, cognition, and a partially restricted association; to get the time of this association, subtract the time in Exp. 4 from this.

7. Judgment.—The signal shall be the naming of two edibles, and the response shall be the naming of the one of these two which is preferred and one other edible thought of beforehand. The response becomes the signal for the next, and so on. In other respects proceed as in Exp. 4.

To get the time of judgment proper, measure the time of simple reaction after cognition when the signal and the response each consist of two words, as above, and subtract that time from the above gross time.

What have we measured in these complex reactions? We have measured the time of certain purely mental acts of discrimination, choice, cognition, association, memory, and judgment.

But here a warning and qualification is necessary. Complex mental acts are not made up of simple acts, each butting end to end against one another in time. The total process is ordinarily a fusion in which, how-

ever, we may trace essential elements or movements. Thus, although the mode of signaling and the mode of response were identical in Exps. 1 and 2, it is not legitimate to assume that the act of discrimination was sandwiched in between these without modifying them, or that the discrimination followed step 2 in the simple reaction without modifying that step. The act of discrimination gradually fused, on the one hand, with the act of perception of the signal and, on the other hand, with the response. The perception-discrimination-response became one act.

The process of elimination which we have followed therefore does some violence to fact, and many authorities prefer not to use it. For the purpose of most psychological measurements the time of the total complex act is quite as serviceable as the time of an isolated portion of the act. But to measure the time of a mental process strictly, it is necessary to use the method of elimination. And it is justified provided we make no superficial assumptions as to rigid demarcations between mental components of an act and adapt the method to the purpose in hand. Even allowing for a reasonable amount of fusion or overlapping, the time-measurement cannot be far from right. In stating a measurement, the fusion is taken for granted. But it is literally indisputable, e.g., that a given act of discrimination united with a simple reaction lengthens the time by .06 sec.

Someone may contend that these are all purely physiological processes that we have measured. Paradoxical though it may seem, we may admit the correctness of the contention. Modern psychology rests upon

the hypothesis that there is a neural process parallel to every mental process. There is great diversity of opinion as to the nature of the connection, but as to the fact of correlation all are agreed. If we are capable of thinking of these processes in terms of neural action, it is certainly correct and legitimate to do so. Instead of speaking of the mental acts of choice, memory, and judgment, we are at liberty to speak of these acts in terms of their neural concomitants. But what do we know about those? Express the fact of judgment in terms of neural action if you can! Try to get any sort of crude conception of it and you fail. The thing we have experienced, the thing we know most concretely, is the mental act. The fact of a neural concomitant is a good hypothesis, but we have no direct knowledge of the nature of that neural process. We know infinitely more of the mental than of the physical: and the mental is the object of interest and use, the physical being merely a condition; hence we prefer to speak in terms of the mental.

All the mental processes here studied are correlated with the neural process mentioned in step 2 of the outline of simple reaction; there is only a difference in complexity. But cerebral physiology and physiological psychology have very little to tell us in the way of differentiation or description of these central processes.

There are three factors in the customary numerical records of reaction-measurements which are often of equal if not greater significance than the average time of the act. These are the mean variation, the number and kind of errors, and the "mode." The mean variation is a measure of the reliability of the measurement

and the uniformity of the act, and the errors are a measure of the quality of the work done. The mode is that record around which the other records tend to bunch; it may or may not be the average. If a series of records has more than one mode, that indicates that there is some disturbing factor in the measurement. The four factors taken together may measure changes in capacity for quickness, uniformity, and reliability of action.

Knowledge of the time of a mental process is in itself of little value. The value of mental chronometry lies in its being a means of comparison. But the time-measurement becomes a sort of scale or foot-rule which may be employed in a great variety of ways. It has probably been used more than any other mode of measurement of its class in psychology. Indeed, in the early period of experimental psychology, persons would ask if experimental psychology had anything but reaction-experiments to offer.

It may be employed to measure certain changes in capacity, such as the effect upon mental capacity of drugs, different types of exercise, rest, practice, fatigue, effort, mental encouragement, health, ideational type, etc. One method of studying fatigue may serve to illustrate this class of applications. The experiment may be so arranged that an individual engages in a chain of reactions. Each response brings out the signal for the next. He must work at maximum speed and without interruption for a long period, say one, two, or three hours. The reaction is the work which fatigues, and the continuous graphic record of the whole series of re-

action-times contains the measure of capacity for this particular work under various stages of fatigue. The average time in a given minute is the measure of the alertness, the mean variation of the reaction-times during the same period is a measure of the power of application, and the record of the number and kind of errors is a measure of the quality of the work done.

It may be used in the comparison of groups of individuals for statistical, anthropological, educational, commercial, and other purposes. It then shows the minimum time, the variability, and the quality of any act on which we may make the comparison. Do women ordinarily form quicker judgments than men in a given situation? In either case, which is the more likely to be right? How does readiness in form-discrimination vary with age, sex, intelligence, race, type of high-school training, etc.? What element in form is it that gives one sprinter the advantage over another in the start? Which of several candidates has the best natural ability for bank-teller? Such are some of the questions that may be solved by appropriate reaction-measurements.

It may be used as a measure of discernible differences in any of the senses; e.g., to determine which one of two or more grays differs most from a given standard gray. It has been of good service in determining the relative legibility of different kinds of printing-type. It may be used as a means of determining individual peculiarities in imagery, in working out laws of association and memory, in studying manifestations of the subconscious, etc. The controlled conditions which it demands are most favorable to a close and intimate view of the inter-

relations of elements in a complex act. And it is not without value as a rigid discipline in practical exercises for the development of keenness in perception, memory, reasoning, and action.

Historically, interest in the reaction-measurement has passed through several phases. It began over a hundred years ago in the study of the personal equation of astronomers. Then the physiologists became interested in the measurement of the speed of the nerve-impulse by this method. This roused the psychologists to the measurement of the time of mental processes. At the present time the interest of the psychologists centers upon its use as an aid in the analysis and synthesis of action.

