

ROORKEE TREATISE

ON

CIVIL ENGINEERING.

SECTION XIII.

DRAWING,

FOR ENGINEER STUDENTS.

BY

Major E. H. deV. ATKINSON, R.E.,

Principal, Thomason Civil Engineering College, Roorkee.

REVISED BY

C. J. VEALE, F.R.G.S., F.R.A.S.

Professor, Survey and Drawing, Thomason Civil Engineering College, Roorkee.

PART I.

ALLAHABAD:

PRINTED BY THE SUPERINTENDENT, GOVERNMENT PRESS, UNITED PROVINCES.

1922.

On sale at the Book Depot, Thomason College, Roorkee.

[Rights reserved by the Secretary of State for India in Council.]

UNIVERSAL
LIBRARY

OU_174114

UNIVERSAL
LIBRARY

ROORKEE TREATISE
ON
CIVIL ENGINEERING,

SECTION XIII.

DRAWING,

FOR ENGINEER STUDENTS.

BY

Major E. H. deV. ATKINSON, R.E.,

Principal, Thomason Civil Engineering College, Roorkee.

REVISED BY

C. J. VEALE, F.R.G.S., F.R.A.S.,

*Professor, Survey and Drawing, Thomason Civil Engineering
College, Roorkee.*

PART I.

ALLAHABAD:

PRINTED BY THE SUPERINTENDENT, GOVERNMENT PRESS, UNITED PROVINCES.

1922.

On sale at the Book Depot, Thomason College, Roorkee.

[Allrights reserved by the Secretary of State for India in Council.]

PREFACE TO THE ROORKEE TREATISE ON CIVIL ENGINEERING IN INDIA.

THE Roorkee Treatise was originally compiled by Lieut.-Col. J. G. Medley, R.E., in 1866 and issued in two volumes.

The Treatise grew out of the various College Manuals, dealing for the most part with subjects which required special treatment to suit the climate and methods used in India, and has been constantly revised and re-written. It is found advisable now to publish the Treatise in separate Sections, so that each Section can be re-written or revised and brought up-to-date whenever opportunity occurs, to keep pace with modern methods and discoveries.

The Treatise now contains the following Sections :—

Section I.	Building materials	Under revision.
„ II.	Masonry	1920.
„ III.	Carpentry	1910.
„ IV.	Earthwork (revised)	In the Press.
„ V.	Estimating	Ditto.
„ VI.	Buildings (revised)	Ditto.
„ VII.	Bridges	Ditto.
„ VIII.	Roads	1920.
„ IX.	Railways	1919.
„ X.	Irrigation Works	{	Vol. I	1919.
			„ II	1919.
„ XI.	Water-supply	In the Press.
„ XII.	Sanitary Engineering	1917.
„ XIII.	Drawing	{	Part I	1921.
			„ II	1908.
„ XIV.	Surveying	1911.
„ XV.	Surveying (revised)	{	Part I	In the Press.
			„ II	1915.

Dated 4th April, 1922.

PREFACE TO DRAWING,

FOR ENGINEER STUDENTS.

PART I.

THE chief aim in compiling this Manual has been to include in it only such information as is generally necessary to the various grades of Engineers educated in the College. It is divided into two parts. Part I is a preparatory course and with Part II that for Engineers and Draftsmen.

Among the books consulted are—Pulford's Theory and Practice of Drawing, Chambers' Treatise on Civil Architecture, Leoni's Architecture of Palladio, Atkinson's Practical Solid Geometry, and Watson's Descriptive Geometry.

March, 1922.

C. J. V.

CONTENTS.

SECTION XIII—DRAWING.

CHAPTER I.—DRAWING PAPER—INSTRUMENTS— COPYING AND REDUCING DRAWINGS.

	PAGE.
Drawing Paper	1
Instruments	5
Copying and Reducing Drawings	16
Ferrotypes and other Printing Processes	22

CHAPTER II.—PRINTING—GENERAL RULES APPLIC- ABLE TO ALL GEOMETRICAL DRAWINGS— INSTRUCTIONS FOR THE PREPARATION OF FINISHED ARCHITECTURAL AND TOPOGRAPHICAL DRAWINGS— CONVENTIONAL SIGNS.

Printing	36
Italic Printing	38
Instructions for the Preparation of Finished Drawings	40
Scales	40
Flat Washes	40
Drawings required	43
Conventional Signs	44

CHAPTER III.—CONSTRUCTION OF SCALES.

Plain Scales	49
Comparative Scales	51
Diagonal Scales	53
Vernier Scales	54
Examples	55

CHAPTER IV.—PLANE GEOMETRY.

Rules for Drawing	59
Definitions	59
Lines and Angles	61

	PAGE.
Exercises on Lines and Angles	63
Triangles	63
Exercises on Triangles	65
Quadrilateral Figures	66
Polygons	66
Exercises on Quadrilateral Figures and Polygons	68
Circles	68
Circles touching Lines and Circles	69
Exercises on Circles	72
Inscribed Figures	72
Exercises on Inscribed Figures	78
Circumscribed Figures	78
Exercises on Circumscribed Figures	79
Ratio and Proportion	80
Exercises on Ratio and Proportion	81
Areas	81
Exercises on Areas	86
The Sections of the Cone and other Curves	87
Tracery	90
Arches	90
Mouldings	92
Spirals	94

CHAPTER V.—ELEMENTARY SOLID GEOMETRY.

Orthographic Projection... ..	98
Definitions	99
Rules for Lettering Drawings	100

CHAPTER VI.—ELEMENTARY PROJECTION OF SOLIDS.

Definitions	102
The Four cases	103
Solids of Revolution	106
Examples	108

CHAPTER VII.—SECTIONS OF SOLIDS.

Sections	110
Exercises	114

CHAPTER VIII.—ELEMENTARY PROJECTION OF
POINTS, LINES AND PLANES.

The Trace System	117
The Horizontal system	117
Points	118
Examples on Points	119
Lines	119
Planes	120
To find the form of any Plane Figure			124
Exercises	127

CHAPTER IX.—ISOMETRIC PROJECTION.

The Isometric Scale	132
Lines not parallel to the Isometric Axes			133
Curves	133
Exercises	134

CHAPTER X.—THE APPLICATION OF CONTOURS
TO THE DELINEATION OF SLOPING GROUND 136

PART I.

CHAPTER I.

DRAWING PAPER—INSTRUMENTS—COPYING AND REDUCING DRAWINGS.

Drawing paper.—The paper, of good quality but not too highly glazed, should present as smooth a surface as possible. Anything that tends to destroy the surface, such as erasures, excessive rubbing with India-rubber, washing, etc., should be avoided as much as possible. If India-rubber is necessary, it should be used sparingly, and pressed very lightly on the paper.

Bread should be used instead of India-rubber when possible.

For survey work, or any work requiring accuracy, the paper should *never* be wetted, stretched or mounted on a drawing board, on account of the distortion that takes place when the stretched paper is cut off. Unequal expansion or contraction should above all things be guarded against.

If the paper is buckled and requires flattening, the following method should be employed :—Mount the paper as described on page 3. When nearly dry, cut it off the board, and place the sheets flat in a drawer, where they must be allowed to remain for three weeks at least, till they are thoroughly seasoned.

During the time occupied in plotting an extensive survey, the paper which receives the work is affected by the changes which take place in the hygrometrical state of the air, and the parts laid down from the same scale, at different times, will not exactly correspond, unless this scale has been first laid down upon the paper itself, and all the dimensions have been taken from the scale so laid down.

For plotting an extensive survey, and accurately filling in the minutæ, a diagonal or vernier scale may advantageously be laid down upon the paper upon which the drawing is to be made. A vernier scale is preferable to a diagonal scale, because in the latter it is extremely difficult to draw the diagonals with accuracy, and there is no check on its errors; while in the former the uniform manner in which the strokes of one scale separate from those of the other is some evidence of the truth of both. The construction of scales will be treated of further on,

Drawing paper, properly so called, is made to certain standard size as follows :—

Demy	20 inches by 15½ inches.
Medium	22½ „ „ 17½ „
Royal	24 „ „ 19½ „
Super-Royal	27½ „ „ 19½ „
Imperial	30 „ „ 22 „
Elephant	28 „ „ 23 „
Columbier	35 „ „ 23½ „
Atlas	34 „ „ 26 „
Double Elephant	40 „ „ 27 „
Antiquarian	53 „ „ 31 „
Emperor	68 „ „ 41 „

Of those, Double Elephant and Imperial are the most generally useful sizes. Whatman's pressed paper is the quality most usually employed for finished drawings. For ordinary sketching or working drawings, cartridge paper may be used. It bears the use of India-rubber well, receives ink on the original undamped surface freely, shows a good line, but it does not take colours or tints very well. Cartridge paper can be obtained in any length up to 200 yards and in width 53 or 60 inches, and consequently is useful in certain cases. For delicate small-scale line-drawing, the thick blue paper, imperial size, such as is made for ledgers, etc., answers exceedingly well.

Tracing paper is a preparation of tissue paper, rendered transparent and qualified to receive ink lines and tinting without spreading. When placed over a drawing already executed, the drawing is distinctly visible through the paper, and may be copied or *traced* directly in Indian ink; thus an accurate copy may be made with great expedition. Tracings may be folded and stowed away very conveniently; but, if likely to be frequently used, they should be mounted on cloth, or on paper and cloth, with paste.

Tracing paper may be prepared from Double Crown tissue paper by lightly and evenly sponging over one surface with a mixture of one part of raw linseed oil or nut oil and five parts of turpentine. Five gills of turpentine, and one of oil, will go over from 1½ to 2 quires of twenty-four sheets.

Tracing cloth is a similar preparation of linen, and has the advantage of toughness and durability.

In colouring drawings on tracing paper or tracing cloth, the colour must be laid on the reverse side of the paper or cloth to that on which the lines are drawn.

The colour laid on should be much darker than the tint required in the drawing.

Mounting Drawing paper on Drawing boards.—The edges of the paper should be first cut straight, and as near as possible at right angles with each other; also the sheet should be so much larger than the intended drawing and its margin, as to admit of being afterwards cut from the board.

The paper must be first thoroughly and equally damped with a sponge and clean water, *on the opposite side from that on which the drawing is to be made.* When the paper absorbs the water, which may be seen by the wetted side becoming dim, as its surface is viewed slantwise against the light, it is to be laid on the drawing board with the wetted side downwards, and placed so that its edges may be nearly parallel with those of the board: otherwise in using a T-square inconvenience may be experienced.

This done, lay a straight flat ruler on the paper with its edge parallel to, and about half an inch from, one of its edges. The ruler must now be held firmly while the projecting half inch of paper is turned up along its edge; then a brush containing strong paste must be passed once or twice along the turned up edge, after which by sliding the ruler over the pasted border the paper will again be laid flat, and the ruler being pressed down upon it, that edge of the paper will adhere to the board. In exactly the same manner fix down an *adjoining* edge, after which paste the longer of the two remaining edges and finally the shorter edge. If the opposite and parallel edges of the paper are pasted first, a much greater degree of care is required to prevent undulations appearing as the paper dries, and even then success is not always certain. The mounted paper should be allowed to dry gradually, and the process should not be hastened by putting it before a fire or in the strong sunshine, otherwise the unpasted portion, which dries more quickly than the pasted portion, is very apt to tear itself away from the pasted border.

A small quantity of alum is a very good thing to mix with the paste, for it not only enhances the adhesive properties of the paste, but the drawing, when dry, is not so stiff as if paste only is used.

Mounting Drawing paper on Canvas or Linen.—Large sheets, destined for rough usage and frequent reference, should be mounted on linen or canvas. The latter should be well stretched upon a smooth flat surface,

such as drawing board or table, and its edges pasted down as recommended in stretching drawing paper. The flat surface on which the canvas is stretched must either be well varnished or well greased (all superfluous grease being removed), for if this is not done, the subsequent operations will cause the canvas to stick to the surface. The canvas being stretched, strong paste is to be spread upon it with a brush (this is not necessary if fine linen be used) and is to be beaten in till the grain of the canvas is all filled up; this, when dry, will prevent the canvas from shrinking when subsequently removed. Having cut the edges of the paper straight, paste one side of every sheet, and lay them upon the canvas sheet by sheet, overlapping each other a small quantity. If the drawing paper is strong, it is better to let every sheet lie for some five minutes after the paste is put on it; for as the paste soaks in, the paper will stretch, and may be better spread smoothly on the canvas, whereas if it be laid on before the paste has moistened the paper, it will stretch afterwards and rise in blisters when laid upon the canvas. When the paste has soaked in, it is as well therefore to go again over the paper with the paste brush containing very little paste; this is done to moisten the whole surface again and to take off any lumps or superfluous paste; it should then be placed on the canvas as gently as possible, and the centre be pressed down on to the canvas by means of a cloth or something soft; from that work outwards towards the edges, the lines of pressure exerted always tending from the centre. Air bubbles between the canvas and paper may be got rid of by puncturing the spot with a fine needle and then pressing it down with a handkerchief. The paper should not be cut off until thoroughly dry, neither should the drying be hastened, but allowed to take place in a dry room.

The Pencil, either an F or an H, should have a moderately fine point and when being used, should be gently pressed upon the paper, and slightly inclined in the direction in which the line is being drawn, care being taken to keep it, throughout the operation, in the same position with reference to the ruler.

The point should be cut chisel shaped and not conical. The lead can be best kept sharp on a small smooth file, or a piece of fine glass paper.

Indian Ink. — If a stick of ink is used, it should be carefully rubbed up with water, free from grit, and above all, not too thick. One or two trials (by drawing two or three lines on a piece of waste paper), while the ink is being prepared, will ensure a proper consistency.

Great care should be taken to see that it is worked up sufficiently to ensure a thoroughly black line.

Fresh ink should be prepared daily, as stale ink cannot produce neat work and black lines.

Liquid Indian ink, however, can now be obtained of excellent quality, and is in many ways more convenient to use than stick Indian ink.

Instruments.—A case of Instruments generally contains —

- | | |
|---|---------------------------|
| (a) Compasses with movable parts—(1) Plain Point; (2) Pencil Point; (3) Ink Point; (4) Lengthening Bar. | (e) Drawing Pens. |
| (b) Ink Bow Compass. | (f) Plain Dividers. |
| (c) Pencil Bow Compass. | (g) Parallel Ruler. |
| (d) A set of spring Bows—(1) Dividers; (2) Pen; (3) Pencil. | (h) Pricker. |
| | (i) Protractor. |
| | (j) Marquois' Scales. |
| | (k) Sector. |
| | (l) Proportional Compass. |
| | (m) Curves. |

Cheap cases do not contain all these instruments, while some Draftsmen use many other varieties. Other useful instruments are—

- | | |
|------------------|-----------------------|
| (1) Set squares. | (3) A Beam Compass. |
| (2) T-square. | (4) Pump Bow Compass. |

COMPASSES should be held at the top between the forefinger and thumb, with one or more fingers under the hinge to increase or diminish the distance between the points gradually and without a jerk; in all cases the steel points should be guided by the finger of the other hand to the centre of the circle to be drawn, or to the line or scale to be measured. When several concentric circles are to be drawn, great care is requisite to avoid enlarging the centre hole. Persons unaccustomed to the use of compasses are very apt to turn them over and over in the same direction when spacing off a number of equal distances on the divisions of a scale. This necessitates a constant change of the hold by means of the finger and thumb, which often causes the point of the compass to be forced into the paper, or to be jerked off the point fixed altogether. To obviate this, the points of the dividers should be worked alternately above and below the line along which the divisions are being set off; by this means the manipulation will be much more delicate, and there will be no liability of the compasses shifting.

THE DRAWING PEN.—In using a pen, first of all dip the blades in water and then wipe them dry; then with a clean nib or piece of paper take

up some ink and insert it between the nibs. The pen is now ready for use. Hold the pen firmly against the ruler, and, as in the case of the pencil, slightly inclined in the direction of the line to be drawn; be very careful to make both nibs touch the paper, to preserve an even pressure and the same position of the pen with regard to the paper and ruler throughout, and a slow but equal motion along the ruler. By attending to these points, the pen will mark throughout the whole length of the line, an equal thickness of line will be secured, and rugged edges avoided. If after working some time it is found that the ink does not run freely from the pen, it may be amended by passing a small slip of paper between the nibs. Above all things the paper must be kept clean: it should not be touched by the hands more than possible, as the hand makes the paper greasy; and when once the paper has acquired this defect, clean sharp lines are impossible. In inking in over pencil lines, work from the top of the paper towards the bottom; this will prevent any risk of smearing. The pen should be carefully cleaned and dried before being laid aside.

PARALLEL RULERS.—These are of two kinds:—

(1) The Plain Parallel ruler. This should be tested to see that the distances between the pivots on the rulers and the length of the bars are exactly equal in each case.

(2) The Rolling Parallel ruler. This should be heavy enough to ensure stability. It can be tested by running it in one direction and ruling two parallel lines and then reversing the run and noting the error, if any, between the lines drawn at the end of each run.

For accurate work it is best to avoid all parallel rulers and to use Marquois' Scales.

PROTRACTOR.—The most general use of the Protractor is for setting off upon paper any given angle. A variety of scales are, however, drawn on both sides of the instrument which are extremely convenient.

The following is a detailed description of the method of using the Protractor:—

The *Protractor* is generally a rectangular piece of ivory or boxwood 6 inches long by $1\frac{1}{2}$ inches to 3 inches broad. Round three of its edges the angles are marked (the lines radiating from a point in the centre of the fourth side) and should be numbered in two rows, the outside from 0° to 180° , and the inside from 180° to 360° . The method of using it to set off any required angle is easily seen by an example.

Suppose we wish to draw from the point C in the line CA another line making an angle of 40° with CA [*Fig. 1, Plate I*]. Place at C the centre mark on the lower edge of the protractor, and keeping it there, move the protractor round till the line numbered 40° , on the radiated edge, coincides with CA. Draw the line CD along the edge; DCA is the required angle, which has thus been simply transferred from the scale to the paper.

When the line CA is not long enough to admit of the above construction, it will be necessary to place the lower edge of the protractor on that line, with the centre on C [*Fig. 2, Plate I*], then to make a mark against the upper edge at the line indicating the required angle, and removing the protractor, draw a line through the two points.

Protractors are usually of two patterns:—The Draftsman's pattern and the Military pattern.

The Draftsman's pattern contains a variety of scales on both sides—they are simple scales. Those marked 0, 35, 40, 45, 50, 60 being the same as those on the Marquis' Scales described further on (page 9). These numbers simply representing the number of parts into which the inch is divided, i.e., on the 30 scale, thirtieths of an inch can be taken off; on the 40 scale, fortieths of an inch, and so on. The use of these scales is found when we have to employ for a drawing a scale such that one of these divisions represents a convenient unit of measurement, such as 1 foot, 1 yard, 10 feet, 10 yards, etc., etc.

The scales marked In. $\frac{7}{8}$, $\frac{3}{4}$, etc., etc., are also simple proportional scales. The numbers $\frac{7}{8}$, $\frac{3}{4}$, etc., refer to the length of one division, which is divided into 12 parts. That marked In. being one inch long, that marked $\frac{7}{8}$, $\frac{7}{8}$ th of an inch long, and so on. These scales are useful for measurements involving feet and inches on account of the duodecimal minor divisions. They are not generally so convenient, however, as the other scales just described. The diagonal scale is an ordinary one. The inch being divided into 10 parts, 1-100th of an inch being obtained by means of the diagonal lines, where the $\frac{1}{2}$ inch is divided into 10 parts, we can, of course, obtain 1-200th of an inch. The principle of this and the method of construction will be explained further on.

The scale marked Cho. is a scale of chords, and deserves attention. It is constructed in this manner:—Take a quadrant AOB, *Fig. 3*, divide the arc into arcs of 10° , and number these 10, 20, 30, up to 90, from B to A. Join AB, and with B as centre and radii from B to these various divisions describe arcs cutting AB, in the points 10, 20, 30, etc. These

various radii are the chords of the different arcs ; consequently AB is called a scale of chords. Each scale will vary with the length of the radius ; but Euclid IV, 15, proves that the side of a hexagon is equal to the radius of the circumscribing circle ; or, in other words, the radius of the circle = the chord of 60° .

Fig. 3.

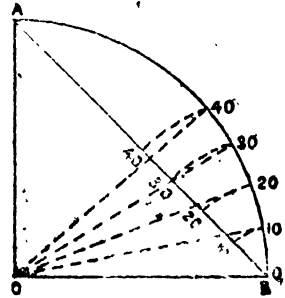

To use the Scale.—With centre C [Fig. 4, Plate I], and radius equal to the distance from zero to 60° on the scale of chords [Fig. 1, Plate I], describe an arc HK, cutting CA in H, and with centre H, and radius equal to the distance from zero to 40° , or other given angle, on the same scale of chords describe an arc intersecting HK in K, join CK ; KCH is the required angle.

This method of protracting angles is much to be preferred to simply laying them off by the protractor, as it is more accurate, and the greater the radius the greater the accuracy.

The Military pattern protractor generally differs from the above in having none of the above scales marked except the diagonal scale. As it is usually used for surveying purposes, in place of the scales described above, scales of one, two, four, six and eight inches to the mile are given, together with a normal scale of horizontal equivalents (for description see Survey Manual). The protractor can also be used as a clinometer, by boring a small hole near the edge of the protractor and suspending a small weight by a thread.

MARQUOIS' SCALES.—The box of *Marquois' Scales* contains two rectangular rulers and a right-angled triangle, of which the hypotenuse or longest side is three times the length of the shortest. Each ruler is a foot long, and has parallel to each of its edges, two scales, one placed close to the edge, and the other immediately within this, the outer being termed the artificial, and the inner the natural scale. The divisions upon the outer scales are three times the length of those upon the inner scale, so as to bear the same proportion to each other that the longer side of the triangle bears to the shorter. Each inner or natural scale is in fact a simply divided scale of equal parts having the primary divisions numbered from the left hand throughout the whole extent of the rule. In the artificial scales the zero point is placed in the middle of the edge of the rule, and the primary divisions are numbered both ways, from the centre point outwards. Each division on this scale

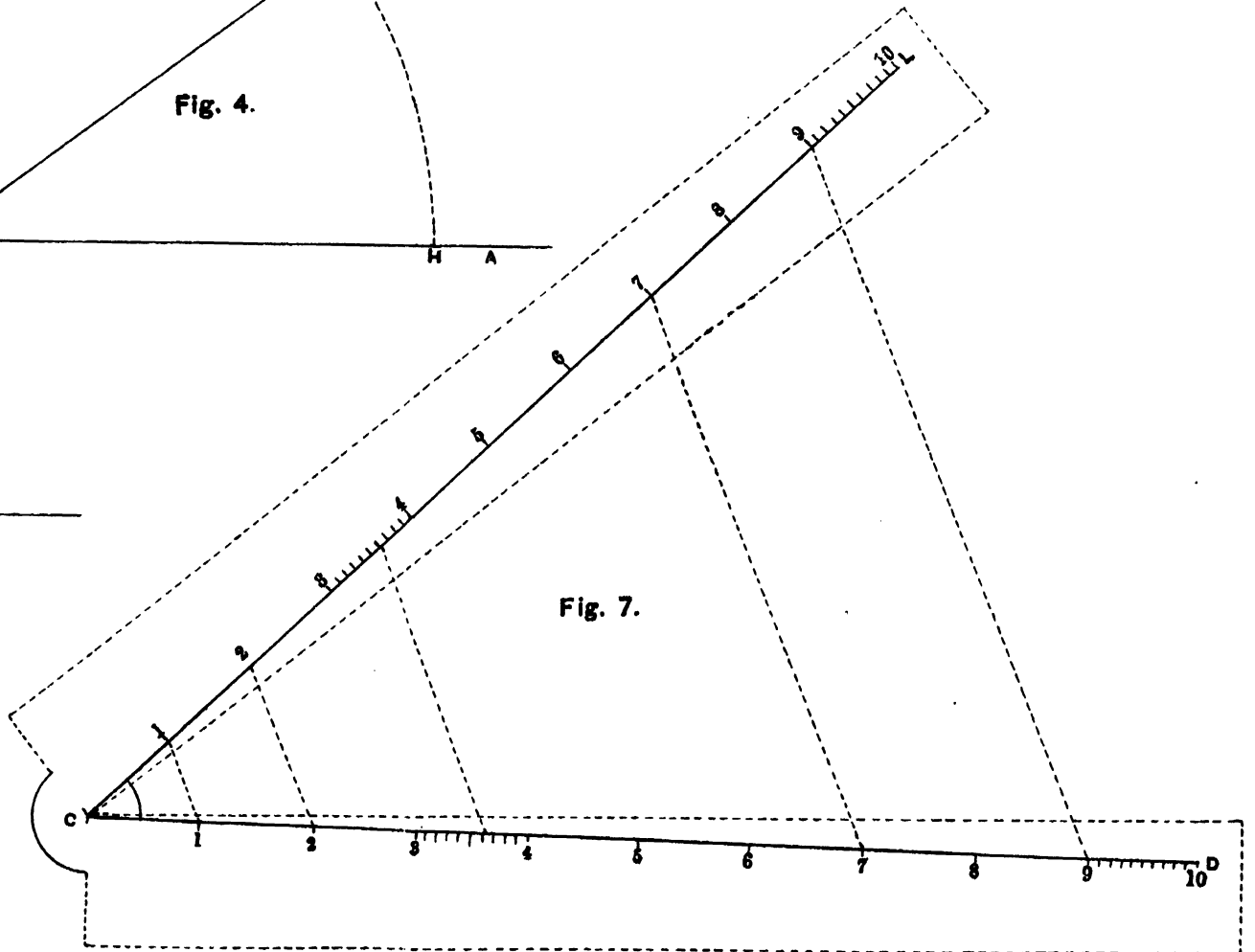
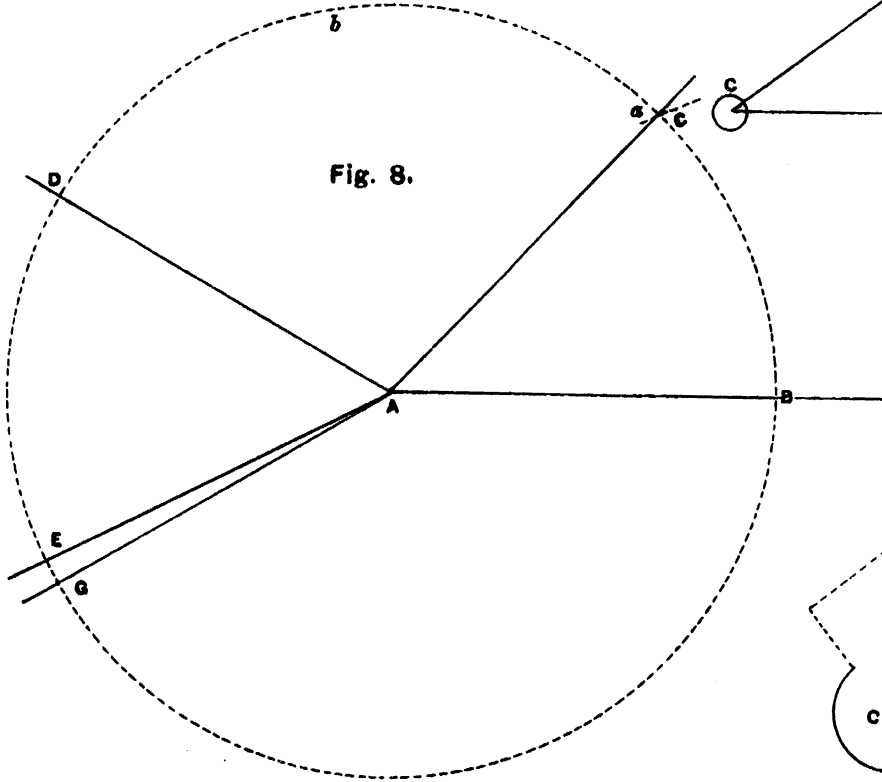
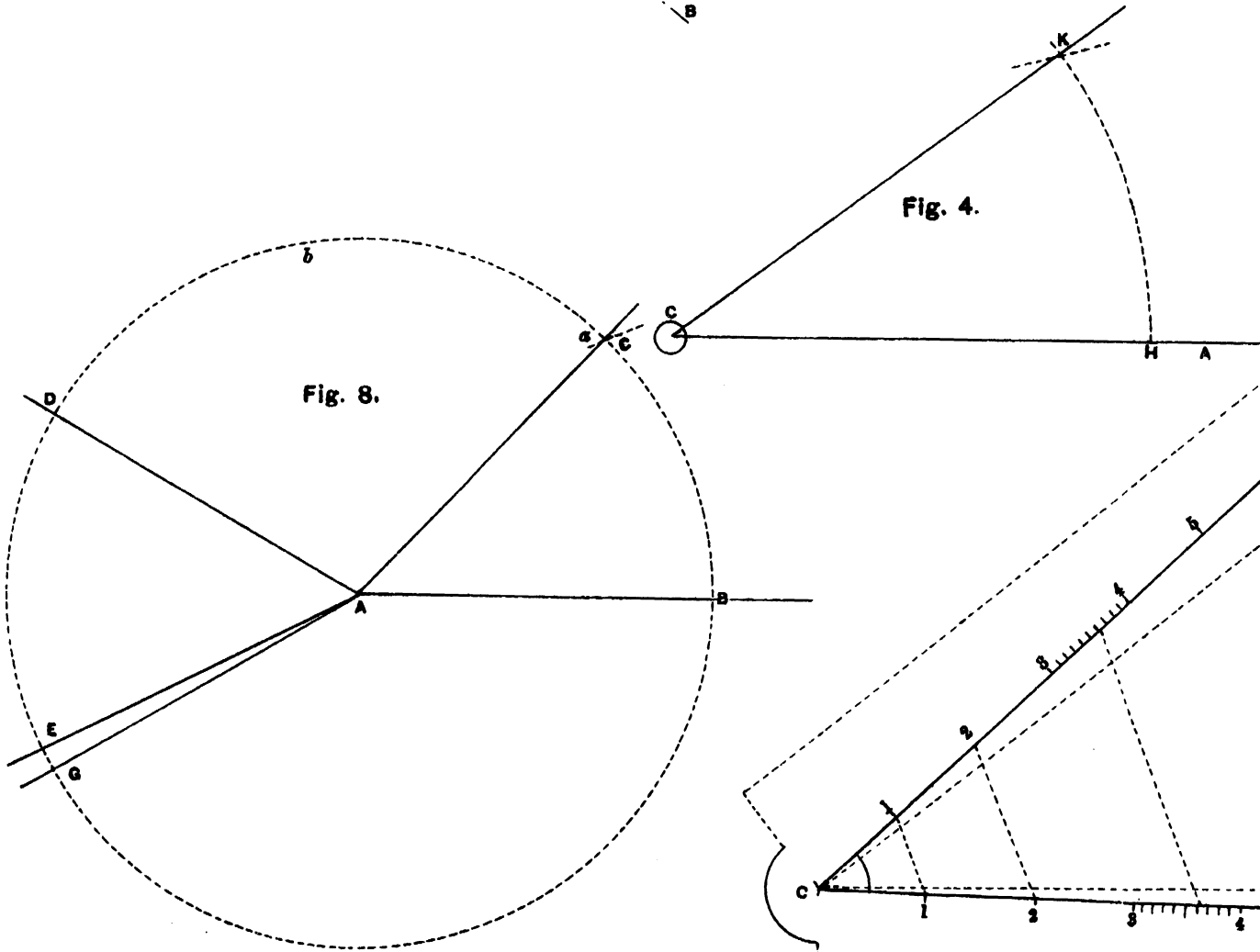
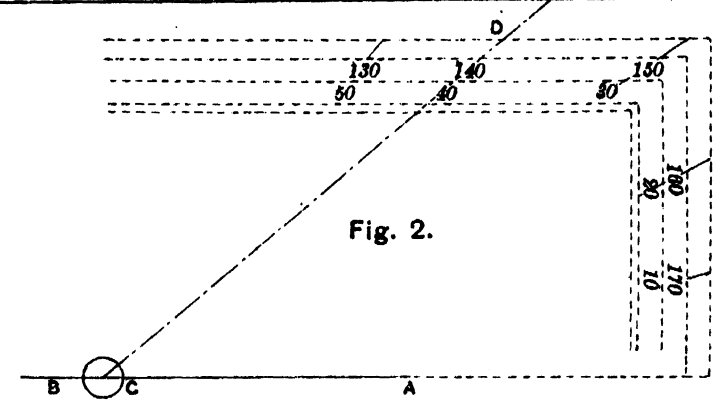
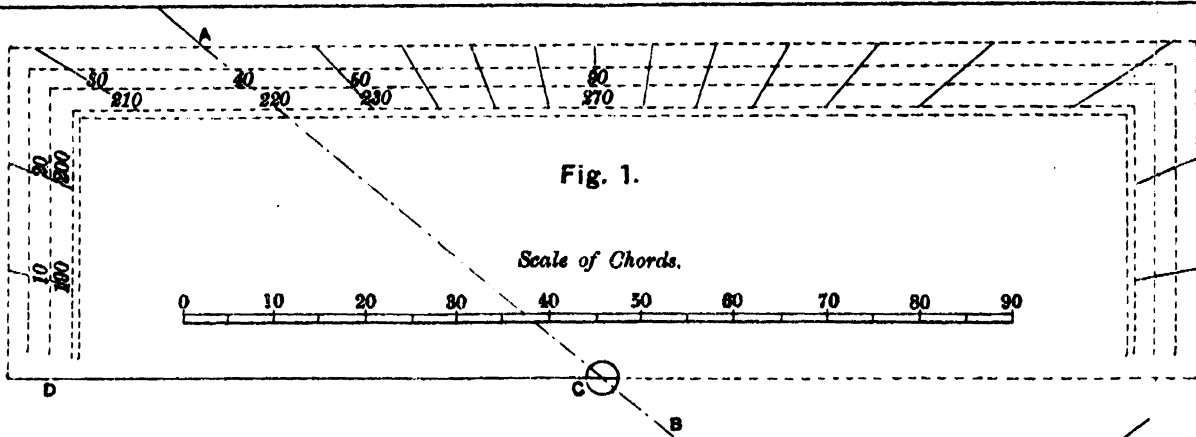

is three times the length of a corresponding division on the natural scale. The triangle has a short line drawn perpendicular to the hypotenuse, near the middle of it, to serve as an index or pointer; and the longer of the two sides has a bevelled edge.

The rectangular rulers have numbers 25, 30, 35, 40, 45, 50, 54, 60, marked on each scale: these numbers simply show how many divisions the inch is divided into on the natural scale; the artificial divisions being three times the natural division we are enabled by the method shown below to draw parallel lines from $\frac{1}{2}$ th to $\frac{1}{60}$ th of an inch apart, or any multiples of these fractions.

To draw a line parallel to a given line at a given distance from it.

1. Having applied the given distance to one of the natural scales which is found to measure it most conveniently, place the triangle with its sloped edge coincident with the given line, or rather at such a small distance from it, that the pen or pencil passes directly over it when drawn along this edge. 2. Set the ruler closely against the hypotenuse, making the zero point of the corresponding artificial scale coincide with the index upon the triangle. 3. Move the triangle along the ruler, to the left or right, according as the required line is to be above or below the given line, until the index coincides with the division or sub-division corresponding to the number of divisions or sub-divisions of the natural scale, which measures the given distance, and the line drawn along the sloped edge in its new position will be the line required.

The proof of this is as follows:—If ABC, *Fig. 5*, represent the triangle in its new position, and the dotted lines represent its original position, by similar triangles ABC, A'AD.

$AD : AA' = BC : BA = 1 : 3$
and, therefore AD contains as many divisions of the natural as AA' contains of the artificial scale.

Fig. 5.

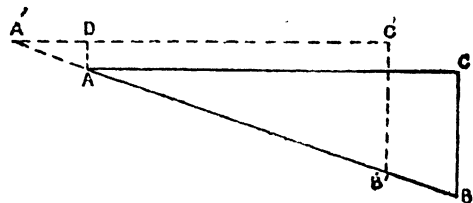

SECTOR.—The Sector is a ruler 12 inches long and about half an inch broad, jointed in the centre so as to allow of its being folded together, in the direction of its depth. A sector either of wood or ivory is generally supplied with ordinary instrument boxes. A more detailed description of its construction is therefore necessary.

The most important scales and the ones which are really of most service in geometrical construction are the line of lines, the line of chords, and the line of polygons.

Line of Lines.—The principle of the use of the line of lines is as follows:—Let the lines AB, AC, represent a pair of sectoral lines, and BC, DE any transverse distances taken on this pair of lines; then, from the construction of the instrument $AB=AC$ and $AD=AE$, so that

$$AB : AC = AD : AE$$

and the triangles ABC, ADE have the angle at A common, and the sides about the equal angle proportional (Euc. VI., 6); they are, therefore, similar,

$$\text{and } AB : BC = AD : DE.$$

From the above, the use of the *line of lines* is self-evident. For example:—

To divide a line 3.11 inches long into 7 equal parts. Take the length of the line into the compasses, and having set one point in the division which is numbered 7, open the instrument till the other point of the compasses meets the 7th division on the other limb, then the distance between the two points marked 1, will obviously be the $\frac{1}{7}$ th part of the line as required, or equal to .44 of an inch nearly; but it must be observed that owing to the inevitable imperfection and wear of all instruments, this distance must be stepped along the line to ascertain whether it may not require a small correction.

Example 1.—To determine $\frac{2}{7}$ ths of a line 3 inches long; take that length in the compasses and open the sector until it coincides with the primary divisions 7, 7, when the distance between 2 and 2, is that required.

Example 2.—To find $\frac{9}{23}$ rds of a line 4.09 inches long. [Fig. 7, Plate I.]

Since there are only ten primary divisions, recourse must be had to the secondary divisions to solve this problem. In order to bring the construction some distance from the centre, which will insure the accuracy of the result, multiply the numerator and denominator of the fraction by some number which will make the denominator when so multiplied near, but not greater than 100: in this case 4 is a convenient multiplier; then $\frac{9}{23} = \frac{36}{92}$, having taken off 4.09 inches in the compasses, make that length a transverse distance at the secondary division 92, then the transverse distance at 36 will give the part required.

Note.—A *lateral distance* is a distance measured from the centre along any sectoral line.

A *transverse distance* is a distance measured from a point in one line of a pair of sectoral lines to the corresponding point in the other line.

Fig. 6.

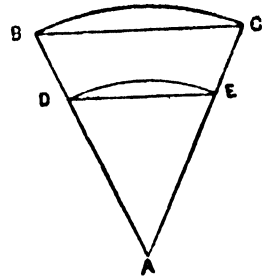

Line of Chords.—This scale is similar to the one marked Cho. on the protractor, and is used for the same purpose; but the double scales of chords on the sector are generally more useful than the single scale on the protractor; for on the sector the radius with which the arc is to be described may be of any length between the transverse distance of 60 and 60 when the legs are closed, and that of the transverse of 60 and 60 when the legs are opened as far as the instrument will admit of; but with the scale on the protractor, the arc described must always be of the same radius.

To lay down an angle which shall contain a given number of degrees:—

1. When the angle is less than 60° , say 46° .

Make the transverse distance of 60 and 60 equal to the length of the radius of the circle, and with that opening describe the arc BC [Fig. 8, Plate I.]. Take the transverse distance of the given degrees 46° , and lay this distance on the arc from the point B to C. Join AC, AB; the angle CAB is the one required.

2. When the angle contains more than 60° , say 148° .

Describe the arc BCD, making the radius equal to the transverse distance of 60 and 60, as before. Take the transverse distance of $\frac{1}{2}$ or $\frac{1}{3}$, etc., of the given number of degrees, and lay this distance on the arc twice or thrice, as from B to *a*, *a* to *b* and *b* to D. Join BA, AD; BAI is the angle required.

3. When the required angle contains less than 5° , suppose $3\frac{1}{2}^\circ$, it will be better to proceed thus:—With the given radius, and from the centre A, describe the arc DG, and from some point D lay off the chord of 60° , thus giving the point G such that the angle DAG = 60° . From the same point D lay off in the same direction the chord of $56\frac{1}{2}^\circ$ (= $60^\circ - 3\frac{1}{2}^\circ$), thus giving the point E such that the angle DAE = $56\frac{1}{2}^\circ$. Then the angle GAE is the angle required.

Line of Polygons.—The line of polygons is chiefly useful for the ready division of the circumference of a circle into any number of equal parts from 4 to 12; it forms, therefore, a ready means of inscribing regular polygons in a circle. To do this, set off the radius of the given circle (which is always equal to the side of the inscribed hexagon) as the transverse distance of 6 and 6 upon the line of polygons. Then the transverse distance of 4 and 4 will be the side of the inscribed square; that of 5 and 5 the inscribed pentagon, that of 7 and 7 the inscribed heptagon and so on.

If it be required to form a polygon upon a given right line, set off the extent of the given line as a transverse distance between the points upon the line of polygons, answering to the number of sides of which the polygon is to consist ; as for a pentagon between 5 and 5, or an octagon between 8 and 8, then the transverse distance of 6 and 6 will be the radius of the circle which is to be described so as to contain the given line, if now we set off the length of this line round the circumference of the circle, we shall obtain a regular polygon of the required number of sides.

PROPORTIONAL COMPASSES.—These, though of great service in many problems which occur in plan drawing, are not supplied with the ordinary Instrument boxes. A description of the method of using them is, however, considered necessary.

They consist of two equal and similarly formed parts or limbs **AE** and **BD** (see *Fig. 9*), opening upon a centre **C**, and forming a double pair of compasses whose points are **A**, **B**, **E**, **D**. When shut up, the two limbs appear as one, and a small stud fixed in one fits into a notch made in the other, and retains the instrument in its closed position. The adjustment of the instrument must be made when both limbs coincide ; as it is only in this position that the centre piece **C** can be moved up and down. The

Fig. 9.

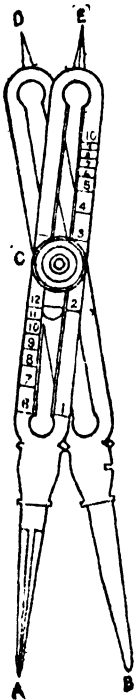

chief use of the Proportional Compasses is to reduce or enlarge a drawing in any given proportion. To do this the centre **C** is shifted up or down as required, thereby shortening one set of legs and lengthening the other. The distance on the original drawing is measured off with one set of legs, and the distance shown by the other pair will be the corresponding length, reduced or enlarged from the original length in a ratio depending upon the position of the centre **C**. As in the Sector, various other geometrical constructions can be performed by means of the different scales given on either side of the limbs ; it will be sufficient, however, to describe the method of adjusting the instrument for laying off distances on a plan, the scale of which is to bear a certain proportion to that of a given plan.

On the face of each limb there are four sets of divisions, one denominated "Lines," a second "Circles," a third "Planes," and the fourth "Solids." It is with the first of these, viz., the Line, of Lines that we have to do.

When the zero of the centre on the dove-tailed sliding piece is set to the division marked I on the line of lines, and clamped by turning the mill headed screw C, any opening of the compasses will give equal distances at both extremities. When the zero is in a similar manner set to 2 on the line of lines, the proportions between the openings of the points A, B, and the corresponding openings of the points D E will be as 2 to 1, in other words, any distance set off by D E will be half the distance measured by A, B. Similarly if the zero be set to 3, the distance set off will be to the distances measured as 1 to 3, and so on for the other divisions which extend up to 10.

CURVES.—For curves which are not circular, but variously elliptic or otherwise, “French” curves made of thin wood, of variable curvature, are very serviceable. The two examples (*Figs. 10 and 11*) have been found from experience to meet almost all the requirements of ordinary drawing practice. Whatever be the nature of the curve, some portion of one of these “French” curves will be found to coincide with its commencement and other portions can be used to complete the curve.

Fig. 10.

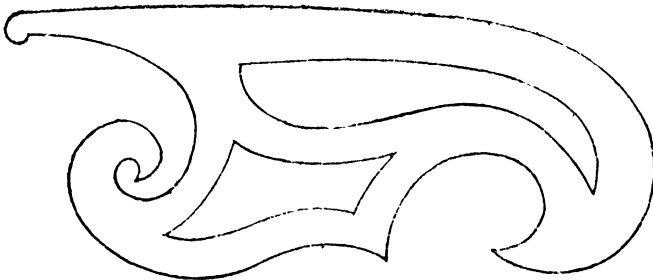

“French” Curve—One-fourth full size

Fig. 11.



“French” Curve—One-fourth full size.

SET-SQUARES.—A few Set-squares of various sizes are useful. They consist of triangular pieces of wood, celluloid or vulcanite. One angle is invariably a right angle, and the other angles may be 45, 30 and 60 degrees. Set-squares are used in conjunction with a straight-edge for drawing lines at right angles to each other, or for drawing parallel lines.

T-SQUARE.—The T-square (*Fig. 12*) is a blade or “straight-edge” *a*, usually of mahogany, fitted at one end with a stock *b*, applied transversely

at right angles. The stock being so formed as to fit and slide against one edge of the board, the blade reaches over the surface, and presents an edge of its own at right angles to that of the board, by which parallel straight lines may be drawn upon the paper. To suit a 41-inch board the blade should measure 40 inches long clear of the stock, or one inch

Fig. 12.

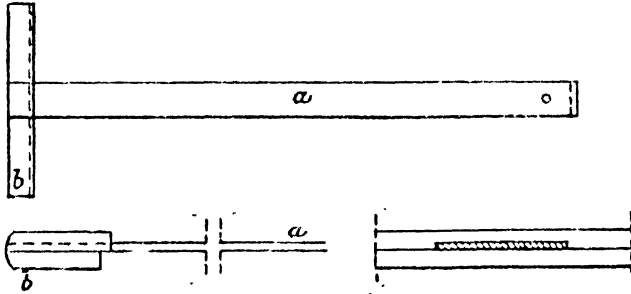

Details of T-square.

shorter than the board, to remove risk of injury by overhanging at the end: it should be $2\frac{1}{2}$ inches broad by $\frac{3}{32}$ inch thick, as this section makes it sufficiently stiff laterally and vertically. If thinner, the blade is too slight and too easily damaged by falls and other accidents, and is liable to warp; if thicker, it is too heavy and cumbersome; if broader, it is heavier without being stiffer. The tip of the blade may be secured from splitting by binding it with a thin strip inserted in a saw-cut as shown. The stock should be 14 inches long, to give sufficient bearing on the edge of the board, 2 inches broad, and $\frac{3}{8}$ inch thick, in two equal thicknesses glued together. With a blade and stock of these sizes a well-proportioned T-square may be made, and the stock will be heavy enough to act as a balance to the blade, and to relieve the operation of handling the square. The blade should be sunk flush into the upper half of the stock on the inside, and very exactly fitted. It should be inserted full breadth, as shown in the figure; notching and dove-tailing is a mistake, as it weakens the blade and adds nothing to the security. The lower half of the stock should be only $1\frac{1}{4}$ inches broad, to leave a $\frac{1}{4}$ inch check or lap, by which the upper half rests firmly on the board, and secures the blade lying flatly on the paper.

One-half of the stock *c* (*Fig. 13*) is in some cases made loose, to turn upon a brass pin to any angle with the blade *a* and to be clenched by a screwed nut and washer. The turning stock is useful for drawing parallel

lines obliquely to the edges of the board. In most cases, however, the sector, and the other appendages above described, answer the purpose, and do so more conveniently. A square of this sort should be rather as an addition to the fixed square, and used only when the bevel edge is required as it is not so handy as the other.

The edges of the blade should be very slightly rounded, as the pen will thereby work the more freely. It is a mistake to chamfer the edges—that is, to plane them down to a very thin edge, as is sometimes done, with the object of insuring the correct position of the lines; for the edge is easily damaged, and the pen is liable to catch or ride upon the edge, and to leave ink upon it.



A small hole should be made in the blade near the end, by which the square may be hung up out of the way when not in use.

Drawing Square with Swivelling Stock.

No varnish of any description should be applied to the T-square, or indeed to any of the wood instruments employed in drawing. The best and brightest varnish will soil the paper. The natural surface of the wood, cleaned and polished occasionally with a dry cloth, is the best and cleanest for working with

BEAM COMPASSES — Beam compasses are used for setting off accurate distances which are beyond the sketch of an ordinary compass.

They consist of two beam heads moving on a graduated bar of wood or

Fig. 14.

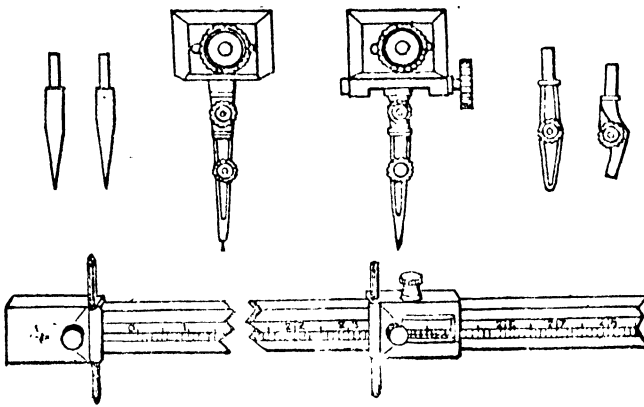

electrum. Each beam head has a clamp to hold a pointer or pencil. One of these heads is fixed at one end of the bar, and is provided with a

vernier screw for making fine adjustments, while the other is free to move up and down on the bar and can be clamped in any position.

If a scale is given on the bar, it should never be used for accurate work, but distances should be taken direct from a scale drawn on the paper on which the plan has been plotted. Beam compasses are used to test the rectangular margins of sheet, and the perpendicularity of the central meridian line of a survey to a parallel of latitude, by the usual method of checking right angle, viz., measuring 3 and 4 (or their multiples) on the perpendiculars, and testing the hypotenuse with the distance 5 for its multiple.

PUMP BOW COMPASS.—Besides the ordinary spring bow compasses a pump bow compass is also obtainable. It consists of a long steel needle arm encased in a sliding sleeve, to which is attached a removable ink or pencil point. It is by means of this sleeve that the pen or pencil point revolves freely round the needle arm, can be lifted from the paper after drawing a circle, and adjusted for a different radius.

This new pattern compass has proved very useful for drawing small circles with ease, accuracy, and quickness in survey plots or other drawings containing a large number of small circles. It is supplied in a separate case.

Copying and Reducing Drawings.—*Copying Plans, Maps, etc., by hand.*—There are several methods of doing this when the copy is to be of the same size as the original, such as placing the plan to be copied with a sheet of paper over it on tracing glass, placed in such a position that a strong light may fall on *it from behind* and then tracing it off. Or by placing a sheet of thin paper, having its under-side blackened (by rubbing finely powdered black lead, or a soft lead pencil over it), on the sheet of paper that is to receive the copy, the original being placed over both, and the whole made steady by placing weights thereon: all the lines of the copy must now be carefully passed over with a fine tracing point, and with a pressure proportionate to the thickness of the paper: the paper beneath will receive corresponding marks forming an exact copy, which may afterwards be inked in. All these systems of copying hurt, in a more or less degree, the original drawing. Tracing cloth is generally used in Engineer's office. This cloth admits of very fine detail work being traced off, and will permit colour being applied. The colour should be applied on the reverse side of the cloth, as it is difficult to get it to lay evenly on the cloth. Such unevenness in a flat shade scarcely shows when seen through the tracing cloth. Tracing paper was formerly much used,

but has now been entirely superseded by tracing cloth. In India, tracing paper soon gets dry and brittle, and will not stand handling.

When the drawing is to be reduced or enlarged, the Pantagraph, Eidograph, the Method of Copying Squares, or the lens, must be resorted to.

The Pantagraph consists of four rulers, AB, AC, DF, and EF (*Fig. 15*), made of stout brass. The two longer rulers, AB and AC, are connected together as A, and have a motion round it as a centre. The two shorter rulers are connected in like manner with each other at F, and with the longer rulers at D and E, and being equal in length to the portions AD and AE of the longer rulers, form with them an accurate parallelogram, ADFE, in every position of the instrument. Several ivory castors support the instrument, parallel to the paper, and allow it to move freely over it in all directions. The arms AB and DF are graduated and marked $\frac{1}{2}$, $\frac{1}{3}$, etc., and have each a sliding index, which can be fixed at any of the divisions by a milled-headed clamping screw, seen in the engraving. The sliding indexes have each of them a tube, adapted either to slide on a pin rising from a heavy circular weight, called the fulcrum, or to receive a sliding holder with a pencil or pen, or blunt tracing point as may be required.

When the instrument is correctly set, the tracing point, pencil, and fulcrum will be in one straight line, as shown by the dotted line in the figure. The motions of the tracing point and pencil are then each compounded of two circular motions, one about the fulcrum, and the other about the joints at the ends of the rulers upon which they are respectively placed. The radii of these motions form sides about equal angles of two similar triangles, of which the straight line GC, passing through the tracing point, pencil and fulcrum, forms the third side. The distances passed over by the tracing point and pencil, in consequence of either of these motions, have then the same ratio; therefore, the distances passed over, in consequence of the combination of the two motions, have also the same ratio, which is that indicated by the setting of the instrument.

The diagram represents the pantagraph in the act of reducing a plan to a scale of half the original. For this purpose the sliding indexes are first clamped at the divisions upon the marks marked $\frac{1}{2}$; the tracing point is then fixed in a socket at C, over the original drawing; the pencil is next placed in the tube of the sliding index upon the ruler DF, over the paper to receive the copy; and the fulcrum is fixed to that at G upon the

ruler AB. The instrument being now ready for use, if the tracing point at C be passed delicately and steadily over every line of the plan, a true copy, but of one-half the scale of the original, will be marked by the pencil on the paper beneath it. The fine thread represented as passing from the pencil quite round the instrument to the tracing point at C, enables

Fig. 15.

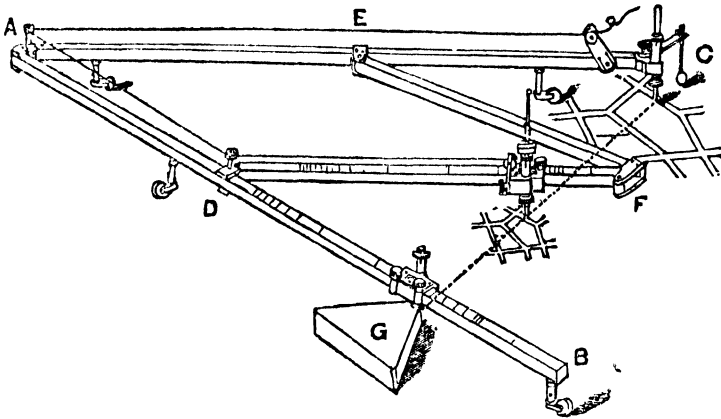

the draftsman at the tracing point to raise the pencil from the paper, whilst he passes the tracer from one part of the original to another, and thus to prevent false lines from being made on the copy. The pencil holder is surmounted by a cup, into which sand or shot may be put, to press the pencil more heavily on the paper, when found necessary.

If the object is to enlarge the drawing to double its scale, then the tracer must be placed upon the arm DF, and the pencil at C: and if a copy is required of the same scale as the original, then the sliding indexes still remaining at the same divisions upon DF and AB, the fulcrum must take the middle station, and the pencil and tracing point those on the exterior arms, AB and AC, of the instrument.

The Eidograph, which is represented in the accompanying engraving (*Fig. 16*), is a far superior instrument to the pantograph.

It has but one, in place of several points of support on the drawing, and is susceptible of more accurate adjustment. It can be used to reduce plans in any desired proportion, instead of following fixed fractions.

The point of support when the instrument is at work is a heavy weight shown at H, from the under-side of which three or four projecting needle points fix the instrument firmly to the drawing paper. Springing from this weight is a short standard or fulcrum, attached to a sliding box, K, in which slides the centre beam, C, and to any part of which it may be clamped by means of a clamping screw.

At the ends of the central beam are two pulley wheels, J, J, the centre pins of which revolve in sockets at the ends of the beam. Two steel bands, I, I, attached to the pulley wheels, give them an exactly simultaneous motion, and these bands have a screw adjustment, L, by means of which they may be tightened.

The arms A and B are made to slide through boxes under the pulley wheels, and may be clamped at any proportion of their lengths in the same manner as the central beam, C, may be made to slide and clamp in the box K.

The arm B carries a tracing point, G, and the arm A carries a pencil point, D. The pencil holder may be raised by means of a cranked lever, F, attached to a cord, E, which passes over the central beam, and thence to the tracing point, G.

The two arms and the beams are divided into 200 equal parts, which are figured 100 each way from the centre and may be read to 1000th by means of the verniers on the sliding boxes.

There is a loose weight which may be attached when the instrument has been set, the object of which is to steady it when there is a great difference in the proportions to which the instrument is being worked.

It will be observed that the pulley wheels give the easiest possible motion: these wheels should be of exactly equal diameter, and as

Fig. 16.

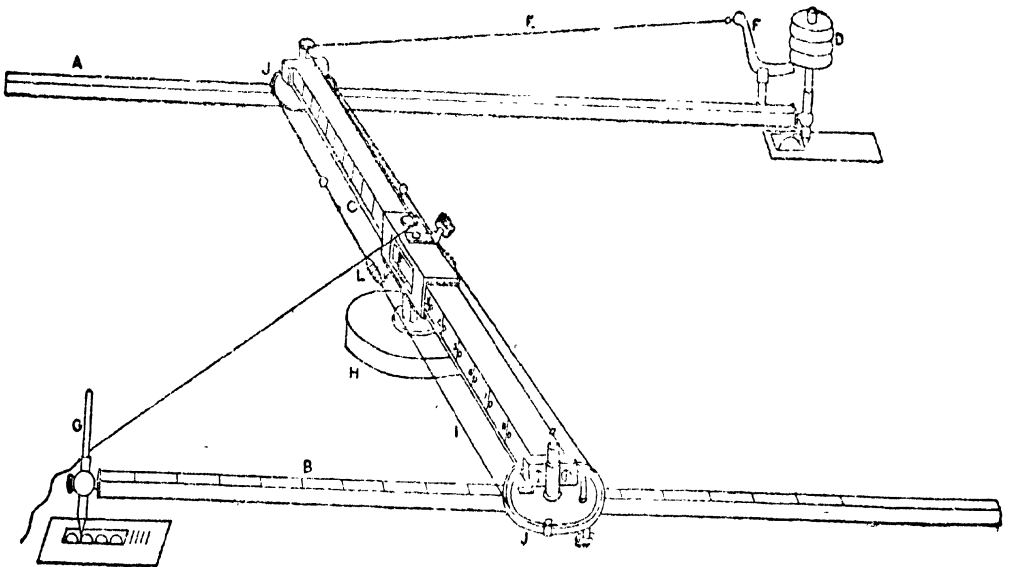

they are turned in a lathe, this equality may be obtained to the greatest perfection.

To bring the instrument into adjustment let the verniers be set to zero, which will bring them to the centres of the arms and of the central beam; place the arms at right angles to the beam, as near as you may guess, and make a mark with the tracer and pencil point, and turn the instrument round so as to bring the pencil point into the mark made by the tracer; by doing this you will make the tracer move exactly to the mark previously made by the pencil, if the instrument is in adjustment; otherwise, the error in difference should be bisected, and the adjusting screws on the band should be moved until the tracing point comes exactly into the bisection.

The following is the ordinary rule for using the instrument:—"Multiply the difference between the denominator and numerator by 100, and divide the result by the sum." For example, to reduce to $\frac{1}{2}$ of the original

$$\frac{100(2-1)}{8} = \frac{100}{8} = 33 \cdot 3.$$

Set this number on all three arms.

Copying or reducing a drawing by means of squares.—Let *Fig. 17* in the annexed engraving represent a plan of an estate, which it is required to copy to a reduced scale of one-half. The copy will therefore be half the length and half the breadth, and consequently will occupy but one-fourth the space of the original.

Draw the lines FI, FG, at right angles to each other; from the point F towards I and G, set off any number of equal parts; as *Fa, ab, bc*, etc., on the lines FI and *Fi, ik, kl*, etc., on the line FG, from the points in the line FI, draw lines parallel to the other line FG, as *aa, bb, cc*, etc., and from the points on FG, draw lines parallel to FI, as *ii, kk, ll*, etc., which being sufficiently extended towards I and G, the whole of the original drawing will be covered with a network of small but equal squares. Next draw upon the paper intended for the copy a similar set of squares, but having each side only one-half the length of the former, as is represented in *Fig. 18*. It will now be evident that if the lines AB, BC, CD, etc. (*Fig. 17*), be drawn in the corresponding squares in *Fig. 18*, a correct copy of the original will be produced, and of half the original scales. Commencing then at A, observe where in the original the angle (A) falls, which is towards the bottom of the square, marked *de* in the line FI. In the corresponding square, therefore, of the copy, and in the same proportion towards the left hand side of it, place the same point in the copy; from thence trace where the curved line AB crosses the bottom

line of that square, which crossing is about two-fifths of the width of the square from the left hand corner towards the right, and cross it similarly

Fig. 17.

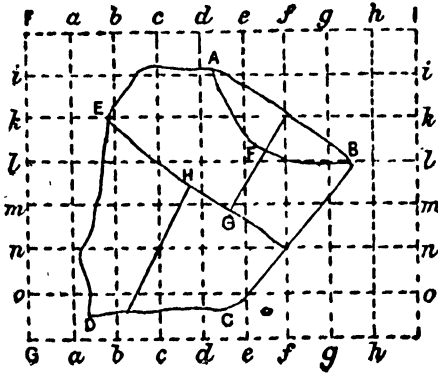
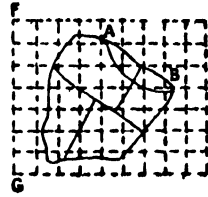

Fig. 18.



in the copy. Again, as it crosses the right hand bottom corner, in the second square below *de*, describe it so in the copy; find the position of the points similarly where it crosses the lines *ff* and *gg*, above the line *ll*, by comparing the distances of such crossings from the nearest corner of square in the original, and similarly marking the required crossings on the corresponding lines on the copy. Lastly, determine the place of the point *B*, in the third square below *gh* on the top line; and a line drawn from *A* in the copy, through these several points to *B*, will be a correct reduced copy of the original line. Proceed in like manner with every other line on the plan, and its various details, and thus will be obtained the plot or drawing, laid down to a small scale, yet bearing all the proportions in itself exactly as the original.

It may appear almost superfluous to remark that the process of enlarging drawings, by means of squares, is a similar operation to the above, excepting that the points are to be determined on the smaller squares of the original, and transferred to the larger squares of the copy. The process of enlarging, under any circumstances, does not, however, admit of the same accuracy as reducing.

It is also as well to remember that when a drawing is reduced to half the scale, the size is diminished to $\frac{1}{4}$ th; or if the scale is $\frac{1}{3}$ rd of the original, then the size will be $\frac{1}{9}$ th; and *vice versa*, if the drawing is enlarged.

The Lens.—A suitable lens fitted to a camera can be used to reduce plans by replacing the ground glass with a sheet of clear glass covered by

fine tracing paper. The drawing or plan to be reduced should be pinned on a vertical stand in strong sunlight, and when focussed to the required scale the lines thrown on the tracing paper can be followed with a fine pencil. The process is trying to the eyes of the operator, but is useful when only one copy of the reduction is required.

Copying Plans, Maps, etc., by Process Work.—When the copy is to be of the same size as the original and only a small number of copies required, the Ferrotyping Process is suitable. For enlargements or reductions of scale, or when a large number of copies are required, no hand work can equal Photo-mechanical Process work. The details of the operations necessary for successful work with this system of reproduction are not suitable for inclusion in a Treatise on Surveying, but a description of the proper method of preparing drawings for Photographic reproduction and the Ferrotyping process is given below.

Ferrotyping and other Printing Processes.—The Ferro-prussiate, Positive Cyanotype, Ferro-gallate, and other printing processes are employed for the copying of plans, patterns, or other drawings and consist of printing the required design on sensitised paper or cloth, by the transmission of light through the design, by the methods explained.

Prints by those processes may be said to be permanent and to be unchangeable by light or damp.

FERRO-PRUSSIAN PROCESS. (*White lines on a blue ground.*)

Method of Sensitising the Paper.—The following solutions have been found to give satisfactory results:—

1.	{	Ammonia citrate of iron (ferric salt)	100 grains.
		Water	1 ounce.
2.	{	Potassium ferri-cyanide (Red Prussiate of Potash)	70 grains.
		Water	1 ounce.

The solutions nos. 1 and 2 will keep good for a long time, but should be stored in the dark. Mix equal parts of the two solutions immediately before use, and apply the mixture to one side of any suitable paper by means of a sponge, or large flat brush. The sponge, which will be found more useful for the purpose, should have an even surface; if it is not even, the sponge should be cut with a knife or scissors to bring about this result, so that the surface may bear uniformly on the paper.

Charge the sponge as full as it will hold of the mixture, and apply the solution liberally to the paper for about two minutes, which time may be more or less according to the season. In the hot dry season a long application is necessary, about three minutes; during the rainy season a less time is required, generally about one minute. Cover the surface of the paper rapidly with the solution, using long, free, light strokes of the sponge, working in one direction, until the surface is covered; then go over the whole surface again, crossing the strokes at about right angles to those first applied, and so on, repeating the operations until the paper has had a liberal application of the mixture. Now take the sponge nearly full, and drag it, without applying pressure, over the surface of the paper, using long strokes to remove the surplus solution, yet leaving a thin film of it on the paper, the object being to obtain as even a coating as possible,

During the operation of coating, the paper should be pinned down on a drawing board or other flat surface; when the coating is finished, the paper is hung up to dry in a dark room and should not be used till it is thoroughly dry.

When using any hard, smooth-surfaced paper, the operations of coating and drying may be repeated several times. By this means a very deep blue ground in the finished print can be produced.

Owing to the excessive dampness which pervades everything during the rains, special care should be taken during this season in preparing and storing sensitised paper. Before the paper is sensitised it should be well dried over a charcoal fire or stove to expel all dampness, after which the sensitising solution is immediately applied. This is to be done in the manner already described, but in this case, should be carried out as quickly as possible, to prevent too great a penetration of the sensitising solution into the pores of the paper. After sensitising, the paper may be dried over a charcoal fire or stove, or may be hung up to dry in a room in which a charcoal fire is burning. Immediately the paper is dry, it should be stored for subsequent use in a cylindrical tin box with a "take-off" lid, round which should be placed an India-rubber band to exclude air and moisture, and the box should always be kept in a dry place. In damp weather the sensitised paper should be dried over a charcoal fire before putting it into the printing frame.

The paper, when freshly prepared, should be of a yellowish orange, but will change to a blue colour by keeping. By adding a small quantity of gum arabic or of dextrine to the mixed sensitising solution, and also bichromate of potassium in the proportion of 2 grains to each ounce of the sensitising mixture, the printing qualities of the paper remain intact, and the paper will not change colour for some time.

The Ferro-prussiate paper of commerce is generally of a bluish tint. This, however, does not impair the printing qualities of the paper to appreciable extent, but the prints prepared on it will require a more prolonged washing, than if made on freshly prepared paper.

Printing.—Open the pressure frame and lay the tracing, drawing downwards, on the glass of the frame, and over it a sheet of the sensitised paper with the prepared side in contact with the back of the tracing. Over the paper lay a pad of felt, or some sheets of clean smooth paper, which should have been previously dried in the sun, or over a fire, and with both hands carefully smooth the pad outwards from the centre. Then put in the back board of the frame, care being taken that the paper below does not slide one way or the other, and close the cross-bars. If the frame has more than two cross-bars, the centre bar should first be closed and then the side ones. Unless the glass, tracing, and sensitised paper are in close and uniform contact all over, it will be impossible to obtain sharpness in the finished print. The frame is then taken outside and exposed to the direct rays of the sun, which should strike the glass face perpendicularly. If the paper is fresh and dry and the sun bright, from 6 to 8 minutes during the cold season will be found sufficient. After the rains, when the sky is clear and the light very intense, the exposure will vary from about 3 to 6 minutes; but at first it is recommended to make exact observations till the right length of time to expose has been ascertained. This can be done by trying different exposures on a small slip of sensitised paper; expose one-half for about 4 minutes, the other half being covered over so that no light acts on it. Now uncover the unexposed half for about 6 minutes, and cover over the exposed half. After this has been done the paper is removed and washed in several changes of clean water, when the distinctness of the lines and the strength of the blue ground will indicate which half of the slip gives the better result. This will be a guide as to the exposure required for the large sheet.

Assuming that the correct length of time for exposure has been determined and that the paper has been exposed, then quickly take it out of the pressure frame and float in a dish or tray of clean water, moving it rapidly from side to side, and changing the water several times till the water is no longer tinged yellow, and the drawing shows out in clear lines, after which the drawing is hung up to dry.

Any paper will answer for this process, but the best results have been obtained on papers "Nos. 50 and 51," specially prepared for this purpose by Messrs. Schleicher and Schull, and obtainable from Messrs. Treacher and Co., Bombay. Good results have also been obtained on ordinary lithographic paper obtainable from the Government Stationery Office, Calcutta. The latter paper is very much cheaper than that of Schleicher and Schull, and the results are nearly as good. With these two brands of paper the lines show out of a pure white or bluish white, while with other papers the lines are more or less of a brownish tinge.

Ready sensitised paper is an article of commerce, and is prepared by Messrs. Marion and Co., 22 and 23, Soho Square, London, W., and obtainable from most of the photographic firms in this country. Marion's paper has been found to give very good results, and will keep without deteriorating for a considerable time if stood in cylindrical tin boxes and kept in a dry place, as before described.

Specially prepared tracing cloth may also be obtained from Messrs. Marion & Co. Prints prepared on it require from four to six times the exposure that a print on paper would require; otherwise, other conditions being equal, the procedure in preparing prints on the cloth is the same as for paper. When the print is dry, the slight creases in the cloth may be removed by rolling it tightly round an ordinary office ruler and keeping it so for an hour or more.

It is desirable that the drawings to be copied should be on a very translucent material, such as fine white tracing paper or good fine tracing cloth, the drawings to be made with perfectly black ink, in firm full lines, especially the finer ones, so that they may be quite opaque. A little burnt sienna may be added to the Indian ink to give it increased opacity. Care should be taken to keep the back and surface of the tracing clean and free from anything which might print through and interfere with the clearness of the drawing.

As far as possible, all lines usually drawn in colours should be drawn in black dotted lines of different kinds. However, if the use of colour in the original is compulsory, red lines should be drawn in thick vermilion; yellow lines with Indian yellow; brown with burnt umber; blue and green lines with a mixture of chrome yellow and dark prussian blue in different proportions. All washes of colour to be avoided if possible, but where necessary they may be replaced by cross-hatching of the required colour.

If desired, coloured tracings can be copied, and provided the coating of colour be not too heavy, fairly satisfactory prints are obtained.

Although the best results are got by copying tracings, it is possible to get quite useful results from drawings even on fairly thick drawing paper, a very long exposure being given to compensate for the opacity of the paper.

When the process is regularly used in workshops, etc., in England, it is a common practice to omit the inking in of the drawing on drawing paper, and to make a tracing on very transparent tracing cloth to serve as a standard drawing to be kept in the office. This tracing then serves for the reproduction of blue copies for the shop, etc.

White lines, figures, and printing may be taken out of a drawing or obliterated, by going over them with a pen charged with a solution of prussian blue mixed to the depth of colour required.

Additions in white of lines, figures or printing may be made with a clean pen dipped in a solution of—

Oxalate of potash	150 grains.
*Saturated solution of gum	40 minims.
Water	1 ounce.

After applying the solution, wait till the lines, figures, or printing are quite white and clear; then blot off with a piece of clean blotting paper and immerse the print rapidly in clean water and wash it well, changing the water a few times.

In applying the solutions given on page 22 to sensitise the paper the fingers become discoloured. These stains can be removed by applying a little of the above solution without the gum arabic: rub the solution over the fingers till the stains disappear, after which the hands should be well washed.

This solution may be conveniently kept in a wide-mouthed bottle, large enough to be able to dip the fingers into.

The pressure frame required will be similar to those used for ordinary photographic work, and should be large enough to take the largest tracing or drawing required. The front will have a piece of good, thick, clear plate glass, and the back will have a board, which should be jointed in two, three, or more pieces, according to its size, and have cross-bars and springs to correspond to the number of joints. A piece of felt or thick flannel should be cut to the size of the frame and kept with it, or in place of the felt several sheets of clean soft paper may be used.

The glass of the frame should be kept clean on both sides and free from scratches, and the felt or paper pads should be thoroughly well dried in the sun, or over a fire, before use.

Pressure frames of any required size are made up in the Canal Foundry and Workshops, Roorkee. The cost of a frame suitable for drawings up to 30"×22" is about Rs. 16. Good plate glass, ¼ inch thick, and of various sizes, can be procured in the Fatehpuri Bazar, Delhi, or at Calcutta. A piece measuring 30"×22"×¼" can be had for about Rs. 10, and the charge is proportionate for the other sizes.

A pressure frame as described may not always be to hand. In such a case the following method answers well:—

Take a drawing board, or any flat board with a fairly even surface, and on it place a piece of any sort of soft cloth, neatly folded so as to give a thickness of about an inch, the cloth to be free from lumps or irregularities, and when folded to be somewhat larger than the drawing to be copied. On the cloth place the prepared paper with the sensitised side upwards; on the paper place the tracing or drawing with its face upwards; and over the whole place a piece of good plate glass a little larger in size than the drawing it is desired to copy; the object being to bring the prepared paper and drawing into close contact with each other, and to keep them in one position during exposure. The weight of the glass supplies the pressure, and the cloth, being soft and yielding, is pressed against the glass plate, and into any inequalities that may exist, bringing the prepared paper and tracing with it, and thus securing the contact required. A small strip of wood might be put round the board in the form of a ledge to prevent the glass from sliding when it is tilted to bring the plane of its surface at right angles to the sun's rays. If the paper and tracing are in perfect contact, tilting the board is not of much consequence. Good results have been obtained when the board has been in a nearly horizontal position, but if the board be not tilted towards the

* The function of the gum solution is to give consistency to the mixture and so prevent spreading of the lines and figures

sun a longer exposure will be required. The correct length of time may be ascertained by means of a small slip of prepared paper, as already described.

Dishes or trays, three or four inches deep, for washing prints, may be of porcelain or of strong sheet zinc or tin, and should be a little larger in size than the largest print. It is recommended to coat the inside of the tin or zinc trays with black Japan varnish, obtainable from any general merchant, or with ordinary shellac varnish (shellac 8 oz., methylated spirit 1 pint). The varnish to be removed occasionally as required, and to be applied to the trays with a brush, like a coating of paint. Trays made of tin will last better if the varnish be applied all over the inside and outside surface.

A flat board or ordinary drawing board will be required for sensitising the paper; also some drawing pins, to keep it in position while being coated with the sensitising solution; a fair-sized sponge to apply the solution; some wooden clips to hold the paper while drying; a graduated 4 oz. measure for solution; and a small set of scales and weights for weighing chemicals.

Defects in Ferro-Prussiate Prints.

When the print is weak-looking, with the back ground rather a light blue but lines clear.—We conclude that the print is under-exposed. Try another print and give a longer exposure; or if the defect is not very marked, immerse the print for a few minutes in the following weak acid solution, 10 drops of hydrochloric acid to 10 ozs. of water; or 100 grains citric acid to a pint of water. This intensifies the blue ground and the white lines show clearer by contrast. Another method, and one which gives better results, is to immerse the print for a short time in a bath of 20 grains of carbonate of soda to one quart of water. The print should be left in this bath only just long enough to change the blue ground to a deeper blue, after which it should be at once removed and quickly immersed in a tray of plain water (to stop the further action of the soda), and then well washed, the water to be renewed several times. When the print is put in the soda bath the lines become clearer and the blue ground rapidly intensifies up to a certain point, after which it begins to lose its blue colour and gradually changes to a light yellowish colour. Care therefore should be taken to remove the print from the bath when it is judged that the maximum depth of blue colour has been reached.

Ground of print of a very deep blue colour, but lines not clear and of a bluish tinge, the fine lines of the original drawing very indistinct and broken, or not seen at all.—Print has been over-exposed. If these defects are very decided, reject the print and prepare another, giving less exposure. If not too decided the print may be reduced by prolonged washing in several changes of water, and then immersing it in the carbonate of soda bath given above, till the desired reduction has taken place, after which the print is washed in several changes of plain water.

Prints weak and having a somewhat "sunk-in" appearance, ground of a dull blue colour, with lines rather indistinct and of a yellowish brown.—This is due to dampness owing to insufficient care in preparing, drying or storing the paper, as already described. See remarks on preparing and storing paper during the rains, page 23.

Print generally clear and well defined, but at places the lines blurred and of a bluish colour.—This arises from imperfect contact between the sensitised paper and tracing. Place the sensitised paper carefully in position and avoid crumpling it, as the tracing and prepared paper should be perfectly smooth and even.

Streaks of white and white spots in the blue ground of print.—These are due to want of care in coating the paper with the sensitising solution. If the solution be applied liberally as directed, the whole surface of the paper covered with it, and the excess solution removed carefully, these markings will not show.

Marking in print corresponding to the form of finger tips.—These are due to handling the sensitive surface of the paper when the hands are in a heated state. The remedy in this case is obvious; the sensitive surface should be touched as little as possible with the fingers.

Ground of print of a light blue colour and lines of a light bluish tint, when it is known that the print has not had more than the normal exposure to sunlight.—This is due to the sensitised paper having deteriorated by keeping, or the paper may have been exposed to white light, which would occasion a blue deposit over the whole surface. Nothing can be done in this case; the print will show a want of force and brilliancy due to the blue deposit on the lines, which in good, fresh and properly prepared paper would be of a pure white.

POSITIVE CYANOTYPE PROCESS. (*Blue lines on a white ground.*)

Paper specially prepared for this process is an article of commerce, and can be had from Marion & Co., 22 and 23, Soho Square, London, W. It will be found more convenient to purchase the paper ready for use than to prepare it. Without proper appliances and practice it is difficult to get an even coating.

If, however, it is considered desirable to prepare sensitive paper for this process, hard and well-sized paper should be selected; so that the sensitising solution may be kept, as far as possible, on its surface. Good ordinary drawing paper is suitable, also Rives' or Saxe paper generally used for photographic prints, but the papers Nos. 50 and 51 by Messrs. Schleichner and Schull, already described, have been found to give the best results.

The following solutions are required for sensitising the paper:—

	A				
Gum arabic	1 oz.
Water	5 „
	B				
Ammonia-citrate of iron..	1 oz.
Water	2 „
	C				
Perochloride of iron	1 oz.
Water	2 „

Solution A can only be kept for a few days; solutions B and C will keep for several weeks in well-stoppered bottles. When required for use, they are mixed together in the proportions of 20 parts of A, 8 parts of B, and 5 parts of C, and in the order given, or the gum will be coagulated. Should this occur, the mixture may again be rendered liquid by the addition of a few drops of glacial acetic acid.

Sensitising the paper.—This operation and all the subsequent ones, except the exposure to sunlight, must be performed in a room illuminated by yellow light passing through one or two thicknesses of yellow paper or calico fastened over the windows, or weak lamp light. The paper is pinned down to a drawing board, and the solution applied as described for sensitising paper in the Ferro-prussiate process, only more care has to be exercised; the coating to be as even as possible, so as to avoid streaks. It is important that the paper should dry quickly, so that the solution may not sink into its substance. As soon as the paper is dry, it will be well to put it away carefully in an air-tight tin case.

Exposure.—The exposure will vary with the intensity of the light. In direct sunlight from 15 to 40 seconds will be found sufficient; in the shade or dull light from 1 to 5 minutes; in rain from 5 to 15 minutes; and in dull foggy weather as much as from 15 to 30 minutes or longer may be required. By practice one

soon learns to guess the proper exposure under ordinary conditions of working. It is important, however, that in this process the exposure should be exactly right, and therefore, unless the exact time required is known from past experience, it is advisable to try different exposures on a thin slip of sensitive paper in the manner already described for Ferro-prussiate prints.

Development of the print.—This operation must be performed in yellow light. The developing solution to consist of a saturated solution of ferro-cyanide of potassium.

A sufficient quantity of the solution should be poured into a dish or tray so as to fill it to a depth of about an inch. Before commencing to develop, the print is laid face downwards on a table, and the edges turned up carefully with the aid of a straight-edge, so as to form a sort of tray about $\frac{1}{2}$ inch in depth. The copy is now floated face downwards on the developing solution; the turned-up edges prevent any of the solution from getting on the back of the copy, which would cause blue stains to appear. Any air bubbles must be removed by quickly lifting each of the corners of the copy in turn by one hand and gently lowering it again, the other hand being used at the same time to drive out the air bubbles from the centre. After floating the copy on the developing solution for about half a minute, remove it carefully, hold it up, and allow the action of the developer to continue, but only so long as the yellow ground remains free of blue spots. The longer the film of prussiate can be kept on the print, the stronger and darker will the lines come out. As soon as any sign of a blue spot begins to show, immerse the print at once face downwards in a tray of clean water, and wash it in several changes.

After washing, immerse it in a bath of hydrochloric acid, 1 ounce to 10 ounces of water; keep it in this bath from 5 to 10 minutes, after which remove and place it face upwards in a tray of clean water, and well wash and rub the surface with a sponge to remove the blue mucilage; then copiously flush with clean water. The lines of the copy will now be found to stand out blue on a clear white ground.

For the developing and acid solutions: trays of lead in wooden frames will be required; the inside of the trays to be coated with Bates' black photographic or shellac varnish, the coating to be renewed as necessary. For washing the print, trays as described for the Ferro-prussiate process will answer.

Causes of failure.

The ground appears blue.—This arises from under-exposure to the light, or from the print having been kept too long exposed to the action of the developing bath.

The ground remains white, while the lines are broken and pale.—This may be due to over-exposure, or to the lines of the tracing not being sufficiently opaque to stop the passage of light through them.

When the print is put in the acid bath, the lines turn a dark blue, which washes off when being brushed.—This arises from insufficient development in the prussiate bath. If the ground is also spotted blue, it is due to under-exposure.

To obtain prints showing blue lines on a clear ground by a modification of the ordinary Ferro-Prussiate Process.—Place the drawing or tracing to be copied with its back against the glass of the printing frame; then place over the drawing or tracing a piece of prepared sensitised tracing cloth, with its sensitised surface down against the face of the drawing; close the printing frame and give a prolonged exposure to light, the exposure to be three or four times longer than would be required for an ordinary Ferro-prussiate copy.

After exposure proceed as described in the Ferro-prussiate process. When dry., the print may be treated with a weak solution of carbonate of soda, to intensify the blue

ground and clear the lines, after which it should be well washed and hung up to dry. When dry, roll the print round an ordinary office ruler, the object being to remove all creases from the cloth.

When the copy is smooth and even, place it in the printing frame with its back against the glass, then place a piece of sensitised paper or cloth, with the sensitised surface down, on the face of the prepared negative copy, and operate as already described for obtaining an ordinary ferro-prussiate print. As the light is passed through a negative copy, a positive print—one showing blue lines on a clear ground—will be produced.

Instead of preparing the negative copy on tracing cloth, paper may be used; the paper print can be made transparent by rubbing it over with vaseline, or by applying a mixture of one part castor oil and five parts spirits of wine.

FERRO-GALLATE PRINTING PROCESS.—(*This process is useful in the reproduction in black lines on a clear ground of fac-simile copies of drawings, plans and tracings.*)

Paper.—For this process a hard well-sized paper is indispensable. Schleicher and Schull's paper Nos. 50 and 51, obtainable from Messrs. Thacker & Co, or from Messrs. Treacher & Co., Bombay, answer fairly well, and are the best of their kind for this purpose to be had in India.

Developing Trays.—Trays for developing should be made of wood, lined with sheet lead, the lead to be protected with a coating of black Japan varnish. Trays of zinc or tin protected with Japan varnish answer fairly well, but the acid solution when not in use should not be kept in the trays, but should be stored in an earthenware vessel.

For washing purposes zinc or tin trays are quite suitable.

Sensitising the papers.—This operation must be carried out in a room illuminated by yellow light passing through one or two thicknesses of yellow paper, or cloth fastened over the windows, or by candle, or weak lamp light. The following formulæ are recommended for sensitising the paper—either No. 1 or No. 2 may be used:—

No. 1.

Water	15 ounces.
Gelatine	½ ounce.
Perchloride of iron	1 „
Tartaric acid	½ „
Persulphate of zinc	½ „

No. 2.

Water	30 ounces.
Gelatine	1 ounce.
Perchloride of iron (solid)	2 ounces.
Tartaric acid	10 drams.
Ferric-sulphate	10 „

The paper is laid smoothly down on a drawing board, glass plate, or other flat surface, and should be fastened down on two sides with pins or clips.

The sensitising solution is applied to the paper by means of a fine sponge, which should be passed lightly over the paper, up and down and across, taking care to equalise the coating as much as possible, and to avoid streaks or other markings. Before applying the sensitising solution it is advisable to dry the paper over a charcoal fire or stove to expel all dampness, after which the solution should be immediately applied. It is important that the sensitised paper should dry quickly so that the solution may not sink into its substance; it should, therefore, be hung up to dry in a room in which a stove or charcoal fire is burning. This of course would not be necessary in the hot dry

season. When thoroughly dry the sensitised paper should be stored for subsequent use in a tin cylindrical box with a take-off lid, round which should be placed an India-rubber band to exclude air and moisture.

Exposure.—The exposure to sunlight is about the same as for ferro-prussiate prints, that is, from 5 or 10 minutes according to the intensity of the light. To ascertain if the exposure has been sufficient, open the pressure frame and lift up one corner of the sensitised paper; if the greenish-yellow tint has disappeared, except where covered by the lines, it shows that the exposure has been sufficient, and the print should be removed from the pressure frame.

Developing.—This operation must be carried out in yellow or red light. The copy is floated face downwards on the following solution:—

Gallic acid	1 ounce.
Oxalic „	5 grains.
Methylated alcohol	10 ounces.
Water..	50 „

Care is to be observed in floating the paper. Hold two opposite corners of the paper, and bring the hands nearly together, a convex form is thus given to the sheet, the middle of which should first touch the solution, the corners held by the hands to be gradually brought down till the sheet floats on the liquid. The formation of air bubbles is thus prevented; should, however, any be formed, they can be removed by the aid of a glass stirring rod.

The copy should be allowed to remain on the solution till the lines show up clear and black. It is then removed and washed thoroughly, and, if necessary, the surface rubbed with a soft sponge to remove any stains or markings, after which the print is hung up to dry.

The following can be recommended also as giving satisfactory results:—

Sensitising mixture.

A. {	Gum arabic	1 ounce.
	Water	10 ounces.
B. {	Tartaric acid	1 ounce.
	Water	4 ounces.
C.	Solution of Ferric chloride, 45° Beaume	2 „
D. {	Ferrous sulphate	5 drams
	Water	4 ounces

Solution D is added to B, and the mixture added slowly with constant stirring to A; finally solution C is gradually added stirring well the whole time during admixture.

Tough smooth well-sized paper should be used. The sensitising mixture is applied by means of a brush, and the paper quickly dried by heat. Exposure is complete when the ground of the print is nearly white, the parts protected from the light being of a light yellow colour. Development is effected by floating the print for about one minute face downwards on—

Gallic acid	1 dram.
Oxalic „	3 grains.
Water	50 ounces.

The print is then removed from the developing bath and washed well in plain water.

Ready-sensitised paper.—Paper ready-sensitised (Ferro-gallic paper) is prepared by J. R. Gotz, 19, Buckingham Street, Strand, London, and can be purchased from Thacker & Co., Bombay.

The following is a good developing formula for ready sensitised paper :—

Galloic acid	1 ounce.
Alum	1 „
Water	8 pints.

The acid and alum should first be dissolved in two pints of hot water, after which the remaining water should be added.

To develop prints on this paper the copy is immersed in the developing solution till the drawing shows up clear and the lines black, after which it is washed and hung up to dry in the usual way.

Defects.—Over-exposure is known by the lines being faint and broken, the thick lines only to be seen while the ground is white and clear.

When the ground of the print is dark and discoloured it denotes under-exposure

The lines after prolonged immersion in the developing solution are of a dull brown colour, while the ground is clear. This shows that the acid in the solution is nearly exhausted. Add more acid, or if, owing to a number of prints having been developed with the solution, it is very much discoloured, a fresh developing solution should be made up.

The basis on which the preceding processes are founded is that a ferric salt is reduced to the ferrous state by the action of light. Thus, taking ferric chloride (Fe Cl_3) as an example, this salt on exposure to light throws off one atom of chlorine and becomes ferrous chloride (Fe Cl_2). If a solution of a ferric salt be applied to one side of a smooth-surfaced paper, the surface of the paper when dry will present a yellowish colour inclined to orange; if the paper be placed in a pressure frame under a transparent drawing or tracing, and exposed to sunlight for a fixed time, a change will be found to have taken place; the parts of the paper immediately under the transparent parts of the drawing or tracing will be of a light brownish colour, nearly white, while the other parts of the paper immediately under the lines will be found unchanged, and on the paper we shall have a copy of the drawing or tracing in yellowish orange lines on a nearly white ground; this is the visible change. The chemical change is that where the light has passed through the transparent parts of the drawing to the prepared paper immediately below and in contact with it, the ferric salt on the paper has been reduced to the ferrous state in these parts by the action of light; while, owing to the opacity of the ink lines of the drawing or tracing, no light can reach the paper immediately below the lines, and therefore no change takes place, consequently under the lines we have the unchanged ferric salt. Thus, we have a ferrous and a ferric salt on the paper; the ground of the drawing will be of a ferrous salt, while the lines will be made up of a ferric salt. By applying re-agents, which act differently on these two salts of iron, this reduction is made apparent, and a coloured picture or drawing is produced. Thus, if ferri-cyanide of potassium ($\text{K}_3 \text{Fe Cy}_6$) be applied, all the parts acted upon by light become blue; that is, when ferri-cyanide of potassium is added to a ferrous salt a deep-blue precipitate is produced of ferrous ferri-cyanide [$\text{Fe}_2 (\text{Fe Cy}_6)_3$], called Turnbull's blue, and the blue matter thus produced is insoluble. The ferri-cyanide of potassium causes no change in the ferric salt (which corresponds to the lines of the drawing or tracing), which being soluble can be washed out in water, giving a print on the paper of white lines on a blue ground. Prints thus produced are called ferro-prussiate prints.

Ferri-cyanide of potassium ($\text{K}_3 \text{Fe Cy}_6$) acts on the unexposed parts or parts not acted on by light, that is, on the ferric salt, and produces with it a deep blue precipitate of ferric-ferrocyanide [$\text{Fe}_4 (\text{Fe Cy}_6)_3$], which is insoluble. The ferro-cyanide of potassium occasions no change in the ferrous salt, which is therefore soluble and can be washed out in water, thus giving a copy on the paper of blue lines on a white ground. Prints produced by this method are called positive cyanotype prints.

Similarly, gallic acid ($\text{L}_3 \text{H}_6 \text{O}_4$) or tannic acid ($\text{C}_{12} \text{H}_{10} \text{O}_{12}$) used in place of the ferro-cyanide of potassium, produces a black nearly insoluble compound (ink) with a ferric salt (corresponding to the parts not acted on by light), and causes no change to a ferrous salt (corresponding to the parts acted on by light), which remains soluble and can be washed out in water, giving a drawing of black lines on a nearly white ground.

For the production of drawings giving white lines on a blue ground (ferro-prussiate prints), instead of applying a solution of ferri-cyanide of potassium after exposure to light as described, in practice it has been found more convenient to mix the ferro-cyanide of potassium with ferric salt before exposure: the mixture is spread on a paper and dried in a dark room. It will be observed that the ferro-cyanide of potassium produces no change with a ferric salt, but if the paper so prepared be placed in a pressure frame under a transparent

drawing or tracing and exposed to light, the ferric salt immediately under the transparent parts of the drawing is reduced to the ferrous state by the light, as already described, and conjointly with this reduction the ferri-cyanide of potassium acts on the ferrous salt thus found and produces with it an insoluble blue matter, the unchanged ferric salt on the paper immediately under the opaque lines of the drawing remains soluble and washes off in water, thus giving a drawing of white lines on a blue ground.

ANILINE PRINTING PROCESS.—(*Reproduction in dark lines on a clear ground from a tracing.*)

This process is dependent on the action of bichromates on organic matter, and the oxidation of aniline by chromic acid. Thus aniline salts have the property of sticking certain colours when brought in contact with acidified bichromates. Sized paper is sensitised by brushing over it an acidified solution of the bichromates of potassium or ammonium, and is dried quickly in the dark, or in a photographic dark room. The paper is then exposed to light under a tracing, and when the lines and figures are visible, is exposed to the action of aniline vapour. Those parts protected from light by the lines or figures of the tracing become deeply coloured by the action of the aniline vapour which reacts on the chromic compound not reduced by light, and causes no action with the reduced chromium salts, as these acquire a neutral reaction and will not readily assimilate bases.

Sensitising solutions.

1.	{	Potassium bichromate	160 grains.
		Phosphoric acid solution	2 ounces.
		Distilled water	5 ,,
	{	Ammonium bichromate	160 grains.
		„ chloride	160 ,,
2.	{	Sulphate of copper	30 ,,
		Sulphuric acid	$\frac{1}{2}$ ounce.
		Water	10 ounces.

Either 1 or 2 may be used.

The solutions keep in good condition for a long time, but it is advisable that they be stored in the dark.

Only good well-sized paper should be used; and sensitising may be carried out by brushing or floating.

Sensitising.—The preparation of the paper may be carried out by lamp light, subdued day-light, or yellow light, but the paper must be dried in the dark, or in a photographic dark room. It will be found more economical to apply the sensitising solution by means of a brush, which should be fairly large and flat. The solution should be applied as quickly and evenly as possible so that it may not penetrate too far into the body of the paper. The surface of the paper only should be impregnated, otherwise the ground would be more or less discoloured, and the lines and figures being imbedded would not be sharp. After sensitising the paper should be dried as quickly as possible, and should be used on the day it is prepared, or, at most, the next day, as it does not keep.

Printing.—The printing is carried out as described in the ferro-prussiate process; the paper, however, is more sensitive than ferro-prussiate paper. The print should be exposed till the lines and figure of the drawing appear of a faint yellow colour on a greenish-white ground. In bright sunlight the exposure is generally from one to two minutes,

Development.—The print is put into the bottom of a shallow box with a close-fitting lid. On the lid is fastened a piece of damp flannel, and on this piece is attached another bit of flannel on which a little of the following developing solution is sprinkled:—

Aniline solution	1 ounce.
Benzole	12 ounces.

Development is completed in from five to ten minutes dependent on the duration of the exposure to light. The best result is obtained by a fairly long exposure and prolonged development.

When a good dark tone is produced, the print is washed in plain water and then immersed for a short time in a bath of Sulphuric acid $\frac{1}{2}$ ounce, water 50 ounces.

It is again washed in a few changes of water and finally immersed for a few seconds in a bath of—Liquor ammonia $\frac{1}{2}$ ounce, water 40 ounces. The print is then removed, washed and hung up to dry. The acid and ammonia baths are not essential, but better results are obtained by their use.

Moisture is absolutely necessary in the development of aniline prints. Care should, therefore, be observed that the flannel attached to the lid of the box is thoroughly damp. Should the air in the box be dry development will not be satisfactory.

Development may also be carried out by pinning the exposed print to the lid of the box, and having the damp flannel, with the piece on which the aniline solution is sprinkled, at the bottom. Also, instead of sprinkling the developing solution on the flannel, the solution may be placed in a shallow dish at the bottom of the box, and when development is completed, the solution removed and stored for future use in a well-fitting stoppered bottle.

FERRIC CHLORIDE AND GELATINE PROCESS.—(*Dark lines and figures on a clear ground from a tracing.*)

This process is dependent on the action of a ferric salt on gelatine, in that ferric chloride has the property of rendering gelatine insoluble.

Paper is coated with gelatine to which a pigment is added as below:—

Gelatine	300 grains.
Water	10 ounces.

The gelatine should first be soaked in half the given water, until it is fairly soft, then the remainder of the water added, and the mixture stirred and dissolved by means of a gentle heat. Indian ink or any suitable pigment is then added in sufficient quantity to bring about the required colour.

The warm pigmented gelatine solution should be applied to the paper by brushing, care to be observed that the coating is thin and uniform.

The paper is then dried and should present a uniformly coloured surface.

When dry the paper is sensitised by *immersion* in a solution of—

Ferric chloride	2 ounces.
Tartaric acid	300 grains.
Water	20 ounces.

After sensitising the paper is dried in the dark or in a photographic dark room. Printing is carried out as described in the Ferro-gallate process: the exposure to sunlight being about from 5 to 15 minutes according to the intensity of the light.

The part exposed to light, that is, the ground of drawing, becomes soluble in hot water, while the parts protected from light by the lines and figures of the tracing

remain insoluble ; hence development is effected by immersion in hot water, and a print is obtained, according to the pigment used, showing dark or coloured lines on a clear ground.

ACIDIFIED INK PROCESS.—(*Black lines on a clear ground.*)

Paper is uniformly and thinly coated by brushing with—

Gelatine	300 grains.
Water.. .. .	10 ounces.

When dry it is sensitised by brushing *on the back* a solution of—

Bichromate of potassium	150 grains.
Ammonia	$\frac{1}{2}$ dram.
Water	10 ounces.

The solution should be allowed to thoroughly imbue the paper ; to effect this a second brushing should be resorted to, after which the paper is dried in a dark room. When dry it is exposed to light under a tracing in a pressure frame until the lines and figures of the drawing are well defined.

The paper is then immersed in hot water and the bichromatised gelatine not rendered insoluble by the action of light, that is, those parts protected by the lines and figures for the tracing, dissolved out, leaving bare paper at these parts.

The paper is then blotted and brushed over with—

Liquid Indian Ink	1 ounce.
Sulphuric acid	30 minims.
Caustic potash	12 ,,

The ink solution fixes itself only on the bare paper, which represents the lines and figures of the drawing, and a copy showing black lines on a clear ground is produced.

MODIFIED CARBON PROCESS.—(*Black lines on a clear ground.*)

Paper is coated with gelatine and sensitised with bichromate of potassium as described in the Acidified Ink Process. It is dried in a dark room, and when dry exposed, in a pressure frame, to light under a tracing until the lines and figures of the drawing are clearly visible. The paper is then immersed in cold water and sponged, the water being changed several times to remove the chromium salt not reduced by light. The paper is now blotted fairly dry and its surface brushed over with—

Liquid Indian ink	1 ounce.
Bichromate of potash	10 grains.

After applying the solution the paper is dried in the dark or in a photographic dark room. When dry it is placed in a pressure frame, with the *back* of the paper next to the glass of the frame, and exposed to sunlight for about two minutes. The paper is then immersed in plain water, and the ground cleared by means of a hard brush or sponge until the drawing shows up in black lines on a clear ground.

The rationale of the foregoing is that in the first exposure to light under a tracing the ground of the drawing was, by the action of the light, rendered insoluble and practically non-absorbent ; while the parts protected from light, which correspond to the lines and figures of the drawing, remain unchanged and absorbent ; consequently the lines and figures only take up the bichromatised Indian ink and thereby become re-sensitised.

When the back of the copy is exposed in the pressure frame light acts through and on the lines and figures, rendering these insoluble, but practically causing no action on the ground of the print, which is easily cleared by means of a sponge or brush, and thus a drawing showing black lines on a clear ground is produced.

NOTE.—The bichromates of potassium and ammonium are highly poisonous.

Preparation of Drawings for Photo-Mechanical Reproduction.—Photo-mechanical processes for the reproduction of line drawings are economical and rapid, in proportion to the complexity of the drawing, or the amount of detail in it, or when the drawing has to be reduced or enlarged.

An important point in favour of Photo-mechanical reproduction is that the result is a fac-simile of the original in all but scale. The scale, or rather the size of a copy of the original, can be altered without any additional expense, and this renders the process peculiarly well adapted for Record or Type plans, which can be reduced to a dimension suitable for binding in book form without sensible loss of clearness and with a great increase in convenience.

Paper.—The paper should be perfectly white or slightly bluish, but of no other tint; it should be of good substance and of uniform texture, and the surface smooth but not too highly glazed. Hand-made is preferable to machine-made paper; the ordinary white and blue Imperial, and white Double Elephant papers, as supplied by Government, are suitable.

Ink.—The best quality of stick Indian ink should invariably be used. The ink should be freshly made, being evenly rubbed down, using a light pressure on a smooth surface, till it is sufficiently thick to give full dense black lines.

Good ink should be perfectly free from grit: a black, bronzy, shining appearance in the stick when broken is generally indicative of good ink, while a dull fracture generally denotes an inferior quality. Unless thoroughly well ground black ink is used for a drawing, the reproduction will not be perfect.

Inking.—The inking in of a drawing should be done, as far as practicable, entirely in pure black lines, or dots of uniform intensity. The lines to be firmly and clearly drawn, smooth, even, and unbroken, not too fine, and not too close together; the finest lines must be quite black with a good deposit of ink on them.

Lines of section, water-level, etc., usually shown in red or blue, should be drawn in black dotted lines.

Washes or shading of any colour are inadmissible; cross-hatching should be used to distinguish different materials or parts of structures.

All printing, figures, etc., should be bold and open with the "thin" strokes not too fine.

Drawings intended for reproduction to a reduced scale should, generally, be drawn in a much more open style than would be suitable for finished drawings on the same scale. Care should be observed not to crowd in lines in the shaded parts, nor to use too many lines, printing, and figures than are really necessary.

Tracings.—Drawings for reproduction may also be executed on tracing paper.

Special papers are manufactured for use in connection with the reproduction of drawings by process work. These papers are white or slightly bluish, and should be used in preference to the ordinary kinds, which are generally of a yellowish colour and quite unsuitable.

Scale.—The scales on drawings intended for reduction should generally be shown in terms of a single unit of measurement (see Fig. 19) as "Scale of miles, yards, feet, etc.," and not as relative to any second unit, as "Scale, 20 feet to 1 inch."

Fig. 19.

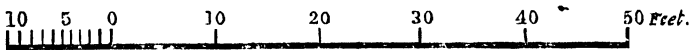

General.—All drawings or tracings intended for reproduction by photography should, when practicable, be kept flat or rolled but not folded: care should be observed to keep them as clean as possible on both surfaces, and free from stains, creases and wrinkles.

In preparing finished drawings, with a view to reproduction, and subsequent publication, the greatest care should be taken to give them a high degree of neatness and finish. Photography produces only a fac-simile, and unless the original drawing be well finished in every particular with good lines, printing, figures, etc., reproduced copy will not look well. Due care, therefore, should be observed in preparing drawings, so that after they are copied the results may be fit for immediate issue, and not require alterations and working up, which mean delay in carrying out work and add considerably to the expense.

CHAPTER II.

PRINTING—GENERAL RULES APPLICABLE TO ALL GEOMETRICAL DRAWINGS—INSTRUCTIONS FOR THE PREPARATION OF FINISHED ARCHITEC- TURAL AND TOPOGRAPHICAL DRAWINGS— CONVENTIONAL SIGNS.

Printing.—It cannot be too strongly insisted upon that a finished drawing cannot be produced without first class printing. Too much care cannot be given to this matter, as a good style of printing is essential to the production of a really good Engineering or Topographical Drawing, more specially the latter, as the names of towns and villages are all over the place.

This perfection cannot be attained without a great deal of practice, care and perseverance. It must, however, be pointed out that this perfection should only be expected from, and sought after by, Draftsmen and the subordinate ranks.

Engineers and superior officers should seldom waste their time in endeavouring to print up a drawing with fine headings and copper-plate printing. They should content themselves with producing neat and legible words, and leave the finished work to their less highly educated inferiors.

This Chapter, however, will be devoted to showing how any intelligent man, with care and perseverance, can become a first-rate printer.

As a rule BLOCK PRINTING is decidedly the best for all kinds of Headings, being neat and legible. For Main Headings fancy letters may occasionally be used, but it may be laid down as an axiom that the plainer the lettering on a drawing the better.

Block printing may be either upright or sloping. The proportion of breadth to height varies considerably in different alphabets, and may range from the "square" form, in which the breadth is equal to the height down to the "elongated," in which the breadth is reduced to anything down to one-third of the height.

The first thing to do is to decide the height of the letters it is proposed to use for a heading. This must entirely depend on the size of the drawing, and should be strictly in proportion. Having decided the height, it

A B C D E F G H I J K L M N O P Q R S T U V W X Y Z

1 2 3 4 5 6 7 8 9 0

1 2 3 4 5 6 7 8 9 0

A B C D E F G H I J K L M N O P Q R S T U V W X Y Z

SURVEY OF ROORKEE.

GANGES CANAL BRIDGE.

DETAIL PLAN OF RAJBAHA HEAD.

M. L. DIVISION JUMNA CANAL

Detail of Junction at Regulator and Weir Sluices.

Regulating Bridge.

USE	AVOID	USE	AVOID
A	A	N	N
B	B	Q	Q
C	C	R	R
D	D	S	S
E	E	V	V
G	G	W	W
J	J	X	X
K	K	Y	Y
M	M	Z	Z

The most symmetrical in appearance and the easiest to execute is an alphabet in which the breadth of the larger number of the letters is four-fifths of the height. Divide the height selected into five spaces (*Plate II*).

Then most of the letters are four of these spaces broad. The exceptions are --I = 1, J = 3, F L = 3½, M T W = 5. The spaces between the letters may be 2 or 1½, and between the words 5 or 6 according to taste.

Then to put in a heading, after selecting size, write it roughly thus—

P	L	A	N	A	N	D	S	E	C	T	I	O	N	spaces=53½
4	3½	4	4	4	4	4	4	4	4	5	1	4	4	,, =34
2	2	2	6	2	2	6	2	2	2	2	2	2	2	,, =34

Total = 87½

Take 87½ spaces and place centrally. Then rule the boundary lines of each letter, and after, if necessary, the single space lines within each letter. This gives as little ruling as possible, and also gives spaces correct. If single space lines are ruled all along, one letter of the 3½ breadth throws out all those after it.

If a more upright narrower style is required, instead of taking spaces ½th the height, take them ¼th or ⅓th.

It should be borne in mind that the terminations of all letters should be always flat, never pointed or rounded.

One of the difficulties of the beginner is to know what is bad and what is good printing; it will, therefore, be useful to point out a few of the mistakes to avoid, and points to be noted in the formation of certain letters. Refer for each letter to *Plate II*.

In the letter A the cross stroke should be about one-third of the way from the bottom of the letter.

In the letter B the upper portion should be about one-tenth smaller and not quite so broad as the lower portion.

In the letter C take care that you place the lower termination exactly below the upper one.

In the letter E the upper horizontal stroke should be slightly shorter than the lower one, but be careful to avoid exaggeration.

In the letter G avoid all fancy forms.

In the letter K the upper diagonal meets the perpendicular stroke two-thirds of the way down. The lower diagonal joins the upper one in such a position that if it were produced it would meet the perpendicular stroke one-third of the distance from the top.

The letter M requires to be treated with a certain amount of discretion; if the strokes used are broad the letter should be five spaces broad

to avoid looking heavy; if the strokes used are thin the letter should be only four spaces broad.

In the letter R the lower termination of the tail should be flattened.

The letter S is a very difficult letter to form; the upper half should be less broad than the lower, and a horizontal line dividing the upper and lower curves should be nearer the top than the bottom. If the two curves are made the same the letter will look top-heavy as may be seen in the Plate.

The upper stroke of the letter Z should be somewhat shorter than the lower stroke.

ITALIC PRINTING (*Plate III*) is well adapted for the information to be entered on ordinary plates and surveys. To execute this, the beginner should rule three lines parallel to each other to regulate the heights of the small letters and capitals. The distance apart of these lines will depend on the size of the printing desired, but lines three and four-sixtieths apart will be found convenient to start on. Parallel lines should then be ruled at intervals of about half an inch to define the slope of the printing.

The beginner should pencil each letter in with the greatest care before inking in, avoiding the use of India-rubber. When he has gained sufficient proficiency through practice, the pencil may be dispensed with. Students should remember that it is impossible to print after taking any violent exercise as the hand is not sufficiently steady.

In *Plate IV* is given an example of another style of printing, which is fairly easy to acquire and which may be occasionally useful.

GENERAL RULES APPLICABLE TO ALL GEOMETRICAL DRAWINGS.

1. Instruments, especially *ruling pens*, should be kept scrupulously clean. *Clean drawings* cannot be executed without *clean hands*. Keep a piece of paper under the hand when working. Wooden and ebonite rulers can be cleaned by rubbing them with bread. Always rub them on a piece of paper before commencing work.

2. Never draw a single line that is not absolutely necessary. Always work with a sharp point to your pencil. Do not cut it at the lettered end. Pencil work should be done as *lightly* as possible. If the lines are heavy they are difficult to rub out and soil the rulers.

3. If lines are drawn wrong, mark them lightly with one or two dashes; but as a rule omit all corrections of pencil work with rubber till the plan is inked in, and then at one operation rub out all the pencil lines. Every use of the rubber raises the paper surface into a roughness in which dust catches, and gets ingrained.

A B C D E F G H I J K L M N O P Q R S T U V W X Y Z.

a b c d e f g h i j k l m n o p q r s t u v w x y z

1 2 3 4 5 6 7 8 9 10 $\frac{1}{4}$ $\frac{1}{2}$ $\frac{3}{4}$

Buildings. Bridges. Plan. Elevation. Section Scale.

Scantlings of Rafters. Purlin. Tie Beams. Strap.

Bolt 1" diameter. Flat Arch. Relieving Arch. Ground line.

Bressummer. Slope 1 in 20. Wall-Plate. Rafter.

Weather-Boarding. Ridge-Pole. Ventilator. King post truss.

Angle-Iron. Sheet-Iron. T-Iron. Calcutta. Allahábád.

Roor-kee. Kashmere. Indus. Ganges. To Morádábád.

Fr. Bareilly.

Italic printing is well adapted for the information to be entered on ordinary Plates and Surveys.

To execute this, the beginner should rule three lines parallel to each other to regulate the heights of the small letters and capitals. The distance apart of these lines will depend on the size of the printing desired, but lines three and four sixtieths apart will be found convenient to start on. Parallel lines should then be ruled at intervals of about half an inch to define the slope of the printing. The beginner should pencil each letter in with the greatest care before inking in, avoiding the use of India rubber. When he has gained sufficient proficiency through practice, the pencil may be dispensed with. Students should remember that it is impossible to print after taking any violent exercise as the hand will not be sufficiently steady.

A B C D E F G H I J K L M N O P Q R S T U V W X Y Z.

a b c d e f g h i j k l m n o p q r s t u v w x y z

1 2 3 4 5 6 7 8 9 10

Buildings. Bridges. Plan. Elevation. Section. Scale.

Scantlings of Rafters. Purlin. Tie-Beams. Strap.

Bolt 1" diameter. Flat Arch. Relieving Arch. Ground line.

Bressummer Slope 1 in 20. Wall-Plate. Rafter.

Weather-Boarding. Ridge-Pole. Ventilator. King-Post Truss.

Angle-Iron. Sheet-Iron. T-Iron. Calcutta. Allahabad.

Roorkee. Kashmir. Indus. Ganges. To Moradabad.

From Bareilly.

Italic printing is well adapted for the information to be entered on ordinary Plates and Surveys.

To execute this, the beginner should rule three lines parallel to each other to regulate the heights of the small letters and capitals. The distance apart of these lines will depend on the size of the printing desired, but lines three- and four-sixtieths apart will be found convenient to start on. Parallel lines should then be ruled at intervals of about half an inch to define the slope of the printing. The beginner should pencil each letter in with the greatest care before inking in, avoiding the use of India-rubber. When he has gained sufficient proficiency through practice, the pencil may be dispensed with. Students should remember that it is impossible to print after taking any violent exercise as the hand will not be sufficiently steady.

4. No attempt should be made to produce a finished pencil drawing, the outline only should be drawn in pencil, and no shading or shadow lines, as the lead rubs off and dirties the paper.

5. When about to draw a right line between two points, place the ruler as nearly as possible in the same position with reference to both, and then see whether the line will pass exactly through both points, before drawing it on the paper with either pen or pencil. Also in drawing an arc through several points, try it with plain dividers, to see if the centre is exact before drawing the line.

6. All lines should be drawn sufficiently long at first, to avoid the necessity for subsequently producing them, a long line should never be obtained by producing a short one, unless some distant point in the prolongation has been first found by other means.

7. Whenever it is practicable, lines should be drawn *from* a given point and *not* to it; and if there are several points, in one of which two or more lines meet, the lines should be drawn from that one to the other; thus radii of a circle should be drawn from the centre to points in the circumference.

8. The larger the scale on which any problem, or part of one, is constructed, the less liable is the result to error. Hence all angles should be set off, and points determined by means of the largest circles which circumstances will allow to be described.

9. In determining a point by the intersection of circular arcs or straight lines, the radii should meet at that point at an angle of not more than 30° .

10. When one arc or straight line intersects another, as above, the second arc or line need not be drawn, but the *point* of intersection *only* should be marked so as to avoid unnecessary lines.

11. Avoid setting off equal lengths on a given straight line by continual repetition of one such length, but mark off on the line a convenient multiple of the given length, and sub-divide it, i.e., work from the whole to parts, not from parts to the whole; this is a great principle in surveying as well as plan drawing, and is especially to be observed in the construction of scales.

12. In laying off a length along a line with a scale, it is always well to check, either by reading off the distance along another part of the same scale, or by applying the scale so that it shall read backwards. This is a simple check, and a very useful one, as in plotting a survey it may often prevent considerable unnecessary labour.

13. Every drawing should have one or more long lines put in first across the paper, and at right angles to these, all new lines should be laid off from these guide lines, not from short lines of some part of the plan. The right angle guide lines should be laid with the compasses in the ordinary geometric way, not with the protractor. If a T square and large set square is used, this should be more accurate than any other way if carefully managed.

INSTRUCTIONS FOR THE PREPARATION OF FINISHED ARCHITECTURAL
AND TOPOGRAPHICAL DRAWINGS.

Drawing paper.—The drawing paper should be carefully examined to see which is the right side and that no mouldy spots exist. If any such spots are detected, the paper should be rejected, as it is impossible to paint over the discoloured spots.

Scales.—Before commencing any drawing, the scale on which it is to be made should be carefully constructed at the foot of the paper. All measurements should be taken from this scale. No discrepancy will then exist, when the paper is removed from the board, between the measurements on the drawing and the corresponding ones on the scale. Such discrepancy is often very considerable when separate pieces of paper are employed for the scale and drawing: drawing paper is very sensitive to atmospheric conditions, and often shrinks considerably after removal from the board.

The Drawing.—The drawing should now be put in with fine pencil lines, which, when complete, may be inked in with a fine drawing pen and the best Indian ink. No thick ink lines are on any account to be drawn till all the colours have been laid on. Care should be taken not to overshoot the corners where two lines intersect, and the lines should be kept as fine as possible.

Circles and arcs of circles should be inked in before straight lines. In drawing circles, care must be taken not to allow the point of the compass to penetrate the paper; the holes thus formed are liable to become filled up with colour and cause an unsightly blemish. The fine outlines of the drawing having been inked in, the paper should be thoroughly cleaned with dry clean bread and India-rubber, but the latter should be used as sparingly as possible.

Flat washes.—In laying on a flat wash the drawing board is always to be inclined so as to let the colour float downwards, the brush being only needed to give direction. If the paper is horizontal, the wash,

from remaining stagnant on one spot, deposits some of the solid colouring matter on the paper as a kind of precipitate, thus giving rise to unsightly blotches and cut shades.

It is quite unnecessary to wet the paper before laying on a flat wash if the following directions are observed :—

Sufficient colour should be mixed to last for the whole of the wash required ; any sediment should then be allowed to settle, and the clear solution poured off into another saucer. A wash should never be commenced without having a piece of blotting paper handy. A large brush should be used, and the colour kept running across the paper, working it gradually down the slope, and no portion of the “ working ” edge of the colour be allowed to dry up even for a second till the whole wash is completed. Red lines should not be washed over, or the colour will run. When a flat wash is uneven, or contains a cut shade (probably from allowing that portion to dry), or it is required to take out lines, or washes of colour, which are mistakes in the drawing, use a small soft sponge dipped in water, but not too full, apply the sponge boldly but lightly, and have a piece of blotting paper at hand with which to blot off the moisture. Where the colour to be erased is near other colours which the sponge might also touch, an aperture should be cut in a piece of paper, of the exact dimensions of the extent to be washed, the paper is then held firmly down upon the drawing, so that only required portion of it is visible, and the sponge can then be applied without risk of soiling the adjacent parts of the drawing. The sponge should never be used, either for, or near to, thick ink lines ; the ink is sure to run. Ink lines on tracing cloth can be taken out by means of moist brush and some blotting paper. The spot operated upon will, however, lose its glaze, and any ink line drawn over it afterwards will be liable to run.

When, as is often the case, a blot or small blemish in a flat wash of colour has to be erased and fresh colour to be afterwards applied, it is important to keep the texture of the paper as intact as possible ; the India-rubber should, therefore, be passed very lightly over the previously slightly moistened spot, and this operation should be repeated till a perfectly clean surface is obtained. The colour is then to be stippled in by separate strokes ; not washed in ; as in this latter case, the rough surface of the paper produced by rubbing would take the colour unevenly, and cause an unsightly blotch.

Choice of tints.—The main point to bear in mind is to preserve harmony in the drawing. Bright colours go with strong lines and bold

printing, while light shades, fine lines and unobstrusive printing go together.

Thick lines and shadows.—These will not be often used, but are useful in certain cases in showing up a drawing. Their position is determined by the supposition that the light enters from the top left hand corner of the paper.

Thus in the block plan of a building the dark lines will be on the right hand and lower faces.

This convention only applies to buildings in outline on plan ; if the drawing involves cast shadows the rules detailed in Chapter XV, Part II, must be followed.

Lettering and printing.—The size and thickness of lettering and printing should be in harmony with the size and boldness of the drawing. All dimensions should be given ; they *cannot be too full or too numerous* ; without them the drawing is almost useless, as even with a scale attached, great labour will be required to make use of the drawing by its means only. The scale should, however, be considered by the draftsman as non-existent except, for the measurement of a few exceptional points. Every single dimension which an Engineer is likely to require to know should be written on the plate in large legible figures. *The draftsman is not to consider either, that it is sufficient to give a dimension once, upon the plan for instance, and to omit it in consequence in the corresponding section : an individual, for whose inspection an architectural drawing is constructed, should never have to refer for information regarding a dimension either to a scale, or to another portion of the plate. Dimensions should be attached thus :—*



the extent to which they refer being indicated by a dotted line terminated at each end by an arrow head. In printing, the letters are to be *large and legible*. With regard to the *direction* of all printing upon a drawing the following rules should always be observed :—The drawing being laid before the spectator in the position in which it is intended to be read, the edge nearest to him may be termed the lower edge, that to his right hand, the right edge : all printing must be when possible parallel to, and readable from, the lower edge : when this is impossible, the printing must be parallel to, and readable from, the right edge.

Drawings required.—The drawings usually required for the correct representations of a building are Plans, Sections and Elevations. (For Definitions, *see* Chapter V.)

The plan is most usually a horizontal section of the building close above the ground floor; the floor, staircases, steps, etc., alone are shown in actual plan. By this means we obtain the positions and dimensions of the walls and rooms of the house. The roof is generally shown as a separate drawing, containing full details of all its parts.

If there is more than one floor to the building, a plan, or as we have just explained, a horizontal section, must be furnished at each different level.

The method of representing doors, windows and arches in a plan is shown in the accompanying sketches—the shaded portion represents Crimson Lake :—



Fire-places are of course drawn according to their particular outlines in plan.

In a plan it is only necessary to colour the section of the walls. The floor, steps, etc., are drawn in outline only.

The number of sections will depend upon the regularity of the building; generally it will be found that two-half sections are sufficient for most symmetrically constructed houses.

These two half-sections are generally placed side by side, divided by a single line. The lines on which they are constructed must be drawn very distinctly upon the plan, and lettered with Block Capital Letters. The section is then indicated as "section" or "half-section" on AB, CD, etc., as the case may be.

Besides these sections, a partial elevation is sometimes constructed on the same line, i.e., on the plane of section in question, the result is then termed "A Sectional Elevation" on AB, CD, etc. In some cases the elevation of important parts of a building cannot really be seen, from the intervention of earth or other detail of structure, between it and the plane of projection. In this case the section is to be coloured and completed as under ordinary circumstances, the outlines of the hidden elevation being drawn in with dotted lines only.

Detailed sections on larger scales are at times required for some of the details of construction, such as cornices, joints of rafters, etc., etc. Longitudinal sections are necessary for giving information otherwise unobtainable from the rest of the drawings.

Elevations generally represent the whole of one side of the building; every side which may differ from the others must have its own particular elevation. The sides may either be lettered in plan, and the elevation referred to its proper side by means of these letters, or the plan may be lettered North and South, in which case the elevations would be termed those of the North, South, East or West faces, respectively.

In constructing these drawings, the plan should first be drawn, then the sections, and finally the elevations. Sections of the various walls must of course be supplied before the plan can be constructed.

Conventional signs.—It is obvious that some convention or method is desirable to obtain a uniform representation of each material or object by a colour or sign. The conventional colours and signs given below include those laid down in the Public Works department Code, Vol. I, Chapter VII, and the topographical signs used by the Survey of India.

Only the most important conventions are given, but there are many others which are used in special branches, such as Irrigation and Military Surveys, and the details of which can be obtained from the various Conventional charts. If any special signs or abbreviations are used, a table showing their meaning should be attached to the plan.

LIST OF GENERAL COLOUR CONVENTIONS IN USE.

Maps.

Hills	Brown.
Sand hills	Brown.
Natural drainage	Cobalt, if perennial, otherwise black.
Tanks or jhils	Cobalt, if perennial, otherwise black.
Natural ravines and dry nalas			Black.
Rivers and streams	Cobalt, if perennial, otherwise black.
Village sites	{	Brick houses...	Vermilion.
		Mud houses ...	Vermilion.
Roads, metalled...	Vermilion.
Roads, unmetalled	Vermilion.
Railways	Black.
Canals	Cobalt,

Survey of India

Conventional Signs to be used on Topographical Maps.

Items.	Colours.	1 Inch and 2 Inches = 1 Mile.
City, Town or Village.	Vermilion	
(1) Deserted Village, Plantations, (2) walled, (3) open	(1) Vermilion	
Railways—		
Broad Gauge 5'6" Double Line		
—under construction		
" " Single "		
—under construction		
Other Gauges Double "		
—under construction		
" " Single "		
—under construction		
Mineral Lines and Tramways		
—under construction		
Main Cart Road, metalled, with mile-stone and Bridge.	Vermilion	
" " " unmetalled	Do.	
Villain Cart track in the plains, Camel road in Hills	Do.	
Mule-path, Bridle-path (1) Pass	Do.	
Foot-path	Do.	
Canal with (1) Distributary, (2) Bridge, (3) Lock	Cobalt	
(1) Cutting, (2) Embankment, (3) Tunnel	(1) & (2) Brown	
(1) Impenetrable Forest or Jungle, with Forest Limits	Dark green wash	

Items.	Colours.	1 Inch and 2 Inches = 1 Mile.
(2) Open Forest or Jungle, with Reserved Forest Boundary Symbol	Light green wash	
(1) Extensive Grass Lands in the plains, (2) Sand Hills	(2) Brown	
(1) Lake, Tanks, (2) with Embankment, (3) excavated and Hoed	Cobalt	
Breams—(1) perennial, (2) non-perennial (3) Limit of Cultivation, (4) Swamp	(1) & (4) Cobalt	
Karez—showing depth at well	Do.	
Wells—(1) Masonry lined, (2) unlined, (3) Spring	Do.	
Telegraph Line		
Gr. Trigl. Stations—Principal, Secondary		
Tertiary Station & Intersected Point		
Height—Trigonometrical, Clinometric, Relative		
Levelled Bench-mark		
Boundary External of India, Province or State		
" Division		
" District		
" Sub-Division, Tahsil, Pargana, &c.		
Post Office, Telegraph Office & P.O. & T.O. combined		
Dib Bungalow, Rest-house, Camping Ground, Police Station		
Fort, Frontier Watch-tower	Vermilion	
Temple or Pagoda, Mosque, Hponyng Kyaung	Do.	

FOR PLANS OF WORKS.

In section.

- Earthwork, natural ... A light wash of Burnt Sienna with the edges shaded with a darker tint of the same.
- Do artificial ... A light wash of Burnt Sienna with Indian ink etching shown for the made earth.

In Plan.

- Earthwork, natural ... Indian ink shading on slopes.
- Do. artificial ... Green shading on slopes.
- Concrete ... A light wash of Burnt Umber with fine dots of the same colour in section. The covered edges to be shown by thin broken black lines in Plan. If the concrete used for the floor of a room is plastered over, use the conventional colour for the plaster used.
- Brickwork, pucca, in mortar Lake flat wash in section. For archwork vertical hachures of Lake may be added. Black outline plain in elevation.
- Brickwork, pucca, in mud ... A light wash of Light Red in section. Black outline plain in elevation.
- Stone work ... A light wash of Burnt Umber with alternate firm and broken hachures of the same colour in section. A light wash of Burnt Umber in elevation.
- Rubble stone, boulder, or kunkar masonry in mortar. A light wash of Lake with broken hachures of dark Lake in section. Black outline with black broken hatching in elevation.
- Rubble stone, boulder, or kunkar masonry without mortar. A light wash of Burnt Umber hatched with Indian ink in section. Black outline dotted with Indian ink in elevation.
- Brickwork, kucha, in mud ... Indian ink light wash in section. Black outline plain in elevation.
- Cast-iron ... { Section—dark Indigo.
Elevation—light Indigo.

Wrought-iron	{ Section-- dark Prussian Blue. Elevation—light Prussian Blue.
Woodwork, Fir wood	A dark wash of Yellow Ochre with Burnt Sienna graining in section. A light wash of Yellow Ochre with Burnt Sienna graining in elevation.
Woodwork, hard wood	A wash of Burnt Sienna with Burnt Umber graining in section. A light wash of Burnt Umber in elevation.
Doors and windows	In section—woodwork, same as specified for wood Glasswork, Cobalt. In elevation—woodwork, same as specified. Glasswork, a triangular shaped flat wash of Cobalt in the upper left hand corner of each pane of glass.
Steel	Purple (Crimson Lake and Cobalt) with hachures of the same in section. A light wash of Purple in elevation.
Brass	Chrome Yellow mixed with a little Lake with hachures of the same in section. A light wash of the same colour in elevation.
Copper	Burnt Carmine mixed with a little Chrome Yellow with hachures of the same in section. A light wash of the same colour in elevation.
Lead	Indigo and a little Sepia mixed with hachures of the same in section. A light wash of the same colour in elevation.
Slate	Neutral Tint with hachures of the same in section. A light wash of Neutral Tint in elevation.
Tile	Lake in section. Lake and Burnt Sienna mixed (light wash), shaded, if necessary, to represent a slope, with Neutral Tint in elevation.

Corrugated iron	A light wash of Payne's Grey with hachures of the same in Section. A light wash of Payne's Grey in Elevation.
Thatch	Burnt Umber with hachures of the same in Section. A light wash of Burnt Umber in Elevation.
Pointing brickwork	A light wash of Light Red and a little Lake mixed together in Elevation.
Lime plaster, ordinary	A wash of Light Red in Elevation.
Do. slate-coloured	A wash of Neutral Tint in Elevation.
Do. sand	A wash of Payne's Grey in Elevation.
Do. surkhi-coloured		...	A wash of Light Red over a light one of Neutral Tint in Elevation.
Cement-plaster	A light wash of Payne's Grey in Elevation.
Whitewash	A light wash of Neutral Tint in Elevation.
Colour-wash	A tint of the same colour as the colour wash in Elevation.

Plate V shows the conventional signs used in the Survey of India.

CHAPTER III.

CONSTRUCTION OF SCALES.

REPRESENTATIVE FRACTIONS—PLAIN SCALES—COMPARATIVE SCALES —DIAGONAL SCALES—VERNIER SCALES—EXAMPLES.

When anything which has to be represented on paper is so large that it would be inconvenient to make a full-sized drawing of it, the drawing, or map, is made to another scale, that is, each line in the plan, using this word as a general term, is made with a fixed and known proportion to the line it represents.

Suppose, for example, that in a drawing of a house a line one inch long represents in plan a wall 100 feet long. Then, if the drawing is "drawn to scale," every other detail of the house will be represented by lines drawn in the same proportion. This proportion is called the scale of the drawing, and in this case the drawing is said to be drawn to a scale of 100 feet to an inch. Further, it is evident that the actual length of each piece of the building is 1,200 times the length of the line which represents it in the drawing; or every line in the drawing is $\frac{1}{1200}$ th part of the corresponding line in the object.

This fraction which represents the proportion of the drawing to the object is called the "*Representative Fraction*," and this fraction should be entered in a conspicuous place on every plan.

The student must clearly understand what is meant by the representative fraction, to find which he must reduce the number of units represented by 1 inch in plan to inches.

This will be the denominator of the fraction. The numerator will invariably be 1.

For example—

Find the representative fraction of a scale of 1 furlong to an inch.

The denominator is then $12 \times 3 \times 220 = 7,920$ and the representative fraction is $\frac{1}{7920}$.

In addition to the representative fraction, some means must be given by which any distance on the plan may be measured off, and the real length of the object it represents may be ascertained. This is done by means of a graduated straight line called the **SCALE**.

Scales may be divided into—

- (1) Plain Scales.
- (2) Comparative Scales.
- (3) Diagonal Scales.
- (4) Vernier Scales.

Before proceeding to consider the construction of scales it will be necessary to show how a given line can be divided into any desired number of parts, as this construction is frequently required in the construction of scales.

To divide a given line AB into five equal parts (Plate VI, Fig. 1.)

From the point A in the given line AB, draw a line AC making any convenient angle with the line AB. This angle should not be too acute. Along AC mark off five equal divisions 1, 2, 3, 4, 5. Join 5B. Through 1, 2, 3, 4 draw lines parallel to 5B, cutting AB in P_1, P_2, P_3, P_4 . These points will divide the line AB into five equal parts. Care should be taken to arrange the length of the divisions taken along AC in such a manner that the line 5B may be nearly at right angles to AB. If the angle at which the line 5B meets AB is too acute, it will be difficult to fix the points of intersection P_1, P_2, P_3, P_4 exactly.

Plain Scales.

In all scales it is evident that if they fulfil the functions explained above the unit of length of the scale must bear the proportion shown by the representative fraction to a real unit, and any length on the scale the same to the real length.

We will now give a few examples embodying the chief points to be kept in mind in the construction of scales.

Example 1.—To construct a scale of 100 feet to an inch to read to 10 feet. (Plate VI, Fig. 2.)

Scales are usually made about 6 inches long. For this case 6 inches will be found convenient as it represents 600 feet.

Draw a line 6 inches long and divide it into six equal parts.

The left hand division is always used to show the smallest unit required; in this case 10 feet. Divide this division into 10 equal parts. These will each represent 10 feet. Ink in two lines for the scale $\frac{4}{60}$ ths of an inch apart, the bottom one being darker than the top one. Draw perpendicular lines $\frac{8}{60}$ ths of an inch high to show the primary divisions, and $\frac{4}{60}$ ths of an inch high to show the secondary sub-divisions. The right hand point of the left hand division is invariably marked 0; the secondary sub-divisions starting from that point are marked from right to left, and

the primary divisions from left to right. Print in the title of the scale and the representative fraction, and the unit (feet) which the primary and secondary divisions represent. On the right hand side of *Fig. 2* are shown convenient distances at which the various lines for construction and printing may be drawn.

Example 2.—The representative fraction of a plan is $\frac{1}{60}$, construct a scale to read to feet (Plate VI, Fig 3.)

Here 60 inches, or 5 feet, represents one inch, and 6 inches on the scale will represent 30 feet. Lay down 6 inches and divide it into three parts, and the left hand sub-division into 10 parts. Finish as in Example 1.

Example 3.—To construct a scale of 13 yards to an inch, to read to yards. (Plate VI, Fig. 4.)

Here do not follow the too common error of laying down inches, and dividing the left hand inch into 13, and numbering the others 13, 26, 39, etc., so that nothing can be conveniently measured on it, but proceed thus. Here 13 yards equal 1 inch, therefore 6 inches represent 78 yards. The nearest next numbered scale to this will be 70 yards, i.e., 10 units to left, and 60 to right, of zero. So, as 78 : 70 :: 6 : 5·39. Lay down 5·39 inches and divide into 7 parts, and the left hand part into 10. Representative fraction $\frac{1}{13 \times 3 \times 12} = \frac{1}{468}$.

For the method of laying off a distance of 5·39 inches, see Diagonal Scales, Example 13.

Example 4. To construct a scale of 2 miles to the inch, showing miles and furlongs. (Plate VI, Fig. 5.)

Here 6 inches = 12 miles, but 1 mile to left and 11 miles to right would not look well. So as 12 : 11 :: 6 : 5·5 inches. Lay down 5·5 inches and divide into 11 spaces, and divide the left hand space into 8 for furlongs. Representative fraction $\frac{6}{12 \times 5280 \times 12} = \frac{1}{126720}$.

Example 5.—To draw a scale of 6 inches to a mile to read to yards. No figures are given for Examples 5, 6, 7 and 8.)

It will be most convenient to draw primary divisions to show 1,500 yards and secondary sub-divisions to show 100 yards. Six inches represent 1,760 yards. So, 1,760 : 1,600 :: 6 : 5·45.

Lay down 5·45 inches and divide as usual. Representative fraction $\frac{6}{760 \times 3 \times 12} = \frac{1}{10560}$.

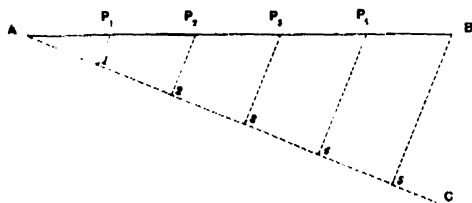

Fig. 1.

Scale—100 Feet to 1 Inch ($\frac{1}{100}$).

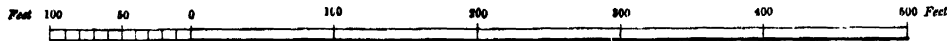

Fig. 2.

Scale—5 Feet to 1 Inch ($\frac{1}{6}$).



Fig. 3.

Scale—13 Yards to 1 Inch ($\frac{1}{13}$).



Fig. 4.

Scale—2 Miles to 1 Inch ($\frac{1}{2}$).

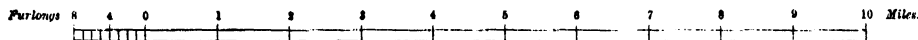

Fig. 5.

Scale for Horse trotting 240 Yards a minute ($\frac{1}{240}$).



Fig. 6.

Comparative Scale of Feet ($\frac{1}{12}$).

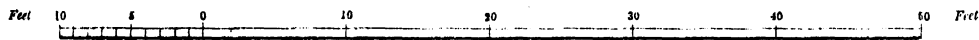

Fig. 7.

Comparative Scale of Miles ($\frac{1}{2}$).



Fig. 8.

Example 6.—To construct a scale of 8 inches to the mile, in paces of 30 inches.

Here 8 inches = 5,280 feet, or $\frac{5280}{2.5} = 2,112$ paces. Then say 1,600 paces is the length chosen. As $2112 : 1600 :: 8 : x$, etc.

Example 7.—To construct a scale of $\frac{1}{20000}$ showing chains of 100 feet.

Here 1 foot = 20,000 feet, and 6 inches = 10,000 feet, or 100 chains. Then 110 chains will be the length of the scale. So, as $100 : 110 :: 6 : \text{etc.}$

Example 8.—The representative fractions of two plans of a Russian fort are $\frac{1}{800}$ and $\frac{1}{1260}$ construct a scale of French toises for the former, and one of Russian archines for the other. The toise = 2.13142 yards, the archine = .7777 yards.

In the first, 1 toise or 2.13 yards represents 800 toises. Reduced to inches, 76.68 inches on plan equals 800 toises, or 7.67 inches = 80 toises. Thus 60 will be nearest suitable length for scale, and $80 : 60 :: 7.67 : \text{etc.}$, etc. The other is just similar.

Example 9.—In a rapid reconnaissance, when time will not admit of distances being measured by a chain or perambulator, they can be roughly measured by time. If the rate of a horse is known, when trotting or at a gallop, etc., a scale can be made by which distances are at once taken off from simple observations on the time which has elapsed. (Plate VI, Fig. 6.)

Suppose a scale of 6 inches to a mile ($\frac{1}{10560}$) is required, adapted to the pace of a horse which trots at the rate of 240 yards a minute.

Then in 9 minutes a horse will trot 2,160 yards. Make a scale of 6 inches to a mile to show 2,160 yards. The length of this line will be $10,560 : 2160 \times 36 :: 1 : 7.36$.

Lay off a line 7.36 inches long and divide it into 9 equal parts. Each part will represent the distance over which the horse travels in a minute, or 240 yards. Sub-divide the left hand division into 6, which will then read to 10 seconds.

Comparative Scales.

When the given scale of a plan reads in a certain measure, *and it be desired to construct a scale* for the plan reading in some other measure, this new scale is called a Comparative Scale.

Thus if the scale of the plan of a French building reads in decimetres, and it is desired to take measurements off the plan in feet, a Comparative scale must be constructed. The main point to bear in mind is that the representative fractions of the two scales must be the same.

Example 10.—The scale of an Indian plan is drawn in **Haths**. It is found by measuring the scale that one inch represents 6·75 Haths. It is required to draw a comparative scale of feet.

(1 **Hath**=18 inches.) (Plate VI, Fig. 7.)

The representative fraction is $\frac{1}{6\cdot75 \times 18} = \frac{1}{121\cdot5}$.

Take a length of scale to show 60 feet, then

$$121\cdot5 : 720 :: 1 : 5\cdot92$$

Lay down a line 5·92 inches long and divide it into 6 parts, and the left hand division into 10 parts. These now represent feet.

Example 11.—The scale of a map of France is in French leagues (1 French league=4262·84 English yards.) It is found by measuring the scale that 3·75 inches represent 25 leagues. Construct the corresponding scale of English miles. (Plate V, Fig. 8.)

Here 25 leagues = $\frac{4262\ 84}{1760} \times 25 = 60\cdot5$ miles.

Consequently, 60·5 miles are represented by 3·75 inches, so the scale may show 110 without being very long. So, 60·5 : 110 :: 3·75 : 6·81.

Divide then a line 6·81 inches long into 11 equal parts, to show spaces of 10 miles; sub-divide the first primary division into 10 equal parts to show miles.

Example 12.—A map is drawn to a scale of 2 miles to an inch ($\frac{1}{126720}$). Construct a comparative scale of Russian versts. (No figure is given.)

1 Russian verst=1166·6 English yards.

As the two scales must have the same representative fraction, this question is at once reduced to that of making a scale of $\frac{1}{126720}$ to show versts. But it can also be found directly as follows:—

As one inch represents 2 English miles, and 2 English miles = $\frac{1760 \times 2}{1116\cdot6}$ Russian versts, therefore one inch will represent $\frac{1760 \times 2}{1116\cdot6} = 3\cdot02$ versts. The scale will be best 21 versts long.

$$\frac{1760 \times 2}{1116\cdot6} \text{ versts} : 21 \text{ versts} :: 1 \text{ inch} : x \text{ inches.}$$

$$\therefore x = \frac{21 \times 1 \times 1116\cdot6}{1760 \times 2} = 6\cdot96 \text{ inches.}$$

Set off a line 6·96 inches long, and divide it into 21 parts, each part will represent a verst. Divide the left hand space into quarters.

In *Plate VII., Fig. 1*, is shown another sort of Comparative scale which is sometimes useful in enlarging or reducing a plan.

If the same distance on two plans on different scales be represented by **AB** and **AC**, then all lines parallel to **BC** will cut off lengths from **A** in the proportion of **AB** : **AC**. Therefore, taking any measurement on one plan with the compass and applying it from **A** along its line, say **AB**, the

length of the same measurement on the other plan will be found by moving the right leg of the compass down the cross line AC to C.

Diagonal Scales.

It will be seen from the preceding examples that some method of representing a decimal notation is often required. Further, on a plain scale it is only possible to read in two dimensions, such as yards and feet, inches and tenths of an inch, etc. It may be desired to read in three dimensions, such as yards, feet and inches, tenths of inches and hundredths of inches. For this purpose a diagonal scale is used.

Example 13.—To draw a diagonal scale of inches, to read to one hundredth of an inch. (Plate VII., Fig. 2.)

Draw a line 6 inches long and divide it into six parts. Divide the left hand sub-division into 10 parts, and at the extreme left raise a perpendicular. On this perpendicular lay off 10 equidistant points, and through them draw 10 lines parallel to the scale line. Divide the top line in the left hand sub-division into 10 parts. Draw lines straight up through the divisions right of zero, but to the left of zero draw diagonal lines to the divisions to the left on the top line, and number as shown in the Figure.

Then it is evident that each division we move along the bottom line from 0 to 10 we get $\frac{1}{10}$, $\frac{2}{10}$, etc., further from zero, but if we move along one of the diagonal lines, say from zero to the first division to the left on the top line, then every time a fresh line is crossed we have moved $\frac{1}{100}$ th of an inch further from zero.

The cross marks on the figure show 3.69 and 5.32 inches respectively reading from the top.

The main point to remember in drawing a diagonal scale is that the left hand sub-division must be divided into the number of units of the second dimension required, and the number of parallel lines drawn above the scale line must be the same as the number of units there are of the third dimension in a unit of the second dimension.

For example, if it was required to draw a diagonal scale of yards, feet and inches, the primary divisions would be yards, the left hand division would be divided into 3 for feet, and the number of parallel lines required would be 12.

Latitude and Longitude.—Diagonal scales are invariably used for plotting data on Geographical maps, and since Geographical maps are divided up into graticules of some integral part of degrees, a scale of degrees, minutes and seconds will be required. For example, a

standard map of India drawn to a scale of 1 inch to a mile is 15 minutes in latitude and 15 minutes in longitude. Here the scales suitable for plotting will be of 5 minutes each. To make these scales, take off one-third of the length in latitude, and in longitude, divide it into five equal parts, and sub-divide the left hand part into six parts of 10 seconds each. To be able to read to one second, draw ten horizontal lines, and complete the diagonal part. It must be remembered that the length of one degree of latitude and longitude varies and decreases from the equator northwards and southwards. Scale for each 5 minutes in length will be found sufficient.

Vernier Scales.

Vernier scales are sometimes used instead of diagonal scales. The principle on which they are constructed is as follows:—

If we have any length of scale representing n units of measurements and divide it into n equal parts, each part will represent one unit. If now we take a line equal to $(n+1)$ of these units, and divide it also into n parts, each minor division will be equal to $\frac{n+1}{n}$ units, and the difference between one minor division of the last and one minor division of the first will be $\frac{n+1}{n} - \frac{n}{n} = \frac{1}{n}$ of the original unit. And, similarly, the difference between two divisions of the one and two of the other will be $\frac{2}{n}$ of a unit—between 3 of one and 3 of the other $\frac{3}{n}$, and so on.

Example 14. To construct a scale of $\frac{1}{100}$ to show feet and tenths. (Plate VII., Fig. 3.)

Let the scale be drawn in the ordinary way, but sub-divided throughout its entire length; each sub-division shows one foot; set off to the left, on the upper line, a distance equal to 11 sub-divisions commencing from the zero of the scale; divide this into 10 equal parts as in the figure. Since 11 sub-divisions of the plain scale have been divided into 10 equal parts on the vernier scale, each division on the vernier will represent $\frac{11}{10} = 1.1$ of the sub-divisions on the plain scale, and as these show feet, each division on the vernier will show 1.1 foot; consequently the several distances from the zero of the scales to the successive divisions on the vernier will show 1.1, 2.2, 3.3, 4.4, 5.5, 6.6, 7.7, 8.8, 9.9, and 11 feet. The scale is used thus—

Let it be required to take off 26.7 feet.

Now the seventh division on the vernier will give us a reading of 7.7

Fig. 1.

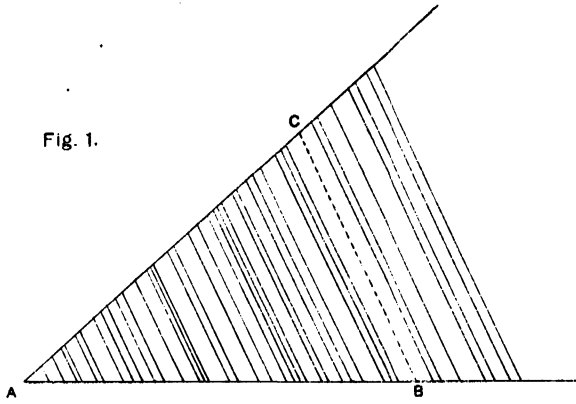

Fig. 5.

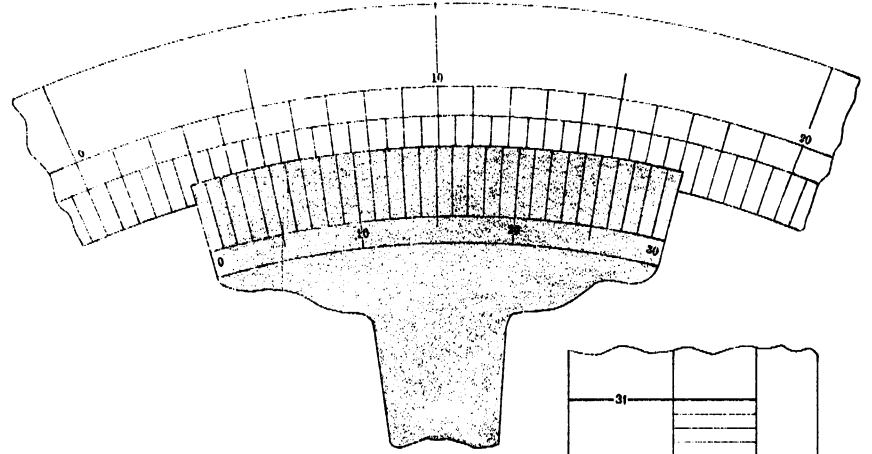

Fig. 2.

Diagonal Scale of Inches.

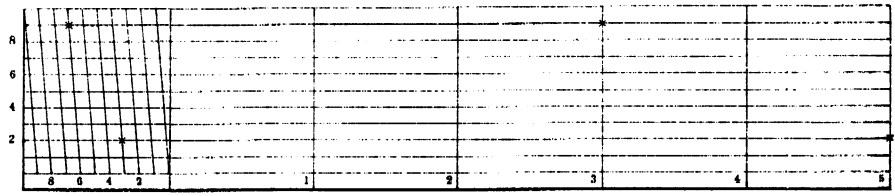

Fig. 4.

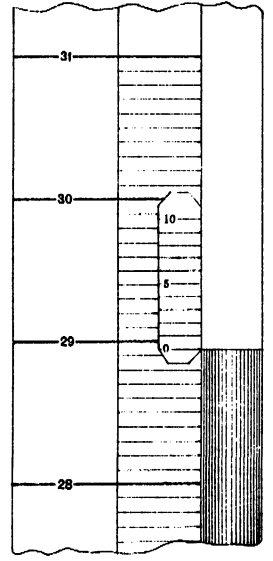
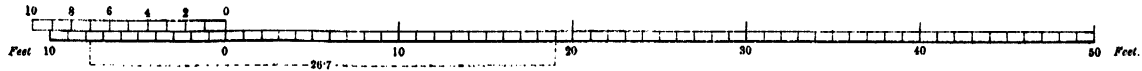

Fig. 3.

Vernier Scale of Feet (1/10).



Subtract $7\cdot7$ from $26\cdot7$, the remainder is 19 ; place one point of the compass on the 19 th sub-division on the upper line of the plain scale, and the other on the 7 th division of the vernier; this distance represents $26\cdot7$ feet.

Vernier scales, when applied to instruments, are constructed so that the vernier can be made to slide on the main scale. In this case it is more convenient if the vernier and scale read the same way, and for this purpose it is necessary to take the $n-1$ units to divide n . The difference is just the same; it is $1 - \frac{n-1}{n} = \frac{1}{n}$ of a unit.

Example 15.—It is required to measure the rise and fall of the mercury in a barometer to the 100 th of an inch. (Plate VII, Fig. 4.)

The main scale is divided into inches and tenths of inches. For the vernier take 9 sub-divisions and divide this distance into 10 parts.

When the top of the mercury falls between any two of the divisions on the main scale, it is only necessary to slide the zero of the vernier to fit with the top of the column, and read the number of the division that coincides with one of the plain scale. Here the reading is $28\cdot97$ inches. The difference between the top of the mercury or zero of vernier, and $28\cdot9$, is that between 7 divisions on the fixed and 7 on the vernier scale, or $\frac{7}{100}$. If the student will just mark off the divisions of the vernier on a separate slip of paper, and slide this about to fit any different height of mercury, the process will be immediately clear.

Example 16.—Construct a movable vernier to read minutes to a surveying instrument of which the arc is graduated to degrees and half degrees. (Plate VII, Fig. 5.)

Here the smallest division on the graduated arc is 30 minutes. Take a length of 29 minutes, and divide it into 30 for the vernier. In reading read to nearest half degree, and add the number of minutes shown by the vernier. In this case it is $2^\circ 30' + 11'$, or $2^\circ 41'$.

EXAMPLES.

1. Construct a scale of $\frac{1}{1760}$ to read to 20 feet.
2. Construct a scale of $8\cdot5$ feet to an inch to read to single feet.
3. Construct a scale of metres $\frac{1}{240}$ (metre = $1\cdot0936$ yards).
4. Finding that the distance between two points on a Swedish map is 7 inches, and the real distance on the ground $5,000$ alners. Construct a scale of feet (1 alner = $\cdot6493$ yard).
5. Construct a scale 22 yards to an inch, on which single yards can be measured.
6. Construct a scale of 6 inches to a mile, showing chains (100 feet).

7. The distance between Roorkee and Saharanpur is 23 miles, and measures on a map $13\cdot57$ inches. Draw the scale of the map showing miles and furlongs, and mark off 7 miles 3 furlongs on it.

8. Construct a scale of $\frac{1}{33000}$ to show versts (1 verst = 1,166·68 yards).

9. On a plan 3·21 inches represent 47 feet. Construct a scale.

10. The plan of a building is a square of $3\frac{1}{2}$ inches side, the length of the diagonal represents 100 feet. Construct a scale to read to inches, and mark off 63 feet 8 inches on it.

11. Draw a scale of miles and furlongs, in which $1\frac{1}{2}$ furlongs equal $\frac{1}{4}$ of an inch.

12. Construct a diagonal scale of 9 inches to a mile to read to furlongs.

13. Construct a scale of 5 miles to an inch and a comparative scale of Russian versts (1 verst = 1,166·68 yards).

14. Draw a diagonal scale to read to the thousandth of a foot.

15. A Prussian fathom contains 6 Rhenish feet, each equal to 1·0297 English feet. Construct a scale of fathoms $\frac{1}{234}$, showing feet diagonally.

16. An Englishman, wishing to examine a Spanish plan, finds only a scale of Spanish palms, 20 to an inch; supply him with a corresponding scale of English feet, taking the palm as $\cdot634$ of an English foot. Show 50 feet.

17. Draw scales of $\frac{1}{1500}$ to represent English feet, French metres, and Greek cubits. 1 metre = 3·27 feet, 1 cubit = $\cdot45$ metre.

18. Construct a scale of 6 inches to a mile, to measure furlongs and diagonally spaces of 60 feet.

19. A map is 36 inches long and 30 inches broad; it represents an area of 25 acres; draw the scale of the map to show poles, yards, and (diagonally) feet (4,840 square yards = 1 acre).

20. Required a scale of Russian archines, for a plan on which the breadth of a river, really 50 sachsen, is represented by 12 English inches, 3 archines = 1 sachsen = 2·3332 English yards.

21. Construct a scale of 8 inches to 1 mile to read to 20 paces, and by a vernier to 5 paces. 1 pace = 30 inches.

22. The distance between two points, 1 Austrian mile apart, is represented on a map by 2·66 English inches. Construct a diagonal scale of English miles. 1 Austrian mile = 3·3312 English miles.

23. Construct a scale of $\frac{1}{15000}$ to take off intervals of time adapted to the trot of a pony, which goes over 180 yards per minute at a fast trot. Show 10 minutes.

24. A horse passes over about 280 yards per minute at a gallop. Construct a scale of $\frac{1}{20000}$ adapted to time. Show 10 minutes.

25. On a plan 1,200 yards are represented by 15 inches. Draw a comparative scale of French metres (1 metre = 1.0936 yards).

26. The representative fraction of a scale on a Russian map is $\frac{1}{1700}$. Draw a comparative scale of French metres (1 metre = 39.37 inches).

27. A distance on a French map which is known to be 3 miles measures 18 inches. Taking a pace to be 32 inches, construct a scale of paces for the map.

28. Construct a vernier scale of $\frac{1}{100}$ to show feet and inches, and mark off 25 feet 7 inches on it.

29. Construct a scale of $\frac{1}{275}$ to show poles and yards, and by a vernier to read feet.

30. Construct a diagonal scale of $\frac{1}{60}$ to show metres, decimetres, and centimetres (1 metre = 3.28 feet).

31. A scale of 4 inches to the mile is attached to a map. On this I find the distance between two points to be 1 mile 5 furlongs. I measure the same distance on the ground and find it to be 1 mile 3 furlongs. Knowing the survey to be correct, construct a correct scale to the map to read to miles and furlongs.

32. Construct a scale of chords and by means of it set off from a line an angle of 75° .

33. One degree on a scale is represented by $\frac{3}{10}$ of an inch. Construct a scale showing degrees and quarter degrees, with a movable vernier to read minutes. On this scale mark off $4^\circ 34'$.

34. You are given a survey of a portion of country drawn to a scale of 16 inches to a mile. The paper it is on measures 32 inches long by 26 inches broad. Find the area of the country and the area of paper required to copy the survey to a scale of 12 inches to a mile.

What are the representative fractions of the two scales?

35. A map is 40 inches long and 27 inches broad; it represents an area of 50 square miles. Draw the scale of the map to show miles, furlongs, and diagonally chains.

36. A cavalry officer finds that his horse canters 16 miles an hour. Construct a diagonal scale of $\frac{1}{25344}$ adapted to time, and mark off on it the distance he traverses in 7 minutes 42 seconds.

37. Two posts of the handrail of a staircase have their axes vertical, and the top of the lower, and the base of the upper are in a horizontal line, 3 yards 1 foot 4 inches apart centre to centre. Draw a diagonal scale $\frac{1}{81}$ to read yards, feet, and inches. If the line joining the centres of the tops slopes 1 in 2, show it graphically on your scale, and write down its length to the nearest inch.

38. A standard map of India in a certain latitude measures 15 inches in longitude and 17·1 inches in latitude. Construct a scale of latitude and longitude for the map, and show 2 feet 37 inches both in latitude and longitude. Standard maps of India are 15 minutes in latitude and longitude.

39. Construct a scale of 3 inches to a mile, and add a vernier to read in spaces of 60 feet. On this scale mark off a distance of 1 mile, 3 furlongs, 420 feet.

40. Illustrate by examples how you would enlarge or reduce a drawing, (a) when the figure is regular, (b) when the figure is irregular.

CHAPTER IV.

PLANE GEOMETRY.

Plane Geometry deals with the representation of plane surfaces (having length and breadth only) on a plane surface, such as paper.

RULES FOR DRAWING.

1. GIVEN lines to be THIN CONTINUOUS LINES.
2. RESULTING lines to be THICK CONTINUOUS LINES.
3. All construction lines to be FINE COMMON DOTTED LINES.

DEFINITIONS.

1. A *point* is that which has position but not magnitude.
2. A *line* is that which has only length. Hence the extremities of a line are points, and the intersections of one line with another are also points.
3. A *straight line* is the shortest distance between its extreme points.
4. Every line which is neither straight nor composed of straight lines is a *curve*.
5. Straight lines which are in the same plane, and being produced ever so far both ways, do not meet, are called *parallel lines*.
6. A *plane rectilineal angle* is the inclination of two straight lines to one another, which meet together, but are not in the same straight line.
7. When a straight line, standing on another straight line, makes the adjacent angles equal to one another, each of these angles is called a *right angle*, and the straight line which stands on the other is called a *perpendicular* to it.
8. An *obtuse angle* is that which is greater than a right angle ; and an *acute angle* is that which is less than a right angle.
9. The complement of an angle is that which it requires to complete a right angle.
10. The supplement of an angle is that which it requires to complete two right angles.
11. A *plane figure* is a plane terminated everywhere by lines. If the lines be straight it is called a *rectilineal figure*, or a *polygon*, and the lines themselves constitute the *perimeter* of the polygon.

12. When a rectilinear figure has three sides, it is called a *triangle*; when it has four, it is called a *quadrilateral*; when it has five, a *pentagon*; when six, a *hexagon*; and so on.

13. An *equilateral* triangle is that which has three equal sides; an *isosceles* triangle is that which has only two equal sides; and a *scalene* triangle is that which has all its sides unequal.

14. A *right-angled* triangle is that which has a right angle; the side opposite to the right angle is called the *hypotenuse*. An *obtuse-angled* triangle is that which has an obtuse angle; and an *acute-angled* triangle is that which has three acute angles.

15. Of quadrilateral figures, a *square* is that which has all its sides equal and all its angles right angles. A *rectangle* is that which has all its angles right angles, but not all its sides equal. A *rhombus* is that which has all its sides equal, but its angles are not right angles. A *parallelogram* is that which has its opposite sides parallel. A *trapezoid* is that which has only two of its opposite sides parallel. All other four-sided figures are called *trapeziums*.

16. The vertex of an angle is the point where the two lines forming the angle meet.

17. A *diagonal* is a straight line which joins the vertices of two angles which are not adjacent to each other.

18. An *equilateral polygon* is that which has all its sides equal; and an *equiangular polygon* is that which has all its angles equal. If a polygon be both equilateral and equiangular, it is called a *regular polygon*.

19. A *circle* is a plane figure contained by one curved line which is called the *circumference*, and is such that all straight lines drawn from a certain point within the figure, called the CENTRE, to the circumference are equal to one another.

20. A *diameter* of a circle is any straight line drawn through the centre and terminated both ways by the circumference.

21. The *radius* of a circle is a straight line drawn from the centre to the circumference.

22. A *semicircle* is half a circle, and a *quadrant* is a quarter of a circle.

23. An *arc of a circle* is any portion of its circumference.

24. A *chord* is a straight line which joins the extremities of an arc.

25. A *segment of a circle* is the figure contained by an arc and its chord.

26. A *sector* of a circle is the portion of a circle contained by two radii and the arc between them.

27. A *tangent* is a straight line which touches a circle in a point but which when produced does not cut it.

LINES AND ANGLES.

Unless otherwise stated, "a line" means "a straight line."

Problem 1—To bisect a given line **AB** or regular curve **AEB** (Plate VIII, Fig. 1)

With centres **A** and **B** and any convenient radius, describe arcs intersecting at **C** and **D**. Join **CD**, cutting **AB** in **F** and **AEB** in **E**. Then the given straight line is bisected at **F**, and the given regular curve at **E**.

Problem 2.—Through a given point **P** to draw a line perpendicular to a given line **AB**.

Case 1. When the point **P** is at or near the middle of the given line (Plate VIII, Fig. 2). Make **PA** equal to **PB**. With centres **A** and **B** and any convenient radius, draw arcs intersecting at **C**.

Join **C P**. Then **CP** is perpendicular to **AB**, and passes through the point **P**.

Case 2. When the point **P** is at or near the extremity of the given line (Plate VIII, Fig. 3). Take any convenient point **C**. With **C** as centre and **CP** as radius, describe a semicircle cutting **AB** in **D**. Join **DC**, and produce the line to cut the semicircle in **E**. Join **EP**. Then **EP** is the required perpendicular.

Case 3. When the point **P** is not in the given line but opposite or nearly opposite the middle of the line (Plate VIII, Fig. 4). With **P** as centre and any convenient radius, describe an arc cutting **AB** in **C** and **D**. With centres **C** and **D** and any radius, describe arcs intersecting at **E**. Join **EP**. Then **EP** is the required perpendicular.

Case 4. When the point **P** is not in the given line but opposite or nearly opposite an extremity (Plate VIII, Fig. 5).

Draw any line **PC** cutting **AB** in **C**. On **CP** as diameter describe a semicircle cutting **AB** in **E**. Join **PE**. Then **PE** is the required perpendicular.

Case 5. When the point **P** is beyond the extremity of the given line (Plate VII, Fig. 6).

With centres **A** and **B** and radii **AP** and **BP**, describe arcs intersecting at **P** and **C**. Join **PC**. Then **PC** is the required perpendicular.

Problem 3.—To draw a line parallel to a given line **AB**. (Plate VIII, Fig. 7.)

At any two points C and D in AB erect perpendiculars, and on these mark off equal distances CE and DF. Join EF. Then EF is the required line parallel to AB.

Problem 4.—Through a given point P to draw a line parallel to a given line AB. (Plate VIII, Fig 8)

With P as centre and any radius draw the arc DC cutting AB in C. With C as centre and CP as radius, draw the arc PE cutting AB in E. Make CD equal to EP. Join DP. Then DP is the required line parallel to AB.

Problem 5.—To bisect a given angle ABC. (Plate VIII, Fig. 9.)

With centre B and any convenient radius, describe the arc DE cutting BA in D and BC in E. With centres D and E and any radius, draw arcs intersecting at F. Join BF. Then the line BF bisects the angle ABC.

Problem 6.—To determine the direction of the line which would bisect the angle contained by two given lines AB and CD, intersecting beyond the limits of the paper. (Plate VIII, Fig. 10.)

From any point E in AB draw a line EF parallel to CD. With E as centre and any convenient radius EF, describe the arc FG cutting AB in G. Join GF, and produce it to cut CD in H. Draw MN bisecting GH at right angles; this is the required line.

Problem 7.—Through a given point P to draw a line which would, if produced, pass through the angular point in which two given lines AB and CD would meet if produced. (Plate VIII, Fig. 11.)

Draw any line EF cutting AB in E and CD in F. Join EP and FP. Draw GH parallel to EF and GK and HK parallel to EP and FP. Join PK. Then PK is the required line.

Problem 8.—To trisect a right angle ABC (Plate VIII, Fig 12.)

Draw any convenient arc AC. With A and C as centres and BA as radius, mark off points F and E on the arc AC. Join BE and BF. Then the lines BE and BF trisect the right angle ABC.

Problem 9.—To trisect any given angle ABC. (Plate VIII, Fig. 13.)
(Approximate method.)

Draw any convenient arc DE. Bisect the angle ABC in BF. Join DE. On DE describe the semicircle DFE, and with centres D and E and radius equal to half DE, mark off points G and H on the semicircle DFE. Make KL=DE. Join LG and LH, cutting the arc DE in M and N. Join BM and BN. Then the lines BM and BN trisect the angle ABC.

Problem 10—To find a point P and a given line AB equidistant from two given points C and D. (Plate VIII, Fig. 14.)

Join CD and bisect it at right angles by the line EP, cutting AB in P. Then P is the required point.

Problem 11.—From two given points *C* and *D* to draw two straight lines to make equal angles with a given line *AB* (Plate VIII, Fig. 15)

Draw *CEF* perpendicular to *AB*, and make *EF* equal to *EC*. Join *FD* cutting *AB* in *P*. Join *CP*. Then *CP* and *DP* are the two required lines.

Problem 12.—Through a point *P* to draw a line making equal angles with two converging lines *AB* and *CD*. (Plate VIII, Fig. 16.)

Through any point *A* in *AB* draw the line *EF* parallel to *CD*. Bisect the angle *BAE* by the line *GA*. Through *P* draw *PH* parallel to *GA*. Then *PH* is the required line.

Problem 13.—Through a point *P* between two converging lines *AB* and *CD* to draw a line terminating in *AB* and *CD* and bisected in *P* (Plate VIII, Fig. 17.)

Draw *PF* perpendicular to *CD*. Produce *FP* and make *PE* equal to *PF*. Draw *EL* parallel to *CD* cutting *AB* in *L*. From *L* draw *LH*, passing through *P*. Then *LH* is the required line and is bisected in *P*.

EXERCISES—LINES AND ANGLES.

Compasses and rulers are only to be used unless the use of set squares is specified.

1. From one extremity of a line 3 inches long draw a perpendicular 2 inches long without producing the line.
2. Divide a line 3 inches long into seven equal parts.
3. A line 5 inches long is divided into six equal parts, draw parallel lines half an inch apart through the divisions of the given line.
4. Bisect a given line 3 inches long by use of set squares with angles of 45° and 60° .
5. Bisect a given angle by the use of set squares.
6. Divide a given angle into eight equal angles.
7. Draw an angle equal to the sum of two given angles.
8. Construct angles of 60° , 45° , 105° , 150° with the aid of compasses and ruler only.
9. Construct angles of 75° , 120° , 135° , and 15° with the aid of set squares (of 45° and 60°) only.
10. Divide a line 3 inches long into five equal parts with the use of compasses and ruler only.

TRIANGLES.

Problem 14.—To draw an isosceles triangle, given the base *AB* and the length of a side *C*. (Plate VIII., Fig. 18.)

With centres *A* and *B* and radius equal to *C*, describe arcs intersecting at *D*. Join *AD* and *BD*. Then *ABD* is the required triangle.

(If the base *AB* equals *C*, the triangle will be an equilateral triangle.)

Problem 15.—To draw an isosceles triangle, given the length of a side C , and the angle at the base α . (Plate VIII, Fig. 19.)

Make the angle BAD equal to α . Make AD equal to C , and with centre D and radius equal to C mark the point B on AB . Then ABD is the required triangle.

Problem 16.—To draw an isosceles triangle, given the base AB and the vertical angle β (Plate VIII, Fig. 20)

Make ab equal to ac and join bc . On AB make AE equal to bc , and the triangle EAF equal to the triangle cba . Draw BC parallel to EF and produce AF until it meets BC in C . Then BAC is the required triangle.

Problem 17.—To draw an isosceles triangle, given the altitude AB and the vertical angle α . (Plate VIII, Fig. 21.)

Bisect the angle α . At A lay off on each side of BA angles BAE and BAF equal to half α . Through B draw GBH perpendicular to BA . Then GAH is the required triangle.

Problem 18.—To draw an isosceles triangle, given the altitude AB and a base angle α (Plate VIII, Fig. 22.)

Through B draw CD perpendicular to BA . Make the angle DBE equal to α . Draw AC parallel to BE . Make BD equal to BC . Join DA . Then DCA is the required triangle.

Problem 19.—To draw any triangle, given the base AB , the vertical angle β and a base angle α . (Plate VIII, Fig. 23.)

At A make the angle BAD equal to α . In β make the angle abc equal to α . At B make the angle ABD equal to β . Then ABD is the required triangle.

Problem 20.—To draw any triangle, given the altitude AB and the two base angles α and β . (Plate VIII, Fig. 24.)

Through A and B draw lines EF and CD perpendicular to AB . Make the angle EAC equal to β and the angle FAD equal to α . Then ACD is the required triangle.

Problem 21.—To draw any triangle, given the base AB , the altitude C , and the vertical angle α . (Plate VIII, Fig. 25.)

Bisect AB at right angles by the line FE . Make FE equal to C . Make the angle FAO equal to α . Draw AD perpendicular to AO cutting FE in D . With centre D and radius DA describe the segment of a circle AGB . Through E draw GH parallel to AB , cutting the circumference of the circle in G . Join GA and GB . Then GAB is the required triangle.

Problem 22.—To draw any triangle of perimeter equal to a given length DE and similar to a given triangle ABO . (Plate VIII, Fig. 26.)

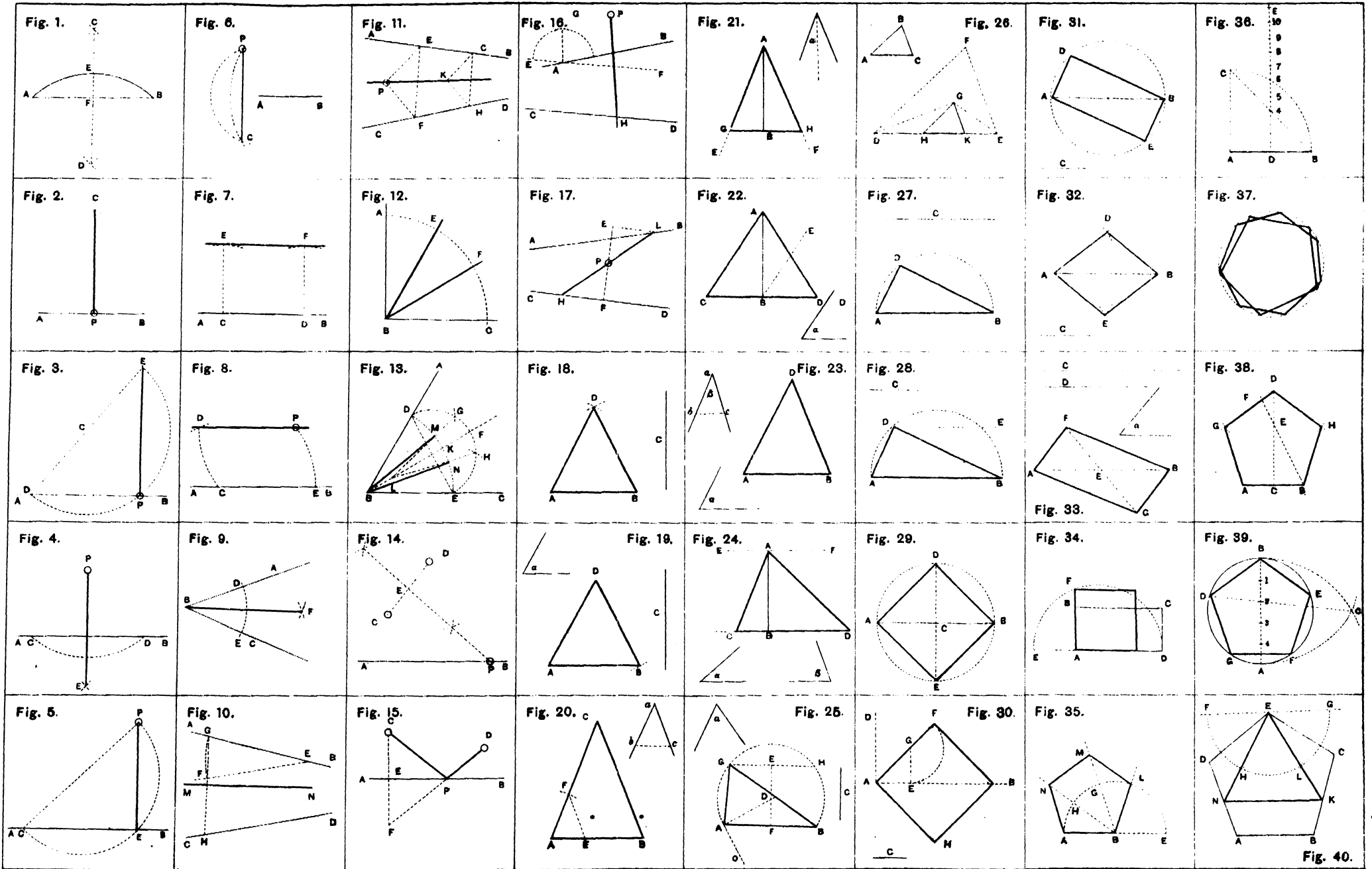

On DE draw the triangle DFE similar to ABC. Bisect the angles FDE and FED by lines meeting in G. Draw GH parallel to FD and GK parallel to FE. Then GHK is the required triangle.

Problem 23.—To draw a right-angled triangle, given the hypotenuse AB and the length of one side C (Plate VIII, Fig. 27.)

On AB describe a semicircle. With centre B and radius equal to C, cut off a point D on the circumference. Join AD and BD. Then ADB is the required triangle

(If the base angle is given instead of the length of the side, make angle ABD equal to the base angle.)

Problem 24.—To draw a right-angled triangle, given the length of the hypotenuse AB and the perpendicular C let fall on to it from the opposite angle. (Plate VIII, Fig. 28.)

On AB describe a semicircle. Draw DE parallel to AB, and at a distance from AB equal to C, cutting the semicircle in D and E. Join AD and BD. Then ADB is the required triangle.

EXERCISES.—TRIANGLES.

1. Draw a triangle, the sides of which are 3.5, 1.75, and 2.5 inches respectively.

2. On a base of $1\frac{1}{2}$ inches construct an isosceles triangle with a vertical angle of 45° .

Bisect the base AB by a perpendicular CD. With C as centre and CA as radius cut DC in E. With E as centre, and radius EA describe the arc AFB cutting CD in F. Join AF, BF.

3. On a base of 2 inches, construct an isosceles triangle with a vertical angle of 30° .

4. Construct a triangle, given the length of the altitude, one side and the base.

5. Construct a triangle, given the length of the altitude and the two sides.

6. Construct a triangle on a base of 2 inches having angles in the proportion of 2, 5, 7.

Produce the base AB. With centre A and any radius, describe a semicircle, and divide it into 14 parts. Join B5. Make the opposite angle BAC equal to $2\angle AOB$.

7. Construct a triangle with a perimeter of 4 inches, the sides to be in the proportion of 2, 3, 4.

Divide 4 inches into 9 parts, with centres 2 and 5 and radii 2, 0; 5, 9, describe arcs intersecting in B; then 2 5 B is the required triangle.

8. Construct a right-angled triangle with a hypotenuse of 2 inches and an acute angle of 15° .

9. Construct a right-angled triangle having angles in the proportion of 2, 4, 6.

10. Construct a right-angled triangle with a hypotenuse of 2 inches and a side of $\frac{3}{4}$ inch.

QUADRILATERAL FIGURES.

Problem 25.—To draw a square, given a diagonal AB. (Plate VIII, Fig. 29.)

On AB as diameter describe a circle. Bisect AB at right angles by the line DE, cutting the circumference of the circle in D and E. Join AD, DB, BE, and EA. Then ADBE is the required square.

Problem 26.—To draw a square, given the difference in length C between the diagonal and side. (Plate VIII, Fig. 30.)

Draw any line AB and erect a perpendicular AD. Bisect the angle BAD by the line AF. Make AE equal to C. Draw EG perpendicular to AB and cutting AF in G. With centre G and radius GE describe an arc cutting AF in F. On AF describe the required square AFBH.

Problem 27.—To draw a rectangle, given the diameter AB and one side C. (Plate VIII, Fig. 31.)

On AB as diameter describe a circle. With A and B as centres and C as radius draw arcs cutting the circumference in D and E. Join the points AD, BE. Then ADBE is the required rectangle.

Problem 28.—To draw a rhombus, given the diagonal AB and length of sides C. (Plate VIII, Fig. 32.)

With centres A and B and radius equal to C draw arcs intersecting at D and E. Join the points AD, BE. Then ADBE is the required rhombus.

Problem 29.—To draw a parallelogram, given the length of two diagonals C and D and the included angle α . (Plate VIII, Fig. 33.)

Draw any line AB equal to C. Bisect AB in E. Make the angle AEF equal to α . Make EF and EG each equal to half D. Join the points AF, BG. Then AFBG is the required parallelogram.

Problem 30.—To draw a square equal to a given rectangle ABCD. (Plate VIII, Fig. 34.)

Produce DA to E. Make AE equal to AB. On DE as diameter describe a semicircle. Produce AB to cut the circumference in F. On AF describe the required square.

POLYGONS.

Problem 31.—To describe a regular polygon (say a pentagon) of any number of sides on a given line AB. First method. (Plate VIII, Fig. 35.)

With B as centre and radius BA describe a semicircle cutting AB produced in E. Divide the semicircle into as many parts as there are sides in the polygon; in this case five. From B draw lines through each division commencing from the SECOND from the right.

Make BL equal to BA and complete the pentagon ABLMN.

Second method (Fig. 36).—At A erect AC perpendicular and equal to AB. Join BC. Bisect AB at right angles by the line DE, cutting BC in 4. With centre A and radius AB describe the arc BC cutting DE in 6. Bisect 4, 6 at 5. Lay off the distance 4, 5 from 6 along the line DE marking the points 7; 8, 9, etc.

Then 4 is the centre of the circle described about a square of side AB, and 5 the centre of the circle described about a pentagon of side AB, and so on.

Third method.—The most accurate method is to use the Line of Polygons on the sector (*see* Chapter I, p. 12). The sector is opened so that the distance between the two corresponding numbers representing the number of sides of the polygon, on the two lines of polygons, is equal to the given length AB. The transverse distance at 6 for this same opening will give the radius of the circle to be described about the required polygon. *Fig. 37* a pentagon and a heptagon are drawn by this method.

Problem 32.—To describe a pentagon on a line AB, Special method. (Plate VIII, Fig. 38.)

Bisect AB by the line CD drawn perpendicular to it. Make CE equal to AB. Join BE and produce the line. Make EF equal to AC. Cut off on CD a point D so that BD is equal to BF. With centres A, B, and D and radius AB draw arcs intersecting at G and H. Then ABHDG is the required pentagon.

Problem 33.—To inscribe a regular polygon in a given circle BGF (say a pentagon). (Plate VIII, Fig. 39.)

Draw a diameter AB and divide it into as many parts as there are to be sides to the polygon required, in this case 5.

From A and B as centres, with AB as radius, describe arcs intersecting at C. Through C and the SECOND division draw the line C2D, cutting the circle in D. Join BD. Then BD is the side of the inscribed polygon, which can be completed.

Problem 34.—To inscribe an equilateral triangle in a given pentagon ABCED. (Plate VIII, Fig. 40.)

Through E draw GF parallel to AB. With E as centre and with any radius, describe a semicircle FGH. From G and F as centres and with the same radius, describe arcs cutting the semicircle FGH in H and L. From E draw the lines ELK and EHN meeting the sides of the pentagon in K and N. Join the points ENK. Then ENK is the required inscribed equilateral triangle.

EXERCISES—QUADRILATERAL FIGURES AND POLYGONS.

1. Construct an equilateral triangle 2.5 inches high.
2. Construct a rhombus, the length of one side being 1 inch and one angle being 30° .
3. Construct a rhombus, one side of which is equal to $1\frac{1}{2}$ inches and the diagonal equal to 2 inches.
4. Construct a trapezium, diagonal 2 inches, sides 1 inch and $1\frac{1}{2}$ inches.
5. Construct a heptagon with a side of 2 inches.
6. Construct an octagon with side of 1 inch.
7. Two sides of a pentagon AB and BC are given in position, complete the pentagon.
8. Construct an irregular octagon, the adjacent sides being $\frac{1}{2}$, $\frac{1}{2}$, 1 and $1\frac{1}{2}$ inches, the opposite sides are equal and parallel.

CIRCLES.

(For sake of brevity a given circle is usually referred to by the letter indicating its centre.)

Problem 35.—To find the centre of a given circle BAC. (Plate IX, Fig. 1.)

Draw any two chords BA and AC. Bisect each chord by lines intersecting at D which is the required centre.

(The same construction would be used to draw a circle through three given points B, A and C or to complete a circle of which the arc BC is given.)

Problem 36.—To draw a tangent to a circle from a point P. (I) in the circumference. (Plate IX, Fig. 2.)

Find the centre A. Join AP. Draw BP perpendicular to AP. Then BP is the required tangent.

(II) Outside the circle. (Plate IX, Fig. 3.)

Join the centre A with P. Bisect AP in B. With centre B and radius BP describe arcs cutting the circle in C and D. Then PC and PD are the required tangents.

Problem 37.—To draw a tangent to an arc through a point P in the circumference when the centre is inaccessible. (Plate IX, Fig. 4.)

Draw any chord PA. Bisect it at right angles by the line CD, meeting the arc in D. Join PD. Make angle DPF equal to angle DPA. Then PF is the required tangent.

Problem 38.—To draw a tangent to an arc through a point P outside the arc when the centre is inaccessible. (Plate IX, Fig. 5.)

From P draw any line PAB cutting the arc in A and B and on PB describe a semicircle. Draw AC perpendicular to PB, meeting the semicircle in C. On the arc cut off PD equal to PC. Join PD. Then PD is the required tangent.

Problem 39.—To draw an exterior tangent to two circles A and B. Case 1.
When the circles are apart. (Plate IX, Fig. 6.)

Join the two centres A and B and bisect AB in C. With centre A, the centre of the larger circle, and radius equal to the difference between the radii of the two given circles, describe a circle. With centre C and radius CA mark off a point D on this circle. Join AD and produce the line to cut the circle A in E. Draw BF parallel to AE. Join EF. Then EF is the required tangent.

Case 2.—When the circles touch. (Plate IX, Fig. 7.)

Join the centres AB by a line cutting the circles in the point C. On AB describe a semicircle. At C erect CE perpendicular to AB cutting the semicircle in E. With centre E and radius EC draw arcs cutting the two circles in F and G. Join FG. Then FG is the required tangent.

Case 3.—When the circles intersect. (Plate IX, Fig. 8.)

Join the centres A and B. Draw any two parallel radii cutting the circumferences in C and D. Join DC and produce it to cut the line BA produced in E. Describe a semicircle on BE cutting the bigger circle in F. Join FE. Then FE is the required tangent.

Problem 40.—To draw an interior tangent to two circles A and B. (Plate IX, Fig. 9.)

Join the centres A and B. With centre B and radius equal to the sum of the radii of the two circles, describe a circle. From A draw AC a tangent to this circle. Join CB cutting the circumference in E. Draw ED the required tangent parallel to AC.

CIRCLE TOUCHING LINES AND CIRCLES.

Problem 41.—To describe a circle to touch a given line AB in a point P, and to pass through any given point Q. (Plate IX, Fig. 10.)

Draw PC perpendicular to AB. Join PQ. Bisect PQ at right angles by the line DC cutting PC in C. Then C is the centre of the required circle.

Problem 42.—To describe a circle of any given radius R to touch a line AB, and pass through a given point P. (Plate IX, Fig. 11.)

At a distance equal to R draw CD parallel to AB. With centre P and radius R cut off a point E on CD. Then E is the centre of the required circle.

Problem 43.—To describe a circle to pass through two given points P and Q and to touch a given line AB. (Plate IX, Fig. 12.)

Join PQ and produce the line to cut AB in C. Bisect PQ at right angles by the line DE. With D as centre and DC as radius, describe a semicircle. Draw PF perpendicular to PQ cutting the semicircle in F. Make CG equal to PF. Draw GE perpendicular to AB cutting DE in E. Then E is the centre of the required circle.

Problem 44 —To describe a circle to touch three given lines **AB**, **CD**, and **EF**. (Plate IX, Fig. 13.)

Produce the given lines to meet in the points **G** and **H**. Bisect the angles **BGH** and **GHF** by lines meeting in **K**. Then **K** is the centre of the required circle. From **K** draw **KL** perpendicular to **EF**. Then **KL** is the radius of the required circle.

Problem 45 —To describe a circle of given radius **R** to touch two converging lines **AB** and **CD** which do not meet on the paper. (Plate IX, Fig 14.)

At distance **R** draw two lines parallel to **AB** and **CD** intersecting at **E**. Then **E** is the centre of a required circle.

Problem 46.—To describe a circle to touch two converging lines **AB** and **CD**, and touching one in a given point **P**. (Plate IX, Fig. 15.)

Produce **AB** and **CD** to meet in **E**. Bisect the angle **AEC** in **EF**. Through **P** draw **PF** perpendicular to **EC** meeting **EF** in **F**. Then **F** is the centre of the required circle.

Problem 47.—To describe a circle to touch two converging lines **AB** and **CD**, and passing through a given point **P**. (Plate IX, Fig. 16.)

Proceed as in Problem 46 and draw any circle **BGD** touching the two given lines. Join **EP** cutting this circle in **G**. Join the centre **H** to **G**. Draw **PK** parallel to **GH** cutting the bisecting line **EF** in **K**. Then **K** is the centre of the required circle.

Problem 48.—To describe a succession of circles touching two converging lines **AB** and **CD**, and each other. (Plate IX, Fig. 17.)

By Problem 6 draw a line **GH** bisecting the angle between **AB** and **CD**. At any point **E** draw **EF** perpendicular to **AB**, and with centre **E** and radius **EF** describe the first circle cutting **GH** in **J**. At **J** draw **JK** tangent to the circle. With centre **K** and radius **KJ** describe an arc **JL** cutting **AB** in **L**. Draw **LM** perpendicular to **AB**. Then **M** is the centre of the second circle. Proceed in the same way for the rest.

Problem 49.—To describe a circle of given radius **R** to touch a line **AB** and a given circle **C**. (Plate IX, Fig. 18.)

At a distance equal to **R** draw a line **DE** parallel to **AB**. With centre **C** and radius equal to the radius of the given circle plus the distance **R** draw an arc cutting **DE** in **F**. Then **F** is the centre of the required circle.

Problem 50.—To describe two circles of given radius **A** and **B** to touch each other and a given circle internally. (Plate IX, Fig. 19.)

Draw **CD** any diameter of the given circle through the centre **F**. Draw a circle of radius equal to **A** to touch this circle in **C** having its centre at **K** and cutting the diameter in **E**. Make **EG** and **DH** equal to **B**. With centre **K** and radius **KG**, and centre **F** and radius **FH**, draw arcs intersecting in **L**. Then **L** is the centre of the third circle.

Problem 51.—To describe a circle to touch a given line AB and a given circle C in a point P . (Plate IX, Fig. 20, externally ; Fig. 21 internally.)

Join the centre of the given circle C with P and produce the line CP or PC . At P draw a tangent to the circle cutting AB in D . Bisect the angle BDP by a line cutting CP or PC produced in E . Then E is the centre of the required circle.

Problem 52.—To describe a circle to touch a given circle C and a given line AB in a point P .

Touching the given circle externally. (Plate IX, Fig. 22.)

Case 1. Through P and C draw PG and DC perpendicular to AB . Produce DC to cut the circumference in E . Join EP cutting the circle in F . Join CF and produce it to meet the perpendicular from P in G . Then G is the centre of the required circle.

Touching the given circle internally. (Plate IX, Fig. 23.)

Case 2. Through P and C draw PG and CD perpendicular to AB . Join P with E the point where the perpendicular CD cuts the circle. Produce PE to cut the circle in F . Join FC and produce it to cut the perpendicular from P in G . Then G is the centre of the required circle.

Problem 53.—To describe a circle to touch two given circles A and B , and one of them (A) in a given point P . (Plate IX, Fig. 24, to include both circles ; Fig. 25 to include one circle only.)

Join PA and produce the line. Make PC equal to the radius of the second circle B . Join CB and bisect it at right angles by a line ED cutting PC or CP produced in D . Then D is the centre of the required circle.

Problem 54.—To describe a circle with a given radius R to touch two given circles A and B . (Plate IX, Fig. 26, externally ; Fig. 27 internally.)

Join AB and produce it if necessary. Make CF and DE equal to R . With centres A and B and radii AF and BE describe arcs intersecting at G , which is the centre of the required circle.

Problem 55.—To describe three circles touching each other when the three positions of their centres A , B , and C are given. (Plate IX, Fig. 28)

Join the three points and bisect the angles BCA and CAB by lines intersecting in D . Draw DE perpendicular to AC .

With centres A and C and radii AE and CE , describe circles ; complete the figure.

Problem 56.—To describe three circles touching each other when the lengths of their radii A , B , and C are given. (Plate IX, Fig. 29.)

Draw any line EF , and on this as diameter draw two circles touching each other with radii equal to A and B and centres at G and H .

With G as centre and radius equal to A plus C and with H as centre and radius equal to B plus C , draw arcs intersecting at K . Then K is the centre of the required circle.

EXERCISES—CIRCLES, ETC.

1. A and B are 1 inch distant from C and 2 inches distant from each other. Draw a circle to pass through the three points.
2. Draw two tangents to a circle which shall make an angle of 30° with each other.
3. A circle C has a radius of $1\frac{1}{2}$ inches. Find a line equal in length to half its circumference
4. Two straight lines intersect at an angle of 35° . Draw a circle of 2.25 inches radius touching both lines.
5. Given a circle of 2 inches radius. Draw a chord so that the angle subtended at the circumference of the circle is equal to 25° .
6. AB 2 inches in length is a chord. Construct an arc of a circle which shall subtend an angle of 30° .
7. From a point P $2\frac{1}{2}$ inches from the centre of a circle of 1 inch radius, draw a line cutting the circle in two points A and B, so that AB shall be equal to $\frac{1}{2}$ inch.
8. Centres of three circles of $\frac{1}{2}$ inch diameter are $1\frac{1}{2}$, 2, and $1\frac{3}{4}$ inches apart. Describe a circle to enclose the three circles tangentially.
9. Trisect a right angle and describe three circles of $\frac{1}{2}$ inch radius to touch each pair of adjacent lines.
10. AC and BD, the extremities of two straight lines, each 3 inches long, are $\frac{3}{4}$ inch and 2 inches apart respectively. Draw a circle of 1 inch radius which shall touch both lines.

INSCRIBED FIGURES.

Problem 57.—In a given triangle ABC to inscribe a square. (Plate IX, Fig. 30)

From vertex B draw BD perpendicular to the opposite side AC. Draw BE parallel to AC and equal to BD. Join EA cutting BC in F. Draw FG parallel to AC and complete the required square FGHJ.

Problem 58.—In a given triangle ABC to inscribe a rectangle, one side of given length L. (Plate IX, Fig. 31.)

Make AD equal to the length L. Draw DE parallel to AB. Draw EF parallel to AC, and complete the required rectangle EHGJ.

Problem 59.—In a given triangle ABC to inscribe a circle. (Plate IX, Fig. 32.)

Bisect any two angles of the given triangle by lines meeting at D. Draw DF perpendicular to AC. With D as centre and DF as radius describe the required circle.

NOTE.—Any polygon can be inscribed in a triangle by first inscribing the circumscribing circle of the polygon.

Problem 60.—In a given equilateral triangle ABC to inscribe three equal circles, each to touch one side and two circles. (Plate IX, Fig. 33.)

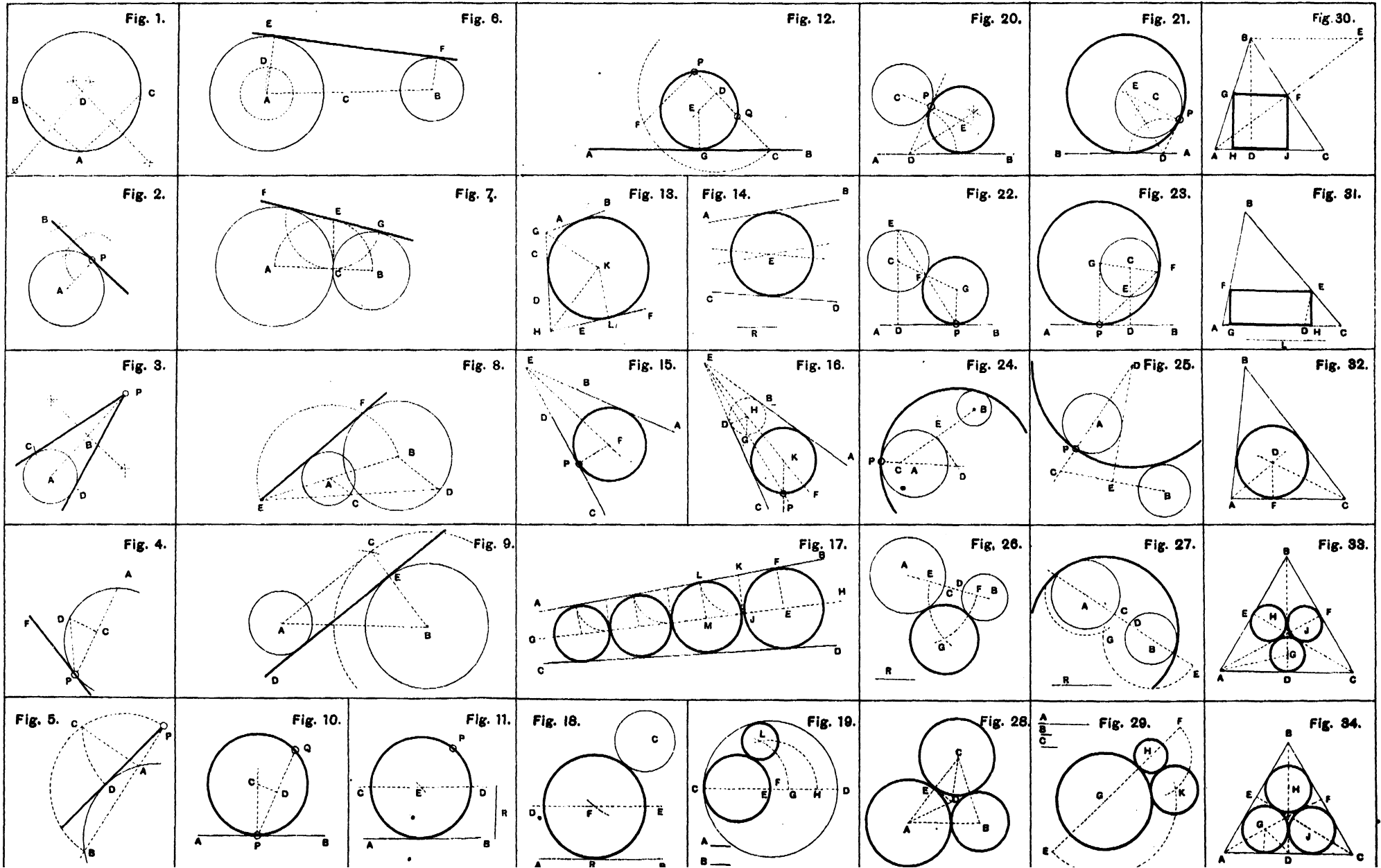

Bisect each angle of the given triangle by the lines CE , AF , and BD . Bisect the angle FAD by a line AG cutting BD in G . Make EH and FJ equal to DG . Then H , J , and G are the centres of the three required circles.

Problem 61.—In a given equilateral triangle ABC to inscribe three equal circles, each to touch two sides and two circles. (Plate IX, Fig. 34.)

Bisect each angle of the given triangle by the lines CE , AF , and BD . Bisect the angle BDA by a line DG cutting AF in G . Make BH and CJ equal to AG . Then H , J , and G are the centres of the three required circles.

Problem 62.—In a given equilateral triangle ABC to inscribe six equal circles. (Plate X, Fig. 1.)

Find the point G as in Problem 60. Draw LGM parallel to AC . On LM describe an equilateral triangle. Then N , J , M , G , L , and H are the centres of the six circles required.

Problem 63.—In a given isosceles triangle ABC to inscribe a semicircle. (Plate X, Fig. 2.)

Bisect the vertical angle ABC by the line BD . Bisect the right angle BDC by the line DE , meeting CB in E . Draw EF parallel to AC , cutting BD in G . With centre G and radius GD describe a semicircle.

Problem 64.—In any given triangle ABC to inscribe three circles, each to touch one side and each other. (Plate X, Fig. 3.)

Bisect each angle of the given triangle by lines meeting at the point D , called the centre of the triangle. Then the given triangle is divided into three triangles in each of which describe a circle by Problem 59.

Problem 65.—In any given triangle ABC to inscribe three circles, each to touch two sides and each other. (Plate X, Fig. 4.)

Find D the centre of the triangle and drop perpendiculars DC , DE , and DF to the opposite sides.

Bisect the angles AFD , DFC , and DEB , by lines FG , FH , and EL , meeting AD , CD , and BD , in the points G , H , and L respectively. Then these three points are the centres of the required circles, and their radii can be found by dropping perpendiculars to the adjacent sides.

It should be noted that the triangle is divided into three trapezia in which circles can be inscribed by Problem 68.

Problem 66.—In a given equilateral triangle ABC to inscribe three semicircles each touching one side of the triangle. (Plate X, Fig. 5.)

Find D the centre of the triangle, which is now divided into three triangles, complete by Problem 63.

Problem 67.—In a given equilateral triangle ABC to inscribe three semicircles, each touching two sides of the triangle. (Plate X, Fig. 6.)

Bisect each side of the triangle in the points D, E, F, and join each of these points to the vertex of the opposite angle. Draw DH perpendicular to AB and on DA cut off DL equal to DH. Join LB cutting CF in G. Draw GK parallel to AC, KM parallel to AB, and MG parallel to BC, cutting BD, CF, and AE in P, Q, and O, which are the centres of the required semicircles.

Problem 68.—In a given trapezium ABCD having pairs of equal adjacent sides to inscribe a circle. (Plate X, Fig 7.)

Draw a diagonal AC. Bisect the angle ADC by a line DE meeting AC in E. Draw EF perpendicular to AB. With E as centre and EF as radius describe the required circle.

Problem 69.—In a given trapezium ABCD having pairs of equal adjacent sides to inscribe a square. (Plate X, Fig 8)

Draw the diagonal BD. Draw BE perpendicular and equal to BD. Join EA cutting BC in F, which is a corner of the required square. Draw the sides of the square parallel to the diagonals of the trapezium.

Problem 70.—In a given trapezium ABCD having pairs of equal adjacent sides to inscribe a semicircle. (Plate X, Fig. 9.)

Draw the diagonals AC and BD intersecting at E. On AC describe a semicircle. Draw EF perpendicular to BC meeting the semicircle in F. Join FD cutting BC in G. Draw GH parallel to FE. With centre H and radius HG describe the required semicircle.

Problem 71.—In a given square ABCD to inscribe a circle (Plate X, Fig. 10.)

Draw the diagonals AC and BD intersecting at F. Draw FE perpendicular to AD. With centre F and radius FE describe the required circle.

Problem 72.—In a given square ABCD to inscribe an equilateral triangle. (Plate X, Fig 11.)

Draw a diagonal BD and on it describe the equilateral triangle BED.

Draw CF parallel to ED and CG parallel to EB. Join GF. Then GCF is the required equilateral triangle.

Problem 73.—In a given square ABCD to inscribe an isosceles triangle, the length of the base L being given. (Plate X, Fig. 12.)

Draw a diagonal AC. Make OE equal to L. Draw EF parallel to BC and FG parallel to AC. Join GD and FD. Then FGD is the required isosceles triangle.

Problem 74.—In a given square ABCD to inscribe the largest possible semicircle. (Plate X, Fig. 13.)

Draw the diagonals intersecting in E, and on BD describe a semicircle. Draw EF perpendicular to AB cutting the semicircle in F. Join FC cutting AB in G. Draw GH parallel to FE. With centre H and radius JG describe the required semicircle.

Problem 75.—In a given square $ABCD$ to inscribe two circles each to touch each other and two sides of the square. (Plate X, Fig. 14.)

Draw diagonals AC and BD intersecting at E . Bisect the angle EAD by a line AF meeting ED in F . Make EG equal to EF . Draw FH perpendicular to AD . With centres F and G and radius FH describe the two required circles.

Problem 76.—In a given square $ABCD$ to inscribe four equal semicircles (each to touch one side of the square, and to have their diameters adjacent. (Plate X, Fig. 15.)

Draw the diagonals which divide the square into four equal triangles ; complete by Problem 63.

Problem 77.—In a given square $ABCD$ to inscribe four equal semicircles, each to touch two sides of the square, and to have their diameters adjacent. (Plate X, Fig. 16.)

Draw the diagonals AC and BD and the diameters EG and HF intersecting in P . Bisect EC and FD in J and K . Join JK cutting HF in L . Make PM , PN , and PQ equal to PL , and join the points L , M , N , and Q . These lines are the adjacent diameters on which the required semicircles may be described.

Problem 78.—In any given regular polygon (say a pentagon $ABCDE$) to inscribe a square. (Plate X, Fig. 17.)

Draw any diagonal BE . Draw BF equal and perpendicular to BE . Join FA cutting BC in H . Draw HG parallel to BE and on it describe the required square.

(Special methods for the hexagon and octagon can be worked out by the Student.)

Problem 79.—In any given regular polygon to inscribe a similar figure Bisect each side of the given polygon, and join the points so obtained.

Problem 80.—In any given regular polygon (say a hexagon $ABCDEF$) to inscribe as many semicircles as the figure has sides, each touching one side and having their diameters adjacent (Plate X, Fig. 18.)

Draw all the diameters of the polygon intersecting at E and dividing it into a number of isosceles triangles. In each describe a semicircle by Problem 63.

Problem 81.—In any given polygon (say a pentagon $ABCDE$) to inscribe as many semicircles as the figure has sides, each to touch two sides of the polygon, and have their diameters adjacent. (Plate X, Fig. 19.)

Draw the diameters intersecting in F . The polygon is then divided up into a number of trapezia, in which semicircles can be described by Problem 70.

Problem 82.—In a given hexagon $ABCDEF$ to inscribe an isosceles triangle of given base L . (Plate X, Fig. 20.)

Draw a diagonal CF . Draw FG perpendicular to CF equal to half the given base L . Draw GH parallel to CF cutting AF in H . Draw HK parallel to GF . Join HC and KC . Then CHK is the required isosceles triangle.

Problem 83.—In a given hexagon $ABCDEF$ to inscribe a rectangle, having a given side M . (Plate X, Fig. 21.)

Draw a diagonal CF . Join AE , and on it cut off a length AG equal to M . Draw GH parallel to AF meeting FE in H . Draw HK parallel to FC , and HJ and KL parallel to AE . Join LJ . Then $HKLJ$ is the required rectangle.

Problem 84.—In a given sector BCD to inscribe a square. (Plate X, Fig. 22.)

Join CD . Make CE equal and perpendicular to CD . Join EB cutting the arc DC in F . Draw FH parallel to CD and on it describe the required square.

Problem 85.—In a given sector ABC to inscribe a circle. (Plate X, Fig. 23.)

Bisect the angle BAC by the line AD . At D draw the tangent EDF . Produce AB and AC to meet the tangent in E and F . In the triangle EAF inscribe the required circle.

Problem 86.—In a given sector ABC to inscribe a semicircle. (Plate X, Fig. 24.)

In the same way as the last problem obtain the triangle EAF and in it inscribe a semicircle by Problem 63.

Problem 87.—In a given circle to inscribe a square. (Plate X, Fig. 25.)

Draw two diameters AC and BD at right angles to each other. Join AB , BC , CD , and DA . Then $ABCD$ is the required square.

Problem 88.—In a given circle to inscribe an equilateral triangle. (Plate X, Fig. 26.)

Find the centre C and draw any diameter AB . With A as centre and AC as radius describe an arc cutting the circle in D and E . Join DE , EB , and BD . Then DEB is the required equilateral triangle.

Problem 89.—In a given circle to inscribe a triangle similar to a given triangle ABC . (Plate X, Fig. 27.)

At any point D in the circumference of the given circle draw a tangent EDF . Make the angle EDG equal ACB , and the angle FDH equal to the angle CAB . Join GH . Then GDH is the required triangle.

Problem 90.—In a given circle to inscribe any regular polygon, say a pentagon. (Plate X, Fig. 28.)

Draw any diameter AB and divide it into as many parts as there are sides to the required polygon—in this case 5. With A and B as centres and AB as radius, describe arcs intersecting in C . Through C and the

second division draw a line $C2D$ cutting the circle in D . Join BD which is a side of the inscribed polygon which can be completed. This is only an approximate method but good enough for practical purposes.

When a regular polygon of any number of sides is inscribed in a circle we may always inscribe a polygon of double the number of sides by bisecting each of the former arcs, and joining the points of bisection. Thus from a square may be inscribed a regular octagon, a regular polygon of 16, 32, etc., sides; from a hexagon may be inscribed a regular polygon of 12, 24, 48, etc., sides; from a decagon may be inscribed a regular polygon of 20, 40, 80, etc., sides; and from a pentadecagon a regular polygon of 30, 60, 120, etc., sides.

It was long supposed that these were the only regular polygons which could be inscribed in a circle by the aid of elementary geometry, or by the intersections of straight lines and circles only. It can, however, be proved that a regular polygon of m sides can always be inscribed in a circle by similar methods when m is a *prime* number and equal to $2^n + 1$.

Problem 91.—In a given circle, to inscribe a pentagon. **Special method.** (Plate X, Fig. 29.)

Draw any two diameters at right angles AB and CD intersecting in the centre E . Bisect EB in F . With centre F and radius FC draw an arc cutting AE in G . With centre C and radius CG draw an arc cutting the circle in H . Join HC which is a side of the required pentagon.

Problem 92.—In a given circle, to inscribe any number of equal circles (say five). (Plate X, Fig. 30.)

Divide the circumference of the circle into twice as many parts as there are to be circles, and through these points draw diameters. Let AB and CD be two adjacent diameters. At B draw a tangent BF meeting CD produced in F . Bisect the angle BFD by a line FH meeting AB in H . Then H is the centre of one circle and the rest can be drawn.

Problem 93.—In a given circle, to draw any number of equal semicircles having adjacent diameters (say five). (Plate X, Fig. 31.)

Divide the circumference of the given circle into twice as many equal parts as there are to be semicircles and draw the diameters.

Let AB and CD be two adjacent diameters. At B draw a tangent EB . Bisect the angle EBA by a line cutting DC in F .

Let O be the centre of the circle. On the diameter GH mark off OK equal to F . Join FK . On it describe one of the required semicircles, and the figure can be completed.

This figure is called a *Cinque-foil*. If there are four semicircles it is called a *Quater-foil*; if three a *Trefoil*.

Problem 94.—In a given circle, to inscribe any number (say four) of equal circles, equidistant from each other and from the circumference of the given circle. (Plate X, Fig. 32.)

Divide the circle into three times the number of equal sectors, as circle required—in this case 12. Then join up into four equal triangles and inscribe in them the required circles.

EXERCISES—INSCRIBED FIGURES.

1. In a square, the sides of which are 2 inches, inscribe a rectangle the length of one side being $\frac{3}{4}$ inch.
2. Inscribe a circle within a trapezium having pairs of equal adjacent sides 1 inch and $2\frac{1}{2}$ inches long.
3. Within a square, side 2 inches, inscribe eight equal circles.
4. Within a circle of 2 inches radius, inscribe a triangle the angles of which are as follows:— 37° , 73° , and 70° .
5. In a pentagon, side 1.75 inches, place a pentagon of 1 inch side having a common centre with the first pentagon.
6. In a heptagon, side 1.25 inches, inscribe the largest and possible equilateral triangle.
7. In a square, side 2 inches, inscribe a square a corner of which shall lie on one side and $\frac{3}{4}$ inch from a corner of the first square.
8. In a hexagon, side 1 inch, inscribe a dodecagon.
9. In an isosceles triangle inscribe three circles, each touching two sides of the triangle and two other circles.

CIRCUMSCRIBED FIGURES.

Problem 95.—About a given triangle ABC to describe a circle. (Plate X, Fig. 33.)

Bisect any two sides of the given triangle by lines EF and DF drawn at right angles to the sides; meeting each other in the point F. Then F is the centre of the required circle.

Problem 96.—About a given triangle ABC to describe a triangle similar to a given triangle DEF. (Plate X, Fig. 34.)

On one side AB of the given triangle describe a triangle ABG similar to DEF. Through C draw a line HK parallel to AB. Produce GA and GB to meet HK in the points H and K. Then HGK is the required triangle.

Problem 97.—About a given isosceles triangle ABC, to describe a square. (Plate X, Fig. 35.)

On the base BC describe a semicircle. Bisect the angle BAC by a line AD meeting the semicircle in D. Join DC and DB and produce them. Draw AE parallel to BD and AF parallel to CD. Then AEDF is the required square.

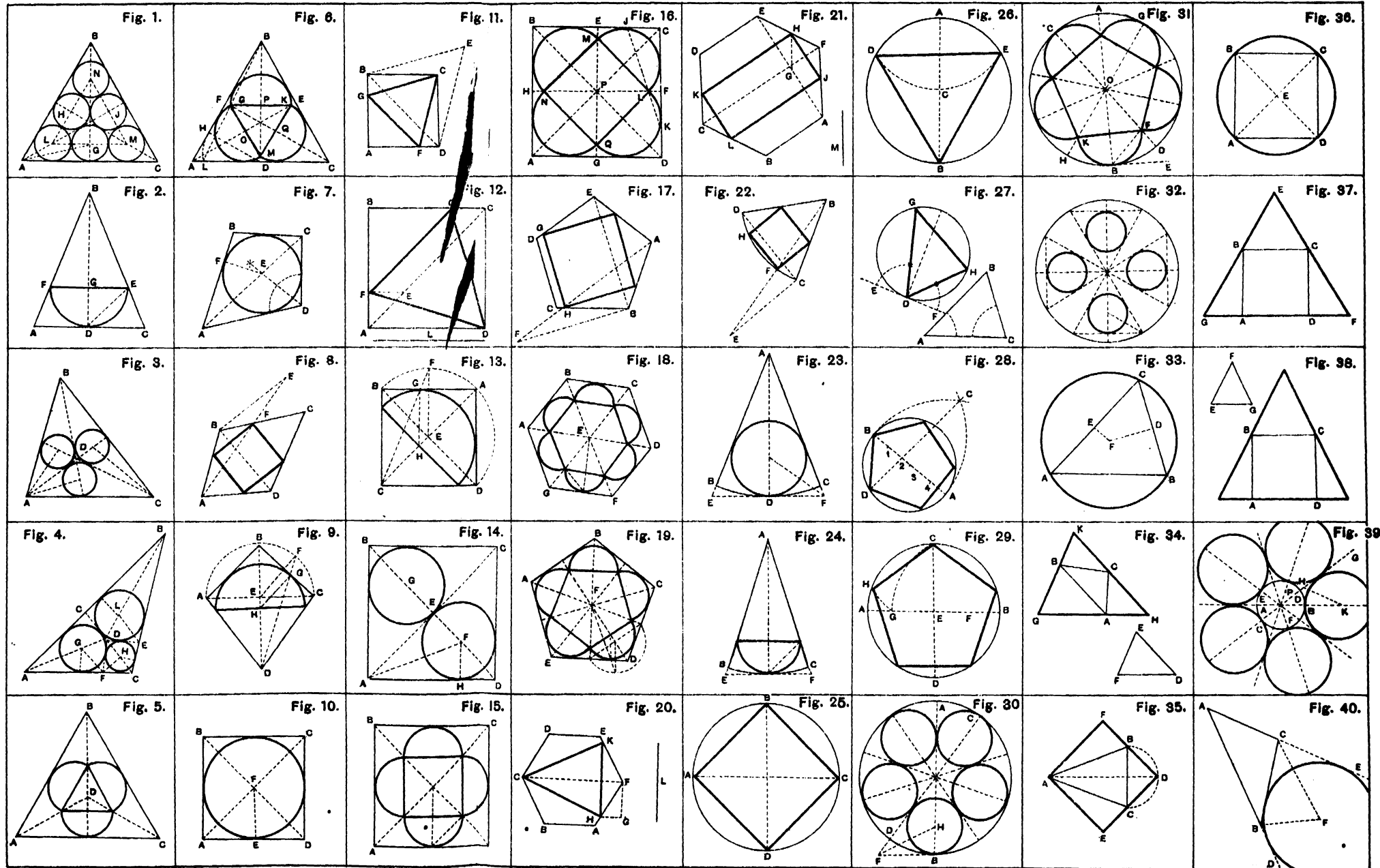

Problem 98.—About any given rectangle $ABCD$ (say a square) to describe a circle. (Plate X, Fig. 36.)

Draw the two diagonals intersecting in E . Then E is the centre of the required circle. The same construction holds good in the case of any regular polygon.

Problem 99.—About a given square $ABCD$ to construct an equilateral triangle. (Plate X, Fig. 37.)

On BC construct an equilateral triangle BEC . Produce EC and EB to meet AD produced in F and G . Then FEG is the required equilateral triangle.

Problem 100.—About a given square $ABCD$ to construct a triangle similar to a given triangle EFG . (Plate X, Fig. 38.)

On BC construct a triangle similar to EFG , then proceed as in the last problem.

Problem 101.—About a given circle to describe any number of equal circles (say five), touching each other and the circumference of the given circle. (Plate X, Fig. 39.)

Find the centre of the given circle P . Divide the circle into twice as many parts as there are circles required—in this case 10. Let AB , CD , and EF be three adjacent diameters. At B draw a tangent BH meeting CD produced in H . Produce CH to G . Bisect the angle GHB by a line HK meeting AB produced in K . Then K is the centre of one circle, and the rest can be drawn in the same way.

Problem 102.—To draw an inscribed circle to any triangle ABC . (Plate X, Fig. 40.)

Produce the sides AB and AC to D and E . Bisect the angles DBC and ECB by lines BF and CF meeting in F , which is the centre of the inscribed circle.

EXERCISES—CIRCUMSCRIBED FIGURES.

1. Describe a square about a circle of $1\frac{1}{2}$ inches radius.
2. About a circle of 1 inch radius describe a triangle having angles of 65° , 35° , and 80° .
3. About a circle of 1 inch radius describe a pentagon.
4. About a circle of 1 inch radius describe an equilateral triangle, touching the circle in a fixed point P .
5. A triangle ABC has sides of the following length:— $\cdot 75$, $\cdot 6$, and $1\cdot 2$ inches. About a circle of 1 inch radius describe a triangle similar to the triangle ABC .
6. About a circle of half inch radius to describe six equal circles, each touching the given circle and two other circles.
7. About a pentagon of 1 inch side describe five equal circles, each touching the pentagon and two other circles.

RATIO AND PROPORTION.

Before attempting to work out the following problems, the student should have an intimate knowledge of the Chapters on Ratio and Proportion in Algebra, and should commit to memory the following propositions of Euclid:—Book II, 14 Cor.; Book V, Def. 3, Prop. 6; Book VI, 2, 4, 13.

Problem 103.—To divide a given straight line AB proportionately to a given divided line CD. (Plate XI, Fig. 1.)

Place the two given lines parallel to each other. Join CA and DB and produce these lines to meet in E. Join each given division in CD with E. These lines will divide AB similarly to the given line CD.

Problem 104.—To find a mean proportional between two given lines AB and BC. (Plate XI, Fig. 2.)

Place AB and BC in one straight line. On AC describe a semicircle. At B draw BD perpendicular to AC cutting the semicircle in D. The BD is the mean proportional, or

$$AB : BD :: BD : BC.$$

Problem 105.—To find a third proportional to two given lines A and B. (Plate XI, Fig. 3.)

Draw any two lines CD and CE making an acute angle with each other.

Make CF equal to A and CD and CG equal to B. Join FG, and draw DE parallel to FG. Then CE is the third proportional required, or

$$CF : CG :: CD : CE,$$

$$\text{i.e. } A : B :: B : CE.$$

CE is a third proportional greater. The student should by the same method draw a third proportional less.

Problem 106.—To find a fourth proportional to three given lines A, B, and C. (Plate XI, Fig. 4.)

Draw any two lines HD and HE making an acute angle with each other.

Draw HF equal to A, HG equal to B, and FE equal to C. Join FG, and draw ED parallel to FG. Then GD is the required fourth proportional, or

$$HF : HG :: FE : GD,$$

$$\text{i.e. } A : B :: C : GD.$$

Problem 107.—To divide a given line AB in extreme and mean Ratio. (Plate X, Fig. 5.)

Erect BC perpendicular and equal to half AB. Join AC. With centre C and radius CB, draw an arc cutting AC in D. With centre A and radius AD draw an arc cutting AB in E.

Then $AB : AE :: AE : EB.$

Problem 108.—To divide a given straight line AB harmonically. (Plate XI, Fig. 6.)

Take any point C in AB and on CB describe a semicircle. Draw AE a tangent to the semicircle, and from E draw EF perpendicular to AB .

Then $AB : AC :: BF : FC.$

Problem 109.—To determine the roots $\sqrt{2}, \sqrt{3}, \sqrt{4}, \sqrt{5}, \sqrt{6}, \sqrt{7}, \sqrt{8}, \sqrt{9}, \sqrt{10}.$ (Plate XI, Fig. 7.)

Let AB equal unity, with A as centre and radius AB describe a circle and divide the circumference into six equal parts at the points $B, C, D, E, F,$ and $G.$ With centres B and E and radius BD draw arcs intersecting at H and $J.$ With C and G as centres and radius $CG,$ describe arcs intersecting at $K.$ Join HJ cutting the circumference in L and $M.$ With centres $L, E,$ and M and radius AB describe arcs intersecting at P and $Q.$ Then $AH = \sqrt{2}; BD = \sqrt{3}; BE = \sqrt{4}; PB = \sqrt{5}; JK = \sqrt{6}; DK = \sqrt{7}; HJ = \sqrt{8}; EK = \sqrt{9}; PK = \sqrt{10}.$

EXERCISES—RATIO AND PROPORTION.

1. Draw a third proportional to two lines whose lengths are 1.25 and 1.6 inches. What is its length?
2. Find a mean proportional between two lines 2.4 and 3.8 inches long.
3. Find a line which shall have the same ratio to a line 1.5 inches long that 3 inches has to 1.75 inches.
4. Divide 5.4 inches so that the parts may be to each other in the proportion of the numbers 7, 8, 9, 11.
5. A point P is 2.75 inches from the centre of a circle of 1 inch radius. From P draw a line to cut the circumference of the circle in two points A and $B,$ so that PA is to AB as 2 is to 3.

AREAS.

Before working out the Problems on Areas, the student should be sufficiently advanced in Mensuration and Euclid to be able to prove each Problem. The following Propositions of Euclid should be committed to memory:—Book I, 35, 36, 37, 38, 41, 47; Book VI, 1, 19, 20, 31.

Problem 110.—To draw a triangle ABC equal in area to a given regular polygon, say pentagon. (Plate XI, Fig. 8.)

Divide the polygon into a number of isosceles triangles, then the area of the triangle required is one with a base five times and an altitude equal to one of the isosceles triangles, or a base $2\frac{1}{2}$ times and an altitude double of one of the isosceles triangles. (The problem can also be worked by Problem 123.)

Problem 111.—To draw a triangle ABC equal in area to any given parallelogram. (Plate XI, Fig. 9.)

Draw a triangle with a base equal to double the base of the rectangle and the same altitude.

Problem 112.—To draw a triangle ABC of any given area (no figure given).

Draw a rectangle equal to the given area and a triangle equal to the rectangle.

Problem 113.—To divide a triangle ABC into any number of equal parts by lines drawn from one corner (say three equal parts). (Plate XI, Fig. 10.)

Trisect one side AB in D and E . Join DC and EC . The triangle is now trisected into three equal parts. (By the same method the triangle can be divided in any given ratio.)

Problem 114.—To divide a triangle ABC into two equal parts by a line drawn parallel to the altitude. (Plate XI, Fig. 11.)

Bisect AB in E . Draw the altitude CD . Find BF a mean proportional between BD and BE . Make BH equal to BF . Draw HK parallel to DC and bisecting the triangle.

Problem 115.—To divide a triangle ABC into any number of equal parts by lines drawn parallel to one of the sides (say two). (Plate XI, Fig. 12.)

On AB describe a semicircle. Divide AB into as many parts as it is required to divide the triangle into. In this case bisect it in D . Draw DE perpendicular to AB . With B as centre and BE as radius describe an arc cutting AB in F . Draw FH parallel to AC bisecting the triangle.

Problem 116.—To divide a triangle ABC into any number of equal areas by lines drawn from a point P within the triangle, say three equal areas. (Plate XI, Fig. 13.)

Divide AC into three equal parts in the points 1 and 2. Join these points to P and draw the line PB . Draw BD parallel to $P2$ and join PD . If we draw a line from B parallel to $P1$, it would fall outside the triangle. So join $B1$. Draw $F1$ parallel to AB . Join PA and draw FG parallel to PA . Join PG . Then PD , PB , and PG divide the triangle into three equal areas.

Problem 117.—To divide a triangle ABC into three equal areas by three lines drawn from the angles meeting at a point P within the triangle. (Plate XI, Fig. 14.)

Divide AB into three parts in D and E . Draw DF parallel to AC and bisect it in P . Join AP , CP , and BP trisecting the triangle.

Problem 118.—To draw an equilateral triangle equal in area to a given triangle ABC . (Plate XI, Fig. 15.)

On AB construct an equilateral triangle ADB . From C draw CE parallel to AB meeting DB produced in E . Find BF a mean proportional between DB and BE . Then BF is one side of the required equilateral triangle BFG .

Problem 119.—To draw a triangle on a given base AB equal in area to a given triangle CDE . (Plate XI, Fig. 16.)

Find EF the altitude of the given triangle. Find a fourth proportional GH to AB , CD , and EF . Then BK is the altitude of the required triangle having a base AB .

Problem 120—To draw a triangle $\frac{1}{2}$ the area of a given triangle ABC . (Plate XI, Fig. 17.)

Produce AB to D making BD equal to $\frac{1}{2} AB$. Find BF a mean proportional to AB and BD . Make AG equal to BF and draw GH parallel to BC . Then AHG is the required triangle.

Problem 121.—To draw a triangle equal in area to a given triangle ABC , but of a given altitude H . (Plate XI, Fig. 18.)

Draw EF parallel to AC at a distance from it equal to H . Produce CB to cut EF in G . Join GA . Draw BJ parallel to GA and join GJ . Then GJC is the required triangle.

Problem 122.—To draw a triangle equal in area to and standing on the same line as a given triangle ABC , but with its vertex in a point P . (Plate XI, Fig. 19.)

Draw BD parallel to AC . Through P draw APD cutting BD in D . Join PC . Draw DE parallel to PC cutting AC produced in E . Join PE . Then APE is the required triangle.

Problem 123—To draw a triangle equal in area to any rectilineal figure $ABCDEF$. (Plate XI, Fig. 20.)

It is best to begin at the re-entering angle. Join DF . Draw EG parallel to DF , and join DG and CG . Draw DH parallel to CG , and join CH . Join CA , and draw BJ parallel to CA , and join CJ . Then JCH is the required triangle.

Problem 124.—To draw a triangle equal in area to any number of square units (say five). (Plate XI, Fig. 21.)

Make the base equal to the given number of units—in this case five—and the altitude invariably two units.

Problem 125.—To draw an equilateral triangle equal in area to any number of given square units (say four). (Plate XI, Fig. 22.)

Make AB equal to four units and draw BC perpendicular to AB equal to two units. Make the angle ABH equal to 60° . Draw CD parallel to AB cutting BH in D . Join DA . Find the mean proportional BE between AB and BD . Make BF and BG equal to BE . Then BFG is the required equilateral triangle.

Problem 126.—To draw a square equal in area to a given triangle ABC . (Plate XI, Fig. 23)

Find the altitude CD of the given triangle. Find BE the mean proportional between the base AB and half the altitude DC . This is the side of the required square.

(In the same way a square may be drawn equal in area to any given rectilinear figure, by reducing the latter to a triangle.)

Problem 127.—To draw a square equal in area to a given rectangle **ABCD**. (Plate XI, Fig. 24.)

Find **BE** the mean proportional between two sides of the rectangle **AB** and **BC**. Then **BE** is the side of the required square.

Problem 128.—To draw a square equal to the sum of two given squares, the sides of which are equal to lines **AB** and **BC**. (Plate XI, Fig. 25.)

Draw **AB** and **BC** at right angles to each other. Join **AC**. Then the square described on **AC** is the required square.

Problem 129.—To draw a square equal to the difference between two given squares the sides of which are equal to lines **AB** and **AC**. (Plate XI, Fig. 26.)

On **AB** describe a semicircle. With centre **A** and radius **AC** cut off a point **C** on the semicircle. Join **BC**. Then the square described on **BC** is the required square.

Problem 130.—To construct a square, the area of which shall be any number of times greater than the area of a given square **ABCD** (say six times). (Plate XI, Fig. 27.)

Produce **AB** and make **BE** equal to six times **AB**. Find **BF** a mean proportional between **AB** and **BE**. This is the side of the required square.

(If **BE** were made equal to $\frac{1}{6}$ th **AB**, then we would get a square equal to $\frac{1}{6}$ th of the given square.)

Problem 131.—To divide a square **ABCD** into any number of equal parts by lines drawn from an angular point **D** (say five). (Plate XI, Fig. 28.)

Divide **BC** and **AB** into five equal parts by the points **E**, **F**, **G**, **H**, **J**, **K**, **L**, and **M**. Join **HD**, **FD**, **JD**, and **LD** dividing the square into five equal parts.

Problem 132.—To divide a square **ABCD** into any number of equal parts by lines drawn from a point **P** in a side (say three). (Plate XI, Fig. 29.)

Divide **AD** into three parts in **E** and **F**. Draw **EG** and **FH** parallel to **AB**. Join **PG** and **PH**. Draw **EJ** and **FK** parallel to **PG** and **PH**. Join **PJ** and **PK**. These lines divide the square into three equal parts.

Problem 133.—To construct a square to contain any number of given square units (say three). (Plate XI, Fig. 30.)

Draw a line **AB** equal to three units and **BC** equal to one unit. Find **BE** a mean proportional to **AB** and **BC**. Then **BE** is the side of the required square.

Problem 134.—To construct a rectangle, with a side equal to a given line **A**, equal in area to a given rectangle **CDEF**. (Plate XI, Fig. 31.)

Produce **CD** to **G**. Make **DG** equal to **AB**. Join **GE** and produce it to meet **CF** produced in **H**. Then **FH** is the height of the required rectangle.

Problem 135. To construct a rectangle equal in area to a given square $\hat{A}BCD$ and having sides in a given ratio (say three to two). (Plate XI, Fig. 32.)

Produce AB and make BE equal to three units and BF equal to two units. Find BG a mean proportional to EB and BF . Join GE and GF . Draw CH and CJ parallel to GE and GF . Make BK equal to BJ and complete the required rectangle $HBKL$, which is equal to the given square, and the side $BH : BK :: 3 : 2$.

Problem 136.—To divide a given parallelogram $ABCD$ into two parts in any given proportion (say three to two) through a point P in one of the sides. (Plate XI, Fig. 33.)

Divide AB at E so that $AE : EB :: 3 : 2$. Draw EF parallel to AD and bisect EF in G . From P draw a line through G meeting one of the opposite sides in H . Then PH divides the parallelogram in the required proportion.

Problem 137.—To divide a given parallelogram into three parts through a point P in one of the sides. (Plate XI, Fig. 34.)

Divide AB into three parts in E and F . Draw EG and FH parallel to AD . Make EJ equal to PG and FL equal to PH . Join PJ and PL . These lines trisect the parallelogram.

Problem 138. - To construct a rectangle of area equal to five square units, with sides in the proportion of three to two. (Plate XI, Fig. 35.)

Make AB equal to five units and BC equal to one unit. Find a mean proportional to them in BD . Make BH equal to three and BF to two units. Describe a semicircle on HF cutting BD produced in G . Join GH and GF , and draw DE and DJ parallel to them. Then BE and BJ are the sides of the required rectangle.

Problem 139.—To construct any regular polygon equal in area to a given triangle ABC , say a pentagon. (Plate XI, Fig. 36.)

Divide one side AB into five parts of which AD is one. Make the angle BAE equal to the angle at the centre of the required polygon. In this case 72° . Draw DF parallel to AC meeting AE in F . Find AG a mean proportional between AC and AF . Then G is the centre of the circle in which the required pentagon can be inscribed.

Problem 140.—To construct any regular polygon which shall have a given area (say a hexagon, with an area of five square units). (Plate XI, Fig. 37.)

Make AB equal to five units and the angle BAC equal to the angle at the centre of the hexagon, in this case 60° .

Make the perpendicular height of the triangle ACB two units and join CB . Then the triangle ACB has an area of five square units. Make AD equal to one-sixth of AB and find DE , a mean proportional between AC and AD . Then DE is the radius of the circle in which the required hexagon can be inscribed.

Problem 141.—To divide a circle into any number of equal parts by concentric circles (say four). (Plate XI, Fig. 38.)

Divide a radius AB into as many equal parts as the circle is to have divisions in this case (four). On AB describe a semicircle and erect perpendiculars to meet it from each point of division. These points C, D, E, give the radii of the circles.

Problem 142.—To divide a circle into any number of equal parts, equal in perimeter and area (say three). (Plate XII, Fig. 1.)

Divide a diameter AB into as many equal parts as the circle is to have divisions (in this case three) in the points C and D. On AC, AD, CB and DB describe semicircles as in the figure.

EXERCISES—AREAS.

1. Draw by a construction a square of 5·36 square inches area.
2. Draw a square equal to the difference of two squares whose sides are 3·25 and 1·94 inches.
3. Describe a rectangle equal in area to a triangle whose sides are 3·5, 1·75 and 2·5 inches respectively.
4. A right-angled triangle has a base of 2 inches and an area of 2·58 square inches; construct it, and also a similar one of half the area.
5. Draw a square equal in area to a polygon; side 1·25 inches.
6. Draw a rectangle on a line 2 inches long equal in area to a square of 2·75 inches side.
7. Construct an isosceles triangle with an area of 3 square inches, and having a vertical angle of 30°.
8. Divide a square of 2 inches side into three equal areas by lines parallel to a diagonal.
9. Within a square of 2 inches side inscribe a square having its angles in the sides of the first and its area to the area of the first square in the proportion of 2 to 3.
10. Within a circle of $1\frac{1}{2}$ inches radius inscribe a rectangle with an area of 2 square inches.
11. Construct an equilateral triangle with any area of 4 square inches.
12. Construct an equilateral triangle equal in area to the triangle given in Question 3.
13. Construct a square which has an area equal to half the area of a given square whose side is 1·75 inches.
14. Divide the triangle given in Question 3 into three parts by lines parallel to one side.

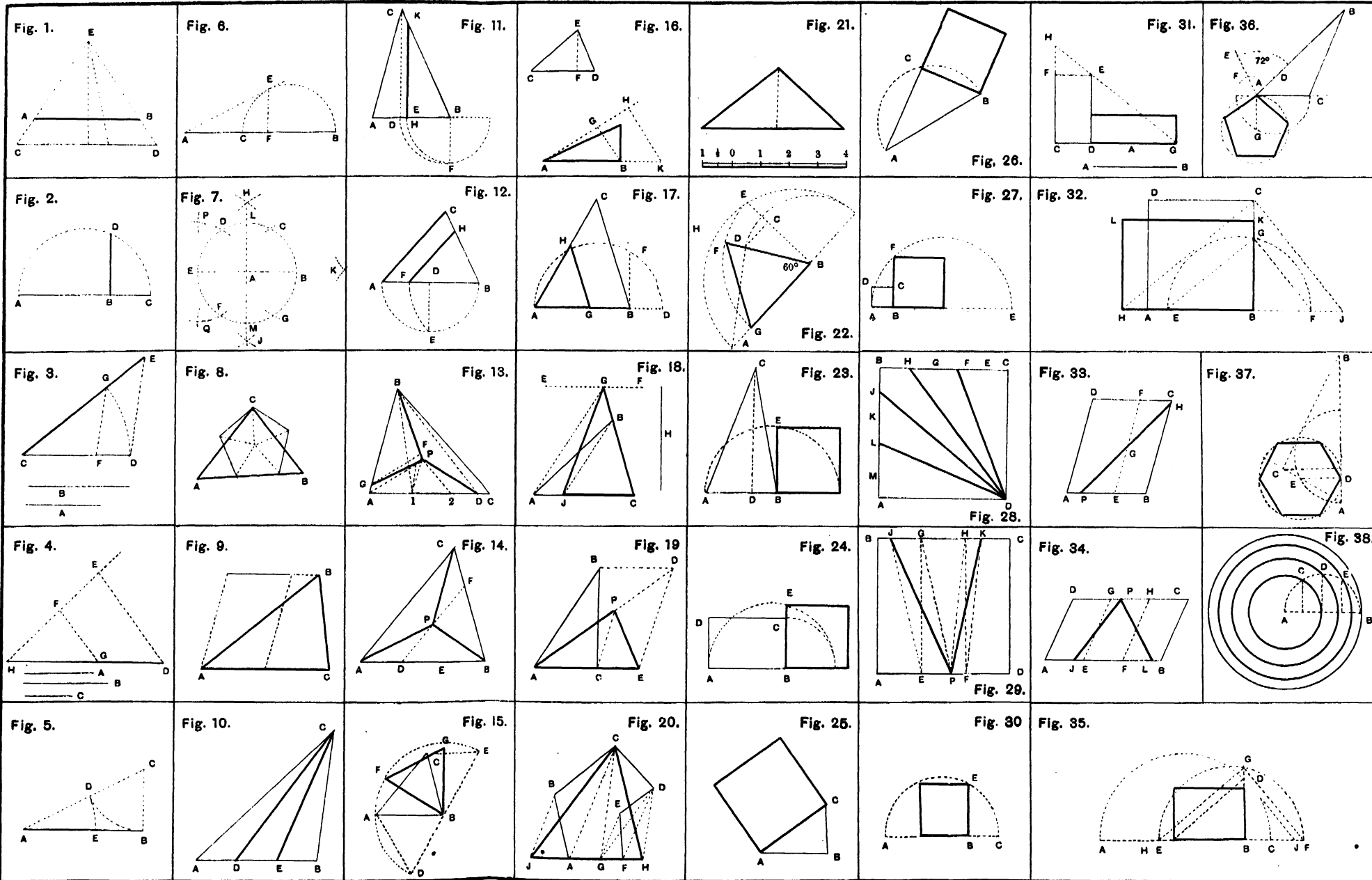

THE SECTIONS OF THE CONE AND OTHER CURVES.

These problems will be found useful to the Student when studying Conic Sections and Graphic Arithmetic.

Practical Methods.

The Ellipse is the section of a cone formed by an oblique plane passing through both sides of the cone.

THE ELLIPSE.

Problem 143.—To draw an ellipse by means of a piece of string, given the major and minor axes AB and CD . (Plate XII, Fig. 2.)

With centre C and radius equal to the semi-major axis, describe an arc cutting the major axis in points F_1 and F_2 . These points are the *foci* of the ellipse. Place pins at F_1 , F_2 and C , and tie a piece of string tightly round the three pins. Take the pin at C out, and insert the point of a pencil in its place, keeping the string tight and the pencil upright; move the pencil round the foci and its point will trace an ellipse.

Problem 144.—To draw an ellipse by means of a paper trammel, given the major and minor axes AB and CD . (Plate XII, Fig. 3.)

Cut a narrow strip of a paper with a straight edge. On this edge make EF equal to the semi-major axis and EG equal to the semi-minor axis. This is called a trammel, and may be made of paper, wood or any convenient material. Place the trammel in such a position over the axes, that G shall always rest on the major axis and F on the minor axis. Then E is a point on the ellipse. Mark as many points as are required, and complete the ellipse by hand or by a "French curve."

Theoretical Methods.

Problem 145.—Given the major and minor axes AB and CD to draw an ellipse. (Plate XII, Fig. 4.)

Describe concentric circles on each axis as diameter, and divide each circle into any number of parts by radii. From the points where these radii cut the smaller circle draw ordinates parallel to AB , and from the points where the radii cut the larger circle, draw ordinates parallel to CD . The points where these ordinates intersect are points on the ellipse which must be completed by hand.

Problem 146.—Given the major and minor axes AB and CD to draw an ellipse. (Plate XII, Fig. 5.)

Find the foci F_1 and F_2 . Between F_1 and the centre of the ellipse O , take any number of points 1, 2, etc., the distance between the points being smaller as they approach F .

With the foci for centres and radii $A1$ and $B1$ draw arcs intersecting at E_1 , E_2 , E_3 and E_4 . With the same centres and radii $A2$ $B2$ draw

arcs intersecting at $G_1, G_2, G_3,$ and G_4 and so on. These are points on the ellipse.

Problem 147. Given any two conjugate axes AB and CD to draw an ellipse. (Plate XII, Fig. 6)

Complete the parallelogram $EFGH$. The sides being parallel to the conjugate axes.

Divide AE into any number of equal parts (say four) in the points 1, 2, 3, and the semi-axis AO into the same number of equal parts in 4, 5, 6. Join C with the points 1, 2, 3. From D through the points 4, 5, 6 draw lines meeting $C1, C2$ and $C3$. The points of intersection are points on the ellipse. Repeat the process for each quadrant and complete the ellipse by hand.

Approximate Methods.

Problem 148. - Given the major axis AB to draw an ellipse approximately by arcs of circles. (Plate XII, Fig. 7.)

Divide AB into four equal parts in C, O and D . With C and D as centres and CA as radius describe circles, and with the same centres and radius CD describe arcs intersecting at F and G .

Draw lines GC, GD, FC and FD , and produce them till they cut the circles in H, J, L and K . From F and G with radius FL , draw arcs connecting L with K and H with J which will complete the figure.

Problem 149. - Given the major and minor axes AB and CD to draw an ellipse approximately by arcs of circles. (Plate XII, Fig. 8.)

From B set off BF equal to CD and divide FA into three equal parts. Set off two of these parts on each side of O , the centre of the ellipse, giving points G_1 and G_2 . With G_1 and G_2 as centres and radius G_1, G_2 , draw arcs intersecting at H and J .

From H and J draw lines through G_1, G_2 and produce them. With centres H and J and radius HD describe arcs cutting these lines produced in $N, M, K,$ and L . With centres G_1 and G_2 and radius G_1, G_2 draw arcs to complete the figure.

Problem 150. - Given an ellipse to find the major and minor axes and to draw a tangent and normal to the ellipse at any given point L . (Plate XII, Fig. 9.)

Draw any two parallel chords EF and GH and bisect them. The line joining the points of bisection will be a diameter, and the centre point of the diameter O is the centre of the ellipse. With centre O draw any arc JK cutting the ellipse in J and K . Join JK . A line AB bisecting JK at right angles will be the major axis, and a line CD drawn through O at right angles to AB will be the minor axis.

To draw a tangent and a normal, find the foci F_1, F_2 .

Join $F_1 L$ and $F_2 L$ and produce the lines to N and M . A line drawn bisecting the angle MLF_1 is a tangent to the curve at L , and a line drawn perpendicular to the tangent at L is a normal to the curve.

(The method of drawing a normal to any curve is useful for obtaining the correct joints in arches.)

Problem 151.—To construct an oval or egg-shaped figure, the width AB being given. (Plate XII, Fig. 10.)

Bisect AB by the line CD , cutting AB in E , and from E , with radius EA , draw a circle cutting CD in F .

From A and B , draw lines through F , and produce them indefinitely.

From A and B , with radius AB , draw arcs cutting the last two lines in H and G .

From F , with radius FG , describe the arc GH , to meet the arcs AG and BH , which will complete the oval.

THE PARABOLA.

The Parabola is a curve formed by a plane cutting a cone parallel to a side.

Problem 152.—To draw parabola, the focus F and the director AB being given. (Plate XII, Fig. 11.)

Draw the axis CD of the parabola through F perpendicular to AB . Bisect FC in E , which is the vertex of the curve. Draw any number of lines parallel to AB . With F as centre and radii equal to the distance of each line from the director AB cut off points on the line which will give points on the parabola.

Problem 153.—The double ordinate AB and abscissa CD being given, to construct a parabola. (Plate XII, Fig. 12.)

Divide CA and CB into any number of equal parts—*viz.*, 1, 2, 3, 4.

Divided AE and BF into the same number of equal parts.

From D , draw lines to the points in EA and FB .

From points 1, 2, 3, 4 in AC and CB , draw perpendiculars to meet the lines drawn from D to the points in EA and FB .

The curve is to be drawn through the point where the perpendicular 1 meets $D1$, where perpendicular 2 meets $D2$, etc., etc.

Problem 154.—To draw a normal and a tangent to a parabola at any given point C . (Plate XII, Fig. 13.)

Draw an ordinate BC through C . Make DE equal to DB and join EC . This is the required tangent, and the normal will be perpendicular to the tangent.

THE HYPERBOLA.

The Hyperbola is a curve formed by a plane making a greater angle with the base of a cone than the side of the cone makes with the base.

Problem 155.—Given the diameter **AB** the abscissa **BC** and double ordinate **DE**, to construct an hyperbola. (Plate XII, Fig. 14.)

Through **B** draw a line parallel to **DE**, meeting the lines, **DF**, **EG** drawn perpendicular to **DE**, in the points **F** and **G**.

Divide **CD** and **CE** into any number of equal parts 1, 2, 3.

Divide **FD** and **GE** into the same number of equal parts.

From **B**, draw lines to the points in **FD** and **GE**.

From **A**, draw lines to the points in **DE**.

Draw the curve through the points where the lines correspondingly numbered intersect one another.

Problem 156.—The major axis **AB** and the foci **F₁** and **F₂**, being given to draw an hyperbola, and to draw a tangent and a normal at a point **P**. (Plate XII, Fig. 15.)

In **BA** produced take any number of points 1, 2, 3, etc.

With **F₁** and **F₂** as centres and radius **A1** draw arcs at **C**, and with the same centres and radius **B1** intersect these arcs obtaining points on the hyperbola. Proceed in the same way for the remaining points 2, 3 etc.

To draw the tangent and normal, join **F₁P** and **F₂P**. The line bisecting the angle **F₁PF₂** is the tangent at **P**, and a line perpendicular to the tangent is the normal.

TRACERY.

The preceding problems intelligently applied should enable the Student to draw any Architectural tracery or any Ornamental pattern. *Plate XII, Fig. 16* shows the Gothic trefoil, and *Fig. 17* and example of tracery applied to a window.

ARCHES

Problem 157.—To construct a segmental arch given the span **AB** and the rise **CD**. (Plate XII, Fig. 18.)

Join **DB** and bisect it by the perpendicular **EF** cutting **DC** produced in **F**, which is the centre of the required arc **ADB**.

Problem 158.—To construct an equilateral arch the span **AB** being given. (Plate XII, Fig. 19.)

With centres **A** and **B** and radius **AB** draw arcs intersecting at **C**.

Problem 159.—To construct a pointed arch (two centres) the span **AB** and the rise **CD** being given. (Plate XII, Fig. 20.)

Join **DA** and **DB** and bisect these lines at right angles by lines **EF** and **GH**, cutting the span **AB** produced in **F** and **H**, which are the required centres.

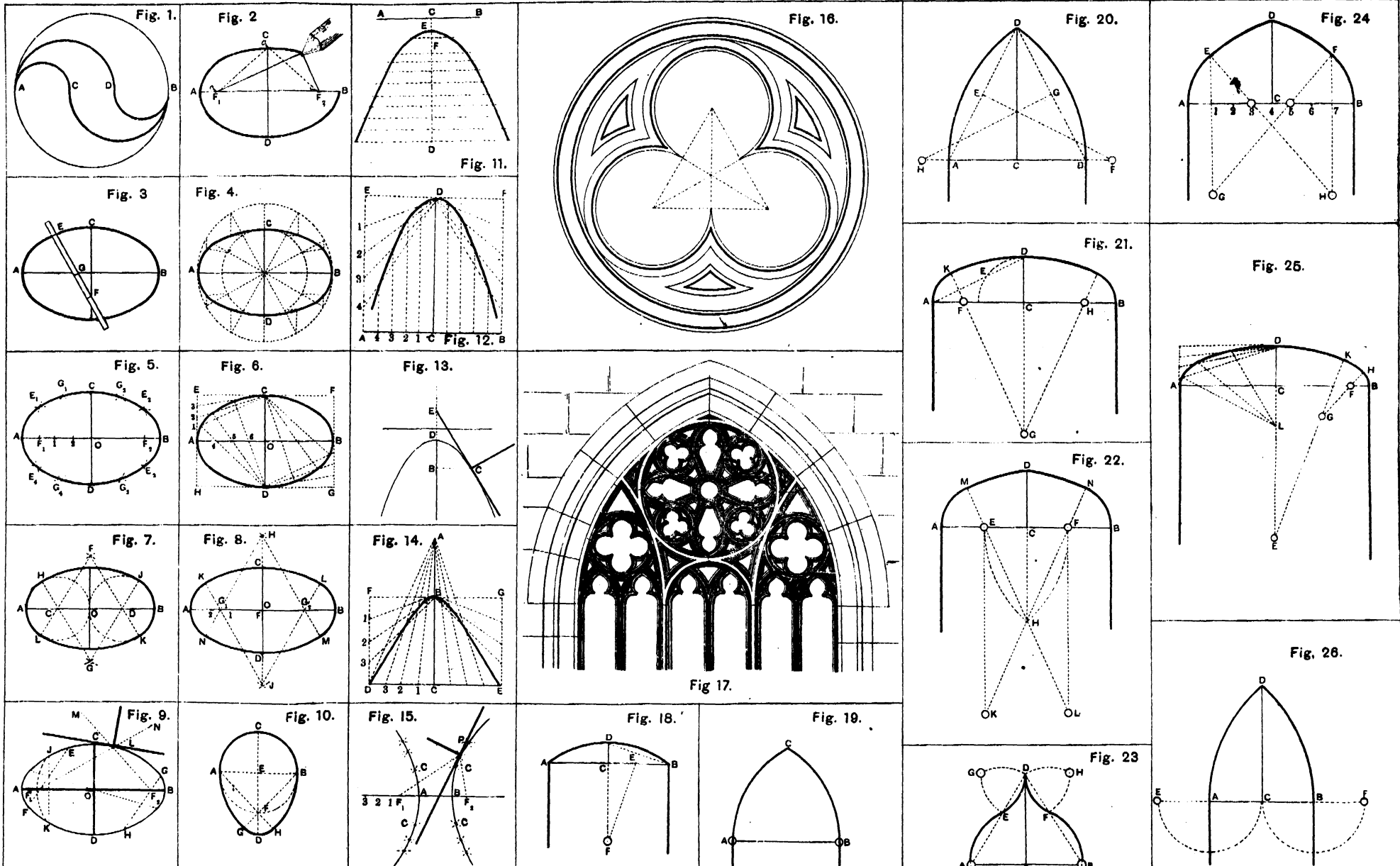

Problem 160.—To construct a semi-elliptical arch (three centres) the span AB and the rise CD being given. (Plate XII, Fig. 21.)

Join AD and make DE equal to AC minus CD . Bisect AE by a line at right angles cutting AC in F and DC produced in G . Then F is the centre of the arc AK and G the centre of the arc KD . Complete the arch.

Problem 161.—To construct a pointed arch (four centres) the span AB and the rise CD being given. (Plate XII, Fig. 22.)

Divide AB into four equal parts in E, C, F . With centres A and B and radius AF , describe arcs intersecting at H . Join FH and EH and produce these lines to meet perpendiculars to AB let fall from E and F , in the points K, L . Then E and F are centres of the arcs AM and BN , and K and L of arcs ND and MD . This solution only holds good when the rise is $\frac{1}{2}$ of the span.

Problem 162.—To draw an Ogee arch, the span AB and the rise CD being given. (Plate XII, Fig. 23.)

Join DA and DB , and divide the lines into any required proportion in the points E and F . Describe the arcs AE and BF . With centres E, D and F and radius ED describe intersecting arcs at G and H . With centres G and H and radius GE complete the curve of the arch.

Problem 163.—To construct a Saracenic arch (four centres) given the span AB and the rise CD . (Plate XII, Fig. 24.)

Divide AB into eight equal parts. Through points 1 and 7 draw lines perpendicular to AB , and with 3 and 5 as centres and radius $3A$ draw arcs AE and BF cutting the perpendiculars through 1 and 7 in E and F . Join $E3$ and $F5$, and produce these lines to cut the perpendiculars through 7 and 1 in the points H and G which are the centres for the rest of the arch.

Problem 164.—To construct a semi-elliptical arch given the span AB and the rise CD . (Plate XII, Fig. 25.)

(i) By five centres—

Produce DC to E and make DE equal to AB . Make BF equal to $\frac{1}{3}$ th of AB . With F as centre and radius equal to $\frac{2}{3}$ ths of AB , and with E as centre and radius equal to $\frac{2}{3}$ rds of AB , describe arcs intersecting at G . Join EG and produce it to K , and GF and produce it to H . Then F is the centre of the arc BH , G of the arc HK , and E of the arc KD .

(ii) Proceed as in Problem 147.

Problem 165.—To construct a Lancet arch, given the span AB . (Plate XII, Fig. 26.)

Produce AB both ways to E and F . Make AE and BF equal to AC . Then E and F are the required centres.

If the rise is fixed, the methods shown in Problem 159 can be used.

MOULDINGS.

Mouldings may be divided into two classes, Roman and Grecian.

Roman mouldings are composed only of parts of circles and straight lines, and are severe in contour. Grecian mouldings are composed, as a rule, of parts of the ellipse, parabola and hyperbola and are more ornate and varied in contour.

Definitions.

Fillet is the rectangular part above or under a moulding. If this ends in a convex semicircle it is called a Bead.

Torus, a convex semicircle or semi ellipse with a fillet above or below it, as in Plate XIII, *Fig. 1*.

Scotia, a concave semicircle or semi ellipse, as in Plate XIII, *Fig. 7*.

Echinus ovolo, or quarter round. When the contour of the moulding is convex, and a part of a circle equal to or less than a quadrant of a circle or part of a conic section, as in Plate XIII, *Figs. 2 and 7 to 13*.

Cavetto, or hollow, is the reverse of the *ovolo*, as in *Figs. 3 and 4*.

Cyma reversa, or ogee, a contour half convex and half concave, as in Plate XIII, *Figs. 6 and 16*.

Cyma recta, or *Cymatium*, is the reverse of the *cyma reversa*, as in Plate XIII, *Figs. 5 and 15*.

Each moulding has its own proper enrichment, for which the enquiring Student may be referred to Chambers's treatise on the decorative part of Civil Architecture, and other works of a like nature.

ROMAN MOULDINGS.

Problem 166—Given the depth of the moulding to draw a *Torus*. (Plate XIII, *Fig. 1*)

Bisect the depth of moulding in a , and draw a semicircle.

Problem 167.—Given the points a and b draw an *Ovolo* and a *Cavetto*. (Plate XIII, *Figs. 2 and 3*)

With centres a and b , describe arcs intersecting at c . Then c is the centre of the curve.

Problem 168.—Given the lines terminating in a and b and a to describe a curve to meet them, and one of them in the point a . (Plate XIII, *Fig. 4*)

Produce the lines to meet in d . Make de equal to da and erect ae and be perpendiculars intersecting at c . Then c is the centre of the curve.

Problem 169.—Given the points a and b to draw a *Cyma recta* and a *Cyma reversa*. (Plate XIII, *Figs. 5 and 6*.)

Join ab and bisect the line in e . On be and ea erect equilateral triangles. The apex of each triangle is the centre of the curve.

GRECIAN MOULDINGS.

Problem 170.—Given the point of turn or quirk at B and the tangent CF at the bottom of the moulding to draw it. (Plate XIII, *Figs. 7, 8, 9, 10, 11 and 12*.)

ROMAN MOULDINGS.

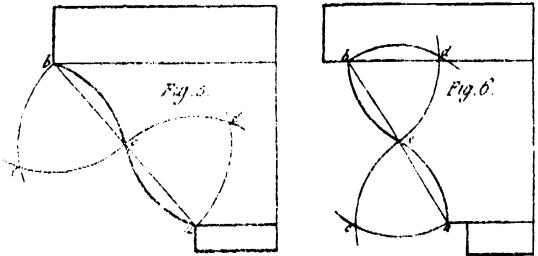
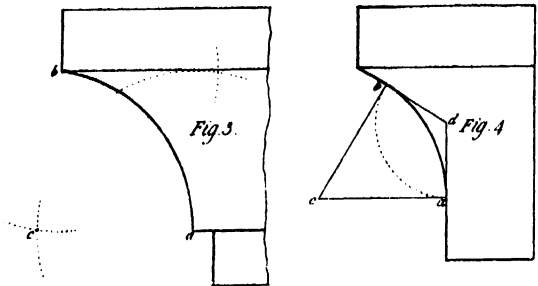
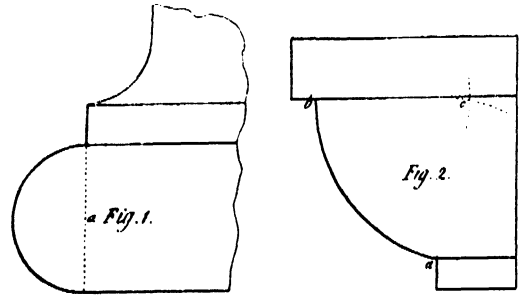

GRECIAN MOULDINGS.

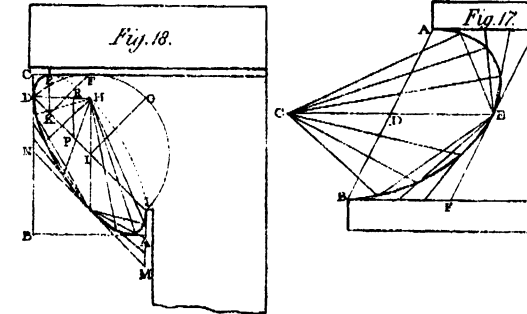
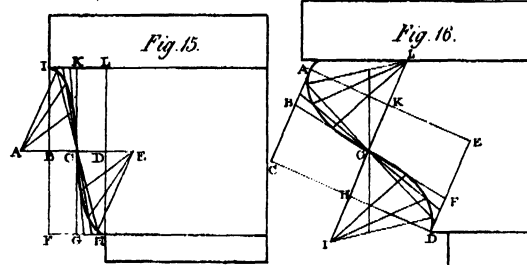
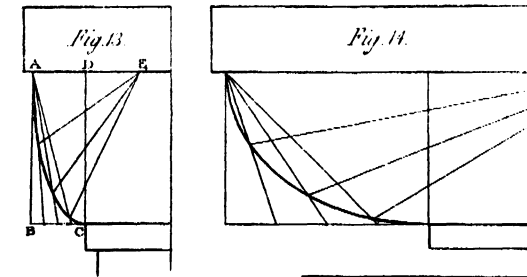
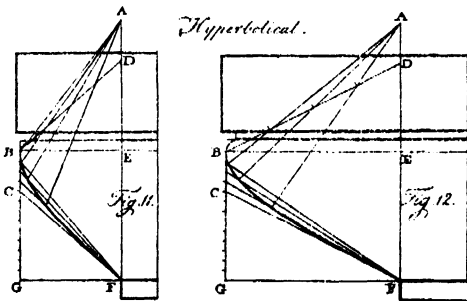
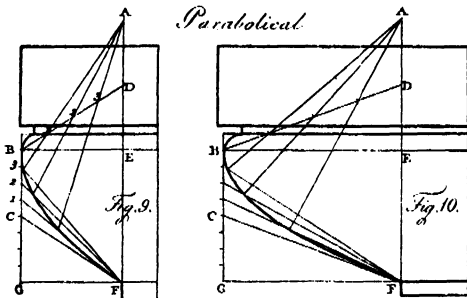
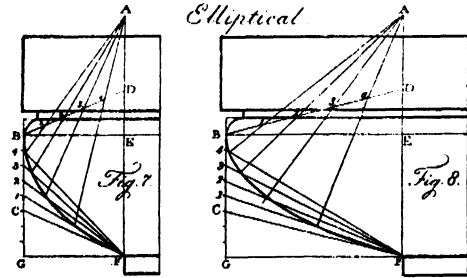

THE IONIC ORDER.

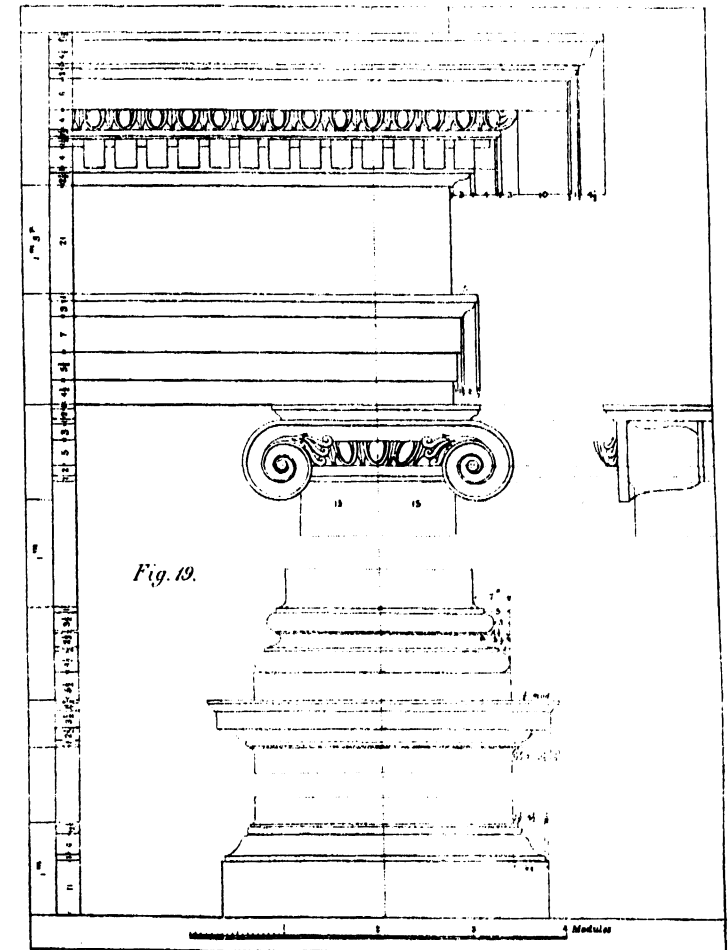

Draw GF, a continuation of the upper line of the under fillet. Through B draw BG perpendicular to GF, meeting GF in G, and the tangent CF in C. Through B draw BE parallel to GF, and through F, draw FEDA parallel to BG, cutting BE in E. Make EA equal to EF, and ED to CG, and join BD. Divide BD and BC into an equal number of parts. From A, through the points 1, 2, 3, 4, in BD draw lines, and from F, through the points 1, 2, 3, 4, in BC, draw lines cutting the former, which gives points on the curve.

If CG be less than one half GB, the moulding will be ELLIPTICAL, *Figs. 7 and 8.*

If CG be one half GB, the moulding will be PARABOLICAL, *Figs. 9 and 10.*

If CG be greater than half GB, the moulding will be hyperbolic *Figs. 11 and 12.*

Problem 171.—Given the semi-transverse and semi-conjugate axes to describe the moulding. (Plate XIII, *Figs. 13, 14, 15, 16 and 17.*)

Complete the rectangle and draw the portion of the ellipse by Problem 147.

Problem 172.—Given the depth of a moulding CB and point of quirk at D. Describe an Echinus quirked at top and bottom. (Plate XIII, *Fig. 18.*)

Make AL equal to DC. Join DL and bisect it in I. DL is a diameter of the required ellipse and it is necessary to find its conjugate to draw the ellipse. Draw IH parallel to CB which gives the direction of the conjugate.

With centre I and radius ID describe a semicircle. Draw any ordinate to the diameter KE parallel to CB. Through K draw KF perpendicular to DL meeting the semicircle in F. Make DP equal to KF and PR parallel and equal to KE. Join DR and produce it to cut IH in H. Then IH is the semi-conjugate diameter, and the ellipse may be drawn by Problem 147.

Orders of Ancient Architecture.

Ancient Architecture is divided into the following orders:—Tuscan, Roman Doric, Grecian Doric, Ionic, Corinthian and Composite.

Fig. 19 gives an example of the Ionic order showing the method of arranging the mouldings in the columns.

. The scale is drawn in Modules.

A module is equal to half the diameter of the foot of the column, and is divided by French architects into 12 minutes for the Tuscan and Doric orders, and 18 minutes for the Ionic, Corinthian and Composite orders. In England the module is often divided uniformly into 30 minutes.

The most characteristic point to be noted is the Ionic volute, the method of drawing which will now be given.

SPIRALS

A Spiral, strictly speaking, signifies a line drawn round the surface of a cone, which line is continually approaching nearer to the axis as it comes nearer to the vertex of the cone.

It has, however, to be drawn on a plane such as a sheet of paper, and may be defined as follows:—

If round a fixed point another be supposed to move continually, approaching or receding from the fixed point, according to some law, the figure so described is called a Spiral.

If the moving point has gone once round the fixed point, the spiral is said to have one revolution, and if twice round, it is said to consist of two revolutions, and so on.

The fixed point is called the centre of the Spiral.

Any straight line drawn from the centre of the spiral and terminated by the curve is called an Ordinate.

If the greatest radius moves uniformly round the centre and at the same time uniformly diminishes, so that both motions begin and end together, the curve is called the SPIRAL OF ARCHIMEDES. (*See Plate XIV, Fig. 1.*)

If the curve be such that if it was everywhere cut by ordinates, the angles made by the tangents at each of these points with the ordinates are equal, then the curve is called the LOGARITHMIC OR PROPORTIONAL SPIRAL. (*Plate XIV, Fig. 2.*)

Problem 173.—To draw an Archimedian spiral of three revolutions, the centre *O* and the greatest ordinate *OA* being given. (*Plate XIV, Fig. 1.*)

Draw two lines intersecting each other perpendicularly at *O*. With radius *OA* describe a circle. Divide the circumference into any number of equal parts (say, eight) and draw lines from each point of division to the centre. Divide *OA* into three equal parts (the spiral having three revolutions). Divide each of these parts again into eight equal parts. Mark on the radius *OB* 23 parts, on *OC* 22, on *OD* 21, and so on, till the centre is reached. The curve drawn through the points so obtained is the required spiral.

If a string is twisted round a globe, in regular order, and a pencil point fixed to its extremity, in unwinding the string, the pencil point, held upright, will describe an Archimedian Spiral.

Problem 174.—To draw a proportional spiral of three revolutions, the centre O and the height AC being given. (Plate XIV. Fig. 2.)

Through O draw DB perpendicular to AC. Find OB a mean proportional between OC and OA. Join AB and BC. Through C draw CD parallel to AB cutting BD in D, and through D draw DE parallel to CB cutting CA in E. Through E draw EF parallel to DC cutting BD in F. Proceed in this way to the end of the last revolution. To find any number of intermediate points, bisect the angles AOB, BOC, COD and DOE by the lines 31 and 42. Make O1 a mean proportional between OA and OB, and O2 a mean proportional between OB and OC. Join A1, 1B, B2, 2C. Draw C3 parallel to A1, 3D parallel to B1, D4 parallel to B2, etc., that is, each parallel to the line subtending its opposite angle. This will give a second set of points, and more may be obtained according to the degree of accuracy required.

If a string be wound round a cylindrical body, one roll outside another, the pencil point will describe this spiral, the thickness of the string determining the greater or less increase of the revolutions of the spiral.

These two spirals are not, however, very graceful, and a more attractive spiral is that known as the Ionic volute. There are several methods among which may be mentioned De Lorme's, Goldman's and Palladio's. Examples of the first two methods are given.

Problem 175.—To draw the Ionic volute, the total height being given by De Lorme's method. (Plate XIV, Figs. 3 and 4)

Divide the total height AB into eight parts. On 3, 4 as diameter describe the eye. In the eye place a square with one diameter coincident with AB. (See enlarged centre *Fig. 4*) Bisect the sides of the square in the points 1, 2, 3 and 4, thus placing a smaller square within the first square. Divide the diagonal 1, 3 and 2, 4 each into six equal parts, and number the points so obtained as in *Fig. 4*. These 12 points are the centres from each of which a quadrant of a circle may be drawn.

To draw the inner fillet, divide the distance 1, 5 in *Fig. 4* into four parts, and mark off one part so obtained on the diagonals from each of the centres, thus obtaining 12 new centres for drawing the fillet.

Problem 176.—To draw the Ionic volute, given the diameter of the eye AB, and the greatest ordinate or cathetus CF, by Goldman's method. (From Sir W. Chambers.) (Plate XIV, Figs. 5 and 6.)

The cathetus should be half a module and the diameter of the eye $\frac{2}{3}$ ths of a module.

Divide the eye into four equal parts by the diameters AB and DE (the operation is enlarged in *Fig. 6*). Bisect the radii CA and CB in 1 and 4, and on the line 1, 4 construct a square 1, 2, 3, 4. From the

centre C to the angles 2, and 3 draw the diagonals C2, C3. Divide the side of the square 1, 4 into six equal parts at 5, 9, C, 12, 8. Through the points 5, 9, 12, 8 draw the lines 5, 6, 9, 10, 12, 11, 8, 7, parallel to the diameter ED which will cut the diagonals in 6, 10, 11, 7, and the points 1, 2, 3, 4, 5, 6, 7, 8, 9, 10, 11, 12 will be the centres of the volute.

From the first centre 1, with radius 1, F, describe the quadrant FG. From the second centre 2, with the radius 2, G, describe the quadrant GH. Continue the operation for all 12 centres. The volute should finish at the point A.

The centres for the fillet are found in this manner:—Construct the triangle of which the side AF is equal to the part of the cathetus contained between A and F, and the side FV equals Cl. On the side AF place the distance FS, from F towards A, equal to the breadth of the fillet ($\frac{1}{9}$ th of a module).

Through S draw ST parallel to FV. Then ST is to Cl in the same proportion as AS is to AF. Place the distance ST on each side of the centre C on the diameter of the eye AB. Divide it into three equal parts, and through the points of division draw lines parallel to the diameter ED which will cut the diagonals C2, C3 and 12 new centres are obtained for the interior contour of the fillet.

Fig. 1.

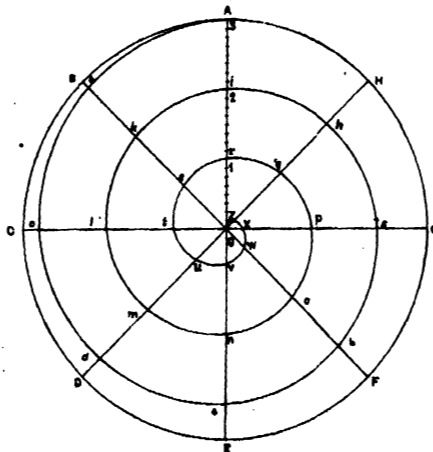

Fig. 3.

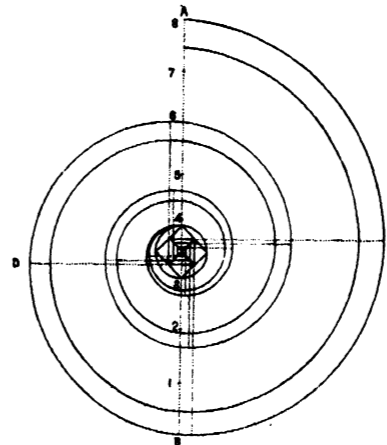

Fig. 4.

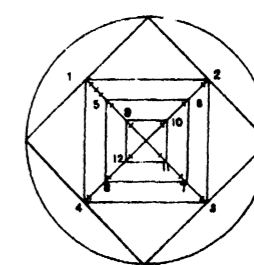

Fig. 2.

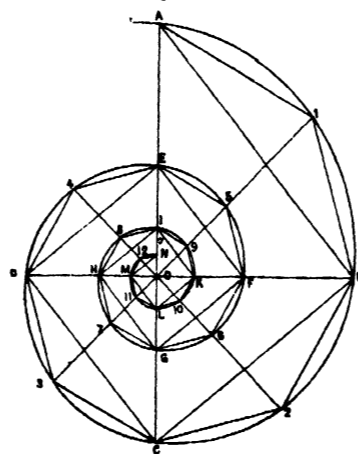

Fig. 5.

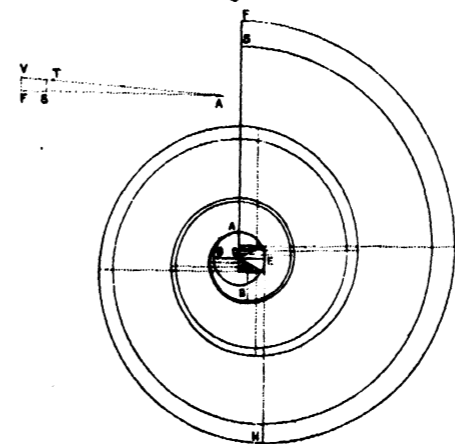
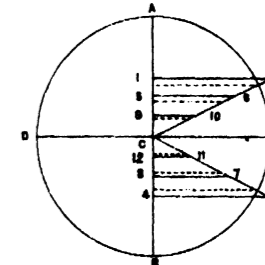

Fig. 6.



CHAPTER V.

ELEMENTARY SOLID GEOMETRY.

The last four chapters have dealt with the representation of plane surfaces (having length and breadth only) on a plane surface, such as drawing paper. But all objects in nature have not only length and breadth, but thickness, so that the points, lines, and surfaces of which they are composed will not lie in one plane only, but in various planes. Some means are obviously desirable by which these objects may be represented on a plane surface, such as drawing paper, in such a manner that they can be accurately measured to scale.

The position of an object in space may evidently be fixed by its relation to, or distance from, certain fixed planes. Take two pieces of wood fixed at right angles to each other, representing two planes, the position of which is known, and let us see how the position of any point in space *A* can be fixed in relation to these planes. Attach two pieces of wire to the point *A*, at right angles to each other and drive them perpendicularly in the two pieces of wood. The position of the two planes represented by the pieces of wood being known, if the length of the two wires is measured, the position of the point *A* in space is known in relation to the two given planes.

The wires may be taken to be lines representing rays of light supposed to be thrown or projected, from every point in the object on to each plane.

These lines or rays are termed "*Projectors*," and the planes are called the "*Planes of Projection*." The outline of the object traced by the projectors on the plane of projection is called the "*Projection*" of the object on that plane.

There are three important methods of projection—

1. Perspective or Natural Projection, which will be dealt with in detail in Chapter XVI.

Note.—A great deal of this chapter is quoted from the Text-Book of Practical Solid Geometry for the use of the Royal Military Academy, Woolwich, by Capt E. H. deV Atkinson, R.E., by kind permission of E. and F. N. Spon, Limited, 125, Strand, London,

2. Orthographic or Perpendicular Projection.

3. Isometric Projection, which will be dealt with in Chapter IX.

Perspective Projection is a geometrical method of obtaining on paper a drawing representing objects as actually seen by the eye. As all the projectors or rays of light from every point in the object converge in

the eye, it follows that there must be distortions, the principles of which are—

- (a) The lengths in the drawing, of lines of equal length in the object, vary with the distance of the lines from the eye. If you look down a receding line of railway, in which the sleepers are at right angles to the rails, although the sleepers are really all the same length, yet they seem to get smaller and smaller the further distant they are from the point of vision.
- (b) Various lines are more or less foreshortened as they are more or less oblique to the plane of projection.

It is, therefore, impossible to take actual measurements from a perspective drawing, and it is to enable this practical necessity to be carried out that we resort to Orthographic Projection.

ORTHOGRAPHIC PROJECTION.

In Orthographic Projection the first distortion mentioned (a), is got over by imagining that the eye is at an infinite distance from the object. Then the rays from every point in the object, instead of converging to the eye, become parallel to each other and perpendicular to the plane of projection. In other words, the eye is supposed to move into a position perpendicular to each point in the object at the same time. This is, of course, physically impossible, and it is important to remember that an object can never be seen as represented in an orthographic projection. Now in *Fig. 1, Plate XV*, we have the orthographic projection of a rectangular box obtained by projecting the base down on the horizontal plane, the eye being supposed to be above the box (as at A), and the exact dimensions of the base of the box can be measured. We, however, see that all lines not parallel to the plane of projection are still foreshortened (distortion b), those at right angles to the base being foreshortened to a point, and to obviate this we introduce another plane of projection, called the Vertical plane, at right angles to the first or Horizontal plane. Shifting the eye to B, we can now make a projection on the vertical plane, and by using as many vertical planes as are necessary parallel to the various sides of the box, we obtain full information as to the size of each side.

The projection on the Horizontal plane, or H. P., is called a "Plan," and the projections on the Vertical planes, or V. P.'s, are called "Elevations."

It may be noted that as the object is supposed to be fixed in space there can be but one Plan; but there can be any number of Elevations,

because vertical planes can be erected all round the object and projections made on them, the object being viewed from any point required. It must be remembered that the object always remains between the observer's eye and the V. P. It is very important to note that as the object is in a fixed position, *each point will be the same height above the H. P. in all elevations.*

In *Figs. 1 and 2*, y represents the height of the box above the horizontal plane, and x the distance from the vertical plane. The Student may now remark that the box is rectangular, and the side being at right angles to the base, it is possible to obtain all necessary dimensions from the H. P. and V. P. If, however, the object was a pyramid with a square base, how would the dimensions of the sloping side be obtained? Would you take a plane parallel to this sloping side and making an angle with the H. P.? No. It is very important to remember that in all cases a V. P. and an H. P. are at right angles to each other. In this case the pyramid would be rotated on one edge of the base till the sloping side was vertical, and a projection would then be made on a V. P. parallel to it, and the necessary dimensions obtained. This will be dealt with in detail further on. A practical difficulty now occurs. The object is to be represented on paper, but it is not possible to keep bending the paper up at right angles to get the V. P. Suppose the two planes in *Fig. 1* are hinged, and that the vertical plane is allowed to drop back a quarter of a circle till it lies in the same plane with the horizontal plane as shown by dotted lines. Viewed from the front the two planes will be as represented in *Fig. 2*. The two projections remain as before, except that they are now in one plane, and it can be seen that each point in plan is exactly under the corresponding point in elevation.

It will be shown in Problem 177 how to go to work in practice to get the two projections of the box on one plane, such as a sheet of drawing paper, but before doing so it is necessary to give a few definitions and rules for lettering.

Definitions.

A **PLAN** is the orthographic projection of an object on the horizontal plane or H. P., which is represented by the drawing paper.

An **ELEVATION** is the orthographic projection of an object on *any* vertical plane or V. P.

A **SECTION** is the representation of the surface that would be exposed, supposing the object to be cut by a plane passing in any required direction.

This imaginary cutting plane is usually vertical, and every part of the solid between the eye and the cutting plane is assumed to be removed.

The **PROFILE** of an object is a section made by a V. P. cutting the object in a direction perpendicular to its length. A profile shows the true breadths, and is the only section that does so.

A **CONTOUR** is the plan of the intersection of a surface by a horizontal plane.

If it is required to draw the plan and elevation of an object in a certain position, it may sometimes be necessary to draw plans and elevations of the object in other positions first, in order to obtain the required projections. These plans and elevations are called "Auxiliary" or "Constructive."

Rules for Lettering Drawings.

It is essential in the more complicated problems to letter distinctly each point in plan and elevation, and, moreover, to do so in a systematic way. The Student should get into the way of doing this by never drawing anything, however simple, without lettering it.

1. For all original points in space use capital letters, A, B, C, etc.

2. An original point A, etc., will have a plan a and an elevation a' . If more than one plan be drawn, the corresponding points will be lettered a_1 , etc., if more than one elevation a'' , a''' , etc.

If a point in plan represents two points in the object (as the point $\frac{a}{a}$ in *Fig. 3, Plate XV*), and consequently has to be marked with two letters, put the letter representing the point *nearest* your eye above the other letter. Deal in the same way with a point in elevation representing two points in plan (as the point $\frac{a'}{a'}$ in *Fig. 9, Plate XV*).

These letters should be printed in black italics $\frac{1}{16}$ ths of an inch high.

3. Given lines to be **THIN CONTINUOUS BLACK LINES**.

4. Resulting projections to be shown in **THICK CONTINUOUS BLACK LINES**.

5. All construction lines and projectors to be **FINE COMMON DOTTED LINES**. In a finished drawing, only the outer projectors need be shown.

6. All auxiliary elevations and plans to be chain-dotted.

7. Elevations projected from plans, *except* auxiliary elevations, to be shown as "results" or new views of the object.

8. The intersection of the co-ordinate planes, commonly called the **XY** line, to be invariably marked with the letters **XY** in block capitals $\frac{1}{16}$ ths of an inch high.

Problem 177.—To draw the plan and elevation of a rectangular box, x inches long, y inches wide, and z inches high, when one of the long sides makes an angle of 30° with the V. P., and one of the faces $abcd$ lies in the H. P. (Plate XV, Fig. 3.)

Draw the plan of the box, which will be a rectangle x inches long and y inches wide. Draw a line representing the hinge of the V. P. making 30° with the plane one of the long sides. Now this line represents both the plans of the V. P. and the elevation of the H. P. It is commonly called the "XY line," the "ground line" or the "datum line."

Each angular point in the plan actually represents two points in the box, *viz.*, the top and bottom corners. Letter them a, b, c, d , representing the bottom of the box, and e, f, g, h , representing the top of the box. From each of these points draw projectors at right angles to the XY line. As the base of the box rests on the H. P. a, b, c, d , must, in elevation, be in the XY line, and can be lettered a', b', c', d' . Draw a line parallel to the XY line at a distance from it equal to the height of the box (z inches). Continue the projectors till they cut this line, and letter the points obtained $e' f' g' h'$ representing the top of the box. The result is the required elevation.

CHAPTER VI.

ELEMENTARY PROJECTION OF SOLIDS.

A "Solid" is that which has length, breadth, and thickness (Euclid, Book XI, Def. 1).

Geometrical solids may be classed—

1. Regular solids which are contained by equal and regular surfaces. Each of them can be inscribed in a sphere, and all their regular points are equidistant from the centre of the sphere. It can be proved that five, and only five, solids can fulfil these conditions. These are—

- (i) The Tetrahedron, contained by four equal and equilateral triangles. (No. 1, *Plate XV, Fig. 4.*)
- (ii) The Cube, contained by six equal squares. (No. 2, *Plate XV, Fig. 4.*)
- (iii) The Octahedron, contained by eight equal and equilateral triangles, (No. 3, *Plate XV, Fig. 4.*)
- (iv) The Dodecahedron, contained by twelve equal pentagons, which are equilateral and equiangular. (No. 4, *Plate XV, Fig. 4.*)
- (v) The Icosahedron, contained by twenty equal and equilateral triangles. (No. 5, *Plate XV, Fig. 4.*)

2. Solids of Revolution, three in number—

- (i) The Sphere. (No. 1, *Plate XV, Fig. 5.*)
- (ii) The Cone. (No. 2, *Plate XV, Fig. 5.*)
- (iii) The Cylinder. (No. 3, *Plate XV, Fig. 5.*)

3. Prisms which are solids having two parallel polygonal ends, equal in size and shape. The sides which unite these ends are parallelograms. If these sides are perpendicular to the ends, the solid is a *right prism*. Prisms are called after the shape of their ends. Thus, if the solid has a pentagonal base it is called a pentagonal prism. (No. 4, *Plate XV, Fig. 5.*)

4. Pyramids, which are solids having one polygonal base. From each of the angles of the base a series of edges converge to a point called the apex. If the line drawn from the apex to the centre of the base is perpendicular to the base, the solid is a *right pyramid*. Pyramids are named in the same way as prisms. (No. 5, *Plate XV, Fig. 5.*)

The object of the exercises in this chapter is to give a Student the groundwork of knowledge which will enable him to produce projections of objects he may meet with in his daily work as an Engineer, in however complicated or difficult position they may be placed.

Solids are assumed for purposes of drawing to be transparent, and the invisible edges are represented by dotted lines. It is sometimes a matter of difficulty to the beginner to decide which lines should be continuous and which dotted.

If you are projecting an elevation from a plan, try and imagine that the V. P. actually rises from the XY line at right angles to the H. P. Get your eye down, and look at it with the object placed in imagination between you and the V. P.

The lines of the solid represented in the plan by lines nearest your eye will be continuous in elevation, and those further away or behind the solid will be dotted.

In the same way, if you are projecting a plan from an elevation, imagine you are looking perpendicularly down on to the object from a point above it. Those lines which are uppermost in elevation will be continuous in plan, and those nearest the XY line in elevation, which represent lines in the object which cannot be seen from above, will be dotted in plan.

Although in many cases the easiest method of obtaining the required projections of a solid will only be recognized by the light of experience, yet all the more important positions can be grouped in the following cases:—

Case 1. One face in or parallel to the H. P.

Case 2. One edge of a face in or parallel to the H. P., the inclination of one of the faces containing that edge being given.

Case 3. One edge of the base in or parallel to the H. P., the inclination of the base being given.

Case 4. One point in or in a plane parallel to the H. P., the inclination of the edge or diagonal passing through the point being given.

Case 5. The inclination of one face, and of a line in that face being given.

Case 6. The inclination of two edges or diagonals being given.

Case 7. The inclination of two adjacent faces being given.

Only the first four cases will be dealt with in this chapter. The remaining cases require some knowledge of the projection of Lines and Planes, and are dealt with in Part II, Chapters XI and XII.

CASE I.

One face in or parallel to the H. P.

Problem 178. —To draw the plan and elevation of a tetrahedron (1 inch side), when one face rests in the H. P., and to find the true size of its sloping sides. (Plate XV, Figs. 6, 7, 8.)

The required plan is the equilateral triangle abc of 1 inch side. The centre of the triangle d is the plan of the apex. (*Fig. 7.*)

To obtain the elevation project each of the points a, b, c, d , up to the XY line. We must now find the height of the tetrahedron. By examining *Fig. 6* it will be seen that the inclined edges of the solid are really equal in length to the edges of the base, being each sides of equal equilateral triangles. It can further be seen that their length in plan is the distance from the angles of the base to the plan of the apex. If a right-angled triangle is constructed with Ad , the foreshortened plan of an inclined edge AD as base, and the real length of the inclined edge AD as hypotenuse, then the perpendicular dD represents the height of the solid.

In *Fig. 7* the plan of the solid with one face resting in the $H. P.$ has been obtained. On ad as base erect a perpendicular dl . With centre a and radius ac cut off on this perpendicular a length al equal to ac . The required right-angled triangle is now obtained, and dl is the height of the tetrahedron. Set it off on the projector from d and complete the elevation.

We have already remarked, on page 106, that in order to obtain the true measurements of a sloping face of an object, we must obtain an elevation of the object on a $V. P.$ at right angles to one edge of the face, and then, using that edge as a hinge, rotate the elevation till the face is perpendicular. In this case, *Fig. 8*, obtain the elevation of the solid on a $V. P.$ at right angles to the edge cb . Rotate the elevation till the face cdb is vertical. To prevent confusion this elevation has been moved to one side and is $a'' d'' c'' b''$. From this project down a plan. Then from this plan project up an elevation on an XY line parallel to the face cdb , and we obtain the true measurements of a sloping face, which is of course an equilateral triangle of 1 inch side. This system of "rotating" is most important, and should be thoroughly grasped, and will again be referred to later on.

Problem 179.—To draw the Plan and elevation of an octahedron when lying with one face in the $H. P.$ (*Plate XV, Fig. 9.*)

This is a good example of the method of obtaining the plan and elevation required by means of an auxiliary plan and elevation.

The Student must, in the case of every problem, examine the data, and see what is the easiest thing to draw first to obtain the required result.

In this case take a model of an octahedron, and place it with one diagonal vertical. We see then we can draw its plan which is a square.

Its elevation can also be projected, as the height in this position is equal to the diagonal of the square $abcd$.

This elevation, however, must be drawn on an XY line perpendicular to one of the sides of the square, because we must rotate the elevation so that the octahedron lies with one face in the $H. P.$

Rotate the elevation, so that each point moves in a plane parallel to the $V. P.$, keeping the point e' fixed till the face $e' b' c'$ rests in the XY line. This is an elevation of the solid in the required position. Drop projectors from each point in the elevation, and draw lines parallel to the XY line from the corresponding points in the auxiliary plan to meet these projectors. Join the points thus obtained. The result is a plan of the octahedron with the face e', b', c' , lying in the $H. P.$, and is a regular hexagon.

CASE II.

One edge of a face in or parallel to the $H. P.$, the inclination of one of the faces containing that edge being given.

When the base is at right angles to the faces, as in a right prism, the easiest thing to draw first will be an auxiliary elevation of the base, so that the elevation of the face of which the inclination is given is represented by a line. Draw the XY line making the given angle with this line, and project the solid. When the base of the solid is not perpendicular to the faces as in the octahedron, pyramids, etc., the method given for Case III must be employed.

Problem 180.—A pentagonal prism rests on one long edge which is 2 inches long. The inclination of one of the faces containing that edge is 25° . The sides of the base are 1 inch long. Draw the plan. (Plate XV, Fig. 10.)

Draw an auxiliary elevation of the base which will be a pentagon of 1 inch side. Draw an XY line making 25° with one of the sides. Project down the plan.

CASE III.

One edge of the base in or parallel to the $H. P.$, the inclination of the base being given.

In this case we must first draw an auxiliary plan of the solid resting on its base in the $H. P.$ Project up an auxiliary elevation of the solid in this position, on an XY line at right angles to the plan of the edge of the base on which the solid is to rest. The base is now represented in this auxiliary elevation as a line, and the edge of the base on which the solid is to rest by a point. Keeping this point fixed as a pivot, rotate the solid till the elevation of the base makes the required angle with the XY line (representing the $H. P.$).

The solid is now in the required position and its projections can be obtained.

This is a most important principle, and should be tried with various solids till the Student thoroughly grasps it. It must be clearly borne in mind that the auxiliary elevation must be made on an XY line at right angles to the plan of the edge of the base on which the solid is to rest, this edge being used as a hinge.

Problem 181.—The letter F is 1 inch high and $\frac{1}{2}$ inch in section. The top and lower arms are $\frac{1}{2}$ inch apart, and the former projects $\frac{1}{2}$ inch. Draw the projections of the solid when the letter rests on the edges of the base and projecting arms. (Plate XV, Fig. 11.)

According to the instructions given above, first draw an auxiliary plan and elevation of the letter resting on its base, on an XY line at right angles to the edge of the base on which it is eventually to rest. Now rotate the auxiliary elevation on this edge as a hinge till the projecting arms lie in the XY line. Then project down the plan. The elevation is moved to one side in Fig. 11 so as not to confuse the plans.

CASE IV.

One point in or in a plane parallel to the H. P., the inclination of the edge or diagonal passing through the point being given.

The method to be followed in dealing with this case is the same as in Case III, with the following important difference. *The XY line must be drawn parallel to the plan of the edge or diagonal of which the inclination is given.* The point on which the solid is to rest will now be the hinge. The XY line being parallel to the plan of the edge or diagonal of which the inclination is given, that edge or diagonal will now move in the V. P. The elevation must be rotated till the given edge makes the required angle with the H. P., and the projections can then be drawn.

Problem 182.—Draw the plan of a square pyramid (1 inch side and 1 inch height), resting on one point in the H. P., an edge passing through that point being vertical. (Plate XV, Fig. 12.)

Let it be required that the edge *ce* shall be vertical. First draw an auxiliary plan, project up an auxiliary elevation on an XY line parallel to the plan of the edge *ce*, keeping the point *c*, on which the solid is to rest, as a pivot, rotate the auxiliary elevation till the edge *c''e''* is vertical, Project down the plan. The elevation is here again moved to one side, in order that the plans may not be confused.

SOLIDS OF REVOLUTION.

The only point of difficulty likely to arise in the projection of solids of revolution is the projection of a circle when the plane containing the circle makes an angle with one or other of the planes of projection.

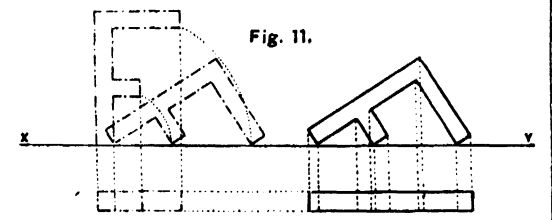
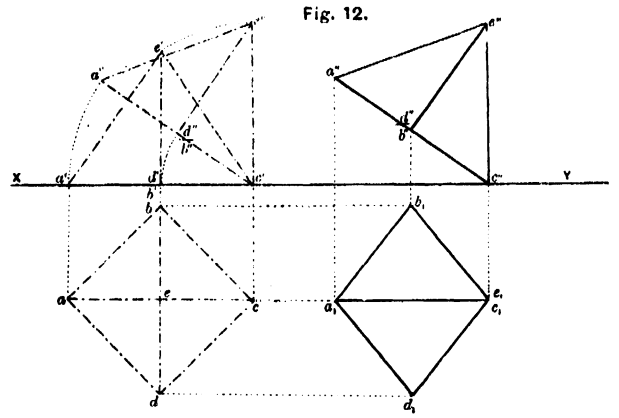
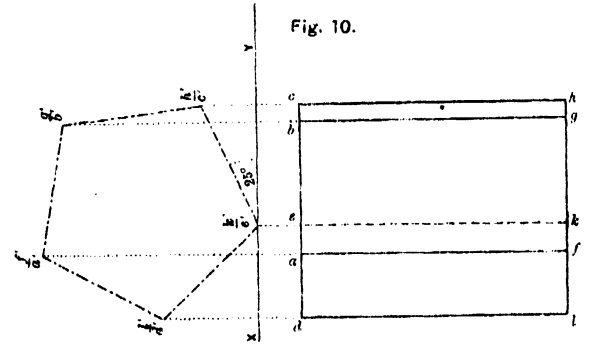
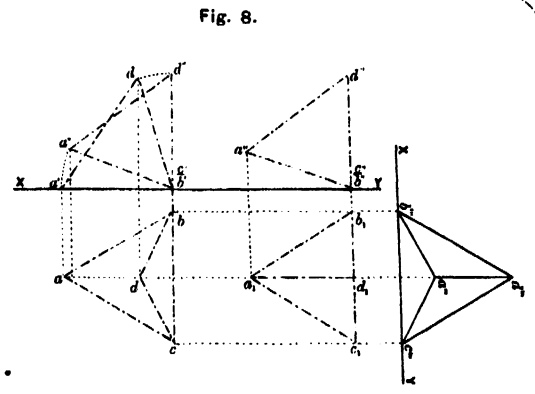
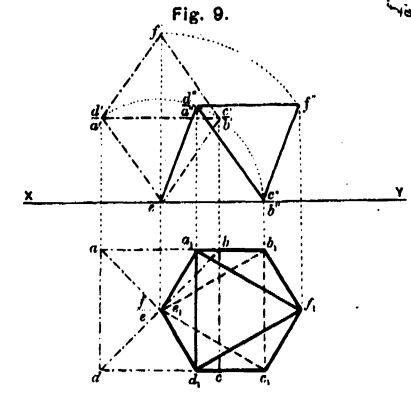
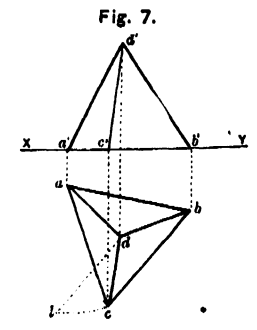
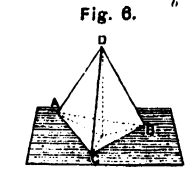
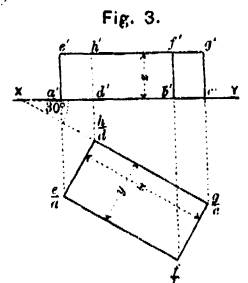
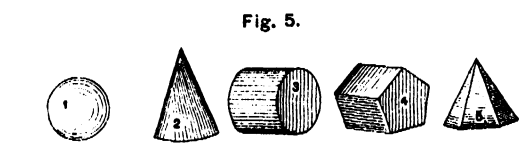
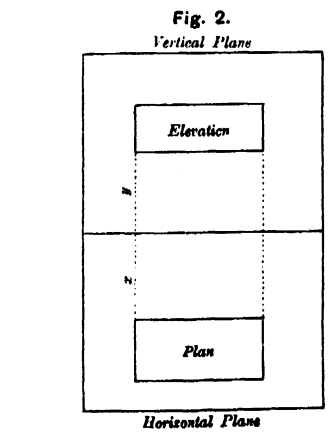
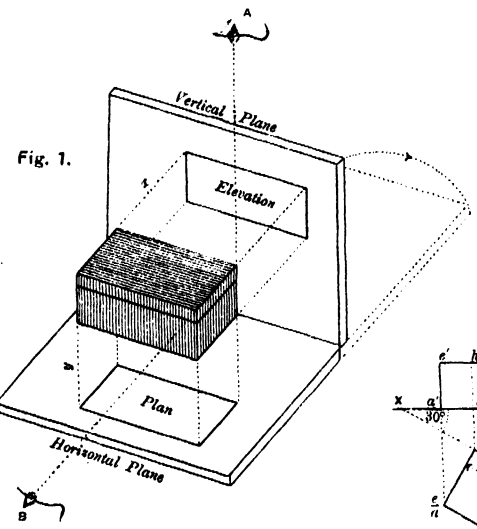

If the plane containing the circle is parallel to the V. P., the plan will be a straight line parallel to the XY line, and equal in length to the diameter, and the elevation will be a circle. If parallel to the H. P. the plan will be a circle and the elevation a straight line.

If the plane containing the circle makes an angle with either plane of projection, one projection will be a straight line equal in length to the diameter, but inclined at the given angle to the XY line; the other projection will be an ellipse, the major axis of which is equal to the diameter of the circle, and will be the projection of that diameter which is parallel to the plane of projection. The direction of the minor axis will vary with the conditions, but having obtained that diameter, whose projection is the major axis, the minor axis can be obtained by finding the corresponding projection of the diameter at right angles to it. The major and minor axis being fixed, the ellipse can be drawn by any of the methods given in Problems 145, 146, etc., or by the method given under Case IV, as in the following example.

Problem 183.—Draw the projections of a circle $1\frac{1}{2}$ inches diameter, when the plane containing it is perpendicular to the V. P., but makes an angle of 45° with the H. P. (Plate XVI, Fig. 1.)

This problem can be treated under Case IV. First draw an auxiliary plan and elevation of a circle parallel to the H. P. and perpendicular to the V. P. The plan as explained above will be the circle $acbd$, and the elevation a straight line $a' b'$ equal in length to the diameter of the circle. (The auxiliary plan is shown in continuous lines in this case to show the points of contact with the projectors more clearly.)

Divide the elevation $a' b'$ into any number of points $1', 2', 3'$, etc., and project these points down to the auxiliary plan. With the point a' as pivot, rotate the elevation into the required position $a'' b''$ making an angle of 45° with the H. P. Project down each of the points $1'', 2'', 3''$, and the points where these projectors meet lines, drawn parallel to the XY line, from the points where the projectors from $1', 2', 3'$, etc., cut the auxiliary plan, are points on the required plan, an ellipse.

Problem 184.—Draw the projections of a cone (diameter of base $1\frac{1}{2}$ inches, height $1\frac{1}{2}$ inches) when the base is inclined to the H. P. at 30° . Also a second elevation on a V. P. inclined at an angle of 60° to the original V. P. (Plate XVI, Fig. 2.)

The first plan and elevation required can be drawn by Problem 183.

To get the second elevation, draw an XY line making 60° with the first XY line. Project up from the plans of the extremities of the major and minor axes. Measure above the new XY line the heights of the corresponding points above the first XY line.

The lines joining the points thus obtained will be conjugate axes of the second ellipse, which is the elevation of the base of the cone in the required position.

From the points 1, 2, 3, etc., on the plan, draw projectors to the second XY line, marking on them heights above the XY line, equal to the heights of the elevations of the corresponding points above the first XY line. By this means a number of points 1", 2", etc., on the new ellipse are obtained, and it can be drawn. If the parallelogram $fhjg$ is drawn about the plan of the base of the cone, and its angular points are projected up to the new elevation, the parallelogram $f''h''j''g''$ is obtained. The ellipse must lie in this parallelogram, and must touch it in the points $a''c''b''d''$, which are the extremities of the conjugate axes.

Examples.

1. Draw the projections of a cube (1 inch side) one face of which is inclined at 35° to the H. P., and an adjacent face being parallel to the V. P.
2. Draw the projections of a cube (1 inch side) one face of which is inclined at 35° to the H. P. and an adjacent face at 45° to the V. P.
3. Draw the projections of a hexagonal prism ($\frac{3}{4}$ inch edge of base, 2 inches length), the axis of which is inclined at 65° to the H. P.
4. Draw the projections of a pentagonal prism ($\frac{3}{4}$ inch edge of base, 2 inches length), the base of which is inclined at 25° to the H. P. and one face at 18° to the V. P.
5. Draw the projections of an octahedron (1 inch side) with one edge resting in the H. P., and the face containing that edge inclined at 20° to the H. P.
6. Draw the projections of a pentagonal prism (edge of base $\frac{3}{4}$ inch, length 2 inches) resting on one edge of the base, the face containing that edge inclined at 30° to the H. P. Also an elevation on a V. P. making 20° with the plan of the edge.
7. Draw the plan of a cube when one of its diagonals is vertical (edge $1\frac{1}{2}$ inches).
8. Draw the projections of a square prism (height 2 inches, breadth 1 inch) when a diagonal of a face is horizontal and it is resting with one of the shorter edges in the H. P.
9. The letter T is $\frac{3}{4}$ inch in section, the projecting arms are half the length of the stem, which is $2\frac{1}{4}$ inches long. Draw the projections when one face of the stem is inclined at 45° to the V. P., and an edge of that face is inclined at 30° to the H. P.
10. A hollow cylinder (height $2\frac{1}{2}$ inches, diameter 2 inches, diameter of hole 1 inch) stands on one end and supports a sphere of $2\frac{1}{2}$ inches diameter. Draw the projection.

11. Four spheres (1 inch diameter) lie on the ground in a pyramid. Draw their projections.

12. Draw the plan of a cylinder (radius of base 1 inch, length 3 inches) resting on a point in the edge of the base, which is inclined at 30° to the H. P., also an elevation when its axis is inclined at 40° to the V. P.

13. The upper face of a cube ($1\frac{1}{2}$ inches edge) forms the base of a regular pyramid (2 inches high). One edge of the cube remote from the pyramid is in the H. P., and the vertex of the pyramid is 2 inches above the H. P. Draw an elevation of the compound solid on a V. P. parallel to one of the slant edges of the pyramid.

14. Draw the plan of a double pentagonal pyramid, consisting of two right pentagonal pyramids each of the following dimensions:—Side of base $1\frac{1}{2}$ inches, height $1\frac{3}{4}$ inches, the line joining their vertices being inclined to the H. P. at 35° .

15. A hexagonal prism (height 2 inches, edge of base 1 inch) supports a tetrahedron, three of whose corners rest on three of the top corners of the prism. Draw the projections.

16. Draw the projections of an octahedron ($1\frac{1}{2}$ inches side) when an axis is inclined at 60° to the H. P. and one edge at 30° to the V. P.

17. Draw the projections of a tetrahedron (2 inches edge) when one of its faces is vertical.

18. A cylindrical bolt ($\frac{1}{2}$ inch diameter, 1 inch height) has a hexagonal nut (edge of base 1 inch, thickness $\frac{1}{2}$ inch). Draw the projection when the axis is inclined at 30° to the H. P., and one side of the nut makes an angle of 20° with the V. P.

19. A cylinder (3 inches long, diameter 2 inches) lies on its side in the H. P., with its axis inclined at 30° to the V. P. A hoop 3 inches diameter lies with one point touching the edge of the base of the cylinder and in a plane perpendicular to the V. P., and making 30° with the H. P. Draw the projections.

20. A rectangular block of wood ($5'' \times 2'' \times 1''$) rests on the H. P., its long side parallel to the V. P. A cylindrical ruler 3 inches long rests on and at right angles to the block, one end resting on the H. P. and 1 inch projecting over the block. Draw the projections.

21. Draw the projections of a hollow octagonal prism under the following conditions:—

Axis of prism inclined at 30° to the H. P., and 45° to the V. P. Length of prism 6 inches, side of octagon $1\frac{1}{2}$ inches, diameter of hole 3 inches. The lower end of the prism to be to the front.

NOTE. —Scale for all the questions, full size.

CHAPTER VII.

SECTIONS OF SOLIDS.

In most Engineering Drawings, unless of a very simple nature, the plan and elevation alone will not give sufficient information to enable the object to be constructed. It will usually be necessary to have details of the interior arrangements, the design, thickness, etc., of walls, floors, beams, etc. These details are obtained by means of sections.

If the object is cut into two portions and the portion nearest the eye removed, the form of the freshly cut surface is called a "*Section.*" The plane by which the object was cut is called the "*Secant Plane.*" If any portion of the exterior of the object can be seen in elevation or plan as well as the section, according as the secant plane is Vertical or Horizontal, the result is termed a "*Sectional Elevation*" or a "*Sectional Plan.*"

The Secant Plane may be either—

1. Perpendicular to one plane and parallel to the other plane of projection.

This is the section most useful in practice, as it gives the true form of the section from which actual measurements may be taken.

2. Perpendicular to one plane and inclined to the other plane of projection.

The section thus obtained is of little practical use, as it does not show the true form of the section; but the latter can be readily obtained by using a new XY line parallel to the secant plane, as shown in Problem 188.

3. Inclined to both planes of projection.

The sections obtained are seldom of any practical use, and will not be dealt with in this chapter.

A section by an inclined secant plane is more useful as an academical exercise than for any other purpose, as it does not show the true shape of the object. *To obtain the true shape, the plane of projection must be parallel to the secant plane.*

The simpler cases of intersections of planes with solids and the resulting sections will only be treated of in this chapter,

Sections by planes perpendicular to one and parallel to the other plane of projection according to the condition given.

The secant plane is represented in plan or elevation by a line, called the Section Line, usually represented by the letters LM. The problem is usually stated thus—"To draw a section or sectional plan or elevation of a given object on a line LM." This means that it is required to show the section or sectional plan or elevation of the object made by a horizontal or vertical plane LM.

It must be remembered, firstly, that the XY line must be drawn parallel to the section line if it is required to obtain the true form of the section; and secondly, that the portion of the object between the observer's eye and the secant plane is assumed to be cut off and removed. No part of it, therefore, can possibly appear in the result.

Problem 185.—The plan of a tetrahedron (1 inch side) is given, one face resting in the H. P., and one edge making 15° with the V. P. Draw a section on a line parallel to the V. P. and $\frac{1}{2}$ inch from the nearest corner of the plan of the tetrahedron. (Plate XVI, Fig. 3.)

Draw the XY line making 15° with the edge ab , and LM, the section line, parallel to the XY line and half-inch from the point c . Project up the elevation. Mark each point where LM cuts each edge of the plan of the tetrahedron by numerals, going round the solid upwards from left to right. (It is most important to follow some principle in this lettering, as in more intricate figures it is easy to get confused.) Now LM cuts ac in 1. Project up from one till the projector cuts $a'c'$ in $1'$. LM cuts dc in 2. Project up from 2 till the projector cuts $d'c'$ in $2'$. Do the same for 3. In the elevation join the points $1'$, $2'$, $3'$, and the result is the required section, showing the true shape. As only the section is asked for, nothing else should appear in the result, but to show the working, the rest of the solid is shown dotted. This would, however, be shown as a "result" if a sectional elevation had been asked for.

Problem 186.—A pentagonal prism ($\frac{3}{4}$ inch edge of base, $1\frac{1}{2}$ inches long) rests with one edge of the base in the H. P. and perpendicular to the V. P., the side containing that edge being inclined at $20'$ to the H. P. Draw a sectional plan on a line LM about 1 inch above and parallel to the H. P. (Plate XVI, Fig. 4.)

In the same way as in the last problem, number consecutively each point where the section line cuts an edge of the solid in elevation, going round the solid from left to right. Project each point down on to the plan of the corresponding line and obtain the section as shown in Fig. 4.

Problem 187.—A cylinder (base 1 inch diameter, height 2 inches) has its axis parallel to the V. P. and rests on a point of the edge of the base in the H. P. The base is inclined at 60° to the H. P. Draw a sectional plan on a line LM,

parallel to the H. P., and passing through the corner of the upper base of the cylinder as shown in elevation. (Plate XVI, Fig. 5.)

On one end on the base in elevation, draw a semi-circle. Draw any number of generators as $a' a'$, $b' b'$, etc., and produce these to meet the circumference of the semi circle in k' , l' , etc.

Figure each point where the line LM cuts a generatrix with the numerals 1', 2', 3', etc., and project these points down on to the plan of the axis of the cylinder. LM cuts $r' v'$ in 1'. Project down 1' on to the plan, and mark the point, obtained 1. LM cuts $a' a'$ in 2', $b' b'$ in 3', etc. Project each point down to the axis and lay off on each side of the axis the heights $a' k'$, $b' l'$, etc., obtaining the points 2, 3, etc. The completed section is an ellipse.

Sections by planes perpendicular to one plane and inclined to the other plane of projection.

The procedure in this case is exactly the same as that already described. Great care should be taken to number the secant points consecutively, going round the solid from left to right. The result, however, does not show the true form of the solid, and to obtain this a second elevation must be made on an XY line parallel to the secant plane.

Problem 188. An octahedron (1 inch side) lies with one face in the H. P. Draw a sectional elevation on a line LM making an angle of 45° with the V. P. Also show the true shape of the section. (Plate XVI, Fig. 6.)

Draw the elevation. Number the secant points in plan, in accordance with the principles laid down, and obtain the sectional elevation. The left hand portion of the solid as shown in dotted lines in the elevation should not appear at all, and is only shown so that the construction may be followed easily.

To obtain the true form, draw an XY line parallel to LM. Project up each of the secant points 1, 2, 3, etc. Now as the same point in every elevation of an object will always be the same height above the XY line, the height above the XY line of each point 1", 2", b'' , etc., can be obtained by measurement from the first elevation, and the true form of the section obtained.

Problem 189.—A hexagonal pyramid ($\frac{1}{2}$ inch edge, $1\frac{1}{2}$ inches height) rests on its base in the H. P. Draw a sectional elevation on a line LM parallel to an edge of the base, and also show the true form of the section. (Plate XVI, Fig. 7.)

This example is worked in exactly the same way as the last, and is only introduced to show (in the next problem) that the section of a cone can be obtained by considering the cone a pyramid of an infinitesimal number of sides.

Fig. 1.

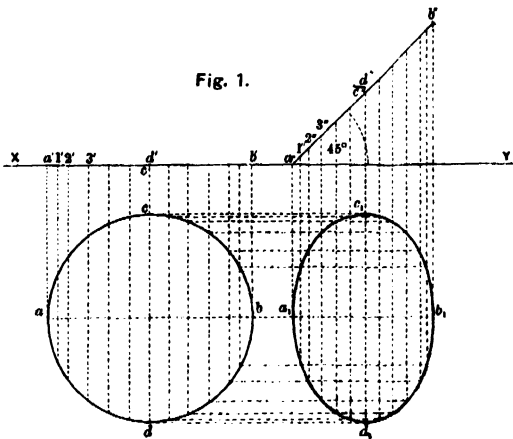

Fig. 2.

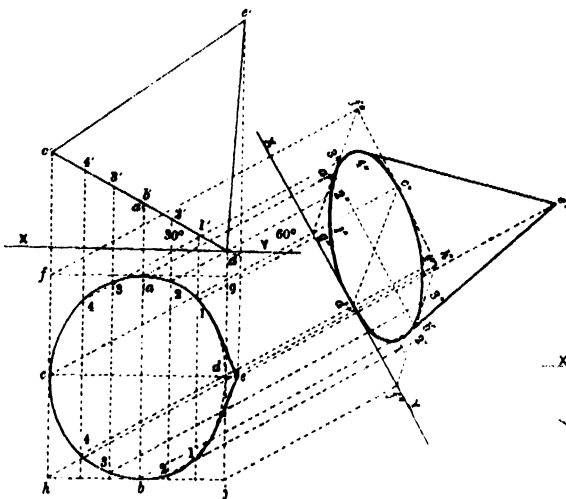

Fig. 3.

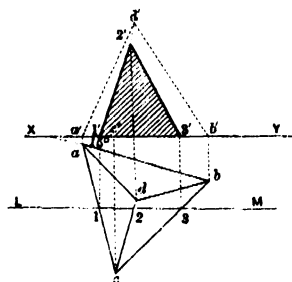

Fig. 6.

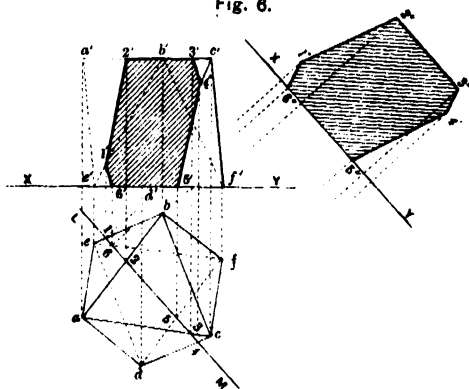

Fig. 4.

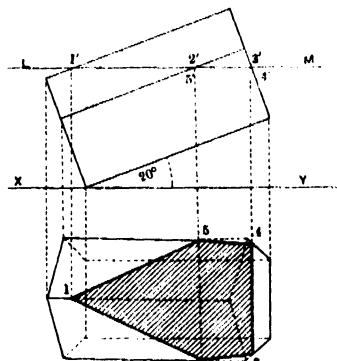

Fig. 5.

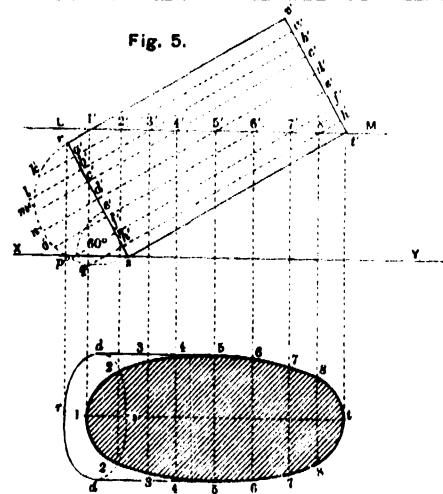

Fig. 10.

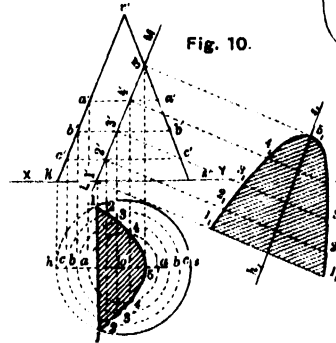

Fig. 9.

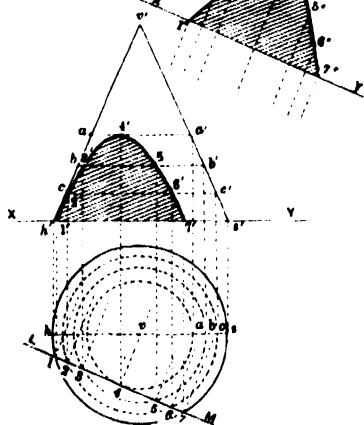

Fig. 7.

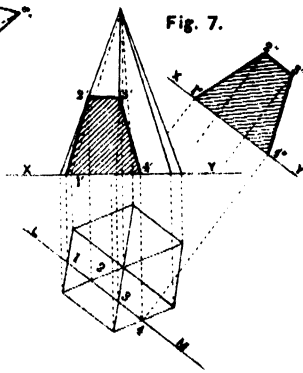
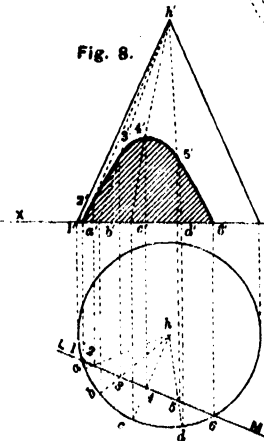

Fig. 8.



Problem 190.—A cone (diameter of base 1.4 inches, height $1\frac{1}{2}$ inch) rests on its base in the H. P. Draw a section on a line LM making 22° with the V. P., and show the true form of the section. (Plate XVI, Figs. 8 and 9.)

Method I.—Regard the cone as a pyramid with an infinitesimal number of sides, and proceed as in last problem. Draw the projections of any number of generatrices ha, hb, hc , etc. Project up the point where LM cuts the plan of each generatrix, till the projector cuts the elevation of the generatrix. These will give any number of points on the curved outline of the section.

Method II.—Regard the cone as composed of any number of concentric circles of various size.

Draw the plans of these circles and project up the points a, b, c , where they cut the plans of the outside generatrices, vs and vh , to the elevations of the generatrices, obtaining the points $a b c$. Through a', b', c' , draw lines parallel to the XY line.

These lines are the elevations of the circles of which the plans have been drawn; and the points where the section line LM cuts the plans of the circles, *viz.*, 1, 2, 3, etc., may be projected up to the corresponding elevations and the points 1, 2, 3, on the curve obtained. The vertex of the parabola is obtained by drawing a circle $a, 4$ to touch the line LM. The true shape of the section may be now obtained in the usual way by taking an XY line parallel to the secant plane.

Problem 191.—A cone (diameter of base 1 inch, height $1\frac{1}{2}$ inches) rests on its base in the H. P. Draw the sectional plan made by a plane perpendicular to V. P., and parallel to one generatrix. Show the true shape of the section. (Plate XVI, Fig. 10.)

Proceed by the method shown in Method II, Problem 190. Draw the plan and elevation of any number of concentric circles a, b, c , etc. Project down on to the plan of each circle the point where LM cuts the elevation and obtain the required sectional plan.

To obtain the true shape strictly in accordance with the "Principle of Rotation" as laid down on page 113, we should now rotate the elevation, keeping the point $1'$ fixed as a hinge till the line LM rests in the H. P., and obtain the true shape of the section by the method used in Problem 181. This, however, is a cumbersome method for the more advanced Students, who should now have grasped the principle. Take a line $h_1 s_1$ parallel to LM to represent hs in its new position. Project down from $1', 2', 3'$, etc., on to $h_1 s_1$ and lay off on each side of $h_1 s_1$ the distances 1, 2, 3, etc., from hs in the plan. The results are points on the curve showing the true section, a parabola.

EXERCISES.

1. A cube (1 inch edge) rests on one face in the H. P. with one face inclined at 20° to the V. P. Draw a sectional elevation on a line passing through the centre points of two adjacent edges of the base.

2. A pentagonal prism (edge of base 1 inch) rests on one long edge (3 inches long). The inclination of one of the faces containing this edge is 20° . Draw a sectional elevation on a line passing through the centre of the edge on which the solid rests, and making 45° with that edge.

3. A pentagonal pyramid (edge of base 1 inch, height 2 inches) rests on its base on the H. P. with one edge of the base perpendicular to the V. P. Draw a sectional plan on a line passing through this edge and inclined at 40° to the H. P. Also show the true form of the section.

4. A square (2 inches edge) is the base of a pyramid. Three faces of the pyramid are inclined at 40° , 70° , 55° . The pyramid rests with its largest face in the H. P., one edge of that face being inclined at 45° to the V. P. Draw a sectional elevation on a line parallel to the V. P., passing through the centre of one of the long edges of the face on which the pyramid is resting.

5. A cone (diameter of base 2 inches, height $2\frac{1}{2}$ inches) has one generatrix vertical. Draw a sectional elevation on a line passing through the centre of the base and perpendicular to the V. P.

6. A cylinder (diameter of base 2 inches, length 3 inches) rests on the H. P., on a point of the edge of a base, which is inclined at 20° to the H. P. Draw a sectional plan on a straight line parallel to the H. P. and passing through the centre of the upper base.

7. An octahedron (1 inch side) has one diagonal vertical. Draw the section on a line parallel to the H. P. and passing through the other diagonal.

8. A cone (diameter of base 2 inches, height 2 inches) rests on its base in the H. P. Draw the sectional plan on a line passing through the edge of the base and cutting the outer generatrix in elevation $\frac{3}{4}$ inch from the vertex. Show the true shape of the section.

9. A pentagonal prism (side 1 inch, height 3 inches) lies on one side in the H. P., and one long edge parallel with the V. P. Draw a sectional elevation on a line bisecting the axis at 50° , and show the true form of the section.

10. Draw from measurement, all plans, sections, and elevations required for the working plans to enable a carpenter to make one of the tables in your class room.

11. A hollow pentagonal prism composed of two concentric pentagonals (edges 2 inches and $1\frac{1}{2}$ inches) is 3 inches long. It is cut into two equal portions by a plane perpendicular to one face and inclined at 45° to a base. Draw the plan of one-half when it is resting on the section end.

12. The base of a pyramid ($2\frac{1}{2}$ inches high) is a square (1 inch edge). The pyramid rests on one of its triangular faces in the H. P. Draw the sectional elevation on a line bisecting the plan of the axis and making an angle of 50° with it.

13. A cylindrical pillar (diameter 1 inch, height 4 inches) rests concentrically on a hexagonal prism (edge 1 inch, height 1 inch). Draw the sectional plan on a line passing through the edge of the upper end of the pillar and the opposite lower edge of the prism, and show the true shape of the section.

14. Draw the sectional plan of a sphere (2 inches diameter) on a line $\frac{1}{2}$ inch from the centre and inclined at 45° to the H. P. Show the true shape of the section.

15. A rectangular block, 4 inches long, 2 inches wide, and 3 inches high, has on each face a circle described with centre at the middle point of the longer side and diameter equal to the shorter side. The block rests so that the projection on the H. P. makes an angle of 35° with the V. P., and the axis of the block makes an angle of 30° with the H. P. Draw the plan and elevation of the block, and also, in a separate figure, a sectional elevation on a plane making an angle of 15° with the V. P. and bisecting the axis of the block.

16. Two equilateral triangular prisms (side of base $1\frac{1}{2}$ inches, length 3 inches) stand on the H. P., each on an edge of the triangular end. If these edges are perpendicular to the V. P., and the faces containing them make 60° with the H. P., and meet at their top edges so as to contain a space in the form of an equilateral triangle in elevation, draw the plan and elevation of the prisms, also a sectional elevation on a plane parallel to the cutting plane, which bisects the line of intersection, and makes an angle of 30° with the V. P. in plan.

17. A cylinder (diameter 2 inches, length $3\frac{1}{2}$ inches) supports the apex portion of a pentagonal pyramid (edge $1\frac{1}{2}$ inches, height $3\frac{1}{2}$ inches) in the centre of its length, which is perpendicular to the V. P. If the pyramid rests on an edge of the base in the H. P., and the face containing this edge makes 45° with the H. P., draw the plan and elevation, also a sectional elevation parallel to a cutting plane, which passes through the centres of the pentagonal base of the pyramid, and the front circular end of the cylinder.

18. An octagonal slab (side $1\frac{1}{4}$ " thickness $\frac{1}{2}$ ") rests with its base in the H. P., and supports a cone (diameter $2\frac{1}{2}$ inches, height 3 inches concentrically. If a pair of the opposite sides of the slab are parallel to the V. P., draw the plan and elevation, also a sectional plan parallel to a plane, which bisects the axis of the cone, and makes 30° with the H. P. in elevation.

19. A cylindrical rivet (diameter of cylinder 2 inches, length $2\frac{1}{2}$ inches) having a hemispherical head, diameter $2\frac{1}{2}$ inches, rests on a point on the vertical circular face of its head in the H. P., so that the axis of the cylinder is perpendicular to the V. P. Draw a sectional elevation of the solid parallel to a cutting plane, which passes through the left hand extremity of the front circular face of the cylinder, and makes 30° with its axis.

20. A cone (diameter of base 3 inches, height 2 inches) rests on its base in the H. P., and supports a pentagonal pyramid (side of pentagon $1\frac{1}{2}$ inches, height $2\frac{1}{3}$ inches) having its base parallel to the H. P. with one side of the base perpendicular to the V. P. If the apices of the two solids meet, and their axes are in one vertical line, draw a sectional plan parallel to a cutting plane, which is perpendicular to the V. P., and intersects the bases of the cone and pyramid at points $\frac{1}{2}$ inch right and left of their left and right hand extremities respectively.

N.B.—Scale for all the questions other than question 10 to be full size Scale for

CHAPTER VIII.

ELEMENTARY PROJECTION OF POINTS, LINES, AND PLANES.

The Student being now familiar with the meaning of Orthographic Projection, the use of the Planes of Projection and the more elementary problems in the Projection of Solids, may now proceed to investigate the more complicated problems which arise in representing on a plane surface objects consisting of a number of intersecting planes and lines of various inclinations.

There are two systems of working out problems in Orthographic Projection —

(i) **THE TRACE SYSTEM.**—In this system each line and plane is represented by its traces in the H. P. and V. P.

The “Traces of a Line” are the points in which the original line cuts the Planes of Projection. The point of intersection with the H. P. is called the “horizontal trace,” that with the V. P. the “vertical trace.”

The “Traces of a Plane” are the straight lines in which it intersects the co-ordinate planes. As in the case of lines, they are distinguished as the horizontal and vertical traces of the plane.

As no two planes can have the same trace, it follows that if the horizontal and vertical traces of a plane are given, the plane can be identified.

(ii) **THE HORIZONTAL OR INDEX SYSTEM.**—In this system objects are fully represented on the horizontal plane, elevations on vertical planes being used, as in the projection of solids, to work out problems when necessary. In buildings, irrigation works, and the representation of ground, by far the greater part of the detail is required on the H. P., and this system will be used in preference to the Trace System.

If an original point A is projected on to the H. P., and the length of the projector is measured, the height of the point above the H. P. is determined. If the height of that point is marked against the plan of the point, the position of the point in space is as fully indicated as if both plan and elevation had been drawn.

In the same way with a line. Suppose the plan *ab* of the extremities of a line AB are obtained, and the lengths of the projectors measured and found to be three and seven units, respectively. If we mark the plans *a*₃,

b_7 , we can at any time obtain all information about the line, such as its true length and its angle of inclination to the H. P., by drawing an elevation on an XY line *parallel to the line itself*, making the point a' three units and b' seven units above the H. P. The elevation then gives the true length of the line, and the angle of inclination the elevation makes with the XY line is the actual angle at which AB is inclined to the H. P.

Thus, in the Index System, a projection on the H. P. need only be made. The information with regard to the V. P. is supplied for each point by numbers, representing the height of that point above the H. P.

These numbers are called Indices. They are generally written below the letter they refer to, as a . If the point is above the H. P., no sign is affixed to the index. If it is below the H. P., the sign (—) is affixed.

If the indices are high numbers, it would be inconvenient in making an elevation to refer them to an H. P. level o . The H. P. may be assumed at any convenient level and figured accordingly; it is then called the "Datum Plane" or "Plane of Reference."

In the actual working, plans of a building, etc., these indices are seldom used, except with reference to ground levels. They would be used in working out any complication in the intersection of planes and lines in the plan, by the methods given in the following problems. Finally, from the indexed plan, all necessary elevations and sections would be drawn for actually working from, and the indices, being no longer required, could be rubbed out.

POINTS.

The Horizontal and Vertical Planes of Projection, commonly called the Co-ordinate Planes, are of indefinite extent, and since they intersect in the XY line they form four quadrants (*see Plate XVII, Fig. 1*).

These four quadrants are known as the first, second, third, and fourth dihedral angles.

So far in the preceding chapter we have only investigated the projection of an object in the first dihedral angle, but it is obvious that portions of the object might lie in any quadrant, according to the position in which we fix the XY line.

Take two pieces of paper and fit them together at right angles, to represent the two co-ordinate planes, forming the four dihedral angles. (*Plate XVII, Fig. 1*.)

Take four points in space A, B, C, D, one in each dihedral angle and draw their projections.

If the two pieces of paper are separated the projections will appear as in *Plate XVII, Fig. 2*.

As explained on page 105, some method is required to show this result on a plane surface such as a sheet of drawing paper. Join the two pieces of paper again at right angles. Rotate the sheet representing the V. P. on the XY line as a hinge, in the direction represented by the arrow, till it lies flat on the paper representing the H. P., and prick the points obtained on the V. P. on to the H. P. The result is as shown in *Plate XVII, Fig. 3*, and is the conventional method of obtaining on a horizontal plane the projection of the four points A, B, C, D, shown in *Fig. 1*, situated in the four dihedral angles.

We have, however, the power of fixing our co-ordinate planes, and consequently our XY line, wherever it is most convenient. In practice, therefore, an object is usually regarded as situated in the first dihedral angle unless otherwise stated. The Student should, however, work out the following examples to see that he thoroughly grasps the principle of the four dihedral angles :—

Examples.

1. A point A is 1 inch below the H. P. and $\frac{1}{2}$ inch behind the V. P.
2. A point B is $\frac{3}{4}$ inch above the H. P. and 1 inch behind the V. P.
3. A point C is 1 inch above the H. P. and $\frac{3}{4}$ inch in front of the V. P.
4. A point D is 2 inches below the H. P. and $\frac{3}{4}$ inch in front of the V. P.

LINES.

The projections of a line are made up by projecting each point of the line.

If the line is a straight line, it lies evenly between its extreme points, and if the projections of the extreme points be obtained and joined up, the projections of the straight line will be found.

If the line is not a straight line, the projections of a sufficient number of points must be obtained in order to get the projections of the line.

The following are the various conditions under which the projections of a line (AB) may be required :—

1. When the line is parallel to both planes of projection. (*Plate XVII, Fig. 4*.) The plan and elevation will both be parallel to the XY line and equal in length to the original line.

2. When the line is perpendicular to one plane and parallel to the other plane of projection. (*Plate XVII, Figs. 5 and 6*.)

One projection will be a point and the other equal to the original line and perpendicular to the XY line.

3 When the line is inclined to one and parallel to the other plane of projection. (*Plate XVII, Figs. 7 and 8.*)

Draw the plan or elevation (as the case may be) inclined at the given angle to the XY line, and project the other plan or elevation parallel to the XY line.

4. When the line is inclined to one and in a plane perpendicular to the other plane of projection This is not so obvious and will be explained in the following Problem :—

Problem 192.—Draw the projections of a line AB ($1\frac{1}{2}$ inches long) inclined to the V. P. at 25° and in a plane perpendicular to the H. P. (*Plate XVII, Figs. 9 and 10.*)

First look at *Fig. 9* which represents the case graphically. It is evident, to get the true lengths of the plan and elevation ab and $a'b'$, we must get a right-angled triangle of which the hypotenuse is the real length AB inclined at 25° to the V. P.

Both projections will be perpendicular to the XY line. In *Fig. 10* draw an indefinite straight line $ba b'$, perpendicular to the XY line, cutting it in a . Draw aB making 25° with this line and equal in length to AB. From B drop a perpendicular Bb' on to the line $ba b'$. Then Bb' is the length of the plan and ab' the length of the elevation of the line AB in the required position, and may be measured off on $ba b'$ from the point a .

In *Fig. 9*, the line CD is shown inclined to the H. P. at 20° and in a plane perpendicular to the V. P.

PLANES.

A plane may be defined as "a surface" such that, if any two points in it are taken, the straight line passing through them lies wholly in the surface. A plane in space is determined, if we are given—

- (1) two right lines parallel or intersecting lying in the plane,
- (2) a point and a right line lying in the plane;
- (3) three points lying in the plane.

As a plane is indefinite in extent, to obtain both projections, a plane must be inclined to one, or other, or both co-ordinate planes, otherwise it is parallel to one of the co-ordinate planes and only one projection is obtainable. Let us take a plane perpendicular to one plane of projection and see how we can obtain its projections.

Problem 193.—Draw a plane inclined at 50° to the H. P. (*Plate XVII, Figs. 11 and 12.*)

Looking at *Fig. 12*, in which the problem is graphically represented, the elevation is obviously an indefinite straight line inclined at 50° to the *XY* line. Draw the elevations of a series of horizontal planes intersecting the given plane at successive equal intervals above the H. P. (say 5 units), in the points 5', 10', 15' etc. These elevations will be straight lines parallel to the *XY* line and 5, 10, 15, etc., units respectively distant from it. In *Fig. 11* project down the points representing the elevations of the intersections of these planes with the given plane, viz. 5', 10', 15'. The plans will be indefinite parallel straight lines perpendicular to the *XY* line and equidistant from each other. These lines are termed "contours" of the plane, and are shown conventionally as double chain-dotted lines. Now draw two parallel straight lines perpendicular to the contours to represent a scale, and figure 0, 5, 10, 15, etc., as in *Fig. 11*. This scale is called the "Scale of Slope," and must always be at right angles to the contours. Conventionally the left-hand line, looking up the scale, is always made thick, and the right-hand line thin.

We have now found a method of determining the projections of any plane. If its Scale of Slope is given, its elevation and inclination to the H. P. can be obtained by making an elevation on an *XY* line PARALLEL to the Scale of Slope.

It must be remembered that the H. P. is always the same; we can only alter its height, but its position is fixed. The V. P., however, can be put up anywhere to suit our convenience, so the only case we need take into consideration is that of a plane of given inclination to the H. P. Of course a problem may be so stated that the plane is inclined at so many degrees to the H. P. and so many to the V. P., thus fixing the V. P. for that problem, but this will not assist us in our practical work, and will not be considered in this Manual.

A plane is, therefore, determined by its inclination to the H. P., as shown by the vertical interval of its contours marked on its Scale of Slope. The distance apart in plan of the contours is called the *Horizontal Equivalent of a plane* inclined at so many degrees at so many unit vertical interval. In *Plate XVII, Fig. 11*, the perpendicular distance in plan between the contours is the Horizontal Equivalent of a plane inclined at 50° at 5 units vertical interval. The Student should thoroughly grasp the above, as he will find it very useful to him when commencing his study of Survey.

A plane is not always expressed in degrees. It is sometimes referred to as a fraction such as $\frac{1}{2}$ (one in two). This means that for every unit

of vertical height, the horizontal equivalent is two units. In other words, the fraction represents the tangent of the angle of inclination.

In the Problems now given, when it is required to "draw a plane," it is the Scale of Slope of that plane which is wanted. In the same way if it is required to draw a line, or find a point, it is the plan of that line or point which is required.

In certain cases freehand drawings are given, showing practically the methods of working out the problems. These should be further explained in Class by models. Although a plane is of indefinite extent, in these practical drawings it is shown bounded by a rectangle.

In all problems and exercises, a uniform scale of 10 units to an inch is used unless otherwise stated.

Each of the ten elementary problems now given are so arranged as to lead up to Problem 204, *Plate XIX*, which is a practical example of the application of each of these problems to a piece of work which any man may be called upon to do in his daily work as an Engineer.

Problem 194.—Through a given line to draw a plane of given inclination. (*Plate XVII, Figs 13 and 14*)

Let a_{10} , b_{20} , be the given line through which it is required to draw a plane incline at 75° . Referring to *Fig. 13*, place a cone, the generatrix of which makes 75° with the base, on an H. P., level (10). Let the height of the cone be 10 units (the difference in level between the two ends of the given line AB). Place the line AB so that the end A (10 units) rests on the H. P. (10), and the end B (20 units) on the vertex of the cone. Then it is apparent that if we rest a sheet of paper representing a plane so that it touches the line AB and rests against the cone it will be the required plane as it is inclined at 75° and contains the line AB.

For the practical construction of this problem turn to *Fig. 14*. Draw an elevation of the line $a_{10} b_{20}$ on an XY line, level (10), parallel to $a_{10} b_{20}$. At the point b_{20} draw the plan and elevation of a cone, the height of which is the difference in level between the two ends of the line (10 units), the inclination being 75° and the vertex at b' . Through a_{10} draw a tangent to the circle which represents the plan of the base of the cone, and through b_{20} a line parallel to the tangent. These are the contours of the required plane P, and the scale can be drawn.

It can further be seen from *Fig. 13* that two planes can be drawn to fulfil the conditions, one on either side of the cone, and the line AB is the intersection of the two planes. The second plane Q is shown in *Fig. 14*.

Fig. 1.

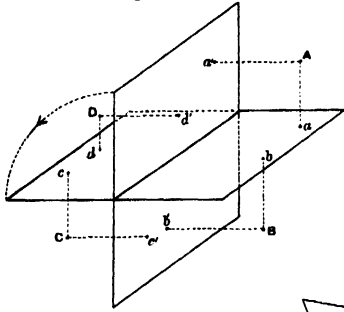

Fig. 2.

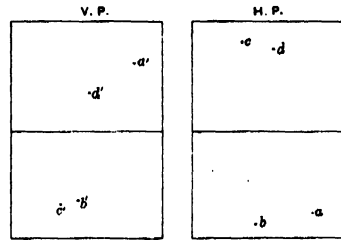

Fig. 3.

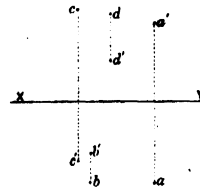

Fig. 6.

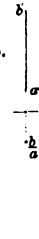

Fig. 7.

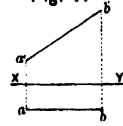

Fig. 8.

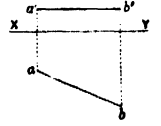

Fig. 4. Fig. 5.

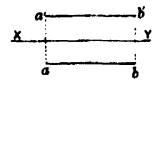

Fig. 9.

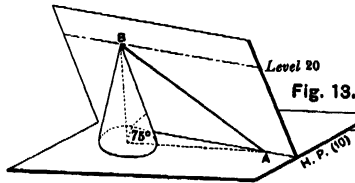
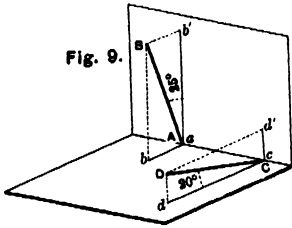

Fig. 11.

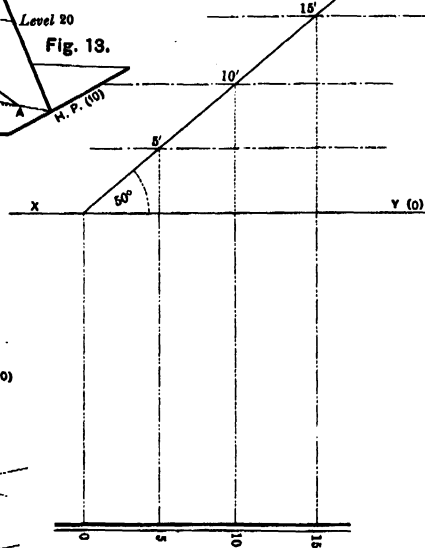

Fig. 15.

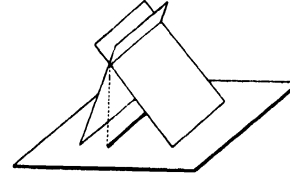

Fig. 16.

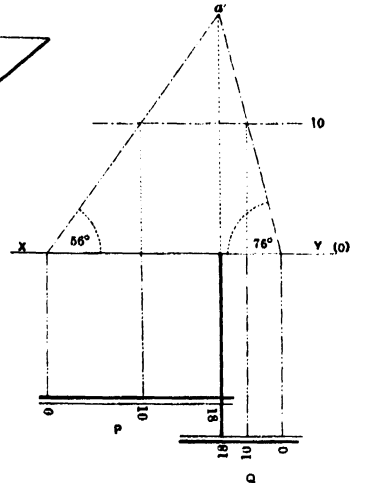

Fig. 10.

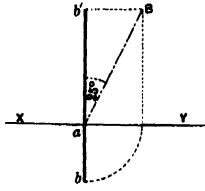

Fig. 14.

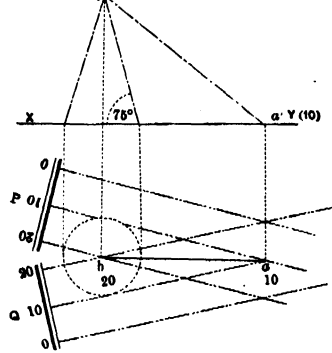
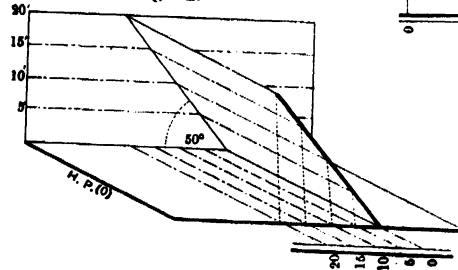

Fig. 12.



Problem 195.—To find the intersection of two planes—

- (i) when the contours of the two planes are not parallel. (Plate XVII, Figs. 13 and 14);
- (ii) when the contours of the planes are parallel. (Plate XVII, Figs. 15 and 16.)

In the first case we have already seen in the last problem that the intersection of two planes, the contours of which are not parallel, is the line joining the intersection of similarly figured contours of each plane. The intersection of the two planes P and Q (*Fig. 14*) is the line $a_{10} b_{20}$.

In the second case, by referring to *Fig. 15*, it will be evident that the intersection of two planes, the contours of which are parallel, is a straight line parallel to the contours. Let the two planes (*Fig. 16*) be P and Q inclined respectively at 56° and 76° . Draw an elevation of the planes on an XY line parallel to the Scale of Slope, and find a' the point of intersection of the elevations. Project down a' on to the Scale Slope of the two planes and figure the point obtained, which is 18 on both Scale of Slope

Problem 196.—Through a given point to draw—

- (i) a plane parallel to a given plane;
- (ii) a line parallel to a given line. (Plate XVIII, Fig. 1)

Let a_7 be the given point and P the given plane, and $b_{13} c_{21}$ the given line.

It is evident that if a plane or line in space is parallel to another plane or line, the plans and elevations must be parallel, therefore the contours and scales of slopes of the planes are parallel, and the contours of both planes are the same distance apart. Further, the indices must rise or fall in the same direction.

Through a_7 (*Fig. 1*) draw a plane Q the contours of which are the same distance apart as those of the given plane P. Index the scale in the same direction.

Secondly, through a_7 draw a line parallel and equal to $b_{13} c_{21}$. Then since the difference in level between the extremities of the given line is 8, the extremity of the new line may be figured d_{15} .

Problem 197.—To pass a plane through two given intersecting lines, or through three points not in the same straight line. (Plate XVIII, Fig. 2.)

The two conditions are obviously identical. Let $a_3 b_9$ and $a_3 c_7$ be two straight lines which intersect at the point a_3 or let $a_3 b_9 c_7$ be three given points. On $a_3 b_9$ find a point d_7 by means of an elevation. Join $d_7 c_7$. This line is the (7) contour of the required plane. Another contour can be drawn through a_3 and the scale graduated.

Problem 198.—Through a given point to draw a line perpendicular to a given plane, and to find the distance of the point from the plane. (Plate XVIII, Fig. 3.)

Let a_7 be the given point and P the given plane inclined at 45° . If a line is perpendicular to a plane, it is evident that its plan must be perpendicular to the contours of the plane, therefore any straight line drawn through a_7 perpendicular to the contours of the plane P will represent the plan of the required line.

To find the distance of A from the plane P we must find the point where the perpendicular from A intersects the plane P. Make an elevation of the point and the plane. Through a' draw a line $a'b'$ perpendicular to the elevation of the plane P and intersecting it in the point b' . Then $a'b'$ is the elevation of the perpendicular drawn from A to the plane P, and b' is the point of intersection. Project b' down on to the plan of the line which can then be indexed b_{13} from the elevation.

Problem 199.—To find the point in which a given line intersects a given plane.

This problem is worked in the same way as the last by making an elevation of the plane and line, and projecting down the point of intersection. It is left as an exercise for the Student.

Problem 200.—In a given plane and from a given point in the plane to draw a line of given inclination. (Plate XVIII, Figs. 4 and 5.)

Let P be the given plane inclined at 45° and a_0 a given point in the plane. It is required to draw in the plane a P from a_0 a line inclined at 30° .

Turn to the sketch (*Fig. 4*). In the plane P place a line AB inclined at 30° to the H. P., and project down the point B where the line cuts the 10 contour of the plane P. Then $a_0 b_{10}$ is evidently the required plan, and further a second line $a_0 c_{10}$ may be obtained fulfilling the same conditions.

To work the problem out on paper turn to *Fig. 5*. Make an elevation of the plane P and the point a_0 . At a' lay off a line inclined at 30° to the H. P., and where this line cuts the level (10) obtain the point b' . Project down b' , then $a'b$ is the plan length of the required line and may be laid off from a_0 between the 0 and 10 contours of the plane P, giving the lines $a_0 b_{10}$ and $a_0 c_{10}$.

It is evident that if the inclination of the line is greater than the inclination of the plane, the problem is impossible.

If the inclination of the line is equal to the inclination of the plane only one line will be obtained perpendicular to the contours of the plane.

TO FIND THE TRUE FORM OF ANY PLANE FIGURE.

We now come to an important principle in Solid Geometry, how to find the true form of any plane figure, and consequently how to measure

Fig. 1.

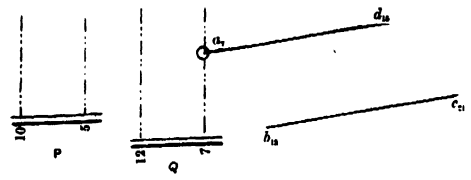

Fig. 6.

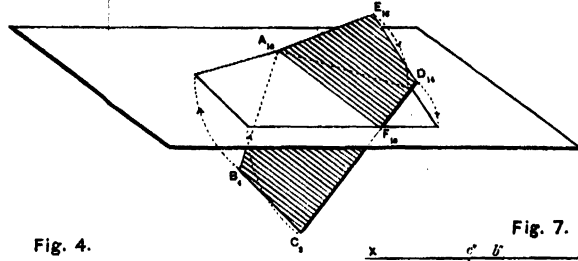

Fig. 8.



Fig. 2.

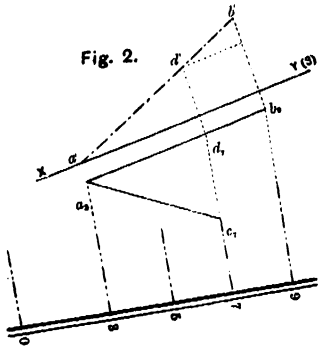

Fig. 4.

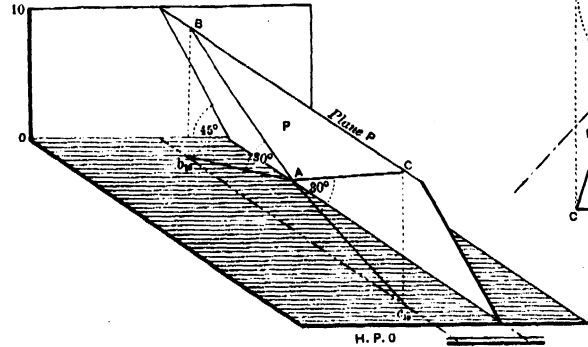

Fig. 7.

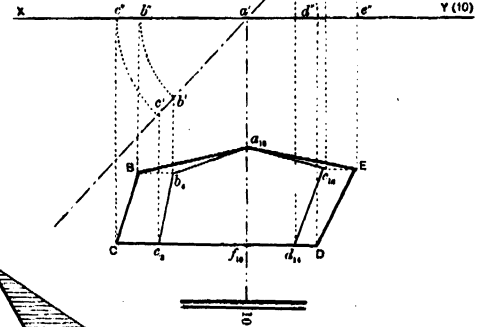

Fig. 9.

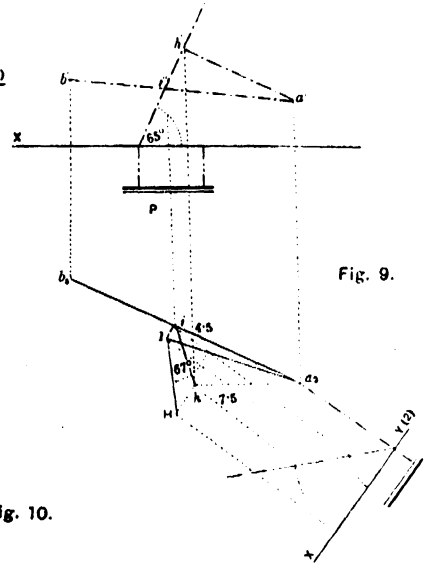

Fig. 3.

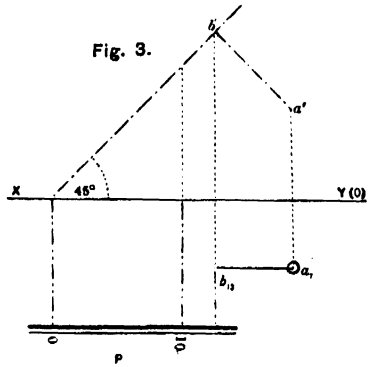

Fig. 5.

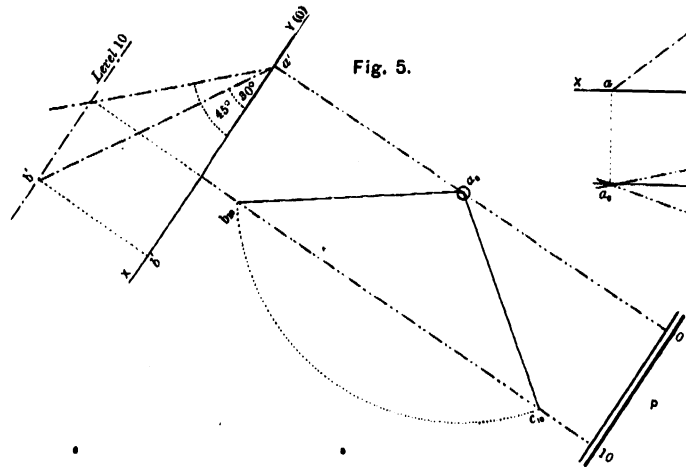
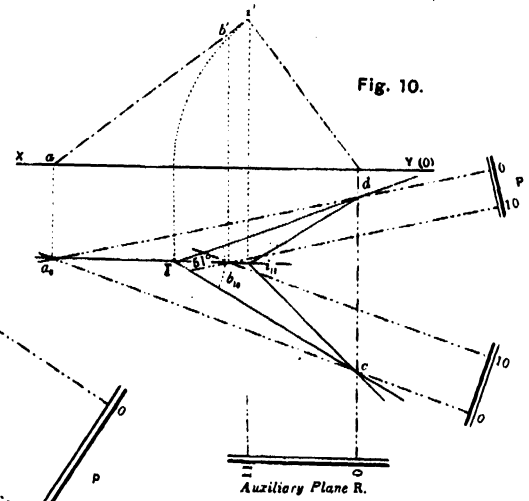

Fig. 10.



the angle between any two right lines or two planes in space. (Compare page 118.) The principle is to find any convenient contour of the plane containing the figure, and using this as a hinge to turn the figure up or down into the horizontal plane of the level of the hinge.

For instance, in *Fig. 6*, take the polygon $A_{10} B_4 C_3 D_{14} E_{18}$. In the edge $C_3 D_{14}$ find a point F_{10} . Join $A_{10} F_{10}$, and using this as a hinge, turn the points E_{18} and D_{14} down, and the points $B_4 C_3$ up into the $H. P_{10}$, thus obtaining the true form of the polygon. This process is termed "Constructing" or "Rabating" a figure. All points in the true form of any figure obtained by "constructing" will be marked by capital letters.

Problem 201.—To find the true form of a given polygon and to measure the angles between the lines bounding the polygon. (Plate XVIII, Figs. 6 and 7).

Let $a_{10} b_4 c_3 d_{14} e_{18}$ be the given polygon. In $c_3 d_{14}$ find the point f_{10} by Problem 197. Join $a_{10} f_{10}$ representing the 10 contours of the plane containing the polygon. Make an elevation of the plane and project up each point obtaining the points $c' b' a' d' e'$. With centre a' (representing the hinge) and a radii $a' b', a' c'$, etc., turn the points $b' c'$, etc., up and down to the XY line, obtaining $b'' c'' d'' e''$. From these points draw projectors down till they intersect with lines drawn through $c_3 b_4 d_{14} e_{18}$ parallel to the XY line. Join the points so obtained, *viz.*, C, B, D, E , and obtain the true shape of the polygon, and the angles between any two lines bounding the polygon can be measured.

Problem 202.—To measure the angle a given line makes with a given plane. (Plate XVIII, Figs. 8 and 9.)

Let $a_2 b_5$ be the given line and P the given plane inclined at 65° .

From a consideration of *Fig. 8*, it is evident that if a perpendicular AH is dropped from any point A in the line AB on to the plane, the angle between the line and the plane is the angle AIH , I being the point where the line intersects the plane. In *Fig. 9*, draw an elevation of the line and plane and find their point of intersection i' . From any point, say a_2 , draw $a' h'$ a perpendicular to the plane. The points i and h can be figured $i_{4.5} h_{7.5}$ from the elevation. Then $a_2 i_{4.5} h_{7.5}$ is the angle the line makes with the plane, and if constructed down into the horizontal plane level 2 (Problem 201), the true form of the angle $a I H$ is obtained and is found to be 67° .

Problem 203.—To measure the angle between two given planes. (Plate XVIII, Fig. 10.)

Let P and Q be the given planes. If the Student makes a model he will see that if we take any auxiliary plane R at right angles to the intersection of the given planes, the intersection lines of the auxiliary

plane and the given planes will give the angle the two planes make with each other. In *Fig. 10* find $a_0 b_{10}$, the intersection of the given planes, and draw its elevation. Draw the elevation of an auxiliary plane perpendicular to $a' b'$, and draw its plan and scale of slope. Find i' the point of intersection of the auxiliary plane R and $a' b'$ and find its plan i . Then $d i c$ is the angle between the two planes P and Q and if constructed into HP (o) gives the true angle $d I c = 51^\circ$.

Problem 204.—Draw the contoured plan of an earthen embankment under the following conditions. (Plate XIX., Fig. I.)

Scale $\frac{1}{120}$; contours 1 foot vertical interval. The ground slopes up from the right-hand top corner of the paper which is level (+ 5) at $\frac{1}{14}$. The top of the embankment is 10 feet broad and parallel to the ground. The left-hand edge of the top of the embankment may be drawn 2 inches from the bottom of the paper and is $7\frac{1}{2}$ feet above ground level. (Line AB.)

From this edge the earth slopes down to the left at $\frac{1}{2}$ for a width of 10 feet. The slope then continues at $\frac{1}{4}$ till it meets the ground. From the right-hand edge of the top of the embankment the earth slopes at $\frac{1}{2}$ till it meets the ground. A berm of 4 feet is left and then comes a borrow pit. The near slope is $\frac{1}{3}$. The bottom of the pit is 3 feet wide, parallel to the ground and everywhere 2 feet deep. A point C , level 8.5 feet is given where the further slope of the borrow pit meets the ground.

There is a road leading perpendicularly through the embankment, 10 feet wide at bottom, with side slopes of $\frac{1}{4}$. The road crosses the borrow pit by a wooden bridge.

At a point D , level 20 in the centre line of the roadway, a wooden pole is to be planted perpendicular to the left side slope of the roadway. Show its point of intersection with the slope.

A pipe line runs from the point E , level 19, to F , level 14. Show the points where it enters and leaves the embankment, and the angles it makes with the slopes on entering and leaving the embankment. From a point G , level 17 on the embankment path inclined at 20, runs down the further slope.

Further, it is required to find the angle the left-hand side slope of the road makes with the further slope of the embankment, and the angles the boundary lines of the left hand side slope of the road make with each other.

The first thing to do is to draw a plane inclined at $\frac{1}{14}$ by Problem 193, No. 5 contour being at the right-hand top corner of the paper. This represents the ground. Draw the line AB for the near top edge of the embankment 2 inches from the bottom of the paper. As this edge is $7\frac{1}{2}$ feet above ground level, the points where it cuts the ground contours 11 and 12 will be levels $18\frac{1}{2}$ and $19\frac{1}{2}$. The levels 16, 17, 18, 19, 20, 21 may now be obtained and marked.

Dealing with the near slopes we now have to pass a plane inclined at $\frac{1}{3}$ through the line AB by Problem 194. The width for this slope is 10 feet which gives the terminating line of this slope. Through this line

pass a plane of $\frac{1}{4}$ by Problem 194 till it intersects with the ground plane.

This intersection line will be obtained by Problem 195. The top of the embankment is parallel to the ground plane and 10 feet wide. Through AB pass a plane parallel to the given ground plane by Problem 196, and obtain the further edge of the top of the embankment.

Through this line pass a plane inclined at $\frac{1}{2}$ and obtain its intersection with the ground plane. The berm is 4 feet wide. The near slope of the pit may then be drawn at $\frac{1}{3}$. The bottom of the pit is 3 feet wide, parallel to ground and everywhere 2 feet deep. The contours of the bottom will, therefore, be continuations of the ground contours but marked 2 feet lower.

Now we are given a point level $8\frac{1}{2}$ on the upper edge of the further slope. Take two points, say 7 and 8, on the further edge of the bottom of the pit, and through these three points pass a plane by Problem 197. Find the intersection of this plane with the ground.

Find the inclination of the plane by Problem 193.

The roadway is 10 feet wide at bottom and perpendicular to the embankment and the side slopes are $\frac{1}{4}$. Draw two lines representing the bottom of the roadway 10 feet apart. Through any two points on these lines obtained by the levels of the ground contours, pass planes inclined at $\frac{1}{4}$, and find their intersections with the embankment.

From the point D, level 20, a pole is to be placed perpendicular to the left-hand side slope of the roadway. The plane of the pole will of course be perpendicular to the contours of the plane, and its point of intersection may be obtained by Problem 198.

The pipe line $E_{10} F_{14}$ may now be put in and its intersection found by Problem 199, and the angles it makes with the slopes by Problem 202. A pathway leads from G, level 17 down the further slope inclined at 20° . This may be done by Problem 200. From a point G_1 place a line inclined at 20° in a plane inclined at $\frac{1}{2}$.

The angle between the left-hand side slope of the road and the further slope of the embankment is 132° , and may be found by Problem 203.

The angles which the boundary lines of the left-hand side slope of the road make with each other may be found by Problem 201. They are starting from the bottom of the paper and going round from left to right, 57° , 143° , 158° , 150° , 32° .

EXERCISES.

1. The plan of a line $a_8 b_{15}$ is $1\frac{1}{2}$ inches long. Find its inclination and true length.

2. Which is the largest, the horizontal equivalent of a plane of 75° or a plane of 25° at 5 units vertical interval?

3. a_7 and b_{31} (2 inches apart) are the plans of two points in space. Find the real distance between the two points in space.

4. Draw the plan of a line AB (2 inches long) when it is inclined at 45° to the H. P., and parallel to the V. P., and also when it is inclined at 90° to the H. P.

5. Draw the scales of slope of planes inclined at 70° , $\frac{1}{4}$ and 20° .

6. The contours of a plane are $\frac{1}{2}$ an inch apart in plan at 5 units vertical interval. Find the inclination of the plane.

7. Draw the projections of a line (3 inches long) inclined at 45° to the H. P., and in a vertical plane inclined to the XY line at 20° .

8. A cube 2 inches square rests with one edge in the H. P., the face containing that edge being inclined at 30° . What is the inclination of its diagonals?

9. A rectangular box is $5'' \times 3'' \times 2''$. Find the length of its diagonal.

10. Through a line $a_3 b_{17}$ draw a plane inclined at $\frac{1}{5}$.

11. The contours of two planes inclined at 45° and 60° intersect at 72° . Find the intersection of the planes.

12. Two planes inclined at 15° and 75° have their contours parallel, and their scales of slope rise in the same direction. Find their intersection.

13. Draw three parallel lines at intervals of 1 inch. The outer ones which are respectively at the levels 10 and 20 are contours of planes which intersect in the third line. The plane passing through the contour 10 is inclined at 60° . What is the inclination of the other plane?

14. A window shade, $10' \times 15'$, slopes downwards from a wall at 40° . Draw another window shade of the same slope 10 feet higher up the wall.

15. The handrail of a straight staircase rises at 30° from level 4 feet to level 24 feet. From a point level 22 feet immediately above the commencement of the first handrail draw a second one parallel to the first.

16. a_{10} , b_{13} , c_{17} are points on the top of the walls of a house and are at the corners of an isosceles triangle. Base $ab=15'$, height of triangle $20'$. Draw the plane of the roof passing through these three points, and find its inclination.

17. Three points a_3 , b_{21} , c_{27} form in plan an equilateral triangle of $2\frac{1}{2}$ inches side. A point d lies in the same plane as the three given points and

is distant on plan 2 inches from a , and $1\frac{1}{2}$ inches from c . Determine the index of d .

18. The base of a telegraph pole 10 feet high is 4 feet from the lower edge of the slope of an embankment inclined at $\frac{1}{4}$. Draw the stay of the telegraph pole which enters the embankment at right angles to the slope.

19. The plan of a line AB, inclined at 35° , makes an angle of 65° with the contours of a plane inclined at 60° . The point B in the line is 5 units vertically above the 0 contour of the plane. Determine the point of intersection of the line and the plane when they are sloping in opposite directions.

20. The points a b c form an equilateral triangle of 3 inches side, a_{30} b_{10} is the plan of a line and b c is the 20 contour of a plane inclined at 45° . Determine the intersection of the line and the plane.

21. The angular points of a square are marked a , b , c , d . Do the diagonals really intersect?

22. An embankment is 30 feet high and its side slopes are $\frac{1}{4}$. Show a road leading down from the top to the bottom inclined at 20° .

23. The contours 0 and 10 of a plane are 1 inch apart in plan. In the plane draw two lines each really 2 inches long, one having the greatest and the other the least possible inclination.

24. Two lines at right angles in plan intersect at a point whose index is 18. One is inclined at 32° and the other at 48° . Each line is really 2 inches long. Determine the inclination of the plane containing the lines.

25. a — c , b — c , d , e are the angular points of a pentagon of 2 inches side. Find its true shape.

26. The plans of two lines a , c_{30} and b , c_{30} are each 2 inches long and intersect at right angles.

Determine the real angle between the lines, and from a point c_{30} draw a line cd (making CD 3 inches long) perpendicular to the plane containing ABC. Measure its length in plan.

27. a , b , c , d are the four corner points of a square of 2 inches side. bd is a contour of a plane inclined at 40° . Find the angle the line ac makes with the plane.

28. The two side slopes of the nose of a stone breakwater are inclined at 60° and 50° . The plan of the top is an equilateral triangle 20 feet side. Find the angle of inclination between the side slopes.

29. Two planes are each inclined at 50° and their contours intersect at 30° . Determine the angle contained between the two planes.

30. The ground slopes from the left-hand upper corner (level 1) of the paper diagonally across at $\frac{1}{18}$ to the right-hand bottom corner. Scale $\frac{1}{80}$. Contours one foot vertical interval. A rectangle $12' \times 15'$ in the centre of the paper represents the top of a mound. The level of three of the corners is 9, 8, 10 in succession. The slopes of the four sides are $\frac{3}{4}$, $\frac{1}{1}$, 30° , 45° . Draw the mound.

CHAPTER IX.

ISOMETRIC PROJECTION.

Isometric projection is a conventional manner of representing objects which have their principal planes at right angles to each other, such as buildings, machinery, etc. The result somewhat resembles a perspective view, with the advantage that the lines situated in three visible planes at right angles to each other, retain their exact relative dimensions, and can therefore be measured by reference to the same scale. For this projection only one drawing is required instead of several, as is the case in Orthographic Projection.

In Isometric Projection the object is always in a fixed and constant position with regard to the plane of projection which is the H. P. This position is such that the three principal rectangular axes or edges of the object (such as the length, breadth, and height of a rectangular prism) shall be equally inclined to the H. P.; and all straight lines coincident with, or parallel to, those axes are drawn in proportion to the same scale. These axes are called Isometric Axes.

The position is best explained by the orthographic projection of a cube resting on a point O in the H. P., the diagonal passing through that point being vertical. (*Plate XX, Fig. 1.*) The plan of the cube in this position is the Isometric Projection of the cube, the three principal rectangular edges, the length, breadth, and height being all equally inclined to the plane of projection. These three edges OX , OY , and OZ are now represented in plan by the lines ox , oy , oz making 120° with each other, and are the three isometric axes.

To obtain the isometric projection of any object it must be placed in this position, and the method is best explained by the following problem:—

Problem 205.—To draw the Isometric Projection of a hollow rectangular prism 2 inches broad, $2\frac{1}{2}$ inches long, and 1 inch high. The prism is $\frac{1}{4}$ inch thick. (*Plate XX, Figs. 2 and 3.*)

First draw the plan of the hollow prism resting on one face and letter it. Take any two *convenient* lines at right angles to each other; in this case the length ab and the breadth ad , and mark them $O_1 X_1$, $O_1 Y_1$, corresponding to two axes. The third axis OZ cannot be shown in this orthographic plan but is an imaginary line $O_1 Z_1$ perpendicular to $O_1 X_1$ and $O_1 Y_1$, and corresponding with the height of the prism. We must now tilt the figure so that it rests on the point O and the axes $O\dot{X}_1$, OY

and OZ_1 are equally inclined to the H. P. Draw three lines (*Fig. 3*) making 120° with each other, and figure them OX , OY , OZ . Draw OZ straight up the paper. These are the three isometric axes. The line ab being coincident with O , X_1 must be measured along OX , ad being coincident with O , Y_1 must be measured along OY . Draw DC parallel to OB and BC parallel to OD , obtaining $OBCD$ the isometric projection of the bottom of the prism.

The height 1 inch can now be set up along OZ and on line drawn parallel to OZ through B , C , and D . The top of the prism can now be drawn parallel to the bottom. To obtain the hollow internal rectangle shown in plan by the points $efgh$, measure from O a $\frac{1}{4}$ inch along OX , and a $\frac{1}{4}$ inch along OY , through the points so obtained draw parallels to OY and OX obtaining the point E . The remainder of the points can be obtained in the same manner, and the isometric projection completed.

THE ISOMETRIC SCALE.

If the Student refers to *Plate XX*, *Fig. 1*, he will notice that the edges of the cube in the isometric projection are somewhat shorter than the real length of the edges. The square $fXhE$ has become the rhombus $f\alpha h e$. The diagonal fh being parallel to the plane of projection remains its original length.

On fh as diagonal describe a square $fXhE$, representing the true form of the face of the cube. Then since the angle Xfh is 45° and the angle αfh is 30°

$$\begin{aligned} \therefore Xf : \alpha f &:: \sin 120^\circ : \sin 45^\circ. \\ &:: \sqrt{3} : \sqrt{2} \end{aligned}$$

which is the relation between the real length of a line and its isometric projection. From this it is apparent that the isometric projection drawn to the natural or orthographic scale in *Fig. 3* is somewhat larger than it should be, and to obtain the true size of the prism, the original length of each line should be reduced in the proportion of $\sqrt{3} : \sqrt{2}$ when plotted on to the isometric projection. To enable us to do this we must have an Isometric Scale.

In practice this is seldom used, and if the natural or orthographic scale is employed all measurements can be taken, and the projection will only be slightly exaggerated. The Student should, however, know how to make an isometric scale if necessary.

Problem 206.—To draw an Isometric Scale. (*Plate XX*, *Fig. 4*.)

Draw a right-angled triangle ABC , of which the side $AB =$ the side $BC =$ one unit (say, 1 inch). Then, since $AC^2 = AB^2 + BC^2$, the

hypotenuse $AC = \sqrt{2}$. Along BA produced measure $BD = AC$. Join DC . Then, since $DC^2 = DB^2 + BC^2 \therefore DC = \sqrt{3}$. Measure the scale of the drawing (in this case 1 inch is taken) along DC , and project each of the divisions on to DB , and draw along DB produced the isometric scale proportional to the natural or orthographic scale measured along DC .

LINES NOT PARALLEL TO THE ISOMETRIC AXES.

The position of these lines must be fixed on the original by means of co-ordinates or offsets referred to the principal axes, and these co-ordinates transferred to the isometric axes as in the case of the point E , Problem 204.

Problem 207.—To draw the isometric Projection of a pentagonal pyramid (1.1 inch edge of base, height 2 inches). (Plate XX, Figs. 5 and 6.) (Natural Scale.)

Draw the plan of the pyramid (*Fig. 5*). Choose any two convenient directions for the axes $O_1 X_1, O_1 Y_1$. To obtain the point B , from b drop a perpendicular bf on $O_1 X_1$. Measure the distance af along OX (*Fig. 6*), and obtain the point F . Draw FB parallel to OY and equal to fb , and obtain the point B . In the same way the other points in the base may be obtained. To find the vertex draw kv parallel to $O_1 X_1$. Make KV' equal to kv , and parallel to OX . From V' draw $V'V$ parallel to OZ and equal to the height (2 inches). Join the vertex V with the points of the base.

If a certain corner, e.g. corner a , is required to be to the front, the axes $O_1 X_1, O_1 Y_1$ must be so placed as to make the point O_1 coincide with the corner a , and each of the axes $O_1 X_1$ and $O_1 Y_1$ inclined at 45° to av , the bisector of the angle eab (*Plate XX, Fig. 5*). To obtain the point B , from b draw a perpendicular bf to $O_1 X_1$. Set off AF equal to af on OX (*Fig. 6*). Draw FB parallel to OY and equal to fb , and obtain the point B . Obtain the other points in the base in the same manner. To find the vertex V proceed as above.

NOTES 1.—The same process will apply to the case of any regular polygon.

2. When a side of the base of any regular polygon is required to be to the front, the point O_1 must coincide with the centre of that side, and each of the axes $O_1 X_1$ and $O_1 Y_1$ make 45° with the bisector of the side.

CURVES.

We will now consider the application of Isometric Projection to curved lines.

The isometric projection of a circle is an ellipse. In *Plate XX, Fig. 7*, $abcd$ is the plan of a cube in the faces of which circles have been inscribed, and *Fig. 8* represents the isometric projection of the cube.

Then, as the projection of one of the diagonals of each face of the cube and consequently one of the diameters of the circle, is of the same size as the original, we have at once the major axis of the ellipse, which the projection of the circle forms, and as the circle touches each side of the square, we have also four points in the conference of the ellipse, and we have only to find the isometric projection of its minor axis. From the intersections of the diagonals of the faces of the cube, set off on the major axes the radius of the circle at a, b, c, d, e, f , and through the points thus obtained, draw isometric lines cutting the minor axes in 1, 2, 3, 4, 5, 6 and we thus obtain the length of the minor axes. The ellipses can then be sketched by hand, or trammelled by a slip of paper. A similar method to this can be employed for determining the isometrical projection of every curve. The principal of the construction is the same as that already indicated for lines not parallel to an isometric axis, and will be fully understood by carefully examining the next problem.

Problem 208.—To draw the Isometric Projection of a padlock with a square staple. (Plate XX, Figs. 9 and 10.) (Natural Scale.)

Choose any two axes O_1, X_1, O_1, Y_1 , and by the aid of a convenient number of co-ordinates sketch in the isometric projection of the base. Each point so obtained must now be lifted the height of the padlock to obtain the finished projection.

EXERCISES.

1. Draw the isometric projection of an octahedron (3 inches edge) lying on one face. Scale, full size (orthographic).
2. Draw the isometric projection of a hollow hexagonal prism (edge of base 2 inches, height 4 inches). The diameter of the bore is 2 inches. Scale, full size (isometric).
3. A stone cross rests on a pedestal of two steps. The lower step is 4 feet square and the next step 3 feet square. They are each 1 foot high. The shaft of the cross is 6 feet high and 1 foot square. One foot from the top the arms of the cross each project 1 foot and are 1 foot square. Draw its isometric projection. Scale 1' to 1" (orthographic).
4. A box is 2 inches long, $1\frac{1}{2}$ inches wide, and 1 inch high. It has a lid semi-circular in section. Draw the isometric projection when the lid is open at an angle of 30° . Scale, full size (orthographic).
5. A cube of 3 inches edge has its top edge bevelled off to an angle of 45° , so that its top face becomes $1\frac{1}{2}$ inches square. Draw its isometric projection. Scale, full size (orthographic).
6. A rectangular wooden case is 2 feet 6 inches high, the top being 1 foot 6 inches square. It is supported by four legs at the corners 1 foot

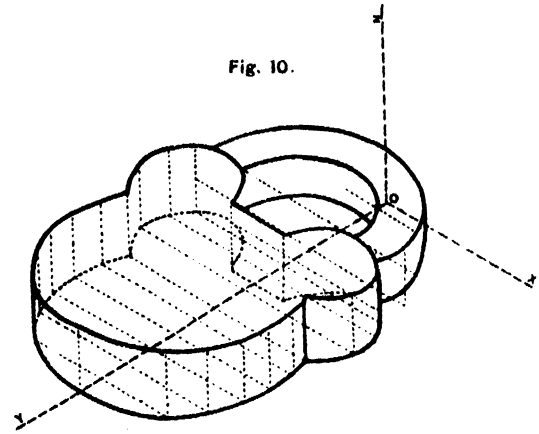
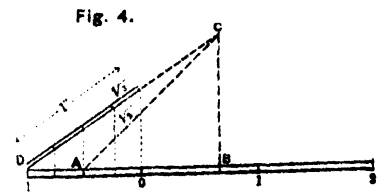
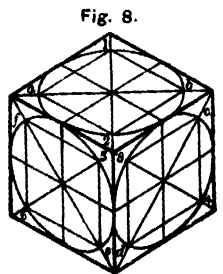
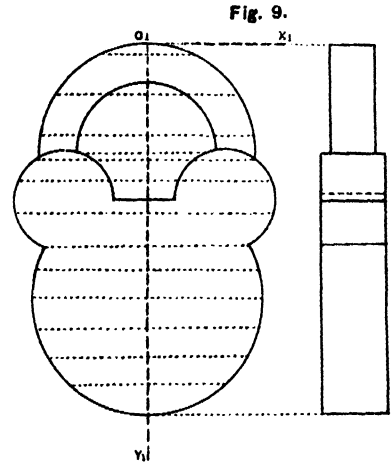
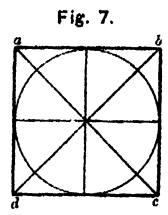
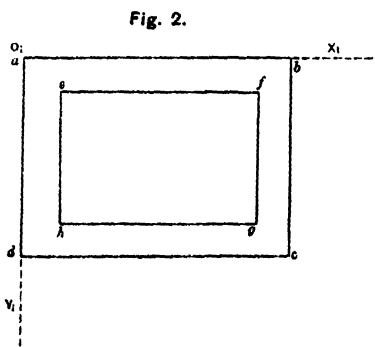
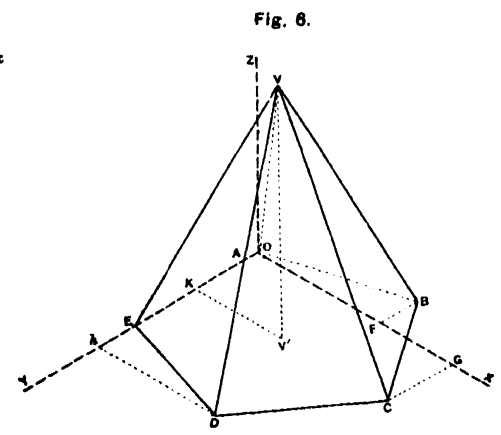
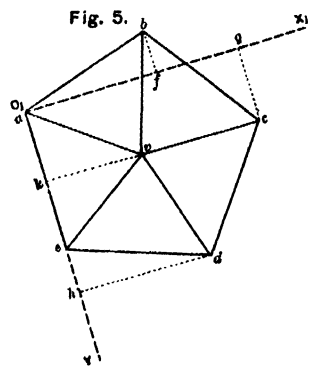
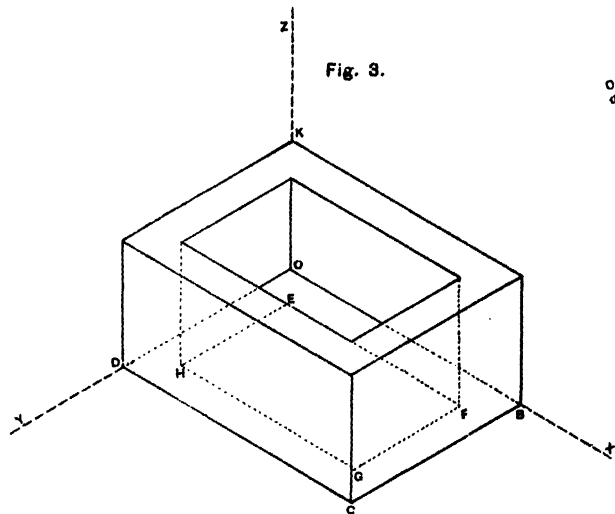
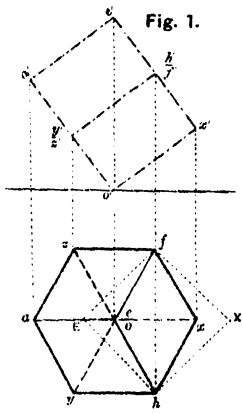

long and 2 inches square. At the top is a circular hole 1 foot in diameter, and in the middle of each side is a rectangular opening 4 inches high and 6 inches square. Draw an isometric projection neglecting the thickness of the wood. Scale, 1' to 1" (orthographic).

7. A carpenter's tray is 7 inches long and 5 inches broad and $3\frac{1}{2}$ inches high. The wood is $\frac{1}{2}$ inch thick. There is a central partition across it $\frac{1}{2}$ inch thick. In the left-hand portion fits a tray $3\frac{1}{4}'' \times 4\frac{1}{2}'' \times 2''$ deep, being let into the wood by cutting a quarter of an inch off as a support to the tray. The tray is divided into two equal parts by a partition $\frac{1}{2}$ inch thick. Draw an isometric projection. Scale, $\frac{1}{2}$ size (orthographic).

8. Draw an isometric view of an ordinary stool from measurement. Scale, $\frac{1}{2}'$ to 1" (orthographic).

9. Make out an isometric view of the drawing table given in question 10, page 114. Scale, 1' to 1" (orthographic).

10. Draw an isometric view of the solid given in question 15, page 109; (a) when a corner of the hexagonal base is to the front, (b) when a side of the hexagonal base is to the front. Scale, full size (orthographic).

CHAPTER X.

THE APPLICATION OF CONTOURS TO THE DELINEATION OF SLOPING GROUND.

Problem 204, Chapter VIII, shows how to delineate by the means of contours any object bounded by intersecting planes. These contours may be regarded as the plans of the outlines traced on the object by a series of horizontal secant planes at fixed equal vertical intervals. It, therefore, follows that contours would be a useful method of delineating any object even though it is not bounded by intersecting planes; and they are the foundation of most methods of delineating hilly or sloping ground.

The use of contours to show the undulations of the ground can be seen at a glance by reference to *Plate XXI, Fig. 1.*

In practice, the contour lines of any portion of ground are obtained by fixing a series of points on the ground at certain levels by means of a levelling instrument, the manipulation of which belongs to the study of Surveying (*see Survey Manual, page 231*). These points are then plotted on paper, each series being the requisite vertical distance apart. It follows then that by joining up these points, we obtain a series of curves, approaching or receding from each other, according as the ground between them is more or less steep; since, for the same vertical interval, the contours will be evidently much closer together in plan, when the ground is steep, than when the slope of the ground is gentle. Further, the nearer the horizontal secant planes are taken to each other, the more accurate will be the representation of the ground in question. A contoured map thus shows the absolute height of any point above a particular level and its relative height with reference to any other point. Besides this contours show the shape of a hill, whether it is convex or concave in section and the exact degree of slope whether gentle or steep.

Plate XXI, Fig. 2, shows a contoured plan of a piece of country.

It will be seen that it would be impossible to determine whether a contoured plan represents a depression or an elevation unless the contours are numbered. It is, therefore, necessary to select some convenient level, called the datum line, from which all heights should be measured and numbered. It is, therefore, usual to assume a level as "datum" which is below the lowest point of the ground shown in the sketch, and to draw

all sections with reference to this, so that all relative heights of the ground may be compared. This is done so that all altitudes on the sketch may be above the datum and positive, and not below and negative.

As contours are horizontal and at equal vertical intervals, it follows that one contour cannot join another unless there is a vertical precipice. In this case the contours which disappear or run into each other will reappear where the precipice ends as at C. (*Plate XXI, Fig. 2.*)

If a contour forms a ring which does not enclose any other, it may be assumed that it represents the top of a hill, as the only other form it could represent would be the interior of an inverted cone, such as a crater or bed of a lake.

In projects for roads and railways, it is generally necessary to make a section along the proposed line.

A section shows all the elevations and depressions, and whether one point is visible from another, and the amount of cutting and filling required. In drawing sections it is usual to exaggerate the heights so as to show more strikingly the changes of a slope which in a true section would hardly be perceptible. In such a case a section does not give a true picture of the height of the ground. The exaggeration or proportion of the vertical to the horizontal scale should be stated underneath the section as "heights to distances 5 to 1."

Problem 209.—Draw the section elevational on the line AB of the ground shown in *Plate XXI, Fig. 2.* (Scale $\frac{1}{4}$ inch = 10 feet.) Heights to distances 4 to 1.

Take an XY or datum line parallel to AB of a convenient height (*o*). The contours are 5 feet vertical interval, and are to be exaggerated in the section in the proportion of 4 to 1.

Draw a series of equidistant lines parallel to XY to represent the contour planes at intervals corresponding to the conditions. That is, $5 \times 4 = 20$ feet. The scale is $\frac{1}{4}$ inch = 120 feet to the inch. Therefore—
 $120 : 20 :: 1 : \cdot 166$.

These lines must be drawn $\cdot 16$ inch apart and figured from 0 to 40. Now project each point where AB cuts the contours down to the XY line, and mark the points where the projectors cut parallel lines of similar index. Join these points up to obtain the section. The elevation can be obtained in the same manner. The standard method of drawing a section for a Road or Railway Project can be seen in the *Survey Manual, Plate XV*, and in more detail in *Enclosure IV* of the Rules for the preparation of Railway Projects obtainable from the Technical Section, Simla.

The method of representing ground by means of contours is so similar to the conditions investigated in Chapter VIII, that the problems therein given will be found constantly applicable to questions of contoured maps. The practical application of Problem 200 is so important, in enabling us to lay down at once on a contoured map, the direction of a road which is not to exceed a certain gradient, that an example is given.

Problem 210.— From the point A (Plate XXI, Fig. 3) trace the course of a road which shall not exceed the gradient of $\frac{1}{20}$. (Scale, $\frac{1}{4800}$)

The vertical interval being 10 feet. The horizontal equivalent for $\frac{1}{20}$ will be 200 feet. The scale is 400 feet to an inch, so we can take the distance of half an inch on the compass and lay it off between contours. The horizontal distance between A and contour 10 is more than 200 feet, so we can draw Ab perpendicular to the contours. From b draw an arc cutting contour 20. The arc will cut the contour in two points; so there are two directions the road may take. Continue the same process for each contour till the top of the hill is reached. It will be remarked that there are probably two possible directions for the road as each contour is crossed, but the selection of the actual line will depend on the conditions under which the road is being made and need not be discussed here.

INDEX.

A

Acidified Ink Process, 34.
Aniline Printing Process, 32.
Areas, 86.
Arches, 43, 90.
Architecture, orders of, 93.
Archimedian Spiral, 94.

B

Beam Compasses, 15.
Bread, the use of, 1, 38.
Block Printing, 36.

C

Carbon, Modified Process, 34.
Cavetto, 92.
Circles, 68.
Circles touching Lines and Circles, 69.
Circumscribed Figures, 79.
Comparative Scales, 51.
Compasses, 5.
Cone, 102.
Constructing a figure, 125.
Contour, 100.
Contours applied to ground, 136.
Conventional Signs, 44.
Cube, 102.
Curves, French, 13.
Cylinder, 102.
Cymatium, 92.
Cyma recta, 92.
Cyma reversa, 92.

D

Datum plane, 118, 136.
Definitions, Plane Geometry, 59.
Diagonal Scales, 53
Dodecahedron, 102.
Drawing Pen, 5
Drawings, Copying and Reducing, 16
———, Geometrical. Rules for, 85, 59.
———, Instructions for the preparation
of, 40.
———, required, 43
———, Rules for lettering, 100.
Drawing Paper, 1, 40.
———, flattening out, 1.
———, mounting on boards, 3.
———, mounting on canvas, 3.
———, standard sizes of, 2.
———, wetting, 1.

E

Echinus, ovolo, 92
Eidograph, 18.
Elevations, 44, 100, 110.
Ellipse, 87.
Exercises on areas, 86.
——— Circles, 72.
——— Circumscribed figures, 79.
——— Inscribed figures, 78.
——— Isometric Projection 134.
——— Lines and Angles, 63.
——— Lines and Planes, 127.
——— Points, 119.
——— Polygons, 68.
——— Quadrilaterals, 68.
——— Scales, 55.
——— Sections of Solids, 114.
——— Projections of Solids, 108.
——— Triangles, 65.

F

Ferric-Chloride Process, 33.
Ferro-Gallate Process, 29.
Ferro-Prussiate Process, 22.
Ferrotypes and other Printing Processes,
22.
Fillet, 92.
Flat washes, 40.

G

Gelatine Process, 33.
Geometrical Drawing, Rules for, 38.
Grecian mouldings, 92.

H

Horizontal system, 117.
Hyperbola, 69.

I

Icosahedron, 102.
Index system, 117.
India-rubber, the use of, 1.
Indian Ink, 4.
Indices, 118.
Inscribed figures, 72.
Instruments, Drawing, 5.
Intersection of planes, 123.
Ionic volute, 95
Isometric Axes, lines not parallel to, 133
——— Curves, 133.
——— Projection, 97, 131.
——— Scale, 132.

L

Lens for copying drawings 21.
 Lines, 119
 Lines and angles, 61.
 Line of Chords, 11.
 ——— Lines, 10.
 ——— Polygons, 11.

M

Marquois' Scales, 8.
 Modified Carbon Process, 34
 Mouldings, 92.
 Mounting Drawing paper on boards, 3
 ——— Drawing paper on canvas, 3.

O

Octahedron, 102.
 Ogee, 91.
 Orthographic Projection, 98
 Ovolo, 92.

P

Pantagraph, 17.
 Parabola, 89
 Parallel Rulers, 6.
 Pen, Drawing, 5.
 Pencil, 4.
 Perspective, 97.
 Plain Scales, 49
 Planes, 120
 Plane Geometry, 59.
 Planes of Projection, 97.
 ——— Reference, 118
 Plan, 43, 98, 99.
 ——— sectional, 110
 Points, 118.
 Polygons, 66
 Positive Cyanotype Process, 27.
 Printing, 36, 42.
 Prisms, 102.
 Process work, copying plans by, 22.
 Profile, 100.
 Proportion, 80.
 Proportional Compasses, 12.
 Protractor, 6
 Projectors, 97
 Pyramids, 102.

Q

Quadrilateral figures, 66.

R

Rabattting, 125.
 Ratio and Proportion, 80.
 Representative Fraction, 48.
 Roman Mouldings, 92.
 Rules applicable to all Geometrical drawings, 38.

S

Secant Plane, 110.
 Sections, 43, 99, 110, 137.
 Sectional elevation, 43.
 Sector, 9.
 Set-squares, 13.
 Scales, 40, 46.
 Scale of Chords, 7,
 ——— Slope, 121.
 Scotia, 92.
 Shadows, 44.
 Solids, regular, 102
 ——— of Revolution, 102, 106.
 Sphere, 102
 Spirals, 94.
 Squares, copying drawings by means of, 20.

T

T-Square, 13.
 Tetrahedron, 102.
 Tints, choice of, 41.
 Torus, 92.
 Trace System, 117.
 Tracery, 90.
 Tracing cloth, 2, 41.
 ——— paper, 2.
 Triangles, 63.
 True form of any plane figure, 124

V

Vernier Scales, 54.
 Volute, Ionic, 95.

X

XY-Line, 100.

