

**TEXT FLY WITHIN
THE BOOK ONLY**

UNIVERSAL
LIBRARY

OU_158456

UNIVERSAL
LIBRARY

OSMANIA UNIVERSITY LIBRARY

Call No. 536.6/S97.M. Accession No. 324

Author

Title

This book should be returned on or before the date last marked below.

MICROCALORIMETRY

by

W. SWIETOSŁAWSKI

*Professor in absentia of Physical Chemistry
of the Institute of Technology, Warsaw
Senior Fellow, Mellon Institute, Pittsburgh, Pa.*

REINHOLD PUBLISHING CORPORATION

330 West Forty-second St., New York, U. S. A.

1946

COPYRIGHT, 1946, BY
REINHOLD PUBLISHING CORPORATION

All rights reserved

Printed in the United States of America by
THE HADDON CRAFTSMEN, INC., SCRANTON, PA.

To the Nation of Poland—the
country that fought to the end,
was tortured, crucified and shall
rise again from the dead.

Preface

The purpose of this book is to give a comprehensive description of the methods used in measuring small amounts of heat developed by different objects. There have been a few books published on calorimetry, but none on microcalorimetry. As the application of microcalorimetric measurements has increased steadily, the appearance of this book may be timely. Microcalorimetric measurements have been employed recently in physics, in physical chemistry, in physiology and in biology. In addition, they have found applications in metallurgy, in the cement industry and in other industrial research. It is expected that a wider application of this method lies ahead.

After the manuscript of this book had been written, Volume I of "Physical Methods of Organic Chemistry," edited by Dr. A. Weissberger and published by Interscience Publishers, Inc., New York, N. Y., appeared. It contains an excellent presentation of "Calorimetry" by Dr. J. M. Sturtevant. It is the belief of the writer that it would be useful to the reader to be acquainted with that chapter before reading this volume. In this way two somewhat different presentations of similar and sometimes identical methods may be studied. Some historical details given in § 16 of this book may be interesting because they are not known to the majority of American chemists.

The writer wishes to explain how it was possible for him to write three books dealing with quite different subjects. In fact, "Coke Formation Process and Physicochemical Properties of Coals" and "Ebulliometric Measurements" pertain to subjects which are quite different from those associated with measurements of very small amounts of heat. The explanation is very simple. After Poland was reborn in 1918, and the writer started his work in Warsaw, he was surrounded for twenty years by his young friends, boys and girls, whose only desire was to contribute in any possible manner to the development of science and industry in Poland. This was merely the consequence of the liberation of a nation after 150 years of lack of political freedom and independence. According to the writer's conviction, his duty was to give the young generation in Poland not one but several fields in which they could develop their own creative power. In that way teamwork was developed in two places—at the Physicochemical Laboratory of the Institute of Technology and at the Chemical Research Institute, both in Warsaw—so that problems dealing with "Ebulliometry," "Thermochemistry" and "Microcalorimetry" were

studied at the Institute of Technology, and "Physicochemical Properties of Coals" at the Chemical Research Institute. The enthusiastic support given to the writer by those young friends is responsible for the appearance of the three books written in the United States during World War II. The writer was the coordinator and the "prior" of the fraternity that wanted to build a great Poland through development of science.

I wish to extend my gratitude to Dr. W. A. Hamor who encouraged me to publish this book. I express my thanks to my friends Drs. J. R. Anderson, H. R. McGraw and R. Smoluchowski for their valuable help and suggestions resulting from reading the manuscript and the proof. I extend my gratitude to all my associates and friends in Poland who contributed in developing some of the microcalorimetric methods described in the following pages.

I am grateful to Mr. G. G. Hawley of Reinhold staff for editorial help.

W. Świątosławski

Mellon Institute, Pittsburgh, Pa.

May, 1946

Contents

	PAGE
PREFACE.....	v
CHAPTER I. MICROTHERMAL PROCESSES OF LONG AND SHORT DURATION	
1. Microcalorimetric Measurements.....	1
2. Thermal Processes of Long Duration.....	2
3. Classification of Thermal Processes of Long Duration.....	4
4. Thermal Processes of Short Duration.....	9
CHAPTER II. CALORIMETER JACKETS, THERMOSTATS AND THERMOMETERS	
5. Jackets Protected by Insulation.....	10
6. Adiabatic and Isothermal Calorimeter Jackets.....	10
7. Constant-temperature Room.....	11
8. Thermostats Used in Microcalorimetry.....	13
9. Multi-jacket Thermostats.....	20
10. Precise Determination of the Average Temperature of the Thermostat.....	21
11. Electrical Resistance and Mercury Thermometers Used in Microcalorimetry.....	25
12. Thermocouples and Thermopiles.....	26
13. Galvanometers.....	27
CHAPTER III. METHOD OF COMPARATIVE MEASUREMENTS	
14. Comparative Measurements in Physics.....	28
15. Method of Comparative Measurements in Physical Chemistry.....	28
16. Comparative Measurements in Thermochemistry.....	28
17. Absolute and Comparative Measurements.....	32
18. Comparative Measurements in Microcalorimetry.....	32
19. Temperature Measurements.....	33
20. Elimination of the Correction for Heat Gains or Losses.....	34
21. Processes of Short Duration.....	35
22. Energy Equivalent of the Calorimetric System.....	35
23. Compensation Method.....	37
24. Method of Successive Comparative Measurements.....	38

	PAGE
25. Reference Substances.....	39
26. Use of Comparative Measurements for Studying Endothermal Processes.....	39
27. Conclusions.....	41
 CHAPTER IV. TWIN MICROCALORIMETERS USED IN RADIOLOGY	
28. First Determinations of Heat Developed by Radium.....	42
29. Compensation Method.....	43
30. The Use of Standard Radium Preparations.....	44
31. Twin Microcalorimeters with Electrical Resistance Thermometers.....	44
32. Ether Twin Microcalorimeters.....	46
33. Differential Method for Measuring the Heat of Absorption of Gamma Rays.....	49
34. General Discussion.....	51
 CHAPTER V. USE OF THE ICE CALORIMETER IN MICROTHERMAL MEASUREMENTS	
35. Application of the Ice Calorimeter in Radiology.....	53
36. Precht's Determination of Heat of Absorption of Radium Radiation.....	54
37. Experiments with Twin Ice Calorimeters.....	54
38. Secondary Phenomena Inside the Ice Calorimeter.....	55
39. Ice Calorimeter for Microthermal Measurements.....	59
40. Freezing the Thin Layer of Water and Refilling the Jacket with Ice.....	64
41. Blank Experiments.....	65
42. Heat Produced by Pitchblende.....	66
43. Behavior of Rare Elements.....	68
44. Specific Heat of Minerals and Salts Containing Rare Elements	69
45. General Discussion.....	70
 CHAPTER VI. TIAN'S INVESTIGATIONS IN MICROCALORIMETRY	
46. Peltier's Effect as Compensation Factor.....	71
47. Fundamental Equation.....	72
48. Tian's Microcalorimeter.....	74
 CHAPTER VII. MICROTHERMAL MEASUREMENTS OF PROCESSES OF SHORT DURATION	
49. Heat of Dilution of Electrolytes.....	76
50. Microcalorimeters for Measuring the Heat of Solution.....	76

CONTENTS

ix

PAGE

51. Results Obtained in Lange's and Gucker's Measurements	91
52. General Discussion	92
53. Microcalorimetric Measurements of Heat of Absorption	92
54. Hill's Investigations on Heat Produced by Nerve	95
55. Whipp's Theoretical Considerations on Microcalorimeters	100

CHAPTER VIII. ADIABATIC MICROCALORIMETER

56. Adiabatic Method in Macrocalorimetry	102
57. Temperature Measurements in the Adiabatic Macrocalorimeter	103
58. Adiabatic Microcalorimeter	103
59. Simplified and Improved Adiabatic Microcalorimeter	106
60. Calculation of the Heat Developed	108
61. Correction for Heating the Air	109
62. Correction for Heat Gains or Losses	111
63. Thermal Inertness of the Calorimetric System	112
64. Use of the Method of Comparative Measurements	113
65. Twin Adiabatic Calorimeters	115
66. Accuracy of Measurements	115
67. Applicability of the Adiabatic Method	117
68. Heat Developed by Radioactive Elements	118
69. Adiabatic Microcalorimeters for Measuring the Heat Produced by Gamma Rays and Beta Particles	121
70. Specific Heat Determination of Solid and Liquid Substances	126
71. Determination of Heat of Vaporization and Adsorption	127
72. Application of the Adiabatic Microcalorimeter in Biology	132
73. Heat of Setting of Cements	132

CHAPTER IX. STATIC AND KINETIC METHODS OF MICROTHERMAL MEASUREMENTS

74. General Discussion	134
75. Cooling and Heating Curves of Thermally Inert Massive Blocks	134
76. Cooling and Heating Curves of a Thermally Active Block	135
77. General Scheme of the Apparatus	137
78. Static Method of Microthermal Measurement	139
79. Kinetic Method Based on Measuring the Rate of Heating Under Adiabatic Conditions	142
80. Kinetic Method Based on Examination of Cooling and Heating Curves	144
81. Determination of Heat Developed by Pitchblende	147
82. Heat Produced by Changes in the Internal Structure of Lead	148
83. Thermal Stability of Nitrocellulose Artillery Powders	150

	PAGE
84. Heat of Aging of Aluminum Alloys.....	151
85. Applicability of the Static and Kinetic Methods.....	153
86. Asymmetry in the Cooling and Heating Curves.....	153
87. Elimination of Corrections.....	156
 CHAPTER X. LABYRINTH FLOW CALORIMETER	
88. Junkers' Flow Calorimeter.....	159
89. Labyrinth Flow Microcalorimeter.....	159
90. Improved Labyrinth Flow Calorimeter.....	162
91. Applicability of the Labyrinth Flow Calorimeter.....	165
92. Possibility of Replacing Water with Air.....	166
93. Application of the Method of Comparative Measurements....	166
94. Accuracy of the Labyrinth Flow Calorimeter Method.....	167
95. Application of Labyrinth Flow Calorimeter for Measuring the Heat of Hardening of Cements.....	167
96. Thermal Characteristics of Three Different Cements.....	171
97. Heat of Mixing of Cement with Water.....	173
98. Determination of Heat of Vaporization.....	173
99. Application of Labyrinth Flow Calorimeter in Physiology and Biology.....	174
100. Application of the Labyrinth Flow Calorimeter for Measuring the Heat Developed by Plants and Animals Living in Water	175
101. Conclusions.....	175
 CHAPTER XI. THE CHOICE OF A METHOD	
102. Variety of Microthermal Processes.....	177
103. Processes of Short and Long Duration.....	177
104. Specification of Thermal Processes of Long Duration.....	177
105. Survey of Processes of Long Duration and of Methods Employed	178
106. Use of Adiabatic Jackets in Microcalorimetry.....	182
107. Use of Isothermic Jackets in Microcalorimetry.....	183
108. Equipment Required for Microcalorimetric Research.....	184
109. Elimination of Corrections.....	185
110. Temperature Measurements.....	186
 Postscript.....	 187
 References.....	 189
 Author Index.....	 193
 Subject Index.....	 197

Chapter I

Microthermal Processes of Long and Short Duration

§ 1. **Microcalorimetric Measurements.** Recent progress in physics,⁸⁸ physical chemistry, physiology^{4, 11, 14} and biology,^{6, 115, 117} as well as in some branches of industry,^{36, 45, 71, 124} has stimulated the development of a special branch of calorimetry which deals with measuring the very small thermal effects produced by different objects. Some of these thermal processes are of very short duration, while others last for hours. There are also processes which liberate constant quantities of heat for months and years.

The variety of objects which are or might be examined by the calorimetric method is so great that it is impossible to enumerate all of them. Also, it is difficult to predict how far the technique of calorimetric and microcalorimetric measurements may extend. For this reason several examples are given to illustrate how different in nature and in type these thermal and microthermal processes can be.^{17, 51, 61, 101}

The measurement of the heat developed by natural or artificial radioactivity is a typical example of those processes which require the use of microcalorimetric measurements. The technique of those measurements was developed when problems originated in examining radioactive elements and minerals.

The evolution of heat by the adsorption or absorption of gases and vapors, by the slow recrystallization of metallic alloys, and by the evaporation of small amounts of volatile liquids are processes which may be examined by the microcalorimetric method. The heat produced by a growing plant, by bacteria and by the germination of seeds has been measured by this method.

The variety of thermal processes, the investigation of which is of industrial importance, is also very large. For instance, there are many problems associated with the gradual change in the structure of metallic alloys which are or may be important to the metallurgist. Thermal phenomena taking place when different kinds of cements react with water give a direct indication of how to use them in the cold and in the warm seasons or in building huge concrete blocks.

The solution of certain geological problems may be based on microcalorimetric researches, although at the present stage of the development

of microcalorimetry it is difficult to predict the outcome of these. The heat developed by some radioactive minerals or by the absorption of cosmic rays may be considered as typical examples of this kind.

§ 2. **Thermal Processes of Long Duration.** In the past there were no calorimetric methods which could be employed for measuring the heat evolved by processes of long duration.^{73, 80, 120} Most of the calorimetric measurements then made—for instance, the determination of the heat of condensation of vapors or evaporation of liquids, the heat of neutralization, the heat of combustion, etc.—could be completed in a relatively short time. It was believed, not without reason, that the accuracy of calorimetric measurements carried out in conventional apparatus decreased considerably if the process lasted more than fifteen minutes. This was explained by the uncertainty in calculating the correction for the heat losses or gains of the calorimeter during the time when the heat was liberated by the process under examination. For this reason, the number of thermal processes which could be examined by the calorimetric method was rather limited.

Real progress in calorimetry was made after Richards, Henderson and Forbes⁸⁵ introduced the adiabatic calorimeter and employed that method for measuring the heat of combustion, vaporization, etc. In this way the error associated with the calculation of the heat exchanged between the calorimeter and the jacket has been practically eliminated, or at least reduced considerably.

Richards understood the importance of using the adiabatic method and he intended to apply it in measuring the heat evolved by processes of long duration. In 1926, when the writer had a personal conversation with this eminent American scientist, Richards had planned to examine directly the heat developed by slowly proceeding reversible chemical reactions. Unfortunately, his sudden death interrupted the experiments, which were at that time in the stage of preparation.

Another method was employed in the past by physiologists for examining the heat produced by animals and human beings. This method consisted in maintaining a constant temperature in the jacket of the calorimeter and measuring the heat which was steadily removed from the calorimeter. The famous investigations carried out by F. G. Benedict¹¹ and his associates at the Carnegie Nutrition Laboratory at Boston are typical examples of the manner in which large amounts of heat evolved by physiological processes can be measured in experiments which last a long period of time.^{4, 6, 115}

The ice calorimeter has been considered as a rare device by means of which thermal processes of relatively long duration can be examined with satisfactory accuracy. Unfortunately, the temperature of 0° C is far too

low for measuring the heat produced by numerous chemical reactions. In addition, special precautions should be taken to avoid the errors which are the result of the occurrence of secondary phenomena in the ice calorimeter (§ § 37, 38). To avoid the low temperature of the calorimeter, substances other than water have been suggested.^{89, 93} These types of "solid-liquid phase" calorimeters have found restricted application because of the inconveniences associated with their functioning.

Since the ice calorimeter may find some application in microcalorimetry, the type adapted for measuring a small amount of heat is described in § 39.

Figure 1.

Temperature Increases with Time, the Objects Being Surrounded by an Adiabatic Jacket.

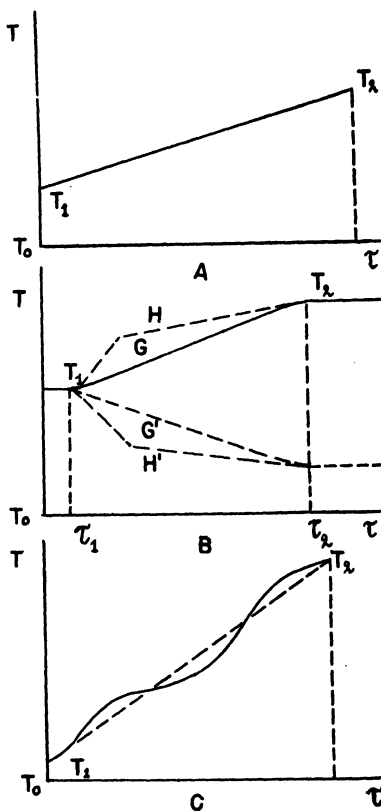

The real progress in microcalorimetry started about forty years ago when it was urgently important to determine the heat liberated by the radiations of radioactive elements. Since then, a number of microcalorimeters have been built and the functioning of isothermic and adiabatic jackets has been improved considerably. Temperature increases can now be measured with a very high precision. Time has ceased to be an obstacle in measuring the heat of processes of long duration.

§ 3. Classification of Thermal Processes of Long Duration. For making a correct choice of the method to be employed (see Chapter XI) it is important to have at least a general idea of the character of the thermal process to be examined. The variety of those processes is too great to permit a description of all of them. Below, an attempt is made to give a graphical presentation of typical cases.

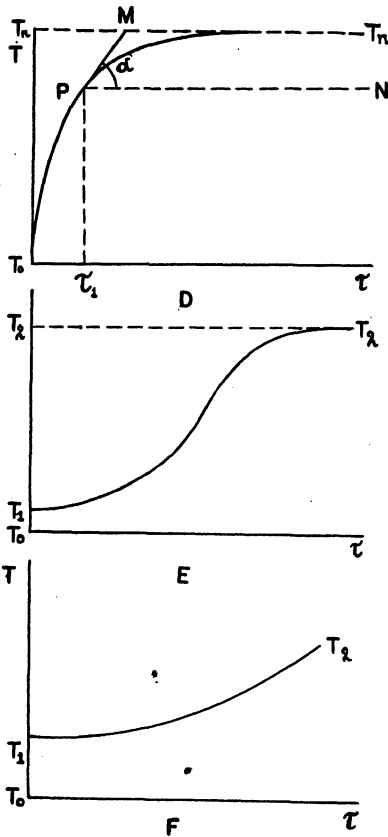

Figure 2.

Temperature Increases With Time, the Objects Being Surrounded by an Adiabatic Jacket.

Two kinds of curves may serve for this purpose. First, it may be assumed that the object or the calorimeter with the object is located in an adiabatic jacket. In this case, the temperature of the system is plotted against time. The curves thus obtained may be represented by the symbol (T, τ) .

In A, Figure 1, the case is represented in which the temperature increase is a linear one. That means that the object develops steadily a constant amount of heat per unit of time, sometimes independently of the tempera-

ture at which the process takes place. Diagram *B* shows that at a certain moment, τ_1 , the process starts and then proceeds until time τ_2 is reached, at which no more heat is developed. Two examples (*G* and *H*) are represented in which positive amounts of heat are evolved, and two (*G'* and *H'*) in which instead of a liberation an absorption of heat takes place.

Another case is represented in diagram *C*. It is characterized by fluctuations, which constitute positive and negative deviations from straight line T_1T_2 . The thermal process shown in diagram *D*, Figure 2, is typical in thermochemistry. At the start a large amount of heat is developed; then, as the process continues, the liberation of heat becomes smaller and the curve merges asymptotically with line T_nT_n , parallel to the axis of time.

Diagram *E*, Figure 2, represents a thermal process which shows the existence of a maximum of heat development per unit of time, then its steady decrease. At the last stage the curve merges asymptotically with the horizontal line T_2T_2 , as in case *D*. Finally, a rather rare case is represented in diagram *F*, Figure 2, in which the reaction starts with the development of moderate quantities of heat; then it becomes more and more energetic and a point is reached at which the experiment should be stopped because of the danger of an explosion (see § 83).

In most of the cases in microcalorimetry only a small portion of curve (T, τ) is examined; for this reason the average temperature $\frac{1}{2}(T_n + T_0)$ may be considered as that during which the process has been examined. Usually, the differences ($T_n - T_0$) between the final and the starting temperatures do not exceed 0.2 to 0.5°. In spite of this, the change in temperature from T_0 to T_n may cause a change in the velocity of the reaction and consequently a change in the amount of heat developed per unit of time. For this reason, in a number of cases it is important to carry out the experiments in such a way as to keep the object at a constant temperature. One of the calorimeters which makes it possible to measure the heat developed by the object at constant temperature is described in Chapter X. This apparatus is called a labyrinth flow calorimeter, because it is provided with a number of labyrinth passageways through which water is circulated with constant speed and with constant initial temperature T_0 . The water removes the heat from the calorimeter and in doing so its temperature changes to T_n when leaving the system. The amount of heat developed is calculated from the equation:

$$dQ = v \cdot c \cdot \Delta T \cdot d\tau \quad (1)$$

in which dQ is the amount of heat liberated in time $d\tau$, v is the volume of water passing through the labyrinth during that time, c is the specific heat of water and $\Delta T = T_n - T_0$ is the actual difference between the

temperature of the water leaving and entering the labyrinth flow calorimeter.

The use of that calorimeter or any other in which the object is kept at constant temperature offers the possibility of another graphical presentation of thermal processes. For convenience, in Figures 3 and 4 all processes previously described are redrawn so as to show how ΔT values in equation (1) change with the time τ . The curves thus obtained may be characterized

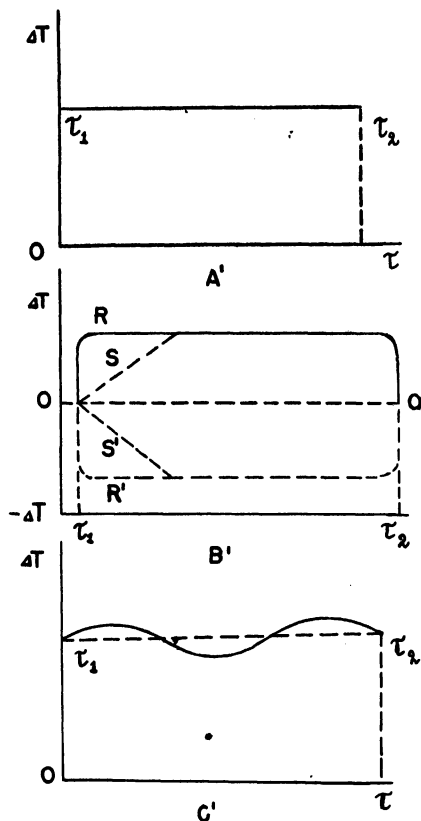

Figure 3.

Curves Expressing $\Delta T, \tau$ Relation; ΔT being the Differences Between the Temperatures of Water Leaving and Entering the Labyrinth Flow Calorimeter, and τ the Time.

by the symbol $(\Delta T, \tau)$. Usually ΔT (or dT) is proportional or approximately proportional to $\Delta Q/\Delta \tau$ (or $dQ/d\tau$) values calculated or graphically determined from the curves shown in Figures 1 and 2. For instance, in Case D, Figure 2, ΔT is proportional or at least is close to the tangent of the angle NPM formed by the horizontal line, and by the tangent drawn through point P on curve (T, τ) .

It is easy to see that if the object develops a constant amount of heat the process is represented by a straight line, $\tau_1\tau_2$ (diagram A', Figure 3).

Exo- or endothermal processes which start at τ_1 and end at τ_2 are represented by two curves (R and S) lying on the positive side (above line OO, which corresponds to $\Delta T = 0$) and by another two (R' and S') found on the negative side of the line OO ($\Delta T < 0$). Diagram C', Figure 3, represents a process similar to that shown in diagram A', with the exception that instead of constant quantities of heat there are fluctuations down and up. The process characterized by a steady decrease in heat production (to zero)

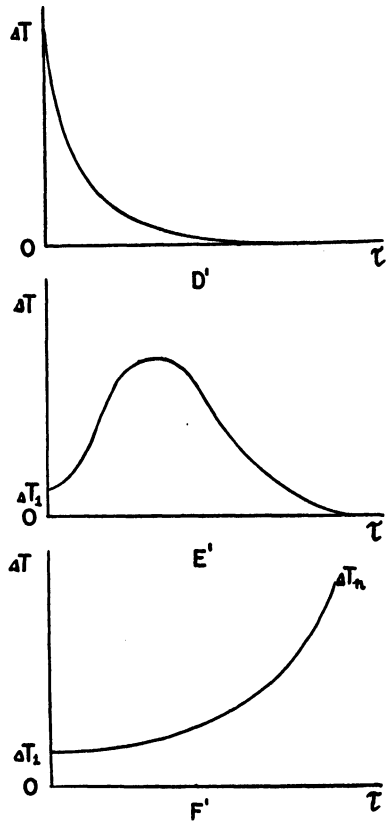

Figure 4.

Curves Expressing the ΔT , τ Relation; ΔT being the Differences Between the Temperatures of Water Leaving and Entering the Labyrinth Flow Calorimeter, and τ the Time.

is represented by the curve shown in diagram D', Figure 4. E' shows in another way the process in which there is first a steady increase in heat production until a maximum is reached, and then a steady decrease to zero. Finally, diagram F', Figure 4, is quite similar to F, Figure 2. It represents the process of steady increase in heat production.

The following examples may illustrate cases in which these thermal processes may be found in nature. Diagrams A and A', Figures 1 and 3, represent numerous thermal processes found in radiology.

Radium preparations in which the radioactive equilibrium has been practically established, and radioactive minerals in which that equilibrium has existed for centuries are substances which liberate constant amounts of heat during arbitrarily long periods of time. The last period of the hardening of cements, when a small amount of heat is developed for months, showing a very small decrease in heat liberated, also may be considered as an example of that kind of process. In that case no change in heat development may be found for many hours. Similar, but not identical phenomena, exist in biology. Plants and animals placed in calorimeters for long periods of time may show a constant average amount of heat evolved per hour, although fluctuations are found as shown in graphs *C* and *C'*, Figures 1 and 3

If the heat of absorption of vapors or gases by solid substances, for instance, activated carbon, is examined, or if the heat of vaporization of volatile liquids is measured, the curves shown in *B* or *B'* may be considered typical for those processes.

Numerous chemical or physicochemical reactions and the transformation of some radioactive elements, characterized by a short half life, are thermal processes which may be represented by curves *D* or *D'*.

Diagrams *E* and *E'* illustrate processes of slow aging of metallic alloys or of hardening of cement when mixed with water (see § § 84, 95). Curves *F* and *F'* show the behavior of some artillery powders which previously have been heated to 75° C and kept at that temperature for several hours. Sometimes it is dangerous to continue the measurement because an explosion may occur.

All the processes represented in Figures 1 and 2 have been examined by different microcalorimetric methods. It is probable that a number of other processes of long duration may be found which will show some similarity or will be represented graphically by different kinds of curves.

One important matter relating to most microcalorimetric measurements of processes of long duration is that the calorimeters are used without stirrers. This technique was adopted in the earliest stage of the development of microcalorimeters and still remains one of the main conditions of conducting measurements which last several hours or more. In 1933 Tian¹¹³ emphasized that calorimeters without any stirring devices should be used even if the substances measured are liquids. In 1931 the writer and his associates⁹⁹ proved the applicability of microcalorimeters without a stirrer in measuring the heat capacity of pyridine. Most of the objects examined in microcalorimetry, however, are not liquids. Their nature differs considerably from those which have been examined in the past by any kind of conventional macrocalorimetric method. In this respect microcalorimetry has opened a wide field of application which had never

been considered to be associated with microthermal investigations. New applications, including those which are associated with nuclear transformations or with cosmic radiation, are to be expected. Recognizing the importance of these applications, the writer has discussed some technical problems (§ § 85, 86) which may be found valuable when new objects are examined.

§ 4. **Thermal Processes of Short Duration.** There are many physical, physicochemical^{43, 64-69, 114} and physiological⁵¹ processes which last such a short time that the heat exchange between the object and the calorimeter takes more time than that in which the whole amount of heat is developed. In those cases there is no reason to examine the shape of the curves as described in the previous paragraph. If such a process is to be examined, it is necessary to know or to find by direct experiment the time required for the heat exchange, so that the temperature established in the calorimeter after that time has passed may be considered as the final one.

It should be emphasized that the methods employed for measuring the heat liberated in processes of short duration differ considerably from those used in processes of long duration. This statement is essential for anyone who is interested in choosing an adequate method for his investigation.

Chapter II

Calorimeter Jackets, Thermostats and Thermometers

§ 5. **Jackets Protected by Insulation.** In numerous calorimetric experiments in the past, the calorimeter was placed in a jacket that was well insulated thermally but without temperature regulation.^{73, 120} To make the heat exchange between the calorimeter and the jacket more uniform, the calorimeter was placed inside one or two empty cylindrical containers, so as to have a layer of air as insulation, and the calorimeter and containers were placed in a double-walled vessel filled with a large amount of water. This vessel was closed by a cap sealed to the vertical walls, with only one opening left for filling and, if necessary, for stirring the water. This type of jacket was used when making calorimetric measurements of processes which lasted a short time. It was assumed that in a short period of time there were no measurable changes in the temperature of the large jacket filled with water, and that consequently the correction for the heat exchange between the calorimeter and the jacket could be calculated by using empirical formulas based on Newton's cooling law.

In the first stage of the development of microcalorimetry, similar jackets were used for making a large number of measurements. The temperature was kept constant by adequate insulation of the external vessels. To eliminate the correction for the heat exchange of the calorimeter with the surrounding vessel, twin microcalorimeters (§§ 28, 31, 32) were employed and the so-called compensation method was applied. This was one of the modifications of the method of comparative measurements, which played and still plays the most important role in microcalorimetry (see Chapter III).

Progress of outstanding importance was made in microcalorimetry when the insulated jacket was abandoned and either the isothermal or adiabatic jacket was adopted.^{9, 10, 44, 46, 48, 49, 51, 56, 59, 63, 84}

§ 6. **Adiabatic and Isothermal Calorimeter Jackets.** The possibility of measuring the heat evolved by thermal processes of long duration was assured after adiabatic⁸⁵ or isothermal jackets were employed. In fact, the use of those jackets made it possible to keep the heat gains or losses of the calorimetric system under strict control. The terms *isothermal* and *adiabatic* indicate that in one case the temperature of the jacket is

kept constant and in the other it is changed so that the temperature of the jacket will be equal to that of the calorimeter throughout the experiment. If such equality of temperature is maintained for an arbitrarily long time, no heat exchange takes place between the calorimeter and its surroundings; thus the thermal process is kept under strictly adiabatic conditions.

To be specific it should be emphasized that because of the limited thermal conductivity of the calorimeter as a whole, the possibility exists that inside the calorimeter the distribution of temperature may be such that in the center the temperature may be higher than on the surface (see Figure 49). In that case the temperature of the jacket should be maintained the same as at the surface of the calorimeter. In this way, it will be assured that there will be no heat exchange between the calorimeter and the jacket. If an endothermal process is under investigation, the temperature in the center of the calorimeter may be lower than at its surface. In this case also the equality of the temperatures of that surface and of the jacket is the essential condition for maintaining the "adiabatic course" of the measurement.

An isothermal jacket is used in all cases in which it is necessary that the calorimeter be surrounded by a uniform and constant temperature. The calorimetric methods in which isothermal jackets are used are so different that no definite rule can be given for conducting the measurements. In all cases one condition is essential: the constancy of the temperature in the jacket must be maintained with the smallest possible fluctuations from the average temperature (§ § 8, 9, 10).

§ 7. **Constant-temperature Room.** Independently of whether an adiabatic or an isothermal jacket is used for thermal protection of the calorimetric system, it is important to locate the whole apparatus in a constant-temperature room. A number of descriptions of how a constant temperature may be maintained in a room may be found in the literature. Usually it is important to have either a considerably lower or a slightly higher temperature in the room than in the rest of the building. In laboratories adapted for microcalorimetric measurements the best solution is to have a constant temperature which is slightly higher than that of the surrounding rooms.

Below a description is given of a constant-temperature room used for microcalorimetric measurements in the Physicochemical Laboratory at the Institute of Technology, Warsaw, Poland. The temperature fluctuations in that room did not exceed $\pm 0.1^\circ$; usually they were of the magnitude of $\pm 0.05^\circ$. That constancy of temperature could be maintained for weeks.

To make the fluctuations of the temperature in the room as small as possible it was necessary to fulfill the following conditions: (1) the temperature in the constant-temperature room should be at least 3 to 5° C higher

than that of the rest of the building; (2) the heat supplied by the electric heater attached to the thermoregulator should be large enough to compensate the heat losses in the shortest time possible. Under these conditions it was possible to have two persons in the room for an indefinite period of time and three persons for several minutes.

In Figure 5 the scheme of a constant-temperature room adapted for microcalorimetric measurements is presented.¹⁰⁸ The room did not have any windows and only one door connecting it with the hall. Along the walls of the room the wire of the electric heater, *BBB*, was fastened so as

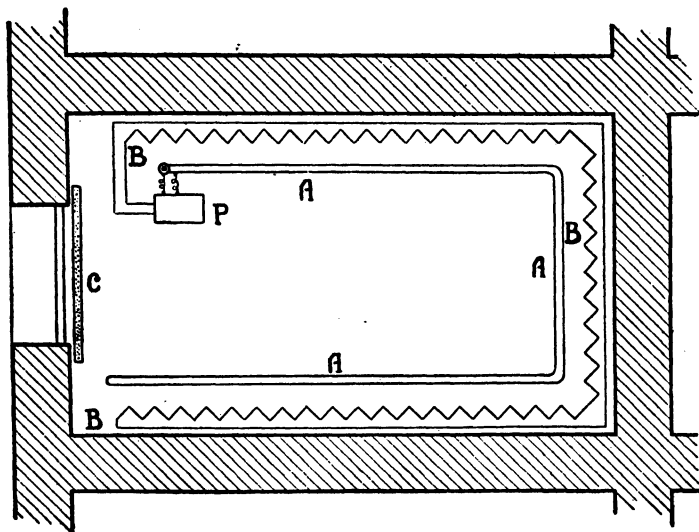

Figure 5. Scheme of the Constant-Temperature Room for Microcalorimetric Measurements.

to assure a uniform heating of the whole space. The thermoregulator, *AAA*, consisted of an iron pipe containing three kilograms of mercury. This pipe was fastened also along the three walls of the room, sufficiently far from the electric heater. In that way the thermoregulator was influenced by the average temperature in the whole room. The air in the room was thoroughly circulated with a fan located nine feet above the floor. The relay of the thermoregulator used an electric current which did not exceed 12 milliamperes. Because of this small current, the mercury-steel needle contact (§ 8) of the relay could function for a long time without being contaminated.

It should be pointed out that, in spite of the fact that the constancy of ± 0.05 to 0.10° was usually maintained for a number of days or weeks, the average temperature in the room changed slightly from time to time, so

that over long periods of time small increases or decreases in the average value could be noticed. For instance, for several days the average was $25.24^{\circ} \pm 0.05^{\circ}$ and then another value, $25.26^{\circ} \pm 0.05^{\circ}$, for the next several days. These slight changes in the average temperature of the room did not have any undesirable influence on the measurements themselves, which usually were completed in a relatively short time.

In Figure 5 it is shown that a thick curtain, *C*, separated the door from the room. The thermoregulator, *P*, was usually located in the vicinity of the calorimeter jacket, which is not shown in the figure.

§ 8. **Thermostats Used in Microcalorimetry.** It is not the purpose of this book to give a survey of the improvements made in building thermostats. The attempt to use a thermostat with temperature fluctuations in the range of $\pm 0.001^{\circ}$ was made many years ago.^{9, 10, 18, 44, 46, 47, 50, 55, 76, 84,} To maintain a constant temperature in a small or a large container was for years and still is a very important technical problem, because most precise physical, physicochemical and biological experiments require the temperature of the object to be constant at the moment when the readings or any other kind of observations are made. For instance, the measurement or direct comparison of the length of two standards, barometric readings, the measurement of electromotive forces and the examination of any kind of equilibrium established in a system should be carried out at a known and constant temperature. New ideas which give hope of reaching a constancy of temperature far exceeding that of $\pm 0.001^{\circ}$ have had very restricted application.^{112, 116}

Three essential parts are required in any kind of thermostat: the thermoregulator, the relay, and the heater. If the fluctuations should not exceed $\pm 0.001^{\circ}$, it is necessary to take into consideration all secondary phenomena which can make it impossible to attain such an accuracy.

Let us examine the most typical equipment used for thermostats and see the phenomena which may prevent its proper functioning. We may start with the thermoregulator. If the thermostat is large enough, there is no limitation in using a large amount of mercury or of mercury and toluene as the liquid with which the container of a thermoregulator is filled. For instance, the volume of 1600 ml of toluene is large enough to assure sufficient changes in volume to control the temperature within $\pm 0.001^{\circ}$.

The shape of the container plays an important role. To measure the average temperature of the thermostat and to be positive that the stirring mixes the liquid in the thermostat properly, it is important that the container of the thermoregulator be similar to that shown in Figure 6. It consists of a number of vertical tubes sealed at one end and attached by the other to a horizontal (slightly inclined) tube. To that tube another

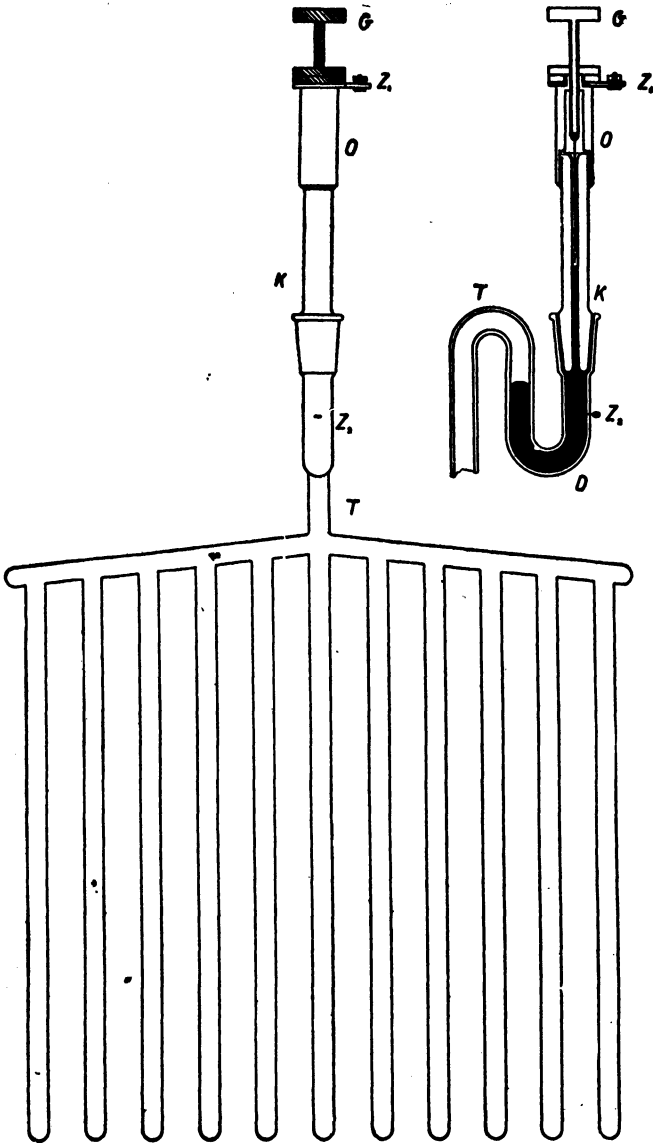

Figure 6. Thermoregulator Filled With Toluene and Mercury.

vertical tube, *T*, with bending, *D*, is attached. The whole thermoregulator is filled with toluene and the bent tube, *D*, is filled with mercury (part *Z*₂). *D* is provided with a ground joint. To the male joint capillary tube *K* is attached and the end of the capillary tube is joined with the metallic tube,

O, with micro-screw *G*. All metallic parts are made according to the description given by W. D. Harkins and F. E. Brown.⁵⁰

The platinum needle used by the writer and his collaborators was 0.2 mm thick. It was attached to micro-screw, *G*, and could be moved in a capillary tube, *K*. Special attention should be paid to the proper construction of this needle. S. Kambara and M. Matsui⁵⁹ have proved that the needle should be thin, to avoid sparking. However, if it is too thin, it is difficult to keep it in the central position, especially when moving it by means of the screw. To avoid this inconvenience it is necessary to provide the needle with a glass bead. Good results have been observed when the bead was fastened 5 mm above the end of the needle.

According to Harkins and Brown, iron or nickel needles may also be used, because mercury does not adhere to those metals. It has been pointed out by the same authors that iron and nickel needles work better than platinum because of a certain time-lag which often takes place when platinum needles are employed. To avoid corrosion of iron or nickel, a constant stream of an inert gas should be passed through the place of direct contact of the needle with the mercury. The corrosion may be reduced considerably by decreasing the intensity of the electric current in the thermoregulator circuit. This condition is essential for any kind of needle, and it can be fulfilled easily by using a relay reducing the current to one or two milliamperes.

The diameter of the capillary tube *K* (Figure 6) cannot be smaller than 0.8 mm. If the capillary tube is too thin the mercury stem within it may be broken.

The average temperature in the thermostat may fluctuate because of the effect of changes in pressure, both atmospheric and hydraulic, on the volume of the thermoregulator. For this reason the level of the water in the thermostat should be kept constant, and the walls of the thermoregulator should be made as thick as is consistent with adequate sensitivity.

To reduce the electric current in the thermoregulator the relay should be provided with an arrangement similar to that used in radio receivers. A number of these relays are described in the literature. The writer and his associates used with success a relay similar to those described by P. van Campen,¹⁸ D. J. and J. J. Beaver,¹⁰ and T. J. B. Stior.⁹⁵ It was built by E. Jurkowski,¹⁰⁸ who introduced some improvements in the scheme (Figure 7). It consists of the following parts: R_1 and R_2 , rheostats one megohm each; R_3 , thousand-ohm rheostat; R_4 , twenty thousand-ohm slide rheostat; R_5 , thirty-ohm slide rheostat; C_1 , 20,000-cm condenser; C_2 , 0.5 microfarad block condenser; C_3 and C_4 , two microfarad block condensers; C_5 , one microfarad block condenser; v_1 , normal thirty-milliamper anode tube; v_2 , normal twenty-five milliamper anode tube; (both of these tubes are for an anode

potential of 250 volts and for a heating potential of 4 volts); T_1 , transformer 120/220 volts (working at $2 \times 2v \times 2.5A$; $4v \times 0.6A$; anode coils 30 milliampere \times 330 volts); T_2 , transformer 220/5 volts; P , line commutator 120/220 volts; G , electric heater; R , relay; S_1 , signal light tube (green); S_2 , signal light tube (red); T , thermoregulator.

In this relay another small but important improvement was made, namely, an electromagnetic coil with a yoke and a movable block to move the mercury-neon commutator. This arrangement was built by W.

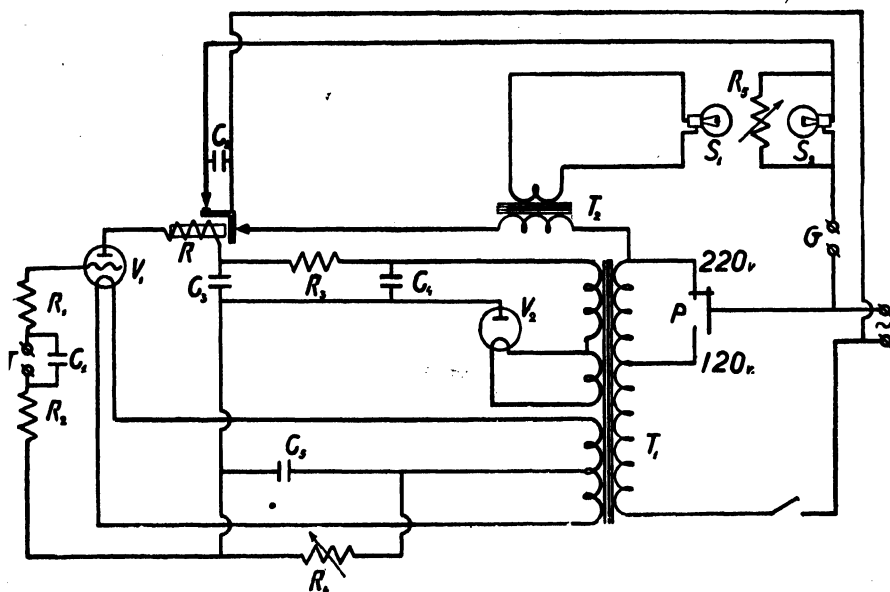

Figure 7. E. Jurkowski's Relay.

Swidzinski for another apparatus; thereafter it was employed in all relays used by the writer and his collaborators.

The relay functions in the following manner. When the circuit of triode, v_1 , is closed, which happens when the needle of the thermoregulator touches the mercury, the triode screen has a negative charge, caused by the fall of voltage along resistance, R_4 . As a result, the normal current in the anode circuit, in which relay R is included, is decreased. The block of the relay falls and shuts off circuit line, $R-G$. If the screen circuit remains open, the net is charged more positively and the anode current increases because of the change to the right of the working point on the characteristic of the triode. Then the block of the relay is pulled up and the heating circuit in line $R-G$ is closed.

Quivering of the mercury may cause some pulsations of the relay.

This can be avoided by blocking the thermoregulator with a capacity condenser, C_1 . The latter causes a certain time lag, which has a favorable influence in the proper functioning of the relay. By changing the capacity of condenser, C_1 , the time lag can be regulated easily, to avoid pulsation of the relay.

In Figure 8 a simple relay is shown, which was used for the constant-temperature room thermoregulator (§ 7). The letters in the figure stand for: B , safety plug; mA , milliammeter; T_r , thermoregulator plug; T , transformer 220/8; R , relay; N , mercury-neon commutator; S , signal lamp; G , plug for the electric heater.

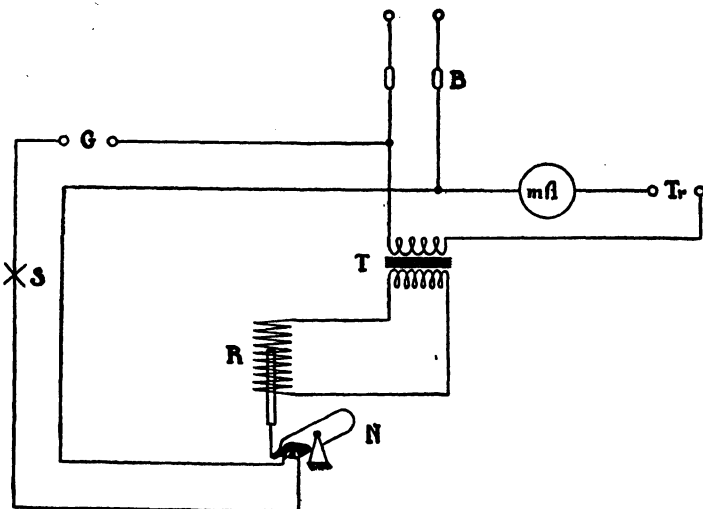

Figure 8. Relay for Constant Temperature Room Thermoregulator.

The size, location, and insulation of the electric heaters play an important role in the proper functioning of the thermostat. No general rules can be given as to all details because they depend largely upon the temperature changes in the room and on the size of the thermostat. For precise microcalorimetric measurements it is important to have a large thermostat (for instance, 300–350 gallons), proper stirring of the water in it, and a constant-temperature room. The temperature in the thermostat should be slightly higher than the average room temperature, so that most of the time the electric current is heating the thermostat. If the surface of the water is not covered with paraffin oil, large heat losses are caused by evaporation. Experiments have shown that it is more convenient to compensate these losses by heating the thermostat than to cover the surface of the water with oil. In fact, the proper functioning of the thermostat requires such an energetic stirring that it is rather difficult to keep a thin

layer of oil on the surface. Very often this layer is destroyed, small drops of the oil are dispersed below the surface, and a large portion of the surface of the water remains uncovered and is vaporized.

In order to make the functioning of the thermoregulator more regular, two electric heaters may be used, one functioning all the time without interruption, the other connected to the thermoregulator. In such an arrangement the first heater compensates most of the heat losses resulting from radiation and evaporation of water from the thermostat. The second supplies small quantities of heat which are not compensated by the first heater.

One of the most important factors is to decrease the time lag of the second heater to the largest extent possible. The insulation of that heater plays an important role in decreasing large fluctuations of the temperature in the thermostat caused by the time lag. Fortunately, there are now available electric heaters with such a thin layer of insulating material that both the negative and positive deviations from the average temperature in the thermostat may be made small and are not far from being symmetrical. The deviations become larger and less symmetrical if the insulation is too thick. In that case the rise of the temperature in the thermostat is noticed a few seconds later than in the case of thin insulation. In addition, the temperature increase is larger, in spite of the proper functioning of the relay.

Proper stirring is a very essential factor; therefore, blank experiments should be made to see how long it takes to reach uniformity of the temperature, if that uniformity was purposely disturbed.

Preliminary experiments with the thermostat are important because its proper functioning depends on several factors. Before starting any microcalorimetric measurements it is necessary to get all information concerning the functioning of the thermostat. This examination should consist in placing a calorimetric thermometer in the thermostat and carrying out a long series of temperature readings to establish: (a) the average temperature of the thermostat; (b) the average period of time in which the whole temperature wave with one maximum and one minimum temperature is observed (see Figure 10); (c) the shape of the positive and the negative parts of the curve, forming together one temperature wave; (d) the uniformity of the temperature in the thermostat; (e) the susceptibility of the thermoregulator to changes in atmospheric pressure.

If the fluctuations are too large or if the duration of the wave is too short, it is important to change the conditions under which the thermoregulator is working. Usually the most essential change consists in adjusting the current in that heater which functions permanently, so as to compensate the heat losses caused by vaporization of water and by radia-

tion. In some cases it is more convenient to increase the temperature in the constant-temperature room, to decrease the radiation of the thermostat. If the humidity in the calorimeter room can be kept high and constant, the permanently working electric heater can be removed and the room temperature kept higher than that of the thermostat. The heat gained by the thermostat from outside then compensates the heat loss caused by evaporation of water from its surface. There is, however, the danger that occasionally the temperature of the thermostat may become so high that the thermoregulator is put out of action.

High maxima lasting short periods of time should be considered as an indication that the electric current is too strong or that the insulation of the heater is too thick. This means that the time lag of the heater is too large. If decreasing the electric current passing through the heater does not produce a decrease in the height of the positive maxima, or if that decrease is still too small, this should indicate that the insulation is too thick and is responsible for the thermostat not functioning properly.

The lack of uniformity of temperature inside the thermostat is another defect in that apparatus. It is caused by an inadequate stirring of the liquid in the thermostat. To examine the uniformity, two Beckmann thermometers or a sensitive thermocouple, preferably with several thermojunctions, may be used and a series of observations made to prove that, at least in the central part far away from the heater, no differences in temperature can be noticed. If the temperature in the thermostat is to be constant within $\pm 0.001^\circ$ the differences should be kept smaller than 0.001° . Exception should be made for that part of the liquid which is close to the heater.

For proper mixing a number of stirrers have been described, quite different in shape and in stirring capacity. Some of them are very effective but produce relatively large amounts of heat. For this reason these stirrers should be considered as permanently functioning heaters. If they stop functioning, even for a short time, they may disturb the work of the thermoregulator so that the thermostat may be put out of action for some time. This is highly undesirable, especially if the measurement lasts for a number of hours (§ § 67, 78, 79, 80, 95, 99).

A definite answer should be given to the question: Does the danger exist that the stirrer may produce an amount of heat great enough to raise the temperature above the average of the thermostat? In that case the functioning of the thermostat will be entirely disturbed because the thermoregulator will be put out of action.

The writer and his associates used a large thermostat provided with three propellers on vertical shafts, arranged in a row. The two outside propellers revolved in one direction while the middle one revolved in the

opposite direction. All of them made from 60 to 80 revolutions per minute. Direct experiments proved that their functioning could not compensate all heat losses of the thermostat.

§ 9. **Multi-jacket Thermostats.** Tian¹¹² was the first to suggest locating the thermostat in the center of a system composed of several jackets placed one in another to assure constancy of temperature. According to Tian's idea, each of the jackets should be thermally insulated from outside and filled with water or, generally speaking, with a liquid. Only the outside container should be provided with the thermoregulator and relay. In principle this is the only jacket which is subject to the direct exchange of heat with the surrounding room and the air in it.

Tian examined the conditions of heat exchange between all the vessels located one in another and he proved that in a three-jacket system the temperature fluctuations in the central thermostat are very small.

There are, however, some inconveniences associated with the multi-jacket thermostat. First, it takes a long time for the whole system, characterized by a very large thermal inertia, to reach thermal equilibrium. To avoid this it seems desirable to use an electric heater to establish in advance in the central vessel the temperature expected to be the final one, corresponding to the equilibrium between the inside and outside jackets. Under these conditions the equilibrium can be established in a much shorter time than if the system had to reach that equilibrium by direct slow heat exchange between all the vessels. Another inconvenience is associated with small variations in the average temperature of the outside vessel, caused either by very small changes in the volume of the thermoregulator (filled with mercury or with mercury and toluene) or by secondary phenomena taking place in the capillary tube (*K*, Figure 6) where the needle touches the mercury surface. This may be explained in the following way.

Let us assume that after a long time the average temperature, 26.32° C, which has been established everywhere, undergoes slight change and becomes 26.41° C. If such a shift occurs, the whole system has to readjust its thermal equilibrium; therefore the heat exchange proceeds until the temperature in the whole system reaches its new level. If several hours or one day later there is a new change in the average temperature, the thermal equilibrium may be disturbed once more, even before the system has reached its new equilibrium occasioned by the first slight shifting of the average temperature. If such small variations in the average temperature of the outside thermostat cannot be eliminated, it may happen that the central system will never reach any permanent state of equilibrium and will be subject to small fluctuations of temperature, each of them extending a long period.

In all the cases described by Tian,¹¹² the fluctuations of temperature in

the outside vessel were considerably larger than those which can be permitted in a thermostat adapted for microcalorimetric measurements. However, the fluctuations in the central container were very small indeed. Tian was right in calling his multi-jacket thermostat a thermal damping system. In fact, the temperature fluctuation waves penetrate into the deeper portion of the thermostat, losing amplitude steadily. The maxima and the minima tend to disappear even before reaching the central jacket. There may be found a place where the amplitude of that wave is entirely extinguished. Because of that, if an adequate number of vessels, located one in another, is used, the temperature may really remain constant in the central container in which the microcalorimeter is located, if the vessels are large enough, and if the average temperature in the outside thermostat does not undergo any change.

The writer could not find any evidence that Tian himself used such a thermostat for precise microcalorimetric measurements; Ward,¹¹⁶ however, made use of such a thermostat. He succeeded in maintaining the temperature constant in the central part of the thermostat with an accuracy of 0.000002° , which had never been achieved in any investigations in the past. Ward's microcalorimetric measurements relate exclusively to thermal processes of short duration. This circumstance facilitated the establishment of a very constant temperature for the completion of the measurement. Hope is expressed that Tian's sound idea will be fully utilized in examining processes of long duration, and that the inconveniences associated with thermal inertia and oscillations of temperature caused by small and slow changes of the average temperature of the thermostat may be overcome.

§ 10. **Precise Determination of the Average Temperature of the Thermostat.** In a number of microcalorimetric measurements (Chapter IX, §§ 78, 79) the difference between the temperature of the calorimeter and that of the thermostat should be determined with the highest precision possible. For this reason any regular or irregular fluctuations which take place in the thermostat cause direct errors, or at least necessitate the calculation of a correction for the average temperature of the thermostat. Consequently, the precise determination or the elimination of that correction plays an essential role in those measurements. If the temperature of the thermostat shows regular fluctuations with typical positive and negative deviations from the straight line, the ordinate of which is the average temperature of the thermostat (see Figure 10), direct observations may lead to the determination of the position of that straight line. M. Lazniewski found another solution to that problem. This solution is essential for certain microcalorimetric methods because it not only saves time, making observations of the fluctuation curve unnecessary, but guarantees accurate

and direct temperature readings, eliminating the calculation of any correction. It is interesting to note that his idea is somewhat similar to that on which Tian's multi-jacket thermostat was based. In fact, it is an oscillation "damper," as is Tian's thermostat (§ 9). In Figure 9 a scheme of a somewhat modified arrangement of Lazniewski's device is shown.

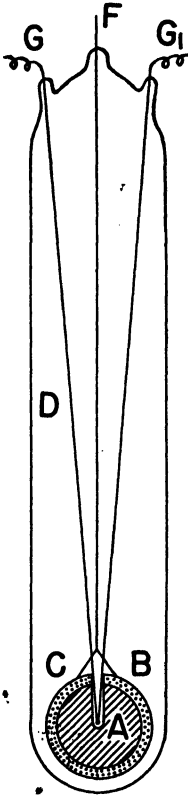

Figure 9.

Device for Measuring the Average Thermostat Temperature Based on Lazniewski's Idea.

Let us suppose that metallic sphere *A* is suspended in the middle of an elongated glass vessel, *D*. This sphere is insulated by a layer of a poor thermal conductor, *B*, which is covered by a thin metallic sphere, *C*, with a well polished outside surface to assure the proper reflection of radiations. In the center of *A*, one contact of a thermocouple (or several, if a thermopile is used) is located; the other (or the others) is fastened near the outside surface of the calorimeter (§ 77, Figure 44). This arrangement is immersed in the thermostat. Lazniewski gave the theory of the functioning of his device, proving by direct experiments that, after thermal equilibrium between the thermostat and the device has been reached, no fluctuations in the center of sphere *A* can be observed. The following simple explana-

tion is given to show under what conditions the idea suggested by Lazniewski is justified.

In Figure 10 the temperature-time curve which characterizes the functioning of a thermostat is shown. Generally, this curve is never symmetrical with respect to its positive and negative deviations. The "degree of asymmetry" and the shape of the maxima depend largely upon the functioning of the thermoregulator, the heater, its insulation, and the intensity of the current in the heater. In spite of that asymmetry, the fundamental condition should be fulfilled, namely, that the areas of the positive deviations shown in the graph should be equal to the areas of the negative deviations. If this condition is disturbed, a steady increase or decrease of the temperature in the thermostat will occur. The equality of heat gains and losses in the thermostat during one "fluctuation wave" is essential for the proper functioning of the device shown in Figure 9. In fact, during the positive deviation of the temperature in the thermostat,

Figure 10.

Temperature-Time Curve
Characterizing the Functioning
of a Thermostat.

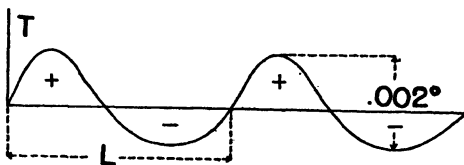

only a very small amount of heat is transferred to the insulating material (layer B) by radiation and conductivity through the air still remaining in D. During heat losses by the thermostat, sphere C radiates some heat, because at that time its temperature is somewhat higher than that of the thermostat, which is in its "negative deviation" phase. These small heat gains and losses originate very small temperature fluctuations in the insulating layer (B). Its thickness should be large enough to extinguish the temperature waves following each other and having opposite signs in their amplitudes. If this condition is fulfilled, the central part of the device is entirely protected against any temperature fluctuations: its temperature remains constant.

It is quite possible that, if the fluctuations are greater than 0.001 or 0.002°, the temperature in the center of sphere may undergo very small fluctuations. That is not the case in microcalorimetric measurements in which thermostats with precise temperature regulators are used.

As was previously pointed out, Lazniewski tried to establish a theoretical basis for predicting in advance whether or not temperature fluctuations larger than the error in temperature readings might be expected. This should depend upon the thermal protection of the sphere (A in Figure 9), upon its cooling constant, upon the temperature fluctuations of the thermo-

stat, and upon their amplitude. In practice, it is important to have direct proof that the device is functioning properly. For this reason it is recommended that a direct experiment be made which would determine definitely whether fluctuations in temperature take place in the device. This experiment consists in placing two devices in the same thermostat, one more protected from heat gains or losses, the other less protected. They should be connected with each other so that their temperatures can be compared. In addition, another arrangement should be made so as to measure the differences between the actual temperatures in the thermostat and inside both of those devices. If direct comparison does not show any difference in temperature and if identical temperature-time curves are established for the thermostat, it may be concluded that both temperature fluctuation dampers function properly.

It should be emphasized that in Lazniewski's experiments no layer of insulation (*B* in Figure 9) was used and the spheres, 2 cm in diameter, were in one case of silver, in another of copper. Both functioned very well. The invasion of Poland interrupted all experiments then under way and no publication appeared on the subject described in this paragraph.

The writer and his associates did not use any device for regulating the rate of heating of adiabatic jackets. Recently, however, a number of papers have been published on the subject of regulating automatically the temperature in the jacket in order to maintain the adiabatic conditions of calorimetric measurements.^{49, 74, 86} In all the devices the photoelectric cell is used so as to discover any difference in temperature of the calorimeter and the jacket.

Independently of whether an automatic device or a regulation of the temperature by the experimenter himself is used, the adiabatic jacket should be provided with an adequate stirrer, and one or two electric heaters. It is important to have a cooling device so that the water in the jacket can be cooled to any desired temperature before the experiment starts or during the experiment if the rate of heating is regulated by the experimenter himself.

Automatic devices have been described also for carrying out experiments in which endothermal processes can be examined.⁸⁶

If the regulation of the temperature is made by the experimenter, it is essential to complete the measurement in a reasonably limited time. Usually, the time ranges from 3 to 5 hours. In exceptional cases the experiment lasts 10, 15, and even 24 hours. In those cases several experimenters work in two or sometimes in several shifts.

In a number of adiabatic microcalorimetric measurements carried out at Warsaw and at the Curie Radium Institute in Paris, cylindrical adiabatic jackets were used which contained from 100 to 150 liters of water. It

was found convenient to use air saturated with water vapor for stirring. If two electrical heaters were used, one was for a rapid rise of temperature, the other for small increases. The jacket was provided with a spiral of metallic tubing through which cold water, usually taken directly from the line, could be passed so that any desired decrease of temperature could be produced.

In most adiabatic microcalorimetric measurements the temperature increases are small. Ordinarily they are of the order of 0.1 to 0.2° per hour, but in many cases they are considerably lower than that. It is not difficult to maintain such a rate of heating the jacket, and deviations from the adiabatic course of the measurement are usually very small and last not more than several seconds. They should be noted each time so that the correction for the heat gains and losses they cause can be calculated.

§ 11. **Electrical Resistance and Mercury Thermometers Used in Microcalorimetry.** In a number of microcalorimetric measurements the accuracy of the measurement depends largely upon the precision with which the determination of very small temperature increases or decreases can be made.³ The nature of the thermal processes and the size of the objects usually make it impossible to employ any other devices for temperature readings than thermocouples. In a number of cases^{49, 51, 64, 66, 113, 116} thermopiles with a large number of thermojunctions are used. In spite of this restriction, electrical resistance thermometers and even calorimetric mercury thermometers are still employed. These thermometers, however, are used exclusively for measuring the temperature of the isothermic or adiabatic jacket. In exceptional cases electrical resistance thermometers have been employed in direct contact with the microcalorimeter. Such an arrangement may be used in those calorimeters in which the compensation method is applied where the heat produced by the electric current cannot be a source of error (§ 31). In all other cases it is rather dangerous to employ resistance thermometers because the heat produced by the object is sometimes of the same magnitude and, in a number of thermal processes, much smaller than the heat produced by the electric current passing through the resistance wire of the thermometer.

The calorimetric mercury thermometers are too large, and their stems extend too far to be located inside the microcalorimeter. They are, however, employed very often for measuring the temperature changes of isothermic and adiabatic jackets. They are in general much more convenient than electrical resistance thermometers because the change in temperature is measured directly and the experimenter can act immediately upon noticing an undesirable change in temperature. This is very essential for maintaining a strictly adiabatic course of temperature changes if no automatic regulation of the temperature in the jacket is employed. In a

number of cases in which isothermic jackets are used (§ § 77, 78, 79, 89–100), electrical resistance thermometers are very useful.

As to mercury thermometers, it is difficult to expect new, far-reaching improvements that will increase considerably the precision in measuring small temperature changes. So-called Ultra-Beckmann thermometers have not shown any substantial improvement in that respect. It should be emphasized, however, that as yet they have not been built for the purpose of measuring small temperature changes in a thermostat. It is believed to be important not to increase the volume of the thermometer bulb beyond certain limits. The walls of that bulb were made so thin in the past that the changes in the volume of the bulb were mainly responsible for irregularities in temperature readings. In a large thermostat, in which the constancy of $\pm 0.001^\circ$ is maintained, the thermometer lag plays a much less important role; hence the structure of both the bulb and the capillary may be readjusted to the special conditions governing the thermometer in a thermostat used in microcalorimetry. At any rate it should be kept in mind that the corrections for the retardation in temperature measurements caused by the thermal inertia of the thermometer do not play a substantial role.

It should be expected that some improvements may be introduced in both the electrical resistance and the mercury thermometers which are especially adapted for microcalorimetric measurements and for thermostats in which a constant temperature is maintained for a long time.

§ 12. **Thermocouples and Thermopiles.** As far as recent experiments show, the use of thermocouples or thermopiles is unavoidable. They are employed for several different purposes. If twin microcalorimeters (§ § 29, 30, 31, 32) are used and the compensation method is applied, they serve for direct proof that in both calorimeters the rates of temperature increase are the same, or show only small differences. In most cases, however, and especially in processes of long duration, thermocouples serve to measure the difference between the temperature of the calorimeter, or that of its surface, and the temperature of the jacket (§ § 78, 79, 89, 90, 91). If an adiabatic jacket is employed, thermocouples are used for maintaining the identity of temperatures of the calorimeter (or of its surface) and of the jacket (§ § 58, 59, 60). Finally, when measuring the heat developed by an object in a thermal process of short duration, thermocouples are used for direct determination of the temperature increase due to that process (§ § 50, 53, 54).

The number of thermojunctions varies from two to as many as one thousand and even more. It largely depends upon a great many specific conditions under which the microcalorimetric measurement is carried out. For this reason, no rules can be given as to the type and the number of

thermojunctions which should be used in any particular case.^{49, 51, 66, 77, 116} For successful microcalorimetric measurements it is essential to have the proper skill in handling thermocouples and galvanometers. Special training in this field is advisable for anyone who wishes to carry out microcalorimetric measurements. One general suggestion should be added. In any case in which thermocouples are used, it is essential to fix all the junctions and even the conducting wires at least one day before starting the measurements. Any bending of the conducting wires just before the readings may affect the result of the measurement. It is essential to maintain both the galvanometer and the conducting wires at a constant or at least at a precisely known condition of temperature.

§ 13. **Galvanometers.** The variety of high-precision galvanometers^{49, 51, 116, 121} is so great that it is impossible to recommend definitely one or even several types in preference to the others. Generally, galvanometers are used for direct readings of temperature differences and as zero instruments, *i.e.*, for proving that there is no current in the circuit in which the thermocouple or the thermopile is included. In the latter case, it is possible to have only one circuit, and no potentiometer is required. If differences of temperature are measured in numerous cases, a potentiometer should be used. For those who start their research work in microcalorimetry, it would be advisable to take a practical course in how to handle precise galvanometers and, especially, in how to get optimum results when using an adequately chosen galvanometer. The papers published by A. F. H. Ward,¹¹⁶ A. Tian,¹¹³ W. P. White,^{121, 122} and especially Gucker and his associates⁴⁹ and Hill⁵¹ should be recommended to those who are planning to carry out microcalorimetric measurements. It is advisable to choose first the method to be used and then to decide what kind of galvanometer should be installed.

Chapter III

Method of Comparative Measurements

§ 14. **Comparative Measurements in Physics.** The fact is well known that in physics the method of comparative measurements has been generally accepted and employed in everyday practice for many years. The national and international bureaus of measures or standards have standards of the meter, kilogram and other units. These are called physical standards. When being used they undergo physical changes, for instance, their temperature or volume may change; but after the measurements have been completed and the standards have been stored in a protected place, they return to their former state. Generally speaking, they remain practically unchanged.

§ 15. **Method of Comparative Measurements in Physical Chemistry.**¹⁰⁴ No evidence can be found in the literature that before 1917 the general idea had ever been discussed of using "physicochemical standards" in a somewhat similar way as the physical standards are used in physics. There is no doubt that in numerous branches of physical chemistry, especially in radiology^{20, 21} and even more often in analytical chemistry, the method of comparative measurements has been used for years. For instance, pure reagents have played the role of reference substances without being recognized internationally as being either physicochemical or analytical standards. The term "physicochemical standard" was often used without precise definition.¹⁰⁴

In 1919, under the auspices of the International Union of Chemistry, the International Bureau of Physicochemical Standards was created;¹⁰⁴ since then, it has been generally understood that any substance characterized by a high degree of purity and employed as a reference substance for any kind of experiment or measurement may be called a "physicochemical standard."

Nobody has raised the question: What is the difference between that substance and any other which is also pure and may be used for any kind of physicochemical experiments?

§ 16. **Comparative Measurements in Thermochemistry.** In 1914 the question of the necessity of establishing an internationally recognized standard arose suddenly and perhaps even accidentally. This standard was suggested by a thermochemist for use in thermochemistry.^{103, 104} It

is not without reason that a brief history of the development of that idea is given in a book dealing with microcalorimetry.

The fact is well known that in 1869 the famous French scientist, M. Berthelot, invented a new method for measuring the heat of combustion of organic substances. He used the so-called calorimetric bomb in which organic substances could be burned in oxygen under a pressure of from 25 to 35 atmospheres. The experiment seemed to be so simple and the results so precise that for years nobody suspected that the absolute determination of the heat of combustion required the introduction of at least twenty corrections.^{96, 102, 104} In the past, three or four of them were taken into consideration. Sometimes the thermometric corrections were also made.

The calorimetric bomb method required the precise determination of the energy equivalent of the whole calorimetric system, including the bomb, which was made of a number of quite different materials. Berthelot ordered the bomb maker to provide him with the exact weights of all of the materials used for constructing the bomb. In addition, on his request, a sphere was made of the same steel used for the bomb, so that the heat capacity of the steel could be determined separately. He was then convinced that the problem of calculating the energy equivalent of his bomb was solved once and for all.

In 1914 the author of this book disclosed^{102, 104} that Berthelot made a considerable error in determining the heat capacity of the steel. Instead of measuring that capacity in the range from 17 to 21°, which was the average temperature at which the heat of combustion was measured, Berthelot used the value which corresponded to the average heat capacity of steel for the range 20 to 100°. It was easy to prove that this error was really committed, because the same error was made several years later by the well known Russian thermochemists, W. Louginine and P. Zoubow. Both of them used a calorimetric bomb made by Golaz, who constructed the first calorimetric bomb for Berthelot. At the time when Berthelot's error was discovered, Zoubow was alive and could confirm the correctness of the fact that the heat capacity of steel used for calculating the energy equivalent of the bomb was considerably higher than the real one measured for the range from 17 to 21°. For this reason he authorized the writer to recalculate¹⁰⁴ his own thermochemical data so as to bring them in accordance with recent thermochemical figures.

In connection with the fact that numerous thermochemical data contained systematic errors, the author undertook further investigations on that subject. Special attention was paid to the investigations of the famous German scientist, Emil Fischer, who published in 1904⁴⁰ and in 1909⁴¹ two important papers for the purpose of eliminating the disagreement in data which existed in that branch of thermochemistry.

Here is a brief story of the investigations of Emil Fischer and F. Wrede. In 1903 Fischer asked the Physikalisch Technische Reichsanstalt to determine the energy equivalent of his calorimetric bomb. The well known physicists of the Reichsanstalt, W. Jaeger and H. Steinwehr,⁵³ decided to use the electrical method for measuring that value for the whole calorimetric system. A very precise electrical resistance thermometer was used and all thermometric corrections were made. In spite of this, some criticism could be raised with respect to the method used by Jaeger and Steinwehr. With this method the heat equivalent of the solid parts of the calorimetric system could be measured with an accuracy from 7 to 8 times lower than that with which the energy equivalent of the whole system, including a large amount of water, was determined. One might ask why the heat capacity of water had to be measured, if in principle it was possible to carry out the combustion so as to produce a rise of temperature from 14.5 to 15.5°. In that case the heat capacity of water is equal to unity, and there is no need to measure the energy equivalent of that part of the calorimetric system. For that reason other authors^{26, 102} used methods in which the energy equivalents of the solid parts of the calorimeter were measured separately with much higher precision. [Details on that subject are given in the writer's book "Thermochemistry," published in German (1928) and in French (1932).¹⁰⁴ The reader can find there the description of Dickinson's investigation, carried out in 1914 at the National Bureau of Standards, Washington, D. C.].²⁶

There was, however, another reason why the numerical data published by Fischer and Wrede in 1904⁴⁰ could not be accepted.¹⁰⁴ In spite of the fact that the determination of the energy equivalent of the calorimetric system was made by highly skilled scientists of the German bureau (P. T. R.), an unexplained error committed in this investigation made Fischer and Wrede's values too high. It took another three years⁵³ for Jaeger and Steinwehr to complete a new set of measurements in which another lower energy equivalent of the calorimetric system was found. Based on that value Fischer⁴¹ and Wrede¹²⁵ published in 1909 and in 1910 papers in which the heats of combustion of naphthalene, benzoic acid, and cane sugar were presented; these values were recommended to other experimenters for measuring the heat equivalent of their calorimetric bombs (see ref. 125). Six years later the writer, in collaboration with M. Popow, undertook the investigation,¹⁰² having in view the determination of the heat of combustion of benzoic acid and the examination of the influence of numerous thermometric and calorimetric corrections on the values obtained by burning an organic substance in the calorimetric bomb.

This investigation showed that without an international understanding on how to measure the energy equivalent of calorimetric systems, no

agreement in numerical data could be reached in that branch of thermochemistry. This idea was strengthened by the fact that the results obtained by the writer and by Popow¹⁰² did not agree with those obtained by Fischer and Wrede in their second series of measurements. The idea was conceived that at least the cause of that discrepancy should be found. For this reason, two months before the outbreak of World War I the writer went to Berlin to discuss the matter with Fischer personally. In the conversations held in May, 1914, the writer expressed the idea that benzoic acid should be recognized internationally as a standard in thermochemistry and he asked Fischer to give his support to that idea. As the result an agreement was reached that at the next international congress of chemistry the proposal would be presented by both Fischer and the writer.

After Fischer's death (1919) the writer was free to act for himself, and he published in the *Journal of the American Chemical Society* a paper⁹⁶ in which he insisted on the necessity of establishing a thermochemical standard for measuring the energy equivalent of calorimetric bombs. In 1919 he prepared a proposal on that matter. The Polish Chemical Society accepted it and gave its support, sending it to the International Union of Chemistry.¹⁰³ At the Rome Conference of that Union a Committee on Thermochemistry was created. Finally, in 1922, the proposal was accepted by the International Union of Chemistry at its conference held in Lyon, France.¹⁰³ Since then the National Bureau of Standards, Washington, D. C., undertook the work of supplying scientific and industrial laboratories with pure benzoic acid for the calibration of calorimetric bombs. The Standing International Committee on Thermochemistry and the International Union of Chemistry⁶¹ published a booklet in which directions were given as to the use of the standard substance and how to eliminate most of the thermometric and calorimetric corrections, reducing them to three.

In 1926, W. Jaeger and H. Steinwehr⁵⁴ published a third paper in which a new calibration of the calorimetric bomb was made and the heat of combustion of benzoic acid was given, which agreed perfectly with other data published at that time.

The whole story of the establishment of a thermochemical standard for organic substances is given here to show how important it is to eliminate as far as possible thermometric and calorimetric corrections in any kind of calorimetric measurements. In addition, this story should be considered as a warning to those who underestimate the difficulties associated with the measurement of the energy equivalents of calorimetric systems by the electrical method. It may be seen that highly skilled physicists of the Physikalisch Technische Reichsanstalt had to repeat their measurements twice in order to reach an agreement with the results of measurements of

other investigators, who used somewhat modified methods of measuring the heat equivalent of the solid parts of the calorimetric system.

§ 17. **Absolute and Comparative Measurements.** Considerable progress has been made since the establishment of the first physicochemical standard. In 1932 a Committee of Physicochemical Data was created by the International Union of Chemistry and its proposal to divide all physicochemical measurements into two groups, absolute and comparative, was accepted by the Union at its Conferences at Lucerne in 1936 and at Rome in 1938.¹⁰⁴ According to that division, absolute physicochemical measurements should be carried out in rare cases, and exclusively by specialists working at bureaus of measures and standards or in laboratories sufficiently adapted for high-precision measurements and provided with adequate facilities to express values in C.G.S. units of measure or in their derivatives. Comparative measurements may be made by any experimenter using ordinary apparatus and instruments. This kind of measurement consists in relating the measured value to that of the standard reference substance.¹⁰⁴

§ 18. **Comparative Measurements in Microcalorimetry.** In microcalorimetry *the most essential problem is to perform the measurements in such a way as to eliminate systematic or accidental errors.* The use of the comparative method makes it possible to avoid those errors by reducing to a minimum the number of corrections for secondary phenomena. At the same time it assures that the energy equivalent of the calorimetric system may be determined properly.

The sources of systematic and accidental errors are numerous, and they vary to a large extent from one case to another. These errors may be divided into three groups: (1) inadequate temperature measurements; (2) unchecked or improperly checked heat gains and losses; and (3) side reactions. The latter may remain undiscovered or their positive or negative influence on the measured value may not be calculated properly, so that the results may be too high or too low.

The method of comparative microcalorimetric measurements may involve: (1) using twin calorimeters and in compensating the heat developed in one calorimeter by electrical energy introduced into the other; (2) carrying out two successive measurements in one calorimeter, so as to produce the same thermal effect by an electric current as that developed by the object under examination; (3) using two series of successive measurements, as mentioned above, with the difference that in one experiment the heat is developed by the object only, and in the other by the object and an electric current; and (4) comparing the heat liberated by the object with that produced by a standard substance.^{22, 121, 127} The use of all these methods is described in this book, and the easiest is indicated in each particular case.

As electrical energy is most often used for carrying out comparative

measurements, it is of great importance to give a definite answer to the question: What is the accuracy with which an amount of electrical energy can be measured? The opinion often expressed in this matter is rather too optimistic. It should be taken into consideration that the determination of the value of the mechanical equivalent of heat has very often been made by measuring the heat developed by an electric current. In spite of the fact that a number of those measurements were made by highly skilled experimenters, the numerical value of that equivalent has changed very often in the past. It is true that the differences between the values found by different experimenters have become smaller in the last two decades, but a warning should be given to those who believe that this measurement is a simple one. It should be borne in mind that the experiments on the determination of the energy equivalent of the calorimetric bomb, measured by the electrical method by the physicists at the Physikalisch Technische Reichsanstalt, were made three times, and that twice the values were found to be too high.^{53, 54, 104}

When measuring the heat developed by an electric current, four values should be determined and all expressed in absolute units of measure: (1) the resistance of the heater, r ; (2) the voltage, v , or the intensity of the electrical current, i ; (3) the time, τ ; and (4) the temperature increase, ΔT . In publishing the results of any microcalorimetric measurements it is urgently necessary to indicate clearly the precision with which each of the values r , v , τ , and ΔT were determined. To avoid the necessity of measuring these values the method of twin calorimeters (see § 22) may be used.

Special attention should be paid to the fact that the method of comparative measurements offers proper results in those cases in which not only the energy equivalent of the calorimetric system is measured but also a number of corrections are eliminated. The experimenter should indicate the secondary processes which, according to his estimation, were eliminated by the comparative method employed in his experiments.

§ 19. **Temperature Measurements.** In one of the previous paragraphs (§ 11) it was pointed out that the use of electrical resistance thermometers and so-called calorimetric mercury thermometers is restricted to those cases in which the temperature of the isothermic or adiabatic jacket is measured. As far as is known to the writer, there is only one microcalorimetric method (§ 31) in which the electrical resistance thermometer constitutes a part of the calorimeter itself. In that case twin calorimeters and the compensation method were employed.

Independently of where the thermometer is located for measuring the change in temperature produced by the object, it is important to avoid as far as possible all thermometer corrections by using the method of comparative measurements, so that identical or approximately equal temper-

ature increases can be observed both in the main process and in that in which electrical energy or the energy liberated by a standard substance is used for compensation or direct comparison of the heat evolved.

Since thermocouples with one, several, or a great number of thermo-junctions are usually employed, it is of great importance to prove that no accidental or systematic errors are committed because of secondary phenomena which often take place. This is especially true if a very small quantity of heat is evolved by the object. The fact that some amount of heat may be transferred and lost or gained by the calorimeter because of the large number of wires in a multi-junction thermopile is often underestimated. Special attention should be paid to the fact that heat may be lost because of the Peltier effect. All these errors can be avoided by using an adequately chosen method of comparative measurements. Special control experiments should be conducted to prove that all secondary phenomena accompanying the temperature readings are properly checked.

§ 20. Elimination of the Correction for Heat Gains or Losses. One of the most important problems the experimenter ever faces in any kind of calorimetric research is to check properly or to eliminate the danger of uncontrolled heat gains or losses of the calorimeter.⁷³ The use, since 1905, of the adiabatic method⁸⁵ has reduced considerably but has not entirely eliminated the very small heat exchange between the calorimeter and its jacket. In fact, even if adiabatic conditions are entirely fulfilled, there still remains the heat exchange of the calorimeter with the air in the space between the calorimeter and the jacket. This heat exchange may also be considerably reduced if a vacuum is established in that space. However, the vacuum is never complete, and a very small amount of air is heated or cooled by the surface of the calorimeter. The jacket contributes also in heating or cooling that air (§ 62).

Experiments have proved that the correction for the heat exchange between the calorimeter and the jacket may be eliminated if an adequate method of comparative measurements is employed. In the early stage of the development of microcalorimetry, when well insulated jackets were used, the purpose of the method of twin calorimeters and thermal compensation by electric heaters was to avoid, or at least to reduce to a minimum, the necessity for calculating the correction for the heat gains or losses of the calorimeter. Later, these jackets were practically abandoned, because of the superiority of isothermic and adiabatic jackets, which offer a greater guarantee that no uncontrolled heat exchange can take place even if the thermal process lasts for a long time.

From the description given in §§ 63, 64, 87, and 93 it may be concluded that the methods used recently for eliminating the correction for the heat gains or losses are more effective than ever before. This enabled con-

siderable progress to be made in microcalorimetry in the last two decades. By the proper use of the method of comparative measurements, the heat exchange produced by the conductivity of the wires of a multi-junction thermopile can also be eliminated^{49, 66} (§§ 50, 54).

§ 21. **Processes of Short Duration.** If the energy equivalent of the calorimetric system is very small and the thermal process lasts a very short time, difficulties arise in applying any method to eliminate the corrections for the heat exchange between the object and the jacket and for any other calorimetric or thermometric corrections. One of the difficulties consists in determining whether the thermopile is functioning properly. If such a determination is made before the thermopile is placed in its proper location in the calorimetric system, the question still arises as to whether it functions in precisely the same manner after having been built into the system. Microcalorimetric measurements of the heat of adsorption carried out by Ward¹¹⁶ (§ 53) and of the heat developed by excited nerves (§ 54) examined by Hill⁵¹ are typical examples in which no conventional methods of comparative measurements could be used. Both these eminent scientists found a way of checking the proper functioning of their apparatus. In addition, Ward used his own method of control by dividing the adsorption process into two steps.

In other cases, for instance, in Lange's^{64, 65, 66, 67, 68, 69} measurements of the heat of dilution of dilute solutions of electrolytes, the conventional method of comparative measurements could be used and the functioning of the thermopiles could be controlled after they had been properly located in the calorimeter (§§ 50, 51, 52). The same refers to the measurements of Gucker and his associates.⁴⁹

§ 22. **Energy Equivalent of the Calorimetric System.** In a number of cases the determination of the energy equivalent of the calorimetric system is very often carried out with the purpose of finding not the real but the "apparent value" of that equivalent, so that by the adequate use of it a number of thermometric and calorimetric corrections can be eliminated. Before discussing this particular case, let us examine the general case, in which the purpose is to find the amount of heat required for heating the whole calorimetric system one degree. In various national standardizing laboratories, for evaluating the heat evolved in the standard calibrating reactions, such as the combustion of benzoic acid or the formation of water from hydrogen and oxygen, the energy equivalent of the calorimeter has been determined with electrical energy in terms of the international joule. These measurements are preferably performed by utilizing the so-called substitution method described by Rossini and Deming.⁸⁷ According to this method, the heat evolved by a measured amount of a chemical reagent is compared directly with that evolved by a measured amount of

electrical energy. The calorimeter is a fixed system serving as the absorber and comparator of the two kinds of energies. The two successive experiments should be carried out over the same interval of temperature and under the same conditions, to eliminate the thermometric and calorimetric corrections.

Up to the present time, however, there have been difficulties in measuring with sufficient accuracy the amount of heat produced by an electric current. A classical example has been given (§ § 15, 16, 17) showing that relatively large errors have been committed in the past in carrying out such absolute measurements. For this reason a method of comparative measurement of the energy equivalent is described in which practically all the difficulties encountered in any kind of absolute measurement have been eliminated.

The method consists¹⁰⁴ in using two calorimeters; one of these is constructed of materials the specific heat of which is well known; the other is the one which is to be used for the measurements proper. The latter usually consists of many different parts with unknown specific heats. They are placed side by side and each is provided with an electric heater. The heaters are connected in series. Let us suppose that R_1 and R_2 are the resistances of heaters, K_1 and K_2 the energy equivalents of the two calorimeters, including the liquid or liquids they are filled with, and t_1 and t_2 the temperature increases observed when the current passes through both heaters. The unknown value K_2 may be calculated from the equation:

$$K_2 = \frac{K_1 \cdot \Delta t_1 \cdot R_2}{\Delta t_2 \cdot R_1} \quad (1)$$

For calculating K_2 it is necessary to know the values of the ratios R_2/R_1 and $\Delta t_1/\Delta t_2$. These can be determined much more easily than the absolute values R_1 , R_2 , Δt_1 and Δt_2 . Ordinary equipment for measuring the electric resistance is precise enough for comparing R_1 and R_2 directly. The ratio $\Delta t_1/\Delta t_2$ may be determined by direct comparison of the two thermometers used. The only value which should be calculated and expressed in absolute or conventional units of measure (calories) is the energy equivalent K_1 . The following equation may be used for this purpose:

$$K_1 = m_w \cdot c_w + \Sigma mc \quad (2)$$

In this equation m_w represents the mass of water used, c_w its specific heat and Σmc the energy equivalent of all parts of the calorimeter including the thermometer and the stirrer. As the specific heat of water is well known, and m_w can be measured with sufficient accuracy, the only error which may be committed is associated with the calculation of the value Σmc . For this reason it is important to use materials whose specific heat is well known and to reduce as far as possible the ratio $\Sigma mc/m_w \cdot c_w$.

With regard to the temperature increases, Δt_1 and Δt_2 , it is important to carry out the experiment in such a way as to have the value of Δt_1 as close as possible to the temperature increase observed in the microcalorimetric measurement proper. This is important for any kind of thermometer employed.

The method just described was used in a number of cases.⁴⁹ It may be applied independently of the size and the shape of the microcalorimeter. If so-called twin differential calorimeters (§ § 28, 29, 31, 65, 70) with electric compensation current are used, a third calorimeter filled with water should be placed side by side with the calorimeter containing the object. This calorimeter should be provided with an electric heater, so arranged that it is a part of the calorimetric system. In that case the calibration of the calorimeter may include the elimination of both the thermometric and calorimetric corrections which are associated with the heat exchange of the calorimeter with the jacket. In § 86, 87 examples are described in which the calibration should be made without removing the object. This is essential if the object constitutes the main part of the calorimetric system.

§ 23. **Compensation Method.** In the previous paragraph it was pointed out that in most microcalorimetric measurements it is essential to determine not the real but the "apparent" energy equivalent of the calorimetric system. The term "apparent" indicates that, when using this value for calculation, a number of thermometric and calorimetric corrections are included in it; if the experiments are conducted under constant and strictly fixed conditions all these corrections can be eliminated. In the compensation comparative method used in microcalorimetry a number of corrections are also eliminated. This method was applied in the past in order to simplify the problem of calculating the correction for the heat gains or losses taking place because of the heat exchange between the calorimeter and the jacket.

Two typical compensation methods have been employed. One consisted in using identical twin microcalorimeters (§ 29, 31, 32). One of them contained the object, the other an electric heater. The experiment consisted in finding the intensity of the current which would produce the same amount of heat per unit of time as the object. This method can be employed only when examining exothermal processes in which a constant amount of heat is evolved by the object (see Figures 1 and 3, diagrams *A* and *A'*). In the other method, only one calorimeter was used and the heat liberated by the object was compensated by the Peltier effect^{12, 35, 113} (§ 46). In this method a thermopile should be used for transferring the heat from the "warm contacts" to the "cold" ones. Unfortunately, it is impossible to transfer all the heat evolved by using the Peltier effect, because of the

Joule heat produced by the electric current in that circuit. Therefore, the use of this method requires a correction, the calculation of which may involve either a systematic or an accidental error.

It should be pointed out that in the first stage of the development of microcalorimetry the accuracy in measuring the heat in microthermal processes was relatively low. For this reason, the precision of the direct determination of the amount of heat produced by an electric current was high enough when compared with the magnitude of the experimental error. If, however, the accuracy is higher than 0.3 to 0.5 per cent, the method described in § 22 should preferably be used, to avoid the necessity of measuring R , v , τ , ΔT , and expressing them in absolute units of measure.

The compensation method based on the Peltier effect is less convenient. As was pointed out, it requires correction for the Joule effect, and this circumstance makes it impossible to eliminate the correction for the heat exchange between the calorimeter and the jacket. These two disadvantages reduce the applicability of that method considerably. Perhaps it may be employed in some particular cases in which no other methods can be used.

§ 24. Method of Successive Comparative Measurements. If only one calorimeter is used, the method of successive comparative measurements may be employed. This consists in carrying out two successive measurements under the same conditions. This method is in general use in thermochemistry.¹⁰⁴ When determining the heat of combustion of organic substances the "apparent energy equivalent" of the calorimetric system is determined by burning a given amount of benzoic acid (§ 16). Using that energy equivalent, the heat of combustion of other substances can easily be determined. All corrections except three are eliminated. A somewhat modified method also may be employed in microcalorimetry. Instead of a standard substance, as in thermochemistry, an electric current may be used. It is essential to produce by the heater the same quantity of heat as liberated by the object, and in the same period of time. If these conditions are strictly fulfilled, all the thermometric and in many cases all the calorimetric corrections may be eliminated. In some particular cases calorimetric corrections resulting from secondary phenomena must be taken into consideration because they cannot be eliminated by the electric calibration. For this reason it is very important to examine in detail all conditions of the experiment so as not to overlook any side reaction (see § 26, 64, 86, 87, 93).

If the method of successive comparative measurements is applied, the experimenter should choose in advance the conditions under which all the measurements will be carried out. This is important, because any change in those conditions will require a redetermination of the "apparent energy

equivalent" of the calorimeter. The experimenter should decide also whether the accuracy of the measurements is lower or higher than the precision with which the electric energy can be measured with the equipment at his disposal. If there is some doubt, it is advisable to use the comparative method of calibration as described in § 22.

Independently of the microcalorimetric method employed, it should be accepted as a rule that in the successive comparative measurement of the "apparent energy equivalent" of the calorimetric system the list of corrections should be given which, according to investigator, have been eliminated by the calibration.

§25. **Reference Substances.** In radiology Madame Curie^{20, 21} initiated the use of a standard radium preparation for measuring the radioactivity of substances containing radioactive elements. As the period of half-life of radium is long, the standard radium preparation may be considered as a physical rather than a physicochemical standard (see §14, 15). Madame Curie's idea found direct application in microcalorimetry, because in many cases it is very convenient to use a radium preparation as a reference source of heat. In a number of cases radium preparations^{21, 35, 101, 127} and even other radioactive substances¹³⁰ have been used for carrying out comparative microcalorimetric measurements. The only limitation in applying this method is the necessity of using calorimeters made with thick walls of high absorptive capacity, to absorb not only the alpha and beta particles but also most of the gamma rays. In a number of cases (§68, 81, 82) this limitation does not play any role because the calorimeter is large and is made of a material dense enough to have a high absorption of gamma rays. The correction for gamma rays which are not absorbed is small and cannot be considered as a source of systematic error.

In a limited number of cases there is the possibility of using other reference substances for comparison. For instance, if a series of determinations of the heat of vaporization is made, it is advisable to choose one of the liquids as a reference substance and to determine its heat of vaporization with the greatest care. Then this figure may be used as a reference value for the heat of vaporization of the other liquids. In doing so, the experimenter is enabled to recalculate his figures, if a systematic error, found later, had shifted the results of his measurements in one direction or the other by a given fraction of a per cent.

§ 26. **Use of Comparative Measurements for Studying Endothermal Processes.** Tian emphasized¹¹³ that in measuring the heat absorbed by an endothermal process the compensation method may be used by introducing a known equivalent amount of heat by means of an electric current.⁴⁹ This statement is correct with only one provision: that this simple internal compensation will not be a source of a systematic or accidental error.

From the theoretical point of view, this is quite clear. If the calorimeter is surrounded by an isothermal jacket and the same temperature is established in both the calorimeter and the jacket, the electric compensation of the heat absorbed by an endothermal process should be made in such a manner as to maintain the temperature in the calorimeter constant. Under these conditions the process will be at the same time both adiabatic and isothermal. No heat exchange will take place; consequently, no calorimetric corrections will be required. From this point of view, the conditions seem to be excellent for calorimetric measurements. However, great care should be taken to avoid errors which may be caused by lack of uniformity in compensating the rate of cooling the calorimetric system by the electric current. To avoid these undesirable phenomena the temperature in the jacket and that at any place along the whole surface of the calorimeter (§ 58) should be kept the same during the whole calorimetric measurement. This can be done if the rate of cooling is equal to the rate of heating throughout the measurement. In addition, the thermal conductivity of the calorimeter should be high enough to assure uniform distribution of heat in the system.

The fulfillment of those conditions is rather difficult. Very often it is quite difficult to reproduce the endothermal process "in reverse" with an electric heater. Moreover, it is not easy to obtain a uniform distribution of temperature in a system in which two different processes, one endothermal and the other exothermal, take place.

There is also another possibility of using the electric current for measuring the heat absorbed in an endothermal process, namely, that of measuring in a separate experiment the electric energy required for heating and for producing an increase in temperature, Δt , equal to the decrease produced by the object in an endothermal process. In this case the process is also reproduced "in reverse," but it is much easier than in the combined operation suggested by Tian. It should be emphasized, however, that in both cases, *i. e.*, by Tian's method or by two separate measurements, it is much easier to employ two calorimeters, as described in § 22. In fact, it seems that in this case the only easy method of measuring the electric energy is by using the equation:

$$\Delta Q = K_2 \cdot \Delta t_2 = K_1 \cdot \Delta t_1 \cdot R_2/R_1 \quad (3)$$

which is a simple modification of equation (1) discussed in § 22. Using two calorimeters, ΔQ can be measured even if the electric current undergoes a steady change. The curve expressing the function $\Delta t = f(\tau)$, in which Δt is the temperature change and τ the time, can be easily reproduced. It is obvious that in the equation: $\Delta t = f(\tau)$, Δt is negative in the main calori-

metric measurement (endothermal process) and positive when the electric heater functions.

§ 27. **Conclusions.** An effort has been made to show that the only way to avoid both systematic and accidental errors is to use the method of comparative measurements. It makes possible the elimination of most of the corrections and it simplifies considerably the technique of conducting any kind of microcalorimetric measurements. The question still remains open: Which method of comparative measurements is the best to employ? The experimenter must decide whether it is more convenient to carry out an absolute measurement of the electrical energy by determining with the required accuracy all the values involved (Δt , v , R and τ , § 18) or to use two calorimeters and employ a strictly comparative method for the energy equivalent determination, in a manner similar to or identical with that described in § 22.

In spite of so many simplifications, the experimenter must examine in detail all conditions of the experiment, to avoid any error that may result from a side reaction which has remained unchecked. It is necessary to bear in mind that the history of calorimetry and thermochemistry gives many examples in which small or great errors have been made by eminent and highly skilled specialists because certain secondary phenomena had been neglected.

Chapter IV

Twin Microcalorimeters Used in Radiology

§ 28. **First Determinations of Heat Developed by Radium.** The fact is well known that the heat produced by radioactive elements is the result of the absorption of alpha and beta particles as well as of gamma rays by the surroundings. This was not so obvious at the very beginning of the work with radium and other radioactive elements. It was necessary to prove this by direct microcalorimetric measurements. Pierre Curie and A. Laborde²³ were the first to undertake this investigation. They employed the differential method and used the twin microcalorimeters shown in Figure 11. Two Dewar flasks of equal size and shape, both insulated in the same manner, served as the calorimetric vessels. One of

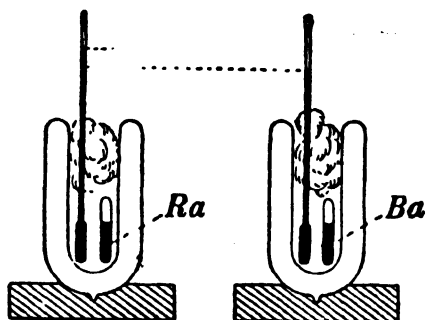

Figure 11.

Pierre Curie and Laborde's
Twin Differential Microcalori-
meters.

them contained a glass tube with the preparation of radium bromide, the other a glass tube of the same size with barium bromide. By transferring the thermometer, from time to time, from one Dewar flask to the other it was found that the temperature inside the flask containing radium bromide was always higher than that in the flask containing barium bromide. In spite of the fact that the method was not a precise one, Curie and Laborde proved that under the conditions of the experiment one gram of radium bromide developed approximately one hundred calories per hour.

In connection with the results obtained, Curie and Laborde made a remark that is important from the historical point of view. They stated that "the cause of such a development of heat may consist in an internal

transformation. This transformation should be associated with a deep change and may be a result of a modification of the atom of radium itself."

Several months later Pierre Curie and J. Dewar²² used liquid oxygen and hydrogen to show that the amount of energy developed by radium or other radioactive elements did not depend upon the temperature. At that time this observation was very important. It indicated that the nature of radioactivity is entirely different and cannot be compared with any other known phenomena. In all other thermal processes known in physics and chemistry the rate at which heat is developed changes with temperature.

§ 29. **Compensation Method.** Since the investigation of Curie and Laborde, twin microcalorimeters have been employed frequently, not only in radiology but also in other microcalorimetric investigations.^{6, 19, 49, 64}

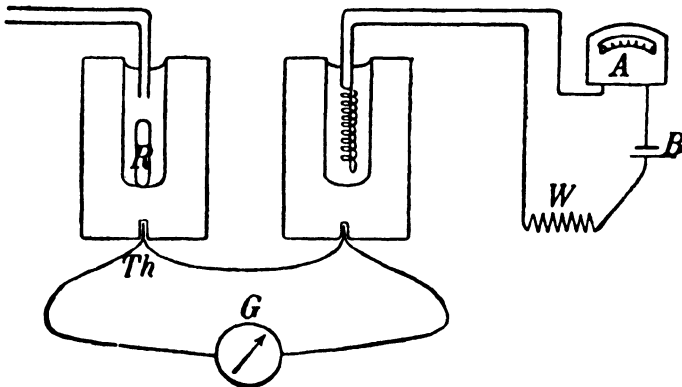

Figure 12. Twin Microcalorimeter Adapted for the Compensation Method.

In the first stage of the development of this method, neither the adiabatic nor the isothermal jacket had been employed. The method has been improved merely by insulating the calorimeter adequately and by using the so-called compensation electric current. This involves having an electric heater in the second microcalorimeter to compensate by electric energy the heat produced by the object located in the first or main calorimeter. The measurements consist in finding that intensity of electric current which heats the second calorimeter at a rate equal to that observed in the first calorimeter. In Figure 12 the scheme of this kind of apparatus is presented.

The method requires that both calorimeters be characterized by equal energy equivalents. It is assumed that under these conditions the heat produced by the object in one hour is equal to the heat developed by the electric current, so that the following equation may be used:

$$\Delta Q_h = J \cdot i^2 \cdot R \cdot 3600$$

In this equation ΔQ_h is the heat developed by the object in one hour, i the intensity of the electric current, R the resistance of the heater, and J the mechanical equivalent of heat.

K. Ångström,²³ E. V. Schweidler and V. F. Hess,⁹² L. Wertenstein and H. Herszfeld,¹¹⁸ D. Yovanovitch,^{127, 128} and A. Dorabalska²⁷ used the compensation method with small modifications.

For measuring the temperature thermocouples were usually employed. In using the compensation method, one should change the electric current so as to observe and maintain the needle of the galvanometer in the zero position for a reasonably long period of time.

§ 30. **The Use of Standard Radium Preparations.** Further improvement in the method of twin microcalorimeters was made by D. Yovanovitch¹²⁷ and employed by him in collaboration with A. Dorabalska.¹²⁸ The method required two sets of measurements, one with the substance examined, the other with the standard radium preparation. The use of this method was facilitated by the fact that the investigations were carried out at the Curie Institute of Radium in Paris; therefore a standard preparation of radium could be used. The "history" of the radium preparation being known, it was possible to calculate with sufficient accuracy the quantity of heat developed and to compare that heat with the heat liberated by the object under examination.

The measurement consisted in determining the intensities of the two currents, i_s and i_x , which compensated the heat produced by the standard (Q_s) and by the substance examined (Q_x). If dQ_s/dt and dQ_x/dt represent the rates of heat liberated by the standard and the object, the following equation could be written:

$$(dQ_x/dt) : (dQ_s/dt) = Q_x : Q_s = i_x^2 : i_s^2$$

In this equation Q_x and Q_s stand for the heat liberated in the same interval of time by the object and the standard radium preparation.

§31. **Twin Microcalorimeters with Electrical Resistance Thermometers.** E. Rutherford and H. T. Barnes⁹⁹ and several years later E. Rutherford and H. Robinson⁹⁰ used twin microcalorimeters with electrical resistance thermometers built into each of them. In Figure 13 a schematic presentation of these apparatus is given. They consisted of two long glass tubes, R and R_1 , each provided with a coil of thin platinum wire attached to the inside surface. These platinum wires served as resistance thermometers and they "formed two arms of a Wheatstone bridge, while the ratio arms consisted of two equal coils, 3 and 4, of a manganin wire, each of about the same resistance as the platinum coils." In Figure 13 the disposition of the arms of the Wheatstone bridge is shown. "The glass tubes, in which the platinum coils were wound, were placed in brass tubes

passing through a water bath." "A calibration of the scale of the galvanometer was made by placing a heating coil of small dimension of covered manganin wire within one of the platinum coils, and noting the steady deflection when known currents were sent through it." The deflection thus served as a direct measure of the heating effect.

From the description given above it may be concluded that the method represents a typical example of the application of the principle of compara-

Figure 13.

E. Rutherford's Twin Microcalorimeters with Two Resistance Thermometers Forming Two Arms of a Wheatstone Bridge.

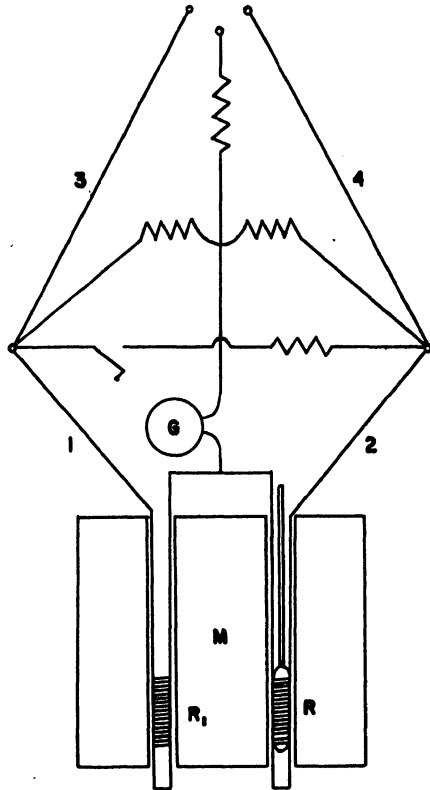

tive measurements. A number of thermometric and calorimetric corrections were eliminated and for this reason the heat produced by the current passing through the platinum resistance thermometers could also be neglected. It was included in the calibration of the apparatus. It should be emphasized that the method could easily be used for examining thermal effects of short duration. The authors pointed out that "It was essential to employ a method whereby rapidly changing heating effects could be followed with ease and accuracy."

To this statement another remark should be added. The method could not be used for measuring thermal processes of long duration, first, because of the jacket, which was not adapted to such experiments and, secondly, because of the heat developed by the current passing through the resistance thermometers.

§ 32. **Ether Twin Microcalorimeters.** Another type of twin calorimeter was described by W. Duane.³⁵ The method used by this investigator

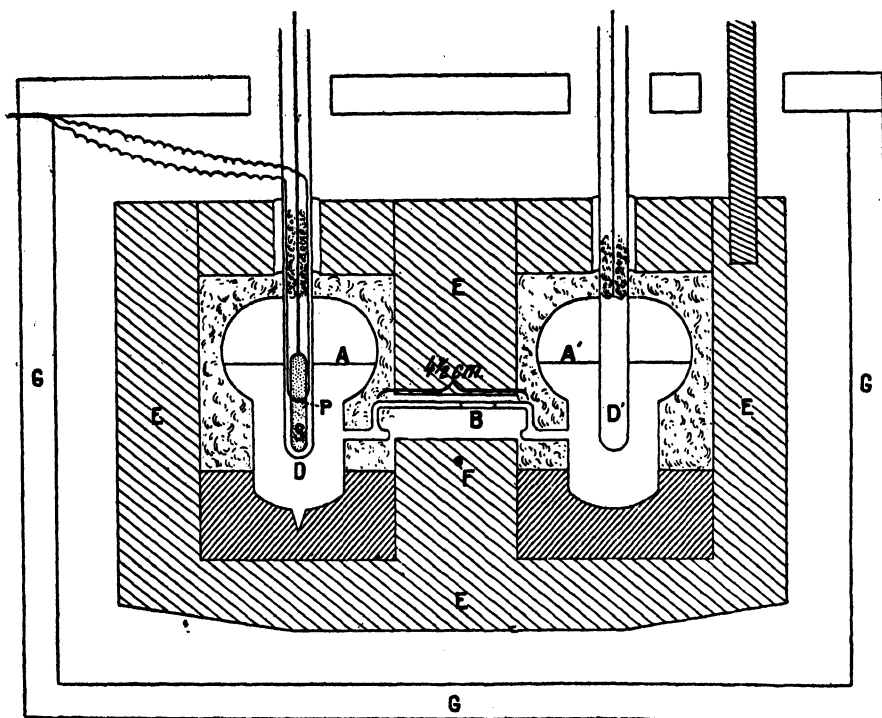

Figure 14. Duane's Ether Differential Microcalorimeters.

was quite different from those previously described. It was based on the observation of the change in vapor tension of ether caused by the temperature changes produced by either the object or an electric current. In Figure 14 Duane's twin calorimeters are shown. Both of them were filled with ether up to the level *A* and *A'*. They were located side by side in box, *G*, and protected by insulation, *E*, against heat exchange with the surroundings. In the center of each of the vessels a tube was sealed in (*D* and *D'*) so that the object, *S*, under examination might be transferred from one calorimeter to the other, or one tube might contain the object

and the other an electric heater. In that case the electric current compensated the heat produced by the object.

The vessels were connected by a narrow tube, *B*, filled with liquid ether. In the middle of the tube there was a bubble of air. About one-half of the volume of each of the calorimeters was left free and contained only ether vapor.

The box containing the apparatus should be located in a constant-temperature room, to avoid any change in temperature. The experiment is started by proving that thermal equilibrium has been established. At equilibrium the air bubble remains in its zero position. Then the object is placed in one of the vessels. Because of the heat liberated, the vapor tension increases inside that vessel and the air bubble starts moving toward the second calorimeter. Transferring the object from one vessel to the other, one may observe a change in the direction of the movement of the air bubble.

Duane pointed out that two other methods may also be used. One consists in keeping the bubble moving until a state of equilibrium is established, the other in compensating electrically the heat liberated by the object. To do this an electric heater should be located in the second vessel.

According to Duane,³⁵ the accuracy of the method is great enough to measure the amount of heat produced in one hour to the order of 10^{-3} calorie. He emphasized the importance of completing the measurement in a very short time.

Duane used a radium preparation as a reference substance. He described an experiment³⁵ in which he found that a certain preparation of polonium developed the same amount of heat (0.0117 gram calorie per hour) as 0.749 mg of radium bromide. From this observation he concluded that "the quantities of radium and polonium which were characterized by the same ionization current evolved almost the same quantities of heat. This is in accordance with the hypothesis that the heat liberated by these substances was caused by the kinetic energy of the alpha rays." It is possible to assume that Duane himself classified his method as one which should be based entirely on comparative observations. If so, it may easily be explained why he did not give any theoretical background to explain the details of the functioning of his apparatus.

The writer and his collaborators tried to employ Duane's microcalorimeter for measuring the heat developed by radioactive minerals. The results were rather negative. This may be explained by the fact that the amount of heat produced by those minerals was too small. It seems, however, that there are factors which make the proper functioning of the ether twin microcalorimeters rather uncertain.

The main factor which may cause errors is the lack of uniformity in the

distribution of the temperature on the surface of the liquid ether from which the vapors evaporate. This lack of uniformity may easily be explained because there is no stirring inside the liquid; therefore it may be expected that there is a complex distribution of the temperature in those layers which are more or less close to the central tube in which the object producing heat is located. The convection of the "warmer" part of the ether which touches the walls of the tube cannot assure proper mixing of the liquid, even in the vicinity of the tube. Under such conditions the vapor tension of the ether cannot correspond to the saturated state related to any temperature which may exist on the surface of the liquid phase. In addition, a difference in temperature should exist between the liquid touching the walls of the tube and any other surface in contact with ether vapors. Because of that, one may expect that vaporization, as well as condensation of the ether may take place, especially on the walls of the vessel far from the central tube in which the object or the electric heater liberates some heat. Under these conditions it is difficult to know exactly what vapor tension will correspond to the "dynamic" or the "static" equilibrium which might be established inside the system. The state of such a dynamic equilibrium can be reached and the air bubble in capillary tube *B* may remain motionless (Figure 14) at the moment that the amount of ether evaporated in the vicinity of the central tube is equal to the amount condensed on the upper (cooler) walls of the vessel. The overpressure in the vessel will not correspond to any static conditions and the "average" temperature inside the vessel will not be uniform and equal to that which could be calculated from the vapor pressure-temperature relation for ether.

The phenomena associated with the surface tension of ether also have an unfavorable influence on the functioning of Duane's calorimeter. In spite of the low surface tension of ether, it is great enough to cause a lag in the movement of the air bubble in the capillary tube joining the two calorimeters. This lag becomes a source of error if very small thermal effects are measured. The same phenomenon is observed if the compensation method is employed and the movement of the bubble is caused by very small differences in vapor pressures of ether established in the twin apparatus. Because of this, the bubble remains in its zero position in spite of the fact that small differences in heat development caused by the object and the electric heater may still exist.

Duane emphasized that the Peltier effect may be used to compensate the heat evolved by the object. This method, however, required a correction for the Joule effect, and its calculation may be associated with some difficulties because of the unknown heat balance of the whole calorimetric process taking place.

In conclusion, it should be pointed out that without further improve-

ments in the structure and in the functioning of the Duane ether micro-calorimeters their application must be very limited.

§ 33. **Differential Method for Measuring the Heat of Absorption of Gamma Rays.** In the first experiments on the determination of the heat developed by radioactive elements little attention was paid to the exact

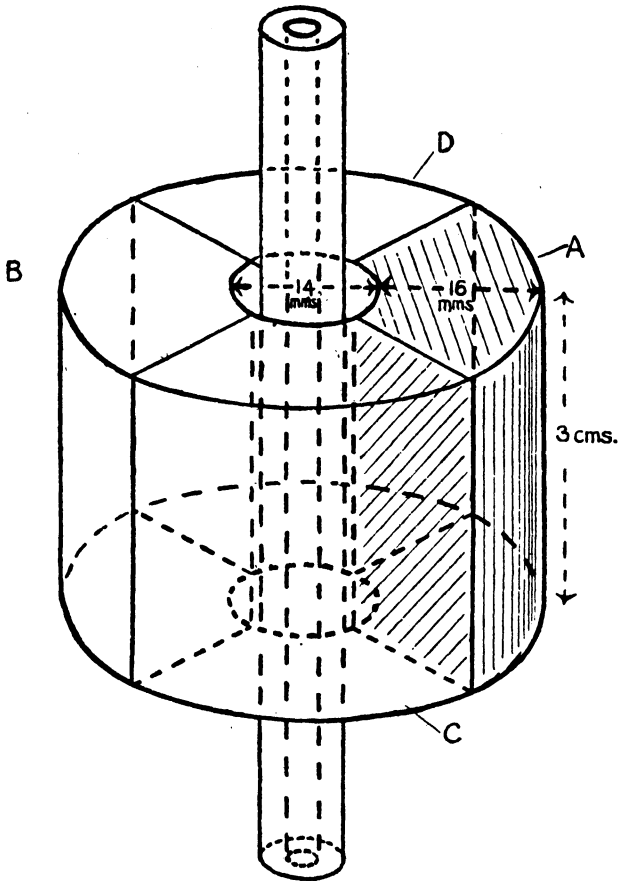

Figure 15. Ellis and Wooster's Calorimeter for Gamma Rays.

determination of the heat of absorption of gamma rays. The latter constituted a relatively small percentage of the total amount of heat. In addition, it was not possible to absorb all of the gamma radiation. There were also difficulties in measuring exclusively the heat of absorption of gamma rays because alpha and beta particles were absorbed by the same screen. The first experiments in which exclusively the heat of absorption of gamma rays was measured were carried out in 1925 and 1927 by C. D. Ellis and

W. A. Wooster.^{37, 38} They succeeded in building an apparatus in which the alpha and beta particles were removed by absorption before the gamma rays reached the screen of the calorimeter proper.

It should be emphasized that at the time that Ellis and Wooster made their investigations there was no precise method for measuring the heat of absorption of all the particles and most of the gamma radiation in such a way as to be able to calculate the heat of absorption of the gamma rays alone. For this reason, it was important to measure with reasonable accuracy the heat produced only by gamma rays.

In Figure 15 the apparatus used by Ellis and Wooster is shown schematically. The glass tube, 8 mm in length, containing the radioactive substance was located in a copper rod provided with a hole, 8 mm in diameter, bored throughout its length. This rod was placed in the center of a hollow cylinder made of four equal sectors. "Two opposing ones, *A* and *B*, were respectively of lead and aluminum, and they were insulated from one another by the two other sectors, *C* and *D*, of balsa wood" . . . "This composite cylinder was fixed inside another closely fitting cylinder of balsa wood and caps of balsa wood placed at each end. The whole fitted inside a thick copper case. Nineteen silver-constantan thermocouples in series were wound round the composite cylinder so as to record any temperature difference of the lead and aluminum sector."

Since the alpha and most of the beta particles are easily absorbed by relatively thin layers of copper, none of the alpha particles and only a few of the beta particles could penetrate the copper rod. A given percentage of gamma radiations were absorbed by the copper walls; most of them however, reached the sectors of the cylinders. As the absorption coefficients of lead and aluminum are different and the numerical values could be determined directly, it becomes possible to calculate the difference between the amount of gamma rays absorbed by each of these two sectors. This difference in absorption produced a difference in temperature which could be measured by the thermocouples.

To avoid secondary phenomena resulting from the difference in the specific heat of lead and aluminum, sector *A*, made of aluminum, was provided with holes so that the energy equivalents of both the aluminum and lead sectors would be equal. Because of this, the heat radiated by the copper rod, due to the absorption of alpha and beta particles (and some of the gamma rays), exerted the same influence on the changes in temperature of both the aluminum and the lead sectors. For this reason, the rates of heating of those sectors were identical. Consequently, the difference in temperature found in *A* and *B* was caused by the difference in absorption of gamma rays by the lead and aluminum sectors. The authors explained³⁷ that "the method of making measurements was to observe the maximum

deflection reached when the rate of heat supply was equal to the rate of heat losses." They added that "the actual rise curve was rather complicated, a maximum deflection being reached in 45 minutes, after which the deflection decreased slowly."

It is obvious that the method was based entirely on the principle of comparative measurements, with the main purpose of eliminating corrections, as far as possible, especially those related to the heat losses caused by the lack of an adiabatic jacket.

To give the reader an idea of how accurate the measurements could be made, the following table is given.

Values of Source (millicuries)	Deflection (millimeters)	Deflection for 70.5 millicuries
58.02	5.60	6.81
58.45	4.69	6.83
40.47	3.81	6.64
33.80	3.31	6.90
28.23	2.75	6.87
	Mean.....	<u>6.81</u>

The experimental error for this relative value is rather small. To calculate the heat produced by the absorption of gamma rays a number of supplementary values should be known or measured. First of all, the precise figures for the absorption coefficients of gamma rays for lead and aluminum should be determined or known in advance.

Ellis and Wooster gave the following summary of the results obtained:

(1) "the heating effect of the total gamma rays emitted by the quantity of radium B and radium C in equilibrium with one gram of radium has been found to be 8.6 calories an hour; (2) of this, 0.86 calorie an hour is to be attributed to radium B and 7.7 calories an hour to radium C."

Another method of direct measurement of the heat produced by gamma radiations^{107, 129} is discussed in Chapter VIII (§ 69).

§ 34. **General Discussion.** From the point of view of the history of microcalorimetric measurements, all the methods described in this chapter form a natural transition from the macrocalorimetric methods used in the past to the new technique based on using isothermal or adiabatic jackets. Even though they were better adjusted for measuring thermal processes of long duration than the old calorimetric methods, it still was advisable to complete the measurements in the shortest possible time. Two factors were responsible for this. First, in spite of the proper insulation of the jacket, the heat exchange between the calorimeter and the jacket could not be as constant and as regular as desired. Secondly, because of the complexity of secondary processes taking place in the calorimeter, it was dangerous to prolong the experiment. In spite of this, these methods constitute an important improvement in the technique of conducting the

measurements when compared with the methods applied in the past. In all of them the principle of absolute measurements was abandoned. The simplicity of the method of comparative measurements was so obvious that it became a dominating factor in the new technique in calorimetry as a whole. The fact that this is the only way to eliminate most thermometric and calorimetric corrections seems to have been recognized by all the specialists in this field.

Chapter V

Use of the Ice Calorimeter in Microthermal Measurements

§ 35. **Application of the Ice Calorimeter in Radiology.** It has been pointed out that the ice calorimeter was the only apparatus which in the past could be used for measuring the heat developed by a thermal process of long duration. For this reason, it can easily be understood that attempts were made to employ this apparatus in radiology. J. Precht^{82, 83} first published such results obtained with Bunsen's ice calorimeter. Nevertheless, it is very probable that experiments with the ice calorimeter were carried out in Paris before and after Precht's papers. The writer discussed this question with Madame Curie. She was of the opinion that radiations had an effect unfavorable to the proper functioning of the ice calorimeter. It is possible that because of uncertain results no publication from the Radium Institute at Paris appeared at that time.

The question whether or not secondary phenomena make the precise determination of radiations impossible, or at least difficult, remains unanswered. In fact, in the first stage of microcalorimetric investigations in radiology no thick lead screens were employed for absorption of all the alpha and beta particles and most of the gamma rays. As far as is known to the writer, a conventional type of ice calorimeter was used, in which the central tube provided no space for massive lead screens. A conventional type of Bunsen's ice calorimeter was employed also in Precht's measurements.

At the present time it is possible to absorb all the alpha and beta particles and to use lead screens thick enough to remove at least ninety per cent of the gamma rays. If, however, the remaining ten per cent of gamma rays may cause secondary phenomena (§ 38) the use of the ice calorimeter in radiology should be abandoned once and for all. No evidence whatsoever has been found that systematic errors may appear in microcalorimetric measurements of this kind. It is quite possible that negative results found in applications of the ice calorimeter in radiology could be caused by penetration of beta particles into the space where direct contact exists between ice and water. To avoid any misinterpretation, a general discussion of the phenomena taking place in the ice calorimeter is given (see § 38, 45). From that discussion one may conclude that, in

spite of the apparent simplicity of the phenomena on which the functioning of the ice calorimeter is based, there still remain undiscovered factors which create difficulties in conducting calorimetric measurements of high precision.

§ 36. **Precht's Determination of Heat of Absorption of Radium Radiation.** Apparently the screen used by J. Precht in his first measurements for absorption of alpha and beta particles and of gamma rays was not very effective. Under these conditions it is possible that not only a high percentage of gamma rays but also some number of beta particles penetrated the space filled with ice and water. For this reason, the values found in Precht's first determinations were too low. These values did not differ from those found by other experimenters, who employed quite different methods but also used screens which were too thin. According to a summary of results given in 1918 by E. Schweidler and V. F. Hess,⁹² the following values have been found for the heat of absorption of particles and rays emitted by one gram of radium.

Author	Year	Method	Gramcalories per gram per hour
Curie and Laborde	1903		100
Runge and Precht	1903		105
Rutherford and Barnes	1903	Twin Calor. Comp. Method	110
Precht	1904	Ice Calor.	113.3
Ångström	1905	Twin Cal. Comp. Method	117
Precht	1906	Ice Calorimeter	134
Schweidler	1908	Twin Cal. Comp. Method	118

Since in the past no precise indications were given regarding the use of the screen and the percentage of absorbed particles and rays, it is difficult to draw any definite conclusion about the superiority of other methods when compared with the ice calorimeter. Apparently no systematic errors were committed in Precht's investigations which could disqualify the ice calorimeter. In order to determine definitely whether or not the gamma radiation may originate undesirable secondary phenomena affecting the regular melting or freezing of water (see § 38, 45), additional investigations should be made not only with radium preparations but also with x-rays.

§ 37. **Experiments with Twin Ice Calorimeters.** Twin ice calorimeters of conventional size and equal volume were used by the writer and his associates to establish whether or not the rate of volume changes would be the same, when both calorimeters were placed in the same large thermostat filled with pure ice and distilled water. The results of this experiment were *negative*. No other explanation can be given to that fact than that some secondary phenomena take place inside the ice calorimeter, and that the strictly isothermal thermostat, which protects the calorimeter against any heat exchange with the outside surroundings, cannot prevent their appear-

ance. This should be considered as the cause of errors which may be made when using the ice calorimeter for measuring a very small amount of heat. The purpose of further investigations consisted in finding the conditions under which these unspecified phenomena, associated with some irregular melting of ice or freezing of water, could be controlled or at least considerably reduced, so as to make it possible to undertake microcalorimetric measurements in that apparatus.

§ 38. **Secondary Phenomena Inside the Ice Calorimeter.** Let us assume that a Bunsen ice calorimeter of usual size and shape has been located in a large container filled with ice and surrounded by a larger vessel also filled with ice. Let us also suppose that the outside surface of tube, *O*, located in the center (see Figure 16) is covered with a layer of ice, *I*, so that the calorimeter is ready for starting an experiment. It should be remembered that in the Bunsen ice calorimeter there is a bent glass tube (see Figure 20) sealed to the bottom so that it connects the inside space of the calorimeter with the capillary tube. The latter is located on a level somewhat higher than the upper level of the calorimeter. It can be inclined as shown in Figure 20. Because the vertical and the capillary tubes are filled with mercury, the mixture of ice and water in the ice calorimeter is under a pressure higher than atmospheric. It changes along the height of the calorimeter and reaches a maximum at its bottom. Because of these conditions no thermodynamic equilibrium can exist between the solid and liquid phase inside the calorimeter. The same phenomena exist to some extent in the container filled with ice, although it is usually considered as a zero temperature thermostat. It is true that the temperature is very close to zero, but no thermodynamic equilibrium exists at any level inside that container, except the upper layer, which is kept under atmospheric pressure. Inside the container the ice is kept under hydraulic pressure which increases from zero to that existing at the bottom of the apparatus. For this reason the melting of ice should take place both in the calorimeter and in the jacket. Consequently, certain thermal phenomena should take place everywhere in the calorimeter and in the jacket even if no heat is developed by the object under examination.

Let us examine first the phenomena which occur in the jacket. On any level inside the jacket the melting of ice should take place. As the melting of ice is associated with an absorption of heat, a somewhat lower temperature will be established at that layer. If, however, the container is kept under strictly adiabatic conditions a "migration of ice" will be observed. After a long period of time only one layer of ice, at the top of the container, will be found.

Inside the vessel of the ice calorimeter a migration of ice should also take place. In fact, along the height of central tube *O* (Figure 16) the

pressure increases steadily from the top to the bottom. This is due not only to the change in hydraulic pressure of water but, to a larger extent, to the pressure of mercury in the side tube joining the calorimeter with the capillary tube (Figure 20).

In the discussion given above, the time was not limited, since the conditions of a thermodynamic equilibrium were discussed. These conditions are never fulfilled in any experiment with the ice calorimeter. For this reason not only the migration of ice but other secondary phenomena take place. These phenomena are responsible for the differences in the behavior of the twin ice calorimeters, when they were kept under strictly identical conditions.

The writer is unable to give any numerical data concerning the velocity of crystallization of water in the case where the supercooling is extremely slight. If under the conditions prevailing in the ice calorimeter that velocity is not great enough, secondary phenomena taking place are caused primarily by that slowly proceeding process. The convection caused by the change in density complicates the phenomena. In some places the supercooled water is brought into contact with ice. In those places the crystallization is certainly speeded up. As a result, relatively large and rapid displacements of the mercury meniscus in the capillary tube are observed. These phenomena should certainly be noticed in both of the twin ice calorimeters located in a common ice jacket. However, the formation of ice may take place earlier in one calorimeter and later in the other. For this reason the twin ice calorimeters behave differently.

Independently of what is happening because of a slow migration of ice, there are other secondary phenomena which appear after the calorimetric measurement is started. These phenomena do not play a significant role in macrocalorimetric measurements. They cannot be neglected, however, if microthermal processes are examined.

Let us start with a general case independently of whether small or large amounts of heat are produced by the object or transferred with it. Three cases are very characteristic. First, the volume of object B (Figure 16) may be large and its surface may be similar to that of central tube O . Secondly, the object may be small and may occupy a small part of the space in O . The amount of heat produced by the latter object may cause the melting of ice somewhere near the bottom of tube O , as shown in Figure 17. No connection between W and W_1 will be observed. Finally, it may happen that the amount of heat produced by the object will be so large that the layer of ice may be melted through at the bottom, so that a direct connection will be established between water, W (obtained by melting of ice) and W_1 found on the other side of the layer of ice, I .

Let us discuss these three cases separately. The first case is presented

in Figure 16. The heat evolved by the object produces a melting of some amount of ice; however, the layer of ice is not melted through. At the beginning of the melting it may happen that no direct connection between W and C will exist. Because of that, even a low pressure may be established in W . This state cannot last but a few seconds. Shortly after the start of

Figure 16.

Object B Forms a Regular Layer of Water W . Only a "Capillary" Connection Somewhere Along the Surface of Tube O is Formed Between W and C .

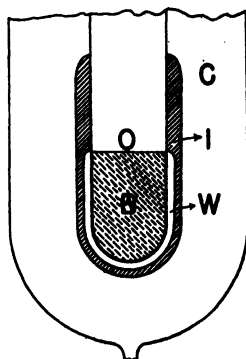

the experiment, a connection will be established between W and C due to a capillary layer of water formed along tube O . Usually it appears at the moment when the "warm" object is transferred into the calorimeter.

In macrothermal measurements this transition stage has no significance. If a capillary layer of water is not formed, the ice may be broken somewhere and a rapid decrease in the volume of the ice-water mixture will be observed.

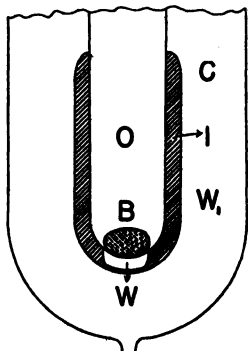

Figure 17.

Formation of Large Amount of Water at the Bottom of Tube O . No Connection Between W and W_1 .

In microcalorimetric measurements a lack of connection between layer W and the water phase in C may cause some trouble. To avoid this, it is necessary to melt in advance a very small amount of ice along central tube O , so as to facilitate the connection between the water obtained by the melted ice, W , and that which is found outside the solid phase in C .

The conditions are quite different if a large amount of heat is introduced by an object occupying a small volume. In this case a large amount of ice is melted at the bottom of central tube *O*. Two possibilities exist, both of which are schematically shown in Figures 17 and 18.

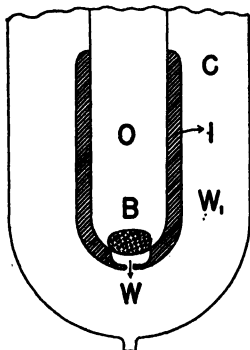

Figure 18.

Formation of Large Amount of Water at the Bottom of Tube *O*. Connection Formed Between *W* and *W*₁.

It may happen that a relatively large amount of water will be formed at the bottom of central tube *O*. In this case some portion of that water may be heated to a higher temperature than 0°C . Therefore, the experimenter should carefully note the changes in the position of the meniscus so as to find the proper moment when the whole heat exchange is really completed.

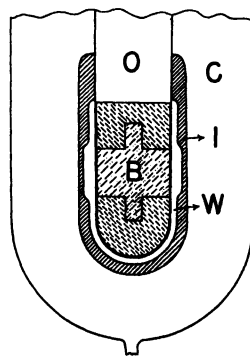

Figure 19.

Complex Form of the Layer of Water Because of Lack of Uniformity in the Structure of the Object.

Another case is shown in Figure 18. Here the amount of heat developed in one particular place was too great; as a result, the layer of ice at the bottom of the tube was melted through. A direct connection has been established between *W* and *W*₁. If occasionally no "warm" water has left space *W*, the experiment may be a successful one. If, however, some amount of water heated to a temperature higher than 0°C had penetrated into space *W*₁ the danger exists that no precise reading corresponding to the final stage of the heat exchange could be made.

In both cases shown in Figures 17 and 18 the freezing of water in *W* should be made before the start of any new experiment.

In Figure 19 another case is presented. It may happen that the object may consist of several parts made of different materials. In this case care should be taken to avoid melting through the ice layer. The example shown in Figure 19 is simple and does not cause any trouble. If, however, the surface of the object is uneven and if there is a lack of uniformity in the structure of the object, the layer of ice may be melted through. If that kind of object is examined, special care should be taken to prevent the ice from melting through where the development of the largest amount of heat is expected.

In addition to these preparatory operations, during the experiment the proper time should be found at which all the heat evolved has been used for melting the ice. To obtain proper results the rate of displacement of the mercury meniscus should be observed longer than usual. The errors which may result because of these phenomena are relatively small in macrocalorimetric measurements. In microcalorimetry, however, their influence is usually so great that special precautions should be taken to get proper results. For this reason the writer decided to change the structure of the apparatus and the method of carrying out the measurements.

§ 39. **Ice Calorimeter for Microthermal Measurements.** In 1934 the writer and his associates¹⁰⁵ built and examined the performance of an ice calorimeter adapted for microthermal measurements. After a series of preliminary experiments, it was found that the following conditions should be fulfilled: (1) the calorimeter should be made of stainless steel; (2) the capacity of the central tube, serving as the calorimetric space proper, should be at least 500 ml, to facilitate the examination of large objects; (3) the space filled with ice and water should be as small as possible; (4) the layer of ice should be thin; (5) between the central tube and the layer of ice a very thin layer of water should be formed before the start of an experiment; (6) the layer of water found between the ice and the outside walls of the calorimeter should be from 60 to 70 per cent of the total amount of water and ice found in that space; (7) an arrangement should be made to make it possible to maintain inside the calorimeter an over- or under-pressure in the range from 0.3 up to 1.5 atmospheres. This could be accomplished by joining the free end of capillary tube *H* (Figure 20) with differential manometer *M*.

Figure 20 shows the ice calorimeter which fulfilled all the conditions mentioned above. To protect it against any temperature changes the calorimeter (*B*) was immersed in container *C*, which was filled with pure ice and distilled water. The series of coaxial vessels *D*, *E*, *F* and *G* which protected the central jacket against heat gains were filled with ordinary ice.

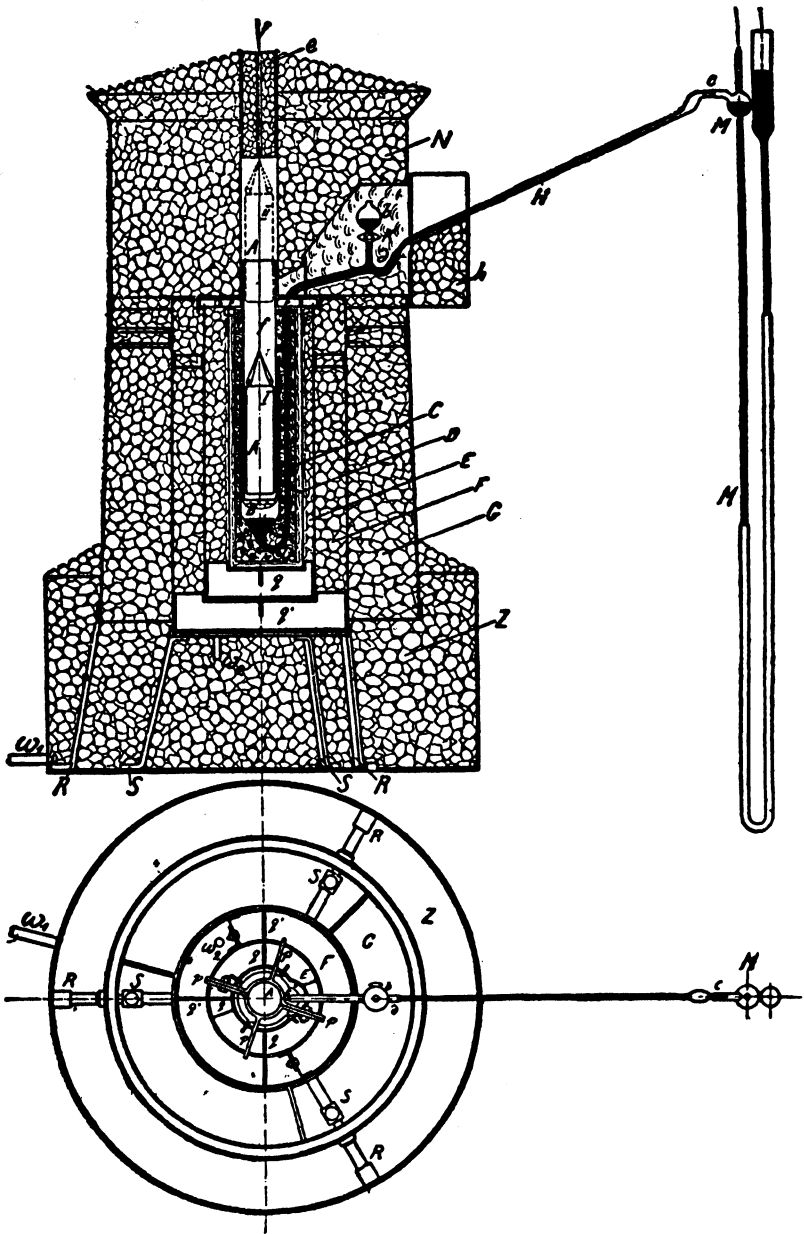

Figure 20. Ice Calorimeter Made of Steel With Arrangement for Establishing a Desired Pressure in the Space Filled With Ice and Water.

Experiments have shown that the temperature fluctuations during the whole period in which a set of measurements could be made (two to three weeks) did not exceed $\pm 0.002^\circ \text{C}$ in the jacket.

The following details in structure and in handling the apparatus have been found essential. The central steel tube was provided with a prolongation and the latter was kept at the temperature of melting ice by means of large vessel *N*, filled with ice. This vessel served at the same time as the cap of the external calorimetric jacket, *G*. The object was kept in that prolongation (position II, Figure 20) for several hours before it was immersed in the calorimeter (position I). The upper end of the central tube was also thermally protected by means of small vessel *e*, so that the upper part of object *A* could not be heated from outside.

The temperature of ice in *N* as well as in *C*, *D*, *E*, *F* and *G* was usually lower by $0.009 - 0.010^\circ \text{C}$ than the freezing temperature of chemically pure ice. This was found by direct experiments. This lowering of the freezing temperature of ice could be easily explained by the presence of carbon dioxide and mineral salts contained in the frozen water. A very small depression of the freezing temperature could appear also as the result of the hydraulic pressure, inside the vessel. This difference in temperature was mainly responsible for a small "positive" displacement of the meniscus in the capillary tube each time after the object had been transferred from the upper portion into "working" space, *A*, of the calorimeter.

It has been established by direct experiments that once every several weeks the layer of ice should be melted in *B* and a new uniform ice layer should be formed. Before starting this operation it was necessary to open the outlet tube attached to the bulb, *M*, of the manometer in order to establish the atmospheric pressure in the apparatus. Then stopcock *K* (Figure 21) should be turned on so as to establish a direct connection of mercury in *b* with that in the calorimeter and in the capillary tube. From that moment on, large changes in volume of the ice-water mixture could be made without danger that the mercury in the capillary tube would be thrown out or pulled down into the vertical tube. Having this in view, capillary tube *H* was inclined so that large changes in the level of mercury in *b* could produce but small displacements of the mercury meniscus in *H*. This was essential, because it made it possible to melt the ice layer in the calorimeter and to form a new layer, without the necessity of removing the capillary tube and of leaving the ground joint open.

Another detail in the structure was also important. It consisted in leaving the outside surface of steel tube *A* purposely rough in order to have the layer of ice firmly attached to the walls even after a very tiny layer of water had been formed between the surface of tube *A* and the ice layer.

The details of the structure of the ice calorimeter for microthermal

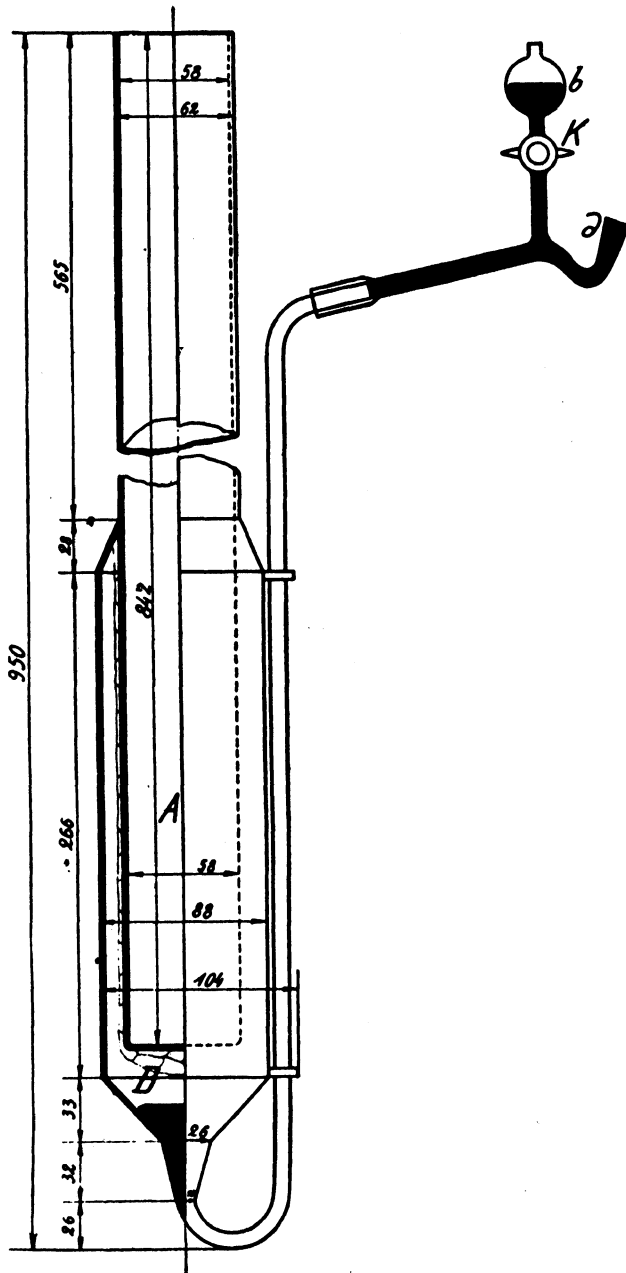

Figure 21. Ice Calorimeter Made of Steel With Capillary Tube and Safety Container *b* Filled with Mercury.

measurements are shown in Figure 21. All the dimensions are given in millimeters. The surface of the outside tube covered with the layer of ice was about 650 sq cm. The capillary tube was 450 mm long. One division on its scale corresponded to 1.37 calories, so that the largest amount of heat which could be measured was 30 calories. These figures show how important it was to use vessel *b* filled with mercury, and to have extended tube *A* so as to cool the object to 0° C (it sometimes weighed several kilograms) before transferring it to the calorimeter proper (position I, Figure 20).

The formation of the ice layer was one of the operations which required some skill. First, it was necessary to supercool the water by immersing a metallic cylinder cooled to a temperature lower than 0° C. In most cases no formation of ice was observed. The water remained supercooled. At that time the metallic cylinder was removed and a metallic rod, cooled to a very low temperature, was rapidly transferred into the calorimeter and was moved up and down in different places along the outside surface of tube *A* so as to produce a large number of small crystals of ice attached to that surface. If such a formation of seeding crystals was successful, the layer of ice was formed in a few minutes. Otherwise, it was necessary to repeat the whole operation from the beginning.

The next operation consisted in the formation of a thin layer of water between the layer of ice and the walls of tube *A*. This was usually made by immersing the same metallic cylinder at a temperature slightly above the melting point of ice. The thickness of that layer should not be greater than a few hundredths of a millimeter. It was necessary to carry out this operation after the connection between vessel *b* and the calorimeter was discontinued. For this reason stopcock *K* should be turned off. From then on, the calorimeter was ready for establishment of an appropriate pressure in order to reduce to a minimum the rate of the displacement of the mercury meniscus in the capillary tube. A large number of observations have shown that it is more convenient to work with a "positive displacement" of the meniscus, at least before transferring the object. This meant that such a pressure had to be established in the calorimeter to observe the slow freezing of water and not the melting of ice. The pressure could be regulated to such an extent that in twelve hours not more than 0.01 to 0.02 gram of ice was formed. It was evident that the water found in the tiny layer between the walls of the calorimeter and the layer of ice, and not that found outside this layer, underwent freezing.

It should be emphasized that the migration of ice inside the calorimeter (see § 37) could take place even if no movement of the meniscus was observed. In fact, the migration consists in the melting of ice at one level and its formation at another. If both phenomena take place simultane-

ously with the same velocity, no changes in volume occur. If, however, the melting in one place and freezing in another proceed at different rates, the mercury in the capillary tube is moving up or down, and often these displacements are irregular. This is the most dangerous phenomenon in microthermal measurements because it cannot be controlled. Usually, it is not observed if the migration of ice takes place exclusively in the tiny layer between the ice and central tube *A*. The migration may be reduced to a minimum by establishing an appropriate pressure in the calorimeter. Experiments have shown that this pressure has to be found by direct observation. It cannot be calculated in advance.

The object or metallic screens used for absorption of particles and rays emitted by radioactive elements play an important role in speeding the process of the migration of ice. The following consideration makes it clear. Suppose that the calorimeter is used for measuring the heat developed by a radium preparation sealed into a tiny glass tube. It is easy to carry out the measurement in the following way. The cylinder of lead provided with the hole bored through its center up to the middle of its height may be located one or two hours before the start of the measurement in the lower part of the central tube (position I, Figure 20). Another massive cylinder should be located in the upper part of the tube (position II). The glass tube containing radium should be located in the cylinder. In that way it can be cooled to 0° C. At a given moment the glass tube is transferred from the upper cylinder to the lower one, and the measurement starts at this point.

Let us examine the influence of the cylinder of lead on the migration of ice inside the calorimeter. The thermal conductivity of lead favors the heat exchange between different layers of ice and water in the neighborhood of the wall of the central tube (Figure 20). The melting of ice in one place and the freezing of water in another may be speeded up by the heat transfer through the massive block of lead. Because of this phenomenon the displacements of the mercury meniscus in the capillary tube (*H*, Figure 20) are more regular in the presence of the metallic screen than without it.

§ 40. Freezing the Thin Layer of Water and Refilling the Jacket with Ice. In the previous paragraph the formation of new layers of ice and water have been described. If several measurements follow one after another it is not necessary to melt the ice each time and to start from the beginning the complicated procedure of forming a new layer. It suffices to freeze only the layer of water which has been produced by the heat evolved by the object. This operation should be made each time after a measurement has been completed. The description which follows refers to both macro- and microcalorimetric measurements. The difference

consists only in the amount of water to be frozen and in the shape of the layer of water formed. The latter varies to a large extent and depends upon the volume and the shape of the object, as well as upon the amount of heat developed per unit of its volume. Some typical cases have been discussed in § 37 and schematically shown in Figures 16, 17, 18, and 19. In microcalorimetric measurements there are fewer variations in the shape of the water layer, because in general the volume of water obtained by the melting of ice is very small. Usually it does not exceed 0.4 ml. In most cases a very thin layer of ice along the whole working surface undergoes melting so that the micro-layer of water is rather regular.

The freezing of any kind of layer of water found between the ice and the walls of the central tube can be made in the following manner. A metallic cylinder (or a sphere in macrocalorimetric measurements in which a large bubble of water was formed, as shown in Figure 17) with walls well adjusted to those of the central tube of the calorimeter is cooled to the temperature required to compensate the heat liberated by the object in the previous experiment.

If, for some reason, the object was not cylindrical (or spherical in macrocalorimetric experiments), a shape similar to that of the object should be used. After an adequate cooling, the cylinder (or, generally speaking, the object) should be transferred as rapidly as possible to the calorimeter. Enough time should be given to complete the heat exchange. Afterwards the object should be removed. The temperature of the cylinder should be low enough to freeze all the water found in the layer between the walls of the calorimeter and the ice layer. Before starting the next measurement a tiny layer of water should be formed. This operation should be performed as carefully as possible. The same metallic cylinder may be used, and it should be heated to such a temperature as to produce a layer of water 0.01 to 0.03 millimeter thick.

The refilling of outside jacket *G* (Figure 20) with ice is a simple operation. It should be done once or twice in 24 hours. In the case described in § 39 the refilling was made once a day and it could be completed in 20 minutes. As the melted water in *G*, as well as in all other containers, could flow down to the bottom of container *Z*, it was automatically removed from there into the tank through outlet tube *W*₁. It was necessary to add ice in *G* and to put some pieces of it in *C*, *D*, *E* and *F* (once every several days). The refilling of cover *N* was done twice a day.

The insulation of the apparatus could very easily be removed for refilling. It protected the calorimeter to such an extent that the daily consumption of ice in the summer did not exceed 25 kg.

§ 41. **Blank Experiments.** The functioning of the calorimeter described in § 39 was examined by using an electric heater built in a massive

cylinder of lead weighing 1900 g. First of all it was necessary to answer the question: What is the smallest amount of heat which could be detected? It was essential also to produce very small capillary surfaces of water between the walls of the calorimeter and the layer of ice, and to see whether some secondary phenomena caused by the surface tension of water could take place. No undesirable phenomena were observed. In spite of this, the measurements were carried out in the presence of a thin layer of water purposely formed by melting the ice. This was necessary in order to start the experiment with a "positive displacement" of the mercury in the capillary (see § 39). Experiments have shown that the smallest amount of heat which could be measured was 0.03 gram calories per hour. Therefore, if a cylinder made of a radioactive mineral like pitchblende weighing from 1000 to 1900 g was placed in the calorimeter, 10^{-5} calorie per gram per hour could be detected. The error, however, was relatively high.

The following data have been obtained in a series of measurements in which an electric heater with a resistance of 0.065 ohm was used.

i	0.132	0.132	0.132	0.250	0.061	0.062	0.041	0.041
Δq_m	1.054	0.944	1.054	3.682	0.219	0.233	0.093	0.095
Δq_c	0.994	0.978	1.008	3.510	0.209	0.216	0.094	0.094
Differences	+0.060	-0.034	+0.046	(+0.172)	-0.010	-0.017	-0.001	+0.001

In this table i is the intensity of the electric current expressed in amperes, Δq_m and Δq_c are the amounts of heat in calories measured and calculated. If the value +0.172 is rejected because of an unusually large deviation, the average error is somewhat lower than 0.03 calorie.

In addition to these experiments with an electric heater the following series of measurements was made in which 4.47 mg of radium in a sealed tube was located in the center of the same massive cylinder of lead:

v	Δv	ΔQh
-0.67	-0.48	0.657
-0.64	-0.46	0.630
-1.81	-0.49	0.671
-0.71	-0.50	0.684
-0.79	-0.51	0.698
-0.64	-0.48	0.657
-0.07	-0.49	0.671

Average: $0.667 \pm 2.4\%$

In all these experiments the v values were negative, which meant that the pressure in the calorimeter was high enough to melt the ice even after the radium preparation had been removed. The average value, 0.667 calorie per hour, was close to that found by another method (0.676 cal/h).

§ 42. Heat Produced by Pitchblende. Another series of experiments was made using pitchblende as the object. In these measurements

a massive cylinder made of pitchblende was located in a thin (2-mm) copper cylinder. Under these conditions, taking into consideration that the calorimeter walls were made of steel, no alpha and beta particles could penetrate into the water-ice system and about 90 per cent of the gamma rays were also absorbed. Some portion of these rays, radiated from the layer found in the vicinity of the outside surface of the cylinder, could reach and even pass through the water and ice layers.

The pitchblende used in these measurements was from Jachimovo (Joachimstal) in Czechoslovakia. It was delivered in 1932 by the Ministry of Labor of that country. The sample was taken directly from the plant and its composition could be considered as corresponding to the average composition of the mineral used for manufacturing radium salts.

To avoid any irregularities in the functioning of the calorimeter, new layers of ice and water were formed as previously described (§ 40) and the pressure inside the calorimeter was established so as to have a small positive displacement of the mercury meniscus. Only one experiment (last in the table) gave negative values of v .

Heat Developed by Pitchblende

v	Δv	Q	$Q/g \cdot h$
+ 1.20	- 0.11	+ 0.151	9×10^{-5}
+ 0.54	- 0.09	+ 0.123	7.3×10^{-5}
+ 0.52	- 0.11	+ 0.151	9×10^{-5}
- 0.19	- 0.13	+ 0.178	10.5×10^{-5}
Average value:			8.9×10^{-5} cal.

In the table Δv represents the displacement of the mercury meniscus caused by the heat developed by the pitchblende in an hour; Q the total amount of heat developed by that mineral; $Q/g \cdot h$ the amount of heat developed by one gram of the pitchblende in an hour.

In another series of measurements with the same massive cylinder, a tube containing 4.47 mg of radium was located in the center of the calorimeter. The radium developed 0.676 calorie per hour. The following results were obtained.

Heat Developed by the Pitchblende and 4.47 mg of Radium

v	Δv	ΔQ_1	ΔQ_{R_2}	$\Delta Q_1 - \Delta Q_{R_2}$	$\Delta Q/g \cdot h$
+ 0.64	- 0.59	0.807	0.676	0.131	$7.7 \cdot 10^{-5}$
+ 0.46	- 0.56	0.767	0.676	0.091	$5.4 \cdot 10^{-5}$
- 0.00	- 0.58	0.794	0.676	0.118	$6.9 \cdot 10^{-5}$
Average value:					$6.7 \cdot 10^{-5}$

There is a lack of agreement between the values obtained in two series of measurements which cannot be explained otherwise than by assuming that some secondary phenomena accompanied one series of the measure-

ments. Which is the correct value cannot be concluded without comparison with the data obtained by other methods.

The final conclusion is that the heat liberated by the pitchblende was rather too small to be examined precisely by the method of the ice calorimeter (see § 81).

§ 43. Behavior of Rare Elements. In 1932 the question was raised whether minerals or salts containing rare elements, with atomic numbers from 57 to 73, or even other elements, like arsenic and antimony, develop a very small amount of heat.^{32, 38} In 1934 the Physicochemical Laboratory of the Institute of Technology, Warsaw, Poland, had a number of pure salts and some minerals of rare elements prepared by B. Brauner and J. Sterba Böhm, of Prague, Czechoslovakia. The amounts of these samples were, too small to examine them separately. A large number of them, however, could be located in a cylinder with thin walls made of copper. The whole charge weighed about 1060 g.

In the following table the results of measurements are quoted:

Heat Developed by 1060 g of Different Salts Containing Rare Elements

v	Δv	Q
+0.41	+0.02	-0.027
+0.62	+0.02	-0.027
+1.14	+0.01	-0.013
+0.48	-0.02	+0.027
+0.22	-0.03	+0.041
Average		0.000

In the table v represents positive displacements of the mercury meniscus in the capillary tube in one hour; Δv the decrease or increase of that displacement after the vessel containing the salts had been located in the calorimeter; Q the thermal effect expressed in calories per hour. From the figures obtained it could be concluded that no thermal effect was found exceeding that which is within the limits of experimental error.

The same experiment was repeated after 4.47 g of radium was placed in the center of the cylinder. The total amount of heat developed was equal to 0.684 calorie per hour. This was 0.008 calorie higher than the value 0.676 found by another microcalorimetric method. From those experiments the conclusion could be drawn that all or at least most of the rare elements do not develop heat which could be measured by the method of the ice microcalorimeter. The total amount of heat could be considerably smaller than that evolved by an equal quantity of pitchblende.

In addition to those experiments another was made with sand. Practically the same positive and negative deviations in Q -values were found. This indicated that these deviations were caused by experimental errors

which were of the order of ± 0.03 calorie in experiments lasting one or more hours.

§ 44. **Specific Heat of Minerals and Salts Containing Rare Elements.** To prove the proper functioning of the ice calorimeter described in § 39 a series of measurements of specific heat c of minerals and salts containing rare elements was made.¹⁰⁵ In this series a much smaller ice calorimeter was employed and the measurements resembled conventional experiments with a macrocalorimeter.

In the table below is given the range of temperature for which the average heat capacity was determined. In all cases, except one determination for saccharose, the substance heated to a temperature higher than 0°C was transferred to the ice calorimeter. In one experiment with saccharose the latter was cooled to -14°C and then transferred to the calorimeter. The results of these measurement are as follows:

Iohannite +15-0° C	Thorite +14-0° C	Samarskite +16-0° C	Monazite +37.8-0° C
0.1289	0.1329	0.1073	0.1027
0.1281	0.1340	0.1087	0.1020
0.1291	0.1307	0.1075	0.1024
0.1297	0.1306	0.1078	
0.1290	0.1320		
Scandium Fluorite (ScF ₂ ·3NH ₃ F) +15.4-0° C		Yttrium Nitrate (Y(NO ₃) ₃) +15.5-0° C	
0.4226		0.2772	
0.4212		0.2735	
0.4232		0.2748	
0.4223		0.2752	
Lanthanum Nitrate (La(NO ₃) ₃ ·6H ₂ O) +15.5-0° C		Yttrium Oxalate (Y ₂ (C ₂ H ₄) ₂ ·12H ₂ O) +16.8-0° C	
0.2705		0.4642	
0.2718		0.4642	
0.2716		0.4656	
0.2713		0.4647	
	Lanthanum Oxalate (La ₂ (C ₂ H ₄) ₂ ·12½H ₂ O) +16.6-0° C		
	0.2652		
	0.2623		
	0.2667		
	0.2647		

In addition the specific heats of saccharose, silver and antimony were determined:

Saccharose (C ₁₂ H ₂₂ O ₁₁) +15-0° C	Saccharose (C ₁₂ H ₂₂ O ₁₁)* -14-0° C
0.2783	0.2630
0.2751	0.2608
0.2789	0.2620
0.2774	0.2602
	0.2615

*The purest sample of saccharose available was presented to the writer by the Sugar Research Institute, Warsaw, Poland.

Or $c_0 = 0.2689$ and $dc/dt = 0.00113$ for the range from -14° to $+15^\circ$ C

Silver	Antimony
+4-0° C	+14-0° C
0.05510	0.04748
0.05546	0.04755
0.05573	0.04731
<u>0.05543</u>	0.04759
	0.04730
	0.04745

§ 45. **General Discussion.** In spite of the fact that some improvements in the structure and in the performance of measurements have been introduced, the ice calorimeter is still far from being a convenient apparatus for microcalorimetric measurements. The main obstacle—establishment of a stable thermodynamic equilibrium—could not be removed, and it seems to be doubtful whether it can be done in principle. The use of a differential manometer for maintaining an adequately chosen pressure inside the calorimeter reduces considerably the spontaneous melting or freezing rate observed in the ice-water mixture.

When establishing a pressure which reduces considerably the rate of melting the ice or of freezing the water, one increases the accuracy of the measurement. If a metallic massive or thick-walled cylinder is located in the calorimeter, the latter seems to function more regularly. The formation of a very thin layer of water between the wall of the calorimeter and the layer of ice seems to decrease the unexpected irregularities in the displacement of the meniscus. In spite of all these improvements, the experimenter may face from time to time some unexpected positive or negative displacements of the meniscus which might be explained by the assumption that somewhere a very small amount of ice has been melted or some amount of supercooled water has been frozen because of the thermodynamic instability of the system. From this point of view the following conclusion can be drawn: the opinion, generally accepted in the past, that the ice calorimeter was the only apparatus suitable for examining thermal processes of long duration was not justified. In fact, it is true that measurements in the ice calorimeter could last longer than those carried out in any other type of calorimeter used in the past. Even so, these experiments could not last more than one to three hours.

It should be emphasized also that the experimenter should be skilled in handling the ice calorimeter, especially if microthermal processes have to be examined. This also refers to all calorimeters in which water is replaced by other substances.⁹³

Chapter VI

Tian's Investigations in Microcalorimetry

§ 46. **Peltier's Effect as Compensation Factor.** In Chapters III and IV (§ 22, 28, 29, 30, 32) several methods have been described in which twin calorimeters were used, the heat developed by the object in one calorimeter being compensated by electrical energy in the other. As the energy equivalents of both calorimeters were the same, the measured electrical energy introduced into one calorimeter was equal to the heat liberated by the object in the other.

Apparently Duane³⁵ was the only experimenter who, in a system of two microcalorimeters, has tried to compensate by the Peltier effect the heat developed by the object. No details of these measurements can be found in the literature, so that it is difficult to answer the question: How effective was that method of compensation, and how accurately could the correction for the Joule effect be determined? It should be remembered that Duane employed the system of twin calorimeters filled with ether, and that in this respect they differed from other twin microcalorimeters used in radiology.

In spite of the similarity of the idea, Tian used the Peltier effect in another way. He recommended using one calorimeter only and compensating the heat produced by the object in that calorimeter. He emphasized the importance of the correction for the Joule effect. However, since Tian's main idea was to measure, by means of the absolute method, the heat developed by the object, he insisted in calculating all the corrections. No emphasis was put on the necessity of eliminating the corrections by the method of comparative measurements.

The importance of Tian's investigations on microcalorimetry consists in a detailed discussion of the most important problems associated with any kind of microcalorimetric measurement. Credit and special attention should be given to his paper published in 1933.¹¹³ He came to the conclusion that no stirrer should be used even if the calorimeter contained some liquid. In addition, he recommended the use of a large container filled with water instead of a thermostat, and that it be placed in a basement built deep in the ground, to reduce the temperature changes to a minimum. He emphasized the importance of such a solution because under these conditions no temperature fluctuations except steady small temperature increases

or decreases were observed. In addition, he tried also to build multi-jacket thermostats for protecting the central and main container against any temperature fluctuations.¹¹² His idea found direct application in Ward's investigations¹¹⁶ and in Lazniewski's apparatus for the precise measurement of the average temperature in a thermostat. Hill⁶¹ emphasized the importance of using a somewhat similar device.

As mentioned before, Tian recommended that the temperature increase in the calorimeter by the Peltier effect be reduced to a minimum, and he stressed the importance of calculating the correction for the heat developed by the electric current which passed through the wires of the thermocouples used for the compensation.

§ 47. **Fundamental Equation.** Tian's calorimeter required the calculation of all the corrections accompanying the main thermal process under investigation. The use of the following equation was recommended by Tian:

$$Wdt - Pdt - p(T_j - T_c)dt = -cdT_c \quad (1)$$

In this equation T_j and T_c represent the temperatures of the jacket and of the calorimeter at its outside surface; c the energy equivalent of the calorimeter; p the amount of heat lost by the calorimeter under the condition that $(T_j - T_c)$ is equal to one degree; W the amount of heat developed by the object per unit of time so that in time dt the heat liberated is $dQ = Wdt$. Value dQ is partly compensated by the Peltier effect; Pdt , partly, by the heat exchange which is equal, according to the definition of coefficient p , to $p(T_j - T_c)$.

Instead of measuring directly T_j and T_c , the difference $(T_j - T_c)$ is determined in terms of the deflection observed on the galvanometer scale.

$$(T_j - T_c) = \frac{\Delta}{g}$$

If the temperature of the jacket remains constant ($T_j = \text{constant}$), dQ/dt is equal to $-\frac{d\Delta}{gdt}$:

$$Wdt = Pdt + \frac{P\Delta}{g}dt + \frac{c}{g}d\Delta \quad (2)$$

In this equation $d\Delta$ represents the change in the deflection of the galvanometer in time interval dt .

The amount of heat produced during time t can be calculated from the equation:

$$Q = \int_0^t Wdt = \int_0^t Pdt + \frac{c}{g} \int_{\Delta_0}^{\Delta} d\Delta + \frac{p}{g} \int_0^t \Delta dt \quad (3)$$

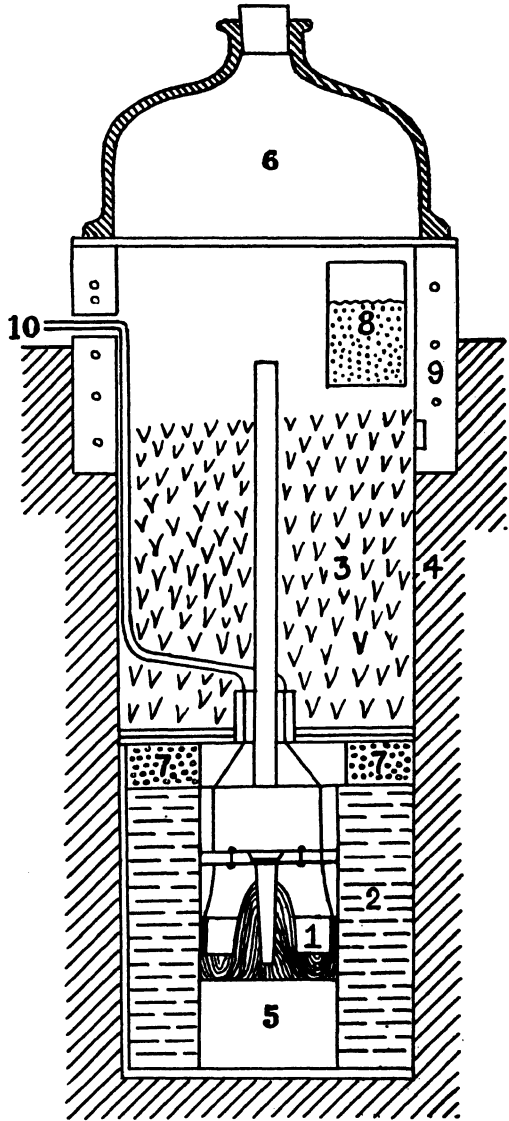

Figure 22.
A. Tian's Microcalorimeter.

Term $\int_0^t P dt = A$ is the amount of heat developed by the object, which has been compensated by the Peltier effect. $\int_{\Delta_0}^{\Delta} d\Delta = \Delta_1 - \Delta_0$ represents the difference of the galvanometer deflection at the end (Δ_1) and at the

beginning (Δ_0) of the measurement. $\int_0^t \Delta dt = B$ represents the area limited by the curve, by the bottom of the axis of time and by both sides of the two extreme ordinates, at the start of the experiment and when it has been completed. Replacing the values in equation (3), we obtain the final equation:

$$Q = A + \frac{c}{g}(\Delta_1 - \Delta_0) + \frac{p}{g}B \quad (4)$$

Term Bp/g may be reduced by decreasing either B or p/g . It still depends upon the difference in temperature of the jacket and the calorimeter; therefore, p/g cannot be deliberately made as small as desirable.

§ 48. **Tian's Microcalorimeter.** A schematic presentation of Tian's microcalorimeter is given in Figure 22. It has been located deep in the ground (4) and thermally protected by the larger container (2) filled with water. Two vessels (7) were filled with barium oxide and vessel (8) with a dehydrating material. From the top, it was protected by a thick layer of insulating material (3). It was covered by large glass cover (6), located on an ebonite frame (9). The junctions of the thermopile were attached to the outside surface of calorimeter (1). Two conducting wires (10) joined the thermopile with the galvanometer, which is not shown in the figure. Another series of thermojunctions formed a thermopile used for compensating the heat developed by the object by means of Peltier's effect.

As was mentioned before, Tian paid a great deal of attention to all corrections to be calculated. This was important because he planned to study thermal phenomena taking place in the liquid phase without using a stirrer in the calorimeter. For this reason he had to take into consideration the complicated distribution of temperature in the calorimeter which could not be uniform in the whole calorimetric system.

According to Tian, his calorimeter was adapted for measuring the heat developed either by processes of long or of short duration. Fluctuations in heat developed by the object have been also taken into consideration. This universality of Tian's microcalorimeter seems to be attractive. The question arises, however, whether the absolute method of measurements requiring a number of corrections can be considered as preferable when compared with measurements based on the principle of comparative measurements. The latter permits one to eliminate as far as possible all or nearly all the corrections. This is perhaps the weakest point in the method suggested by Tian. The history of thermochemistry and calorimetry is rich in examples proving that systematic errors have been often made mainly because of the persistent idea of carrying out absolute measurements, in which all the corrections ought to be checked as carefully as

possible. In spite of all the precautions a number of secondary phenomena have been overlooked, or the corrections for them have not been calculated accurately enough. This is perhaps one of the main obstacles in using the Peltier effect for *partial compensation* of the heat developed by the object.

In Tian's microcalorimeter the correction for the Joule effect is not the only one which should be made. For this reason it would be reasonable to accept the valuable suggestions given by Tian, with the one additional condition that the method of eliminating the calorimetric and other corrections be fully utilized.

Apparently, the war interrupted Tian's investigations. In fact, no practical applications of his method, discussed theoretically in detail, are known to the author.

Chapter VII

Microthermal Measurements of Processes of Short Duration

§49. **Heat of Dilution of Electrolytes.** Recent theory of electrolytes has created the necessity of developing a new technique in measuring the very small amounts of heat evolved or absorbed by dilution of electrolytes. According to the theory developed by P. Debye and E. Hückel,²⁵ it was to be expected that further dilution of dilute solutions of electrolytes should be associated with the liberation of heat and not with its absorption. The latter was known as a typical phenomenon accompanying the dilution of concentrated water solutions of electrolytes.

To confirm by direct experiments the prediction of Debye and Hückel's theory, a new calorimetric device had to be built to make it possible to measure extremely small temperature increases observed when diluting with water a dilute solution of salts. E. Lange and a number of his associates^{64, 65, 66, 67, 68, 69} have developed that branch of microthermal measurements. They succeeded in elaborating a microcalorimetric method in which both the use of an adiabatic jacket and the application of the principle of comparative measurements were fully utilized. The use of thermopiles with one thousand or even more thermojunctions made it possible to measure the changes in temperature with an accuracy of 0.000001°C .

From the point of view of the classification of thermal processes the dilution of electrolytes is a typical phenomenon of short duration. It lasts as long as is required to mix the solution with water.

§50. **Microcalorimeters for Measuring the Heat of Solution.** In Figures 23 and 24 the cross-section and the top view of the microcalorimeter built by E. Lange^{64, 65} are presented. In this calorimeter the Dewar flask placed in the middle of a large adiabatic jacket is divided so as to form two symmetrical and equal spaces. The latter are separated by a wall containing one thousand or more thermojunctions connected in series.

In Figure 25 the details of multiple-junction thermocouples are shown. In the paper of E. Lange and A. L. Robinson⁶⁶ one finds the description of two possible types of these connections. They form at the same time the central wall separating the two twin calorimeters. This can be seen easily

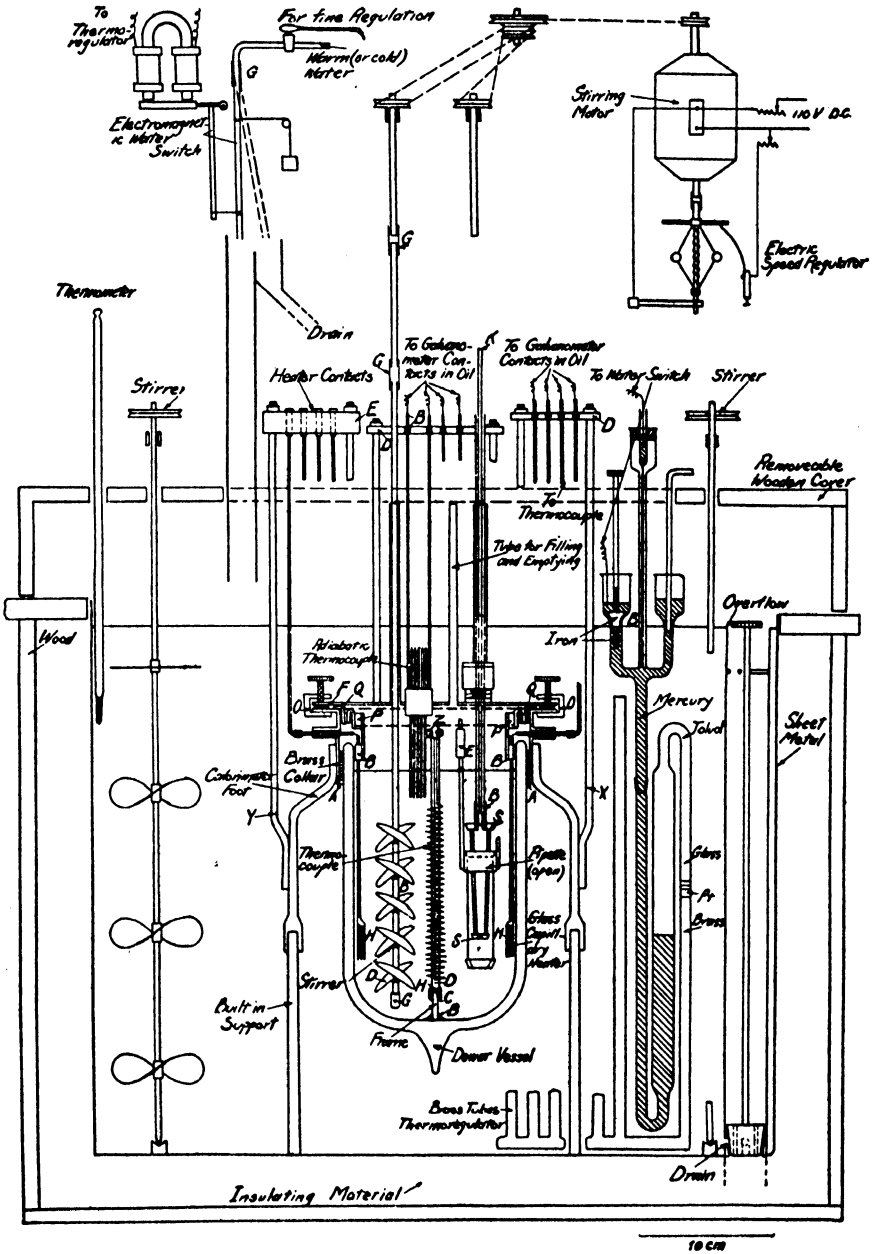

Figure 23. Lange's Adiabatic Microcalorimeter for Measuring the Heat of Dilution of Diluted Electrolytes.

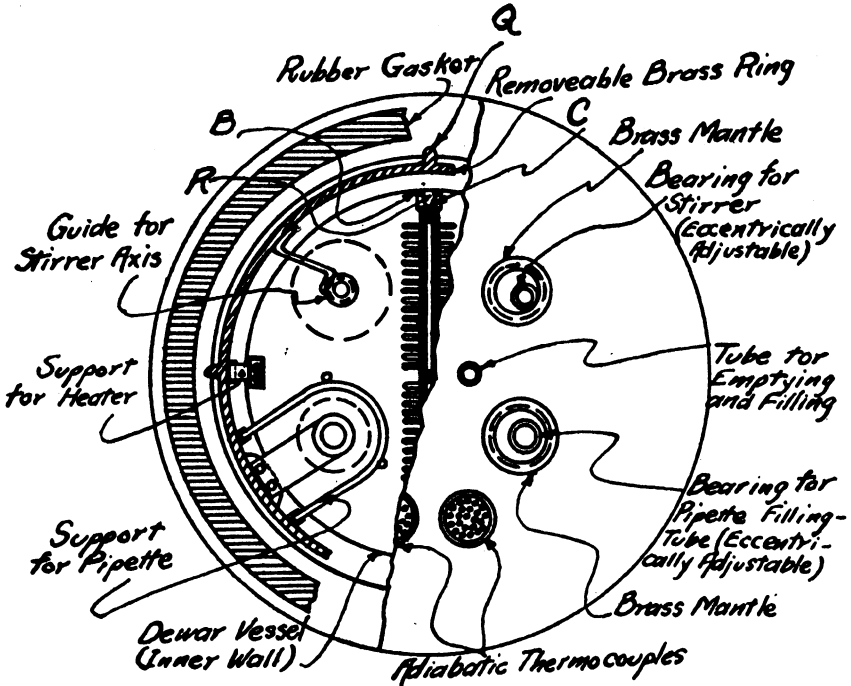

Figure 24. Top View of Calorimeter Vessel.

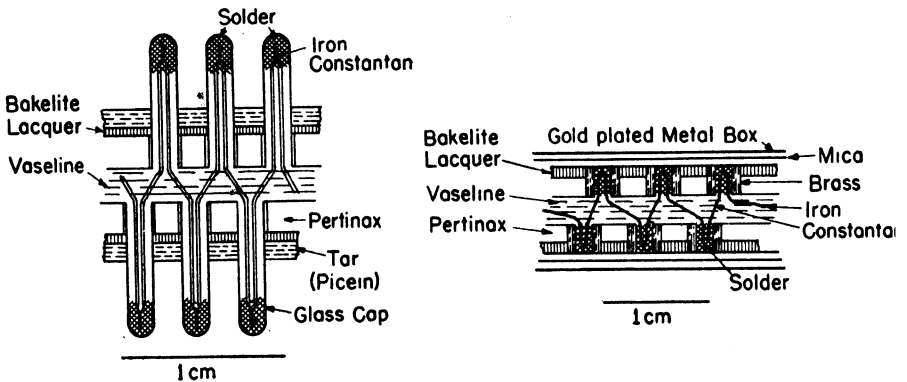

Figure 25. Portion of the Central Wall Containing the Multi-junction Thermopile. Two Different Structures of the Wall.

in Figure 23, which shows that the type shown on the left side of Figure 25 has been used in that case.

In one of these twin calorimeters the dilution is carried out. The other vessel is filled with water. It contains an electric heater, so that

in the case of an exothermal process compensation of the heat developed in the main calorimeter can be made by heating the second calorimeter by an electric current. The current should be chosen so as to keep the needle of the galvanometer on its zero position.

The following few details concerning the structure of the apparatus have been taken from the paper published in 1931 by E. Lange and A. L. Robinson.⁶⁶ The unsilvered Dewar flask of two liters capacity was 200 mm high and 120 mm in inner diameter. In order to be able to remove the thermopile from the Dewar flask, the junctions were cemented into Pertinax or hollow German Silver frames which had previously been fastened with Picein to the inside of the flask. The box containing the thermopile was tightened with a mixture of one part wax and three parts lanolin. To aid the insertion and removal of the thermopile an insulated constantan resistance wire was built in between the frame and the box containing the thermopile. Electric heating of the wire permitted the easy withdrawal of the thermocouple system.

"The Dewar vessel was fitted with a lead monoxide-glycerine cement into a flanged brass collar onto which the calorimeter cover, also of brass, was fastened with screw clamps. Inside the calorimeter, resting on its brass collar, is a removable brass ring from which were supported the heating elements, the pipettes and bearings for the stirrer axis. An electric clock and a record arrangement were used. This permitted the time of heating to be determined to within one hundredth of a second.

"The solution was kept in a metal pipette. It could be filled and emptied without being removed from the calorimeter. The volume of the pipette as well as the volume of the solution to be diluted was always precisely defined. The constancy of the speed of two stirrers was assured by the use of an electrical speed regulator.

"A moving-coil mirror galvanometer made by Kipp and Zonen (Model 2a) was used to measure the potential developed by the thermocouple. Its maximum sensitivity was 1.5×10^{-10} ampere per millimeter scale deflection at a distance of a meter. . . . The internal resistance of the galvanometer was 25 ohms. The thermocouple had a resistance of about 75 ohms. One binding post of the galvanometer was permanently connected to its case; the electrostatic disturbances were thus eliminated."

The temperature in the adiabatic jacket was regulated within 0.001°C or better. The dilution could be completed in a very short time; it was necessary, however, to maintain the constant temperature of the jacket for a relatively long time to be sure that the solution and the water had the same temperature before being mixed. In addition, all preparations for the measurement also took time, during which no changes in the temperature of the jacket were allowed.

Small changes in temperature, which were required to maintain the adiabatic course of the measurement, were made by adding small and known amounts of cold or warm water. The thermopile, consisting of twenty-four iron-constantan elements, was built into the calorimeter. It was used for measuring the difference between the temperatures of the calorimeter and of the jacket.

Preliminary experiments were made to calculate small corrections resulting from the differences in temperature of the jacket and of the calorimeter. These experiments were based strictly on the comparative principle. The deviations from the adiabatic course were always very small.

The necessity of introducing another correction could result from a difference in heat produced by the two stirrers. Care was taken to have identical stirrers and to maintain the same number of revolutions. In that case it could be expected that the heat produced in both calorimeters would be the same. Blank experiments were carried out to prove whether this assumption was correct. In the case of a difference in stirring, the correction to be made could be determined directly before or after the completion of the measurement.

Thermal conductivity of a great number of wires in the system of thermocouples could be also a source of an error. In the case of very dilute solutions the correction for the heat transfer could be calculated. This was small when compared with other factors involved. If relatively large negative or positive thermal dilution effects were observed, the comparative compensation method was applied, and one or another of the calorimeters was electrically heated to maintain the same temperature in both of the twin calorimeters. In that way no heat transfer could take place.

To guard against any changes in the conditions, all particularities had been carefully examined by using electric heaters or by repeating the experiments with solutions previously examined each time before a new series of measurements was started. Electric energy was also used in those experiments in which the scale of the galvanometer was calibrated.

It should be pointed out that success in carrying out experiments in a system containing numerous parts and a great number of thermojunctions has been achieved because of the elimination of all corrections involved. The advantage of compensating the heat liberated or absorbed by electric energy was fully exploited. The error did not exceed two or three per cent of the total amount of heat evolved or absorbed, which is small in that kind of experiment.

Since Lange's investigation considerable progress has been made in measuring the heat of dilution of dilute solutions. In 1939 F. T. Gucker, Jr., H. B. Pickard and R. W. Planck described the structure and the functioning of new twin microcalorimeters.⁴⁹ They determined the heat of dilu-

tion of aqueous solutions of sucrose at 20 and 30° C and the heat capacity of those solutions. They found that the heat of dilution of sucrose is proportional to the concentration, and not to the square root of the concentration as is the case for typical electrolytes.

The essential progress in the structure and functioning of the micro-calorimeters consisted in greatly reducing the number of thermocouples (sixty instead of one thousand); in using an automatic device for maintaining the adiabatic rate of heating the jacket; and in separating and increasing the size of the twin calorimeters. Considerable improvements were made in a number of details which are quoted below. The energy equivalent of the calorimeters was measured by a method similar to that described in § 22 of this book. Parts of this important paper are quoted below without any change, except the numbers of the figures and the omission of the references. The spelling of some words and the abbreviations for certain units of measure have also been unified with other parts of the book.

Apparatus

“General Description. A general idea of the apparatus can be obtained from the simplified section Fig. 26, and plan, Fig. 27. It is a differential adiabatic apparatus, similar in many respects to that developed in this laboratory for the precise measurement of specific heats of solutions. Two similar tantalum calorimeters, *C, C*, each containing a dilution pipette *P*, are suspended from the lid of a water-tight submarine jacket, *J*, immersed in the water-bath, *B*. The submarine jacket is supported from an aluminum plate, *R*, by means of four brass tubes which accommodate the stirrer and lifter shafts. Two of these are shown in Fig. 26. The aluminum plate, suitably counterpoised, can be raised and clamped to a frame of iron pipe to permit the opening of the submarine jacket and the adjustment of the calorimeters. The large copper tank containing the water-bath, and the galvanized sheet-iron cover, *L*, are insulated by 5 cm of hair-felt, indicated by cross-hatching. A sprocket-chain, driven from a synchronous motor, rotates the calorimeter stirrers at 180 rpm, two large 3-stage stirrers, *W, W*, in the water-bath at 270 rpm, and the large sprockets, *F*. The leakage of heat down the stirrer and lifter shafts is reduced by insulating sections of Lucite.* The calorimeter lids are spaced from the top of the submarine jacket by four tightly fitting cones of the same material, two of which are shown as *D* and *E* in Fig. 26.

“The difference in temperature between the calorimeters is measured

*“Lucite” is the trade name of a methyl methacrylate resin made by the du Pont Company. Its coefficient of thermal conductivity, 4.3×10^{-4} cal/cm²/sec/°C/cm, is about that of hard rubber. This and its other physical and chemical properties are summarized in an article entitled “Methacrylate Resins,” *Ind. Eng. Chem.*, **28**, 1160 (1936). Its heat capacity recently was measured in this Laboratory: Gucker and Ford, *J. Am. Chem. Soc.*, **60**, 2563 (1938).

to 1 microdegree by means of a thermel, *M*, connected to a Paschen astatic galvanometer. The current sensitivity of this instrument is so great that

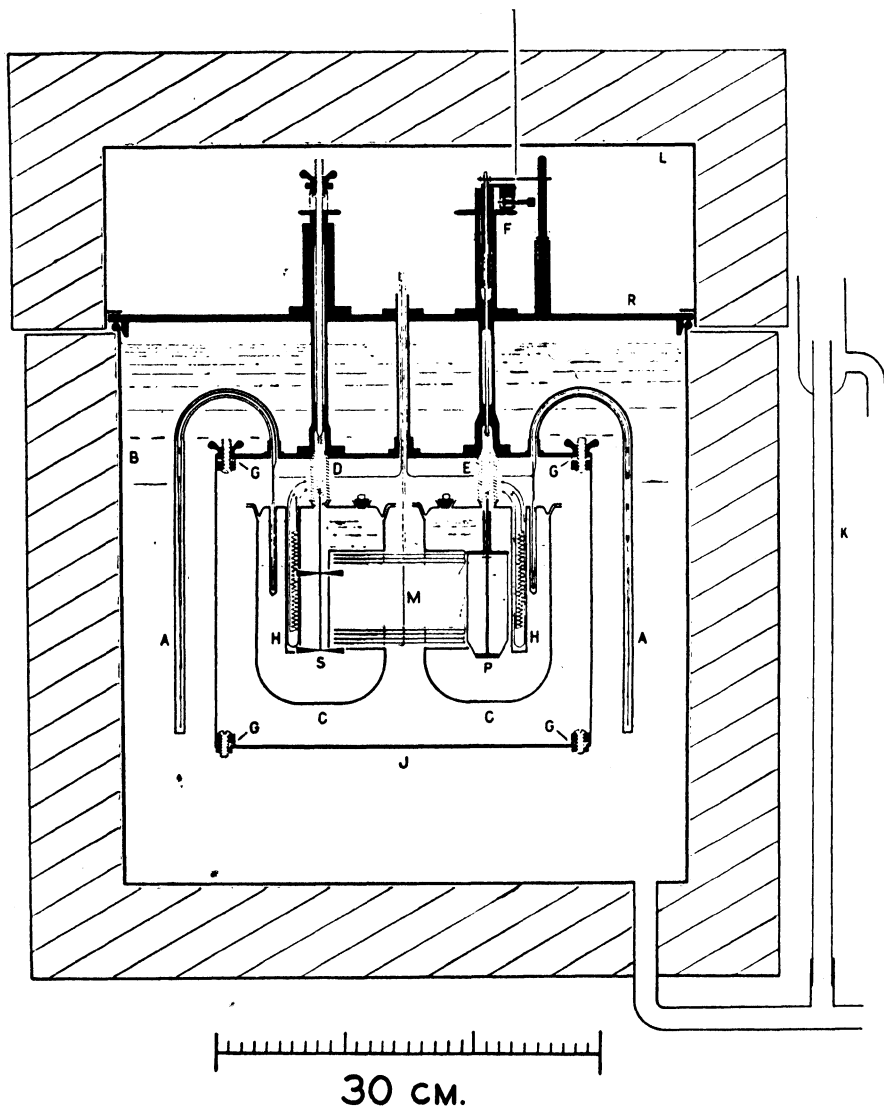

Figure 26. General View of the Calorimetric Apparatus of Gucker and His Associates.

a 60-junction thermel is adequate. Therefore, we are able to use a more conventional calorimetric arrangement than had been employed previously for this type of work. Fewer junctions and a 3-cm gap between the calori-

meters reduces thermal conduction between them to a small fraction of that in a calorimeter of Lange's type.

"The air gap between our calorimeters and the walls of the jacket was 3 cm. The heat conductivity constant between each calorimeter and the outer bath was found to be 0.003/min. This is just half of the value given by Gulbransen and Robinson for an apparatus of Lange's type, employing an *unsilvered* Dewar flask, in which the blackbody radiation is the controlling factor.

"The difference in temperature between calorimeters and water-bath is determined by means of the adiabatic thermels, *A, A*, connected in series. These operate an automatic control which regulates the current through the four bath heaters, *U* [Fig. 27] so as to make the process practically adiabatic. Since the temperature changes involved in dilution are so small it is also practically isothermal. The advantages of the adiabatic method are well summarized in W. P. White's authoritative book and need not be described here.

"Submarine Jacket. The top and bottom of the submarine jacket were made of 3-mm sheet copper, nickel-plated and polished on the inner surfaces. The top plate was fastened tightly to the flanged lower ends of its supporting tubes. The Monel metal walls of the jacket, burnished on the inside, were soldered to brass flanges which were bolted to the top and bottom through suitable gaskets, *G, G*. The bottom connection was made permanently with machine screws. After the calorimeters are installed, the upper flange of the jacket is attached by means of 12 wing-nuts.

"Calorimeters. The twin calorimeters, each holding about 1 liter, were made entirely of tantalum on account of its mechanical strength and its chemical inertness. A well was welded into the side of each calorimeter to receive the main thermel, *M*. The lid of each calorimeter was ground to fit, and the joint was made tight with a grease consisting of 1 part paraffin to 3 of Vaseline. Wells in each lid received the electrical heater, *H*, and one end of the adiabatic control thermel. An opening in the lid, fitted with a ground plug, allowed the introduction of the diluting liquid without removing the entire lid. Each calorimeter was suspended by four loops of dental floss from adjustable hooks fastened to the top of the submarine jacket. A similar arrangement was described fully in connection with the specific heat apparatus. Four Lucite spacers, two of which, *D, E*, are shown in Fig. 26, were machined to the proper length with conical ends fitting snugly into the calorimeter lids and the top of the jacket. Lucite is preferable to glass, which was first used, since its coefficient of thermal conductivity is only one-fifth as great, it is easily machined to the proper length and taper, and it does not crack or break so easily.

"Each dilution pipette, *P*, having a capacity of 60 ml, was suspended

from the lid of the calorimeter by three rods (not shown) and could be removed easily for washing and drying, preparatory to re-loading. Each

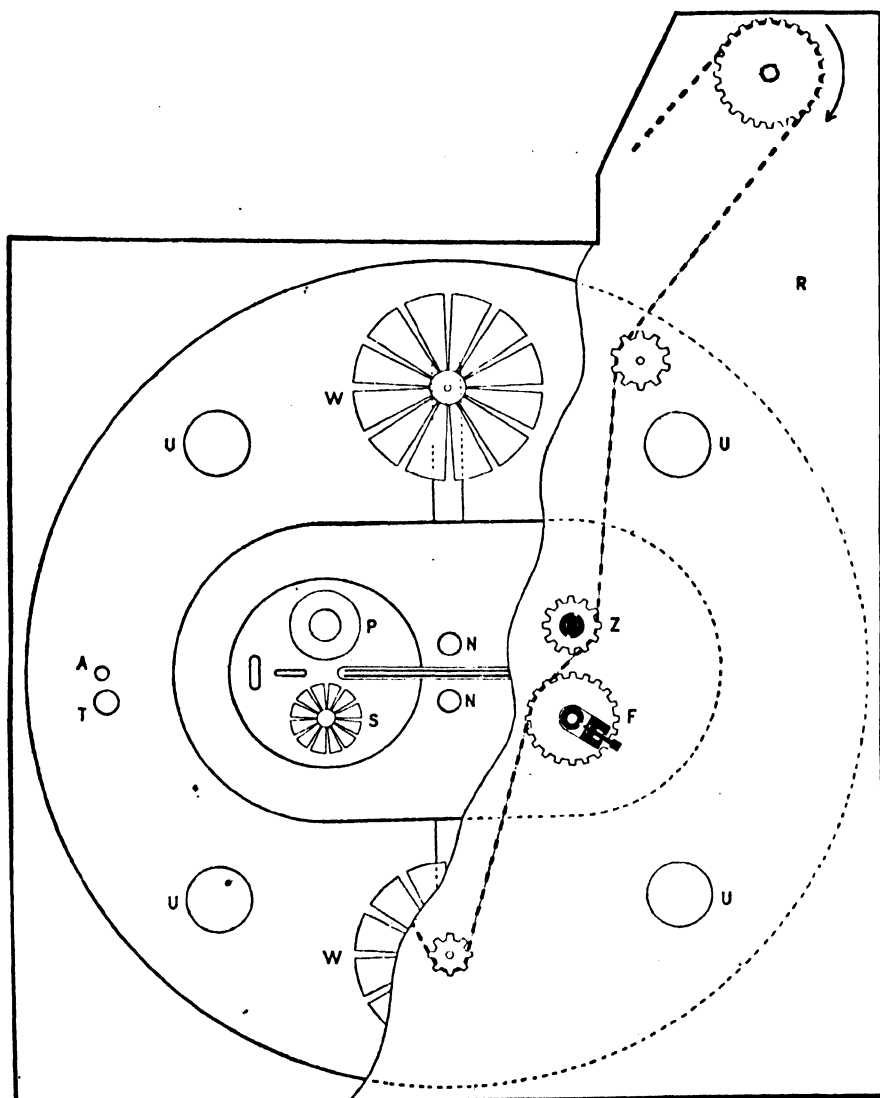

Figure 27. Plan of the Calorimetric Apparatus.

pipette was closed with heavy valves ground into the top and bottom. The valves were sealed with the best available grade of commercial Vaseline. Careful tests were made to see whether this contained any electrolytes

which might dissolve in water. Distilled water that stood in contact with this Vaseline for several days failed to show any increased conductance due to electrolytes leached from it.

“Main Thermel. The difference in temperature between the calorimeters was measured by a 60-junction copper-constantan thermel of 12 ohms resistance connected to a Paschen astatic galvanometer with a guaranteed sensitivity of 14.6 m. per microampere at 1 meter scale distance, and with a period of six seconds. It was usually operated at a sensitivity of 6 m. per microampere, or 1.8 microdegrees per mm. Our thermel extended directly across the 3-cm air gap between the calorimeters and projected 3.4 cm into the wells in the calorimeters. Preliminary studies by K. H. Schminke showed that this arrangement was adequate to register the true temperature of the calorimeter, since this type of thermel gave the same emf as a conventional U-shaped thermel immersed to a greater depth in the same calorimeter. The straight thermel, however, has only a third of the resistance of the U-shaped one, and delivers a correspondingly larger *current*. It has a distinct advantage over the short thermels used by Lange since it gives a true reading of temperature differences even when these are relatively large.

“We originally set 0.001° per minute for the heat conductivity constant along the thermel. Thus a temperature difference of 0.001° (over 3 times the greatest temperature rise in the present measurements) would be reduced by 2 microdegrees per minute. Since each calorimetric system has a heat capacity of almost 1000 cal per degree, the heat transfer would be 0.001 cal per minute. We can calculate the best size and number of wires as follows:

“To give the maximum ratio of electrical to thermal conductance, W. P. White calculated that the cross-section of the constantan wire should be 21.4 times that of the copper. From the known thermal conductances of the metals and the distance between the calorimeters, we find the allowable cross-sections are 0.0257 sq cm for the copper and 0.549 sq cm for the constantan. Taking into account the specific resistivities of the two metals and the length of each wire, the total resistance of n pairs of wires turns out to be $1.602 \times 10^{-3}n^2$ ohms. The galvanometer resistance is 12 ohms. Since each pair of junctions develops 43 microvolts per degree, the thermal current is

$$I = \frac{E}{R} = \frac{43 \times 10^{-6}n}{12 + 1.602 \times 10^{-3}n^2}$$

Inspection of the graph of this equation [Fig. 28] shows that 86 junctions give the maximum current, but that 60 junctions are practically as good, since the last 26 junctions increase the current by only 8 per cent.

“The main thermel [M in Fig. 26] consisted of two identical halves of

30 junctions each, made from double silk-covered No. 17 B and S gage constantan wire and No. 30 copper, the cross-sections of which were as nearly as possible those indicated in the above calculations. An attempt to test the constantan for homogeneity by the method of White proved difficult because the wire was so stiff. Since no unsatisfactory portions appeared in about eight feet (2.4 meters), further testing was discontinued.

"The arrangement of the wires is shown in Figs. 26 and 27. The thickness of the junctions was reduced by bending the thin copper wire over a V-shaped notch in the end of the heavy constantan wire, instead of

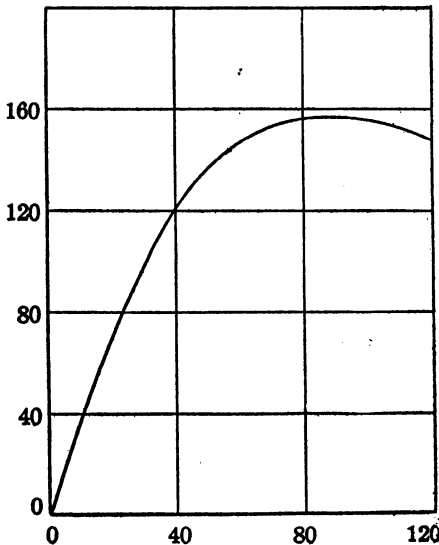

Figure 28.

Thermel Sensitivity Curve for
Constant Thermal Conduction.

wrapping it around the latter. A rosin flux was used in soldering the wires, as recommended by White.

"Each half of the thermel was mounted on a rectangular card of mica 0.2 mm thick, notched along the ends to space the junctions properly. After being coated with Resoglass the two halves were placed between thinner sheets of mica to provide electrical insulation.

"The copper case was made in two sections, each slightly longer than the depth of the thermel-well in the calorimeter. To prevent contact between the junctions and the case, a sheet of mica, less than 0.02 mm thick, was folded around each end of the thermel as it was slipped into its half of the case. After both halves of the case were in place, they were connected by short sections of constantan wire of low thermal conductivity, flattened at the ends, and soldered to the top and bottom of the cases. The measured heat conductivity constant of the completed thermel was 0.0011 per minute.

“Four-lead cable, of the type used on platinum resistance thermometers, was employed for the leads. The insulation resistance between two leads was found to exceed 500 megohms. The silk insulation is much more permanent than rubber. The leads were carried out of the submarine jacket through a copper tube as shown in Fig. 26. The leads of both thermels were connected to their galvanometers through copper reversing switches submerged in a well-insulated oil-bath to eliminate parasitic currents in the galvanometer circuits. These switches, shown in Fig. 29 as S_1 to S_4 , were similar to those described in detail by Rubin. By means of shunt resistances, C , F , the sensitivity of each galvanometer could be decreased in several steps to 0.1% of its full sensitivity. The cross-

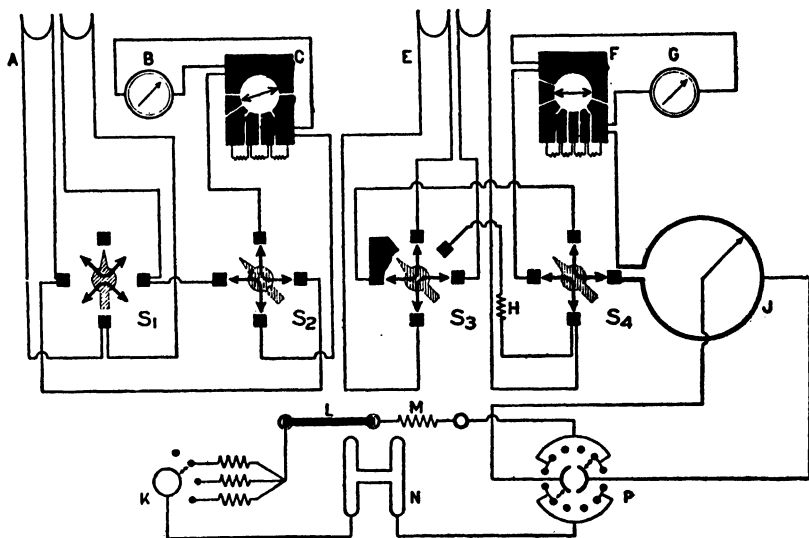

Figure 29. Thermel and Potentiometer Circuits.

hatched arrows represent the knobs of the reversing switches. The thermel and galvanometer leads were sheathed in flexible woven-copper tubing, forming an equipotential shield to eliminate stray external currents.

“**Recording Potentiometer.** Since the sensitivity of the Paschen galvanometer, G , was not constant across the full length of the scale and since the temperature changes caused by the dilution frequently exceeded the full scale deflection, the thermel emf had to be balanced and the galvanometer used as a null instrument. To accomplish this we constructed a recording potentiometer, the wiring of which is shown in Fig. 29. The No. 18 manganin slide-wire, J , was mounted in a small groove machined in the edge of a circular disk of Bakelite, immersed in the same oil-bath

which held the reversing switches. One end of this wire was soldered directly to the proper contact of the reversing switch, as shown in the drawing. The outer end was soldered to one of the galvanometer leads. This junction was clamped directly above the first one, from which it was insulated by pieces of mica 0.05 mm thick. Thus, the two copper-manganin junctions were maintained at practically the same temperature. Any parasitic effects due to them would be eliminated by the method of double deflections.

"The source of the potential was a large saturated Weston cadmium cell, N , in series with a resistance of 100,000, 400,000 or 1,000,000 ohms selected by the switch, K . The size of the series resistance determined the magnitude of the potential applied to the slide wire and hence the sensitivity of the potentiometer. The potential produced by the standard cell was reversed by means of a modified two-circuit, six-point switch, P , mounted directly beneath the Bakelite panel forming the top of the reversing switch box, and connected to the same shaft which reversed the galvanometer circuit. Pairs of adjacent contacts on the switch were connected by soldering thin copper strips across them as shown. Thus as the knob S_4 is turned clockwise from the position shown in the diagram to reverse the thermel and the Weston cell, the galvanometer circuit is broken before the potentiometer circuit and closed after it. This avoids violent galvanometer deflections which would occur if this circuit were closed while the cell circuit was open. One of the potentiometer circuit leads, consisting of No. 24 enameled copper wire, was silver-soldered to the middle of the resistance wire, making as narrow a joint as possible. With this arrangement the potential could be applied to the slide wire in either direction. The sliding contact was made by means of a short piece of manganin wire, soldered to a brass arm, which exerted an inward pressure against the resistance wire. The arm was fastened to a brass rod which made contact through a bushing to which the second lead was soldered. A short collar of Lucite served to insulate the lower section of this rod from the upper section, which carried a large dial.

"In order to test the sensitivity of the Paschen galvanometer, a known potential was applied to the circuit, with the switch S_3 turned to the vertical position, so that the thermels were replaced by a coil of copper wire, H , having the same resistance.

"A 100-ohm resistor, M , in the potentiometer circuit allowed the potential of the standard cadmium cell to be checked from time to time. In order that the resistor itself might be standardized, the brass bar, L , held between two binding posts, could be removed and a standard resistor put in its place. The ratio of the two resistances could then easily be determined potentiometrically.

"The position of the sliding contact was automatically recorded by the potentiometer. A large gear, fastened to the shaft directly beneath the dial, was connected through a pinion to a rack which moved in a closely-fitting section of square brass tubing and carried a recording pen mounted on one end.

"A typewriter platen, mounted on top of the potentiometer box, was driven by a Telechron electric clock motor through a train of reducing gears and carried the record paper forward at the rate of 12.5 mm a minute. The pen moved across the paper along the top of the platen and made a permanent record of the potential applied to the slide-wire, which was proportional to the temperature difference of the two calorimeters. A displacement of 1 mm on the paper corresponded to a temperature change of from 0.3 to 3 microdegrees, depending on the resistance in the circuit. A large part of the work was done with a sensitivity of 0.6 microdegree per mm.

"**Paschen Galvanometer Suspension.** Because of its extreme sensitivity, the Paschen galvanometer required a support that was free from vibration. A Julius suspension hung from the ceiling proved inadequate. A solid concrete pier weighing about 8 tons then was built upon the ground free from the floor and walls of the building. A heavy iron pipe-frame, 2 meters high, rested solidly on the pier and supported a modified Julius suspension by means of a single wire. A set of vanes on the bottom plate of the suspension extended into a tank filled with transformer oil and aided in damping out any mechanical vibrations. To avoid disturbances due to air currents, the pipe-frame was surrounded with a Celotex housing having a door in one side to permit galvanometer adjustments and a narrow open window in the front through which the light beam passed.

"**Adiabatic Control.** In order to maintain adiabatic conditions, the temperature of the water-bath was kept the same as that of the calorimeters by an automatic control of the current supplied to the bath heaters. The temperature difference between the bath and each calorimeter was measured by means of a 10-junction copper-constantan thermel. These thermels, similar in construction and mounting to the adiabatic control thermels in the specific heat apparatus to which reference has already been made, are shown at *A* in Fig. 29. The wires were No. 34 copper and sections of No. 26 constantan which passed White's test for homogeneity. The leads were the same type of silk-insulated cable used for the main thermel. By means of switch S_1 , the thermels could be connected either individually (for testing) or in series (for operating) through the reversing switch, S_2 , to the Leeds and Northrup type-HS galvanometer, *B*.

"Light from a 32 c.p. lamp was reflected from the galvanometer mirror onto a photocell which was part of a "Fotoswitch" unit that operated a

two-circuit relay. This relay was connected to a Variac and to a reversible Telechron clock motor which was geared to the shaft of the Variac. When the calorimeters and bath were at the same temperature and there was no deflection of the galvanometer, light fell upon the photocell and the clock motor slowly turned the shaft of the Variac to reduce the voltage output. When the bath temperature dropped below that of the calorimeters the light moved off the photocell, the current through the bath heaters was turned on, and the clock motor was reversed so that it slowly increased the voltage delivered by the Variac. In this way the Variac was adjusted to such a voltage that the heaters were on and off for equal intervals of time, giving the best regulation. When the calorimeters were heated and thermal balance between the bath and calorimeters was disturbed, the heater current was automatically turned on until balance was again restored, maintaining adiabatic conditions within $\pm 0.0003^\circ$. The output voltage was stepped down by a transformer in the ratio of 1/11 so that the potential applied to the heaters varied from 4 to 10 v. This low voltage caused no deflections of the Paschen galvanometer as the full 110 v had done.

"When the experimental temperature was below that of the room, a steady ice-water drip was used in conjunction with the automatic control. The temperature of the bath was measured with Beckmann thermometers which had previously been standardized against a platinum resistance thermometer.

Calorimeter Heaters. Each main calorimeter heater, having a resistance of about 50 ohms, was made of No. 38 manganin wire, wound on a thin strip of mica and annealed. It was enclosed in a flat copper case made in two sections connected by two flattened pieces of constantan wire. The resulting 15-mm opening in the case reduced thermal conduction to the lid of the calorimeter. The heater was sandwiched between two thin mica strips to insulate it from the case. Each heater had two No. 24 copper leads to carry the current and two potential leads of No. 30 wire, fastened to the current leads half-way between the calorimeter lid and the top of the submarine jacket. To raise the temperature of the calorimeters rapidly, alternating current from a Variac was passed through the heaters either separately or in series. For a quantitative heating period the source of current was a 3-volt heavy-duty dry cell. The potential was determined with a Leeds and Northrup type K_2 potentiometer and the current by measuring with the same instrument the potential drop across a standard 100-ohm resistor in series with the heater. The current was passed through a 50-ohm substitute resistance for at least twenty minutes before a quantitative heating period, since the current drawn from the dry cell decreases appreciably for the first few minutes. In timing the heating period a Cenco impulse-counter was used as a super-sensitive stop watch. One side of a

double-pole, double-throw switch turned the current from the substitute resistance into the heater while the other side started 60-cycle a.c. through the impulse-counter. This arrangement counted the half-cycles and measured the heating periods with a sensitivity of 1/120 second and an accuracy of 0.1% with which the frequency was regulated. Preliminary experiments showed that the closing and opening of the two circuits was simultaneous (within one half-cycle). The resistance of the heater was determined in nearly every experiment after the heating, by measuring the potential drop across it and across the standard resistor. The resistance of the heaters did not vary more than 0.04% over a period of several months. Previous tests of the resistance of heaters made from the same spool of manganin wire showed that the resistance varied less than 0.01% as the current was increased from 0.005 to 0.015 amp., the latter being the current used in the experiment.

"Each heater case contained, beside the main heater, a short section of No. 30 "salamanca"-coated constantan wire, having a resistance of about 1.5 ohms. This was used as an auxiliary heater to balance out, within a microdegree per minute, any temperature trend between the calorimeters due to unequal stirring or evaporation. A 1.5-volt dry cell was connected through two rheostats so that the current could be varied from 0 to 20 m.a. and could balance out a trend of 10 microdegrees per minute, which might be caused by the evaporation of 0.08 mg of water per minute from one calorimeter."

§ 51. **Results Obtained in Lange's and Gucker's Measurements.** It is not the purpose of this book to quote the results obtained using the apparatus described in the previous paragraph. The reader can find these in the original literature (see references given in the previous paragraph).

It should be pointed out that below 0.01 molar concentration the heat of dilution for typical electrolytes is positive, and the numerical values are relatively close to the proportionality of the square root of the concentrations. This agrees with the figures calculated by using the equations given by Debye and Hückel.²⁵ The uncertainty still lies in the precise value of the dielectric constants of the solutions involved. In the range of higher concentrations there are indications that other factors than the interionic effects may produce some changes in the heat of dilution of electrolytes.

The heat of dilution was examined also by other authors.^{43, 66} In reference to the results of the measurements of Gucker and his associates, the following quotation can be given: "within an experimental uncertainty of about ± 3 microdegrees, the heat of dilution of sucrose at 20 and 30° changes linearly with the first power of the concentration in very dilute solutions. This proves for the first time a distinct and clear-cut difference

between the behavior of a typical non-electrolyte and electrolytes, for which the limiting slope is linear with the square root of the concentration."

§ 52. **General Discussion.** The measurements of the heat of further dilution of dilute electrolytes and non-electrolytes presents a classical example of microcalorimetric investigations in which neither the amount of the solutions nor the time play any role. Very large calorimetric vessels may be employed, to use large amounts of the solution and of water. This would not change the temperature increase, which is very small. Because of this, the only way of increasing the accuracy of the measurements was to use a thermopile with a very large number of thermojunctions; thus very small temperature changes could be measured with an accuracy of 2.10^{-7} degree. It can be seen from this classical example that the methods used for measuring the heat developed by thermal processes of short duration differ considerably from those in which the experiments last for hours.

It was pointed out in the previous paragraph that in microcalorimetric investigations of this kind the proper functioning of the stirrers in the twin calorimeters played an important role. Any asymmetry in the heat produced by the stirrers might be a source of an error. The correction for the difference in this respect was eliminated, together with other corrections, by applying the method of comparative measurements as described in Chapter III.

Another peculiarity in conducting the adiabatic heating or cooling of the jacket in Lange's calorimeter consisted in using warm or cold water for this purpose. This method was used in 1919¹⁰⁴ by the writer, and experiments have proved its applicability and convenience. In Lange's experiments it was much easier to use water than an electric heater. In fact, there were many measurements in which the heat of dilution was not positive, but negative. In addition, if temperature increases were observed it was more convenient not to use the electric heater because of the lag in the rapid temperature distribution throughout the water in the jacket. An efficient stirrer offered the advantage of obtaining uniformity of the temperature in the adiabatic jacket in a very short time.

§ 53. **Microcalorimetric Measurements of Heat of Adsorption.** Another example of a microthermal process of short duration is that of adsorption of gases by solid substances. A number of macrocalorimetric measurements have been made in the past on that subject. In most of them activated carbon or activated silica was employed as adsorbent.⁹⁸ Usually the average heat of adsorption was measured. E. P. Barrett⁷ was the first investigator in the United States to employ the adiabatic method for measuring the heat of adsorption of water vapor by massive gold. Barrett's calorimeter differed only in some details from the apparatus of the famous American scientist T. W. Richards.⁸⁵ Barrett's investiga-

tions may be considered as a gradual transition from the macro- to the microcalorimetric method. A. F. H. Ward¹¹⁶ was the first to really use a microcalorimetric method for measuring the heat of adsorption of gases by solid substances. He was also the first to make practical use of the multi-jacket thermostat described by Tian.¹¹² He succeeded in maintaining the constancy of temperature in the central container (§ 9) with an accuracy of 0.000002°C or even better.

The following citations concerning some details of Ward's investigations are taken from his two papers.¹¹⁶ First, he discussed the results obtained by other investigators who had found differences in the initial heat of adsorption of a small amount of the sorbed substance and the heat of adsorption in the final stage shortly before saturation had been reached. Ward could not confirm this in his experiments: "It seemed of interest, therefore to study in some detail the heat evolutions for initial small quantities of adsorbed gas. . . . Using a sensitive microcalorimeter capable of measuring heats over the range of low pressure, and applying several important corrections which were found necessary, no low initial heat was found but in all cases the heat of adsorption of hydrogen was independent of the amount of gas already on the copper surface. Special precautions were taken to insure the purity of material used.

"The apparatus used in making adsorption measurements is shown in Figure 30. All joints were glass seals. The copper powder was placed in tube *F*. This adsorption vessel had a tube running down the center with numerous perforations to allow free passage of the gas from the center to the copper in the annular space between the two tubes. The copper was protected from poisoning by mercury vapor by a liquid air trap between it and the mercury vapor diffusion pump, and also a trap of cadmium turnings and a bulb into which sodium had been distilled onto glass wool.

Pressure measurements were made by McLeod gauge *E* over the lowest range, or rotating gauge *D*. . . . Before the copper was put into the apparatus, the volumes of the various parts were determined." The copper had been outgassed before the adsorption started.

The microcalorimeter "was mounted on a platform so that it could be raised to surround the adsorption bulb. This made close sliding contact with a copper tube (enclosed in a Dewar flask) to whose outer surface were attached the junctions of thirty-one iron-constantan junctions of the thermocouples." The other set of thermocouple junctions "was kept at a constant temperature by being held in holes in a ring of brass in a thermostat." A moving-coil galvanometer was used and the readings were plotted against time. The heat evolution corresponding to an adsorption of gas was found from the rise of temperature of the system inside the Dewar flask. The correction for the cooling by the heat exchange was calculated. The

apparatus was calibrated electrically. The energy equivalent of the system was about 50 cal and the detection of 0.0005 cal was possible. This means that a temperature elevation of 0.00001°C could be detected.

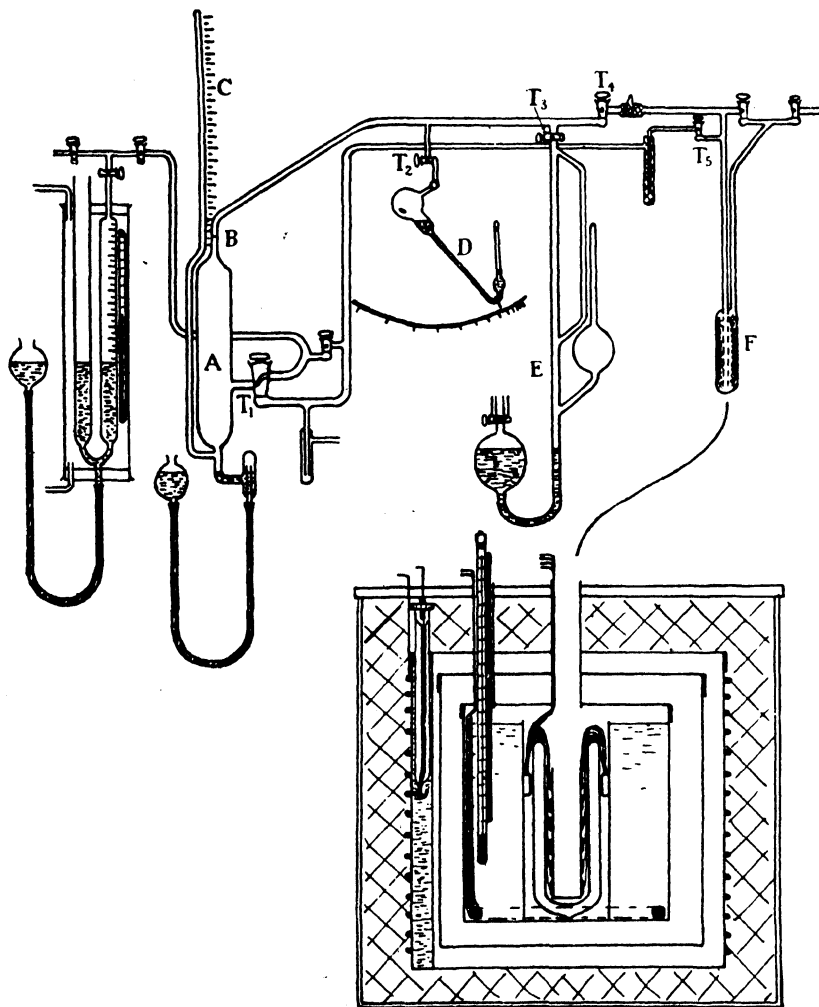

Figure 30. Ward's Microcalorimeter for Measuring the Heat of Adsorption of Gases.

It should be emphasized that Ward succeeded in measuring the heat of adsorption when using not only new, uncovered surfaces, but also when using surfaces partly covered with hydrogen. In that way Ward could prove that there was no difference in the initial heat of adsorption when

compared with the heat developed when larger quantities of hydrogen were attached to the surface.

The statement refers to the case when molecules similar to those of hydrogen undergo adsorption. If activated carbon is used as adsorbent, and vapors of liquids or easily liquefied gases are absorbed by it, there are considerable differences in the heat of adsorption, which depend upon the amount of vapors and gases previously adsorbed. It is probable that these differences are associated with two different phenomena: adsorption by the solid surface and liquefaction of the adsorbed substance in the capillaries of the adsorbent.

Ward's experiments are important from the point of view of the method applied for measuring the heat developed in microthermal processes of short duration. He succeeded in measuring very small temperature increases by using a thermopile composed of only thirty-one thermojunctions. This is a simplification when compared with the thousand thermojunctions employed by Lange (§ 50). When using Ward or Gucker's method one can avoid all the difficulties associated with the building of a thermopile with a thousand thermojunctions. Furthermore in Ward's experiments, Tian's multi-jacket thermostat was successfully employed for the first time. Tian himself did not have an opportunity to show the applicability of his ingenious ideas in maintaining the constancy of the temperature within $\pm 0.000002^\circ \text{C}$. This success was possible, however, only because the measurement lasted a relatively short time (see § 9).

§ 54. Hill's Investigations on Heat Produced by Nerve. In the history of microcalorimetric measurements of thermal effects lasting a very short time, the investigations carried out in 1933 by A. V. Hill⁵¹ should be considered as classical. Their purpose was to measure the heat developed by nerves after they had been electrically excited. In executing such a measurement the experimenter was restricted by a number of factors, so that the method employed had to be adjusted to fulfill all the conditions required by the object. This was not the case in a number of other investigations in which the experimenter had the opportunity of selecting the size of the calorimeter and the amount of the heat-evolving material. Hill succeeded in measuring 2×10^{-6} calorie developed per gram per second.

In Figure 31 the apparatus used by Hill is shown and its description is taken from his paper. *A* represents the "sheet of 150 couples of constantan-iron (hard-soldered), the 'hot' junctions being down the middle line, the 'cold' junctions alternately on either side and insulated by a thin sheet of mica and by Bakelite from the brass frame *B*. The groove containing the hot junctions is formed between two walls, (*C*) of paraffin wax; there are similar paraffin wax walls and a similar groove on the opposite side. *D* represents stimulating electrodes drawn up as far as possible; and *E* is a

large silver plate built up at the back with silver blocks, held by the Bakelite clips (*F*). The silver plate *E* cuts off heat conducted from *D* toward *A*, and acts also as the upper warming electrodes during calibration. *G* is the lower warming electrode, consisting of a thick silver wire. *H* is a rubber stopper forced into a glass tube, *J*, which has a hole at the bottom to admit gas, or to withdraw Ringer's solution, as required. Another tube leading through the stopper for the admission of gas is not shown. The entire

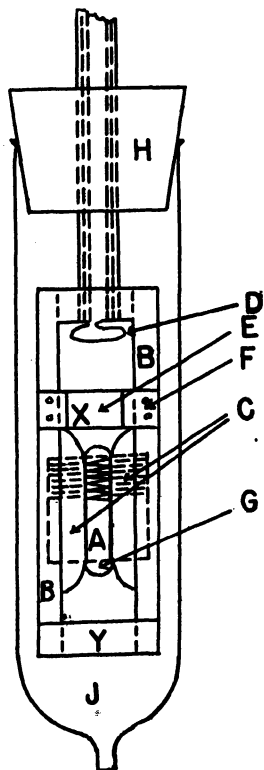

Figure 31.

Hill's Microcalorimeter for Measuring the Heat Developed by Nerves.

brass frame is thickly insulated with bakelite varnish; the thermopile is completely insulated from the brass frame, as also are the silver plates and electrodes, and the whole is waterproofed by dipping in hot paraffin wax to make a thin film on its surface. This film is very thin on the thermopile fan, but is renewed by melting with a minute gas flame before each experiment. The nerves are held in place during an experiment with threads stuck by plasticine to *X* and *Y*."

Thermal protection of the device was made in the following manner. "The complete arrangement was then sunk in a large Dewar flask filled

with water or paraffin oil. The flask had been mounted in a box filled with cork dust: this box was then placed in a second, larger box filled with cork dust, a funnel-shaped space being left above the flask and boarded in at the sides. The second box had a felt-lined cover dropping into the top of the funnel and a close-fitting lid. It in turn was placed in a still larger box also filled with cork dust, and supplied with another close-fitting lid. Leads for the thermopile, for the stimulating electrodes, and for the warming electrodes, were permanently fixed in the funnel-shaped space, as also were rubber and glass connections to the outside for the tubes to the nerve chamber. The conical space above the Dewar flask was closely packed with cotton wool, as also was that between the covers of the second and third boxes.

"The water or the oil in the Dewar flask was stirred by a slow stream of air or gas."

In the author's opinion this protection of the jacket worked better than a thermostat. The temperature of the Dewar flask changed continuously without undergoing fluctuations as in a most precise thermostat. "This was the most successful method discovered of avoiding temperature disturbances, particularly when the temperature of the room was maintained approximately constant by means of a pentane regulator, a pair of electric relays and an electric radiator."

A Zernike Ze Kipp and Zonen, Delft, galvanometer was used. Its resistance was 25 ohms (50 ohms external resistance). At 2.2 m distance 10^{-6} volt gave about 40 mm deflection, so that 1 mm deflection corresponded to a current of 3.3×10^{-10} amp.

The deflection of the moving coil galvanometer was read directly to 0.1 mm on a scale. It was amplified by the photoelectric cell used with a Downing moving magnet galvanometer of about 50 ohms resistance.

"In the experiments at 0° C the Dewar flask was filled with crushed ice and stirred with a slow stream of air."

To give an idea how difficult are the microcalorimetric measurements of processes of short duration carried out with a very small amount of material developing heat, the following two citations are given: "Curious disturbances were sometimes witnessed when the thermostat was slowly cooling, or after a gas, which had bubbled through a wash-bottle in the room, was introduced into the chamber at 0° C. Without warning, but usually after the stimulating circuit had been touched, a large prolonged deflection occurred in the heating direction, which one could only attribute to a 'rainstorm' in the chamber, started off probably by an electric charge on the stimulating wires. At more ordinary sensitiveness such disturbances might be disregarded; at that of the present experiments they could make observations impossible. The condensation of 1 mg of water *per day* would

give out five times the 'initial' heat (at 20° C) of 180 mg of nerve stimulated continuously; the 'total heat' in a 1-second stimulus, say 1.2×10^{-4} cal per gram, or 2.4×10^{-5} cal, could be equalled by the deposition of 4×10^{-8} g of water. It was necessary to avoid such disturbances. At high temperature, therefore, the room temperature was arranged to be slightly above that of the thermostat, so that in the chamber the temperature tended to rise rather than to fall, and super-saturation did not occur. At 0° C dry oxygen was introduced directly from a cylinder, avoiding the wash-bottle.

"Another curious disturbance is caused by compression of the gas in the chamber. With a chamber volume of 150 ml a pinch of the rubber pressure tubing connecting it to the outside might, at high sensitivity, cause a deflection of several hundred millimeters. This is quite intelligible when we reflect that an adiabatic change of volume of one part in a million should cause a change of temperature of about 0.0001° C—enough, at the highest sensitivity used, to send the spot of light about 500mm. . . . In all experiments, therefore, the chamber was completely sealed up, the thick rubber tubes being closed with taps, and so far as possible windy and disturbed days were avoided for the experiments." To these instructive remarks the following was added in proof: "Another thermostat is being constructed in which the thermopile is to be surrounded by three metal cylinders of high thermal conductivity, separated by nonconducting media, and to be shut off entirely from the atmosphere." In principle this device is similar to the multi-stage thermostat built by Tian (§ 9) and the device used by Lazniewski (§ 10) for avoiding temperature fluctuations in the space where the thermo-junction for measuring the average temperature of the thermostat was located.

As the writer is far from being familiar with the subject investigated by Hill, he prefers to give *in extenso* the summary of the results published by A. V. Hill in the paper entitled "Heat Production of Nerve." Other conclusions can be found in Hill's other paper listed in the references.

(1) "The heat production of stimulated frogs' nerves has been investigated with improved methods, including (a) a more sensitive and quieter thermopile; (b) galvanometer amplification by photoelectric cell; (c) condenser stimulation and (d) photographic recording.

(2) "It has proved possible to record the heat in stimuli as short as $\frac{1}{2}$ second (at 20° C), and to analyze it in $\frac{1}{2}$ -second intervals."

(3) "At 20° C the rate of heat production rises rapidly at first during stimulation and falls rapidly at first when stimulation ends. Experiments at this temperature provided no decisive evidence of the existence of 'initial' heat; the whole heat might have been due to 'recovery.'

(4) "At 0° C the heat production is less, but can still be recorded and analyzed. The processes in nerve are so much slower at 0° C that the

analysis is much more effective; it provides decisive evidence that "initial" heat exists as a separate entity.

(5) "In maximal stimulation of a fresh nerve the initial heat at 0°C is about 2 microcalories (2×10^{-6} cal) per gram per second; at 20°C no exact value can be given, but it is not greater than the heat rate in the first second, *viz.*, about 8 microcalories per gram per second.

(6) "The effect on the heat production of frequency of stimulation has been reinvestigated at two temperatures. At 0°C a maximum response occurs already at 30 shocks per second; at 20°C not below 400 per second. The smaller heat in stimulating at low temperature is due solely to the lower frequency of possible response.

(7) "The 'initial' heat in a single isolated impulse at 0°C is 0.26 microcalorie per gram; at 20°C it is not greater than 0.067 microcalorie per gram. The greater heat at the lower temperature is probably connected, as in muscle, with the greater duration of the single response.

(8) "For a given energy in the stimulus, the heat response of a nerve varies with the time of discharge of the condenser supplying it; if F microfarad be the capacity employed and R the resistance in series with it, the heat is a function of RF . The 'optional' stimulus at about 20°C is for $RF = 160$, at 0°C for $RF = 900$. These represent times of half discharge of 0.11 sigma and 0.58 sigma respectively.

(9) "In prolonged stimulation at 20°C the rate of heat production goes on rising for a long time until an approximately steady state is reached. Recovery is not complete for an hour.

(10) "In prolonged stimulation at 0°C the rate of heat production soon reaches a maximum; there is no steady state, the response diminishes as stimulation continues.

(11) "The absence of oxygen causes a progressive fall in the size, but no change in the shape, of the heat response to stimulation. Fifteen hours of asphyxiation at 0°C reduces the total response to one half, but recovery is relatively unaltered. This is further evidence for the existence, in nerve, of some form of oxidizing reserve.

(12) "Previous values of the ratio (initial heat): (total heat) are too high owing to the fact that a considerable amount of recovery heat was included in the estimated initial heat. For a short stimulus at 20°C the initial heat is not more than 4 or 5 per cent of the whole.

(13) "The recovery heat occurs in two phases, one (A) of high initial rate, falling rapidly and ending in a few seconds, the other (B) of low initial rate, falling slowly and lasting probably for an hour. Regarding these as separate processes, the former (A) is of the same order of size as the initial heat and may be directly connected with it; the latter (B) is very much greater and possibly represents a 'secretory' activity by which the

ionic state of the nerve is restored after the electromotive changes of activity.

(14) "Employing a double experimental curve to represent these two factors, it is possible to calculate the rate of heat production during and after a stimulus of any length or distribution; the result has the same characteristics as the heat production actually observed.

(15) "The possibility that the initial heat is due to phosphagen breakdown or lactic acid formation is discussed; the quantities available are sufficient. It may be that the initial process and the (A) process in recovery are analogous to similar processes in muscle. It is possible, however, that the initial heat is due simply to the discharge, or the partial discharge, on an electrical capacity distributed along a surface in the fiber."

§ 55. Whipp's Theoretical Considerations on Microcalorimeters. In the literature two papers can be found^{113, 119} in which the method of microcalorimetric measurements was discussed without giving a series of figures proving the applicability of the conclusions resulting from theoretical considerations. In spite of this, both papers should be considered as valuable contributions to the development of microcalorimetry. One was published in 1933 by A. Tian, the other is B. Whipp's article, which appeared in 1934. In both these papers important suggestions and information are given concerning the best methods of temperature measurements and the adequate protection against uncontrolled heat exchange between the calorimeter and its jacket.

The following table given in Whipp's paper may serve the investigators who are interested in knowing the variety of conditions under which microthermal processes of short duration were or could be examined.

Whipp's Table Characterizing the Microcalorimeter

	Ward	Hill	Lange	Whipp
Energy equivalent of calorimeter	50	0.6 (calc.)	1000	1
Number of thermocouples	31	150	c. 1000	5
Temperature sensitivity	4×10^{-5}	10^{-6}	0.6×10^{-6}	3×10^{-6}
Heat sensitivity	2×10^{-3}	0.5×10^{-6}	0.6×10^{-3}	3×10^{-6}
Resistance of thermocouples	11.5	50	75	1
Resistance of galvanometer	8.5	25	25	1
Sensitivity of galvanometer	3.5×10^{-9}	3.3×10^{-10}	10^{-9}	3×10^{-10}
Insulation of thermocouples	organic	organic	organic	glass
Relative sensitivity (cal per thermocouple)	4	240	1	1120
Heat sensitivity per one couple	6.2×10^{-2}	7.5×10^{-5}	0.6	1.5×10^{-5}

The details concerning Whipp's theoretical considerations may be found in his paper. It should be emphasized, however, that in spite of

an evident importance of this general discussion, the variety of thermal processes and of special conditions under which the measurements must be carried out is too great to give general rules or general indications as to how the measurement should be made and what kind of calorimetric system should be employed. This question is discussed in Chapter XI.

Chapter VIII

Adiabatic Microcalorimeter

§ 56. **Adiabatic Method in Macrocalorimetry.** It is generally known that T. W. Richards was the first to introduce the method of adiabatic measurements in macrocalorimetry.⁸⁵ The writer can hardly agree with the opinion expressed by F. T. Gucker⁴⁸ in 1931 that the French scientist, C. C. Person,⁸¹ is really the founder of the adiabatic method in calorimetry. It is true that Person's paper entitled "Calorimeter in which the Heat Losses are Eliminated" appeared many years before Richards' first paper. It is also true that Person used an adequately heated jacket to reduce to a large extent the calorimeter heat losses. In reading his paper, it can be noted, however, that one of the main uncontrolled heat losses, the evaporation of the calorimetric liquid, was not eliminated but *compensated*. In fact the upper surface of the calorimeter was not protected by a jacket; therefore the heat losses due to the evaporation really took place. The term "adiabatic process" has a precise definition. According to thermodynamics, in an adiabatic process no heat exchange can take place between the object and the surroundings. For this reason in an adiabatic calorimeter the time-temperature curve characterizing the thermal process must be reproduced in the jacket, if the term "adiabatic measurement" is to be applied. If some small deviations in the reproduction of that curve occur, they should be considered as positive or negative deviations from the adiabatic rate of heating or cooling of the jacket. The calorimeter must be also protected against evaporation of the liquid from its surface.

What Person really has done, and what was at that time an important improvement, consisted in using a comparative method for eliminating the correction for the heat losses due to the evaporation of the calorimetric liquid. In blank experiments he replaced the calorimetric liquid with warm water and in that way found the difference in temperature to be maintained between the jacket and the calorimeter for compensating the heat losses resulting from evaporation of the liquid from its surface. Full credit should be given to Person for his ingenious idea. For years the importance of using the compensating method was not fully utilized in calorimetry.

Returning to the priority in using the adiabatic calorimeter, it seems that those facts have been taken into consideration and that was the reason no one in France ever raised the question of Richards' priority in introducing the adiabatic method in calorimetry.

§ 57. **Temperature Measurements in the Adiabatic Macrocalorimeter.** There has never been a discussion as to how the temperature of the Macrocalorimeter must be measured. Everybody understood clearly that there were no difficulties in measuring directly the temperature in both the calorimeter and in the jacket. Richards used two Beckmann thermometers for that purpose. In numerous experiments carried out by other workers the electrical resistance thermometer has been often employed. At any rate, the direct and "independent" temperature measurements of the calorimeter and the jacket were generally recognized in macrocalorimetry.

Since the importance of using the adiabatic method was fully recognized in microcalorimetry, it was obvious that an essential modification in temperature readings had to be introduced because neither the mercury thermometer nor the electrical resistance thermometer could be used for measuring the temperature of the microcalorimetric system (§ 11 and § 31).

§ 58. **Adiabatic Microcalorimeter.** In 1927 Miss A. Dorabalska and the author described⁹⁷ the construction of an adiabatic microcalorimeter in which the problem of measuring the temperature increases produced by the object in the microcalorimeter was solved. The essential idea in carrying out adiabatic measurements was to use a thermocouple or a thermopile to insure that the temperature of the jacket was kept equal to that of the calorimeter. In doing so, the temperature increases could be measured by any kind of a *thermometer located in the jacket*.

The adiabatic conditions of the measurements could be fulfilled by keeping during the experiment the needle of the galvanometer on its zero position. In that way the equality of the rates of heating of the microcalorimeter by the object and of the jacket by the electric heater were assured.

In Figure 32 the first model of the adiabatic microcalorimeter is shown.⁹⁷ This apparatus was designed for measuring the heat of absorption of particles and rays emitted by radioactive substances. The walls of the microcalorimeter served as screens which absorbed the radiation.

The microcalorimeter proper (*C*) consists of a cylinder the diameter of which may be changed. It is provided with a hole in its center wide enough to accommodate a glass tube containing the radioactive substance. It is suspended inside a massive metallic vessel, *A*, resembling the calorimetric bomb. At the surface of the calorimeter, or in the hole bored in the vicinity of its surface, one junction of the thermocouple is located. The other junction is placed inside cover *B*, which is also made of a massive lump of steel. Cylinder *A* is located in large container *D* (over 100 liters capacity) filled with water. The latter is thoroughly stirred with a stream of air saturated with vapor. In that way the evaporation of water from

container *D* is practically eliminated. Container *D* is provided with an electric heater. If necessary, the jacket can be cooled by a stream of cold water passing through a metallic tube wound in a spiral. Both the heater and the spiral are shown in Figure 33 (§ 59). Using the heater and, if

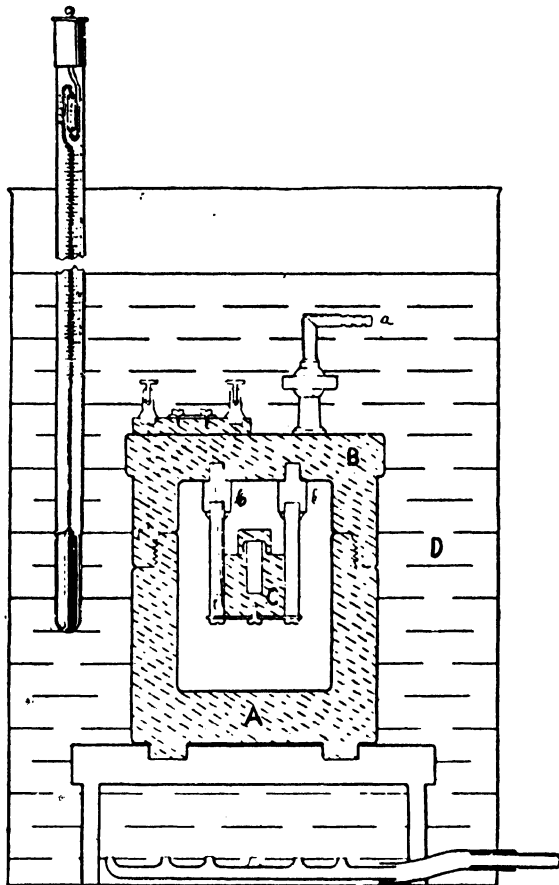

Figure 32. A. Dorabialska and W. Swietoslowski's Adiabatic Microcalorimeter for Measuring the Heat of Absorption of Particles and Rays Emitted by Radioactive Substances.

necessary, the stream of cold water, the adiabatic conditions of the process can be easily maintained.

If the equality of temperatures of the calorimeter and the jacket is maintained during the experiment, it suffices to measure only the temperature fluctuations of the jacket. This is an essential change when compared with the method applied by T. W. Richards⁸⁵ and by a number of

other investigators. If the temperature increases are large enough, a Beckmann or Ultra-Beckmann thermometer may be used. It should be immersed into the water in the jacket. The use of L. Keffler's microscope⁶⁰ makes it possible to read the temperature of the jacket with an accuracy of $\pm 0.0005^\circ \text{C}$ even on the scale of the ordinary Beckmann thermometer.

Let us suppose that a sealed tube containing several milligrams of radium is placed in the microcalorimeter. The performance of the measurements consists in the following: First, it should be determined whether the temperature of the calorimeter differs from that of the jacket. As this is usually the case, a deflection of the galvanometer is noticed. To return it to zero position it is necessary to change the temperature of the jacket by heating or by cooling it. When the zero point is reached, the measurement proper may start. From then on the temperature of the jacket should be kept equal to that of the calorimeter. This is the way to maintain adiabatic conditions of measurement. To do this it is necessary to heat (or to cool when endothermal processes are examined) the jacket so that no deflection of the galvanometer is observed.

Let us suppose that the temperature at which the experiment starts is t_0 , and from that moment the temperature of the jacket is always the same as that of the calorimeter; in other words, the rate of heating (or cooling) of the jacket is equal to the rate with which the calorimeter was heated by the object. Under these conditions no heat exchange between the calorimeter and the jacket can take place, and the experiment is therefore carried out under strictly adiabatic conditions. Let us suppose that the measurement is carried out for three hours and that at the end of the experiment the temperature of the jacket is t_n . The difference, $\Delta t = t_n - t_0$, represents the increase in temperature both in the jacket and in the microcalorimeter. If k represents the energy equivalent of the calorimetric system, the heat produced by the object per hour is:

$$\Delta q = \frac{k \cdot \Delta t}{3} = \frac{(t_n - t_0)k}{3} \quad (1)$$

The method just described enables one to carry out the experiment for an arbitrarily long period of time, so as to obtain a reasonably large increase in temperature Δt . The error of the measurement depends upon the accuracy with which readings t_0 and t_n can be made and upon the precision with which the rate of heating of the jacket can be kept equal to that of the calorimeter. If these conditions are fulfilled adequately the heat gains or losses of the calorimeter will be equal to zero.

Usually small positive and negative deviations from the adiabatic course of the measurement are observed. The following example is given to illustrate both the performance of the measurement and the magnitude of these deviations.

A calorimeter made of silver was used. Its energy equivalent was $k = 3.284$ calories. Instead of having an object, the heat was produced by an electric heater. After half an hour of heating it was assumed that a thermal equilibrium inside the calorimeter was established and that a certain distribution of temperature inside the calorimeter corresponded to that equilibrium. From that moment the temperature of the jacket was changed so as to keep the galvanometer on its zero position. The following readings were made:

Time	Differences on Galvanometer Scale (mm)	Difference (expressed in °C)	Temperature of the Jacket (°C)
9 ^h 30'	0.0	—	1.272
10 ^h 00'	- 0.1	- 0.0014	1.324
10 ^h 30'	+ 0.2	+ 0.0028	1.373
11 ^h 00'	- 0.2	- 0.0028	1.425
11 ^h 30'	- 0.1	- 0.0014	1.475
12 ^h 00'	- 0.1	- 0.0014	1.524
12 ^h 30'	+ 0.1	+ 0.0014	1.576
3 ^h			$\Delta t = 0.304$

It can be concluded that the calorimeter was heated adiabatically at the rate of

$$\Delta t = 0.304/3 = 0.101_3^\circ \text{ per hour.}$$

The heat developed by the electric heater was 0.333 cal per hour.

To calculate the correction for the deviations from the adiabatic course of the experiment it was necessary to find, by direct experiments, what was the rate of heating or of cooling of the calorimeter when a known and constant difference of temperature was maintained between the calorimeter and the jacket. Knowing that value, it was easy to calculate the correction involved. Usually, however, the deviations are partly positive and partly negative and are symmetrically distributed on both sides of the curve showing the rate of heating of the calorimeter by the object. In that case the heat gains are compensated by the heat losses and the correction is equal to zero. If positive or negative deviations are predominant, a correction should be calculated (§ 61).

§ 59. **Simplified and Improved Adiabatic Microcalorimeter.** The calorimeter described in the previous paragraph has been largely improved and somewhat simplified.^{89, 99, 104} The improvement consists in placing the galvanometer, the thermocouple conducting wires, and the commutator inside the adiabatic jacket. The simplification involves replacing the massive metallic vessel with a container made of glass. Figure 33 shows one of the calorimeters used for measuring the heat of vaporization of liquids or of adsorption of vapors by activated carbon.

Calorimeter proper, *A*, is made of silver, copper or lead. It is located

in glass container P , provided with a hole large enough to pass sphere A . In vessel P two cavities are made, one (T_2) for placing in it the thermo-junction, the other (L) for fastening the calorimeter in its central position by means of a silk thread. Three other silk threads are attached to the three points at the surface of the upper part of the calorimeter and to

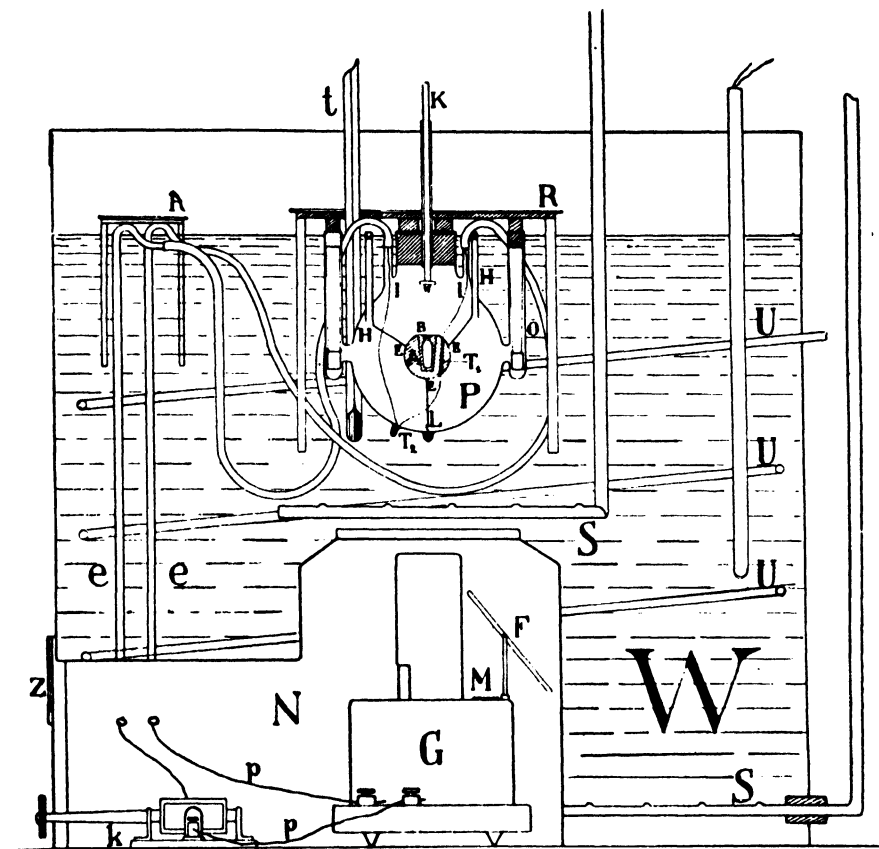

Figure 33. Swietoslowski's Improved Microcalorimeter.

glass tubes H , as shown in Figure 33. The other thermojunction (T_1) is located inside calorimeter A as close as possible to its surface (in Figures 32 and 33 thermojunctions T_1 are located too deep inside sphere A). Container P may be provided with any kind of side tubes which may be required for the execution of the measurement. In Figure 33 two such side tubes (O) are shown.

The stopper should be provided with a necessary number of holes. For instance, for measuring the heat of vaporization or adsorption only one hole

is required for accommodating rod K , to which the arrangement described in § 71 and shown in Figure 40 is attached.

The essential improvement of the adiabatic jacket consists in providing it with chamber N in which the galvanometer and the commutator are located. Metallic tubes (e, e) found inside the jacket make it possible to pass through them the conducting wires of the thermocouple.

To avoid any heat gains or losses through the stopper or the glass tubes which extend a little out of water in jacket W , massive copper plates (R) are used to cover all these parts. A number of massive rods made of copper are attached to plates R . They are immersed deep in the water. Because of the high thermal conductivity of copper, these rods supply heat enough to compensate the heat losses of plates R , so that they are heated to practically the same temperature as the jacket. Consequently, the extending parts of the apparatus are thermally well protected. Mirror F , attached to galvanometer G , is used for adjusting the galvanometer to its proper position.

For heating the calorimeter, an electric heater is used. For cooling, a stream of cold water taken from the water line could pass through tube (U, U) wound in a spiral.

For stirring, two perforated tubes (S, S) are used. One of them is located beneath container P , the other on the bottom of jacket W . A constant stream of air saturated with vapor is maintained in both rings.

Usually air from container P (§ 69) was removed before the start of the experiment. In some cases, however, (§ 71) the conditions of the experiment does not permit a vacuum between the calorimeter and container P . If so, the correction (§ 62) should be made. Usually it constitutes less than 0.15 per cent of the total amount of heat evolved.

The temperature of the water in the jacket is measured by using either a Beckmann or Ultra-Beckmann thermometer. The use of an electrical resistance thermometer is very convenient, especially, if the rates of temperature increases are very small.

§ 60. **Calculation of the Heat Developed.** If t_0 and t_n represent the temperatures of the adiabatic jacket at the start and at the end of the calorimetric process, and k is the energy equivalent of the microcalorimeter, the following equation should be used for calculating the heat produced by the object:

$$\Delta Q = k(t_n - t_0) + \Sigma p \quad (1)$$

Σp represents the heat developed by all the secondary phenomena.

If the object, for instance, radium or a radioactive mineral, develops a constant amount of heat during an unlimited, or practically unlimited period of time, the amount of heat liberated in one hour is either:

$$\Delta Q_h = \frac{k(t_n - t_0)}{h} + \Sigma p \quad (2)$$

or

$$\Delta Q_h = \frac{k(t_n - t_0) + \Sigma p}{h} \quad (3)$$

The use of equation (2) or (3) depends upon the nature of the secondary phenomena. In most of the cases Σp is proportional to the total temperature increase Δt , and Δt increases proportionally to time h ; thus Σp increases also proportionally to the number of hours during which the measurement is carried out.

An adequately chosen method of comparative measurements (§ 23, 24, 27) eliminates all or nearly all the corrections [Σp in equations (2) and (3)]. In spite of this, it is important to examine the influence of two main corrections. One is associated with the loss of heat by the calorimeter in heating a certain amount of air found between calorimeter *A* and vessel *P* (Figure 33); the other is the result of small positive or negative deviations of the temperature of the jacket when compared with that of the calorimeter.

§ 61. **Correction for Heating the Air.** A strictly adiabatic calorimetric measurement requires that the temperature in the jacket be kept equal to that of the calorimeter. If that condition is maintained during the experiment, no heat exchange between the surfaces of vessel (*P*) and calorimeter (*A*) (Figure 33) takes place. However, between vessel (*P*) and calorimeter (*A*) there is still some air. The amount is very small, if a low pressure (vacuum) is established in *P*; it is much larger if, for some reason, the air cannot be removed (§ 71). In that space the air is heated at practically the same rate as the calorimeter and the jacket, so that the correction for the heat loss of the calorimeter is proportional to the increase of the temperature ($t_n - t_0$). Since in the heating of air both the surfaces of vessel (*P*) and calorimeter (*A*) take part, it is reasonable to assume that the heat supplied by *P* and *A* is proportional to the surfaces involved. This is accepted as a basis for calculating the correction.⁹⁹

Two cases are discussed below, one for a spherical, the other for a cylindrical calorimeter.

Let us assume that both calorimeter *A* and vessel *P* (§ 59) are spherical, and that r and R represent the radii of these spheres. If v is the volume of air found between vessel *P* and calorimeter *A*, the following equation may be written:

$$v = \frac{4}{3}\pi(R^3 - r^3)$$

The amount of heat used for heating the air from t_0 to t_n is:

$$q = v \cdot c_v \cdot d(t_n - t_0) = \frac{4}{3}\pi(R^3 - r^3)c_v \cdot d(t_n - t_0) \quad (1)$$

In this equation c_v is the specific heat of air at constant volume, and d is its density. As the total surface participating in heating is:

$$S = 4\pi(R^2 + r^2)$$

the heat supplied by the surface of the calorimeter is:

$$\Delta q = \frac{q \cdot 4\pi r^2}{4\pi(R^2 + r^2)} = \frac{qr^2}{R^2 + r^2} \quad (2)$$

or finally:

$$\Delta q = \frac{4}{3}\pi \frac{(R^3 - r^3)d \cdot c_v(t_n - t_0)}{R^2 + r^2} \quad (3)$$

Correction Δq may be expressed in percentage of the total amount of heat developed during the calorimetric measurement. If k is the energy equivalent of the calorimeter (see § 22), the total amount of heat developed is:

$$\Delta Q = k(t_n - t_0)$$

or correction p expressed in per cent is:

$$p\% = \frac{100\Delta q}{\Delta Q}$$

or:

$$p\% = \frac{4}{3}\pi \frac{d \cdot c_v(t_n - t_0)(R^3 - r^3)r^2 \cdot 100}{k(R^2 + r^2)(t_n - t_0)}$$

$$p\% = 418.6 \frac{d \cdot c_v(R^3 - r^3)r^2}{k(R^2 + r^2)} \quad (4)$$

If the air remains under atmospheric pressure and the temperature of the experiment is close to 20° C, density d is 0.00129 and the specific heat $c_v = 0.2$. In this case equation (5) may be written:

$$p\% = 0.1079 \frac{(R^3 - r^3)r^2}{k(R^2 + r^2)} \quad (5)$$

Below one example is given: If $R = 5$ cm; $r = 2$ cm; $k = 18.7$ cal. then:

$$p\% = 0.09\%$$

The correction is somewhat less than 0.1 per cent. If a cylindrical calorimeter is used and vessel P is a sphere, equation (5) is changed to

$$p\% = \frac{0.0810 \left(\frac{4}{3}R^3 - hr^2 \right) (hr + r^2)}{(R^2 + hr + r^2)k} \quad (6)$$

In this equation r is the radius of the cylinder and h its height. If the calorimeter is made of aluminum and r is 1.3 cm and $h = 4.3$ cm, then $k = 13.2$ cal. If R is (as before) 5 cm and the pressure of air is one atmosphere (at 20° C) then $p\% = 0.12\%$.

If the conditions permit one to establish a vacuum in space P (Figure 33), the correction for heating the air becomes so small that it may be neglected. In fact it is many times smaller than the experimental error.

§ 62. **Correction for Heat Gains or Losses.** As mentioned before (§ 60) it is difficult to heat the jacket at exactly the same rate that the calorimeter is heated by the object. Because of this, small positive or negative differences between the temperatures of the jacket and of the calorimeter are observed. Usually these differences are of very short duration. In spite of this, some small heat gains or losses may result from these temperature deviations. The following simple procedure permits one to express this correction in degrees of the thermometric or in divisions of the galvanometric scale.

Let us suppose that the object was removed and replaced by a thermally inert body having the same energy equivalent as the object. Suppose that the state has been reached at which the galvanometer does not show any current in the circuit, so the temperature of the jacket, t_0 , is equal to that of the calorimeter.

Let us now change, as rapidly as possible, the temperature of the jacket by $+0.1^\circ$ or -0.1° and let us notice the time and change in the deflection of the galvanometer, Δv . Ten or fifteen minutes later the jacket should be cooled or heated so as to establish exactly the same temperature as before (t_0). Thereafter a new reading of the galvanometer deflection follows; a difference, Δn , found on the galvanometer scale, results because during the experiment the calorimeter has lost or gained some amount of heat because of the difference in the temperature which was purposely established. It can be accepted for small changes in temperature and short periods of time that the deflections are proportional to the time intervals. Then coefficient B may be found from the equation:

$$B = \frac{\Delta n}{\Delta t \cdot \Delta \tau} \quad (7)$$

In this equation Δt is the initial difference in temperature and $\Delta \tau$ the interval of time between the start and the end of the experiments. It is easy to express Δt , like Δn , in terms of the galvanometer scale, and $\Delta \tau$ in minutes.

Several experiments should be carried out changing each time Δt and *its sign* in order to prove that constant values for B are found. If B is higher (or lower) when $\Delta t > 0$ and lower (or higher) if $\Delta t < 0$, it may result from some secondary phenomena, showing that the calorimetric system is not thermally inert (see § 63). If an exceptionally high accuracy is required the kinetic method described in § 80 should be used for calculating value B in equation (7).

The success of an adiabatic measurement depends to a large extent upon the manner of heating or cooling the adiabatic jacket. It is important to avoid the deviations in reproducing the rate of temperature changes in the jacket. Fortunately, the temperature increases are usually very small and it is easy to acquire skill in handling either the electric heater or the valve of the water line, to keep the deviations in the range ± 0.001 to $\pm 0.002^\circ \text{C}$. In the case of some deviations it is important also to have the fluctuations as symmetrical as possible. The symmetry of those deviations means that the positive deviations compensate the negative ones. In that way the correction for the heat exchange of the calorimeter becomes really very small. For instance, in the example quoted in § 58 the sum of the negative deviations is equal to that of the positive. If the fluctuations in Δn are too large and too irregular, the experiment should be considered unsuccessful and the numerical values should not be taken into consideration.

§63. **Thermal Inertness of the Calorimetric System.** Before considering the secondary phenomena taking place during the measurement, it should be pointed out that a preliminary examination of the calorimetric system should be made in order to prove that the calorimetric system is *thermally inert*. In general, it may happen that due to some adsorption phenomena or to the evaporation of water from the surface of the calorimeter (desorption), some thermal phenomena may accompany the process examined. Consequently, an error may be committed because at the start the calorimetric system was not thermally inert. Besides adsorption or evaporation, aging phenomena (§ 84) or mechanical deformation (§ 82) of the calorimeter may also take place, which may cause some error. For this reason it is absolutely necessary to carry out blank experiments to prove that no thermal phenomena occur which are peculiar to the calorimeter itself. The test consists in establishing the same temperature in the calorimeter and in the jacket and in maintaining this temperature in the jacket for one hour or more. If during this time no deflection of the galvanometer is observed, the calorimetric system may be considered as thermally inert.

To avoid the phenomena associated with changes in the structure of massive metallic blocks (§ 82) or with aging of metallic alloys (§ 84) it is advisable to keep a calorimeter made of such materials in the calorimetric room for several weeks. They should be suspended in the same way as it is planned to suspend them in container *P* (Figure 33). Massive blocks should be located on a steel plate to which metallic wires or silver threads should be attached (§ 82).

In some cases, however, it is impossible to carry out the blank experiments as previously described. For instance, if the heat of aging metallic

alloys is measured, heat is liberated even before the experiment starts. In that case the experiment should last long enough to determine whether any irregularities in the heat development occur at the beginning of the experiment. Usually, the adsorption or evaporation of very small amounts of water attached to the surface of the calorimeter is completed in 12 to 20 minutes, and then regular changes in the heat development can be observed. In that case the first temperature readings should be rejected.

If radioactive minerals constitute the object of the measurement, it is also advisable to repeat the experiment several times and not to take into consideration the first measurement, especially if the results obtained are unusually high or low. It is important to repeat the same series of measurements two or three weeks after the first series to see whether any irregularities existed which might have caused changes in the heat evolved in the experiments carried out shortly after the calorimeter was set up. No heating and no welding of some parts of the calorimeter is permissible for a period from ten to fourteen days before the start of the measurements.

§ 64. **Use of the Method of Comparative Measurements.** In § 60 it was pointed out that the heat developed by the object is calculated by the equation:

$$\Delta Q = k(t_n - t_0) + \Sigma p$$

In that paragraph an explanation of the symbols was given. It is of great importance to use such a method of successive comparative measurements that will eliminate most of the thermometric and calorimetric corrections. At the same time the corrections associated with measuring the temperature increase $(t_n - t_0)$ and energy equivalent k of the calorimeter may be eliminated.

In general, the method of successive comparative measurements described in § 24 may be used. It consists in a direct comparison of the heat developed by the object with the heat evolved by an electric current. The resistance of the wire and the intensity of the current should be chosen so as to reproduce the time-temperature curve which characterizes the process under examination. The experimenter should decide whether the equipment he disposes permits him to measure with the required accuracy the amount of heat produced by the electric energy. Very often this is not the case; therefore, it is convenient to use the method described in § 22. This involves determining the heat liberated by the electric current in comparison with the heat produced by the same current in another calorimeter, with a known energy equivalent. This method is especially useful if the time-temperature curve is irregular so that the electric current often needs to be changed in order to reproduce the same rate of heating as in the main calorimeter.

The electric heater is usually built into the calorimetric system. Its energy equivalent should be included in the value k (§ 22) of the whole calorimetric system. The location of the resistance wire and the diameter of the spiral in which it should be wound play an important role. In fact, this must be done *to keep the rate of heating of the outside layer of the calorimeter walls equal to that produced by the object*. Sometimes the electric heater should be located in the center of the calorimeter. In that case it should be removed and replaced by the object (for instance, by the glass tube with the radium preparation) before carrying out the measurements proper.

If the identity of conditions of two successive measurements, one with the object, another with the electrical heater, are fulfilled, the following two equations may be written.

$$\Delta Q = k(t_n - t_0) + \Sigma p = k\Delta t + \Sigma p$$

$$\Delta E = J \cdot i^2 \cdot r \cdot \tau = k(t'_n - t'_0) + \Sigma p' = k\Delta t' + \Sigma p'$$

If $\Delta t'$ is equal to Δt ; $\Sigma p'$ should be equal to Σp , and therefore:

$$\Delta E = J \cdot i^2 \cdot r \cdot \tau = \Delta Q$$

In that case it is not necessary to determine separately the energy equivalent of the calorimeter, k . In addition, $\Delta t = (t_n - t_0)$ can be expressed in degrees of the arbitrary thermometric scale.

If the time-temperature relation of the thermal process is expressed by a straight line, a direct measurement of electric energy becomes more convenient. In fact, the electric current may be kept constant and time τ may be measured with sufficient accuracy without special expensive equipment. For instance, if the heating is carried out for three hours, an ordinary stop-watch may be used and time τ may be determined within ± 1 second, which is an error of one part in 10,800.

In measuring the heat developed by radioactive substances some authors have used another method of comparative measurements,^{35, 127} *i.e.*, replacing the radioactive substance under examination by a standard radium preparation. If this method is used, the temperature increases, Δt and Δt_s , are not equal (as they can be, when an electric heater is used). In spite of this, if the assumption that Σp changes proportionally to temperature increase Δt is correct, the equation:

$$\Delta Q : \Delta Q_s = \Delta t : \Delta t_s$$

may still be employed. In this equation the subscript letter relates to the experiment with the standard preparation.

The determination of the heat developed by radioactive minerals changes the conditions of the experiment so that none of the conventional

comparative methods (§ 22, 23, 24) can be applied. In these investigations the calorimeter is made of thin metallic walls, and it is filled with the radioactive mineral. In addition, because of very small amounts of heat evolved by radioactive minerals, the experiments last as long as 16, 24 and even 36 hours. To employ the method of comparative measurements in that case the following modification may be recommended. The electric heater should be located in the microcalorimeter so as to heat the whole charge of the radioactive mineral as uniformly as possible. At least two, and better a series of measurements should be carried out. First, the heat developed by the mineral alone should be measured, then the heat developed by the mineral and by successive electric currents i_1, i_2, i_3 , etc., should be determined. Assuming that Σp changes proportionally with time τ and temperature increase Δt , one may use the following series of equations:

$$\frac{\Delta Q}{\Delta Q + J \cdot i_1^2 \cdot r \cdot 3600} = \frac{\Delta t}{\Delta t_1}$$

$$\frac{\Delta Q}{\Delta Q + J \cdot i_2^2 \cdot r \cdot 3600} = \frac{\Delta t}{\Delta t_2}, \text{ etc.}$$

In these equations ΔQ is the heat developed by the object in one hour; $\Delta t, \Delta t_1, \Delta t_2, \Delta t_3$, etc., are the hourly temperature increases; r is the resistance of the wire; and i_1, i_2, i_3 , etc.; are the intensities of the electric currents. If ΔQ varies within the limits of the experimental error it may be concluded that Σp increases proportionally with τ (and Δt). If so, these equations can be used.

§ 65. **Twin Adiabatic Calorimeters.** In the previous paragraph it was pointed out that if precise equipment for measuring time intervals, τ , resistance, r , and intensity of electric current, i , is lacking, or if for reproducing the time-temperature curve the intensity of the current should undergo steady changes, the absolute determination of value ΔE (see equation in § 64) should be abandoned and the method of twin adiabatic calorimeters (§ 22 and 70) should be used. One of the calorimeters should be made of silver or copper so that its energy equivalent k_1 (see equation in § 22) can be calculated with sufficient accuracy.

§ 66. **Accuracy of Measurements.** There are usually so many factors which exert their influence on the accuracy of microcalorimetric measurements that it is almost impossible to express in percentages the limits of experimental errors in those measurements. For simplification, the following assumptions can be made: (1) No side reactions take place. (2) The general conditions of the experiment permit one to remove air from the space between the calorimeter and vessel P of the jacket (Figure 33). (3) The object produces heat at a constant rate. (4) The adiabatic conditions are maintained so that no measurable amount of heat is lost or

gained by the calorimeter. (5) All thermometric and calorimetric corrections are eliminated by an adequate use of the method of comparative measurements. If all these conditions are fulfilled, the equation

$$\Delta Q = \frac{k \cdot \Delta t}{h}$$

may be used for calculating the absolute and the relative error of the experiment.

The absolute error depends on the accuracy with which "apparent" energy equivalent k is determined. This largely depends on the size of the microcalorimeter and on the method used for measuring the energy equivalent, k , of the calorimeter. It is probable that under favorable conditions the absolute error may be equal or even lower than 0.2 per cent. If very small microcalorimeters are used the error may be slightly greater.

The relative error of the experiment depends upon temperature increase, Δt , and the accuracy with which this increase can be determined. It should be remembered that for determining the starting and the final temperature only two temperature readings, t_0 and t_n , are involved. The other readings are carried out with the purpose of maintaining the adiabatic conditions of the process. In each case, however, not only the temperature readings but also the determination of the difference between the temperatures of the calorimeter and of the jacket may cause an error. It should be assumed that both temperature readings, t_0 and t_n , are made at the conveniently chosen moment when no deflection of the galvanometer needle is observed. This means that at these moments the temperature of the jacket is equal within the limit of experimental error to the temperature of the calorimeter (its surface). These readings, however, may also include errors; hence the determination of t_0 and t_n may be shifted toward one or the other side by the errors of temperature and galvanometer readings. The temperature readings can be made with an accuracy of $\pm 0.0005^\circ$, if a mercury thermometer and an adequate microscope are used. The error may be reduced to $\pm 0.0001^\circ$ if an electrical resistance thermometer is employed for measuring the temperature of the jacket. The reason why a further increase in the precision of the thermometer readings does not increase the accuracy of the calorimetric measurement is discussed in § 67.

The accuracy with which the difference between the temperatures of the jacket and the outside surface of the calorimeter can be determined depends on the number of thermojunctions of the thermopile. In principle, that number may be large enough to permit highly accurate galvanometer readings. However, under the conditions which usually exist the increase of this accuracy may be ineffective; it depends largely on the object and on the size of the calorimeter. If one thermocouple is employed, an error

of 0.0014° in measuring the difference of temperature may be made. Consequently, $\Delta t = t_n - t_0$ may be determined with an error of $2(0.0005 + 0.0014) = 0.0038^\circ$. If the heat developed by the object in one hour is examined, the relative error of the experiment is

$$E\% = \frac{k \cdot 0.0038 \cdot 100}{\Delta Q \cdot h} \% = \frac{0.0038 \cdot 100}{\Delta t \cdot h} \%$$

As in a number of cases Δt increases proportionally with the time during which the measurement is conducted, the error decreases with increase of the duration of the experiment. For instance, when measuring the heat developed by absorption of alpha and beta particles and most of the gamma radiation emitted by radium, the error does not exceed 0.2 to 0.3 per cent, because the experiment can last as long as desired. The determination of the heat of evaporation of volatile liquids may be determined with an accuracy of ± 0.3 per cent. Further improvements may still increase the accuracy of measurements by the adiabatic method just described.

§ 67. **Applicability of the Adiabatic Method.** In connection with the applicability of the method of the adiabatic microcalorimeter described in previous paragraphs, the following questions were discussed: Does the use of multi-junction thermocouples and some improvement in the accuracy of temperature readings increase the accuracy of the measurements? At the same time can the number of objects examined by this method also be increased? Up to this time these questions remain without any definite answer. Two facts are responsible for this. There are but few systematic and precise microcalorimetric measurements which show a satisfactory applicability to automatic regulation of the rate of heating the adiabatic jacket.^{49, 63} Secondly, soon after the adiabatic microcalorimeter had been employed, other methods were found^{100, 101, 109} more precise and perhaps more convenient. They require the use of an isothermic jacket, for which the problem of self-recording equipment and autoregulation has been solved by a number of authors (see § 6, 8).

The increase in precision of the adiabatic method is associated mainly with the accuracy with which the rate of heating the adiabatic jacket can be accomplished. At present the heating curve can be established with an accuracy of ± 0.001 to 0.002° . This is the main reason why a considerable increase in precision of temperature and galvanometer readings remains ineffective.

In most cases *it is more important to increase the duration of the experiment than to increase the precision of measuring the temperature of the jacket and the difference Δt between the temperature of the calorimeter and of the jacket.*

There is only one particular case in which precision in temperature and

galvanometer readings may be considerably increased. It consists in measuring the very small and constant amount of heat developed by objects which may be used in large quantities. Radioactive minerals are typical objects of that kind. Heating the jacket at a constant rate does not present any difficulty and the measurement can last a number of hours so as to have a reasonably large increase in temperature. In that case multi-junction thermopiles may be used and the accuracy of temperature readings considerably increased.

There is another limitation in the use of the adiabatic microcalorimeter. This method cannot be used if the temperature in the calorimeter changes rapidly and if the amount of heat developed by the object per unit of time increases with temperature. This applies to chemical reactions the velocity of which increases rapidly with temperature. Another case in which it is undesirable to have large temperature increases in the calorimeter is any kind of physiological or biological investigation, in which the object should be kept at constant temperature. The hardening of cement is a typical reaction in which a change of temperature of the calorimeter, even of a small fraction of a degree, changes the amount of heat produced in unit time.

In spite of these inconveniences, if no other calorimetric method can be used, the experiments might be carried out so as to avoid these complications to a large extent (§ 73).

§ 68. **Heat Developed by Radioactive Elements.** In 1928 Miss A. Dorabialska used for the first time the adiabatic microcalorimeter shown in Figure 32. Her first measurements were made at the Curie Radium Institute, Paris. She continued her investigations at Warsaw^{28, 29, 30, 31, 32} and applied the adiabatic method later³⁴ at the Physicochemical Laboratory of the Institute of Technology, Lwow. Using a strong preparation of polonium, she succeeded in determining the half-life of this element by the calorimetric method. The value obtained was close to that found by other methods. She found that the heat developed by pitchblende of Joachimovo (Joachimstal), Czechoslovakia, was: 6.37×10^{-5} cal/g/hr. She and J. Sterba Böhm noticed^{32, 111} that in some cases the salts and the sulfides or oxides of both rare and common elements, like arsenic and antimony, develop a very small amount of heat at room temperature. The results obtained by A. Dorabialska have stimulated the writer to improve the structure and the functioning of the microcalorimeter^{99, 104} so that 10^{-5} calorie per gram in an hour could be measured with sufficient accuracy (see § 81). A number of experiments have been made with the new equipment, and they have shown that at least some materials have liberated small amounts of heat for weeks and even months (§ 82, 83, 84).

After the precision of 0.2 to 0.3 per cent had been reached, Madame M.

Curie agreed with the writer that two special microcalorimeters should be built in Warsaw and their functioning examined with the radium preparation of the Sklodowska-Curie Radium Institute at Warsaw; afterwards, these two calorimeters would be sent to Paris for measuring the heat developed by the standard radium preparation. It was planned to repeat the measurements every few years to observe the change in heat development with time. In 1933 I. Zlotowski completed the preliminary investigations carried out in Warsaw and then went to Paris, where he worked for several months before and several years after Madame Curie's death. In addition to his own investigations, Madame Curie gave him a series of

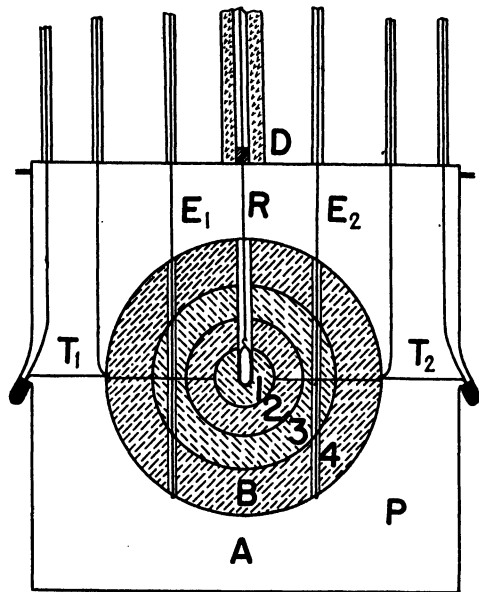

Figure 34.

Adiabatic Calorimeter
With a Series of Coaxial Lead
Spheres for Measuring the
Heat of Radium Radiations.

radioactive substances for measuring the heat liberated. As far as is known to the writer, no results of these measurements have been published because of the death of Madame Curie in 1934.

In Figure 34 the first type of apparatus used by I. Zlotowski is shown. In principle it is the same as that shown in Figure 33. The essential difference consisted in the use of several concentric spheres made of lead, to allow changing the thickness of the screen from 2 to 7.3 cm.

Using the smallest sphere one could measure the heat of absorption of all the alpha and practically all the beta particles. The percentage of gamma rays absorbed could be calculated when their absorption coefficient was known. The largest sphere was thick enough to absorb 97.5 per cent of the gamma rays. In that way it was possible to draw the curve express-

ing the relation between the diameter of the sphere and the total amount of heat measured in the experiment. It was possible also to draw the curve expressing the change of the heat produced exclusively by the gamma rays with the change of thickness of the screen.

To avoid any accidental error associated with galvanometer readings two independent thermocouples were used, both attached close to the surface of the calorimeter wall. The deviations from the adiabatic course of the measurements have never exceeded $\pm 0.002^\circ$.

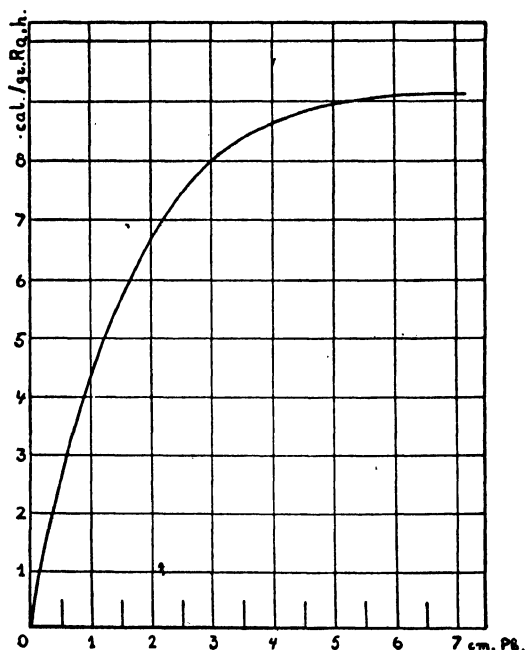

Figure 35.

Curve Showing the Change in Heat Developed by Gamma Rays With the Change of the Diameter of the Screen.

In Figure 35 the absorption curve for gamma rays is shown. According to calculations the screen of lead 6.0 cm thick absorbs approximately 97.5 per cent of the gamma radiation. The experiments have shown that the gamma radiation is not uniform; hence the curve differs to some extent from that expressed by the simple exponential equation. After it has passed a screen 2 cm thick it becomes practically uniform. Zlotowski¹²⁹ gave the following figures for the heat of absorption of the radiation. The figures relate to one gram of radium in one hour:

Heat liberated by absorption of alpha and beta particles 130.5 cal/gh

Heat liberated by absorption of gamma rays (RaB and RaC) 9.1 cal/gh

The total amount of heat—139.6 calories per gram in one hour—represents the heat liberated by absorption of all particles and rays emitted

by radium and its transformation products including RaC. The average error is ≈ 0.2 per cent, which seems to be the lowest ever reached in direct calorimetric measurements of this kind. The results obtained by Zlotowski agree well with those based on calculations of the kinetic energy of alpha and beta particles.

Ten years have passed since then, and it is important to repeat the measurements using the same equipment, which is still at the disposal of the Curie Radium Institute, Paris.

§ 69. **Adiabatic Microcalorimeters for Measuring the Heat Produced by Gamma Rays and Beta Particles.** It has been mentioned above that according to an agreement with Madame Curie another microcalorimeter was built in Warsaw and tested at the Sklodowska-Curie Radium Institute. Its purpose was to measure exclusively the heat produced by gamma rays. The cross section of this apparatus is presented in Figure 36. It is composed of two parts: a central device (*A*) for absorption of the heat developed by alpha and beta particles and a small portion of the gamma rays, and the calorimeter proper (*B*) for measuring the heat of absorption of the part of the gamma radiation retained by the lead screen (*B*). The central device resembled the labyrinth flow calorimeter described in detail in Chapter X (§ 89, 90). In the center of that device, consisting of two coaxial glass tubes 1 and 2, tube *R* containing the radium preparation was suspended. All the alpha and most of the beta particles emitted by the radium preparation were absorbed by water streaming through the labyrinth. The water entered the labyrinth through inlet tube O_1 ; it was taken directly from the adiabatic jacket, which is not shown in the figure. After passing through passageways 1 and 2, the water left the device through outlet tube O_2 . Since the temperature of entering water is, at any moment, equal to the temperature of the calorimeter (*B*), no heat is transferred by this stream from outside the calorimeter. The amount of water passing through the calorimeter was large enough to keep the difference between the temperatures of water leaving and entering the labyrinth equal to or less than 0.001° . Under these conditions the difference in temperature between water in the outside passageway (1) and the calorimeter (*B*) was so small that no influence on the latter could be noticed. To protect the calorimeter more effectively against any radiation from either tube 1 or the jacket, a high vacuum was maintained in container *P*. A series of blank experiments in which the radium preparation (*R*) was replaced by an electric heater proved that no measurable quantities of heat were transferred from passageway (1) to the calorimeter (*B*).

The calorimeter (*B*) was suspended by means of silk threads (*C*) attached to hooks (E_1 , E_2 and E_3). Two thermocouples (T_1 and T_2) were used. One copper-constantan junction of each of the thermocouples was

attached to the surface of the calorimeter (*B*); the other was located in a side tube as shown in Figure 36.

Blank experiments have proved that the calorimeter made of lead was thermally inert (see § 63 and § 82).

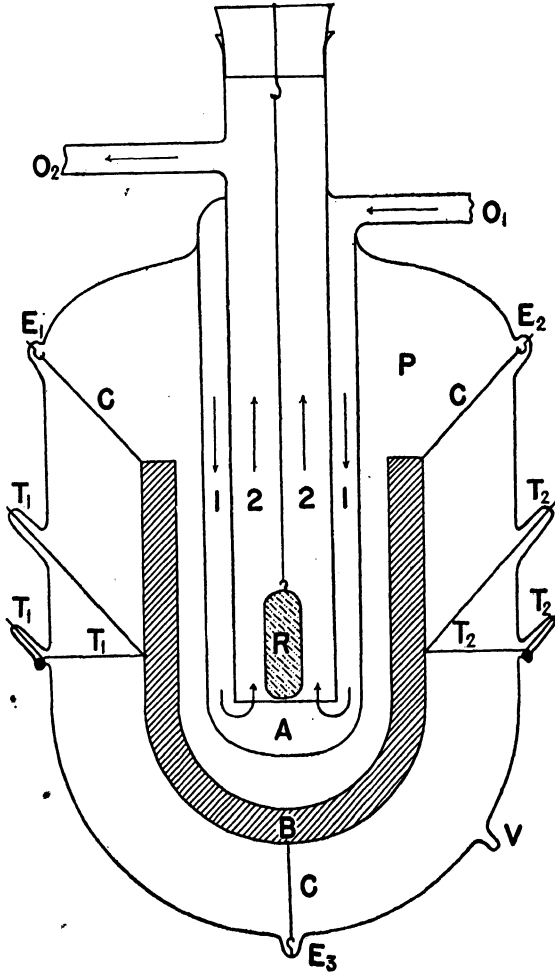

Figure 36. Swietoslowski and Zlotowski's Microcalorimeter for Measuring the Heat of Absorption of Gamma Rays.

The experiment was conducted like any other in an adiabatic calorimeter. The only difference was that at the beginning it was necessary to stop the stream of water in the labyrinth to open the stopper and to suspend tube *R* (Figure 36) with the radium preparation. Each experiment lasted long enough to observe a sufficiently large temperature increase.

The accuracy of the measurements depended not only upon the precision with which the amount of heat could be determined, but also upon the determination of the percentage of gamma rays absorbed by the walls of the calorimeter. To calculate this, it was necessary to take several factors into consideration: first, the percentage of gamma rays absorbed by the glass and water in the labyrinth; secondly, the percentage of the radiation absorbed by the screen of lead; and finally the fraction of gamma rays which left the apparatus without passing the screen. To avoid errors resulting from these calculations, several calorimeters different in size and shape were built and used. Some of them were similar to that shown in Figure 36. They differed only in wall thickness. The others were cylindrical and were left open at both top and bottom. The results of the measurements with all these calorimeters agreed satisfactorily.

After all the details of handling this type of apparatus were carefully examined at Warsaw, Zlotowski went to Paris and completed a series of investigations at the Curie Radium Institute, Paris. He found that the total amount of heat evolved by gamma rays of RaB and RaC contained in one gram of radium was 9.1 calories in one hour. The error, ± 0.15 calorie per hour expressed in percentage, was ± 1.7 . It was lower than the errors with which that value was measured or calculated in the past.

Zlotowski's paper¹²⁹ contains a number of numerical data relating to the apparatus shown in Figures 34 and 36. They cannot be given here in detail. The following two statements of the author translated from French as literally as possible may be found important: "The calorimetric method based on theoretical considerations may be accepted as being most qualified for measuring the energy of the radiation of radioactive elements." "All values obtained have resulted from direct experiment; they may be considered as a good proof of the correctness of some theoretical conceptions. They confirm the results obtained in various other ways."

In 1941 I. Zlotowski¹³⁰ published another paper in which a somewhat modified adiabatic microcalorimeter was described for determining the mean energy of beta particles emitted by radium E. The experiments were made at the Laboratory of Nuclear Chemistry, College de France, Paris.¹³⁰ In Figure 37 the microcalorimeter used by Zlotowski is shown. It consisted of a hollow nickel cylinder (*P*) suspended as in other cases (§ 59) by means of four silk threads inside the container (*P* in Figure 33) which was immersed in the adiabatic jacket (shown in Figure 33). Microcalorimeter *P* was covered with a well-fitted upper screen *R*. Radioactive deposit found on the small disk (*S*) made of nickel could be easily located between *P* and *R*. The mass of the calorimeter did not exceed 10 g; in spite of this all alpha or beta particles emitted by the radioactive substance were absorbed by the nickel screen. Alpha particles emitted by polonium served for the

calibration of the calorimeter. The adiabatic conditions of measurement were controlled by means of two copper-constantan thermocouples, shown in Figure 37. The junctions of the thermocouples were separated from the source by at least 4 mm of nickel, to avoid the influence of thermoelectric circuits produced by beta particles. Zernicke's galvanometer, with a sensitivity of 1.8×10^{-3} volt per mm at 2 meters, was used. This permitted the measurement of differences in temperature of $\pm 0.0005^\circ$. The temperature of the adiabatic jacket was kept equal to that of the microcalorimeter

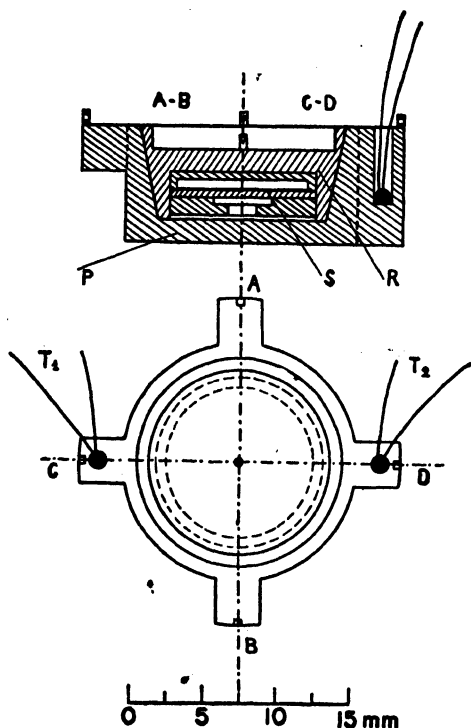

Figure 37.

Zlotowski's Microcalorimeter
for Measuring the Heat of
Absorption of Beta Particles
Emitted by RaE.

by adding hot water through a tube provided with a number of small holes. This tube was located near the bottom of the jacket. Air saturated with water vapor was used for stirring, as described in § 58 and 59.

The energy equivalent of the calorimeter was determined for each of the series of measurements separately by measuring the heat of absorption of polonium deposited on nickel foil. Its strength was close to "the amount of Po built up in the used RaE source after the practically complete decay of the parent substance. The measurements with six sources of Po between 400 and 4000 e.s.u. (1 millicurie of Po equals 1340 e.s.u., solid

angle 2π) yielded an increase of temperature of 0.0166° per hour for each 1000 e.s.u. of Po with no determination varying more than 0.0001° from the mean." "The accuracy of measurements depended directly upon the electrometric evaluation of the polonium source. By using the Madame Curie absolute apparatus with its precision of one to two per cent, it appears reasonable to assume that the energy equivalent of the calorimeter could be determined with an accuracy of two per cent."

"With precautions to obtain thermal equilibrium before readings were taken, RaE sources of 40 to 80 millicuries were used and the temperature rise (0.2° to 0.4°) over a four-hour period noted. Such sets of readings were made daily over a period of about 30 days, until the parent RaE had practically disappeared." In Figure 38 two curves expressing the change in

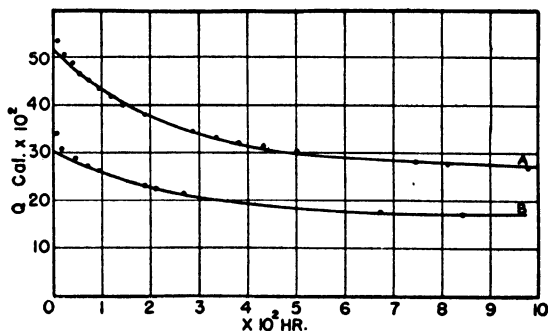

Figure 38. Diagram of the Heat Evolution from RaE Sources. Curve A, RaE Source of 80 mc. Curve B, RaE Source of 45.5 mc.

heat production with time are shown. "In each set of experiments the values found in the first 36 hours were systematically high. Since the first set was carried out in air, it was supposed that supplementary effects had been produced by some chemical reactions with oxygen. Hence, a second series of measurements was carried out in an atmosphere of nitrogen, but despite this precaution the effect was not suppressed." The author gave an explanation of this phenomenon. "It appears at first that the discrepancies observed are due to some secondary chemical phenomena taking place either in the material of the source support or in the radioactive deposit under the action of oxygen in the air, or to traces of some oxidizing agents not eliminated from the source by the preparatory treatment. This assumption seems to find confirmation in the fact that, after a comparatively short period of time, all measurements carried out during many subsequent days lead to E_{RaE} values lying within experimental error."

In the original paper a detailed description of the method of calculat-

ing the results obtained is given. Two examples showing the execution of the calorimetric measurements are also presented, and a table containing seventeen measurements carried out in a period of about five weeks is included.

"The mean value of the energy of disintegration of RaE, deduced from our measurements, is $320,000 \pm 5000$ ev," concluded the author. "If the amount of RaE is expressed in millicuries, the heat effect due to the emitted beta rays is equal to 1.61 ± 0.03 cal/mc of RaE per hr." The data obtained by Zlotowski have been compared with those obtained by other experimenters.

"Ellis and Wooster³⁸ have obtained by calorimetric methods values somewhat higher ($350,000 \pm 40,000$ ev)." Zlotowski expresses his opinion that an error of about ten per cent in this value should be expected.

"The integration of the continuous spectra of RaE beta rays, obtained by various workers, leads to an average energy value differing little from 330,000 ev. The most probable value given by Sargent,¹³⁰ as a result of an analysis of all experimental investigations," published in the period from 1915 to 1933, "is 340,000 ev. Recently, Neary⁷⁸ found a similar figure from a new experimental study of beta-ray distribution." Zlotowski emphasizes that this value is also too high. Other experiments mentioned in his paper have led to values which are lower than that obtained in his experiments ($300,000$ ev,^{1, 2} and $250,000$ ⁷⁰ ev).

The value calculated by Martin and Townsend,⁷⁶ concludes the author, was found to be equal to 321,000 ev, and "the very precise energy distribution (down to 5 Kev) published by Flammersfeld,⁴² after our work was completed, leads to a value from 315,000 to 320,000, which nearly agrees with our (Zlotowski's) evaluation."

§ 70. Specific Heat Determination of Solid and Liquid Substances. The adiabatic twin calorimeters have been used for determining the specific heat of solid and liquid substances. S. Rybicka, W. Solodkowska and the writer⁹⁹ employed this method to show its applicability for measuring the heat capacity not only of solid bodies but also of liquids, and to prove whether energy equivalent k of microcalorimeters may be determined as described in § 22. A calorimeter made of copper served as standard for the energy equivalent determination.

Pyridine was the liquid, the specific heat of which was measured by the adiabatic method. It has been proved that in spite of the poor thermal conductivity of the liquid it was possible to attain equalization of temperature inside the calorimeter.

The figures quoted below show the difference in precision of measuring the specific heat of aluminum and pyridine.

Heat Capacity of Aluminum at 17°

t_1	t_2	c_{17}
0.160	0.245	0.2145
0.117	0.180	0.2137
		0.2141 ± 0.05%

Heat Capacity of Pyridine at 17°

t_1	t_2	c_{17}
0.153	0.298	0.4090
0.157	0.305	0.4109
0.156	0.304	0.4088
0.152	0.298	0.4057
0.162	0.315	0.4112
		0.4091 ± 0.4%

In the tables t_1 and t_2 are the temperature at the beginning and at the end of the experiment, c is the heat capacity of the object examined at 17°.

In Figure 39 the twin adiabatic calorimeters are shown. At the time when the experiments were carried out the adiabatic jackets were not pro-

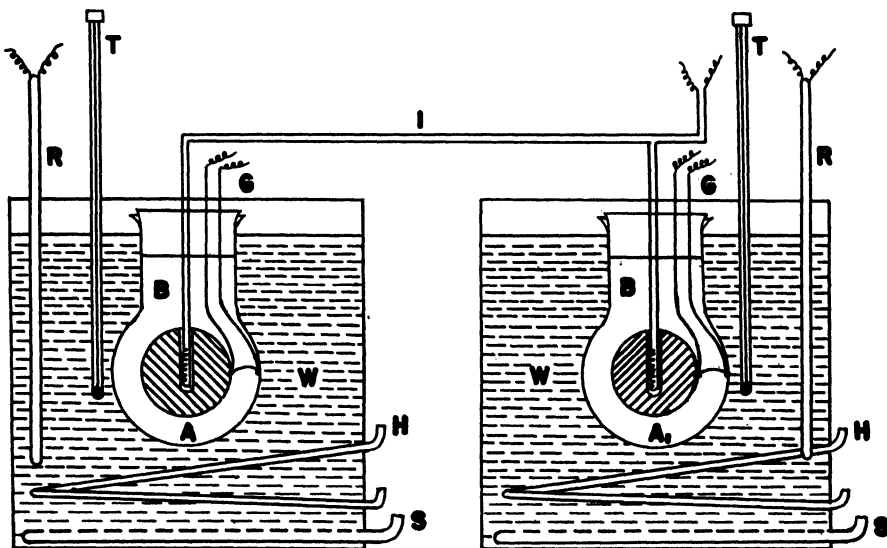

Figure 39. Twin Microcalorimeters for Specific Heat Determination.

vided with a chamber for the galvanometer, as shown in Figure 34. A. Dorabalska used the same method for measuring the specific heat of radioactive minerals and salts containing rare elements.³³

§ 71. Determination of Heat of Vaporization and Adsorption. E. Bartoszewicz⁸ and the writer⁹⁸ employed the adiabatic microcalorimeter for measuring the heat of adsorption of vapors by activated carbon and the

heat of vaporization of volatile liquids. The vaporization of the liquid from inside the calorimeter took place at room temperature. To carry out these experiments the device shown in Figure 40 was used. The details of the structure of the whole equipment are shown in Figure 33 (§ 59). For both of these experiments vessel *P* was provided with two side tubes, *O* and *O'*. In these was located either the liquid, the vapors of which were to be adsorbed, or activated carbon for adsorbing the vapors of the liquid found in the calorimeter. In experiments dealing with adsorption the calorimeter was filled with activated carbon; for determining heat of vaporization, it contained the volatile liquid to be evaporated.

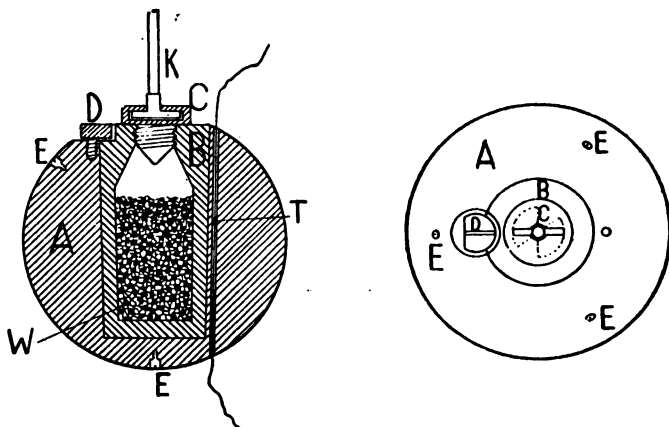

Figure 40. Microcalorimeter for Measuring the Heat of Adsorption and Vaporization.

The microcalorimeter was made of silver. It consisted of two parts, sphere *A* and cylindrical vessel *B*. Sphere *A* was located in the center of vessel *P*, as shown in Figure 33, and fastened there by means of four silk threads. For this purpose, sphere *A* was provided with four screws, *E*, to which the silk threads were attached. Vessel *B* (Figure 40) could be removed from the calorimeter for filling with the substance under examination and for weighing on a microbalance before and after completion of the measurement. By means of rod *K*, cup *C* (shown on the vertical projection in Figure 40) could be removed at the start of the measurement and put once more in its place after the experiment was completed. The screw attached to cover *C* fitted well and made impossible the penetration of the vapors through that place. To tighten this connection the whole surface of the cover and the screw was covered with a tiny layer of Vaseline. In that way the slightest diffusion of vapors through the cup could be stopped. Thermocouple *T* was located closer to the surface of sphere *A* than shown in the figure.

The heat of adsorption was measured in the following manner. After vessel *B*, containing a known amount of activated carbon, was placed in the calorimeter, some of the liquid under examination was poured into two small glass test tubes, each of which was placed in one of the tubes *O* (Figure 33). Then the identity of the temperature in the calorimeter and in the jacket was established. This was possible by changing in a proper way the temperature of the jacket so as to eliminate the deflection of the galvanometer. After the zero point on the galvanometer scale was reached, the preliminary experiment could be started. This consisted in proving that there is no penetration of vapors into vessel *B*. In case of such a penetration heat would be liberated and the temperature of the microcalorimeter would become higher.

It should be emphasized that after the space in vessel *P* is filled with vapors of the liquid under examination, all the surfaces, including that of the microcalorimeter, adsorbed a small amount of vapor. Usually this phenomenon lasted a very short time. It was completed before the test of the tightness of the calorimeter was made.

The experiment started after it had been demonstrated that the temperature of the microcalorimeter did not change for at least one hour. The adsorption started shortly after the removal of the cover. The process was similar to that shown in diagrams *B* and *B'* in Figures 1 and 3. First, a rapid rise of temperature was observed, then its linear increase with time could be noted. The vessel (*B*) was finally closed after a reasonable increase of temperature was reached, and rod *K* was rapidly removed, after the cover had been located in its proper place. The thermal equilibrium was usually established in two or three minutes, so that the temperature of the calorimeter remained constant. The test of the tightness of the calorimetric cover followed each of these measurements.

In the process just described the calorimeter has a uniform temperature at the start and after the completion of the measurement. This is not so during the experiment. The temperature of the activated carbon is higher than that of the walls of the calorimeter. To decrease this lack of temperature uniformity, several pieces of thick silver wire were placed in *B*. Because of the high thermal conductivity of silver, the local rise of the temperature of the activated carbon could be considerably reduced.

The method described made it possible to measure the average heat of adsorption of the vapors, which means that not only the surface, but the capillaries of the activated carbon were filled with the substance which was adsorbed (see § 53).

The following results have been obtained by Miss E. Batoszewicz and the writer.^{3, 98}

Heat of Adsorption of Benzene Vapors by Activated Carbon

a (mg)	Δt	K (cal)	Q (Kcal)
22.7	0.320°	13.42	14.75
74.9	0.992°	13.79	14.75
50.0	0.655°	13.78	14.09
71.0	0.994°	13.79	14.65
Average:			14.56 ± 1.8%

In this and in the following two tables a is the amount of vapor of the volatile liquid adsorbed, Δt is the temperature increase, K is the energy equivalent of the microcalorimeter, and Q the heat of adsorption of one gram-molecule of the liquid expressed in Kilocalories.

Heat of Adsorption of Ethanol by Activated Carbon

a (mg)	Δt	K (cal)	Q (Kcal)
18.7	0.475°	13.40	15.75
17.9	0.444°	13.74	15.55
16.5	0.405°	13.74	15.59
Average:			15.63 ± 0.05%

Heat of Adsorption of Carbon Tetrachloride by Activated Carbon

a (mg)	Δt	K (cal)	Q (Kcal)
98.3	0.720°	13.76	15.61
66.7	0.526°	13.39	16.20
90.1	0.688°	13.39	15.71
Average:			15.84 ± 1.5%

The heat of vaporization of volatile liquids was made in a similar way. This time the liquid was located in the microcalorimeter. Small test tubes filled with activated carbon or phosphoric anhydride were placed in two side tubes, O and O' , of vessel P (Figure 33).

The execution of the experiments has been somewhat improved and the experimental error has been decreased when compared with the measurements of the heat of adsorption. In the tables the symbols are as follows: a the weight in milligrams of the liquid evaporated, h the duration of the experiment expressed in hours, Δt the temperature decrease of the calorimeter, ΔQ the heat absorbed, l_{20} the heat of vaporization of one gram of the liquid expressed in calories, L_{20} the molecular heat of vaporization, expressed in Kilocalories.

Methanol

a (mg)	h (hrs)	$-\Delta t$	$-\Delta Q$ (cal)	l_{20} (cal)	L_{20} (Kcal)
25.49	3½	0.395°	7.349	288.3	9.23
40.30	3½	0.618°	11.557	286.7	9.18
20.30	5	0.387°	5.808	286.1	9.16
Average:				287.0	9.19 ± 0.3%

Ethanol

a (mg)	h (hrs)	$-\Delta t$	$-\Delta Q$ (cal)	l_{20} (cal)	L_{20} (Kcal)
16.57	3:00	0.198°	3.725	224.8	10.35
18.38	3:20	0.217°	4.084	222.2	10.22
24.97	4:00	0.302°	5.648	226.2	10.41
			Average:	224.4	10.33 \pm 0.7%

Propanol

32.47	6:00	0.315°	5.891	181.4	10.89
23.83	4:00	0.228°	4.264	178.9	10.74
25.97	4:30	0.250°	4.675	180.0	10.81
			Average:	180.1	10.81 \pm 0.5%

Isopropanol

24.47	5:00	0.230°	4.301	175.7	10.55
22.99	4:00	0.217°	4.077	177.3	10.65
25.61	5:14	0.239°	4.469	174.5	10.48
			Average:	175.8	10.56 \pm 0.6%

Normal Butanol

24.35	5:25	0.192°	3.602	147.9	10.96
22.22	5:25	0.177°	3.335	150.0	11.12
29.03	7:10	0.232°	4.373	150.7	11.16
			Average:	149.5	11.08 \pm 0.7%

Water

10.60	8:00	0.327°	6.199	585	10.54
7.50	8:00	0.231°	4.354	580	10.45
7.78	8:30	0.241°	4.520	581	10.47
7.05	7:00	0.218°	4.079	578	10.41
			Average:	581	10.47 \pm 0.3%

Benzene

74.9	5:00	0.392°	7.329	97.8	7.63
63.3	3:00	0.327°	6.231	98.4	7.68
60.5	6:00	0.315°	5.958	98.5	7.69
			Average:	98.2	7.66 \pm 0.3%

Chloroform

15.9	1:07	0.056°	1.058	66.5	7.95
102.8	2:00	0.345°	6.873	66.8	7.97
35.2	1:25	0.125°	2.364	67.1	8.01
			Average:	66.8	7.97 \pm 0.3%

The experimental error varied from ± 0.3 to 0.7 per cent. The duration of the measurements depended to a large extent on the volatility of the liquid. For instance, it took about two hours to determine the heat of vaporization of chloroform and eight hours to carry out the experiment with water. The amount of chloroform evaporated during two hours was 100 milligrams, and that of water only 7 milligrams, in spite of the fact that the experiment lasted four times longer. These observations have shown that it is easier to operate with highly volatile liquids. This conclusion is important, because, if the method of measuring the condensation

of vapors is used, it is just the opposite; it is more difficult to operate with more volatile than with less volatile liquids, so that the experimental error increases with the increase in volatility of the liquid. In this way the adiabatic method of measuring the heat of vaporization of liquids should be used in those cases in which the conventional method of measuring the heat of condensation of vapors presents difficulties. There is another reason why preference should sometimes be given to the adiabatic method. It often happens that the pure organic liquid is available only in small quantities; 100 milligrams of the liquid is sufficient to complete one and sometimes several measurements.

§ 72. **Application of the Adiabatic Microcalorimeter in Biology.** Mrs. W. Solodkowska⁹⁴ has employed the adiabatic microcalorimeter for measuring the heat of germination of seeds and the heat developed by growing plants. The seeds could be located in the calorimetric chamber under the conditions usually applied for determining the percentage of healthy seeds. In the case of plants, a stream of air should pass the calorimeter and the humidity of air entering and leaving the chamber should be controlled. In both these experiments care was taken to interrupt the experiment when the temperature increases became too large.

Shortly after these measurements were completed, the labyrinth flow calorimeter (§ 95) was built; this was found much more convenient for physiological and biological purposes. In fact, it offers an important advantage, namely, that the object can be kept during the completion of one and even several experiments at an adequately chosen and constant temperature.

§ 73. **Heat of Setting of Cements.** At the Physicochemical Laboratory of the Polish Institute of Technology, Warsaw, the adiabatic method was employed for preliminary measurements of heat developed by the reaction of cement with water.¹⁰⁶ Experiments have shown, however, that the temperature increases in the adiabatic calorimeter were too large, so that the velocity of the reaction underwent changes. In addition, very sharp maxima of the heat development were observed which made the execution of the experiment rather difficult. After the maximum had been passed, the liberation of heat decreased, and it was easier to conduct the adiabatic measurement. The time-temperature curve resembled that shown in Figure 55 (§ 95).

To avoid these inconveniences, successive measurements were made with interruptions during which the temperature of the jacket was dropped rapidly. Hence the temperature of the calorimeter containing the mixture of cement and water also decreased rapidly. After the initial temperature, t_0 , of the first experiment had been reached, the jacket was heated once more, to make it equal to that of the calorimeter. Then the experiment started again. These interruptions were repeated time and

again to obtain a series of observations permitting one to draw a curve expressing the time-temperature or time-heat production relation for the main period of the hardening of cement.

In the way just described, Rosinski¹⁰⁶ succeeded in establishing five typical curves for five samples manufactured by different cement plants in Poland. Figure 41 gives the curves expressing the relation between the amount of heat developed per unit of time (dQ/dt) and time elapsed after the cement was mixed with water. In all these experiments the same amount of water, namely 0.31 gram per gram of cement was used.

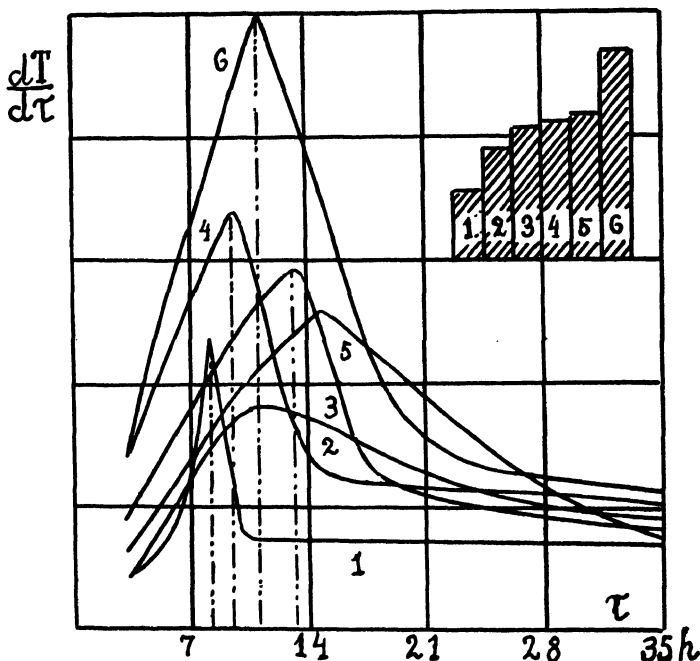

Figure 41. Rosinski's Curves Showing the Change of dQ/dt Values with Time t .

A short time after the completion of Rosinski's experiments it was found that the labyrinth flow calorimeter (§ 90, 96) was more suitable for measuring the heat of hardening of cements. For this reason no more experiments were made with the adiabatic microcalorimeter. It has been found, however, that the adiabatic method may be successfully applied for measuring the very small amount of heat liberated in the last stage of the reaction. For instance, after two or even three months from the start of the reaction thermal effects of the order of 10^{-4} to 10^{-5} calorie per gram in one hour could be discovered and measured easily by the adiabatic method.

Chapter IX

Static and Kinetic Methods of Microthermal Measurements

§ 74. **General Discussion.** In spite of the satisfactory results obtained with the adiabatic microcalorimeter, it seemed important to find another method which could not only increase the accuracy of the measurements but also avoid the inconvenience of maintaining the adiabatic rate of heating the jacket.

First of all, it is more expensive and considerably more difficult to build an automatic device for maintaining the "adiabatic rate" of heating or cooling of the jacket than to build a thermostat. In addition, it seemed to the writer to be of importance to use quite different calorimetric methods for measuring extremely small amounts of heat per gram in an hour. This is of especially great value when large amounts of material are available. The processes under consideration proceed very slowly and, for the duration of a calorimetric experiment, practically constant amounts of heat are liberated by the object. Experiments in that direction were started in 1934,¹⁰⁰ and finally two microcalorimetric methods were developed which may be called the *static* and the *kinetic* methods of microcalorimetric measurement.

§ 75. **Cooling and Heating Curves of Thermally Inert Massive Blocks.** Let us suppose that massive block *B* (Figure 44) is suspended in container *A* located in a thermostat in which constant temperature t_0 is maintained within $\pm 0.001^\circ$ (§ 8).

Let us also suppose that in *A* a vacuum is created, and that at the start the block is heated to temperature t_2 which is higher than t_0 . If a thermocouple or a multi-junction thermopile is used for measuring the difference between the temperatures of the block and the thermostat, one may draw a curve in which the differences $(t_2 - t_0)$, $(t_2' - t_0)$, etc. are plotted against time, τ . In this way, a "cooling curve" may be obtained which will show that there is a limit of time after which no measurable difference in temperature between the block and the thermostat can be found. At that moment and afterward the cooling curve will practically coincide with straight line $t_0 t_0$, as shown in Figure 42.

The same experiment may be repeated in such a way that at the start the block is cooled to temperature t_1 which is lower than t_0 . Now the jacket will radiate heat and difference $(t_1 - t_0)$ will steadily decrease, so that

the "heating curve" of the block may be observed. Finally, a moment will be reached when the difference in the temperatures will be smaller than can be measured by the thermocouple or thermopile. At that moment the heating curve merges with line t_0t_0 in the same way as in the experiment in which the cooling curve is examined. Experiments have shown that, if initial differences of temperature $(t - t_0)$ are not greater than 0.2° , no deviations from Newton's cooling law can be observed. Therefore the equations:

$$\frac{dt}{d\tau} = B\Delta t = B(t - t_0) \tag{1}$$

or

$$\frac{t_1 - t_0}{t_2 - t_0} = e^{-B(\tau_2 - \tau_1)} \tag{2}$$

express, in the limits of the experimental error, the thermal phenomenon under examination. Consequently, the cooling and the heating curves are

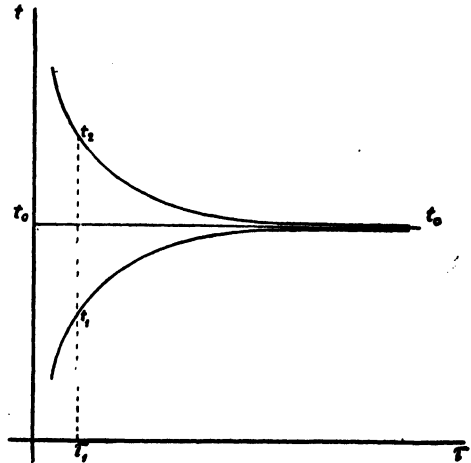

Figure 42.
Cooling and Heating Curves
of a Thermally Inert Block.

located on either side of line t_0t_0 and are symmetrical with respect to each other.

This can be considered as proof that the massive block is thermally inert. In the discussion below, t_2t_0 and t_1t_0 will be called the "cooling" and "heating" curves of the block.

§ 76. Cooling and Heating Curves of a Thermally Active Block.

Let us suppose that instead of containing a thermally inert block, the calorimeter contains a material, such as a radioactive mineral, which liberates a constant amount of heat. If the cooling and the heating curves are examined, different phenomena will be observed.

In cooling the system the difference, $\Delta t = (t_2 - t_0)$, will decrease, as before, but curve t_2t_a (Figure 43) will never coincide with line t_0t_0 . Thermal

equilibrium will be established so that the amount of heat radiated by the block (calorimeter) will be equal to that liberated by the substance forming the block. After this equilibrium is reached, the cooling curve t_2t_a will merge with line $t_a t_a$ parallel to the axis of time and found somewhere on a higher level than line $t_0 t_0$. The condition of that equilibrium may be expressed by the equation:

$$\frac{dt}{dr} = B(t_a - t_0) = B\Delta t = a \tag{3}$$

in which Δt is the difference between the temperature of the block and that of the thermostat after the thermal equilibrium has been established.

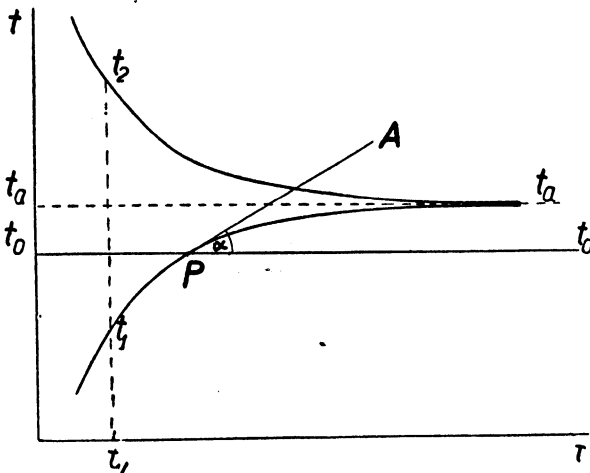

Figure 43. Cooling and Heating Curves Observed for a Thermally Active Block.

The heating curve $t_1 t_a$ is even more interesting than the cooling curve. It offers more valuable information because it somewhere crosses line $t_0 t_0$. At the crossing point P (Figure 43) the temperature of the outside surface of the calorimeter is equal to temperature t_0 of the thermostat, so that no heat exchange between the calorimeter and the thermostat takes place at that moment. The process is strictly adiabatic at that point.

For this reason the angle of the tangent drawn through point P plays an important role in measuring the heat developed by the object, because *the rate at which the block is heated when kept under strictly adiabatic conditions can be directly determined from the equation:*

$$\frac{dt}{dr} = \tan \alpha = a$$

In this equation α represents angle APt_0 , and a is the rate at which the

temperature of the calorimeter would rise if it were kept under adiabatic conditions.

After point P is passed, curve t_1t_a steadily approaches line $t_a t_a$ and practically merges with it after some time. From the experimental point of view this means that the difference, Δt , between the temperature of the block and the thermostat becomes constant, and within the limit of temperature readings is equal to that which is found for the cooling curve.

From the discussion given above the conclusion may be drawn that when examining the heating and the cooling curves (t_2t_a and t_1t_a , Figure 43) one may determine the amount of heat liberated by the object in *three different ways*. First, it is possible to determine the difference ($t_a - t_0$) between the block and the thermostat after the final state of thermal equilibrium has been established. This method will be called the *static method* of microthermal measurement. Secondly, it is possible to determine value a which represents the rate of heating of the calorimeter under adiabatic conditions of the experiment. Thirdly, the amount of heat can be determined from equation (3), or by examining the cooling (t_2t_a) and the heating (t_1t_a) curves. Both the second and third methods may be called *kinetic methods* of microthermal measurement.

§ 77. **General Scheme of the Apparatus.** In Figure 44 a general scheme is given of a universal apparatus which may be used either for employing the static and kinetic methods or for carrying out adiabatic measurements. The apparatus consists of a large thermostat (W) with a chamber (N) where the galvanometer (G) and commutator (K) are located. The thermostat should be provided, as usual, with a thermoregulator, a relay, a stirrer and an electric heater as described in § 6, 7, 8. In the figure only the heater (H) is shown. For carrying out adiabatic measurements, the air stirrer (S) and metallic tubes (C) for cold water, wound in a spiral, are built in. Cold water, taken from the water line, may pass through tubes C as in an adiabatic jacket (§ 59, Figure 33). Near the center of the thermostat vessel A is located. It can be suspended or placed on a stand. These details are not shown in the scheme. Tube E may be used, if the air should be pumped from container A . The calorimeter or the massive block, made of material liberating heat, is suspended by threads or wires attached to the steel plate on which block B is located.

To the surface of block B one junction (V_1) of the thermocouple is attached. The other junction (V_2) is located in the middle of the sphere suspended in container D (Lazniewski's device, see § 10 Figure 9). In V_2 the average temperature of the thermostat is maintained. It does not depend upon the fluctuations of the temperature in the thermostat. In the middle of the block another thermojunction (V_3) is located. If necessary, it can be joined to another device (D) or to another thermojunction.

tion attached to the surface of the block in a similar way such as V_1 . In that way the difference between the temperature in the center and at the surface of the block can be measured. An essential part of the calori-

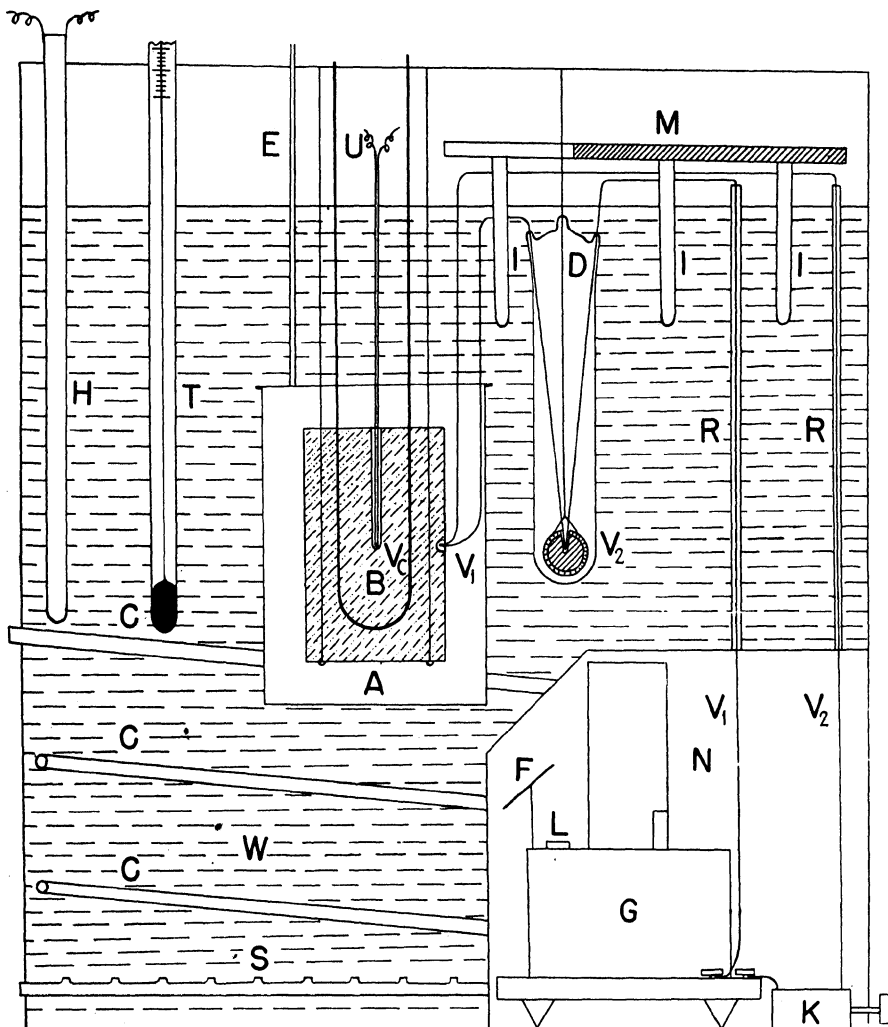

Figure 44. General Scheme of the Apparatus for Using the Static or Kinetic Method of Microthermal Measurements.

meter is tube U passing through the massive block. It is made of copper and its diameter should be as small as possible. It should be joined by means of tiny rubber tubes (not shown in the figure) to the outlet tubes. The latter are connected with a spiral in which air or other gas can be

cooled several degrees below the temperature of the thermostat. By passing a stream of cold gas through tube U , block B may be cooled down to a temperature lower (0.1 to 0.2°) than the temperature of the thermostat. In that way the heating of the calorimeter by thermal radiation may be observed and the shape of the heating curve examined (§ 76). The device for protecting against radiation all the parts extending above the water level is also shown. Copper plate M and thick copper rods I immersed in water serve for this purpose (see § 59, Figure 33). Because of the high thermal conductivity of copper the temperature of the plate (M) is practically equal to that of the thermostat. In that way the conducting wires and any other parts of the calorimeter are well protected thermally.

A thermometer (T) is used for controlling the changes in temperature in W . This is essential if the apparatus is used for adiabatic measurements. If container W is used as a thermostat it is important also to measure its temperature from time to time in order to see whether the relay and the thermoregulator function properly (§§ 6, 8).

§ 78. **Static Method of Microthermal Measurement.** In the previous paragraph it has been pointed out that the heat developed by the object per unit of time may be calculated, if difference $\Delta t = t_a - t_0$ (Figure 43) corresponding to the state of thermal equilibrium between the temperature of the calorimeter, t_a , and that of the jacket, t_0 , is known. Under these conditions the following relation should exist:

$$\frac{dt}{dt} = B\Delta t = B(t_a - t_0) = a \quad (4)$$

In equation (4), a is the rate of heating the calorimetric system by the object under adiabatic conditions and B is the cooling constant of the calorimeter. The application of the static method consists in measuring the difference Δt . Value B should be determined separately by measuring the time required to cool the calorimetric system from temperature t_1 to $t'_1 = (t_1 - t_0)/2$. Knowing B and Δt , one may calculate the amount of heat produced by the object in one hour using the equation:

$$\Delta Q = k \cdot B(t_a - t_0) = k \cdot a \quad (5)$$

In this equation k is the energy equivalent of the calorimetric system.

For adequately measuring the difference $\Delta t = (t_a - t_0)$, it is important to use a thermopile similar to or identical with that described by Whipp (§ 55).

If an adequate method of comparative measurements is employed (Chapter II, §§ 18, 24, 26, and 27), there is no need to determine value B . It is necessary only to examine two or several states of thermal equilibrium in one of the ways described below. The corrections can be easily eliminated in that way.

The method of comparative measurements may be employed in two different ways: (1) by using an electric heater built directly into the calorimetric system, or (2) by using a standard radium preparation. Independently, whether the electric heater or the radium preparation is used, two states of thermal equilibrium may be examined, one when the calorimeter is heated exclusively by the object, another when both the object and another source liberate heat. In the latter case equation (4) may be written as follows:

$$B(\Delta t + \Delta t') = B(t_b - t_a) = a + b, \quad (6)$$

or taking into consideration equations (4) and (6), equations (7) and (8) may be derived:

$$\frac{\Delta t}{\Delta t + \Delta t'} = \frac{t_a - t_0}{t_b - t_0} = \frac{a}{a + b} \quad (7)$$

and

$$\frac{\Delta t}{\Delta t'} = \frac{t_a - t_0}{t_b - t_a} = \frac{a}{b} \quad (8)$$

In these equations $\Delta t'$ is the difference of temperatures ($t_b - t_a$) which can be calculated when knowing what were the equilibrium temperatures, when the heat was developed one time by the object (Δt) and another time by the object and the electric heater or radium preparation ($\Delta t + \Delta t'$). Symbol a , as before, represents the rate of heating of the calorimeter by the object under adiabatic conditions; $(a + b)$ is the rate of heating by the object and by another source of heat under the same conditions. Usually both a and $(a + b)$ are expressed in degrees per hour.

To calculate the heat produced, a and $(a + b)$ respectively should be multiplied by K , the energy equivalent of the calorimetric system. Thus, if an electric heater is employed, one may use the equation:

$$\frac{t_a - t_0}{t_b - t_a} = \frac{K \cdot a}{K \cdot b} = \frac{\Delta Q}{J \cdot i^2 \cdot r \cdot 3600} \quad (10)$$

In this equation, ΔQ is the amount of heat produced by the object in one hour, and $J \cdot i^2 \cdot r \cdot 3600$ is the heat developed by the electric heater in one hour. Finally:

$$\Delta Q = \frac{t_a - t_0}{t_b - t_a} = J \cdot i^2 \cdot r \cdot 3600 \quad (11)$$

The experiment consists in measuring $\Delta E = J \cdot i^2 \cdot r \cdot 3600$ and two differences:

$$\text{and} \quad \begin{aligned} \Delta t &= t_a - t_0 & (12) \\ \Delta t' &= t_b - t_a & (13) \end{aligned}$$

Difference $(t_b - t_a)$ represents the increase of the equilibrium temperature of the calorimeter caused by the electric current only.

If a standard radium preparation is used, the expression $J \cdot i^2 \cdot r \cdot 3600$ in

equation (11) should be replaced by ΔQ_* , which represents the heat evolved by the radium preparation in one hour.

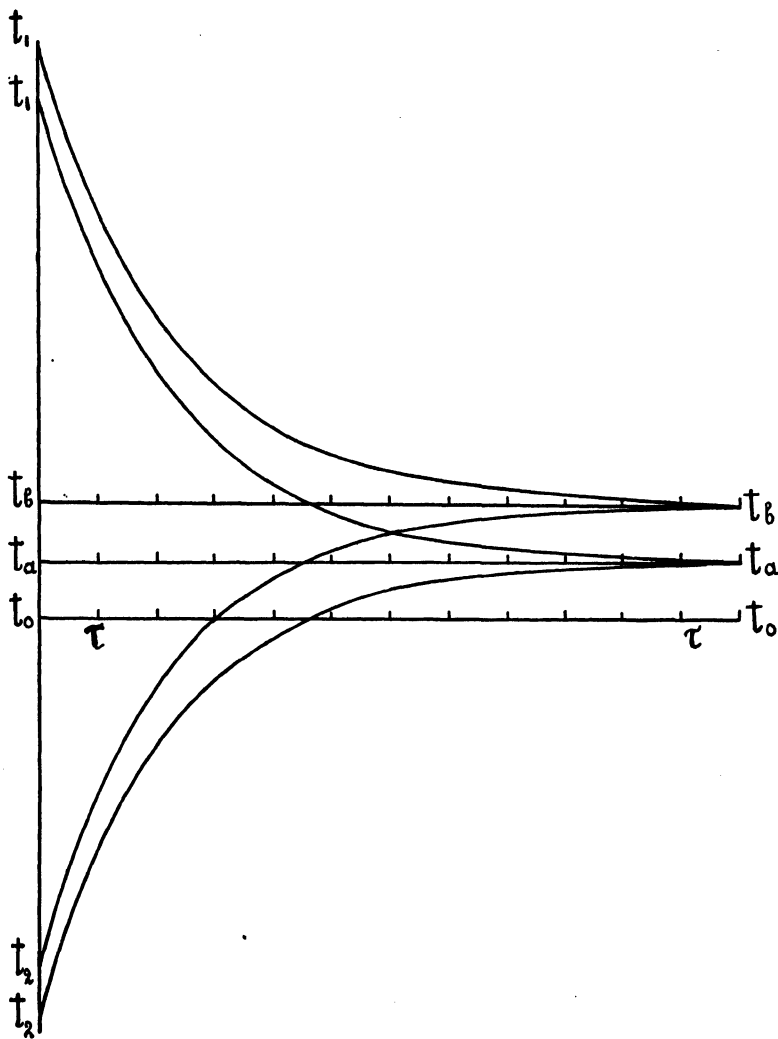

Figure 45. Cooling and Heating Curves; the Calorimeter Being Heated One Time by the Object, Another by the Object and by Electric Current.

In Figure 45 two cooling and two heating curves are represented. Curves t_1t_a and t_2t_a represent the cooling and the heating curves, respectively, when the calorimeter was heated only by the object, curves t_1t_b and t_2t_b , when both the object and the electric current participated in heat-

ing the calorimeter. Horizontal lines t_0t_0 , $t_a t_a$ and $t_b t_b$ have been drawn through points t_0 , t_a and t_b representing: t_0 , the average temperature of the thermostat, t_a , the equilibrium temperature of the calorimeter when it was heated by the object, and t_b , the equilibrium temperature of the calorimeter when it was heated by the object and by the electric current.

The method, as described, offers some advantages in using the static method. It makes it possible to eliminate not only the corrections but also the determination of the numerical value of constant B (see § 78, equation 6).

§ 79. **Kinetic Method Based on Measuring the Rate of Heating Under Adiabatic Conditions.** In § 76 it was pointed out that two different kinetic methods may be used for determining the heat developed at a constant rate by an object. One of them is based on the determination of the rate of heating of the calorimeter at the moment when the heating curve crosses the horizontal line t_0t_0 drawn through the point representing the average temperature of the thermostat. Based on considerations previously described, the following equation may be written:

$$\frac{dt}{d\tau} = \tan \alpha = a \quad (14)$$

In this equation α is the angle formed by the tangent to the heating curve drawn through the crossing point (P , Figure 43) of the curve with line t_0t_0 . Usually, the galvanometer readings are carried out from one to two hours before the crossing, at the moment of the crossing, and one to two hours after the crossing. In that way the determination of value a in equation (14) becomes more accurate. Value a is usually expressed in degrees per hour. It represents the rate of heating of the calorimeter under adiabatic conditions.

To start the experiment, it is necessary to cool the calorimeter to a temperature about 0.2° lower than t_0 . This can be done by passing cold air or another gas through tube U (Figure 44).

Usually the calorimeter is a massive block of the material examined or is used as a screen for absorption of alpha and beta particles and gamma rays. For this reason, its energy equivalent K is usually large. In a number of experiments which are described below it was equal to or even greater than 300 calories per degree. The temperature changes were small and the crossing point could be easily observed.

If comparative measurements can be carried out as previously described (§ 78), it is not necessary to remove the air from container A (Figure 46) because the correction for heat losses due to the heating of air can be eliminated. In that case the device shown in Figure 46 may be used. It does not differ in principle from that previously described (§ 77, Figure 44). It contains only one additional part, namely, cooler K . The latter con-

sists of two metallic walls and a metallic spiral tube located between them. One end of that tube is connected to the water line, the other to a convenient drain. At the bottom of the thermostat "nest" K is located. After cooling the calorimeter, the cooler should be transferred down to that place. The use of the movable cooler is essential because, during the execution of the measurements, the *calorimeter cannot be moved*. This precaution is necessary to avoid undesirable secondary phenomena in the galvanometer circuit.

The heat developed by the object may be calculated from the equation

$$\Delta Q = K \cdot a = K \frac{\Delta t}{\Delta \tau}$$

in which ΔQ is the heat liberated by the object in one hour, K the energy equivalent of the calorimeter, and $a = \Delta t / \Delta \tau$, as was previously defined, is

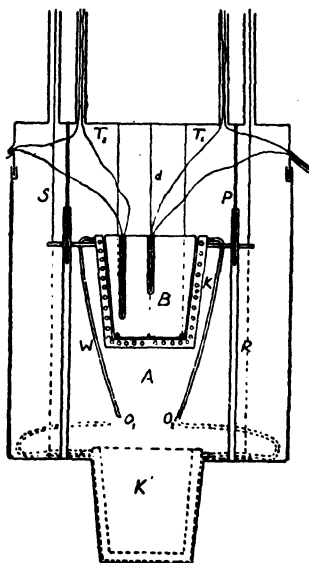

Figure 46.

Calorimeter with Movable Cooler.

the hourly increase of the temperature of the calorimeter if it is kept under adiabatic conditions.

The method of comparative measurements may be used in a similar way as described in § 78. Either an electric heater or a standard radium preparation may be utilized.

Let us consider the case in which the heat produced by a radioactive mineral is examined. Suppose that a standard radium preparation is developing Δq calories per hour under the condition of the experiment

(thickness and density of the screen). The two following equations may be written:

$$\Delta Q = K \cdot a = K \frac{\Delta t}{\Delta \tau} \quad (15)$$

$$\Delta Q' = \Delta Q + \Delta q = K(a + a') = K \frac{\Delta t'}{\Delta \tau} \quad (16)$$

It is easy to see that equation:

$$\Delta Q = \frac{\Delta t}{\Delta t' - \Delta t} \Delta q \quad (17)$$

may be derived for calculating ΔQ . In this equation Δt is the rate of adiabatic heating of the calorimeter by the object alone, and $\Delta t'$ by the object and the standard radium preparation.

The method may be used with success if the temperature fluctuations in the thermostat are small ($\pm 0.001^\circ$) and regular. The precision increases with the increase of the size of the massive block used as the calorimeter. Experiments carried out with the purpose of determining the highest precision which might be reached by this method were under way in Warsaw (M. Lazniewski) when Poland was invaded by the Germans. No definite answer can therefore be given by the writer concerning the highest precision of the method described. In experiments, carried out under conditions which could not be considered as the best, thermal effects of the order of 10^{-4} to 10^{-5} calorie per gram in one hour could be measured with an accuracy of from one to two per cent.

§ 80. **Kinetic Method Based on Examination of Cooling and Heating Curves.** M. Lazniewski has made an extensive study of applications of both the static and kinetic methods of measuring microthermal phenomena. The results of his investigations were prepared for publication shortly before the outbreak of World War II. Since the chemistry building of the Institute of Technology at Warsaw was completely destroyed there is little hope that his manuscripts have survived. Because of that the description given below does not cover Lazniewski's experiments in full. The presentation may even differ in some details, and in the graphical method of calculation, from what Lazniewski intended to publish. Even the term "static and kinetic" methods are used here by the writer for the first time. In principle, however, the description of the experimental facts cannot differ from that which Lazniewski found. Below a graphical method is described which makes possible the determination of $\Delta t = t_a - t_0$ (see Figure 43) and B (§ 75 equation 1) by examining the shape of the cooling and heating curves.

In Figure 47 all the operations associated with the graphical determination of the equilibrium temperature are presented. To get the experimental data needed, it is necessary to carry out two experiments: one for

establishing a portion of "cooling" curve t_1t_1 , the other for getting a portion of "heating" curve t_2t_2 . Both these curves may be obtained by plotting the actual temperature differences between the calorimeter and the thermostat against time, τ . It is obvious that, if both these curves are adequately located on one drawing they should be symmetrical with respect to each other. Both of them should merge with line $t_a t_a$, the position of which should be found. Temperature t_a represents the temperature

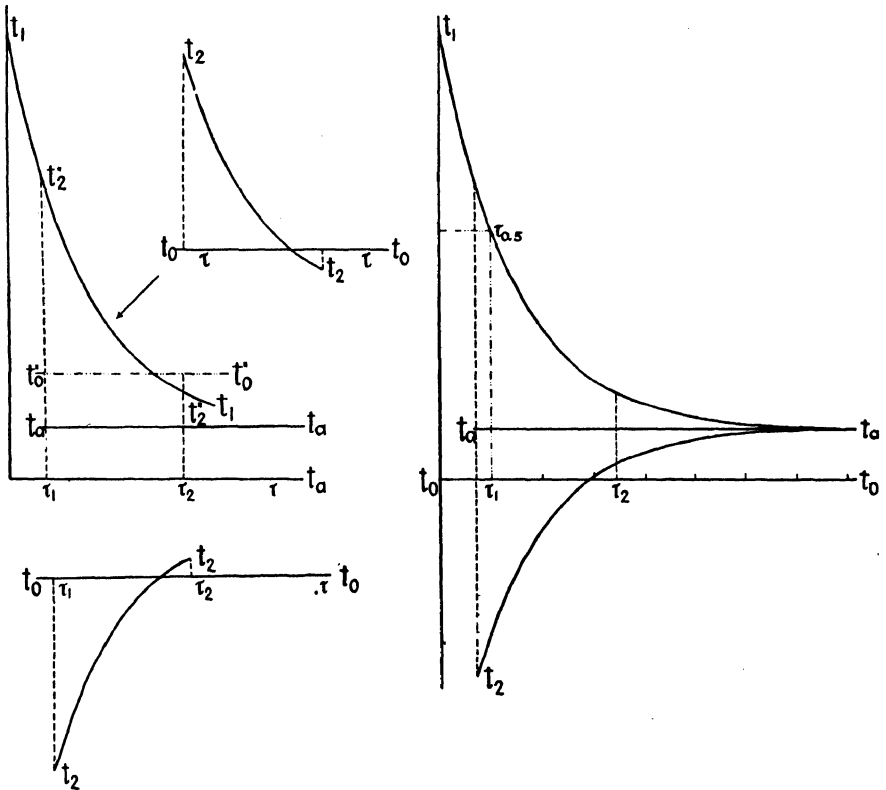

Figure 47. Graphical Method of Determination of Temperature of the Block Corresponding to its Thermal Equilibrium with the Thermostat.

at which thermal equilibrium is established between the thermostat kept at temperature t_0 and the calorimeter kept at constant temperature t_a by heat liberated by the object. Neither temperature t_a nor the proper location of the two curves as shown in the drawing on the right side of Figure 47 are known. That position should be found by the following operations. First, the drawing representing the heating curve (t_2t_2), which is shown on the left side in the lower part of the figure, should be reversed as shown in the upper part of the figure. Afterward it should be located on curve t_1t_1 ,

and the position should be found at which the two curves coincide. Afterward, two arbitrarily chosen vertical lines, for instance $t_2''\tau_1$ and $t_2''\tau_2$ should be drawn. The points of intersection of these two lines with line t_0t_0 represents those points which should coincide with points τ_1 and τ_2 found on line t_0t_0 . Now the graph with curve t_2t_2 should be reversed once more and should be located as shown in the diagram found on the right side of the figure. Points τ_1 and τ_2 of the sections of the two curves should coincide with each other. The position of line $t_a t_a$ or value t_a can be easily found, because it is *lying in the middle of any vertical line crossing the two curves*.

The position of line $t_a t_a$ may be found also in another way. Using the left upper part of the figure one may notice that $t_a t_a$ is lying in the middle and between lines $t_0 t_0$ and $t_0'' t_0''$.

It should be recalled that both the cooling and the heating curves are asymptotic to the axis $t_a t_a$. Theoretically they merge with $t_a t_a$ at infinity; practically, however, they coincide with it and with each other after the point is reached at which the differences in temperature between t_a and the calorimeter are smaller than can be discovered by direct galvanometer readings.

The point of the "practical" coincidence may be calculated in advance in the following way. First, from the graph found on the right side of Figure 47, one should find half cooling time $\tau_{0.5}$; *i.e.*, the time required to decrease by half the original difference in temperature between the calorimeter and the thermostat. For instance, if the difference at the starting point was $t_1 - t_a$, interval of time $\tau_{0.5}$ should be found which is required to reach temperature t' , so that:

$$t' = \frac{t_1 - t_a}{2}$$

Let us suppose that at the start $t_1 - t_a$ was 0.1° , and $\tau_{0.5} = 3$ hours was found. The following differences will be found after 3, 6, 9 etc. hours from the start of the experiment:

Number of half periods	Difference of temperature between the calorimeter and the jacket (°C)	Time in hours from the beginning of the experiment (hours)
0	0.1	0
1	0.05	3
2	0.025	6
3	0.0125	9
4	0.00625	12
5	0.003125	15
6	0.00156	18
7	0.00078	21
8	0.00039	24
9	0.00018	27
10	0.00009	30
11	0.00005	33

If the temperature readings by means of the galvanometer were made with an accuracy of 0.001° , the point of coincidence of the heating and the cooling curve with line $t_a t_a$ would be found after seven half periods, or after twenty-one hours. If a thermopile is used allowing one to measure the differences in temperatures within 0.00005° , it will take thirty-three hours to find the point at which the temperature of the calorimeter and the thermostat will be practically equal to each other, and so forth.

Another method consists in plotting logarithms of differences $(t_1 - t_a)$, and $(t_a - t_2)$ against time τ . If t_a has been calculated with sufficient accuracy, a linear proportionality will be found for that relation.

§ 81. **Determination of Heat Developed by Pitchblende.** In 1933 the Ministry of Labor of Czechoslovakia provided the Physicochemical Laboratory of the Institute of Technology, Warsaw, with five kilograms of pitchblende from Jachimovo (Joachimstahl). The total amount of that mineral was located in a vessel made of a thin sheet of copper.

In the middle of the vessel one iron-constantan junction, V_e , was fastened as shown in Figure 44, and the junction of another thermocouple was attached to the surface of the cylinder in the middle of its height, V_1 . In that way the difference between the temperature in the middle and at the surface could be measured (see § 86). The copper calorimetric vessel was sealed and kept for several months in the constant-temperature room before the experiments started.

The experiments were carried out by J. Salcewicz in 1934. At that time the thermostat described in § 7 had not been put into action, so that the temperature was manually kept constant within $\pm 0.001^\circ$.

The hourly increase of the temperature $\frac{dt}{d\tau} = a$ under adiabatic conditions was determined by using four methods: the adiabatic (§ 59), the static, and the two kinetic methods previously described in §§ 78, 79 and 80. The following results were obtained:

Method	$a = \frac{\Delta t}{\Delta \tau}$ °C per hour
Adiabatic (§ 59)	0.00207 \pm 10%
Static (§ 78)	0.00210 \pm 2.5%
Kinetic (§ 78)	0.00207 \pm 3.0%
Kinetic based on analysis of heating and cooling curves (§ 79)	0.00207 \pm 4.0%

The purpose of this investigation was to compare the accuracy of the different methods for studying microthermal processes. At the time when the measurements were made, the method of comparative measurement as described in §§ 18, 20, 23, 24, 25, 26 was not fully utilized. The analysis of the pitchblende was not made either, because the container was sealed

and was used up to the outbreak of the war as a standard for testing different methods of microthermal investigations.

Experiments carried out by Lazniewski shortly before the outbreak of the war have shown that the accuracy of measurements by using either the static or the kinetic method may be increased so that the error may not exceed one or two per cent. The vacuum in the space between vessel *A* and calorimeter *B* (Figure 44), and device *D* (Figure 9) for measuring the temperature of the thermostat should be used for that purpose.

§ 82. **Heat Produced by Changes in the Internal Structure of Lead.** L. Keffler, and the writer¹⁰¹ undertook experiments to see whether or not some heat might be developed by a massive block of lead, suspended so that its own weight could produce changes in its internal structure. The importance of such experiments consists in the fact that in numerous experiments in radiology massive screens made of lead had been often used for measuring the heat of absorption of particles and gamma rays emitted by radioactive elements. Very often they were suspended in such a way that some deformations or even recrystallization could take place due to the internal tension created by the weight of the lead. It was therefore necessary to prove by direct experiments the thermal inertness of such massive blocks.

A massive block made of lead and weighing about eighteen kilograms was used as an object. It was provided with two holes for thermocouples, one near the outside surface, and the other near the center. In the center a third hole was bored reaching the middle of the cylinder. Using that hole, one could locate in it a standard radium preparation so as to compare the thermal effects observed with and without the radium preparation.

The cylinder could be suspended in two different ways: (1) it could be placed on a plate of steel suspended by means of three steel wires, or (2) the wires could be attached by means of three screws to the upper surface of the cylinder. In the first case no measurable or very small amount of heat could be expected; in the second, under the influence of its own weight, the lead could be subjected to some larger deformations, especially in the neighborhood of the screws, and they could be associated with the development of heat. Direct observations proved that such deformations took place. For instance, several days after the cylinder had been suspended, the capillary tube with the thermojunction could not be removed, in spite of the fact that before the experiment the hole was large enough and quite straight so that the tube could easily be removed and replaced.

Microcalorimetric measurements were repeated time and again for several months. Every time, when the cylinder rested on the steel plate it was thermally inert. Its behavior changed radically each time, when it was suspended by means of wires attached to its upper surface. The heat

developed was not constant and it decreased slowly with time. No state was reached at which the block ceased to develop heat. The experiments were interrupted because the apparatus was used for other experiments and L. Keffler was forced to leave Poland and to return to Liverpool.

In the table below the results of the measurements are given. The headings are: D the number of days during which the block was suspended, as previously described; N the duration of measurements expressed in hours and minutes; Δt the difference between the temperatures of the block and of the thermostat at the beginning of the measurement, t_a the temperature difference after thermal equilibrium had been reached, $a = dt/d\tau$ the hourly temperature increase which would be observed if the block was kept under adiabatic conditions. In the last column the heat developed by one gram of lead in one hour is given.

Development of Heat Due to Internal Transformation of Lead

No.	D	N	Δt (°C)	t_a (°C)	a	cal/gh
1	4	15:30	-0.088	0.0042	1.3×10^{-3}	4.0×10^{-5}
2	5	13:00	+0.091	0.0044	1.29×10^{-3}	3.5×10^{-5}
3	12	17:00	-0.091	0.0049	1.41×10^{-3}	4.3×10^{-5}
4	18	14:30	+0.125	0.0023	0.78×10^{-3}	2.0×10^{-5}
5	19	7:30	-0.090	0.0024	0.71×10^{-3}	2.2×10^{-5}
6	24	14:30	-0.094	0.0021	0.61×10^{-3}	2.0×10^{-5}

The following conclusions were drawn from the experiments: Because of some mechanical deformations taking place in the heavy cylinder under the influence of its own weight, heat of the order of 10^{-5} calorie per gram in one hour was produced. Small changes were observed in the heat liberation each time after the cylinder had stood for several days on a shelf or on the steel plate. Decreases in the amount of heat liberated were observed with time when the cylinder was suspended on wires attached to its upper surface, and allowed to remain in that position for a number of days.

The results obtained in the investigation were important for microcalorimetric researches in radiology. It appeared obvious that any microcalorimeters made of lead should be supported by a plate made of steel, to avoid errors which might result from internal deformation of the lead. If this condition is not fulfilled, the danger will exist of getting a result higher than the actual one. In addition, the experiments made with lead have shown that the possibility exists of using the static or the kinetic method for measuring the heat of aging metallic alloys after they are quenched. Finally, these experiments have explained that secondary thermal phenomena observed previously in some microcalorimetric measurements, in which a massive screen of lead had been used, are associated with the change of mechanical structure, and not with the radioactive con-

tamination of lead. The presence of radioactive elements in lead cannot be denied, especially, in some particular samples of lead. However, the amount of heat liberated by those contaminations is many times smaller than the heat observed in the investigation just described.

Similar experiments were made with a block made of aluminum. Its weight was considerably smaller because of its low density. No measurable heat was developed when it was suspended on wires attached to its upper horizontal surface.

§ 83. **Thermal Stability of Nitrocellulose Artillery Powders.** From a general point of view, it seemed to be of importance to examine the thermal stability of nitrocellulose artillery powder. The experiments were made by T. Urbanski, a specialist on explosives in Poland, and by Calus and the writer.¹¹⁰ Several samples of powder were examined. One was an old Austrian artillery powder, left by the Austrian Army in Poland after World War I. Its thermal inertness was examined, first after it was taken from the powder arsenal, then after it had been kept for several hours at 75° and then cooled. In addition, a Polish artillery powder was examined. The latter was obtained directly from the plant. The behavior of the powders was quite different. Experiments showed that the old artillery powder was initially thermally inert (§ 63). This property, however, underwent a radical change after it was kept at 75° for several hours. After this treatment it developed heat, and this was obviously associated with its decomposition. The rate of that decomposition increased so rapidly with time that, after several consecutive calorimetric measurements, it was necessary to interrupt the experiment and to destroy the powder because of the danger of an explosion. The behavior of the powder which was prepared several days before the start of the experiment was quite different. At the beginning some amount of the solvent underwent slow evaporation. Because of this, negative thermal effects were observed. Several hours later, after the space inside the calorimeter was saturated with the vapor of the solvent, no more thermal effects could be detected. This phenomenon was observed several times. Each time the air saturated with vapors was driven off and replaced by dry air, so that its saturation could proceed as before. In that way the negative thermal effects could be explained.

As a result of the microcalorimetric measurements with artillery powders the authors have come to the conclusion that the method takes too much time and requires equipment which is too expensive to be recommended for everyday laboratory work. Nevertheless, a general conclusion drawn from these investigations was interesting from another point of view. These measurements have proved that even such unstable organic substances as nitrocellulose powders are thermally inert if they are kept at a

low temperature. This conclusion is correct within the experimental error which was of the order of 10^{-5} calorie per gram in one hour.

The results have been confirmed in experiments in which a standard radium preparation was located in the center of the block. The same preparation was used as in the experiments with the ice calorimeter (§ 42).

§ 84. **Heat of Aging of Aluminum Alloys.** In 1936 an attempt was made by J. Czochralski²⁴ and the writer¹⁰⁹ to employ the kinetic method of microthermal measurement for examining the behavior of some quenched aluminum alloys. The object could be used in any desired quantity and the massive blocks of these alloys could serve as calorimeters without any protection. From this point of view the alloys could be regarded as ideal objects for the application of the kinetic or adiabatic method. As to the type of the thermal processes, it was reasonable to expect that they would resemble the process schematically shown in diagrams *E* and *E'*, Figures 2 and 4. Experiments have fully confirmed this assumption. In addition, it was found that the aging started shortly after the block of aluminum alloy was kept for some time at 510° and then rapidly cooled to room temperature. The rate of heat evolution accompanying the aging increased with time, passed through a maximum and then slowly decreased, so that after approximately 250 hours the heat produced by the alloy was too small to be measured.

From this point of view the alloys, as objects of microcalorimetric measurements, differed radically from radioactive minerals or radium preparations. The following details concerning the measurements of the heat developed by the aging of quenched aluminum alloys were kindly given to the writer by R. Smoluchowski, now residing in the United States. The investigation was made by him and by H. Calus in Warsaw.¹⁷ "The measurements of the rate of heat evolution had to be carried out as frequently as possible, preferably in a continuous manner. Such data are necessary for calculating the total heat developed. To do this, various methods were applied. First, using the kinetic method (§ 79) the rates of heat evolution at four different times after the quenching, as shown in Figure 48, were determined. These few points were insufficient to interpolate between them so that additional values were calculated from the equation:

$$\frac{dQ}{dt} = c[m - K(T_0 - T)] \quad (18)$$

in which *c* is the specific heat of the alloy, *m* the slope of the temperature-time curve, *K* the cooling constant and *T*₀ and *T* the temperatures of the calorimeter and the alloy. In that manner a sufficient number of points

were obtained to draw the $\frac{dQ}{d\tau}$ versus τ curve and to determine the total heat from the area under that curve:

$$Q = \int_{\tau_0}^{\infty} \frac{dQ}{d\tau} d\tau$$

“The use of this equation has the advantage that a number of values can be obtained shortly after the quenching (roughly one hour); thus waiting

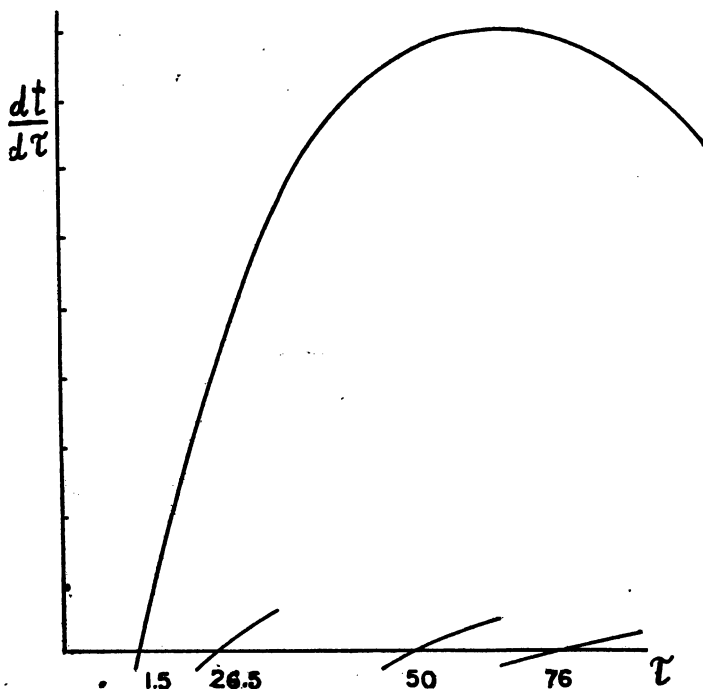

Figure 48. Application of the Kinetic Method for Measuring the Heat Developed by the Aging of Aluminum Alloys.

for the moment when the heating curve crosses the line $t_0 t_0$ can be avoided. The most interesting part of the curve is observed in the early stage of the reaction. A duralumin alloy (Cu 4.2, Fe 0.66, Mn 0.33, Mg 0.63 and Si 0.54) quenched from 510° evolved about 1.7 cal per gram; the maximum rate of heat evolution took place a few hours after quenching.

“The same results were obtained when employing the adiabatic method. The maximum was observed earlier since the temperature of the sample increased gradually in the adiabatic process so that the aging was somewhat accelerated.”

Recently a paper was published by Czochralski²⁴ in which he claimed that a new method was developed which allowed one to start the measurement sooner after quenching. The total heat developed by the aging process was found to be 1.67 calories per gram of duralumin. The error was 0.05 cal.

§ 85. **Applicability of the Static and Kinetic Methods.** If one takes into consideration the special devices used by Lange, Gucker and his associates, Ward, Hill and Lazniewski, he may conclude that a number of improvements can be introduced in using the static and kinetic methods described in § 78, 79, and 80. This refers especially to experiments with objects available in arbitrarily large quantities. In these cases large calorimeters or large massive blocks of material under examination can be used so as to increase considerably the accuracy of measurements. Thermopiles with a large number of junctions and multi-jacket thermostats, described by Tian and used by Ward, could be employed, and Lazniewski's device could be used for measuring the exact average temperature of the central container of Tian's multi-jacket thermostat. If all these improvements were introduced, it would be possible to increase the precision of measuring not only the heat developed by radioactive minerals but also the heat of cosmic radiation. Further experiments may prove whether the static or one of the two kinetic methods will offer better possibilities. From this point of view, the experiments previously described should be considered rather as preliminary steps which will lead to further improvements. The possibility of that development encourages the writer to discuss some peculiarities of the kinetic method, which did not play any part in the measurements described in previous paragraphs.

§ 86. **Asymmetry in the Cooling and Heating Curves.** In the description of the calorimeter and in Figures 33 and 44 the location of two thermojunctions was shown. One was located near the surface of the calorimeter, the other in its center. In that way, the difference in the temperatures inside and at the surface of the block could be measured at any desired moment. In the static method this difference in temperature has no effect. In the kinetic method it can produce *an asymmetry in the shape of the cooling and heating curves*. This depends: (1) upon the energy equivalent of the calorimeter, and (2) upon the heat produced by the object and its location in the calorimeter. For instance, if two calorimeters of the same energy equivalent K are used, and if one of them contains a radioactive mineral producing Δq calories per hour and the other a standard radium preparation developing the same quantity of heat, the distribution of temperature inside the calorimeter would not be the same, because in one case the object radiates heat from the center, in the other everywhere throughout the whole volume of the calorimeter.

For this reason a larger difference between the temperatures in the center and at the surface of the calorimeter would be found in the case of a radium preparation, and a smaller one if the calorimeter were filled with a radioactive mineral.

Let us consider the case when the block is made of material characterized by high thermal conductivity. Suppose that it is thermally inert (§ 75). If the cooling and heating curves were examined, perfect symmetry of these curves would be found. After reaching the state of thermal equilibrium the same temperature, t_0 , which corresponds to the average temperature of the thermostat, would be found everywhere inside the block and at its surface. This will not be the case if the calorimeter were built of a thermally active material. In Figure 49 the distribution of temperatures

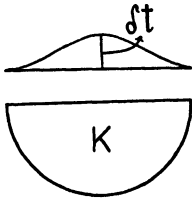

Figure 49.

The Temperature Distribution Inside
a Thermally Active Block.

inside the block is shown, after thermal equilibrium has been reached. The temperature of the layer near the surface of the block will be higher than that of the thermostat (§ 78). Difference $\Delta t = t_a - t_0$, as well as the equation:

$$\frac{dt}{dr} = B(t_a - t_0)$$

represent the conditions of thermal equilibrium between the outside surface of the calorimeter and the thermostat. Temperature t_a depends upon the heat steadily developed by the object. The steady liberation of heat and some lag in heat transfer through the material causes the center of the calorimeter to be heated to a temperature δt higher than temperature t_a at the surface. Difference δt depends upon several factors, namely: (1) the amount of heat produced by the object; (2) the thermal conductivity of the block, and (3) the size of the block. The following consideration may explain why the cooling and the heating curves cannot be symmetrical.

Let us suppose that before starting the experiments for establishing the shape of the cooling and the heating curves the calorimeter is maintained for several hours at t_1 , which is higher than t_0 , and another time at t_2 , which is lower than t_0 .

Let us examine the change in temperatures at the surface and inside of the calorimeter. At the start the temperature in the center of the block will be higher than that at the surface. Afterward the temperature in those

two places will undergo changes in a way represented schematically in Figure 50. These changes are different in experiments with cooling and heating the block, in spite of the fact that in both cases, after thermal equilibrium is reached, the final distribution of temperature will be the same. In both experiments the surface of the block will be heated to the temperature $(t_a - t_0) = \Delta t^\circ$ degrees higher than t_0 , and the temperature in the center will be δt° higher than at the surface. The temperature in the center will undergo different changes during the cooling and the heating of the block. When examining the cooling curve, one may observe that the temperature inside the calorimeter remains still higher than at its surface. This will not be the case when the calorimeter is heated by radiation from the ther-

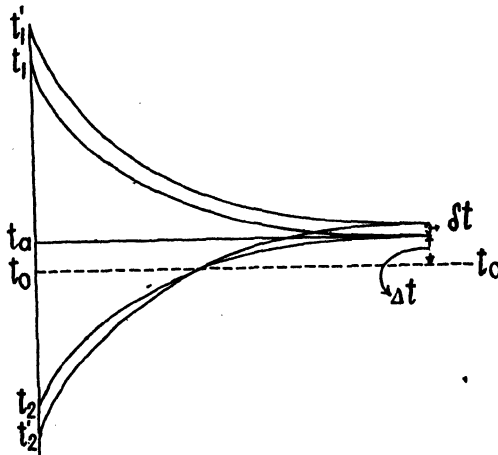

Figure 50. Changes in Temperature at the Surface and in the Center of a Thermally Active Block During the Heat Exchange with the Thermostat.

mostat (vessel *P*, Figure 44). Soon after the start of the experiment the heat radiated by the thermostat will be many times larger than that produced by the object. Because of this the layers near the outside surface will be heated to a higher temperature than those near the center. At that time a minimum temperature will be found in the center of the block. With the decrease of difference $(t_2 - t_0)$ the temperature changes will become smaller, and a point will be reached at which δt will be zero. Afterward, it will be positive and will start to increase slowly. Finally, the curve representing the time-temperature relation for the center of the block will merge with a line parallel to $t_a t_a$ and drawn through point δt , so that the same state will be reached as in the experiment previously described.

Lack of symmetry in the shape of the cooling and heating curves may be great enough to produce a difference in value *B* and $\tau_{0.5}$ respectively.

This should be taken into consideration when the kinetic methods of measurement are used. If so, either the correction should be calculated or such a method of comparative measurements should be employed that this correction is eliminated. For that purpose, in experiments previously described, a standard radium preparation was used.

§ 87. **Elimination of Corrections.** It may be expected that further improvements will increase the accuracy of measurements in which either the static or the kinetic method will be used. For this reason care should be taken to eliminate all the corrections involved. Below the question is discussed for two objects: (1) a radioactive mineral which steadily develops a small amount of heat, (2) an aluminum alloy which, after being quenched, liberates heat for about 250 hours, its amount changing with time. In both cases an electric heater may be used to measure the heat developed one time by the object only, the other by the object and by the electric current. The location of the spiral of the resistance wire should be so chosen that the material will be heated as uniformly as possible. In order to obtain better uniformity of heating, it is preferable not to use a radium preparation, because this occupies a small volume in the center, and about 85 to 90 per cent of the heat evolved is absorbed in the vicinity of the center of the calorimeter.

If the object, such as a radioactive mineral, develops a constant amount of heat, no difficulties are encountered in using an electric heater, as previously described (§ 78, Figure 44). If the kinetic method is based on examining the cooling and heating curves, the experiments should be repeated with different electric currents in order to find whether asymmetry in the shape of the two curves appears (§ 86). In that way a series of cooling and heating curves may be obtained and compared with those in which no electric current was used.

If the heat developed by the object changes with time, the use of the method of comparative measurements encounters difficulties. Its application largely depends upon the nature of the process. For instance, if it is the aging of an aluminum alloy (§ 84), two possibilities exist. One consists in using the electric heater at the moment when no more measurable amounts of heat are developed. At that moment the object should be considered thermally inert. The other method involves carrying out several experiments successively one after another, so as to have the heating one time by the object alone, another by the object and by an electric current. The experiments should proceed one after another as rapidly as possible. In that way it is possible to have one measurement of the heat liberated by the object between two experiments in which a known and constant electric current developed an additional amount of heat. In this series $\tan \alpha$ should be determined each time.

Figure 51 shows in detail how this method can be employed in a case where the object develops heat in a way similar to that associated with the aging of aluminum alloys (§ 84). In diagram A a curve is represented in which $\frac{dT}{d\tau}$ (which is proportional to $\frac{dQ}{d\tau}$) is plotted against time, expressed

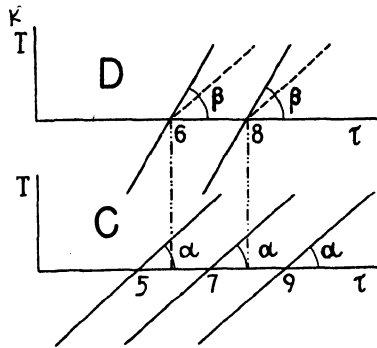
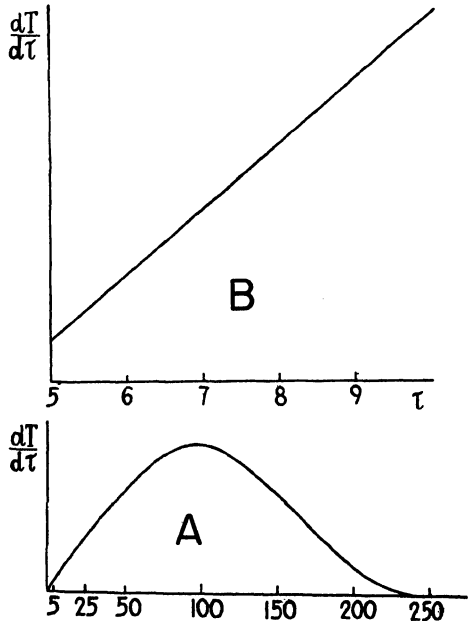

Figure 51.

Graphical Presentation of an Electric Calibration of the Calorimeter Containing Material Developing Changeable Amounts of Heat.



in hours. In diagram B one portion of curve A is selected so that for a period of five hours small changes in heat development are noticed. Diagram C represents three graphical determinations of values $\frac{dT}{d\tau}$, namely $\tan \alpha_5 = a_5$; $\tan \alpha_7 = a_7$ and $\tan \alpha_9 = a_9$ which should be determined five,

seven and nine hours, respectively, from the start of the experiments. In diagram *D* two graphical determinations of $\tan \beta_6 = b_6$ and $\tan \beta_8 = b_8$ are shown. This time the measurements were made after six and eight hours elapsed from the start of the experiment. In these measurements the electric heater was put into action.

If *K* represents the energy equivalent of the calorimeter the following equations may be written:

$$\Delta q_6 = K \cdot a_6 = K \tan \alpha_6 \quad (1)$$

$$\Delta q_7 = K \cdot a_7 = K \tan \alpha_7 \quad (2)$$

$$\Delta q_9 = K \cdot a_9 = K \tan \alpha_9 \quad (3)$$

and

$$\Delta q_6 = K \cdot b_6 = K \tan \beta_6 = E + K \cdot a'_6 \quad (4)$$

$$\Delta q_8 = K \cdot b_8 = K \tan \beta_8 = E + K \cdot a'_8 \quad (5)$$

In these equations Δq_6 , Δq_7 , Δq_9 , Δq_6 and Δq_8 are the amounts of heat liberated per hour either by the object or the object and the electric heater; *E* is equal to $i^2 \cdot r \cdot 3600$ joules; a'_6 and a'_8 are the temperature increases which would be produced at $\tau = 6$ and $\tau = 8$ hours if the calorimetric system were heated by the object alone. From equations (1), (2) and (3) values a_6 and a_8 can be calculated by interpolation. The latter can be compared with a'_6 and a'_8 calculated from equations (4) and (5). If no secondary phenomena took place, a_6 should be equal to a'_6 , and a_8 to a'_8 .

If a_6 is not equal to a'_6 , and a_8 to a'_8 , the ratios, which represent the correction factors:

$$\frac{a'_6}{a_6} = x_6 \quad \text{and} \quad \frac{a'_8}{a_8} = x_8$$

should be equal to each other. If they are found unequal, it would indicate that there might be an accidental or systematic error in one or in both series of measurements. If x_6 and x_8 differ in the limit of experimental error, it would mean that a_1 , a_3 and a_5 should be multiplied by $x = (x_6 + x_8)/2$, to eliminate all the corrections involved.

If *K* is expressed in calories, $i^2 \cdot r \cdot 3600$ should be multiplied by the mechanical equivalent of heat.

The writer is unable to say whether this or another method was ever used by Lazniewski. It would be desirable to examine its applicability in detail.

Chapter X

Labyrinth Flow Calorimeter

§ 88. **Junkers' Flow Calorimeter.** Since Junkers⁵⁷ built the well-known flow calorimeter for measuring the heat of combustion of gases very little progress has been made in improving this apparatus or employing it for other uses. Junkers' excellent idea of protecting the calorimeter against heat losses by a system of coaxial walls forming several passageways for water has never been utilized completely for increasing the accuracy of the measurements and extending the applications of this method. The improvements of Junkers' calorimeter were associated rather with providing it with a self-recording device. In that way it could function automatically day and night. Other types of flow calorimeters,¹⁵ in which two reacting solutions were mixed in a continuous flow, did not find any broad applications. In addition they offered no advantages when compared with other calorimetric methods.

The purpose of this chapter is to describe the efforts made by the writer and his associates to improve flow calorimeters and to broaden their application. These improvements were directed toward better protection of the apparatus against heat gains and losses, and toward the elimination of errors by applying the method of comparative measurements.

§ 89. **Labyrinth Flow Microcalorimeter.** The experiments associated with the idea of using a labyrinth flow calorimeter sufficiently protected against heat gains or losses were started in 1935. At that time J. Malawski and the writer¹⁰⁸ gave the description of a small glass labyrinth flow calorimeter. In Figure 52 the first model of that type of microcalorimeter is shown.

The following considerations may explain the principle of its functioning. Let us suppose that the object which develops heat in a process of long duration is located in tube *A* found in the center of the apparatus. This tube is surrounded with water which flows uniformly through that space as well as through the other coaxial passageways (1, 2, 3 and 4) of the apparatus. Water enters the central passageways from the bottom at *c* and leaves at the top at *O*₂. The water is taken from a thermostat, where it is kept at constant temperature within $\pm 0.001^\circ$ (§ 8).

The whole apparatus is located in a container immersed in the same thermostat.

According to the principle on which the labyrinth flow calorimeter is based, each coaxial passageway protects against heat losses the next one located nearer to the center of the apparatus. However, as some heat exchange exists between the liquid found in two neighboring passageways, there is some penetration of heat from the center to the outside passageway. The problem was to find the number of passageways which could make the heat losses due to this penetration of heat immeasurably small.

To find this, let us suppose that a given amount of heat is transferred, by contact through the glass walls, from the water flowing through the central part of the calorimeter to that moving along the next passageway

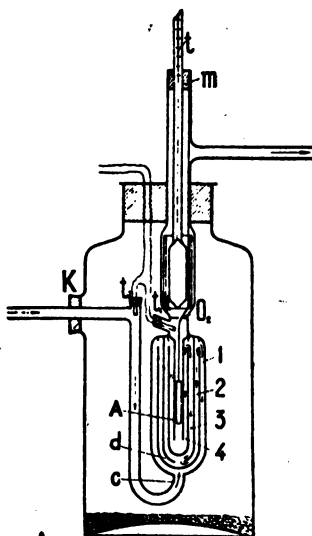

Figure 52.

First Model of the Labyrinth Flow Microcalorimeter.

(4). This heat will not be lost, but will be transferred with the water when the water reaches the central portion of the apparatus. The heat transfer from the water moving in passageway 4 to that flowing through passageway 3 will not be lost either, because some time later this water will reach passageway 4 and then the central part of the calorimeter. The same considerations can be repeated in the case of passageways 2 and 1.

In addition it should be taken into consideration that the heat transfer from the central part of the calorimeter to the next passageway may be relatively large. The transfer from passageway 4 to 3 will be considerably smaller. This heat exchange will rapidly decrease with the increase of the number of passageways in the labyrinth. Consequently, if the number of passageways is great enough, the heat exchange between the last two passageways most removed from the object can be made smaller than the

limit of experimental error. Under these conditions practically all the heat developed by the object will be recovered and measured.

We have discussed the method of recovering heat transferred in the labyrinth including that from the central part in which the object is located. To measure the heat, it is necessary to have the junction of a thermocouple (or the bulb of a mercury thermometer) as close as possible to the object. It is essential, however, to mix the water before it reaches the place where the thermojunction is located, in order to maintain a uniform temperature throughout all the water leaving the labyrinth. For this reason the upper labyrinth (O_2) is joined to the main lower labyrinth as shown in Figure 53 (§ 90).

For measuring the heat developed per unit of time by the object, it is necessary to know: (1) the difference, Δt , between the temperatures of the water leaving and entering the calorimeter; and (2) the amount of water, v , passing per unit of time through the calorimeter. If the object is developing a constant amount of heat per hour, the equation to be applied is:

$$\Delta Q = v \cdot D \cdot c \cdot \Delta t \quad (1)$$

in which v is the volume of water passing in one hour through the calorimeter, D its density, c its specific heat, and Δt the difference in temperatures of water leaving and entering the labyrinth. This value is measured after thermal equilibrium has been established in the whole apparatus.

If the thermal effect starts at moment τ_1 and stops at τ_2 , and if the amount of heat liberated changes with time, the total amount of heat, Q , produced during the experiment is:

$$Q = \int_{\tau_1}^{\tau_2} v \cdot D \cdot c \cdot \Delta t \cdot d\tau \quad (2)$$

In this equation v is the volume of water which passes through the calorimeter per unit of time, Δt the *actual difference* in temperature of the water leaving (t) and entering the calorimeter (t_0), so that $\Delta t = (t - t_0)$, and $d\tau$ is the increase of time. Difference Δt is certainly a function of time.

The first experiments carried out by Malawski¹⁰⁸ were made with the idea of proving the applicability of the labyrinth flow calorimeter even in the simple model presented in Figure 52. An electric heater was used and the intensity of the current was varied to produce from one to ten calories in one hour. The average error found in a series of experiments was ± 0.5 per cent. No higher precision could be reached because v and Δt in equation (1) could not be measured precisely enough. Malawski has found also that liquids other than water could be used. The specific heat of the

liquid may be considerably smaller than that of water, and much larger temperature increases, Δt , could be observed.

Further studies on the application of the labyrinth flow microcalorimeters were postponed because it was found that the method could be applied with success in measuring the heat of setting of cements. This work was urgently needed at that time in Poland. Other experiments were directed toward finding the general applicability of the method in macrocalorimetry. The invasion of Poland interrupted the investigations having in view the use of labyrinth flow calorimeters in microcalorimetry. For this reason only the macrocalorimetric investigations are described in this chapter.

§ 90. **Improved Labyrinth Flow Calorimeter.** In Figure 53, a new type of labyrinth flow calorimeter is presented. It is composed of two labyrinths, the main one constituting the lower part of the apparatus and an upper one which serves at the same time as a cover.

The object under examination is located or suspended in vessel *A* found in the center of the lower labyrinth. Direct heat exchange takes place between vessel *A* and the water streaming through the central container, which forms together with vessel *A* the last passageway of the lower labyrinth. The central part of the apparatus is surrounded by four coaxial passageways, three of which are separated by air.

In principle the calorimeter functions in a way similar to that shown in Figure 52. It is also located in large container *B* which is immersed in a very large thermostat, the temperature of which is kept constant within $\pm 0.001^\circ$.

The stream of water enters tube, *k*, passes through a short piece of rubber tube *g* and then through the bent metallic tube. Finally, at the bottom of the lower labyrinth it reaches hole *C*, through which the water passes into the first labyrinth passageway 1. It reaches the top, passes through constriction *a* and enters passageway 2. At the end of that passageway the water passes through the hole leading to passageway 3, in which it moves in the opposite direction. In a similar way water reaches passageway 4, in which it flows vertically down so as to pass the bending. Through hole *b* it enters the central container where the calorimeter with the object is located. To make sure that the stream of water is as uniform as possible everywhere in the labyrinth, a series of constrictions (e_1, e_2, e_3 , etc.) was built in; in these, the speed of the water is many times greater than in the passageways. Thus the water is forced to flow through all these constrictions and then to be spread everywhere in the passageway where the cross-section is much larger. Experiments have shown that the constrictions play an essential role in assuring a uniform distribution of water in the labyrinth. Constrictions e_1, e_2 , etc. were made by soldering copper

wires around one of the cylindrical walls forming the corresponding passageway.

It has been pointed out that water streaming through the central vessel (Figure 53) comes in direct contact with the calorimeter (A) containing the object. At the start of the experiment, the heat exchange between the calorimeter and the water cannot be complete. For this

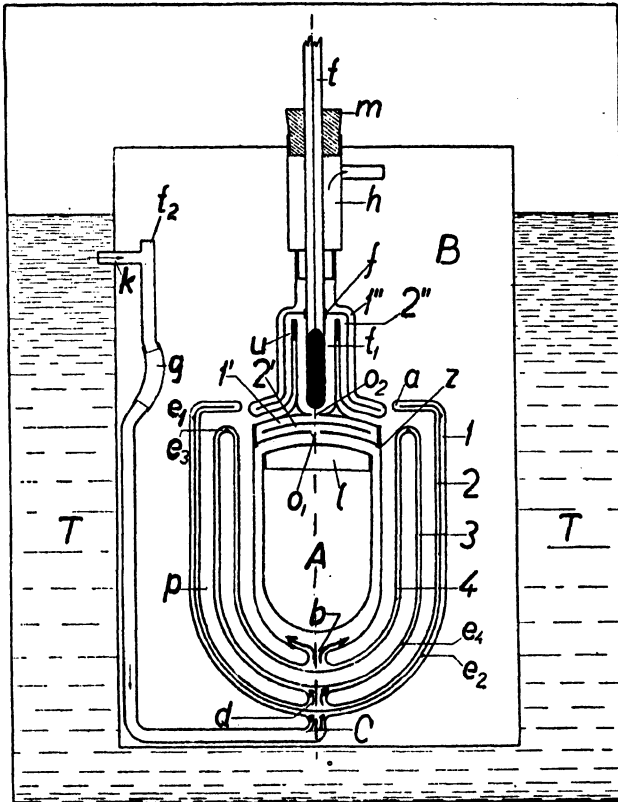

Figure 53. Swietoslowski's Labyrinth Flow Calorimeter.

reason, the temperature of the object is somewhat higher than that of the water leaving the central space surrounding the calorimeter (A). Shortly, however, a thermal equilibrium between the calorimeter and the water is established, which corresponds to a certain distribution of the temperature inside the object or inside the screen located between the object and the walls of the calorimeter. This distribution of the temperature is similar to that which characterizes the state of thermal equilibrium inside other calorimeters (Figure 49, § 86). Once this distribution of temperature is

established, a constant flow of heat passes through the walls of the calorimeter and is absorbed by water streaming through the central part of the labyrinth.

The lower labyrinth functions in a similar way, as described in the case of the small glass labyrinth calorimeter (Figure 52), with the exception that in all passageways separated by a layer of air the heat exchange is much smaller. Therefore, the heat exchange between these passageways is considerably smaller than that in the first model previously described. From that point of view, the calorimeter is better protected against heat losses. For instance, the radiation from the central vessel of the labyrinth produces some temperature increase in passageway 4. However, the latter is separated by a layer of air from passageway 3, so that the heat radiated from the surface of wall 4 is considerably reduced. The same can be said with respect to the heat exchange between the two passageways 3 and 2, which are also separated from each other by a layer of air. As pointed out in § 89, the heat radiated by the walls located closer to the center and absorbed by those which are closer to the outside passageways *is not lost*. It is *recovered and transferred to the center by the stream of water*. The only place in which a very small amount of heat might be entirely lost is between the lower and upper labyrinths (space between *a* and the walls of the upper labyrinth). *An adequately chosen method of calibration of the calorimeter (§ 93) eliminates entirely the error which may result from such heat loss*. Experiments carried out shortly before the invasion of Poland have proved that 99.5 per cent of the electric energy produced by an electric heater located in chamber A (Figure 53) could be recovered. Therefore, 0.5 per cent constitutes the correction which should be eliminated by using an adequate method of successive comparative measurements* (§ 24, 27).

Another essential improvement in the structure of the labyrinth flow calorimeter consisted in providing the apparatus with an upper labyrinth which functioned better than that shown in Figure 52. Its purpose was to protect against heat losses not only the upper part of the calorimeter, but also the water after it has left the lower labyrinth. In that way, the temperature increases, $\Delta t = (t - t_0)$, could be properly measured. The central space of the second labyrinth was made large enough to accommodate either a calorimetric mercury thermometer, a thermocouple, or a thermopile composed of a number of thermojunctions. Consequently, any *desired accuracy in measuring the difference between the temperatures of the water leaving and entering the labyrinth could be obtained*.

The upper labyrinth played another important role. It was essential to mix the water leaving the lower labyrinth so as to establish a uniform temperature before it reached the place where the thermometer was

located. For this reason, two horizontal passageways, 1' and 2', were located below hole O_2 leading into t_1 . In t_1 the water flows vertically up and enters passageway 2'', changes its direction, reaches the bending opposite constriction a of the lower labyrinth, and flows up through passageway 1''. Finally, it reaches space h and the side tube from which it is lifted by a syphon. The latter is not shown in Figure 53. By changing the lower level of the syphon, the speed of water everywhere in the apparatus can be regulated.

From the description given above, it can be seen that a is the only place in which water streaming through the lower (main) labyrinth may absorb some heat radiated from the upper labyrinth (lower part of passageway 1''). It is in that place that the water leaves passageway 1 and enters passageway 2. Because of this, some of the heat lost by radiation in the lower labyrinth is recovered. These gains or losses of heat should not play any essential role, since the calibration of the calorimeter by an electric heater should eliminate all the errors resulting either from radiation or from heat exchange between the two labyrinths.

It should be pointed out that cover l of the calorimeter can be tightened by any kind of semi-liquid plastic mass. The same refers to surface Z found between the rim of the central container and the upper labyrinth. In a number of cases a screw and tiny rubber ring have been used. For carrying out experiments under pressure (in A) the cover was fastened in a way similar to that used in Berthelot's calorimetric bomb. An insulation in U was made by placing an insulator there. At f a small piece of rubber tube separated space t_1 from t'' . Finally, by means of stopper m the thermocouple or calorimetric thermometer could be fastened. At the same time it tightened the hole so that the syphon could function properly.

§ 91. **Applicability of the Labyrinth Flow Calorimeter.** It should be pointed out that the labyrinth flow calorimeter resembles not only Junkers' apparatus used for measuring the heat of combustion of gases or volatile liquids, but, to some extent, the apparatus used in biology and physiology.^{4, 11} The similarity may be seen in the fact that the energy equivalents of the objects and the apparatus are not taken into consideration in both kinds of apparatus.

The labyrinth flow calorimeter offers another advantage, which is essential in both physicochemical and physiological researches. It consists in the fact that the objects can be kept at constant or practically constant temperature. The latter is always close to that of the thermostat. In addition, if during the experiment the object produces more or less heat, it is possible to change the amount of water passing through the calorimeter. In that way desirable increases or decreases in Δt can be achieved.

Small changes in the structure of the apparatus make it applicable for

measuring the heat developed by fishes and other animals, or even plants living in fresh or in salt water. Even large changes in the quantity of heat liberated in one or another stage of the reaction do not play any essential role.

No difficulties are encountered in switching from a system of two thermojunctions to a thermopile with a large number of junctions. Finally, self-recording systems may be used so that the apparatus may function for a long time without supervision.

The simplicity of the method is evident. All thermometric and calorimetric corrections can be eliminated by using the proper method of calibration (§ 20, 27).

§ 92. **Possibility of Replacing Water with Air.** At the Physico-chemical Laboratory of the Institute of Technology, Warsaw, preliminary experiments have been made on the problem of replacing the water in the labyrinth with air. This change may be found important for using this type of calorimeter for measuring the heat developed by human beings and animals. In carrying out these measurements, arrangements should be made for absorption of carbon dioxide and air. Correction for the heat absorbed by air due to its expansion should be determined by blank experiments. This can be eliminated also by using the method of comparative measurements.

Experiments made by the writer and his collaborators have shown that both the structure and the material used for building the air flow calorimeter should be somewhat different. No details are given in this book because the investigations were interrupted by the war before the method could be examined adequately.

§ 93. **Application of the Method of Comparative Measurements.** It was pointed out in a previous paragraph that any kind of method of comparative measurement may be applied for eliminating the corrections when using the labyrinth flow calorimeter. It is easy also to reproduce the conditions of the experiments because they depend exclusively upon the proper functioning of the thermostat (§ 6, 8) and the thermocouple for measuring the difference, Δt , in equation (1) (§ 89), and upon the amount of water streaming through the labyrinth. The main purpose of the calibration is *elimination of the correction for the heat losses*. The latter are not large when compared with the amount of heat developed by the object or by an electric heater. It is, however, important to carry out a series of supplementary measurements in which some larger and smaller amounts of heat than that liberated by the object are produced by the electric current. If in this set of experiments no unexpected variations of the results are found, it may be assumed that the elimination of the correction has been made properly. Otherwise, the cause of unexpected deviations should be

found by additional calibration experiments in which some changes in conducting the measurements should be made. In that way the influence of factors which had remained unchecked in the first series of calibration experiments may be detected.

§ 94. **Accuracy of the Labyrinth Flow Calorimeter Method.** The writer is quite aware that at the present time no definite answer can be given to the question regarding the highest accuracy which may be obtained by using the labyrinth flow calorimeter. In fact, no special investigations have been carried out for finding the magnitude of experimental errors both in macro- and microcalorimetric measurements. These experiments were postponed because of the necessity of using the labyrinth flow calorimeter for measuring the heat of hardening of cement. This application was so important that hundreds of experiments have been carried out on the thermochemical characteristic of different cements. For this purpose a self-recording device was built and the measurements could be performed easily without interruptions for 30 to 36 hours. In that way, the thermochemical properties of cements should be investigated more precisely than by any other method used in the past.^{5, 13, 16, 36, 45, 58, 62, 71, 72, 79, 91, 95, 124}

Other experiments made with the apparatus have shown that the limits of the errors may be kept at least in the same range as in any other macrocalorimetric methods.

§ 95. **Application of Labyrinth Flow Calorimeter for Measuring the Heat of Hardening of Cements.** In the past, several methods were used for measuring the heat developed by cement after it has been mixed with water.^{13, 88} Most of these methods were indirect. For instance, in the United States the method was based on measuring the heat of dissolution of the sample. Using this method, one had to determine first the heat developed by the starting material, and then that which was evolved after a known amount of cement and water had been mixed and allowed to stay at a constant temperature a certain number of hours or days. The difference in the heat of dissolution was used for calculating the heat of hardening of the sample.⁹⁵ In the labyrinth flow calorimeter provided with a self-recording device (see Figure 54) a curve could be obtained showing the heat produced by the reaction of cement with water at any stage of the process. The heat developed in the period of about half an hour after the mixture was prepared could not be measured, because that time was required to put the apparatus into operation. J. Pomorski started these investigations in 1935 and obtained about one hundred diagrams for different kind of cements. Many of the samples were prepared by cement plants especially for his investigations. Most of them, however, were manufactured for building large hydraulic installations in Poland (Roznow and Porembka). Before the invasion of Poland, J. Pomorski was pre-

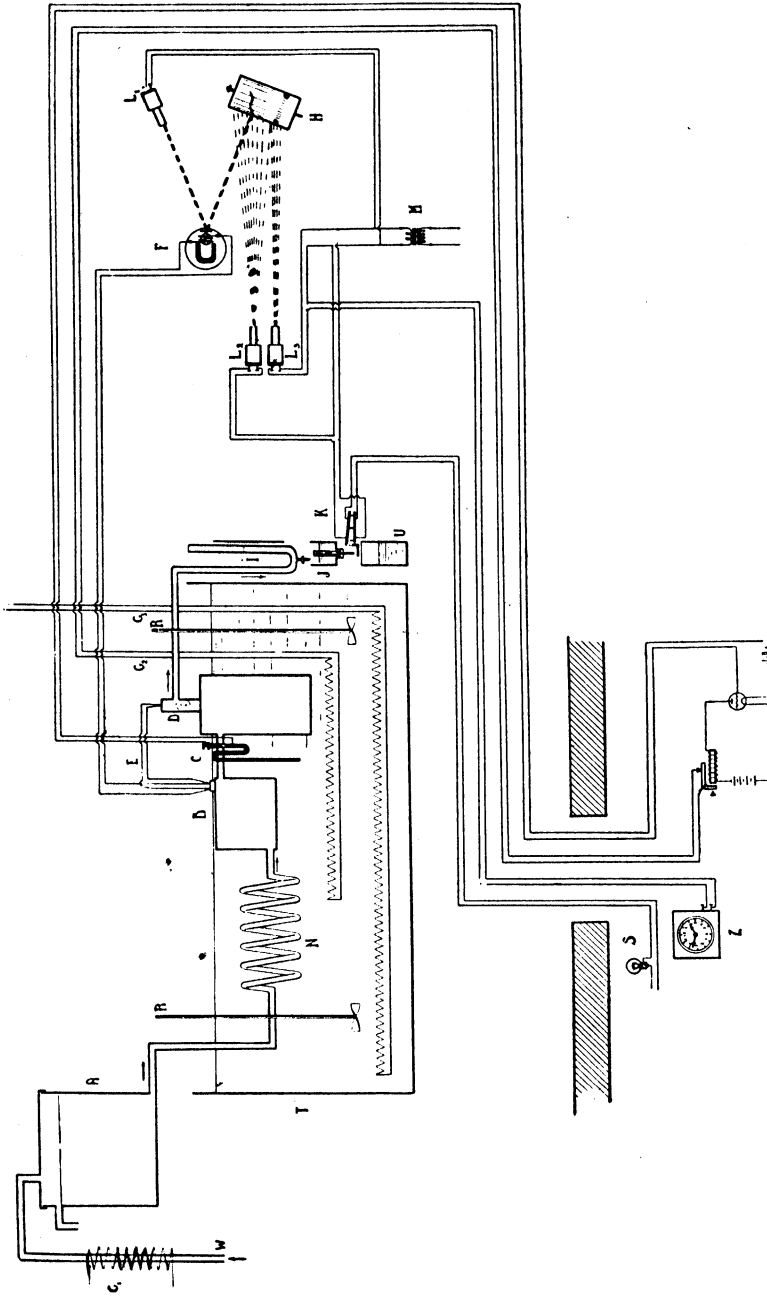

Figure 54. Labyrinth Flow Calorimeter With Thermostat and Self-recording Device. General scheme of the apparatus. Arrangement of the whole system together with the automatic registration. There are: thermostat T , stirrers K_1 and K_2 , heaters G_1 , G_2 and G_3 , thermostat regulator C and cathode relay P .

pared to publish a monograph on that subject. The writer does not know whether Pomorski succeeded in saving his figures and diagrams, which he had collected for several years. The results of experiments described below were published in 1939 by Pomorski and the writer as preliminary investigations.¹⁰⁸ The self-recording device shown in Figure 54 was used for getting a diagram in which time τ , difference $(t_2 - t_1)$, and amount of water, v , passing the calorimeter in known intervals of time were automatically recorded.

Because a large amount of water was required, it was taken directly from the water line. Before entering the thermostat it was kept in container *A* (forty liters in capacity). From this container water entered copper tube *N* which was wound in a spiral. The latter was located in thermostat *T* in which temperature t_1 was kept constant within $\pm 0.001^\circ$ (see § 7, 8).

After passing the spiral, water reached container *B* which was also immersed in the thermostat. For the proper functioning of the water meter (Figure 55) it was essential to remove by filtration all the particles of dust which could be occasionally found in the water. The first filtration was made before the water reached container *A*. The second filter was located between the spiral and container *B*. From *B*, water entered the labyrinth of the calorimeter. In Figure 54 points *B* and *D* are shown where the thermojunctions were located for measuring the difference between the temperatures of water entering and leaving the calorimeter. The details of the structure of the calorimeter were the same as described in § 90. They are shown in Figure 53. The bulb of a Beckmann thermometer was usually located in container *B*, to measure from time to time the temperature of the water in that container. Another Beckmann thermometer was placed in the vicinity of the thermojunction in *c* so that the temperature of the water in the thermostat could be measured. This was essential for controlling the functioning of the thermoregulator (see § 8 and 9). A conventional type of self-recording device was used (Mirror *F*, light bulb *L*, and recording cylinder *H*).

After passing the upper part of the second labyrinth (*D* in Figure 54) and syphon *I*, in which the water level was regulated by the stopcock attached to the U-tube, the water entered water meter *J*. The details of that device are shown in Figure 55. It resembles an automatically functioning hydraulic apparatus. Each time when the container was filled with water to such an extent that it could flow down through the central outlet tube, a syphon was formed and the water flowed down and emptied the container. The stream of water exerted a pressure on the arm of relay *K*, and the electric current appeared in the circuit in which light bulb L_1 was located. Consequently, each time that a known amount of water

passed through the water meter, a vertical line appeared on the photographic paper (cylinder H). Finally, in a similar way, every ten minutes an electric watch, t , closed another circuit with light bulb L_2 . In that way time intervals were recorded on the same photographic paper. It was important to supervise the functioning of the apparatus without entering the constant-temperature room (§ 7). For this reason, three signal bulbs,

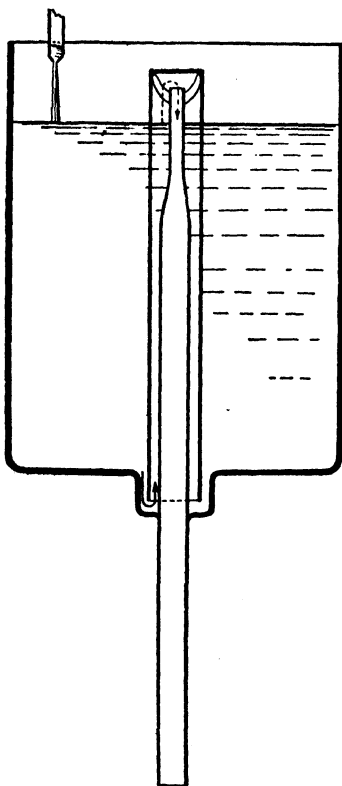

Figure 55
Water Meter

red, green and yellow, were located in a neighboring room so that the experimenter could observe the proper functioning of all the devices. If it was necessary to enter the calorimetric room, the experimenter used a red light.

It should be emphasized that a relatively strong motor used for stirring (§ 8) was located in the hall, outside the constant-temperature room, so that one source of heat was removed from the room in which the measurement was carried out. From time to time it was necessary to interrupt the functioning of the device which recorded the galvanometer deflections to permit the zero point to be fixed on the graph.

The recording device was made by the Cambridge Electric Instrument Company, England. The cylinder was large enough so that 12×42 cm photographic paper could be fastened on its surface. The device was located in a wooden box in front of which the lens gathering the beams of light was found.

Experiments have shown that the error in measuring the amount of water which passed the labyrinth flow calorimeter did not exceed 0.5 per cent. To protect the galvanometer from vibration it was located on a concrete block weighing about 150 kg. The latter was placed on four rubber balls.

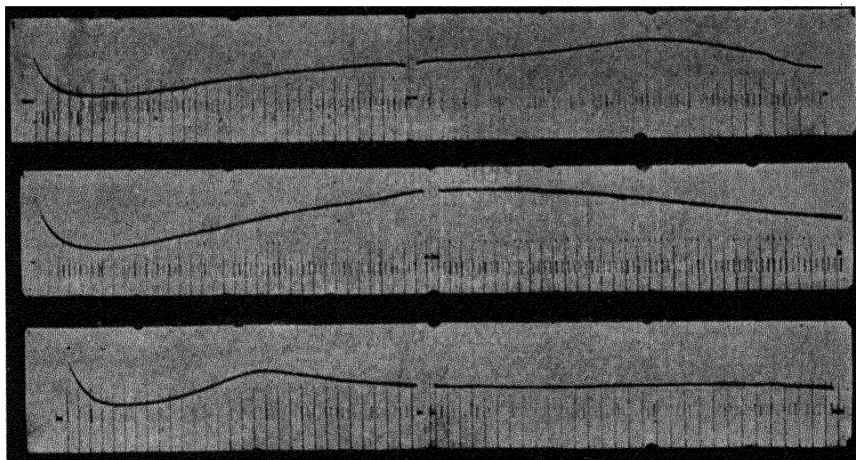

Figure 56. Photographs Characterizing Thermochemical Properties of Three Different Cements. Time, Amount of Water Passing Through the Labyrinth and Difference in Temperature of Water Leaving and Entering the Labyrinth Have Been Recorded.

All the light bulbs worked on a 4-volt circuit. Transformer *M* connected with the line of alternating current, was used for that purpose.

§ 96. **Thermal Characteristics of Three Different Cements.** It has been pointed out that J. Pomorski used the device just described for an extensive investigation of a very large number of cements. Usually, the experiment started half an hour after the cement had been mixed with water. For getting the complete thermochemical characteristics of a cement it was necessary to carry out the measurement for at least 24 hours. In a number of cases the experiment was extended to 36 hours.

The writer is able to give the photographs for three cements only (Figure 56). They have been published in the report presented to the Academy of Technical Sciences in Warsaw.¹⁰⁸ Two of these cements were considered

at the time the publication appeared, as extreme cases; the third showed properties which are rather similar to those of cements mostly used in practice. As has been pointed out, the experiments started half an hour after mixing the cement with water. During this time a relatively large amount of heat was developed, due to adsorption and absorption of water and to the hydration of free calcium oxide in the cement. About 30 to 45 minutes later the development of heat decreased rapidly, and a minimum of heat production could be observed. The final stage of this phenomenon is represented in the graph. The curves showed that, after the first stage of the reaction had passed, the heat development increased rapidly with time. It reached a maximum and then steadily decreased. In spite of the similarity of all the diagrams, different cements vary considerably with respect to the location of the maximum. They differ also in the total amount of heat developed in the first period of hardening, which lasts for 24 or 36 hours. In the last stage of hardening only small amounts of heat are developed for a number of weeks and even months. J. Pomorski found that it is important to have three diagrams, the first for the period from $\frac{1}{2}$ to 12 hours, the second from 12 to 24 hours, and the third from 24 to 36 hours. The last stage of the reaction could be examined by either the adiabatic (§ 58), the static (§ 78) or the kinetic method (§ 79, 80).

As to the samples, the thermal characteristics of which are represented in Figure 56, the following may be pointed out: (1) the first (upper) curve shows that the sample examined had a long period of a steady increase of heat production, and that the maximum appeared about 19 hours after the start of the reaction. After passing the maximum a rapid decrease in heat development was observed. (2) The middle curve represents another example. The increase in heat development is more rapid and the maximum appears 14 hours after the cement has been mixed with water. Less rapid and nearly a linear decrease of heat development was observed during the next ten hours. (3) The lower curve shows the thermal properties of a cement which was manufactured with the purpose of slowing down the development of heat in the first period of the reaction. For this reason not only did the maximum of heat production appear in the early stage of hardening, but the heat produced at that time was much smaller than in the other two cases. After the maximum was passed, a rapid decrease in heat production was observed. In the next period, of about 12 hours duration, the curve was slightly inclined to the axis of time, which meant that a relatively large and nearly constant amount of heat was developed.

Other cements examined by Pomorski were characterized by various curves lying somewhere between two extreme cases shown in the first and in the third diagrams (Figure 56).

It is not the purpose of this book to enter into details concerning the

factors which were responsible for the changes in the shape of the curves and in the total amount of heat liberated by the setting of different cements. Both the composition of the cements and the size of the particles caused the change in the shapes of the curves. The amount of water mixed with the cement should be constant. In all experiments previously described 31 grams of water were mixed with 100 grams of cement. From the description given above, one conclusion may be drawn: the method of the labyrinth flow calorimeter offers valuable information concerning how the thermal process proceeds and how the development of heat of hardening cements changes with time.

§ 97. **Heat of Mixing of Cement with Water.** The technique of the experiments carried out by Pomorski¹⁰⁸ and Rosinski¹⁰⁶ did not permit measuring the heat developed during the first 30 minutes of the reaction of cement with water. For examining the first stage of the reaction a special calorimeter has been built. In this apparatus the development of heat can be measured from the very beginning of mixing the cement with water up to the moment when the observation can be carried out by using the labyrinth flow calorimeter.

The calorimeter used for this purpose consisted of a drum immersed in water and rotating with a constant speed on its horizontal axis. The calorimeter was surrounded with an adiabatic jacket so that the experiment could last an arbitrarily long period of time. Before starting the measurement, the drum was loaded with a given amount of dry cement and the loading hole was closed by a membrane.

First, it was necessary to determine the heat produced by stirring and by friction of all movable parts of the apparatus. In addition to that, some amount of heat was developed by the tumbling of the cement in the drum. After the correction for that heat was determined, the membrane was removed for a moment, an excess of water heated to the same temperature was poured into the drum, and it was closed once more by the membrane. The main calorimetric process started at once and was conducted for one hour; thus the heat produced by mixing of cement with water and the first stage of the reaction could be determined and added to that measured by means of the labyrinth flow calorimeter.

Unfortunately, the writer is unable to give any figures obtained by Pomorski relating to this stage of the reaction of water with cement. It is possible that they have been burned together with the Chemistry Building of the Warsaw Institute of Technology.

§ 98. **Determination of Heat of Vaporization.** A series of determinations of the heat of vaporization of volatile liquids has been made, to prove whether the labyrinth flow calorimeter is suitable for this kind of measurement. For this purpose central vessel *A* (Figure 53) was somewhat changed

in its structure. Instead of metallic vessel *A* a glass container resembling a gas-washing vessel provided with a spiral was used. To speed up the evaporation of the liquid a constant stream of air was passed through the vessel and the spiral. Before entering the calorimeter it traversed a long copper tube, wound in a spiral and located in the same thermostat, which served as an isothermal jacket and as the source of water entering the labyrinth.

The amount of the liquid evaporated in the calorimeter could be measured in two different ways: (1) by weighing the vessel before and after the experiment, and (2) by determining the increase in weight of several U-tubes filled with activated carbon and attached in series to the outlet tube of the calorimetric vessel. For determining the weight of the liquid adsorbed by activated carbon a correction was introduced for the adsorption of the small amount of air. This correction was determined directly by carrying out a blank experiment. The experimental error of the determination of the heat of vaporization did not exceed 0.5 per cent. It was usually closer to 0.3 per cent.

Both the method of the labyrinth flow calorimeter and the adiabatic method are suitable for measuring the heat of vaporization of highly volatile liquids. It has been pointed out (§ 71) that this is not the case if the method of measuring the heat of condensation of vapors is employed. In the latter experiments better results are obtained for high-boiling liquids.

§ 99. **Application of Labyrinth Flow Calorimeter in Physiology and Biology.** Experiments have shown that the labyrinth flow calorimeter can be easily applied for measuring the heat developed by animals. Preliminary investigations were made by using a small calorimeter for mice and a larger one for rats, guinea pigs, rabbits and other animals weighing not more than 5 kg. Self-recording devices could be easily applied as in the experiments with the heat of setting of cements. The only difference in the structure of the central part of the calorimeter consisted in providing central vessel *A* (Figure 53) with a metallic tube wound in a spiral and located between the cover and the horizontal part of the upper labyrinth. In addition, the air before entering the calorimeter had to pass through a long metallic tube located in the thermostat in order to bring it to the temperature of the latter.

A number of preliminary experiments proved the applicability of the labyrinth flow calorimeter, and it was planned to build a large calorimeter for men and animals weighing up to 100 kg. It seemed convenient in these large calorimeters to replace the stream of water in the labyrinth by a stream of air. The same air could also pass through the central chamber in which the object was to be placed. It was believed that such a change would simplify the whole structure of the apparatus and would decrease

its weight. The invasion of Poland interrupted the realization of these plans.

§ 100. **Application of the Labyrinth Flow Calorimeter for Measuring the Heat Developed by Plants and Animals Living in Water.** The war interrupted also the experiments with fishes, other animals and plants living either in fresh or in salt water. The structure and the functioning of the labyrinth flow calorimeter seemed to be suitable and convenient for carrying out such investigations. For instance, a stream of fresh or salt water saturated with air or oxygen might pass through the lower labyrinth, then through the calorimeter containing the object, and finally through the upper labyrinth. If necessary, special arrangements might be added so as to keep some amount of air in the upper part of the calorimeter. The velocity of the stream of water could be so chosen as to have a reasonable increase of temperature of the water leaving the lower labyrinth. Self-recording devices could facilitate conducting the measurements over a long period of time.

§ 101. **Conclusions.** It seems that the construction of the labyrinth flow calorimeter offers so many advantages that this apparatus may find numerous applications in the future. Using the lower and the upper labyrinths as described in § 90, one may protect the calorimeter against heat gains or losses so as to reduce to a minimum the correction for the heat exchange of the calorimetric system with the surroundings.

In addition, this correction can be entirely eliminated by carrying out blank experiments with an electric heater, as previously described (§ 93). The convenience of the method lies in the flexibility of conditions under which experiments can be made. The precision with which differences, Δt , between the temperatures of water leaving and entering the calorimeter can be measured is entirely in the hands of the experimenter. There is, however, one important factor which may play a predominant role in microcalorimetric measurements, namely, temperature fluctuations of the thermostat. If the object develops a constant amount of heat, the influence of these fluctuations is not very great because positive deviations usually are compensated by negative ones. If, however, the development of heat is not constant, the fluctuations may be a source of systematic or accidental errors. These errors may be large if the object liberates very small, irregular or changeable amounts of heat.

The flexibility of the conditions under which the measurements may be conducted consists: (1) in changing the size of the calorimeter, (2) in changing the amount of water passing through the labyrinth per unit of time; (3) in replacing the water with another liquid or with air; (4) in changing the accuracy with which temperature differences, Δt , are measured. Other changes associated with passing the air or the water

through the vessel in which the object is located have been previously discussed.

The author is convinced that further changes in the structure of the labyrinths may lead to further improvements and simplifications of the apparatus. For instance, at the present time it is difficult to estimate the accuracy of microcalorimetric measurements. Up to now, no systematic and precise determinations of the heat losses by the labyrinth in the case of microthermal processes have been made. The application of macro- and microcalorimeters of this kind in biology was in its preliminary stage. Studies should be made with the purpose of applying Tian's multi-stage thermostat in such a way as to avoid fluctuations of the temperature of the water entering the labyrinth.

Chapter XI

The Choice of a Method

§ 102. **Variety of Microthermal Processes.** In the previous chapters a number of microcalorimetric methods and their applications for examining different microthermal processes have been described. From that description it is easy to see that the variety of these processes is very large. For this reason, it seems that it would be impossible to find one universal microcalorimetric method which could replace all those used in the past. The objects examined and the nature of the thermal processes are so different that, before choosing the method, all conditions under which the measurements might be carried out ought to be examined carefully.

In this chapter a comprehensive description is given of the methods which have been used up to this time, in order to facilitate proper choice of the method to be employed in any particular case.

§ 103. **Processes of Short and Long Duration.** First of all the experimenter should determine whether the process he intends to study belongs to the group of short or long duration (§ 2, 3, 4). In general it can be assumed that all processes which last less than fifteen minutes belong to the first group. Each time a process of short duration is examined, the question should be answered: Can it really be brought to a desired state in that short a period of time? The shape of the curve which expresses the relation between the amount of heat produced and time does not play any essential part in processes of very short duration. If the adiabatic method must be employed, the shape of the time-temperature curve should be examined in blank experiments. This is the only way to learn how to maintain the adiabatic conditions of the calorimetric experiment unless an automatic device is employed.

If processes of long duration are examined it is important to know how much heat is liberated by the object at any particular moment, because this has a direct influence on the choice of the method. Sometimes it is necessary to measure the heat liberated during a particular stage of a reaction, and not the total amount developed during a long period of time. All these conditions ought to be taken into consideration when selecting the microcalorimetric method to be used.

§ 104. **Specification of Thermal Processes of Long Duration.** For a proper specification of a thermal process of long duration the following questions are important. (1) What is the approximate quantity of heat

per unit of time produced by the object? (2) What is the approximate shape of the curve expressing the relation between the amount of heat produced and time (see § 2, 3)? (3) What is the amount of material producing heat which is or can be available for a microcalorimetric measurement? (4) What is the approximate value of the energy equivalent of the calorimetric system (K)? (5) How long will the experiment last? In addition to these general questions the following may also be important: (a) Should a stream of air pass through the calorimeter during the experiment? (b) Can the air be removed from the vessel in which the calorimeter is suspended (§ 61, 77)? (c) Is it necessary to keep the object at constant temperature? (d) Does the heat developed by the object per unit of time change with the change of temperature? (e) Are there some other specific conditions which should be fulfilled?

Negative or positive answers to all these questions should play a decisive role in choosing the microcalorimetric method to be employed in each particular case.

§ 105. Survey of Processes of Long Duration and of Methods Employed. In the tables which follow, a list of thermal processes of long duration thus far examined is given. The methods used are briefly characterized in "Remarks." For convenience, in the last horizontal line the numbers of the paragraphs are given in which the details of the microcalorimetric method employed in that particular case are described. The numbers found in the first column are used for references in the discussion which follows.

Number	1	2	3	4
Determination	Heat of radioactive transformation (Absorption of alpha, and beta particles and gamma rays)			
Object	Radium	Radium	Radium	Polonium
Method used	Twin calorimeter	Ice calorimeter	Adiabatic Microcalorimeter	Adiabatic Microcalorimeter
Amount of material available	Small	Small	Small	Very small
Energy equivalent, K , of the calorimeter	Relatively large, deliberately chosen	Plays no role	Large and interchangeable	Relatively small
$dQ/d\tau$	Constant	Constant	Constant	Decreasing with time
Duration of measurements	Relatively short	Deliberately chosen, not very long	Deliberately chosen, extending up to 30 hours	Several hours
Jacket	Well insulated, but not isothermic	Isothermic	Adiabatic	Adiabatic

Number	1	2	3	4
Specific conditions	Screen for absorption of particles and gamma rays	Screen for absorption of particles and gamma rays	Interchangeable lead screens	—
Remarks	In the early stage no attention has been paid to the absorption of a large percentage of gamma rays.	In the early stage no attention has been paid to the absorption of a large percentage of gamma rays.	Up to 97 per cent of gamma radiation could be absorbed.	Half period disintegration time could be measured.
Paragraphs	§ 28, 29, 30, 31, 33	§ 36, 39	§ 68	§ 68

Number	5	6	7	8	9
Determination	Heat of absorption of gamma rays	Heat developed by radioactive minerals (Absorption of alpha and beta particles and gamma rays.)			
Object	Radium	Pitchblende	Pitchblende	Pitchblende	Pitchblende
Method used	Combined adiabatic and labyrinth flow calorimeter	Adiabatic micro-calorimeter	Static	Kinetic	Ice micro-calorimeter
Amount of material available	Relatively small	As large as possible	As large as possible	As large as possible	As large as possible
Energy equivalent, K_1 of the calorimeter	Large	Large	Large	Large	Plays no role
dQ/dr	Constant very small	Constant very small	Constant very small	Constant very small	Constant very small
Duration of measurements	Several hours	From 10 to 36 hours	From 16 to 36 hours	From 16 to 36 hours	10 to 15 hours
Jacket	Adiabatic	Adiabatic	Isothermic	Isothermic	Isothermic
Specific conditions	Heat of absorption of alpha and beta particles removed	Vacuum in between calorimeter and jacket desirable	Use of thermopile with multiple thermo-contacts desirable	Use of thermopile with multiple thermo-contacts desirable	Device for establishing desirable pressure inside the calorimeter required
Remarks	Known percentage of gamma rays absorbed	Total absorption of alpha and beta particles high percentage of gamma rays	Precise functioning of the thermostat required	Determination of $\tan \alpha$ or observation of the cooling and heating curves	Difficulties associated with secondary phenomena inside the calorimeter
Paragraphs	§ 69	§ 68	§ 78, 81	§ 80, 81	§ 42

Number	10	11	12	13	14
Determination	Heat of vaporization	Heat of absorption	Head of mechanical deformation	Heat of aging	Heat of decomposition and evaporation of solvent
Object	Volatile liquids	Activated carbon	Lead	Aluminum alloy	Artillery powder
Method used	Adiabatic micro-calorimeter	Adiabatic	Kinetic	Kinetic and Static	Kinetic and adiabatic
Amount of material available	7 to 80 mg.	Deliberately chosen	Several Kg or more	Several Kg or more	100-300 g or more
Energy equivalent, K , of the calorimeter	Conveniently chosen	Conveniently chosen	Depends upon the weight of material	Depends upon the weight of the block	Depends upon the weight of powder
dQ/dr	Endothermic variable	Variable	Decreases very slowly	Varies with time	Exothermic or endothermic, varies with time
Duration of measurements	1 to 4 hours	1 to 4 hours	Several hours	Several hours	Several hours
Jacket	Adiabatic	Adiabatic	Adiabatic	Isothermic	Isothermic
Specific conditions	Calorimeter hermetically closed before and after the measurement	Calorimeter hermetically closed before and after the measurement	Block suspended by means of screws attached to its top	A number of experiments repeated day after day	Calorimeter hermetically closed
Remarks	Convenient method for very volatile liquids	Convenient for measuring the average heat of absorption	Heat of mechanical deformation produced by the weight of the block	Heat of aging of quenched alloy, Q/dT increases, passes a maximum and decreases reaching zero	Decomposition evaporation of the solvent reaction with air
Paragraph	§ 71	§ 71	§ 82	§ 84	§ 83

Upon examining these tables one may conclude that the variety of objects investigated was very great and that the specific conditions under which the experiments were made also differed considerably. For instance, there were cases in which the experimenter could use an arbitrarily large amount of material, in other cases materials were available only in very small quantities. Investigations are found in which it was necessary to

Number	15	16	17	18	19
Determination	Specific heat of solids or liquids	Hardening of Cements	Heat of vaporization	Heat developed by animals	Heat of germination
Object	Solid or liquid substances	Cement	Volatile liquids	Animals	Seeds
Method used	Twin calorimeters	Labyrinth flow calorimeter	Labyrinth flow calorimeter	Labyrinth flow calorimeter	Adiabatic micro-calorimeter
Amount of material available	Deliberately chosen	Deliberately chosen	Deliberately chosen	From 60 g to 2 Kg	Several grams
Energy equivalent, K , of the calorimeter	Depends upon the weight of the material examined	Plays no role	Plays no role	Plays no role	Relatively small
$dQ/d\tau$	Constant produced by electric current	Variable	Mostly constant	Constant or fluctuating	Increases with time
Duration of measurements	Usually 1-3 hours	Usually 36 hours	1-2 hours	1-3 hours	1-3 hours
Jacket	Adiabatic	Isothermic	Isothermic	Isothermic	Adiabatic
Specific conditions	—	Automatic record of all values involved	Convenient for highly volatile liquids	Stream of air passing through the calorimeter	Stream of air passing through if necessary
Remarks	Determination of specific heat of liquid or solid substance	Curves (Q, τ) characterize the properties of cements	Heat of vaporization measured	Convenient for fishes and animals living in fresh and salt water	In between successive measurements the seeds were kept at constant room temperature
Paragraphs	§ 70	§ 95	§ 98	§ 99	§ 99

place the object in a massive sphere of lead so as to have a thick and dense screen absorbing all kinds of radiation. Processes were examined which did not depend upon the temperature. In most of the cases, however, it was important to avoid any change in the temperature of the object. In some instances the experimenter could decide himself how long the measurement should last. In general, however, he had to carry out the experiments for a length of time dictated by the nature of the process under examination.

The conclusion which can be drawn from the examination of the fore-

going tables is that for an adequate choice of a microcalorimetric method a large number of factors should be taken into consideration.

Besides the problems associated with the nature of thermal processes, another question should be answered by the experimenter. This refers to the case in which microcalorimetric investigations are planned for a laboratory which is not adapted for that kind of measurement. In that case the question arises whether the solution of one particular problem is sought, or whether a variety of measurements are going to be undertaken. The answer to this question is essential from both the scientific and practical points of view. If extensive microcalorimetric measurements are planned, it is essential to have a constant-temperature room and a large thermostat. Otherwise more simple and less expensive equipment can or must be used.

The accuracy of microcalorimetric measurements is also a problem which should be examined before the method is chosen. In the past it was believed that the experimental error of microcalorimetric measurements was high. Forty years ago the experimenter was satisfied if the results of his measurements fluctuated within 10 or even 20 per cent. At the present time it is difficult to give the range in which the average error of different microcalorimetric measurements may vary. It is, however, reasonable to suppose that in most cases the error has been reduced to $\pm 0.2 - 0.5$ per cent. Exception should be made for those cases in which it is more important to use a self-recording device than to reach high accuracy in the measurement. Before deciding on a method, the experimenter should decide the limit of experimental error which may be admitted in his measurements.

The main question, however, which should be settled first, consists in choosing the type of calorimetric jacket. One should take into consideration not only the nature of the objects but also the expense associated with purchasing the equipment required by a given method. For this reason the usefulness of both the adiabatic and isothermic jackets is discussed in the next two paragraphs.

§ 106. **Use of Adiabatic Jackets in Microcalorimetry.** A general discussion of the advantages and disadvantages of the adiabatic method was given in Chapter VIII. The results of this discussion can be summarized as follows: The adiabatic method cannot be applied: (1) if the heat developed changes rapidly with the temperature; (2) if the object should be kept at constant temperature (for instance an animal or a plant); (3) if the amount of heat developed per unit of time undergoes irregular fluctuations so that it becomes difficult to maintain strictly adiabatic conditions; (4) if the temperature increases are so small that it takes too much time to get a desired temperature increase in the calorimeter; (5) if the process

starts before all preparations for making the measurement can be arranged (for instance, first period of the reaction between cement and water (§ 97)).

When choosing the adiabatic method the experimenter should decide whether he intends to build automatic equipment for heating the jacket or whether he wants to maintain the adiabatic conditions manually.

The use of a thermocouple or a multi-junction thermopile is another question which should be answered at the start of the construction of a microcalorimeter. The method of measuring the temperature of the jacket plays an important role. If an accuracy of 0.0005° can be exceeded, the time of the measurement may be shortened. This should be considered as an essential improvement in the adiabatic method. In fact, if the temperature increases are kept below 0.1° or even 0.05° , the restrictions listed above under (1) and (2) may be considered as not essential, because in a number of cases such small changes in temperature can be admitted even if the heat developed by the object depends upon the temperature.

In spite of the restrictions which have been previously discussed there exist numerous thermal processes which can be examined very easily by employing the adiabatic microcalorimeter. It seems that the following processes may be investigated easily by using this method. (a) Determination of the heat produced by very small amounts of strong radioactive elements, especially, if the heat liberated during several hours can be considered as constant (3) (4) (6). (b) Determination of heat of vaporization of volatile liquids (10). (c) Determination of heat of adsorptions of vapors by activated absorbents (11). (d) Determination of the specific heat of solid or liquid substances, especially if they are available only in small quantities (15).

The adiabatic method can also be applied in all those cases in which the heat evolved per unit of time does not change rapidly with small changes in temperature. This applies to some objects in biochemistry, physiology, and biology.

Finally, it should be emphasized that the whole equipment for carrying out adiabatic measurements is less expensive than that required in other microcalorimetric methods. For this reason the adiabatic calorimeter may be used, if the experimenter does not intend to carry out systematic microthermal investigations over an extended period of time. The equipment becomes more expensive if an automatic device is used for maintaining the adiabatic condition of the measurement.

§ 107. **Use of Isothermic Jackets in Microcalorimetry.** There are several different microcalorimetric methods which require an isothermic jacket. These include the static (13) (14) and the kinetic methods (14) (§ 78, 79, 80) the labyrinth flow calorimeter (16) (17) (18) (§ 90), and the ice calorimeter method (9). With regard to the latter, a detailed

description and discussion has been given in another chapter of this book, and no supplementary comments are given in this paragraph (§ 39, 45).

The static and the kinetic methods differ to such an extent from the method of the labyrinth flow calorimeter that there should not be any doubt regarding which to choose. The following general recommendations may be given. If the heat developed by the object in one hour is not too small, for instance, if it is not less than one calorie, and if the shape of the curve expressing the relation between $dl/d\tau$ and the time (τ) is complicated (sudden unexpected changes and fluctuations), preference should be given to the labyrinth flow calorimeter. On the contrary, if the object evolves a constant and very small amount of heat per gram in one hour and if it can be used in large quantities, either the static or one of the two kinetic methods should be employed. Both of them are much more precise than the method of the labyrinth flow calorimeter, (at least at the present stage of its development). In addition, it should be borne in mind that the precision of both the static and the kinetic methods can be considerably improved with increases in the amount of the material used, and with increases in the precision of temperature and galvanometer readings (§ 80, 85).

The application of the static and kinetic method is somewhat restricted in the thermal processes in which the amount of heat produced decreases or increases slowly with time. In these cases the method based on measuring the angle formed by the tangent to the heating curve and the horizontal line can be successfully employed (13) (§ 84). Both these methods can be applied if the last stage of a slowly proceeding thermal process has to be examined. For instance, the heat developed three months after cement has been mixed with water, or that which is produced in the last stage of aging of aluminum alloys (13) can be measured with high accuracy by either the static or the kinetic method. If these experiments are repeated with relatively long intervals of time, the results show that the heat produced changes slowly with time and can be graphically represented by a straight line slightly inclined to the time axis.

In brief the following recommendation may be given as to where the isothermic jacket can be used: In physiology and biology preference should be given to the labyrinth flow calorimeter; in radiology and in all investigations associated with slowly proceeding thermal processes the static or the kinetic method should be considered more suitable for accurate results.

§ 108. **Equipment Required for Microcalorimetric Research.** In microcalorimetry the possibility exists of building the jacket for use either in measurements requiring a thermostat or in those in which adiabatic conditions must be maintained. For this reason, the thermostat should be provided with all necessary devices not only for keeping the temperature

THE CHOICE OF A METHOD

of the thermostat as constant as possible, but also for using the same vessel as an adiabatic jacket.

In Figure 44 a jacket is shown, which is provided with cooler *S* (cold water from the water line) and with air stirrer *U*. If this jacket has to be used as a thermostat, a mechanical stirrer and device *D* for exact determination of the average temperature of the thermostat (Figure 9, § 10) should be employed.

The thermostat should be large enough to accommodate any supplementary vessels and tubes which may be used for the labyrinth flow calorimeter and for any other apparatus required for biological or physiological research. A careful choice of the equipment built or purchased at the start of microcalorimetric investigations will save money if some time later another method must be employed, or if two or three calorimeters must be located in the same thermostat.

At the present time it is difficult to give a definite answer as to whether Tian's multi-stage thermostat might be used. Further investigations carried out on a larger scale are required for proving its applicability. It should be borne in mind that the question discussed in § 9 has not been answered as yet. It concerns protecting the thermoregulator against small changes in its volume, because these changes produce unexpected changes in the average temperature of the thermostat. They might complicate the problem of maintaining the central thermostat in a state of stable thermal equilibrium. If this obstacle were removed, the use of Tian's multiple thermostat would increase considerably the accuracy of microthermal measurements, with either the static, the kinetic, or the labyrinth flow calorimeter methods.

§ 109. **Elimination of Corrections.** On many occasions the writer has pointed out the importance of carrying out microcalorimetric measurements so as to avoid systematic errors. This can be done by using any kind of comparative method, instead of trying to carry out an absolute measurement and to calculate all calorimetric and thermometric corrections. Numerous examples can be given to prove that many systematic or accidental errors have been made because the experimenter did not try to simplify and improve his measurements by avoiding the absolute method of measurements.

In using a comparative method one should explain in detail how he eliminated all or most of the thermometric and calorimetric corrections. If, in spite of all the advantages of comparative measurements, one has some reason to undertake an absolute microcalorimetric measurement, he should describe in detail how he avoided committing errors, and he should prove that he really did not overlook any secondary phenomenon. He should also give all the information regarding how the corrections have been calculated.

No general rules can be given as to which of the comparative methods must be used in any particular case. The experimenter should take into consideration all possibilities and should decide which is the best. If possible, two methods or several modifications of one method chosen should be employed.

§ 110. **Temperature Measurements.** It has been previously (§ 11) pointed out that the temperature of the microcalorimeter cannot be measured by a mercury thermometer. In a number of cases the electrical resistance thermometer cannot be used either. Thermocouples or multi-junction thermopiles are usually employed.

On the contrary, the temperature of the jacket can be measured with mercury or electrical resistance thermometers. Since in most cases the difference between the temperatures of the calorimeter and the jacket are expressed in terms of divisions of the galvanometer scale, the method of comparative measurements has more often been used in temperature readings than in any other kinds of measurement. There always exists the danger, which should never be underestimated, that the heat transfer through the wires connecting the thermojunctions may be the source of a systematic error. In each particular case the experimenter should prove that this error has been eliminated.

Postscript

The main purpose of this book was to give a comprehensive description of the microcalorimetric methods which have been used or discussed. A number of these methods were known to the writer from the literature or from personal discussions with those who had used them. The writer has tried to describe them so as to show all their advantages and disadvantages. He could not give, however, in all cases as many details as he has presented in describing the methods which have been used and examined by himself and his collaborators at the Physicochemical Laboratory of the Institute of Technology, Warsaw. For this reason he preferred to give direct quotations from the papers of other experimenters in order to avoid mistakes.

The writer believes that microcalorimetric methods will be rapidly developed in the postwar period. More applications in different fields will be found, and perhaps, the method of comparative measurements will be used more often than it has in the first stages of the development of calorimetry and thermochemistry.

References

1. Alichanian, A. I., Dzelepov, B. S., *Bull. Acad. Sci. U.S.S.R., Ser Phys.* (19), **5**, 375 (1936).
2. Alichanow/Alichanian/, A. I., *Phys. Zeit. Sowietunion*, **10**, 78 (1936).
3. American Institute of Physics, "Temperature: Its Measurements and Control in Science and Industry" pp. 180-205, Reinhold Publishing Corp., (1941).
4. August, A., Lefèvre, J., *C. R. Soc. Biol.*, **100**, 251 (1928); *Bull. Soc. Hyg. Aliment*, **17**, 445 (1927); **18**, 328 (1930)
5. Avdalian, D. K., *Vsesoyuz. Nauch. Isledovatel. Inst. Tsement*, **2**, 89 (1937).
6. Bayne-Jones, S., *J. Bacteriology*, **17**, 105 (1929).
7. Barrett, E. P., *J. Am. Chem. Soc.*, **55**, 4006 (1933).
8. Bartoszewicz, E., *Bull. Acad. Polonaise Sci.*, **1931A**, 348.
9. Beattie, J. A., Jacobus, D. D., *J. Phys. Chem.*, **34**, 1254 (1930).
10. Beaver, D. J., Beaver, J. J., Jr., *Ind. Eng. Chem.*, **15**, 359 (1923).
11. Benedict, F. G., *Bull. Soc. Hyg. Aliment.*, **11**, 342 (1923)
12. Berenger, Calvet, Mme., *J. Chim. Phys.*, **24**, 325 (1927).
13. Biddle, S. B., Jr., Kelly, J. W., *Proc. Am. Soc. Testing Materials*, **3**, Part II, 571 (1934).
14. Bothe, W., Wollschitt, H., *Arch. Ges. Physiol.* (Plügers), **238**, 168 (1936).
15. Boys, P. V., *Proc. Royal Soc., London*, (A) **77**, 122 (1906).
16. Budnikow, P. P., Gulnova, L., *Kolloid. Zeit.*, **67**, 88 (1934).
17. Calus, H., Smoluchowski, R., *Phys. Rev.*, **58**, 205 (1940); *Roczniki Chem.*, **18**, 411 (1938), *Wiad. Inst. Met.*, **4**, 112, (1937); Czochralski, J., *Wiad. Inst. Met.*, **4**, 45 (1937).
18. Campen van, P., *Z. Elektrochem.*, **35**, 265 (1929).
19. Conn, J. B., Kistiakowsky, G. B., Roberts, R. M., *J. Am. Chem. Soc.*, **62**, 1895 (1940); see also, Lipsett, S. G., Johnson, F. M. G., Maas, O., *J. Am. Chem. Soc.*, **50**, 1030 (1928).
20. Curie, P. Mme., *J. Chim. Phys.*, **22**, 142 (1925).
21. ———, "Recherches sur les Substances Radioactives," p. 100, 2ième Edition, Paris, 1904.
22. Curie, P., Dewar, J., *Comp. rend.*, **138**, 190 (1904).
23. ———, Laborde, A., *Comp. rend.*, **136**, 673 (1903), see also: Ångström, K., *Phys. Zeit.*, **6**, 685 (1905).
24. Czochralski, J., *Schweiz. Arch. Angew. Wiss.*, **6**, 167 (1940).
25. Debye, P., Hückel, E., *Phys. Zeit.*, **24**, 193 (1923).
26. Dickinson, H. C., *J. Wash. Acad.*, **4**, 434 (1914); *J. Res. Nat. Bureau Stand.*, **11**, 189 (1914).
27. Dorabialska, A., Yovanovitch, D. K., *Comp. rend.*, **182**, 1037 (1926); **182**, 1459 (1926).
28. ———, *Roczniki Chem.*, **8**, 475 (1928); *Bull. Acad. Polonaise Sci.*, **1931A**, 521.
29. ———, *ibid.*, **9**, 494 (1929), **9**, 615 (1929).
30. ———, *ibid.*, **10**, 304 (1930).
31. ———, *ibid.*, **11**, 35 (1931); **11**, 467 (1931); **11**, 727 (1931).
32. ———, *ibid.*, **14**, 24 (1934); *Bull. Acad. Polonaise Sci.*, **1934A**, 352. Störba-Böhm, I.S., *Roczniki Chem.*, **12**, 879 (1933) *Collection Czechoslov. Chem. Communications*, **5**, 233 (1933).
33. ———, Niwinski, T., Turska, E., *Roczniki Chem.*, **11**, 727 (1931); *Bull. Acad. Polonaise Sci.*, **1931A**, 512.
34. ———, Turska, E., *J. Chem. Phys.*, **34**, 21 (1937).
35. Duane, W., *Comp. rend.*, **148**, 1443 (1909); **148**, 1665 (1909).
36. Eitel, W., Schwiete, H. E., Wilmanns, K., *Zement*, **27**, 554 (1938).
37. Ellis, C. D., Wooster, W. A., *Phil. Mag.*, **50**, 521 (1925); *Proc. Camb. Phil. Soc.*, **22**, 585 (1925).
38. Ellis, C. D. Wooster, W. A., *Proc. Roy. Soc.*, **A117**, 109 (1927).
39. Evtropiev, K. S., *J. Phys. Chem., U.S.S.R.*, **8**, 130 (1936).

40. Fischer, E., Wrede, F., *Ber. Berl. Akad.*, 1904, 15.
41. ———, ———, *Z. Phys. Chem.*, 69, 234 (1909).
42. Flammersfeld, A., *Zeit. Phys.*, 112, 727 (1939).
43. Fontell, N., *Soc. Sci. Fennica Commentationes, Phys. Math.*, 10, No. 5, 18 (1938).
44. Geer, W. C., *J. Phys. Chem.*, 6, 85 (1902).
45. Giertz-hedstorm, S., *IVA*, 1934, 67.
46. Griffith, R., "Thermostats and Temperature Regulating Instruments" 2nd Edition, London, 1934.
47. Grunwald, A., "Temperatur Messungen and Regelgerate," Berlin, 1934.
48. Gucker, F. T., Jr., *J. Chem. Educ.*, 8, 2398 (1931).
49. ———, Pickard, H. B., Planck, R. W., *J. Am. Chem. Soc.*, 61, 459 (1939).
50. Harkins, W. D., Brown, F. E., *J. Am. Chem. Soc.*, 38, 246 (1916).
51. Hill, A. V., *Proc. Roy. Soc., London*, 111B, 106 (1932); 113B, 356 (1933); 113B, 345, 356, 366, 367, 386 (1933).
52. Iijin, B. V., Kiselew, A. V., *J. Phys. Chem. U.S.S.R.*, 13, 568 (1939).
53. Jaeger, W., Steinwehr, H., *Ber. Phys. Ges.*, 5, 30 (1903); *Ann. Phys.* (4), 21, 23 (1906); *Z. Instr.*, 8, 237 (1906); *Ber. Berl. Akad.*, 1908, 123.
54. ———, ———, *Z. Phys. Chem.*, 135, 305 (1928).
55. Jelinek, B., *Bull. Soc. Chim. (France)*, (5), 4, 1811 (1937).
56. Jombart, F., *Rev. Metal.*, 24, 573 (1937).
57. Junkers, H., *J. Gasbel.*, 50, 520 (1907).
58. Kallauner, O., Burgl, B., *Chem. Listy*, 24, 238 (1935).
59. Kambard, S., Matsui, M., *J. Chem. Ind. Japan*, 34, 94B, 167B, 273B (1931).
60. Keffler, L., *J. Phys. Chem.*, 34, 1006 (1930).
61. ———, Swietoslowski, W., "First Report of the Standing Committee on Thermochemistry of Inter. Union of Chemistry," Paris, Inter. Union of Chemistry, 1934.
62. Kind, V. V., *Prom. Stroitel. Material.*, 2, No. 8, 70 (1940).
63. Kubaschewski, O., Walter, A., *Z. Elektrochem.*, 45, 630 (1939).
64. Lange, E. W., Messner, G., *Naturwiss.*, 33, 521 (1927).
65. ———, Rounsefell, E. O., *Z. Phys. Chem.*, 142A, 351 (1929).
66. ———, Robinson, A. L., *Z. Phys. Chem.*, 148A, 97 (1930), *Chem. Reviews*, 9, 89 (1931) *J. Am. Chem. Soc.*, 52, 2811 (1930), *Z. Elektrochem.*, 36, 772 (1930); see also Robinson, A. L., Gulbransen, E. A., *J. Am. Chem. Soc.*, 56, 2638 (1934); Robinson, A. L., Wallace, W. E., *Chem. Reviews*, 30, 195 (1942), *J. Am. Chem. Soc.*, 63, 958 (1941), Offnut, W. F., *J. Am. Chem. Soc.*, 65, 347 (1943), and Mason, L. S., *J. Am. Chem. Soc.*, 66, 362 (1944).
67. ———, Monheim, J., *Z. Phys. Chem.*, 149A, 51 (1931); 150A, 349 (1931).
68. ———, Streeck, H., *Z. Phys. Chem.*, 151A, 1 (1931); *Naturwiss.*, 19, 359 (1931).
69. ———, Wust, J., *Z. Phys. Chem.*, 116, 161 (1925); *Z. Elektrochem.*, 30, 523 (1924).
70. Lecoin, M., *J. Phys. Rad.* (7), 9, 81 (1938).
71. Lerch, W., Bogue, R. H., *Concrete*, 42, 36-37, 39-42 (1934).
72. ———, *Eng. News.*, 113, 523 (1934).
73. Louginine, W., "Calorimétrie," Moscow, 1905.
74. Makarov, S. Z., Oreshko, V. F., *Bull Acad. Sci., U.S.S.R., Class Sci. Techn.* 1940, No. 2, 49.
75. Martin, L. H., Townsend, A., *Proc. Roy. Soc.*, A170, 190 (1939).
76. Marshall, H., *Chem. News*, 104, 295 (1911).
77. Mason, L. S., *Rev. Sci. Instruments*, 15, 205 (1944).
78. Neary, G. J., *Proc. Roy. Soc.*, 175A, 71 (1940).
79. Noland, T. J., Jr., *Civil Eng.*, 4, 365 (1934).
80. Parr, S. W., *J. Chem. Educ.*, 7, 1199 (1930); *Ind. Eng. Chem.* 18, 1194 (1926); *Instruments*, 3, 71 (1930).
81. Person, C. C., *Ann. Chim. Phys.* (3), 270, (1849); see also Gucker, F. T. Jr., *J. Chem. Educ.*, 8, 2398 (1931).
82. Precht, J., *Ber. Deutsch. Phys. Ges.*, 6, 101 (1904); *Ann. Phys.* (4), 21, 595 (1906); *Ber. Deutsch. Phys. Ges.*, 4, 437 (1906).
83. ———, *Ber.*, 38, 783 (1903).
84. Ray, W. N., Reilley, J., *Chem. News*, 117, 181 (1918).
85. Richards, T. W., Henderson, L. J., Forbes, G. S., *Proc. Am. Acad. Sci.*, 41, 11 (1905); *Z. Phys. Chem.*, 52, 560 (1905).
86. Rieche, H., Gau, R., *Z. Techn. Phys.*, 12, 284 (1931).
87. Rossini, F. D., Deming, W. E., *Wash Acad. Sci.*, 29, 416 (1939).

88. Rump, W., *Z. Physik*, **43**, 258 (1927), see also Magee, J. L., Daniels, F., *J. Am. Chem. Soc.*, **62**, 2825 (1940).
89. Rutherford, E., Barnes, H. T., *Phil. Mag.* (6), **7**, 202 (1904); *Nature*, **68**, 622 (1903).
90. ———, Robinson, H., *Phil. Mag.*, **25**, 314 (1913).
91. Salmoni, R., Schwiete, H. E., *Zement*, **22**, 593 (1933).
92. Schweidler, E., Hess, V. F., *Monatsh. Chem.*, **29**, 853 (1908).
93. Shchukarew, A. N., *Med. exptl. Ukraine*, **1936**, No. 6, 114.
94. Solodkowska, W., Rudowska, K., *Bull. Acad. Polonaise Sci.*, **1932A**, 95.
95. Stenzel, R. W., Morris, S. B., *Ind. Eng. Chem. (Anal. Ed.)*, **6**, 246 (1934); Stior, T. J., *Science*, **73**, 289 (1931).
96. Swietoslawski, W., *J. Am. Chem. Soc.*, **39**, 2595 (1917).
97. ———, Dorabialska, A., *Comp. rend.*, **185**, 763 (1927); *Roczniki Chem.*, **7**, 559 (1927).
98. ———, Bartoszewicz, E., *Bull. Acad. Polonaise Sci.*, **1931A**, 336; **1934A**, 69.
99. ———, Rybicka, S., Solodkowska, W., *Bull. Acad. Polonaise Sci.*, **1931A**, 322; *Roczniki Chem.*, **11**, 65 (1931).
100. ———, Salcewicz, J., *Compt. rend.*, **199**, 935 (1935); *Roczniki Chem.*, **14**, 621 (1934).
101. ———, Keffler, L., *Bull. Acad. Polonaise Sci.*, **1937A**, 546.
102. ———, Popow, M. M., *J. Russ. Phys. Chem. Soc.*, **46**, 935 (1914).
103. ———, *Compt. rend. I Conf. Intern. Chim., Bruxelles*, **1920**, 37; *III Conf. Intern. Chim., Lyon*, **1922**, 109; *IV Conf. Intern. Chim. Cambridge*, **1923**, 56.
104. ———, *Compt. rend., XII Conf. Intern. Chim., Rome*, **1938**, *Bull. Polish Inst. Arts Sci. Am.*, **1**, 351 (1943), **1**, 366 (1943); see also "Thermochemie" v. VII, *Handbuch der Allgemeinen Chemie*, Leipzig, 1928; "Thermochemie," Paris, 1933; *Bull. Acad. Polonaise Sci.*, **1927A**, 33; *J. Chim. Phys.*, **22**, 391 (1925).
105. ———, Salcewicz, J., Usakiewicz, J., Zlotowski, I., Zmaczynski, A., *Compt. rend.*, **196**, 1970 (1933); *Roczniki Chem.*, **14**, 250 (1934); **14**, 301 (1934); **14**, 1474 (1934); **15**, 12 (1935).
106. ———, Rosinski, S., *Przemysl Chem.*, **18**, 590 (1934).
107. ———, Zlotowski, I., *Compt. rend.*, **200**, 660 (1935).
108. ———, *Roczniki Chem.*, **15**, 343 (1935); *Przemysl Chem.*, **19**, 183 (1935); Pomorski, J., **17**, 254 (1937); **17**, 262 (1937); *Ann. Acad. Sci. Techn. Varsovie*, **4**, 168 (1937); **4**, 173 (1937).
109. ———, Czochralski, J., *Wiadom. Inst. Metalurg.*, **3**, 59 (1936).
110. ———, Urbanski, T., Calus, H., Rosinski, S., *Roczniki Chem.*, **17**, 144 (1937).
111. Szentpaly, N., *Sitz. Akad. Wiss., Wien, Math.-Naturw. Klasse, Abt. IIa*, **146**, 223 (1937).
112. Tian, A., *Bull. Soc. Chim., France* (4), **31**, 535 (1922); *J. Chim. Phys.*, **20**, 132 (1923).
113. ———, *Compt. rend.*, **178**, 705 (1924); *J. Chim. Phys.*, **30**, 665 (1933).
114. Waddle, H. M., Imhoff, R. E., *J. Chem. Educ.*, **15**, 191 (1938).
115. Wagner, R., *Z. Biolog.*, **82**, 114 (1924).
116. Ward, A. F. H., *Proc. Cambridge Phil. Soc.*, **26**, 278 (1930); *Proc. Royal Soc.* **A133**, 511 (1931).
117. Welsch, H., *Bull. Soc. Roy. Sci., Liège*, **6**, 73-76, 316-325 (1937).
118. Wertenstein, L., Herszfinkiel, B. H., *J. Phys. Radium*, **1**, 143 (1920).
119. Whipp, B., *Phil. Mag.* (7), **18**, 745 (1934).
120. White, W. P., "The Modern Calorimeter," Chem. Catalog Co., New York, 1927.
121. ———, *Phys. Rev.*, **31**, 149 (1910), *J. Am. Chem. Soc.*, **36**, 1858 (1914).
122. ———, Dickinson, H. C., Mueller, E. F., *Phys. Rev.*, **31**, 159 (1910).
123. Winand, L., *J. Phys. Radium*, **10**, 361 (1930); *J. Phys. Radium*, **8**, 429 (1937).
124. Woods, H., Steinour, H. R., *Ind. Eng. Chem.*, **24**, 1209 (1932).
125. Wrede, F., *Z. Phys. Chem.*, **75**, 92 (1910).
126. Yost, D. M., Garner, C. S., Osborne, D. W., Rubin, T. R., Russel, H. Jr., *J. Am. Chem. Soc.*, **63**, 3488 (1941).
127. Yovanovitch, D. K., *Compt. rend.*, **179**, 163 (1924).
128. ———, Dorabialska, A., *Compt. rend.*, **182**, 1459 (1926).
129. Zlotowski, I., *Compt. rend.*, **199**, 284 (1934); *J. Phys. Radium* (7), **6**, 242 (1935).
130. ———, *Phys. Rev.*, **60**, 483 (1941); Sargent, B. W., *Proc. Roy. Soc.*, **A139**, 659 (1933).

Note: *The author index is arranged in a somewhat unusual manner. The following makes it clear:*

Lazniewski, M., §§ 10, 46, 79, 80, 85, 87

Rump, W., ref. 88, §§ 1, 95

The above indicates that Lazniewski's name was mentioned in the paragraphs listed in spite of the fact that he did not publish his investigations. On the contrary, in §§ 1, 95 reference 88 was given to Rump's paper; his name, however, was not mentioned in the book.

Author Index

The first figures indexed here refer to the References, the second to the number of Paragraphs.

- Alichanow (Alichanian), A. I., ref. 2, § 69
Alichanian (Alichanow), A. I., Dzelepov, B. S., ref. 1, § 69
American Institute of Physics, ref. 3, § 3
Ångström, K., ref. 23, § 29
August, A., Lefèvre, J., ref. 4, §§ 1, 2, 91
Avdalian, D. K., ref. 5, § 95
- Bayne-Jones, S., ref. 6, §§ 1, 2, 29
Barrett, E. P., ref. 7, § 53
Bartoszewicz, E., ref. 8, § 71
Bartoszewicz, E., Swietoslowski, W., ref. 98, §§ 43, 53, 59, 71
Beattie, J. A., Jacobus, D. B., ref. 9, §§ 5, 8
Beaver, D. J., Beaver, J. J., ref. 10, §§ 5, 8
Beaver, J. J., Beaver, D. J., ref. 10, §§ 5, 8
Benedict, F. G., ref. 11, §§ 1, 2, 91
Berenget-Calvet, Mme, ref. 12, §§ 2, 3, 23
Berthelot, M., § 16
Biddle, S. B., Jr., Kelly, J. W., ref. 13, §§ 1, 94, 95
Bogue, R. H., Lerch, W., ref. 11, §§ 1, 95
Bothe, W., Wollschitt, H., ref. 14, §§ 1, 91
Boys, P. V., ref. 15, § 88
Brauner, B., Stérba-Böhm, J., § 43
Brown, F. E., Harkins, W. D., ref. 50, §§ 5, 8
Budnikow, P. P., Gulinowa, L., ref. 16, §§ 8, 94
Bunsen, R., § 35
Burgle, B., Kallauner, O., ref. 58, § 94
- Calvet-Berenger, Mme., ref. 12, §§ 2, 3
Calus, H., Smoluchowski, R., ref. 17, § 84
Calus, H., Czochralski, J., Smoluchowski, J., ref. 17, § 84
Calus, H., Rosinski, S., Swietoslowski, W., Urbanski, T., ref. 110, § 83
- Campen, van, P., ref. 18, § 8
Conn, J. B., Kistiakowsky, G. B., Roberts, R. M., ref. 19, §§ 9, 29
Curie, P. Mme, ref. 20, 21, §§ 9, 14, 16, 18, 25
Curie, P., Dewar, J., ref. 22, § 29
Curie, P., Laborde, A., ref. 23, §§ 28, 30
Czochralski, J., ref. 24, § 84
Czochralski, J., Calus, H., Smoluchowski, R., ref. 17, § 84
Czochralski, J., Swietoslowski, W., ref. 109, §§ 67, 84
- Debye, P., Hückel, R., ref. 25, §§ 49, 51
Deming, W. E., Rossini, F. D., ref. 87, § 22
Dewar, J., Curie, P., ref. 22, § 29
Dickinson, H. S., ref. 26, § 16
Dzelepov, P. S., Alichanian (Alichanow), A. I., ref. 2, § 69
Dorabialska, A., ref. 28, 29, 30, 31, 32, §§ 43, 68
Dorabialska, A., Niwinski, T., Turska, E., ref. 33, § 70
Dorabialska, A., Stérba-Böhm, I. S., ref. 32, §§ 43, 68
Dorabialska, A., Swietoslowski, W., ref. 97, § 58
Dorabialska, A., Turska, E., ref. 34, § 68
Dorabialska, A., Yovanovitch, D. K., ref. 27, § 30
Duane, W., ref. 35, §§ 23, 25, 32, 46, 64
Dzelepov, B. S., Alichanian (Alichanow), A. I., ref. 1, § 69
- Eiter, W., Schwiete, H. E., Wilmanns, K., ref. 36, §§ 1, 95
Ellis, C. D., Wooster, W. A., ref. 37, 38, §§ 2, 33, 69
Evstropiew, K. S., ref. 39, § 2

- Fischer, E., Wrede, F., ref. 40, 41, § 16
 Flammersfeld, A., ref. 42, § 69
 Fontell, N., ref. 43, § 51
 Forbes, G. S., Henderson, L. J., Richards, Th. W., ref. 85, §§ 2, 6, 20, 53, 56, 58
- Gau, R., Rieche, H., ref. 86, § 10
 Garner, C. S., Yost, D. M., Osborne, D. W., Rubin, T. R., Russell, H. Jr., ref. 126, § 5
- Geer, W., ref. 44, §§ 5, 8
 Giertz-Hedstrom, S., ref. 45, §§ 1, 94
 Griffith, R., ref. 46, §§ 5, 8
 Grünwald, A., ref. 47, § 8
 Gucker, F. T., Jr., ref. 48, § 56
 Gucker, F. T., Jr., Pickard, H. B., Planck, R. W., ref. 49, §§ 4, 5, 10, 11, 12, 13, 20, 21, 23, 26, 29, 50, 51, 56, 67, 85
 Gulbrausen, N. E. A., Robinson, A. L., ref. 66, § 50
 Gulinova, L., Budnikow, P. P., ref. 16, § 94
- Harkins, W. D., Brown, F. E., ref. 50, §§ 5, 8
 Henderson, L. J., Forbes, G. S., Richards, Th. W., ref. 85, §§ 2, 6, 21, 53, 56, 58
 Herszfinkiel, B. H., Wertenstein, L., ref. 118, § 30
 Hess, V. F., Schweidler, E., ref. 92, §§ 30, 36
 Hill, A. V., ref. 51, §§ 2, 4, 11, 12, 13, 21, 22, 46, 54, 67, 85
 Hückel, E., Debye, P., ref. 25, §§ 49, 52
- Iljin, B. V., Kiselew, A. V., ref. 52, § 1
 Imhoff, R. E., Waddle, H. M., ref. 114, § 8
- Jacobus, J. J., Beattie, J. A., ref. 9, §§ 5, 8
 Jaeger, W., Steinwehr, H., ref. 53, 54, §§ 16, 18
 Jelinek, B., ref. 55, §§ 8, 54
 Jombert, F., ref. 56, § 5
 Junkerts, H., ref. 57, § 88
 Jurkowski, E., § 8
- Kallauner, O., Burgle, B., ref. 58, § 94
 Kambard, S., Matsui, M., ref. 59, §§ 6, 8
 Kelly, J. W., Biddle, S. B., ref. 11, §§ 1, 94, 95
- Kiselew, A. V., Iljin, B. V., ref. 52, § 1
 Kistiakowsky, G. B., Conn, J. B., Roberts, R. M., ref. 19, §§ 9, 29
 Keffler, L., ref. 60, § 58
 Keffler, L., Swietoslowski, W., ref. 61, 101, §§ 16, 18, 74, 82
 Kind, V. V., ref. 62, § 94
 Kubaschewski, O., Water, A., ref. 63, §§ 5, 67
- Laborde, A., Curie, P., ref. 23, §§ 23, 30
 Lange, E. W., Messner, G., ref. 64, §§ 4, 11, 15, 21, 22, 29, 49, 50
 Lange, E. W., Monheim, J., ref. 67, §§ 4, 21, 22, 49
 Lange, E. W., Rounsefell, E. O., ref. 65, §§ 11, 21, 22, 49, 50
 Lange, E. W., Robinson, A. L., ref. 66, §§ 4, 11, 12, 20, 21, 22, 49, 50, 85
 Lange, E. W., Streeck, H., ref. 68, §§ 4, 11, 21, 22, 49
 Lange, E. W., Wust, J., ref. 69, §§ 4, 21, 22, 49
 Lazniowski, M., §§ 10, 46, 79, 80, 85, 87
 Lecoin, M., ref., 70, § 69
 Lefèvre, T., August, A., ref. 4, §§ 1, 2, 91
 Lerch, W., ref. 71, §§ 1, 94
 Lerch, W., Bogue, R. H., ref. 72, §§ 68, 94
 Louginine, W., ref. 73, §§ 2, 5, 16, 20, 68
- Makarov, S. Z., Oreshko, V. F., ref. 74, § 10
 Malawski, § 82
 Martin, L. H., Townsend, A., ref. 75, § 69
 Marshall, H., ref., 76, § 8
 Mason, L. S., ref. 77, § 8
 Mason, L. S., Robinson, A. L., Wallace, W. E., ref. 66, § 50
 Matsui, M., Kambard, S., ref. 59, § 8
 Monheim, J., Lange, E. W., ref. 67, §§ 4, 21, 22, 49
 Messner, G., Lange, E. W., ref. 64, §§ 4, 11, 15, 21, 22, 29, 49
 Morris, R. W., Stenzel, R. W., ref. 95, § 94
- Neary, G. J., ref. 78, § 69
 Niwinski, T., Dorabialska, A., Turska, E., ref. 33, § 70
 Noland, T. J., ref. 79, § 94

- Offnut, W. E., Robinson, A. L., Wallace, W. E., ref. 66, § 50
- Oreshko, V. F., Makarov, S. Z., ref. 74, § 10
- Osborne, D. W., Garner, C. S., Yost, D. M., Rubin, T. R., Russell, H., Jr., ref. 126, § 5
- Parr, S. W., ref. 80, § 2
- Person, C. C., ref. 81, § 56
- Pickard, H. B., Gucker, F. T., Planck, R. W., ref. 49, §§ 4, 5, 10, 11, 12, 13, 20, 21, 23, 26, 29, 50, 51, 56, 67
- Planck, R. W., Gucker, F. T., Pickard, H. B., ref. 48, §§ 4, 5, 10, 11, 13, 20, 21, 23, 26, 29, 50, 51, 56, 67
- Pomorski, J., Swietoslowski, W., ref. 108, §§ 95, 96, 97
- Popow, M. M., Swietoslowski, W., ref. 102, § 16
- Precht, J., ref. 82, 83, § 35, 36
- Precht, J., Runge, C., § 36
- Ray, W. N., Reilley, J., ref. 84, §§ 6, 8
- Reilly, J., ref. 84, §§ 5, 8
- Richards, Th. W., Henderson, L. J., Forbes, G. S., ref. 85, §§ 2, 6, 20, 53, 56, 58
- Rieche, H., Gau, R., ref. 86, § 10
- Roberts, R. M., Conn, J. B., Kistiakowski, G. B., ref. 19, §§ 9, 29
- Robinson, A. L., Gulbrausen, E. A., ref. 66, § 50
- Robinson, A. L., Lange, E. W., ref. 66, §§ 4, 11, 12, 20, 21, 47, 50
- Robinson, A. L., Wallace, W. E., ref. 66, § 50
- Robinson, A. L., Wallace, W. E., Mason, L. S., ref. 66, § 50
- Robinson, A. L., Wallace, W. E., Offnut, W. F., ref. 66, § 50
- Rosinski, S., Swietoslowski, W., ref. 106, §§ 73, 97
- Rosinski, S., Calus, H., Swietoslowski, W., Urbanski, T., ref. 110, § 83
- Rossini, F. D., Deming, W. E., ref. 87, § 22
- Rounsefell, E. O., Lange, E. W., ref. 65, §§ 22, 49
- Rubin, T. R., § 50
- Rubin, T. R., Garner, C. S., Yost, D. M., Osborne, D. W., Russell, H., Jr., ref. 126, § 5
- Rudowska, K., Solodkowska, W., ref. 94, § 72
- Rump, W., ref. 88, §§ 1, 95
- Runge, C., Precht, J., § 36
- Russell, H., Jr., Garner, C. S., Yost, D. M., Osborne, D. W., Rubin, T. R., ref. 126, § 5
- Rutherford, E., Barnes, H. T., ref. 89, § 31
- Rutherford, E., Robinson, H., ref. 90, § 31
- Rybicka, S., Solodkowska, W., Swietoslowski, W., ref. 99, §§ 59, 61, 68, 70
- Salcewicz, J., Swietoslowski, W., Usakiewicz, J., Zlotowski, I., Zmaczynski, A., ref. 105, §§ 39, 44
- Salcewicz, J., Swietoslowski, W., ref. 100, §§ 67, 74, 81
- Sargant, B. W., ref. 130, § 69
- Salmoni, R., ref. 91, §§ 54, 94
- Schminke, K. H., § 50
- Schweidler, E., Hess, V. F., ref. 92, §§ 30, 36
- Schwiete, H. E., Eitel, W., Wilmanns, K., ref. 36, §§ 1, 95
- Schukarew, A. N., ref. 93, §§ 2, 45
- Solodkowska, W., ref. 94, § 72
- Solodkowska, W., Rudowska, K., ref. 94, § 72
- Solodkowska, W., Rybicka, S., Swietoslowski, W., ref. 99, §§ 59, 61, 68, 70
- Steinwehr, H., Jaeger, W., ref. 53, 54, §§ 16, 18
- Steinour, H. W., Woods, H., ref. 124, §§ 1, 95
- Stenzel, R. W., Morris, S. B., ref. 91, § 94
- Stërba-Böhm, J., Brauner, B., § 43
- Stërba-Böhm, J., Dorabalska, A., ref. 32, §§ 23, 68
- Stior, T. J., ref. 95, § 8
- Streeck, H., Lange, E. W., ref. 68, §§ 5, 21, 22, 49
- Smoluchowski, M., Calus, H., ref. 17, § 84
- Smoluchowski, M., Calus, H., Czochral-ski, J., ref. 17, § 84
- Swidzinski, W., § 8
- Swietoslowski, W., ref. 96, 103, 104, 108, 109, §§ 7, 8, 14, 16, 17, 22, 24, 53, 55, 59, 68, 89, 95, 96

- Swietoslowski, W., Bartoszewicz, E., ref. 98, §§ 43, 53, 59, 71
- Swietoslowski, W., Czochralski, J., ref. 109, § 84
- Swietoslowski, W., Dorabialska, A., ref. 97, § 58
- Swietoslowski, W., Keffler, L., ref. 61, §§ 1, 16, 18, 67, 74, 82
- Swietoslowski, W., Pomorski, J., ref. 102, § 97
- Swietoslowski, W., Popow, M. M., ref. 102, § 16
- Swietoslowski, W., Rosinski, S., ref. 106, §§ 73, 97
- Swietoslowski, W., Rybicka, S., Solodkowska, W., ref. 99, § 59
- Swietoslowski, W., Calus, H., Rosinski, S., Urbanski, T., ref. 100, § 83
- Swietoslowski, W., Salcewicz, J., ref. 100, §§ 67, 74
- Swietoslowski, W., Salcewicz, J., Usakiewicz, J., Zlotowski, I., Zmaczynski, A., ref. 105, §§ 39, 44
- Szentpaly, N., ref. 111, § 43
- Tian, A., ref. 112, 113, §§ 9, 11, 13, 23, 26, 41, 53, 55, 85, 112
- Townsend, A., Martin, L. H., ref. 75, § 69
- Turska, E., Dorabialska, A., Niwinski, T., ref. 33, § 70
- Turska, E., Dorabialska, A., ref. 34, § 68
- Urbanski, T., Calus, H., Rosinski, S., Swietoslowski, W., ref. 110, § 83
- Usakiewicz, J., Salcewicz, J., Swietoslowski, W., Zlotowski, I., Zmaczynski, A., ref. 105, §§ 39, 44
- Waddle, H. M., Imhoff, R. E., ref. 114, § 8
- Wagner, R., ref. 115, §§ 1, 2, 4
- Wallace, W. E., Robinson, A. L., ref. 66, § 50
- Wallace, W. E., Robinson, A. L., Mason, L. S., ref. 66, § 50
- Wallace, W. E., Robinson, A. L., Offnut, W. F., ref. 66, § 50
- Ward, A. F. H., ref. 116, §§ 8, 9, 11, 12, 13, 21, 22, 46, 53
- Water, H., Kubaschewski, O., ref. 63, §§ 5, 67
- Welsch, H., ref. 117, § 1
- Wertenstein, L., Herszfkniel, B. H., ref. 118, § 30
- Whipp, B., ref. 119, § 55
- White, W. P., ref. 120, 121, 122, §§ 2, 5, 13, 50
- Wilmanns, K., Eitel, W., Schwiete, W., ref. 36, §§ 1, 94
- Winand, L., ref. 123, § 33
- Woods, H., Steinour, H. H., ref. 124, §§ 1, 94
- Wooster, W. A., Ellis, C. D., ref. 37, 38, §§ 2, 33
- Wrede, F., ref. 125, § 16
- Wrede, F., Fischer, E., ref. 40, 41, § 16
- Wust, I., Lange, E. W., ref. 69, §§ 4, 21, 22, 49
- Yost, D. M., Garner, C. S., Osborne, D. W., Rubin, T. R., Russell, H., Jr., ref. 126, § 5
- Yovanovitch, D. K., ref. 127, §§ 18, 25, 29, 30, 64
- Yovanovitch, D. K., Dorabialska, A., ref. 128, §§ 29, 30
- Zlotowski, I., ref. 129, 130, §§ 25, 34, 68, 69
- Zlotowski, I., Salcewicz, J., Swietoslowski, W., Usakiewicz, J., ref. 105, §§ 39, 44
- Zlotowski, I., Swietoslowski, W., ref. 107, §§ 34, 89
- Zmaczynski, A., Salcewicz, J., Swietoslowski, W., Usakiewicz, J., Zlotowski, I., ref. 105, §§ 39, 44
- Zubow, P., § 16

Subject Index

The figures indexed here refer to the numbers of Paragraphs.

- Absorption, heat of, 53, 71
—, of alpha particles, 68
—, of beta particles, 68
—, curve of gamma rays, 68, 69
Absolute measurements, 17
Adiabatic microcalorimeter, adiabatic control, 50, 71
—, advantages and disadvantages, 105, 106
—, application in biology, 72
—, energy equivalent determination, 64
—, for measuring: the heat of adsorption, 77; the heat of hardening of cement, 73; the heat of vaporization, 71
—, precision of measurements, 66
—, use in radiology, 68, 69
Aging of aluminum alloys, heat produced by, 84
Air, use in labyrinth flow calorimeter, 92, 99
Alpha particles, heat of absorption, 68
—, removal of their influence in labyrinth device, 69
Artillery powder, change in stability when heated, 83
—, properties of newly prepared, 83
—, thermal stability, 83
Assymetry of cooling and heating curves, 86, 87
Average temperature of a thermostat, 10
—, determination of, 10
Benzoic acid, standard in thermochemistry, 16
Beta particles, absorption in the labyrinth calorimeter, 69
—, heat of absorption, 68, 69
Calorimeter, adiabatic, 56, 57, 58
—, ice, 35, 36, 37, 39
—, for beta radiation, 69
Calorimeter—Cont.
—, for gamma radiation, 33, 69
—, for measuring the heat of dilution, 50
—, labyrinth flow, 88, 89, 90
—, twin differential, 22, 32
—, twin for energy equivalent determination, 22
—, with adiabatic jacket, 56, 57, 58
—, with isothermal jacket, 75, 76, 77, 78, 79
—, with ordinary insulation, 28, 31, 32
Cement, heat of hardening, 73, 95
—, thermal characteristics, 95
—, typical curves of heat development, 95
Choice of the method, 102, 103, 104, 105, 106, 107, 108, 109, 110
Classification of thermal processes, 2
— of long duration, 2
— of short duration, 2, 4
Comparative measurements, 14, 15
—, application when the object produces heat, 86, 87
—, application in the adiabatic method, 64
—, application in the kinetic method, 86, 87
—, application in microcalorimetry, 18
—, application in physical chemistry, 14
—, application in the static method, 78
—, application in thermochemistry, 16
—, compensation method, 23, 29
—, elimination of the corrections, 20
—, successive method, 24
—, using labyrinth flow calorimeter, 93
—, using twin calorimeters, 70
Constant temperature room, 7
Correction for heat gains and losses, 26
—, its elimination by comparative measurements, 18, 20, 23, 29, 64, 70, 78, 86, 87

- Curve, cooling and heating of thermally active substance, 75
- , cooling and heating of thermally inert object, 76
- , symmetry and assymetry of cooling and heating curves, 86
- , typical for different thermal processes, 3
- Device for measuring the average temperature of the thermostat, 10
- Dilution of diluted electrolytes, heat produced, 49, 50
- of diluted nonelectrolytes, heat produced, 49, 50
- Elimination of calorimetric corrections, 18, 20, 23, 24, 26, 27, 70, 86, 87
- of the influence of secondary phenomena, 16
- of thermometric corrections, 14, 16, 17, 18, 19
- Equilibrium, thermal, in adiabatic calorimeter, 67
- , —, in Duane calorimeter, 32
- , —, in ice calorimeter, 38
- , —, in the static method, 78
- Equipment required for microcalorimetric measurements, 108
- Errors, systematical in thermochemistry, 14, 16
- Galvanometers, Paschen's, its suspension, 50
- , used in microcalorimetry, 13, 50, 54, 55
- , with amplification, 54, 68
- Germination of seeds, measuring of heat, 72
- Half period cooling and heating time, 75, 80
- Heat of adsorption, 50, 71
- of aging of aluminum alloys, 84
- of dilution of electrolytes and nonelectrolytes, 49, 50
- of germination of seeds, 72
- produced by hardening of cement, 95
- produced by mechanical deformation of lead, 82
- produced by stimulated nerve, 54
- Heat of adsorption—Cont.
- produced by vaporization of volatile liquids, 71, 98
- Ice calorimeter, advantages and disadvantages, 45
- , formation of new ice layer, 40
- , formation of microfilm of water, 40
- , for microthermal measurements, 42, 43
- , secondary phenomena, 38
- , use in radiology, 35, 36
- Inertness of calorimeter system, 63
- Jacket, adiabatic, 6, 106
- , isothermal, 6, 107
- , insulated, 5
- , multi-, 9
- , submarine, 50
- Kinetic method of measuring the heat, 79, 80, 86, 87
- Labyrinth flow calorimeter, 88
- , application in biology, and physiology, 99, 100
- , application in cement industry, 95
- , application for measuring the heat of vaporization, 98
- , calibration of, 93
- , elimination of correction for heat losses, 93
- , protection against heat losses, 89, 90
- , use of other liquids than water, 92, 99
- , use of air, 92, 99
- Measurements, absolute, 17
- , comparative, 14, 15, 16, 17, 18
- , elimination of corrections, 19, 20
- Migration of ice in ice calorimeter, 38, 41, 45
- Multistage thermostat, 9
- Nerve, heat produced by, 55
- Parasitic current, 13
- Peltier's effect, 20, 23, 32, 46
- Physicochemical standard, 15
- Potentiometer, recording, 50
- Radiation of radioactive elements, heat of absorption of, 28, 29, 31, 33, 69
- , heat of absorption of alpha particles, 68, 69

- Radiation of radioactive elements—Cont.
 —, heat of absorption of beta particles, 68, 69
 —, heat of absorption of gamma rays, 33, 69
- Recording device for labyrinth flow calorimeter, 100
 —, for maintaining the adiabatic course of heating, 50
- Reference substances, 25, 30, 41, 42
- Relay, reducing the sparking, 8
- Screen, for absorption of, alpha particles, 33, 68, 69
 —, —, beta particles, 33, 68, 69
 —, —, gamma radiation, 33, 68, 69
- Standards in microcalorimetry, 30, 41, 42, 43, 62, 84
 — in physical chemistry, 15
 — in thermochemistry, 16
- Static method of measuring microthermal effects, 78
- Submarine jacket, 50
- Systematic errors, calorimetric, 16
 —, in microcalorimetry, 17
 —, in thermochemistry, 16
 —, methods of their elimination, 18
 —, resulting from secondary phenomena, 16
 —, thermometric, 16
- Thermal equilibrium, in adiabatic calorimeter, 67
 —, in Duane's ether calorimeter, 32
 —, in ice calorimeter, 38
 —, in massive thermally active block, 78
- Thermal processes, classification, 2
 —, composed of several processes, 3, 95, 96, 97
 —, of adsorption, 3
 —, of evaporation, of liquids, 3, 98
 —, of hardening of cements, 3, 95, 96
 —, of long duration, 2, 3, 74
- Thermal processes—Cont.
 —, of short duration, 4, 21, 49, 50, 53, 54
 —, producing constant amount of heat, 3
 —, with sharp starting and ending points, 3, 71
- Thermally active substances, 76
 — inactive substances, 75
 —, methods of examination, 78, 79
- Thermocouples, for compensation by Peltier's effect, 46
 —, multijunction, 12, 50, 53, 54, 55
 —, use in microcalorimetry, 12, 50, 53, 54, 55
- Thermometer, electrical resistance, 11, 31
 —, mercury, 11
- Temperature measurements, by using, electrical resistance thermometers, 11, 31
 —, by using mercury thermometers, 12
 —, by using thermocouples, 12
 —, by using thermopiles, 12, 46, 50, 53, 54, 55, 110
- Thermoregulators, 8
- Thermostat, for microcalorimetric measurements, 6
 —, fluctuations in average temperature, 10
 —, its heating, 6
 —, its stirring, 6
 —, multijacket, 9
 —, volume of, 10
- Twin calorimeters, adiabatic, 50, 65, 70
 —, energy equivalent determination, 22
 —, ether, 32
 —, for measuring the heat of dilution, 50
 —, used in radiology, 28, 29, 30, 31, 32
 —, with electrical resistance thermometers, 31
- Vaporization, measuring the heat of, 71
 98
- Water meter, 95

