

UNIVERSAL
LIBRARY

OU 160081

UNIVERSAL
LIBRARY

Osmania University Library.

.....Hydari. Collection

C. No
Accession No. 621.38.5

A. No 5577

Call No. 93370

FR. W. GUST

TELEPHONES AND TELEPHONY



SIEMENS

SIEMENS (INDIA) LTD. · CALCUTTA

P. O. BOX No. 2109

BOMBAY, P. O. BOX No. 898 · LAHORE, P. O. BOX No. 147

Third, revised edition
Copyright 1935 by Fr. W. Gust

Contents.

	Page
Preface	5
The Fundamentals of Telephony	6
The Process of Transmission	8
Apparatus for Speaking and Listening. (Telephone Equipment for Two Stations)	10
The Subscriber's Apparatus (Subscriber's Station)	10
Telephone Equipment for Several Parties.	15
Telephone Equipments without Central Exchange	15
Telephone Equipments with Central Exchange	17
Manual Exchange Systems	18
Automatic Systems	20
The Switches in an Automatic System	25
The Mechanics of the Switches	25
Multipling, the Multiple	34
What is Preselection? Preselector and Call-finder	36
The Building up of a Connection in Larger Systems	38
Group Selection, Second Preselection	38
Private Branch Exchange Systems (Concern Telephone Systems)	44
Intercommunicating Systems. (Series-connected Systems)	47
Private Branch Exchange Systems with Central Exchange Equipment	55
Manual P.B.X. Systems.	55
Automatic P.B.X. Systems	64
Private Branch Exchanges on the Key-sender System	74
Fully Automatic Private Branch Exchange Systems	79
Private Branch Exchanges on the Neha System	81
Neha Relay Exchanges for 1 Exchange Line and up to 4 Extensions	83
Neha Relay Exchanges for 1 Exchange Line and 2 Extensions	88
Neha Relay Exchanges for 1 Exchange Line and 6 to 10 Extensions	89
Neha Relay Exchanges for 2 Exchange Lines and up to 10 Extensions	90
Neha Rotary-switch Exchanges for 2 to 5 Exchange Lines and up to 27 Extensions	93
Large Neha Exchange with Unlimited Capacity	104
Trunking	112
Selective Ringing Telephones	118

	Page
Auxiliary Apparatus	123
Conference Telephones	123
Conference-call Equipment for Inclusion in P.B.Xs.	125
Staff-finding System	127
Connecting Equipment for Privileged Subscribers (Principal and Secretary Stations)	129
“Engaged” Lamp (Conference Indicator) with Remote Control	131
Deputy’s Line	132
Transfer Equipment	132
Testing and Supervisory Equipment	133
Current Supply Equipment	136
The Planning of a Telephone System	141
Appendix of Illustrations	147

Preface.

The last (second) edition of "Telephones and Telephony" appeared in May, 1932. Since then Siemens & Halske have brought out various new developments, for which space had to be found in this third edition.'

Of particular interest was the development in the sphere of private branch exchanges.

Here the Neha principles have finally established themselves; to-day they are without doubt representative of modern German P.B.X. principles. To the description of these principles, therefore, a correspondingly large amount of space is devoted.

The object of this work, to present a review of certain spheres of telephone engineering in a readily comprehensible form, applies also to this edition. I have, therefore, kept the same kind of description and illustrations of the two last editions which have met with approval.

Berlin-Siemensstadt, October, 1935.

Fr. W. Gust.

The Fundamentals of Telephony.

By means of the telephone acoustic effects are transmitted over any desired distance with the help of electricity and suitable transmission apparatus.

Every transmission system consists in principle of the three parts: transmitter, receiver and conductor.

In the telephone, from the economic and cultural point of view certainly one of the most important systems of transmission, the microphone is the transmitter. Reception is effected by means of the receiver. The metallic connection between the microphone and the receiver is the conductor. On the subject of wireless telephony, in which there is no metallic connection between the transmitter and the receiver, no discussion will be undertaken in this work.

Microphone

The microphone consists of the diaphragm, which is a thin disc of carbon, and a carbon back-plate. Between the diaphragm and the back-plate suitable material is used to form a chamber, which is partly filled

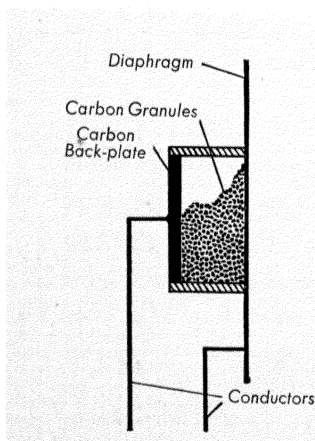

Schematic Diagram.

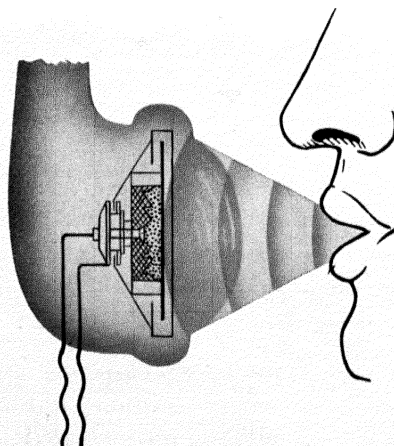

Microphone.

Method of Operation.

with very fine grains of carbon, the carbon granule. The whole is enclosed in a metal capsule, the front of which is so shaped that the rather fragile carbon diaphragm is protected against mechanical damage without obstructing or impeding the passage of the sound waves to it.

The receiver has a diaphragm of sheet-iron and a magnet, which carries a winding of fine copper wire. The magnet system is likewise housed in a metal capsule, and the diaphragm is so arranged that to

Receiver

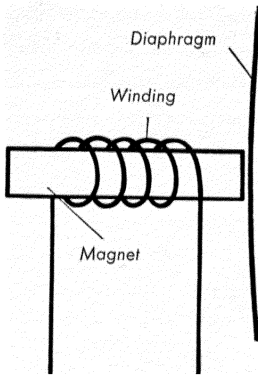

Schematic Diagram.

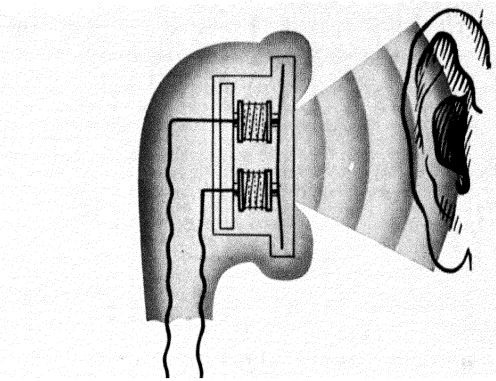

Receiver.

Method of Operation.

a certain extent it forms a cover for this capsule. The tiny gap between the magnet poles and the diaphragm can be regulated by means of an adjusting device.

The conductor, the metallic connection between the microphone and the receiver, generally consists of copper wire. This, however, is not absolutely essential. If the conductor is of some other metal, e.g., aluminium or iron wire, its shorter range must be counterbalanced by a suitable increase in the cross-sectional area or by some other technical means (e.g., repeaters).

Conductor

In most cases the current supply is provided by means of accumulator batteries, which can be recharged again and again. The principles of charging apparatus have been the subject of considerable development. Modern charging equipments have been extensively automatised. For small selector installations without auxiliary apparatus primary cells are frequently used; these are replaced, when they are exhausted. For automatic systems with relay selectors mains supply units have been used with considerable success. The working voltage varies with the different systems. The smallest systems operate on 3 volts; for larger systems voltages of from 12 to 60 are used.

Current Supply

The Process of Transmission.

How then is transmission carried out by means of the telephone? It is well known that the sounds perceived by our ears are oscillations of the air, i. e., sound waves, the number (frequency) of which depends on the pitch, and the oscillation width (amplitude) of which depends on the tone strength. The spoken word consists, especially if the overtones or characteristic frequencies are also taken into consideration, of an

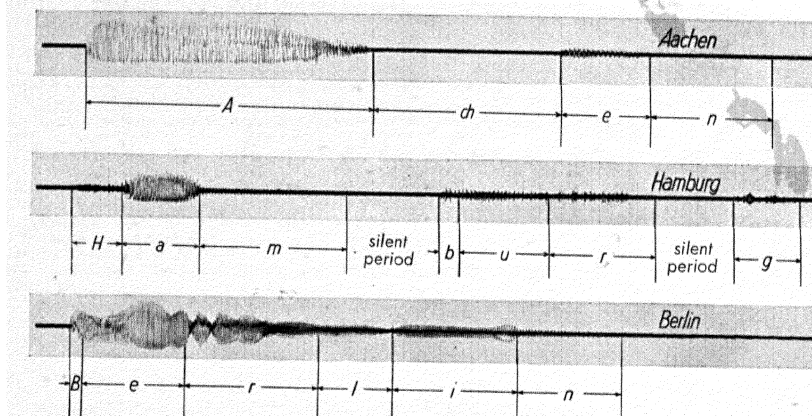

Oscillographically recorded sound pictures of the words Aachen, Hamburg, Berlin.

extraordinarily complicated frequency mixture, by which certain sensations (the auditory sensation) are produced in our ears. When such sounds impinge upon the diaphragm of the microphone, they are converted into oscillations, which in their number (per second) and width are similar to those of the sound waves that impinged on the microphone. The position of the carbon granules contained in the microphone chamber is being continually altered by the vibrations emanating from the diaphragm, and this gives rise to a greater or smaller number of points of contact between the individual carbon particles. These variations in contact have the effect of a variable resistance and thus affect the strength of the electrical current that is continuously flowing in the conductor, and therefore also through the microphone. When the diaphragm swings against the capsule, the carbon particles are pressed more closely together, the resistance becomes less and the current flow consequently greater. On the return oscillation of the diaphragm the process is reversed. The oscillations of the diaphragm give rise to current variations, which in

their frequency and amplitude are similar to the sound waves impinging on the microphone.

What then has happened in the microphone (transmitter)? Sound waves have been converted by the microphone into current variations. In this process an amplifying effect is also obtained, in that the microphone amplifies the applied sound energy about a hundredfold and passes it on as electrical energy.

The current variations are carried via the conductor to the receiver (telephone). The permanent magnet of the receiver is surrounded by a coil, by which it is magnetised with varying intensity in very rapid alternations. This magnetisation causes it to attract in the same rapid alternations and to a greater or less extent the diaphragm, which lies in its magnetic field and is therefore subjected to a magnetic effect of varying intensity. Thus there are set up in the receiver diaphragm oscillations, whose characteristics correspond to the variations of the electrical current in the line and therefore also to the oscillations of the sound waves that impinged on the microphone. The oscillations of the receiver diaphragm are transmitted to the surrounding air. This gives rise to air oscillations which, when of sufficient strength, are perceived by our ear and conducted by the ear's own diaphragm system (ear-drum) to the auditory nerves and produce the auditory sensation.

What then has happened in the transmission system? Sound waves are converted by the microphone into current variations. The current

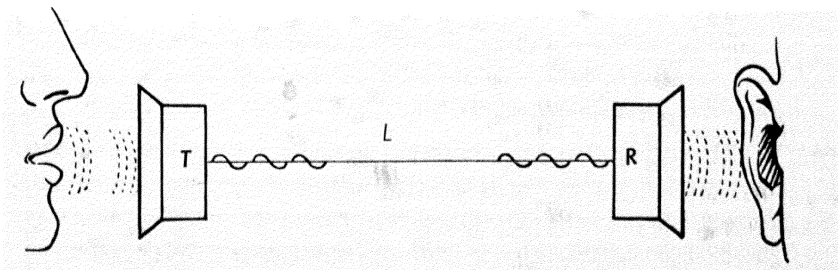

Schematic diagram of the transmission principle.

T = Transmitter (Microphone). L — Metallic Conductor. R = Receiver.

variations proceed along the conductor to the receiver and are there re-converted into air oscillations (sound waves).

These are in brief outline the most elementary physical rudiments essential to the comprehension of the transmission process.

Apparatus for Speaking and Listening. *(Telephone Equipment for Two Stations.)*

A conversation consists of speaking and listening. In a transmission system, therefore, each participator in the conversation has to be provided with a microphone and a receiver. Such an arrangement of apparatus, accompanied by a suitable calling device (bell or buzzer), constitutes a telephone system for two stations.

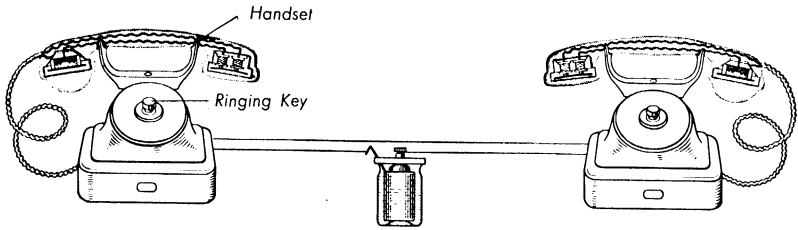

Telephone system for two subscribers.

Such very small systems are again being used to an extraordinarily large extent, especially in recent times. To meet this demand, Siemens & Halske have produced a special type of station, the "Converser".

The Subscriber's Apparatus (Subscriber's Station).

The exchange equipment (abbreviated: exchange), the line network (network) and the subscribers' stations (stations) together form the complete telephone system.

General

The stations thus acquire a special significance, because the exchange equipment in the system is directly controlled by them. Insufficient maintenance and errors in manipulation reduce the operating efficiency of the whole system. That is quite an important point of view for the designer and necessitates, in addition to a simple method of operation that excludes as far as possible errors in manipulation, easy maintenance (ready cleaning). Attractive external shapes are, however, also demanded. Technically essential and architectural requirements must, therefore, be well attuned to one another. Of equal importance is the choice of materials and the consideration of the costs, which play their part in affecting the economy of the whole system.

The telephone station is the subscriber's apparatus resulting from the assembly of the microphone, the receiver, the calling device and the other accessories. The microphone and the receiver are built into a handle, known as a handset or microtelephone, in such a way that when in use the receiver lies against the ear and the microphone is so placed in front

*Handset
(Microtelephone)*

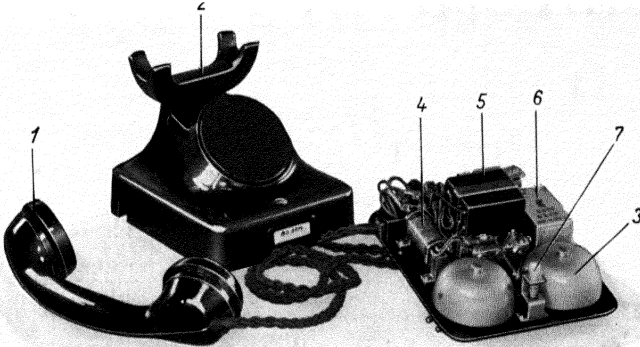

Subscriber's apparatus (Station).

- | | |
|----------------------------|-------------------------------------|
| <i>1 = Handset</i> | <i>5 = Interference-eliminating</i> |
| <i>2 = Handset Carrier</i> | <i>Condenser</i> |
| <i>3 = Bell</i> | <i>6 = Condenser</i> |
| <i>4 = Induction Coil</i> | <i>7 = Farthing Key</i> |

of the mouth that as many as possible of the sound waves produced by the speech can impinge upon the microphone diaphragm. This effect is assisted by a suitable shaping of the mouthpiece, behind which the microphone lies.

The funnel-type mouthpiece formerly in common use merely acted as a sound-catcher. As a result of its special shape the recently designed mouthpiece has in addition to its sound-pressure amplifying effect the characteristic of conducting the higher frequencies to the microphone especially well. For this purpose, however, the mouthpiece must be so constructed that the so-called extraneous noises, such as machine or street noises or the conversation of other speakers in the same room, are as far as possible prevented from reaching the microphone diaphragm. Contrary to previous practice the channels in the microphone mouthpiece are, therefore, arranged diagonally across the mouth. By this means and

by means of the new noise-damping circuit (special circuit arrangement of the receiver and the microphone) a comprehensive suppression of extraneous noises has been achieved.

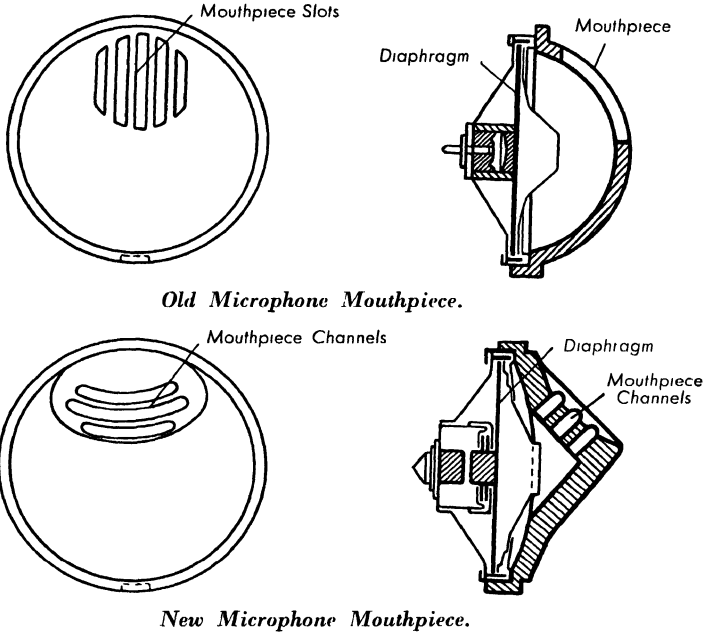

The shape of the handset and its other constructional details are of considerable importance to the transmission system from the electro-acoustic point of view. After making careful measurements of the head-

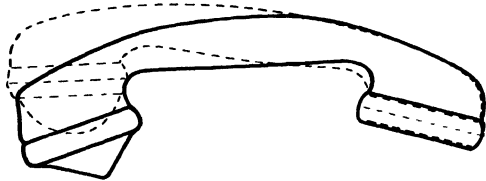

----- old, ——— new
Old and new shape of handset.

shapes of 5000 individuals, Siemens & Halske have, therefore, produced a new type of handset, which has an adaptability factor of 98·5 p. c., i. e., for 98·5 p. c. of the users of the new Siemens station the handset is “made

to measure". A comparison with the earlier type shows in addition to a reduction in the distance between the middle of the receiver cap and the middle of the microphone mouthpiece a greater curvature of the handle, whereby the position of the microphone with respect to the mouth is made more satisfactory.

Finally, the handle has been given a rounded triangular cross-section, so that it "lies well in the hand" and produces no signs of fatigue even when held for a considerable period.



Old

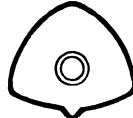

New

Cross-section through the handle of the old and new handset.

Microphone and Receiver

By far the most important portions of the station are the microphone and the receiver. On them depend the degree of intelligibility, the range and in fact, the quality of the whole transmission system. Formerly the so-called intelligibility standard, i. e., the percentage of syllables correctly apprehended, stood at about 74 p.c. Tests with the new Siemens & Halske microtelephone showed an intelligibility standard of about 82 p.c. This important improvement in efficiency may to the same extent be attributed to the above-mentioned remodelling of the handset and to the improved transmission properties of the new microphone.

The new microphone transmits a frequency band from about 300 to 3000 cycles per second (i. e., sound oscillations or current variations per second). Though higher and lower frequencies do indeed have an effect on the sound timbre, they have none on the intelligibility of the speech. The new microphone is also characterised by the fact that it achieves an extensive uniformity in the transmission of the individual frequencies, i. e., that as a result of the elimination of the so-called resonance points all the frequencies lying in the speech transmission range are transmitted uniformly. Previously it has been possible to approach this ideal of a microphone only by sacrificing a certain amount of volume. Further important characteristics of the new microphone are the suppression of the contact noises emanating from the microphone and a considerable degree of independence on position, which is achieved by the use of immersed electrodes.

It was also possible to increase somewhat the efficiency of the new Siemens & Halske receiver as compared with the old type. Of importance also is the new receiver's independence of temperature. This is achieved by tensioning the diaphragm between materials with the same coefficient of linear expansion. The earlier arrangement occasionally caused the diaphragm to be drawn tight to the magnet poles.

Case The new instrument case is made entirely of moulded material and its essential distinguished lines are an architectural masterpiece. It is intentionally built on the basic shape of the earlier Siemens instrument, which was manufactured to an extent of more than a million items and was extraordinarily well received throughout the world as a German quality product.

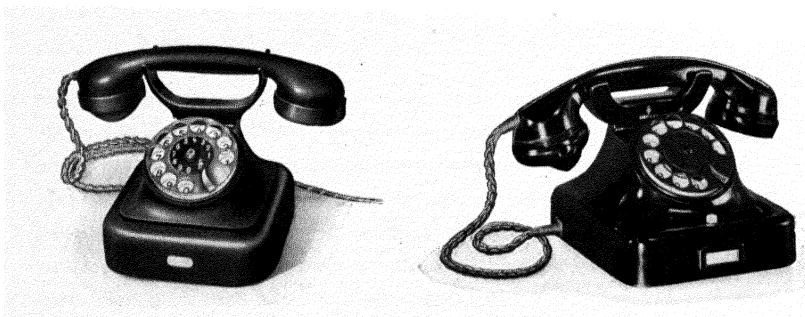

Old

New

Old and new types of automatic instruments.

Another feature pleasing to the eye is the rectangular shape of the base, which in the earlier instrument was square and, therefore, did not always give satisfaction. The new Siemens & Halske model again embodies the moving cradle, i. e., when the receiver is lifted, the handset-carrier itself effects the switching from the rest or called position to the speaking position. After numerous careful tests with other switching arrangements the conclusion was reached that from the service point of view the cradle switch is to be preferred. Attractive though it was to adopt some method of switching that is simpler from the manufacturing point of view, e. g., pin switching with a fixed handset-carrier, Siemens & Halske nevertheless thought that in the interests of the reliability of the instruments it was inadvisable to retain this method.

Telephone Equipment for Several Parties.

According to present-day ideas regarding suitable service organisation all sections of a concern should as far as possible be given the facility of communicating with one another by telephone. That lightens the conduct of business and renders the service more elastic.

Telephone equipments for several subscribers are generally so constructed that the connections are set up from a central point, the so-called exchange. There are also, however, systems having no central exchange; the connections are then set up by each individual subscriber himself. A distinction is, therefore, drawn between:

- Telephone systems without a central exchange and
- Telephone systems with a central exchange.

Telephone Equipments without Central Exchange.

The typical characteristics of such a system lie in the design of the instruments and in the line network. In addition to the microphone, the receiver and the calling device the instruments are equipped with all the switching elements that are necessary for setting up connections with any other desired subscriber on the system, without having to claim the

Intercommunicating Instruments

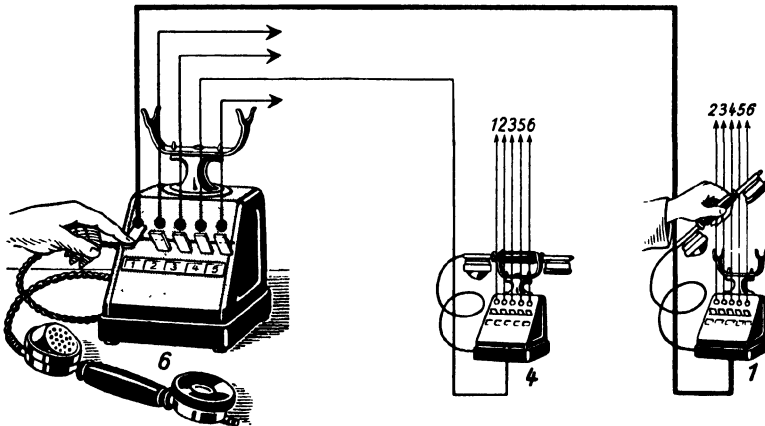

*Schematic diagram of an intercommunicating system.
Subscriber No. 6 has called station 1 by pressing line key 1.
In the same way stations 2, 3, etc. can be reached.*

services of a mechanically or manually operated exchange equipment. The line network is so constructed that every station is connected with every other by a separate direct line. If, for example, such a system has ten subscribers, then from each of the ten stations there are nine lines running to the other nine stations. Each station is equipped with keys, the so-called line keys, corresponding to the number of outgoing wires. With every key is associated a contact spring set, at which a wire or line begins or ends. By pressing one of these keys, the associated spring set is operated, and the connection is thereby set up. The calling of the required subscriber is effected by the pressing of the key, which can naturally be repeated in the event of the called party not answering at once. The connection is automatically broken down by replacing the receiver. The line key then returns to the rest position of its own accord.

Switching Device

Setting up the Connection

Calling

Ringling off

There are intercommunicating instruments of various types, which according to the method of setting up the connections are known as lever type, press-button type, plug type or rotary line selector instruments. On account of its interesting switching mechanism the last mentioned will be briefly described here.

Dial Type Intercommunicating Instruments

Switching Arrangement

All the wires are terminated on an arc-shaped ten-point contact segment. To a spindle there is firmly fixed a switch arm, which is set to any desired contact on the segment by rotating the spindle. On the same spindle but separated by a round disc, which is situated on the



10-line lever-type intercommunicating instrument.



Rotary line selector instrument.

front of the instrument and around the edge of which the names of the subscribers are inscribed, there is a crank-like handle, the so-called setting crank. When this crank is so adjusted that it stands over the name of

Setting up the Connection

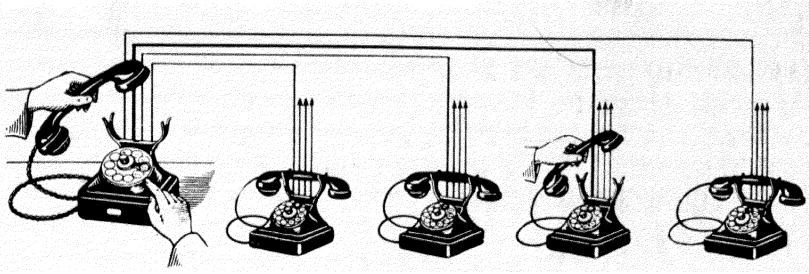

Rotary line selector system, extensible up to 10 lines.

After lifting the handset the connection with the desired station is completed by setting the pointer. By pressing the button mounted on the dial the calling signal is transmitted to the selected station.

the desired subscriber, the switch-arm is similarly moved underneath the plate and stands on the corresponding subscriber's contact. By this means the line to the selected subscriber is seized. On the spindle of the line switch there is also a ringing button. The connection is automatically broken down on replacing the handset. The switch does not need to be restored to its rest position.

*Ringing and
Release*

An advantage of systems of this nature is the rapid and easy method of setting up connections. A disadvantage is the comparatively extensive subscribers' network and the difficulty of effecting an extension, when there are no more spare lines. With rotary line selector instruments an extension up to nineteen stations is possible. For concerns, in which in all probability more than nineteen stations will never be required, such systems are quite suitable. The cost of the line network is indeed more than that of a so-called exchange network, but once properly laid such a network has an almost unlimited life and involves no maintenance costs.

Telephone Equipments with Central Exchange.

In a telephone system with a central exchange equipment every subscriber should be able at will to be connected to any other subscriber on the system rapidly and without possibility of error. According as to whether the switching operations in the exchange are carried out by hand or by mechanical switching devices a distinction is drawn between

*What is the
Meaning of Cen-
tral Exchange?*

hand-operated (manual) systems and
automatic systems.

The Network

In both systems each station is connected to the central exchange equipment by means of a double conductor. The subscribers' stations in manual systems consist merely of microphones, receivers and calling devices.

The Stations

In automatic systems they also have a mechanism, the so-called dial, by means of which the calling numbers of the required subscribers are transmitted to the mechanical switching devices in the exchange.

Manual Exchange Systems.

*Switchboard
("Exchange")*

The switching operations are carried out by hand at the switchboard. At this switchboard, which often takes a form similar to that of a piano,

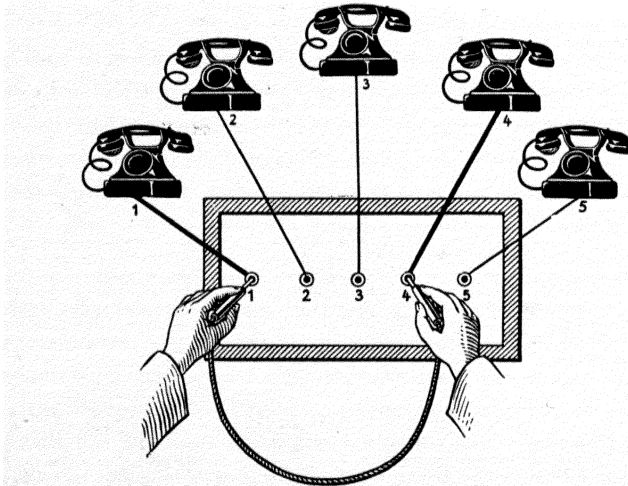

Schematic diagram of the fundamental circuit of a manual exchange system.

*Jacks and the
Jack Panel*

the wires coming in from the subscribers' stations are terminated on small metal bushes, the subscribers' jacks. Every subscriber is thus represented at the switchboard by such a jack. All the subscribers' jacks together form the jack panel. Directly above each jack and behind a ground-glass cap, on which is inscribed the relevant subscriber's number, there is a small signal lamp known as the calling lamp. It is automatically switched on, as soon as a subscriber lifts his handset, and thus indicates to the exchange operator: "Line X wishes to make a call". This subscriber must then be asked for the number of the desired line.

The answering plug is attached to one end of a connecting cord and consists of a metal plug about 4 in.

long, which is inserted in the calling subscriber's jack. The multi-stage plug operates a spring set located behind the jack by means of which the operator's telephone is first of all connected with the calling subscriber's line. At the same time the calling lamp is switched off. After the operator's acceptance of the call the further

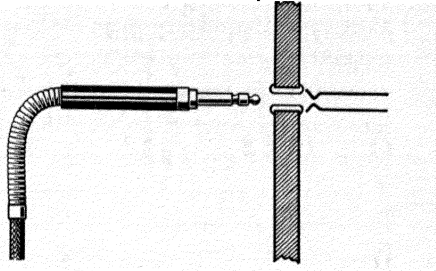

Plug, jack and springset (schematic).

building up of the connection is effected with the help of the connecting plug, which is inserted in the wanted subscriber's jack. The connection then runs from the calling subscriber's station, along this subscriber's line, via the answering plug, connecting cord, connecting plug, wanted subscriber's jack and line to his instrument.

In large manually operated exchanges, where the jack panel is repeated on several positions, before switching through takes place,

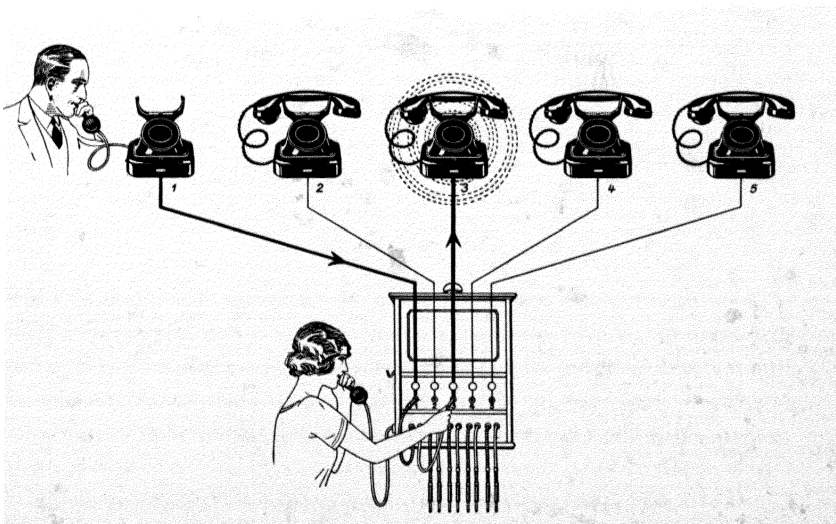

Diagram of the connecting process in a manual telephone exchange. After taking particulars the operator has inserted the connecting plug.

*Testing for "free"
or "engaged"*

a check is made for "free" or "engaged" by the operator momentarily touching the wanted subscriber's jack with the tip of the plug. If the line is already engaged, she hears a clicking noise in her receiver. In such cases the calling party is informed that the wanted line is engaged, either orally or by means of an acoustic signal. If the line is free, the connection is switched through to the wanted subscriber's station by inserting the connecting plug in the jack. The bell at the wanted station rings, the receiver is lifted, and the connection is thereby finally completed. The ringing signal for the called party can also be transmitted to the calling party's handset. In this way he is aurally notified that the wanted subscriber is being rung. If after repeated ringing the called subscriber does not lift his handset, the connection is broken down and the calling party notified.

*Completing the
Connection*

*Ringing Signal
Switching
through*

*Breaking down
the Connection*

At the end of the conversation the replacing of the handset causes clearing lamps to light up on the switchboard. That is the signal for the operator to break down the connection by withdrawing the plug.

Operator's Load

*Number of
Operators'
Positions*

Multiplying

The number of cord pairs is fixed according to the traffic density. As a rule it amounts to about 10% of the subscribers connected. An operator in a public exchange can on the average deal with about 230 local calls per hour, i. e., set them up, supervise them and break them down. From the number of subscribers and the traffic density is also obtained the number of operators' positions required, and, as already mentioned elsewhere, the subscribers' jacks are repeated on several positions. In this connection the term "multiplying" of the jacks is used, and the jack panel becomes a "multiple".

Automatic Systems.

In recent years manually operated exchange systems have been displaced to an ever increasing extent by the automatic system. Only in a few special cases, such as transportable field exchanges for the army, operators' positions in trunk exchanges and emergency and control exchanges in the air service, they have still retained their importance.

*Operating
Characteristics
of Manual
Exchanges*

Their operating disadvantages, namely dependence on the operator, waiting times of varying duration when setting up and breaking down the connections, wrong connections and other operating errors,

the effect of the operators' rest hours and the associated question of the provision to be made for reserve operators, and the uneconomic service, have essentially deprived manual exchanges of their justification for existence. In addition, the service required in a telephone exchange is extraordinarily heavy and exacting. In any concern, whether public or private, for the operating staff (mostly women) can be found other positions with considerable advantage, both economically and from the point of view of the health of those concerned.

Automatic Exchanges

An automatic exchange is independent of operating staff. The rapid error-free setting up of the connections, the permanent readiness for service both day and night, Sundays and holidays, the absolute secrecy of the conversations and the service economy are reasons for its introduction and its ever growing extension.

In the automatic system the operator's activities, which have been indicated in the outline of manually operated exchange systems, are replaced by switching mechanisms electrically driven and controlled. These switching mechanisms are known as selectors, because with their help any subscriber can select from the whole of the connected lines, i. e., stations, just the one he desires. This basic function of a selector will first of all be illustrated here by means of a simple example.

From ten incandescent lamps one will be selected and switched on with the help of a rotary selector. Thus this switch will be given ten contacts, which are arranged in an arc around a spindle and can be successively touched by a metal tongue rotating about the spindle. On this metal tongue, which may be termed "wiper", is terminated the current-carrying lead. If the spindle of this switching mechanism is

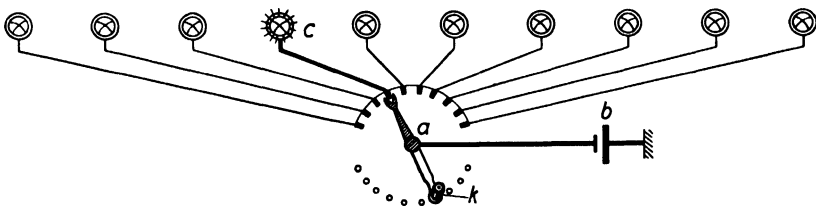

Explanation of the principle of a step-by-step mechanism.

The switch-arm "a" sets up the connection between the current source "b" and the load "c"; setting of the switch-arm is effected by means of crank "k".

rotated with the help of the selector to the first contact, for example, the first lamp obtains current over the current-carrying wiper and is thus illuminated. On rotating the wiper to contact 4 the fourth lamp lights up, and so on.

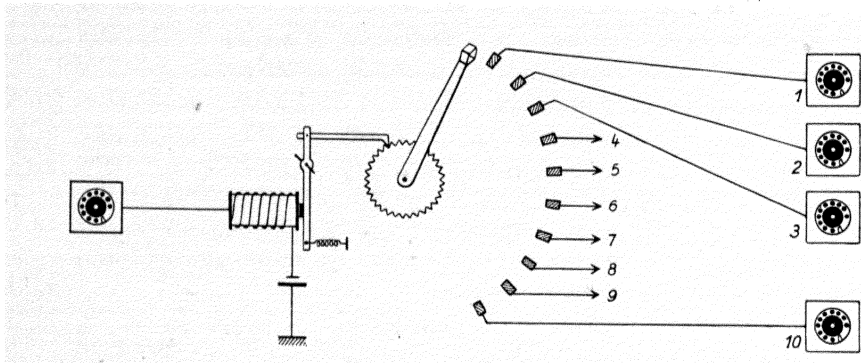

*Schematic diagram of a dial-type intercommunication system.
The electro-magnet controlled by the subscriber carries out the positioning of the switch-arm on the desired contact.*

If such a switch is so converted that the wiper is set on the desired contact by means of remotely controlled electro-magnets, then we already have a switching mechanism that has a resemblance to the rotary switch used in automatic systems. This automatic switching mechanism is constructed in the following manner: The selector of the hand-switch is replaced by a small toothed wheel. A metal finger, the so-called driving

Construction of a Rotary Switch



Automatic telephone station, latest model.

pawl, is connected to the armature of an electric magnet in such a way that, whenever the electro-magnet is subjected to current and as a result attracts its armature, the driving pawl engages with a tooth of the toothed wheel, which it thus moves on one step. Like the toothed wheel, the wiper is also firmly joined to the switch spindle. As a result it follows the rotary movement of the spindle and is in this way switched on from contact to contact.

On each contact a subscriber's line is terminated; on the switch wiper is terminated the calling subscriber's line. With ten subscribers connected ten such switching mechanisms are required, so that every station can be reached from every other station. For the purpose of setting the switches every station is provided with an impulse sender, the so-called dial. By means of this device uniform impulses are produced at exactly measured intervals. These impulses take effect on the electro-magnets of the selector and cause the switching mechanism to operate in the manner outlined above.

The Dial

The dial consists of the number switching mechanism and the dial plate. The latter is a round metal disc about 3 in. in diameter, which is rotatably fixed to a spindle on the front of the subscriber's instrument. It is provided at the edge with ten finger-holes, which are designated with the digits 1 to 9 and 0. The dial also has a number ring and a finger-stop, which is fixed to the front of the apparatus. For each dialling operation the dial plate must be pulled round so far that the

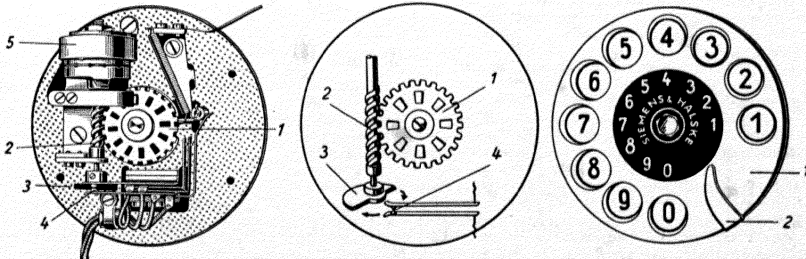

Rear view of a dial.

- 1 = Driving wheel
- 2 = Worm spindle
- 3 = Impulse vane
- 4 = Impulse contact
- 5 = Brake

Schematic diagram of a dial.

- 1 = Driving wheel
- 2 = Worm spindle
- 3 = Impulse vane
- 4 = Impulse contact

Front view of a dial.

- 1 = Dial plate
- 2 = Finger-stop

finger of the individual dialling just touches the finger-stop. The number ring is located at a distance of about $\frac{1}{4}$ in. below the dial plate.

The switching mechanism is a clockwork-like mechanism, which by means of a driving wheel, a worm spindle and an impulse vane operates an impulse contact. The speed of return is regulated by a brake.

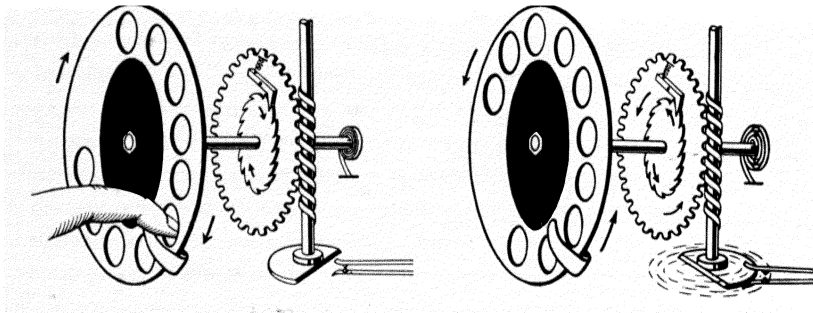

Schematic diagram of the function of a dial.

The pulling of the dial.

The spring fixed to the spindle is tensioned. The small wheel rotates, but the large wheel remains at rest.

The return motion of the dial.

The worm spindle, together with the impulse vane, is now rotated by the large driving wheel.

Dialling

If, for example, subscriber No. 5 is to be called, the dial plate is rotated in a clockwise direction from hole 5 to the finger-stop. Then it is allowed to run back of its own accord. On the return of the dial plate to its normal position the mechanism of the dial switch is operated in such a manner that the impulse contact opens and closes the path to the selector in the exchange as often as is indicated by the digit that has been dialled—in our example five times. We speak of five impulses, which operate the magnet of the selector. The impulses are comparable to telegraphic signals, which are received by the selector and cause a corresponding movement. How this happens has already been described in the previous paragraph. The process just outlined—the dialling—is effected in the following time: The complete running down time of the dial switch, i. e., when a 0 has been dialled, amounts to about one second. Thus each impulse takes a total time of $\frac{1}{10}$ second, 60 ms for the opening and 40 ms for the closing of the impulse contact. With the same speed the selectors follow the impulses from the dial. The dialling of a two-digit number requires an average of about four seconds. Every further

digit requires about another extra second. Thus a six-digit number can be dialled in about seven to eight seconds.

The Switches in an Automatic System.

It has already been said of the switches (selectors) that they have to perform all the duties which in manual systems fall to the operators. The calling subscriber's wish must first be ascertained and his line rapidly and accurately connected to the wanted subscriber. Then the wanted subscriber must be rung. Further, if the ringing is not heeded immediately, it must be repeated until the called party answers, or at least as long as the calling subscriber does not replace his handset and thus announces that he is still waiting for the called party. It is best for this waiting time not to be of too long a duration, for, when the wanted subscriber has been rung three or four times without his replying, it can be assumed that he is not available. During the ringing the calling party must also receive a signal, so that he knows that the connection is completed. This signal sounds in the calling party's receiver and is an audible buzzing tone of the same rhythm as the actual ringing. If the wanted subscriber is engaged, i. e., he is already speaking to another subscriber, the calling party must receive a busy tone. This is generally an uninterrupted buzzing tone and is thus very easily distinguishable from the previously described ringing tone. There is also a third subscribers' signal, the so-called dialling tone. It is heard on lifting the handset and has the rhythm of the Morse signal a (\cdot —); it indicates that the switches required for the building up of the required connection are free and that the dialling can be commenced. All the signals just described are produced by a signalling apparatus installed in the exchange. After the conversation has been concluded and the handset replaced, the connection must be broken down. This is effected by the automatic return of the switches to their normal positions. They are then once more available for further connections.

The Duties of the Switches

*Answering a Call
Making the Connection*

Ringing and Re-ringing

Ringing Tone

Busy Tone

Dialling Tone

Breaking down the Connection

The Mechanics of the Switches.

In Siemens & Halske's automatic system step-by-step switches are used, rotary switches of various sizes and 100-pt two-motion (vertical and rotary) switches. It has already been stated previously that a rotary switch is comparable to a multicontact switch, in which the switching

Rotary Switches

movement, i. e., the switching on of the wiper from contact to contact is carried out not by hand but by an electrically driven mechanism that is remotely controlled.

Every step-by-step switch has three main components:

1. Contact bank.
2. Wiper.
3. Driving mechanism.

Contact Bank

The contact bank of a rotary switch consists of layers of contact springs, known as tags or contacts, which are carefully insulated from each other and are arranged axially around an arc. The number of contact springs lying on one plane is fixed in accordance with the number of lines which are to be reached from the wipers of the switching

mechanism. According to the purpose for which the switch is to be used and the size of the system from 10-pt to 50-pt rotary switches are employed. According to the nature of the circuit every contact spring is repeated three or four times in the contact bank, and in certain special cases even more often; the various contacts are distinguished by being designated the a-, b-, c-, etc. contacts. As a rule it is on the a- and b-contacts that the two-wire speaking line is terminated. The c-contact is for the testing line, and the other contacts are provided for special switching functions. In a comparison with the manual exchange the contact bank represents the jack panel. The a-, b-, c-, etc. contacts are found in the spring set, which, as we know, belongs to every jack. Like the jack panel of the manual exchange, the contact banks of the switches are also multiplied, i. e., the switch contacts having the same numbers

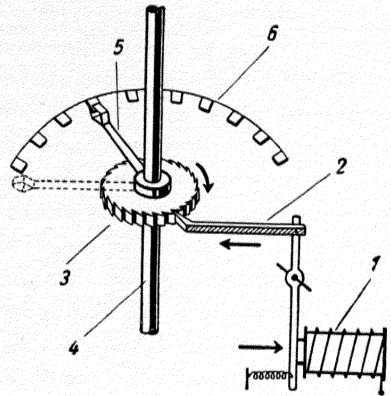

Schematic diagram of a rotary switch.

- | | |
|--------------------|------------------|
| 1 = Driving magnet | 4 = Spindle |
| 2 = Driving pawl | 5 = Wiper |
| 3 = Driving wheel | 6 = Contact bank |

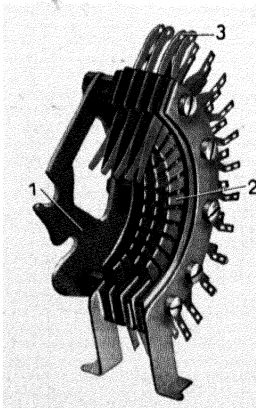

The contact bank.

- | |
|-------------------|
| 1 = Base-plate |
| 2 = Bank contacts |
| 3 = Feed springs |

are connected to each other. Further details on this subject will be given in a later paragraph.

The wiper of the switch is comparable to the plug of a connecting cord pair in the manual exchange. Corresponding to the arrangement of a-, b-, c-, etc. contacts in the contact bank the wipers are also distinguished by being designated a-, b-, c-, etc. They are located next to each other on the spindle in such a way that with the rotation of the axis the wipers revolve like the hands of a clock and can be positioned

The Wiper

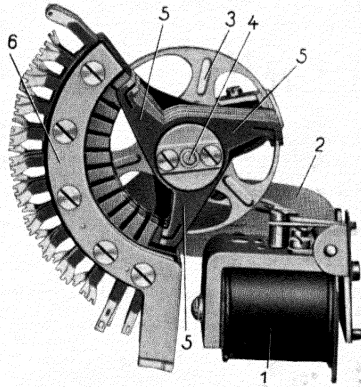

Natural picture of a rotary switch.

- | | |
|--|------------------|
| 1 = Driving magnet | 4 = Spindle |
| 2 = Driving pawl | 5 = Wipers |
| 3 = Digit drum. Behind the drum is the driving wheel | 6 = Contact bank |

on any desired contact. Reliable contact-making is one of the first requirements demanded of the switch. For this reason every wiper is made double and is so arranged that the contacts are touched on the upper and lower sides simultaneously. In addition, each tongue of the wiper is slit, so that in practice there are four points of contact. Associated with the wipers there is also a number ring, which indicates the actual position of the switch or the wipers.

The drive consists of the driving magnet, the driving pawl and the driving wheel (toothed wheel). The constructional arrangement is such that at every operation of the armature the driving pawl is thrust into a tooth-gap of the driving wheel, which is rigidly fixed to the spindle. By this means the toothed wheel with the spindle attached and the wipers are given a rotary movement.

The Driving Mechanism

*Method of
Operation*

Dialling

*Setting up the
Connection*

It is desired to reach subscriber No. 7, whose line, as we know, is terminated on the 7th contact of the rotary switch. With his dial the calling subscriber dials a 7 and thus interrupts the line loop seven times, in the manner previously described. These interruptions take effect as impulses on the driving magnet of the switch. The armature of the magnet is attracted seven times in succession; a like number of times the driving pawl attached to the armature is thrust into a tooth-gap of the driving wheel. In this way the shaft is rotated step by step, and the wipers are switched over contacts 1 to 6 to the 7th contact. Receiving

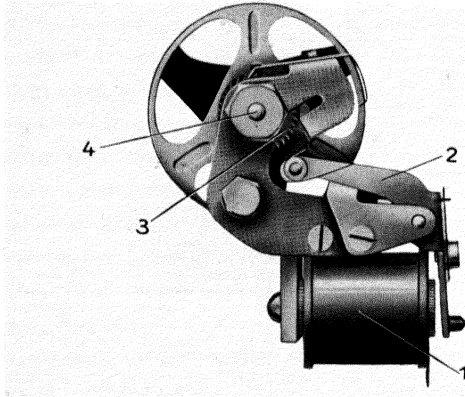

The switch mechanism.

*1 = Driving magnet
2 = Driving pawl*

*3 = Driving wheel
4 = Spindle*

The Release

no further impulses, the switch comes to rest and the connection is then complete. At the conclusion of the conversation, released by the replacing of the handset, a special circuit arrangement ensures that the driving magnet automatically continues to receive impulses until the wipers have again returned to their rest or receiving position. From the receiving position back to the rest position they have thus performed a complete revolution.

*Two-motion
Switches*

It is, of course, quite possible to construct rotary switches with more than ten contacts. Indeed it is done in special cases. In order, however, to prevent the positioning times from becoming intolerably long and having regard to certain difficulties in the numbering of the sub-

scribers' lines, it is better for large systems to employ switching mechanisms which can accommodate 100 lines and yet have very short positioning times.

A 100-pt two-motion switch consists of three main components:

1. The contact bank.
2. The wiper.
3. The driving mechanism.

The 3×100 tags (contact springs) of the contact bank of a 100-pt two-motion switch are so arranged in layers that each 100 tags consist of ten rows of ten tags each. Each 100 tags form a contact bank, which is designated an a-, b- or c-bank according as to whether the a/b- speaking line or the c-testing wire is terminated on its contacts.

The Contact Bank

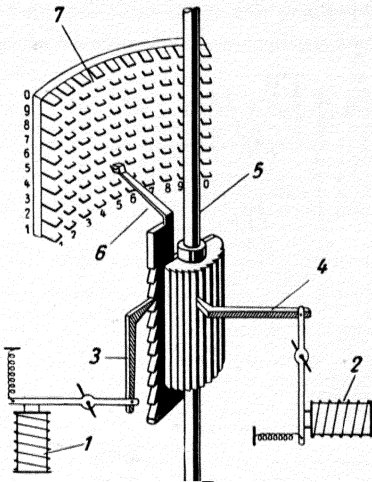

Schematic diagram of a two-motion switch.

- | | |
|---------------------|------------------|
| 1 = Vertical magnet | 5 = Spindle |
| 2 = Rotary magnet | 6 = Wiper |
| 3 = Lifting pawl | 7 = Contact bank |
| 4 = Turning pawl | |

on a spindle about 4 in. long in such a way that by means of a 10-toothed bar and a switching cylinder provided with 10 longitudinal ribs they are

The wipers for the a-, b-, and

The Wiper

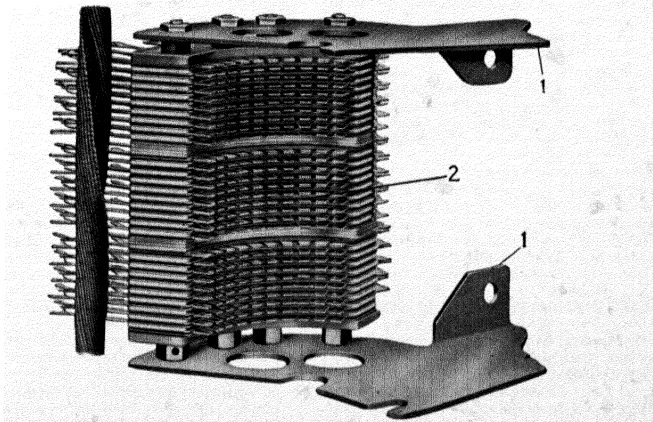

The contact bank.

- | | |
|-----------------|-------------------|
| 1 = Base-plates | 2 = Bank contacts |
|-----------------|-------------------|

lifted 10 steps and rotated 10 steps respectively. With every vertical step they are raised to the level of a 10-pt contact row (decade) and with every rotary step in the horizontal direction, exactly as with the rotary switch, they are set on the desired contact within a decade. The contact

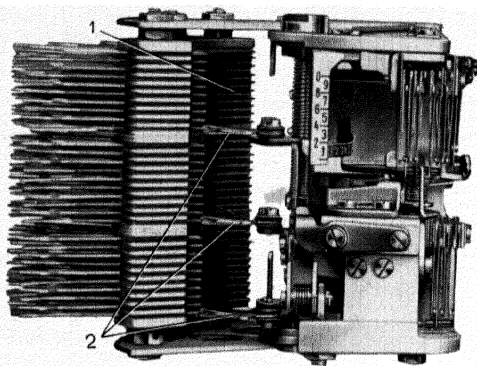

View of a two-motion switch.
 1 = Contact bank 2 = Wipers

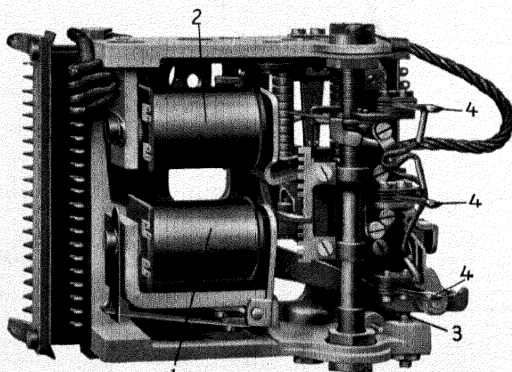

Two-motion switch (contact bank removed).
 1 = Vertical magnet 3 = Spindle
 2 = Rotary magnet 4 = Wipers

field is arranged in the form of a cylindrical shell, so that the wipers can reach every individual contact by means of a straight vertical and a circular horizontal movement.

The Driving Mechanism

The drive is constructed to correspond to the two directions of movement of the wipers; it consists of the lifting and the rotating

mechanisms. Thence arises the term "two-motion switch". The lifting mechanism consists of the vertical magnet, the lifting pawl and the toothed bar. The rotary mechanism has a rotary magnet and in place of the toothed bar a switching drum provided with 10 vertical ribs.

The other necessary contacts (off-normal and shaft contacts) are mounted on the switch block. For various other switching operations relays are provided, which, collected together in a special relay set, are generally accommodated with the switch on a common base-plate.

The Contacts and Relays

Relays are the electro-magnets which are used in great numbers in telephone engineering and which operate contact springs by means of their armatures, i. e., they convert electrical energy into mechanical power and thus open or close circuits, or in brief, perform all sorts of switching operations.

Subscriber No. 35 is to be called. Contact 35 is the 5th contact in the 3rd row of ten. The calling subscriber has by means of his dial first a 3 and then a 5. The three impulses of the first impulse train take effect on the vertical magnet, whose armature operates the driving pawl three times, and the toothed bar with the wipers attached to it is lifted three steps. Thus each of the ten teeth of the toothed bar means a tens stage or decade. The wipers are now standing in front of the 3rd decade. The short pause which occurs after the last lifting impulse owing to the re-pulling of the dial, is utilised for the automatic change-over within the relay set of the switch from the vertical to the rotary operation. The second impulse train—in this case the 5 had to be dialled—thus takes effect on the rotary magnet, which now moves on

Method of Operation

Dialling

The Lifting Operation

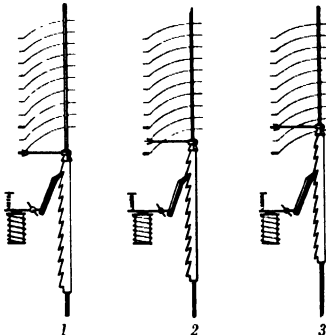

Schematic diagram of the vertical motion.

(The subscriber has dialled 3 as the first digit.)

- 1 = Effect of the first impulse*
- 2 = Effect of the second impulse*
- 3 = Effect of the third impulse*

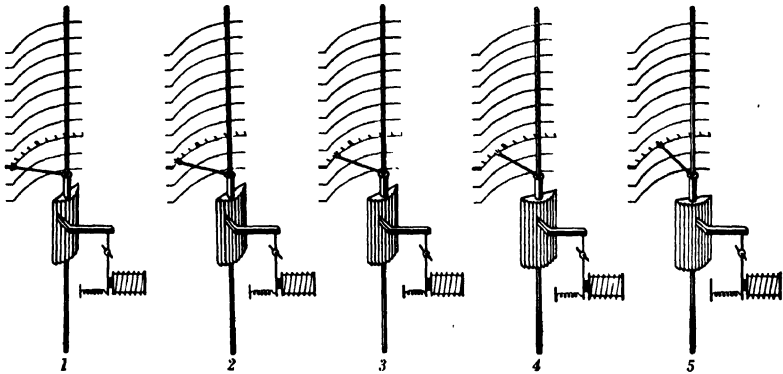

Schematic diagram of the rotary operation. (The subscriber has dialled 5 as the second digit.)

1 to 5 = effect of the first to the fifth impulse.

the wipers in the same way as the vertical magnet, i. e., they are moved with a horizontal circular movement over contacts 1 to 4 to contact No. 5. As compared with the operations in a manual exchange, this operation resembles the search for jack No. 35 and the insertion of the plug into

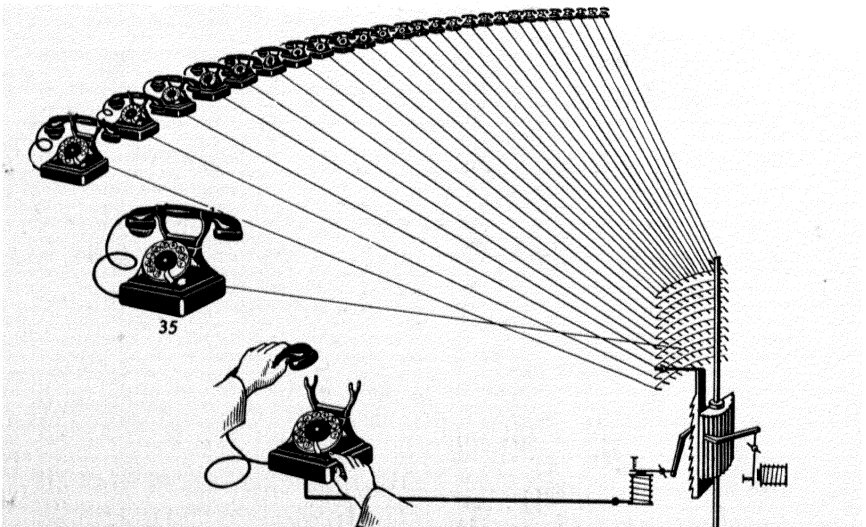

Setting up a connection by means of a two-motion switch (Operation 1). On lifting the handset the calling party's station is immediately connected with the vertical magnet of the two-motion switch. The number 3 is dialled. The spindle, together with the wiper, has been raised three steps.

this jack, which is situated in the jack panel in the middle of the 3rd tens row (horizontal row).

At the moment when the wiper reaches the correct subscriber's contact and finds it free, ringing of the wanted subscriber is automatically carried out by a ringing equipment, which is common to all subscribers, being connected at fixed intervals to the line leading to the wanted subscriber. With the lifting of the handset the ringing is switched off and the connection completed.

*Testing
Ringing*

At the end of the conversation the subscribers restore their handsets. Impulses are then automatically transmitted to the rotary magnet, until the wipers have been switched over all the remaining contacts in the decade; they then fall down under gravitational force and are restored to their initial position by spring tension. As a rule the release of the connection is effected from the calling subscriber's end. With the release operation there is also associated the switching on of the subscriber's meter, which naturally does not occur if the connection was not completed,

*Breaking down
the Connection
(Release)*

Metering

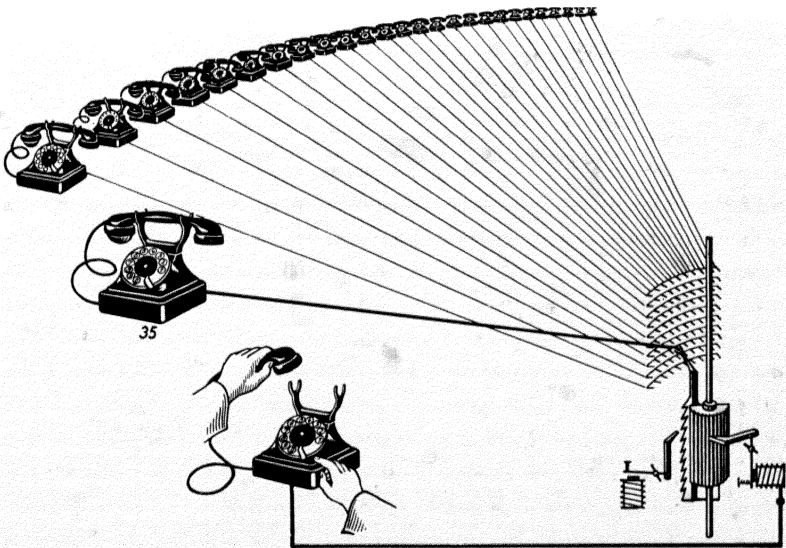

Setting up a connection by means of a two-motion switch (Operation 2).

The calling party's station is now disconnected from the vertical magnet and connected to the rotary magnet. The number 5 is now dialled and the rotary magnet rotates the switch spindle five steps. Contact No. 35 is connected to the wanted subscriber's station.

i. e., the called subscriber was already in conversation (subscriber busy), or the handset of the called station was not removed (subscriber absent).

The return of the switches to their normal positions occurs so rapidly that the subscriber can set up a fresh connection practically immediately after replacing the receiver.

Multiplying, the Multiple.

If it is assumed that in a manual system for 100 subscribers only one connection would be required at a time, the switchboard need only be equipped with one answering and one connecting plug, i. e., with one cord pair. Under the same assumption only one 100-pt two-motion switch would be necessary in an automatic exchange for 100 subscribers. In practice, however, conditions are such that, especially in the hours of active telephone traffic, the so-called busy hours, ten, twelve and even more simultaneous calls are in progress per 100 subscribers. In order to be able to fulfil this requirement, an exchange operator in a manual exchange must have ten cord pairs available. In an automatic exchange, therefore, one switch is also insufficient, and the system must be equipped with 10 per cent or more switches, according to the percentage of simultaneous connections likely to occur during the busy hours. (This must be determined during the planning of a system by means of careful traffic observations.) We, therefore, speak of a system with 10 per cent, 12 per cent or more connectors. Naturally, each of the 100 subscribers must be represented by a contact on every one of the switches provided. This is arranged by the similarly numbered contacts on all the switches being connected to each other by means of multiple lines. Every line can then be reached by every one of the available final selectors. If an FS (final selector) is already engaged on a connection, the next one automatically steps in and accepts the impulse trains. If two subscribers set up a connection to one line at the same time, i. e., dial the same number, then only that one is connected, who first finishes dialling. The second and any others receive the busy tone. From the description of the manual exchange multiple field it was seen how the exchange operator determined by touching the jack with the tip of the connecting plug, whether the relevant subscriber's line was not already engaged on a connection, i. e., had been taken into use at one of the other positions. The automatic switch carries out the same testing operation. If the wiper comes to a contact already seized over the multiple by another switch,

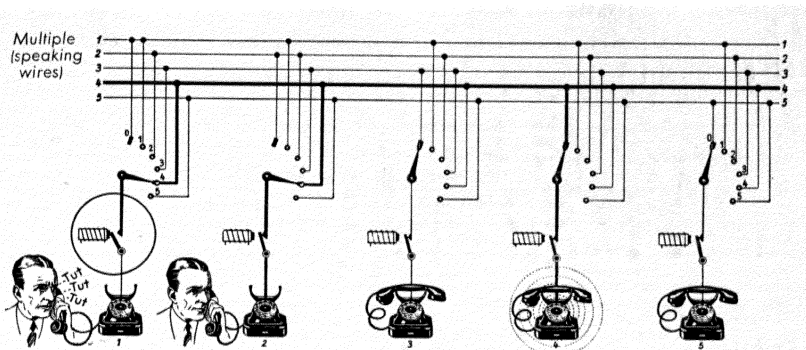

Schematic diagram of a multiple circuit.

Switch contacts 1 to 5 are connected to the multiple wires 1 to 5. Station 1 and switch 1 are permanently connected via the zero position of the switch to line 1. Similarly station 2 and switch 2 are connected to line 2, and so on. Subscriber No. 2 has dialled subscriber No. 4 and by so doing has seized multiple wire 4. Subscriber No. 1 is also endeavouring to reach subscriber No. 4. His switch finds multiple wire 4 engaged. The disconnecting device (in circle) interrupts the circuit. Subscriber No. 1 receives the busy tone.

the connection is not set up and the subscriber receives the busy tone. This testing operation is carried out very rapidly and under all circumstances correctly, for the switching on to an engaged line would disturb the existing connection and destroy the basis of the secrecy of conversations (double connections).

In special cases, however, circuit arrangements can be made to render it possible to intervene in an existing connection. For instance, the trunk exchange must be given the ability to notify a subscriber during a local call, on which he is already engaged, that there is a trunk call awaiting his attention. In private systems also the tapping facility is requested for privileged stations, e. g., it must be possible for the operator of the P.B.X. switchboard to notify a house subscriber already engaged in conversation that there is an exchange call waiting for him. In this case, however, the speakers are notified by a ticking signal in their receivers, that someone has intervened in the connection. For special supervisory purposes this tapping signal can be suppressed by means of a suitable circuit arrangement.

The Possibility of Tapping by Privileged Subscribers

What is Preselection? Preselector and Call-finder.

*General
Considerations
regarding
Preselection*

If a system for 100 subscribers, as previously described, is equipped with 10, 12 or possibly 14 switches, the question then arises, how the small number of switches are to be distributed over the 100 subscribers, or how the individual subscriber can obtain connection to one of the two-motion switches. This is done by means of so-called preselection. Before there were any preselectors, it was necessary to associate with every subscriber a 100-pt connecting switch—a costly business. In a system thus equipped all the 100 subscribers could telephone simultaneously. But even with such a conversation frequency, which never occurs in practice, 50 switches are superfluous, for every two subscribers occupy for a connection only one switch. One of the speakers is always the called party and therefore does not have to set a switch.

Preselectors

In preselector systems every subscriber is provided with a small rotary switch, which has as many contacts in its contact bank as there are connecting switches to be reached. Such a switching mechanism is, naturally, considerably cheaper than a two-motion switch; otherwise preselection would be purposeless. In practice preselection is carried out in the following manner: The subscriber's line is carried to the axis of the wiper of a rotary switch. On the contacts in the contact bank are terminated the lines which lead to the individual connecting switches, *viz.*, on contact No. 1 two-motion switch No. 1, on contact No. 2 switch

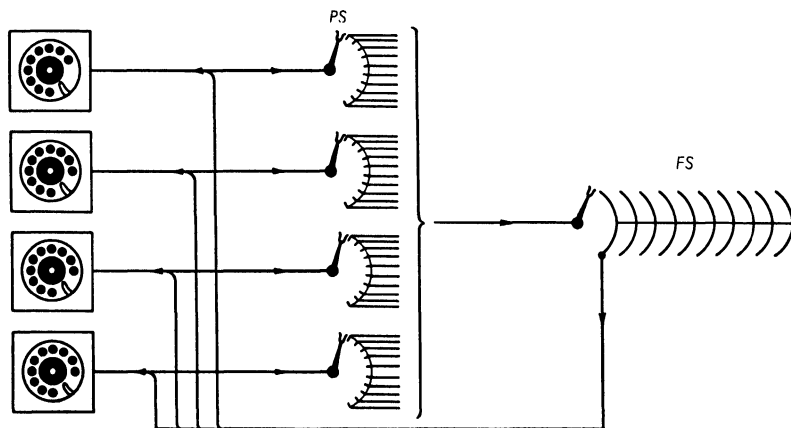

Principle of preselection with preselectors.

No. 2, and so on. When the subscriber lifts his handset, his preselector (PS) sets itself in motion entirely of its own accord and sets its wiper on the first free contact, i. e., on the first free connecting line. If, for example, the first four switches are already engaged, the next free one, i. e., the fifth connecting switch, will be seized and positioned. Preselection is an absolutely automatic selection, because the subscriber does not initiate it by dialling. It proceeds so rapidly that the subscriber is entirely unaware that it is happening at all.

Compared with a manual exchange this phase in the building up of a connection is like the seizing by the exchange operator of the next free answering plug and its insertion into the jack of the calling subscriber. For this operation no consideration is required. It is apparent at a glance, which plug pair is free. In a manual exchange, however, this operation takes longer, even if the operator is not already engaged in some other activity at the switchboard—perhaps setting up or breaking down another connection, or giving information.

The call-finder is also a preselecting mechanism, for fundamentally the same task is allotted to it as to the preselector. Whereas, however, in preselector systems (PS) every subscriber has his own preselecting mechanism, in CF (call-finder) systems a number of call-finders suited to the conversation frequency is allotted to a group of subscribers. In construction the call-finder is similar to a preselector. The circuit, however, is fundamentally different. On the axis of the switch is ter-

Call-finder

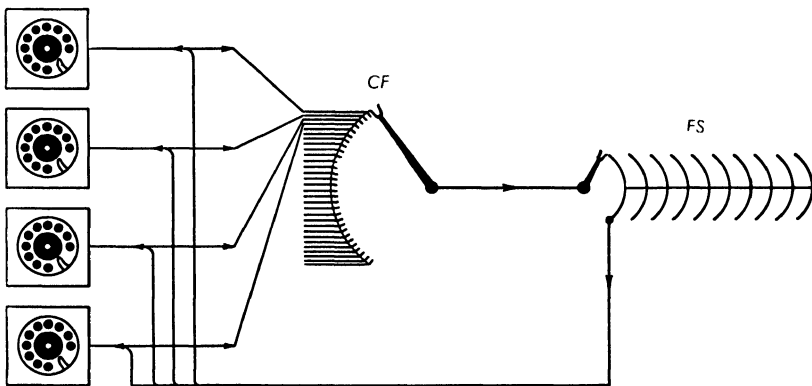

Principle of preselection with call-finders.

minated the line to a final selector (or group selector), while on the tags of the contact bank the subscribers' lines are terminated. The wiring is thus exactly opposite to that of a preselector. If a subscriber in the group lifts his handset, the call-finder automatically starts up and continues to rotate, until its wiper stands on the line contact, on which is terminated the line found to be in the calling state. The function of the call-finder is thus to find the calling subscriber—hence its name.

If several subscribers in a group want to set up connections at the same time, there takes place within the CFs available for this group a certain kind of switch distribution, i. e., if a group of subscribers has, for example, five call-finders associated with it, then the first caller seizes CF 1, the second CF 2, and so on.

The number of call-finders to be installed is determined, as is the case with the numbers of switches (with the exception of the preselectors), from the traffic density. As a rule the number of call-finders coincides with that of connecting switches. A call-finder system may thus be somewhat cheaper, because the expenditure on apparatus is less.

The call-finder principle has been almost universally successful in private systems of small and average size. In larger systems, especially in those with irregular, spasmodic traffic the preselector principle is preferred owing to its greater adaptability.

The Building up of a Connection in Larger Systems.

Group Selection, Second Preselection.

*Building up
a Connection*

An explanation of the term “building up a connection” is of importance for the comprehension of the method of operation of an automatic exchange. By “building up a connection” is understood broadly the way and manner, in which the switches lying in the route of a connection are successively positioned. The number of switch ranks used in setting up a connection from one subscriber to another depends on the ultimate capacity, for which the exchange is designed. The number of switch ranks has thus nothing to do with the conversation frequency mentioned in an earlier paragraph; on the latter depends, as we have seen, the number of switches within a rank.

A system with an ultimate capacity of 100 has one preselecting stage and one numerical selecting stage. As soon as the number of subscribers to be connected exceeds the number of contacts on a two-motion switch, which we know to be 100, a new switch rank must be introduced. By

this means a 100-line system is turned into a 1000-line system having one preselecting stage, two numerical selecting stages and an ultimate capacity of 1000 subscribers' contacts. If the system is to cater for more than 1000 subscribers, then yet another switch rank must be introduced, and a 10000-line system is created with an ultimate capacity of 10000 subscribers' contacts. In a similar manner 100000-line and million-line systems are formed.

The sequence, in which the individual switches are called upon in the building up of a connection, has an essential influence on the circuit design of a system. In this connection clarity in design and accessibility are essential characteristics for satisfactory supervision and maintenance and therefore for the reliability of the system.

The building up of a connection in the 100-line system is comparatively simple and readily comprehensible. As we know, every subscriber has access through his preselecting mechanism to all the 100-pt final selectors (FS). On the contacts of the final selectors are terminated the lines of the 100 subscribers, each of which can be reached by setting the final selector in the known manner.

The 100-line System

In view of the number of contacts on the final selectors the 1000 subscribers on a 1000-line system are divided into ten groups of 100 lines each and are distinguished as the 1st, 2nd, 3rd up to 10th hundreds group. The result of this formation of groups is that if, for example, subscriber No. 55 in the third hundreds group is required, some switching mechanism must be available, which, like a shunting switch controlled by the subscriber, first of all connects that subscriber's line to one of the final selectors in the third hundreds group. Thus the relevant group has to be selected. The switch, to which this task is allotted, is, therefore, known as a group selector (GS). Connection is brought about in the following manner. On the lifting of the handset the preselecting mechanism does not, as in the 100-line system, immediately and automatically set itself on a final selector, but first of all sets up a connection to a free group selector. To this group selector the command is given by dialling the relevant digit—in this case 3—to select a free connecting line to one of the final selectors in the third hundreds group. After that has been done, the final selector is—as usual—set to the wanted subscriber's contact.

1000-line System

If it is desired to call subscriber No. 55 of the eighth hundreds group, the group selector must by dialling the digit 8 be made to set

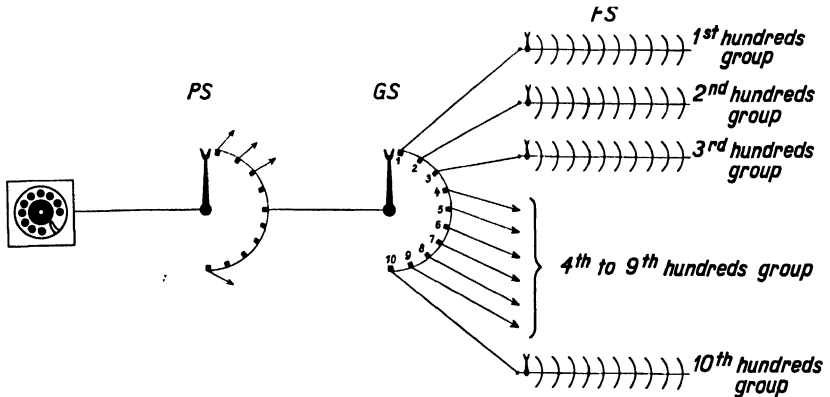

Schematic diagram of the function of a group selector.

The first impulse train sets the group selector in operation and connects it with that hundreds group, whose number has been dialled by the subscriber as the first digit. As is well known, the preselector sets itself without any assistance from the subscriber. The group selector is normally a 100-point two-motion switch (see page 42); for the sake of clarity it is here shown as a rotary switch.

up a connection to a free final selector in the eighth hundreds group. Exactly similar is the function performed in setting up a connection to a subscriber in any other desired hundreds group. Now the influence of the formation of groups on the numbering of the lines has been made clear. Subscriber No. 55 of group 1 has the number 155, No. 55 of group 2 has the number 255, and so on. At the beginning of this section it was stated that the 1000-line system has two numerical selecting stages; it is now clear that the first numerical selecting stage is the group selector and the second numerical selecting stage is the final selector.

*10000-line
System*

In a system with an ultimate capacity of 10000 lines a further group formation must be effected, *viz.*, each 1000 subscribers, i. e., ten hundreds groups, are collected together into one 1000-line group. Just as in the 1000-line system a group selecting mechanism was required for the selection of the desired hundreds group, a further group selector is now necessary for the selection of the desired thousands group. The group selector, which has to select the thousands group, is in this system called the 1st GS and that, which has to select the desired hundreds group, is known as the 2nd GS. Thus the 10000-line system has one preselecting stage and three numerical selecting stages, of which two are group selectors and one the final selectors. The building up of a connection in a 10000-line system is effected as follows:— The preselecting

mechanism automatically sets itself on a free 1st GS. By means of the first impulse train the 1st GS is directed to the required thousands group, The second impulse train positions a 2nd GS, to which, as we know, the task is allotted of searching out the required hundreds group. The last two impulse trains are intended for the setting of the FS. In the four-digit subscriber's number of a 10000-line system, therefore, the

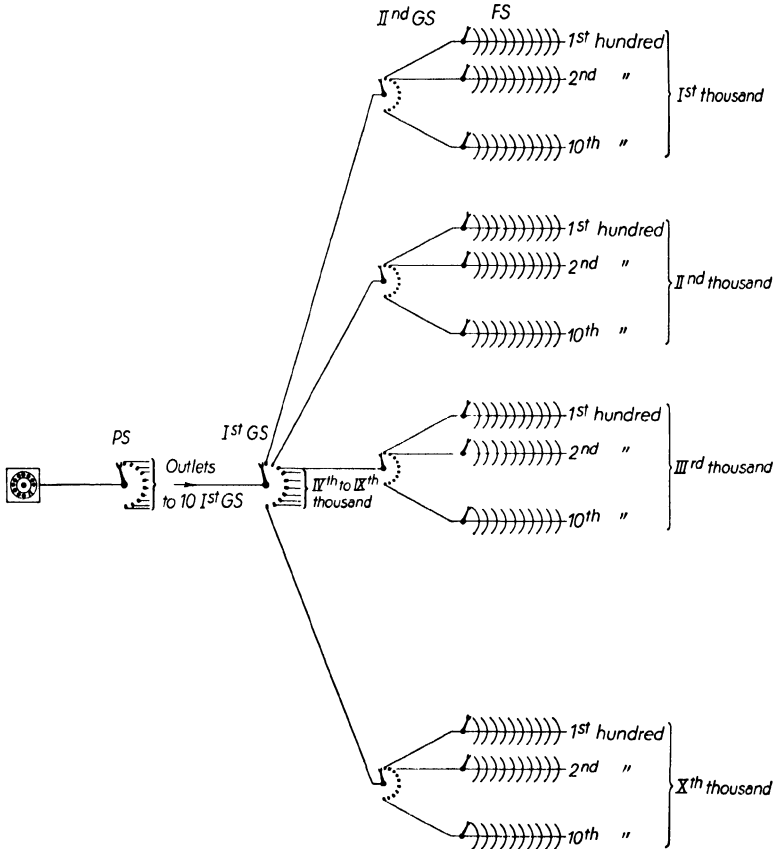

Principle of setting up a connection in an exchange having two stages of group selectors (10000-line exchange). The 1st and 2nd group selectors are normally 100-point two-motion switches, which for the sake of clarity are here shown as rotary switches.

first digit indicates the thousands group, the second the hundreds group and the last two digits are destined for the FS. Subscriber No. 55 in the second thousands group and the third hundreds group must consequently be given the number 2355.

100 000-line System

Following the same idea, in systems having more than 10000 lines yet another group has to be formed, *viz.*, for each 10000 lines. This new group formation necessitates a further GS stage, and thus all the subscribers' numbers have to be increased by one digit.

Million-line System

In the same way 100000-line groups are also formed. Thus is obtained an exchange with an ultimate capacity of a million lines and four GS stages. The subscribers' numbers in a million-line system, therefore, have six digits. Since a six-digit number is already comparatively difficult for many people to memorise, the first figure is often replaced by a letter and together with the second digit is set somewhat apart from the last four digits. A means 1, B means 2, C means 3, and so on. The subscriber's designation J 9 4170 is thus identical with the subscriber's number 994170.

Hunting in the Group Selector

Group selectors are mostly 100-pt two-motion switches. In group selectors the dial impulses affect only the lifting steps. Within the decade, as with the preselector, hunting is carried out, i. e., the wiper of the GS searches from contact to contact in the horizontal direction, until it has found from the whole of the connecting lines available to it, a free line to a FS or to the next GS rank. If there is no free connecting line, the switch rotates over all the contacts and returns to its normal position. Disconnection occurs, and the subscriber receives the busy tone.

Second Preselection

The traffic load on a system increases, when to every subscriber as large as possible a number of number receivers, i. e., group selectors

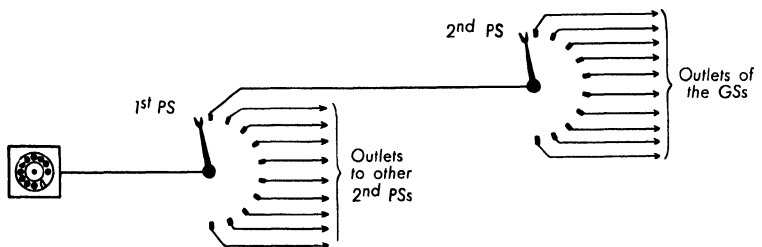

Theory diagram of a system with double preselection.

and final selectors are available. In large systems, therefore, a second preselecting stage is added, which in principle operates as follows: The 1st PS, as we know, has ten contacts and therefore ten outlets to the 1st GS. Thus of its own accord it can reach ten GSs successively. If these ten GSs are busy, disconnection occurs, i. e., the connection is not completed. If now to each of the ten contacts of the 1st PS we connect not the actual connecting lines to the GS, but yet another 10-pt rotary switch, which at every step can reach a GS, it is evident that $10 \times 10 = 100$ GSs can be reached automatically. Thus in an exchange for 1000 subscribers with 10 p. c. GSs all the 100 GSs are available to every subscriber. This means the greatest possible occupancy of the switches and the avoidance of losses, by which are meant connections that have not been completed, because there were not sufficient switches available, or because assistance was not provided by switches belonging to other groups not so heavily loaded.

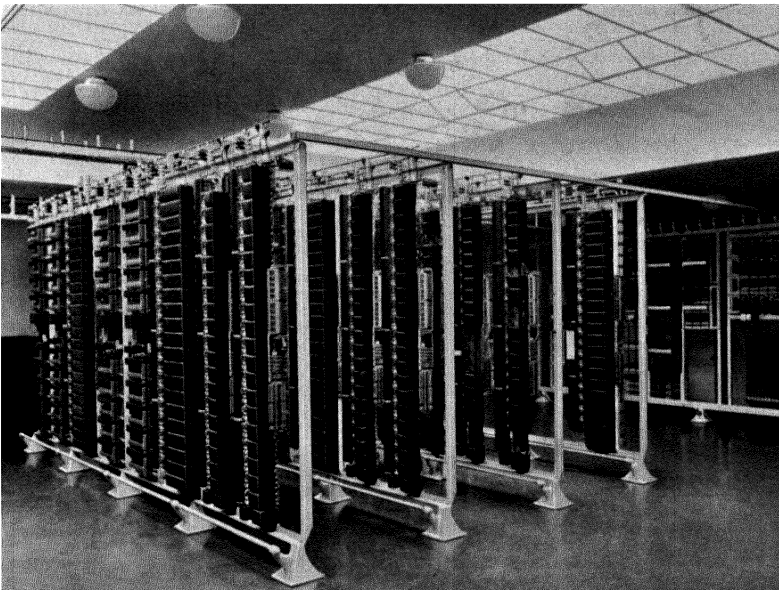

View of the switch-room of a large exchange.

Private Branch Exchange Systems.

(Concern Telephone Systems.)

Private branch exchange systems are concern telephone systems. Under this heading are included combined telephone exchanges, to which essentially two tasks are allotted:

1. The handling of telephone connections for internal service (internal traffic).
2. The setting up of connections from and to the public telephone exchange with the extensions (exchange traffic).

It is desirable first of all to explain some of the terms repeatedly used in the following sections.

Exchange Line. This is the connecting line between the exchange equipment in the public telephone exchange (abbreviated to exchange) and the P.B.X. switchboard or the main station; it is placed at the disposal of the subscriber for a fixed monthly fee.

Main Set (Main Station). This is the subscriber's station, to which the exchange line is directly connected. A subscriber may have several main sets.

Extension Stations are stations which, without being main sets, can be connected to the exchange lines by means of special apparatus (private branch exchange). Several extensions may be associated with one exchange line, but the exchange line should not be overloaded. The number of exchange lines required is ascertained from the conversation frequency of the extensions. Experience has shown that one exchange line can accommodate about four to six extensions. In addition to the call fees each extension is subject to an extension fee specified in the Post Office scale of charges.

P.B.X. Switchboard. This apparatus is used to deal with all connections between the exchange lines and the extensions, among the extensions themselves and with house stations. In Germany P.B.Xs. are manufactured by private firms. The subscriber's system can be installed by private firms or by the Post Office, and the subscriber can acquire a P.B.X. system by purchase or can rent it.

House Stations are stations, which must not be connected to the exchange lines. Thus they are used purely for internal traffic. They can be connected to extension stations, which are always house stations also. No fees have to be paid for house stations.

External Extension Stations. These are extensions, which are located on premises situated apart from the P.B.X. switchboard. The Post Office provides the line between the external extension and the premises, in which the main station is situated, on a rental basis (line owned by the Post Office).

Extension Stations with restricted Exchange Facilities. As far as the Post Office is concerned, these stations count as normal extensions. Only from the technical point of view are they distinguished from extension stations with full exchange facilities, in that they cannot set up connections to the exchange without the assistance of the operator, whereas—as will be discussed later—the extensions with full exchange facilities themselves appropriate the exchange lines. By wiring changes, however, extensions with restricted exchange facilities can at any time be converted to extensions with full exchange facilities.

Tie-Lines. By tie-lines are understood the connecting lines between two service telephone systems on different premises. The traffic between the two systems is carried on without passing through the public exchange.

Incoming and Outgoing Traffic. The calls coming in from the exchange are “incoming traffic”; calls to the exchange are on the other hand “outgoing traffic”. Exchange lines may be operated at will as incoming, outgoing or mixed lines. This means that of all the available exchange lines some may be arranged purely for outgoing traffic, others purely for incoming traffic and yet others for both incoming and outgoing traffic.

Until a few years ago the P.B.X. switchboard and the house exchange were kept separate from each other. That is an uneconomic arrangement, because two different exchanges and a double subscribers' network were required. Moreover, for every subscriber, who was entitled to house

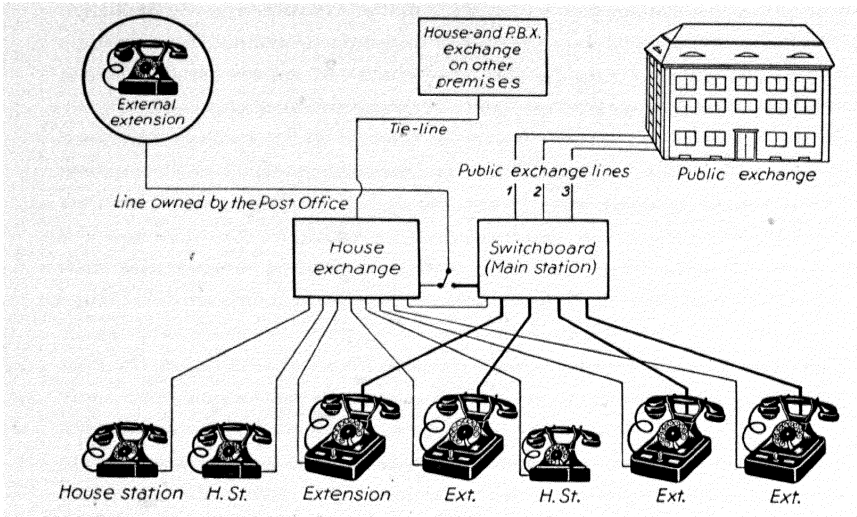

Concern telephone system with separate house- and P.B.X. exchange equipment (Double-loop principle).

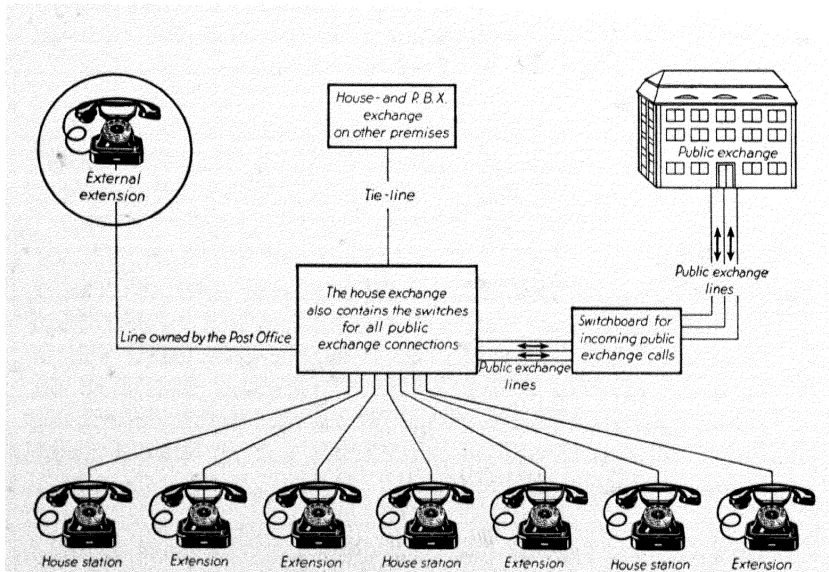

Concern telephone system with common house- and P.B.X. exchange equipment (Single-loop principle).

and exchange facilities, two stations had to be installed. In modern service telephone systems all connections are set up from *one* exchange. The network is simple and accessible, because both exchange and house calls are carried over the same lines. The subscribers' instruments also serve both for house and for exchange traffic. The decision that house stations shall have no connections to exchange lines, is taken care of by circuit arrangements on the switchboard.

The importance of P.B.X. principles is evidenced by the fact that more than 40 p.c. of all the telephone stations in Germany are extensions and that by far the greatest proportion (about 60 p.c.) of the calls, which are handled in the public telephone exchanges, emanate from P.B.X. systems.

Siemens & Halske manufacture P.B.X. systems of all sizes and various systems, in order to be able to offer the equipment, best suited to extent and character of the undertaking concerned. Although the trend of development in P.B.X. engineering is more and more towards the Neha principle, some of the previously normal equipments have maintained their importance to a considerable degree. Their essential characteristics will, therefore, be described in the following sections.

Intercommunicating Systems.

(Series-Connected Systems.)

Series-connection of the exchange line means that the exchange lines are carried to each extension in series. According to the Post Office regulations current in Germany, however, the line may only be looped through a maximum of 15 stations. Each extension subscriber sets up outgoing exchange connections by pressing his exchange key, which is repeated on the station as many times as there are exchange lines available. Incoming calls are accepted by a station, which is arranged as main station, and are passed on to the required extension in various ways according to the nature of the system. The answering and passing on of the call is a simple operation, which takes little time and can be performed in a lobby in the concern by any porter, registrar, secretary or any other person. The internal house traffic is generally arranged on the line selector principle. Frequently also an automatic exchange is used as the

Basic Meaning

exchange for the house traffic; this exchange can then be coupled in a suitable manner to the exchange series-connected system.

Series-Connected System

Of the collection of series-connected equipments the Reiha system is the smallest. The word "Reiha" means **Reihenschalt-Hausanlage** (series-connected house system). Its maximum capacity is one exchange line and five stations. In addition to the microphone, the receiver and

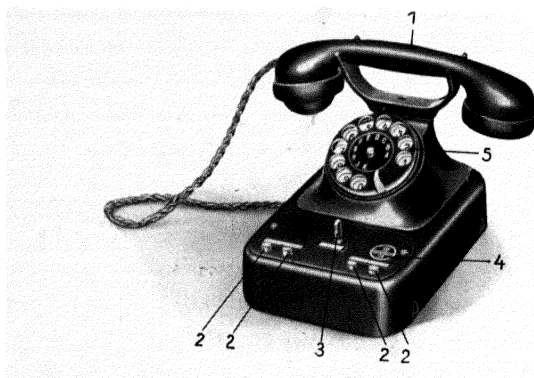

Reiha station.

- | | |
|------------------------|-------------------------|
| 1 = Handset | 3 = Public exchange key |
| 2 = House calling keys | 4 = Engaged indicator |
| | 5 = Dial |

the dial (the latter for dialling exchange subscribers), the stations are equipped with an exchange and listening key, a busy indicator and four, recently five, house ringing keys.

Outgoing Exchange Call

The busy indicator, a rotary indicator on the principle of the galvanoscope, is associated with the exchange line and is automatically switched on at all stations, as soon as the exchange key on any station has been thrown to the "exchange" position. By this latter operation the exchange line is seized and marked as busy on all stations by means of the indicator. As soon as the exchange line is released, the indicator is again automatically disconnected.

Incoming Exchange Call

A call coming from the exchange switches on the bell in the main station. After lifting the handset and throwing the key to "exchange", the call is answered. Assume that station No. 2 is required. The exchange

switch is thrown to the enquiry position (see page 50), station No. 2 is rung by pressing line key No. 2 and is notified that there is an exchange call waiting. As soon as extension No. 2 lifts the receiver and throws the exchange key to the "exchange" position, it is connected to the calling exchange subscriber. At this moment also the busy indicator at the main station appears and is a signal to it that the connection has been correctly completed and that its receiver can be replaced.

Calling the Extension

Stations without exchange facilities (house stations) can also be connected to a Reiha system. For this purpose simple battery stations are used, which normally can only speak internally with one station, and that station is as a rule the main station. The battery station has no dial, because from it no connection can be made to the exchange line and thus there are also no selectors to be positioned in the public exchange.

House Stations

An external extension, e. g., in the residence of the head of the concern, can also be connected to the Reiha system. For the switching arrangements two methods are usual: One is described as the manual method and even for outgoing calls requires the assistance of the main station. The automatic auxiliary equipment for external extensions, on the other hand, offers the same traffic conditions as a normal internal extension, i. e., automatic connection of the exchange line.

External Extensions

At temporarily unattended main stations an exchange call is automatically switched through to the external extension after about 25 seconds.

Passing on an Exchange Call from an unattended Main Station

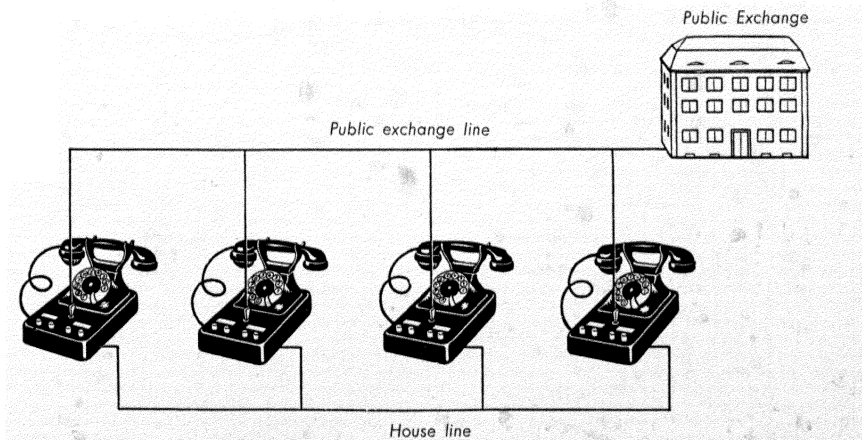

Schematic diagram of a Reiha system.

At times when the main station is unstaffed, the exchange line is directly connected to the external extension by setting the key on the auxiliary apparatus.

House Traffic The internal house traffic is carried over the line network, the wanted station being rung by pressing the relevant ringing key. The connection is completed as soon as the handset is lifted.

Enquiry During the course of an exchange call the extension can enquire another extension over the house line network. For this purpose the exchange switch is thrown to the in-between position, and the exchange line is "held". The setting up of the in-between connection is thereafter the same as for an ordinary house call. By restoring the key to the "exchange" position the house connection is broken down and the exchange connection restored.

Listening Facility Privileged stations can be given the listening facility. It is obtained by pressing a "listening key". The listening control is secret.

The Reipos System The next larger representative of the collection of series-connected systems is the Reipos system. It has a capacity of up to two exchange lines and ten stations. In the method of dealing with the exchange and house traffic there is no material difference from the Reiha system.

Enquiry Facility on the second Exchange Line In addition to the internal enquiring facility already mentioned, an enquiry on a second exchange line can also be made with a Reipos system having two exchange lines. In this case also, as with every enquiry facility, the subscriber waiting on the first exchange line cannot, of course, overhear the in-between conversation.

Reipos station.

- 1 = Handset
- 2 = Dial
- 3 = Ringing keys
- 4 = Exchange keys
- 5 = Enquiring keys
- 6 = Engaged indicator

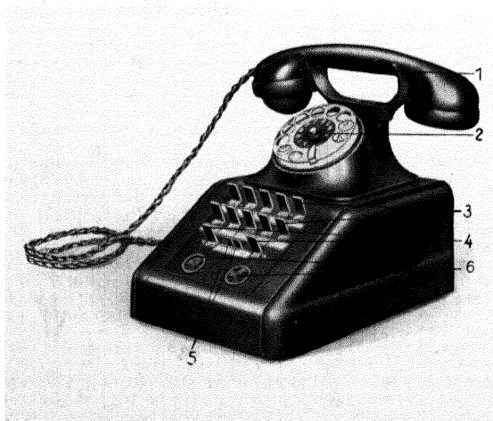

The subscribers' stations have, in addition to the two exchange keys and the indicators, as many line keys as there are lines available. The outgoing and incoming exchange traffic as well as the internal house traffic is carried on in a similar manner as with the Reiha system or with the intercommunication system described on page 15 and the following pages.

*The Subscribers
Stations*

The connection of external extensions is also possible, and again either by the technically simpler manual method or by the more convenient automatic method. Since there are two exchange lines, there may also be two external extensions. By means of the automatic auxiliary equipment the enquiring facility can also be provided between two external extensions. Assume that external extension No. 1 is speaking to the exchange and during the course of the conversation desires to enquire to external extension No. 2. By pressing the enquiry key, which is fitted to all external extensions, the in-between connection is built up, and by pressing the key a second time it is broken down again.

*External
Extensions*

If required, Reipos stations can be supplied fitted with listening keys, which permit to the stations thus equipped an imperceptible supervision of the conversations conducted on the exchange lines.

Listening Facility

The series-connection of the exchange lines and the automatic exchange for house traffic, those are the two important characteristics of the Reiaut system. The exchange portion of the stations is similar to that in Reipos systems. For every exchange line there is an exchange

*The Reiaut
System*



Reiaut station.

- 1 = Handset
- 2 = Dial
- 3 = Exchange ringing key
- 4 = Exchange keys

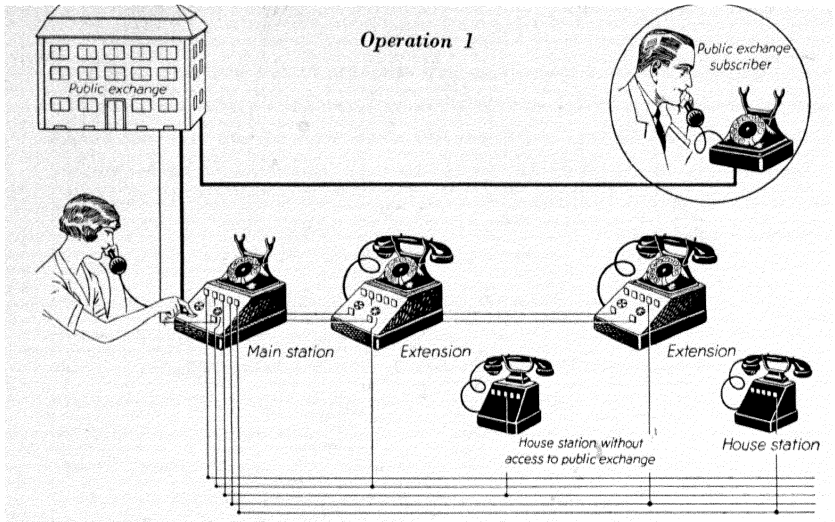

Schematic diagram of the function of a Reipos system.

A public exchange subscriber is ringing up. The public exchange has set up the connection to and rung the main station. The operator at the main station presses a public exchange key indicated by a rotary indicator fitted on the pedestal of the instrument. She is thereby connected to the public exchange subscriber and makes a note of his requirements (she answers the call). At all stations, with the exception of the main station, the engaged exchange line is indicated as "busy" by means of the star indicator.

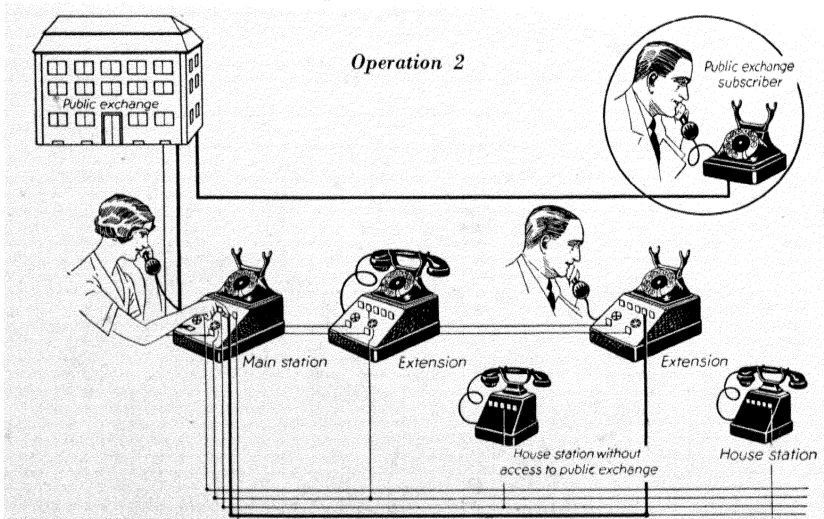

The public exchange subscriber desires connection to an extension. The operator at the main station informs the relevant extension subscriber via the house line, on which exchange line he is required. The indicator associated with exchange line 1 indicates "busy" at all stations with the exception of the main station.

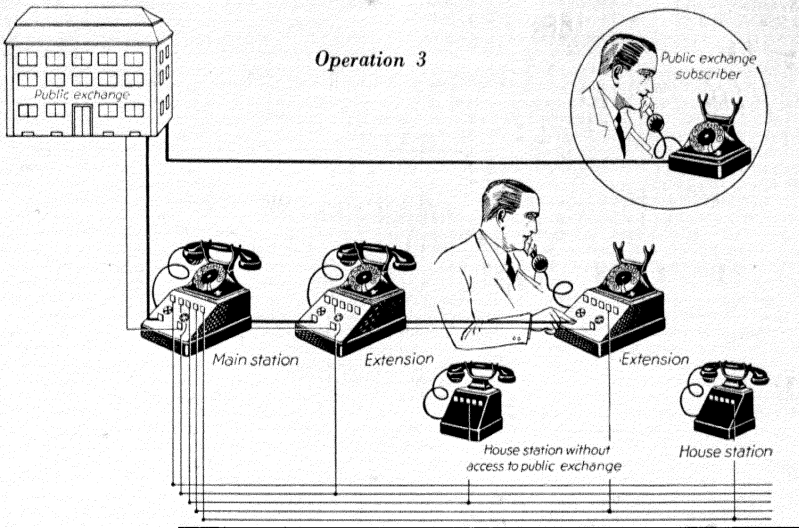

The extension subscriber has made connection to the exchange line indicated to him. The operator, who was notified of this by the indicator, is free to carry on her other duties. At the main station also the engaged exchange line is now marked as "busy"

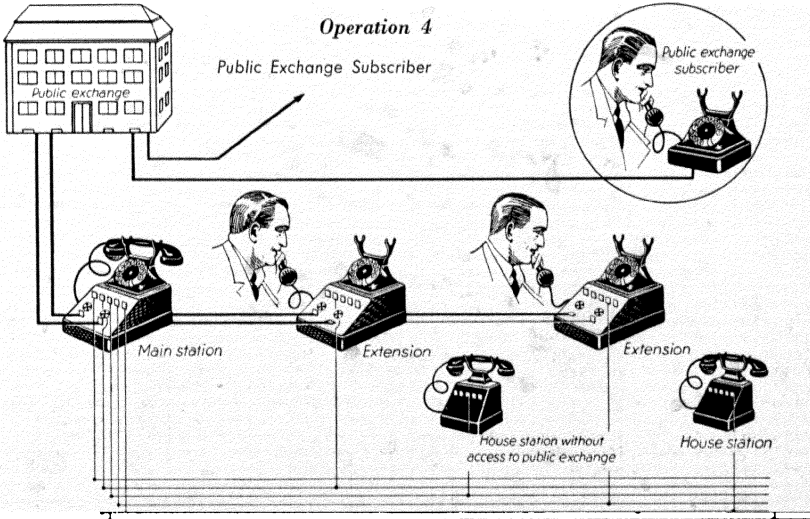

During the succeeding conversation another extension also wants to make an exchange call. By pressing the exchange key associated with the second exchange line he is immediately connected to the exchange. Thus for outgoing calls there is no sort of exchange operation to be performed at the main station. Now the indicators belonging to the second exchange line also stand at "busy" on all stations.

key, and in place of the previous rotary indicators supervisory lamps are provided. The maximum capacity of the Reiaut system is 4 exchange lines and 15 extensions. The number of house stations is unlimited. The notification of the extensions that there is an exchange call waiting,

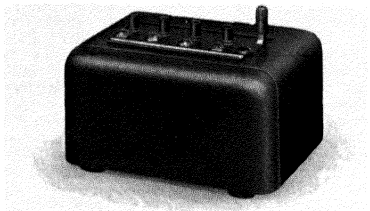

Auxiliary apparatus for exchange enquiry, containing also the exchange calling lamps.

is effected in the known manner via the switches in the house exchange. The connection of external extensions, the listening facility, the enquiry facility within the concern and on other exchange lines are provided in the same way as with the previously described series-connected systems.

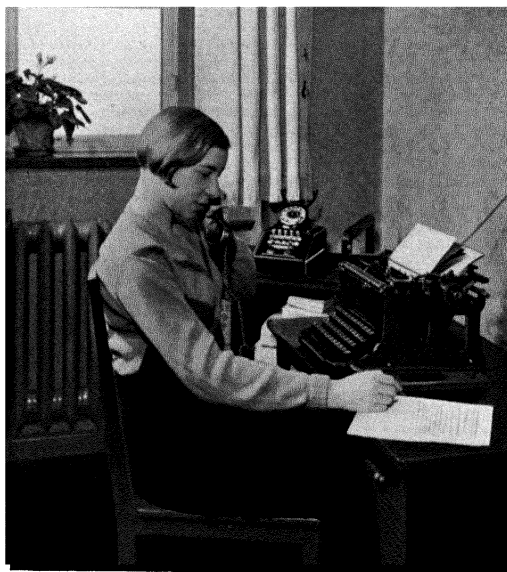

Main station of a Reipos system in the secretariat.

Private Branch Exchange Systems with Central Exchange Equipment.

In the long series of these P.B.X. systems a distinction is drawn between:—

Manual P.B.X. Systems. All connections, both internal and with the exchange, are set up by hand.

Automatic P.B.X. Systems, where all exchange and house connections are dealt with entirely or partly by selectors.

Manual P.B.X. Systems.

According to the size of the system, which is fixed by the number of exchange lines, extensions and house stations, the case of an Okli exchange is made up as a wall-type or as a floor-type switchboard. *Okli Exchange**

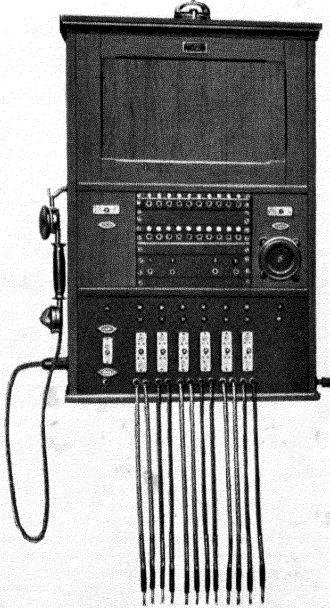

Wall type Okli switchboard (Okli = Offene Klinken = open jacks) for 4 exchange lines and 20 extensions.

The extension and house lines are terminated on jacks in the jack *Equipment of the Exchange* field, the exchange lines on exchange jacks. The essential items in an

exchange of this type are cord pairs with answering and connecting plugs, answering and ringing keys, lamp sets for calling and clearing signals and the answering handset for the operator. The relay sets for controlling the various switching operations are conveniently and accessibly arranged in the switchboard.

The Network

The line network is a single-loop network, i. e., both the exchange and the internal calls are carried from the extensions on the same wires.

The Subscribers' Stations

The stations are so-called C.B. stations (central battery stations) with or without dials, according as to whether the public exchange is automatic or not. In the house stations there are no dials, because, as we know, they can obtain no connections to the exchange lines and consequently do not have to dial any exchange subscribers.

The condition, that house stations may never be put into connection with exchange lines, is still fulfilled by circuit arrangements at the switchboard.

House Traffic

Extensions can be connected not only to exchange lines and to other extensions, but also to house stations. Likewise house stations can speak

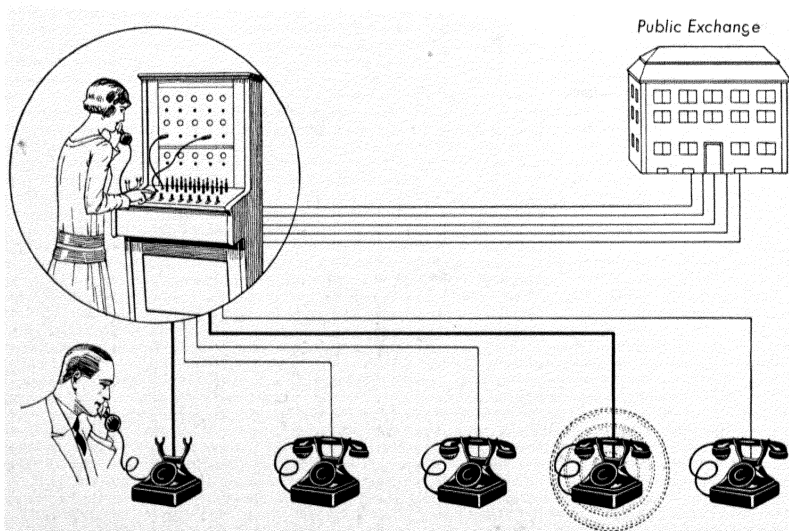

Schematic diagram of the function of an Okli system (Operation 1).

Setting up an internal connection (Connecting and ringing).

The connection is set up by the connecting plug being inserted after the answering plug into the wanted subscriber's jack. By throwing the switching key to the position "ring" the wanted subscriber is rung.

to extensions. This internal traffic is dealt with by the operator with answering and connecting plugs in the manner already described on page 18 and the following pages. It is not, therefore, necessary to discuss again the details of the establishment of a connection.

From the technical point of view the obtaining of an exchange connection differs from the building up of an internal connection only in this, that the operator inserts the connecting plug into a free exchange jack instead of into a subscriber's jack. The extension subscriber is thereby connected to the public exchange and there asks for the wanted subscriber or, in the case of an automatic exchange, dials the wanted subscriber's number. At the conclusion of the conversation the replacing of the hand set causes the clearing lamps to glow in the P.B.X. switchboard. The connection is then already broken down, although the plugs are not yet withdrawn.

Outgoing Exchange Traffic

The dialling of the exchange subscriber's number can also be undertaken by the P.B.X. switchboard. For this purpose the switchboard is equipped with a so-called dialling plug, which, inserted into the dialling jack of the relevant exchange line, connects the switchboard dial to the

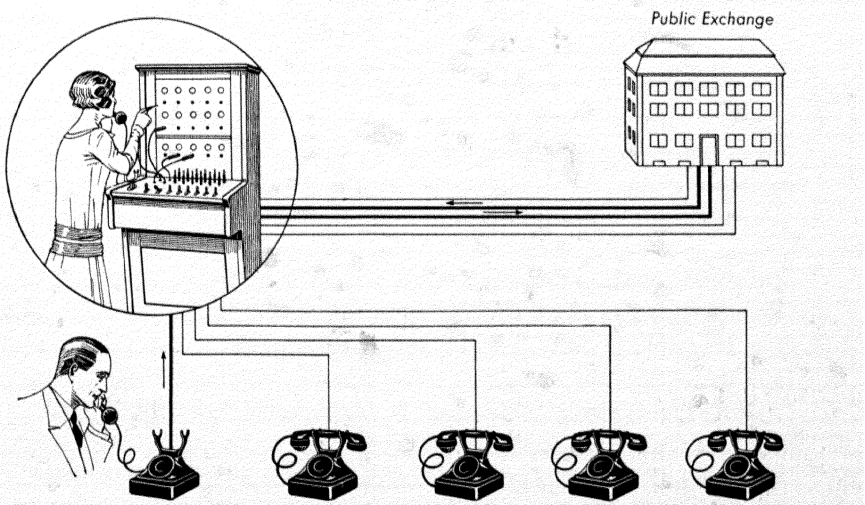

Schematic diagram of the function of an Okli system (Operation 2).

Connection from and to the public telephone exchange.

It is shown how during an existing exchange conversation a second (incoming) exchange connection is set up. The answering plug of the second line is already inserted. The switch is in the "answering" position.

exchange line and thus enables the exchange subscriber to be dialled. Every exchange line has associated with it a dialling jack.

*Incoming
Exchange Traffic*

The exchange call switches in the exchange calling lamp associated with every exchange line and the common calling bell (which can be disconnected). The call is answered by inserting an answering plug into the exchange jack indicated by the calling lamp. The connection to the extension subscriber is obtained with the help of the connecting plug belonging to the same cord pair. The extension is rung by throwing the ringing key.

Enquiry

For every extension subscriber with the enquiring facility the normal equipment provides a second line loop to the exchange and a second



Station with house exchange-key and flashing key for extension subscriber having the enquiring facility.

The public exchange is of the automatic type.

connection (jack) on the switchboard. In this case the station has a change-over device, that is a switching key, with which one or the other loop can be seized at will. The calling signal appears at the switchboard, and the in-between connection is set up in the same manner as in internal traffic. The exchange subscriber is disconnected from the handset of the extension subscriber by throwing the switching key, and cannot, therefore, overhear the in-between conversation. By restoring the switching key the connection to the exchange subscriber is set up once more.

Call Transfer

If during the course of a conversation an extension subscriber desires to transfer an exchange call to another extension, he has to initiate this operation by throwing the switching key to the in-between position. In

order to prevent the exchange connection from being broken down prematurely, the dialling plug has to be inserted into the dialling jack associated with the exchange jack already seized. Then the switchboard operator withdraws the connecting or answering plug from the first extension subscriber's jack and inserts it into the other extension jack.

For privileged subscribers exchange lines can be connected to special so-called series stations. They operate on the same principle as series-connected stations and thus enable an exchange line to be directly seized, i. e., the switchboard is by-passed. If all the exchange lines running through a series station are already engaged, the attention of the switchboard operator can be attracted by pressing a key; the call is then dealt with in the normal manner.

Okli switchboards can be constructed for as many exchange lines and subscribers as desired. On multi-position switchboards the subscriber and exchange jacks are multiplied in the known manner.

The nature of many concerns, e. g., hotels, boarding-houses, hospitals, sanatoria, necessitates a telephone equipment with a manual exchange, because in such cases the operator has to a large extent to perform the duties of an information bureau, and because also a check has to be kept on the exchange or trunk calls made by the guests or patients for the purpose of calculating the fees due. For this reason the further development of manual P.B.X. systems has not been neglected, but has been energetically pursued. In the first place the manual operations required for the setting up of a connection must be reduced to a minimum. Attention must then be given to service requirements of recent origin, e. g., the enquiring facility on a double line, the transfer of calls, the connection of external extensions, night switching and the like. Finally, by using suitable materials and designs for the apparatus space and money must be saved.

*Indicating
Switchboard*

In the indicating switchboard these requirements are all fulfilled, and it may, therefore, be described as the most modern purely manual telephone exchange.

In this switchboard a mixed single-cord-double-cord principle is employed. The exchange lines are dealt with on the single-cord principle for both directions of traffic; all internal connections, on the other hand,

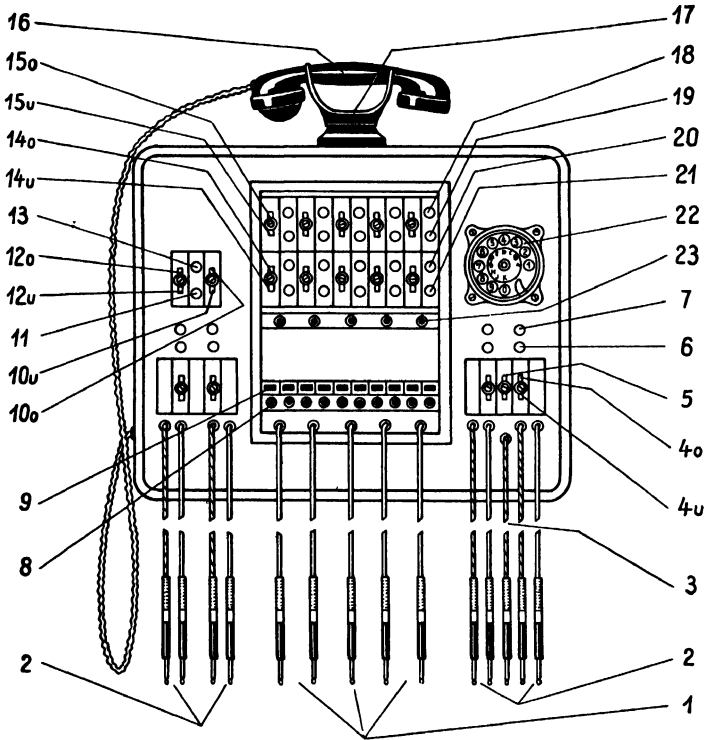

Schematic diagram of an indicating switchboard for house and public exchange traffic.

- | | |
|---|----------------------------------|
| 1 -- Exchange plug | 12u -- General night key |
| 2 == House plug pairs | 13 - Calling supervisory lamp |
| 3 == Auxiliary plug | 14o -- Extension ringing key |
| 4o -- Ringing key | 14u == Exchange answering key |
| 4u -- Answering key (house) | 15o == Holding switch |
| 5 == One-position ringing key | 15u -- Night key |
| 6 == Clearing lamp (called subscriber) | 16 -- Handset |
| 7 == Clearing lamp (calling subscriber) | 17 == Cradle |
| 8 == Extension jack | 18 -- Exchange clearing lamp |
| 9 == Calling indicator | 19 -- Extension supervisory lamp |
| 10o == Exchange ringing key (LB) | 20 = Busy lamp |
| 10u == Enquiry key | 21 == Exchange calling lamp |
| 11 = Fuse supervisory lamp | 22 = Dial |
| 12o == Bell disconnecting key | 23 - Enquiring jack |

follow the double-cord principle. The latter is already known from the description of the Okli switchboard. In the single-cord principle the incoming line is terminated not on a jack, but in a plug. When a call has come in and has been answered, the plug is simply inserted into the wanted subscriber's jack.

*Incoming
Exchange Traffic*

In the outgoing direction the procedure is such that the next free exchange plug is inserted into the jack of the subscriber wanted by the exchange line, the call having been previously answered. Since, when accepting the call, the operator does not know whether the calling extension subscriber wants an exchange or an internal connection, the answering operation is performed with a free house answering plug. If the exchange is wanted, this answering plug is simply replaced by a free exchange plug. If an internal connection is to be set up, the answering plug is left in the jack, and the connecting plug is inserted into the jack of the wanted extension or house subscriber.

*Outgoing
Exchange Traffic*

If an extension is found to be busy and the exchange subscriber is willing to wait, the call can be stored for a certain time by throwing

Holding Circuit

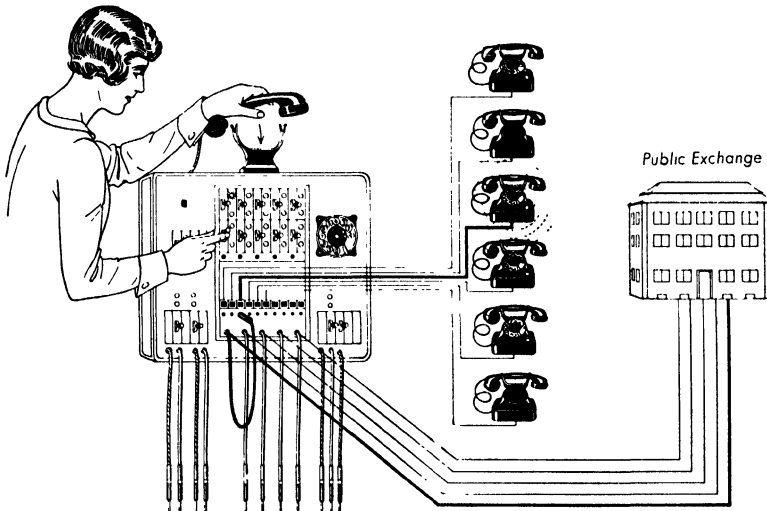

*Schematic diagram of the function of an indicating switchboard (Operation 1).
Dealing with an exchange call.*

After answering the call the exchange plug is inserted into the jack of the wanted subscriber. The extension ringing key is thrown. The supervisory lamp glows until the handset at the extension is lifted.

the night key to the "hold" position. During this waiting time, the exchange busy lamp is continuously switched on and off by a relay in order that it may be controlled by the operator. Experience has shown that more attention is paid to this flashing signal than to a continuously glowing supervisory lamp.

Enquiring during an Exchange Call

To initiate an enquiry, the enquiring key to be found on every extension must be pressed. On receipt of the flashing signal thus produced at the switchboard, the operator sets up a connection to the extension by means of a house answering plug, which she inserts into the enquiring jack belonging to each exchange line. The connecting plug of the same cord pair is then inserted into the jack of that house or extension subscriber, with whom the in-between conversation is to be conducted. At the end of this conversation the enquiring key is again pressed, thus causing the connection to the exchange subscriber to be immediately restored, without the in-between connection having to be first broken down by the operator.

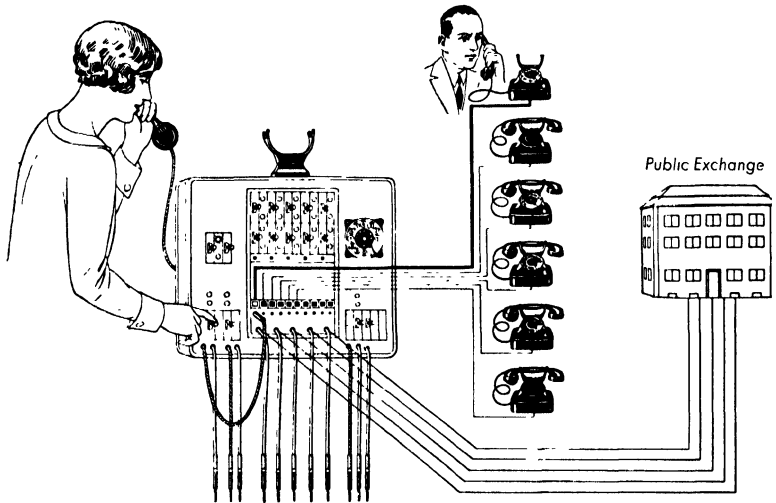

Schematic diagram of the function of an indicating switchboard (Operation 2)

An extension subscriber desires a connection.

When he lifts his handset, the calling supervisory lamp glows, and the indicator at his jack appears. The operator inserts the answering plug of a free house cord pair into the jack indicated and sets up the connection to the house subscriber by operating the answering key associated with the house cord pair.

If the exchange call is to be transferred to another extension, the exchange plug is simply inserted into the jack of the second extension subscriber. The premature release of the exchange connection is prevented by seizing the enquiring jack.

*Transferring
a Call*

Internal house connections are set up in the known manner via the answering and connecting plugs.

House Traffic

When all the house cord pairs are in use, the operator can set up a connection to the calling party by means of the auxiliary plug and allot him a free exchange line.

Auxiliary Plug

Since every station is arranged on the single-loop principle, i. e., is connected to the switchboard by one a/b line, external extensions can be connected without special auxiliary switching apparatus. They have the same traffic facilities as internal extensions.

*External
Extensions*

During the night or while the operating staff is absent, the exchange lines can be directly allotted to certain extensions, so that calls reach the

Night Circuit

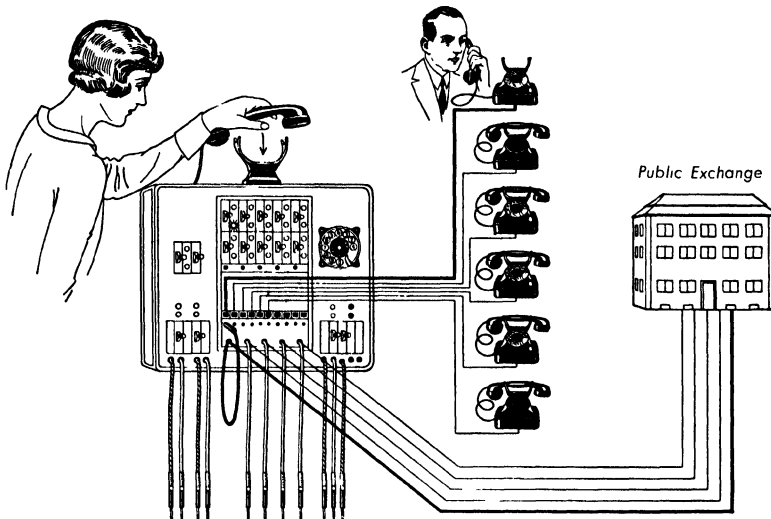

*Schematic diagram of the function of an indicating switchboard (Operation 3).
Connecting the extension to the exchange.*

The house subscriber asked for an exchange connection. By exchanging the house answering plug for a free exchange plug this connection is set up. The exchange is automatically rung; a supervisory lamp glows until the exchange answers.

extension immediately, without being answered or switched through. This is done by the plugs of the exchange lines shown in the telephone directory as night numbers being inserted into the jacks of the extensions, which are to function as night stations. In addition, the night key has to be thrown to the "night" position, so that the clearing lamps at the switchboard do not remain continuously in circuit.

Indicating switchboards are designed for a capacity of up to 5 exchange lines and 50 extensions. All connecting sets and relays are contained in metal cases ($20\frac{1}{2} \times 16 \times 12$ in.). The small space requirements permit the use of table type equipment.

For internal calling signals the apparatus used is not incandescent lamps, but indicators that are extremely reliable and involve low operating costs and little space. It is from these new-type indicators also that this switchboard derives its name.

Automatic P.B.X. Systems.

General As is well known, private branch exchanges have essentially two basic tasks to perform, namely the handling of the internal house connections and the handling of exchange calls in both directions. In most concerns the internal house traffic is numerically the most important; indeed in many systems experience has shown that it accounts for up to two-thirds of all the connections. The rest is made up of outgoing and incoming exchange traffic. The setting up of the internal house connections and the setting up of the outgoing connections to the public exchange are carried out entirely automatically in these systems. The incoming exchange traffic is also to a large extent automatised, i. e., an operator is indeed necessary for setting up the connection, but in Neha systems and cordless switchboards, for example, she has nothing to do with supervision and clearing or with transfers or in-between connections. She is thus to a certain extent merely an information position, where the calling party is enquired, to whom he should be connected, and has to initiate the setting up of the connection by pressing a key or by dialling according to the nature of the system employed. Even when using P.B.X. boards, where the operator has to switch through incoming calls by means of plugs and cords, her duties require but little time, because various functions, e. g., the calling of the extension subscriber and the setting up of in-between connections, are as a rule automatically performed.

Frequently the connections do not need to be broken down immediately on the conclusion of the conversation, because disconnection has already been performed by the replacing of the handset, and the connecting plugs can be withdrawn from the jacks, when there is time to spare. The subscribers' apparatus is immediately released for other connections.

What is the meaning of P.B.X. boards? In automatic P.B.X. systems, as is well known, internal house connections and outgoing exchange connections are set up entirely automatically by the selectors. Incoming exchange connections, on the other hand, are switched through by means of plugs and cords in systems having P.B.X. boards, i. e., the exchange line is connected to the subscriber's line between the subscriber's station and the first selecting stage, or in other words the exchange line is "connected in series" with the selectors. The arrangement becomes clear, if the theory diagrams on pages 66 and 67 are studied. The "series-connection" of the exchange call among other things brings the advantage that the selectors at the switchboard are not required for this direction of traffic.

*B. P. X. boards
(Double-Cord
System)*

In their external appearance the P.B.X. boards are similar to the normal manual exchanges, as already described in earlier sections. The equipment includes jacks, plugs and cords, answering and enquiring keys, calling, busy and clearing lamps, operator's handset, calling bell and a dial for the setting up of connections to the house stations or for the setting of the selectors in the public exchange to provide for

*Equipment of the
B. P. X. board*

Answering plug, connecting plug, key and lamps on a double-cord P.B.X. board.

- | | | | |
|----|-----------------------|----|----------------------------------|
| 1 | Extension jack | 9 | = Answering key |
| 2 | = Designation plate | 9a | = "Extension" answering position |
| 3 | = Extension busy lamp | 9b | = "Exchange" answering position |
| 4 | = Exchange jack | | |
| 5 | Exchange calling lamp | | |
| 6 | = Exchange busy lamp | | |
| 7 | = Answering plug | | |
| 7a | = Connecting plug | | |
| 8 | = Clearing lamp 1 | | |
| 8a | = Clearing lamp 2 | | |

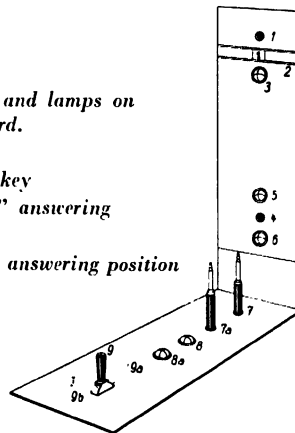

the case, where the extension itself does not wish to dial or where the operator herself desires to make an exchange call. Many equipments are also fitted with a listening plug, with which the operator can intervene in an existing connection. Suitable keys and signals are also provided for the operation of record circuits.

*Incoming
Exchange Traffic*

As usual, the calling of the exchange switches on the exchange calling lamp and the calling supervisory bell (which can be disconnected). The call is answered by inserting the answering plug of a free cord pair into the exchange jack indicated by the calling signal and throwing the answering key to the "exchange" position. The connection is then switched through by inserting the connecting plug into the jack of the extension subscriber to be called.

Ringling is carried out automatically by a switching mechanism in the P.B.X., which applies alternating current to the subscriber's line at regular intervals.

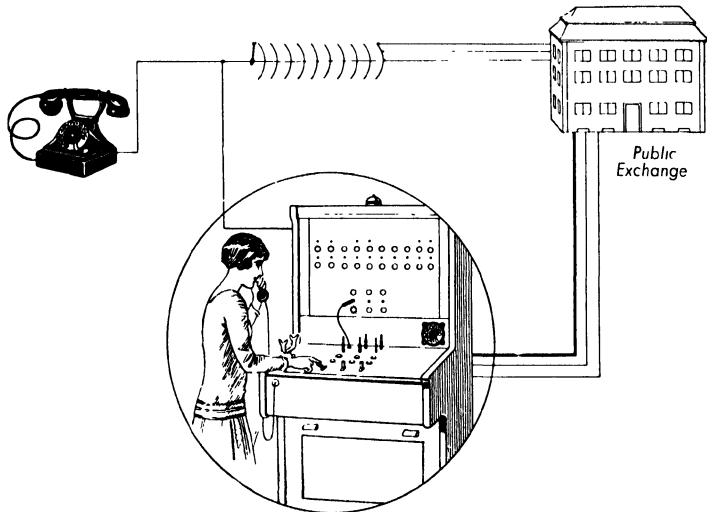

*Schematic diagram of the function of a double-cord P. B. X. board
(Operation 1).*

Incoming exchange call (answering): -- The calling of the exchange causes the exchange calling lamp to glow. The operator inserts the answering plug into the exchange jack indicated and answers the call in the manner already described (lifts the operator's handset and throws the answering key).

In systems having extension break jacks, which are, however, only seldom used, any existing connection is immediately cleared by inserting the plug. First of all, therefore, the operator has to test for free or busy with the tip of the plug. Such testing is superfluous, when the switch-board is equipped with extension busy lamps. These light up, as soon as the relevant subscriber commences a call. And in this respect it is immaterial whether the call concerned is a house or exchange one. With the help of the listening plug the operator can enter the connection and request the conversation to be terminated. The subscribers are made aware of such an intervention by a ticking signal. If the wanted subscriber is engaged in an outgoing exchange call, the exchange connection intended for him can be held by means of the holding jack, until he is free. During this waiting time one of the clearing lamps glows as a supervisory lamp, and until the handset is lifted, it lights up with the same rhythm as the actual calling. When subscribers' parallel jacks are used, the operation is similar, except that the existing connection is not cleared. If no subscribers' busy lamps are provided, the operator recognises that a line

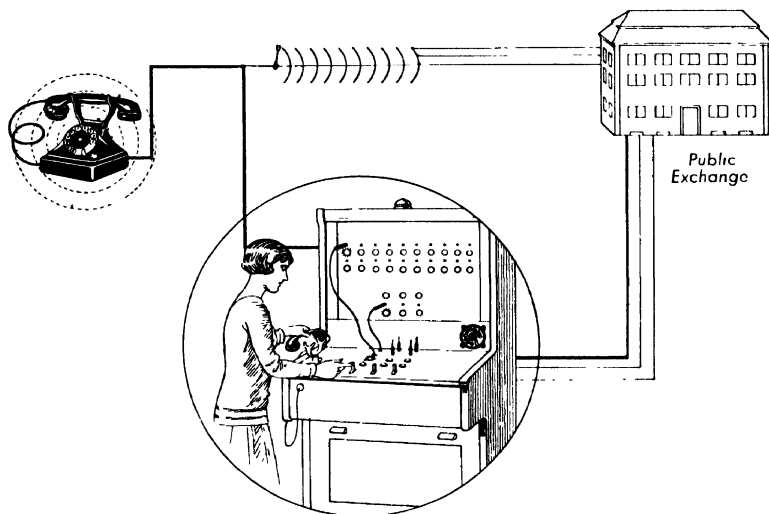

*Schematic diagram of the function of a double-cord P.B.X. board
(Operation 2).*

Incoming exchange call (connecting): — The connecting plug was inserted in the jack of the wanted extension subscriber. This operation caused the extension line to be switched in series with the house exchange. The answering key is restored to its normal position.

is busy from the fact that at the moment of inserting the connecting plug one of the clearing lamps lights up. The connecting plug can be left in the jack, because at the conclusion of the existing conversation the waiting exchange line is automatically switched through. The switching in of the operator's telephone set is notified to the subscribers by a ticking signal.

Clearing the Connection

The restoration of the handset at the conclusion of the call causes both clearing lamps to light up. The connection is then already cleared, although the plugs have not yet been withdrawn from the exchange or extension jacks. Immediately after the restoration of the handset, therefore, the extension subscriber can set up a fresh connection or can be immediately called again. The operator withdraws the plugs, as soon as she has the time.

Outgoing Exchange Traffic

The exchange lines for outgoing traffic and those for mixed traffic are terminated on a decade of the FS or GS according to the system

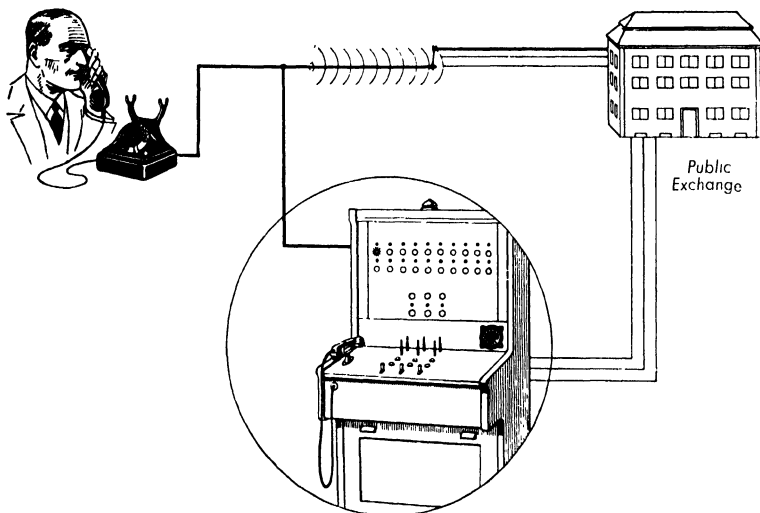

Schematic diagram of the function of a double-cord P.B.X. board (Operation 3).

Outgoing exchange connection: — The subscriber has only to lift his handset and dial the exchange number. To provide supervision for the operator, the extension busy lamp glows. The inclusion of this signal is often omitted.

used in the house exchange. For this purpose the last (10th) decade of the 1st GS or of the FS is used in most cases. As we know, the GS hunts within the decade, i. e., after the dialling of a single-digit number, so that the exchange lines available for outgoing traffic are tested in sequence for free or busy. In systems without GS (100-line systems) the FS is equipped for hunting over the exchange lines by the addition of P.B.X. contacts. Then, when the exchange digit is dialled, all the exchange lines are tested in sequence, just as in the GS. The first line found to be free is seized.

In order to render the carrying on of exchange calls impossible for the house stations, either grouping is carried out in such a manner that only extensions have access to that group of GS or FS, to whose 10th decade the exchange lines are connected, or such grouping is avoided and

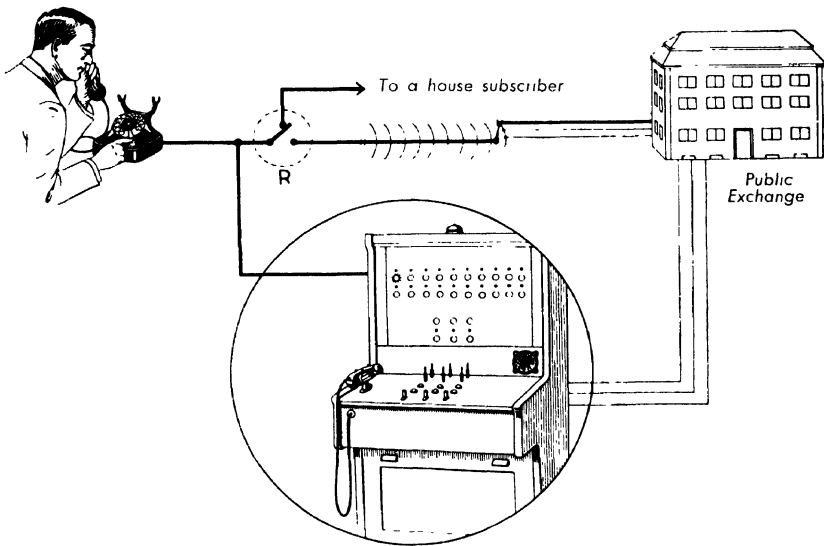

Schematic diagram of the function of a double-cord P.B.X. board (Operation 4).

Enquiry during an exchange call: — The enquiring key is pressed and by means of contact R a connecting set is seized in the house exchange. By pressing the key a second time the house connection is released and the connection to the exchange subscriber restored.

unauthorised connection to the exchange lines is prevented by circuit arrangements.

Enquiry If during an exchange call an extension desires to make an enquiry, the connection is transferred from the exchange line to the switches of the house exchange by pressing the enquiring key. This operation disconnects the extension subscriber's line and apparatus from the exchange for the duration of the enquiry and connects them to a call-back line. For each exchange line an enquiry apparatus is provided, and this takes the form either of a preslector or of a connection to a call-finder according to the type of automatic system in use. The extension subscriber then sets up the in-between connection by dialling, so that at the end of the enquiry he can again release the internal connection by once more pressing the enquiring key and at the same time obtain re-connection to the exchange line. In this case also, as with all in-between circuits, the exchange subscriber is, of course, unable to overhear the in-between conversation.

Call Transfer If an existing exchange call has to be transferred to another extension, the operator is invited by means of the flashing signal to enter the connection. The transfer is effected by throwing the relevant keys and changing the connecting plug. In transferring outgoing exchange calls, after the call has been answered from the flashing extension, the connection is handled like an incoming one, i. e., connected by means of a cord pair. The flashing signal for the operator is in most cases produced by a long pressure on the enquiring key.

Record Lines For conversations with the P.B.X. operator the extension subscribers are provided with certain lines, which are known as record lines. Over these record lines, for example, trunk calls are announced or other instructions given.

For traffic with the house subscribers every operator's position in the P.B.X. has a house connecting set available.

Night Circuit By throwing the night key exchange lines can be directly connected to extensions, so that exchange calls arriving when the switchboard is unstaffed, are carried direct to the extensions. Thus all "night-circuit" extensions have complete freedom of communication, i. e., they can at

will set up both exchange and house connections. If a night extension is already engaged in conversation, a freshly arriving exchange call is notified by a ticking signal. The switching through is then automatically carried out, when the handset is again lifted.

In double-cord exchanges, as we know, the incoming exchange lines are terminated on jacks exactly in the manner of the extension subscribers' lines, and with them calls are answered first of all by inserting the answering plug and then passed on to the relevant extensions with the help of the connecting plug. In exchanges on the single-cord system the exchange lines are each terminated on a plug, which by being inserted into the jack of the wanted extension subscriber switches through the connection.

*P. B. X.
Board (Single-
Cord System)*

In all the remaining functions the differences as compared with the double-cord P.B.X. boards are scarcely noteworthy; they will, therefore, only be mentioned quite briefly in this section.

According to the size of the system, i. e., the number of exchange lines and extensions, the components are accommodated either in a floor-type or a wall-type cabinet. In addition to the already mentioned exchange plugs and subscribers' jacks, the equipment also includes the usual keys and alarm lamps as well as a dial and a telephone set for the operator.

*Equipment of the
Exchange*

The line network is a single-loop network for all subscribers' groups.

The Network

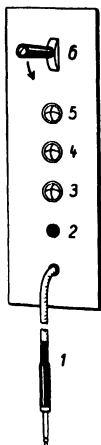

Schematic diagram of the arrangement of connecting plug, key, jacks and lamps on a single-cord switchboard.

- 1 — Connecting plug
- 2 — Extension jack
- 3 — Exchange calling lamp
- 4 — Busy lamp
- 5 — Clearing lamp
- 6 — Answering key

The extension stations are fitted with a signalling key for the initiation of in-between connections and for transmitting the flashing signal to the P.B.X. operator.

The Stations

The call from the exchange operates the visual and acoustic signal in the normal manner. After the call has been answered, a test must first of all be made to ascertain whether the wanted extension subscriber is free. If the subscriber's line is free, a common test lamp lights up.

*Incoming
Exchange Traffic*

The exchange plug is then simply inserted into the wanted subscriber's jack. Ringing is automatically transmitted by a switching mechanism in the exchange. With the same rhythm as the ringing the supervisory lamp lights up, but is extinguished on the lifting of the handset and only reappears on the restoration of the handset at the conclusion of the conversation. This is a signal to the operator to clear the connection by withdrawing the plug.

*Outgoing
Exchange Traffic*

The incoming exchange lines are terminated on the contacts of a decade of a GS or FS. The extension subscriber reaches the public exchange by dialling a code digit. The exchange connection in the outgoing direction is automatically cleared. In many concerns it is also required that the outgoing exchange connections also must be set up by the operator, e. g., in hotels and hospitals for the purpose of supervising the fees and also of assisting the guests and patients. In an exchange equipped for this purpose calling lamps are arranged above the subscribers' jacks. These are caused to light up by dialling a certain code digit,

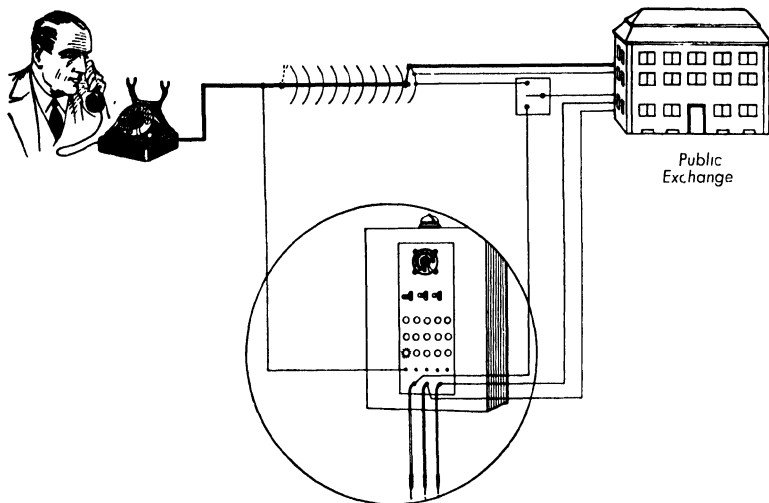

*Schematic diagram of the function of a single-cord P.B.X. board
(Operation 1).*

Outgoing exchange call: — The subscriber has to dial a number by means of his dial. A selector in the house exchange thereupon sets up the connection to a free outgoing exchange line. As a means of supervision the extension busy lamp in the P.B.X. glows.

whereupon the operator allots an exchange line to the calling subscriber by inserting a free exchange plug.

An enquiry is initiated in the usual manner by pressing the in-between key. A second pressure on the key releases the in-between (house) connection and again re-connects the exchange line to the station of the extension making the enquiry. Enquiries can be repeated as often as desired. *Enquiry*

By a longer pressing of the key the extension can transmit the flashing signal to the operator. By throwing the answering switch of the relevant exchange line and of the common enquiry key connection is established with the extension, which has sent out the flashing signal. The connection is then transferred by moving the exchange plug. *Transferring a Connection*

As far as there are exchange lines available, night calls can be passed direct to any desired extensions. For this purpose the exchange plugs *Night Circuit*

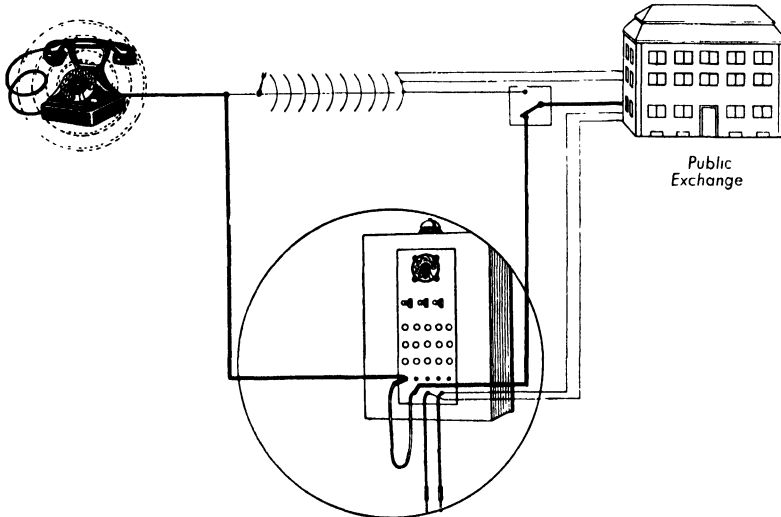

Schematic diagram of the function of a single-cord P.B.X. board (Operation 2).

Incoming exchange call: The exchange call caused the exchange calling lamp on the switchboard to glow. The operator answered the call in the known manner and inserted the exchange plug into the jack of the wanted extension subscriber.

are inserted into the relevant extension jacks and the night switch is thrown. Even at night an enquiry can be made during an exchange call. Night-circuit extension, like the others, can naturally set up outgoing exchange and house connections even at night.

Holding an Exchange Call

If an exchange subscriber desires to speak to several extensions one after another, the exchange line can be held by throwing the holding key, i. e., the connection is not released, even when the first extension subscriber replaces his handset. When re-called, the operator again enters the connection and sets up the new one. The final release of the connection is not effected, until the holding key has been restored.

Busying

By throwing a busying key, faulty or unreliable exchange lines can be busied to outgoing traffic, until the fault has been cleared.

Private branch exchanges on the single-cord system were developed so as to be able to offer an automatic P.B.X. even to concerns of smaller size.

Private Branch Exchanges on the Key-Sender System.

The character of this P.B.X. developed for the larger concerns and for heavy traffic is indicated by the fact that even for the switching through of incoming exchange calls to the extensions selectors are used. In place of the connecting cords and plugs there are selectors, which are positioned by the operator at the switchboard with the help of the key-sending apparatus.

The Key-Sender

The key-sending apparatus consists of 1 to a maximum of 6 rows each containing 11 keys, which are designated with 1 to 9 and 0 in the manner of an ordinary dial. The 11th unlabelled (red) key is the start key. The number of rows of keys depends on the type of switching employed in the system. If, for example, the system is arranged for a maximum of 1000 lines (1000-line system), the subscribers' numbers are, as we know, three-digit ones; consequently there are also three rows of keys, so that the first may be used for transmitting the impulse-trains intended for the GS and the other two for transmitting those intended for the FS. Assume that the subscriber's number 329 is to be set up. Then in the first row key 3, in the second row key 2 and finally in the

last row key 9 will be pressed. This operation sets up on the key-bars of the key-sender certain contact combinations, which, after the red start key has been pressed, co-operate with the actual sender (a relay combination) in such a manner that the impulse-trains corresponding to the number set up are transmitted to the selectors in the correct form and at correct intervals. The start key just mentioned is only pressed once, the one to be used being that in the same row as the number key last pressed.

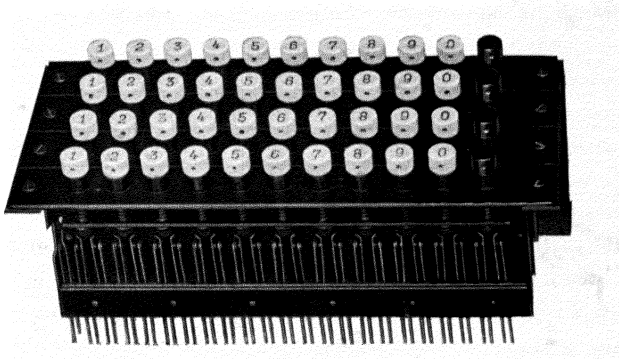

The key-board of the key sender.

The high service value of the key-sender lies in the fact that the operator can carry on other duties immediately after setting the keyboard, which takes about 2 to 3 seconds, whilst the key-sender carries on with setting of the selectors. Owing to the omission of connecting cords manual clearing of the connection at the end of the call is also eliminated.

The keyboard of the key-sending apparatus is mounted on a floor-type switchboard, which is also equipped with the necessary keys and lamps as well as a dial and an operator's telephone set. The relays belonging to the actual key-sender and the relays for all the other switching functions are mounted in company with the selectors on special racks in the exchange switchroom. Key-sending systems can be extended to an unlimited capacity by the addition of further selectors. The number of operator's positions required is determined from the number of the incoming exchange lines and the call frequency. If the number of lines

*Equipment of the
Switchboard*

and the call frequency are too high for one operator to deal with, the exchange lines are multiplied over the second position, which has then to be provided (see illustration of a key-sender switchboard in the appendix).

Incoming Exchange Traffic

As usual, every incoming exchange call switches on the calling lamp of the relevant exchange line and the calling supervisory bell (which can be disconnected) via a calling relay. By throwing the answering key the operator obtains connection with the calling party. At the same time the calling lamp and the calling bell are switched off, and the busy lamp associated with the relevant exchange line lights up. After the call has been answered, the key-sender keyboard is operated in the manner described above, and the setting of the selectors is initiated by pressing the start key. This concludes the operator's duties. She can follow the operation of the key-sender from the lighting up of the key-sender supervisory lamp. The successful completion of the connection is indicated by the extinguishing of the hold lamp provided for each exchange line. If the hold lamp does not go out, it means that the called subscriber is either busy or absent. The steps then to be taken by the operator are mentioned in the subsequent sections. The restoration of the number keys is unnecessary, because release is automatically effected by pressing the first key to set up the next connection. If the next connection requires the same key to be pressed, no fresh setting is necessary.

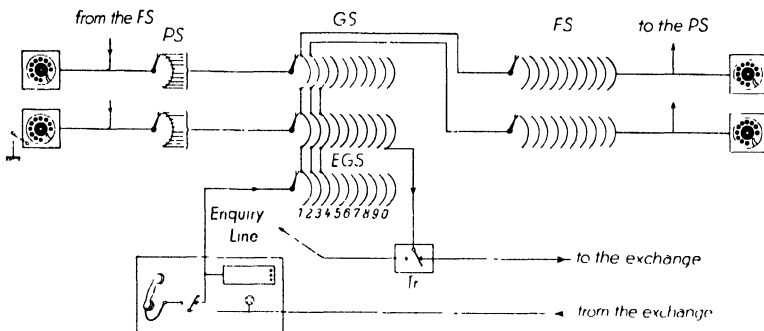

Building up a connection in a key-sending system I.

The extension group has outlets to the public exchange. For incoming exchange calls the EGS and the FS are positioned by means of the key sender. Enquiry is automatic through the enquiry apparatus.

On every connection an automatic hold circuit adjusted to about 40 seconds is switched in; if the called subscriber does not lift his handset, this circuit brings the exchange call back to the operator's position. To indicate that it is a case of re-call, the busy lamp lights up at the same time, while in the case of a fresh call only the calling lamp glows. The call is answered again, and the connection is then set up to another extension or is cleared.

Automatic Holding Circuit

The operator, who is notified by the glowing of the hold lamp that the connection has not been completed, can also enter the connection before the expiration of the 40 seconds and inform the extension subscriber that there is an exchange call waiting for him; the latter can then terminate the existing call, if he so desires. If, however, the extension is carrying on a conversation, the premature termination of which is not desirable, a waiting time can be agreed upon with the exchange subscriber. In this case the operator sets up a connection to the exchange subscriber by throwing the answering switch and connects the call to the holding equipment, which has no time-limit. As a supervisory indication for the operator the hold lamp continues to flash. During a pause in her duties she once more enters the existing connection and ascertains whether in the meanwhile the wanted line has been released. If it has, she again sets up the connection in the known manner.

Holding Circuit

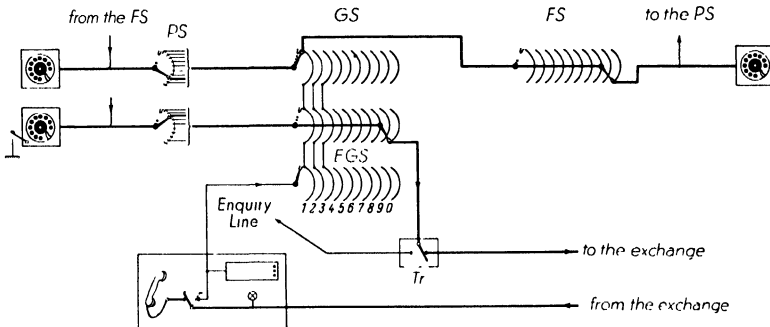

Building up a connection in a key-sending system II.

The theory diagram shows the course of a house connection, the building up of an outgoing exchange connection and the answering of an incoming exchange call.

Enquiry

In this system also an automatic in-between circuit is provided for all outgoing and incoming connections. It is initiated in the normal manner by pressing the key on the station. This change-over interrupts the line to the exchange for the duration of the enquiry, i. e., the call is in a certain sense stored, and the subscriber's line is connected via a in-between preselecting mechanism (PS or CF) associated with each exchange line to a GS or FS of the house exchange. By a second pressing of the key the in-between connection is again released. At the same time the interrupted exchange connection is once more restored.

*Transferring
Exchange Calls*

Instructions to transfer a call are conveyed to the operator by means of a flashing signal from the extension. The connection to the exchange is held by throwing the answering key of the relevant exchange line the first extension is asked for the new number and then the connection is set up again to the second extension subscriber. The old connection has been previously released by pressing the clearing key.

*Listening and
Listening
Supervision*

By simultaneously switching on a ticking signal the operator at the switchboard can listen in on any conversation conducted over the exchange lines. The ticking signal is always perceptible, when the operator's telephone is switched into an existing connection.

*Outgoing
Exchange Traffic*

Outgoing exchange connections are set up in the known manner via decades of the GS or FS (code digit dialling). The seizure of exchange lines is made impossible for the house stations by means of grouping

In addition to the record lines for the direct traffic between the extensions and the house exchange, it is usual to equip the switchboard with conference-call equipment (see page 125), special operating lines to other service exchanges, and supervisory apparatus.

It is, naturally, also possible for the operator to set up her own connections to the public exchange, i. e., in the outgoing direction. She does this by throwing the answering key of a free exchange line and by positioning the selectors in the public exchange with the help of her dial.

Fully Automatic Private Branch Exchange Systems.

In this case also, as with the key-sender system just described, selectors are used for passing on the incoming exchange calls. Normally, however, and herein lies the essential novelty of this system, these selectors are positioned not by an operator but by the calling person himself. It is here assumed that all the extensions are given numbers in the public telephone directory, whilst in all previous cases the specification of the P.B.X. number and in some cases the night numbers was sufficient.

Assume that a firm has the number 6075 as a P.B.X. number. If, for example, extension No. 375 is to be called, the exchange subscriber has to dial 6075/375. By dialling the number 6075 the selectors in the public exchange have been positioned and the private telephone system of the relevant firm is reached. The three-digit extension number indicates a 1000-line system, i. e., within the private telephone system the group selector (GS) is positioned by the first impulse-train and the final selector (FS) by the next two impulse-trains. The extension subscriber is then rung automatically, as in a normal automatic exchange, and the connection is cleared in the same way at the end of the conversation.

*Building up
a Connection*

Every extension can itself set up in-between connections in the manner already described. Even the exchange connections are automatically transferred by the replacement of the handset at the extension first of all clearing the existing connection, but only within the service system, and the exchange subscriber then dialling the number of the next extension required. Under certain circumstances the first extension can relieve the exchange subscriber of this task by ringing the next wanted subscriber over the "in-between route"; the latter then takes over the exchange connection by pressing the signalling key on his station.

*Enquiry and
Transfer*

Of the exchange traffic in the outgoing direction there is nothing new to be said here. As in the series systems previously described, the extensions have access to the groups of GS or FS, to whose decades the exchange lines are connected (code digit dialling).

Thus from the purely technical point of view the ideal service telephone system is attained: fully automatic traffic in both directions for exchange calls and for internal traffic, automatic enquiring and transfer

facilities and the elimination of all waiting times due to the answering and clearing of calls. More cannot be offered by the present state of exchange engineering.

The complete utilisation of the extensive traffic capabilities of this system is to a certain extent dependent on the users of the system. It is at its best, when all the subscribers calling from the public exchange "dial through", i. e., first position the selectors in the public exchange and then also those in the service exchange itself in the manner previously described. The percentage of the connections dialled through will vary with the nature of the concern. For example, experience has shown that administrations' systems have a higher through-dialling figure, while owing to the widely varying circle of callers private concerns (factories, commercial houses, banks) cannot show such favourable figures. In any case, however, the operator is to a considerable extent relieved; the relief is all the greater, the higher the percentage of connections dialled through directly.

*In formation
Position*

For the remainder of the callers an operator's position is provided, which from the nature of its functions can be termed an information position. After a short waiting time it automatically takes up the calls that "remain standing", and the operator informs the callers what extension numbers to dial, but she is also in a position herself to call the wanted extension and thus provide a kind of exchange service.

It is desirable to provide responsible individuals with special stations, so that they cannot be called by everyone unchecked. It is best for calls to such stations to be answered first at a secretary's station. For such cases the principal and secretary stations described on page 129 are indicated.

The information position is fitted with an equipment, which carries the keys and alarm lamps required for the various functions. If a subscriber does not dial through, a lamp indicator associated with the relevant exchange line is brought into circuit on the switchboard after about four seconds. The information operator sets up a connection to the caller, i. e., answers the call and informs him what extension number he has to dial or in case of need sets up the connection for him.

"Sana" systems (**S**elbst-**A**nschluß-**N**ebenstellen-**A**nlagen) are permitted only in the Bavarian postal area.

Private Branch Exchanges on the Neha System.

*A few Stages in
Development*

Some time before the Great War automatic telephone engineering was in Germany given ample opportunity in exchanges for public telephone service to demonstrate its technical and economic advantages over the earlier manual equipments. After the highly positive result of these experiments it was no wonder that it found ready acceptance also in commercial undertakings and with national and municipal authorities. The existing manual equipments were removed from service, in as far as they were concerned with the setting up of internal house connections, and only those portions of the exchange were used, that were intended for dealing with the telephone traffic with the subscribers on the public exchange. This already meant a considerable easing of the service situation, for the internal house traffic very heavily loaded the exchange equipment and with it the operators, and not infrequently the traffic with the subscribers on the public network suffered from this overloading. The technical advantages of automatic telephony resulted in a considerable increase in internal telephone traffic. This meant nothing other than that time-wasting correspondence, which even in conducting internal business often assumed considerable proportions, could be reduced to a reasonable amount. With one blow automatic telephony eliminated the "telephonophobia", which was founded on the shortcomings of the manual service. This throughout redounded to the advantage of the service, for the result was a demand for direct personal touch with the various business offices, with the resultant happy effects on good co-operation.

The fact that the complete or partial automatism of the exchange traffic was not yet possible, produced the result that thenceforth there were two telephone exchanges in every concern, *viz.*, the automatic system for the internal house traffic and the manual P.B.X. for dealing with the exchange connections. Two completely separate networks were then also necessary, and until the production of the combined station for the two types of traffic the extension subscriber even had two stations on his desk, *viz.*, a house station and a public exchange station.

The aim of the telephone engineer remained permanently directed towards the automatism of the exchange traffic also, as far as ever possible. For the traffic in the outgoing direction a solution was soon

found. The exchange lines utilised for this purpose were connected to the selectors in the house exchange, and every subscriber (extension) with exchange facilities was able to appropriate an exchange line by dialling a code digit. Thus the reasons for the "two-loop network" were eliminated, for the incoming calls were simply connected by the public exchange operator to the two-wire subscriber's line leading to the automatic exchange (P.B.X. principle). Only in special cases were 2×2 lines still required, *viz.*, where an extension subscriber had to be given the enquiry facility. In this case he had to hold one line engaged, while he switched his microphone and receiver over to the other line loop with the help of the switching key on his combined station. But this type was also soon obsolescent. Circuits were developed that made automatic enquiry possible. With these arrangements a call-back no longer busied a second line loop, but the existing connection was held within the exchange, *i. e.*, to a certain extent it was stored. The subscriber's line was temporarily released for the setting up of the in-between connection. Pressure on the signalling key, with which the stations of all extension subscribers then had to be fitted, set up the enquiry conditions, and a second pressure on the keys restored the original conditions. By repeatedly pressing the key the enquiry could be repeated as often as desired.

The key-sender system and certain transition systems with extension allocation keys first brought the use of selectors also into the building up of incoming exchange connections. The operator then had merely to answer the call and by pressing a key to initiate the transmission of the impulses for setting the selectors. Thus the service operator became more an information position than an exchange position, for the actual operating portion of her duties took only a very small fraction of her time. According to the size of the system and the frequency of the incoming calls she was more or less occupied with office work, *e. g.*, clerking or calculation work.

The use of selectors for both directions of exchange traffic and in the house exchange permitted the combination of the two portions of the system in one exchange, and this produced switching facilities, which previously had been obtainable only with a certain amount of difficulty.

With the creation of combined service telephone systems of this nature the German P.B.X. engineering has reached a certain finality.

All demands, which can economically be placed on a service telephone system, are capable of fulfilment, and they are also fulfilled by the Neha principles developed by Siemens & Halske, irrespective of whether the system concerned is small, moderate-sized or large; everywhere we find the same basic principles in design, in essentials everywhere the same requirements and therefore also the same traffic capacities. It is self-evident that from a system originally intended for a very few subscribers it is impossible to make one suitable for several hundred subscribers. This idea is frequently fostered among users by unintelligible descriptions. Such a construction is indeed possible, but it is uneconomic. For this reason even telephone exchanges have to be designed in types, so that taking all possible account of the extension possibilities demanded in practice the manufacturing prices and operating costs may be kept at a reasonable level. Siemens & Halske have divided up their Neha exchanges on the basis of their decades of experience in constructing private branch exchange systems. There are four types of equipment available, *viz.*,

for 1 to 2 exchange lines and up to about 10 subscribers:

Neha Relay Exchanges,

for 2 to 5 exchange lines and up to 27 subscribers:

Neha Rotary-Switch Exchanges,

for 5 to 20 exchange lines and 180 subscribers:

Neha Exchanges with Rotary-Switches,

for 5 up to as many exchange lines as desired and for as large a number of subscribers as desired:

Neha Two-Motion-Switch Exchanges (Large Neha System).

*Neha Relay Exchanges for 1 Exchange Line
and up to 4 Extensions.*

It is an essential basis in the development of the Neha principles, that almost all traffic conditions should be fulfilled even in exchanges of the smallest scope. To these important traffic conditions belong, in addition to automatic house traffic, the dialling of the public exchange and the easy and rapid handling of the incoming exchange calls as self-evident basic requirements, the automatic enquiry and call transfer facilities, the automatic passing-on of non-answered exchange calls, the listening facility for privileged subscribers and the night circuit.

*General Details
concerning Relay
Exchanges*

The use of the single-loop principle has also to be included. This facilitates the connection of external extensions and also permits subscribers' instruments of the simplest design to be employed.

Next to reliability and traffic capacity comes the demand for economy in the system. In systems of the relay group this demand is met by the use of new relays, which are cheap for any conceivable grade of service; to them in this case are allotted the tasks that in larger exchanges are performed by selectors. In relay exchanges the lifting of the handset appropriates the connecting set consisting of a relay combination. The impulses from the dial bring into circuit certain relays lying on the route of the wanted connection and in this way the lines of the calling and the called parties are connected to the common speaking line. The signalling (ringing signal, dialling tone, busy signal and ringing supervision) is arranged in a similar manner to that in systems using selectors. As a rule batteries are used for the current supply of the system. The smaller types can be supplied with a built-in mains supply unit, with the result that battery and charging equipment are then unnecessary. Direct feeding from the mains is, of course, only possible where alternating current (50-cycle) is available.

On this exchange, as is already indicated by its description, one exchange line and four subscribers' lines can be terminated; the latter can be arranged either for extensions or for house stations.

The relays required for the various switching operations, and in the case of mains-fed exchanges the mains supply units also, are mounted in a wall-type sheet-iron case, which is fitted with a lock. (Dimensions $16 \times 12 \times 8$ in.)

*The Subscribers'
Stations*

The stations with exchange facilities have instruments with earthing keys, by means of which the exchange line is seized or in the case of an already existing exchange connection an enquiry is initiated within the concern. The main station, at which the incoming exchange calls are normally answered, is equipped with a combined instrument. This enables the exchange line to be seized irrespective of the condition of the private exchange; its functions will be described in detail later on.



*Table type instrument with earthing key
(white button below the dial).*

The subscribers' line network is a single-loop network. External extensions can, therefore, be connected without any auxiliary apparatus and enjoy the same traffic facilities as all the internal extensions.

By lifting the handset the subscriber seizes a relay combination serving as a connecting set (selector) and thus switches himself on to the speaking line. The dialling brings into circuit the relays lying on the route of the wanted connection and thus the connection is set up. Assume that subscriber No. 2 dials subscriber No. 4. The dial is pulled

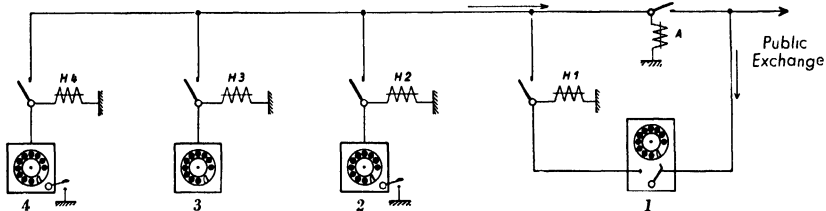

Connecting diagram of a Neha relay exchange for one exchange line and four stations.

House traffic: When the receiver is lifted, relay H connects the station to the speaking line. Impulses from the dial take effect on the relay H of the called station via the relay selector (not shown). Both stations are then connected to the speaking line.

Outgoing exchange traffic: When the handset has been lifted and the earthing key pressed, the speaking line is selectors through to the exchange via the contact of relay A. The exchange selectors are then positioned in the normal way.

Incoming exchange traffic: The exchange call-bell in the main stations (1) rings. The call is answered by throwing the switching key to the right (to "exchange" position). The connection is completed as in the case of an internal call after throwing the switching key to the house side (enquiry position). The called subscriber lifts his handset and speaks to the main station. On pressing the earthing key the speaking line is switched through to the exchange via relay A.

from the number 4. In addition to certain auxiliary relays the four dial impulses energise relay No. 4, which by means of its contacts effects the switching through of the connection. At the same time the signalling set is also brought into circuit and according to the fate of the connection transmits either the ringing signal or the busy signal. By way of ringing supervision the ringing signal is heard in the calling party's receiver. Subscriber No. 4 lifts his handset from his instrument. This prepares the line for conversation and the ringing signal is switched off. At the end of the call the relays lying on the route of the connection are again restored to normal by the replacement of the handset.

Unlike the house stations, the extension stations are all fitted with an earthing key. By pressing this earthing key the exchange line is seized, i. e., the exchange relay—here let it be called the A relay—is brought into circuit via certain auxiliary relays, and, with its contacts, closes the line loop to the exchange and sets the preselector in motion in the public automatic exchange, or in the case of a manual exchange switches on the calling signal.

Enquiry

If, during the course of an exchange call, an enquiry has to be made to a subscriber on the house exchange, the earthing key already mentioned has to be pressed again. This operation initiates a change-over of such a kind that the existing exchange connection is held and the house connector seized. At the conclusion of the enquiry a further pressure on the key restores the original condition, i. e., the house connection is cleared and the exchange connection is taken over once more. The enquiry can be repeated in this way as many times as desired.

Call Transfer

If the exchange call has to be transferred to another extension, the connection to the second subscriber is first of all set up in the same manner as for an enquiry. When the second subscriber has been notified, he takes over the connection by pressing his key. In this way a call can be transferred any number of times.

*Incoming
Exchange Call*

As usual, the exchange call switches on the exchange bell at the main station. The call is then answered by throwing the switching key to the "exchange" position. The passing on of the connection is carried out in a similar manner to that already described for transferring a call, *viz.*, the switching key is thrown to the in-between position, the wanted subscriber is dialled and then informed of the presence of an exchange call. The wanted extension takes over the connection by pressing his signalling key. At this instant the main station receives the busy signal and replaces the handset. The switching key then returns to normal of its own accord.



*Main station of the Neha-
exchange 1/4.*

*The switching key has two operating
positions: Enquiring and exchange.*

If the main station operator finds the internal speaking line engaged, by pressing her key she can intervene in the existing connection and leave it to the two speakers whether or not they terminate the internal call in favour of the exchange call. On the other hand it is not possible for the main station to intervene in an exchange call.

*Intervention of
the Main Station*

When owing to delay at the main station an exchange call is not answered within about 20 to 25 seconds, the automatic ringing transfer circuit comes into operation and immediately causes a bell to ring also at an extension arranged as an auxiliary answering position. If the exchange call is not accepted by this station within about 20 to 25 seconds, this operation is repeated until the exchange subscriber hangs up his receiver and the public exchange ceases to transmit ringing current. The ringing transfer circuit is essentially the function of the so-called thermal relay, the contacts of which are heated up on the passage of current, gradually bend round and thus after a certain time, which depends on the setting (adjustment) of the contact, current is transmitted to the second extension. From the circuit point of view it is also possible to provide a visual busy indication, which according to the nature of the arrangement indicates the engaged condition of the exchange line to all the extensions or to individual ones. Normally, as we know, the engaged condition of the exchange line is made known by an acoustic busy signal.

Ringing Transfer

*Visual Busy
Indication*

The use of the single-loop principle renders the connection of external extensions readily possible. In most cases the external extension is arranged as a night station, so that calls arriving during the night or while the operator is absent for a considerable period can be immediately switched through to the residence of the principal or the office manager. The switching through is effected for the duration of the operator's absence by throwing the night key on the switchboard. The key has two positions: in one position all exchange calls are switched to extension 2 and in the other position to extension 3. According to existing conditions in the concern various extensions can thus be operated as night positions.

*External
Extensions*

For service reasons the main station is in every case in a position to listen in on internal conversations and to intervene. The intervention of the main station into an existing house connection, however, gives rise to a damped buzzing signal, which is plainly perceptible in the receivers of the conversing subscribers and thus the intervention is indicated. The unauthorised operation of the listening key is thus prevented.

Listening

One of the extensions can be arranged for listening by means of special equipment. This listening facility serves for supervisory purposes and includes not only internal but also exchange calls. In this case, however, in view of its special purpose the buzzing signal used with the main station listening apparatus is suppressed. A further difference from the listening facility provided for the main station is that the listening key need only be pressed once and not kept pressed during the whole duration of the listening period.

Traffic Possibilities

It is possible to carry on simultaneously: a house call from a house station or extension to another house station or extension, or an exchange call from an extension with an internal enquiry; or a house call from an extension or house station *and* an exchange call from the main station.

Current Supply

Relay exchanges of this type can be operated with a mains supply unit. In this case the unit is included in the wall-type exchange cabinet. It consists essentially of a mains transformer, which can be connected to A.C. potential (50-cycle) of 110, 125, 220 or 240 volts, a dry rectifier and a double filter for producing a pure D.C. potential of 24 volts. Battery-fed relay exchanges contain a pole-changer for the production of the ringing current and the buzzing tone.

*Neha Relay Exchanges for 1 Exchange Line
and 2 Extensions.*

Construction and Method of Operation

The smallest private branch exchange generally possible is constructed in a similar manner to the exchanges just described for one exchange line and four extensions. In addition to the main station there is only one other extension. The two subscribers each have a station fitted with a signalling key for appropriating the exchange line and for initiating the enquiring and the transfer of connections. In an internal connection the wanted station is called by pulling the dial from a pre-determined digit. In this case the operation of the dial does not effect the building up of a connection, but serves merely for the transmission of the ringing signal. In addition to the enquiry and call-transfer facilities already mentioned, this small exchange also provides for automatic ringing transfer in the case of an unstaffed main station, the night circuit and the listening facility for the extension. It is, moreover,

possible to include a visual busy signal, which then indicates to both stations the engaged condition of the exchange line. Normally, as we know, the engaged condition of the exchange line is indicated acoustically.

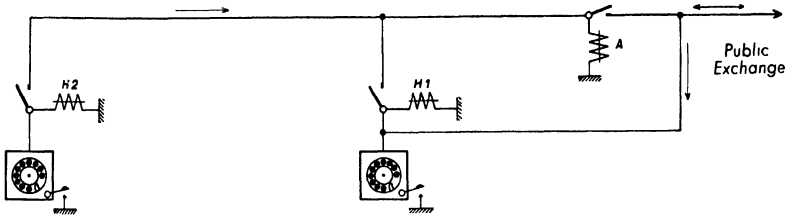

Connecting diagram of a Neha relay exchange for one exchange line and two stations. The operations are in essentials the same as with the exchange for one exchange line and four stations. With an incoming exchange call the earthing key is pressed before the call is switched through. The second subscriber, called over the in-between route, lifts his handset and by pressing the key connects himself to the exchange line via relay contact A.

As in the case of exchange 1/4, a mains supply unit provides the current supply for the exchange. If no A.C. is available, it is necessary to provide a 24-volt battery, a suitable charging equipment and in addition a pole-changer for producing the ringing alternating current. (Dimensions of the exchange $16 \times 12 \times 8$ in.)

Neha Relay Exchanges for 1 Exchange Line and 6 to 10 Extensions.

Owing to the larger number of subscribers this relay exchange has a public exchange connecting set independent of the house network, i. e., there is an exchange line available independent of the house speaking line, so that even when the house speaking line is engaged, an exchange call and an enquiry can be conducted not only by the main station, but also by any extension.

Construction

In this case the building up of all exchange and house connections is likewise carried out by relays in the manner already described.

An incoming exchange call is answered at station (1), which is arranged as a main station; this operation is performed simply by lifting the receiver. The passing on of the connection to one of the extensions is effected over the in-between route, which is appropriated by pressing the key. The wanted subscriber is informed and requested to take over

Exchange Call

the call. This is done in exactly the same way as with the other relay systems, by pressing the key.

Enquiry and Transfer

Enquiry during an exchange connection, the transferring of calls, exchange ringing transfer and night traffic as well as the listening supervision for privileged subscribers are all arranged in the same manner as with the relay exchanges described previously.

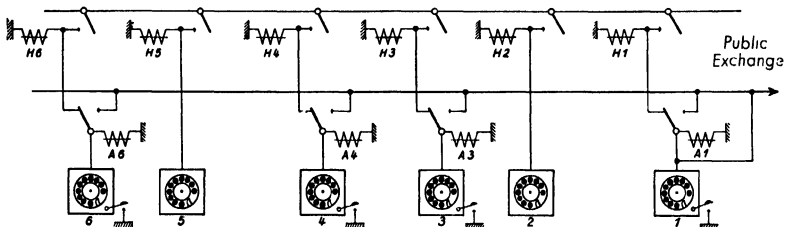

Connecting diagram of a Neha relay exchange for one exchange line and 6 to 10 stations.

The operations are similar to those with the exchange for one exchange line and four stations. For the purpose of seizing the exchange line the extensions disconnect themselves from the houseline by pressing a key and obtain connection to the exchange line via the relay contact A. House stations have no earthing keys and are, therefore, unable to seize the exchange line. Incoming traffic is handled as with the exchange for one exchange line and two stations.

Current Supply

The current supply can be provided by means of a mains supply unit or, if alternating current is not available, by batteries. In this type of exchange the mains supply unit is, naturally, not included in the same case as the exchange, but must be mounted separately as an auxiliary equipment. The relays for the exchange itself are mounted in a wall-type sheet-iron case. (Dimensions $24 \times 12 \times 8$ in.)

Neha Relay Exchanges for 2 Exchange Lines and up to 10 Extensions.

The maximum of 10 stations on this exchange are provided with two exchange lines and two house lines. Thus two house, two exchange and two in-between conversations can be conducted at the same time. The case of the exchange has the dimensions $36 \times 24 \times 8$ in. For handling the public exchange traffic coming in on the two exchange lines the main station is equipped with a special instrument.

With the exception of the incoming traffic and certain operations in the internal traffic between the subscriber and the main station, the

functions, including the outgoing traffic, learnt from the previously described relay exchanges remain the same and thus do not need to be mentioned again here.

In addition to the normal dial and handset the main station has various switching keys and supervisory lamps for the operation of the exchange lines. *Main Station*

The call from the public exchange switches on the exchange bell at the main station and also one of the two calling lamps (white). Pressure on the answering key (AK) associated with the calling line connects the operator's handset to the calling exchange line. When the call has been answered, the operator's set and the dial are switched over to the house lines by pressing the switchboard key (SK). *Exchange Call and its Answering*

The wanted subscriber is requested to take over the exchange connection by pressing the earthing key on his station. As soon as this has been done, the calling lamp is extinguished, and the supervisory lamp (green) associated with the exchange line in use glows throughout the call. The handset at the main station is then replaced. *Completing the Connection*



Main stations for a relay exchange with two exchange lines.

The main station can obtain the extension wanted by the exchange subscriber, even when it is already engaged in a house or exchange call, the intervention being automatically carried out at the instant the operator finishes dialling the number of the relevant extension. As an indication of the effective intervention all the subscribers concerned receive a *Intervention of the Main Station*

clearly perceptible ticking signal, which, however, does not impair intelligibility.

*Exchange Call
and Enquiry
from the Main
Station*

By pressing an exchange key the main station can be directly connected to an exchange line, and position the selectors in the public exchange. An enquiry with an internal subscriber can be conducted by the main station after pressing key SK and dialling the number of the relevant subscriber. When the enquiry is finished, the key AK of the waiting exchange line is again pressed.

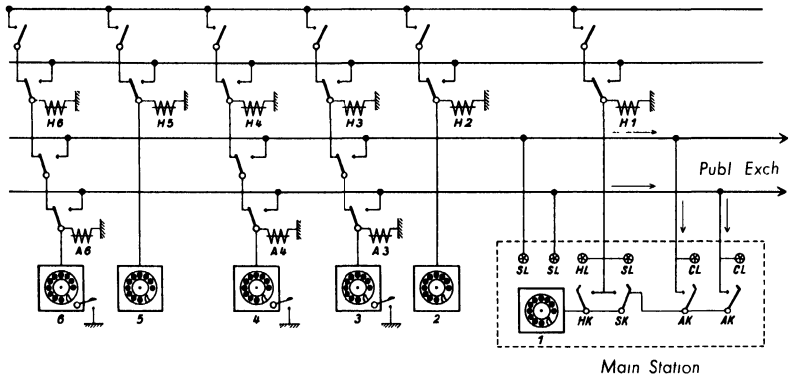

Connecting diagram of a Neha relay exchange for two exchange lines and up to 10 stations.

The operations for internal and outgoing exchange traffic are similar to those with the systems already described. Since there are two house and two exchange connection routes, automatic change-over to the second route is provided, when the first is found to be engaged. If the second is also engaged, the busy signal is given. All exchange connections are indicated at the switchboard by the supervisory lamp SL.

Incoming exchange calls switch on calling lamp CL. Calls are answered with the help of answering key AK. Connection to the wanted extension is set up via switchboard key SK.

For house calls the main station operates house key HK. Lamp HL glows for supervisory purposes.

If during an exchange call from the main station another call comes in on the second line, the main station can give this new call preference simply by pressing the answering key of the second exchange line. This automatically switches the first exchange connection to the hold circuit. For supervisory purposes the supervisory lamp of line 1 flashes throughout this waiting period and does not glow steadily again until the connection is once more taken over by renewed pressure on the answering key.

To set up an internal house connection the main station has to press the house key HK and then to dial the number of the internal subscriber. The house lamp HL glows throughout the house call.

*House Traffic
from the Main
Station*

The extensions have two possibilities of making an enquiry to the main station during an exchange call. Either they can dial the number of the main station (No. 1) or by a continuous pressure on the key they can flash the calling lamp of the busy exchange line. The main station then enters the connection in the known manner.

*Enquiry to the
Main Station*

A night circuit is provided for two of the extensions. By circuit arrangements at the switchboard distributor the calls on the first exchange line can be connected to extension 3 and those on the second exchange line to extension 4. It is, however, possible for the exchange calls on both exchange lines to be connected to one night station.

*Automatic
Exchange Call
Transfer, Night
Circuit*

By setting the night key (rotary switch on the operator's station) the main station is to a certain extent by-passed by an exchange call. If the night station is already carrying on a conversation and a further exchange call arrives during this time, the second call is announced by a ticking signal. At the conclusion of the first conversation (handset restored) the second call is automatically notified.

The current supply for this exchange is usually provided by batteries. The working voltage is 24 volts.

Current Supply

Neha Rotary-Switch Exchanges for 2 to 5 Exchange Lines and up to 27 Extensions.

Traffic capacity, reliability and economy, those are the three equally essential considerations, which must be taken into account in the planning of telephone systems of whatever size.

As regards these principles the economically most satisfactory point has been reached with the relay systems, for it was found that exchanges for larger numbers of exchange and subscribers' lines could be manufactured relatively more cheaply by using selectors as connecting elements. Thus, when equal traffic capacity and quality of service is demanded for exchanges of this size, the system question is not difficult to decide.

In Neha systems for a maximum of 5 exchange lines and 27 extensions, therefore, step-by-step rotary selectors are used for setting up connections between the subscribers and to the public exchange. A house connecting set consists of the CF as preselecting mechanism and the FS. The exchange switches, i. e., the mechanisms provided in the private branch exchange for setting up all exchange connections, operate in the outgoing direction as call-finders (CF), but in the incoming direction as final selectors (FS). The number of connecting sets, which, it is understood, are the connecting paths available to the subscribers, vary in accordance with the number of extensions. As a rule, but with possible variations depending on the working conditions in each case, the number of connecting sets provided for the first 15 subscribers is two, for 25 subscribers three and for 27 subscribers four. Thus it is possible to set up simultaneously two, three or four internal connections respectively.

The number of exchange calls possible depends on the number of exchange lines available. With each exchange line is associated one of the already mentioned exchange selectors, which in company with a number of relays constitutes an exchange connecting set. In these exchanges all the exchange lines are equally available for both directions of traffic, i. e., they are used for outgoing or incoming traffic according to requirements.

In addition to the normal house connecting sets each exchange also has an auxiliary connecting set. To this is allotted the task of securing another route to a free exchange selector, when all the house connecting sets, which are taken into use for a brief period to start up an exchange selector, are already engaged. Since this auxiliary connecting set also takes but a few seconds to set up a connection to the public exchange, there is practically no possibility, that a free exchange line cannot be used in the outgoing direction, because there is no house connecting set free, especially as it is made impossible by circuit arrangements to take an auxiliary connecting set into use for any other purpose.

For incoming exchange calls neither the house connecting sets nor the auxiliary set are used.

By circuit arrangements at the switchboard the subscribers can be given extension stations with full or restricted exchange facilities or house

stations according to the requirements of the concern. The distinguishing characteristics of the extensions with full and restricted exchange facilities will be gathered from the subsequent explanation of their functions. For initiating in-between connections the extensions have fitted to their stations the earthing key already mentioned several times.

Privileged extensions can be provided with the facility of intervening in existing house connections, so as to be able at any time to obtain the wanted connection. By way of an intervention signal a ticking signal is provided, which is audible in the receivers of the three parties concerned.

The network is a single-loop network. The working voltage is 24 volts. In view of the size of the system mains supply units are not desirable. A later section gives details regarding suitable batteries and charging equipment. The whole switching equipment with the associated relays and the apparatus for generating the signals is mounted in a wall-type sheet-iron case. The dimensions are given in the appendix of illustrations.

*Network and
Battery*

For the answering of incoming exchange calls and their transference to the extensions the system is provided with a special operator's station, which can carry on internal conversations in both directions and also exchange calls. The operator's station, made up in the form of a desk-like table instrument, contains in addition to the answering apparatus and the dial, the keys and supervisory lamps for answering, passing on and supervising the calls. The auxiliary connecting box also belonging to the exchange contains the line distributor.

Neha exchanges on this system are built in various sizes for a maximum of five exchange lines and 27 extensions.

Coming to details, the exchange performs the following functions:

The operations for setting up house connections are already known from the foregoing descriptions (see page 25 and the following pages). The subscriber has to lift his handset and wait for the internal ringing signal (Morse S), and then dial the number of the wanted subscriber. The release of the connection at the end of the conversation is effected by replacing the handset. If the line is engaged, the usual busy signal is heard. If one of the connecting sets is engaged, the next free one

House Traffic

automatically comes into operation. Only if all the connecting sets are engaged, does disconnection occur.

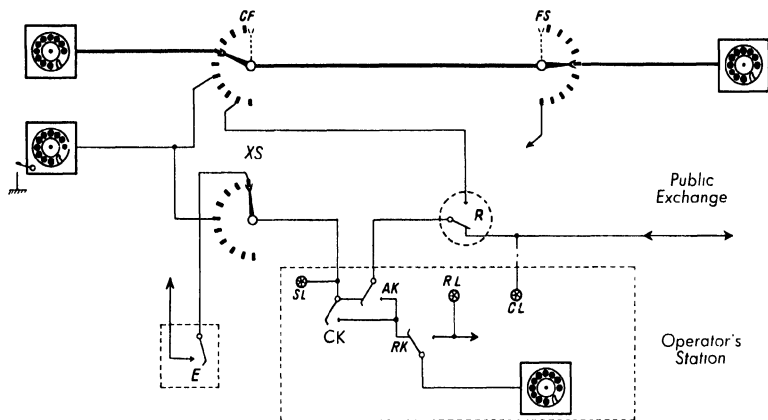

*Connecting diagram of a Nehu rotary-switch exchange (Operation 1).
A house connection via a call-finder and final selector of
a house equipment.*

*Outgoing
Exchange Traffic
from the Exten-
sions with full
Exchange
Facilities*

Via the contact marked 2, for example, on the final selectors of the house connecting sets or the auxiliary connecting set the extensions with full exchange facilities reach one of the available exchange selectors, which starts up automatically like a call-finder and sets itself on the line of the calling subscriber. The house connecting set temporarily taken into use for this switching operation is again released the moment the setting of the exchange switch is completed. On the pivot of every exchange selector is terminated an exchange line. Thus the exchange line is seized by the positioning of the XS on the extension subscriber's line. The subscriber then positions the selectors in the public exchange or gives the operator there instructions for setting up the connection (manual operation).

The switchboard operator, therefore, has taken no part in the setting up of an outgoing connection. The engaged exchange line is indicated on the operator's station by a supervisory lamp (green).

It is also essential that all subscribers with exchange facilities should have access to all the exchange connecting sets.

Extensions with limited exchange facilities cannot appropriate an exchange line by code digit dialling, but only with the assistance of the operator (for supervisory purposes). When they want to speak to the

*Outgoing
Exchange Traffic
from the Extensions with
Restricted
Exchange
Facilities*

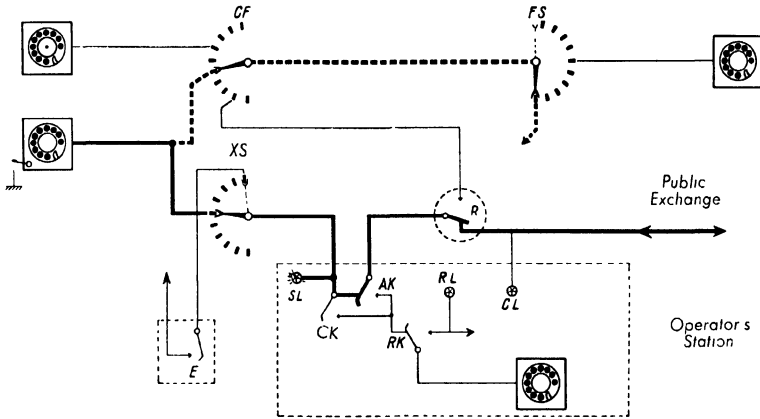

Connecting diagram of a Nehu rotary-switch exchange (Operation 2).

The exchange selector is started up via a contact on the final selector (of a house equipment) and automatically sets itself to a free exchange line. At the operator's station the green supervisory lamp SL associated with the relevant exchange line lights up.

public exchange, they dial the house number of the main station (1). The operator's attention is attracted by the sounding of a buzzer, whereupon by pressing the record key RK she sets up a connection to the calling party, in this case the subscriber with restricted exchange facilities. While the call is being answered, the record lamp RL (white) lights up as a supervisory lamp. The operator allots the subscriber an exchange line by pressing the clearing key. In this way the house call is cleared and a free exchange switch is made to set itself on the relevant extension line. The lamp RL, which flashes during the positioning of the exchange switch, then glows steadily. The operator thus recognises that the exchange line is switched through.

Under no circumstances can the house stations be put into connection with the exchange lines. If they dial the exchange code digit or if the operator endeavours to allot them an exchange line in the manner just described, the busy signal always sounds in their receiver.

The call from the public exchange switches on not only the exchange calling buzzer, but also the calling lamp CL (white) associated with the relevant exchange line.

*Incoming
Exchange Traffic*

The operator accepts a call by pressing the accept key AK associated with the relevant exchange line. In addition to the white calling lamp CL, the green supervisory lamp SL associated with the same exchange line

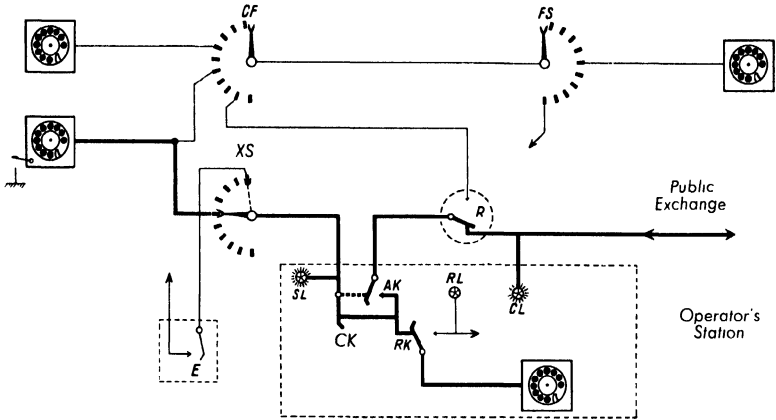

Connecting diagram of a Neha rotary-switch exchange (Operation 3).

The exchange call switches on the bell and the calling lamp CL (white). The call is answered by means of answering key AK. The connection runs: Exchange—contact R—key AK—key RK—to the operator's telephone set. To set up the connection: Connecting key CK is pressed. The exchange selector is positioned by the dial impulses from the operator's station. The connection runs: Operator's telephone set (dial)—key RK—key CK—exchange selector—subscriber. The supervisory lamp lights up and is extinguished in the rhythm of the ringing, until the subscriber lifts his handset; then it glows permanently until the conclusion of the call. When key CK has again been released, the connection runs: Exchange—contact R—key AK (against the dotted line)—exchange selector—subscriber. Enquiry during the exchange call: The subscriber presses the key on his station. The enquiring contact R is thereby changed over and a free house connecting set seized. Restoration of the exchange connection is obtained by pressing the key once more. If the subscriber called for the in-between conversation presses his key (he must therefore be an extension), the exchange call is automatically put through to him.

also lights up. The switching through of the call is effected by first operating the switchboard key CK and then dialling the number of the wanted extension. The impulses emanating from the dial of the operator's station take effect on the exchange switch, which is then positioned on the line of the wanted subscriber in the manner of a final selector. Normally the duties of the operator are then finished, and she can replace her handset.

Ringing is then automatically transmitted to the subscriber every 5 seconds. To provide ringing supervision the green supervisory lamp

continues to go out and light up with this same rhythm, until the extension takes over the call by lifting the handset. Thereafter it glows steadily throughout the call. The white calling lamp previously mentioned is extinguished as soon as the operator has dialled and has replaced her handset.

If the extension is engaged on a house or exchange call, the green *Extension Busy* supervisory lamp flashes with a rapid rhythm on the completion of dialling. The operator can then intervene in the existing connection by pressing key CK. As a tapping signal all the subscribers concerned receive a ticking signal. The operator informs the subscriber of the presence of an exchange call and then replaces her handset. The exchange call just dealt with is thereby automatically switched to the “hold” circuit. At the conclusion of the first call the waiting exchange call is automatically notified, i. e., the extension subscriber, who was previously found engaged, receives the ringing signal. The green supervisory lamp, which was flashing during the waiting period, then glows steadily throughout the call.

If the operator does not desire to enter the existing connection, the partly completed connection can be released by a brief pressure on the clearing key and passed on to another extension subscriber.

As with all Neha systems, an enquiry is initiated by pressing the signalling key on the station. This causes the switching of the extension line to a free house connecting set. On the completion of the in-between conversation, the exchange line, which has in the meanwhile been “held”, is switched back by a renewed pressure on the signalling key, i. e., it is once more connected to the extension. *House Enquiry*

If the subscriber called in the enquiry remains at his instrument with his receiver at his ear, the enquiry can be repeated as many times as desired by repeatedly pressing the key. Such a repetition of the enquiry operation is frequently termed “brokering”.

Via the in-between route just described, an in-between conversation can also be held with an exchange subscriber by first pressing the key and then re-dialling, across the house set, the exchange code digit, thus appropriating another exchange switch and with it another exchange line. A second pressure on the key clears the exchange in-between connection in favour of the waiting first exchange connection. *Enquiry to a second Exchange Line*

If during an in-between connection the extension inadvertently replaces the handset, the connection to the public exchange is, nevertheless, not cleared, but the relevant exchange line makes a fresh call at the operator's station. The operator again enters the connection by pressing the answering key and, as in the normal case, passes it on to the wanted subscriber.

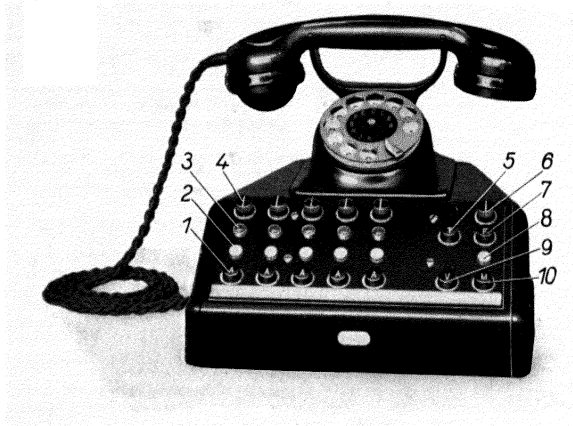

Operator's station for a Neha rotary switch exchange with 5 exchange lines.

- | | |
|-----------------------|-----------------------------|
| 1 = Answering keys | 6 = Night key |
| 2 = Calling lamps | 7 = Flashing button |
| 3 = Supervisory lamps | 8 = Record supervisory lamp |
| 4 = Chain key | 9 = Switchboard button |
| 5 = Clearing button | 10 = Record button |

Call Transfer An exchange call can be transferred from extension to extension over the in-between route. The extension called in the enquiry takes over the connection by pressing his key. The extension transferring the call then receives the busy signal.

Automatic Holding Circuit

The automatic holding circuit, as the term implies, has the effect of call storage. Supposing the operator tests a line and finds it engaged (green supervisory lamp flashes), the holding circuit immediately comes into operation. When the subscriber found engaged concludes the existing conversation, he automatically receives the calling signal from the waiting exchange call. The same process is repeated for each successive exchange call, which is switched to this subscriber, and the waiting exchange calls are automatically notified again in succession. The operator can follow

the progress of the calls from the flashing, illuminating and extinguishing of the supervisory lamps.

After answering a call, however, the operator can also switch it at once to "hold", without endeavouring to pass it on. For this purpose she has to set the so-called chain key associated with the relevant exchange line. The key thus set reminds her that there is an exchange line in the "hold" condition.

If an exchange subscriber desires to speak to several extensions in succession, he declares his intention to the operator, who by setting the chain key protects the exchange line concerned from unintentional clearing, i. e., premature replacement of the handset by one extension prevents from clearing the exchange connection. The exchange call is repeated until at the conclusion of the last conversation the operator again restores the chain switch to its normal position. The circuit is so arranged that in the meantime the operator can via the house network inform the other wanted subscribers of the presence of an exchange call. This arrangement is of particular importance for trunk calls. *Chain Switching*

If specially requested, a switching arrangement can be included, which at an unattended operator's station automatically transfers an exchange call after about 20 seconds to an auxiliary exchange position—a normal internal or external extension. If no reply is obtained from this station either, this process is continued just as from the public exchange. In this way care is taken as far as possible to see that no exchange call goes unobserved. *Exchange Call Transfer*

During the night or during a lengthy absence of the operator the individual exchange lines can be connected to certain extensions by throwing the night switch, which is fitted on the operator's station. The extensions concerned are specially marked with their night numbers in the telephone directory. *Night Circuit*

If desired, the switchboard can be so arranged that all exchange calls are carried to *one* night position. Like every other extension, this night position can also pass on the incoming calls over the enquiry route. *General Night Circuit*

As an auxiliary to the switchboard another device has been developed, which permits some exchange lines to be connected to individual night *Individual and General Night Circuit*

stations and at the same time others to be connected to a night position. In this case the night operator is given the facility of intervening in existing house connections and, in the event of her being engaged on the arrival of an incoming exchange call, it is notified to her every 5 seconds by damped ringing current.

In the case of the individual night circuit the signalling of incoming exchange calls by damped ringing current is provided by means of a special auxiliary equipment.

Night Ringing Transfer

As with day traffic, a ringing transfer facility to an auxiliary position can also be included for night traffic, if required.

A further auxiliary equipment enables a simultaneous day and night ringing transfer facility to be included in the exchange.

For the rest the night circuit places no restrictions whatever on the extensions or house stations in their house or exchange traffic.

House Traffic and Flashing to the Operator's Position

Normally the operator's position is obtainable via a house connecting set (line No. 1). The house calling buzzer sounds, and the operator switches herself in by pressing the key RK (record key).

If during an exchange call an extension subscriber wants to ask the operator to enter the connection, he has to keep the key on his instrument pressed until the operator answers. This continuous pressing of the key causes the supervisory lamp on the operator's station to flash. The operator enters the connection by pressing the common key SK and the answering key associated with the exchange line indicated by the flashing supervisory lamp. By way of an intervention signal a ticking signal is again audible.

Flickering to the Trunk Exchange

During a trunk call the operator can transmit a flashing signal to the trunk operator by repeatedly pressing the flashing key, in order, for example, to ask her to enter the connection.

Special Functions

To prevent false holding of a house connecting set, a circuit arrangement is provided, which comes into operation, when a subscriber lifts his handset but does not dial within about 20 seconds. The connecting set is then released for other connections. The same safeguard comes into operation in the case of a faulty subscriber's line. Moreover,

after about a further 30 seconds the signalling equipment is also switched off.

In the case of connections to manual exchanges the re-appropriation of an outgoing exchange line just released is prevented by a 20-second blocking circuit, until the operator in the public exchange has cleared the connection by withdrawing her plug. If the Neha exchange is working to an automatic local exchange, this blocking period lasts for only 10 seconds.

*20-seconds
Blocking Circuit
for Connections
from the Neha
exchange to
a Manual
Exchange*

The exchanges are suitable for the connection of special equipments, such as principals' stations, listening equipments, staff finding systems, door blocking systems and the like.

*Special
Equipment*



Main station of a Neha concern telephone system in the secretariat.

Large Neha Exchange with Unlimited Capacity.

(Neha Decimal System.)

General
Construction

This system can be extended upwards to an unlimited number of lines. Even the lower limit cannot be definitely determined. Primarily economic considerations have to be taken into account in the choice of a system; naturally, probable extensions of service, possible future amalgamations and the like have also to be taken into consideration. It has already been stated that in producing a service telephone system it is not the first prime costs alone that should be the determining factors, but that long-sighted planning should ultimately achieve the highest degree of economy.

The system is designed with preselectors and also with call-finders in the preselecting rank. Economic considerations were the reason for this arrangement. From the outlines of the preselection principle (see page 36 et seq.) it can be seen that in non-combined and especially in smaller installations (only for internal traffic) the call-finder system may be somewhat cheaper, because every subscriber is not allotted his own preselecting mechanism, but each group of 50 to 100 subscribers only is provided with a number of preselecting mechanisms (call-finders) suited to the traffic conditions.

Matters are somewhat different in large combined exchanges having numerous exchange transfer sets and performing functions typical of the Neha systems.

In this case the use of the preselection principle offers circuit advantages, which ultimately result in minimum requirements of switches and relays. Thus it cannot be categorically stated that here a preselector system is suitable and there call-finders will be more satisfactory. The question must be decided for each individual case.

Whether a 100-line, a 1000-line or a 10000-line system should be used, depends primarily on the number of subscribers to be connected. As we know, the 100-line system has capacity for 100 subscribers, but it must be borne in mind that a number of the lines must be kept free for special facilities, e. g., for public exchange traffic, for junction traffic and for the connection of auxiliary equipments. It must also be remembered that immediately the number of subscribers exceeds 100, the first group selection rank becomes necessary.

The 1000-line system takes up to 1000 lines and has one group selection stage. The 10000-line system with two group selection stages has a maximum capacity of 10000 subscribers. There are also: the 100000-line system with three group selection stages and a maximum of 100000 lines, and the million-line system with four group selection stages and a maximum of a million subscribers (see details on page 38 et seq.).

Thus the choice of the system depends mostly on the number of subscribers' instruments to be connected. It must, nevertheless, be considered, whether the choice of the next larger system is not justified

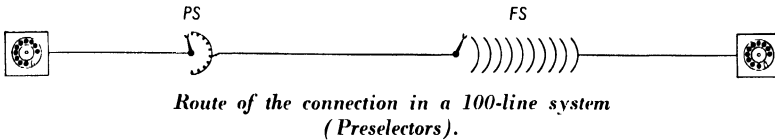

in view of the extensions that may eventuate. Even though the large Neha exchange is prepared for any extension demanded, the question must be examined for each individual case, whether in certain limiting cases it is not more economic to include suitable group selection stages in the first installation of the system.

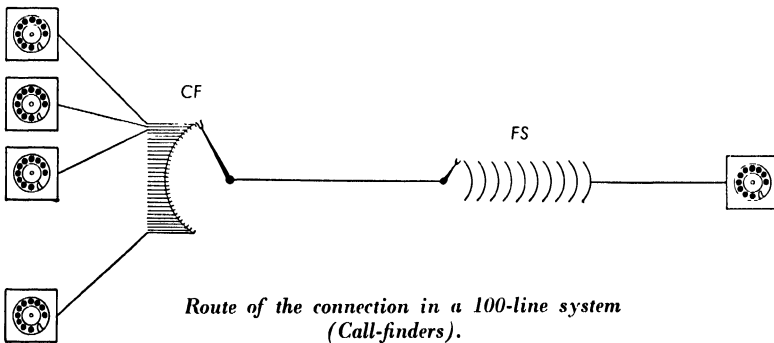

In the sketches the basic design of the system will be explained. In the diagrams the switch symbol with one arc signifies a rotary switch and the symbol with ten arcs a 100-pt two-motion switch.

In a 100-line system with preselectors the connection runs from the subscriber via the preselector and the final selector to the subscriber to be called.

*100-line System
(PS)*

100-line System (CF)

In a call-finder system of the same size the connection runs from the calling party's apparatus via a free call-finder in the relevant group and the final selector to the called subscriber. (For the sake of simplicity the following descriptions are all based on a preselector system.)

1000-line System

In a 1000-line system the subscribers are divided into groups each containing 100 subscribers. Thus with 1000 subscribers there are 10 groups of

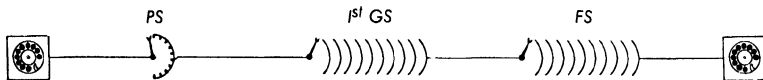

Route of the connection in a 1000-line system.

100 subscribers each. The connection runs via PS, GS—the wanted subscriber's group being selected by the latter—and FS to the subscriber.

10000-line System

The 10000-line system has two group selector stages. In the first stage one of the ten 1000-line groups is selected and in the second one of the ten 100-line groups.

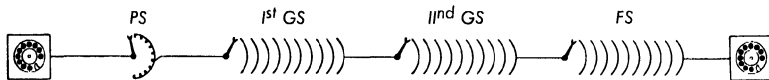

Route of the connection in a 10000-line system.

100000-line System

The 100000-line system has three group selector stages. In this case the first stage selects one of the 10000-line groups. The second stage selects a 1000-line group, and so on. The system with an ultimate capacity for one million subscribers has four group selector stages.

From these sketches it can be seen that conversion to a system of the next larger size is carried out by adding a further group selector stage.

Extensions within the system, e. g., in a 1000-line system from 500 to 700 lines, is effected by increasing the numbers of preselectors or call-finders, FS, GS and finally subscribers' instruments.

Switching Apparatus and Arrangements for Public Exchange Traffic

In this case, as in all other Neha systems, the selectors and other switching apparatus for the public exchange traffic are coupled to the selectors and switching apparatus for the house system and are to a certain extent entirely amalgamated therewith. In large systems it is usual to divide the available public exchange lines into outgoing, incoming and both-way lines.

All the exchange lines available for the outgoing direction are terminated on decades of the first group selector range or, in systems without GS, on contacts of the FS. They are appropriated by the

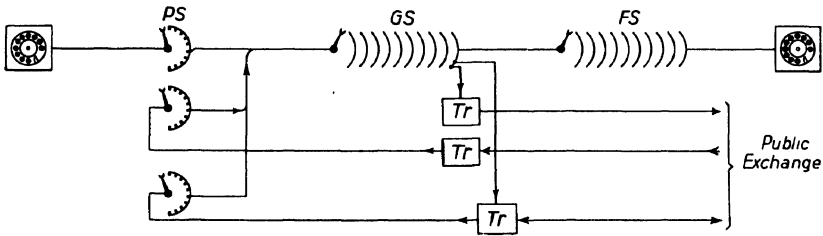

Routes of the outgoing, incoming and both-way exchange lines in a 1000-line system.

Outgoing: Preselector—0 decade of the group selector—Transfer equipment—Public exchange.

Incoming: Public exchange—Transfer equipment—Preselecting mechanism—Group selector—Final selector.

Both-way: From the group selector to the transfer equipment — outgoing; from the transfer equipment to the preselector = incoming; from the exchange to the transfer equipment both-way. (The operator's position for the incoming traffic is not shown here.)

extensions by means of code digit dialling. For subscribers without exchange facilities (house lines) the appropriation of exchange lines is rendered impossible by suitable arrangements in the subscribers' or preselector circuits. With every exchange line there is associated a transfer set, about whose duties further particulars will be given in the course of the description.

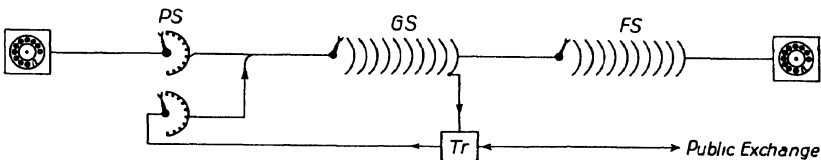

Theory diagram of the route of the both-way exchange line.

In the outgoing direction the exchange line is terminated on a decade of the group selector and reaches the exchange via the transfer equipment. In the incoming direction it runs via the operator's position and the transfer equipment to a preselecting mechanism. (The operator's position is not shown in the diagram.)

The incoming exchange lines are connected behind the answering position and the transfer set to a special preselecting mechanism (PS or CS). The distinction between subscribers with and without exchange

facilities is drawn by circuit arrangements associated with the operator's position.

*System with
Special Public
Exchange Group
Selectors*

To relieve the house exchange selectors in large systems it is preferable to provide special public exchange group selectors, which serve only the

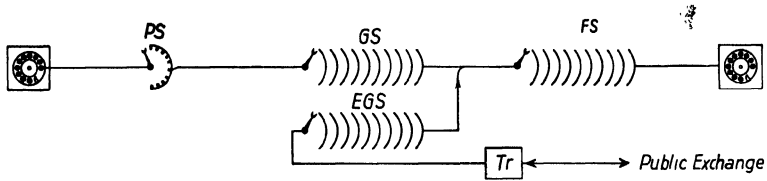

Route of an exchange line operated only for incoming traffic, using a special exchange group selector.

incoming traffic. In this case each individual incoming exchange line has associated with it a special exchange group selector, which is positioned by the operator in the normal manner.

*Answering and
Exchange
Position*

For the purpose of answering and passing on the calls coming in from the public exchange the operator's position is provided with suitable lamps, switches and exchange equipment. In essentials the equipment of the operator's position is not very different from that of the operator's station in the Neha exchanges previously described. For this reason it is not necessary here to describe the details of the operator's position. What is of interest, however, is the new type of calling device often used

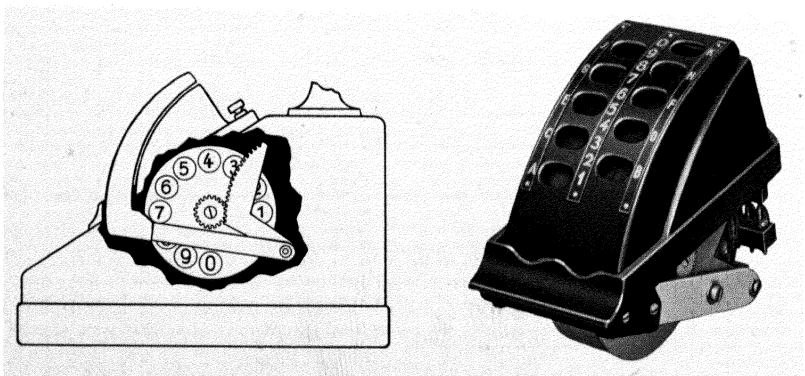

Straight-pull calling device (edgewise calling device).

Schematic diagram.

Natural view.

The normal calling device is provided with a driving device, by means of which the former rotary dialling movement is converted into a straight-line operation.

on the operator's position of this system. The switching mechanism itself remains unchanged. The circular finger-plate is replaced by a bow-shaped number-plate of moulded material, in which the finger-holes 1 to 9 and 0 are arranged in two adjacent rows: the odd numbers 1, 3, 5, 7, 9 are on the left and the even ones 2, 4, 6, 8, 0 on the right. This arc-shaped number-plate is coupled to the switching mechanism by means of a gear in such a way that during its spring-controlled return movement the same effect is obtained as with the normal dial. The advantage of this construction is that it facilitates dialling, because the straight pulling operation is less tiring than the circular movement.

The edgewise calling device, which owing to its being operated by an almost straight pull is also known as the "straight-pull calling device", can be removed from the operator's station or desk by loosening a single screw, and can be rapidly replaced. Wiring connections do not have to be undone, because the so-called jack-in contact strips are used.

First Enquiry

The change-over relays for enquiry connections and for the transferring of calls from extension to extension belong to the transfer set associated with each exchange line. An enquiry is initiated as usual by operating the enquiry key. The enquiry contact *c* is changed over, the exchange line is temporarily disconnected and the station of the party making the enquiry is connected to a second preselecting mechanism, by which the in-between connection is then set up.

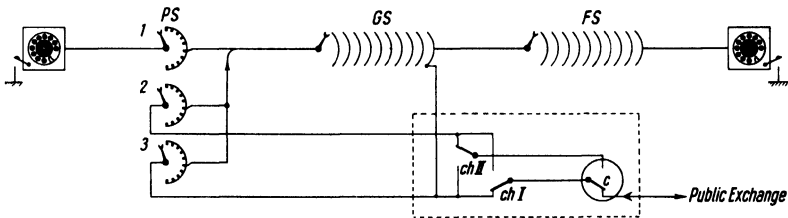

Theory diagram of the contacts provided in the transfer equipment for in-between connections and call transfers.

In the case of an outgoing call the in-between connection runs:— Subscriber, preselecting mechanism 1, GS, change-over contact *chI*, the changed-over enquiring contact *c*, change-over contact *chII*, preselecting mechanism 2, GS, FS, subscriber (see illustration on page 110).

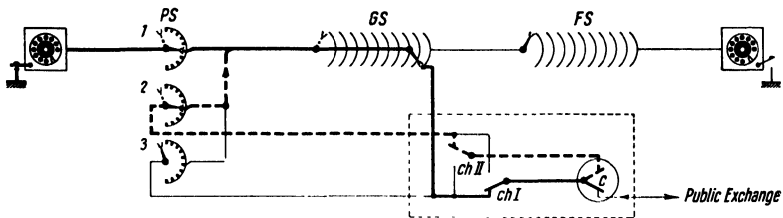

Route of the first in-between connection.

The subscriber has pressed the enquiry key. Via the changed-over contact c, chII, PS 2 a free connecting equipment is seized and the enquiring subscriber is dialled.

For an incoming call the connection runs:—

Subscriber, FS, GS, preselecting mechanism 3, change-over contact chI, the changed-over enquiring contact c, change-over contact chII, preselecting mechanism 2, GS, FS, subscriber.

The in-between connection is cleared by pressing the enquiry key a second time. The connecting set seized for the in-between connection is released, and the exchange line is again connected to the extension line via contact c, which has been restored to normal.

First Enquiry

If the outcome of an in-between conversation is that the call has to be transferred to the extension subscriber enquired, this second subscriber has to press his key. This causes the enquiry contact c to be restored to its original position, i. e., the exchange line again becomes active, but via the now changed-over contact chI it is then connected through the preselecting mechanism 2 to the second extension subscriber.

The connection then runs:—

Public exchange, enquiry contact c in its normal position, changed-over contact chI, preselecting mechanism 2, GS, FS, subscriber.

Contact chII, which is changed over simultaneously with chI, again prepares a path for a possible second enquiry.

Second Enquiry

If the key is again pressed for the purpose of a second enquiry, contact c is again changed over to the in-between position. The second in-between connection then runs:—

Subscriber, FS, GS, preselecting mechanism 2, changed-over contact chI, changed-over contact 3, changed-over contact chII, preselecting mechanism 3, GS, FS, subscriber.

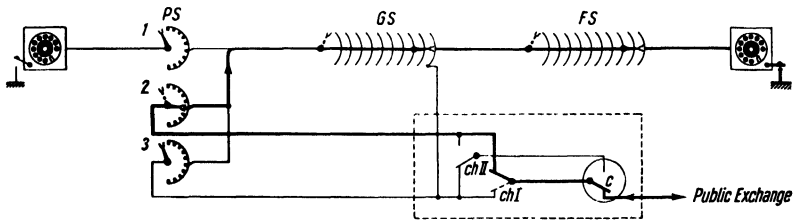

Route of the connection after the first transfer.

The subscriber called for the first enquiry has now pressed his key. Via the in-between route PS 2, chI and the restored contact c he takes over the exchange connection. Contact chII already prepares the next in-between route.

If the second enquiry also leads to a transfer, the extension subscriber, who is to take over the call, presses the enquiry key on his station. Contact c again switches the exchange line to the extension line, which then runs via contact chI and preselecting mechanism 3. In the meanwhile a fresh enquiring path is again prepared by contact chII.

After two in-between connections and two transfers the original positions of contacts c and ch are again reached. If still further in-between conversations and transfers eventuate, the operations are repeated in the same manner.

In the larger systems the preselecting mechanisms, the GSs and the FSs are mounted on special PS (or CF), GS and FS racks. A PS rack accommodates ten shelves of 10 preselectors or two CF shelves, each of which when fully equipped can take ten 50-pt CFs. A GS or FS rack carries 20 two-motion selectors with their associated relay sets.

*Construction
of the System*

The mechanisms belonging to the exchange transfer sets are mounted seven on a rack. According to the size of the system a 5 VA (up to 500 subscribers), a 15 VA (up to 3000 subscribers) or a 60 VA (for more than 3000 subscribers) signalling machine can be used. The mechanisms required for answering and passing on the exchange calls are mounted on the operator's desk. A portion of the switching mechanism is accommodated on a shelf available to each operator's position.

An operator's position is provided for every 20 public exchange lines. Every two positions can be multiplied, so that the exchange calls can be handled both at position 1 and also at position 2. For smaller systems special arrangements have been developed, in which the PS shelves and the FS shelves are accommodated on a common rack.

Trunking.

By this term is understood the circuit arrangements made to enable several exchanges to be connected together by means of a network of junctions to form a single composite system.

The division of a system into main and sub-exchanges may arise from various causes. In many cases decentralisation is inevitable owing to the subsequent combination of various premises having their own telephone exchanges, which are to be connected to the existing network in a suitable manner. In new systems one of the most important reasons for decentralisation is the economic lay-out of the subscribers' network, which as a rule accounts for the greatest portion of the cost of a telephone system.

As a safety precaution to provide against the risk of an air raid in times of war, decentralisation of communication systems should be promoted, particularly by vital industrial concerns.

* *Example*

Let us suppose that a concern is made up of five works situated partly on the same and partly on separate premises. A total of 520 stations are to be considered, which are divided up in the following manner:—

Works A (main works and administration)	250 lines,
Works B (on the same premises)	125 lines,
Works C (on separate premises)	75 lines,
Works D (on separate premises)	20 lines,
Works E (on separate premises)	50 lines.

The exchange in works E is not yet converted to automatic operation; the connections are set up on a plug-and-cord switchboard.

With a centralised arrangement of the whole system 125 line pairs would have to be laid from A to B, 75 from A to C, 20 from A to D and 50 from A to E. Such a network would possibly be practicable, if all the works were on the same premises and not too far from the location of the common exchange. If, as in the example selected, such is not the case, then for economic reasons the lay-out of the network must be fundamentally different.

In planning a decentralised system a division into one main and several sub-exchanges must be undertaken with the object of keeping

the numerous subscribers' lines as short as possible and of arranging for the junction traffic between the sub-exchanges and the main exchange and among the sub-exchanges themselves over a few lines, the so-called junctions. For exchanges C to E cost calculations would definitely demonstrate these measures to be correct, for in the example selected here they are situated on premises separated by some distance from the main exchange. In such a case the laying of cables would involve heavy costs. Whether it is right also to erect a sub-exchange for works B may be questionable in view of the special conditions assumed in this case (the same premises—not far apart). It is, therefore, supposed that from cost calculations the laying of a multi-pair cable to works B is practicable and that the 125 stations of works B are directly connected by subscribers' lines to the selectors in the main exchange. The exchanges A and B are thus amalgamated and form the 375-line main exchange A. The sub-exchanges B to D (previously C to E) are dealt with by junction traffic. The number of junctions depends on the amount of traffic flowing from and to exchanges B to D. In most cases special cables are not provided. The Post Office scale of charges gives the terms, on which Post Office lines can be rented.

In the example selected here the junctions leading to sub-exchanges B to D are connected to the 1st to 3rd decade of the group selectors in the main exchange and in exchanges B and C are terminated on a final selector serving only for the incoming junction traffic. In exchange D, which in the example selected here is still manually operated, the junctions are terminated on subscribers' multiple jacks. The lines running from the sub-exchanges to the main exchange are likewise terminated—according to the type of system in use there—on contacts of the group selectors or, in systems without group selectors, on contacts of the final selectors. The operation of the system is then carried out in the following manner:—

*Principles of
Junction Traffic*

The line running to sub-exchange B is terminated on the first decade of the group selectors. If a subscriber on the main exchange desires to reach a subscriber on sub-exchange B, he has to prefix the latter's number with the code digit 1. If it is desired to reach a subscriber on sub-exchange C from the main exchange, the code digit to be dialled is 2, because the line running to C is connected to the second decade of the group selectors. The code digit 3 is, of course, applicable to subscribers on exchange D. As soon as subscribers on the main exchange have

dialled the code digit, they are connected via a transfer set to a final selector in B or C, which they can then position in the known manner.

In exchange D the operator of the manual exchange there answers the dialling of the code digit 3 and sets up the wanted connection.

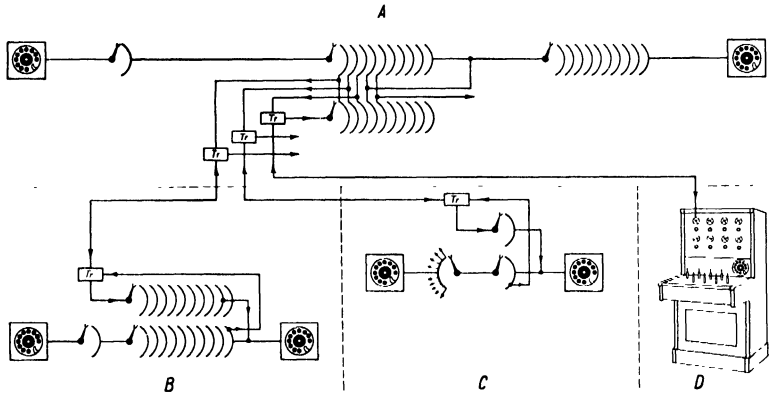

Schematic diagram of the junction traffic between four telephone exchanges (System with open code digits).

For each direction of traffic in every exchange a code digit is fixed. For the incoming traffic a selector per line is available. In the manual exchange D the junction is terminated on a jack in the subscribers' multiple panel.

Example: A subscriber on exchange A desires to reach exchange C. He has to dial the code digit 2, thus seizing a final selector in C, which he positions by dialling the wanted subscriber's number.

In the reverse direction, i. e., from a sub-exchange to the main exchange, the subscribers have first of all to dial the code digit for the junction running to A. They are thus connected to the group selector associated with their line and can then dial the wanted subscriber on the main exchange. If a subscriber on sub-exchange B desires a connection to sub-exchange C and there does not happen to be a direct line between these two exchanges, he first of all dials the code digit of the junction running to A. Then he dials the code digit of the line running to C and finally the actual number of the C exchange subscriber.

For the traffic flowing from D to A the switchboard is equipped with a dial. If the switchboard is arranged for "through-dialling", the subscribers can themselves position the selectors in the main exchange,

after the operator has allotted them a junction. In such a case their stations must, naturally, be equipped with dials.

From this basic example it can be seen that for junction traffic with open code digits there is no uniform numbering of the subscribers, because a subscriber on exchange B, for example, is reached within his own exchange with a number different from that with which he is reached by a subscriber on exchange A. Other different numbers apply for the same subscriber according as he is called from C or from D. This makes it difficult to compile a uniform directory for all exchanges. Modern telephone engineering has, however, produced excellent auxiliary devices for surmounting these difficulties, which may make themselves particularly conspicuous in the ramified network of a large concern, e. g., of a municipal system with its numerous associated works.

With such an arrangement the subscribers' numbers, which are uniform for all the exchanges, are made up in such a way that by means of switching mechanisms specially provided for this purpose automatic routing to the various traffic paths is carried out by the wipers of the switching mechanisms performing a kind of "feeling" operation, to ascertain to which exchange the subscriber just dialled is connected, so as to make sure of selecting the correct connecting path. These switching mechanisms are rotary selectors, which from their special functions derive the name of routing selectors. Their contact segments are divided into several parts corresponding to the number of traffic routes. Each part-segment denotes a different traffic route. It can now be understood that according to the digit dialled lines on the various part-segments, i. e., various traffic routes, can be seized.

*Junction Traffic
with hidden Code
Digits*

In the case of junction traffic arranged in this manner, operation is carried out as follows:—

Let us suppose that a subscriber on sub-exchange B desires to reach a subscriber on the main exchange. On lifting his handset he is immediately switched through to the main exchange via his preselector and the routing switch. In the subsequent dialling the impulses flowing into the system from his instrument are controlled by a relay switching mechanism provided for the purpose and, since according to the numbering of the main exchange subscribers the first digit will be either a 3 or a 4, there will be no routing by the routing selector. The main system selectors

are positioned on the wanted line. If, on the other hand, the subscriber dials 1 as the first digit, he indicates thereby that he wants to reach a subscriber on his own exchange. The routing selector is then made to release the junction and to switch over to a final selector in the same exchange (B), which then receives the subsequent impulses.

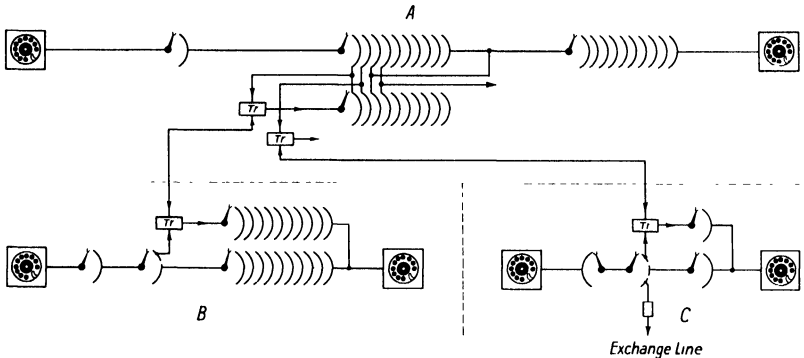

Schematic diagram of the junction traffic between three telephone exchanges (System with concealed code digits).

The subscribers' numbers contain the codes of the various directions of traffic. Routing is carried out automatically by the routing selectors. In exchange C exchange lines are connected to a segment of the routing selector.

From this it can be seen that even with this system code digits are used, which are, however, combined with the subscriber's number. In such a case we talk of a system with concealed code digits.

In method of operation the routing switch may even be compared with a group selector, which, as we have seen, is also controlled by impulses reaching it from the switches of the various groups, without the code digits associated with the various groups being recognised as such, because they are nothing but component parts of the subscriber's number.

It is, of course, also possible to use simultaneously in one network both systems of junction traffic just outlined. If the system with concealed code digits is to be used, all the exchanges in the network must, of course, be automatic.

The outgoing public exchange traffic of the various sub-exchanges can also be carried via the routing selectors. The method of operation

is exactly the same as if the exchange lines were terminated on group selector decades or on final selector contacts. If the sub-exchange has no P.B.X. of its own, the incoming exchange calls can be answered at the main exchange and passed on via the junction to the extension subscriber on the sub-exchange.

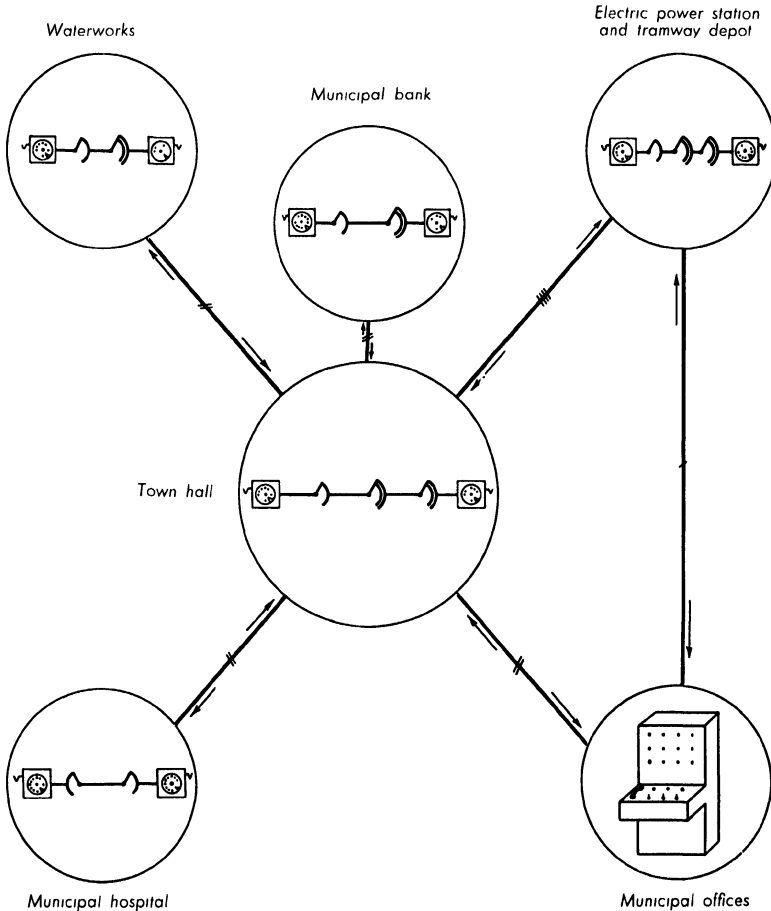

Junction network of a municipal system (schematic).

Selective Ringing Telephones.

General What in a normal exchange system is self-evident, namely, that every subscriber can at will call any other desired subscriber, can be achieved with the selective ringing system only by means of special constructional and circuit arrangements. The reason for this is as follows. Whereas in the exchange system every station is provided with a double line, in the selective ringing system there is only a single subscribers' line, the selective ringing line, to which all the stations are connected in parallel. Normally a call made on this line would be audible at all the stations connected. Formerly, such systems were actually constructed in this way, the subscribers' instruments being equipped with magnetos, by means of which agreed calling signals were transmitted. The signals were heard at all stations but were heeded only at the one, for which they were intended. It is self-evident that such a primitive system was inadequate for any considerable amount of traffic, quite apart from the fact that it provided no secrecy of conversation.

An automatic selective ringing system is intended for use where a telephone connection has to be provided for several service stations lying along a line, e. g. for the section supervisors on railway tracks, switching stations on high-tension lines, lock-keepers on canals and rivers, and the like. A network on the principle of exchange systems would be economically unjustifiable in view of the generally considerable distances to be covered, especially as the call-frequency of the individual stations in such systems is not high at all generally.

The automatic selective ringing system is an automatic dialling system. The subscribers' stations are among other things equipped with dials, the impulses from which control the switching mechanisms similar to rotary switches and distributed among the various stations, and thus cause ringing signals to be transmitted to the wanted station.

*Protection
against High
Voltage*

Since selective ringing lines are often subjected to the influence of trolley-wire and high-tension lines, a metallic connection between the stations and the speaking line must be avoided as a protective measure for the apparatus and for the subscribers themselves. The stations are, therefore, coupled to the line by means of a protective transformer.

*The Dialling
Principle*

This special protective device makes it necessary for the subscribers' dialling, i. e., the positioning of the switching mechanisms, to employ

a different method from that which is usual with normal automatic telephone systems. The impulses emanating from the dial have to be inductively transmitted to the line via the protective transformers. This method is in principle as follows: At the calling station the current source is applied by means of an impulse contact controlled by the dial to the primary winding of the transformer in the rhythm of the return movement of the dial and a number of times varying in accordance with the number of impulses. This produces in the secondary winding two impulses of opposite direction for each impulse in the primary, one impulse arising on the switching on and the second on the switching off of the current source. At the receiving stations the two impulses take effect in such a manner that the armature of a special relay (polarised relay) is moved by the first impulse to its operating position and by the second to its normal position. The first, which may be termed the "operating stroke" of the polarised relay, takes effect on the receiving magnet of the switching mechanism in the auxiliary apparatus box belonging to the called station. The dialling principle very roughly outlined here is described as "D.C. inductive dialling".

The technical equipment of each station comprises an instrument with handset, dial, busy indicator and tapping key. The switching mechanism with the other switching apparatus, such as relays, condensers, etc. is mounted in an auxiliary apparatus box.

*The Equipment of
the Stations*

The current source is also decentralised. Each station has a 6-volt accumulator, which is automatically recharged by means of a dry rectifier.



*Station on a selective ringing system.
1 --- Tapping key 2 --- Busy indicator*

By means of suitable transformer equipments a selective ringing line can be put in connection with telephone systems of any desired type, so that the individual stations on the selective ringing line can also call any desired subscriber on the exchange system. Vice versa, the subscribers on the exchange system can also reach the selective ringing line by code digit dialling.

The number of stations that can be connected to a selective ringing line depends on the constitution of the line. Ten stations will be taken as a rule. If the number of stations is to be greater than this, the line is divided up into one or more sections by means of suitable coupling transformers. This arrangement also has the advantage that, when one conversation is being conducted on one section, a second call can be made on another. In principle the system operates as follows:—

Outgoing Calls When a handset is lifted, the busy indicators on all stations in the section are operated.

The wanted subscriber's number is dialled in the normal manner. The impulses from the dial synchronously step on in the manner previously described all the switching mechanisms located in the auxiliary

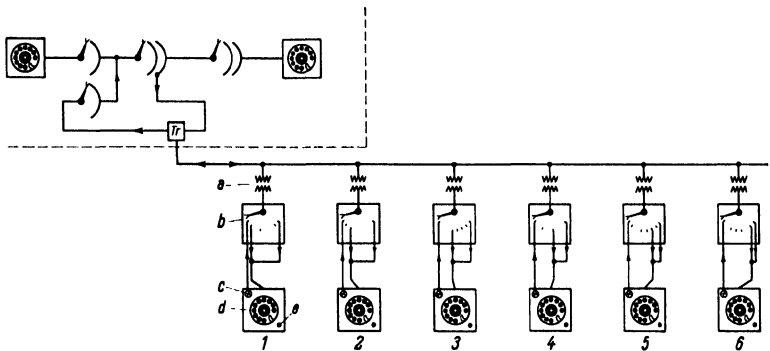

Schematic diagram of a selective ringing system.

- | | |
|---|---------------------------------|
| <i>a</i> — Protective transformer | <i>c</i> — Busy indicator |
| <i>b</i> — Switching mechanism in auxiliary apparatus | <i>d</i> — Dial |
| | <i>e</i> — Tapping key (sealed) |

The switching mechanisms are located in the auxiliary apparatus boxes b. They are all simultaneously positioned by the impulses from the dial. For dialling the junction to the main exchange a code digit is arranged.

apparatus boxes of the various stations. When, for example, a 4 is dialled, the wipers of all the switching mechanisms are moved in the manner of a normal rotary switch from the rest position over contacts 1 to 3 to contact 4. Whereas the bell of station 4 is connected to contact 4 of the switching mechanism of that station, the contacts No. 4 of all the other stations are unoccupied, i. e., it is only in station 4 that the bell is in circuit. When the handset of the called station is lifted, the connection is finally completed.

If the whole line is divided up into various sections and a subscriber dials a number on his own section, the other section or sections are released, as soon as the switching mechanisms have been positioned, so that a further connection can be set up on each of the other sections.

*Release of other
Sections of the
Line*

The remaining subscribers on the engaged line have observed nothing of the dialling operation, but merely recognise the engaged state of the line from the operated busy indicators.

Moreover, an existing connection cannot be disturbed by the lifting of a handset or the operation of a dial, unless the special switching device provided for tapping is operated.

It is just in the concerns, for which selective ringing telephones represent important installations, that there often arises the necessity to release the engaged line immediately, for example, to report an accident. For this purpose each station is equipped with a sealed key, which is pressed after the seal has been broken, and tapping into the existing connection is effected. The intervening party's call is, naturally, urgent, and the other subscribers release the line (replace their handsets).

*Tapping into
a Busy Selective
Ringing Line*

On the conclusion of a call the replacement of the handsets restore all the switching mechanisms to their rest positions. At the same moment the disengaged state of the line is indicated by the switching off of the busy indicators.

*Conclusion of
a Call*

The general call is provided in all selective ringing systems. If, for example, an important notification is intended for all stations, all the switching mechanisms are switched to the general call contact by dialling a code digit, the general call number. On this contact are terminated the bells of all the stations. On lifting their handset all the subscribers find themselves connected with equal rights to the common speaking line.

*General Call and
Group Call*

A group call similar to the general call is also often included. This to a certain extent “partial general call” applies only to the stations on one section of the line or, according to the circuit, only to selected stations. A special code digit has again to be fixed for the group call.

Junction Traffic An exchange system connected to the selective ringing line is reached by code-digit dialling. The impulses following after the code digit take effect on the switches in this system. If the connected system is still manually operated, the operator answers and sets up the further connection, as required.

In the reverse direction, i. e., from the exchange system to the selective ringing telephone system, the subscribers also have to dial a code digit, or have to give the code word of the relevant selective ringing line the operator at the switchboard. The subsequent impulses take effect in the usual manner on the step-by-step switching mechanisms of the selective ringing stations.

Line Break In the event of a break in the selective ringing line the stations on a portion of the line (merely broken and not affected by other disturbances) can obtain connections to each other, just as if the whole line were divided into sections by repeaters.

*Precautions
against False
 Busying* If a subscriber lifts his handset and thus seizes the line, but does not dial, his station is automatically disconnected after a few seconds and the line released. In this case, however, the station concerned is not blocked, i. e., it can even be called in this condition. This disconnection in the event of false busying is effected by thermo-contacts, whose operating time, i. e., switching time, can be regulated by adjustment.

Auxiliary Apparatus.

Conference Telephones.

The conference telephones have been developed as an auxiliary equipment for a selector exchange and serve to connect together several subscribers for the purpose of a telephone conference. The conference subscribers hear in their normal receivers the speech and counter-speech of all the other parties participating in the conference. Except for the station of the convener of the conference normal telephone instruments are used, and the line network is also the same. Moreover, a conference system may also be equipped with several convening stations.

Purpose of the Equipment

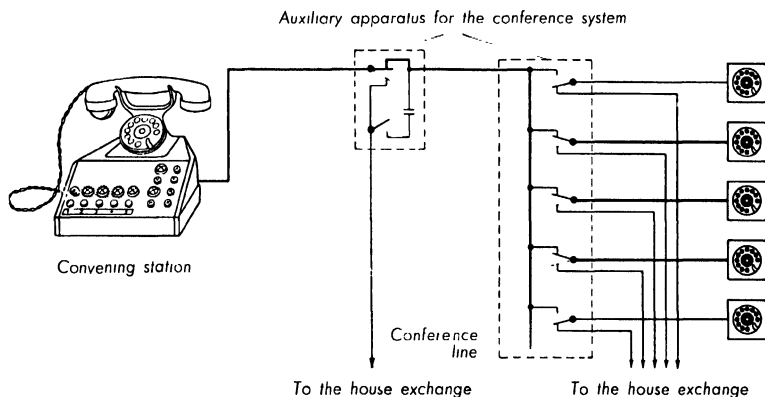

Schematic diagram of an automatic conference system.

*Subscribers 2, 3 and 4 are summoned to a conference (shown in heavy lines).
The supervisory lamps of these lines are switched on.*

The relays, condensers, etc. and also the ringing equipment for each five subscribers are mounted on a framework, which is located in the exchange switchroom. In the larger systems a repeater equipment may be necessary, which depends on various circumstances in each individual case, because in this connection the line conditions also play an important part.

The convening of a telephone conference is effected at one of the convening stations. On these stations each of the "permanent" conference subscribers is represented by a key for switching on and off and a signalling lamp for switching in and busy supervision. The first pressing of the key immediately connects the line of the relevant subscriber, if free, to the conference line. Until the subscriber answers (lifts his handset), the

*The Convening of
a Telephone
Conference*

supervisory lamp is switched on and off in rapid rhythm (flashing). When the handset has been lifted, the lamp continues to glow steadily throughout the conference. An existing house call is indicated by the slow switching on and off of the supervisory lamp. The convener then has the facility of intervening in the existing house connection by pressing the tapping key. If circumstances necessitate it, he can even clear the existing connection in favour of the conference by pressing the clearing key.

*Terminating the
Telephone
Conference*

The switching off of an individual subscriber is effected by a second pressure on that particular subscriber's key. The supervisory lamps are at the same time switched off. If all the subscribers are to be switched off (termination of the conference), the handset of the convening station is replaced.

In this way the convener can during the course of the conference switch the "permanent" subscribers on and off, as desired, and can supervise the switching operations by means of the supervisory lamps.

Up till now only the "permanent" conference subscribers have been mentioned. In addition to these, however, a special S key normally enables another desired subscriber on the house exchange to be summoned to the conference. He is dialled with the dial of the convening station via the normal house line. In as far as all the conference subscribers are arranged as extensions, the conference line can also be connected to a public exchange line.



Conference-convening station.

The station is arranged for four permanent conference subscribers and a house connection.

With the help of the key provided for the purpose the convener can conduct in-between conversations on the conference line during a normal call. Moreover, he can switch his station from the house line to the conference line, and during a conference he can also switch over from the conference line to the house line.

As can be seen from the foregoing, the convening station is at the same time the convener's normal instrument. It operates as such, if for the initiation of a call the handset is merely lifted. It is also worthy of note that the calling buzzer of the convening station can be set in operation even during a conference, so that incoming calls can be answered during a conference.

The keys and supervisory lamps of the convening station are often mounted on a separate base-plate, which is let into the top of the desk at an appropriate position. Another satisfactory solution that is frequently employed is the mounting of the whole apparatus in a small trolley-like telephone cabinet. As a rule this cabinet also houses the special principal's apparatus, e. g., the listening equipment. The equipment is protected against improper use by means of a roll-top fitted with a lock.

The conference system has become an indispensable equipment for every large concern, for nowadays more than ever it is desirable to settle difficult business questions in the shortest possible time. A telephone conference can be convened in a few seconds and discussion can begin without delay.

Conference-Call Equipment for Inclusion in P.B.X.s.

With this equipment several subscribers can be connected to a common "conference-call line" for the purpose of a "conference-call". If not more than twelve subscribers are to take part at the same time in the common call, special repeater equipment can be done without under normal line conditions. For larger numbers of subscribers and if long distances have to be bridged, a suitable repeater must be provided. The maximum number of subscribers to be connected together for a conference-call and the line conditions are always the deciding factors.

The connecting keys and supervisory lamps are mounted on the P.B.X. switchboard, a connecting switch (CK), a red busy lamp and

a green clearing lamp being provided for each subscriber. The ringing key (RK) is always common to twelve subscribers.

Connecting up for a Conference-Call

The subscriber's circuit intended for a conference-call is switched to the common speaking line by the switchboard operator, who throws the relevant connecting switches. The throwing of the switch disconnects the conference-call subscribers from the house exchange, so that for the duration of the conference-call they cannot be disturbed by house calls.

House calls on the part of conference-call subscribers are indicated on the switchboard by a red busy lamp. The call would be cleared, if

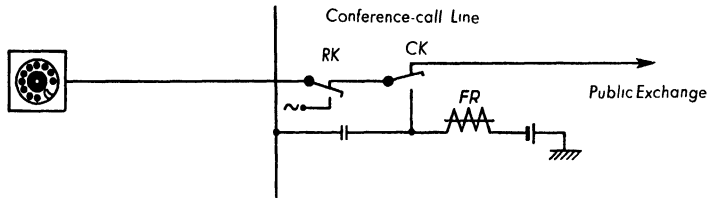

Theory circuit of the switching arrangements for conference-call subscribers.

The subscribers are individually connected to the common conference-call line by key CK. Each group of 12 subscribers is rung by means of ringing switch RK. Clearing of the conference-call connection is effected by restoring switch CK.

the connecting switch were thrown, while the busy lamp was glowing. In most cases the tapping facility is provided for the operator, so that she can intervene in an existing connection and inform the relevant subscriber that he is wanted to take part in a conference-call.

As soon as all the subscribers are connected to the conference-call line, the ringing switch provided for a group of twelve subscribers is operated. The subscribers who lift their handset are indicated by the lighting up of the relevant red busy lamps. The repetition of the ringing affects only those subscribers, who have not already lifted their receivers.

Release of the Conference-Call

At the conclusion of the conference-call the feeding relay Fr is deprived of current by the replacement of the handset. At the same time the green clearing lamps are brought into circuit. The operator then restores the connecting switches to normal. The subscribers' lines are

then once more connected to the preselecting mechanisms in the house exchange.

Circuit arrangements can also be provided to make it possible to summon at will one or more subscribers on the house exchange, who are not permanently connected as conference-call subscribers. It is likewise possible to connect a public exchange line to the conference-call line. In this connection it is, of course, assumed that all the conference-call subscribers have extension stations.

Except for the principles of effecting connection a conference-call system is comparable to the conference system previously described.

Staff-Finding System.

The staff-finding system is a valuable complement to the telephone equipment in a concern. It has been developed as an auxiliary equipment to the automatic exchange and serves rapidly to trace important individuals and to provide telephonic communication with them, when they are not in their normal places but are elsewhere on the premises.

*Purpose of the
Equipment*

Without having to enlist anyone else in the find, the finding party can send out the search signal from any desired telephone station on the private system. Likewise the party wanted is directly put into connection with the finder, as soon as the agreed number has been dialled from any telephone station. Telephone calls can also be transferred to the desired individual.

The finding lamps—in normal systems they are generally made up in sets of five—are mounted in lamp indicators coloured alternately red and white, and are erected in visible positions in the more important sections of the concern. A bell or hooter is mounted direct on each indicator, and this sounds every five seconds until the wanted party replies, in order to draw attention to the switching on of a finding signal. By way of finding supervision the calling party hears in his receiver a buzzing tone of the same rhythm.

The individual finding lamps or lamp combinations (with a five-part indicator there are 27 of them) are switched on by two switching mechanisms, which are normal rotary switches that can be positioned on the various finding lines by dial impulses. Here again the switching mechanisms are seized by dialling a code digit common to all the lines,

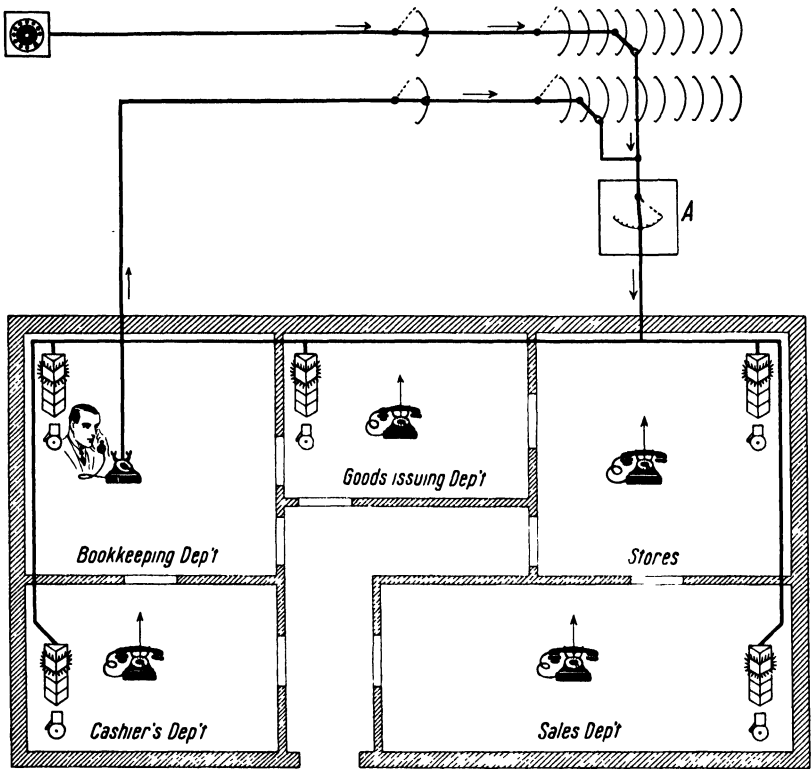

Schematic diagram of a staff-finding system.

The finding party is connected to the auxiliary equipment A by dialling the finder number. By dialling the relevant number the switches in the auxiliary equipment are positioned, and this lights up the lamps allocated to the wanted individual on all indicators. At regular intervals the bells are ringing. The wanted individual dials the specified number from the nearest station and is immediately put into connection with the finding party.

i. e., a connection on the final selector of the telephone system is the connection point for the connecting line running to the auxiliary equipment. The finder number has always two digits. The first impulse-train sets one and the second the other rotary switch on the wanted contact. Every subscriber connected to the finding equipment has a special search number, by means of which the corresponding lamp combinations are made to light up.

When his finder lamp or lamp combination lights up, the wanted party has to dial the answering code digit common to all subscribers from any telephone station that happens to be in his vicinity, and he is then directly connected to the finding party.

If two people are to be found simultaneously, the finder equipment has to be provided in duplicate, i. e., two auxiliary equipments have to be provided and two indicators at each selected point. Equipments have also been developed, with which as many as five people can be found simultaneously. In addition, there are also finder equipments that only operate acoustically; in these the finder signal is sent out in Morse code. In practice, however, acoustic finder equipments have not proved as good as the optical systems.

Normally the finder lamps are fed from the telephone system battery (24 volts or 60 volts). In the larger systems with ramified networks and more than about 10 to 15 indicators, the lamps are connected directly to the lighting network by means of heavy-current relays. The same remark applies to the feeding of bells and hooters.

Connecting Equipment for Privileged Subscribers (Principal and Secretary Stations).

The equipment consists of a principal's station, a secretary's station and an auxiliary apparatus box, which contains all the relays, condensers, etc. required for the various switching functions. The principal's station in a black-enamelled, desk-shaped metal case contains in addition to the

*Principal's
Station*



*Principal's station
equipped for 1 exchange line, 1 house line and 1 secretary's line. Listening
equipment is provided for the secretary, 2 rotary keys for call changing over, and
keys for locking door, messenger and chauffeur calling and the like.*

microphone, the dial and the bell, the keys and supervisory lamps for an extension line, a house line, a direct line to the secretary, a listening device for the secretary, two rotary keys for changing over at will from the extension line to the house line on the secretary's instrument, an on- and off-key for a door-blocking signal and three keys for messenger calling, chauffeur calling or the like.



Secretary's station

equipped for own and principal's exchange lines and for own and principal's house lines. Listening equipment is provided and various keys for messenger calling, etc.

*Secretary's
Station*

In a similar case the secretary's station contains keys and supervisory lamps for its own extension line and a principal's extension line, for its own and the principal's house line, a direct line to the principal, a key for listening in to the principal's calls (only to be made effective from the master instrument) and four messenger calling keys. For principal and secretary stations other patterns can, of course, be provided. The pattern described here is the one most frequently used in practice.

The principal can at will accept all incoming calls himself, or by setting the rotary key provided for the purpose he can automatically switch them through to the secretary's station. The calls then go to him direct, only when he restores the rotary key to normal. The provision of two keys for this call-transferring operation enables him to switch through all or only the house or only the exchange calls to the secretary's station.

When the rotary keys are set, the secretary accepts the incoming calls for the principal, in order that according to his authority he may

deal with the calls himself or in important cases offer the connection to his principal. For this purpose he is provided with a direct line to the principal's instrument, where the call is taken over by pressing a key. From the lighting up and extinguishing of the supervisory lamps associated with the individual lines it is possible at any time to ascertain on what lines calls are in progress.

The principal can either set up outgoing calls himself, or he can instruct the secretary via the secretary's line to set up the connections for him and only offer them to him, when the wanted individual is already at his instrument.

During a call the principal can request the secretary to listen in. For this purpose the relevant keys have to be pressed on both stations. In this way it is made impossible for the secretary to overhear any conversations conducted at the principal's station without the latter's sanction. By pressing the listening key on the principal's station a second time the secretary can be switched off and the listening connection broken.

The switching on and off of the door blocking indicator (indication of a conference) is effected by pressing the door blocking key. As usual, all switching operations are initiated by the simple pressing of a key. Every switching operation can be supervised by means of the supervisory lamps.

The keys and lamps can be mounted on a suitable base-plate, which can be built into the desk or a special telephone cabinet in a position readily accessible to the principal or secretary.

“Engaged” Lamp (Conference Indicator) with Remote Control.

On the doors of the offices of principal individuals there is often to be found a so-called engaged or conference lamp, which is switched

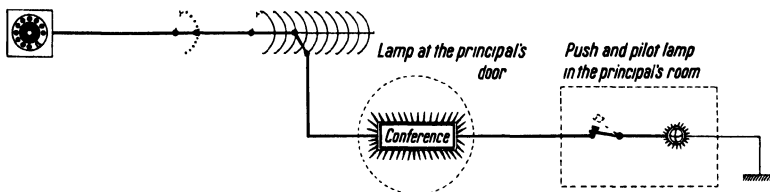

Schematic diagram of the conference indicator.

A certain line on the house exchange is connected to the conference indicator. If the conference lamp is switched on, everyone who dials the number of this line, receives the busy signal. He then knows that the principal does not desire to be disturbed.

on from inside the room and in this condition is intended to keep out visitors. By a suitable connection to the automatic exchange the lamp of every station can be tested from there to ascertain whether it is on or off, so that the calling party may know whether his visit—possible merely his telephone call—is desired or not.

In the automatic exchange a special testing connection has to be provided. When this testing line is dialled, the ringing signal is heard, if the lamp is not alight. Otherwise the normal busy signal is audible in the receiver.

Deputy's Line.

Two subscribers, one of whom may act as a deputy, can be connected to a common speaking line. An incoming call reaches both stations, but the deputy's line is switched off at the instant the principal subscriber lifts his handset. The switching relay required for this switching operation and also a resistance and a condenser are accommodated in a small metal cabinet, which can suitably be located in proximity to the stations.

Transfer Equipment.

The transfer equipment operates in a similar manner, except that in this case the deputy's line is not directly connected to the common speaking line but via a thermal relay, and its thermocontact is not switched on until the call coming in to the main station has remained unanswered for about 15 to 20 seconds. The necessary relays, etc. are accommodated in the automatic exchange.

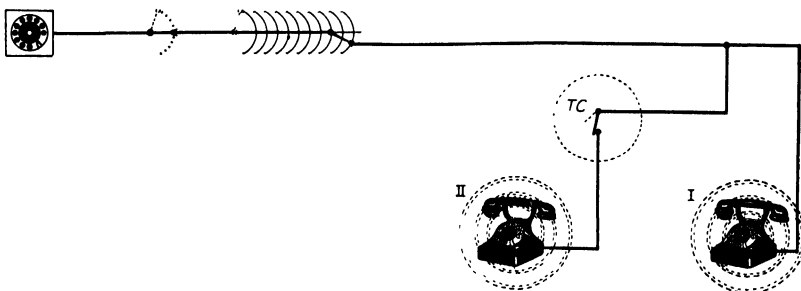

Schematic diagram of a transferring equipment.

Assume that the wanted subscriber (I) is not at his working position. After repeated ringing a thermo-contact (TC) is operated in the exchange and ringing is then also applied to the station of the deputy (II), who can take the call and deal with it.

Testing and Supervisory Equipment.

The essential maintenance of any technical device is indispensable to its permanent readiness for service and its faultless operation. But the operating costs and the system's life, as judged reasonable in each instance, are also to a large extent dependent on whether it is maintained and, what is actually still more important, whether it is *suitably* maintained.

In itself a telephone system is no more sensitive than similar electrical equipments, but it is a peculiar characteristic of the telephone system that any faults occurring may be considerably more perceptible than they are in other service systems. For example, interruptions of the concern's connection with the outside world, when there are faults on the exchange lines or in the P.B.X., generally have unpleasant consequences.

Automatic systems are, therefore, provided according to their size with various devices, which as far as possible indicate deviations from the normal state. In this connection endeavours are made to indicate irregularities in operation, before they have become apparent to the subscribers as faults.

Of the greatest importance is the continuous supervision of the numerous fuses, the selectors and the lines. The different types of irregularity are most suitably indicated by means of lamps of various colours; for example, the lighting up of a red lamp indicates damage to an individual fuse, and a blue lamp indicates that an important main fuse is faulty. If a "fruitless appropriation" occurs, i. e., if a subscriber

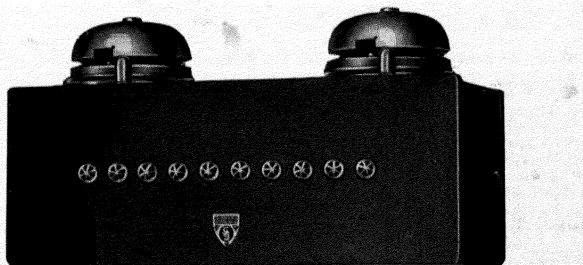

*Alarm indicator,
giving visual (of various colours) and acoustic signals, when fuses burn out, faults occur on the selectors and so on.*

lifts his handset, but does not dial, a yellow lamp glows. A mat white lamp means line alarm and indicates line faults. Every selector operation is supervised by a green lamp, and every engaged connecting set is indicated by a clear white lamp.

These alarm lamps, which normally only appear in the larger systems, are combined in a lamp indicator, which besides being mounted in the switchroom is often also repeated in the office of the maintenance officer or the service superintendent. The optical indicators may be supplemented by acoustic signals (bells), which facilitate supervision for the maintenance staff at night, especially in large exchanges.

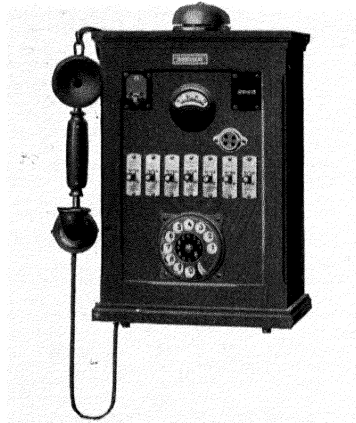

Test panel for an automatic telephone exchange.

This panel serves for various investigations and measurements on selectors, dials and lines.

The damaging of cables due to removals and reconstructions may give rise to line faults. With the help of an ingenious testing equipment, which contains a number of special measuring instruments, the state of the outside lines can be supervised in a simple manner. The testing equipment also contains instruments for testing dials. The investigation shows whether a dial is sending out, in the correct form and with the prescribed spacing, the selecting impulses on which mainly depends the correct positioning of the selectors. Deviations, which generally indicate wrong connections, can readily be corrected when they are discovered. On the same test panel selectors are also tested to ascertain whether their mechanical and electrical state is satisfactory. These tests

are not postponed until a selector becomes faulty. Regular tests prevent irregularities from developing into faults.

A new portable impulse recorder has recently been developed for measuring the impulses from dials, impulse relays and other impulsing

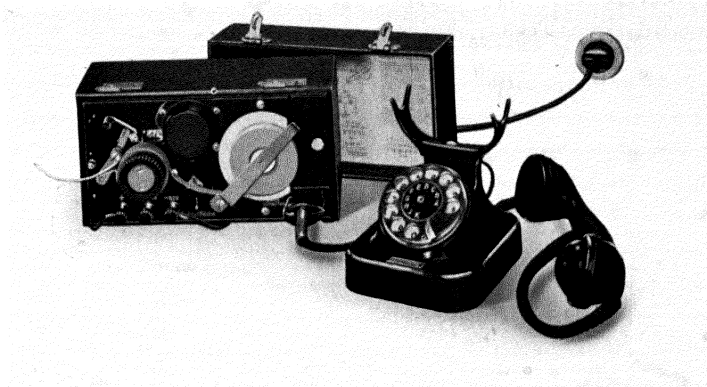

Impulse recorder

for measuring the impulses from impulsing devices of various types. The equipment is connected to 220-volt 50-cycle mains. For 110-volt mains a transformer is required. Manipulation is limited to the connection of the impulsing device, the starting up of the synchronous motor, the pressing of a small lever and the operation of the impulsing device.

The illustration shows the impulse recorder connected to a station for testing purposes.

devices. It can be connected to any A.C. mains and is simple to operate. The measured results are directly recorded on a specially prepared colour tape. The equipment is accommodated in a small leather case and provides a very satisfactory aid to investigations at the test panel and during installation. The precision of measurement amounts on the average to ± 1 ms.

Current Supply Equipment.

The quality of service of a telephone system is also to a large extent dependent on the state of the equipment for supplying the current. Primarily it must be so amply dimensioned that it can effectively perform the work required of it. Just like any other machine, it requires suitable maintenance, more especially because it must always be ready for service.

It is by no means superfluous to emphasise this point, for experience daily renewed shows how often it is just this vital portion of the system that is regarded as incidental and handled as such. This is less the case during planning than later in service. The designer will avoid exercising undesirable economy in this portion of his plans, for he knows too well the subsequent "effects" of a wrongly calculated current supply system. On the other hand, in the actual provision and subsequently in maintenance those undesirable economies are frequently effected, which very much to the detriment of the whole system may prove the source of appreciable faults.

According to the system employed telephone installations operate on a direct voltage of 12 to 60 volts. Exceptions to this rule are the smallest types of house system, which are fed by 3-volt dry cells, and certain special systems, e. g., selective ringing systems, which operate on 6-volts D.C.

Dry Cells

Normally the smaller series-connected systems are fed by dry cells, several of which are connected together to form a 12-volt battery. In such systems the current consumption is so small that accumulator batteries with the necessary charging equipment are seldom sufficiently economic. In those cases where any auxiliary equipments are included, the use of accumulator batteries may, nevertheless, prove more suitable in view of the dependence of such equipments on the potential available.

Mains Units

In recent years thoroughly satisfactory results have been obtained with mains units, which have been used for the direct feeding of small relay-switch exchanges. Such apparatus renders accumulator batteries superfluous. The working current is derived from the public lighting mains via a plug and cord and is first applied to a transformer, which transforms the mains voltage to the voltage required by the telephone system. Thereafter the alternating current is rectified by means of a dry

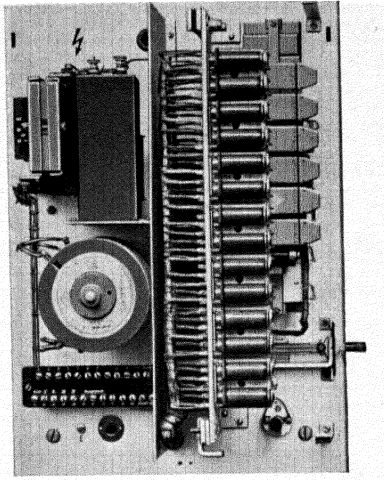

Mains unit (in the left half of the illustration), together with a Neha relay exchange for four exchange lines.

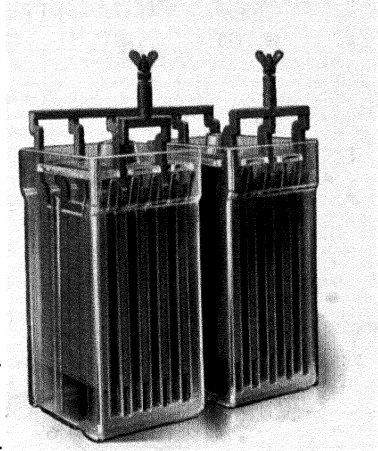

2 cells of an accumulator battery.

Illustration by: Akkumulatorenfabrik AG, Varta, Berlin.)

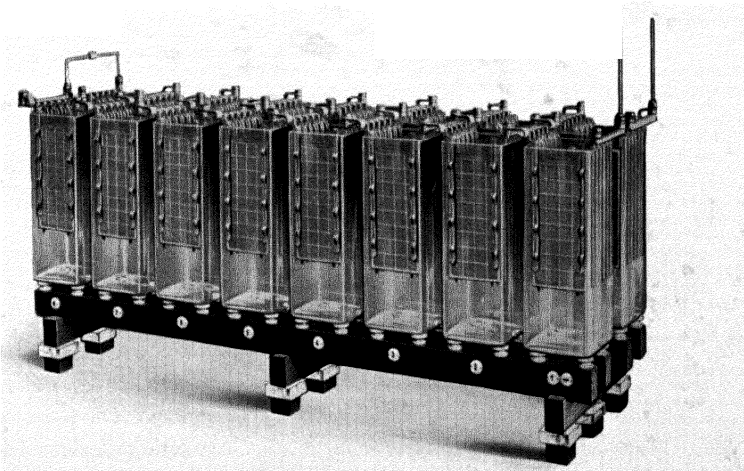

Accumulator battery with 16 cells for a larger telephone system.

(Illustration by: Akkumulatorenfabrik AG, Berlin.)

rectifier. On the mains side, i. e., on the side of the power mains, the transformer is provided with a series of tapping points, which permit the apparatus to be connected to all the most usual mains voltages. On the low-voltage side (secondary side of the transformer) there are likewise tappings for various voltages. It is thus possible to obtain several different voltages, so that no special current source is required even for the ringing current of a higher voltage than the working voltage.

Accumulators

Current for the automatic exchanges, which are more sensitive to voltage variations, is more satisfactorily supplied by accumulator batteries. In most cases it is usual to provide stationary accumulators with large plate surfaces, which as compared with the cheaper types have among other advantages that of longer life and greater insensitivity to occasional overloads.

Charging Equipment

The accumulator battery has to be charged either continuously (continuous charging) or periodically by means of a charging equipment, which will be dealt with in the following section. During the periodic charging the voltage rises to 2.7 volts per cell. Shortly after charging it reverts to the normal potential of 2 volts per cell. An accumulator is in a state of discharge, if the voltage has fallen to 1.8 volts per cell. Any further discharge is harmful to the plates. The state of charge or discharge of a battery can also be ascertained with the help of a hydrometer, for the acid density is known to decrease with progressive discharge.

In the discharged state the acid has a density of 1.18. A fully charged cell has an acid density of 1.20 to 1.21.

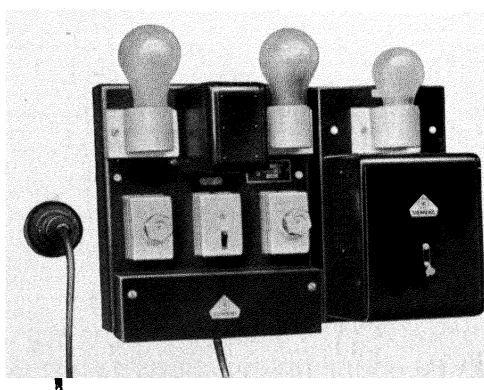

*24-volt D.C. charging apparatus, with auxiliary equipment for automatic regulation of charging.
Load: 1 or 2 amps at 220 or 110 volts.*

Small and medium-sized accumulators are charged from D.C. mains by means of a D.C. charging equipment for continuous charging, complete with a regulating device. In such an equipment the mains voltage is generally reduced to the required value by

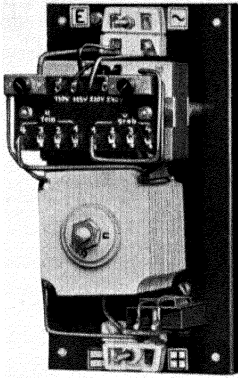

*0.2-amp,
24-volt
dry rectifier.*

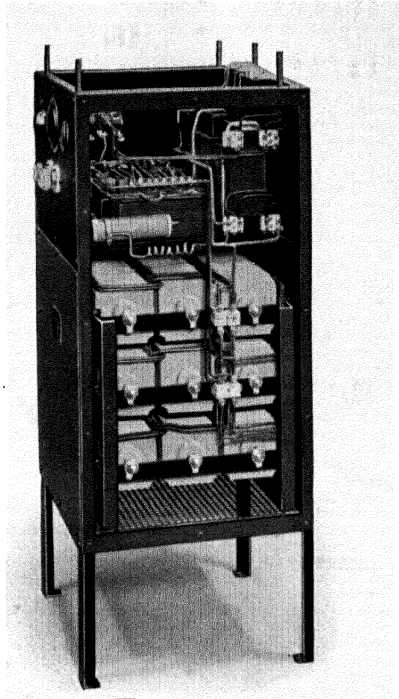

*8 to 12-amp, 24-volt
dry rectifier.*

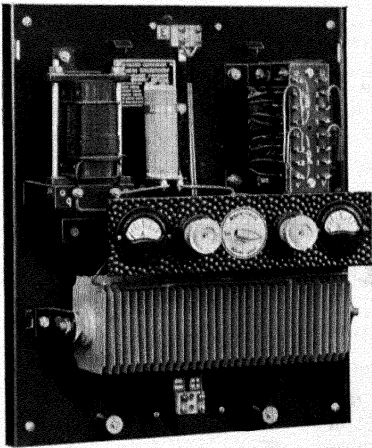

*0.7 to 1.3-amp, 24-volt
dry rectifier.*

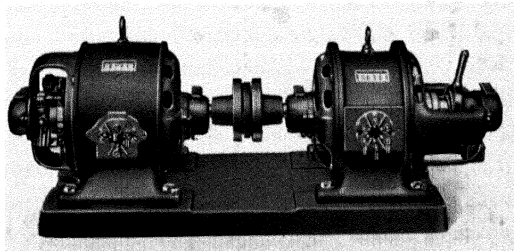

Converter set.

means of resistance lamps. The regulating device adapts the current supply for the battery to the current drain in such a way that the battery always stands at the prescribed working voltage.

If the public power mains carry alternating current, the charging of the battery is carried out by means of an A.C. charging equipment with copper-plate—or hot-cathode—rectifiers, or in the larger systems with mercury arc rectifiers. A.C. charging equipments are likewise fitted with the previously mentioned regulating device, and in addition filters are provided for smoothing the residual A.C. overtones.

*Converters for
Large Systems*

Large accumulator batteries, such as, for example, are installed in public telephone exchanges, are as a rule charged by means of converters (motor generators). This method of battery charging, naturally, requires

more supervision than that employing continuous charging equipments, which once adjusted, operate almost without supervision. In large exchanges it is usual to provide two batteries, which are charged and discharged alternately. Experience has shown, however, that systems with a floating battery and modern charging equipment correctly dimensioned operate with great reliability.

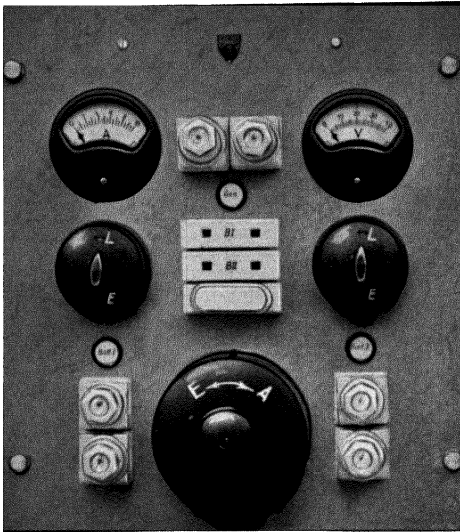

Charging panel for 2-battery operation.

naturally, required. The availability of a second battery is to be regarded as such a safeguard. In this case the safety arrangements are even carried so far that to provide against a lengthy breakdown of the public power network special petrol engines are held in readiness for charging the batteries.

In systems for the public telephone service extensive safeguards are,

The Planning of a Telephone System.

By this term should be understood the precise planning of the constructional design. The finished system will meet the demands all the more satisfactorily, the more completely the original planning deals with all the operating and traffic questions, which may have an influence on the constructional design.

In the previous sections of this work quite a considerable series of systems has been described. It has become so mixed and so lengthy, because as a result of the extraordinary diversity of the concerns involved new tasks have been given—one might almost say—daily to the circuit engineers and designers. Actually, among the thousands of service telephone systems there would be only a few that are alike in every particular.

Naturally, the choice of a system is also a question of prime cost. This consideration alone, however, should never play the deciding part. A concern's telephone system should be one of the most important tools in the hands of the principals and of every single worker in the concern. This necessitates primarily the closest adaptation to the characteristics of the concern—and with it is generally associated the decision to adopt the most efficient system. The planner entrusted with this adaptation must be given the opportunity to obtain a precise knowledge of the concern and its whole organic construction. He, who year in, year out is engaged in obtaining knowledge of innumerable concerns of various types in all branches, will then from the rich store of his experiences be able with certainty to include in his plans whatever may be of service to the concern involved. The value of an irreproachable communication system justifies in every case the employment of the best technical knowledge and the most fruitful experience.

The drawing up of plans of all the rooms in the concern and the inscription of the staff members with their responsibilities form the best basis for the determination of the size of system required and the division of the subscribers into various groups, such as house subscribers, extensions, extensions with limited traffic facilities, night positions and the like. Whether the systems should also be equipped with spares for pending extensions, is generally a question of judgement.

The number of extensions gives an indication for the planning of the public exchange lines. Careful observation of the traffic from and to the exchange will enable the number of exchange lines to be corrected

and in the larger systems the division into the various traffic routes to be determined.

Junction Traffic The same care is demanded in the planning of the junction traffic between various exchanges. The line network generally entails considerable expenditure; for this reason the maximum efficiency must be obtained from it. It is just in the arrangement of the junction traffic that long-sighted measures may afford economic and organising advantages that more than justify the higher initial expenditure.

Location of the Exchange A point that is frequently not understood, is the location of the exchange. The automatic exchange is certainly much less exacting than the manual exchange in its claims regarding location—but nevertheless: the planner will pay due regard to the reliability and the life of the precision switching mechanisms, only if he is warned against putting the exchange in any dusty, unheated, damp, unventilated cellar or attic. There are no machines in existence that can continuously perform their duties faultlessly without maintenance, to say nothing of unsympathetic handling and unsuitable location. No man puts his beautiful, nice-looking motor-car in a coal shed, unless he is prepared to forego the “beautiful and nice-looking” appearance after a very few weeks.

Current Supply The larger telephone systems are fed from accumulator batteries. The current, the life-blood of the electrical system, must always be available in the correct form and in sufficient quantity. The batteries must be adequately dimensioned and properly maintained. Naturally, the charging equipment must also be exactly adapted to the individual case. Modern charging sets possess a high degree of reliability and require scarcely any attention.

A suitable room is almost as essential for the battery as for the exchange itself. It must be fitted up to fulfil its purpose. The acid fumes occurring during charging must be able to be rapidly dispersed; an acid-proofing treatment of the walls and a suitable floor covering are essential to protect the health of the maintenance staff and to prevent damage to the equipment and to the buildings.

The Network For the satisfactory operation of the system much depends on the state of the network. The planning of the network and its laying demand equal care. Bad material soon avenges itself. In a network constructed in a correct manner and with good material faults should only occur owing to extraneous damage. Before old networks are put into service again, however, careful testing and overhaul must be undertaken.

The neat visible wiring of the distributing frame facilitates maintenance and any changes that may subsequently be found necessary.

In new buildings care should be taken to see that provision is made not only for the lighting network, but also for the network for the telephone systems. The preparatory work in a new building (the cutting of channels for risers, the drawing in of conduit for house lines, the provision of recesses for distributing boxes and the like) involves only a fraction of the cost that has to be borne for subsequent installation, to say nothing at all of the appearance of the workrooms and passages.

The subscribers' stations have primarily to be fitted for the purpose, i. e., easy to operate. On hygienic grounds alone they require good maintenance. In damp or even acid-bearing rooms specially protected instruments must be used. Special protective measures have to be adopted for stations in mines, powder factories, chemical works where there is danger of explosion, and the like.

The Stations

The following summary contains a few questions that are particularly important for planning. It can scarcely be so exhaustive that with its help alone a satisfactory project can be evolved, because a telephone system that is to fulfil in every respect, what is expected of it, must, so to speak, be of the "best made-to-measure" variety.

1. How many public exchange lines are to be used?
 - a) How many subscribers are to be connected altogether?
 - b) How many of them are to have access to the public exchange (extensions)?
 - c) How is the night service to be arranged?
2. How many of the subscribers under 1 b) are located on other premises?
3. What system is considered the most suitable for your concern?
 - a) Series-connected system (see page 47 et seq.).
 - b) P.B.X. board with automatic house exchange (see page 64 et seq.).
 - c) Neha exchange (see page 81 et seq.).
4. Are any auxiliary equipments to be considered?
 - a) Staff finding system.
 - b) Door blocking circuits.
 - c) Conference-call equipments.
 - d) Conference systems.
 - e) Principal's instruments.
5. What is the nature of the heavy-current mains?
 - a) Direct or alternating current?
 - b) Voltage?

APPENDIX OF ILLUSTRATIONS

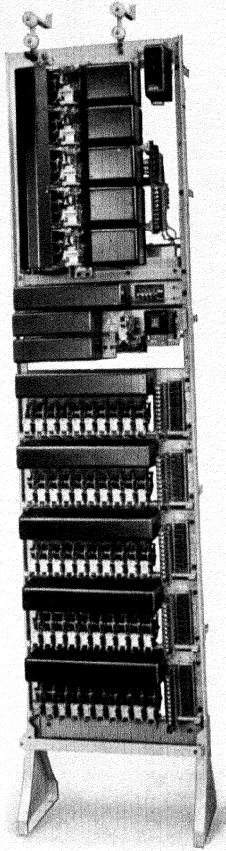

Automatic telephone exchange of the preselector type, equipped for 50 subscribers.

For every subscriber a preselector is provided, together with the relevant relays and fuses. For every 10 subscribers there is one final selector. Thus five connections can be set up simultaneously. In addition the rack carries the equipment for producing the ringing and busy signals, and also fuses, distributors and alarm lamps for various control purposes. The exchange can also be supplied equipped for less than 50 subscribers and can be extended without limit beyond 50 subscribers by the addition of further racks. A 24-volt D.C. supply is required for its operation.

Automatic telephone exchange of the call-finder type, equipped for 50 subscribers.

The iron rack accommodates: 5 connecting sets, consisting of 5 rotary selectors used as call-finder and 5 two-motion selectors used as final selectors. Thus for every ten subscribers one call-finder and one final selector are available. Five connections can, therefore, be set up simultaneously. In addition the rack carries the equipment for producing the ringing and busy signals, distributors, fuses, etc. Alarm lamps are provided for various control purposes. The exchange it also obtainable equipped for less than 50 subscribers. It can be extended without limit beyond 50 subscribers by the addition of further racks. A 24-volt D.C. supply is required for its operation.

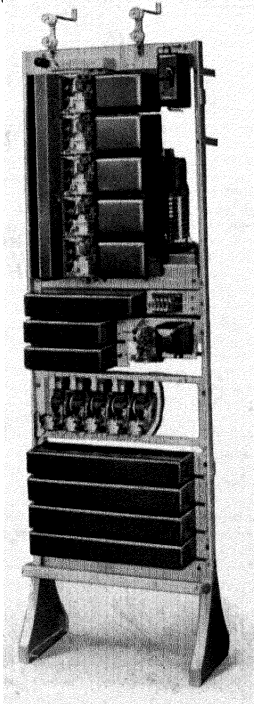

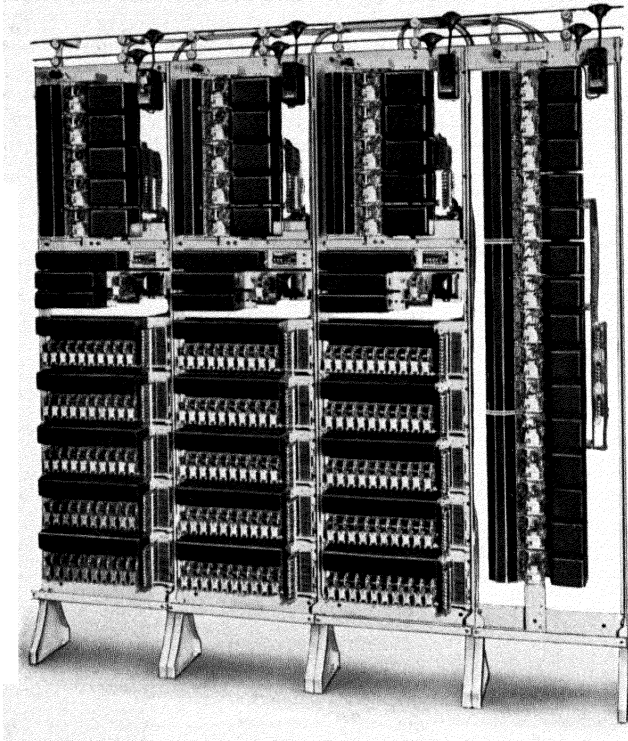

*24-volt automatic telephone system for 150 subscribers
(preselector type).
On the right 15 group selectors, on the left 3 frameworks each carrying 5 final
selectors, below 150 preselectors.
Approximate dimensions: Height 80"; Width 80"; Depth 8".*

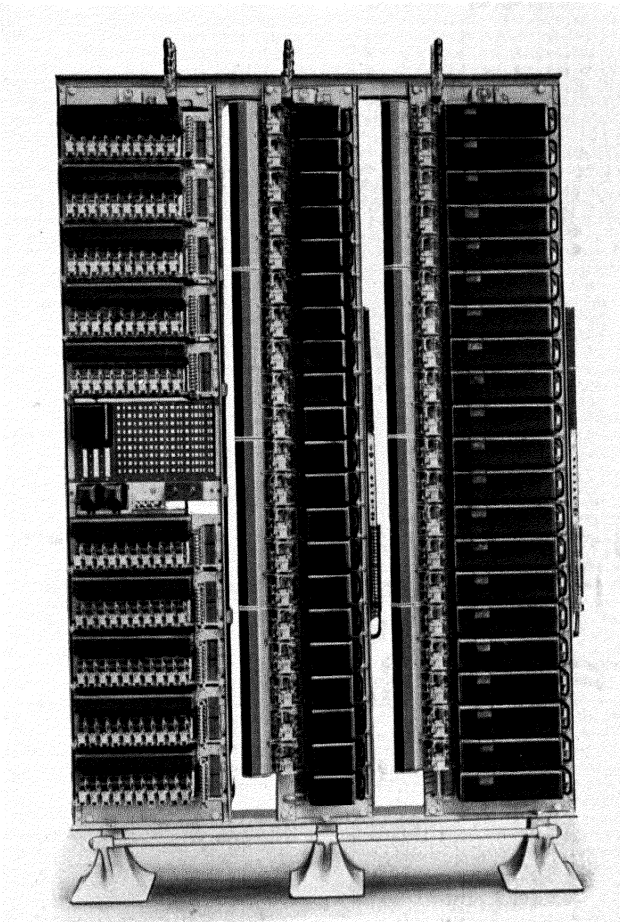

Automatic telephone exchange, equipped for 100 subscribers on the preselector principle (1000-line system).

This system consists of a preselector for every subscriber and a group and final selector for every five subscribers. Thus 20 connections can be set up simultaneously. Group selectors are not yet required in a system of not more than 100 lines. The exchange depicted above, however, is equipped on the 1000-line principle with a definite object; this arrangement is preferred in those cases, where an extension of the exchange beyond 100 subscribers is confidently to be expected. This exchange can, of course, also be supplied equipped on the 100-line principle (i. e., without group selectors) and with fewer than 20 p. c. group selectors + final selectors.

A 60-volt D. C. supply is required for the operation of this exchange.

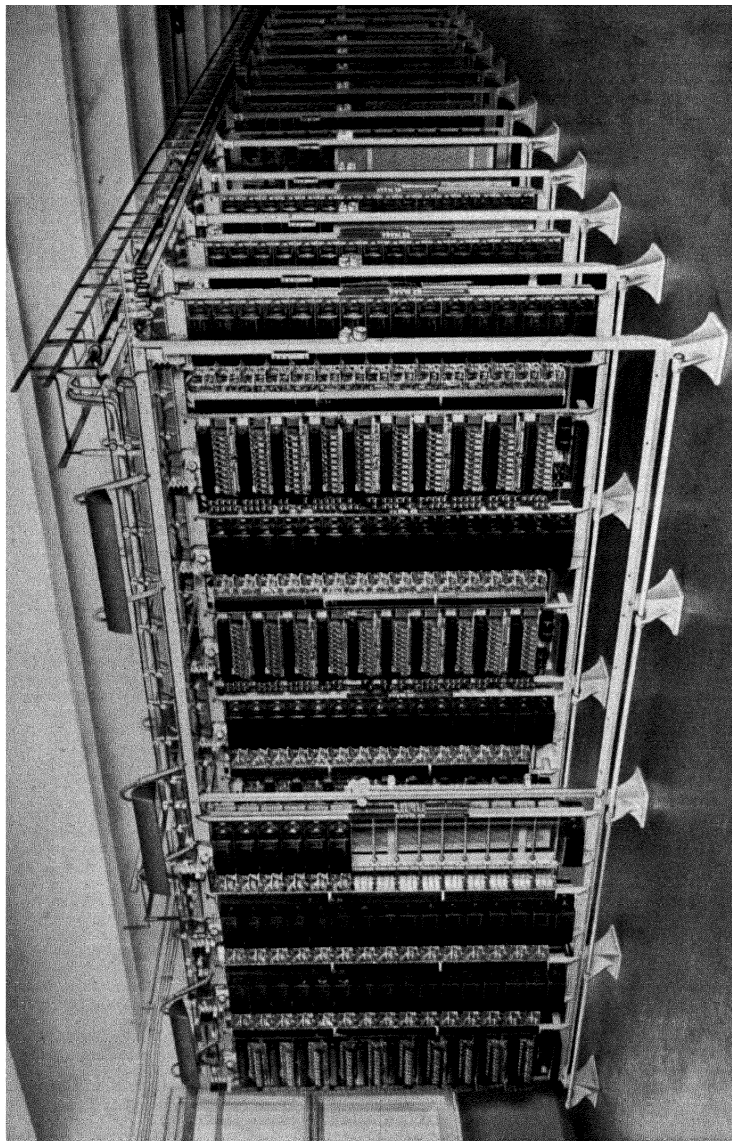

*View of a large automatic telephone exchange. On the front racks are frameworks each carrying 100 preselectors.
At the top of the racks are the coloured alarm lamps and the softfit lighting units.*



Automatic house exchange in a large German work.

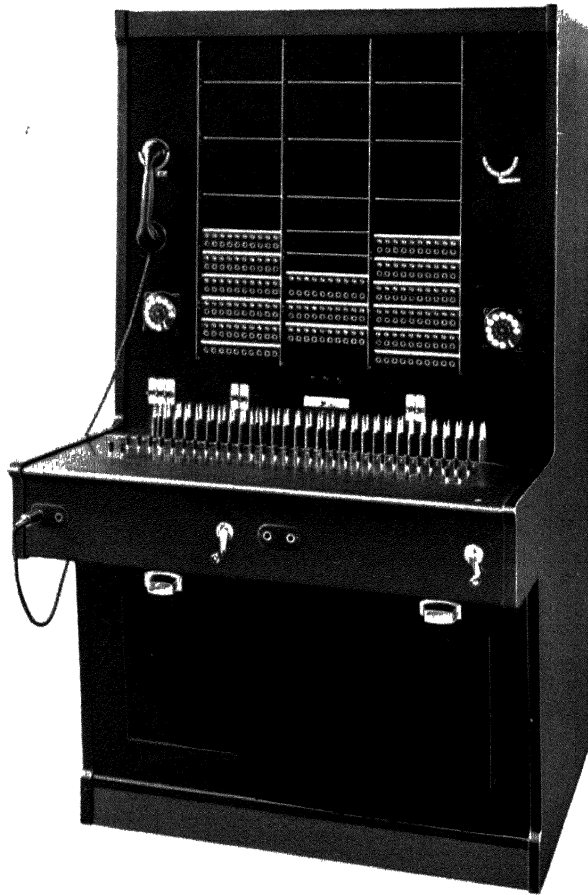

Manual telephone exchange (Okli system) for handling exchange and house connections with the same plug pairs, for 30 exchange lines, 30 pairs of cords and 3 hundreds groups. Approximate dimensions: Height 70"; Width 40"; Depth 42".

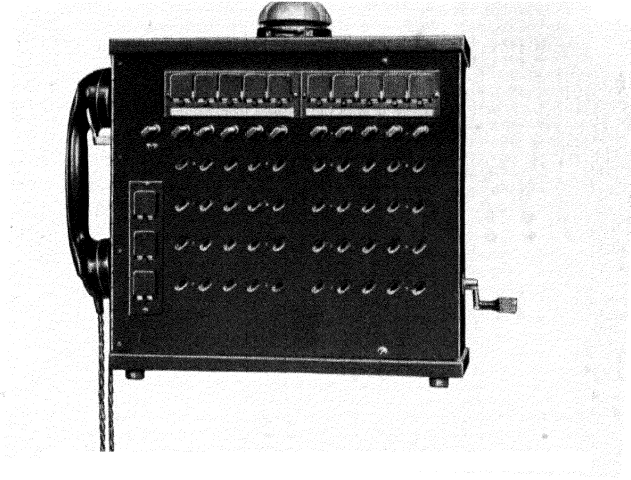

*Cordless switchboard for 10 lines (magneto ringing).
3 connecting sets, ringing and clearing indication by drop indicators. Wooden case
stained brown.*

Approximate dimensions: Height 14"; Width 14 $\frac{1}{2}$ "; Depth 6".

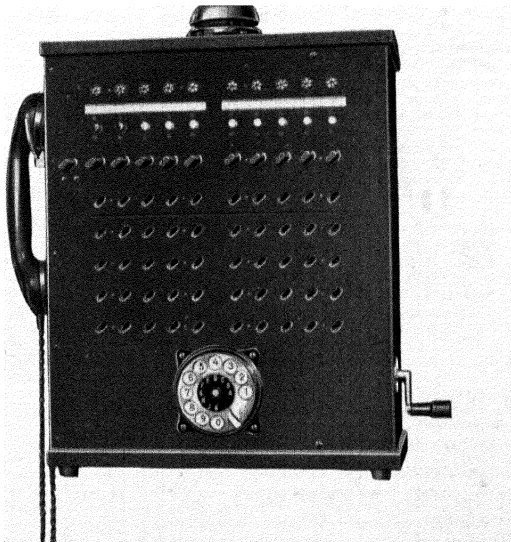

*Cordless switchboard for 2 exchange lines and 8 extensions for automatic lamp
signalling, 4 connector rows, wooden case stained brown.*

Approximate dimensions: Height 17 $\frac{1}{2}$ "; Width 14 $\frac{1}{2}$ "; Depth 8 $\frac{1}{2}$ ".

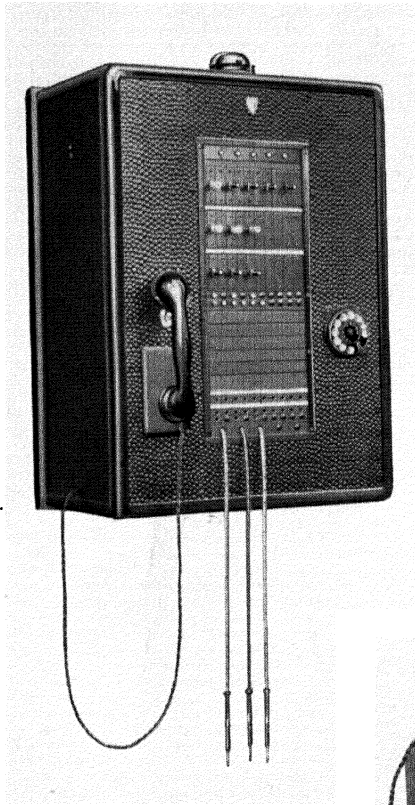

Semi-automatic P.B.X. (single-cord switchboard) in wall-type case. Outgoing exchange connections are set up automatically; for incoming calls an operator is required. The exchange illustrated is equipped for 3 exchange lines and 20 extensions; capacity up to 5 exchange lines and 50 extensions.

Black-enamelled iron case. Approximate dimensions: Height 29"; Width 22"; Depth 14".

Combined single-cord—double-cord indicating switchboard, equipped for 2 exchange lines and 30 extensions with 3 cord pairs and 1 auxiliary answering plug. Maximum capacity: 5 exchange lines, 50 extensions and 4 plug pairs. The case is of black-enamelled iron. Approximate dimensions: Height 17"; Width 20 1/2"; Depth 12".

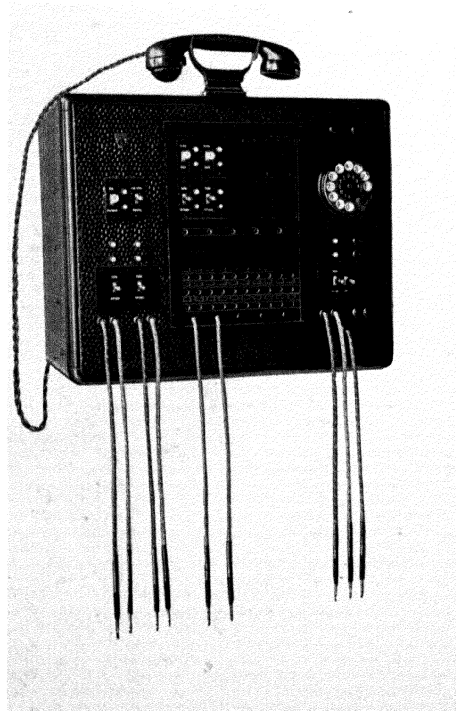

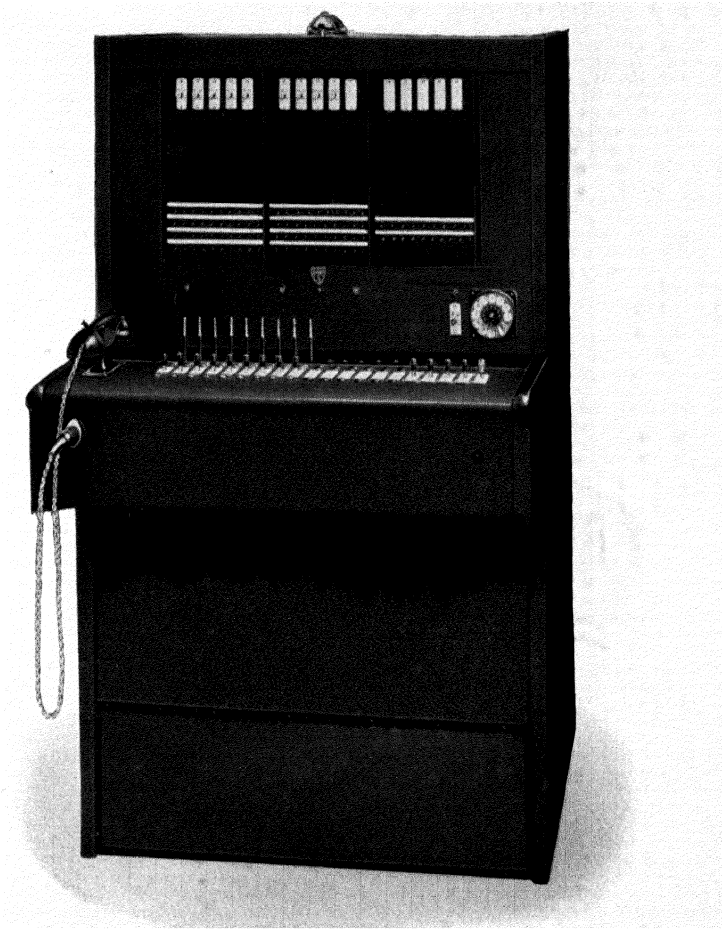

Private branch exchange (single-cord switchboard).

This exchange is equipped for 9 exchange lines and 100 extensions. Capacity up to 15 exchange lines and 300 extensions. The outgoing exchange calls are handled by the selectors of the house exchange. The switchboard case is made of black-enamelled iron.

Approximate dimensions: Height 57"; Width 34"; Depth 38".

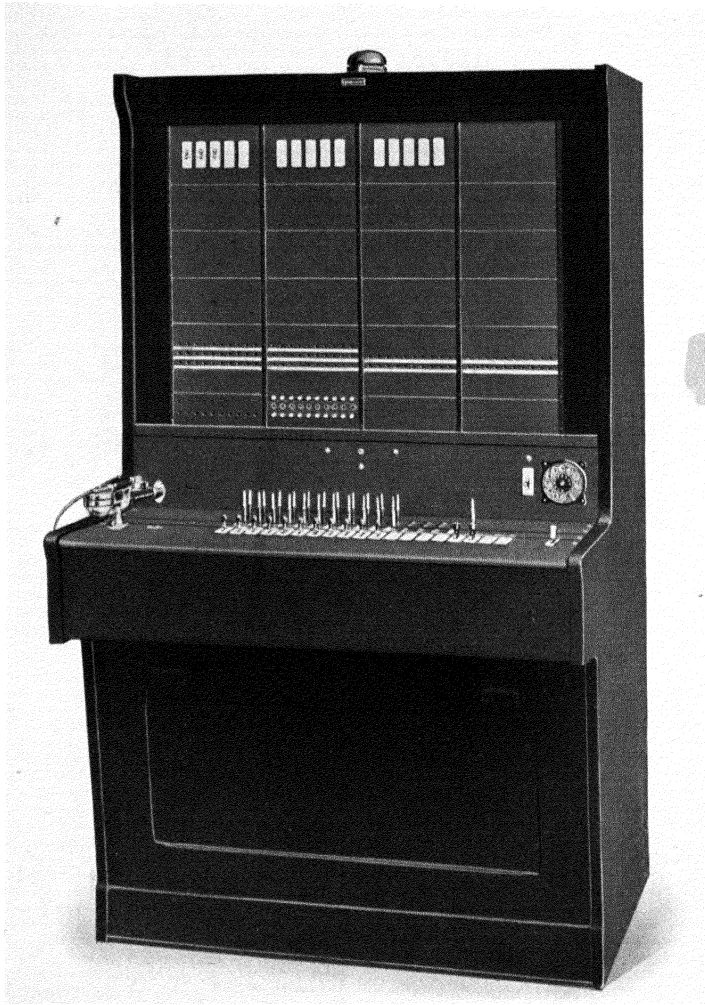

Private branch exchange (double-cord switchboard).

Outgoing connections are set up automatically; incoming calls are dealt with by means of cord and plug. There are P.B.X. boards of any desired capacity. The above exchange is equipped for 10 exchange lines and 100 extensions. Capacity up to 15 exchange lines and 800 extensions. The case is stained walnut colour.

Approximate dimensions: Height 70"; Width 40"; Depth 38 $\frac{1}{2}$ ".

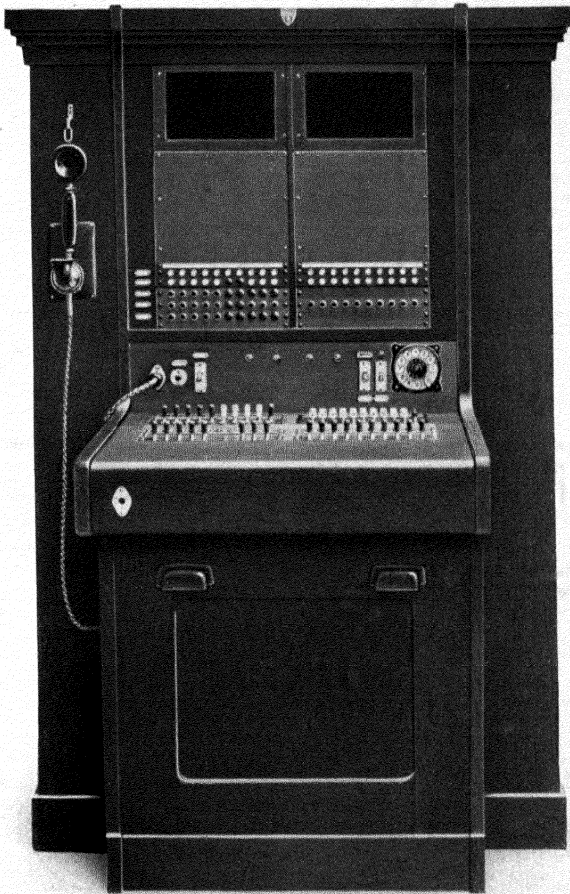

Key-sender switchboard.

For every 20 incoming exchange lines an operator's position has to be provided. The equipment contains in addition to the items for the service of the exchange lines the apparatus for record and information lines. The case is of stained oak.

Approximate dimensions: Height 62"; Width 41"; Depth 36 $\frac{1}{2}$ ".

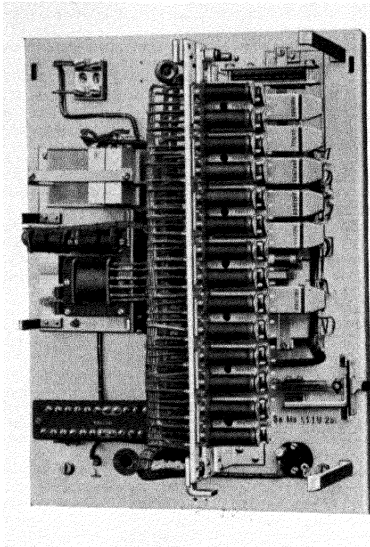

*Neha Relay Exchange
for 1 exchange line and 4 stations.
The equipment is fed from a 24-volt
accumulator battery. The case is of
black-enamelled iron.
Approximate dimensions: Height 16 $\frac{1}{2}$ '';
Width 12 $\frac{1}{2}$ ''; Depth 8 $\frac{1}{2}$ ''.*

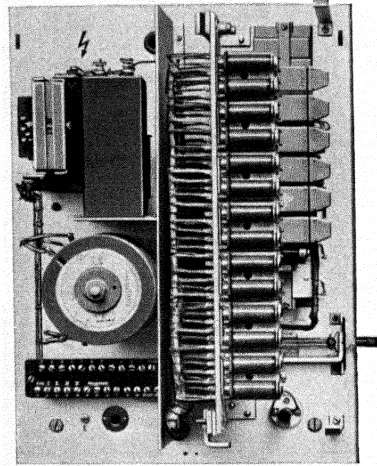

*Neha Relay Exchange
for 1 exchange line and 4 stations.
The equipment is housed in a wall-type
case of black-enamelled sheet-iron. It
contains also the mains apparatus requir-
ed for supplying the operating current;
this apparatus is separated from the actual
exchange by a metal wall and is intended
for connection to 50-cycle A.C. mains.*

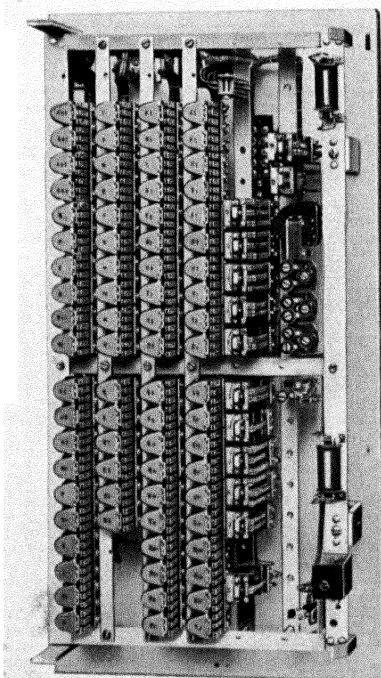

*Neha Relay Exchange
for 1 exchange line and up to 10 stations.
The equipment is mounted in a wall-type
case of black-enamelled sheet-iron and
contains all the relays, condensers, etc.
necessary for its operation.
Working voltage: 24 volts D.C.
Approximate dimensions: Height 23 $\frac{1}{2}$ '';
Width 12''; Depth 8''.*

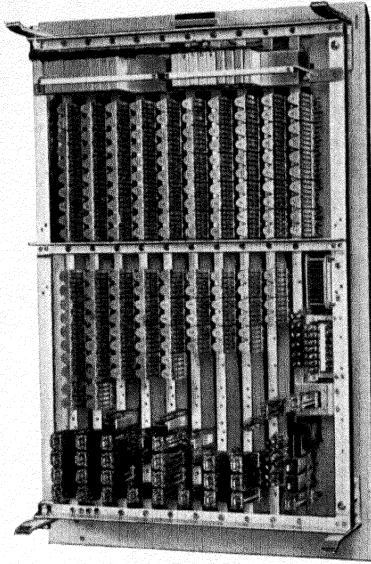

*Neha Relay Exchange
for 2 exchange lines and up to 10 sta-
tions. The equipment is housed in a
black-enamelled sheet-iron case.
Approximate dimensions: Height 36";
Width 35 $\frac{1}{2}$ "; Depth 8".*

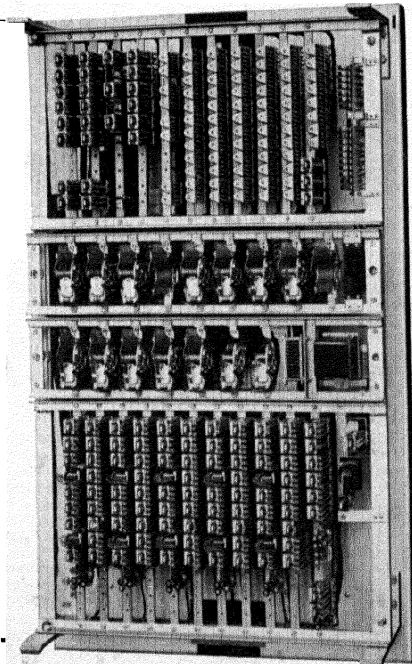

*Neha Rotary-Switch Exchange
for 5 exchange lines and 27 stations.
3 sets of switches are mounted (in
the upper switch-row). In the lower
switch-row are the 5 exchange switches,
1 auxiliary final selector and 1 rotary
switch as a signalling mechanism. The
upper part of the exchange carries the
subscribers' relays. Below are the
relays for the 5 exchange sets, pole-
changers, etc.*

*Wall-type case of black-enamelled
sheet-iron.
Approximate dimensions: Height 46";
Width 28"; Depth 12".*

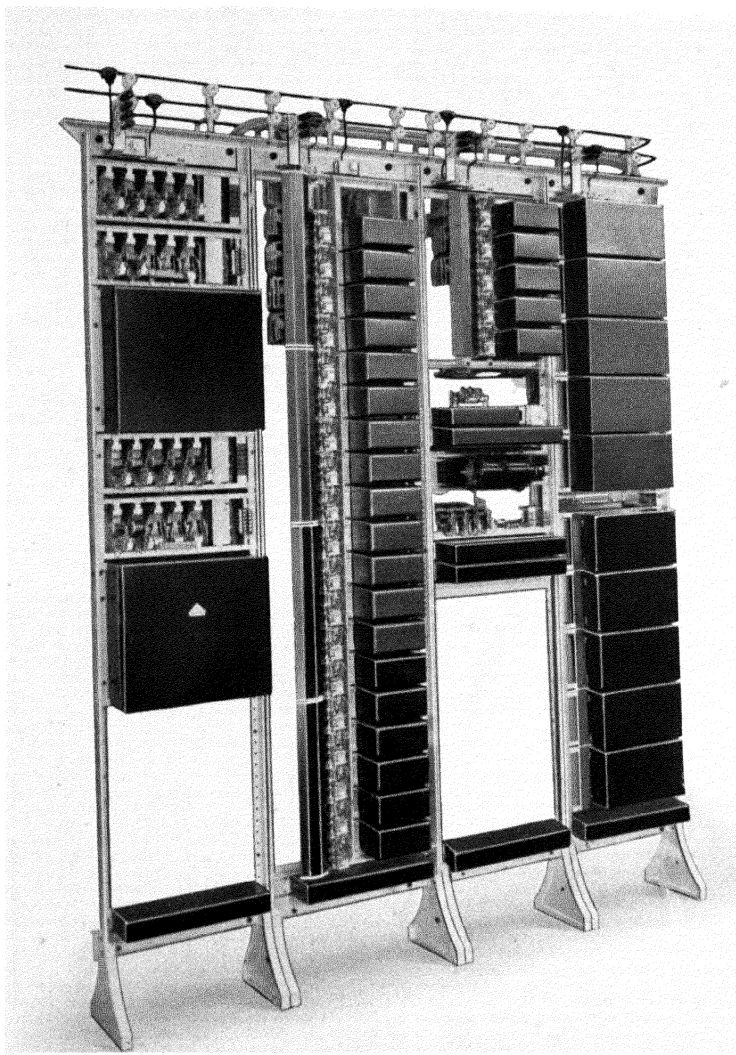

*Large Neha exchange (only partly equipped).
On the left are the frameworks carrying the call-finders and the subscribers' relays.
In the middle the group and final selectors. On the right the exchange selectors
with the relay sets, and among them the signalling machine.*



Operator's station for a Neha exchange with 5 exchange lines.



*Operator's station for a Neha exchange with 10 exchange lines.
The equipment can comfortably be accommodated on the desk.*



*Operator's station
for a Neha relay exchange
with 2 exchange lines.*

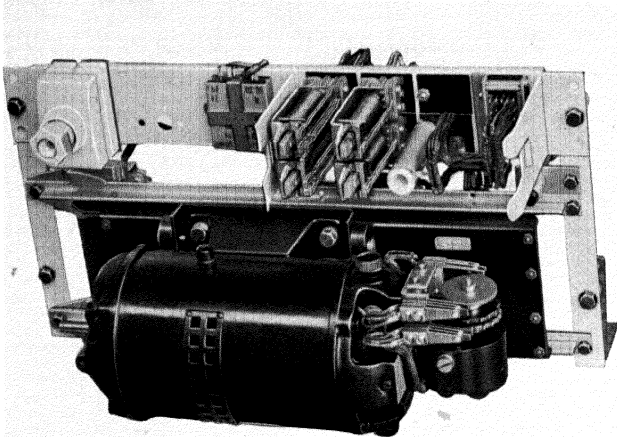

Ring and signalling machine set for a large P.B.X. The machine is spring-mounted on the switch-rack. On the right of the machine are the cams for the various signals.

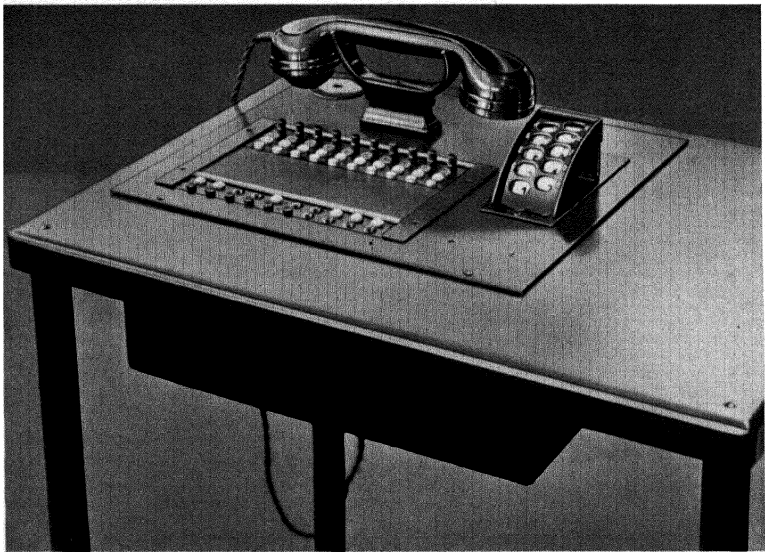

Operator's desk for a large Neha exchange. Equipped for 10 exchange lines. Space is provided for a further 10 exchange lines. On the right of the illustration is the straight-pull dial (for description see page 108).



Below the dial are the sealed switching key and the busy indicator.

Connecting set with floating battery for a selective ringing line. At the top on the right is the line distributor. In the middle on the left is the polarised relay and under it the switching mechanism (almost entirely hidden by the relay).

Dimensions: Height about 24''; Width about 10''; Depth about 8''.

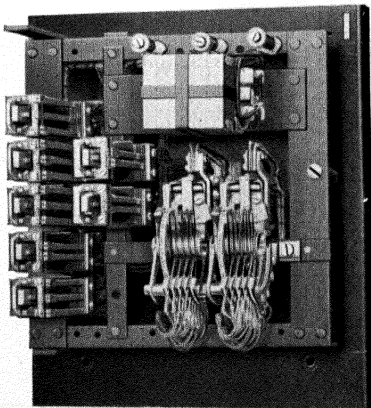
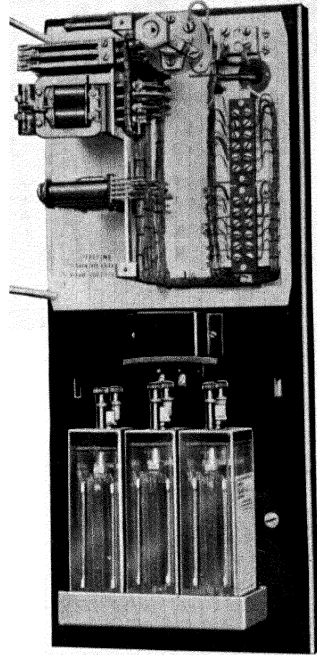

Auxiliary equipment for a staff finding system. The equipment contains 2 rotary switches as well as relays, condensers and resistances.

Dimensions: Height about 10 $\frac{1}{2}$ ''; Width about 9''; Depth about 7 $\frac{1}{2}$ ''.

Lamp indicator for a staff finding system.

Dimensions: Height about 16''; Width about 2 $\frac{1}{2}$ ''; Depth about 5 $\frac{1}{2}$ ''.

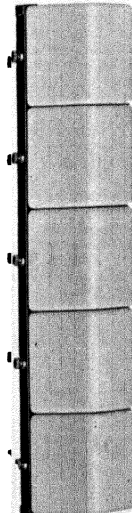



*Principal's station
for 1 exchange line, 1 extension line
and 1 line to the secretary. Two
switch-over keys and various keys
for messenger calling, secretary
calling and door locking.*

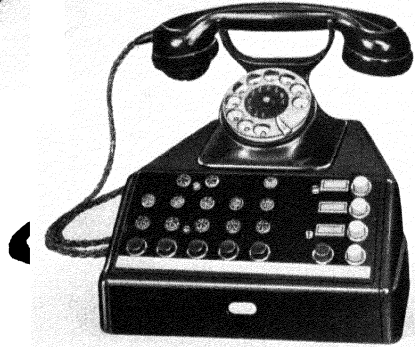

*Secretary's station
for 2 exchange lines and
2 extension lines.
A direct line to the principal,
a listening key and staff
calling keys.*

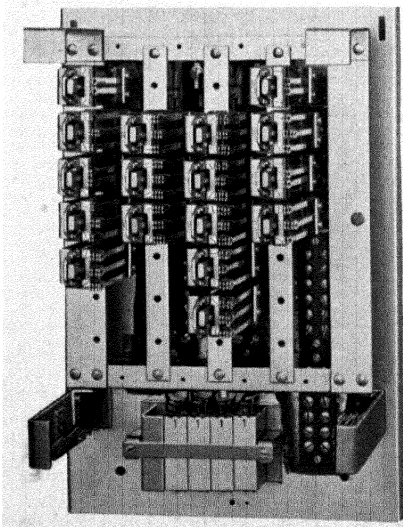

*Relay set for a principal's and secre-
tary's station.*

*The case is of black-enamelled sheet-
iron.*

*Dimensions: Height about 18";
Width about 12"; Depth about 6 1/4".*



*Conference-convening station
for 4 permanent and 1 optional con-
ference subscriber.*

*Firedamp-proof
automatic wall station
for mines, chemical
factories and the like.*



*Table telephone station
with listening and speaking equip-
ment. The station is equipped for
10 lines. Dial and signalling key
for its own connections.*

